

IBM System Storage TS2260



# Setup, Operator, and Service Guide

*Machine Type 3580 Model H6S*



IBM System Storage TS2260



# Setup, Operator, and Service Guide

*Machine Type 3580 Model H6S*

**Note!**

Before using this information and the product it supports, be sure to read the general information in "Notices."

To ensure that you have the latest publications, visit the web at <http://www.ibm.com/storage/ltc>.

**Released May 2014**

This edition applies to the *IBM System Storage TS2260 Tape Drive*, GA32-2226-01, and to the subsequent releases and modifications until otherwise indicated in new editions.

© **Copyright IBM Corporation 2010, 2014.**

US Government Users Restricted Rights – Use, duplication or disclosure restricted by GSA ADP Schedule Contract with IBM Corp.

---

## Read this first

This product might not be certified in your country for connection by any means whatsoever to interfaces of public telecommunications networks. Further certification might be required by law before making any such connection. Contact IBM® for information.

---

## Accessing online technical support

It is the customer's responsibility to set up this tape drive or library and to ensure that the drive and library have the latest firmware (unless you have purchased a service contract).

For online technical support:

1. Visit <http://www.ibm.com>.
2. Click **Get Support**.
3. Click **Customer Support** and follow on-screen instructions.

---

## Sending us your comments

Your feedback is important in helping IBM provide accurate and useful information. If you have comments or suggestions for improving this publication, send your comments by:

- Emailing IBM:
  - Internet or IBMLink from US: *starpubs@us.ibm.com*
  - IBMLink from Canada: *STARPUBS at TORIBM*

Include the following information in your email:

- Exact publication title
- Form number (for example, GA32-1234-02) or part number (on the back cover of the publication)
- Page, table, or illustration numbers that you are commenting on
- A detailed description of any information that should be changed



---

## Summary of Changes

The following list indicates the changes to the most recent edition of the document.

---

### 2nd Edition

- | • Added information about the optional tape drive with SAS/USB ports and  
| cables that can be purchased for the tape drive (Feature Codes 5501, 5760, and  
| 5761)





# Contents

## Read this first . . . . . iii

Accessing online technical support. . . . . iii

Sending us your comments . . . . . iii

## Summary of Changes . . . . . v

2nd Edition. . . . . v

## Figures . . . . . ix

## Tables . . . . . xi

## Safety notices . . . . . xiii

Completing the safety inspection procedure . . . . . xiv

Tape drive ac grounding inspection . . . . . xiv

Class I laser product . . . . . xv

Rack safety . . . . . xvi

Power cords . . . . . xviii

End of life (EOL) plan . . . . . xix

## Environmental notices. . . . . xxi

## Preface. . . . . xxiii

## Chapter 1. Introduction . . . . . 1-1

Drive features . . . . . 1-1

Front panel of the drive . . . . . 1-2

Rear panel of the drive . . . . . 1-2

Drive performance. . . . . 1-3

Cartridge compatibility . . . . . 1-3

Speed matching. . . . . 1-4

Channel calibration . . . . . 1-5

Data cartridge capacity scaling. . . . . 1-5

Encryption . . . . . 1-5

Inhibiting firmware down-leveling . . . . . 1-5

SAS interface . . . . . 1-5

USB interface . . . . . 1-6

Supported servers and operating systems . . . . . 1-6

Supported device drivers . . . . . 1-6

Ethernet port . . . . . 1-7

Linear tape file system (LTFS) . . . . . 1-7

Specifications . . . . . 1-7

## Chapter 2. Installation . . . . . 2-1

Avoiding drive damage . . . . . 2-1

Unpacking the drive . . . . . 2-1

Verifying the shipment . . . . . 2-2

Installing the rack mount kit (optional) . . . . . 2-2

Inspecting the power cord and outlet . . . . . 2-2

Positioning the tape drive . . . . . 2-3

Installing the SAS host adapter card (if required) . . . . . 2-3

Connecting the SAS interface cable . . . . . 2-3

Connecting the USB interface cable (optional). . . . . 2-4

Connecting power . . . . . 2-5

Running drive diagnostics . . . . . 2-5

Installing device drivers . . . . . 2-5

Configuring the tape drive to a server/host . . . . . 2-5

Updating firmware . . . . . 2-6

Registering for My Support. . . . . 2-8

## Chapter 3. Operations . . . . . 3-1

Operating modes . . . . . 3-1

Power button . . . . . 3-1

Single-character display (SCD). . . . . 3-1

Status lights . . . . . 3-2

Unload button . . . . . 3-5

Inserting a tape cartridge . . . . . 3-6

Removing a tape cartridge . . . . . 3-7

Mid-tape recovery . . . . . 3-7

Cleaning the drive head . . . . . 3-7

Cleaning the tape drive . . . . . 3-8

Tape Drive Status web page . . . . . 3-8

Diagnostic and maintenance functions . . . . . 3-9

    Entering Maintenance mode . . . . . 3-11

    Exiting Maintenance mode. . . . . 3-11

    Function code 0: Maintenance mode . . . . . 3-12

    Function code 1: Run drive diagnostics . . . . . 3-12

    Function code 2: Update drive firmware from FMR tape . . . . . 3-13

    Function code 3: Create FMR tape . . . . . 3-13

    Function code 4: Force a drive dump . . . . . 3-14

    Function code 5: Copy drive dump. . . . . 3-14

    Function code 6: Run host interface wrap test . . . . . 3-15

    Function code 7: Run RS-422 wrap test . . . . . 3-16

    Function code 8: Unmake FMR tape . . . . . 3-17

    Function code 9: Display error code log . . . . . 3-18

    Function code A: Clear error code log . . . . . 3-18

    Function code C: Insert cartridge into tape drive . . . . . 3-18

    Function code E: Test cartridge & media . . . . . 3-18

    Function code F: Write performance test . . . . . 3-19

    Function code H: Test head . . . . . 3-20

    Function code J: Fast read/write test . . . . . 3-21

    Function code L: Load/unload test . . . . . 3-22

    Function code P: Post Error Reporting enabled . . . . . 3-23

    Function code U: Post Error Reporting disabled . . . . . 3-23

Tape drive diagnostic and maintenance web page . . . . . 3-24

## Chapter 4. Ultrium media . . . . . 4-1

Data cartridges . . . . . 4-1

    Cartridge Compatibility . . . . . 4-3

    Capacity Scaling . . . . . 4-3

WORM (Write Once, Read Many) cartridges . . . . . 4-3

    WORM media . . . . . 4-3

    Data security on WORM media . . . . . 4-4

    WORM media errors . . . . . 4-4

    WORM requirements . . . . . 4-4

Cleaning cartridge . . . . . 4-4

Cartridge memory chip (LTO-CM) . . . . . 4-5

Bar code label . . . . .	4-5
Guidelines for bar code labels . . . . .	4-7
Write-Protect switch . . . . .	4-7
Handling the cartridges . . . . .	4-8
Providing training . . . . .	4-8
Ensuring proper packaging . . . . .	4-9
Proper acclimation and environmental conditions . . . . .	4-10
Completing a thorough inspection . . . . .	4-10
Handling the cartridge carefully . . . . .	4-11
Examples of cartridge problems . . . . .	4-11
Repositioning or reattaching a leader pin . . . . .	4-12
Repositioning a leader pin . . . . .	4-12
Reattaching a leader pin . . . . .	4-14
Environmental and shipping specifications for tape cartridges . . . . .	4-18
Disposing of tape cartridges . . . . .	4-19
Ordering media supplies . . . . .	4-20
Ordering bar code labels . . . . .	4-22

**Chapter 5. Troubleshooting . . . . . 5-1**

Procedure 1: Determining firmware level and capturing drive dump . . . . .	5-1
Procedure 2: Inspecting a cartridge for damage . . . . .	5-2
Procedure 3: Checking SAS host connections . . . . .	5-3
Procedure 4: Verifying host interface communications . . . . .	5-3
Resolving problems reported by the server . . . . .	5-4
Resolving media-related problems . . . . .	5-4
Pre-call checklist . . . . .	5-4
Replacing the tape drive . . . . .	5-5

**Appendix A. Error codes and messages . . . . . A-1**

**Appendix B. TapeAlert flags . . . . . B-1**

**Appendix C. Ordering optional features, replacement parts, and power cords . . . . . C-1**

**Appendix D. Installing a 19-inch rack mount kit (optional). . . . . D-1**

Rack safety . . . . .	D-1
Verify kit contents . . . . .	D-3
Tools required . . . . .	D-3
Installing the shelf . . . . .	D-4

Removing the shelf from the rack . . . . .	D-5
--	-----

**Appendix E. Information for trained service personnel . . . . . E-1**

Removing the internal drive . . . . .	E-1
Step 1. Removing the cover . . . . .	E-1
Step 2. Removing the internal drive . . . . .	E-3
Manually removing a tape cartridge . . . . .	E-4
Before you begin . . . . .	E-5
Recommended tools . . . . .	E-5
Beginning procedure . . . . .	E-5
Tape spooled off supply reel . . . . .	E-6
Tape pulled from or broken near leader pin . . . . .	E-8
Tape broken in mid-tape . . . . .	E-9
Tape tangled along tape path . . . . .	E-10
No apparent failure or damage to tape . . . . .	E-11
Replacing the internal drive . . . . .	E-14
Step 1. Replacing the internal drive . . . . .	E-14
Step 2. Replacing the cover . . . . .	E-14

**Notices . . . . . F-1**

Trademarks . . . . .	F-2
Electronic emission notices . . . . .	F-3
Federal Communications Commission statement . . . . .	F-3
Industry Canada compliance statement . . . . .	F-4
European Union electromagnetic compatibility directive . . . . .	F-4
People's Republic of China Class A Electronic Emission statement . . . . .	F-5
Taiwan Class A compliance statement . . . . .	F-6
Taiwan contact information . . . . .	F-6
Japan VCCI Council Class A statement . . . . .	F-6
Japan Electronics and Information Technology Industries Association (JEITA) statement (less than or equal to 20 A per phase) . . . . .	F-6
Japan Electronics and Information Technology Industries Association (JEITA) statement (greater than 20 A per phase) . . . . .	F-7
Korean Communications Commission (KCC) Class A Statement . . . . .	F-7
Russia Electromagnetic Interference (EMI) Class A statement . . . . .	F-7

**Glossary . . . . . G-1**

**Index . . . . . X-1**

---

## Figures

1.	AC grounding diagram (50 Hz and 60 Hz)	xv	4-11.	Leader pin reattachment kit	4-15
1-1.	View of the drive	1-1	4-12.	Attaching the leader pin attach tool to the cartridge	4-16
1-2.	Front panel element descriptions	1-2	4-13.	Winding the tape out of the cartridge	4-17
1-3.	Drive rear panel element descriptions - dual SAS ports	1-2	4-14.	Removing the C-clip from the leader pin	4-17
1-4.	Drive rear panel element descriptions - single SAS/USB ports	1-3	4-15.	Attaching the leader pin to the tape	4-18
2-1.	Example of connecting one SAS device to the server	2-3	5-1.	Flowchart for Analyzing Maintenance Problems	5-1
2-2.	Example of connecting the SAS device to two servers	2-4	5-2.	RID tag on rear panel	5-6
2-3.	Example of connecting the USB device to the server	2-5	C-1.	Types of receptacles	C-5
3-1.	Inserting a cartridge into the drive	3-6	D-1.	Front view of shelf attached to rack rails	D-4
3-2.	Drive Status web page	3-8	D-2.	Rear view of shelf with cables attached to rack rails with tie wraps	D-5
3-3.	Drive Status web page - topic details	3-9	E-1.	Removing the screws that secure the cover and internal drive	E-2
3-4.	Tape drive diagnostic page	3-25	E-2.	Removing cables from the internal drive	E-3
4-1.	The IBM LTO Ultrium data cartridge	4-1	E-3.	Releasing the drive from the chassis	E-4
4-2.	Ultrium Data and WORM Tape Cartridges	4-4	E-4.	Sliding the drive forward	E-4
4-3.	Sample bar code label on the LTO Ultrium 6 Tape Cartridge	4-7	E-5.	Removing the bezel and the cover from the internal drive	E-6
4-4.	Setting the write-protect switch	4-8	E-6.	Rewinding tape into cartridge	E-7
4-5.	Tape cartridges in a Turtlecase	4-9	E-7.	Drive with cover removed to reveal gear train	E-8
4-6.	Double-boxing tape cartridges for shipping	4-10	E-8.	Leader block assembly (LBA)	E-9
4-7.	Checking for gaps in the seams of a cartridge	4-11	E-9.	Rewinding tape into cartridge	E-10
4-8.	Leader pin in the incorrect and correct positions	4-13	E-10.	Rewinding tape into cartridge	E-11
4-9.	Placing the dislodged leader pin into the correct position	4-13	E-11.	Rewinding tape into cartridge	E-12
4-10.	Rewinding the tape into the cartridge	4-14	E-12.	Drive with cover removed to reveal gear train	E-13
			E-13.	Leader block assembly (LBA)	E-13



---

## Tables

1-1.	Performance characteristics . . . . .	1-3	4-6.	Cartridges and VOLSERS compatible with the Ultrium Tape Drives . . . . .	4-6
1-2.	Performance parameters . . . . .	1-4	4-7.	Location of the write-protect switch . . . . .	4-8
1-3.	Specifications . . . . .	1-7	4-8.	Environment for operating, storing, and shipping the LTO Ultrium Tape Cartridge . . . . .	4-19
3-1.	Meaning of Status lights and single-character display (SCD) . . . . .	3-3	4-9.	Media supplies . . . . .	4-20
3-2.	Functions that the Unload Button completes . . . . .	3-5	4-10.	Authorized suppliers of custom bar code labels . . . . .	4-22
3-3.	Diagnostic and maintenance functions . . . . .	3-10	A-1.	Error codes on the Single-character Display . . . . .	A-1
4-1.	Cartridge types and colors . . . . .	4-1	C-1.	Optional features . . . . .	C-1
4-2.	Cartridge data capacity and recording formats . . . . .	4-2	C-2.	Replacement parts . . . . .	C-1
4-3.	Nominal cartridge life: Load/unload cycles . . . . .	4-3	C-3.	Power cords . . . . .	C-2
4-4.	Ultrium data cartridge compatibility with Ultrium tape drive . . . . .	4-3			
4-5.	Bar code label requirements for Ultrium tape drives and libraries . . . . .	4-5			



## Safety notices

Observe the safety notices when using this product. These safety notices contain danger and caution notices. These notices are sometimes accompanied by symbols that represent the severity of the safety condition.

Most danger or caution notices contain a reference number (Dxxx or Cxxx). Use the reference number to check the translation in the *IBM Systems Safety Notices*, G229-9054 manual.

The sections that follow define each type of safety notice and give examples.

### Danger notice





A danger notice calls attention to a situation that is potentially lethal or extremely hazardous to people. A lightning bolt symbol always accompanies a danger notice to represent a dangerous electrical condition. A sample danger notice follows:



**DANGER:** An electrical outlet that is not correctly wired could place hazardous voltage on metal parts of the system or the devices that attach to the system. It is the responsibility of the customer to ensure that the outlet is correctly wired and grounded to prevent an electrical shock. (D004)

### Caution notice

A caution notice calls attention to a situation that is potentially hazardous to people because of some existing condition, or to a potentially dangerous situation that might develop because of some unsafe practice. A caution notice can be accompanied by one of several symbols:

If the symbol is...	It means...
	A generally hazardous condition not represented by other safety symbols.
	This product contains a Class II laser. Do not stare into the beam. (C029) Laser symbols are always accompanied by the classification of the laser as defined by the U. S. Department of Health and Human Services (for example, Class I, Class II, and so forth).
	A hazardous condition due to mechanical movement in or around the product.
	This part or unit is heavy but has a weight smaller than 18 kg (39.7 lb). Use care when lifting, removing, or installing this part or unit. (C008)

Sample caution notices follow:

**Caution**

The battery is a lithium ion battery. To avoid possible explosion, do not burn. Exchange only with the IBM-approved part. Recycle or discard the battery as instructed by local regulations. In the United States, IBM has a process for the collection of this battery. For information, call 1-800-426-4333. Have the IBM part number for the battery unit available when you call. (C007)

**Caution**

The system contains circuit cards, assemblies, or both that contain lead solder. To avoid the release of lead (Pb) into the environment, do not burn. Discard the circuit card as instructed by local regulations. (C014)

**Caution**

When removing the Modular Refrigeration Unit (MRU), immediately remove any oil residue from the MRU support shelf, floor, and any other area to prevent injuries because of slips or falls. Do not use refrigerant lines or connectors to lift, move, or remove the MRU. Use handholds as instructed by service procedures. (C016)

**Caution**

Do not connect an IBM control unit directly to a public optical network. The customer must use an additional connectivity device between an IBM control unit optical adapter (that is, fibre, ESCON<sup>®</sup>, FICON<sup>®</sup>) and an external public network . Use a device such as a patch panel, a router, or a switch. You do not need an additional connectivity device for optical fibre connectivity that does not pass through a public network.

---

## Completing the safety inspection procedure

Before you service the unit, complete the safety inspection procedure:

1. Stop all activity on the host bus.
2. Turn off the power to the tape drive.
3. Disconnect the host interface cable.
4. Unplug the tape drive's power cord from the electrical outlet.
5. Check the tape drive's power cord for damage, such as a pinched, cut, or frayed cord.
6. Check the tape drive's host interface cable for damage.
7. Check the cover of the tape drive for sharp edges, damage, or alterations that expose its internal parts.
8. Check the cover of the tape drive for proper fit. It should be in place and secure.
9. Check the product label on the tape drive to make sure that it matches the voltage at your outlet.

---

## Tape drive ac grounding inspection

1. Power off the drive.
2. Disconnect all cables.
3. See Figure 1 on page xv which is provided for reference only. Disconnect the power cord from its source.



4. Inspect the power cable for visible cracks, wear, or damage.

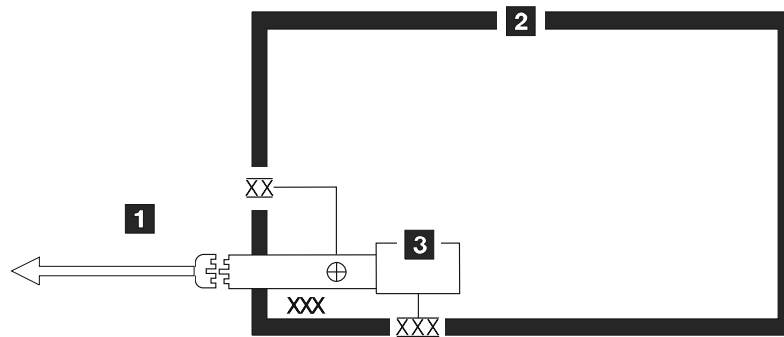

Legend:

- XX External tooth lock washer  
Green/yellow ground wire terminated to chassis or ground
- ⊕ Green/yellow ground wire terminated with slip-on spade terminal
- XXX Redundant ground path to frame
- XXXX External tooth lock washer

a1400040

Figure 1. AC grounding diagram (50 Hz and 60 Hz)

---

## Class I laser product

Before the library is used, review the following laser safety information.

The product might contain a laser assembly that complies with the performance standards set by the US Food and Drug Administration for a Class I laser product. Class I laser products do not emit hazardous laser radiation. The product has the necessary protective housing and scanning safeguards to ensure that laser radiation is inaccessible during operation or is within Class I limits. External safety agencies reviewed the product and obtained approvals to the latest standards as they apply.

---

## Rack safety

The following general safety information must be used for all rack mounted devices.

### DANGER



- Always lower the leveling pads on the rack cabinet.
- Always install stabilizer brackets on the rack cabinet.
- To avoid hazardous conditions because of uneven mechanical loading, always install the heaviest devices in the bottom of the rack cabinet. Always install servers and optional devices, starting from the bottom of the rack cabinet.
- Rack mounted devices are not to be used as a shelf or workspace. Do not place any object on top of rack mounted devices.
- Each rack cabinet might have more than one power cord. Be sure to disconnect all power cords in the rack cabinet before you service any device in the rack cabinet.
- Connect all devices that are installed in a rack cabinet to power devices installed in the same rack cabinet. Do not plug a power cord from a device that is installed in one rack cabinet into a power device that is installed in a different rack cabinet.
- An electrical outlet that is not correctly wired might place hazardous voltage on the metal parts of the system or the devices that attach to the system. It is the responsibility of the customer to ensure that the outlet is correctly wired and grounded to prevent an electrical shock.

**CAUTION:**



- Do not install a unit in a rack where the internal rack ambient temperatures might exceed the manufacturer's recommended ambient temperature for all your rack mounted devices.
- Do not install a unit in a rack where the air flow is compromised. Ensure that air flow is not blocked or reduced on any side, front, or back of a unit that is used for air flow through the unit.
- Consideration must be given to the connection of the equipment to the supply circuit so that overloading of the circuits does not compromise the supply wiring or overcurrent protection. To provide the correct power connection to a rack, refer to the rating labels on the equipment in the rack to determine the total power requirement of the supply circuit.
- (For sliding drawers) Do not pull out or install any drawer or feature if the rack stabilizer brackets are not attached to the rack. Do not pull out more than one drawer at a time. The rack might become unstable if you pull out more than one drawer at a time.
- (For fixed drawers) This drawer is a fixed drawer and must not be moved for servicing unless specified by the manufacturer. Attempting to move the drawer partially or out of the rack might cause the rack to become unstable or cause the drawer to fall out of the rack.

*(R001)*

**CAUTION:**



Removing components from the upper positions in the rack cabinet improves rack stability during relocation. Follow these general guidelines whenever you relocate a populated rack cabinet within a room or building:

- Reduce the weight of the rack cabinet by removing equipment, starting at the top of the rack cabinet. When possible, restore the rack cabinet to the configuration of the rack cabinet as you received it. If this configuration is not known, you must do the following:
  - Remove all devices in the 32U position and above.
  - Ensure that the heaviest devices are installed in the bottom of the rack cabinet.
  - Ensure that there are no empty U-levels between devices that are installed in the rack cabinet below the 32U level.
- If the rack cabinet you are relocating is part of a suite of rack cabinets, detach the rack cabinet from the suite.
- Inspect the route that you plan to take to eliminate potential hazards.
- Verify that the route that you choose can support the weight of the loaded rack cabinet. Refer to the documentation that comes with your rack cabinet for the weight of a loaded rack cabinet.
- Verify that all door openings are at least 760 x 2032 mm (30 x 80 in.).
- Ensure that all devices, shelves, drawers, doors, and cables are secure.
- Ensure that the four leveling pads are raised to their highest position.
- Ensure that there is no stabilizer bracket that is installed on the rack cabinet during movement.
- Do not use a ramp that is inclined at more than 10 degrees.
- When the rack cabinet is in the new location:
  - Lower the four leveling pads.
  - Install stabilizer brackets on the rack cabinet.
  - If you removed any devices from the rack cabinet, repopulate the rack cabinet from the lowest position to the highest position.
- If a long-distance relocation is required, restore the rack cabinet to the configuration of the rack cabinet as you received it. Pack the rack cabinet in the original packaging material, or equivalent. Also, lower the leveling pads to raise the casters off the pallet and bolt the rack cabinet to the pallet.

*(R002)*

---

## Power cords

For your safety, IBM provides a power cord with a grounded attachment plug to use with this IBM product. To avoid electrical shock, always use the power cord and plug with a properly grounded outlet.

IBM power cords used in the United States and Canada are listed by Underwriter's Laboratories (UL) and certified by the Canadian Standards Association (CSA).

For units intended to be operated at 115 volts: Use a UL-listed and CSA-certified cord set consisting of a minimum 18 AWG, Type SVT or SJT, three-conductor cord, a maximum of 15 feet in length and a parallel blade, grounding-type attachment plug rated 15 amperes, 125 volts.

For units intended to be operated at 230 volts (U.S. use): Use a UL-listed and CSA-certified cord set consisting of a minimum 18 AWG, Type SVT or SJT, three-conductor cord, a maximum of 15 feet in length and a tandem blade, grounding-type attachment plug rated 15 amperes, 250 volts.

For units intended to be operated at 230 volts (outside the U.S.): Use a cord set with a grounding-type attachment plug. The cord set should have the appropriate safety approvals for the country in which the equipment will be installed.

IBM power cords for a specific country or region are usually available only in that country or region.

---

## **End of life (EOL) plan**

This product is a purchased unit. Therefore, it is the sole responsibility of the purchaser to dispose of it in accordance with local laws and regulations at the time of disposal.

This product contains recyclable materials. The materials should be recycled where facilities are available and according to local regulations. In some areas IBM provides a product take-back program that ensures proper handling of the product. For more information, contact your IBM representative.



---

## Environmental notices

The environmental notices that apply to this product are provided in the *Environmental Notices and User Guide, Z125-5823-xx* manual. A copy of this manual is located on the publications CD.





---

## Preface

This guide describes how to install and use the IBM TS2260 tape drive.

Chapter 1, “Introduction,” on page 1-1 describes the product, supported servers, operating systems, and device drivers, and lists hardware specifications.

Chapter 2, “Installation,” on page 2-1 gives unpacking, set up, and configuration information.

Chapter 3, “Operations,” on page 3-1 describes the **Power** button, **Unload** button, and Status lights and explains the function of the Single-character Display. It gives instruction on inserting and removing a tape cartridge, describes methods of updating drive firmware, and explains how to clean the tape drive. It also lists diagnostic and maintenance functions.

Chapter 4, “Ultrium media,” on page 4-1 describes the types of tape cartridges to use and defines the conditions for storing and shipping them. It also describes how to handle the cartridges, how to set a cartridge's write-protect switch, and how to order more cartridges.

Chapter 5, “Troubleshooting,” on page 5-1 gives tips for solving problems with the drive.

Appendix A, “Error codes and messages,” on page A-1 describes the error and informational codes that display on the single-character display.

Appendix B, “TapeAlert flags,” on page B-1 describes where to find information about TapeAlert messages that are supported and that can assist with problem determination.

Appendix C, “Ordering optional features, replacement parts, and power cords,” on page C-1 lists parts and supplies and provides information about the power cords that are used in different countries or regions.

Appendix D, “Installing a 19-inch rack mount kit (optional),” on page D-1 gives the procedure for installing a 19-inch rack mount kit.

Appendix E, “Information for trained service personnel,” on page E-1 gives the procedure for removing a tape cartridge that does not eject from the drive and other servicing procedures.

### Related publications

- *IBM System Storage Ultrium Tape Drive Quick Reference*, GC27-2278 illustrates how to install the drive.
- *IBM System Storage LTO Ultrium Tape Drive SCSI Reference*, GA32-0450, gives information about the supported SCSI commands and protocol that govern the behavior of the SCSI interface for LTO drives. The SCSI reference also includes information about the TapeAlert flags that are supported.
- *IBM Tape Device Drivers Installation and User's Guide*, GC27-2130, provides instructions for attaching IBM supported hardware to open-systems operating systems. It indicates what devices and levels of operating systems are supported,

gives the requirements for adapters, and tells how to configure servers to use the device driver with the Ultrium family of devices. You can obtain this reference at the website <http://www.ibm.com/support/fixcentral>

- *IBM Tape Device Drivers Programming Reference, GA32-0566*, supplies information to application developers who want to integrate their open-systems applications with IBM supported Ultrium hardware. The reference contains information about the application programming interfaces (APIs) for each of the various supported operating-system environments. You can obtain this reference at the website <http://www.ibm.com/support/fixcentral>.
- *IBM Translated Safety Notices, 96P0851*, provides translation of danger and caution notices.

---

## Chapter 1. Introduction

The IBM TS2260 Tape Drive is a high-performance, high-capacity data-storage device that is designed to back up and restore open systems applications. It is the sixth generation in the Ultrium series of products, and is available with a Serial Attached SCSI interface (SAS), or with an optional SAS/USB interface. This model incorporates the Linear Tape-Open (LTO) IBM Ultrium 6 Half-High Tape Drive.

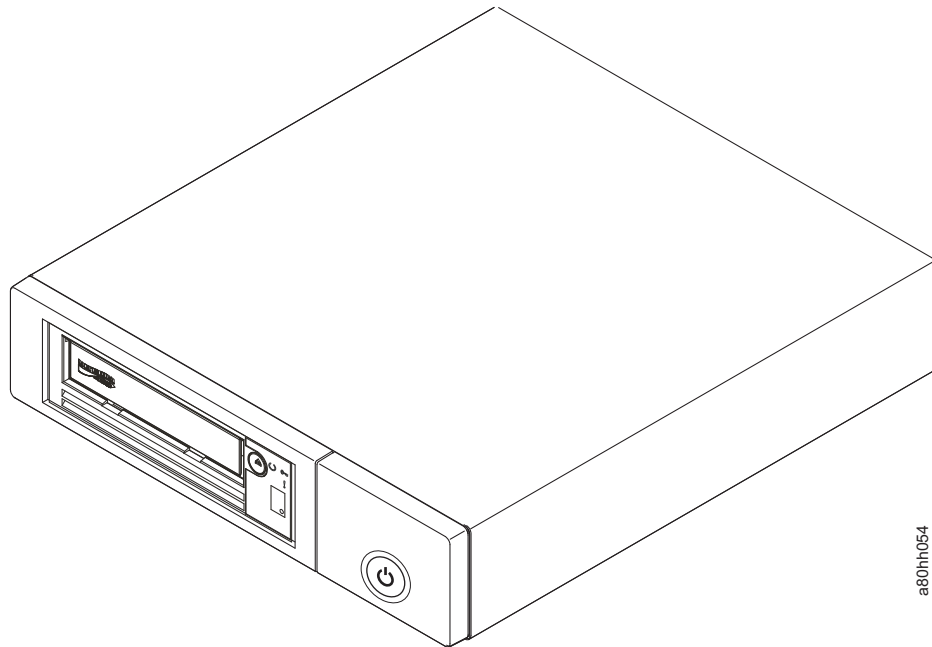

Figure 1-1. View of the drive

---

### Drive features

The drive offers these features:

- Native storage capacity of 2500 GB per cartridge (6250 GB at 2.5:1 compression with Ultrium 6 cartridges)
- Maximum native data transfer rate of up to 160 MB per second
- Burst data transfer rate of 600 MB per second
- Dual port 6 Gbps Serial Attached Small Computer Systems Interface (SAS) or optional single 6 Gbps SAS port and single USB 3.0 port (FC 5760)
- Half height form factor
- Support for WORM (Write Once Read Many) on WORM cartridge types
- 512 MB read-and-write cache
- Support for encryption on Ultrium 5 and Ultrium 6 tape cartridges
- Single Character Display (SCD) operator panel
- Ready, Fault, and Encryption status lights
- Maintenance Mode functions
- 1 Gbps Ethernet port for drive status and service
- LTFS capable

## Front panel of the drive

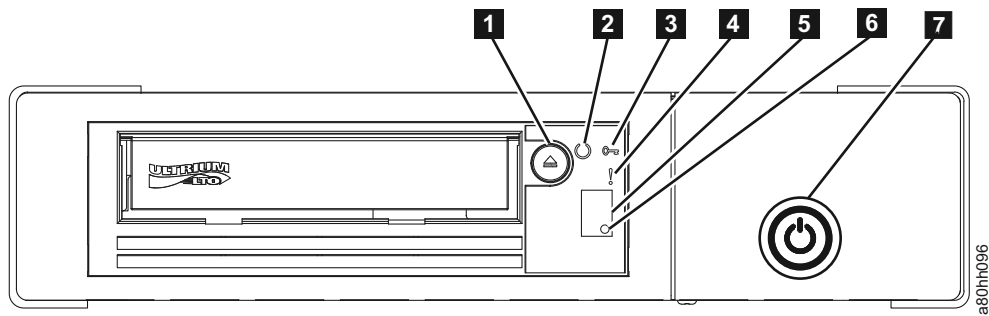

Figure 1-2. Front panel element descriptions

- |          |                          |          |                                |
|----------|--------------------------|----------|--------------------------------|
| <b>1</b> | Cartridge unload button  | <b>4</b> | Fault light (amber)            |
| <b>2</b> | Ready light (green)      | <b>5</b> | Single Character Display (SCD) |
| <b>3</b> | Encryption light (white) | <b>6</b> | SCD dot                        |
|          |                          | <b>7</b> | Drive power button             |

## Rear panel of the drive

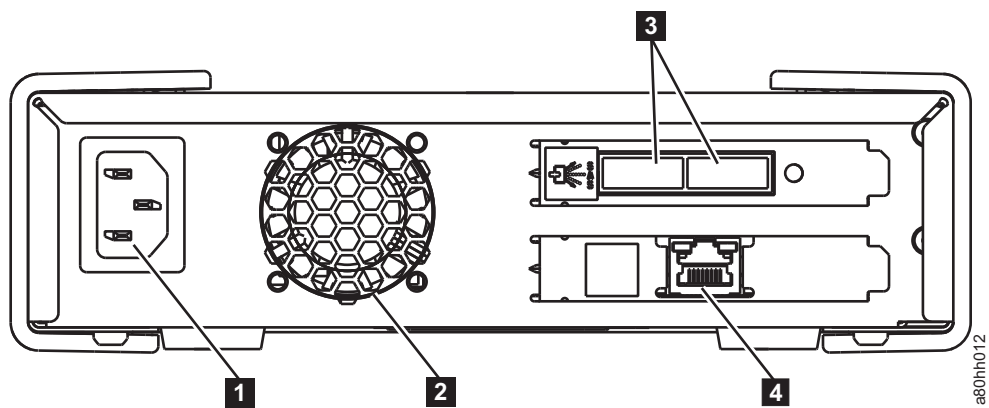

Figure 1-3. Drive rear panel element descriptions - dual SAS ports

- |          |  |
|----------|--|
| <b>1</b> | Power receptacle                                       |
| <b>2</b> | Fan vent   |
| <b>3</b> | SAS connectors   |
| <b>4</b> | Ethernet connector (for drive status and service only) |

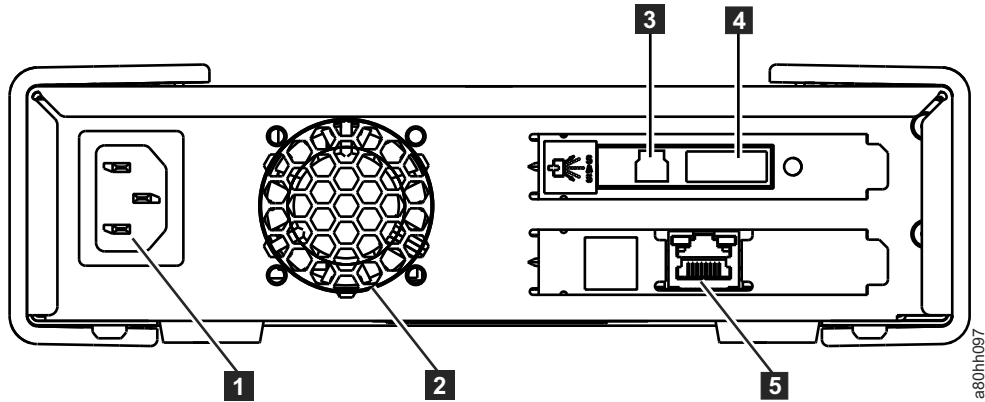

Figure 1-4. Drive rear panel element descriptions - single SAS/USB ports

- |          |  |
|----------|--|
| <b>1</b> | Power receptacle                                       |
| <b>2</b> | Fan vent   |
| <b>3</b> | USB connector  |
| <b>4</b> | SAS connector  |
| <b>5</b> | Ethernet connector (for drive status and service only) |

## Drive performance

If you run applications that are highly dependent on tape-processing speed, take advantage of the significant performance improvements that are provided by this tape drive.

Table 1-1. Performance characteristics

Performance Characteristics	TS2260 Tape Drive
Native data rate	160 MB/s (with Ultrium 6 media)
Maximum sustained data rate (at maximum compression)	550 MB/s
Burst data rate	600 MB/s
Nominal load-to-ready time	12 seconds
Nominal unload time	17 seconds
Average rewind time	62 seconds
<b>Note:</b> All sustained data rates are dependent on the capabilities of the interconnect.	

By using the built-in data-compression capability of the tape drive, greater data rates than the native data transfer rate are achieved. However, the actual throughput is a function of many components, such as the host system processor, disk data rate, block size, data compression ratio, SAS bus capabilities, and system or application software.

## Cartridge compatibility

The TS2260 uses the IBM LTO Ultrium 2500 GB data cartridge and is compatible with the cartridges of its predecessors, the IBM Ultrium Tape Drive Generation 5, and Generation 4. The drive completes these functions:

- Reads and writes Ultrium 6 cartridges to Ultrium 6 format, including WORM and Data Encryption

- Reads and writes Ultrium 5 cartridges to Ultrium 5 format, including WORM and Data Encryption
- Reads but does not write Ultrium 4 cartridges
- Does not read or write Ultrium 3, Ultrium 2, and Ultrium 1 cartridges

The drive reads tapes that are written by other licensed Ultrium 4, 5, and 6 drives, and writes to tapes that are read by other licensed Ultrium 5 and 6 drives.

In addition to using the IBM LTO Ultrium Data Cartridge with up to 2500 GB capacity, the drive offers read/write capability for certified LTO Ultrium tape cartridges.

---

## Speed matching

To improve system performance, the drive uses a technique that is called *speed matching* to dynamically adjust its native (uncompressed) data rate to the slower data rate of a server. With speed matching, the drive operates at different speeds when it is reading or writing the Ultrium 5 or Ultrium 6 cartridge format. Native data rates are shown in the table.

Table 1-2. Performance parameters

	Ultrium Generation Media		
	Generation 6 Media	Generation 5 Media	Generation 4 Media
Speed matching data rates (MB/sec)	160.0	140.0	120.0
	150.77	130.0	113.1
	141.54	120.0	106.0
	132.31	112.7	99.2
	123.08	105.5	92.3
	113.85	98.2	85.3
	104.62	90.9	78.5
	95.38	83.6	71.4
	86.15	76.4	64.6
	76.92	69.1	57.6
	67.69	61.8	50.7
	58.46	53.5	43.8
	49.23	46.3	36.9
	40.00	40.0	30.5

If the server's net (compressed) data rate is between two of the preceding native data rates, the drive calculates the appropriate data rate at which to operate. Speed matching dramatically reduces backhitch, the condition that occurs when a tape stops, reverses, and restarts motion. A backhitch is usually the result of a mismatch between the data rates of the server and the drive.

---

## Channel calibration

System performance is further optimized by a feature that is called *channel calibration*, in which the drive automatically customizes each read/write data channel to compensate for variations in such things as the recording channel's transfer function, the media, and characteristics of the drive head.

---

## Data cartridge capacity scaling

The SET CAPACITY SCSI command enables a customer to capacity scale a data cartridge to enable faster random access. As an example, a customer can capacity scale a data cartridge to 20% of its normal length that improves the average access time by almost a factor of 5. However, it also reduces the native capacity of the tape to 500 GB.

---

## Encryption

The IBM TS2260 Tape Drive supports host Application Managed Encryption (AME), with T10 encryption methods. Data encryption is supported by LTO Ultrium 4, Ultrium 5 and Ultrium 6 data cartridges only.

The encryption-enabled drive contains the necessary hardware and firmware to encrypt and decrypt host tape application data. Encryption policy and encryption keys are provided by the host application. A drive digital certificate is installed at manufacturing time. Each drive receives a unique serial number and certificate. The T10 Application can validate each drive instance by checking the drive's digital certificate.

Application-managed encryption is supported on AIX®, Windows Server, Linux®, and Solaris. Encryption requires the latest device drivers available on the website: <http://www.ibm.com/support/fixcentral>.

For more details, see the *IBM Tape Device Drivers Encryption Support* documentation, and the *IBM TotalStorage LTO Ultrium Tape Drive SCSI Reference* documentation.

---

## Inhibiting firmware down-leveling

The drive provides the capability to prevent loading and installing drive microcode by way of a Field Microcode Replace (FMR tape) if the firmware level contained in the FMR tape is older than the code level already installed. This option is controlled by the host application. No checking is done if the firmware level is loaded by way of the host interface or the library interface.

---

## SAS interface

The drive has a dual port 6 Gbps SAS (Serial Attached SCSI) host interface, or an optional single 6 Gbps SAS port and single USB 3.0 port (see “USB interface” on page 1-6).

A drive with a SAS interface can be linked directly to controllers. SAS is a performance improvement over traditional SCSI because SAS enables multiple devices (up to 128) of different sizes and types to be connected simultaneously with thinner and longer cables; its full-duplex signal transmission supports 6.0 Gb/s. In addition, SAS drives can be hot-plugged.

SAS drives auto-negotiate speed. There are no configurable topologies thus no feature switches associated with SAS.

### Physical characteristics

The drive contains a single or dual port, SFF-8088 SAS connector. A list of compatible cables is shown in Appendix C, "Ordering optional features, replacement parts, and power cords," on page C-1.

---

## USB interface

The drive has a single SAS port and a single USB port host interface if the optional Feature Code 5760 is ordered. The USB host interface supports USB 3.0 connectivity and can negotiate a "Super Speed" transfer rate. It also supports USB 2.0 connectivity at the slower transfer rates. The USB interface auto-negotiates speed. There are no configurable topologies, thus no feature switches associated with USB. The tape drive with SAS/USB ports requires a device driver for USB 3.0 operation.

### Physical characteristics

The drive has a single port, USB 3.0 Type B connector. A USB 3.0 compatible cable is required to connect at the USB 3.0 "Super Speed" transfer rate. A list of compatible cables is shown in Appendix C, "Ordering optional features, replacement parts, and power cords," on page C-1.

---

## Supported servers and operating systems

To determine the latest supported attachments, visit the web at <http://www.ibm.com/storage/lto> and look for the System Storage interoperability information. For specific instructions about attaching the drive, see Chapter 2, "Installation," on page 2-1.

---

## Supported device drivers

Device drivers enable the drive to interact with various servers. To properly install an IBM device driver (if required), refer to the *IBM Tape Device Drivers Installation and User's Guide*. For applications that use other device drivers, see the application's documentation to determine which drivers to use.

IBM maintains the levels of device drivers and driver documentation for the drive on the Internet. You can access this material at the website: <http://www.ibm.com/support/fixcentral>

**Note:** The device driver and driver documentation for the SAS/USB drive is at <http://www.ibm.com/support/fixcentral> on the TS2260 web page.

**Note:** If you do not have Internet access and you need information about device drivers, contact your sales representative.

**Note:** The device driver for System i<sup>®</sup> servers is included in the OS/400<sup>®</sup> operating system.



---

## Ethernet port

The IBM System Storage TS2260 Tape Drive has a single 1 Gbps Ethernet port on the rear panel, with an RJ45 connector. The Default IP address is **169.254.0.3**, but the drive's IP address can be changed as needed. Refer to ITDT to see how to this change is made.

The ethernet port is used only for monitoring drive status and servicing the drive, not for data transmission.

---

## Linear tape file system (LTFS)

The linear tape file system (LTFS) is a file system that works with LTO Generation tape technology to access data stored on an IBM tape cartridge.

LTFS uses the file system's format and resources of the operating system (OS) on which it is running to graphically display the contents of a tape cartridge in the OS's graphical user interface (GUI) format; typically a folder/tree structure. With the host operating system's graphical File Manager, reading data on an LTO tape cartridge is as easy as dragging and dropping. Users can run any application that is designed for disk files against tape data without concern for the fact that the data is physically stored on tape.

---

## Specifications

Specifications for the tape drive. Specifications for tape cartridges are given in "Environmental and shipping specifications for tape cartridges" on page 4-18.

*Table 1-3. Specifications*

Physical Specifications			
Specification	Dimensions		
Width	213 mm (8.4 in.)		
Length	332 mm (13.1 in.)		
Height	58 mm (2.3 in.)		
Weight	4.3 kg (9.4 lbs.)		
Power Specifications			
AC line voltage	100 - 240 Vac		
Line frequency	50 - 60 Hz, auto-ranging		
Line current at 100 Vac	0.48 A		
Line current at 240 Vac	0.20 A		
Other Specifications			
Maximum altitude	3048 m (10,000 ft)		
Maximum altitude for shipping	12192 m (40,000 ft)		
Environmental Specifications			
Environmental Factor	Operating	Storage	Shipping

Table 1-3. Specifications (continued)

Physical Specifications			
Specification	Dimensions		
Temperature	10 - 38°C (50 - 100°F)	-40 to 60°C (-40 to 140°F)	-40 to 60°C (-40 to 140°F)
Relative humidity	20 - 80%	10 - 90%	10 - 90%
Maximum wet bulb temperature	26°C(79°F)	Non-condensing	Non-condensing

---

## Chapter 2. Installation

This is a customer setup unit. It is the customer's responsibility to install this product.

Installation involves the following steps:

1. "Avoiding drive damage"
2. "Unpacking the drive"
3. "Verifying the shipment" on page 2-2
4. "Installing the rack mount kit (optional)" on page 2-2
5. "Inspecting the power cord and outlet" on page 2-2
6. "Positioning the tape drive" on page 2-3
7. "Installing the SAS host adapter card (if required)" on page 2-3
8. "Connecting the SAS interface cable" on page 2-3
9. "Connecting the USB interface cable (optional)" on page 2-4
10. "Connecting power" on page 2-5
11. "Running drive diagnostics" on page 2-5
12. "Installing device drivers" on page 2-5
13. "Configuring the tape drive to a server/host" on page 2-5
14. "Updating firmware" on page 2-6
15. "Registering for My Support" on page 2-8

---

### Avoiding drive damage

To avoid static electricity damage when the drive is handled, use the following precautions:

- Limit your movement. Movement can cause static electricity to build around you.
- Always handle the drive carefully. Never touch exposed circuitry.
- Prevent others from touching the drive.
- Before you unpack and install the drive into an enclosure, touch its static-protective packaging to an unpainted metal surface on the enclosure for at least 2 seconds. This procedure reduces static electricity in the packaging and your body.
- When possible, remove the drive from its static-protective packaging and install it directly into an enclosure without setting it down. When this action is not possible, place the drive's packaging on a smooth, level surface and place the drive on the packaging.
- Do not place the drive on the cover of the enclosure or on any other metal surface.

---

### Unpacking the drive

Unpack the drive and store the packaging for future moves or shipping.

**Attention:** If you return the unit for service, ship it in its original or equivalent packing material, or the warranty might be invalidated.

1. Inspect the unit for shipping damage. If there is damage, do not install the unit, and report the damage immediately. Contact your place of purchase.
2. Locate the label on the bottom panel of the unit with the machine type, model number, and serial number of the unit. Make a note of these numbers and store them in an easily accessible place. If you must contact Technical Support, you are asked for these numbers.

---

## Verifying the shipment

Ensure that the following items are included in the shipment:

- Power cord (For the appropriate cord for your country or region, see Appendix C, “Ordering optional features, replacement parts, and power cords,” on page C-1)
- IBM LTO Ultrium Cleaning Cartridge
- Single-connector SAS wrap tool
- Optional Rack Mount kit
- The *IBM System Storage TS2260 Tape Drive Quick Reference* (GC27-2276-01)
- The *IBM System Storage TS2260 Tape Drive Setup, Operator, and Service Guide* GA32-2226-00
- Documentation CD (includes library documentation, translated safety information, and translated warranty information)
- SAS or USB cables are not part of the ship group. They must be ordered separately.

---

## Installing the rack mount kit (optional)

Refer to Appendix D, “Installing a 19-inch rack mount kit (optional),” on page D-1. If you did not order the optional kit, proceed to “Inspecting the power cord and outlet.”

If you ordered a 24-inch rack mount kit, refer to the installation instructions included in the kit.

---

## Inspecting the power cord and outlet

1. Inspect the power cord plug to ensure that it matches the power receptacle. If it does not match, see “Power cords” on page C-2 to determine the appropriate power cord.
2. Ensure that all associated electrical outlets are properly grounded and that the circuit breaker is turned on.



### DANGER

An electrical outlet that is not correctly wired could place hazardous voltage on metal parts of the system or the devices that attach to the system. It is the responsibility of the customer to ensure that the outlet is correctly wired and grounded to prevent an electrical shock. (D004)

---

## Positioning the tape drive

Position the unit so it is convenient to the server. The only restrictions are the length of the power cord and the length of the cable to the server. Recommended locations are

- Away from high-traffic areas, especially if the floor is carpeted.
- Out of printer or copy rooms to avoid toner and paper dust. Do not store paper supplies next to any unit.
- Away from moving air, such as doorways, open windows, fans, and air conditioners.
- Off the floor.
- In a horizontal position.
- Where the tape cartridge can be easily inserted.

The unit should not be stacked. Do not place anything on top of the unit.

---

## Installing the SAS host adapter card (if required)

If no other devices are attached to your server, a SAS host adapter might need to be installed in the server. To install an adapter, refer to the instructions that accompany it, also to the section about host adapter installation in your server's documentation. For a list of supported adapters and required interposers, visit the web at <http://www.ibm.com/storage/lto>.

---

## Connecting the SAS interface cable

Each tape drive is required to have a dedicated bus to the initiator, referred to as point-to-point connection. SAS architecture does not support multiple tape drives connected to a single host adapter port. The maximum SAS cable length that can be used to connect the host adapter to the tape drive is 5.5 m.

To connect the cable:

1. Ensure that the tape drive is powered OFF.
2. Since there are several types of SAS connectors, verify that the SAS cable has the correct connectors for the SAS host adapter and for the tape drive.
3. The tape drive has two SAS ports and can be connected to two servers. Refer to the appropriate figure that represents your configuration for cabling information (see Figure 2-1 or Figure 2-2 on page 2-4) and then connect the SAS cables to SAS host adapters and to the tape drive as shown.

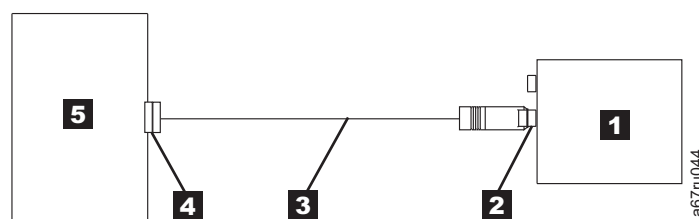

Figure 2-1. Example of connecting one SAS device to the server

- |          |               |          |                  |
|----------|---------------|----------|------------------|
| <b>1</b> | Tape drive    | <b>4</b> | SAS host adapter |
| <b>2</b> | SAS connector | <b>5</b> | Server           |
| <b>3</b> | SAS cable     |          |                  |

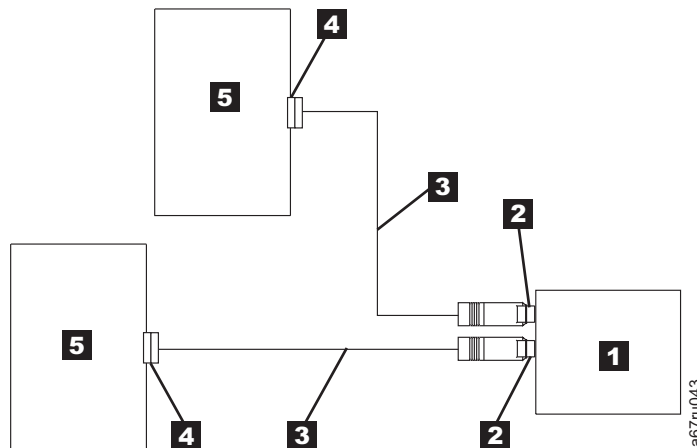

Figure 2-2. Example of connecting the SAS device to two servers

- |          |               |          |                  |
|----------|---------------|----------|------------------|
| <b>1</b> | Tape drive    | <b>4</b> | SAS host adapter |
| <b>2</b> | SAS connector | <b>5</b> | Servers          |
| <b>3</b> | SAS cables    |          |                  |

4. Ensure that the host adapter and the server are configured correctly for a SAS bus operation. Refer to the host adapter and server documentation for instructions.
5. If the power cord is already installed, turn power to the tape drive ON.

## Connecting the USB interface cable (optional)

If the tape drive was ordered with Feature Code 5760, it has a single USB 3.0 port and a single SAS port. To use SAS connectivity, refer to “Connecting the SAS interface cable” on page 2-3.

The USB architecture does not support multiple tape drives connected to a single host USB port. Each tape drive is required to have a dedicated USB connection to the host. Connecting the tape drive to a USB hub is not supported. It is recommended that a USB 3.0 compatible cable is used to connect the host to the tape drive. Whether a USB 3.0 or USB 2.0 compatible cable is used to connect this device, it must be 3 meters or less in length.

To connect the cable:

1. Ensure that the tape drive is powered OFF.
2. Verify that the USB cable is USB 3.0 compatible and has a Type B connector to plug into the tape drive.
3. Connect the USB cable into the host and tape drive as shown. (see Figure 2-3 on page 2-5).

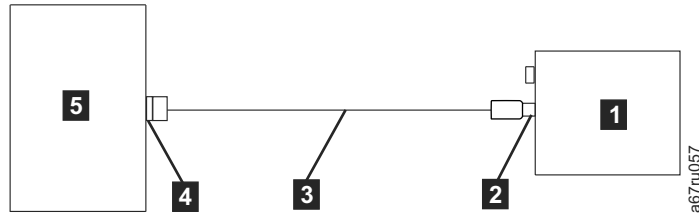

Figure 2-3. Example of connecting the USB device to the server

- |  |   |
|--|---|
| <p><b>1</b> Tape drive</p> <p><b>2</b> USB connector</p> <p><b>3</b> USB cable</p> | <p><b>4</b> USB port</p> <p><b>5</b> Server</p> |
|--|---|

4. Ensure that the host is configured correctly for USB 3.0 operation. The tape drive with SAS/USB ports requires a device driver for the USB 3.0 operation. The device driver and driver documentation for the SAS/USB drive is at <http://www.ibm.com/support/fixcentral> on the TS2260 web page.
5. If the power cord is already installed, turn power to the tape drive ON.

---

## Connecting power

1. If the power cord is already installed, skip to step 3.
2. Plug the power cord into the rear panel (see Figure 1-3 on page 1-2), then plug the other end into a grounded electrical outlet.
3. Power on the unit by pressing **Power**. The POST runs, which check all hardware except the drive head. During the POST, the Single-character Display (SCD) flashes several segmented characters. Each segmented character represents a test that is completed during the POST. When the POST finishes, the SCD momentarily lights all segmented characters and then goes blank.

---

## Running drive diagnostics

Run the Standalone Diagnostic procedure. See “Function code 1: Run drive diagnostics” on page 3-12 for instructions.

---

## Installing device drivers

A device driver is firmware that enables the tape drive to interact with various servers. Refer to “Supported device drivers” on page 1-6 for instructions on downloading the latest device drivers.

If you intend to use the tape drive with a commercial software application, refer to that application's installation instructions to install the device driver and configure the tape drive.

If you do not intend to use the tape drive with a commercial software application, refer to the *IBM Ultrium Device Drivers Installation and User's Guide*.

---

## Configuring the tape drive to a server/host

1. Ensure that the tape drive is powered on.
2. To configure the tape drive, refer to the documentation for your server/host and application software.

---

## Updating firmware

**Attention:** When firmware is updated, do not power off the drive until the update is complete, or the firmware might be lost.

It is the customer 's responsibility to ensure that this drive has the latest firmware. Periodically check for updated levels of drive firmware by visiting the web at <http://www.ibm.com/support/fixcentral>. The drive firmware can be downloaded from this website. Update drive firmware with:

- The host interface
- The ITDT tool
- A field microcode replacement (FMR) tape cartridge
- The ethernet interface

For instructions on obtaining a new firmware image, visit <http://www.ibm.com/support/fixcentral>. To update the firmware, refer to the following sections.

### Updating firmware through the host interface

When drive firmware is updated with the host interface, the procedure varies depending on whether your server uses an IBM tape device driver or a non-IBM tape device driver (such as a driver from Sun, Hewlett-Packard, or Microsoft).

For instructions about updating firmware from a server that uses an IBM tape device driver, refer to the *IBM Ultrium Device Drivers Installation and User 's Guide*.

To update firmware from a server that uses a non-IBM tape device driver, refer to the documentation for that device driver.

### ITDT firmware update, dump retrieval and library/drive test tool

ITDT is a tool with multiple functional capability and is a quick, convenient, and efficient method for both drive and library firmware updates. As a note, both drive and library memory dump retrievals can be completed by the tool as well.

Some of the capabilities of this tool:

- Firmware update capability to all IBM LTO Tape Drive and Tape Library products.
- The tool does not require any special device drivers.
- The tool is available for most major platforms (Windows, AIX®, Solaris, Linux, HP-UX, i5/OS).
- The tool can upload drive and library dump files.
- The tool 's primary function is thoroughly testing a drive. However, if the library is online to the server/host where the tool resides, ITDT communicates with the drive through the library to load and unload a test cartridge, exercising some library functions.
- The tool scans the host bus and finds and displays for selection all IBM LTO devices. The tool does not display and allow for selection any non-IBM device.
- Each function has a "Help" selection that explains the required syntax and a brief explanation of the particular function.
- A Readme text file is posted with the .exe for a thorough explanation of initial tool download information from the web and an explanation of tool capabilities.



Refer to the ITDT Readme text file for information about tool usage. You can also refer to the web at <http://www.ibm.com/support/fixcentral> and look for information about the ITDT site.

- The tool is available in two editions, ITDT-SE (Standard Edition) and ITDT-GE (Graphical Edition). More information about the ITDT editions can be found at <http://www.ibm.com/support/fixcentral>.

## Updating the firmware with an FMR tape cartridge

**Attention:** A SAS drive requires a SAS firmware image. Other types of firmware images do not load on the SAS drive.

To update the drive 's firmware from an FMR tape cartridge:

1. Create an FMR tape (see "Function code 3: Create FMR tape" on page 3-13). A single FMR tape can be used to update multiple drives if the drives are the same drive type (for example, LTO Gen 6) and host interface (for example, SAS).
2. Update the drive firmware (see "Function code 2: Update drive firmware from FMR tape" on page 3-13).

After the drive firmware is updated, the FMR tape can be used as a data cartridge by with the "Unmake FMR Tape" function (see "Function code 8: Unmake FMR tape" on page 3-17).

The SCD presents a series of random characters during the firmware download

and update. The SCD briefly displays , then becomes blank (not lit) when the firmware download and update is complete and there are no errors. An error code is displayed if a firmware download or update error is detected. The Ready light and the Fault light flash briefly during the firmware download and update. The Ready light turns On after the firmware download and update are complete.

## Updating the firmware with the ethernet port

**Note:** The drive uses a limited version of FTP protocol to communicate on the ethernet interface. It is recommended to use a simple, command-line FTP session, such as the DOS command prompt, to communicate with the drive.

1. Obtain the latest drive firmware from the web..
2. Connect an ethernet patch cable to the drive 's ethernet interface and to a computer. In order to meet electromagnetic immunity requirements, a shielded ethernet cable is required.
3. Create an FTP session between the drive and the computer. The drive 's IP address: **169.254.0.3**
4. At the user prompt, type *guest* and press **Enter**.
5. At the password prompt, press **Enter**. No response is needed.
6. Type *bin* to set the communication mode to binary.
7. Type *put <firmware name>* to transfer the firmware to the drive. Replace *<firmware name>* with the actual firmware name. The drive resets automatically when the transfer is complete and the FTP session closes.
8. After the drive resets, the new firmware will be loaded on the drive.
9. Remove the ethernet patch cable from the drive 's ethernet interface and the computer.

---

## Registering for My Support

My Support registration provides email notification when new firmware levels are updated and available for download and installation. To register for My Support, visit the web at <http://www.ibm.com/support/mySupport>

---

## Chapter 3. Operations

Operating the drive involves the front panel items:

- Power button
- Single-character Display (SCD)
- SCD dot
- Ready and Fault status lights
- Unload button
- Encryption status light

---

### Operating modes

The drive functions in these modes:

- Operation mode - functions include reading and writing data, cartridge manipulation, error reporting, and firmware updating with an FMR cartridge. For more information, see “Status lights” on page 3-2.
- Maintenance mode - functions include drive diagnostic, creation/unmake FMR cartridge, and drive dump manipulation (force to RAM, copy to tape, copy to flash memory, and erase flash). For more information, see “Diagnostic and maintenance functions” on page 3-9.

The Unload button is used to switch between modes. For more information, see “Unload button” on page 3-5.

---

### Power button

The **Power** button is a push button that turns the tape drive on or off. The button is located on the front panel (see **7** in “Front panel of the drive” on page 1-2). When **Power** is in the off position, the primary electrical power within the enclosure is still active. To remove all electrical power to the enclosure, unplug the power cord from the receptacle at the rear of the drive.

When the unit is powered-on but idle, the Ready light (see **2** in “Front panel of the drive” on page 1-2) is solid green; when it is performing a function, the Ready light is flashing green.

---

### Single-character display (SCD)

The SCD (**5** in “Front panel of the drive” on page 1-2) presents a single-character code for:

- Error conditions and informational messages
- Diagnostic or maintenance functions (while in maintenance mode only)

Appendix A, “Error codes and messages,” on page A-1 lists the codes for error conditions and informational messages. If multiple errors occur, the code with the highest priority (represented by the lowest number) displays first. When the error is corrected, the code with the next highest priority displays, and so on, until no errors remain.

“Diagnostic and maintenance functions” on page 3-9 lists the single-character codes that represent diagnostic or maintenance functions. To initiate a function, the unit must be in maintenance mode.

The SCD is blank during normal operation.

### SCD dot

If a drive memory dump is present while the drive is in maintenance mode, a single dot illuminates in the lower right corner of the SCD (see **6** in “Front panel of the drive” on page 1-2). To copy the memory dump, see “Function code 5: Copy drive dump” on page 3-14.

The SCD dot is on solid if the memory dump is in RAM memory. The SCD dot flashes if the memory dump is in flash memory.

The SCD dot turns off when you obtain a dump (by using ITDT or a SCSI command) or update the drive firmware.

**Note:** If the drive memory dump is stored in RAM memory (SCD dot on solid), the memory dump is lost when you turn OFF the power or reset the drive.

---

## Status lights

The status lights (**2**, **3** and **4** in “Front panel of the drive” on page 1-2) are light-emitting diodes (LEDs) that provide information about the state of the drive. The Ready status light is green and the Fault status light is amber, and (when lit) solid or flashing. The Encryption status light is white.

Mode	SCD	Ready LED (green)	Fault LED (amber)
Operational	blank	On	Off
Activity (tape movement) in Operational Mode	blank	Flashing	Off
Maintenance	solid character	Flashing	On
Executing Maintenance Selection	flashing character	Off	On
Error Condition	solid character	Off	Flashing
Power-On / Reset Initialization	random segments	Off	On

**Note:** The white Encryption status light is on when the tape drive has a cartridge that is loaded and all data on this cartridge is encrypted (excluding the label). LTO Ultrium 6 and Ultrium 5 cartridges only.

Table 3-1 on page 3-3 lists the conditions of the status lights and Single-character Display (SCD) and provides an explanation of what each condition means.

Table 3-1. Meaning of Status lights and single-character display (SCD)

If the green Ready Status Light is...	and the amber Fault Status Light is...	and the Encryption Status Light is...	and the SCD is...	and the SCD dot is...	Meaning
Off	Off	Off	Off	Off	The drive has no power or is powered off.
On	Off	On/Off	Off	Off	The drive is powered on and in an idle state. <b>Note:</b> If a cartridge is loaded, the white Encryption status light is on when all the data on the cartridge is encrypted (excluding the label). LTO Ultrium 6 and Ultrium 5 cartridges only.
Flashing (once per second)	Off	On/Off	Off	Off	The drive is reading from the tape, writing to the tape, rewinding the tape, locating data on the tape, loading the tape, or unloading the tape. <b>Note:</b> The white Encryption status light is on when all the data on the cartridge is encrypted (excluding the label). LTO Ultrium 6 and Ultrium 5 cartridges only.
Flashing (once per second)	Off	Off	Off	Off	If the drive contains a cartridge during the power-on cycle, the drive completes POST and slowly rewinds the tape. The process might take up to 13 minutes. The light stops flashing and becomes solid when the drive completes the recovery and is ready for a read or write operation. To eject the cartridge, press <b>Unload</b> .
Off	On	Off	Displaying an error code or Maintenance Mode Function	On/Off	The drive is displaying error codes from the error code log on the SCD. For more information, see "Function code 9: Display error code log" on page 3-18 and Appendix A, "Error codes and messages," on page A-1.

Table 3-1. Meaning of Status lights and single-character display (SCD) (continued)







If the green Ready Status Light is...	and the amber Fault Status Light is...	and the Encryption Status Light is...	and the SCD is...	and the SCD dot is...	Meaning
On/Off	On/Off	On/Off	Displaying random segments/ Blank/ displaying random segments/ displaying  /Blank	On/Off	During power-on, or a drive reset, the drive front panel displays drive progress as follows: <ol style="list-style-type: none"> <li>1. SCD displays random segments (no Lights ON).</li> <li>2. SCD displays random segments (Ready light ON).</li> <li>3. SCD displays random segments (Fault light ON)</li> <li>4. SCD displays [8] (Ready, Fault, Encryption, and SCD dot lights ON).</li> <li>5. SCD goes blank (Ready light ON) after a successful power-on or reset.</li> </ol> If an error is detected during the power-on or reset, the tape drive posts an error code to the SCD. To determine the error, locate the code in Appendix A, "Error codes and messages," on page A-1.
Off	On	Off		On/Off	The drive is entering or exiting from maintenance mode. For more information, see "Function code 0: Maintenance mode" on page 3-12.
Off	On	Off	Flashing selected function	On/Off	The drive is running the selected function while in maintenance mode.
Off	Flashing (once per second)	Off	Displaying error code	Off	An error occurred and the drive or media might require service, or it might require cleaning. Note the code on the SCD, then go to Appendix A, "Error codes and messages," on page A-1 to determine the action that is required.
Off	Flashing	Off	Displaying 	Off	The drive needs cleaning.
Off	Flashing	Off	Displaying Function Code  or Flashing	Off	The drive is updating firmware. <sup>1</sup> The SCD displays a  with an FMR cartridge. The SCD is off with the host interface. For more information, see "Updating firmware" on page 2-6.
Off	Flashing (twice per second)	Off	Off	Off	The drive detected an error and is completing a firmware recovery. It resets automatically.
Off	On	Off	Flashing 	Off	The drive is requesting a cartridge to be loaded.

Table 3-1. Meaning of Status lights and single-character display (SCD) (continued)

If the green Ready Status Light is...	and the amber Fault Status Light is...	and the Encryption Status Light is...	and the SCD is...	and the SCD dot is...	Meaning
Off	Flashing (twice per second)	Off	Off	On	There is a drive memory dump in flash memory.

<sup>1</sup> Power must not be removed from the drive until the microcode update is complete. The drive indicates that the update is complete by resetting and completing POST.

## Unload button

The **Unload** button ( **1** in “Front panel of the drive” on page 1-2) completes the following functions:

Table 3-2. Functions that the Unload Button completes



Unload Button Function	How to Initiate the Function
Rewind the tape into the cartridge and eject the cartridge from the drive	Press <b>Unload</b> . The Ready light flashes while the drive is rewinding and unloading. <b>Note:</b> During a rewind and eject operation, the drive does not accept host interface commands.
Place the drive in maintenance mode	Ensure that the drive is unloaded. Then, within 2 seconds, press <b>Unload</b> three times.  The drive is in maintenance mode when the Ready light is flashing and  displays in the SCD. <b>Note:</b> While in maintenance mode, the drive does not accept host interface commands. <b>Note:</b> If you attempt to enter Maintenance mode with a cartridge in the drive, the drive rewinds and ejects the cartridge. Remove the cartridge and repeat the steps for entering Maintenance mode.
Scroll through the maintenance functions	While in maintenance mode, press <b>Unload</b> once per second to increment the display characters by one. When you reach the character of the diagnostic or maintenance function that you want (see “Diagnostic and maintenance functions” on page 3-9), press and hold <b>Unload</b> for 3 seconds.
Exit maintenance mode	Press <b>Unload</b> once per second to increment the display character until  displays. Then, press and hold <b>Unload</b> for 3 seconds. Maintenance mode is exited when the Ready light is On and the SCD becomes blank.
Force a drive memory dump (part of the maintenance mode)	<b>Attention:</b> If the drive detects a permanent error and displays an error code, it automatically forces a drive memory dump (also known as a save of the firmware trace). If you force a drive memory dump, the existing memory dump is overwritten and data is lost. After you force a drive memory dump, do not turn off the power to the drive or you might lose the memory dump data.  Choose one of these procedures: <ul style="list-style-type: none"> <li>• If the drive is in maintenance mode (Ready light is flashing and Fault light is On for Maintenance mode), refer to “Function code 4: Force a drive dump” on page 3-14.</li> <li>• If the drive is in operating mode (Ready light is On or flashing), press and hold <b>Unload</b> for 10 seconds.</li> </ul> If captured memory dump data exists, the drive places it into a memory dump area (for information about retrieving the data, see “Procedure 1: Determining firmware level and capturing drive dump” on page 5-1).

Table 3-2. Functions that the Unload Button completes (continued)

Unload Button Function	How to Initiate the Function
Reset the drive	Press and hold <b>Unload</b> until the drive begins the reset procedure (Fault light turns On when reset starts). <b>Note:</b> If a tape cartridge is loaded in the drive, it unloads the tape. Repeat the "Reset the drive" procedure after the tape is unloaded. The drive saves a memory dump of the current drive state, then reboots to allow communication. Do not cycle power as this action erases the contents of the memory dump.

## Inserting a tape cartridge

To insert a tape cartridge:

1. Ensure that the drive is powered-on.
2. Ensure that the write-protect switch on the tape cartridge is properly set (see "Write-Protect switch" on page 4-7).
3. Grasp the cartridge so that the write-protect switch faces you (see **1** in Figure 3-1).
4. Slide the cartridge into the tape load compartment.

**Note:**

- a. If the cartridge is already in an ejected position and you want to reinsert it, remove the cartridge, then insert it again.
- b. If the cartridge is already loaded and you cycle the power (turn it off, then on), the tape reloads.
- c. Do not attempt to load a cartridge when the drive is in Maintenance mode until the drive requests it.

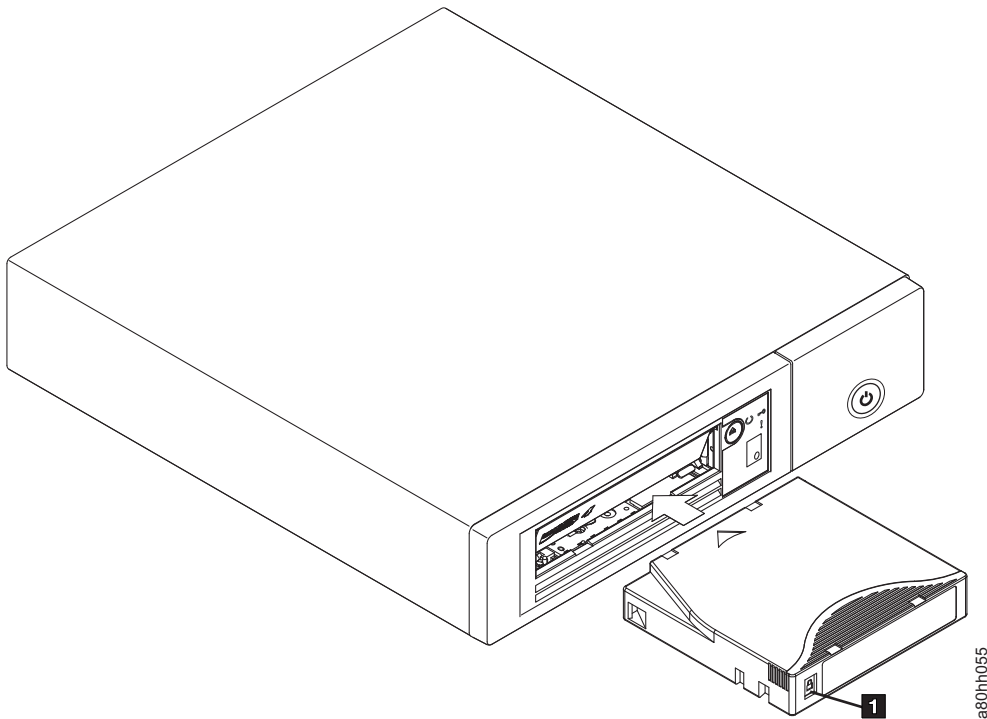

a80hr055

Figure 3-1. Inserting a cartridge into the drive



---

## Removing a tape cartridge

To remove a tape cartridge:

1. Ensure that the drive is powered-on.
2. Press **Unload**. The drive rewinds the tape and partially ejects the cartridge. The Ready light flashes while the tape rewinds, then goes out before the cartridge partially ejects.
3. After the cartridge partially ejects, grasp the cartridge and remove it.

**Important:** Always remove an ejected cartridge before it is reinserted.

Whenever you unload a tape cartridge, the drive writes any pertinent information to the cartridge memory.

---

## Mid-tape recovery

If reset occurs while a cartridge is loaded, the drive slowly rewinds the tape and ejects the cartridge. If a power cycle occurs while a cartridge is loaded, the drive slowly rewinds the tape. The drive does not automatically eject the cartridge.

The Ready light flashes and the SCD is counting down from 9 to 0, indicating the approximate cartridge rewinding status. Between the counts, the SCD displays random segments while the tape is rewinding into the cartridge. Push **Unload** to eject the cartridge when the Ready light stops flashing.

---

## Cleaning the drive head

**Attention:** When the drive head is cleaned, use the IBM LTO Ultrium cleaning cartridge (see “Ordering media supplies” on page 4-20). You might use another LTO cleaning cartridge, but it might not meet the standards of reliability that is established by IBM.

Clean the drive head whenever  displays on the Single-character Display and the Fault light is flashing once per second. It is not recommended that you clean the drive head on a periodic basis; only when the drive requests to be cleaned.

**Note:** In Maintenance mode, a flashing  with the Fault light On, means to insert a cartridge, not to clean the drive head.

To clean the head, insert the cleaning cartridge into the tape load compartment (see “Front panel of the drive” on page 1-2). The drive completes the cleaning automatically in less than 3 minutes, then ejects the cartridge. The drive completes a short load/unload test while the cartridge is ejected. Wait for the drive to finish before the cartridge is removed.

**Note:** The drive automatically ejects an expired cleaning cartridge.

The IBM LTO Ultrium Cleaning Cartridge is valid for 50 uses, and then must be replaced.

---

## Cleaning the tape drive

Clean the exterior surface of the tape drive with a damp towel. If a liquid all-purpose cleaner is used, apply it to the towel. Do not spray the tape drive.

Do not clean the interior of the tape drive; damage might result.

---

## Tape Drive Status web page

The status of the tape drive is accessible from the tape drive's ethernet port. The drive status can be viewed only; the status cannot be changed from this page. The tape drive status is available when the drive is operating or idle (the drive must be powered on).

1. Connect the host computer or a laptop to the tape drive's ethernet port (RJ45 connector) with an ethernet patch cable.
2. With a web browser, connect to <http://169.254.0.3> to view the current tape drive status on an HTML web page. (If the drive's IP address was changed, use that address instead.) The web page is static, so it must be refreshed frequently to show the latest drive status.

### ULT3580-HH6 Drive YR1013000128

Text Only version (for cut and paste)

system time: 2012/06/15 09:06:39  
drive time : 259 seconds

<input type="checkbox"/> Drive Information	
<input type="checkbox"/> Host Interface	
<input type="checkbox"/> Ethernet Settings	<input type="checkbox"/> VPD Encryption Settings
<input type="checkbox"/> Drive Statistics	<input type="checkbox"/> Tape Statistics
<input type="checkbox"/> Error Code Log	

a67b0026

Figure 3-2. Drive Status web page

The tape drive model and serial number are shown at the top of the page.

The web page is divided into sections by topic. The topics are

- Drive Information
- Host Interface
- Ethernet Settings
- VPD Encryption Settings
- Drive Statistics
- Tape Statistics (if a cartridge is loaded in the tape drive)
- Engineering Error Log

Click in the box by the title of the section to see the topic details.

## ULT3580-HH6 Drive YR1013000128

Text Only version (for cut and paste)

system time: 2012/06/15 09:06:39  
drive time : 259 seconds

<input checked="" type="checkbox"/> Drive Information			
Serial Number	YR1013000128	Single Character Display	
Model	ULT3580-HH6	Status Indicators	
Code Level	LTO6_C68N	Current Time (origin)	259 seconds (Power On)
Status	idle		
<input checked="" type="checkbox"/> Host Interface			
	Port 0	Port 1	
Status	unknown	unknown	
WWID	50050763124B6B89	50050763128B6B89	
SAS Address			
Speed	unknown	unknown	
Transport Layer Retries this Power-On	0	0	
<input checked="" type="checkbox"/> Ethernet Settings		<input checked="" type="checkbox"/> VPD Encryption Settings	
	Port 0	Encryption Method	None
IP Addresses (Current)	169.254.0.3/24 fe80::221:5eff:ed5:e49d/64	Key Management	Default (by Method)
MAC Address (VPD)	00:21:5E:D5:E4:9D	BOP Encryption	Disabled
Drive IP Address 1 (VPD)	not set		
Drive IP Address 2 (VPD)	not set		
DHCP (VPD)	disabled		
<input checked="" type="checkbox"/> Drive Statistics		<input checked="" type="checkbox"/> Tape Statistics	
Drive Mounts	45	Volume Serial	
Drive MB Written	280830	Tape Mounts	94
Drive MB Read	948131	Tape MB Written	1894168
Power On Hours (current / VPD)	36 / 35	Tape MB Read	1434841
<input type="checkbox"/> Error Code Log			

ac7b0027

Figure 3-3. Drive Status web page - topic details

The web page format is changed to text mode by selecting the “Text Only version” box near the top of the web page. In text mode, the tape drive status information can be copied and pasted easily if it must be sent to support personnel.

## Diagnostic and maintenance functions

The drive can:

- Run diagnostics
- Test write and read functions
- Test a suspect tape cartridge
- Update firmware
- Perform other diagnostic and maintenance functions

The drive must be in maintenance mode to perform these functions.

**Attention:** Maintenance functions cannot be performed concurrently with read or write operations. While in maintenance mode, the tape drive does not accept host interface commands from the server. The tape drive does accept LDI or RS-422 commands.

Table 3-3 on page 3-10 describes each diagnostic and maintenance function that the drive can perform, gives the function code which appears on the Single-character

Display (SCD), and directs you to the instructions for performing the function. It is recommended that you use a customer-supplied scratch (blank) data cartridge for diagnostic testing. The diagnostic and maintenance functions are not supported on the WORM and partitioned data tape cartridges.

Table 3-3. Diagnostic and maintenance functions

Function Code	Diagnostic or Maintenance Function	Instructions Location
0	<b>Exit Maintenance Mode:</b> Causes the drive to become available for reading and writing data.	"Function code 0: Maintenance mode" on page 3-12
1	<b>Run Drive Diagnostics:</b> Runs tests to determine whether the drive can properly load and unload cartridges, and read and write data.	"Function code 1: Run drive diagnostics" on page 3-12
2	<b>Update Tape Drive Firmware from FMR Tape:</b> Loads updated firmware from a field microcode replacement (FMR) tape.	"Function code 2: Update drive firmware from FMR tape" on page 3-13
3	<b>Create FMR Tape:</b> Copies its field microcode replacement (FMR) data to a customer-supplied scratch (blank) data cartridge.	"Function code 3: Create FMR tape" on page 3-13
4	<b>Force a Drive Dump:</b> Performs a dump of data (also known as saving a microcode trace).	"Function code 4: Force a drive dump" on page 3-14
5	<b>Copy Drive Dump:</b> Copies data from a drive dump (captured by using Function Code 4) to the beginning of a customer-supplied scratch (blank) data cartridge, copies a drive dump to flash memory, or erases a dump from flash memory.	"Function code 5: Copy drive dump" on page 3-14
6	<b>Run Host Interface Wrap Test:</b> Performs a check of the circuitry from and to the connector.	"Function code 6: Run host interface wrap test" on page 3-15
7	<b>Run RS-422 Wrap Test:</b> This test causes the drive to perform a check of the circuitry and connector for the RS-422 interface.	"Function code 7: Run RS-422 wrap test" on page 3-16
8	<b>Unmake FMR Tape:</b> Erases the FMR data on a customer-supplied scratch (blank) data cartridge and rewrite the cartridge memory on the tape. This turns the cartridge into a valid customer-supplied scratch data cartridge.	"Function code 8: Unmake FMR tape" on page 3-17
9	<b>Display Error Code Log:</b> Displays the last 10 error codes, one at a time (the codes are ordered; the most recent is presented first and the oldest (tenth) is presented last).	"Function code 9: Display error code log" on page 3-18
A	<b>Clear Error Code Log:</b> Erases the contents of the error code log.	"Function code A: Clear error code log" on page 3-18
C	<b>Insert Cartridge into Tape Drive:</b> This function cannot be selected by itself, but is a part of other maintenance functions (such as Run Tape Drive Diagnostics and Create FMR Tape) that require a tape cartridge to be loaded.	"Function code C: Insert cartridge into tape drive" on page 3-18
E	<b>Test Cartridge &amp; Media:</b> Performs tests to ensure that a suspect cartridge and its magnetic tape are acceptable.	"Function code E: Test cartridge & media" on page 3-18
F	<b>Write Performance Test:</b> Performs tests to ensure that the drive can read from and write to tape.	"Function code F: Write performance test" on page 3-19
H	<b>Test Head:</b> Performs tests to ensure that the tape drive's head and tape-carriage mechanics are working correctly.	"Function code H: Test head" on page 3-20

Table 3-3. Diagnostic and maintenance functions (continued)

Function Code	Diagnostic or Maintenance Function	Instructions Location
J	<b>Fast Read/Write Test:</b> Performs tests to ensure that the drive can read from and write to tape.	"Function code J: Fast read/write test" on page 3-21
L	<b>Load/Unload Test:</b> Tests the drive's ability to load and unload a tape cartridge.	"Function code L: Load/unload test" on page 3-22
P	<b>Enable Post Error Reporting:</b> When selected, deferred-check conditions are reported to the host.	"Function code P: Post Error Reporting enabled" on page 3-23
U	<b>Disable Post Error Reporting:</b> When selected, deferred-check conditions are NOT reported to the host.	"Function code U: Post Error Reporting disabled" on page 3-23

## Entering Maintenance mode

The drive must be in maintenance mode to run drive diagnostic tests or maintenance functions. To place the unit in maintenance mode:

1. Make sure that no cartridge is in the drive.
2. Press **Unload** three times within 2 seconds. J displays in the Single-character Display (SCD), the Ready light is flashing, and the Fault light turns On.

**Note:** If a cartridge is in the tape drive, it ejects the first time that you press **Unload** and the drive is placed in maintenance mode. To continue placing the drive in maintenance mode, complete the preceding step. While in Maintenance mode, the drive does not accept a cartridge unless

the drive requests it. The SCD displays a flashing L to indicate a cartridge must be inserted.

Maintenance functions cannot be completed concurrently with read or write operations. While in maintenance mode, the drive does not receive host interface commands from the server.

## Exiting Maintenance mode

The drive must be in Function Code J to exit Maintenance mode.

To exit Maintenance mode:

1. Press and hold **Unload** for 3 or more seconds to take the drive out of maintenance mode. If no error is detected, J temporarily displays in the SCD, then goes blank. The drive then exits maintenance mode and the Ready light turns On.
2. If an error is detected, the SCD shows an error code but still exits maintenance mode. To determine the error, locate the code in Appendix A, "Error codes and messages," on page A-1. To clear the error, turn off the power, then on again.

**Note:** The drive also exits maintenance mode automatically after it completes a maintenance function or after 10 minutes if no action occurred.

## Function code 0: Maintenance mode

Function code  makes the drive available for running drive diagnostic tests or maintenance functions, or exiting from Maintenance mode.

1. Place the drive in Maintenance mode. For instructions, see "Entering Maintenance mode" on page 3-11.
2. To exit Maintenance mode, see "Exiting Maintenance mode" on page 3-11.

The drive exits Maintenance mode automatically after it completes a maintenance function or after 10 minutes if no action occurred.

## Function code 1: Run drive diagnostics



Approximate Run Time = 5 minutes per loop

Total Number of Loops = 1





Function code  runs tests that determine whether the drive can properly load and unload cartridges and read and write data.

Record the time that it takes for the test to complete. Compare the recorded time with the "Approximate Run Time". If the test runs successfully but the execution time is longer than the "Approximate Run Time," run "Function code F: Write performance test" on page 3-19. If the Write Performance Test fails, replace the media and exit maintenance mode.

**Attention:** For this test, insert only a scratch (blank) data cartridge or a cartridge that might be overwritten. During the test, the drive overwrites the data on the cartridge.

**Note:** If you inserted an invalid tape cartridge (Ultrium 3 or WORM tape cartridge), error code  or  displays in the SCD. If you inserted a write-protected cartridge, or the media has read-only compatibility (Ultrium 4 tape cartridge), error code  displays in the SCD. In either case, the tape drive unloads the cartridge and exits Maintenance mode after the cartridge is removed.

### Steps to Run Drive Diagnostic Tests:



1. Place the drive in Maintenance mode. For instructions, see "Entering Maintenance mode" on page 3-11.
2. Press **Unload** once per second until  displays in the SCD. (If you cycle past the wanted code, press **Unload** once per second until the code reappears.)
3. Press and hold **Unload** for three or more seconds, then release it to select function . Wait for the SCD to change to a flashing , requesting a cartridge.
4. Insert a scratch (blank) data cartridge. The SCD changes to a flashing  and the test begins. During the test, the drive unloads and loads the cartridge. Do not remove the cartridge during the test.

- If no error is detected, the diagnostic test loops and begin again. To stop the loop, press **Unload** for 1 second and release. When the loop ends,  temporarily displays in the SCD, and the tape drive exits Maintenance mode.
- If an error is detected, the Fault light flashes and the drive posts an error code to the SCD. To determine the error, locate the code in Table A-1 on page A-1. To clear the error either turn the power off and then on again, or reboot the drive by pressing and holding **Unload** for 10 seconds.

## Function code 2: Update drive firmware from FMR tape

**Attention:** When drive firmware is updated, do not turn the drive off until the update is complete or the firmware might be lost.



Function code  loads drive firmware from a field microcode replacement (FMR) tape. The FMR tape must be created from an LTO Ultrium 6 tape drive with the same host interface (SAS or Fibre Channel).

1. Place the drive in Maintenance mode. For instructions, see “Entering Maintenance mode” on page 3-11.
2. Press **Unload** once per second until  displays in the SCD. (If you cycle past the wanted code, press **Unload** once per second until the code reappears.)
3. Press and hold **Unload** for three or more seconds, then release it to select the function. The SCD changes to a flashing , requesting a cartridge.
4. Insert the FMR tape cartridge. The SCD changes to a flashing . The Fault light is ON solid during tape movement and flashing while code is being loaded. The Ready light is OFF. The tape drive loads the updated firmware from the FMR tape into its erasable programmable read-only memory (EPROM) area.
  - If the update completes successfully, the tape drive rewinds and unloads the FMR tape, resets itself, and is ready to use the new firmware. The drive automatically reboots.
  - If the update fails, the tape drive posts an error code to the SCD. To determine the error, locate the code in Table A-1 on page A-1. The drive then unloads the FMR tape and exits maintenance mode after the cartridge is removed. Contact IBM technical support for problem determination or machine replacement.

## Function code 3: Create FMR tape

Function code  copies the drive's field microcode replacement (FMR) data to a scratch data cartridge. The resulting FMR tape is used only to update the firmware on other LTO Ultrium 6 tape drives with the same host interface (SAS or Fibre Channel).

**Attention:** For this function, insert only a scratch (blank) data cartridge or a cartridge that might be overwritten. During the test, the drive overwrites the data on the cartridge.

**Note:** If you inserted an invalid tape cartridge (Ultrium 3 or WORM tape cartridge), error code  or  displays in the SCD. If you inserted a

write-protected cartridge, or the media has read-only compatibility (Ultrium 4 tape cartridge), error code  $\boxed{P}$  displays in the SCD. In either case, the tape drive unloads the cartridge and exits Maintenance mode after the cartridge is removed.

1. Place the drive in Maintenance mode. For instructions, see “Entering Maintenance mode” on page 3-11.
2. Press **Unload** once per second until  $\boxed{3}$  displays in the SCD. (If you cycle past the wanted code, press **Unload** once per second until the code reappears.)
3. Press and hold **Unload** for three or more seconds, then release it to select the function. The SCD changes to a flashing  $\boxed{C}$ , requesting a cartridge.
4. Insert a scratch (blank) data cartridge that is not write protected (or the tape drive exits maintenance mode). The SCD changes to a flashing  $\boxed{3}$ . The tape drive copies the FMR data to the scratch data cartridge.
  - If the tape drive creates the FMR tape successfully, it rewinds and unloads the new tape, exits Maintenance mode, and the tape is ready to use.
  - If the tape drive fails to create the FMR tape, it displays an error code. To determine the error, see Table A-1 on page A-1. The tape drive then unloads the FMR tape, and exits Maintenance mode after the cartridge is removed.

## Function code 4: Force a drive dump

Function code  $\boxed{4}$  completes a memory dump of data that is collected by the drive (this process is also known as saving a microcode trace).

1. Place the drive in Maintenance mode. For instructions, see “Entering Maintenance mode” on page 3-11.
2. Press **Unload** once per second until  $\boxed{4}$  displays in the SCD. (If you cycle past the wanted code, press **Unload** once per second until the code reappears.)
3. Press and hold **Unload** for three or more seconds, then release it to select the function. The drive completes the memory dump. The SCD shows  $\boxed{0}$ , then goes blank, and the drive exits Maintenance mode. To access the contents of the memory dump, see “Function code 5: Copy drive dump.”

**Note:** You can also force a drive dump when the tape drive is in normal operating mode. Press and hold **Unload** for 10 seconds. This action causes the drive to reboot.

## Function code 5: Copy drive dump

Function code  $\boxed{5}$  copies data from a drive memory dump (captured in Function Code 4) to the beginning of a scratch (blank) data cartridge.

**Attention:** For this function, insert only a scratch (blank) data cartridge or a cartridge that might be overwritten. During the test, the drive overwrites the data on the cartridge.

**Note:** If you inserted an invalid tape cartridge (Ultrium 3 or WORM tape cartridge), error code  $\boxed{U}$  or  $\boxed{7}$  displays in the SCD. If you inserted a



write-protected cartridge, or the media has read-only compatibility (Ultrium 4 tape cartridge), error code  $\boxed{P}$  displays in the SCD. In either case, the tape drive unloads the cartridge and exits Maintenance mode after the cartridge is removed.

1. Place the drive in Maintenance mode. For instructions, see “Entering Maintenance mode” on page 3-11.
2. Press **Unload** once per second until  $\boxed{5}$  displays in the SCD. If you cycle past the wanted code, press **Unload** once per second until the code reappears.
3. Press and hold **Unload** for three or more seconds, then release it to select the function.
4. Press **Unload** once per second to cycle through the following functions:
  - $\boxed{5} - \boxed{0}$  : no function
  - $\boxed{5} - \boxed{1}$  : copy memory dump to tape; clears RAM memory dump
  - $\boxed{5} - \boxed{2}$  : copy memory dump to flash memory; clears RAM memory dump
  - $\boxed{5} - \boxed{3}$  : erase flash memory

If you cycle past the wanted code, press **Unload** once per second until the code reappears.

5. Press and hold **Unload** for three or more seconds, then release it to select one of the functions.
6. If you selected  $\boxed{5} - \boxed{0}$  the drive exits Maintenance mode. If you selected  $\boxed{5} - \boxed{2}$  or  $\boxed{5} - \boxed{3}$  the SCD changes to a flashing  $\boxed{5}$  while the procedure is completing. After the procedure is completed the drive exits Maintenance mode. If you selected  $\boxed{5} - \boxed{1}$  the SCD changes to a flashing  $\boxed{C}$  indicating that a data cartridge is to be inserted.
7. Insert a scratch (blank) data cartridge within 60 seconds, or the drive exits Maintenance mode. Ensure that the scratch cartridge is not write protected, or the tape drive exits maintenance mode. The SCD flashes the selection number while the function is completing.
  - If the copy operation completes successfully, the tape drive rewinds and unloads the tape, and exits Maintenance mode after the cartridge is removed.
  - If the copy operation fails, an error code displays in the SCD. To determine the error, locate the code in Table A-1 on page A-1. The tape drive unloads the tape cartridge and exits Maintenance mode after the cartridge is removed.

## Function code 6: Run host interface wrap test

Approximate Run Time = 10 seconds per loop

Number of Loops = This test runs until stopped by pressing **Unload**.

Function code  $\boxed{6}$  completes a check of the host interface circuitry and host connector on the drive.

1. Make sure that the host interface wrap plug is connected to the host interface connector at the rear of the drive<sup>1</sup>.
  - Connect the wrap plug to the SAS port to be tested.
2. Place the drive in Maintenance mode. For instructions, see “Entering Maintenance mode” on page 3-11.
3. Press **Unload** once per second until **6** appears in the SCD.
  - To test the SAS interface on the drive,
    - a. Index through the Maintenance mode options until **6** appears in the SCD.
    - b. Press and hold **Unload** for 3 seconds to select Function code **6**.
    - c. After Function code **6** is selected, the SCD displays option **6** - **1**.
    - d. Press **Unload** within 5 seconds to make a different selection. If no other selection is made, the drive completes option **6** - **1**.
4. Continue to press **Unload** once per second to cycle through the following functions:
  - **6** - **1** : test the primary SAS port
  - **6** - **2** : test the secondary SAS port<sup>2</sup>
  - **6** - **3** : test both primary and secondary SAS ports at the same time (requires a wrap plug in both ports)<sup>2</sup>
  - **6** - **0** : exit
5. Press and hold **Unload** for three or more seconds, then release it to select one of the functions. The drive automatically starts the test. If you cycle past the wanted code, press **Unload** once per second until the code reappears.
6. The SCD displays a flashing **6** during the test.
  - If no error is detected, the diagnostic test loops and begin again. To stop the loop, press **Unload** for 1 second and release. When the loop ends, **0** temporarily displays in the SCD, and the tape drive exits Maintenance mode.
  - If an error is detected, the Fault light flashes and the drive posts an error code to the SCD. To determine the error, locate the code in Table A-1 on page A-1. To clear the error either turn the power off and then on again, or reboot the drive by pressing and holding **Unload** for 10 seconds.

**Note:** <sup>1</sup>Not supported on the USB port. <sup>2</sup>Not supported on the SAS/USB drive.

## Function code 7: Run RS-422 wrap test

**Note:** This function is described here for information only. It is not supported on the IBM System Storage TS2260 tape drive.

This test causes the drive to process a check of the circuitry and connector for the RS-422 interface. This connector supports the Library Drive Interface (LDI) and the Automation Drive Interface (ADI).

Before this function is selected, attach an LDI or RS-422 wrap plug to the drive's LDI or RS-422 connector (in place of the LDI or RS-422 cable).

1. Make sure that no cartridge is in the drive, and the appropriate wrap plug is attached to the RS-422 connector.
2. Place the drive in Maintenance mode. For instructions, see "Entering Maintenance mode" on page 3-11.
3. Press **Unload** once per second until  $\boxed{7}$  appears in the Single-character Display (SCD). If you cycle past  $\boxed{7}$ , continue to press **Unload** until the code is displayed again.
4. To select the function, press and hold **Unload** for 3 seconds. After you select the function,  $\boxed{7}$  flashes and the drive automatically starts the test.
  - If no error is detected, the diagnostic test loops and begin again. To stop the loop, press **Unload** for 1 second and release. When the loop ends,  $\boxed{7}$  temporarily displays in the SCD, and the tape drive exits Maintenance mode.
  - If an error is detected, the Fault light flashes and the drive posts an error code to the SCD. To determine the error, locate the code in Table A-1 on page A-1. To clear the error either turn the power off and then on again, or reboot the drive by pressing and holding **Unload** for 10 seconds.

## Function code 8: Unmake FMR tape

Function code  $\boxed{8}$  erases the field microcode replacement (FMR) data and rewrites the cartridge memory on the tape. This action converts the cartridge into a valid scratch (blank) data cartridge.

1. Place the drive in Maintenance mode. For instructions, see "Entering Maintenance mode" on page 3-11.
2. Press **Unload** once per second until  $\boxed{8}$  appears in the SCD. (If you cycle past the wanted code, press **Unload** once per second until the code reappears.)
3. Press and hold **Unload** for three or more seconds, then release it to select function  $\boxed{8}$ . The SCD changes to a flashing  $\boxed{8}$ , requesting a cartridge.
4. Insert the FMR data cartridge (or the tape drive exits Maintenance mode). The SCD changes to a flashing  $\boxed{8}$ . The tape drive erases the firmware on the tape and rewrites the header in the cartridge memory to change the cartridge to a valid scratch (blank) data cartridge: The drive then ejects the cartridge and exits Maintenance mode.

**Note:** If you inserted an invalid tape cartridge (Ultrium 3 or WORM tape

cartridge), error code  $\boxed{U}$  or  $\boxed{7}$  displays in the SCD. If you inserted a write-protected cartridge, or the media has read-only compatibility

(Ultrium 4 tape cartridge), error code  $\boxed{P}$  displays in the SCD. In either case, the tape drive unloads the cartridge and exits Maintenance mode after the cartridge is removed.

- If the tape drive creates the scratch tape successfully, it rewinds and unloads the new tape, exits Maintenance mode, and the tape is ready to use.

- If the tape drive fails to create the scratch tape, it displays an error code. To determine the error, see Table A-1 on page A-1. The tape drive then unloads the FMR tape, and exits Maintenance mode after the cartridge is removed.

## Function code 9: Display error code log

Function code **9** displays the last 10 error codes, one at a time (the codes are ordered; the most recent is presented first and the oldest is presented last). If there are no errors in the log, function code **0** displays in the Single-character Display (SCD) and exits Maintenance Mode.

1. Place the drive in Maintenance mode. For instructions, see “Entering Maintenance mode” on page 3-11.
2. Press **Unload** once per second until **9** appears in the SCD. (If you cycle past the wanted code, press **Unload** once per second until the code reappears.)
3. Press and hold **Unload**, then release it to view the most recent error code.
4. Press and release **Unload** again to view successive error codes. Allow 2 - 3 seconds pass between each depression. The Ready light and Fault light flash On/Off once for each successive error code. The SCD displays **0** when all the error codes are displayed.
5. After all error codes are viewed, exit this function by pressing **Unload** again. The SCD displays **0** and exits Maintenance mode.

## Function code A: Clear error code log

Function code **A** erases the contents of the error code log.

1. Place the drive in Maintenance mode. For instructions, see “Entering Maintenance mode” on page 3-11.
2. Press **Unload** once per second until **A** displays in the SCD. (If you cycle past the wanted code, press **Unload** once per second until the code reappears.)
3. Press and hold **Unload** for three or more seconds, then release it to select the function. **A** flashes in the SCD, followed by **0**. The tape drive erases all errors from the error code log and exits Maintenance mode.

## Function code C: Insert cartridge into tape drive

This function cannot be selected by itself, but is part of other maintenance functions (such as Run tape drive diagnostics and Create FMR tape) that require a tape cartridge to be inserted.

## Function code E: Test cartridge & media

Approximate Run Time = 15 minutes per loop

Total Number of Loops = 10

Function code **E** completes tests that determine whether a suspect cartridge and its magnetic tape are acceptable.

Press **Unload** to stop the diagnostic test and exit Maintenance mode. Pressing **Unload** once stops the test at the end of the current test loop. Pressing **Unload** twice stops the test immediately. Wait for the drive to rewind the tape and unload the cartridge.

**Attention:** When you complete this test, data on the suspect tape is overwritten.

**Note:** If you inserted an invalid tape cartridge (Ultrium 3 or WORM tape cartridge), error code  $\square U$  or  $\square 7$  displays in the SCD. If you inserted a write-protected cartridge, or the media has read-only compatibility (Ultrium 4 tape cartridge), error code  $\square P$  displays in the SCD. In either case, the tape drive unloads the cartridge and exits Maintenance mode after the cartridge is removed.

1. Place the drive in Maintenance mode. For instructions, see “Entering Maintenance mode” on page 3-11.
2. Press **Unload** once per second until  $\square E$  displays in the SCD. (If you cycle past the wanted code, press **Unload** once per second until the code reappears.)
3. Press and hold **Unload** for three or more seconds, then release it to select the function. The SCD changes to a flashing  $\square C$ , requesting a cartridge.
4. Ensure that the write-protect switch on the cartridge is off, then insert the cartridge (or the tape drive exits Maintenance mode). The SCD changes to a flashing  $\square E$ . The tape drive runs the tests.
  - If no error is detected, the diagnostic test loops and begin again. To stop the loop, press **Unload** for 1 second and release. When the loop ends,  $\square D$  temporarily displays in the SCD, and the tape drive exits Maintenance mode.
  - If an error is detected, the Fault light flashes and the drive posts an error code to the SCD. To determine the error, locate the code in Table A-1 on page A-1. To clear the error either turn the power off and then on again, or reboot the drive by pressing and holding **Unload** for 10 seconds.

## Function code F: Write performance test

Approximate Run Time = 7 minutes per loop

Total Number of Loops = 10

Function code  $\square F$  performs tests to ensure that the drive can read from and write to tape.

Press **Unload** to stop the diagnostic test and exit Maintenance mode. Pressing **Unload** once stops the test at the end of the current test loop. Pressing **Unload** twice stops the test immediately. Wait for the drive to rewind the tape and unload the cartridge.

**Attention:** For this test, insert only a scratch (blank) data cartridge or a cartridge that can be overwritten. During the test, the drive overwrites the data on the cartridge.

**Note:** If you inserted an invalid tape cartridge (Ultrium 3 or WORM tape cartridge), error code  $\boxed{U}$  or  $\boxed{7}$  displays in the SCD. If you inserted a write-protected cartridge, or the media has read-only compatibility (Ultrium 4 tape cartridge), error code  $\boxed{P}$  displays in the SCD. In either case, the tape drive unloads the cartridge and exits Maintenance mode after the cartridge is removed.

1. Place the drive in Maintenance mode. For instructions, see "Entering Maintenance mode" on page 3-11.
2. Press **Unload** once per second until  $\boxed{F}$  displays in the SCD. (If you cycle past the wanted code, press **Unload** once per second until the code reappears.)
3. Press and hold **Unload** for three or more seconds, then release it to select the function. The SCD changes to a flashing  $\boxed{L}$ , requesting a cartridge.
4. Insert a scratch (blank) data cartridge. The SCD changes to a flashing  $\boxed{F}$  and the tape drive runs the tests.
  - If no error is detected, the diagnostic test loops and begin again. To stop the loop, press **Unload** for 1 second and release. When the loop ends,  $\boxed{D}$  temporarily displays in the SCD, and the tape drive exits Maintenance mode.
  - If an error is detected, the Fault light flashes and the drive posts an error code to the SCD. To determine the error, locate the code in Table A-1 on page A-1. To clear the error either turn the power off and then on again, or reboot the drive by pressing and holding **Unload** for 10 seconds.

## Function code H: Test head

Approximate Run Time = 12 minutes per loop

Total Number of Loops = 10

Function code  $\boxed{H}$  completes tests to ensure that the tape drive's head and tape-carriage mechanics work correctly.

When you begin this test, the diagnostic test begins the loop sequence. Time the first loop by pressing **Unload** once to stop the diagnostic test after the completion of the first loop, then record the time that it takes for the test to complete. Compare the recorded time with the "Approximate Run Time". If the test runs successfully but the execution time is longer than the "Approximate Run Time", run "Function code F: Write performance test" on page 3-19. If the Write Performance Test fails, replace the media and exit Maintenance mode.

Press **Unload** to stop the diagnostic test and exit Maintenance mode. Pressing **Unload** once stops the test at the end of the current test loop. Pressing **Unload** twice stops the test immediately. Wait for the drive to rewind the tape and unload the cartridge.

**Attention:** For this test, insert only a scratch (blank) data cartridge or a cartridge that can be overwritten. During the test, the drive overwrites the data on the cartridge.

**Note:** If you inserted an invalid tape cartridge (Ultrium 3 or WORM tape cartridge), error code  $\square$  or  $\square$  displays in the SCD. If you inserted a write-protected cartridge, or the media has read-only compatibility (Ultrium 4 tape cartridge), error code  $\square$  displays in the SCD. In either case, the tape drive unloads the cartridge and exits Maintenance mode after the cartridge is removed.

1. Place the drive in Maintenance mode. For instructions, see "Entering Maintenance mode" on page 3-11.
2. Press **Unload** once per second until  $\square$  displays in the SCD. (If you cycle past the wanted code, press **Unload** once per second until the code reappears.)
3. Press and hold **Unload** for three or more seconds, then release it to select the function. The SCD changes to a flashing  $\square$ , requesting a cartridge.
4. Insert a scratch (blank) data cartridge. The SCD changes to a flashing  $\square$ . The tape drive runs the tests.
  - If no error is detected, the diagnostic test loops and begin again. To stop the loop, press **Unload** for 1 second and release. When the loop ends,  $\square$  temporarily displays in the SCD, and the tape drive exits Maintenance mode.
  - If an error is detected, the Fault light flashes and the drive posts an error code to the SCD. To determine the error, locate the code in Table A-1 on page A-1. To clear the error either turn the power off and then on again, or reboot the drive by pressing and holding **Unload** for 10 seconds.

## Function code J: Fast read/write test

Approximate Run Time = 7 minutes per loop

Total Number of Loops = 10

Function code  $\square$  completes tests to ensure that the drive can read from and write to tape.

When you begin this test, the diagnostic test begins the loop sequence. Time the first loop by pressing **Unload** once to stop the diagnostic test after the completion of the first loop, then record the time that it takes for the test to complete. Compare the recorded time with the "Approximate Run Time". If the test runs successfully but the execution time is longer than the "Approximate Run Time", run "Function code F: Write performance test" on page 3-19. If the Write Performance Test fails, replace the media and exit Maintenance mode.

Press **Unload** to stop the diagnostic test and exit Maintenance mode. Pressing **Unload** once stops the test at the end of the current test loop. Pressing **Unload** twice stops the test immediately. Wait for the drive to rewind the tape and unload the cartridge.

**Attention:** For this test, insert only a scratch (blank) data cartridge or a cartridge that can be overwritten. During the test, the drive overwrites the data on the cartridge.

**Note:** If you inserted an invalid tape cartridge (Ultrium 3 or WORM tape cartridge), error code  $\square$  or  $\square$  displays in the SCD. If you inserted a write-protected cartridge, or the media has read-only compatibility (Ultrium 4 tape cartridge), error code  $\square$  displays in the SCD. In either case, the tape drive unloads the cartridge and exits Maintenance mode after the cartridge is removed.

1. Place the drive in Maintenance mode. For instructions, see “Entering Maintenance mode” on page 3-11.
2. Press **Unload** once per second until  $\square$  displays in the SCD. (If you cycle past the wanted code, press **Unload** once per second until the code reappears.)
3. Press and hold **Unload** for three or more seconds, then release it to select the function. The SCD changes to a flashing  $\square$ , requesting a cartridge.
4. Insert a scratch (blank) data cartridge. The SCD changes to a flashing  $\square$  and the tape drive runs the tests.
  - If no error is detected, the diagnostic test loops and begin again. To stop the loop, press **Unload** for 1 second and release. When the loop ends,  $\square$  temporarily displays in the SCD, and the tape drive exits Maintenance mode.
  - If an error is detected, the Fault light flashes and the drive posts an error code to the SCD. To determine the error, locate the code in Table A-1 on page A-1. To clear the error either turn the power off and then on again, or reboot the drive by pressing and holding **Unload** for 10 seconds.

## Function code L: Load/unload test

Approximate Run Time = 30 seconds per loop

Total Number of Loops = 10

Function code  $\square$  tests the drive 's ability to load and unload a tape cartridge.

Press **Unload** to stop the diagnostic test and exit Maintenance mode. Pressing **Unload** once stops the test at the end of the current test loop. Pressing **Unload** twice stops the test immediately. Wait for the drive to rewind the tape and unload the cartridge.

**Attention:** Even though no data is written during this test, it is recommended that you use a blank (scratch) cartridge for this test.

**Note:** If you inserted an invalid tape cartridge (Ultrium 3 or WORM tape cartridge), error code  $\square$  or  $\square$  displays in the SCD. If you inserted a write-protected cartridge, or the media has read-only compatibility (Ultrium 4 tape cartridge), error code  $\square$  displays in the SCD. In either case, the tape drive unloads the cartridge and exits Maintenance mode after the cartridge is removed.

1. Place the drive in Maintenance mode. For instructions, see “Entering Maintenance mode” on page 3-11.



2. Press **Unload** once per second until **L** displays in the SCD. (If you cycle past the wanted code, press **Unload** once per second until the code reappears.)
3. Press and hold **Unload** for three or more seconds, then release it to select the function. The SCD changes to a flashing **L**, requesting a cartridge.
4. Insert a scratch (blank) data cartridge. The SCD changes to a flashing **L** and the tape drive runs the tests.
  - If no error is detected, the diagnostic test loops and begin again. To stop the loop, press **Unload** for 1 second and release. When the loop ends, **L** temporarily displays in the SCD, and the tape drive exits Maintenance mode.
  - If an error is detected, the Fault light flashes and the drive posts an error code to the SCD. To determine the error, locate the code in Table A-1 on page A-1. To clear the error either turn the power off and then on again, or reboot the drive by pressing and holding **Unload** for 10 seconds.

## Function code P: Post Error Reporting enabled

When Post Error Reporting is enabled, deferred-check conditions are reported to the host and temporary errors are reported in the sense data. Function code **P** is displayed in Maintenance mode when the drive has Post Error Reporting enabled.

This selection is normally used as a request from support personnel.







1. Place the drive in Maintenance mode. For instructions, see “Entering Maintenance mode” on page 3-11.
2. Press **Unload** once per second until either **P** or **L** displays in the SCD. **P** or **L** displays in the SCD to indicate the current setting for Post Error Reporting. If you cycle past the desired code, press **Unload** once per second until the code reappears.
3. Exit Maintenance mode if you do not want to change the current setting for Post Error Reporting. For instructions, see “Exiting Maintenance mode” on page 3-11.
4. To disable Post Error Reporting, press and hold **Unload** for 3 seconds while **P** displays in the SCD. The SCD changes to **L** after you release **Unload**.
5. Press **Unload** once per second to select another Maintenance mode function. To exit Maintenance mode, refer to “Exiting Maintenance mode” on page 3-11.

## Function code U: Post Error Reporting disabled

When Post Error Reporting is disabled, deferred-check conditions are not reported to the host and temporary errors are not reported in the sense data. This setting is normal (default) for the drive. When the drive has Post Error Reporting that is

disabled, Function code **U** is displayed in Maintenance mode. The drive defaults to Post Error Reporting disabled after a reboot or power off/on cycle.

1. Place the drive in Maintenance mode. For instructions, see “Entering Maintenance mode” on page 3-11.

2. Press **Unload** once per second until either  or  displays in the SCD.   
or  displays in the SCD to indicate the current setting for Post Error Reporting. If you cycle past the wanted code, press **Unload** once per second until the code reappears.
3. Exit Maintenance mode if you do not want to change the current setting for Post Error Reporting. For instructions, see “Exiting Maintenance mode” on page 3-11.
4. To disable Post Error Reporting, press and hold **Unload** for 3 seconds while   
displays in the SCD. The SCD changes to  after you release **Unload**.
5. Press **Unload** once per second to select another Maintenance mode function. To exit Maintenance mode, refer to “Exiting Maintenance mode” on page 3-11.

---

## Tape drive diagnostic and maintenance web page

Several of the tape drive’s maintenance functions are run with the tape drive’s ethernet port. These functions are the same maintenance functions that are run with **Unload** on the drive’s front panel.

Refer to the “Diagnostic and maintenance functions” on page 3-9 section in this User’s Guide for information about these maintenance functions.

1. Connect the host computer or a laptop to the tape drive’s ethernet port (RJ45 connector) with an ethernet patch cable.
2. With a web browser, connect to <http://169.254.0.3/service.html> to access the tape drive maintenance function menu on an HTML web page. (If the drive’s IP address was changed, use that address instead.)

The tape drive model and serial number are shown at the top of the page. A list of the maintenance functions is shown on the page.

# ULT3580-HH6 Drive YR1013000128

**Select function:**

- 1: Run Drive Diagnostics
- 2: Update Drive Firmware from FMR Tape
- 3: Create FMR Tape
- 4: Force a Drive Dump
- 5.1: Copy Drive Dump - copy dump to tape
- 5.2: Copy Drive Dump - copy dump to flash
- 5.3: Copy Drive Dump - erase flash memory
- 6.1: Run Host Interface Wrap Test - primary port
- 6.2: Run Host Interface Wrap Test - secondary port
- 6.3: Run Host Interface Wrap Test - both ports
- 8: Unmake FMR Tape
- 9: Display Error Code Log
- A: Clear Error Code Log
- E: Test Cartridge & Media
- F: Write Performance Test
- H: Test Head
- J: Fast Read/Write Test
- L: Load/Unload Test

**Drive response (press refresh to display current drive status):**

Select a test and press run.

a67b0025

Figure 3-4. Tape drive diagnostic page

Click the button next to the maintenance function, then click **Run** to start the maintenance function.

If the tape drive is installed in a library, some of the maintenance functions cannot be run with the ethernet procedure.

The status of the maintenance function is shown under the Drive Response. The web page is static so it must be refreshed frequently to show the latest maintenance function status.

Press **Cancel now** or **Cancel at end of loop** to stop the maintenance function. It can take several minutes for the maintenance function to end.

**Note:** Functions 6.2 and 6.3 are not supported on the SAS/USB drive.



---

## Chapter 4. Ultrium media

IBM Ultrium media is available in the following types:

- Data cartridge
- WORM (Write Once, Read Many) cartridge
- Cleaning cartridge

To ensure that your IBM Ultrium tape drive conforms to IBM's specifications for reliability, use only IBM LTO Ultrium tape cartridges. You can use other LTO-certified data cartridges, but they might not meet the standards of reliability that are established by IBM. The IBM LTO Ultrium data cartridge cannot be interchanged with the media used in other IBM non-LTO Ultrium tape products.

Figure 4-1 shows the IBM LTO Ultrium data cartridge and its components.

- |          |                      |          |                      |
|----------|----------------------|----------|----------------------|
| <b>1</b> | LTO cartridge memory | <b>4</b> | Write-protect Switch |
| <b>2</b> | Cartridge door       | <b>5</b> | Label area           |
| <b>3</b> | Leader Pin           | <b>6</b> | Insertion guide      |

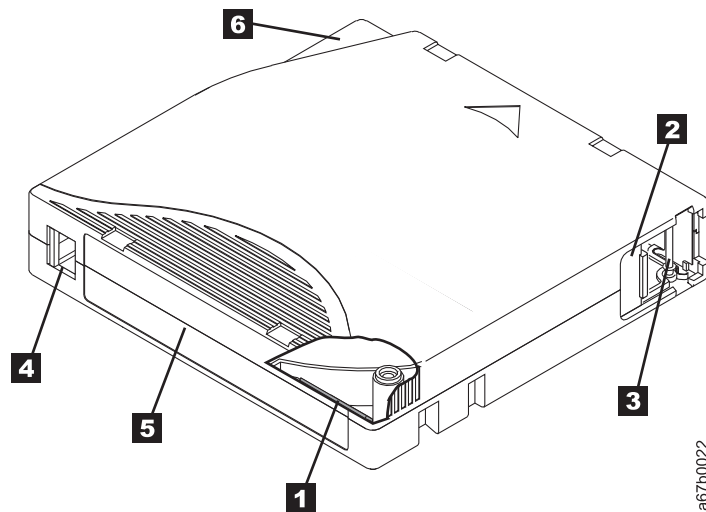

Figure 4-1. The IBM LTO Ultrium data cartridge

---

### Data cartridges

The different generations of IBM Ultrium data cartridges are identified by color:

Table 4-1. Cartridge types and colors

Type	Color
Ultrium 6	Black
Ultrium 6 WORM	Black and Silvery gray
Ultrium 5	Burgundy
Ultrium 5 WORM	Burgundy and Silvery gray
Ultrium 4	Green

Table 4-1. Cartridge types and colors (continued)

Type	Color
Ultrium 4 WORM	Green and Silvery gray
Ultrium 3	Slate Blue
Ultrium 3 WORM	Slate Blue and Silvery gray
Ultrium 2	Purple
Ultrium 1	Black

All generations contain 1/2-inch, dual-coat, magnetic tape.

You can order tape cartridges with the bar code labels included, or you can order custom labels. To obtain tape cartridges and bar code labels, see “Ordering media supplies” on page 4-20.

When tape is processed in the cartridges, Ultrium Tape Drives use a linear, serpentine recording format. The native data capacity and recording format of Ultrium data cartridges is as follows:

Table 4-2. Cartridge data capacity and recording formats

Type	Native Data Capacity	Recording Format
Ultrium 6	2500 GB (6250 GB at 2.5:1 compression)	Reads and writes data on 2176 tracks, 16 tracks at a time
Ultrium 5	1500 GB (3000 GB at 2:1 compression)	Reads and writes data on 1280 tracks, 16 tracks at a time
Ultrium 4	800 GB (1600 GB at 2:1 compression)	Reads and writes data on 896 tracks, 16 tracks at a time.
Ultrium 3	400 GB (800 GB at 2:1 compression)	Reads and writes data on 704 tracks, 16 tracks at a time
Ultrium 2	200 GB (400 GB at 2:1 compression)	Reads and writes data on 512 tracks, 8 tracks at a time
Ultrium 1	100 GB (200 GB at 2:1 compression)	Reads and writes data on 384 tracks, 8 tracks at a time

The first set of tracks is written from near the beginning of the tape to near the end of the tape. The head then repositions to the next set of tracks for the return pass. This process continues until all tracks are written and the cartridge is full, or until all data is written.

The cartridge door ( **2** Figure 4-1 on page 4-1) protects the tape from contamination when the cartridge is out of the drive. The tape is attached to a leader pin ( **3** in in Figure 4-1 on page 4-1) behind the door. When the cartridge is inserted into the drive, a threading mechanism pulls the pin (and tape) out of the cartridge, across the drive head, and onto a non-removable take-up reel. The head can then read or write data from or to the tape.

The write-protect switch ( **4** in Figure 4-1 on page 4-1) prevents data from being written to the tape cartridge. For more information, see “Write-Protect switch” on page 4-7.

The label area ( **5** in Figure 4-1 on page 4-1) provides a location to place a label. For more information, see “Bar code label” on page 4-5.

The insertion guide ( **6** in Figure 4-1 on page 4-1) is a large, notched area that prevents the cartridge from being inserted incorrectly.

Table 4-3. Nominal cartridge life: Load/unload cycles

Type	Load/Unload Cycles
Ultrium 6	20,000 (20k)
Ultrium 5	20,000 (20k)
Ultrium 4	20,000 (20k)
Ultrium 3	20,000 (20k)
Ultrium 2	10,000 (10k)
Ultrium 1	5000 (5k)

## Cartridge Compatibility

Table 4-4. Ultrium data cartridge compatibility with Ultrium tape drive

IBM Ultrium Tape Drive	IBM LTO Ultrium Data Cartridges					
	2500 GB Ultrium 6	1500 GB Ultrium 5	800 GB Ultrium 4	400 GB Ultrium 3	200GB Ultrium 2	100GB Ultrium 1
Ultrium 6	Read/Write	Read/Write	Read Only			
Ultrium 5		Read/Write	Read/Write	Read only		
Ultrium 4			Read/Write	Read/Write	Read only	
Ultrium 3				Read/Write	Read/Write	Read only
Ultrium 2					Read/Write	Read/Write
Ultrium 1						Read/Write

## Capacity Scaling

To control the capacity of the cartridge (for example, to obtain a faster seek time) issue the SCSI command SET CAPACITY. For information about this command, refer to the *IBM Ultrium Tape Drive SCSI Reference*.

---

## WORM (Write Once, Read Many) cartridges

Certain records retention and data security applications require a Write Once, Read Many (WORM) method for storing data on tape. The LTO Ultrium 6, Ultrium 5, and Ultrium 4 drives enable WORM support when a WORM tape cartridge is loaded into the drive.

### WORM media

Because standard read/write media are incompatible with the WORM feature, a specially formatted WORM tape cartridge (see Figure 4-2 on page 4-4) is required. Each WORM cartridge has a unique, worldwide cartridge identifier (WWCID), which comprises the unique CM chip serial number and the unique tape media serial number. Ultrium 6 WORM cartridges are two-tone black and silvery-gray. See “Ordering media supplies” on page 4-20 for information about how to choose

and purchase the appropriate WORM tape cartridges for your tape drive.

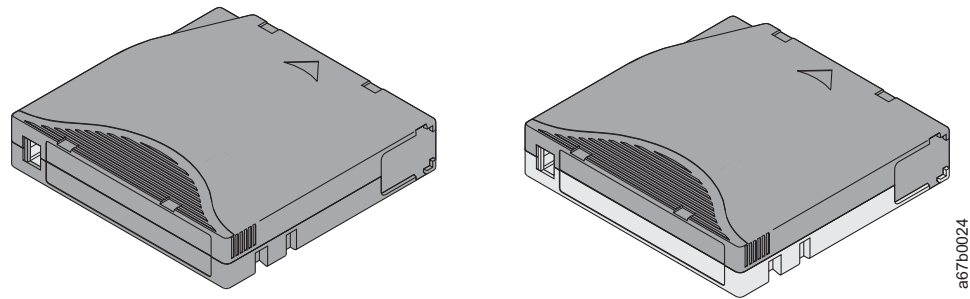

Figure 4-2. Ultrium Data and WORM Tape Cartridges

## Data security on WORM media

Certain built-in security measures help ensure that the data written on a WORM cartridge does not become compromised. For example:

- The format of an Ultrium 6, Ultrium 5, or Ultrium 4 WORM Tape Cartridge is unlike that of standard read/write media. This unique format prevents a drive that lacks WORM-capable firmware from writing on a WORM tape cartridge. For LTO 6, native data capacity is 2500 GB and compressed data capacity is 6250 GB.
- When the drive senses a WORM cartridge, the firmware prohibits the changing or altering of user data that is already written on the tape. The firmware keeps track of the last appendable point on the tape.

## WORM media errors

The following conditions cause WORM media errors to occur:

- Information in the servo manufacturer's word (SMW) on the tape must match information from the cartridge memory (CM) module in the cartridge. If it does not match, a media Error Code 7 posts on the drive's single-character display (SCD).
- Inserting a WORM tape cartridge into a drive that is not compatible with WORM causes the cartridge to be treated as an unsupported medium. The drive reports a media Error Code 7. Upgrading the drive firmware to the correct code level resolves the problem.

## WORM requirements

To add WORM capability to your IBM LTO Ultrium 6 drives, you must use either IBM Ultrium 6 2500 GB WORM tape cartridges or IBM Ultrium 5 1500 GB WORM tape cartridges. See "Ordering media supplies" on page 4-20.

---

## Cleaning cartridge

A specially labeled IBM LTO Ultrium Cleaning Cartridge is used to clean the drive head. The drive itself determines when a head must be cleaned. It alerts you by

the SCD flashing a . To clean the head manually, insert a cleaning cartridge into the tape load compartment (see Figure 3-1 on page 3-6). The drive completes the cleaning automatically. When the cleaning is finished, the drive ejects the cartridge, and the SCD is blank.



**Note:** The drive automatically ejects an expired cleaning cartridge without running the cleaning process. Replace the expired cleaning cartridge with a new cleaning cartridge and insert it into the drive.

The IBM cleaning cartridges are valid for 50 uses. The cartridge's LTO-CM chip tracks the number of times that the cartridge is used.

**Important:** After 50 uses, the cleaning cartridge expires. It is no longer usable, and must be replaced

---

## Cartridge memory chip (LTO-CM)

All generations of the IBM LTO Ultrium Data Cartridges include a Linear Tape-Open Cartridge Memory (LTO-CM) chip ( **1** in Figure 4-1 on page 4-1), that contains information about the cartridge and the tape (such as the name of the manufacturer that created the tape), and also statistical information about the cartridge's use. The LTO-CM enhances the efficiency of the cartridge. For example, the LTO-CM stores the end-of-data location which, when the next time this cartridge is inserted and the Write command is issued, enables the drive to quickly locate the recording area and begin recording. The LTO-CM also aids in determining the reliability of the cartridge by storing data about its age, how many times it was loaded, and how many errors it accumulated. Whenever a tape cartridge is unloaded, the tape drive writes any pertinent information to the cartridge memory.

The storage capacity of the LTO Generation 4 and 5 LTO-CM is 8160 bytes. LTO Generations 1, 2, and 3 have an LTO-CM capacity of 4096 bytes.

---

## Bar code label

A bar code label contains:

- A volume serial number (VOLSER) that is human-readable
- A bar code that the library can read

**Note:** The LTO Ultrium 5 and 6 Tape Drives do not require bar code labels, but you might choose to use labels for tape cartridge identification purposes.

*Table 4-5. Bar code label requirements for Ultrium tape drives and libraries*

Ultrium Tape Drive/Library	Bar Code Label Requirements
3573	Required
3576	Required
3580	Not required
3581	Required with optional Bar Code Reader
3582	Required
3583	Required
3584	Required

When read by a library's bar code reader, the bar code identifies the cartridge's VOLSER to the library. The bar code also tells the library whether the cartridge is a data cartridge or cleaning cartridge. In addition, the bar code includes the two-character media-type identifier Lx, where x equals 1, 2, 3, 4, 5 or 6. L identifies

the cartridge as an LTO cartridge and the number represents the generation of cartridge for that cartridge type. Figure 4-3 on page 4-7 shows a sample bar code label for the LTO Ultrium Tape Cartridge.

Tape cartridges are ordered with the labels included or with custom labels. To order tape cartridges and bar code labels, see “Ordering media supplies” on page 4-20. The bar code for usage in IBM tape libraries must meet predefined specifications. They include (but are not limited to):

- Eight uppercase alphanumeric characters, where the last 2 characters must be L6, L5, L4, L3, L2, or L1 (LW, LV, LU, or LT for Ultrium WORM cartridges)
- Label and printing to be non-glossy
- Nominal narrow line or space width of 0.423 mm (0.017 in.)
- Wide to narrow ratio of 2.75:1
- Minimum bar length of 11.1 mm (0.44 in.)

*Table 4-6. Cartridges and VOLSERs compatible with the Ultrium Tape Drives*

Cartridges	VOLSER
Ultrium 6 Data Cartridge	xxxxxxL6
Ultrium 6 WORM Cartridge	xxxxxxLW
Ultrium 5 Data Cartridge	xxxxxxL5
Ultrium 5 WORM Cartridge	xxxxxxLV
Ultrium 4 Data Cartridge	xxxxxxL4
Ultrium 4 WORM Cartridge	xxxxxxLU
Ultrium 3 Data Cartridge	xxxxxxL3
Ultrium 3 WORM Cartridge	xxxxxxLT
Ultrium 2 Data Cartridge	xxxxxxL2
Ultrium 1 Data Cartridge (READ ONLY)	xxxxxxL1
LTO Ultrium Cleaning Cartridge	CLNxxxLx
*An Ultrium 3 Tape Drive must have a minimum firmware level of 54xx for it to be compatible with the WORM cartridge.	

To determine the complete specifications of the bar code and the bar code label, visit the web at <http://www.ibm.com/> and enter "IBM LTO Ultrium Cartridge Label Specification" in the search box. Or contact your IBM sales representative.

When a bar code label is attached to a tape cartridge, place the label only in the recessed label area (see **5** in Figure 4-1 on page 4-1). A label that extends outside of the recessed area can cause loading problems in the drive.

**Attention:** Do not place any type of mark on the white space at either end of the bar code. A mark in this area might prevent the library from reading the label.

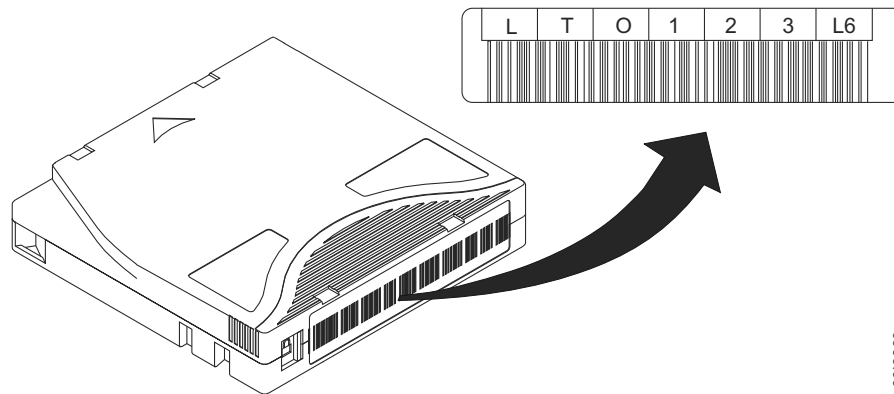

Figure 4-3. Sample bar code label on the LTO Ultrium 6 Tape Cartridge. The volume serial number (LTO123) and bar code are printed on the label.

## Guidelines for bar code labels

Apply the following guidelines whenever using bar code labels:

- Use only IBM-approved bar code labels on cartridges to be used in an IBM tape library.
- Do not reuse a label or reapply a used label over an existing label.
- Before you apply a new label, remove the old label by slowly pulling it at a right angle to the cartridge case.
- Use peel-clean labels that do not leave a residue after it is removed. If there is glue residue on the cartridge, remove it by gently rubbing it with your finger. Do not use a sharp object, water, or a chemical to clean the label area.
- Examine the label before it is applied to the cartridge. Do not use the label if it has voids or smears in the printed characters or bar code. A library's inventory operation takes much longer if the bar code label is not readable.
- Remove the label from the label sheet carefully. Do not stretch the label or cause the edges to curl.
- Position the label within the recessed label area (see **5** in Figure 4-1 on page 4-1).
- With light finger pressure, smooth the label so that no wrinkles or bubbles exist on its surface.
- Verify that the label is smooth and parallel, and has no roll-up or roll-over. The label must be flat to within 0.5 mm (0.02 in.) over the length of the label and have no folds, missing pieces, or smudges.
- Do not place other machine-readable labels on other surfaces of the cartridge. They might interfere with the ability of the drive to load the cartridge.

---

## Write-Protect switch

The position of the write-protect switch on the tape cartridge (see **1**) determines whether you can write to the tape. If the switch is set to:

- The locked position  (solid red), data cannot be written to the tape.
- The unlocked position (black void), data can be written to the tape.

If possible, use your server's application software to write-protect your cartridges (rather than manually setting the write-protect switch). This setting allows the

server's software to identify a cartridge that no longer contains current data and is eligible to become a scratch (blank) data cartridge. Do not write-protect scratch (blank) cartridges; the tape drive is not able to write new data to them.

If you must manually set the write-protect switch, slide it left or right to the wanted position.

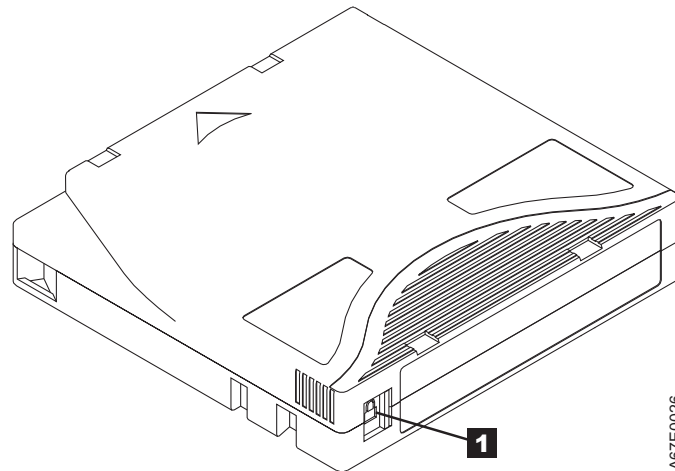

Figure 4-4. Setting the write-protect switch

Table 4-7. Location of the write-protect switch

<b>1</b>	Write-protect switch
----------	----------------------

---

## Handling the cartridges

**Attention:** Do not insert a damaged tape cartridge into the drive. A damaged cartridge can interfere with the reliability of a drive and might void the warranties of the drive and the cartridge. Before a tape cartridge is inserted, inspect the cartridge case, cartridge door, and write-protect switch for breaks.

Incorrect handling or an incorrect environment can damage cartridges or their magnetic tape. To avoid damage to your tape cartridges and to ensure the continued high reliability of your IBM LTO Ultrium Tape Drives, use the following guidelines:

### Providing training

- Post procedures that describe appropriate media handling in places where people gather.
- Ensure that anyone who handles tape is properly trained in handling and shipping procedures. This training includes operators, users, programmers, archival services, and shipping personnel.
- Ensure that any service or contract personnel who complete archiving procedures are properly trained in media-handling procedures.
- Include media-handling procedures as part of any services contract.
- Define and make personnel aware of data recovery procedures.

## Ensuring proper packaging

- When a cartridge is shipped, use the original or better packaging.
- Always ship or store a cartridge in a jewel case.
- Use only a recommended shipping container that securely holds the cartridge in its jewel case during transportation. Ultrium Turtlecases (by Perm-A-Store) are tested and found to be satisfactory (see Figure 4-5). They are available at <http://www.turtlecase.com>.



Figure 4-5. Tape cartridges in a Turtlecase

- Never ship a cartridge in a commercial shipping envelope. Always place it in a box or package.
- If you ship the cartridge in a cardboard box or a box of a sturdy material, ensure that you
  - Place the cartridge in polyethylene plastic wrap or bags to protect it from dust, moisture, and other contaminants.
  - Pack the cartridge snugly; do not allow it to move around.
  - Double-box the cartridge (place it inside a box, then place that box inside the shipping box) and add padding between the two boxes (see Figure 4-6 on page 4-10).



Figure 4-6. Double-boxing tape cartridges for shipping

## Proper acclimation and environmental conditions

- Before you use a tape cartridge, acclimate it to the operating environment for 24 hours or the time necessary to prevent condensation in the drive. The time varies, depending on the environmental extremes to which the cartridge was exposed.
- Ensure that all surfaces of a cartridge are dry before it is inserted.
- Do not expose the cartridge to moisture or direct sunlight.
- Do not expose recorded or blank cartridges to stray magnetic fields of greater than 100 oersteds (for example, terminals, motors, video equipment, X-ray equipment, or fields that exist near high-current cables or power supplies). Such exposure causes the loss of recorded data or makes the blank cartridge unusable.
- Maintain the conditions that are described in “Environmental and shipping specifications for tape cartridges” on page 4-18.

## Completing a thorough inspection

After a cartridge is purchased and before it is used, complete the following steps:

- Inspect the cartridge 's packaging to determine potential rough handling.
- When a cartridge is inspected, open only the cartridge door. Do not open any other part of the cartridge case. The upper and lower parts of the case are held together with screws; separating them destroys the usefulness of the cartridge.
- Inspect the cartridge for damage before it is used or stored.
- Inspect the rear of the cartridge (the part that loads first into the tape load compartment) and ensure that there are no gaps in the seam of the cartridge case (see **1** in Figure 4-7 on page 4-11 and **4** in Figure 4-9 on page 4-13). If there are gaps in the seam (see Figure 4-7 on page 4-11), the leader pin might be dislodged. Go to “Repositioning or reattaching a leader pin” on page 4-12.

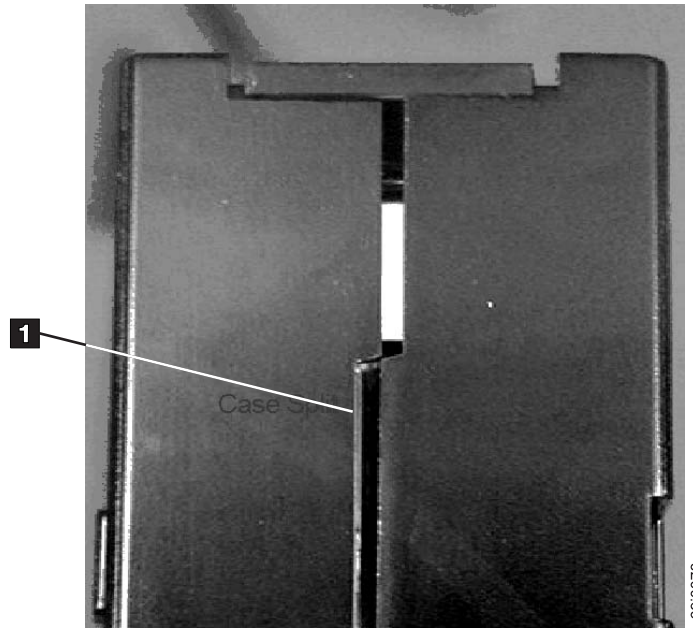

Figure 4-7. Checking for gaps in the seams of a cartridge

- Check that the leader pin is properly seated (see **2** in Figure 4-8 on page 4-13).
- If you suspect that the cartridge was mishandled but it appears usable, copy any data onto a good cartridge immediately for possible data recovery. Discard the mishandled cartridge.
- Review handling and shipping procedures.

### Handling the cartridge carefully

- Do not drop the cartridge. If the cartridge drops, slide the cartridge door back and ensure that the leader pin is properly seated in the pin-retaining spring clips. See **2** in Figure 4-8 on page 4-13. If the leader pin becomes dislodged, go to “Repositioning or reattaching a leader pin” on page 4-12.
- Do not handle tape that is outside the cartridge. Handling the tape can damage the tape 's surface or edges, which might interfere with read or write reliability. Pulling on tape that is outside the cartridge can damage the tape and the brake mechanism in the cartridge.
- Do not stack more than six cartridges.
- Do not degauss a cartridge that you intend to reuse. Degaussing makes the tape unusable.

### Examples of cartridge problems

Split cartridge case. See Figure 4-7.

The cartridge 's case is damaged. There is a high possibility of media damage and potential loss.

1. Look for cartridge mishandling.
2. Use the IBM Leader Pin Reattachment Kit (part number 08L9129) to correctly seat the pin (see “Repositioning or reattaching a leader pin” on page 4-12). Then, immediately use data recovery procedures to minimize chances of data loss.
3. Review media-handling procedures.

Improper placement of leader pin. See Figure 4-8 on page 4-13.

The leader pin is misaligned.

1. Look for cartridge damage.
2. Use the IBM Leader Pin Reattachment Kit (part number 08L9129) to correctly seat the pin (see “Repositioning or reattaching a leader pin”). Then, immediately use data recovery procedures to minimize chances of data loss.

---

## Repositioning or reattaching a leader pin

**Attention:** Use a repaired tape cartridge only to recover data and move it to another cartridge. Continued use of a repaired cartridge might void the warranties of the drive and the cartridge.

If the leader pin in your cartridge becomes dislodged from its pin-retaining spring clips or detaches from the tape, you must use the IBM Leader Pin Reattachment Kit (part number 08L9129) to reposition or reattach it. (Do not reattach the pin if you must remove more than 7 meters (23 feet) of leader tape.) The sections that follow describe each procedure.

### Repositioning a leader pin

A leader pin that is improperly seated inside a cartridge interferes with the operation of the drive. Figure 4-8 on page 4-13 shows a leader pin in the incorrect **1** and correct **2** positions.

To place the leader pin in its proper position, you need the following tools:

- Plastic or blunt-end tweezers
- Cartridge manual rewind tool (from Leader Pin Reattachment Kit, part number 08L9129)



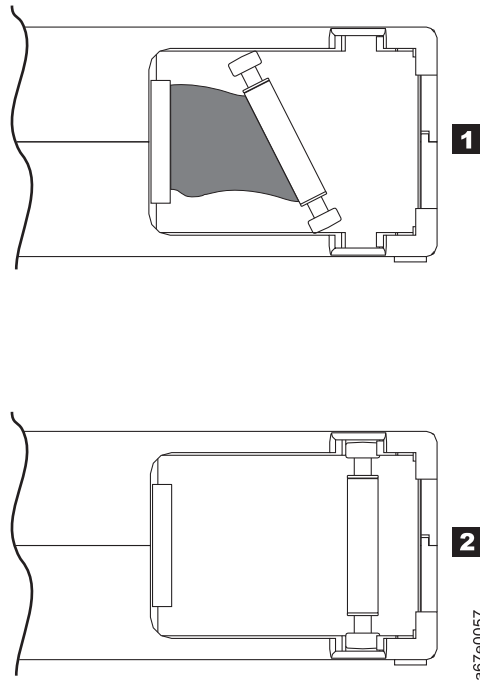

Figure 4-8. Leader pin in the incorrect and correct positions. The cartridge door is open and the leader pin is visible inside the cartridge.

To reposition the leader pin:

1. Slide open the cartridge door ( **1** in Figure 4-9) and locate the leader pin **2** (you might need to shake the cartridge gently to roll the pin toward the door).
2. With plastic or blunt-end tweezers, grasp the leader pin and position it in the pin-retaining spring clips **3**.
3. Press the leader pin gently into the clips until it snaps into place and is firmly seated.
4. Close the cartridge door.

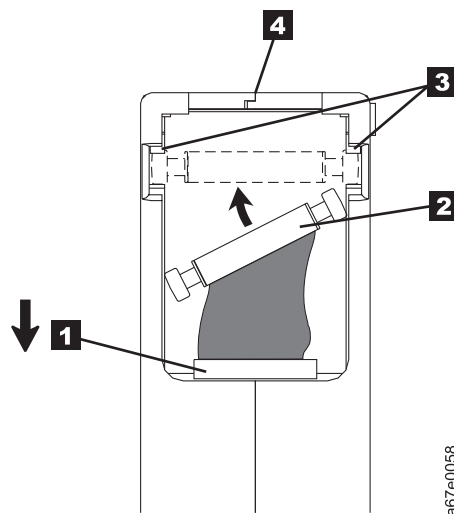

Figure 4-9. Placing the dislodged leader pin into the correct position. The cartridge door is open to show the leader pin.

5. To rewind the tape, insert the cartridge manual rewind tool (**1** in Figure 4-10) into the cartridge 's hub **2** and turn it clockwise until the tape becomes taut.

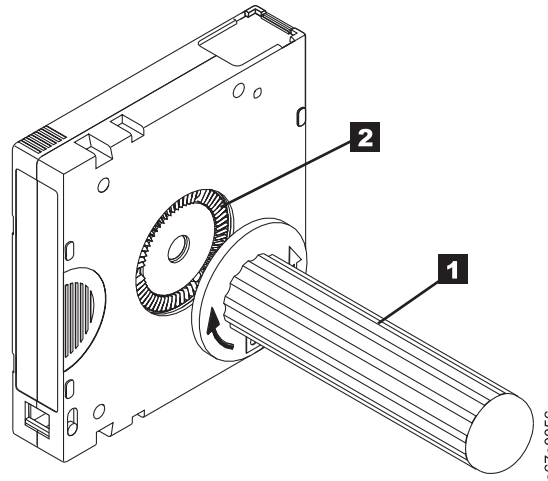

Figure 4-10. Rewinding the tape into the cartridge

6. Remove the rewind tool by pulling it away from the cartridge.
7. If you suspect that the cartridge was mishandled but it appears usable, copy any data onto a good cartridge immediately for possible data recovery. Discard the mishandled cartridge.

## Reattaching a leader pin

The first meter of tape in a cartridge is leader tape. When the leader tape is removed there is a possibility of tape breakage. After the leader pin is reattached, transfer data from the defective tape cartridge. **Do not reuse the defective tape cartridge.**

The Leader Pin Reattachment Kit contains three parts:

- **Leader pin attach tool** (See **1** in Figure 4-11 on page 4-15). A plastic brace that holds the cartridge door open.
- **Cartridge manual rewind tool** (See **2** in Figure 4-11 on page 4-15). A device that fits into the cartridge 's hub and enables you to wind the tape into and out of the cartridge.
- **Pin supplies** (See **3** in Figure 4-11 on page 4-15). Leader pins and C-clips.

**Attention:**

- Use only the IBM Leader Pin Reattachment Kit to reattach the leader pin to the tape. Other methods of reattaching the pin damages the tape, the drive, or both.
- Use this procedure on your tape cartridge only when the leader pin detaches from the magnetic tape and you must copy the cartridge 's data onto another cartridge. Destroy the damaged cartridge after you copy the data. This procedure might affect the performance of the leader pin during threading and unloading operations.
- Touch only the end of the tape. Touching the tape in an area other than the end can damage the tape 's surface or edges, which might interfere with read or write reliability.

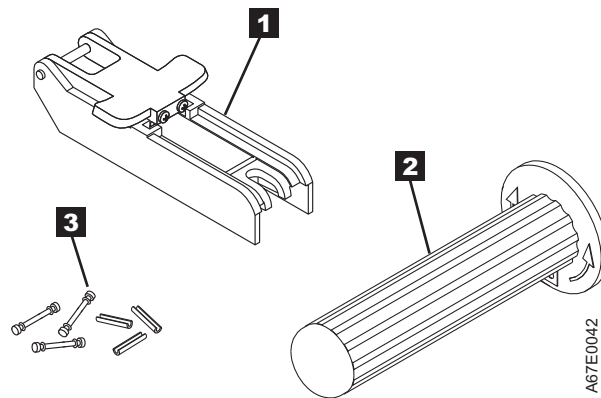
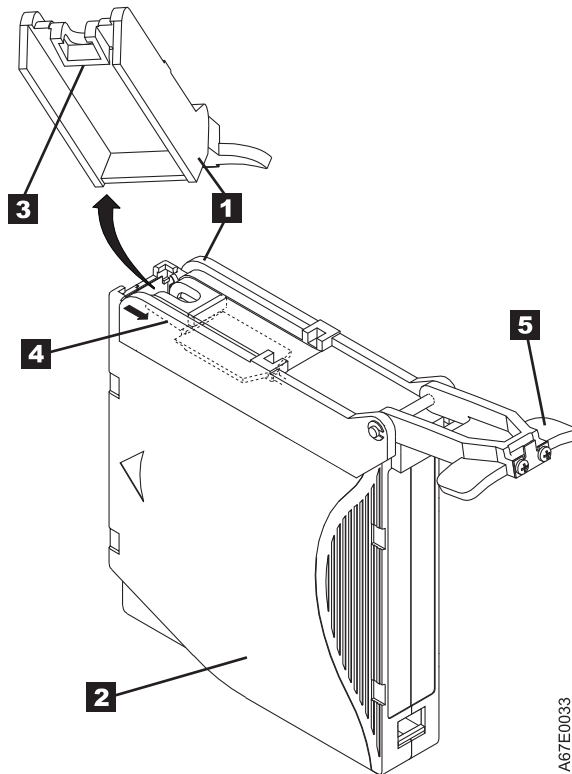

Figure 4-11. Leader pin reattachment kit

This procedure describes how to reattach a leader pin.

To reattach a leader pin with the IBM leader pin reattachment kit:

1. Attach the leader pin attach tool ( **1** in Figure 4-12 on page 4-16) to the cartridge **2** so that the tool 's hook **3** latches into the cartridge 's door **4** . Pull the tool back to hold the door open, then slide the tool onto the cartridge. Open the tool 's pivot arm **5** .



A67E0033

Figure 4-12. Attaching the leader pin attach tool to the cartridge. To hold the cartridge door open, hook the tool into the door and pull the tool back.

2. To find the end of the tape inside the cartridge, attach the cartridge manual rewind tool ( **1** in Figure 4-13 on page 4-17) to the cartridge 's hub **2** by fitting the tool 's teeth between the teeth of the hub. Turn the tool clockwise until you see the end of the tape inside the cartridge. Then, slowly turn the rewind tool counterclockwise to bring the tape edge toward the cartridge door **3** .
3. Continue to turn the rewind tool counterclockwise until approximately 13 cm (5 in.) of tape hangs from the cartridge door. If necessary, grasp the tape and pull gently to unwind it from the cartridge.
4. Remove the rewind tool by pulling it away from the cartridge. Set the tool and the cartridge aside.

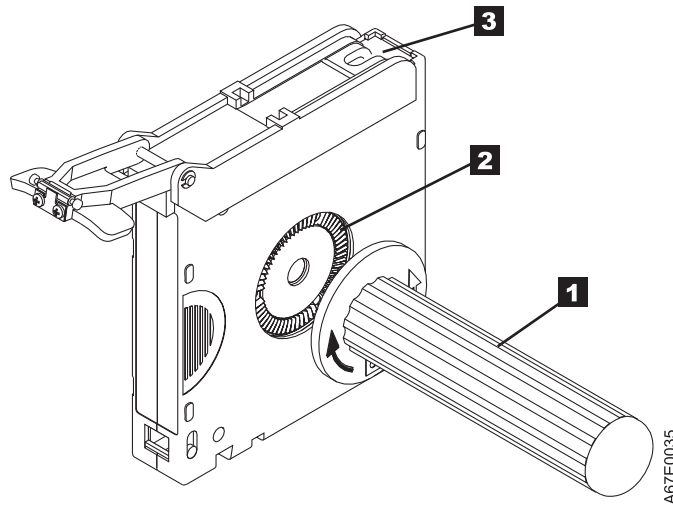

Figure 4-13. Winding the tape out of the cartridge. Turn the cartridge manual rewind tool clockwise to see the end of the tape, then turn it counterclockwise to bring the tape to the cartridge door.

5. On the leader pin ( **1** in Figure 4-14), locate the open side of the C-clip ( **2** ). The C-clip is a small black part that secures the tape ( **3** ) to the pin.
6. Remove the C-clip from the leader pin by using your fingers to push the clip away from the pin. Set the pin aside and discard the clip.

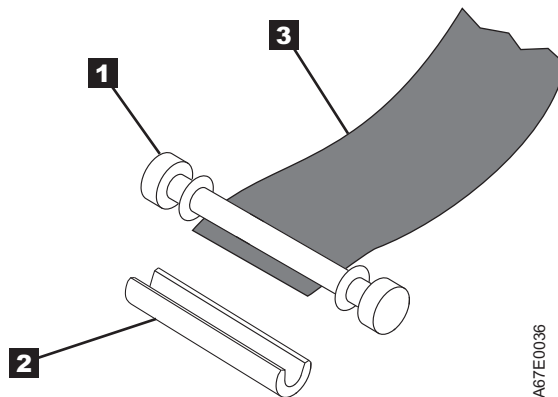
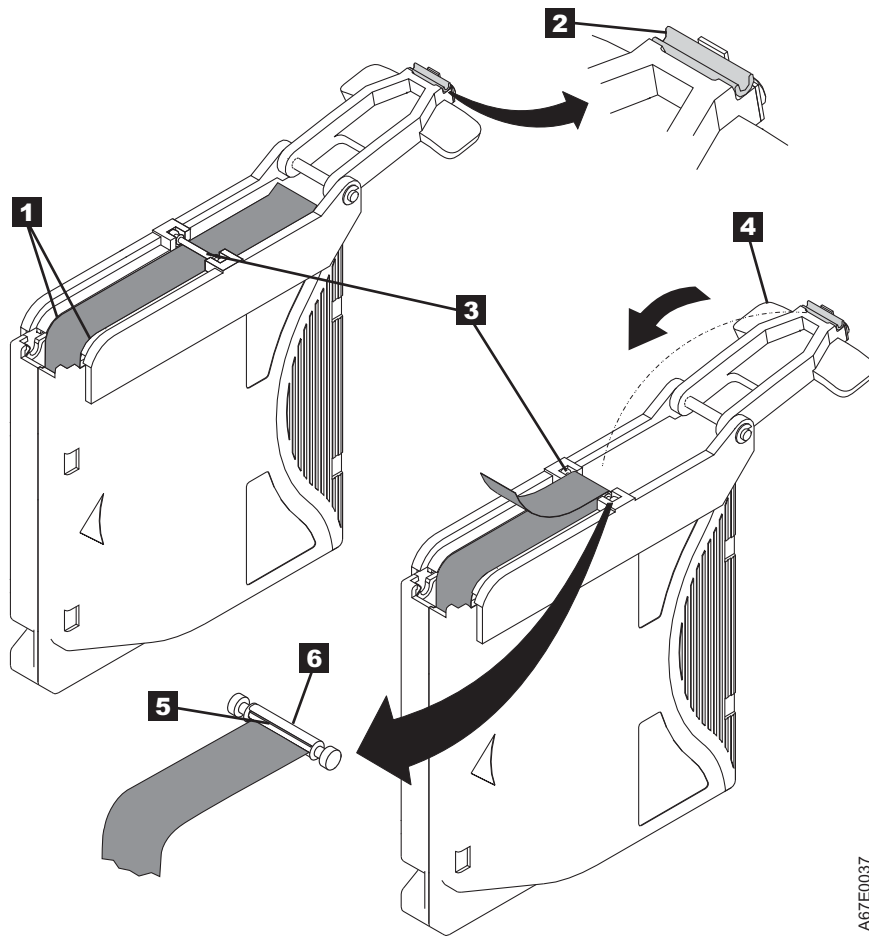

Figure 4-14. Removing the C-clip from the leader pin. Use your fingers to push the C-clip from the leader pin.

7. Position the tape in the alignment groove of the leader pin attach tool (see **1** in Figure 4-15 on page 4-18).
  8. Place a new C-clip into the retention groove ( **2** (Figure 4-15 on page 4-18) on the leader pin attachment tool and make sure that the clip 's open side faces up.
  9. Place the leader pin (from step 6) into the cavity ( **3** (Figure 4-15 on page 4-18) of the leader pin attach tool.
- Attention:** To prevent the leader pin from rolling into the cartridge, in the following step use care when the tape is folded over the pin.
10. Fold the tape over the leader pin and hold it with your fingers (see Figure 4-15 on page 4-18).

**Note:** Use care to ensure that the tape is centered over the leader pin. Failure to properly center the tape on the pin causes the repaired cartridge to fail. When the tape is properly centered, a 0.25 mm (0.01-in.) gap exists

on both sides of the pin.



A67E0037

Figure 4-15. Attaching the leader pin to the tape

11. Close the pivot arm **4** of the leader pin attach tool by swinging it over the leader pin so that the C-clip snaps onto the pin and the tape.
12. Swing the pivot arm open and trim the excess tape **5** so that it is flush with the reattached leader pin **6**.
13. Use your fingers to remove the leader pin from the cavity **3** in the leader pin attach tool.
14. Use the cartridge manual rewind tool to wind the tape back into the cartridge (wind the tape clockwise). Ensure that the leader pin is latched by the pin-retaining spring clips on each end of the leader pin.
15. Remove the rewind tool.
16. Remove the leader pin attach tool by lifting its end away from the cartridge.

---

## Environmental and shipping specifications for tape cartridges

Before you use a tape cartridge, acclimate it to the operating environment for 24 hours or the time necessary to prevent condensation in the drive. The time varies, depending on the environmental extremes to which the cartridge was exposed.

The best storage container for the cartridges (until they are opened) is the original shipping container. The plastic wrapping prevents dirt from accumulating on the cartridges and partially protects them from humidity changes.

When you ship a cartridge, place it in its jewel case or in a sealed, moisture-proof bag to protect it from moisture, contaminants, and physical damage. Ship the cartridge in a shipping container that has enough packing material to cushion the cartridge and prevent it from moving within the container.

Table 4-8 gives the environment for operating, storing, and shipping LTO Ultrium Tape Cartridges.

*Table 4-8. Environment for operating, storing, and shipping the LTO Ultrium Tape Cartridge*

Environmental Factor	Environmental Specifications			
	Operating	Operational Storage <sup>1</sup>	Archival Storage <sup>2</sup>	Shipping
Temperature	10 - 45°C (50 - 113°F)	16 - 32°C (61 - 90°F)	16 - 25°C (61 - 77°F)	-23 to 49°C (-9 to 120°F)
Relative humidity (non-condensing)	10 - 80%	20 - 80%	20 - 50%	5 - 80%
Maximum wet bulb temperature	26°C (79°F)	26°C (79°F)	26°C (79°F)	26°C (79°F)
<b>Note:</b>				
1. The short term or operational storage environment is for storage durations of up to six months.				
2. The long term or archival storage environment is for durations of six months up to 10 years.				

## Disposing of tape cartridges

Under the current rules of the US Environmental Protection Agency (EPA), regulation 40CFR261, the LTO Ultrium Tape Cartridge is classified as non-hazardous waste. As such, it might be disposed of in the same way as normal office trash. These regulations are amended from time to time, and you must review them at the time of disposal.

If your local, state, country (non-US), or regional regulations are more restrictive than EPA 40CFR261, you must review them before you dispose of a cartridge. Contact your account representative for information about the materials that are in the cartridge.

If a tape cartridge must be disposed of in a secure manner, you can erase the data on the cartridge with a high-energy ac degausser (use a minimum of 4000 oersted peak field over the entire space that the cartridge occupies). The tape must make two passes through the field at 90 degree orientation change for each pass to achieve complete erasure. Some commercial degaussers have two magnetic field regions offset 90 degrees from each other to accomplish complete erasure in one pass for higher throughput. Degaussing makes the cartridge unusable.

If you burn the cartridge and tape, ensure that the incineration complies with all applicable regulations.

## Ordering media supplies

Table 4-9 lists the cartridges and media supplies that you can order for the drive.

Table 4-9. Media supplies

Supply Item	Methods of Ordering
<b>20-PACK IBM LTO Ultrium 6 2500 GB Data Cartridge (with attached labels)</b>	Order the cartridge from your IBM Sales Representative or any authorized IBM Business Partner by specifying Machine Type 3589 Model 550. Specify the VOLSER characters that you want.  You can also order through an IBM-authorized distributor.
<b>20-PACK IBM LTO Ultrium 6 2500 GB Data Cartridge (without labels)</b>	Order the cartridge from your IBM Sales Representative or any authorized IBM Business Partner by specifying Machine Type 3589 Model 650.  You can also order through an IBM-authorized distributor.
<b>5-PACK IBM LTO Ultrium 6 2500 GB Data Cartridge (black and white labels unattached)</b>	Order as part number 35P1902 through an IBM-authorized distributor.
<b>20-PACK IBM Ultrium 6 2500 GB WORM Tape Cartridge (with attached labels)</b>	Order the cartridge from your IBM Sales Representative or any authorized IBM Business Partner by specifying Machine Type 3589 Model 570.  You can also order through an IBM-authorized distributor.
<b>20-PACK IBM Ultrium 6 2500 GB WORM Tape Cartridge (without labels)</b>	Order the cartridge from your IBM Sales Representative or any authorized IBM Business Partner by specifying Machine Type 3589 Model 670.  You can also order through an IBM-authorized distributor.
<b>20-PACK IBM LTO Ultrium 5 1500 GB Data Cartridge (with attached labels)</b>	Order the cartridge from your IBM Sales Representative or any authorized IBM Business Partner by specifying Machine Type 3589 Model 014. Specify the VOLSER characters that you want.  You can also order through an IBM-authorized distributor.
<b>20-PACK IBM LTO Ultrium 5 1500 GB Data Cartridge (without labels)</b>	Order the cartridge from your IBM Sales Representative or any authorized IBM Business Partner by specifying Machine Type 3589 Model 015.  You can also order through an IBM-authorized distributor.
<b>5-PACK IBM LTO Ultrium 5 1500 GB Data Cartridge (black and white labels unattached)</b>	Order as part number 46C2084 through an IBM-authorized distributor.
<b>20-PACK IBM Ultrium 5 1500 GB WORM Tape Cartridge (with attached labels)</b>	Order the cartridge from your IBM Sales Representative or any authorized IBM Business Partner by specifying Machine Type 3589 Model 034.  You can also order through an IBM-authorized distributor.
<b>20-PACK IBM Ultrium 5 1500 GB WORM Tape Cartridge (without labels)</b>	Order the cartridge from your IBM Sales Representative or any authorized IBM Business Partner by specifying Machine Type 3589 Model 035.  You can also order through an IBM-authorized distributor.



Table 4-9. Media supplies (continued)

Supply Item	Methods of Ordering
<b>20-PACK IBM LTO Ultrium 4 800 GB Data Cartridge (with attached labels)</b>	Order the cartridge from your IBM Sales Representative or any authorized IBM Business Partner by specifying Machine Type 3589 Model 010. Specify the VOLSER characters that you want.  You can also order through an IBM-authorized distributor.
<b>20-PACK IBM LTO Ultrium 4 800 GB Data Cartridge (without labels)</b>	Order the cartridge from your IBM Sales Representative or any authorized IBM Business Partner by specifying Machine Type 3589 Model 011.  You can also order through an IBM-authorized distributor.
<b>5-PACK IBM LTO Ultrium 4 800 GB Data Cartridge (black and white labels unattached)</b>	Order as part number 95P4278 through an IBM-authorized distributor.
<b>20-PACK IBM Ultrium 4 800 GB WORM Tape Cartridge (with attached labels)</b>	Order the cartridge from your IBM Sales Representative or any authorized IBM Business Partner by specifying Machine Type 3589 Model 032.  You can also order through an IBM-authorized distributor.
<b>20-PACK IBM Ultrium 4 800 GB WORM Tape Cartridge (without labels)</b>	Order the cartridge from your IBM Sales Representative or any authorized IBM Business Partner by specifying Machine Type 3589 Model 033.  You can also order through an IBM-authorized distributor.
<b>IBM LTO Ultrium 3 400 GB Data Cartridge</b>  Order VOLSER labels separately (see "Ordering bar code labels" on page 4-22).	Order as part number 24R1922 through an IBM-authorized distributor.
<b>IBM LTO Ultrium 3 400 GB WORM Tape Cartridge</b>  Order VOLSER labels separately (see "Ordering bar code labels" on page 4-22).	Order as part number 96P1203 through an IBM-authorized distributor.
<b>IBM LTO Ultrium 2 200 GB Data Cartridge</b>  Order VOLSER labels separately (see "Ordering bar code labels" on page 4-22).	Order as part number 08L9870 through an IBM-authorized distributor.
<b>IBM LTO Ultrium 1 100 GB Data Cartridge</b>  Order VOLSER labels separately (see "Ordering bar code labels" on page 4-22).	Order as part number 08L9120 through an IBM-authorized distributor.
<b>IBM LTO Ultrium Cleaning Cartridge</b> (universal cleaning cartridge for use with Ultrium drives)  VOLSER labels are included.	Order as part number 35L2086 through an IBM-authorized distributor.
<b>Leader Pin Reattachment Kit</b>	Order as part number 08L9129 through an IBM-authorized distributor.
<b>Manual Rewind Tool</b>	Order as part number 08L9130 through an IBM-authorized distributor.

To find the closest IBM-authorized distributor, visit the web at <http://www.ibm.com/storage/media> or call 1-888-IBM-MEDIA.

## Ordering bar code labels

The LTO Ultrium 3 and 4 Tape Drives do not require cartridge bar code labels. However, if you use your data cartridges or cleaning cartridges in an IBM tape library product, you might need cartridge bar code labels if your tape library product requires them (see Table 4-5 on page 4-5). You can order these labels separately from the IBM data cartridges and cleaning cartridges.

You can order bar code labels directly from the authorized label suppliers in Table 4-10.

Table 4-10. Authorized suppliers of custom bar code labels

In America	In Europe and Asia
EDP/Colorflex Broomfield, CO U. S. A. Telephone: 800-438-8362 <a href="http://www.tri-optic.com">http://www.tri-optic.com</a>	EDP Europe, Ltd. U. K. Telephone: 44 (0) 1245-322380 <a href="http://www.edpeurope.com/media-label">http://www.edpeurope.com/media-label</a>
Dataware Houston, TX 77274 U. S. A. Telephone: 800-426-4844 <a href="http://www.datawarelabels.com/">http://www.datawarelabels.com/</a>	Dataware Labels Europe Australia Telephone: (029) 496-1111 <a href="http://www.datawarelabels.com/">http://www.datawarelabels.com/</a>
NetC Trumbell, CT U. S. A. Telephone: 203-372-6382 <a href="http://www.netc11c.com/">http://www.netc11c.com/</a>	NetC Europe Ltd U. K. Telephone: 44 (0) 1823 49 1439 <a href="http://www.netclabels.co.uk">http://www.netclabels.co.uk</a>
	NetC Asia Pacific Pty Ltd Australia Telephone: 61 (0) 7 5442 6263 <a href="http://www.netclabels.com.au">http://www.netclabels.com.au</a>

## Chapter 5. Troubleshooting

If you encounter problems when running the drive, refer to the flowchart in Figure 5-1. For explanations of codes on the Single-character Display (SCD), see “Single-character display (SCD)” on page 3-1. Please review the “Pre-call checklist” on page 5-4 before calling IBM Technical Support.

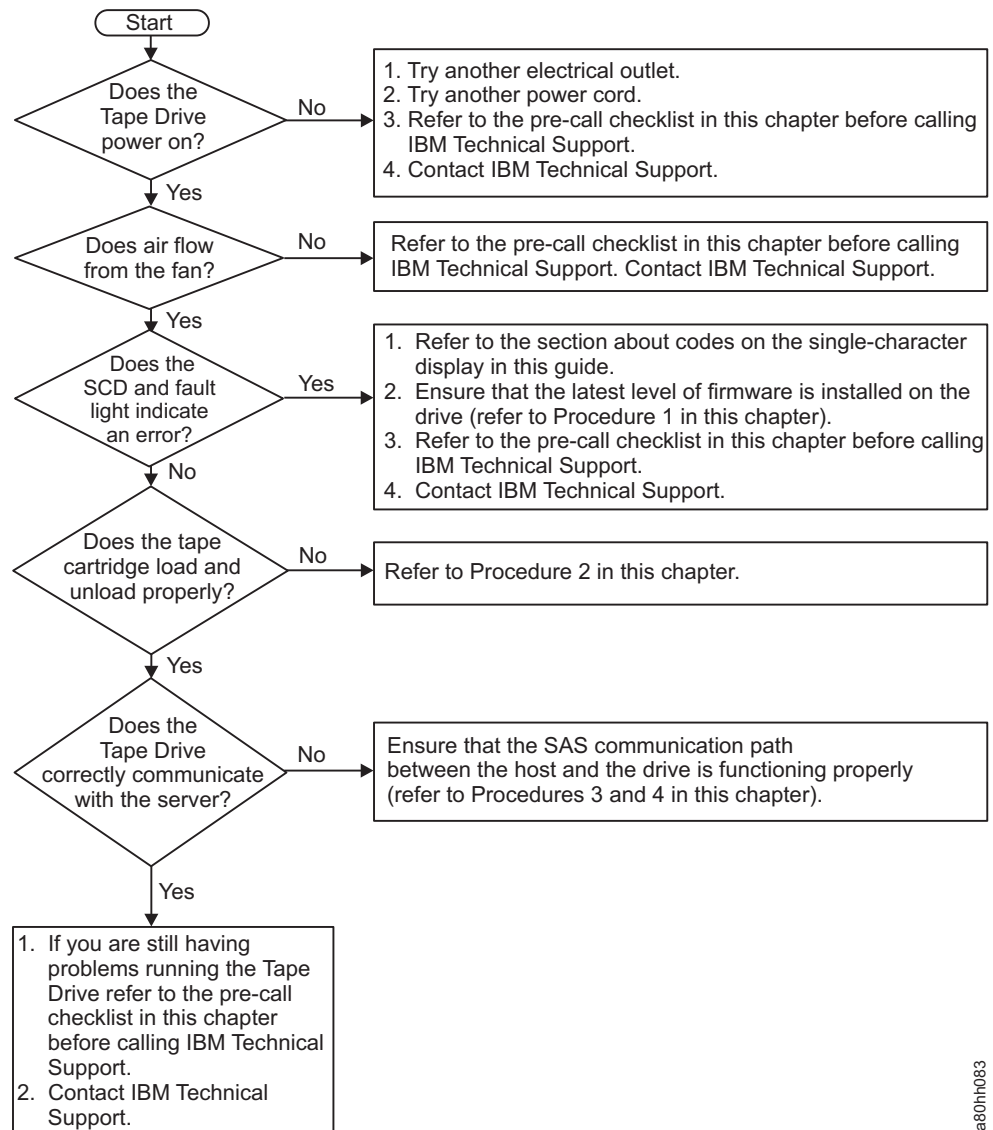

Figure 5-1. Flowchart for Analyzing Maintenance Problems

### Procedure 1: Determining firmware level and capturing drive dump

Customers are responsible for updating Firmware. For optimum performance, the customer must obtain the latest level of firmware for the unit by downloading the firmware from <http://www.ibm.com/support/fixcentral>.

The ITDT utility (see “ITDT firmware update, dump retrieval and library/drive test tool” on page 2-6) is used to update the firmware level and to capture a drive memory dump that might be requested by technical support to aid in problem analysis.

For instructions about updating firmware from a server that uses an IBM tape device driver, refer to the *IBM Tape Device Drivers Installation and User's Guide*.

To update firmware from a server that uses a non-IBM tape device driver, refer to the documentation for that device driver.

Perform the following steps to determine the current firmware level that is installed on the drive.

1. Use the ITDT utility (available on the web at <http://www.ibm.com/support/fixcentral>) to view the current drive firmware level.
2. Compare this level with the latest available firmware level by visiting the same website. For more information about the ITDT utility, see “Updating firmware” on page 2-6.

**Note:** The ITDT utility is used to either update drive firmware to the latest level or to capture drive memory dumps from a drive that might be experiencing problems.

Another way to capture a drive memory dump is with the ethernet port. To capture a memory dump on the drive with the Ethernet interface follow the steps.

**Note:** The drive uses a limited version of FTP protocol to communicate on the ethernet interface. It is recommended to use a simple, command-line FTP session, such as the DOS command prompt, when communicating with the drive.

1. Obtain the latest drive firmware from the web.
2. Connect an ethernet patch cable to the drive 's ethernet interface and to a computer. To meet electromagnetic immunity requirements, a shielded ethernet cable is required.
3. Create an FTP session between the drive and the computer. The drive 's IP address: 169.254.0.3
4. At the user prompt, type *guest* and press **Enter**.
5. At the password prompt, press **Enter**. No response is needed.
6. Type *bin* to set the communication mode to binary.
7. Type *mget \*.dmp* to transfer a drive memory dump to the computer. If a memory dump exists, the drive shows you the memory dump name and ask if you want to transfer it to the computer. Type *y* to transfer the existing memory dump or *n* to skip this dump file. Then the drive asks if you want a forced memory dump. Type *y* to force a memory dump and to transfer the forced memory dump to the computer, or type *n* to skip forcing a memory dump.
8. Type *quit* to end the FTP session.
9. Remove ethernet patch cable from the drive 's ethernet interface and the computer.

---

## Procedure 2: Inspecting a cartridge for damage

If the cartridge fails to load or unload properly, complete the following steps:

1. Check that the leader pin is attached and properly seated (see “Repositioning a leader pin” on page 4-12) by opening the cartridge door and observing the pin's placement.
2. Inspect the cartridge case, the cartridge door, and the write-protect switch for damage.
3. Inspect the rear of the cartridge (the part that you load first into the tape load compartment) and ensure that there are no gaps in the seam of the cartridge case (see **1** in Figure 4-7 on page 4-11 and **4** in Figure 4-9 on page 4-13). If there are gaps, the leader pin might be dislodged. Go to “Repositioning or reattaching a leader pin” on page 4-12.
4. Try loading or unloading another tape cartridge.
  - If it fails, contact your service representative for more problem determination.
  - If it is successful, discard the cartridge that originally failed.

**Note:**

1. If a damaged or mishandled cartridge is the problem, see “Handling the cartridges” on page 4-8 for instructions about handling the media. It is possible that your other cartridges might also be damaged.
2. If your cartridge does not eject properly, contact your service representative. (IBM service personnel must go to Appendix E, “Information for trained service personnel,” on page E-1.)

---

### Procedure 3: Checking SAS host connections

Check the host connections for your drive by following the steps.

If your server is not communicating with the SAS drive, the problem might be with the SAS cable, the SAS host adapter, or the SAS host adapter setup.

1. Check whether the tape drive power is on.
2. Verify that the SAS cable is connected properly to the server and to the tape drive.
3. Check whether the parameters for the SAS host adapter installation are correct.
4. Verify that the SAS host adaptor is supported by the tape drive.
5. Ensure that there is a point-to-point connectivity between the server and the tape drive. SAS connectivity does not support multiple drive connections (daisy-chaining of devices).
6. Check the length of the SAS cable. It cannot exceed 5.5 m (18 ft).

---

### Procedure 4: Verifying host interface communications

The Wrap Diagnostic tests the communication function at the device interface. However, to thoroughly verify host-to-device communications, it is highly recommended to exercise activity over the SAS interface bus from the host to the drive and back. A recommended utility to complete this test is the ITDT utility available on the web at <http://www.ibm.com/support/fixcentral>. This utility is especially effective for updating the drive firmware and for completing the Test Device function. For more information about the ITDT utility, see “Updating firmware” on page 2-6. Complete these steps:

1. If the ITDT utility is not installed on your system, download the appropriate operating system version from the web into a directory or folder of your choice.

2. When installation is complete, run the SCAN (s) option to determine whether your system can detect all of the Ultrium tape drive devices (including any libraries or autoloaders that might be on the bus).
3. Select the drive that is to be tested or to have firmware that is downloaded.
4. For testing, select the Test Device (t) option.

**Note:** This option completes a series of LOADS, UNLOADS, and WRITE/READ operations. Both tape drive control commands and data are sent to the device over the interface bus.

5. If allowed to complete, the test runs for at least 30 minutes. At any time an ABORT (a) is entered to end the device test early if it is determined that interface communications are satisfactorily achieved.

---

## Resolving problems reported by the server

The procedure for fixing interface bus errors varies, depending on whether the error is consistent or intermittent, and on your configuration. These sections describe how to fix an error.

### Fixing SAS bus errors

1. Check whether the tape drive power is on.
2. Verify that the SAS cable is connected properly to the server and to the tape drive.
3. Replace SAS cable if it shows any signs of damage.

---

## Resolving media-related problems

To resolve problems that are related to media, the drive 's firmware includes

- Test Cartridge & Media diagnostic test that verifies whether a suspect cartridge and its magnetic tape are acceptable for use.
- Statistical Analysis and Reporting System (SARS) to help with isolating failures between media and hardware. To determine the cause of failure, SARS uses the cartridge performance history that is saved in the cartridge memory (CM) and the drive performance history that is kept in the drive 's VPD (Vital Product Data) area in NVRAM. Any failures that SARS detects are reported as TapeAlert flags on the server (see *IBM LTO Ultrium Tape Drive SCSI Reference*).

**Attention:** If you insert the IBM LTO Ultrium Data Cartridge into another manufacturer 's drive, the SARS data in the cartridge memory might become lost or invalid.

If you encounter a media-related problem, refer to “Function code E: Test cartridge & media” on page 3-18.

---

## Pre-call checklist

If you have questions or problems, go through this checklist before IBM technical support is contacted. Ensure that the total SAS cable length does not exceed 5.5 m (18 ft). Complete these steps before you call IBM technical support. Where instructions refer you to the web, visit <http://www.ibm.com/support/fixcentral>.

1. Perform a general checkup of the hardware and connections:
  - Verify that all cables are connected properly at both ends.
  - Before the SAS cables are attached, ensure that the connector does not contain bent or recessed pins.

- Ensure that all retention screws for the SAS cable are securely tightened.
- 2. Verify that the drive 's firmware is at the most recent level. To determine the latest release of firmware, visit the web. See “Updating firmware” on page 2-6 for instructions about downloading the latest firmware.
- 3. Verify that your device drivers are at the most recent level:
  - For IBM device drivers, visit the web.
  - For the device drivers of independent software vendors (ISVs), visit the appropriate third-party website.
- 4. Verify whether your hardware and software configuration is supported. To determine the latest supported attachments, visit the web.
- 5. Review “Frequently Asked Questions and “Hints and Tips” on the web.
- 6. Run one of the diagnostic methods:
  - Local diagnostic tests:
    - a. Run “Function code 1: Run drive diagnostics” on page 3-12 to determine whether the drive can properly load and unload cartridges, and read and write data. Optionally, you might run one of the following diagnostic procedures:
      - “Function code E: Test cartridge & media” on page 3-18 to determine whether a suspect cartridge and its magnetic tape are acceptable.
      - “Function code F: Write performance test” on page 3-19 to ensure that the drive can read from and write to tape.
      - “Function code H: Test head” on page 3-20 to ensure that the tape drive 's head and tape-carriage mechanics work correctly.
      - “Function code J: Fast read/write test” on page 3-21 to ensure that the drive can read from and write to tape.
      - “Function code L: Load/unload test” on page 3-22 to test the drive 's ability to load and unload a tape cartridge.
    - b. Run “Function code 6: Run host interface wrap test” on page 3-15.
  - Remote diagnostic test:
    - With the ITDT utility, run the SCAN as described in “Procedure 4: Verifying host interface communications” on page 5-3

---

## Replacing the tape drive

To replace your tape drive, complete these steps:

1. Remove the replacement unit from its packaging.
2. Locate the repair identification (RID) tag (included with the replacement unit). See **1** in Figure 5-2 on page 5-6)
3. Write down the serial number of the failed unit on the RID tag.
4. Affix the repair tag to the rear panel of the replacement unit (below the serial number label).
5. Place the failed unit into the packaging of the replacement unit.
6. Follow the instructions (included with the replacement unit) for returning the failed unit.

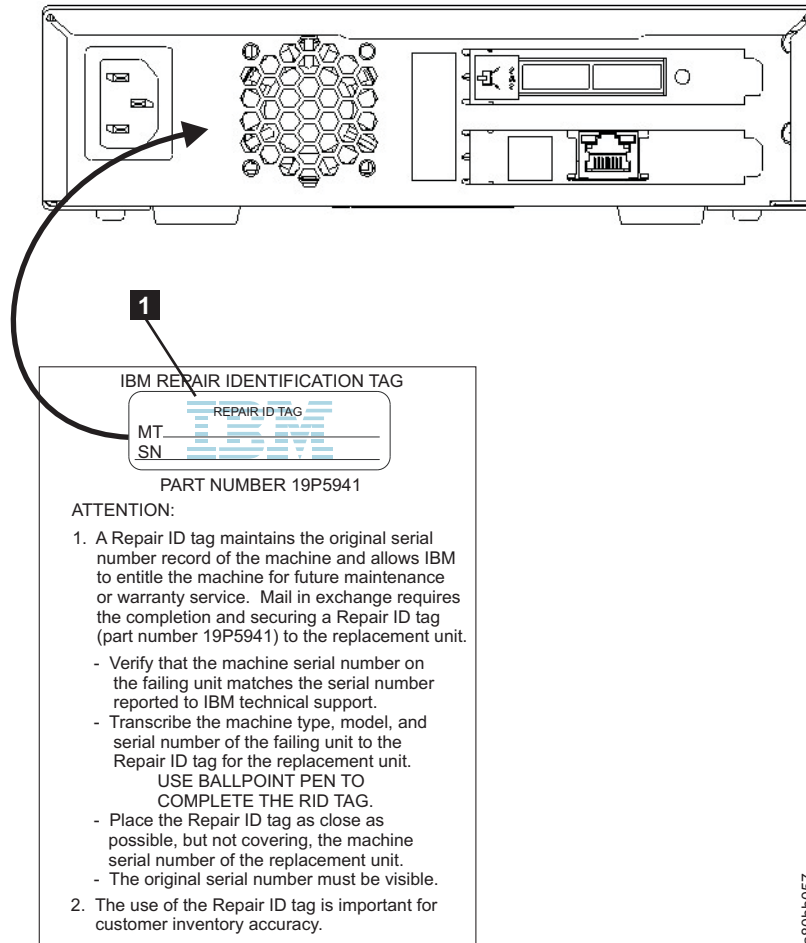

Figure 5-2. RID tag on rear panel



## Appendix A. Error codes and messages

If the drive detects a permanent error, it displays the error code on the SCD and flashes the Fault light (Ready light is Off).

- Make note of the SCD error code before a cartridge is removed or the SCD error code is cleared.
- If an error occurred with a cartridge in the drive, push **Unload** to eject the cartridge.
- To clear the SCD error code and power cycle the drive, press **Unload** for 10 seconds. A drive memory dump is created.

**Attention:** If the drive detects a permanent error and displays an error code other than , it automatically completes a drive memory dump. If you force a drive memory dump, the existing memory dump is overwritten and data is lost. After you force a drive memory dump, do not turn off the power to the drive or you might lose the memory dump data.

Table A-1. Error codes on the Single-character Display



Error Code	Cause and Action
	No error occurred and no action is required. This code displays when diagnostic tests are finished running and no error occurred. <b>Note:</b> The Single-character Display is blank during normal operation of the tape drive.
	Temperature problem. The tape drive detected that the recommended operating temperature was exceeded. Complete one or more of these actions: <ul style="list-style-type: none"> <li>• Ensure that the cooling fan is rotating and is quiet. If not, refer to your enclosure documentation.</li> <li>• Remove any blockage that prevents air from flowing freely through the tape drive.</li> <li>• Ensure that the operating temperature and airflow is within the specified range (see “Specifications” on page 1-7).</li> </ul> Clear the error code by power-cycling the tape drive or placing the drive in Maintenance mode. If the operating temperature and airflow are within the specified range, and the problem persists, replace the drive.
	Power problem. The tape drive detected that the externally supplied power is outside the specified voltage limits (the tape drive is not operating). Complete this action: <ol style="list-style-type: none"> <li>1. Ensure that the power connector is properly seated.</li> <li>2. Turn power off/on the tape drive to see whether the problem repeats.</li> <li>3. Replace the tape drive if the problem persists.</li> </ol> The error code clears when you place the tape drive in maintenance mode.

Table A-1. Error codes on the Single-character Display (continued)

Error Code	Cause and Action
3	<p>Firmware problem. The tape drive determined that a firmware error occurred. Complete this action:</p> <ol style="list-style-type: none"> <li>1. Collect a drive memory dump. <ul style="list-style-type: none"> <li><b>Note:</b> Do not force a new memory dump; the tape drive created one. <ul style="list-style-type: none"> <li>• Server 's host interface with a device driver utility or system tool such as ITDT. For instructions about ITDT, visit the web at <a href="http://www.ibm.com/support/fixcentral">http://www.ibm.com/support/fixcentral</a>.</li> <li>• Ultrium tape drive (to copy and read a drive memory dump, use "Function code 5: Copy drive dump" on page 3-14)</li> </ul> </li> </ul> </li> <li>2. Power the tape drive off and on, then retry the operation that produced the error.</li> <li>3. If the problem persists, download new firmware and retry the operation.</li> <li>4. If the problem persists, send the drive memory dump that you collected in step <b>1</b> to your IBM Support Center.</li> </ol> <p>The error code clears when you place the tape drive in Maintenance mode.</p>
4	<p>Firmware or hardware problem. The tape drive determined that a firmware or tape drive hardware failure occurred. Complete this action:</p> <ol style="list-style-type: none"> <li>1. Collect a drive dump. <ul style="list-style-type: none"> <li><b>Note:</b> Do not force a new memory dump; one exists. <ul style="list-style-type: none"> <li>• Server 's host interface with a device driver utility or system tool such as ITDT. For instructions about using ITDT, visit the web at <a href="http://www.ibm.com/support/fixcentral">http://www.ibm.com/support/fixcentral</a>.</li> <li>• Ultrium tape drive (to copy and read a drive memory dump, use "Function code 5: Copy drive dump" on page 3-14)</li> </ul> </li> </ul> </li> <li>2. Power the tape drive off and on, then retry the operation that produced the error. The error code clears when you place the tape drive in Maintenance mode.</li> <li>3. If the problem persists, download new firmware and retry the operation; if new firmware is not available, replace the drive.</li> </ol>
5	<p>Tape drive hardware problem. The drive determined that a tape path or read/write error occurred. To prevent damage to the drive or tape, you cannot insert a cartridge if the current cartridge was successfully ejected. The error code might clear when you cycle power to the tape drive or place it in maintenance mode. If the problem persists, replace the drive.</p> <p><b>Note:</b> Copy the drive memory dump to flash memory before the drive is returned. For instructions, refer to "Function code 5: Copy drive dump" on page 3-14.</p>
6	<p>Tape drive or media error. The tape drive determined that an error occurred, but it cannot isolate the error to faulty hardware or to the tape cartridge. Ensure that the tape cartridge is the correct media type:</p> <ul style="list-style-type: none"> <li>• Ultrium 1, 2 and 3 cartridges are not supported in the Ultrium 6 tape drive.</li> <li>• Drive does not accept an expired Cleaning Cartridge.</li> <li>• Drive does not accept a WORM cartridge when diagnostic tests are run in Maintenance mode.</li> <li>• Drive does not write over existing data sets on a WORM cartridge. Ensure that you are appending data sets on WORM media rather than attempting to write over existing data sets.</li> </ul> <p>If the tape cartridge is the correct media type, complete this action:</p>

Table A-1. Error codes on the Single-character Display (continued)

Error Code	Cause and Action
	<p><b>Problems with Writing Data</b></p> <p>If the problem occurred while the tape drive was writing data to the tape, retry the operation with a different cartridge:</p> <ul style="list-style-type: none"> <li>• If the operation succeeds, the original cartridge was defective. Copy data from the defective cartridge and discard it.</li> <li>• If the operation fails and another tape drive is available, insert the cartridge into the other unit and retry the operation.               <ul style="list-style-type: none"> <li>– If the operation fails, discard the defective cartridge.</li> <li>– If the operation succeeds, insert a scratch data cartridge into the first unit and run “Function code 1: Run drive diagnostics” on page 3-12.                   <ul style="list-style-type: none"> <li>- If the diagnostic tests fail, replace the tape drive.</li> <li>- If the diagnostic tests succeed, the error was temporary.</li> </ul> </li> </ul> </li> <li>• If the operation fails and another tape drive is not available, insert a scratch data cartridge into the unit and run “Function code 1: Run drive diagnostics” on page 3-12.               <ul style="list-style-type: none"> <li>– If the diagnostic tests fail, replace the tape drive.</li> <li>– If the diagnostic tests succeed, discard the cartridge.</li> </ul> </li> </ul> <p>If the problem occurs with multiple tape cartridges, run “Function code 1: Run drive diagnostics” on page 3-12:</p> <ul style="list-style-type: none"> <li>• If the diagnostic tests fail, replace the tape drive.</li> <li>• If the diagnostic tests succeed, run “Function code H: Test head” on page 3-20.               <ul style="list-style-type: none"> <li>– If the diagnostic test fails, replace the tape drive.</li> <li>– If the diagnostic test succeeds, replace the cartridges that caused the problem.</li> </ul> </li> </ul> <p>The error code clears when you remove the tape cartridge or place the tape drive in Maintenance mode.</p> <p><b>Problems with Reading Data</b></p> <p>If the problem occurred while the tape drive was reading data from the tape, complete one of these procedures:</p> <ul style="list-style-type: none"> <li>• If another tape drive is available, insert the cartridge into the other unit and retry the operation:               <ul style="list-style-type: none"> <li>– If the operation fails, discard the defective cartridge.</li> <li>– If the operation succeeds, insert a scratch data cartridge into the first unit and run “Function code 1: Run drive diagnostics” on page 3-12:                   <ul style="list-style-type: none"> <li>- If the diagnostic test fails, replace the tape drive.</li> <li>- If the diagnostic test succeeds, the error was temporary.</li> </ul> </li> </ul> </li> <li>• If another tape drive is not available, insert a scratch data cartridge into the unit and run “Function code 1: Run drive diagnostics” on page 3-12:               <ul style="list-style-type: none"> <li>– If the diagnostic test fails, replace the tape drive.</li> <li>– If the diagnostic test succeeds, discard the cartridge.</li> </ul> </li> </ul> <p>If the problem occurs with multiple tape cartridges, run “Function code 1: Run drive diagnostics” on page 3-12.</p> <ul style="list-style-type: none"> <li>• If the diagnostic test fails, replace the tape drive.</li> <li>• If the diagnostic test succeeds, run “Function code H: Test head” on page 3-20.               <ul style="list-style-type: none"> <li>– If the diagnostic test fails, replace the tape drive.</li> <li>– If the diagnostic test succeeds, replace the cartridges that caused the problem.</li> </ul> </li> </ul> <p>The error code clears when you remove the tape cartridge or place the tape drive in Maintenance mode.</p>

Table A-1. Error codes on the Single-character Display (continued)

Error Code	Cause and Action
<p style="text-align: center;">7</p>	<p>Media error. The tape drive determined an error occurred because of a faulty tape cartridge or an invalid tape cartridge. Ensure that the tape cartridge is the correct media type:</p> <ul style="list-style-type: none"> <li>• Ultrium 1, 2 and 3 cartridges are not supported in the Ultrium 6 tape drive.</li> <li>• Drive does not accept an expired Cleaning Cartridge.</li> <li>• Drive does not accept a WORM cartridge when diagnostic tests are run in Maintenance mode.</li> <li>• Drive does not accept an FMR tape unless the drive is completing "Function code 8: Unmake FMR tape" on page 3-17.</li> <li>• Drive does not write over existing data sets on a WORM cartridge. Ensure that you are appending data sets on WORM media rather than attempting to write over existing data sets.</li> <li>• Drive does not Create an FMR Tape (Maintenance mode, Function code 3) with a cartridge that is already an FMR tape. Use another cartridge or run Maintenance mode Function code 8: Unmake FMR tape.</li> <li>• Drive does not Unmake FMR tape (Maintenance code 8) with a cartridge that is not an FMR tape.</li> </ul> <p>If the tape cartridge is the correct media type, try another tape cartridge. If the problem occurs with multiple tape cartridges, use this procedure:</p> <ol style="list-style-type: none"> <li>1. If possible, run the tape cartridge in a different tape drive. If the operation in the other unit fails and 6 or 7 displays, replace the media. If the operation succeeds, run "Function code E: Test cartridge &amp; media" on page 3-18.</li> </ol> <p><b>Attention:</b> When you run the Test Cartridge &amp; Media diagnostic test, data on the suspect tape is overwritten. Use only a scratch data cartridge to run the test.</p> <ul style="list-style-type: none"> <li>• If the diagnostic test fails, replace the media.</li> <li>• If the diagnostic test succeeds, clean the drive head (see "Cleaning the drive head" on page 3-7) and run "Function code 1: Run drive diagnostics" on page 3-12.             <ul style="list-style-type: none"> <li>– If the drive diagnostic test fails, replace the drive.</li> <li>– If the drive diagnostic test succeeds, complete the operation that produced the initial media error.</li> </ul> </li> </ul> <p>The error code clears when you remove the tape cartridge or place the tape drive in Maintenance mode.</p>
<p style="text-align: center;">8</p>	<p>Interface problem. The tape drive determined that a failure occurred in the tape drive 's hardware or in the host bus. See Chapter 5, "Troubleshooting," on page 5-1. If 8 was displayed while "Function Code 6: Host Interface Test" was running:</p> <ol style="list-style-type: none"> <li>1. Verify that the correct interface wrap tool was attached in the correct interface port during the test. The test fails if the correct interface wrap tool is not attached.             <p><b>Note:</b> The interface wrap test is not supported on the USB port and displays an invalid error if run.</p> </li> <li>2. If the correct interface wrap tool was attached during the test, replace the drive. The error code clears when you place the tape drive in Maintenance mode.</li> </ol>
<p style="text-align: center;">9</p>	<p>Tape drive or RS-422 error. The tape drive determined that a failure occurred in the tape drive 's hardware or in the RS-422 connection. See "Function code 7: Run RS-422 wrap test" on page 3-16 or refer to the library procedures to isolate the problem to the drive. The error code clears when you place the tape drive in Maintenance mode.</p>

Table A-1. Error codes on the Single-character Display (continued)

Error Code	Cause and Action
<p style="text-align: center;">A</p>	<p>Degraded operation. The tape drive determined that a problem occurred which degraded the operation of the tape drive, but it did not restrict continued use. If the problem persists, determine whether the problem is with the drive or the media.</p> <p><b>Note:</b> The drive is usable, though the Single-character Display continues to indicate an error and the Fault light flashes. The error code might clear when you cycle power to the tape drive or place it in Maintenance mode.</p> <p>To determine whether the problem is with the drive hardware, or the tape media, complete these procedures:</p> <ol style="list-style-type: none"> <li>1. If possible, run the tape cartridge in a different drive. If the operation in the other drive fails and <span style="border: 1px solid black; padding: 0 2px;">E</span> or <span style="border: 1px solid black; padding: 0 2px;">7</span> displays, replace the media. If the operation succeeds, run the Test Cartridge &amp; Media diagnostic test (see "Function code E: Test cartridge &amp; media" on page 3-18).</li> <li>2. If the Test Cartridge &amp; Media diagnostic test fails, replace the media. If it runs successfully, clean the failing drive and run the drive diagnostic tests (see "Cleaning the drive head" on page 3-7 and "Function code 1: Run drive diagnostics" on page 3-12). When you begin this test, the diagnostic test begins the loop sequence. Time the first loop by pressing <b>Unload</b> once to stop the diagnostic test after the completion of the first loop, then record the time that it takes for the test to complete. Compare the recorded time with the "Approximate Run Time". If the test runs successfully but the execution time is longer than the "Approximate Run Time", run "Function code F: Write performance test" on page 3-19. If the Write Performance Test fails, replace the media and exit Maintenance mode. If the drive diagnostic tests run successfully, complete the operation that produced the initial drive error.</li> <li>3. If the problem persists, replace the drive.</li> </ol> <p>If it is not possible to run the tape cartridge in a different drive, complete these procedures:</p> <ol style="list-style-type: none"> <li>1. Clean the failing drive and run the drive diagnostic tests (see "Cleaning the drive head" on page 3-7 and "Function code 1: Run drive diagnostics" on page 3-12). When you begin this test, the diagnostic test begins the loop sequence. Time the first loop by pressing <b>Unload</b> once to stop the diagnostic test after the completion of the first loop, then record the time that it takes for the test to complete. Compare the recorded time with the "Approximate Run Time". If the test runs successfully but the execution time is longer than the "Approximate Run Time", run "Function code F: Write performance test" on page 3-19. If the Write Performance Test fails, replace the media and exit Maintenance mode. If the drive diagnostic tests run successfully, run the Test Cartridge &amp; Media diagnostic test (see "Function code E: Test cartridge &amp; media" on page 3-18).</li> <li>2. If the Test Cartridge &amp; Media diagnostic test fails, replace the media. If it runs successfully, complete the operation that produced the initial drive error.</li> <li>3. If the problem persists, replace the drive.</li> </ol>
<p style="text-align: center;">C</p>	<p>The tape drive must be cleaned. Clean the tape drive. See "Cleaning the drive head" on page 3-7.</p> <p>The error code clears when you clean the tape drive or place it in Maintenance mode.</p>
<p style="text-align: center;">d</p>	<p>Fiber AL_PA conflict. Two drives on fiber loop have the same AL_PA. Modify the tape drive AL_PA to eliminate the conflict. NOT SUPPORTED ON THIS DRIVE.</p>

Table A-1. Error codes on the Single-character Display (continued)

Error Code	Cause and Action
<p style="text-align: center;">E</p>	<p>Encryption Error. Displayed when the drive detects an error that is associated with an encryption operation. If the problem occurred while the tape drive was writing data to, or reading data from, tape:</p> <ol style="list-style-type: none"> <li>1. Check the host application to ensure that the host application is providing the correct encryption key. <ul style="list-style-type: none"> <li>• Refer to the <i>IBM LTO Ultrium Tape Drive SCSI Reference</i> documentation for the sense data that is returned for an encryption operation.</li> <li>• Retry the encryption operation after the host application problems are resolved.</li> </ul> </li> <li>2. Check the operation of the tape drive by resetting the drive and running POST. See Table 3-2 on page 3-5. <ul style="list-style-type: none"> <li>• Refer to the error code displayed on the SCD if the drive reset and POST fails.</li> <li>• Retry the encryption operation if the drive reset and POST complete without errors.</li> </ul> </li> <li>3. Check the media. <ul style="list-style-type: none"> <li>• Ensure that the correct media is used. Data encryption is supported by LTO Ultrium 4, 5 and 6 Data Cartridges only.</li> <li>• Retry the encryption operation with the tape cartridge in another encryption enabled drive. Replace the media if the problem repeats with the same tape cartridge in multiple drives.</li> </ul> </li> </ol> <p>If the problem occurred while the tape drive was running POST or diagnostic tests, replace the drive.</p> <p>The error code clears with the first attempted write/read after the encryption key is changed, or when the drive is placed in Maintenance mode.</p>
<p style="text-align: center;">E</p>	<p>Fiber Port offline. NOT SUPPORTED ON THIS DRIVE.</p>
<p style="text-align: center;">F</p>	<p>Fibre Channel error. NOT SUPPORTED ON THIS DRIVE.</p>
<p style="text-align: center;">U</p>	<p>Incompatible media. The tape drive detected that an unsupported cartridge was loaded or the cartridge that is loaded has an incompatible format. Ultrium 1, 2 and 3 cartridges are not supported in the Ultrium 6 tape drive.</p>
<p style="text-align: center;">P</p>	<p>Write operation to a write protected cartridge was attempted (includes any attempt to overwrite a WORM protected tape). Ensure that the tape cartridge is the correct media type. Writes to Ultrium 1, 2, 3 or 4 tape cartridges are not supported in the Ultrium 6 tape drive. If the tape cartridge is the correct media type, check the write-protect switch on the cartridge. The drive does not write to a write-protected cartridge. The error code clears when you remove the tape cartridge or place the tape drive in Maintenance mode.</p>

---

## Appendix B. TapeAlert flags

TapeAlert is a patented technology and standard of the American National Standards Institute (ANSI) that defines conditions and problems that are experienced by tape drives. The technology enables a server to read TapeAlert flags from a tape drive through the host interface. The server reads the flags from Log Sense Page 0x2E. Refer to the *IBM LTO Ultrium Tape Drive SCSI Reference* for the list of TapeAlert flags that are supported by this tape drive.





---

## Appendix C. Ordering optional features, replacement parts, and power cords

For ordering information, refer to the following sections:

- “Optional features”
- “Replacement parts”
- “Power cords” on page C-2

For information about ordering media and bar code labels, see “Ordering media supplies” on page 4-20.

### Optional features

*Table C-1. Optional features*

Feature Code	Description
5402	2.0 m SAS/Mini-SAS 1x Cable
5501	1.0 m Mini-SAS/Mini-SAS 1x Cable
5502	2.0 m Mini-SAS/Mini-SAS 1x Cable
5760	TS2260 (3580 H6S) Half High Bridgebox - SAS/USB ports
5761	2.7 m USB3 Type A-B cable

### Replacement parts

*Table C-2. Replacement parts*

Part Number	Description
46C2805	TS2260 (3580-H6S) Half High SAS Bridgebox CRU - dual SAS ports
46C3297	TS2260 (3580-H6S) Half High Bridgebox CRU - SAS/USB ports
95P4587	2 m SAS/Mini-SAS 1x Cable
95P4488	2 m Mini-SAS/Mini-SAS 1x Cable
95P6566	SAS wrap tool
05H5080	2.7 m USB3 Type A-B cable CRU
12X4292	1.0 m Mini-SAS/Mini-SAS 1x Cable

## Power cords



To avoid electrical shock, a power cord with a grounded attachment plug is provided. Use only properly grounded outlets.

The table lists the power cord part number, feature code, the country, or region where the power cord can be used, and the plug 's standard reference. The last column in the table contains an index number that you can match to a specific receptacle type in Figure C-1 on page C-5.

All power cords use an appliance coupler that complies with the International Electrotechnical Commission (IEC) Standard 320, Sheet C13.

If the power cord that you receive does not match your receptacle, contact your local dealer.

Power cords that are used in the United States and Canada are listed by Underwriter 's Laboratories (UL), are certified by the Canadian Standards Association (CSA), and comply with the plug standards of the National Electrical Manufacturers Association (NEMA). For other worldwide geographies, plug standards are listed in the table.

Table C-3. Power cords

Description, Feature Code (FC), and Part Number (PN)	Plug Standard Reference	Country or Region	Index Number in Figure C-1 on page C-5
<b>US/Canada</b> <ul style="list-style-type: none"> <li>• 2.8 m, 125 V</li> <li>• FC 9800</li> <li>• PN 39M5081</li> <li>• (See Note)</li> </ul>	NEMA 5-15P	Aruba, Bahamas, Barbados, Bermuda, Bolivia, Brazil, Canada, Cayman Islands, Colombia, Costa Rica, Curacao, Dominican Republic, Ecuador, El Salvador, Guatemala, Guyana, Haiti, Honduras, Jamaica, Japan, Liberia, Mexico, Netherlands Antilles, Nicaragua, Panama, Peru, Philippines, Saudi Arabia, South Korea, Suriname, Taiwan, Trinidad Tobago, Venezuela, US	1
<b>Chicago</b> <ul style="list-style-type: none"> <li>• 1.8 m, 125 V</li> <li>• FC 9986</li> <li>• PN 39M5080</li> </ul>	NEMA 5-15P	Chicago, US	1
<b>US/Canada</b> <ul style="list-style-type: none"> <li>• 2.8 m, 250 V</li> <li>• FC 9833</li> <li>• PN 39M5095</li> </ul>	NEMA 6-15P	Aruba, Bahamas, Barbados, Bermuda, Bolivia, Brazil, Canada, Cayman Islands, Costa Rica, Curacao, Dominican Republic, Ecuador, El Salvador, Guatemala, Guyana, Haiti, Honduras, Jamaica, Japan, Liberia, Netherlands Antilles, Nicaragua, Panama, Peru, Philippines, Suriname, Taiwan, Thailand, Trinidad Tobago, Venezuela, US	2
<b>Australia</b> <ul style="list-style-type: none"> <li>• 2.8 m, 250 V</li> <li>• FC 9831</li> <li>• PN 39M5102</li> </ul>	AS 3112 NZS 198	Argentina, Australia, China, Colombia, New Zealand, Papua New Guinea, Paraguay, Uruguay, Western Samoa	3
<b>France, Germany</b> <ul style="list-style-type: none"> <li>• 2.8 m, 250 V</li> <li>• FC 9820</li> <li>• PN 39M5123</li> </ul>	CEE 7 - VII	Afghanistan, Algeria, Andorra, Angola, Aruba, Austria, Belgium, Benin, Brazil, Bulgaria, Burkina Faso, Burundi, Cameroon, Central African Republic, Chad, Congo-Brazzaville, Curacao, Czech Republic, Democratic Republic of Congo, Denmark, Egypt, Finland, France, French Guiana, Germany, Greece, Guinea, Hungary, Iceland, Indonesia, Iran, Ivory Coast, Jordan, Kenya, Korea, Lebanon, Luxembourg, Macau, Malagasy, Mali, Martinique, Mauritania, Mauritius, Monaco, Morocco, Mozambique, Netherlands, Netherlands Antilles, New Caledonia, Niger, Norway, Poland, Portugal, Romania, Russia, Saudi Arabia, Senegal, Spain, Sweden, Sudan, Syria, Togo, Tunisia, Turkey, Yugoslavia, Zaire, Zimbabwe, Vietnam	4

Table C-3. Power cords (continued)

Description, Feature Code (FC), and Part Number (PN)	Plug Standard Reference	Country or Region	Index Number in Figure C-1 on page C-5
<b>Denmark</b> <ul style="list-style-type: none"> <li>• 2.8 m, 250 V</li> <li>• FC 9821</li> <li>• PN 39M5130</li> </ul>	DK2-5A	Denmark	5
<b>South Africa</b> <ul style="list-style-type: none"> <li>• 2.8 m, 250 V</li> <li>• FC 9829</li> <li>• PN 39M5144</li> </ul>	SABS 164	Bangladesh, Burma, Pakistan, South Africa, Sri Lanka	6
<b>United Kingdom</b> <ul style="list-style-type: none"> <li>• 2.8 m, 250 V</li> <li>• FC 9825</li> <li>• PN 39M5151</li> </ul>	BS 1363	Antigua, Bahrain, Bermuda, Brunei, Channel Islands, China (Hong Kong S.A.R.), Cyprus, Fiji, Ghana, Guyana, India, Iraq, Ireland, Jordan, Kenya, Kuwait, Malaysia, Malawi, Malta, Nepal, Nigeria, Oman, Polynesia, Qatar, Sierra Leone, Singapore, Tanzania, Uganda, UK, United Arab Emirate (Dubai), Yemen, Zambia	7
<b>Switzerland</b> <ul style="list-style-type: none"> <li>• 2.8 m, 250 V</li> <li>• FC 9828</li> <li>• PN 39M5158</li> </ul>	SEV SN 416534	Liechtenstein, Switzerland	8
<b>Italy</b> <ul style="list-style-type: none"> <li>• 2.8 m, 250 V</li> <li>• FC 9830</li> <li>• PN 39M5165</li> </ul>	CEI 23- 16	Chile, Ethiopia, Italy, Libya, Somalia	9
<b>Israel</b> <ul style="list-style-type: none"> <li>• 2.8 m, 250 V</li> <li>• FC 9827</li> <li>• PN 39M5172</li> </ul>	S11-32-1971	Israel	10
<b>Argentina</b> <ul style="list-style-type: none"> <li>• 2.8 m, 250 V</li> <li>• FC 9834</li> <li>• PN 39M5068</li> </ul>	IEC 83-A5	Argentina, Brazil, Colombia, Paraguay, Trinidad Tobago, Uruguay	11
<b>China</b> <ul style="list-style-type: none"> <li>• 2.8 m, 250 V</li> <li>• FC 9840</li> <li>• PN 39M5206</li> </ul>	CCEE	People 's Republic of China	12
<b>Taiwan LV*</b> <ul style="list-style-type: none"> <li>• 2.8 m, 125 V</li> <li>• FC 9835</li> <li>• PN 39M5247</li> </ul>	CNS 10917-3	Taiwan	13
<b>Taiwan HV**</b> <ul style="list-style-type: none"> <li>• 2.8 m, 250 V</li> <li>• FC 9841</li> <li>• PN 39M5254</li> </ul>	CNS 10917-3	Taiwan	14
<b>Japan LV*</b> <ul style="list-style-type: none"> <li>• 2.8 m, 125 V</li> <li>• FC 9842</li> <li>• PN 39M5199</li> </ul>	JIS C8303, C8306	Japan	15

Table C-3. Power cords (continued)

Description, Feature Code (FC), and Part Number (PN)	Plug Standard Reference	Country or Region	Index Number in Figure C-1 on page C-5
<b>Korea HV**</b> • 2.8 m, 250 V • FC 9844 • PN 39M5219	KS C8305, K60884-1	Korea	17
<b>India HV**</b> • 2.8 m, 250 V • FC 9845 • PN 39M5226	IS 6538	India	18
<b>Brazil HV**</b> • 2.8 m, 250 V • FC 9847 • PN 39M5240	InMetro NBR 14136	Brazil	20
* Low Voltage ** High Voltage			

### Types of Receptacles

The figure shows the plugs that are available on the power cords in “Power cords” on page C-2. Match the index number that is beside each plug to the index number in Table C-3 on page C-2.

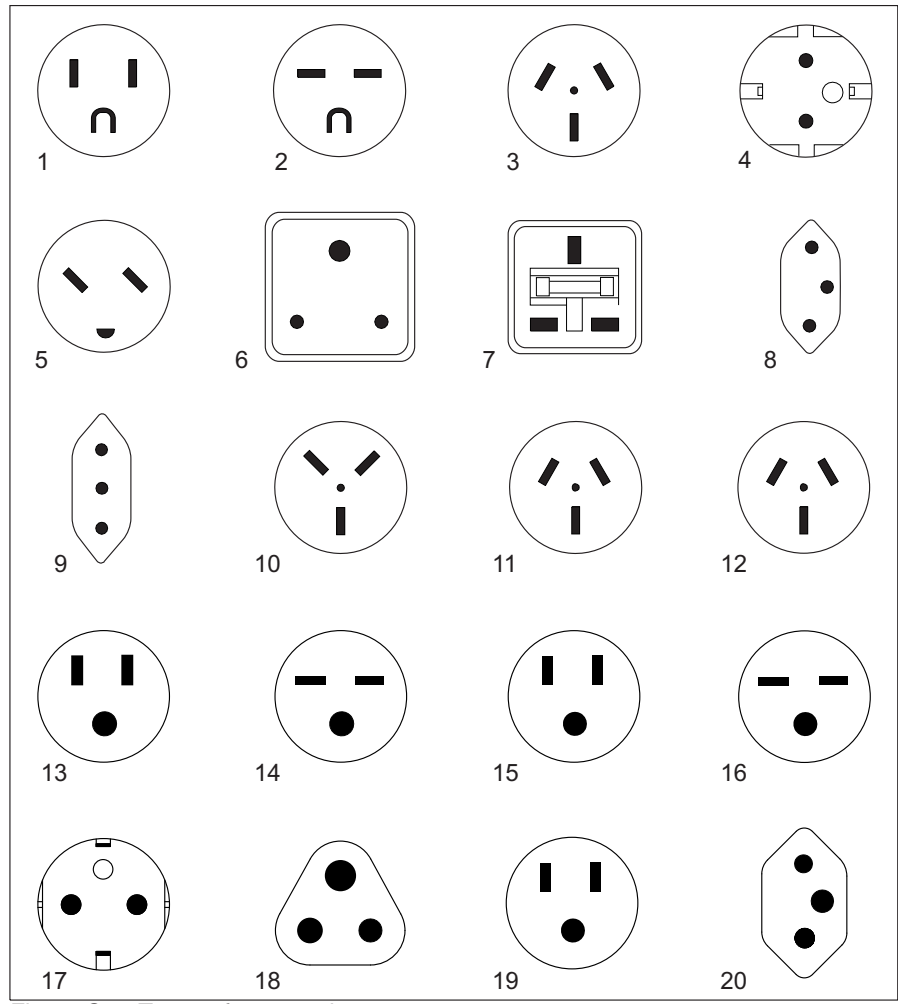

Figure C-1. Types of receptacles

a77ug005



---

## Appendix D. Installing a 19-inch rack mount kit (optional)

Before you begin, read these instructions to familiarize yourself with the installation procedure.

---

### Rack safety

This general safety information must be used for all rack-mounted devices:

#### DANGER

- Always lower the leveling pads on the rack cabinet.
- Always install stabilizer brackets on the rack cabinet.
- To avoid hazardous conditions because of uneven mechanical loading, always install the heaviest devices in the bottom of the rack cabinet. Always install servers and optional devices starting from the bottom of the rack cabinet.
- Rack-mounted devices are not to be used as a shelf or workspace. Do not place any object on top of rack-mounted devices.
- Each rack cabinet might have more than one power cord. Be sure to disconnect all power cords in the rack cabinet before any device is serviced in the rack cabinet.
- Connect all devices that are installed in a rack cabinet to power devices installed in the same rack cabinet. Do not plug a power cord from a device that is installed in one rack cabinet into a power device that is installed in a different rack cabinet.
- An electrical outlet that is not correctly wired can place hazardous voltage on the metal parts of the system or the devices that attach to the system. It is the responsibility of the customer to ensure that the outlet is correctly wired and grounded to prevent an electrical shock.

**CAUTION:**

- **Do not install a unit in a rack where the internal rack ambient temperatures exceeds the manufacturer 's recommended ambient temperature for all your rack-mounted devices.**
- **Do not install a unit in a rack where the air flow is compromised. Ensure that air flow is not blocked or reduced on any side, front, or back of a unit that is used for air flow through the unit.**
- **Consideration must be given to the connection of the equipment to the supply circuit so that overloading of the circuits does not compromise the supply wiring or overcurrent protection. To provide the correct power connection to a rack, refer to the rating labels on the equipment in the rack to determine the total power requirement of the supply circuit.**
- **(For sliding drawers.) Do not pull out or install any drawer or feature if the rack stabilizer brackets are not attached to the rack. Do not pull out more than one drawer at a time. The rack can become unstable if you pull out more than one drawer at a time.**
- **(For fixed drawers.) This drawer is a fixed drawer and must not be moved for servicing unless specified by manufacturer. Attempting to move the drawer partially or completely out of the rack can cause the rack to become unstable or cause the drawer to fall out of the rack.**



## CAUTION:

Removing components from the upper positions in the rack cabinet improves rack stability during relocation. Follow these general guidelines whenever you relocate a populated rack cabinet within a room or building:

- Reduce the weight of the rack cabinet by removing equipment, starting at the top of the rack cabinet. When possible, restore the rack cabinet to the configuration of the rack cabinet as you received it. If this configuration is not known, you must do these procedures:
  - Remove all devices in the 32U position and above.
  - Ensure that the heaviest devices are installed in the bottom of the rack cabinet.
  - Ensure that there are no empty U-levels between devices that are installed in the rack cabinet below the 32U level.
- If the rack cabinet you are relocating is part of a suite of rack cabinets, detach the rack cabinet from the suite.
- Inspect the route that you plan to take to eliminate potential hazards.
- Verify that the route that you choose can support the weight of the loaded rack cabinet. Refer to the documentation that comes with your rack cabinet for the weight of a loaded rack cabinet.
- Verify that all door openings are at least 760 x 230 mm (30 x 80 in.).
- Ensure that all devices, shelves, drawers, doors, and cables are secure.
- Ensure that the four leveling pads are raised to their highest position.
- Ensure that there is no stabilizer bracket that is installed on the rack cabinet during movement.
- Do not use a ramp that is inclined at more than 10 degrees.
- Once the rack cabinet is in the new location, do these procedures:
  - Lower the four leveling pads.
  - Install stabilizer brackets on the rack cabinet.
  - If you removed any devices from the rack cabinet, repopulate the rack cabinet from the lowest position to the highest position.
- If a long-distance relocation is required, restore the rack cabinet to the configuration of the rack cabinet as you received it. Pack the rack cabinet in the original packaging material, or equivalent. Also, lower the leveling pads to raise the casters off of the pallet and bolt the rack cabinet to the pallet.

(R002)

---

## Verify kit contents

Qty	Description
1	fixed shelf
4	screws
2	tie wraps
	Installation Instructions (Feature 7003)

---

## Tools required

- 7 mm nut driver or 7 mm socket wrench

## Installing the shelf

1. Decide at what level you want to install the shelf. The 3580 requires 3 units (EIAs) of rack space (see **2** in Figure D-1).

**Note:** All vertical rack measurements are given in rack units (U). One U is equal to 4.45 cm (1.75 in.). The U levels are marked on labels on one front mounting rail and one rear mounting rail.

2. With the sides and back of the shelf facing up, carefully lift the shelf into the rack between the front and back rack rails with the shelf flanges behind the front rack rails.
3. Align the holes in the shelf flange exactly with the holes in the front rack rails.
4. Holding the shelf **1** level, insert a screw through the top hole **3** in each front flange of the shelf. Loosely thread the screws into the front mounting rails.

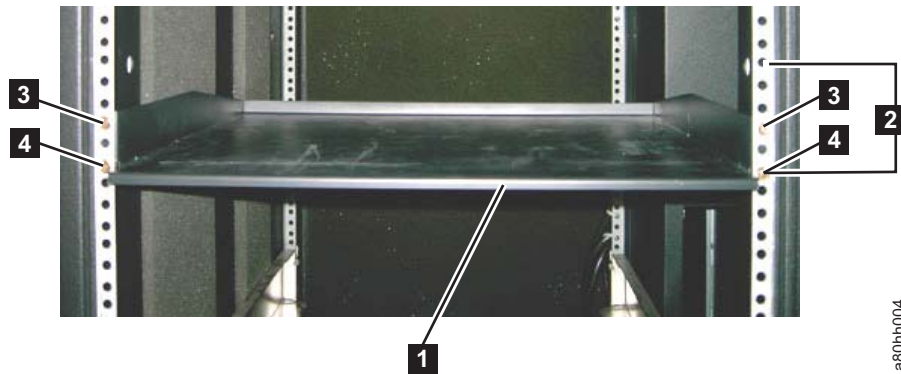

Figure D-1. Front view of shelf attached to rack rails

5. Check that the shelf is at the same level on the four mounting rails.
6. Insert a screw through the bottom hole **4** in each front flange of the shelf. Loosely thread the screws into the front mounting rails.
7. Tighten all mounting screws with a 7 mm nut driver or a 7 mm socket wrench.
8. Route cables down one of the rear rack rails by threading each tie wrap (see **5** in Figure D-2 on page D-5) through a hole in the rail and around the cables. One tie wrap must be located near the rear of the 3580; the other must be located farther down the rack rail. Tighten cable ties securely around the cables so the cables cannot be pulled out. Cut off tie wrap excess.



*Figure D-2. Rear view of shelf with cables attached to rack rails with tie wraps*

The shelf installation is complete. You can now install your equipment on the shelf.

---

## **Removing the shelf from the rack**

To remove the shelf from the rack, reverse the steps in the installation procedure.



---

## Appendix E. Information for trained service personnel

### Attention

- It is strongly recommended that the drive and stuck tape be returned to IBM for removal and recovery.
- If the cartridge in the drive is an INPUT tape containing ACTIVE or 'ONLY COPY' data (i.e., there is no backup), eject commands issued at the host fail to unload the tape, and power-cycling the drive fails to eject the cartridge, make no further attempts to unload this tape. Call Technical Support and open a PMR if one isn't already open, to initiate the process of sending the drive with the loaded cartridge in for recovery.
- These procedures must be performed only by a trained IBM service provider. SSRs should claim their time against service code 33 ECA 013 when performing this procedure.
- Inform the customer the following procedure has high risk of damaging the drive and high risk of not being able to recover the data.

---

## Removing the internal drive

This procedure is to be completed by IBM service personnel only.

**Note:** One of the four screws that secure the cover to the chassis is a tamperproof screw. A T20 Torx tamperproof screwdriver is required to remove the cover.

### Step 1. Removing the cover

1. Unplug all cables from the rear panel of the unit.
2. Move the unit to a clean and sturdy work surface.
3. Turn the unit on its side with the bottom of the unit facing you.
4. Remove the 4 screws ( **1** in Figure E-1 on page E-2) by the feet.

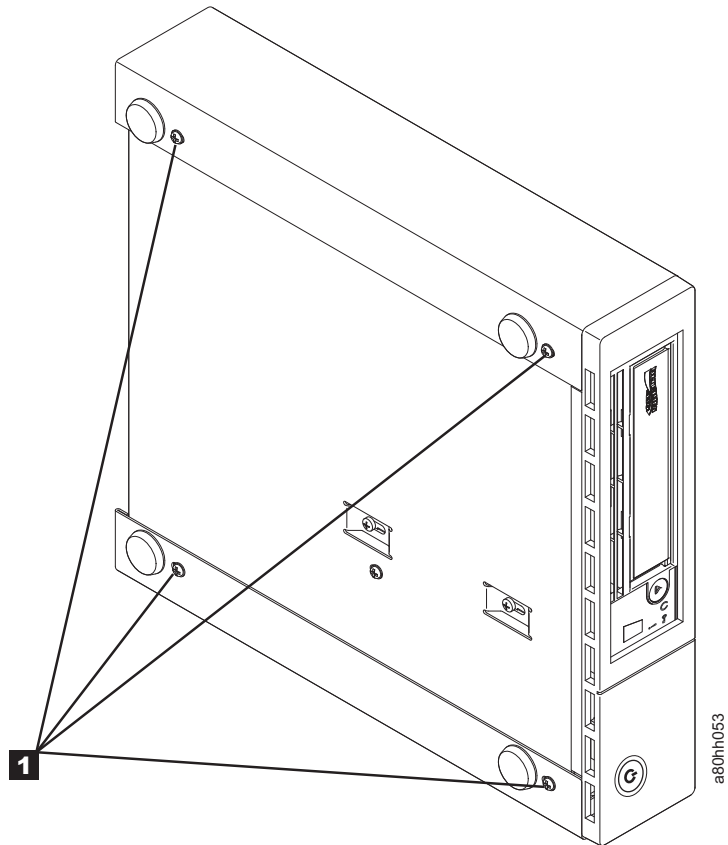

*Figure E-1. Removing the screws that secure the cover and internal drive*

5. Return the unit to its upright position.
6. Gently push the drive 's rear panel to remove the chassis from the cover (see Figure E-2 on page E-3).

## Step 2. Removing the internal drive

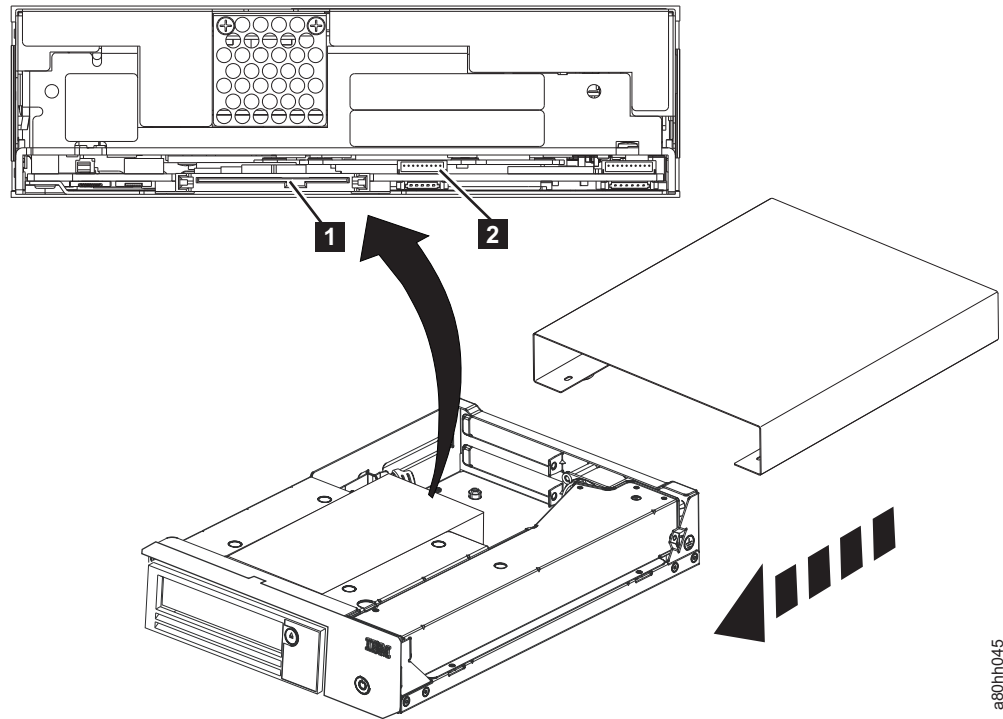
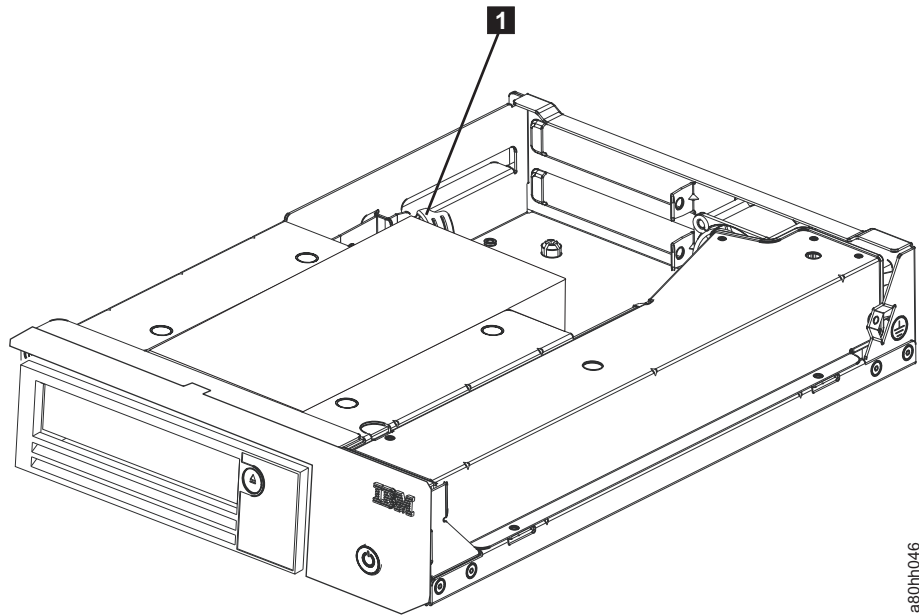

Figure E-2. Removing cables from the internal drive

1. Unplug the SAS interface cable and the ethernet interface cable ( **1** and **2** in Figure E-2) from the drive. Disconnecting the internal SAS interface cable disconnects both the SAS interface and electrical power from the drive.

**Attention:** DO NOT UNPLUG THE INTERNAL POWER CABLE.

2. Press the latch assembly to release the drive.



a80hh046

Figure E-3. Releasing the drive from the chassis

3. Slide the internal drive forward towards the front of the chassis to clear the front bezel.

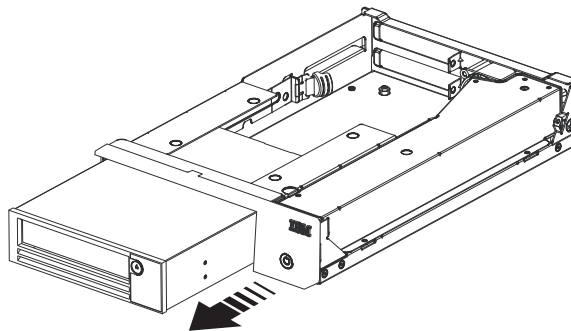

a80hh047

Figure E-4. Sliding the drive forward

---

## Manually removing a tape cartridge

**This Procedure is to be performed by IBM service personnel only.**

The purpose of this section is to assist you in determining the condition of the cartridge or the magnetic tape and to direct you to the procedure you must follow to remove the cartridge.

### Attention

- The best solution for recovering data on a damaged cartridge is to send it to IBM for professional data recovery.
- Before this procedure is used, you must exhaust all other means of removing the tape cartridge from the drive. Use this procedure only if you cannot remove the tape cartridge with any other means.



- Determine from the customer if the cartridge contains critical customer data. If the cartridge contains sensitive data that cannot leave the site, inform the customer that certain failure conditions diagnostic tests are done to test the drive for continued use.
- The following removal procedures can destroy customer data! Use extreme care when handling or removing the customer's tape cartridges to minimize tape damage and lost data.
- DO NOT TOUCH the magnetic tape or tape path. Both are sensitive to the oil and salt from your skin. Use clean, lint-free gloves when working around magnetic tape or the tape path components.
- Electrostatic-sensitive components: Consider using an ESD Kit.
- After you remove the tape cartridge, advise the customer to copy the data to another cartridge and to remove this tape cartridge from service.
- Do not use power tools or magnetic tools to complete this procedure.
- To avoid contamination and electrostatic-discharge damage to the drive, never touch the head or electronic components inside the drive.
- If you cannot remove the cartridge from the drive with the following procedures, contact your next level of support.
- The cartridge does not eject automatically at the end of a mid-tape recovery. Instead, the tape is reloaded into the drive and might result in the loss of data.
- INTERNAL COMPONENTS OF THE DRIVE ARE DELICATE AND CAN EASILY BE DAMAGED. EXERCISE EXTREME CAUTION WHEN MANUALLY REMOVING A CARTRIDGE THAT WILL NOT EJECT AFTER PRESSING UNLOAD.

## Before you begin

1. Attempt to remove the cartridge with the device power ON and with library manager, a host application, or **Unload**. Press and hold **Unload** for 12 seconds. This procedure causes the drive to eject the cartridge when it completed the mid-tape recovery.
2. Attempt to remove the cartridge by power-cycling the drive. Look for the drive to attempt a mid-tape recovery.
 

**Note:** It can take up to 15 minutes for the cartridge to rewind and unload.
3. If the cartridge unloads, inform the operator that the cartridge is unloaded. If the cartridge does not unload, repeat steps 2 and 3 again before you continue with this procedure.

## Recommended tools

- #1 Phillips screwdriver
- ESD kit
- Flashlight (optional)
- #1 Flathead screwdriver (optional)

## Beginning procedure

1. Refer to the enclosure documentation for instructions on removing the drive.
2. Place the drive on a non-slip, sturdy work surface.
3. Ground yourself to the drive with the ESD kit.
4. Remove the cover of the drive:

- a. To remove the drive bezel, pull the right side of the bezel from the front of the drive, then pull the left side of the bezel out of the frame of the drive.
- b. Remove the cover of the internal drive:
  - 1) Remove the four cover-mounting screws ( **1** in Figure E-5). Two screws are on each side of the drive.
  - 2) Remove the cover by lifting it up.

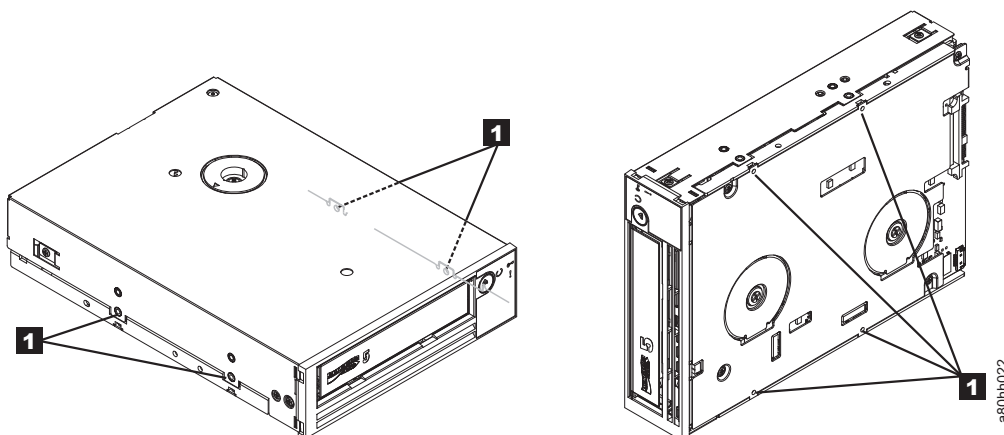

Figure E-5. Removing the bezel and the cover from the internal drive

5. Inspect the drive to decide which of the following conditions most closely match the symptom on the drive:
  - **Tape spooled off the supply reel** - All the tape appears to be on the takeup reel and no tape is on the supply reel (inside the cartridge). Test the drive after the procedure is completed.
  - **Tape pulled from leader pin (or broken at the front end)** - All the tape appears to be on the supply reel (inside the cartridge) and little or no tape appears to be on the takeup reel. The leader block is positioned in the takeup reel. Return the drive after the procedure is completed.
  - **Tape broken in mid-tape** - Tape appears to be on both the supply reel (inside the cartridge) and takeup reel. Test the drive after the procedure is completed.
  - **Tape tangled along tape path** - Tape appears to be tangled and damaged but intact. Return the drive after the procedure is completed.

-- OR --

  - **No damage to tape (or no apparent failure)** - There appears to be no damage or slack to the tape. Return the drive after the procedure is completed.

## Tape spooled off supply reel

**Attention: DO NOT TOUCH THE OUTER GUIDE RAIL ( **2** in Figure E-6 on page E-7). THIS RAIL IS VERY DELICATE AND EASILY DAMAGED.**

1. From the takeup reel, pull an arm 's length of tape around the rear of the tape path and over the head and rollers on the left side of the drive.
2. Set the drive on its left side with the head and tape path facing up.
3. Make sure that the tape is not twisted. Untwist tape if required.
4. Moisten a cotton swab with water and wet approximately 13 mm (0.5 in.) of the tape end and feed it onto the supply reel (inside the cartridge).

- Turn the supply reel ( **4** in Figure E-6) clockwise, allowing the moistened tape to adhere to the hub as it winds around the supply reel (inside the cartridge).

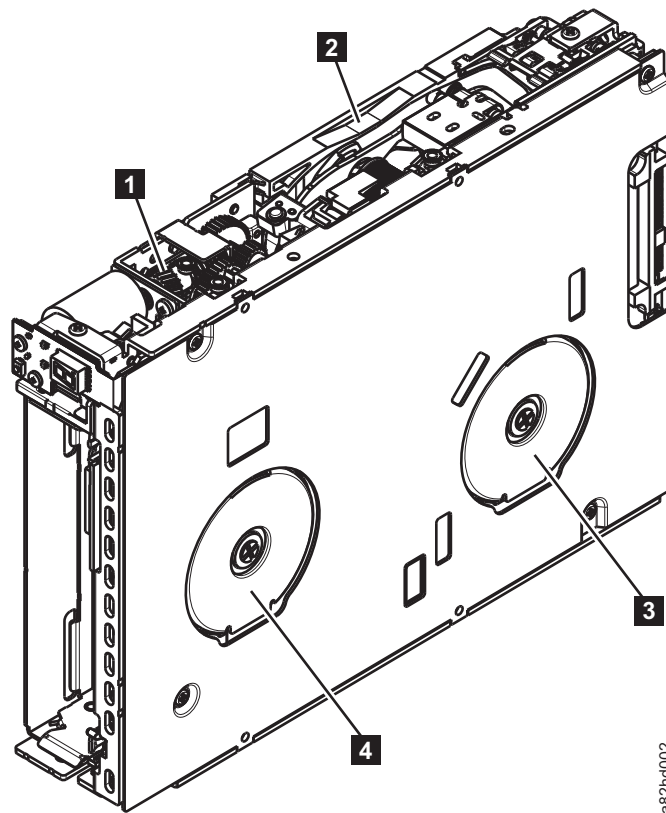

Figure E-6. Rewinding tape into cartridge

- |          |                        |          |                   |
|----------|------------------------|----------|-------------------|
| <b>1</b> | Loader motor worm gear | <b>3</b> | Takeup reel motor |
| <b>2</b> | Outer guide rail       | <b>4</b> | Supply reel motor |
- WARNING: DO NOT TOUCH

- Continue spooling into the cartridge until the tape is taut and remains within the flanges of the tape guiding rollers. Turn the supply reel ( **4** in Figure E-6) 10 more turns. Ensure that you do not stretch the tape.
- Reassemble the drive, reversing the steps in “Beginning procedure” on page E-5.
- Reassemble the drive chassis, following the steps in “Replacing the internal drive” on page E-14.
- Reinstall the drive canister into the cradle assembly. Ensure that the connector on the drive is seated properly into the connector on the cradle.
- Allow the drive to complete mid-tape recovery. This action takes several minutes. When this activity completes, push **Unload** to eject the cartridge.
- Test the drive (see “Function code 1: Run drive diagnostics” on page 3-12) to determine if it needs to be replaced.

## Tape pulled from or broken near leader pin

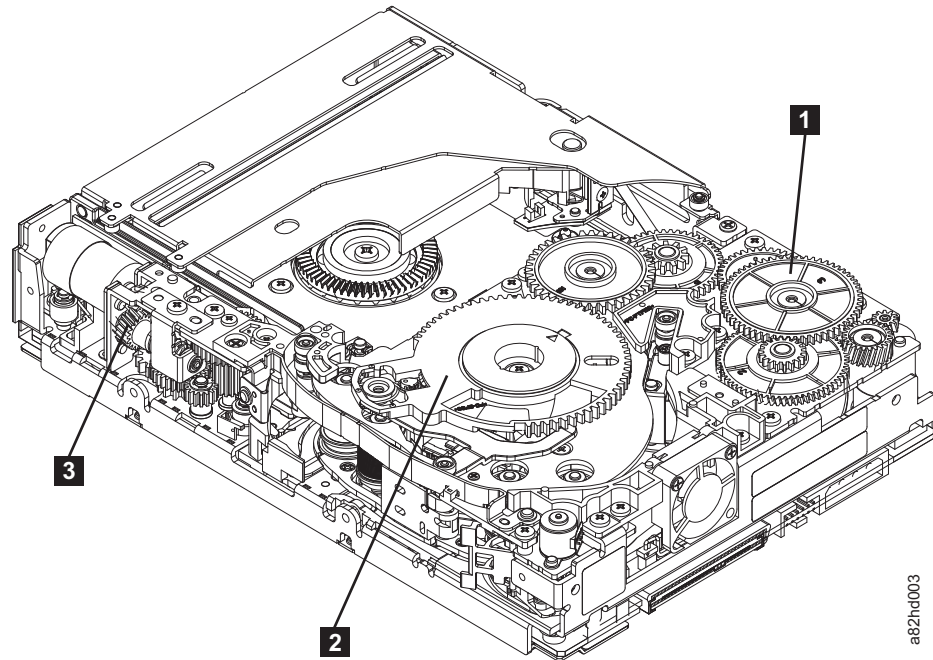

Figure E-7. Drive with cover removed to reveal gear train.

<b>1</b>	Threader intermediate gear	<b>2</b>	Threader mechanism gear	<b>3</b>	Loader motor worm gear
----------	----------------------------	----------	-------------------------	----------	------------------------

1. Pull out tape from the takeup reel.

**Note:** If there is more than approximately 0.6 m (2 ft.) of tape on the takeup reel, go to “Tape broken in mid-tape” on page E-9.

2. If there is less than approximately 0.6 m (2 ft.) of tape on the takeup reel, cut off the excess tape as close to the leader pin as possible.
3. Reattach the leader pin to the remaining tape. For instructions, see “Repositioning or reattaching a leader pin” on page 4-12.
4. Locate the threader intermediate gear (**1** in Figure E-7) near the rear of the drive. You can use your finger to rotate the threader intermediate gear (**1** in Figure E-7) and slowly rotate the threader mechanism gear (**2** in Figure E-7) clockwise.

This draws the tape leader block assembly (LBA) into the cartridge.

5. As the leader pin is secured in the cartridge, you hear the leader pin retention spring clips click into place. If you do not hear the click, continue rolling until the threader intermediate gear (**1** in Figure E-7) stops. The LBA is in the correct position.

**Note:** Be sure to keep tension on the tape as the LBA is drawn into the cartridge.

6. Rotate the loader motor worm gear (**3** in Figure E-7) clockwise as viewed from the front of the drive until it stops. This action releases the LBA leader pin.

7. Rotate the threader intermediate gear ( **1** in Figure E-7 on page E-8) counterclockwise until the leader block is in front of the read/write head. This action moves the LBA out of the cartridge.

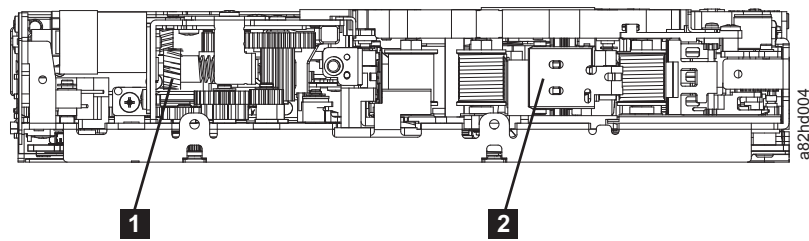

Figure E-8. Leader block assembly (LBA)

- 1** Loader motor worm gear      **2** Leader block assembly (LBA)

8. Rotate the loader motor worm gear ( **3** in Figure E-7 on page E-8) counterclockwise as viewed from the front of the drive until it stops.
9. Remove the cartridge from the cartridge loader tray.
10. Reassemble the drive by reversing the procedure in Step 4 in “Beginning procedure” on page E-5.
11. Reassemble the drive chassis.
12. Refer to the appropriate procedure to install the new drive and return the failed drive.

## Tape broken in mid-tape

1. With the front of the drive facing you, pull an arm 's length of tape out of the takeup reel. From the takeup reel, thread tape around the rear of the tape path and over the head rollers on the left side of the drive.

**Note:** If there is less than approximately 5 cm (2 in.) of tape on the takeup reel, go to “Tape pulled from or broken near leader pin” on page E-8.

2. From the supply reel inside the cartridge, pull approximately 0.3 m (1 ft.) of tape.
3. Make sure that the tape is not twisted. Untwist tape if required.
4. Moisten a cotton swab with water, and wet approximately 13 mm (0.5 in.) of the tape end. Overlap the tape ends, loosely mending them together.
5. Set the drive on its left side with the head and tape path facing up.
6. Turn the supply reel ( **4** in Figure E-9 on page E-10) clockwise, carefully guiding the mended portion of the tape to wind around the hub of the supply reel that is located inside the cartridge. Continue spooling into the cartridge until the tape is taut. The tape must remain within the flanges of the tape guiding rollers. Turn the supply reel ( **4** in Figure E-9 on page E-10) 10 more turns. Ensure that you do not stretch the tape.

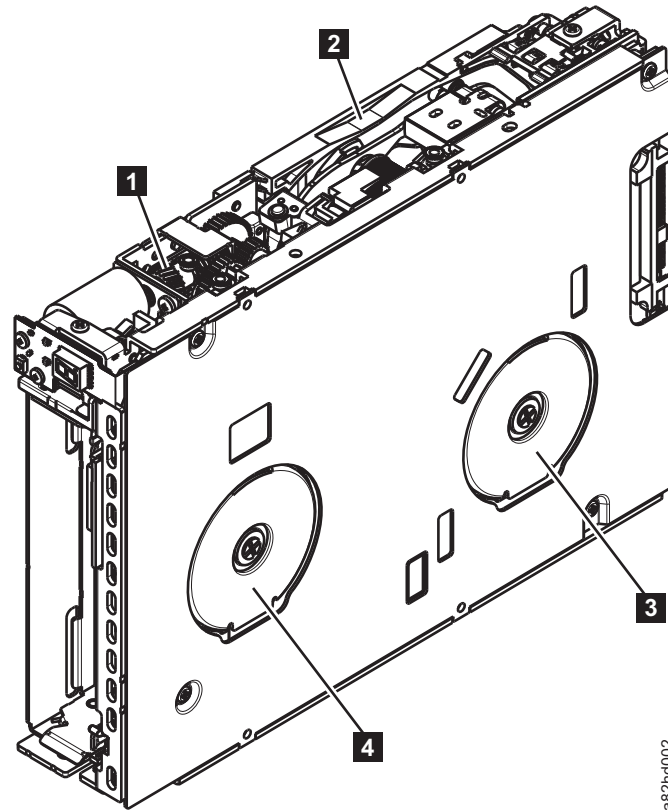

a82hd002

Figure E-9. Rewinding tape into cartridge

- |   |   |
|---|---|
| <p><b>1</b> Loader motor worm gear</p> <p><b>2</b> Outer guide rail</p> | <p><b>3</b> Takeup reel motor</p> <p><b>4</b> Supply reel motor</p> |
|---|---|
- WARNING: DO NOT TOUCH

7. Reassemble the drive by reversing the procedure in Step 4 in “Beginning procedure” on page E-5.
8. Reassemble the chassis by following the steps in “Replacing the internal drive” on page E-14.
9. Allow the drive to complete mid-tape recovery. This action takes several minutes. When this activity completes, push **Unload** to eject the cartridge.
10. Test the drive (see “Function code 1: Run drive diagnostics” on page 3-12) to determine whether it needs to be replaced.

## Tape tangled along tape path

1. Carefully pull out excess tape and untangle.

**Note:** If you find the tape to be broken, try one of these procedures:

- “Tape spooled off supply reel” on page E-6
- “Tape pulled from or broken near leader pin” on page E-8
- “Tape broken in mid-tape” on page E-9

2. Set the drive on its left side with the head and tape path facing up.

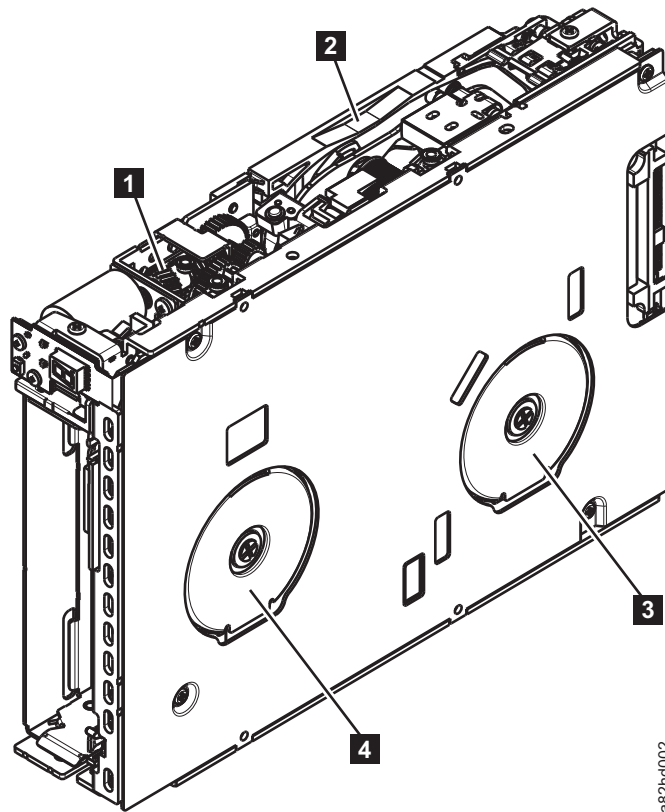

a82hd002

Figure E-10. Rewinding tape into cartridge

- |          |                        |          |                   |
|----------|------------------------|----------|-------------------|
| <b>1</b> | Loader motor worm gear | <b>3</b> | Takeup reel motor |
| <b>2</b> | Outer guide rail       | <b>4</b> | Supply reel motor |
- WARNING: DO NOT TOUCH

3. Turn the supply reel ( **4** in Figure E-10) clockwise.
4. Continue spooling into the cartridge until the tape is taut and remains within the flanges of the tape guiding rollers. Turn the supply reel ( **4** in Figure E-10) 10 turns. Ensure that you do not stretch the tape.
5. Reassemble the chassis by following the steps in “Replacing the internal drive” on page E-14.
6. Allow the drive to complete mid-tape recovery. This action takes several minutes. When this activity completes, push **Unload** to eject the cartridge.
7. Test the drive (see “Function code 1: Run drive diagnostics” on page 3-12) to determine whether it needs to be replaced.

## No apparent failure or damage to tape

1. Set the drive on its left side with the head and tape path facing up.

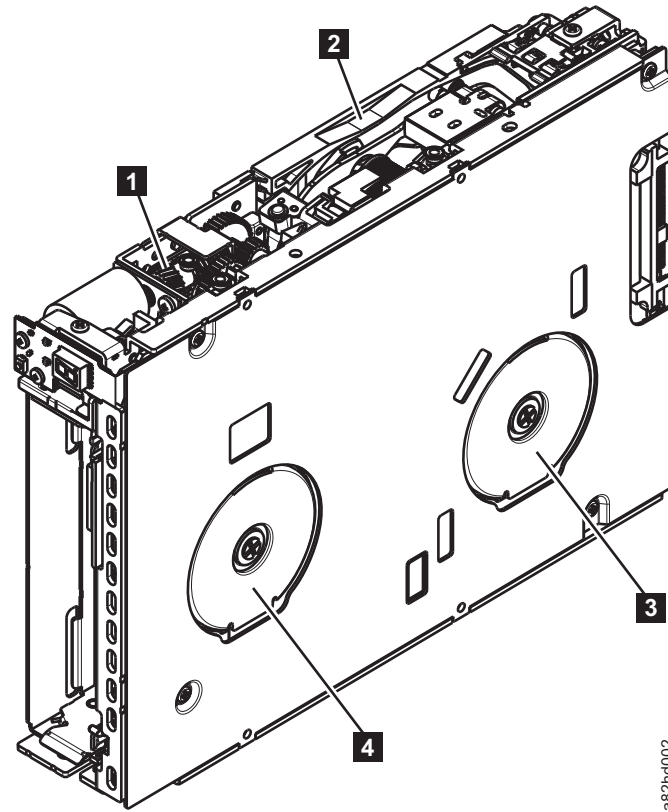

a82hd002

Figure E-11. Rewinding tape into cartridge

<b>1</b>	Loader motor worm gear	<b>3</b>	Takeup reel motor
<b>2</b>	Outer guide rail	<b>4</b>	Supply reel motor

WARNING: DO NOT TOUCH

2. Begin spooling the tape back into the cartridge by turning the supply reel motor (**4** in Figure E-11) clockwise.
3. Continue spooling into the cartridge until the tape is taut and remains within the flanges of the tape guiding rollers. Ensure that you do not stretch the tape. Continue spooling until all tape is removed from the takeup reel (**3** in Figure E-11).
4. Locate the threader intermediate gear (**1** in Figure E-12 on page E-13) near the rear of the drive. You can use your finger to rotate the threader intermediate gear (**1** in Figure E-12 on page E-13) and slowly rotate the threader mechanism gear (**2** in Figure E-12 on page E-13) clockwise. This action draws the tape leader block assembly (LBA) into the cartridge.



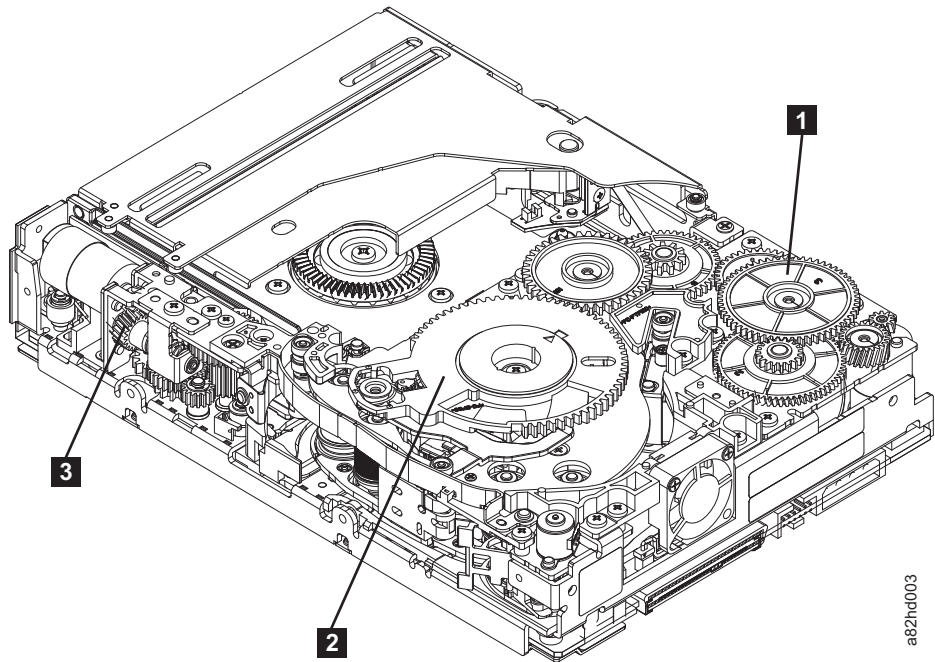

Figure E-12. Drive with cover removed to reveal gear train.

- |          |                            |          |                         |          |                        |
|----------|----------------------------|----------|-------------------------|----------|------------------------|
| <b>1</b> | Threader intermediate gear | <b>2</b> | Threader mechanism gear | <b>3</b> | Loader motor worm gear |
|----------|----------------------------|----------|-------------------------|----------|------------------------|

- As the leader pin is secured in the cartridge, you hear the leader pin retention spring clips click into place. If you do not hear the click, continue rolling until the threader intermediate gear (**1** in Figure E-12) stops. The LBA is in the correct position.

**Note:** Be sure to keep tension on the tape as the LBA is drawn into the cartridge.

- Rotate the loader intermediate gear (**1** in Figure E-13) clockwise as viewed from the front of the drive until it stops. This action releases the LBA leader pin.
- Rotate the threader motor worm gear (**3** in Figure E-13) counterclockwise until the leader block is in front of the read/write head. This action moves the LBA out of the cartridge.

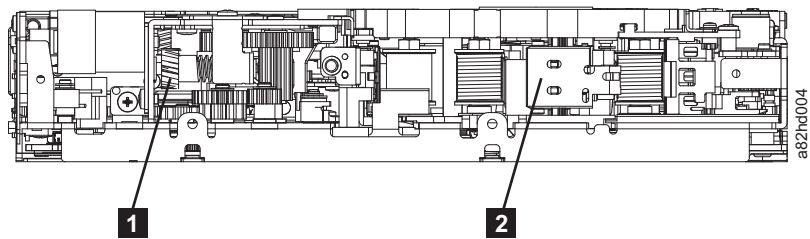

Figure E-13. Leader block assembly (LBA)

- |          |                        |          |                             |
|----------|------------------------|----------|-----------------------------|
| <b>1</b> | Loader motor worm gear | <b>2</b> | Leader block assembly (LBA) |
|----------|------------------------|----------|-----------------------------|

8. Rotate the loader motor worm gear ( **3** in Figure E-13 on page E-13) counterclockwise as viewed from the front of the drive until it stops.
9. Remove the cartridge from the cartridge loader tray.
10. Reassemble the drive by reversing the procedure in Step 4 in "Beginning procedure" on page E-5.
11. Reassemble the drive chassis by following the steps in "Replacing the internal drive."
12. Refer to the appropriate procedure to install the new drive and return the failed drive.

---

## Replacing the internal drive

### Step 1. Replacing the internal drive

1. Place the internal drive part way into the chassis.
2. Reconnect the internal interface cable to the drive.
3. Reconnect the internal power cable to the drive.
4. Slide the internal drive completely into the chassis until the latch assembly locks the drive in place.

### Step 2. Replacing the cover

1. Gently push the chassis into the cover.
2. Turn the unit on its side with the bottom of the unit facing you.
3. Align the four screw holes in the cover by the feet with the screw holes in the chassis.
4. Replace the 4 screws by the feet.
5. Reconnect all cables to the rear panel of the unit.

---

## Notices

The information provided by this media supports the products and services described with consideration for the conditions described herein.

IBM may not offer the products, services, or features discussed in this document in other countries. Consult your local IBM representative for information on the products and services currently available in your area. Any reference to an IBM product, program, or service is not intended to state or imply that only that IBM product, program, or service may be used. Any functionally equivalent product, program, or service that does not infringe any IBM intellectual property right may be used instead. However, it is the user's responsibility to evaluate and verify the operation of any non-IBM product, program, or service.

IBM may have patents or pending patent applications covering subject matter described in this document. The furnishing of this document does not give you any license to these patents. You can send license inquiries to:

*IBM Director of Licensing  
IBM Corporation  
North Castle Drive  
Armonk, NY 10504-1785  
U.S.A.*

For license inquiries regarding double-byte character set (DBCS) information, contact the IBM Intellectual Property Department in your country or send inquiries, in writing, to:

*Intellectual Property Licensing  
Legal and Intellectual Property Law  
IBM Japan Ltd.  
19-21, Nihonbashi-Hakozakicho, Chuo-ku  
Tokyo 103-8510, Japan*

**The following paragraph does not apply to the United Kingdom or any other country where such provisions are inconsistent with local law:**

INTERNATIONAL BUSINESS MACHINES CORPORATION PROVIDES THIS PUBLICATION "AS IS" WITHOUT WARRANTY OF ANY KIND, EITHER EXPRESS OR IMPLIED, INCLUDING, BUT NOT LIMITED TO, THE IMPLIED WARRANTIES OF NON-INFRINGEMENT, MERCHANTABILITY OR FITNESS FOR A PARTICULAR PURPOSE. Some states do not allow disclaimer of express or implied warranties in certain transactions, therefore, this statement may not apply to you.

This information could include technical inaccuracies or typographical errors. Changes are periodically made to the information herein; these changes will be incorporated in new editions of the publication. IBM may make improvements and/or changes in the product(s) and/or the program(s) described in this publication at any time without notice.

Any references in this information to non-IBM Web sites are provided for convenience only and do not in any manner serve as an endorsement of those Web

sites. The materials at those Web sites are not part of the materials for this IBM product and use of those Web sites is at your own risk.

IBM may use or distribute any of the information you supply in any way it believes appropriate without incurring any obligation to you.

Any performance data contained herein was determined in a controlled environment. Therefore, the results obtained in other operating environments may vary significantly. Some measurements may have been made on development-level systems and there is no guarantee that these measurements will be the same on generally available systems. Furthermore, some measurement may have been estimated through extrapolation. Actual results may vary. Users of this document should verify the applicable data for their specific environment.

Information concerning non-IBM products was obtained from the suppliers of those products, their published announcements or other publicly available sources. IBM has not tested those products and cannot confirm the accuracy of performance, compatibility or any other claims related to non-IBM products. Questions on the capabilities of non-IBM products should be addressed to the suppliers of those products.

All statements regarding IBM's future direction or intent are subject to change or withdrawal without notice, and represent goals and objectives only.

This information is for planning purposes only. The information herein is subject to change before the products described become available.

This information contains examples of data and reports used in daily business operations. To illustrate them as completely as possible, the examples include the names of individuals, companies, brands, and products. All of these names are fictitious and any similarity to the names and addresses used by an actual business enterprise is entirely coincidental.

---

## Trademarks

The following terms are trademarks of the International Business Machines Corporation in the United States, other countries, or both.

- AIX
- Enterprise Storage Server
- ESCON
- FICON
- i5/OS
- iSeries
- IBM
- pSeries
- S/390
- System Storage
- TotalStorage
- z/OS
- zSeries

IBM, the IBM logo, and ibm.com are trademarks or registered trademarks of International Business Machines Corporation in the United States, other countries,

or both. If these and other IBM trademarked terms are marked on their first occurrence in this information with a trademark symbol ((R) or (TM)), these symbols indicate U.S. registered or common law trademarks owned by IBM at the time this information was published. Such trademarks may also be registered or common law trademarks in other countries. A current list of IBM trademarks is available on the Web at "Copyright and trademark information" at <http://www.ibm.com/legal/copytrade.shtml>.

Adobe, the Adobe logo, PostScript, and the PostScript logo are either registered trademarks or trademarks of Adobe Systems Incorporated in the United States, and/or other countries.

Java and all Java-based trademarks are trademarks of Sun Microsystems, Inc. in the United States, other countries, or both.

Microsoft, Windows, and Windows NT are trademarks of Microsoft Corporation in the United States, other countries, or both.

Intel, Intel logo, Intel Inside, Intel Inside logo, Intel Centrino, Intel Centrino logo, Celeron, Intel Xeon, Intel SpeedStep, Itanium, and Pentium are trademarks or registered trademarks of Intel Corporation or its subsidiaries in the United States and other countries.

UNIX is a registered trademark of The Open Group in the United States and other countries.

Linux is a registered trademark of Linus Torvalds in the United States, other countries, or both.

Other company, product, and service names may be trademarks or service marks of others.

---

## **Electronic emission notices**

This section contains the electronic emission notices or statements for the United States and other countries.

### **Federal Communications Commission statement**

This explains the Federal Communications Commission's (FCC) statement.

This equipment has been tested and found to comply with the limits for a Class A digital device, pursuant to Part 15 of the FCC Rules. These limits are designed to provide reasonable protection against harmful interference when the equipment is operated in a commercial environment. This equipment generates, uses, and can radiate radio frequency energy and, if not installed and used in accordance with the instruction manual, might cause harmful interference to radio communications. Operation of this equipment in a residential area is likely to cause harmful interference, in which case the user will be required to correct the interference at his own expense.

Properly shielded and grounded cables and connectors must be used in order to meet FCC emission limits. IBM is not responsible for any radio or television interference caused by using other than recommended cables and connectors, or by unauthorized changes or modifications to this equipment. Unauthorized changes or modifications could void the user's authority to operate the equipment.

This device complies with Part 15 of the FCC Rules. Operation is subject to the following two conditions: (1) this device might not cause harmful interference, and (2) this device must accept any interference received, including interference that might cause undesired operation.

## Industry Canada compliance statement

This Class A digital apparatus complies with Canadian ICES-003.

Cet appareil numérique de la classe A est conform à la norme NMB-003 du Canada.

## European Union electromagnetic compatibility directive

This product is in conformity with the protection requirements of European Union (EU) Council Directive 2004/108/EC on the approximation of the laws of the Member States relating to electromagnetic compatibility. IBM cannot accept responsibility for any failure to satisfy the protection requirements resulting from a non-recommended modification of the product, including the fitting of non-IBM option cards.

**Attention:** This is an EN 55022 Class A product. In a domestic environment this product might cause radio interference in which case the user might be required to take adequate measures.

Responsible Manufacturer:

International Business Machines Corp.  
New Orchard Road  
Armonk, New York 10504  
914-499-1900

European community contact:

IBM Deutschland GmbH  
Technical Regulations, Department M372  
IBM-Allee 1, 71139 Ehningen, Germany  
Tele: +49 (0) 800 225 5423 or +49 (0) 180 331 3233  
email: halloibm@de.ibm.com

## Australia and New Zealand Class A statement

**Attention:** This is a Class A product. In a domestic environment this product might cause radio interference in which case the user might be required to take adequate measures.

## Germany electromagnetic compatibility directive

**Deutschsprachiger EU Hinweis: Hinweis für Geräte der Klasse A EU-Richtlinie zur Elektromagnetischen Verträglichkeit**

Dieses Produkt entspricht den Schutzanforderungen der EU-Richtlinie 2004/108/EG zur Angleichung der Rechtsvorschriften über die elektromagnetische Verträglichkeit in den EU-Mitgliedsstaaten und hält die Grenzwerte der EN 55022 Klasse A ein.

Um dieses sicherzustellen, sind die Geräte wie in den Handbüchern beschrieben zu installieren und zu betreiben. Des Weiteren dürfen auch nur von der IBM empfohlene Kabel angeschlossen werden. IBM übernimmt keine Verantwortung für

die Einhaltung der Schutzanforderungen, wenn das Produkt ohne Zustimmung der IBM verändert bzw. wenn Erweiterungskomponenten von Fremdherstellern ohne Empfehlung der IBM gesteckt/eingebaut werden.

EN 55022 Klasse A Geräte müssen mit folgendem Warnhinweis versehen werden:

"Warnung: Dieses ist eine Einrichtung der Klasse A. Diese Einrichtung kann im Wohnbereich Funk-Störungen verursachen; in diesem Fall kann vom Betreiber verlangt werden, angemessene Maßnahmen zu ergreifen und dafür aufzukommen."

### **Deutschland: Einhaltung des Gesetzes über die elektromagnetische Verträglichkeit von Geräten**

Dieses Produkt entspricht dem "Gesetz über die elektromagnetische Verträglichkeit von Geräten (EMVG)." Dies ist die Umsetzung der EU-Richtlinie 2004/108/EG in der Bundesrepublik Deutschland.

### **Zulassungsbescheinigung laut dem Deutschen Gesetz über die elektromagnetische Verträglichkeit von Geräten (EMVG) (bzw. der EMC EG Richtlinie 2004/108/EG) für Geräte der Klasse A**

Dieses Gerät ist berechtigt, in Übereinstimmung mit dem Deutschen EMVG das EG-Konformitätszeichen - CE - zu führen.

Verantwortlich für die Einhaltung der EMV Vorschriften ist der Hersteller:

International Business Machines Corp.  
New Orchard Road  
Armonk, New York 10504  
Tel: 914-499-1900

Der verantwortliche Ansprechpartner des Herstellers in der EU ist:

IBM Deutschland GmbH  
Technical Regulations, Abteilung M372  
IBM-Allee 1, 71139 Ehningen, Germany  
Tele: +49 (0) 800 225 5423 or +49 (0) 180 331 3233  
email: halloibm@de.ibm.com

### **Generelle Informationen:**

Das Gerät erfüllt die Schutzanforderungen nach EN 55024 und EN 55022 Klasse A.

## **People's Republic of China Class A Electronic Emission statement**

### **中华人民共和国“A类”警告声明**

#### **声明**

此为A级产品，在生活环境中，该产品可能会造成无线电干扰。在这种情况下，可能需要用户对其干扰采取切实可行的措施。

## Taiwan Class A compliance statement

警告使用者：  
這是甲類的資訊產品，在  
居住的環境中使用時，可  
能會造成射頻干擾，在這  
種情況下，使用者會被要  
求採取某些適當的對策。  
talenti

## Taiwan contact information

This topic contains the product service contact information for Taiwan.

IBM Taiwan Product Service Contact Information:  
IBM Taiwan Corporation  
3F, No 7, Song Ren Rd., Taipei Taiwan  
Tel: 0800-016-888

台灣IBM 產品服務聯絡方式：  
台灣國際商業機器股份有限公司  
台北市松仁路7號3樓  
電話：0800-016-888

f2c00790

## Japan VCCI Council Class A statement

この装置は、クラス A 情報技術装置です。この装置を家庭環境で使用する  
と電波妨害を引き起こすことがあります。この場合には使用者が適切な対策  
を講ずるよう要求されることがあります。  
VCCI-A

## Japan Electronics and Information Technology Industries Association (JEITA) statement (less than or equal to 20 A per phase)

高調波ガイドライン適合品

jeita1



## Japan Electronics and Information Technology Industries Association (JEITA) statement (greater than 20 A per phase)

高調波ガイドライン準用品

jeita2

### Korean Communications Commission (KCC) Class A Statement

이 기기는 업무용(A급)으로 전자파적합기기로서 판매자 또는 사용자는 이 점을 주의하시기 바라며, 가정외의 지역에서 사용하는 것을 목적으로 합니다.

### Russia Electromagnetic Interference (EMI) Class A statement

ВНИМАНИЕ! Настоящее изделие относится к классу А. В жилых помещениях оно может создавать радиопомехи, для снижения которых необходимы дополнительные меры

rusemi



---

## Glossary

This glossary defines the special terms, abbreviations, and acronyms that are used in this publication. If you do not find the term that you are looking for, refer to the index or to the *Dictionary of Computing*, 1994.

### Numbers

#### 2:1 compression

The relationship between the quantity of data that can be stored with compression as compared to the quantity of data that can be stored without compression. In 2:1 compression, twice as much data can be stored with compression as can be stored without compression.

### A

**A** Ampere.

**ac** Alternating current.

#### access method

A technique for moving data between main storage and input or output devices.

#### adapter card

A circuit board that adds function to a computer.

**adj** Adjustment.

**AIX** Advanced Interactive Executive. IBM's implementation of the UNIX operating system. The RS/6000 system, among others, uses AIX as its operating system.

#### alphanumeric

Pertaining to a character set that contains letters, numerals, and other characters, such as punctuation marks.

**alter** To change.

#### ambient temperature

The temperature of air or other media in a designated area, particularly the area that surrounds equipment.

#### ampere (A)

A unit of measure for electric current that is equivalent to a flow of one coulomb per second, or to the current produced by one volt applied across a resistance of one ohm.

**ANSI** American National Standards Institute.

#### archive

To collect and store files in a designated place.

**ASCII** American National Standard Code for Information Interchange. A 7 bit coded character set (8 bits including parity check) that consists of control characters and graphic characters.

#### assigning a device

The establishing of the relationship of a device to a running task, process, job, or program.

**assignment**

The naming of a specific device to complete a function.

**asynchronous**

Pertaining to two or more processes that do not depend upon the occurrence of specific events such as common timing signals.

**attention (notice)**

A word for calling attention to the possibility of danger to a program, device, or system, or to data. Contrast with *caution* and *danger*.

**ATTN** Attention.

**B****backup**

To make extra copies of documents or software for safekeeping.

**bar code**

A code that represents characters by sets of parallel bars of varying thickness and separation that are read optically by transverse scanning.

**bar code label**

Paper bearing a bar code and having an adhesive backing. The bar code label must be affixed to a tape cartridge to enable the library to identify the cartridge and its volume serial number.

**bar code reader**

A laser device that is specialized for scanning and reading bar codes and converting them into either the ASCII or EBCDIC digital character code.

**bezel** Decorative and safety cover.

**bicolored**

Having two colors.

**bit** Either of the digits 0 or 1 when used in the binary numbering system.

**BM or bill of materials**

A list of specific types and amounts of direct materials that are expected to be used to produce a specific job or quantity of output.

**browser**

A client program that initiates requests to a Web server and displays the information that the server returns.

**buffer**

A routine or storage that is used to compensate for a difference in rate of flow of data or time of occurrence of events, when data is transferred from one device to another.

**bus** A facility for transferring data between several devices that are located between two end points, only one device that is able to transmit at a specific moment.

**byte** A string that consists of bits (usually 8) that are treated as a unit and represent a character. A fundamental data unit.

**C****capacity**

The amount of data that can be contained on storage media and expressed in bytes of data.

**cartridge manual rewind tool**

A device that can be fitted into the reel of a cartridge and used to rewind tape into or out of the cartridge.

**cartridge storage slot**

Individual slot that is located within a magazine that is used to house tape cartridges.

**caution (notice)**

A word to call attention to possible personal harm to people. Contrast with *attention* and *danger*.

**CE** Customer engineer; field engineer; service representative.

**centimeter (cm)**

One one-hundredth of a meter (0.01 m). Approximately 0.39 inch.

**channel command**

An instruction that directs a data channel, control unit, or device to complete an operation or set of operations.

**char** Character.

**CHK** Check.

**cleaning cartridge**

A tape cartridge that is used to clean the heads of a tape drive. Contrast with *data cartridge*.

**command**

A control signal that initiates an action or the start of a sequence of actions.

**compact disc (CD)**

A disc, usually 4.75 inches in diameter, from which data is read optically by using a laser.

**compression**

The process of eliminating gaps, empty fields, redundancies, and unnecessary data to shorten the length of records or blocks.

**concurrent**

Refers to diagnostic procedures that can be run on one control unit while the rest of the subsystem remains available for customer applications.

**contingent connection**

A connection between a channel path and a drive that is caused when a unit check occurs during an I/O operation.

**controller**

A device that provides the interface between a system and one or more tape drives.

**CP** Circuit protector.

**ctrl** Control.

**CU** Control unit.

**D**

**danger (notice)**

A word to call attention to possible lethal harm to people. Contrast with *attention* and *caution*.

- data** Any representations such as characters or analog quantities to which meaning is or might be assigned.
- data buffer**  
The storage buffer in the control unit. This buffer is used to increase the data transfer rate between the control unit and the channel.
- data cartridge**  
A tape cartridge that is dedicated to storing data. Contrast with *cleaning cartridge*.
- data check**  
A synchronous or asynchronous indication of a condition that is caused by invalid data or incorrect positioning of data.
- dc** Direct current.
- degauss**  
To make a magnetic tape nonmagnetic by using electrical coils that carry currents that neutralize the magnetism of the tape.
- degausser**  
A device that makes magnetic tape nonmagnetic.
- degradation**  
A decrease in quality of output or throughput or an increase in machine error rate.
- degraded**  
Decreased in quality of output or throughput or increased machine error rate.
- deserialize**  
To change from serial-by-bit to parallel-by-byte.
- detented**  
A part that is held in position with a catch or lever.
- device** Any hardware component or peripheral device, such as a tape drive or tape library, that can receive and send data.
- device driver**  
A file that contains the code that is needed to use an attached device.
- DIAG**  
Diagnostic section of maintenance information manual.
- differential**  
See *High Voltage Differential (HVD)*.
- direct access storage**  
A storage device in which the access time is independent of the location of the data.
- DNS** Directory Name System. This system allows the library to recognize text-based addresses instead of numeric IP addresses.
- download**  
To transfer programs or data from a computer to a connected device, typically a personal computer.  
  
To transfer data from a computer to a connected device, such as a workstation or microcomputer.

**DRAM**

Dynamic random-access memory.

**drive, magnetic tape**

A mechanism for moving magnetic tape and controlling its movement.

**DRV** Drive.

**DSE** Data security erase.

**DSP** Digital signal processor.

**E****EBCDIC**

Extended binary-coded decimal interchange code.

**EC** Edge connector. Engineering change.

**ECC** Error correction code.

**EEPROM**

Electrically erasable programmable read-only memory.

**EIA** Electronics Industries Association.

**EIA unit**

A unit of measure, which is established by the Electronic Industries Association, equal to 44.45 millimeters (1.75 inches).

**eject** To remove or force out from within.

**electronic mail**

Correspondence in the form of messages that are transmitted between user terminals over a computer network.

**email** See *electronic mail*.

**EPO** Emergency power off.

**EPROM**

Erasable programmable read only memory.

**EQC** Equipment check.

**equipment check**

An asynchronous indication of a malfunction.

**Error log**

A data set or file in a product or system where error information is stored for later access.

**ESD** Electrostatic discharge.

**F****fault symptom code (FSC)**

A hexadecimal code that is generated by the drive or the control unit microcode in response to a detected subsystem error.

**FC** Feature code.

**FCC** Federal communications commission.

**FE** Field engineer, customer engineer, or service representative.

**fiducial**

A target that is used for teaching a physical location to a robot.

**field replaceable unit (FRU)**

An assembly that is replaced in its entirety when any one of its components fails.

**file** A named set of records that are stored or processed as a unit. Also referred to as a dataset.

**file protection**

The processes and procedures that are established in an information system that are designed to inhibit unauthorized access to, contamination of, or deletion of a file.

**file transfer protocol (FTP)**

In the Internet suite of protocols, an application layer protocol that uses TCP and Telnet services to transfer bulk-data files between machines or hosts.

**firmware**

Proprietary code that is delivered as microcode as part of an operating system. Firmware is more efficient than software loaded from an alterable medium and more adaptable to change than pure hardware circuitry. An example of firmware is the Basic Input/Output System (BIOS) in read-only memory (ROM) on a PC motherboard.

**FLASH EEPROM**

An electrically erasable programmable read-only memory (EEPROM) that can be updated.

**FMR** Field microcode replacement.

**format**

The arrangement or layout of data on a data medium.

**formatter**

Part of a magnetic tape subsystem that completes data conversion, speed matching, encoding, first-level error recovery, and interfaces to one or more tape drives.

**FP** File protect.

**frayed** Damaged as if by an abrasive substance.

**FRU** Field replaceable unit.

**FSC** Fault symptom code.

**FSI** Fault symptom index.

**functional microcode**

Microcode that is resident in the machine during normal customer operation.

**G**

**g** Gram.

**GB** gigabyte.

**GBIC** Gigabit Interface Converter.

**Gbi** gigabit

**Generation 1**

The informal name for the IBM Ultrium 1 Tape Drive, which is the first



generation of the Ultrium tape drive. The Generation 1 drive has a native storage capacity of up to 100 GB per cartridge and a native sustained data transfer rate of 15 MB per second.

**Generation 2**

The informal name for the second-generation version of the IBM Ultrium Tape Drive. The Generation 2 drive has a native storage capacity of up to 200 GB per cartridge and a native sustained data transfer rate of 35 MB per second.

**Generation 3**

The informal name for the third-generation version of the IBM Ultrium Tape Drive. The Generation 3 drive has a native storage capacity of up to 400 GB per cartridge and a native sustained data transfer rate of 135 MB per second.

**Generation 4**

The informal name for the fourth-generation version of the IBM Ultrium Tape Drive. The Generation 4 drive has a native storage capacity of up to 800 GB per cartridge and a native sustained data transfer rate of 135 MB per second.

**Generation 5**

The informal name for the fifth-generation version of the IBM Ultrium Tape Drive. The Generation 5 drive has a native storage capacity of up to 1500 GB per cartridge and a native sustained data transfer rate of 140 MB per second.

**Generation 6**

The informal name for the sixth-generation version of the IBM Ultrium Tape Drive. The Generation 6 drive has a native storage capacity of up to 2500 GB per cartridge and a native sustained data transfer rate of 160 MB per second.

**gigabit (Gbit)**

1 000 000 000 bits.

**gigabyte (GB)**

1 000 000 000 bytes.

**Gigabit Interface Converter (GBIC)**

Converts copper interface to optic interface.

**gnd** Ground.

**H**

**hertz (Hz)**

Unit of frequency. One hertz equals one cycle per second.

**hex** Hexadecimal.

**High Voltage Differential (HVD)**

A logic-signaling system that enables data communication between a supported host and the library. HVD signaling uses a paired plus and minus signal level to reduce the effects of noise on the SCSI bus. Any noise that is injected into the signal is present in both a plus and minus state, and is canceled. Synonymous with *differential*.

**HVD** SCSI Bus High Voltage Differential

**Hz** Hertz (cycles per second).

## I

### **IBM Ultrium Tape Drive**

Located within the library, a data-storage device that controls the movement of the magnetic tape in an IBM LTO Ultrium Tape Cartridge. The drive houses the mechanism (drive head) that reads and writes data to the tape.

**ID** Identifier.

### **identifier (ID)**

(1) In programming languages, a lexical unit that names a language object; for example, the names of variables, arrays, records, labels, or procedures. An identifier usually consists of a letter optionally followed by letters, digits, or other characters. (2) One or more characters that are used to identify or name data element and possibly to indicate certain properties of that data element. (3) A sequence of bits or characters that identifies a program, device, or system to another program, device, or system.

**IML** Initial microprogram load.

### **initial microprogram load (IML)**

The action of loading a microprogram from an external storage to writable control storage.

### **initiator**

The component that runs a command. The initiator can be the host system or the tape control unit.

**INST** Installation.

### **interface**

A shared boundary. An interface might be a hardware component to link two devices or it might be a portion of storage or registers accessed by two or more computer programs.

### **interposer**

The part that is used to convert a 68-pin connector to a 50-pin D-shell connector.

### **intervention required**

Manual action is needed.

## **INTRO**

Introduction.

**I/O** Input/output.

**IOP** Input/output processor.

**IPL** Initial program load.

**ITST** Idle-time self-test.

## **K**

### **kilogram (kg)**

One thousand grams (approximately 2.2 pounds).

**km** kilometer. 1000 Meters, Approximately 5/8 mile.

## **L**

**LAN** Local area network. A computer network within a limited area.

**LCD** See *liquid crystal display*.

**LDAP** Lightweight Directory Access Protocol. This protocol allows the library to use login and password information that is stored on a server to grant access to the library functionality.

**LED** Light-emitting diode.

**Linear Tape File System (LTFS)**

A file system that works with LTO Generation tape technology to access data stored on an IBM tape cartridge.

**Linear Tape-Open (LTO)**

A type of tape storage technology that is developed by the IBM Corporation, Hewlett-Packard, and Certance. LTO technology is an “open format” technology, which means that its users have multiple sources of product and media. The “open” nature of LTO technology enables compatibility between different vendors' offerings by ensuring that vendors comply with verification standards. The LTO technology is implemented in two formats: the Accelis format focuses on fast access; the Ultrium format focuses on high capacity. The Ultrium format is the preferred format when capacity (rather than fast access) is the key storage consideration. An Ultrium cartridge has a compressed data capacity of up to 800 GB (2:1 compression) and a native data capacity of up to 400 GB.

**liquid crystal display (LCD)**

A low-power display technology that is used in computers and other I/O devices.

**loadable**

Having the ability to be loaded.

**LTO cartridge memory (LTO-CM)**

Within each LTO Ultrium data cartridge, an embedded electronics and interface module that can store and retrieve a cartridge's historical usage and other information.

**LVD** SCSI Bus Low Voltage Differential

**M**

**m** Meter. In the Metric System, the basic unit of length; equal to approximately 39.37 inches.

**magnetic tape**

A tape with a magnetic surface layer on which data can be stored by magnetic recording.

**MAP** Maintenance analysis procedure.

**mask** A pattern of characters that controls the retention or elimination of portions of another pattern of characters. To use a pattern of characters to control the retention or elimination of portions of another pattern of characters.

**master file**

A file that is used as an authority in a specific job and that is relatively permanent, even though its contents might change. Synonymous with main file.

**MB** Mega Byte (expressed as data rate in MB/s or MB/second).

**media capacity**

The amount of data that can be contained on a storage medium, expressed in bytes of data.

**media-type identifier**

Pertaining to the bar code on the bar code label of the IBM Ultrium Tape Cartridge, a 2-character code, L1, that represents information about the cartridge. L identifies the cartridge as one that can be read by devices that incorporate LTO technology; 1 indicates that it is the first generation of its type.

**mega** One million of.

**meter** In the Metric System, the basic unit of length; equal to approximately 39.37 inches.

**micro** One millionth of.

**microcode**

(1) One or more micro instructions. (2) A code, representing the instructions of an instruction set, which is implemented in a part of storage that is not program-addressable. (3) To design, write, and test one or more micro instructions. (4) See also *microprogram*.

**microdiagnostic routine**

A program that runs under the control of a supervisor, usually to identify field replaceable units.

**microdiagnostic utility**

A program that is run by the customer engineer to test the machine.

**microinstruction**

A basic or elementary machine instruction.

**microprogram**

A group of microinstructions that when run completes a planned function.

The term microprogram represents a dynamic arrangement or selection of one or more groups of microinstructions for execution to run a particular function. The term microcode represents microinstructions that are used in a product as an alternative to hard-wired circuitry to implement certain functions of a processor or other system component.

**MIM** Media information message.

**mm** Millimeter.

**modifier**

That which changes the meaning.

**mount a device**

To assign an I/O device with a request to the operator.

**MP** Microprocessor.

**ms** Millisecond.

**MSG** Message.

**multipath**

Pertaining to using more than one path.

**N**

**N/A** Not applicable.

- node** In a network, a point at which one or more functional units connect channels or data circuits.
- NTP** Network Time Protocol. This protocol allows the library to set its internal date and time that is based on the date and time of a sever.
- NVS** Nonvolatile storage. A storage device whose contents are not lost when power is cut off.

## O

### oersted

The unit of magnetic field strength in the unrationalized centimeter-gram-second (cgs) electromagnetic system. The oersted is the magnetic field strength in the interior of an elongated, uniformly wound solenoid that is excited with a linear current density in its winding of one abampere per  $4\pi$  centimeters of axial length.

### offline

Pertaining to the operation of a functional unit without the continual control of a computer. Contrast with *online*.

**online** Pertaining to the operation of a functional unit that is under the continual control of a computer. Contrast with *offline*.

**OPER** Operation.

**ov** Over voltage.

### overrun

Loss of data because a receiving device is unable to accept data at the rate it is transmitted.

### overtightening

To tighten too much.

## P

### parameter

A variable that is given a constant value for a specified application and that can denote the application.

**p bit** Parity bit.

**PC** Parity check.

**PCC** Power control compartment.

**PDF** Portable Document Format.

**PE** Parity error. Product engineer.

**pick** Pertaining to the library, to remove, by using a robotic device, a tape cartridge from a storage slot or drive.

**picker** A robotic mechanism that is located inside the library that moves cartridges between the cartridge storage slots and the drive.

**PM** Preventive maintenance.

**POR** Power-on reset.

**port** A physical connection for communication between the 3590 and the host processor. The 3590 has two SCSI ports.

**Portable Document Format (PDF)**

A standard that is specified by Adobe Systems, Incorporated, for the electronic distribution of documents. PDF files are compact, can be distributed globally (email, the Web, intranets, or CD-ROM), and can be viewed with the Acrobat Reader. The Acrobat Reader is software from Adobe Systems that can be downloaded at no cost from the Adobe Systems home page.

**PROM**

Programmable read only memory.

**PS** Power supply.

**PWR** Power.

**R**

**rack** A unit that houses the components of a storage subsystem, such as the library.

**rackmount kit**

A packaged collection of articles that are used to install the rack-mounted version of the library.

**RAM** Random access memory.

**Random access memory**

A storage device into which data is entered and from which data is retrieved in a nonsequential manner.

**RAS** Reliability, availability, and serviceability.

**record** A collection of related data or words, which are treated as a unit.

**recording density**

The number of bits in a single linear track measured per unit of length of the recording medium.

**recoverable error**

An error condition that allows continued execution of a program.

**ref** Reference.

**reg** Register.

**reinventory**

To inventory again.

**retension**

The process or function of tightening the tape onto the cartridge, if it is sensed that the tape has a loose wrap on the cartridge.

**robot** Picker.

**robotics**

Picker assembly.

**RPQ** Request for price quotation.

**R/W** Read/write.

**S**

**s** Seconds of time.

**SAC** Service Action Code. Code that is developed to indicate possible FRU or FRUs to replace to repair the hardware.

**SAS** Serial attached SCSI interface.

**scratch cartridge**

A data cartridge that contains no useful data, but can be written to with new data.

**SCSI** Small computer system interface.

**segment**

A part.

**sel** Select.

**serialize**

To change from parallel-by-byte to serial-by-bit.

**serializer**

A device that converts a space distribution of simultaneous states that represents data into a corresponding time sequence of states.

**servo, servos**

An adjective for use in qualifying some part or aspect of a servomechanism.

**servomechanism**

A feedback control system in which at least one of the system signals represents mechanical motion.

**Small Computer Systems Interface (SCSI)**

A standard that is used by computer manufacturers for attaching peripheral devices (such as tape drives, hard disks, CD-ROM players, printers, and scanners) to computers (servers). Pronounced "scuzzy". Variations of the SCSI interface provide for faster data transmission rates than standard serial and parallel ports (up to 160 megabytes per second). The variations include

- Fast/Wide SCSI: Uses a 16-bit bus, and supports data rates of up to 20 MBps.
- SCSI-1: Uses an 8-bit bus, and supports data rates of 4 MBps.
- SCSI-2: Same as SCSI-1, but uses a 50-pin connector instead of a 25-pin connector, and supports multiple devices.
- Ultra SCSI: Uses an 8- or 16-bit bus, and supports data rates of 20 or 40 MBps.
- Ultra2 SCSI: Uses an 8- or 16-bit bus and supports data rates of 40 or 80 MBps.
- Ultra3 SCSI: Uses a 16-bit bus and supports data rates of 80 or 160 MBps.
- Ultra160 SCSI: Uses a 16-bit bus and supports data rates of 80 or 160 MBps.

**SNS** Sense.

**special feature**

A feature that can be ordered to enhance the capability, storage capacity, or performance of a product, but is not essential for its basic work.

**SR** Service representative, see also *CE*.

**SRAM** Static random access memory.

**SS** Status store.

**ST** Store.

**standard feature**

The significant design elements of a product that are included as part of the fundamental product.

**START**

Start maintenance.

**subsystem**

A secondary or subordinate system, capable of operating independently of, or asynchronously with, a controlling system.

**SUPP** Support.

**sync** Synchronous, synchronize. Occurring with a regular or predictable time relationship.

**T**

**tachometer, tach**

A device that emits pulses that are used to measure/check speed or distance.

**tape cartridge**

A container-holding magnetic tape that can be processed without separating it from the container.

**tape void**

An area in the tape in which no signal can be detected.

**TCP/IP**

Transmission Control Protocol/Internet Protocol.

**TCU** Tape control unit.

**TH** Thermal.

**thread/load operation**

A procedure that places tape along the tape path.

**TM** Tapemark.

**U**

**UART** Universal asynchronous receiver/transmitter.

**Universal Serial Bus (USB)**

An interface standard that manufacturers use to connect peripheral devices (such as tape drives, hard disk drives, and printers) to computers (host servers). Variations of the USB interface have different data transmission rates. The variations include USB 1.1, USB 2.0, USB 3.0.

**unload**

Prepare the tape cartridge for removal from the drive.

**utilities**

Utility programs.



**utility programs**

A computer program in general support of the processes of a computer; for instance, a diagnostic program.

**uv** Under voltage.

**V****VOLSER**

Volume serial number.

**volume**

A certain portion of data, together with its data carrier, that can be handled conveniently as a unit.

**VPD** Vital product data. The information that is contained within the tape drive that requires nonvolatile storage that is used by functional areas of the drive, and information that is required for manufacturing, RAS, and engineering.

**W**

**word** A character string that is convenient for some purpose to consider as an entity.

**Write** Write command.

**WT** world trade.

**X**

**XR** External register.

**XRA** External register address register.



---

# Index

## A

- ac grounding diagram xv
- ac grounding inspection xiv
- adjust data rate 1-4
- attaching tape drive to server 1-6

## B

- Bar code labels 4-5
  - guidelines for using 4-7
  - ordering 4-22

## C

- Cables
  - connecting SAS interface 2-3
  - connecting USB interface 2-4
- Capacity scaling 1-5
- cartridge
  - compatibility 1-3
  - manual removal from drive E-4
- Cartridge 4-1
  - capacity scaling 4-1, 4-3
  - Capacity scaling 1-5
  - cleaning 4-4
  - compatibility 4-3
  - data 4-1
  - disposal of 4-19
  - inserting 3-6
  - leader pin 4-12
  - memory chip 4-5
  - mid-tape recovery 3-7
  - ordering 4-20
  - proper handling 4-8
  - removing 3-7
  - specifications 4-18
  - write-protect switch 4-7
- Cartridge, environment 4-10
- Cartridges
  - inspecting for damage 5-2
  - repairing E-1
  - testing 3-18
- channel calibration 1-5
- cleaning the drive 3-8
- Cover
  - removing E-1
- customize each data channel 1-5

## D

- description of drive 1-1
- Device drivers
  - installing 2-5
  - supported 1-6
- Diagnostic, tape drive 3-24
- diagnostics 2-5
- Diagnostics 3-24
  - clear error code log 3-18
  - copying drive dump to tape 3-14

- Diagnostics (*continued*)
  - disabling post error reporting 3-23
  - display error code log 3-18
  - enabling post error reporting 3-23
  - Fast Read/Write Test 3-21
  - forcing a drive dump 3-14
  - Host Interface Wrap Test 3-15
  - Load/Unload Test 3-22
  - RS-422 Wrap Test 3-16
  - selecting function 3-9
  - tape drive 3-12
  - test cartridge 3-18
  - Test Head 3-20
  - Write Performance Test 3-19

- Display
  - SCD dot 3-1
  - single-character 3-1

- drive
  - avoiding damage 2-1
  - description 1-1

- Drive
  - features 1-1
  - removing E-1
  - replacing E-14
  - specifications 1-7

- drive cleaning 3-8
- drive diagnostics 2-5

- Drive dump
  - capturing 5-1
  - copying to tape 3-14
  - forcing 3-14

- Drive head
  - cleaning 3-7
- drive monitoring 1-7
- drive servicing 1-7

## E

- Encryption 1-5
- end of life plan xix
- Error code log
  - clear 3-18
  - display 3-18
- Error codes A-1
- Ethernet (RJ45) 3-24
- ethernet port 1-7

## F

- Fast Read/Write Test 3-21
- Features of drive 1-1
- Feedback
  - Comments
    - sending iii
  - sending iii
- firmware
  - inhibiting down-leveling 1-5
- Firmware
  - determining level 5-1
  - updating 2-6

- Firmware (*continued*)
  - with FMR tape 2-6
  - with ITDT Tool 2-6

- FMR tape
  - create 3-13
  - unmake 3-17
  - update firmware 3-13
- front panel features 1-2

## G

- glossary G-1
- grounding diagram xv

## H

- host interface
  - physical characteristics 1-5, 1-6
- Host Interface Wrap Test 3-15

## I

- Insert Cartridge 3-18
- installation
  - rack
    - safety xvi
- Installation 2-1
- Internal drive
  - removing E-3
  - replacing E-14

## L

- Labels
  - bar code 4-5
  - guidelines for using 4-7
  - ordering 4-22
- laser
  - compliance xv
  - safety xv
- Linear Tape File System 1-7
- Load/Unload Test 3-22
- Location rules 2-3
- LTFS 1-7

## M

- Maintenance
  - create FMR tape 3-13
  - update firmware with FMR tape 3-13
- Maintenance Function
  - selecting function 3-9
  - unmaking an FMR tape 3-17
- Maintenance Mode
  - entering 3-11
  - exiting 3-11, 3-12
- Maintenance, tape drive 3-24
- media
  - cartridge compatibility 1-3

Media 4-1  
  Capacity scaling 1-5  
  inserting 3-6  
  mid-tape recovery 3-7  
  removing 3-7  
  resolving problems 5-4  
Message codes A-1  
My Support iii, 2-8

## O

operating instructions 3-1  
operating modes 3-1  
Operating systems supported 1-6  
operating systems, supported 1-6  
ordering  
  bar code labels C-1  
  media C-1  
  optional features C-1  
  power cords C-1  
  replacement parts C-1  
Ordering Media  
  Ordering WORM cartridges 4-3

## P

Performance 1-3  
Post error reporting  
  disabling 3-23  
  enabling 3-23  
Power  
  button 3-1  
  connecting 2-5  
  cord inspection 2-2  
  outlet inspection 2-2  
Problem determination 5-1  
  checklist 5-4  
Problems reported by server  
  resolving 5-4

## R

Rack  
  safety D-1  
rack installation  
  safety xvi  
Rack installation D-1  
Rack Mount Kit  
  install D-1  
Read/Write capability 4-3  
rear panel features 1-2  
Remove  
  cover E-1  
Removing  
  internal drive E-3  
Replacement procedure 5-5  
Replacing  
  cover E-14  
  internal drive E-14  
requirements for attaching tape drive to  
  server 1-6  
RS-422 Wrap Test 3-16

## S

safety  
  end of life plan xix  
safety information  
  laser compliance xv  
  laser safety xv  
safety inspection xiv  
SAS Host Adapter Card  
  installation 2-3  
SAS Host connections  
  checking 5-3  
SAS interface cables 2-3  
sending your comments iii  
Server connection  
  configuring 2-5  
Servers supported 1-6  
servers, supported 1-6  
Shipment  
  verify 2-2  
  Verify shipment 2-2  
Specifications  
  cartridges 4-18  
  environmental 1-7  
  physical 1-7  
  power 1-7  
speed matching 1-4  
Status Light 3-2  
Status, tape drive 3-8  
support notification iii  
supported SAN components 1-6  
supported servers and operating  
  systems 1-6

## T

Tape Drive Status 3-8  
Tape Drive Status, web page 3-8  
TapeAlert flags B-1  
technical support iii  
Technical Support  
  accessing online iii  
  My Support iii  
Test Drive Head 3-20  
Trademarks F-2

## U

Unload Button 3-5  
Unpacking shipment 2-1  
Updating firmware 2-6  
  with FMR tape 2-6  
  with Host Interface 2-6  
  with ITDT Tool 2-6  
USB interface cables 2-4

## V

Verifying Host Interface  
  Communications 5-3

## W

WORM 4-3  
WORM (Write Once, Read Many) 4-3

Write Once, Read Many (see  
  WORM) 4-3  
Write Performance Test 3-19  
Write-Protect switch  
  setting 4-7

---

## Readers' Comments — We'd Like to Hear from You

IBM System Storage TS2260  
Setup, Operator, and Service Guide  
Machine Type 3580 Model H6S

Publication No. GA32-2226-01

We appreciate your comments about this publication. Please comment on specific errors or omissions, accuracy, organization, subject matter, or completeness of this book. The comments you send should pertain to only the information in this manual or product and the way in which the information is presented.

For technical questions and information about products and prices, please contact your IBM branch office, your IBM business partner, or your authorized remarketer.

When you send comments to IBM, you grant IBM a nonexclusive right to use or distribute your comments in any way it believes appropriate without incurring any obligation to you. IBM or any other organizations will only use the personal information that you supply to contact you about the issues that you state on this form.

Comments:

Thank you for your support.

Send your comments to the address on the reverse side of this form.

If you would like a response from IBM, please fill in the following information:

\_\_\_\_\_  
Name

\_\_\_\_\_  
Address

\_\_\_\_\_  
Company or Organization

\_\_\_\_\_  
Phone No.

\_\_\_\_\_  
Email address



Fold and Tape

Please do not staple

Fold and Tape



NO POSTAGE  
NECESSARY  
IF MAILED IN THE  
UNITED STATES

# BUSINESS REPLY MAIL

FIRST-CLASS MAIL PERMIT NO. 40 ARMONK, NEW YORK

POSTAGE WILL BE PAID BY ADDRESSEE

International Business Machines Corporation  
Information Development  
Department GZW  
9000 South Rita Road  
Tucson, Arizona U.S.A. 85775-4401

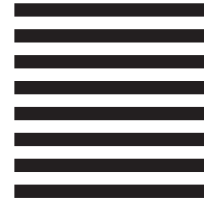

Fold and Tape

Please do not staple

Fold and Tape





Part Number: 46C2798

Printed in USA

GA32-2226-01



(1P) P/N: 46C2798





Spine information:



IBM System Storage TS2260

TS2260 Tape Drive Setup, Operator and Service  
manual

Machine Type 3580 Model  
H6S