



# BladeCenter T

Types 8720 and 8730

## Installation and User's Guide

### Welcome.

This *Installation and User's Guide* contains information for setting up, configuring, and using your BladeCenter T unit.

For detailed information about your BladeCenter T unit, view the publications on the Documentation CD.

You can also find the most current information about your BladeCenter T unit and servers at: <http://www.ibm.com/support>

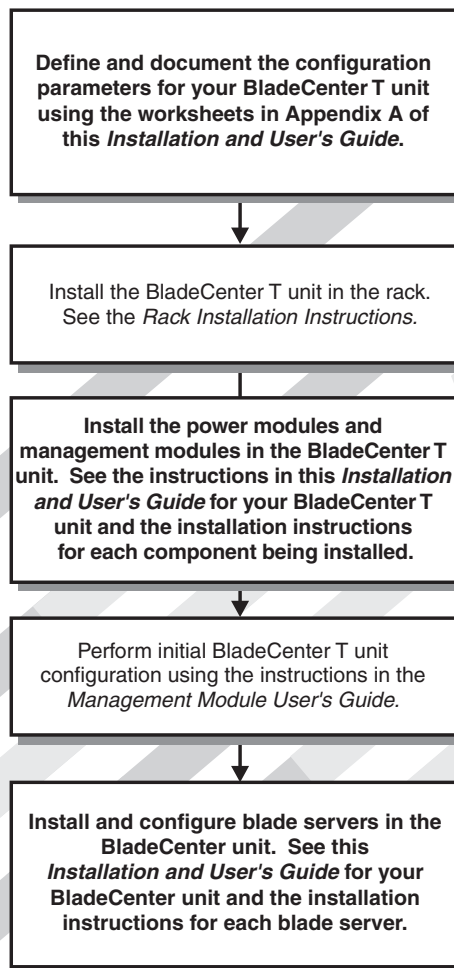

# Server Support

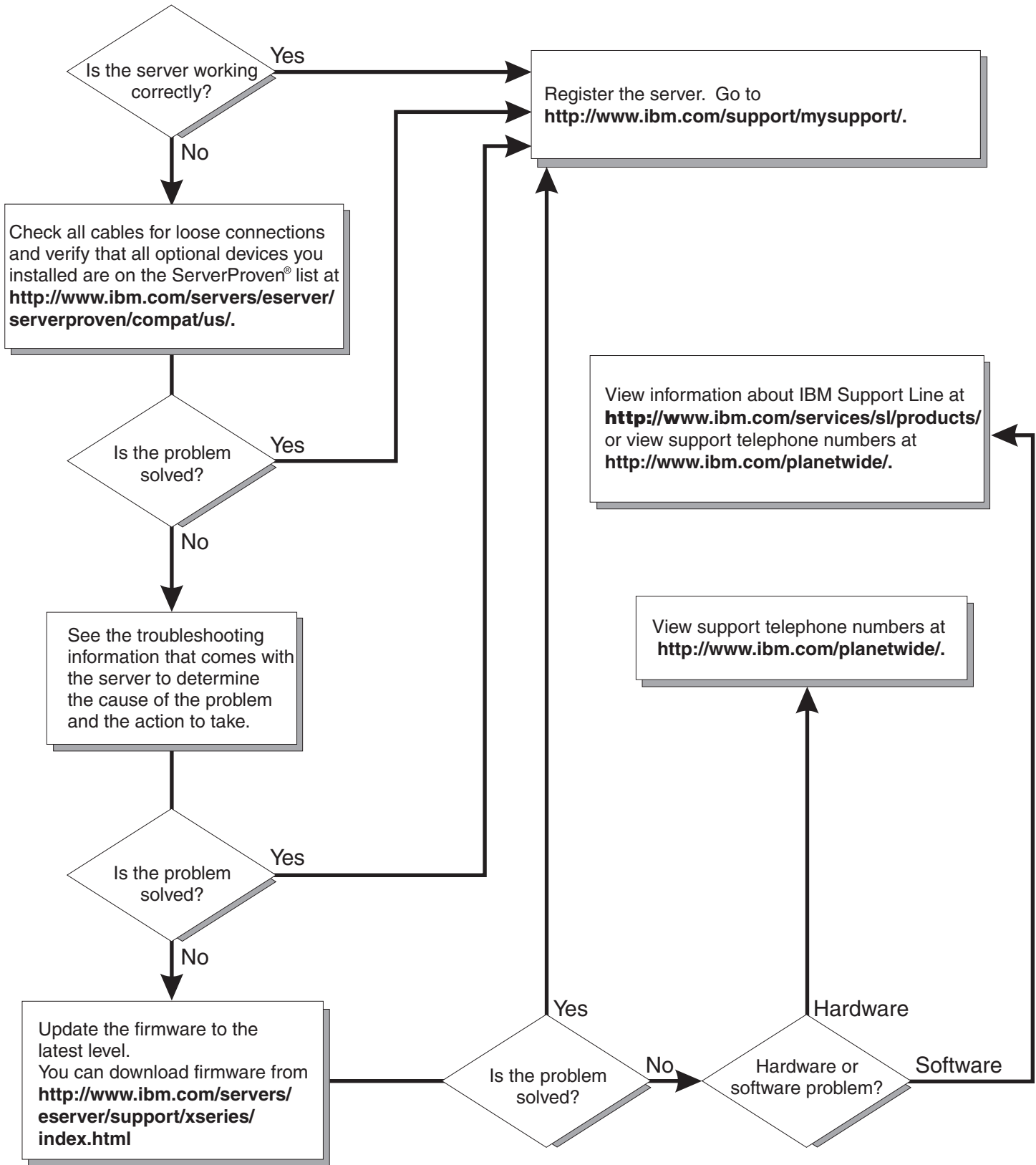

BladeCenter T  
Types 8720 and 8730



# Installation and User's Guide

**Note:**

Before using this information and the product it supports, read the general information in Appendix C, "Notices," on page 83, and the Warranty and Support Information document on the IBM Documentation CD.

**Fifth Edition (November 2006)**

**© Copyright International Business Machines Corporation 2006. All rights reserved.**

US Government Users Restricted Rights – Use, duplication or disclosure restricted by GSA ADP Schedule Contract with IBM Corp.

---

# Contents

<b>Safety</b> . . . . .	vii
<b>Chapter 1. Introduction</b> . . . . .	1
Inventory Checklist . . . . .	3
Related documentation . . . . .	3
Features and specifications of the BladeCenter T Type 8720 unit . . . . .	5
Features and specifications of the BladeCenter T Type 8730 unit . . . . .	7
The IBM BladeCenter T Documentation CD . . . . .	9
Hardware and software requirements . . . . .	9
Using the Documentation Browser . . . . .	9
Notices and statements used in this document . . . . .	10
What the BladeCenter T unit offers . . . . .	10
Reliability, availability, and serviceability features . . . . .	13
Major components of the BladeCenter T Types 8720 and 8730 . . . . .	14
Front view . . . . .	14
Rear view Type 8720 . . . . .	15
Rear view Type 8730 . . . . .	15
<b>Chapter 2. Setting up the BladeCenter T hardware</b> . . . . .	17
Rack installation guidelines . . . . .	17
Option installation guidelines . . . . .	18
System reliability considerations . . . . .	18
Handling static-sensitive devices . . . . .	19
Connecting the BladeCenter T unit to power . . . . .	21
Connecting the BladeCenter T type 8720 to dc power . . . . .	22
Connecting the BladeCenter T type 8730 to ac power . . . . .	23
Starting the BladeCenter T unit . . . . .	24
Shutting down the BladeCenter T unit . . . . .	26
<b>Chapter 3. Removing and installing BladeCenter T modules and options</b> . . . . .	27
Preinstallation steps . . . . .	28
Removing and installing the bezel assembly . . . . .	29
Removing the bezel assembly . . . . .	29
Installing the bezel assembly . . . . .	30
Removing and installing the bezel air filter . . . . .	30
Removing and installing power modules . . . . .	32
Removing a power module . . . . .	33
Installing a power module . . . . .	34
Removing and installing the media tray . . . . .	35
Removing the media tray . . . . .	36
Installing the media tray . . . . .	36
Removing and installing management modules . . . . .	37
Removing a management module . . . . .	38
Installing a management module . . . . .	39
Removing and installing blower modules . . . . .	40
Removing a blower module . . . . .	41
Installing a blower module . . . . .	41
Removing and installing the KVM (keyboard, video, mouse) module . . . . .	42
Removing the KVM module . . . . .	43
Installing the KVM module . . . . .	43
Removing and installing the LAN module . . . . .	44
Removing the LAN module . . . . .	45
Installing the LAN module . . . . .	45

Removing and installing I/O modules . . . . .	46
Removing an I/O module . . . . .	48
Installing an I/O module . . . . .	48
Blade servers . . . . .	49
Blade server expansion options . . . . .	49
Removing and installing a blade server or filler module . . . . .	50
<b>Chapter 4. BladeCenter T components, controls, and LEDs . . . . .</b>	<b>53</b>
Front view . . . . .	53
System service cards . . . . .	53
Management module controls and indicators . . . . .	54
Media tray . . . . .	55
Power modules . . . . .	56
Rear view . . . . .	57
Blower modules . . . . .	57
KVM (keyboard, video, mouse) module indicators and input/output connectors . . . . .	58
LAN-module indicators and input/output connectors . . . . .	60
I/O modules . . . . .	61
<b>Chapter 5. Configuration and networking guidelines . . . . .</b>	<b>63</b>
Configuring the BladeCenter unit . . . . .	63
Configuring the management module . . . . .	63
Configuring I/O modules . . . . .	63
Configuring blade servers . . . . .	63
BladeCenter networking guidelines . . . . .	64
IBM Director . . . . .	64
<b>Chapter 6. Solving problems . . . . .</b>	<b>67</b>
Diagnostic tools overview . . . . .	67
Troubleshooting charts . . . . .	68
Monitor problems . . . . .	68
Power problems . . . . .	69
Management module problems . . . . .	69
Blower module problems . . . . .	70
Options problems . . . . .	70
Light path diagnostics feature . . . . .	71
Identifying problems using the light path diagnostics feature . . . . .	71
Light path diagnostics LEDs . . . . .	72
<b>Chapter 7. Sharing resources among the blade servers . . . . .</b>	<b>75</b>
<b>Appendix A. BladeCenter management module configuration worksheet . . . . .</b>	<b>77</b>
<b>Appendix B. Getting help and technical assistance . . . . .</b>	<b>81</b>
Before you call . . . . .	81
Using the documentation . . . . .	81
Getting help and information from the World Wide Web . . . . .	81
Software service and support . . . . .	82
Hardware service and support . . . . .	82
IBM Taiwan product service . . . . .	82
<b>Appendix C. Notices . . . . .</b>	<b>83</b>
Trademarks . . . . .	83
Important notes . . . . .	84
Product recycling and disposal . . . . .	85
Battery return program . . . . .	86

Electronic emission notices . . . . .	87
Federal Communications Commission (FCC) statement . . . . .	87
Industry Canada Class A emission compliance statement . . . . .	87
Australia and New Zealand Class A statement . . . . .	88
United Kingdom telecommunications safety requirement. . . . .	88
European Union EMC Directive conformance statement. . . . .	88
Taiwanese Class A warning statement . . . . .	88
Chinese Class A warning statement . . . . .	88
Japanese Voluntary Control Council for Interference (VCCI) statement . . . . .	89
<b>Index . . . . .</b>	<b>91</b>





# Safety

Before installing this product, read the Safety Information.

قبل تركيب هذا المنتج، يجب قراءة الملاحظات الأمنية

Antes de instalar este produto, leia as Informações de Segurança.

在安装本产品之前，请仔细阅读 **Safety Information** (安全信息)。

安裝本產品之前，請先閱讀「安全資訊」。

Prije instalacije ovog produkta obavezno pročitajte Sigurnosne Upute.

Před instalací tohoto produktu si přečtěte příručku bezpečnostních instrukcí.

Læs sikkerhedsforskrifterne, før du installerer dette produkt.

Lees voordat u dit product installeert eerst de veiligheidsvoorschriften.

Ennen kuin asennat tämän tuotteen, lue turvaohjeet kohdasta Safety Information.

Avant d'installer ce produit, lisez les consignes de sécurité.

Vor der Installation dieses Produkts die Sicherheitshinweise lesen.

Πριν εγκαταστήσετε το προϊόν αυτό, διαβάστε τις πληροφορίες ασφάλειας (safety information).

לפני שתתקינו מוצר זה, קראו את הוראות הבטיחות.

A termék telepítése előtt olvassa el a Biztonsági előírásokat!

Prima di installare questo prodotto, leggere le Informazioni sulla Sicurezza.

製品の設置の前に、安全情報をお読みください。

본 제품을 설치하기 전에 안전 정보를 읽으십시오.

Пред да се инсталира овој продукт, прочитајте информацијата за безбедност.

Les sikkerhetsinformasjonen (Safety Information) før du installerer dette produktet.

Przed zainstalowaniem tego produktu, należy zapoznać się z książką "Informacje dotyczące bezpieczeństwa" (Safety Information).

Antes de instalar este produto, leia as Informações sobre Segurança.

Перед установкой продукта прочтите инструкции по технике безопасности.

Pred inštaláciou tohto zariadenia si pečítajte Bezpečnostné predpisy.

Pred namestitvijo tega proizvoda preberite Varnostne informacije.

Antes de instalar este producto, lea la información de seguridad.

Läs säkerhetsinformationen innan du installerar den här produkten.

**Statement 1:**



**DANGER**

**Electrical current from power, telephone, and communication cables is hazardous.**

**To avoid a shock hazard:**

- **Do not connect or disconnect any cables or perform installation, maintenance, or reconfiguration of this product during an electrical storm.**
- **Connect all power cords to a properly wired and grounded electrical outlet.**
- **Connect to properly wired outlets any equipment that will be attached to this product.**
- **When possible, use one hand only to connect or disconnect signal cables.**
- **Never turn on any equipment when there is evidence of fire, water, or structural damage.**
- **Disconnect the attached power cords, telecommunications systems, networks, and modems before you open the device covers, unless instructed otherwise in the installation and configuration procedures.**
- **Connect and disconnect cables as described in the following table when installing, moving, or opening covers on this product or attached devices.**

**To Connect:**

1. Turn everything OFF.
2. First, attach all cables to devices.
3. Attach signal cables to connectors.
4. Attach power cords to outlet.
5. Turn device ON.

**To Disconnect:**

1. Turn everything OFF.
2. First, remove power cords from outlet.
3. Remove signal cables from connectors.
4. Remove all cables from devices.

**Statement 2:**



**CAUTION:**

When replacing the lithium battery, use only IBM Part Number 33F8354 or an equivalent type battery recommended by the manufacturer. If your system has a module containing a lithium battery, replace it only with the same module type made by the same manufacturer. The battery contains lithium and can explode if not properly used, handled, or disposed of.

*Do not:*

- Throw or immerse into water
- Heat to more than 100°C (212°F)
- Repair or disassemble

Dispose of the battery as required by local ordinances or regulations.

**Statement 3:**



**CAUTION:**

When laser products (such as CD-ROMs, DVD drives, fiber optic devices, or transmitters) are installed, note the following:

- Do not remove the covers. Removing the covers of the laser product could result in exposure to hazardous laser radiation. There are no serviceable parts inside the device.
- Use of controls or adjustments or performance of procedures other than those specified herein might result in hazardous radiation exposure.



**DANGER**

Some laser products contain an embedded Class 3A or Class 3B laser diode. Note the following.

Laser radiation when open. Do not stare into the beam, do not view directly with optical instruments, and avoid direct exposure to the beam.

Class 1 Laser Product  
Laser Klasse 1  
Laser Klass 1  
Luokan 1 Laserlaite  
Appareil À Laser de Classe 1

**Statement 4:**



≥ 18 kg (39.7 lb)

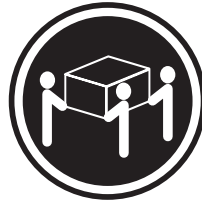

≥ 32 kg (70.5 lb)

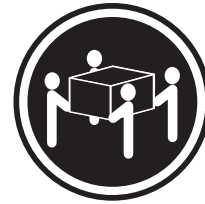

≥ 55 kg (121.2 lb)

**CAUTION:**

Use safe practices when lifting.

**Statement 5:**



**CAUTION:**

The power control button on the device and the power switch on the power supply do not turn off the electrical current supplied to the device. The device also might have more than one power cord. To remove all electrical current from the device, ensure that all power cords are disconnected from the power source.

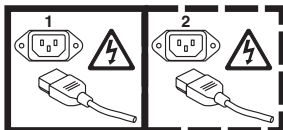

Statement 8:



**CAUTION:**

Never remove the cover on a power supply or any part that has the following label attached.



Hazardous voltage, current, and energy levels are present inside any component that has this label attached. There are no serviceable parts inside these components. If you suspect a problem with one of these parts, contact a service technician.

Statement 12:



**CAUTION:**

The following label indicates a hot surface nearby.



Statement 13:



**DANGER**

Overloading a branch circuit is potentially a fire hazard and a shock hazard under certain conditions. To avoid these hazards, ensure that your system electrical requirements do not exceed branch circuit protection requirements. Refer to the information that is provided with your device for electrical specifications.

**Statement 20:**



**CAUTION:**

To avoid personal injury, before lifting the unit, remove all the blades to reduce the weight.

**Statement 21:**



**CAUTION:**

Hazardous energy is present when the blade is connected to the power source. Always replace the blade cover before installing the blade.

---

## Chapter 1. Introduction

The IBM® BladeCenter® T Types 8720 and 8730 units are rack-mounted, high-density, high-performance blade server systems developed for NEBS telecommunications network applications and other applications requiring physical robustness.

The BladeCenter T unit uses blade servers, switches, and other components that are common to the IBM BladeCenter product line. This common component strategy makes it ideal for applications in telecommunications networks that need high levels of computing power and access to common off-the-shelf middleware packages that are used in IT data centers. The BladeCenter T unit supports up to eight blade servers and four I/O modules, making it ideally suited for networking environments that require a large number of high-performance servers in a small amount of space. The BladeCenter T unit provides common resources that are shared by the blade servers, such as power, cooling, system management, network connections, backplane, and I/O (CD-ROM drive and connectors for USB, network interfaces, and--for blade servers that support the KVM function--keyboard, video, and mouse).

Performance, ease of use, reliability, robustness (NEBS/ETSI compliance), and expansion capabilities were key considerations in the design of the BladeCenter T unit. These design features make it possible for you to customize the system hardware to meet your needs today, while providing flexible expansion capabilities for the future.

This *Installation and User's Guide* provides information about:

- Setting up and cabling the BladeCenter T unit
- Starting and configuring the BladeCenter T unit
- Installing options in the BladeCenter T unit
- Performing basic troubleshooting of the BladeCenter T unit

This *Installation and User's Guide* and other documents that provide detailed information about the BladeCenter T unit are provided in Portable Document Format (PDF) on the IBM *BladeCenter T Documentation* CD.

The BladeCenter T unit comes with a three-year limited warranty. You can obtain up-to-date information about the BladeCenter T Type 8720 or 8730 model and other IBM server products at <http://www.ibm.com/eserver/xseries/>.

You can register the BladeCenter T unit and blade servers at <http://www.ibm.com/support/mysupport>.

Record information about your BladeCenter T unit in the following table. You will need this information when you register the BladeCenter T unit with IBM.

<b>Product name</b>	IBM BladeCenter T unit
<b>Machine type (8720 or 8730)</b>	_____
<b>Model number</b>	_____
<b>Serial number</b>	_____

The serial number and model number are located in three places on the BladeCenter T unit:

- Top of the BladeCenter T unit.
- Front of the bezel assembly.
- Front of the BladeCenter T unit.

The labels on the top and the front of the bezel assembly of the BladeCenter T unit are shown in the following illustration.

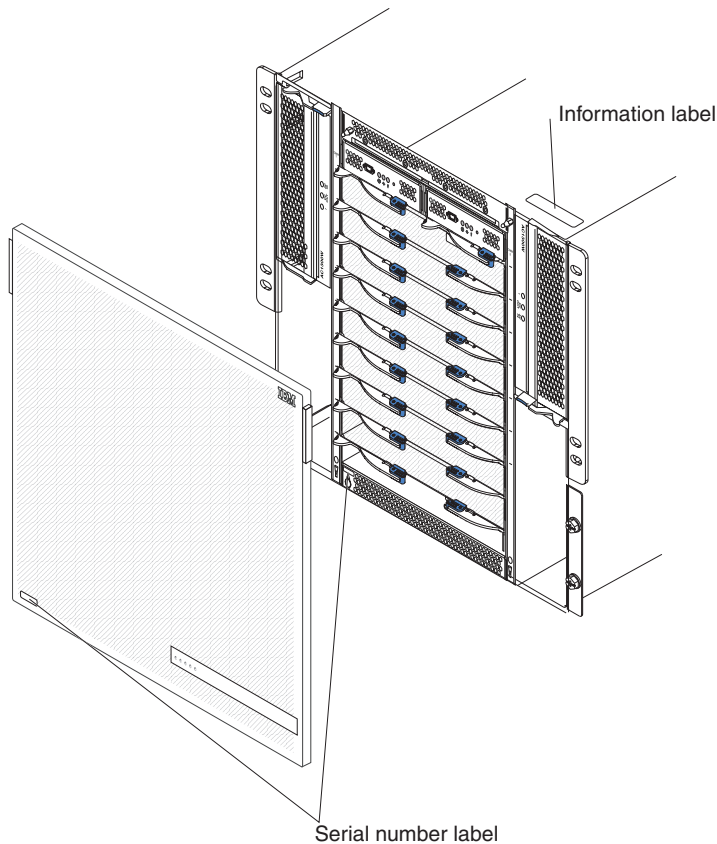

A set of user labels comes with each blade server. When you install a blade server in the BladeCenter T unit, write identifying information on a label and place the label on the BladeCenter T unit bezel.

The following illustration shows the placement of the label, to the side of the blade server, on the BladeCenter T unit.



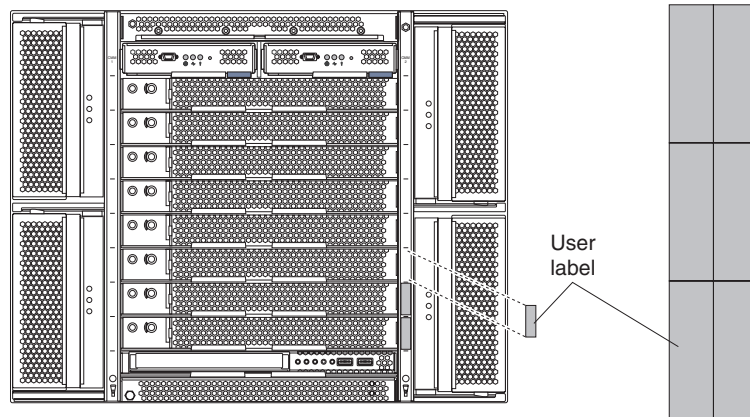

**Important:** Do not place the label on the blade server itself or in any way block the ventilation holes on the blade server.

---

## Inventory Checklist

The IBM BladeCenter T Type 8720 or 8730 unit comes with the following items:

- Bezel assembly (with filter)
- BladeCenter T unit lift handles (4)
- One alarm panel cable
- Two power distribution unit (PDU) power cords (Type 8730 only)
- Documentation package, which includes the IBM *BladeCenter T Documentation CD*

---

## Related documentation

In addition to this *Installation and User's Guide*, the following documentation is provided in PDF on the IBM *BladeCenter T Documentation CD* that comes with your IBM BladeCenter T unit:

- *Safety Information*  
This document contains translated caution and danger statements. Each caution and danger statement that appears in the documentation has a number that you can use to locate the corresponding statement in your language in the *Safety Information* document.
- BladeCenter T rack installation instructions  
These documents contain instructions for installing the BladeCenter T unit in a 4-post and 2-post rack.  
  
**Note:** The BladeCenter T unit can also be installed in some xSeries and pSeries racks, such as the IBM Netbay42 Enterprise Rack Model 9308. See the installation instructions that come with those racks.
- *BladeCenter T Types 8720 and 8730 Hardware Maintenance Manual and Troubleshooting Guide*  
This document contains information to help you solve BladeCenter T problems yourself, and it contains information for service technicians.

Additional documents might be included on the IBM *BladeCenter T* and IBM *BladeCenter T Advanced Management Module Documentation CD*s.

Your BladeCenter T unit or blade servers might have features that are not described in the documentation that you received with the BladeCenter T unit. The

documentation might be updated occasionally to include information about those features, management module firmware updates, or technical updates. To check for updated documentation and technical updates, complete the following steps:

1. Go to <http://www.ibm.com/support/>.
2. Under **Search technical support**, type **8720 or 8730** and click **Search**.

In addition to reviewing the documents in this library, review the IBM *@server BladeCenter T Planning and Installation Guide* at <http://www.ibm.com/support/> for information to help you prepare for system installation and configuration.

## Features and specifications of the BladeCenter T Type 8720 unit

The following table provides a summary of the features and specifications of the BladeCenter T Type 8720 unit.

Table 1. BladeCenter T Type 8720 features and specifications

<p><b>Media tray (on front):</b></p> <ul style="list-style-type: none"> <li>DVD/CD-RW drive: slim IDE</li> <li>Two Universal Serial Bus (USB) v1.1 ports</li> <li>System-status panel</li> </ul> <p><b>Module bays (on front):</b></p> <ul style="list-style-type: none"> <li>Eight hot-swap blade bays</li> <li>Four hot-swap power-module bays</li> <li>Two hot-swap management module bays</li> </ul> <p><b>Module bays (on rear):</b></p> <ul style="list-style-type: none"> <li>Four hot-swap I/O module bays</li> <li>Four hot-swap blower bays</li> <li>One hot-swap KVM (keyboard, video, mouse) module</li> <li>One hot-swap LAN module</li> </ul> <p><b>Power modules:</b></p> <ul style="list-style-type: none"> <li>Standard: Two 1300-watt or greater hot-swap -48 V dc (-40 to -60 V dc) power modules <ul style="list-style-type: none"> <li>Power modules 1 and 2 supply power to: <ul style="list-style-type: none"> <li>Blade bays 1 through 4</li> <li>Management modules 1 and 2</li> <li>I/O modules 1 and 2</li> <li>Media tray</li> <li>All KVM, LAN, and alarm interfaces</li> <li>All four blower modules</li> </ul> </li> <li>Power modules 1 and 2 provide redundancy to each other</li> </ul> </li> <li>Maximum: Four 1300-watt or greater hot-swap -48 V dc (-40 to -60 V dc) power modules <ul style="list-style-type: none"> <li>Power modules 3 and 4 supply power to: <ul style="list-style-type: none"> <li>Blade bays 5 through 8</li> <li>I/O modules 3 and 4</li> </ul> </li> <li>Power modules 3 and 4 provide redundancy to each other</li> <li>Blowers are powered by all four power modules</li> </ul> </li> </ul> <p><b>LAN module:</b> (see Note)</p> <ul style="list-style-type: none"> <li>Two 10/100 Mb Ethernet remote management connections</li> <li>One DSUB 15P alarm connector</li> </ul> <p><b>KVM module:</b></p> <ul style="list-style-type: none"> <li>Video port (analog)</li> <li>PS/2<sup>®</sup> keyboard port</li> <li>PS/2 mouse port</li> <li>System-status panel</li> </ul>	<p><b>I/O modules:</b> (see Note below)</p> <ul style="list-style-type: none"> <li>Standard: None</li> <li>Maximum: Four <ul style="list-style-type: none"> <li>Two hot-swap 1 Gb Ethernet four-port switch modules</li> <li>Two hot-swap switch modules of another network-communication standard, such as Fibre Channel</li> </ul> </li> </ul> <p><b>Management module:</b></p> <ul style="list-style-type: none"> <li>Standard: One hot-swap management module providing system-management functions for the BladeCenter T unit</li> <li>Maximum: Two hot-swap management modules (one active, one redundant)</li> </ul> <p><b>Redundant cooling:</b></p> <p>Four variable-speed hot-swap blowers</p> <p><b>Front bezel with changeable filter</b></p> <p><b>Upgradeable microcode:</b></p> <ul style="list-style-type: none"> <li>Management module firmware</li> <li>I/O-module firmware (not all I/O module types)</li> <li>Blade server service processor firmware (BIOS, service processor)</li> </ul> <p><b>Size (8 U):</b></p> <ul style="list-style-type: none"> <li>Height: 349.25 mm (13.75 in. or 8 U)</li> <li>Depth: 508 mm (20 in.) from front of chassis to rear I/O connector plane Maximum depth: 600 mm (23.62 in.) including bezel, handles, and cable bend radius.</li> <li>Width: 442 mm (17.4 in.)</li> <li>Weight: <ul style="list-style-type: none"> <li>Fully configured with modules and blade servers: Approx. 100.2 kg (221 lb)</li> <li>Fully configured without blade servers: Approx. 61.7 kg (136 lb)</li> </ul> </li> </ul> <p><b>Security features:</b></p> <ul style="list-style-type: none"> <li>Login password for remote connection</li> <li>Lightweight Directory Access Protocol (LDAP) and role based security for user authentication and authorization</li> <li>Secure Shell (SSH) for remote command-line interface</li> <li>Secure socket layer (SSL) security for remote Web interface access</li> </ul>	<p><b>Predictive Failure Analysis<sup>®</sup> (PFA) alerts:</b></p> <ul style="list-style-type: none"> <li>Blowers</li> <li>Blade-dependent features</li> <li>Power supplies</li> </ul> <p><b>Declared acoustical noise emission levels for normal operations:</b></p> <ul style="list-style-type: none"> <li>Sound-power levels (upper-limit): 7.8 bels</li> <li>Sound-pressure levels (average), for four one-meter bystander positions: 63 dBA</li> </ul> <p>The noise emission levels stated are the declared upper limit sound-power levels, in bels, for a random sample of machines. All measurements made in accordance with ISO 7779 and reported in conformance with ISO 9296.</p> <p><b>Environment:</b></p> <ul style="list-style-type: none"> <li>Air temperature: <ul style="list-style-type: none"> <li>Altitude: -60 to 1800 m (-197 ft to 6000 ft) <ul style="list-style-type: none"> <li>BladeCenter T on: 5° to 40°C (41° to 104°F)</li> <li>BladeCenter T on (short term): -5° to 55°C (23° to 131°F)</li> </ul> </li> <li>Altitude: 1800 m to 4000 m (6000 ft to 13000 ft) <ul style="list-style-type: none"> <li>BladeCenter T on: 5° to 30°C (41° to 86°F)</li> <li>BladeCenter T on (short term): -5° to 45°C (23° to 113°F)</li> </ul> </li> <li>System unit off: uncontrolled</li> </ul> </li> <li>Rate of temperature change: 30°C/hour (54°F/hour)</li> <li>Humidity: <ul style="list-style-type: none"> <li>BladeCenter T on: 5% to 85%</li> <li>BladeCenter T on (short term): 5% to 90% not to exceed 0.024 water/kg of dry air</li> <li>BladeCenter T off: uncontrolled</li> </ul> </li> </ul> <p><b>Electrical input:</b></p> <ul style="list-style-type: none"> <li>dc power</li> <li>Input voltage: -48 V dc (-40 V dc to -60 V dc)</li> </ul> <p><b>Heat output:</b></p> <ul style="list-style-type: none"> <li>Input kilovolt-amperes (kVA) approx. <ul style="list-style-type: none"> <li>Minimum configuration: 0.2 kVA</li> <li>Maximum configuration: 3.7 kVA</li> </ul> </li> <li>BTU output <ul style="list-style-type: none"> <li>Ship configuration: 673 Btu/hour (197 watts)</li> <li>Full configuration: 12640 Btu/hour (3707 watts)</li> </ul> </li> </ul>
---	---	--

**Note:** The intra-building ports of the equipment or subassembly are suitable for connection to intra-building or unexposed wiring or cabling only. The intra-building

ports of the equipment or subassembly must not be metallicly connected to interfaces that connect to the outside plant (OSP) or its wiring. These interfaces are designed for use as intra-building interfaces only (type 2 or type 4 ports as described in GR-1089-CORE, Issue 4) and require isolation from the exposed OSP cabling. The addition of primary protectors is not sufficient protection in order to connect these interfaces metallicly to OSP wiring.

## Features and specifications of the BladeCenter T Type 8730 unit

The following table provides a summary of the features and specifications of the BladeCenter T Type 8730 unit.

Table 2. BladeCenter T Type 8730 features and specifications

<p><b>Media tray (on front):</b></p> <ul style="list-style-type: none"> <li>• DVD/CD-RW drive: slim IDE</li> <li>• Two Universal Serial Bus (USB) v1.1 ports</li> <li>• System-status panel</li> </ul> <p><b>Module bays (on front):</b></p> <ul style="list-style-type: none"> <li>• Eight hot-swap blade bays</li> <li>• Four hot-swap power-module bays</li> <li>• Two hot-swap management module bays</li> </ul> <p><b>Module bays (on rear):</b></p> <ul style="list-style-type: none"> <li>• Four hot-swap I/O module bays</li> <li>• Four hot-swap blower bays</li> <li>• One hot-swap KVM (keyboard, video, mouse) module</li> <li>• One hot-swap LAN module</li> </ul> <p><b>Power modules:</b></p> <ul style="list-style-type: none"> <li>• Standard: Two 1300-watt or greater 220-volt (200-240 V ac) hot-swap power modules <ul style="list-style-type: none"> <li>– Power modules 1 and 2 supply power to: <ul style="list-style-type: none"> <li>- Blade bays 1 through 4</li> <li>- Management modules 1 and 2</li> <li>- I/O modules 1 and 2</li> <li>- Media tray</li> <li>- All KVM, LAN, and alarm interfaces</li> <li>- All four blower modules</li> </ul> </li> <li>– Power modules 1 and 2 provide redundancy to each other</li> </ul> </li> <li>• Maximum: Four 1300-watt or greater 220-volt (200-240 V ac) hot-swap power modules <ul style="list-style-type: none"> <li>– Power modules 3 and 4 supply power to: <ul style="list-style-type: none"> <li>- Blade bays 5 through 8</li> <li>- I/O modules 3 and 4</li> </ul> </li> <li>– Power modules 3 and 4 provide redundancy to each other</li> <li>– Blowers are powered by all four power modules</li> </ul> </li> </ul> <p><b>LAN module:</b> (see Note)</p> <ul style="list-style-type: none"> <li>• Two 10/100 Mb Ethernet remote management connections</li> <li>• One DSUB 15P alarm connector</li> </ul>	<p><b>KVM module:</b></p> <ul style="list-style-type: none"> <li>• Video port (analog)</li> <li>• PS/2 keyboard port</li> <li>• PS/2 mouse port</li> <li>• System-status panel</li> </ul> <p><b>I/O modules:</b> (see Note below)</p> <ul style="list-style-type: none"> <li>• Standard: None</li> <li>• Maximum: Four <ul style="list-style-type: none"> <li>– Two hot-swap 1 Gb Ethernet four-port switch modules</li> <li>– Two hot-swap switch modules of another network-communication standard, such as Fibre Channel</li> </ul> </li> </ul> <p><b>Management module:</b></p> <ul style="list-style-type: none"> <li>• Standard: One hot-swap management module providing system-management functions for the BladeCenter T unit</li> <li>• Maximum: Two hot-swap management modules (one active, one redundant)</li> </ul> <p><b>Redundant cooling:</b></p> <p>Four variable-speed hot-swap blowers</p> <p><b>Front bezel with changeable filter</b></p> <p><b>Upgradeable microcode:</b></p> <ul style="list-style-type: none"> <li>• Management module firmware</li> <li>• I/O-module firmware (not all I/O module types)</li> <li>• Blade server service processor firmware (BIOS, service processor)</li> </ul> <p><b>Size (8 U):</b></p> <ul style="list-style-type: none"> <li>• Height: 349.25 mm (13.75 in. or 8 U)</li> <li>• Depth: 508 mm (20 in.) from front of chassis to rear I/O connector plane</li> <li>• Maximum depth: 600 mm (23.62 in.) including bezel, handles, and cable bend radius.</li> <li>• Width: 442 mm (17.4 in.)</li> <li>• Weight: <ul style="list-style-type: none"> <li>– Fully configured with modules and blade servers: Approx. 100.2 kg (221 lb)</li> <li>– Fully configured without blade servers: Approx. 61.7 kg (136 lb)</li> </ul> </li> </ul>	<p><b>Security features:</b></p> <ul style="list-style-type: none"> <li>• Login password for remote connection</li> <li>• Secure Shell (SSH) for command-line interface</li> <li>• Secure socket layer (SSL) security for remote Web management access</li> </ul> <p><b>Predictive Failure Analysis (PFA) alerts:</b></p> <ul style="list-style-type: none"> <li>• Blowers</li> <li>• Blade-dependent features</li> <li>• Power supplies</li> </ul> <p><b>Declared acoustical noise emission levels for normal operations:</b></p> <ul style="list-style-type: none"> <li>• Sound-power levels (upper-limit):7.8 bels</li> <li>• Sound-pressure levels (average), for four one-meter bystander positions: 63 dBA</li> </ul> <p>The noise emission levels stated are the declared upper limit sound-power levels, in bels, for a random sample of machines. All measurements made in accordance with ISO 7779 and reported in conformance with ISO 9296.</p> <p><b>Environment:</b></p> <ul style="list-style-type: none"> <li>• Air temperature: <ul style="list-style-type: none"> <li>– BladeCenter T on: 10° to 35°C (50° to 95°F). Altitude: 0 to 914 m (2998.69 ft).</li> <li>– BladeCenter T on: 10° to 32°C (50° to 89.6°F). Altitude: 914 m to 2134 m (2998.69 ft to 7000 ft).</li> <li>– BladeCenter T off: -40° to 60° C (-40° to 140°).</li> </ul> </li> <li>• Humidity: <ul style="list-style-type: none"> <li>– Server on: 8% to 80%</li> <li>– Server off: 8% to 80%</li> </ul> </li> </ul> <p><b>Electrical input:</b></p> <ul style="list-style-type: none"> <li>• Sine-wave input (50 or 60 Hz single-phase) required</li> <li>• Input voltage: <ul style="list-style-type: none"> <li>– Minimum: 200 V ac</li> <li>– Maximum: 240 V ac</li> </ul> </li> </ul> <p><b>Heat output:</b></p> <ul style="list-style-type: none"> <li>• Input kilovolt-amperes (kVA) approx. <ul style="list-style-type: none"> <li>– Minimum configuration: 0.2 kVA</li> <li>– Maximum configuration: 3.5 kVA</li> </ul> </li> <li>• BTU output <ul style="list-style-type: none"> <li>– Ship configuration: 673 Btu/hour (197 watts)</li> <li>– Full configuration: 11900 Btu/hour (3490 watts)</li> </ul> </li> </ul>
---	--	--

**Note:** The intra-building ports of the equipment or subassembly is suitable for connection to intra-building or unexposed wiring or cabling only. The intra-building ports of the equipment or subassembly must not be metallicly connected to interfaces that connect to the outside plant (OSP) or its wiring. These interfaces are

designed for use as intra-building interfaces only (type 2 or type 4 ports as described in GR-1089-CORE, Issue 4) and require isolation from the exposed OSP cabling. The addition of primary protectors is not sufficient protection in order to connect these interfaces metallicity to OSP wiring.

---

## The IBM BladeCenter T Documentation CD

The IBM *BladeCenter T Documentation* CD contains documentation for your server in Portable Document Format (PDF) and includes the IBM Documentation Browser to help you find information quickly.

### Hardware and software requirements

The IBM *BladeCenter T Documentation* CD requires the following minimum hardware and software:

- Microsoft® Windows NT® 4.0 (with Service Pack 3 or later), Windows® 2000, or Red Hat Linux
- 100 MHz microprocessor
- 32 MB of RAM
- Adobe Acrobat Reader 3.0 (or later) or xpdf, which comes with Linux operating systems

**Note:** Acrobat Reader software is included on the CD, and you can install it when you run the Documentation Browser.

### Using the Documentation Browser

Use the Documentation Browser to browse the contents of the CD, read brief descriptions of the books, and view books using Adobe Acrobat Reader or xpdf. The Documentation Browser automatically detects the regional settings in use in your system and displays the books in the language for that region (if available). If a book is not available in the language for that region, the English version is displayed.

Use one of the following procedures to start the Documentation Browser:

- If Autostart is enabled, insert the CD into your CD-ROM drive. The Documentation Browser starts automatically.
- If Autostart is disabled or is not enabled for all users:
  - If you are using a Windows operating system, insert the CD into your CD-ROM drive and click **Start --> Run**. In the **Open** field, type  
`e:\win32.bat`

where *e* is the drive letter of your CD-ROM drive, and click **OK**.

- If you are using Red Hat Linux, insert the CD into your CD-ROM drive; then, run the following command from the `/mnt/cdrom` directory:

```
sh runlinux.sh
```

Select your server from the **Product** menu. The **Available Topics** list displays all the books for your server. Some books might be in folders. A plus sign (+) indicates each folder or book that has additional books under it. Click the plus sign to display the additional books.

When you select a book, a description of the book appears under **Topic Description**. To select more than one book, press and hold the Ctrl key while you select the books. Click **View Book** to view the selected book or books in Acrobat Reader or xpdf. If you selected more than one book, all the selected books are opened in Acrobat Reader or xpdf.

To search all the books, type a word or word string in the **Search** field and click **Search**. The books in which the word or word string appears are listed in order of

the most occurrences. Click a book to view it, and press Ctrl+F to use the Acrobat search function or Alt+F to use the xpdf search function within the book.

Click **Help** for detailed information about using the Documentation Browser.

---

## Notices and statements used in this document

The caution and danger statements that appear in this document are also in the multilingual *Safety Information* document, which is on the IBM *BladeCenter T Documentation* CD. Each statement is numbered for reference to the corresponding statement in the *Safety Information* document.

The following notices and statements are used in this document:

- **Notes:** These notices provide important tips, guidance, or advice.
- **Important:** These notices provide information or advice that might help you avoid inconvenient or problem situations.
- **Attention:** These notices indicate potential damage to programs, devices, or data. An attention notice is placed just before the instruction or situation in which damage could occur.
- **Caution:** These statements indicate situations that can be potentially hazardous to you. A caution statement is placed just before the description of a potentially hazardous procedure step or situation.
- **Danger:** These statements indicate situations that can be potentially lethal or extremely hazardous to you. A danger statement is placed just before the description of a potentially lethal or extremely hazardous procedure step or situation.

---

## What the BladeCenter T unit offers

The design of the BladeCenter T unit takes advantage of advancements in server technology. It provides up to eight functionally separate servers and their shared resources in a single center. The BladeCenter T unit with blade servers installed has the following features:

- **IBM Enterprise X-Architecture**

IBM Enterprise X-Architecture™ technology leverages proven innovative IBM technologies to build powerful, scalable, reliable Intel®-processor-based servers. Enterprise X-Architecture technology includes features such as light path diagnostics, Predictive Failure Analysis (PFA), scalability, and Real Time Diagnostics.

- **Expansion capabilities**

You can add blade servers to the BladeCenter T unit as needed, to a maximum of eight blade servers.

**Note:** If any blade server or option is in blade bay 5 through 8 or if an I/O module is in I/O-module bay 3 or 4, power modules must be present in all four power-module bays.

Some blade servers have connectors for options that add capabilities to the blade server, such as an I/O expansion card to add a network interface, or a storage expansion unit to add SCSI hard disk drives.

- **Hot-swap capabilities**

The front bays on the BladeCenter T unit are hot-swap blade, power-module, and management module bays; the rear bays on the BladeCenter T unit are hot-swap I/O, KVM, LAN, and blower-module bays. You can add, remove, or replace blade



servers or power, management, I/O, KVM, LAN or blower modules in hot-swap bays within specified time limits and without removing power from the BladeCenter T unit. See Chapter 3, “Removing and installing BladeCenter T modules and options,” on page 27 for detailed instructions.

**Attention:** To maintain proper system cooling, each unoccupied bay must contain a filler blade or filler module.

- **Redundancy capabilities**

The following redundant components in the BladeCenter T unit enable continued operation if one of the components fails:

- Power modules: In normal operation, the redundant power modules provide redundant power feeds to share the system load. If one of the power modules fails, the working power module handles the entire load. You can then replace the failed power module without shutting down the BladeCenter T unit.
- Blowers: In normal operation, the redundant blower modules share the system load. If one of the blowers fails, the other three working blowers handle the entire load. You can then replace the failed blower without shutting down the BladeCenter T unit.
- Management modules: Only one management module is active at a time. If a second management module has been installed and the active management module fails, the secondary (redundant) management module becomes the active management module containing the current BladeCenter T configuration and status information. You can then replace the failed management module without shutting down the BladeCenter T unit.
- BladeCenter T backplane characteristics: The backplane has the following redundancy characteristics:
  - Hot-pluggable connectors for the following components:
    - Eight blade servers
    - Four I/O modules
    - Two management modules
    - Four power supplies
    - Four blowers
  - Redundant high-speed SERDES interconnects between blade servers and switches
  - Support for redundant management modules
    - Redundant I2C communications between management modules and all modules (except the blade servers)
    - Redundant RS-485 communications between management modules and blade servers
    - Redundant analog video connections from blade servers to management modules
    - Redundant USB connections between blade servers and management modules
    - Redundant, secure Ethernet management port between switches and management modules

- **Redundant network connection capabilities**

Configuring a pair of Ethernet switch modules in I/O-module bays 1 and 2 provides support for Ethernet failover configured on blade servers. See your management module *User's Guide* and *Command Line Interface Reference Guide* for instructions. If the I/O expansion options in your blade servers can be

configured for failover, configuring a pair of switch modules in I/O-module bays 3 and 4 provides support for the failover configured on the I/O expansion options.

**Note:** A system configuration with I/O expansion options in I/O-module bays 3 and 4 requires a unit configuration with power supplies in power-module bays 3 and 4.

Other network-interface I/O expansion options, such as the IBM BladeCenter Fibre Channel Expansion Card, can have similar capability for redundant network connections. See the documentation that comes with the I/O expansion module and I/O module for more information about configuring for redundant network connections.

- **System-management capabilities**

The BladeCenter T unit comes with a service processor in the management module. The service processor in the management module, the system-management firmware that is provided with your BladeCenter T unit, and the service processor in each blade server, enable you to remotely manage the BladeCenter T unit, its components, and the blade servers. The management module also multiplexes the keyboard, mouse, and video ports (for blade servers that support the KVM function) and the USB port across the multiple blade servers.

The service processor in each blade server provides blade server system monitoring, event recording, and alert capability.

See Chapter 5, “Configuration and networking guidelines,” on page 63 for more information.

- **Network environment support**

This BladeCenter T unit supports up to two Ethernet-compatible I/O modules (switch modules or pass-thru modules), for blade server integrated Ethernet controller communication with the network. Each I/O module provides one internal connection to each blade server, up to eight internal connections per I/O module.

The BladeCenter T unit also supports two additional I/O modules, for a total of four I/O modules. The two additional I/O modules support the network interface on the optional I/O expansion card installed on one or more blade servers in the BladeCenter T unit.

**Note:** The two additional I/O modules must be compatible with the network interface on the optional I/O expansion cards in the blade servers.

Each of these two additional I/O modules provides one internal connection to the optional I/O expansion card, up to eight internal connections per I/O module.

---

## Reliability, availability, and serviceability features

Three of the most important features in server design are reliability, availability, and serviceability (RAS). These factors help to ensure the integrity of the data that is stored on your blade server; that your blade server is available when you want to use it; and that should a failure occur, you can easily diagnose and correct the failure with minimal inconvenience.

The BladeCenter T unit has the following RAS features:

- Shared key components, such as power, cooling, backplane, and I/O
- All components serviced from the front or rear of the BladeCenter T unit
- Automatic error retry and recovery
- Automatic restart after a power failure
- Built-in monitoring for blower, power, temperature, and voltage
- Built-in monitoring for module redundancy
- Customer support center 24 hours a day, 7 days a week<sup>1</sup>
- Error codes and messages
- Fault-resistant startup
- Remote system management through the management module
- Remote management module firmware upgrade
- Remote upgrade of blade server service processor microcode
- Built-in self-test (BIST)
- Predictive Failure Analysis (PFA) alerts
- Redundant components
  - Blowers with speed-sensing capability
  - I/O modules
  - Management modules
  - Power modules
- Redundant system features in the backplane
- Hot-swap components
  - Blade servers
  - Blowers with speed-sensing capability
  - I/O modules
  - KVM module
  - LAN module
  - Management module
  - Media tray
  - Power modules
- System automatic inventory at startup
- System error logging

---

1. Service availability will vary by country. Response time varies; may exclude holidays.

## Major components of the BladeCenter T Types 8720 and 8730

The following illustration shows the major components of the BladeCenter T unit.

**Note:** The illustrations in this document might differ slightly from your hardware.

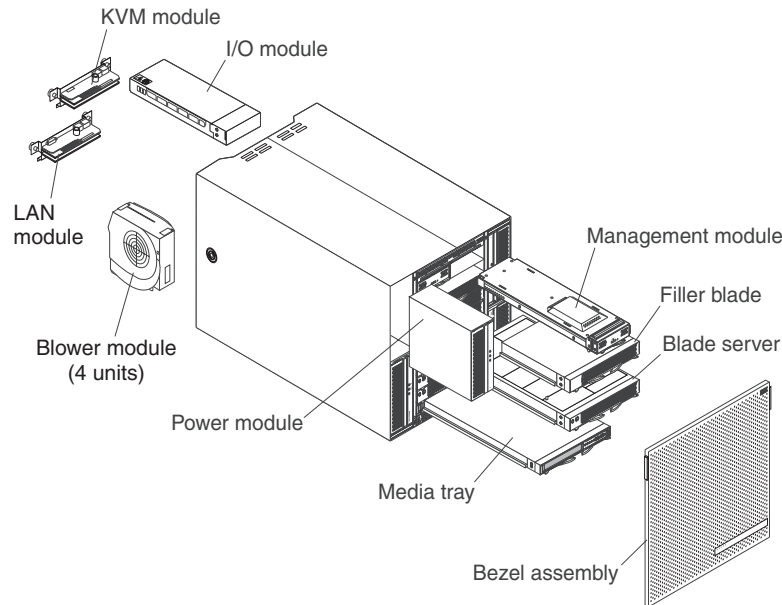

**Attention:** To maintain proper system cooling, each module bay must contain either a module or a filler module; each blade bay must contain either a blade server or a filler blade.

### Front view

The following illustration shows the components on the front view of the BladeCenter T Types 8720 and 8730 unit.

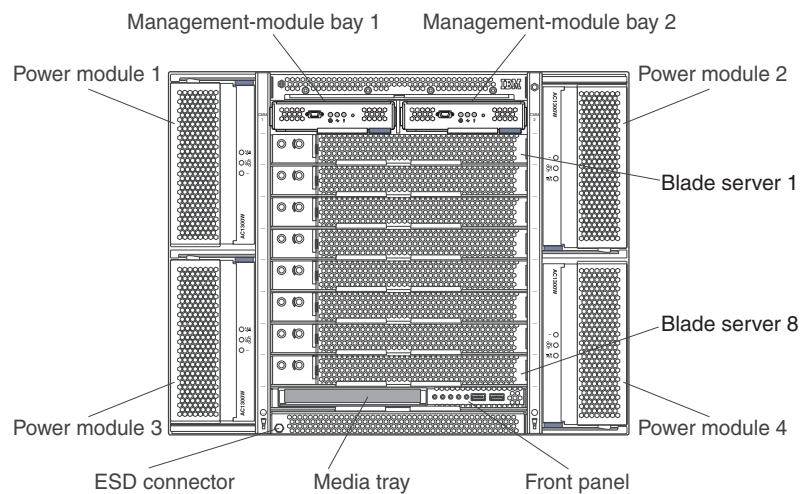

See Chapter 4, “BladeCenter T components, controls, and LEDs,” on page 53 for details about the components and indicators.

## Rear view Type 8720

The following illustration shows the components on the rear of the BladeCenter T Type 8720 unit.

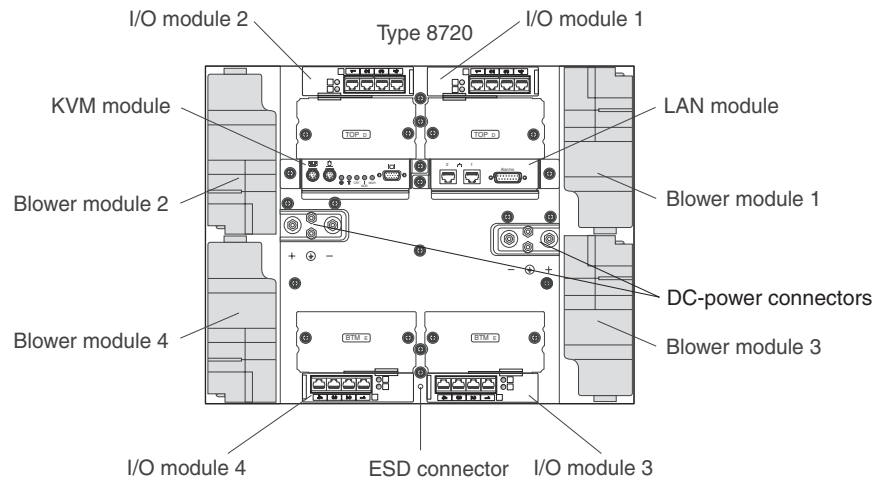

See Chapter 4, “BladeCenter T components, controls, and LEDs,” on page 53 for details about the components and indicators.

## Rear view Type 8730

The following illustration shows the components on the rear of the BladeCenter T Type 8730 unit.

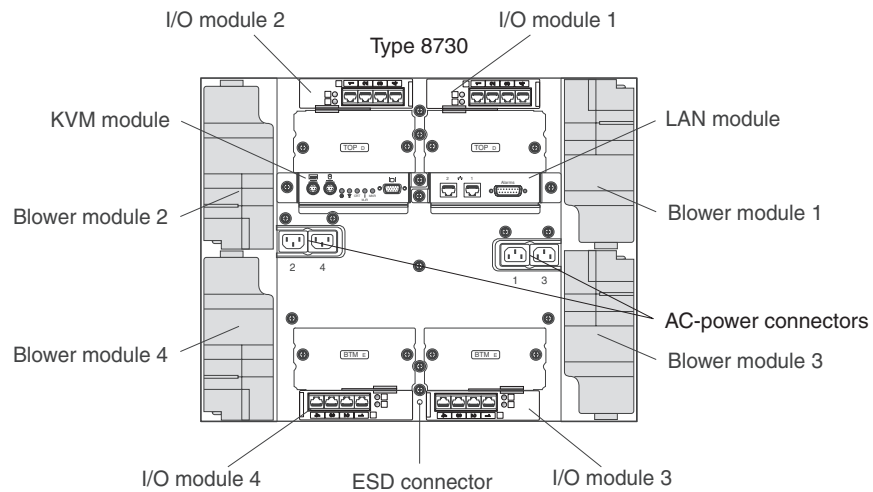

See Chapter 4, “BladeCenter T components, controls, and LEDs,” on page 53 for details about the components and indicators.



---

## Chapter 2. Setting up the BladeCenter T hardware

This chapter provides instructions for setting up, connecting to system power, starting, and shutting down the BladeCenter T unit.

---

### Rack installation guidelines

Statement 20:



**CAUTION:**

To avoid personal injury, before lifting the unit, remove all the blades to reduce the weight.

Statement 4:

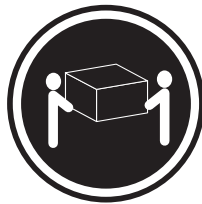

≥ 18 kg (39.7 lb)



≥ 32 kg (70.5 lb)



≥ 55 kg (121.2 lb)

**CAUTION:**

Use safe practices when lifting.

Before you begin to install the BladeCenter T unit in a rack, read the following information:

- Install the BladeCenter T unit in a rack before installing any blowers, power modules, or blade servers in the BladeCenter T unit.
- If your BladeCenter unit has blowers, power modules, or blade servers already installed, remove them first. See Chapter 3, “Removing and installing BladeCenter T modules and options,” on page 27 for detailed instructions on removing these devices.

**Important:** Reinstalling a blade server into a different bay than the one from which it was removed could have unintended consequences. Some configuration information and update options are established according to bay number. You might need to reconfigure the blade server.

- Detailed instructions for installing and cabling a BladeCenter T unit in a rack are in the rack installation instructions that come with the rack kits.

---

## Option installation guidelines

Before you begin to install options in the BladeCenter T unit, read the following information:

- Read the safety information beginning on page vii and the guidelines in “Handling static-sensitive devices” on page 19. This information will help you work safely with your BladeCenter T unit and options.
- Blue on a component indicates touch points, where you can grip the component to remove it from or install it in the server, open or close a latch, and so on.
- Orange on a component or an orange label on or near a component indicates that the component can be hot-swapped, which means that you can remove or install the component while the BladeCenter T unit is running. (Orange can also indicate touch points on hot-swap components.) See the instructions for removing or installing a specific hot-swap component for any additional procedures that you might have to perform before you remove or install the component.
- You do not have to disconnect the BladeCenter T unit from power to install or replace any of the hot-swap modules in the BladeCenter T unit. You must shut down the operating system and turn off a hot-swap blade server on the front of the BladeCenter T unit before removing the blade server, but you do not have to shut down the BladeCenter T unit itself.
- For a list of supported options for your server, go to <http://www.ibm.com/servers/eserver/serverproven/compat/us/>.

## System reliability considerations

To help ensure proper cooling and system reliability, make sure that:

- Each of the module bays on the front and rear of the BladeCenter T unit has either a module or filler module installed.
- Each of the blade bays on the front of the BladeCenter T unit has either a blade server or filler blade installed.
- Each of the drive bays in a blade server storage expansion option has either a hot-swap drive or a filler panel installed.
- Each of the PCI slots in a blade server PCI I/O expansion option has either a PCI adapter or a PCI filler bracket installed.
- A removed hot-swap module or drive is replaced within 1 minute of removal.
- A removed hot-swap blade is replaced within 20 minutes of removal.
- A failed blower is replaced as soon as possible, to restore cooling redundancy.



## Handling static-sensitive devices

**Attention:** Static electricity can damage electronic devices and your system. To avoid damage, keep static-sensitive devices in their static-protective packages until you are ready to install them.

Use an ESD wrist strap and the ESD connectors on the BladeCenter T unit. Electrostatic discharge (ESD) is the release of stored static electricity that can damage electric circuits. Static electricity is often stored in your body and discharged when you come in contact with an object with a different potential. The ESD wrist strap safely channels the electricity from your body to a proper ground (the BladeCenter T unit).

Use an ESD wrist strap whenever you are working on the BladeCenter T unit, especially when you are handling modules, options, and blade servers. To work properly, the wrist strap must have a good contact at both ends (touching your skin at one end and connected to the ESD connector on the front or back of the BladeCenter T unit).

### Location of ESD connector (front of unit)

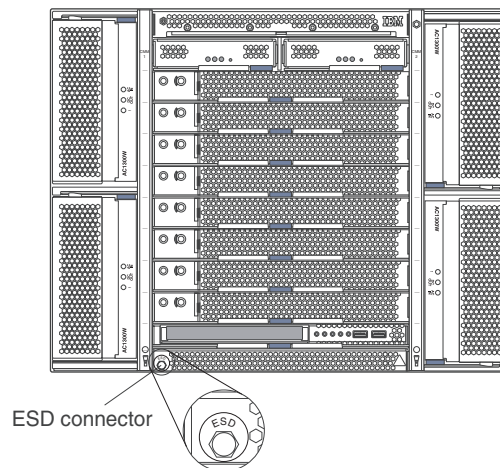

### Location of ESD connector (rear of unit)

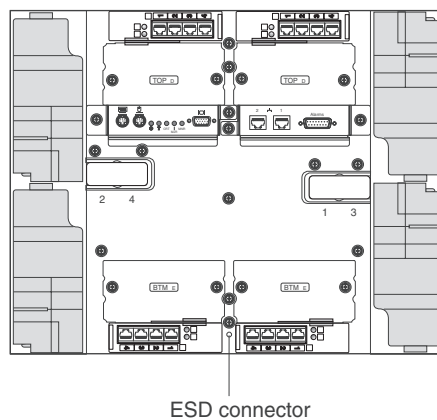

To reduce the possibility of electrostatic discharge, observe the following precautions:

- Limit your movement. Movement can cause static electricity to build up around you.
- Handle the device carefully, holding it by its edges or its frame.
- Do not touch solder joints, pins, or exposed printed circuitry.
- Do not leave the device where others can handle and damage it.
- While the device is still in its static-protective package, touch it to an unpainted metal part of the system unit for at least 2 seconds. This drains static electricity from the package and from your body.
- Remove the device from its package and install it directly into the system unit without setting the device down. If it is necessary to set down the device, place it back into its static-protective package. Do not place the device on the system unit or on a metal surface.
- Take additional care when handling devices during cold weather. Heating reduces indoor humidity and increases static electricity.

---

## Connecting the BladeCenter T unit to power

The BladeCenter T unit can support two or four power modules.

### Attention:

- Remove all power modules or confirm that they are removed, before making the power connections. See Chapter 3, “Removing and installing BladeCenter T modules and options,” on page 27 for detailed instructions for removing modules and fillers from the BladeCenter T unit.
- Install the BladeCenter T unit in a rack before connecting to power or installing any blowers, power modules, or blade servers in the BladeCenter T unit. See “Rack installation guidelines” on page 17 for more information.

### Statement 1:



### DANGER

**Electrical current from power, telephone, and communication cables is hazardous.**

#### To avoid a shock hazard:

- **Do not connect or disconnect any cables or perform installation, maintenance, or reconfiguration of this product during an electrical storm.**
- **Connect all power cords to a properly wired and grounded electrical outlet.**
- **Connect to properly wired outlets any equipment that will be attached to this product.**
- **When possible, use one hand only to connect or disconnect signal cables.**
- **Never turn on any equipment when there is evidence of fire, water, or structural damage.**
- **Disconnect the attached power cords, telecommunications systems, networks, and modems before you open the device covers, unless instructed otherwise in the installation and configuration procedures.**
- **Connect and disconnect cables as described in the following table when installing, moving, or opening covers on this product or attached devices.**

#### To Connect:

1. Turn everything OFF.
2. First, attach all cables to devices.
3. Attach signal cables to connectors.
4. Attach power cords to outlet.
5. Turn device ON.

#### To Disconnect:

1. Turn everything OFF.
2. First, remove power cords from outlet.
3. Remove signal cables from connectors.
4. Remove all cables from devices.

## Connecting the BladeCenter T type 8720 to dc power

The BladeCenter T Type 8720 unit comes with one pair of dc hot-swap power modules in power-module bays 1 and 2. Each active power module supplies 12-volt power to the blade bay that it services. The BladeCenter T unit supports a second pair of power modules in power-module bays 3 and 4. Power modules are not needed in bays 3 and 4 unless you install blade servers and options in blade bays 5 through 8, or I/O modules in I/O-module bays 3 or 4.

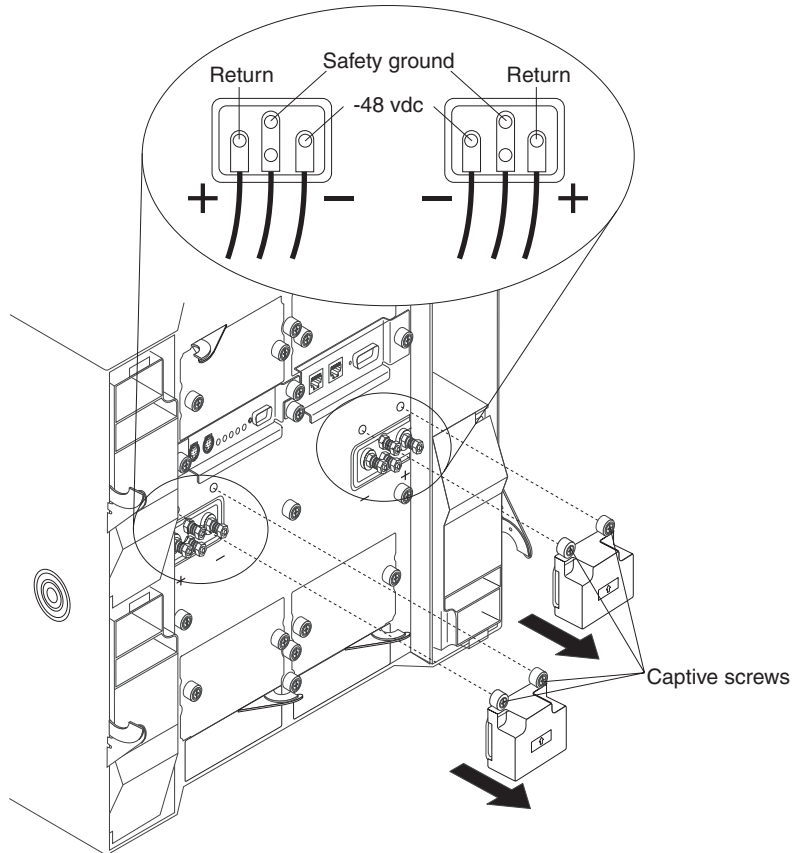

The BladeCenter T unit does not have a power switch. The BladeCenter T Type 8720 (dc power) unit has two dc-power terminal connectors each powering two power modules. The left connection (looking from the rear) supplies power to power-module bays 2 and 4, and the connection on the right supplies power to power-module bays 1 and 3. Each dc terminal has four #M6 (0.25-inch) studs, one for -48 V dc, one for RETURN, and two for connecting the safety ground wire. The following guidelines are provided for connecting to the -48 V dc power source:

- DC wire rating of 4AWG (7x7x34/36 TC), 105C, 300V UL 10198, CSA approved and VW1 rated
- Ring terminal designed for M6 stud, 4AWG wire, wire size (circular Mil area) of 33100-52600, and a wire insulation diameter of 12.8 mm to 13.1 mm

**Note:** The actual wire gauge and ring terminal will be determined by the current draw and the length of the wire run or as specified by the customer premises guidelines.

- A two-lug ring terminal, required by NEBS for connecting the single safety ground wire.

- BladeCenter T Type 8720 employs an isolated dc return (DC-I) design. The -48V return terminal shall not be connected to the chassis ground.

To provide true redundant power, BladeCenter T power modules 1 and 3 must be connected to a different power source than power modules 2 and 4.

## Connecting the BladeCenter T type 8730 to ac power

The BladeCenter T Type 8730 unit comes with one pair of 220-volt hot-swap ac power modules in power-module bays 1 and 2. The BladeCenter T unit supports a second pair of power modules in power-module bays 3 and 4. Each active power module supplies 12-volt power to the blade bays that it services.

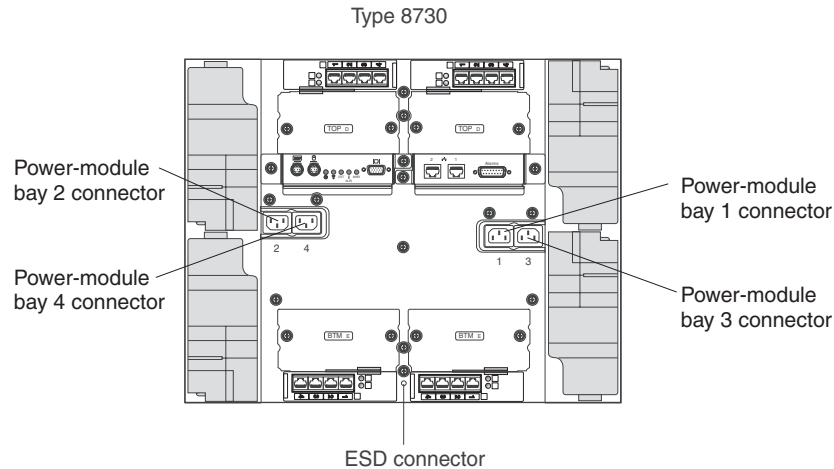

There are four IEC320 power connectors on the rear of the Type 8730 (ac power) unit, marked 1-4 on the rear panel. Power is applied to the corresponding power modules according to the numbering convention on the rear panel. (For example, power connector 1 supplies power to power module 1, and so on.)

The BladeCenter T unit does not have a power switch. To start the BladeCenter T Type 8730 (ac power) unit, connect one end of a power cord into input power connector 1 and 2 on the rear of the BladeCenter T unit, and the other end of each power cord into a 220-volt power distribution unit (PDU) that is connected into an appropriate electrical outlet.

**Note:** BladeCenter T Type 8730 does not require an external Surge Protective Device (SPD).

If you have a second pair of power modules to install in power-module bays 3 and 4; then, connect power cords to input power connectors 3 and 4 on the rear of the BladeCenter T unit, and the other end of each power cord into a 220-volt power distribution unit (PDU) that is connected into an appropriate electrical outlet.

**Important:** In a redundant pair of power modules, a power module that is not connected to a 220-volt power source creates a nonredundant condition.

To provide true redundant power, BladeCenter T power modules 1 and 3 must be connected to a different power source than power modules 2 and 4. Connect BladeCenter T power modules 1 and 3 to a different PDU than power modules 2 and 4; then, connect each PDU to an ac power source (building power source or service entrance) that is controlled by a separate circuit breaker.

---

## Starting the BladeCenter T unit

Complete the following steps to start the BladeCenter T unit:

1. Read the information in “System reliability considerations” on page 18.
2. Reinstall the four blowers into the rear of the BladeCenter T unit if you have not done so already. See Chapter 3, “Removing and installing BladeCenter T modules and options,” on page 27 for detailed instructions.

**Note:** The blowers will not start until the power modules are installed.

3. When the power connections are in place, you can reinstall the power modules in the BladeCenter T unit. After you connect power to the BladeCenter T unit, all the power-module bays receive power. To start the BladeCenter T unit, install power modules in all four power-module bays or install power modules in power-module bays 1 and 2 and filler modules in bays 3 and 4. See Chapter 3, “Removing and installing BladeCenter T modules and options,” on page 27 for detailed instructions.

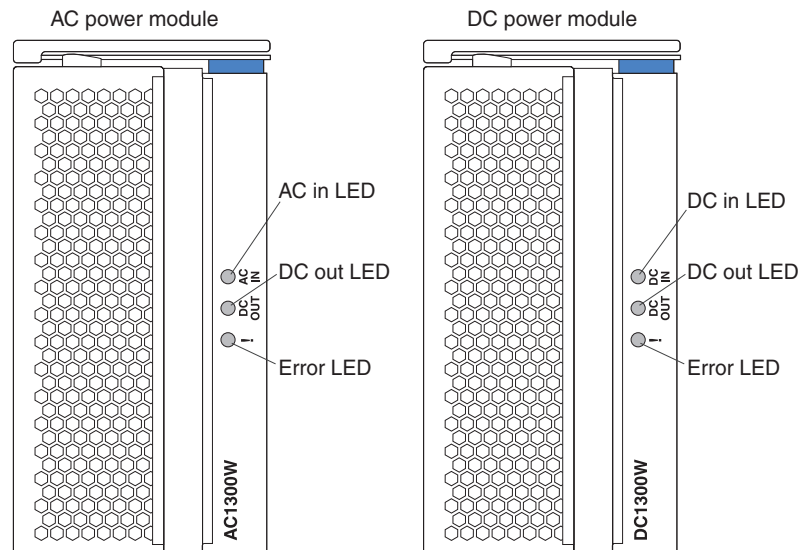

Make sure that the LEDs on the power modules indicate that they are operating correctly. Make sure that the input and output power LEDs on each power module are lit, and the error LEDs are not lit.

4. Before proceeding, make sure that the LEDs on the blower modules indicate that they are operating correctly. Make sure that the power LED on each blower is lit, and the error LEDs are not lit.
5. Make sure that the following BladeCenter T modules are installed correctly. See Chapter 4, “BladeCenter T components, controls, and LEDs,” on page 53 for the location of the LEDs on these modules.
  - Media tray
  - KVM module
  - LAN module
  - Management module
  - I/O modules
6. Install the blade servers or filler modules in all of the blade server bays before you power on any of the blade servers. See “Removing and installing a blade server or filler module” on page 50 for detailed instructions. Make sure that the power LED on each blade server is flashing.

7. Install the bezel assembly on the front of the BladeCenter T unit by inserting the bottom bezel hooks into the bezel slots at the bottom of the BladeCenter T unit. Push in the bottom and the top of the bezel assembly until they both lock firmly into place.

**Notes:**

1. Within 2 minutes after power has been connected to the BladeCenter T unit, the management module applies power to the I/O modules.
2. If a power failure occurs, the BladeCenter T unit restarts automatically when power is restored.
3. The blade server power button turns on or turns off the blade server if local power control has not been disabled through the management module.
4. The blade server power button turns on the blade server only if the green power light on the blade server is flashing slowly. If the light flashes rapidly, the blade server has not yet synchronized with the management module, and pressing the power button will have no effect. See Chapter 4, “BladeCenter T components, controls, and LEDs,” on page 53 for more information about the controls and indicators on the BladeCenter T unit modules.

See the Installation and User's Guide for your blade server on the IBM *Documentation* CD that comes with the blade server for the location of the blade server LEDs.

---

## Shutting down the BladeCenter T unit

You can shut down the BladeCenter T unit by turning off the blade servers and disconnecting the BladeCenter T unit from the power source.

Complete the following steps to shut down the BladeCenter T unit.

1. See your blade server operating-system documentation for the procedure to shut down the operating system in the blade servers; then, shut down each operating system.
2. Press the power-control button on the front of each blade server. Wait until the solid green power LED on the blade server goes to a slow flash indicating that the blade server drives have stopped spinning.

### Statement 5:



### CAUTION:

The power control button on the device and the power switch on the power supply do not turn off the electrical current supplied to the device. The device also might have more than one power cord. To remove all electrical current from the device, ensure that all power cords are disconnected from the power source.

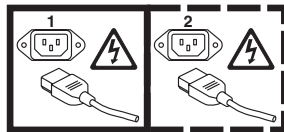

**Note:** The BladeCenter T Type 8720 and 8730 units do not have a power switch. The units also have more than one connection to power. To remove all electrical current from the unit, make sure that all connections to input power are disconnected at the power input terminals or connectors.

3. If you have a BladeCenter T Type 8720 (dc-power) unit, disconnect the unit from the input power at the dc power distribution panel by switching the circuit breakers to the Off position or removing the fuses as applicable. Make sure that both circuits are disconnected or turned off.

If you have a BladeCenter T Type 8730 (ac-power) unit, disconnect all power cords on the BladeCenter T unit from the ac power distribution unit (PDU).

**Note:** After you disconnect the BladeCenter T unit from power, wait at least 5 seconds before you connect the BladeCenter T unit to power again.



---

## Chapter 3. Removing and installing BladeCenter T modules and options

This chapter provides instructions for removing and installing modules, options, and blade servers in the BladeCenter T unit.

Each module is keyed so that it can be inserted only in an appropriate bay. For example, you can insert an I/O module only in an I/O-module bay.

This section describes the following BladeCenter T modules and options and how to remove and install them:

- Bezel assembly
- Bezel air filter
- Power module
- Media tray
- Management module
- Blower module
- KVM module
- LAN module
- I/O modules
- Blade server

See the “Rear view” on page 57 and “Front view” on page 53 for the location of each module. These modules supply common functions to the blade servers that are installed in the blade bays at the front of the BladeCenter T unit.

The KVM module and media tray supply I/O (CD-ROM drive, USB ports, keyboard, video, and mouse) that is available to all the blade servers that support those I/O functions, selected by any one blade server at a time.

**Attention:** To help ensure proper cooling, performance, and system reliability, make sure that each of the module bays on the front and rear of the BladeCenter T unit has a module or filler module installed. When replacing components, do not operate the BladeCenter T unit for more than the following time limits:

- 1 minute without either a module or a filler module installed in each module bay
- 20 minutes without a server blade or blade filler

---

## Preinstallation steps

Before you begin, read the documentation that comes with your module or option.

### Statement 8:



### CAUTION:

Never remove the cover on a power supply or any part that has the following label attached.



**Hazardous voltage, current, and energy levels are present inside any component that has this label attached. There are no serviceable parts inside these components. If you suspect a problem with one of these parts, contact a service technician.**

Complete the following steps before you install or remove a module or option in the BladeCenter T unit.

**Note:** These instructions assume the BladeCenter T unit is connected to power.

1. Read the safety information beginning on page vii and the guidelines in “Handling static-sensitive devices” on page 19. This information will help you work safely with your BladeCenter T unit and options.
2. If you are installing or removing a module at the front of the BladeCenter T unit, complete the following steps:
  - a. Remove the bezel assembly from the front of the BladeCenter T unit. See “Removing the bezel assembly” on page 29 for instructions.
  - b. Connect an ESD wrist strap to the ESD connector at the front of the BladeCenter T unit (see the illustration on page 19 for the location of the ESD connector).
3. If you are installing or removing a module at the rear of the BladeCenter T unit, connect an ESD wrist strap to the ESD connector at the rear of the BladeCenter T unit (see the illustration on page 19 for the location of the ESD connector).
4. Go to the instructions for the module or option you wish to install.

---

## Removing and installing the bezel assembly

The BladeCenter T unit comes with a bezel assembly containing a removable and replaceable air filter. There are software features in the management module that detect a clogged filter and generate system alerts based on the severity of the airflow reduction. The typical service interval for the filter is approximately three to six months depending on your environment. Be sure to replace the air filter when indicated.

**Important:** If the BladeCenter T unit contains any blade servers with standard (high-profile) release levers, the bezel assembly will not fit on the chassis. The bezel assembly and air filter can be used only if all blade servers in the chassis have low-profile release levers.

See “Removing and installing the bezel air filter” on page 30 for instructions for removing and replacing the bezel air filter.

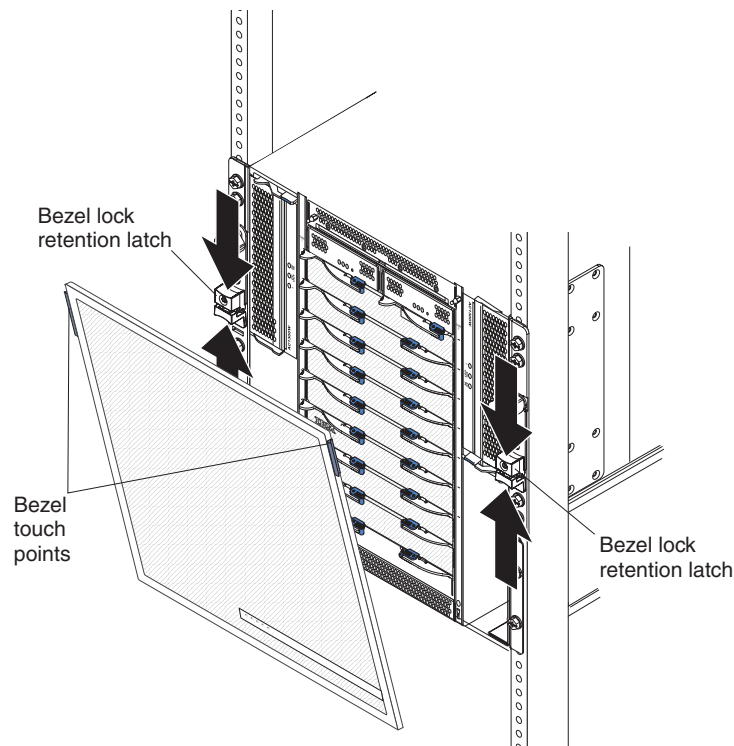

### Removing the bezel assembly

Complete the following steps if you are removing the bezel assembly from the front of the BladeCenter T unit:

1. Squeeze the upper and lower halves of the bezel lock retention latches together to open the bezel locks on each side as shown in the illustration; then, forcefully pull forward on the blue touch points at the top sides of the bezel.
2. Lift the bezel assembly up and out of the BladeCenter T unit. Carefully set the bezel assembly aside in a safe location.

## Installing the bezel assembly

Complete the following steps if you are installing the bezel assembly at the front of the BladeCenter T unit:

1. Ensure that the bezel lock is open; then, insert the bottom bezel hooks into the bezel slots at the bottom of the BladeCenter T unit.
2. Push in the bottom and the top of the bezel assembly until they both click firmly into place; then, close the bezel locks by sliding the bottom half of the bezel lock retention latch down until it stops.

---

## Removing and installing the bezel air filter

The air filter is installed behind the front bezel of the BladeCenter T unit.

**Important:** If the BladeCenter T unit contains any blade servers with standard (high-profile) release levers, the bezel assembly will not fit on the chassis. The bezel assembly and air filter can be used only if all blade servers in the chassis have low-profile release levers.

**Note:**

- Read “Option installation guidelines” on page 18.
- Read “Safety” on page vii.
- Read “Handling static-sensitive devices” on page 19.

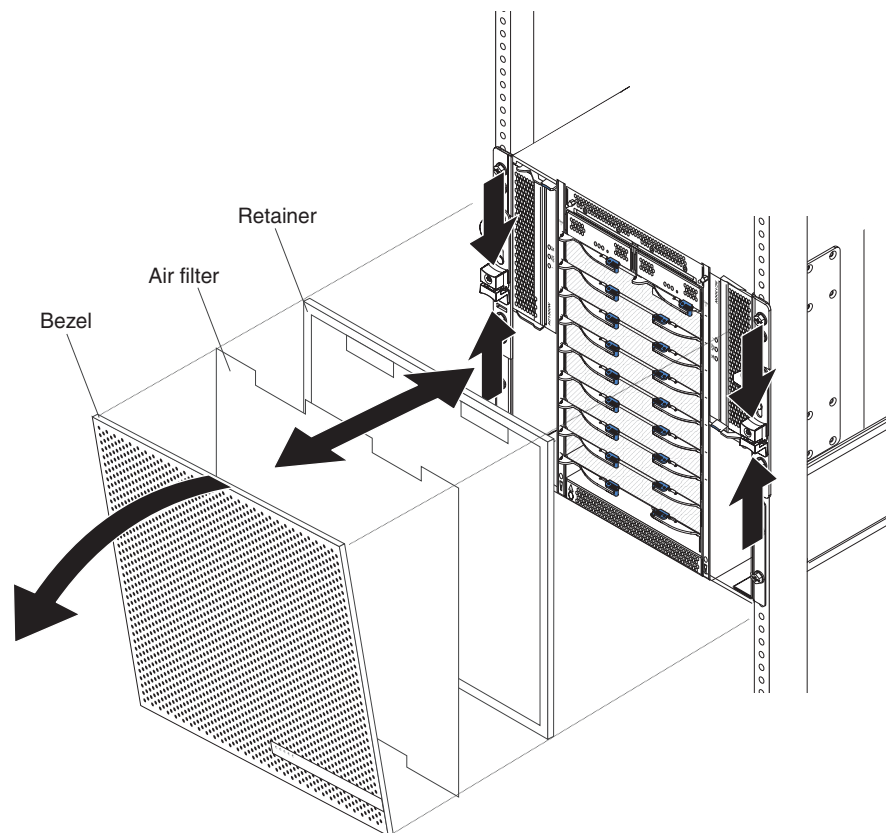

Complete the following steps to replace the front bezel air filter in the BladeCenter T unit:

1. Remove the bezel from the front of the BladeCenter T® unit (see “Removing the bezel assembly” on page 29 for instructions).
2. Place the bezel front-side down on a work surface.
3. Remove the air-filter retainer by pulling the retainer upwards and off the ball-stud fasteners on the bezel.
4. Remove the old air filter from the bezel frame.
5. Remove the new air filter from its packaging.

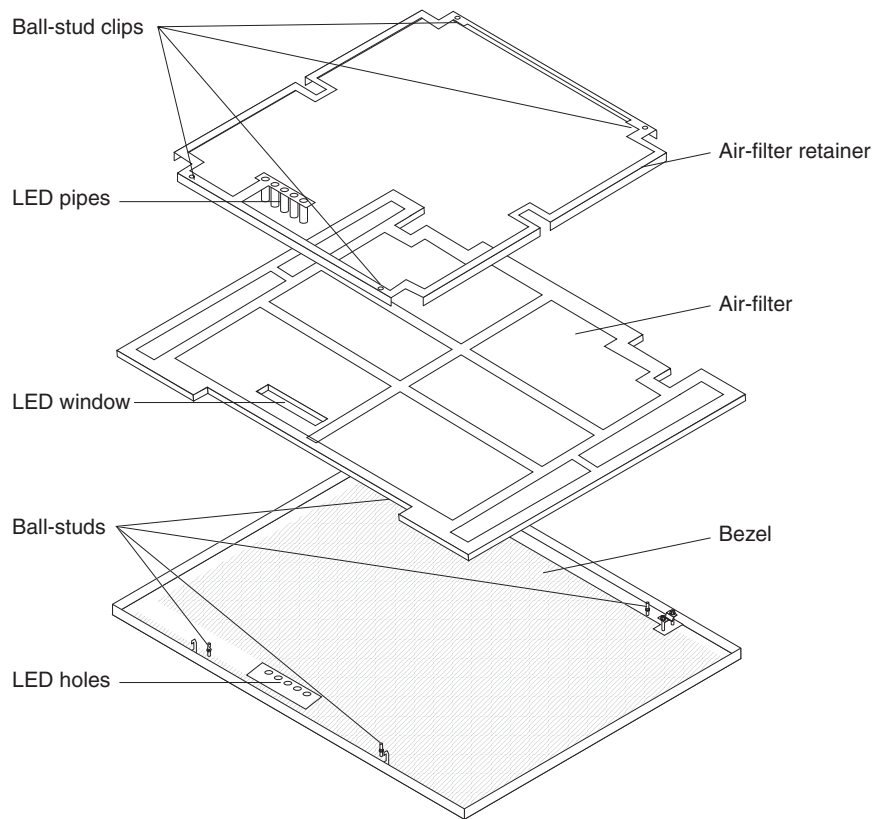

6. Align the LED window of the filter with the holes for the LEDs on the bezel and lay the filter into the bezel frame.
7. Align the air-filter retainer over the filter with the ball-stud clips facing down and the LED light pipe lined up with the LED holes on the bezel.
8. Gently push the air-filter retainer down until it snaps into the ball-stud fasteners on the back of the bezel.
9. Install the bezel on the front of the system (see “Installing the bezel assembly” on page 30 for instructions).

---

## Removing and installing power modules

The BladeCenter T unit is separated into two power domains. To support devices in power domain B, a power-supply module option (consisting of two power modules) must be installed.

The following table summarizes the modules that are powered by each power domain.

Power domain	Power-module bays	Modules powered by the power domain
A	1 and 2	I/O-module bays 1 and 2 management module bays 1 and 2 Media tray Blade bays 1 through 4
B	3 and 4	Blade bays 5 through 8 I/O-module bays 3 and 4

All four blowers are required for redundant system operation. Power for all four blowers is shared by all installed power modules. One failed blower creates a nonredundant configuration.

If a power module fails or an input power failure occurs, BladeCenter T units that are configured for redundant power operation will operate in a nonredundant mode. You must replace the failing power module or restore input power as soon as possible to regain redundant power operation.

**Important:**

1. The power modules must be installed in pairs in a domain and must match each other in capacity (wattage, amperage, and so on).
2. To provide true redundant power, BladeCenter T power modules 1 and 3 must be connected to a different input power source than power modules 2 and 4.

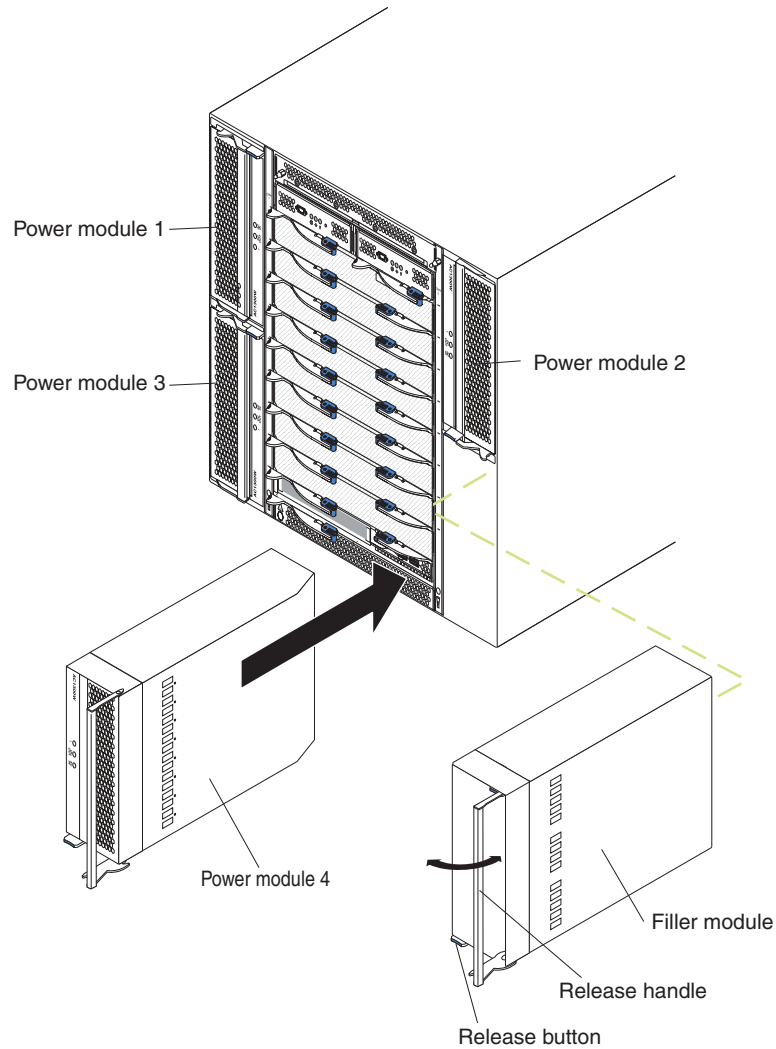

## Removing a power module

Complete the following steps to remove a power module or filler panel from the front of the BladeCenter T unit. The procedure is the same for both ac-power and dc-power modules.

**Attention:** To help ensure proper cooling and system reliability, make sure that you replace a removed power module or filler panel with a power module within 1 minute.

**Important:** If you are removing a functional power module, make sure that both the ac-power LED and the dc-power LED on the remaining power module are lit; otherwise, shut down the operating systems and turn off all of the blade servers that are supported by the power module you are removing, before you remove it. (See the documentation that comes with the blade server for instructions for shutting down the blade server operating system and turning off the blade server.)

1. Press the blue release button on the front of the new power module to release the power-module handle; then, move the power-module handle outward until it is in the open position (90° from the closed position).

2. Grip the power-module handle with one hand and slowly pull the power module out of the bay. Use your other hand to support the bottom of the power module as you pull the power module out from the bay.

**Attention:** Do not carry the power module by only the power-module handle. You must support the weight of the power module.

3. Place the power module in a safe location.
4. Within 1 minute, install either another power module or a filler module into the selected power-module bay.

## Installing a power module

Complete the following steps to install a power module at the front of the BladeCenter T unit. The procedure is the same for both ac-power and dc-power modules.

**Attention:** To help ensure proper cooling and system reliability, make sure that you replace a removed power-module filler panel with a power module within 1 minute.

1. Note the orientation of the power module or filler you are removing; then, remove the filler or power module from the selected power-module bay and set it aside.
2. Press the blue release button on the front of the new power module to release the power-module handle; then, move the power-module handle outward until it is in the open position (90° from the closed position).
3. Grip the power-module handle with one hand and support the bottom of the power module with the other hand.

**Attention:** Do not carry the power module by only the power-module handle. You must support the weight of the power module.

4. Orient the new power module to the selected power-module bay; then, slide the power module into the bay until it stops.
5. Push the power-module handle in until it locks into the latch next to the blue release button.
6. Make sure the LEDs on the power module indicate that it is operating correctly. Make sure that:
  - The input power LED is lit.
  - The output power LED is lit.
  - The error LED is not lit.
7. If you have other modules to install at the front of the unit, do so now. Otherwise reinstall the bezel assembly at the front of the BladeCenter T unit.



---

## Removing and installing the media tray

The media tray is a hot-swappable unit that is installed in the front of the BladeCenter T unit and contains the system-status panel, two USB connectors, and the CD-ROM drive. See Chapter 4, “BladeCenter T components, controls, and LEDs,” on page 53 for information about the system-status panel controls and indicators.

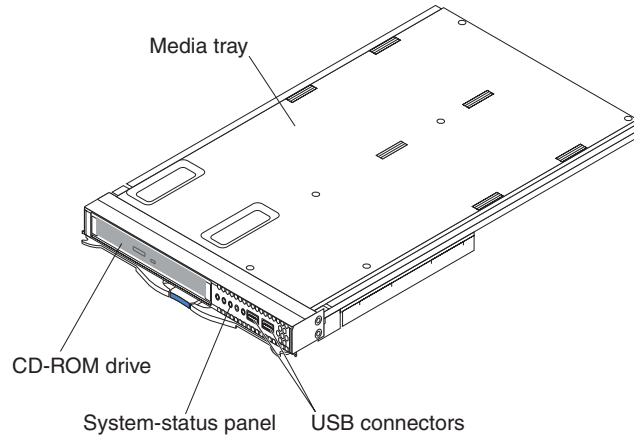

Use the instructions in this section to remove or install the media tray at the front of the BladeCenter T unit.

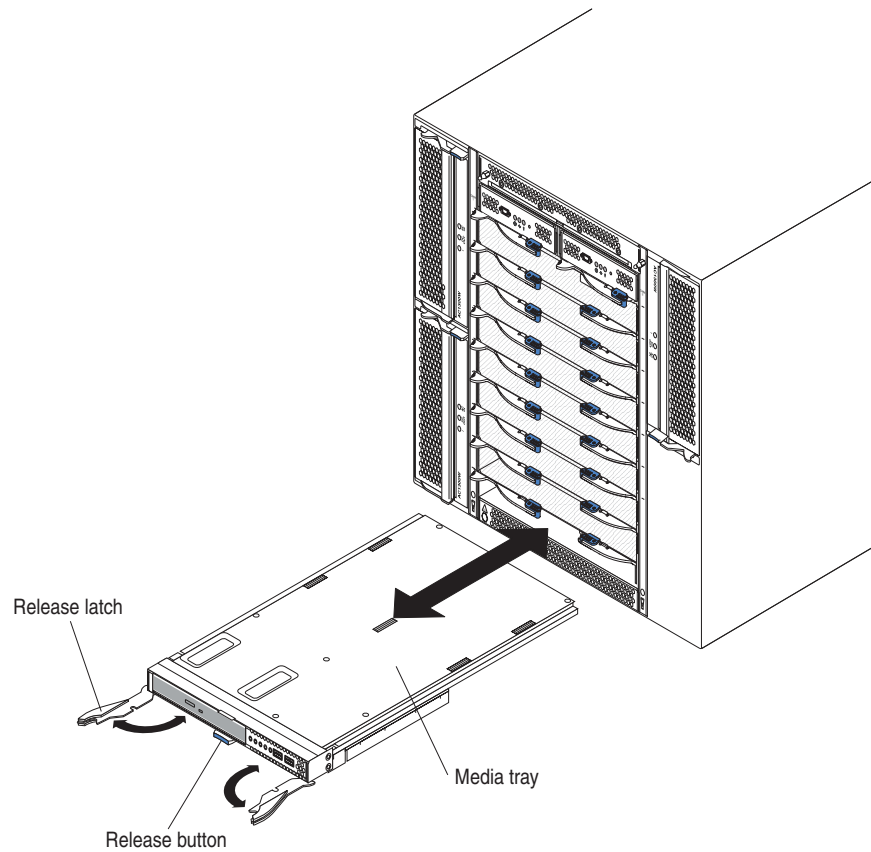

## Removing the media tray

Complete the following steps to remove the media tray in the front of the BladeCenter T unit:

1. Open the two release levers as shown in the illustration. The media tray moves out of the bay approximately 0.6 cm (0.25 inch).
2. Make sure that the release latches are in the open position (90° from the closed position).
3. Grasp the media tray at the front of each side of the module and carefully pull the module all the way out of the bay. Set it in a safe place.
4. Within 1 minute, install another media tray into the BladeCenter T unit.

## Installing the media tray

Complete the following steps to install the media tray in the front of the BladeCenter T unit:

1. Hold the media tray at the front of each side of the module and orient the media tray to the top of the media-tray bay. Carefully position the module into the rails in the media-tray bay.
2. Make sure that the release latches are in the open position (90° from the closed position).
3. Slide the media tray forward into the media-tray bay until it stops.
4. Push the media tray in until you feel it lock into position.
5. Push both release latches in until they lock.
6. Make sure that the power LED is lit on the system-status panel.
7. If you have other modules to install at the front of the unit, do so now. Otherwise, reinstall the bezel assembly at the front of the unit.

---

## Removing and installing management modules

The BladeCenter T unit comes with one hot-swap management module in management module bay 1. You can add a second management module in management module bay 2.

**Note:** Only one management module is active; the second management module, if present, provides redundancy.

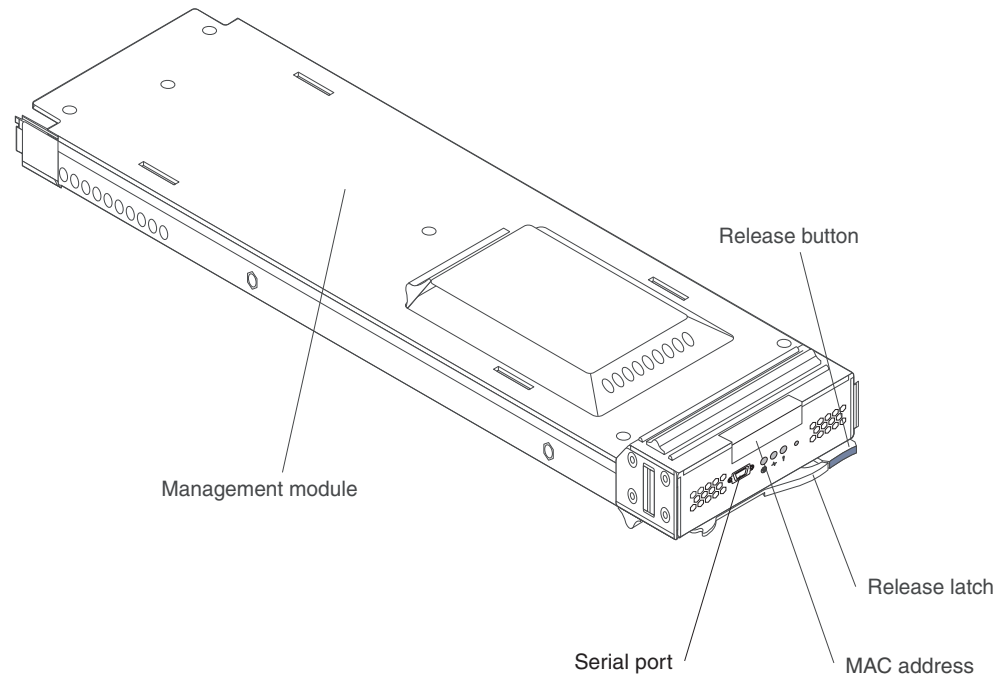

The management module performs system-management functions for the BladeCenter T unit. Through the management module, you configure the BladeCenter T unit and modules, and such information as the Internet protocol (IP) addresses of the management module and I/O modules. The management module also performs PS/2-to-USB conversions for the system keyboard and mouse and can send the video graphics array (VGA) data stream to a remote console for viewing. See “Management module controls and indicators” on page 54 for information about the controls and indicators.

The management module communicates with the service processor in each blade server for functions such as:

- Blade server power-on requests
- Blade server error and event reporting
- Blade server requests for keyboard, mouse, and video
- Blade server requests for CD-ROM drive and USB ports

The management module also communicates with the I/O modules, power modules, blower modules, and blade servers to detect presence or absence and any error conditions, sending alerts when required.

Use the instructions in this section to remove or install a management module at the front of the BladeCenter T unit.

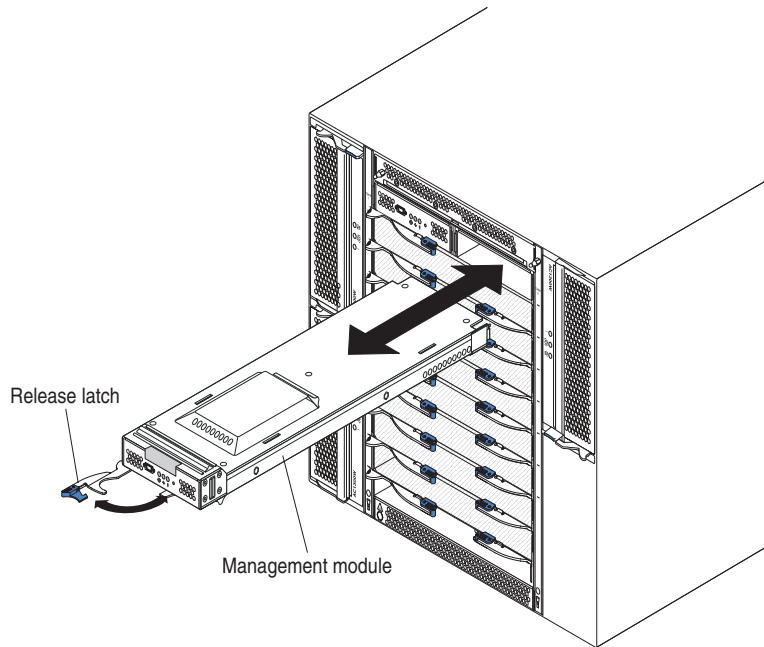

## Removing a management module

### Notes:

1. If you are removing the only management module in the BladeCenter T unit, to avoid unexpected termination of sessions, stop all management module local and remote sessions before proceeding.
2. If you are removing the only management module in the BladeCenter T unit, be aware that as soon as you remove the module, the BladeCenter T blowers will increase to full speed.
3. If you are replacing the only management module in the BladeCenter T unit and the management module is functional, save the configuration file to another medium before you proceed (in the **MM Control** section in the navigation pane, click **Configuration File** and follow the instructions under **Save MM Configuration**); you will be able to restore the saved configuration file to the replacement management module.
4. If you have just installed a second management module in the BladeCenter T unit, do not remove the first (primary) management module for approximately 2 minutes; the second (secondary) management module needs the time to receive initial status information.

Complete the following steps to remove a management module or filler module from the front of the BladeCenter T unit:

1. Press the blue release button at the front of the management module.
2. Pull the release latch all the way toward the left side of the management module until it stops, as shown in the illustration. The module moves slightly out of the bay.
3. Grip the management module with one hand and slowly pull the management module out of the bay. Use your other hand to support the bottom of the management module as you pull it out from the bay.

**Important:** Within 1 minute, you must place either another module of the same type or a filler module in the bay.

## Installing a management module

Complete the following steps to install a management module in the BladeCenter T unit:

1. If you are installing a second management module, see the *IBM BladeCenter Management Module User's Guide* on the *IBM BladeCenter T Advanced Management Module Documentation* CD for information about management module redundancy.
2. If you are replacing a management module, remove the current module from the bay (see "Removing a management module" on page 38). If you are adding a management module, remove the filler module from the selected management module bay and store the filler module for future use.

**Note:** You will be able to apply a saved configuration file to the replacement management module. See your management module *User's Guide* and *Command Line Interface Reference Guide* for instructions.

3. If you have not already done so, touch the static-protective package that contains the new management module to an unpainted metal part of the BladeCenter T unit or any unpainted surface on any other grounded rack component for at least 2 seconds.
4. Remove the management module from its static-protective package.
5. Press the blue release button on the management module to open the release latch. Make sure that the release latch on the management module is in the open position (90° from the closed position).
6. Holding the management module at the front with one hand, and in the middle with the other hand, orient the management module to the bottom of the selected management module bay and gently slide the management module into the bay until it stops. Push the management module in until the release latch starts to close.
7. Push the release latch on the front of the management module to the closed position.
8. Make sure that the error LED on the management module is not lit, indicating that the management module is operating correctly.
9. If this is the only management module in the BladeCenter T unit, configure the new management module. See the *IBM BladeCenter Management Module User's Guide* on the *IBM BladeCenter T Advanced Management Module Documentation* CD for detailed instructions. If this is the secondary management module and you followed the instructions in the *IBM BladeCenter T Management Module User's Guide*, no configuring is necessary. The secondary management module receives the configuration and status information automatically from the primary management module when necessary. However, you must apply the latest level of firmware from the IBM Support Web site at <http://www.ibm.com/support/> to ensure smooth changeovers (see the *IBM BladeCenter Management Module User's Guide* on the *IBM BladeCenter T Advanced Management Module Documentation* CD for more information).

### Notes:

- a. Do not initiate any management module changeover for approximately 2 minutes after installing the secondary management module; the secondary management module needs the time to receive initial configuration and status information.
- b. Reinstall the bezel assembly on the BladeCenter T unit after you have finished installing the management module. However, if you connected a

cable to the serial port on the management module, you will not be able to install the bezel assembly, which contains an air filter for the BladeCenter T unit. If you cannot install the bezel assembly, a filter must be provided on the rack.

10. If you have other modules to install at the front of the unit, do so now. Otherwise reinstall the bezel assembly on the front of the BladeCenter T unit.

---

## Removing and installing blower modules

The BladeCenter T unit comes with four hot-swap blowers for cooling redundancy. The blowers are installed at the rear of the system. The blower speeds vary depending on the ambient air temperature at the front of the BladeCenter T unit. If a blower fails, the remaining blowers increase their speed to cool the BladeCenter T unit and blade servers.

All four blowers are required for redundant system operation. Power for all four blowers is shared by all installed power modules. One failed blower creates a nonredundant configuration.

**Note:** Each power module has cooling fans that are independent from the system cooling.

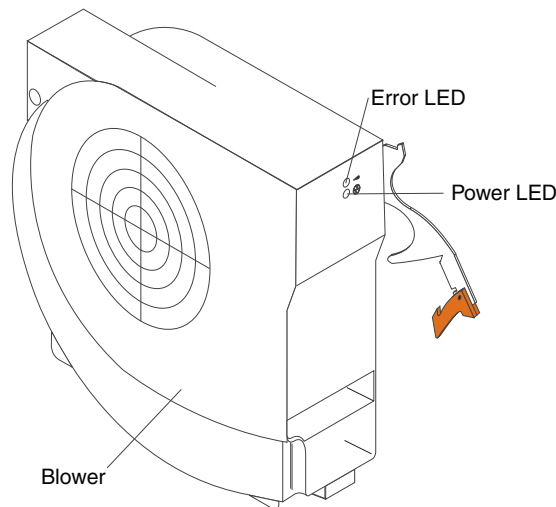

**Important:** Replace a failed blower as soon as possible to restore cooling redundancy.

Use the instructions in this section to remove or install a blower module at the rear of the BladeCenter T unit.

**Note:** Blowers on the left side of the system are installed with the release lever pointing upward, and blowers on the right side are installed with the release lever facing downward.

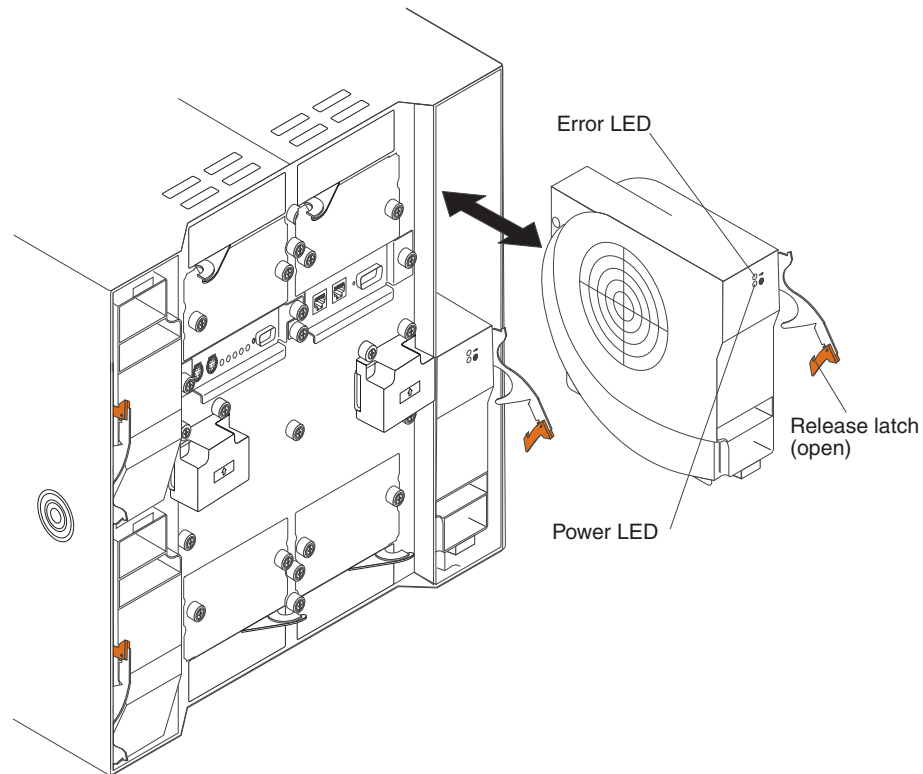

## Removing a blower module

Use the following instructions to remove a blower at the rear of the BladeCenter T unit.

1. Press the release lever at the end of the release latch and pull the latch to the open position. The blower module moves slightly out of the bay.
2. Slide the module out of the blower bay and set it aside.
3. Within 1 minute, install another blower module into the bay.

## Installing a blower module

Complete the following steps to install a blower module into the rear of the BladeCenter T unit:

1. Press the release lever at the end of the release latch and pull the latch to the open position.
2. Insert the blower into the selected blower bay.
3. Push the blower module into the bay until it stops. The release latch moves slightly toward the closed position.
4. Close the release latch until it locks into position.
5. Make sure that the blower power LED is lit and the blower error LED is not lit.

---

## Removing and installing the KVM (keyboard, video, mouse) module

The KVM module is a hot-swap unit that is installed in the rear of the BladeCenter T unit and is held in place by captive thumbscrews. The KVM module provides the electrical and mechanical interface to the BladeCenter T unit for a local keyboard, RGB VGA video monitor, and a mouse. Five LEDs on the KVM module system-status panel are used for system status information: power, location, minor alarm, major alarm, and critical alarm. See “KVM (keyboard, video, mouse) module indicators and input/output connectors” on page 58 for information about the controls and indicators.

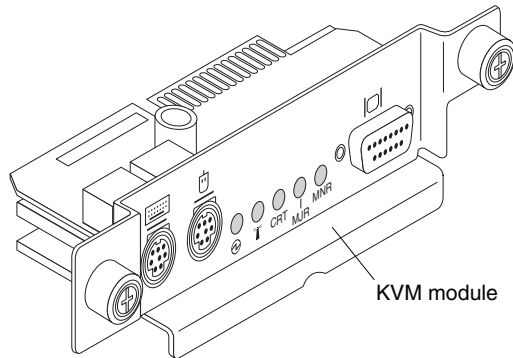

Use the instructions in this section to remove or install the KVM module from the rear of the BladeCenter T unit. The KVM module is held in place by captive thumbscrews. You can use either your fingers or a screwdriver to install or remove the KVM module. If you use a screwdriver, make sure that you do not overtighten the thumbscrews.

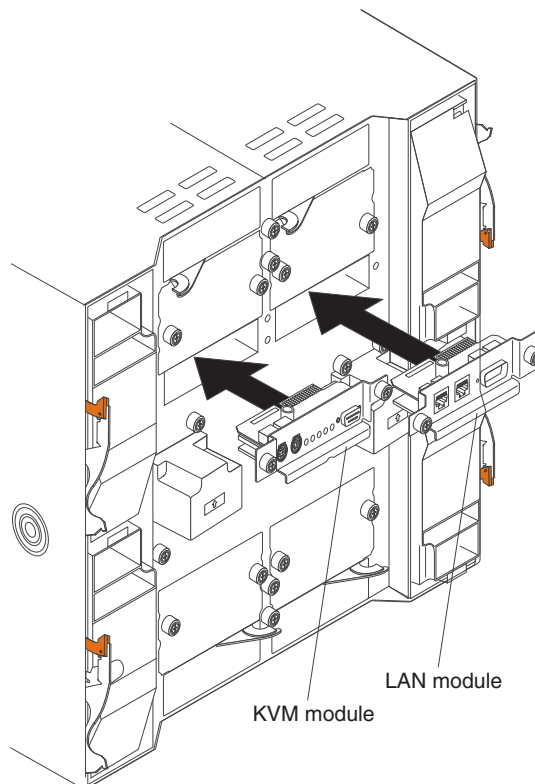



## Removing the KVM module

Complete the following steps to remove the KVM module at the rear of the BladeCenter T unit:

1. Remove the keyboard, mouse, and video cables if any are connected.
2. Fully loosen each thumbscrew counterclockwise.
3. Hold the KVM module by both thumbscrews.
4. Carefully pull the KVM module outward from the KVM module bay until you feel it release.
5. Remove the KVM module from the bay and set it aside.
6. Within 1 minute, install a new KVM module.

## Installing the KVM module

Complete the following steps to install the KVM module at the rear of the BladeCenter T unit:

1. Hold the KVM module by both thumbscrews.

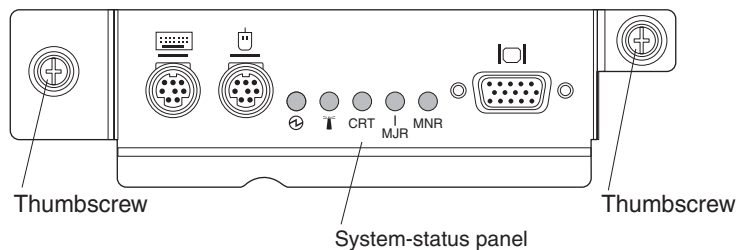

2. Position the KVM module into the rails inside the KVM-module bay.
3. Push the KVM module into the bay until you feel it stop. Make sure that it is snug.
4. Turn each thumbscrew clockwise until it is finger tight. If you use a screwdriver, make sure that you do not overtighten the thumbscrews.
5. Make sure that the power LED on the front of the KVM module is lit.
6. Connect any peripheral devices that you want to use at this time (for example, keyboard, mouse, and video monitor).

## Removing and installing the LAN module

The LAN module is a hot-swap unit that is installed in the rear of the BladeCenter T unit and is held in place by captive thumbscrews. The LAN module provides the electrical and mechanical interface to the BladeCenter T system for the two local area network (Ethernet) connections, as driven from each management module, and the telco external alarms. This module contains two RJ45 connectors with LEDs for the management interface and one DSUB 15P male telco alarm connector. See the “LAN-module indicators and input/output connectors” on page 60 for more information.

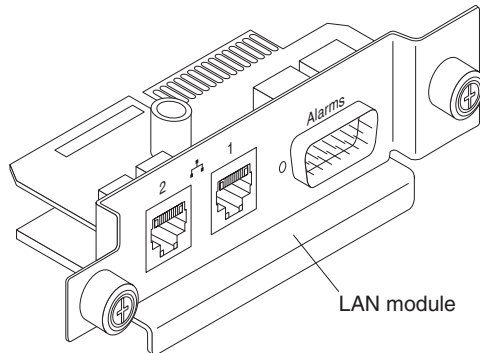

Use the instructions in this section to remove or install the LAN module into the rear of the BladeCenter T unit (see the illustration of the KVM and LAN modules on page 42). The LAN module is held in place by captive thumbscrews. You can either use your fingers or a screwdriver to install or remove the LAN module. If you use a screwdriver, make sure that you do not overtighten the thumbscrews.

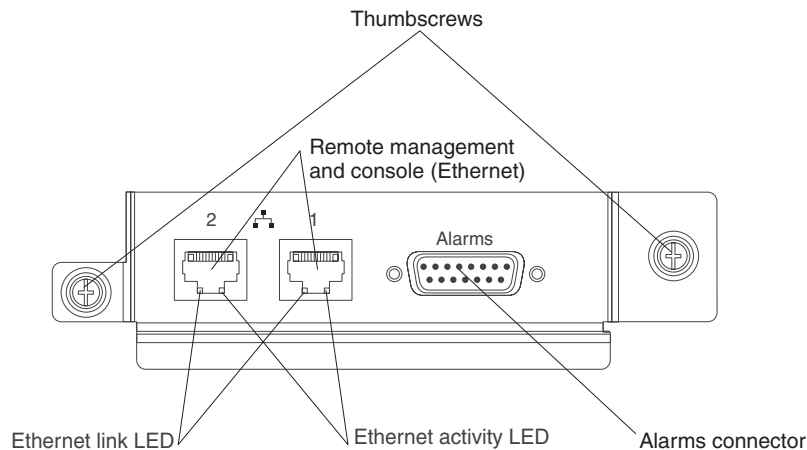

## Removing the LAN module

Complete the following steps to remove a LAN module from the rear of the BladeCenter T unit:

1. Fully loosen each thumbscrew counter clockwise.
2. Grasp the LAN module by both thumbscrews.
3. Carefully pull the LAN module outward from the LAN module bay until you feel it release from the card edge connector on the backplane.
4. Remove the LAN module from the bay and set it aside.
5. Within 1 minute, install the new LAN module.

## Installing the LAN module

Complete the following steps to install a LAN module into the rear of the BladeCenter T unit:

1. Hold the LAN module by both thumbscrews.
2. Position the LAN module into the rails inside the LAN module bay (see the illustration of the KVM and LAN modules on page 42).
3. Push the LAN module into the bay until it stops. Make sure that it is snug.
4. Turn each thumbscrew clockwise until it is finger tight. If you use a screwdriver, make sure that you do not overtighten the thumbscrews.

---

## Removing and installing I/O modules

For blade server communication with the network, the BladeCenter T unit supports up to four hot-swap I/O modules. Table 3 identifies the types of I/O modules that you can install in each I/O-module bay. Go to the IBM Support Web site at <http://www.ibm.com/support/> to see the list of supported I/O modules.

The BladeCenter T unit supports a minimum of one hot-swap Ethernet switch module or pass-thru module, in I/O-module bay 1 or 2. This I/O module provides an internal connection to an integrated Ethernet controller in all the blade servers in the BladeCenter T unit, up to eight internal connections per I/O module. To provide an internal connection for the second integrated Ethernet controller in each blade server, install an Ethernet switch module or pass-thru module in the available I/O-module bay of the pair (I/O-module bay 1 or bay 2). The management modules are connected to the switch module through the backplane using a transformerless 100 Mbps connection and an I2C interface.

The BladeCenter T unit supports two additional I/O modules in I/O-module bays 3 and 4. Each of these I/O modules provides an internal connection to one of the two network-interface controllers on each of the I/O expansion options that are installed on blade servers in the BladeCenter T unit. The I/O module must be compatible with the network interface on each of the I/O expansion options. For example, if you install a Fibre Channel I/O expansion card on a blade server, the I/O modules that you install in I/O-module bays 3 and 4 must be Fibre Channel switch modules or pass-thru modules.

**Important:** The switch modules in I/O module bays 3 and 4 and all blade server interface options in the BladeCenter T unit, must use the same interface type. For example, if you install an Ethernet interface option on a blade server, the switch modules that you install in I/O module bays 3 and 4 must be Ethernet. All other interface options in the BladeCenter T unit must also be Ethernet interface options.

**Note:** You can use a pass-thru module in any I/O-module bay, provided that the associated controller in the blade servers or I/O expansion options is compatible with it.

The following table summarizes the types of modules that can be used in each I/O-module bay. See “Rear view” on page 57 for the location of the I/O-module bays on the BladeCenter T unit.

*Table 3. Hot-swap I/O module types by location for redundancy*

Bays	I/O-module function	Permissible I/O module
1 and 2	Network connections 1 and 2 (Ethernet) for all blade servers in the BladeCenter T unit	One of the following combinations: <ul style="list-style-type: none"><li>• Two Ethernet switch modules</li><li>• Two pass-thru modules</li><li>• One Ethernet switch module and one pass-thru module</li></ul>

Table 3. Hot-swap I/O module types by location for redundancy (continued)

Bays	I/O-module function	Permissible I/O module
3 and 4	Network connections 3 and 4 (for all I/O expansion options on blade servers in the BladeCenter T unit)	<p>One of the following combinations.</p> <ul style="list-style-type: none"> <li>• Two Ethernet switch modules</li> <li>• Two Fibre Channel switch modules</li> <li>• Two pass-thru modules</li> </ul> <p><b>Important:</b></p> <ul style="list-style-type: none"> <li>• The modules used must support the network interface that is used on the blade server I/O expansion options.</li> <li>• The I/O modules in bays 3 and 4 must be the same type.</li> </ul>

**Notes:**

1. The enumeration of the Ethernet controllers in a blade server is operating-system dependent. You can verify the Ethernet controller designations that a blade server uses through your operating-system settings.
2. The routing of an Ethernet controller to a particular I/O-module bay depends on the type of blade server. You can verify which Ethernet controller is routed to which I/O-module bay by using the following test:
  - a. Install only one Ethernet switch module or pass-thru module, in I/O-module bay 1.
  - b. Make sure that the ports on the switch module or pass-thru module are enabled (**I/O Module Tasks ” Management ” Advanced Management** in the management module Web-based user interface).
  - c. Enable only one of the Ethernet controllers on the blade server. Note the designation that the blade server operating system has for the controller.
  - d. Ping an external computer on the network that is connected to the switch module or pass-thru module.

If you can ping the external computer, the Ethernet controller that you enabled is associated with the I/O module in I/O-module bay 1. The other Ethernet controller in the blade server is associated with the I/O module in I/O-module bay 2.

3. If you have installed an I/O expansion option on a blade server, communications from the option are routed to I/O-module bays 3 and 4. You can verify which controller on the option is routed to which I/O-module bay by performing the test in note 2, using a controller on the I/O expansion option and a compatible switch module or pass-thru module in I/O-module bay 3 or 4.

Use the instructions in this section to remove or install an I/O module at the rear of the BladeCenter T unit.

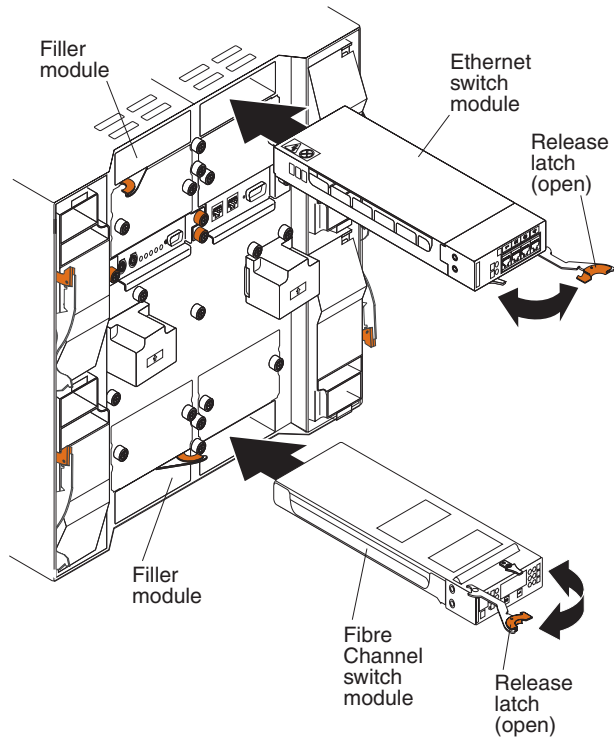

## Removing an I/O module

Use the following instructions to remove an I/O module or filler module from the rear of the BladeCenter T unit.

1. Press the release lever at the end of the release latch and pull the latch to the open position. The I/O module moves slightly out of the bay.
2. Slide the I/O module out of the I/O-module bay and set it aside.
3. Within 1 minute, install another I/O module or filler module into the bay.

## Installing an I/O module

Complete the following steps to install an I/O module into the rear of the BladeCenter T unit.

1. Press the release lever at the end of the release latch and pull the latch to the open position.
2. Insert the I/O module into the selected I/O-module bay.
3. Push the I/O module into the bay until it stops. The release latch moves slightly toward the closed position.
4. Close the release latch until it locks into position.

---

## Blade servers

The BladeCenter T unit supports up to eight high-performance blade servers. Each blade server is an enclosure that contains microprocessors, memory, a control chip set, an I/O bus, Ethernet controllers, hard disk drives or flash drives, and user-interface controls, and connectors for expansion options. The blade server receives its power, network connection, and I/O devices (CD-ROM, keyboard, mouse, and video ports, USB port, remote monitoring port) from the BladeCenter T unit, reducing the number of cables that are required.

### Blade server expansion options

Some blade servers contain connectors for options that add capabilities to the blade server. You can add these options before installing the blade server in the BladeCenter T unit.

Go to <http://www.ibm.com/servers/eserver/serverproven/compat/us/> for a list of available options for your IBM blade server.

#### I/O expansion option

Some blade servers have connectors for adding an I/O expansion option, such as an IBM BladeCenter Fibre Channel Expansion Card. The BladeCenter T unit routes network communication signals from the I/O expansion option to I/O modules 3 and 4 on the BladeCenter T unit. The I/O expansion option is attached directly to the blade server and does not occupy an additional blade bay.

**Note:** If an I/O expansion option is installed on any blade server, I/O modules that are compatible with that network interface must be installed in I/O-module bays 3 and 4 on the BladeCenter T unit. See “Removing and installing I/O modules” on page 46 for more information.

#### Expansion unit option

You can install an optional BladeCenter SCSI Storage Expansion Unit or Peripheral Card Interface (PCI) I/O Expansion Unit on your blade server.

**Storage Expansion Unit option:** Some blade servers have a connector for adding an expansion unit, such as an IBM BladeCenter SCSI Storage Expansion Unit. The storage expansion unit supports up to two hot-swap SCSI hard-disk drives. The expansion option is attached directly to the blade server and occupies an additional blade server bay.

**PCI I/O-expansion Unit option:** Some blade servers have a connector for adding an expansion unit, such as an IBM BladeCenter PCI I/O Expansion Unit. The PCI I/O-expansion unit supports up to two PCI-X adapters. The expansion unit is attached directly to the blade server and occupies an additional blade server bay.

## Removing and installing a blade server or filler module

Use the instructions in this section to remove or install a blade server at the front of the BladeCenter T unit.

**Important:** Reinstalling a blade server into a different bay than the one from which it was removed could have unintended consequences. Some configuration information and update options are established according to bay number. You might need to reconfigure the blade server.

**Attention:** To maintain proper system cooling, do not operate the BladeCenter T unit for more than 20 minutes without either a blade server or a filler blade installed in each blade bay. If you fail to replace a blade server or filler blade within 20 minutes, system performance might be affected.

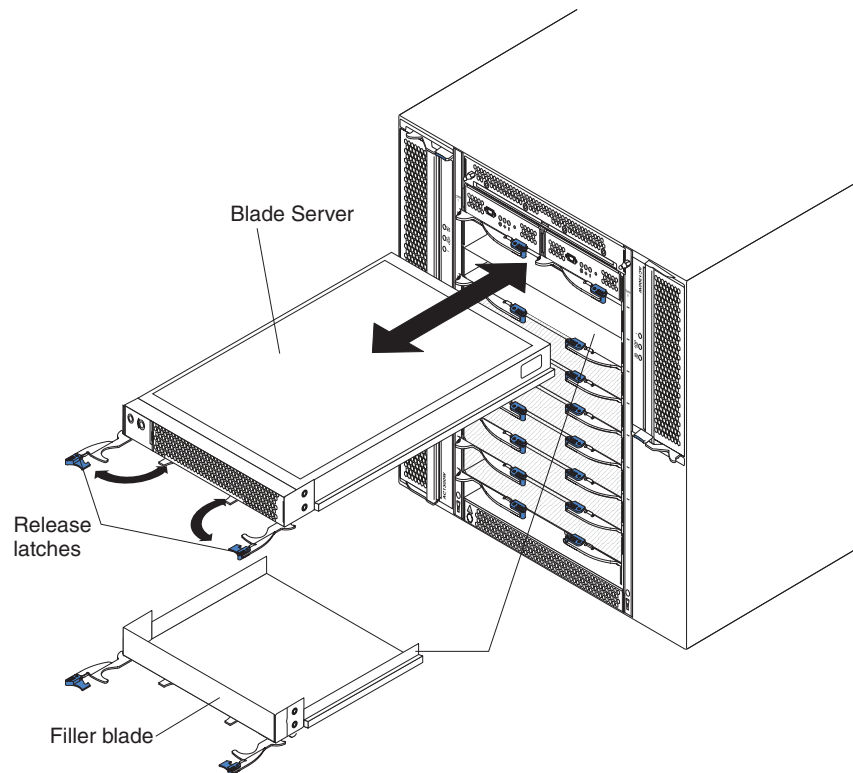



## Installing a blade server

Complete the following steps to install a blade server or filler blade in the BladeCenter T unit.

### Statement 21:



#### CAUTION:

**Hazardous energy is present when the blade is connected to the power source. Always replace the blade cover before installing the blade.**

1. Install any options that you need, such as hard disk drives or memory, in the blade server. See the documentation that comes with the blade server for instructions.
2. Select the bay for the blade server.

#### Notes:

- a. If a blade server has a SCSI Storage Expansion Unit or PCI I/O-expansion Unit installed on it, the blade server and expansion option require an additional adjacent blade bay.
  - b. If you install a blade server or option in bay 5 through 8, you must install power modules in power-module bays 3 and 4.
3. Remove the filler blade from the bay and store in a safe place.
  4. Make sure that the release latches on the blade server are in the open position (horizontal to the blade server).
  5. Slide the blade server into the bay until it stops.
  6. Push the release latches on the front of the blade server until they are closed.
  7. Turn on the blade server by pressing the power-control button on the blade server control panel. See the documentation that comes with the blade server for more instructions.
  8. Make sure that the power LED on the blade server control panel is lit, indicating that the blade server is receiving power.
  9. (Optional) Write identifying information on one of the user labels that come with the blade server; then, place the label on the BladeCenter T unit to the right of the blade server, as shown in the following illustration.

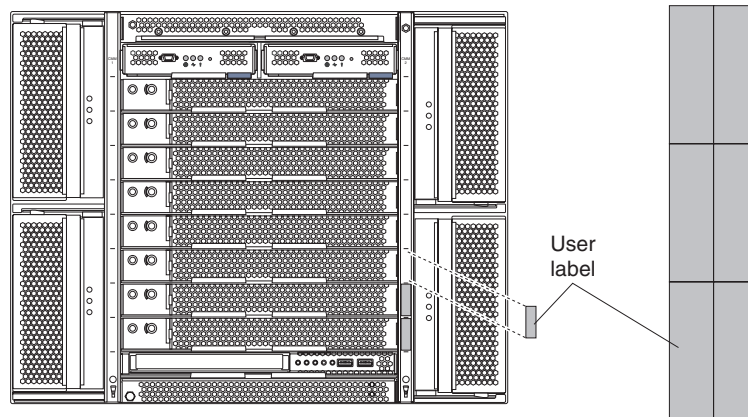

**Important:** Do not place the label on the blade server or in any way block the ventilation holes on the blade server.

10. If you have other modules to install at the front of the unit, do so now. Otherwise reinstall the bezel assembly on the front of the BladeCenter T unit.

**Note:** Reinstall the bezel assembly on the BladeCenter T unit after you have finished installing the blades. However, if you installed an option such as a PCI I/O Expansion Unit with PCI adapters that require cables, you will not be able to install the bezel assembly, which contains an air filter for the BladeCenter T unit. If you cannot install the bezel assembly, a filter must be provided on the rack.

If this is the initial installation for a blade server in the BladeCenter T unit, you must configure the blade server with the blade server Configuration/Setup Utility program and install the blade server operating system. See the documentation that comes with the blade server for instructions.

### **Removing a blade server**

Complete the following steps to remove a blade server from the BladeCenter T unit.

**Note:** If you do not shut down a blade server properly, it cannot be restarted using the Wake on LAN feature.

1. Shut down the blade server operating system; then, press the blade server power-control button (behind the blade server control panel door) to turn off the blade server. Wait at least 30 seconds until the drives stop spinning, before proceeding to the next step.
2. Open the two release latches as shown in the illustration on page 50. The blade server moves slightly out of the bay.
3. Pull the blade server out of the bay.
4. Place either a filler blade or another blade server in the bay within 20 minutes.

## Chapter 4. BladeCenter T components, controls, and LEDs

This section describes the components, controls and light-emitting diodes (LEDs) and how to start and shut down the BladeCenter T unit.

**Note:** The illustrations in this document might differ slightly from your hardware.

### Front view

This section identifies the components, controls, and LEDs on the front of your BladeCenter T unit.

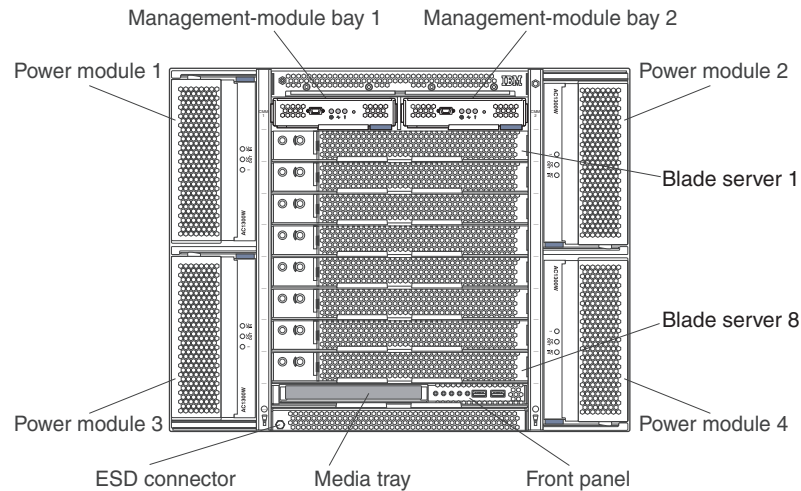

### System service cards

These cards contain system service instructions and a writable area for your use. The cards are located in a slot just above the management module bays. To access the service cards, slide out the cards as shown in the following illustration.

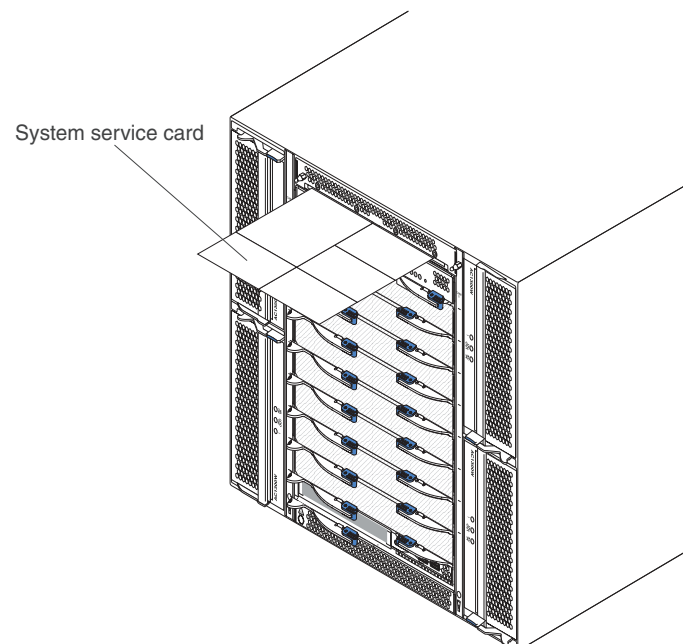

## Management module controls and indicators

These management module controls and indicators provide status information about the management module and remote management connection. For additional information, see the *Hardware Maintenance Manual and Troubleshooting Guide* on the IBM *BladeCenter T Documentation CD*.

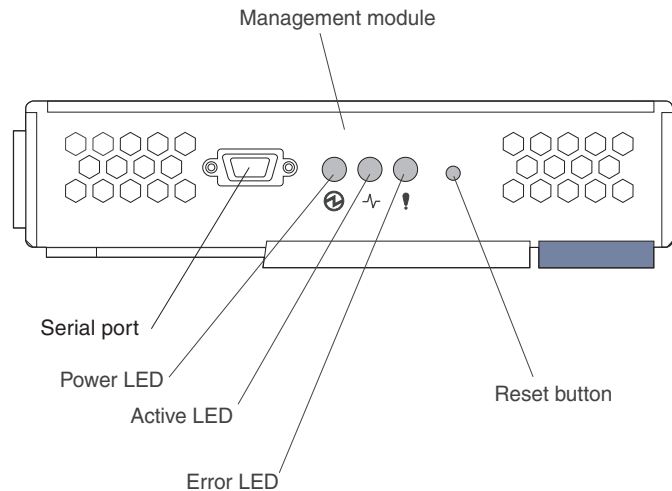

**Management module LEDs:** These LEDs provide status information about the management module and remote management connection.

- **Power:** When this green LED is lit, it indicates that the management module has power.
- **Active:** When this green LED is lit, it indicates that the management module is actively controlling the BladeCenter T unit. Only one management module actively controls the BladeCenter T unit. If two management modules are installed in the BladeCenter T unit, this LED is lit on only one.
- **Error:** When this amber LED is lit, it indicates that an error has been detected somewhere on the management module. When this LED is lit, the system error LED (critical, major, or minor) on each of the BladeCenter T system-status panels is also lit.

**Management module reset button:** *Do not* press this button unless you intend to erase your configured IP addresses for the management module and lose connection with the remote management station, the switch modules, and the blade servers. If you press this button, you will have to reconfigure the management module settings (see your management module *User's Guide* and *Command Line Interface Reference Guide* for instructions.).

Press this recessed button to reset the IP configuration of the management module network interfaces (Ethernet 1, Ethernet 2, gateway address, and so on) to the factory defaults and then restart the management module.

Use a straightened paper clip to press the button.

**Serial connector:** Use this connection for configuring and managing the BladeCenter components over a serial line through the command-line interface (CLI) user-interface. This port provides access and redirection to the serial-over-LAN (SOL) interface of any processor blade server. For example, you can connect a laptop device to the serial connector and use a terminal-emulator program to configure the assorted IP addresses, user accounts, and other management settings through the CLI user-interface.

## Media tray

The media tray is a hot-swap unit that is installed on the front of the BladeCenter T unit and contains the system-status panel, I/O, and CD-ROM drive.

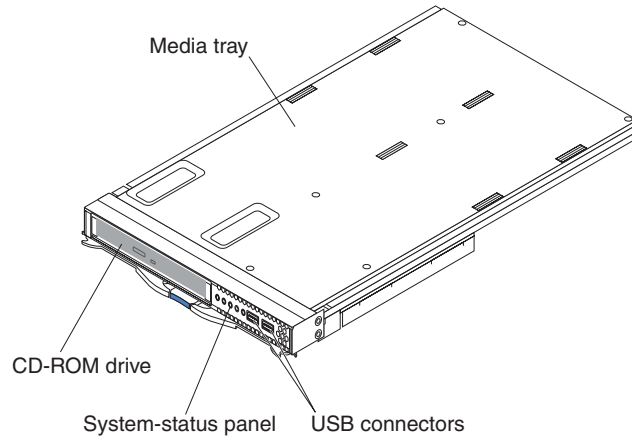

The following illustration shows the system-status LEDs on the system-status panel on the front of the media tray in the BladeCenter T unit.

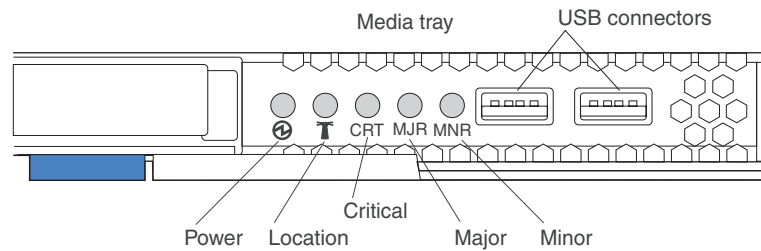

The system-status panel on the front of the media tray in the BladeCenter T system has five system-status LEDs and two USB connectors.

**System status LEDs:** The LEDs on this part of the panel provide status information for the BladeCenter T unit.

- **Power:** When continuously lit, this green LED indicates the presence of power in the BladeCenter T unit. The LED turns off when the power source is interrupted.  
**Attention:** If the power LED is off, it does not mean electrical power is not present in the BladeCenter T unit. The LED might be burned out. To remove all electrical power from the BladeCenter T unit, you must disconnect all power cords from the rear of the BladeCenter T unit.
- **Location:** This blue LED is for system identification. A system administrator or servicer uses this LED to locate a specific BladeCenter T unit for service or repair. You can turn off the location LED through the Web interface or a remote management console.

**Alarm LEDs:** These LEDs provide alarm notifications for the BladeCenter T unit.

- **CRT (Critical alarm, amber (default) or red):** When continuously lit, this LED indicates the presence of a critical system fault. The system comes with amber as the default. See the *BladeCenter Management Module User's Guide* on the *IBM BladeCenter T Advanced Management Module Documentation CD* for information on setting the color of this LED.

A critical system fault is an error or event that is unrecoverable. In this case, the system cannot continue to operate. An example is the loss of a large section of memory that causes the system to be incapable of operating.

- **MJR (Major alarm, amber (default) or red):** When continuously lit, this LED indicates the presence of a major system fault. The system comes with amber as the default. See the *BladeCenter Management Module User's Guide* on the IBM *BladeCenter T Advanced Management Module Documentation* CD for information on setting the color of this LED.  
A major system fault is an error or event that has a discernible impact to system operation. In this case, the system can continue to operate but with reduced performance. An example is the loss of one of two mirrored disks.
- **MNR (Minor alarm, amber):** When continuously lit, this LED indicates the presence of a minor system fault. A minor system fault is an error or event that has little impact to system operation. An example is a correctable ECC error.

**USB connectors:** There are two USB connectors on the front system-status panel. You can use these USB connectors to connect two USB peripheral devices without an external hub. If more devices are required, you can connect an external hub to any of the built-in connectors.

## Power modules

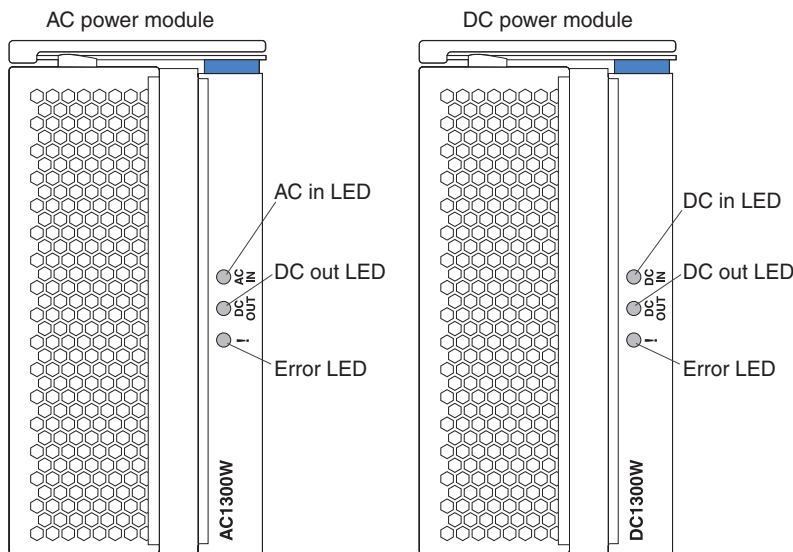

**Power module LEDs:** Each power module has three LEDs to indicate the status of the power module.

- **AC (or DC) in:** When continuously lit, this green LED indicates that the input power source is working. If the LED is not lit, it indicates that the input power source is not present or is incorrect.
- **DC out:** When continuously lit, this green LED indicates that the output power is present. If the LED is not lit, it indicates that the output power is not present.
- **! (Error):** When continuously lit, this amber LED indicates that there is a error condition within the power module.

## Rear view

This section identifies the components and indicators on the rear of the BladeCenter T unit.

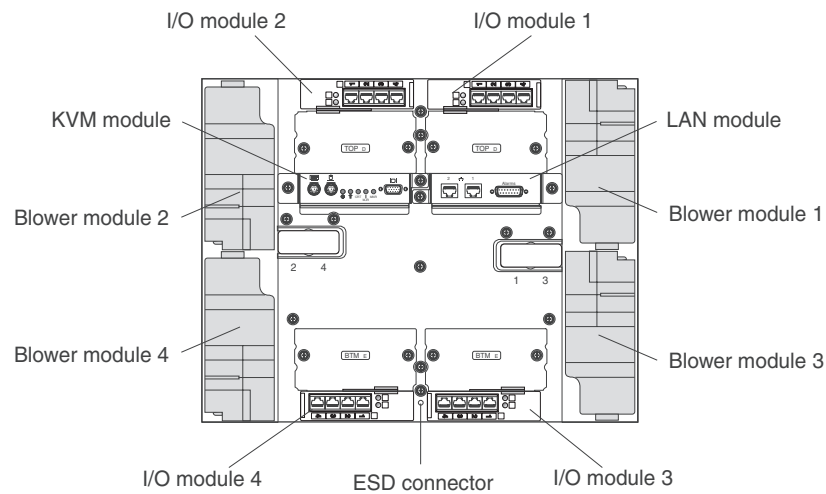

## Blower modules

The blower modules are hot-swap units that are installed into the rear of the system. The BladeCenter T unit comes with four blowers that are in a 3+1 redundancy configuration. All the cooling requirements are met if one blower fails. All blowers contain a backflow device that prevents the system from drawing air into the exhaust port of a failed blower. The management module in the BladeCenter T unit controls the blower speed and detects blower failures.

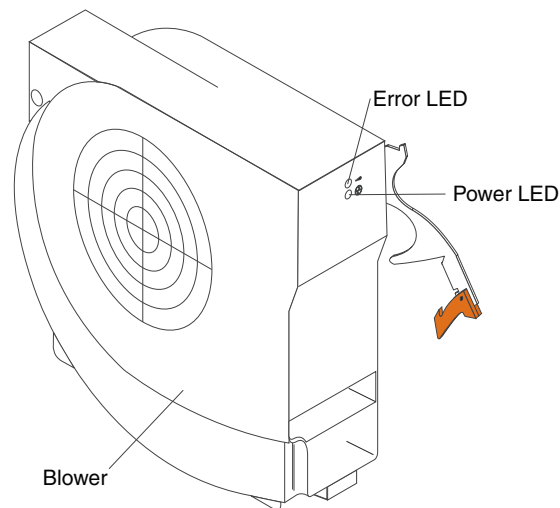

**Blower LEDs:** The LEDs on each blower provide status information about the blower.

- **Power:** When this green LED is lit, it indicates that the blower module has power.
- **Error:** This amber LED is lit and stays lit when an error has been detected in the blower. The system error LED on the BladeCenter system-status panel is also lit.

## KVM (keyboard, video, mouse) module indicators and input/output connectors

The KVM module is a hot-swap module that is installed on the rear of the BladeCenter T unit and is held in place by captive thumbscrews. This module contains two PS/2 connectors for the keyboard and mouse, a system-status panel, and an HD-15 video connector.

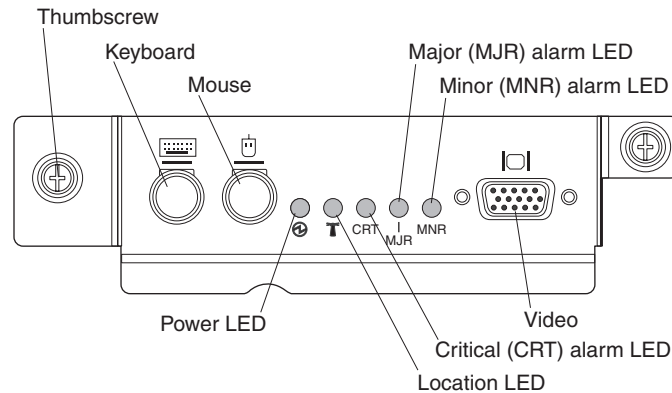

**System-status LEDs:** These LEDs provide status information for the BladeCenter T unit.

- **Power:** When continuously lit, this green LED indicates the presence of power in the BladeCenter T unit. The LED turns off when the power source is interrupted.  
**Attention:** If the power LED is off, it does not mean electrical power is not present in the BladeCenter T unit. The LED might be burned out. To remove all electrical power from the BladeCenter T unit, you must disconnect all power cords from the rear of the BladeCenter T unit.
- **Location:** This blue LED is for system identification. A system administrator or servicer uses this LED to locate a specific BladeCenter T unit for service or repair. You can turn off the location LED through the Web interface or a remote management console.

**Alarm LEDs:** These LEDs provide alarm notifications for the BladeCenter T unit.

- **CRT (Critical alarm, amber (default) or red):** When continuously lit, this LED indicates the presence of a critical system fault. The system comes with amber as the default. See the *BladeCenter Management Module User's Guide* on the IBM *BladeCenter T Advanced Management Module Documentation* CD for information on setting the color of this LED. A critical system fault is an error or event that is unrecoverable. In this case, the system cannot continue to operate. An example is the loss of a large section of memory that causes the system to be incapable of operating.
- **MJR (Major alarm, amber (default) or red):** When continuously lit, this LED indicates the presence of a major system fault. The system comes with amber as the default. See the *BladeCenter Management Module User's Guide* on the IBM *BladeCenter T Advanced Management Module Documentation* CD for information on setting the color of this LED. A major system fault is an error or event that has a discernible impact to system operation. In this case, the system can continue to operate but with reduced performance. An example is the loss of one of two mirrored disks.
- **MNR (Minor alarm, amber):** When continuously lit, this LED indicates the presence of a minor system fault. A minor system fault is an error or event that has little impact to system operation. An example is a correctable ECC error.



**Connectors:** The KVM module has the following I/O connectors:

- **Keyboard connector:** The BladeCenter T KVM module contains one PS/2-style keyboard connector.

Use this connector to connect a PS/2 keyboard to the BladeCenter T unit.

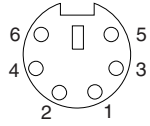

- **Mouse connector:** The BladeCenter T KVM module contains one PS/2-style mouse connector.

Use this connector to connect a PS/2 mouse to the BladeCenter T unit.

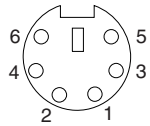

- **Video connector:** The BladeCenter T KVM module contains one standard video connector. The integrated video controller on each blade server is compatible with SVGA and VGA and communicates through this video port.

Use this connector to connect a video monitor to the BladeCenter T unit.

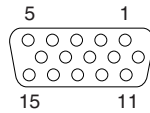

## LAN-module indicators and input/output connectors

The LAN module is a hot-swap module that is installed on the rear of the BladeCenter T unit and is held in place by captive thumbscrews. The LAN module provides the electrical and mechanical interface to the BladeCenter T unit for the two local area network (Ethernet) connections, as driven from each management module, and the telco external alarms. This module contains two RJ-45 connectors with LEDs and one DSUB 15P telco alarm connector.

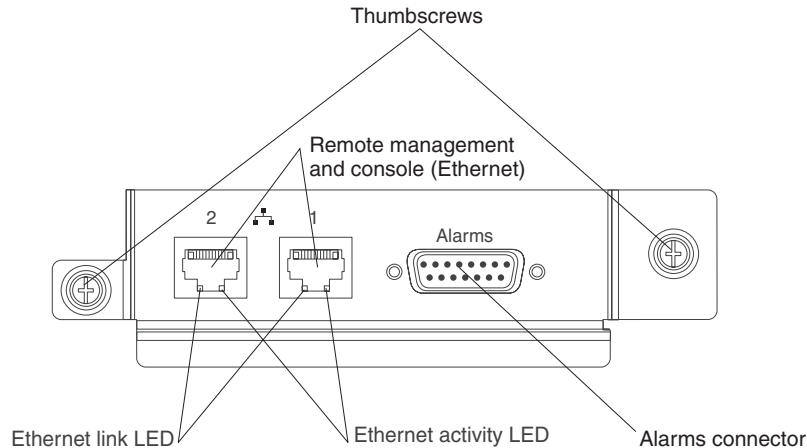

**LAN-module LEDs:** These LEDs provide status information about the LAN connection:

- **Ethernet link:** When this green LED is lit, there is an active connection through the port to the network.
- **Ethernet activity:** When this green LED is flashing, it indicates that there is activity through the port over the network link.

### LAN-module connectors:

- **Remote management and console (Ethernet) connectors:** The LAN module provides two Ethernet RJ-45 connectors.

**Note:** All Ethernet cables must be shielded and grounded at both ends per GR-1089-CORE.

The BladeCenter T LAN module contains two 10/100 Mb Ethernet connectors that provide the remote connections, driven from each management module, to the network management station on the network.

Use these ports for remote management and remote console.

The network management station, through these connectors, can access control functions running in the management module, the service processor on each blade server, or within each switch module. However, it cannot use these ports to communicate with application programs running in the blade servers. The network management station must direct those communications through a network connected to the external ports in the I/O modules in the BladeCenter T unit.

- **Alarms connector:** The LAN module provides one telco DB15 alarms connector (male) for critical, major, and minor telco alarms. Each of the alarms has a relay that enables multiple system alarm indicators to be daisy-chained together. Table 4 on page 61 shows the pinouts for the telco alarms connector.

## Alarms

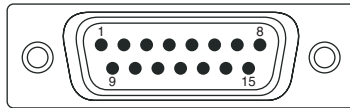

**Note:** The service processor, management module, or systems-management function must monitor the alarm reset inputs to maintain the fault condition that you set for the unit. The alarm reset inputs can be voltages in excess of standard logic levels, so you must electrically or optically isolate them from the monitoring logic.

Table 4. Alarms connector pinout

Pin #	Description	I/O	Pin #	Description	I/O
1	Minor alarm reset +	I	9	Minor alarm normally closed	O
2	Minor alarm reset -	I	10	Minor alarm common	O
3	Major alarm reset +	I	11	Major alarm normally open	O
4	Major alarm reset -	I	12	Major alarm normally closed	O
5	Critical alarm normally open	O	13	Major alarm common	O
6	Critical alarm normally closed	O	14	Reserved	O
7	Critical alarm common	O	15	Reserved	O
8	Minor alarm normally open	O			

The electrical specifications for the alarms connector are as follows:

– **Outputs**

- Voltage range: 0 V dc to -100 V dc (maximum current 0.3 A at 100 V dc)
- Current range: 0 A to 1 A (maximum voltage 30 V dc at 1 A)
- Worst-case VA: 1 A at -30 V dc (30 VA maximum) indefinitely

– **Inputs**

- Voltage range: 0 V dc to -100 V dc (including transients)
- Differential input voltage: 3 V dc to 72 V dc

– **Reset input activation**

Pulse width: 200 ms (minimum) to 300 ms

## I/O modules

You can install a maximum of four I/O modules at the rear of the system (a maximum of four Gbit Ethernet switches, or a maximum of two Gbit Ethernet switches and two Fibre Channel switches). The minimum system configuration requires one Gbit Ethernet switch or pass-thru module. The I/O switch modules provide high-performance connectivity between the blade servers.

**Note:** All Ethernet cables must be shielded and grounded at both ends per GR-1089-CORE.

See the documentation that comes with each I/O module for a description of the LEDs and connectors on the I/O module.



---

## Chapter 5. Configuration and networking guidelines

The BladeCenter components are configured and managed using a management module. Depending on your management module type, you can configure the management module and the BladeCenter unit components using a local or remote connection and management-module user interfaces or system management tools. See your management module *User's Guide* and *Command Line Interface Reference Guide* for instructions about configuring the BladeCenter.

---

### Configuring the BladeCenter unit

General configuration of the BladeCenter and installed components is performed through the management module. See your management module *User's Guide* and *Command Line Interface Reference Guide* for information and instructions. Some devices installed in the BladeCenter unit, such as I/O modules and blade servers, might also require additional configuration. See the documentation that comes with each device for information and instructions.

### Configuring the management module

All management modules are preconfigured with the same static IP address. You can use the management module to assign a new static IP address. To establish connectivity, the management module attempts to use dynamic host control protocol (DHCP) to acquire its initial IP address for the management-module Ethernet port. If DHCP is not installed or is enabled and fails, the management module uses the static IP address. Use the management module to configure other BladeCenter component settings, such as user accounts, DHCP, or Wake on LAN. See your management module *User's Guide* and *Command Line Interface Reference Guide* for instructions.

### Configuring I/O modules

You need to install and configure at least one external (in-band) port on an Ethernet switch module in I/O-module bay 1 or 2 to communicate with the Ethernet controllers integrated on each blade server. See your management module *User's Guide* and *Command Line Interface Reference Guide* for information about configuring external ports on I/O modules. For I/O device settings, see the documentation that comes with your I/O device.

**Note:** If a pass-thru module is installed in I/O-module bay 1 or 2, you will need to configure the network switch that the pass-thru module is connected to; see the documentation that comes with the network switch.

### Configuring blade servers

To achieve blade server redundancy, you must configure the Ethernet controllers in one or more blade servers for failover. When failover occurs on a blade server, the secondary Ethernet controller takes over network communications, using the I/O module associated with that controller. Install a pair of Ethernet switches in I/O-module bays 1 and 2, then configure them and your network infrastructure so that they can direct traffic to the same destinations. You can also install a pass-thru module that is connected to an external Ethernet switch in either or both of these I/O-module bays. See the documentation that comes with your blade server and operating system for instructions.

---

## BladeCenter networking guidelines

The network administrator should assist in the configuration of the network infrastructure prior to connecting the BladeCenter unit to a LAN switch or similar network device.

Each blade server has two independent Ethernet controllers, each with its own MAC address and a dedicated 1000-Mbps link to one of the switch modules in I/O module bays 1 and 2. There is no internal data path between the two switches within the BladeCenter unit; an external network device is required for data packets to flow from one internal switch to the other.

The management module has a separate internal 100-Mbps link to each switch. These links are for internal management and control only. No data packets are allowed to flow from application programs on the blade servers to the management module over this path.

---

## IBM Director

With IBM Director, a network administrator can perform the following tasks:

- View the hardware configuration of remote systems, in detail.
- Monitor the usage and performance of critical components, such as microprocessors, disks, and memory.
- Centrally manage individual or large groups of IBM and non-IBM Intel processor-based servers, desktop computers, workstations, and mobile computers on a variety of platforms.

IBM Director provides a comprehensive entry-level workgroup hardware manager. It includes the following key features:

- Advanced self-management capabilities for maximum system availability.
- Multiple operating-system platform support, including Microsoft Windows 2000 Server, Windows XP Professional, Red Hat Linux, SUSE LINUX, and Novell NetWare. For a complete list of operating systems that support IBM Director, see the IBM Director Compatibility Document. This document is in PDF at [http://www.ibm.com/servers/eserver/xseries/systems\\_management/sys\\_migration/ibmdiragent.html](http://www.ibm.com/servers/eserver/xseries/systems_management/sys_migration/ibmdiragent.html) and is updated every 6 to 8 weeks.
- Support for IBM and non-IBM servers, desktop computers, workstations, and mobile computers.
- Support for systems-management industry standards.
- Integration into leading workgroup and enterprise systems-management environments.
- Ease of use, training, and setup.

IBM Director also provides an extensible platform that supports advanced BladeCenter tools that are designed to reduce the total cost of managing and supporting networked systems. By deploying IBM Director, you can achieve reductions in ownership costs through the following benefits:

- Reduced downtime
- Increased productivity of IT personnel and users
- Reduced service and support costs

For more information about IBM Director, see the documentation on the *IBM Director* CD that comes with the BladeCenter unit, the IBM Director Information Center at <http://publib.boulder.ibm.com/infocenter/eserver/v1r2/topic/dirinfo/>

fgm0\_main.htm, and the IBM xSeries Systems Management Web page at [http://www.ibm.com/servers/eserver/xseries/systems\\_management/xseries\\_sm.html](http://www.ibm.com/servers/eserver/xseries/systems_management/xseries_sm.html), which present an overview of IBM Systems Management and IBM Director.





---

## Chapter 6. Solving problems

This section provides basic troubleshooting information to help you solve some common problems that might occur while setting up the BladeCenter T unit.

If you cannot locate and correct the problem using the information in this section, see the *Hardware Maintenance Manual and Troubleshooting Guide* on the IBM *BladeCenter T Documentation* CD for more information.

---

### Diagnostic tools overview

The following tools are available to help you identify and solve hardware-related problems:

- **Troubleshooting charts**

These charts list problem symptoms and steps to correct the problems. See the “Troubleshooting charts” on page 68 for more information.

- **Diagnostic programs and error messages**

The built-in self-test (BIST) program checks the BladeCenter T unit during startup and generates error messages if problems are found.

The system diagnostic program, Real Time Diagnostics Version 1.3, tests the major components of your BladeCenter T unit. It is run from the IBM Director Management Console window (under the **BladeCenter T** task in the Task panel).

Complete the following steps to obtain the Real Time Diagnostics program:

1. Go to <http://www.ibm.com/pc/support/>.
2. Select **Servers** from the list on the left side of the window.
3. Select **Downloadable files** from the list on the left side of the window.
4. In the **Downloadable files by category** list, select **Diagnostic**.
5. Click the entry for Real Time Diagnostics and follow the instructions on that page.

- **Light path diagnostics feature**

Use the light path diagnostics feature to identify system errors quickly. On the BladeCenter T unit, the light path diagnostics feature consists of the LEDs on the front of the BladeCenter T unit and on the front of the modules and blade servers.

---

## Troubleshooting charts

You can use the troubleshooting charts in this section to find solutions to problems that have definite symptoms.

**Note:** The symptoms for monitor, keyboard, and mouse apply only to the devices connected to the management module; they do not apply to the remote console.

See the *Hardware Maintenance Manual and Troubleshooting Guide* on the IBM BladeCenter T Documentation CD for more detailed information about testing the BladeCenter T unit. If you have run the diagnostic test programs or if running the tests does not reveal the problem, call for service.

**Attention:** If diagnostic error messages appear that are not listed in the *Hardware Maintenance Manual and Troubleshooting Guide*, make sure that your BladeCenter T unit has the latest level of firmware code installed.

If you have just added a new option and your system is not working, complete the following procedure before using the troubleshooting charts:

1. Remove the option that you just added.
2. Run the diagnostic tests to determine if your system is running correctly.
3. Reinstall the new device.

## Monitor problems

**Note:** The monitor screen remains blank until directed to a blade server that is turned on; this is normal behavior.

Some IBM monitors have their own self-tests. If you suspect a problem with your monitor, see the information that comes with the monitor for instructions for testing and adjusting the monitor. If you cannot diagnose the problem, call for service.

Device	Suggested action
The monitor screen goes blank when you direct it to a working blade server or goes blank when you start some application programs in the blade servers.	Make sure that the monitor cable is connected to the video connector on the BladeCenter T KVM module and that the KVM module LEDs indicate that the module is functioning. Some IBM monitors have their own self-tests. If you suspect a problem with your monitor, see the information that comes with the monitor for adjusting and testing instructions.  If you cannot diagnose the problem, try replacing the KVM module. If the problem remains, replace the monitor.
The screen is blank.	Make sure that: <ul style="list-style-type: none"><li>• The power cords are properly connected to the BladeCenter T unit.</li><li>• The monitor cables are connected correctly.</li><li>• The monitor is turned on and the brightness and contrast controls are adjusted correctly.</li><li>• The monitor is owned by a blade server that is turned on and that supports the keyboard, video, and mouse (KVM) feature.</li></ul> If the problem remains, call for service.
Only the cursor appears.	Try switching the monitor to another blade server. <ul style="list-style-type: none"><li>• If the problem goes away, troubleshoot the blade server for which only the cursor appears.</li><li>• If the problem remains, call for service.</li></ul>

Device	Suggested action
The monitor has screen jitter, or the screen image is wavy, unreadable, rolling, or distorted.	<p>If the monitor self-tests show the monitor is working correctly, consider the location of the monitor. Magnetic fields around other devices (such as transformers, appliances, fluorescent lights, and other monitors) can cause screen jitter or wavy, unreadable, rolling, or distorted screen images. If this happens, turn off the monitor. (Moving a color monitor while it is turned on might cause screen discoloration.) Then move the device and the monitor at least 305 mm (12 in.) apart. Turn on the monitor.</p> <p><b>Notes:</b></p> <ol style="list-style-type: none"> <li>1. Non-IBM monitor cables might cause unpredictable problems.</li> <li>2. An enhanced monitor cable with additional shielding is available for the 9521 and 9527 monitors. For information about the enhanced monitor cable, contact your IBM marketing representative or authorized reseller.</li> </ol> <p>If the problem remains, call for service.</p>
All other symptoms	Troubleshoot the blade server that is the current owner of the keyboard, video, and monitor.

## Power problems

Device	Suggested action
The BladeCenter T unit does not start.	<ul style="list-style-type: none"> <li>• Make sure that the LEDs on the power module are on.</li> <li>• Make sure that the power cords are properly connected to the BladeCenter T unit.</li> <li>• For type 8730 (ac), make sure that the 220-volt PDU or electrical outlet is working correctly.</li> <li>• For type 8720 (dc), make sure either that the fuses are good or that the circuit breakers are turned to the On position in the dc power distribution panel.</li> <li>• If you just installed an option, remove it, and restart the BladeCenter T unit. If the BladeCenter T unit now starts, you might have installed more options than the power module supports.</li> </ul> <p>If the problem remains, call for service.</p>

## Management module problems

Device	Suggested action
Management module does not complete changeover to redundant module on hardware failure.	Call for service.

## Blower module problems

Device	Suggested action
<p>Blower module operates at full speed, with no regulation.  <b>Note:</b> Blower modules will run at full speed to compensate for a failed or non-working blower.</p>	<ul style="list-style-type: none"> <li>• Check for a failed blower module. Look for any of these indications:               <ul style="list-style-type: none"> <li>– Error LED is lit</li> <li>– Blower fan is not blowing</li> <li>– Fan speed of blowers in a pair differs by more than approximately 5 percentage points of each other, as viewed on the management module Web interface.</li> </ul> <p>If a blower module has failed, replace the module as soon as possible.</p> </li> <li>• Swap the blower modules in pairs (top-to-bottom or side-to-side).               <ul style="list-style-type: none"> <li>– If relocating a blower to a known good blower bay fails to start the blower, the blower module has failed and needs to be replaced as soon as possible. Call for service to obtain a replacement blower.</li> <li>– If swapping the blower modules produces no change, or if a known good blower is installed in a blower bay and fails to start, the problem is within the BladeCenter T unit or with the active management module. If you have redundant management modules, perform the following steps:                   <ol style="list-style-type: none"> <li>1. Pull the active management module out of its bay to cause a failover to the redundant management module.</li> <li>2. Wait about two minutes for the redundant management module to assume full control of the blower speeds; then, recheck the blower status.</li> <li>3. If all blower speeds are normal, then the management module that was pulled is defective. Call for service to obtain a replacement management module.</li> </ol> <p>If the management module that was pulled is not defective, or you do not have redundant management modules, call for service.</p> </li> </ul> </li> </ul> <p><b>Important:</b> Leave a failed blower in place until a replacement is obtained. The blower, even if defective, blocks air from being pulled into the chassis from the open blower bay and causing improper cooling to other components in the BladeCenter T unit.</p>

## Options problems

Device	Suggested action
<p>An IBM option that was just installed does not work.</p>	<p>Make sure that:</p> <ul style="list-style-type: none"> <li>• The option is designed for the BladeCenter T unit. See the “Server Support” flowchart on the inside of the front cover for information about obtaining ServerProven® compatibility information from the World Wide Web.</li> <li>• You followed the installation instructions that come with the option.</li> <li>• The option is installed correctly.</li> <li>• You have not loosened any other installed options or cables.</li> </ul> <p>If the problem remains, call for service.</p>
<p>An IBM option that used to work does not work now.</p>	<ul style="list-style-type: none"> <li>• Make sure that all of the option hardware and cable connections are secure.</li> <li>• If the option comes with test instructions, use those instructions to test the option.</li> </ul> <p>If the problem remains, call for service.</p>

---

## Light path diagnostics feature

On the BladeCenter T system, the light path diagnostics feature consists of the LEDs on the front and rear of the BladeCenter T unit and on the front of the modules and blade servers. If a system-alarm LED on the system-status panels on the BladeCenter T unit is lit, one or more error LEDs on the BladeCenter T components also might be on. These LEDs help identify the cause of the problem.

## Identifying problems using the light path diagnostics feature

This section provides the information to identify, using the light path diagnostics feature, problems that might arise during installation.

To locate the actual component that caused the error, you must locate the lit error LED on that component.

The following example illustrates how to use the light path diagnostics feature to diagnose a system error:

1. Note that a BladeCenter T system-error LED is lit on the system-status panel.
2. Locate the module or blade server that also has an error LED lit (see Chapter 4, “BladeCenter T components, controls, and LEDs,” on page 53 for the location of error LEDs; see the documentation that comes with your blade server for the location of error LEDs on the blade server).
  - a. If the component is a module, replace the module.
  - b. If the component is a blade server with its system error LED lit, follow the instructions in the documentation that comes with the blade server to isolate and correct the problem.

## Light path diagnostics LEDs

A system-alarm LED on the system-status panel is lit when certain system errors occur. If one of the system-alarm LEDs on your BladeCenter T unit is lit, use the following table to help determine the cause of the error and the action you should take.

**Note:** You can configure the major and critical alarm LEDs to be either amber or red through the management module.

Table 5. Light path diagnostics

Lit LED	Cause	Action
<b>BladeCenter T system-status panel</b>		
Location	A condition has occurred in the BladeCenter T unit that has caused the remote system management to identify the BladeCenter T unit as needing attention.	Look for any information or error LEDs on the system-status panels, the modules, and the blade servers in this BladeCenter T unit, and follow the instructions in this table for those LEDs.
Minor (MNR)	A noncritical event has occurred that should be looked at, such as the wrong I/O module inserted in a bay.	Check the error log for the messages. Check the LEDs on the BladeCenter T unit and the blade servers to isolate the component.
Major (MJR)	A major system error has occurred, such as the loss of one of two mirrored disks. <b>Note:</b> You can configure the major error LED to be either red or amber through the management module.	<ul style="list-style-type: none"> <li>• Check the error log for messages.</li> <li>• Look for an error LED on the modules and blade servers to locate the component:               <ul style="list-style-type: none"> <li>– If the error LED is on a module, follow the instructions for the module in this table.</li> <li>– If the error LED is on a blade server, see the documentation that comes with the blade server.</li> </ul> </li> </ul>
Critical (CRT)	A critical system error has occurred, such as nonredundancy on the power modules or a system error in a blade server. <b>Note:</b> You can configure the critical error LED to be either red or amber through the management module.	<ul style="list-style-type: none"> <li>• Check the error log for messages.</li> <li>• Look for an error LED on the modules and blade servers to locate the component:               <ul style="list-style-type: none"> <li>– If the error LED is on a module, follow the instructions for the module in this table.</li> <li>– If the error LED is on a blade server, see the documentation that comes with the blade server.</li> </ul> </li> </ul>
<b>Management module</b>		
System error	A critical error has occurred in the management module.	<ul style="list-style-type: none"> <li>• If your BladeCenter T unit has only one management module:               <ol style="list-style-type: none"> <li>1. Try reseating the management module.</li> <li>2. Restart the management module.</li> </ol>               If the problem remains, replace the management module.             </li> <li>• If your BladeCenter T unit has two management modules, the BladeCenter T unit continues to function using the redundant module. Replace the failed management module.</li> </ul>

Table 5. Light path diagnostics (continued)

Lit LED	Cause	Action
Active	Primary management module.	If your BladeCenter T has two management modules, the Active LED indicates which is the primary management module.
<b>Power module</b>		
System error	A critical error has occurred in the power module.	Reseat the power module. If the problem remains, replace the module. If your BladeCenter T unit has a redundant module for this power module, the BladeCenter T unit continues to function using the redundant module.
<b>Blower module</b>		
System error	The blower has failed or is operating too slowly.	Reseat the blower module. If the problem remains, replace the blower module as soon as possible, to regain cooling redundancy. The BladeCenter T unit continues to function. The remaining three blowers increase their speed to cool the BladeCenter T unit and blade servers.
<b>I/O module</b>		
System error	A critical error has occurred in the I/O module.	Reseat the I/O module. If the problem remains, replace the module.







---

## Chapter 7. Sharing resources among the blade servers

The IBM BladeCenter T Type 8720 or 8730 unit provides resources that are available to all blade servers at all times, such as power modules, cooling, system management, and network I/O modules; no user intervention is required. Some resources are selectable for use by a single blade server at a time, such as the CD-ROM drive, USB port units (media tray), or the keyboard-video-mouse (KVM) module (on blade servers that support the KVM feature). There are several ways to select resources for a blade server:

- Each blade server has two selection buttons on the front of the blade: **CD** and .

- To switch the keyboard, video, and mouse to a specific blade server, press the  button on that blade server.

**Note:** Some blade servers have only the CD selection button; those blade servers do not support the KVM function.

- To switch the CD-ROM and USB ports to a specific blade server, press the **CD** button on that blade server.

The management module immediately assigns the resource to the blade server requesting it.

- You can use the management module Web interface to change ownership of the keyboard, video, and mouse, or the CD-ROM drive, and USB ports (**Blade tasks” Remote control**).
- You can press keyboard keys in the following sequence to switch KVM control between blade servers:

NumLock NumLock *blade\_server\_number* Enter

Where *blade\_server\_number* is the two-digit number for the blade bay in which the blade server is installed. When using some keyboards, such as the 28L3644 (37L0888) keyboard, you will need to hold down the Shift key while entering this key sequence.

### Notes:

1. The keyboard sequence switches KVM control only to a blade server that supports the KVM feature.
2. It can take up to 20 seconds for the operating system in the switched-to blade server to recognize the CD-ROM drive, and USB ports, or the keyboard, video, and mouse.
3. If you install Microsoft Windows 2000 on a blade server while it is not the current owner of the keyboard, video, and mouse, the first time the blade server requests ownership after the operating system has been installed, it can take up to 1 minute for the operating system to recognize the devices (this is a one-time-only occurrence).
4. The operating system in the blade server must provide USB support for the blade server to recognize and use the keyboard, mouse, and CD-ROM drive. The BladeCenter T unit uses USB for internal communication with these devices.
5. Do not switch control of the shared CD-ROM drive or diskette drive to another blade server until the activity lights on both the CD-ROM drive and diskette drive are off, indicating that no read or write operations are in progress.

6. Before switching ownership of the CD-ROM drive to another blade server, safely stop the CD-ROM device on the blade server that currently owns it, using the facilities available through the operating system, such as a task bar icon or an unmount command.
7. You can use the management module Web interface to enable or disable the select buttons (**Blade tasks” Remote control**) on the blade servers.
8. The monitor attached to the BladeCenter T management module normally shows the video output from the blade server that is the current owner of the keyboard, video, and mouse (KVM). When there is no actively selected video from any blade server, the video from blade server 8 is routed to the management module. While the management module is restarting, there is temporarily no current KVM owner. The video from blade server 8 displays on the monitor briefly until the management module uses its NVRAM values to reestablish ownership of the KVM and media tray (CD-ROM drive, and USB ports). After that, the video from the blade server that is the current KVM owner is displayed on the monitor.

**Attention:** Do not switch the CD-ROM drive, and USB ports to another blade server while a transaction is taking place on the CD-ROM drive. (Activity lights on the CD-ROM drive must be off.) Data damage can occur.

## Appendix A. BladeCenter management module configuration worksheet

Use the worksheets in this appendix to record the information for configuring the management module in your BladeCenter unit. Information about using the worksheet is provided in the IBM *BladeCenter Management Module User's Guide* for your management module type.

### General Settings

Management module name	
Contact name	
Physical location	
Clock settings	

### Login profiles

Login ID	Password	Authority level	
		R/O	R/W

### External network interface (eth0)

Interface	<input type="checkbox"/> Enabled <input type="checkbox"/> Disabled
DHCP	<input type="checkbox"/> DHCP with rollover to static <input type="checkbox"/> DHCP only <input type="checkbox"/> Static IP only
Host name	
Static IP configuration (configure only if DHCP is disabled)	
IP address	____.____.____.____
Subnet mask	____.____.____.____
Gateway IP address	____.____.____.____

### Internal network interface (eth1)

Interface IP address	____.____.____.____
----------------------	---------------------

Subnet mask	____.____.____.____
Locally-administered MAC address	____.____.____.____

## Alerts

<b>Remote Alert Recipients</b>		
Receives critical alerts only		
	Status	
	Notification method	<input type="checkbox"/> SNMP over LAN <input type="checkbox"/> e-mail over LAN <input type="checkbox"/> IBM Director
	Host name (or IP address)	
	e-mail address	
<b>Global remote alert settings</b>		
Remote alerts retry limit		
Delay between retries		
Include event log with e-mail alerts	<input type="checkbox"/> Yes <input type="checkbox"/> No	
<b>Alerts to be monitored</b>		
Critical alerts	Select all critical alerts	
	Hard disk drive	
	Multiple blower failures	
	Power failure	
	Temperature	
	VRM failure	
	Multiple switch module failures	
	Invalid configuration	
Warning alerts	Select all critical alerts	
	Single blower failure	
	Temperature	
	Voltage	
	KVM/media tray switching failure	
	Redundant module failure	
System alerts	Power off	
	Inventory	
	Log 75% full	

## Network protocols

<b>SNMP</b>	
SNMP agent	<input type="checkbox"/> Enable <input type="checkbox"/> Disable
SNMP traps	<input type="checkbox"/> Enable <input type="checkbox"/> Disable
Community name	
Host name (or IP address)	
<b>SMTP</b>	
Host name (or IP address)	
<b>DNS</b>	
DNS	<input type="checkbox"/> Enable <input type="checkbox"/> Disable
DNS Server IP address 1	____.____.____.____
DNS Server IP address 2	____.____.____.____
DNS Server IP address 3	____.____.____.____

## Security

Secure Socket Layer (SSL)	<input type="checkbox"/> Enabled <input type="checkbox"/> Disabled
Certificates	<input type="checkbox"/> Self-signed <input type="checkbox"/> Provided by a certificate authority



---

## Appendix B. Getting help and technical assistance

If you need help, service, or technical assistance or just want more information about IBM products, you will find a wide variety of sources available from IBM to assist you. This appendix contains information about where to go for additional information about IBM and IBM products, what to do if you experience a problem with your BladeCenter<sup>®</sup> product or optional device, and whom to call for service, if it is necessary.

---

### Before you call

Before you call, make sure that you have taken these steps to try to solve the problem yourself:

- Check all cables to make sure that they are connected.
- Check the power switches to make sure that the system and any optional devices are turned on.
- Use the troubleshooting information in your system documentation, and use the diagnostic tools that come with your system. Information about diagnostic tools is in the *Hardware Maintenance Manual and Troubleshooting Guide* or *Problem Determination and Service Guide* on the IBM Documentation CD that comes with your system.
- Go to <http://www.ibm.com/servers/eserver/support/bladecenter/index.html> to check for information to help you solve the problem.

You can solve many problems without outside assistance by following the troubleshooting procedures that IBM provides in the online help or in the documentation that is provided with your IBM product. The documentation that comes with BladeCenter systems also describes the diagnostic tests that you can perform. Most BladeCenter systems, operating systems, and programs come with documentation that contains troubleshooting procedures and explanations of error messages and error codes. If you suspect a software problem, see the documentation for the software.

---

### Using the documentation

Information about your IBM BladeCenter system and preinstalled software, if any, or optional device is available in the documentation that comes with the product. That documentation can include printed documents, online documents, readme files, and help files. See the troubleshooting information in your system documentation for instructions for using the diagnostic programs. The troubleshooting information or the diagnostic programs might tell you that you need additional or updated device drivers or other software. IBM maintains pages on the World Wide Web where you can get the latest technical information and download device drivers and updates. To access these pages, go to <http://www.ibm.com/servers/eserver/support/bladecenter/index.html> and follow the instructions. Also, some documents are available through the IBM Publications Center at <http://www.ibm.com/shop/publications/order/>.

---

### Getting help and information from the World Wide Web

On the World Wide Web, the IBM Web site has up-to-date information about IBM BladeCenter systems, optional devices, services, and support at <http://www.ibm.com/servers/eserver/support/bladecenter/index.html>.

---

## Software service and support

Through IBM Support Line, you can get telephone assistance, for a fee, with usage, configuration, and software problems with BladeCenter products. For information about which products are supported by Support Line in your country or region, see <http://www.ibm.com/services/sl/products/>.

For more information about Support Line and other IBM services, see <http://www.ibm.com/services/>, or see <http://www.ibm.com/planetwide/> for support telephone numbers. In the U.S. and Canada, call 1-800-IBM-SERV (1-800-426-7378).

---

## Hardware service and support

You can receive hardware service through IBM Services or through your IBM reseller, if your reseller is authorized by IBM to provide warranty service. See <http://www.ibm.com/planetwide/> for support telephone numbers, or in the U.S. and Canada, call 1-800-IBM-SERV (1-800-426-7378).

In the U.S. and Canada, hardware service and support is available 24 hours a day, 7 days a week. In the U.K., these services are available Monday through Friday, from 9 a.m. to 6 p.m.

---

## IBM Taiwan product service

台灣IBM 產品服務聯絡方式：  
台灣國際商業機器股份有限公司  
台北市松仁路7號3樓  
電話：0800-016-888

IBM Taiwan product service contact information:  
IBM Taiwan Corporation  
3F, No 7, Song Ren Rd.  
Taipei, Taiwan  
Telephone: 0800-016-888



---

## Appendix C. Notices

This information was developed for products and services offered in the U.S.A.

IBM may not offer the products, services, or features discussed in this document in other countries. Consult your local IBM representative for information on the products and services currently available in your area. Any reference to an IBM product, program, or service is not intended to state or imply that only that IBM product, program, or service may be used. Any functionally equivalent product, program, or service that does not infringe any IBM intellectual property right may be used instead. However, it is the user's responsibility to evaluate and verify the operation of any non-IBM product, program, or service.

IBM may have patents or pending patent applications covering subject matter described in this document. The furnishing of this document does not give you any license to these patents. You can send license inquiries, in writing, to:

*IBM Director of Licensing  
IBM Corporation  
North Castle Drive  
Armonk, NY 10504-1785  
U.S.A.*

INTERNATIONAL BUSINESS MACHINES CORPORATION PROVIDES THIS PUBLICATION "AS IS" WITHOUT WARRANTY OF ANY KIND, EITHER EXPRESS OR IMPLIED, INCLUDING, BUT NOT LIMITED TO, THE IMPLIED WARRANTIES OF NON-INFRINGEMENT, MERCHANTABILITY OR FITNESS FOR A PARTICULAR PURPOSE. Some states do not allow disclaimer of express or implied warranties in certain transactions, therefore, this statement may not apply to you.

This information could include technical inaccuracies or typographical errors. Changes are periodically made to the information herein; these changes will be incorporated in new editions of the publication. IBM may make improvements and/or changes in the product(s) and/or the program(s) described in this publication at any time without notice.

Any references in this information to non-IBM Web sites are provided for convenience only and do not in any manner serve as an endorsement of those Web sites. The materials at those Web sites are not part of the materials for this IBM product, and use of those Web sites is at your own risk.

IBM may use or distribute any of the information you supply in any way it believes appropriate without incurring any obligation to you.

---

## Trademarks

The following terms are trademarks of International Business Machines Corporation in the United States, other countries, or both:

Active Memory	IBM	TechConnect
Active PCI	IBM (logo)	Tivoli
Active PCI-X	IntelliStation	Tivoli Enterprise
AIX	NetBAY	Update Connector
Alert on LAN	Netfinity	Wake on LAN

BladeCenter	Predictive Failure Analysis	XA-32
Chipkill	ServeRAID	XA-64
e-business logo	ServerGuide	X-Architecture
@server	ServerProven	XpandOnDemand
FlashCopy	System x	xSeries
i5/OS		

Intel, Intel Xeon, Itanium, and Pentium are trademarks or registered trademarks of Intel Corporation or its subsidiaries in the United States and other countries.

Microsoft, Windows, and Windows NT are trademarks of Microsoft Corporation in the United States, other countries, or both.

UNIX is a registered trademark of The Open Group in the United States and other countries.

Java and all Java-based trademarks and logos are trademarks of Sun Microsystems, Inc. in the United States, other countries, or both.

Adaptec and HostRAID are trademarks of Adaptec, Inc., in the United States, other countries, or both.

Linux is a trademark of Linus Torvalds in the United States, other countries, or both.

Red Hat, the Red Hat “Shadow Man” logo, and all Red Hat-based trademarks and logos are trademarks or registered trademarks of Red Hat, Inc., in the United States and other countries.

Other company, product, or service names may be trademarks or service marks of others.

---

## Important notes

Processor speeds indicate the internal clock speed of the microprocessor; other factors also affect application performance.

CD drive speeds list the variable read rate. Actual speeds vary and are often less than the maximum possible.

When referring to processor storage, real and virtual storage, or channel volume, KB stands for approximately 1000 bytes, MB stands for approximately 1 000 000 bytes, and GB stands for approximately 1 000 000 000 bytes.

When referring to hard disk drive capacity or communications volume, MB stands for 1 000 000 bytes, and GB stands for 1 000 000 000 bytes. Total user-accessible capacity may vary depending on operating environments.

Maximum internal hard disk drive capacities assume the replacement of any standard hard disk drives and population of all hard disk drive bays with the largest currently supported drives available from IBM.

Maximum memory may require replacement of the standard memory with an optional memory module.

IBM makes no representation or warranties regarding non-IBM products and services that are ServerProven, including but not limited to the implied warranties of merchantability and fitness for a particular purpose. These products are offered and warranted solely by third parties.

IBM makes no representations or warranties with respect to non-IBM products. Support (if any) for the non-IBM products is provided by the third party, not IBM.

Some software may differ from its retail version (if available), and may not include user manuals or all program functionality.

---

## Product recycling and disposal

This unit must be recycled or discarded according to applicable local and national regulations. IBM encourages owners of information technology (IT) equipment to responsibly recycle their equipment when it is no longer needed. IBM offers a variety of product return programs and services in several countries to assist equipment owners in recycling their IT products. Information on IBM product recycling offerings can be found on IBM's Internet site at <http://www.ibm.com/ibm/environment/products/prp.shtml>.

Esta unidad debe reciclarse o desecharse de acuerdo con lo establecido en la normativa nacional o local aplicable. IBM recomienda a los propietarios de equipos de tecnología de la información (TI) que reciclen responsablemente sus equipos cuando éstos ya no les sean útiles. IBM dispone de una serie de programas y servicios de devolución de productos en varios países, a fin de ayudar a los propietarios de equipos a reciclar sus productos de TI. Se puede encontrar información sobre las ofertas de reciclado de productos de IBM en el sitio web de IBM <http://www.ibm.com/ibm/environment/products/prp.shtml>.

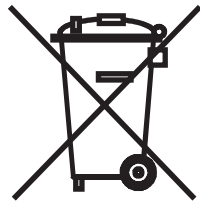

**Notice:** This mark applies only to countries within the European Union (EU) and Norway.

This appliance is labeled in accordance with European Directive 2002/96/EC concerning waste electrical and electronic equipment (WEEE). The Directive determines the framework for the return and recycling of used appliances as applicable throughout the European Union. This label is applied to various products to indicate that the product is not to be thrown away, but rather reclaimed upon end of life per this Directive.

注意: このマークは EU 諸国およびノルウェーにおいてのみ適用されます。

この機器には、EU 諸国に対する廃電気電子機器指令 2002/96/EC(WEEE) のラベルが貼られています。この指令は、EU 諸国に適用する使用済み機器の回収とリサイクルの骨子を定めています。このラベルは、使用済みになった時に指令に従って適正な処理をする必要があることを知らせるために種々の製品に貼られています。

**Remarque :** Cette marque s'applique uniquement aux pays de l'Union Européenne et à la Norvège.

L'étiquette du système respecte la Directive européenne 2002/96/EC en matière de Déchets des Equipements Electriques et Electroniques (DEEE), qui détermine les dispositions de retour et de recyclage applicables aux systèmes utilisés à travers l'Union européenne. Conformément à la directive, ladite étiquette précise que le produit sur lequel elle est apposée ne doit pas être jeté mais être récupéré en fin de vie.

In accordance with the European WEEE Directive, electrical and electronic equipment (EEE) is to be collected separately and to be reused, recycled, or recovered at end of life. Users of EEE with the WEEE marking per Annex IV of the WEEE Directive, as shown above, must not dispose of end of life EEE as unsorted municipal waste, but use the collection framework available to customers for the return, recycling, and recovery of WEEE. Customer participation is important to minimize any potential effects of EEE on the environment and human health due to the potential presence of hazardous substances in EEE. For proper collection and treatment, contact your local IBM representative.

---

## Battery return program

This product may contain a sealed lead acid, nickel cadmium, nickel metal hydride, lithium, or lithium ion battery. Consult your user manual or service manual for specific battery information. The battery must be recycled or disposed of properly. Recycling facilities may not be available in your area. For information on disposal of batteries outside the United States, go to <http://www.ibm.com/ibm/environment/products/batteryrecycle.shtml> or contact your local waste disposal facility.

In the United States, IBM has established a return process for reuse, recycling, or proper disposal of used IBM sealed lead acid, nickel cadmium, nickel metal hydride, and battery packs from IBM equipment. For information on proper disposal of these batteries, contact IBM at 1-800-426-4333. Have the IBM part number listed on the battery available prior to your call.

**For Taiwan:** Please recycle batteries.



**For the European Union:**

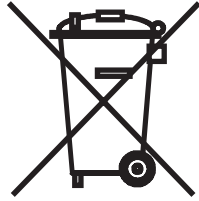

**For California:** Perchlorate material – special handling may apply. See <http://www.dtsc.ca.gov/hazardouswaste/perchlorate/>.

The foregoing notice is provided in accordance with California Code of Regulations Title 22, Division 4.5 Chapter 33. Best Management Practices for Perchlorate Materials. This product/part may include a lithium manganese dioxide battery which contains a perchlorate substance.

---

## Electronic emission notices

### Federal Communications Commission (FCC) statement

**Note:** This equipment has been tested and found to comply with the limits for a Class A digital device, pursuant to Part 15 of the FCC Rules. These limits are designed to provide reasonable protection against harmful interference when the equipment is operated in a commercial environment. This equipment generates, uses, and can radiate radio frequency energy and, if not installed and used in accordance with the instruction manual, may cause harmful interference to radio communications. Operation of this equipment in a residential area is likely to cause harmful interference, in which case the user will be required to correct the interference at his own expense.

Properly shielded and grounded cables and connectors must be used in order to meet FCC emission limits. IBM is not responsible for any radio or television interference caused by using other than recommended cables and connectors or by unauthorized changes or modifications to this equipment. Unauthorized changes or modifications could void the user's authority to operate the equipment.

This device complies with Part 15 of the FCC Rules. Operation is subject to the following two conditions: (1) this device may not cause harmful interference, and (2) this device must accept any interference received, including interference that may cause undesired operation.

### Industry Canada Class A emission compliance statement

This Class A digital apparatus complies with Canadian ICES-003.

### Avis de conformité à la réglementation d'Industrie Canada

Cet appareil numérique de la classe A est conforme à la norme NMB-003 du Canada.

## Australia and New Zealand Class A statement

**Attention:** This is a Class A product. In a domestic environment this product may cause radio interference in which case the user may be required to take adequate measures.

## United Kingdom telecommunications safety requirement

### Notice to Customers

This apparatus is approved under approval number NS/G/1234/J/100003 for indirect connection to public telecommunication systems in the United Kingdom.

## European Union EMC Directive conformance statement

This product is in conformity with the protection requirements of EU Council Directive 89/336/EEC on the approximation of the laws of the Member States relating to electromagnetic compatibility. IBM cannot accept responsibility for any failure to satisfy the protection requirements resulting from a nonrecommended modification of the product, including the fitting of non-IBM option cards.

This product has been tested and found to comply with the limits for Class A Information Technology Equipment according to CISPR 22/European Standard EN 55022. The limits for Class A equipment were derived for commercial and industrial environments to provide reasonable protection against interference with licensed communication equipment.

**Attention:** This is a Class A product. In a domestic environment this product may cause radio interference in which case the user may be required to take adequate measures.

## Taiwanese Class A warning statement

警告使用者：  
這是甲類的資訊產品，在居住的環境中使用時，可能會造成射頻干擾，在這種情況下，使用者會被要求採取某些適當的對策。

## Chinese Class A warning statement

声 明  
此为 A 级产品。在生活环境中，该产品可能会造成无线电干扰。在这种情况下，可能需要用户对其干扰采取切实可行的措施。

## Japanese Voluntary Control Council for Interference (VCCI) statement

この装置は、情報処理装置等電波障害自主規制協議会（VCCI）の基準に基づくクラスA情報技術装置です。この装置を家庭環境で使用すると電波妨害を引き起こすことがあります。この場合には使用者が適切な対策を講ずるよう要求されることがあります。





---

# Index

## A

- ac power LED 56
- acoustical noise emissions 5, 7
- attention notices 10
- availability features 13

## B

- backplane, redundancy characteristics 11
- bezel
  - installing 31
  - removing 31
- bezel assembly
  - installing 30
  - removing 29
  - removing and installing 29
- blade filler, installing 51
- blade server
  - installing 50, 51
  - removing 52
- BladeCenter T unit
  - connecting to power 22
  - installing in a rack 17
  - setting up 17
  - shutting down 26
  - starting 24
- BladeCenter, configuring 63
- blower module 40
  - error LED 57
  - installing 41
  - LEDs 57
  - power LED 57
  - problems 70
  - removing 41

## C

- caution statements 10
- CD
  - BladeCenter T Documentation 9
- CD-ROM
  - drive 55
  - drive specifications 5, 7
- Class A electronic emission notice 87
- components
  - hot-swap 13
  - location of 14
  - major 14
- configuration sheet, management module 77
- configuring
  - BladeCenter unit 63
  - I/O module 63
- configuring the management module 63
- connector
  - Ethernet 60
  - Ethernet, remote management and console 60
  - input/output 60

- connector (*continued*)
  - keyboard 59
  - KVM module 59
  - PS/2 mouse 59
  - remote management 60
  - serial 54
  - telco alarms 60
  - USB 56
  - video 59
- controls 53
- cooling 5, 7

## D

- danger statements 10
- diagnostic tools 67
- documentation CD 9

## E

- electrical input 5, 7
- electronic emission Class A notice 87
- environment 5, 7
- ESD
  - connector 19
  - wrist strap 19
- Ethernet
  - activity LED 60
  - connectors 60
  - remote management and console 60
  - switch 46
- Ethernet-link status LED 60
- expansion options
  - I/O 49
  - PCI I/O Expansion Unit 49
  - Storage Expansion Unit 49

## F

- FCC Class A notice 87
- features
  - BladeCenter T unit 5, 7
  - reliability, availability, and serviceability 13
  - server 10

## H

- handling static-sensitive devices 19
- hardware problems 67
- heat output 5, 7
- hot-swap components 13

## I

- I/O module 46
  - configuring 63
  - installing 48

- I/O module (*continued*)
  - removing 48
  - types 46
- IBM Director 64
- important notices 10
- installation guidelines 18
- installing
  - air filter 30
  - bezel 31
  - bezel assembly 30
  - blade filler 51
  - blade server 51
  - BladeCenter T unit 17
  - blower module 41
  - I/O module 48
  - in a rack 17
  - KVM module 43
  - LAN module 45
  - management module 39
  - media tray 36
  - modules 27
  - options 18, 27
  - power module 33
  - power module filler 33
  - SCSI Storage Expansion Unit 49
- Internet protocol (IP) address
  - resetting 54
- IP reset button, management module 54

## K

- keyboard connector 59
- KVM module 42
  - connectors
    - keyboard 59
    - mouse 59
    - video 59
  - installing 43
- LEDs
  - critical telco alarm 58
  - location 58
  - major telco alarm 58
  - minor telco alarm 58
  - power 58
- removing 43
- system-status panel 58

## L

- labels
  - model number 2
  - serial number 2
  - user 2, 51
- LAN module 44
  - function 60
  - installing 45
- LEDs
  - Ethernet activity 60
  - Ethernet link 60
- removing 45

- LEDs
  - ac power 56
  - alarm 55, 58
    - critical 55, 58
    - major 56, 58
    - minor 56, 58
  - blower 57
  - blower module 57
  - Ethernet activity 60
  - Ethernet-link status 60
  - front of server 55
  - front view 53
  - KVM module 58
  - LAN module 60
  - location 55
  - management module 54
    - active 54
    - error 54
    - power 54
  - power module 56
  - rear view 57
  - system-status panel 43, 55
    - power 55, 58
- light path diagnostics
  - error table 72
  - feature 67, 71
- location
  - serial connector on management module 54

## M

- major components 14
- management module 37
  - alerts 78
  - configuration sheet 77
  - configuring 63
  - external network interface 77
  - function 37
  - general settings 77
  - installing 39
  - internal network interface 77
  - IP reset button 54
  - LEDs 54
    - active 54
    - error 54
    - power 54
  - login profiles 77
  - network protocols 79
  - power LED 54
  - redundant, automatic changeover 72
  - removing 38
  - security 79
  - serial connector 54
- media tray 35, 55
  - CD-ROM drive 55
  - installing 36
  - removing 36
  - system-status panel 35, 55
- modules
  - blower 40
  - I/O 46

modules (*continued*)  
installing 27  
KVM 42  
LAN 44  
management 37  
media tray 35  
power  
    Type 8720 (DC) 22  
    Type 8730 (AC) 23  
mouse connector 59

## N

network  
    environment support 12  
network connections, redundant 11  
networking guidelines 64  
notes 10  
notes, important 84  
notices  
    electronic emission 87  
    FCC, Class A 87  
    notices and statements 10

## O

options, installation guidelines 18

## P

port  
    *See* connector  
power module  
    AC 23  
    DC 22  
    installing 33  
    LEDs 56  
    removing 33  
    specifications 5, 7  
    Type 8720  
        function 22  
        redundancy 22  
    Type 8730  
        function 23  
        redundancy 23  
power.  
    *See* system power  
problem  
    blower 70  
    hardware 67  
    management module 69  
    monitor 68  
    option 70  
    power 69  
    solving 67  
product  
    data 1  
    registration 1

## R

rack, installing BladeCenter in 17  
RAS  
    *See also* features  
    reliability, availability, and serviceability 13  
redundant  
    components 11  
    network connection capabilities 11  
reliability features 13  
remote management connector 60  
removing  
    bezel 31  
    bezel assembly 29  
    blade server 52  
    blower module 41  
    I/O module 48  
    KVM module 43  
    LAN module 45  
    management module 38  
    media tray 36  
    power module 33  
replacing air filter 30  
reset button, management module, IP 54

## S

serial connector 54  
service replaceable units  
    air filter 30  
serviceability features 13  
shutting down BladeCenter T unit 26  
size 5, 7  
specifications 5, 7  
statements and notices 10  
static electricity 19  
static-sensitive devices  
    ESD connector 19  
    ESD wrist strap 19  
    handling 19  
system  
    capabilities  
        expansion 10  
        hot-swap 10  
        management 12  
        redundancy 11  
        redundant network connection 11  
    connecting to power 21  
    front view 14  
    power  
        Type 8720 (DC) 22  
        Type 8730 (AC) 23  
    rear view Type 8720 15  
    rear view Type 8730 15  
    reliability 18  
    service cards 53  
    setting up 17  
    shutting down 26  
    starting 24  
system-status  
    LEDs 43, 53, 55

system-status (*continued*)  
panel 35, 42, 58  
systems management 64

## **T**

telco alarms connector 60  
temperature 5, 7  
trademarks 83  
troubleshooting, charts 67, 68

## **U**

United States electronic emission Class A notice 87  
United States FCC Class A notice 87  
USB connectors 56

## **V**

video connector 59  
video output, unexpected or blank 76

## **W**

weight 5, 7





Part Number: 42C5000

Printed in USA

(1P) P/N: 42C5000

