

42U Enterprise Primary Rack and  
42U Enterprise Expansion Rack



# Installation Guide



42U Enterprise Primary Rack and  
42U Enterprise Expansion Rack



# Installation Guide

**Note:** Before using this information and the product it supports, read the general information in Appendix B, "Notices," on page 27, the *Rack Safety Information* and *Environmental Notices and User Guide* documents on the IBM *Documentation CD*, and the *Important Notices* and *Warranty Information* documents that comes with the product.

**Third Edition (November 2010)**

**© Copyright IBM Corporation 2001, 2010.**

US Government Users Restricted Rights – Use, duplication or disclosure restricted by GSA ADP Schedule Contract with IBM Corp.

---

# Contents

<b>Safety</b> . . . . .	v
<b>Chapter 1. Introduction</b> . . . . .	1
The IBM Documentation CD . . . . .	1
Hardware and software requirements . . . . .	1
Using the Documentation Browser . . . . .	2
Notices and statements in this document . . . . .	3
<b>Chapter 2. Installing a rack cabinet</b> . . . . .	5
Size and weight specifications . . . . .	6
Lowering the leveling feet and installing the stabilizer bracket . . . . .	7
Removing and installing the lower and upper side covers . . . . .	8
Removing and installing the lower side covers . . . . .	8
Removing and installing the upper 6U side covers . . . . .	9
Removing and installing rack doors . . . . .	10
Removing and installing the front door . . . . .	10
Removing and installing the rear door . . . . .	11
Attaching rack cabinets in a suite . . . . .	12
Installing optional devices . . . . .	13
Installing clip nuts . . . . .	14
<b>Chapter 3. Managing cables</b> . . . . .	15
Using the cable-access opening in the top of the rack . . . . .	16
<b>Chapter 4. Moving a rack cabinet</b> . . . . .	17
<b>Chapter 5. Customer replaceable unit parts</b> . . . . .	21
<b>Appendix A. Getting help and technical assistance</b> . . . . .	25
Before you call . . . . .	25
Using the documentation . . . . .	25
Getting help and information from the World Wide Web . . . . .	25
Software service and support . . . . .	26
Hardware service and support . . . . .	26
IBM Taiwan product service . . . . .	26
<b>Appendix B. Notices</b> . . . . .	27
Trademarks . . . . .	27
Important notes . . . . .	28
Particulate contamination . . . . .	29
Documentation format . . . . .	29
Electronic emission notices . . . . .	30
Federal Communications Commission (FCC) statement . . . . .	30
Industry Canada Class A emission compliance statement . . . . .	30
Avis de conformité à la réglementation d'Industrie Canada . . . . .	30
Australia and New Zealand Class A statement . . . . .	30
European Union EMC Directive conformance statement . . . . .	30
Germany Class A statement . . . . .	31
Japan VCCI Class A statement . . . . .	32
Korea Communications Commission (KCC) statement . . . . .	32
Russia Electromagnetic Interference (EMI) Class A statement . . . . .	32
People's Republic of China Class A electronic emission statement . . . . .	32
Taiwan Class A compliance statement . . . . .	33

**Index** . . . . . 35

# Safety

Before installing this product, read the Safety Information.

قبل تركيب هذا المنتج، يجب قراءة الملاحظات الأمنية

Antes de instalar este produto, leia as Informações de Segurança.

在安装本产品之前，请仔细阅读 **Safety Information** (安全信息)。

安裝本產品之前，請先閱讀「安全資訊」。

Prije instalacije ovog produkta obavezno pročitajte Sigurnosne Upute.

Před instalací tohoto produktu si přečtěte příručku bezpečnostních instrukcí.

Læs sikkerhedsforskrifterne, før du installerer dette produkt.

Lees voordat u dit product installeert eerst de veiligheidsvoorschriften.

Ennen kuin asennat tämän tuotteen, lue turvaohjeet kohdasta Safety Information.

Avant d'installer ce produit, lisez les consignes de sécurité.

Vor der Installation dieses Produkts die Sicherheitshinweise lesen.

Πριν εγκαταστήσετε το προϊόν αυτό, διαβάστε τις πληροφορίες ασφάλειας (safety information).

לפני שתתקינו מוצר זה, קראו את הוראות הבטיחות.

A termék telepítése előtt olvassa el a Biztonsági előírásokat!

Prima di installare questo prodotto, leggere le Informazioni sulla Sicurezza.

製品の設置の前に、安全情報をお読みください。

본 제품을 설치하기 전에 안전 정보를 읽으십시오.

Пред да се инсталира овој продукт, прочитајте информацијата за безбедност.

Les sikkerhetsinformasjonen (Safety Information) før du installerer dette produktet.

Przed zainstalowaniem tego produktu, należy zapoznać się z książką "Informacje dotyczące bezpieczeństwa" (Safety Information).

Antes de instalar este produto, leia as Informações sobre Segurança.

Перед установкой продукта прочтите инструкции по технике безопасности.

Pred inštaláciou tohto zariadenia si pečítajte Bezpečnostné predpisy.

Pred namestitvijo tega proizvoda preberite Varnostne informacije.

Antes de instalar este producto, lea la información de seguridad.

Läs säkerhetsinformationen innan du installerar den här produkten.

**Important:** Each caution and danger statement in this document is labeled with a number. This number is used to cross reference an English-language caution or danger statement with translated versions of the caution or danger statement in the *IBM® Rack Safety Information* document.

For example, if a caution statement is labeled “Statement 1,” translations for that caution statement are in the *IBM Rack Safety Information* document under “Statement 1.”

Be sure to read all caution and danger statements in this document before you perform the procedures. Read any additional safety information that comes with the server or optional device before you install the device.

**Statement 1:**



**CAUTION:**

To ensure safety, all configurations of the rack cabinet must be certified by a nationally recognized testing laboratory in order to verify compliance with country-specific safety regulations. This process ensures that the end product remains safe for the operator and service personnel under normal and foreseeable misuse conditions.

**Statement 2:**



**DANGER**

- Always lower the leveling pads on the rack cabinet.
- Always install stabilizer brackets on the rack cabinet.
- Always install servers and optional devices starting from the bottom of the rack cabinet.
- Always install the heaviest devices in the bottom of the rack cabinet.



**Statement 3:**



**DANGER**

- Do not extend more than one sliding device at a time.
- The maximum allowable weight for devices on slide rails is 80 kg (176 lb). Do not install sliding devices that exceed this weight.

**Statement 4:**



**DANGER**

**Electrical current from power, telephone, and communication cables is hazardous.**

**To avoid a shock hazard:**

- Do not connect or disconnect any cables or perform installation, maintenance, or reconfiguration of this product during an electrical storm.
- Connect all power cords to a properly wired and grounded electrical outlet.
- Connect to properly wired outlets any equipment that will be attached to this product.
- When possible, use one hand only to connect or disconnect signal cables.
- Never turn on any equipment when there is evidence of fire, water, or structural damage.
- Disconnect the attached power cords, telecommunications systems, networks, and modems before you open the device covers, unless instructed otherwise in the installation and configuration procedures.
- Connect and disconnect cables as described in the following table when installing, moving, or opening covers on this product or attached devices.

**To Connect:**

1. Turn everything OFF.
2. First, attach all cables to devices.
3. Attach signal cables to connectors.
4. Attach power cords to outlet.
5. Turn device ON.

**To Disconnect:**

1. Turn everything OFF.
2. First, remove power cords from outlet.
3. Remove signal cables from connectors.
4. Remove all cables from devices.

**Statement 5:**

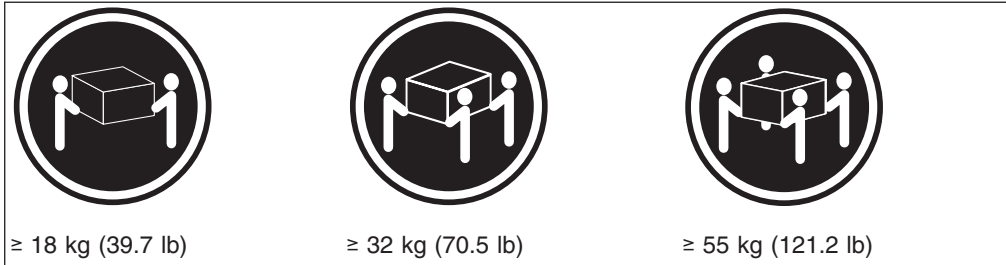

**CAUTION:**

Use safe practices when lifting.

**Statement 6:**



**CAUTION:**

Do not place any object on top of a rack-mounted device unless that rack-mounted device is intended for use as a shelf.

**Statement 8:**



**DANGER**

- Plug power cords from devices in the rack cabinet into electrical outlets that are located near the rack cabinet and are easily accessible.
- Each rack cabinet might have more than one power cord. Be sure to disconnect all power cords in the rack cabinet before servicing any device in the rack cabinet.
- Install an emergency-power-off switch if more than one power device (power distribution unit or uninterruptible power supply) is installed in the same rack cabinet.
- Connect all devices installed in a rack cabinet to power devices installed in the same rack cabinet. Do not plug a power cord from a device installed in one rack cabinet into a power device installed in a different rack cabinet.

**Statement 10:**



**CAUTION:**

Removing components from the upper positions in the Enterprise Rack cabinet improves rack stability during relocation. Follow these general guidelines whenever you relocate a populated rack cabinet within a room or building:

- Reduce the weight of the rack cabinet by removing equipment starting at the top of the rack cabinet. When possible, restore the rack cabinet to the configuration of the rack cabinet as you received it. If this configuration is not known, you must do the following:
  - Remove all devices in the 32U position and above.
  - Ensure that the heaviest devices are installed in the bottom of the rack cabinet.
  - Ensure that there are no empty U-levels between devices installed in the rack cabinet below the 32U level.
- If the rack cabinet you are relocating is part of a suite of rack cabinets, detach the rack cabinet from the suite.
- Inspect the route that you plan to take to eliminate potential hazards.
- Verify that the route that you choose can support the weight of the loaded rack cabinet. Refer to the documentation that comes with your rack cabinet for the weight of a loaded rack cabinet.
- Verify that all door openings are at least 760 x 2030 mm (30 x 80 in.)
- Ensure that all devices, shelves, drawers, doors, and cables are secure.
- Ensure that the four leveling pads are raised to their highest position.
- Ensure that there is no stabilizer bracket installed on the rack cabinet.
- Do not use a ramp inclined at more than ten degrees.
- Once the rack cabinet is in the new location, do the following:
  - Lower the four leveling pads.
  - Install stabilizer brackets on the rack cabinet.
  - If you removed any devices from the rack cabinet, repopulate the rack cabinet from the lowest position to the highest position.

If a long distance relocation is required, restore the rack cabinet to the configuration of the rack cabinet as you received it. Pack the rack cabinet in the original packaging material, or equivalent. Also, lower the leveling pads to raise the casters off of the pallet and bolt the rack cabinet to the pallet.

Statement 12:



**CAUTION:**

See the instructions in the rack documentation before you install devices, remove devices, or relocate the rack.

Statement 13:



**CAUTION:**

The weight of this part or unit is more than 55 kg (121.2 lb). It takes specially trained persons, a lifting device, or both to safely lift this part or unit.



	<p><b>Use Only Professional Movers!</b></p> <p>يجب الاستعانة بخبرات نقل متخصصة</p> <p>Utilizar somente transportadores profissionais</p> <p>Faire appel à des professionnels seulement pour déplacer l'équipement.</p> <p>只能使用专业搬运机</p> <p>Maak gebruik van professionele verhuizers</p> <p>Faites exclusivement appel à des déménageurs professionnels.</p> <p>Nur professionelle Transportunternehmen mit der Durchführung beauftragen.</p> <p>Να μετακινείται μόνο από επαγγελματίες μεταφορείς</p> <p>העזרו במובילים מקצועיים בלבד</p> <p>Csak hivatásos szállítóval költöztesse</p> <p>Avvalersi solo di trasportatori esperti</p> <p>機器を移動する際には専門の業者に依頼してください。</p> <p>전문 운송 인력만이 이동시킬 수 있습니다.</p> <p>Należy korzystać wyłącznie z usług wyspecjalizowanych firm.</p> <p>El traslado del equipo debe realizarlo personal especializado</p> <p>Trebaju raditi samo profesionalni transportni radnici</p> <p>Použite pouze profesionální stěhováky</p> <p>Brug kun professionelle flyttefolk.</p> <p>Käytä vain ammattitaitoista kuljetusliikettä</p> <p>Utstyret må kun flyttes av godkjent flyttepersonell</p> <p>Contacte apenas transportadoras profissionais</p> <p>Используйте только профессиональных грузчиков</p> <p>Na presun použite len profesionálov</p> <p>Använd endast professionell flyttpersonal</p>
<p><b>Use Only Professional Movers!</b></p>	



**Note:** Each stand-alone rack must be attached to the floor by a trained service technician according to your local building codes. Place a fastener in each corner of the rack. Each fastener must have a rated pull-out force of at least 460 newtons.

**United Kingdom - Notice to Customers:**

This apparatus is approved under approval number NS/G/1234/J/100003 for indirect connection to public telecommunication systems in the United Kingdom.



---

## Chapter 1. Introduction

This document contains general installation instructions for the IBM 42U Enterprise Rack and IBM 42U Enterprise Expansion Rack cabinets. Always read the documentation that comes with your server or optional device for detailed installation instructions.

Installing the rack cabinet consists of the following tasks:

1. Unpack the rack according to the *Unpacking Instructions* document that comes with the rack cabinet.
2. Locate the rack according to the *IBM eServer™ xSeries® Rack Planning Guide*.
3. Install rack stabilizer brackets on all racks.
4. Prepare the rack for optional devices:
  - Remove the side covers, if applicable.
  - Remove the front and rear doors from all racks, if necessary.
  - Attach expansion racks to a standard rack or to each other to form suites.
5. Install one or more optional devices.

**Note:** Install the heaviest devices in the bottom of the rack cabinet.

6. Complete the rack cabinet installation:
  - Reinstall side covers on all racks or on the outermost racks in a suite.
  - Reinstall front and rear doors on all racks cabinets.

If documentation updates are available, you can download them from the IBM website. The rack cabinet might have features that are not described in the documentation that comes with the rack, and the documentation might be updated occasionally to include information about those features, or technical updates might be available to provide additional information that is not included in the rack documentation. To check for updates, complete the following steps.

**Note:** Changes are made periodically to the IBM website. Procedures for locating documentation might vary slightly from what is described in this document.

To check for updates, go to <http://www.ibm.com/supportportal/>. For firmware updates, click **Downloads**. For documentation updates, click **Documentation**.

For more information about rack cabinets and options, see <http://www.ibm.com/systems/xbc/cog/rackcabinetsoptions/rackcabinetsoptions.html>.

---

## The IBM Documentation CD

The IBM *Documentation* CD contains documentation for the rack cabinet in Portable Document Format (PDF) and includes the IBM Documentation Browser to help you find information quickly.

## Hardware and software requirements

The IBM *Documentation* CD requires the following minimum hardware and software:

- Microsoft Windows XP, Windows 2000, or Red Hat Linux
- 100 MHz microprocessor
- 32 MB of RAM

- Adobe Acrobat Reader 3.0 (or later) or xpdf, which comes with Linux operating systems

## Using the Documentation Browser

Use the Documentation Browser to browse the contents of the CD, read brief descriptions of the documents, and view documents, using Adobe Acrobat Reader or xpdf. The Documentation Browser automatically detects the regional settings in your computer and displays the documents in the language for that region (if available). If a document is not available in the language for that region, the English-language version is displayed.

Use one of the following procedures to start the Documentation Browser:

- If Autostart is enabled, insert the CD into the CD or DVD drive. The Documentation Browser starts automatically.
- If Autostart is disabled or is not enabled for all users, use one of the following procedures:
  - If you are using a Windows operating system, insert the CD into the CD or DVD drive and click **Start --> Run**. In the **Open** field, type  
`e:\win32.bat`  
  
where *e* is the drive letter of the CD or DVD drive, and click **OK**.
  - If you are using Red Hat Linux, insert the CD into the CD or DVD drive; then, run the following command from the `/mnt/cdrom` directory:  
`sh runlinux.sh`

Select the rack cabinet from the **Product** menu. The **Available Topics** list displays all the documents for the rack. Some documents might be in folders. A plus sign (+) indicates each folder or document that has additional documents under it. Click the plus sign to display the additional documents.

When you select a document, a description of the document is displayed under **Topic Description**. To select more than one document, press and hold the Ctrl key while you select the documents. Click **View Book** to view the selected document or documents in Acrobat Reader or xpdf. If you selected more than one document, all the selected documents are opened in Acrobat Reader or xpdf.

To search all the documents, type a word or word string in the **Search** field and click **Search**. The documents in which the word or word string appears are listed in order of the most occurrences. Click a document to view it, and press Ctrl+F to use the Acrobat search function, or press Alt+F to use the xpdf search function within the document.

Click **Help** for detailed information about using the Documentation Browser.



---

## Notices and statements in this document

The caution and danger statements in this document are also in the multilingual *IBM Rack Safety Information* document that comes with the rack cabinet. Each statement is numbered for reference to the corresponding statement in your language in the *Rack Safety Information* document.

The following notices and statements are used in this document:

- **Note:** These notices provide important tips, guidance, or advice.
- **Important:** These notices provide information or advice that might help you avoid inconvenient or problem situations.
- **Attention:** These notices indicate potential damage to programs, devices, or data. An attention notice is placed just before the instruction or situation in which damage might occur.
- **Caution:** These statements indicate situations that can be potentially hazardous to you. A caution statement is placed just before the description of a potentially hazardous procedure step or situation.
- **Danger:** These statements indicate situations that can be potentially lethal or extremely hazardous to you. A danger statement is placed just before the description of a potentially lethal or extremely hazardous procedure step or situation.



---

## Chapter 2. Installing a rack cabinet

The primary and expansion rack cabinets are 42U-high<sup>1</sup> racks. The primary rack cabinet comes with side covers installed. The expansion rack cabinet does not come with side covers but includes the required hardware for building a suite of racks. You need one standard rack cabinet per suite.

### Notes:

1. Each stand-alone rack must be attached to the floor by a trained service technician according to your local building codes.
2. The illustrations in this document might differ slightly from your hardware.

### Statement 1:



### CAUTION:

To ensure safety, all configurations of the rack cabinet must be certified by a nationally recognized testing laboratory in order to verify compliance with country-specific safety regulations. This process ensures that the end product remains safe for the operator and service personnel under normal and foreseeable misuse conditions.

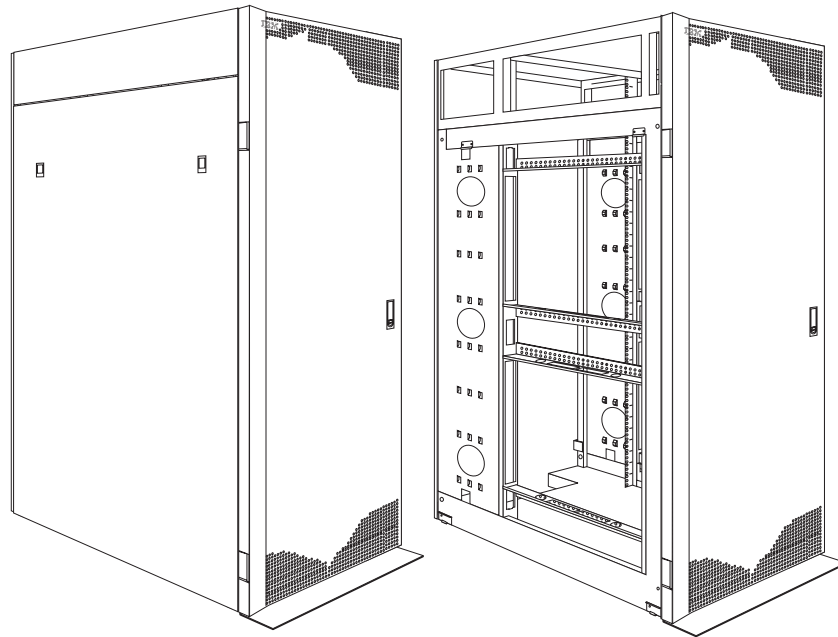

*Figure 1. Primary rack cabinet with side covers and expansion rack cabinet without side covers*

---

1. One U is equal to 4.45 cm (1.75 in.)

---

## Size and weight specifications

The 42U enterprise rack and 42U enterprise expansion rack conform to the Electronic Industries Association (EIA) standard *EIA-310-D Cabinets, Racks, Panels, and Associated Equipment (1992)*. For the rack cabinet dimensions and weights, see Table 1 and Table 2.

*Table 1. IBM 42U Enterprise Primary Rack and IBM 42U Enterprise Expansion Rack physical dimensions*

<b>Configuration</b>	<b>Dimensions</b>
9308-4PX 42U enterprise primary rack cabinet	2019 mm x 648 mm x 1105 mm (79.4 in. x 25.5 in. x 43.5 in.)
9308-4PX 42U enterprise expansion rack cabinet	2019 mm x 640 mm x 1105 mm (79.4 in. x 25.2 in. x 43.5 in.)

*Table 2. IBM 42U Enterprise Primary Rack and IBM 42U Enterprise Expansion Rack weights*

	<b>9308-4PX 42U enterprise primary rack</b>	<b>9308-4EX 42U enterprise expansion rack</b>
<b>Empty</b>	220 kg (485 lb)	177 kg (390 lb)
<b>Maximum load</b>	950 kg (2094 lb)	950 kg (2094 lb)
<b>Maximum configuration</b>	1170 kg (2579 lb)	1127 kg (2485 lb)

## Lowering the leveling feet and installing the stabilizer bracket

See the unpacking instructions that come with the rack cabinet for information about how to unpack and locate the rack; then, lower the rack-leveling feet and install the front stabilizer bracket for added stability.

### Statement 2:



### DANGER

- Always lower the leveling pads on the rack cabinet.
- Always install stabilizer brackets on the rack cabinet.
- Always install servers and optional devices starting from the bottom of the rack cabinet.
- Always install the heaviest devices in the bottom of the rack cabinet.

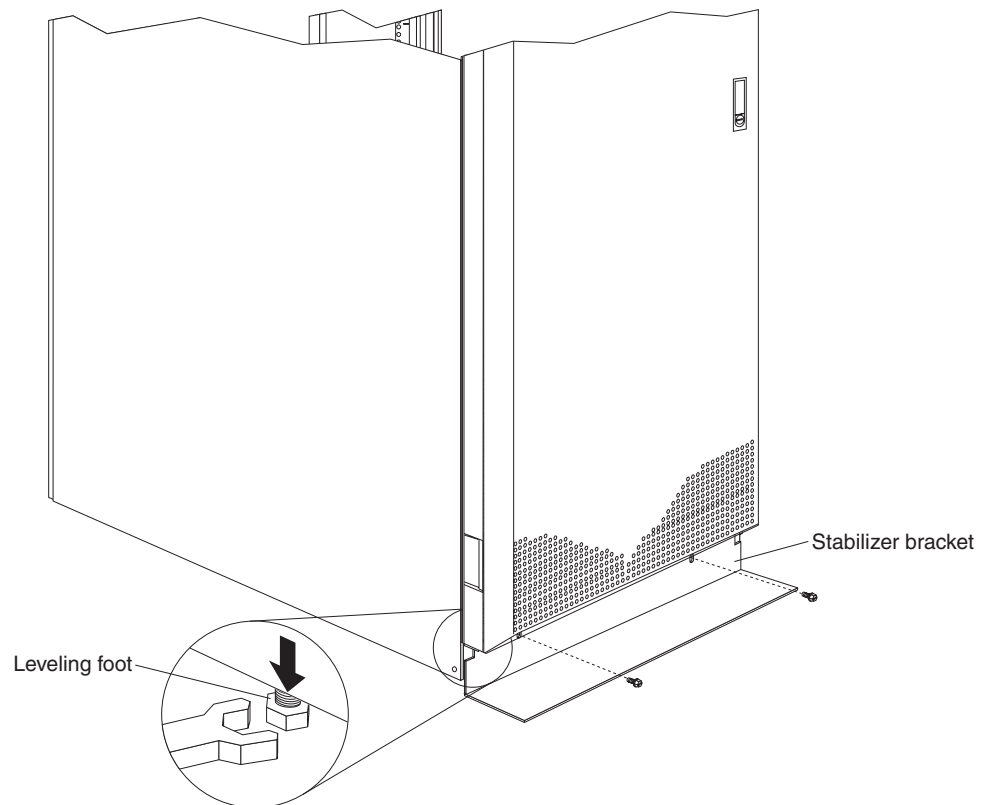

Figure 2. Lowering the leveling feet and installing the stabilizer bracket

To lower the leveling feet and install the front stabilizer bracket, complete the following steps:

1. Using the leveling pad wrench that comes with the rack cabinet, lower each of the four leveling feet just enough so that they touch the floor. The rack casters support the weight of the rack cabinet. The feet prevent the rack from rolling.

2. Attach the stabilizer bracket to the front of the rack cabinet with the two M8 x 25 mm screws that come with the bracket.

---

## Removing and installing the lower and upper side covers

The primary rack cabinet comes with side covers installed. Remove the side covers from a primary rack cabinet, or the outermost rack cabinets in a suite, before you install or remove optional devices.

### Removing and installing the lower side covers

To remove the lower side covers, complete the following steps.

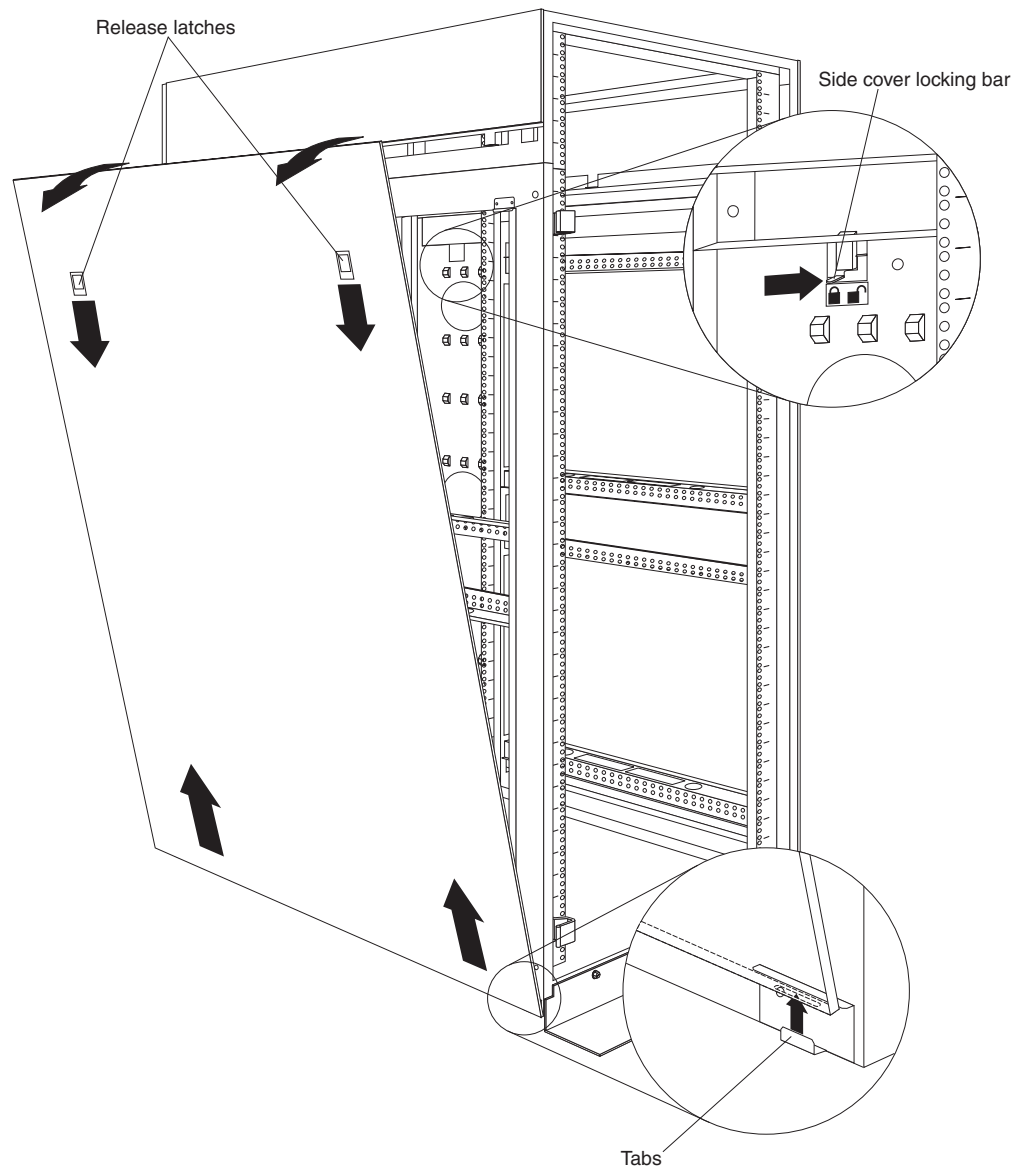

Figure 3. Removing the lower side cover

1. From the inside rear of the rack cabinet, slide the side cover locking bar toward the unlocked position.
2. Push down the release latches and tilt the side panel slightly toward you; then, lift the side cover away from the tabs on the bottom of the rack cabinet.

3. Repeat this procedure to remove the other side cover.

Reverse this procedure to install the lower side covers. Slide the locking bar to the locked position to secure the side cover to the rack cabinet.

## Removing and installing the upper 6U side covers

**Note:** You do not need to remove the upper 6U side covers unless you are building a suite of rack cabinets.

To remove the upper 6U side covers from the rack cabinet, complete the following steps.

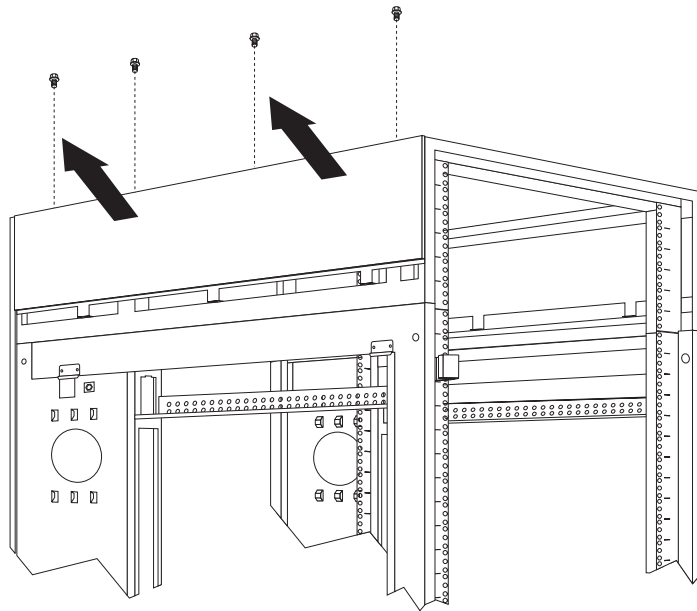

*Figure 4. Removing the upper 6U side covers from the rack cabinet*

1. On the top of the rack cabinet, loosen the four screws that hold the side cover in place.
2. Tilt the side cover slightly toward you; then, remove it from the rack cabinet.
3. Repeat this procedure to remove the other upper side cover.

Reverse this procedure to install the upper 6U side covers on the rack cabinet.

---

## Removing and installing rack doors

All enterprise racks come with front and rear doors installed. Remove the rack doors when you install and remove devices in the rack, if part of the rack is obstructed by the door as you install devices.

### Removing and installing the front door

To remove a front door from the rack cabinet, complete the following steps.

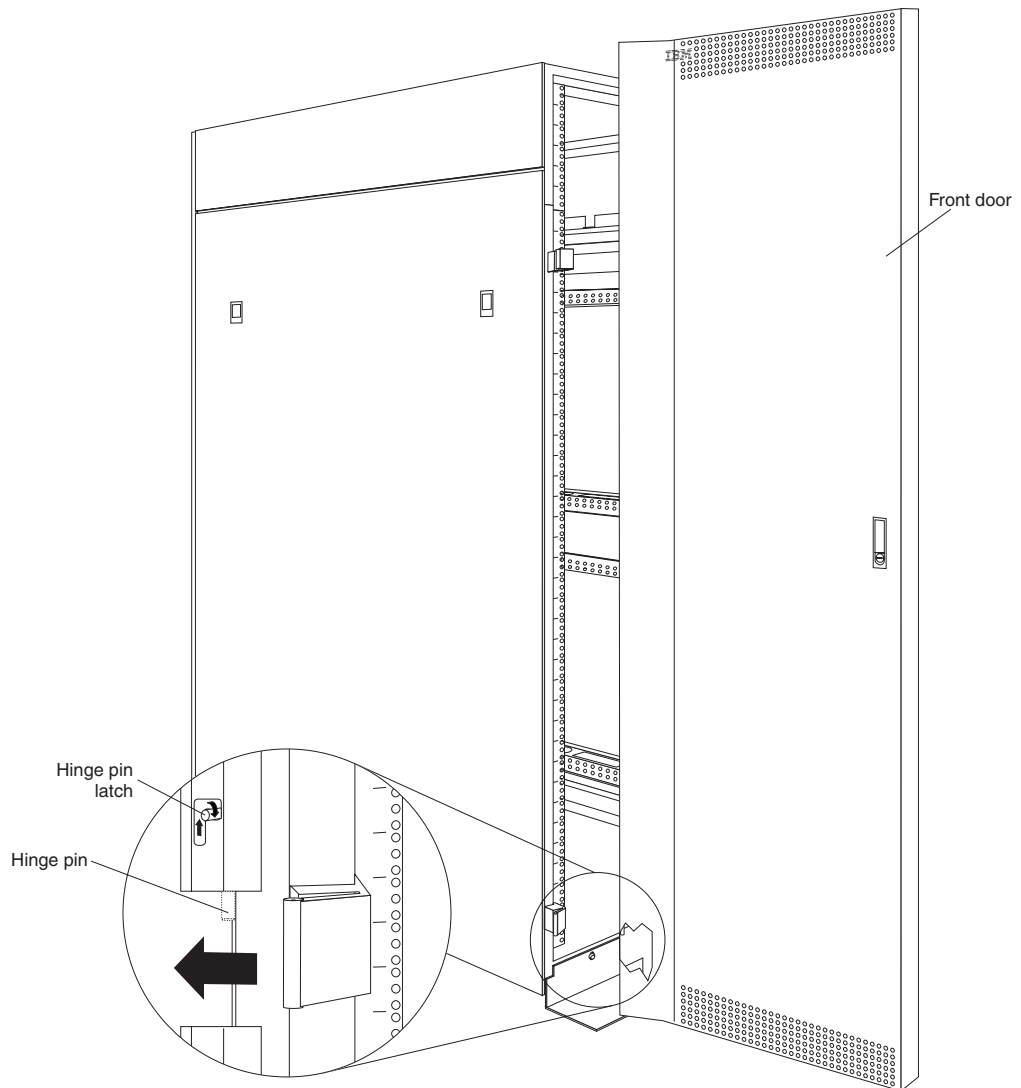

Figure 5. Removing a front door from the rack cabinet

1. Unlock and open the front door.
2. Holding the door firmly with one hand, push each hinge pin latch up and to the right to release the hinge pins.
3. Grasp the door firmly with both hands and pull it away from the rack cabinet; then, set the door aside.



Reverse this procedure to install the front door on the rack cabinet.

**Attention:** When you install the front door, make sure that you align the hinge pins with the hinges on the rack cabinet before you set the hinge pins into place.

## Removing and installing the rear door

To remove a rear door from the rack cabinet, complete the following steps.

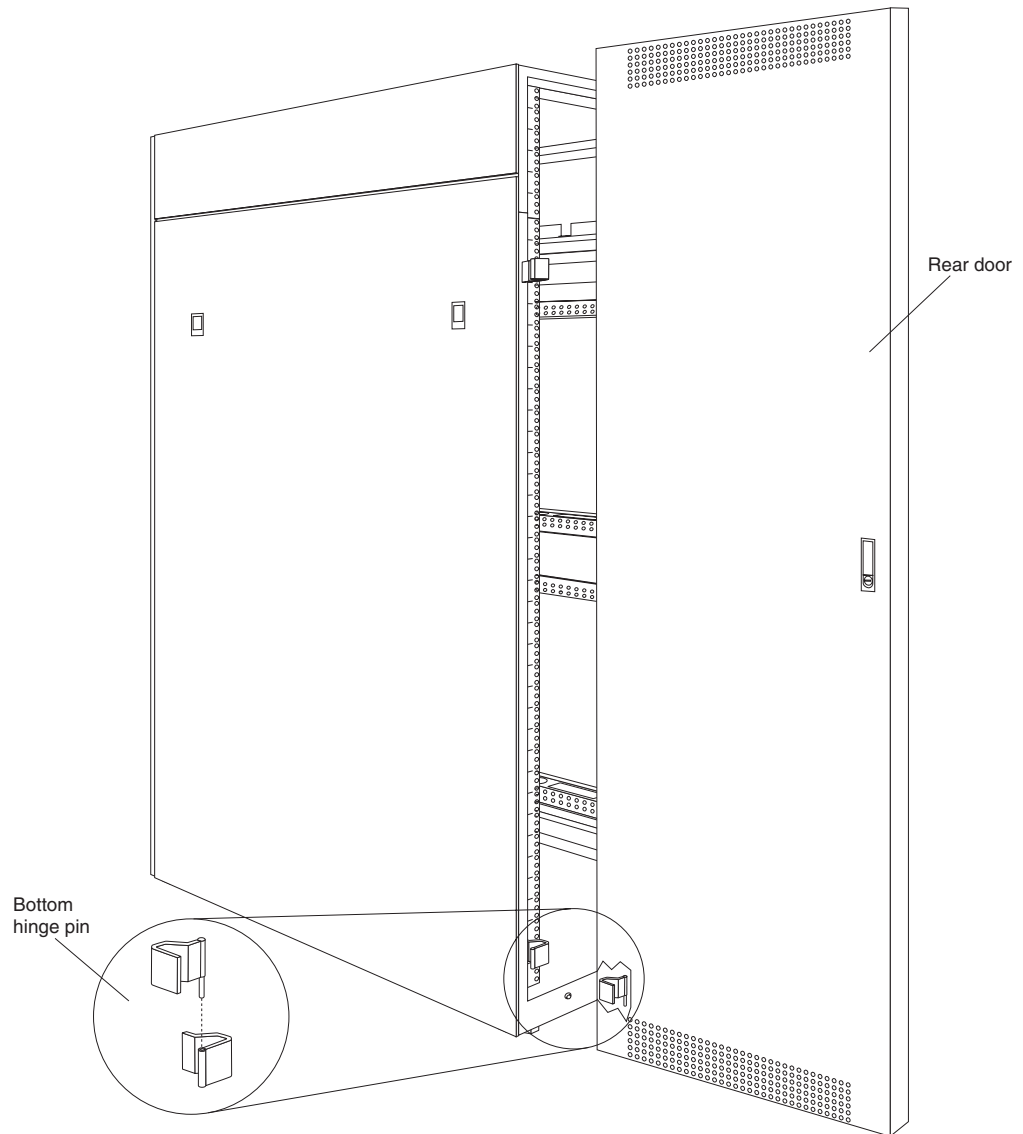

*Figure 6. Removing a rear door from the rack cabinet*

1. Unlock and open the rear door.
2. Grasp the door firmly with both hands, lift it up, and pull it away from the hinges; then, set the door aside.

Reverse this procedure to install the rear door on the rack cabinet.

**Attention:** The bottom hinge pin on the rear door is longer than the top hinge pin. Make sure that you engage the bottom hinge pin first when you install a rear door on the rack cabinet.

## Attaching rack cabinets in a suite

Expansion rack cabinets come with all the hardware that is required for you to attach rack cabinets together and form a suite. To attach rack cabinets together in a suite, complete the following steps.

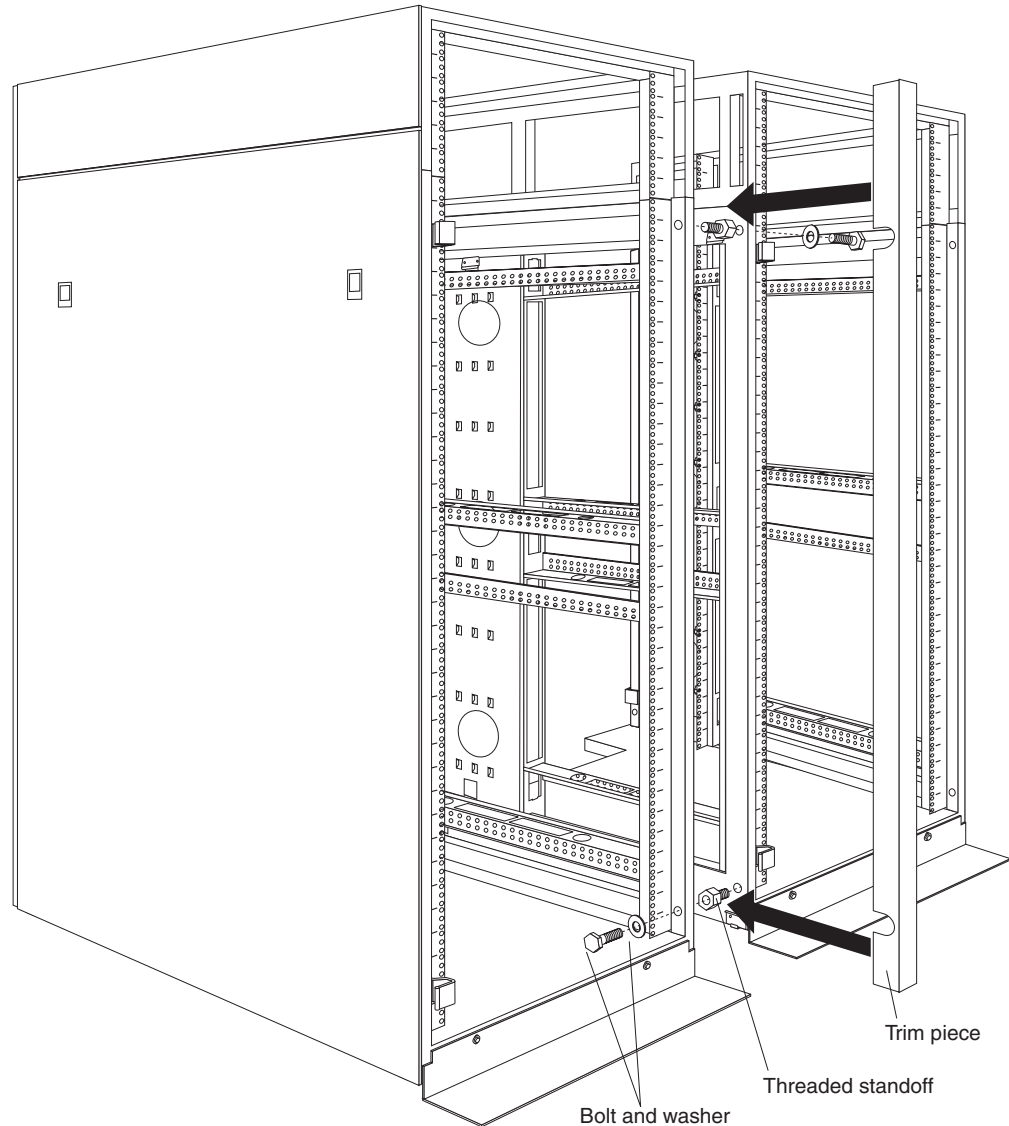

Figure 7. Attaching two adjacent rack cabinets to each other to form a suite

1. Remove the side covers (see “Removing and installing the lower and upper side covers” on page 8) from the side of a primary rack cabinet that is adjacent to an expansion rack in a suite.
2. Remove the front and rear doors (see “Removing and installing rack doors” on page 10) from both rack cabinets.

3. On the facing sides of the two adjacent rack cabinets, install the four threaded standoffs that come with the expansion rack cabinet:
  - a. Install two threaded standoffs on the rack cabinet to the left, one on the top-front and one on the bottom-rear.
  - b. Install the other two threaded standoffs on the rack cabinet to the right, one on the bottom-front and one on the top-rear.
4. Attach the rack cabinets together, using four bolts and washers that come with the expansion rack cabinet.

**Note:** You must install the top-front and bottom-rear bolts from right-to-left; then, install the bottom-front and top-rear bolts from left-to-right.

5. Snap the trim pieces into place between the adjacent rack cabinets. Install one trim piece in the front and one in the rear.
6. Install the side panels that you removed in step 1 on the expansion rack cabinet.
7. Install the front and rear doors on both rack cabinets.

Repeat this procedure to attach additional expansion rack cabinets to the suite.

---

## Installing optional devices

There are many servers and optional devices that you can install in the rack cabinet. Always read the documentation that comes with your server or optional device for detailed installation instructions.

When you install devices in the rack cabinet, secure each device or the rails for that device on rack-mounting flanges. Some devices come with threaded holes on the rail-mounting flanges. Other devices require that you use clip nuts to install them in the rack cabinet.

Always install the heaviest devices in the bottom of the rack cabinet. A configurator tool is available at <http://www.ibm.com/systems/x/configtools.html> to assist you with determining where to install optional devices in the rack.

For information about optional, compatible devices that you can install in the rack cabinet, go to the ServerProven® website at <http://www.ibm.com/systems/info/x86servers/serverproven/compat/us/>.

## Installing clip nuts

You must use clip nuts for all optional devices that do not have threaded holes. Install clip nuts on the rack-mounting flanges as shown in Figure 8.

**Note:** The rack cabinet comes with a supply of clip nuts, and devices that require them come with clip nuts.

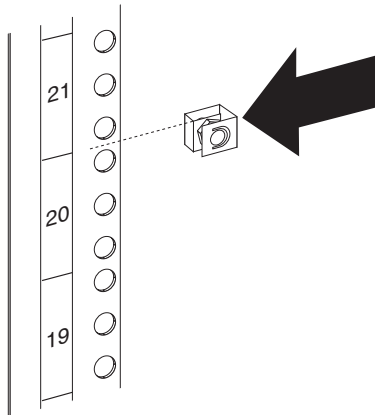

*Figure 8. Installing clip nuts on the rack-mounting flanges*

Some devices might require that you install clip nuts on the rail instead of clip nuts on the rack-mounting flanges. For information about when you must install the clip nuts, see the device documentation.

---

## Chapter 3. Managing cables

Always read the instructions that come with your server or optional device for detailed cable-management information.

### Statement 8:



### DANGER

- **Plug power cords from devices in the rack cabinet into electrical outlets that are located near the rack cabinet and are easily accessible.**
- **Each rack cabinet might have more than one power cord. Be sure to disconnect all power cords in the rack cabinet before servicing any device in the rack cabinet.**
- **Install an emergency-power-off switch if more than one power device (power distribution unit or uninterruptible power supply) is installed in the same rack cabinet.**
- **Connect all devices installed in a rack cabinet to power devices installed in the same rack cabinet. Do not plug a power cord from a device installed in one rack cabinet into a power device installed in a different rack cabinet.**

Use the following general guidelines when you cable servers or other devices that you install in a rack cabinet.

- Do not run cables in front of or behind other devices that will prevent service access to those devices.
- Do not bend a fiber-optic cable beyond its limited specifications.
- Label all cables so that they are clearly distinguishable from each other.
- When installing devices mounted on slide rails, such as servers:
  - Run the cables neatly along equipment cable-management arms and secure the cables to the arms using provided cable straps.
  - Leave enough extra cable so that the device can fully extend without straining the cables.
  - Secure the cables so that the device can retract without pinching or cutting the cables.
- When installing devices mounted on fixed rails:
  - Run the cables neatly along the posts or side rails in the rack cabinet out of the way of other installed devices.
  - Secure the cables with the provided cable straps.
- Make sure that the cables cannot be pinched or cut by the rack cabinet rear door or other devices.
- Run internal cables that connect devices in adjoining rack cabinets through the large openings provided in the rear of the rack cabinet.
- Run external cables through the holes in the bottom of the rack cabinet or through the removable section in the top of the rack cabinet.

---

## Using the cable-access opening in the top of the rack

You can route external cables through the rectangular cable-access opening in the top rear of the primary or expansion rack.

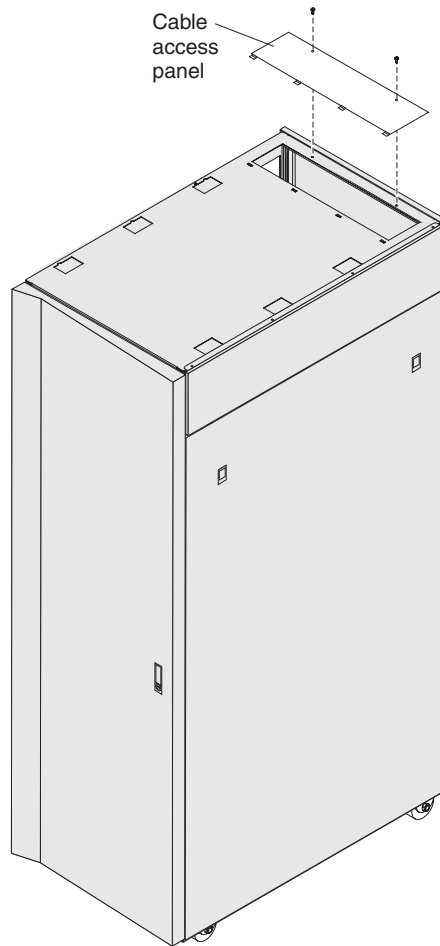

*Figure 9. Location of the cable-access opening*

To remove the cable-access panel, remove the two screws on the rear of the cable-access panel and remove the panel.

## Chapter 4. Moving a rack cabinet

Before you move the rack cabinet to another location, read the important guidelines in this chapter.

When you move a rack cabinet, observe the following safety guidelines.

 > 500 lbs. (> 227 kg.)		<p><b>Use Only Professional Movers!</b></p> <p>يجب الاستعانة بخبرات نقل متدّنة</p> <p>Utilizar somente transportadores profissionais</p> <p>Faire appel à des professionnels seulement pour déplacer l'équipement.</p> <p>只能使用专业搬运机</p> <p>Maak gebruik van professionele verhuizers</p> <p>Faites exclusivement appel à des déménageurs professionnels.</p> <p>Nur professionelle Transportunternehmen mit der Durchführung beauftragen.</p> <p>Να μετακινείται μόνο από επαγγελματίες μεταφορείς</p> <p>העזרו במובילים מקצועיים בלבד</p> <p>Csak hivatásos szállítóval költöztesse</p> <p>Avvalersi solo di trasportatori esperti</p> <p>機器を移動する際には専門の業者に依頼してください。</p> <p>전문 운송 인력만이 이동시킬 수 있습니다.</p> <p>Należy korzystać wyłącznie z usług wyspecjalizowanych firm.</p> <p>El traslado del equipo debe realizarlo personal especializado</p> <p>Trebaju raditi samo profesionalni transportni radnici</p> <p>Použite pouze profesionální stěhováky</p> <p>Brug kun professionelle flyttefolk.</p> <p>Käytä vain ammattitaitoista kuljetusliikettä</p> <p>Utstyret må kun flyttes av godkjent flyttepersonell</p> <p>Contacte apenas transportadoras profissionais</p> <p>Используйте только профессиональных грузчиков</p> <p>Na presun použite len profesionálov</p> <p>Använd endast professionell flyttpersonal</p>
  Use Only Professional Movers!		

### Statement 8:



### DANGER

- **Plug power cords from devices in the rack cabinet into electrical outlets that are located near the rack cabinet and are easily accessible.**
- **Each rack cabinet might have more than one power cord. Be sure to disconnect all power cords in the rack cabinet before servicing any device in the rack cabinet.**
- **Install an emergency-power-off switch if more than one power device (power distribution unit or uninterruptible power supply) is installed in the same rack cabinet.**
- **Connect all devices installed in a rack cabinet to power devices installed in the same rack cabinet. Do not plug a power cord from a device installed in one rack cabinet into a power device installed in a different rack cabinet.**

**Statement 10:**



**CAUTION:**

Removing components from the upper positions in the Enterprise Rack cabinet improves rack stability during relocation. Follow these general guidelines whenever you relocate a populated rack cabinet within a room or building:

- Reduce the weight of the rack cabinet by removing equipment starting at the top of the rack cabinet. When possible, restore the rack cabinet to the configuration of the rack cabinet as you received it. If this configuration is not known, you must do the following:
  - Remove all devices in the 32U position and above.
  - Ensure that the heaviest devices are installed in the bottom of the rack cabinet.
  - Ensure that there are no empty U-levels between devices installed in the rack cabinet below the 32U level.
- If the rack cabinet you are relocating is part of a suite of rack cabinets, detach the rack cabinet from the suite.
- Inspect the route that you plan to take to eliminate potential hazards.
- Verify that the route that you choose can support the weight of the loaded rack cabinet. Refer to the documentation that comes with your rack cabinet for the weight of a loaded rack cabinet.
- Verify that all door openings are at least 760 x 2030 mm (30 x 80 in.)
- Ensure that all devices, shelves, drawers, doors, and cables are secure.
- Ensure that the four leveling pads are raised to their highest position.
- Ensure that there is no stabilizer bracket installed on the rack cabinet.
- Do not use a ramp inclined at more than ten degrees.
- Once the rack cabinet is in the new location, do the following:
  - Lower the four leveling pads.
  - Install stabilizer brackets on the rack cabinet.
  - If you removed any devices from the rack cabinet, repopulate the rack cabinet from the lowest position to the highest position.

If a long distance relocation is required, restore the rack cabinet to the configuration of the rack cabinet as you received it. Pack the rack cabinet in the original packaging material, or equivalent. Also, lower the leveling pads to raise the casters off of the pallet and bolt the rack cabinet to the pallet.



To move the rack cabinet to another location, complete the following general steps:

1. Follow the safety guidelines in this chapter.
2. Know the weight of the rack cabinet. To help determine the weight of the rack, see Table 2 on page 6. A general guideline is to assume a weight of 23 kg (50 lb) per rack U-space.
3. Use the following weight limit guidelines:
  - If the rack cabinet is empty, at least two people are required to move the rack.
  - If the rack cabinet weight is between 142 and 227 kg (between 313 and 500 lb), three or four people are required to move the rack.
  - If the rack cabinet weight is greater than 227 kg (500 lb), professional movers are required to move the rack.
4. Carefully move the rack cabinet to the new location by using the safety guidelines in this chapter.



---

## Chapter 5. Customer replaceable unit parts

The replaceable components that are available for the IBM 42U Enterprise Primary Rack and IBM 42U Enterprise Expansion Rack are described in this chapter.

For an updated parts listing, go to <http://www.ibm.com/supportportal/>.

Replaceable components are of three types:

- **Tier 1 customer replaceable unit (CRU):** Replacement of Tier 1 CRUs is your responsibility. If IBM installs a Tier 1 CRU at your request, you will be charged for the installation.
- **Tier 2 customer replaceable unit:** You may install a Tier 2 CRU yourself or request IBM to install it, at no additional charge, under the type of warranty service that is designated for your server.
- **Field replaceable unit (FRU):** FRUs must be installed only by trained service technicians.

For information about getting service and assistance, see “Getting help and information from the World Wide Web” on page 25. For information about the terms of the warranty, see the *Warranty Information* document that comes with the rack cabinet.

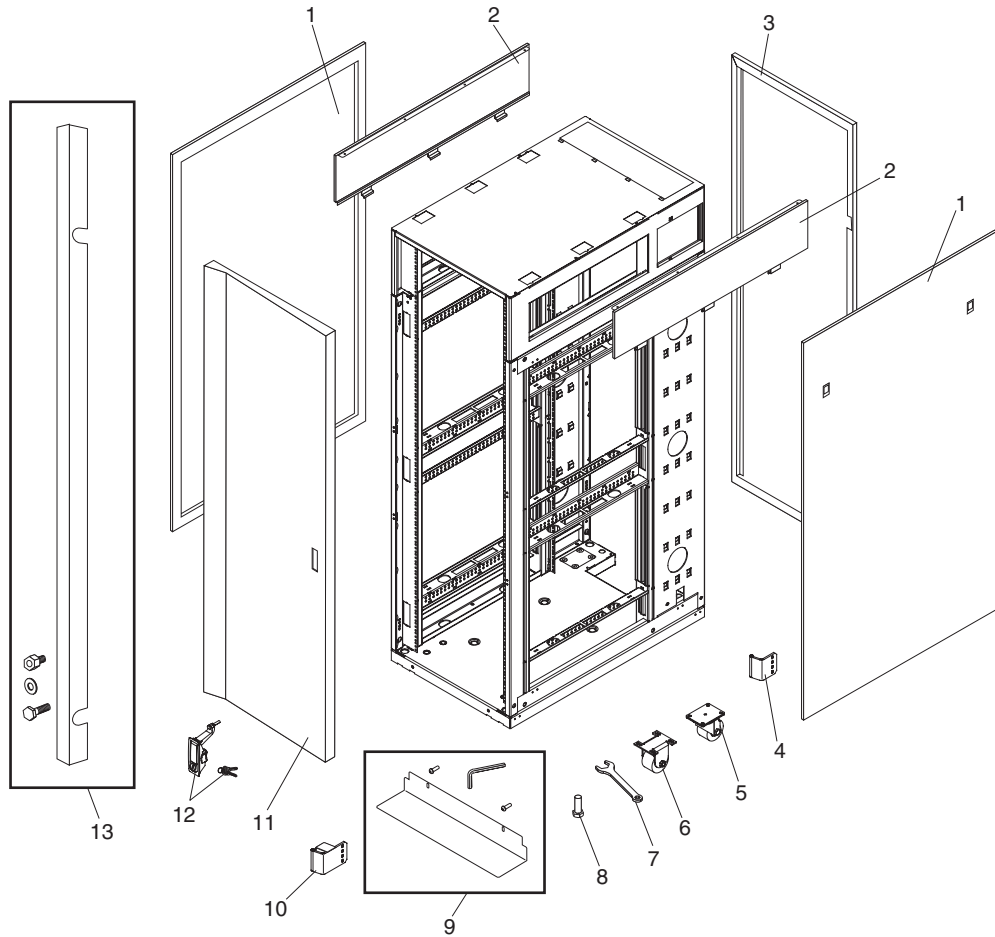

Table 3. Parts listing for IBM 42U Enterprise Primary Rack, Type 9308-4PX, and IBM 42U Enterprise Expansion Rack, Type 9308-4EX

Index	Description	CRU part number (Tier 1)	CRU part number (Tier 2)	FRU part number
1	Side cover, lower	05N6478		
2	Side cover, upper	05N4906		
3	Door, rear	41Y0558		
4	Hinge, rear door	05N4902		
5	Caster, swivel (rear)			05N4916
6	Caster, fixed (front)			05N4915
7	Wrench, leveling pad	05N4927		
8	Foot, leveling			05N4914
9	Stability kit (stabilizer bracket, hex key wrench, and screws)	41V0584		
10	Hinge, front door	09N9695		
11	Door, front	41Y0559		
12	Door latch with lock	05N4903		
13	Rack attachment kit (marriage kit)	05N4908		

Table 3. Parts listing for IBM 42U Enterprise Primary Rack, Type 9308-4PX, and IBM 42U Enterprise Expansion Rack, Type 9308-4EX (continued)

Index	Description	CRU part number (Tier 1)	CRU part number (Tier 2)	FRU part number
	Support bar kit (for use if the upper 6U portion of the rack cabinet is removed)	12K0489		
	Hook and loop fastener	51H9502		



---

## Appendix A. Getting help and technical assistance

If you need help, service, or technical assistance or just want more information about IBM products, you will find a wide variety of sources available from IBM to assist you. This section contains information about where to go for additional information about IBM and IBM products, what to do if you experience a problem with your system, and whom to call for service, if it is necessary.

---

### Before you call

Before you call, make sure that you have taken these steps to try to solve the problem yourself:

- Check all cables to make sure that they are connected.
- Check the power switches to make sure that the system and any optional devices are turned on.
- Use the troubleshooting information in your system documentation, and use the diagnostic tools that come with your system. Information about diagnostic tools is in the *Problem Determination and Service Guide* on the *IBM Documentation CD* that comes with your system.
- Go to the IBM support website at <http://www.ibm.com/systems/support/> to check for technical information, hints, tips, and new device drivers or to submit a request for information.

You can solve many problems without outside assistance by following the troubleshooting procedures that IBM provides in the online help or in the documentation that is provided with your IBM product. The documentation that comes with IBM systems also describes the diagnostic tests that you can perform. Most systems, operating systems, and programs come with documentation that contains troubleshooting procedures and explanations of error messages and error codes. If you suspect a software problem, see the documentation for the operating system or program.

---

### Using the documentation

Information about your IBM system and preinstalled software, if any, or optional device is available in the documentation that comes with the product. That documentation can include printed documents, online documents, readme files, and help files. See the troubleshooting information in your system documentation for instructions for using the diagnostic programs. The troubleshooting information or the diagnostic programs might tell you that you need additional or updated device drivers or other software. IBM maintains pages on the World Wide Web where you can get the latest technical information and download device drivers and updates. To access these pages, go to <http://www.ibm.com/systems/support/> and follow the instructions. Also, some documents are available through the IBM Publications Center at <http://www.ibm.com/shop/publications/order/>.

---

### Getting help and information from the World Wide Web

On the World Wide Web, the IBM website has up-to-date information about IBM systems, optional devices, services, and support. The address for IBM System x<sup>®</sup> and xSeries information is <http://www.ibm.com/systems/x/>. The address for IBM BladeCenter<sup>®</sup> information is <http://www.ibm.com/systems/bladecenter/>. The address for IBM IntelliStation<sup>®</sup> information is <http://www.ibm.com/intellistation/>.

You can find service information for IBM systems and optional devices at <http://www.ibm.com/systems/support/>.

---

## Software service and support

Through IBM Support Line, you can get telephone assistance, for a fee, with usage, configuration, and software problems with System x and xSeries servers, BladeCenter products, IntelliStation workstations, and appliances. For information about which products are supported by Support Line in your country or region, see <http://www.ibm.com/services/sl/products/>.

For more information about Support Line and other IBM services, see <http://www.ibm.com/services/>, or see <http://www.ibm.com/planetwide/> for support telephone numbers. In the U.S. and Canada, call 1-800-IBM-SERV (1-800-426-7378).

---

## Hardware service and support

You can receive hardware service through your IBM reseller or IBM Services. To locate a reseller authorized by IBM to provide warranty service, go to <http://www.ibm.com/partnerworld/> and click **Find Business Partners** on the right side of the page. For IBM support telephone numbers, see <http://www.ibm.com/planetwide/>. In the U.S. and Canada, call 1-800-IBM-SERV (1-800-426-7378).

In the U.S. and Canada, hardware service and support is available 24 hours a day, 7 days a week. In the U.K., these services are available Monday through Friday, from 9 a.m. to 6 p.m.

---

## IBM Taiwan product service

台灣 IBM 產品服務聯絡方式：  
台灣國際商業機器股份有限公司  
台北市松仁路7號3樓  
電話：0800-016-888

IBM Taiwan product service contact information:  
IBM Taiwan Corporation  
3F, No 7, Song Ren Rd.  
Taipei, Taiwan  
Telephone: 0800-016-888



---

## Appendix B. Notices

This information was developed for products and services offered in the U.S.A.

IBM may not offer the products, services, or features discussed in this document in other countries. Consult your local IBM representative for information on the products and services currently available in your area. Any reference to an IBM product, program, or service is not intended to state or imply that only that IBM product, program, or service may be used. Any functionally equivalent product, program, or service that does not infringe any IBM intellectual property right may be used instead. However, it is the user's responsibility to evaluate and verify the operation of any non-IBM product, program, or service.

IBM may have patents or pending patent applications covering subject matter described in this document. The furnishing of this document does not give you any license to these patents. You can send license inquiries, in writing, to:

*IBM Director of Licensing  
IBM Corporation  
North Castle Drive  
Armonk, NY 10504-1785  
U.S.A.*

INTERNATIONAL BUSINESS MACHINES CORPORATION PROVIDES THIS PUBLICATION "AS IS" WITHOUT WARRANTY OF ANY KIND, EITHER EXPRESS OR IMPLIED, INCLUDING, BUT NOT LIMITED TO, THE IMPLIED WARRANTIES OF NON-INFRINGEMENT, MERCHANTABILITY OR FITNESS FOR A PARTICULAR PURPOSE. Some states do not allow disclaimer of express or implied warranties in certain transactions, therefore, this statement may not apply to you.

This information could include technical inaccuracies or typographical errors. Changes are periodically made to the information herein; these changes will be incorporated in new editions of the publication. IBM may make improvements and/or changes in the product(s) and/or the program(s) described in this publication at any time without notice.

Any references in this information to non-IBM websites are provided for convenience only and do not in any manner serve as an endorsement of those websites. The materials at those websites are not part of the materials for this IBM product, and use of those websites is at your own risk.

IBM may use or distribute any of the information you supply in any way it believes appropriate without incurring any obligation to you.

---

## Trademarks

IBM, the IBM logo, and [ibm.com](http://www.ibm.com) are trademarks or registered trademarks of International Business Machines Corporation in the United States, other countries, or both. If these and other IBM trademarked terms are marked on their first occurrence in this information with a trademark symbol (® or ™), these symbols indicate U.S. registered or common law trademarks owned by IBM at the time this information was published. Such trademarks may also be registered or common law trademarks in other countries. A current list of IBM trademarks is available on the web at "Copyright and trademark information" at <http://www.ibm.com/legal/copytrade.shtml>.

Adobe and PostScript are either registered trademarks or trademarks of Adobe Systems Incorporated in the United States and/or other countries.

Cell Broadband Engine is a trademark of Sony Computer Entertainment, Inc., in the United States, other countries, or both and is used under license therefrom.

Intel, Intel Xeon, Itanium, and Pentium are trademarks or registered trademarks of Intel Corporation or its subsidiaries in the United States and other countries.

Java and all Java-based trademarks are trademarks of Sun Microsystems, Inc., in the United States, other countries, or both.

Linux is a registered trademark of Linus Torvalds in the United States, other countries, or both.

Microsoft, Windows, and Windows NT are trademarks of Microsoft Corporation in the United States, other countries, or both.

UNIX is a registered trademark of The Open Group in the United States and other countries.

Other company, product, or service names may be trademarks or service marks of others.

---

## Important notes

Processor speed indicates the internal clock speed of the microprocessor; other factors also affect application performance.

CD or DVD drive speed is the variable read rate. Actual speeds vary and are often less than the possible maximum.

When referring to processor storage, real and virtual storage, or channel volume, KB stands for 1024 bytes, MB stands for 1,048,576 bytes, and GB stands for 1,073,741,824 bytes.

When referring to hard disk drive capacity or communications volume, MB stands for 1,000,000 bytes, and GB stands for 1,000,000,000 bytes. Total user-accessible capacity can vary depending on operating environments.

Maximum internal hard disk drive capacities assume the replacement of any standard hard disk drives and population of all hard disk drive bays with the largest currently supported drives that are available from IBM.

Maximum memory might require replacement of the standard memory with an optional memory module.

IBM makes no representation or warranties regarding non-IBM products and services that are ServerProven, including but not limited to the implied warranties of merchantability and fitness for a particular purpose. These products are offered and warranted solely by third parties.

IBM makes no representations or warranties with respect to non-IBM products. Support (if any) for the non-IBM products is provided by the third party, not IBM.

Some software might differ from its retail version (if available) and might not include user manuals or all program functionality.

---

## Particulate contamination

**Attention:** Airborne particulates (including metal flakes or particles) and reactive gases acting alone or in combination with other environmental factors such as humidity or temperature might pose a risk to the device that is described in this document. Risks that are posed by the presence of excessive particulate levels or concentrations of harmful gases include damage that might cause the device to malfunction or cease functioning altogether. This specification sets forth limits for particulates and gases that are intended to avoid such damage. The limits must not be viewed or used as definitive limits, because numerous other factors, such as temperature or moisture content of the air, can influence the impact of particulates or environmental corrosives and gaseous contaminant transfer. In the absence of specific limits that are set forth in this document, you must implement practices that maintain particulate and gas levels that are consistent with the protection of human health and safety. If IBM determines that the levels of particulates or gases in your environment have caused damage to the device, IBM may condition provision of repair or replacement of devices or parts on implementation of appropriate remedial measures to mitigate such environmental contamination. Implementation of such remedial measures is a customer responsibility.

Table 4. Limits for particulates and gases

Contaminant	Limits
Particulate	<ul style="list-style-type: none"> <li>The room air must be continuously filtered with 40% atmospheric dust spot efficiency (MERV 9) according to ASHRAE Standard 52.2<sup>1</sup>.</li> <li>Air that enters a data center must be filtered to 99.97% efficiency or greater, using high-efficiency particulate air (HEPA) filters that meet MIL-STD-282.</li> <li>The deliquescent relative humidity of the particulate contamination must be more than 60%<sup>2</sup>.</li> <li>The room must be free of conductive contamination such as zinc whiskers.</li> </ul>
Gaseous	<ul style="list-style-type: none"> <li>Copper: Class G1 as per ANSI/ISA 71.04-1985<sup>3</sup></li> <li>Silver: Corrosion rate of less than 300 Å in 30 days</li> </ul>

<sup>1</sup> ASHRAE 52.2-2008 - *Method of Testing General Ventilation Air-Cleaning Devices for Removal Efficiency by Particle Size*. Atlanta: American Society of Heating, Refrigerating and Air-Conditioning Engineers, Inc.

<sup>2</sup> The deliquescent relative humidity of particulate contamination is the relative humidity at which the dust absorbs enough water to become wet and promote ionic conduction.

<sup>3</sup> ANSI/ISA-71.04-1985. *Environmental conditions for process measurement and control systems: Airborne contaminants*. Instrument Society of America, Research Triangle Park, North Carolina, U.S.A.

---

## Documentation format

The publications for this product are in Adobe Portable Document Format (PDF) and should be compliant with accessibility standards. If you experience difficulties when you use the PDF files and want to request a web-based format or accessible PDF document for a publication, direct your mail to the following address:

*Information Development  
IBM Corporation  
205/A015*

3039 E. Cornwallis Road  
P.O. Box 12195  
Research Triangle Park, North Carolina 27709-2195  
U.S.A.

In the request, be sure to include the publication part number and title.

When you send information to IBM, you grant IBM a nonexclusive right to use or distribute the information in any way it believes appropriate without incurring any obligation to you.

---

## Electronic emission notices

### Federal Communications Commission (FCC) statement

**Note:** This equipment has been tested and found to comply with the limits for a Class A digital device, pursuant to Part 15 of the FCC Rules. These limits are designed to provide reasonable protection against harmful interference when the equipment is operated in a commercial environment. This equipment generates, uses, and can radiate radio frequency energy and, if not installed and used in accordance with the instruction manual, may cause harmful interference to radio communications. Operation of this equipment in a residential area is likely to cause harmful interference, in which case the user will be required to correct the interference at his own expense.

Properly shielded and grounded cables and connectors must be used in order to meet FCC emission limits. IBM is not responsible for any radio or television interference caused by using other than recommended cables and connectors or by unauthorized changes or modifications to this equipment. Unauthorized changes or modifications could void the user's authority to operate the equipment.

This device complies with Part 15 of the FCC Rules. Operation is subject to the following two conditions: (1) this device may not cause harmful interference, and (2) this device must accept any interference received, including interference that may cause undesired operation.

### Industry Canada Class A emission compliance statement

This Class A digital apparatus complies with Canadian ICES-003.

### Avis de conformité à la réglementation d'Industrie Canada

Cet appareil numérique de la classe A est conforme à la norme NMB-003 du Canada.

### Australia and New Zealand Class A statement

**Attention:** This is a Class A product. In a domestic environment this product may cause radio interference in which case the user may be required to take adequate measures.

### European Union EMC Directive conformance statement

This product is in conformity with the protection requirements of EU Council Directive 2004/108/EC on the approximation of the laws of the Member States relating to electromagnetic compatibility. IBM cannot accept responsibility for any failure to satisfy the protection requirements resulting from a nonrecommended modification of the product, including the fitting of non-IBM option cards.

**Attention:** This is an EN 55022 Class A product. In a domestic environment this product may cause radio interference in which case the user may be required to take adequate measures.

Responsible manufacturer:  
International Business Machines Corp.  
New Orchard Road  
Armonk, New York 10504  
914-499-1900

European Community contact:  
IBM Technical Regulations, Department M456  
IBM-Allee 1, 71137 Ehningen, Germany  
Telephone: +49 7032 15-2937  
E-mail: tjahn@de.ibm.com

## Germany Class A statement

### Deutschsprachiger EU Hinweis:

#### **Hinweis für Geräte der Klasse A EU-Richtlinie zur Elektromagnetischen Verträglichkeit**

Dieses Produkt entspricht den Schutzanforderungen der EU-Richtlinie 2004/108/EG zur Angleichung der Rechtsvorschriften über die elektromagnetische Verträglichkeit in den EU-Mitgliedsstaaten und hält die Grenzwerte der EN 55022 Klasse A ein.

Um dieses sicherzustellen, sind die Geräte wie in den Handbüchern beschrieben zu installieren und zu betreiben. Des Weiteren dürfen auch nur von der IBM empfohlene Kabel angeschlossen werden. IBM übernimmt keine Verantwortung für die Einhaltung der Schutzanforderungen, wenn das Produkt ohne Zustimmung der IBM verändert bzw. wenn Erweiterungskomponenten von Fremdherstellern ohne Empfehlung der IBM gesteckt/eingebaut werden.

EN 55022 Klasse A Geräte müssen mit folgendem Warnhinweis versehen werden: "Warnung: Dieses ist eine Einrichtung der Klasse A. Diese Einrichtung kann im Wohnbereich Funk-Störungen verursachen; in diesem Fall kann vom Betreiber verlangt werden, angemessene Maßnahmen zu ergreifen und dafür aufzukommen."

#### **Deutschland: Einhaltung des Gesetzes über die elektromagnetische Verträglichkeit von Geräten**

Dieses Produkt entspricht dem "Gesetz über die elektromagnetische Verträglichkeit von Geräten (EMVG)". Dies ist die Umsetzung der EU-Richtlinie 2004/108/EG in der Bundesrepublik Deutschland.

#### **Zulassungsbescheinigung laut dem Deutschen Gesetz über die elektromagnetische Verträglichkeit von Geräten (EMVG) (bzw. der EMC EG Richtlinie 2004/108/EG) für Geräte der Klasse A**

Dieses Gerät ist berechtigt, in Übereinstimmung mit dem Deutschen EMVG das EG-Konformitätszeichen - CE - zu führen.

Verantwortlich für die Einhaltung der EMV Vorschriften ist der Hersteller:  
International Business Machines Corp.  
New Orchard Road  
Armonk, New York 10504  
914-499-1900

Der verantwortliche Ansprechpartner des Herstellers in der EU ist:  
IBM Deutschland  
Technical Regulations, Department M456  
IBM-Allee 1, 71137 Ehningen, Germany  
Telephone: +49 7032 15-2937  
E-mail: tjahn@de.ibm.com

#### Generelle Informationen:

Das Gerät erfüllt die Schutzanforderungen nach EN 55024 und EN 55022  
Klasse A.

### Japan VCCI Class A statement

この装置は、クラス A 情報技術装置です。この装置を家庭環境で使用する  
と電波妨害を引き起こすことがあります。この場合には使用者が適切な対策  
を講ずるよう要求されることがあります。 VCCI-A

This is a Class A product based on the standard of the Voluntary Control Council for Interference (VCCI). If this equipment is used in a domestic environment, radio interference may occur, in which case the user may be required to take corrective actions.

### Korea Communications Commission (KCC) statement

이 기기는 업무용으로 전자파 적합등록을 받은 기기  
이오니, 판매자 또는 사용자는 이점을 주의하시기  
바라며, 만약 잘못 구입하셨을 때에는 구입한 곳에  
서 비업무용으로 교환하시기 바랍니다.

Please note that this equipment has obtained EMC registration for commercial use. In the event that it has been mistakenly sold or purchased, please exchange it for equipment certified for home use.

### Russia Electromagnetic Interference (EMI) Class A statement

ВНИМАНИЕ! Настоящее изделие относится к классу А.  
В жилых помещениях оно может создавать радиопомехи, для  
снижения которых необходимы дополнительные меры

### People's Republic of China Class A electronic emission statement

中华人民共和国“A类”警告声明

声明  
此为A级产品，在生活环境中，该产品可能会造成无线电干扰。在这种情况下，  
可能需要用户对其干扰采取切实可行的措施。

## Taiwan Class A compliance statement

警告使用者：  
這是甲類的資訊產品，在居住的環境中使用時，可能會造成射頻干擾，在這種情況下，使用者會被要求採取某些適當的對策。





---

# Index

## Numerics

6U upper side cover, removing and installing 9

## A

accessible documentation 29  
assistance, getting 25  
attaching racks in a suite 12  
attention notices 3

## B

bracket, stabilizer 7

## C

cable-access opening 16  
cables, routing 15  
caution statements 3  
Class A electronic emission notice 30  
clip nuts, installing 14  
contamination, particulate and gaseous 29  
CRU part numbers 22

## D

danger statements 3  
devices, installing 13  
documentation CD 1  
documentation format 29  
documentation updates, obtaining 1

## E

electronic emission Class A notice 30  
enterprise primary and expansion racks  
CRU part numbers 22

## F

FCC Class A notice 30  
feet, lowering 7  
front door, removing and installing 10  
front stabilizer bracket, installing 7  
FRU part numbers 22

## G

gaseous contamination 29  
getting help 25

## H

hardware service and support 26  
help, getting 25

## I

IBM Support Line 26  
important notices 3  
installing  
clip nuts 14  
front door 10  
front stabilizer bracket 7  
lower side cover 8  
optional devices 13  
rear door 11  
upper 6U side cover 9  
installing rack, tasks overview 1

## L

leveling feet, lowering 7

## M

managing cables 15  
moving a rack 17

## N

notes 3  
notes, important 28  
notices 27  
electronic emission 30  
FCC, Class A 30  
notices and statements 3

## O

optional devices, installing 13

## P

particulate contamination 29  
parts listing 22

## R

rack  
installation tasks overview 1  
moving 17  
size and weight specifications 6  
rear door, removing and installing 11  
relocating a rack 17  
removing  
front door 10  
lower side cover 8  
rear door 11  
upper 6U side cover 9  
routing cables 15, 16

## S

- side cover, removing and installing
  - lower 8
  - upper 9
- size and weight specifications of rack 6
- software service and support 26
- stabilizer bracket, installing 7
- statements and notices 3
- suite of racks, attaching 12
- support, website 25

## T

- telephone numbers 26
- trademarks 27

## U

- United States electronic emission Class A notice 30
- United States FCC Class A notice 30
- upper 6U side cover, removing and installing 9

## W

- website
  - publication ordering 25
  - support 25
  - support line, telephone numbers 26
- weight and size specifications of rack 6





Part Number: 46D0953

Printed in USA

(1P) P/N: 46D0953

