



xSeries 200 Type 8479 and xSeries 200VL Type 8481  
Hardware Maintenance Manual







xSeries 200 Type 8479 and xSeries 200VL Type 8481  
Hardware Maintenance Manual

**Note**

Before using this information and the product it supports, read "Notices" on page 137.

**Third Edition (August 2008)**

**The following paragraph does not apply to the United Kingdom or any country where such provisions are inconsistent with local law:**

INTERNATIONAL BUSINESS MACHINES CORPORATION PROVIDES THIS PUBLICATION "AS IS" WITHOUT WARRANTY OF ANY KIND, EITHER EXPRESS OR IMPLIED, INCLUDING, BUT NOT LIMITED TO, THE IMPLIED WARRANTIES OF MERCHANTABILITY OR FITNESS FOR A PARTICULAR PURPOSE. Some states do not allow disclaimer of express or implied warranties in certain transactions, therefore, this statement may not apply to you.

This publication could include technical inaccuracies or typographical errors. Changes are periodically made to the information herein; these changes will be incorporated in new editions of the publication. IBM may make improvements and/or changes in the product(s) and/or the program(s) described in this publication at any time.

This publication was developed for products and services offered in the United States of America. IBM may not offer the products, services, or features discussed in this document in other countries, and the information is subject to change without notice. Consult your local IBM representative for information on the products, services, and features available in your area.

Requests for technical information about IBM products should be made to your IBM reseller or IBM marketing representative.

**© Copyright International Business Machines Corporation 2001. All rights reserved.**

US Government Users Restricted Rights – Use, duplication or disclosure restricted by GSA ADP Schedule Contract with IBM Corp.

---

## About this manual

This manual contains diagnostic information, a Symptom-to-FRU index, service information, error codes, error messages, and configuration information for the IBM® @server xSeries 200™ Type 8479 server and xSeries 200VL Type 8481 server.

**Important:** This manual is intended for trained servicers who are familiar with IBM PC Server products. Before servicing an IBM product, be sure to review "Safety information" on page 103.

---

## Important safety information

Be sure to read all caution and danger statements in this book before performing any of the instructions.

Leia todas as instruções de cuidado e perigo antes de executar qualquer operação.

---

### 注意和危险声明 (简体中文)

重要事项:

本书中的所有注意和危险声明之前都有编号。该编号用于英语的注意或危险声明与 *Safety Information* 一书中可以找到的翻译版本的注意或危险声明进行交叉引用。

例如，如果一个注意声明以编号 1 开始，那么对该注意声明的翻译出现在 *Safety Information* 一书中的声明 1 中。

在按说明执行任何操作前，请务必阅读所有注意和危险声明。

---

### 注意及危险声明 (中文)

重要資訊:

本書中所有「注意」及「危險」的聲明均以數字開始。此一數字是用來作為交互參考之用，英文「注意」或「危險」聲明可在「安全資訊」(Safety Information) 一書中找到相同內容的「注意」或「危險」聲明的譯文。

例如，有一「危險」聲明以數字 1 開始，則該「危險」聲明的譯文將出現在「安全資訊」(Safety Information) 一書的「聲明」1 中。

執行任何指示之前，請詳讀所有「注意」及「危險」的聲明。

Prenez connaissance de toutes les consignes de type Attention et

Danger avant de procéder aux opérations décrites par les instructions.

Lesen Sie alle Sicherheitshinweise, bevor Sie eine Anweisung ausführen.

Accertarsi di leggere tutti gli avvisi di attenzione e di pericolo prima di effettuare qualsiasi operazione.

---

## 주의 및 위험 경고문(한글)

### 중요:

이 책에 나오는 모든 주의 및 위험 경고문은 번호로 시작됩니다. 이 번호는 *Safety Information* 책에 나오는 영문판 주의 및 위험 경고문과 한글판 주의 및 위험 경고문을 상호 참조하는데 사용됩니다.

예를 들어 주의 경고문이 번호 1로 시작되면 *Safety Information* 책에서 이 주의 경고문은 경고문 1번 아래에 나옵니다.

지시를 따라 수행하기 전에 먼저 모든 주의 및 위험 경고문을 읽도록 하십시오.

Lea atentamente todas las declaraciones de precaución y peligro ante de llevar a cabo cualquier operación.

---

## Online support

Use the World Wide Web (WWW) to download Diagnostic, BIOS Flash, Device Driver files and documents.

The Web address is:

**<http://www.ibm.com/pc/support>**

---

# Contents

## About this manual . . . . . iii

Important safety information . . . . . iii

Online support . . . . . iv

## General checkout . . . . . 1

## General information . . . . . 3

Features and specifications. . . . . 3

Server features. . . . . 4

Notices and statements used in this book. . . . . 5

Reliability, availability, and serviceability . . . . . 5

Server controls and indicators . . . . . 7

    Turning on the server . . . . . 8

    Turning off the server . . . . . 8

## Diagnostics . . . . . 9

Diagnostic tools overview . . . . . 9

POST . . . . . 9

    POST beep code descriptions . . . . . 9

    POST error messages . . . . . 9

Small computer system interface messages (some models). . . . . 10

Diagnostic programs and error messages . . . . . 10

    Text messages . . . . . 11

    Starting the diagnostic programs . . . . . 12

        Using the diagnostics CD. . . . . 12

        Creating a diagnostics diskette from the CD . . . . . 12

        Downloading the diagnostics program . . . . . 12

        Using the diagnostic diskette . . . . . 13

    Viewing the test log . . . . . 13

    Diagnostic error message tables. . . . . 13

Power checkout . . . . . 14

Recovering BIOS . . . . . 14

Clearing CMOS . . . . . 15

Replacing the battery . . . . . 15

Temperature checkout . . . . . 17

Diagnosing errors . . . . . 17

Troubleshooting the Ethernet controller . . . . . 17

    Network connection problems . . . . . 17

    Ethernet controller troubleshooting chart . . . . . 18

Ethernet controller messages. . . . . 19

    Novell NetWare or IntraNetWare system ODI driver teaming messages . . . . . 19

    NDIS 4.0 Windows driver messages . . . . . 21

    Ethernet teaming messages: . . . . . 22

## Configuration . . . . . 25

Using the Configuration/Setup Utility program . . . . . 25

    Starting the Configuration/Setup Utility program . . . . . 25

    Choices available from the Configuration/Setup main menu . . . . . 26

    Using passwords . . . . . 28

Using the SCSISelect utility program (some models) . . . . . 28

    Starting the SCSISelect utility program . . . . . 28

    Choices available from the SCSISelect menu . . . . . 29

Using the PXE Boot Agent Utility program . . . . . 31

    Starting the PXE Boot Agent Utility program . . . . . 31

    Choices available from the PXE Boot Agent Utility menu . . . . . 31

    Utility menu . . . . . 31

Using the ServerGuide CDs . . . . . 32

    Features at a glance . . . . . 32

    Setup and configuration overview . . . . . 34

    System partition . . . . . 35

    Typical NOS installation . . . . . 35

    Setting up or updating multiple servers . . . . . 35

    Installing the NOS without ServerGuide. . . . . 36

    Additional programs included with ServerGuide . . . . . 36

## Installing options . . . . . 37

Major components of the xSeries 200 . . . . . 37

    System and PCI extender board . . . . . 37

        System and PCI extender board options connectors. . . . . 37

        System board internal cable connectors . . . . . 38

        System board external connectors . . . . . 39

        System board jumpers. . . . . 39

Before you begin . . . . . 40

    Working inside the server with the power on . . . . . 40

    System reliability considerations . . . . . 40

Stabilizing feet . . . . . 41

Side cover removal . . . . . 42

Bezel removal . . . . . 43

Removing the support bracket assembly. . . . . 45

Working with adapters . . . . . 46

    Adapter considerations . . . . . 46

    Adapter installation . . . . . 47

SCSI or ServeRAID adapter installation . . . . . 48

Internal drive installation. . . . . 49

    Internal drive bays . . . . . 50

    Preinstallation steps (all bays) . . . . . 51

    Drive installation in bay 2 or 4 . . . . . 51

    Hard disk drive installation in bay 5, 6, or 7 . . . . . 53

Memory modules . . . . . 54

Microprocessor . . . . . 56

    Microprocessor removal . . . . . 56

    Microprocessor installation . . . . . 59

Installing a security U-bolt . . . . . 61

Completing the installation . . . . . 62

    Installing the cover . . . . . 62

    Updating the server configuration. . . . . 63

    Connecting external options. . . . . 64

    I/O connector locations . . . . . 64

Input/output connectors . . . . . 65

    Mouse connector . . . . . 66

    Keyboard connector . . . . . 66

    Parallel connector . . . . . 67

        Viewing or changing the connector assignments . . . . . 67

        Parallel connector . . . . . 67

Serial connectors . . . . .	68	Bezel release latch . . . . .	84
Viewing or changing the serial-connector assignments . . . . .	68	Top/side cover . . . . .	85
Serial connectors. . . . .	68	Handle assembly . . . . .	86
Ethernet connector . . . . .	69	Adapter retainer. . . . .	87
Configuring the Ethernet controller . . . . .	69	<b>Symptom-to-FRU index . . . . .</b>	<b>89</b>
High performance Ethernet modes . . . . .	69	Beep symptoms . . . . .	89
Teaming mode . . . . .	69	No beep symptoms. . . . .	90
Priority Packet mode . . . . .	70	Diagnostic error codes. . . . .	90
Virtual LAN mode . . . . .	71	Error symptoms . . . . .	92
Ethernet connector . . . . .	72	POST error messages . . . . .	95
Universal Serial Bus connectors. . . . .	72	ServeRAID . . . . .	97
USB cables and hubs . . . . .	72	Undetermined problems . . . . .	97
USB connectors . . . . .	72	<b>Parts listing . . . . .</b>	<b>99</b>
Audio connectors . . . . .	73	System . . . . .	100
Line out . . . . .	73	Keyboards . . . . .	101
Line in . . . . .	73	Power cords. . . . .	102
Mic . . . . .	73	<b>Related service information . . . . .</b>	<b>103</b>
MIDI connector . . . . .	73	Safety information. . . . .	103
Video connector . . . . .	74	General safety . . . . .	103
Ultra160 SCSI connector (some models) . . . . .	74	Electrical safety. . . . .	104
SCSI cabling requirements . . . . .	74	Safety inspection guide . . . . .	105
Setting SCSI IDs. . . . .	75	Handling electrostatic discharge-sensitive devices . . . . .	106
<b>FRU information (service only) . . . . .</b>	<b>77</b>	Grounding requirements . . . . .	106
Hard disk drive cage . . . . .	77	Safety notices (multi-lingual translations) . . . . .	107
Power supply . . . . .	78	Send us your comments! . . . . .	136
Rear fan . . . . .	79	Problem determination tips. . . . .	137
System board. . . . .	79	Notices . . . . .	137
CD-ROM drive . . . . .	80	Trademarks . . . . .	138
Floppy disk drive . . . . .	81		
Button kit . . . . .	82		
Guide assembly / speaker . . . . .	83		



---

## General checkout

The server diagnostic programs are stored on the IBM *Enhanced Diagnostics CD*. These programs are the primary method of testing the major components of the server: The system board, Ethernet controller, video controller, RAM, keyboard, mouse (pointing device), diskette drive, serial ports, hard drives, and parallel port. You can also use them to test some external devices. See "Diagnostic programs and error messages" on page 10.

Also, if you cannot determine whether a problem is caused by the hardware or by the software, you can run the diagnostic programs to confirm that the hardware is working properly.

When you run the diagnostic programs, a single problem might cause several error messages. When this occurs, work to correct the cause of the first error message. After the cause of the first error message is corrected, the other error messages might not occur the next time you run the test.

A failed system might be part of a shared DASD cluster (two or more systems sharing the same external storage device(s)). Prior to running diagnostics, verify that the failing system is not part of a shared DASD cluster.

A system might be part of a cluster if:

- The customer identifies the system as part of a cluster.
- One or more external storage units are attached to the system and at least one of the attached storage units is additionally attached to another system or unidentifiable source.
- One or more systems are located near the failing system.

If the failing system is suspected to be part of a shared DASD cluster, all diagnostic tests can be run except diagnostic tests which test the storage unit (DASD residing in the storage unit) or the storage adapter attached to the storage unit.

### Notes:

1. For systems that are part of a shared DASD cluster, run one test at a time in looped mode. Do not run all tests in looped mode, as this could enable the DASD diagnostic tests.
2. If multiple error codes are displayed, diagnose the first error code displayed.
3. If the computer hangs with a POST error, go to the "Symptom-to-FRU index" on page 89.
4. If the computer hangs and no error is displayed, go to "Undetermined problems" on page 97.
5. Power supply problems, see "Symptom-to-FRU index" on page 89.
6. Safety information, see "Safety information" on page 103.
7. For intermittent problems, check the error log; see "POST error messages" on page 9.

**1. IS THE SYSTEM PART OF A CLUSTER?**

**YES.** Schedule maintenance with the customer. Shut down all systems related to the cluster. Run storage test.

**NO.** Go to step 2.

**2. IF THE SYSTEM IS NOT PART OF A CLUSTER:**

- Power-off the computer and all external devices.
- Check all cables and power cords.
- Set all display controls to the middle position.
- Power-on all external devices.
- Power-on the computer.
- Record any POST error messages displayed on the screen. If an error is displayed, look up the first error in the "POST error messages" on page 95.
- Check the System Error Log. If an error was recorded by the system, see "Symptom-to-FRU index" on page 89.
- Start the Diagnostic Programs. See "Diagnostic programs and error messages" on page 10.
- Check for the following responses:
  - a. One beep.
  - b. Readable instructions or the Main Menu.

**3. DID YOU RECEIVE BOTH OF THE CORRECT RESPONSES?**

**NO.** Find the failure symptom in "Symptom-to-FRU index" on page 89.

**YES.** Run the Diagnostic Programs. If necessary, refer to "Diagnostic programs and error messages" on page 10.

If you receive an error, go to "Symptom-to-FRU index" on page 89.

If the diagnostics completed successfully and you still suspect a problem, see "Undetermined problems" on page 97.

---

## General information

The IBM xSeries 200 server delivers performance and affordability for general server applications. It is ideally suited for networking environments that require superior microprocessor performance, efficient memory management, flexibility, and large amounts of reliable data storage.

The server serial number and model number are located on labels on the bottom of the server and on the lower-right side of the bezel. With access to the World Wide Web, up-to-date information about the server model and other IBM server products is available at the following World Wide Web address:  
<http://www.ibm.com/eserver/xseries>

---

## Features and specifications

The following provides a summary of the features and specifications for the xSeries 200 server. Depending on the server model, some features and specifications might not apply.

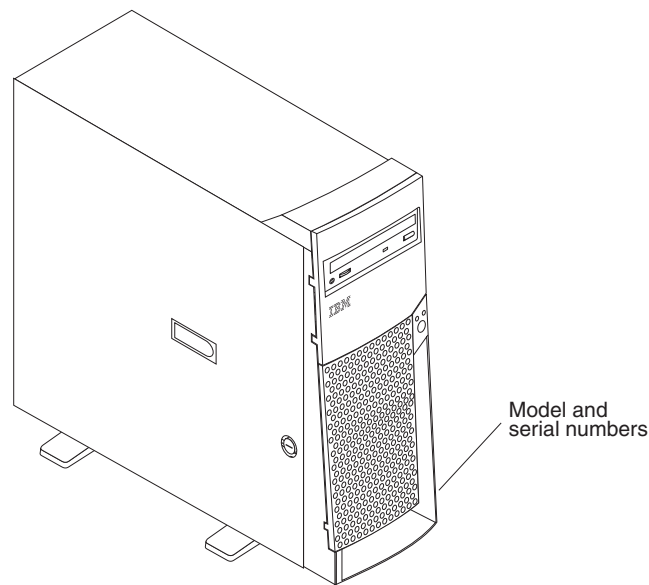

Table 1. Features and specifications

<p><b>Microprocessor:</b> Supports one microprocessor (depending on your model)</p> <ul style="list-style-type: none"> <li>• Intel Pentium® III with 256 KB or 512 KB Level-2 cache and MMX™ (MMX2) technology</li> <li>or</li> <li>• Intel Celeron with 128 KB Level-2 cache and MMX (MMX2) technology</li> </ul> <p><b>Memory:</b></p> <ul style="list-style-type: none"> <li>• Minimum: 128 MB</li> <li>• Maximum: 1.5 GB</li> <li>• Type: PC133 MHz, ECC SDRAM, unregistered DIMMs</li> <li>• Slots: Three dual inline</li> </ul> <p><b>Drives:</b> (depending on your model)</p> <ul style="list-style-type: none"> <li>• Diskette: 1.44 MB</li> <li>• CD-ROM: IDE</li> <li>• Hard disk drive</li> </ul> <p><b>Expansion bays (depending on model):</b></p> <ul style="list-style-type: none"> <li>• Two 5.25-in. bays (one CD-ROM drive installed)</li> <li>• Two 3.5-in. bays (one diskette drive installed)</li> <li>• Three 3.5-in. slim-high bays available</li> </ul> <p><b>PCI expansion slots:</b></p> <ul style="list-style-type: none"> <li>• Three 33 MHz/32-bit on the system board (some models come with a SCSI adapter installed)</li> <li>• Two 33 MHz/32-bit on the PCI extender board</li> </ul> <p><b>AGP slot:</b></p> <p>Accelerated graphics port (AGP) (contains the video adapter)</p>	<p><b>Power supply:</b></p> <p>One 330 watt (90-240 V ac) <b>Video:</b> ATI Rage XL</p> <ul style="list-style-type: none"> <li>• AGP video adapter</li> <li>• Compatible with SVGA and VGA</li> <li>• 8 MB SDRAM video memory</li> </ul> <p><b>Size:</b></p> <ul style="list-style-type: none"> <li>• Height: 470 mm (18.5 in.)</li> <li>• Depth: 508 mm (19.9 in.)</li> <li>• Width: 165 mm (6.5 in.)</li> <li>• Weight: approximately 19.5 kg (43 lb) when fully configured or 15.9 kg (35 lb) minimum</li> </ul> <p><b>Integrated functions:</b></p> <ul style="list-style-type: none"> <li>• One 10BASE-T/100BASE-TX, Intel Ethernet controller with Alert on LAN™ and Wake on LAN® support</li> <li>• Two serial ports</li> <li>• Parallel port</li> <li>• Two USB ports</li> <li>• Keyboard port</li> <li>• Mouse port</li> <li>• MIDI port</li> <li>• Audio ports <ul style="list-style-type: none"> <li>– Line out</li> <li>– Line in</li> <li>– Mic</li> </ul> </li> <li>• Dual-channel bus mastering IDE controller</li> </ul> <p><b>Acoustical noise emissions:</b></p> <ul style="list-style-type: none"> <li>• Sound power, idling: 5.1 bel maximum</li> <li>• Sound power, operating: 5.3 bel maximum</li> </ul>	<p><b>Environment:</b></p> <ul style="list-style-type: none"> <li>• Air temperature: <ul style="list-style-type: none"> <li>– Server on: 10° to 35° C (50.0° to 95.0° F). Altitude: 0 to 914 m (2998.7 ft)</li> <li>– Server on: 10° to 32° C (50.0° to 89.6° F). Altitude: 914 m (2998.7 ft) to 2133 m (6998.0 ft)</li> <li>– Server off: 10° to 43° C (50.0° to 109.4° F). Maximum altitude: 2133 m (6998.0 ft)</li> </ul> </li> <li>• Humidity: <ul style="list-style-type: none"> <li>– Server on: 8% to 80%</li> <li>– Server off: 8% to 80%</li> </ul> </li> </ul> <p><b>Heat output:</b></p> <p>Approximate heat output in British thermal units (Btu) per hour</p> <ul style="list-style-type: none"> <li>• Minimum configuration: 341 Btu (100 watts)</li> <li>• Maximum configuration: 1604 Btu (470 watts)</li> </ul> <p><b>Electrical input:</b></p> <ul style="list-style-type: none"> <li>• Sine-wave input (50-60 Hz) required</li> <li>• Input voltage low range: <ul style="list-style-type: none"> <li>– Minimum: 90 V ac</li> <li>– Maximum: 137 V ac</li> </ul> </li> <li>• Input voltage high range: <ul style="list-style-type: none"> <li>– Minimum: 180 V ac</li> <li>– Maximum: 265 V ac</li> </ul> </li> <li>• Input kilovolt-amperes (kVA) approximately: <ul style="list-style-type: none"> <li>– Minimum: 0.095 kVA</li> <li>– Maximum: 0.470 kVA</li> </ul> </li> </ul>
---	--	---

## Server features

The design of the server takes advantage of advancements in data storage and memory management. The server includes:

- Impressive performance using an innovative approach to microprocessor utilization

The server comes with one Celeron or Pentium III microprocessor installed.

- Large system memory

The memory bus in the server supports up to 1.5 GB of system memory. The memory controller provides error code correction (ECC) support for up to three industry-standard PC133, 3.3 V, 168-pin, 133 megahertz (MHz), unregistered, synchronous dynamic random access memory (SDRAM) dual in-line memory modules (DIMMs).

- Systems-management capabilities  
See the documentation provided with your systems-management software for more information.
- Integrated network environment support  
The server comes with an Ethernet controller on the system board. This Ethernet controller has an interface for connecting to 10-MBps or 100-MBps networks. The server automatically selects between 10BASE-T and 100BASE-TX environments. The controller provides full-duplex (FDX) capability, which enables simultaneous transmission and reception of data on the Ethernet local area network (LAN). These controllers support Alert on LAN 2 technology.
- IBM *ServerGuide*™ CDs  
The *ServerGuide* CDs that are included with the server provide programs to help you set up the server and install the network operating system (NOS). The *ServerGuide* program detects the hardware options that are installed and provides the correct configuration programs and device drivers. In addition, the *ServerGuide* CDs include a variety of application programs for the server.  
For more information about the *ServerGuide* CDs, see “Using the *ServerGuide* CDs” on page 32.

---

## Notices and statements used in this book

The caution and danger statements also appear in the multilingual safety book provided on the *IBM xSeries Documentation* CD. Each statement is numbered for easy reference to the corresponding statement in the safety book.

The notice and statement definitions are as follows:

- **Notes:** These notices provide important tips, guidance, or advice.
- **Important:** These notices provide information that might help you avoid inconvenient or problem situations.
- **Attention:** These notices indicate possible damage to programs, devices, or data. An attention notice is placed just before the instruction or situation in which damage could occur.
- **Caution:** These statements indicate situations that can be potentially hazardous to you. A caution statement is placed just before a description of a potentially hazardous procedure step or situation.
- **Danger:** These statements indicate situations that can be potentially lethal or extremely hazardous to you. A danger statement is placed just before the description of a potentially lethal or extremely hazardous procedure step or situation.

---

## Reliability, availability, and serviceability

Three of the most important considerations in server design are reliability, availability, and serviceability (RAS). The RAS features help to ensure the integrity of the data that is stored on the server; that the server is available when you want to use it; and that should a failure occur, you can easily diagnose and repair the failure with minimal inconvenience.

The following is an abbreviated list of the RAS features that the server supports.

- Reliability features
  - Boot block recovery
  - Cooling fans with speed-sensing capability
  - Customer-upgradable basic input/output system (BIOS)

- ECC front-side buses (FSBs)
- ECC L2 cache
- ECC memory
- Parity checking on the small computer system interface (SCSI)
- Advanced configuration and power interface (ACPI)
- Power-on self-test (POST)
- SDRAM with serial presence detect (SPD)
- Availability features
  - Advanced desktop management interface (DMI) features
  - Auto-restart initial program load (IPL) power supply
  - Automatic error retry or recovery
  - Automatic server restart
  - Automatic restart after power failure
  - Built-in, menu-driven configuration programs
  - Built-in, menu-driven SCSI configuration programs (some models)
  - Built-in, menu-driven setup programs
  - Failover Ethernet support
  - Menu-driven diagnostic programs on CD-ROM
  - Microsoft® Windows NT® failover support
  - Monitoring support for temperature, voltage, and fan speed
  - Server management
  - ServeRAID™ adapter support
  - Wake on LAN capability
- Serviceability features
  - Adaptec 29160 built-in self-test (BIST)
  - Alert on LAN 2
  - CD-ROM-based diagnostics
  - Diagnostic support of Ethernet adapters
  - Error codes and messages
  - Processor serial number access
  - Read-only memory (ROM) checksums
  - Vital product data (VPD) (includes serial number information and replacement part numbers, stored in nonvolatile memory, for easier remote maintenance)

---

## Server controls and indicators

This section identifies the controls and indicators on the front and rear of the server.

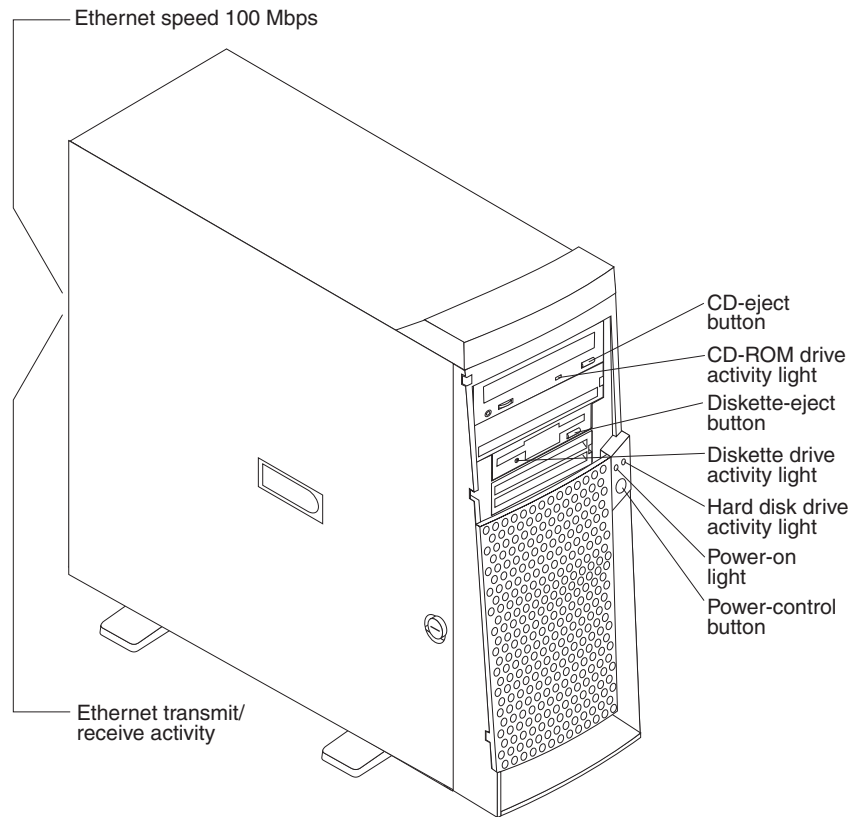

**CD-eject button:** Push this button to open the CD tray to insert or remove a CD.

**CD-ROM drive activity light:** When this light is on, the CD-ROM drive is in use.

**Diskette-eject button:** Push this button to release a diskette from the drive.

**Diskette drive activity light:** When this light is on, the diskette drive is in use.

**Ethernet speed 100 MBps:** When this light is on, the Ethernet speed is 100 MBps. When the light is off, the Ethernet speed is 10 MBps. The Ethernet speed light is located on the Ethernet (RJ-45) connector on the rear of the server.

**Ethernet transmit/receive activity:** When this light is on, there is activity between the server and the network. The Ethernet transmit/receive activity light is located on the Ethernet (RJ-45) connector on the rear of the server.

**Hard disk drive activity light:** When this light is on, the hard disk drive is in use.

**Power-on light:** This status indicator lights when you turn on the server.

**Power-control button:** Press this button to manually turn the server on or off.

See "I/O connector locations" on page 64 for the location of the input/output (I/O) connectors on the rear of the server.

## Turning on the server

After you plug one end of the server power cord into the power supply outlet on the rear of the server, and the other end of the power cord into an electrical outlet, the server can start as follows:

- You can press the power-control-button on the front of the server to start the server.
- If the server is turned on and a power failure occurs, the server will start automatically when power is restored.

## Turning off the server

You can turn off the server in the following ways:

**Statement 5:**



**CAUTION:**

The power control button on the device and the power switch on the power supply do not turn off the electrical current supplied to the device. The device also might have more than one power cord. To remove all electrical current from the device, ensure that all power cords are disconnected from the power source.

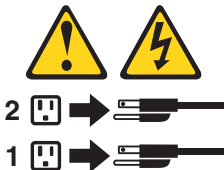

- You can press the power-control button on the front of the server. This starts an orderly shutdown of the operating system, if this feature is supported by your operating system, and places the server in standby mode.

**Note:** After turning off the server, wait at least 5 seconds before you press the power-control button to turn on the server again.

- You can press and hold the power-control button for more than 4 seconds to cause an immediate shutdown of the server and place the server in standby mode. You can use this feature if the operating system stops functioning.
- You can disconnect the server power cords from the electrical outlets to shut off all power to the server.

**Note:** After disconnecting the power cords, wait approximately 15 seconds for your system to stop running.



---

## Diagnosics

This section provides basic troubleshooting information to help you resolve some common problems that might occur with the server.

If you cannot locate and correct the problem using the information in this section, refer to "Symptom-to-FRU index" on page 89 for more information.

---

### Diagnostic tools overview

The following tools are available to help you identify and resolve hardware-related problems:

- **POST beep codes**

The power-on self-test (POST) generates beep codes and messages to indicate successful test completion or the detection of a problem. See "POST" for more information.

- **Diagnostic programs and error messages**

The server diagnostic programs are provided on the IBM *Enhanced Diagnostics* CD. These programs test the major components of the server. See "Diagnostic programs and error messages" on page 10 for more information.

---

### POST

When you turn on the server, it performs a series of tests to check the operation of server components and some of the options installed in the server. This series of tests is called the power-on self-test or POST.

If POST finishes without detecting any problems, the first window of the operating system or application program appears.

**Note:**

1. If you have a power-on password or administrator password set, you must type the password and press Enter, when prompted, before POST will continue.
2. A single problem might cause several error messages. When this occurs, work to correct the cause of the first error message. After you correct the cause of the first error message, the other error messages usually will not occur the next time you run the test.

### POST beep code descriptions

POST generates beep codes to indicate successful completion or the detection of a problem.

- One short beep indicates the successful completion of POST.
- More than one beep indicates that POST detected a problem. For more information, see "Beep symptoms" on page 89.

### POST error messages

The possible types of beep codes that your system might emit are:

### Repeating long beeps

Indicates that a memory error has occurred. Ensure that all DIMMs are correctly installed.

### One long beep and two short beeps

Indicates that a video error has occurred and the BIOS cannot initialize the video screen to display any additional information. Ensure that the video adapter is correctly installed.

For a list of POST errors, see “POST error messages” on page 95.

---

## Small computer system interface messages (some models)

The following table lists actions to take if you receive a SCSI error message.

**Note:** If the server does not have a SCSI hard disk drive, ignore any message that indicates that the BIOS is not installed.

You will get these messages only when running the SCSI Select Utility.

Table 2. SCSI messages

SCSI Messages	Description
All	<p>One or more of the following might be causing the problem.</p> <ul style="list-style-type: none"><li>• A failing SCSI device (adapter or drive)</li><li>• An improper SCSI configuration</li><li>• Duplicate SCSI IDs in the same SCSI chain</li><li>• An improperly installed SCSI terminator</li><li>• A defective SCSI terminator</li><li>• An improperly installed cable</li><li>• A defective cable</li></ul> <p><b>Action:</b> Verify that:</p> <ul style="list-style-type: none"><li>• The external SCSI devices are turned on. External SCSI devices must be turned on <i>before</i> the server.</li><li>• The cables for all external SCSI devices are connected correctly.</li><li>• The last device in each SCSI chain is terminated properly.</li><li>• The SCSI devices are configured correctly.</li></ul> <p>If the above items are correct, run the diagnostic programs to obtain additional information about the failing device.</p>

---

## Diagnostic programs and error messages

The server diagnostic programs are stored on the IBM *Enhanced Diagnostics CD*. These programs provide the primary methods of testing the major components of the server.

Diagnostic error messages indicate that a problem exists; they are not intended to be used to identify a failing part. Troubleshooting and servicing of complex problems that are indicated by error messages should be performed by trained service personnel.

Sometimes the first error to occur causes additional errors. In this case, the server displays more than one error message. Always follow the suggested action instructions for the *first* error message that appears.

The following sections contain the error codes that might appear in the detailed test log and summary log when running the diagnostic programs.

The error code format is as follows:

fff-ttt-iii-date-cc-text message

where:

- fff** is the three-digit function code that indicates the function being tested when the error occurred. For example, function code 089 is for the microprocessor.
- ttt** is the three-digit failure code that indicates the exact test failure that was encountered.
- iii** is the three-digit device ID.
- date** is the date that the diagnostic test was run and the error recorded.
- cc** is the check digit that is used to verify the validity of the information.
- text message** is the diagnostic message that indicates the reason for the problem.

## Text messages

The diagnostic text message format is as follows:

Function Name: Result (test specific string)

where:

### Function Name

is the name of the function being tested when the error occurred. This corresponds to the function code (fff) given in the previous list.

**Result** can be one of the following:

#### Passed

This result occurs when the diagnostic test completes without any errors.

**Failed** This result occurs when the diagnostic test discovers an error.

#### User Aborted

This result occurs when you stop the diagnostic test before it is complete.

#### Not Applicable

This result occurs when you specify a diagnostic test for a device that is not present.

#### Aborted

This result occurs when the test could not proceed because of the server configuration.

#### Warning

This result occurs when a possible problem is reported during the diagnostic test, such as when a device that is to be tested is not installed.

### Test Specific String

This is additional information that is used to analyze the problem.

## Starting the diagnostic programs

The IBM Enhanced Diagnostics programs will isolate the server hardware from software that you have installed on your hard disk drive. The programs run independently of the operating system, and *must be run either from the CD or from the diskette*. This method of testing is generally used when other methods are not accessible or have not been successful in isolating a problem suspected to be hardware related.

An IBM *Enhanced Diagnostics* CD comes with the server. You can also download the latest image of the diagnostics from the World Wide Web at <http://www.ibm.com/pc/support>.

### Using the diagnostics CD

To start the IBM Enhanced Diagnostics from the diagnostics CD, do the following:

1. Turn off the server and any peripheral devices.
2. Turn on all attached devices; then, turn the server on.
3. When you see Press F1 For Configuration/Setup, press the F1 key.
4. When the Configuration/Setup Utility menu appears, select **Start Options**.
5. From the Start Options menu, select **Startup Sequence**.
6. Note the device selected as the First Startup Device. Later, you must restore this setting.
7. Select **CD-ROM** as the First Startup Device.
8. Press Esc two times to return to the Configuration/Setup Utility menu.
9. Place the IBM *Enhanced Diagnostics* CD in the CD-ROM drive.
10. Select **Save & Exit Setup** and follow the prompts. The diagnostics will load. Follow the instructions on the screen to run the diagnostics.

#### Important

When you finish running the diagnostics and utilities, remove the CD from the CD-ROM drive and turn off the server. You must restore the First Startup Device to the original setting. Use steps 2 through 8 of this procedure to do this.

**Creating a diagnostics diskette from the CD:** To create a diagnostics floppy diskette from the CD, do the following:

1. Format a floppy diskette (or have a preformatted diskette available).
2. Boot the system from the diagnostics CD.
3. From the menu that appears, select Create diagnostic diskette.
4. Insert the formatted floppy diskette into the floppy disk drive when the message on the screen prompts you to do so, and press Enter.
5. The diagnostics CD can then be removed and the system rebooted with the newly created diskette.

### Downloading the diagnostics program

Do the following to download the latest image of the IBM Enhanced Diagnostics from the World Wide Web and create a startable Enhanced Diagnostics diskette:

1. Go to the following World Wide Web site: <http://www.ibm.com/pc/support>

2. Download the diagnostics file for the server to a hard disk drive directory (not to a diskette).
3. Go to a DOS prompt and change to the directory where the file was downloaded.
4. Insert a blank high-density diskette in diskette drive A.
5. Type in the following, and then press Enter: *filename a:* where *filename* is the name of the file you downloaded from the Web.

The downloaded file is self-extracting and will be copied to the diskette. When the copy completes, you have a startable IBM Enhanced Diagnostics diskette.

### Using the diagnostic diskette

Do the following to start the IBM Enhanced Diagnostics using the diagnostics diskette, do the following:

1. Turn off the server and any peripheral devices.
2. Insert the IBM Enhanced Diagnostics diskette into the diskette drive.
3. Turn on all attached devices; then, turn on the server.
4. Follow the instructions on the screen.
5. Place the IBM *Enhanced Diagnostics* CD in the CD-ROM drive. The diagnostics will load. Follow the instructions on the screen to run the diagnostics.

When the tests have completed, you can view the Test Log by selecting **Utility** from the top of the screen.

If the hardware checks out OK but the problem persists during normal server operations, a software error might be the cause. If you suspect a software problem, refer to the information that comes with the software package.

## Viewing the test log

The test log records data about system failures and other pertinent information. The test log will not contain any information until after the diagnostic program has run.

**Note:** If you already are running the diagnostic programs, begin with step 4

1. Insert the *IBM Enhanced Diagnostics* CD or diskette in the appropriate drive.
2. Turn on the system and watch the screen.

If the system is on, shut down your operating system and restart the system.

3. If a power-on password is set, the system prompts you for it. Type in the appropriate password; then, press Enter.
4. Run the appropriate diagnostics program and when the Diagnostic Programs screen appears, select **Utility**.
5. Select **View Test Log** from the list that appears; then, follow the instructions on the screen.
6. You can save the test log to a file on a diskette or to your hard disk drive.

**Note:** The system maintains the test-log data while the system is powered on. When you turn off the power to the server, the test log is cleared.

## Diagnostic error message tables

For descriptions of the error messages that might appear when you run the diagnostic programs, see "Diagnostic error codes" on page 90. If diagnostic error

messages appear that are not listed in those tables, make sure that the server has the latest levels of BIOS, Advanced System Management Processor, ServeRAID, and diagnostics microcode installed.

---

## Power checkout

Power problems can be difficult to troubleshoot. For instance, a short circuit can exist anywhere on any of the power distribution busses. Usually a short circuit will cause the power subsystem to shut down because of an overcurrent condition.

A general procedure for troubleshooting power problems is as follows:

1. Power off the server and disconnect the AC cord(s).
2. Check for loose cables in the power subsystem. Also check for short circuits, for instance if there is a loose screw causing a short circuit on a circuit board.
3. Remove adapters and disconnect the cables and power connectors to all internal and external devices until server is at minimum configuration required for power on (see "Minimum operating requirements" on page 97).
4. Reconnect the AC cord and power on the server. If the server powers up successfully, replace adapters and devices one at a time until the problem is isolated. If server does not power up from minimal configuration, replace FRUs of minimal configuration one at a time until the problem is isolated.

To use this method it is important to know the minimum configuration required for a server to power up (see page 97).

---

## Recovering BIOS

If the BIOS code has become damaged, such as from a power failure during a flash update, you can recover the BIOS code using a BIOS flash diskette.

You can obtain a BIOS flash diskette from one of the following sources:

- Use the ServerGuide program to make a BIOS flash diskette.
- Download files from the World Wide Web to make a BIOS flash diskette. Go to <http://www.ibm.com/pc/support/> select IBM System Support, and then make the selections for your system.

Complete the following steps to recover the BIOS code:

1. When prompted, insert the BIOS flash diskette into the diskette drive.
2. Restart the server. The BIOS begins the power-on self-test.
3. The BIOS flash utility automatically starts.
4. When prompted as to whether you want to save the current code to a diskette, select N.
5. When prompted, press Y to continue the flash process.
6. The system automatically starts the flash utility a second time.
7. When prompted as to whether you want to save the current BIOS code, stop the process by removing the BIOS flash diskette from the diskette drive.
8. Restart the server, which should start up normally.

---

## Clearing CMOS

If you need to *erase* configuration information, you must move the CMOS jumper.

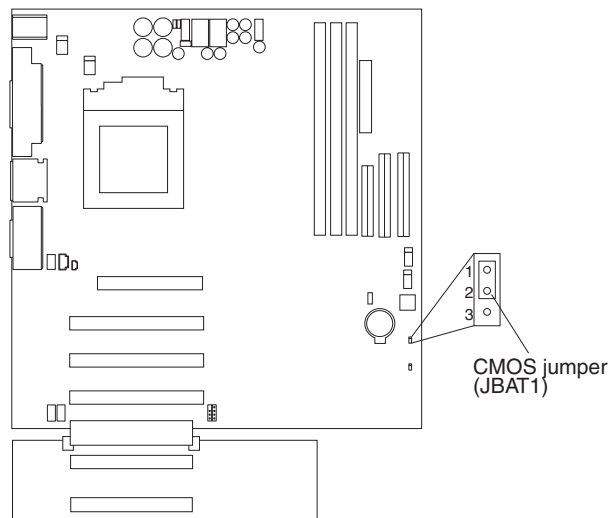

The default position is a jumper installed on pins 1 and 2. Before you change the position of this jumper, you *must* turn off the server and peripheral devices, and disconnect all external cables and power cords. Remove the cover and then move the jumper to pins 2 and 3.

After moving the jumper, wait at least 5 minutes for the CMOS information to clear.

Changing the position of this jumper erases all configuration and setup information, including the power-on and administrator passwords. Therefore, you must reconfigure the server after clearing CMOS memory (see “Configuration” on page 25). If possible, record the server configuration information *before* moving the CMOS jumper.

After you clear the CMOS information, move the jumper back to its normal position (pins 1 and 2). Reconnect the external cables and power cords; then, turn on the peripheral devices and the server.

---

## Replacing the battery

When replacing the battery, you must replace it with a lithium battery of the same type from the same manufacturer. To avoid possible danger, read and follow the safety statement below.

To order replacement batteries, call 1-800-772-2227 within the United States, and 1-800-465-7999 or 1-800-465-6666 within Canada. Outside the U.S. and Canada, call your IBM reseller or IBM marketing representative.

**Note:** After you replace the battery, you must reconfigure your system and reset the system date and time.



**CAUTION:**

When replacing the battery, use only IBM Part Number 33F8354 or an equivalent type battery recommended by the manufacturer. If the server has a module containing a lithium battery, replace it only with the same module type made by the same manufacturer. The battery contains lithium and can explode if not properly used, handled, or disposed of.

*Do not:*

- **Throw or immerse into water**
- **Heat to more than 100°C (212°F)**
- **Repair or disassemble**

**Dispose of the battery as required by local ordinances or regulations.**

Do the following to replace the battery:

1. Read “Before you begin” on page 40, and follow any special handling and installation instructions supplied with the replacement battery.
2. Turn off the server and peripheral devices and disconnect all external cables and power cords; then, remove the server cover.
3. Remove the battery:
  - a. Use one finger to press the top of the battery clip away from the battery until the battery releases upward from the socket.
  - b. Lift and remove the battery from the battery socket.

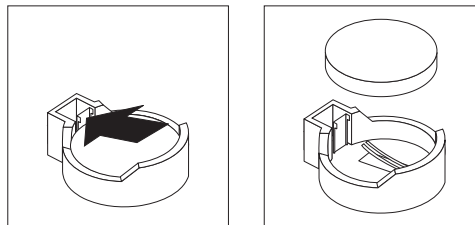

4. Do the following to insert the new battery:
  - a. Tilt the battery so that you can insert it into the socket under the battery clip.
  - b. As you slide it under the battery clip, press the battery down into the socket.

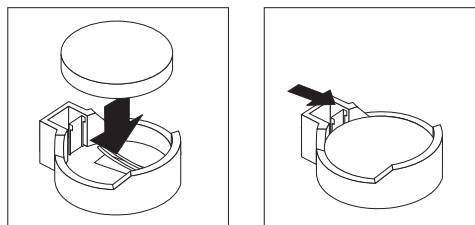

5. Reinstall the server cover and connect the cables.
6. Turn on the server.
7. Start the Configuration/Setup Utility program and set configuration parameters.
  - Set the server date and time.
  - Set the power-on password.
  - Reconfigure the server.



---

## Temperature checkout

Proper cooling of the server is important for proper operation and server reliability. For a typical xSeries server, you should make sure:

- Each of the drive bays has either a drive or a filler panel installed
- Each of the power supply bays has either a power supply or a filler panel installed
- The server cover is in place during normal operation
- There is at least 50 mm (2 inches) of ventilated space at the sides of the server and 100 mm (4 inches) at the rear of the server
- The server cover is removed for no longer than 30 minutes while the server is operating
- The processor housing cover covering the processor and memory area is removed for no longer than ten minutes while the server is operating
- A removed hot-swap drive is replaced within two minutes of removal
- Cables for optional adapters are routed according to the instructions provided with the adapters (ensure that cables are not restricting air flow)
- The fans are operating correctly and the air flow is good
- A failed fan is replaced within 48 hours

In addition, ensure that the environmental specifications for the server are met. See “Features and specifications” on page 3.

**Note:** The speed of the fans will increase if:

- One fan fails.
- Ambient temperature gets too high.

---

## Diagnosing errors

To find solutions to problems that have definite symptoms, see “Error symptoms” on page 92.

If you cannot find the problem there, go to “Starting the diagnostic programs” on page 12 to test the server.

If you have just added new software or a new option and the server is not working, do the following before using the error symptoms table:

- Remove the software or device that you just added.
- Run the diagnostic tests to determine if the server is running correctly.
- Reinstall the new software or new device.

---

## Troubleshooting the Ethernet controller

This section provides troubleshooting information for problems that might occur with the 10/100 MBps Ethernet controller.

### Network connection problems

If the Ethernet controller cannot connect to the network, check the following:

- Make sure that the cable is installed correctly.

The network cable must be securely attached at all connections. If the cable is attached but the problem persists, try a different cable.

If you set the Ethernet controller to operate at 100 MBps, you must use Category 5 cabling.

If you directly connect two workstations (without a hub), or if you are not using a hub with X ports, use a crossover cable.

**Note:** To determine whether a hub has an X port, check the port label. If the label contains an X, the hub has an X port.

- Determine if the hub supports auto-negotiation. If not, try configuring the integrated Ethernet controller manually to match the speed and duplex mode of the hub.
- Check the LAN activity light (if available) on the front of the server. The LAN activity light illuminates when the Ethernet controller sends or receives data over the Ethernet network. If the LAN activity light is off, make sure that the hub and network are operating and that the correct device drivers are loaded.
- Make sure that you are using the correct device drivers, supplied with the server.
- Check for operating server-specific causes for the problem.
- Make sure that the device drivers on the client and server are using the same protocol.
- Test the Ethernet controller.

The way you test the Ethernet controller depends on which operating system you are using (see the Ethernet controller device driver README file).

## Ethernet controller troubleshooting chart

You can use the following troubleshooting chart to find solutions to 10/100 MBps Ethernet controller problems that have definable symptoms.

*Table 3. Ethernet troubleshooting chart*

Ethernet controller problem	Suggested Action
The server stops running when loading device drivers.	<p>The PCI BIOS interrupt settings are incorrect.</p> <p>Check the following:</p> <ul style="list-style-type: none"> <li>• Determine if the IRQ setting assigned to the Ethernet controller is also assigned to another device in the Configuration/Setup Utility program.</li> </ul> <p>Although interrupt sharing is allowed for PCI devices, some devices do not function well when they share an interrupt with a dissimilar PCI device. Try changing the IRQ assigned to the Ethernet controller or the other device. For example, for NetWare Versions 3 and 4 it is recommended that disk controllers not share interrupts with LAN controllers.</p> <ul style="list-style-type: none"> <li>• Make sure that you are using the most recent device driver available from the World Wide Web.</li> <li>• Run the network diagnostic program.</li> </ul>
The LAN activity light (when available) does not light.	<p>Check the following:</p> <ul style="list-style-type: none"> <li>• Make sure that you have loaded the network device drivers.</li> <li>• The network might be idle. Try sending data from this workstation.</li> <li>• Run diagnostics on the LEDs.</li> </ul>

Table 3. Ethernet troubleshooting chart (continued)

Ethernet controller problem	Suggested Action
Data is incorrect or sporadic.	<p>Check the following:</p> <ul style="list-style-type: none"> <li>• Make sure that you are using Category 5 cabling when operating the server at 100 MBps.</li> <li>• Make sure that the cables do not run close to noise-inducing sources like fluorescent lights.</li> </ul>
The Ethernet controller stopped working when another adapter was added to the server.	<p>Check the following:</p> <ul style="list-style-type: none"> <li>• Make sure that the cable is connected to the Ethernet controller.</li> <li>• Make sure that your PCI server BIOS is current.</li> <li>• Reseat the adapter.</li> <li>• Determine if the IRQ setting assigned to the Ethernet adapter is also assigned to another device in the Configuration/Setup Utility program.</li> </ul> <p>Although interrupt sharing is allowed for PCI devices, some devices do not function well when they share an interrupt with a dissimilar PCI device. Try changing the IRQ assigned to the Ethernet adapter or the other device.</p>
The Ethernet controller stopped working without apparent cause.	<p>Check the following:</p> <ul style="list-style-type: none"> <li>• Run diagnostics for the Ethernet controller.</li> <li>• Try a different connector on the hub.</li> <li>• Reinstall the device drivers. Refer to your operating system documentation and to the ServerGuide information.</li> </ul>

## Ethernet controller messages

The integrated Ethernet controller might display messages from the following device drivers:

- Novell NetWare™ or IntraNetWare system open data-link interface (ODI)
- Network driver interface specification (NDIS) adapter for level 4.0 (Windows NT)

## Novell NetWare or IntraNetWare system ODI driver teaming messages

This section provides explanations of the error messages for the Novell NetWare or IntraNetWare system ODI driver, and suggested actions to resolve each problem.

Table 4. NetWare driver messages for the Ethernet controller

Message	Description
Couldn't allocate resources.	<p><b>Explanation:</b> An unknown error has occurred when trying to allocate needed resources for the AFT Module.</p> <p><b>Action:</b></p> <ul style="list-style-type: none"> <li>• Check the server configuration. If the problem persists, contact your network supplier.</li> <li>• Verify that the Ethernet controller is enabled. If the Ethernet controller is enabled, run the diagnostic programs.</li> </ul>
AFT group for primary adapter in slot <i>nnn</i> already exists.	<p><b>Explanation:</b> An attempt was made to rebind an adapter already in an AFT group.</p> <p><b>Action:</b> Check the AFT slot numbers for existing AFT teams. If the problem persists, contact your network supplier.</p>

Table 4. NetWare driver messages for the Ethernet controller (continued)

Message	Description
Error locating device control table (DCT) addresses in internal table. Make sure that you have loaded LAN drivers after loading AFT.NLM.	<b>Explanation:</b> The bind command was entered prior to loading the device driver. The device driver must be loaded after loading AFT.NLM, but before any bind command can be issued. <b>Action:</b> Load the driver for the supported adapter and try loading the AFT module again. If the problem persists, contact your network supplier.
Insufficient number of arguments specified.	<b>Explanation:</b> The appropriate or expected number of parameters was not entered in a command. <b>Action:</b> Check the parameters required for the given command. If the problem persists, contact your network supplier.
Duplicate slot numbers detected.	<b>Explanation:</b> An attempt has been made to bind the same slot number more than once. <b>Action:</b> Check the slot numbers entered during the bind. Adapter slot numbers must be valid and unique. If the problem persists, contact your network supplier.
'xxx' is not supported for AFT team.	<b>Explanation:</b> A bind command has been issued for adapters not supported by AFT.NLM. <b>Action:</b> Make sure that you attempt to bind only adapters supported by AFT.NLM.
Primary and Secondary adapters do not match. AFT group is not created.	<b>Explanation:</b> A bind command was entered for an adapter team that is a combination of server and client adapters. An AFT team must be a grouping of the same classification of adapter. <b>Action:</b> Verify that all the adapters bound in a team are of the same classification.
Requested number of Secondary cards are not found.	<b>Explanation:</b> The number of adapters specified in the bind command could not be located. <b>Action:</b> Verify the numbers and slot locations of the adapters to be bound. If the problem persists, contact your network supplier.
Failed to create AFT group. Make sure that the drivers for supported adapters are loaded, primary adapter is bound to protocols, and secondary adapter is not bound to any protocols.	<b>Explanation:</b> Binding of protocol failed. Protocol is either not bound to any adapter or is bound to more than one adapter in the group. <b>Action:</b> Ensure that the protocol is bound to only adapter in an AFT team.
Error identifying slot numbers for the specified board names.	<b>Explanation:</b> The mapping between the board name entered and the slot number for an adapter could not be established. <b>Action:</b> Check the board name for the adapter before issuing the bind command. If the problem persists, contact your network supplier.
Can't unbind specified slot from AFT group. Make sure that the slot you specified is for the primary adapter in an AFT group.	<b>Explanation:</b> The number entered in the unbind command was not the primary adapter in an AFT group. <b>Action:</b> Reissue the unbind command and specify the slot number for the primary adapter.

Table 4. NetWare driver messages for the Ethernet controller (continued)

Message	Description
LAN adapter at slot <i>nnnn</i> (Port 0xaa) failed to reset. Check the state of the adapter.	<p><b>Explanation:</b> The adapter that you specified could not be initialized.</p> <p><b>Action:</b></p> <ol style="list-style-type: none"> <li>1. Load the driver for the supported adapter.</li> <li>2. Check that the adapter is seated properly in the slot and try loading the AFT module again.</li> </ol> <p>If the problem persists, contact your network supplier.</p>
AFT is not supported on this version of NetWare™.	<p><b>Explanation:</b> The NetWare on the server is not a version supported by AFT.</p> <p><b>Action:</b> Load and bind AFT only on supported versions of NetWare (currently version 4.11 and above).</p>
Failed to allocate resources tags.	<p><b>Explanation:</b> An unknown error has occurred when trying to allocate needed resources for the AFT module.</p> <p><b>Action:</b> Check server configuration. If the problem persists, contact your network supplier.</p>
Please unload all LAN drivers before unloading AFT.NLM.	<p><b>Explanation:</b> An attempt was made to unload the AFT.NLM module before unloading the adapter driver.</p> <p><b>Action:</b> Unload the adapter driver before unloading the AFT module.</p>

## NDIS 4.0 Windows driver messages

This section contains the error messages for the NDIS 4.0 drivers. The explanation and recommended action are included with each message.

Table 5. NDIS (Windows NT or Windows 2000) driver messages for the Ethernet controller

Error code (hex)	Description
0x00	<p><b>Explanation:</b> The driver could not register the specified interrupt.</p> <p><b>Action:</b> Using the Configuration/Setup Utility program, make sure that a PCI interrupt is assigned to your Ethernet card, and that Ethernet is enabled.</p>
0x01	<p><b>Explanation:</b> One of the PCI cards did not get the required resources.</p> <p><b>Action:</b> Using the Configuration/Setup Utility program, make sure that a PCI interrupt is assigned to your Ethernet card, and that Ethernet is enabled.</p>
0x02	<p><b>Explanation:</b> Bad node address (multicast address).</p> <p><b>Action:</b> Make sure the locally administered address is valid, if one is specified. The address can not be a multicast address.</p>
0x03	<p><b>Explanation:</b> Failed self-test.</p> <p><b>Action:</b> Make sure a cable is attached to the Ethernet connector.</p>
0x0D	<p><b>Explanation:</b> Could not allocate enough memory for transmit queues.</p> <p><b>Action:</b></p> <ol style="list-style-type: none"> <li>1. From the Windows NT desktop, select <b>Start " Control Panel " Networks " Adapters.</b></li> <li>2. Select your IBM Ethernet adapter from the list.</li> <li>3. Select <b>Properties " Advanced.</b></li> <li>4. Lower the resource values that apply to the transmit queue.</li> </ol>

Table 5. NDIS (Windows NT or Windows 2000) driver messages for the Ethernet controller (continued)

Error code (hex)	Description
0x0E	<p><b>Explanation:</b> Could not allocate enough memory for receive queue.</p> <p><b>Action:</b></p> <ol style="list-style-type: none"> <li>1. From the Windows NT desktop, select <b>Start "Control Panel "Networks "Adapters.</b></li> <li>2. Select your IBM Ethernet adapter from the list.</li> <li>3. Select <b>Properties "Advanced.</b></li> <li>4. Lower the resource values that apply to the receive queue.</li> </ol>
0x0F	<p><b>Explanation:</b> Could not allocate enough memory for other structures.</p> <p><b>Action:</b></p> <ol style="list-style-type: none"> <li>1. From the Windows NT desktop, select <b>Start " Control Panel " Networks " Adapters.</b></li> <li>2. Select your IBM Ethernet adapter from the list.</li> <li>3. Select <b>Properties "Advanced.</b></li> <li>4. Lower the value for the resource named in the message.</li> </ol>
0x10	<p><b>Explanation:</b> Did not find any Ethernet controllers.</p> <p><b>Action:</b> Using the Configuration/Setup Utility program, make sure that Ethernet is enabled.</p>
0x11	<p><b>Explanation:</b> Multiple Ethernet controllers found, but none matched the required ID.</p> <p><b>Action:</b> Using the Configuration/Setup Utility program, make sure that Ethernet is enabled.</p>
0x13	<p><b>Explanation:</b> Did not find any Ethernet controllers that matched the required subven/subdev.</p> <p><b>Action:</b> Using the Configuration/Setup Utility program, make sure that Ethernet is enabled.</p>
0x16	<p><b>Explanation:</b> Single adapter found, but multiple instances tried to load.</p> <p><b>Action:</b> Using the Configuration/Setup Utility program, make sure that Ethernet is enabled, and that the slot containing the IBM xSeries 200 10/100 Ethernet Adapter or the IBM 10/100 Etherjet PCI adapter is enabled.</p>
0x17	<p><b>Explanation:</b> Slot parameter not specified in the registry.</p> <p><b>Action:</b> Remove the adapter driver and reinstall it.</p>

## Ethernet teaming messages:

This section displays the messages associated with Ethernet teaming.

Table 6. NDIS (Windows NT or Windows 2000) driver teaming messages for the Ethernet controller

Event ID	Type	Description
01	Error	<p><b>Explanation:</b> Team name and physical adapter name are the same. This is an invalid configuration.</p> <p><b>Action:</b> Reconfigure the adapter team by double-clicking the PROSet icon in the control panel.</p>
02	Error	<p><b>Explanation:</b> Unable to allocate required resources.</p> <p><b>Action:</b> Free some memory resources and restart.</p>

Table 6. NDIS (Windows NT or Windows 2000) driver teaming messages for the Ethernet controller (continued)

Event ID	Type	Description
03	Error	<b>Explanation:</b> Unable to read required registry parameters. <b>Action:</b> Reconfigure the adapter team by double-clicking the PROSet icon in the control panel.
04	Error	<b>Explanation:</b> Unable to bind to physical adapter. <b>Action:</b> Reconfigure the adapter team by double-clicking the PROSet icon in the control panel.
05	Error	<b>Explanation:</b> Unable to initialize an adapter team. <b>Action:</b> Reconfigure the adapter team by double-clicking the PROSet icon in the control panel.
06	Informational	<b>Explanation:</b> Team <i>nm</i> . Primary adapter is initialized. <b>Action:</b> None.
07	Informational	<b>Explanation:</b> Team <i>nm</i> . Secondary adapter is initialized. <b>Action:</b> None.
08	Informational	<b>Explanation:</b> Team <i>nm</i> . Virtual adapter or Team is initialized. <b>Action:</b> None.
09	Informational	<b>Explanation:</b> Team <i>nm</i> . Primary adapter is switching over. <b>Action:</b> None.
10	Warning	<b>Explanation:</b> Team <i>nm</i> . Adapter link down. <b>Action:</b> Make sure the adapter is functioning properly.
11	Informational	<b>Explanation:</b> Team <i>nm</i> . Secondary adapter took over. <b>Action:</b> None.
12	Warning	<b>Explanation:</b> Team <i>nm</i> . Secondary adapter is deactivated from the Team. <b>Action:</b> Make sure the secondary adapter is functioning properly and that the adapter cable is securely connected to the LAN.
13	Informational	<b>Explanation:</b> Team <i>nm</i> . Secondary adapter has rejoined the Team. <b>Action:</b> None.
14	Informational	<b>Explanation:</b> Team <i>nm</i> . Secondary adapter link is up. <b>Action:</b> None.
15	Error	<b>Explanation:</b> Team <i>nm</i> . The last adapter has lost its link. Network connection has been lost. <b>Action:</b> Shut down the server and replace the adapters; then, restart the server to reestablish the connection.
16	Informational	<b>Explanation:</b> Team <i>nm</i> . An adapter has reestablished the link. Network connection has been restored. <b>Action:</b> None.
17	Informational	<b>Explanation:</b> Team <i>nm</i> . Preferred primary adapter has been detected. <b>Action:</b> None.
18	Informational	<b>Explanation:</b> Team <i>nm</i> . Preferred secondary adapter has been detected. <b>Action:</b> None.

Table 6. NDIS (Windows NT or Windows 2000) driver teaming messages for the Ethernet controller (continued)

Event ID	Type	Description
19	Informational	<b>Explanation:</b> Team <i>nm</i> . Preferred primary adapter took over. <b>Action:</b> None.
20	Informational	<b>Explanation:</b> Team <i>nm</i> . Preferred secondary adapter took over. <b>Action:</b> None.
21	Warning	<b>Explanation:</b> Team <i>nm</i> . Primary adapter does not sense any Probes. Possible reason: partitioned Team. <b>Action:</b> Make sure the cables of the adapter team are connected to the same LAN segment. Reconfigure the team if necessary.



---

## Configuration

The following configuration programs are provided with the server:

- **Configuration/Setup Utility**

The Configuration/Setup Utility program is part of the BIOS code that comes with the server. You can use this program to configure serial- and parallel-connector assignments, change the drive startup sequence, set the date and time, and set passwords. See “Using the Configuration/Setup Utility program” for more information.

- **SCSISelect Utility (some models)**

With the SCSISelect Utility program, you can configure the devices that are attached to the SCSI adapter. Use this program to change default values, resolve configuration conflicts, and perform a low-level format on a SCSI hard disk drive. See “Using the SCSISelect utility program (some models)” on page 28 for more information.

- **PXE Boot Agent Utility**

The Preboot eXecution Environment (PXE) Boot Agent Utility program is part of the BIOS code that comes with the server. Depending on the server model, you can use this program to change network startup (boot) protocols and startup order, to select operating-system wake-up support, and to set menu wait times. See “Using the PXE Boot Agent Utility program” on page 31 for more information.

**Attention:** The network startup protocols and startup order options are not supported on this product.

- **ServeRAID programs**

The ServeRAID programs come with the optional ServeRAID adapters and with server models that have a ServeRAID adapter preinstalled. If a ServeRAID adapter has been installed in the server, you must use the ServeRAID configuration program to define and configure the disk-array subsystem *before* you install the operating system. More information is available from the *IBM xSeries Documentation* CD that was shipped with the server.

- **ServerGuide CDs**

The ServerGuide CDs include software setup and installation tools specifically designed for IBM xSeries servers. You can use these CDs during the initial installation of the server to configure the server hardware and simplify the NOS installation. The ServerGuide CDs also contain a collection of application programs, which you can install after the server is up and running. See “Using the ServerGuide CDs” on page 32 for more information.

---

## Using the Configuration/Setup Utility program

This section provides the instructions for starting the Configuration/Setup Utility program and also provides descriptions of the menu choices that are available.

### Starting the Configuration/Setup Utility program

Complete the following steps to start the Configuration/Setup Utility program:

1. Turn on the server and watch the monitor screen.
2. When the message Press F1 for Configuration/Setup appears, press the F1 key.

3. Follow the instructions that appear on the screen.

## Choices available from the Configuration/Setup main menu

From the Configuration/Setup Utility main menu, you can select settings that you want to change. The Configuration/Setup Utility main menu is similar to the following illustration:

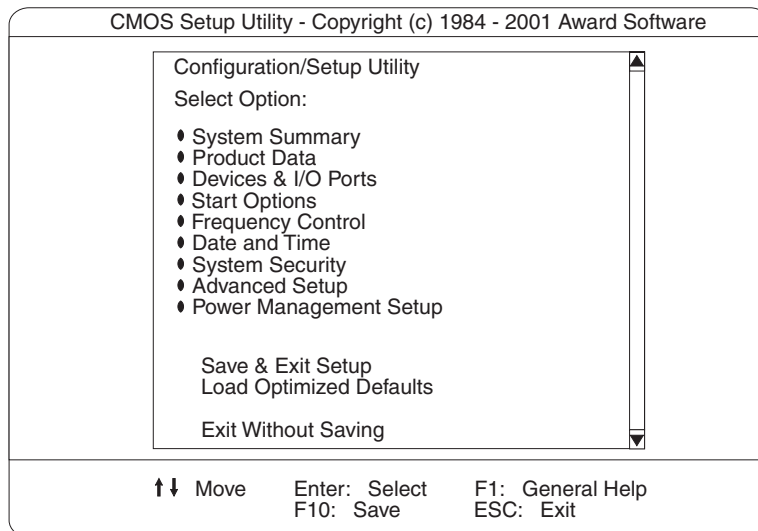

### Notes:

1. You can press the F1 key to display help information for a selected menu item.
2. Some menu choices might differ, depending on the types of passwords set for the system and IBM system management adapters, or in the version of BIOS code installed on the server.

Descriptions of the choices that are available from the main menu are as follows:

- **System summary**

Select this choice to display configuration information. This includes the type and speed of the microprocessors and the amount of memory that is installed. Changes that you make to configuration settings appear on this summary screen. You cannot edit the fields.

This choice appears on both the full and limited Configuration/Setup Utility menus.

- **Product data**

Select this choice to view system information, such as the machine type and model, the server serial number, and the revision level or issue date of the BIOS stored in the flash electronically erasable programmable read-only memory (EEPROM).

- **Devices and I/O ports**

Select this choice to view or change the assignments for devices and input/output ports. This choice appears only on the full Configuration/Setup Utility main menu.

- **Start Options**

Select this choice to view or change the start options. Start options take effect when you start the server.

You can select keyboard operating characteristics, such as the keyboard speed. You also can specify whether the server starts with the keyboard number lock on or off.

The server uses a startup sequence to determine the device from which the operating system starts. For example, you can define a startup sequence that checks for a startable diskette in the diskette drive, then checks the hard disk drive in a drive bay, and then checks a network adapter.

You can enable a virus-warning test that checks for changes in the master boot record at startup. You also can choose to run POST in the quick mode, and read the microprocessor serial number.

- **Frequency Control**

Select this choice to enable or disable the auto-detect DIMM/PCI clock.

- **Date and Time**

Select this choice to set the system date and time.

The system time is in a 24-hour format: hour:minute:second.

**Note:** You may also set the date and time using the procedures provided on the *ServerGuide* CDs.

- **System Security**

Select this choice to set a power-on or an administrator password. See “Using passwords” on page 28 for more information.

- **Advanced Setup**

Select this choice to change values for advanced hardware features, such as Cache Control and PCI configuration.

A message appears above the choices on this menu to alert you that the system might malfunction if these options are configured incorrectly. Follow the instructions on the screen carefully.

- **Cache Control**

Select this choice to enable or disable the microprocessor cache.

**Attention:** The Cache Control should only be modified by an IBM authorized service representative.

- **ROM Shadowing**

Select this choice to enable or disable the state of a ROM shadowing.

- **Chipset Feature**

Select this choice to modify settings that control features of the core chip set on the system board.

**Attention:** The Chipset Feature should only be modified by an IBM authorized service representative.

- **Memory Settings**

If a memory error is detected during POST or memory configuration, the server can automatically disable the failing memory bank and continue operating with reduced memory capacity. If this occurs, you must manually enable the memory bank after the problem is corrected. Select **Memory Settings** from the Advanced Setup menu, use the arrow keys to highlight the bank that you want to enable; then, use the arrow keys to select **Enable**.

- **Power Management Setup**

Select this choice to enable or disable system power savings.

- **Save and Exit Setup**

Select this choice to save the customized settings.

- **Load Optimized Defaults**  
Select this choice to discard changes and restore the factory settings.
- **Exit Without Saving**  
Select this choice if you want to exit without saving changes, or if no changes have been made.

## Using passwords

The **System Security** choice appears only on the full Configuration/Setup Utility menu. After you select this choice, you can set a power-on password or an administrator password.

You can use any combination of up to seven characters (A–Z, a–z, and 0–9) for the power-on password. Keep a record of the password in a secure place. If you forget the power-on password, you can regain access to the server through either of the following methods:

- Start the Configuration/Setup Utility program and change the power-on password.
- Change the jumper position on the CMOS jumper as described in “Clearing CMOS” on page 15.
- If both a power-on and administrator password are set, you can type either password at the password prompt *that appears as you start the computer*. However, if you want to change any settings in the Configuration/Setup Utility program, you must type the administrator password at the password prompt *that appears when you try to access the Configuration/Setup Utility program*. If you type the power-on password at this prompt, you will be able to view limited information in the Configuration/Setup Utility program, but you will not be able to change any settings.

---

## Using the SCSISelect utility program (some models)

SCSISelect is a built-in, menu-driven configuration utility program that you can use to:

- View the default SCSI IDs
- Locate and correct configuration conflicts

The following sections provide the instructions for starting the SCSISelect Utility program and descriptions of the menu choices that are available.

**Note:** If the server has a redundant arrays of independent disks (RAID) adapter installed, use the configuration method that is supplied with the RAID adapter to view or change SCSI settings for attached devices.

## Starting the SCSISelect utility program

Complete the following steps to start the SCSISelect Utility program:

1. Turn on the server.
2. When the <<< Press <CTRL><A> for SCSISelect Utility! >>> prompt appears, press Ctrl+A.
3. When the Would you like to configure the host adapter or run the SCSI disk utility? question appears, make your selection and press **Enter**.
4. Use the arrow keys to select a choice from the menu.
  - Press Esc to exit the SCSI Select Utility program.

- Press the F5 key to switch between color and monochrome modes (if your monitor permits).
5. Follow the instructions on the screen to change the settings of the selected items; then, press Enter.

## Choices available from the SCSISelect menu

The following choices appear on the SCSISelect Utility menu:

- **Configure/View Host Adapter Settings**

Select this choice to view or change the SCSI controller settings. To reset the SCSI controller to its default values, press the F6 key; then, follow the on-screen instructions.

You can view or change the following controller settings:

- **Host Adapter SCSI ID**

Select this choice to view the SCSI controller identification (ID), which is usually 7.

- **SCSI Parity Checking**

Select this choice to view the assigned value. The assigned value is *Enabled*, and cannot be changed.

- **Host Adapter SCSI Termination**

Select this choice to view the assigned value. The assigned value is *Automatic*, and cannot be changed.

- **Boot Device Options**

Select this choice to configure startable-device parameters. Before you can make updates, you must know the ID of the device whose parameters you want to configure.

- **SCSI Device Configuration**

Select this choice to configure SCSI-device parameters. Before you can make updates, you must know the ID of the device whose parameters you want to configure.

**Note:** The Maximum Sync Transfer Rate is the transfer rate for Ultra SCSI devices.

- The transfer rate for Ultra 160 low voltage differential (LVD) devices is 160.0 MBps.
- The transfer rate for Ultra2 SCSI LVD devices is 80.0 MBps.
- The transfer rate for Fast SCSI devices is 20.0 MBps.

- **Advanced Configuration Options**

Select this choice to view or change the settings for advanced configuration options. These options include support for large hard disk drives and support for drives with UltraSCSI speeds.

- **SCSI Disk Utilities**

Select this choice to view the SCSI IDs that are assigned to each device or to format a SCSI device.

To use the utility program, select a drive from the list. Read the on-screen instructions carefully before making a selection.

**Note:** If you press Ctrl+A before the selected drives are ready, an Unexpected SCSI Command Failure screen might appear. Restart the server and watch the SCSISelect messages as each drive starts. After the drive that you want to view or format starts, press Ctrl+A.

- **Format Disk**

**Attention:** The Low-Level Format program erases *all* data and programs.

Select this choice to perform a low-level format on a hard disk drive. Depending on the hard disk drive capacity, the Low-Level Format program could take up to two hours.

Use the Low-Level Format program:

- When you are installing software that requires a low-level format.
- When you get recurring messages from the diagnostic tests directing you to run the Low-Level Format program on the hard disk drive
- As a last resort before replacing a failing hard disk drive

**Note:** If the server has a PCI RAID adapter installed, refer to the RAID adapter documentation for instructions for performing low-level formats on hard disk drives attached to the adapter.

To start the Low-Level Format program:

1. If the hard disk drive is working, make a backup copy of all the files and programs on the hard disk drive. (See the operating system information for instructions.)
2. Select **Format Disk**; then, follow the instructions on the screen.

**Note:** Hard disk drives normally contain more tracks than their stated capacity (to allow for defective tracks). A message appears on the screen if the defect limit is reached. If this happens, replace the hard disk drive.

---

## Using the PXE Boot Agent Utility program

The PXE boot agent is a built-in, menu-driven configuration utility program that you can use to:

- Select whether to display the setup prompt
- Set menu wait time
- Select operating-system wake-up support

**Attention:** The network startup protocols and startup order options are not supported on this product.

The following sections provide instructions for starting the PXE Boot Agent Utility program and descriptions of the menu choices that are available.

### Starting the PXE Boot Agent Utility program

To start the PXE Boot Agent Utility program:

1. Turn on the server.
2. When the Initializing Intel (R) Boot Agent Version X.X.XX PXE 2.0 Build XXX (WfM 2.0) prompt appears, press Ctrl+S.

**Note:** By default, you will have 2 seconds after the prompt appears on the screen to press Ctrl+S.

3. Use the arrow keys or press Enter to select a choice from the menu.
  - Press Esc to return to the previous menu.
  - Press the F4 key to exit.
4. Follow the instructions on the screen to change the settings of the selected items; then, press Enter.

### Choices available from the PXE Boot Agent Utility menu

The following choices appear on the PXE Boot Agent Utility menu:

- **Network Boot Protocol**

PXE is the default value for this menu item.

**Note:** Do not change this value. There are no other network boot protocols supported.

- **Boot Order**

**Attention:** This option is not supported on this product. To change the boot order use the Configuration/Setup utility. See "Using the Configuration/Setup Utility program" on page 25 for more information.

- **Show setup prompt**

Select this choice to either display the PXE setup prompt or disable it. **Disable** is the default setting.

When this choice is enabled, Press Ctrl+S to enter the setup menu will appear on the screen under the initializing prompt.

- **Setup time wait menu**

Select this choice to set the amount of time (in seconds) that the system will pause during initialization for a Ctrl+S input.

- 2 seconds (default)
- 3 seconds
- 5 seconds

- 8 seconds
- **Legacy OS wake up support**  
Select this choice to enable or disable the legacy operating system wake-up support.
  - Disabled (default)
  - Enabled

**Notes:**

1. Use the default setting for Advanced Configuration and Power Interface (ACPI) aware operating systems, such as Windows® 2000 and Windows NT.
2. If the server is running a non-ACPI operating system, you must set this selection to Enabled to use the Wake on LAN support.
3. When using a non-ACPI operating system, do not send a wake-up packet to the server while it is turned on. If a wake-up packet has been sent while the server is on and you are unable to turn the server off, see “Error symptoms” on page 92 for more information.

---

## Using the ServerGuide CDs

The ServerGuide CDs include easy-to-use software setup and installation tools that are specifically designed for the IBM server. The ServerGuide Setup and Installation program detects the server model and hardware options that are installed and uses that information during setup to configure the hardware. The ServerGuide tools simplify network operating system (NOS) installations by providing updated device drivers, and in some cases, installing them automatically.

If a newer version of the ServerGuide software is available, you can purchase an update package. For details, see the ServerGuide Updates form that comes with the server library, or go to the ServerGuide fulfillment Web site at <http://www.ibm.com/pc/coupon>.

The ServerGuide software has these features to make setup easier:

- An easy-to-use interface with online help
- Diskette-free setup, and configuration programs that are based on detected hardware
- Performance Optimizer program, which easily tunes the ServeRAID adapter settings for the server environment
- A system BIOS update program, which updates the BIOS code directly from the CD
- Device drivers that are provided for the server model and detected hardware
- NOS partition size and file-system type that are selectable during setup
- Powerful application programs and administration tools

## Features at a glance

The following is a summary of ServerGuide features.

**Note:** Exact features and functions can vary with different versions of the ServerGuide software. To learn more about the version that you have, start the *Setup and Installation* CD and view the online Overview.



<p><b>Setup and Installation CD</b>  <b>Note:</b> The ServerGuide program requires a supported IBM server with an <i>enabled</i> startable (bootable) CD-ROM drive. Not all features are supported on all models.</p> <ul style="list-style-type: none"> <li>• Sets system date and time.</li> <li>• Detects the ServeRAID adapter or controller and runs the ServeRAID configuration program.</li> <li>• Updates the licensed internal code (firmware) level without creating diskettes.</li> <li>• Checks the system BIOS code and microcode (firmware) levels of supported options to determine whether a later level is available from the CD. You can perform updates without the use of diskettes.</li> <li>• Provides the Performance Optimizer program to easily tune the ServeRAID adapter settings for the server environment.</li> <li>• Creates a System Partition on the default drive. You can run server-specific utility programs after setup.</li> <li>• Detects installed hardware options and provides updated device drivers for most adapters and devices.</li> </ul>	<p><b>Setup and Installation CD</b>  (continued)</p> <ul style="list-style-type: none"> <li>• Creates a <i>Setup Replication Diskette</i> for replicating setup selections for other servers of the same model.</li> <li>• Provides diskette-free installation for Microsoft Windows 2000, Windows NT, Novell NetWare, SCO UnixWare, and Red Hat Linux operating systems.</li> <li>• Provides a replicated installation path for multiple Windows 2000, Windows NT Server 4.0, Windows Enterprise Edition, and Red Hat Linux installations.</li> <li>• Includes an online README file with links to tips for the hardware and NOS installation.</li> </ul> <p><b>Note:</b> Installation requires the NOS CD.</p> <p><b>System Updates and Applications CD</b></p> <ul style="list-style-type: none"> <li>• Creates diagnostic, RAID, device driver, and other support diskettes from the CD; or, with an Internet connection, you can check for an update from a dedicated IBM file transfer protocol (FTP) server.</li> <li>• Installs some updates without requiring diskettes. Where applicable, you can run executable files directly from the CD or unzip files to any drive on the server or another server on the network.</li> </ul>	<p><b>System Updates and Applications CD</b>  (continued)</p> <ul style="list-style-type: none"> <li>• Includes a vast library of fully tested device drivers for the server.</li> <li>• Includes a search function to help you locate updates by title or keywords.</li> <li>• Installs powerful applications directly from the CD. See the CD label for a current list of applications.</li> </ul>
--	--	--

## Setup and configuration overview

When you use the *Setup and Installation* CD, you do not need setup diskettes. You can use the CD to configure any supported IBM server model. The setup program checks the system BIOS, service processors, and other system hardware to determine if system updates are available. The setup program provides a list of tasks that are required to set up the server model. On RAID servers, you can run the ServeRAID Manager program to create logical drives.

**Note:** Exact features and functions can vary with different versions of the ServerGuide software.

When you start the *Setup and Installation* CD, the following happens:

- You are prompted for your language, country, and keyboard layout. (This information is stored and later passed on to the NOS installation program.)
- The ServerGuide program displays choices for running the configuration programs. For example:
  - The Express Configuration method runs the required programs for the server, based on the hardware that is detected.
  - The Custom Configuration method displays all programs that are available for the server, and you decide which programs to run.
  - The Replicated Configuration method provides the option of duplicating the setup selections to other servers that are the same model.
- If you select the Custom Configuration method, the following programs are optional. If you select the Express Configuration method, some or all of these programs are run, depending on the hardware that is detected.
  - The Set Date and Time feature is provided so that you do not have to use the Configuration/Setup Utility program to access these settings.
  - The Clear Hard Disks program is provided so you can delete all partitions on all hard disk drives. If the server has a ServeRAID adapter installed, you can select to restore the configuration on the ServeRAID adapter to the factory default settings.
  - The ServerGuide program checks the server BIOS code and microcode (firmware) levels for supported options and then checks the CD for a newer level. CD content can be newer than the hardware. The ServerGuide program can perform a flash update of the BIOS code and supported microcode (firmware) options without the use of diskettes.
  - The ServeRAID program starts, leading you through the entire configuration process.
  - The Performance Optimizer program easily tunes the server for the environment.
  - The ServerGuide program creates a System Partition on the default drive.
- The ServerGuide program displays a confirmation summary, so that you will know when you have completed all the required tasks. Then, you are ready to install the NOS.

### Notes:

1. Plug and Play adapters are configured automatically. Non-Plug and Play adapters or non-IBM adapters might require switch settings, additional device drivers, and installation after the NOS is installed. See the documentation that comes with the adapter.
2. Diagnostics for the server come in BIOS code or on a separate diagnostics CD.

## System partition

The ServerGuide program creates a 50 MB system partition on the default drive. The system partition contains server-specific utility programs such as service processor disk operating system (DOS) utilities, system diagnostics, flash BIOS updates, and other programs.

**Note:** Programs in the system partition vary by server model, and not all server models run utility programs from the system partition. To determine which ones do, start the *Setup and Installation* CD and view the online Overview.

After setup is complete, you can access programs in the system partition by restarting the server and pressing Alt+F1 when the prompt is displayed. The system partition menu displays the programs that are available on the server model.

## Typical NOS installation

You can use the ServerGuide program to shorten the installation time. The ServerGuide program provides the necessary device drivers, based on the hardware that you have and the NOS that you are installing. The following is a brief explanation of a typical ServerGuide NOS installation.

**Note:** Exact features and functions can vary with different versions of the ServerGuide software.

- After you have completed the setup process, the operating-system installation program starts. (You will need a copy of the NOS CD to complete the installation.)
- The ServerGuide program stores information about the server model, service processor, hard disk controllers, and network adapters. It then checks the CD for newer device drivers. This information is stored and then passed to the NOS installation program.
- With some NOS installations, you can create a *NOS Replication Diskette* for setting up additional servers. The diskette will contain the Internet protocol (IP) address, server name, and other selections.
- The ServerGuide program presents NOS partition options that are based on the NOS selection and the installed hard disk drives.
- If you are installing the NOS from diskette, the ServerGuide program displays the required diskettes that you must create and the optional diskettes that you might want to create. The diskettes that you can create are the device-driver diskettes for the installed adapters or controllers.

The ServerGuide program prompts you to insert the NOS CD and restart the server. At this point, the installation program for the NOS (for example, Microsoft Windows 2000) takes control to complete the installation.

## Setting up or updating multiple servers

You can use the ServerGuide program to create diskettes that help you set up or update multiple servers. You can modify information on the diskettes as you use them to set up or update other servers.

**Note:** Availability and function can vary by server model and by the hardware that is installed.

You can create a setup-replication diskette, which contains the hardware configuration selections. Use this diskette to replicate selections to other servers that are of the same model.

You can create a NOS-replication diskette, which contains the server name, domain name, and other information that you need to complete multiple installations. This feature supports systems running Windows 2000, Windows NT Server 4.0, and Red Hat Linux operating systems.

## Installing the NOS without ServerGuide

If you have already configured the server hardware and you decide not to use the ServerGuide program to install the NOS, download the latest NOS installation instructions:

1. Go to <http://www.ibm.com/pc/support>.
2. Click **Servers**.
3. From the **Family** field, select the server model.
4. Click **OS installation**. The available installation instructions are displayed.

## Additional programs included with ServerGuide

As a convenience, the ServerGuide program comes with additional software to assist you with the server installation.

A variety of powerful applications are included with the ServerGuide software. Offerings can vary with the different versions of the ServerGuide software. Check the application CD labels for a list of applications, or start the *Setup and Installation* CD and view the online Overview.

---

## Installing options

This chapter provides instructions to help install options to the server. For a list of supported options for the server, see the ServerProven<sup>®</sup> list at <http://www.pc.ibm.com/compat>

---

### Major components of the xSeries 200

The blue color on components and labels indicates touch points where a component can be gripped, a latch moved, and so on.

**Note:** The illustrations in this document might differ slightly from your hardware.

The following illustration shows the major components of the server.

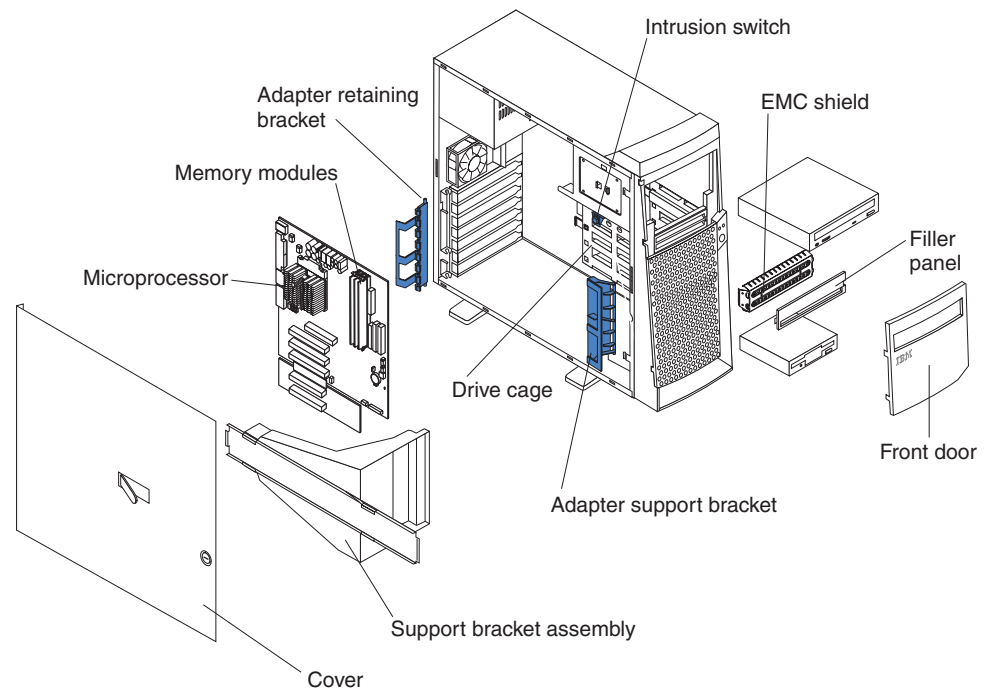

### System and PCI extender board

The illustrations in the following sections show the connectors and jumpers on the system and PCI extender boards.

#### System and PCI extender board options connectors

The following illustration identifies system and PCI extender-board connectors for options that can be installed.

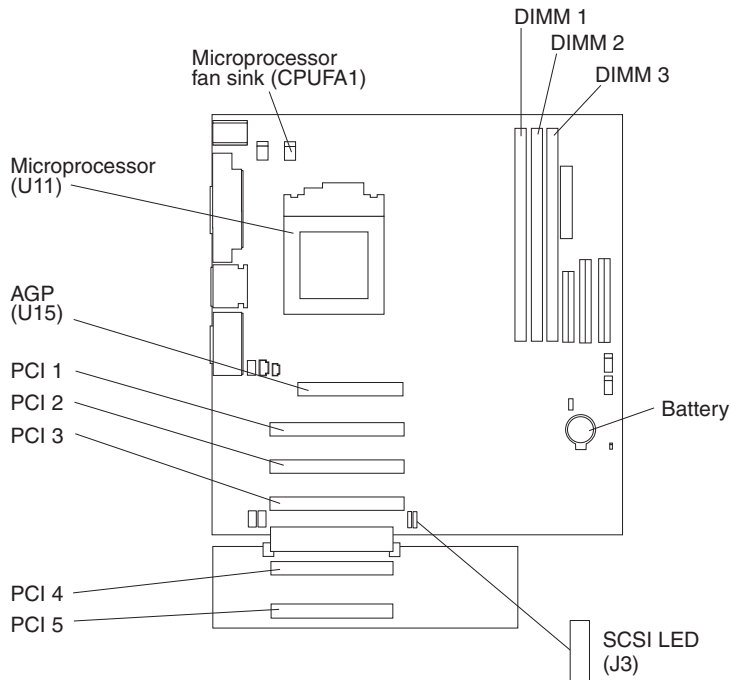

### System board internal cable connectors

The following illustration identifies system board connectors for internal cables.

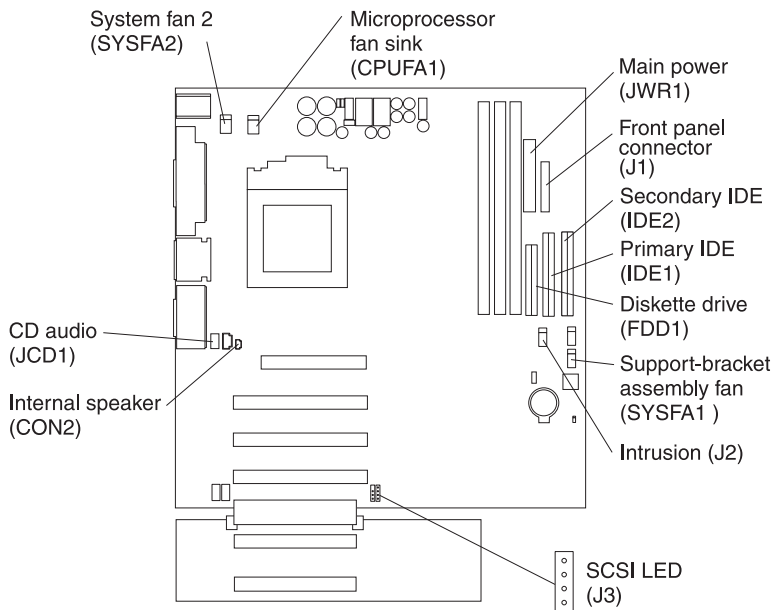

## System board external connectors

The following illustration identifies system board connectors for external devices.

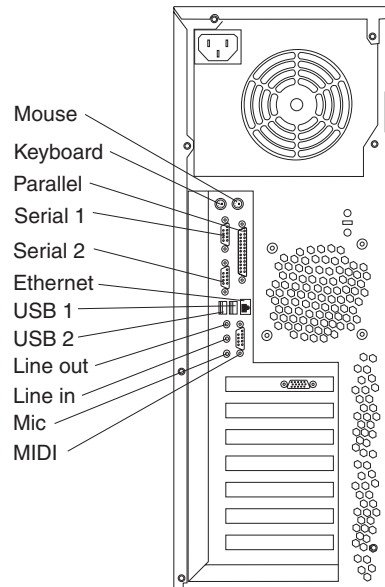

## System board jumpers

The following illustration identifies the jumpers on the system board.

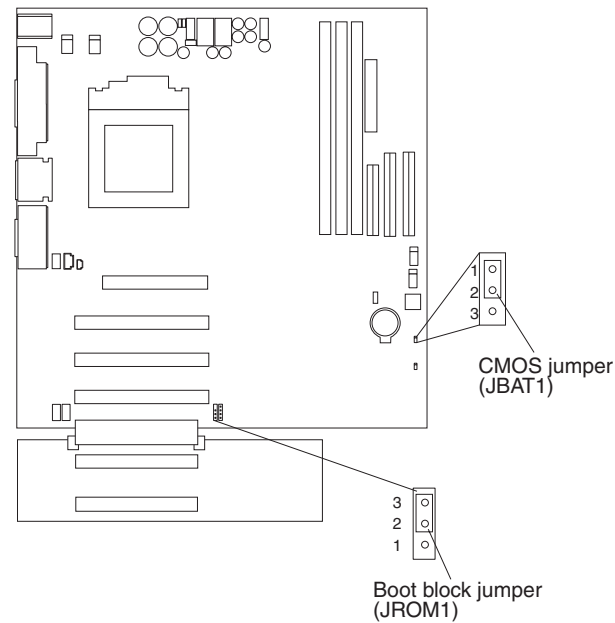

### Boot block jumper

For normal operations of the system, a jumper is installed on pins 2 and 3 of the boot block jumper.

**Note:** The boot block jumper (JROM1) should only be removed by an IBM authorized service representative.

### CMOS jumper

For typical operation of the system, a jumper is installed on pins 1 and 2 of the complementary metal oxide semiconductor (CMOS) jumper. See “Clearing CMOS” on page 15 for information about the CMOS jumper.

---

## Before you begin

Before you begin to install options in the server, read the following information:

- Become familiar with the safety and handling guidelines provided in:
  - “Safety information” on page 103;
  - “Handling electrostatic discharge-sensitive devices” on page 106; and
  - “Safety notices (multi-lingual translations)” on page 107.

These guidelines will help you work safely while working with the server or options.

- The blue color on components and labels identifies touch points where a component can be gripped, a latch moved, and so on.
- When you need to access the inside of the server to install options, you might find it easier to lay the server on its side. If you do so, make sure the stabilizing feet are in the horizontal position. Otherwise, the feet might break off because of the weight of the server.
- Before you place the server in an upright position, rotate the two front feet a quarter turn away from the server. For complete details, see “Stabilizing feet” on page 41.
- Make sure that you have an adequate number of properly grounded electrical outlets for the server, monitor, and any other options that you intend to install.
- Back up all important data before you make changes to hard disk drives.
- Have a small, flat-blade screwdriver available.
- For a list of supported options for the xSeries 200, refer to <http://www.ibm.com/pc/compat> on the World Wide Web.

## Working inside the server with the power on

The server is designed with safety in mind. Follow these guidelines when you work inside a server that is turned on:

- Avoid loose-fitting clothing on your forearms. Button long-sleeved shirts before working inside the server; do not wear cuff links while you are working inside the server.
- Do not allow your necktie to hang inside the server.
- Remove jewelry, such as bracelets, necklaces, rings, and loose-fitting wrist watches.
- Remove items from your shirt pocket (such as pens or pencils) that could fall into the server as you lean over it.
- Avoid dropping any metallic objects, such as paper clips, hair pins, or screws, into the server.

## System reliability considerations

To help ensure proper cooling and system reliability, make sure that:

- Each of the drive bays either has a drive, or a filler panel and electromagnetic compatibility (EMC) shield installed.
- There is space around the server to allow the server cooling system to work properly. Leave about 127 mm (5 in.) of space around the front and rear of the server.



- Cables for optional adapters are routed according to the instructions that are provided with the adapters.
- A failed fan is replaced within 1 hour.

---

## Stabilizing feet

The four feet on the bottom of the server provide additional stability when the feet are placed in the stabilizing position.

Complete the following steps to place the feet in the stabilizing position.

1. Place the server on its side.
2. Locate the release tab inside the foot; then, lift up on the tab.

**Note:** The following illustration shows the rear feet located on the bottom rear of the server.

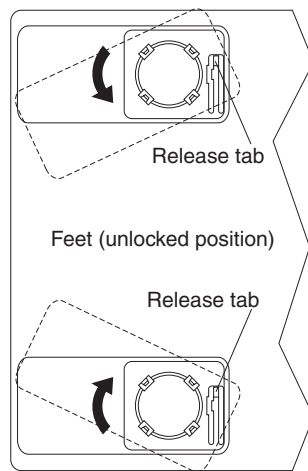

3. Rotate the foot inward to the unlocked position; then, remove the foot from the server.
4. Align the post in the center of the foot with the hole on the bottom of the server and place the foot between the guides as indicated.

**Note:** The following illustration shows the rear feet located on the bottom rear of the server.

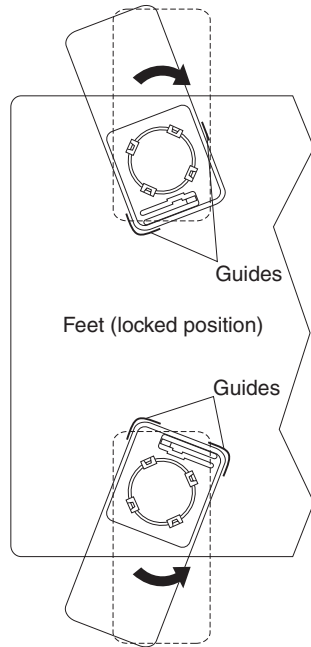

5. Rotate the foot outward until the foot locks into place.
6. Complete steps 2 through 5 for each foot.

**Note:** When you need to access the inside of the server to install options, you might find it easier to lay the server on its side. If you do so, make sure the feet are in the horizontal position (see the previous steps). Otherwise, the feet might break off the server because of the weight of the server.

---

## Side cover removal

The following illustration shows how to remove the side cover.

**Note:** The illustrations in this document might differ slightly from your hardware.

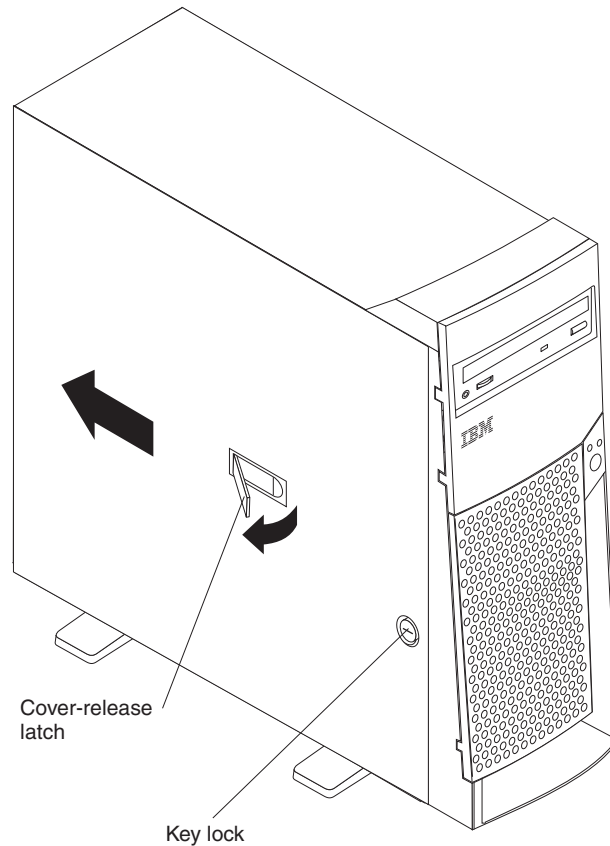

Complete the following steps to remove the side cover of the server:

1. Review the information in “Before you begin” on page 40.
2. Turn off the server and peripheral devices and disconnect all external cables and power cords.
3. If necessary, unlock the server cover.
4. Pull out on the cover-release latch, which will slide the cover toward the rear of the server about 12.7 mm (0.5 in.). Then, remove the cover from the server and set it aside.

To replace the side cover, see “Installing the cover” on page 62.

**Attention:** For proper cooling and airflow, replace the cover before turning on the server. Operating the server for extended periods of time (over 30 minutes) with the cover removed might damage server components.

---

## Bezel removal

The following illustration shows how to remove the bezel from the server.

**Note:** The illustrations in this document might differ slightly from your hardware.

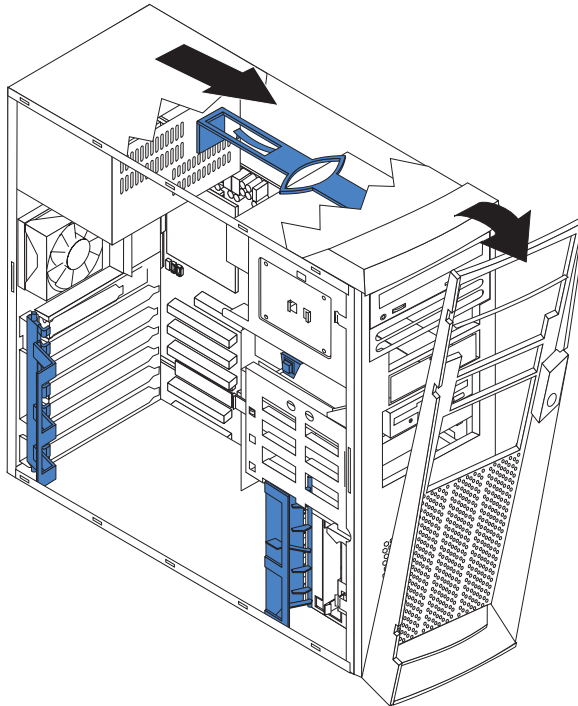

Complete the following steps to remove the bezel:

1. Review the information in “Before you begin” on page 40.
2. Turn off the server and peripheral devices and disconnect all external cables and power cords.
3. Remove the side cover (see “Side cover removal” on page 42).
4. Press the bezel-release latch at the top of the server to disconnect the top of the bezel from the server.
5. Release the two tabs at the top edge of the bezel and pull the top of the bezel slightly away from the server.
6. Pull the bezel up to release the two tabs at the bottom edge of the bezel. Store the bezel in a safe place.

---

## Removing the support bracket assembly

When working with some options such as hard disk drives, microprocessors, and memory modules you must first remove the support bracket assembly to access the location of the option.

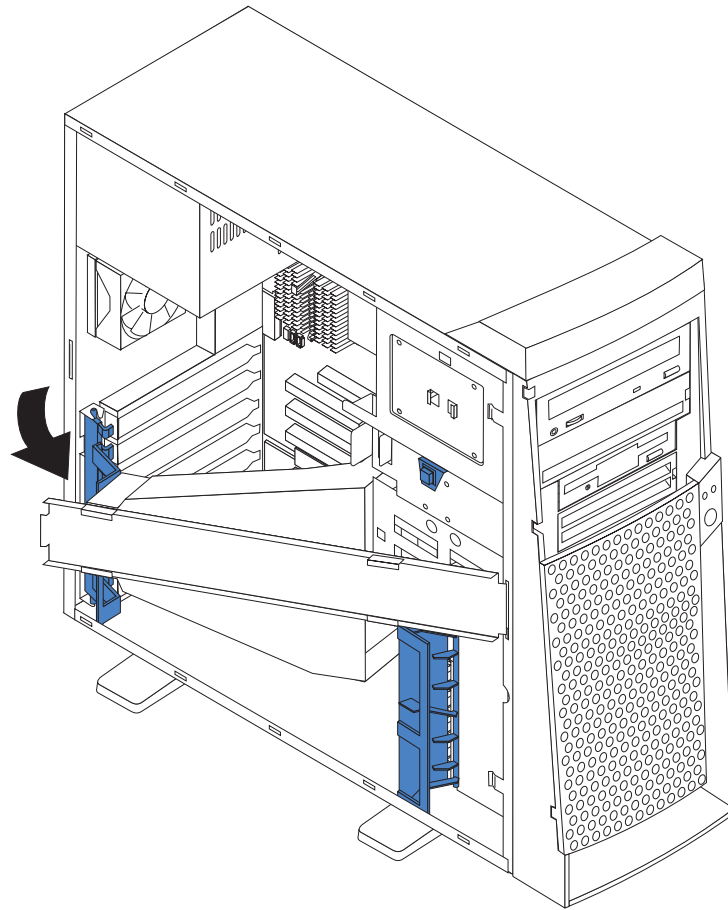

Complete the following steps to remove the support bracket assembly:

1. Review the information in “Before you begin” on page 40.
2. Turn off the server and peripheral devices and disconnect all external cables and power cords; then remove the side cover (see “Side cover removal” on page 42).
3. Disconnect the support bracket assembly fan cable from the connector (SYSFA1) on the system board. For the location of the fan connector, see “System board internal cable connectors” on page 38.
4. Locate the end of the support-bracket assembly near the rear of the server. Pull it out approximately 152.4 mm (6 in.).
5. Pull the front end of the support bracket assembly away from the server and place the assembly aside.

To reinstall the support bracket assembly, reverse the previous steps.

## Working with adapters

The server comes with adapter connectors, called *slots*. The AGP video adapter is installed in the AGP slot. You can install up to five PCI adapters in PCI slots 1 through 5. All PCI expansion slots are 32-bit, 33 MHz slots.

**Note:** The illustrations in this document might differ slightly from your hardware.

The following illustration shows the location of the system expansion slots on the system and PCI extender boards.

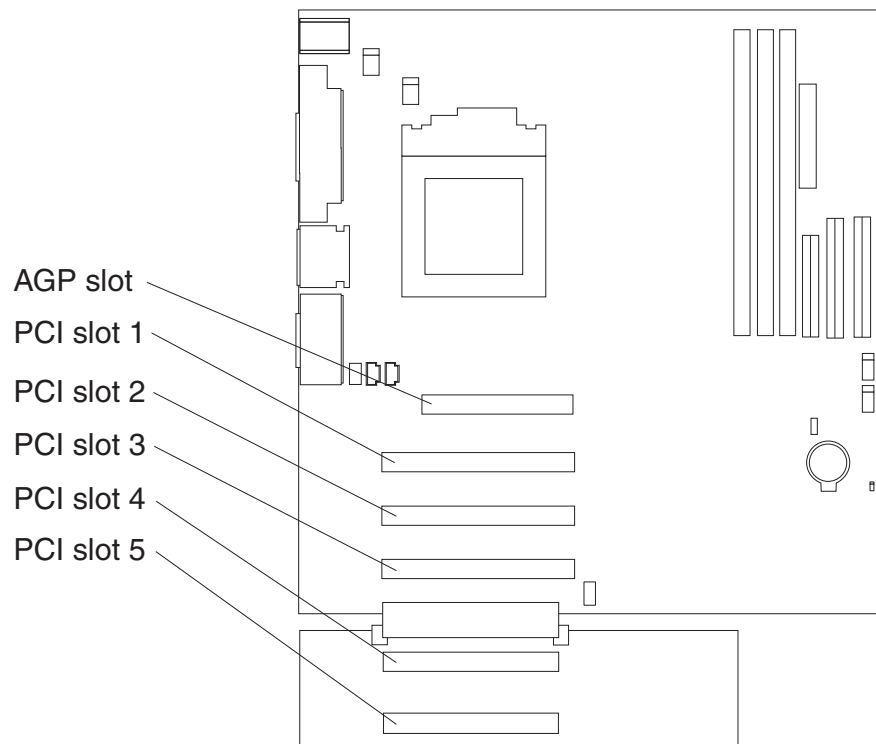

## Adapter considerations

Before you install an adapter, review the following:

- Locate the documentation that comes with the adapter and follow those instructions in addition to the instructions given in this chapter. If you need to change the switch or jumper settings on your adapter, follow the instructions that come with the adapter.
- You can install full-length adapters in all five PCI expansion slots.
- The server supports 5.0 V and universal PCI adapters; it does not support 3.3 V adapters.
- The server uses a rotational interrupt technique to configure PCI adapters. Because of this technique, you can install a variety of PCI adapters that currently do not support sharing of PCI interrupts.
- If you are installing or replacing an adapter that will control your startup (boot drive), install the adapter in PCI expansion slot 2.
- PCI expansion slots 1 through 5 are on PCI bus 0. The system scans the AGP slot and PCI expansion slots 1 through 5 to assign system resources; then, the system starts (boots) the PCI devices in the following order, if you have not

changed the default boot sequence: PCI expansion slots 1 through 5; then the system board integrated drive electronics (IDE) or SCSI devices.

**Note:** To change the startup sequence for PCI devices, start the Configuration/Setup Utility program, select **Start Options** from the main menu, select **Startup Sequence**; then, select **Second device (SCSI)** to designate the adapter boot sequence. See “Configuration” on page 25 for details on using the Configuration/Setup Utility program.

- For a list of supported options for the server, refer to <http://www.ibm.com/pc/compat> on the World Wide Web.

## Adapter installation

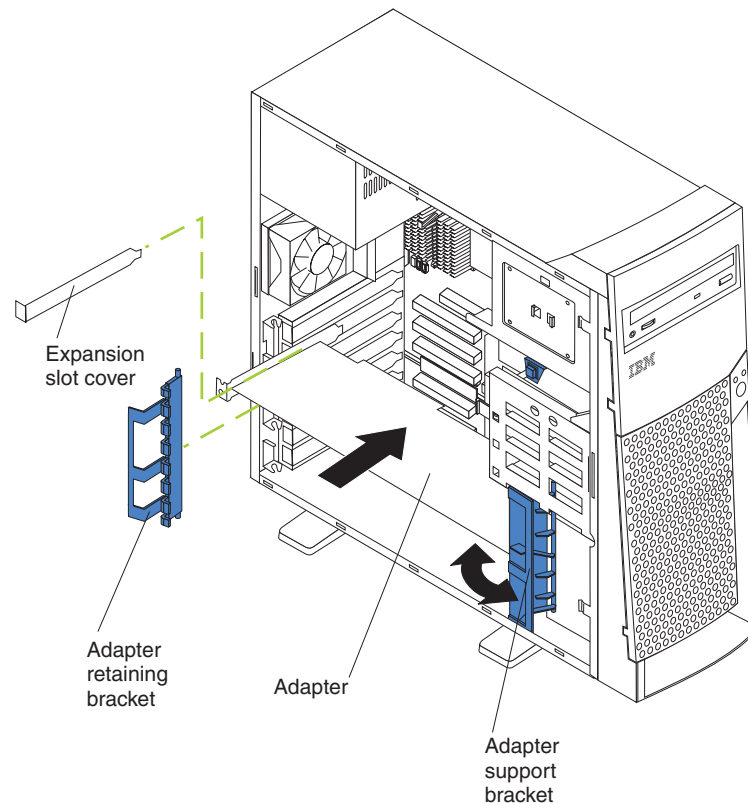

Complete the following steps to install an adapter:

**Attention:** When you handle static-sensitive devices, take precautions to avoid damage from static electricity. For details on handling these devices, see “Handling electrostatic discharge-sensitive devices” on page 106.

1. Review the information in “Before you begin” on page 40.
2. Turn off the server and peripheral devices and disconnect all external cables and power cords; then, remove the side cover. See “Side cover removal” on page 42 for details.
3. Determine which PCI expansion slot you will use for the adapter.

**Note:** If you are installing or replacing an adapter that will control your startup (boot) drive, install the adapter in PCI expansion slot 2.

4. If you are installing a full-length adapter, rotate the front adapter support bracket to the open (unlocked) position.

5. Rotate the rear adapter retaining bracket to the open (unlocked) position, and then remove it from the server.
6. Remove the PCI expansion-slot cover. From the rear of the server, press in on the slot cover. Grasp it and pull it out of the slot. Store it in a safe place for future use.  
**Attention:** PCI expansion-slot covers must be installed on all vacant slots. This maintains the electromagnetic emissions characteristics of the server and ensures proper cooling of server components.
7. Touch the static-protective package containing the adapter to any unpainted metal surface on the server. Then, remove the adapter from the static-protective package. Avoid touching the components and gold-edge connectors on the adapter.
8. Place the adapter, component-side up, on a flat, static-protective surface.
9. Set any jumpers or switches as described by the adapter manufacturer.
10. To install the adapter, carefully grasp the adapter by its top edge or upper corners, and align it with the expansion slot guides; then, press the adapter *firmly* into the PCI expansion slot.  
**Attention:** When you install an adapter in the server, be sure that it is completely and correctly seated in the PCI expansion slot before you turn on the server. Incomplete insertion might cause damage to the system board or the adapter.
11. Connect required cables to the adapter.  
**Attention:** Route cables so that they do not block the flow of air from the fans.
12. If you have another adapter or other options to install, do so now.
13. If you have installed a full-length adapter, rotate the front adapter support bracket to the closed (locked) position.
14. Reinstall the rear adapter retaining bracket; then, rotate the bracket to the closed (locked) position.
15. Reinstall the side cover, see “Installing the cover” on page 62 for details.
16. Reconnect the external cables and power cords; then, turn on the peripheral devices and the server.

---

## SCSI or ServeRAID adapter installation

Complete the following steps to install a SCSI or ServeRAID adapter:

1. If you have not already installed the SCSI adapter, complete steps 1 through 10 of “Adapter installation” on page 47. Then, return here to complete the installation.



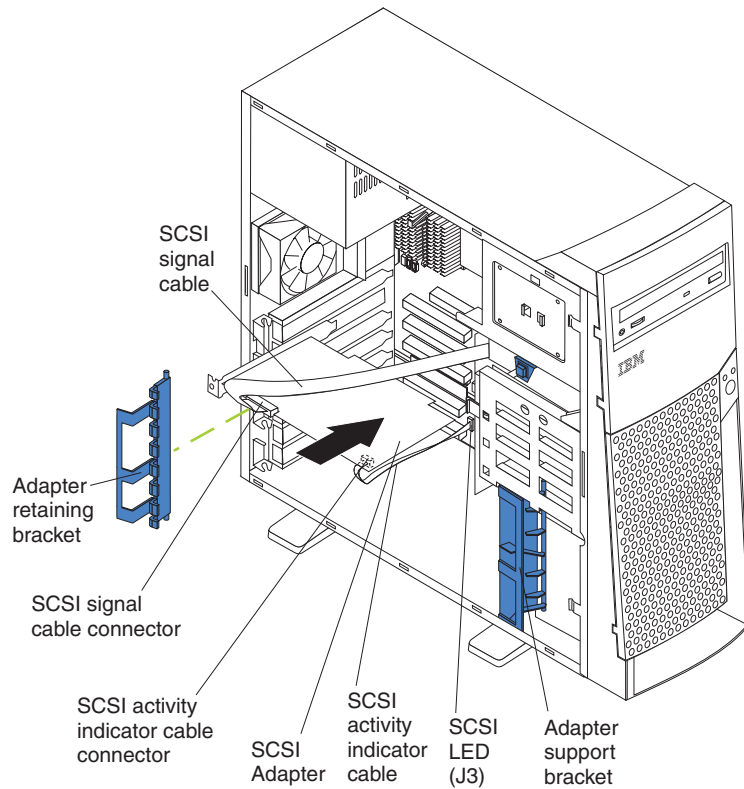

2. Connect the SCSI signal cable to the adapter and one or more of the signal cable connectors to the rear of the SCSI devices.
3. Connect the SCSI activity indicator cable to the adapter and to the SCSI LED connector (J3) on the system board. See "System board internal cable connectors" on page 38 for the location of this connector.

**Note:** If you are installing or replacing an adapter that will control your startup (boot) drive, install the adapter in PCI expansion slot 2.

4. If you have another adapter to install or remove, do so now.
5. If you have installed a full-length adapter, rotate the front adapter support bracket to the closed (locked) position.
6. Reinstall the rear adapter retaining bracket; then, rotate the bracket to the closed (locked) position.
7. If you have other options to install, do so now.
8. Reinstall the side cover (see "Installing the cover" on page 62).
9. Reconnect the external cables and power cords; then, turn on the peripheral devices and the server.

---

## Internal drive installation

Depending on the server model, you might have one or more of the following drives installed.

- Diskette
- Hard disk
- CD-ROM

## Internal drive bays

The server comes with an IDE CD-ROM drive installed in bay 1 and a 1.44 MB diskette drive installed in bay 3. Some server models have a hard disk drive installed in bay 5. For instructions on installing drives in bays 1 and 3, see “CD-ROM drive” on page 80 and “Floppy disk drive” on page 81.

**Note:** The illustrations in this document might differ slightly from your hardware.

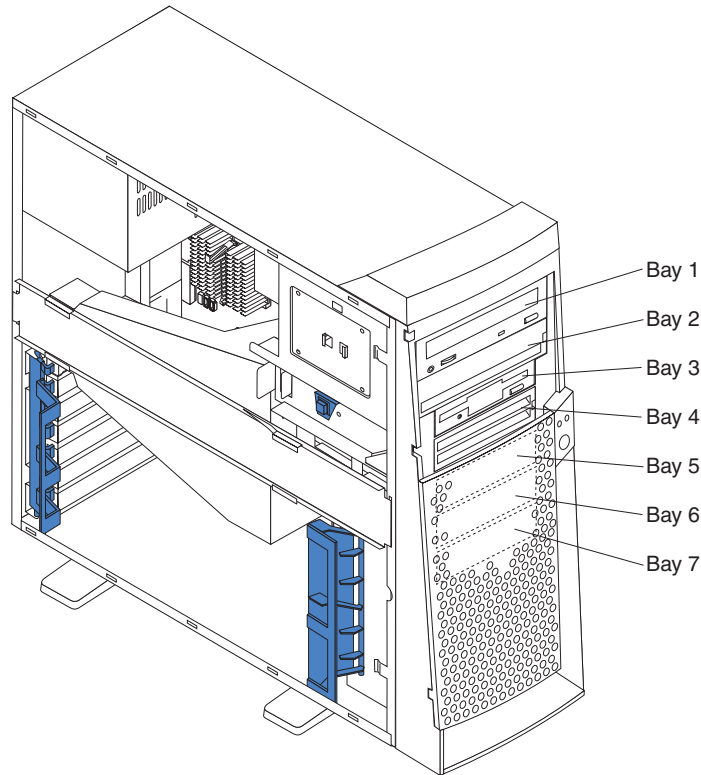

### Notes:

1. Diskette drives, tape drives, and CD-ROM drives are removable-media drives. You can install removable-media drives in bays 1, 2, 3, and 4.
2. You can install a 3.5-in., slim-high, or a 5.25-in., half-high, removable-media drive, such as a tape backup drive, in bay 2.
3. You can only install a 3.5-in., slim-high, removable-media drive in bay 4.
4. The xSeries 200 server supports only one diskette drive, which uses 1 MB and 2 MB diskettes.
5. Before you install a 3.5-in. drive in a 5.25-in. bay, you must attach the 5.25 in. conversion kit, supplied with your option, to the 3.5-in drive. Refer to the documentation that comes with the option for the conversion kit installation instructions.

**Note:** Only 3.5-in. options that ship with proper mounting hardware can be supported in the 5.25-in. bays.

6. If you have a tape backup drive in the server, use a dry process cleaning cartridge to clean the tape head two hours after you first use a new data cartridge. Then, clean the tape head once a month, or after each eight hours of continuous read/write operations, whichever occurs first. For complete details about the tape backup drive, refer to the documentation that comes with the server or your backup option.

7. The electromagnetic interference (EMI) integrity and cooling of the server are both protected by having bays 1 through 4 covered or occupied. When you install a drive, save the EMC shield and filler panel from the bay, in case you later remove the drive and do not replace it with another.
8. For a list of supported options for the server, refer to <http://www.ibm.com/pc/us/compat> on the World Wide Web.

## Preinstallation steps (all bays)

Before you install drives in the server, verify that you have all the cables and other equipment specified in the documentation that comes with the drive. You might also need to perform certain preinstallation activities. Some of the steps are required only during the initial installation of an option.

1. Read "Safety information" on page 103 and the documentation that comes with your drive.
2. Choose the bay in which you want to install the drive.

**Note:** You can only install a 3.5-in. device in bay 4.

3. Check the instructions that come with the drive to see if you need to set any switches or jumpers on the drive. If you are installing a SCSI device, be sure to set the SCSI ID for that device.

## Drive installation in bay 2 or 4

Complete the following steps to install a drive in bay 2 or 4:

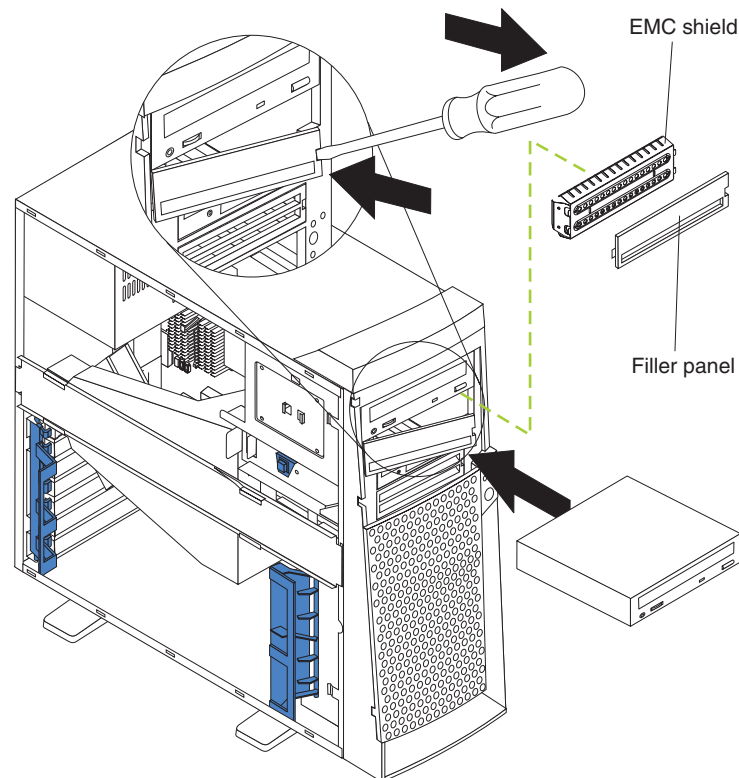

**Attention:** When you handle static-sensitive devices, take precautions to avoid damage from static electricity. For details on handling these devices, see "Handling electrostatic discharge-sensitive devices" on page 106.

1. Read the information in "Preinstallation steps (all bays)" and "Safety information" on page 103.

2. Turn off the server and peripheral devices and disconnect external cables and power cords; then, remove the side cover (see “Side cover removal” on page 42 for details).
3. Remove the support bracket assembly and disconnect the fan cable from the connector (SYSFA1) on the system board. See “Removing the support bracket assembly” on page 45 and “System board internal cable connectors” on page 38 for the location of the fan cable connector.
4. Use a screwdriver to gently pry the filler panel and EMC shield away from the server.

**Note:** If you are installing a drive that is a laser product, observe the following safety precaution:

**Statement 3:**



**CAUTION:**

When laser products (such as CD-ROMs, DVD drives, fiber optic devices, or transmitters) are installed, note the following:

- Do not remove the covers. Removing the covers of the laser product could result in exposure to hazardous laser radiation. There are no serviceable parts inside the device.
- Use of controls or adjustments or performance of procedures other than those specified herein might result in hazardous radiation exposure.



**DANGER:** Some laser products contain an embedded Class 3A or Class 3B laser diode. Note the following: Laser radiation when open. Do not stare into the beam, do not view directly with optical instruments, and avoid direct exposure to the beam.

5. Touch the static-protective package containing the drive to any unpainted metal surface on the server; then, remove the drive from the package and place it on a static-protective surface.
6. Set any jumpers or switches on the drive according to the documentation that comes with the drive.
7. Install the drive.
  - If you are installing a 5.25-in drive in bay 2, push the drive into the bay; then, use the two screws to attach the drive to the drive cage.
  - If you are installing a 3.5-in drive in bay 2, you must attach the 5.25-in conversion kit, supplied with your option, to the 3.5-in drive.
8. Cable the drive.
  - If the drive is an IDE device, plug one connector of the IDE signal cable into the back of the drive and the other end of the cable into the IDE connector (IDE1) on the system board. For the location of the IDE connectors, see “System board internal cable connectors” on page 38.

- If the drive is a SCSI device, plug one connector of the SCSI signal cable into the back of the drive and the other end of the cable into the SCSI adapter. See “Adapter installation” on page 47.

**Note:** Make sure to route the signal cable so that it does not block the air flow to the rear of the drives or over the microprocessor.

9. If you have another drive to install or remove, do so now.
10. Plug one of the power cables from the power supply into the back of the drive. The connectors are keyed and can be inserted only one way.
11. Replace the support-bracket assembly and reconnect the fan cable to the connector (SYSFA1) on the system board. See “Removing the support bracket assembly” on page 45 for details. See “System board internal cable connectors” on page 38 for the location of the fan cable connector.
12. If you have other options to install, do so now.
13. Reinstall the side cover. See “Installing the cover” on page 62 for details.
14. Reconnect the external cables and power cords; then, turn on the peripheral devices and the server.

## Hard disk drive installation in bay 5, 6, or 7

Complete the following steps to install a hard disk drive in bay 5, 6, or 7.

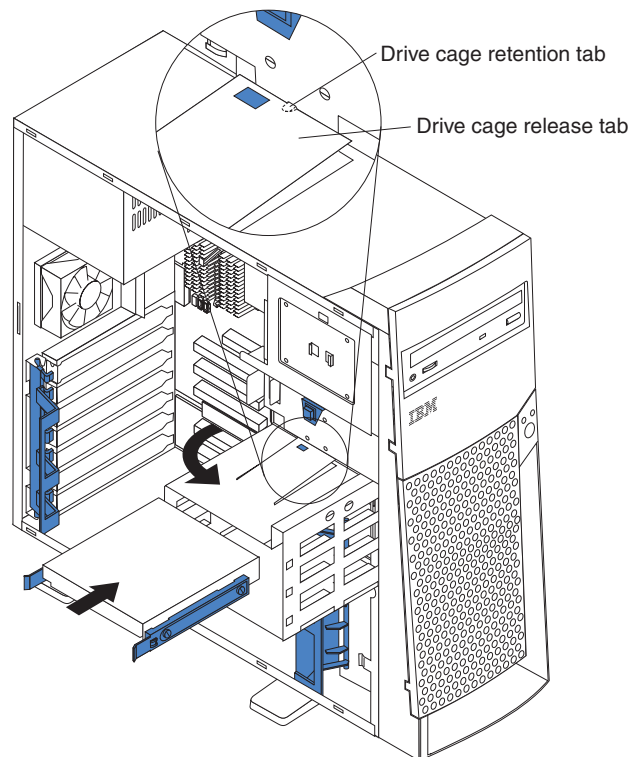

**Attention:** When you handle static-sensitive devices, take precautions to avoid damage from static electricity. For details on handling these devices, see “Handling electrostatic discharge-sensitive devices” on page 106.

1. Read the information in “Preinstallation steps (all bays)” on page 51.
2. Turn off the server and peripheral devices and disconnect all external cables and power cords; then, remove the cover (see “Side cover removal” on page 42 for details).

3. Remove the support-bracket assembly and disconnect the fan cable from the connector (SYSFA1) on the system board. See “Removing the support bracket assembly” on page 45 for details. See “System board internal cable connectors” on page 38 for the location of the fan cable connector.
4. Access the drive cage.
  - a. If the server has hard disk drives installed in the drive cage, disconnect the power and signal cables from the rear of the drives.
  - b. Rotate the drive cage out of the server until it locks into place over the drive cage retention tab.

**Note:** Before you install a hard disk drive, ensure that the drive cage locks into place over the drive cage retention tab by pressing on the side of the drive cage.

5. Touch the static-protective package containing the drive to any unpainted metal surface on the server; then, remove the drive from the package and place it on a static- protective surface.
6. Set any jumpers or switches on the drive according to the documentation that comes with the drive.
7. Attach the blue plastic guide rails to the sides of the drive using the screws and guide rails provided in the drive cage.
8. Slide the drive into the drive cage until the plastic tabs on the guide rails lock into place in the drive cage.
9. Lift the drive cage up and press in on the drive cage release tab; then, rotate the drive cage back into the server.

**Note:** Clear any cables that might impede the replacement of the drive cage.

10. Connect the power and signal cables to the rear of each drive.

**Note:** Make sure to route the signal cable so that it does not block the air flow to the rear of the drives or over the microprocessor.

11. If you have other options to install or remove, do so now.
12. Replace the support-bracket assembly and reconnect the fan cable to the connector (SYSFA1) on the system board. See “Removing the support bracket assembly” on page 45 for details. See “System board internal cable connectors” on page 38 for the location of the fan cable connector.
13. Reinstall the side cover. See “Installing the cover” on page 62 for details.
14. Reconnect the external cables and power cords; then, turn on the peripheral devices and the server.

---

## Memory modules

Adding memory to the server is an easy way to make programs run faster. You can increase the amount of memory in the server by installing options called memory modules. The server uses a noninterleaved memory configuration.

Memory considerations:

- The server comes with a DIMM installed on the system board in DIMM connector 1. When installing additional memory modules, install the second memory module in DIMM connector 2, and the third in DIMM connector 3. (See the illustration in this section for memory connector locations.)
- The xSeries 200 server supports 128 MB, 256 MB, and 512 MB DIMMs. The server supports a minimum of 128 MB and a maximum of 1.5 GB of system

memory. See the ServerProven list at <http://www.ibm.com/pc/compat> for a list of memory modules for use with the server.

- Installing or removing DIMMs changes the configuration information in the server. Therefore, after installing or removing a DIMM, you must change and save the new configuration information by using the Configuration/Setup Utility program. When you restart the server, the system displays a message indicating that the memory configuration has changed. Start the Configuration/Setup Utility program and select **Save Settings**. See “Configuration” on page 25 for more information
- The illustrations in this document might differ slightly from your hardware.

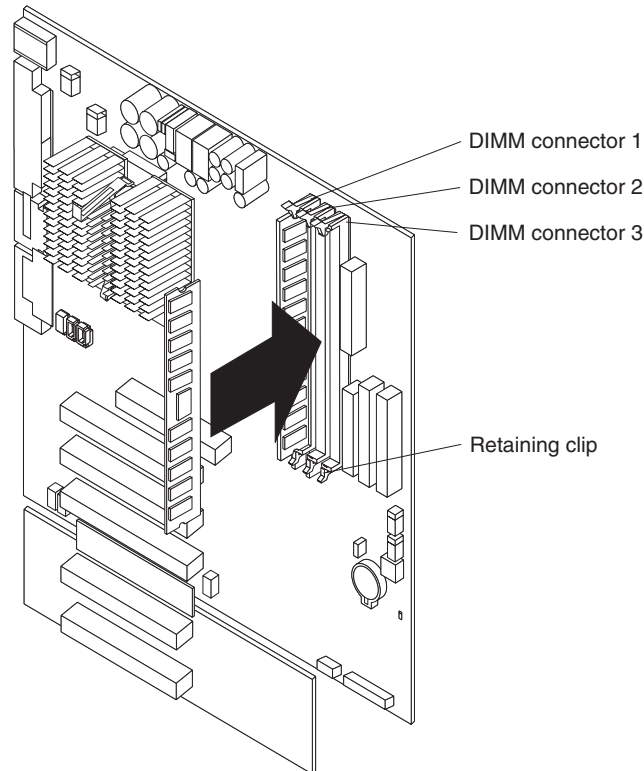

Complete the following steps to install a DIMM.

**Attention:** When you handle static-sensitive devices, take precautions to avoid damage from static electricity. For details on handling these devices, see “Handling electrostatic discharge-sensitive devices” on page 106.

1. Review the safety precautions in Statement 1 and Statement 5 in “Safety notices (multi-lingual translations)” on page 107.
2. Turn off the server and peripheral devices and disconnect all external cables and power cords; then, remove the cover (see “Side cover removal” on page 42 for details).
3. Remove the support-bracket assembly and disconnect the fan cable from the connector (SYSFA1) on the system board. See “Removing the support bracket assembly” on page 45 for details. See “System board internal cable connectors” on page 38 for the location of the fan cable connector.
4. Install the DIMM:
  - a. If you are installing a DIMM in connector 1, remove the AGP video adapter.

Remove the AGP video adapter only if you are replacing the DIMM in connector 1. See “System and PCI extender board options connectors” on page 37 for the location of the AGP slot.

- b. Open the retaining clip on each end of the DIMM connector. Turn the DIMM so that the pins align correctly with the connector.  
**Attention:** To avoid breaking the retaining clips or damaging the DIMM connectors, open and close the clips gently.
  - c. Touch the static-protective package containing the DIMM to any unpainted metal surface on the server. Then, remove the DIMM from the package.
  - d. Turn the DIMM so that the pins align correctly with the connector.
  - e. Insert the DIMM into the connector by aligning the DIMM edges with the slots at each end of the DIMM connector. Firmly press the DIMM straight down into the connector by applying pressure on both ends of the DIMM simultaneously. Be sure that the retaining clips snap into the locked position when the DIMM is firmly seated in the connector.
  - f. If a gap exists between the DIMM and the retaining clips, the DIMM has not been properly installed. In this case, open the retaining clips and remove the DIMM; then, reinsert the DIMM.
  - g. If you removed the AGP video adapter, reinstall it now. See “Adapter installation” on page 47.
5. If you have other options to install or remove, do so now.
  6. Replace the support-bracket assembly and reconnect the fan cable to the connector (SYSFA1) on the system board. See “Removing the support bracket assembly” on page 45 for details. See “System board internal cable connectors” on page 38 for the location of the fan cable connector.
  7. Replace the side cover. See “Installing the cover” on page 62.
  8. Reconnect the external cables and power cords; then, turn on the peripheral devices and the server.

If you want to remove a DIMM, reverse these steps.

---

## Microprocessor

The server only supports one microprocessor, which is installed on the system board in the microprocessor connector (U11).

### Notes:

1. Before you install a new microprocessor, review the documentation that comes with the microprocessor, so that you can determine whether you need to update the server BIOS code. The latest level of the BIOS for the server is available through the World Wide Web; see <http://www.ibm.com/support/>.
2. For a list of supported operating systems, see <http://www.ibm.com/pc/compat/> on the World Wide Web.

**Note:** The illustrations in this document might differ slightly from your hardware.

## Microprocessor removal

The server comes with a heat sink or a fan sink installed on the microprocessor, depending on your server model.



**Note:** The following illustration shows a heat sink installed on the microprocessor.

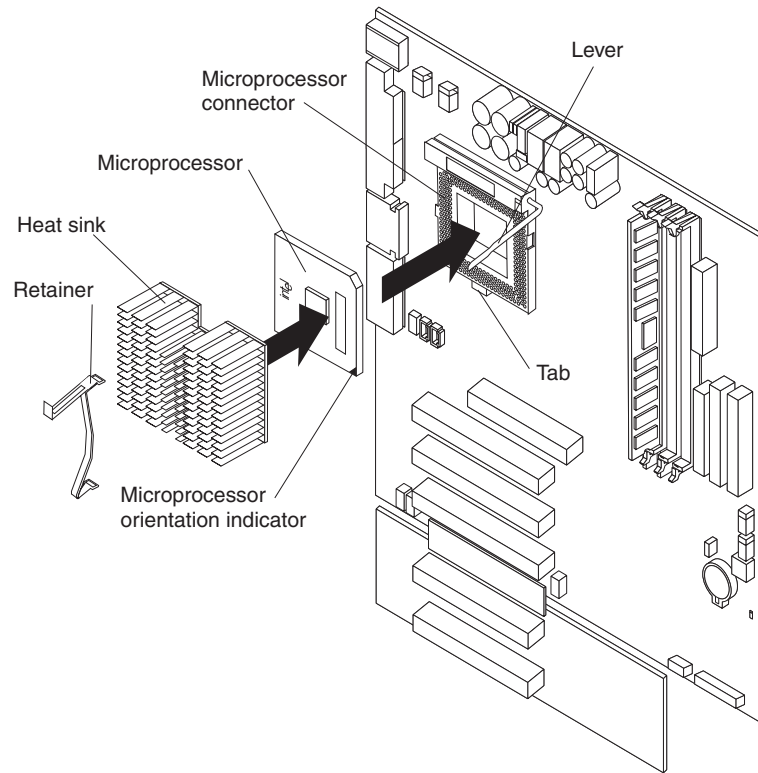

**Note:** This illustration shows the fan sink installed on the microprocessor.

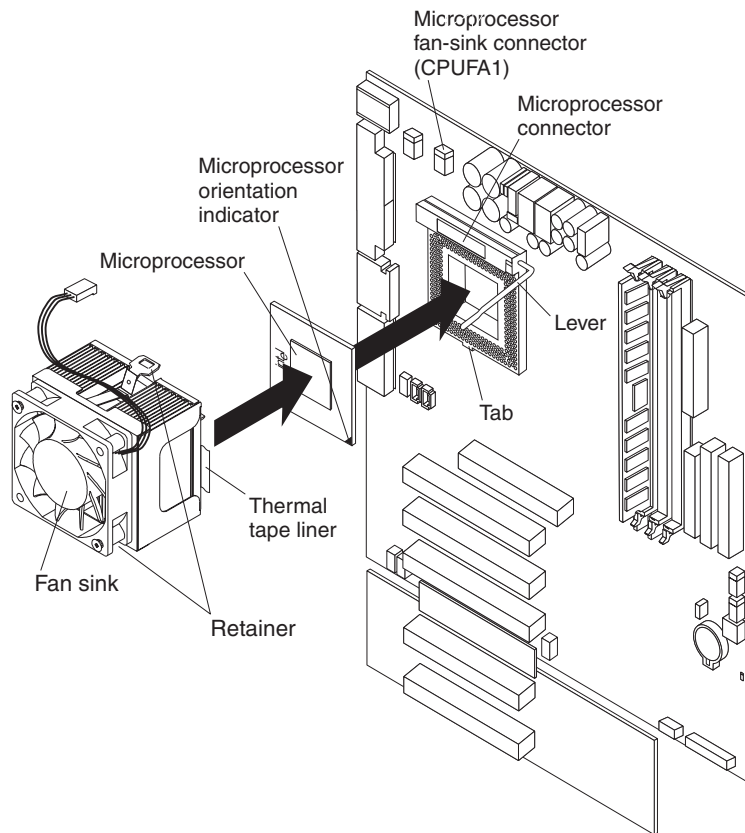

Complete the following steps to remove a microprocessor.

**Attention:** When you handle ESD-sensitive devices, take precautions to avoid damage from static electricity. For details on handling these devices, see “Handling electrostatic discharge-sensitive devices” on page 106.

1. Review the safety precautions listed in Statement 1 and Statement 5 in “Safety notices (multi-lingual translations)” on page 107.
2. Turn off the server and peripheral devices and disconnect all external cables and power cords; then, remove the cover (see “Side cover removal” on page 42 for details).
3. Remove the support-bracket assembly and disconnect the fan cable from the connector (SYSFA1) on the system board. See “Removing the support bracket assembly” on page 45 for details. See “System board internal cable connectors” on page 38 for the location of the fan cable connector.
4. Push down and back on the retainer to remove it from the heat sink or the fan sink.

**Note:** Allow sufficient time for the heat sink to cool, before you remove it from the microprocessor.

5. If you are removing a fan sink from the microprocessor, disconnect the fan-sink power cable from the microprocessor fan-sink connector located on the system board. See “System board internal cable connectors” on page 38 for the location.
6. Firmly grasp the heat sink and lift it off the microprocessor.

7. Pull out and lift up the release lever and remove the microprocessor from the connector. Store the microprocessor in a static-protective package for possible future use.
8. To install a new microprocessor, continue with step 4 in “Microprocessor installation.”

## Microprocessor installation

Complete the following steps to install a microprocessor:

**Attention:** When you handle ESD-sensitive devices, take precautions to avoid damage from static electricity. For details on handling these devices, see “Handling electrostatic discharge-sensitive devices” on page 106.

1. Review the safety precautions listed in Statement 1 and Statement 5 in “Safety information” on page 103.
2. Turn off the server and peripheral devices and disconnect all external cables and power cords; then, remove the cover (see “Side cover removal” on page 42 for details).
3. Remove the support-bracket assembly and disconnect the fan cable from the connector (SYSFA1) on the system board. See “Removing the support bracket assembly” on page 45 and “System board internal cable connectors” on page 38 for instructions.
4. Install the microprocessor:
  - a. Touch the static-protective package containing the new microprocessor to any unpainted metal surface on the server; then, remove the microprocessor from the package.
  - b. Pull out and lift up on the microprocessor-release lever to unlock the microprocessor connector.
  - c. Arrange the microprocessor over the microprocessor connector as shown in the following illustration. Carefully press the microprocessor into the connector.

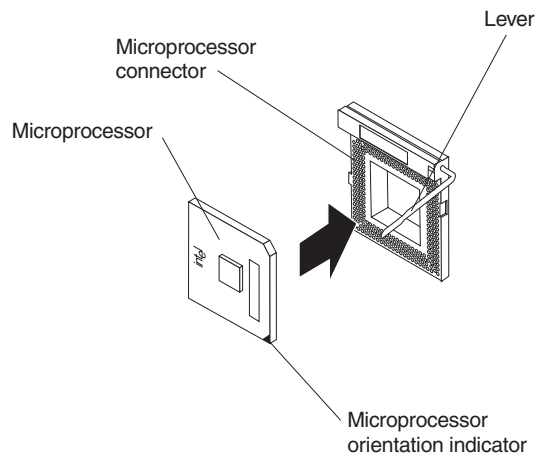

**Attention:** Do not use excessive force when pressing the microprocessor into the connector.

5. Push the microprocessor-release lever down to lock the microprocessor into the connector.
6. Install the new heat or fan sink that comes with the microprocessor option.

- a. Peel the plastic protective strip off the bottom of the heat or the fan sink. Make sure the square of thermal material is still on the bottom of the heat sink or fan sink; if not, replace the it with a new heat sink or fan sink.
- b. Align and place the heat sink or the fan sink on top of the microprocessor.
- c. Locate the tab on the front of the microprocessor socket (the side facing the PCI slots). Then, press down and latch the retainer onto the tab.
- d. Locate the tab on the rear of the microprocessor socket (the side facing the power supply). Then, press down and latch the retainer onto the tab.
- e. If you have installed a fan sink, connect the fan-sink power cable to the microprocessor fan-sink connector (CPUFA1) on the system board. See "System board internal cable connectors" on page 38 for the location of the microprocessor fan-sink connector.

**Note:** Make sure the cable is not in a position to interfere with the fan sink operation.

7. If you have other options to install or remove, do so now.
8. Replace the support-bracket assembly and reconnect the fan cable to the connector (SYSFA1) on the system board. See "Removing the support bracket assembly" on page 45 for details. See "System board internal cable connectors" on page 38 for the location of the fan cable connector.
9. Reinstall the side cover. See "Installing the cover" on page 62.
10. Reconnect the external cables and power cords; then, turn on the peripheral devices and the server.

---

## Installing a security U-bolt

To help prevent hardware theft, you can add a security U-bolt and cable to the server. After you add the security cable, make sure that it does not interfere with other cables that are connected to the server.

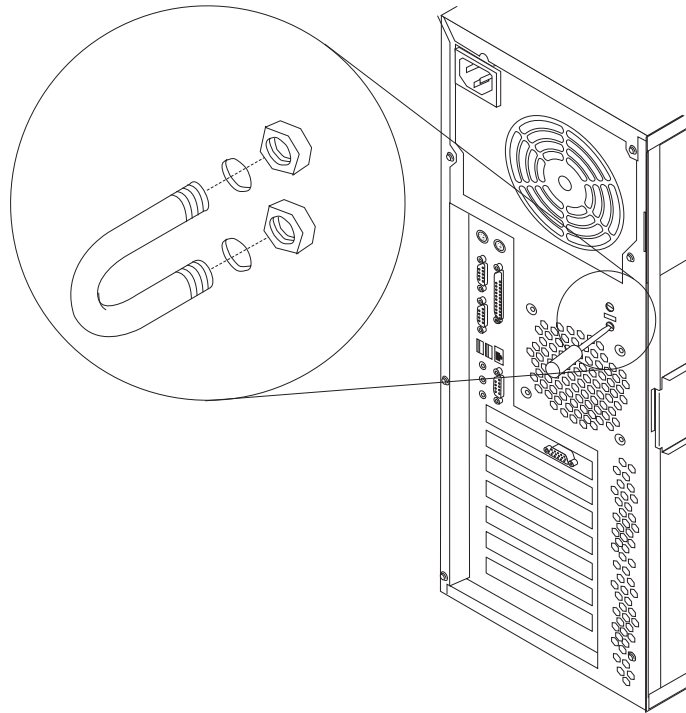

Before you begin:

- Obtain the following items:
  - A flat-blade screwdriver
  - An adjustable wrench
  - A 19 mm (0.75 in.) U-bolt or wire rope (similar to National Manufacturing No. 3230, Stock No. 176-735)
  - Threaded nuts that fit the U-bolt
  - A security cable
  - A lock, such as a combination lock or padlock
- Read “Safety information” on page 103 and “Handling electrostatic discharge-sensitive devices” on page 106.

Complete the following steps to install a U-bolt.

1. Turn off the server and peripheral devices and disconnect all external cables and power cords; then, remove the cover (see “Side cover removal” on page 42 for details).
2. Use a screwdriver to remove the two metal knockouts.
3. Insert the U-bolt through the rear panel; then, attach and tighten the nuts.
4. If you have other options to install or remove, do so now.
5. Reinstall the side cover. See “Installing the cover” on page 62 for details.

6. Thread the cable through the U-bolt and around an object that is a part of or permanently secured to the building structure or foundation, and from which it cannot be removed; then, fasten the cable ends together with a lock.
7. Reconnect the external cables and power cords; then, turn on the peripheral devices and the server.

---

## Completing the installation

**Attention:** For correct cooling and airflow, install the cover before turning on the server. Operating the server for extended periods of time (over 30 minutes) with the top cover removed might damage server components.

To complete the installation, you must reinstall the cover, reconnect all the cables that you disconnected earlier and, for certain options, run the Configuration/Setup Utility program. Follow the instructions in this section.

**Note:** If you have just plugged the power cords of the server into an electrical outlet, you will have to wait approximately 20 seconds before pressing the power-control button.

## Installing the cover

The following information describes how the cover installation procedure.

**Notes:**

1. The illustrations in this document might differ slightly from your hardware.
2. If you removed the support-bracket assembly after you removed the cover, reinstall it before you install the cover. See “Removing the support bracket assembly” on page 45 for details.

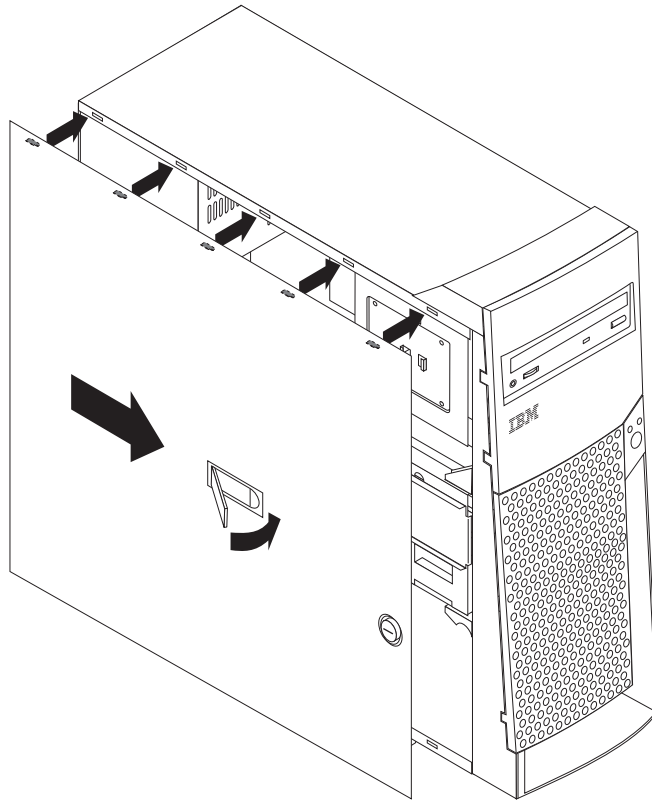

Complete the following steps to install the server cover:

1. Clear any cables that might impede the replacement of the cover.
2. Install the side cover:

**Note:** The cover-release latch must be in the unlocked (opened) position before reinstalling the cover on the server.

- a. Insert the tabs located inside the cover into the slots located on the server chassis.
- b. Close the cover-release latch to secure the cover in place.

**Note:** Make sure each tab on the cover is in its corresponding slot before closing the cover-release latch.

3. Lock the cover.
4. If you have not done so already, make sure the stabilizing feet are in the stabilizing position so that they properly support the server. See “Stabilizing feet” on page 41 for details.
5. Reconnect the external cables and power cords to the server, and then plug the power cords into electrical outlets.
6. Turn on all peripheral devices; then, turn on the server.

## Updating the server configuration

When you start the server for the first time after you add or remove an internal option or an external SCSI device, you might see a message telling you that the configuration has changed. The Configuration/Setup Utility program automatically starts so that you can save the new configuration information. See “Configuration” on page 25.

Some options have device drivers that you need to install. Refer to the documentation that comes with your option for information about installing any required device drivers.

If the server has a ServeRAID adapter installed and you have installed or removed a hard disk drive, refer to the documentation that comes with your ServeRAID adapter for information about reconfiguring your disk arrays.

## Connecting external options

If you install a SCSI adapter in the server, you can attach a SCSI storage expansion enclosure.

To attach an external device:

1. Read “Before you begin” on page 40 and the documentation that comes with your options.
2. Be sure the server and all peripheral devices are turned off.
3. Follow the instructions that come with the option to prepare it for installation and to connect it to the server.

**Note:** If you are attaching a SCSI device, see “Ultra160 SCSI connector (some models)” on page 74 for SCSI ID and cabling information.

## I/O connector locations

The following illustration shows the input/output connectors (ports) and the expansion slots on the rear of the server. For pin assignments and other details about these connectors, see “Input/output connectors” on page 65.

If the server cables and connector panel have color-coded connectors, match the color of the cable end with the color of the connector. For example, match a blue cable end with a blue panel connector, a red cable end with a red panel connector, and so on.



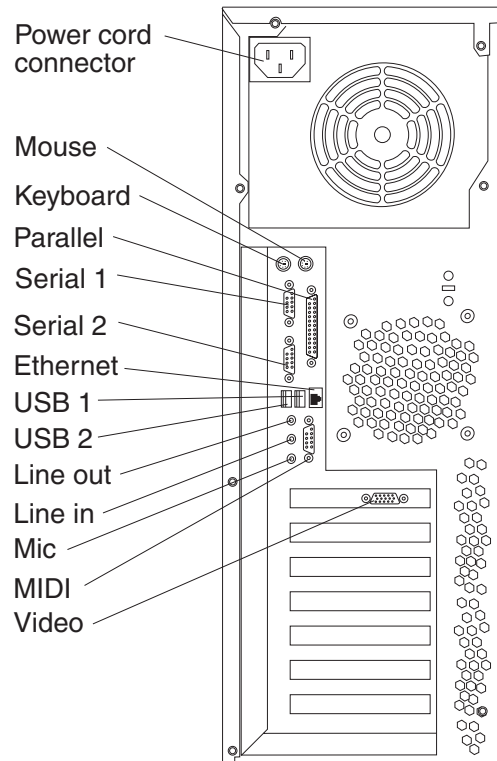

**Note:** If the server is a SCSI model, the SCSI adapter will be located in PCI slot 2; the external connector will be located in a slot below the video connector. See “System and PCI extender board options connectors” on page 37 for the location of the PCI slots.

If the server cables and connector panel have color-coded connectors, match the color of the cable end with the color of the connector. For example, match a blue cable end with a blue panel connector, a red cable end with a red panel connector, and so on.

---

## Input/output connectors

This section provides information about the following I/O connectors on the server:

- One mouse
- One keyboard
- One parallel
- Two serial
- One Ethernet
- Two USB
- Line out
- Line in
- Mic
- MIDI
- One video
- One Ultra160 SCSI (some models)

## Mouse connector

The system board has one mouse connector that supports a mouse or other pointing device. The mouse connector is located on the rear of the server. See “I/O connector locations” on page 64 for its location. The following table shows the pin-number assignments for the mouse connector.

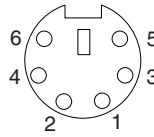

Table 7. Mouse connector pin-number assignments

Pin	Signal
1	Data
2	Not connected
3	Ground
4	+5 V dc
5	Clock
6	Not connected

## Keyboard connector

There is one keyboard connector on the rear of the server. See “I/O connector locations” on page 64 for its location.

**Note:** If you attach a standard (non-USB) keyboard to the keyboard connector, the USB connectors and devices will be disabled during the power-on self-test.

The following table shows the pin-number assignments for the keyboard connector.

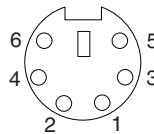

Table 8. Keyboard connector pin-number assignments

Pin	I/O	Signal
1	I/O	Data
2	N/A	Reserved
3	N/A	Ground
4	N/A	+5 V dc
5	I/O	Keyboard clock
6	N/A	Reserved

## Parallel connector

The server has one parallel connector. This connector supports three standard Institute of Electrical and Electronics Engineers (IEEE) 1284 modes of operation: standard parallel port (SPP), enhanced parallel port (EPP), and extended capability port (ECP).

### Viewing or changing the connector assignments

You can use the built-in Configuration/Setup Utility program to configure the parallel connector as bidirectional that is, so that data can be both read from and written to a device. In bidirectional mode, the server supports the ECP and EPP modes.

Complete the following steps to view or change the parallel-connector assignment:

1. Restart the server and watch the monitor screen.
2. When the message Press F1 for Configuration/Setup appears, press the F1 key.
3. When the Configuration/Setup Utility menu appears, select **Devices & I/O Ports**; then, press Enter.
4. Select the parallel connector; then, use the arrow keys to advance through the settings available.

**Note:** When you configure the parallel connector as bidirectional, use an IEEE 1284-compliant cable. The cable must not exceed 3 meters (9.8 feet).

5. Press Esc twice to return to the Configuration/Setup main menu; then, select **Save & Exit Setup** to exit from the Configuration/Setup Utility main menu.

### Parallel connector

There is a 25-pin, female D-shell parallel connector on the rear of the server. See "I/O connector locations" on page 64 for the location of this connector. The following table shows the pin-number assignments for the parallel connector.

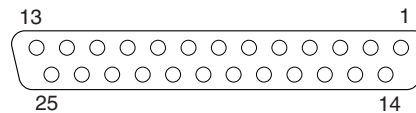

Table 9. Parallel connector pin-number assignments

Pin	I/O	SPP/ECP Signal	EPP Signal
1	O	-STROBE	-WRITE
2	I/O	Data 0	Data 0
3	I/O	Data 1	Data 1
4	I/O	Data 2	Data 2
5	I/O	Data 3	Data 3
6	I/O	Data 4	Data 4
7	I/O	Data 5	Data 5
8	I/O	Data 6	Data 6
9	I/O	Data 7	Data 7
10	I	-ACK	-ACK
11	I	BUSY	-WAIT
12	I	PE (paper end)	PE (paper end)

Table 9. Parallel connector pin-number assignments (continued)

Pin	I/O	SPP/ECP Signal	EPP Signal
13	I	SLCT (select)	SLCT (select)
14	O	-AUTO FD (feed)	-AUTO FD
15	I	-ERROR	-ERROR
16	O	-INIT	-INIT
17	O	-SLCT IN	-SLCT IN
18	-	Ground	Ground
19	-	Ground	Ground
20	-	Ground	Ground
21	-	Ground	Ground
22	-	Ground	Ground
23	-	Ground	Ground
24	-	Ground	Ground
25	-	Ground	Ground

## Serial connectors

The server has two standard serial connectors located on the rear of the server.

Some application programs require specific connectors, and some modems function properly only at certain communication connector addresses. You might need to use the Configuration/Setup Utility program to change communication connector address assignments to prevent or resolve address conflicts.

### Viewing or changing the serial-connector assignments

Complete the following steps to view or change the serial-connector assignments.

1. Restart the server and watch the monitor screen.
2. When the message Press F1 for Configuration/Setup appears, press the F1 key.
3. When the Configuration/Setup Utility menu appears, select **Devices & I/O Ports**; then, press Enter.
4. Select the serial connector; then, use the arrow keys to advance through the available settings.
5. Press Esc twice to return to the Configuration/Setup Utility main menu; then, select **Save & Exit Setup** to exit from the Configuration/Setup Utility main menu.

### Serial connectors

There are two 9-pin, male D-shell serial connectors on the rear of the server. See "I/O connector locations" on page 64 for the location of these connectors. The following table shows the pin-number assignments for the serial connectors.

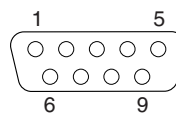

Table 10. Serial connector pin-number assignments

Pin	Signal	Pin	Signal
1	Data carrier detect	6	Data set ready
2	Receive data	7	Request to send
3	Transmit data	8	Clear to send
4	Data terminal ready	9	Ring indicator
5	Signal ground		

## Ethernet connector

The server comes with an integrated Ethernet controller. This controller provides an interface for connecting to 10-MBps or 100-MBps networks and provides full-duplex capability, which enables simultaneous transmission and reception of data on the Ethernet LAN.

To access the Ethernet connector, connect a Category 3, 4, or 5 unshielded twisted-pair (UTP) cable to the Ethernet (RJ-45) connector on the rear of the server. See “I/O connector locations” on page 64.

**Note:** The 100BASE-TX Fast Ethernet standard requires that the cabling in the network be Category 5.

### Configuring the Ethernet controller

When you connect the server to the network, the Ethernet controller automatically detects the data-transfer rate (10 MBps or 100 MBps) on the network and then sets the controller to operate at the appropriate rate. In addition, if the Ethernet connector that the server is connected to supports auto-negotiation, the Ethernet controller will set the appropriate duplex state. That is, the Ethernet controller will adjust to the network data rate, whether the data rate is standard Ethernet (10BASE-T), Fast Ethernet (100BASE-TX), half duplex (HDX), or full duplex (FDX). The controller supports HDX and FDX modes at both speeds.

The Ethernet controller is integrated on the system board. You do not need to set any jumpers or configure the controller for your operating system before you use the Ethernet controller. However, you must install a device driver to enable your operating system to address the Ethernet controller. The device drivers are provided on the *ServerGuide* CDs.

### High performance Ethernet modes

Your Ethernet controller supports optional modes, such as teaming, priority packets, and virtual LANs, which provide higher performance and throughput for the server.

**Teaming mode:** Your Ethernet controller provides options, called *teaming options*. These options increase throughput and fault tolerance when running with Windows NT 4.0 or NetWare 4.1x or later.

- **Adapter Fault Tolerance (AFT)** provides automatic redundancy for your adapter. If the primary adapter fails, the secondary adapter takes over. Adapter fault tolerance supports from two to four adapters per team.
- **Adaptive Load Balancing (ALB)** enables you to balance the transmission data flow among two to four adapters. ALB also includes the AFT option. You can use ALB with any 100BASE-TX switch.

- **Cisco Fast EtherChannel (FEC)** creates a team of two to four adapters to increase transmission and reception throughput. FEC also includes the AFT option. You can use FEC only with a switch that has FEC capability.

Teaming requires you to install at least one additional Ethernet adapter. For additional information about the teaming modes, refer to the documentation that comes with these additional adapters.

**Priority Packet mode:** Priority Packet is a traffic-prioritization utility that enables you to set up filters to process high-priority traffic before normal traffic. You can send information from critical nodes or applications with an indicated priority. Because you set this priority at the host or entry point of the network, the network devices can base forwarding decisions on priority information defined in the packet.

Priority Packet information is available on the IBM Networking Web site at <http://www.ibm.com/networking/support>.

Priority Packet prioritizes traffic based on priority filters. These are parameters you assign to outgoing (transmit) packets. Using the Priority Filter Wizard, you can set up predefined or custom priority filters based on a node medium access control (MAC) address, Ethernet type, or by various properties of the protocol and connector. Priority Packet provides two different methods for prioritizing traffic: IEEE 802.1p tagging and High Priority Queue.

IEEE 802.1p is an IEEE standard for tagging, or adding additional bytes of information to packets with different priority levels. Packets are tagged with 4 additional bytes, which increase the packet size and indicate a priority level. When you send these packets out on the network, the higher priority packets are transferred first. Priority packet tagging (also known as Traffic Class Expediting) enables the adapter to work with other elements of the network (such as switches and routers) to deliver priority packets first. You can assign specific priority levels from 0 (low) to 7 (high).

You can assign values to packets based on their priority when you use the IEEE 802.1p standard for packet tagging. This method requires a network infrastructure that supports packet tagging. The routing devices receiving and transferring these packets on your network must support 802.1p for tagging to be effective.

After you set up the priority filter in Priority Packet, you must start IBMSet and select **802.1p/802.1Q Tagging** on the Advanced tab.

**Note:** IEEE 802.1p tagging increases the size of the packets it tags. Some hubs and switches will not recognize the larger packets and will drop them. Check your hub or switch documentation to see if they support 802.1p. (You can configure the switch to strip the tags from the packets and send it on to the next destination as normal traffic.) If these devices do not support 802.1p, or if you are not sure, use high priority queue (HPQ) to prioritize network traffic.

The requirements for effectively using IEEE 802.1p tagging are:

- The other devices receiving and routing 802.1p tagged packets must support 802.1p.
- The adapters on these devices must support 802.1p. The Ethernet controller in your xSeries 200 and all IBM 10/100 Ethernet Security Adapters support 802.1p.

- The adapter cannot be assigned to an adapter team.
- If you are setting up virtual local area networks (VLANs) and packet tagging on the same adapter, 802.1p/802.1Q tagging must be enabled on the IBMSet Advanced tab.

If your network infrastructure devices do not support IEEE 802.1p or you are not sure, you can still define filters and send packets as high priority. While HPQ does not provide the precise priority levels of 802.1p tagging, it does assign traffic as either high or low priority and sends high priority packets first. Therefore, if there are multiple applications on a system sending packets, the packets from the application with a filter are sent out first. HPQ does not change network routing, nor does it add any information to the packets.

To assign HPQ, you can specify it using Priority Packet when you create or assign a filter.

To effectively use HPQ, the adapter cannot be assigned to an adapter team.

**Virtual LAN mode:** A virtual LAN is a logical grouping of network devices put together as a LAN, regardless of their physical grouping or collision domains. Using VLANs increases network performance and improves network security.

VLANs offer you the ability to group users and devices together into logical workgroups. This can simplify network administration when connecting clients to servers that are geographically dispersed across the building, campus, or enterprise network.

Typically, VLANs are configured at the switch and any server can be a member of one VLAN per installed network adapter. Your Ethernet controller supersedes this by communicating directly with the switch, enabling multiple VLANs on a single network adapter (up to 64 VLANs).

To set up VLAN membership, your Ethernet controller must be attached to a switch that has VLAN capability. You also need to use Windows NT 4.0 or later, or Novell NetWare 4.1x or later.

**Notes:**

1. Windows NT versions prior to 4.0 do not support VLANs.
2. VLANs require NT 4.0 with Service Pack 3.0 and the network driver interface specification (NDIS) driver hotfix from Microsoft.
3. In Windows NT, VLANs cannot be implemented on controllers that have been configured for teaming options. NetWare can support teaming options and VLANs on the same adapters.

Complete the following steps to join a VLAN from Windows NT 4.0.

1. Create a VLAN on the switch. Use the parameters you assign there to join the VLAN from the server. Refer to your switch documentation for more information.
2. Double-click the **Network** icon in the Control Panel window.
3. On the Adapters tab, select the adapter you want to be on the VLAN and click **Properties**.
4. In IBMSet, click **Join VLAN**. Note that VLANs cannot be assigned to adapters that are already defined to have an adapter teaming option.

5. Type the VLAN ID and VLAN name. The VLAN ID must match the VLAN ID of the switch. The ID range is from 1 to 1000. The VLAN name is for information only and does not need to match the name on the switch.
6. Click **Join VLAN**. Repeat steps 3 through 5 for each VLAN you want the server to join. The VLANs you add are listed on the Adapters tab.
7. Click **Close** and restart the server.

### Ethernet connector

There is an RJ-45 Ethernet connector on the back of the server. See “I/O connector locations” on page 64 for the location of this connector. The following table shows the pin-number assignments for the Ethernet connector.

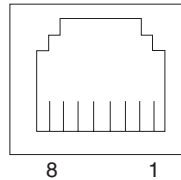

Table 11. Ethernet RJ-45 connector pin-number assignments.

Pin	Signal	Pin	Signal
1	+ Transmit data	5	Not connected
2	- Transmit data	6	- Receive data
3	+ Receive data	7	Not connected
4	Not connected	8	Not connected

## Universal Serial Bus connectors

The server has two Universal Serial Bus (USB) connectors, which are configured automatically. USB is a serial interface standard for telephony and multimedia devices. It uses Plug and Play technology to determine the type of device that is attached to the connector.

### Notes:

1. If you attach a standard (non-USB) keyboard to the keyboard connector, the USB connectors and devices will be disabled during the power-on self-test.
2. If you install a USB keyboard that has a mouse connector, the USB keyboard emulates a mouse, and you will not be able to disable the mouse settings in the Configuration/Setup Utility program.
3. Some operating systems do not support USB devices. Refer to your operating-system documentation to determine whether your operating system supports USB devices.

### USB cables and hubs

You need a 4-pin cable to connect devices to a USB 1 or USB 2. If you plan to attach more than two USB devices, you must use a hub to connect the devices. The hub provides multiple connectors for attaching additional external USB devices.

USB technology transfers data at up to 12 MBps with a maximum of 127 external devices and a maximum signal distance of five meters (16 ft) per segment.

### USB connectors

There are two USB connectors located on the rear of the server for attaching USB-compatible devices. See “I/O connector locations” on page 64 for the location



of the USB connectors. The following table shows the pin-number assignments for the USB connectors.

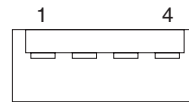
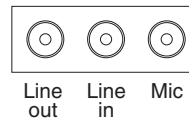

Table 12. USB connector pin-number assignments

Pin	Signal
1	+5 V
2	-Data
3	+Data
4	Ground

## Audio connectors

The audio connectors are used to connect external audio equipment to the server. See “I/O connector locations” on page 64 for the location of these connectors.



### Line out

This connector is used to send audio signals from the server to external devices, such as powered speakers with built-in amplifiers, headphones, multimedia keyboards, or the audio line-in connector on a stereo system.

### Line in

This connector is used to accept audio signals from external devices, such as line output from a stereo, television, or musical instrument into the server sound system.

### Mic

This connector is used to connect a microphone to the server when you want to record voice or other sounds on the hard disk drive. It might also be used by speech- recognition software.

## MIDI connector

The musical instrument digital interface (MIDI) connector enables the server to interact with musical instruments and other musical equipment. You might use the MIDI connector as an interface between the server and a synthesizer to edit and store sound information for the synthesizer on the server. See “I/O connector locations” on page 64 for the location of the MIDI connector. The following table shows the pin-number assignments for the MIDI connector.

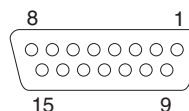

Table 13. MIDI connector pin-number assignments

Pin	Signal	Pin	Signal	Pin	Signal
1	+5 V	6	Joystick 1 -- Y	11	Joystick 2 -- X
2	Joystick 1 Switch A	7	Joystick 1 Switch B	12	MIDI - OUT
3	Joystick 1 -- X	8	+5 V	13	Joystick 2 -- Y
4	Switch Common	9	+5 V	14	Joystick 2 Switch D
5	Switches Common	10	Joystick 2 Switch C	15	MIDI - IN

## Video connector

The server uses an AGP video adapter located in the AGP slot on the system board. There is a 15-pin analog video connector located on the rear of the server. See “I/O connector locations” on page 64 for the location of this connector. The following table shows the pin-number assignments for the video connector.

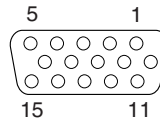

Table 14. Video connector pin-number assignments

Pin	Signal	Pin	Signal	Pin	Signal
1	Red	6	Ground	11	Not connected
2	Green or monochrome	7	Ground	12	DDC SDA
3	Blue	8	Ground	13	Horizontal synchronization (Hsync)
4	Not connected	9	+5 V dc DDC	14	Vertical synchronization (Vsync)
5	Ground	10	Ground	15	DDC SCL

## Ultra160 SCSI connector (some models)

Some xSeries 200 server models come with a SCSI adapter, which supports a single Ultra160 SCSI channel in a full-featured PCI 2.1-/2.2-compliant bus master package. This configuration supports a zero wait state, 32-bit memory transfers at 160 MB per second, when low voltage differential (LVD) SCSI peripherals are attached. This channel supports up to 15 SCSI devices. In addition, the SCSI adapter uses:

- Double-transition clocking to achieve high transfer rates
- Domain name validation to negotiate compatible data transfer speeds with each device
- Cyclic-redundancy checking, instead of the usual parity checking, to significantly improve data reliability

**Note:** If you install a RAID adapter, you can move the SCSI signal cable from the SCSI connector on the SCSI adapter to an internal channel connector on the RAID adapter to control the internal drives from the RAID adapter.

## SCSI cabling requirements

You can install five internal SCSI devices using the SCSI signal cable that comes with the server or purchased separately, depending on the server model. If you

plan to attach external SCSI devices, you must install an optional SCSI PCI adapter and order additional SCSI cables. To select and order the correct cables for use with external devices, contact your IBM reseller or IBM marketing representative.

For information about the maximum length of a SCSI cable between the terminated ends of the cable, refer to the American National Standards Institute (ANSI) SCSI standards. Adhering to these standards will help ensure that the server operates correctly.

### Setting SCSI IDs

Each SCSI device connected to a SCSI controller must have a unique SCSI ID. This ID enables the SCSI controller to identify the device and ensure that different devices on the same SCSI channel do not attempt to transfer data simultaneously. SCSI devices that are connected to different SCSI channels can have duplicate SCSI IDs.

To install external SCSI devices, you must first install an optional SCSI PCI adapter. Refer to the information that is provided with the device for instructions to set its SCSI ID.

If a SCSI adapter is installed in the server, you can use its 68-pin SCSI connector to connect different types of SCSI devices. The following table shows the pin-number assignments for the SCSI connector.



Table 15. 68-pin SCSI connector pin-number assignments

Pin	Signal	Pin	Signal
1	+Data 12	35	-Data 12
2	+Data 13	36	-Data 13
3	+Data 14	37	-Data 14
4	+Data 15	38	-Data 15
5	+Data P1	39	-Data P1
6	+Data 0	40	-Data 0
7	+Data 1	41	-Data 1
8	+Data 2	42	-Data 2
9	+Data 3	43	-Data 3
10	+Data 4	44	-Data 4
11	+Data 5	45	-Data 5
12	+Data 6	46	-Data 6
13	+Data 7	47	-Data 7
14	+Data P	48	-Data P
15	Ground	49	Ground
16	DIFFSENS	50	Ground
17	Term power	51	Term power
18	Term power	52	Term power

Table 15. 68-pin SCSI connector pin-number assignments (continued)

Pin	Signal	Pin	Signal
19	Reserved	53	Reserved
20	Ground	54	Ground
21	+Attention	55	-Attention
22	Ground	56	Ground
23	+Busy	57	-Busy
24	+Acknowledge	58	-Acknowledge
25	+Reset	59	-Reset
26	+Message	60	-Message
27	+Select	61	-Select
28	+Control/Data	62	-Control/Data
29	+Request	63	-Request
30	+Input/Output	64	-Input/Output
31	+Data 8	65	-Data 8
32	+Data 9	66	-Data 9
33	+Data 10	67	-Data 10
34	+Data 11	68	-Data 11

---

## FRU information (service only)

Field Replacement Units (FRUs) should be replaced by qualified service personnel only.

---

### Hard disk drive cage

**Before you begin:**

- Read “Safety information” on page 103.
- Review the information in “Before you begin” on page 40.

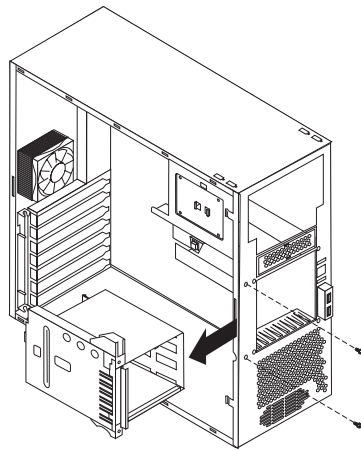

To remove the hard disk drive cage, do the following:

1. Power-off the server, if it is on.
2. Unplug the server.
3. Remove the front bezel (see “Bezel removal” on page 43).
4. Remove the cover (see “Side cover removal” on page 42).
5. Remove the support bracket (see “Removing the support bracket assembly” on page 45).
6. Remove any hard disk drives or drive fillers from the drives.
7. Disconnect the hard disk drive cables from the system board.
8. Remove the screws from the front of the hard disk drive cage.
9. Move the cage slightly in and up until it is free of the chassis and lift it out of the server.

**Note:** Take care not to dislodge the memory when you remove the cage.

---

## Power supply

### Before you begin:

- Read “Safety information” on page 103.
- Review the information in “Before you begin” on page 40.

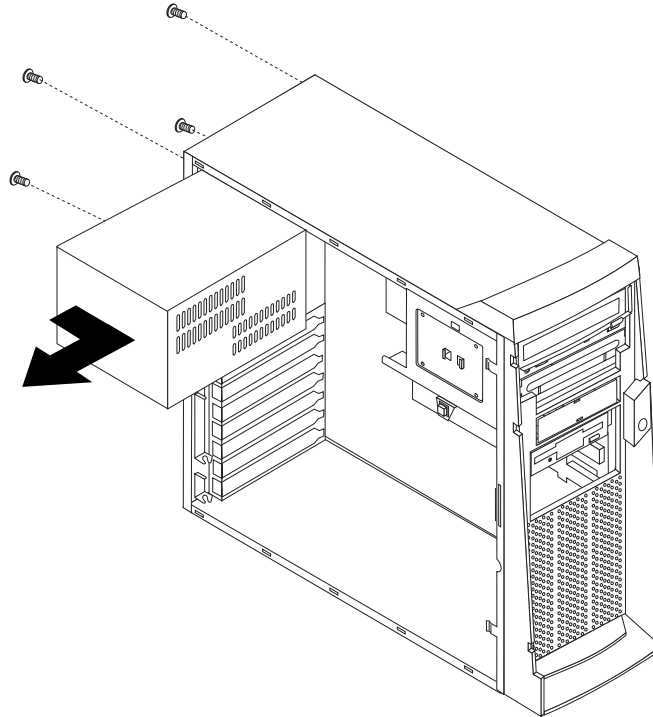

To remove the power supply, do the following:

1. Power-off the server, if it is on.
2. Unplug the server.
3. Remove the cover (see “Side cover removal” on page 42).
4. Disconnect the power cables from the system board.
5. Remove the screws from the rear of the server.
6. Gently move the power supply away from the chassis and lift it out of the server.

---

## Rear fan

### Before you begin:

- Read “Safety information” on page 103.
- Review the information in “Before you begin” on page 40.

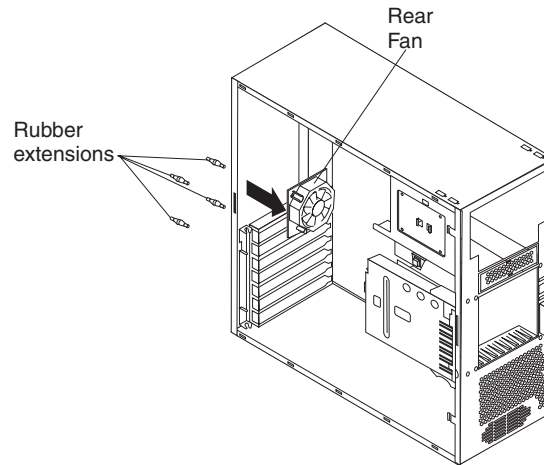

To remove the rear fan, do the following:

1. Power-off the server, if it is on.
2. Unplug the server.
3. Remove the cover (see “Side cover removal” on page 42).
4. Remove the support bracket (see “Removing the support bracket assembly” on page 45).
5. Remove the fan cable from the system board.
6. Use side cutters to sever the four rubber extensions on the outside of the server.
7. Gently pry the fan away from the server and lift it up and out.
8. To install the new fan assembly, place the fan in position at the rear of the server.
9. Guide the rubber extensions through the apertures.
10. Use needle-nosed pliers to pull the extensions through the apertures.
11. Reconnect cables.

---

## System board

### Before you begin:

- Read “Safety information” on page 103.
- Review the information in “Before you begin” on page 40.

**Note:** It is recommended that the server be placed on its left side before performing this service procedure. Rotate the feet in toward the server so they do not detach due to the weight of the server.

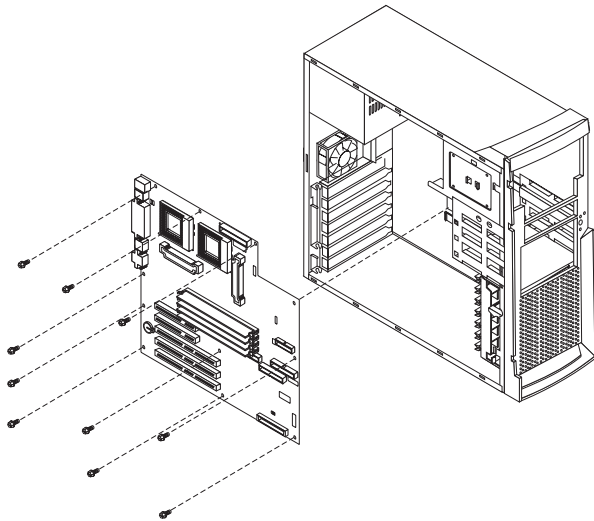

To remove the system board, do the following:

1. Power-off the server, if it is on.
2. Unplug the server.
3. Remove the cover (see “Side cover removal” on page 42).
4. Remove the front bezel (see “Bezel removal” on page 43).
5. Remove the support bracket (see “Removing the support bracket assembly” on page 45).
6. Disconnect the cables.
7. Remove the adapter cards and both adapter retaining brackets (see “Adapter installation” on page 47).
8. Remove the hard disk drive cage (see “Hard disk drive cage” on page 77).
9. Remove memory modules (see “Memory modules” on page 54).
10. Remove microprocessors and/or terminator cards (see “Microprocessor” on page 56).
11. Remove screws and lift the system board out of the server.

---

## CD-ROM drive

### Before you begin:

- Read “Safety information” on page 103.
- Review the information in “Before you begin” on page 40.

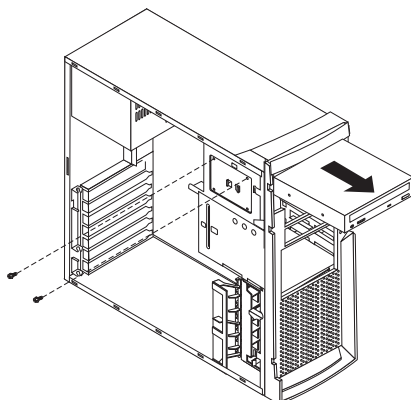



To remove the CD-ROM drive, do the following:

1. Power-off the server, if it is on.
2. Unplug the server.
3. Remove the cover (see "Side cover removal" on page 42).
4. Disconnect the cables.
5. Remove the screws from the CD-ROM drive cage.
6. Gently slide the CD-ROM drive toward the front of the server and lift it out.

---

## Floppy disk drive

**Before you begin:**

- Read "Safety information" on page 103.
- Review the information in "Before you begin" on page 40.

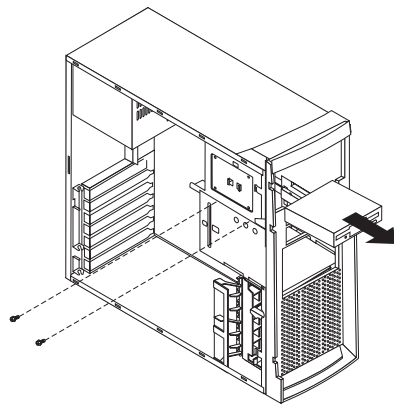

To remove the floppy disk drive, do the following:

1. Power-off the server, if it is on.
2. Unplug the server.
3. Remove the cover (see "Side cover removal" on page 42).
4. Disconnect the cables.
5. Remove the screws from the floppy disk drive cage.
6. Gently slide the floppy disk drive toward the front of the server and lift it out.

---

## Button kit

### Before you begin:

- Read “Safety information” on page 103.
- Review the information in “Before you begin” on page 40.

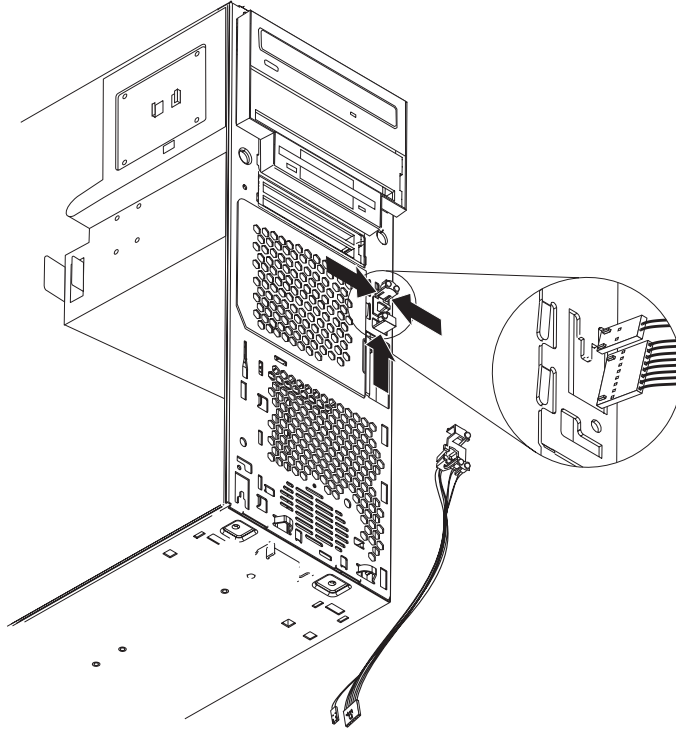

To remove the button kit, do the following:

1. Power-off the server, if it is on.
2. Unplug the server.
3. Remove the cover (see “Side cover removal” on page 42).
4. Remove the front bezel (see “Bezel removal” on page 43).
5. Remove hard disk drive cage (see “Hard disk drive cage” on page 77).
6. Disconnect the cable of the button kit from the system board.
7. Place a screwdriver against the bottom release latch of the button kit and gently press upward and slide the latch through the aperture.
8. Gently pinch together the upper release latches and slide the latches through the aperture and remove the button kit.

---

## Guide assembly / speaker

### Before you begin:

- Read “Safety information” on page 103.
- Review the information in “Before you begin” on page 40.

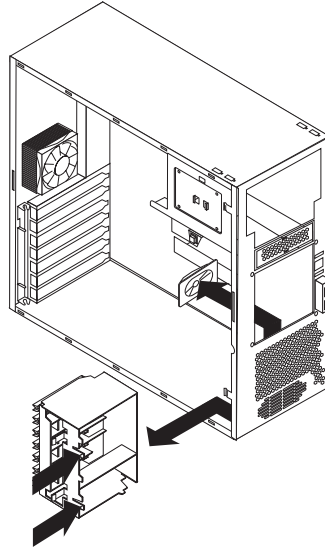

To remove the speaker, do the following:

1. Power-off the server, if it is on.
2. Unplug the server.
3. Remove the cover (see “Side cover removal” on page 42).
4. Remove the front bezel (see “Bezel removal” on page 43).
5. Remove the support bracket (see “Removing the support bracket assembly” on page 45).
6. Remove all adapter cards.
7. Unplug the speaker from the system board.
8. Gently push the two tabs of the adapter guide assembly inward until the assembly is released; lift it up and out of the server.
9. Slide the speaker up and out of the server.

---

## Bezel release latch

### Before you begin:

- Read “Safety information” on page 103.
- Review the information in “Before you begin” on page 40.

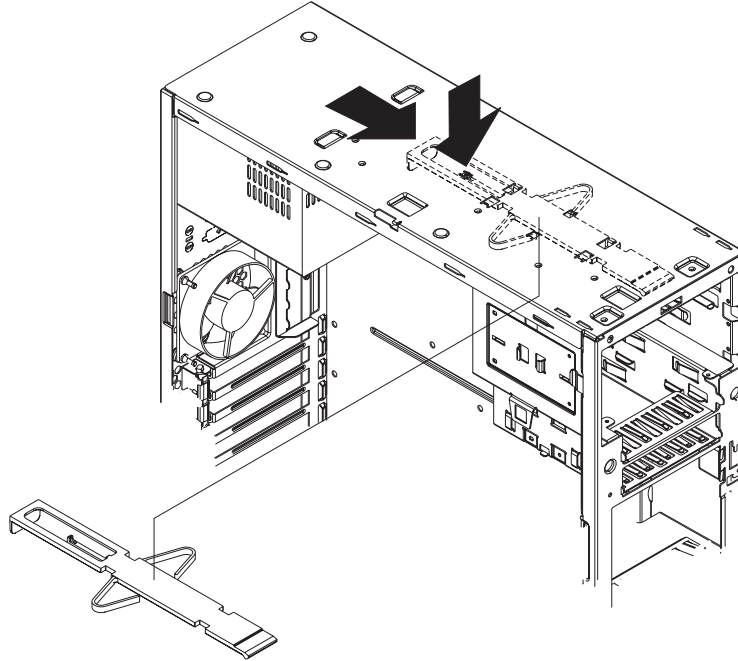

To remove the bezel release latch, do the following:

1. Power-off the server, if it is on.
2. Unplug the server.
3. Remove the cover (see “Side cover removal” on page 42).
4. Remove the front bezel (see “Bezel removal” on page 43).
5. Remove the handle assembly (see “Handle assembly” on page 86).
6. Remove the top/side cover (see “Top/side cover” on page 85).
7. Press down on the tab.
8. From the underside, grasp the bezel release latch in the center and gently pull it back and away from the server.

---

## Top/side cover

### Before you begin:

- Read “Safety information” on page 103.
- Review the information in “Before you begin” on page 40.

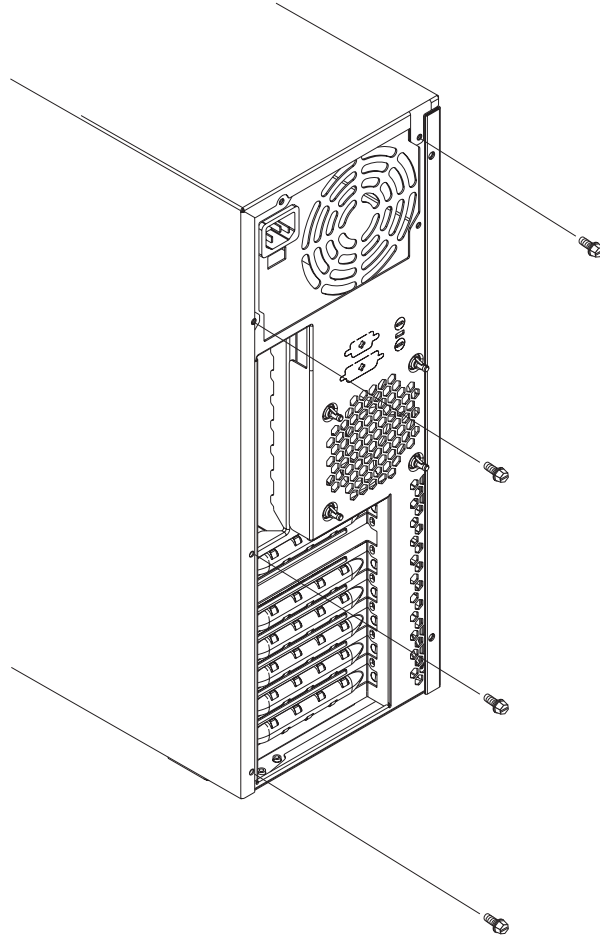

To remove the top/side cover, do the following:

1. Power-off the server, if it is on.
2. Unplug the server.
3. Remove the cover (see “Side cover removal” on page 42).
4. Remove the front bezel (see “Bezel removal” on page 43).
5. Remove the handle assembly (see “Handle assembly” on page 86).
6. Remove the four screws from the back of the server and put them in a safe place.
7. Using a screwdriver, gently pry the cover away from the server in the rear and slide the unit away from the server.

---

## Handle assembly

### Before you begin:

- Read “Safety information” on page 103.
- Review the information in “Before you begin” on page 40.

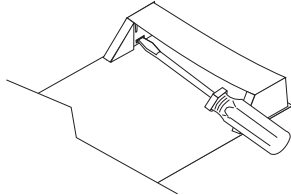

To remove the handle cap, do the following:

1. Power-off the server, if it is on.
2. Unplug the server.
3. Use a flathead screwdriver to gently press in and down on the tabs located on the interior side wall of the handle.
4. Lift up on the handle cap to separate it from the handle support.

To remove the handle support, do the following:

1. Power-off the server, if it is on.
2. Unplug the server.
3. Firmly grasp the handle support and slide it away from the front bezel.
4. Lift up on the handle support to remove it from the slots in the top of the chassis.

---

## Adapter retainer

### Before you begin:

- Read “Safety information” on page 103.
- Review the information in “Before you begin” on page 40.

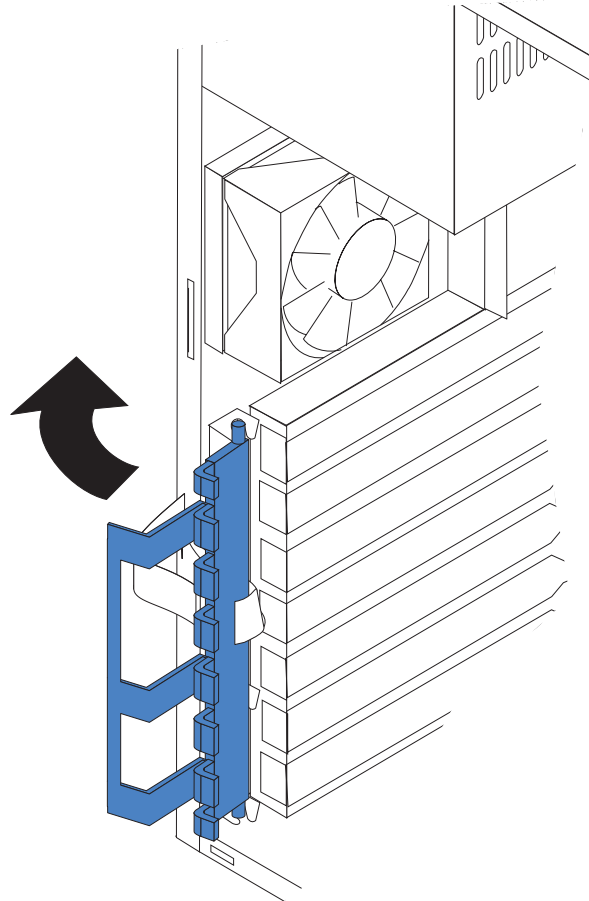

To remove the adapter retainer, do the following:

1. Power-off the server, if it is on.
2. Unplug the server.
3. Remove the cover (see “Side cover removal” on page 42).
4. Remove all adapter cards (see “Adapter installation” on page 47).
5. Rotate the adapter retainer to the open position.
6. Grasp the adapter retainer and gently slide the top and bottom tabs out of the notches.





---

## Symptom-to-FRU index

This index supports xSeries 200 servers.

### Notes:

1. Check the configuration before you replace a FRU. Configuration problems can cause false errors and symptoms.
2. The default configuration can be loaded by starting the system and then pressing the reset button four times, waiting 15 seconds between each press. Once the configuration has reset to the default, it must be saved in Setup to be stored in CMOS.
3. For IBM devices not supported by index, refer to the manual for that device.
4. Always start with "General checkout" on page 1.

The Symptom-to-FRU lists symptoms, errors, and the possible causes. The most likely cause is listed first. Use this Symptom-to-FRU index to help you decide which FRUs to have available when servicing the computer. The POST BIOS displays POST error codes and messages on the screen.

---

## Beep symptoms

Beep symptoms are short tones or a series of short tones separated by pauses (intervals without sound). See the following examples.

**Note:** One beep after successfully completing POST indicates the system is functioning properly.

Beeps	Description
1-2-3	<ul style="list-style-type: none"><li>• One beep</li><li>• A pause (or break)</li><li>• Two beeps</li><li>• A pause (or break)</li><li>• Three Beeps</li></ul>
4	Four continuous beeps

Beep/Symptom	FRU/Action
Repeating Beeps (endless loop) (memory error)	<ol style="list-style-type: none"><li>1. DIMM</li><li>2. System Board</li></ol>
One Long and Three Short Beeps (video error)	<ol style="list-style-type: none"><li>1. Video adapter (if present)</li><li>2. System Board</li></ol>
One Long and Two Short Beeps (video error)	<ol style="list-style-type: none"><li>1. Video adapter (if present)</li><li>2. Reseat monitor cable</li><li>3. System Board</li></ol>

## No beep symptoms

No Beep Symptom	FRU/Action
No beep and the system operates correctly.	<ol style="list-style-type: none"> <li>1. Check speaker cables</li> <li>2. Speaker</li> <li>3. System board</li> </ol>
No Beeps occur after successfully completing POST	<ol style="list-style-type: none"> <li>1. Check speaker connections</li> <li>2. Speaker</li> <li>3. System board</li> </ol>
No ac power	<ol style="list-style-type: none"> <li>1. Check the power cord.</li> <li>2. Power supply.</li> </ol>
No beep and no video	1. See "Undetermined problems" on page 97

## Diagnostic error codes

**Note:** In the following error codes, if XXX is 000, 195, or 197, do not replace a FRU. The description for these error codes are:

- 000** The test passed.
- 195** The **Esc** key was pressed to abort the test.
- 197** This is a warning error and may not indicate a hardware failure.

For all error codes, replace/follow the FRU/Action indicated.

Error Code/Symptom	FRU/Action
<b>001-XXX-000</b> (Failed core tests)	1. <b>System Board</b>
<b>001-XXX-001</b> (Failed core tests)	1. <b>System Board</b>
<b>001-250-000</b> (Failed System Board ECC)	1. <b>System Board</b>
<b>001-250-001</b> (Failed System Board ECC)	1. <b>System Board</b>
<b>005-XXX-000</b> (Failed Video test)	<ol style="list-style-type: none"> <li>1. <b>Video Adapter (if installed)</b></li> <li>2. System Board</li> </ol>
<b>011-XXX-000</b> (Failed COM1 Serial Port test)	1. <b>System Board</b>
<b>011-XXX-001</b> (Failed COM2 Serial Port test)	1. <b>System Board</b>
<b>014-XXX-000</b> (Failed Parallel Port test)	1. <b>System Board</b>
<b>015-XXX-001</b> (USB interface not found, board damaged)	1. <b>System Board</b>

<b>Error Code/Symptom</b>	<b>FRU/Action</b>
<b>015-XXX-015</b> (Failed USB External Loopback test)	<ol style="list-style-type: none"> <li>1. Make sure parallel port is not disabled</li> <li>2. Re-run USB External Loopback test</li> <li>3. <b>System Board</b></li> </ol>
<b>015-XXX-198</b> (USB device connected during USB test)	<ol style="list-style-type: none"> <li>1. Remove USB devices from USB1 and USB2</li> <li>2. Re-run test</li> <li>3. <b>System Board</b></li> </ol>
<b>020-XXX-000</b> (Failed PCI Interface test)	<ol style="list-style-type: none"> <li>1. <b>System Board</b></li> </ol>
<b>030-XXX-000</b> (Failed Internal SCSI interface test)	<ol style="list-style-type: none"> <li>1. <b>System Board</b></li> </ol>
<b>030-XXX-00N</b> (Failed SCSI test on PCI slot N. Check system error log before replacing a FRU.)	<ol style="list-style-type: none"> <li>1. <b>Adapter in Slot N</b></li> </ol>
<b>035-XXX-099</b>	<ol style="list-style-type: none"> <li>1. <b>No adapters were found.</b></li> <li>2. If adapter is installed re-check connection.</li> </ol>
<b>035-XXX-S99</b> (Failed RAID test on PCI slot S. S = number of failing PCI slot. Check System Error Log before replacing a FRU.)	<ol style="list-style-type: none"> <li>1. <b>Adapter</b></li> <li>2. SCSI Backplane</li> <li>3. Cable</li> </ol>
<b>035-XXX-SNN</b> (Check System Error Log before replacing a FRU. S = number of failing PCI slot; NN = SCSI ID of failing fixed disk.)	<ol style="list-style-type: none"> <li>1. <b>Fixed Disk with SCSI ID NN on RAID adapter in PCI slot S.</b></li> </ol>
<b>035-253-S99</b> (RAID adapter initialization failure)	<ol style="list-style-type: none"> <li>1. <b>ServeRAID Adapter in slot S is not configured properly.</b> Obtain the basic and extended configuration status and refer to the ServeRAID Hardware Maintenance Manual for more information.</li> <li>2. Cable</li> <li>3. Adapter</li> </ol>
<b>075-XXX-000</b> (Failed Power Supply test)	<ol style="list-style-type: none"> <li>1. <b>Power Supply</b></li> </ol>
<b>089-XXX-001</b> (Failed Microprocessor test)	<ol style="list-style-type: none"> <li>1. <b>Microprocessor</b></li> </ol>
<b>180-XXX-003</b> (Failed System Board LED test)	<ol style="list-style-type: none"> <li>1. <b>System Board</b></li> </ol>
<b>201-XXX-0NN</b> (Failed Memory test, see "Memory Settings" on page 27.) NN = DIMM location.	<ol style="list-style-type: none"> <li>1. <b>DIMM Location J1-J4</b></li> <li>2. Memory card</li> </ol>
<b>201-XXX-999</b> (Multiple DIMM failure, see error text.)	<ol style="list-style-type: none"> <li>1. <b>See error text for failing DIMMs</b></li> </ol>
<b>202-XXX-001</b> (Failed System Cache test)	<ol style="list-style-type: none"> <li>1. <b>Microprocessor CPU 1</b></li> </ol>

<b>Error Code/Symptom</b>	<b>FRU/Action</b>
<b>206-XXX-000</b> (Failed Diskette Drive test)	<ol style="list-style-type: none"> <li><b>Cable</b></li> <li>Diskette Drive</li> <li>System Board</li> </ol>
<b>215-XXX-000</b> (Failed IDE CD-ROM test)	<ol style="list-style-type: none"> <li><b>CD-ROM Drive Cables</b></li> <li>CD-ROM Drive</li> <li>System Board</li> </ol>
<b>217-198-XXX</b> (Could not establish drive parameters)	<ol style="list-style-type: none"> <li><b>Check cable and termination</b></li> <li>SCSI backplane</li> <li>Fixed disk</li> </ol>
<b>217-XXX-000</b> (Failed BIOS Fixed Disk test) <b>Note:</b> If RAID is configured, the fixed disk number refers to the RAID logical array.	<ol style="list-style-type: none"> <li><b>Fixed Disk 1</b></li> </ol>
<b>217-XXX-001</b> (Failed BIOS Fixed Disk test) <b>Note:</b> If RAID is configured, the fixed disk number refers to the RAID logical array.	<ol style="list-style-type: none"> <li><b>Fixed Disk 2</b></li> </ol>
<b>217-XXX-002</b> (Failed BIOS Fixed Disk test) <b>Note:</b> If RAID is configured, the fixed disk number refers to the RAID logical array.	<ol style="list-style-type: none"> <li><b>Fixed Disk 3</b></li> </ol>
<b>301-XXX-000</b> (Failed Keyboard test)	<ol style="list-style-type: none"> <li><b>Keyboard</b></li> </ol>
<b>302-XXX-000</b> (Mouse failed)	<ol style="list-style-type: none"> <li><b>Mouse</b></li> </ol>
<b>305-XXX-000</b> (Video monitor failure)	<ol style="list-style-type: none"> <li><b>Video Monitor</b></li> <li>Video Adapter</li> </ol>
<b>405-XXX-000</b> (Failed Ethernet test on controller on the System Board)	<ol style="list-style-type: none"> <li><b>Verify that Ethernet is not disabled in BIOS.</b></li> <li>System Board</li> </ol>
<b>405-XXX-00N</b> (Failed Ethernet test on adapter in PCI slot N)	<ol style="list-style-type: none"> <li><b>Adapter in PCI slot N.</b></li> <li>System Board</li> </ol>
<b>415-XXX-000</b> (Failed Modem test)	<ol style="list-style-type: none"> <li><b>Cable</b></li> <li>Modem</li> <li>System Board</li> </ol>

## Error symptoms

<b>General</b>	<b>FRU/Action</b>
<b>CD is not working properly.</b>	<ol style="list-style-type: none"> <li><b>Clean the CD.</b></li> <li>Run CD-ROM diagnostics.</li> <li>CD-ROM Drive</li> </ol>

General	FRU/Action
<p><b>CD-ROM drive tray is not working.</b></p> <p>(The server must be powered-on.)</p>	<ol style="list-style-type: none"> <li>1. <b>Insert the end of a paper clip into the manual tray-release opening.</b></li> <li>2. Run CD-ROM diagnostics.</li> <li>3. CD-ROM Drive</li> </ol>
<p><b>CD-ROM drive is not recognized.</b></p>	<ol style="list-style-type: none"> <li>1. <b>Run Configuration/Setup, enable primary IDE channel.</b></li> <li>2. Check cables and jumpers.</li> <li>3. Check for correct device driver.</li> <li>4. Run CD-ROM diagnostics.</li> <li>5. CD-ROM drive</li> <li>6. System Board</li> </ol>
<p><b>Power switch does not work.</b></p>	<ol style="list-style-type: none"> <li>1. <b>Verify that switch number 5 of switch block is Off.</b></li> <li>2. Power Switch Assembly</li> <li>3. System Board</li> </ol>
<p><b>CD-ROM drive cable is not plugged in.</b></p>	<ol style="list-style-type: none"> <li>1. Make sure CD-ROM drive cable is plugged in.</li> </ol>
<p><b>SCSI expansion enclosure used to work, but does not work now.</b></p>	<p>Verify that:</p> <ol style="list-style-type: none"> <li>1. The cables for all external SCSI options are connected correctly.</li> <li>2. The last option in each SCSI chain, or the end of the SCSI cable, is terminated correctly.</li> <li>3. External SCSI options are turned on. You must turn on external SCSI options before turning on the system.</li> </ol> <p>For more information, see the SCSI and expansion enclosure documentation.</p>
<p><b>Diskette drive in-use light stays on, or the system bypasses the diskette drive, or the diskette drive does not work.</b></p>	<ol style="list-style-type: none"> <li>1. <b>If there is a diskette in the drive, verify that:</b> <ol style="list-style-type: none"> <li>a. The diskette drive is enabled in the Configuration/Setup utility program.</li> <li>b. The diskette is good and not damaged. (Try another diskette if you have one.)</li> <li>c. The diskette is inserted correctly in the drive.</li> <li>d. The diskette contains the necessary files to start the server.</li> <li>e. The software program is OK.</li> <li>f. Cable is installed correctly (proper orientation)</li> </ol> </li> <li>2. Run Diskette Drive Diagnostics.</li> <li>3. Cable</li> <li>4. Diskette Drive</li> <li>5. System Board</li> </ol>
<p><b>Not all drives are recognized by fixed disk diagnostic.</b></p>	<ol style="list-style-type: none"> <li>1. <b>Remove first drive that does not show up and rerun diagnostic.</b> If remaining drives show up, replace the one that was removed.</li> <li>2. If remaining drives do not show up, remove successive drives one at a time and rerun diagnostic.</li> </ol>
<p><b>System hangs during fixed disk diagnostic.</b></p>	<ol style="list-style-type: none"> <li>1. <b>Remove hard drive being tested at the time of the hang and rerun the diagnostic.</b> If successful, replace drive that was removed.</li> </ol>
<p><b>Monitor problems (general).</b></p> <p>Some IBM monitors have their own self-tests. If you suspect a problem with the monitor, refer to the information that comes with the monitor for adjusting and testing instructions.</p>	<ol style="list-style-type: none"> <li>1. <b>Monitor</b></li> <li>2. Run Video Diagnostics. If diagnostics pass, the problem may be a video driver.</li> <li>3. Display Adapter / System Board</li> </ol>

General	FRU/Action
<p><b>A problem occurs only occasionally and is difficult to detect.</b></p>	<p>Verify that:</p> <ol style="list-style-type: none"> <li>1. All cables and cords are connected securely to the rear of the system and attached options.</li> <li>2. When the system is turned on, air is flowing from the rear of the system at the fan grille. If there is no air flow, the fan is not working. This causes the system to overheat and shut down.</li> <li>3. Ensure that the SCSI bus and devices are configured correctly and that the last external device in each SCSI chain is terminated correctly.</li> </ol>
<p><b>All or some keys on the keyboard do not work.</b></p>	<ol style="list-style-type: none"> <li>1. Make sure that the keyboard cable is properly connected to the system.</li> <li>2. Make sure that the system and the monitor are turned on.</li> <li>3. Try using another keyboard.</li> </ol>
<p><b>The mouse or pointing device does not work.</b></p>	<ol style="list-style-type: none"> <li>1. Verify that the mouse or pointing-device cable is securely connected and the device drivers are installed correctly.</li> <li>2. Try using another mouse or pointing device.</li> </ol>
<p><b>The amount of memory displayed is less than the amount of memory installed.</b></p>	<p>Verify that:</p> <ol style="list-style-type: none"> <li>1. The memory modules are seated properly.</li> <li>2. You have installed the correct type of memory.</li> <li>3. If you changed the memory, you must update the memory configuration with the Configuration/Setup Utility program.</li> <li>4. All banks of memory on the DIMMs are enabled. The system might have automatically disabled a DIMM bank if it detected a problem, or a DIMM bank could have been manually disabled.</li> </ol>
<p><b>The number of parallel ports displayed is less than the number of parallel ports installed.</b></p>	<p>Verify that:</p> <ol style="list-style-type: none"> <li>1. Each port is assigned a unique address.</li> <li>2. The parallel-port adapter, if you installed one, is seated properly.</li> </ol>
<p><b>The system does not power on.</b></p>	<p>Verify that:</p> <ol style="list-style-type: none"> <li>1. The power cables are properly connected to the server.</li> <li>2. The electrical outlet functions properly.</li> <li>3. The type of memory installed is correct.</li> <li>4. If you just installed an option, remove it, and restart the server. If the server now turns on, you might have installed more options than the power supply supports.</li> </ol>
<p><b>The number of serial ports identified by the operating system is less than the number of serial ports installed.</b></p>	<p>Verify that:</p> <ol style="list-style-type: none"> <li>1. Each port is assigned a unique address by the Configuration/Setup Utility program and none of the serial ports are disabled.  <b>Note:</b> The management C connector is the same as a serial port connector, but it is used only by the integrated ASM processor, and is not available for use by the operating system. This port does not appear in the Configuration/Setup Utility program menus; it can be configured using system management software.</li> <li>2. The serial-port adapter, if you installed one, is seated properly.</li> </ol>
<p><b>A serial device does not work.</b></p>	<p>Verify that:</p> <ol style="list-style-type: none"> <li>1. The device is compatible with the server.</li> <li>2. The serial port is enabled and is assigned a unique address.</li> </ol>
<p><b>A USB device does not work.</b></p>	<p>Verify that:</p> <ol style="list-style-type: none"> <li>1. You are not trying to use a USB device during POST, if you have a standard (non-USB) keyboard attached to the keyboard port.  <b>Note:</b> If a standard (non-USB) keyboard is attached to the keyboard port, then the USB is disabled and no USB device will work during POST.</li> <li>2. The correct USB device driver is installed.</li> <li>3. Your operating system supports USB devices.</li> </ol>

Setup	Action
Setup and Installation CD won't start.	<ul style="list-style-type: none"> <li>• Be sure the server is supported; all eServers with a startable (bootable) CD-ROM drive are supported.</li> <li>• If the startup (boot) sequence settings have been altered, be sure the CD-ROM is first in the boot sequence.</li> <li>• If more than one CD-ROM drive is installed, be sure that only one drive is set as the primary drive. Start the CD from the primary drive.</li> </ul>
ServeRAID program cannot view all installed drives - or - cannot install NOS.	<ul style="list-style-type: none"> <li>• Be sure there are no duplicate SCSI IDs or IRQ assignments.</li> <li>• Be sure that the hard disk drive is connected properly.</li> </ul>
The Operating System Installation program continuously loops.	Free up more space on the hard disk.
ServerGuide won't start your NOS CD.	Be sure the NOS CD you have is supported by ServerGuide. See the <i>Setup and Installation</i> CD label for a list of NOS versions supported.
Can't install NOS - option is grayed out.	Either there is no logical drive defined (ServeRAID systems) or the ServerGuide system partition is not present. Run the setup and configuration program.

TechConnect CD	Action
Can't start TechConnect CD.	Be sure you're starting the CD on a system with Microsoft Windows installed.
Can't view publications from TechConnect CD, or text is unreadable.	Be sure you have the Adobe reader installed (available from the TechConnect CD).

System Updates and Applications CD	Action
Get "time out" or "Unknown host" errors	Be sure you have access to the Internet through FTP directly.

## POST error messages

In the following error codes, X can be any number or letter.

Error Symptom	FRU/Action
BIOS ROM checksum error -- system halted (BIOS code checksum in BIOS chip incorrect; BIOS may be corrupt)	1. <b>Replace BIOS</b>
CMOS battery failed (CMOS battery not functional)	1. <b>Battery</b>
CMOS checksum error -- defaults loaded (CMOS checksum incorrect, system loads default equipment configuration)	<ol style="list-style-type: none"> <li>1. <b>Run Configuration/Setup</b></li> <li>2. <b>Battery</b></li> </ol>
CPU at nnnn (displays running speed of CPU)	1. <b>Informational only; no action necessary.</b>
Press ESC to skip memory test	1. <b>Full memory test may be skipped by pressing Esc key</b>

Error Symptom	FRU/Action
<b>Floppy disk(s) fail</b> (cannot find or initialize floppy drive controller or floppy drive)	<ol style="list-style-type: none"> <li>1. <b>Reseat controller</b></li> <li>2. If no floppy drive installed, be sure Diskette Drive selection in Setup is set to None or Auto.</li> </ol>
<b>HARD DISK initializing</b>	<ol style="list-style-type: none"> <li>1. <b>Informational only; no action necessary.</b></li> <li>2.</li> </ol>
<b>HARD DISK INSTALL FAILURE</b> (cannot find or initialize hard drive controller or hard drive)	<ol style="list-style-type: none"> <li>1. <b>Reseat drive</b></li> <li>2. If no hard drive installed, be sure Hard Drive selection in Setup is set to None.</li> </ol>
<b>Hark disk(s) diagnosis fail</b> (a diagnostic routine has failed)	<ol style="list-style-type: none"> <li>1. <b>Run Configuration/Setup</b></li> <li>2. Battery</li> <li>3. System board</li> </ol>
<b>Keyboard error or no keyboard present</b> (cannot initialize keyboard)	<ol style="list-style-type: none"> <li>1. <b>Reattach keyboard</b></li> <li>2. Ensure no keys are pressed during POST</li> <li>3. To configure system to run without a keyboard, set error halt condition in Setup to HALT ON ALL, BUT KEYBOARD. BIOS will then ignore missing keyboard during POST.</li> </ol>
<b>Keyboard is locked out -- Unlock the key</b> (key(s) pressed during keyboard tests)	<ol style="list-style-type: none"> <li>1. <b>Ensure no keys are pressed during POST</b></li> <li>2. Clear keyboard of any object resting on it</li> </ol>
<b>Memory Test:</b> (countdown as memory areas are tested)	<ol style="list-style-type: none"> <li>1. <b>Informational only; no action necessary.</b></li> <li>2.</li> </ol>
<b>Memory test fail</b> (POST detected an error during memory testing)	<ol style="list-style-type: none"> <li>1. <b>Note additional information about specific error that appears on the screen</b></li> <li>2. DIMM</li> </ol>
<b>Override enabled -- Defaults loaded</b> (system cannot boot using current CMOS configuration; BIOS has overridden configuration and defaulted to minimal-performance system operations)	<ol style="list-style-type: none"> <li>1. <b>Run Configuration/Setup</b></li> <li>2. Battery</li> <li>3. System board</li> </ol>
<b>Primary master hard disk fail</b> (error detected in primary master IDE hard drive)	<ol style="list-style-type: none"> <li>1. <b>Replace primary master hard drive</b></li> <li>2. System board</li> </ol>
<b>Primary slave hard disk fail</b> (error detected in primary slave IDE hard drive)	<ol style="list-style-type: none"> <li>1. <b>Replace primary slave hard drive</b></li> <li>2. System board</li> </ol>
<b>Secondary master hard disk fail</b> (error detected in secondary master IDE hard drive)	<ol style="list-style-type: none"> <li>1. <b>Replace secondary master hard drive</b></li> <li>2. System board</li> </ol>
<b>Secondary slave hard disk fail</b> (error detected in secondary slave IDE hard drive)	<ol style="list-style-type: none"> <li>1. <b>Replace secondary slave hard drive</b></li> <li>2. System board</li> </ol>



---

## ServeRAID

For ServeRAID error codes and procedures, refer to the Hardware Maintenance Manual for the particular RAID adapter in the system being serviced.

---

## Undetermined problems

You are here because the diagnostic tests did not identify the failure, the Devices List is incorrect, or the system is inoperative.

**Note:** A corrupt CMOS can cause undetermined problems.

If power problems are suspected:

1. Power-off the computer.
2. Be sure the system is cabled correctly.
3. Remove or disconnect the following (one at a time) until you find the failure (power-on the computer and reconfigure each time).
  - Any external devices
  - Modem, printer, mouse, or non-IBM devices
  - Each adapter
  - Drives
  - Memory Modules (Minimum requirement = one 128 MB DIMM)

**Note:** Minimum operating requirements are:

- a. 1 Power Supply
- b. System Board
- c. 1 Microprocessor
- d. 1 Terminator Card in Slot 2
- e. 1 Memory Module (minimum of 1 DIMM in slot labeled DIMM 1)
4. Power-on the computer. If the problem remains, suspect the following FRUs in the order listed:
  - Power Supply
  - System Board

**Notes:**

1. If the problem goes away when you remove an adapter from the system, and replacing that adapter does not correct the problem, suspect the system board, then the power supply.
2. If you suspect a networking problem and all the system tests pass, suspect a network cabling problem external to the system.



# Parts listing

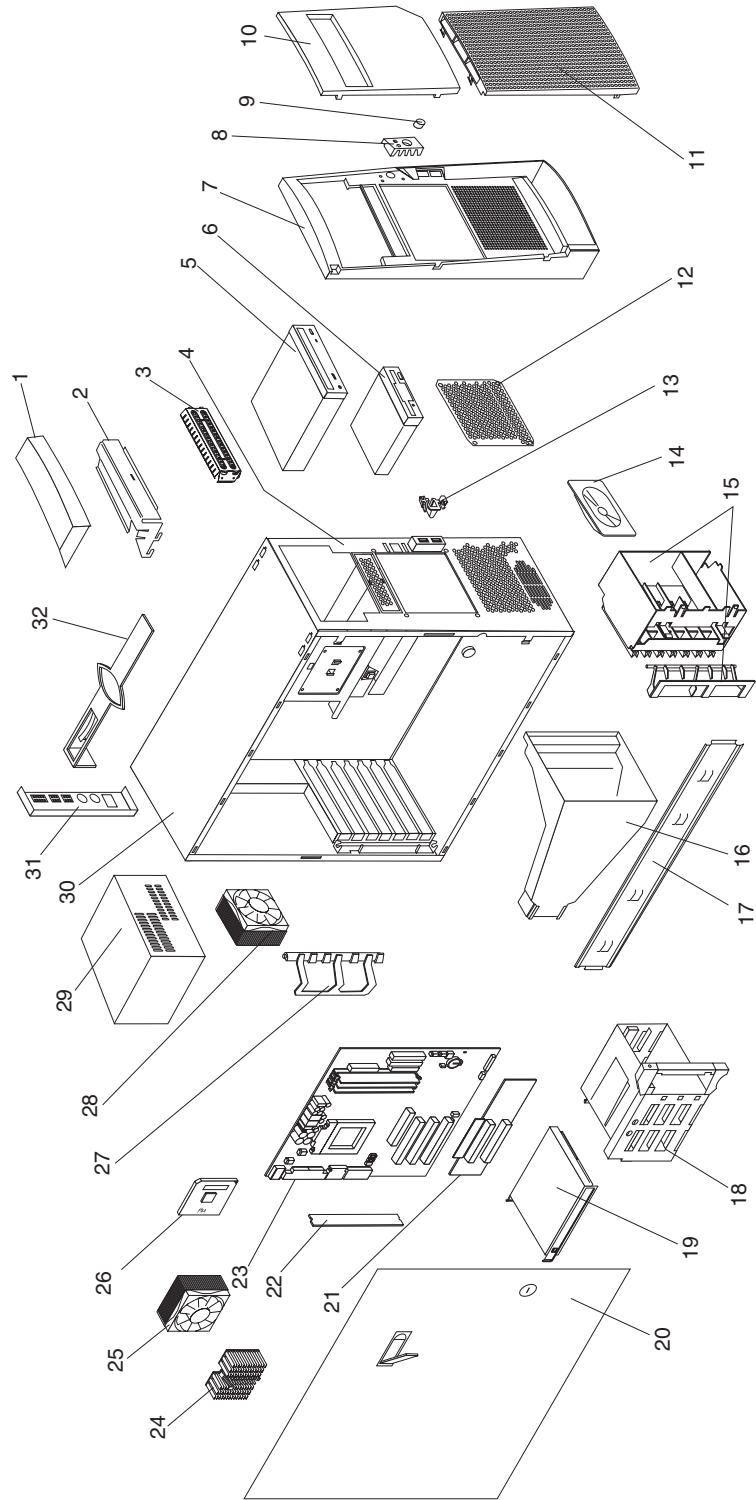

## System

This parts listing supports: Type 8479 models 10X, 11X, 13X, 3AX, 31X, 40X, 41X, 42X, 50X, 51X, 52X, 60X, 61X, 62X; and Type 8481 model 31X.

Index	xSeries 200	FRU No.
1	Handle cap (models 10X, 11X, 13X, 31X, 40X, 41X, 42X, 50X, 51X, 52X, 60X, 61X, 62X)	19K4934
1	Handle cap (model 3AX)	02R0805
2	Handle support (all models)	19K4936
3	Shield, 5.25" EMC (all models)	19K5548
4	Chassis, staked (all models)	06P5856
5	48X CD-ROM drive, black (all models)	19K1531
5	48X CD-ROM drive black, alternate (all models)	06P5167
5	48X CD-ROM drive, alternate (all models)	19K1535
6	Diskette drive (all models)	76H4091
7	Front bezel (models 10X, 11X, 13X, 31X, 40X, 41X, 42X, 50X, 51X, 52X, 60X, 61X, 62X)	19K4958
7	Front bezel (model 3AX)	02R0802
8	Power panel (all models)	19K4942
9	Kit, power button (all models)	19K4940
10	Bezel door with silver logo (all models)	32P0960
11	Panel, full perforation ventilation (all models)	19K4953
12	Plate, EMC (hot swap) (all models)	24P1750
13	Control panel (all models)	24P2621
14	Speaker (all models)	19K4929
15	I/O retainer card assembly (all models)	19K4947
16	Duct assembly with 92x38MM fan (all models)	24P1745
17	Support bracket (all models)	19K4963
18	Cage, DASD rotating (all models)	19K4931
19	18.2 SCSI hard disk drive (models 13X, 42X, 52X, 62X)	19K1485
19	20.0 GB ATA-100 IDE hard disk drive (models 11X, 21X, 31X, 41X, 51X, 61X)	19K1565
20	Door assembly (models 10X, 11X, 13X, 31X, 40X, 41X, 42X, 50X, 51X, 52X, 60X, 61X, 62X)	24P1752
20	Door assembly (model 3AX)	02R0803
21	PCI extender card (all models)	22P9768
22	Memory, 128MB ECC 133MHz SDRAM (all models)	33L3082
22	Memory, 256MB ECC 133MHz SDRAM (model 3AX)	33L3084
23	System board (all models)	24P5254
24	Heatsink (Models 10X, 11X, 13X)	09N4372
24	Heatsink w/clip (models 50X, 51X, 52X, 60X, 61X, 62X, 8481-31X)	22P4368
25	Fan sink (models 21X, 31X, 40X, 41X, 42X)	22P4370
26	Processor, 100/850MHz 128K (models 10X, 11X, 13X)	32P1181
26	Processor, 100/1000MHz 128K (models 8479-31X, 3AX)	59P5449
26	Processor, 133/1000MHz 256K-T (models 21X, 40X, 41X, 42X)	32P1112
26	Processor, 133/1133MHz 512K (models 50X, 51X, 52X)	25P2605
26	Processor, 100/1200MHz 256K (model 8481-31X)	59P1891
26	Processor, 133/1266MHz 512K (models 60X, 61X, 62X)	25P2601
27	Card guide (all models)	19K4945
28	Fan 80x25MM (all models)	22P4373
29	Power supply, 330W PFC (all models)	00N7718
30	Cover, side/top (models 10X, 11X, 13X, 31X, 40X, 41X, 42X, 50X, 51X, 52X, 60X, 61X, 62X)	19K4957
30	Cover, side/top (model 3AX)	02R0804
31	Shield, 3.5" EMC (all models)	19K4943
32	Bezel release bar (all models)	19K4946
	Lock/key assembly (all models)	24P1751
	System feet (all models)	12J4506
	Feet, snap-in (4) (all models)	01N2196

<b>Index</b>	<b>xSeries 200</b>	<b>FRU No.</b>
	Miscellaneous hardware kit (contains: screws, M3.5 (7); EMC gasket (1); I/O blank bracket (1); power supply bracket (1); isolator support (4); key holder bracket (1); slotted M3x5 screws (4); RFID clip (1); system board spacer (4); SCSI cable clamp (1); and slotted M3.5 screws (6)) (all models)	09N5764
	Kit, USB blank rack bezel (all models)	19K4951
	Kit, DASD hard disk drive rail (all models)	23P1328
	Shield, system board EMC (all models)	22P0105
	Shield, system board EMC (all models)	22P0105
	Ferrite core, single (all models)	32P0296
	Ferrite core, bulk quantity (30) (all models)	32P8511
	System service label (all models)	32P0980
	SCSI U160 adapter (all models)	06P2215
	ATI video card (all models)	25P2814
	Bezel kit (all models)	00N7082
	Door, bezel (all models)	24P4006
	Cable, SCSI 5-drop (models 10X, 13X, 40X, 42X, 52X, 60X, 62X)	00N7110
	Cable, IDE 2-drop (models 10X, 11X, 21X, 31X, 40X, 41X, 50X, 51X, 60X, 61X)	09N5925
	Cable, floppy disk drive (all models)	76H4228
	Cable, SCSI LED (models 10X, 13X, 40X, 42X, 52X, 60X, 62X)	76H7344
	Cable, CD-ROM audio (all models)	75H9219
	Power cord (all models)	93F2364

---

## Keyboards

<b>Keyboard</b>	<b>FRU No.</b>
US English	37L2551
French Canadian	37L2552
LA Spanish	37L2553
Arabic	37L2555
Belgium/French	37L2556
Belgium/UK	37L2557
Bulgarian	37L2558
Czech	37L2559
Danish	37L2560
Dutch	37L2561
French	37L2562
German	37L2563
Greek	37L2564
Hebrew	37L2565
Hungarian	37L2566
Korean	02K0901
Iceland	37L2567
Italy	37L2568
Norwegian	37L2569
Polish	37L2570
Portuguese	37L2571
Romanian	37L2572
Russian	37L2573
Serbian/Cyrillic	37L2574
Slavic	37L2575
Spanish	37L2576
Swedish/Finn	37L2577
Swiss, F/G	37L2578

<b>Keyboard</b>	<b>FRU No.</b>
Turkish (179)	37L2579
Turkish (440)	37L2580
UK English	37L2581
Yugosl/Lat	37L2582
US English-EMEA	37L2583
Chinese/US	37L2585
Thailand	37L2587
French Canadian	37L0913

---

## Power cords

<b>Power cord</b>	<b>FRU No.</b>
China (PRC)	01K9851
Japan	01K9853
Thailand	12J5120
Israel	12J5122
Bangladesh, Burma, India, Pakistan, South Africa, Sri Lanka	12J5124
Chile, Ethiopia, Italy, Libya, Somalia	12J5126
Argentina, Australia, New Zealand, Papua New Guinea, Paraguay, Uruguay, Western Samoa	12J5128
Antigua, Bahrain, Brunei, Channel Islands, China (Hong Kong S.A.R.), Cyprus, Dubai, Fiji, Ghana, Iraq, Ireland, Kenya, Kuwait, Malawi, Malaysia, Malta, Nepal, Nigeria, Polynesia, Qatar, Sierra Leone, Singapore, Tanzania, Uganda, United Kingdom, Yemen, Zambia	12J5987
Afghanistan, Algeria, Andorra, Angola, Austria, Belgium, Benin, Bulgaria, Burkina Faso, Burundi, Cameroon, Central African Rep., Chad, China (Macau S.A.R.), Czech Republic, Egypt, Finland, France, French Guiana, Germany, Greece, Guinea, Hungary, Iceland, Indonesia, Iran, Ivory Coast, Jordan, Lebanon, Luxembourg, Malagasy, Mali, Martinique, Mauritania, Mauritius, Monaco, Morocco, Mozambique, Netherlands, New Caledonia, Niger, Norway, Poland, Portugal, Romania, Senegal, Slovakia, Spain, Sudan, Sweden, Syria, Togo, Tunisia, Turkey, former USSR, Vietnam, former Yugoslavia, Zaire, Zimbabwe	55H6643
Denmark, Switzerland, Liechtenstein	55H6646
Bahamas, Barbados, Bermuda, Bolivia, Brazil, Canada, Cayman Islands, Colombia, Costa Rica, Dominican Republic, Ecuador, El Salvador, Guatemala, Guyana, Haiti, Honduras, Jamaica, Korea (South), Liberia, Mexico, Netherlands Antilles, Nicaragua, Panama, Peru, Philippines, Saudi Arabia, Suriname, Taiwan, Trinidad (West Indies), Venezuela	76H4865
United States of America	6952301 (110) 1838574 (220) 36L8886 (220V/15A)

---

## Related service information

**Note:** The service procedures are designed to help you isolate problems. They are written with the assumption that you have model-specific training on all computers, or that are familiar with the computers, functions, terminology, and service information provided in this manual.

---

## Safety information

The following section contains the safety information that you need to be familiar with before servicing an IBM computer.

### General safety

Follow these rules to ensure general safety:

- Observe good housekeeping in the area of the machines during and after maintenance.
- When lifting any heavy object:
  1. Ensure you can stand safely without slipping.
  2. Distribute the weight of the object equally between your feet.
  3. Use a slow lifting force. Never move suddenly or twist when you attempt to lift.
  4. Lift by standing or by pushing up with your leg muscles; this action removes the strain from the muscles in your back. *Do not attempt to lift any objects that weigh more than 16 kg (35 lb) or objects that you think are too heavy for you.*
- Do not perform any action that causes hazards to the customer, or that makes the equipment unsafe.
- Before you start the machine, ensure that other service representatives and the customer's personnel are not in a hazardous position.
- Place removed covers and other parts in a safe place, away from all personnel, while you are servicing the machine.
- Keep your tool case away from walk areas so that other people will not trip over it.
- Do not wear loose clothing that can be trapped in the moving parts of a machine. Ensure that your sleeves are fastened or rolled up above your elbows. If your hair is long, fasten it.
- Insert the ends of your necktie or scarf inside clothing or fasten it with a nonconductive clip, approximately 8 centimeters (3 inches) from the end.
- Do not wear jewelry, chains, metal-frame eyeglasses, or metal fasteners for your clothing.

**Remember:** Metal objects are good electrical conductors.
- Wear safety glasses when you are: hammering, drilling soldering, cutting wire, attaching springs, using solvents, or working in any other conditions that might be hazardous to your eyes.
- After service, reinstall all safety shields, guards, labels, and ground wires. Replace any safety device that is worn or defective.
- Reinstall all covers correctly before returning the machine to the customer.

## Electrical safety



### CAUTION:

Electrical current from power, telephone, and communication cables can be hazardous. To avoid personal injury or equipment damage, disconnect the attached power cords, telecommunication systems, networks, and modems before you open the server covers, unless instructed otherwise in the installation and configuration procedures.

Observe the following rules when working on electrical equipment.

**Important:** Use only approved tools and test equipment. Some hand tools have handles covered with a soft material that does not insulate you when working with live electrical currents.

Many customers have, near their equipment, rubber floor mats that contain small conductive fibers to decrease electrostatic discharges. Do not use this type of mat to protect yourself from electrical shock.

- Find the room emergency power-off (EPO) switch, disconnecting switch, or electrical outlet. If an electrical accident occurs, you can then operate the switch or unplug the power cord quickly.
- Do not work alone under hazardous conditions or near equipment that has hazardous voltages.
- Disconnect all power before:
  - Performing a mechanical inspection
  - Working near power supplies
  - Removing or installing main units
- Before you start to work on the machine, unplug the power cord. If you cannot unplug it, ask the customer to power-off the wall box that supplies power to the machine and to lock the wall box in the off position.
- If you need to work on a machine that has exposed electrical circuits, observe the following precautions:
  - Ensure that another person, familiar with the power-off controls, is near you.  
**Remember:** Another person must be there to switch off the power, if necessary.
  - Use only one hand when working with powered-on electrical equipment; keep the other hand in your pocket or behind your back.  
**Remember:** There must be a complete circuit to cause electrical shock. By observing the above rule, you may prevent a current from passing through your body.
  - When using testers, set the controls correctly and use the approved probe leads and accessories for that tester.
  - Stand on suitable rubber mats (obtained locally, if necessary) to insulate you from grounds such as metal floor strips and machine frames.

Observe the special safety precautions when you work with very high voltages; these instructions are in the safety sections of maintenance information. Use extreme care when measuring high voltages.

- Regularly inspect and maintain your electrical hand tools for safe operational condition.



- Do not use worn or broken tools and testers.
- *Never assume* that power has been disconnected from a circuit. First, *check* that it has been powered-off.
- Always look carefully for possible hazards in your work area. Examples of these hazards are moist floors, nongrounded power extension cables, power surges, and missing safety grounds.
- Do not touch live electrical circuits with the reflective surface of a plastic dental mirror. The surface is conductive; such touching can cause personal injury and machine damage.
- Do not service the following parts with the power on when they are removed from their normal operating places in a machine:
  - Power supply units
  - Pumps
  - Blowers and fans
  - Motor generators
 and similar units. (This practice ensures correct grounding of the units.)
- If an electrical accident occurs:
  - Use caution; do not become a victim yourself.
  - Switch off power.
  - Send another person to get medical aid.

## Safety inspection guide

The intent of this inspection guide is to assist you in identifying potentially unsafe conditions on these products. Each machine, as it was designed and built, had required safety items installed to protect users and service personnel from injury. This guide addresses only those items. However, good judgment should be used to identify potential safety hazards due to attachment of non-IBM features or options not covered by this inspection guide.

If any unsafe conditions are present, you must determine how serious the apparent hazard could be and whether you can continue without first correcting the problem.

Consider these conditions and the safety hazards they present:

- Electrical hazards, especially primary power (primary voltage on the frame can cause serious or fatal electrical shock).
- Explosive hazards, such as a damaged CRT face or bulging capacitor
- Mechanical hazards, such as loose or missing hardware

The guide consists of a series of steps presented in a checklist. Begin the checks with the power off, and the power cord disconnected.

Checklist:

1. Check exterior covers for damage (loose, broken, or sharp edges).
2. Power-off the computer. Disconnect the power cord.
3. Check the power cord for:
  - a. A third-wire ground connector in good condition. Use a meter to measure third-wire ground continuity for 0.1 ohm or less between the external ground pin and frame ground.

- b. The power cord should be the appropriate type as specified in the parts listings.
- c. Insulation must not be frayed or worn.
4. Remove the cover.
5. Check for any obvious non-IBM alterations. Use good judgment as to the safety of any non-IBM alterations.
6. Check inside the unit for any obvious unsafe conditions, such as metal filings, contamination, water or other liquids, or signs of fire or smoke damage.
7. Check for worn, frayed, or pinched cables.
8. Check that the power-supply cover fasteners (screws or rivets) have not been removed or tampered with.

## Handling electrostatic discharge-sensitive devices

Any computer part containing transistors or integrated circuits (ICs) should be considered sensitive to electrostatic discharge (ESD). ESD damage can occur when there is a difference in charge between objects. Protect against ESD damage by equalizing the charge so that the machine, the part, the work mat, and the person handling the part are all at the same charge.

### Notes:

1. Use product-specific ESD procedures when they exceed the requirements noted here.
2. Make sure that the ESD protective devices you use have been certified (ISO 9000) as fully effective.

When handling ESD-sensitive parts:

- Keep the parts in protective packages until they are inserted into the product.
- Avoid contact with other people.
- Wear a grounded wrist strap against your skin to eliminate static on your body.
- Prevent the part from touching your clothing. Most clothing is insulative and retains a charge even when you are wearing a wrist strap.
- Use the black side of a grounded work mat to provide a static-free work surface. The mat is especially useful when handling ESD-sensitive devices.
- Select a grounding system, such as those listed below, to provide protection that meets the specific service requirement.

**Note:** The use of a grounding system is desirable but not required to protect against ESD damage.

- Attach the ESD ground clip to any frame ground, ground braid, or green-wire ground.
- Use an ESD common ground or reference point when working on a double-insulated or battery-operated system. You can use coax or connector-outside shells on these systems.
- Use the round ground-prong of the ac plug on ac-operated computers.

## Grounding requirements

Electrical grounding of the computer is required for operator safety and correct system function. Proper grounding of the electrical outlet can be verified by a certified electrician.

## Safety notices (multi-lingual translations)

The caution and danger safety notices in this section are provided in the following languages:

- English
- Brazilian/Portuguese
- Chinese
- French
- German
- Italian
- Korean
- Spanish

**Important:** All caution and danger statements in this IBM documentation begin with a number. This number is used to cross reference an English caution or danger statement with translated versions of the caution or danger statement in this section.

For example, if a caution statement begins with a number 1, translations for that caution statement appear in this section under statement 1.

Be sure to read all caution and danger statements before performing any of the instructions.

- Statement 1



### DANGER

Electrical current from power, telephone and communication cables is hazardous.

To avoid a shock hazard:

- **Do not connect or disconnect any cables or perform installation, maintenance, or reconfiguration of this product during an electrical storm.**
- **Connect all power cords to a properly wired and grounded electrical outlet.**
- **Connect to properly wired outlets any equipment that will be attached to this product.**
- **When possible, use one hand only to connect or disconnect signal cables.**
- **Never turn on any equipment when there is evidence of fire, water, or structural damage.**
- **Disconnect the attached power cords, telecommunications systems, networks, and modems before you open the device covers, unless instructed otherwise in the installation and configuration procedures.**
- **Connect and disconnect cables as described in the following table when installing, moving, or opening covers on this product or attached devices.**

To Connect	To Disconnect
<ol style="list-style-type: none"> <li>1. Turn everything OFF.</li> <li>2. First, attach all cables to devices.</li> <li>3. Attach signal cables to connectors.</li> <li>4. Attach power cords to outlet.</li> <li>5. Turn device ON.</li> </ol>	<ol style="list-style-type: none"> <li>1. Turn everything OFF.</li> <li>2. First, remove power cords from outlet.</li> <li>3. Remove signal cables from connectors.</li> <li>4. Remove all cables from devices.</li> </ol>

- Statement 2



**CAUTION:**

When replacing the lithium battery, use only IBM Part Number 33F8354 or an equivalent type battery recommended by the manufacturer. If your system has a module containing a lithium battery, replace it only with the same module type made by the same manufacturer. The battery contains lithium and can explode if not properly used, handled, or disposed of.

*Do not:*

- Throw or immerse into water
- Heat to more than 100°C (212°F)
- Repair or disassemble

Dispose of the battery as required by local ordinances or regulations.

- Statement 3



**CAUTION:**

When laser products (such as CD-ROMs, DVD-ROM drives, fiber optic devices, or transmitters) are installed, note the following:

- Do not remove the covers. Removing the covers of the laser product could result in exposure to hazardous laser radiation. There are no serviceable parts inside the device.
- Use of controls or adjustments or performance of procedures other than those specified herein might result in hazardous radiation exposure.



**DANGER:** Some laser products contain an embedded Class 3A or Class 3B laser diode. Note the following:

Laser radiation when open. Do not stare into the beam, do not view directly with optical instruments, and avoid direct exposure to the beam.

- Statement 4

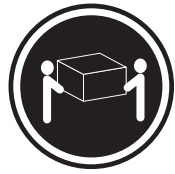

≥18 kg (37 lbs)



≥32 kg (70.5 lbs)



≥55 kg (121.2 lbs)

**CAUTION:**  
Use safe practices when lifting.

- Statement 5



**CAUTION:**  
The power control button on the device and the power switch on the power supply do not turn off the electrical current supplied to the device. The device also might have more than one power cord. To remove all electrical current from the device, ensure that all power cords are disconnected from the power source.



- Statement 10

**CAUTION:**

Do not place any object weighing more than 82 kg (180 lbs.) on top of rack-mounted devices.



## Importante:

Todas as instruções de cuidado e perigo da IBM documentation começam com um número. Este número é utilizado para fazer referência cruzada de uma instrução de cuidado ou perigo no idioma inglês com as versões traduzidas das instruções de cuidado ou perigo encontradas nesta seção.

Por exemplo, se uma instrução de cuidado é iniciada com o número 1, as traduções para aquela instrução de cuidado aparecem nesta seção sob a instrução 1.

Certifique-se de ler todas as instruções de cuidado e perigo antes de executar qualquer operação.

### Instrução 1



## PERIGO

A corrente elétrica proveniente de cabos de alimentação, de telefone e de comunicações é perigosa.

Para evitar risco de choque:

- Não conecte ou desconecte cabos e não realize instalação, manutenção ou reconfiguração deste produto durante uma tempestade com raios.
- Conecte todos os cabos de alimentação a tomadas elétricas corretamente instaladas e aterradas.
- Conecte todos os equipamentos ao qual esse produto será conectado a tomadas corretamente instaladas.
- Sempre que possível, utilize apenas uma das mãos para conectar ou desconectar cabos de sinal.
- Nunca ligue qualquer equipamento quando existir evidência de danos por fogo, água ou na estrutura.
- Desconecte cabos de alimentação, sistemas de telecomunicação, redes e modems antes de abrir as tampas dos dispositivos, a menos que especificado de maneira diferente nos procedimentos de instalação e configuração.
- Conecte e desconecte cabos conforme descrito na seguinte tabela, ao instalar ou movimentar este produto ou os dispositivos conectados, ou ao abrir suas tampas.

Para Conectar:	Para Desconectar:
<ol style="list-style-type: none"><li>1. DESLIGUE Tudo.</li><li>2. Primeiramente, conecte todos os cabos aos dispositivos.</li><li>3. Conecte os cabos de sinal aos conectores.</li><li>4. Conecte os cabos de alimentação às tomadas.</li><li>5. LIGUE os dispositivos.</li></ol>	<ol style="list-style-type: none"><li>1. DESLIGUE Tudo.</li><li>2. Primeiramente, remova os cabos de alimentação das tomadas.</li><li>3. Remova os cabos de sinal dos conectores.</li><li>4. Remova todos os cabos dos dispositivos.</li></ol>

## Instrução 2



### **CUIDADO:**

Ao substituir a bateria de lítio, utilize apenas uma bateria IBM, Número de Peça 33F8354 ou uma bateria de tipo equivalente, recomendada pelo fabricante. Se o seu sistema possui um módulo com uma bateria de lítio, substitua-o apenas pelo mesmo tipo de módulo, do mesmo fabricante. A bateria contém lítio e pode explodir se não for utilizada, manuseada e descartada de maneira correta.

Não:

- Jogue ou coloque na água
- Aqueça a mais de 100°C (212°F)
- Conserte nem desmonte

Para descartar a bateria, entre em contato com a área de atendimento a clientes IBM, pelo telefone (011) 889-8986, para obter informações sobre como enviar a bateria pelo correio para a IBM.

## Instrução 3



### **PRECAUCIÓN:**

Quando produtos a laser (unidades de CD-ROM, unidades de DVD, dispositivos de fibra ótica, transmissores, etc.) estiverem instalados, observe o seguinte:

- Não remova as tampas. A remoção das tampas de um produto a laser pode resultar em exposição prejudicial à radiação de laser. Nenhuma peça localizada no interior do dispositivo pode ser consertada.
- A utilização de controles ou ajustes ou a execução de procedimentos diferentes dos especificados aqui pode resultar em exposição prejudicial à radiação.

### **PERIGO**

Alguns produtos a laser contêm um diodo laser da Classe 3A ou Classe 3B embutido. Observe o seguinte:

Radiação de laser quando aberto. Não olhe diretamente para o raio a olho nu ou com instrumentos óticos, e evite exposição direta ao raio.

## Instrução 4





≥18 kg (37 lbs)



≥32 kg (70.5 lbs)



≥55 kg (121.2 lbs)

**CUIDADO:**

Ao levantar a máquina, faça-o com segurança.

Instrução 5



**CUIDADO:**

Os botões Liga/Desliga localizados no dispositivo e na fonte de alimentação não desligam a corrente elétrica fornecida ao dispositivo. O dispositivo também pode ter mais de um cabo de alimentação. Para remover toda a corrente elétrica do dispositivo, assegure que todos os cabos de alimentação estejam desconectados da fonte de energia elétrica.



**CUIDADO:**

Instrução 10



**CUIDADO:**



Não coloque nenhum objeto com peso superior a 82 kg (180 lbs.) sobre dispositivos montados em rack.



## 重要:

Server Library 中的所有提醒和危险条款前都有一个数字标识。该数字是用来交叉引用一个英文的提醒和危险条款及本部分中的与之对应的已翻译成其它文字的提醒和危险条款。

例如, 如果一个提醒条款前的数字为 1, 则本部分中相应的译文也带有标号 1。

在执行任何指示的操作之前, 请确保您已经阅读了全部提醒和危险条款。

### 声明 1



#### 危险

电源、电话和通信电缆中带有危险电流。

为避免电击:

雷电期间不要拆接电缆或安装、维修及重新配置本产品。

将所有电源线连接至正确布线并已安全接地的电源插座上。

将与本产品连接的所有设备连接至正确布线的插座上。

尽量只使用单手拆接信号电缆。

有水、火及结构损坏迹象时, 请勿打开任何设备。

除非在安装配置过程中有明确指示, 否则, 打开设备机盖前应首先断开与电源线、远程通信系统、网络和调制解调器的所有连接。

安装、移动或打开本产品及其附带设备的机盖时, 应按下表所述连接和断开电缆。

#### 连接时:

1. 关闭所有设备。

2. 首先将所有电缆连接至设备。

3. 将信号电缆连接至接口。

4. 将电源线连接至插座。

#### 断开连接时:

1. 关闭所有设备。

2. 首先从插座中拔出电源线。

3. 从接口上拔下信号电缆。

## 声明 2



### 警告:

更换锂电池时，只能使用 IBM 产品号 33F8354 或者是厂商推荐的等同类型的电池。

如果系统模块中含有锂电池，则只能使用同一厂商制造的同类型的模块进行更换。电池中含有锂，如果使用、拿放或处理不当，可能会发生爆炸。

请勿对电池进行下列操作：  
扔入或浸入水中。  
加热超过 100 ° (212 F)  
进行修理或分解  
请按本地法规要求处理电池。

## 声明 3



### 警告:

安装激光产品（如 CD-ROM、DVD 驱动器、光纤设备或送话器）时，应注意以下事项：

不要拆除外盖。拆除激光产品的外盖可能会导致激光辐射的危险，本设备中没有用户可维修的部件。

非此处指定的其它控制、调整或与性能有关的操作都有可能致激光辐射的危险。



### 危险

某些激光产品中包含内嵌的 3A 级或 3B 级激光二极管。请注意以下事项。

打开时会产生激光辐射。不要直视光束，不要使用光学仪器直接观看光束，避免直接暴露于光束之下。

声明 4



≥18 kg (37 磅)



≥32 kg (70.5 磅)



≥55 kg (121.2 磅)

警告：  
抬起时请采用安全操作方法。

声明 5



警告：

使用设备上的电源控制按钮和电源上的开关部不能断开本设备上的电流。  
另外，本设备可能带有多条电源线。如要断开设备上的所有电流，请确  
保所有电源线均已与电源断开连接。



声明 6



警告：

如果在电源线连接设备的一端安装了固定松紧夹，则必须将电源线的另一端连接至  
使用方便的电源。

声明 7



警告:

如果设备带有外门，则在移动或抬起设备前应将其拆除或固定以避免造成人员伤害。外门支撑不了设备的重量。

声明 8



警告:

不要拆除电源外盖或贴有下列标签的任何部件。



贴有此标签的组件内部存在高电压、高电流的危险。这些组件中没有用户可维修的部件。如果怀疑其中的部件存在问题，应与服务技术人员联系。

声明 9



警告:

为避免人员伤害，拆除设备上的风扇前应拔下热插拔风扇电缆。

声明 10



警告:

机柜安装的设备上面不能放置重于 82kg (180 磅) 的物品。



> 82 kg (180 磅)

声明 11



警告:

下面的标签表明附近有锋利的边、角或接头。



声明 12



警告:

下面的标签表明附近有高热表面。



## 重要資訊：

**Server Library** 中所有「注意」及「危險」的聲明均以數字開始。此一數字是用來作為交互參考之用，英文「注意」或「危險」聲明可在本節中找到相同內容的「注意」或「危險」聲明的譯文。

例如，有一「危險」聲明以數字 1 開始，則該「危險」聲明的譯文將出現在本節的「聲明」1 中。

執行任何指示之前，請詳讀所有「注意」及「危險」的聲明。

### 聲明 1



#### 危險

電源、電話及通信電纜上所產生的電流均有危險性。

欲避免電擊危險：

- 在雷雨期間，請勿連接或切斷本產品上的任何電纜線，或安裝、維修及重新架構本產品。
- 請將電源線接至接線及接地正確的電源插座。
- 請將本產品隨附的設備連接至接線正確的插座。
- 儘可能使用單手來連接或切斷信號電纜線。
- 當設備有火燒或泡水的痕跡，或有結構性損害時，請勿開啓該設備的電源。
- 在安裝及架構之時，若非非常熟悉，在開啓裝置蓋子之前，請切斷電源線、電信系統、網路及數據機。
- 在安裝、移動本產品或附加裝置，或開啓其蓋子時，請依照下表中「連接」及「切斷」電纜線的步驟執行。

#### 連接：

1. 關閉所有開關。
2. 先將所有電纜線接上裝置。
3. 將信號電纜接上接頭。
4. 再將電源線接上電源插座。
5. 開啓裝置的電源。

#### 切斷：

1. 關閉所有開關。
2. 先自電源插座拔掉電源線。
3. 拔掉接頭上的所有信號電纜。
4. 再拔掉裝置上的所有電纜線。

### 聲明 2



#### 注意：

更換鋰電池時，只可使用 IBM 零件編號 33F8354 的電池，或製造商建議之相當類型的電池。若系統中具有包含鋰電池的模組，在更換此模組時，請使用相同廠商製造的相同模組類型。如未正確使用、處理或丟棄含有鋰的電池時，可能會引發爆炸。

請勿將電池：

- 丟入或浸入水中
- 加熱超過 100 °C (212 °F)
- 修理或拆開

請遵照當地法令規章處理廢棄電池。

### 聲明 3



注意：

安裝雷射產品(如 CD-ROM、DVD 光碟機、光纖裝置或發射器)時，請注意下列事項：

- 請勿移開蓋子。移開雷射產品的蓋子，您可能會暴露於危險的雷射輻射之下。裝置中沒有需要維修的組件。
- 不依此處所指示的控制、調整或處理步驟，您可能會暴露於危險的輻射之下。



危險

有些雷射產品含有內嵌式 Class 3A 或 Class 3B 雷射二極體。請注意下列事項：

開啓時會產生雷射輻射。請勿凝視光束，不要使用光學儀器直接觀察，且應避免直接暴露在光束下。

### 聲明 4



≥ 18 公斤 (37 磅) ≥ 32 公斤 (70.5 磅) ≥ 55 公斤 (121.2 磅)

注意：

抬起裝置時，請注意安全措施。

### 聲明 5



注意：

裝置上的電源控制按鈕及電源供應器上的電源開關均無法關閉裝置上的電流。

本裝置可能有一條以上的電源線。如要移除裝置上的所有電流，請確認所有電源線已與電源分離。



聲明 10



注意：

請勿將任何重量超過 82 公斤 (180 磅) 的物品置於已安裝機架的裝置上方。



>82 公斤 (180 磅)



## Important:

Toutes les consignes Attention et Danger indiquées dans la bibliothèque IBM documentation sont précédées d'un numéro. Ce dernier permet de mettre en correspondance la consigne en anglais avec ses versions traduites dans la présente section.

Par exemple, si une consigne de type Attention est précédée du chiffre 1, ses traductions sont également précédées du chiffre 1 dans la présente section.

Prenez connaissance de toutes les consignes de type Attention et Danger avant de procéder aux opérations décrites par les instructions.

Notice n° 1



## DANGER

Le courant électrique passant dans les câbles de communication, ou les cordons téléphoniques et d'alimentation peut être dangereux.

Pour éviter tout risque de choc électrique:

- Ne manipulez aucun câble et n'effectuez aucune opération d'installation, d'entretien ou de reconfiguration de ce produit au cours d'un orage.
- Branchez tous les cordons d'alimentation sur un socle de prise de courant correctement câblé et mis à la terre.
- Branchez sur des socles de prise de courant correctement câblés tout équipement connecté à ce produit.
- Lorsque cela est possible, n'utilisez qu'une seule main pour connecter ou déconnecter les câbles d'interface.
- Ne mettez jamais un équipement sous tension en cas d'incendie ou d'inondation, ou en présence de dommages matériels.
- Avant de retirer les carters de l'unité, mettez celle-ci hors tension et déconnectez ses cordons d'alimentation, ainsi que les câbles qui la relient aux réseaux, aux systèmes de télécommunication et aux modems (sauf instruction contraire mentionnée dans les procédures d'installation et de configuration).
- Lorsque vous installez ou que vous déplacez le présent produit ou des périphériques qui lui sont raccordés, reportez-vous aux instructions ci-dessous pour connecter et déconnecter les différents cordons.

Connexion	Déconnexion
1. Mettez les unités hors tension.	1. Mettez les unités hors tension.
2. Commencez par brancher tous les cordons sur les unités.	2. Débranchez les cordons d'alimentation des prises.
3. Branchez les câbles d'interface sur des connecteurs.	3. Débranchez les câbles d'interface des connecteurs.
4. Branchez les cordons d'alimentation sur des prises.	4. Débranchez tous les câbles des unités.
5. Mettez les unités sous tension.	



Notice n° 2

**ATTENTION:**

Remplacez la pile au lithium usagée par une pile de référence identique exclusivement - voir la référence IBM - ou par une pile équivalente recommandée par le fabricant. Si votre système est doté d'un module contenant une pile au lithium, vous devez le remplacer uniquement par un module identique, produit par le même fabricant. La pile contient du lithium et présente donc un risque d'explosion en cas de mauvaise manipulation ou utilisation.

- Ne la jetez pas à l'eau.
- Ne l'exposez pas à une température supérieure à 100 °C.
- Ne cherchez pas à la réparer ou à la démonter.

Pour la mise au rebut, reportez-vous à la réglementation en vigueur.



Notice n° 3

**ATTENTION:**

Si des produits laser sont installés (tels que des unités de CD-ROM ou de DVD, des périphériques contenant des fibres optiques ou des émetteurs-récepteurs), prenez connaissance des informations suivantes:

- N'ouvrez pas ces produits pour éviter une exposition directe au rayon laser. Vous ne pouvez effectuer aucune opération de maintenance à l'intérieur.
- Pour éviter tout risque d'exposition au rayon laser, respectez les consignes de réglage et d'utilisation des commandes, ainsi que les procédures décrites dans le présent document.



**DANGER**

Certains produits laser contiennent une diode laser de classe 3A ou 3B. Prenez connaissance des informations suivantes:

Rayonnement laser lorsque le carter est ouvert. évitez de regarder fixement le faisceau ou de l'observer à l'aide d'instruments optiques. évitez une exposition directe au rayon.

Notice n° 4





≥18 kg (37 lbs)



≥32 kg (70.5 lbs)



≥55 kg (121.2 lbs)

**ATTENTION:**

Faites-vous aider pour soulever ce produit.

Notice n° 5



**ATTENTION:**

**Le bouton de mise sous tension/hors tension de l'unité et l'interrupteur d'alimentation du bloc d'alimentation ne coupent pas l'arrivée de courant électrique à l'intérieur de la machine. Il se peut que votre unité dispose de plusieurs cordons d'alimentation. Pour isoler totalement l'unité du réseau électrique, débranchez tous les cordons d'alimentation des socles de prise de courant.**



Notice n° 10



**ATTENTION:**

Ne posez pas d'objet dont le poids dépasse 82 kg sur les unités montées en armoire.

## Wichtig:

Alle Sicherheitshinweise in dieser IBM documentation beginnen mit einer Nummer. Diese Nummer verweist auf einen englischen Sicherheitshinweis mit den übersetzten Versionen dieses Hinweises in diesem Abschnitt.

Wenn z. B. ein Sicherheitshinweis mit der Nummer 1 beginnt, so erscheint die Übersetzung für diesen Sicherheitshinweis in diesem Abschnitt unter dem Hinweis 1.

Lesen Sie alle Sicherheitshinweise, bevor Sie eine Anweisung ausführen.

Hinweis 1



## VORSICHT

Elektrische Spannungen von Netz-, Telefon- und Datenübertragungsleitungen sind gefährlich.

Aus Sicherheitsgründen:

- Bei Gewitter an diesem Gerät keine Kabel anschließen oder lösen. Ferner keine Installations-, Wartungs- oder Rekonfigurationsarbeiten durchführen.
- Gerät nur an eine Schutzkontaktsteckdose mit ordnungsgemäß geerdetem Schutzkontakt anschließen.
- Alle angeschlossenen Geräte ebenfalls an Schutzkontaktsteckdosen mit ordnungsgemäß geerdetem Schutzkontakt anschließen.
- Signalkabel möglichst einhändig anschließen oder lösen.
- Keine Geräte einschalten, wenn die Gefahr einer Beschädigung durch Feuer, Wasser oder andere Einflüsse besteht.
- Die Verbindung zu den angeschlossenen Netzkabeln, Telekommunikationssystemen, Netzwerken und Modems ist vor dem Öffnen des Gehäuses zu unterbrechen. Es sei denn, dies ist in den zugehörigen Installations- und Konfigurationsprozeduren anders angegeben.
- Nur nach den nachfolgend aufgeführten Anweisungen arbeiten, die für Installation, Transport oder Öffnen von Gehäusen von Personal Computern oder angeschlossenen Einheiten gelten.

Kabel anschließen:	Kabel lösen:
<ol style="list-style-type: none"><li>1. Alle Geräte ausschalten und Netzstecker ziehen.</li><li>2. Zuerst alle Kabel an Einheiten anschließen.</li><li>3. Signalkabel an Anschlußbuchsen anschließen.</li><li>4. Netzstecker an Steckdose anschließen.</li><li>5. Gerät einschalten.</li></ol>	<ol style="list-style-type: none"><li>1. Alle Geräte ausschalten.</li><li>2. Zuerst Netzstecker von Steckdose lösen.</li><li>3. Signalkabel von Anschlußbuchsen lösen.</li><li>4. Alle Kabel von Einheiten lösen.</li></ol>

Hinweis 2



#### **ACHTUNG:**

Eine verbrauchte Batterie nur durch eine Batterie mit der IBM Teilenummer 33F8354 oder durch eine vom Hersteller empfohlene Batterie ersetzen. Wenn Ihr System ein Modul mit einer Lithium-Batterie enthält, ersetzen Sie es immer mit dem selben Modultyp vom selben Hersteller. Die Batterie enthält Lithium und kann bei unsachgemäßer Verwendung, Handhabung oder Entsorgung explodieren.

Die Batterie nicht:

- mit Wasser in Berührung bringen.
- über 100 C erhitzen.
- reparieren oder zerlegen.

Die örtlichen Bestimmungen für die Entsorgung von Sondermüll beachten.

Hinweis 3



#### **ACHTUNG:**

Wenn ein Laserprodukt (z. B. CD-ROM-Laufwerke, DVD-Laufwerke, Einheiten mit Glasfaserkabeln oder Transmitter) installiert ist, beachten Sie folgendes.

- Das Entfernen der Abdeckungen des CD-ROM-Laufwerks kann zu gefährlicher Laserstrahlung führen. Es befinden sich keine Teile innerhalb des CD-ROM-Laufwerks, die vom Benutzer gewartet werden müssen. Die Verkleidung des CD-ROM-Laufwerks nicht öffnen.
- Steuer- und Einstellelemente sowie Verfahren nur entsprechend den Anweisungen im vorliegenden Handbuch einsetzen. Andernfalls kann gefährliche Laserstrahlung auftreten.



#### **VORSICHT**

Manche CD-ROM-Laufwerke enthalten eine eingebaute Laserdiode der Klasse 3A oder 3B. Die nachfolgend aufgeführten Punkte beachten.

Laserstrahlung bei geöffneter Tür. Niemals direkt in den Laserstrahl sehen, nicht direkt mit optischen Instrumenten betrachten und den Strahlungsbereich meiden.

Hinweis 4





≥18 kg



≥32 kg



≥55 kg

**ACHTUNG:**

Beim Anheben der Maschine die vorgeschriebenen Sicherheitsbestimmungen beachten.

Hinweis 5



**ACHTUNG:**

Mit dem Betriebsspannungsschalter an der Vorderseite des Servers und dem Betriebsspannungsschalter am Netzteil wird die Stromversorgung für den Server nicht unterbrochen. Der Server könnte auch mehr als ein Netzkabel aufweisen. Um die gesamte Stromversorgung des Servers auszuschalten, muß sichergestellt werden, daß alle Netzkabel aus den Netzsteckdosen herausgezogen wurden.



Hinweis 10



**ACHTUNG:**



Keine Gegenstände, die mehr als 82 kg wiegen, auf Rack-Einheiten ablegen.

## Importante:

Tutti gli avvisi di attenzione e di pericolo riportati nella pubblicazione IBM documentation iniziano con un numero. Questo numero viene utilizzato per confrontare avvisi di attenzione o di pericolo in inglese con le versioni tradotte riportate in questa sezione.

Ad esempio, se un avviso di attenzione inizia con il numero 1, la relativa versione tradotta è presente in questa sezione con la stessa numerazione.

Prima di eseguire una qualsiasi istruzione, accertarsi di leggere tutti gli avvisi di attenzione e di pericolo.

Avviso 1



## PERICOLO

La corrente elettrica circolante nei cavi di alimentazione, del telefono e di segnale è pericolosa.

Per evitare il pericolo di scosse elettriche:

- Non collegare o scollegare i cavi, non effettuare l'installazione, la manutenzione o la riconfigurazione di questo prodotto durante i temporali.
- Collegare tutti i cavi di alimentazione ad una presa elettrica correttamente cablata e munita di terra di sicurezza.
- Collegare qualsiasi apparecchiatura collegata a questo prodotto ad una presa elettrica correttamente cablata e munita di terra di sicurezza.
- Quando possibile, collegare o scollegare i cavi di segnale con una sola mano.
- Non accendere qualsiasi apparecchiatura in presenza di fuoco, acqua o se sono presenti danni all'apparecchiatura stessa.
- Scollegare i cavi di alimentazione, i sistemi di telecomunicazioni, le reti e i modem prima di aprire i coperchi delle unità, se non diversamente indicato nelle procedure di installazione e configurazione.
- Collegare e scollegare i cavi come descritto nella seguente tabella quando si effettuano l'installazione, la rimozione o l'apertura dei coperchi di questo prodotto o delle unità collegate.

Per collegare:	Per scollegare:
1. SPEGNERE tutti i dispositivi.	1. SPEGNERE tutti i dispositivi.
2. Collegare prima tutti i cavi alle unità.	2. Rimuovere prima i cavi di alimentazione dalle prese elettriche.
3. Collegare i cavi di segnale ai connettori.	3. Rimuovere i cavi di segnale dai connettori.
4. Collegare i cavi di alimentazione alle prese elettriche.	4. Rimuovere tutti i cavi dalle unità.
5. ACCENDERE le unità.	

Avviso 2



**ATTENZIONE:**

Quando si sostituisce la batteria al litio, utilizzare solo una batteria IBM con numero parte 33F8354 o batterie dello stesso tipo o di tipo equivalente consigliate dal produttore. Se il sistema di cui si dispone è provvisto di un modulo contenente una batteria al litio, sostituire tale batteria solo con un tipo di modulo uguale a quello fornito dal produttore. La batteria contiene litio e può esplodere se utilizzata, maneggiata o smaltita impropriamente.

Evitare di:

- Gettarla o immergerla in acqua
- Riscaldarla ad una temperatura superiore ai 100°C
- Cercare di ripararla o smontarla

Smaltire secondo la normativa in vigore (D.Lgs 22 del 5/2/9) e successive disposizioni nazionali e locali.

Avviso 3



**ATTENZIONE:**

Quando si installano prodotti laser come, ad esempio, le unità DVD, CD-ROM, a fibre ottiche o trasmettitori, prestare attenzione a quanto segue:

- Non rimuovere i coperchi. L'apertura dei coperchi di prodotti laser può determinare l'esposizione a radiazioni laser pericolose. All'interno delle unità non vi sono parti su cui effettuare l'assistenza tecnica.
- L'utilizzo di controlli, regolazioni o l'esecuzione di procedure non descritti nel presente manuale possono provocare l'esposizione a radiazioni pericolose.



**PERICOLO**

Alcuni prodotti laser contengono all'interno un diodo laser di Classe 3A o Classe 3B. Prestare attenzione a quanto segue:

Aperto l'unità vengono emesse radiazioni laser. Non fissare il fascio, non guardarlo direttamente con strumenti ottici ed evitare l'esposizione diretta al fascio.

Avviso 4





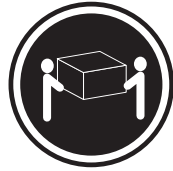

≥18 kg



≥32 kg



≥55 kg

**ATTENZIONE:**

Durante il sollevamento della macchina seguire delle norme di sicurezza.

Avviso 5



**ATTENZIONE:**

Il pulsante del controllo dell'alimentazione situato sull'unità e l'interruttore di alimentazione posto sull'alimentatore non disattiva la corrente elettrica fornita all'unità. L'unità potrebbe disporre di più di un cavo di alimentazione. Per disattivare la corrente elettrica dall'unità, accertarsi che tutti i cavi di alimentazione siano scollegati dalla sorgente di alimentazione.



Avviso 10



**ATTENZIONE:**



Non poggiare oggetti che pesano più di 82 kg sulla parte superiore delle unità montate in rack.

## 중요:

본 *Server Library*에 있는 모든 주의 및 위험 경고문은 번호로 시작합니다. 이 번호는 영문 주의 혹은 위험 경고문과 이 절에 나오는 번역된 버전의 주의 혹은 위험 경고문을 상호 참조하는 데 사용됩니다.

예를 들어, 주의 경고문이 번호 1로 시작하면, 번역된 해당 주의 경고문을 본 절의 경고문 1에서 찾아볼 수 있습니다.

모든 지시사항을 수행하기 전에 반드시 모든 주의 및 위험 경고문을 읽으십시오.

### 경고문 1



위험

전원, 전회 및 통신 케이블로부터 흘러 나오는 전류는 위험합니다.

전기 충격을 피하려면:

- 뇌우를 동반할 때는 케이블의 연결이나 철수, 이 제품의 설치, 유지보수 또는 재구성을 하지 마십시오.
- 모든 전원 코드를 적절히 배선 및 접지해야 합니다.
- 이 제품에 연결될 모든 장비를 적절하게 배선된 콘센트에 연결하십시오.
- 가능한 한 신호 케이블을 한 손으로 연결하거나 끊으십시오.
- 화재, 수해 또는 구조상의 손상이 있을 경우 장비를 켜지 마십시오.
- 설치 및 구성 프로시저에 다른 설명이 없는 한, 장치 덮개를 열기 전에 연결된 전원 코드, 원거리 통신 시스템, 네트워크 및 모뎀을 끊어 주십시오.
- 제품 또는 접속된 장치를 설치, 이동 및 덮개를 열 때 다음 설명에 따라 케이블을 연결하거나 끊도록 하십시오.

연결하려면:	연결을 끊으려면:
1. 모든 스위치를 끕니다.	1. 모든 스위치를 끕니다.
2. 먼저 모든 케이블을 장치에 연결합니다.	2. 먼저 콘센트에서 전원 코드를 뽑습니다.
3. 신호 케이블을 커넥터에 연결합니다.	3. 신호 케이블을 커넥터에서 제거합니다.
4. 콘센트에 전원 코드를 연결합니다.	4. 장치에서 모든 케이블을 제거합니다.
5. 장치 스위치를 켭니다.	

### 경고문 2



주의:

리튬 배터리를 교체할 때는 IBM 부품 번호 33F8354 또는 제조업체에서 권장하는 동등한 유형의 배터리를 사용하십시오. 시스템에 리튬 배터리를 갖고 있는 모듈이 있으면 동일한 제조업체에서 생산된 동일한 모듈 유형으로 교체하십시오. 배터리에 리튬이 있을 경우 제대로 사용, 처리 또는 처분하지 않으면 폭발할 수 있습니다.

다음은 주의하십시오.

- 던지거나 물에 담그지 않도록 하십시오.
- 100°C(212°F) 이상으로 가열하지 마십시오.
- 수리하거나 분해하지 마십시오.

지역 법령이나 규정의 요구에 따라 배터리를 처분하십시오.

경고문 3



주의:  
레이저 제품(CD-ROMs, DVD 드라이브, 광 장치 또는 트랜스미터 등과 같은)이 설치되어 있을 경우 다음을 유의하십시오.

- 덮개를 제거하지 마십시오. 레이저 제품의 덮개를 제거했을 경우 위험한 레이저 광선에 노출될 수 있습니다. 이 장치 안에는 서비스를 받을 수 있는 부품이 없습니다.

- 여기에서 지정하지 않은 방식의 제어, 조절 또는 실행으로 인해 위험한 레이저 광선에 노출될 수 있습니다.



위험

일부 레이저 제품에는 클래스 3A 또는 클래스 3B 레이저 다이오드가 들어 있습니다. 다음을 주의하십시오.

열면 레이저 광선에 노출됩니다. 광선을 주시하거나 광학 기계를 직접 쳐다보지 않도록 하고 광선에 노출되지 않도록 하십시오.

경고문 4



≥ 18 kg (37 lbs)



≥ 32 kg (70.5 lbs)



≥ 55 kg (121.2 lbs)

주의:

기계를 들 때는 안전하게 들어 올리십시오.

경고문 5



주의:

장치의 전원 제어 버튼 및 전원 공급기의 전원 스위치는 장치에 공급되는 전류를 차단하지 않습니다. 장치에 둘 이상의 전원 코드가 연결되어 있을 수도 있습니다. 장치에서 모든 전류를 차단하려면 모든 전원 코드가 전원으로부터 차단되어 있는지 확인하십시오.



경고문 10



주의:  
서랍형 모델의 장치 상단에 82 kg(180 lbs.)이 넘는 물체를 올려  
놓지 마십시오.



>82 kg (180 lbs)

### Importante:

Todas las declaraciones de precaución de esta IBM documentation empiezan con un número. Dicho número se emplea para establecer una referencia cruzada de una declaración de precaución o peligro en inglés con las versiones traducidas que de dichas declaraciones pueden encontrarse en esta sección.

Por ejemplo, si una declaración de peligro empieza con el número 1, las traducciones de esta declaración de precaución aparecen en esta sección bajo Declaración 1.

Lea atentamente todas las declaraciones de precaución y peligro antes de llevar a cabo cualquier operación.

Declaración 1



### PELIGRO

La corriente eléctrica de los cables telefónicos, de alimentación y de comunicaciones es perjudicial.

Para evitar una descarga eléctrica:

- No conecte ni desconecte ningún cable ni realice las operaciones de instalación, mantenimiento o reconfiguración de este producto durante una tormenta.
- Conecte cada cable de alimentación a una toma de alimentación eléctrica con conexión a tierra y cableado correctos.
- Conecte a tomas de alimentación con un cableado correcto cualquier equipo que vaya a estar conectado a este producto.
- Si es posible, utilice una sola mano cuando conecte o desconecte los cables de señal.
- No encienda nunca un equipo cuando haya riesgos de incendio, de inundación o de daños estructurales.
- Desconecte los cables de alimentación, sistemas de telecomunicaciones, redes y módems conectados antes de abrir las cubiertas del dispositivo a menos que se indique lo contrario en los procedimientos de instalación y configuración.
- Conecte y desconecte los cables tal como se describe en la tabla siguiente cuando desee realizar una operación de instalación, de traslado o de apertura de las cubiertas para este producto o para los dispositivos conectados.

Para la conexión	Para la desconexión
<ol style="list-style-type: none"><li>1. APÁGUELO todo.</li><li>2. En primer lugar, conecte los cables a los dispositivos.</li><li>3. Conecte los cables de señal a los conectores.</li><li>4. Conecte cada cable de alimentación a la toma de alimentación.</li><li>5. ENCIENDA el dispositivo.</li></ol>	<ol style="list-style-type: none"><li>1. APÁGUELO todo.</li><li>2. En primer lugar, retire cada cable de alimentación de la toma de alimentación.</li><li>3. Retire los cables de señal de los conectores.</li><li>4. Retire los cables de los dispositivos.</li></ol>

## Declaración 2



### **PRECAUCIÓN:**

Cuando desee sustituir la batería de litio, utilice únicamente el número de pieza 33F8354 de IBM o cualquier tipo de batería equivalente que recomiende el fabricante. Si el sistema tiene un módulo que contiene una batería de litio, sustitúyalo únicamente por el mismo tipo de módulo, que ha de estar creado por el mismo fabricante. La batería contiene litio y puede explotar si el usuario no la utiliza ni la maneja de forma adecuada o si no se desprende de la misma como corresponde.

No realice las acciones siguientes:

- Arrojarla al agua o sumergirla
- Calentarla a una temperatura que supere los 100°C (212°F)
- Repararla o desmontarla

Despréndase de la batería siguiendo los requisitos que exija el reglamento o la legislación local.

## Declaración 3



### **PRECAUCIÓN:**

Cuando instale productos láser (como, por ejemplo, CD-ROM, unidades DVD, dispositivos de fibra óptica o transmisores), tenga en cuenta las advertencias siguientes:

- No retire las cubiertas. Si retira las cubiertas del producto láser, puede quedar expuesto a radiación láser perjudicial. Dentro del dispositivo no existe ninguna pieza que requiera mantenimiento.
- El uso de controles o ajustes o la realización de procedimientos que no sean los que se han especificado aquí pueden dar como resultado una exposición perjudicial a las radiaciones.



### **PELIGRO**

Algunos productos láser contienen un diodo de láser incorporado de Clase 3A o de Clase 3B. Tenga en cuenta la advertencia siguiente.

Cuando se abre, hay radiación láser. No mire fijamente el rayo ni lleve a cabo ningún examen directamente con instrumentos ópticos; evite la exposición directa al rayo.

## Declaración 4



≥18 kg



≥32 kg

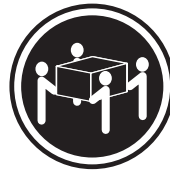

≥55 kg

### PRECAUCIÓN:

Tome medidas de seguridad al levantar el producto.

Declaración 5



### PRECAUCIÓN:

El botón de control de alimentación del dispositivo y el interruptor de alimentación de la fuente de alimentación no apagan la corriente eléctrica suministrada al dispositivo. Es posible también que el dispositivo tenga más de un cable de alimentación. Para eliminar la corriente eléctrica del dispositivo, asegúrese de desconectar todos los cables de alimentación de la fuente de alimentación.



Declaración 10



### PRECAUCIÓN:



No coloque ningún objeto que pese más de 82 kg (180 libras) encima de los dispositivos montados en bastidor.

---

## Send us your comments!

We want to know your opinion about this manual (part number 24P2927). Your input will help us to improve our publications.

Please photocopy this survey, complete it, and then fax it to **IBM HMM Survey at 919-543-8167 (USA)**.

Name: \_\_\_\_\_

Phone number: \_\_\_\_\_

1. Do you like this manual?

Yes  No

\_\_\_\_\_

\_\_\_\_\_

2. What would you like to see added, changed, or deleted in this manual?

\_\_\_\_\_

\_\_\_\_\_

3. What is your service experience level?

Less than five years

More than five years

4. Which servers do you service most?

\_\_\_\_\_

\_\_\_\_\_

\_\_\_\_\_

**Thank you for your response!**



---

## Problem determination tips

Due to the variety of hardware and software combinations that can be encountered, use the following information to assist you in problem determination. If possible, have this information available when requesting assistance from Service Support and Engineering functions.

- Machine type and model
- Processor or hard disk upgrades
- Failure symptom
  - Do diagnostics fail?
  - What, when, where, single, or multiple systems?
  - Is the failure repeatable?
  - Has this configuration ever worked?
  - If it has been working, what changes were made prior to it failing?
  - Is this the original reported failure?
- Reference/Diagnostics version
  - Type and version level
- Hardware configuration
  - Print (print screen) configuration currently in use
  - BIOS level
- Operating system software
  - Type and version level

**Note:** To eliminate confusion, identical systems are considered identical only if they:

1. Are the exact machine type and models
2. Have the same BIOS level
3. Have the same adapters/attachments in the same locations
4. Have the same address jumpers/terminators/cabling
5. Have the same software versions and levels
6. Have the same Reference/Diagnostics Diskette (version)
7. Have the same configuration options set in the system
8. Have the same setup for the operation system control files

Comparing the configuration and software set-up between "working and non-working" systems will often lead to problem resolution.

---

## Notices

References in this publication to IBM products, programs, or services do not imply that IBM intends to make these available in all countries in which IBM operates. Any reference to an IBM product, program, or service is not intended to state or imply that only that IBM product, program, or service may be used. Subject to IBM's valid intellectual property or other legally protectable rights, any functionally equivalent product, program, or service may be used instead of the IBM product, program, or service. The evaluation and verification of operation in conjunction with other products, except those expressly designated by IBM, are the responsibility of the user.

IBM makes no representations or warranties regarding non-IBM products. For non-IBM software, third-party software licenses may apply.

GHz, MHz only measures microprocessor internal clock speed, not application performance. Many factors affect application performance.

When referring to hard disk drive capacity, GB equals one billion bytes. Total user-accessible capacity may vary depending on operating environments.

IBM makes no warranties, express or implied, regarding non-IBM products and services that are ServerProven, including but not limited to the implied warranties of merchantability and fitness for particular purpose. These products are offered and warranted solely by third parties.

---

## Trademarks

The following terms are trademarks of the IBM Corporation in the United States, other countries, or both:

Alert on LAN	OS/2 Warp
EtherJet	ServeRAID
e-business logo	ServerGuide
HelpCenter	ServerProven
HelpWare	TechConnect
HelpCenter	Tivoli
IBM	Update Connector
OS/2	Wake on LAN
NetView	xSeries

Lotus and Domino are trademarks of Lotus Development Corporation in the United States, other countries, or both.

Intel, MMX, LANDesk, Pentium, Pentium II Xeon, Celeron and Pentium III Xeon are trademarks of Intel Corporation in the United States, other countries, or both.

Microsoft, Windows, and Windows NT are trademarks of Microsoft Corporation in the United States, other countries, or both.

UNIX is a registered trademark of The Open Group in the United States and other countries.

Java and all Java-based trademarks and logos are trademarks or registered trademarks of Sun Microsystems, Inc. in the United States, other countries, or both.

Other company, product, and service names may be trademarks or service marks of others.





Part Number: 24P2927

(1P) P/N: 24P2927

