



 eServer

iSeries 270, 8xx

Upgrading the System Unit from
Twinaxial Console to Operations
Console (Features 5544, 5546, 5548)

Version 5





@server

iSeries 270, 8xx

Upgrading the System Unit from
Twinaxial Console to Operations
Console (Features 5544, 5546, 5548)

Version 5

Note

Before using this information and the product it supports, be sure to read the information in "Notices," on page 19.

Fourth Edition (August 2005)

This edition applies to version 5, release 3, modification 0 of IBM Operating System/400[®] (product number 5722-SS1) and to all subsequent releases and modifications until otherwise indicated in new editions. This version does not run on all reduced instruction set computer (RISC) models nor does it run on CISC models.

© Copyright International Business Machines Corporation 2000, 2005. All rights reserved.

US Government Users Restricted Rights – Use, duplication or disclosure restricted by GSA ADP Schedule Contract with IBM Corp.

Contents

Upgrade twinaxial console to Operations

Console 1

Before you begin 1

Powering off the system unit 2

Selecting Operations Console as the console device 3

Connecting the Operations Console cable 4

System-unit control panel 7

Unit covers 9

270, 800, 810 or 820 system units 9

825 system unit 10

830, 840, 870, 890, SB2, SB3, 5074, 5079, and 5094 units 10

270 and 810 units in a rack 12

PCI card locations 15

270 system unit 15

820 system unit 16

830, 840, 890 system unit 17

Appendix. Notices 19

Trademarks 20

Terms and conditions for downloading and printing

publications 21

Code disclaimer information. 22

Electronic Emission Notices 22

 Federal Communications Commission (FCC)

 statement 22

Electronic Emission Notices 24

 Federal Communications Commission (FCC)

 statement 24

Upgrade twinaxial console to Operations Console

These instructions contain steps on how to upgrade your twinaxial console to an Operations Console.

If you are going to connect a remote control panel cable, ensure that you have the cable available before you begin this upgrade.

Install the Operations Console prerequisites on the personal computer (PC). See the Operations Console topic in the *Information Center* for prerequisites.

If you are installing LAN connectivity, go to the Operations Console topic in the *Information Center*.

You are changing the console device, the iSeries system value **QAUTOCFG** must be set to **ON**. Use the following to verify or set this system value on the iSeries:

- ___ 1. Enter **WRKSYSVAL QAUTOCFG** on an OS/400® command line and press Enter.
- ___ 2. Select **Change option** from the *Work with System Values* display and press Enter.
- ___ 3. Type **1 (ON)** from the *Change System Values* display and press Enter.
- ___ 4. The **Work with System Values** display appears. Press F3 once to return to the *Main Menu*.

Before you begin

Before you begin a replacement or installation task, follow these steps:

- ___ 1. **For an installation and if possible, for a replacement, ensure that you have a current backup of your system (including operating system, licensed programs, and data).** If you have backed up the operating system and licensed programs since the last time you applied PTFs, that backup is acceptable.
- ___ 2. Ensure that you take a few minutes to become familiar with these instructions.
- ___ 3. Ensure that you have access to a medium flat-bladed screwdriver.
- ___ 4. If there are incorrect, missing, or visibly damaged parts, contact one of the following:
 - Your authorized service provider
 - In the United States: IBM® Rochester Manufacturing Automated Information Line (R-MAIL) at 1-800-300-8751
 - In countries outside of the United States: Use the following Web site to locate your service and support numbers:
<http://www.ibm.com/planetwide>
- ___ 5. If you are installing new hardware in logical partitions, you need to plan and understand the requirements to be successful. Go to Logical partitions in the *Information Center*. Then return to these instructions.
- ___ 6. If you encounter difficulties during the procedure, contact your authorized service provider or your authorized dealer.

- ___ 7. Determine if there are any existing PTF prerequisites before you install your new feature. Go to the following Web site:
http://www-912.ibm.com/s_dir/slkbase.NSF/slkbase
 - a. Select **All Documents**.
 - b. Select **General Information**.
 - c. Select **Offerings**.
 - d. Select **Feature Prerequisites**.
 - e. Select **Customer Installation Features Prerequisites**.
 - f. Locate your feature number and OS/400 release, and check the prerequisites.

Powering off the system unit

- ___ 1. If an Integrated xSeries Adapter (IXA) is present on the system, shut it down using OS/400 options.
- ___ 2. Ensure that all jobs are complete.
- ___ 3. When all jobs are complete, type **pwrdownsys *immed** on a command line and press Enter.
- ___ 4. Is your system unit an iSeries 270, 800, 810 or 820 or 825?
 - ___ **270 or 810:** Continue with the next step.
 - ___ **820 or 825:** Go to step 7.
- ___ 5. Look at the Function/Data display on the control panel. Refer to "System-unit control panel" on page 7.
- ___ 6. Does **01 B M V=x** (x is either F or S) appear in the Function/Data display?
 - ___ **Yes:** Go to step 9 on page 3.
 - ___ **No:** Do the following:
 - ___ a. Press the Increment/Decrement push button until **02** appears in the Function/Data display.
 - ___ b. Press the Enter push button on the control panel.
 - ___ c. Press the Increment/Decrement push button until **B** appears in the Function/Data display.
 - ___ d. Press the Enter push button on the control panel.
 - ___ e. Press the Increment/Decrement push button until **M** appears in the Function/Data display.
 - ___ f. Press the Enter push button on the control panel.
 - ___ g. Press the Increment/Decrement push button until **S** appears in the Function/Data display.
 - ___ h. Press the Enter push button on the control panel.
 - ___ i. Press the Increment/Decrement push button until **01** appears in the Function/Data display.
 - ___ j. Press the Enter push button on the control panel.
01 B M S should appear in the Function/Data display. If it does not, repeat steps 6a through 6j.
 - ___ k. Go to step 9 on page 3.
- ___ 7. Look at the Function/Data display on the control panel.
- ___ 8. Does **01 B V=S** appear in the Function/Data display, and is the Manual mode indicator (a small hand) illuminated?
 - ___ **Yes:** Continue with the next step.

- ___ **No:** Do the following:
 - ___ a. Press the Mode Select button until the Manual mode indicator (a small hand) lights up.
 - ___ b. Press the Increment/Decrement push button until **02** appears in the Function/Data display.
 - ___ c. Press the Enter push button on the control panel.
 - ___ d. Press the Increment/Decrement push button until **B** appears in the Function/Data display.
 - ___ e. Press the Enter push button on the control panel.
 - ___ f. Press the Increment/Decrement push button until **S** appears in the Function/Data display
 - ___ g. Press the Enter push button on the control panel.
 - ___ h. Press the Increment/Decrement push button until **01** appears in the Function/Data display.
 - ___ i. Press the Enter push button on the control panel.
01 B S should appear in the Function/Display panel and the manual mode indicator (a small hand) lights up. If it does not appear, repeat steps 8a through 8h.
- ___ 9. Press the Power push button that is located on the control panel. There is approximately a 10-second delay before the power-on light comes on, and data appears in the Function/Data display.

Note: The system takes approximately 5 to 10 minutes to power on and complete an IPL. When the IPL is complete, the *IPL or Install the System* display should appear on your system unit console.

Selecting Operations Console as the console device

If you plan to select Operations Console (LAN), go to the Operations Console topic in the *Information Center*.

Use this section to select Operations Console (Direct) as the console device for your dial-up LCS. When the *IPL or Install the System* display appears:

- ___ 1. Select **Use Dedicated Service Tools (DST)** and press Enter.
- ___ 2. Use your current dedicated service tools password.
- ___ 3. Type **your service tools user ID and service tools password** for the *DST user* and the *DST password* on the *Dedicated Service Tools (DST) Sign On* display and press Enter.
- ___ 4. Select **Work with DST environment** from the *Use Dedicated Service Tools (DST)* display and press Enter.
- ___ 5. Select **System devices** from the *Work with DST Environment* display and press Enter.
- ___ 6. Select **Console mode** from the *Work with System Devices* display and press Enter.
- ___ 7. Select **Operations console (Direct)** from the *Select Console Type* display and press Enter.

Important: Make sure that you type 2 and press Enter even if 2 already exists. This forces a rewrite of the value.

If you selected LAN, go to the Operations Console topic in the *Information Center*.

- ___ 8. Press the F3 key until you return to the *Use Dedicated Service Tools (DST)* display.
- ___ 9. Select **Start a service tool** and press Enter.
- ___ 10. Select **Operator panel functions** and press Enter.
- ___ 11. Select the function key to power off the system (F10).
- ___ 12. Press Enter to confirm that you want to power down.
- ___ 13. Power off and unplug attached workstations and printers.

Connecting the Operations Console cable

- ___ 1. Remove the covers. Refer to “Unit covers” on page 9.
- ___ 2. **If possible, use a wrist strap to prevent electrostatic discharge from damaging your hardware.** If you do not have a wrist strap, touch a metal surface of the system or expansion unit before installing or replacing hardware.
If you received the 2209 Disposable Wrist Strap, follow these steps:
 - ___ a. Attach the disposable wrist strap.  View video.
 - ___ b. When you unroll the strap, remove the liner from the copper foil at the end.
 - ___ c. Attach the adhesive part of the copper foil to an **exposed, unpainted** metal surface on the frame of the unit.

Note: Follow the same precautions you would use without the wrist strap. The 2209 Disposable Wrist Strap is for static control. It will not increase or decrease your risk of receiving electric shock when using or working on electrical equipment.

- ___ 3. If you have a **270 System Unit**, locate position C07. See “PCI card locations” on page 15 for more information.
If you have a **820 System Unit**, locate position C06. See “PCI card locations” on page 15 for more information.
If you have a **830, 840, or 890 System Unit**, locate position C02. See “PCI card locations” on page 15 for more information.
- ___ 4. Connect the Operations Console cable **part number 97H7557** to the right connector on the 2771, 9771, 9793, 9799 card.
- ___ 5. Connect the other end of the cable to the first available serial port on your PC that will be used for Operations Console.
- ___ 6. Do you have a Remote Control Panel cable to connect?
 - ___ **No:** Continue with the next step.
 - ___ **Yes:** Connect the Remote Control Panel cable (the end with a missing pin) to the connector on the back of the system unit labeled **Debug**. Connect the other end of the Remote Control Panel cable (97H7591) to the parallel port on the back of the PC being used as the console. Continue with the next step.
- ___ 7. Install the system unit covers.

___ 8. DANGER

An electrical outlet that is not correctly wired could place hazardous voltage on metal parts of the system or the products that attach to the system. It is the customer's responsibility to ensure that the outlet is correctly wired and grounded to prevent an electrical shock. (RSFTD201)

Plug the following power cords into an electrical outlet.

- System unit

Note: Do **not** power on your system unit at this time.

- System unit console
- System expansion unit

___ 9. Power on the workstation or PC that is your console.

___ 10. Is your system unit a 270/810 or 820/825?

___ **270 or 810:** Continue with the next step.

___ **820 or 825:** Go to step 13.

___ 11. Look at the Function/Data display on the control panel.

___ 12. Does **01 B N V=S** appear in the Function/Data display?

___ **Yes:** Go to step 15 on page 6.

___ **No:** Do the following:

___ a. Press the Increment/Decrement push button until **02** appears in the Function/Data display.

___ b. Press the Enter push button on the control panel.

___ c. Press the Increment/Decrement push button until **B** appears in the Function/Data display.

___ d. Press the Enter push button on the control panel.

___ e. Press the Increment/Decrement push button until **N** appears in the Function/Data display.

___ f. Press the Enter push button on the control panel.

___ g. Press the Increment/Decrement push button until **S** appears in the Function/Data display.

___ h. Press the Enter push button on the control panel.

___ i. Press the Increment/Decrement push button until **01** appears in the Function/Data display.

___ j. Press the Enter push button on the control panel.

01 B N S should appear in the Function/Data display. If it does not, repeat steps 12a through 12i.

Go to step 15 on page 6.

___ 13. Look at the Function/Data display on the control panel.

___ 14. Does **01 B V=S** appear in the Function/Data display with IPL mode Normal (OK) selected?

• Yes: Continue with the next step.

• No: Do the following:

___ a. Press the Mode Select button until the manual mode indicator (a small hand) lights up.

___ b. Press the Increment/Decrement push button until **02** appears in the Function/Data display.

- ___ c. Press the Enter push button on the control panel.
 - ___ d. Press the Increment/Decrement push button until **B** appears in the Function/Data display.
 - ___ e. Press the Enter push button on the control panel.
 - ___ f. Press the Increment/Decrement push button until **S** appears in the Function/Data display
 - ___ g. Press the Enter push button on the control panel.
 - ___ h. Press the Mode Select button until the Normal indicator (**OK**) lights up.
 - ___ i. Press the Increment/Decrement push button until **01** appears in the Function/Data display.
 - ___ j. Press the Enter push button on the control panel.
01 B S should appear in the Function/Display display and **OK** lights up. If it does not appear, repeat steps 14a on page 5 through 14i.
- ___ 15. Press the Power push button that is located on the control panel. There is approximately a 10 second delay before the power-on light comes on, and data appears in the Function/Data display.
- Note:** The system takes approximately 5 to 20 minutes to power on and complete an IPL. When the IPL is complete, 01 B N S appears in the Function/Data display.
- ___ 16. Place the *iSeries Setup and Operations CD-ROM*, SK3T-4098-02, in your PC's CD-ROM drive and select the EZ-Setup Wizard option to set up your iSeries. Follow the installation prompts until completed.
- ___ 17. Plug in and power on all attached devices, such as printers and displays when Operations Console is operating.

System-unit control panel

Go to the front of your iSeries system unit. Open the control panel door.

Your control panel looks like either Figure 1 or Figure 2 on page 8. Refer to the control panel for your unit.

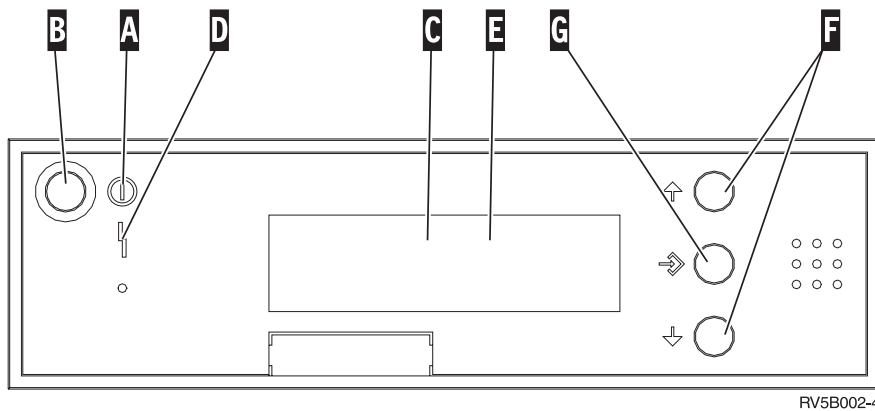

Figure 1. Control panel without Electronic Keystick

Following are the descriptions of the Figure 1 callouts:

- A** Power On Light
 - A blinking light indicates power to the unit.
 - A constant light indicates that the unit is on and working.
- B** Power Push button
- C** Processor Activity
- D** System Attention
- E** Function/Data Display
- F** Increment/Decrement buttons
- G** Enter Push button

If your control panel looks like Figure 2 on page 8, before you can use **F** Increment/Decrement buttons and **G** Enter push button, you need to press **H** Mode Selects to select Manual mode **N**. To use Mode Select, the keystick needs to be inserted.

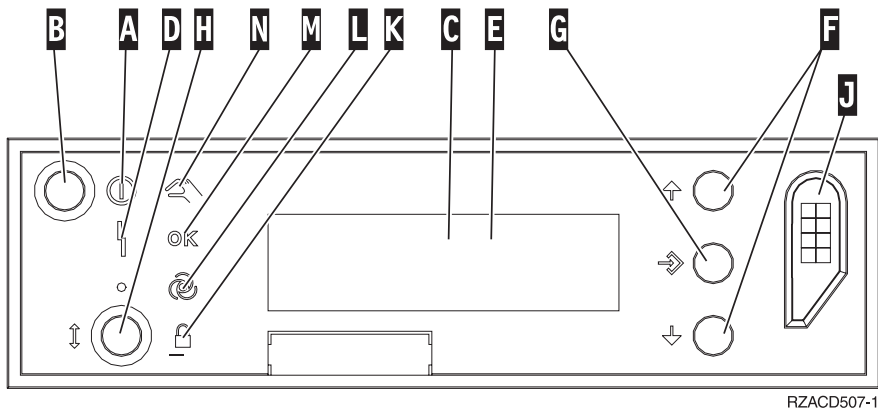

Figure 2. Control panel with Electronic Keystick

- A** Power On Light
 - A blinking light indicates power to the unit.
 - A constant light indicates that the unit is on and working.
- B** Power Push button
- C** Processor Activity
- D** System Attention
- E** Function/Data Display
- F** Increment/Decrement buttons
- G** Enter Push button
- H** Mode Selects
- J** Electronic Keystick Slot
- K** Secure
- L** Auto
- M** Normal
- N** Manual

Unit covers

Select your unit:

- “270, 800, 810 or 820 system units”
- “830, 840, 870, 890, SB2, SB3, 5074, 5079, and 5094 units” on page 10
- “270 and 810 units in a rack” on page 12

270, 800, 810 or 820 system units

To access the PCI card location, you need to remove the back cover, if you have one, and the side cover:

- ___ 1. Place your hand near the bottom of the back cover and lift up and out.
- ___ 2. **Attention:** If you are removing the side cover while the server is powered on, errors may occur due to electromagnetic interference.

Remove the right side cover (view from back) by loosening the thumbscrews and sliding the cover from front to back until it stops.

- ___ 3. Pull the cover out.

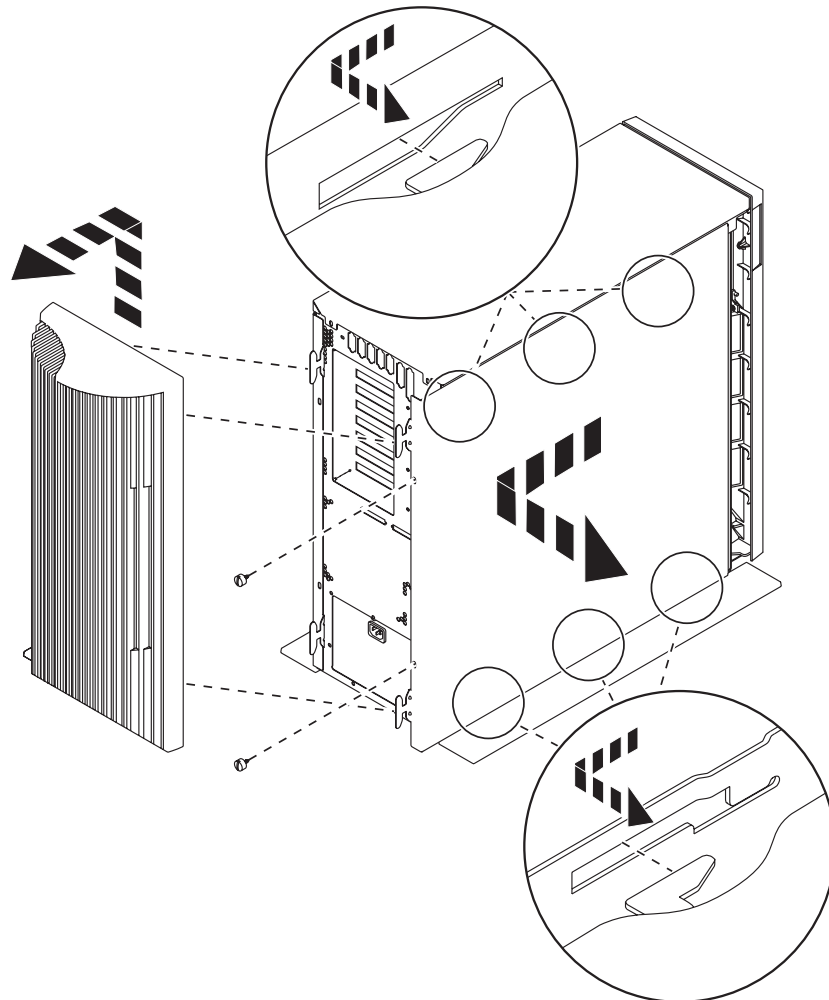

RZAQ2517-0

825 system unit

To access the PCI card location, you need to remove the back cover and the side cover:

- ___ 1. Place your hand near the bottom of the back cover and lift up and out.
- ___ 2. Remove the right side cover (view from back) by loosening the thumbscrews and sliding the cover from front to back until it stops.
- ___ 3. Pull the cover out.

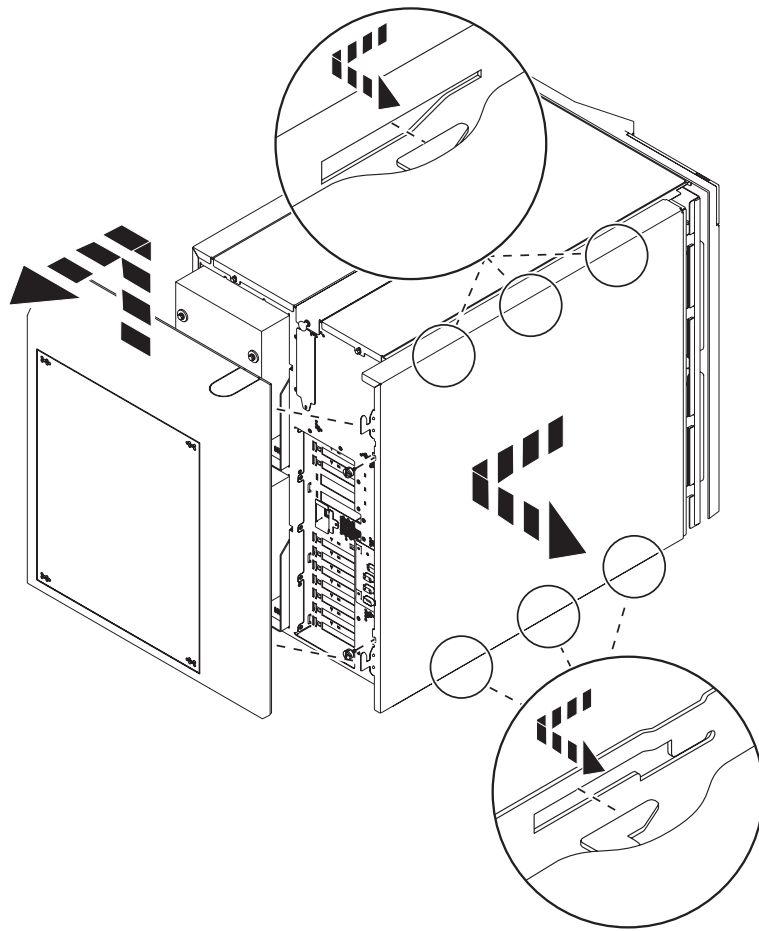

830, 840, 870, 890, SB2, SB3, 5074, 5079, and 5094 units

To access the PCI card location, you need to open the back cover:

- **A** Open the back cover.
- **B** Remove the back cover.
- Remove the PCI card access plate.

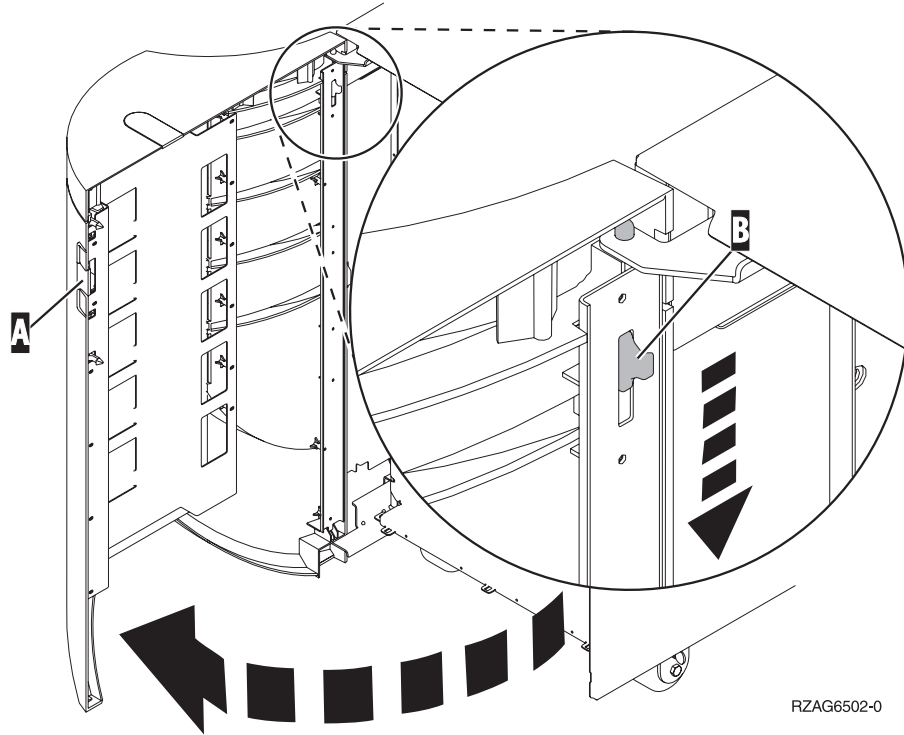

RZAG6502-0

270 and 810 units in a rack

1. Press latches **B** and pull the server out using the handle **C**.

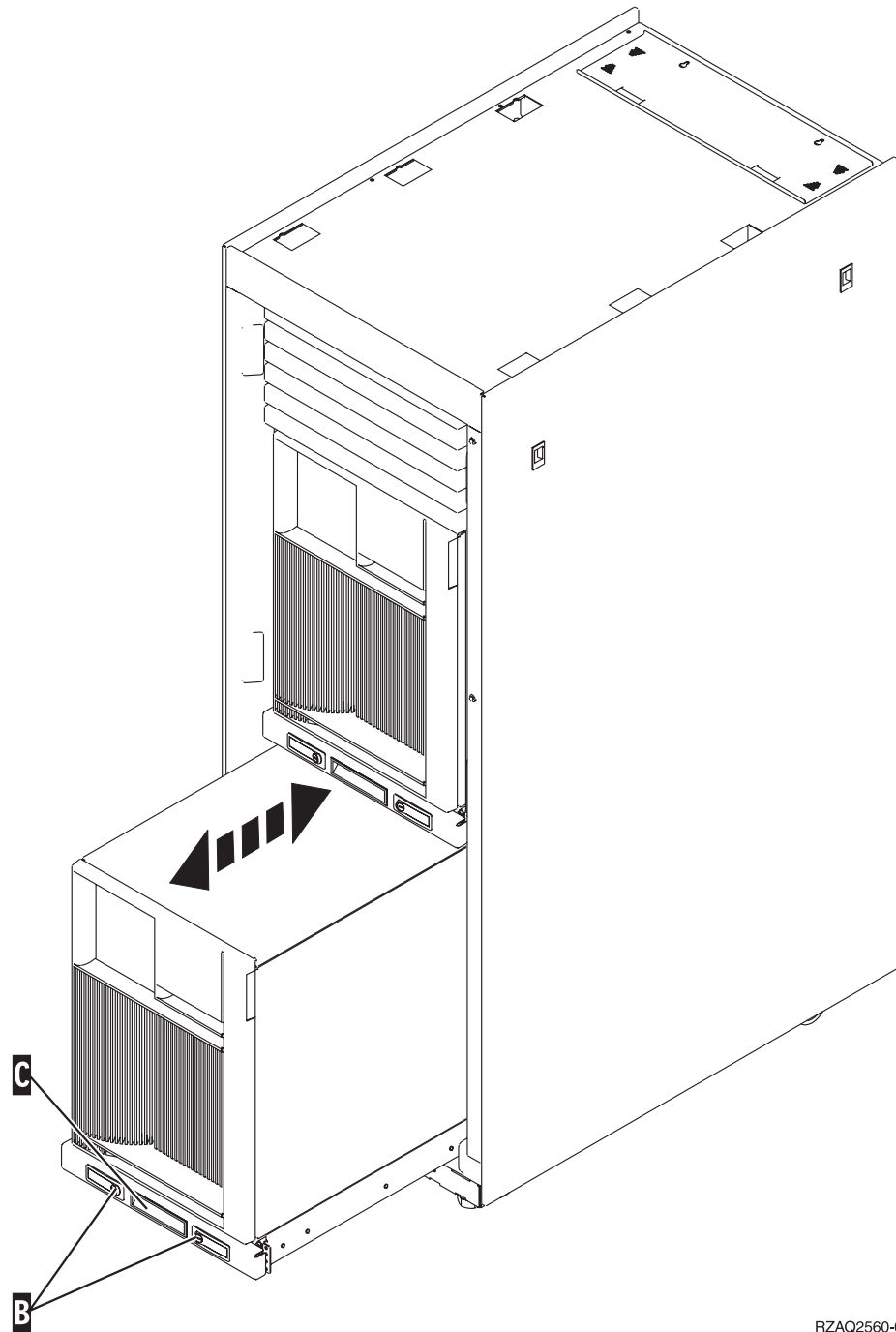

RZAQ2560-0

2. Refer to previous unit diagrams to remove the side cover.
3. If you are cabling the server, feed the excess cabling along the cable management arm **D** and secure the cables with the fasteners.

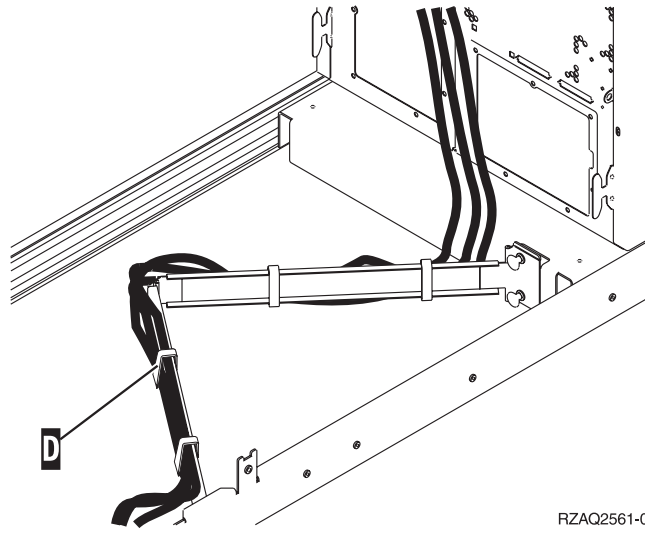

RZAQ2561-0

PCI card locations

Go to your system unit:

- “270 system unit”
- “820 system unit” on page 16
- “830, 840, 890 system unit” on page 17

270 system unit

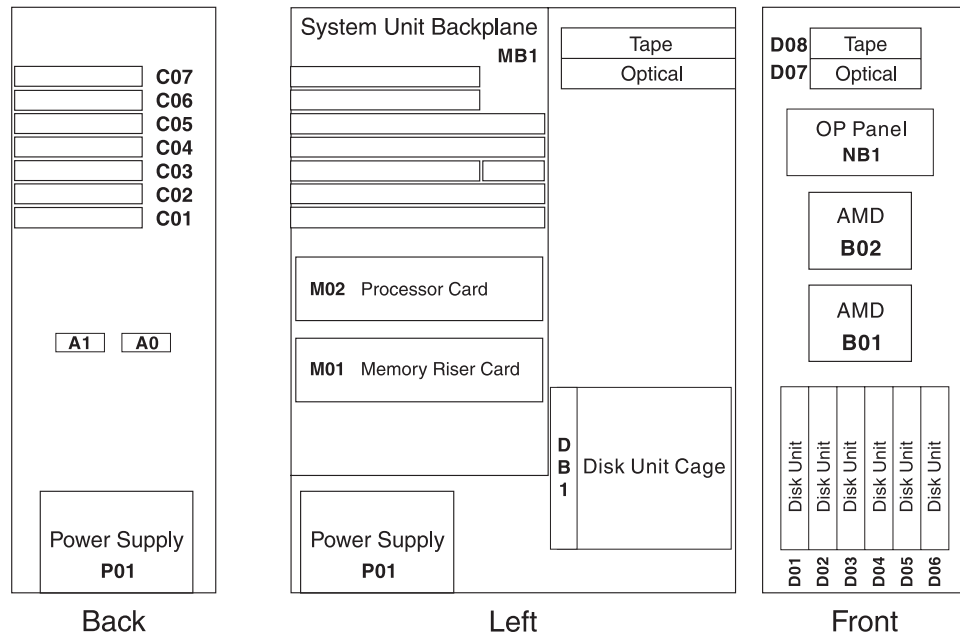

RZAQ2502-5

820 system unit

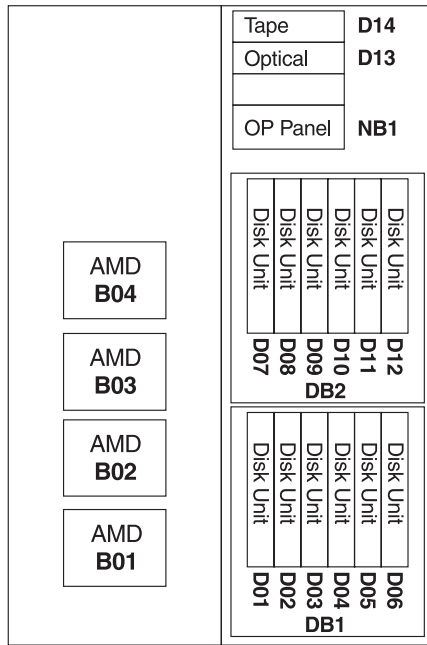

Front

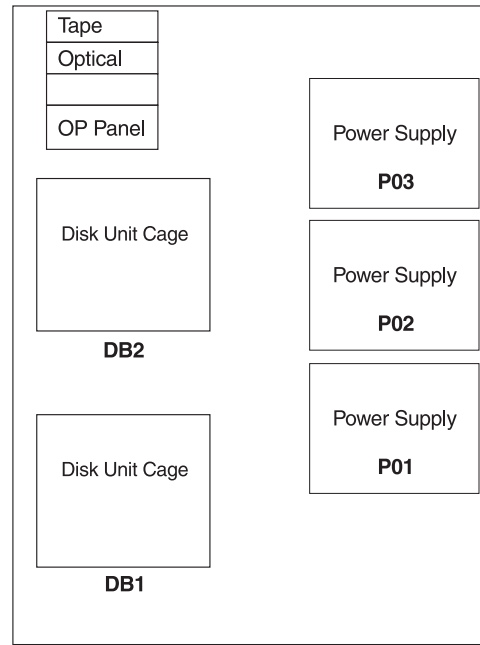

Right

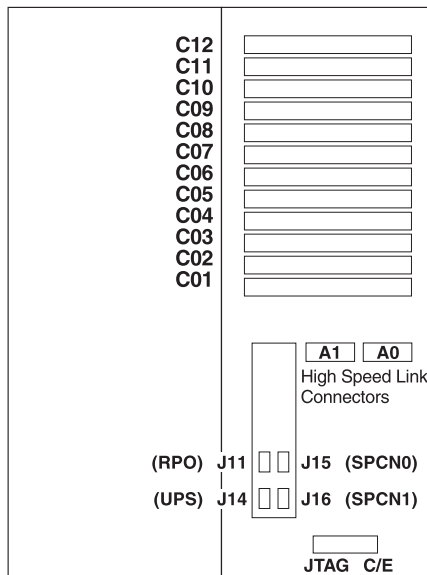

Back

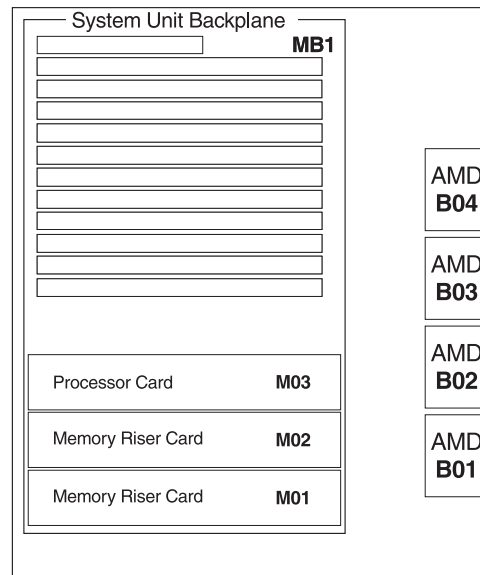

Left

RZAQ2503-6

830, 840, 890 system unit

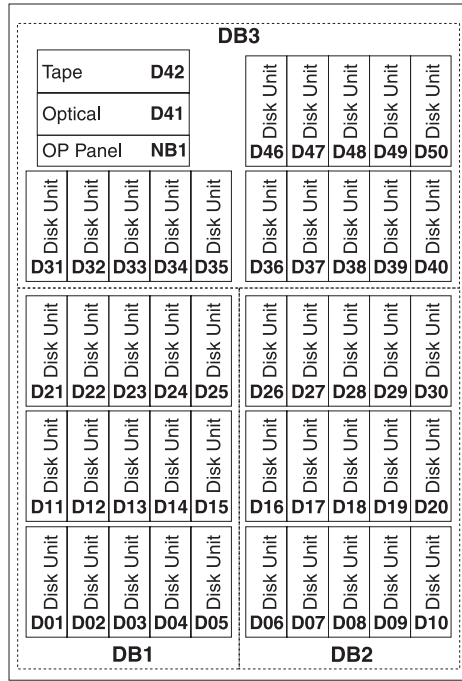

Front

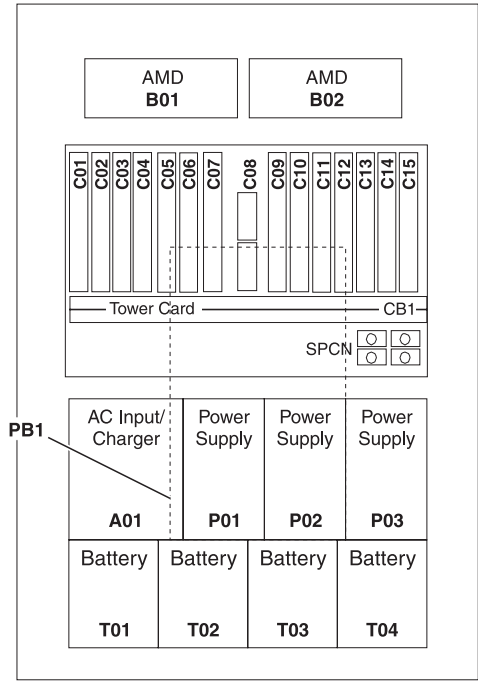

Back

RZAQ2507-4

Appendix. Notices

This information was developed for products and services offered in the U.S.A.

IBM may not offer the products, services, or features discussed in this document in other countries. Consult your local IBM representative for information on the products and services currently available in your area. Any reference to an IBM product, program, or service is not intended to state or imply that only that IBM product, program, or service may be used. Any functionally equivalent product, program, or service that does not infringe any IBM intellectual property right may be used instead. However, it is the user's responsibility to evaluate and verify the operation of any non-IBM product, program, or service.

IBM may have patents or pending patent applications covering subject matter described in this document. The furnishing of this document does not give you any license to these patents. You can send license inquiries, in writing, to:

IBM Director of Licensing
IBM Corporation
North Castle Drive
Armonk, NY 10504-1785
U.S.A.

The following paragraph does not apply to the United Kingdom or any other country where such provisions are inconsistent with local law:

INTERNATIONAL BUSINESS MACHINES CORPORATION PROVIDES THIS PUBLICATION "AS IS" WITHOUT WARRANTY OF ANY KIND, EITHER EXPRESS OR IMPLIED, INCLUDING, BUT NOT LIMITED TO, THE IMPLIED WARRANTIES OF NON-INFRINGEMENT, MERCHANTABILITY OR FITNESS FOR A PARTICULAR PURPOSE. Some states do not allow disclaimer of express or implied warranties in certain transactions, therefore, this statement may not apply to you.

This information could include technical inaccuracies or typographical errors. Changes are periodically made to the information herein; these changes will be incorporated in new editions of the publication. IBM may make improvements and/or changes in the product(s) and/or the program(s) described in this publication at any time without notice.

Any references in this information to non-IBM Web sites are provided for convenience only and do not in any manner serve as an endorsement of those Web sites. The materials at those Web sites are not part of the materials for this IBM product and use of those Web sites is at your own risk.

IBM may use or distribute any of the information you supply in any way it believes appropriate without incurring any obligation to you.

Any performance data contained herein was determined in a controlled environment. Therefore, the results obtained in other operating environments may vary significantly. Some measurements may have been made on development-level systems and there is no guarantee that these measurements will be the same on generally available systems. Furthermore, some measurements may have been estimated through extrapolation. Actual results may vary. Users of this document should verify the applicable data for their specific environment.

Information concerning non-IBM products was obtained from the suppliers of those products, their published announcements or other publicly available sources. IBM has not tested those products and cannot confirm the accuracy of performance, compatibility or any other claims related to non-IBM products. Questions on the capabilities of non-IBM products should be addressed to the suppliers of those products.

All statements regarding IBM's future direction or intent are subject to change or withdrawal without notice, and represent goals and objectives only.

All IBM prices shown are IBM's suggested retail prices, are current and are subject to change without notice. Dealer prices may vary.

This information is for planning purposes only. The information herein is subject to change before the products described become available.

This information contains examples of data and reports used in daily business operations. To illustrate them as completely as possible, the examples include the names of individuals, companies, brands, and products. All of these names are fictitious and any similarity to the names and addresses used by an actual business enterprise is entirely coincidental.

If you are viewing this information softcopy, the photographs and color illustrations may not appear.

The drawings and specifications contained herein shall not be reproduced in whole or in part without the written permission of IBM.

IBM has prepared this publication for use by hardware service representatives in the maintenance or repair of the specific machines indicated. IBM makes no representations that it is suitable for any other purpose.

The drawings and specifications contained herein shall not be reproduced in whole or in part without the written permission of IBM.

IBM has prepared this publication for use by customer personnel for operating and planning for the specific machines indicated. IBM makes no representations that it is suitable for any other purpose.

Trademarks

The following terms are trademarks of International Business Machines Corporation in the United States, other countries, or both:

Application System/400
AS/400
e (logo)
IBM
iSeries
Operating System/400
OS/400
400

Lotus, Freelance, and WordPro are trademarks of International Business Machines Corporation and Lotus Development Corporation in the United States, other countries, or both.

C-bus is a trademark of Corollary, Inc. in the United States, other countries, or both.

ActionMedia, LANDesk, MMX, Pentium, and ProShare are trademarks or registered trademarks of Intel Corporation in the United States, other countries, or both.

Microsoft, Windows, Windows NT, and the Windows logo are trademarks of Microsoft Corporation in the United States, other countries, or both.

SET and the SET Logo are trademarks owned by SET Secure Electronic Transaction LLC.

Java and all Java-based trademarks are trademarks of Sun Microsystems, Inc. in the United States, other countries, or both.

UNIX is a registered trademark of The Open Group in the United States and other countries.

Other company, product or service names may be trademarks or service marks of others.

Terms and conditions for downloading and printing publications

Permissions for the use of the publications you have selected for download are granted subject to the following terms and conditions and your indication of acceptance thereof.

Personal Use: You may reproduce these Publications for your personal, noncommercial use provided that all proprietary notices are preserved. You may not distribute, display or make derivative works of these Publications, or any portion thereof, without the express consent of IBM.

Commercial Use: You may reproduce, distribute and display these Publications solely within your enterprise provided that all proprietary notices are preserved. You may not make derivative works of these Publications, or reproduce, distribute or display these Publications or any portion thereof outside your enterprise, without the express consent of IBM.

Except as expressly granted in this permission, no other permissions, licenses or rights are granted, either express or implied, to the Publications or any information, data, software or other intellectual property contained therein.

IBM reserves the right to withdraw the permissions granted herein whenever, in its discretion, the use of the Publications is detrimental to its interest or, as determined by IBM, the above instructions are not being properly followed.

You may not download, export or re-export this information except in full compliance with all applicable laws and regulations, including all United States export laws and regulations. IBM MAKES NO GUARANTEE ABOUT THE CONTENT OF THESE PUBLICATIONS. THE PUBLICATIONS ARE PROVIDED "AS-IS" AND WITHOUT WARRANTY OF ANY KIND, EITHER EXPRESSED OR IMPLIED, INCLUDING BUT NOT LIMITED TO IMPLIED WARRANTIES OF MERCHANTABILITY AND FITNESS FOR A PARTICULAR PURPOSE

All material copyrighted by IBM Corporation.

By downloading or printing a publication from this site, you have indicated your agreement with these terms and conditions.

Code disclaimer information

This document contains programming examples.

IBM grants you a nonexclusive copyright license to use all programming code examples from which you can generate similar function tailored to your own specific needs.

All sample code is provided by IBM for illustrative purposes only. These examples have not been thoroughly tested under all conditions. IBM, therefore, cannot guarantee or imply reliability, serviceability, or function of these programs.

All programs contained herein are provided to you "AS IS" without any warranties of any kind. The implied warranties of non-infringement, merchantability and fitness for a particular purpose are expressly disclaimed.

Electronic Emission Notices

Federal Communications Commission (FCC) statement

Note: This equipment has been tested and found to comply with the limits for a Class A digital device, pursuant to Part 15 of the FCC Rules. These limits are designed to provide reasonable protection against harmful interference when the equipment is operated in a commercial environment. This equipment generates, uses, and can radiate radio frequency energy and, if not installed and used in accordance with the instruction manual, may cause harmful interference to radio communications. Operation of this equipment in a residential area is likely to cause harmful interference, in which case the user will be required to correct the interference at his own expense.

Properly shielded and grounded cables and connectors must be used in order to meet FCC emission limits. IBM is not responsible for any radio or television interference caused by using other than recommended cables and connectors or by unauthorized changes or modifications to this equipment. Unauthorized changes or modifications could void the user's authority to operate the equipment.

This device complies with Part 15 of the FCC rules. Operation is subject to the following two conditions: (1) this device may not cause harmful interference, and (2) this device must accept any interference received, including interference that may cause undesired operation.

Responsible Party:

International Business Machines Corporation
New Orchard Road
Armonk, NY 10504

Telephone: 1-919-543-2193

Industry Canada Compliance Statement

This Class A digital apparatus meets the requirements of the Canadian Interference-Causing Equipment Regulations.

Avis de conformité à la réglementation d'Industrie Canada

Cet appareil numérique de la classe A respecte toutes les exigences du Règlement sur le matériel brouilleur du Canada.

European Community Compliance Statement

This product is in conformity with the protection requirements of EU Council Directive 89/336/EEC on the approximation of the laws of the Member States relating to electromagnetic compatibility. IBM cannot accept responsibility for any failure to satisfy the protection requirements resulting from a non-recommended modification of the product, including the fitting of non-IBM option cards.

Australia and New Zealand Class A statement

Attention: This is a Class A product. In a domestic environment this product may cause radio interference in which case the user may be required to take adequate measures.

VCCI Statement - Japan

この装置は、クラス A 情報技術装置です。この装置を家庭環境で使用すると電波妨害を引き起こすことがあります。この場合には使用者が適切な対策を講ずるよう要求されることがあります。 V C C I - A

The following is a summary of the VCCI Japanese statement in the box above.

This is a Class A product based on the standard of the Voluntary Control Council for Interference by Information Technology Equipment (VCCI). If this equipment is used in a domestic environment, radio disturbance may arise. When such trouble occurs, the user may be required to take corrective actions.

Electromagnetic Interference (EMI) Statement - People's Republic of China

Per GB 9254-1998, the user manual for a Class A product must carry the following warning message (English translation from the Chinese standard) about use in a residential environment in Chinese (*Simplified Chinese*):

声 明
此为 A 级产品, 在生活环境中,
该产品可能会造成无线电干扰。
在这种情况下, 可能需要用户对其
干扰采取切实可行的措施。

Declaration: This is a Class A product. In a domestic environment this product may cause radio interference in which case the user may need to perform practical action.

Electromagnetic Interference (EMI) Statement - Taiwan

警告使用者：
這是甲類的資訊產品，在居住的環境中使用時，可能會造成射頻干擾，在這種情況下，使用者會被要求採取某些適當的對策。

The following is a summary of the EMI Taiwan statement above.

Warning: This is a Class A product. In a domestic environment this product may cause radio interference in which case the user will be required to take adequate measures.

Radio Protection for Germany

Dieses Gerät ist berechtigt in Übereinstimmung mit Dem deutschen EMVG vom 9.Nov.92 das EG-Konformitätszeichen zu führen.

Der Aussteller der Konformitätserklärung ist die IBM Germany.

Dieses Gerät erfüllt die Bedingungen der EN 55022 Klasse A. Für diese von Geräten gilt folgende Bestimmung nach dem EMVG:

Geräte dürfen an Orten, für die sie nicht ausreichend entstört sind, nur mit besonderer Genehmigung des Bundesministers für Post und Telekommunikation oder des Bundesamtes für Post und Telekommunikation betrieben werden. Die Genehmigung wird erteilt, wenn keine elektromagnetischen Störungen zu erwarten sind.

(Auszug aus dem EMVG vom 9.Nov.92, Para.3, Abs.4)

Hinweis

Dieses Genehmigungsverfahren ist von der Deutschen Bundespost noch nicht veröffentlicht worden.

Electronic Emission Notices

The following Statement applies to this IBM product. The statement for other IBM products intended for use with this product will appear in their accompanying manuals.

Federal Communications Commission (FCC) statement

Note: This equipment has been tested and found to comply with the limits for a class B digital device, pursuant to Part 15 of the FCC Rules. These limits are designed to provide reasonable protection against harmful interference in a residential installation. This equipment generates, uses, and can radiate radio frequency energy and, if not installed and used in accordance with the instructions, may cause harmful interference to radio communications. However, there is no guarantee that interference will not occur in a particular installation. If this equipment does cause harmful interference to radio or television reception, which can be determined by turning the equipment off and on, the user is encouraged to try to correct the interference by one or more of the following measures:

- Reorient or relocate the receiving antenna.
- Increase the separation between the equipment and receiver.
- Connect the equipment into an outlet on a circuit different from that to which the receiver is connected.
- Consult an IBM authorized dealer or service representative for help.

Properly shielded and grounded cables and connectors must be used in order to meet FCC emission limits. Proper cables and connectors are available from IBM authorized dealers. IBM is not responsible for any radio or television interference caused by using other than recommended cables or connectors or by unauthorized changes or modifications to this equipment. Unauthorized changes or modifications could void the user's authority to operate the equipment.

This device complies with Part 15 of the FCC Rules. Operation is subject to the following two conditions: (1) this device may not cause harmful interferences, and (2) this device must accept any interferences received, including interference that may cause undesired operation.

Responsible Party:

International Business Machines Corporation
New Orchard Road
Armonk, NY 10504

Telephone: 1-919-543-2193

Industry Canada Compliance Statement

This Class B digital apparatus meets the requirements of the Canadian Interference-Causing Equipment Regulations.

Avis de conformité à la réglementation d'Industrie Canada

Cet appareil numérique de la classe B respecte toutes les exigences du Règlement sur le matériel brouilleur du Canada.

European Community Compliance Statement

This product is in conformity with the protection requirements of EC Council Directive 89/336/EEC on the approximation of the laws of the Member States relating to electromagnetic compatibility. IBM cannot accept responsibility for any failure to satisfy the protection requirements resulting from a non-recommended modification of the product, including the fitting of non-IBM option cards.

This product has been tested and found to comply with the limits for Class B Information Technology Equipment according to CISPR 22 / European Standard EN 55022. The limits for Class B equipment were derived for typical residential environments to provide reasonable protection against interference with licensed communication devices.

Properly shielded and grounded cables and connectors (IBM part number 75G5958 or its equivalent) must be used in order to reduce the potential for causing interference to radio and TV communications and to other electrical or electronic equipment. Such cables and connectors are available from IBM authorized dealers. IBM cannot accept responsibility for an interference caused by using other than

recommended cables and connectors.



Printed in USA