

Power Systems

*Site and hardware planning*

**IBM**

**Note**

Before using this information and the product it supports, read the information in [“Safety notices” on page v](#), [“Notices” on page 167](#), the *IBM Systems Safety Notices* manual, G229-9054, and the *IBM Environmental Notices and User Guide*, Z125-5823.

This edition applies to IBM® Power Systems servers that contain the POWER9™ processor and to all associated models.

© **Copyright International Business Machines Corporation 2020.**

US Government Users Restricted Rights – Use, duplication or disclosure restricted by GSA ADP Schedule Contract with IBM Corp.

---

# Contents

- Safety notices.....V**
- Site and hardware physical planning overview..... 1**
- Planning activities..... 3**
  - Planning task checklist..... 3
  - General considerations..... 3
  - Site preparation and physical planning guidelines..... 4
- Site and hardware planning..... 7**
  - Hardware specification sheets..... 7
    - Server specifications..... 7
    - Rack specifications.....11
    - Hardware Management Console specifications..... 92
    - Rack switch specifications..... 96
    - Rack installation specifications for racks that are not purchased from IBM..... 99
  - Planning for power.....106
    - Determining your power requirements..... 107
    - Plugs and receptacles.....108
    - Modification of IBM-provided power cords.....113
    - Uninterruptible power supply.....114
    - Power distribution unit and power cord options for 7014, 7953, and 7965 racks.....114
    - Calculating the power load for 7188 or 9188 power distribution units..... 123
  - Planning for cables..... 125
    - Cable management.....125
    - Planning for serial-attached SCSI cables.....129
  - Planning for water cooling.....156
    - Water cooling system specification and requirements.....156
- Notices.....167**
  - Accessibility features for IBM Power Systems servers..... 168
  - Privacy policy considerations ..... 169
  - Trademarks..... 169
  - Electronic emission notices.....169
    - Class A Notices.....169
    - Class B Notices.....173
  - Terms and conditions..... 175





# Safety notices

---

Safety notices may be printed throughout this guide:

- **DANGER** notices call attention to a situation that is potentially lethal or extremely hazardous to people.
- **CAUTION** notices call attention to a situation that is potentially hazardous to people because of some existing condition.
- **Attention** notices call attention to the possibility of damage to a program, device, system, or data.

## World Trade safety information

Several countries require the safety information contained in product publications to be presented in their national languages. If this requirement applies to your country, safety information documentation is included in the publications package (such as in printed documentation, on DVD, or as part of the product) shipped with the product. The documentation contains the safety information in your national language with references to the U.S. English source. Before using a U.S. English publication to install, operate, or service this product, you must first become familiar with the related safety information documentation. You should also refer to the safety information documentation any time you do not clearly understand any safety information in the U.S. English publications.

Replacement or additional copies of safety information documentation can be obtained by calling the IBM Hotline at 1-800-300-8751.

## German safety information

Das Produkt ist nicht für den Einsatz an Bildschirmarbeitsplätzen im Sinne § 2 der Bildschirmarbeitsverordnung geeignet.

## Laser safety information

IBM servers can use I/O cards or features that are fiber-optic based and that utilize lasers or LEDs.

### Laser compliance

IBM servers may be installed inside or outside of an IT equipment rack.



**DANGER:** When working on or around the system, observe the following precautions:

Electrical voltage and current from power, telephone, and communication cables are hazardous. To avoid a shock hazard: If IBM supplied the power cord(s), connect power to this unit only with the IBM provided power cord. Do not use the IBM provided power cord for any other product. Do not open or service any power supply assembly. Do not connect or disconnect any cables or perform installation, maintenance, or reconfiguration of this product during an electrical storm.



- The product might be equipped with multiple power cords. To remove all hazardous voltages, disconnect all power cords. For AC power, disconnect all power cords from their AC power source. For racks with a DC power distribution panel (PDP), disconnect the customer's DC power source to the PDP.
- When connecting power to the product ensure all power cables are properly connected. For racks with AC power, connect all power cords to a properly wired and grounded electrical outlet. Ensure that the outlet supplies proper voltage and phase rotation according to the system rating plate. For racks with a DC power distribution panel (PDP), connect the customer's DC power source to the PDP. Ensure that the proper polarity is used when attaching the DC power and DC power return wiring.
- Connect any equipment that will be attached to this product to properly wired outlets.

- When possible, use one hand only to connect or disconnect signal cables.
- Never turn on any equipment when there is evidence of fire, water, or structural damage.
- Do not attempt to switch on power to the machine until all possible unsafe conditions are corrected.
- When performing a machine inspection: Assume that an electrical safety hazard is present. Perform all continuity, grounding, and power checks specified during the subsystem installation procedures to ensure that the machine meets safety requirements. Do not attempt to switch power to the machine until all possible unsafe conditions are corrected. Before you open the device covers, unless instructed otherwise in the installation and configuration procedures: Disconnect the attached AC power cords, turn off the applicable circuit breakers located in the rack power distribution panel (PDP), and disconnect any telecommunications systems, networks, and modems.
- Connect and disconnect cables as described in the following procedures when installing, moving, or opening covers on this product or attached devices.

To Disconnect: 1) Turn off everything (unless instructed otherwise). 2) For AC power, remove the power cords from the outlets. 3) For racks with a DC power distribution panel (PDP), turn off the circuit breakers located in the PDP and remove the power from the Customer's DC power source. 4) Remove the signal cables from the connectors. 5) Remove all cables from the devices.

To Connect: 1) Turn off everything (unless instructed otherwise). 2) Attach all cables to the devices. 3) Attach the signal cables to the connectors. 4) For AC power, attach the power cords to the outlets. 5) For racks with a DC power distribution panel (PDP), restore the power from the Customer's DC power source and turn on the circuit breakers located in the PDP. 6) Turn on the devices.



- Sharp edges, corners and joints may be present in and around the system. Use care when handling equipment to avoid cuts, scrapes and pinching. (D005)

**(R001 part 1 of 2):**



**DANGER:** Observe the following precautions when working on or around your IT rack system:

- Heavy equipment—personal injury or equipment damage might result if mishandled.
- Always lower the leveling pads on the rack cabinet.
- Always install stabilizer brackets on the rack cabinet if provided, unless the earthquake option is to be installed.
- To avoid hazardous conditions due to uneven mechanical loading, always install the heaviest devices in the bottom of the rack cabinet. Always install servers and optional devices starting from the bottom of the rack cabinet.
- Rack-mounted devices are not to be used as shelves or work spaces. Do not place objects on top of rack-mounted devices. In addition, do not lean on rack mounted devices and do not use them to stabilize your body position (for example, when working from a ladder).



- Stability hazard:
  - The rack may tip over causing serious personal injury.
  - Before extending the rack to the installation position, read the installation instructions.
  - Do not put any load on the slide-rail mounted equipment mounted in the installation position.
  - Do not leave the slide-rail mounted equipment in the installation position.
- Each rack cabinet might have more than one power cord.
  - For AC powered racks, be sure to disconnect all power cords in the rack cabinet when directed to disconnect power during servicing.

- For racks with a DC power distribution panel (PDP), turn off the circuit breaker that controls the power to the system unit(s), or disconnect the customer’s DC power source, when directed to disconnect power during servicing.
- Connect all devices installed in a rack cabinet to power devices installed in the same rack cabinet. Do not plug a power cord from a device installed in one rack cabinet into a power device installed in a different rack cabinet.
- An electrical outlet that is not correctly wired could place hazardous voltage on the metal parts of the system or the devices that attach to the system. It is the responsibility of the customer to ensure that the outlet is correctly wired and grounded to prevent an electrical shock. (R001 part 1 of 2)

**(R001 part 2 of 2):**



**CAUTION:**

- Do not install a unit in a rack where the internal rack ambient temperatures will exceed the manufacturer's recommended ambient temperature for all your rack-mounted devices.
- Do not install a unit in a rack where the air flow is compromised. Ensure that air flow is not blocked or reduced on any side, front, or back of a unit used for air flow through the unit.
- Consideration should be given to the connection of the equipment to the supply circuit so that overloading of the circuits does not compromise the supply wiring or overcurrent protection. To provide the correct power connection to a rack, refer to the rating labels located on the equipment in the rack to determine the total power requirement of the supply circuit.
- *(For sliding drawers.)* Do not pull out or install any drawer or feature if the rack stabilizer brackets are not attached to the rack or if the rack is not bolted to the floor. Do not pull out more than one drawer at a time. The rack might become unstable if you pull out more than one drawer at a time.



- *(For fixed drawers.)* This drawer is a fixed drawer and must not be moved for servicing unless specified by the manufacturer. Attempting to move the drawer partially or completely out of the rack might cause the rack to become unstable or cause the drawer to fall out of the rack. (R001 part 2 of 2)



**CAUTION:** Removing components from the upper positions in the rack cabinet improves rack stability during relocation. Follow these general guidelines whenever you relocate a populated rack cabinet within a room or building.

- Reduce the weight of the rack cabinet by removing equipment starting at the top of the rack cabinet. When possible, restore the rack cabinet to the configuration of the rack cabinet as you received it. If this configuration is not known, you must observe the following precautions:
  - Remove all devices in the 32U position and above.
  - Ensure that the heaviest devices are installed in the bottom of the rack cabinet.

- Ensure that there are little-to-no empty U-levels between devices installed in the rack cabinet below the 32U level, unless the received configuration specifically allowed it.
- If the rack cabinet you are relocating is part of a suite of rack cabinets, detach the rack cabinet from the suite.
- If the rack cabinet you are relocating was supplied with removable outriggers they must be reinstalled before the cabinet is relocated.
- Inspect the route that you plan to take to eliminate potential hazards.
- Verify that the route that you choose can support the weight of the loaded rack cabinet. Refer to the documentation that comes with your rack cabinet for the weight of a loaded rack cabinet.
- Verify that all door openings are at least 760 x 2083 mm (30 x 82 in.).
- Ensure that all devices, shelves, drawers, doors, and cables are secure.
- Ensure that the four leveling pads are raised to their highest position.
- Ensure that there is no stabilizer bracket installed on the rack cabinet during movement.
- Do not use a ramp inclined at more than 10 degrees.
- When the rack cabinet is in the new location, complete the following steps:
  - Lower the four leveling pads.
  - Install stabilizer brackets on the rack cabinet or in an earthquake environment bolt the rack to the floor.
  - If you removed any devices from the rack cabinet, repopulate the rack cabinet from the lowest position to the highest position.
- If a long-distance relocation is required, restore the rack cabinet to the configuration of the rack cabinet as you received it. Pack the rack cabinet in the original packaging material, or equivalent. Also lower the leveling pads to raise the casters off of the pallet and bolt the rack cabinet to the pallet.

(R002)

**(L001)**



**DANGER:** Hazardous voltage, current, or energy levels are present inside any component that has this label attached. Do not open any cover or barrier that contains this label. (L001)

**(L002)**



**DANGER:** Rack-mounted devices are not to be used as shelves or work spaces. Do not place objects on top of rack-mounted devices. In addition, do not lean on rack-mounted devices and do not use them to stabilize your body position (for example, when working from a ladder). Stability hazard:

- The rack may tip over causing serious personal injury.
- Before extending the rack to the installation position, read the installation instructions.

- Do not put any load on the slide-rail mounted equipment mounted in the installation position.
- Do not leave the slide-rail mounted equipment in the installation position.

(L002)

**(L003)**

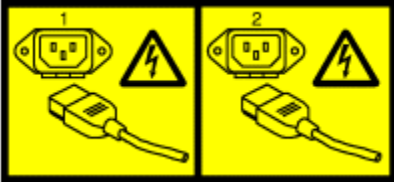

or



or





or



or

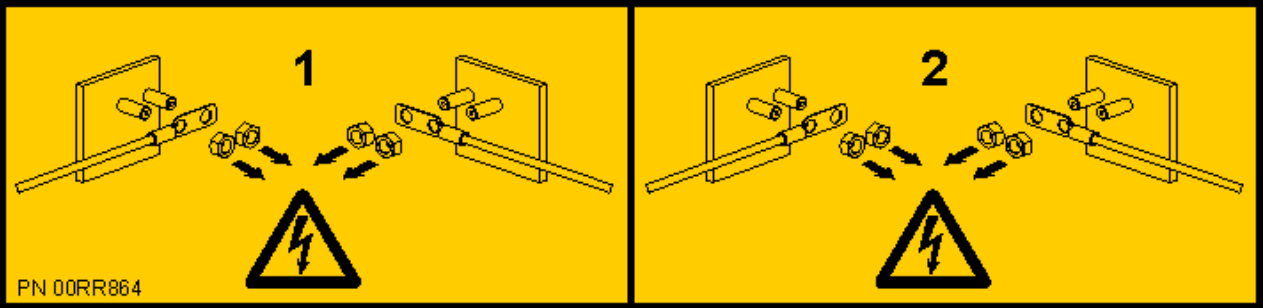



 **DANGER:** Multiple power cords. The product might be equipped with multiple AC power cords or multiple DC power cables. To remove all hazardous voltages, disconnect all power cords and power cables. (L003)

(L007)



 **CAUTION:** A hot surface nearby. (L007)

(L008)



 **CAUTION:** Hazardous moving parts nearby. (L008)

All lasers are certified in the U.S. to conform to the requirements of DHHS 21 CFR Subchapter J for class 1 laser products. Outside the U.S., they are certified to be in compliance with IEC 60825 as a class 1 laser product. Consult the label on each part for laser certification numbers and approval information.

 **CAUTION:** This product might contain one or more of the following devices: CD-ROM drive, DVD-ROM drive, DVD-RAM drive, or laser module, which are Class 1 laser products. Note the following information:

- Do not remove the covers. Removing the covers of the laser product could result in exposure to hazardous laser radiation. There are no serviceable parts inside the device.
- Use of the controls or adjustments or performance of procedures other than those specified herein might result in hazardous radiation exposure.

(C026)



**CAUTION:** Data processing environments can contain equipment transmitting on system links with laser modules that operate at greater than Class 1 power levels. For this reason, never look into the end of an optical fiber cable or open receptacle. Although shining light into one end and looking into the other end of a disconnected optical fiber to verify the continuity of optic fibers may not injure the eye, this procedure is potentially dangerous. Therefore, verifying the continuity of optical fibers by shining light into one end and looking at the other end is not recommended. To verify continuity of a fiber optic cable, use an optical light source and power meter. (C027)



**CAUTION:** This product contains a Class 1M laser. Do not view directly with optical instruments. (C028)



**CAUTION:** Some laser products contain an embedded Class 3A or Class 3B laser diode. Note the following information:

- Laser radiation when open.
- Do not stare into the beam, do not view directly with optical instruments, and avoid direct exposure to the beam. (C030)

(C030)



**CAUTION:** The battery contains lithium. To avoid possible explosion, do not burn or charge the battery.

*Do Not:*

- Throw or immerse into water
- Heat to more than 100 degrees C (212 degrees F)
- Repair or disassemble

Exchange only with the IBM-approved part. Recycle or discard the battery as instructed by local regulations. In the United States, IBM has a process for the collection of this battery. For information, call 1-800-426-4333. Have the IBM part number for the battery unit available when you call. (C003)



**CAUTION:** Regarding IBM provided VENDOR LIFT TOOL:

- Operation of LIFT TOOL by authorized personnel only.
- LIFT TOOL intended for use to assist, lift, install, remove units (load) up into rack elevations. It is not to be used loaded transporting over major ramps nor as a replacement for such designated tools like pallet jacks, walkies, fork trucks and such related relocation practices. When this is not practicable, specially trained persons or services must be used (for instance, riggers or movers).
- Read and completely understand the contents of LIFT TOOL operator's manual before using. Failure to read, understand, obey safety rules, and follow instructions may result in property damage and/or personal injury. If there are questions, contact the vendor's service and support. Local paper manual must remain with machine in provided storage sleeve area. Latest revision manual available on vendor's web site.
- Test verify stabilizer brake function before each use. Do not over-force moving or rolling the LIFT TOOL with stabilizer brake engaged.
- Do not raise, lower or slide platform load shelf unless stabilizer (brake pedal jack) is fully engaged. Keep stabilizer brake engaged when not in use or motion.
- Do not move LIFT TOOL while platform is raised, except for minor positioning.
- Do not exceed rated load capacity. See LOAD CAPACITY CHART regarding maximum loads at center versus edge of extended platform.
- Only raise load if properly centered on platform. Do not place more than 200 lb (91 kg) on edge of sliding platform shelf also considering the load's center of mass/gravity (CoG).
- Do not corner load the platforms, tilt riser, angled unit install wedge or other such accessory options. Secure such platforms -- riser tilt, wedge, etc options to main lift shelf or forks in all four (4x or all other provisioned mounting) locations with provided hardware only, prior to use. Load objects are designed to slide on/off smooth platforms without appreciable force, so take care not

to push or lean. Keep riser tilt [adjustable angling platform] option flat at all times except for final minor angle adjustment when needed.

- Do not stand under overhanging load.
- Do not use on uneven surface, incline or decline (major ramps).
- Do not stack loads.
- Do not operate while under the influence of drugs or alcohol.
- Do not support ladder against LIFT TOOL (unless the specific allowance is provided for one following qualified procedures for working at elevations with this TOOL).
- Tipping hazard. Do not push or lean against load with raised platform.
- Do not use as a personnel lifting platform or step. No riders.
- Do not stand on any part of lift. Not a step.
- Do not climb on mast.
- Do not operate a damaged or malfunctioning LIFT TOOL machine.
- Crush and pinch point hazard below platform. Only lower load in areas clear of personnel and obstructions. Keep hands and feet clear during operation.
- No Forks. Never lift or move bare LIFT TOOL MACHINE with pallet truck, jack or fork lift.
- Mast extends higher than platform. Be aware of ceiling height, cable trays, sprinklers, lights, and other overhead objects.
- Do not leave LIFT TOOL machine unattended with an elevated load.
- Watch and keep hands, fingers, and clothing clear when equipment is in motion.
- Turn Winch with hand power only. If winch handle cannot be cranked easily with one hand, it is probably over-loaded. Do not continue to turn winch past top or bottom of platform travel. Excessive unwinding will detach handle and damage cable. Always hold handle when lowering, unwinding. Always assure self that winch is holding load before releasing winch handle.
- A winch accident could cause serious injury. Not for moving humans. Make certain clicking sound is heard as the equipment is being raised. Be sure winch is locked in position before releasing handle. Read instruction page before operating this winch. Never allow winch to unwind freely. Freewheeling will cause uneven cable wrapping around winch drum, damage cable, and may cause serious injury.
- This TOOL must be maintained correctly for IBM Service personnel to use it. IBM shall inspect condition and verify maintenance history before operation. Personnel reserve the right not to use TOOL if inadequate. (C048)

## **Power and cabling information for NEBS (Network Equipment-Building System) GR-1089-CORE**

The following comments apply to the IBM servers that have been designated as conforming to NEBS (Network Equipment-Building System) GR-1089-CORE:

The equipment is suitable for installation in the following:

- Network telecommunications facilities
- Locations where the NEC (National Electrical Code) applies

The intrabuilding ports of this equipment are suitable for connection to intrabuilding or unexposed wiring or cabling only. The intrabuilding ports of this equipment *must not* be metallically connected to the interfaces that connect to the OSP (outside plant) or its wiring. These interfaces are designed for use as intrabuilding interfaces only (Type 2 or Type 4 ports as described in GR-1089-CORE) and require isolation from the exposed OSP cabling. The addition of primary protectors is not sufficient protection to connect these interfaces metallically to OSP wiring.

**Note:** All Ethernet cables must be shielded and grounded at both ends.

The ac-powered system does not require the use of an external surge protection device (SPD).



The dc-powered system employs an isolated DC return (DC-I) design. The DC battery return terminal *shall not* be connected to the chassis or frame ground.

The dc-powered system is intended to be installed in a common bonding network (CBN) as described in GR-1089-CORE.



---

# Site and hardware physical planning overview

Successful installation requires effective planning of your physical and operational environment. You are the most valuable resource in site planning because you know where and how your system, and the devices that are attached to it, are used.

Site preparation for the complete system is the responsibility of the customer. The primary task of your site planner is to ensure that each system is installed so that it can operate and be serviced efficiently.

Learn about the basic information that you need to plan for your system installation. It provides an overview of each planning task and valuable reference information useful throughout the performance of these tasks. Depending on the complexity of the system that you ordered and your existing computing resource, you might not need to complete all the steps noted here.

First, with the help of your systems engineer, sales representative, or with the help of others who are coordinating your installation, list the hardware for which you need to plan. Use the summary of your order to help you when you make your list. This list is now your “To Do” list. You can use the [Planning task checklist](#) to assist you.

While you are responsible for planning, vendors, contractors, and your sales representative are also available to help with any aspect of the planning. For some system units, a customer service representative installs your system unit and verifies correct operation. Some system units are considered customer-installed. If you are not sure, check with your sales representative.

The physical planning section provides the physical characteristics of many system units, and associated products. For more information about products that are not included in the physical planning section, contact your sales representative or your IBM reseller.

Before you proceed with planning, ensure that the hardware and software you chose meets your needs. Your sales representative is available to answer questions.

While this information is for hardware planning, the system memory and disk storage needed are a function of the software to be used, therefore some things to consider are listed below. Information on software products is generally in or with the software licensed program itself.

In assessing the adequacy of hardware and software, consider the following guidelines:

- Available disk space and system memory for accommodating software, online documentation, and data (including future growth needs resulting from extra users, more data, and new applications).
- Compatibility of all devices.
- Compatibility of software packages with each other and with the hardware configuration.
- Adequate redundancy or backup capabilities in hardware and software.
- Software portability to the new system, if necessary.
- Prerequisites and corequisites of chosen software are satisfied.
- Data to be transferred to the new system.



---

## Planning activities

You can use this information to help you plan the physical installation for your server.

Proper planning for your system facilitates a smooth installation and fast system start-up. Sales and installation planning representatives are also available to help you with installation planning.

As part of your planning activity, you make decisions about where to locate your server and who operates the system.

---

## Planning task checklist

Use this checklist to document your planning progress.

Working with your sales representative, establish completion dates for each of the tasks. You might want to review your planning schedule periodically with your sales representative.

*Table 1. Planning task checklist*

Planning step	Person responsible	Target date	Completion date
Plan your office or computer room layout (physical planning)			
Prepare for power cords and electrical needs			
Prepare for cables and cabling			
Create or modify communications networks			
Perform building alterations, as needed			
Prepare maintenance, recovery, and security plans			
Develop an education plan			
Order supplies			
Prepare for system delivery			

---

## General considerations

Planning your system requires attention to the numerous details.

When you are determining the placement of your system, look the following considerations:

- Adequate space for the devices.
- Working environment of personnel who are using the devices (their comfort, ability to access the devices, supplies, and reference materials).
- Adequate space for maintaining and servicing the devices.
- Physical security requirements necessary for the devices.
- Weight of the devices.
- Heat output of the devices.
- Operating temperature requirements of the devices.
- Humidity requirements of the devices.

- Air flow requirements of the devices.
- Air quality of the location where the devices are used. For example, excess dust can damage your system.

**Note:** The system and devices are designed to operate in normal office environments. Dirty or other poor environments might damage the system or the devices. You are responsible for providing the proper operating environment.

- Altitude limitations of the devices.
- Noise emission levels of the devices.
- Any vibration of equipment near where the devices are placed.
- Paths of power cords.

The following pages contain the information that you need to evaluate these considerations.

## Site preparation and physical planning guidelines

---

These guidelines help you prepare your site for the delivery and installation of your server.

Information that is contained in the [General guidelines for data centers](#) might be helpful for preparing your data center for the arrival of a server.

The [Site preparation and physical planning](#) topic covers the following information:

### **Site selection, building and space considerations**

- Site selection
- Access
- Static electricity and floor resistance
- Space requirements
- Floor construction and floor loading
- Raised floors
- Conductive contamination
- Computer room layout

### **Site environment, safety, and security**

- Vibration and shock
- Lighting
- Acoustics
- Electromagnetic compatibility
- Computer room location
- Material and data storage protection
- Emergency planning for continuous operations

### **Electrical power and grounding**

- General power information
- Power quality
- Voltage and frequency limits
- Power load
- Power source
- Dual power installations

### **Air conditioning**

- Air conditioning determination

- General guidelines for data centers
- Temperature and humidity design criteria
- Temperature and humidity recording instruments
- Relocation and temporary storage
- Acclimation
- System air distribution

#### **Planning for the installation of rear door heat exchangers**

- Planning for the installation of rear door heat exchangers
- Heat exchanger specifications
- Water specifications for the secondary cooling loop
- Water delivery specifications for secondary loops
- Layout and mechanical installation
- Suggested sources for secondary loop components

#### **Communications**

- Planning for communications





# Site and hardware planning

Learn about the specifications that site planners can use to assess the physical site and operational requirements necessary to prepare your site for a new server. This information includes specifications for servers and expansion units, plugs and receptacles, and cables, and information about power-distribution units and uninterruptible power supplies.

## Hardware specification sheets

Hardware specification sheets provide detailed information for your hardware, including dimensions, electrical, power, temperature, environment, and service clearances.

### Server specifications

Server specifications provide detailed information for your server, including dimensions, electrical, power, temperature, environment, and service clearances.

Select the appropriate models to view the specifications for your server.

#### Model 9183-22X server specifications

Server specifications provide detailed information for your server, including dimensions, electrical, power, temperature, environment, and service clearances.

Use the following specifications to plan for your server.

Width	Depth	Height	EIA units	Weight (maximum)
436 mm (17.2 in.)	820 mm (32.3 in.)	86 mm (3.4 in.)	2	32.765 kg (72.23 lb)

Electrical characteristics	Properties
Rated voltage and frequency <sup>1</sup>	200 - 240 V ac at 50 or 60 Hz plus or minus 3 Hz
Thermal output (maximum) <sup>2</sup>	6143 BTU/hr
Maximum power consumption <sup>2</sup>	1800 W
Maximum kVA <sup>3</sup>	1.855 kVA
Phase	Single

**Notes:**

1. The power supplies automatically accept any voltage with the published, rated-voltage range. If dual power supplies are installed and operating, the power supplies draw approximately equal current from the utility (electrical supply) and provide approximately equal current to the load. Each power supply has an IEC 320-C20 inlet.
2. Power draw and heat load vary greatly by configuration. When you plan for an electrical system, it is important to use the maximum values. However, when you plan for heat load, you can use the IBM Systems Energy Estimator to obtain a heat output estimate based on a specific configuration. See the [The IBM Systems Energy Estimator website](#) to determine whether the machine type and model is supported.
3. To calculate the amperage, multiply the kVA by 1000 and divide that number by the operating voltage.

Table 4. Environment requirements

<b>Environment requirements</b>		
<b>Environment (operating)<sup>1</sup></b>		
Properties	Recommended	Allowable <sup>2,3,4</sup>
ASHRAE class		A2 (Fourth edition)
Airflow direction	Front-to-back	
Temperature	18.0°C – 27.0°C (64.4°F – 80.6°F)	10.0°C – 35.0°C (50.0°F – 95.0°F)
Low end moisture	-9.0°C (15.8°F) dew point	-12.0°C (10.4°F) dew point and 8% relative humidity
High end moisture	60% relative humidity and 15°C (59°F) dew point	85% relative humidity and 21.0°C (69.8°F) dew point
Maximum altitude		5000 m (16,400 ft)
<b>Allowable environment (nonoperating)<sup>5</sup></b>		
Temperature	5°C - 45°C (45°C - 113°F)	
Relative humidity	8% to 85%	
Maximum dew point	27°C (80.6°F)	
<b>Environment (shipping)</b>		
Temperature	-40.0°C to 60.0°C (-40°F to 140°F)	
Relative humidity	5% - 100% (no condensation)	
Maximum wet bulb temperature	29.0°C (84.2°F)	
<b>Environment (storage)</b>		
Temperature	1°C - 60°C (33.8°F - 140°F)	
Relative humidity	5% - 80% (no condensation)	
Maximum wet bulb temperature	29°C (84.2°F)	

Table 4. Environment requirements (continued)

<b>Environment requirements</b>	
<b>Notes:</b>	
<ol style="list-style-type: none"> <li>1. IBM provides the recommended operating environment as the long-term operating environment that can result in the greatest reliability, energy efficiency, and reliability. The allowable operating environment represents where the equipment is tested to verify functionality. Due to the stresses that operating in the allowable envelope can place on the equipment, these envelopes must be used for short-term operation, not continuous operation.</li> <li>2. Must derate the maximum allowable temperature 1°C (1.8°F) per 175 m (574 ft) above 900 m (2953 ft) up to a maximum allowable elevation of 3050 m (10000 ft).</li> <li>3. The minimum humidity level is the larger absolute humidity of the -12°C (10.4°F) dew point and the 8% relative humidity. These levels intersect at approximately 25°C (77°F). Below this intersection, the dew point (-12°C) represents the minimum moisture level, while above it, the relative humidity (8%) is the minimum. For the upper moisture limit, the limit is the minimum absolute humidity of the dew point and relative humidity that is stated.</li> <li>4. The following minimum requirements apply to data centers that are operated at low relative humidity: <ul style="list-style-type: none"> <li>• Data centers that have do not have ESD floors and where people are allowed to wear non-ESD shoes might want to consider increasing humidity given that the risk of generating 8 kV increases slightly at 8% relative humidity, when compared to 25% relative humidity.</li> <li>• All mobile furnishings and equipment must be made of conductive or static dissipative materials and be bonded to ground.</li> <li>• During maintenance on any hardware, a properly functioning and grounded wrist strap must be used by any personnel who comes in contact with information technology (IT) equipment.</li> </ul> </li> <li>5. Equipment that is removed from the original shipping container and is installed, but is powered down. The allowable non-operating environment is provided to define the environmental range that an unpowered system can experience short term without being damaged.</li> </ol>	

Table 5. Service clearances

<b>Clearances</b>	<b>Front</b>	<b>Rear</b>	<b>Side<sup>1</sup></b>	<b>Top<sup>1</sup></b>
Operating	762 mm (30 in.)	762 mm (30 in.)		
Nonoperating	762 mm (30 in.)	762 mm (30 in.)	762 mm (30 in.)	762 mm (30 in.)

<sup>1</sup> Side and top clearances are optional during operation.

Table 6. Noise emissions for the 9183-22X

<b>Declared noise emission values in accordance with ISO 9296<sup>1, 2, 3, 4, 5, 6</sup></b>						
<b>Production description</b>	<b>Declared A-weighted mean sound power level, L<sub>WA,m</sub> (B)</b>		<b>Declared A-weighted mean sound pressure level, L<sub>pA,m</sub> (dB)</b>		<b>Statistical adder for verification, K<sub>v</sub> (B)</b>	
	Operating	Idling	Operating	Idling	Operating	Idling
9183-22X with 24 direct-access storage devices (DASDs)	8.3	7.3	68.6	60.1	0.3	0.3

Table 6. Noise emissions for the 9183-22X (continued)

Declared noise emission values in accordance with ISO 9296 <sup>1, 2, 3, 4, 5, 6</sup>						
Production description	Declared A-weighted mean sound power level, $L_{WA,m}$ (B)		Declared A-weighted mean sound pressure level, $L_{pA,m}$ (dB)		Statistical adder for verification, $K_v$ (B)	
	9183-22X with 24 DASDs at maximum operating conditions	8.7	N/A	72.7	N/A	0.3
9183-22X with hot adapters	8.2	7.3	68.8	60.6	0.3	0.3
9183-22X with hot adapters at maximum operating conditions	8.7	N/A	74.0	N/A	0.3	0.3

**Notes:**

1. Declared level  $L_{WA,m}$  is the upper-limit A-weighted sound power level. Declared level  $L_{pA,m}$  is the mean A-weighted emission sound pressure level that is measured at the 1-meter bystander positions.
2. The statistical adder for verification,  $K_v$ , is a quantity to be added to the declared mean A-weighted sound power level,  $L_{WA,m}$ , such that there is a 95% probability of acceptance, when using the verification procedures of ISO 9296, if no more than 6.5% of the batch of new equipment has A-weighted sound power levels greater than  $(L_{WA,m} + K_v)$ .
3. The quantity  $L_{WA,c}$  (formerly called  $L_{WAd}$ ), can be computed from the sum of  $L_{WA,m}$  and  $K_v$ .
4. All measurements made in conformance with ISO 7779 and declared in conformance with ISO 9296.
5. 10 dB (decibel) equals 1 B (bel).
6. Notice: Government regulations (such as those prescribed by OSHA or European Community Directives) might govern noise level exposure in the workplace and might apply to you and your server installation. This IBM system is available in racks with optional acoustical door features that can help reduce the noise that is emitted from this system. The actual sound pressure levels in your installation depend upon various factors, including the number of racks in the installation; the size, materials, and configuration of the room where you designate the racks to be installed; the noise levels from other equipment; the room ambient temperature, and employees' location in relation to the equipment. Further, compliance with such government regulations also depends upon various extra factors, including the duration of employees' exposure and whether employees wear hearing protection. IBM recommends that you consult with qualified experts in this field to determine whether you are in compliance with the applicable regulations.

**Electromagnetic compatibility compliance:** CISPR 32; CISPR 24; FCC, CFR 47, Part 15 (US); VCCI (Japan); Directive 2014/30/EU (EEA); ICES-003, Issue 6 (Canada); ACMA (Australia, New Zealand); CNS 13438 (Taiwan); Radio Waves Act (Korea); EAC (EAEU)

**Safety compliance:** UL 60950-1:2007 Underwriters Laboratory; CAN/CSA22.2 No. 60950-1-07; EN60950-1:2006 + Am1 + Am2 European Norm; IEC 60950-1 2nd Edition + Am1 + Am2 and all National Differences; IS13252 (Part 1): 2010+A1: 2013+A2: 2015

## Rack specifications

Rack specifications provide detailed information for your rack, including dimensions, electrical, power, temperature, environment, and service clearances.

For non-IBM rack specifications, see [“Rack installation specifications for racks that are not purchased from IBM”](#) on page 99.

Select your rack model to view its specifications.

### Related reference

[Rack installation specifications for racks that are not purchased from IBM](#)

Learn about the requirements and specifications for installing IBM systems into racks that were not purchased from IBM.

## Planning for the 7014-T00 and 7014-T42 racks

Rack specifications provide detailed information for your rack, including dimensions, electrical, power, temperature, environment, and service clearances.

Some products can have rack installation limitations. Refer to the specific server or product specifications for any restrictions.

The following provide specifications for the 7014-T00 and 7014-T42 racks.

### Model 7014-T00 rack

Hardware specifications provide detailed information for your rack, including dimensions, electrical, power, temperature, environment, and service clearances.

Rack configuration	Width	Depth	Height	Weight (empty)	Weight (maximum configuration) and EIA unit capacity
Rack Only with side covers	644 mm (25.4 in.)	1016 mm (40.0 in.)	1804 mm (71.0 in.)	244 kg (535 lb)	816 kg (1795 lb) <sup>1</sup> 36 EIA units
Rack with standard rear door only	644 mm (25.4 in.)	1042 mm (41.0 in.)	1804 mm (71.0 in.)	254 kg (559 lb)	N/A
Rack with standard front and rear doors	644 mm (25.4 in.)	1100 mm (43.3 in.)	1804 mm (71.0 in.)	268 kg (590 lb)	N/A
Rack with FC 6101 OEM front door and standard rear door	644 mm (25.4 in.)	1100 mm (43.3 in.)	1804 mm (71.0 in.)	268 kg (590 lb)	N/A
Rack with FC 6068 high perforation front door and standard rear door	644 mm (25.4 in.)	1100 mm (43.3 in.)	1804 mm (71.0 in.)	268 kg (590 lb)	N/A
Rack with FC 6248 acoustic front and rear doors	644 mm (25.4 in.)	1413 mm (55.6 in.)	1804 mm (71.0 in.)	268 kg (589 lb)	N/A

<sup>1</sup> For more information about rack weight distribution and floor loading, see [7014-T00, 7014-T42, and 0553 rack weight distribution and floor loading](#).

Door model	Width	Height	Depth	Weight
Standard front door	639 mm (25.2 in.)	1740 mm (68.5 in.)	56 mm (2.3 in.)	14 kg (31 lb)
Standard rear door	639 mm (25.2 in.)	1740 mm (76.6 in.)	26 mm (1.0 in.)	11 kg (24 lb) With acoustic foam: 14 kg (31 lb)
Standard side covers	10 mm (0.4 in.) each	1740 mm (68.5 in.) each	1042 mm (41.0 in.) each	18 lbs 8.25 kg (18 lb) each
FC 6101 front door (OEM)	639 mm (25.2 in.)	1740 mm (68.5 in.)	56 mm (2.3 in.)	14 kg (31 lb)
FC 6068 front door, high perforation	639 mm (25.2 in.)	1740 mm (68.5 in.)	56 mm (2.3 in.)	14 kg (31 lb)
FC 6248 acoustic doors, front and rear	639 mm (25.2 in.) each	1740 mm (76.6 in.) each	198 mm (7.8 in.) each	12.3 kg (27 lb) each

Electrical characteristics	Properties
Power source loading maximum in kVA <sup>2</sup>	8.4 (FC 6117 <sup>3</sup> ) 8.4 (FC EPB8 <sup>3,4</sup> )
<b>Notes:</b>	
<ol style="list-style-type: none"> <li>1. The total rack power can be derived from the sum of the power that is used by the drawers in the rack.</li> <li>2. For FC EPB8, each side can support a maximum of 600 amps (A) and 10 circuit breakers. The PDP can hold up to twenty (ten per power source) circuit breakers with ratings between 5 A and 90 A. Each power source supports up to 8.4 kVA.</li> <li>3. For more information about FC 6117 and FC EPB8, see “<a href="#">Model 7014-T00 rack with optional DC power distribution panel</a>” on page 13.</li> <li>4. Preliminary data is subject to change.</li> </ol>	

See your individual server or hardware specifications for temperature and humidity requirements.

Rack noise levels depend on the number and type of drawers installed. See your server or hardware specifications for specific requirements.

**Note:** All rack installations require careful site and facilities planning that are designed to both address the cumulative drawer heat output and provide the airflow volume rates necessary to comply with drawer temperature requirements. All rack installations require careful site and facilities planning that are designed to address both the cumulative drawer heat output and provide the airflow volume rates necessary to comply with drawer temperature requirements. Rack airflow requirements depend on the number and type of drawers installed.

**Note:** Acoustic doors are available for IBM racks. Feature code 6248 is available for 7014-T00 racks. Feature code 6249 is available for 7014-T42 racks. The overall sound reduction is approximately 6 dB. The doors add approximately 381 mm (15 in.) to the depth of the racks.

**Related reference**

[7014-T00 and 7014-T42 rack weight distribution and floor loading](#)

Racks can be heavy when populated with several drawers. Use the Weight distribution distances for racks when loaded and Floor loading for racks when loaded tables to ensure proper floor loading and weight distribution.

***Model 7014-T00 rack with optional DC power distribution panel***

Hardware specifications provide detailed information for your rack, including dimensions, electrical, power, temperature, environment, and service clearances.

**Feature code (FC) 6117 (-48 V dc power distribution panel (PDP))**

This feature provides a top-mounted, dual DC power distribution panel for a rack that can contain varying quantities of central processing unit (CPU) drawers, storage subsystems, or both. Up to two DC H80 systems or two DC M80 systems are supported, in addition to up to four DC storage subsystems. This feature is built without attached power cables. It comes with a series of power connectors that are built into its rear bulkhead. The appropriate DC power cables are included with supported drawer systems and plug into the power connectors at the rear of the 6117 PDP.

**FC EPB8 (-48 V dc power distribution panel (PDP))**

This feature provides a top-mounted -48 V dc PDP for model 7014-T00 racks that can contain varying quantities of drawers, storage subsystems, and OEM equipment. This feature is preinstalled on the 7014-T00 rack. The PDP sits on top of the rack and does not take up any EIA space. The PDP supports redundant power with a split A and B side. Each side can support up to 10 circuit breakers that are rated 5 - 90 amperes with a maximum load of 600 amperes. FC EPB8 does not include circuit breakers or DC power cables. The circuit breakers and associated DC power cables are typically supplied with IBM products. For OEM products, you must provide the applicable circuit breakers and DC power cables.

**Note:** Front doors are optional on the 7014-T00 rack.

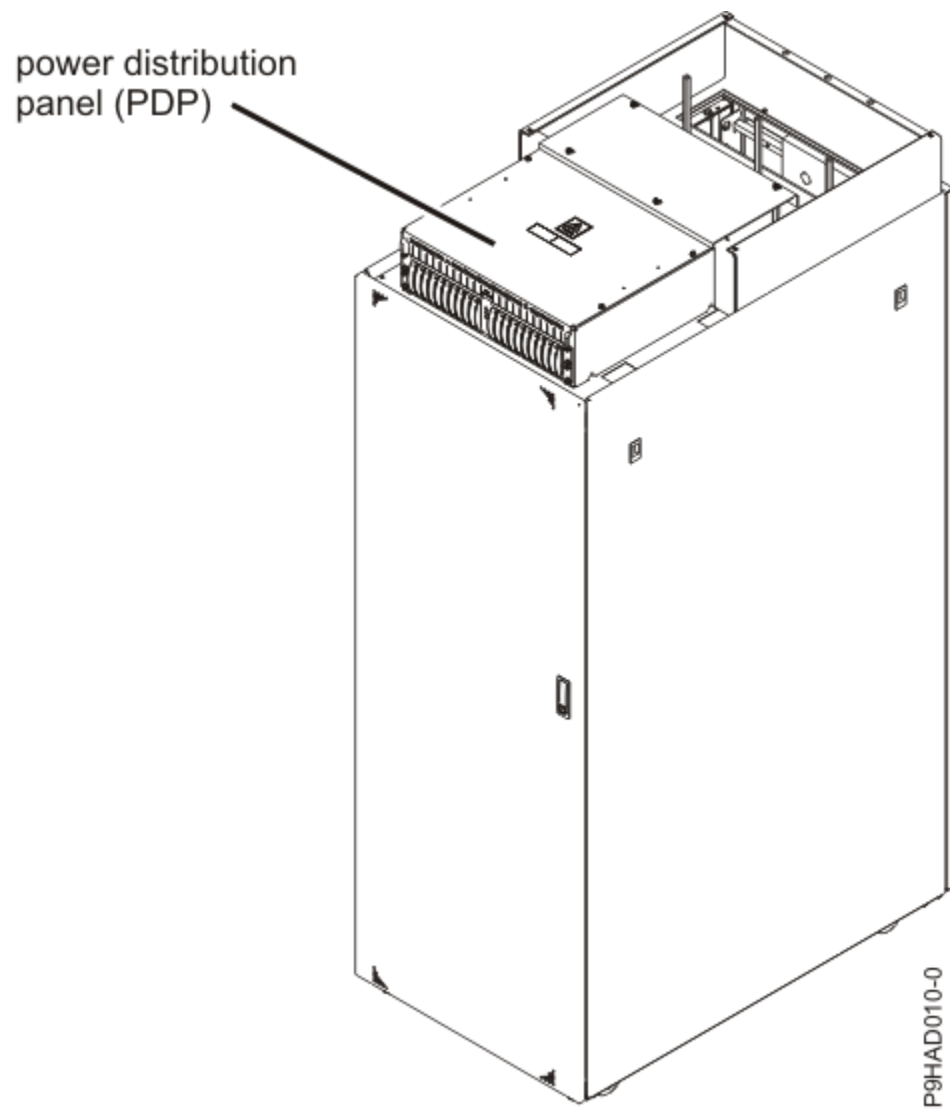

*Figure 1. FC EPB8 - power distribution panel*



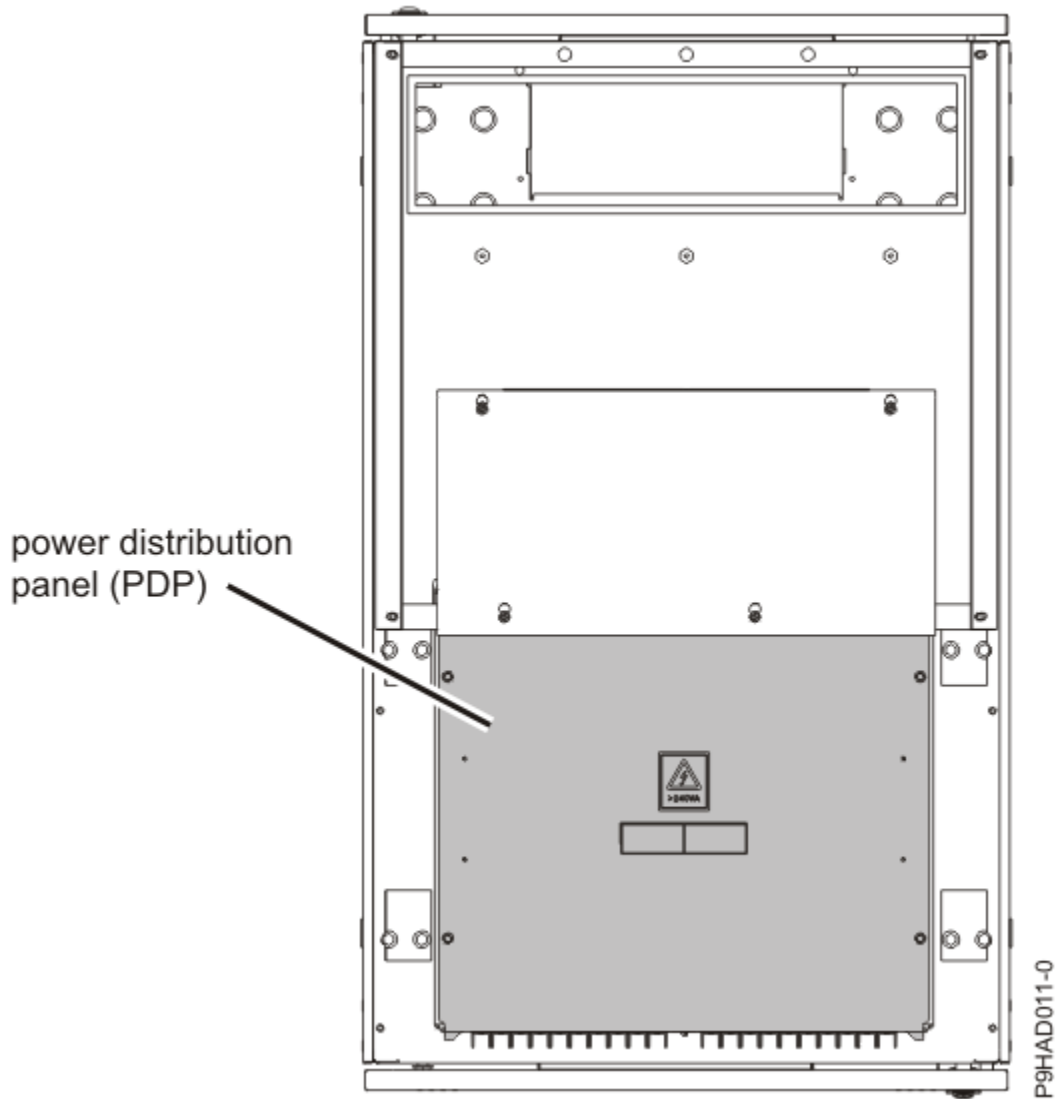

Figure 2. FC EPB8 - power distribution panel (top-down view)

<i>Table 10. Dimensions for 7014-T00 rack with FC 6117 or FC EPB8 installed</i>	
<b>Dimensions</b>	<b>Properties</b>
Width (rack with side panels)	644 mm (25.4 in.)
Depth	1148 mm (45.2 in.)
Height with -48 v DC power only	1926 mm (75.8 in.)
Height with -48 v DC power and overhead cable tray (normally included with FC EPB8)	1941 mm (76.4 in.)

<i>Table 11. Environment requirements for FC 6117 and FC EPB8</i>			
<b>Environment</b>	<b>Recommended operating</b>	<b>Allowable operating</b>	<b>Nonoperating</b>
Temperature		-5°C to 55°C (23°F - 131°F)	
Humidity range		0% - 90% relative humidity (RH) (non-condensing)	

Table 11. Environment requirements for FC 6117 and FC EPB8 (continued)

Environment	Recommended operating	Allowable operating	Nonoperating
Shipping temperature			-40°C to 70°C (-40°F to 158°F)
Shipping relative humidity			0% - 93%

**Model 7014-T42 and 7014-B42 rack**

Hardware specifications provide detailed information for your rack, including dimensions, electrical, power, temperature, environment, and service clearances.

Table 12. Dimensions for rack

Rack configuration	Width	Height	Depth	Weight (empty)	Weight (maximum configuration) and EIA unit capacity
Rack only with side covers	644 mm (25.4 in.)	1016 mm (40.0 in.)	2015 mm (79.3 in.)	261 kg (575 lb)	1597 kg (3521 lb) <sup>2</sup> (1336 kg + 261 kg) 42 EIA units
Rack with standard rear door only	644 mm (25.4 in.)	1042 mm (41.0 in.)	2015 mm (79.3 in.)	273 kg (602 lb)	N/A
Rack with standard front and rear doors	644 mm (25.4 in.)	1098 mm (43.3 in.)	2015 mm (79.3 in.)	289 kg (636 lb)	N/A
Rack with FC 6084 OEM front door and standard rear door	644 mm (25.4 in.)	1098 mm (43.3 in.)	2015 mm (79.3 in.)	289 kg (636 lb)	N/A
Rack with FC 6069 high perforation front door and standard rear door	644 mm (25.4 in.)	1098 mm (43.3 in.)	2015 mm (79.3 in.)	289 kg (636 lb)	N/A
Rack with FC ERG7 770/780 high perforation front door and standard rear door	644 mm (25.4 in.)	1176 mm (46.3 in.)	2015 mm (79.3 in.)	290 kg (639 lb)	N/A
Rack with FC 6249 acoustic front and rear doors	644 mm (25.4 in.)	1413 mm (55.6 in.)	2015 mm (79.3 in.)	289 kg (635 lb)	N/A
Rack with FC 6250 high end appearance front door and standard rear door	644 mm (25.4 in.)	1131 mm (44.5 in.)	2015 mm (79.3 in.)		N/A
Rack with FC ERGB acoustic front door and standard rear door	644 mm (25.4 in.)	1240 mm (48.8 in.)	2015 mm (79.3 in.)	285 kg (627 lb)	N/A
Rack with FC 6858 heat exchanger rear door and standard front door	644 mm (25.4 in.)	1222 mm (48.1 in.)	2015 mm (79.3 in.)	Empty: 306 kg (675 lb)  Full: 312 kg (688 lb)	N/A

Table 12. Dimensions for rack (continued)

Rack configuration	Width	Height	Depth	Weight (empty)	Weight (maximum configuration) and EIA unit capacity
Rack with FC ERG0 rack extension and standard front and rear doors	644 mm (25.4 in.)	1303 mm (51.3 in.)	2015 mm (79.3 in.)	315 kg (694 lb)	N/A
<b>Notes:</b>					
<p>1. The top 6U of the rack can be temporarily detached at the client site to make it easier to move the rack through doors or elevators. The top 6U is then reattached to the rack frame to provide the full 42U rack capacity. The rack is approximately 28 cm (11 in.) shorter when the top is removed. The weight of the top cover is approximately 29 kg (63 lbs).</p> <p>2. For more information about rack weight distribution and floor loading, see <a href="#">7014-T00</a>, <a href="#">7014-T42</a>, and <a href="#">0553</a> rack weight distribution and floor loading.</p>					

Table 13. Dimensions for doors

Door model	Width	Height	Depth	Weight
Standard front door	639 mm (25.2 in.)	1946 mm (76.6 in.)	56 mm (2.3 in.)	16 kg (34 lb)
Standard rear door	639 mm (25.2 in.)	1946 mm (76.6 in.)	26 mm (1.0 in.)	13 kg (27 lb) With acoustic foam: 16 kg (34 lb)
Standard side covers (each)	10 mm (.4 in.)	1740 mm (68.5 in.)	1042 mm (41.0 in.)	18 lbs 8.25 kg(18 lb)
FC 6084 front door (OEM)	639 mm (25.2 in.)	1946 mm (76.6 in.)	56 mm (2.3 in.)	16 kg (34 lb)
FC 6069 front door, high perforation	639 mm (25.2 in.)	1946 mm (76.6 in.)	56 mm (2.3 in.)	16 kg (34 lb)
FC ERG7 front door 770/780 high perforation	639 mm (25.2 in.)	1946 mm (76.6 in.)	134 mm (5.3 in.)	17 kg (37 lb)
FC 6249 acoustic doors, front and rear	639 mm (25.2 in.) each	1946 mm (76.6 in.) each	198 mm (7.8 in.) each	13.6 kg (30 lb) each
FC 6250 high end appearance front door	639 mm (25.2 in.) each	1946 mm (76.6 in.) each	90 mm (3.5 in.)	
FC ERGB acoustic door, front only	639 mm (25.2 in.)	1946 mm (76.6 in.)	198 mm (7.8 in.)	13.6 kg (30 lb)
FC 6238 high end appearance side covers	10 mm (.4 in.)	1740 mm (68.5 in.)	1042 mm (41.0 in.)	8.5 kg (18 lb)

Door model	Width	Height	Depth	Weight
FC 6858 heat exchanger rear door	639 mm (25.2 in.)	1946 mm (76.6 in.)	147 mm (5.8 in.)	Empty: 29.9 kg (66 lb) Full: 35.6 kg (78.5 lb)
FC ERG0 8-inch rack extension	647 mm (25.4 in.)	1957 mm (77.1 in.)	203 mm (8.0 in.)	27 kg (58.0 lb)
FC ERG8 ballast weight specify code	N/A	N/A	N/A	52.1 kg (115 lb)
FC EC07 and EC08 acoustic doors, black IBM, front and rear	639 mm (25.2 in.) each	1946 mm (76.6 in.) each	114.3 mm (4.5 in.) each	19 kg (42 lb)

Electrical characteristics	Properties
Power source loading maximum in kVA	For more information about rack power distribution units and power cord options, see <a href="#">Power distribution unit and power cord options for 7014 racks</a> .

<sup>1</sup> The total rack power can be derived from the sum of the power that is used by the drawers in the rack.

See your individual server or hardware specifications for temperature and humidity requirements.

Rack noise levels depend on the number and type of drawers installed. See your server or hardware specifications for specific requirements.

**Note:** All rack installations require careful site and facilities planning that is designed to address both the cumulative drawer heat output and provide the airflow volume rates necessary to comply with drawer temperature requirements. Rack airflow requirements depend on the number and type of drawers installed.

**Note:** Acoustic doors are available for IBM racks. Feature code 6248 is available for 7014-T00 racks. Feature code 6249 is available for 7014-T42 racks. The overall sound reduction is approximately 6 dB. The doors add approximately 381 mm (15 in.) to the depth of the racks.

## Service clearances

Front	Rear	Sides
915 mm (36 in.)	915 mm (36 in.)	915 mm (36 in.)

**Note:** Recommended minimum vertical service clearance from the floor is 2439 mm (8 ft).

Figure 3 on page 19 provides the caster and leveler locations for 7014-T00 and 7014-T42 racks.

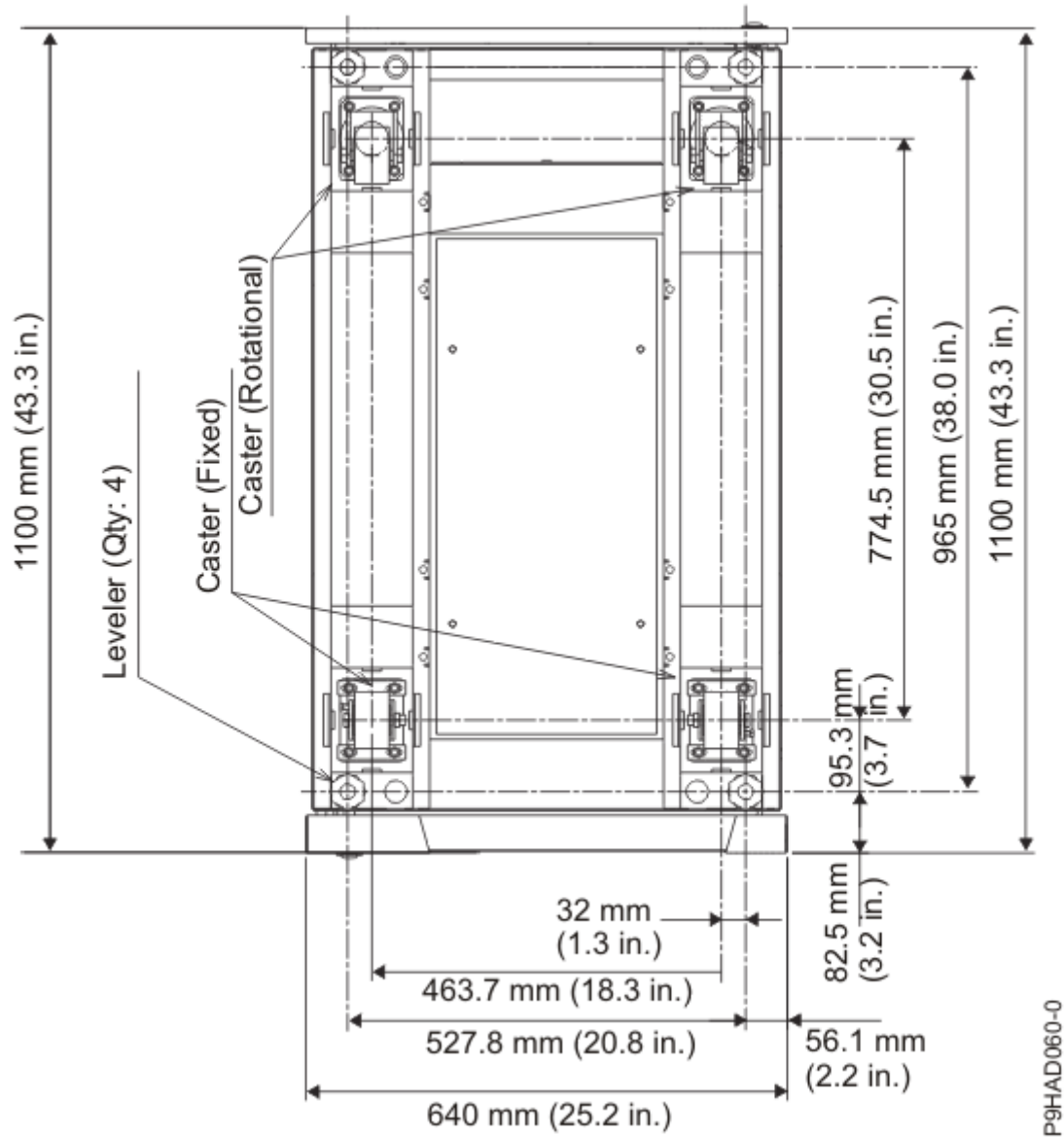

Figure 3. Caster and leveler locations

**Note:** Rack units are large and heavy and are not easily moved. As maintenance activities require access at both the front and the back, extra room is needed. The footprint illustration does not show the radius of the swinging doors on the I/O rack. A service clearance of 915 mm (36 in.) needs to be maintained on front, rear, and sides of the I/O rack.

### 7014-T00 and 7014-T42 service clearances and caster location

Use the service clearances and caster locations for 7014-T00 and 7014-T42 racks to plan the correct service clearances and caster locations for your rack.

### Service clearances

Table 16. Service clearances for 7014-T00 and 7014-T42 racks		
Front	Rear	Sides
915 mm (36 in.)	915 mm (36 in.)	915 mm (36 in.)
<b>Note:</b> Recommended minimum vertical service clearance from the floor is 2439 mm (8 ft).		

Figure 4 on page 20 provides the caster and leveler locations for 7014-T00 and 7014-T42 racks.

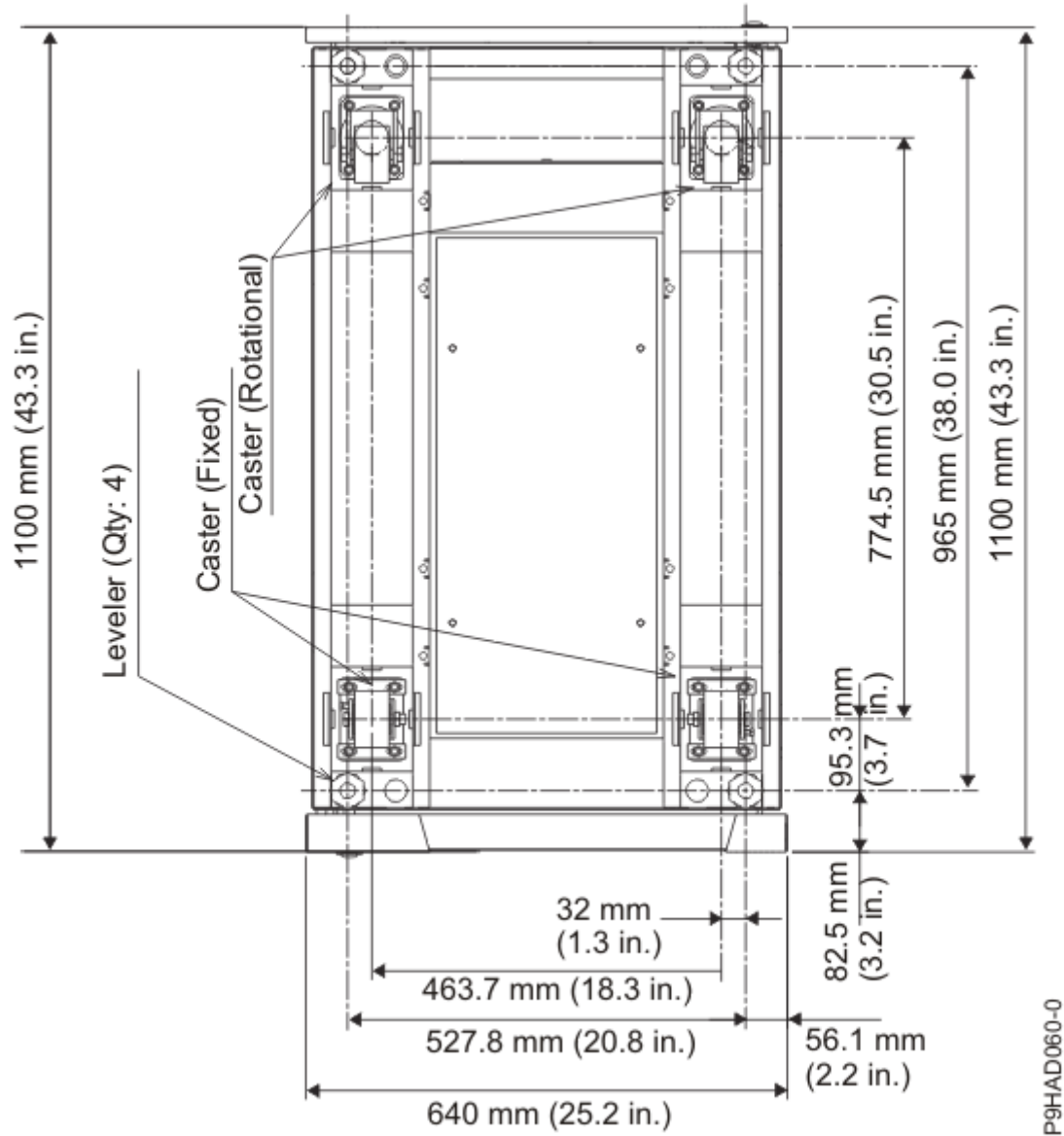

Figure 4. Caster and leveler locations

**Note:** Rack units are large and heavy and are not easily moved. As maintenance activities require access at both the front and the back, extra room is needed. The footprint illustration does not show the radius of the swinging doors on the I/O rack. A service clearance of 915 mm (36 in.) needs to be maintained on front, rear, and sides of the I/O rack.

### Feature code (FC) ERG0

FC ERG0 is an optional rear rack extender that can be used for 7014-T42 racks. The extender is installed on the rear of the 7014-T42 rack and provides 203 mm (8 in.) of extra space to hold cables on the side of the rack and to keep the center area clear for cooling and service access.

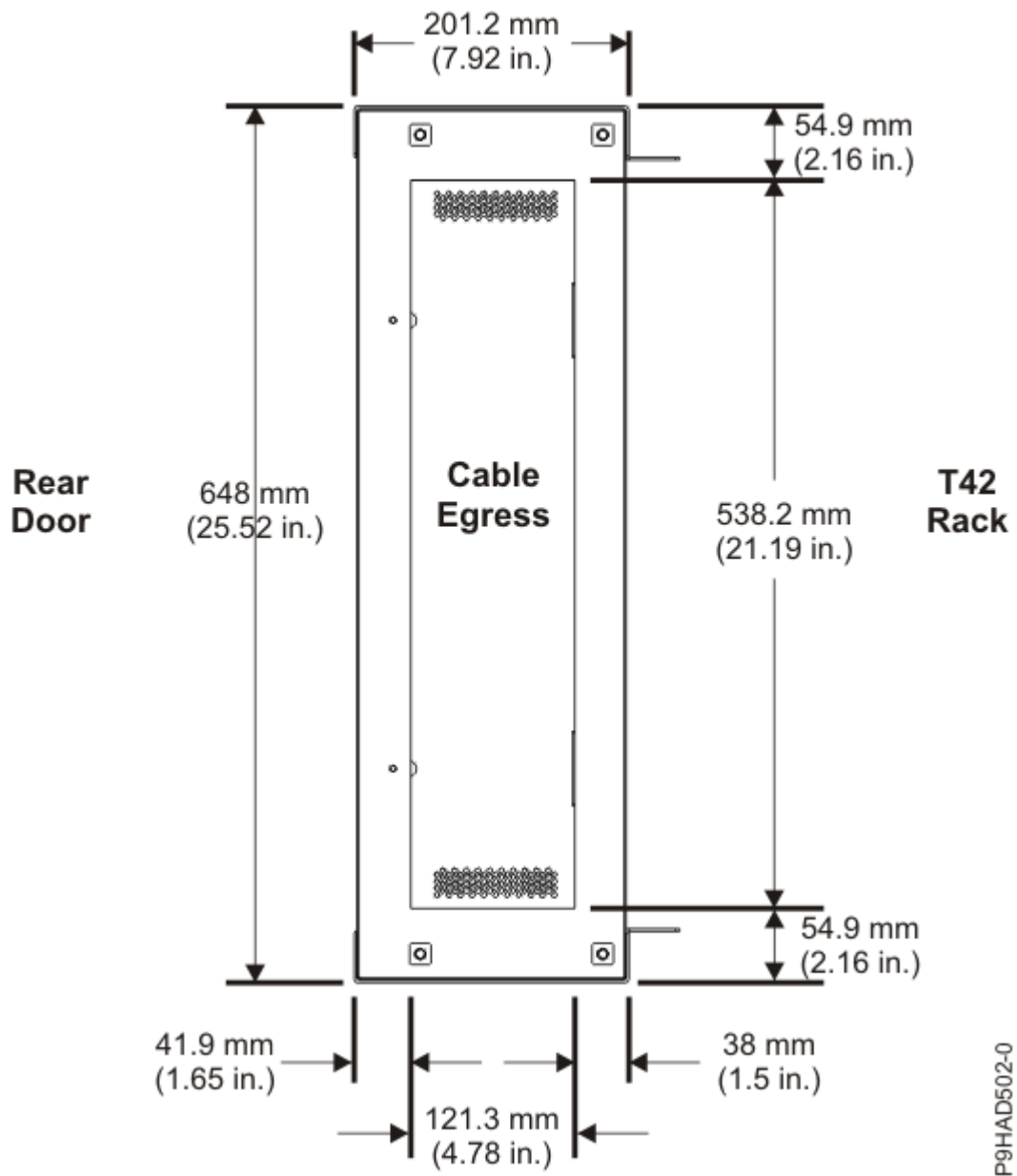

Figure 5. FC ERG0 rear rack extender (top-down view)

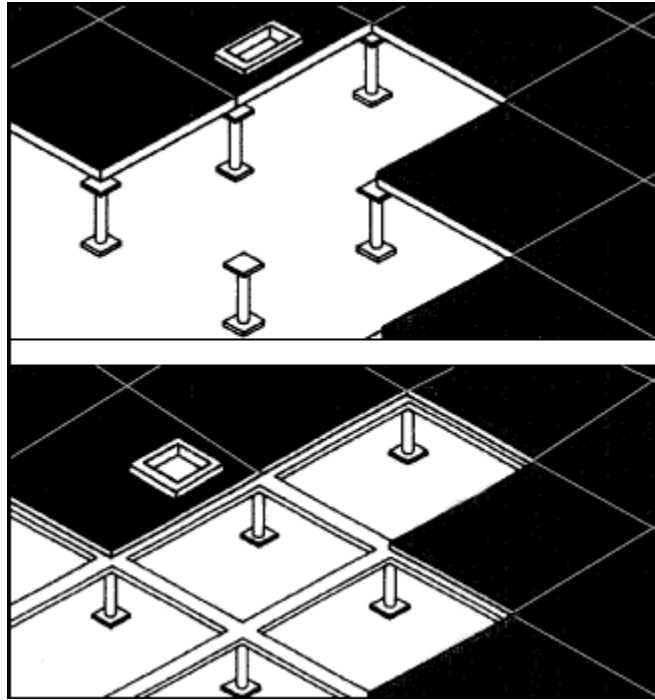
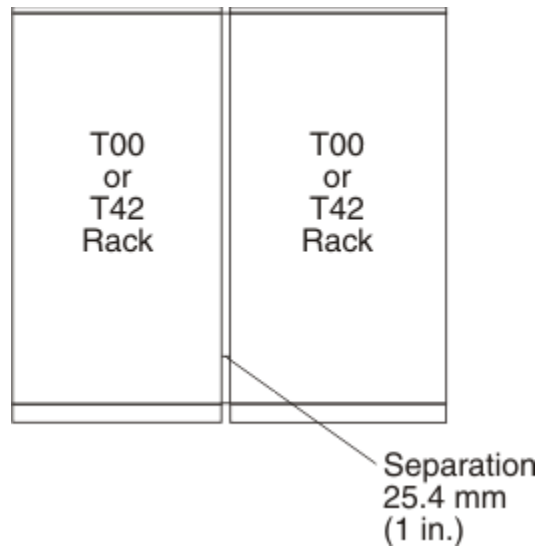

Figure 6. FC ERGO assembled view

**7014-T00 and 7014-T00 racks multiple attachments**

7014-T00 or 7014-T42 racks can be bolted together in a multiple-rack arrangement. This figure shows that arrangement.



A kit is available including the bolts, spacers, and decorative trim pieces to cover the 25.4 mm (1 in.) space. For service clearances, see the service clearances as shown in the table for the model 7014-T00 rack.

**Related reference**

[Model 7014-T00 rack](#)



Hardware specifications provide detailed information for your rack, including dimensions, electrical, power, temperature, environment, and service clearances.

### **7014-T00 and 7014-T42 rack weight distribution and floor loading**

Racks can be heavy when populated with several drawers. Use the Weight distribution distances for racks when loaded and Floor loading for racks when loaded tables to ensure proper floor loading and weight distribution.

The 7014-T00 and 7014-T42 racks can be heavy when several drawers are present. The following table shows the necessary weight distribution distances for the 7014-T00 and 7014-T42 racks when loaded.

<i>Table 17. Weight distribution distances for racks when loaded</i>					
Rack	System weight <sup>1</sup>	Width <sup>2</sup>	Depth <sup>2</sup>	Weight distribution distance <sup>3</sup>	
				Front and back	Left and right
7014-T00 <sup>4</sup>	816 kg (1795 lb)	623 mm (24.5 in)	1021 mm (40.2 in)	515.6 mm (20.3 in), 477.5 mm (18.8 in)	467.4 mm (18.4 in)
7014-T00 <sup>5</sup>	816 kg (1795 lb)	623 mm (24.5 in)	1021 mm (40.2 in)	515.6 mm (20.3 in), 477.5 mm (18.8 in)	0
7014-T00 <sup>6</sup>	816 kg (1795 lb)	623 mm (24.5 in)	1021 mm (40.2 in)	515.6 mm (20.3 in), 477.5 mm (18.8 in)	559 mm (22 in)
7014-T42 <sup>4</sup>	930 kg (2045 lb)	623 mm (24.5 in)	1021 mm (40.2 in)	515.6 mm (20.3 in), 477.5 mm (18.8 in)	467.4 mm (18.4 in)
7014-T42 <sup>5</sup>	930 kg (2045 lb)	623 mm (24.5 in)	1021 mm (40.2 in)	515.6 mm (20.3 in), 477.5 mm (18.8 in)	0
7014-T42 <sup>6</sup>	930 kg (2045 lb)	623 mm (24.5 in)	1021 mm (40.2 in)	515.6 mm (20.3 in), 477.5 mm (18.8 in)	686 mm (27 in)

**Notes:**

1. Maximum weight of fully populated rack, units are lb with kg in parentheses.
2. Dimensions without covers, units are mm with inches in parentheses.
3. The weight distribution distance in all four directions is the area around the rack perimeter (minus covers) necessary to distribute the weight beyond the perimeter of the rack. Weight distribution areas cannot overlap with adjacent computer equipment weight distribution areas. Units are inches with mm in parentheses.
4. Weight distribution distance is 1/2 the service clearance values that are shown in the figure plus cover thickness.
5. No left and right weight distribution distance.
6. Left and right weight distribution distance that is required for a 70 lb/ft<sup>2</sup> raised floor loading objective.

The following table shows the necessary floor loading for the 7014-T00 and 7014-T42 racks when loaded.

<i>Table 18. Floor loading for racks when loaded</i>				
Rack	Floor loading			
	Raised kg/m <sup>1</sup>	Non-raised kg/m <sup>1</sup>	Raised lb/ft <sup>1</sup>	Non-raised lb/ft <sup>1</sup>
7014-T00 <sup>2</sup>	366.7	322.7	75	66
7014-T00 <sup>3</sup>	734.5	690.6	150.4	141.4
7014-T00 <sup>4</sup>	341	297	70	61

Table 18. Floor loading for racks when loaded (continued)

Rack	Floor loading			
	Raised kg/m <sup>1</sup>	Non-raised kg/m <sup>1</sup>	Raised lb/ft <sup>1</sup>	Non-raised lb/ft <sup>1</sup>
7014-T42 <sup>2</sup>	403	359	82.5	73.5
7014-T42 <sup>3</sup>	825	781	169	160
7014-T42 <sup>4</sup>	341.4	297.5	70	61

**Notes:**

1. Dimensions without covers, units are mm with inches in parentheses.
2. Weight distribution distance is one half of the service clearance values that is shown in the figure plus cover thickness.
3. No left and right weight distribution distance.
4. Left and right weight distribution distance that is required for a 70 lb/ft<sup>2</sup> raised floor loading objective.

**Related reference**

Model 7014-T00 rack

Hardware specifications provide detailed information for your rack, including dimensions, electrical, power, temperature, environment, and service clearances.

**Planning for the 7953-94X and 7965-94Y rack**

Rack specifications provide detailed information for your rack, including dimensions, electrical, power, temperature, environment, and service clearances.

The following provide specifications for the 7953-94X and 7965-94Y rack.

**Model 7953-94X and 7965-94Y rack**

Hardware specifications provide detailed information for your rack, including dimensions, electrical, power, temperature, environment, and service clearances.

Table 19. Dimensions for rack

	Width	Depth	Height	Weight (Empty)	Weight (Maximum configuration)	EIA unit capacity
Rack only	600 mm (23.6 in.)	1095 mm (43.1 in.)	2002 mm (78.8 in.)	130 kg (287 lb)	1140 kg (2512 lb)	42 EIA units
Rack with standard doors	600 mm (23.6 in.)	1145.5 mm (45. in.)	2002 mm (78.8 in.)	138 kg (304 lb)	N/A	N/A
Rack with triplex doors	600 mm (23.6 in.)	1206.2 - 1228.8 mm (47.5 - 48.4 in.)	2002 mm (78.8 in.)	147 kg (324 lb)	N/A	N/A
Rack with rear door heat exchanger indicator	600 mm (23.6 in.)	1224 mm (48.2 in.)	2002 mm (78.8 in.)	169 kg (373 lb)	N/A	N/A

Table 19. Dimensions for rack (continued)

	Width	Depth	Height	Weight (Empty)	Weight (Maximum configuration)	EIA unit capacity
<b>Note:</b> When the rack is delivered or is moved, outriggers are needed for stability. For more information about outriggers, see “Side stabilizing outriggers” on page 30.						

Table 20. Dimensions for doors

Door model	Width	Height	Depth	Weight
Standard front door (FC EC01) and standard back door (FC EC02)	597 mm (23.5 in.)	1925 mm (75.8 in.)	22.5 mm (0.9 in.)	7.7 kg (17 lb)
Triplex door (FC EU21) <sup>3</sup>	597.1 mm (23.5 in.)	1923.6 mm (75.7 in.)	105.7 mm (4.2 in.) <sup>1</sup> 128.3 mm (5.2 in.) <sup>2</sup>	16.8 kg (37 lb)
<sup>1</sup> Measured from the front flat surface of the door. <sup>2</sup> Measured from the IBM logo on the front of the door. <sup>3</sup> Multiple racks that are placed side-by-side must have a 6 mm (0.24 in.) minimum clearance between racks to allow the triplex front door to hinge properly. Feature code EC04 (Rack suite attachment kit) can be used to maintain the 6 mm (0.24 in.) minimum clearance between racks.				

Table 21. Dimensions for side covers<sup>1</sup>

Depth	Height	Weight
885 mm (34.9 in.)	1870 mm (73.6 in.)	17.7 kg (39 lb)
<sup>1</sup> Side covers do not increase the overall width of the rack.		

Table 22. Temperature requirements

Operating	Nonoperating
10°C - 38°C (50°F - 100.4°F) <sup>1</sup>	-40°C to 60°C (-40°F to 140°F)
<sup>1</sup> The maximum 38°C (100.4°F) temperature must be derated 1°C (1.8 °F) per 137 m (450 ft) above 1295 m (4250 ft).	

Table 23. Environmental requirements

Environment	Operating	Nonoperating	Maximum altitude
Noncondensing humidity	20% - 80% (allowable) 40% - 55% (recommended)	8% - 80% (including condensing)	2134 m (7000 ft) above sea level
Wet bulb temperature	21°C (69.8°F)	27°C (80.6°F)	

Table 24. Service clearances

Front	Back	Side <sup>1</sup>
915 mm (36 in.)	915 mm (36 in.)	610 mm (24 in.)

<sup>1</sup> Side service clearance is only required when outriggers are on the rack. Side service clearance is not required during normal operation of the rack when outriggers are not installed.

### Rear door heat exchanger

Specifications for Power orderable feature code (FC): EC05 - Rear door heat exchanger indicator (Model 1164-95X).

Table 25. Dimensions for rear door heat exchanger

Width	Depth	Height	Weight (empty)	Weight (filled)
600 mm (23.6 in.)	129 mm (5.0 in.)	1950 mm (76.8 in.)	39 kg (85 lb)	48 kg (105 lb)

For more information, see “[Model 1164-95X rear door heat exchanger specifications](#)” on page 33.

### Electrical

For electrical requirements, see [Power distribution unit and power cord options](#).

### Features

The 7953-94X and 7965-94Y rack has the following features available for use:

- Recirculation prevention plate that is installed at the bottom, front of the rack.
- Stabilizer bracket that is installed at the front of the rack.

### Caster locations

The following diagram provides the caster locations for the 7953-94X and 7965-94Y rack.

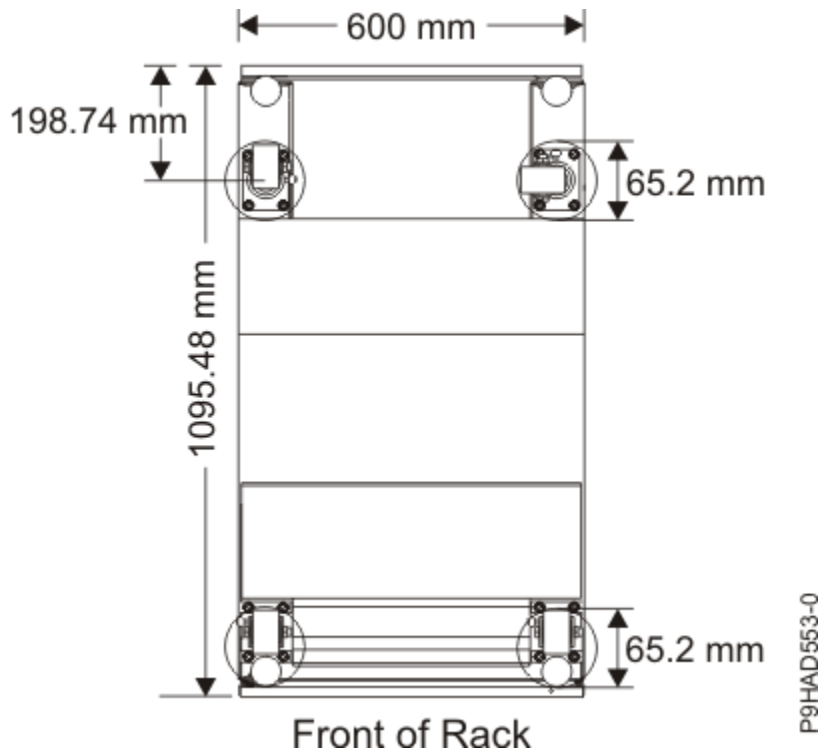

Figure 7. Caster locations

### **Cabling the 7953-94X and 7965-94Y rack**

Learn about the different cable routing options available for the 7953-94X and 7965-94Y rack.

### **Cabling within the rack**

Side cable channels are available in the rack to route cables. Two cable channels are on each side of the rack as shown in [Figure 8 on page 28](#).

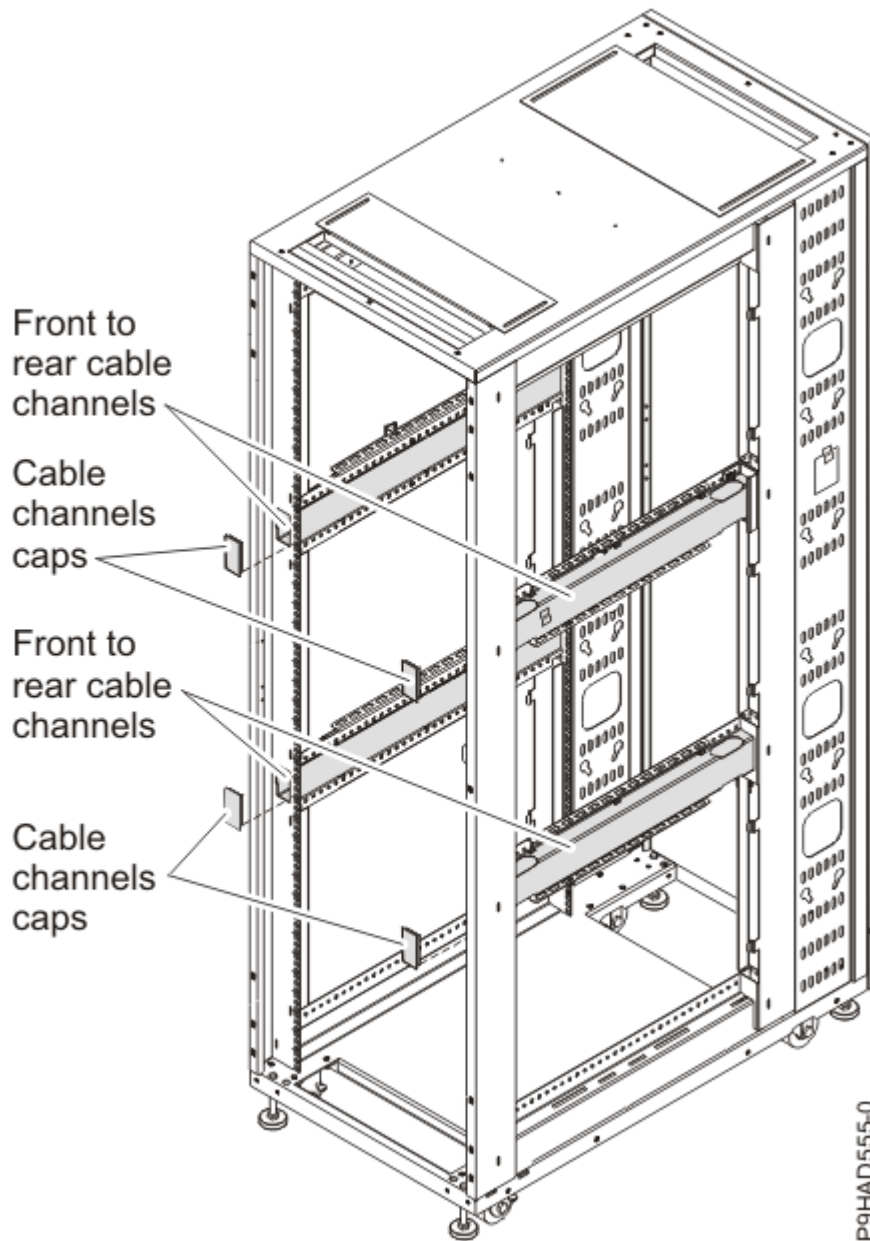

Figure 8. Cabling within the rack

### **Cabling under the floor**

A cable access bar on the bottom rear of the rack helps to route the cables, leaving the rack in place. This bar can be removed for installation and then reattached after the rack is installed and cabled.

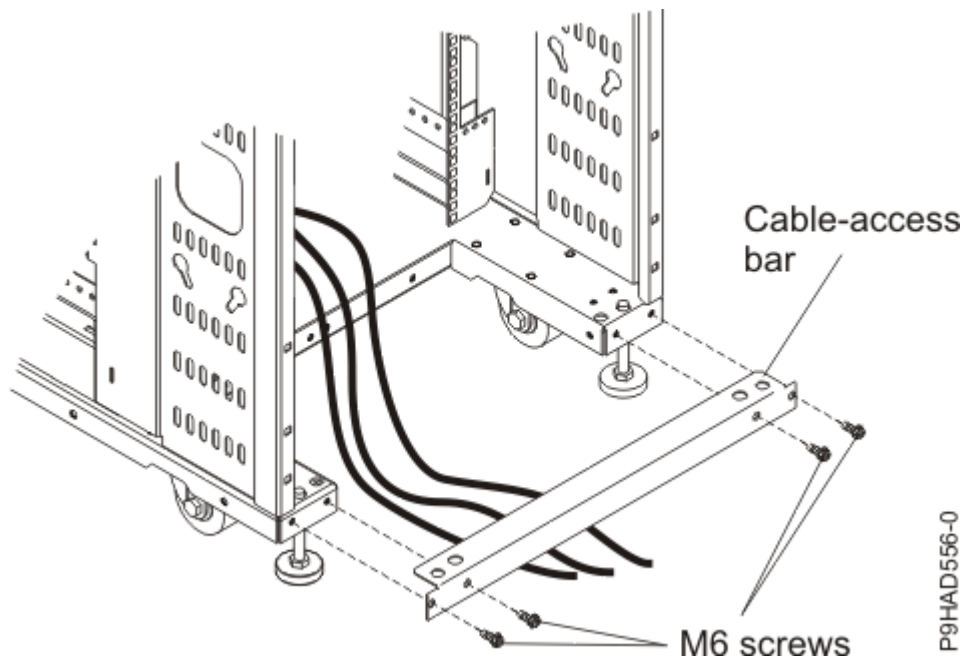

Figure 9. Cable access bar

### **Cabling overhead**

Front and rear rectangular cable access openings that are on the top of the rack cabinet allow cables to be routed up and out of the rack. Cable access covers are adjustable by loosening the side screws and sliding the covers forward or backward.

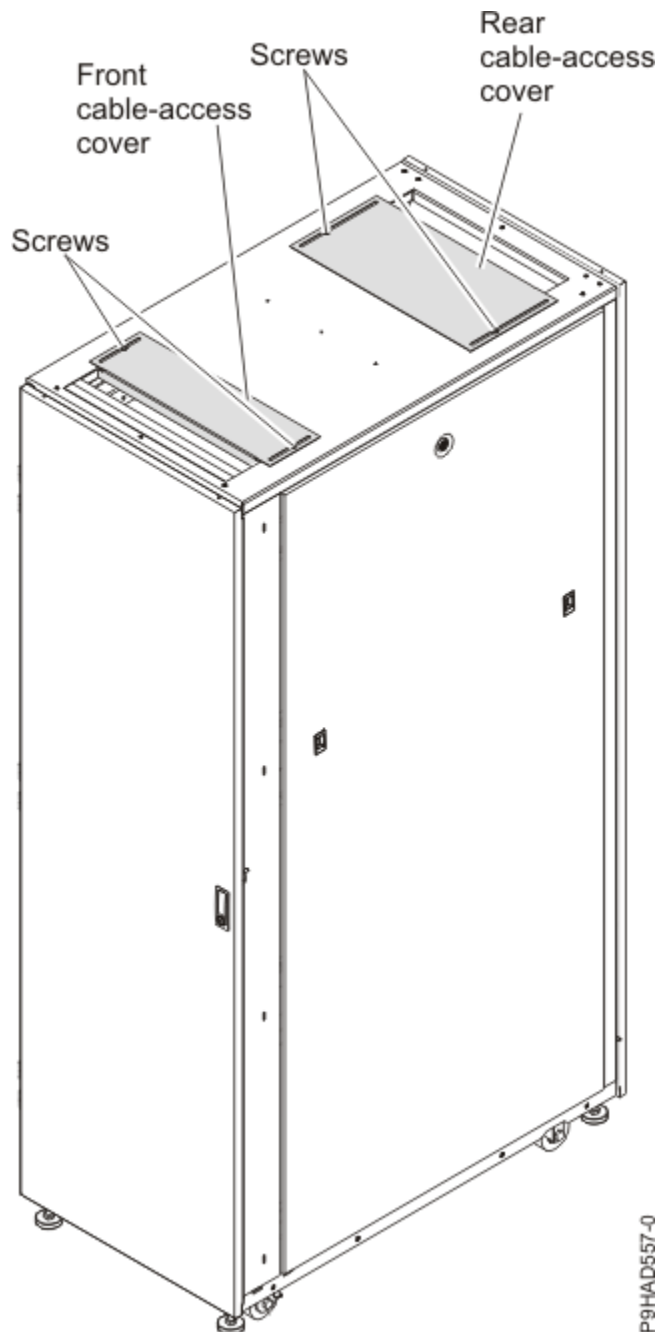

Figure 10. Cable access covers

### **Side stabilizing outriggers**

Learn about the side stabilizing outriggers available for the 7953-94X and 7965-94Y rack.

The outriggers are stabilizers with wheels that are installed on the sides of the rack cabinet. The outriggers can be removed only after the rack is in the final location and is not moved more than 2 m (6 ft) away in any direction.

To remove the outriggers, use a 6 mm hex wrench to remove the four bolts that attach each outrigger to the rack cabinet.

Keep each of the outriggers and bolts in a safe place for future use when you move the rack. Reinstall the outriggers to move the rack cabinet to another location that is greater than 2 m (6 ft) away from its current location.



Table 26. Dimensions for rack with outriggers

Width	Depth	Height	Weight	EIA unit capacity
780 mm (30.7 in.)	1095 mm (43.1 in.)	2002 mm (78.8 in.)	261 kg (575 lb)	42 EIA units

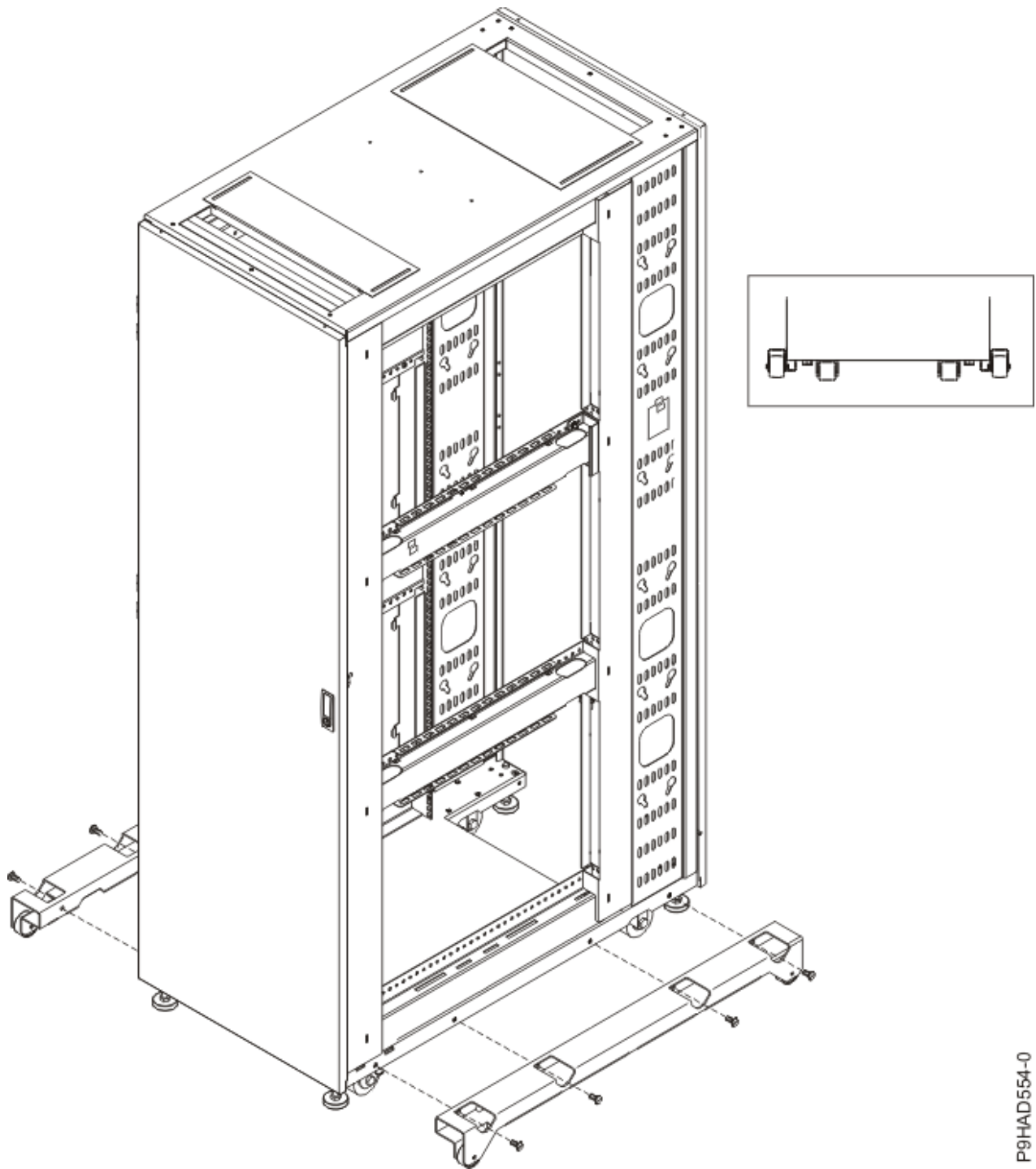

Figure 11. Outrigger locations

P9HAD554-0

## Multiple racks

Learn how to attach multiple 7953-94X and 7965-94Y racks together.

Multiple 7953-94X and 7965-94Y racks can be attached together by using attachment brackets that connect the units at the front of the rack. See [Figure 12](#) on page 32.

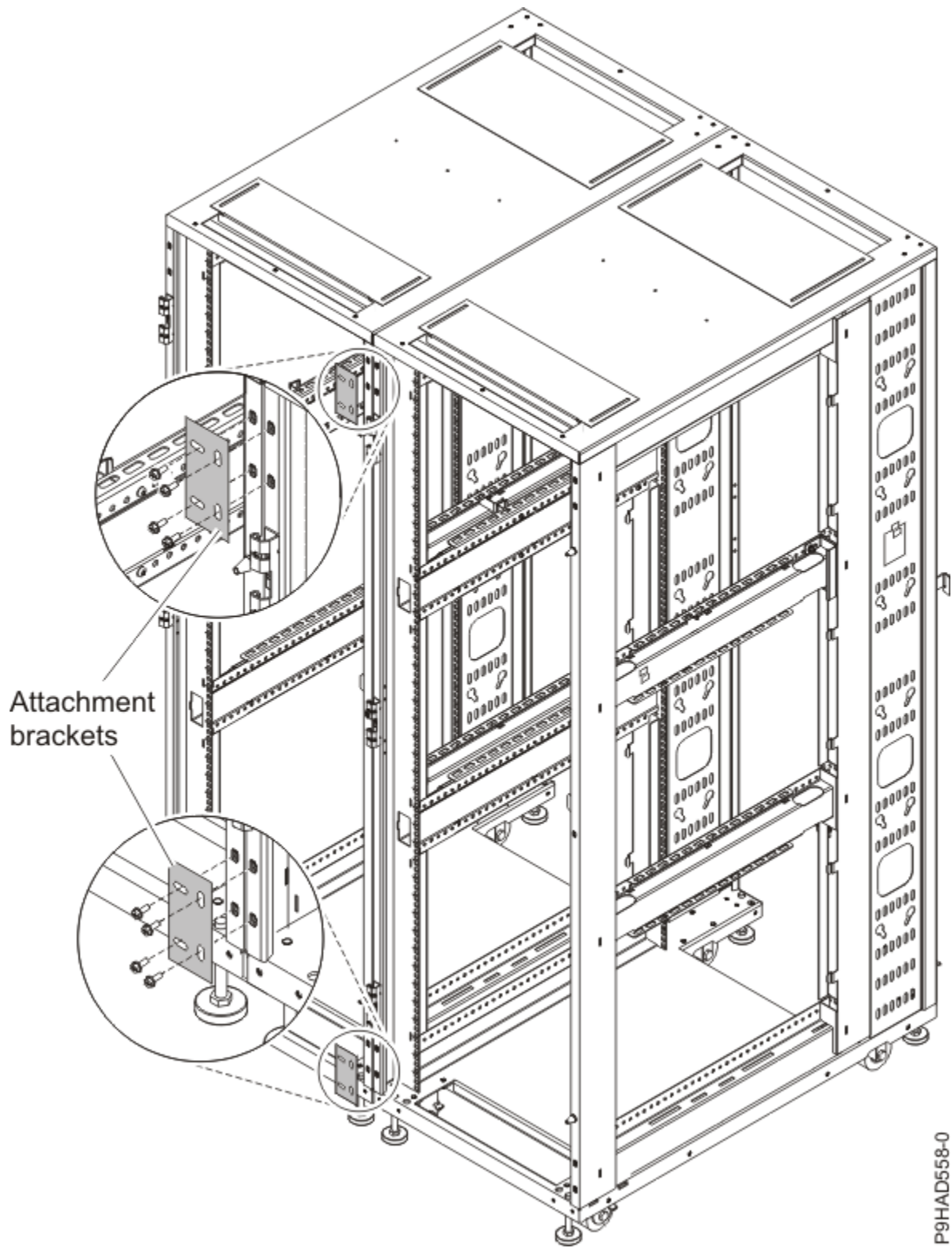

Figure 12. Attachment brackets

## Model 1164-95X rear door heat exchanger specifications

Learn about the specifications of the 1164-95X rear door heat exchanger (feature code ECR2).

Width	Depth	Height	Weight (empty)	Weight (filled)
600 mm (23.6 in.)	129 mm (5.0 in.)	1950 mm (76.8 in.)	39 kg (85.0 lb) <sup>1</sup>	48 kg (105.0 lb)

1. A minimum of three people are required to lift the rear door heat exchanger because of the weight.

### Water specifications

- Pressure
  - Normal operation: <414 kPa (60 psi)
  - Maximum: 689.66 kPa (100 psi)
- Volume
  - Approximately 9 liters (2.4 gallons)
- Temperature
  - Water temperature must be above the dew point in the data center
  - 18°C ± 1°C (64.4°F ± 1.8°F) for ASHRAE Class 1 Environment
  - 22°C ± 1°C (71.6°F ± 1.8°F) for ASHRAE Class 2 Environment
- Required water flow rate (as measured from the supply entrance to the heat exchanger)
  - Minimum: 22.7 liters (6 gallons) per minute
  - Maximum: 56.8 liters (15 gallons) per minute
  - **Note:** The actual flow rate differs per installation, which is based on achieving heat removal requirements.

### Water specifications for the secondary cooling loop

**Important:** The water that is being supplied to the heat exchanger must meet the requirements that are described in this section. Otherwise, system failures might occur over time as a result of any of the following problems:

- Leaks due to corrosion and pitting of the metal components of the heat exchanger or of the water-supply system.
- Buildup of scale deposits inside the heat exchanger, which can cause the following problems:
  - A reduction in the ability of the heat exchanger to cool the air that is exhausted from the rack.
  - Failure of mechanical hardware, such as a hose quick-connect coupling.
- Organic contamination, such as bacteria, fungi, or algae. This contamination can cause the same problems as described for scale deposits.

Contact a water quality and water distribution services expert for designing and implementing the infrastructure and water chemistry of the secondary loop.

### Water-supply requirements for secondary loops

Learn about the specific characteristics of the system that supplies the chilled conditioned water to the heat exchanger.

## Temperature:

The heat exchanger and its supply hose and return hoses are not insulated. Avoid any condition that might cause condensation. The temperature of the water inside the supply hose, return hose, and heat exchanger must be kept above the dew point of the location where the heat exchanger is being used.



**Attention:** Typical primary chilled water is too cold for use in this application because building chilled water can be as cold as 4°C - 6°C (39°F - 43°F).

## Important:

The system that supplies the cooling water must be able to measure the room dew point and automatically adjust the water temperature. Otherwise, the water temperature must be above the maximum dew point for that data center installation. For example, the following minimum water temperature must be maintained:

- 18°C plus or minus 1°C (64.4°F plus or minus 1.8°F). This specification is applicable within an ASHRAE Class 1 Environmental Specification that requires a maximum dew point of 17°C (62.6°F).
- 22°C plus or minus 1°C (71.6°F plus or minus 1.8°F). This specification is applicable within an ASHRAE Class 2 Environmental Specification that requires a maximum dew point of 21°C (69.8°F).

See the *ASHRAE document Thermal Guidelines for Data Processing Environments*.

## Pressure:

The water pressure in the secondary loop must be less than 690 kPa (100 psi). Normal operating pressure at the heat exchanger must be 414 kPa (60 psi) or less.

## Flow rate:

The flow rate of the water in the system must be in the range of 23 - 57 liters (6 - 15 gallons) per minute and high enough to meet heat removal requirements.

Pressure drop versus flow rate for heat exchangers (including quick-connect couplings) is defined as approximately 103 kPa (15 psi) at 57 liters (15 gallons) per minute. For more information, see the pressure vs flow curve in [Figure 18 on page 38](#).

## Water volume limits:

The heat exchanger holds approximately 9 liters (2.4 gallons). The full length of the hose kits (4.26 m (14 ft) of 2.54 cm (1.0 in.) inner diameter hose) for supply and return hoses hold approximately 4.3 liters (1.1 gallons).

## Air exposure:

The secondary cooling loop is a closed loop, with no continuous exposure to room air. After you fill the loop, remove all air from the loop. An air bleed valve is provided at the top of a heat exchanger manifold for purging all air from the system. You must obtain a [bleeding hose](#). The instructions for bleeding the air are located in the [installation instructions](#).

## Heat exchanger performance

A heat removal of 100% indicates an amount of heat that is equivalent to the heat that is generated by the devices that is removed by the heat exchanger and the average air temperature that is leaving the heat exchanger is identical to that entering the rack (27°C (80.6°F) in this example). Heat removal in excess of 100% indicates that the heat exchanger not only removed all of the heat that was generated by the devices, but further cooled the air so that the average air temperature that is leaving the rack is lower than air temperature that is entering the rack.

To help maintain optimum performance of the rear door heat exchanger and provide proper cooling for all rack components, you must take the following precautions:

- Install filler panels over all unoccupied bays.

- Route signal cables at the rear of the rack so that they enter or exit the cabinet through the top and bottom air baffles.
- Bundle signal cables together in a rectangle so that the upper and lower air-baffle sliders are closed as far as possible. Do not bundle signal cables together in a circular formation.

Figure 13 on page 35 - Figure 18 on page 38 allows you to decide what is the required water flowrate per rear door heat exchanger, so the facility and CDU can be sized.

As example, pick one of Figure 13 on page 35 - Figure 17 on page 37, whichever more closely resembles the expected sustained heat load. Interpolate between graphs if necessary. Pick the curve that defines the water temperature that can be provided to the rear door heat exchanger. Determine the water flow rate that is required to achieve 5 - 10% more heat removal than is required for the installation. This additional capacity allows for less than perfect airflow that is blocking and possible air that bypasses the rear door heat exchanger. For instance, if you want the rear door heat exchanger to make the rack data center neutral, you can select a water flow rate that provides 105 - 110% heat removal in order to provide some margin to the cooling design. For rack powers other than what is listed in Figure 13 on page 35 - Figure 17 on page 37, for racks that are far from uniformly populated with heat generating devices, or for racks with significantly different airflow rates than what the curves show (plus or minus 30%), you must take guidance from IBM Power Systems Thermal Development, which is available through the IBM Sales team.

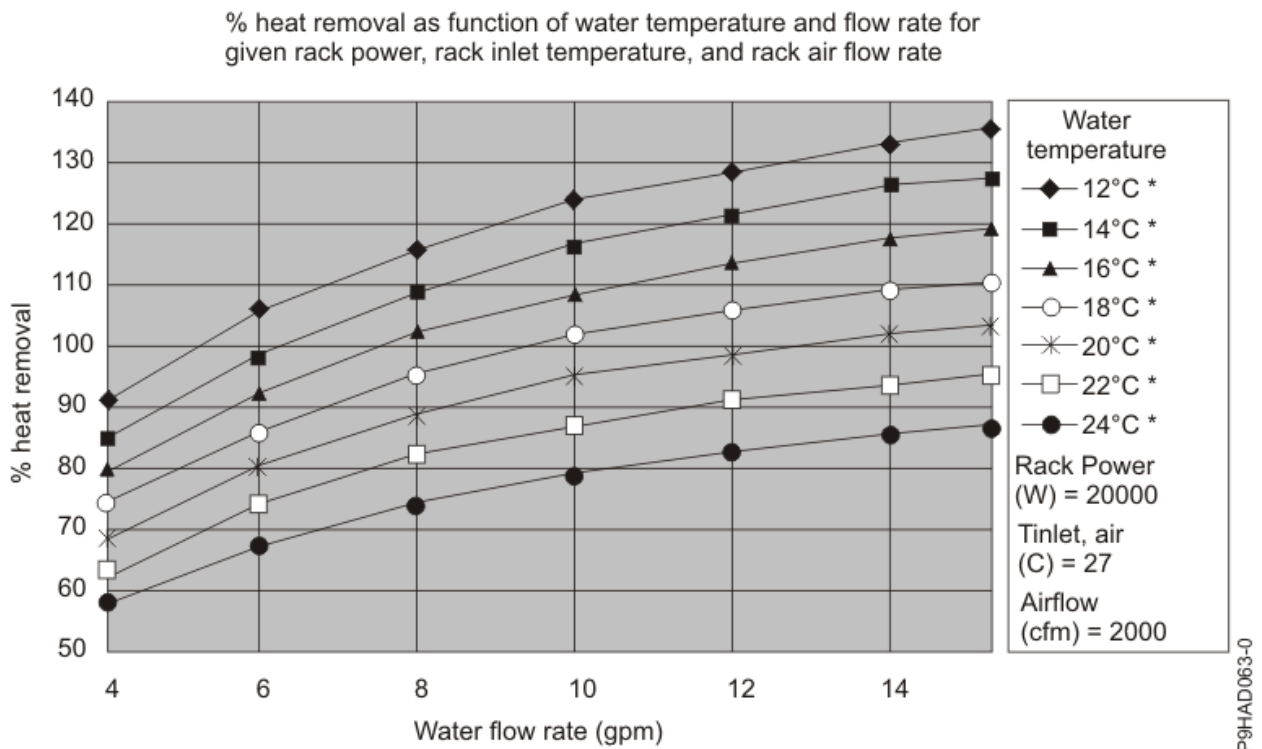

Figure 13. Typical performance of the heat exchanger, 20 kW heat load

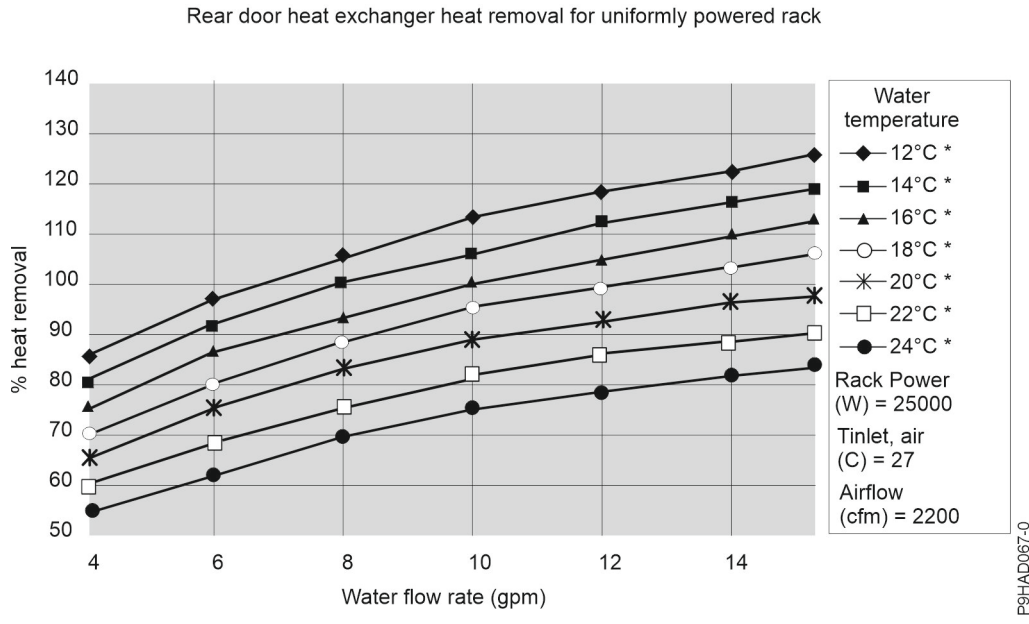

Figure 14. Typical performance of the heat exchanger, 25 kW heat load

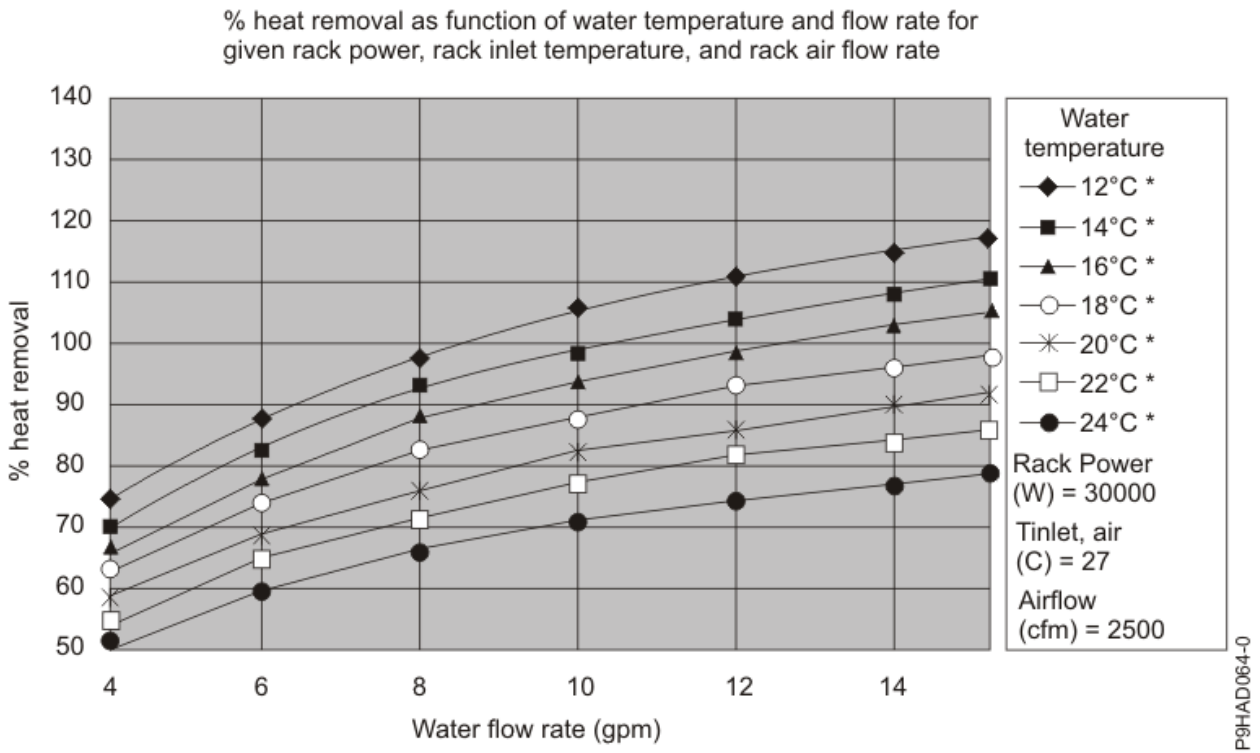

Figure 15. Typical performance of the heat exchanger, 30 kW heat load

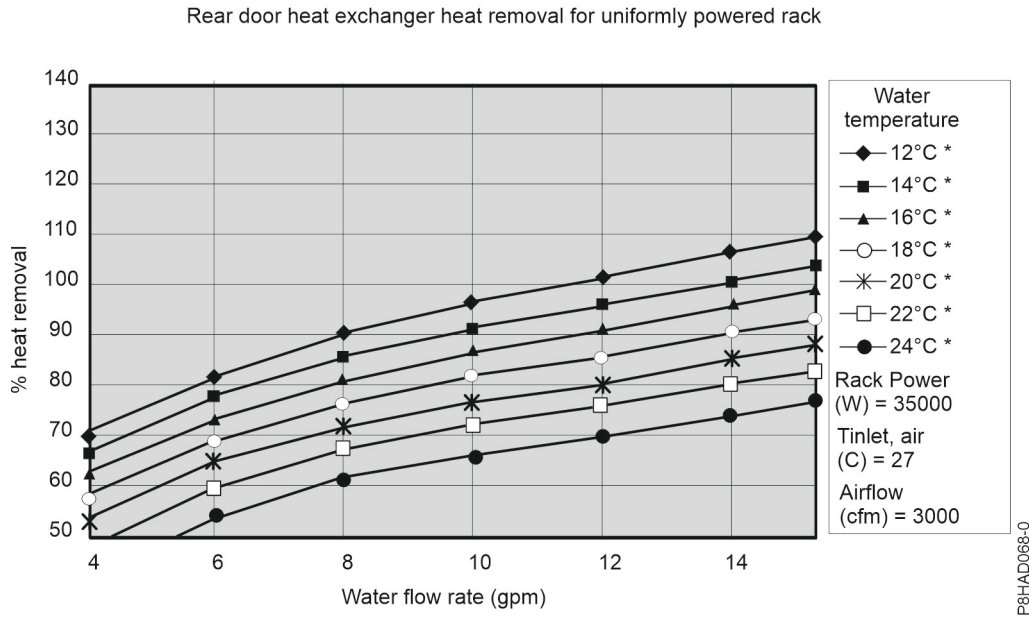

Figure 16. Typical performance of the heat exchanger, 35 kW heat load

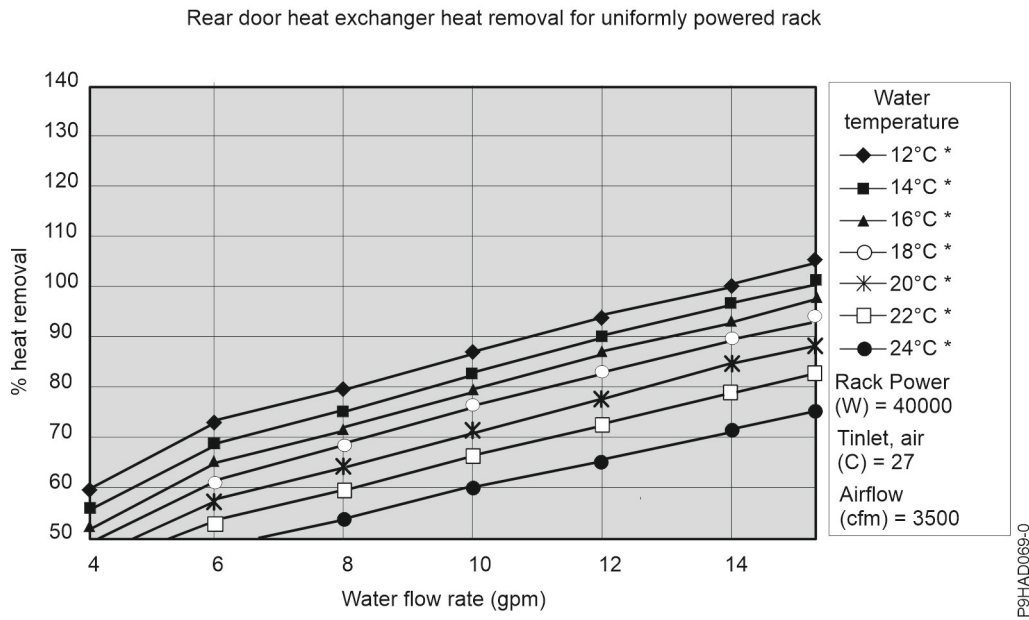
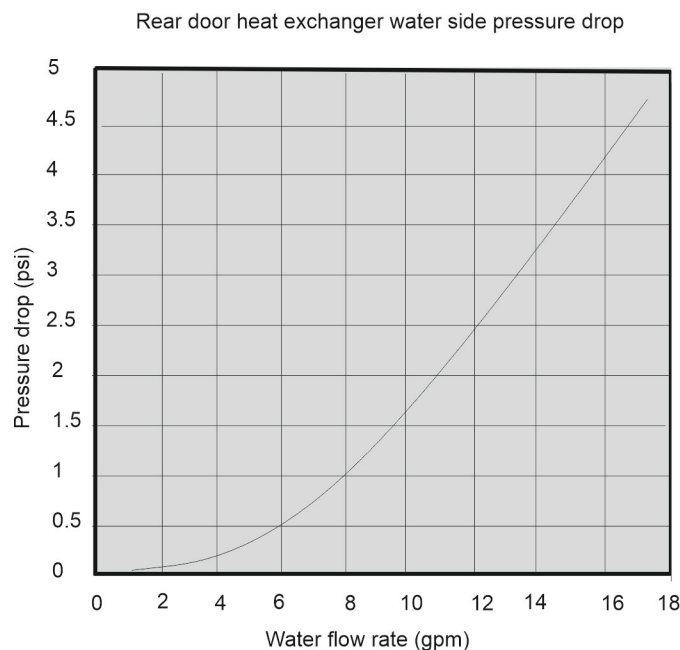

Figure 17. Typical performance of the heat exchanger, 40 kW heat load

After the required water flowrate per rear door heat exchanger is defined per the heat removal information above, the water-side pressure drop of the rear door heat exchanger can be determined from [Figure 18 on page 38](#).

Using the total water flowrate requirement for all of the rear door heat exchangers and the pressure drop for the entire water flow network, which the rear door heat exchanger is a part of, the facility and CDU can be defined to meet these flow and pressure drop requirements.





P9HAD070-0

Figure 18. Pressure drop (standard units)

## Water delivery specifications for secondary loops

Learn about the various hardware components that make up the delivery system secondary loop that provides the chilled, conditioned water to the heat exchanger. The delivery system includes pipes, hoses, and the required connection hardware to connect the hoses to the heat exchanger. Hose management can be used in raised-floor and non-raised-floor environments.

The heat exchanger can remove 100% or more of the heat load from an individual rack when it is running under optimum conditions.

The primary cooling loop is considered to be the building chilled-water supply or a modular chiller unit. The primary loop must not be used as a direct source of coolant for the heat exchanger because the fluid that is delivered to the rear door heat exchanger must be above the dew point. Procurement and installation of the components that are needed to create the secondary cooling loop system are required for this design and are your responsibility. The main purpose is to provide examples of typical methods of secondary loop setup and operating characteristics that are needed to provide an adequate and safe supply of water to the heat exchanger.

You must obtain a cooling distribution unit (CDU) and water that meets cleanliness, filtration, and chemical requirements that are listed in [Planning for water cooling](#). CDUs are available from suppliers such as [Motivair](#) and [Nortek](#). CDUs deliver water at a proper flow rate and temperature to the heat exchanger, while it maintains the temperature above the dew point to avoid condensation. CDUs are also essential to control the closed loop of the water that flows through the heat exchanger to maintain proper water cleanliness, filtration, and chemistry while it controls the wet materials in the loop.



### Attention:

The overpressure safety device must meet the following requirements:

- Comply with *ISO 4126-1*.
- Be installed so that it is easily accessed for inspection, maintenance, and repair.
- Be connected as close as possible to the device that it is intended to protect.
- Be adjustable only with the use of a tool.
- Have a discharge opening that is directed so that discharged water or fluid does not create a hazard or be directed toward any person.



- Be of adequate discharge capacity to ensure that the maximum working pressure is not exceeded.
- Be installed without a shutoff valve between the overpressure safety device and the protected device.

Read the following guidelines before you design the installation:

- A method for monitoring and setting the total flow rate that is delivered to all of the heat exchangers is required. This can be a discrete flowmeter that is built into the flow loop or a flowmeter within the secondary loop of the coolant distribution unit (CDU).
- After you set the total flow rate for all of the heat exchangers by using a flowmeter, it is important to design the plumbing so that it provides the flow rate that you want for each heat exchanger and provides a way to verify the flow rate. Other methods, such as inline or external flowmeters, can provide a more accurate method for setting the flow rate through the individual shutoff valves.
- Design the flow loop to minimize the total pressure drop within the flow loop.

### **Manifolds and piping:**

Manifolds that accept large-diameter feed pipes from a pump unit are the preferred method for splitting the flow of water to smaller-diameter pipes or hoses that are routed to individual heat exchangers. Manifolds must be constructed of materials that are compatible with the pump unit and related piping. The manifolds must provide enough connection points to allow a matching number of supply and return lines to be attached, and the manifolds must match the capacity rating of the pumps and the loop heat exchanger (between the secondary cooling loop and the building chilled-water source). Anchor or restrain all manifolds to provide the required support to avoid movement when quick-connect couplings are connected to the manifolds. Design the manifolds so that there is a minimal pressure drop that is based on the total flow rate through the manifold. The manifold size must be selected to allow an even flow rate through each parallel rear door heat exchanger.

To stop the flow of water in individual legs of multiple circuit loops, install shutoff valves for each supply and return line. This provides a way to service or replace an individual heat exchanger without affecting the operation of other heat exchangers in the loop.

To ensure that water specifications are being met and that the optimum heat removal is taking place, use temperature and flow metering (monitoring) in secondary loops.

Anchor or restrain all manifolds and pipes to provide the required support and to avoid movement when quick-connect couplings are being attached to the manifolds.

[Figure 19 on page 40](#) shows an example of a CDU with a manifold that is plumbed with supply and return ports for each heat exchanger that the CDU flows water to. This example is of an implementation of multiple heat exchangers with a single CDU that allows 35.56 cm (14 in.) or shorter hoses to be connected to the CDU.

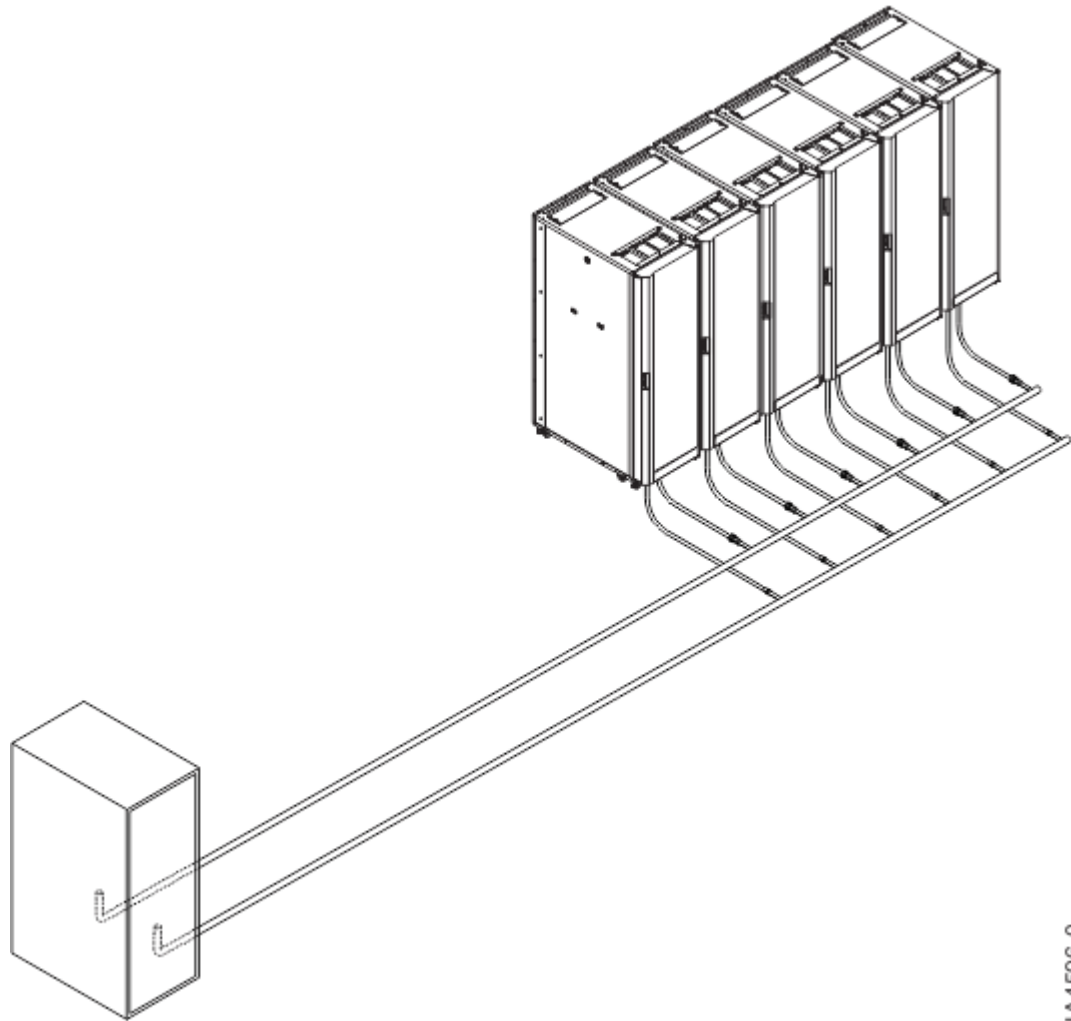

P91A4596-0

*Figure 19. Typical extended manifold*

**Flexible hoses and connections to manifolds and heat exchangers:**

Pipe and hose configurations can vary. You can determine the best configuration for your installation by analyzing the needs of your facilities, or a site preparation representative can provide this analysis.

Flexible hoses that supply and return water between your hard plumbing (manifolds and coolant distribution units) and the heat exchanger (allowing needed movement for opening and closing the rack rear door) are provided by IBM. Hoses can be cut to length, but first must be cleaned so that no particles are inside the hose before installation. Some slack must be kept in the hose for easier installation. For more information about recommended clamping tools and specifications, see the [Oetiker website](#). [Figure 20 on page 41](#) shows what is in the hose kit that is supplied with the heat exchanger.

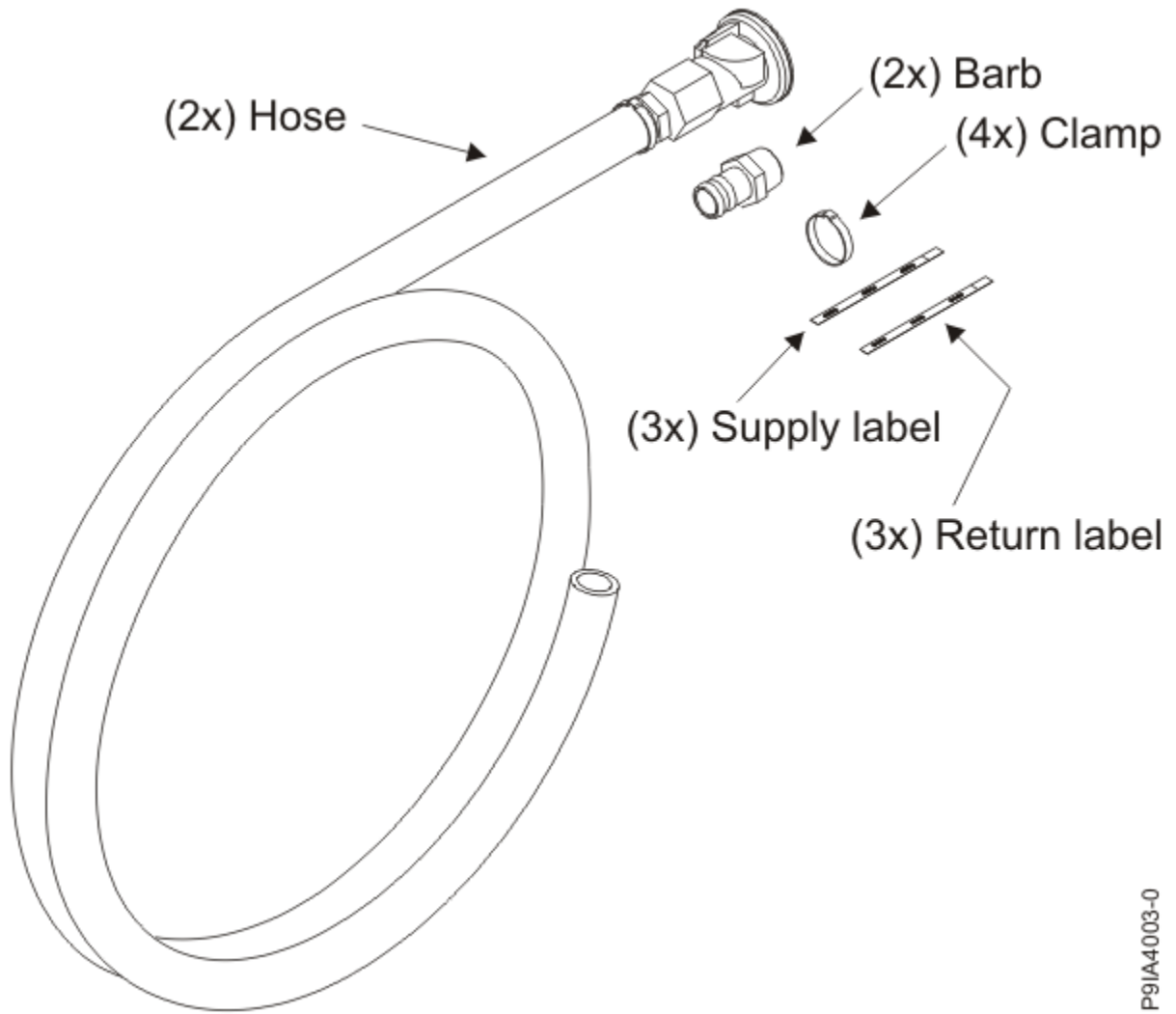

Figure 20. Hose kit

Table 28. Hose kit dimensions	
Hose information	Dimensions or type
Hose length	4.26 m (14 ft)
Hose machine end	Quick-connect
Water supply end	25.4 mm (1 in.) National Pipe Thread Taper (NPT) male barb and clamp <sup>1</sup>
Bend radius	203.2 mm (8 in.)
Hose inside diameter	25.4 mm (1 in.) plus or minus 0.5 mm (0.02 in.)
Hose outside diameter	34.54 mm (1.4 in.) plus or minus 0.76 mm (0.03 in.)

Table 28. Hose kit dimensions (continued)

Hose information	Dimensions or type
<p><b>Notes:</b></p> <p>The facility hose kit is supplied in a separate box from the rack and contains the following items:</p> <ul style="list-style-type: none"> <li>• Two 4.26 m (14 ft) hoses with preattached quick-connects for connection to manifold. At one end of the hose, there is a quick-connect that mates with the quick-connect at the end of the hose from the manifold. The other end is a bare cut end.</li> <li>• Two 25.4 mm (1 in.) NPT male barbs. One end of the fitting is a 25.4 mm (1 in.) barb to fit on the inside of the 25.4 mm (1 in.) inner diameter hose. The other end of the fitting is a 25.4 mm (1 in.) male NPT.</li> <li>• Four Oetiker hose clamps 16703242 (two hose clamps are required and two hose clamps are extra).</li> <li>• Three supply labels (only two supply labels are required). The supply labels need to be installed on the supply end of the hose after it is connected to the facility.</li> <li>• Three return labels (only two return labels are required). The return labels need to be installed on the return end of the hose after it is connected to the facility.</li> </ul> <p><sup>1</sup>You must provide a 25.4 mm (1 in.) NPT female fitting on the facility hoses.</p>	

The customer provided interconnection to the rack (under-the-floor manifold, CDU, and so on) must have a 25.4 mm (1 in.) female NPT fitting for each manifold supply and return connection. The 25.4 mm (1 in.) NPT male barb fitting from the hose kit must be threaded onto the NPT female fitting on the customer CDU plumbing. A thread sealant must be used to create a leak-free connection. Teflon tape cannot be used, as Teflon tape particles might enter the water stream.

To make the connection from the hose to the barb fitting, the facility hoses must first be cut to length. If the CDU plumbing fitting requires a longer hose than the 4.26 m (14 ft) facility hose, the plumbing must be altered to bring the fitting close enough such that the 4.26 m (14 ft) facility hose is sufficient. The end of the hose must be cleaned so that no particles are inside the hose before installation. The clamp is inserted over the hose and then the barb is inserted into the hose. Position the clamp within 5 mm (1.97 in.) of the hex portion of the fitting (not over the barb) and tighten the clamp with an Oetiker clamp tool. For more information about the clamp tool, see [Forged steel Standard Jaw Pincers](#). The ears of the clamp must be tightened so that they make contact with each other. When the clamp is released, the ears relax and a small space is left between. This small space is normal. [Figure 21 on page 42](#) shows dimension **s** that must be fully closed during the clamping process.

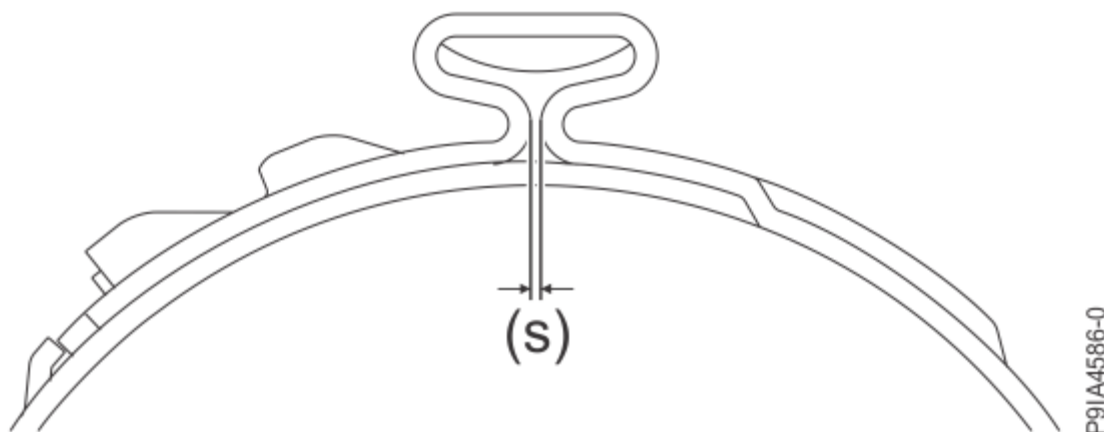

Figure 21. Clamp ear

The supply and return labels must be applied on both ends of the facility hose to indicate the function of each hose. The quick connects on the end of the facility hose can now be connected to the quick connects on the heat exchanger.

## Hose routing and floor tile cutout information

### Raised-floor Environment

If the hose is to be routed under the raised floor, a cutout must be made in the floor tile under the rack. The access hole for the supply and return hoses must be a minimum of 200 mm (8 in.) long by 100 mm (4 in.) wide. Each cutout must be lined with grommets so that the hose is not pulled across sharp edges of the cutout. Consult your floor tile manufacturer to determine whether there are more supports that are required for the cutout, or requirements for the position of the cutout in regard to the edge of the floor tile. The following figures show three different possibilities for floor tile cutout locations and the hose routing for each cutout location. Variations to this routing are allowed. These three figures show the general routing that allows for the door to open and close with minimal hose kinking and movement.

**Note:** These illustrations show the view of the rack from the top, looking down.

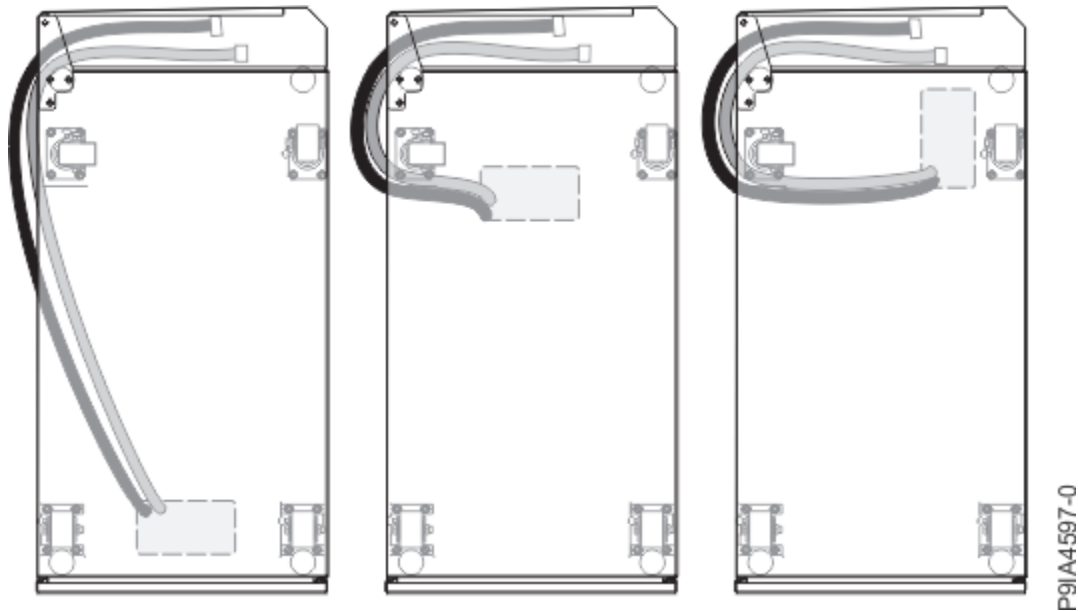

Figure 22. Routing and securing the hoses in a raised floor environment for individual racks

In the following illustration, the numbers represent the suggested placement of racks that share one hole in the floor. For example, if three racks share one hole in the floor, place the racks as shown by numbers 1, 2, and 3. If you want to add a fourth rack that uses the same hole in the floor, then place it next to rack number 1.

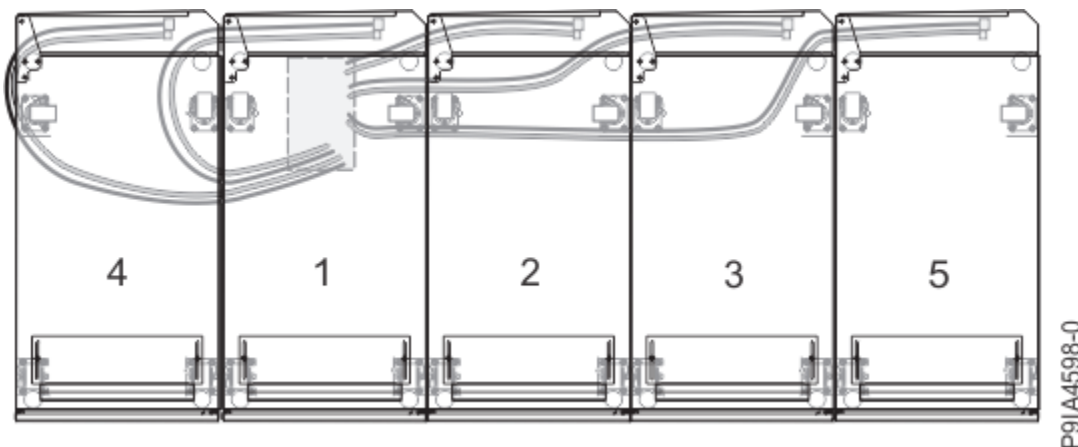

Figure 23. Option for hoses in adjacent racks to share a single hole in the floor

**Note:** If more than one rack uses the same hole in the floor tile, the floor tile cutout must be increased in size.

## Raised-floor and non-raised-floor Environments

If the coolant distribution unit (CDU) that is providing water to the heat exchangers is in a row of racks with the heat exchangers, all hoses can be routed on top of the floor, irrespective of whether it is a raised floor or a slab floor installation. The model type 7965 rack has sufficient clearance underneath the rack to enable the quick connects to be run underneath the rack. This configuration provides a clean hose routing solution with the hoses of minimum length.

**Note:** If this solution is used, you must determine the CDU position such that 4.26 m (14 ft) of hose is sufficient from the CDU to the heat exchanger. Each hose must be routed with a minimum bend radius of 200 mm (8 in.). A bend radius less than 200 mm (8 in.) causes the hose to kink, restricts flow to and from the heat exchanger, and voids the heat exchanger warranty.

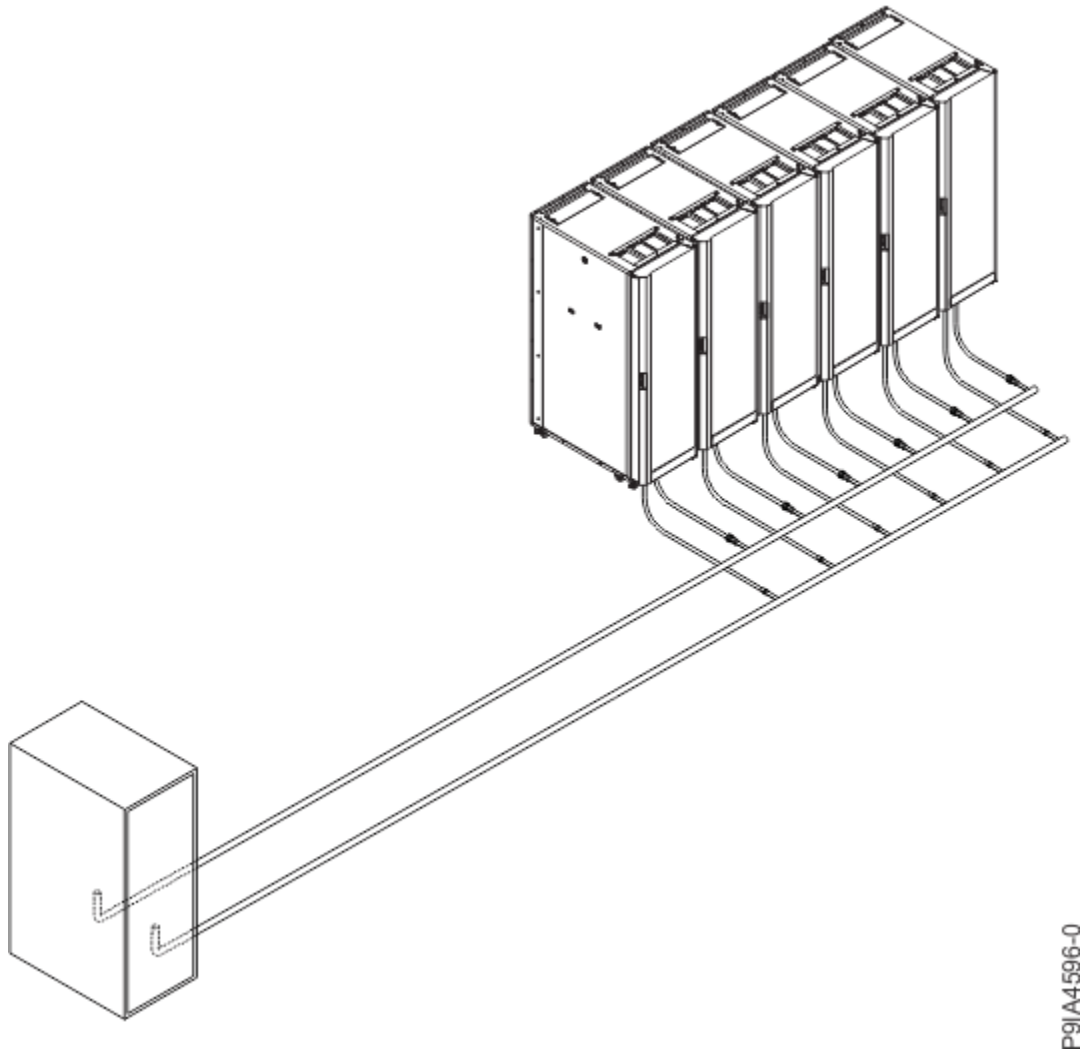

Figure 24. Routing and securing the hoses in a raised-floor and non-raised floor environment

## Overhead hose routing Environment

The heat exchanger can be configured on the rack so that the quick connects are at the top of the rack instead of the bottom. This configuration must be used if the hoses are to be routed above the racks. In this configuration, the hose must be strain relieved and supported by a customer supported structure above the racks.

P91A4596-0

Each hose must be routed with a minimum bend radius of 200 mm (8 in.). A bend radius less than 200 mm (8 in.) causes the hose to kink, restricts flow to and from the heat exchanger, and voids the heat exchanger warranty.

The CDU must be placed so that 4.26 m (14 ft) of hose is sufficient from the CDU to the heat exchanger.

## Placement of 7965 racks with 1164-95X installed

When model type 7965 racks with the 1164-95X rear door heat exchanger are placed directly next to another model type 7965 with the 1164-95X rear door heat exchanger, the rear door heat exchanger can open approximately 130 degrees to allow for rear access.

If a 7965 rack with the 1164-95X rear door heat exchanger is placed next to a wall, building column, or any other obstruction, approximately 38.1 cm (15 in.) of space must be left between the hinge side of the rear door heat exchanger and the wall to ensure proper opening of the rear door heat exchanger for rear service.

If another rack type is placed next to a 7965 rack with the 1164-95X rear door heat exchanger, the other rack must be positioned so that it does not extend beyond the rear of the 7965 rack frame.

## Required tools

The following tools are required onsite to install the rear door heat exchanger:

- [Forged steel Standard Jaw Pincers](#)
- [Hose cutter](#)
- [bleeding hose](#)
- Nut drivers or sockets
- Screwdriver

**Important:** You must obtain these tools before you start the installation process.

## ***Model 7965-94Y water cooling manifold (Feature codes ER22 and ER23)***

Learn about the water cooling manifold that is available for model 7965-94Y racks with feature code (FC) ER22 or ER23 installed.

## Overview

The 7965-94Y water cooling manifold provides water supply and water return for 1 - 20 servers that are mounted in a 7965-94Y 42U slim rack. The manifold is mounted on the right side of the rack (when viewed from the rear of the rack) and extends for 40U. Power distribution unit (PDU) pockets on the right (when viewed from the rear) are not accessible and cannot be populated in the water-cooled configuration. The manifold does not interfere with the placement of servers or other I/O drawers. Quick connect fittings are located every 2U on the manifold for water supply and return that provides 20 pairs of fittings.

**Note:** This solution is only available for use with IBM water-cooled servers.

## Configurations

FC ER22 can be used to order the manifold with water input and output at the top of the rack. Since the hose exits through the top of the rack, the top 2U must be left vacant. All 2U drawers must be populated into the rack on odd EIA increments.

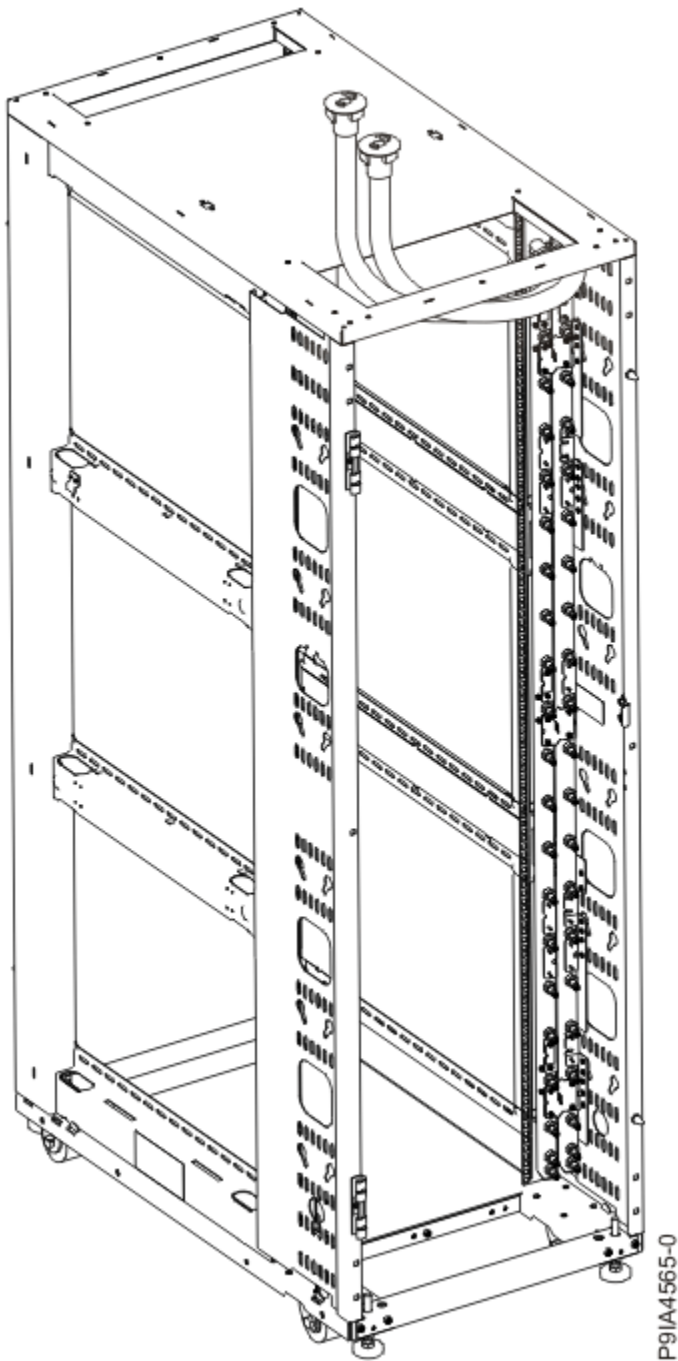

*Figure 25. Rack and manifold with supply and return hoses exiting through the top of the rack*

FC ER23 can be used to order the manifold with water input and output at the bottom of the rack. Since the hose exits through bottom of the rack, some space must be left open on the bottom. When 1U of bottom space is left open, all 2U drawers must be populated into the rack on even EIA increments. When 2U of bottom space is left open, all 2U drawers must be populated at odd EIA increments.



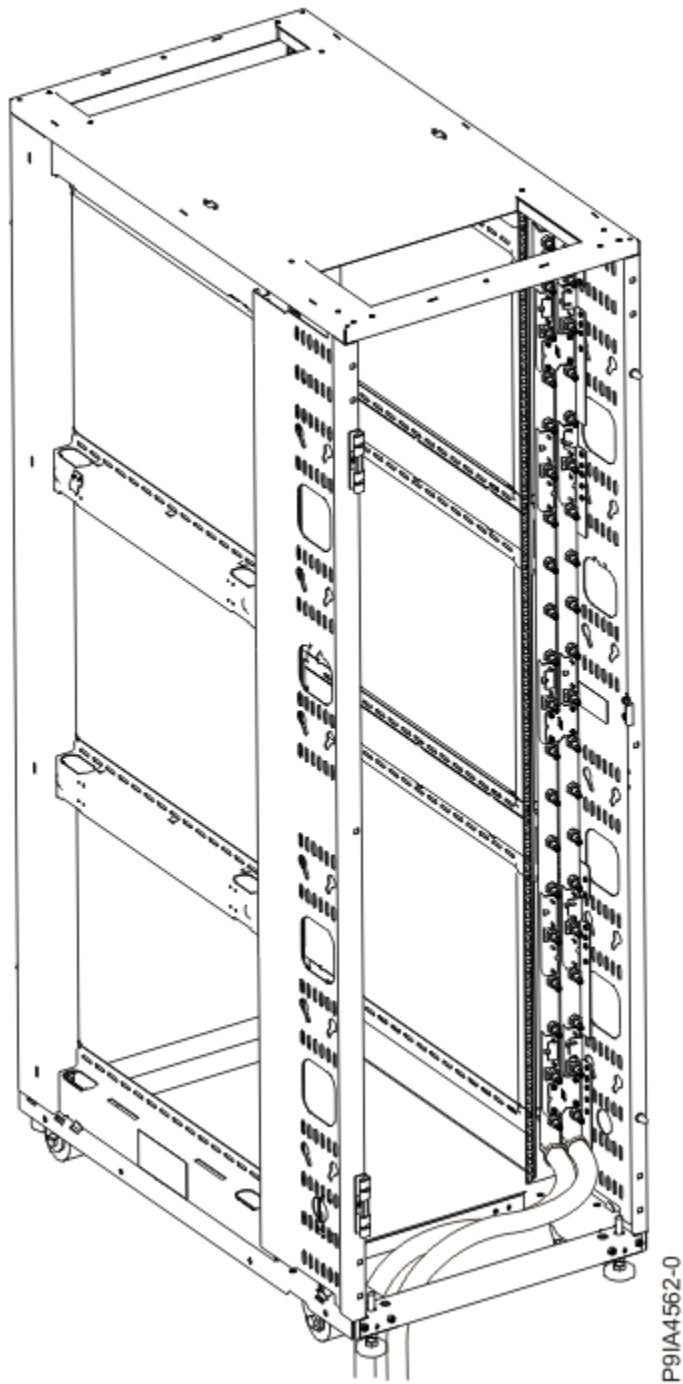
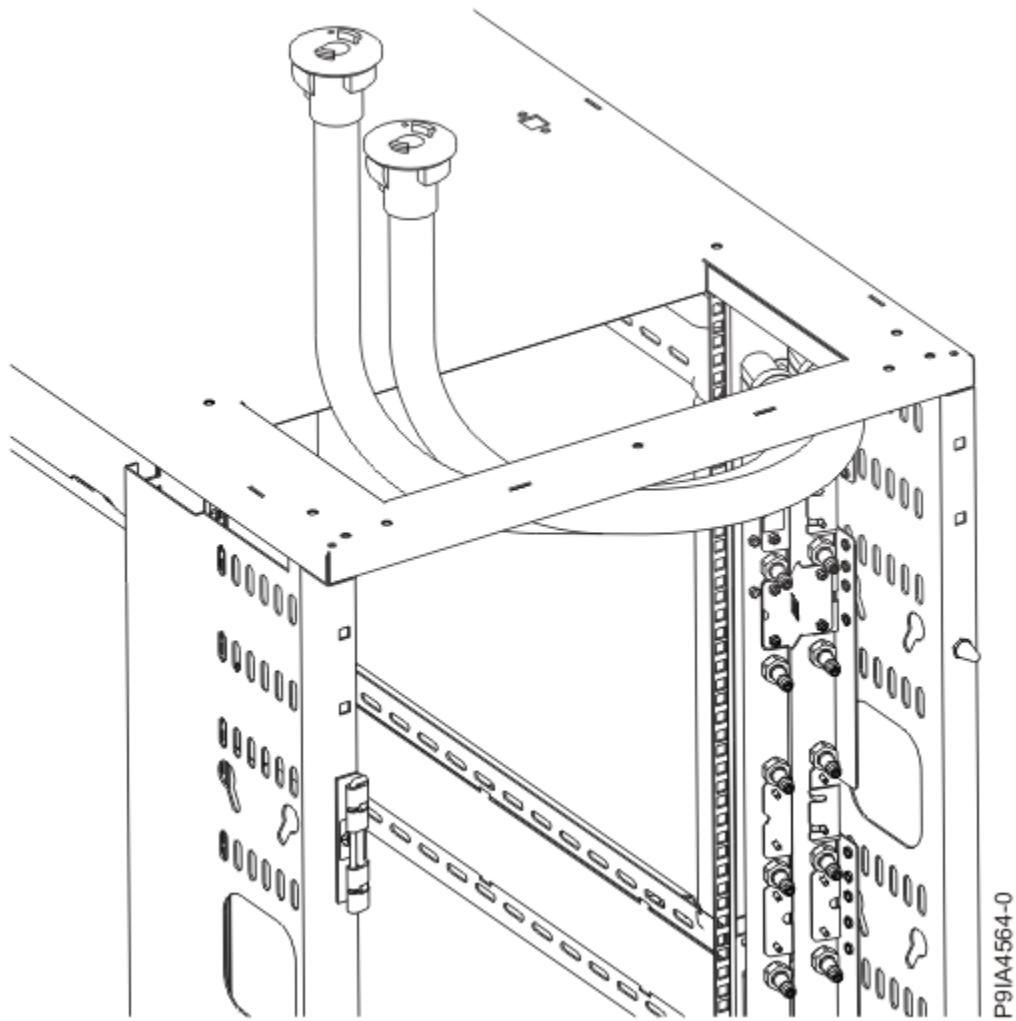

Figure 26. Rack and manifold with supply and return hoses exiting through the bottom of the rack

### **Top hose exit locations**

The following graphics show the location of the hose exiting from the top of the 7965-94Y rack.



P91A4564-0

Figure 27. Top hose exit locations

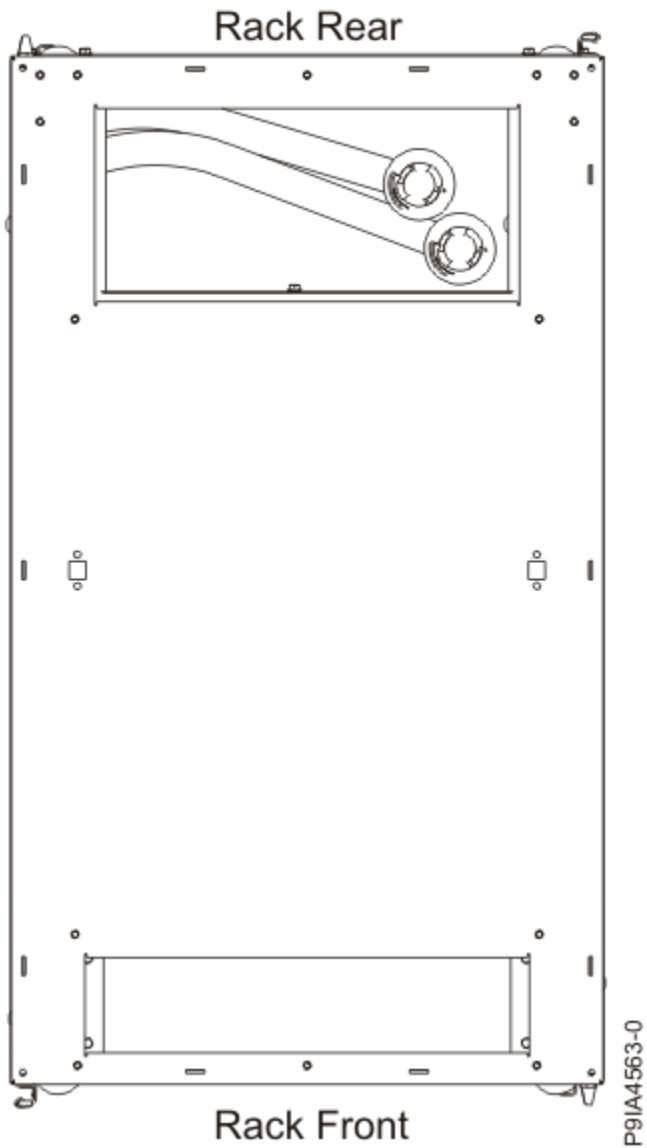
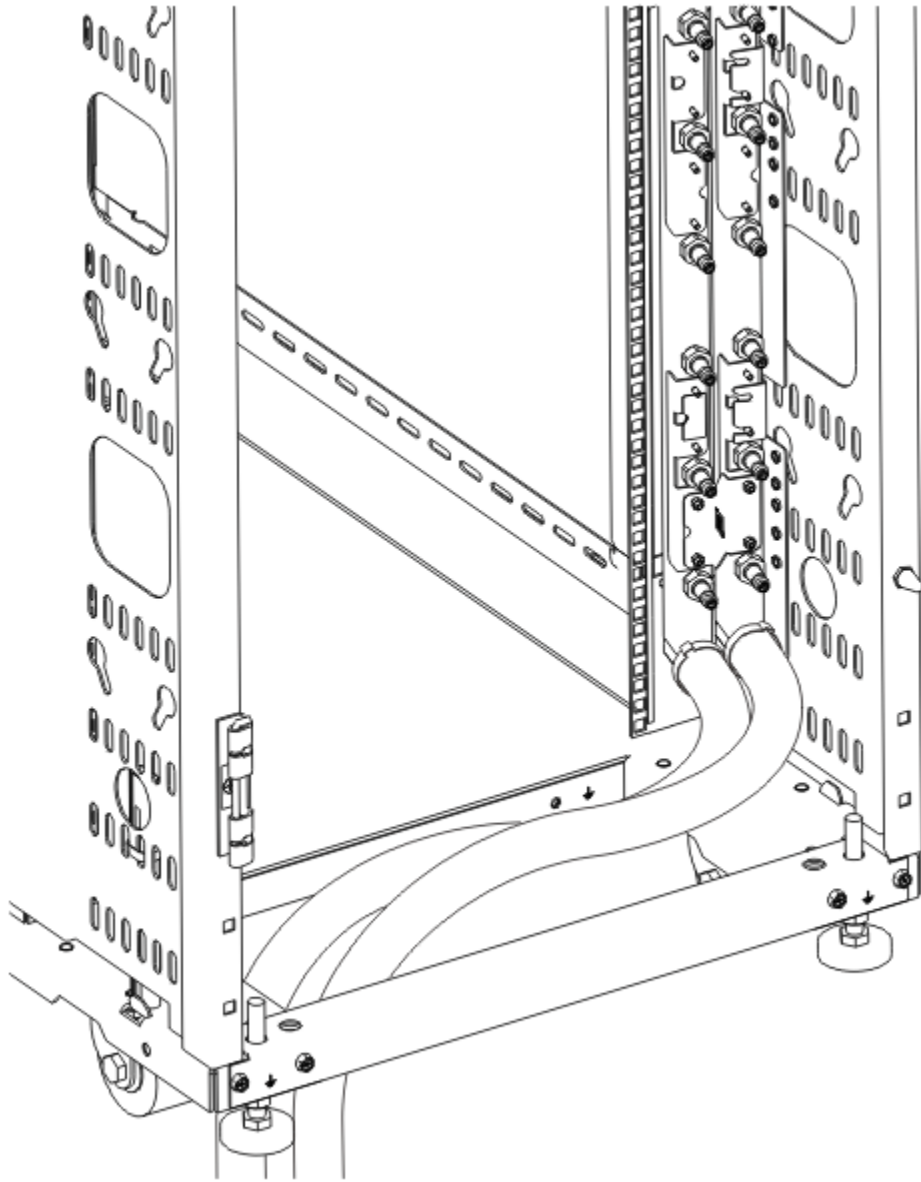

Figure 28. Top hose exit locations (when viewed from the top)

**Note:** Approximately 0.91 m (3 ft.) of hose is available after the hose exits the top of the rack.

### Bottom hose exit locations

The following graphics show the floor cutout locations and dimensions that are required for water hoses that are routed out through the bottom of the rack and under the floor. Power cables can also use this cutout.



P9JA4561-0

Figure 29. Bottom hose exit locations

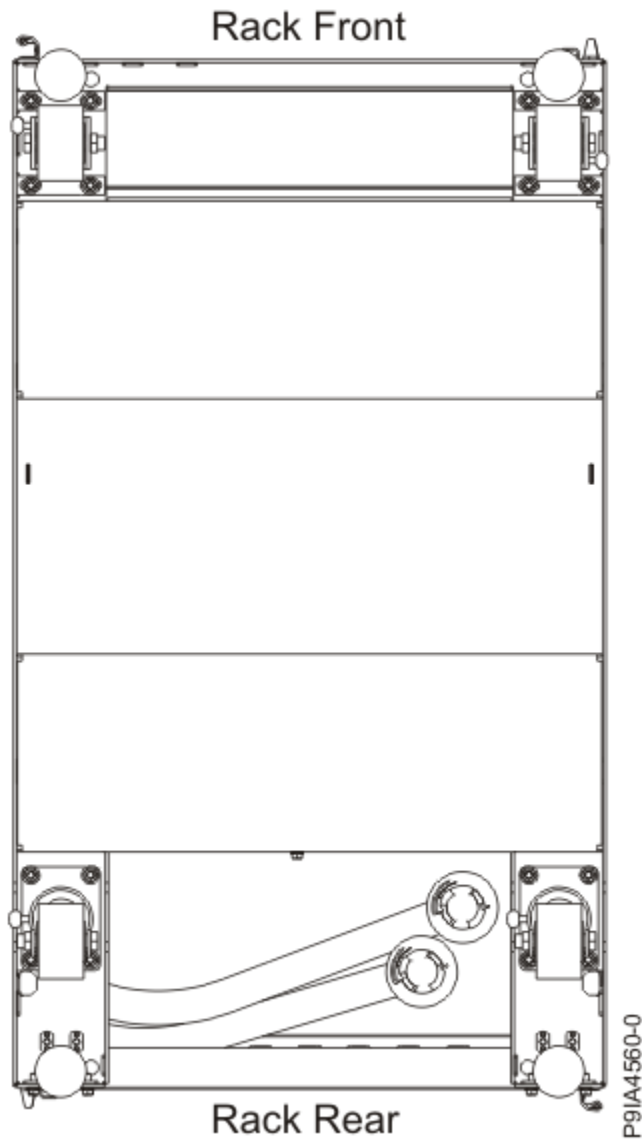

Figure 30. Bottom hose exit locations (when viewed from the bottom)

**Note:** Approximately 0.91 m (3 ft.) of hose is available after the hose exits the bottom of the rack.

## Specifications

<i>Table 29. Manifold specifications</i>	
<b>Manifold characteristics</b>	<b>Properties</b>
Manifold weight - dry	13.6 kg (30 lbs.)
Manifold weight - with water	17.5 kg (38.6 lbs.)
Manifold volume	6 L (1.6 gal)
<b>Note:</b> For more information about rack weight, see <a href="#">“Model 7953-94X and 7965-94Y rack”</a> on page 24.	

The rear door heat exchanger can be used with this rack. For more information about rear door heat exchangers, see [“Model 1164-95X rear door heat exchanger specifications”](#) on page 33.

## Hoses

The servers are connected to the manifold through quick-connects. The manifold has one cold water inlet that leads to the rack and one warm water outlet. Hoses are supplied by IBM. Hoses can be cut to length, but first must be cleaned so that no particles are inside the hose before installation. Some slack must be kept in the hose for easier installation. For more information about recommended clamping tools and specifications, see the [Oetiker](#) website.

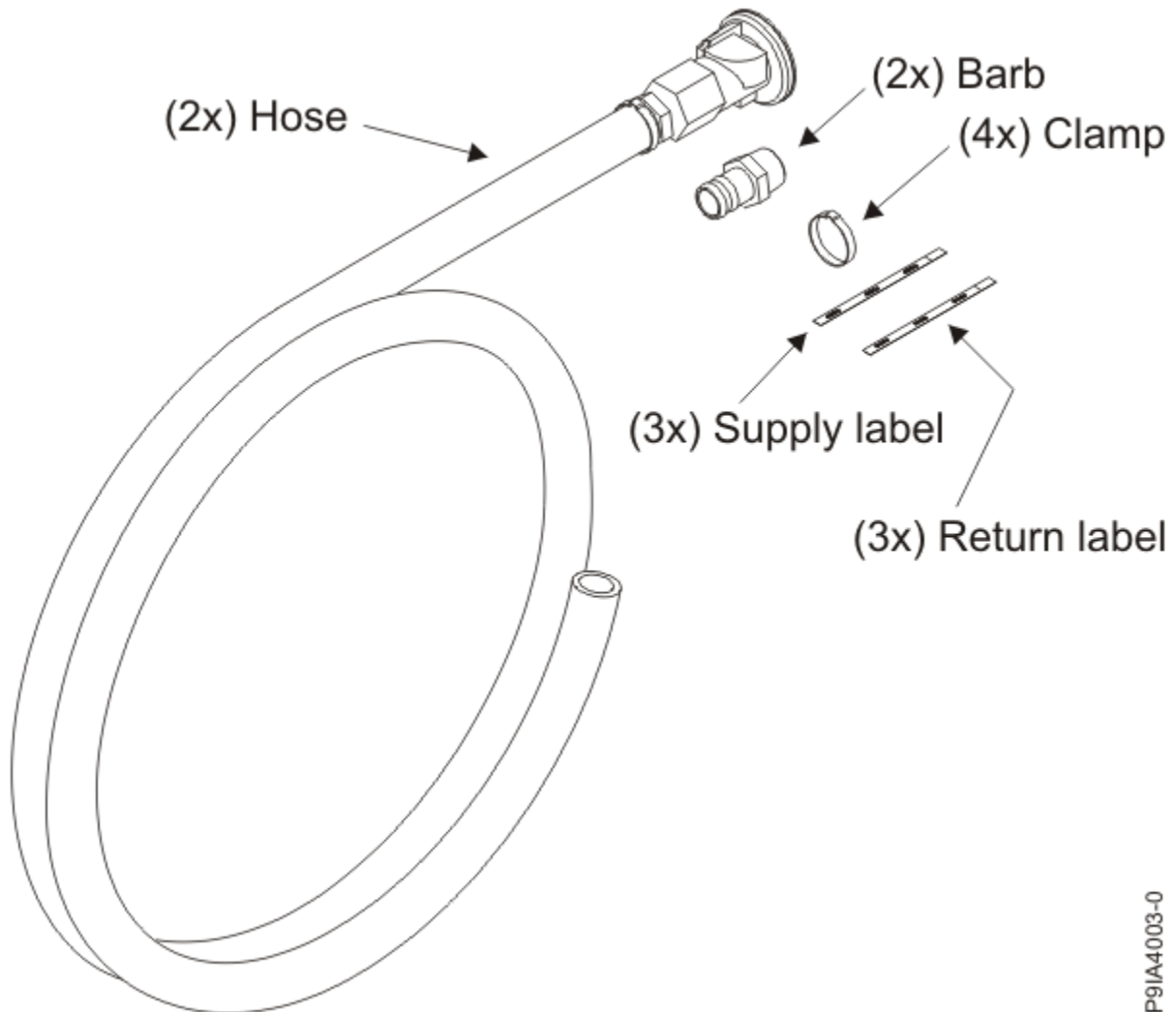

P91A4003-0

Figure 31. Hose kit

Table 30. Hose kit dimensions	
Hose information	Dimensions or type
Hose length	426.72 cm (14 ft)
Hose machine end	Quick-connect
Water supply end	25.4 mm (1 in.) National Pipe Thread Taper (NPT) male barb and clamp <sup>1</sup>
Bend radius	203.2 mm (8 in.)
Hose inside diameter	25.4 mm (1 in.) plus or minus 0.5 mm (0.02 in.)
Hose outside diameter	34.54 mm (1.4 in.) plus or minus 0.76 mm (0.03 in.)

Table 30. Hose kit dimensions (continued)

Hose information	Dimensions or type
<p><b>Note:</b></p> <p>The hose kit that is supplied contains the following items:</p> <ul style="list-style-type: none"><li>• Two hoses with preattached quick-connects for connection to manifold</li><li>• Two 25.4 mm (1 in.) NPT male barbs</li><li>• Four Oetiker hose clamps 16703242</li><li>• Three supply labels</li><li>• Three return labels</li></ul> <p><sup>1</sup>You must provide a 25.4 mm (1 in.) NPT female fitting on the facility hoses.</p>	

### Cooling loop requirements

- A secondary cooling loop, separate from the main site cooling loop, is required for the manifold.
- Cooling distribution units are available from suppliers such as [Eaton-Williams](#).
- The secondary cooling loop must meet the requirements that are outlined in the water chemistry specification.

### Floor cutout

Racks with water hoses and power cords that exit from the bottom of the rack require a floor tile cutout of at least 30.48 cm (12 in.) long by 17.78 cm (7 in.) wide. Due to the hose bend radii, the hole must be positioned towards the side of the rack without the manifold (the left side of the rack when looking at the rear of the rack). The left edge of the hole must be at least 10.16 cm (4 in.) from the side and 5.08 cm (2 in.) from the back edge of the rack (not including doors). The right edge of the hole must be at least 20.32 cm (8 in.) from the right side of the rack (not including side covers). Hole placement on the tile depends on the location of the rack, tile size, and tile load limitations.

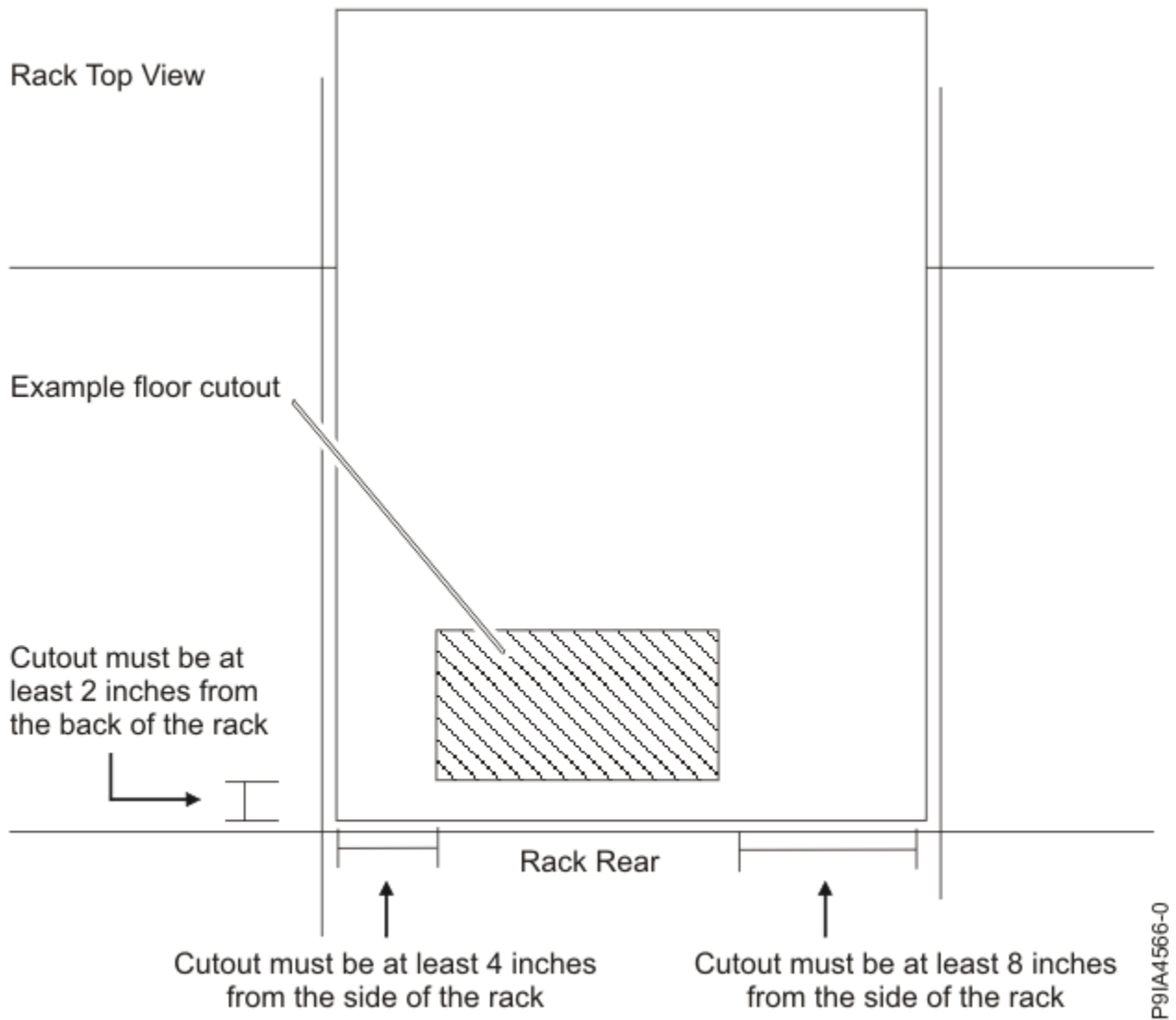

Figure 32. Floor cutout

## Planning for the 7965-S42 rack

Rack specifications provide detailed information for your rack, including dimensions, electrical, power, temperature, environment, and service clearances.

### **Model 7965-S42 rack specifications**

Hardware specifications provide detailed information for your rack, including dimensions, electrical, power, temperature, environment, and service clearances.

	Width	Depth	Height	Weight (Empty)	EIA unit capacity
Rack only	600 mm (23.6 in.)	1070 mm (42.1 in.)	2020 mm (79.5 in.)	166 kg (365 lb)	42 EIA units
Rack with two standard doors	600 mm (23.6 in.)	1132 mm (44.6 in.)	2020 mm (79.5 in.)	177 kg (391 lb)	42 EIA units
Rack with rear door heat exchanger (dry) and standard doors	600 mm (23.6 in.)	1231 mm (48.5 in.)	2020 mm (79.5 in.)	210 kg (463 lb)	42 EIA units



Table 31. Dimensions for rack (continued)

	Width	Depth	Height	Weight (Empty)	EIA unit capacity
Rack with high-end appearance front door and rear door	600 mm (23.6 in.)	1201 mm (47.3 in.)	2020 mm (79.5 in.)	181 kg (398 lb)	42 EIA units

Table 32. Weight capacity limits

Characteristics	Maximum weight	EIA unit capacity
Dynamic (rolling)	1134 kg (2500 lb)	18 kg (40 lb) / EIA average
Static	1678 kg (3700 lb)	32 kg (70 lb) / EIA average
Seismic certified	1170 (2580 lb)	20 kg (45 lb) / EIA maximum

Table 33. Dimensions for doors

Door model	Width	Height	Depth	Weight
Standard front door and standard back door	590 mm (23.2 in.)	1942 mm (76.5 in.)	31 mm (1.2 in.)	5.9 kg (13 lb)
Rear door heat exchanger door	600 mm (23.6 in.)	1950 mm (76.8 in.)	129 mm (5.0 in.)	39 kg (85 lb) - empty
				48 kg (105 lb) - filled
High-end appearance front door	590 mm (23.2 in.)	1942 mm (76.5 in.)	100 mm (3.9 in.)	9.1 kg (20 lb)
FC ECRA and ECRB acoustic doors, black IBM, front and rear	590 mm (23.2 in.)	1942 mm (76.5 in.)	115.5 mm (4.6 in)	17.7 kg (39 lb)
FC ECRC and ECRD acoustic doors, black OEM, front and rear	590 mm (23.2 in.)	1942 mm (76.5 in.)	110 mm (4.3 in)	17.7 kg (39 lb)

Table 34. Dimensions for side covers

Width <sup>1</sup>	Depth	Height	Weight <sup>2</sup>
12 mm (0.5 in.)	1070 mm (42.1 in.)	1942 mm (76.5 in.)	20 kg (44 lb)

<sup>1</sup> Side covers increase the overall width of the rack by 12 mm (0.5 in.) per side, but are only used on the ends of the rows.

<sup>2</sup> Weight is for each side cover.

Environment	Recommended operating	Allowable operating	Nonoperating
ASHRAE class		A3	
Airflow direction		Front-to-back	
Temperature <sup>2</sup>	18°C - 27°C (64°F - 80°F)	5°C - 40°C (41°F - 104°F)	1°C - 60°C (34°F - 140°F)
Humidity range	5.5°C (42°F) dew point (DP) to 60% relative humidity (RH) and 15°C (59°F) dew point	-12.0°C (10.4°F) DP and 8% - 80% RH	8% - 80% RH
Maximum dew point		24°C (75°F)	27°C (80°F)
Maximum operating altitude		3050 m (10000 ft)	
Shipping temperature			-40°C to 60°C (-40°F to 140°F)
Shipping relative humidity			5% - 100%
<p>1. The final ASHRAE class is determined by the hardware that is installed in the rack. Individual specifications for each piece of hardware must be reviewed.</p> <p>2. Derate maximum allowable dry-bulb temperature 1°C per 175 m above 950 m. IBM recommends a temperature range of 18°C - 27°C (64°F - 80.6°F).</p>			

Front <sup>1</sup>	Back
915 mm (36 in.)	915 mm (36 in.)
<sup>1</sup> Storage racks require larger service clearances in the front of the rack.	

## Rear door heat exchanger

Specifications for Power orderable feature code (FC) EC05 (Rear door heat exchanger indicator (Model 1164-95X)).

Width	Depth	Height	Weight (empty)	Weight (filled)
600 mm (23.6 in.)	129 mm (5.0 in.)	1950 mm (76.8 in.)	39 kg (85 lb)	48 kg (105 lb)
For more information, see <a href="#">“Model 1164-95X rear door heat exchanger specifications”</a> on page 33.				

## Electrical

For electrical requirements, see [Power distribution unit and power cord options](#).

## Floor cutout

Racks with water hoses and power cords that exit from the bottom of the rack require a floor tile cutout of at least 30.48 cm (12 in.) long by 22.86 cm (9 in.) wide. Due to the hose bend radii, the hole must be positioned towards the side of the rack without the manifold (the left side of the rack when looking at the rear of the rack). The left edge of the hole must be at least 11.43 cm (4.5 in.) from the side and 3.81 cm

(1.5 in.) from the back edge of the rack (not including doors). Hole placement on the tile depends on the location of the rack, tile size, and tile load limitations.

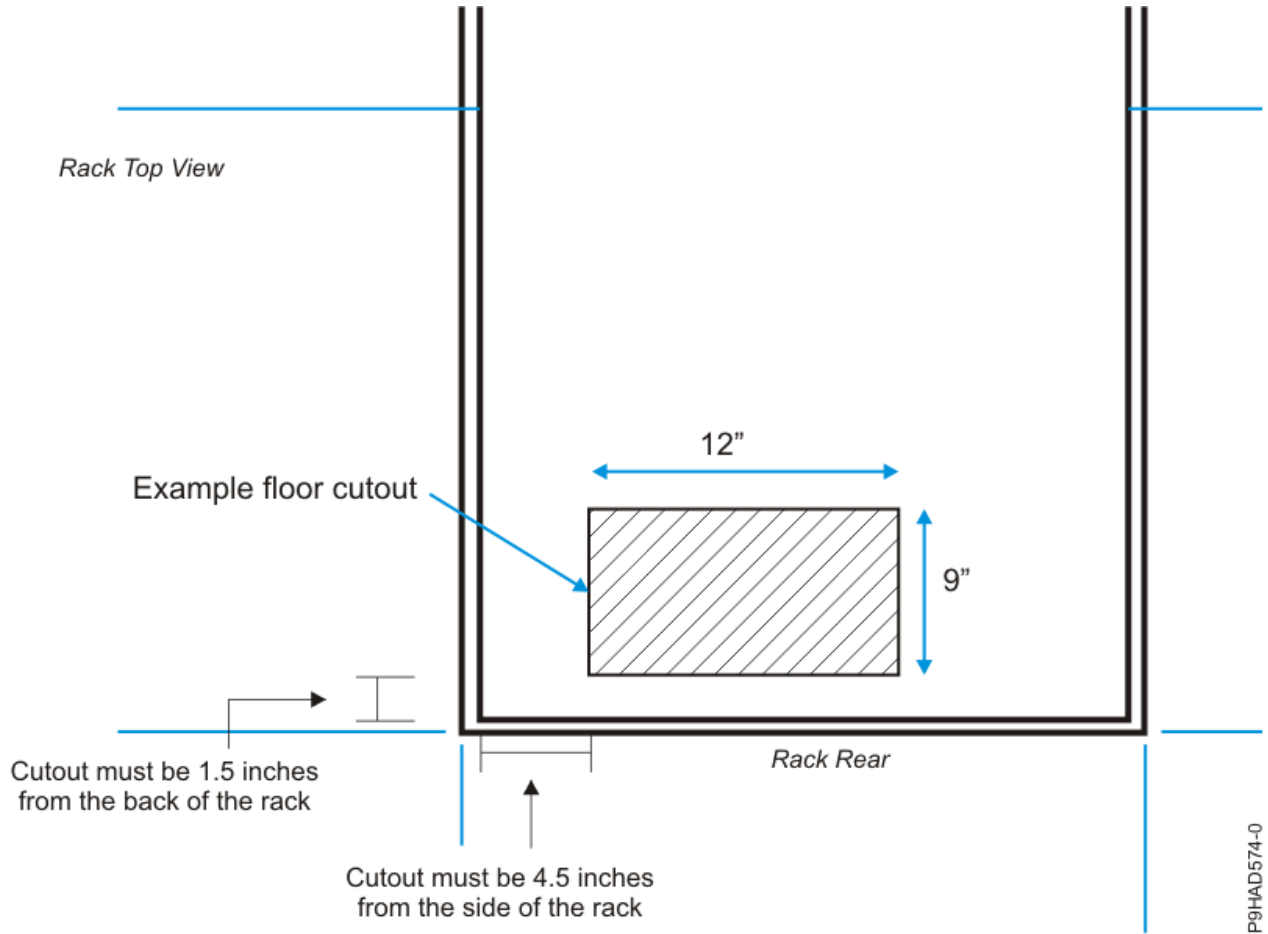

Figure 33. Floor cutout

### **Cabling the 7965-S42 rack**

Learn about the different cable routing options that are available for the 7965-S42 rack.

#### **Cabling within the rack**

Side cable channels are available in the rack to route cables. Three cable channels are on each side of the rack.

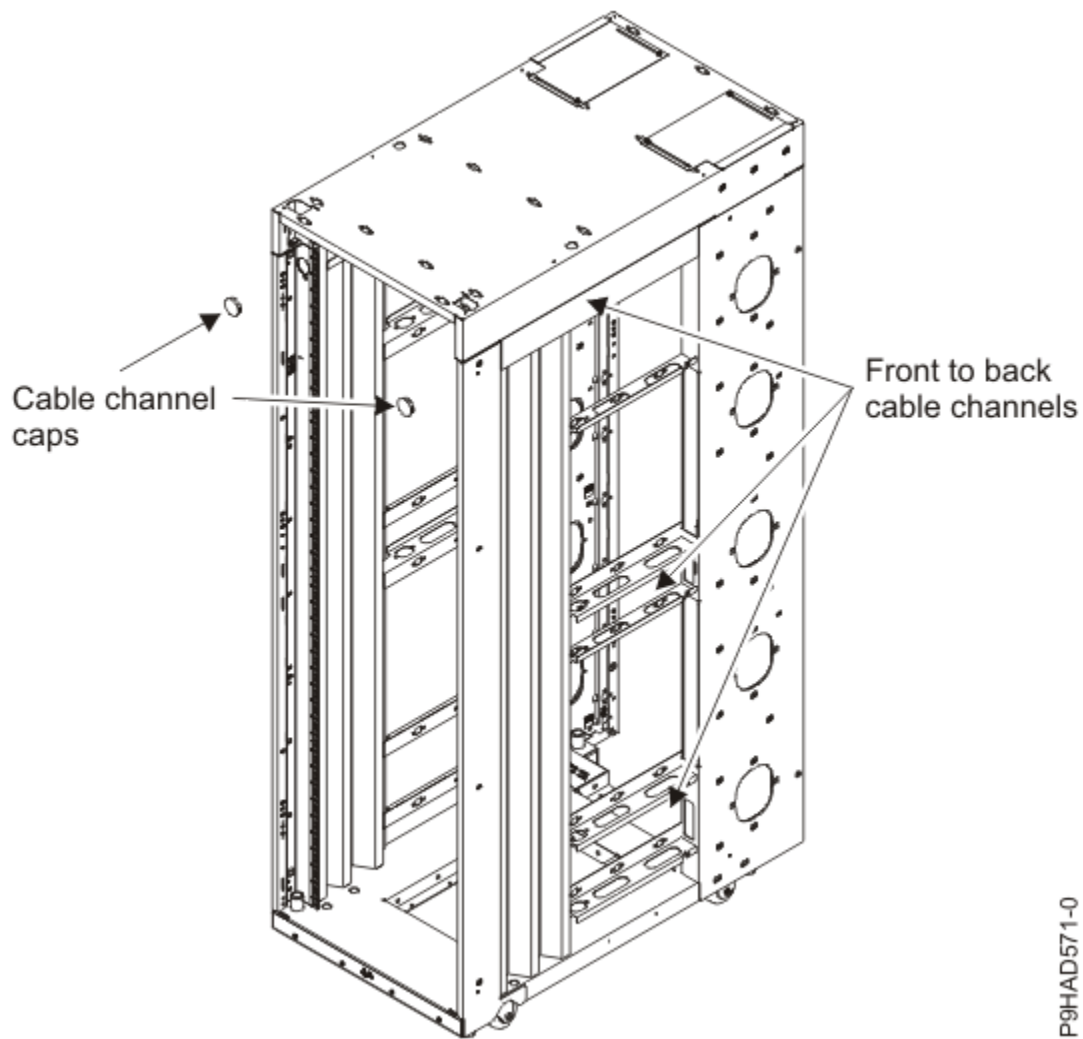
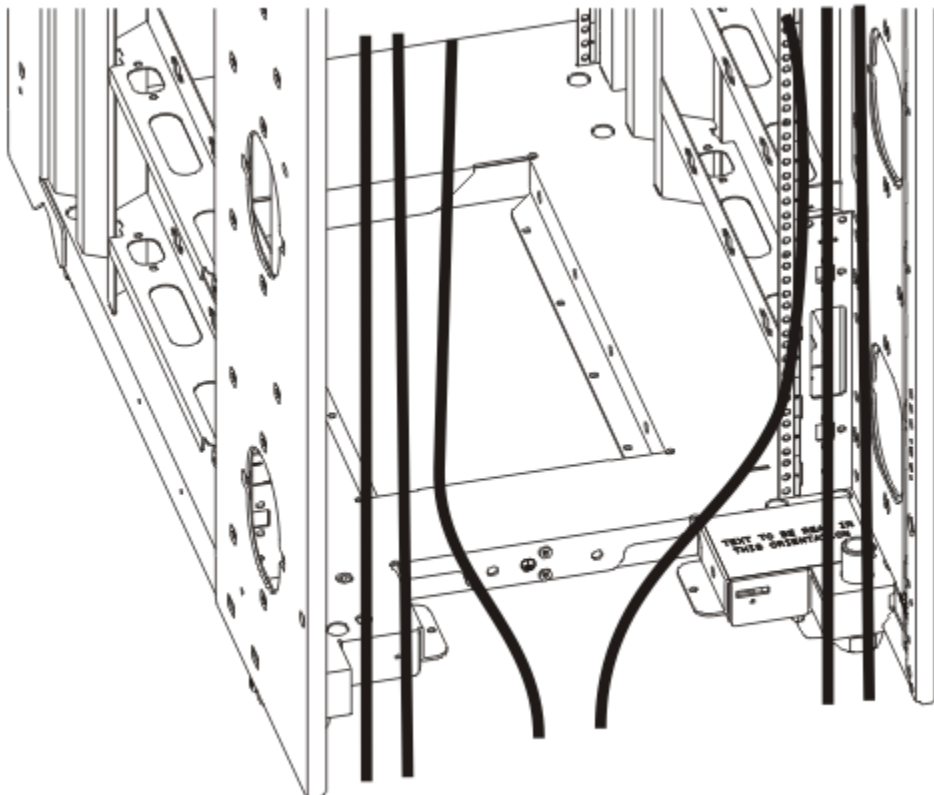

Figure 34. Cabling within the rack

### **Cabling under the floor**

Cables can be routed straight down through the side channels of the rack or routed towards the center of the opening.

P9HAD571-0



Cables can route straight down the side passages or route toward the middle

P9HAD572-0

Figure 35. Cabling under the floor

### Cabling overhead

Front and rear cable access openings that are on the top of the rack cabinet allow cables to be routed up and out of the rack. Cable access covers on the rear are adjustable by loosening the side screws and sliding the covers forward or backward. Because of the smaller size of the cable openings in front, cables that pass through this area must be minimized.

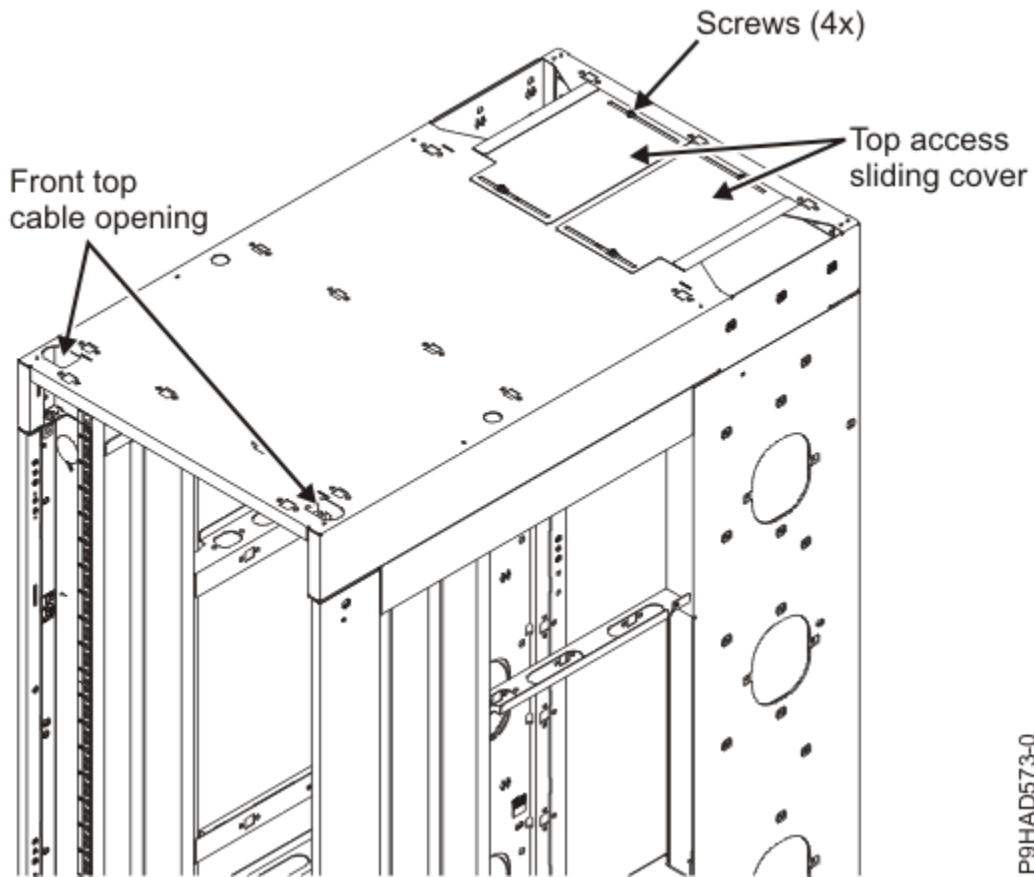

P9HAD573-0

Figure 36. Cabling overhead

### **Multiple racks**

Learn how to attach multiple 7965-S42 racks together.

Multiple 7965-S42 racks can be attached together. For racks that are on a 600 mm (23.6 in.) pitch, you can use screws to clamp the racks together. For racks that are on a 609 mm (24.0 in.) pitch, two spacer brackets must be added to set the proper spacing before you can use screws to clamp the racks together.

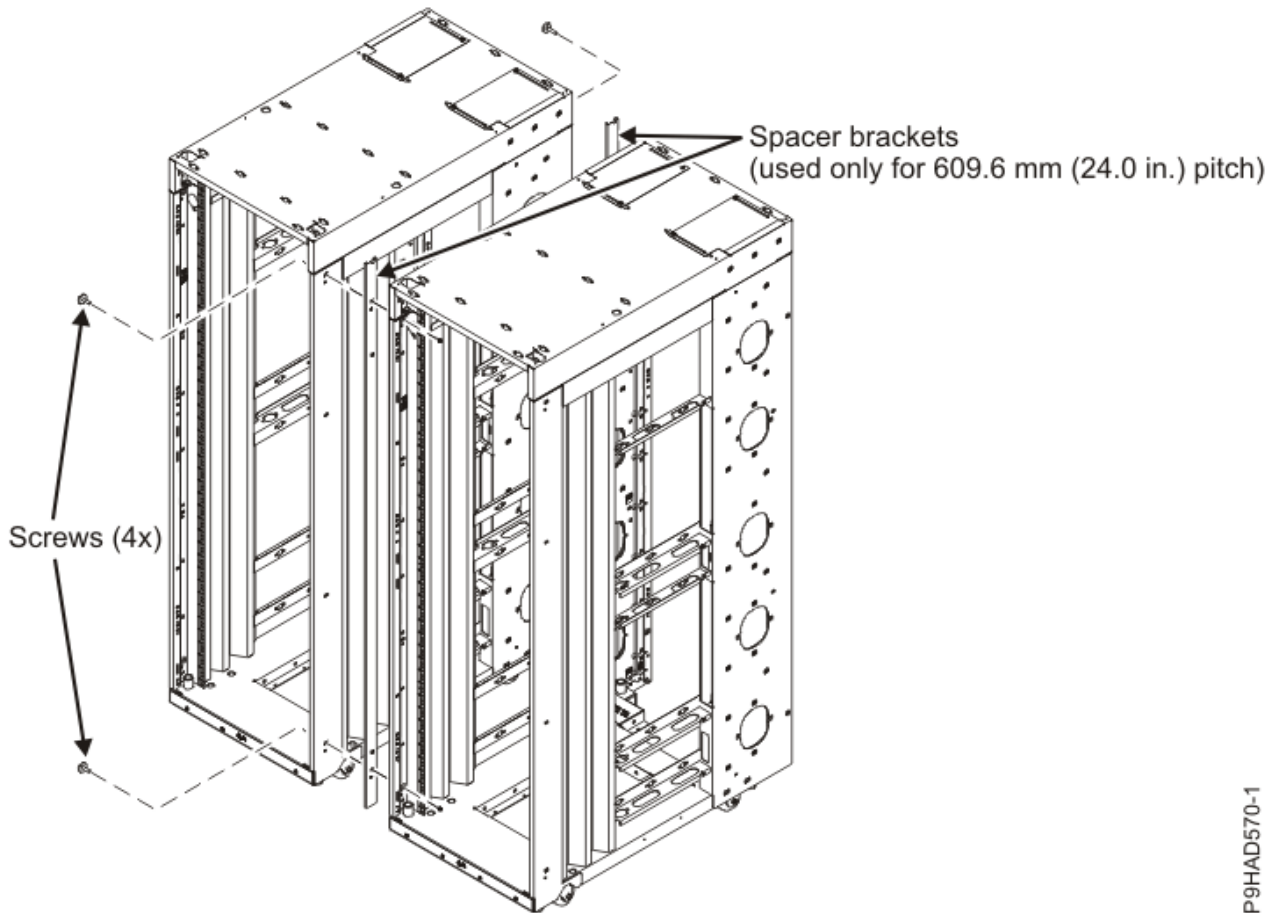

P9HAD570-1

Figure 37. Attaching multiple racks with spacer brackets

**Model 1164-95X rear door heat exchanger specifications**

Learn about the specifications of the 1164-95X rear door heat exchanger (feature code ECR2).

Table 38. Dimensions for the 1164-95X rear door heat exchanger

Width	Depth	Height	Weight (empty)	Weight (filled)
600 mm (23.6 in.)	129 mm (5.0 in.)	1950 mm (76.8 in.)	39 kg (85.0 lb) <sup>1</sup>	48 kg (105.0 lb)

1. A minimum of three people are required to lift the rear door heat exchanger because of the weight.

**Water specifications**

- Pressure
  - Normal operation: <414 kPa (60 psi)
  - Maximum: 689.66 kPa (100 psi)
- Volume
  - Approximately 9 liters (2.4 gallons)
- Temperature
  - Water temperature must be above the dew point in the data center
  - 18°C ± 1°C (64.4°F ± 1.8°F) for ASHRAE Class 1 Environment
  - 22°C ± 1°C (71.6°F ± 1.8°F) for ASHRAE Class 2 Environment

- Required water flow rate (as measured from the supply entrance to the heat exchanger)
  - Minimum: 22.7 liters (6 gallons) per minute
  - Maximum: 56.8 liters (15 gallons) per minute
  - **Note:** The actual flow rate differs per installation, which is based on achieving heat removal requirements.

## Water specifications for the secondary cooling loop

**Important:** The water that is being supplied to the heat exchanger must meet the requirements that are described in this section. Otherwise, system failures might occur over time as a result of any of the following problems:

- Leaks due to corrosion and pitting of the metal components of the heat exchanger or of the water-supply system.
- Buildup of scale deposits inside the heat exchanger, which can cause the following problems:
  - A reduction in the ability of the heat exchanger to cool the air that is exhausted from the rack.
  - Failure of mechanical hardware, such as a hose quick-connect coupling.
- Organic contamination, such as bacteria, fungi, or algae. This contamination can cause the same problems as described for scale deposits.

Contact a water quality and water distribution services expert for designing and implementing the infrastructure and water chemistry of the secondary loop.

## Water-supply requirements for secondary loops

Learn about the specific characteristics of the system that supplies the chilled conditioned water to the heat exchanger.

### Temperature:

The heat exchanger and its supply hose and return hoses are not insulated. Avoid any condition that might cause condensation. The temperature of the water inside the supply hose, return hose, and heat exchanger must be kept above the dew point of the location where the heat exchanger is being used.



**Attention:** Typical primary chilled water is too cold for use in this application because building chilled water can be as cold as 4°C - 6°C (39°F - 43°F).

### Important:

The system that supplies the cooling water must be able to measure the room dew point and automatically adjust the water temperature. Otherwise, the water temperature must be above the maximum dew point for that data center installation. For example, the following minimum water temperature must be maintained:

- 18°C plus or minus 1°C (64.4°F plus or minus 1.8°F). This specification is applicable within an ASHRAE Class 1 Environmental Specification that requires a maximum dew point of 17°C (62.6°F).
- 22°C plus or minus 1°C (71.6°F plus or minus 1.8°F). This specification is applicable within an ASHRAE Class 2 Environmental Specification that requires a maximum dew point of 21°C (69.8°F).

See the *ASHRAE document Thermal Guidelines for Data Processing Environments*.

### Pressure:

The water pressure in the secondary loop must be less than 690 kPa (100 psi). Normal operating pressure at the heat exchanger must be 414 kPa (60 psi) or less.

### Flow rate:

The flow rate of the water in the system must be in the range of 23 - 57 liters (6 - 15 gallons) per minute and high enough to meet heat removal requirements.



Pressure drop versus flow rate for heat exchangers (including quick-connect couplings) is defined as approximately 103 kPa (15 psi) at 57 liters (15 gallons) per minute. For more information, see the pressure vs flow curve in [Figure 43 on page 66](#).

#### **Water volume limits:**

The heat exchanger holds approximately 9 liters (2.4 gallons). The full length of the hose kits (4.26 m (14 ft) of 2.54 cm (1.0 in.) inner diameter hose) for supply and return hoses hold approximately 4.3 liters (1.1 gallons).

#### **Air exposure:**

The secondary cooling loop is a closed loop, with no continuous exposure to room air. After you fill the loop, remove all air from the loop. An air bleed valve is provided at the top of a heat exchanger manifold for purging all air from the system. You must obtain a [bleeding hose](#). The instructions for bleeding the air are located in the [installation instructions](#).

### **Heat exchanger performance**

A heat removal of 100% indicates an amount of heat that is equivalent to the heat that is generated by the devices that is removed by the heat exchanger and the average air temperature that is leaving the heat exchanger is identical to that entering the rack (27°C (80.6°F) in this example). Heat removal in excess of 100% indicates that the heat exchanger not only removed all of the heat that was generated by the devices, but further cooled the air so that the average air temperature that is leaving the rack is lower than air temperature that is entering the rack.

To help maintain optimum performance of the rear door heat exchanger and provide proper cooling for all rack components, you must take the following precautions:

- Install filler panels over all unoccupied bays.
- Route signal cables at the rear of the rack so that they enter or exit the cabinet through the top and bottom air baffles.
- Bundle signal cables together in a rectangle so that the upper and lower air-baffle sliders are closed as far as possible. Do not bundle signal cables together in a circular formation.

[Figure 38 on page 64](#) - [Figure 43 on page 66](#) allows you to decide what is the required water flowrate per rear door heat exchanger, so the facility and CDU can be sized.

As example, pick one of [Figure 38 on page 64](#) - [Figure 42 on page 66](#), whichever more closely resembles the expected sustained heat load. Interpolate between graphs if necessary. Pick the curve that defines the water temperature that can be provided to the rear door heat exchanger. Determine the water flow rate that is required to achieve 5 - 10% more heat removal than is required for the installation. This additional capacity allows for less than perfect airflow that is blocking and possible air that bypasses the rear door heat exchanger. For instance, if you want the rear door heat exchanger to make the rack data center neutral, you can select a water flow rate that provides 105 - 110% heat removal in order to provide some margin to the cooling design. For rack powers other than what is listed in [Figure 38 on page 64](#) - [Figure 42 on page 66](#), for racks that are far from uniformly populated with heat generating devices, or for racks with significantly different airflow rates than what the curves show (plus or minus 30%), you must take guidance from IBM Power Systems Thermal Development, which is available through the IBM Sales team.

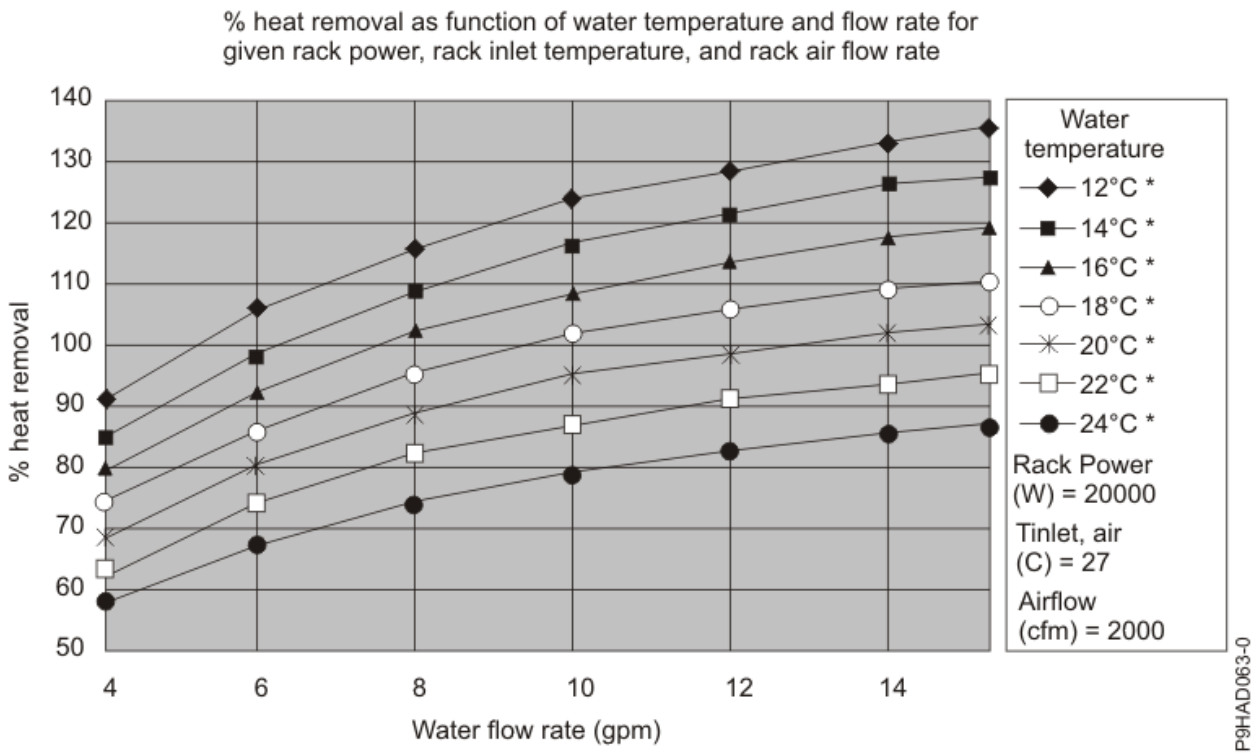

Figure 38. Typical performance of the heat exchanger, 20 kW heat load

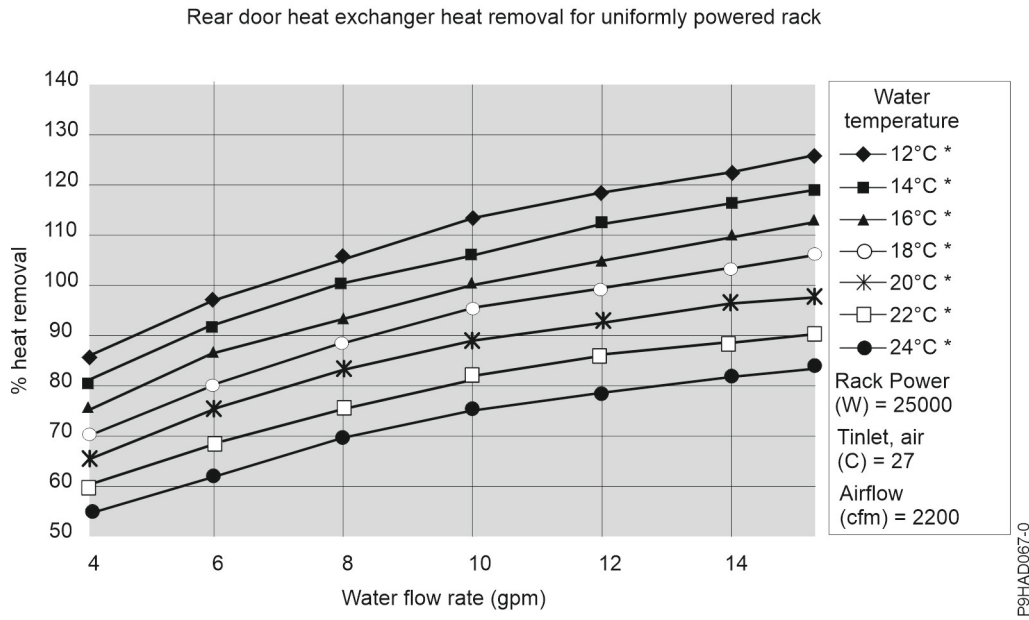

Figure 39. Typical performance of the heat exchanger, 25 kW heat load

% heat removal as function of water temperature and flow rate for given rack power, rack inlet temperature, and rack air flow rate

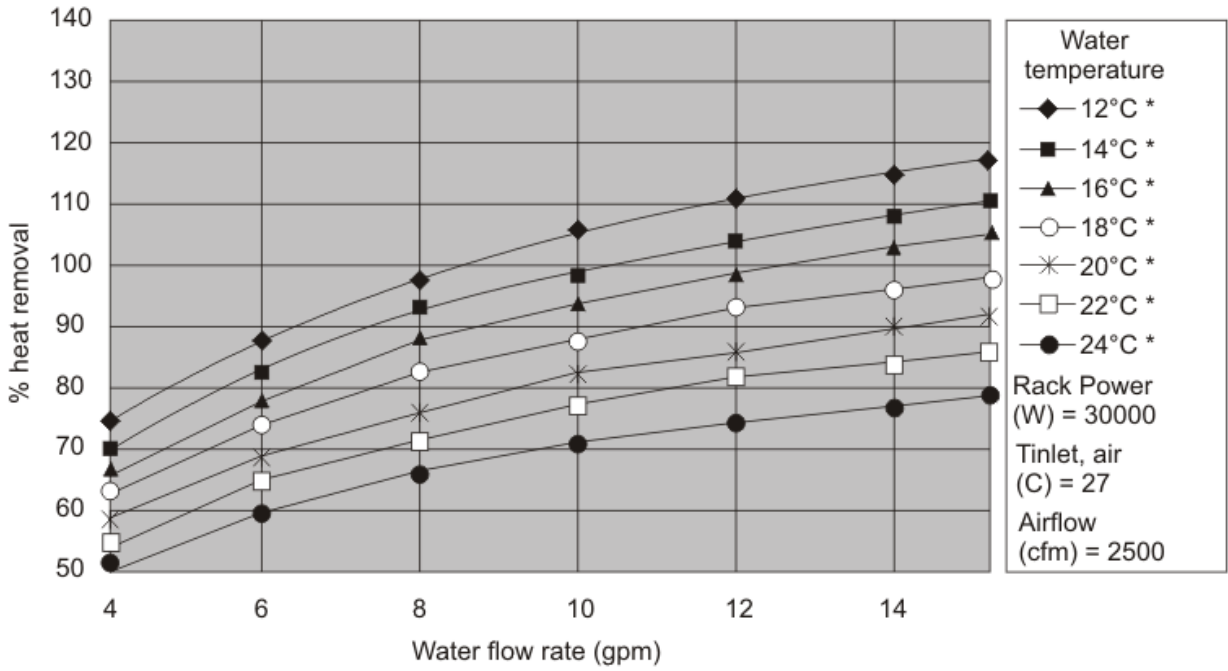

Figure 40. Typical performance of the heat exchanger, 30 kW heat load

Rear door heat exchanger heat removal for uniformly powered rack

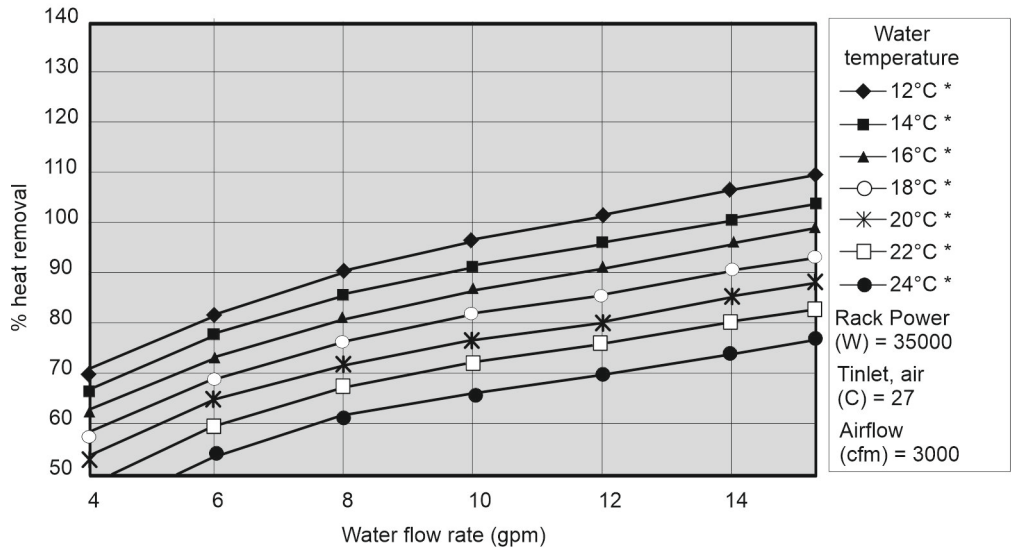

Figure 41. Typical performance of the heat exchanger, 35 kW heat load

Rear door heat exchanger heat removal for uniformly powered rack

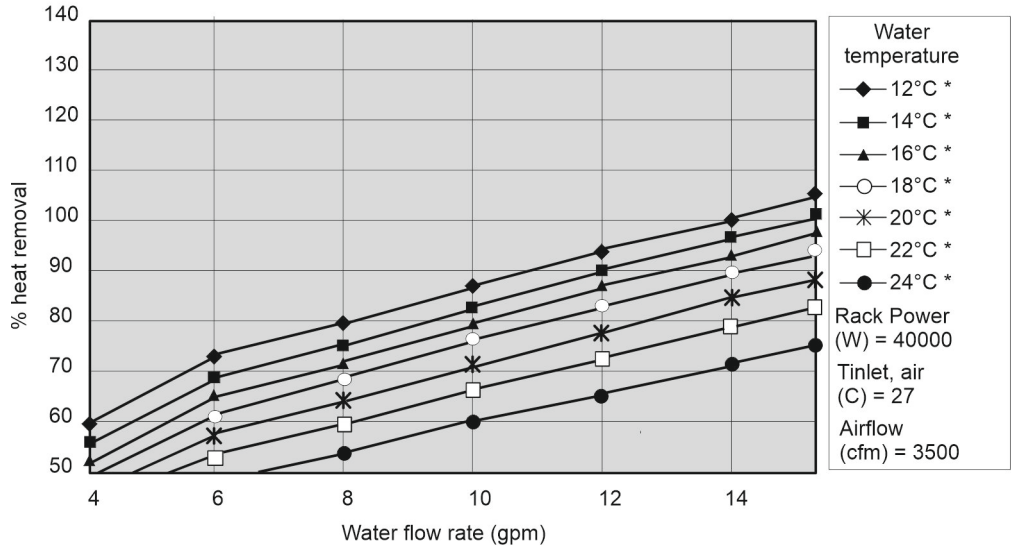

Figure 42. Typical performance of the heat exchanger, 40 kW heat load

After the required water flowrate per rear door heat exchanger is defined per the heat removal information above, the water-side pressure drop of the rear door heat exchanger can be determined from Figure 43 on page 66.

Using the total water flowrate requirement for all of the rear door heat exchangers and the pressure drop for the entire water flow network, which the rear door heat exchanger is a part of, the facility and CDU can be defined to meet these flow and pressure drop requirements.

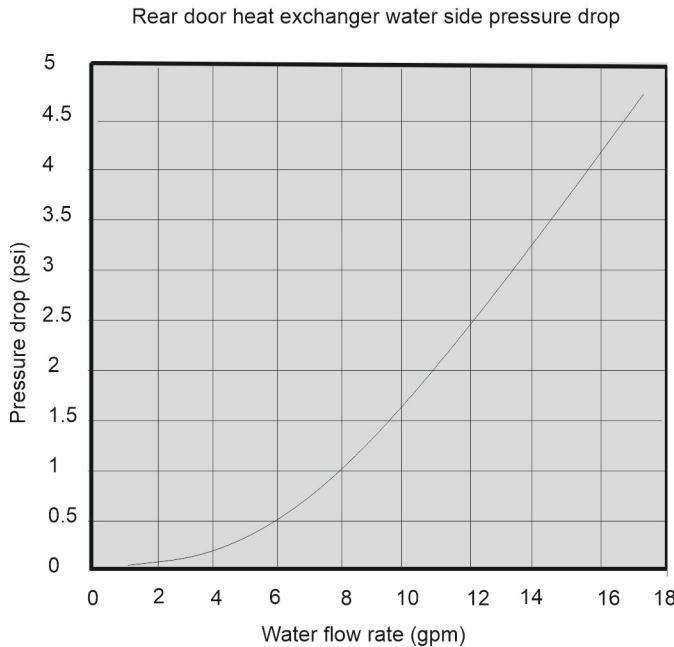

Figure 43. Pressure drop (standard units)

### Water delivery specifications for secondary loops

Learn about the various hardware components that make up the delivery system secondary loop that provides the chilled, conditioned water to the heat exchanger. The delivery system includes pipes, hoses,

and the required connection hardware to connect the hoses to the heat exchanger. Hose management can be used in raised-floor and non-raised-floor environments.

The heat exchanger can remove 100% or more of the heat load from an individual rack when it is running under optimum conditions.

The primary cooling loop is considered to be the building chilled-water supply or a modular chiller unit. The primary loop must not be used as a direct source of coolant for the heat exchanger because the fluid that is delivered to the rear door heat exchanger must be above the dew point. Procurement and installation of the components that are needed to create the secondary cooling loop system are required for this design and are your responsibility. The main purpose is to provide examples of typical methods of secondary loop setup and operating characteristics that are needed to provide an adequate and safe supply of water to the heat exchanger.

You must obtain a cooling distribution unit (CDU) and water that meets cleanliness, filtration, and chemical requirements that are listed in [Planning for water cooling](#). CDUs are available from suppliers such as [Motivair](#) and [Nortek](#). CDUs deliver water at a proper flow rate and temperature to the heat exchanger, while it maintains the temperature above the dew point to avoid condensation. CDUs are also essential to control the closed loop of the water that flows through the heat exchanger to maintain proper water cleanliness, filtration, and chemistry while it controls the wet materials in the loop.



**Attention:**

The overpressure safety device must meet the following requirements:

- Comply with *ISO 4126-1*.
- Be installed so that it is easily accessed for inspection, maintenance, and repair.
- Be connected as close as possible to the device that it is intended to protect.
- Be adjustable only with the use of a tool.
- Have a discharge opening that is directed so that discharged water or fluid does not create a hazard or be directed toward any person.
- Be of adequate discharge capacity to ensure that the maximum working pressure is not exceeded.
- Be installed without a shutoff valve between the overpressure safety device and the protected device.

Read the following guidelines before you design the installation:

- A method for monitoring and setting the total flow rate that is delivered to all of the heat exchangers is required. This can be a discrete flowmeter that is built into the flow loop or a flowmeter within the secondary loop of the coolant distribution unit (CDU).
- After you set the total flow rate for all of the heat exchangers by using a flowmeter, it is important to design the plumbing so that it provides the flow rate that you want for each heat exchanger and provides a way to verify the flow rate. Other methods, such as inline or external flowmeters, can provide a more accurate method for setting the flow rate through the individual shutoff valves.
- Design the flow loop to minimize the total pressure drop within the flow loop.

**Manifolds and piping:**

Manifolds that accept large-diameter feed pipes from a pump unit are the preferred method for splitting the flow of water to smaller-diameter pipes or hoses that are routed to individual heat exchangers. Manifolds must be constructed of materials that are compatible with the pump unit and related piping. The manifolds must provide enough connection points to allow a matching number of supply and return lines to be attached, and the manifolds must match the capacity rating of the pumps and the loop heat exchanger (between the secondary cooling loop and the building chilled-water source). Anchor or restrain all manifolds to provide the required support to avoid movement when quick-connect couplings are connected to the manifolds. Design the manifolds so that there is a minimal pressure drop that is based on the total flow rate through the manifold. The manifold size must be selected to allow an even flow rate through each parallel rear door heat exchanger.

To stop the flow of water in individual legs of multiple circuit loops, install shutoff valves for each supply and return line. This provides a way to service or replace an individual heat exchanger without affecting the operation of other heat exchangers in the loop.

To ensure that water specifications are being met and that the optimum heat removal is taking place, use temperature and flow metering (monitoring) in secondary loops.

Anchor or restrain all manifolds and pipes to provide the required support and to avoid movement when quick-connect couplings are being attached to the manifolds.

Figure 44 on page 68 shows an example of a CDU with a manifold that is plumbed with supply and return ports for each heat exchanger that the CDU flows water to. This example is of an implementation of multiple heat exchangers with a single CDU that allows 35.56 cm (14 in.) or shorter hoses to be connected to the CDU.

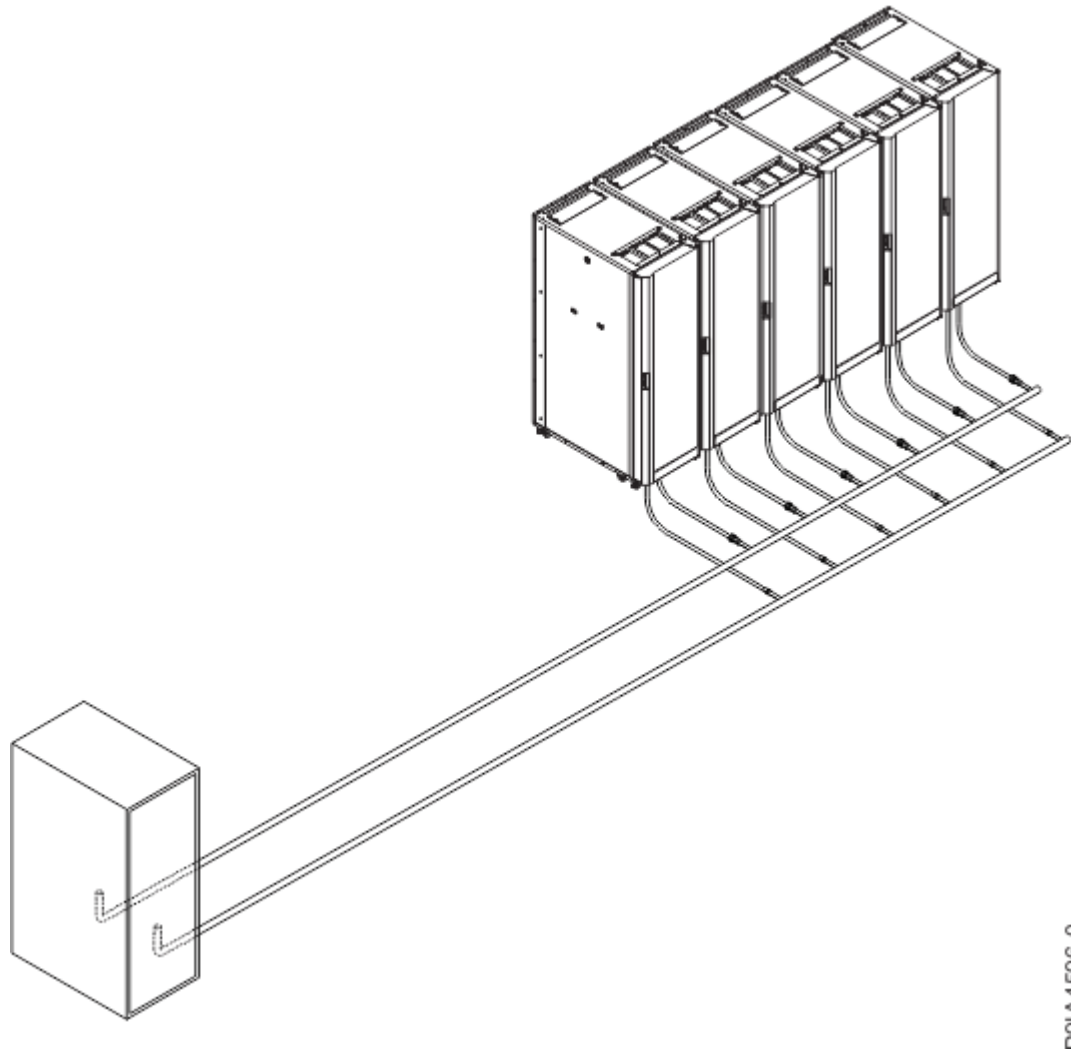

Figure 44. Typical extended manifold

#### **Flexible hoses and connections to manifolds and heat exchangers:**

Pipe and hose configurations can vary. You can determine the best configuration for your installation by analyzing the needs of your facilities, or a site preparation representative can provide this analysis.

Flexible hoses that supply and return water between your hard plumbing (manifolds and coolant distribution units) and the heat exchanger (allowing needed movement for opening and closing the rack rear door) are provided by IBM. Hoses can be cut to length, but first must be cleaned so that no particles are inside the hose before installation. Some slack must be kept in the hose for easier installation. For more information about recommended clamping tools and specifications, see the

Oetiker website. [Figure 45 on page 69](#) shows what is in the hose kit that is supplied with the heat exchanger.

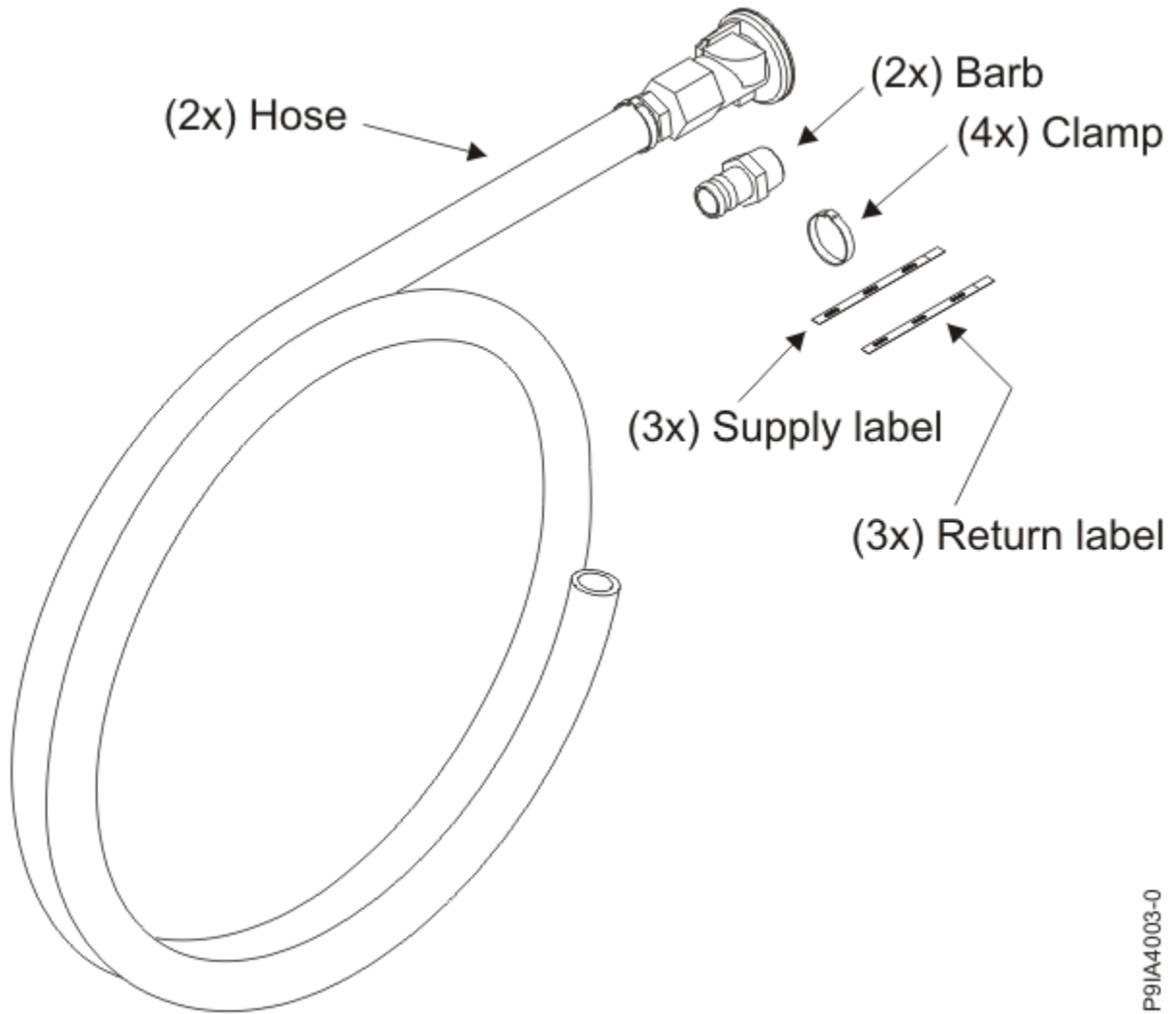

Figure 45. Hose kit

Table 39. Hose kit dimensions	
Hose information	Dimensions or type
Hose length	4.26 m (14 ft)
Hose machine end	Quick-connect
Water supply end	25.4 mm (1 in.) National Pipe Thread Taper (NPT) male barb and clamp <sup>1</sup>
Bend radius	203.2 mm (8 in.)
Hose inside diameter	25.4 mm (1 in.) plus or minus 0.5 mm (0.02 in.)
Hose outside diameter	34.54 mm (1.4 in.) plus or minus 0.76 mm (0.03 in.)



Table 39. Hose kit dimensions (continued)

Hose information	Dimensions or type
<p><b>Notes:</b></p> <p>The facility hose kit is supplied in a separate box from the rack and contains the following items:</p> <ul style="list-style-type: none"> <li>• Two 4.26 m (14 ft) hoses with preattached quick-connects for connection to manifold. At one end of the hose, there is a quick-connect that mates with the quick-connect at the end of the hose from the manifold. The other end is a bare cut end.</li> <li>• Two 25.4 mm (1 in.) NPT male barbs. One end of the fitting is a 25.4 mm (1 in.) barb to fit on the inside of the 25.4 mm (1 in.) inner diameter hose. The other end of the fitting is a 25.4 mm (1 in.) male NPT.</li> <li>• Four Oetiker hose clamps 16703242 (two hose clamps are required and two hose clamps are extra).</li> <li>• Three supply labels (only two supply labels are required). The supply labels need to be installed on the supply end of the hose after it is connected to the facility.</li> <li>• Three return labels (only two return labels are required). The return labels need to be installed on the return end of the hose after it is connected to the facility.</li> </ul> <p><sup>1</sup>You must provide a 25.4 mm (1 in.) NPT female fitting on the facility hoses.</p>	

The customer provided interconnection to the rack (under-the-floor manifold, CDU, and so on) must have a 25.4 mm (1 in.) female NPT fitting for each manifold supply and return connection. The 25.4 mm (1 in.) NPT male barb fitting from the hose kit must be threaded onto the NPT female fitting on the customer CDU plumbing. A thread sealant must be used to create a leak-free connection. Teflon tape cannot be used, as Teflon tape particles might enter the water stream.

To make the connection from the hose to the barb fitting, the facility hoses must first be cut to length. If the CDU plumbing fitting requires a longer hose than the 4.26 m (14 ft) facility hose, the plumbing must be altered to bring the fitting close enough such that the 4.26 m (14 ft) facility hose is sufficient. The end of the hose must be cleaned so that no particles are inside the hose before installation. The clamp is inserted over the hose and then the barb is inserted into the hose. Position the clamp within 5 mm (1.97 in.) of the hex portion of the fitting (not over the barb) and tighten the clamp with an Oetiker clamp tool. For more information about the clamp tool, see [Forged steel Standard Jaw Pincers](#). The ears of the clamp must be tightened so that they make contact with each other. When the clamp is released, the ears relax and a small space is left between. This small space is normal. [Figure 46 on page 70](#) shows dimension **s** that must be fully closed during the clamping process.

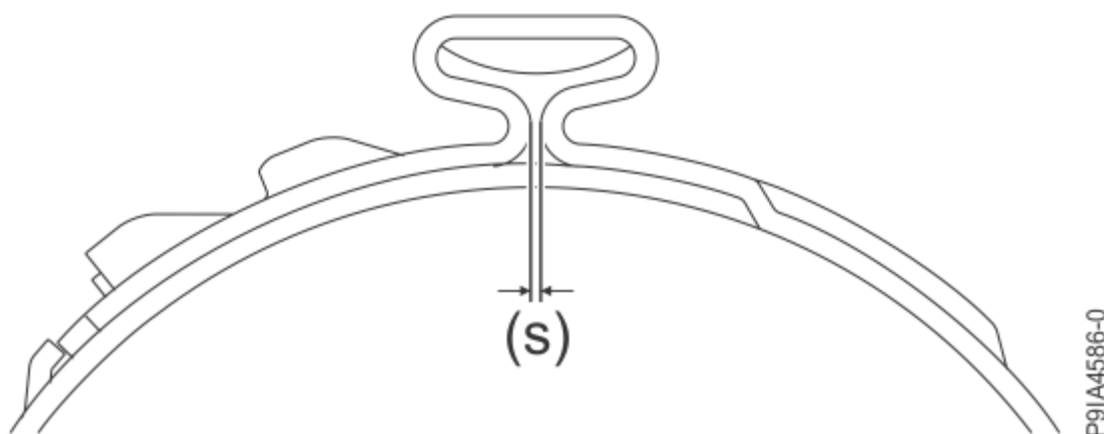

Figure 46. Clamp ear

The supply and return labels must be applied on both ends of the facility hose to indicate the function of each hose. The quick connects on the end of the facility hose can now be connected to the quick connects on the heat exchanger.



## Hose routing and floor tile cutout information

### Raised-floor Environment

If the hose is to be routed under the raised floor, a cutout must be made in the floor tile under the rack. The access hole for the supply and return hoses must be a minimum of 200 mm (8 in.) long by 100 mm (4 in.) wide. Each cutout must be lined with grommets so that the hose is not pulled across sharp edges of the cutout. Consult your floor tile manufacturer to determine whether there are more supports that are required for the cutout, or requirements for the position of the cutout in regard to the edge of the floor tile. The following figures show three different possibilities for floor tile cutout locations and the hose routing for each cutout location. Variations to this routing are allowed. These three figures show the general routing that allows for the door to open and close with minimal hose kinking and movement.

**Note:** These illustrations show the view of the rack from the top, looking down.

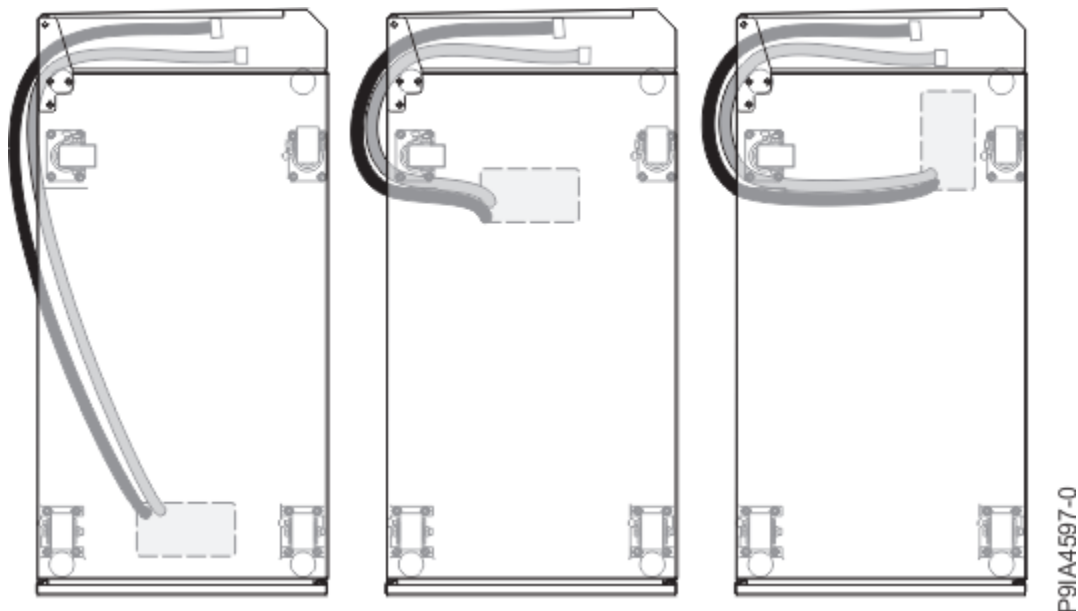

Figure 47. Routing and securing the hoses in a raised floor environment for individual racks

In the following illustration, the numbers represent the suggested placement of racks that share one hole in the floor. For example, if three racks share one hole in the floor, place the racks as shown by numbers 1, 2, and 3. If you want to add a fourth rack that uses the same hole in the floor, then place it next to rack number 1.

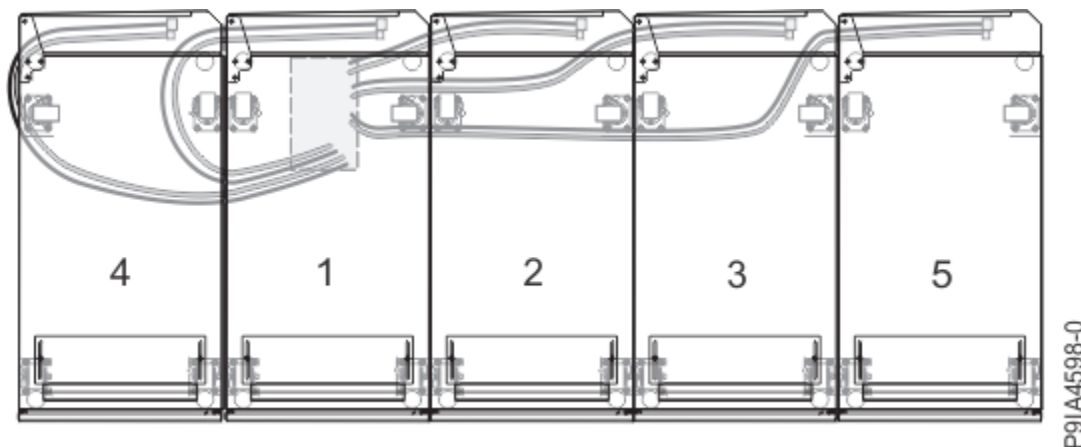

Figure 48. Option for hoses in adjacent racks to share a single hole in the floor

**Note:** If more than one rack uses the same hole in the floor tile, the floor tile cutout must be increased in size.

## Raised-floor and non-raised-floor Environments

If the coolant distribution unit (CDU) that is providing water to the heat exchangers is in a row of racks with the heat exchangers, all hoses can be routed on top of the floor, irrespective of whether it is a raised floor or a slab floor installation. The model type 7965 rack has sufficient clearance underneath the rack to enable the quick connects to be run underneath the rack. This configuration provides a clean hose routing solution with the hoses of minimum length.

**Note:** If this solution is used, you must determine the CDU position such that 4.26 m (14 ft) of hose is sufficient from the CDU to the heat exchanger. Each hose must be routed with a minimum bend radius of 200 mm (8 in.). A bend radius less than 200 mm (8 in.) causes the hose to kink, restricts flow to and from the heat exchanger, and voids the heat exchanger warranty.

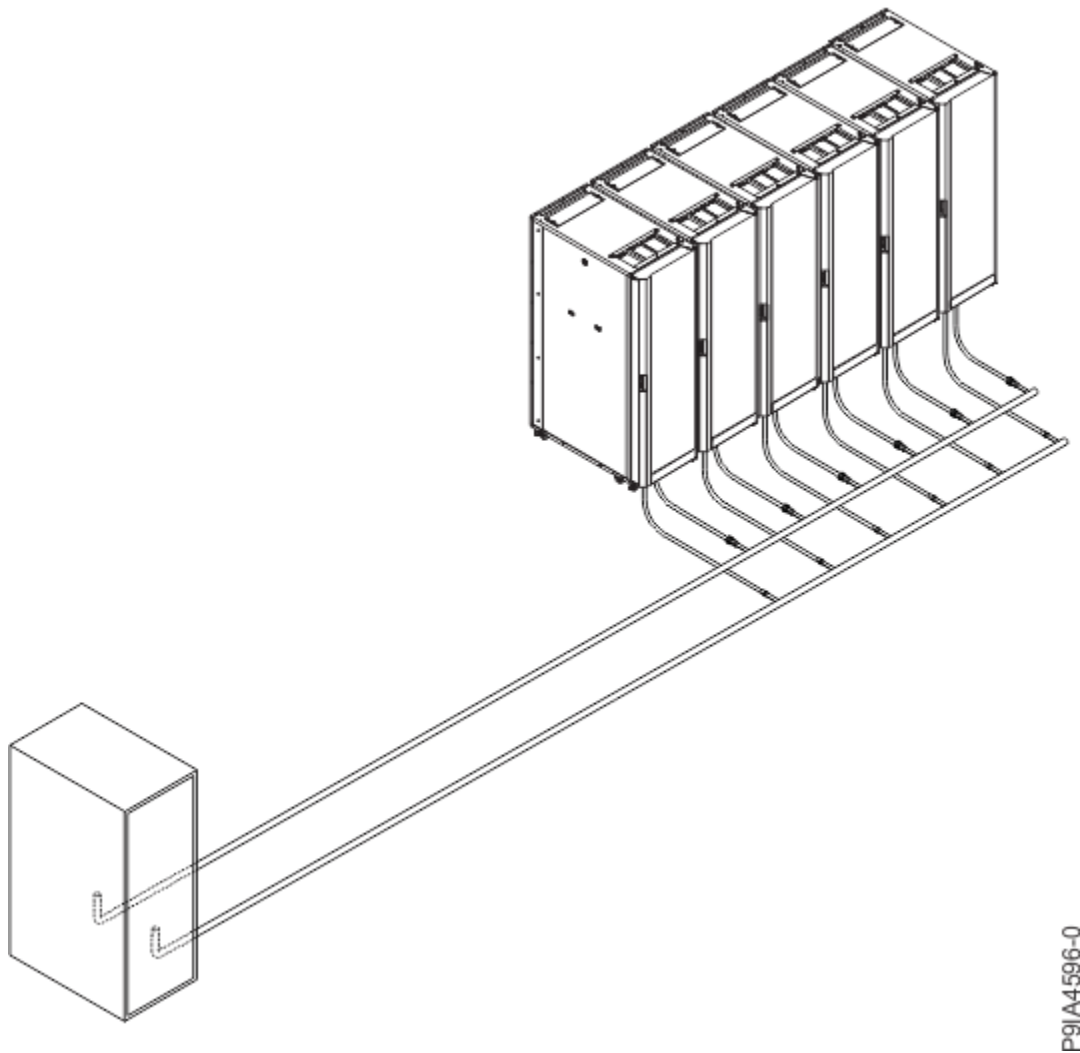

Figure 49. Routing and securing the hoses in a raised-floor and non-raised floor environment

## Overhead hose routing Environment

The heat exchanger can be configured on the rack so that the quick connects are at the top of the rack instead of the bottom. This configuration must be used if the hoses are to be routed above the racks. In this configuration, the hose must be strain relieved and supported by a customer supported structure above the racks.

Each hose must be routed with a minimum bend radius of 200 mm (8 in.). A bend radius less than 200 mm (8 in.) causes the hose to kink, restricts flow to and from the heat exchanger, and voids the heat exchanger warranty.

The CDU must be placed so that 4.26 m (14 ft) of hose is sufficient from the CDU to the heat exchanger.

## Placement of 7965 racks with 1164-95X installed

When model type 7965 racks with the 1164-95X rear door heat exchanger are placed directly next to another model type 7965 with the 1164-95X rear door heat exchanger, the rear door heat exchanger can open approximately 130 degrees to allow for rear access.

If a 7965 rack with the 1164-95X rear door heat exchanger is placed next to a wall, building column, or any other obstruction, approximately 38.1 cm (15 in.) of space must be left between the hinge side of the rear door heat exchanger and the wall to ensure proper opening of the rear door heat exchanger for rear service.

If another rack type is placed next to a 7965 rack with the 1164-95X rear door heat exchanger, the other rack must be positioned so that it does not extend beyond the rear of the 7965 rack frame.

## Required tools

The following tools are required onsite to install the rear door heat exchanger:

- [Forged steel Standard Jaw Pincers](#)
- [Hose cutter](#)
- [bleeding hose](#)
- Nut drivers or sockets
- Screwdriver

**Important:** You must obtain these tools before you start the installation process.

## ***Model 7965-S42 water cooling manifold (Feature codes ECR3 and ECR4)***

Learn about the water cooling manifold that is available for model 7965-S42 racks with feature code (FC) ECR3 or ECR4 installed.

## Overview

The 7965-S42 water cooling manifold provides water supply and water return for 1 - 20 servers that are mounted in a 7965-S42 42U slim rack. The manifold is mounted on the right side of the rack (when viewed from the rear of the rack) and extends for 40U. Power distribution unit (PDU) pockets on the right (when viewed from the rear) are not accessible and cannot be populated in the water-cooled configuration. The manifold does not interfere with the placement of servers or other I/O drawers. Quick connect fittings are located every 2U on the manifold for water supply and water return that provides 20 pairs of fittings.

**Note:** This solution is only available for use with IBM water-cooled servers.

## Requirements

You must obtain a cooling distribution unit (CDU) and water that meets cleanliness, filtration, and chemical requirements that are listed in [Planning for water cooling](#).

CDUs are available from suppliers such as [Motivair](#) and [Nortek](#). CDUs deliver proper water flow rate and temperature to cool the servers, while it maintains the temperature above the dew point to avoid condensation. CDUs are also essential to control the closed loop of the water that flows through the servers to maintain proper water cleanliness, filtration, and chemistry while it controls the wet materials in the water loop.

## Configurations

The manifold can be used only with a 7965-S42 rack. The water cooling feature of IBM servers cannot be configured in a non-IBM rack.

The manifold can be used only in the rack to cool servers, or it can be used with a rear door heat exchanger (RDHx) in a series flow to cool the remaining heat that is transferred to the air. For more information about RDHx information, see [Model 1164-95X rear door heat exchanger](#).

## Manifold only configurations

FC ECR3 can be used to order the manifold with water input and output at the top of the rack. Since the hose exits through the top of the rack, the top 2U must be left vacant. All 2U drawers must be populated into the rack on odd EIA increments.

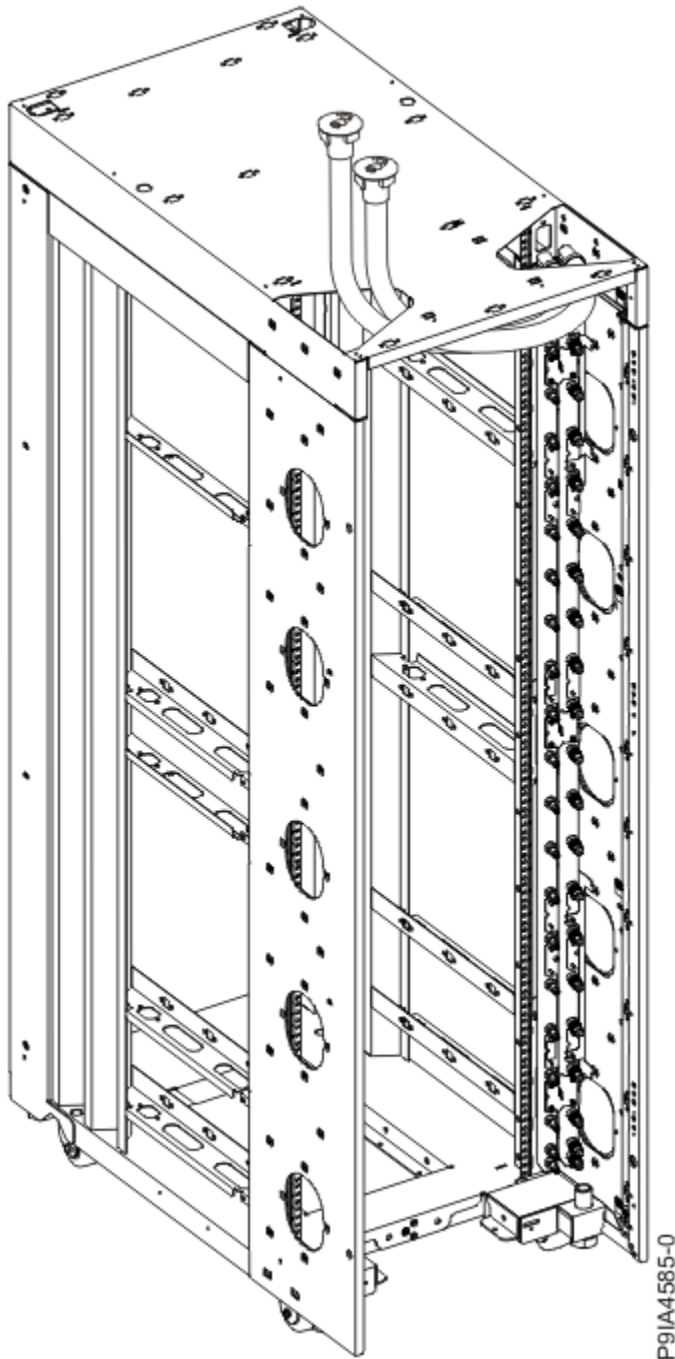

Figure 50. Rack and manifold with supply and return hoses that exits through the top of the rack

FC ECR4 can be used to order the manifold with water input and output at the bottom of the rack. Since the hose exits through bottom of the rack, some space must be left open on the bottom of the rack. When 1U of the bottom space is left open, all 2U drawers must be populated into the rack on even EIA increments. When 2U of the bottom space is left open, all 2U drawers must be populated at odd EIA increments.

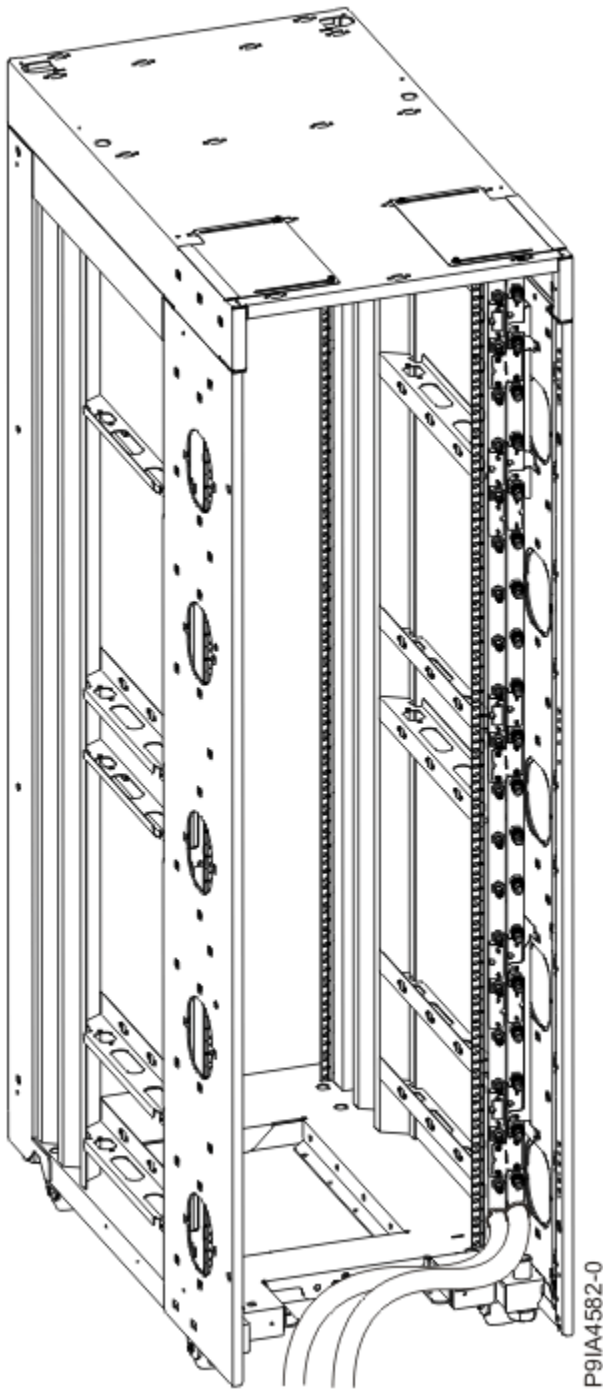
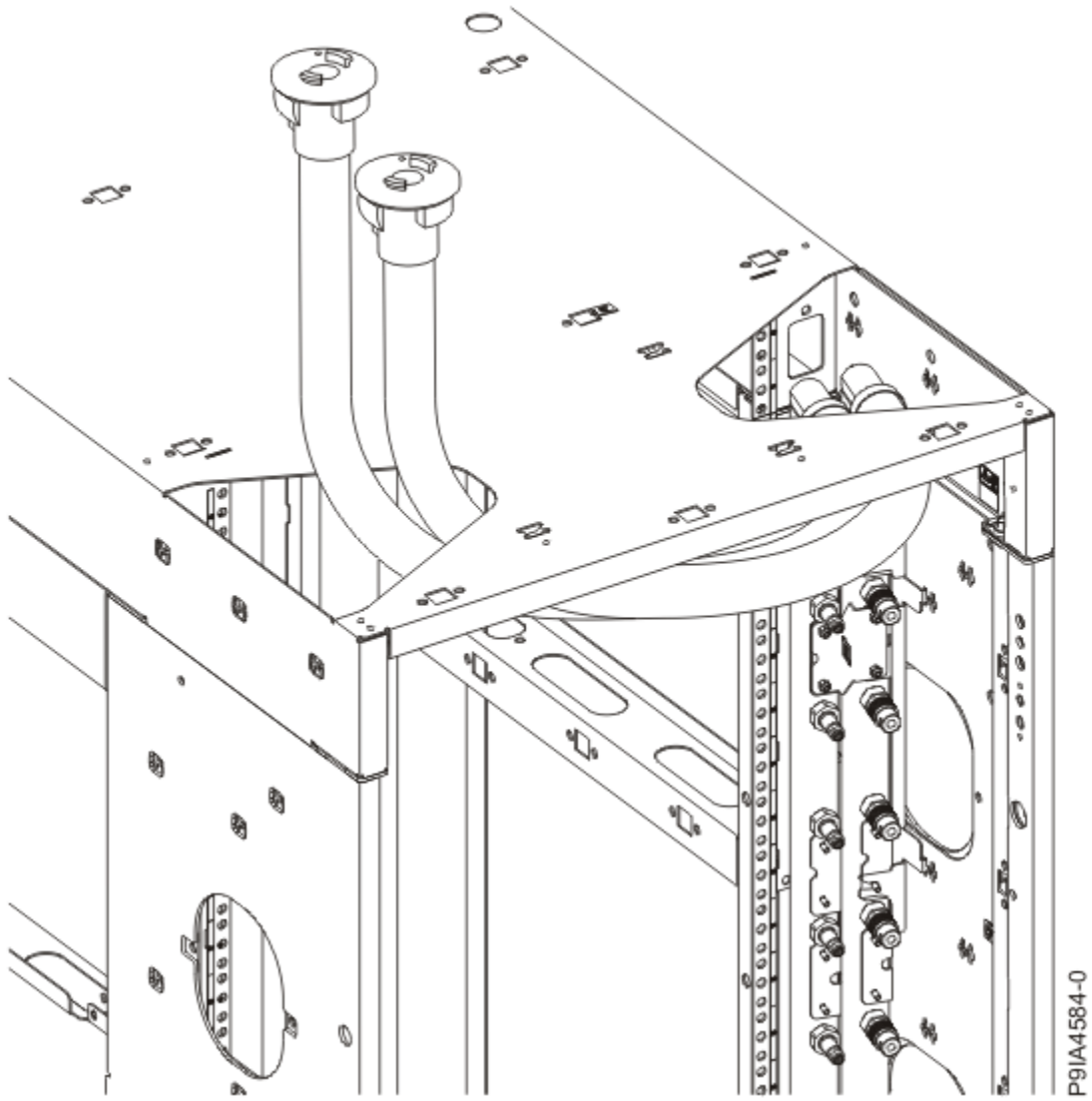

Figure 51. Rack and manifold with supply and return hoses that exits through the bottom of the rack

### Top hose exit locations

The following graphics show the location of the hose that exits from the top of the 7965-S42 rack.



P9IA4584-0

Figure 52. Top hose exit locations

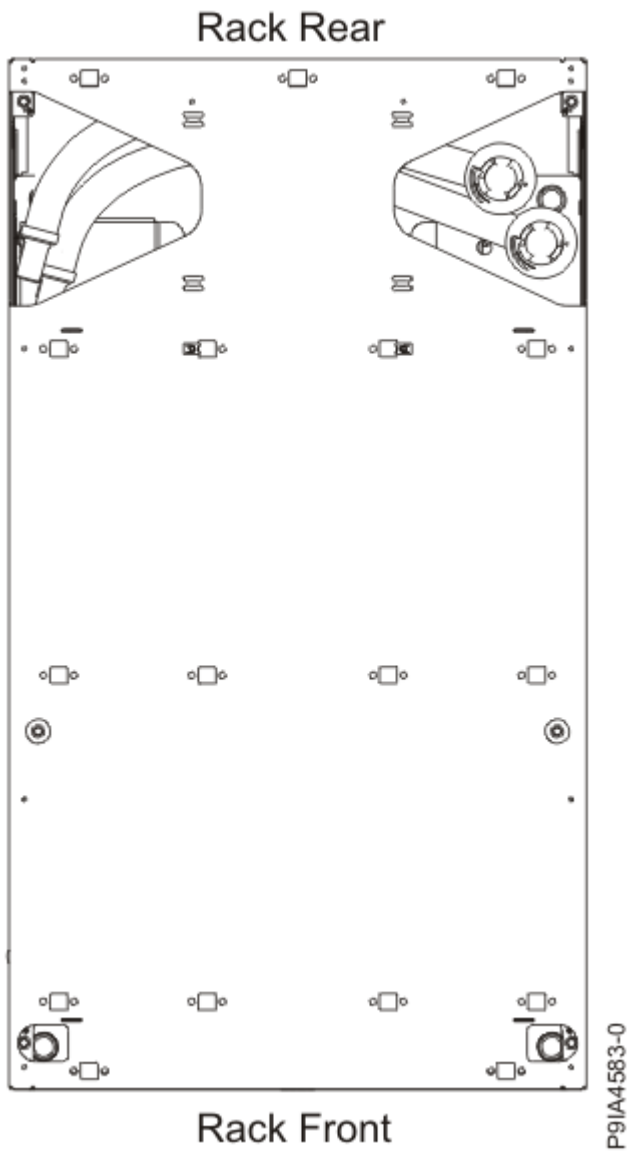

Figure 53. Top hose exit locations (when viewed from the top)

**Note:** Approximately 0.91 m (3 ft.) of hose is available after the hose exits the top of the rack.

### Bottom hose exit locations

The following graphics show the floor cutout locations and dimensions that are required for water hoses that are routed out through the bottom of the rack and under the floor. Power cables can also use this cutout.

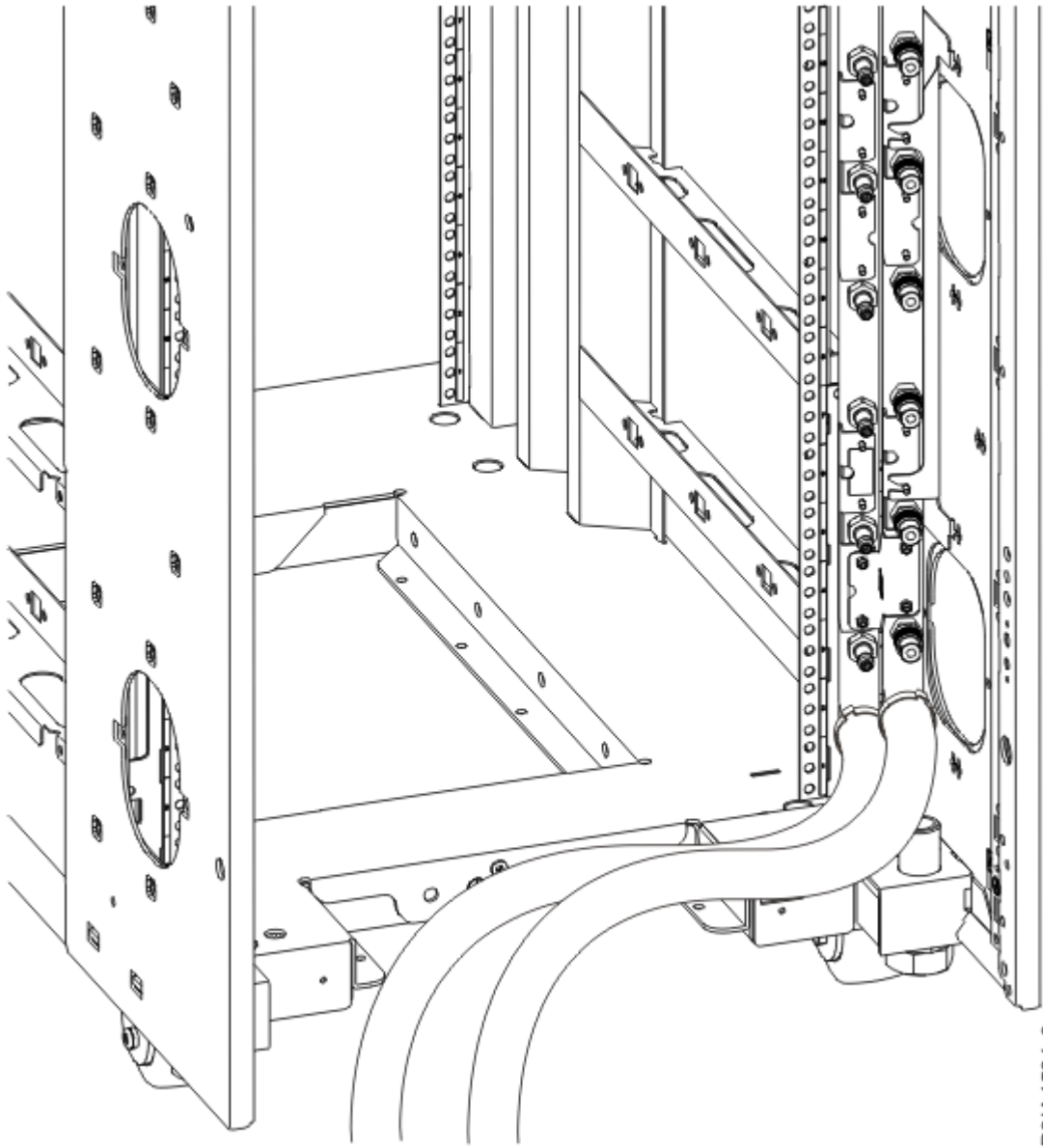

Figure 54. Bottom hose exit locations



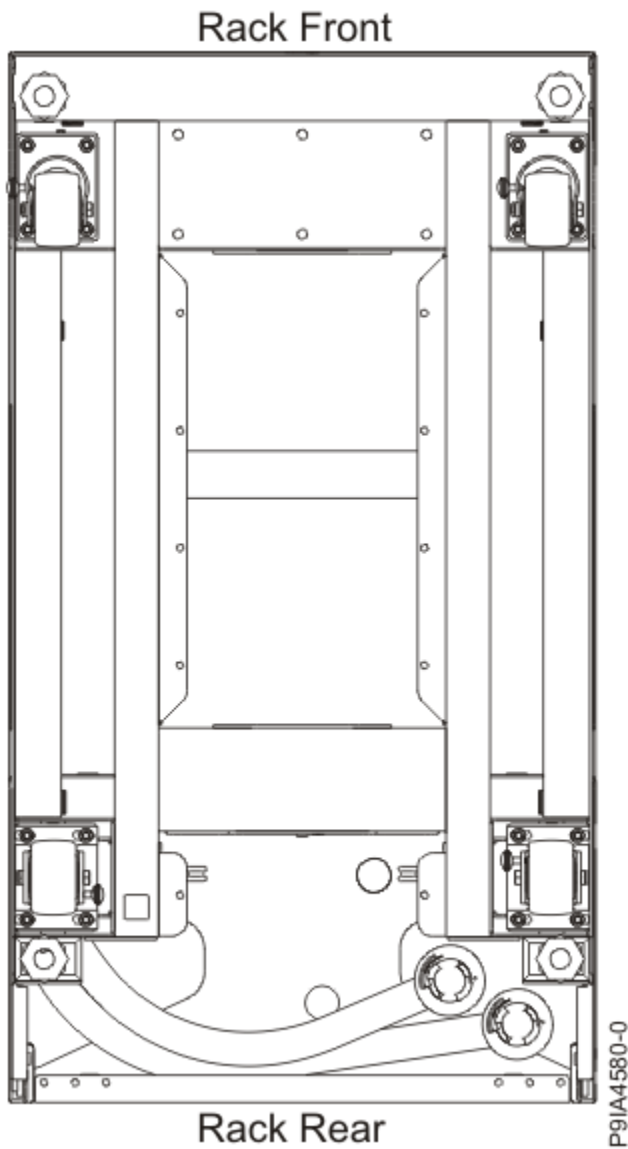

Figure 55. Bottom hose exit locations (when viewed from the bottom)

**Note:** Approximately 0.91 m (3 ft.) of hose is available after the hose exits the bottom of the rack.

## Specifications

<i>Table 40. Manifold specifications</i>	
<b>Manifold characteristics</b>	<b>Properties</b>
Manifold weight - dry	13.6 kg (30 lbs.)
Manifold weight - with water	17.5 kg (38.6 lbs.)
Manifold volume	6 L (1.6 gal)
<b>Note:</b> For more information about the rack weight, see <a href="#">“Model 7953-94X and 7965-94Y rack”</a> on page 24.	

The rear door heat exchanger can be used with this rack. For more information about rear door heat exchangers, see [“Model 1164-95X rear door heat exchanger specifications”](#) on page 33.

## Hoses

The servers are connected to the manifold through quick-connects. The manifold has one cold water inlet that leads to the rack and one warm water outlet. Hoses are supplied by IBM. Hoses can be cut to length, but first must be cleaned so that no particles are inside the hose before installation. Some slack must be kept in the hose for easier installation. For more information about suggested clamping tools and specifications, see the [Oetiker](#) website.

The manifold has 182.9 cm (6 ft.) of 25.4 mm (1 in.) inner diameter flexible hoses on the supply side and 182.9 cm (6 ft.) of 25.4 mm (1 in.) inner diameter flexible hoses on the return side. After accounting for hose length inside of the rack, there is approximately 91.4 cm (3 ft.) of hose for each of the supply and return hose that exits the rack.

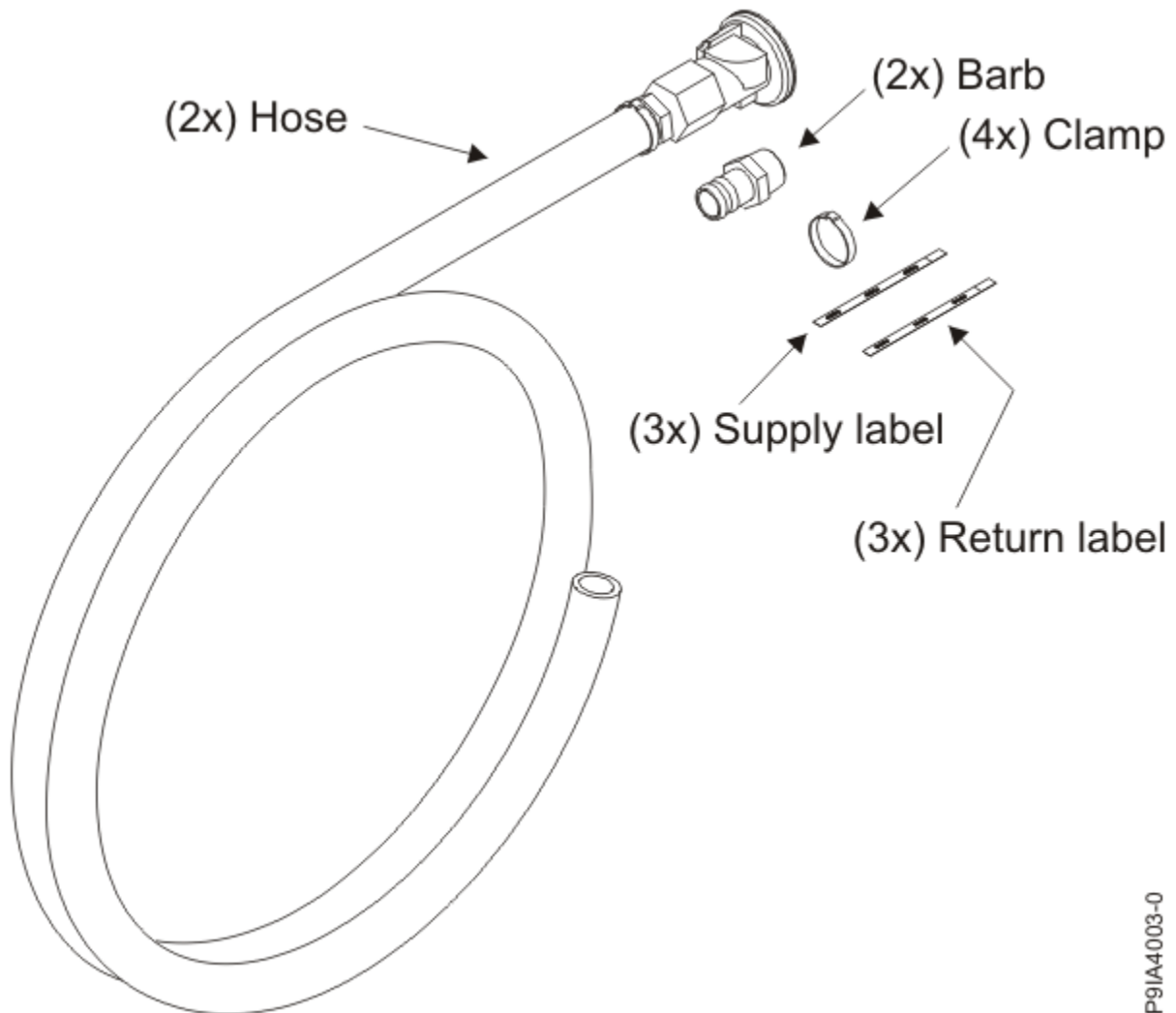

Figure 56. Hose kit

P91A4003-0

Table 41. Hose kit dimensions	
Hose information	Dimensions or type
Hose length	426.72 cm (14 ft)
Hose machine end	Quick-connect
Water supply end	25.4 mm (1 in.) National Pipe Thread Taper (NPT) male barb and clamp <sup>1</sup>
Bend radius	203.2 mm (8 in.)

Table 41. Hose kit dimensions (continued)

Hose information	Dimensions or type
Hose inside diameter	25.4 mm (1 in.) plus or minus 0.5 mm (0.02 in.)
Hose outside diameter	34.54 mm (1.4 in.) plus or minus 0.76 mm (0.03 in.)

**Notes:**

The facility hose kit is supplied in a separate box from the rack and contains the following items:

- Two 182.9 cm (6 ft.) hoses with preattached quick-connects for connection to manifold. At one end of the hose, the quick-connect mates with the quick-connect at the end of the hose that returns from the manifold. The other end of the hose is a bare cut end.
- Two 25.4 mm (1 in.) NPT male barbs. One end of the fitting is a 25.4 mm (1 in.) barb to fit on the inside of the 25.4 mm (1 in.) inner diameter hose. The other end of the fitting is a 25.4 mm (1 in.) NPT male barb.
- Four Oetiker hose clamps 16703242 (two hose clamps are required and two hose clamps are extra).
- Three supply labels (only two supply labels are required). The supply labels need to be installed on the supply end of the hose after it is connected to the facility.
- Three return labels (only two return labels are required). The return labels need to be installed on the return end of the hose after it is connected to the facility.

<sup>1</sup>You must provide a 25.4 mm (1 in.) NPT female barb fitting on the facility hoses.

The customer provided interconnection to the rack (under-the-floor manifold, CDU, and so on) must have a 25.4 mm (1 in.) female NPT fitting for each manifold supply and return connection. The 25.4 mm (1 in.) NPT male barb fitting from the hose kit must be threaded onto the NPT female barb fitting on the customer CDU plumbing fitting. A thread sealant must be used to create a leak-free connection. You cannot use Teflon tape, as Teflon tape particles might enter the water stream.

To make the connection from the hose to the barb fitting, the facility hoses must first be cut to length. If the CDU plumbing fitting requires a longer hose than the 426.72 cm (14 ft) facility hose, the plumbing fitting must be altered to bring the fitting close enough such that the 426.72 cm (14 ft) facility hose is sufficient. The ends of the hose must be cleaned before the installation so that no particles are inside the hose. The clamp is inserted over the hose and then the barb is inserted into the hose. Position the clamp near the hex portion of the barb fitting (not over the barb) and tighten the clamp with an Oetiker clamp tool. For more information about the clamp tool, see *Forged steel Standard Jaw Pincers*. The ears of the clamp must be tightened so that they make contact with each other. When the clamp is released, the ears of the clamp relax and a small space is left between the ears. This small space is normal. [Figure 57](#) on [page 81](#) shows the dimension **S** that must be fully closed during the clamping process.

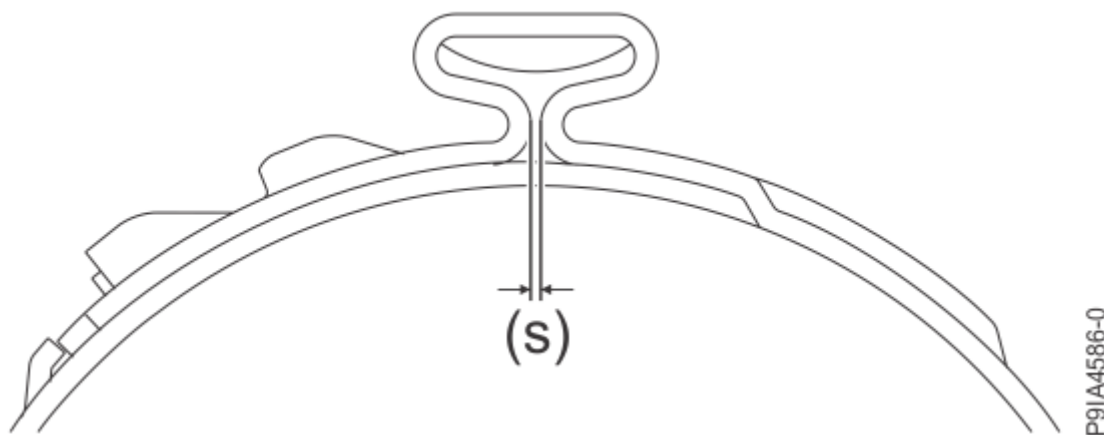
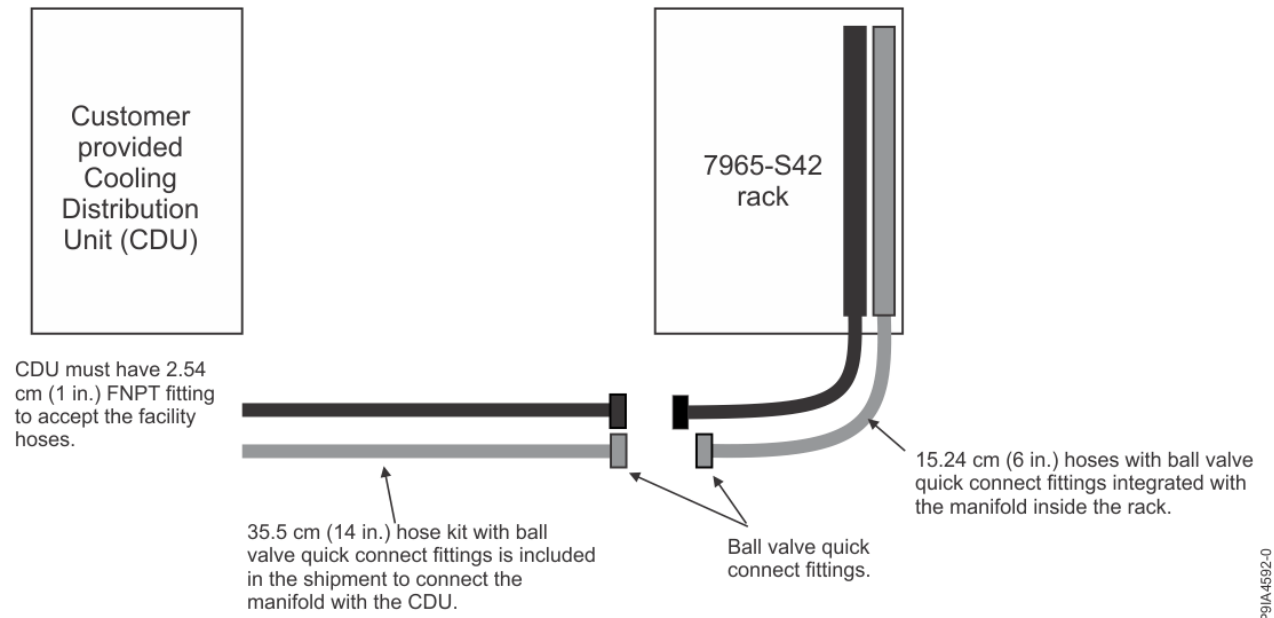

Figure 57. Clamp ear

The supply and return labels must be applied on both ends of the facility hose to indicate the function of each facility hose. The quick connects on the end of the facility hose can now be connected to the quick connects on the manifold. For more information about mating quick connects, see step 3 at [Replacing the water manifold in the 8335-GTW or 8335-GTX system](#).

The following graphics show the CDU schematics of facility hose connections.



P81A-6592-0

Figure 58. CDU schematic with facility hoses that connects directly to the CDU

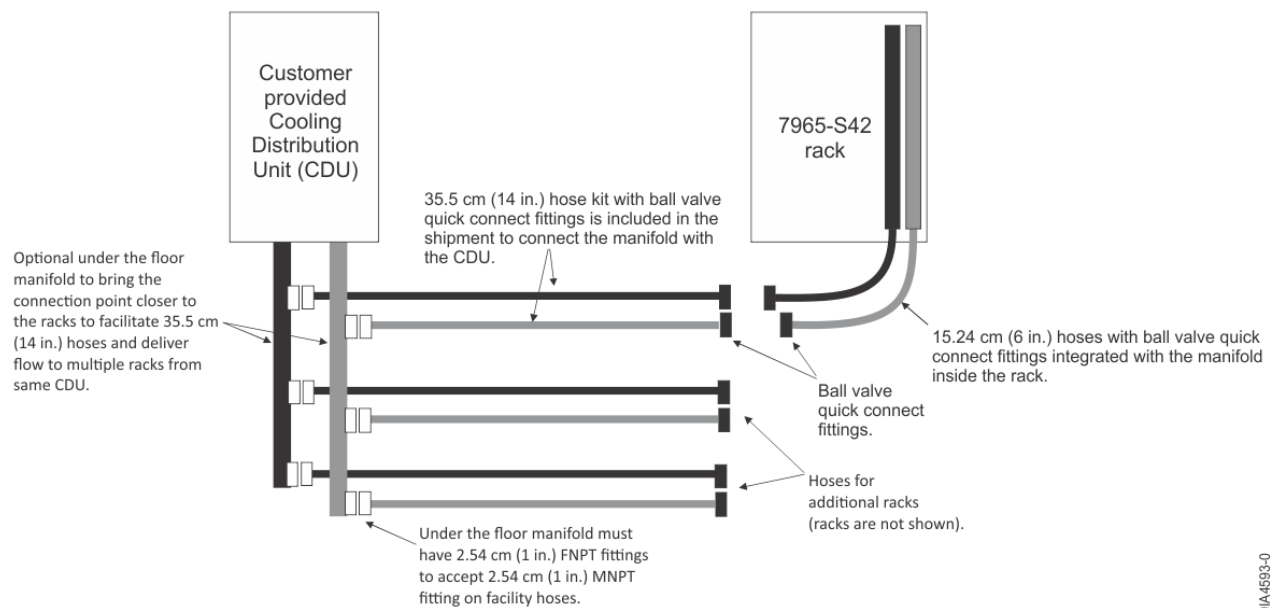

P81A-6593-0

Figure 59. CDU schematic with facility hoses that connects to an under-the-floor manifold

Part Description	Water volume
Manifold (supply tube, return tube, and hoses)	6 liters (1.6 gallons)
Each 30.4 cm (1 ft) of the facility hose	0.15 liters (0.04 gallons)

## Water flow

Water does not flow through the manifold unless the supply and return circuits are connected. This situation normally occurs when a water-cooled server is connected to the manifold. An option to flow water through the manifold before servers are connected is to attach the bleed tool that is included along with the manifold. If you want to commission the system before the servers are connected, the bleed tool can be used to allow water to flow. With the bleed tool connected, a limited amount of water (7.5 - 11.3 liters (2 - 3 gallons) per minute per rack) can flow through the manifold. It is advised to continue to have the water flow until the servers are connected to avoid stagnant water from sitting in the manifold for an extended time. For instructions on how to connect the bleed tool, see [“Bleeding air from the manifold” on page 85](#).

## Initial filling of the rack and servers with water

To initially fill the water to the rack with servers that are connected to the manifold, complete the following steps:

1. Ensure that the bleed valves and CDUs are open in your facility infrastructure.
2. Ensure that the cap on the bleed tool is loosened as far as possible, but without falling off. For more information, see [Figure 60 on page 84](#).
3. Place the air bleed valve on top of the rack and secure it to the top of the rack. A screw must be used to secure the bleed tool to the rack. For more information, see [Figure 61 on page 85](#).
4. Connect the bleed tool to the top most quick connects on both manifolds. Connecting the bleed tool to the manifold before you add water, removes the excess pressure that is included in the components.
5. Make sure that all servers have quick connects plugged to the supply and return manifolds in the rack.
6. Fill the rack as slowly as possible to create less mixing of the water that enters the bottom of the rack with the air that exits from the top of the rack.

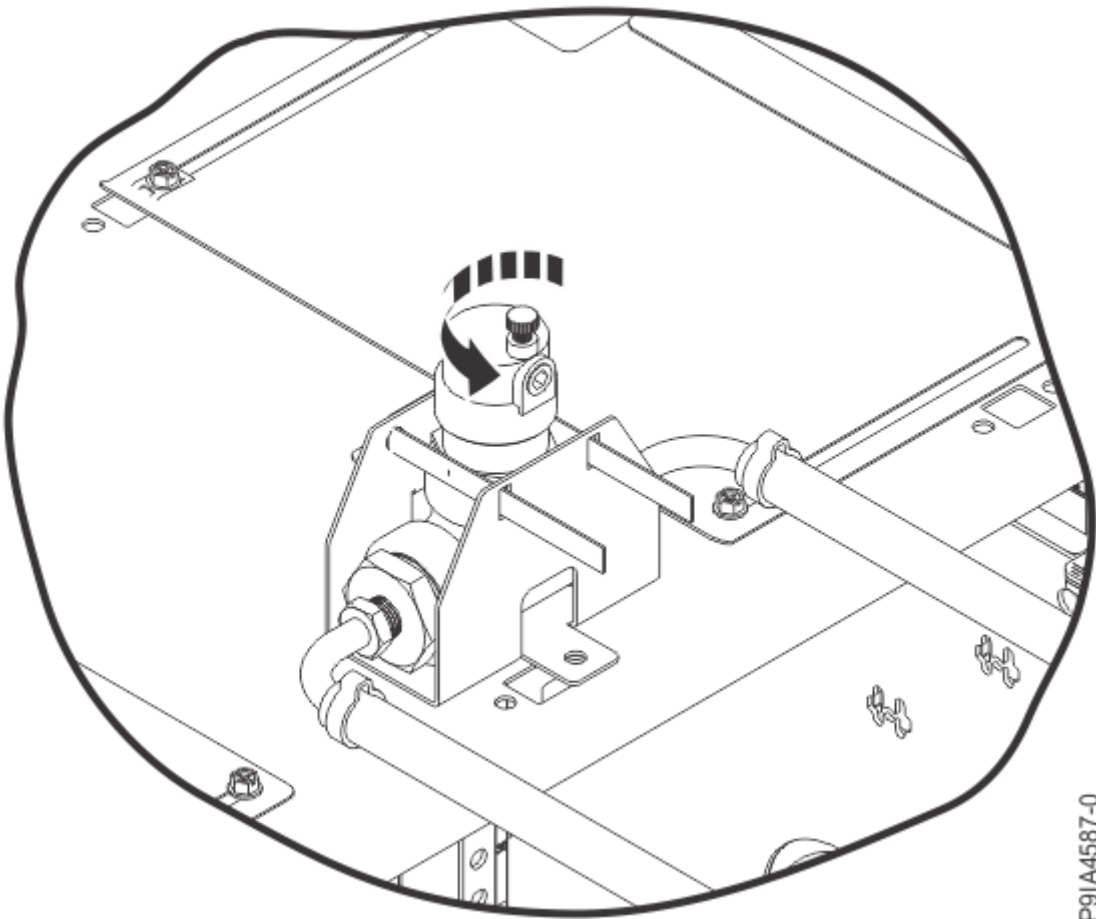

Figure 60. Opening the cap in the bleed tool

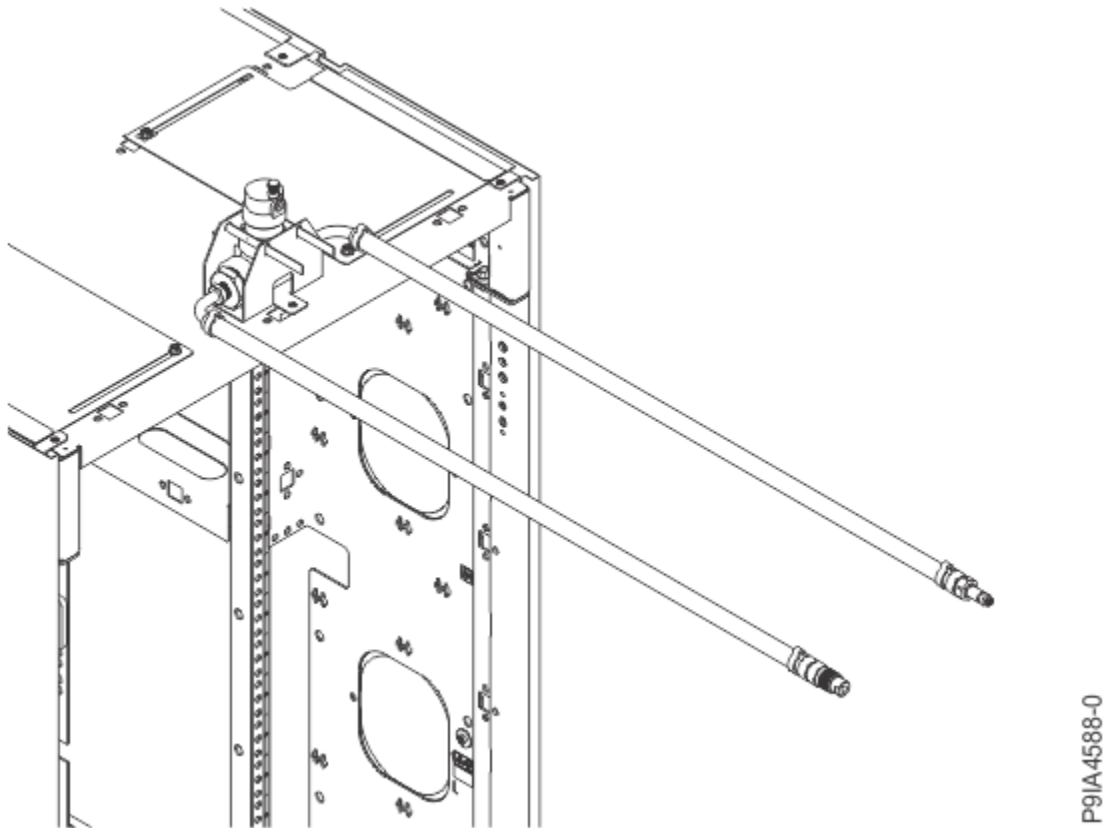

Figure 61. Attaching the bleed tool to the top of the rack

## Bleeding air from the manifold

Air must be bled from the system when the servers are first connected and the water starts to flow. This step must be repeated if more servers are added to the rack, or if a new cold plate is introduced to the water loop, such as a cold plate field replaceable unit (FRU) replacement.

To bleed the air from the water loop, follow the procedure regarding the initial filling of the loop. Ensure that you connect the two quick connects on the ends of the hoses of the bleed tool to the top-most quick connects on the supply and return manifolds. If possible, temporarily increase the water flow rate to the rack during the bleeding process up to an average of 5.6 liters (1.5 gallons) per minute per drawer to help free bubbles from internal surfaces. Do not increase the water flow rate to the point that the inlet pressure to the rack exceeds 6894 pascals (40 pounds per square inch (psi)).

It is important not to leave the bleed tool connected to the system during normal operation. You must allow twice the amount of water flow through the bleed hose as through a server, which decreases the amount of water that flows through the servers. For example, when there are 18 servers in a rack with the bleed tool that is attached to both manifolds, then following water flow rates apply:

- If you are delivering 68.13 liters (18 gallons) per minute to the rack, then 7.57 liters (2 gallons) per minute goes to the bleed tool and 3.33 liters (0.88 gallons) per minute goes to each server.

**Note:** 3.33 liters (0.88 gallons) per minute is calculated by 60.56 liters divided by 18 servers (16 gallons divided by 18 servers)..

- If you increase the water flow to 75.7 liters (20 gallons) per minutes to the rack, then 7.57 liters (2 gallons) per minute goes to the bleed tool and 3.78 liters (1 gallon) per minute goes to each server.
- If you are delivering 34.06 liters (9 gallons) per minute to the rack, then 3.78 liters (1 gallon) per minute goes to the bleed tool and 1.66 liters (0.44 gallons) per minute goes to each server.
- If you increase the water flow to 37.85 liters (10 gallons) per minute to the rack, then 3.78 liters (1 gallon) per minute goes to the bleed tool and 1.89 liters (0.5 gallons) per minute goes to each server.

The bleed valve must be left in place for as long as practical. The more slowly the water is initially added to the water loop, the shorter the time that is needed to bleed the air. Keep the bleed tool connected for at least 24 hours after the initial water filling of the system. The bleed tool can be connected for a longer time if there is a concern about bleeding more air. The bleed tool must be removed during the normal operation of the servers to prevent less water from flowing through the servers than intended. The bleed tool can be disconnected from the manifold by actuating the collar on the quick connects (on one manifold, the collar is pulled and on the other manifold, the collar is pushed in).

The bleeding process must be repeated after a high heat load is introduced into the system for the first time. After a high heat load is introduced into the system for the first time, reconnect the bleed tool and leave it connected for at least 12 hours. The air is now purged from the water loop. Keep the bleed tool on hand in case it needs to be reconnected if a new server or a new cold plate is added to the water loop. The bleed tool can be reconnected at a future point if you feel that air is in the loop and needs to be purged.

If there is a troublesome rack, then the following procedure can be used to jump-start this process, before following the preceding bleeding air from the manifold process. This process is not realistic to deploy on every rack in a large installation. The goal is to remove a large amount of air that might be trapped at the top of either manifold. The following clean process prevents the air from being reabsorbed into the water.

1. Ensure that the cap on the bleed tool is loosened as far as possible, but without the cap falling off.
2. Start with the return manifold (the rightmost manifold as viewed from the rear of the manifold). Connect the bleed tool to this manifold only. Lift the bleed valve as high as possible, assuring that the hose monotonically increases in height from the quick connect coupling to the bleed valve. Gently shake the bleed valve and the hose near the quick connect. This step might allow a large air bubble to travel up the hose and escape out of the bleed tool. You might hear the valve as the air is expelled or see a tiny amount of moisture on the valve. This situation does not occur always.
3. Continue to gently shake the bleed valve. Another air bubble might travel up the hose to the bleed valve. Expect approximately 30 seconds for the bubble to travel upwards and escape from the bleed tool.
4. Repeat this step 10 times.  
**Note:** If you continue to hear air that is escaping or see water that is escaping from the bleed tool, repeat the step until it no longer occurs.
5. Remove the quick connect from the return manifold.
6. Attach the other hose to the supply manifold (the leftmost manifold as viewed from the rear of the manifold).
7. Repeat steps [“1” on page 86](#) - [“4” on page 86](#) for the supply manifold.
8. Proceed to [“Bleeding air from the manifold” on page 85](#).

## Manifold and RDHx configurations

The 7965-S42 manifold can be used in conjunction with the 1164-95X RDHx to remove heat from the air that is passed through the servers. To make this connection, the supply water must be connected to the supply port of the RDHx first. The supply port of the RDHx is the quick connect coupling that is closest to the outside of the door. The outlet of the RDHx (the quick connect that is closest to the rack) must be connected to the supply of the manifold. The return of the manifold must be connected to the return of the CDU plumbing fitting. This step ensures that the coldest water enters the RDHx first. This maximizes the performance of the RDHx.

The manifold and RDHx can be configured with hoses that exits from the top of the rack or from the bottom of the rack. The following graphics show the RDHx that is connected to the manifold in a top exit orientation.



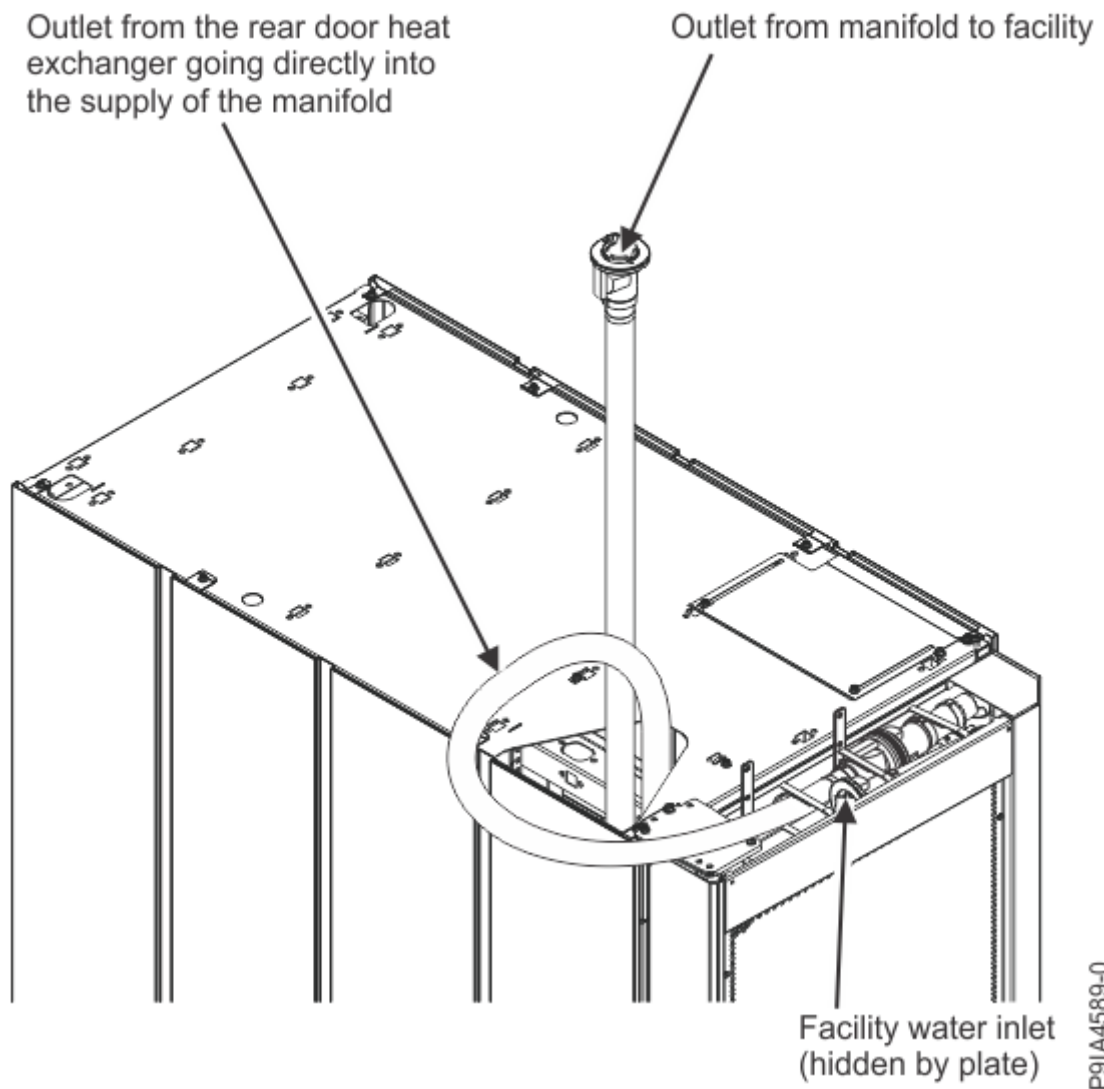

Figure 62. Top exit configuration

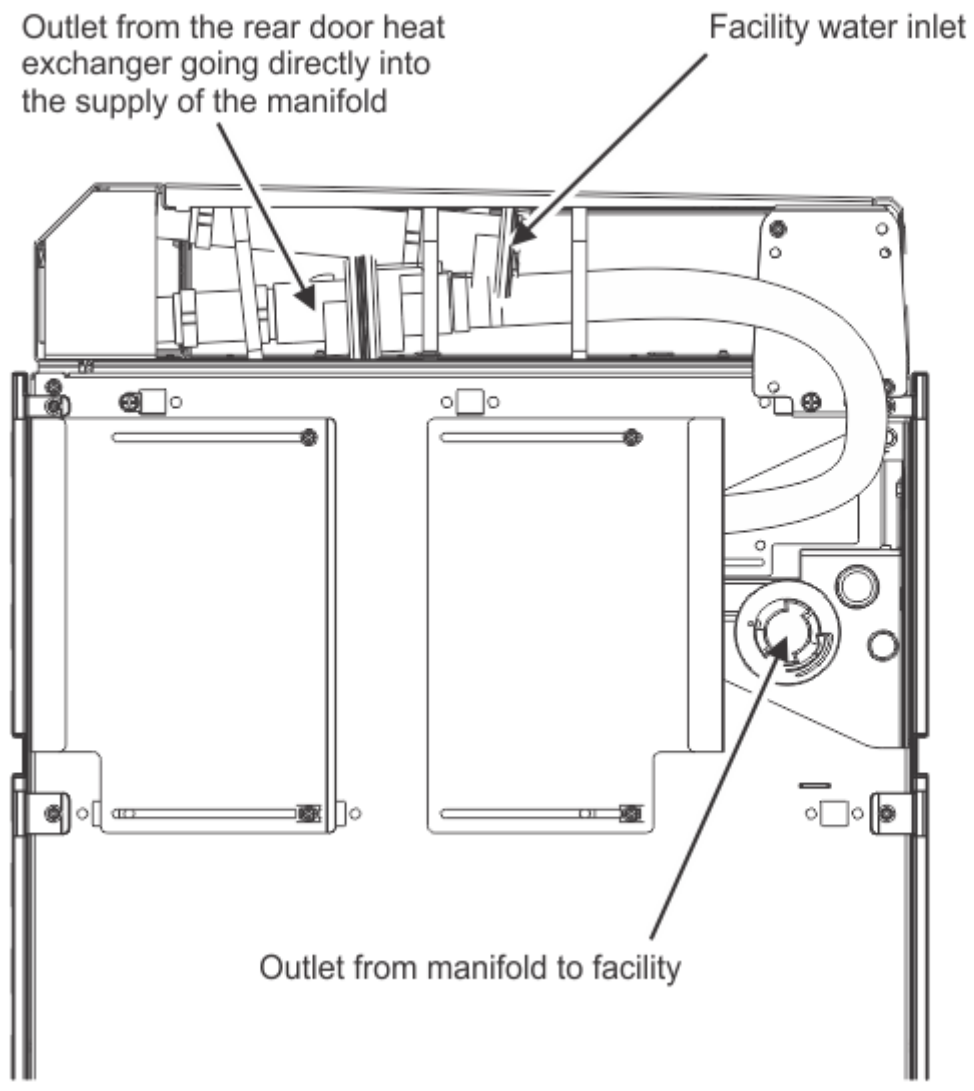

Figure 63. Top exit configuration (top-down view)

When the RDHx and the manifold are oriented with the hoses pointed down, the hose loop from the RDHx to the manifold can either be fitted below the raised floor or between the floor and the bottom of the rack. A hose loop can be formed directly under the rack. The following figure shows the RDHx quick connect locations. The order of plumbing is the same as the top exit configuration.

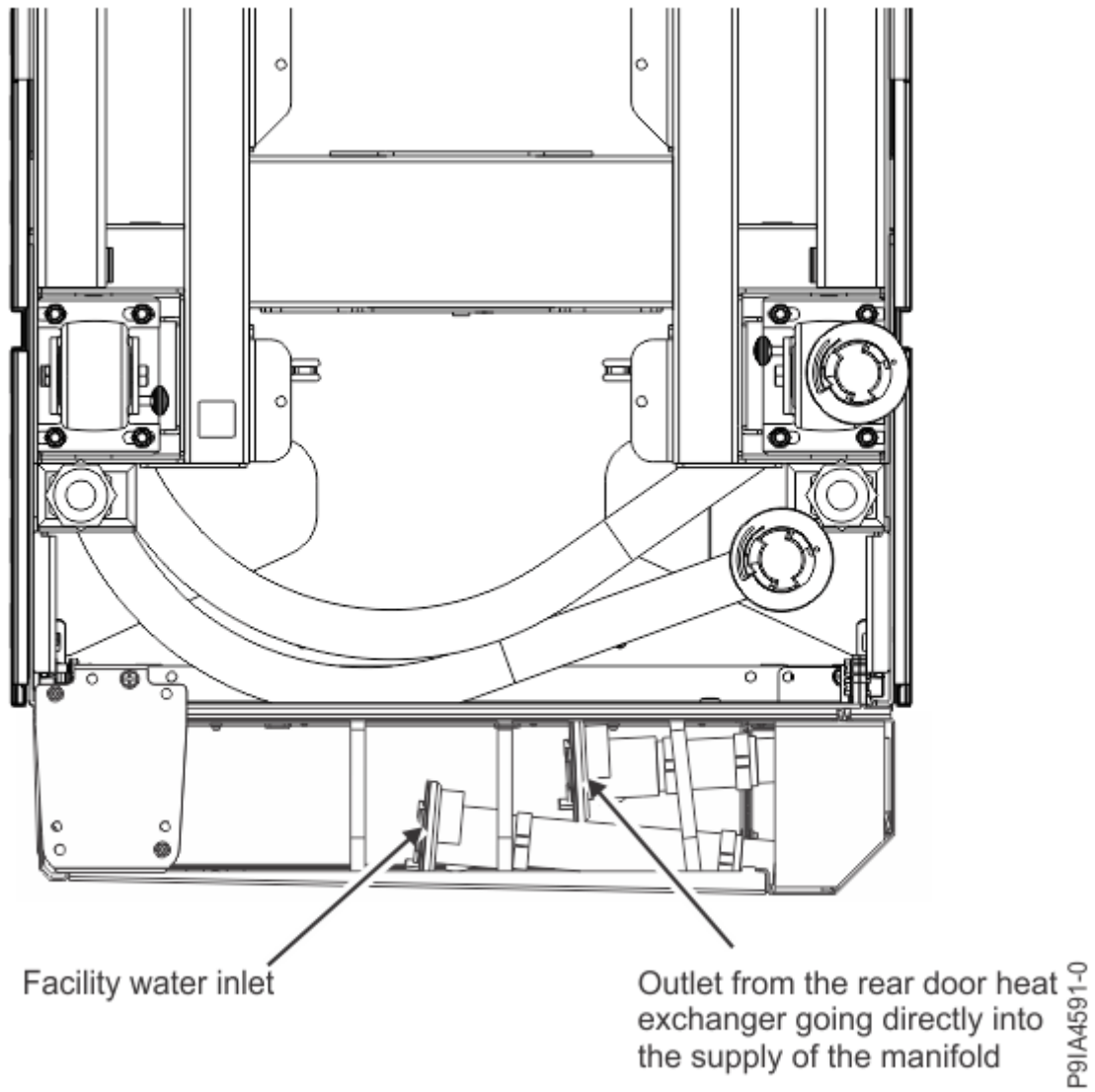

Figure 64. Bottom exit configuration

### Facility hose for the RDHx

The same facility hose kit that is included with the manifold is also included with the RDHx. The same process to connect the hose to the manifold must be followed for the RDHx. If the RDHx is used in the same hose loop as the manifold, then an extra facility hose kit might not be used.

The following graphics show the CDU schematics of facility hose connections of the CDU, the RDHx, and the manifold connected together in one hose loop.

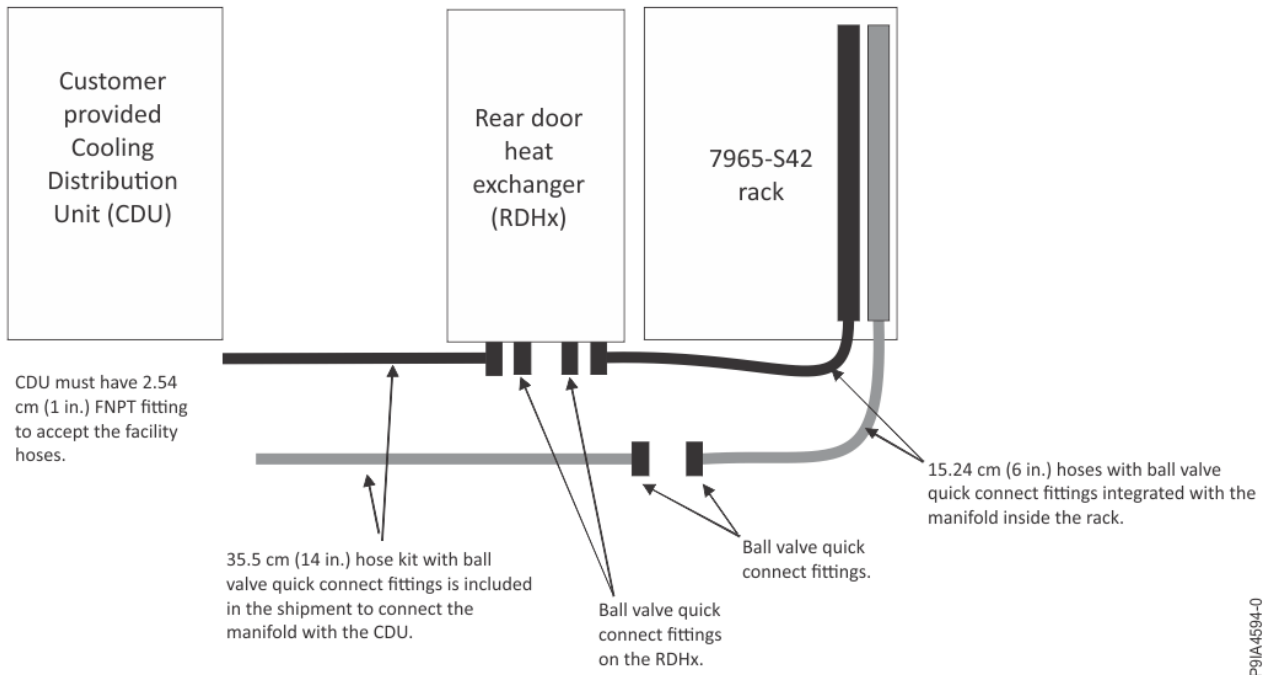

Figure 65. CDU schematic with facility hoses for a manifold and RDHx that connects directly to the CDU

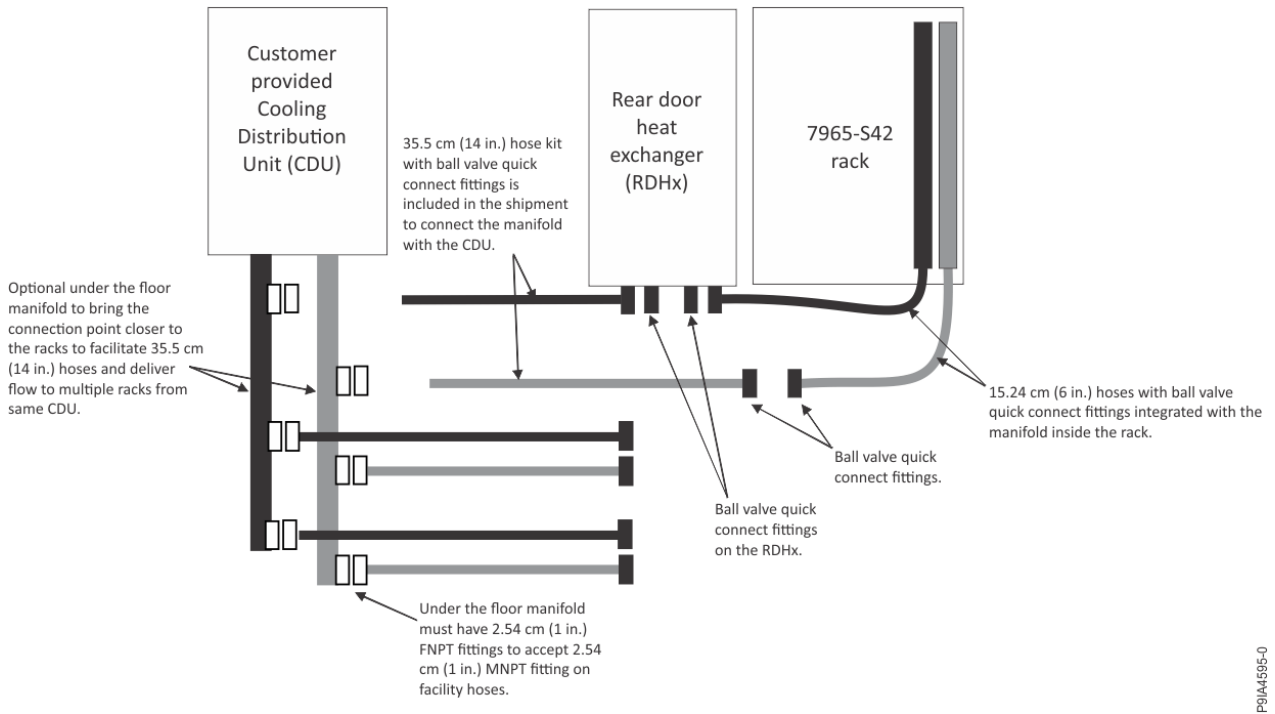

Figure 66. CDU schematic with facility hoses for a manifold and RDHx that connects to an under-the-floor manifold

The following table shows the water volume through each part.

Part Description	Water volume
Manifold (supply tube, return tube, and hoses)	6 liters (1.6 gallons)
Rear door heat exchanger	9 liters (2.4 gallons)

Table 43. Water volume (continued)

Part Description	Water volume
Each 30.4 cm (1 ft) of the facility hose	0.15 liters (0.04 gallons)

### Two different loops (hot and cold water)

If you want to run warm water through the manifold and servers and cold water through the RDHx, you can plumb two hose loops to each rack. The water connections to the manifold and RDHx are performed separately as though the other entity does not exist. Facility hose kits are provided for each manifold and RDHx. You must plan carefully to ensure that adequate space is available for two hose kits per rack.

### Cooling loop requirements

- A secondary cooling loop, separate from the main site cooling loop, is required for the manifold.
- Cooling distribution units are available from suppliers such as [Motivair](#) and [Nortek](#).
- The secondary cooling loop must meet the requirements that are outlined in the water chemistry specification.

### Floor cutout

Racks with water hoses and power cords that exit from the bottom of the rack require a floor tile cutout of at least 30.48 cm (12 in.) long by 22.86 cm (9 in.) wide. Due to the hose bend radii, the hole must be positioned towards the side of the rack without the manifold (the left side of the rack when looking at the rear of the rack). The left edge of the hole must be at least 11.43 cm (4.5 in.) from the side and 3.81 cm (1.5 in.) from the back edge of the rack (not including doors). Hole placement on the tile depends on the location of the rack, tile size, and tile load limitations.

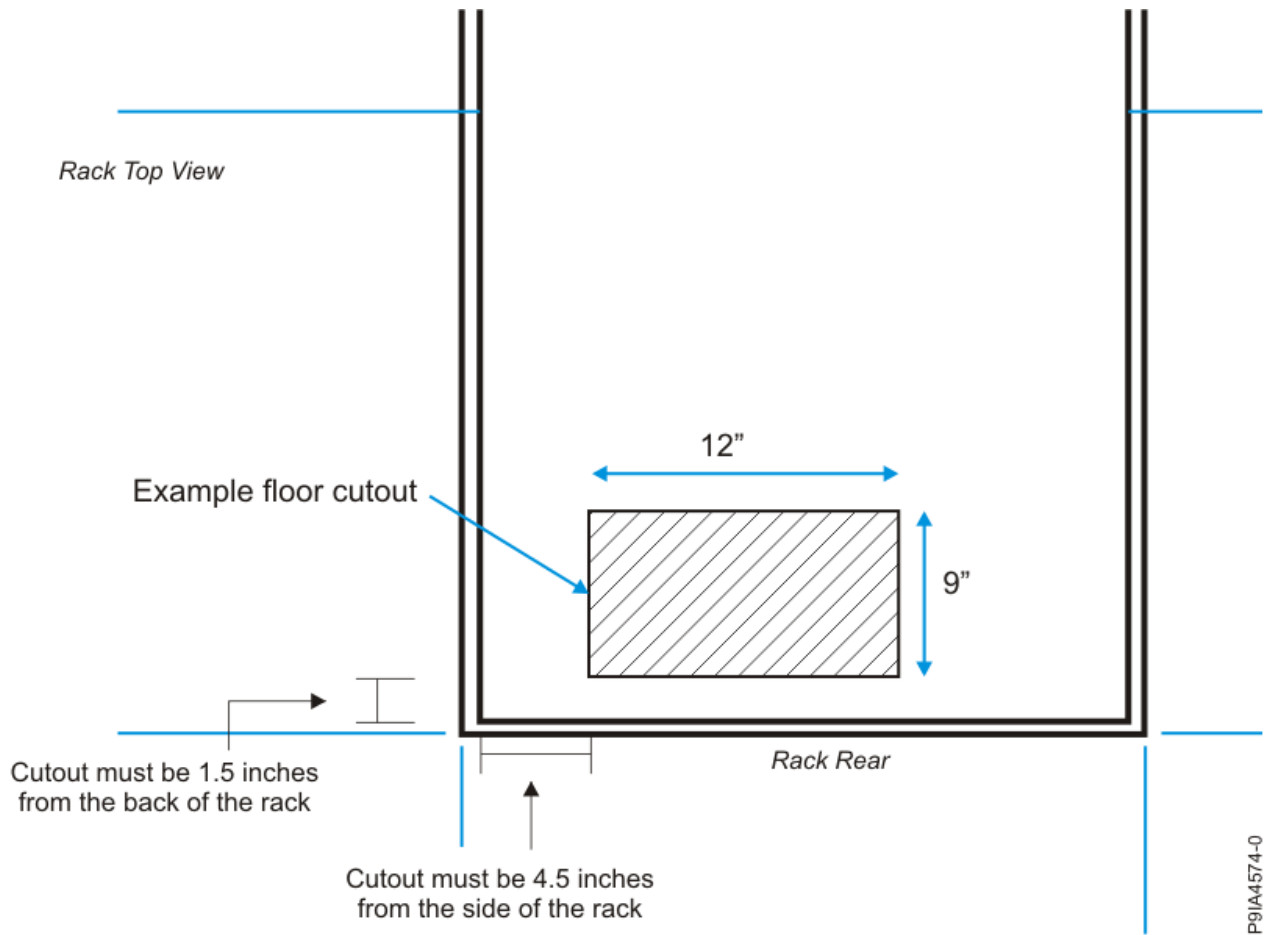

Figure 67. Floor cutout

## Hardware Management Console specifications

Hardware Management Console (HMC) specifications provide detailed information for your HMC, including dimensions, electrical, power, temperature, environment, and service clearances.

### Model 7063-CR1 Hardware Management Console specifications

Hardware specifications for model 7063-CR1 provide detailed information for your Hardware Management Console (HMC), including dimensions, electrical, power, temperature, environmental specifications, and noise emissions.

The HMC controls managed systems, including the management of logical partitions and the use of capacity on demand. Using service applications, the HMC communicates with managed systems to detect, consolidate, and send information to IBM for analysis. The HMC provides service technicians with diagnostic information for systems that can operate in a multiple-partitioned environment.

Use the following specifications to plan for your HMC.

Width	Depth	Height	Weight
437 mm (17.2 in.)	705.3 mm (27.76 in.)	43.0 mm (1.7 in.)	14.5 kg (32 lb)
Preliminary information is subject to change.			

Table 45. Electrical <sup>1</sup>

Electrical characteristics	Properties
Maximum measured power	300 W
Maximum kVA	300
Maximum thermal output	1024 BTU/hr
Input voltage	100 - 127 V ac or 200 - 240 V ac
Frequency	50 or 60 Hz
1. Power consumption and heat output vary depending on the number and type of optional features that are installed and the power-management optional features that are in use.	

Table 46. Environment requirements

Environment	Recommended operating requirements	Allowable operating requirements	Nonoperating requirements
ASHRAE class		A2	
Airflow direction <sup>1</sup>		Front-to-back	
Temperature <sup>2</sup>	18°C - 27°C (64°F - 80°F)	10°C - 35°C (50°F - 95°F)	5°C - 45°C (41°F - 113°F)
Humidity range	5.5°C (42°F) dew point (DP) to 60% relative humidity (RH) and 15°C (59°F) dew point	20% - 80% RH	8% - 80% RH
Maximum dew point		21°C (70°F)	27°C (80°F)
Maximum operating altitude		3050 m (10000 ft)	
Shipping temperature			-40°C to 60°C (-40°F to 140°F)
Shipping relative humidity			5% - 100%
1. Nominal cubic feet per minute (CFM) is approximately 2030. Maximum CFM is approximately 4025.			
2. Derate maximum allowable dry-bulb temperature 1°C (1.8°F) per 175 m (574 ft) above 950 m (3117 ft).			

Table 47. Noise emissions<sup>1, 2, 3</sup>

Product description	Declared A-weighted sound power level, L <sub>Wad</sub> (B)		Declared A-weighted sound pressure level, L <sub>pAm</sub> (dB)	
	Operating	Idle	Operating	Idle
Model 7063-CR1 (1-socket) FC EKBO	7.8 <sup>5</sup>	6.8	62	50
Model 7063-CR1 (1-socket) at maximum temperature and operation.	8.7 <sup>4, 5</sup>	8.7 <sup>4, 5</sup>	69	69

Table 47. Noise emissions<sup>1, 2, 3</sup> (continued)

Product description	Declared A-weighted sound power level, L <sub>Wad</sub> (B)		Declared A-weighted sound pressure level, L <sub>pAm</sub> (dB)	
Model 7063-CR1 (1-socket) at maximum temperature with acoustical doors (front and rear), FC EC08 and FC EC07, installed.	7.9 <sup>4, 5</sup>	7.9 <sup>4, 5</sup>	63	63

**Notes:**

1. Declared level L<sub>Wad</sub> is the upper-limit A-weighted sound power level. Declared level L<sub>pAm</sub> is the mean A-weighted emission sound pressure level that is measured at the 1-meter bystander positions.
2. All measurements made in conformance with ISO 7779 and declared in conformance with ISO 9296.
3. 10 dB (decibel) equals 1 B (bel).
4. Under certain environments, configurations, system settings, and workloads, fan speeds are increased that result in higher noise levels.
5. Notice: Government regulations (such as those prescribed by OSHA or European Community Directives) might govern noise level exposure in the workplace and might apply to you and your server installation. This IBM system is available with an optional acoustical door feature that can help reduce the noise that is emitted from this system. The actual sound pressure levels in your installation depend upon various factors, including the number of racks in the installation; the size, materials, and configuration of the room where you designate the racks to be installed; the noise levels from other equipment; the room ambient temperature, and employees' location in relation to the equipment. Further, compliance with such government regulations also depends upon various extra factors, including the duration of employees' exposure and whether employees wear hearing protection. IBM recommends that you consult with qualified experts in this field to determine whether you are in compliance with the applicable regulations.

## 7063-CR2 Hardware Management Console specifications

Hardware specifications for model 7063-CR2 provide detailed information for your Hardware Management Console (HMC), including dimensions, electrical, power, temperature, environmental specifications, and noise emissions.

The HMC controls managed systems, including the management of logical partitions and the use of capacity on demand. Using service applications, the HMC communicates with managed systems to detect, consolidate, and send information to IBM for analysis. The HMC provides service technicians with diagnostic information for systems that can operate in a multiple-partitioned environment.

Use the following specifications to plan for your HMC.

Table 48. Dimensions<sup>1</sup>

Width	Depth	Height	Weight
434.1 mm (16.9 in.)	726.76 mm (28.6 in.)	43.71 mm (1.7 in.)	17.6 kg (38.8 lb)
Preliminary information is subject to change.			

Table 49. Electrical<sup>1</sup>

Electrical characteristics	Properties
Maximum measured power	W
Maximum kVA	



Table 49. Electrical <sup>1</sup> (continued)

Electrical characteristics	Properties
Maximum thermal output	BTU/hr
Input voltage	100 - 127 V ac or 200 - 240 V ac
Frequency	50 or 60 Hz
1. Power consumption and heat output vary depending on the number and type of optional features that are installed and the power-management optional features that are in use.	

Table 50. Environment requirements

Environment	Recommended operating requirements	Allowable operating requirements	Nonoperating requirements
ASHRAE class		A2	
Airflow direction <sup>1</sup>		Front-to-back	
Temperature <sup>2</sup>	18°C - 27°C (64°F - 80°F)	10°C - 35°C (50°F - 95°F)	5°C - 45°C (41°F - 113°F)
Humidity range	5.5°C (42°F) dew point (DP) to 60% relative humidity (RH) and 15°C (59°F) dew point	20% - 80% RH	8% - 80% RH
Maximum rate of change		5°C/20 hrs	
Maximum dew point		21°C (70°F)	27°C (80°F)
Maximum operating altitude		3050 m (10000 ft)	
Shipping temperature			-40°C to 60°C (-40°F to 140°F)
Shipping relative humidity			5% - 100%
1. Nominal cubic feet per minute (CFM) is approximately 2030. Maximum CFM is approximately 4025.			
2. Derate maximum allowable dry-bulb temperature 1°C (1.8°F) per 175 m (574 ft) above 950 m (3117 ft).			

Table 51. Noise emissions<sup>1, 2, 3</sup>

Product description	Declared A-weighted sound power level, L <sub>Wad</sub> (B)		Declared A-weighted sound pressure level, L <sub>pAm</sub> (dB)	
	Operating	Idle	Operating	Idle
Model 7063-CR2	5			
Model 7063-CR2	4, 5	4, 5		
Model 7063-CR2 (	4, 5	4, 5		

Table 51. Noise emissions<sup>1, 2, 3</sup> (continued)

Product description	Declared A-weighted sound power level, L <sub>Wad</sub> (B)	Declared A-weighted sound pressure level, L <sub>pAm</sub> (dB)
<b>Notes:</b>		
<ol style="list-style-type: none"> <li>Declared level L<sub>Wad</sub> is the upper-limit A-weighted sound power level. Declared level L<sub>pAm</sub> is the mean A-weighted emission sound pressure level that is measured at the 1-meter bystander positions.</li> <li>All measurements made in conformance with ISO 7779 and declared in conformance with ISO 9296.</li> <li>10 dB (decibel) equals 1 B (bel).</li> <li>Under certain environments, configurations, system settings, and workloads, fan speeds are increased that result in higher noise levels.</li> <li>Notice: Government regulations (such as those prescribed by OSHA or European Community Directives) might govern noise level exposure in the workplace and might apply to you and your server installation. This IBM system is available with an optional acoustical door feature that can help reduce the noise that is emitted from this system. The actual sound pressure levels in your installation depend upon various factors, including the number of racks in the installation; the size, materials, and configuration of the room where you designate the racks to be installed; the noise levels from other equipment; the room ambient temperature, and employees' location in relation to the equipment. Further, compliance with such government regulations also depends upon various extra factors, including the duration of employees' exposure and whether employees wear hearing protection. IBM recommends that you consult with qualified experts in this field to determine whether you are in compliance with the applicable regulations.</li> </ol>		

**Electromagnetic compatibility compliance:** CISPR 22:2008; CISPR 32:2012, CNS 13438 (Taiwan); EN 55032:2012 (EU, Australia); EN 55024:2010 (EU); EN 61000-3-2:2014 (EU, Japan); EN 61000-3-3:2013 (EU); FCC, Title 47, Part 15 (USA); GB 9254-2008 (China); GB 17625.1-2012 (China); GB 17625.2-2007 (China); GOCT 30804.3.2-2013 (IEC 61000-3-2:2009) (EAEU); GOCT 30804.3.3-2013 (IEC 61000-3-3:2008) (EAEU); GOCT 30805.22-2013 (CISPR 22:2006) (EAEU); GOCT CISPR 24-2013 (EAEU); ICES-003, Issue 6, January 2016 (Canada); KN 32:2015 (Korea); KN 35:2015 (Korea); TCVN 7189:2009 (Vietnam); VCCI, April 2015 (Japan)

**Safety compliance:** UL 60950-1, 2nd Edition, 2014-10-14; CAN/CSA C22.2 No. 60950-1-07, 2nd Edition, 2014-10, IEC 60950-1:2005 (Second Edition); Am1:2009 + Am2:2013; EN 60950-1:2006 + A1:2010 + A11:2009 + A12:2011 + A2:2013

## Rack switch specifications

Rack switch specifications provide detailed information for your IBM BNT RackSwitch, including dimensions, electrical, power, temperature, environment, and service clearances.

Select the appropriate models to view the specifications for your rack switch.

### G8052R RackSwitch specification sheet

Hardware specifications provide detailed information for your IBM BNT RackSwitch, including dimensions, electrical, power, temperature, environment, and service clearances.

Table 52. Dimensions

Height	Width	Depth	Weight (maximum)
44 mm (1.73 in.)	439 mm (17.3 in.)	445 mm (17.5 in.)	8.3 kg (18.3 lb)

Table 53. Electrical

Electrical characteristics	Properties
Power requirements	200 W

<i>Table 53. Electrical (continued)</i>	
<b>Electrical characteristics</b>	<b>Properties</b>
Voltage	90 - 264 V ac
Frequency	47 - 63 Hz
Maximum thermal output	682.4 Btu/hr
Phase	1
kVA	0.204

<i>Table 54. Environmental and acoustical requirements</i>		
<b>Environment/Acoustical</b>	<b>Operating</b>	<b>Storage</b>
Airflow direction	Rear-to-front	
Temperature, ambient operating	0°C - 40°C (32°F - 104°F)	
Temperature, operating (fan failure)	0°C - 35°C (32°F - 95°F)	
Temperature, storage		-40°C to +85°C (-40°F to 185°F)
Relative humidity range (non-condensing)	10% - 90% RH	10% - 90% RH
Maximum altitude	3050 m (10000 ft)	12190 m (40000 ft)
Heat dissipation	444 Btu/hr	
Acoustic noise	Less than 65 dB	

## **G8124ER RackSwitch specification sheet**

Hardware specifications provide detailed information for your IBM BNT RackSwitch, including dimensions, electrical, power, temperature, environment, and service clearances.

<i>Table 55. Dimensions</i>			
<b>Height</b>	<b>Width</b>	<b>Depth</b>	<b>Weight (maximum)</b>
44 mm (1.73 in.)	439 mm (17.3 in.)	381 mm (15.0 in.)	6.4 kg (14.1 lb)

<i>Table 56. Electrical</i>	
<b>Electrical characteristics</b>	<b>Properties</b>
Power requirements	275 W
Voltage	100 - 240 V ac
Frequency	50 - 60 Hz
Maximum thermal output	938.3 Btu/hr
Phase	1
kVA	0.281

<i>Table 57. Environmental and acoustical requirements</i>		
<b>Environment/Acoustical</b>	<b>Operating</b>	<b>Storage</b>
Airflow direction	Rear-to-front	

<i>Table 57. Environmental and acoustical requirements (continued)</i>		
<b>Environment/Acoustical</b>	<b>Operating</b>	<b>Storage</b>
Temperature, ambient operating	0°C - 40°C (32°F - 104°F)	
Temperature (fan failure) operating	0°C - 35°C (32°F - 95°F)	
Temperature, storage		-40°C to +85°C (-40°F to 185°F)
Relative humidity range (non-condensing)	10% - 90% RH	10% - 95% RH
Maximum altitude	3050 m (10000 ft)	4573 m (15000 ft)
Heat dissipation	1100 Btu/hr	
Acoustic noise	Less than 65 dB	

## **G8264R RackSwitch specification sheet**

Hardware specifications provide detailed information for your IBM BNT RackSwitch, including dimensions, electrical, power, temperature, environment, and service clearances.

<i>Table 58. Dimensions</i>			
<b>Height</b>	<b>Width</b>	<b>Depth</b>	<b>Weight (maximum)</b>
44 mm (1.73 in.)	439 mm (17.3 in.)	513 mm (20.2 in.)	10.5 kg (23.1 lb)

<i>Table 59. Electrical</i>	
<b>Electrical characteristics</b>	<b>Properties</b>
Power requirements	375 W
Voltage	100 - 240 V ac
Frequency	50 - 60 Hz
Maximum thermal output	1280 Btu/hr
Phase	1
kVA	0.383

<i>Table 60. Environmental and acoustical requirements</i>		
<b>Environment/Acoustical</b>	<b>Operating</b>	<b>Storage</b>
Airflow direction	Rear-to-front	
Temperature, ambient operating	0°C - 40°C (32°F - 104°F)	
Temperature (fan failure) operating	0°C - 35°C (32°F - 95°F)	
Temperature, storage		-40°C to +85°C (-40°F to 185°F)
Relative humidity range (non-condensing)	10% - 90% RH	10% - 90% RH
Maximum altitude	1800 m (6000 ft)	12190 m (40000 ft)
Heat dissipation	1127 Btu/hr	
Acoustic noise	Less than 65 dB	

## G8316R RackSwitch specification sheet

Hardware specifications provide detailed information for your IBM BNT RackSwitch, including dimensions, electrical, power, temperature, environment, and service clearances.

Height	Width	Depth	Weight (maximum)
43.7 mm (1.72 in.)	439 mm (17.3 in.)	483 mm (19.0 in.)	9.98 kg (22.0 lb)

Electrical characteristics	Properties
Power requirements	400 W
Voltage	100 - 240 V ac
Frequency	50 - 60 Hz
Maximum thermal output	1365 Btu/hr
Phase	1
kVA	0.408

Environment	Operating
Airflow direction	Rear-to-front
Temperature, ambient operating	0°C - 40°C (32°F - 104°F)
Relative humidity range (non-condensing)	10% - 90% RH
Maximum altitude	3050 m (10000 ft)
Heat dissipation	1100 Btu/hr

## Rack installation specifications for racks that are not purchased from IBM

Learn about the requirements and specifications for installing IBM systems into racks that were not purchased from IBM.

Learn about the requirements and specifications for 19-inch racks. These requirements and specifications are provided as an aid to help you understand the requirements to install IBM systems into racks. It is your responsibility, working with your rack manufacturer, to ensure that the rack that is chosen meets the requirements and specifications that are listed here. Mechanical drawings of the rack, if available from the manufacturer, are recommended for comparison against the requirements and specifications.

IBM maintenance services and installation planning services do not cover verification of non-IBM racks for compliance to Power Systems rack specifications. IBM offers racks for IBM products that are tested and verified by IBM development labs to comply with applicable safety and regulatory requirements. These racks are also tested and verified to fit and function well with IBM products. The customer is responsible for verifying with the rack manufacturer that any non-IBM racks comply with IBM specifications.

**Note:** IBM 7014-T00, 7014-T42, and 7014-B42 racks meet all the requirements and specifications.

### Rack specifications

The general rack specifications include the following specifications:

- The rack or cabinet must meet the EIA Standard EIA-310-D for 19-inch racks published August 24, 1992. The EIA-310-D standard specifies internal dimensions, for example, the width of the rack opening (width of the chassis), the width of the module mounting flanges, the mounting hole spacing, and the depth of the mounting flanges. The EIA-310-D standard does not control the overall external width of the rack. There are no restrictions on the location of side walls and corner posts relative to the internal mounting space.
- The front rack opening must be 450 mm wide + 0.75 mm (17.72 in. + 0.03 in.), and the rail-mounting holes must be 465 mm + 0.8 mm (18.3 in. + 0.03 in.) apart on center (horizontal width between vertical columns of holes on the two front-mounting flanges and on the two rear-mounting flanges).

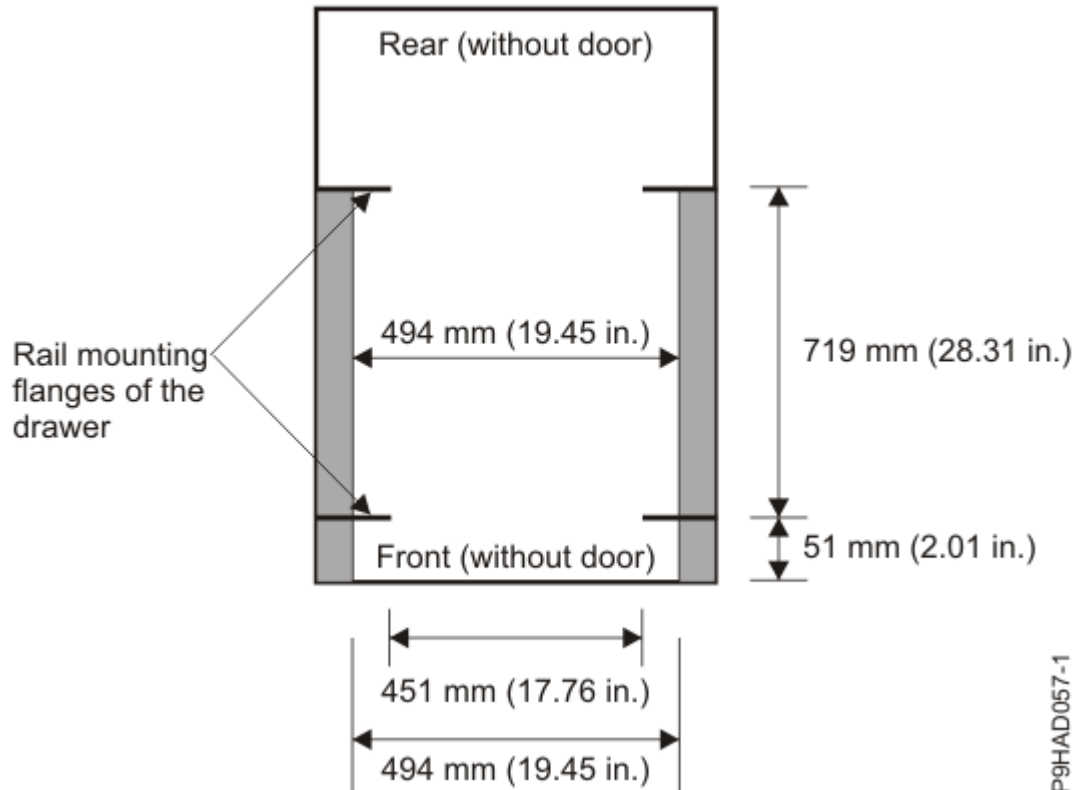

The vertical distance between mounting holes must consist of sets of three holes spaced (from bottom to top) 15.9 mm (0.625 in.), 15.9 mm (0.625 in.), and 12.67 mm (0.5 in.) on center (making each three-hole set of vertical hole spacing 44.45 mm (1.75 in.) apart on center). The front and rear mounting flanges in the rack or cabinet must be 719 mm (28.3 in.) apart and the internal width that is bounded by the mounting flanges at least 494 mm (19.45 in.), for the IBM rails to fit in your rack or cabinet (see the following figure).

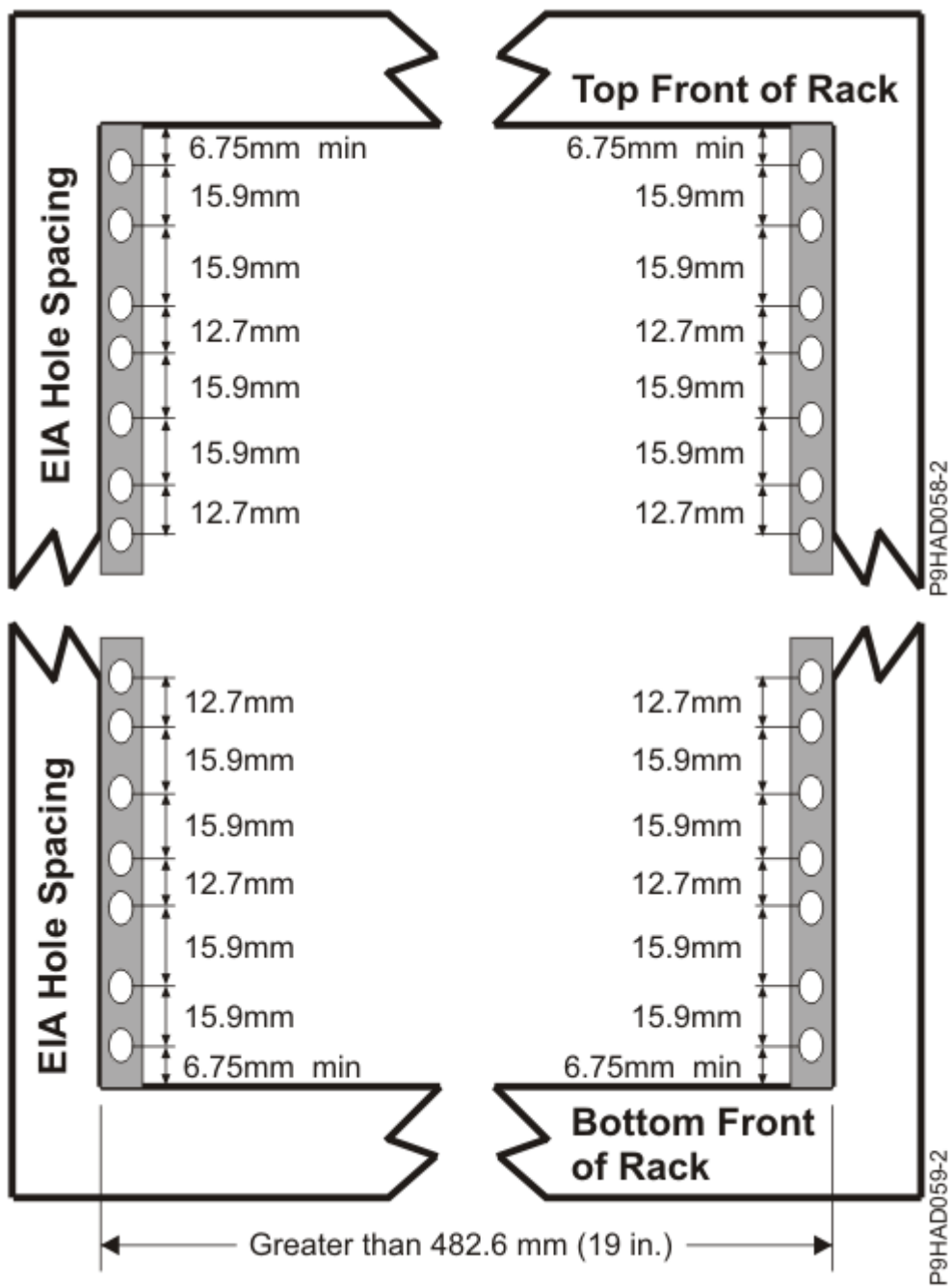

- The front rack opening must be 535 mm (21.06 in.) wide for dimension C (the width between the outsides of the standard mounting flanges, see [Figure 68 on page 102](#)). The back rack opening must be 500 mm (19.69 in.) wide for dimension C (the width between the outsides of the standard mounting flanges).

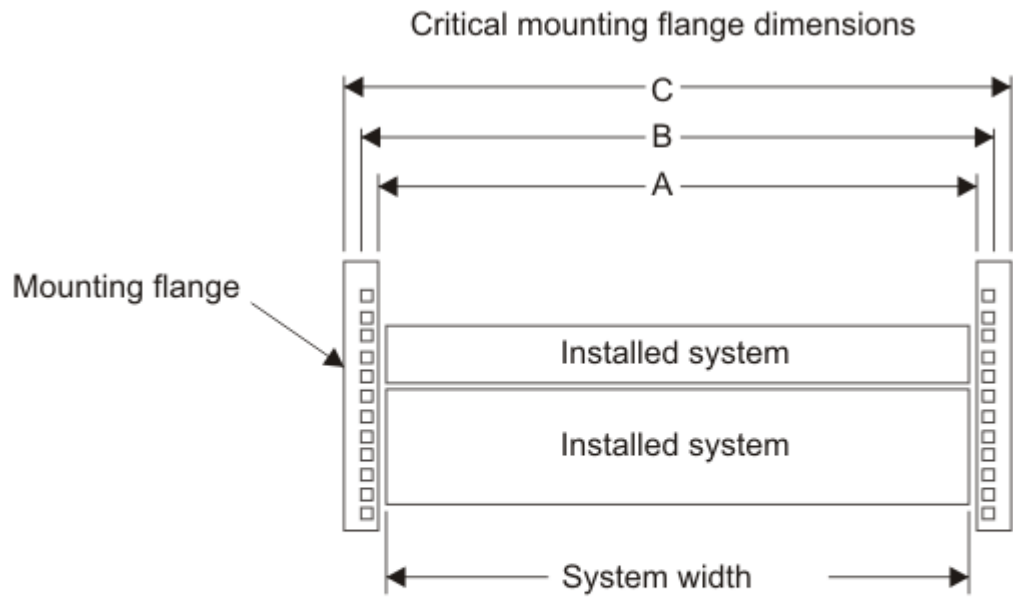

Notable dimensions:

Dimension A = 450 mm (17.72 in.) minimum

Dimension B = 465 mm (18.31 in.) normal

Dimension C = 500 mm (19.69 in.) minimum

P9HAD200-1

Figure 68. Critical mounting flange dimensions



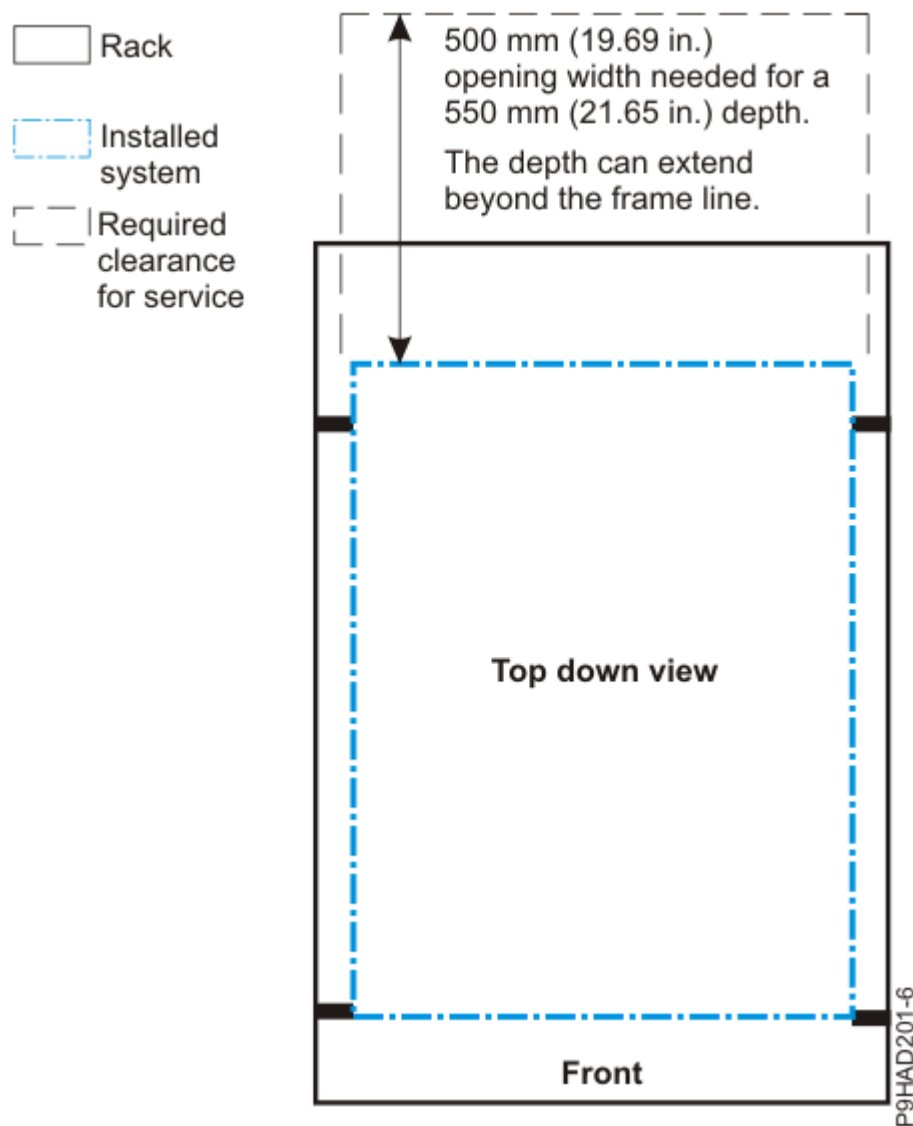

Figure 69. Critical mounting flange dimensions

- The rack or cabinet must be capable of supporting an average load of 15.9 kg (35 lb) of product weight per EIA unit.

For example, a four EIA drawer has a maximum drawer weight of 63.6 kg (140 lb).

The following rack hole sizes are supported for racks where IBM hardware is mounted:

- 7.1 mm plus or minus 0.1 mm
- 9.5 mm plus or minus 0.1 mm
- All parts that are shipped with the Power Systems products must be installed.
- Only ac power drawers are supported in the rack or cabinet. It is strongly recommended to use a power distribution unit that meets the same specifications as IBM power distribution units to supply rack power (for example, feature code 7188). Rack or cabinet power distribution devices must meet the drawer voltage, amperage, and power requirements, as well as that of any additional products that are connected to the same power distribution device.

The rack or cabinet power receptacle (power distribution unit, uninterruptible power supply, or multi-outlet strip) must have a compatible plug type for your drawer or device.

- The rack or cabinet must be compatible with the drawer-mounting rails. The rail-mounting pins and screws must fit securely and snugly into the rack or cabinet rail-mounting holes. It is strongly recommended that the IBM mounting rails and mounting hardware that are included with the product is

used to install it in the rack. The mounting rails and mounting hardware that are provided with IBM products are designed and tested to safely support the product during operation and service activities, and to safely support the weight of your drawer or device. The rails must facilitate service access by allowing the drawer to be safely extended, if necessary, forward, backward, or both. Some rails, with IBM features for non-IBM racks, provide drawer-specific anti-tip brackets, rear lock-down brackets, and cable management guides that require clearance on the rear side of the rails.

**Note:** If the rack or cabinet has square holes on the mounting flanges, a plug-in hole adapter might be required.

If non-IBM rails are used, the rails must be product-safety certified for use with the IBM products. At a minimum, mounting rails must be able to support four times the maximum rated product weight in its worst-case position (fully extended front and rear positions) for one full minute without catastrophic failure.

- The rack or cabinet must have stabilization feet or brackets installed both in the front and rear of the rack, or have another means of preventing the rack/cabinet from tipping while the drawer or device is pulled into its extreme front or rear service positions.

**Note:** Examples of some acceptable alternatives: The rack or cabinet might be securely bolted to the floor, ceiling or walls, or to adjacent racks or cabinets in a long and heavy row of racks or cabinets.

- There must be adequate front and rear service clearances (in and around the rack or cabinet). The rack or cabinet must have sufficient horizontal width clearance in the front and rear to allow the drawer to be fully slid into the front and, if applicable, the rear service access positions (typically this requires 914.4 mm (36 in.) clearance in both the front and rear).
- If present, front and rear doors must be able to open far enough to provide unrestrained access for service or be easily removable. If doors must be removed for service, it is the customer's responsibility to remove them before service.
- The rack or cabinet must provide adequate clearance around the rack drawer.
- There must be adequate clearance around the drawer bezel so that it can be opened and closed, according to the product specifications.
- Front or rear doors must also maintain a minimum of 51 mm (2 in.) front, 203 mm (8 in.) rear, door to mounting flange clearance, and 494 mm (19.4 in.) front, 571 mm (22.5 in.) rear, side-to-side clearance for drawer bezels and cables.
- The rack or cabinet must provide adequate front-to-back ventilation.

**Note:** For optimum ventilation, it is recommended the rack or cabinet not have a front door. If the rack or cabinet has doors, the doors must be fully perforated so that there is proper front-to-back airflow to maintain the required drawer ambient inlet temperature as specified in the server specifications. The perforations should yield at least 34 % minimum open area per square inch. Rear doors should not create back pressure that can interfere with server fan operation.

## General safety requirements for IBM products installed in a non-IBM rack or cabinet

The general safety requirements for IBM products that are installed in non-IBM racks are:

- Any product or component that plugs into either an IBM power distribution unit or mains power (by using a power cord), or uses any voltage over 42 V ac or 60 V dc (considered to be hazardous voltage) must be Safety Certified by a Nationally Recognized Test Laboratory (NRTL) for the country in which it is installed.

Some of the items that require safety certification might include the rack or cabinet (if it contains electrical components integral to the rack or cabinet), fan trays, power distribution unit, uninterruptible power supplies, multi-outlet strips, or any other products that are installed in the rack or cabinet that connect to hazardous voltage.

Examples of OSHA-approved NRTLs for the US:

- UL
- ETL

- CSA (with CSA NRTL or CSA US mark)

Examples of approved NRTLs for Canada:

- UL (ULc mark)
- ETL (ETLc mark)
- CSA

The European Union requires a CE mark and a Manufacturer's Declaration of Conformity (DOC).

Certified products must have the NRTL logos or marks somewhere on the product or product label. However, proof of certification must be made available to IBM upon request. Proof consists of such items as copies of the NRTL license or certificate, a CB Certificate, a Letter of Authorization to apply the NRTL mark, the first few pages of the NRTL certification report, Listing in an NRTL publication, or a copy of the UL Yellow Card. Proof should contain the manufacturer's name, product type, and model, standard to which it was certified, the NRTL name or logo, the NRTL file number or license number, and a list of any Conditions of Acceptance or Deviations. A Manufacturer's Declaration is not proof of certification by an NRTL.

- The rack or cabinet must meet all electrical and mechanical safety legal requirements for the country in which it is installed. The rack or cabinet must be free of exposed hazards (such as voltages over 60 V dc or 42 V ac, energy over 240 VA, sharp edges, mechanical pinch points, or hot surfaces).
- There must be an accessible and unambiguous disconnect device for each product in the rack, including any power distribution unit.

A disconnect device might consist of either the plug on the power cord (if the power cord is no longer than 1.8 m (6 ft)), the appliance inlet receptacle (if the power cord is of a detachable type), or a power on/off switch, or an Emergency Power Off switch on the rack, provided all power is removed from the rack or product by the disconnect device.

If the rack or cabinet has electrical components (such as fan trays or lights), the rack must have an accessible and unambiguous disconnect device.

- The rack or cabinet, power distribution unit and multi-outlet strips, and products that are installed in the rack or cabinet must all be properly grounded to the customer facility ground.

There must be no more than 0.1 Ohms between the ground pin of the power distribution unit or rack plug and any touchable metal or conductive surface on the rack and on the products that are installed in the rack. Grounding method must comply with applicable country's electric code (such as NEC or CEC). Ground continuity can be verified by your IBM service personnel, after the installation is completed, and must be verified before the first service activity.

- The voltage rating of the power distribution unit and multi-outlet strips must be compatible with the products plugged into them.

The power distribution unit or multi-outlet strips current and power ratings are rated at 80% of the building supply circuit (as required by the National Electrical Code and the Canadian Electrical Code). The total load that is connected to the power distribution unit must be less than the rating of the power distribution unit. For example, a power distribution unit with a 30 A connection is rated for a total load of 24 A (30 A x 80 %). Therefore, the sum of all equipment that is connected to the power distribution unit in this example must be lower than the 24 A rating.

If an uninterruptible power supply is installed, it must meet all the electrical safety requirements as described for a power distribution unit (including certification by an NRTL).

- The rack or cabinet, power distribution unit, uninterruptible power supply, multi-outlet strips, and all products in the rack or cabinet must be installed according to the manufacturer's instructions, and in accordance with all national, state or province, and local codes and laws.

The rack or cabinet, power distribution unit, uninterruptible power supply, multi-outlet strips, and all products in the rack or cabinet must be used as intended by the manufacturer (per manufacturer's product documentation and marketing literature).

- All documentation for use and installation of the rack or cabinet, power distribution unit, uninterruptible power supply, and all products in the rack or cabinet, including safety information, must be available onsite.
- If there is more than one source of power in the rack cabinet, there must be clearly visible safety labels for Multiple Power Source (in the languages that are required for the country in which the product is installed).
- If the rack or cabinet or any products that are installed in the cabinet had safety or weight labels that are applied by the manufacturer, they must be intact and translated into the languages that are required for the country in which the product is installed.
- If the rack or cabinet has doors, the rack becomes a fire enclosure by definition and must meet the applicable flammability ratings (V-0 or better). Totally metal enclosures at least 1 mm (0.04 in.) thick are considered to comply.

Nonenclosure (decorative) materials must have a flammability rating of V-1 or better. If glass is used (such as in rack doors), it must be safety glass. If wood shelves are used in the rack/cabinet, they must be treated with a UL Listed flame-retardant coating.

- The rack or cabinet configuration must comply with all IBM requirements for "safe to service" (contact your IBM Installation Planning Representative for assistance in determining if the environment is safe).

There must be no unique maintenance procedures or tools that are required for service.

Elevated service installations, where the products to be serviced are installed between 1.5 m and 3.7 m (5 ft and 12 ft) above the floor, require the availability of an OSHA- and CSA-approved nonconductive step ladder or ladders. If a ladder or ladders are required for service, the customer must supply the OSHA- and CSA- approved nonconductive step ladder (unless other arrangements are made with the local IBM Service Branch Office). Some products can have rack installation limitations. Refer to the specific server or product specifications for any restrictions. Products that are installed over 2.9 m (9 ft) above the floor require a Special Bid to be completed before they can be serviced by IBM service personnel.

For products not intended for rack-mounting to be serviced by IBM, the products and parts that are replaced as part of that service must not weigh over 11.4 kg (25 lb) Contact your Installation Planning Representative if in doubt.

There must not be any special education or training that is required for safe servicing of any of the products that are installed in the racks. Contact your Installation Planning Representative if you are in doubt.

### **Related reference**

#### Rack specifications

Rack specifications provide detailed information for your rack, including dimensions, electrical, power, temperature, environment, and service clearances.

## **Planning for power**

---

Planning the power for your system requires knowledge of your server's power requirements, the power requirements of compatible hardware, and the uninterruptible power supply needs for your server. Use this information to build a complete power plan.

Before you begin your planning tasks, be sure that you complete the items in the following checklist:

- Know your server power requirements.
- Know your compatible hardware requirements.
- Know your uninterruptible power supply needs.

### **Review power considerations**

Complete the following checklist:

- Consult a qualified electrician for power needs.



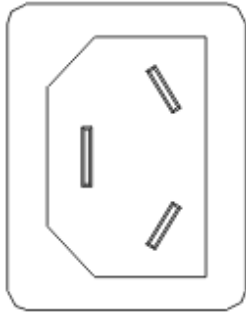
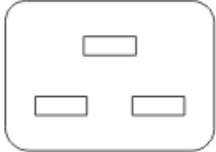
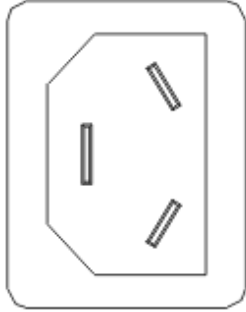
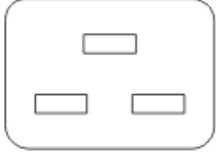
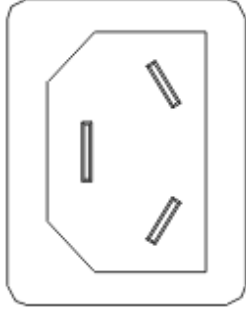
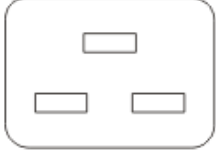

Table 66. Supported server to PDU power cords

Feature codes (FC)	Description	Voltage, amperage, and length	Power cord (left end)	Power cord (right end)
<b>EPAJ</b>	Rong Feng High Voltage Socket to IEC 320-C20 power jumper cord	200 - 240 V ac, 10 A, 2.0m (6.5 ft)	Rong Feng RF-203P-M 	Plug Type 61 IEC 320 C20 
<b>EPAL</b>	Rong Feng High Voltage Socket to IEC 320-C20 power jumper cord	200 - 240 V ac, 10 A, 2.8 m (9 ft)	Rong Feng RF-203P-M 	Plug Type 61 IEC 320 C20 
<b>EPAM</b>	Rong Feng High Voltage Socket to IEC 320-C20 power jumper cord	200 - 240 V ac, 10 A, 4.3 m (14 ft)	Rong Feng RF-203P-M 	Plug Type 61 IEC 320 C20 

### Supported PDU power cords

Find out which power distribution unit (PDU) power cords are supported for your system.

Use the following table to determine the appropriate PDU power cord to use with your system in your country.

Table 67. Supported PDU power cords for PDU feature codes (FCs) EPTG, EPTJ, EPTM, EPTN, ECJG, ECJJ, ECJM, and ECJN with Souriau inlet







Feature code (FC)	Description <ul style="list-style-type: none"> <li>• Voltage</li> <li>• Amperage</li> <li>• Phase</li> <li>• Length</li> <li>• Wall plug</li> </ul>	IBM shipped plug	View of plug	Matched female connector (on cord)	Matched female wall receptacle (on wall)	IBM part number	Countries
6489	Power cord, PDU to wall <ul style="list-style-type: none"> <li>• 230 V ac output</li> <li>• 32 A</li> <li>• 3-phase wye</li> <li>• 4.3 m (14 ft)</li> <li>• IEC 309, 3P+N+G</li> </ul>	Plug type 532P6W 		Connector type 532C6W	Receptacle type 532R6W 	39M5413	Europe, Middle East, Africa (EMEA)
6491	Power cord, PDU to wall <ul style="list-style-type: none"> <li>• 230 V ac</li> <li>• 63 A</li> <li>• Single phase</li> <li>• 4.3 m (14 ft)</li> <li>• IEC 309, P+N+G</li> </ul>	Plug type 363P6W 		Connector type 363C6W	Receptacle type 363P6W	39M5415	Europe, Middle East, Africa (EMEA)
6492	Power cord, PDU to wall <ul style="list-style-type: none"> <li>• 200 - 208 V ac or 240 V ac</li> <li>• 60 A plug (48 A derated)</li> <li>• Single phase</li> <li>• 4.3 m (14 ft)</li> <li>• IEC 309, 2P+G</li> </ul>	Plug type 360P6W 		Connector type 360C6W	Receptacle type 360P6W 	39M5417	United States, Canada, Latin America, Japan, and Taiwan
6653	Power cord, PDU to wall <ul style="list-style-type: none"> <li>• 230 V ac output</li> <li>• 16 A</li> <li>• 3-phase wye</li> <li>• 4.3 m (14 ft)</li> <li>• IEC 309, 3P+N+G</li> </ul>	Plug type 516P6W 		Connector type 516C6W	Receptacle type 516R6W 	39M5412	Switzerland

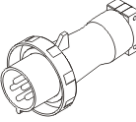
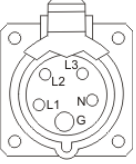

Table 67. Supported PDU power cords for PDU feature codes (FCs) EPTG, EPTJ, EPTM, EPTN, ECJG, ECJJ, ECJM, and ECJN with Souriau inlet (continued)

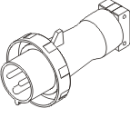

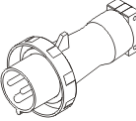
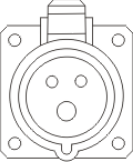

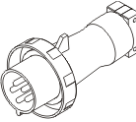
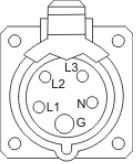

Feature code (FC)	Description <ul style="list-style-type: none"> <li>• Voltage</li> <li>• Amperage</li> <li>• Phase</li> <li>• Length</li> <li>• Wall plug</li> </ul>	IBM shipped plug	View of plug	Matched female connector (on cord)	Matched female wall receptacle (on wall)	IBM part number	Countries
<b>6654</b>	Power cord, PDU to wall <ul style="list-style-type: none"> <li>• 200 - 208 V ac or 240 V ac</li> <li>• 30 A plug (24 A derated)</li> <li>• Single phase</li> <li>• 4.3 m (14 ft)</li> <li>• NEMA L6-30</li> </ul>	Plug type NEMA L6-30P 			Receptacle type NEMA L6-30R 	39M5416	United States, Canada, Latin America, Japan, and Taiwan
<b>6655</b>	Power cord, PDU to wall <ul style="list-style-type: none"> <li>• 200 - 208 V ac or 240 V ac</li> <li>• 30 A plug (24 A derated)</li> <li>• Single phase</li> <li>• 4.3 m (14 ft)</li> <li>• RS 3750DP (Watertight)</li> </ul>					39M5418	United States, Canada, Latin America, Japan, and Taiwan
<b>6656</b>	Power cord, PDU to wall <ul style="list-style-type: none"> <li>• 230 V ac</li> <li>• 32 A</li> <li>• Single phase</li> <li>• 4.3 m (14 ft)</li> <li>• IEC 309, P+N+G</li> </ul>	Plug type 60309 		Connector type 60309	Receptacle type 60309 	39M5414	Europe, Middle East, Africa (EMEA)

Table 67. Supported PDU power cords for PDU feature codes (FCs) EPTG, EPTJ, EPTM, EPTN, ECJG, ECJJ, ECJM, and ECJN with Souriau inlet (continued)





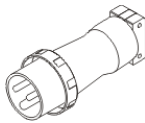

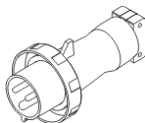
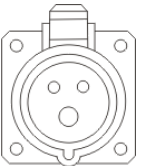



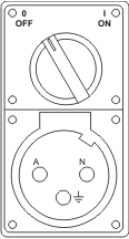

Feature code (FC)	Description <ul style="list-style-type: none"> <li>• Voltage</li> <li>• Amperage</li> <li>• Phase</li> <li>• Length</li> <li>• Wall plug</li> </ul>	IBM shipped plug	View of plug	Matched female connector (on cord)	Matched female wall receptacle (on wall)	IBM part number	Countries
6657	Power cord, PDU to wall <ul style="list-style-type: none"> <li>• 230 - 240 V ac</li> <li>• 32 A</li> <li>• Single phase</li> <li>• 4.3 m (14 ft)</li> <li>• PDL</li> </ul>	Plug type 56P332 		Connector type 56P332	Receptacle type 56CV332 	39M5419	Australia and New Zealand
6658	Power cord, PDU to wall <ul style="list-style-type: none"> <li>• 220 V ac</li> <li>• 30 A plug (24 A derated)</li> <li>• Single phase</li> <li>• 4.3 m (14 ft)</li> <li>• Korean plug SJ-P3302</li> </ul>	Plug type KP 32A 		Connector type KP	Receptacle type KP 	39M5420	South Korea
6667	Power cord, PDU to wall <ul style="list-style-type: none"> <li>• 230 - 240 V ac output</li> <li>• 32 A</li> <li>• 3-phase wye</li> <li>• 4.3 m (14 ft)</li> <li>• PDL 56P532</li> </ul>	Plug type 56P532 		Connector type 56P532	Receptacle type 56P532 	69Y1619	Australia and New Zealand

Table 68. Supported PDU power cords for PDU feature codes ECJK, ECJL, ECJP, and ECJQ with Amphenol inlet

Feature code (FC)	Description <ul style="list-style-type: none"> <li>• Voltage</li> <li>• Amperage</li> <li>• Phase</li> <li>• Length</li> <li>• Wall plug</li> </ul>	IBM shipped plug	View of plug	Matched female connector (on cord)	Matched female wall receptacle (on wall)	IBM part number	Countries
<b>ECJ5</b>	<ul style="list-style-type: none"> <li>• 200 - 240 V ac</li> <li>• 24 A</li> <li>• 3 phase delta</li> <li>• 4.3 m (14 ft)</li> <li>• IEC 309, 3P+N+G</li> </ul>	Plug type 430P9W 		Connector type 430C9W	Receptacle type 430R9W	02WN660	United States, Canada, Latin America, Japan, and Taiwan
<b>ECJ7</b>	<ul style="list-style-type: none"> <li>• 200 - 240 V ac</li> <li>• 48 A</li> <li>• Three phase delta</li> <li>• 4.3 m (14 ft)</li> <li>• IEC 309, 3P+G</li> </ul>	Plug type 460P9W 		Connector type 460C9W	Receptacle type 460R9W	02WN658	United States, Canada, Latin America, Japan, and Taiwan

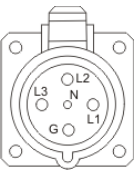
## Modification of IBM-provided power cords

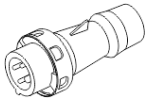
Modification of IBM-provided power cords must be done only in rare circumstances because the power cords that are provided with IBM systems meet stringent design and manufacturing specifications.

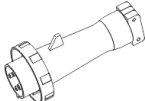
IBM encourages the use of an IBM released power cord because of the specifications that must be met for both the design and manufacture of IBM power cords. The specifications, the components that are used in the design, and the manufacturing process is an external safety agency approved process that is audited by safety agencies on a periodic and ongoing basis to ensure quality and compliance with design requirements.

When a server leaves the manufacturing site, it is safety agency listed, therefore, IBM does not recommend modifying IBM-provided power cords. In the rare circumstance where modification of an IBM provided power cord is deemed essential, you must:

- Discuss the modification with the insurance provider to assess the effect, if any, on insurance coverage.
- Consult with a professional electrician about compliance with local codes.

The following excerpts from the Services Reference Manual (SRM) explains IBM policy on power cord alteration and the liabilities involved.

### SRM excerpts

A cable group that is associated with a purchased IBM machine, and bearing an IBM label, is the property of the IBM machine owner. All other IBM furnished cable groups (except cable groups for which specific purchase invoices are paid) are the property of IBM.

Customers assume all risks that are associated with turning a machine over to others for the performance of technical work such as, but not limited to, the installation or removal of features, alterations or attachments.

IBM will advise the customer of any limitation, resulting from the alteration, affecting IBM's ability to provide Warranty Service or Maintenance after review by the appropriate Service Delivery and Field Marketing Practices personnel.

### **Definition of an alteration**

An alteration is any change to an IBM machine that deviates from IBM physical, mechanical, electrical, or electronic design (including microcode) whether extra devices or parts are used. An alteration is also an interconnection at some place other than an IBM-defined interface. See the Multiple Supplier Systems Bulletin for more detail.

For an altered machine, service is confined to the unaltered portions of the IBM machine.

After inspection, IBM will continue to make Warranty Service or Maintenance available, as appropriate, for the unaltered portion of an IBM machine.

IBM does not maintain the altered portion of an IBM machine under either an IBM Agreement or on an Hourly Service basis.

If you have more questions about power cord modification, contact an IBM service representative.

## **Uninterruptible power supply**

Uninterruptible power supplies are available to meet the power protection needs of IBM servers.

You can use any third-party UPS with compatible electrical requirements (for example, voltage and current ratings, receptacles). You can choose whether to establish communications with the third-party UPS. The most common method is to put the UPS as a node on an Ethernet network and install the software of the UPS manufacturer on each operating system (OS) instance. You then need to configure the software to look for messages that are broadcast from the UPS over the Ethernet network.

## **Power distribution unit and power cord options for 7014, 7953, and 7965 racks**

Power distribution units (PDUs) can be used with 7014, 7953, and 7965 racks. The various configurations and specifications are provided.

### **Power distribution unit**

The following figure shows the four vertical PDU locations in 7014-T00, 7014-T42, 7014-B42, and 7965-S42 racks. The 7953-94X and 7965-94Y racks have six vertical PDU locations. Three locations are on the left side of the rack and three locations are on the right side of the rack.

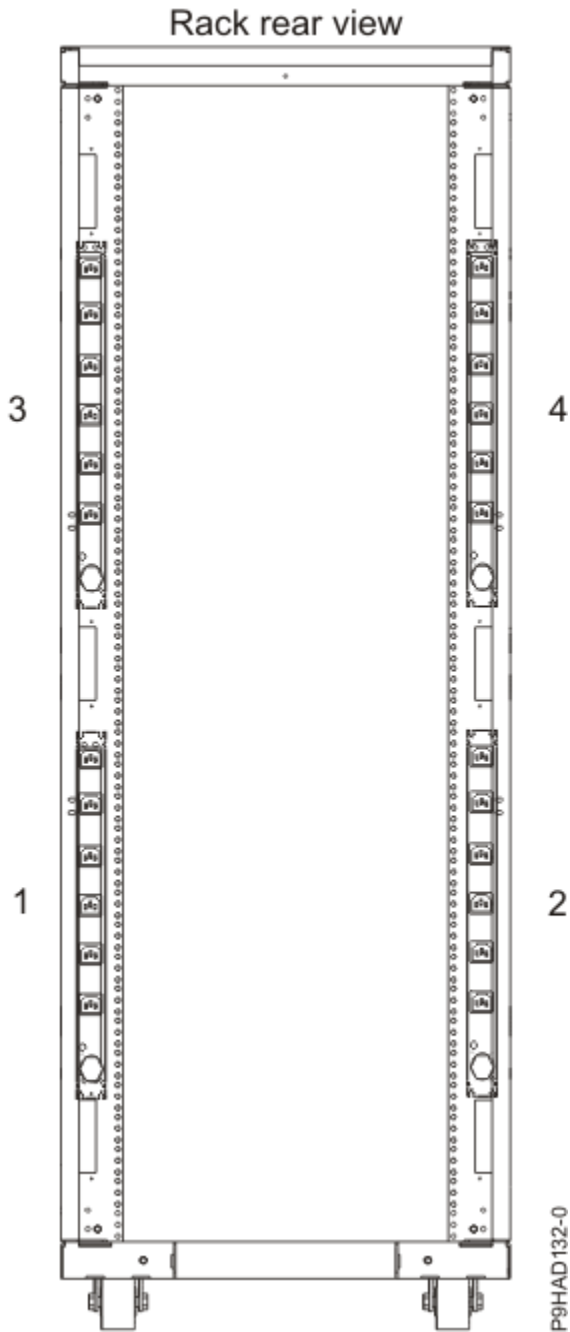

Figure 70. Power distribution unit vertical locations

Power distribution units (PDUs) are required for all IBM racks except for the 7014-B42 rack. If a PDU is not defaulted or ordered, a power cord is provided with each individual rack-mounted drawer for connection to a country-specific utility mains receptacle or uninterruptible power supply. See the individual rack-mounted drawer specifications for the appropriate power cords.

### 7188 or 9188 universal PDU

Table 69. 7188 or 9188 universal PDU features	
PDU Number	Supported power cords (PDU to wall)
7188 or 9188 universal PDU	For model "Supported PDU power cords" on page 109

The amperage rating of the PDU is either 16 A, 24 A, 48 A, or 63 A, single phase or three-phase, depending on the power cord.

**Note:** All power cords are 4.3 m (14 ft). For installation in Chicago, only 2.8 m (6 ft) of the 4.3 m (14 ft) power cord can extend beyond the perimeter of the rack frame. If more than 2.8 m (6 ft) can exit the rack, retain any additional cordage within the rack frame with hook-and-loop fastener ties in the cable management space until 2.8 (6 ft) or less exits the rack.

The PDU has twelve customer-usable IEC 320-C13 outlets that are rated at 200 - 240 V ac. Six groups of two outlets that are fed by six circuit breakers. Each outlet is rated up to 10 A (220 - 240 V ac) or 12 A (200 - 208 V ac), but each group of two outlets is fed from one 20 A circuit breaker derated to 16 A.

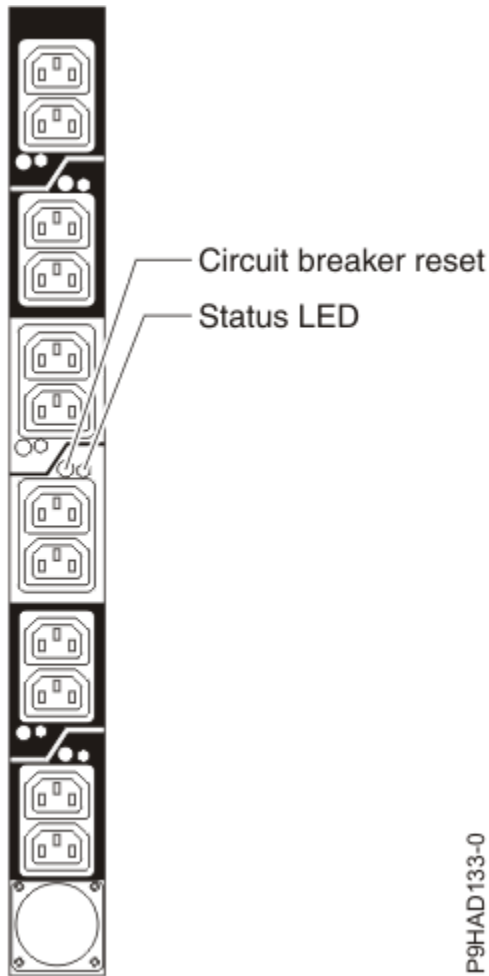

Figure 71. PDU outlet graphic

## Typical rack and PDU configurations

See *7014 rack configurations* for typical configurations and PDUs when the rack is populated with various server models.

## Power distribution unit plus specifications

The power distribution unit plus (PDU+) has power-monitoring capabilities. The PDU+ is an intelligent AC power distribution unit (PDU+) that monitors the amount of power that is being used by the devices that are plugged into it. The PDU+ provides twelve C13 power outlets and receives power through a Souriau UTG connector. It can be used in many locations worldwide and for many applications by varying the PDU-to-wall power cord, which must be ordered separately. Each PDU+ requires one PDU-to-wall power cord. When the PDU+ is connected to a dedicated power source, it conforms to UL60950, CSA C22.2-60950, EN-60950, and IEC-60950 standards.

## 7109 or 5889 PDU+

<i>Table 70. 7109 or 5889 PDU+ features</i>	
<b>PDU Number</b>	<b>Supported power cords (PDU to wall)</b>
7109 or 5889 PDU+	“Supported PDU power cords” on page 109

<i>Table 71. 7109 PDU+ specifications</i>	
<b>Characteristics</b>	<b>Properties</b>
PDU number	7109
Height	43.9 mm (1.73 in.)
Width	447 mm (17.6 in.)
Depth	350 mm (13.78 in.)
Additional clearance	25 mm (0.98 in.) for circuit breakers
	3 mm (0.12 in.) for outlets
Weight (not including power cord)	6.3 kg (13.8 lb)
Weight of power cord (approximate)	5.4 kg (11.8 lb)
Operating temperature at 0 - 914 m (0 - 3000 ft) (room ambient)	10°C - 32°C (50°F - 90°F)
Operating temperature at 914 - 2133 m (3000 - 7000 ft) (room ambient)	10°C - 35°C (50°F - 95°F)
Operating humidity	8% - 80% (noncondensing)
Localized air temperature in PDU	60°C (140°F) maximum
Rated frequency (all feature codes)	50 - 60 Hz
Circuit breakers	Six double-pole branch rated circuit breakers that are rated at 20 A
Power outlet	12 IEC 320-C13 outlets that are rated at 10 A (VDE) or 15 A (UL/CSA)

## 7196 PDU+

<i>Table 72. 7196 PDU+ features</i>	
<b>PDU Number</b>	<b>Supported power cords (PDU to wall)</b>
7196 PDU+	Fixed power cord with IEC 60309, 3P+E, 60 A plug

<i>Table 73. 7196 PDU+ specifications</i>	
<b>Characteristics</b>	<b>Properties</b>
PDU number	7196
Height	43.9 mm (1.73 in.)
Width	447 mm (17.6 in.)
Depth	350 mm (13.78 in.)

Table 73. 7196 PDU+ specifications (continued)

<b>Characteristics</b>	<b>Properties</b>
Additional clearance	25 mm (0.98 in.) for circuit breakers
	3 mm (0.12 in.) for outlets
Weight (not including power cord)	6.3 kg (13.8 lb)
Weight of power cord (approximate)	5.4 kg (11.8 lb)
Operating temperature at 0 - 914 m (0 - 3000 ft) (room ambient)	10 - 32°C (50 - 90°F)
Operating temperature at 914 - 2133 m (3000 - 7000 ft) (room ambient)	10 - 35°C (50 - 95°F)
Operating humidity	8 - 80% (noncondensing)
Localized air temperature in PDU	60 °C (140 °F) maximum
Rated frequency (all feature codes)	50 - 60 Hz
Circuit breakers	Six double-pole branch rated circuit breakers that are rated at 20 A
Power outlet	Six IEC 320-C19 outlets that are rated at 16 A (VDE) or 20 A (UL/CSA)



200-208Vac 3 Phase Delta, 48A, (39M2819).

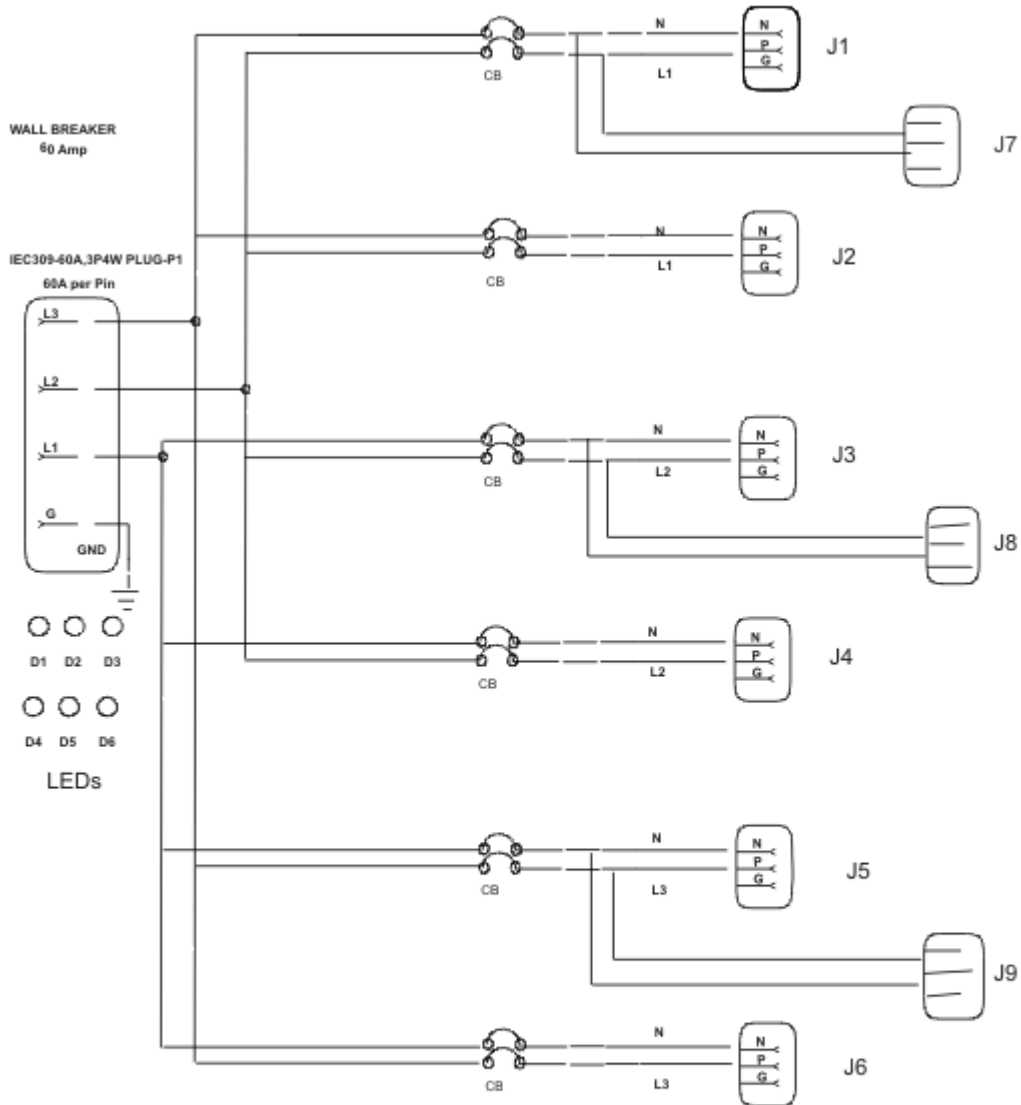

**NOTES:**

1. GND WIRE AT J (14 AWG).
2. P1 TO BREAKER, (6 AWG).
3. BREAKER TO RY or J, (14 AWG).
4. P1 TO GROUND, G (6 AWG).

Figure 72. Wiring diagram for the 7196 PDU+

P9HAD006-0

**HVDC PDU**

Table 74. HVDC PDU features	
PDU Number	Supported power cords (PDU to wall)
EPAA	Not applicable - fixed power cord

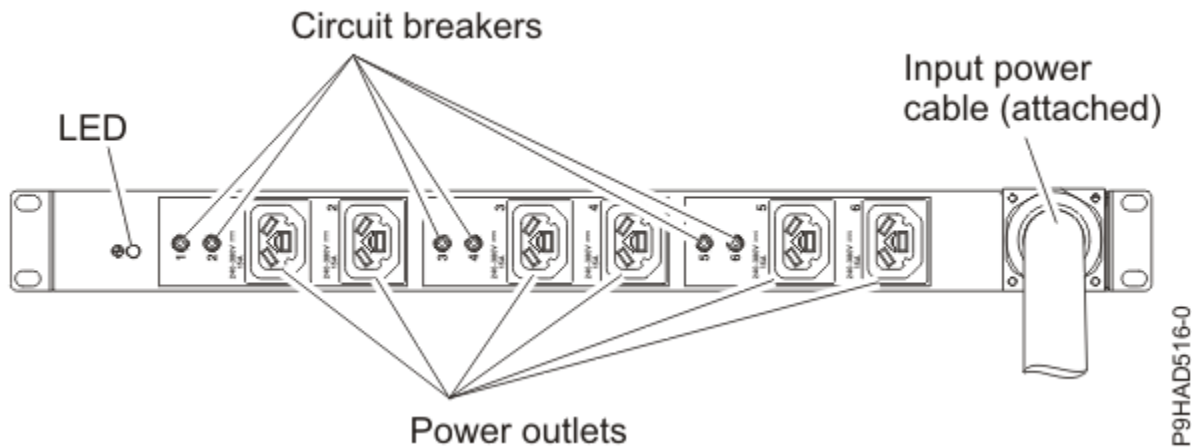

Figure 73. HVDC PDU

The rating of the HVDC PDU is 240 - 380 V dc, 90 A. The HVDC PDU has a permanently attached 4.3 m (14 ft) power cord and is unterminated (no plug). The minimum cross-sectional area of the two conductors and grounding conductor is 16 AWG (1.3 mm).

This PDU has six customer-usable Rong Feng RF-203P outlets that are rated at 240 - 380 V dc. Each outlet is rated up to 10 A and is fed from one 20 A circuit breaker derated to 16 A. The HVDC PDU does not have the nationally recognized test laboratory certification that is required for use in North America.

This PDU can be either vertically mounted in the rack side pockets or horizontally mounted by using feature code (FC) EBA5 (mounting kit). If horizontally mounted, the PDU uses 1U of rack space.

### Intelligent Switched PDU

Feature code (FC)	Description	Provided power receptacles	Supported power cords (PDU to wall)
EPTG (Base)	<ul style="list-style-type: none"> <li>• 200 - 240 V ac</li> <li>• Single phase or three phase<sup>1</sup></li> <li>• 16 A, 24 A, 32 A, 48 A, or 63 A<sup>1</sup></li> </ul>	9 IEC 320-C19 and 3 IEC 320-C13 receptacles	"Supported PDU power cords" on page 109
EPTJ (Additional)			
EPTK (Base)	<ul style="list-style-type: none"> <li>• 208 V ac</li> <li>• 60 A</li> <li>• Three-phase</li> </ul>	9 IEC 320-C19 and 3 IEC 320-C13 receptacles	Not applicable - fixed IEC 60309, 60 A, plug (3P+G) power cord
EPTL (Additional)			
EPTM (Base)	<ul style="list-style-type: none"> <li>• 200 - 240 V ac</li> <li>• Single phase or three phase<sup>1</sup></li> <li>• 16 A, 24 A, 32 A, 48 A, or 63 A<sup>1</sup></li> </ul>	Twelve IEC 320-C13 receptacles	"Supported PDU power cords" on page 109
EPTN (Additional)			

Table 75. Intelligent Switched PDU features (continued)

Feature code (FC)	<b>Description</b> <ul style="list-style-type: none"> <li>• Voltage</li> <li>• Amperage</li> <li>• Phase</li> </ul>	Provided power receptacles	Supported power cords (PDU to wall)
EPTP (Base)	<ul style="list-style-type: none"> <li>• 208 V ac</li> <li>• 60 A</li> <li>• Three-phase</li> </ul>	Twelve IEC 320-C13 receptacles	Not applicable - fixed IEC 60309, 60 A, plug (3P+G) power cord
EPTQ (Additional)			

<sup>1</sup>Amperage and phase depend on the power cord that is used. Three phase is wye wired. The voltage is 380 - 415 V ac at the PDU input and 220 - 240 V ac at the PDU output.

Table 76. Intelligent Switched PDU specifications

Characteristics	Properties
Height	43.9 mm (1.73 in.)
Width	447 mm (17.6 in.)
Depth	350 mm (13.78 in.)
Additional clearance	25 mm (0.98 in.) for circuit breakers
	3 mm (0.12 in.) for outlets
Weight (not including power cord)	6.3 kg (13.8 lb)
Weight of power cord (approximate)	5.4 kg (11.8 lb)
Operating temperature at 0 - 914 m (0 - 3000 ft) (room ambient)	10°C - 60°C (50°F - 140°F)
Operating temperature at 914 - 2133 m (3000 - 7000 ft) (room ambient)	10°C - 60°C (50°F - 140°F)
Operating humidity	8 - 80% (noncondensing)
Localized air temperature in PDU	60 °C (140 °F) maximum
Rated frequency (all feature codes)	50 - 60 Hz
Circuit breakers	<p>Nine double-pole branch rated circuit breakers that are rated at 20 amps for 1U C19 PDU models.</p> <p>Six double-pole branch rated circuit breakers that are rated at 20 amps for 1U C13 PDU models.</p>

The intelligent, switched AC power distribution unit (PDU) provides the capability to monitor the amount of electrical power that is being used by devices that are plugged into the PDU. The PDU can also cycle power to individual receptacles by using the switched function.

## Intelligent Switched PDU+

Feature code (FC)	Description <ul style="list-style-type: none"> <li>• Voltage</li> <li>• Amperage</li> <li>• Phase</li> </ul>	Provided power receptacles	Supported power cords (PDU to wall)
ECJG (Base)	<ul style="list-style-type: none"> <li>• 200 - 240 V ac</li> <li>• Single phase or three phase<sup>1</sup></li> <li>• 16 A, 24 A, 32 A, 48 A, or 63 A<sup>1</sup></li> </ul>	9 IEC 320-C19 and 3 IEC 320-C13 receptacles	<a href="#">“Supported PDU power cords” on page 109</a>
ECJJ (Additional)			
ECJK (Base)	<ul style="list-style-type: none"> <li>• 200 - 240 V ac</li> <li>• 24 A, 40 A, 48 A</li> <li>• Three-phase<sup>2</sup></li> </ul>	9 IEC 320-C19 and 3 IEC 320-C13 receptacles	<a href="#">“Supported PDU power cords” on page 109</a>
ECJL (Additional)			
ECJM (Base)	<ul style="list-style-type: none"> <li>• 200 - 240 V ac</li> <li>• Single phase or three phase<sup>1</sup></li> <li>• 16 A, 24 A, 32 A, 48 A, or 63 A<sup>1</sup></li> </ul>	Twelve IEC 320-C13 receptacles	<a href="#">“Supported PDU power cords” on page 109</a>
ECJN (Additional)			
ECJP (Base)	<ul style="list-style-type: none"> <li>• 200 - 240 V ac</li> <li>• 24 A, 40 A, 48 A</li> <li>• Three-phase<sup>2</sup></li> </ul>	Twelve IEC 320-C13 receptacles	<a href="#">“Supported PDU power cords” on page 109</a>
ECJQ (Additional)			
<b>Notes:</b> <ol style="list-style-type: none"> <li>1. Amperage and phase depend on the power cord that is used. Three phase is wye wired. The voltage is 380 - 415 V ac at the PDU input and 220 - 240 V ac at the PDU output.</li> <li>2. Three phase is delta wired.</li> </ol>			

Characteristics	Properties
Height	42.5 mm (1.67 in.)
Width	447.5 mm (17.6 in.)
Depth	351 mm (13.82 in.)
Additional clearance	25 mm (0.98 in.) for circuit breakers
	3 mm (0.12 in.) for outlets
Weight	C19 PDU models: 5.25 kg (11.6 lb)
	C13 PDU models: 4.3 kg (9.5 lb)
Operating temperature at 0 - 914 m (0 - 3000 ft) (room ambient)	10°C - 60°C (50°F - 140°F)

Characteristics	Properties
Operating temperature at 914 - 2133 m (3000 - 7000 ft) (room ambient)	10°C - 60°C (50°F - 140°F)
Operating humidity	8 - 80% (noncondensing)
Localized air temperature in PDU	60 °C (140 °F) maximum
Rated frequency (all feature codes)	50 - 60 Hz
Circuit breakers	Nine double-pole branch rated circuit breakers that are rated at 20 amps for 1U C19 PDU models.  Six double-pole branch rated circuit breakers that are rated at 20 amps for 1U C13 PDU models.

The intelligent switched AC power distribution unit (PDU+) provides the capability to monitor the amount of electrical power that is being used by devices that are plugged into the PDU. The PDU can also cycle power to individual receptacles by using the switched function.

## Calculating the power load for 7188 or 9188 power distribution units

Learn how to calculate the power load for power distribution units.

### Rack-mounted 7188 or 9188 power distribution unit

Learn about the power loading requirements and proper loading sequence for the 7188 or 9188 power distribution unit.

The IBM 7188 or 9188 rack-mounted power distribution unit (PDU) contains 12 IEC 320-C13 outlets that are connected to six 20 amps (A) circuit breakers (two outlets per circuit breaker). The PDU employs an inlet current that allows various power cord options that are listed in the following chart. Based on the power cord that is used, the PDU can supply from 24 amps to 63 amps.

Feature code	Power cord description	Amps
6489	Power cord, PDU to wall, 4.3 m (14 ft), 230 V ac, 3-phase wye, Souriau UTG, IEC 60309, 3P+N+E plug	96 A (32 A x 3)
6491	Power cord, PDU to wall, 4.3 m (14 ft), 200 - 240 V ac, single phase, Souriau UTG, IEC 60309, P+N+E plug	63 A
6492	Power cord, PDU to wall, 4.3 m (14 ft), 200 - 240 V ac, single phase, Souriau UTG, IEC 60309, 2P+E plug	60 A (48 A derated)
6653	Power cord, PDU to wall, 4.3 m (14 ft), 230 V ac, 3-phase wye, Souriau UTG, IEC 60309, 3P+N+E plug	48 A (16 A x 3)
6654	Power cord, PDU to wall, 4.3 m (14 ft), 200 - 240 V ac, single phase, Souriau UTG, plug type 12 plug	30 A (24 A derated)
6655	Power cord, PDU to wall, 4.3 m (14 ft), 200 - 240 V ac, single phase, Souriau UTG, plug type 40 plug	30 A (24 A derated)
6656	Power cord, PDU to wall, 4.3 m (14 ft), 200 - 240 V ac, single phase, Souriau UTG, IEC 60309, P+N+E plug	32 A

Table 79. Power cord options (continued)

Feature code	Power cord description	Amps
6657	Power cord, PDU to wall, 4.3 m (14 ft), 200 - 240 V ac, single phase, Souriau UTG, plug type PDL plug	32 A
6658	Power cord, PDU to wall, 4.3 m (14 ft), 200 - 240 V ac, single phase, Souriau UTG, plug type KP plug	30 A (24 A derated)
6667	Power cord, PDU to wall, 4.3 m (14 ft), 230 - 240 V ac, 3-phase wye, PDL 56P532	96 A (32 A x 3)

## Loading requirements

The power loading of the 7188 or 9188 PDU must follow these rules:

1. Total power load that is connected to the PDU must be limited to below the amperage that is listed in the table.
2. Total power load that is connected to any one circuit breaker must be limited to 16 A (derating of circuit breaker).
3. Total power load that is connected to any one IEC320-C13 outlet must be limited to 10 A.

**Note:** The load on the PDU when a dual line configuration is used is only half of the total load of the system. When you are calculating the power load on the PDU, you must include the total power load of each drawer even if the load is distributed over two PDUs.

## Loading sequence

Follow these loading sequence steps:

1. Collect power requirements for all units that are connected to the 7188 or 9188 PDU. See your server specifications for specific power requirements.
2. Sort list by total power that is required from highest power draw to lowest power draw.
3. Connect highest power drawer to outlet 1 on circuit breaker 1.
4. Connect next highest power drawer to outlet 3 on circuit breaker 2.
5. Connect next highest power drawer to outlet 5 on circuit breaker 3.
6. Connect next highest power drawer to outlet 7 on circuit breaker 4.
7. Connect next highest power drawer to outlet 9 on circuit breaker 5.
8. Connect next highest power drawer to outlet 11 on circuit breaker 6.
9. Connect next highest power drawer to outlet 12 on circuit breaker 6.
10. Connect next highest power drawer to outlet 10 on circuit breaker 5.
11. Connect next highest power drawer to outlet 8 on circuit breaker 4.
12. Connect next highest power drawer to outlet 6 on circuit breaker 3.
13. Connect next highest power drawer to outlet 4 on circuit breaker 2.
14. Connect next highest power drawer to outlet 2 on circuit breaker 1.

Following these rules allows the load to be distributed more evenly across the six PDU circuit breakers. Ensure that your total power load is below the maximum that is listed in the table and that each circuit breaker is not loaded above 16 A.

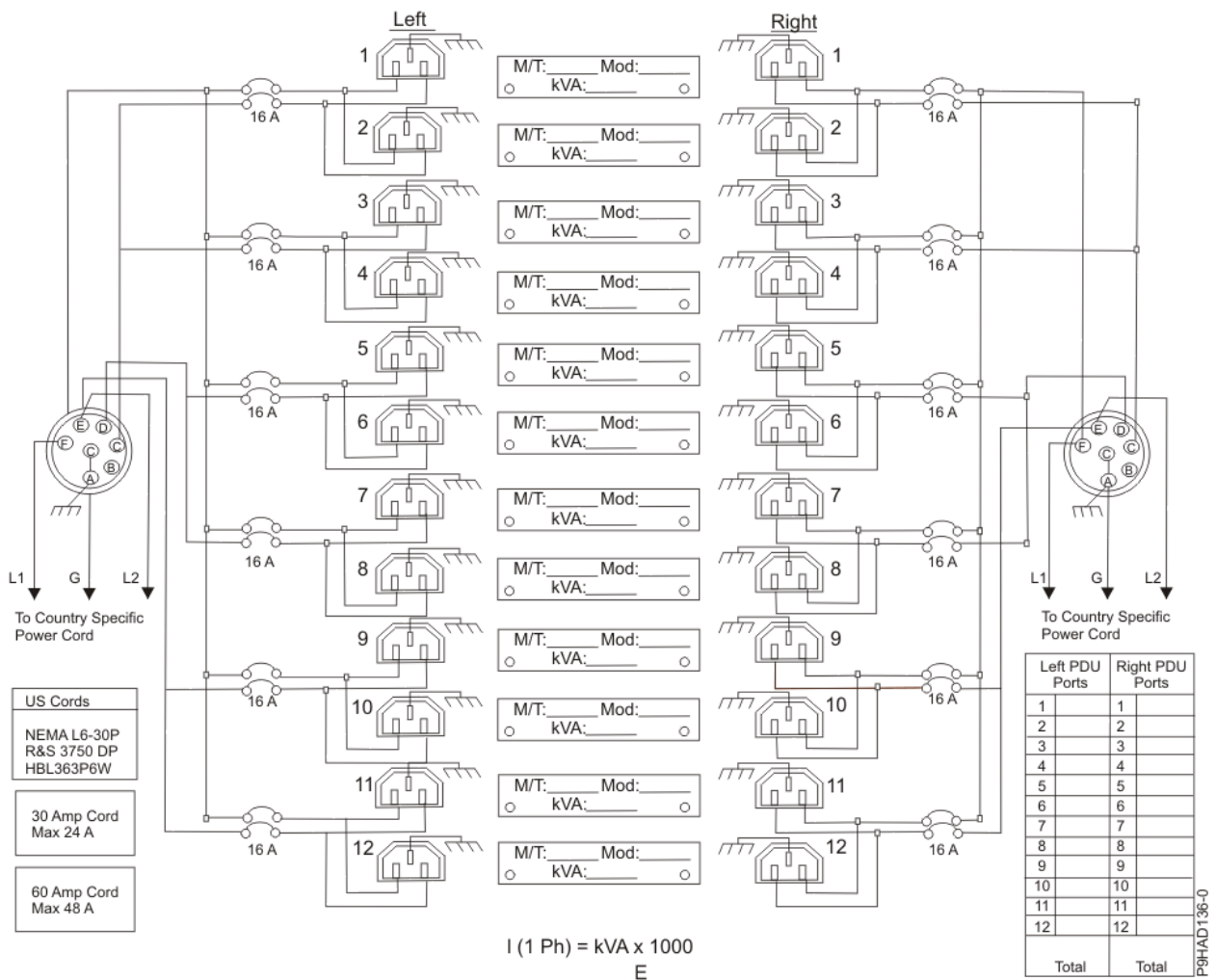

## Planning for cables

Learn how to develop plans for cabling your server and devices.

### Cable management

These guidelines ensure that your system and its cables have optimal clearance for maintenance and other operations. The guidelines also provide guidance in correctly cabling your system and using the appropriate cables.

The following guidelines provide cabling information for installing, migrating, relocating, or upgrading your system:

- Position drawers in racks to allow enough space, where possible, for cable routing on the bottom and top of the rack, and between drawers.
- Shorter drawers must not be placed between longer drawers in the rack (for example, placing a 19-inch drawer between two 24-inch drawers).
- When a specific cable plugging sequence is required, for example, for concurrent maintenance (symmetric multiprocessing cables), label the cables and note the sequence order.
- To facilitate cable routing, install cables in the following order:
  1. Power cables
  2. Communications (serial attached SCSI, InfiniBand, remote input/output, and peripheral component interconnect express) cables

**Note:** Install and route the communications cables, starting with the smallest diameter first and then progressing to the largest diameter. This applies to installing them into the cable management arm and retaining them to the rack, brackets, and other features that might be provided for cable management.

- Install and route the communications cables, starting with smallest diameter first and then progressing to the largest diameter.
- Use the innermost cable-management bridge lances for power cables.
- Use the middle cable-management bridge lances for communications cables.
- The outermost row of cable-management bridge lances is available for use when routing cables.
- Use the cable raceways on the sides of the rack to manage excess power cables.
- Four cable-management bridge lances are on the top of the rack. Use these bridge lances to route the cables from one side of the rack to the other, by routing to the top of the rack, where possible. This routing helps to avoid having a cable bundle that blocks the cable exit opening at the bottom of the rack.
- Use the cable management brackets that are provided with the system to maintain concurrent maintenance routing.
- Maintain a minimum bend diameter of 101.6 mm (4 in.) for communications (SAS, IB, and PCIe) cables.
- Maintain a minimum bend diameter of 50.8 mm (2 in.) for power cables.
- Use the shortest-length cable available for each point-to-point connection.
- If cables must be routed across the rear of a drawer, leave enough slack to reduce the tension on the cables for maintenance of the drawer.
- When routing cables, leave enough slack around the power connection on the power distribution unit (PDU) so that the wall-to-PDU power cord can be attached to the PDU.
- Use hook-and-loop fasteners where necessary.

**Note:**



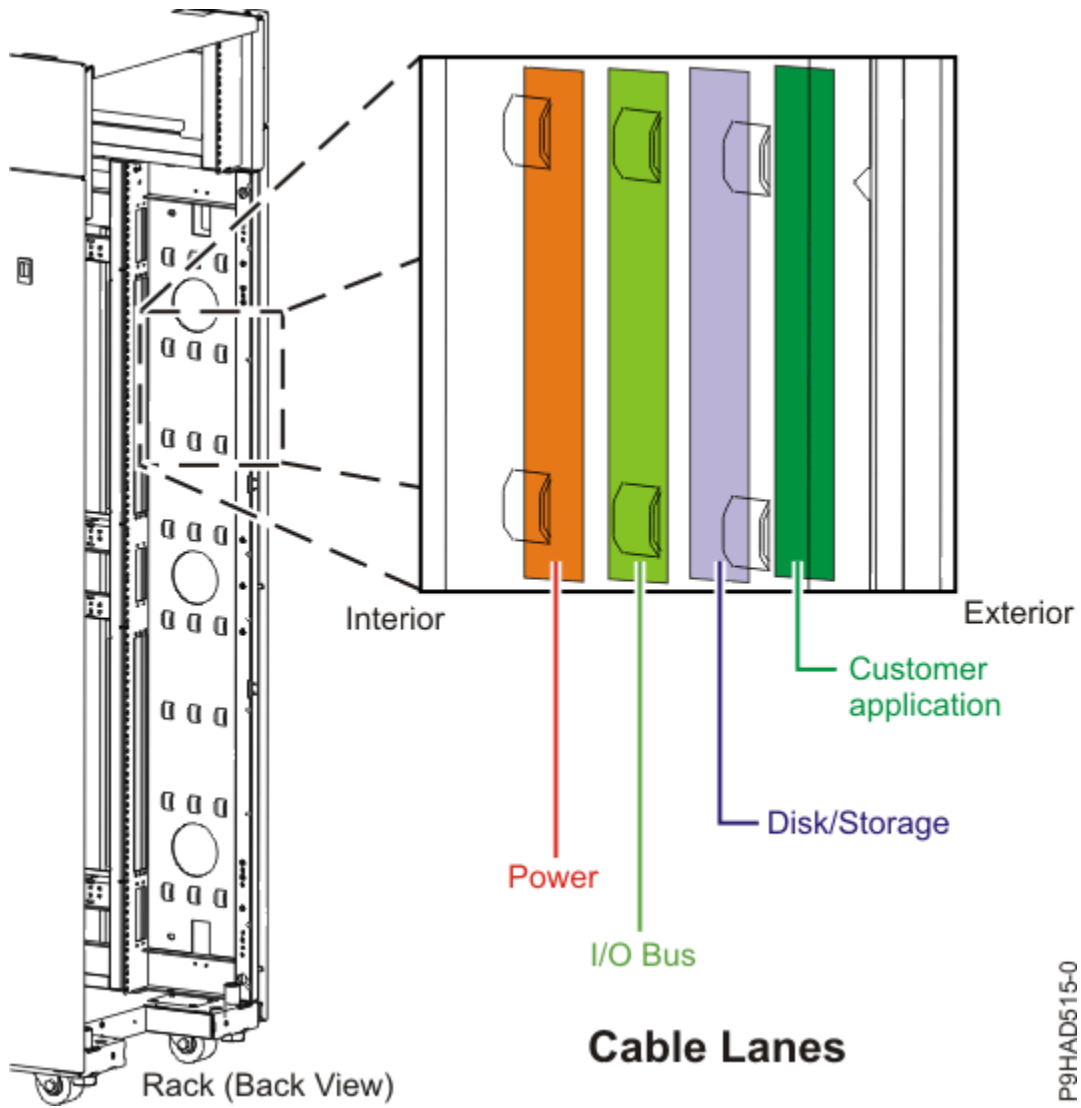

Figure 74. Cable management bridge lances

# Cable bend radius

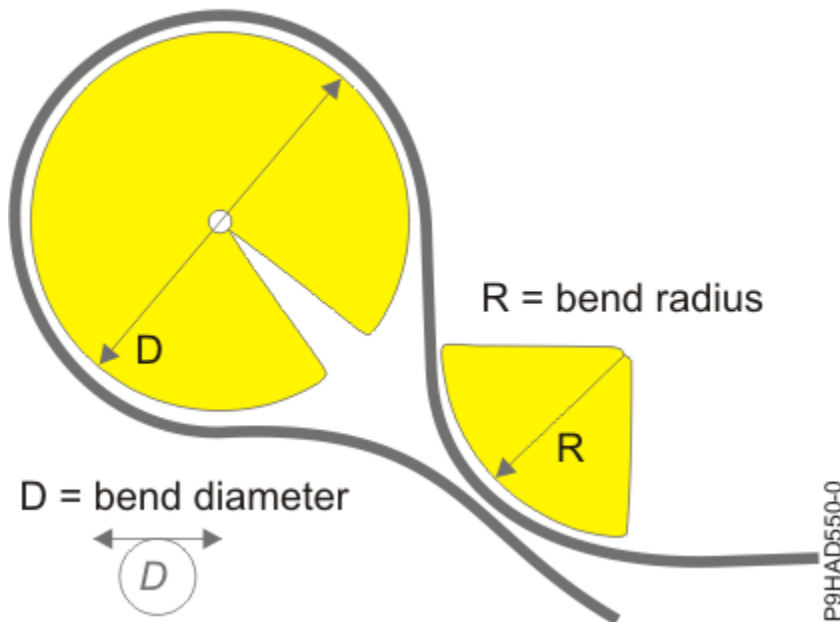

Figure 75. Cable bend radius

## Power cord routing and retention

Proper power cord routing and retention ensures that your system remains connected to a power supply.

The primary purpose of power cord retention is to prevent unexpected power loss to your system that can potentially cause system operations to stop functioning.

Different types of power cord retention are available. Some of the most commonly used types of retention include:

- Cable management arms
- Rings
- Clamps
- Plastic straps
- Hook-and-loop fasteners

Power cord retainers are typically found at the rear of the unit and on the chassis or pedestal near the alternating current (AC) power cord input.

Systems that are rack-mounted and are on rails must use the provided cable management arm.

Systems that are rack-mounted, but are not on rails must use the provided rings, clamps, or straps.

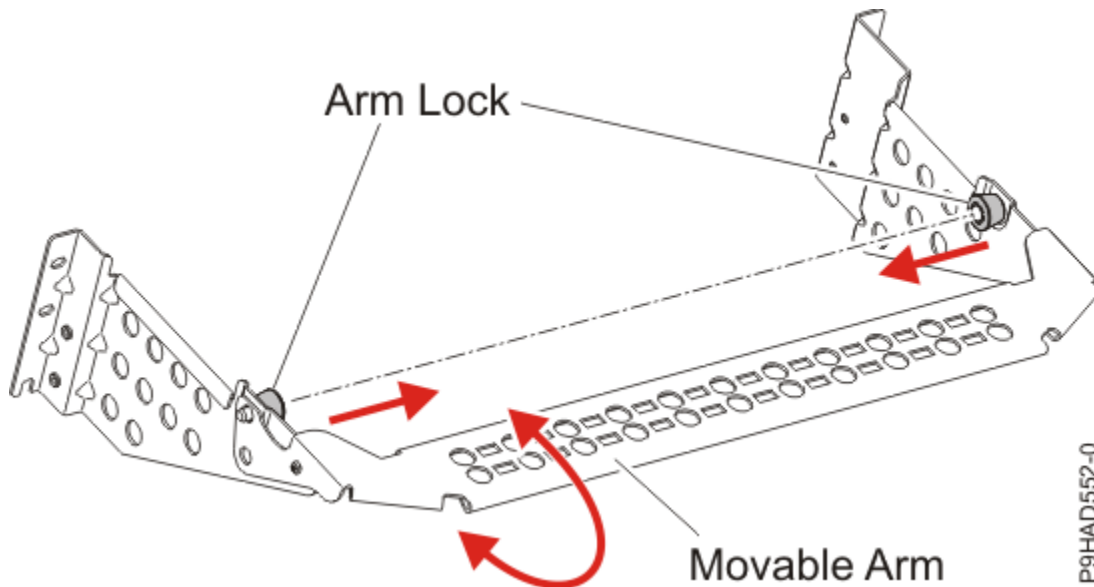

Figure 76. Cable management bracket

## Planning for serial-attached SCSI cables

Serial-attached SCSI (SAS) cables provide serial communication for transfer of data for directly attached devices, such as hard disk drives, solid-state drives, and CD-ROM drives.

### SAS cable overview

Serial-attached SCSI (SAS) is an evolution of the parallel SCSI device interface into a serial point-to-point interface. SAS physical links are a set of four wires that are used as two differential signal pairs. One differential signal transmits in one direction while the other differential signal transmits in the opposite direction. Data might be transmitted in both directions simultaneously. SAS physical links are contained in ports. A port contains one or more SAS physical links. A port is a wide port if there are more than one SAS physical link in the port. Wide ports are designed to enhance performance and provide redundancy in case an individual SAS physical link fail.

There are two types of SAS connectors, mini SAS and mini SAS high density (HD). High-density cables are typically needed to support 6 Gb/s SAS.

Each SAS cable contains four SAS physical links that are typically organized into either a single 4x SAS port or two 2x SAS ports. Each end of the cable uses a mini SAS or mini SAS HD 4x connector. Review the following design and installation criteria before you install SAS cables:

- Only specific cabling configurations are supported. Many configurations can be constructed that are not supported and will either not function correctly or generates errors. See [“SAS cabling configurations”](#) on page 134 for figures of the supported cabling configurations.
- Each mini-SAS 4x connector is keyed to help prevent cabling an unsupported configuration.
- HD SAS cables have a key that prevents the cable retention from latching if the cable is oriented incorrectly. HD SAS cables slide in easily and latch correctly if they are inserted with the blue release tab on the right side of the card connector.
- Each cable end has a label that graphically describes the correct component port to which it is connected, such as:
  - SAS adapter
  - Expansion drawer
  - System external SAS port
  - Internal SAS disk slots connection.

- Cable routing is important. For example, YO and X cables must be routed along the right side of the rack frame (as viewed from the rear) when you connect to a disk expansion drawer. Additionally, X cables must be attached to the same numbered port on both SAS adapters to which it connects.
- When a choice of cable lengths is available, select the shortest cable that provides the needed connectivity.
- Always use care when you insert or remove a cable. The cable should slide easily into the connector. Forcing a cable into a connector can cause damage to the cable or connector. When you remove a cable, pull straight back on the blue release tab. Do not pull the blue release tab off to the side, otherwise breakage might occur. After the cable latch is released, pull on the black cable to remove it from the connector.
- New SAS cables with mini-SAS HD narrow connectors are required for any PCIe3 SAS adapter connection. These cables are also compatible with earlier PCIe2 SAS adapters.
- Not all cabling configurations are supported when you use solid-state drives (SSD). See *Installing and configuring Solid State Drives* for more information.

### Supported SAS cable information

The following table contains a list of the supported serial-attached SCSI (SAS) cable types and their designed usage.

Cable type	Function
AA cable	This cable is used to connect the top one or two ports between two PCIe3 caching SAS RAID adapters.
AE cable	These cables are used to connect a SAS adapter to a media expansion drawer.
YO cable	This cable is used to connect a SAS adapter to a disk expansion drawer. The cable must be routed along the right side of the rack frame (as viewed from the rear) when you connect to a disk expansion drawer.
X cable	This cable is used to connect two SAS adapters to a disk expansion drawer in a RAID configuration. The cable must be routed along the right side of the rack frame (as viewed from the rear) when you connect to a disk expansion drawer.
AE1 cable	This 4 m (13.1 ft) SAS cable connects a PCIe3 SAS adapter to a SAS tape drive or DVD I/O enclosure. The AE cable has two connectors, one mini-SAS HD narrow connector and one mini-SAS connector. The mini-SAS HD Narrow connector attaches to a PCIe3 SAS adapter. The mini-SAS connector attaches to a SAS tape drive or DVD enclosure.
YE1 cable	This 3 m (9.8 ft) SAS cable connects a PCIe3 SAS adapter to one or two SAS tape drives in an I/O enclosure. The YE1 cable has three connectors, one mini-SAS HD (High Density) narrow connector and two mini-SAS connectors. The Mini-SAS HD Narrow connector attaches to a PCIe3 SAS adapter. Each mini-SAS connector attaches to a different SAS tape drive.
AS cable	This 3 m (9.8 ft) SAS cable is used to attach a DCS3700 to PCIe3 LP RAID SAS adapter.

The following table contains specific information about each supported SAS cable for PCIe SAS adapters.

<i>Table 81. Supported SAS cables for PCIe SAS adapters</i>			
<b>Name</b>	<b>Length</b>	<b>IBM part number</b>	<b>Feature code</b>
SAS 4x AE cable	3 m (9.8 ft)	44V4163	3684
	6 m (19.6 ft)	44V4164	3685

The following table contains specific information about each supported SAS cable feature with narrow HD connectors for PCIe3 SAS adapters.

<i>Table 82. Supported SAS cables for PCIe3 SAS adapters</i>			
<b>Name</b>	<b>Length</b>	<b>IBM part number</b>	<b>Feature code</b>
HD SAS AA12 narrow connector cable, SAS adapter to SAS adapter	0.6 m (1.9 ft)	01AF505	ECE0
	1.5 m (4.9 ft)	01AF506	ECE2
	3 m (9.8 ft)	01AF507	ECE3 <sup>1</sup>
	4.5 m (14.8 ft) AOC <sup>2</sup>	78P4917	ECE4
HD SAS X12 narrow connector cable, SAS adapter to storage enclosure	3 m (9.8 ft)	01AF504	ECDJ
	4.5 m (14.8 ft) AOC <sup>2</sup>	78P4918	ECDK
	10 m (32.8 ft) AOC <sup>2</sup>	78P4919	ECDL
HD SAS YO12 narrow connector cable, two SAS adapters to storage enclosure	1.5 m (4.9 ft)	01AF502	ECDT
	3 m (9.8 ft)	01AF503	ECDU
	4.5 m (14.8 ft) AOC <sup>2</sup>	78P4920	ECDV
	10 m (32.8 ft) AOC <sup>2</sup>	78P4921	ECDW
HD SAS AA narrow connector cable, SAS adapter to SAS adapter	0.6 m (1.9 ft)	00E6287	ECC0
	1.5 m (4.9 ft)	00E6288	ECC2
	3 m (9.8 ft)	00E6289	ECC3
	6 m (19.6 ft)	00E6290	ECC4
HD SAS X narrow connector cable	3 m (9.8 ft)	00E6297	ECBJ
	6 m (19.6 ft)	00E6298	ECBK
	10 m (32.8 ft)	00E6299	ECBL
	15 m (49.2 ft)	00E6300	ECBM

Table 82. Supported SAS cables for PCIe3 SAS adapters (continued)

Name	Length	IBM part number	Feature code
HD SAS YO narrow connector cable	1.5 m (4.9 ft)	00E6292	ECBT
	3 m (9.8 ft)	00E6293	ECBU
	6 m (19.6 ft)	00E6294	ECBV
	10 m (32.8 ft)	00E6295	ECBW
	15 m (49.2 ft)	00E6296	ECBX
HD SAS AE1 narrow connector cable	4 m (13.1 ft)	46C2900	ECBY/5507
HD SAS YE1 narrow connector cable	3 m (9.8 ft)	46C2902	ECBZ/5509
HD SAS AS narrow connector cable	3 m (9.8 ft)	00FW799	ECC5

1. Can be used to attach just a bunch of disks (JBOD) storage enclosures to adapters.  
2. Active optical cables (AOC).

The following table contains cable label information. The graphic labels are designed to match the correct component port to which the cable end is to be attached.

Table 83. SAS cable labeling

Name	Connects	Label
SAS 4x AE cable	SAS adapter to a media expansion drawer or two SAS adapters to a disk expansion drawer in a unique JBOD configuration	
SAS AA cable	SAS adapter to SAS adapter	

Table 83. SAS cable labeling (continued)

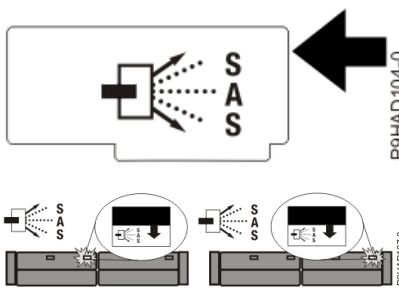
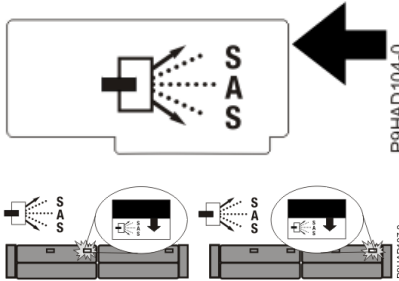
Name	Connects	Label
SAS YO cable	SAS adapter to a disk expansion drawer	
SAS X cable	Two SAS adapters to a disk expansion drawer in a RAID configuration	

**Cable section lengths**

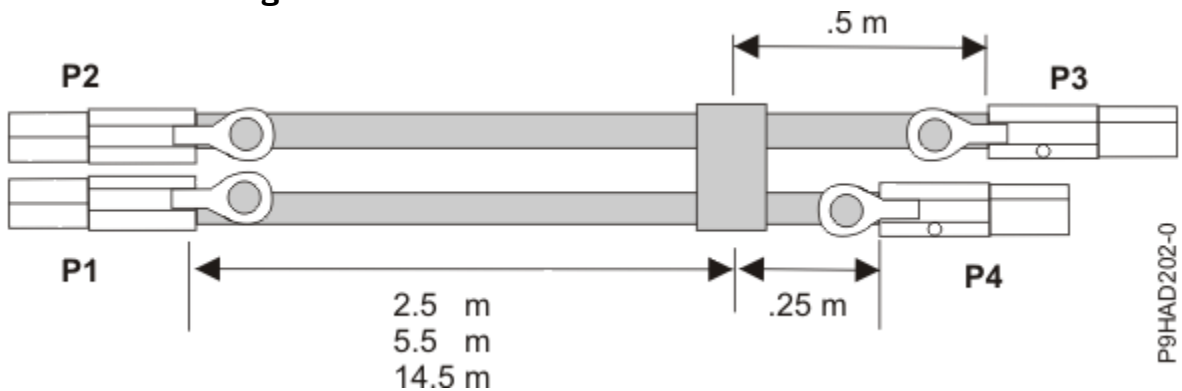

Figure 77. SAS external X cable assembly cable lengths

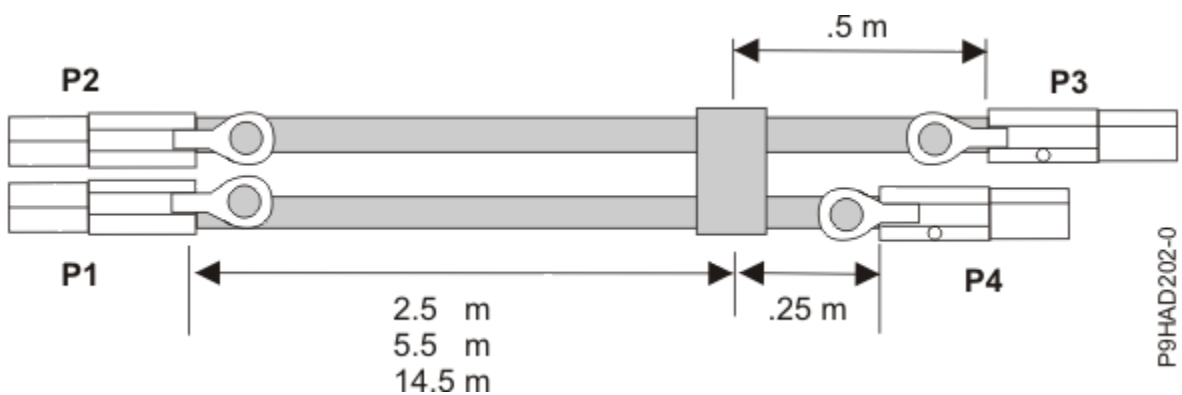

Figure 78. SAS external YO-cable assembly cable lengths

## SAS cabling configurations

The following sections provide the typical supported SAS cabling configurations. Many configurations can be constructed that are not supported and will either not function correctly or generates errors. To avoid problems, restrict cabling to only the general types of configurations that are shown in the following sections.

- [“SAS adapter to media expansion drawer” on page 134](#)
- [“SAS adapter to expansion drawer combinations” on page 135](#)
- [“System external SAS port to disk expansion drawer” on page 135](#)
- [“Two RAID SAS adapters with HD connectors to disk expansion drawer in a multi-initiator high availability \(HA\) mode \(dual storage adapter configuration\)” on page 136](#)

### SAS adapter to media expansion drawer

Figure 79 on page 134 illustrates connecting a SAS adapter to a media expansion drawer. It is also possible to connect a second media expansion drawer to the second port of the SAS adapter.

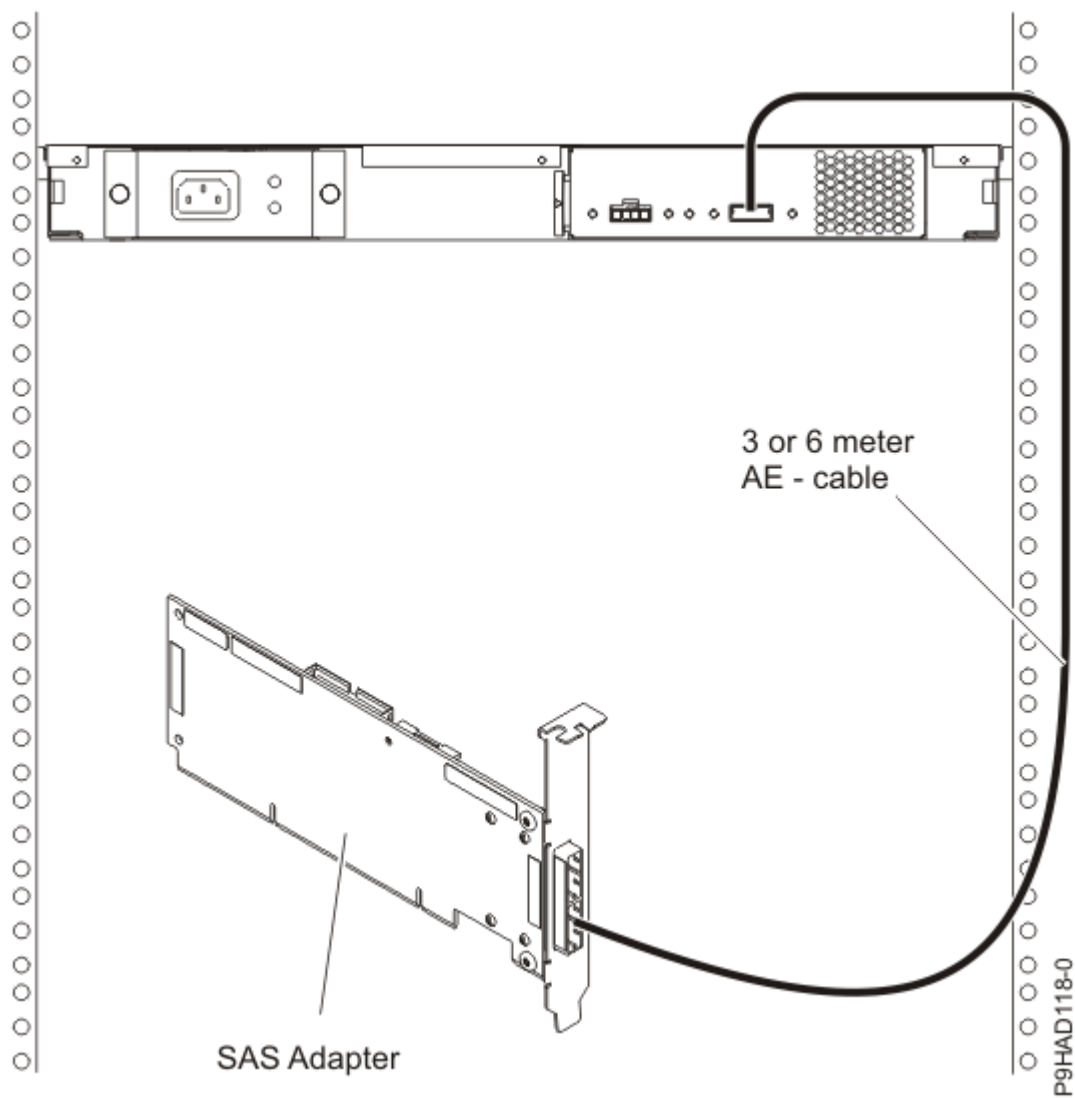

Figure 79. SAS adapter to a media expansion drawer



## SAS adapter to expansion drawer combinations

Figure 80 on page 135 illustrates connecting a PCIe SAS adapter to both a disk expansion drawer and a media expansion drawer on separate adapter ports.

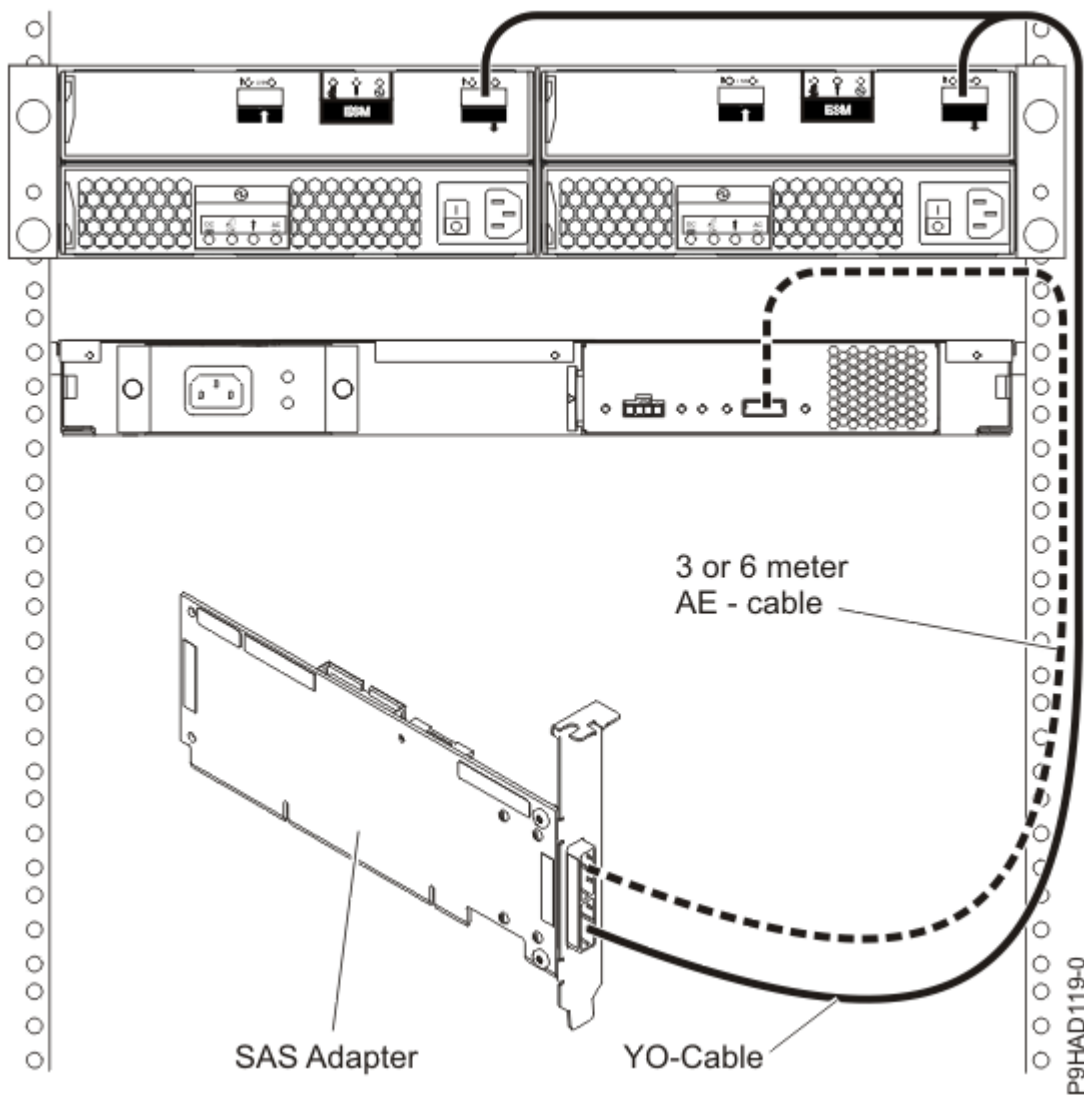

Figure 80. SAS adapter to both a disk expansion drawer and a media expansion drawer

**Note:** The YO cable must be routed along the right side of the rack frame.

## System external SAS port to disk expansion drawer

Figure 81 on page 136 illustrates connecting a system external SAS port to a disk expansion drawer. Disk expansion drawers cannot be cascaded.

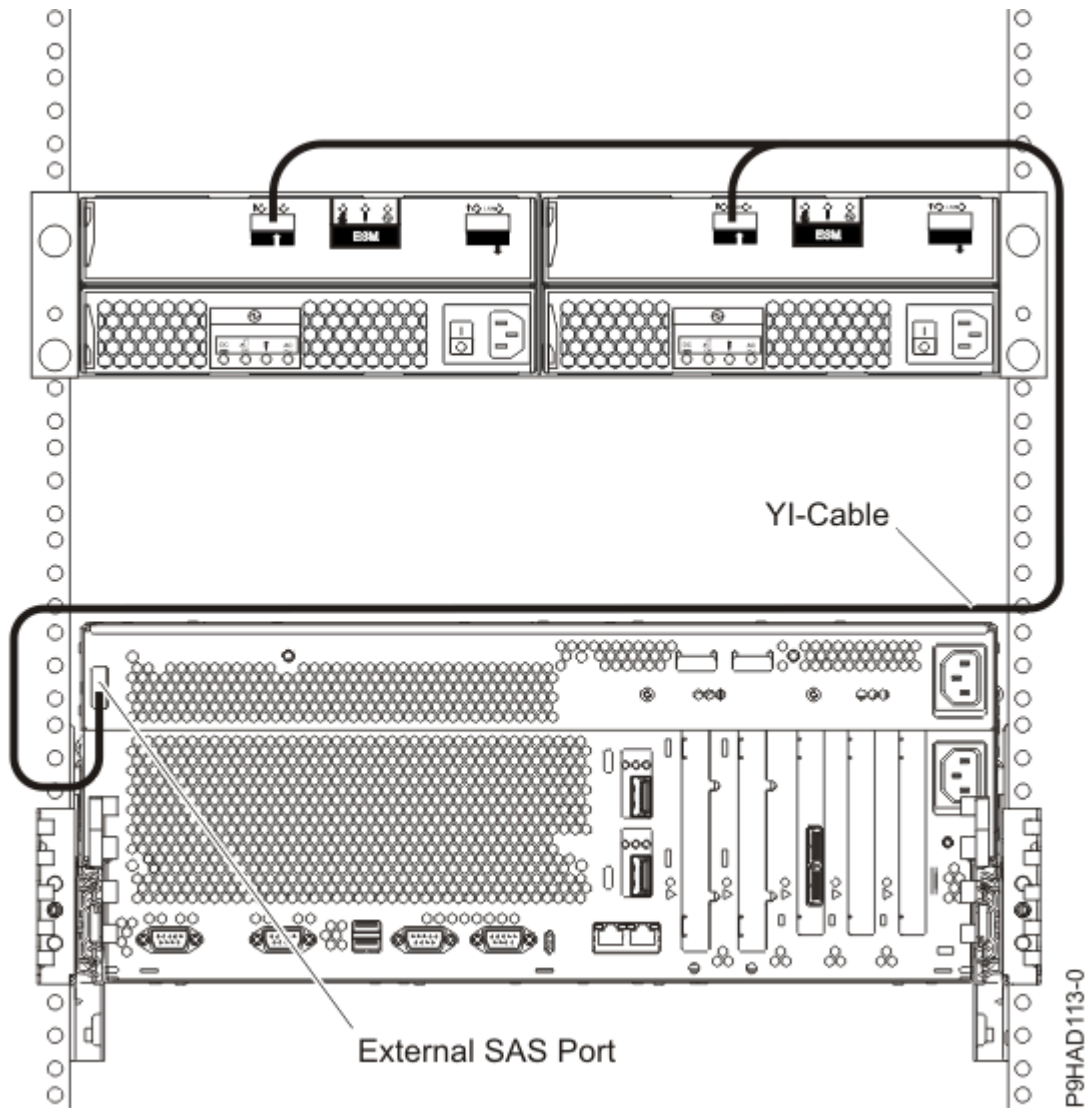
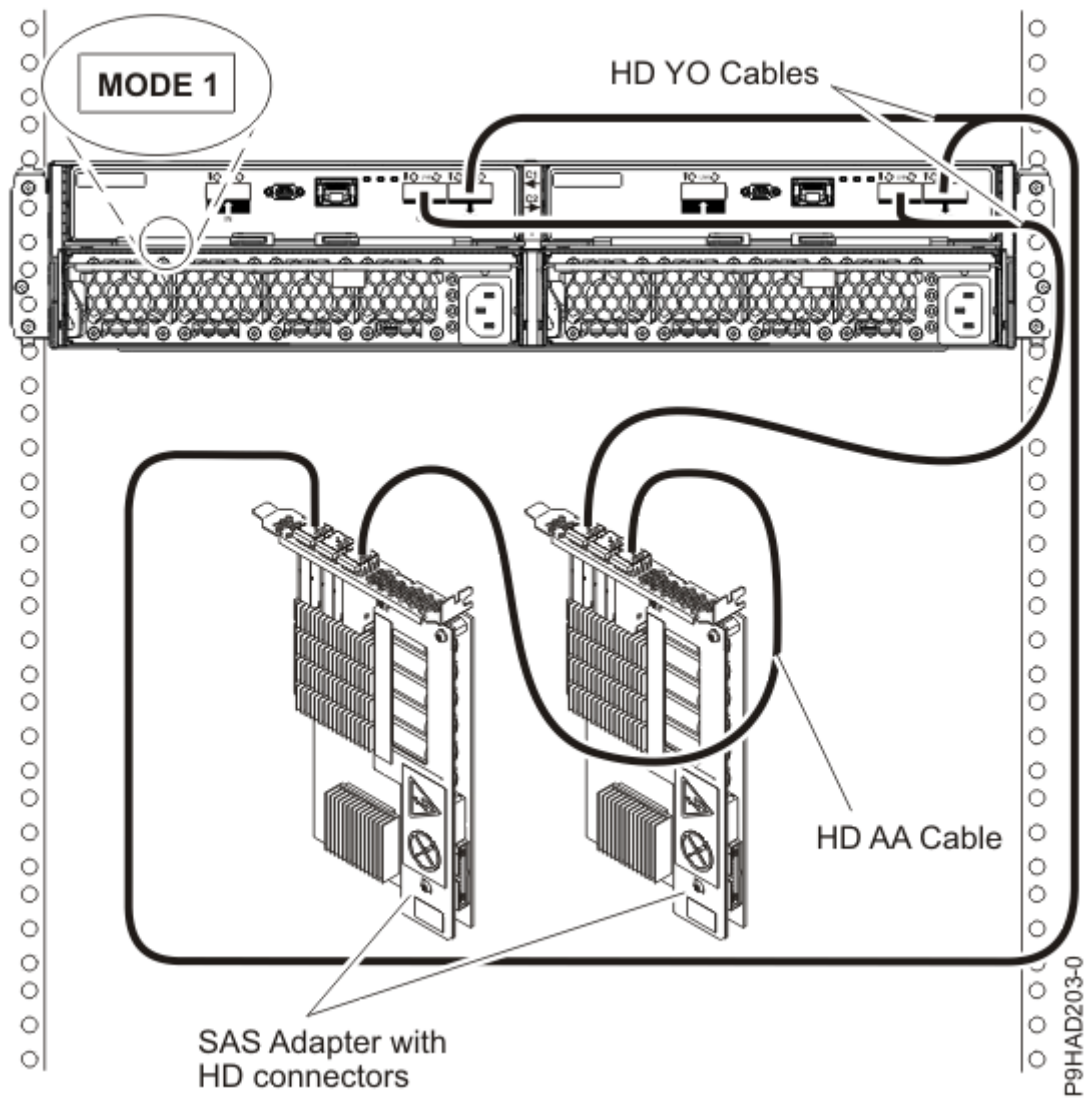

Figure 81. System external SAS adapter port to a disk expansion drawer

### Two RAID SAS adapters with HD connectors to disk expansion drawer in a multi-initiator high availability (HA) mode (dual storage adapter configuration)

Figure 82 on page 137, Figure 83 on page 138, and Figure 84 on page 139 illustrate connecting two SAS RAID adapters with HD connectors to one, two, or three disk expansion drawers in a multi-initiator HA mode.

Figure 85 on page 140 illustrates connecting two pair of SAS RAID adapters with HD connectors to one disk expansion drawer in a multi-initiator HA mode.



**Notes:**

- No cascading allowed for the 5887 storage drawer.
- The 5887 storage drawer is connected to same numbered port on each adapter.
- HD AA cable is required.

*Figure 82. Two RAID SAS adapters with HD connectors to a disk expansion drawer in a multi-initiator HA mode*

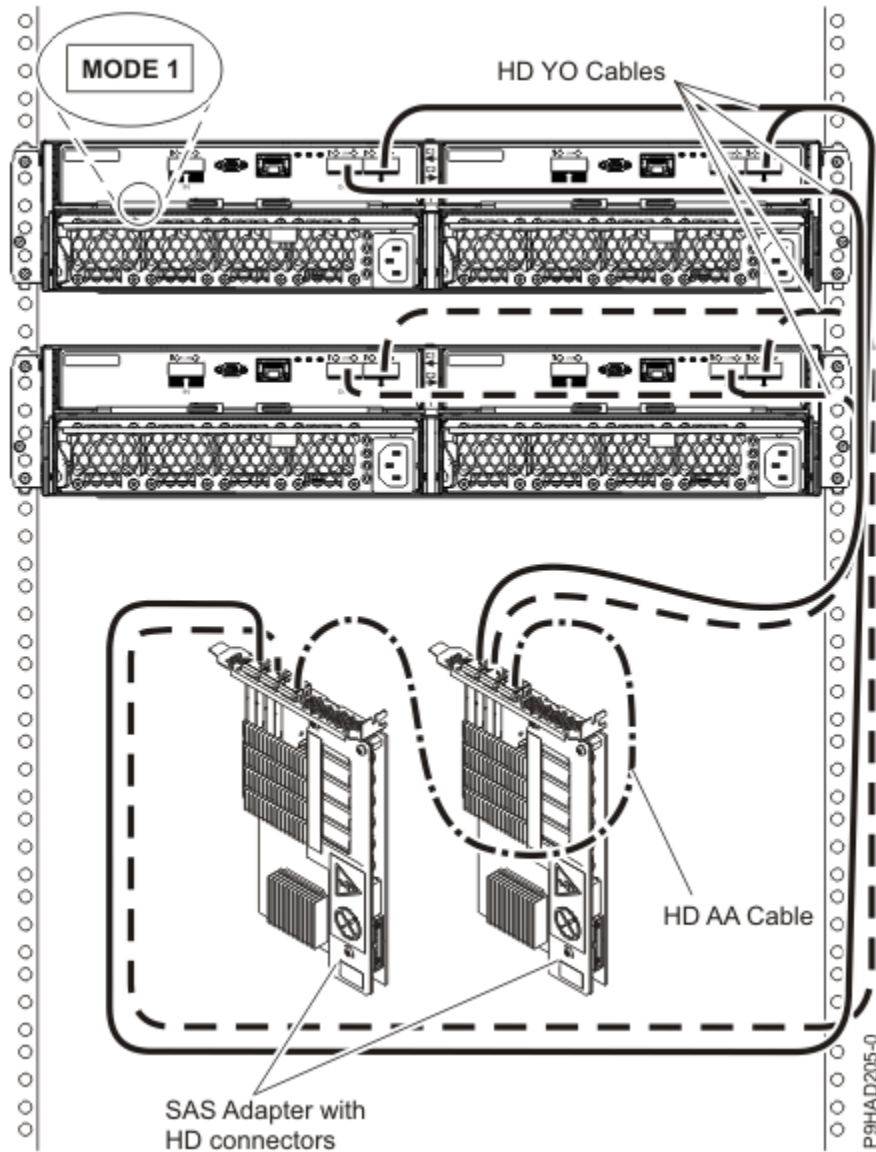

**Notes:**

- No cascading allowed for the 5887 storage drawer.
- The 5887 storage drawers are connected to same numbered port on each adapter.
- HD AA cable is required.

*Figure 83. Two RAID SAS adapters with HD connectors to two disk expansion drawer in a multi-initiator HA mode*

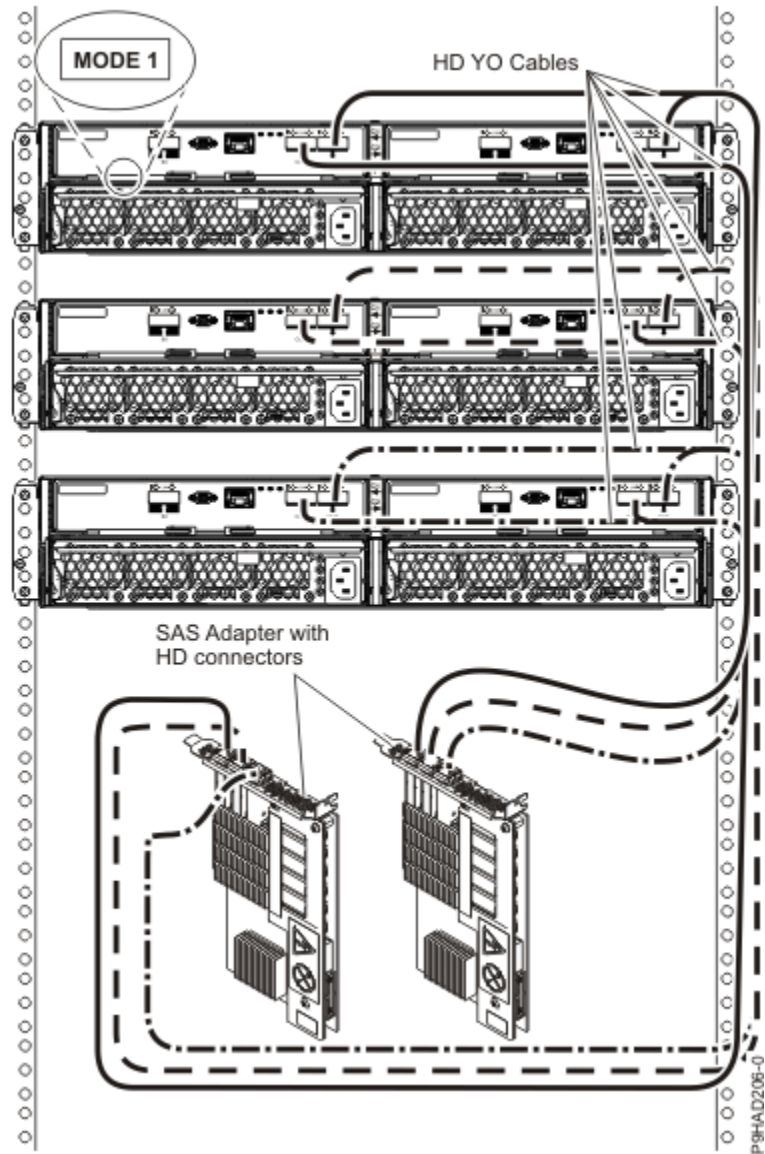

**Note:**

- No cascading allowed for the 5887 storage drawer.
- The 5887 storage drawers are connected to same numbered port on each adapter.

*Figure 84. Two RAID SAS adapters with HD connectors to three disk expansion drawers in a multi-initiator HA mode*

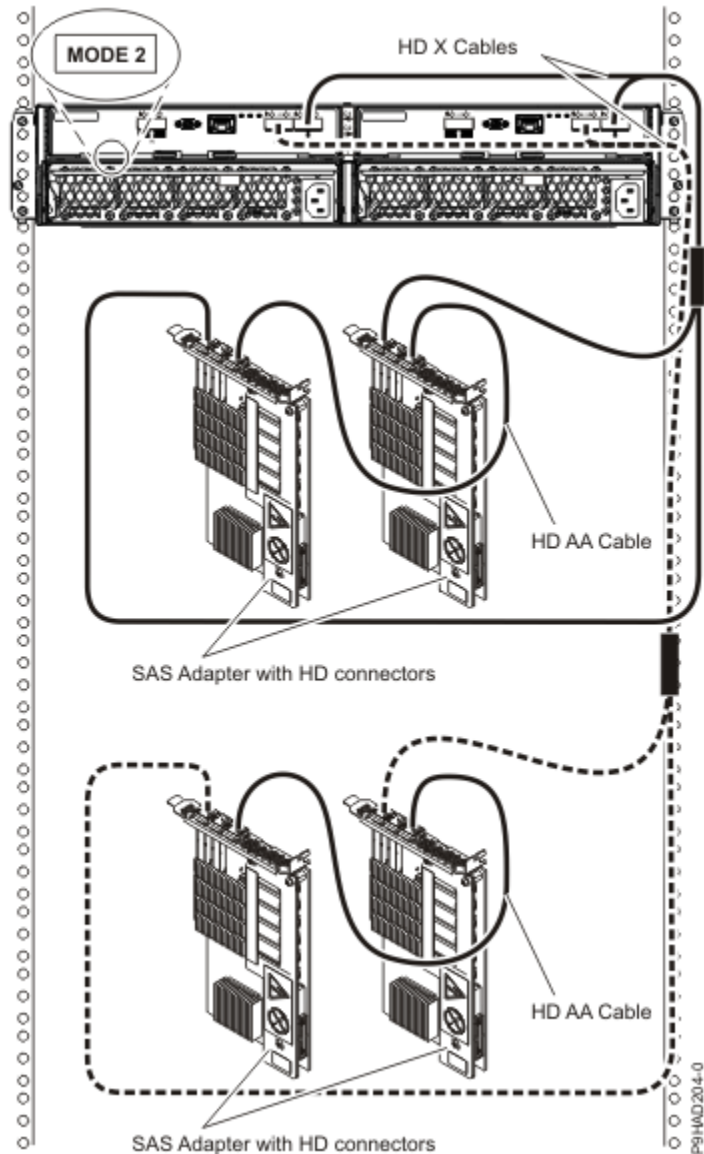

**Notes:**

- No cascading allowed for the 5887 storage drawer.
- The 5887 storage drawer is connected to same numbered port on each adapter.
- HD AA cable is required.

*Figure 85. Two pairs of RAID SAS adapters with HD connectors to a disk expansion drawer – Mode 2 in a multi-initiator HA mode*

**Internal disk drive sharing**

The following information is for use after the FC 5901 SAS Storage adapter is installed. Install the adapter and then return here. For more information about the PCI adapters topic, see .

Please review the tasks in the section before you proceed with the following procedure.

This feature allows you to split the internal disks in the system unit enclosure into groups that you can manage separately.

1. Stop and power off the system. For more information, see .
2. Cable a single system unit enclosure by completing the following steps:



- a. Attach the cable to the SAS port on the rear bulkhead of the system unit enclosure to the top port in the SAS Storage Controller as shown in the following figure.

**Restriction:** Internal disk drive sharing is only available when internal cable feature FC 1815 is installed from the DASD backplane to the rear bulkhead of the system unit enclosure. Also FC 5662 175 MB cache RAID - dual IOA enablement card must not be installed. The SAS Storage Controller might be in any of the other slots that support it.

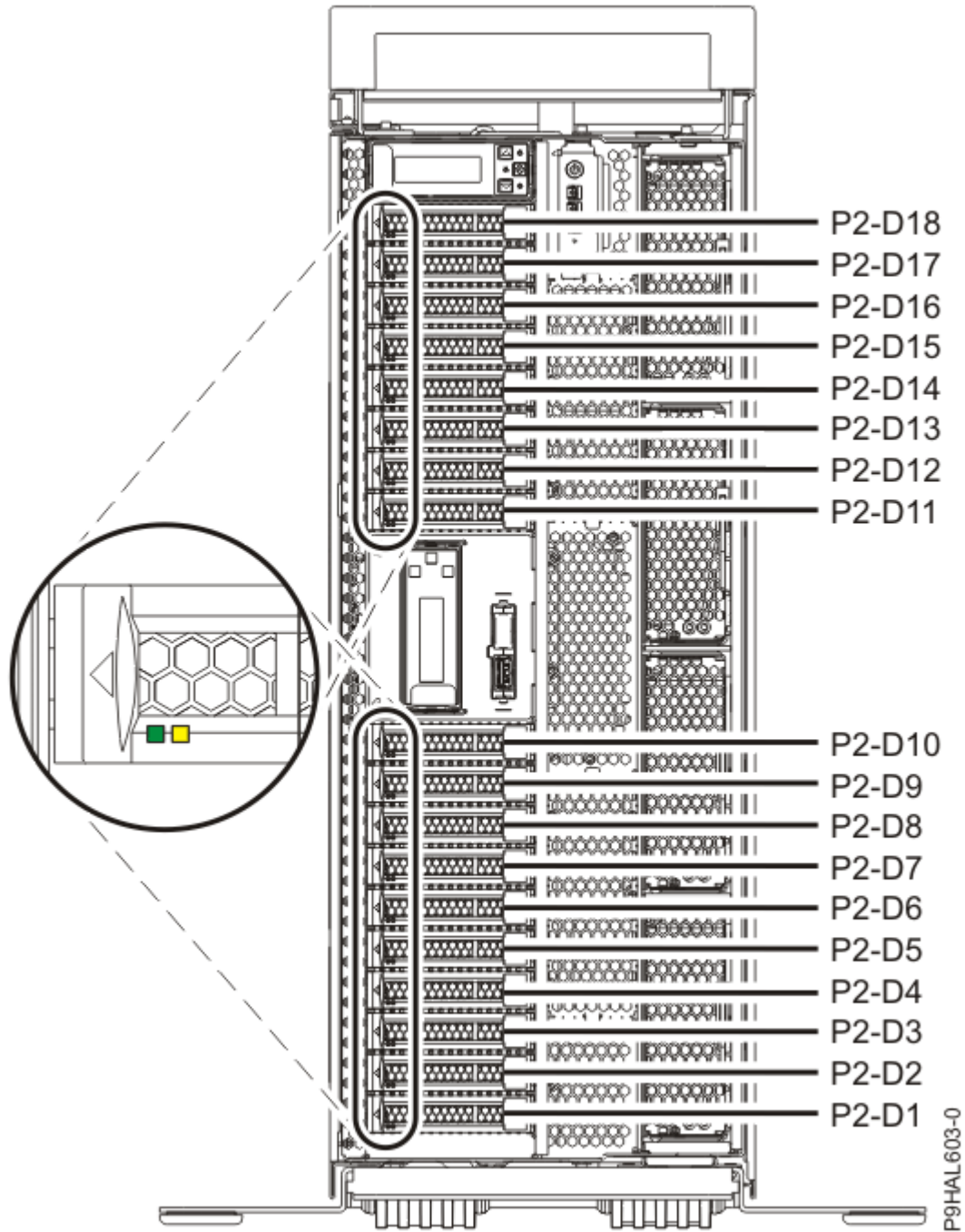

- b. Secure any extra cable.
3. Start the system. For more information, see .
4. Verify that the feature is installed and is working. For more information, see .

With this function installed, two of the six disks (D3 and D6) in the system enclosure is managed by the SAS storage controller adapter.

**Note:** The removable media device is always controlled by the separate embedded SAS controller on the system board.

## **SAS cabling for the 5887 disk drive enclosure**

Learn about the different serial-attached SCSI (SAS) cabling configurations that are available for the 5887 disk drive enclosure.

For more information about connecting the 5887 disk drive enclosure to the system, see [Connecting the 5887 disk drive enclosure to your system \(http://www.ibm.com/support/knowledgecenter/POWER9/p9ee3/p9ee3\\_connect\\_to\\_server.htm\)](http://www.ibm.com/support/knowledgecenter/POWER9/p9ee3/p9ee3_connect_to_server.htm).

## **SAS adapter to the 5887**

There are seven supported configurations to connect SAS adapters to the 5887.

### **Notes:**

1. No solid-state drives (SSDs) supported with SAS adapters.
2. No cascading of 5887 enclosures.
3. No support for IBM i.
4. The long end (0.5 m) of the YO cable must be connected to the left side of the enclosure (as viewed from the rear). The short end (0.25 m) of the YO cable must be connected to the right side of the enclosure (as viewed from the rear).

The following list describes the supported configurations for connecting SAS adapters to a 5887:

1. Single SAS adapter to one 5887 enclosure by using a mode 1 connection.
  - 5887 enclosure with one set of 24 hard disk drives (HDDs).
  - Connection using SAS YO cables to connect to the 5887 enclosure.



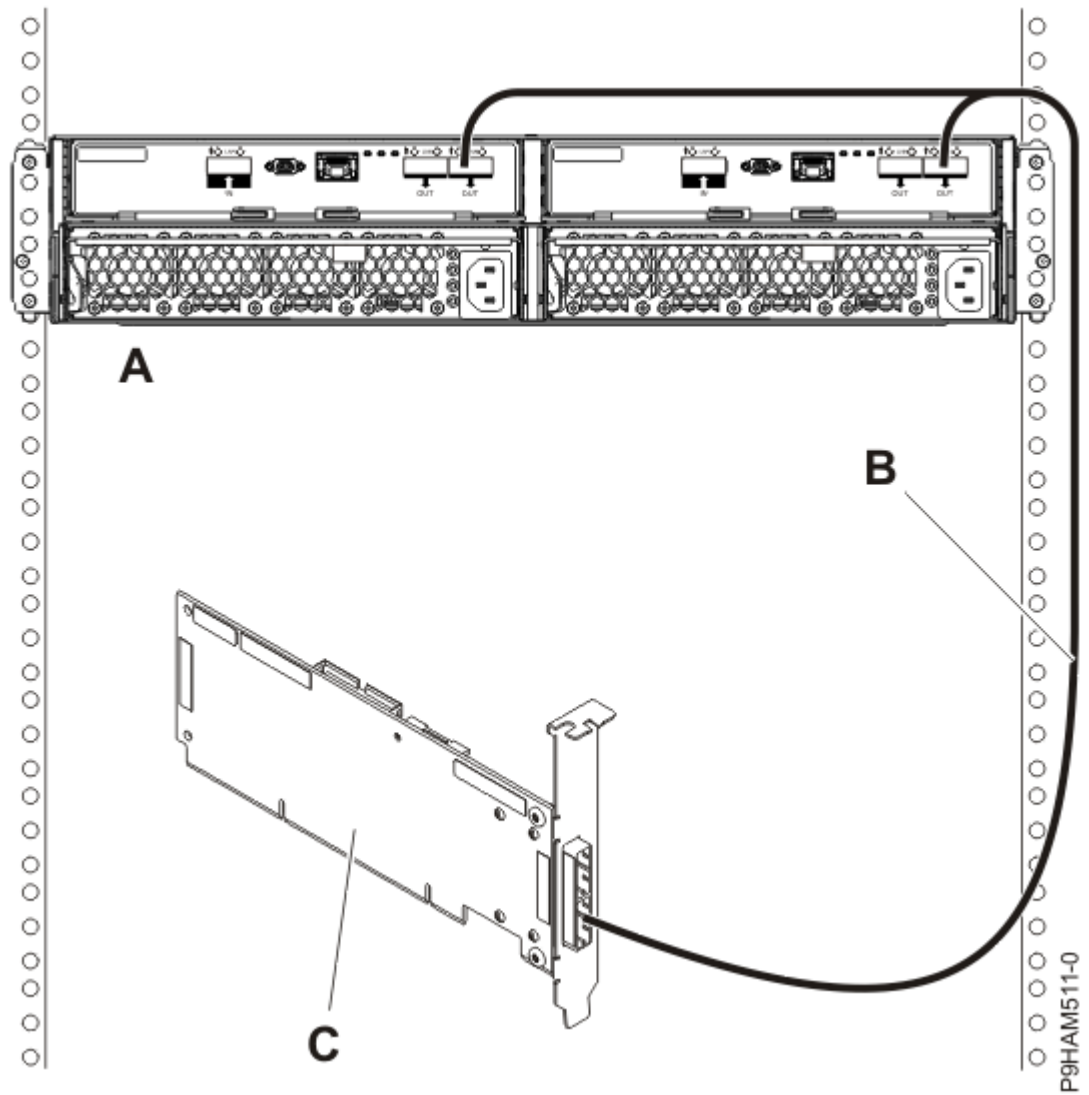

Figure 86. Mode 1 connection of a 5887 enclosure by using a YO cable to a single SAS adapter

2. Single SAS adapter to two 5887 enclosures by using a mode 1 connection.

- 5887 enclosures with two sets of 24 hard disk drives (HDDs).
- Connection using SAS YO cables to connect to the 5887 enclosures.

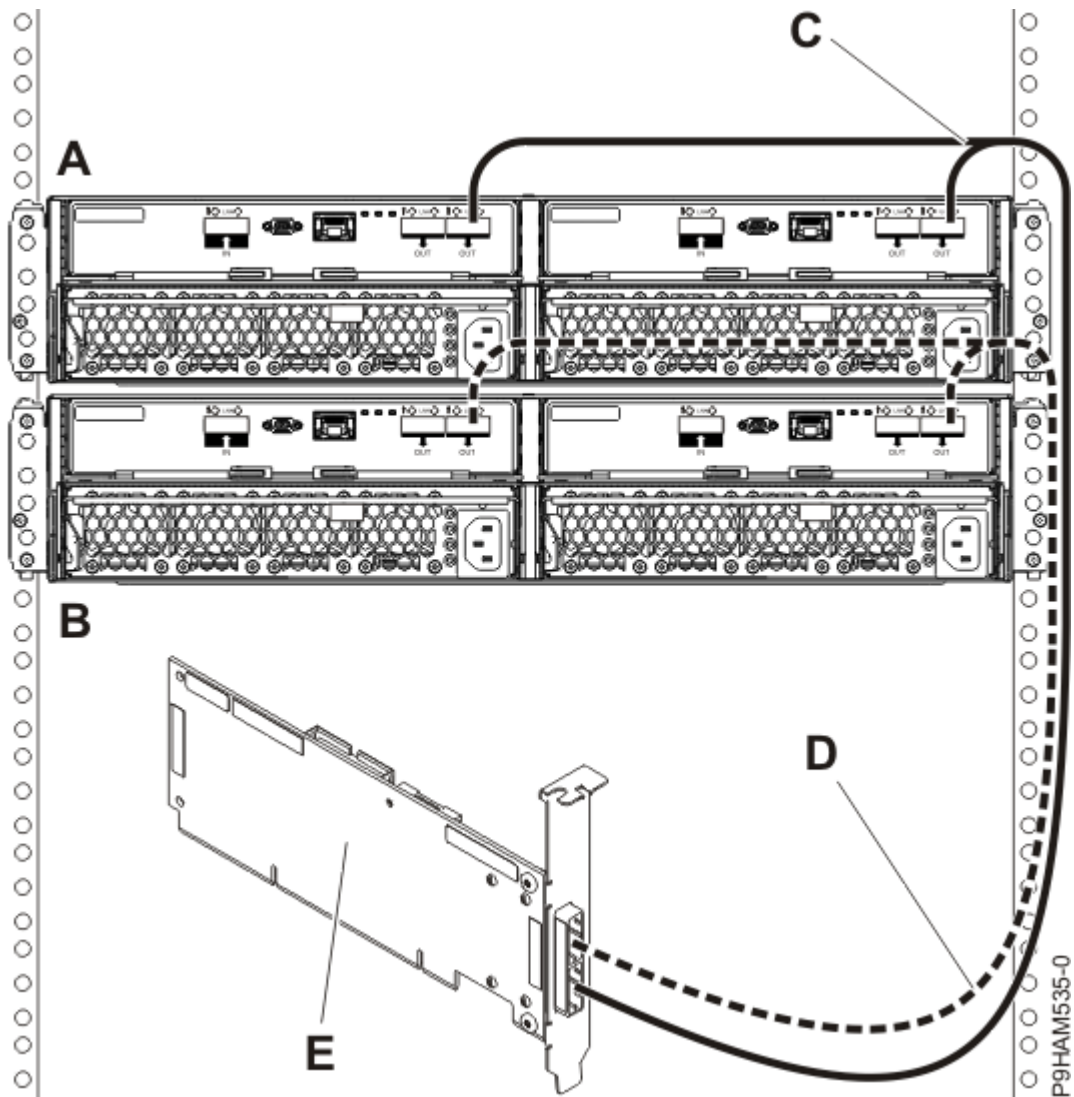

Figure 87. Mode 1 connection of two 5887 enclosures by using YO cables to a single SAS adapter

3. Dual SAS adapters to one 5887 enclosure by using a mode 1 connection.

- 5887 enclosure with one set of 24 hard disk drives (HDDs).
- Connection using dual SAS YO cables to connect to the 5887 enclosure.

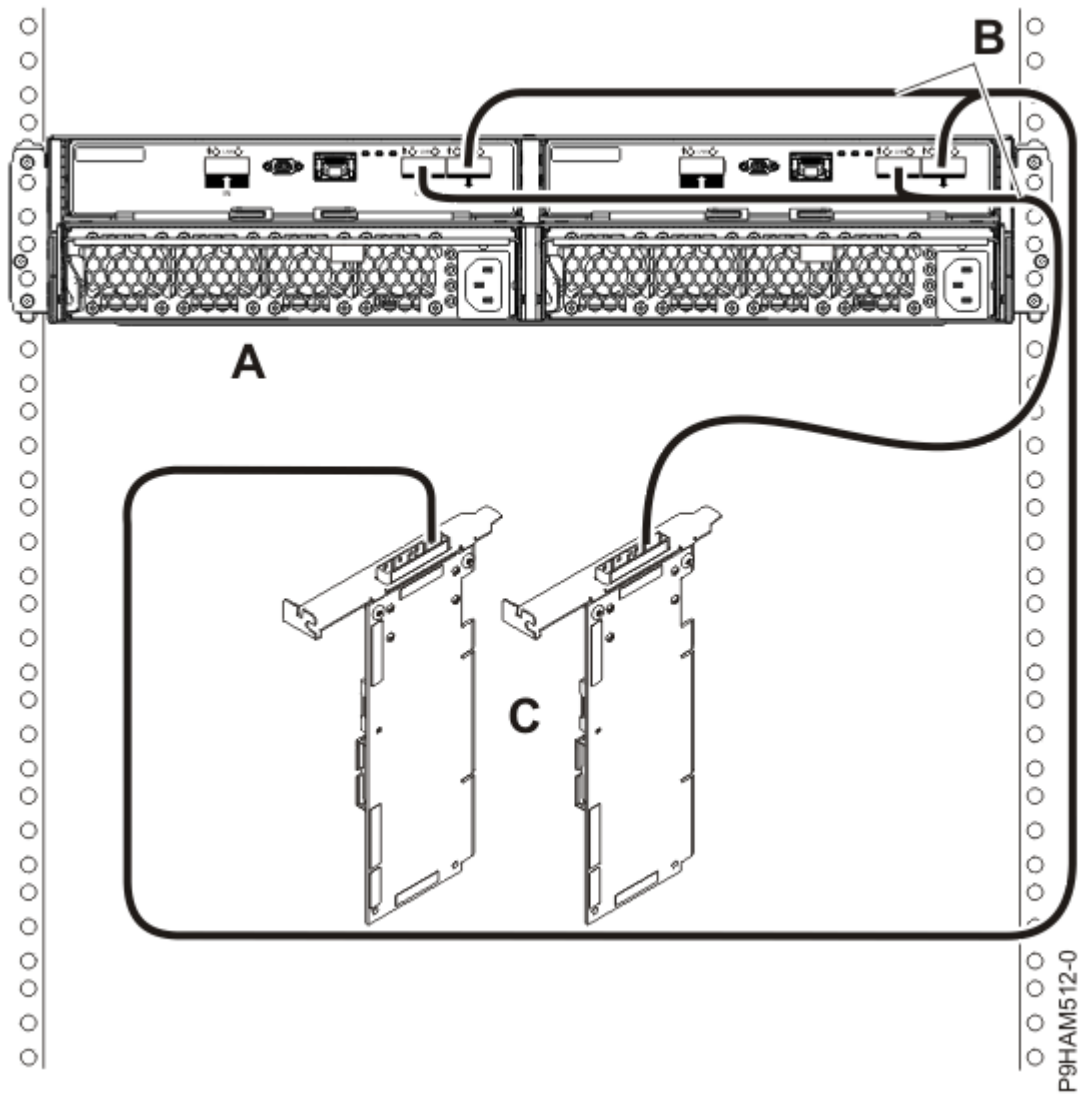
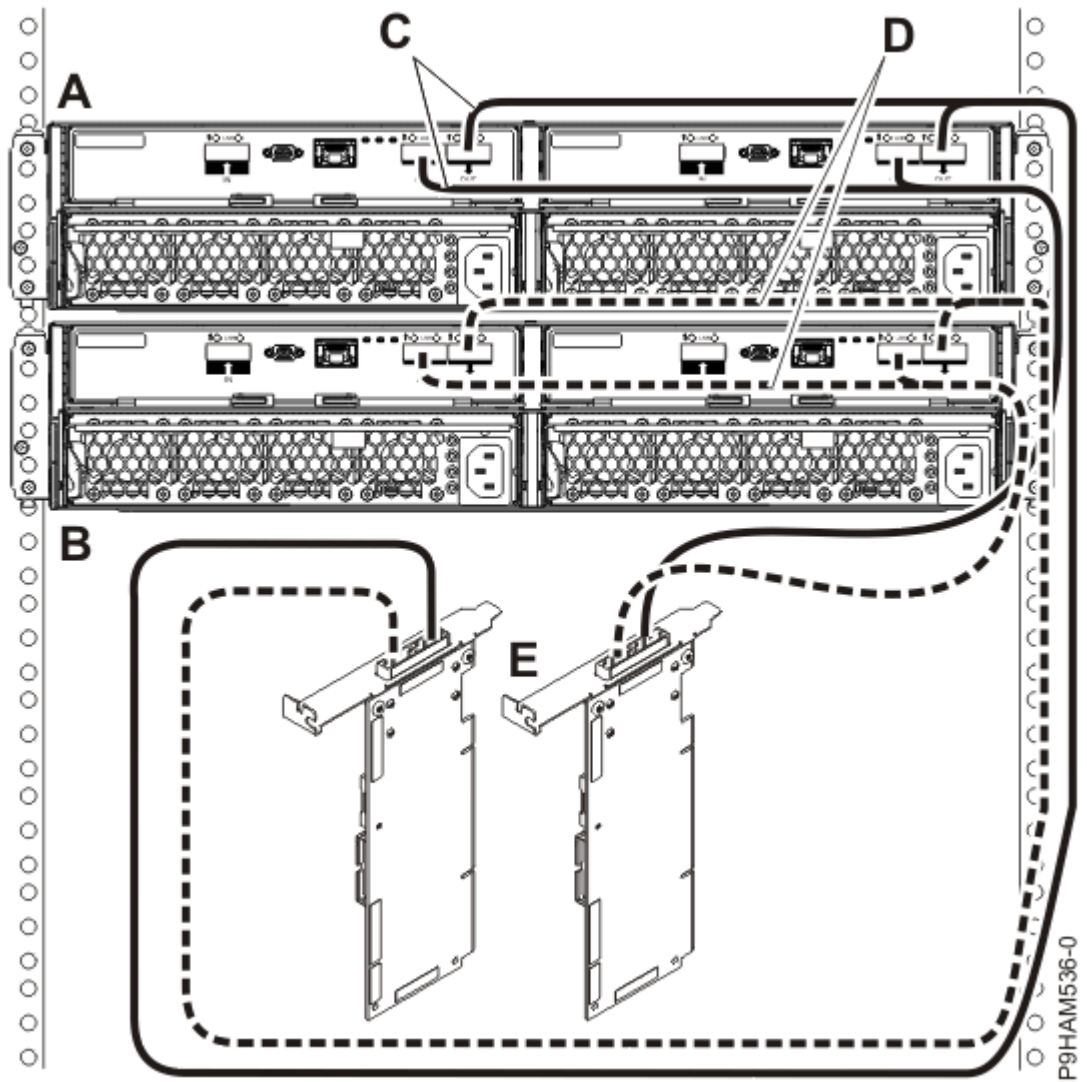

Figure 88. Mode 1 connection of one 5887 enclosure by using YO cables to a SAS adapter pair

4. Dual SAS adapters to two 5887 enclosures by using a mode 1 connection.

- 5887 enclosures with two sets of 24 hard disk drives (HDDs).
- Connection using dual SAS YO cables to connect to the 5887 enclosure.



P9HAM536-0

Figure 89. Mode 1 connection of two 5887 enclosures by using YO cables to a SAS adapter pair

5. Two SAS adapters to one 5887 enclosure by using a mode 2 connection.

- 5887 enclosure with two sets of 12 hard disk drives (HDDs).
- Connection using two SAS YO cables to connect to the 5887 enclosure.
- Each pair of SAS adapters controls half of the 5887 enclosure.

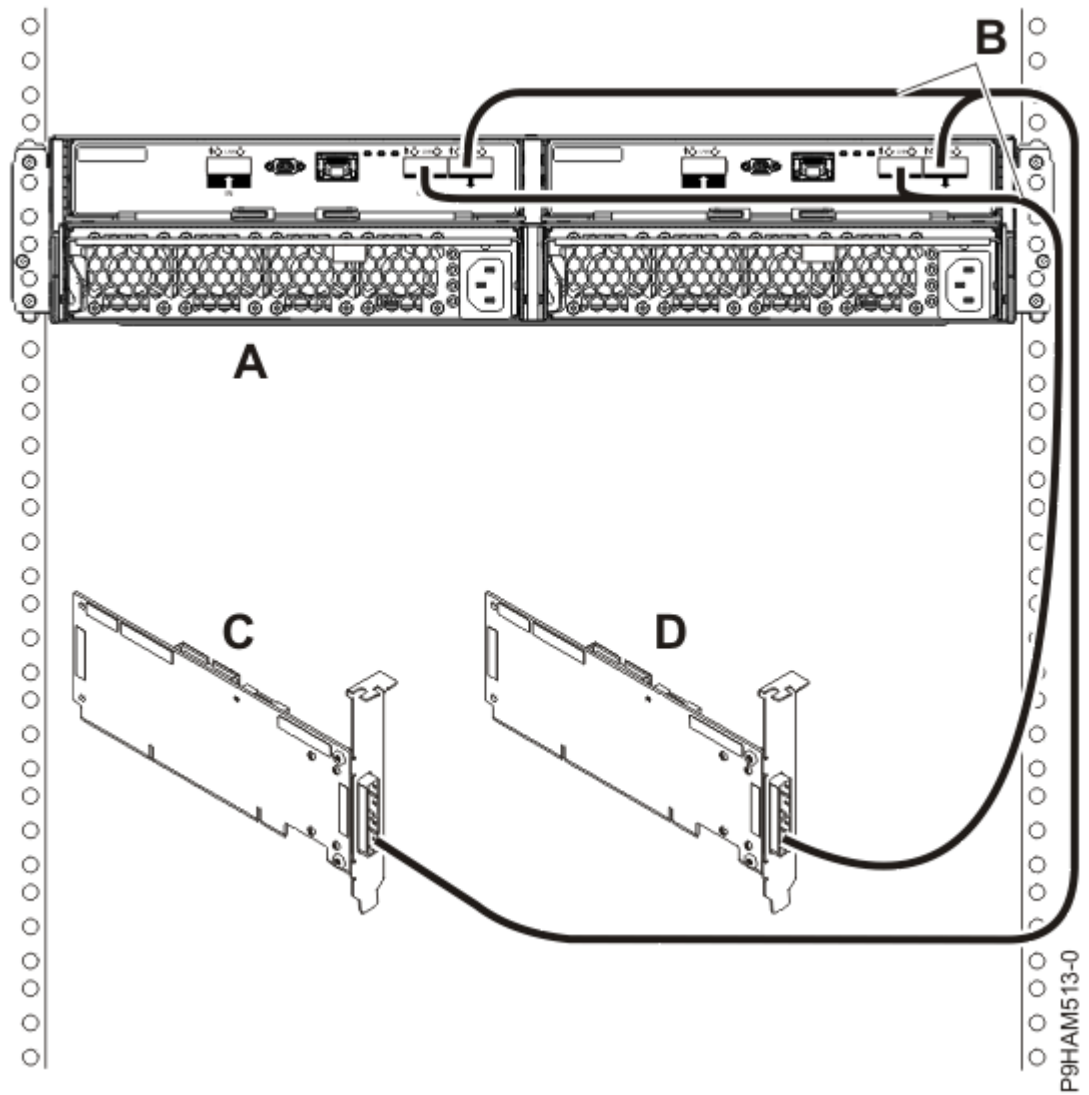
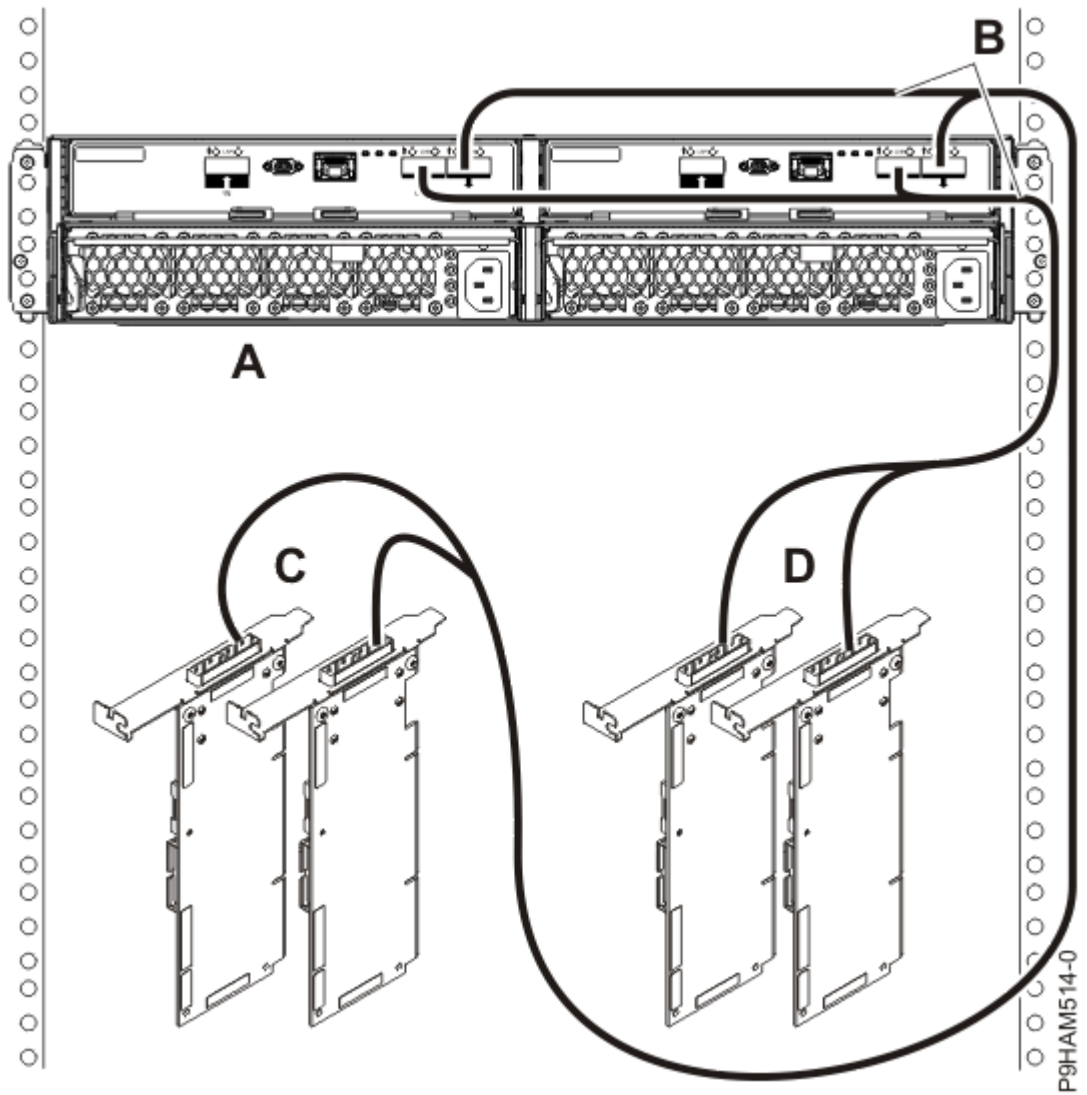

Figure 90. Mode 2 connection of one 5887 enclosure by using YO cables to two independent SAS adapters

6. Two SAS adapter pairs to one 5887 enclosure by using a mode 2 connection.
  - 5887 enclosure with two sets of 12 hard disk drives (HDDs).
  - Connection using dual SAS X cables to connect to the 5887 enclosure.
  - Each pair of SAS adapters controls half of the 5887 enclosure.



P9HAM514-0

Figure 91. Mode 2 connection of a 5887 enclosure by using X cables to two SAS adapter pairs  
 7. Four independent SAS adapters to one 5887 enclosure by using a mode 4 connection.

- 5887 enclosure with four sets of six hard disk drives (HDDs).
- Connection using dual SAS X cables to connect to the 5887 enclosure.

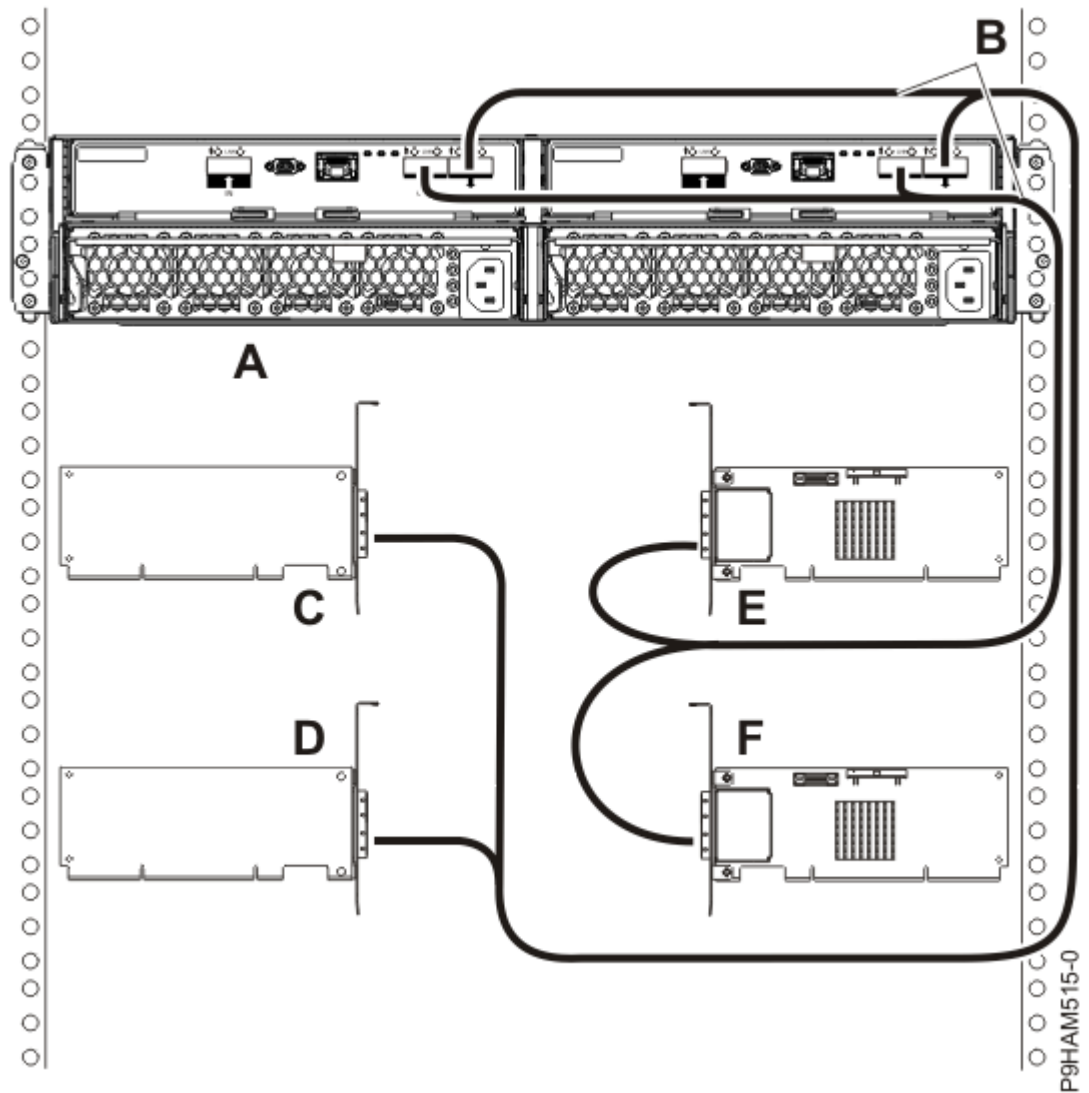

Figure 92. Mode 4 connection of one 5887 enclosure by using X cables to four independent SAS adapters

## SAS cabling for the ESLL and ESLS storage enclosures

Learn about the different serial-attached SCSI (SAS) cabling configurations that are available for the ESLL and ESLS storage enclosures.

For more information about connecting ESLL and ESLS storage enclosures to the system, see [Connecting an ESLL or ESLS storage enclosure to your system](http://www.ibm.com/support/knowledgecenter/POWER9/p9eiu/p9eiu_connect_to_server.htm) ([http://www.ibm.com/support/knowledgecenter/POWER9/p9eiu/p9eiu\\_connect\\_to\\_server.htm](http://www.ibm.com/support/knowledgecenter/POWER9/p9eiu/p9eiu_connect_to_server.htm)).

## SAS adapter to the ESLL and ESLS storage enclosures

The following list describes some of the supported configurations for connecting SAS adapters to the ESLL and ESLS storage enclosures:

1. Single SAS adapter to one ESLL or ESLS storage enclosure by using a mode 1 connection.
  - Connection by using SAS YO12 cables to connect to the ESLL or ESLS storage enclosure.

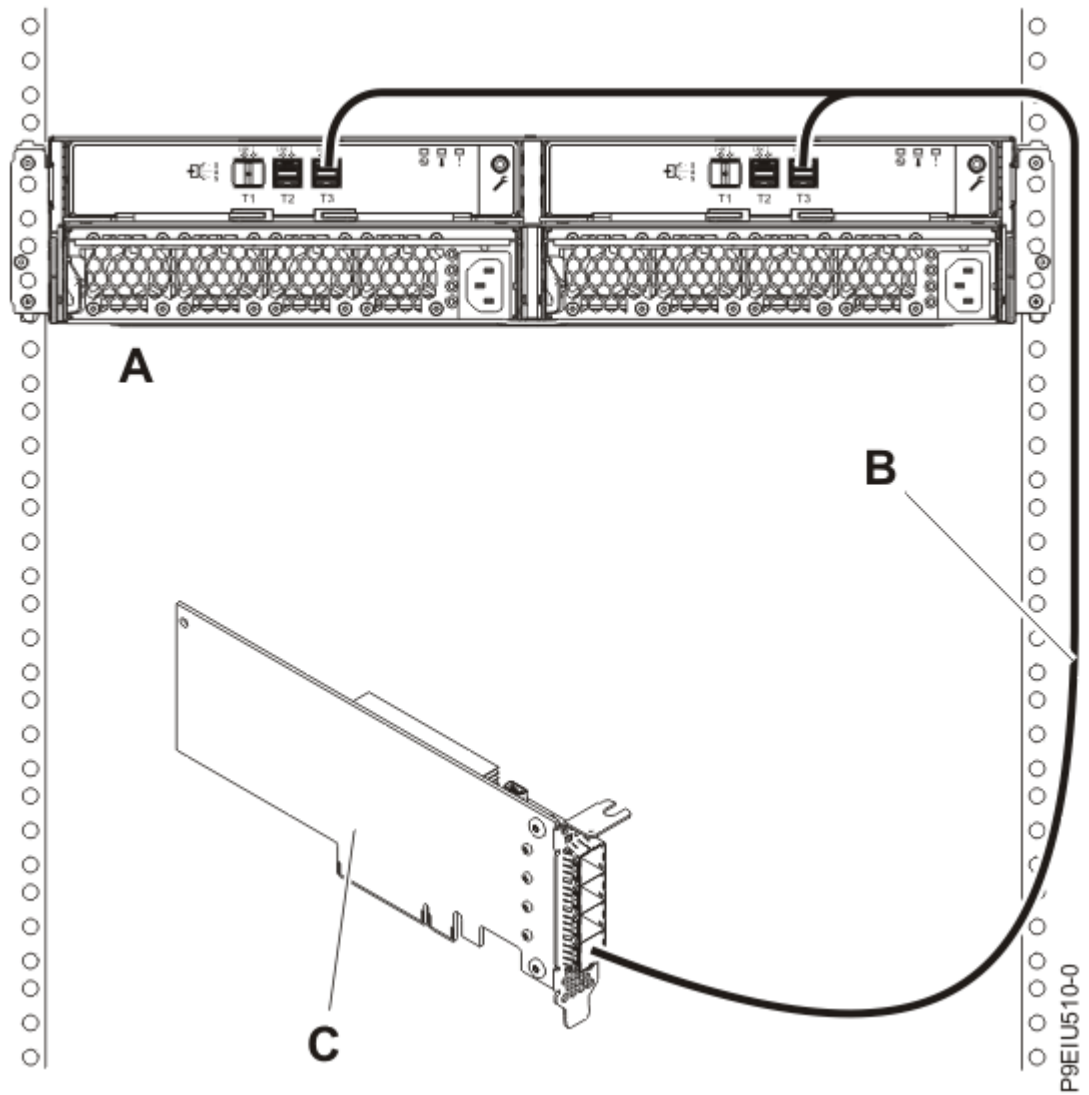

Figure 93. Mode 1 connection of one ESLL or ESLS storage enclosure by using a YO12 cable to a single SAS adapter

2. Single SAS adapter to two ESLL or ESLS storage enclosures by using a mode 1 connection.
  - Connection by using SAS YO12 cables to connect to the ESLL or ESLS storage enclosure.



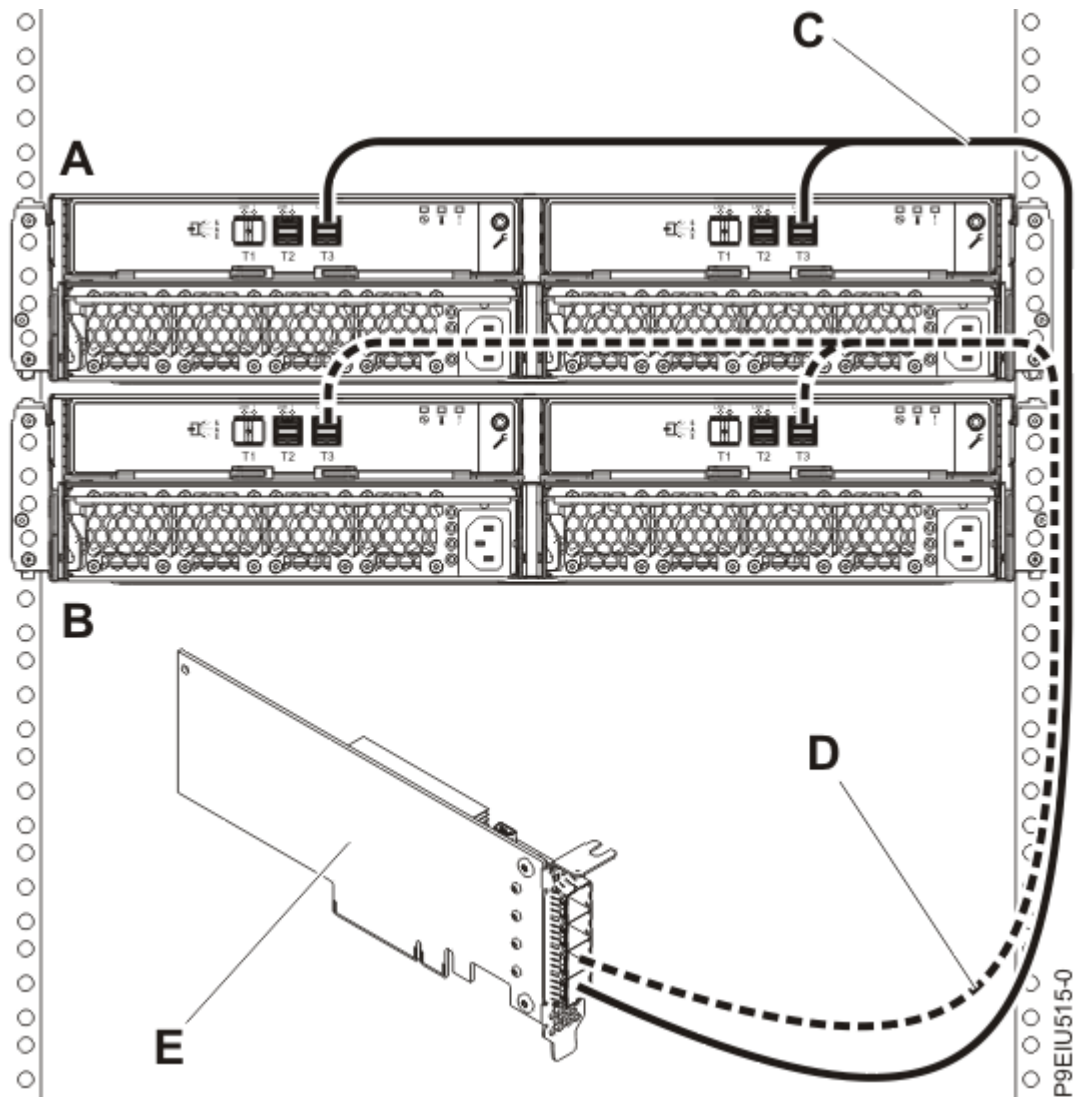

Figure 94. Mode 1 connection of two ESLL or ESLS storage enclosures by using YO12 cables to a single SAS adapter

3. One pair of SAS adapters to one ESLL or ESLS storage enclosure by using a mode 1 connection.
  - For SAS adapter pairs, you must attach the SAS cables to the same port on both adapters.
  - Connection by using SAS YO12 cables to connect to the ESLL or ESLS storage enclosure.

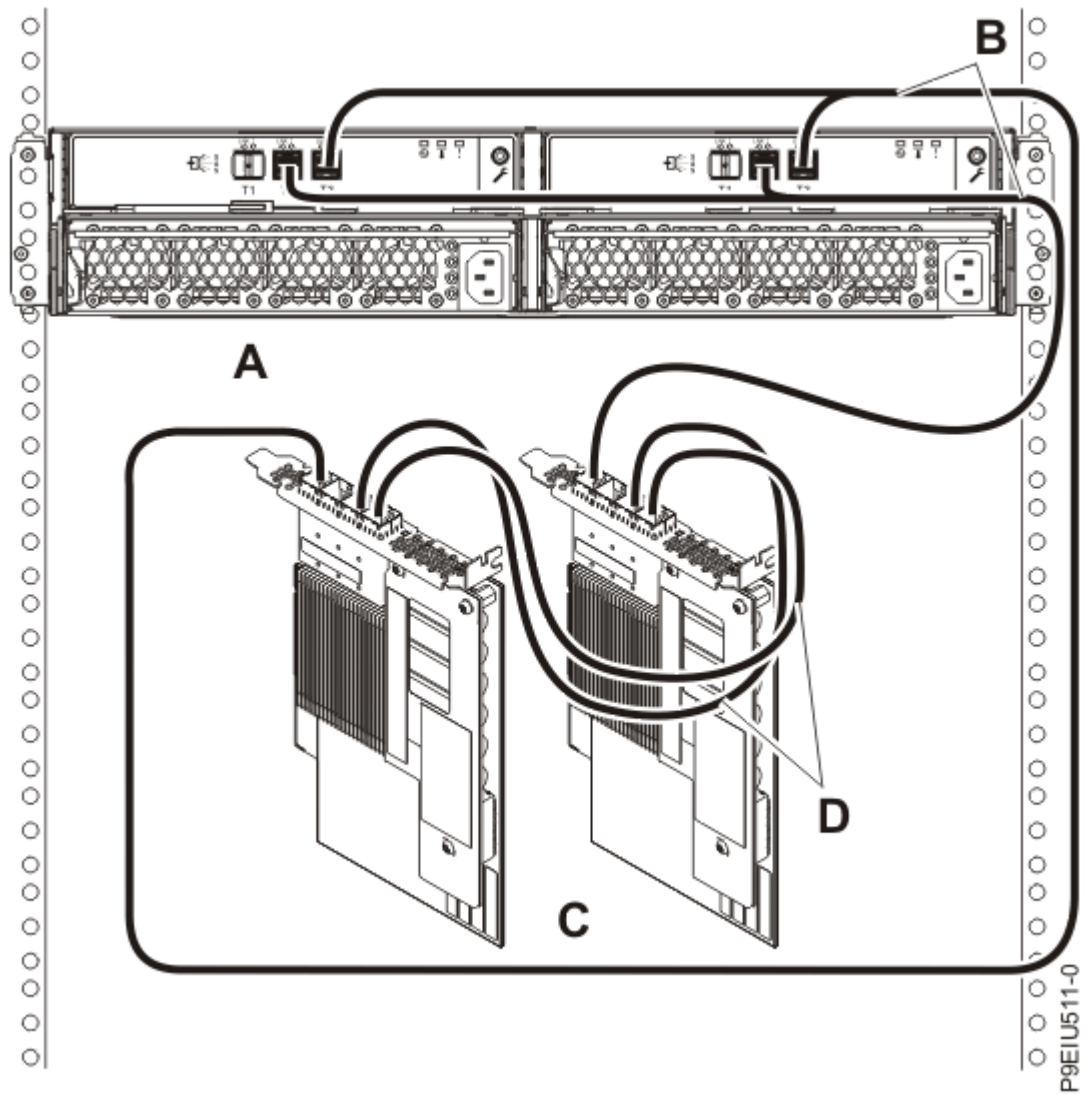
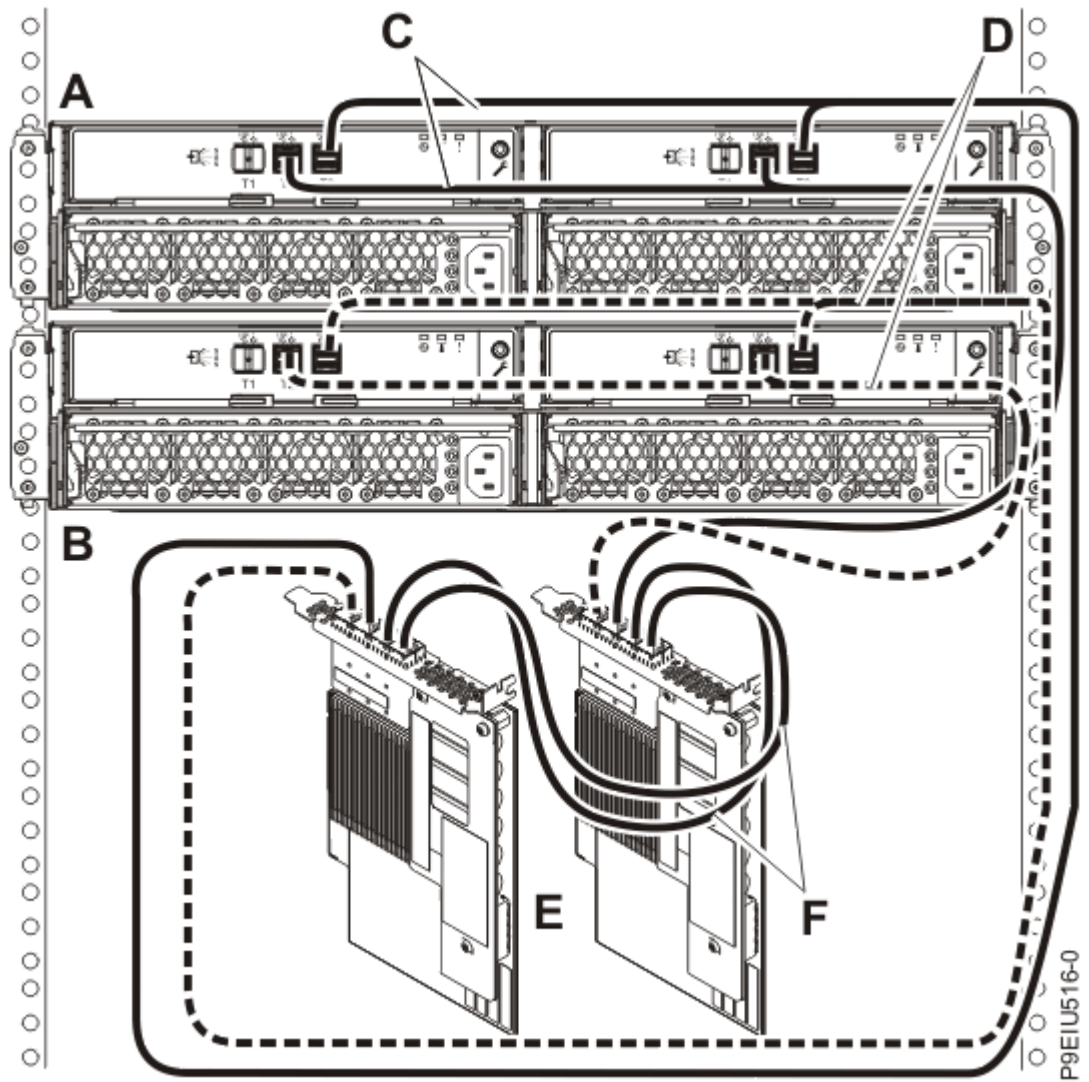

Figure 95. Mode 1 connection of one ESLL or ESLS storage enclosure by using YO12 cables to one pair of SAS adapters

4. One pair of SAS adapters to two ESLL or ESLS storage enclosures by using a mode 1 connection.
  - For SAS adapter pairs, you must attach the cables to the same port on both adapters.
  - Connection by using dual SAS YO12 cables to connect to the 5887 enclosure.



5. Two independent SAS adapters to one ESLL or ESLS storage enclosure by using a mode 2 connection.
- Connection by using two SAS YO12 cables to connect to the ESLL or ESLS storage enclosure.

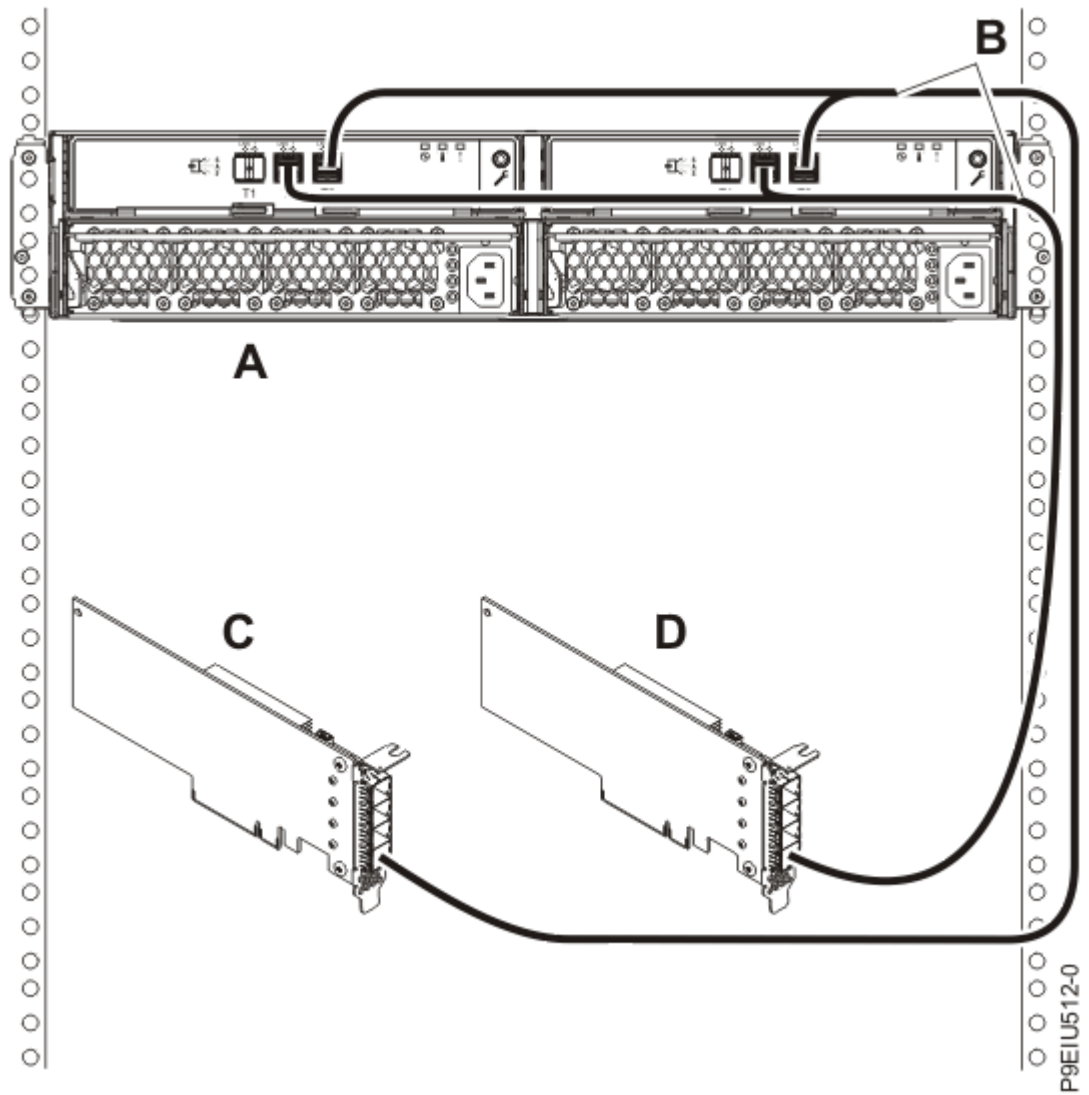

Figure 97. Mode 2 connection of ESLL or ESLS storage enclosure by using YO12 cables to two independent SAS adapters

6. Two pairs of SAS adapters to one ESLL or ESLS storage enclosure by using a mode 2 connection.
  - For SAS adapter pairs, you must attach the cables to the same port on both adapters.
  - Connection by using SAS X12 cables to connect to the ESLL or ESLS storage enclosure.

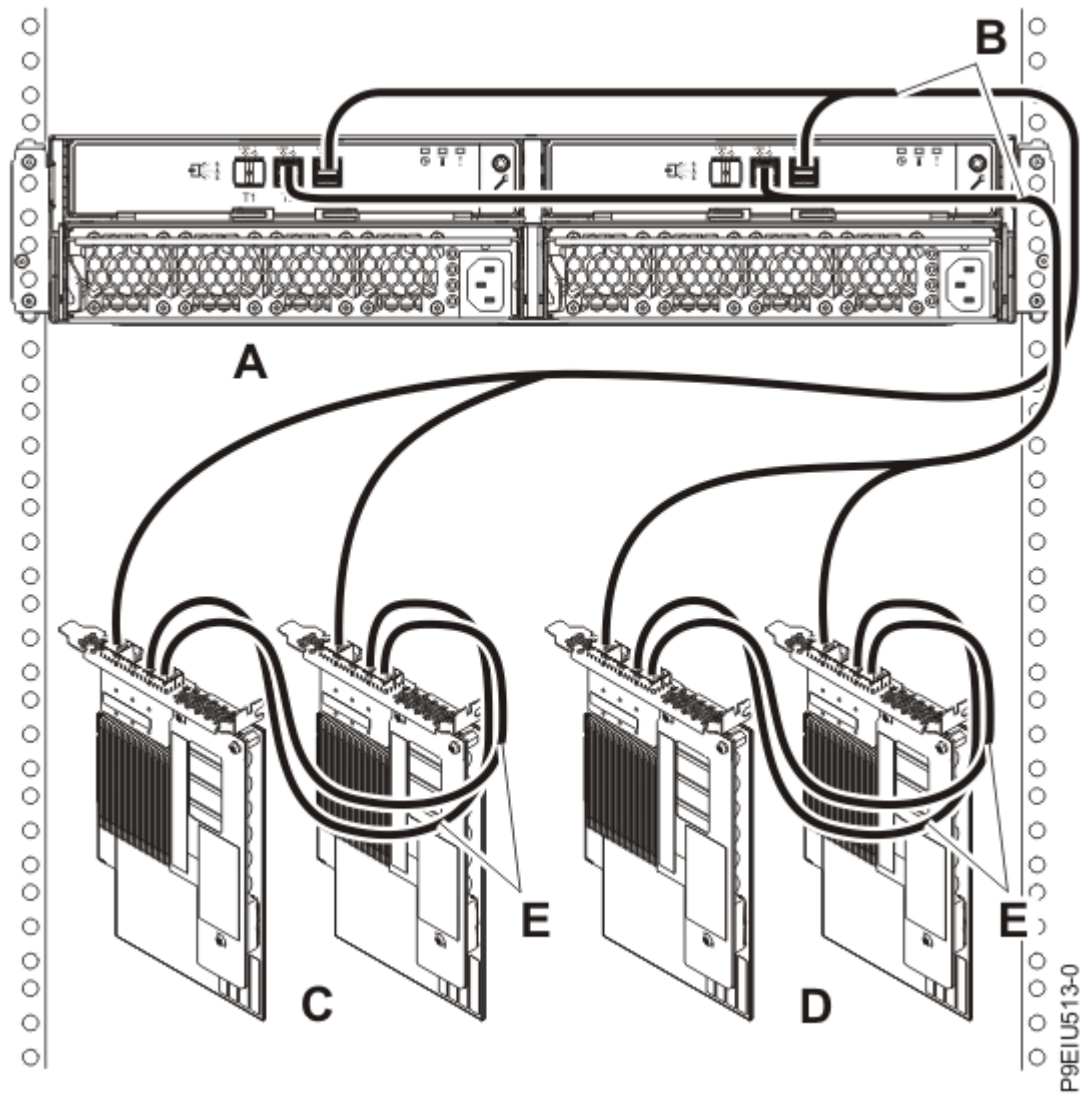

Figure 98. Mode 2 connection of one ESLL or ESLS storage enclosure by using X12 cables to two pairs of SAS adapters

7. Four independent SAS adapters to one ESLL or ESLS storage enclosure by using a mode 4 connection.
  - For SAS adapter pairs, you must attach the cables to the same port on both adapters.
  - Connection by using SAS X12 cables to connect to the ESLL or ESLS storage enclosure.

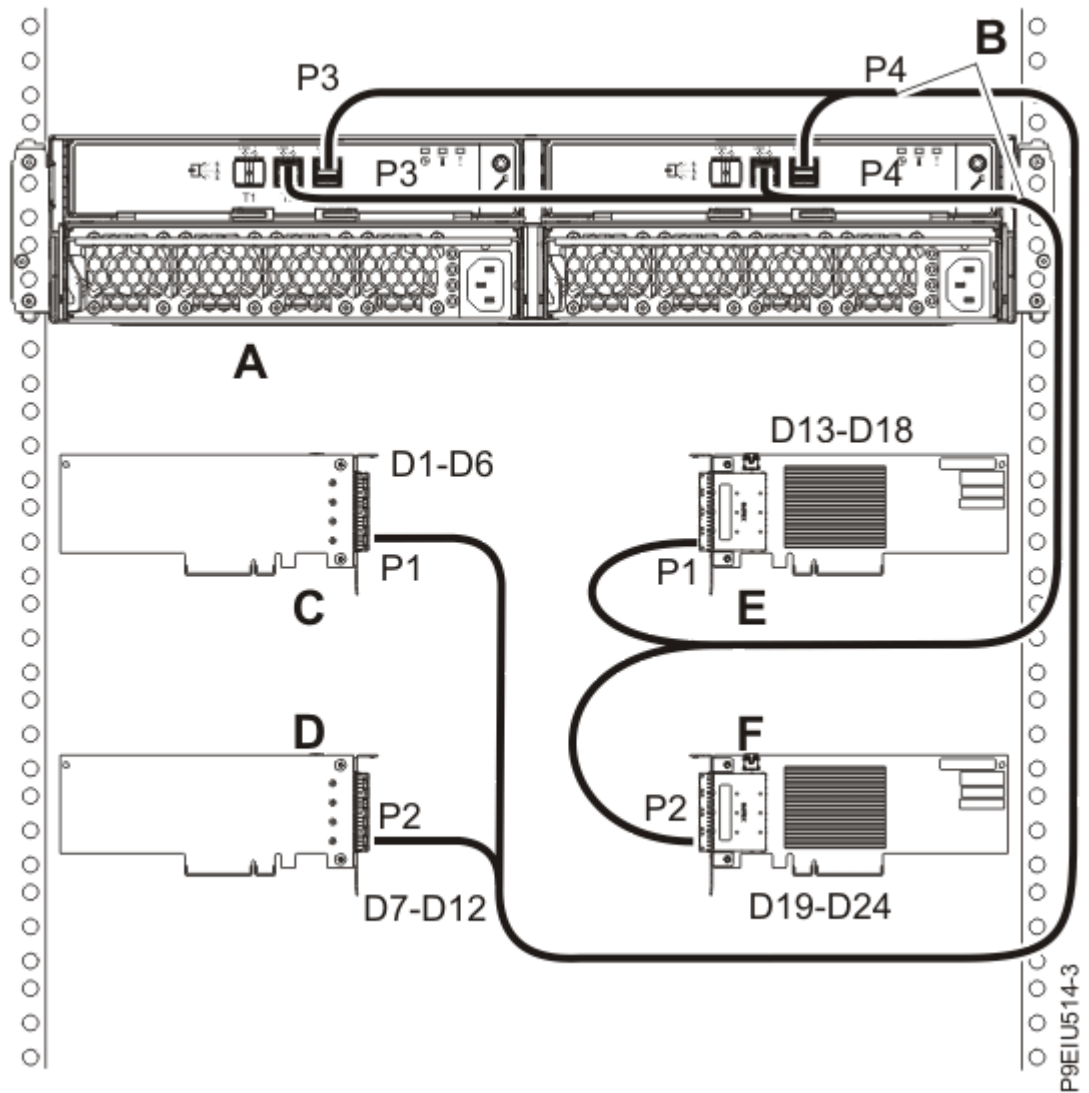

Figure 99. Mode 4 connection of one ESLL or ESLS storage enclosure by using X12 cables to four independent SAS adapters

## Planning for water cooling

Learn about the water cooling requirements for IBM Systems.

### Water cooling system specification and requirements

Learn about the specific water treatment procedures and requirements that are needed for situations where the facilities water system (FWS) water or the technology cooling system (TCS) water can be used to directly cool the datacom equipment.

#### Overview

The datacom equipment cooling system (DECS) is a water loop in which the water comes in contact with the components to be cooled. There are cases where the DECS water is supplied by an in-rack coolant distribution unit (CDU) or can be supplied by an external CDU that service multiple racks. For details of potential liquid cooling systems and loops within a data center and the terminology that is used, see [Figure 100 on page 157](#).



The water quality standards that are specified pertain only to the DECS water loop that comes into contact with compute components. The ongoing monitoring and maintenance procedures are also described.

The cooling loop hardware consists mainly of corrosion resistant alloys, such as copper alloys and stainless steels. Ethylene propylene diene monomer (EPDM) rubber must form the inner lining of all the hoses in the system. The chemistry of the cooling water must be properly maintained to avoid system disruption or shutdown due to any of the four common water-related problems of corrosion, microbiological growth, scale formation, and fouling.

The details of the water treatment depend on whether the local municipality allows the disposal of water that contains some cleaning chemicals down a sanitary drain. If the local municipality does not allow the disposal of contaminated water down a sanitary drain, a deionizing bypass can be included in the water cooling loop to allow the cleaning of the water to purity levels corresponding to resistivity  $> 0.1 \text{ M}\Omega\cdot\text{cm}$  (conductivity  $< 10 \text{ }\mu\text{S}/\text{cm}$ ) before pouring the water down the drain. You are responsible for verifying the local regulations before you dispose any water.

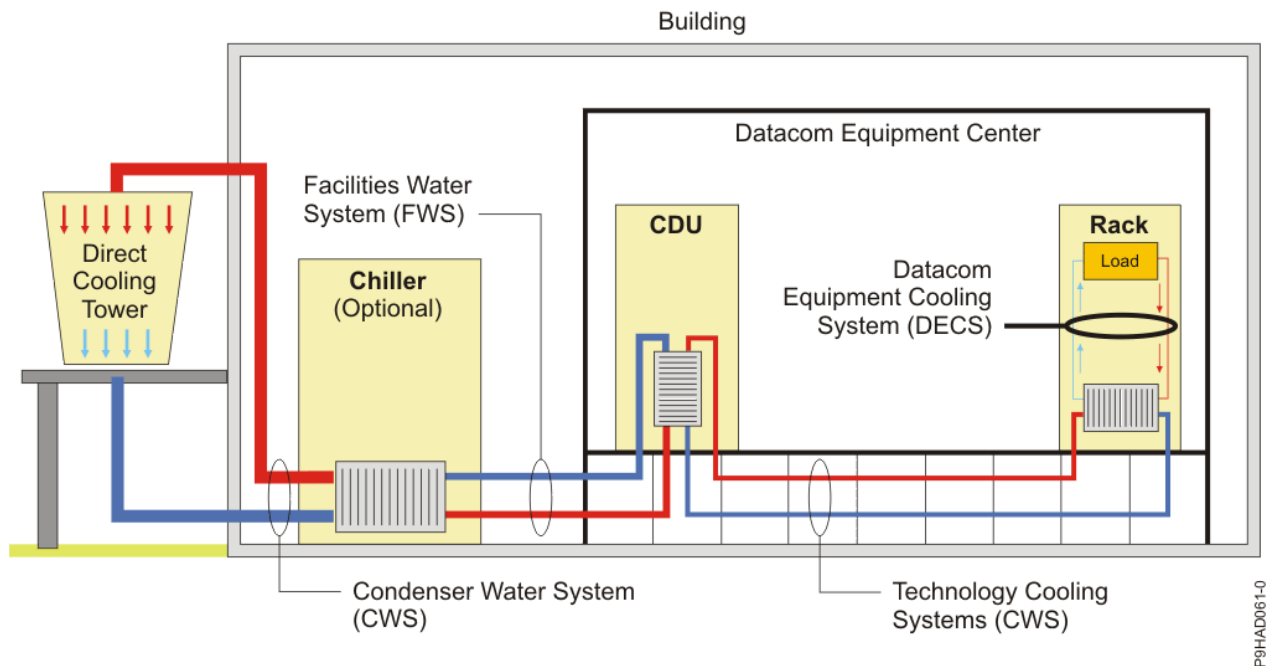

Figure 100. Example of liquid cooling systems and loops within a data center

## Water-related problems

Proper treatment of the water is necessary to avoid the following common water-related problems: corrosion, microbiological growth, scale formation, and fouling. Any of these problems can significantly reduce the cooling efficiencies and increase the risk of system downtime.

- Corrosion - corrosion can take on many forms. The common forms of corrosion that are relevant to the cooling loop include the following forms:
  - Uniform corrosion, also referred to as general corrosion, is the spatially uniform removal of metal from the surface. It is the typical expected mode of corrosion.
  - Pitting corrosion is a localized attack of a metal surface that in the case of copper tubes can lead to water leaks with a typical mean time to failure of around 2 years.
  - Galvanic corrosion arises when two metals that are wide apart in the galvanic series are in electrical contact and immersed in the same water environment. The potential difference that arises between the two metals in contact, forces electrons to flow from the less noble to the more noble metal. On the less noble metal surface, corrosion occurs, giving off electrons that are consumed on the more noble metal surface by a reduction reaction that can take many chemical forms. Examples are the reduction of metal ions or the consumption of oxygen and water to form hydroxyl ions. Even when not

in electrical contact, aluminum can be galvanically attacked by copper because of dissolved copper ions in low concentrations that deposit on the aluminum surface forming the galvanic corrosion couple.

- Microbiological growth - microbiological growth in water cooling systems can lead to deposition, fouling, and corrosion within the cooling loop. Prevention of microbiological growth involves making sure that the cooling loop hardware is assembled from components that are free of biological organisms and treatment with biocides to control the bacteria population. To avoid biological growth, the water cooling loops must be shipped and stored dry. Every effort must be made to blow out the water and dry the water cooling loop as much as possible before shipping and storage.
- Scale formation - scaling is the deposition of dense, adherent material on the cooling loop surfaces. Scaling occurs when the solubilities of salts in water are exceeded because of high concentrations or because of increased temperature.
- Fouling - fouling of cooling loops is the deposition of non-scale-forming substances such as corrosion products and organics. Fungi, such as *Fusarium* sp, are known to grow, foul, and plug filters and fine finned heat sinks. They generally grow at the water line in cooling tower basins or sumps.

## Avoiding water-related problems

The following best practices can be used to avoid water-related problems:

- Design clean - Restrict the water-wetted metallurgies to copper alloys and stainless steels. Avoid the use of plain-carbon steel hardware that can rust and foul the water cooling loop.
- Build clean - Ensure that the cooling loop components are clean and free of bacteria and fungi. The cooling loop assembly must be free of soldering, brazing fluxes, or both. Clean water must be used in the assembly operations. Any residual water must be blown out of the assembly. The finished assembly must be clean and dry.
- Ship clean - Any residual water from the assembly, testing operations, or both must be blown out from the cooling loop before any shipping to avoid corrosion and microbiological growth. As a final step, use nitrogen gas to dry the system. Plug ends and ship the system with the cooling loop pressurized with nitrogen gas.
- Install clean - The cooling loop must be kept clean during the installation step. Brazing is preferred over soldering. Problem with soldering is porous joints that keep leaching out flux residue. All flux residues must be cleaned off. Fill the system with clean water and, if possible, include a secondary step to deionize the water in the cooling loop before the addition of biocide and corrosion inhibitors.
- Maintain clean - Monitor and maintain the pH, water conductivity, bacteria count, and the corrosion inhibitor concentration.

## Water quality requirements

Use the following requirements to plan for the water quality in your system:

- The water that is required to initially fill the system side cooling loop must be reasonably clean, bacteria-free water (less than 100 CFU/ml), such as demineralized water, reverse osmosis water, deionized water, or distilled water.
- The water must be filtered with an in-line 50 µm filter.
- If reasonably clean water is not available, the following guidelines are recommended. It is especially useful for large cooling loops: In this method, the water is deionized before any of the racks are connected to the water loop.
  - It is important to ensure that the system water is cleaned before any chemicals are added to the water. This can be accomplished by deionizing the water by using deionizing cartridges that are installed in the cooling loop. An example is shown in [Figure 101 on page 159](#). Even if deionized water is used to fill the system, a deionizing step is prudent for two reasons: the first is to ensure that the starting water is deionized and the second is to remove any ions that might leach off the walls of the cooling loop.



- When the water needs to be deionized, the valves V2 and V3 can be opened and valve V1 partially closed to bypass some of the water through the deionizing canister.
- During this deionizing step, the cooling loop and the computers can keep operating normally.
- When the deionization is complete, the V2 and V3 valves must be closed and V1 fully opened.
- The deionization step raises the resistivity of the water greater than 1 MΩ.cm.
- Under normal operation, the V2 and V3 valves are closed and V1 valve is fully open.

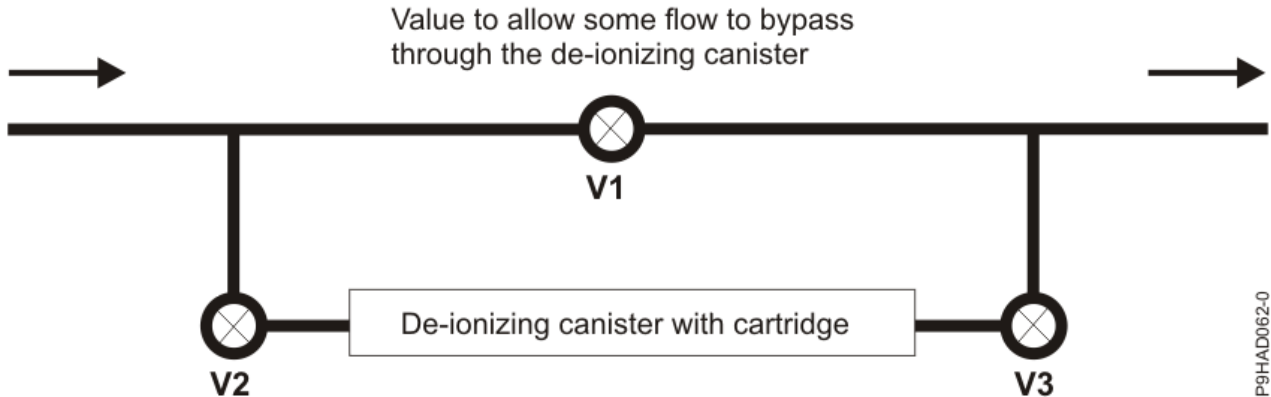

Figure 101. Deionizing the water using deionizing cartridges installed in the cooling loop

### Water quality chemical requirements

The following measurements must be performed before you add any chemicals to the water loop. It is the starting point that defines a clean water base.

- All metals less than or equal to 0.10 ppm
- Calcium less than or equal to 1.0 ppm
- Magnesium less than or equal to 1.0 ppm
- Manganese less than or equal to 0.10 ppm
- Phosphorus less than or equal to 0.50 ppm
- Silica less than or equal to 1.0 ppm
- Sodium less than or equal to 0.10 ppm
- Bromide less than or equal to 0.10 ppm
- Nitrite less than or equal to 0.50 ppm
- Chloride less than or equal to 0.50 ppm
- Nitrate less than or equal to 0.50 ppm
- Sulfate less than or equal to 0.50 ppm
- Conductivity less than or equal to 10.0 μS/cm. Conductivity must be measured at 20°C - 25°C (68°F - 77°F). Conductivity increases approximately 5% for every degree Celsius rise in temperature
- pH 6.5 – 8.0
- Turbidity (NTU) less than or equal to 1

### Plumbing materials requirements

All piping must be composed of specified materials to prevent scaling and to allow proper reactions with the chemistry of the water within the system. Threaded joints must not be sealed with polytetrafluoroethylene tape, as particles from the tape may enter the water stream and create clogs. Instead, a thread sealant, must be used to seal threaded fittings. Piping must be large enough, as dictated by industry best practices, to avoid excessive water velocity as well as undue pressure drop.

Material selection and installation is a complex issue that is governed by building codes and other local requirements. You are encouraged to consult with appropriate authorities that have jurisdiction (such as building inspectors, fire departments, insurance providers, and code compliance officers) before you plan and install cooling distribution systems. The following information is provided for chemical compatibility purposes.

The following alloys must be avoided in the plumbing system:

- Aluminum and aluminum alloys.
- Brass with greater than 15% zinc.
- Free-cutting brasses, especially brasses that contain lead. One example of such brass is copper alloy C36000 called free-cutting yellow brass.
- High lead brasses are especially a concern because of stress corrosion cracking when subjected to high tensile stress.
- Steels that are not stainless steel.
- Stainless steels that are not properly solution treated.

The following materials are preferred:

- Copper alloys:
  - Lead-free copper alloys with less than 15% zinc.
- Stainless steels:
  - Low carbon stainless steels are preferred.
  - Must be solution treated. Stainless steel that is solution-treated undergoes a specific heat treatment to improve its resistance to corrosion.
  - Passivation is desirable as long there is low possibility of acid entrapment in crevices.
  - Avoid sensitization during welding.
  - Avoid brazing; welding is preferred.
- Polyvinyl chloride (PVC) (not allowed inside IBM products due to flammability concerns, but can be used at a facility level. Appropriate authorities that have jurisdiction must be consulted).
- EPDM rubber is the preferred material for hoses:
  - Flammability rating must be CSA or UL VW-1 or better.
  - Peroxide cured hoses are preferred because they do not absorb triazoles.

Metal joining operations:

- Solder joints that come in contact with water must be avoided. Solder joints are porous and they leach flux residue into the cooling loop. Solder joints might pass inspection and pressure tests as manufactured, but still might be unreliable.
- Brazed joints are preferred for joining copper plumbing pieces.
- Braze joints must not be used to join stainless steels. Tungsten inert gas (TIG) and metal inert gas (MIG) welding are preferred for joining stainless steels. Sensitization must be avoided. Welded assembly must be cleaned and, if possible, passivated if there is a low possibility of acid entrapment in crevices.

## Deionizing equipment

Deionizing equipment is optional. It is recommended for use in large cooling loops. When the water needs to be deionized, some of the water can be bypassed to flow through the deionizing cartridge.

## Dosing Equipment

The following equipment is used to dose the cooling loop:

- Recommend using a stainless steel or fiberglass chemical shot feeder.

- System volumes less than 378.5 liters (100 gallons) use a 0.38 liter (0.1 gallon) size feeder
- System volumes less than 3875 liters (1000 gallons) use a 3.8 liter (1 gallon) size feeder
- System volumes greater than 3875 liters (1000 gallons) use a 9.5 liter (2.5 gallon) size feeder.
- Chemical pump according to Nalco or another water treatment contractor specification.

## Monitoring equipment

The following equipment is used to monitor the cooling loop:

- 3D TRASAR® Controller (#060-TR5500.88) for systems larger than 250 gallons to enable precise and continuous monitoring of system water chemistries: conductivity, pH, corrosion rate, and turbidity.
- Azole test kit
  - Nalco P/N 460-P3119.88 – Triazole Reagent Set, 25 mL
  - Nalco P/N 500-P2553.88 – UV Lamp with power supply, 115 VAC
  - Nalco P/N 400-P0890.88 – Nalco DR/890 Colorimeter
  - Nalco P/N 500-P1204.88 – 25 mL graduated cylinder
- Nalco bacteria test kit
  - Nalco P/N 500-P3054.88 – Bacteria dip slides
- Water resistivity monitor with 0-10 MΩ.cm range
  - Nalco P/N 400-C006P.88

## Required materials and equipment

The following items must be available to properly and safely complete the initial system start:

- De-ionizing cartridges of appropriate capacity (optional).
- Nalco treatment chemicals in appropriate quantities.
  - System with 75.7 liters (20 gallons) or less coolant: Use a suggest prepackaged cleaner and inhibitor solution: Nalco 460-CCL2567 or Nalco CCL2567 and Nalco 460-CCL100 or Nalco CCL100. If exposure to bacterial is suspected or a concern, biocides such as Nalco H-550 or Nalco 73500 can be used. If fungi are suspected or a concern, Nalco 77352 can be used.
  - System with greater than 75.7 liters (20 gallons) of coolant: Use a suggest using concentrated chemicals. The cleaner in concentrated form is Nalco 2567. The inhibitor in concentrated form is Nalco 3DT-199. If exposure to bacterial is suspected or a concern, biocides such as Nalco H-550 or Nalco 73500 can be used. If fungi are suspected or a concern, Nalco 77352 can be used.
- A method to add chemicals: Use an installed system chemical shot feeder, an appropriately sized chemical feed pump, or both.
- Source of demineralized water, reverse osmosis water, deionized water, or distilled water.
- Proper personal protective equipment.
- Approved drainage to drain pre-cleaning waters (for example, sanitary sewer). You are responsible for the drainage process according to local regulations.
- Appropriate test kits to monitor Nalco 3DT-199 residual and bacteria count after Nalco H-550, Nalco 73500 or Nalco 77352 addition.
- Water resistivity monitor with 0-10 MΩ.cm range.

## Initial treatment for systems smaller than 75.7 liters (20 gallons)

Use the following procedure to clean your system:

**Note:** This procedure must be performed on the cooling loop before any computer racks are connected to the system.

1. System must be empty. If it is not empty, you must drain the system completely.
2. Remove all the filters from the filter housings.
3. Ensure that bypass hoses are connected between the supply and return portions of the cooling loop to ensure the cleaning of all sections of the system.
4. One of the following two cleansing procedures can be used:
  - a. Chemical cleaning - This method is the most effective way for cleaning the plumbing loop.
    - i) Fill the system with cleaning solution. The suggested cleaning solutions are Nalco 460-CCL2567 or Nalco CCL2567.
    - ii) Circulate the cleaning solution for a minimum of 30 minutes (longer if time permits) to ensure that it reaches all sections of the system.
    - iii) Drain the system completely, disposing of the cleaning solution according to local regulations
    - iv) Refill with demineralized water, reverse osmosis water, deionized water, or distilled water.
    - v) Circulate the water for 15 minutes.
    - vi) Drain the system completely, disposing of the cleaner according to local regulations.
    - vii) Immediately proceed to fill the system with water that contains premixed inhibitor and preservative.
  - b. Cleaning with deionized water. This procedure can be used if the cleaning chemical cannot be obtained or if local laws prevent the disposal of the chemicals.
    - i) Completely fill the system with demineralized water, reverse osmosis water, deionized water, or distilled water.
    - ii) Deionize the water by bypassing some of the water flow through the deionizing cartridge or cartridges and circulate the water normally through the complete system until the resistivity of the water increases above 1 MΩ cm.
    - iii) Proceed to the chemical dosing procedure.

### **Chemical dosing procedure for systems smaller than 75.7 liters (20 gallons)**

Use the following procedure for chemical dosing:

1. Install a new or cleaned 50 µm filter in the filter housings.
  2. One of the following two dosing procedures can be used:
    - a. If the system was cleaned by using cleaning solution Nalco 460-CCL2567 or Nalco CCL2567 and if at the end of the cleaning step, the system was empty with no water in it, complete the following steps:
      - i) Fill the coolant reservoir with Nalco 460PCCL100 / Nalco CCL100. Add 120 ppm of Nalco 3DT-199 to raise the azole concentration to 40 ppm.
      - ii) If bacteria or fungi is suspected or is a serious concern, add one of the following biocides:
        - 100 parts per million (ppm) of Nalco H-550 (glutaraldehyde)
        - 200 ppm of Nalco 73500 (glutaraldehyde)
        - 100 ppm of Nalco 77352 (isothiazolone)

The choice of biocide depends on the expected microbiological material in the cooling loop. Glutaraldehyde biocide is more effective against anaerobic bacteria. Isothiazolone is more effective against aerobic bacteria, fungi, and algae. When in doubt, use the isothiazolone biocide.
      - iii) Confirm azole residual using Nalco azole test kit.
- If the system was cleaned by using deionized water only and the system is full of deionized water, complete the following steps:
- i) Add one of the following biocides:

- 100 parts per million (ppm) of Nalco H-550 (glutaraldehyde)
- 200 ppm of Nalco 73500 (glutaraldehyde)
- 100 ppm of Nalco 77352 (isothiazolone)

The choice of biocide depends on the expected microbiological material in the cooling loop. Glutaraldehyde biocide is more effective against anaerobic bacteria. Isothiazolone is more effective against aerobic bacteria, fungi, and algae. When in doubt, use the isothiazolone biocide.

- ii) Add 120 ppm of Nalco 3DT-199 to achieve 40 ppm azole concentration.
- iii) Confirm azole residual using Nalco azole test kit.

### **Initial treatment for systems larger than 75.7 liters (20 gallons)**

Use the following procedure to clean your system:

**Note:** This procedure must be performed on the cooling loop before any computer racks are connected to the system.

1. System must be empty. If it is not empty, you must drain the system completely.
2. Remove all the filters from the filter housings.
3. Ensure that bypass hoses are connected between the supply and return manifolds of the cooling loop to ensure the cleaning of all surfaces of the cooling loop.
4. One of the following two cleansing procedures can be used:
  - a. Chemical cleaning - This method is the most effective way for cleaning the plumbing loop.
    - i) Fill the system with demineralized water, reverse osmosis water, deionized water, or distilled water.
    - ii) Add the required volume of cleaning solution Nalco 2567 according to the manufacturer recommendation.
    - iii) Circulate the cleaning solution for a minimum of 4 hours.
    - iv) Drain the system completely utilizing all drain ports available, disposing of the cleaning solution according to local regulations
    - v) Refill with demineralized water, reverse osmosis water, deionized water, or distilled water.
    - vi) Circulate the water for 1 hour.
    - vii) Drain the system completely utilizing all drain ports available, disposing of the cleaning solution according to local regulations
    - viii) Refill with demineralized water, reverse osmosis water, deionized water, or distilled water.
    - ix) Circulate for 15 minutes.
    - x) Immediately proceed to the chemical dosing procedure.
  - b. Cleaning with deionized water. This procedure can be used if the cleaning chemical cannot be obtained or if local laws prevent the disposal of the chemicals.
    - i) Completely fill the system with demineralized water, reverse osmosis water, deionized water, or distilled water.
    - ii) Deionize the water by bypassing some of the water flow through the deionizing cartridge or cartridges and circulate the water normally through the complete system until the resistivity of the water increases above 1MΩ cm.
    - iii) Proceed to the chemical dosing procedure.

### **Chemical dosing procedure for systems larger than 75.7 liters (20 gallons)**

Use the following procedure for chemical dosing:

**Note:** The dosing procedure for systems larger than 75.7 liters (20 gallons) is the same regardless of the cleaning technique.

1. Install a new or cleaned 50 µm filter in the filter housings.
2. One of the following two dosing procedures can be used:
  - a. If the system was cleaned by using cleaning solution Nalco 460-CCL2567 or Nalco CCL2567 and if at the end of the cleaning step, the system was empty with no water in it, complete the following steps:
    - i) Fill the coolant reservoir with Nalco 460PCCL100 / Nalco CCL100. Add 120 ppm of Nalco 3DT-199 to raise the azole concentration to 40 ppm.
    - ii) If bacteria or fungi is suspected or is a serious concern, add one of the following biocides:
      - 100 parts per million (ppm) of Nalco H-550 (glutaraldehyde)
      - 200 ppm of Nalco 73500 (glutaraldehyde)
      - 100 ppm of Nalco 77352 (isothiazolone)

The choice of biocide depends on the expected microbiological material in the cooling loop. Glutaraldehyde biocide is more effective against anaerobic bacteria. Isothiazolone is more effective against aerobic bacteria, fungi, and algae. When in doubt, use the isothiazolone biocide.

  - iii) Confirm azole residual using Nalco azole test kit.

If the system was cleaned by using deionized water only and the system is full of deionized water, complete the following steps:

- i) Add one of the following biocides:
  - 100 parts per million (ppm) of Nalco H-550 (glutaraldehyde)
  - 200 ppm of Nalco 73500 (glutaraldehyde)
  - 100 ppm of Nalco 77352 (isothiazolone)

The choice of biocide depends on the expected microbiological material in the cooling loop. Glutaraldehyde biocide is more effective against anaerobic bacteria. Isothiazolone is more effective against aerobic bacteria, fungi, and algae. When in doubt, use the isothiazolone biocide.
- ii) Add 120 ppm of Nalco 3DT-199 to achieve 40 ppm azole concentration.
- iii) Confirm azole residual using Nalco azole test kit.

## System monitoring and maintenance

Use the following guidelines for system monitoring and maintenance:

- It is important to conduct a bacteria test on a quarterly basis and add 100 ppm of Nalco H-550 or 200 ppm of Nalco 73500 biocide if the bacteria count is greater than 1000 CFU/ml. Nalco 77352 fungicide can be added if fungi have been a concern in the past.
  - Fungi might not be detected in the water, even though it can grow and cause blockage of cooling channels in cold plates that are used to cool the computer processors. Reduced coolant flow rate through the cold plates might be an indication of blocked channels due to fungi growth.
- On large systems that have more than 250 gallons of water, Nalco 3D TRASAR® controller must be installed on the system cooling loop to enable precise and continuous monitoring of system water chemistries, conductivity, pH, corrosion rate, and turbidity.
- It is important to conduct an azole test on an annual basis and add Nalco 3DT-199 to bring the azole concentration to the wanted 40 ppm level or any other desirable ppm level.

## Multiple racks

Use the following guidelines when adding additional racks:

- Racks arrive from IBM ready for installation.
- Install rack or racks and open flow from existing system.
- Make sure that the automated water make up on the chiller coolant reservoir is activated. If there is no automated water make up feature, top off the system side reservoir.
- Within 2 hours of installing the new rack or racks, add one of the following biocides:
  - 100 parts per million (ppm) of Nalco H-550 (glutaraldehyde)
  - 200 ppm of Nalco 73500 (glutaraldehyde)
  - 100 ppm of Nalco 77352 (isothiazolone)

The choice of biocide depends on the expected microbiological material in the cooling loop.

Glutaraldehyde biocide is more effective against anaerobic bacteria. Isothiazolone is more effective against aerobic bacteria, fungi, and algae. When in doubt, use the isothiazolone biocide.

- Add 120 ppm of Nalco 3DT-199 to achieve 40 ppm of azole concentration. The amount of inhibitor dosage is calculated based on the volume of the makeup water.
- Confirm azole residual using Nalco azole test kit.

## Refreshing the water

Situations might arise where the water must be refreshed (for example, the system must be cleaned and the biocide and corrosion inhibitor is added again). To refresh the water, use one of the two following procedures:

If you prefer that no water goes down the sanitary sewer, use the following procedure:

1. Remove the inline 50 µm filter from the filter housing.
2. Insert new deionization cartridges into the canisters and bypass some of the water through the deionizing cartridges until the resistivity of the water increases above 1 MΩ.cm. During this period, the systems and cooling system can be left on and be fully functional.
3. Stop the bypassing of the water flow through the deionizing filter and add a new or cleaned 50 µm filter to the inline filter housings.
4. Add one of the following biocides:
  - 100 parts per million (ppm) of Nalco H-550 (glutaraldehyde)
  - 200 ppm of Nalco 73500 (glutaraldehyde)
  - 100 ppm of Nalco 77352 (isothiazolone)

The choice of biocide depends on the expected microbiological material in the cooling loop.

Glutaraldehyde biocide is more effective against anaerobic bacteria. Isothiazolone is more effective against aerobic bacteria, fungi, and algae. When in doubt, use the isothiazolone biocide.

5. Circulate for 30 minutes.
6. Add 120 ppm of Nalco 3DT-199 to achieve 40 ppm of azole concentration.
7. Circulate for 30 minutes.
8. Confirm azole residual using Nalco azole test kit.

If the water can be poured down the sanitary sewer, use the following procedure:

1. Pour the water down the drain with the permission of the local municipality.
2. Fill the system by using one of the following procedures:
  - Systems less than 75.7 liters (20 gallons): [“Initial treatment for systems smaller than 75.7 liters \(20 gallons\)” on page 161.](#)

- Systems larger than 75.7 liters (20 gallons): “Initial treatment for systems larger than 75.7 liters (20 gallons)” on page 163.

## Moving or storing the system

If you need to move your system or put it into storage, the water in the system must be drained. You can drain the water in one of two ways:

- The water can be deionized to a purity corresponding to resistivity greater than 0.1 MΩ.cm and then can be poured down any municipal drain.
- The water can be poured down a sanitary drain with the permission of the local municipality.

## Disposal of water and cartridges

The deionizing cartridges must be disposed off in accordance with local municipality ordinances.

IBM is not responsible for the disposal of water. You are responsible for determining the local regulations that govern the disposal of water.

## Troubleshooting

If you encounter any problems with your water-cooled system, use the following table to troubleshoot your problem.

Problem	Solution
Poor cooling performance	Contact IBM Service
Reduced water flow	Contact IBM Service.
Chemical pump issues (where installed and used)	Follow procedures that are provided by installer, contact your site water treatment contractor or local Nalco office, or both.
3D TRASAR® alarms or operational issues	Contact the local Nalco office.
Discolored water	Might be an indication of corrosion and or microbiological issues. Refresh the water supply.
Slime in flow meter areas	Might be an indication of corrosion and or microbiological issues. Refresh the water supply.
Elevated microbial counts	<ul style="list-style-type: none"> <li>• For systems of smaller than 75.7 liters (20 gallons), refresh the water supply.</li> <li>• For systems of larger than 75.7 liters (20 gallons), add 100 parts per million (ppm) of Nalco H-550 or Nalco 73500 biocide. Retest the bacteria content between 24 – 48 hours after biocide dosing. If the bacteria level is not less than 100 CFU/ml contact Nalco or your water treatment company.</li> </ul>
Fungi	Contact Nalco or your water treatment company.
Any other problems	Contact IBM Service.



---

## Notices

This information was developed for products and services offered in the US.

IBM may not offer the products, services, or features discussed in this document in other countries. Consult your local IBM representative for information on the products and services currently available in your area. Any reference to an IBM product, program, or service is not intended to state or imply that only that IBM product, program, or service may be used. Any functionally equivalent product, program, or service that does not infringe any IBM intellectual property right may be used instead. However, it is the user's responsibility to evaluate and verify the operation of any non-IBM product, program, or service.

IBM may have patents or pending patent applications covering subject matter described in this document. The furnishing of this document does not grant you any license to these patents. You can send license inquiries, in writing, to:

*IBM Director of Licensing*  
*IBM Corporation*  
*North Castle Drive, MD-NC119*  
*Armonk, NY 10504-1785*  
*US*

INTERNATIONAL BUSINESS MACHINES CORPORATION PROVIDES THIS PUBLICATION "AS IS" WITHOUT WARRANTY OF ANY KIND, EITHER EXPRESS OR IMPLIED, INCLUDING, BUT NOT LIMITED TO, THE IMPLIED WARRANTIES OF NON-INFRINGEMENT, MERCHANTABILITY OR FITNESS FOR A PARTICULAR PURPOSE. Some jurisdictions do not allow disclaimer of express or implied warranties in certain transactions, therefore, this statement may not apply to you.

This information could include technical inaccuracies or typographical errors. Changes are periodically made to the information herein; these changes will be incorporated in new editions of the publication. IBM may make improvements and/or changes in the product(s) and/or the program(s) described in this publication at any time without notice.

Any references in this information to non-IBM websites are provided for convenience only and do not in any manner serve as an endorsement of those websites. The materials at those websites are not part of the materials for this IBM product and use of those websites is at your own risk.

IBM may use or distribute any of the information you provide in any way it believes appropriate without incurring any obligation to you.

The performance data and client examples cited are presented for illustrative purposes only. Actual performance results may vary depending on specific configurations and operating conditions.

Information concerning non-IBM products was obtained from the suppliers of those products, their published announcements or other publicly available sources. IBM has not tested those products and cannot confirm the accuracy of performance, compatibility or any other claims related to non-IBM products. Questions on the capabilities of non-IBM products should be addressed to the suppliers of those products.

Statements regarding IBM's future direction or intent are subject to change or withdrawal without notice, and represent goals and objectives only.

All IBM prices shown are IBM's suggested retail prices, are current and are subject to change without notice. Dealer prices may vary.

This information is for planning purposes only. The information herein is subject to change before the products described become available.

This information contains examples of data and reports used in daily business operations. To illustrate them as completely as possible, the examples include the names of individuals, companies, brands, and products. All of these names are fictitious and any similarity to actual people or business enterprises is entirely coincidental.

If you are viewing this information in softcopy, the photographs and color illustrations may not appear.

The drawings and specifications contained herein shall not be reproduced in whole or in part without the written permission of IBM.

IBM has prepared this information for use with the specific machines indicated. IBM makes no representations that it is suitable for any other purpose.

IBM's computer systems contain mechanisms designed to reduce the possibility of undetected data corruption or loss. This risk, however, cannot be eliminated. Users who experience unplanned outages, system failures, power fluctuations or outages, or component failures must verify the accuracy of operations performed and data saved or transmitted by the system at or near the time of the outage or failure. In addition, users must establish procedures to ensure that there is independent data verification before relying on such data in sensitive or critical operations. Users should periodically check IBM's support websites for updated information and fixes applicable to the system and related software.

## Homologation statement

This product may not be certified in your country for connection by any means whatsoever to interfaces of public telecommunications networks. Further certification may be required by law prior to making any such connection. Contact an IBM representative or reseller for any questions.

## Accessibility features for IBM Power Systems servers

---

Accessibility features assist users who have a disability, such as restricted mobility or limited vision, to use information technology content successfully.

### Overview

The IBM Power Systems servers include the following major accessibility features:

- Keyboard-only operation
- Operations that use a screen reader

The IBM Power Systems servers use the latest W3C Standard, [WAI-ARIA 1.0](http://www.w3.org/TR/wai-aria/) ([www.w3.org/TR/wai-aria/](http://www.w3.org/TR/wai-aria/)), to ensure compliance with [US Section 508](http://www.access-board.gov/guidelines-and-standards/communications-and-it/about-the-section-508-standards/section-508-standards) ([www.access-board.gov/guidelines-and-standards/communications-and-it/about-the-section-508-standards/section-508-standards](http://www.access-board.gov/guidelines-and-standards/communications-and-it/about-the-section-508-standards/section-508-standards)) and [Web Content Accessibility Guidelines \(WCAG\) 2.0](http://www.w3.org/TR/WCAG20/) ([www.w3.org/TR/WCAG20/](http://www.w3.org/TR/WCAG20/)). To take advantage of accessibility features, use the latest release of your screen reader and the latest web browser that is supported by the IBM Power Systems servers.

The IBM Power Systems servers online product documentation in IBM Knowledge Center is enabled for accessibility. The accessibility features of IBM Knowledge Center are described in the [Accessibility](http://www.ibm.com/support/knowledgecenter/doc/kc_help.html#accessibility) section of the IBM Knowledge Center help ([www.ibm.com/support/knowledgecenter/doc/kc\\_help.html#accessibility](http://www.ibm.com/support/knowledgecenter/doc/kc_help.html#accessibility)).

### Keyboard navigation

This product uses standard navigation keys.

### Interface information

The IBM Power Systems servers user interfaces do not have content that flashes 2 - 55 times per second.

The IBM Power Systems servers web user interface relies on cascading style sheets to render content properly and to provide a usable experience. The application provides an equivalent way for low-vision users to use system display settings, including high-contrast mode. You can control font size by using the device or web browser settings.

The IBM Power Systems servers web user interface includes WAI-ARIA navigational landmarks that you can use to quickly navigate to functional areas in the application.

## Vendor software

The IBM Power Systems servers include certain vendor software that is not covered under the IBM license agreement. IBM makes no representation about the accessibility features of these products. Contact the vendor for accessibility information about its products.

## Related accessibility information

In addition to standard IBM help desk and support websites, IBM has a TTY telephone service for use by deaf or hard of hearing customers to access sales and support services:

TTY service  
800-IBM-3383 (800-426-3383)  
(within North America)

For more information about the commitment that IBM has to accessibility, see [IBM Accessibility \(www.ibm.com/able\)](http://www.ibm.com/able).

## Privacy policy considerations

---

IBM Software products, including software as a service solutions, (“Software Offerings”) may use cookies or other technologies to collect product usage information, to help improve the end user experience, to tailor interactions with the end user, or for other purposes. In many cases no personally identifiable information is collected by the Software Offerings. Some of our Software Offerings can help enable you to collect personally identifiable information. If this Software Offering uses cookies to collect personally identifiable information, specific information about this offering’s use of cookies is set forth below.

This Software Offering does not use cookies or other technologies to collect personally identifiable information.

If the configurations deployed for this Software Offering provide you as the customer the ability to collect personally identifiable information from end users via cookies and other technologies, you should seek your own legal advice about any laws applicable to such data collection, including any requirements for notice and consent.

For more information about the use of various technologies, including cookies, for these purposes, see IBM’s Privacy Policy at <http://www.ibm.com/privacy> and IBM’s Online Privacy Statement at <http://www.ibm.com/privacy/details/us/en/> in the section entitled “Cookies, Web Beacons and Other Technologies”.

## Trademarks

---

IBM, the IBM logo, and [ibm.com](http://www.ibm.com)<sup>®</sup> are trademarks or registered trademarks of International Business Machines Corp., registered in many jurisdictions worldwide. Other product and service names might be trademarks of IBM or other companies. A current list of IBM trademarks is available on the web at [Copyright and trademark information](#).

INFINIBAND, InfiniBand Trade Association, and the INFINIBAND design marks are trademarks and/or service marks of the INFINIBAND Trade Association.

## Electronic emission notices

---

### Class A Notices

The following Class A statements apply to the IBM servers that contain the POWER9 processor and its features unless designated as electromagnetic compatibility (EMC) Class B in the feature information.

When attaching a monitor to the equipment, you must use the designated monitor cable and any interference suppression devices supplied with the monitor.

## Canada Notice

CAN ICES-3 (A)/NMB-3(A)

## European Community and Morocco Notice

This product is in conformity with the protection requirements of Directive 2014/30/EU of the European Parliament and of the Council on the harmonization of the laws of the Member States relating to electromagnetic compatibility. IBM cannot accept responsibility for any failure to satisfy the protection requirements resulting from a non-recommended modification of the product, including the fitting of non-IBM option cards.

This product may cause interference if used in residential areas. Such use must be avoided unless the user takes special measures to reduce electromagnetic emissions to prevent interference to the reception of radio and television broadcasts.

Warning: This equipment is compliant with Class A of CISPR 32. In a residential environment this equipment may cause radio interference.

## Germany Notice

### **Deutschsprachiger EU Hinweis: Hinweis für Geräte der Klasse A EU-Richtlinie zur Elektromagnetischen Verträglichkeit**

Dieses Produkt entspricht den Schutzanforderungen der EU-Richtlinie 2014/30/EU zur Angleichung der Rechtsvorschriften über die elektromagnetische Verträglichkeit in den EU-Mitgliedsstaaten und hält die Grenzwerte der EN 55022 / EN 55032 Klasse A ein.

Um dieses sicherzustellen, sind die Geräte wie in den Handbüchern beschrieben zu installieren und zu betreiben. Des Weiteren dürfen auch nur von der IBM empfohlene Kabel angeschlossen werden. IBM übernimmt keine Verantwortung für die Einhaltung der Schutzanforderungen, wenn das Produkt ohne Zustimmung von IBM verändert bzw. wenn Erweiterungskomponenten von Fremdherstellern ohne Empfehlung von IBM gesteckt/eingebaut werden.

EN 55032 Klasse A Geräte müssen mit folgendem Warnhinweis versehen werden:

"Warnung: Dieses ist eine Einrichtung der Klasse A. Diese Einrichtung kann im Wohnbereich Funk-Störungen verursachen; in diesem Fall kann vom Betreiber verlangt werden, angemessene Maßnahmen zu ergreifen und dafür aufzukommen."

### **Deutschland: Einhaltung des Gesetzes über die elektromagnetische Verträglichkeit von Geräten**

Dieses Produkt entspricht dem "Gesetz über die elektromagnetische Verträglichkeit von Geräten (EMVG)". Dies ist die Umsetzung der EU-Richtlinie 2014/30/EU in der Bundesrepublik Deutschland.

### **Zulassungsbescheinigung laut dem Deutschen Gesetz über die elektromagnetische Verträglichkeit von Geräten (EMVG) (bzw. der EMC Richtlinie 2014/30/EU) für Geräte der Klasse A**

Dieses Gerät ist berechtigt, in Übereinstimmung mit dem Deutschen EMVG das EG-Konformitätszeichen - CE - zu führen.

Verantwortlich für die Einhaltung der EMV Vorschriften ist der Hersteller:

International Business Machines Corp.

New Orchard Road

Armonk, New York 10504

Tel: 914-499-1900

Der verantwortliche Ansprechpartner des Herstellers in der EU ist:

IBM Deutschland GmbH

Technical Relations Europe, Abteilung M456

IBM-Allee 1, 71139 Ehningen, Germany

Tel: +49 (0) 800 225 5426

email: HalloIBM@de.ibm.com

Generelle Informationen:

**Das Gerät erfüllt die Schutzanforderungen nach EN 55024 und EN 55022 / EN 55032 Klasse A.**

### **Japan Electronics and Information Technology Industries Association (JEITA) Notice**

(一社) 電子情報技術産業協会 高調波電流抑制対策実施  
要領に基づく定格入力電力値： Knowledge Centerの各製品の  
仕様ページ参照

This statement applies to products less than or equal to 20 A per phase.

高調波電流規格 JIS C 61000-3-2 適合品

This statement applies to products greater than 20 A, single phase.

高調波電流規格 JIS C 61000-3-2 準用品

本装置は、「高圧又は特別高圧で受電する需要家の高調波抑制対策ガイドライン」対象機器（高調波発生機器）です。

- 回路分類：6（単相、PFC回路付）
- 換算係数：0

This statement applies to products greater than 20 A per phase, three-phase.

高調波電流規格 JIS C 61000-3-2 準用品

本装置は、「高圧又は特別高圧で受電する需要家の高調波抑制対策ガイドライン」対象機器（高調波発生機器）です。

- 回路分類：5（3相、PFC回路付）
- 換算係数：0

### **Japan Voluntary Control Council for Interference (VCCI) Notice**

この装置は、クラスA 情報技術装置です。この装置を家庭環境で使用すると電波妨害を引き起こすことがあります。この場合には使用者が適切な対策を講ずるよう要求されることがあります。

VCCI-A

### **Korea Notice**

이 기기는 업무용 환경에서 사용할 목적으로 적합성평가를 받은 기기로서 가정용 환경에서 사용하는 경우 전파간섭의 우려가 있습니다.

## People's Republic of China Notice

### 声 明

此为 A 级产品,在生活环境中,  
该产品可能会造成无线电干扰。  
在这种情况下,可能需要用户对其  
干扰采取切实可行的措施。

## Russia Notice

**ВНИМАНИЕ!** Настоящее изделие относится к классу А.  
В жилых помещениях оно может создавать  
радиопомехи, для снижения которых необходимы  
дополнительные меры

## Taiwan Notice

### 警告使用者：

此為甲類資訊技術設備，  
於居住環境中使用時，可  
能會造成射頻擾動，在此  
種情況下，使用者會被要  
求採取某些適當的對策。

### IBM Taiwan Contact Information:

台灣IBM 產品服務聯絡方式：  
台灣國際商業機器股份有限公司  
台北市松仁路7號3樓  
電話：0800-016-888

## United States Federal Communications Commission (FCC) Notice

This equipment has been tested and found to comply with the limits for a Class A digital device, pursuant to Part 15 of the FCC Rules. These limits are designed to provide reasonable protection against harmful interference when the equipment is operated in a commercial environment. This equipment generates, uses, and can radiate radio frequency energy and, if not installed and used in accordance with the instruction manual, may cause harmful interference to radio communications. Operation of this equipment in a residential area is likely to cause harmful interference, in which case the user will be required to correct the interference at his own expense.

Properly shielded and grounded cables and connectors must be used in order to meet FCC emission limits. Proper cables and connectors are available from IBM-authorized dealers. IBM is not responsible for any radio or television interference caused by using other than recommended cables and connectors or by unauthorized changes or modifications to this equipment. Unauthorized changes or modifications could void the user's authority to operate the equipment.

This device complies with Part 15 of the FCC rules. Operation is subject to the following two conditions: (1) this device may not cause harmful interference, and (2) this device must accept any interference received, including interference that may cause undesired operation.

Responsible Party:  
International Business Machines Corporation  
New Orchard Road  
Armonk, NY 10504  
Contact for FCC compliance information only: fccinfo@us.ibm.com

## **Class B Notices**

The following Class B statements apply to features designated as electromagnetic compatibility (EMC) Class B in the feature installation information.

When attaching a monitor to the equipment, you must use the designated monitor cable and any interference suppression devices supplied with the monitor.

### **Canada Notice**

CAN ICES-3 (B)/NMB-3(B)

### **European Community and Morocco Notice**

This product is in conformity with the protection requirements of Directive 2014/30/EU of the European Parliament and of the Council on the harmonization of the laws of the Member States relating to electromagnetic compatibility. IBM cannot accept responsibility for any failure to satisfy the protection requirements resulting from a non-recommended modification of the product, including the fitting of non-IBM option cards.

### **German Notice**

#### **Deutschsprachiger EU Hinweis: Hinweis für Geräte der Klasse B EU-Richtlinie zur Elektromagnetischen Verträglichkeit**

Dieses Produkt entspricht den Schutzanforderungen der EU-Richtlinie 2014/30/EU zur Angleichung der Rechtsvorschriften über die elektromagnetische Verträglichkeit in den EU-Mitgliedsstaaten und hält die Grenzwerte der EN 55022/ EN 55032 Klasse B ein.

Um dieses sicherzustellen, sind die Geräte wie in den Handbüchern beschrieben zu installieren und zu betreiben. Des Weiteren dürfen auch nur von der IBM empfohlene Kabel angeschlossen werden. IBM übernimmt keine Verantwortung für die Einhaltung der Schutzanforderungen, wenn das Produkt ohne Zustimmung von IBM verändert bzw. wenn Erweiterungskomponenten von Fremdherstellern ohne Empfehlung von IBM gesteckt/eingebaut werden.

#### **Deutschland: Einhaltung des Gesetzes über die elektromagnetische Verträglichkeit von Geräten**

Dieses Produkt entspricht dem "Gesetz über die elektromagnetische Verträglichkeit von Geräten (EMVG)". Dies ist die Umsetzung der EU-Richtlinie 2014/30/EU in der Bundesrepublik Deutschland.

#### **Zulassungsbescheinigung laut dem Deutschen Gesetz über die elektromagnetische Verträglichkeit von Geräten (EMVG) (bzw. der EMC Richtlinie 2014/30/EU) für Geräte der Klasse B**

Dieses Gerät ist berechtigt, in Übereinstimmung mit dem Deutschen EMVG das EG-Konformitätszeichen - CE - zu führen.

Verantwortlich für die Einhaltung der EMV Vorschriften ist der Hersteller:  
International Business Machines Corp.  
New Orchard Road  
Armonk, New York 10504  
Tel: 914-499-1900

Der verantwortliche Ansprechpartner des Herstellers in der EU ist:  
IBM Deutschland GmbH  
Technical Relations Europe, Abteilung M456  
IBM-Allee 1, 71139 Ehningen, Germany

Tel: +49 (0) 800 225 5426  
email: HalloIBM@de.ibm.com

Generelle Informationen:

**Das Gerät erfüllt die Schutzanforderungen nach EN 55024 und EN 55032 Klasse B**

## **Japan Electronics and Information Technology Industries Association (JEITA) Notice**

(一社) 電子情報技術産業協会 高調波電流抑制対策実施  
要領に基づく定格入力電力値： Knowledge Centerの各製品の  
仕様ページ参照

This statement applies to products less than or equal to 20 A per phase.

高調波電流規格 JIS C 61000-3-2 適合品

This statement applies to products greater than 20 A, single phase.

高調波電流規格 JIS C 61000-3-2 準用品

本装置は、「高圧又は特別高圧で受電する需要家の高調波抑制対策ガイドライン」対象機器（高調波発生機器）です。

- 回路分類：6（単相、PFC回路付）
- 換算係数：0

This statement applies to products greater than 20 A per phase, three-phase.

高調波電流規格 JIS C 61000-3-2 準用品

本装置は、「高圧又は特別高圧で受電する需要家の高調波抑制対策ガイドライン」対象機器（高調波発生機器）です。

- 回路分類：5（3相、PFC回路付）
- 換算係数：0

## **Japan Voluntary Control Council for Interference (VCCI) Notice**

この装置は、クラスB情報技術装置です。この装置は、家庭環境で使用することを目的としていますが、この装置がラジオやテレビジョン受信機に近接して使用されると、受信障害を引き起こすことがあります。

取扱説明書に従って正しい取り扱いをして下さい。

VCCI-B



## Taiwan Notice

台灣IBM 產品服務聯絡方式：  
台灣國際商業機器股份有限公司  
台北市松仁路7號3樓  
電話：0800-016-888

## United States Federal Communications Commission (FCC) Notice

This equipment has been tested and found to comply with the limits for a Class B digital device, pursuant to Part 15 of the FCC Rules. These limits are designed to provide reasonable protection against harmful interference in a residential installation. This equipment generates, uses, and can radiate radio frequency energy and, if not installed and used in accordance with the instructions, may cause harmful interference to radio communications. However, there is no guarantee that interference will not occur in a particular installation. If this equipment does cause harmful interference to radio or television reception, which can be determined by turning the equipment off and on, the user is encouraged to try to correct the interference by one or more of the following measures:

- Reorient or relocate the receiving antenna.
- Increase the separation between the equipment and receiver.
- Connect the equipment into an outlet on a circuit different from that to which the receiver is connected.
- Consult an IBM-authorized dealer or service representative for help.

Properly shielded and grounded cables and connectors must be used in order to meet FCC emission limits. Proper cables and connectors are available from IBM-authorized dealers. IBM is not responsible for any radio or television interference caused by using other than recommended cables and connectors or by unauthorized changes or modifications to this equipment. Unauthorized changes or modifications could void the user's authority to operate the equipment.

This device complies with Part 15 of the FCC rules. Operation is subject to the following two conditions:

(1) this device may not cause harmful interference, and (2) this device must accept any interference received, including interference that may cause undesired operation.

Responsible Party:

International Business Machines Corporation  
New Orchard Road  
Armonk, New York 10504  
Contact for FCC compliance information only: [fccinfo@us.ibm.com](mailto:fccinfo@us.ibm.com)

## Terms and conditions

---

Permissions for the use of these publications are granted subject to the following terms and conditions.

**Applicability:** These terms and conditions are in addition to any terms of use for the IBM website.

**Personal Use:** You may reproduce these publications for your personal, noncommercial use provided that all proprietary notices are preserved. You may not distribute, display or make derivative works of these publications, or any portion thereof, without the express consent of IBM.

**Commercial Use:** You may reproduce, distribute and display these publications solely within your enterprise provided that all proprietary notices are preserved. You may not make derivative works of these publications, or reproduce, distribute or display these publications or any portion thereof outside your enterprise, without the express consent of IBM.

**Rights:** Except as expressly granted in this permission, no other permissions, licenses or rights are granted, either express or implied, to the publications or any information, data, software or other intellectual property contained therein.

IBM reserves the right to withdraw the permissions granted herein whenever, in its discretion, the use of the publications is detrimental to its interest or, as determined by IBM, the above instructions are not being properly followed.

You may not download, export or re-export this information except in full compliance with all applicable laws and regulations, including all United States export laws and regulations.

IBM MAKES NO GUARANTEE ABOUT THE CONTENT OF THESE PUBLICATIONS. THE PUBLICATIONS ARE PROVIDED "AS-IS" AND WITHOUT WARRANTY OF ANY KIND, EITHER EXPRESSED OR IMPLIED, INCLUDING BUT NOT LIMITED TO IMPLIED WARRANTIES OF MERCHANTABILITY, NON-INFRINGEMENT, AND FITNESS FOR A PARTICULAR PURPOSE.



