

Power Systems

*Installing the System and Ordered Parts
for the IBM Power System AC922 (8335-
GTX)*



Note

Before using this information and the product it supports, read the information in “Safety notices” on page v, “Notices” on page 111, the *IBM Systems Safety Notices* manual, G229-9054, and the *IBM Environmental Notices and User Guide*, Z125-5823.

This edition applies to IBM® Power Systems servers that contain the POWER9™ processor and to all associated models.

© **Copyright International Business Machines Corporation 2018, 2021.**

US Government Users Restricted Rights – Use, duplication or disclosure restricted by GSA ADP Schedule Contract with IBM Corp.

Contents

Safety notices.....	v
Installing and configuring the system.....	1
Installing the 8335-GTX system.....	1
Prerequisite for installing the rack-mounted server.....	1
Completing inventory for your server.....	1
Determining and marking the location in the rack.....	2
Installing the 8335-GTW or 8335-GTX system by using fixed rails.....	3
Setting up a preinstalled server.....	6
Completing server setup.....	10
Installing a disk drive.....	11
Upgrading memory.....	14
Memory plugging rules.....	14
Upgrading memory modules.....	14
Installing PCIe adapters.....	19
PCIe adapter placement rules and slot priorities for the 8335-GTG, 8335-GTH, or 8335-GTX system.....	20
PCIe adapters by feature code.....	22
Installing a PCIe adapter in the 8335-GTG, 8335-GTH, or 8335-GTX system.....	76
Common procedures for servicing or installing features.....	78
Before you begin.....	78
Identifying the system that contains the part to replace.....	83
Preparing the system to remove and replace internal parts.....	86
Preparing the system for operation.....	90
Starting and stopping the system.....	92
Sensor status.....	94
Removing and replacing covers.....	94
Service and operating positions.....	97
Removing and replacing power cords.....	102
Updating the system firmware level of a BMC card to OP940.20, or later, in an 8335-GTH or 8335-GTX system.....	107
Notices.....	111
Accessibility features for IBM Power Systems servers.....	112
Privacy policy considerations	113
Trademarks.....	113
Electronic emission notices.....	114
Class A Notices.....	114
Class B Notices.....	117
Terms and conditions.....	119

Safety notices

Safety notices may be printed throughout this guide:

- **DANGER** notices call attention to a situation that is potentially lethal or extremely hazardous to people.
- **CAUTION** notices call attention to a situation that is potentially hazardous to people because of some existing condition.
- **Attention** notices call attention to the possibility of damage to a program, device, system, or data.

World Trade safety information

Several countries require the safety information contained in product publications to be presented in their national languages. If this requirement applies to your country, safety information documentation is included in the publications package (such as in printed documentation, on DVD, or as part of the product) shipped with the product. The documentation contains the safety information in your national language with references to the U.S. English source. Before using a U.S. English publication to install, operate, or service this product, you must first become familiar with the related safety information documentation. You should also refer to the safety information documentation any time you do not clearly understand any safety information in the U.S. English publications.

Replacement or additional copies of safety information documentation can be obtained by calling the IBM Hotline at 1-800-300-8751.

German safety information

Das Produkt ist nicht für den Einsatz an Bildschirmarbeitsplätzen im Sinne § 2 der Bildschirmarbeitsverordnung geeignet.

Laser safety information

IBM servers can use I/O cards or features that are fiber-optic based and that utilize lasers or LEDs.

Laser compliance

IBM servers may be installed inside or outside of an IT equipment rack.



DANGER: When working on or around the system, observe the following precautions:

Electrical voltage and current from power, telephone, and communication cables are hazardous. To avoid a shock hazard: If IBM supplied the power cord(s), connect power to this unit only with the IBM provided power cord. Do not use the IBM provided power cord for any other product. Do not open or service any power supply assembly. Do not connect or disconnect any cables or perform installation, maintenance, or reconfiguration of this product during an electrical storm.



- The product might be equipped with multiple power cords. To remove all hazardous voltages, disconnect all power cords. For AC power, disconnect all power cords from their AC power source. For racks with a DC power distribution panel (PDP), disconnect the customer's DC power source to the PDP.
- When connecting power to the product ensure all power cables are properly connected. For racks with AC power, connect all power cords to a properly wired and grounded electrical outlet. Ensure that the outlet supplies proper voltage and phase rotation according to the system rating plate. For racks with a DC power distribution panel (PDP), connect the customer's DC power source to the PDP. Ensure that the proper polarity is used when attaching the DC power and DC power return wiring.
- Connect any equipment that will be attached to this product to properly wired outlets.

- When possible, use one hand only to connect or disconnect signal cables.
- Never turn on any equipment when there is evidence of fire, water, or structural damage.
- Do not attempt to switch on power to the machine until all possible unsafe conditions are corrected.
- When performing a machine inspection: Assume that an electrical safety hazard is present. Perform all continuity, grounding, and power checks specified during the subsystem installation procedures to ensure that the machine meets safety requirements. Do not attempt to switch power to the machine until all possible unsafe conditions are corrected. Before you open the device covers, unless instructed otherwise in the installation and configuration procedures: Disconnect the attached AC power cords, turn off the applicable circuit breakers located in the rack power distribution panel (PDP), and disconnect any telecommunications systems, networks, and modems.
- Connect and disconnect cables as described in the following procedures when installing, moving, or opening covers on this product or attached devices.

To Disconnect: 1) Turn off everything (unless instructed otherwise). 2) For AC power, remove the power cords from the outlets. 3) For racks with a DC power distribution panel (PDP), turn off the circuit breakers located in the PDP and remove the power from the Customer's DC power source. 4) Remove the signal cables from the connectors. 5) Remove all cables from the devices.

To Connect: 1) Turn off everything (unless instructed otherwise). 2) Attach all cables to the devices. 3) Attach the signal cables to the connectors. 4) For AC power, attach the power cords to the outlets. 5) For racks with a DC power distribution panel (PDP), restore the power from the Customer's DC power source and turn on the circuit breakers located in the PDP. 6) Turn on the devices.



- Sharp edges, corners and joints may be present in and around the system. Use care when handling equipment to avoid cuts, scrapes and pinching. (D005)

(R001 part 1 of 2):



DANGER: Observe the following precautions when working on or around your IT rack system:

- Heavy equipment—personal injury or equipment damage might result if mishandled.
- Always lower the leveling pads on the rack cabinet.
- Always install stabilizer brackets on the rack cabinet if provided, unless the earthquake option is to be installed.
- To avoid hazardous conditions due to uneven mechanical loading, always install the heaviest devices in the bottom of the rack cabinet. Always install servers and optional devices starting from the bottom of the rack cabinet.
- Rack-mounted devices are not to be used as shelves or work spaces. Do not place objects on top of rack-mounted devices. In addition, do not lean on rack mounted devices and do not use them to stabilize your body position (for example, when working from a ladder).



- Stability hazard:
 - The rack may tip over causing serious personal injury.
 - Before extending the rack to the installation position, read the installation instructions.
 - Do not put any load on the slide-rail mounted equipment mounted in the installation position.
 - Do not leave the slide-rail mounted equipment in the installation position.
- Each rack cabinet might have more than one power cord.
 - For AC powered racks, be sure to disconnect all power cords in the rack cabinet when directed to disconnect power during servicing.

- For racks with a DC power distribution panel (PDP), turn off the circuit breaker that controls the power to the system unit(s), or disconnect the customer's DC power source, when directed to disconnect power during servicing.
- Connect all devices installed in a rack cabinet to power devices installed in the same rack cabinet. Do not plug a power cord from a device installed in one rack cabinet into a power device installed in a different rack cabinet.
- An electrical outlet that is not correctly wired could place hazardous voltage on the metal parts of the system or the devices that attach to the system. It is the responsibility of the customer to ensure that the outlet is correctly wired and grounded to prevent an electrical shock. (R001 part 1 of 2)

(R001 part 2 of 2):



CAUTION:

- Do not install a unit in a rack where the internal rack ambient temperatures will exceed the manufacturer's recommended ambient temperature for all your rack-mounted devices.
- Do not install a unit in a rack where the air flow is compromised. Ensure that air flow is not blocked or reduced on any side, front, or back of a unit used for air flow through the unit.
- Consideration should be given to the connection of the equipment to the supply circuit so that overloading of the circuits does not compromise the supply wiring or overcurrent protection. To provide the correct power connection to a rack, refer to the rating labels located on the equipment in the rack to determine the total power requirement of the supply circuit.
- *(For sliding drawers.)* Do not pull out or install any drawer or feature if the rack stabilizer brackets are not attached to the rack or if the rack is not bolted to the floor. Do not pull out more than one drawer at a time. The rack might become unstable if you pull out more than one drawer at a time.



- *(For fixed drawers.)* This drawer is a fixed drawer and must not be moved for servicing unless specified by the manufacturer. Attempting to move the drawer partially or completely out of the rack might cause the rack to become unstable or cause the drawer to fall out of the rack. (R001 part 2 of 2)



CAUTION: Removing components from the upper positions in the rack cabinet improves rack stability during relocation. Follow these general guidelines whenever you relocate a populated rack cabinet within a room or building.

- Reduce the weight of the rack cabinet by removing equipment starting at the top of the rack cabinet. When possible, restore the rack cabinet to the configuration of the rack cabinet as you received it. If this configuration is not known, you must observe the following precautions:
 - Remove all devices in the 32U position and above.
 - Ensure that the heaviest devices are installed in the bottom of the rack cabinet.

- Ensure that there are little-to-no empty U-levels between devices installed in the rack cabinet below the 32U level, unless the received configuration specifically allowed it.
- If the rack cabinet you are relocating is part of a suite of rack cabinets, detach the rack cabinet from the suite.
- If the rack cabinet you are relocating was supplied with removable outriggers they must be reinstalled before the cabinet is relocated.
- Inspect the route that you plan to take to eliminate potential hazards.
- Verify that the route that you choose can support the weight of the loaded rack cabinet. Refer to the documentation that comes with your rack cabinet for the weight of a loaded rack cabinet.
- Verify that all door openings are at least 760 x 2083 mm (30 x 82 in.).
- Ensure that all devices, shelves, drawers, doors, and cables are secure.
- Ensure that the four leveling pads are raised to their highest position.
- Ensure that there is no stabilizer bracket installed on the rack cabinet during movement.
- Do not use a ramp inclined at more than 10 degrees.
- When the rack cabinet is in the new location, complete the following steps:
 - Lower the four leveling pads.
 - Install stabilizer brackets on the rack cabinet or in an earthquake environment bolt the rack to the floor.
 - If you removed any devices from the rack cabinet, repopulate the rack cabinet from the lowest position to the highest position.
- If a long-distance relocation is required, restore the rack cabinet to the configuration of the rack cabinet as you received it. Pack the rack cabinet in the original packaging material, or equivalent. Also lower the leveling pads to raise the casters off of the pallet and bolt the rack cabinet to the pallet.

(R002)

(L001)



DANGER: Hazardous voltage, current, or energy levels are present inside any component that has this label attached. Do not open any cover or barrier that contains this label. (L001)

(L002)



DANGER: Rack-mounted devices are not to be used as shelves or work spaces. Do not place objects on top of rack-mounted devices. In addition, do not lean on rack-mounted devices and do not use them to stabilize your body position (for example, when working from a ladder). Stability hazard:

- The rack may tip over causing serious personal injury.

- Before extending the rack to the installation position, read the installation instructions.
- Do not put any load on the slide-rail mounted equipment mounted in the installation position.
- Do not leave the slide-rail mounted equipment in the installation position.

(L002)

(L003)

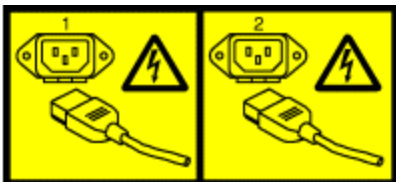

or



or



or



or



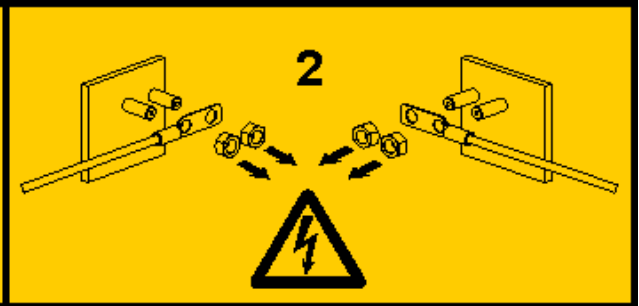
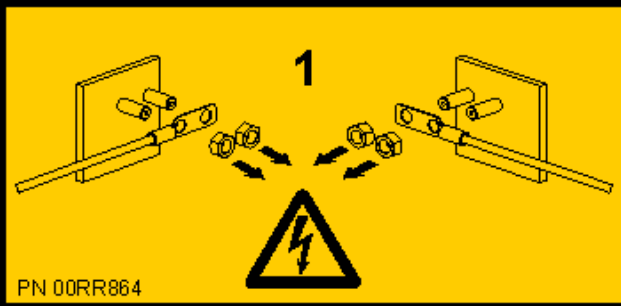

DANGER: Multiple power cords. The product might be equipped with multiple AC power cords or multiple DC power cables. To remove all hazardous voltages, disconnect all power cords and power cables. (L003)

(L007)



CAUTION: A hot surface nearby. (L007)

(L008)



CAUTION: Hazardous moving parts nearby. (L008)

All lasers are certified in the U.S. to conform to the requirements of DHHS 21 CFR Subchapter J for class 1 laser products. Outside the U.S., they are certified to be in compliance with IEC 60825 as a class 1 laser product. Consult the label on each part for laser certification numbers and approval information.



CAUTION: This product might contain one or more of the following devices: CD-ROM drive, DVD-ROM drive, DVD-RAM drive, or laser module, which are Class 1 laser products. Note the following information:

- Do not remove the covers. Removing the covers of the laser product could result in exposure to hazardous laser radiation. There are no serviceable parts inside the device.
- Use of the controls or adjustments or performance of procedures other than those specified herein might result in hazardous radiation exposure.

(C026)



CAUTION: Data processing environments can contain equipment transmitting on system links with laser modules that operate at greater than Class 1 power levels. For this reason, never look into the end of an optical fiber cable or open receptacle. Although shining light into one end and looking into the other end of a disconnected optical fiber to verify the continuity of optic fibers may not injure the eye, this procedure is potentially dangerous. Therefore, verifying the continuity of optical fibers by shining light into one end and looking at the other end is not recommended. To verify continuity of a fiber optic cable, use an optical light source and power meter. (C027)



CAUTION: This product contains a Class 1M laser. Do not view directly with optical instruments. (C028)



CAUTION: Some laser products contain an embedded Class 3A or Class 3B laser diode. Note the following information:

- Laser radiation when open.
- Do not stare into the beam, do not view directly with optical instruments, and avoid direct exposure to the beam. (C030)

(C030)



CAUTION: The battery contains lithium. To avoid possible explosion, do not burn or charge the battery.

Do Not:

- Throw or immerse into water
- Heat to more than 100 degrees C (212 degrees F)
- Repair or disassemble

Exchange only with the IBM-approved part. Recycle or discard the battery as instructed by local regulations. In the United States, IBM has a process for the collection of this battery. For information, call 1-800-426-4333. Have the IBM part number for the battery unit available when you call. (C003)



CAUTION: Regarding IBM provided VENDOR LIFT TOOL:

- Operation of LIFT TOOL by authorized personnel only.
- LIFT TOOL intended for use to assist, lift, install, remove units (load) up into rack elevations. It is not to be used loaded transporting over major ramps nor as a replacement for such designated tools like pallet jacks, walkies, fork trucks and such related relocation practices. When this is not practicable, specially trained persons or services must be used (for instance, riggers or movers).
- Read and completely understand the contents of LIFT TOOL operator's manual before using. Failure to read, understand, obey safety rules, and follow instructions may result in property damage and/or personal injury. If there are questions, contact the vendor's service and support. Local paper manual must remain with machine in provided storage sleeve area. Latest revision manual available on vendor's web site.
- Test verify stabilizer brake function before each use. Do not over-force moving or rolling the LIFT TOOL with stabilizer brake engaged.
- Do not raise, lower or slide platform load shelf unless stabilizer (brake pedal jack) is fully engaged. Keep stabilizer brake engaged when not in use or motion.
- Do not move LIFT TOOL while platform is raised, except for minor positioning.
- Do not exceed rated load capacity. See LOAD CAPACITY CHART regarding maximum loads at center versus edge of extended platform.
- Only raise load if properly centered on platform. Do not place more than 200 lb (91 kg) on edge of sliding platform shelf also considering the load's center of mass/gravity (CoG).
- Do not corner load the platforms, tilt riser, angled unit install wedge or other such accessory options. Secure such platforms -- riser tilt, wedge, etc options to main lift shelf or forks in all four

(4x or all other provisioned mounting) locations with provided hardware only, prior to use. Load objects are designed to slide on/off smooth platforms without appreciable force, so take care not to push or lean. Keep riser tilt [adjustable angling platform] option flat at all times except for final minor angle adjustment when needed.

- Do not stand under overhanging load.
- Do not use on uneven surface, incline or decline (major ramps).
- Do not stack loads.
- Do not operate while under the influence of drugs or alcohol.
- Do not support ladder against LIFT TOOL (unless the specific allowance is provided for one following qualified procedures for working at elevations with this TOOL).
- Tipping hazard. Do not push or lean against load with raised platform.
- Do not use as a personnel lifting platform or step. No riders.
- Do not stand on any part of lift. Not a step.
- Do not climb on mast.
- Do not operate a damaged or malfunctioning LIFT TOOL machine.
- Crush and pinch point hazard below platform. Only lower load in areas clear of personnel and obstructions. Keep hands and feet clear during operation.
- No Forks. Never lift or move bare LIFT TOOL MACHINE with pallet truck, jack or fork lift.
- Mast extends higher than platform. Be aware of ceiling height, cable trays, sprinklers, lights, and other overhead objects.
- Do not leave LIFT TOOL machine unattended with an elevated load.
- Watch and keep hands, fingers, and clothing clear when equipment is in motion.
- Turn Winch with hand power only. If winch handle cannot be cranked easily with one hand, it is probably over-loaded. Do not continue to turn winch past top or bottom of platform travel. Excessive unwinding will detach handle and damage cable. Always hold handle when lowering, unwinding. Always assure self that winch is holding load before releasing winch handle.
- A winch accident could cause serious injury. Not for moving humans. Make certain clicking sound is heard as the equipment is being raised. Be sure winch is locked in position before releasing handle. Read instruction page before operating this winch. Never allow winch to unwind freely. Freewheeling will cause uneven cable wrapping around winch drum, damage cable, and may cause serious injury.
- This TOOL must be maintained correctly for IBM Service personnel to use it. IBM shall inspect condition and verify maintenance history before operation. Personnel reserve the right not to use TOOL if inadequate. (C048)

Power and cabling information for NEBS (Network Equipment-Building System) GR-1089-CORE

The following comments apply to the IBM servers that have been designated as conforming to NEBS (Network Equipment-Building System) GR-1089-CORE:

The equipment is suitable for installation in the following:

- Network telecommunications facilities
- Locations where the NEC (National Electrical Code) applies

The intrabuilding ports of this equipment are suitable for connection to intrabuilding or unexposed wiring or cabling only. The intrabuilding ports of this equipment *must not* be metallically connected to the interfaces that connect to the OSP (outside plant) or its wiring. These interfaces are designed for use as intrabuilding interfaces only (Type 2 or Type 4 ports as described in GR-1089-CORE) and require isolation from the exposed OSP cabling. The addition of primary protectors is not sufficient protection to connect these interfaces metallically to OSP wiring.

Note: All Ethernet cables must be shielded and grounded at both ends.

The ac-powered system does not require the use of an external surge protection device (SPD).

The dc-powered system employs an isolated DC return (DC-I) design. The DC battery return terminal *shall not* be connected to the chassis or frame ground.

The dc-powered system is intended to be installed in a common bonding network (CBN) as described in GR-1089-CORE.

Installing and configuring the 8335-GTX

Use this information to install and configure the IBM Power® System AC922 (8335-GTX) server and to install customer-installable hardware features. This information also provides removal and replacement procedures for customer-replaceable hardware features, such as memory modules or fans.

Before you install a feature, ensure that the software that is required to support the feature is installed on the system. For information about software prerequisites, see the [Power Systems Prerequisites](https://www14.software.ibm.com/support/customercare/iprt/home) website (<https://www14.software.ibm.com/support/customercare/iprt/home>). If the required software is not installed, go to the [Fix Central](http://www.ibm.com/support/fixcentral/) website (<http://www.ibm.com/support/fixcentral/>) to download it, and then install it before you continue.

Installing these features is a customer task. You can complete this task yourself, or contact a service provider to complete the task for you. You might be charged a fee by the service provider for this service. See the International Information Bulletin for Customers - Installation of IBM Machines (Publication number: SC27-6601-00) that is available from the IBM Publications Center (<http://www-05.ibm.com/e-business/linkweb/publications/servlet/pbi.wss>). This bulletin provides a list of the key IBM system installation activities and a list of activities that might be billable.

Installing the 8335-GTX system

Learn how to install, cable, and set up your server.

Prerequisite for installing the rack-mounted server

Learn about the prerequisites for installing the server.

Before you begin

Read the following documents before you install the server:

- The latest version of this document is maintained online, see [Installing the IBM Power System AC922 \(8335-GTC, 8335-GTG, and 8335-GTH\) or IBM Power System AC922 \(8335-GTW and 8335-GTX\)](http://www.ibm.com/support/knowledgecenter/POWER9/p8eik/p8eik_install_kickoff.htm) (http://www.ibm.com/support/knowledgecenter/POWER9/p8eik/p8eik_install_kickoff.htm).
- To plan your server installation, see [Planning for the system](http://www.ibm.com/support/knowledgecenter/POWER9/p9ia4/p9ia4_90x_kickoff.htm) (http://www.ibm.com/support/knowledgecenter/POWER9/p9ia4/p9ia4_90x_kickoff.htm).

Procedure

Ensure that you have the following items before you start the installation:

- Phillips screwdriver
- Flat-head screwdriver
- Box cutter
- Electrostatic discharge (ESD) wrist strap
- Rack with two Electronic Industries Association (EIA) units (2U) of space

Completing inventory for your server

Use this information to complete inventory for your server.

Procedure

1. Verify that you received all the boxes you ordered.
2. Unpack the server components as needed.

3. Complete a parts inventory before you install each server component by following these steps:
 - a. Locate the inventory list for your server.
 - b. Ensure that you received all the parts that you ordered.

Note: Your order information is included with your product. You can also obtain the order information from your marketing representative or the IBM Business Partner.

If you have incorrect, missing, or damaged parts, consult any of the following resources:

- Your IBM reseller.
- IBM Rochester manufacturing automated information line at 1-800-300-8751 (United States only).
- The Directory of worldwide contacts website <http://www.ibm.com/planetwide>. Select your location to view the service and support contact information.

Determining and marking the location in the rack

You might need to determine where to install the system unit into the rack.

Procedure

1. Read the [Rack safety notices](http://www.ibm.com/support/knowledgecenter/POWER9/p9hbf/p9hbf_racksafety.htm) (http://www.ibm.com/support/knowledgecenter/POWER9/p9hbf/p9hbf_racksafety.htm).
2. Determine where to place the system unit in the rack. As you plan for installing the system unit in a rack, consider the following information:
 - Organize larger and heavier units into the lower part of the rack.
 - Plan to install system units into the lower part of the rack first.
 - Record the Electronic Industries Alliance (EIA) locations in your plan.

Note: The server is two EIA units high. An EIA unit is 44.55 mm (1.75 in.) in height. The rack contains three mounting holes for each EIA unit of height. This system unit, therefore, is 89 mm (3.5 in.) high and covers six mounting holes in the rack.

3. If necessary, remove the filler panels to allow access to the inside of the rack enclosure where you plan to place the system unit, as shown in [Figure 1 on page 3](#).

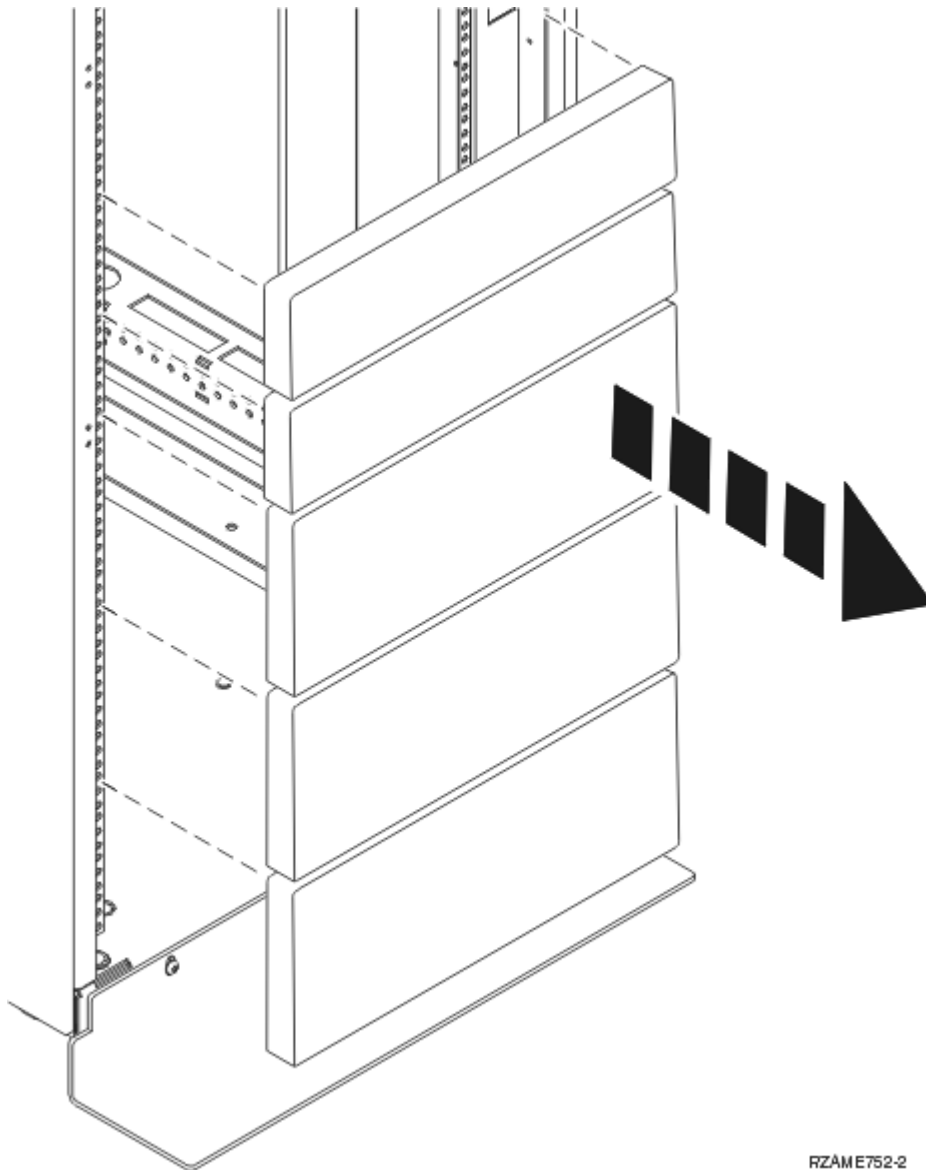

RZAME752-2

Figure 1. Removing the filler panels

4. Facing the front of the rack and working from the right side, use tape, a marker, or pencil to mark the lower hole of each EIA unit.
Mark the rack such that the mark can also be seen from the rear of the rack.
5. Mark the corresponding hole on the left side of the rack.
6. Go to the rear of the rack.
7. On the right side, find the EIA unit that corresponds to the bottom EIA unit marked on the front of the rack.
8. Mark the bottom EIA unit.
9. Mark the corresponding hole on the left side of the rack.

Installing the 8335-GTW or 8335-GTX system by using fixed rails

If you ordered the system with the fixed rail option, use these procedures to install the system into the rack by using fixed rails.

Attaching fixed rails to the rack

Learn how to install fixed rails to the rack

Before you begin

If your rack has square holes, you must install the conversion kit that was provided with fixed rails.

About this task

Note: The system requires 2 EIA rack units (2U) of space.

Procedure

1. Select the appropriate EIA location unit number for fixed rails. Each EIA location contains three holes for mounting hardware.
2. Install the pins onto the front or rear EIA support flanges, at the appropriate locations. The pins are used to secure the system to the rack.
3. Attach a spring to the outside of each fixed rail.
 - a. Attach the circle end of the spring around the stud on the rail.
 - b. Pulling on the spring, attach the hook end of the spring to the tab on the rail.
4. At the rear of the rack, align the bottom of the right rail with the bottom hole of the EIA unit selected, in the rear of the rack. The large locator pins fit into holes of the EIA location that is directly above the lowest EIA unit used.
5. At the front of the rack, align the locator pins into the holes of the EIA location directly above the lowest EIA unit used.
6. Install the spacer bracket between rear rail and the rack hole.
7. Repeat steps “1” on page 4 through “6” on page 4 for the left rail.
8. Secure both rails to the front EIA support flange by using two M5 x 16 mm screws. Install the screws through the pins that you attached.
9. Secure both rails to the rear EIA support flanges by using four M5 x 16 mm screws. Install the screws through the pins that you attached.

Installing the 8335-GTW or 8335-GTX system into the rack by using fixed rails and connecting power cables

Learn how to install the system into the rack by using fixed rails and how to connect power cables.

About this task

Note: This system requires two people to install the system into the rack.

Procedure

1. Remove the shipping cover on the rear and the front of the system, if present.
2. Position one person on the left side of the system and one person on the right side of the system.
3. Complete the following steps:
 - a) Lift the system.
 - b) Tilt the system into position over the fixed rack rails.
 - c) Carefully lower the system until the rear of the system rests on the rails.
4. While one person is supporting the weight of the system, have the second person move to the front of the system and push the system all the way into the rack.
5. Install the screws on either side of the system to secure the system to the rack.

6. Attach the front cover to the front of the system.
See [Figure 2](#) on page 5.

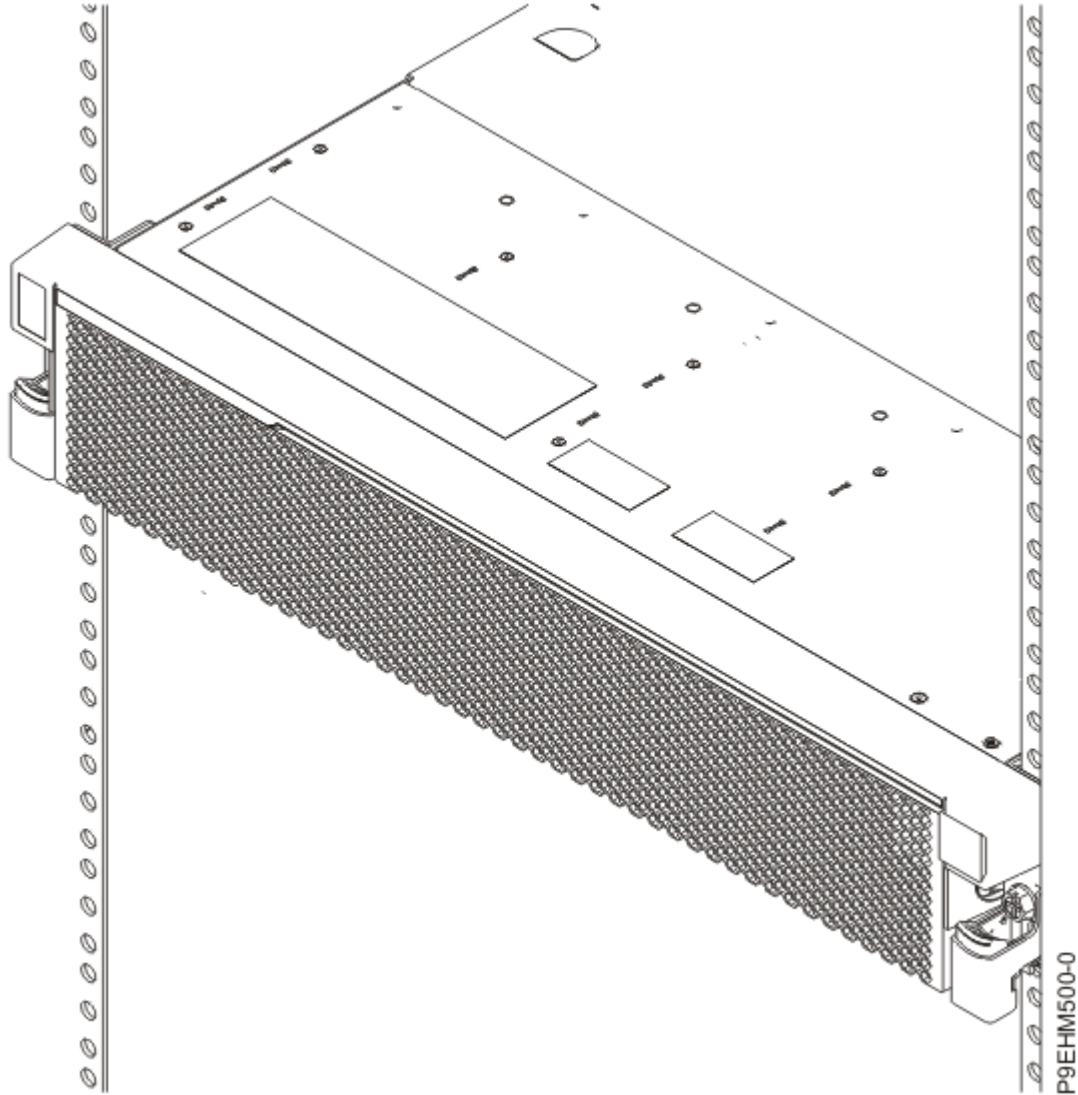

Figure 2. Installing the server in the rack

7. Connect the water hoses at the rear of the rack to the manifold, as shown in the following figure. Ensure that you plug the male hose into the female manifold plug, and plug the female hose into the male manifold plug.



Attention: Before powering on the system, ensure that cooling water is circulating through the system.

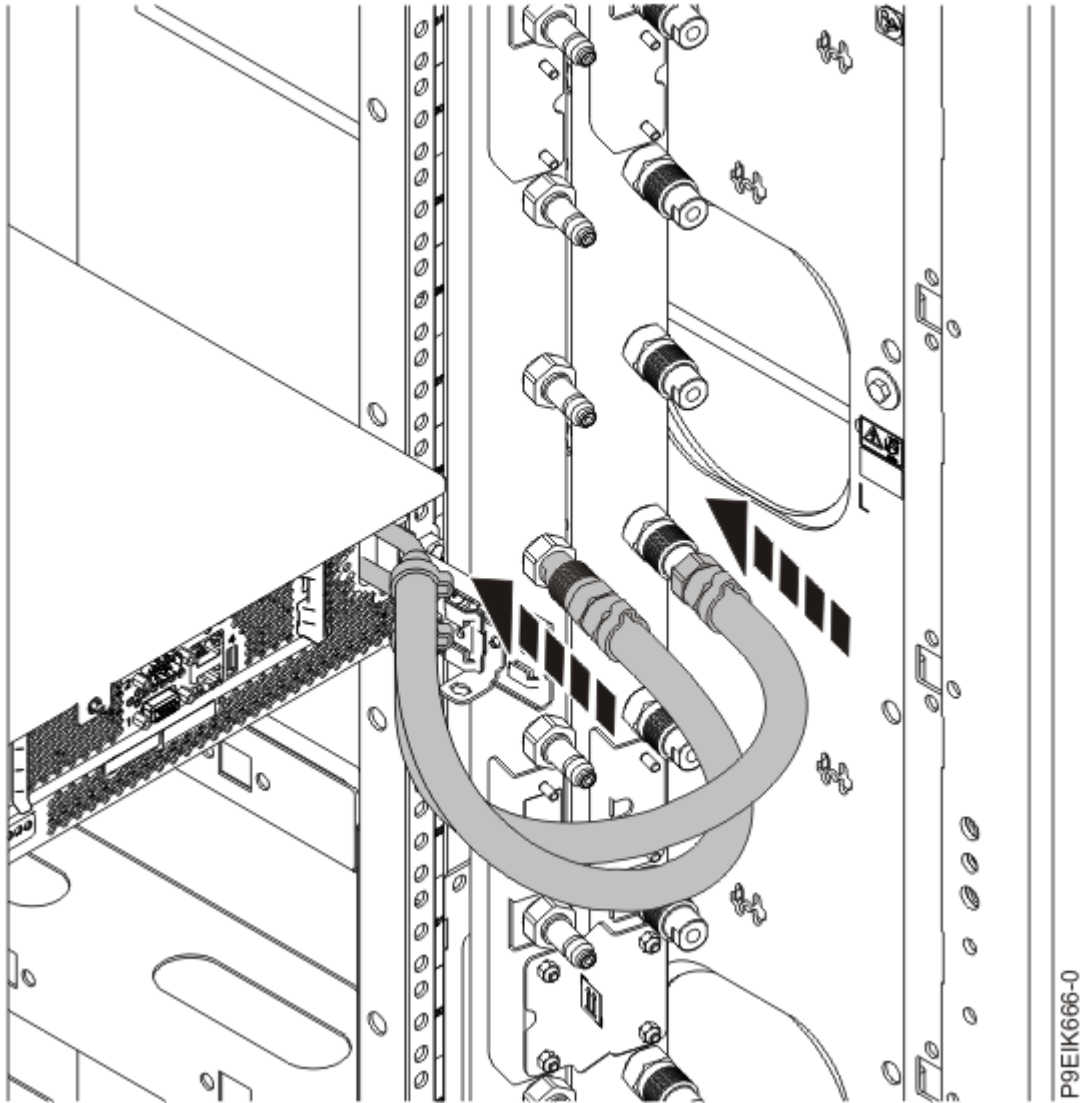

Figure 3. Connecting the water hoses

8. Plug the power cords into the power supplies.

Note: If a plug is covering a port that you need to use on the rear of the system, remove and discard it. The port covers ensure that you are reminded that you must reset the Administrator password on your managed system upon initial system IPL.

9. Attach all cables to the rear of the server.
10. Plug the system power cords and the power cords for any other attached devices into the AC power source.
11. Continue with [“Completing server setup”](#) on page 9.

Setting up a preinstalled server

Use this information to learn how to set up a server that is preinstalled in the rack.

Prerequisite for installing the rack-mounted server

Learn about the prerequisites for installing the server.

Before you begin

Read the following documents before you install the server:

- The latest version of this document is maintained online, see [Installing the IBM Power System AC922 \(8335-GTC, 8335-GTG, and 8335-GTH\) or IBM Power System AC922 \(8335-GTW and 8335-GTX\)](http://www.ibm.com/support/knowledgecenter/POWER9/p8eik/p8eik_install_kickoff.htm) (http://www.ibm.com/support/knowledgecenter/POWER9/p8eik/p8eik_install_kickoff.htm).
- To plan your server installation, see [Planning for the system](http://www.ibm.com/support/knowledgecenter/POWER9/p9ia4/p9ia4_90x_kickoff.htm) (http://www.ibm.com/support/knowledgecenter/POWER9/p9ia4/p9ia4_90x_kickoff.htm).

Procedure

Ensure that you have the following items before you start the installation:

- Phillips screwdriver
- Flat-head screwdriver
- Box cutter
- Electrostatic discharge (ESD) wrist strap
- Rack with two Electronic Industries Association (EIA) units (2U) of space

Completing inventory for your server

Use this information to complete inventory for your server.

Procedure

1. Verify that you received all the boxes you ordered.
2. Unpack the server components as needed.
3. Complete a parts inventory before you install each server component by following these steps:
 - a. Locate the inventory list for your server.
 - b. Ensure that you received all the parts that you ordered.

Note: Your order information is included with your product. You can also obtain the order information from your marketing representative or the IBM Business Partner.

If you have incorrect, missing, or damaged parts, consult any of the following resources:

- Your IBM reseller.
- IBM Rochester manufacturing automated information line at 1-800-300-8751 (United States only).
- The Directory of worldwide contacts website <http://www.ibm.com/planetwide>. Select your location to view the service and support contact information.

Removing the shipping bracket and connecting water hoses and power cords for your preinstalled server

Before you set up a console, you must remove the shipping brackets and connect water hoses and power cords.

About this task

To remove the shipping bracket and connect power cords, do the following:

Procedure

1. Remove the screws that secure the shipping brackets to the chassis.
2. Connect the water hoses at the rear of the rack to the manifold, as shown in the following figure.

Ensure that you plug the male hose into the female manifold plug, and plug the female hose into the male manifold plug.



Attention: Before powering on the system, ensure that cooling water is circulating through the system.

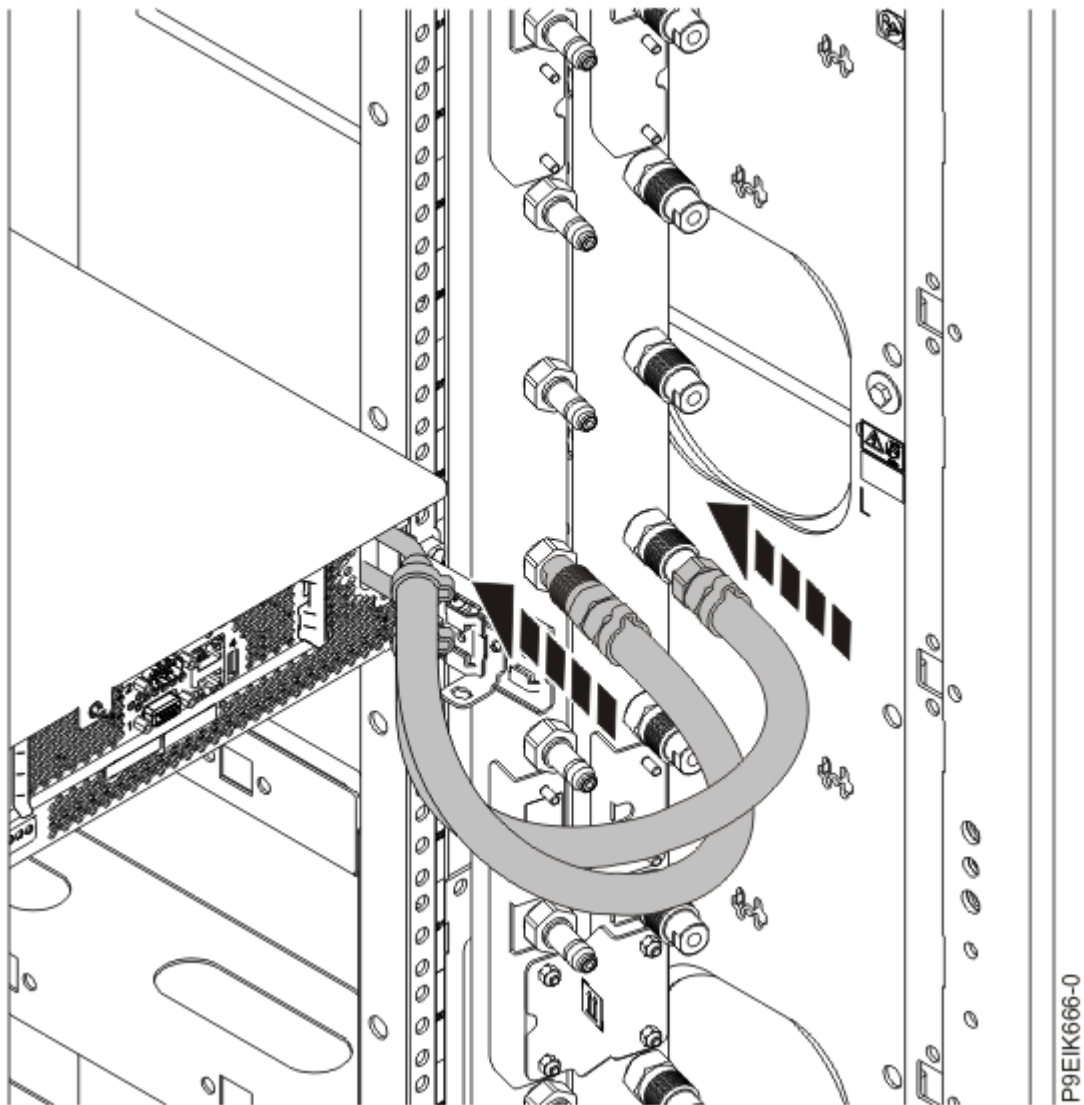

Figure 4. Connecting the water hoses

3. Plug the power cords into the power supplies.

Note: If a plug is covering a port that you need to use on the rear of the system, remove and discard it. The port covers ensure that you are reminded that you must reset the Administrator password on your managed system upon initial system IPL.

4. Attach all cables to the rear of the server.
5. Plug the system power cords and the power cords for any other attached devices into the AC power source.
6. Continue with [“Completing server setup”](#) on page 9.

Completing server setup

Learn how to complete server setup.

Before you begin

You might be required to set the thermal mode of the system to a setting other than the default setting, depending on your system, adapter, and cable type. For details, see [Determining and setting the thermal mode](http://www.ibm.com/support/knowledgecenter/POWER9/p9ei3/p9ei3_thermal_mode.htm) (http://www.ibm.com/support/knowledgecenter/POWER9/p9ei3/p9ei3_thermal_mode.htm).

IBM® Power Systems™ servers use a baseboard management controller (BMC) for system service management, monitoring, maintenance, and control.

More information is available about OpenBMC, including the following topics:

- Downloading and installing the OpenBMC tool
- Configuring the BMC IP address
- Using basic BMC commands
- Managing the system by using the OpenBMC GUI

For more information, see [Managing OpenBMC-based systems](http://www.ibm.com/support/knowledgecenter/POWER9/p9eih/p9eih_openbmc_kickoff.htm) (http://www.ibm.com/support/knowledgecenter/POWER9/p9eih/p9eih_openbmc_kickoff.htm).

Note: For the 8335-GTG system, the BMC must be connected to the network to enable system firmware update and other service tasks.

Procedure

1. Connect your server to a VGA monitor and keyboard.
Only the 1024x768 at 60 Hz VGA setting is supported. Only up to a 3-meter cable is supported.
2. Go to [Getting fixes](http://www.ibm.com/support/knowledgecenter/POWER9/p9ei8/p9ei8_fixes_kickoff.htm) (http://www.ibm.com/support/knowledgecenter/POWER9/p9ei8/p9ei8_fixes_kickoff.htm) and update the system firmware with the most recent level of firmware.
3. You can receive important technical information and updates for specific IBM Support tools and resources by subscribing to receive updates. To subscribe to receive updates, complete the following steps:
 - a. Go to the [IBM Support Portal](#).
 - b. Log in by using your IBM ID and password and click **Sign in**.
 - c. Click **Support notifications**.
 - d. Click **Browse for a product**.
 - e. Select **Power > Firmware**, find your machine type and model and click **Subscribe**.
 - f. Exit the **Browse for a product** screen.
 - g. Click **Delivery preferences** to set email preferences and click **Submit**.
 - h. Click **Edit** to select the types of documentation updates that you want to receive and click **Submit**.
4. You can install the Linux® operating system on bare metal systems, or on non-virtualized systems. For these systems, the operating system runs directly on the Open Power Abstraction Layer (OPAL) firmware.

For more information about installing the Linux operating system on bare metal systems, see [Installing Linux on bare metal systems](https://www.ibm.com/support/knowledgecenter/linuxonibm/liabw/liabw9kickoff.htm) (<https://www.ibm.com/support/knowledgecenter/linuxonibm/liabw/liabw9kickoff.htm>).

Completing server setup

Learn how to complete server setup.

Before you begin

You might be required to set the thermal mode of the system to a setting other than the default setting, depending on your system, adapter, and cable type. For details, see [Determining and setting the thermal mode](http://www.ibm.com/support/knowledgecenter/POWER9/p9ei3/p9ei3_thermal_mode.htm) (http://www.ibm.com/support/knowledgecenter/POWER9/p9ei3/p9ei3_thermal_mode.htm).

IBM® Power Systems™ servers use a baseboard management controller (BMC) for system service management, monitoring, maintenance, and control.

More information is available about OpenBMC, including the following topics:

- Downloading and installing the OpenBMC tool
- Configuring the BMC IP address
- Using basic BMC commands
- Managing the system by using the OpenBMC GUI

For more information, see [Managing OpenBMC-based systems](http://www.ibm.com/support/knowledgecenter/POWER9/p9eih/p9eih_openbmc_kickoff.htm) (http://www.ibm.com/support/knowledgecenter/POWER9/p9eih/p9eih_openbmc_kickoff.htm).

Note: For the 8335-GTG system, the BMC must be connected to the network to enable system firmware update and other service tasks.

Procedure

1. Connect your server to a VGA monitor and keyboard.
Only the 1024x768 at 60 Hz VGA setting is supported. Only up to a 3-meter cable is supported.
2. Go to [Getting fixes](http://www.ibm.com/support/knowledgecenter/POWER9/p9ei8/p9ei8_fixes_kickoff.htm) (http://www.ibm.com/support/knowledgecenter/POWER9/p9ei8/p9ei8_fixes_kickoff.htm) and update the system firmware with the most recent level of firmware.
3. You can receive important technical information and updates for specific IBM Support tools and resources by subscribing to receive updates. To subscribe to receive updates, complete the following steps:
 - a. Go to the [IBM Support Portal](#).
 - b. Log in by using your IBM ID and password and click **Sign in**.
 - c. Click **Support notifications**.
 - d. Click **Browse for a product**.
 - e. Select **Power > Firmware**, find your machine type and model and click **Subscribe**.
 - f. Exit the **Browse for a product** screen.
 - g. Click **Delivery preferences** to set email preferences and click **Submit**.
 - h. Click **Edit** to select the types of documentation updates that you want to receive and click **Submit**.
4. You can install the Linux operating system on bare metal systems, or on non-virtualized systems. For these systems, the operating system runs directly on the Open Power Abstraction Layer (OPAL) firmware.
For more information about installing the Linux operating system on bare metal systems, see [Installing Linux on bare metal systems](https://www.ibm.com/support/knowledgecenter/linuxonibm/liabw/liabw9kickoff.htm) (<https://www.ibm.com/support/knowledgecenter/linuxonibm/liabw/liabw9kickoff.htm>).

Installing a disk drive in the 8335-GTG, 8335-GTH, or 8335-GTX system

To install a disk drive, complete the steps in this procedure.

About this task

You can install disk drives in a system that is powered on and running.

Procedure

1. Determine the slot in which you want to install a disk drive. The disk drive slots are in the front of the system in positions 5 and 6, as shown in [Figure 5 on page 11](#).

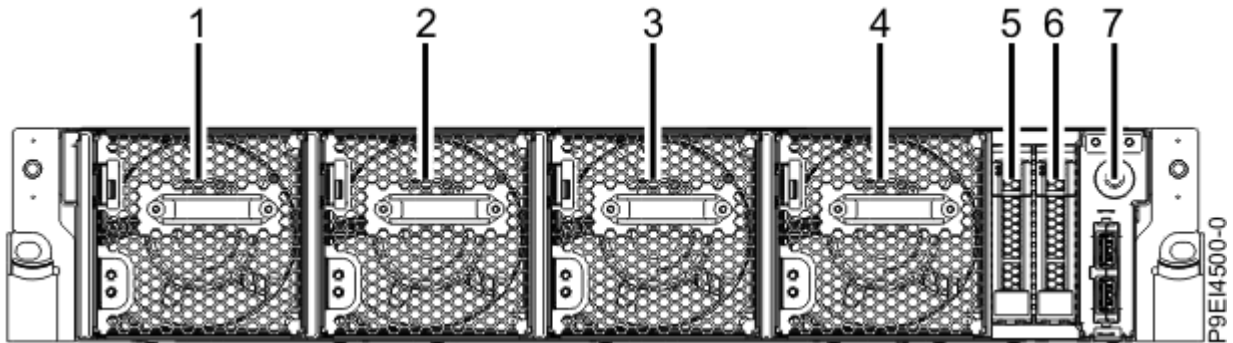

Figure 5. Drive locations; positions 5 and 6

2. Remove the front cover. For instructions, see [“Removing the front cover from an 8335-GTC, 8335-GTG, 8335-GTH, 8335-GTW, or 8335-GTX system” on page 96](#).
3. Attach the electrostatic discharge (ESD) wrist strap.

The ESD wrist strap must be connected to an unpainted metal surface until the service procedure is completed, and if applicable, until the service access cover is replaced.



Attention:

- Attach an electrostatic discharge (ESD) wrist strap to the front ESD jack, to the rear ESD jack, or to an unpainted metal surface of your hardware to prevent the electrostatic discharge from damaging your hardware.
 - When you use an ESD wrist strap, follow all electrical safety procedures. An ESD wrist strap is used for static control. It does not increase or decrease your risk of receiving electric shock when using or working on electrical equipment.
 - If you do not have an ESD wrist strap, just prior to removing the product from ESD packaging and installing or replacing hardware, touch an unpainted metal surface of the system for a minimum of 5 seconds. If at any point in this service process you move away from the system, it is important to again discharge yourself by touching an unpainted metal surface for at least 5 seconds before you continue with the service process.
4. If the slot you want to use contains a disk drive filler, remove the disk drive filler from the slot.
 - a) Push the lock **(A)** on the handle of the disk drive filler.
See [Figure 6 on page 12](#).

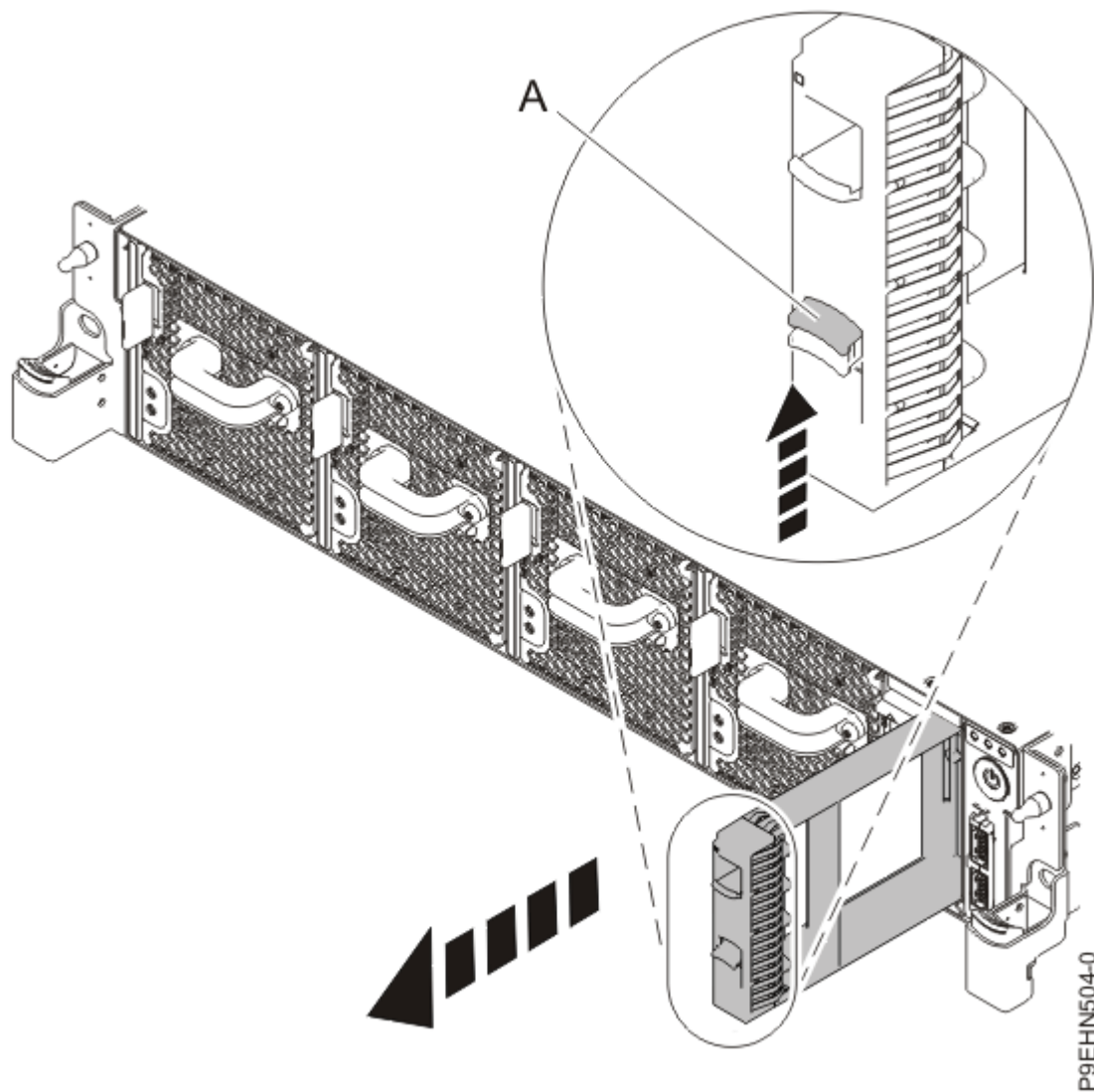

Figure 6. Removing a disk drive filler from a system.

- b) Hold the handle and pull out the disk drive filler from the slot.
- 5. Hold the disk drive by the top and bottom edges as you position the disk drive, and insert it into the disk drive slot.

Important: Ensure that the disk drive is fully seated and is all the way into the system.

- 6. Lock the disk drive bay handle (**A**) by pushing in the handle release.

See [Figure 7 on page 13](#).

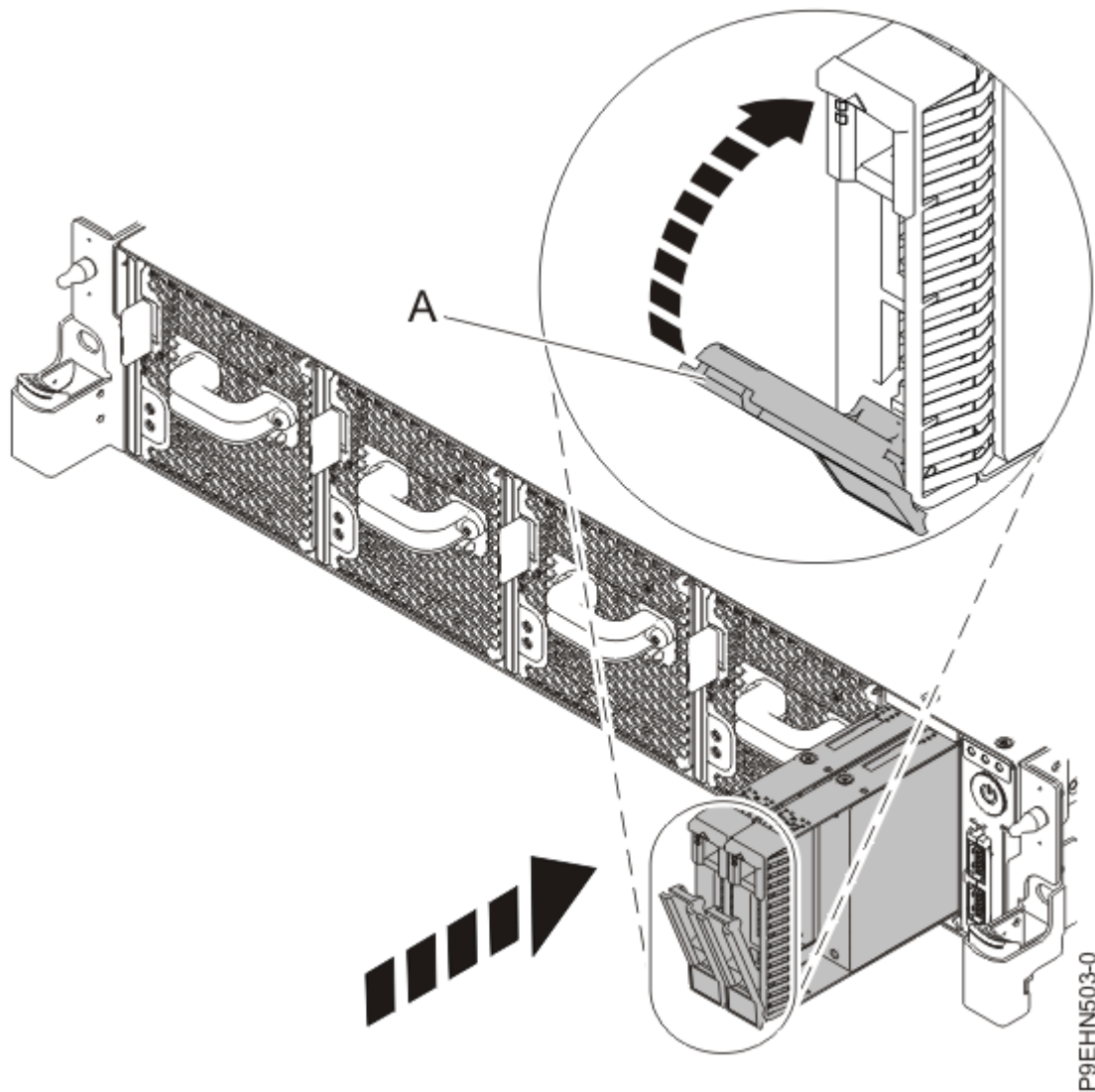

Figure 7. Disk drive lock detail

7. Configure the installed disk drive for your environment.

After you insert the new disk drive, you must scan for the device. Choose one of the following options depending on the operating system that you are using:

- **Ubuntu Linux operating system:**

Ubuntu can automatically detect storage devices. You may not need to rescan the disk drives; proceed to verifying that the new disk drive is active.

To run the **rescan-scsi-bus** command in the Ubuntu Linux operating system, log in to the system as the root user, and run the following command:

```
rescan-scsi-bus
```

The **rescan-scsi-bus** tool is available in the *scsitools* package; install the package by using the following command:

```
sudo apt-get install scsitools
```

- **Red Hat Enterprise Linux (RHEL):** To run the rescan command in the RHEL operating system, log in to the system as the root user, and run the command:

```
rescan-scsi-bus.sh -a
```

The **rescan-scsi-bus** tool is available in the `sg3_utils` package; install the package by using the following command:

```
yum install sg3_utils
```

You may also want to refer to: Adding a Storage Device or Path (https://access.redhat.com/documentation/en-US/Red_Hat_Enterprise_Linux/7/html/Storage_Administration_Guide/adding_storage-device-or-path.html)

Verify that the new drive is active by running the following command:

```
lsscsi
```

8. Load or restore data from your backup media.

Upgrading memory in the 8335-GTG, 8335-GTH, or 8335-GTX system

To upgrade memory in the system, complete the steps in this procedure.

Memory plugging rules in the 8335-GTC, 8335-GTG, 8335-GTH, 8335-GTW, or 8335-GTX system

Learn the memory placement rules for the system.

The system has memory configurations of 128 GB, 256 GB, 512 GB, 1024 GB, or 2048 GB. All memory modules must be installed and must be of the same size and type. The system has a total of 16 memory modules. The supported memory module sizes are either 8 GB, 16 GB, 32 GB, or 128 GB. Mixing of memory module feature codes is not allowed.

Table 1 on page 14 lists the supported memory feature codes.

Supported feature codes (FC)	Size
EM60	8 GB
EM61	16 GB
EM63	32 GB
EM64	64 GB
EM65	128 GB

Upgrading memory modules in the 8335-GTX system

To upgrade memory modules, complete the steps in this procedure.

Before you begin

See “[Memory plugging rules in the 8335-GTC, 8335-GTG, 8335-GTH, 8335-GTW, or 8335-GTX system](#)” on page 14 to ensure that you follow the rules for memory.

Power off the system and place it in the service position. For instructions, see “[Preparing the 8335-GTC, 8335-GTG, 8335-GTH, 8335-GTW, or 8335-GTX system to remove and replace internal parts](#)” on page 86.

Procedure

1. Attach the electrostatic discharge (ESD) wrist strap.

The ESD wrist strap must be connected to an unpainted metal surface until the service procedure is completed, and if applicable, until the service access cover is replaced.



Attention:

- Attach an electrostatic discharge (ESD) wrist strap to the front ESD jack, to the rear ESD jack, or to an unpainted metal surface of your hardware to prevent the electrostatic discharge from damaging your hardware.
- When you use an ESD wrist strap, follow all electrical safety procedures. An ESD wrist strap is used for static control. It does not increase or decrease your risk of receiving electric shock when using or working on electrical equipment.
- If you do not have an ESD wrist strap, just prior to removing the product from ESD packaging and installing or replacing hardware, touch an unpainted metal surface of the system for a minimum of 5 seconds. If at any point in this service process you move away from the system, it is important to again discharge yourself by touching an unpainted metal surface for at least 5 seconds before you continue with the service process.

Remove the existing memory modules:

2. Remove the air baffles **(A)** and **(B)** as shown in [Figure 8 on page 15](#).

Carefully move the baffles around the hoses.

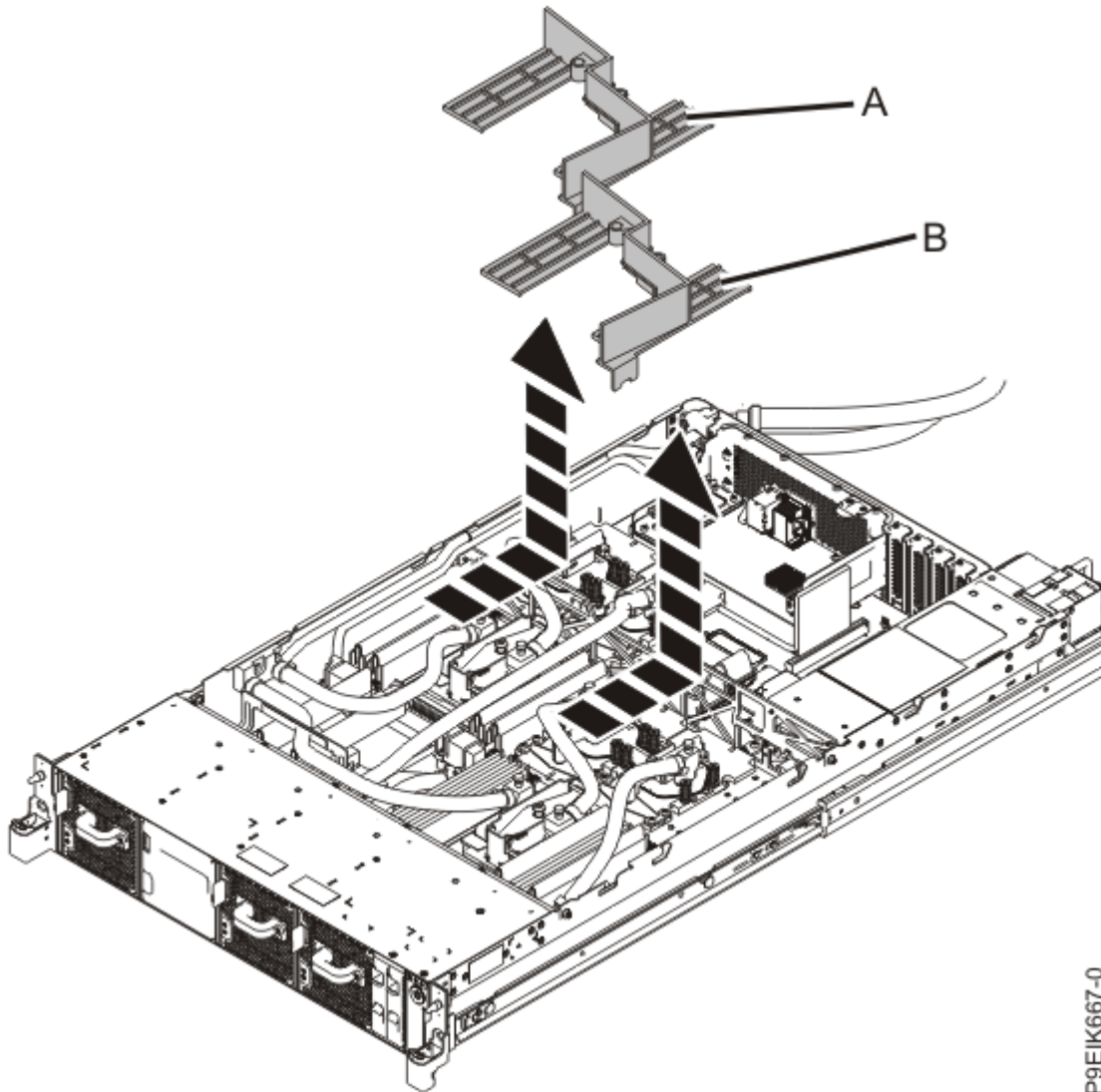

P9EIK667-0

Figure 8. Removing the memory air baffles

3. Locate the memory modules to remove. You need to remove all the memory modules when you upgrade to a larger size of memory; or when you downgrade to a smaller size of memory. [Figure 9](#) on [page 16](#) shows the location of the memory modules.

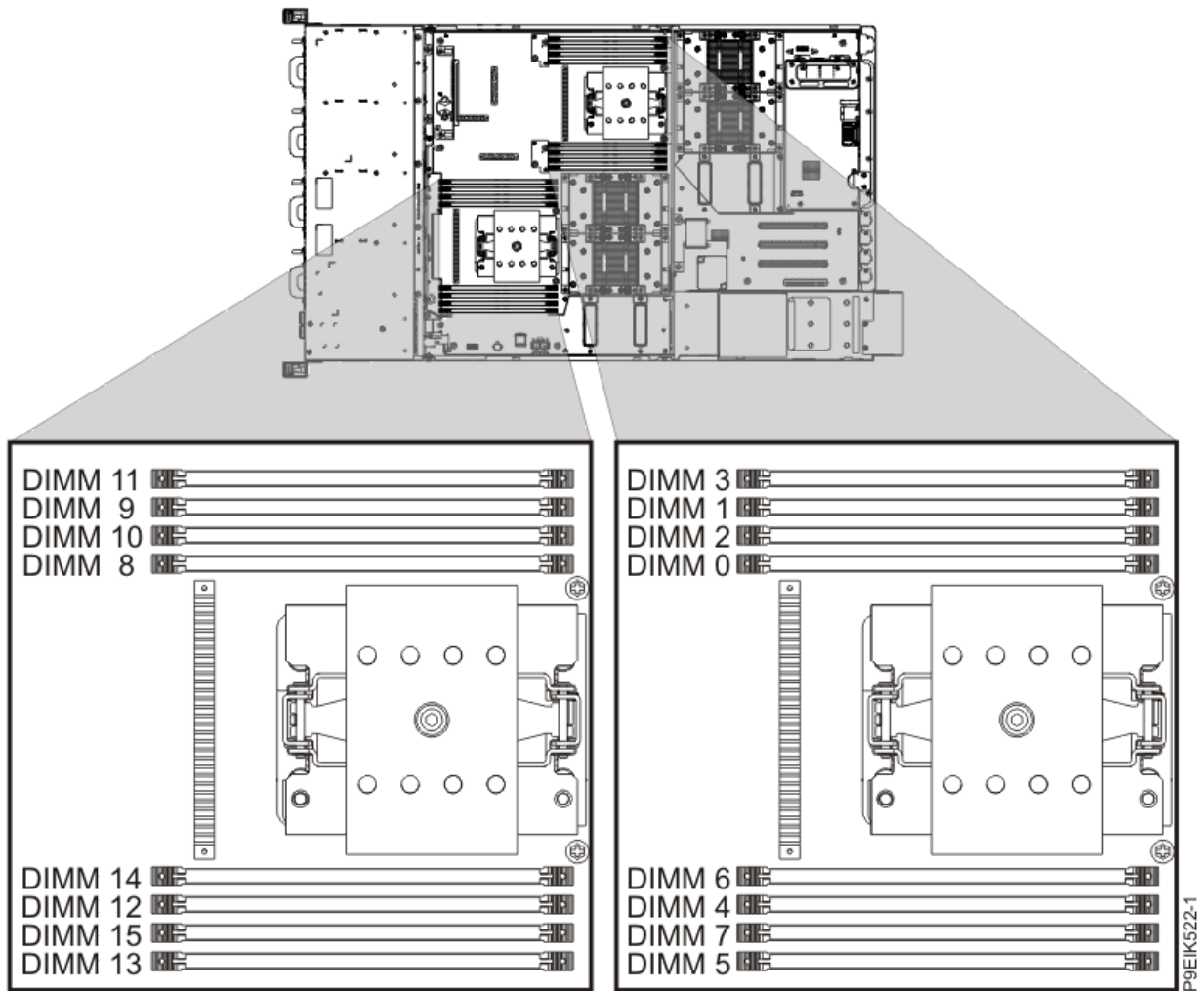
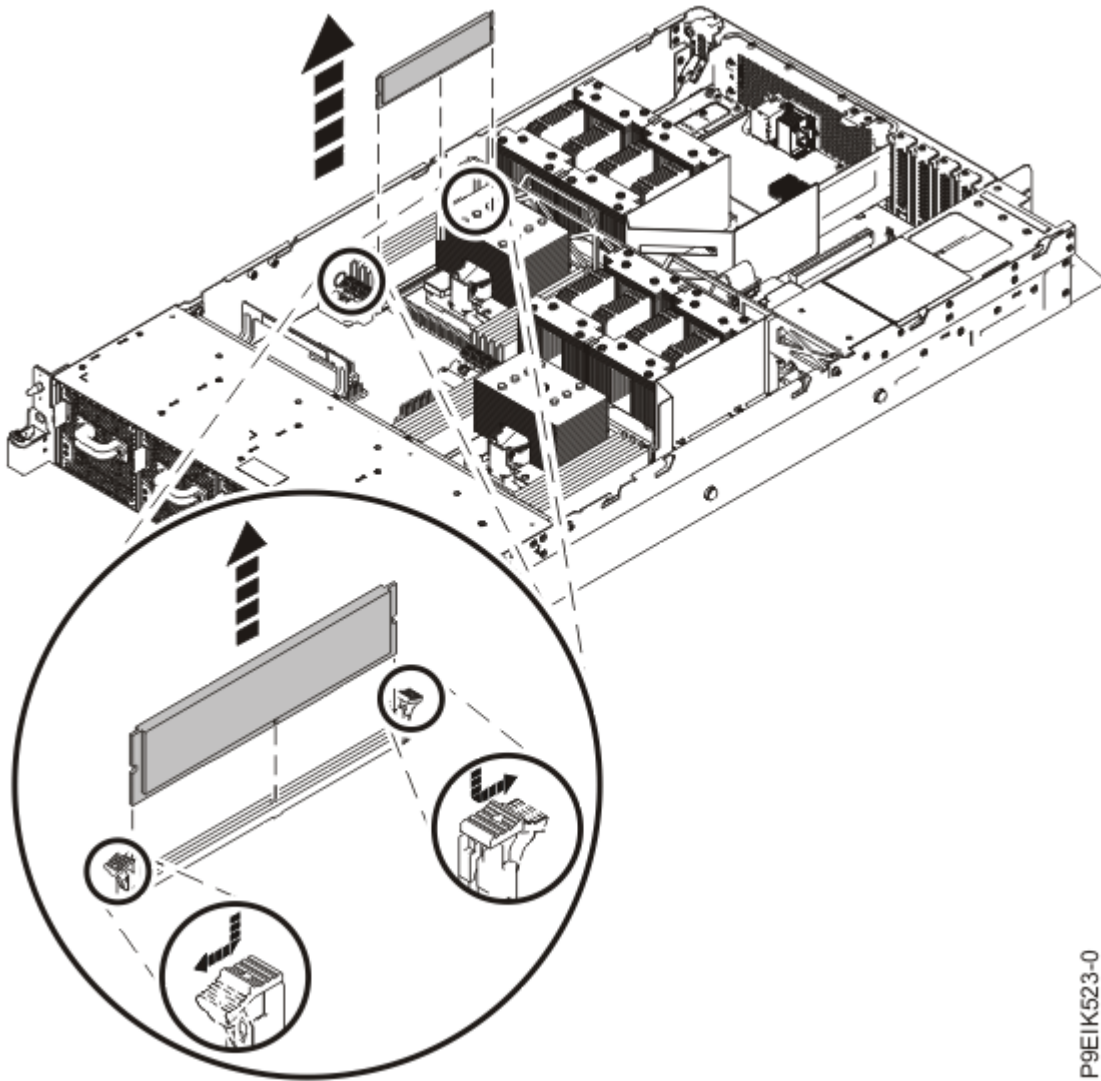

Figure 9. Location of the memory modules

4. Remove all of the memory modules from the system.
- Unlock each memory module by pushing the locking tabs away from the memory module, in the direction shown in [Figure 10](#) on [page 17](#).
The lever action of opening the tabs pushes the memory module out of the slot.



P9EIK523-0

Figure 10. Removing memory modules

- b) Hold the memory module by the edges and pull it out of the slot.
5. Place the memory module on an ESD mat.
6. Repeat steps “4” on page 16 - “5” on page 17 until all the memory modules are removed.

Install the memory modules:

7. To install memory modules, complete the following steps:
 - a) Push the locking tabs to the open position, away from the slot, in the direction shown in [Figure 11](#) on page 18.

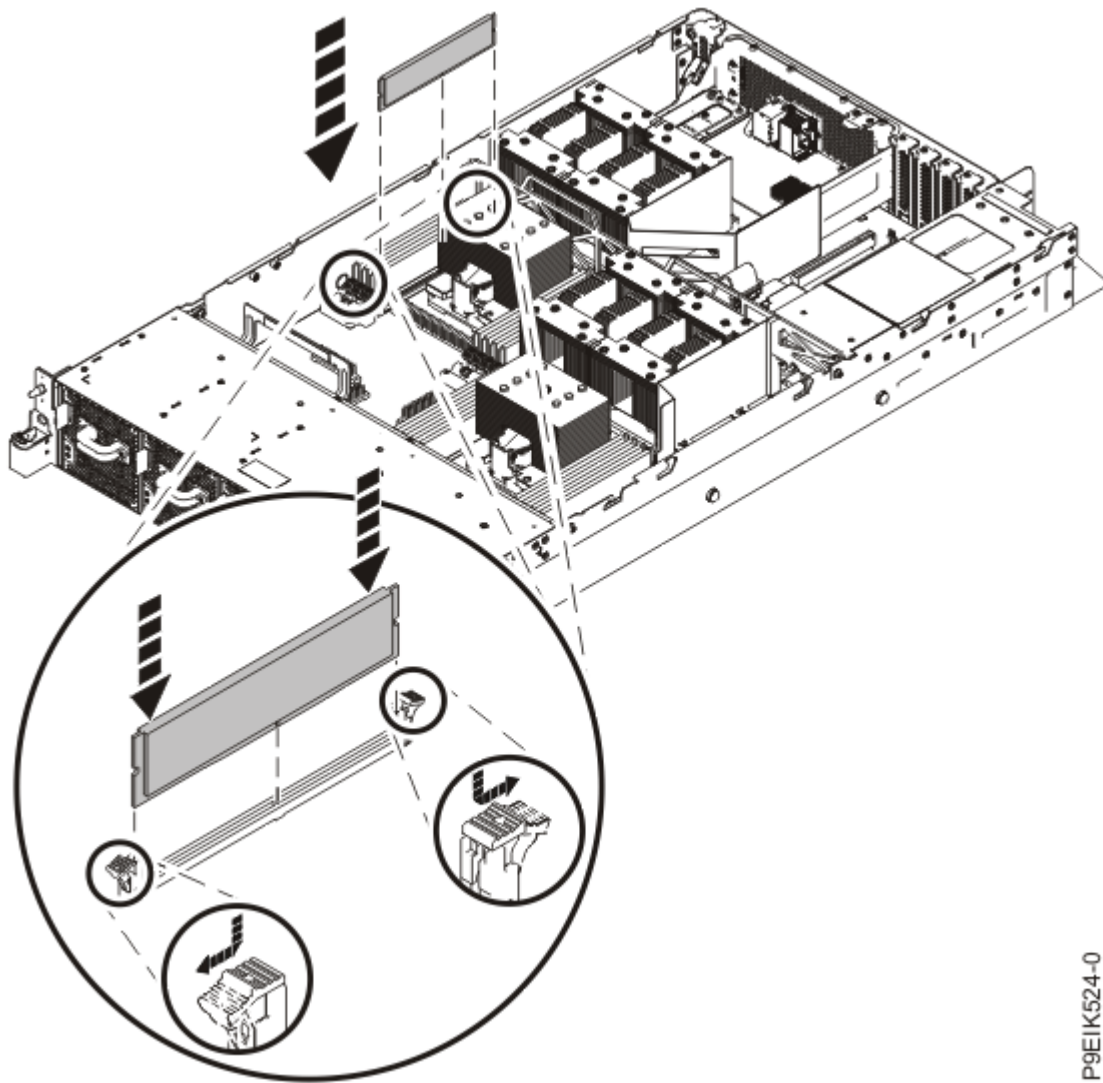

P9EIK524-0

Figure 11. Installing memory modules

b) Grasp the memory module along its edges and align it with the slot.



Attention: The memory module is keyed to prevent it from being installed incorrectly. Note the location of the key tab within the memory connector before you attempt to install it.

c) Press firmly on each side of the memory module until the locking tab locks in place with an audible click.

8. Repeat step “7” on page 17 until all of the memory modules are installed.

9. Replace the air baffles **(A)** and **(B)** as shown in [Figure 12 on page 19](#).

Carefully move the baffles around the hoses.

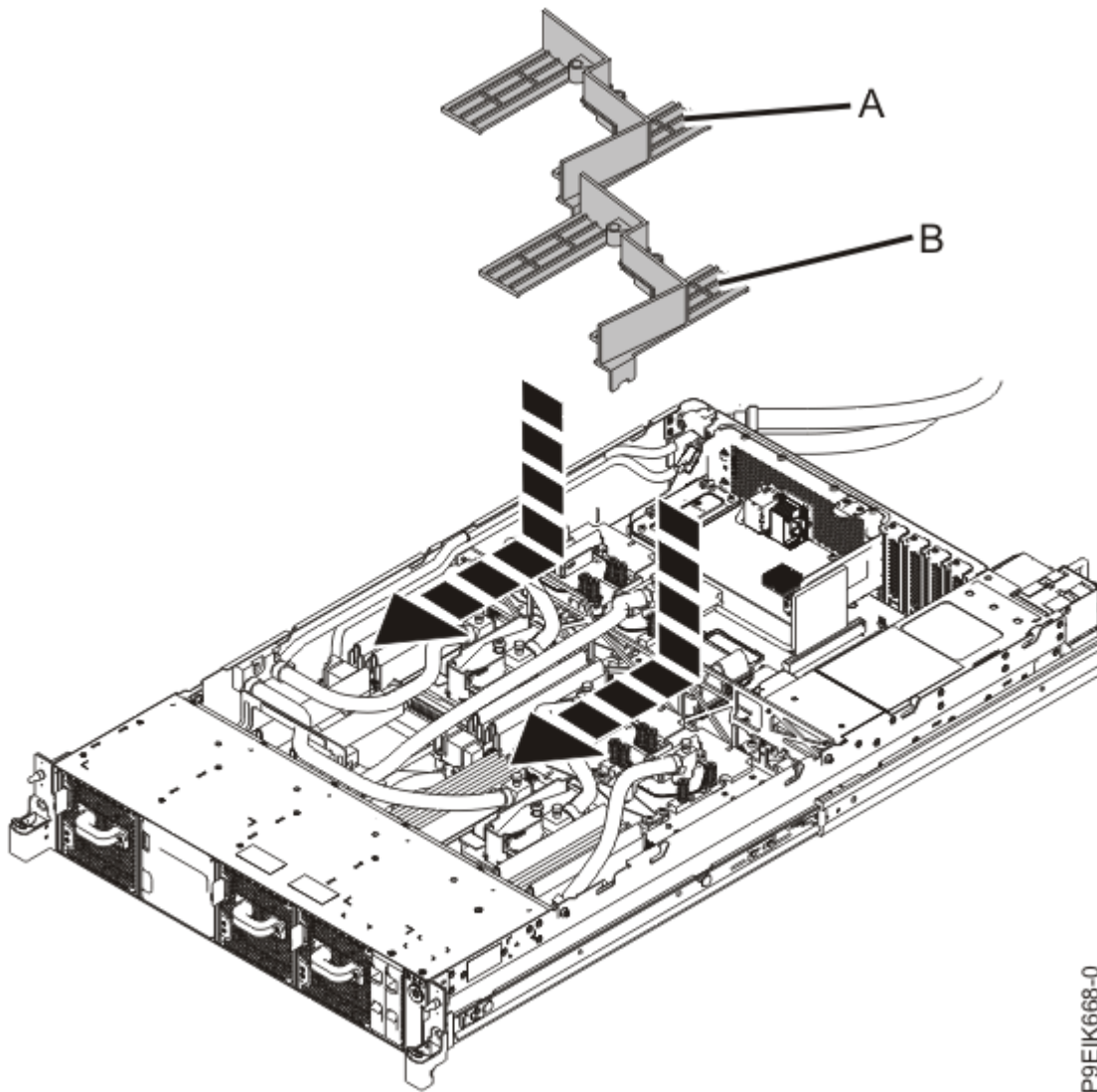

Figure 12. Replacing the memory air baffles

What to do next

Prepare the system for operation. For instructions, see “Preparing the 8335-GTC, 8335-GTG, 8335-GTH, 8335-GTW, or 8335-GTX system for operation after you remove and replace internal parts” on page 90.

Installing PCIe adapters in the 8335-GTG, 8335-GTH, or 8335-GTX system

Find information about removing, installing, using, and managing Peripheral Component Interconnect Express (PCIe) adapters for the system.

Installing this feature is a customer task. You can complete this task yourself, or contact a service provider to complete the task for you. You might be charged a fee by the service provider for this service.

The features that are listed in [Table 2 on page 20](#) are electromagnetic compatibility (EMC) Class B features. See the [Class B Notices](#) in the Hardware Notices section.

Table 2. Electromagnetic compatibility (EMC) Class B features for the 8335-GTG, 8335-GTH, or 8335-GTX system

Feature	Description
EC5A	Non-volatile Memory PCIe3 x8 1.6 TB SSD NVMe adapter (FC EC5A; CCIN 58FC); Adapter FRU number: 01DH573
EC5C	PCIe3 x8 Non-Volatile Memory 3.2 TB SSD NVMe adapter (FC EC5C and EC5D; CCIN 58FD); Adapter FRU number: 01DH361
EC5E	PCIe3 x8 Non-Volatile Memory 6.4 TB SSD NVMe adapter (FC EC5E and EC5F; CCIN 58FE); Adapter FRU number: 01DH365
EL3Z	PCIe2 LP 2-port 10 GbE BaseT RJ45 adapter (FC EL3Z and FC EN0X; CCIN 2CC4); Adapter FRU number: 00E2714

PCIe adapter placement rules and slot priorities for the 8335-GTG, 8335-GTH, or 8335-GTX system

Find information about the placement rules and slot priorities for the Peripheral Component Interconnect Express (PCIe) adapters that are supported for the system.

PCIe slot descriptions

The system provides PCIe generation 4 slots. Table 3 on page 20 lists the PCIe adapter slots and details for the system as viewed from the rear and going from left to right. Figure 13 on page 20 shows the rear view of the system with the PCIe adapter slots. The system supports half-height, half-length and short (low-profile) PCIe adapters.

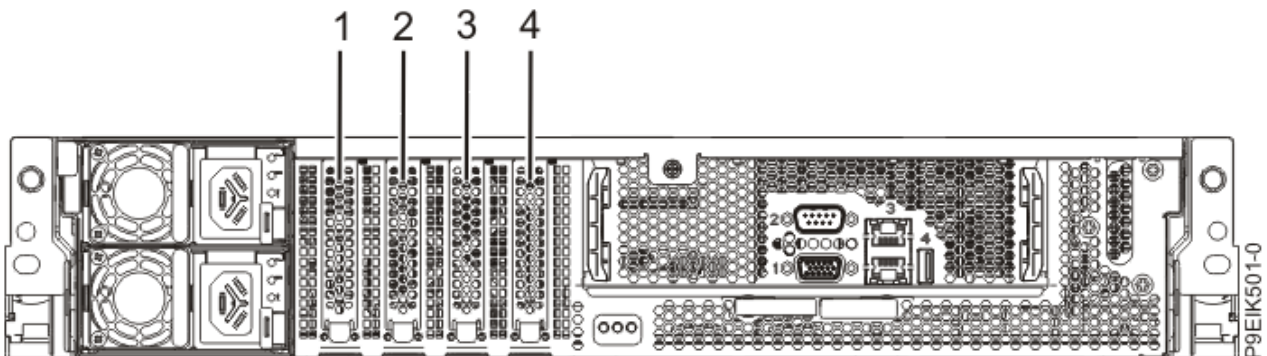

Figure 13. Rear view of a system with PCIe slots indicated

Table 3. PCIe slots and descriptions for the system

Slot identification	Description	Adapter size	Processor module	Coherent Accelerator Processor Interface (CAPI)
1	PCIe4 x4	Half-height, half-length	CPU 0	No
2	PCIe4 x8	Half-height, half-length	CPU 1 (shared)	Yes
3	PCIe4 x16	Half-height, half-length	CPU 1	Yes

Table 3. PCIe slots and descriptions for the system (continued)

Slot identification	Description	Adapter size	Processor module	Coherent Accelerator Processor Interface (CAPI)
4	PCIe4 x16	Half-height, half-length	CPU 0	Yes

PCIe adapter placement rules

Use this information to select slots for installing PCIe adapters in the system. Table 4 on page 21 provides information about the adapters, the slot priorities in the system they are supported on, and the maximum number of adapters that can be installed in the supported system. The link that appears in the feature code column provides more technical information specific to the PCIe adapter.

Table 4. PCIe adapter slot priorities and maximum adapters supported in the system

Feature code	Description	Slot priorities (slot identification 1-4)	Maximum number of adapters supported
EC2R¹	PCIe3 2-port 10 Gb NIC and RoCE SR/CU adapter (FC EC2R and EC2S; CCIN 58FA); Adapter FRU number: 01FT759	3, 4, 2	3
EC2T¹	PCIe3 2-port 25/10 Gb NIC and RoCE SR/CU capable adapter (FC EC2T and EC2U; CCIN 58FB); Adapter FRU number: 01FT753	3, 4, 2	3
EC3L	PCIe3 2-port 100 GbE (NIC and RoCE) QSFP28 adapter (FC EC3L and EC3M; CCIN 2CEC); Adapter FRU number: 00WT078	4, 3	2
EC5A	Non-volatile Memory PCIe3 x8 1.6 TB SSD NVMe adapter (FC EC5A; CCIN 58FC); Adapter FRU number: 01DH573	2, 3, 4	3
EC5C	PCIe3 x8 Non-Volatile Memory 3.2 TB SSD NVMe adapter (FC EC5C and EC5D; CCIN 58FD); Adapter FRU number: 01DH361	4, 3, 2	3
EC5E	PCIe3 x8 Non-Volatile Memory 6.4 TB SSD NVMe adapter (FC EC5E and EC5F; CCIN 58FE); Adapter FRU number: 01DH365	4, 3, 2	3
EC5G	Non-volatile Memory PCIe3 x8 1.6 TB SSD NVMe adapter (FC EC5A and EC5G; CCIN 58FC); Adapter FRU number: 01LK427	4, 3, 2	3
EC62	PCIe4 x16 1-Port EDR 100 Gb InfiniBand ConnectX-5 CAPI capable adapter (FC EC62; CCIN 2CF1); Adapter FRU number: 00WT179	2, 3, 4	3
EC64	PCIe4 x16 2-Port EDR 100 Gb InfiniBand ConnectX-5 CAPI capable adapter (FC EC64; CCIN 2CF2); Adapter FRU number: 00W176	2, 3, 4	3
EC67	PCIe4 x16, 2-port 100 Gb RoCE En ConnectX-5 adapter (FC EC66 and EC67; CCIN 2CF3); Adapter part number: 01FT742	4, 3, 2 Note: If slot 2 is populated by FC EC64 adapter, use slots 4 and 3 for EC67.	3
EL3Z	PCIe2 LP 2-port 10 GbE BaseT RJ45 adapter (FC EL3Z and FC EN0X; CCIN 2CC4); Adapter FRU number: 00E2714	3, 4, 2, 1	4
EL43	PCIe3 LP 16 Gb 2-port Fibre Channel adapter (FC EL43 and FC EN0B; CCIN 577F); Adapter FRU number: 00E3496	3, 4, 2	3
EL4M	PCIe2 LP 4-port 1 GbE adapter (FC 5260, FC 5899, FC EL4L, and FC EL4M; CCIN 576F); Adapter FRU number: 74Y4064	1, 2, 3, 4	4
EL5V	PCIe3 8x 2-port Fibre Channel (32 Gb/s); (FC EN1A, FC EN1B, FC EL5V, and EL5U; CCIN 578F); Adapter FRU number: 01FT704	3, 4, 2	3
EN0T	PCIe2 LP 4-port (10 Gb + 1 GbE) SR+RJ45 adapter (FC EN0T; CCIN 2CC3); Adapter FRU number: 00E2715	3, 4, 2, 1	4
EN0V	PCIe2 LP 4-port (10 Gb + 1 GbE) Copper SFP+RJ45 adapter (FC EN0V; CCIN 2CC3); Adapter FRU number: 00E2715	3, 4, 2, 1	4

Table 4. PCIe adapter slot priorities and maximum adapters supported in the system (continued)

Feature code	Description	Slot priorities (slot identification 1-4)	Maximum number of adapters supported
¹ The adapter is only supported on the 8335-GTH and 8335-GTX systems. * Review SMPPI software restrictions that might prevent you from using more than four RDMA interfaces. Slot 2 is a bifurcated slot. A two port adapter is configured as four RDMA interfaces; two from CPU 0 and two from CPU 1. Therefore the adapters in slot 4, 3, and 2 have 8 RDMA interfaces. ** Due to airflow restrictions, the adapter configuration is restricted to slots 4 and 3.			

PCIe adapter information by feature type for the 8335-GTG, 8335-GTH, or 8335-GTX system

Find information about the Peripheral Component Interconnect Express (PCIe) adapters that are supported for the system.

The table shows the available adapters by feature code (FC), description, customer card identification number (CCIN), adapter FRU number, and provides a link to more details for each adapter.

Important:

- This document does not replace the latest sales and marketing publications and tools that document supported features.
- If you are installing a new feature, ensure that the software that is required to support the new feature is installed. Also, determine whether you must install any existing program temporary fix (PTF) prerequisites. To do determine if software for fixes are available, use the [IBM Power Systems Prerequisite website \(https://www14.software.ibm.com/support/customercare/iprt/home\)](https://www14.software.ibm.com/support/customercare/iprt/home).

Table 5. PCIe adapters supported in the 8335-GTG, 8335-GTH, or 8335-GTX system

Feature code	Description
EC2R	PCIe3 2-port 10 Gb NIC and RoCE SR/CU adapter (FC EC2R and EC2S; CCIN 58FA); Adapter FRU number: 01FT759
EC2T	PCIe3 2-port 25/10 Gb NIC and RoCE SR/CU capable adapter (FC EC2T and EC2U; CCIN 58FB); Adapter FRU number: 01FT753
EC3L	PCIe3 2-port 100 GbE (NIC and RoCE) QSFP28 adapter (FC EC3L and EC3M; CCIN 2CEC); Adapter FRU number: 00WT078
EC5A	Non-volatile Memory PCIe3 x8 1.6 TB SSD NVMe adapter (FC EC5A; CCIN 58FC); Adapter FRU number: 01DH573
EC5C¹	PCIe3 x8 Non-Volatile Memory 3.2 TB SSD NVMe adapter (FC EC5C and EC5D; CCIN 58FD); Adapter FRU number: 01DH361
EC5E¹	PCIe3 x8 Non-Volatile Memory 6.4 TB SSD NVMe adapter (FC EC5E and EC5F; CCIN 58FE); Adapter FRU number: 01DH365
EC5G	Non-volatile Memory PCIe3 x8 1.6 TB SSD NVMe adapter (FC EC5A and EC5G; CCIN 58FC); Adapter FRU number: 01LK427
EC62	PCIe4 x16 1-Port EDR 100 Gb InfiniBand ConnectX-5 CAPI capable adapter (FC EC62; CCIN 2CF1); Adapter FRU number: 00WT179
EC64	PCIe4 x16 2-Port EDR 100 Gb InfiniBand ConnectX-5 CAPI capable adapter (FC EC64; CCIN 2CF2); Adapter FRU number: 00W176
EC67	PCIe4 x16, 2-port 100 Gb RoCE En ConnectX-5 adapter (FC EC66 and EC67; CCIN 2CF3); Adapter part number: 01FT742
EL3Z	PCIe2 LP 2-port 10 GbE BaseT RJ45 adapter (FC EL3Z and FC EN0X; CCIN 2CC4); Adapter FRU number: 00E2714

Table 5. PCIe adapters supported in the 8335-GTG, 8335-GTH, or 8335-GTX system (continued)

Feature code	Description
EL43	PCIe3 LP 16 Gb 2-port Fibre Channel adapter (FC EL43 and FC EN0B; CCIN 577F); Adapter FRU number: 00E3496
EL4M	PCIe2 4-port 1 GbE adapter (FC 5260, FC 5899, FC EL4L, and FC EL4M; CCIN 576F); Adapter part number: 74Y4064
EL5V	PCIe3 8x 2-port Fibre Channel (32 Gb/s); (FC EN1A, FC EN1B, FC EL5V, and EL5U; CCIN 578F); Adapter FRU number: 01FT704
EN0T	PCIe2 LP 4-port (10 Gb + 1 GbE) SR+RJ45 adapter (FC EN0T; CCIN 2CC3); Adapter FRU number: 00E2715
EN0V	PCIe2 LP 4-port (10 Gb + 1 GbE) Copper SFP+RJ45 adapter (FC EN0V; CCIN 2CC3); Adapter FRU number: 00E2715
¹ The adapter is only supported on the 8335-GTH and 8335-GTX systems.	

PCIe3 2-port 10 Gb NIC & RoCE SR/Cu adapter (FC EC2R and EC2S; CCIN 58FA)

Learn about the specifications and operating system requirements for feature code (FC) EC2R and EC2S adapters.

Overview

FC EC2R and EC2S are both the same adapter with different feature codes. FC EC2R is a low-profile adapter and FC EC2S is a full-height adapter.

The PCIe3 2-port 10 Gb NIC & RoCE SR/Cu Adapter is a PCI Express (PCIe) generation 3 (Gen3) x8 adapter. The adapter provides two 10 Gb SFP+ ports and supports both the Ethernet network interface controller (NIC) function and RDMA over Converged Ethernet (RoCE). The adapter can support significantly greater bandwidth with low latency using RoCe. It also minimizes CPU overhead by more efficiently using memory access. This offloads the CPU from I/O networking tasks, improving performance and scalability.

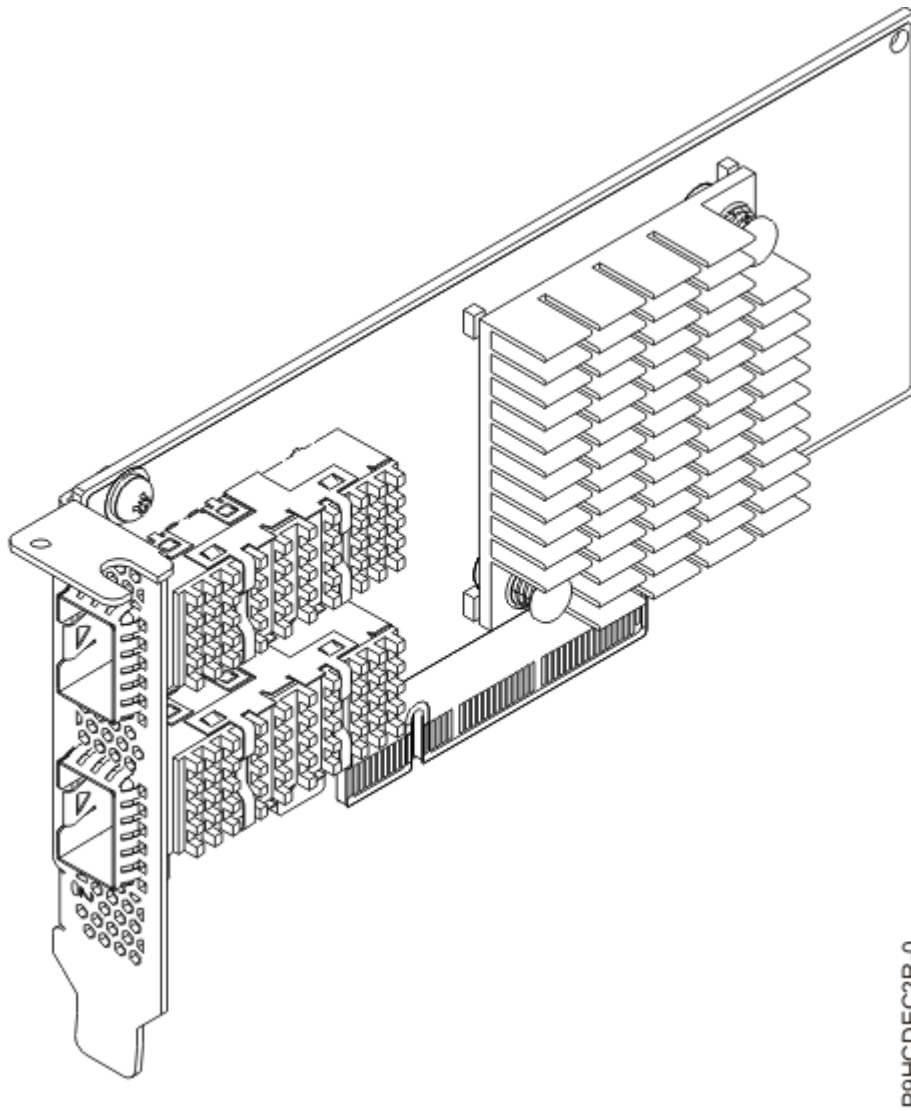
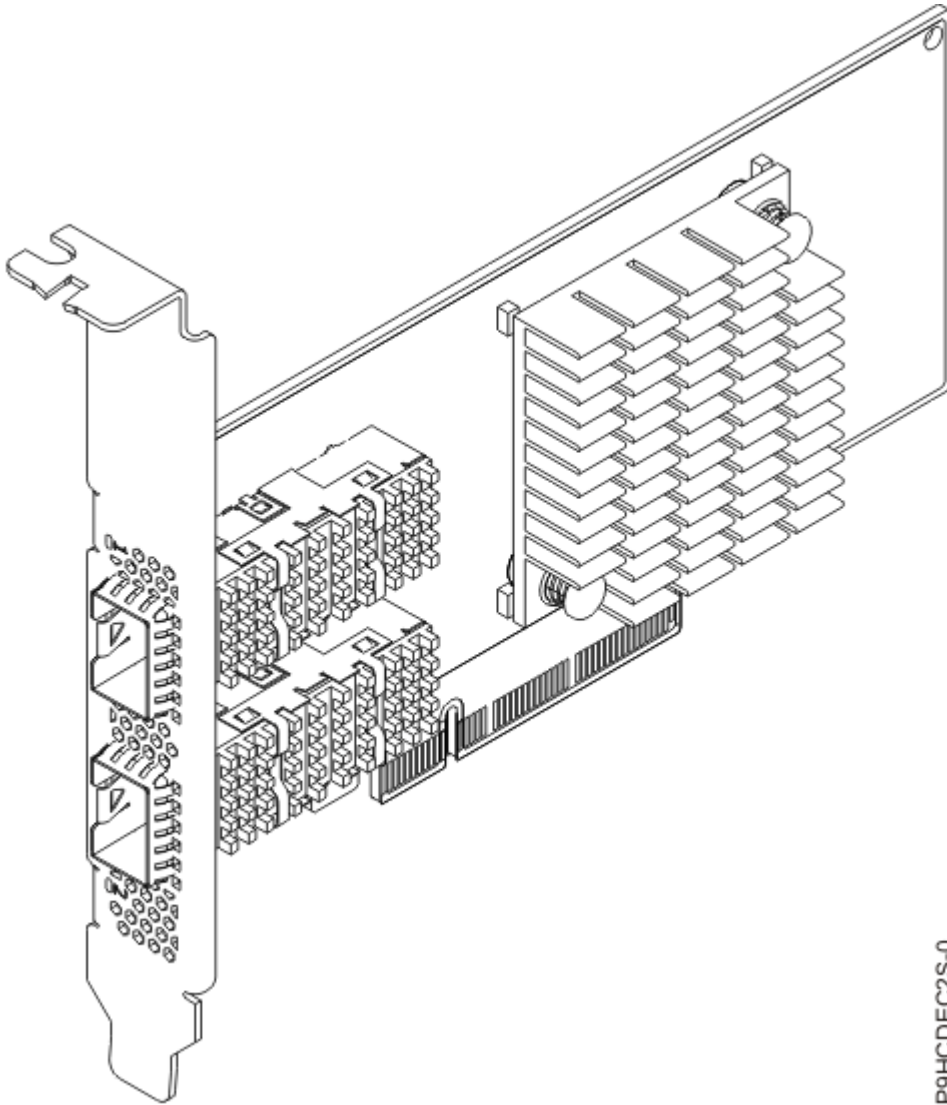

Figure 14. PCIe3 LP 2-port 10 Gb NIC & RoCE SR/Cu Adapter (FC EC2R)



P9HCDEC2S-0

Figure 15. PCIe3 2-port 10 Gb NIC & RoCE SR/Cu Adapter (FC EC2S)

Specifications

Item

Description

Adapter FRU number

01FT759

Wrap Plug FRU number

74Y7010 (Twinax wrap plug)

12R9314 (Optical wrap plug)

I/O bus architecture

PCIe3 x8

Slot requirement

For details about slot priorities, maximums, and placement rules, see [PCIe adapter placement rules and slot priorities \(http://www.ibm.com/support/knowledgecenter/POWER9/p9eab/p9eab_mtm_pciplacement.htm\)](http://www.ibm.com/support/knowledgecenter/POWER9/p9eab/p9eab_mtm_pciplacement.htm) and select the system you are working on.

Voltage

3.3 V, 12 V

Form factor

Short, low-profile (FC EC2R)

Short, with full-height tailstock (FC EC2S)

Attributes provided

RDMA over Converged Ethernet (RoCE)

Dual port 10 Gb Ethernet network connectivity

Supports 10 Gb Ethernet SFP+ connectivity

Supports 10 Gb SFP+ SR connectivity with a 10 Gb optical transceiver (IBM® P/N 77P9336, purchased separately)

AIX® Network Installation Management (NIM) support

PCI Express 3.0 (up to 8 GT/s) x8

PCIe Gen 3.0 compliant, 1.1 and 2.0 compatible

IEEE 802.3ae (10 Gb Ethernet), IEEE 802.3ad (Link Aggregation and Failover), IEEE 802.3az (Energy Efficient Ethernet), IEEE 802.1Q/P (VLAN Tagging), IEEE 802.10au (Congestion Notification), IEEE 802.1Qbg, IEEE 802.3Qaz D0.2 (ETS), IEEE 802.1Qbb D1.0 (PFC), IEEE 1588v2 (PTP)

Jumbo frame support up to 9.6 KB

VXLAN and NVGRE Overlay Network offload support

TCP/UDP/IP stateless offload

TCP/UDP checksum offload

TCP segmentation offload

PowerVM SR-IOV support. For more information see, [PowerVM® SR-IOV FAQs](#).

Cables

For 10 GbE, IBM® offers Direct Attach Copper (DAC) cables up to 5 M. SFP based transceivers are included on each end of these cables. For more information about adapter cabling, see the [“Cable and Transceiver information”](#) on page 26.

Transceivers

IBM® qualifies and supports SFP+ optical transceiver (FC EB46) to install into the adapter. Customers can also use their own optical cabling and SFP+ optical transceiver for the other end. The 10 Gb optical transceiver is capable up to 300 M through the OM3 cable or 82 M through OM2 cable. Either one or both of the adapter’s two SFP+ ports can be populated.

Cable and Transceiver information

Use multimode fiber optic cables with shortwave lasers that adhere to the following specifications:

- OM3 or OM4: Multimode 50/125 micron fiber, 2000 MHz x km bandwidth
- OM2: Multimode 50/125 micron fiber, 500 MHz x km bandwidth
- OM1: Multimode 62.5/125 micron fiber, 200 MHz x km bandwidth

Because core sizes are different, OM1 cables can only be connected to other OM1 cables. For best results, OM2 cables must not be connected to OM3 or OM4 cables. However, if an OM2 cable is connected to an OM3 or OM4 cable, the characteristics of the OM2 cable apply to the entire length of the cables. The following table shows the supported distances for the different fiber optic cable types at different link speeds.

Rate	Cable type and distance		
10 Gb/s	OM1	OM2	OM3
	0.5 m to 33 m (1.64 ft to 108.26 ft)	0.5 m to 82 m (1.64 ft to 269.02 ft)	0.5 meters to 300 meters (1.64 ft to 984.25 ft)

Feature code	Description
EB46	10 Gb optical transceiver (purchased separately)
EN01	10 Gb/s 1 m (3.3 ft) copper active twinax Ethernet cable
EN02	10 Gb/s 3 m (9.8 ft) copper active twinax Ethernet cable
EN03	10 Gb/s 5 m (16.4 ft) copper active twinax Ethernet cable

Operating system or partition requirements

If you are installing a new feature, ensure that you have the software that is required to support the new feature and you must determine any prerequisites that must be met for this feature and the attached devices. For information about operating system and partition requirements, see one of the following topics:

- The latest version of enabling libraries and utilities can be downloaded from the [Fix Central](http://www.ibm.com/support/fixcentral/) website (<http://www.ibm.com/support/fixcentral/>).
- [Power Systems Prerequisites](http://www14.software.ibm.com/support/customercare/iprt/home) website (<http://www14.software.ibm.com/support/customercare/iprt/home>).
- [IBM System Storage Interoperation Center \(SSIC\)](http://www-03.ibm.com/systems/support/storage/ssic/interoperability.wss) website (<http://www-03.ibm.com/systems/support/storage/ssic/interoperability.wss>).
- The latest version of the device driver or IBM Power RAID adapter utilities (iprutils) can be downloaded from the [IBM Service and Productivity Tools](http://www14.software.ibm.com/webapp/set2/sas/f/lopdiags/home.html) website (<http://www14.software.ibm.com/webapp/set2/sas/f/lopdiags/home.html>).
- For information about important notices for Linux on IBM Power Systems, see the [Linux on IBM](http://www14.software.ibm.com/webapp/set2/sas/f/lopdiags/info/LinuxAlerts.html) website (www14.software.ibm.com/webapp/set2/sas/f/lopdiags/info/LinuxAlerts.html).

PCIe3 2-port 25/10 Gb NIC & RoCE SFP28 adapter (FC EC2T and FC EC2U; CCIN 58FB)

Learn about the specifications and operating system requirements for feature code (FC) EC2T and FC EC2U adapters.

Overview

FC EC2T and EC2U are both the same adapter with different feature codes. FC EC2T is a low-profile adapter, and FC EC2U is a full-height adapter.

The PCIe3 2-PORT 25/10 Gb NIC & RoCE SFP28 Adapter (FC EC2T and EC2U) is a PCI Express® (PCIe) generation 3 (Gen3) x8 adapter. The adapter provides two 25 Gb SFP28 ports. The adapter supports both the Ethernet network interface controller (NIC) function and RDMA over Converged Ethernet (RoCE). Using RoCE, the adapter can support significantly greater bandwidth with low latency. It also minimizes CPU

overhead by more efficiently using memory access. This offloads the CPU from I/O networking tasks, improving performance and scalability.

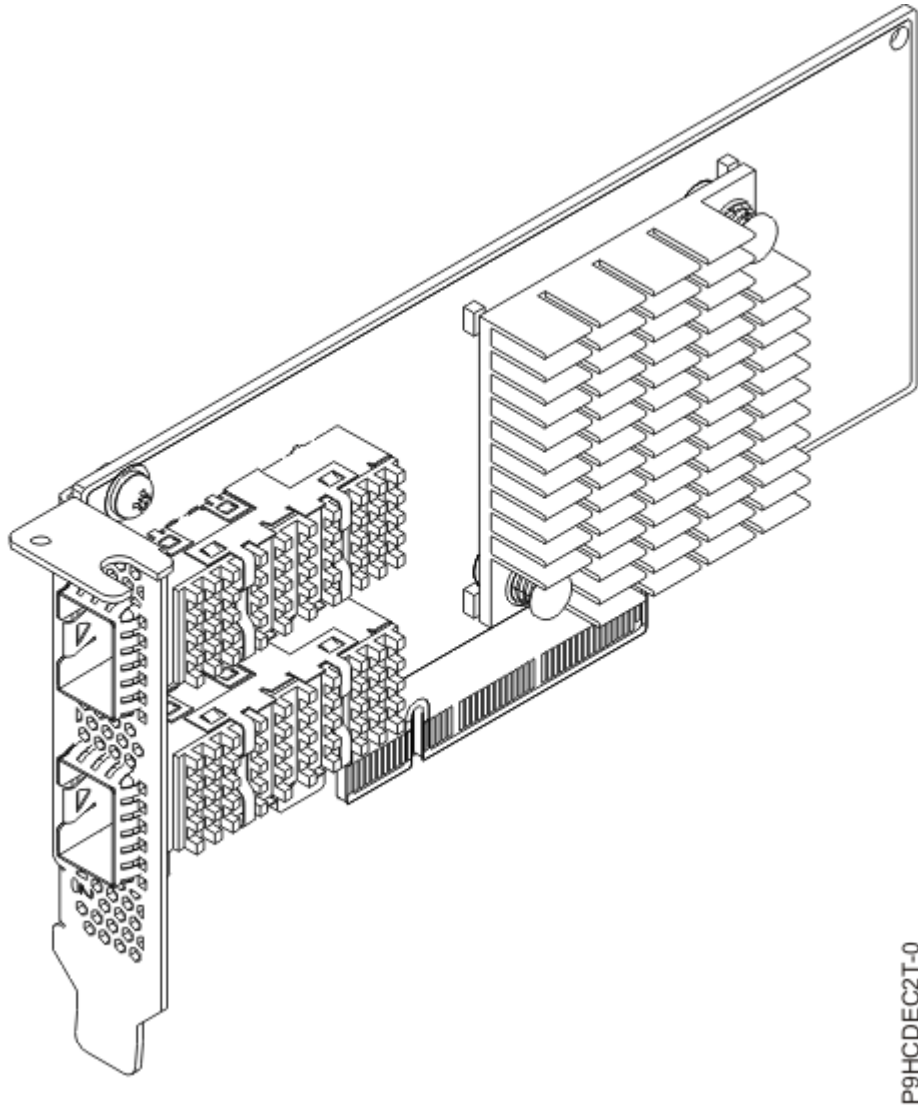

Figure 16. PCIe3 LP 2-port 25/10 Gb NIC & RoCE SFP28 Adapter (FC EC2T)

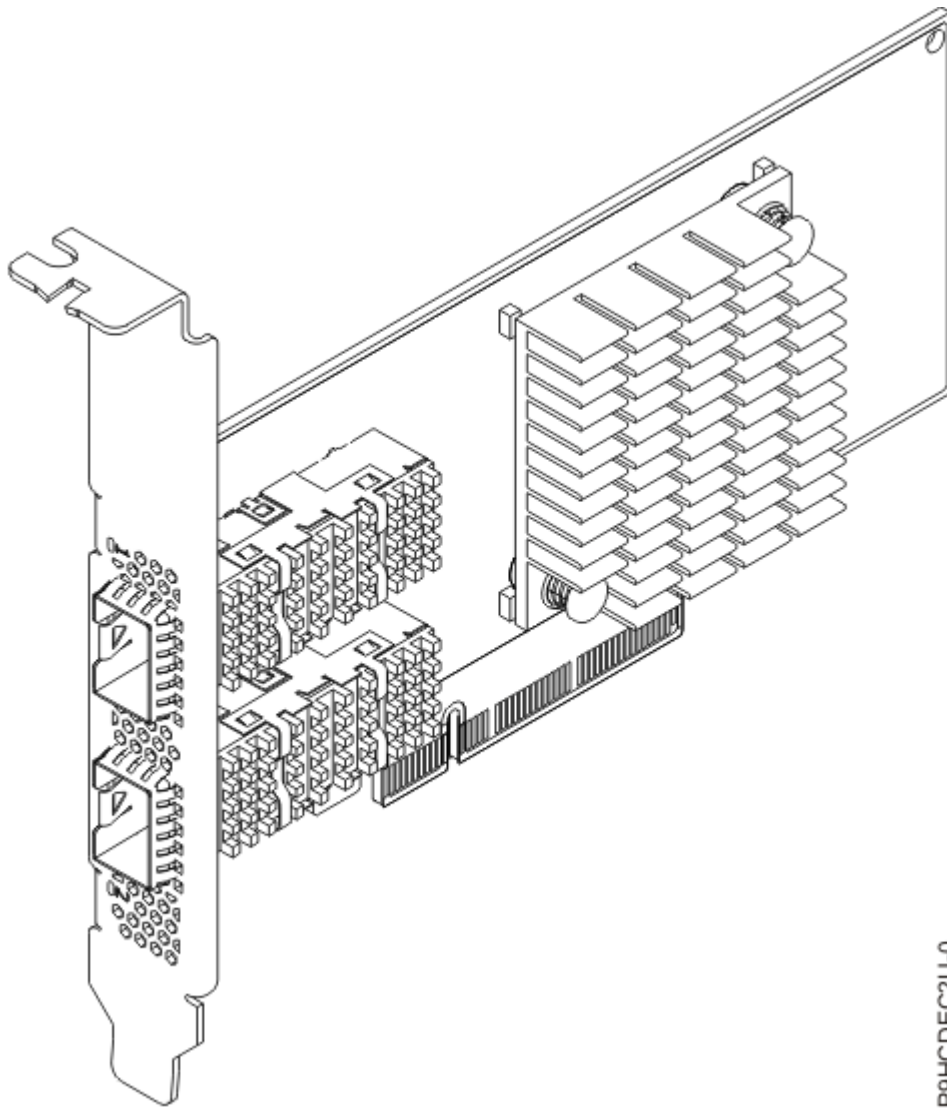

Figure 17. PCIe3 2-port 25/10 Gb NIC & RoCE SFP28 Adapter (FC EC2U)

Specifications

Item

Description

Adapter FRU number

01FT753

Wrap Plug FRU number

74Y7010 (Twinax wrap plug)

12R9314 (Optical wrap plug)

I/O bus architecture

PCIe3 x8

Slot requirement

For details about slot priorities, maximums, and placement rules, see [PCIe adapter placement rules and slot priorities \(http://www.ibm.com/support/knowledgecenter/POWER9/p9eab/p9eab_mtm_pciplacement.htm\)](http://www.ibm.com/support/knowledgecenter/POWER9/p9eab/p9eab_mtm_pciplacement.htm) and select the system you are working on.

Voltage

3.3 V, 12 V.

Form factor

Short, low-profile (FC EC2T).

Short, with full-height tailstock (FC EC2U).

Attributes provided

RDMA over Converged Ethernet (RoCE).

Dual port 25 Gb/10 Gb Ethernet network connectivity.

Supports 25 Gb Ethernet SFP28 connectivity.

Supports 10 Gb Ethernet SFP+ connectivity.

Supports 25 Gb SFP28 SR connectivity with a 25 Gb optical transceiver (IBM P/N 77P5153, purchased separately).

Supports 10 Gb SFP+ SR connectivity with a 10 Gb optical transceiver (IBM P/N 77P9336, purchased separately).

Supports 1 Gb RJ45 connectivity with a 1000BASE-T transceiver (IBM P/N 03FP283, purchased separately). Supports 1 Gb and full-duplex only. PowerVM® SR-IOV not supported for 1 Gb.

AIX Network Installation Management (NIM) support.

PCI Express 3.0 (up to 8 GT/s) x8.

PCIe Gen 3.0 compliant, 1.1 and 2.0 compatible.

IEEE 802.3ae (25Gb or 10Gb Ethernet), IEEE 802.3ad (Link Aggregation & Failover), IEEE 802.3az (Energy Efficient Ethernet), IEEE 802.1Q/P (VLAN Tagging), IEEE 802.10au (Congestion Notification), IEEE 802.1Qbg, IEEE 802.3Qaz D0.2 (ETS), IEEE 802.1Qbb D1.0 (PFC), IEEE 1588v2 (PTP).

Jumbo frame support up to 9.6 KB.

VXLAN and NVGRE Overlay Network offload support.

TCP/UDP/IP stateless offload.

TCP/UDP checksum offload.

TCP segmentation offload.

PowerVM SR-IOV support for 10 Gb and higher speeds.. For more information see, [PowerVM SR-IOV FAQs](#).

Cables

For 25 GbE, IBM offers SFP28 Passive Copper 25 Gb Ethernet cables up to 2 m. SFP28 based transceivers are included on each end of these cables.

For 10 GbE, IBM offers Direct Attach Copper (DAC) cables up to 5 m. SFP-based transceivers are included on each end of these cables. For more information about adapter cabling, see [“Cable and Transceiver information”](#) on page 31.

Transceivers

For 25 GbE, IBM qualifies and supports SFP28 optical transceiver (FC EB47) to install into the adapter. Customers can also use their own optical cabling and SFP28 optical transceiver for the other end. The 25 Gb optical transceiver is capable up to 100 m through the OM4 cable or 70 M through OM3 cable. Either one or both of the adapter’s two SFP28 ports can be populated.

For 10 GbE, IBM qualifies and supports SFP+ optical transceiver (FC EB46) to install into the adapter. Customers can also use their own optical cabling and SFP+ optical transceiver for the other end. The 10 Gb optical transceiver is capable up to 300 M through the OM3 cable or 82 m through OM2 cable. Either one or both of the adapter’s two SFP28 ports can be populated.

For 1000BASE-T, IBM qualifies and supports the RJ45 transceiver (FC EB48) to install into the adapter. Customers can also use their own Cat 5e STP cabling. The 1000BASE-T transceiver is capable up to 100 m through the Cat 5e STP cable. Both of the adapter’s two RJ45 ports can be populated, but mixing 1 Gb with higher speeds is not supported. 100 Mbps or 10 Mbps speeds and half-duplex are not supported. PowerVM SR-IOV is not supported on ports with FC EB48 installed.

Cable and Transceiver information

Use multimode fiber optic cables with shortwave lasers that adhere to the following specifications:

- OM3 or OM4: Multimode 50/125 micron fiber, 2000 MHz x km bandwidth
- OM2: Multimode 50/125 micron fiber, 500 MHz x km bandwidth
- OM1: Multimode 62.5/125 micron fiber, 200 MHz x km bandwidth

Because core sizes are different, OM1 cables can only be connected to other OM1 cables. For best results, OM2 cables must not be connected to OM3 or OM4 cables. However, if an OM2 cable is connected to an OM3 or OM4 cable, the characteristics of the OM2 cable apply to the entire length of the cables. The following table shows the supported distances for the different fiber optic cable types at different link speeds.

Rate	Cable type and distance		
10 Gb/s	OM1	OM2	OM3
	0.5 m to 33 m (1.64 ft to 108.26 ft)	0.5 m to 82 m (1.64 ft to 269.02 ft)	0.5 meters to 300 meters (1.64 ft to 984.25 ft)

Rate	Cable type and distance		
25 Gb/s	OM2	OM3	OM4
	0.5 m to 20 m (1.64 ft to 65.62 ft)	0.5 m to 70 m (1.64 ft to 229.66 ft)	0.5 m to 100 m (1.64 ft to 984.25 ft)

Feature code	Description
EB46	10 Gb optical transceiver (purchased separately)
EB47	25 Gb optical transceiver (purchased separately)
EB48	1 Gb RJ45 transceiver (purchased separately)
EB4J	25 Gb/s 0.5 m (1.6 ft) SFP28 passive copper 25 Gb Ethernet cable
EB4K	25 Gb/s 1.0 m (3.3 ft) SFP28 passive copper 25 Gb Ethernet cable
EB4L	25 Gb/s 1.5 m (4.9 ft) SFP28 passive copper 25 Gb Ethernet cable
EB4M	25 Gb/s 2.0m (6.6-ft) SFP28 passive copper 25 Gb Ethernet cable
EB4P	[100 Gb/s to 4x25 Gb/s] 2.0 m (6.6-ft) QSFP28 passive copper to SFP28 4x25 Gb Ethernet split cable
EN01	10 Gb/s 1 m (3.3 ft) copper active twinax Ethernet cable
EN02	10 Gb/s 3 m (9.8 ft) copper active twinax Ethernet cable
EN03	10 Gb/s 5 m (16.4 ft) copper active twinax Ethernet cable
EN03	10 Gb/s 5 m (16.4 ft) copper active twinax Ethernet cable

Operating system or partition requirements

If you are installing a new feature, ensure that you have the software that is required to support the new feature and you must determine any prerequisites that must be met for this feature and the attached

devices. For information about operating system and partition requirements, see one of the following topics:

- The latest version of enabling libraries and utilities can be downloaded from the [Fix Central](http://www.ibm.com/support/fixcentral/) website (<http://www.ibm.com/support/fixcentral/>).
- [Power Systems Prerequisites](http://www14.software.ibm.com/support/customercare/iprt/home) website (<http://www14.software.ibm.com/support/customercare/iprt/home>).
- [IBM System Storage Interoperation Center \(SSIC\)](http://www-03.ibm.com/systems/support/storage/ssic/interoperability.wss) website (<http://www-03.ibm.com/systems/support/storage/ssic/interoperability.wss>).
- The latest version of the device driver or IBM Power RAID adapter utilities (iprutils) can be downloaded from the [IBM Service and Productivity Tools](http://www14.software.ibm.com/webapp/set2/sas/f/lopdiags/home.html) website (<http://www14.software.ibm.com/webapp/set2/sas/f/lopdiags/home.html>).
- For information about important notices for Linux on IBM Power Systems, see the [Linux on IBM](http://www14.software.ibm.com/webapp/set2/sas/f/lopdiags/info/LinuxAlerts.html) website (www14.software.ibm.com/webapp/set2/sas/f/lopdiags/info/LinuxAlerts.html).

PCIe3 2-port 100 GbE NIC & RoCE QSFP28 Adapter (FC EC3L and EC3M; CCIN 2CEC)

Learn about the specifications and operating system requirements for the feature code (FC) EC3L and EC3M adapter.

Overview

FC EC3L and EC3M are both the same adapter with different tail stock brackets. FC EC3L is a low-profile adapter and FC EC3M is a full-height adapter.

The PCIe3 2-port 100 GbE NIC & RoCE QSFP28 Adapter is a PCI Express (PCIe) generation 3 (Gen3), x16 adapter. The adapter provides two 100 Gb QSFP28 ports. The PCIe3 2-port 100 GbE (NIC and RoCE) QSFP28 Adapter supports both NIC (Network Interface Controller) and IBTA RoCE standards. RoCE is Remote Direct Memory Access (RDMA) over Converged Ethernet. Using RoCE, the adapter can support significantly greater bandwidth with low latency. It also minimizes CPU overhead by more efficiently using memory access. This offloads the CPU from I/O networking tasks, improving performance and scalability.

Note: Each port maximum of 100 Gb assumes that no other system and or switch bottlenecks are present. The adapter allows full bandwidth for a single port in a PCIe3 slot and up to 128 Gb/s minus overheads for both ports.

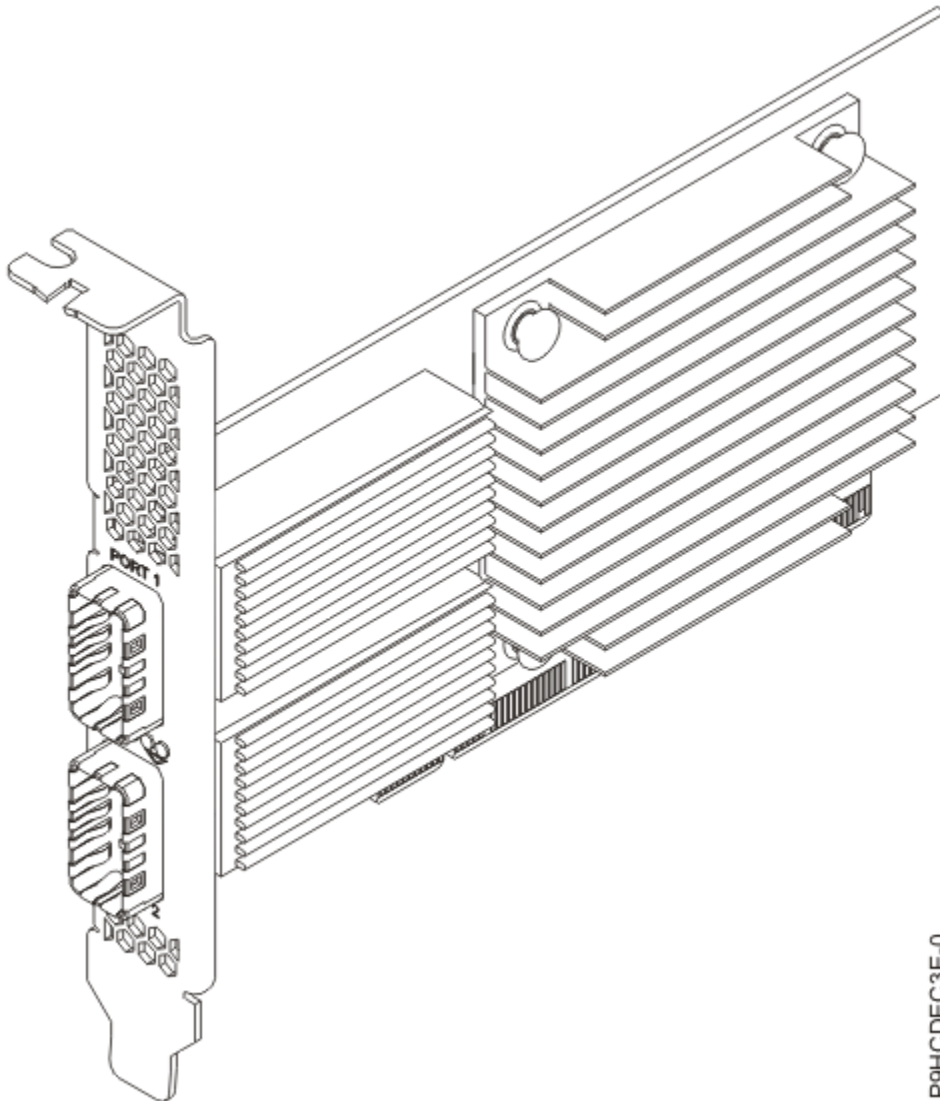

Figure 18. PCIe3 2-port 100 GbE NIC & RoCE QSFP28 Adapter

Specifications

Item

Description

Adapter FRU number
00WT078

I/O bus architecture
PCIe3 x16

Slot requirement

For details about slot priorities, maximums, and placement rules, see PCIe adapter placement rules and slot priorities (http://www.ibm.com/support/knowledgecenter/POWER9/p9eab/p9eab_mtm_pciplacement.htm) and select the system you are working on.

Voltage

3.3 V

Form factor

Short, low-profile (FC EC3L)
Short, with full-height tailstock (FC EC3M)

Cables

For 100G, IBM® offers either Direct Attach Copper (DAC) cables up to 2 M or Active Optical Cables (AOC) up to 100 M. QSFP28 based transceivers are included on each end of these cables. For more information about adapter cabling, see the “Cable and Transceiver Matrix” on page 34.

Note: For 40G, IBM® offers DAC cables up to 5 M. QSFP+ base transceivers are included on each end of these cables. See FC EB2B, EB2H, and ECBN for a 1 M, 3 M, and 5 M copper cables.

Transceivers

IBM qualifies and supports QSFP28 optical transceiver (FC EB59) to install into the adapter. Customers can also use their own optical cabling and QSP28 optical transceiver for the other end. This is a 100GBASE-SR4 based active optical transceiver capable up to 100 M through the OM4 cable or 70 M through OM3 cable. Either one or both of the adapter's two QSP28 ports can be populated. When two ports are filled, both can have copper cables or optical cables. Additionally, one of the cables can be copper and the other can be optical. IBM® also offers QSFP+ optical transceiver (FC EB27) to install into the adapter and allowing the customer to use their own optical cabling and QSP28 optical transceiver for the other end.

Cable and Transceiver Matrix

Feature code	Description
EB59	100GBASE-SR4 Optical Transceiver MTP/MPO cable (purchased separately) <ul style="list-style-type: none">• FC EB2J - 10 M• FC EB2K - 30 M
EB5J	QSFP28 Passive Copper 100 Gb Ethernet Cable - .5 M
EB5K	QSFP28 Passive Copper 100 Gb Ethernet Cable - 1 M
EB5L	QSFP28 Passive Copper 100 Gb Ethernet Cable - 1.5 M
EB5M	QSFP28 Passive Copper 100 Gb Ethernet Cable - 2 M
EB5R	QSFP28 AOC 100 Gb Ethernet Cable - 3 M
EB5S	QSFP28 AOC 100 Gb Ethernet Cable - 5 M
EB5T	QSFP28 AOC 100 Gb Ethernet Cable - 10 M
EB5U	QSFP28 AOC 100 Gb Ethernet Cable - 15 M
EB5V	QSFP28 AOC 100 Gb Ethernet Cable - 20 M
EB5W	QSFP28 AOC 100 Gb Ethernet Cable - 30 M
EB5X	QSFP28 AOC 100 Gb Ethernet Cable - 50 M
EB5Y	QSFP28 AOC 100 Gb Ethernet Cable - 100 M
EB2B	1 M Passive QSFP+ to QSFP+
EB2H	3 M Passive QSFP+ to QSFP+
ECBN	5 M Passive QSFP+ to QSFP+
EB27	QSFP+ 40G BASE-SR transceiver

Attributes provided

The adapter is based on the Mellanox ConnectX-4 adapter, which uses the ConnectX-4 EN Network Controller

Ethernet only supported in Ethernet or RoCE mode

PCIe3 compliant (1.1 and 2.0 compatible)

RDMA over Converged Ethernet (RoCE)

NIC and RoCE are concurrently supported

RoCE supported on Linux and AIX (7.2, and later)

NIC supported on all operati

TCP/UDP/IP stateless offload

LSO, LRO, and checksum offload

NIM boot support

Backward compatible with 40 Gb Ethernet when using compatible cables and transceivers

Improves performance and scalability by offloading the CPU from I/O networking tasks

Minimizes CPU overhead by more efficiently using memory access

PowerVM SR-IOV support. For more information see, [PowerVM® SR-IOV FAQs](#).

Operating system or partition requirements

If you are installing a new feature, ensure that you have the software that is required to support the new feature and you must determine any prerequisites that must be met for this feature and the attached devices. For information about operating system and partition requirements, see one of the following topics:

- The latest version of enabling libraries and utilities can be downloaded from the [Fix Central](http://www.ibm.com/support/fixcentral/) website (<http://www.ibm.com/support/fixcentral/>).
- [Power Systems Prerequisites](http://www14.software.ibm.com/support/customer/home) website (<http://www14.software.ibm.com/support/customer/home>).
- [IBM System Storage Interoperation Center \(SSIC\)](http://www-03.ibm.com/systems/support/storage/ssic/interoperability.wss) website (<http://www-03.ibm.com/systems/support/storage/ssic/interoperability.wss>).
- The latest version of the device driver or IBM Power RAID adapter utilities (iprutils) can be downloaded from the [IBM Service and Productivity Tools](http://www14.software.ibm.com/webapp/set2/sas/f/lopdiags/home.html) website (<http://www14.software.ibm.com/webapp/set2/sas/f/lopdiags/home.html>).
- For information about important notices for Linux on IBM Power Systems, see the [Linux on IBM](http://www14.software.ibm.com/webapp/set2/sas/f/lopdiags/info/LinuxAlerts.html) website (www14.software.ibm.com/webapp/set2/sas/f/lopdiags/info/LinuxAlerts.html).

PCIe3 x8 NVMe 1.6 TB SSD NVMe Flash Adapter (FC EC5A, EC5B, EC5G, EC6U, and EC6V; CCIN 58FC)

Learn about the specifications and operating system requirements for feature code (FC) EC5A, EC5B, EC5G, EC6U, and EC6V adapters.

Overview

FC EC5A, EC5B, EC5G, EC6U, and EC6V are all the same adapters with different feature codes. FC EC5A, EC5G, and EC6U are low-profile adapters. FC EC5B and EC6V are full-height adapters. FC EC5A, EC5B, and EC5G are supported on AIX or Linux operating systems. FC EC6U and EC6V are supported on IBM i operating system.

The PCIe3 x8 NVMe 1.6 TB SSD NVMe adapter is a Peripheral Component Interconnect Express (PCIe) generation 3 (Gen3) x8 adapter. The adapter can be used in either a x8 or x16 PCIe (Gen3) slot in the system and uses Non-Volatile Memory Express (NVMe). NVMe is a high-performance software interface that can read or write flash memory. Compared to a Serial-attached SCSI (SAS) or Serial Advanced

Technology Attachment (SATA) solid-state drive (SSD), the NVMe Flash adapter provides more read or write, input or output operations per second (IOPS) and larger throughput (GB/sec). The type of workload has a great impact on the maximum write capacity. If a high percentage of more sequentially oriented write operations are performed instead of random write operations, the maximum write capacity will be large. To extend the life of the NVMe device, the application that is using the NVMe device must convert small random write operations to larger sequential write operations. The write operations that exceed the maximum write capacity of the adapter continues to operate for some time but the performance will be slow. The life of the device is not affected depending on whether the application uses sequential oriented write operations or random read operations from the device. A Predictive Failure Analysis message is displayed when the adapter that is enabled by the system administrator must be replaced. To monitor the percentage usage of the adapter, see [Checking the amount of remaining life in NVMe devices](#). If the adapter exceeds the maximum write capability, the adapter's replacement is not covered under IBM warranty or maintenance. This adapter has protection against single Flash channel failures. To prevent the entire adapter from failing, software RAID should be used. For high-value applications where the content in the adapter must be protected, additional NVMe Flash adapters with OS mirroring or software Redundant Array of Independent Disks (RAID) are recommended. This adapter is not supported in the PCIe Gen3 I/O drawer.

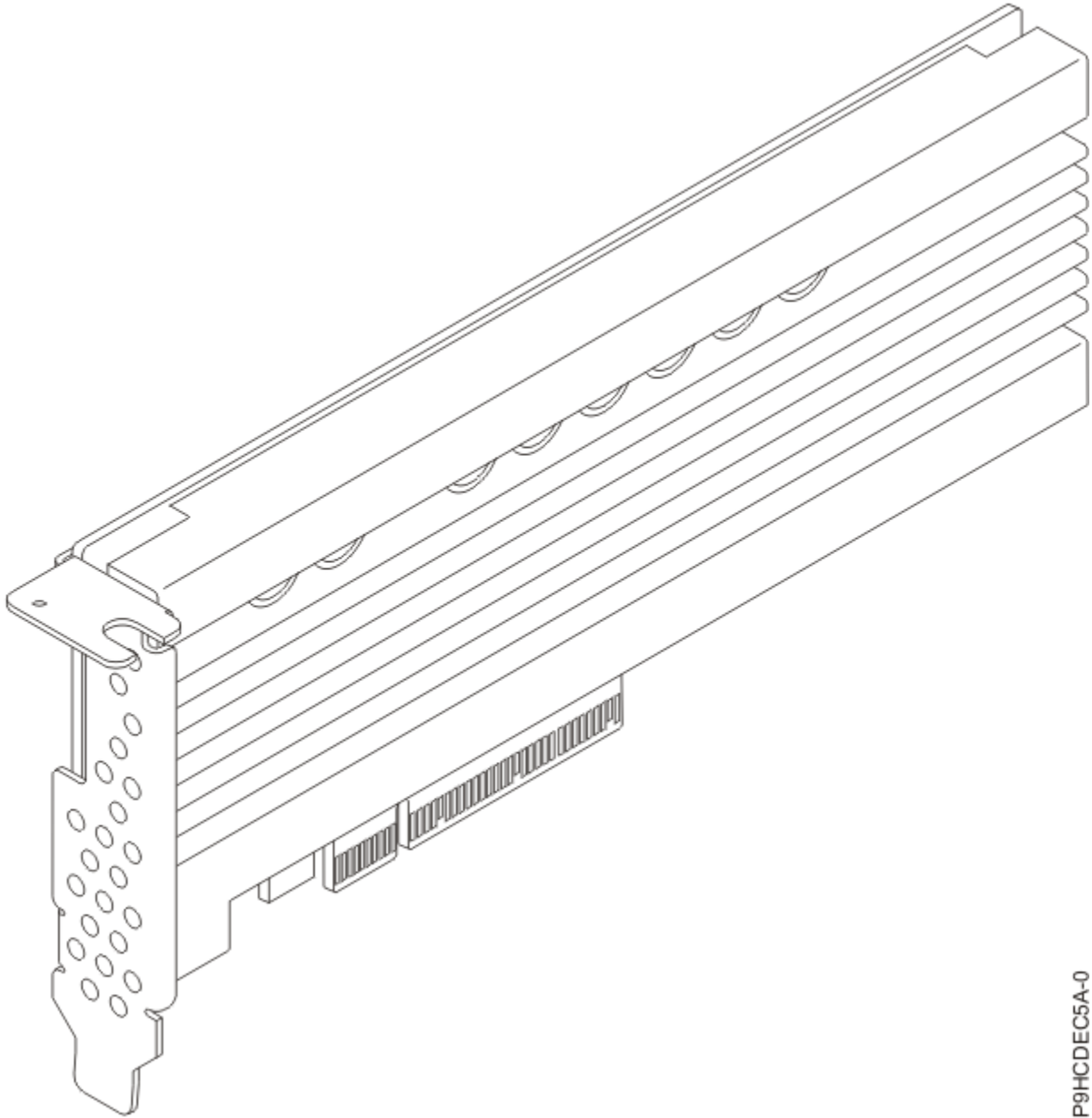

P9HCDEC5A-0

Figure 19. PCIe x8 NVMe 1.6 TB SSD NVMe Flash Adapter

Specifications

Item

Description

Adapter FRU number

01DH570.

I/O bus architecture

PCIe3 x8.

Slot requirement

For details about slot priorities, maximums, and placement rules, see [PCIe adapter placement rules and slot priorities \(http://www.ibm.com/support/knowledgecenter/POWER9/p9eab/p9eab_mtm_pciplacement.htm\)](http://www.ibm.com/support/knowledgecenter/POWER9/p9eab/p9eab_mtm_pciplacement.htm) and select the system you are working on.

Voltage

3.3 V, 12 V.

Form factor

Short, low-profile (FC EC5A, EC5G, and EC6U).

Short, with full-height tail stock (FC EC5B and EC6V).

Maximum number

For details about the maximum number of adapters that are supported, see Adapter placement rules and slot priorities (http://www.ibm.com/support/knowledgecenter/POWER9/p9eab/p9eab_mtm_pciplacement.htm) and select the system you are working on.

Attributes provided

1.6 TB of low latency flash memory.

Non-Volatile Write Buffer.

Hot Plug Capable.

Operating system or partition requirements

If you are installing a new feature, ensure that you have the software that is required to support the new feature and you must determine any prerequisites that must be met for this feature and the attached devices. For information about operating system and partition requirements, see one of the following topics:

- The latest version of enabling libraries and utilities can be downloaded from the [Fix Central](http://www.ibm.com/support/fixcentral/) website (<http://www.ibm.com/support/fixcentral/>).
- [Power Systems Prerequisites](http://www14.software.ibm.com/support/customercare/iprt/home) website (<http://www14.software.ibm.com/support/customercare/iprt/home>).
- [IBM System Storage Interoperation Center \(SSIC\)](http://www-03.ibm.com/systems/support/storage/ssic/interoperability.wss) website (<http://www-03.ibm.com/systems/support/storage/ssic/interoperability.wss>).
- The latest version of the `nvme-cli` tool to manage NVMe devices can be downloaded from the [IBM Service and Productivity Tools](http://www14.software.ibm.com/webapp/set2/sas/f/lopdiags/home.html) website (<http://www14.software.ibm.com/webapp/set2/sas/f/lopdiags/home.html>).
- For information about important notices for Linux on IBM Power Systems, see the [Linux on IBM](http://www14.software.ibm.com/webapp/set2/sas/f/lopdiags/info/LinuxAlerts.html) website (www14.software.ibm.com/webapp/set2/sas/f/lopdiags/info/LinuxAlerts.html).

PCIe3 x8 NVMe 3.2 TB SSD NVMe Flash Adapter (FC EC5C, EC5D, EC6W, and EC6X; CCIN 58FD)

Learn about the specifications and operating system requirements for feature code (FC) EC5C, EC5D, EC6W, and EC6X adapters. FC EC5C and EC6W are low-profile adapters and FC EC5D and EC6X are full-height adapters. FC EC5C and EC5D are supported on AIX or Linux operating systems. FC EC6W and EC6X are supported on the IBM i operating system.

Overview

The PCIe3 x8 NVMe 1.6 TB SSD NVMe adapter is a Peripheral Component Interconnect Express (PCIe) generation 3 (Gen3) x8 adapter. The adapter can be used in either a x8 or x16 PCIe (Gen3) slot in the system and uses Non-Volatile Memory Express (NVMe). NVMe is a high-performance software interface that can read or write flash memory. Compared to a Serial-attached SCSI (SAS) or Serial Advanced Technology Attachment (SATA) solid-state drive (SSD), the NVMe Flash adapter provides more read or write, input or output operations per second (IOPS) and larger throughput (GB/sec). The type of workload has a great impact on the maximum write capacity. If a high percentage of more sequentially oriented write operations are performed instead of random write operations, the maximum write capacity will be large. To extend the life of the NVMe device, the application that is using the NVMe device must convert small random write operations to larger sequential write operations. The write operations that exceed the maximum write capacity of the adapter continues to operate for some time but the performance will be slow. The life of the device is not affected depending on whether the application uses sequential oriented write operations or random read operations from the device. A Predictive Failure Analysis message is displayed when the adapter that is enabled by the system administrator must be replaced. To monitor

the percentage usage of the adapter, see [Checking the amount of remaining life in NVMe devices](#). If the adapter exceeds the maximum write capability, the adapter's replacement is not covered under IBM warranty or maintenance. This adapter has protection against single Flash channel failures. To prevent the entire adapter from failing, software RAID should be used. For high-value applications where the content in the adapter must be protected, additional NVMe Flash adapters with OS mirroring or software Redundant Array of Independent Disks (RAID) are recommended. This adapter is not supported in the PCIe Gen3 I/O drawer.

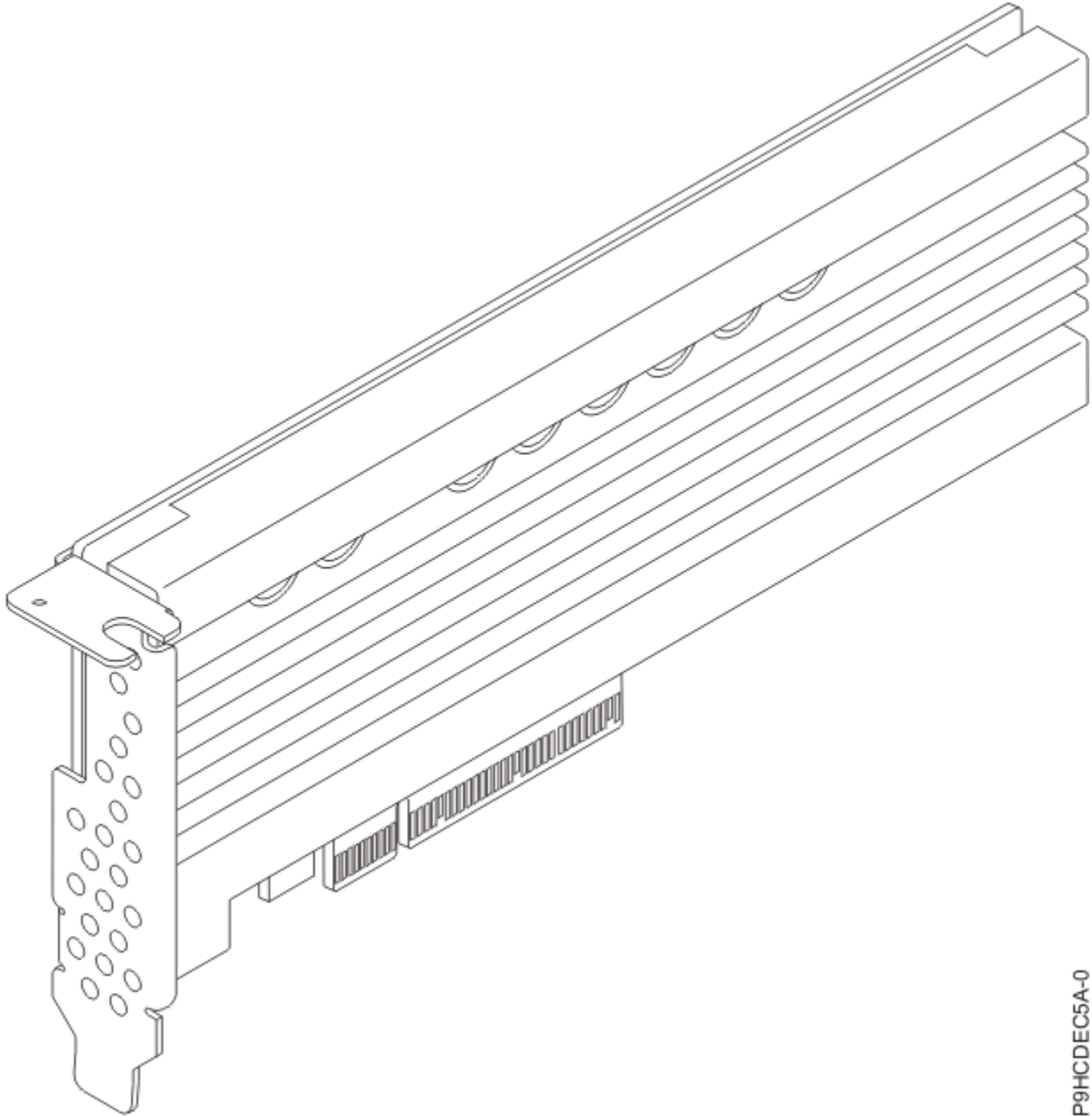

P9HCDEC5A-0

Figure 20. PCIe x8 NVMe 3.2 TB SSD NVMe Flash Adapter

Specifications

Item

Description

Adapter FRU number

01LK431

I/O bus architecture

PCIe3 x8

Slot requirement

For details about slot priorities, maximums, and placement rules, see [PCIe adapter placement rules and slot priorities \(http://www.ibm.com/support/knowledgecenter/POWER9/p9eab/p9eab_mtm_pciplacement.htm\)](http://www.ibm.com/support/knowledgecenter/POWER9/p9eab/p9eab_mtm_pciplacement.htm) and select the system you are working on.

Voltage

3.3 V, 12 V

Form factor

Short, low-profile (FC EC5C and EC6W)

Short, with full-height tailstock (FC EC5D and EC6X)

Maximum number

For details about the maximum number of adapters that are supported, see [Adapter placement rules and slot priorities \(http://www.ibm.com/support/knowledgecenter/POWER9/p9eab/p9eab_mtm_pciplacement.htm\)](http://www.ibm.com/support/knowledgecenter/POWER9/p9eab/p9eab_mtm_pciplacement.htm) and select the system you are working on.

Attributes provided

3.2 TB of low latency flash memory

Non-Volatile Write Buffer

Hot Plug Capable

Operating system or partition requirements

If you are installing a new feature, ensure that you have the software that is required to support the new feature and you must determine any prerequisites that must be met for this feature and the attached devices. For information about operating system and partition requirements, see one of the following topics:

- The latest version of enabling libraries and utilities can be downloaded from the [Fix Central website \(http://www.ibm.com/support/fixcentral/\)](http://www.ibm.com/support/fixcentral/).
- [Power Systems Prerequisites website \(http://www14.software.ibm.com/support/customercare/iprt/home\)](http://www14.software.ibm.com/support/customercare/iprt/home).
- [IBM System Storage Interoperation Center \(SSIC\) website \(http://www-03.ibm.com/systems/support/storage/ssic/interoperability.wss\)](http://www-03.ibm.com/systems/support/storage/ssic/interoperability.wss).
- The latest version of the [nvme-cli tool to manage NVMe devices can be downloaded from the IBM Service and Productivity Tools website \(http://www14.software.ibm.com/webapp/set2/sas/f/lopdiags/home.html\)](http://www14.software.ibm.com/webapp/set2/sas/f/lopdiags/home.html).
- For information about important notices for Linux on IBM Power Systems, see the [Linux on IBM website \(www14.software.ibm.com/webapp/set2/sas/f/lopdiags/info/LinuxAlerts.html\)](http://www14.software.ibm.com/webapp/set2/sas/f/lopdiags/info/LinuxAlerts.html).

PCIe3 x8 NVMe 6.4 TB SSD NVMe Flash Adapter (FC EC5E, EC5F, EC6Y, and EC6Z; CCIN 58FE)

Learn about the specifications and operating system requirements for feature code FC EC5E, EC5F, EC6Y, and EC6Z adapters. FC EC5E and EC6Y are low-profile adapters and EC5F and EC6Z are full-height adapters. FC EC5E and EC5F are supported on AIX or Linux operating systems. FC EC6Y and EC6Z are supported on the IBM i operating system.

Overview

The PCIe3 x8 NVMe 1.6 TB SSD NVMe adapter is a Peripheral Component Interconnect Express (PCIe) generation 3 (Gen3) x8 adapter. The adapter can be used in either a x8 or x16 PCIe (Gen3) slot in the system and uses Non-Volatile Memory Express (NVMe). NVMe is a high-performance software interface that can read or write flash memory. Compared to a Serial-attached SCSI (SAS) or Serial Advanced Technology Attachment (SATA) solid-state drive (SSD), the NVMe Flash adapter provides more read or write, input or output operations per second (IOPS) and larger throughput (GB/sec). The type of workload has a great impact on the maximum write capacity. If a high percentage of more sequentially oriented

write operations are performed instead of random write operations, the maximum write capacity will be large. To extend the life of the NVMe device, the application that is using the NVMe device must convert small random write operations to larger sequential write operations. The write operations that exceed the maximum write capacity of the adapter continues to operate for some time but the performance will be slow. The life of the device is not affected depending on whether the application uses sequential oriented write operations or random read operations from the device. A Predictive Failure Analysis message is displayed when the adapter that is enabled by the system administrator must be replaced. To monitor the percentage usage of the adapter, see [Checking the amount of remaining life in NVMe devices](#). If the adapter exceeds the maximum write capability, the adapter's replacement is not covered under IBM warranty or maintenance. This adapter has protection against single Flash channel failures. To prevent the entire adapter from failing, software RAID should be used. For high-value applications where the content in the adapter must be protected, additional NVMe Flash adapters with OS mirroring or software Redundant Array of Independent Disks (RAID) are recommended. This adapter is not supported in the PCIe Gen3 I/O drawer.

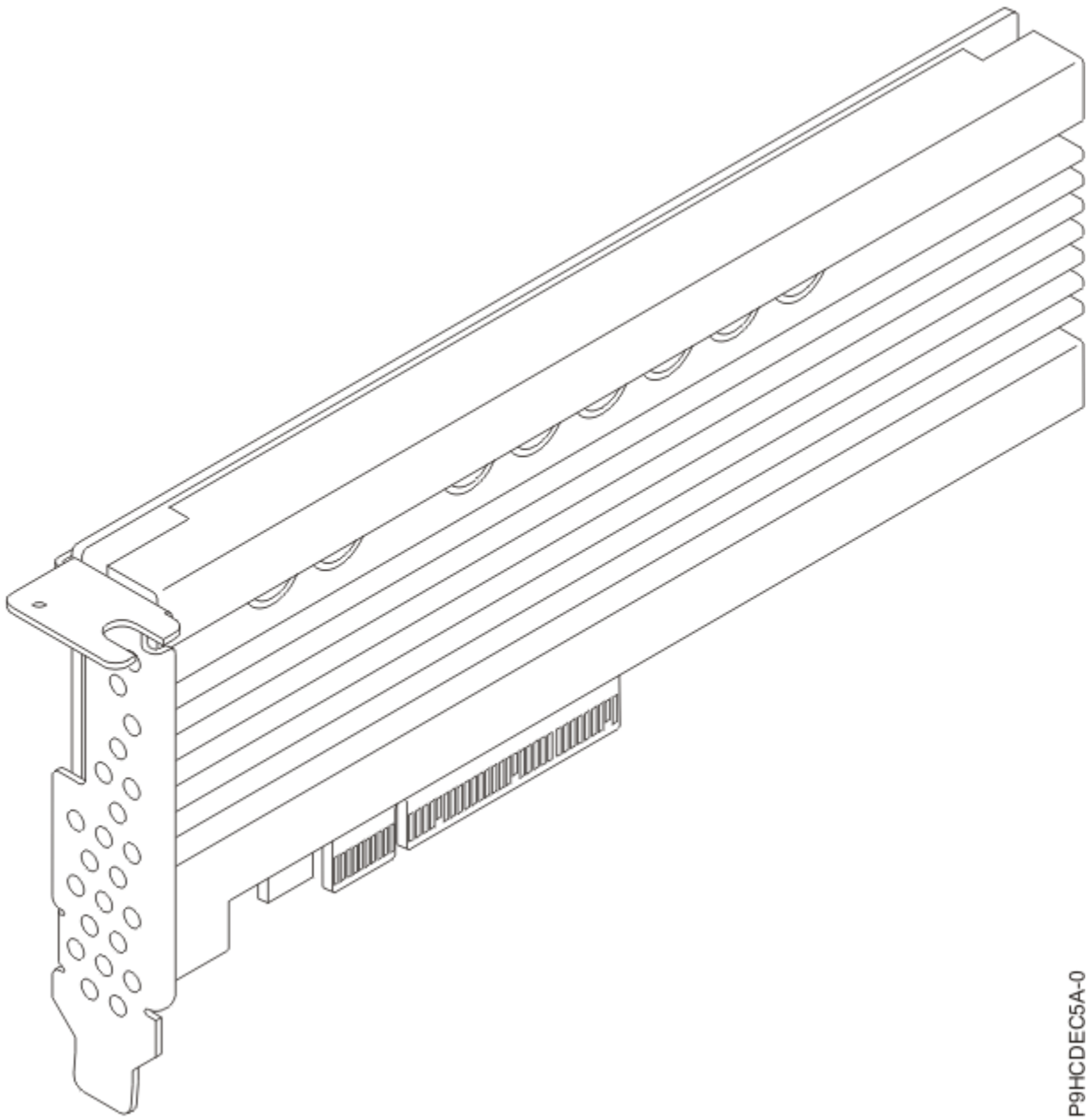

P9HCDEC5A-0

Figure 21. PCIe x8 NVMe 6.4 TB SSD NVMe Flash Adapter

Specifications

Item

Description

Adapter FRU number

01LK435

I/O bus architecture

PCIe3 x8

Slot requirement

For details about slot priorities, maximums, and placement rules, see PCIe adapter placement rules and slot priorities (http://www.ibm.com/support/knowledgecenter/POWER9/p9eab/p9eab_mtm_pciplacement.htm) and select the system you are working on.

Voltage

3.3 V, 12 V

Form factor

Short, low-profile (FC EC5E and EC6Y)

Short, with full-height tailstock (FC EC5F and EC6Z)

Maximum number

For details about the maximum number of adapters that are supported, see Adapter placement rules and slot priorities (http://www.ibm.com/support/knowledgecenter/POWER9/p9eab/p9eab_mtm_pciplacement.htm) and select the system you are working on.

Attributes provided

6.4 TB of low latency flash memory

Non-Volatile Write Buffer

Hot Plug Capable

Operating system or partition requirements

If you are installing a new feature, ensure that you have the software that is required to support the new feature and you must determine any prerequisites that must be met for this feature and the attached devices. For information about operating system and partition requirements, see one of the following topics:

- The latest version of enabling libraries and utilities can be downloaded from the [Fix Central](http://www.ibm.com/support/fixcentral/) website (<http://www.ibm.com/support/fixcentral/>).
- [Power Systems Prerequisites](http://www14.software.ibm.com/support/customercare/iprt/home) website (<http://www14.software.ibm.com/support/customercare/iprt/home>).
- [IBM System Storage Interoperation Center \(SSIC\)](http://www-03.ibm.com/systems/support/storage/ssic/interoperability.wss) website (<http://www-03.ibm.com/systems/support/storage/ssic/interoperability.wss>).
- The latest version of the `nvme-cli` tool to manage NVMe devices can be downloaded from the [IBM Service and Productivity Tools](http://www14.software.ibm.com/webapp/set2/sas/f/lopdiags/home.html) website (<http://www14.software.ibm.com/webapp/set2/sas/f/lopdiags/home.html>).
- For information about important notices for Linux on IBM Power Systems, see the [Linux on IBM](http://www14.software.ibm.com/webapp/set2/sas/f/lopdiags/info/LinuxAlerts.html) website (www14.software.ibm.com/webapp/set2/sas/f/lopdiags/info/LinuxAlerts.html).

PCIe4 x16 1-Port EDR 100 GB IB ConnectX-5 CAPI Capable Adapter (FC EC62 and EC63; CCIN 2CF1)

Learn about the specifications and operating system requirements for feature code (FC) EC62 and EC63 adapters.

Overview

FC EC62 and EC63 are both the same adapter with different feature codes. FC EC62 is a low-profile adapter and FC EC63 is a full-height adapter.

The PCIe4 x16 1-Port enhanced data rate (EDR) 100 GB Infiniband (IB) ConnectX-5 CAPI Capable Adapter is a PCI Express (PCIe) generation 4 (Gen4) x16 adapter. The adapter enables higher HPC performance with new Message Passing Interface (MPI) offloads, such as MPI Tag Matching and MPI AlltoAll operations, advanced dynamic routing, and new capabilities to perform various data algorithms.

Note: The Virtual Protocol Interconnect (VPI) feature is not supported on this adapter. The adapter must be used only as an InfiniBand adapter.

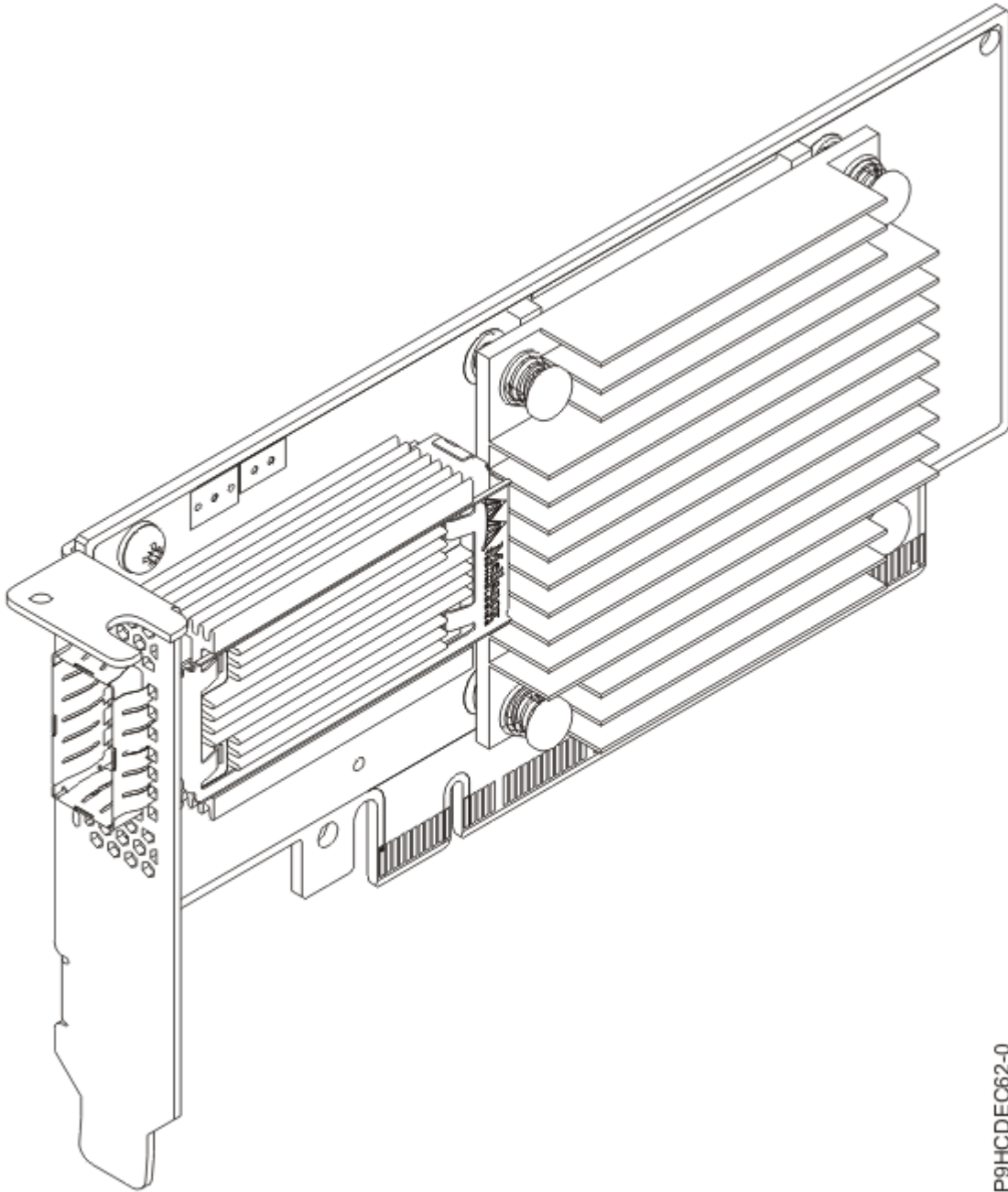

P9HCDEC62-0

Figure 22. PCIe4 x16 1-Port EDR 100 GB IB ConnectX-5 CAPI Capable Adapter

Specifications

Item

Description

Adapter FRU number

00WT179

I/O bus architecture

PCIe4 x16

Slot requirement

For details about slot priorities, maximums, and placement rules, see [PCIe adapter placement rules and slot priorities \(http://www.ibm.com/support/knowledgecenter/POWER9/p9eab/p9eab_mtm_pcplacement.htm\)](http://www.ibm.com/support/knowledgecenter/POWER9/p9eab/p9eab_mtm_pcplacement.htm) and select the system you are working on.

Thermal requirement

If you have an 8335-GTG, 8335-GTH, or 8335-GTX system, you might be required to set the thermal mode of the system to a setting other than the default setting, depending on your system, adapter, and cable type. For details, see [Determining and setting the thermal mode for an 8335-GTG, 8335-GTH, or 8335-GTX system](#).

Voltage

3.3 V, 12 V

Form factor

Short, low-profile (FC EC62)

Short, with full-height tailstock (FC EC63)

Attributes provided

EDR 100 Gb/s InfiniBand or 100 Gb/s Ethernet per port

PCIe4 Support

IBM CAPI v2 support

Tag Matching and Rendezvous Offloads

Hardware-based I/O virtualization

Operating system or partition requirements

If you are installing a new feature, ensure that you have the software that is required to support the new feature and you must determine any prerequisites that must be met for this feature and the attached devices. For information about operating system and partition requirements, see one of the following topics:

- The latest version of enabling libraries and utilities can be downloaded from the [Fix Central](http://www.ibm.com/support/fixcentral/) website (<http://www.ibm.com/support/fixcentral/>).
- [Power Systems Prerequisites](http://www14.software.ibm.com/support/customer/ipt/home) website (<http://www14.software.ibm.com/support/customer/ipt/home>).
- [IBM System Storage Interoperation Center \(SSIC\)](http://www-03.ibm.com/systems/support/storage/ssic/interoperability.wss) website (<http://www-03.ibm.com/systems/support/storage/ssic/interoperability.wss>).
- The latest version of the device driver or IBM Power RAID adapter utilities (iprutils) can be downloaded from the [IBM Service and Productivity Tools](http://www14.software.ibm.com/webapp/set2/sas/f/lopdiags/home.html) website (<http://www14.software.ibm.com/webapp/set2/sas/f/lopdiags/home.html>).
- For information about important notices for Linux on IBM Power Systems, see the [Linux on IBM](http://www14.software.ibm.com/webapp/set2/sas/f/lopdiags/info/LinuxAlerts.html) website (www14.software.ibm.com/webapp/set2/sas/f/lopdiags/info/LinuxAlerts.html).

PCIe4 x16 2-Port EDR 100 GB IB ConnectX-5 CAPI Capable Adapter (FC EC64 and EC65; CCIN 2CF2)

Learn about the specifications and operating system requirements for feature code (FC) EC64 and EC65 adapters.

Overview

FC EC64 and EC65 are both the same adapter with different feature codes. FC EC64 is a low-profile adapter and FC EC65 is a full-height adapter.

PCIe4 x16 2-Port EDR 100 GB IB ConnectX-5 CAPI Capable Adapter is a PCI Express (PCIe) generation 4 (Gen4) x16 adapter. The adapter enables higher HPC performance with new Message Passing Interface (MPI) offloads, such as MPI Tag Matching and MPI AlltoAll operations, advanced dynamic routing, and new capabilities to perform various data algorithms.

Note: The Virtual Protocol Interconnect (VPI) feature is not supported on this adapter. The adapter must be used only as an InfiniBand adapter.

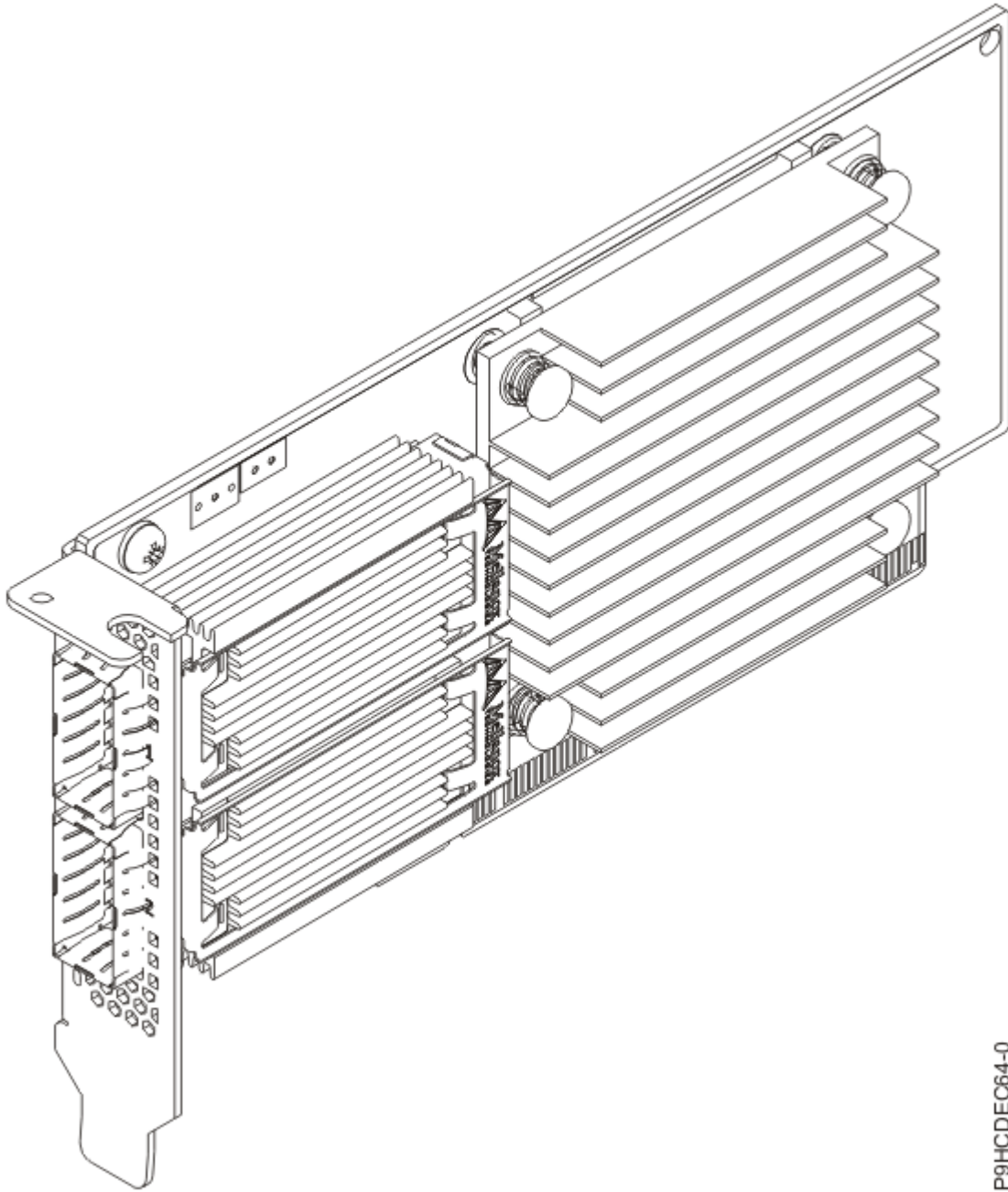

P9HCDEC64-0

Figure 23. PCIe4 x16 2-Port EDR 100 GB IB ConnectX-5 CAPI Capable Adapter

Specifications

Item

Description

Adapter FRU number

00WT176

I/O bus architecture

PCIe4 x16

Slot requirement

For details about slot priorities, maximums, and placement rules, see [PCIe adapter placement rules and slot priorities \(http://www.ibm.com/support/knowledgecenter/POWER9/p9eab/p9eab_mtm_pciplacement.htm\)](http://www.ibm.com/support/knowledgecenter/POWER9/p9eab/p9eab_mtm_pciplacement.htm) and select the system you are working on.

Thermal requirement

If you have an 8335-GTG, 8335-GTH, or 8335-GTX system, you might be required to set the thermal mode of the system to a setting other than the default setting, depending on your system, adapter, and cable type. For details, see [Determining and setting the thermal mode for an 8335-GTG, 8335-GTH, or 8335-GTX system](#).

Voltage

3.3 V, 12 V

Form factor

Short, low-profile

Attributes provided

EDR 100 Gb/s InfiniBand per port

PCIe4 Support

IBM CAPI v2 support

Tag Matching and Rendezvous Offloads

Hardware-based I/O virtualization

Operating system or partition requirements

If you are installing a new feature, ensure that you have the software that is required to support the new feature and you must determine any prerequisites that must be met for this feature and the attached devices. For information about operating system and partition requirements, see one of the following topics:

- The latest version of enabling libraries and utilities can be downloaded from the [Fix Central](http://www.ibm.com/support/fixcentral/) website (<http://www.ibm.com/support/fixcentral/>).
- [Power Systems Prerequisites](http://www14.software.ibm.com/support/customer/ipt/home) website (<http://www14.software.ibm.com/support/customer/ipt/home>).
- [IBM System Storage Interoperation Center \(SSIC\)](http://www-03.ibm.com/systems/support/storage/ssic/interoperability.wss) website (<http://www-03.ibm.com/systems/support/storage/ssic/interoperability.wss>).
- The latest version of the device driver or IBM Power RAID adapter utilities (iprutils) can be downloaded from the [IBM Service and Productivity Tools](http://www14.software.ibm.com/webapp/set2/sas/f/lopdiags/home.html) website (<http://www14.software.ibm.com/webapp/set2/sas/f/lopdiags/home.html>).
- For information about important notices for Linux on IBM Power Systems, see the [Linux on IBM](http://www14.software.ibm.com/webapp/set2/sas/f/lopdiags/info/LinuxAlerts.html) website (www14.software.ibm.com/webapp/set2/sas/f/lopdiags/info/LinuxAlerts.html).

PCIe4 2-port 100 GbE RoCE x16 adapter (FC EC66 and EC67; CCIN 2CF3)

Learn about the specifications and operating system requirements for feature code (FC) EC66 and EC67 adapters.

Overview

FC EC66 is a full-height adapter and FC EC67 is a low-profile adapter.

The PCIe4 2-port 100GbE RoCE Adapter is a PCI Express (PCIe) generation 4 (Gen4) x16 adapter. The adapter provides two 100GbE QSFP28 ports. The PCIe4 2-port 100GbE RoCE Adapter supports both NIC (Network Interface Controller) and IBTA RoCE standards. RoCE is Remote Direct Memory Access (RDMA) over Converged Ethernet. Using RoCE, the adapter can support significantly greater bandwidth with low latency. It also minimizes the CPU overhead by more efficiently using memory access. This offloads the CPU from I/O networking tasks, improving performance and scalability.

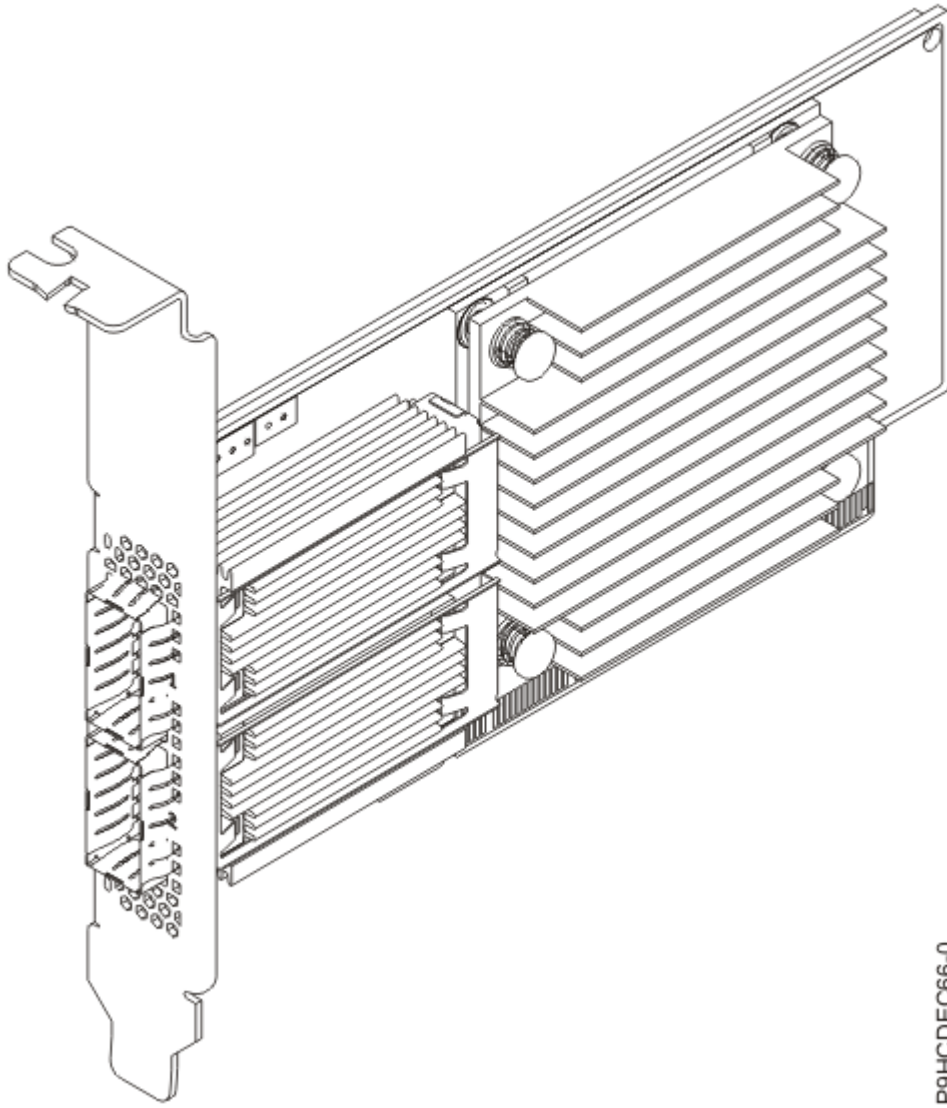

P9HCDEC66-0

Figure 24. 2-port 100 GbE RoCE En Connectx-5 Gen4 PCIe x16 adapter (FC EC66)

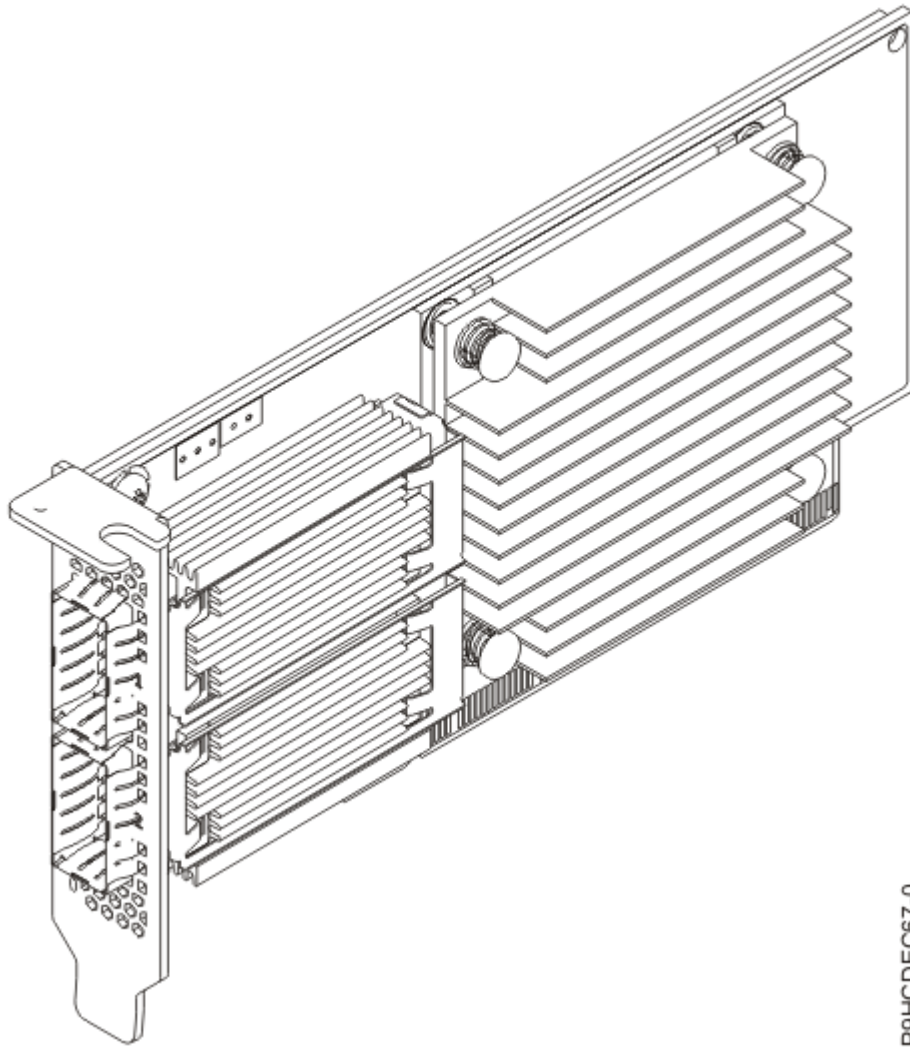

Figure 25. 2-port 100 GbE RoCE En Connectx-5 Gen4 PCIe x16 adapter (FC EC67)

Specifications

Item

Description

Adapter FRU number

01FT742

I/O bus architecture

PCIe4 x16

Slot requirement

For details about slot priorities, maximums, and placement rules, see [PCIe adapter placement rules and slot priorities \(http://www.ibm.com/support/knowledgecenter/POWER9/p9eab/p9eab_mtm_pcplacement.htm\)](http://www.ibm.com/support/knowledgecenter/POWER9/p9eab/p9eab_mtm_pcplacement.htm) and select the system you are working on.

Cables

For 100G, IBM offers either Direct Attach Copper (DAC) cables up to 2 M or Active Optical Cables (AOC) up to 100 M. QSFP28 based transceivers are included on each end of these cables. For more information about adapter cabling, see the (CHANGE TO LINK) Cable and transceiver matrix.

Note: For 40G, IBM offers DAC cables up to 3 M. QSFP+ base transceivers are included on each end of these cables. See FC EB2B and EB2H for a 1 M and 3 M copper cables.

Transceivers

IBM qualifies and supports QSFP28 optical transceiver (FC EB59) to install into the adapter. Customers can also use their own optical cabling and QSP28 optical transceiver for the other end. This is a 100GBASE-SR4 based active optical transceiver capable up to 100 M through the OM4 cable or 70 M through OM3 cable. Either one or both of the adapter's two QSP28 ports can be populated. When two ports are filled, both can have copper cables or optical cables. Additionally, one of the cables can be copper and the other can be optical. IBM® also offers QSFP+ optical transceiver (FC EB27) to install into the adapter and allowing the customer to use their own optical cabling and QSFP+ optical transceiver for the other end.

Cable and transceiver matrix

<i>Table 11. Cable and transceiver matrix</i>	
Feature	Description
EB59	100GBASE-SR4 optical transceiver MTP/MPO cable (purchased separately) <ul style="list-style-type: none"> • FC EB2J - 10 M • FC EB2K - 30 M
EB5J	QSFP28 Passive Copper 100 Gb Ethernet Cable - .5 M
EB5K	QSFP28 Passive Copper 100 Gb Ethernet Cable - 1 M
EB5L	QSFP28 Passive Copper 100 Gb Ethernet Cable - 1.5 M
EB5M	QSFP28 Passive Copper 100 Gb Ethernet Cable - 2 M
EB5R	QSFP28 AOC 100 Gb Ethernet Cable - 3 M
EB5S	QSFP28 AOC 100 Gb Ethernet Cable - 5 M
EB5T	QSFP28 AOC 100 Gb Ethernet Cable - 10 M
EB5U	QSFP28 AOC 100 Gb Ethernet Cable - 15 M
EB5V	QSFP28 AOC 100 Gb Ethernet Cable - 20 M
EB5W	QSFP28 AOC 100 Gb Ethernet Cable - 30 M
EB5X	QSFP28 AOC 100 Gb Ethernet Cable - 50 M
EB5Y	QSFP28 AOC 100 Gb Ethernet Cable - 100 M
EB2B	1 M Passive QSFP+ to QSFP+
EB2H	3 M Passive QSFP+ to QSFP+
EB27	QSFP+ 40G BASE-SR4 optical transceiver MTP/MPO cable (purchased separately) <ul style="list-style-type: none"> • FC EB2J - 10 M • FC EB2K - 30 M

Voltage

3.3 V, 12 V

Form factor

Short, with full-height tailstock (FC EC66)

Short, low-profile (FC EC67)

Attributes provided

PCI Express 4.0 (up to 16GT/s) x16

PCIe Gen 4.0 compliant (1.1, 2.0, and 3.0 compatible)

RDMA over Converged Ethernet (RoCE)

Dual-port of 100 Gb/s Ethernet per port

NIC and RoCE are concurrently supported

RoCE supported on linux and AIX (7.2, and later)

NIC supported on all OSes

TCP/UDP/IP stateless offload

LSO, LRO, and checksum offload

NIM boot support

The adapter is based on the Mellanox ConnectX-5 adapter, which uses the ConnectX-5 EN Network Controller

Backward compatible with 40 Gb Ethernet when using compatible cables and transceivers

Improves performance and scalability by offloading the CPU from I/O networking tasks

Minimizes CPU overhead by more efficiently using memory access

PowerVM SR-IOV support. For more information see, [PowerVM® SR-IOV FAQs](#).

Operating system or partition requirements

If you are installing a new feature, ensure that you have the software that is required to support the new feature and you must determine any prerequisites that must be met for this feature and the attached devices. For information about operating system and partition requirements, see one of the following topics:

- The latest version of enabling libraries and utilities can be downloaded from the [Fix Central](http://www.ibm.com/support/fixcentral/) website (<http://www.ibm.com/support/fixcentral/>).
- [Power Systems Prerequisites](http://www14.software.ibm.com/support/customercare/iprt/home) website (<http://www14.software.ibm.com/support/customercare/iprt/home>).
- [IBM System Storage Interoperation Center \(SSIC\)](http://www-03.ibm.com/systems/support/storage/ssic/interoperability.wss) website (<http://www-03.ibm.com/systems/support/storage/ssic/interoperability.wss>).
- The latest version of the device driver or IBM Power RAID adapter utilities (iprutils) can be downloaded from the [IBM Service and Productivity Tools](http://www14.software.ibm.com/webapp/set2/sas/f/lopdiags/home.html) website (<http://www14.software.ibm.com/webapp/set2/sas/f/lopdiags/home.html>).
- For information about important notices for Linux on IBM Power Systems, see the [Linux on IBM](http://www14.software.ibm.com/webapp/set2/sas/f/lopdiags/info/LinuxAlerts.html) website (www14.software.ibm.com/webapp/set2/sas/f/lopdiags/info/LinuxAlerts.html).

PCIe2 2-port 10 GbE BaseT RJ45 adapter (FC EL3Z, FC EL55, FC EN0W, and FC EN0X; CCIN 2CC4)

Learn about the specifications and operating system requirements for the feature code (FC) EL3Z, FC EL55, FC EN0W, or FC EN0X adapter.

Overview

The PCIe2 2-port 10 GbE BaseT RJ45 adapter is a PCI Express (PCIe) generation 2, x8 adapter. The FC EL3Z and FC EN0X are short form-factor, low-profile adapters. The FC EL55 and FC EN0W are regular height adapters that are low profile capable. The adapters provide two 10 Gb RJ45 ports and a PCIe

2.0 host bus interface. The adapters support the Ethernet network interface controller (NIC) function. The adapters are high-performance adapters that consolidate traffic for networking. The link aggregation and failover features of the adapters make them suitable for critical network applications that require redundancy and high availability.

The ports default to auto negotiate the highest speed either at 10 Gb (10G BaseT), 1Gb (1000 BaseT), or 100 Mb (100 BaseT) full duplex. Each RJ45 port can be configured independent of the other port. Each RJ45 port is connected with a 4-pair, CAT-6A cable, and is supported for distances of up to 100 meters.

The adapter provides the following features:

- The adapter is a PCIe2 NIC network convergence adapter.
- The 10 Gb RJ45 ports can function in the NIC mode.
- The adapter can be used as the host local area network (LAN) adapter.
- The adapter supports interrupt moderation to deliver increased performance while significantly reducing processor utilization
- The adapter supports dual port operation in any PCIe3 or PCIe2 slot.
- The adapter supports auto-negotiation, full-duplex only.
- The adapter supports multiple media-access control (MAC) per interface.
- The adapter supports integrated media-access control (MAC) and physical layer (PHY).
- The adapter supports the following standards for the different ports and functions:
 - IEEE 802.3ae in the 10 GbE ports
 - 802.3ab in the 1 GbE ports
 - Ether II and IEEE 802.3 for encapsulated frames
 - 802.1p for setting up priority levels in tagged VLAN frames
 - 802.1Q for VLAN tagging
 - 802.3x for flow control
 - 802.3ad for load-balancing and failover
 - IEEE 802.3ad and 802.3 for link aggregation
- The adapter provides message signal interrupts (MSI), MSI-X, and support of legacy pin interrupts.
- The adapter supports jumbo frames up to 9.6 KB.
- The adapter supports gigabit EtherChannel (GEC) with the existing software.
- The adapter supports TCP checksum offload transmission control protocol (TCP), user datagram protocol (UDP), TCP segmentation Offload (TSO) for IPv4 and IPv6.
- Supports TCP segmentation or large send offload
- Supports EEPROM-SPI and single EEPROM

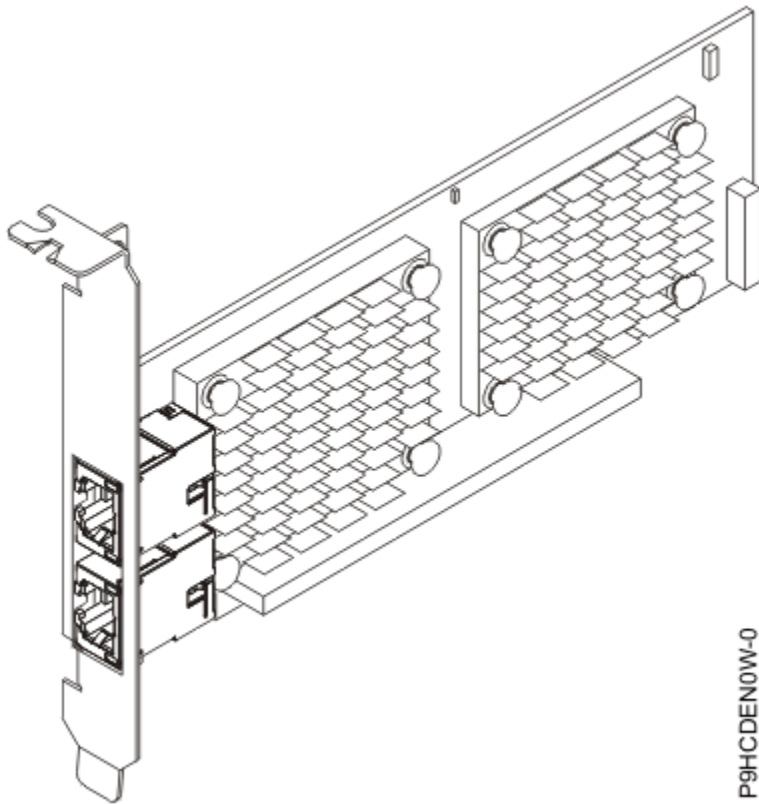

Figure 26. PCIe2 2-port 10 GbE BaseT RJ45 adapter (FC EL55 or FC EN0W)

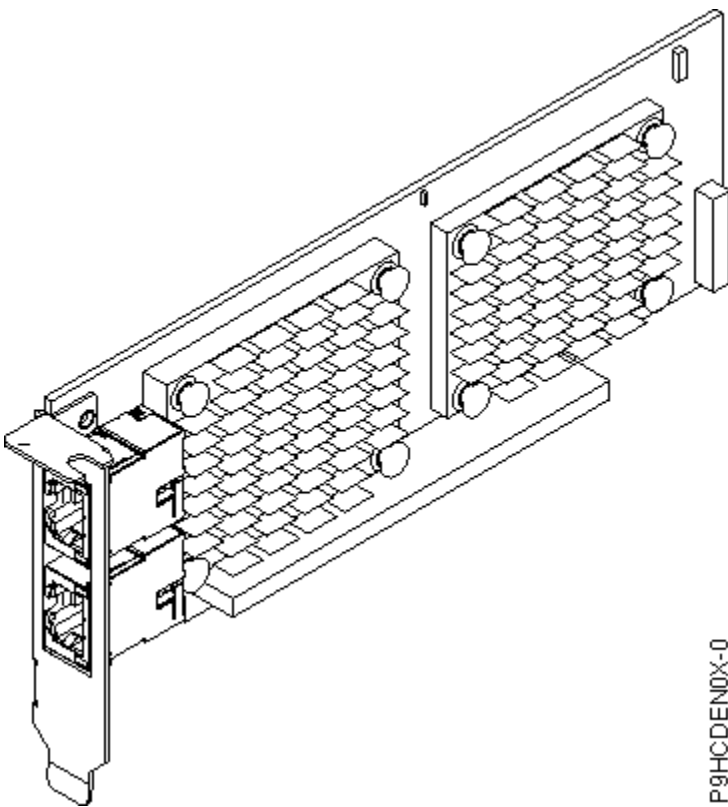

Figure 27. PCIe2 LP 2-port 10 GbE BaseT RJ45 adapter (FC EL3Z or FC EN0X)

Specifications

Item

Description

Adapter FRU number

00E2714

Regular-height tailstock part number: 00E2862.

Low-profile tailstock part number: 00E2721.

Wrap plug FRU number

10N7405 (RJ45 wrap plug).

Note: Wrap plugs are not included with the card and cannot be purchased from IBM.

I/O bus architecture

PCIe2 x8.

Slot requirement

For details about slot priorities, maximums, and placement rules, see [PCIe adapter placement rules and slot priorities \(http://www.ibm.com/support/knowledgecenter/POWER9/p9eab/p9eab_mtm_pciplacement.htm\)](http://www.ibm.com/support/knowledgecenter/POWER9/p9eab/p9eab_mtm_pciplacement.htm) and select the system you are working on.

Cables

CAT-6A cable.

Voltage

3.3 V.

Form factor

Short, low-profile.

Operating system or partition requirements

If you are installing a new feature, ensure that you have the software that is required to support the new feature and you must determine any prerequisites that must be met for this feature and the attached devices. For information about operating system and partition requirements, see one of the following topics:

- The latest version of enabling libraries and utilities can be downloaded from the [Fix Central](http://www.ibm.com/support/fixcentral/) website (<http://www.ibm.com/support/fixcentral/>).
- [Power Systems Prerequisites](http://www14.software.ibm.com/support/customer/ipt/home) website (<http://www14.software.ibm.com/support/customer/ipt/home>).
- [IBM System Storage Interoperation Center \(SSIC\)](http://www-03.ibm.com/systems/support/storage/ssic/interoperability.wss) website (<http://www-03.ibm.com/systems/support/storage/ssic/interoperability.wss>).
- The latest version of the device driver or IBM Power RAID adapter utilities (iprutils) can be downloaded from the [IBM Service and Productivity Tools](http://www14.software.ibm.com/webapp/set2/sas/f/lopdiags/home.html) website (<http://www14.software.ibm.com/webapp/set2/sas/f/lopdiags/home.html>).
- For information about important notices for Linux on IBM Power Systems, see the [Linux on IBM](http://www14.software.ibm.com/webapp/set2/sas/f/lopdiags/info/LinuxAlerts.html) website (www14.software.ibm.com/webapp/set2/sas/f/lopdiags/info/LinuxAlerts.html).

This adapter requires the following drivers:

- AIX: `devices.pciex.e4148e1614109204`
- Linux: `bnx2x` driver

PCIe3 LP 16 Gb 2-port Fibre Channel adapter (FC EL43 and FC EN0B; CCIN 577F)

Learn about the specifications and operating system requirements for the feature code (FC) EL43 and FC EN0B adapter.

Overview

The PCIe3 LP 16 Gb 2-port Fibre Channel Adapter is a low-profile, x8, generation 3, PCIe adapter. This adapter is a high-performance 8x short form adapter also referred to as a PCIe Host Bus Adapter (HBA). The adapter provides two ports of 16 Gb Fibre Channel capability using SR optics. Each port can provide up to 16 Gb Fibre Channel functions simultaneously.

Each port provides single initiator capability over a fibre link or with NPIV, multiple initiator capability is provided. The ports are SFP+ and include an optical SR transceiver. The ports have little connector-type (LC) and utilize shortwave laser optics. The adapter operates at link speeds of 4, 8 and 16 Gbps and will automatically negotiate to the highest speed possible. LEDs on each port provide information on the status and link speed of the port.

The adapter connects to a Fibre Channel switch at 4 Gb, 8 Gb or 16 Gb. It can directly attach to a device without a switch at 16 Gb. Attachment without a switch is not supported at 4 Gb or 8 Gb.

N_Port ID Virtualization (NPIV) capability is supported through VIOS.

The adapter has the following features:

- The adapter is compliant with the PCIe base and Card Electromechanical (CEM) 2.0 specifications with the following characteristics:
 - Provides an x8 lane link interface at 14.025 Gbps, 8.5 Gbps, or 4.25 Gbps (automatic negotiation with system)
 - Provides support for one Virtual Channel (VC0) and one Traffic Class (TC0)
 - Provides configuration and I/O memory read and write, completion, and messaging capabilities
 - Provides support for 64-bit addressing
 - Provides error correction code (ECC) and error protection functions
 - Provides link cyclic redundancy check (CRC) on all PCIe packets and message information
 - Provides a large payload size of 2048 bytes for read and write functions
 - Provides a large read request size of 4096 bytes
- The adapter is compatible with 4, 8, and 16 Gb Fibre Channel interface with the following characteristics:
 - Provides for automatic negotiation between 4 Gb, 8 Gb, or 16 Gb link attachments
 - Provides support for the following Fibre Channel topologies: point-to-point (16Gb only) and fabric
 - Provides support for Fibre Channel class 3
 - Provides a maximum Fibre Channel throughput that is achieved by using full duplex hardware support
- The adapter provides an end-to-end data path parity and CRC protection, including internal data path random-access memory (RAM)
- Provides architectural support for multiple upper layer protocols
- Provides comprehensive virtualization capabilities with support for N_Port ID Virtualization (NPIV) and virtual fabric (VF)
- Provides support for message signaled interrupts extended (MSI-X)
- Provides support for 255 VFs and 1024 MSi-X
- Provides an internal, high-speed static random-access memory (SRAM) memory
- Provides ECC protection of local memory that includes single-bit correction and double-bit protection
- Provides an embedded shortwave optical connection with diagnostics capability

- Provides support for an on-board context management by firmware:
 - Up to 8192 FC port logins
 - I/O multiplexing down to the Fibre Channel frame level
- Provides data buffers capable of supporting 64+ buffer-to-buffer (BB) credits per port for shortwave applications
- Provides link management and recovery that is handled by firmware
- Provides on-board diagnostic capability accessible by an optional connection
- Provides a performance up to 16 Gbps full duplex

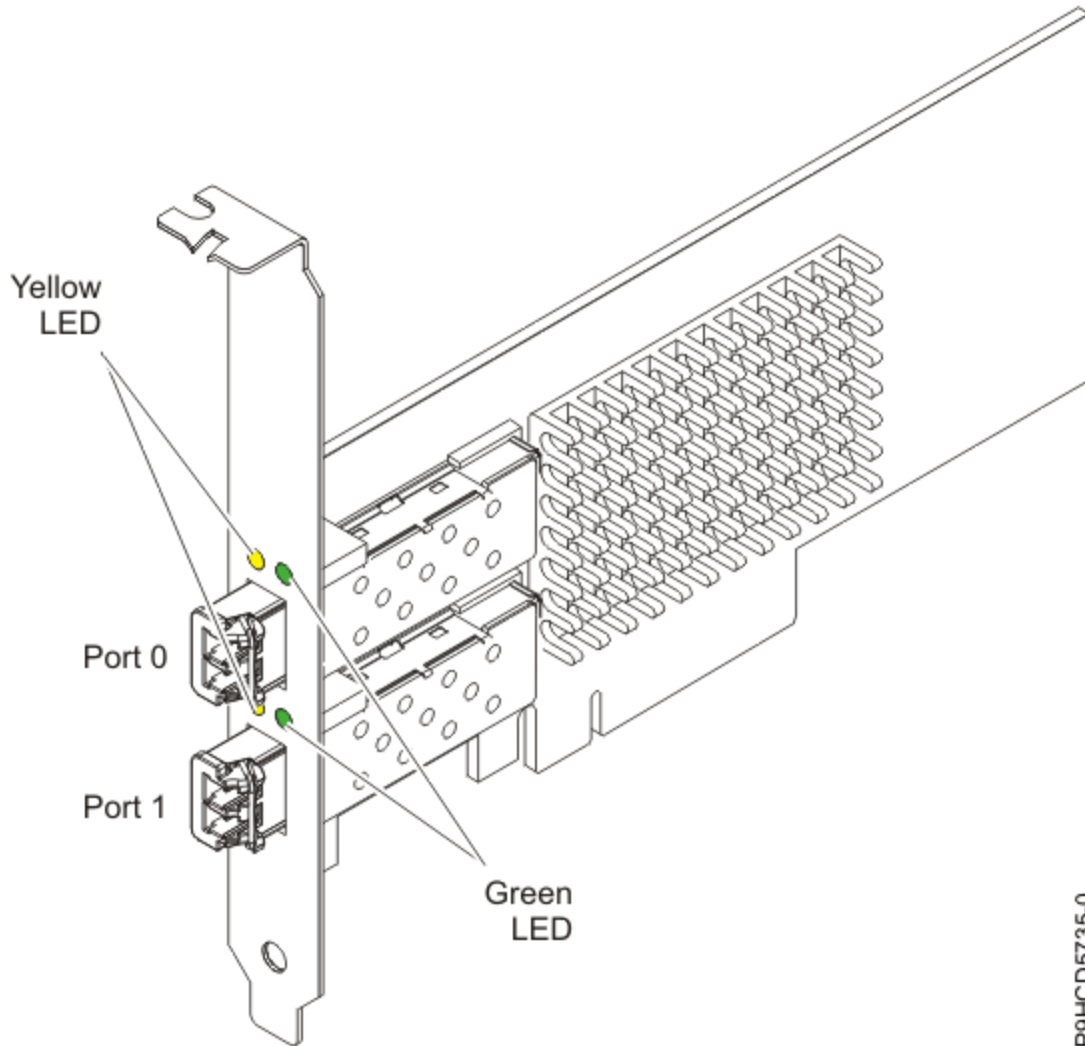

Figure 28. PCIe3 LP 16 Gb 2-port Fibre Channel Adapter

Specifications

Item

Description

Adapter FRU number

00E9283

Wrap plug FRU number

12R9314

Note: The wrap plug is included with the card, and can also be purchased from IBM.

I/O bus architecture

PCIe base and CEM 3.0, x8 PCIe bus interface

Slot requirement

For details about slot priorities, maximums, and placement rules, see [PCIe adapter placement rules and slot priorities \(http://www.ibm.com/support/knowledgecenter/POWER9/p9eab/p9eab_mtm_pciplacement.htm\)](http://www.ibm.com/support/knowledgecenter/POWER9/p9eab/p9eab_mtm_pciplacement.htm) and select the system you are working on.

Voltage

3.3 V, 12 V

Form factor

Short, low-profile

FC compatibility

4, 8, 16 Gb

Cables

Cables are the responsibility of the customer. Use multimode fiber optic cables with shortwave lasers that adhere to the following specifications:

- OM4: Multimode 50/125 micron fiber, 4700 MHz x km bandwidth
- OM3: Multimode 50/125 micron fiber, 2000 MHz x km bandwidth
- OM2: Multimode 50/125 micron fiber, 500 MHz x km bandwidth
- OM1: Multimode 62.5/125 micron fiber, 200 MHz x km bandwidth

Because core sizes are different, OM1 cables can only be connected to other OM1 cables. For best results, OM2 cables must not be connected to OM3 cables. However, if an OM2 cable is connected to an OM3 cable, the characteristics of the OM2 cable apply to the entire length of the cables.

The following table shows the supported distances for the different cable types at the different link speeds.

Header	Cable type and distance			
Rate	OM1	OM2	OM3	OM4
4 Gbps	0.5 - 70 m (1.64 - 229.65 ft)	0.5 - 150 m (1.64 - 492.12 ft)	0.5 - 380 m (1.64 - 1246.71 ft)	0.5 - 400 m (1.64 - 1312.34 ft)
8 Gbps	0.5 - 21 m (1.64 - 68.89 ft)	0.5 - 50 m (1.64 - 164.04 ft)	0.5 - 150 m (1.64 - 492.12 ft)	0.5 - 190 m (1.64 - 623.36 ft)
16 Gbps	0.5 - 15 m (1.64 - 49.21 ft)	0.5 - 35 m (1.64 - 114.82 ft)	0.5 - 100 m (1.64 - 328.08 ft)	0.5 - 125 m (1.64 - 410.10 ft)

Adapter LED states

Green and yellow LEDs can be seen through openings in the mounting bracket of the adapter. Green indicates firmware operation, and yellow signifies port activity. [Table 13 on page 57](#) summarizes normal LED states. A 1 Hz pause occurs when the LED is off between each group of fast flashes (2, 3 or 4). Observe the LED sequence for several seconds to ensure that you correctly identify the state.

Green LED	Yellow LED	State
On	2 fast flashes	4 Gbps link rate: normal, link active
On	3 fast flashes	8 Gbps link rate: normal, link active

Green LED	Yellow LED	State
On	4 fast flashes	16 Gbps link rate: normal, link active

Power-on-self-test (POST) conditions and results are summarized in [Table 14 on page 58](#). These states can be used to identify abnormal states or problems.

Green LED	Yellow LED	State
Off	Off	Wake-up failure of the adapter board
Off	On	POST failure of the adapter board
Off	Slow flash	Wake-up failure monitor
Off	Fast flash	Failure in post
Off	Flashing	Postprocessing in progress
On	Off	Failure while functioning
On	On	Failure while functioning
Slow flash	Off	Normal, link down
Slow flash	On	Not defined
Slow flash	Slow flash	Offline for download
Slow flash	Fast flash	Restricted offline mode, waiting for restart
Slow flash	Flashing	Restricted offline mode, test active
Fast flash	Off	Debug monitor in restricted mode
Fast flash	On	Not defined
Fast flash	Slow flash	Debug monitor in test fixture mode
Fast flash	Fast flash	Debug monitor in remote debug mode
Fast flash	Flashing	Not defined

Operating system or partition requirements

If you are installing a new feature, ensure that you have the software that is required to support the new feature and you must determine any prerequisites that must be met for this feature and the attached devices. For information about operating system and partition requirements, see one of the following topics:

- The latest version of enabling libraries and utilities can be downloaded from the [Fix Central](http://www.ibm.com/support/fixcentral/) website (<http://www.ibm.com/support/fixcentral/>).
- [Power Systems Prerequisites](http://www14.software.ibm.com/support/customer/home) website (<http://www14.software.ibm.com/support/customer/home>).

- IBM System Storage Interoperation Center (SSIC) website (<http://www-03.ibm.com/systems/support/storage/ssic/interoperability.wss>).
- The latest version of the device driver or IBM Power RAID adapter utilities (iprutils) can be downloaded from the [IBM Service and Productivity Tools website](http://www14.software.ibm.com/webapp/set2/sas/f/lopdiags/home.html) (<http://www14.software.ibm.com/webapp/set2/sas/f/lopdiags/home.html>).
- For information about important notices for Linux on IBM Power Systems, see the [Linux on IBM website](http://www14.software.ibm.com/webapp/set2/sas/f/lopdiags/info/LinuxAlerts.html) (www14.software.ibm.com/webapp/set2/sas/f/lopdiags/info/LinuxAlerts.html).

PCIe2 4-port 1 GbE adapter (FC 5260, FC 5899, FC EL4L, and FC EL4M; CCIN 576F)

Learn about the specifications and operating system requirements for the feature code (FC) 5260, FC 5899, FC EL4L, and EL4M adapters.

Overview

FC 5260, FC EL4M, FC 5899, and FC EL4L are the same adapter with different feature codes. FC 5260 and EL4M are low-profile adapters and the FC 5899 and EL4L are full-height adapters.

These adapters provide four 1-Gb Ethernet ports that can be configured to run at 1000 megabits per second (Mbps) (or 1 gigabit per second (Gbps)), 100 Mbps, or 10 Mbps. The adapter connects to a network that uses unshielded twisted pair (UTP) cable for distances of up to 100 meters (328.08 feet). The adapter supports AIX Network Installation Management (NIM) boot capability. The adapter conforms to the IEEE 802.3ab 1000Base-T standard. The adapter supports jumbo frames when running at the 1000 Mbps speed.

Each of the Ethernet ports can be connected by using:

- CAT5e (or later) UTP cables for 1000 Mbps network attachment
- CAT5 or CAT3 UTP cables for 100 Mbps or 10 Mbps network attachment

The cables are attached to the copper RJ45 connectors. Each port is independent of one another and supports full-duplex or half-duplex. The half-duplex mode does not support a speed of 1000 Mbps.

The adapter provides the following features:

- Supports interrupt moderation to deliver increased performance while significantly reducing processor utilization
- Supports dual port operation in almost any PCIe slot, except x1
- Supports auto-negotiation, full-duplex only
- Supports integrated media-access control (MAC) and physical layer (PHY)
- Supports Fast EtherChannel (FEC) with the existing software
- Supports gigabit EtherChannel (GEC) with the existing software
- Supports IEEE 802.3ad (Link Aggregation control protocol)
- Supports IEEE 802.1Q VLANs
- Supports IEEE 802.3 z, ab, u, x flow control support
- Supports IEEE 802.1p
- Supports IEEE 802.3ab for TX
- Supports TCP checksum offload transmission control protocol (TCP), user datagram protocol (UDP), Internet Protocol (IP) for IPv4 and IPv6
- Supports TCP segmentation or large send offload
- Supports EEPROM-SPI and single EEPROM
- Supports interrupt levels INTA and MSI
- Hardware certifications FCC B, UL, CE, VCCI, BSMI, CTICK, MIC

- Network Controller (MAC) Intel 82571EB

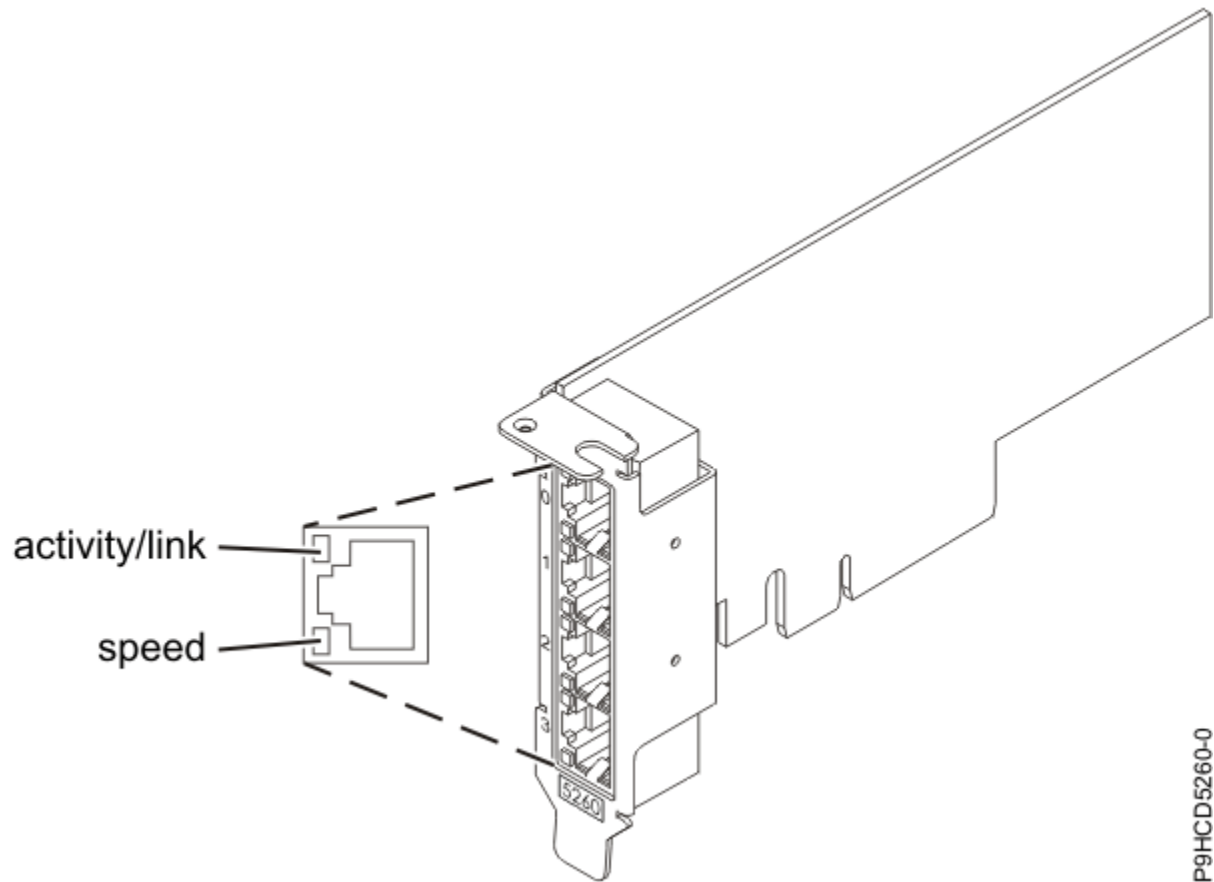

Figure 29. FC 5260 and FC EL4M PCIe2 4-port 1 GbE adapter

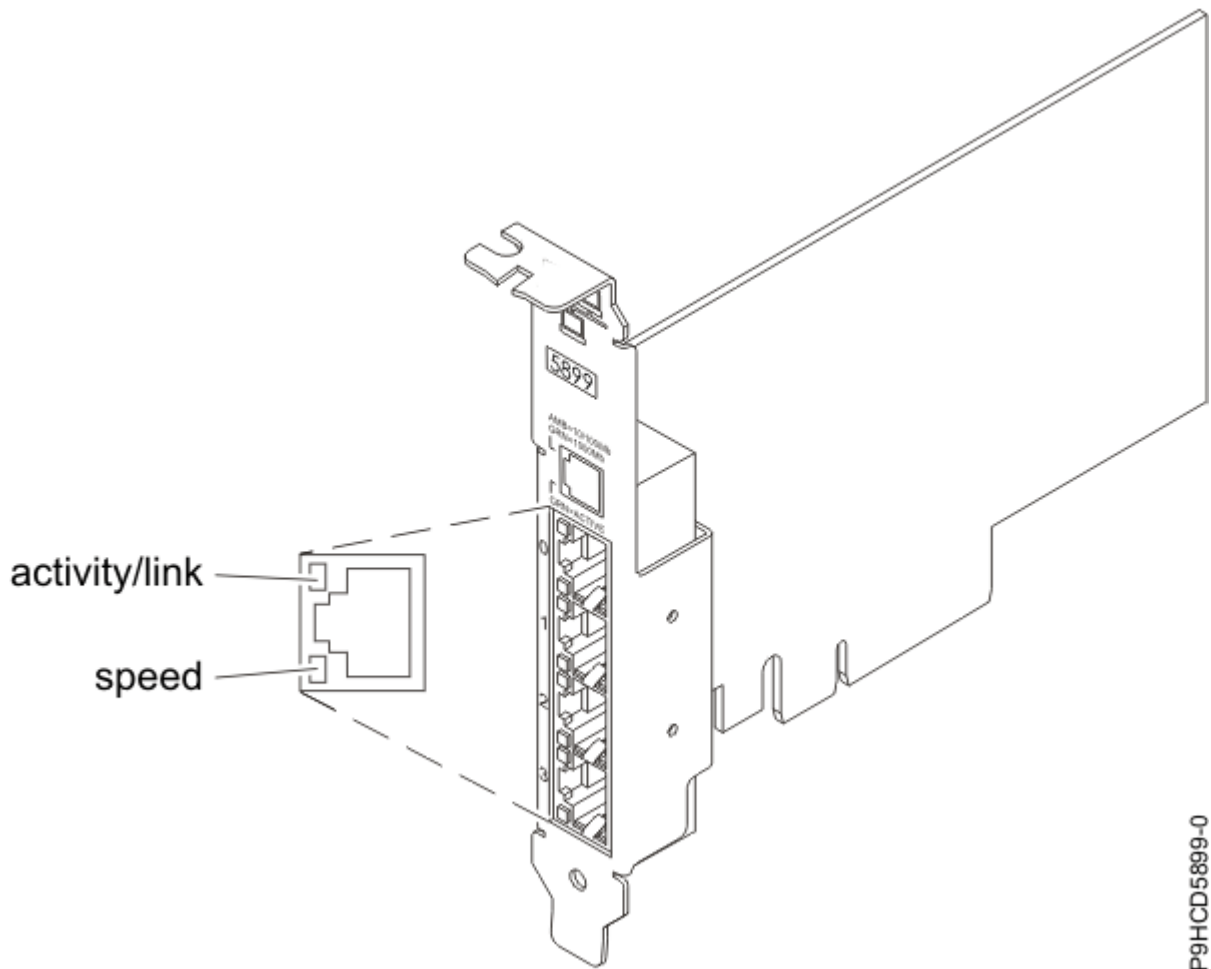

Figure 30. FC 5899 and FC EL4L PCIe2 4-port 1 GbE adapter

Specifications

Item

Description

Adapter FRU number

74Y4064

Wrap plug

10N7405

Note: Wrap plugs are not included with the card and cannot be purchased from IBM.

I/O bus architecture

PCIe2 x4

Slot requirement

For details about slot priorities, maximums, and placement rules, see [PCIe adapter placement rules and slot priorities](http://www.ibm.com/support/knowledgecenter/POWER9/p9eab/p9eab_mtm_pciplacement.htm) (http://www.ibm.com/support/knowledgecenter/POWER9/p9eab/p9eab_mtm_pciplacement.htm) and select the system you are working on.

Voltage

3.3 V

Form factor

short, low-profile

Connector information

- Two RJ-45 ports

- Two LED adapter status indicators per port, for link activity and speed

Cables

4-pair, CAT5e, UTP cables are connected to copper RJ45 connectors.

Attributes provided

- PCIe x4, generation-1 or generation-2
- 4-Port machine access code (MAC)
- High performance IPV4/IPV6 checksum offload
- Supports large send and large receive
- Multiple queues
- VIOS

Adapter LED states

The LEDs on the adapter provide information about the operation status of the adapter. The LEDs are visible through the mounting bracket. [Figure 29 on page 60](#) shows the location of the LEDs. [Table 15 on page 62](#) describes the different LED states and what those states indicate.

LED	Light	Description
Speed	Yellow	10 Mbps or 100 Mbps
	Green	1000 Mbps or 1 Gbps
Activity/link	Green flashing	Active link or data activity
	Off	No link The absence of a link can indicate a defective cable, defective connector, or a configuration mismatch.

Operating system or partition requirements

If you are installing a new feature, ensure that you have the software that is required to support the new feature and you must determine any prerequisites that must be met for this feature and the attached devices. For information about operating system and partition requirements, see one of the following topics:

- The latest version of enabling libraries and utilities can be downloaded from the [Fix Central](http://www.ibm.com/support/fixcentral/) website (<http://www.ibm.com/support/fixcentral/>).
- [Power Systems Prerequisites](http://www14.software.ibm.com/support/customer/ipt/home) website (<http://www14.software.ibm.com/support/customer/ipt/home>).
- [IBM System Storage Interoperation Center \(SSIC\)](http://www-03.ibm.com/systems/support/storage/ssic/interoperability.wss) website (<http://www-03.ibm.com/systems/support/storage/ssic/interoperability.wss>).
- The latest version of the device driver or IBM Power RAID adapter utilities (iprutils) can be downloaded from the [IBM Service and Productivity Tools](http://www14.software.ibm.com/webapp/set2/sas/f/lopdiags/home.html) website (<http://www14.software.ibm.com/webapp/set2/sas/f/lopdiags/home.html>).
- For information about important notices for Linux on IBM Power Systems, see the [Linux on IBM](http://www14.software.ibm.com/webapp/set2/sas/f/lopdiags/info/LinuxAlerts.html) website (www14.software.ibm.com/webapp/set2/sas/f/lopdiags/info/LinuxAlerts.html).

PCIe3 x8 2-port Fibre Channel (32 Gb/s); (FC EN1A, EN1B, EL5U, and EL5V; CCIN 578F)

Learn about the specifications and operating system requirements for feature code (FC) EN1A, EN1B, EL5U, and EL5V adapters.

Overview

FC EN1A, EN1B, EL5V, and EL5U are electronically identical. FCs EN1A and EL5U are full-height adapters, and FCs EN1B and EL5V are low-profile adapters.

The PCIe3 x8 2-port Fibre Channel (32 Gb/s) Adapter is a PCI Express (PCIe) generation 3 (Gen3) x16 adapter. The adapter can be used in either a x8 or x16 PCIe slot in the system. This adapter is a high performance adapter that is based on the Emulex LPe32000-series PCIe host bus adapter (HBA). The adapter provides two ports of 32 Gb Fibre Channel capability that uses SR optics. Each port can provide up to 32 Gb Fibre Channel functions simultaneously. Each port provides single initiator capability over a fiber link or with NPIV, multiple initiator capabilities is provided. The ports are SFP+ and include an optical SR transceiver. The ports have LC type connectors and use shortwave laser optics. The adapter operates at link speeds of 4, 8, 16, and 32 Gbps and automatically negotiates to the highest speed possible. Each port has two LED indicators that are on the bracket next to each connector. These LEDs communicate boot status and give a visual indication of the operating state. The LEDs have five defined state; solid on, solid off, slow flash, fast flash, and steady flashing. The slow flash rate is 1 Hz. The fast blink is 4 Hz, and the flashing refers to an irregular on/off transition that reflects test progress. The operator must observe the LED sequence for several seconds to ensure that the operating state is correctly identified.

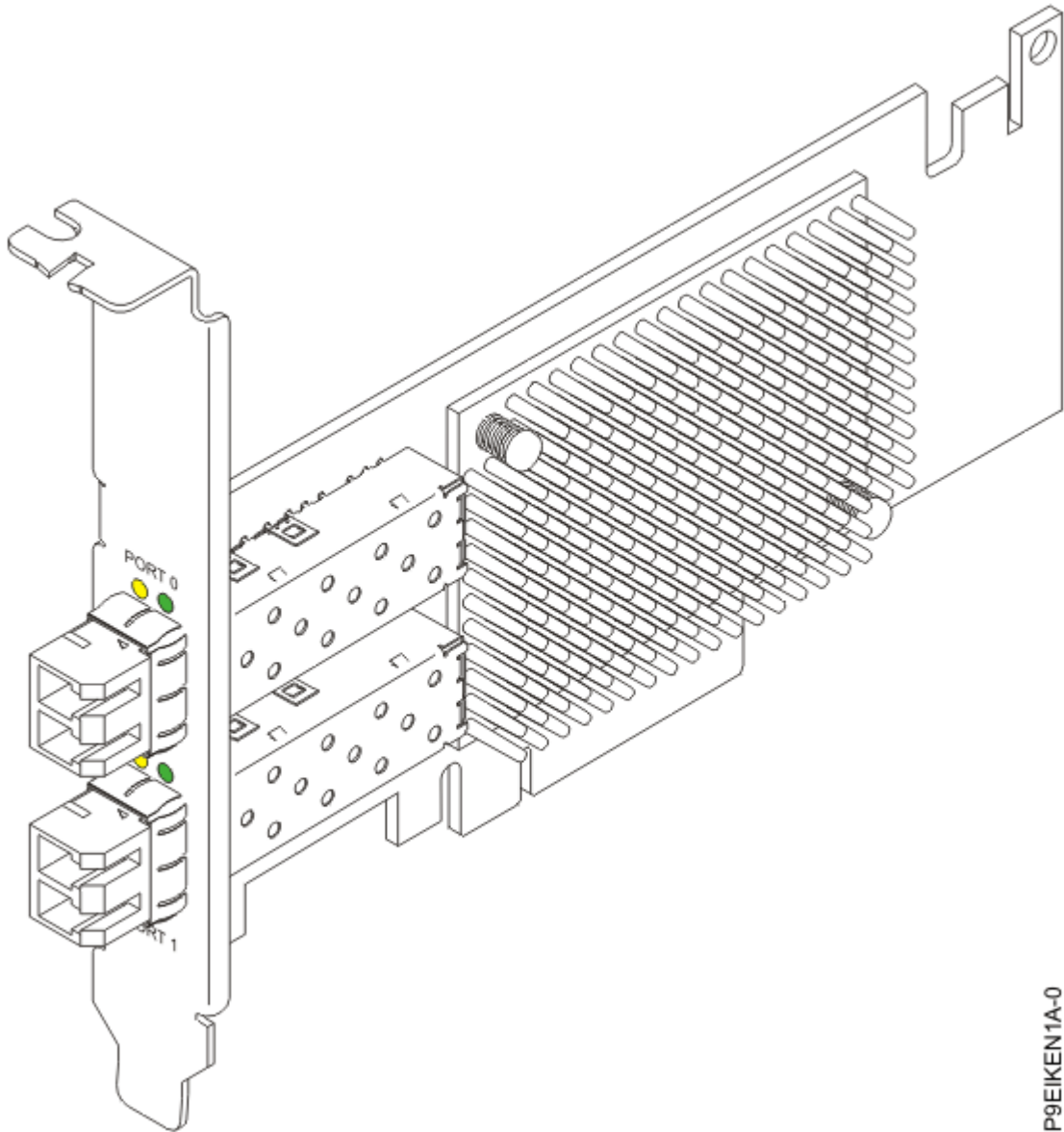

Figure 31. PCIe3 x8 2-port Fibre Channel (32 Gb/s)

Specifications

Item

Description

Adapter FRU number

01FT704

I/O bus architecture

PCIe3 x16.

Slot requirement

For details about slot priorities, maximums, and placement rules, see [PCIe adapter placement rules and slot priorities](http://www.ibm.com/support/knowledgecenter/POWER9/p9eab/p9eab_mtm_pciplacement.htm) (http://www.ibm.com/support/knowledgecenter/POWER9/p9eab/p9eab_mtm_pciplacement.htm) and select the system you are working on.

Voltage

3.3 V, 12 V.

Form factor

Short, low-profile.

Maximum number

For details about the maximum number of adapters that are supported, see [Adapter placement rules and slot priorities \(http://www.ibm.com/support/knowledgecenter/POWER9/p9eab/p9eab_mtm_pciplacement.htm\)](http://www.ibm.com/support/knowledgecenter/POWER9/p9eab/p9eab_mtm_pciplacement.htm) and select the system you are working on.

Attributes provided

- 32 Gb/s of throughput.
- Enhanced diagnostics and manageability.
- Unparalleled performance and more efficient port usage.
- Single initiator capability over a fiber link or with NPIV.
- Multiple initiator capabilities.

Operating system or partition requirements

If you are installing a new feature, ensure that you have the software that is required to support the new feature and you must determine any prerequisites that must be met for this feature and the attached devices. For information about operating system and partition requirements, see one of the following topics:

- The latest version of enabling libraries and utilities can be downloaded from the [Fix Central website \(http://www.ibm.com/support/fixcentral/\)](http://www.ibm.com/support/fixcentral/).
- [Power Systems Prerequisites website \(http://www14.software.ibm.com/support/customercare/iprt/home\)](http://www14.software.ibm.com/support/customercare/iprt/home).
- [IBM System Storage Interoperation Center \(SSIC\) website \(http://www-03.ibm.com/systems/support/storage/ssic/interoperability.wss\)](http://www-03.ibm.com/systems/support/storage/ssic/interoperability.wss).
- The latest version of the device driver or IBM Power RAID adapter utilities (iprutils) can be downloaded from the [IBM Service and Productivity Tools website \(http://www14.software.ibm.com/webapp/set2/sas/f/lopdiags/home.html\)](http://www14.software.ibm.com/webapp/set2/sas/f/lopdiags/home.html).
- For information about important notices for Linux on IBM Power Systems, see the [Linux on IBM website \(www14.software.ibm.com/webapp/set2/sas/f/lopdiags/info/LinuxAlerts.html\)](http://www14.software.ibm.com/webapp/set2/sas/f/lopdiags/info/LinuxAlerts.html).

PCIe2 4-port (10 Gb + 1 GbE) SR / Copper SFP +RJ45 adapter (FC EN0S, FC EN0T, FC EN0U, and FC EN0V; CCIN 2CC3)

Learn about the specifications and operating system requirements for the feature code (FC) EN0S, FC EN0T, FC EN0U, and FC EN0V adapters.

Overview

The PCIe2 4-port (10 Gb + 1 GbE) SR / Copper SFP +RJ45 adapter is a PCI Express (PCIe) generation 2 (Gen2) x8, short form-factor adapter.

- The FC EN0S and EN0U are short, full height adapters. FC EN0S is an SR adapter whereas FC EN0U is a Copper SFP adapter.
- The FC EN0T and EN0V are short, low-profile adapters. FC EN0T is an SR adapter whereas FC EN0V is a Copper SFP adapter.

The adapter provides two 10 Gb SR optical ports and two 1 Gb RJ45 ports. This adapter provides a PCIe 2.0 host bus interface. The adapter supports the Ethernet network interface controller (NIC) function. The adapter is a high-performance adapter that consolidates traffic for networking. The link aggregation and failover features of the adapter make it suitable for critical network applications that require redundancy and high availability.

The four-port adapter provides two 10 Gb small form-factor pluggable (SFP+) optical SR transceiver ports and two 1 Gb RJ45 Ethernet ports. The two 10 Gb SR ports have little connector (LC) duplex-type connectors. The optical transceiver uses shortwave laser optics and is attached with MMF-850nm fiber cabling with LC connectors. See [“Cables” on page 69](#) for more information about the optical cables.

Each 10 Gb port provides Ethernet connectivity with a nominal data rate of 10 Gbps (gigabits per second). [Figure 32 on page 67](#) shows the FC EN0S and FC EN0U adapter. [Figure 33 on page 68](#) shows the FC EN0T and FC EN0V adapter.

Each of the 1 Gb RJ45 port provides Ethernet connectivity at a data rate of 1 Gbps. Each of the 1 Gb ports is connected with a 4-pair, CAT-5 unshielded twisted pair (UTP) cable or with a cable of higher specification, and is supported for distances of up to 100 meters. In addition to 1 Gb (1000 Mb) networks, 100 Mb networks are also supported.

The adapter provides the following features:

- The adapter is a PCIe2 NIC network convergence adapter.
- The 10 Gb SR ports can function in the NIC mode.
- The adapter can be used as the host local area network (LAN) adapter.
- The adapter supports interrupt moderation to deliver increased performance while significantly reducing processor utilization
- The adapter supports dual port operation in any PCIe4 or PCIe3 slot
- The adapter supports auto-negotiation, full-duplex only.
- The adapter supports multiple media-access control (MAC) per interface.
- The adapter supports integrated media-access control (MAC) and physical layer (PHY).
- The adapter supports the following standards for the different ports and functions:
 - IEEE 802.3ae in the 10 GbE ports
 - 802.3ab in the 1 GbE ports
 - Ether II and IEEE 802.3 for encapsulated frames
 - 802.1p for setting up priority levels in tagged VLAN frames
 - 802.1Q for VLAN tagging
 - 802.3x for flow control
 - 802.3ad for load-balancing and failover
 - IEEE 802.3ad and 802.3 for link aggregation
- The adapter provides message signal interrupts (MSI), MSI-X, and support of legacy pin interrupts.
- The adapter supports jumbo frames up to 9.6 KB.
- The adapter supports gigabit EtherChannel (GEC) with the existing software.
- The adapter supports TCP checksum offload transmission control protocol (TCP), user datagram protocol (UDP), TCP segmentation Offload (TSO) for IPv4 and IPv6.
- Supports TCP segmentation or large send offload
- Supports EEPROM-SPI and single EEPROM

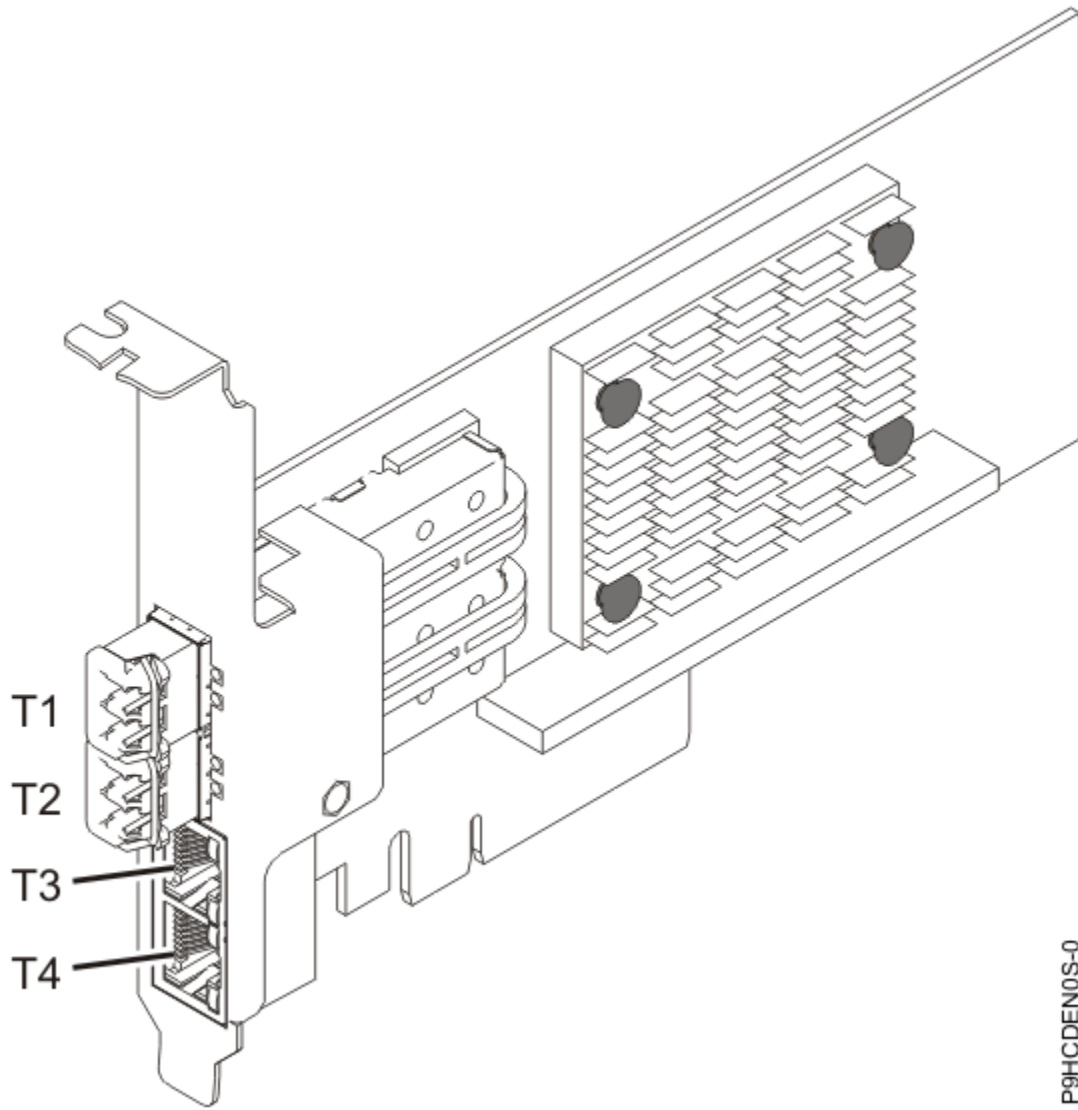

Figure 32. PCIe2 4-Port (10 Gb + 1 GbE) SR / Copper SFP +RJ45 adapter (FC EN0S and FC EN0U)

Note: The ports are numbered from top to bottom as T1, T2, and so on for the AIX and IBM i operating systems.

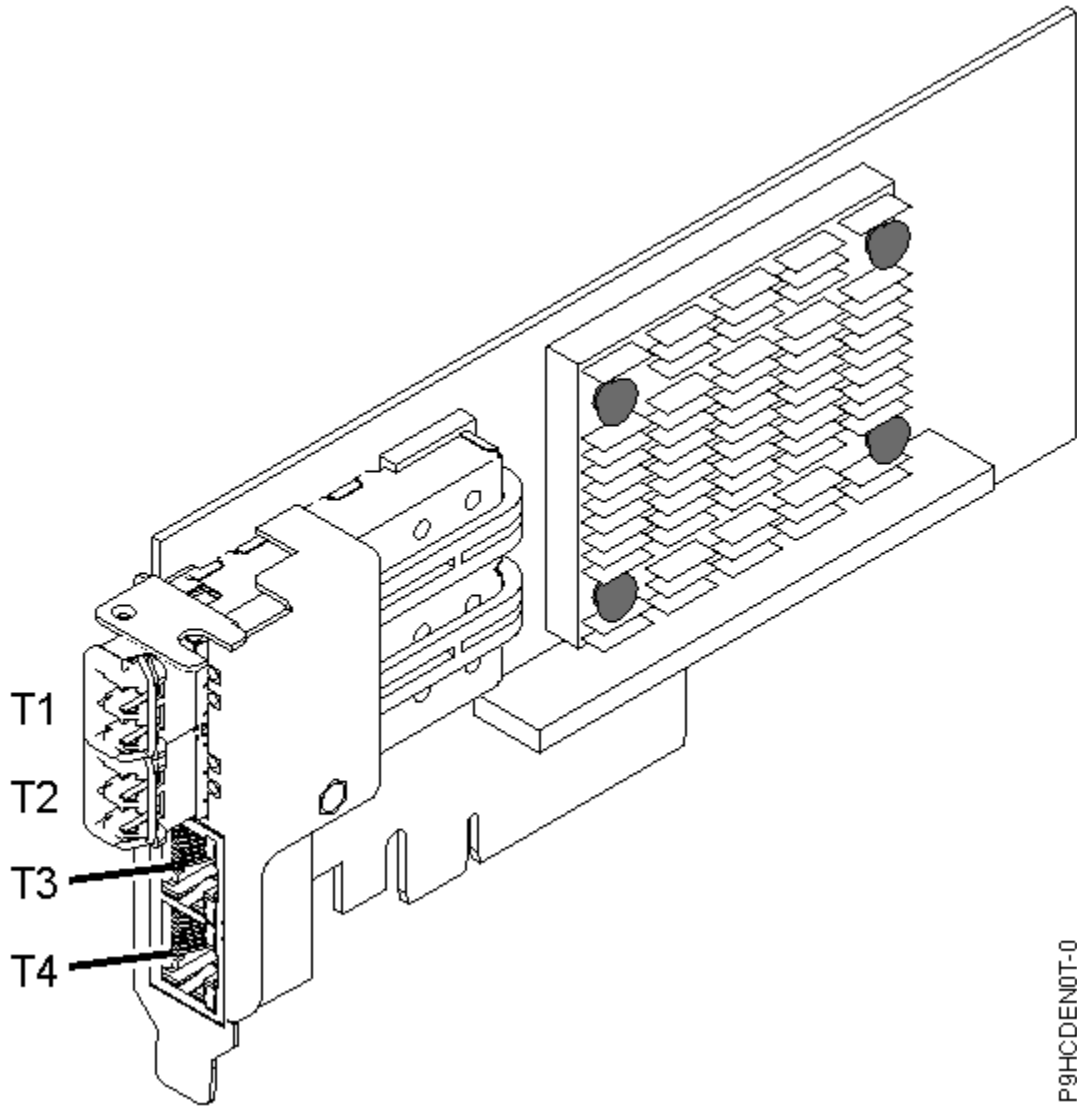

Figure 33. PCIe2 LP 4-port (10Gb+1GbE) SR / Copper SFP +RJ45 adapter (FC EN0T and FC EN0V)

Note: The ports are numbered from top to bottom of the adapter as T1, T2, and so on for the AIX and IBM i operating systems.

Specifications

Item

Description

Adapter FRU number

00E2715

Regular-height tailstock part number: 00E2863

Low-profile tailstock part number: 00E2720

Wrap plug FRU number

12R9314 (SFP+ SR wrap plug)

10N7405 (1 Gb UTP wrap plug)

Note: These wrap plugs are not included with the card. 12R9314 (FC ECW0) is the only wrap plug that can be purchased from IBM.

I/O bus architecture

PCIe2 x8

Slot requirement

For details about slot priorities, maximums, and placement rules, see [PCIe adapter placement rules and slot priorities \(http://www.ibm.com/support/knowledgecenter/POWER9/p9eab/p9eab_mtm_pciplacement.htm\)](http://www.ibm.com/support/knowledgecenter/POWER9/p9eab/p9eab_mtm_pciplacement.htm) and select the system you are working on.

Voltage

3.3 V

Form factor

Short, with full-height tailstock

Cables

See [“Cables” on page 69](#) for details.

Cables

Use multimode fiber optic cables with shortwave lasers that adhere to the following specifications:

- OM3 or OM4: Multimode 50/125 micron fiber, 2000 MHz x km bandwidth
- OM2: Multimode 50/125 micron fiber, 500 MHz x km bandwidth
- OM1: Multimode 62.5/125 micron fiber, 200 MHz x km bandwidth

Because core sizes are different, OM1 cables only can be connected to other OM1 cables. For best results, OM2 cables must not be connected to OM3 or OM4 cables. However, if an OM2 cable is connected to an OM3 or OM4 cable, the characteristics of the OM2 cable apply to the entire length of the cables. The following table shows the supported distances for the different fiber optic cable types at different link speeds.

Header	Cable Type and Distance		
Rate	OM1	OM2	OM3
10 Gbps	0.5 meters to 33 meters (1.64 feet to 108.26 feet)	0.5 meters to 82 meters (1.64 feet to 269.02 feet)	0.5 meters to 300 meters (1.64 feet to 984.25 feet)

Operating system or partition requirements

If you are installing a new feature, ensure that you have the software that is required to support the new feature and you must determine any prerequisites that must be met for this feature and the attached devices. For information about operating system and partition requirements, see one of the following topics:

- The latest version of enabling libraries and utilities can be downloaded from the [Fix Central](http://www.ibm.com/support/fixcentral/) website (<http://www.ibm.com/support/fixcentral/>).
- [Power Systems Prerequisites](http://www14.software.ibm.com/support/customer/home) website (<http://www14.software.ibm.com/support/customer/home>).
- [IBM System Storage Interoperation Center \(SSIC\)](http://www-03.ibm.com/systems/support/storage/ssic/interoperability.wss) website (<http://www-03.ibm.com/systems/support/storage/ssic/interoperability.wss>).
- The latest version of the device driver or IBM Power RAID adapter utilities (iprutils) can be downloaded from the [IBM Service and Productivity Tools](http://www14.software.ibm.com/webapp/set2/sas/f/lopdiags/home.html) website (<http://www14.software.ibm.com/webapp/set2/sas/f/lopdiags/home.html>).
- For information about important notices for Linux on IBM Power Systems, see the [Linux on IBM](http://www14.software.ibm.com/webapp/set2/sas/f/lopdiags/info/LinuxAlerts.html) website (www14.software.ibm.com/webapp/set2/sas/f/lopdiags/info/LinuxAlerts.html).

This adapter requires the following drivers:

- AIX: `devices.pciex.e4148a1614109304` for SFP+ optical ports and `devices.pciex.e4148a1614109404` for RJ45 ports

- Linux: bnx2x driver

PCIe3 LP 4-Port (10Gb+1GbE) SR+RJ45 Adapter (FC EN0T; CCIN 2CC3)

Learn about the specifications and operating system requirements for the feature code (FC) EN0T adapter.

Overview

The PCIe3 LP 4-Port (10Gb+1GbE) SR+RJ45 Adapter is a PCI Express (PCIe) generation 3 (Gen3) x8, short form-factor, low-profile adapter. The adapter provides two 10 Gb SR optical ports and two 1 Gb RJ45 ports. This adapter provides a PCIe 3.0 host bus interface. The adapter supports the Ethernet network interface controller (NIC) function. The adapter is a high-performance adapter that consolidates traffic for networking. The link aggregation and failover features of the adapter make it suitable for critical network applications that require redundancy and high availability.

The four-port adapter provides two 10 Gb small form-factor pluggable (SFP+) optical SR transceiver ports and two 1 Gb RJ45 Ethernet ports. The two 10 Gb SR ports have little connector (LC) duplex-type connectors. The optical transceiver uses shortwave laser optics and is attached with MMF-850nm fiber cabling with LC connectors. See “Cables” on page 72 for more information about the optical cables. Each 10 Gb port provides Ethernet connectivity with a nominal data rate of 10 Gbps (gigabits per second). [Figure 34 on page 71](#) shows the FC EN0T adapter.

Each of the 1 Gb RJ45 port provides Ethernet connectivity at a data rate of 1 Gbps. Each of the 1 Gb ports is connected with a 4-pair, CAT-5 unshielded twisted pair (UTP) cable or with a cable of higher specification, and is supported for distances of up to 100 meters. In addition to 1 Gb (1000 Mb) networks, 100 Mb networks are also supported.

The adapter provides the following features:

- The adapter is a PCIe3 NIC network convergence adapter.
- The 10 Gb SR ports can function in the NIC mode.
- The adapter can be used as the host local area network (LAN) adapter.
- The adapter supports interrupt moderation to deliver increased performance while significantly reducing processor utilization
- The adapter supports dual port operation in any PCIe3 or PCIe2 slot.
- The adapter supports auto-negotiation, full-duplex only.
- The adapter supports multiple media-access control (MAC) per interface.
- The adapter supports integrated media-access control (MAC) and physical layer (PHY).
- The adapter supports the following standards for the different ports and functions:
 - IEEE 802.3ae in the 10 GbE ports
 - 802.3ab in the 1 GbE ports
 - Ether II and IEEE 802.3 for encapsulated frames
 - 802.1p for setting up priority levels in tagged VLAN frames
 - 802.1Q for VLAN tagging
 - 802.3x for flow control
 - 802.3ad for load-balancing and failover
 - IEEE 802.3ad and 802.3 for link aggregation
- The adapter provides message signal interrupts (MSI), MSI-X, and support of legacy pin interrupts.
- The adapter supports jumbo frames up to 9.6 KB.
- The adapter supports gigabit EtherChannel (GEC) with the existing software.
- The adapter supports TCP checksum offload transmission control protocol (TCP), user datagram protocol (UDP), TCP segmentation Offload (TSO) for IPv4 and IPv6.
- Supports TCP segmentation or large send offload

- Supports EEPROM-SPI and single EEPROM
- Compliant with European Union Directive 2002/95/EC on the Restriction of the Use of Certain Hazardous Substances in Electrical and Electronic Equipment

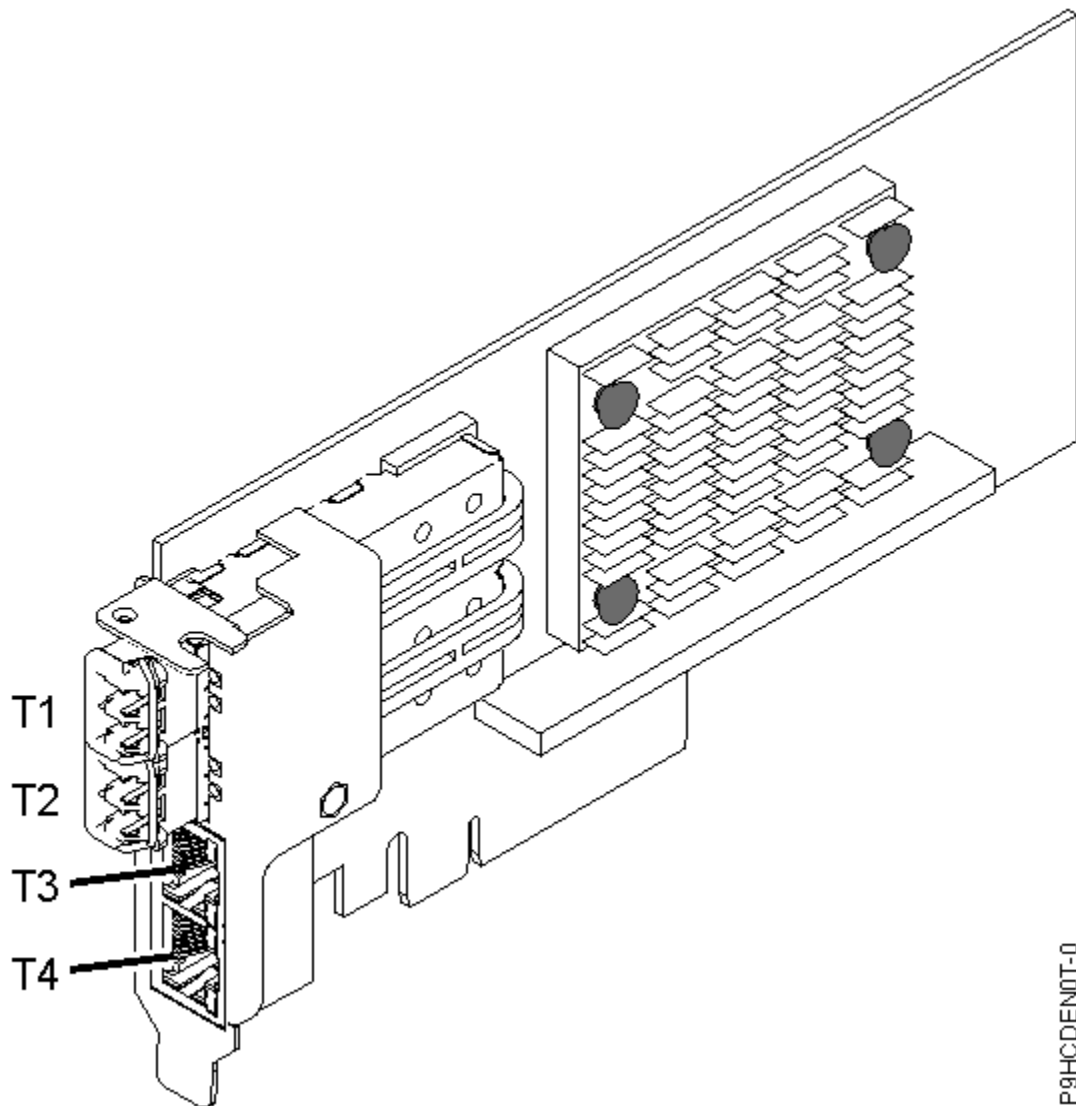

Figure 34. PCIe3 LP 4-Port (10Gb+1GbE) SR+RJ45 Adapter

Note: The ports are numbered from top to bottom of the adapter as T1, T2, and so on for the AIX® and IBM® i operating systems.

Specifications

Item

Description

Adapter FRU number

00E2715

Low-profile tailstock part number: 00E2720

Wrap plug FRU number

12R9314 (SFP+ SR wrap plug)

10N7405 (1 Gb UTP wrap plug)

Note: These wrap plugs are not included with the card. 12R9314 (FC ECW0) is the only wrap plug that can be purchased from IBM.

I/O bus architecture

PCIe3 x8

Slot requirement

For details about slot priorities, maximums, and placement rules, see [PCIe adapter placement rules and slot priorities \(http://www.ibm.com/support/knowledgecenter/POWER9/p9eab/p9eab_mtm_pciplacement.htm\)](http://www.ibm.com/support/knowledgecenter/POWER9/p9eab/p9eab_mtm_pciplacement.htm) and select the system you are working on.

Voltage

3.3 V

Form factor

Short, low-profile

Cables

Use multimode fiber optic cables with shortwave lasers that adhere to the following specifications:

- OM3 or OM4: Multimode 50/125 micron fiber, 2000 MHz x km bandwidth
- OM2: Multimode 50/125 micron fiber, 500 MHz x km bandwidth
- OM1: Multimode 62.5/125 micron fiber, 200 MHz x km bandwidth

Because core sizes are different, OM1 cables only can be connected to other OM1 cables. For best results, OM2 cables must not be connected to OM3 or OM4 cables. However, if an OM2 cable is connected to an OM3 or OM4 cable, the characteristics of the OM2 cable apply to the entire length of the cables. The following table shows the supported distances for the different fiber optic cable types at different link speeds.

Header	Cable Type and Distance		
Rate	OM1	OM2	OM3
10 Gbps	0.5 meters to 33 meters (1.64 feet to 108.26 feet)	0.5 meters to 82 meters (1.64 feet to 269.02 feet)	0.5 meters to 300 meters (1.64 feet to 984.25 feet)

Operating system or partition requirements

If you are installing a new feature, ensure that you have the software that is required to support the new feature and you must determine any prerequisites that must be met for this feature and the attached devices. For information about operating system and partition requirements, see one of the following topics:

- The latest version of enabling libraries and utilities can be downloaded from the [Fix Central](http://www.ibm.com/support/fixcentral/) website (http://www.ibm.com/support/fixcentral/).
- [Power Systems Prerequisites](http://www14.software.ibm.com/support/customer/home) website (http://www14.software.ibm.com/support/customer/home).
- [IBM System Storage Interoperation Center \(SSIC\)](http://www-03.ibm.com/systems/support/storage/ssic/interoperability.wss) website (http://www-03.ibm.com/systems/support/storage/ssic/interoperability.wss).
- The latest version of the device driver or IBM Power RAID adapter utilities (iprutils) can be downloaded from the [IBM Service and Productivity Tools](http://www14.software.ibm.com/webapp/set2/sas/f/lopdiags/home.html) website (http://www14.software.ibm.com/webapp/set2/sas/f/lopdiags/home.html).
- For information about important notices for Linux on IBM Power Systems, see the [Linux on IBM](http://www14.software.ibm.com/webapp/set2/sas/f/lopdiags/info/LinuxAlerts.html) website (www14.software.ibm.com/webapp/set2/sas/f/lopdiags/info/LinuxAlerts.html).

This adapter requires the following drivers:

- AIX: devices.pciex.e4148a1614109304 for SFP+ optical ports and devices.pciex.e4148a1614109404 for RJ45 ports

- Linux: bnx2x driver

PCIe2 LP 4-port (10 Gb + 1 GbE) Copper SFP+RJ45 Adapter (FC EN0V; CCIN 2CC3)

Learn about the specifications and operating system requirements for the feature code (FC) EN0V adapter.

Overview

The PCIe2 LP 4-port (10 Gb + 1 GbE) Copper SFP+RJ45 Adapter is a PCI Express (PCIe) generation 2, x8, short form-factor, low-profile adapter. The adapter provides two 10 Gb copper Twinax small form-factor pluggable (SFP+) ports and two 1 Gb RJ45 ports. This adapter provides a PCIe 2.0 host bus interface. The adapter supports the Ethernet network interface controller (NIC) function. The adapter is a high-performance adapter that consolidates traffic for networking. The link aggregation and failover features of the adapter make it suitable for critical network applications that require redundancy and high availability.

The two 10 Gb are SFP+ and do not include a transceiver. Active Copper Twinax cables up to 5 meter in length are supported such as provided by feature codes EN01, EN02 or EN03. A transceiver is included with these cables. See [“Cables” on page 75](#) for details. Each 10 Gb port provides Ethernet connectivity with a nominal data rate of 10 Gbps (gigabits per second).

Each of the 1 Gb RJ45 port provides Ethernet connectivity at a data rate of 1 Gbps. Each of the 1 Gb ports is connected with a 4-pair, CAT-5 unshielded twisted pair (UTP) cable or with a cable of higher specification, and is supported for distances of up to 100 meters. In addition to 1 Gb (1000 Mb) networks, 100 Mb networks are also supported.

The adapter provides the following features:

- The adapter is a PCIe2 NIC network convergence adapter.
- The 10 Gb ports can function in the NIC mode.
- The adapter can be used as the host local area network (LAN) adapter.
- The adapter supports interrupt moderation to deliver increased performance while significantly reducing processor utilization
- The adapter supports dual port operation in any PCIe3 or PCIe2 slot.
- The adapter supports auto-negotiation, full-duplex only.
- The adapter supports multiple media-access control (MAC) per interface.
- The adapter supports integrated media-access control (MAC) and physical layer (PHY).
- The adapter supports the following standards for the different ports and functions:
 - IEEE 802.3ae in the 10 GbE ports
 - 802.3ab in the 1 GbE ports
 - Ether II and IEEE 802.3 for encapsulated frames
 - 802.1p for setting up priority levels in tagged VLAN frames
 - 802.1Q for VLAN tagging
 - 802.3x for flow control
 - 802.3ad for load-balancing and failover
 - IEEE 802.3ad and 802.3 for link aggregation
- The adapter provides message signal interrupts (MSI), MSI-X, and support of legacy pin interrupts.
- The adapter supports jumbo frames up to 9.6 KB.
- The adapter supports gigabit EtherChannel (GEC) with the existing software.
- The adapter supports TCP checksum offload transmission control protocol (TCP), user datagram protocol (UDP), TCP segmentation Offload (TSO) for IPv4 and IPv6.

- Supports TCP segmentation or large send offload
- Supports EEPROM-SPI and single EEPROM

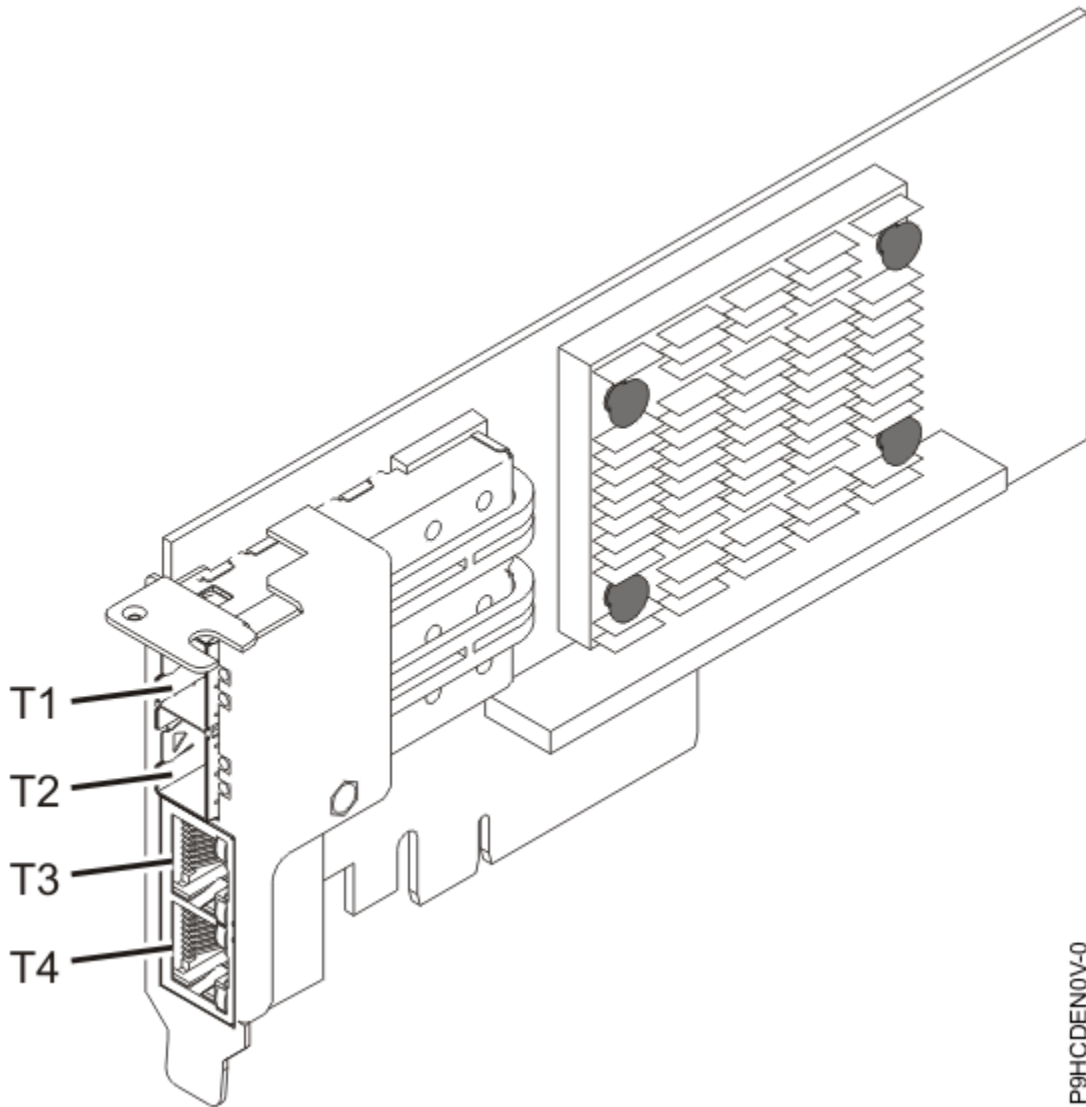

Figure 35. PCIe2 LP 4-port (10 Gb + 1 GbE) Copper SFP+RJ45 Adapter

Note: The ports are numbered from top to bottom as T1, T2, and so on for the AIX® and IBM® i operating systems.

Specifications

Item

Description

Adapter FRU number

00E2715

Low-profile tailstock part number: 00E2720

Wrap plug FRU number

74Y7010 (Twinax wrap plug)

10N7405 (1 Gb UTP wrap plug)

Note: Wrap plugs are not included with the card and cannot be purchased from IBM.

I/O bus architecture

PCIe2 x8

Slot requirement

For details about slot priorities, maximums, and placement rules, see [PCIe adapter placement rules and slot priorities \(http://www.ibm.com/support/knowledgecenter/POWER9/p9eab/p9eab_mtm_pciplacement.htm\)](http://www.ibm.com/support/knowledgecenter/POWER9/p9eab/p9eab_mtm_pciplacement.htm) and select the system you are working on.

Voltage

3.3 V

Form factor

Short, low-profile

Cables

This adapter feature requires the use of compatible SFP+, 10 Gbps, copper, twinaxial, active, Ethernet cables.

Note: These cables are EMC Class A compliant.

See [Table 18 on page 75](#) for details about the feature codes.

Cable length	Feature code	CCIN	Part number
1 m (3.28 ft)	EN01	EF01	46K6182
3 m (9.84 ft)	EN02	EF02	46K6183
5 m (16.4 ft)	EN03	EF03	46K6184

Operating system or partition requirements

If you are installing a new feature, ensure that you have the software that is required to support the new feature and you must determine any prerequisites that must be met for this feature and the attached devices. For information about operating system and partition requirements, see one of the following topics:

- The latest version of enabling libraries and utilities can be downloaded from the [Fix Central](http://www.ibm.com/support/fixcentral/) website (<http://www.ibm.com/support/fixcentral/>).
- [Power Systems Prerequisites](http://www14.software.ibm.com/support/customer/ipt/home) website (<http://www14.software.ibm.com/support/customer/ipt/home>).
- [IBM System Storage Interoperation Center \(SSIC\)](http://www-03.ibm.com/systems/support/storage/ssic/interoperability.wss) website (<http://www-03.ibm.com/systems/support/storage/ssic/interoperability.wss>).
- The latest version of the device driver or IBM Power RAID adapter utilities (iprutils) can be downloaded from the [IBM Service and Productivity Tools](http://www14.software.ibm.com/webapp/set2/sas/f/lopdiags/home.html) website (<http://www14.software.ibm.com/webapp/set2/sas/f/lopdiags/home.html>).
- For information about important notices for Linux on IBM Power Systems, see the [Linux on IBM](http://www14.software.ibm.com/webapp/set2/sas/f/lopdiags/info/LinuxAlerts.html) website (www14.software.ibm.com/webapp/set2/sas/f/lopdiags/info/LinuxAlerts.html).

This adapter requires the following drivers:

- AIX: `devices.pciex.e4148a1614109304` for SFP+ optical ports and `devices.pciex.e4148a1614109404` for RJ45 ports
- Linux: `bnx2x` driver

Installing a PCIe adapter in the 8335-GTG, 8335-GTH, or 8335-GTX system

To install a PCIe adapter, complete the steps in this procedure.

Before you begin

Power off the system and place it in the service position. For instructions, see “Preparing the 8335-GTC, 8335-GTG, 8335-GTH, 8335-GTW, or 8335-GTX system to remove and replace internal parts” on page 86.

About this task

See “PCIe adapter placement rules and slot priorities for the 8335-GTG, 8335-GTH, or 8335-GTX system” on page 20 for information and capabilities of the PCIe slots.



Attention: For safety and airflow purposes, if you remove parts from the system, you must ensure that:

- PCIe tailstock fillers are present.
- Graphic processor unit (GPU) airflow baffles are present.

Procedure

1. Attach the electrostatic discharge (ESD) wrist strap.

The ESD wrist strap must be connected to an unpainted metal surface until the service procedure is completed, and if applicable, until the service access cover is replaced.



Attention:

- Attach an electrostatic discharge (ESD) wrist strap to the front ESD jack, to the rear ESD jack, or to an unpainted metal surface of your hardware to prevent the electrostatic discharge from damaging your hardware.
 - When you use an ESD wrist strap, follow all electrical safety procedures. An ESD wrist strap is used for static control. It does not increase or decrease your risk of receiving electric shock when using or working on electrical equipment.
 - If you do not have an ESD wrist strap, just prior to removing the product from ESD packaging and installing or replacing hardware, touch an unpainted metal surface of the system for a minimum of 5 seconds. If at any point in this service process you move away from the system, it is important to again discharge yourself by touching an unpainted metal surface for at least 5 seconds before you continue with the service process.
2. Pick the correct slot for the PCIe adapter as shown in [Figure 36](#) on page 76.

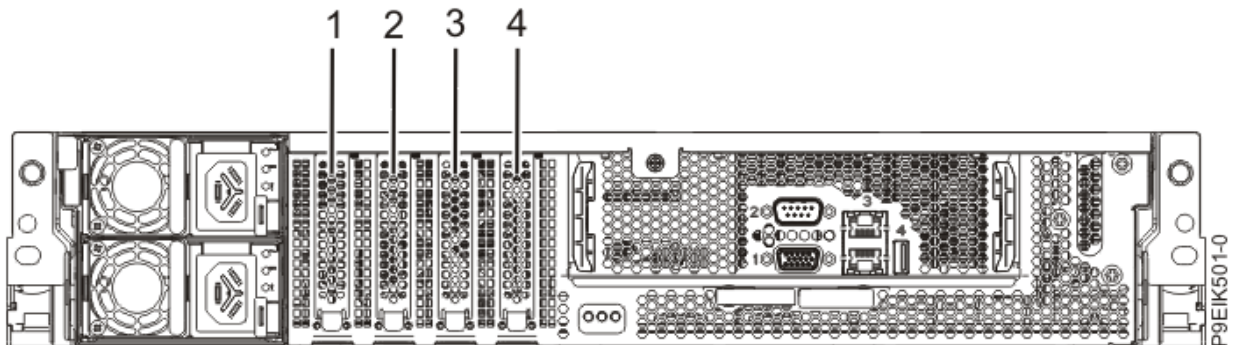
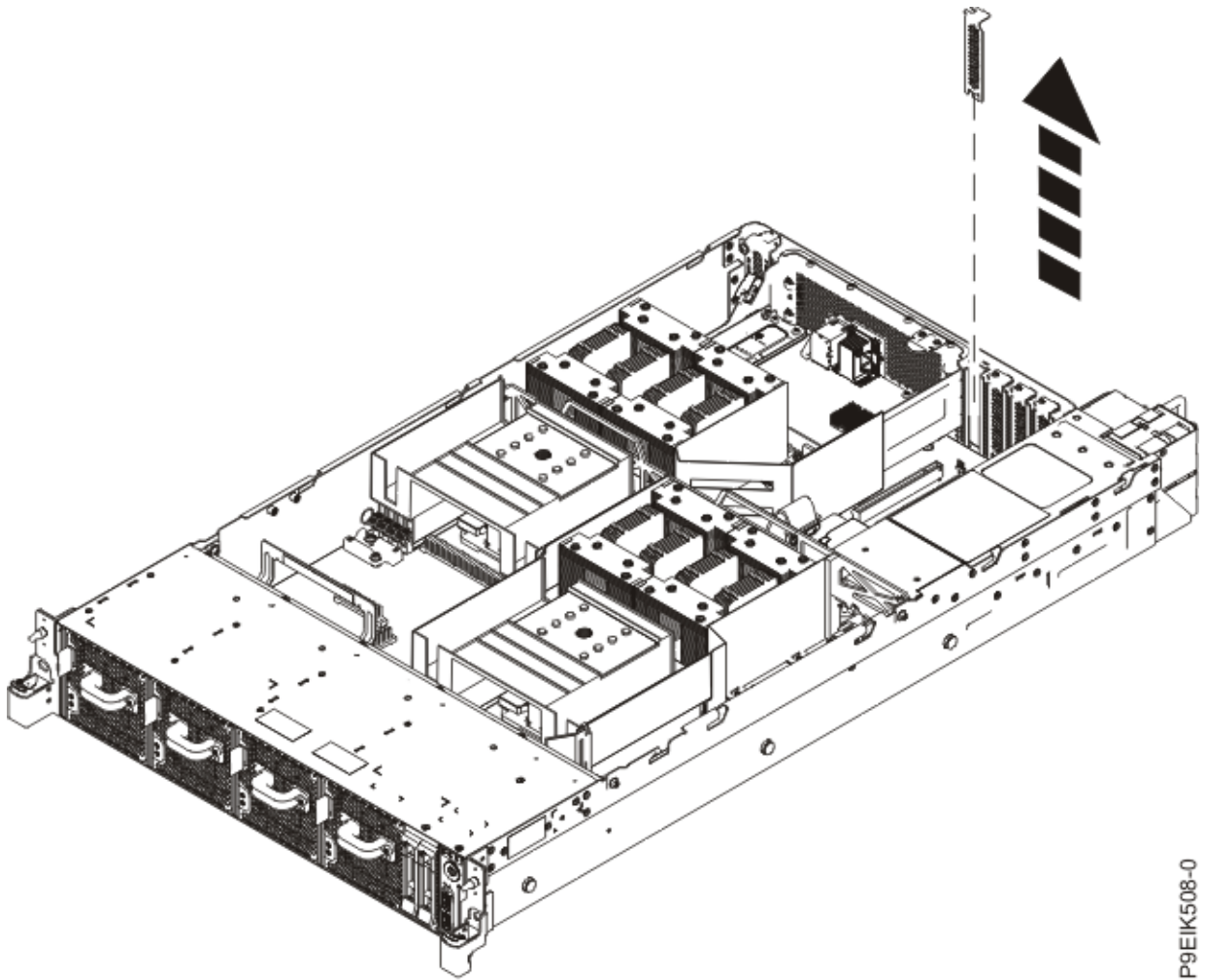

Figure 36. Rear view of a system with PCIe slots indicated

3. Remove the PCIe slot cover as shown in [Figure 37](#) on page 77.



P9EIK508-0

Figure 37. Removing the PCIe slot cover

4. If needed, label and remove any plugs that extend out of the PCIe adapter.
5. Insert the adapter, aligning it properly and inserting it fully into the slot as shown in [Figure 38 on page 78](#).

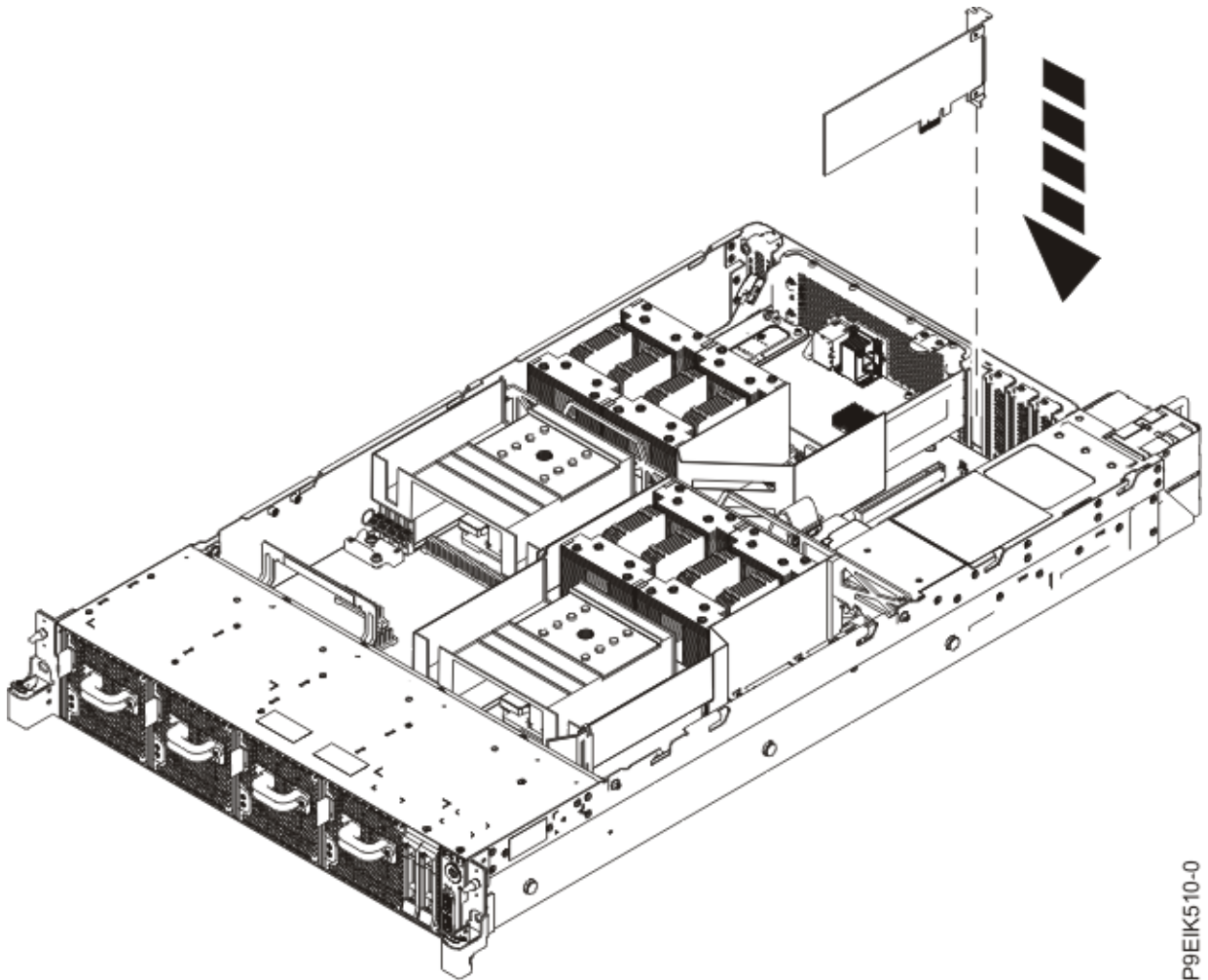

P9EIK510-0

Figure 38. Inserting a PCIe adapter

6. Using your labels, replace any plugs that you removed from the PCIe adapter. Insert the cables into the PCIe adapter.

What to do next

Prepare the system for operation. For instructions, see [“Preparing the 8335-GTC, 8335-GTG, 8335-GTH, 8335-GTW, or 8335-GTX system for operation after you remove and replace internal parts”](#) on page 90.

Common procedures for servicing or installing features in the 8335-GTC, 8335-GTG, 8335-GTH, 8335-GTW, or 8335-GTX system

Learn about the common procedures related to installing, removing, and replacing features in the system.

Before you begin

Observe these precautions when you are installing, removing, or replacing features and parts.

About this task

These precautions are intended to create a safe environment to service your system and do not provide steps for servicing your system. The installation, removal, and replacement procedures provide the step-by-step processes that are required to service your system.



DANGER: When working on or around the system, observe the following precautions:

Electrical voltage and current from power, telephone, and communication cables are hazardous. To avoid a shock hazard: If IBM supplied the power cord(s), connect power to this unit only with the IBM provided power cord. Do not use the IBM provided power cord for any other product. Do not open or service any power supply assembly. Do not connect or disconnect any cables or perform installation, maintenance, or reconfiguration of this product during an electrical storm.



- The product might be equipped with multiple power cords. To remove all hazardous voltages, disconnect all power cords. For AC power, disconnect all power cords from their AC power source. For racks with a DC power distribution panel (PDP), disconnect the customer's DC power source to the PDP.
- When connecting power to the product ensure all power cables are properly connected. For racks with AC power, connect all power cords to a properly wired and grounded electrical outlet. Ensure that the outlet supplies proper voltage and phase rotation according to the system rating plate. For racks with a DC power distribution panel (PDP), connect the customer's DC power source to the PDP. Ensure that the proper polarity is used when attaching the DC power and DC power return wiring.
- Connect any equipment that will be attached to this product to properly wired outlets.
- When possible, use one hand only to connect or disconnect signal cables.
- Never turn on any equipment when there is evidence of fire, water, or structural damage.
- Do not attempt to switch on power to the machine until all possible unsafe conditions are corrected.
- When performing a machine inspection: Assume that an electrical safety hazard is present. Perform all continuity, grounding, and power checks specified during the subsystem installation procedures to ensure that the machine meets safety requirements. Do not attempt to switch power to the machine until all possible unsafe conditions are corrected. Before you open the device covers, unless instructed otherwise in the installation and configuration procedures: Disconnect the attached AC power cords, turn off the applicable circuit breakers located in the rack power distribution panel (PDP), and disconnect any telecommunications systems, networks, and modems.
- Connect and disconnect cables as described in the following procedures when installing, moving, or opening covers on this product or attached devices.

To Disconnect: 1) Turn off everything (unless instructed otherwise). 2) For AC power, remove the power cords from the outlets. 3) For racks with a DC power distribution panel (PDP), turn off the circuit breakers located in the PDP and remove the power from the Customer's DC power source. 4) Remove the signal cables from the connectors. 5) Remove all cables from the devices.

To Connect: 1) Turn off everything (unless instructed otherwise). 2) Attach all cables to the devices. 3) Attach the signal cables to the connectors. 4) For AC power, attach the power cords to the outlets. 5) For racks with a DC power distribution panel (PDP), restore the power from the Customer's DC power source and turn on the circuit breakers located in the PDP. 6) Turn on the devices.



- Sharp edges, corners and joints may be present in and around the system. Use care when handling equipment to avoid cuts, scrapes and pinching. (D005)

(R001 part 1 of 2):



DANGER: Observe the following precautions when working on or around your IT rack system:

- Heavy equipment—personal injury or equipment damage might result if mishandled.
- Always lower the leveling pads on the rack cabinet.
- Always install stabilizer brackets on the rack cabinet if provided, unless the earthquake option is to be installed.

- To avoid hazardous conditions due to uneven mechanical loading, always install the heaviest devices in the bottom of the rack cabinet. Always install servers and optional devices starting from the bottom of the rack cabinet.
- Rack-mounted devices are not to be used as shelves or work spaces. Do not place objects on top of rack-mounted devices. In addition, do not lean on rack mounted devices and do not use them to stabilize your body position (for example, when working from a ladder).



- Stability hazard:
 - The rack may tip over causing serious personal injury.
 - Before extending the rack to the installation position, read the installation instructions.
 - Do not put any load on the slide-rail mounted equipment mounted in the installation position.
 - Do not leave the slide-rail mounted equipment in the installation position.
- Each rack cabinet might have more than one power cord.
 - For AC powered racks, be sure to disconnect all power cords in the rack cabinet when directed to disconnect power during servicing.
 - For racks with a DC power distribution panel (PDP), turn off the circuit breaker that controls the power to the system unit(s), or disconnect the customer's DC power source, when directed to disconnect power during servicing.
- Connect all devices installed in a rack cabinet to power devices installed in the same rack cabinet. Do not plug a power cord from a device installed in one rack cabinet into a power device installed in a different rack cabinet.
- An electrical outlet that is not correctly wired could place hazardous voltage on the metal parts of the system or the devices that attach to the system. It is the responsibility of the customer to ensure that the outlet is correctly wired and grounded to prevent an electrical shock. (R001 part 1 of 2)

(R001 part 2 of 2):



CAUTION:

- Do not install a unit in a rack where the internal rack ambient temperatures will exceed the manufacturer's recommended ambient temperature for all your rack-mounted devices.
- Do not install a unit in a rack where the air flow is compromised. Ensure that air flow is not blocked or reduced on any side, front, or back of a unit used for air flow through the unit.
- Consideration should be given to the connection of the equipment to the supply circuit so that overloading of the circuits does not compromise the supply wiring or overcurrent protection. To provide the correct power connection to a rack, refer to the rating labels located on the equipment in the rack to determine the total power requirement of the supply circuit.
- *(For sliding drawers.)* Do not pull out or install any drawer or feature if the rack stabilizer brackets are not attached to the rack or if the rack is not bolted to the floor. Do not pull out more than one drawer at a time. The rack might become unstable if you pull out more than one drawer at a time.



- (For fixed drawers.) This drawer is a fixed drawer and must not be moved for servicing unless specified by the manufacturer. Attempting to move the drawer partially or completely out of the rack might cause the rack to become unstable or cause the drawer to fall out of the rack. (R001 part 2 of 2)

(L003)

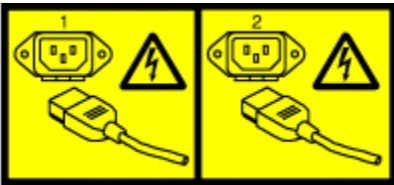

or



or



or



or

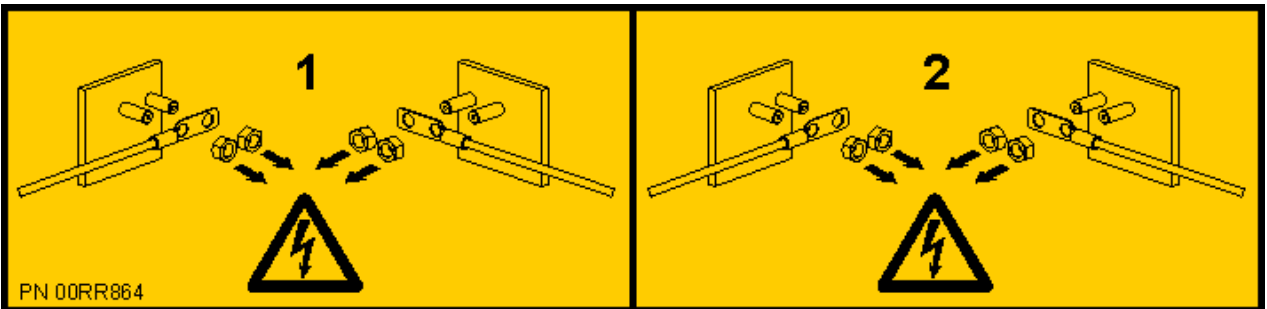

 **DANGER:** Multiple power cords. The product might be equipped with multiple AC power cords or multiple DC power cables. To remove all hazardous voltages, disconnect all power cords and power cables. (L003)

(L005)



 **CAUTION:** Hazardous energy present. Voltages with hazardous energy might cause heating when shorted with metal, which might result in splattered metal, burns, or both. (L005)

Procedure

Before you begin a replacement or installation procedure, do these tasks:

1. If you are installing a new feature, ensure that you install the required software to support the new feature. See [IBM Prerequisite](#).
2. If you are installing or replacing something that might put your data at risk, ensure, wherever possible, that you have a current backup of your system or logical partition (including operating systems, licensed programs, and data).
3. Review the installation or replacement procedure for the feature or part.
4. Note the significance of color on your system.

Blue on a part of the hardware indicates a touch point where you can grip the hardware to remove it from or install it in the system, open or close a latch, and so on.

5. Ensure that you have access to a medium flat-blade screwdriver, a Phillips screwdriver, and a pair of scissors.
6. If parts are incorrect, missing, or visibly damaged, do the following steps:
 - If you are replacing a part, contact the provider of your parts or next level of support.
 - If you are installing a feature, contact one of the following service organizations:
 - The provider of your parts or next level of support.
 - In the United States, the IBM Rochester Manufacturing Automated Information Line (R-MAIL) at 1-800-300-8751.

In countries and regions outside of the United States, see the [Directory of worldwide contacts](http://www.ibm.com/planetwide) (<http://www.ibm.com/planetwide>).

7. If you encounter difficulties during the installation, contact your service provider, your IBM reseller, or your next level of support.
8. For the IBM Power System AC922 (8335-GTC, 8335-GTG, and 8335-GTH) or IBM Power System AC922 (8335-GTW and 8335-GTX) systems, ensure that the top cover is on when the system is running for thermal performance.

Identifying the system that contains the part to replace

Learn how to determine which server or enclosure has the part you want to replace.

About this task

If the part does not have problem indicator LED, you need to use a troubleshooting program such as `impitool` to identify the issue.

LEDs on the 8335-GTC, 8335-GTG, 8335-GTH, 8335-GTW, or 8335-GTX system

Use this information as a guide to the LEDs on the IBM Power System AC922 (8335-GTC, 8335-GTG, and 8335-GTH) or IBM Power System AC922 (8335-GTW and 8335-GTX) system.

The LEDs indicate various system statuses. These LEDs are at the front (as shown in [Figure 39 on page 84](#) and [Figure 40 on page 84](#)) and at the rear of the system (as shown in [Figure 41 on page 85](#)).

- The green LED indicates the power status.
 - A constant light indicates full system power to the unit.
 - A flashing light indicates standby power to the unit.
- The blue LED is used to identify the system that requires service.
- The amber LED indicates a problem in the system. After a part is repaired, the amber LED takes a minute to turn off.

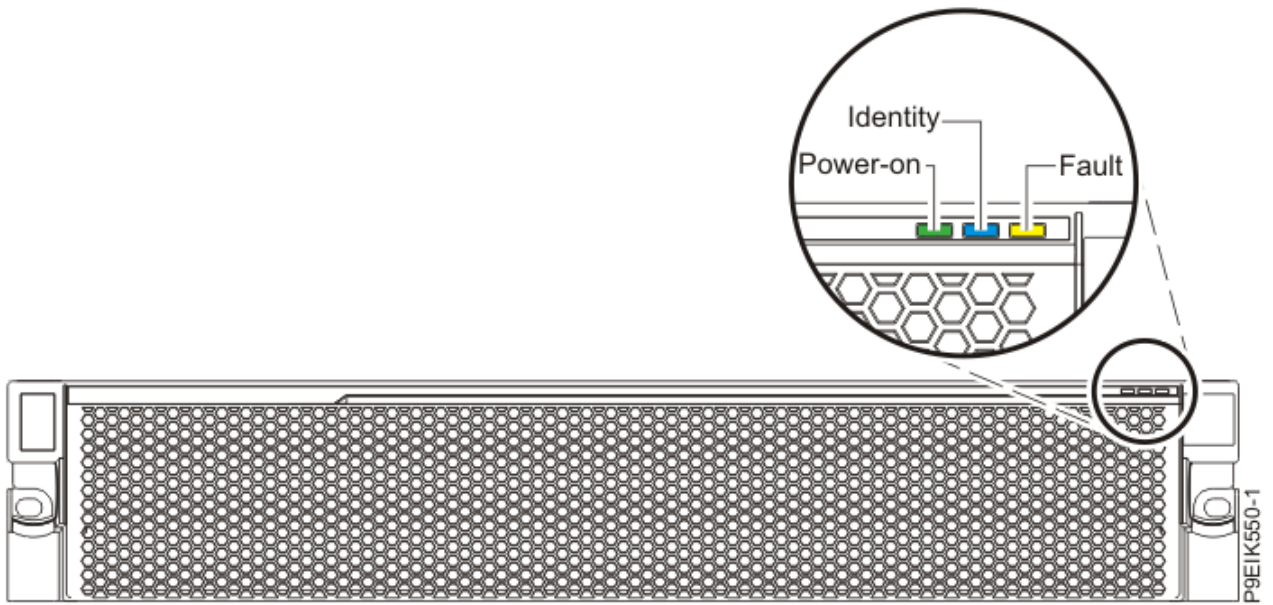

Figure 39. Front LEDs with bezel on

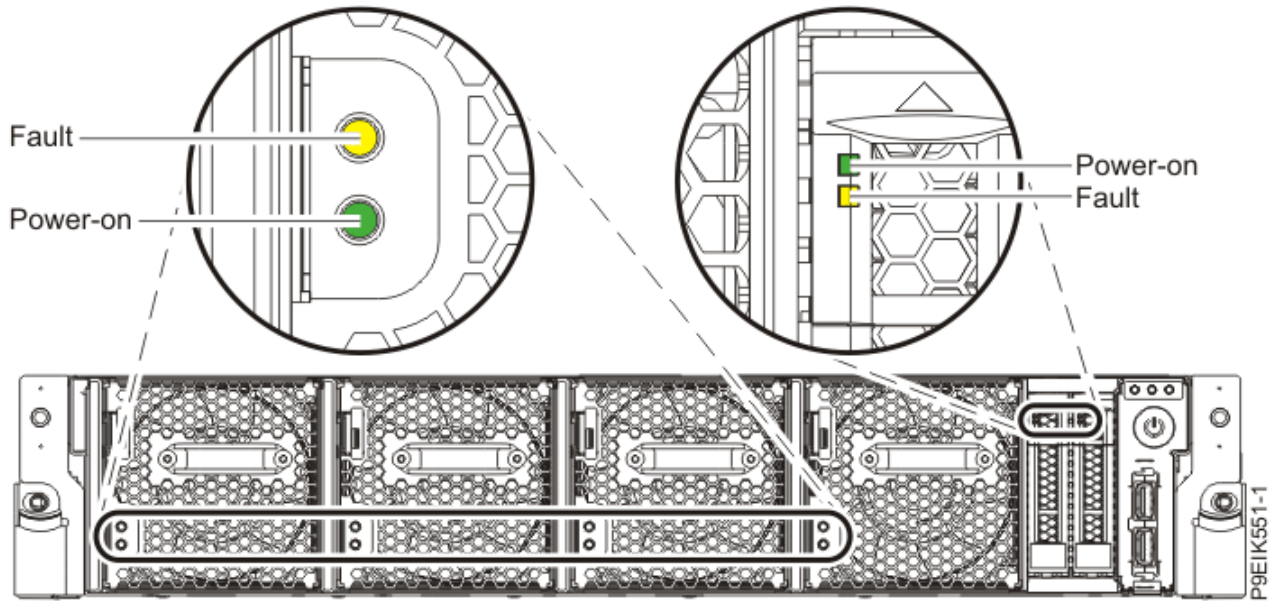

Figure 40. Front LEDs with bezel off

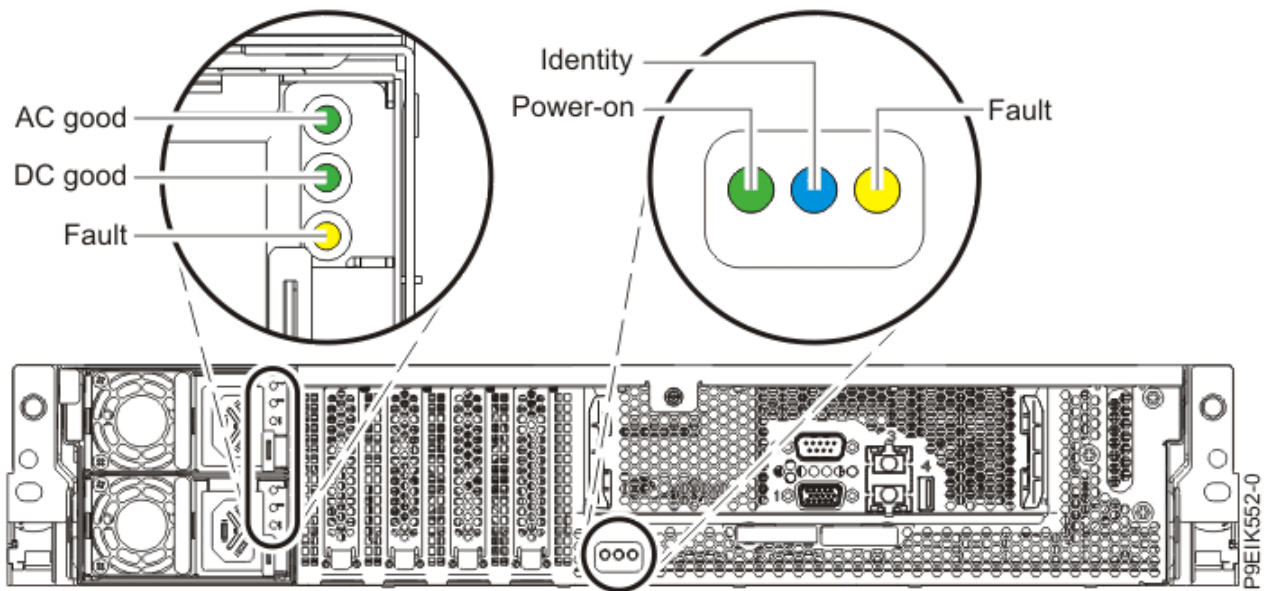

Figure 41. Rear LEDs

LED indicators are on the following parts:

- At the front of the system:
 - Disk drives (green LED indicates activity; amber LED indicates a problem).
 - Fans (green LED indicates activity; amber LED indicates a problem).
- At the rear of the system:
 - Backplane, near the rightmost PCIe slot port: Green, amber, and blue (same as on the front next to the power button).
 - Power supplies (Two green LEDs indicate AC and DC power; amber LED indicates a problem).

Identifying the 8335-GTC, 8335-GTG, 8335-GTH, 8335-GTW, or 8335-GTX system that needs servicing

Learn how to turn on the blue identify LED to help you find the system that needs servicing.

Procedure

To activate the blue system identify LED, use the following command:

```
openbmctool -U <username> -P <password> -H <BMC IP address or BMC host name> chassis identify on
```

To turn off the blue system identify LED, use the following command:

```
openbmctool -U <username> -P <password> -H <BMC IP address or BMC host name> chassis identify off
```

To check the status of the blue system identify LED, use the following command:

```
openbmctool -U <username> -P <password> -H <BMC IP address or BMC host name> chassis identify status
```

Preparing the 8335-GTC, 8335-GTG, 8335-GTH, 8335-GTW, or 8335-GTX system to remove and replace internal parts

To prepare the IBM Power System AC922 (8335-GTC, 8335-GTG, and 8335-GTH) or IBM Power System AC922 (8335-GTW and 8335-GTX) system to remove and replace internal parts, complete the steps in this procedure.

Procedure

1. Complete the prerequisite tasks. For instructions, see [“Before you begin”](#) on page 78.
2. Identify the part and the system that you need to work on. For instructions, see [“Identifying the system that contains the part to replace”](#) on page 83.
3. If applicable, open the rack front door.
4. Attach the electrostatic discharge (ESD) wrist strap.

The ESD wrist strap must be connected to an unpainted metal surface until the service procedure is completed, and if applicable, until the service access cover is replaced.



Attention:

- Attach an electrostatic discharge (ESD) wrist strap to the front ESD jack, to the rear ESD jack, or to an unpainted metal surface of your hardware to prevent the electrostatic discharge from damaging your hardware.
 - When you use an ESD wrist strap, follow all electrical safety procedures. An ESD wrist strap is used for static control. It does not increase or decrease your risk of receiving electric shock when using or working on electrical equipment.
 - If you do not have an ESD wrist strap, just prior to removing the product from ESD packaging and installing or replacing hardware, touch an unpainted metal surface of the system for a minimum of 5 seconds. If at any point in this service process you move away from the system, it is important to again discharge yourself by touching an unpainted metal surface for at least 5 seconds before you continue with the service process.
5. Remove the front cover. For instructions, see [“Removing the front cover from an 8335-GTC, 8335-GTG, 8335-GTH, 8335-GTW, or 8335-GTX system”](#) on page 96.

(L007)



CAUTION: A hot surface nearby. (L007)

6. Stop the system. For instructions, see [“Stopping the 8335-GTC, 8335-GTG, 8335-GTH, 8335-GTW, or 8335-GTX system”](#) on page 93.
7. If applicable, open the rack door at the rear of the system.
8. Disconnect the power source from the system by unplugging the system. For instructions, see [“Disconnecting power cords from an 8335-GTC, 8335-GTG, 8335-GTH, 8335-GTW, or 8335-GTX system”](#) on page 102.

Note: The system might be equipped with redundant power supply. Before you continue with this procedure, ensure that all power to your system is disconnected.

(L003)

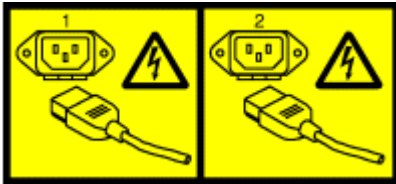

or



or





or



or

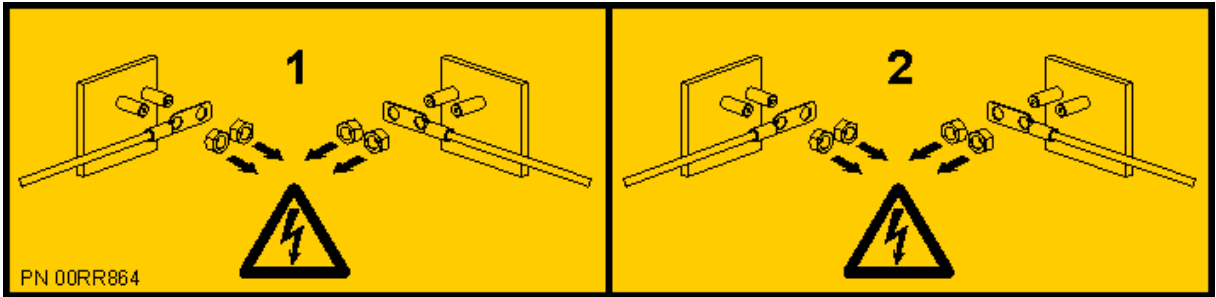



 **DANGER:** Multiple power cords. The product might be equipped with multiple AC power cords or multiple DC power cables. To remove all hazardous voltages, disconnect all power cords and power cables. (L003)

(L005)



 **CAUTION:** Hazardous energy present. Voltages with hazardous energy might cause heating when shorted with metal, which might result in splattered metal, burns, or both. (L005)

9. Remove the power supplies from the system as shown in [Figure 42 on page 89](#).
 - a) To release a power supply from its position in the system, pull the locking-tab **(A)** to the left.
 - b) Grasp the power supply handle with one hand, and pull the power supply **(B)** partially out of the system.
 - c) Place your other hand underneath the power supply and pull the power supply out of the system and place it on an ESD mat.
 - d) Repeat steps “9.a” on page 88 - “9.c” on page 88 for the other power supply.

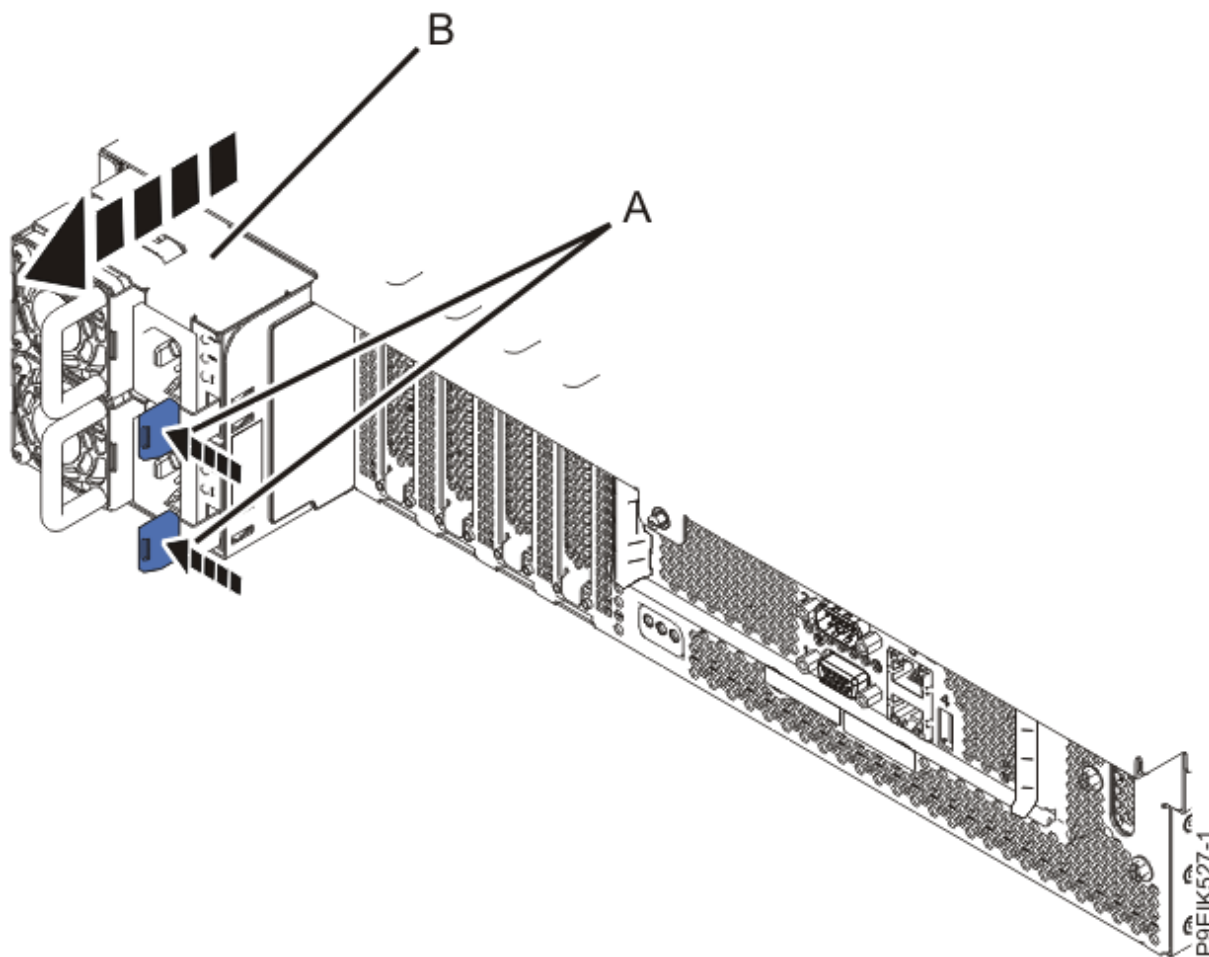

Figure 42. Removing the power supplies from the system

- Place the system into the service position. For instructions, see [“Placing an 8335-GTC, 8335-GTG, 8335-GTH, 8335-GTW, or 8335-GTX system into the service position”](#) on page 97.



CAUTION: Do not place any object on top of a rack-mounted device unless that rack-mounted device is intended for use as a shelf. (R008)

(L012)



CAUTION: Pinch hazard. (L012)

- Remove the service access cover. For instructions, see [“Removing the service access cover from an 8335-GTC, 8335-GTG, 8335-GTH, 8335-GTW, or 8335-GTX system”](#) on page 94.

Preparing the 8335-GTC, 8335-GTG, 8335-GTH, 8335-GTW, or 8335-GTX system for operation after you remove and replace internal parts

To prepare the IBM Power System AC922 (8335-GTC, 8335-GTG, and 8335-GTH) or IBM Power System AC922 (8335-GTW and 8335-GTX) system for operation after you remove and replace internal parts, complete the steps in this procedure.

Procedure

1. Ensure that you have the electrostatic discharge (ESD) wrist strap on and that the ESD clip is plugged into a ground jack or connected to an unpainted metal surface. If not, do so now.
2. Replace the service access cover. For instructions, see [“Installing the service access cover on an 8335-GTC, 8335-GTG, 8335-GTH, 8335-GTW, or 8335-GTX system”](#) on page 95.
3. Place the system into the operating position. For instructions, see [“Placing an 8335-GTC, 8335-GTG, 8335-GTH, 8335-GTW, or 8335-GTX system into the operating position”](#) on page 99.

(L012)



CAUTION: Pinch hazard. (L012)



Attention: For a water-cooled system, before you power on the system, ensure that cooling water is circulating through the system.

4. Replace the power supplies as shown in [Figure 43 on page 91](#).
 - a) Place your other hand underneath the power supply.
 - b) Align the power supply **(A)** with the bay with the fan to the left.
 - c) Slide the power supply into the system until the latch **(B)** locks in place.
 - d) Repeat steps [“4.a” on page 90](#) - [“4.c” on page 90](#) for the other power supply.

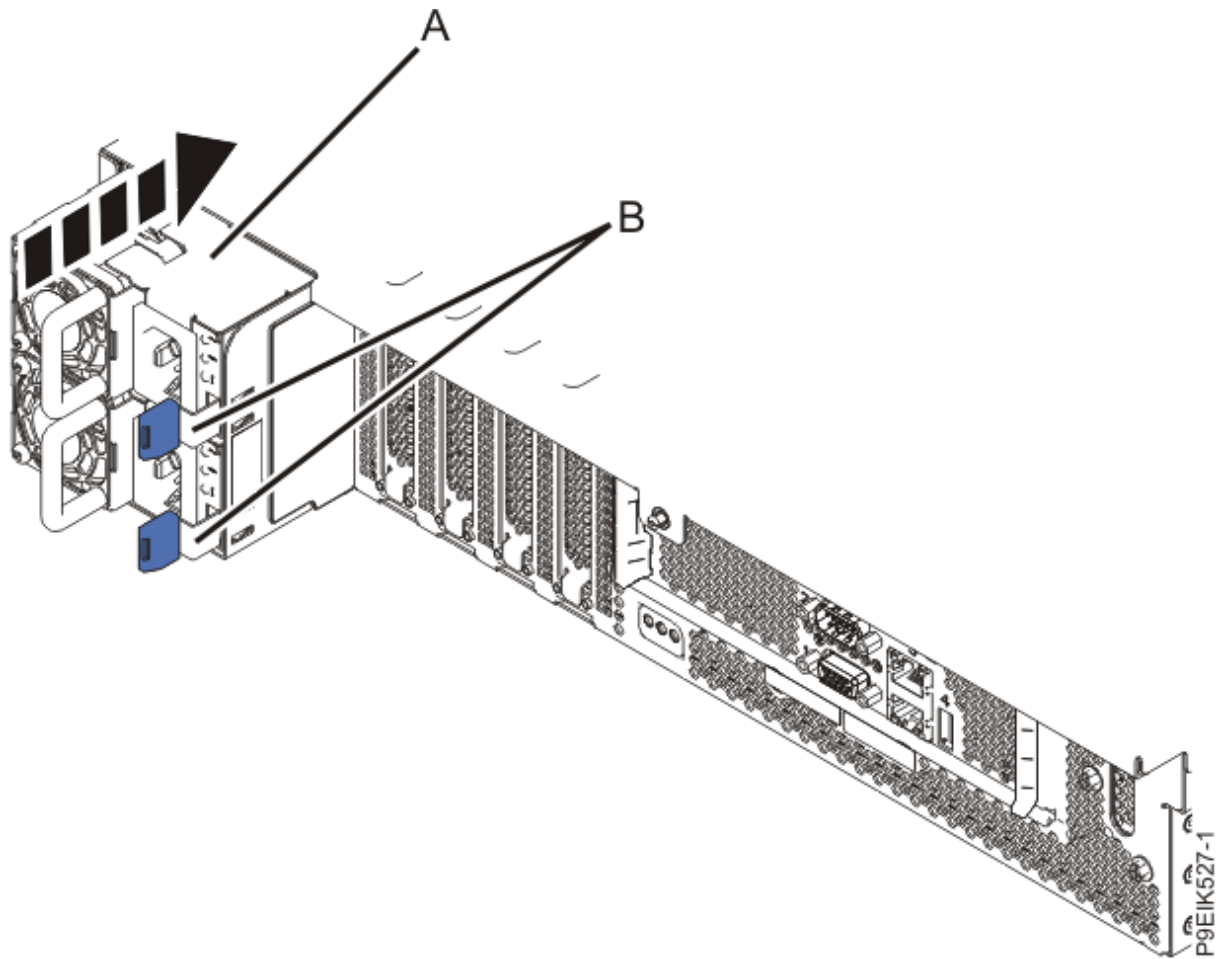

Figure 43. Replacing the power supplies in the system

5. Reconnect the power cords to the power supplies.

For instructions, see [“Connecting power cords to an 8335-GTC, 8335-GTG, 8335-GTH, 8335-GTW, or 8335-GTX system”](#) on page 105.

6. If applicable, close the rack door at the rear of the system.

7. Start the system. For instructions, see [“Starting the 8335-GTC, 8335-GTG, 8335-GTH, 8335-GTW, or 8335-GTX system”](#) on page 92.

8. If the BMC card was replaced continue to the next step, otherwise go to step [“12”](#) on page 92.

9. Configure the BMC IP address.

For instructions, see [Configuring the BMC IP address](#) (www.ibm.com/support/knowledgecenter/POWER9/p9eih/p9eih_configuring_bmc_ip.htm).

10. Enter the network settings that you recorded earlier.

For instructions, see [Network settings](#) (www.ibm.com/support/knowledgecenter/POWER9/p9eih/p9eih_openbmc_networksetting.htm).

11. Complete the following steps to ensure that **fieldmode** is set to **true**:

- a. Logon to the BMC by using Secure Socket Shell (SSH).

- b. Run the following command:

```
fw_printenv fieldmode
```

- c. Is the output of the command **fieldmode=true**?

- **Yes:** Continue with step [“12”](#) on page 92.
- **No:** Continue with step [“11.d”](#) on page 92.

d. Run the following command:

```
fw_setenv fieldmode true
```

12. Replace the front cover. For instructions, see [“Installing the front cover on an 8335-GTC, 8335-GTG, 8335-GTH, 8335-GTW, or 8335-GTX system” on page 97.](#)

13. If applicable, close the rack front door.

14. Verify the installed part.

See [Verifying a repair \(www.ibm.com/support/knowledgecenter/POWER9/p9ei3/p9ei3_verifyrepair.htm\)](http://www.ibm.com/support/knowledgecenter/POWER9/p9ei3/p9ei3_verifyrepair.htm).

Starting and stopping the 8335-GTC, 8335-GTG, 8335-GTH, 8335-GTW, or 8335-GTX system

Learn how to start and stop the IBM Power System AC922 (8335-GTC, 8335-GTG, and 8335-GTH) or IBM Power System AC922 (8335-GTW and 8335-GTX) system to perform a service action or system upgrade operation.

Starting the 8335-GTC, 8335-GTG, 8335-GTH, 8335-GTW, or 8335-GTX system

You use the power button to start the system.

About this task



Attention: For safety, airflow purposes and thermal performance, the service access cover must be installed and fully seated before powering on the system on.



Attention: For a water-cooled system, before you power on the system, ensure that cooling water is circulating through the system.

You can use this procedure to power on the system; or you can use a console to power on the system.

Procedure

1. Open the front rack door, if necessary.
2. Before you press the power button, ensure that the power supplies are connected to the system unit and verify the following items:
 - All system power cables are connected to a power source.
 - The power-on LED as shown in [Figure 44 on page 93](#), is flashing. A flashing light indicates standby power to the unit.
3. Press the power button that is shown in [Figure 44 on page 93](#).

The power-on light stops flashing and remains on, indicating that the system power is on. The system cooling fans first run at a high speed, and after approximately 30 seconds, return to operating speed.

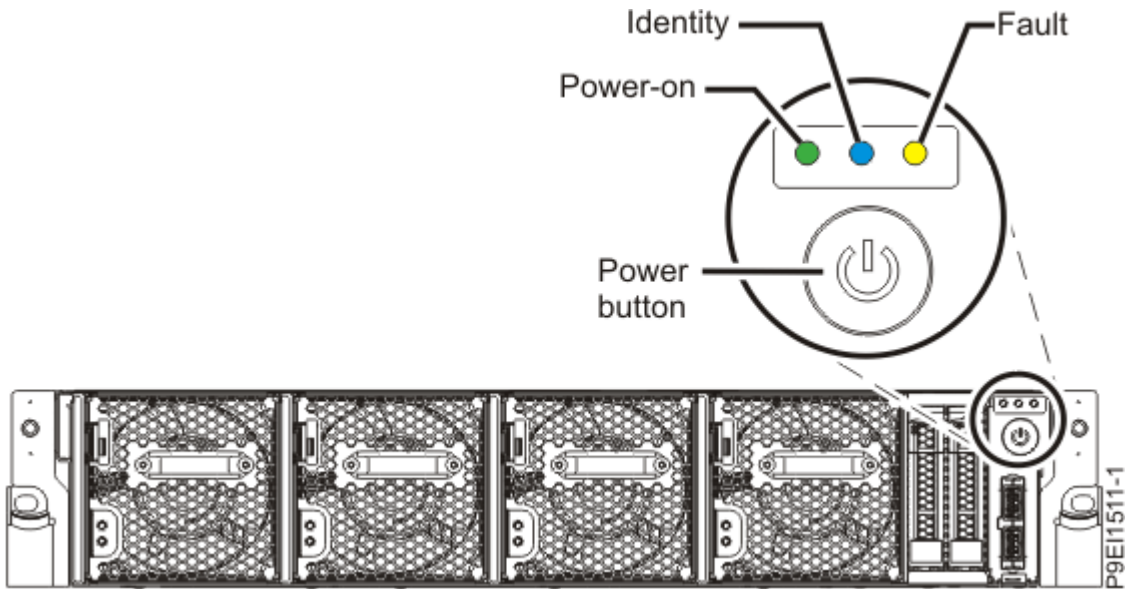

Figure 44. Power button

What to do next

If you press the power button and the system does not start, contact your next level of support or your service provider.

Stopping the 8335-GTC, 8335-GTG, 8335-GTH, 8335-GTW, or 8335-GTX system

You can use the power button or a command to stop the system.

Procedure

- You can press and hold the power button to stop and power off the system.

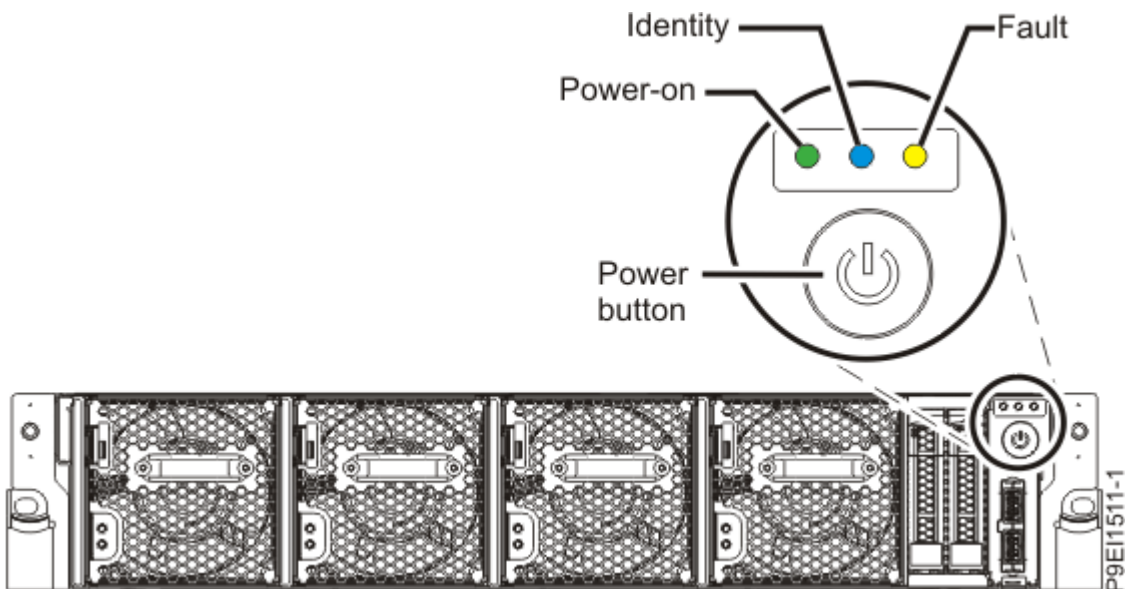

Figure 45. Power button

- You can use the Linux **shutdown** command to stop and power off the system.

For example, the following command shuts down the system in 10 minutes and sends the message "Repairs coming" to the users.

```
shutdown -P +10 "Repairs coming"
```

The `-P` setting instructs the system to shut down and then power off. The `+` indicates the time in minutes before the shutdown occurs.

Sensor status

You can check the sensor status to quickly determine the general health of the system without using the event codes.

To view the sensor status, use the following command:

```
openbmctool -U <username> -P <password> -H <BMC IP address or BMC host name> fru status
```

To view the sensor status and any corresponding event codes, use the following command:

```
openbmctool -U <username> -P <password> -H <BMC IP address or BMC host name> fru status -v
```

Sensors that have a status of **present** and **functional** do not require a service action. Sensors that have a status of **present** and **not functional** require a service action.

Some occurrences of errors in the system might not appear in the sensor status. After you view the sensor status, look for event codes to determine whether a service action is required.

Removing and replacing covers on an 8335-GTC, 8335-GTG, 8335-GTH, 8335-GTW, or 8335-GTX system

Learn how to remove and replace the covers for an IBM Power System AC922 (8335-GTC, 8335-GTG, and 8335-GTH) or IBM Power System AC922 (8335-GTW and 8335-GTX) system so that you can access the hardware parts or service the system.

Removing the service access cover from an 8335-GTC, 8335-GTG, 8335-GTH, 8335-GTW, or 8335-GTX system

To remove the service access cover, complete the steps in this procedure.

Procedure

1. Ensure that you removed both power supplies from the system.

For instructions, see [“Preparing the 8335-GTC, 8335-GTG, 8335-GTH, 8335-GTW, or 8335-GTX system to remove and replace internal parts” on page 86.](#)

(L005)



CAUTION: Hazardous energy present. Voltages with hazardous energy might cause heating when shorted with metal, which might result in splattered metal, burns, or both. (L005)

2. At the rear of the system, loosen the cover screw **(A)** that fastens the cover to the chassis.

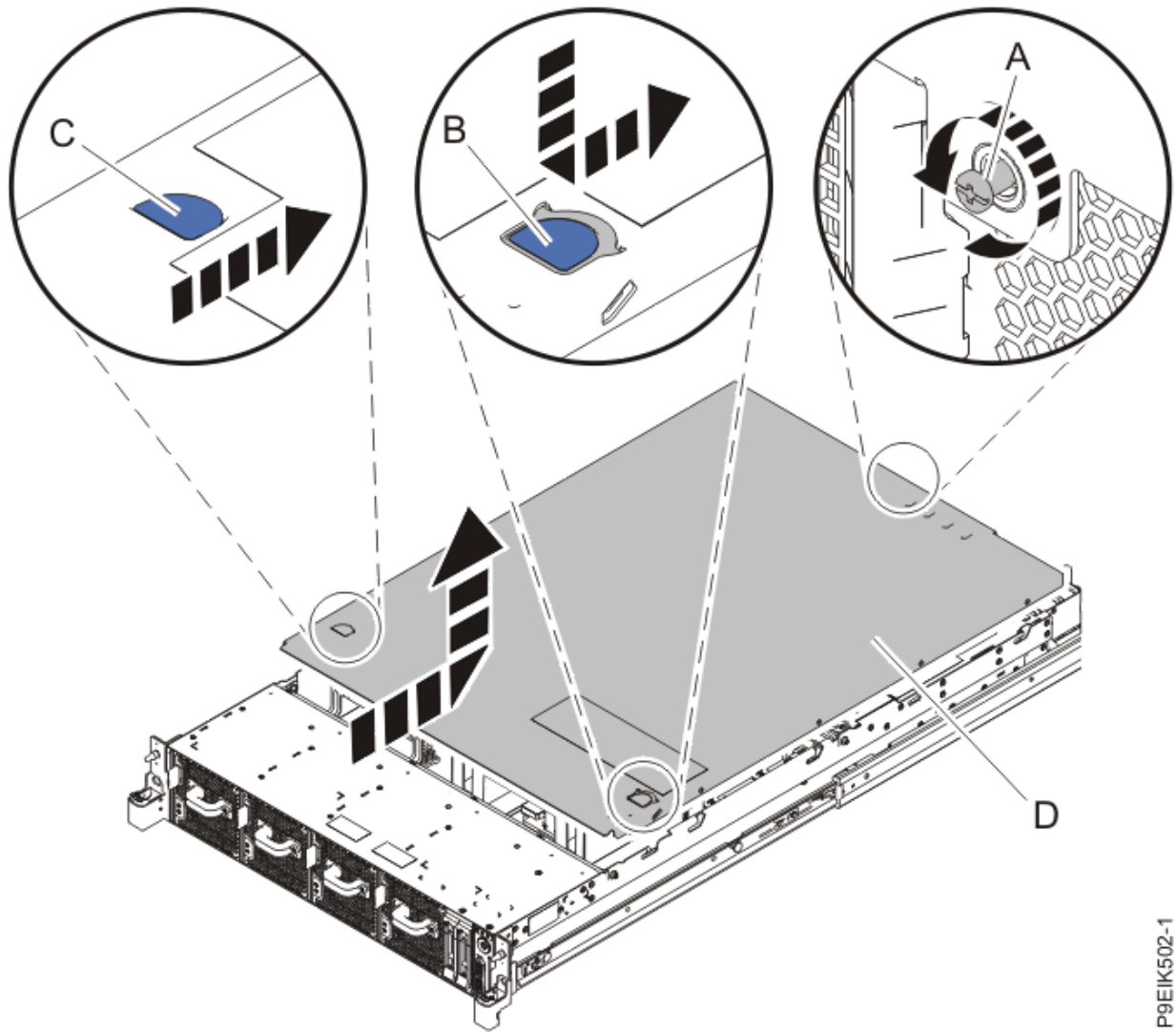

P9EIK502-1

Figure 46. Removing the cover

3. While you press down on latch **(B)** and touch point **(C)**, slide the cover **(D)** towards the rear of the system unit. When the front of the service access cover clears the upper frame ledge, lift the cover up and off the system unit.



Attention: For proper cooling and airflow, replace the cover before you power on the system.

Installing the service access cover on an 8335-GTC, 8335-GTG, 8335-GTH, 8335-GTW, or 8335-GTX system

To replace the service access cover, complete the steps in this procedure.

About this task



Attention: For safety, airflow purposes and thermal performance, the service access cover must be installed and fully seated before powering on the system on.

Procedure

1. Place the cover **(A)** on the system unit such that the alignment pins on the cover are aligned to the slots on the chassis. Slide the cover to the front of the system until the blue release latch **(B)** locks in to place as shown in [Figure 47](#) on page 96.

2. Fasten the cover screw (C) at the rear of the cover.

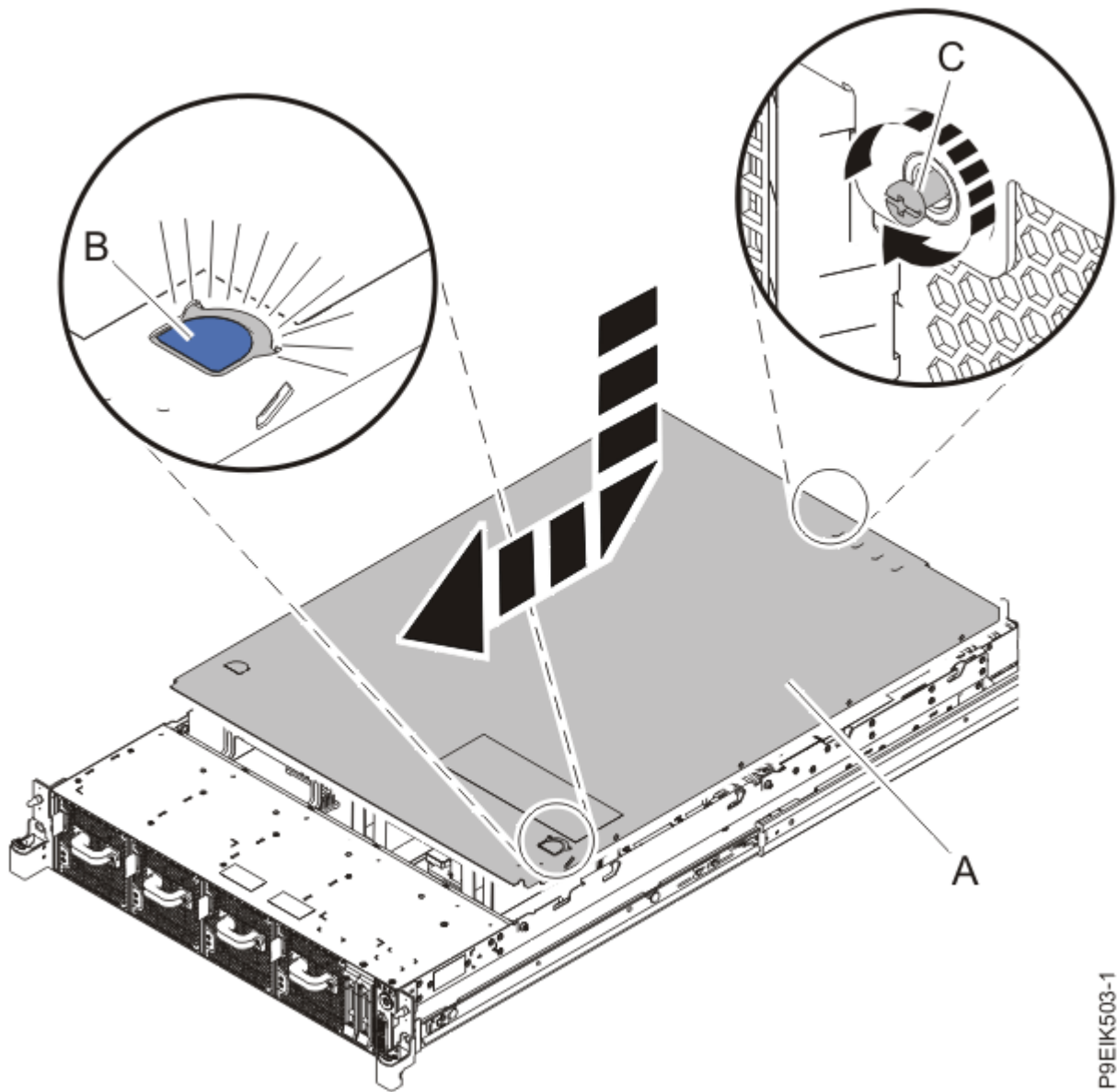

Figure 47. Installing the cover

Removing the front cover from an 8335-GTC, 8335-GTG, 8335-GTH, 8335-GTW, or 8335-GTX system

To remove the front cover, complete the steps in this procedure.

Procedure

1. If necessary, open the front rack door.
2. Ensure that you have the electrostatic discharge (ESD) wrist strap on and that the ESD clip is plugged into a ground jack or connected to an unpainted metal surface. If not, do so now.
3. If applicable, remove the screws that are on both sides of the cover to disengage the cover from the system unit.
4. Pull the cover away from the system.

P9EIK503-1

Installing the front cover on an 8335-GTC, 8335-GTG, 8335-GTH, 8335-GTW, or 8335-GTX system

To replace the front cover, complete the steps in this procedure.

Procedure

1. Ensure that you have the electrostatic discharge (ESD) wrist strap on and that the ESD clip is plugged into a ground jack or connected to an unpainted metal surface. If not, do so now.
2. Position the cover on the front of the system unit so that the pins on the system match the holes at the rear of the cover.
3. Press the cover on to the system unit such that the pins engage with the holes and the cover is firmly seated in place.
4. If applicable, replace the screws on each side of the cover to secure the system to the rack.
5. Close the front rack door.

Service and operating positions for the 8335-GTC, 8335-GTG, 8335-GTH, 8335-GTW, or 8335-GTX system

Learn how to place on an IBM Power System AC922 (8335-GTC, 8335-GTG, and 8335-GTH) or IBM Power System AC922 (8335-GTW and 8335-GTX) system into the service or operating position.

Placing an 8335-GTC, 8335-GTG, 8335-GTH, 8335-GTW, or 8335-GTX system into the service position

To place a system into the service position, complete the steps in this procedure.

About this task

Pick the proper type of rails for your system:

- [“Slide rails” on page 97](#)
- [“Fixed rails” on page 98](#)

Slide rails

Use this procedure when your system is installed using slide rails.

Before you begin

Notes:

- When you place the system into the service position, you must ensure that all stability plates are firmly installed to prevent the rack from toppling. Ensure that only one system unit is in the service position at a time.
- Ensure that the cables at the rear of the system unit do not catch or bind as you pull the system unit forward in the rack.
- When the slide rails are fully extended, the rail safety latches lock into place. This action prevents the system from being pulled out too far.

Procedure

1. Remove the screws on either side of the system that secure the system to the rack.
2. Push down the front latches **(A)** that secure the system unit to the rack.

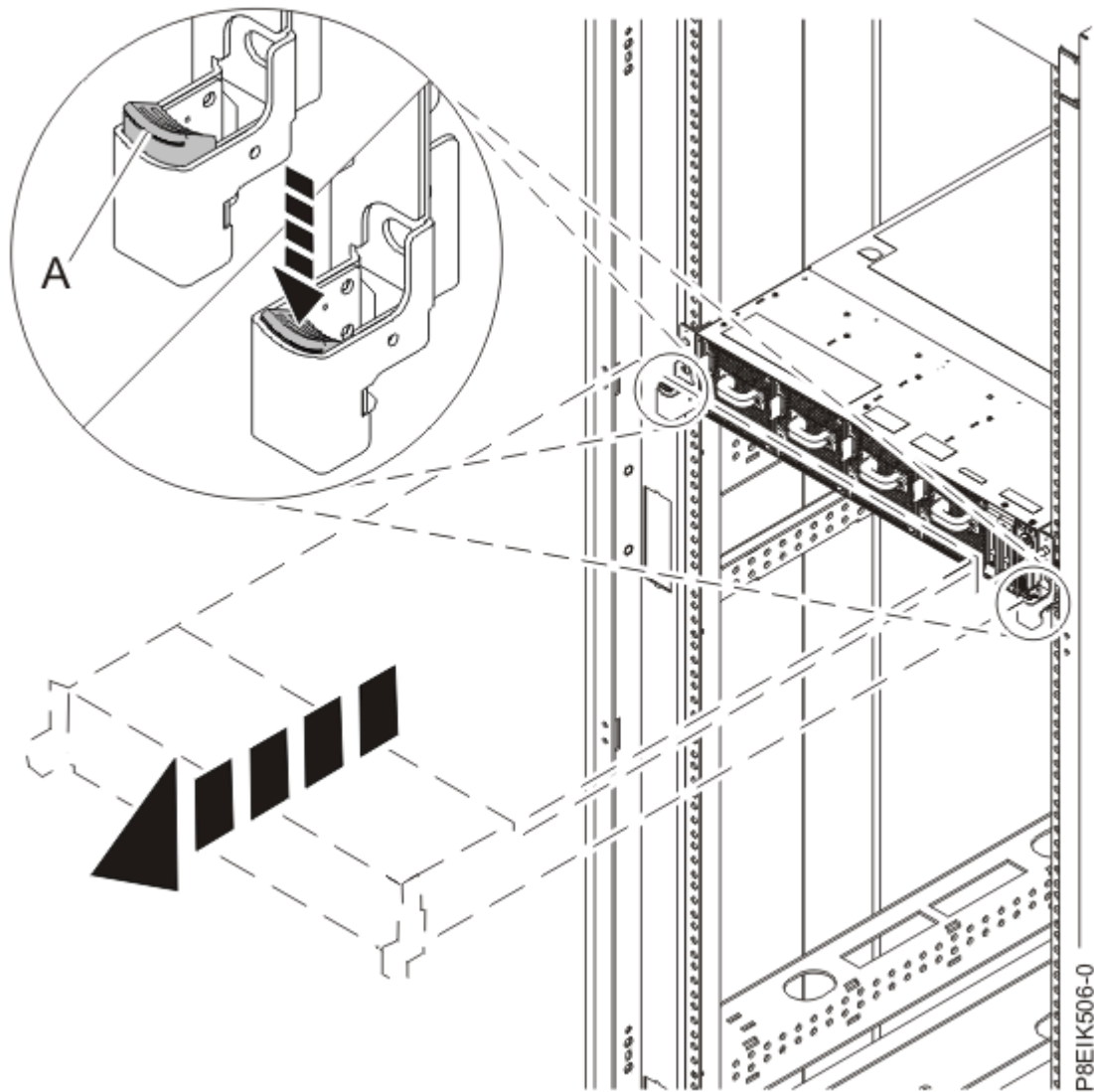

Figure 48. Placing the system into the service position

3. Pull the system unit out of the rack.

Fixed rails

Use this procedure when your system is installed using fixed rails.

Before you begin



CAUTION: This system requires two people to remove the system from the rack. Do not begin this procedure unless physical assistance is available to remove the system from the rack.

Note: When you place the system into the service position, you must ensure that all stability plates are firmly installed to prevent the rack from toppling. Ensure that only one system unit is removed at a time.

Procedure

1. Label and disconnect the cables at the rear of the system unit.
2. For a water-cooled system, label and disconnect the water hoses at the manifold. Pull the coupling toward you to disconnect the water hoses as shown in [Figure 49 on page 99](#).

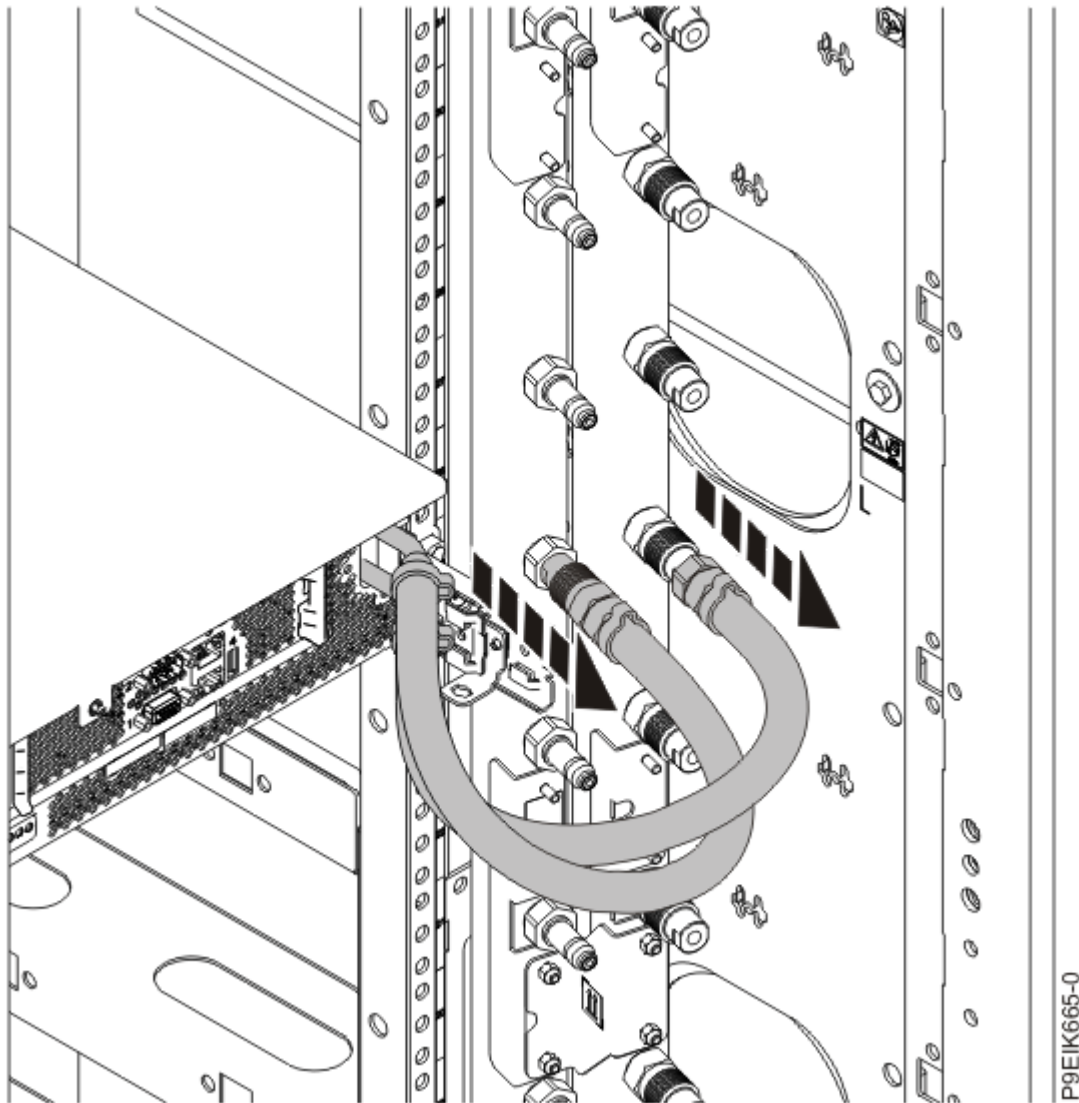

Figure 49. Disconnecting the water hoses

3. Remove the screws on either side of the system that secure the system to the rack.
4. While one person is supporting the weight of the front of the system, have the second person move to the rear of the system and push the system partially out of the rack.
5. Position one person on the left side of the system and one person on the right side of the system.
6. Tilt and lift the system from the rails.
7. Carefully set the system on a table with an appropriate ESD surface.

Placing an 8335-GTC, 8335-GTG, 8335-GTH, 8335-GTW, or 8335-GTX system into the operating position

To place a system into the operating position, complete the steps in this procedure.

About this task

Pick the proper type of rails for your system:

- [“Slide rails” on page 100](#)
- [“Fixed rails” on page 101](#)

Slide rails

Use this procedure when your system is installed using slide rails.

Before you begin

When you place the system in the operating position, ensure that the cables at the rear of the system do not catch or bind as you push the system unit back into the rack.

Procedure

1. Unlock the blue rail safety latches (**A**) by lifting them upward.
2. Align the system unit on to the rails and push the system unit back into the rack until both release latches lock into position.

See [Figure 50 on page 100](#).

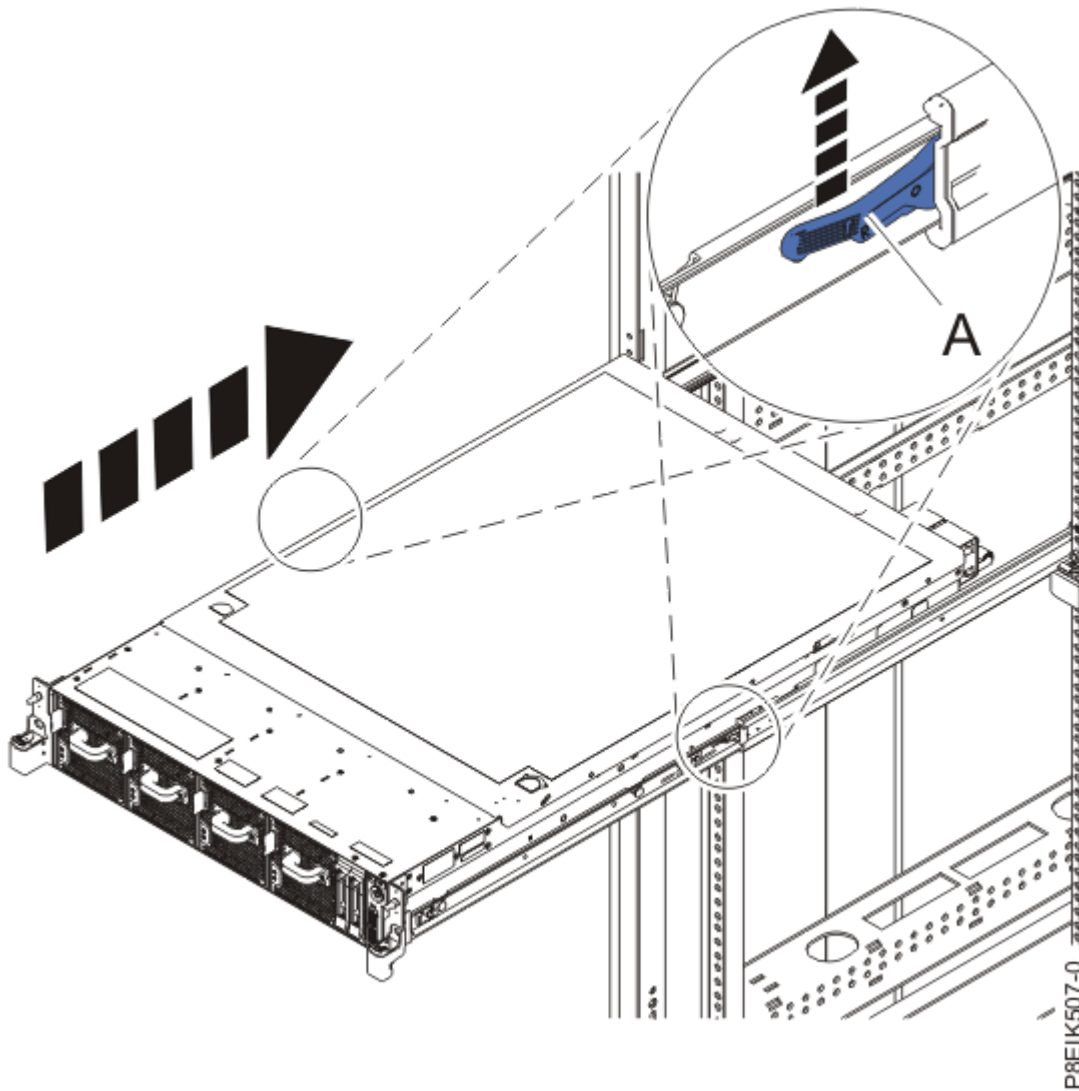

Figure 50. Placing the system into the operating position

3. Replace the screws on either side of the system that secure the system to the rack.

Fixed rails

Use this procedure when your system is installed using fixed rails.

Before you begin



CAUTION: This system requires two people to replace the system into the rack. Do not begin this procedure unless physical assistance is available to replace the system into the rack.

Note: When you place the system into the operating position, you must ensure that all stability plates are firmly installed to prevent the rack from toppling. Ensure that only one system unit is replaced at a time.

Procedure

1. Position one person on the left side of the system and one person on the right side of the system.
2. Lift the system.
3. Tilt the system into position over the fixed rack rails.
4. Carefully lower the system until the rear of the system rests on the rails.
5. While one person is supporting the weight of the system, have the second person move to the front of the system and push the system all the way into the rack.
6. Using your labels, reconnect the cables at the rear of the system unit.
7. For a water-cooled system, connect the water hoses at the rear of the rack to the manifold, as shown in the following figure.

Ensure that you plug the male hose into the female manifold plug, and plug the female hose into the male manifold plug.



Attention: Before powering on the system, ensure that cooling water is circulating through the system.

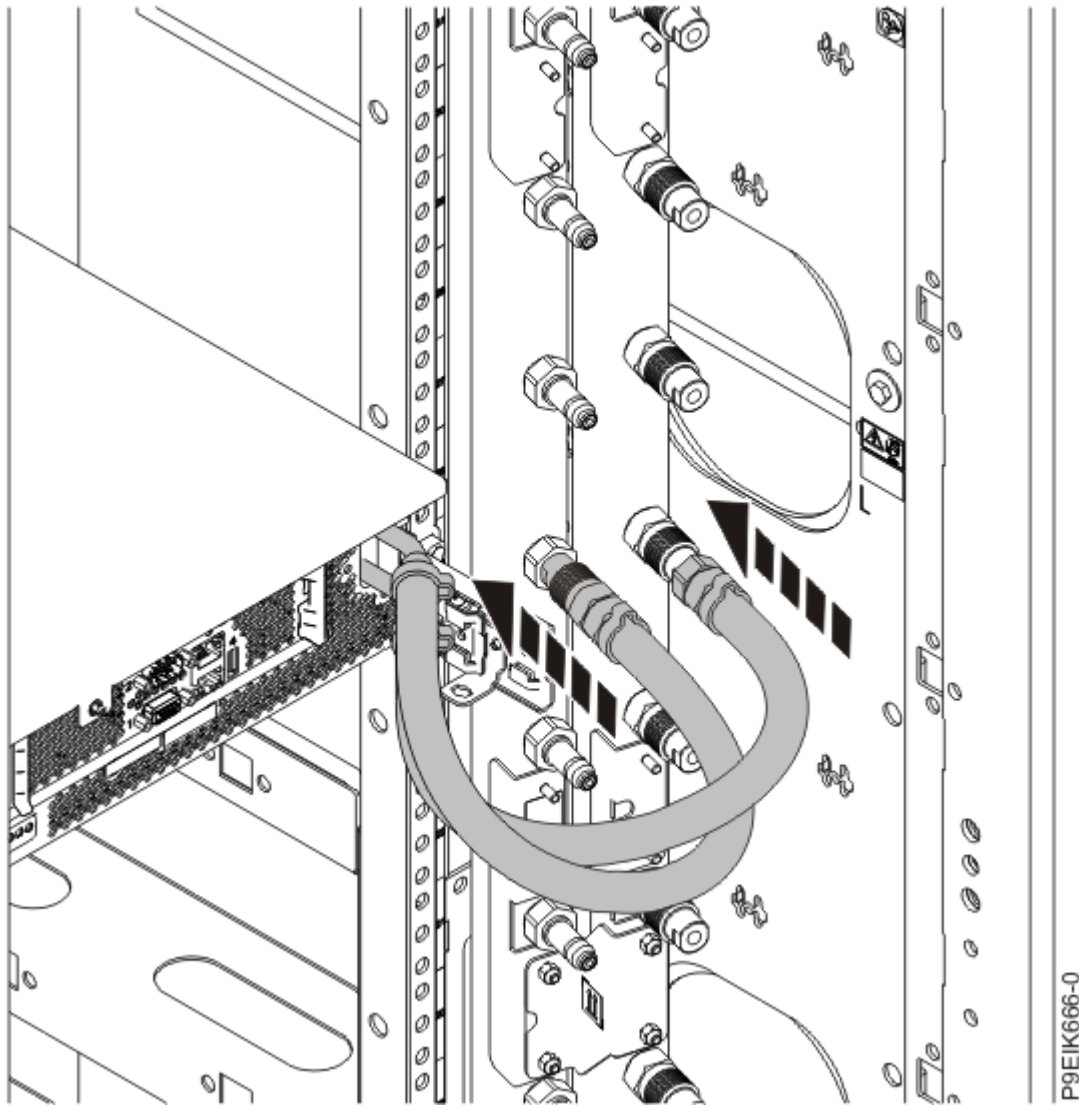

Figure 51. Connecting the water hoses

8. Replace the screws on either side of the system that secure the system to the rack.

Removing and replacing power cords in the 8335-GTC, 8335-GTG, 8335-GTH, 8335-GTW, or 8335-GTX system

Find information about removing and replacing power cords in an IBM Power System AC922 (8335-GTC, 8335-GTG, and 8335-GTH) or IBM Power System AC922 (8335-GTW and 8335-GTX) system.

Disconnecting power cords from an 8335-GTC, 8335-GTG, 8335-GTH, 8335-GTW, or 8335-GTX system

To disconnect a power cord, complete the steps in this procedure.

Procedure

1. Open the rear rack door on the system unit that you are servicing.
2. Identify the system unit that you are servicing in the rack.
3. Label and disconnect the power cords from the power supply handle.

Unfasten the hook-and-loop fastener that ties the power cord to the power supply handle. Note how the power is looped; you need to make that same loop when you reattach the power cords.

Figure 52 on page 103 and Figure 53 on page 104 shows how to loop the cables.

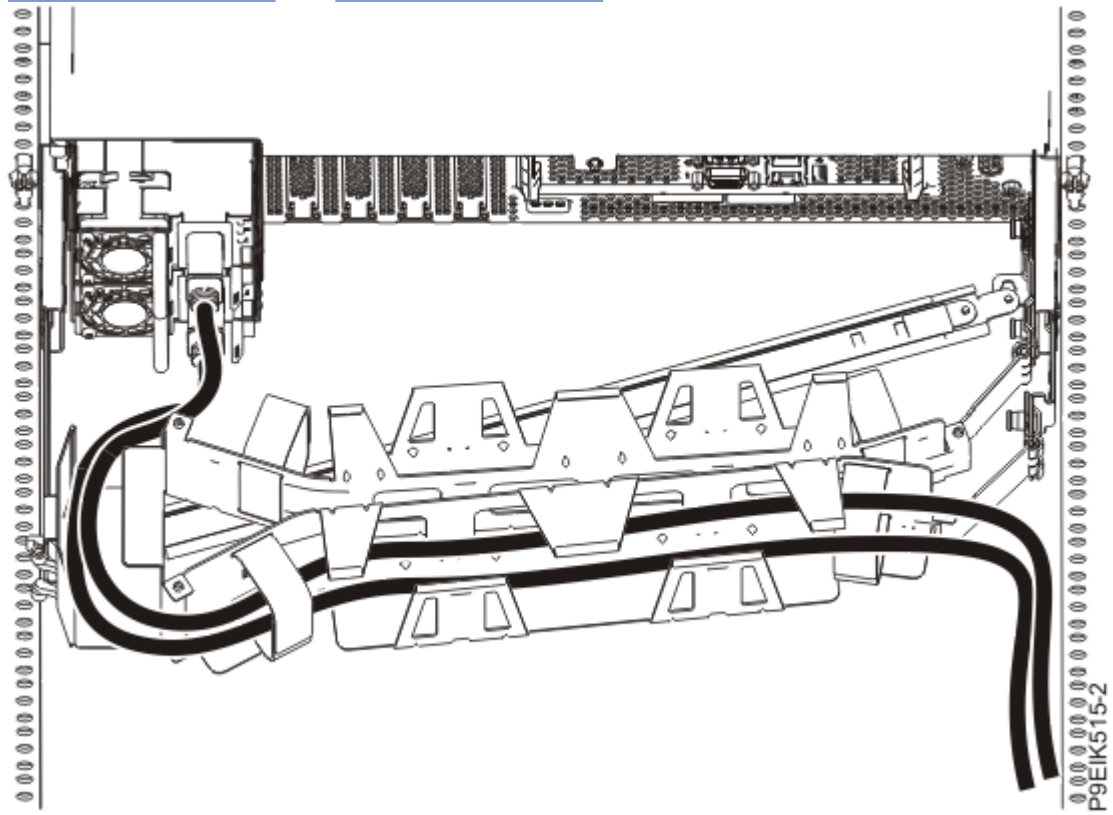

Figure 52. Routing the power cord loop in the cable management arm

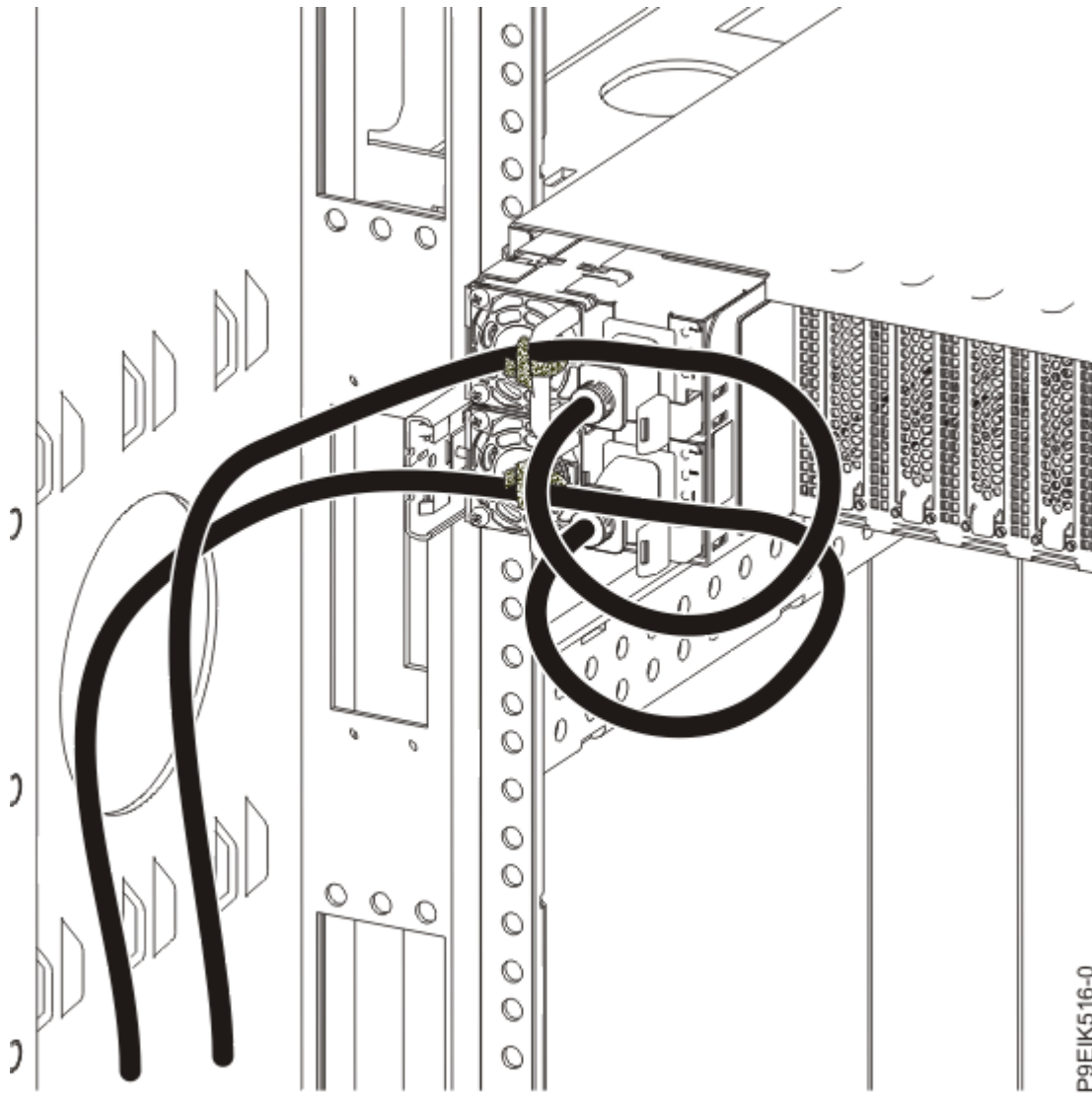

Figure 53. Power cord loop with sidewall routing

4. Disconnect the power cords from the system unit as shown in [Figure 54](#) on page 105.

Note: This system might be equipped with two or more power supplies. If the removing and replacing procedures require the power to be off, then ensure that all the power sources to the system are disconnected.

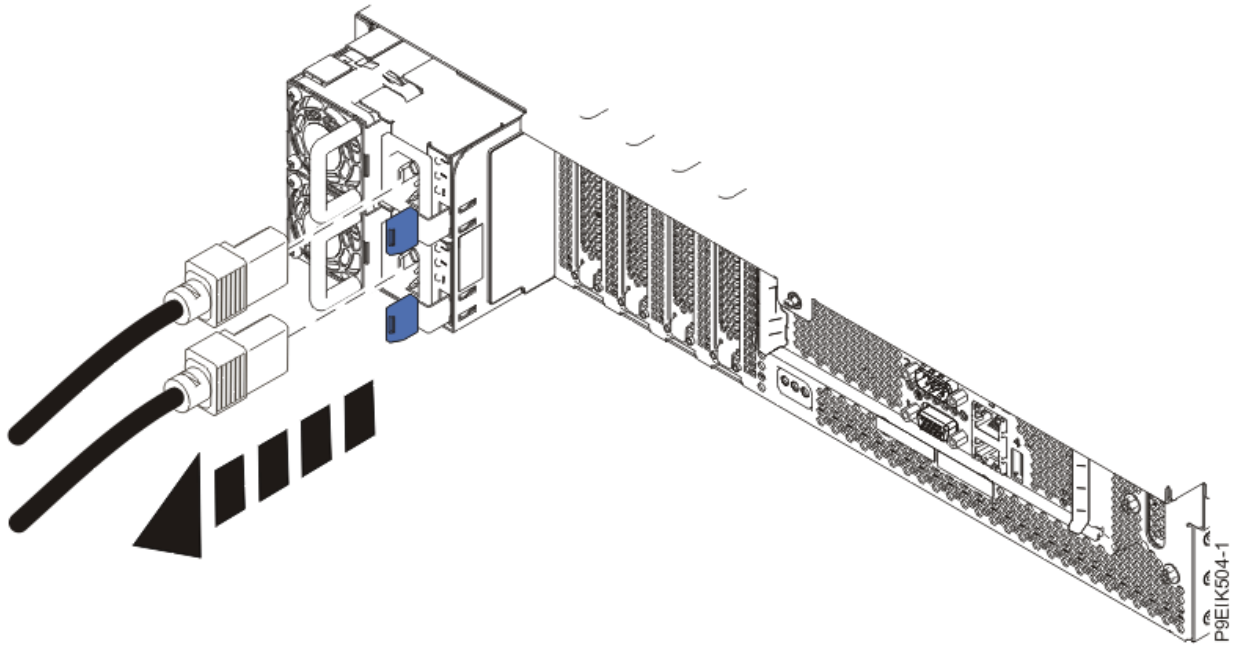

Figure 54. Removing the power cords from the system

Connecting power cords to an 8335-GTC, 8335-GTG, 8335-GTH, 8335-GTW, or 8335-GTX system

To connect a power cord, complete the steps in this procedure.

Procedure

1. Open the rear rack door on the system unit that you are servicing.
2. Using your labels, reconnect the power cords to the system unit as shown in [Figure 55](#) on page 105.

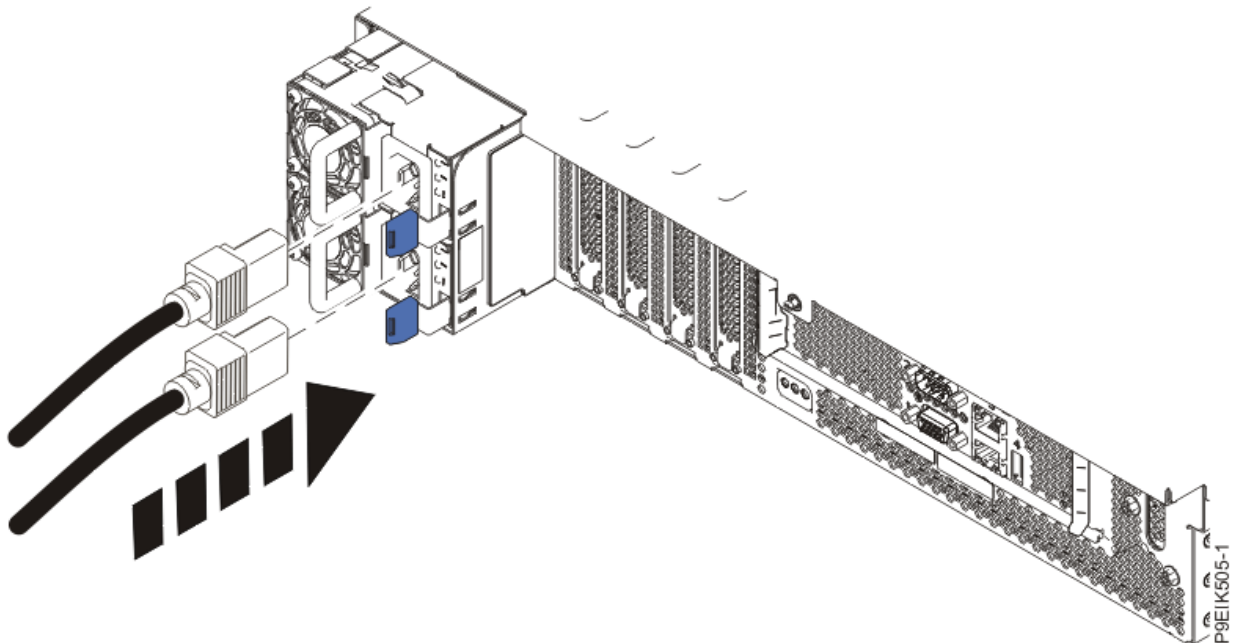

Figure 55. Connecting the power cords to the system

3. Loop and attach the power cords to the power supply handle.

Note how the power is looped; be sure to maintain at least a 5 cm (2 in.) diameter loop. Use the hook-and-loop fastener to tie the power cord to the power supply handle.

Figure 56 on page 106 and Figure 57 on page 107 shows how to loop the cables.

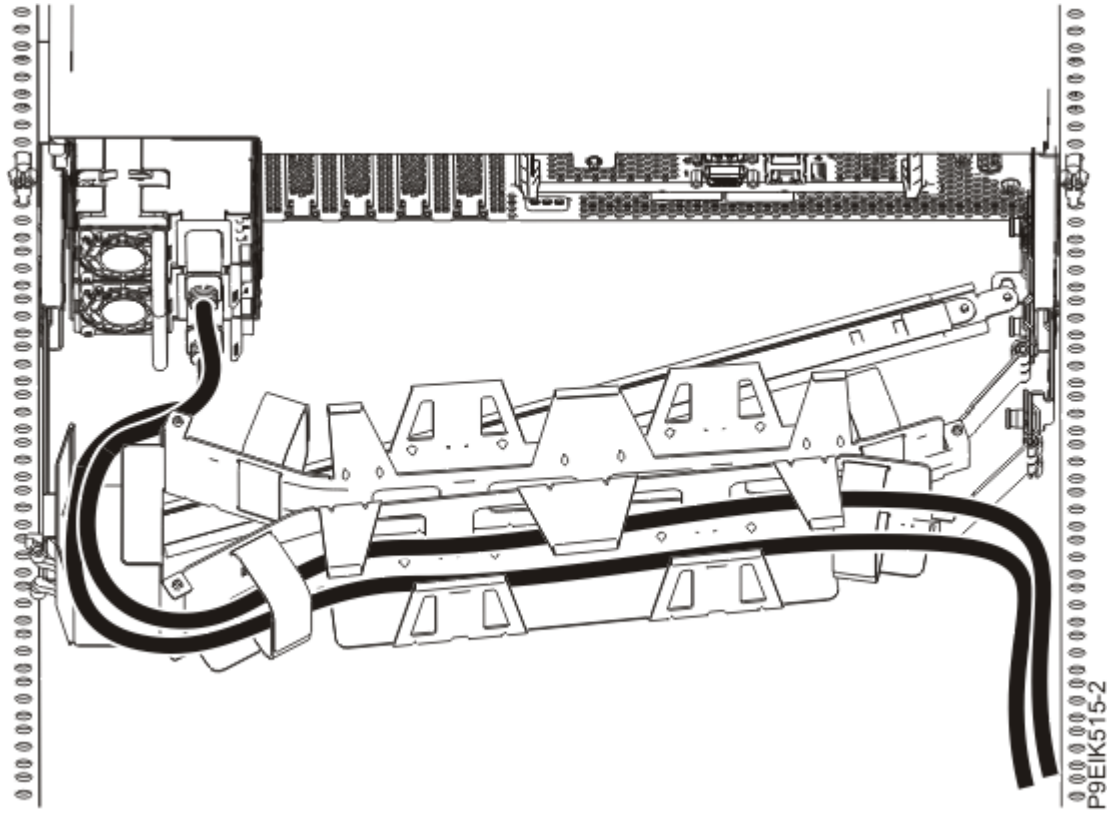

Figure 56. Routing the power cord loop in the cable management arm

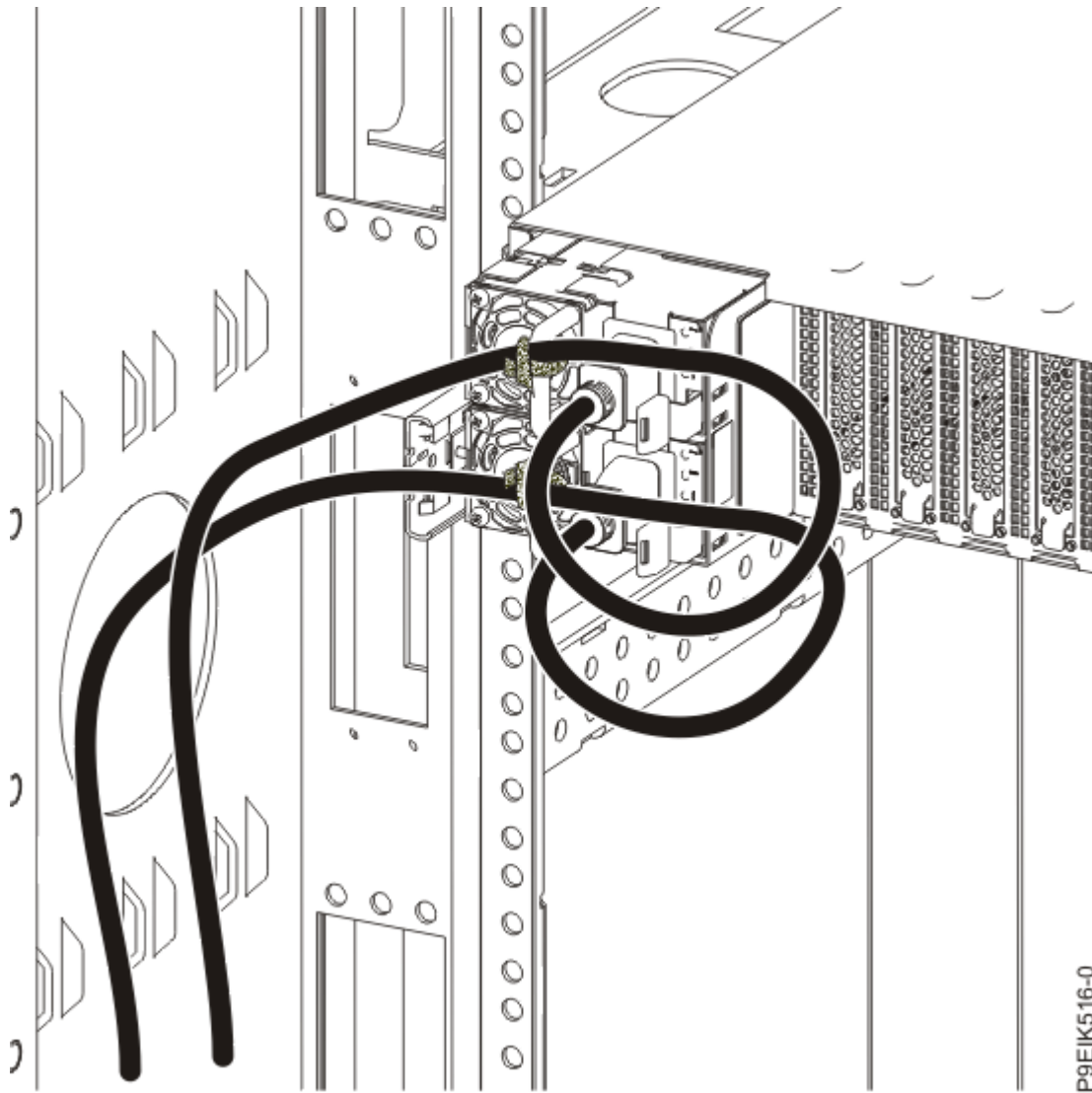

Figure 57. Power cord loop with sidewall routing

4. Close the rack door at the rear of the system.

Updating the system firmware level of a BMC card to OP940.20, or later, in an 8335-GTH or 8335-GTX system

To update the system firmware level of a BMC card to OP940.20, or later, complete the steps in this procedure.

Procedure

1. Are you able to connect the BMC card to the network with a Dynamic Host Configuration Protocol (DHCP) IP address?

If	Then
Yes	Update the system firmware level of the BMC card to OP940.20, or later. For instructions, see Updating the system firmware by using the OpenBMC tool . If you are not able to update the system firmware level, continue with the next step.
No	Continue with the next step.

2. Power off the system and place it in the service position. For instructions, see [“Preparing the 8335-GTC, 8335-GTG, 8335-GTH, 8335-GTW, or 8335-GTX system to remove and replace internal parts”](#) on page 86.

3. Attach the electrostatic discharge (ESD) wrist strap.

The ESD wrist strap must be connected to an unpainted metal surface until the service procedure is completed, and if applicable, until the service access cover is replaced.



Attention:

- Attach an electrostatic discharge (ESD) wrist strap to the front ESD jack, to the rear ESD jack, or to an unpainted metal surface of your hardware to prevent the electrostatic discharge from damaging your hardware.
- When you use an ESD wrist strap, follow all electrical safety procedures. An ESD wrist strap is used for static control. It does not increase or decrease your risk of receiving electric shock when using or working on electrical equipment.
- If you do not have an ESD wrist strap, just prior to removing the product from ESD packaging and installing or replacing hardware, touch an unpainted metal surface of the system for a minimum of 5 seconds. If at any point in this service process you move away from the system, it is important to again discharge yourself by touching an unpainted metal surface for at least 5 seconds before you continue with the service process.

4. Remove the air baffles.

5. Install the system processor jumpers on the system backplane as shown in [Figure 58](#) on page 109.

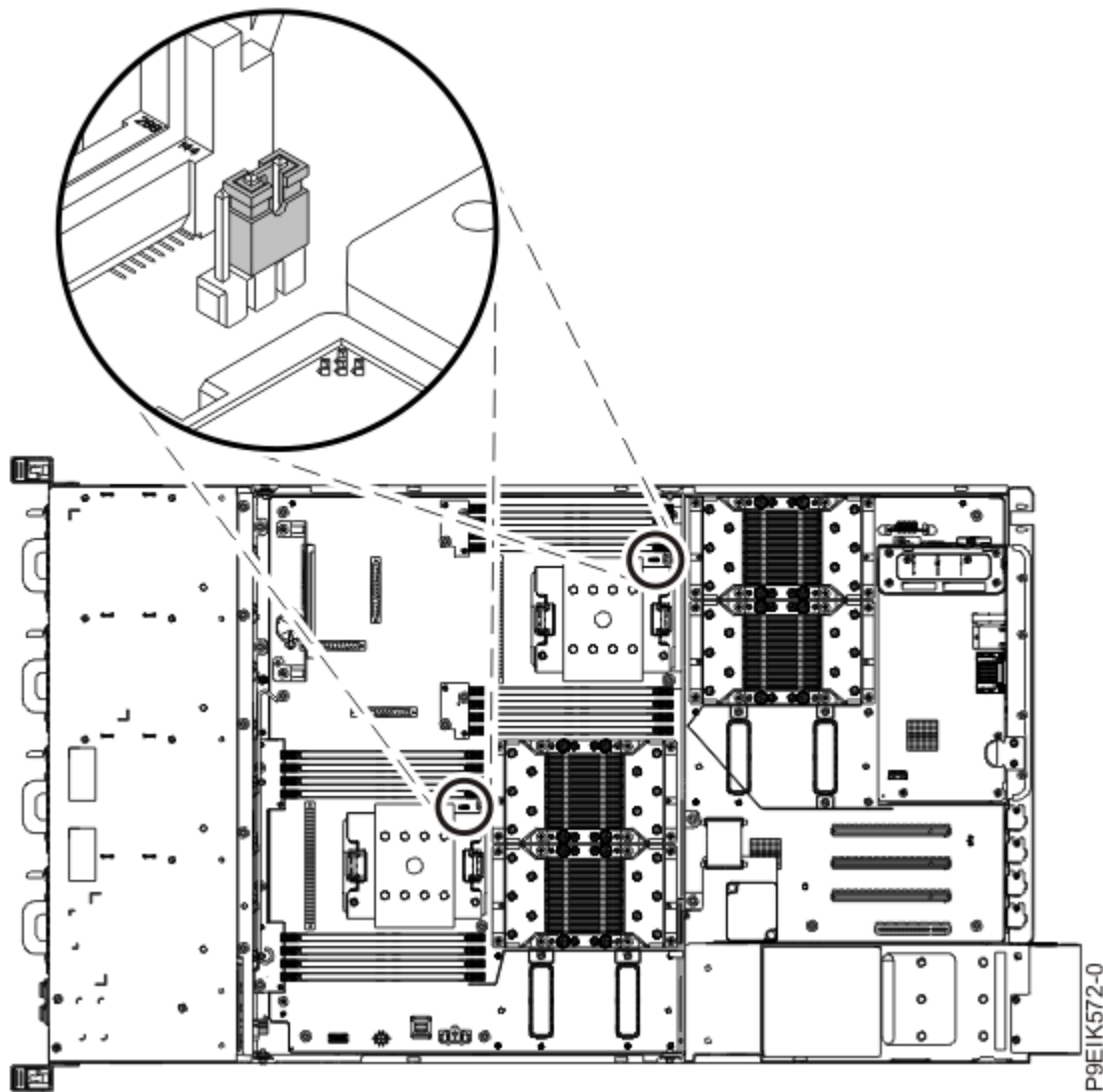

Figure 58. System processor jumper positions

6. Install the air baffles.
7. Prepare the system for operation. For instructions, see “Preparing the 8335-GTC, 8335-GTG, 8335-GTH, 8335-GTW, or 8335-GTX system for operation after you remove and replace internal parts” on page 90.
8. Update the system firmware level of the BMC card to OP940.20, or later. For instructions, see [Updating the system firmware by using the OpenBMC tool](#).

Note: If you are not able to update the system firmware level, contact your next level of support.

9. Power off the system and place it in the service position. For instructions, see “Preparing the 8335-GTC, 8335-GTG, 8335-GTH, 8335-GTW, or 8335-GTX system to remove and replace internal parts” on page 86.
10. Attach the electrostatic discharge (ESD) wrist strap.

The ESD wrist strap must be connected to an unpainted metal surface until the service procedure is completed, and if applicable, until the service access cover is replaced.



Attention:

- Attach an electrostatic discharge (ESD) wrist strap to the front ESD jack, to the rear ESD jack, or to an unpainted metal surface of your hardware to prevent the electrostatic discharge from damaging your hardware.

- When you use an ESD wrist strap, follow all electrical safety procedures. An ESD wrist strap is used for static control. It does not increase or decrease your risk of receiving electric shock when using or working on electrical equipment.
- If you do not have an ESD wrist strap, just prior to removing the product from ESD packaging and installing or replacing hardware, touch an unpainted metal surface of the system for a minimum of 5 seconds. If at any point in this service process you move away from the system, it is important to again discharge yourself by touching an unpainted metal surface for at least 5 seconds before you continue with the service process.

11. Remove the air baffles.

12. Remove the system processor jumpers from the system backplane as shown in [Figure 59 on page 110](#).

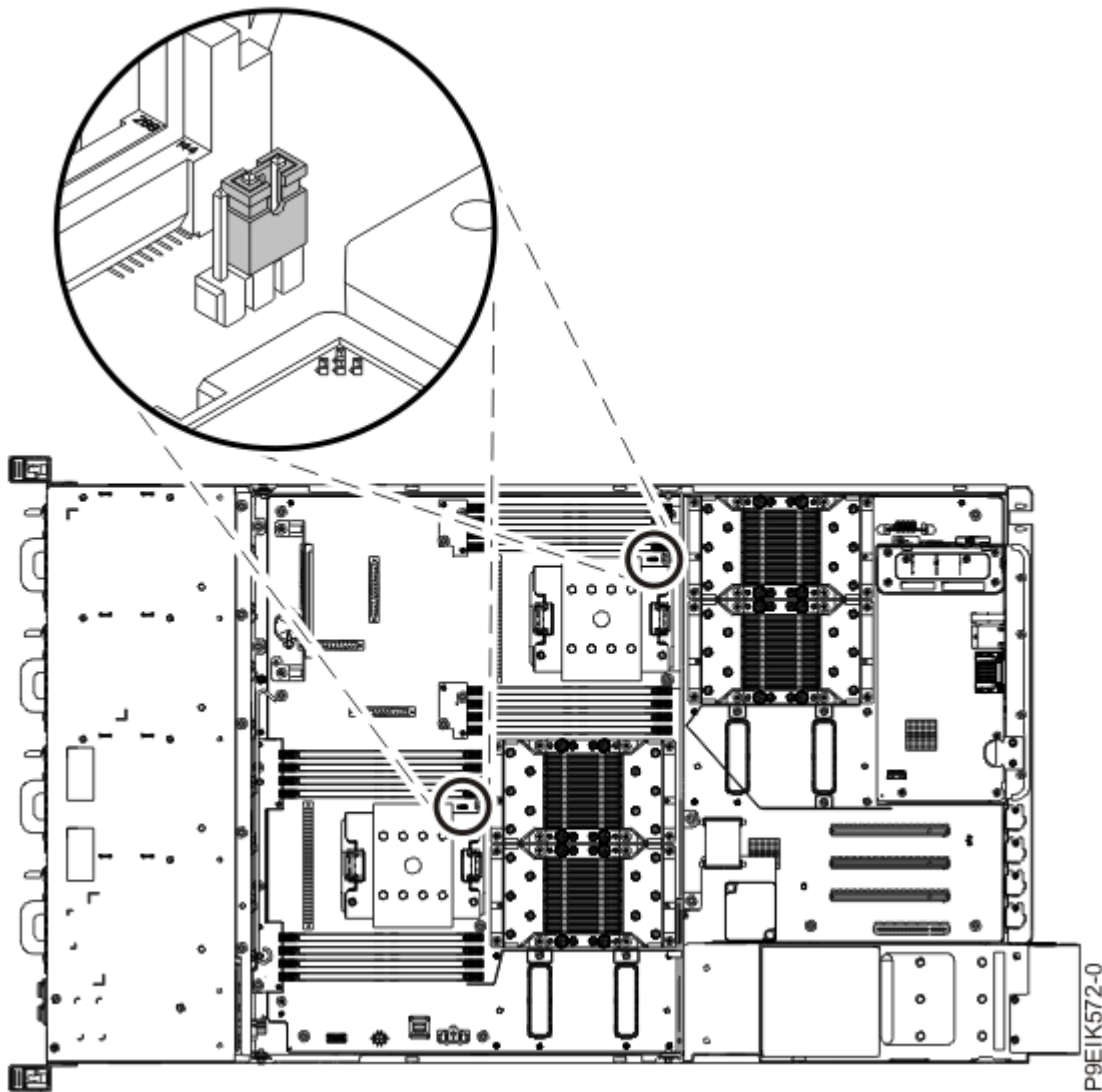

Figure 59. System processor jumper positions

13. Install the air baffles.

14. Prepare the system for operation. For instructions, see [“Preparing the 8335-GTC, 8335-GTG, 8335-GTH, 8335-GTW, or 8335-GTX system for operation after you remove and replace internal parts” on page 90](#).

Notices

This information was developed for products and services offered in the US.

IBM may not offer the products, services, or features discussed in this document in other countries. Consult your local IBM representative for information on the products and services currently available in your area. Any reference to an IBM product, program, or service is not intended to state or imply that only that IBM product, program, or service may be used. Any functionally equivalent product, program, or service that does not infringe any IBM intellectual property right may be used instead. However, it is the user's responsibility to evaluate and verify the operation of any non-IBM product, program, or service.

IBM may have patents or pending patent applications covering subject matter described in this document. The furnishing of this document does not grant you any license to these patents. You can send license inquiries, in writing, to:

IBM Director of Licensing
IBM Corporation
North Castle Drive, MD-NC119
Armonk, NY 10504-1785
US

INTERNATIONAL BUSINESS MACHINES CORPORATION PROVIDES THIS PUBLICATION "AS IS" WITHOUT WARRANTY OF ANY KIND, EITHER EXPRESS OR IMPLIED, INCLUDING, BUT NOT LIMITED TO, THE IMPLIED WARRANTIES OF NON-INFRINGEMENT, MERCHANTABILITY OR FITNESS FOR A PARTICULAR PURPOSE. Some jurisdictions do not allow disclaimer of express or implied warranties in certain transactions, therefore, this statement may not apply to you.

This information could include technical inaccuracies or typographical errors. Changes are periodically made to the information herein; these changes will be incorporated in new editions of the publication. IBM may make improvements and/or changes in the product(s) and/or the program(s) described in this publication at any time without notice.

Any references in this information to non-IBM websites are provided for convenience only and do not in any manner serve as an endorsement of those websites. The materials at those websites are not part of the materials for this IBM product and use of those websites is at your own risk.

IBM may use or distribute any of the information you provide in any way it believes appropriate without incurring any obligation to you.

The performance data and client examples cited are presented for illustrative purposes only. Actual performance results may vary depending on specific configurations and operating conditions.

Information concerning non-IBM products was obtained from the suppliers of those products, their published announcements or other publicly available sources. IBM has not tested those products and cannot confirm the accuracy of performance, compatibility or any other claims related to non-IBM products. Questions on the capabilities of non-IBM products should be addressed to the suppliers of those products.

Statements regarding IBM's future direction or intent are subject to change or withdrawal without notice, and represent goals and objectives only.

All IBM prices shown are IBM's suggested retail prices, are current and are subject to change without notice. Dealer prices may vary.

This information is for planning purposes only. The information herein is subject to change before the products described become available.

This information contains examples of data and reports used in daily business operations. To illustrate them as completely as possible, the examples include the names of individuals, companies, brands, and products. All of these names are fictitious and any similarity to actual people or business enterprises is entirely coincidental.

If you are viewing this information in softcopy, the photographs and color illustrations may not appear.

The drawings and specifications contained herein shall not be reproduced in whole or in part without the written permission of IBM.

IBM has prepared this information for use with the specific machines indicated. IBM makes no representations that it is suitable for any other purpose.

IBM's computer systems contain mechanisms designed to reduce the possibility of undetected data corruption or loss. This risk, however, cannot be eliminated. Users who experience unplanned outages, system failures, power fluctuations or outages, or component failures must verify the accuracy of operations performed and data saved or transmitted by the system at or near the time of the outage or failure. In addition, users must establish procedures to ensure that there is independent data verification before relying on such data in sensitive or critical operations. Users should periodically check IBM's support websites for updated information and fixes applicable to the system and related software.

Homologation statement

This product may not be certified in your country for connection by any means whatsoever to interfaces of public telecommunications networks. Further certification may be required by law prior to making any such connection. Contact an IBM representative or reseller for any questions.

Accessibility features for IBM Power Systems servers

Accessibility features assist users who have a disability, such as restricted mobility or limited vision, to use information technology content successfully.

Overview

The IBM Power Systems servers include the following major accessibility features:

- Keyboard-only operation
- Operations that use a screen reader

The IBM Power Systems servers use the latest W3C Standard, [WAI-ARIA 1.0 \(www.w3.org/TR/wai-aria/\)](http://www.w3.org/TR/wai-aria/), to ensure compliance with [US Section 508 \(www.access-board.gov/guidelines-and-standards/communications-and-it/about-the-section-508-standards/section-508-standards\)](http://www.access-board.gov/guidelines-and-standards/communications-and-it/about-the-section-508-standards/section-508-standards) and [Web Content Accessibility Guidelines \(WCAG\) 2.0 \(www.w3.org/TR/WCAG20/\)](http://www.w3.org/TR/WCAG20/). To take advantage of accessibility features, use the latest release of your screen reader and the latest web browser that is supported by the IBM Power Systems servers.

The IBM Power Systems servers online product documentation in IBM Knowledge Center is enabled for accessibility. The accessibility features of IBM Knowledge Center are described in the [Accessibility section of the IBM Knowledge Center help \(www.ibm.com/support/knowledgecenter/doc/kc_help.html#accessibility\)](http://www.ibm.com/support/knowledgecenter/doc/kc_help.html#accessibility).

Keyboard navigation

This product uses standard navigation keys.

Interface information

The IBM Power Systems servers user interfaces do not have content that flashes 2 - 55 times per second.

The IBM Power Systems servers web user interface relies on cascading style sheets to render content properly and to provide a usable experience. The application provides an equivalent way for low-vision users to use system display settings, including high-contrast mode. You can control font size by using the device or web browser settings.

The IBM Power Systems servers web user interface includes WAI-ARIA navigational landmarks that you can use to quickly navigate to functional areas in the application.

Vendor software

The IBM Power Systems servers include certain vendor software that is not covered under the IBM license agreement. IBM makes no representation about the accessibility features of these products. Contact the vendor for accessibility information about its products.

Related accessibility information

In addition to standard IBM help desk and support websites, IBM has a TTY telephone service for use by deaf or hard of hearing customers to access sales and support services:

TTY service
800-IBM-3383 (800-426-3383)
(within North America)

For more information about the commitment that IBM has to accessibility, see [IBM Accessibility \(www.ibm.com/able\)](http://www.ibm.com/able).

Privacy policy considerations

IBM Software products, including software as a service solutions, (“Software Offerings”) may use cookies or other technologies to collect product usage information, to help improve the end user experience, to tailor interactions with the end user, or for other purposes. In many cases no personally identifiable information is collected by the Software Offerings. Some of our Software Offerings can help enable you to collect personally identifiable information. If this Software Offering uses cookies to collect personally identifiable information, specific information about this offering’s use of cookies is set forth below.

This Software Offering does not use cookies or other technologies to collect personally identifiable information.

If the configurations deployed for this Software Offering provide you as the customer the ability to collect personally identifiable information from end users via cookies and other technologies, you should seek your own legal advice about any laws applicable to such data collection, including any requirements for notice and consent.

For more information about the use of various technologies, including cookies, for these purposes, see IBM’s Privacy Policy at <http://www.ibm.com/privacy> and IBM’s Online Privacy Statement at <http://www.ibm.com/privacy/details/us/en/> in the section entitled “Cookies, Web Beacons and Other Technologies”.

Trademarks

IBM, the IBM logo, and [ibm.com](http://www.ibm.com)[®] are trademarks or registered trademarks of International Business Machines Corp., registered in many jurisdictions worldwide. Other product and service names might be trademarks of IBM or other companies. A current list of IBM trademarks is available on the web at [Copyright and trademark information](#).

Intel, Intel logo, Intel Inside, Intel Inside logo, Intel Centrino, Intel Centrino logo, Celeron, Intel Xeon, Intel SpeedStep, Itanium, and Pentium are trademarks or registered trademarks of Intel Corporation or its subsidiaries in the United States and other countries.

The registered trademark Linux is used pursuant to a sublicense from the Linux Foundation, the exclusive licensee of Linus Torvalds, owner of the mark on a worldwide basis.

Red Hat, JBoss, OpenShift, Fedora, Hibernate, Ansible, CloudForms, RHCA, RHCE, RHCSA, Ceph, and Gluster are trademarks or registered trademarks of Red Hat, Inc. or its subsidiaries in the United States and other countries.

Electronic emission notices

Class A Notices

The following Class A statements apply to the IBM servers that contain the POWER9 processor and its features unless designated as electromagnetic compatibility (EMC) Class B in the feature information.

When attaching a monitor to the equipment, you must use the designated monitor cable and any interference suppression devices supplied with the monitor.

Canada Notice

CAN ICES-3 (A)/NMB-3(A)

European Community and Morocco Notice

This product is in conformity with the protection requirements of Directive 2014/30/EU of the European Parliament and of the Council on the harmonization of the laws of the Member States relating to electromagnetic compatibility. IBM cannot accept responsibility for any failure to satisfy the protection requirements resulting from a non-recommended modification of the product, including the fitting of non-IBM option cards.

This product may cause interference if used in residential areas. Such use must be avoided unless the user takes special measures to reduce electromagnetic emissions to prevent interference to the reception of radio and television broadcasts.

Warning: This equipment is compliant with Class A of CISPR 32. In a residential environment this equipment may cause radio interference.

Germany Notice

Deutschsprachiger EU Hinweis: Hinweis für Geräte der Klasse A EU-Richtlinie zur Elektromagnetischen Verträglichkeit

Dieses Produkt entspricht den Schutzanforderungen der EU-Richtlinie 2014/30/EU zur Angleichung der Rechtsvorschriften über die elektromagnetische Verträglichkeit in den EU-Mitgliedsstaaten und hält die Grenzwerte der EN 55022 / EN 55032 Klasse A ein.

Um dieses sicherzustellen, sind die Geräte wie in den Handbüchern beschrieben zu installieren und zu betreiben. Des Weiteren dürfen auch nur von der IBM empfohlene Kabel angeschlossen werden. IBM übernimmt keine Verantwortung für die Einhaltung der Schutzanforderungen, wenn das Produkt ohne Zustimmung von IBM verändert bzw. wenn Erweiterungskomponenten von Fremdherstellern ohne Empfehlung von IBM gesteckt/eingebaut werden.

EN 55032 Klasse A Geräte müssen mit folgendem Warnhinweis versehen werden:

"Warnung: Dieses ist eine Einrichtung der Klasse A. Diese Einrichtung kann im Wohnbereich Funk-Störungen verursachen; in diesem Fall kann vom Betreiber verlangt werden, angemessene Maßnahmen zu ergreifen und dafür aufzukommen."

Deutschland: Einhaltung des Gesetzes über die elektromagnetische Verträglichkeit von Geräten

Dieses Produkt entspricht dem "Gesetz über die elektromagnetische Verträglichkeit von Geräten (EMVG)". Dies ist die Umsetzung der EU-Richtlinie 2014/30/EU in der Bundesrepublik Deutschland.

Zulassungsbescheinigung laut dem Deutschen Gesetz über die elektromagnetische Verträglichkeit von Geräten (EMVG) (bzw. der EMC Richtlinie 2014/30/EU) für Geräte der Klasse A

Dieses Gerät ist berechtigt, in Übereinstimmung mit dem Deutschen EMVG das EG-Konformitätszeichen - CE - zu führen.

Verantwortlich für die Einhaltung der EMV Vorschriften ist der Hersteller:
International Business Machines Corp.

New Orchard Road
Armonk, New York 10504
Tel: 914-499-1900

Der verantwortliche Ansprechpartner des Herstellers in der EU ist:
IBM Deutschland GmbH
Technical Relations Europe, Abteilung M456
IBM-Allee 1, 71139 Ehningen, Germany
Tel: +49 (0) 800 225 5426
email: HalloIBM@de.ibm.com

Generelle Informationen:

Das Gerät erfüllt die Schutzanforderungen nach EN 55024 und EN 55022 / EN 55032 Klasse A.

Japan Electronics and Information Technology Industries Association (JEITA) Notice

(一社) 電子情報技術産業協会 高調波電流抑制対策実施
要領に基づく定格入力電力値： Knowledge Centerの各製品の
仕様ページ参照

This statement applies to products less than or equal to 20 A per phase.

高調波電流規格 JIS C 61000-3-2 適合品

This statement applies to products greater than 20 A, single phase.

高調波電流規格 JIS C 61000-3-2 準用品

本装置は、「高圧又は特別高圧で受電する需要家の高調波抑制対策ガイドライン」対象機器（高調波発生機器）です。

- 回路分類：6（単相、PFC回路付）
- 換算係数：0

This statement applies to products greater than 20 A per phase, three-phase.

高調波電流規格 JIS C 61000-3-2 準用品

本装置は、「高圧又は特別高圧で受電する需要家の高調波抑制対策ガイドライン」対象機器（高調波発生機器）です。

- 回路分類：5（3相、PFC回路付）
- 換算係数：0

Japan Voluntary Control Council for Interference (VCCI) Notice

この装置は、クラスA 情報技術装置です。この装置を家庭環境で使用すると電波妨害を引き起こすことがあります。この場合には使用者が適切な対策を講ずるよう要求されることがあります。

VCCI-A

Korea Notice

이 기기는 업무용 환경에서 사용할 목적으로 적합성평가를 받은 기기로서 가정용 환경에서 사용하는 경우 전파간섭의 우려가 있습니다.

People's Republic of China Notice

声 明

此为 A 级产品, 在生活环境中, 该产品可能会造成无线电干扰。在这种情况下, 可能需要用户对其干扰采取切实可行的措施。

Russia Notice

ВНИМАНИЕ! Настоящее изделие относится к классу А. В жилых помещениях оно может создавать радиопомехи, для снижения которых необходимы дополнительные меры

Taiwan Notice

警告使用者：
此為甲類資訊技術設備，
於居住環境中使用時，可
能會造成射頻擾動，在此
種情況下，使用者會被要
求採取某些適當的對策。

IBM Taiwan Contact Information:

台灣IBM 產品服務聯絡方式：
台灣國際商業機器股份有限公司
台北市松仁路7號3樓
電話：0800-016-888

United States Federal Communications Commission (FCC) Notice

This equipment has been tested and found to comply with the limits for a Class A digital device, pursuant to Part 15 of the FCC Rules. These limits are designed to provide reasonable protection against harmful interference when the equipment is operated in a commercial environment. This equipment generates, uses, and can radiate radio frequency energy and, if not installed and used in accordance with the instruction manual, may cause harmful interference to radio communications. Operation of this equipment in a residential area is likely to cause harmful interference, in which case the user will be required to correct the interference at his own expense.

Properly shielded and grounded cables and connectors must be used in order to meet FCC emission limits. Proper cables and connectors are available from IBM-authorized dealers. IBM is not responsible for any radio or television interference caused by using other than recommended cables and connectors

or by unauthorized changes or modifications to this equipment. Unauthorized changes or modifications could void the user's authority to operate the equipment.

This device complies with Part 15 of the FCC rules. Operation is subject to the following two conditions: (1) this device may not cause harmful interference, and (2) this device must accept any interference received, including interference that may cause undesired operation.

Responsible Party:
International Business Machines Corporation
New Orchard Road
Armonk, NY 10504
Contact for FCC compliance information only: fccinfo@us.ibm.com

Class B Notices

The following Class B statements apply to features designated as electromagnetic compatibility (EMC) Class B in the feature installation information.

When attaching a monitor to the equipment, you must use the designated monitor cable and any interference suppression devices supplied with the monitor.

Canada Notice

CAN ICES-3 (B)/NMB-3(B)

European Community and Morocco Notice

This product is in conformity with the protection requirements of Directive 2014/30/EU of the European Parliament and of the Council on the harmonization of the laws of the Member States relating to electromagnetic compatibility. IBM cannot accept responsibility for any failure to satisfy the protection requirements resulting from a non-recommended modification of the product, including the fitting of non-IBM option cards.

German Notice

Deutschsprachiger EU Hinweis: Hinweis für Geräte der Klasse B EU-Richtlinie zur Elektromagnetischen Verträglichkeit

Dieses Produkt entspricht den Schutzanforderungen der EU-Richtlinie 2014/30/EU zur Angleichung der Rechtsvorschriften über die elektromagnetische Verträglichkeit in den EU-Mitgliedsstaaten und hält die Grenzwerte der EN 55022/ EN 55032 Klasse B ein.

Um dieses sicherzustellen, sind die Geräte wie in den Handbüchern beschrieben zu installieren und zu betreiben. Des Weiteren dürfen auch nur von der IBM empfohlene Kabel angeschlossen werden. IBM übernimmt keine Verantwortung für die Einhaltung der Schutzanforderungen, wenn das Produkt ohne Zustimmung von IBM verändert bzw. wenn Erweiterungskomponenten von Fremdherstellern ohne Empfehlung von IBM gesteckt/eingebaut werden.

Deutschland: Einhaltung des Gesetzes über die elektromagnetische Verträglichkeit von Geräten

Dieses Produkt entspricht dem "Gesetz über die elektromagnetische Verträglichkeit von Geräten (EMVG)". Dies ist die Umsetzung der EU-Richtlinie 2014/30/EU in der Bundesrepublik Deutschland.

Zulassungsbescheinigung laut dem Deutschen Gesetz über die elektromagnetische Verträglichkeit von Geräten (EMVG) (bzw. der EMC Richtlinie 2014/30/EU) für Geräte der Klasse B

Dieses Gerät ist berechtigt, in Übereinstimmung mit dem Deutschen EMVG das EG-Konformitätszeichen - CE - zu führen.

Verantwortlich für die Einhaltung der EMV Vorschriften ist der Hersteller:
International Business Machines Corp.
New Orchard Road

Armonk, New York 10504
Tel: 914-499-1900

Der verantwortliche Ansprechpartner des Herstellers in der EU ist:
IBM Deutschland GmbH
Technical Relations Europe, Abteilung M456
IBM-Allee 1, 71139 Ehningen, Germany
Tel: +49 (0) 800 225 5426
email: HalloIBM@de.ibm.com

Generelle Informationen:

Das Gerät erfüllt die Schutzanforderungen nach EN 55024 und EN 55032 Klasse B

Japan Electronics and Information Technology Industries Association (JEITA) Notice

(一社) 電子情報技術産業協会 高調波電流抑制対策実施
要領に基づく定格入力電力値 : Knowledge Centerの各製品の
仕様ページ参照

This statement applies to products less than or equal to 20 A per phase.

高調波電流規格 JIS C 61000-3-2 適合品

This statement applies to products greater than 20 A, single phase.

高調波電流規格 JIS C 61000-3-2 準用品

本装置は、「高圧又は特別高圧で受電する需要家の高調波抑制対策ガイドライン」対象機器（高調波発生機器）です。

- 回路分類 : 6 (単相、PFC回路付)
- 換算係数 : 0

This statement applies to products greater than 20 A per phase, three-phase.

高調波電流規格 JIS C 61000-3-2 準用品

本装置は、「高圧又は特別高圧で受電する需要家の高調波抑制対策ガイドライン」対象機器（高調波発生機器）です。

- 回路分類 : 5 (3相、PFC回路付)
- 換算係数 : 0

Japan Voluntary Control Council for Interference (VCCI) Notice

この装置は、クラスB情報技術装置です。この装置は、家庭環境で使用することを目的としていますが、この装置がラジオやテレビジョン受信機に近接して使用されると、受信障害を引き起こすことがあります。

取扱説明書に従って正しい取り扱いをして下さい。

VCCI-B

Taiwan Notice

台灣IBM 產品服務聯絡方式：
台灣國際商業機器股份有限公司
台北市松仁路7號3樓
電話：0800-016-888

United States Federal Communications Commission (FCC) Notice

This equipment has been tested and found to comply with the limits for a Class B digital device, pursuant to Part 15 of the FCC Rules. These limits are designed to provide reasonable protection against harmful interference in a residential installation. This equipment generates, uses, and can radiate radio frequency energy and, if not installed and used in accordance with the instructions, may cause harmful interference to radio communications. However, there is no guarantee that interference will not occur in a particular installation. If this equipment does cause harmful interference to radio or television reception, which can be determined by turning the equipment off and on, the user is encouraged to try to correct the interference by one or more of the following measures:

- Reorient or relocate the receiving antenna.
- Increase the separation between the equipment and receiver.
- Connect the equipment into an outlet on a circuit different from that to which the receiver is connected.
- Consult an IBM-authorized dealer or service representative for help.

Properly shielded and grounded cables and connectors must be used in order to meet FCC emission limits. Proper cables and connectors are available from IBM-authorized dealers. IBM is not responsible for any radio or television interference caused by using other than recommended cables and connectors or by unauthorized changes or modifications to this equipment. Unauthorized changes or modifications could void the user's authority to operate the equipment.

This device complies with Part 15 of the FCC rules. Operation is subject to the following two conditions:

(1) this device may not cause harmful interference, and (2) this device must accept any interference received, including interference that may cause undesired operation.

Responsible Party:

International Business Machines Corporation
New Orchard Road
Armonk, New York 10504
Contact for FCC compliance information only: fccinfo@us.ibm.com

Terms and conditions

Permissions for the use of these publications are granted subject to the following terms and conditions.

Applicability: These terms and conditions are in addition to any terms of use for the IBM website.

Personal Use: You may reproduce these publications for your personal, noncommercial use provided that all proprietary notices are preserved. You may not distribute, display or make derivative works of these publications, or any portion thereof, without the express consent of IBM.

Commercial Use: You may reproduce, distribute and display these publications solely within your enterprise provided that all proprietary notices are preserved. You may not make derivative works of these publications, or reproduce, distribute or display these publications or any portion thereof outside your enterprise, without the express consent of IBM.

Rights: Except as expressly granted in this permission, no other permissions, licenses or rights are granted, either express or implied, to the publications or any information, data, software or other intellectual property contained therein.

IBM reserves the right to withdraw the permissions granted herein whenever, in its discretion, the use of the publications is detrimental to its interest or, as determined by IBM, the above instructions are not being properly followed.

You may not download, export or re-export this information except in full compliance with all applicable laws and regulations, including all United States export laws and regulations.

IBM MAKES NO GUARANTEE ABOUT THE CONTENT OF THESE PUBLICATIONS. THE PUBLICATIONS ARE PROVIDED "AS-IS" AND WITHOUT WARRANTY OF ANY KIND, EITHER EXPRESSED OR IMPLIED, INCLUDING BUT NOT LIMITED TO IMPLIED WARRANTIES OF MERCHANTABILITY, NON-INFRINGEMENT, AND FITNESS FOR A PARTICULAR PURPOSE.

