

Power Systems

*PCIe adapters for the 8408-44E or
8408-E8E*

IBM

Power Systems

*PCIe adapters for the 8408-44E or
8408-E8E*

IBM

Note

Before using this information and the product it supports, read the information in "Safety notices" on page vii, "Notices" on page 125, the *IBM Systems Safety Notices* manual, G229-9054, and the *IBM Environmental Notices and User Guide*, Z125-5823.

This edition applies to IBM Power Systems servers that contain the POWER8 processor and to all associated models.

© Copyright IBM Corporation 2015, 2017.

US Government Users Restricted Rights – Use, duplication or disclosure restricted by GSA ADP Schedule Contract with IBM Corp.

Contents

Safety notices	vii
---------------------------------	------------

Installing, removing, and replacing PCIe adapters for the 8408-44E or 8408-E8E system 1

Installing PCIe adapters in the 8408-44E or 8408-E8E system	1
Installing a PCIe adapter in the 8408-44E or 8408-E8E system with the power turned off	1
Preparing the 8408-44E or 8408-E8E system to install a PCIe adapter with the system power turned off	1
Installing a PCIe adapter in the 8408-44E or 8408-E8E system with the power turned off	5
Preparing the 8408-44E or 8408-E8E system for operation after installing a PCIe adapter	7
Installing a PCIe adapter in the 8408-44E or 8408-E8E system with the power turned on in AIX	8
Preparing the 8408-44E or 8408-E8E system to install a PCIe adapter with the power turned on in AIX	8
Installing a PCIe adapter in the 8408-44E or 8408-E8E system with the power turned on in AIX	11
Preparing the system for operation with the power turned on in AIX	12
Installing a PCIe adapter in the 8408-44E or 8408-E8E system with the power turned on in Linux	13
Preparing the 8408-44E or 8408-E8E system to install a PCIe adapter with the power turned on in Linux	14
Installing a PCIe adapter in the 8408-44E or 8408-E8E system with the power turned on in Linux	16
Preparing the 8408-44E or 8408-E8E system for operation after installing a PCIe adapter in Linux	18
Removing and replacing PCIe adapters in the 8408-44E or 8408-E8E system	19
Removing and replacing PCIe adapters in the 8408-44E or 8408-E8E system with the power turned off	19
Preparing the 8408-44E or 8408-E8E system to remove and replace a PCIe adapter with the power turned off	19
Removing a PCIe adapter from the 8408-44E or 8408-E8E system with the system power turned off	23
Replacing a PCIe adapter in the 8408-44E or 8408-E8E system with the system power turned off	25
Preparing the 8408-44E or 8408-E8E system for operation after removing and replacing a PCIe adapter with the power turned off	27
Removing and replacing a PCIe adapter in the 8408-44E or 8408-E8E system with the power turned on in AIX	28
Preparing the 8408-44E or 8408-E8E system to remove and replace a PCIe adapter with the power turned on in AIX	28
Removing a PCIe adapter from the 8408-44E or 8408-E8E system with the power turned on in AIX	31
Replacing a PCIe adapter in the 8408-44E or 8408-E8E system with the power turned on in AIX	33
Preparing the 8408-44E or 8408-E8E system for operation after removing and replacing a PCIe adapter with the power turned on in AIX	34
Removing and replacing a PCIe adapter in the 8408-44E or 8408-E8E system with the power turned on in Linux	36
Preparing the 8408-44E or 8408-E8E system to remove and replace a PCIe adapter with the power turned on in Linux	36
Removing a PCIe adapter from the 8408-44E or 8408-E8E system with the power turned on in Linux	39
Replacing a PCIe adapter in the 8408-44E or 8408-E8E system with the power turned on in Linux	40
Preparing the 8408-44E or 8408-E8E system for operation after removing and replacing a PCIe adapter with the power turned on in Linux	41
Related procedures for installing and removing PCIe adapters	42
Avoiding electric shock	42
Handling static-sensitive devices	43
Updating the worldwide port name for a new 5735 IOA	44
Removing and replacing the tailstock on a PCIe adapter	44
PCIe hot-plug manager access for AIX	48
Accessing hot-plug management functions	48
PCI hot-plug manager menu	49
Component LEDs	49
Resetting the LEDs in AIX	50
Installing the AIX device driver software	50
Verifying the AIX device driver software	51
Installing or replacing a PCI adapter with the system power on in Virtual I/O Server	51
Getting started	51
Installing a PCI adapter	52
Replacing a PCI adapter	52
Unconfiguring storage adapters	53

Preparing the client logical partitions	53
Verifying that the hot-plug PCI tools are installed for Linux	54
Common procedures for installing, removing, and replacing PCIe adapters	57
Before you begin	57
Identifying a part	60
Identifying the enclosure or server that contains the part	60
Enabling enclosure or server indicators with the ASMI	60
Control panel LEDs.	60
Activating an identify LED for an enclosure or server by using the HMC.	61
Finding the part location code and LED support status.	62
Identifying a part by using the operating system or VIOS	63
Identifying a part in an AIX system or logical partition.	63
Finding the location code for a part in an AIX system or logical partition.	63
Activating the indicator light for a part by using AIX diagnostics	63
Identifying a part in an IBM i system or logical partition	64
Finding the location code and activating the indicator light for a part by using the IBM i operating system	64
Identifying a part in a Linux system or logical partition	65
Finding the location code of a part in a Linux system or logical partition.	65
Activating the indicator light for a part by using the Linux operating system	65
Identifying a part in a VIOS system or logical partition.	65
Finding the location code of a part in a VIOS system or logical partition	65
Activating the indicator light for a part by using the VIOS tools.	66
Identifying a part by using the ASMI.	66
Activating the identify LED by using the ASMI when you know the location code	66
Activating the identify LED by using the ASMI when you do not know the location code	67
Identifying a part by using the HMC.	67
Starting the system or logical partition	68
Starting a system that is not managed by an HMC	68
Starting a system by using the control panel	68
Starting a system by using the ASMI	70
Starting a system or logical partition by using the HMC	70
Starting a system or logical partition by using the HMC Classic or HMC Enhanced interface	70
Starting a system or logical partition by using the HMC Enhanced + Tech Preview (Pre-GA) or HMC Enhanced+ interface	70
Starting an IBM PowerKVM system	71
Stopping a system or logical partition	71
Stopping a system that is not managed by an HMC	71
Stopping a system by using the control panel	72
Stopping a system by using the ASMI	72
Stopping a system by using the HMC	72
Stopping a system by using the HMC Classic or HMC Enhanced interface	73
Stopping a system by using the HMC Enhanced + Tech Preview (Pre-GA) or HMC Enhanced+ interface	73
Stopping an IBM PowerKVM system	73
Removing and replacing covers on an 8408-44E or 8408-E8E system	74
Removing the front cover from an 8408-44E or 8408-E8E system.	74
Installing the front cover on an 8408-44E or 8408-E8E system.	74
Removing the service access cover from an 8408-44E or 8408-E8E system.	75
Installing the service access cover on an 8408-44E or 8408-E8E system	76
Removing and replacing the safety cover in an 8408-44E or 8408-E8E system	77
Removing the safety cover from an 8408-44E or 8408-E8E system	77
Replacing the safety cover in an 8408-44E or 8408-E8E system	78
Opening and closing the I/O latch in an 8408-44E or 8408-E8E system	79
Opening the I/O latch in an 8408-44E or 8408-E8E system.	79
Closing the I/O latch in an 8408-44E or 8408-E8E system	80
Service and operating positions for an 8408-44E or 8408-E8E system	81
Placing an 8408-44E or 8408-E8E system into the service position	81
Placing an 8408-44E or 8408-E8E system into the operating position	82
Power cords	83
Disconnecting the power cords from the system	83

Connecting the power cords to the system	86
Installing or replacing a part with an HMC.	89
Installing a part by using the HMC	89
Removing a part by using the HMC	89
Repairing a part by using the HMC	90
Verifying the installed part	91
Verifying a part by using the operating system or VIOS	91
Verifying an installed feature or replaced part by using an AIX system or logical partition	91
Verifying an installed feature by using the AIX operating system	91
Verifying a replaced part by using the AIX operating system	92
Verifying the installed part by using an IBM i system or logical partition.	94
Verifying an installed part by using a Linux system or logical partition	94
Verifying an installed part by using stand-alone diagnostics	94
Verifying an installed part or replaced part on a system or logical partition by using Virtual I/O Server tools	96
Verifying an installed part by using VIOS	96
Verify the replacement part by using VIOS	96
Verifying the installed part by using the HMC.	98
Viewing serviceable events by using the HMC.	99
Verifying a repair	99
Verifying the repair in AIX	100
Verifying a repair by using an IBM i system or logical partition	103
Verifying the repair in Linux	105
Verifying the repair on an IBM PowerKVM system.	105
Verifying the repair from the management console	106
Closing a service call	107
Closing a service call by using AIX or Linux	110
Closing a service call by using IBM PowerKVM	113
Closing a service call by using Integrated Virtualization Manager	114
Activating and deactivating LEDs	117
Deactivating a system attention LED or partition LED by using the management console	117
Activating or deactivating an identify LED by using the management console.	118
Deactivating a system attention LED or logical partition LED by using the Advanced System Management Interface	119
Activating or deactivating an identify LED by using the Advanced System Management Interface	119
Deactivating an identify LED	120
Deactivating a system attention LED by using the operating system or VIOS tools	120
Deactivating the indicator light for a part by using AIX diagnostics	120
Deactivating the indicator light by using the IBM i operating system.	120
Deactivating the indicator light by using the Linux operating system.	121
Deactivating the indicator light for a part by using the VIOS tools	121
Deactivating a system attention LED by using the ASMI	121
Deactivating the identify LED by using the ASMI when you know the location code	122
Deactivating the identify LED by using the ASMI when you do not know the location code	122
Deactivating a check log indicator (system information indicator) by using the ASMI	122
Deactivating LEDs by using the HMC	123
Deactivating a system attention LED or partition LED by using the HMC	123
Deactivating an identify LED for a FRU by using the HMC	124
Deactivating an identify LED for an enclosure by using the HMC	124
Notices	125
Accessibility features for IBM Power Systems servers	126
Privacy policy considerations	127
Trademarks	128
Electronic emission notices	128
Class A Notices.	128
Class B Notices.	132
Terms and conditions.	135

Safety notices

Safety notices may be printed throughout this guide:

- **DANGER** notices call attention to a situation that is potentially lethal or extremely hazardous to people.
- **CAUTION** notices call attention to a situation that is potentially hazardous to people because of some existing condition.
- **Attention** notices call attention to the possibility of damage to a program, device, system, or data.

World Trade safety information

Several countries require the safety information contained in product publications to be presented in their national languages. If this requirement applies to your country, safety information documentation is included in the publications package (such as in printed documentation, on DVD, or as part of the product) shipped with the product. The documentation contains the safety information in your national language with references to the U.S. English source. Before using a U.S. English publication to install, operate, or service this product, you must first become familiar with the related safety information documentation. You should also refer to the safety information documentation any time you do not clearly understand any safety information in the U.S. English publications.

Replacement or additional copies of safety information documentation can be obtained by calling the IBM Hotline at 1-800-300-8751.

German safety information

Das Produkt ist nicht für den Einsatz an Bildschirmarbeitsplätzen im Sinne § 2 der Bildschirmarbeitsverordnung geeignet.

Laser safety information

IBM® servers can use I/O cards or features that are fiber-optic based and that utilize lasers or LEDs.

Laser compliance

IBM servers may be installed inside or outside of an IT equipment rack.

DANGER: When working on or around the system, observe the following precautions:

Electrical voltage and current from power, telephone, and communication cables are hazardous. To avoid a shock hazard:

- If IBM supplied the power cord(s), connect power to this unit only with the IBM provided power cord. Do not use the IBM provided power cord for any other product.
- Do not open or service any power supply assembly.
- Do not connect or disconnect any cables or perform installation, maintenance, or reconfiguration of this product during an electrical storm.
- The product might be equipped with multiple power cords. To remove all hazardous voltages, disconnect all power cords.
 - For AC power, disconnect all power cords from their AC power source.
 - For racks with a DC power distribution panel (PDP), disconnect the customer's DC power source to the PDP.
- When connecting power to the product ensure all power cables are properly connected.

- For racks with AC power, connect all power cords to a properly wired and grounded electrical outlet. Ensure that the outlet supplies proper voltage and phase rotation according to the system rating plate.
- For racks with a DC power distribution panel (PDP), connect the customer's DC power source to the PDP. Ensure that the proper polarity is used when attaching the DC power and DC power return wiring.
- Connect any equipment that will be attached to this product to properly wired outlets.
- When possible, use one hand only to connect or disconnect signal cables.
- Never turn on any equipment when there is evidence of fire, water, or structural damage.
- Do not attempt to switch on power to the machine until all possible unsafe conditions are corrected.
- Assume that an electrical safety hazard is present. Perform all continuity, grounding, and power checks specified during the subsystem installation procedures to ensure that the machine meets safety requirements.
- Do not continue with the inspection if any unsafe conditions are present.
- Before you open the device covers, unless instructed otherwise in the installation and configuration procedures: Disconnect the attached AC power cords, turn off the applicable circuit breakers located in the rack power distribution panel (PDP), and disconnect any telecommunications systems, networks, and modems.

DANGER:

- Connect and disconnect cables as described in the following procedures when installing, moving, or opening covers on this product or attached devices.

To Disconnect:

1. Turn off everything (unless instructed otherwise).
2. For AC power, remove the power cords from the outlets.
3. For racks with a DC power distribution panel (PDP), turn off the circuit breakers located in the PDP and remove the power from the Customer's DC power source.
4. Remove the signal cables from the connectors.
5. Remove all cables from the devices.

To Connect:

1. Turn off everything (unless instructed otherwise).
2. Attach all cables to the devices.
3. Attach the signal cables to the connectors.
4. For AC power, attach the power cords to the outlets.
5. For racks with a DC power distribution panel (PDP), restore the power from the Customer's DC power source and turn on the circuit breakers located in the PDP.
6. Turn on the devices.

Sharp edges, corners and joints may be present in and around the system. Use care when handling equipment to avoid cuts, scrapes and pinching. (D005)

(R001 part 1 of 2):

DANGER: Observe the following precautions when working on or around your IT rack system:

- Heavy equipment—personal injury or equipment damage might result if mishandled.
- Always lower the leveling pads on the rack cabinet.
- Always install stabilizer brackets on the rack cabinet.
- To avoid hazardous conditions due to uneven mechanical loading, always install the heaviest devices in the bottom of the rack cabinet. Always install servers and optional devices starting from the bottom of the rack cabinet.
- Rack-mounted devices are not to be used as shelves or work spaces. Do not place objects on top of rack-mounted devices. In addition, do not lean on rack mounted devices and do not use them to stabilize your body position (for example, when working from a ladder).



- Each rack cabinet might have more than one power cord.
 - For AC powered racks, be sure to disconnect all power cords in the rack cabinet when directed to disconnect power during servicing.
 - For racks with a DC power distribution panel (PDP), turn off the circuit breaker that controls the power to the system unit(s), or disconnect the customer's DC power source, when directed to disconnect power during servicing.
- Connect all devices installed in a rack cabinet to power devices installed in the same rack cabinet. Do not plug a power cord from a device installed in one rack cabinet into a power device installed in a different rack cabinet.
- An electrical outlet that is not correctly wired could place hazardous voltage on the metal parts of the system or the devices that attach to the system. It is the responsibility of the customer to ensure that the outlet is correctly wired and grounded to prevent an electrical shock.

(R001 part 2 of 2):

CAUTION:

- Do not install a unit in a rack where the internal rack ambient temperatures will exceed the manufacturer's recommended ambient temperature for all your rack-mounted devices.
- Do not install a unit in a rack where the air flow is compromised. Ensure that air flow is not blocked or reduced on any side, front, or back of a unit used for air flow through the unit.
- Consideration should be given to the connection of the equipment to the supply circuit so that overloading of the circuits does not compromise the supply wiring or overcurrent protection. To provide the correct power connection to a rack, refer to the rating labels located on the equipment in the rack to determine the total power requirement of the supply circuit.
- *(For sliding drawers.)* Do not pull out or install any drawer or feature if the rack stabilizer brackets are not attached to the rack. Do not pull out more than one drawer at a time. The rack might become unstable if you pull out more than one drawer at a time.



- *(For fixed drawers.)* This drawer is a fixed drawer and must not be moved for servicing unless specified by the manufacturer. Attempting to move the drawer partially or completely out of the rack might cause the rack to become unstable or cause the drawer to fall out of the rack.

CAUTION:

Removing components from the upper positions in the rack cabinet improves rack stability during relocation. Follow these general guidelines whenever you relocate a populated rack cabinet within a room or building.

- Reduce the weight of the rack cabinet by removing equipment starting at the top of the rack cabinet. When possible, restore the rack cabinet to the configuration of the rack cabinet as you received it. If this configuration is not known, you must observe the following precautions:
 - Remove all devices in the 32U position (compliance ID RACK-001 or 22U (compliance ID RR001) and above.
 - Ensure that the heaviest devices are installed in the bottom of the rack cabinet.
 - Ensure that there are little-to-no empty U-levels between devices installed in the rack cabinet below the 32U (compliance ID RACK-001 or 22U (compliance ID RR001) level, unless the received configuration specifically allowed it.
- If the rack cabinet you are relocating is part of a suite of rack cabinets, detach the rack cabinet from the suite.
- If the rack cabinet you are relocating was supplied with removable outriggers they must be reinstalled before the cabinet is relocated.
- Inspect the route that you plan to take to eliminate potential hazards.
- Verify that the route that you choose can support the weight of the loaded rack cabinet. Refer to the documentation that comes with your rack cabinet for the weight of a loaded rack cabinet.
- Verify that all door openings are at least 760 x 230 mm (30 x 80 in.).
- Ensure that all devices, shelves, drawers, doors, and cables are secure.
- Ensure that the four leveling pads are raised to their highest position.
- Ensure that there is no stabilizer bracket installed on the rack cabinet during movement.
- Do not use a ramp inclined at more than 10 degrees.
- When the rack cabinet is in the new location, complete the following steps:
 - Lower the four leveling pads.
 - Install stabilizer brackets on the rack cabinet.
 - If you removed any devices from the rack cabinet, repopulate the rack cabinet from the lowest position to the highest position.
- If a long-distance relocation is required, restore the rack cabinet to the configuration of the rack cabinet as you received it. Pack the rack cabinet in the original packaging material, or equivalent. Also lower the leveling pads to raise the casters off of the pallet and bolt the rack cabinet to the pallet.

(R002)

(L001)



DANGER: Hazardous voltage, current, or energy levels are present inside any component that has this label attached. Do not open any cover or barrier that contains this label. (L001)

(L002)



DANGER: Rack-mounted devices are not to be used as shelves or work spaces. (L002)

(L003)



or



or



or



or

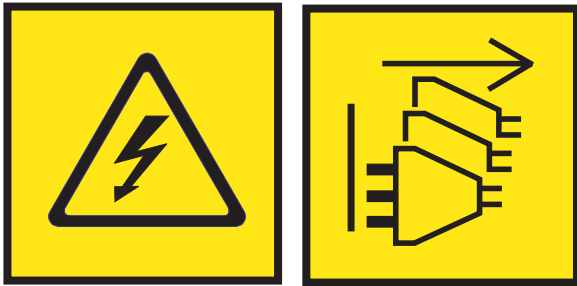

DANGER: Multiple power cords. The product might be equipped with multiple AC power cords or multiple DC power cables. To remove all hazardous voltages, disconnect all power cords and power cables. (L003)

(L007)



CAUTION: A hot surface nearby. (L007)

(L008)



CAUTION: Hazardous moving parts nearby. (L008)

All lasers are certified in the U.S. to conform to the requirements of DHHS 21 CFR Subchapter J for class 1 laser products. Outside the U.S., they are certified to be in compliance with IEC 60825 as a class 1 laser product. Consult the label on each part for laser certification numbers and approval information.

CAUTION:

This product might contain one or more of the following devices: CD-ROM drive, DVD-ROM drive, DVD-RAM drive, or laser module, which are Class 1 laser products. Note the following information:

- Do not remove the covers. Removing the covers of the laser product could result in exposure to hazardous laser radiation. There are no serviceable parts inside the device.
- Use of the controls or adjustments or performance of procedures other than those specified herein might result in hazardous radiation exposure.

(C026)

CAUTION:

Data processing environments can contain equipment transmitting on system links with laser modules that operate at greater than Class 1 power levels. For this reason, never look into the end of an optical fiber cable or open receptacle. Although shining light into one end and looking into the other end of a disconnected optical fiber to verify the continuity of optic fibers may not injure the eye, this procedure is potentially dangerous. Therefore, verifying the continuity of optical fibers by shining light into one end and looking at the other end is not recommended. To verify continuity of a fiber optic cable, use an optical light source and power meter. (C027)

CAUTION:

This product contains a Class 1M laser. Do not view directly with optical instruments. (C028)

CAUTION:

Some laser products contain an embedded Class 3A or Class 3B laser diode. Note the following information: laser radiation when open. Do not stare into the beam, do not view directly with optical instruments, and avoid direct exposure to the beam. (C030)

CAUTION:

The battery contains lithium. To avoid possible explosion, do not burn or charge the battery.

Do Not:

- ___ Throw or immerse into water
- ___ Heat to more than 100°C (212°F)
- ___ Repair or disassemble

Exchange only with the IBM-approved part. Recycle or discard the battery as instructed by local regulations. In the United States, IBM has a process for the collection of this battery. For information, call 1-800-426-4333. Have the IBM part number for the battery unit available when you call. (C003)

CAUTION:

Regarding IBM provided VENDOR LIFT TOOL:

- Operation of LIFT TOOL by authorized personnel only.
- LIFT TOOL intended for use to assist, lift, install, remove units (load) up into rack elevations. It is not to be used loaded transporting over major ramps nor as a replacement for such designated tools like pallet jacks, walkies, fork trucks and such related relocation practices. When this is not practicable, specially trained persons or services must be used (for instance, riggers or movers).
- Read and completely understand the contents of LIFT TOOL operator's manual before using. Failure to read, understand, obey safety rules, and follow instructions may result in property damage and/or personal injury. If there are questions, contact the vendor's service and support. Local paper manual must remain with machine in provided storage sleeve area. Latest revision manual available on vendor's web site.
- Test verify stabilizer brake function before each use. Do not over-force moving or rolling the LIFT TOOL with stabilizer brake engaged.
- Do not move LIFT TOOL while platform is raised, except for minor positioning.
- Do not exceed rated load capacity. See LOAD CAPACITY CHART regarding maximum loads at center versus edge of extended platform.
- Only raise load if properly centered on platform. Do not place more than 200 lb (91 kg) on edge of sliding platform shelf also considering the load's center of mass/gravity (CoG).
- Do not corner load the platform tilt riser accessory option. Secure platform riser tilt option to main shelf in all four (4x) locations with provided hardware only, prior to use. Load objects are designed to slide on/off smooth platforms without appreciable force, so take care not to push or lean. Keep riser tilt option flat at all times except for final minor adjustment when needed.
- Do not stand under overhanging load.
- Do not use on uneven surface, incline or decline (major ramps).
- Do not stack loads.
- Do not operate while under the influence of drugs or alcohol.
- Do not support ladder against LIFT TOOL.
- Tipping hazard. Do not push or lean against load with raised platform.
- Do not use as a personnel lifting platform or step. No riders.
- Do not stand on any part of lift. Not a step.
- Do not climb on mast.
- Do not operate a damaged or malfunctioning LIFT TOOL machine.
- Crush and pinch point hazard below platform. Only lower load in areas clear of personnel and obstructions. Keep hands and feet clear during operation.
- No Forks. Never lift or move bare LIFT TOOL MACHINE with pallet truck, jack or fork lift.
- Mast extends higher than platform. Be aware of ceiling height, cable trays, sprinklers, lights, and other overhead objects.
- Do not leave LIFT TOOL machine unattended with an elevated load.
- Watch and keep hands, fingers, and clothing clear when equipment is in motion.
- Turn Winch with hand power only. If winch handle cannot be cranked easily with one hand, it is probably over-loaded. Do not continue to turn winch past top or bottom of platform travel. Excessive unwinding will detach handle and damage cable. Always hold handle when lowering, unwinding. Always assure self that winch is holding load before releasing winch handle.
- A winch accident could cause serious injury. Not for moving humans. Make certain clicking sound is heard as the equipment is being raised. Be sure winch is locked in position before releasing handle. Read instruction page before operating this winch. Never allow winch to unwind freely. Freewheeling will cause uneven cable wrapping around winch drum, damage cable, and may cause serious injury. (C048)

Power and cabling information for NEBS (Network Equipment-Building System) GR-1089-CORE

The following comments apply to the IBM servers that have been designated as conforming to NEBS (Network Equipment-Building System) GR-1089-CORE:

The equipment is suitable for installation in the following:

- Network telecommunications facilities
- Locations where the NEC (National Electrical Code) applies

The intrabuilding ports of this equipment are suitable for connection to intrabuilding or unexposed wiring or cabling only. The intrabuilding ports of this equipment *must not* be metalically connected to the interfaces that connect to the OSP (outside plant) or its wiring. These interfaces are designed for use as intrabuilding interfaces only (Type 2 or Type 4 ports as described in GR-1089-CORE) and require isolation from the exposed OSP cabling. The addition of primary protectors is not sufficient protection to connect these interfaces metalically to OSP wiring.

Note: All Ethernet cables must be shielded and grounded at both ends.

The ac-powered system does not require the use of an external surge protection device (SPD).

The dc-powered system employs an isolated DC return (DC-I) design. The DC battery return terminal *shall not* be connected to the chassis or frame ground.

The dc-powered system is intended to be installed in a common bonding network (CBN) as described in GR-1089-CORE.

Installing, removing, and replacing PCIe adapters for the 8408-44E or 8408-E8E system

Find information about installing, removing, and replacing PCIe adapters in the IBM Power® System E850 (8408-44E and 8408-E8E) system.

Installing PCIe adapters in the 8408-44E or 8408-E8E system

Learn how to install the Peripheral Component Interconnect (PCI) Express (PCIe) adapters into the system.

Installing a PCIe adapter in the 8408-44E or 8408-E8E system with the power turned off

Learn how to install the Peripheral Component Interconnect (PCI) Express (PCIe) adapters in the system with the system power turned off.

Before you install a feature, ensure that the software that is required to support the feature is installed on your system. For information about software prerequisites, see the IBM Prerequisite website (http://www-912.ibm.com/e_dir/eServerPrereq.nsf). If the required software is not installed, see the following websites to download it, and then install it before you continue:

- To download system firmware updates, software updates, and fix packs, see the Fix Central website (<http://www.ibm.com/support/fixcentral/>).
- To download Hardware Management Console (HMC) updates and fixes, see the Hardware Management Console Support and downloads website (www14.software.ibm.com/webapp/set2/sas/f/hmcl/home.html).

If your system is managed by the Hardware Management Console (HMC), use the HMC to complete the steps for installing a PCIe adapter in the system. For instructions, see “Installing a part by using the HMC” on page 89.

If your system is not managed by an HMC, complete the following steps to install a PCIe adapter in the system:

1. “Preparing the 8408-44E or 8408-E8E system to install a PCIe adapter with the system power turned off.”
2. “Installing a PCIe adapter in the 8408-44E or 8408-E8E system with the power turned off” on page 5.
3. “Preparing the 8408-44E or 8408-E8E system for operation after installing a PCIe adapter” on page 7.

Preparing the 8408-44E or 8408-E8E system to install a PCIe adapter with the system power turned off

To prepare the system to install the Peripheral Component Interconnect (PCI) Express (PCIe) adapters in the system, complete the steps in this procedure.

Procedure

1. Ensure that the software that is required to support the feature is installed on your system. For information about software prerequisites, see the IBM Prerequisite website (http://www-912.ibm.com/e_dir/eServerPrereq.nsf). If the required system firmware, software, or fix packs are not installed on your system, go to the Fix Central website (<http://www.ibm.com/support/fixcentral/>) to download and install them before you continue.
2. Complete the prerequisite tasks. For instructions, see “Before you begin” on page 57.
3. Attach the electrostatic discharge (ESD) wrist strap.

Attention:

- Attach an electrostatic discharge (ESD) wrist strap to the front ESD jack, to the rear ESD jack, or to an unpainted metal surface of your hardware to prevent the electrostatic discharge from damaging your hardware.
 - When you use an ESD wrist strap, follow all electrical safety procedures. An ESD wrist strap is used for static control. It does not increase or decrease your risk of receiving electric shock when using or working on electrical equipment.
 - If you do not have an ESD wrist strap, just prior to removing the product from ESD packaging and installing or replacing hardware, touch an unpainted metal surface of the system for a minimum of 5 seconds.
4. Determine the slot in which you want to install a PCIe adapter. The PCIe adapter slots are at the rear of a system.

Note: The number of the PCIe adapter slots that are available in the system depends on the number of system processors in the system. For the PCIe adapter placement information regarding the available slots in this system, see PCIe adapter placement rules and slot priorities for the 8408-44E or 8408-E8E system.

Figure 1 shows the PCIe adapter location codes and the service indicator locations.

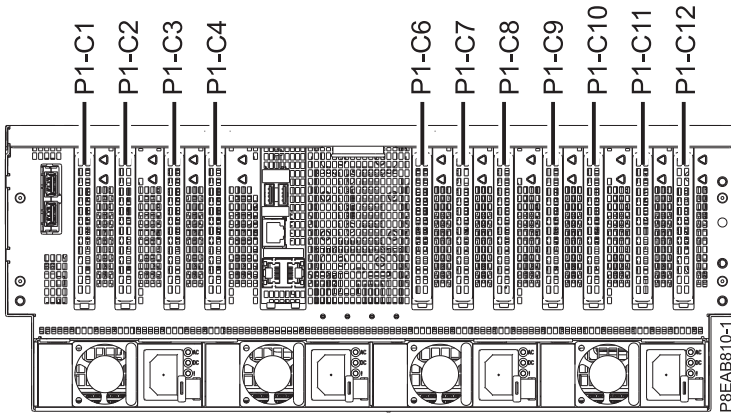

Figure 1. PCIe adapter slot locations in the 8408-44E or 8408-E8E system

5. Identify the part and the system that you will be working on. For instructions, see “Identifying a part” on page 60.
6. Stop the system or logical partition. For instructions, see “Stopping a system or logical partition” on page 71.
7. If applicable, open the rack front door.
8. Place the system into the service position. For instructions, see “Placing an 8408-44E or 8408-E8E system into the service position” on page 81.

CAUTION:

Do not place any object on top of a rack-mounted device unless that rack-mounted device is intended for use as a shelf. (R008)

(L012)

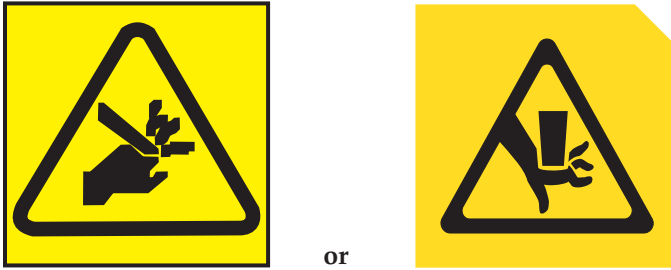

CAUTION: Pinch hazard. (L012)

9. Remove the service access cover. For instructions, see “Removing the service access cover from an 8408-44E or 8408-E8E system” on page 75.
10. Look for the slot in which the PCIe adapter is to be placed that you have identified.
There are two LEDs associated with each PCIe adapter. The following LED states indicate the status of the PCIe adapter.
 - **(B)** Indicates full power to the PCIe adapter. The green power LED (upper LED) is lit solid.
 - **(C)** Indicates a failed PCIe adapter. The amber fault LED (lower LED) is lit solid.
 - **(D)** Identifies an unoccupied slot that was selected by using the identify function. The amber fault LED (lower LED) is flashing.

Note: Do not attempt to remove a PCIe adapter with the green power LED (upper LED) is lit.

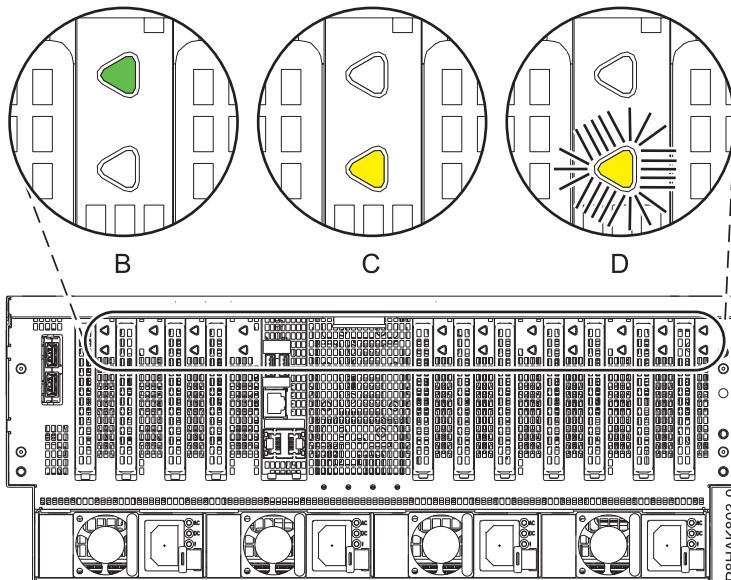
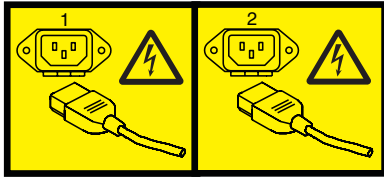

Figure 2. Location of the PCIe adapter LEDs in the 8408-44E or 8408-E8E system

11. Disconnect the power source from the system by unplugging the system. For instructions, see “Disconnecting the power cords from the system” on page 83.

Note: The system might be equipped with redundant power supply. Before you continue with this procedure, ensure that all power to your system is disconnected.

(L003)



or

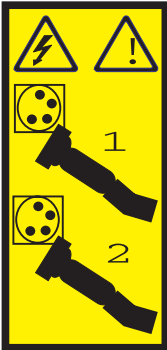

or



or

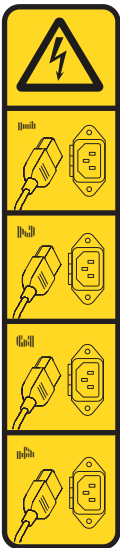

or

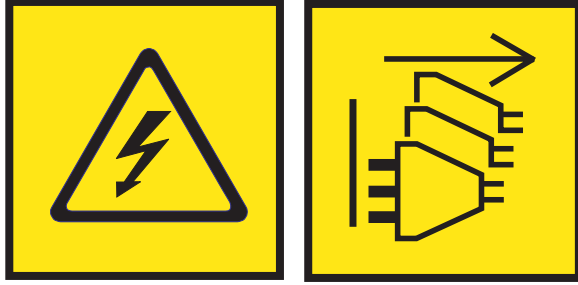

DANGER: Multiple power cords. The product might be equipped with multiple AC power cords or multiple DC power cables. To remove all hazardous voltages, disconnect all power cords and power cables. (L003)

Installing a PCIe adapter in the 8408-44E or 8408-E8E system with the power turned off

To install a PCIe adapter in the system, complete the steps in this procedure.

Procedure

1. Ensure that you have the electrostatic discharge (ESD) wrist strap attached. If not, attach it now.
2. Ensure that the target slot is empty.
3. If the target slot contains a filler, remove the filler.

Note: The left and right I/O retention brackets must be opened before you can access the rear slots. You only need to open the I/O retention bracket for the side you are accessing.

- a. Unscrew the captive thumbscrew of the I/O retention bracket until fully loose. See **(A)** in Figure 3 on page 6.
- b. Open the I/O retention bracket by rotating it up and away from the system. See **(B)** in Figure 3 on page 6.
- c. To remove the filler, carefully grasp the filler **(C)** by its top edge or tailstock, and remove it from the system. See Figure 3 on page 6.
 - You can store the filler in a safe place to use it later to install in an empty slot.
 - You can use the filler tailstock to attach it to a new adapter.

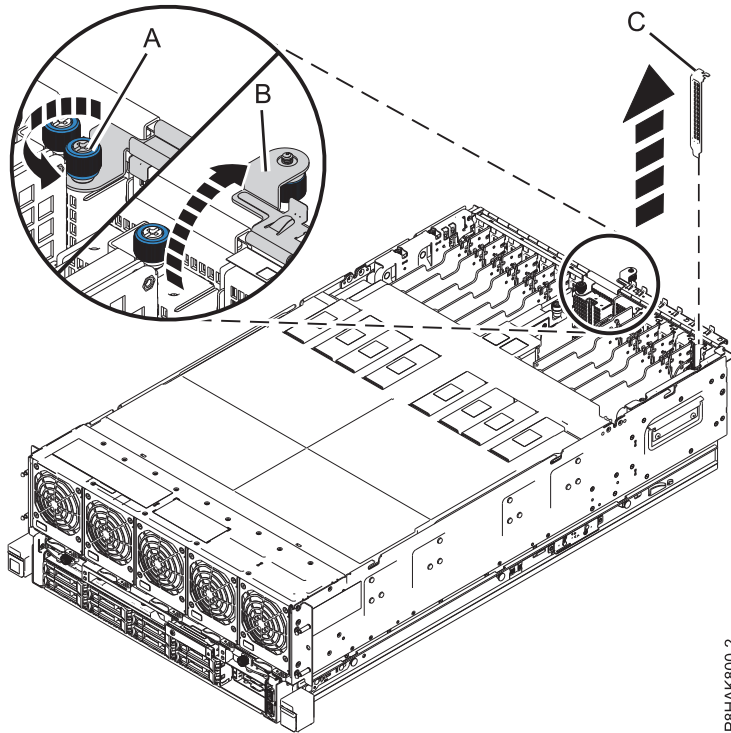

P8HAK800G-2

Figure 3. Removing a filler from a PCIe adapter slot in the 8408-44E or 8408-E8E system

4. If necessary, remove the adapter from the antistatic package.

Attention: Avoid touching the components and gold connectors on the adapter.

5. Place the adapter, component-side up, on a flat, antistatic surface.

Note: Some PCIe adapters are shipped from the manufacturer with a blue handle or support bracket along the back edge of the adapter. To use adapters of this type, you must remove the blue handle or the support bracket from the adapter.

Attention: A pin on the tailstock of the adapter resembles a removable screw. Do not remove this pin. It is required for correct alignment and seating.

6. Carefully grasp the adapter by its top edge or tailstock, and align the adapter with the slot and its connector on the system backplane (A), as shown in Figure 4 on page 7.

Attention: Before you insert the adapter in the PCIe slot, ensure that the adapter has no cables, protective shields, or transceivers that are attached to it. If the adapter has cables, protective shields, or transceivers that are attached, remove them. For instructions to remove protective shields or transceivers, see “Removing and replacing the tailstock on a PCIe adapter” on page 44. The cables, protective shields, or transceivers must be attached to the adapter after the adapter is inserted in the PCIe slot.

7. On the system, press the adapter firmly into its connector.
8. Ensure that the tailstock notch engages with the pin on the system's chassis. See (B) in Figure 4 on page 7.
9. Close the I/O retention bracket (C) by rotating it down and then tighten the captive thumbscrew (D) until it is secured to the system's chassis. See Figure 4 on page 7.

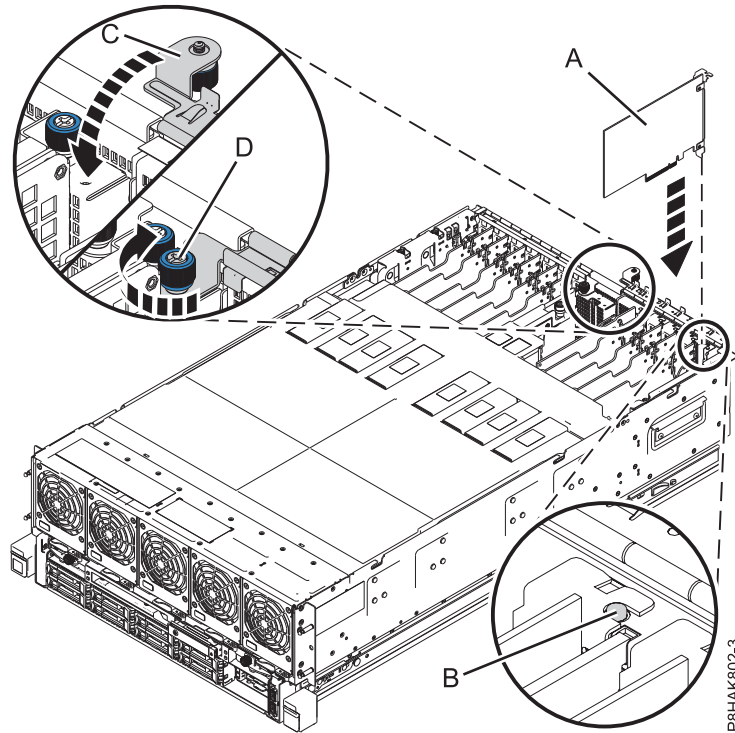

Figure 4. Installing or replacing a PCIe adapter in the 8408-44E or 8408-E8E system

Preparing the 8408-44E or 8408-E8E system for operation after installing a PCIe adapter

To prepare the system for operation after you install the Peripheral Component Interconnect (PCI) Express (PCIe) adapters in the system, complete the steps in this procedure.

Procedure

1. Ensure that you have the electrostatic discharge (ESD) wrist strap attached. If not, attach it now.
2. Install the service access cover. For instructions, see “Installing the service access cover on an 8408-44E or 8408-E8E system” on page 76.
3. Place the system into the operating position. For instructions, see “Placing an 8408-44E or 8408-E8E system into the operating position” on page 82.

(L012)



or



CAUTION: Pinch hazard. (L012)

4. If applicable, close the rack front door.
5. If removed, connect the cables or transceivers to the adapter.

6. If you installed a PCIe3 cable adapter, and want to connect an EMX0 PCIe3 expansion drawer to your system, proceed to Connecting an EMX0 PCIe Gen3 I/O expansion drawer to your system.

Note: Connecting expansion drawer cables is a nonconcurrent procedure, which requires the system to be powered off.

7. Route the cables through the cable-management arm.
8. Reconnect the power cords to the system. For instructions, see “Connecting the power cords to the system” on page 86.
9. Start the system or logical partition. For instructions, see “Starting the system or logical partition” on page 68.
10. Verify the installed part.
 - If you replaced the part because of a service action, verify the installed part. For instructions, see Verifying a repair.
 - If you installed the part for any other reason, verify the installed part. For instructions, see “Verifying the installed part” on page 91.

Installing a PCIe adapter in the 8408-44E or 8408-E8E system with the power turned on in AIX

To install the Peripheral Component Interconnect (PCI) Express (PCIe) adapters in an AIX[®] system or an AIX logical partition with the system power turned on, complete the steps in this procedure.

Before you install a feature, ensure that the software that is required to support the feature is installed on your system. For information about software prerequisites, see the IBM Prerequisite website (http://www-912.ibm.com/e_dir/eServerPrereq.nsf). If the required software is not installed, see the following websites to download it, and then install it before you continue:

- To download system firmware updates, software updates, and fix packs, see the Fix Central website (<http://www.ibm.com/support/fixcentral/>).
- To download Hardware Management Console (HMC) updates and fixes, see the Hardware Management Console Support and downloads website (www14.software.ibm.com/webapp/set2/sas/f/hmcl/home.html).

If your system is managed by the Hardware Management Console (HMC), use the HMC to complete the steps for installing a PCIe adapter in the system. For instructions, see “Installing a part by using the HMC” on page 89.

If your system is not managed by an HMC, complete the following steps to install a PCIe adapter in the system:

1. “Preparing the 8408-44E or 8408-E8E system to install a PCIe adapter with the power turned on in AIX.”
2. “Installing a PCIe adapter in the 8408-44E or 8408-E8E system with the power turned on in AIX” on page 11.
3. “Preparing the system for operation with the power turned on in AIX” on page 12.

Preparing the 8408-44E or 8408-E8E system to install a PCIe adapter with the power turned on in AIX

To prepare the system to install the Peripheral Component Interconnect (PCI) Express (PCIe) adapters in the system, complete the steps in this procedure.

Procedure

1. Ensure that the software that is required to support the feature is installed on your system. For information about software prerequisites, see the IBM Prerequisite website (http://www-912.ibm.com/e_dir/eServerPrereq.nsf). If the required system firmware, software, or fix packs are not

installed on your system, go to the Fix Central website (<http://www.ibm.com/support/fixcentral/>) to download and install them before you continue.

2. Attach the electrostatic discharge (ESD) wrist strap.

Attention:

- Attach an electrostatic discharge (ESD) wrist strap to the front ESD jack, to the rear ESD jack, or to an unpainted metal surface of your hardware to prevent the electrostatic discharge from damaging your hardware.
- When you use an ESD wrist strap, follow all electrical safety procedures. An ESD wrist strap is used for static control. It does not increase or decrease your risk of receiving electric shock when using or working on electrical equipment.
- If you do not have an ESD wrist strap, just prior to removing the product from ESD packaging and installing or replacing hardware, touch an unpainted metal surface of the system for a minimum of 5 seconds.

3. Determine the slot in which you want to install a PCIe adapter. The PCIe adapter slots are at the rear of a system.

Note: The number of the PCIe adapter slots that are available in the system depends on the number of system processors in the system. For the PCIe adapter placement information regarding the available slots in this system, see PCIe adapter placement rules and slot priorities for the 8408-44E or 8408-E8E system.

Figure 5 shows the PCIe adapter location codes and the service indicator locations.

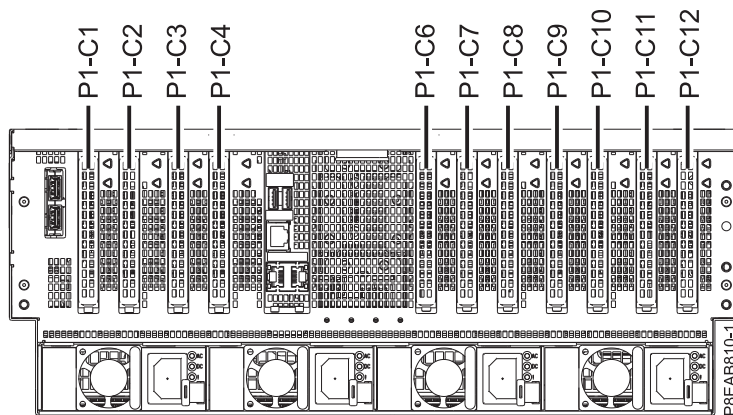

Figure 5. PCIe adapter slot locations in the 8408-44E or 8408-E8E system

4. Use a console to access the PCI Hot Plug Manager.

To access the PCI Hot Plug Manager, complete the following steps:

- a. Log in as root user.
- b. At the command line, type `smitty`.
- c. Select **Devices**.
- d. Select **PCI Hot Plug Manager** and press **Enter**.

The PCI Hot-Plug Manager menu displays.

For details about the menu options in the PCI Hot-Plug Manager screen, see “PCI hot-plug manager menu” on page 49.

5. From the PCI Hot-Plug Manager menu, select **Add a PCI Hot-Plug Adapter**, and then press **Enter**.
The Add a Hot-Plug Adapter window displays.
6. Select the appropriate PCIe slot from the list that is displayed on the screen, and then press **Enter**.
7. If applicable, open the rack front door.

- Place the system into the service position. For instructions, see “Placing an 8408-44E or 8408-E8E system into the service position” on page 81.

CAUTION:

Do not place any object on top of a rack-mounted device unless that rack-mounted device is intended for use as a shelf. (R008)

(L012)

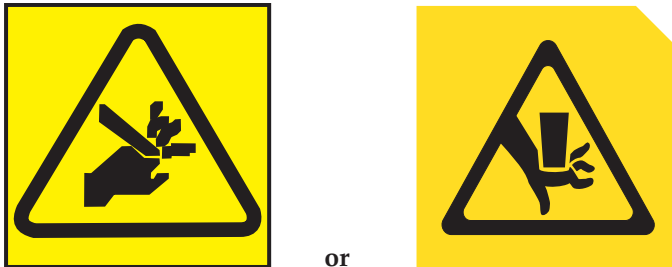

CAUTION: Pinch hazard. (L012)

- Remove the service access cover. For instructions, see “Removing the service access cover from an 8408-44E or 8408-E8E system” on page 75.
- Look for the slot in which the PCIe adapter is to be placed that you have identified.
There are two LEDs associated with each PCIe adapter. The following LED states indicate the status of the PCIe adapter.
 - (B) Indicates full power to the PCIe adapter. The green power LED (upper LED) is lit solid.
 - (C) Indicates a failed PCIe adapter. The amber fault LED (lower LED) is lit solid.
 - (D) Identifies an unoccupied slot that was selected by using the identify function. The amber fault LED (lower LED) is flashing.

Note: Do not attempt to remove a PCIe adapter with the green power LED (upper LED) is lit.

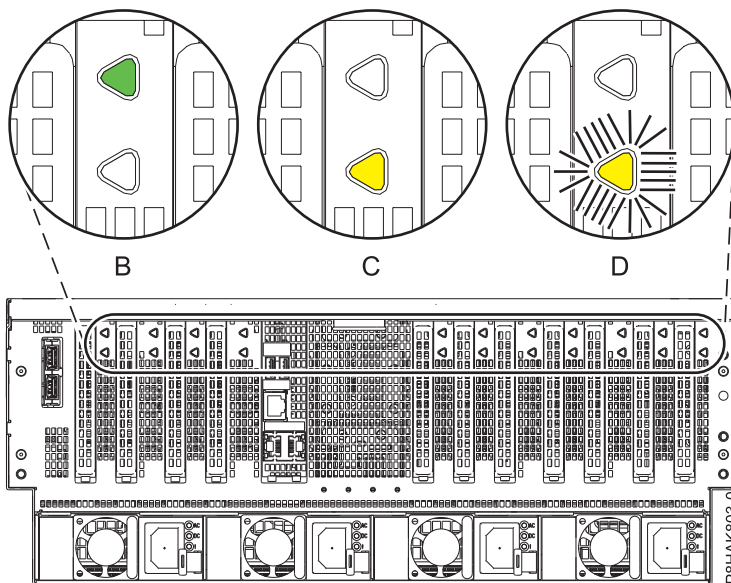

Figure 6. Location of the PCIe adapter LEDs in the 8408-44E or 8408-E8E system

Installing a PCIe adapter in the 8408-44E or 8408-E8E system with the power turned on in AIX

To install the Peripheral Component Interconnect (PCI) Express (PCIe) adapters in an AIX system or an AIX logical partition with the system power turned on, complete the steps in this procedure.

Procedure

1. Ensure that you have the electrostatic discharge (ESD) wrist strap attached. If not, attach it now.
2. Ensure that the target slot is empty.
3. If the target slot contains a filler, remove the filler.

Note: The left and right I/O retention brackets must be opened before you can access the rear slots. You only need to open the I/O retention bracket for the side you are accessing.

- a. Unscrew the captive thumbscrew of the I/O retention bracket until fully loose. See **(A)** in Figure 7.
- b. Open the I/O retention bracket by rotating it up and away from the system. See **(B)** in Figure 7.
- c. To remove the filler, carefully grasp the filler **(C)** by its top edge or tailstock, and remove it from the system. See Figure 7.
 - You can store the filler in a safe place to use it later to install in an empty slot.
 - You can use the filler tailstock to attach it to a new adapter.

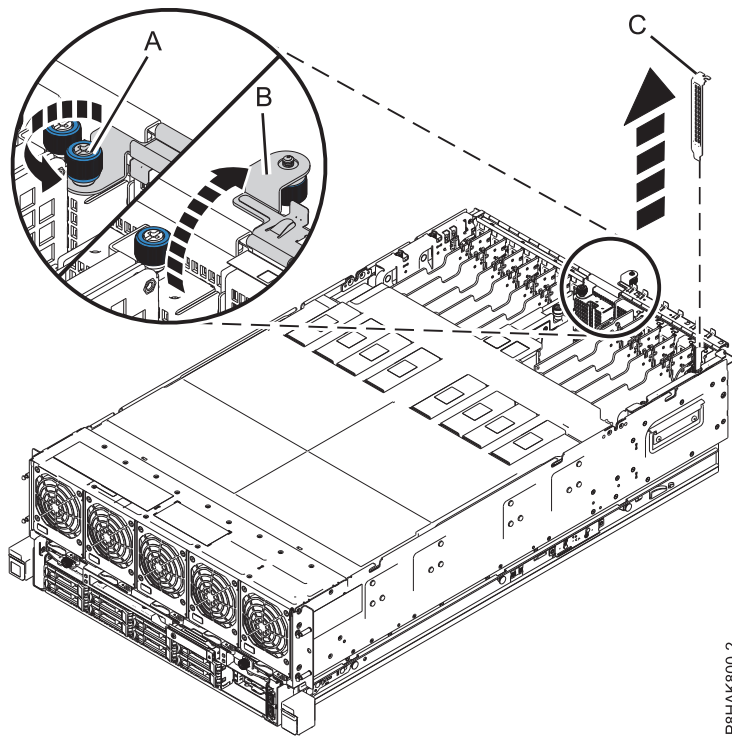

Figure 7. Removing a filler from a PCIe adapter slot in the 8408-44E or 8408-E8E system

4. If necessary, remove the adapter from the antistatic package.

Attention: Avoid touching the components and gold connectors on the adapter.

5. Place the adapter, component-side up, on a flat, antistatic surface.

Note: Some PCIe adapters are shipped from the manufacturer with a blue handle or support bracket along the back edge of the adapter. To use adapters of this type, you must remove the blue handle or the support bracket from the adapter.

Attention: A pin on the tailstock of the adapter resembles a removable screw. Do not remove this pin. It is required for correct alignment and seating.

6. Carefully grasp the adapter by its top edge or tailstock, and align the adapter with the slot and its connector on the system backplane (A), as shown in Figure 8.

Attention: Before you insert the adapter in the PCIe slot, ensure that the adapter has no cables, protective shields, or transceivers that are attached to it. If the adapter has cables, protective shields, or transceivers that are attached, remove them. For instructions to remove protective shields or transceivers, see "Removing and replacing the tailstock on a PCIe adapter" on page 44. The cables, protective shields, or transceivers must be attached to the adapter after the adapter is inserted in the PCIe slot.

7. Carefully grasp the adapter by its top edge or tailstock, and align the adapter with the slot and its connector on the system backplane (A), as shown in Figure 8.
8. On the system, press the adapter firmly into its connector.
9. Ensure that the tailstock notch engages with the pin on the system's chassis. See (B) in Figure 8.
10. Close the I/O retention bracket (C) by rotating it down and then tighten the captive thumbscrew (D) until it is secured to the system's chassis. See Figure 8.

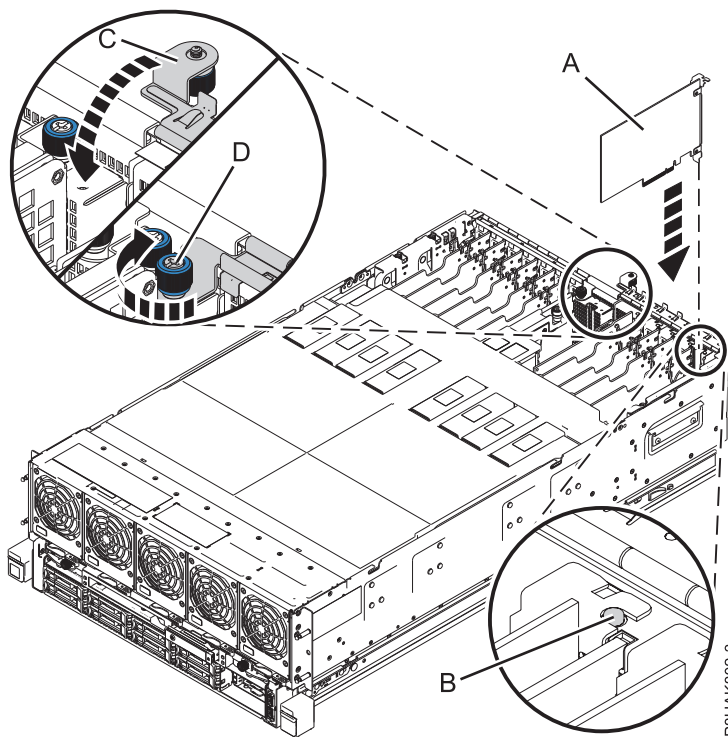

Figure 8. Installing or replacing a PCIe adapter in the 8408-44E or 8408-E8E system

Preparing the system for operation with the power turned on in AIX

To prepare the system for operation after you install the Peripheral Component Interconnect (PCI) Express (PCIe) adapters in the system, complete the steps in this procedure.

Procedure

1. Ensure that you have the electrostatic discharge (ESD) wrist strap attached. If not, attach it now.

2. Install the service access cover. For instructions, see “Installing the service access cover on an 8408-44E or 8408-E8E system” on page 76.
3. Place the system into the operating position. For instructions, see “Placing an 8408-44E or 8408-E8E system into the operating position” on page 82.

(L012)



or



CAUTION: Pinch hazard. (L012)

4. If applicable, close the rack front door.
5. If removed, connect the cables or transceivers to the adapter.
6. If you installed a PCIe3 cable adapter, and want to connect an EMX0 PCIe3 expansion drawer to your system, proceed to Connecting an EMX0 PCIe Gen3 I/O expansion drawer to your system.

Note: Connecting expansion drawer cables is a nonconcurrent procedure, which requires the system to be powered off.

7. Route the cables through the cable-management arm.
8. Close the rack door at the rear of the system.
9. Verify the installed part.
 - If you replaced the part because of a service action, verify the installed part. For instructions, see Verifying a repair.
 - If you installed the part for any other reason, verify the installed part. For instructions, see “Verifying the installed part” on page 91.
10. On the console, enter `cfgmgr` to configure the adapter.

You can install the device drivers for the installed adapter. For instructions, see “Installing the AIX device driver software” on page 50.

Installing a PCIe adapter in the 8408-44E or 8408-E8E system with the power turned on in Linux

To install the Peripheral Component Interconnect (PCI) Express (PCIe) adapters in a Linux system or a Linux logical partition with the system power turned on, complete the steps in this procedure.

Before you install a feature, ensure that the software that is required to support the feature is installed on your system. For information about software prerequisites, see the IBM Prerequisite website (http://www-912.ibm.com/e_dir/eServerPrereq.nsf). If the required software is not installed, see the following websites to download it, and then install it before you continue:

- To download system firmware updates, software updates, and fix packs, see the Fix Central website (<http://www.ibm.com/support/fixcentral/>).
- To download Hardware Management Console (HMC) updates and fixes, see the Hardware Management Console Support and downloads website (www14.software.ibm.com/webapp/set2/sas/f/hmcl/home.html).

If your system is managed by the Hardware Management Console (HMC), use the HMC to complete the steps for installing a PCIe adapter in the system. For instructions, see “Installing a part by using the HMC” on page 89.

If your system is not managed by an HMC, complete the following steps to install a PCIe adapter in the system:

1. “Preparing the 8408-44E or 8408-E8E system to install a PCIe adapter with the power turned on in Linux.”
2. “Installing a PCIe adapter in the 8408-44E or 8408-E8E system with the power turned on in Linux” on page 16.
3. “Preparing the 8408-44E or 8408-E8E system for operation after installing a PCIe adapter in Linux” on page 18.

Preparing the 8408-44E or 8408-E8E system to install a PCIe adapter with the power turned on in Linux

To prepare the system to install the Peripheral Component Interconnect (PCI) Express (PCIe) adapters in the system, complete the steps in this procedure.

Procedure

1. Ensure that the software that is required to support the feature is installed on your system. For information about software prerequisites, see the IBM Prerequisite website (http://www-912.ibm.com/e_dir/eServerPrereq.nsf). If the required system firmware, software, or fix packs are not installed on your system, go to the Fix Central website (<http://www.ibm.com/support/fixcentral/>) to download and install them before you continue.
2. Before you hot-plug an adapter, ensure that the server or partition is at the correct level of the Linux operating system.
3. Attach the electrostatic discharge (ESD) wrist strap.

Attention:

- Attach an electrostatic discharge (ESD) wrist strap to the front ESD jack, to the rear ESD jack, or to an unpainted metal surface of your hardware to prevent the electrostatic discharge from damaging your hardware.
 - When you use an ESD wrist strap, follow all electrical safety procedures. An ESD wrist strap is used for static control. It does not increase or decrease your risk of receiving electric shock when using or working on electrical equipment.
 - If you do not have an ESD wrist strap, just prior to removing the product from ESD packaging and installing or replacing hardware, touch an unpainted metal surface of the system for a minimum of 5 seconds.
4. Verify that the Linux, hot-plug PCI tools are installed. For instructions, see “Verifying that the hot-plug PCI tools are installed for Linux” on page 54.
 5. Determine the slot in which you want to install a PCIe adapter. The PCIe adapter slots are at the rear of a system.

Note: The number of the PCIe adapter slots that are available in the system depends on the number of system processors in the system. For the PCIe adapter placement information regarding the available slots in this system, see PCIe adapter placement rules and slot priorities for the 8408-44E or 8408-E8E system.

Figure 9 on page 15 shows the PCIe adapter location codes and the service indicator locations.

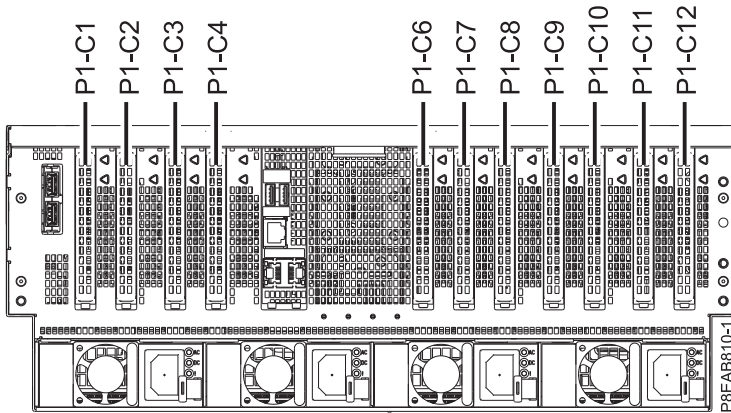

Figure 9. PCIe adapter slot locations in the 8408-44E or 8408-E8E system

6. To identify the hot-plug PCIe slots in the Linux system or a Linux virtual machine (VM), complete the following steps
 - a. Log in to the system console as the root user.
 - b. Run the following command by using the **lsslot** command:

```
lsslot -c pci -a
```

The following screen is an example of the information displayed by this command:

```
# Slot      Description      Device(s)
U7879.001.DQD014E-P1-C1 PCI-X capable, 64 bit, 133MHz slot Empty
U7879.001.DQD014E-P1-C4 PCI-X capable, 64 bit, 133MHz slot Empty
U7879.001.DQD014E-P1-C5 PCI-X capable, 64 bit, 133MHz slot Empty
```

- c. Select the appropriate empty PCIe slot from the slots listed by the command.
7. If applicable, open the rack front door.
8. Place the system into the service position. For instructions, see “Placing an 8408-44E or 8408-E8E system into the service position” on page 81.

CAUTION:

Do not place any object on top of a rack-mounted device unless that rack-mounted device is intended for use as a shelf. (R008)

(L012)



or



CAUTION: Pinch hazard. (L012)

9. Remove the service access cover. For instructions, see “Removing the service access cover from an 8408-44E or 8408-E8E system” on page 75.
10. Look for the slot in which the PCIe adapter is to be placed that you have identified.
There are two LEDs associated with each PCIe adapter. The following LED states indicate the status of the PCIe adapter.

- **(B)** Indicates full power to the PCIe adapter. The green power LED (upper LED) is lit solid.

- (C) Indicates a failed PCIe adapter. The amber fault LED (lower LED) is lit solid.
- (D) Identifies an unoccupied slot that was selected by using the identify function. The amber fault LED (lower LED) is flashing.

Note: Do not attempt to remove a PCIe adapter with the green power LED (upper LED) is lit.

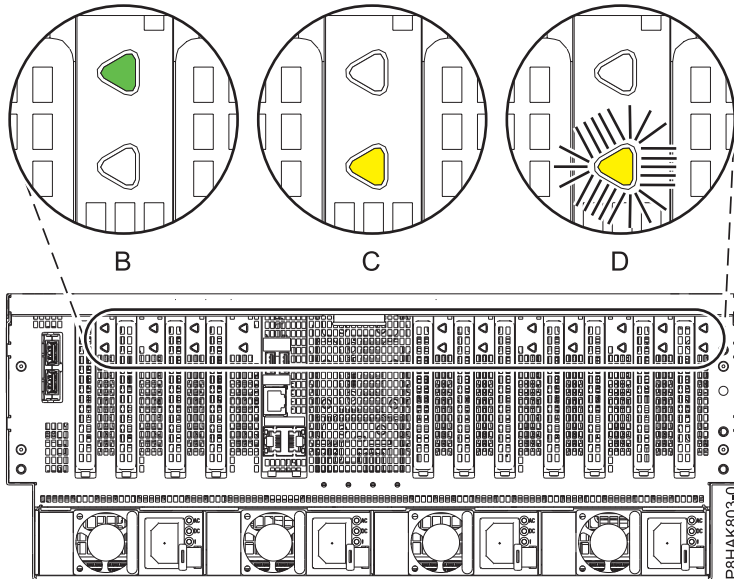

Figure 10. Location of the PCIe adapter LEDs in the 8408-44E or 8408-E8E system

Installing a PCIe adapter in the 8408-44E or 8408-E8E system with the power turned on in Linux

To install the Peripheral Component Interconnect (PCI) Express (PCIe) adapters in a Linux system or a Linux logical partition with the system power turned on, complete the steps in this procedure.

Procedure

1. Ensure that you have the electrostatic discharge (ESD) wrist strap attached. If not, attach it now.
2. Ensure that the target slot is empty.
3. If the target slot contains a filler, remove the filler.

Note: The left and right I/O retention brackets must be opened before you can access the rear slots. You only need to open the I/O retention bracket for the side you are accessing.

- a. Unscrew the captive thumbscrew of the I/O retention bracket until fully loose. See (A) in Figure 11 on page 17.
- b. Open the I/O retention bracket by rotating it up and away from the system. See (B) in Figure 11 on page 17.
- c. To remove the filler, carefully grasp the filler (C) by its top edge or tailstock, and remove it from the system. See Figure 11 on page 17.
 - You can store the filler in a safe place to use it later to install in an empty slot.
 - You can use the filler tailstock to attach it to a new adapter.

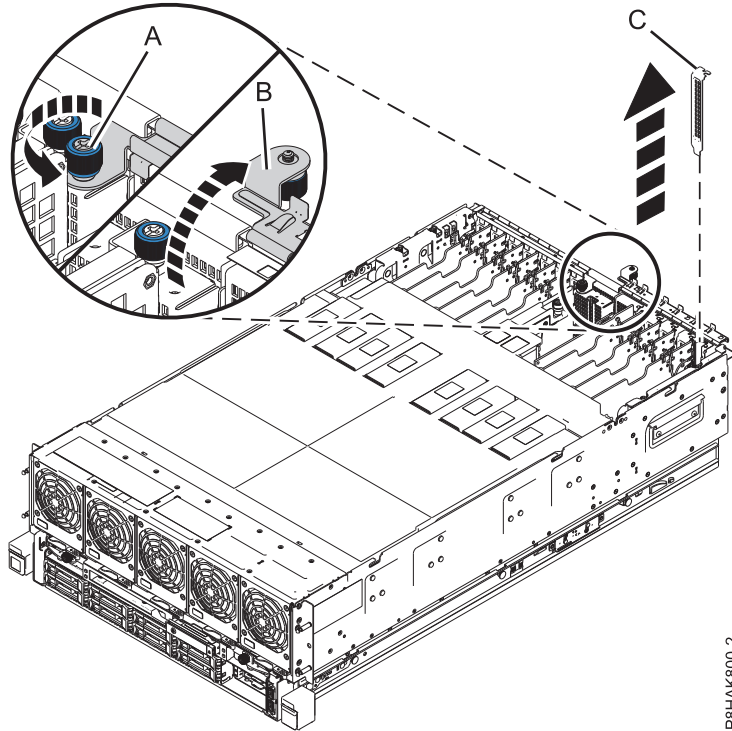

Figure 11. Removing a filler from a PCIe adapter slot in the 8408-44E or 8408-E8E system

4. If necessary, remove the adapter from the antistatic package.

Attention: Avoid touching the components and gold connectors on the adapter.

5. Place the adapter, component-side up, on a flat, antistatic surface.

Note: Some PCIe adapters are shipped from the manufacturer with a blue handle or support bracket along the back edge of the adapter. To use adapters of this type, you must remove the blue handle or the support bracket from the adapter.

Attention: A pin on the tailstock of the adapter resembles a removable screw. Do not remove this pin. It is required for correct alignment and seating.

6. Carefully grasp the adapter by its top edge or tailstock, and align the adapter with the slot and its connector on the system backplane (A), as shown in Figure 12 on page 18.
7. To select the PCIe slot, return to the Linux session on the console and complete the following steps:

- a. Run the **drmgr** command to enable an adapter to be installed.

For example, to install an adapter in slot U7879.001.DQD014E-P1-C3, run: `drmgr -c pci -r -s locationcode`. The following screen is displayed:

The visual indicator for the specified PCI slot has been set to the identify state. Press Enter to continue or enter x to exit.

- b. Press **Enter**. The following screen is displayed:

The visual indicator for the specified PCI slot has been set to the action state. Insert the PCI card into the identified slot, connect any devices to be configured and press Enter to continue. Enter x to exit.

8. On the system, press the adapter firmly into its connector.
9. Ensure that the tailstock notch engages with the pin on the system's chassis. See (B) in Figure 12 on page 18.

10. Close the I/O retention bracket (C) by rotating it down and then tighten the captive thumbscrew (D) until it is secured to the system's chassis. See Figure 12.

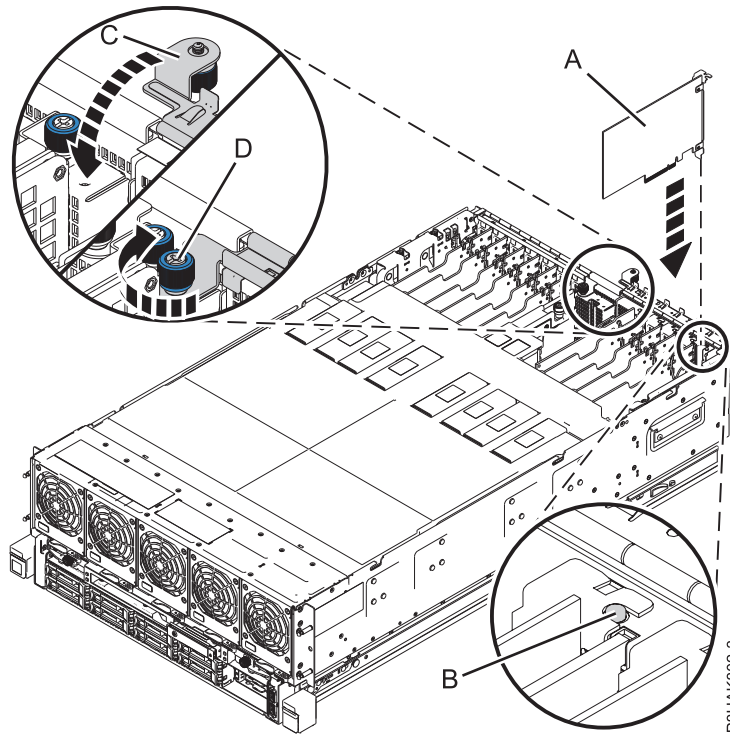

Figure 12. Installing or replacing a PCIe adapter in the 8408-44E or 8408-E8E system

Preparing the 8408-44E or 8408-E8E system for operation after installing a PCIe adapter in Linux

To prepare the system for operation after you install the Peripheral Component Interconnect (PCI) Express (PCIe) adapters in the system, complete the steps in this procedure.

Procedure

1. Ensure that you have the electrostatic discharge (ESD) wrist strap attached. If not, attach it now.
2. Install the service access cover. For instructions, see “Installing the service access cover on an 8408-44E or 8408-E8E system” on page 76.
3. Place the system into the operating position. For instructions, see “Placing an 8408-44E or 8408-E8E system into the operating position” on page 82.

(L012)



or



CAUTION: Pinch hazard. (L012)

4. If applicable, close the rack front door.

5. If removed, connect the cables or transceivers to the adapter.
6. If you installed a PCIe3 cable adapter, and want to connect an EMX0 PCIe3 expansion drawer to your system, proceed to Connecting an EMX0 PCIe Gen3 I/O expansion drawer to your system.

Note: Connecting expansion drawer cables is a nonconcurrent procedure, which requires the system to be powered off.

7. Route the cables through the cable-management arm.
8. Close the rack door at the rear of the system.
9. In the Linux session on the console, press Enter after you have installed the adapter.
10. On the console, use the `lsslot` command to verify that you have installed the PCI adapter in the correct slot.

To verify the installation, complete the following steps:

- a. Enter `lsslot -c pci -a`. The information about the slots is displayed.
- b. Enter the slot information with the `lsslot` command, as shown in the following example.
For example, if the slot in which you installed the PCIe adapter was U7879.001.DQD014E-P1-C3
Enter `lsslot -c pci -s U7879.001.DQD014E-P1-C3`

The following screen is an example of the information that is displayed by this command:

```
# Slot      Description      Device(s)
U7879.001.DQD014E-P1-C3 PCI-X capable, 64 bit, 133MHz slot 0001:40:01.0
```

Removing and replacing PCIe adapters in the 8408-44E or 8408-E8E system

Find information about removing and replacing the Peripheral Component Interconnect (PCI) Express (PCIe) adapters to replace a failing part or as part of another service procedure.

Removing and replacing PCIe adapters in the 8408-44E or 8408-E8E system with the power turned off

Learn how to remove and replace the Peripheral Component Interconnect (PCI) Express (PCIe) adapters in the system with the system power turned off.

If your system is managed by the Hardware Management Console (HMC), use the HMC to repair a part in the system. For instructions, see “Repairing a part by using the HMC” on page 90.

If your system is not managed by an HMC, complete the following steps to remove and replace a PCIe adapter in the system:

1. “Preparing the 8408-44E or 8408-E8E system to remove and replace a PCIe adapter with the power turned off.”
2. “Removing a PCIe adapter from the 8408-44E or 8408-E8E system with the system power turned off” on page 23.
3. “Replacing a PCIe adapter in the 8408-44E or 8408-E8E system with the system power turned off” on page 25.
4. “Preparing the 8408-44E or 8408-E8E system for operation after removing and replacing a PCIe adapter with the power turned off” on page 27.

Preparing the 8408-44E or 8408-E8E system to remove and replace a PCIe adapter with the power turned off

To prepare the system to remove and replace the Peripheral Component Interconnect (PCI) Express (PCIe) adapters in the system, complete the steps in this procedure.

Procedure

1. Familiarize yourself with the locations of the PCIe adapter slots. The PCIe adapters are installed in the rear of the system. Figure 13 shows the locations of the PCIe adapters in an 8408-44E or 8408-E8E system.

Note: The number of the PCIe adapter slots that are available in the system depends on the number of system processors in the system. For the PCIe adapter placement information regarding the available slots in this system, see PCIe adapter placement rules and slot priorities for the 8408-44E or 8408-E8E system.

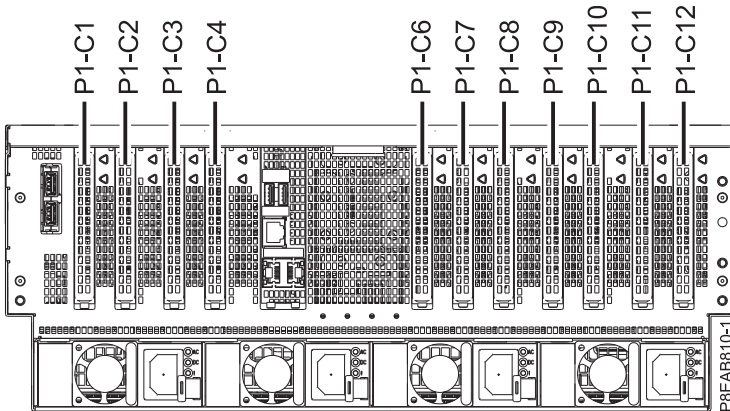

Figure 13. PCIe adapter slot locations in the 8408-44E or 8408-E8E system

2. Use the service indicator light-emitting diodes (LEDs) to help identify the part. For instructions, see “Identifying a part” on page 60.
3. Stop the system or logical partition. For instructions, see “Stopping a system or logical partition” on page 71.
4. Open the rack door at the rear of the system.
5. Attach the electrostatic discharge (ESD) wrist strap.

Attention:

- Attach an electrostatic discharge (ESD) wrist strap to the front ESD jack, to the rear ESD jack, or to an unpainted metal surface of your hardware to prevent the electrostatic discharge from damaging your hardware.
 - When you use an ESD wrist strap, follow all electrical safety procedures. An ESD wrist strap is used for static control. It does not increase or decrease your risk of receiving electric shock when using or working on electrical equipment.
 - If you do not have an ESD wrist strap, just prior to removing the product from ESD packaging and installing or replacing hardware, touch an unpainted metal surface of the system for a minimum of 5 seconds.
6. If you are removing the PCIe adapter as part of another service procedure, record the details about the PCIe adapter and its location code, and then go to the next step.

If you are servicing a failed PCIe adapter, look for the flashing amber LED for the failed PCIe adapter that you set to flash in the step to identify the failed part. Figure 14 on page 21 shows the state of the LEDs.

There are two LEDs associated with each PCIe adapter. The following LED states indicate the status of the PCIe adapter.

- **(B)** Indicates full power to the PCIe adapter. The green power LED (upper LED) is lit solid.
- **(C)** Indicates a failed PCIe adapter. The amber fault LED (lower LED) is lit solid.
- **(D)** Indicates a failed PCIe adapter that was selected by using the identify function. The amber fault LED (lower LED) is flashing.

Note: Do not attempt to remove a PCIe adapter with the green power LED (upper LED) is lit.

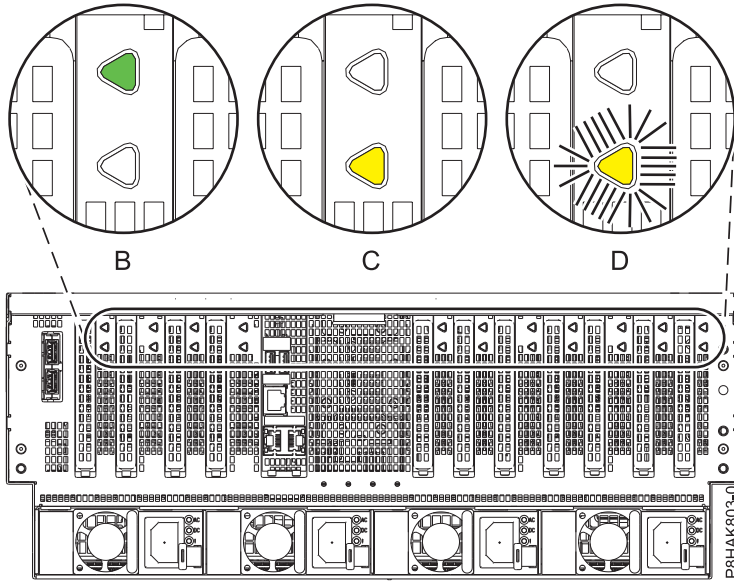

Figure 14. Location of the PCIe adapter LEDs in the 8408-44E or 8408-E8E system

7. Label and disconnect all cables and transceivers that are attached to the adapter you plan to remove. For instructions to remove transceivers, see “Removing and replacing the tailstock on a PCIe adapter” on page 44.
8. If you have not yet recorded the PCIe slot details, record the slot number and location of each adapter being removed.

Note: Adapter slots are numbered on the rear of the system.

9. Disconnect the power source from the system by unplugging the system. For instructions, see “Disconnecting the power cords from the system” on page 83.

Note: The system might be equipped with redundant power supply. Before you continue with this procedure, ensure that all power to your system is disconnected.

(L003)

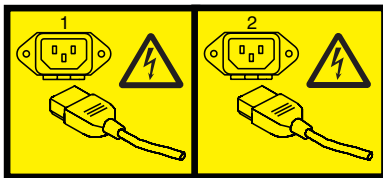

or

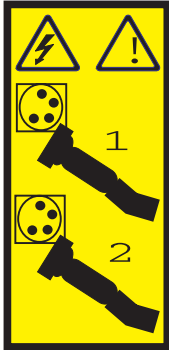

or



or

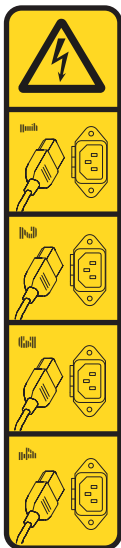

or

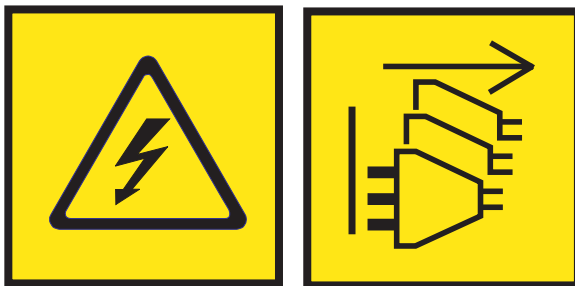

DANGER: Multiple power cords. The product might be equipped with multiple AC power cords or multiple DC power cables. To remove all hazardous voltages, disconnect all power cords and power cables. (L003)

10. If applicable, open the rack front door.

22 Power Systems: PCIe adapters for the 8408-44E or 8408-E8E

11. Place the system into the service position. For instructions, see “Placing an 8408-44E or 8408-E8E system into the service position” on page 81.

CAUTION:

Do not place any object on top of a rack-mounted device unless that rack-mounted device is intended for use as a shelf. (R008)

(L012)



or



CAUTION: Pinch hazard. (L012)

12. Remove the service access cover. For instructions, see “Removing the service access cover from an 8408-44E or 8408-E8E system” on page 75.

Removing a PCIe adapter from the 8408-44E or 8408-E8E system with the system power turned off

To remove a PCIe adapter from the system, complete the steps in this procedure.

Procedure

1. Ensure that you have the electrostatic discharge (ESD) wrist strap attached. If not, attach it now.
2. Remove the PCIe adapter.

Attention:

- Left and right I/O retention brackets must be opened before you can access the rear slots.
 - You only need to open the I/O retention bracket for the side you are accessing.
 - A pin on the tailstock of the adapter resembles a removable screw. Do not remove this pin. It is required for correct alignment and seating.
- a. Unscrew the I/O retention bracket captive thumbscrew until fully loose. See **(A)** in Figure 15 on page 24.
 - b. Open the I/O retention bracket by rotating it up and away from the system. See **(B)** in Figure 15 on page 24.
 - c. Carefully grasp the adapter **(C)** by its top edge or tailstock, and remove adapter from the slot, as shown in Figure 15 on page 24.

Note: If you are removing a low-profile (short) PCIe adapter, disengage the adapter by pushing in the tailstock while you are lifting the adapter out of the slot.

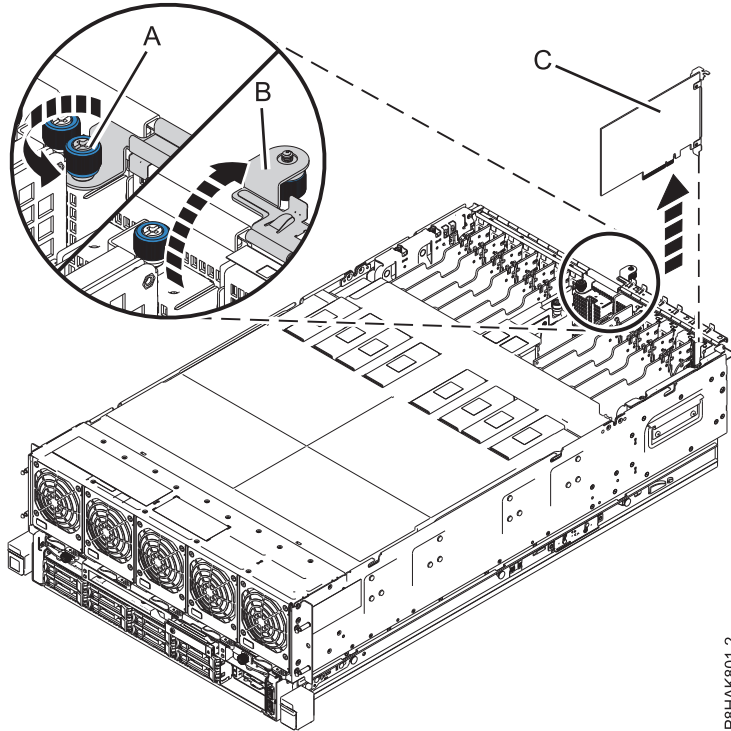

P8HAK801-2

Figure 15. Removing a PCIe adapter from the 8408-44E or 8408-E8E system

3. Place the removed adapter on an approved ESD surface.
4. Choose your next action from the following options:
 - If you are removing a PCIe adapter as part of another procedure, return to that procedure.
 - If you are replacing the failed adapter with a new adapter, go to the procedure for replacing a PCIe adapter.
 - If you are not replacing the PCIe adapter with a new one, you must install a PCIe tailstock filler in the empty slot. To install a PCIe tailstock filler, complete the following steps:
 - a. Carefully grasp the filler tailstock and align the filler with the slot and its connector on the system backplane, see **(A)** in Figure 16 on page 25.
 - b. Press the filler tailstock firmly into the slot.
 - c. Close the I/O retention bracket by rotating it down towards the system **(B)**. See Figure 16 on page 25.
 - d. Screw the I/O retention bracket captive thumbscrew clockwise **(C)**, as shown in Figure 16 on page 25.

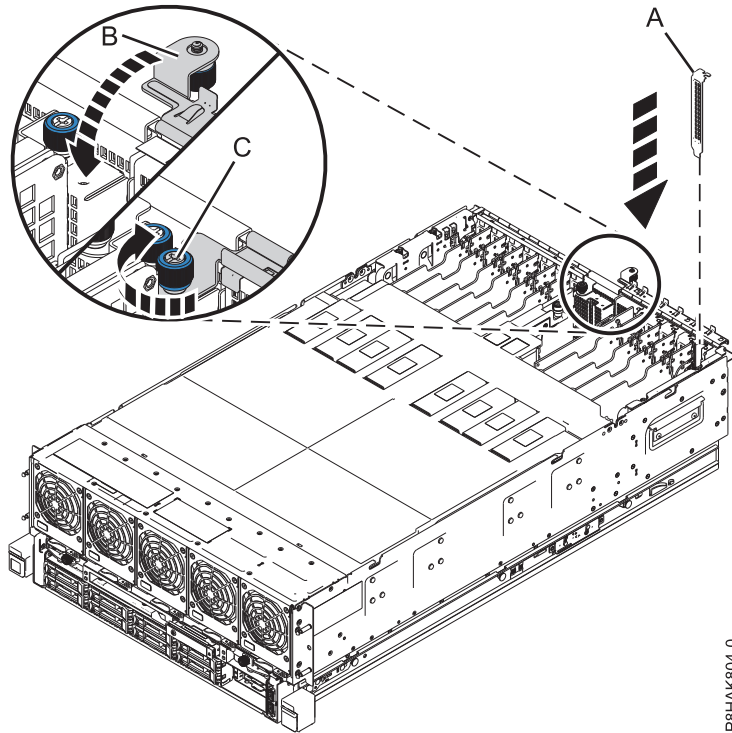

Figure 16. Installing a filler in a PCIe adapter slot in a 8408-44E or 8408-E8E system

Replacing a PCIe adapter in the 8408-44E or 8408-E8E system with the system power turned off

To replace a PCIe adapter in the system, complete the steps in this procedure.

1. Ensure that you have the electrostatic discharge (ESD) wrist strap attached. If not, attach it now.
2. Unscrew the I/O retention bracket.
 - a. Unscrew the I/O retention bracket captive thumbscrew until fully loose. See (A) in Figure 17 on page 26.
 - b. Open the I/O retention bracket by rotating it up and away from the system. See (B) in Figure 17 on page 26.

Attention:

- Left and right I/O retention brackets must be opened before you can access the rear slots.
 - You only need to open the I/O retention bracket for the side you are accessing.
 - A pin on the tailstock of the adapter resembles a removable screw. Do not remove this pin. It is required for correct alignment and seating.
3. Choose from the following options:
 - If you are repairing or exchanging a PCIe adapter in the 8408-44E or 8408-E8E, continue with step 4.
 - If you are adding an additional PCIe adapter in the 8408-44E or 8408-E8E, continue with step 5 on page 26.
 4. Remove the PCIe adapter.
 - a. Carefully grasp the adapter (C) by its top edge or tailstock, and remove adapter from the slot, as shown in Figure 17 on page 26.

Note: If you are removing a low-profile (short) PCIe adapter, disengage the adapter by pushing in the tailstock while you are lifting the adapter out of the slot.

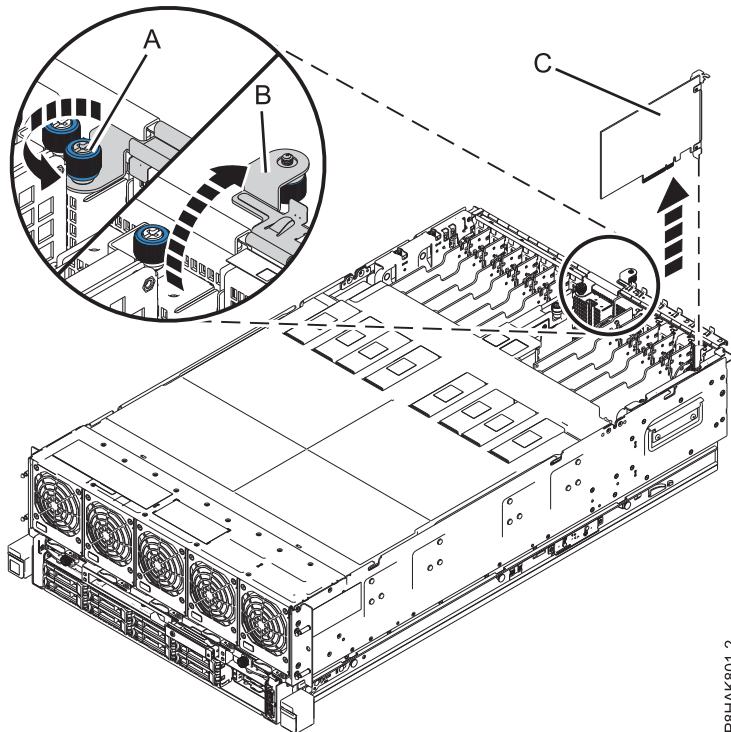

Figure 17. Removing a PCIe adapter from the 8408-44E or 8408-E8E system

5. If necessary, remove the adapter from the antistatic package.

Attention: Avoid touching the components and gold connectors on the adapter.

6. Place the adapter, component-side up, on a flat, antistatic surface.

Note: Some PCIe adapters are shipped from the manufacturer with a blue handle or support bracket along the back edge of the adapter. To use adapters of this type, you must remove the blue handle or the support bracket from the adapter.

Attention: A pin on the tailstock of the adapter resembles a removable screw. Do not remove this pin. It is required for correct alignment and seating.

7. Carefully grasp the adapter by its top edge or tailstock, and align the adapter with the slot and its connector on the system backplane (A), as shown in Figure 18 on page 27.

Attention: Before you insert the adapter in the PCIe slot, ensure that the adapter has no cables, protective shields, or transceivers that are attached to it. If the adapter has cables, protective shields, or transceivers that are attached, remove them. For instructions to remove protective shields or transceivers, see “Removing and replacing the tailstock on a PCIe adapter” on page 44. The cables, protective shields, or transceivers must be attached to the adapter after the adapter is inserted in the PCIe slot.

8. On the system, press the adapter firmly into its connector.
9. Ensure that the tailstock notch engages with the pin on the system's chassis. See (B) in Figure 18 on page 27.
10. Close the I/O retention bracket (C) by rotating it down and then tighten the captive thumbscrew (D) until it is secured to the system's chassis. See Figure 18 on page 27.

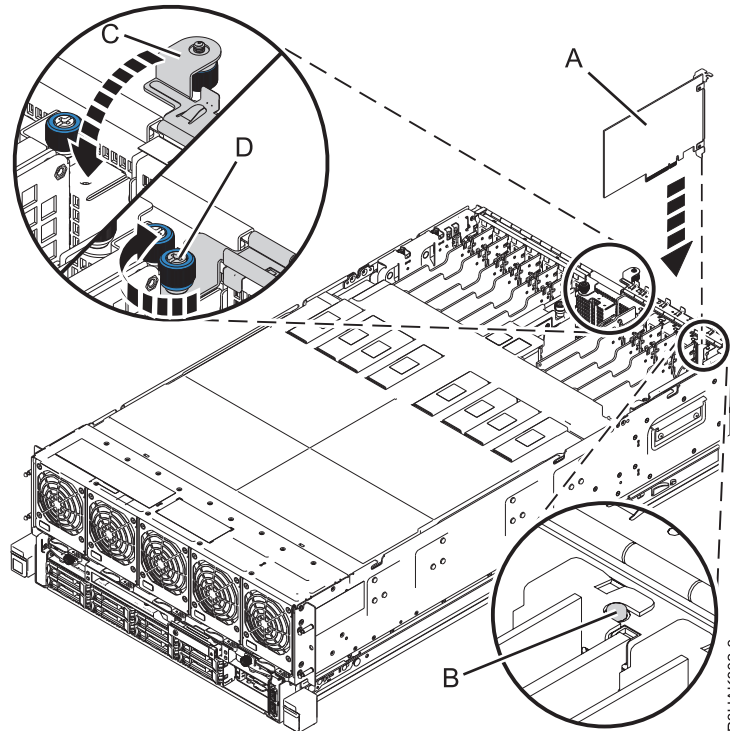

Figure 18. Installing or replacing a PCIe adapter in the 8408-44E or 8408-E8E system

Preparing the 8408-44E or 8408-E8E system for operation after removing and replacing a PCIe adapter with the power turned off

To prepare the system for operation after you replace the Peripheral Component Interconnect (PCI) Express (PCIe) adapters in the system, complete the steps in this procedure.

Procedure

1. Ensure that you have the electrostatic discharge (ESD) wrist strap attached. If not, attach it now.
2. Install the service access cover. For instructions, see “Installing the service access cover on an 8408-44E or 8408-E8E system” on page 76.
3. Place the system into the operating position. For instructions, see “Placing an 8408-44E or 8408-E8E system into the operating position” on page 82.

(L012)



or



CAUTION: Pinch hazard. (L012)

4. If applicable, close the rack front door.
5. If removed, connect the cables or transceivers to the adapter.

6. Route the cables through the cable-management arm.
7. Reconnect the power cords to the system. For instructions, see “Connecting the power cords to the system” on page 86.
8. Start the system or logical partition. For instructions, see “Starting the system or logical partition” on page 68.
9. Verify the installed part.
 - If you replaced the part because of a service action, verify the installed part. For instructions, see Verifying a repair.
 - If you installed the part for any other reason, verify the installed part. For instructions, see “Verifying the installed part” on page 91.

Removing and replacing a PCIe adapter in the 8408-44E or 8408-E8E system with the power turned on in AIX

Learn how to remove and replace the Peripheral Component Interconnect (PCI) Express (PCIe) adapters in an AIX system or an AIX logical partition with the system power turned on.

If your system is managed by the Hardware Management Console (HMC), use the HMC to repair a part in the system. For instructions, see “Repairing a part by using the HMC” on page 90.

If your system is not managed by an HMC, complete the following steps to remove and replace a PCIe adapter in the system:

1. “Preparing the 8408-44E or 8408-E8E system to remove and replace a PCIe adapter with the power turned on in AIX.”
2. “Removing a PCIe adapter from the 8408-44E or 8408-E8E system with the power turned on in AIX” on page 31.
3. “Replacing a PCIe adapter in the 8408-44E or 8408-E8E system with the power turned on in AIX” on page 33.
4. “Preparing the 8408-44E or 8408-E8E system for operation after removing and replacing a PCIe adapter with the power turned on in AIX” on page 34.

Preparing the 8408-44E or 8408-E8E system to remove and replace a PCIe adapter with the power turned on in AIX

To prepare the system to remove and replace the Peripheral Component Interconnect (PCI) Express (PCIe) adapters in the system, complete the steps in this procedure.

Procedure

1. Familiarize yourself with the locations of the PCIe adapter slots. The PCIe adapters are installed in the rear of the system. Figure 19 on page 29 shows the locations of the PCIe adapters in an 8408-44E or 8408-E8E system.

Note: The number of the PCIe adapter slots that are available in the system depends on the number of system processors in the system. For the PCIe adapter placement information regarding the available slots in this system, see PCIe adapter placement rules and slot priorities for the 8408-44E or 8408-E8E system.

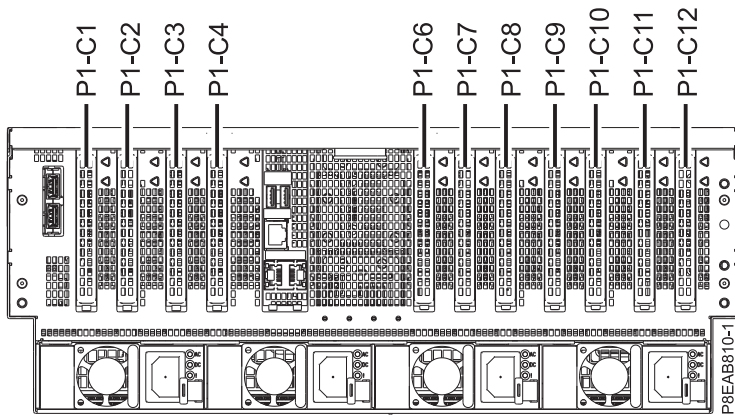

Figure 19. PCIe adapter slot locations in the 8408-44E or 8408-E8E system

2. You must take the PCIe adapter offline before removing and replacing a PCIe adapter with the system power turned on (hot-plugging). Before you take an adapter offline, the devices that are attached to the adapter must be taken offline as well. This action must be done by a system administrator. Taking the PCIe adapter offline prevents a service representative or user from causing an unexpected outage for other users of the system.
3. Before hot-plugging adapters for storage devices, ensure that the file systems on those devices are unmounted.
4. Ensure that any processes or applications that might use the adapter are stopped.
5. To identify the failed PCIe adapter, complete the following steps on the console:
 - a. Log in as root user.
 - b. At the command line, type `diag` and then press **Enter**.
 - c. From the **Function Selection** menu, select **Task Selection**, and then press **Enter**.
 - d. Select **Hot Plug Task**, and then press **Enter**.
 - e. Select **PCI Hot Plug Manager**, and then press **Enter**.
 - f. Select **Unconfigure a Device**, and then press **Enter**.
 - g. Press **F4** (or **Esc +4**) to display the **Device Names** menu.
 - h. Select the adapter you are removing in the **Device Names** menu.
 - i. Use the **Tab** key to answer **N0** to **Keep Definition**. Use the **Tab** key again to answer **YES** to **Unconfigure Child Devices**, and then press **Enter**. The **ARE YOU SURE** screen displays.
 - j. Press **Enter** to verify the information. Successful unconfiguration is indicated by the **OK** message displayed next to the **Command** field at the top of the screen.
 - k. Press **F3** (or **Esc +3**) twice to return to the **Hot Plug Manager** menu.
 - l. Select **replace/remove PCI Hot Plug adapter**.
 - m. Select the slot that has the adapter to be removed from the system.
 - n. Select **remove**. The amber LED for the PCI adapter flashes for the slot that has been identified.
 - o. Press **Enter**. This action places the adapter in the action state, meaning it is ready to be removed from the system.
6. Open the rack door at the rear of the system.
7. Attach the electrostatic discharge (ESD) wrist strap.

Attention:

- Attach an electrostatic discharge (ESD) wrist strap to the front ESD jack, to the rear ESD jack, or to an unpainted metal surface of your hardware to prevent the electrostatic discharge from damaging your hardware.
 - When you use an ESD wrist strap, follow all electrical safety procedures. An ESD wrist strap is used for static control. It does not increase or decrease your risk of receiving electric shock when using or working on electrical equipment.
 - If you do not have an ESD wrist strap, just prior to removing the product from ESD packaging and installing or replacing hardware, touch an unpainted metal surface of the system for a minimum of 5 seconds.
8. If you are removing the PCIe adapter as part of another service procedure, record the details about the PCIe adapter and its location code, and then go to the next step.

If you are servicing a failed PCIe adapter, look for the flashing amber LED for the failed PCIe adapter that you set to flash in the step to identify the failed part. Figure 20 shows the state of the LEDs.

There are two LEDs associated with each PCIe adapter. The following LED states indicate the status of the PCIe adapter.

- **(B)** Indicates full power to the PCIe adapter. The green power LED (upper LED) is lit solid.
- **(C)** Indicates a failed PCIe adapter. The amber fault LED (lower LED) is lit solid.
- **(D)** Indicates a failed PCIe adapter that was selected by using the identify function. The amber fault LED (lower LED) is flashing.

Note: Do not attempt to remove a PCIe adapter with the green power LED (upper LED) is lit.

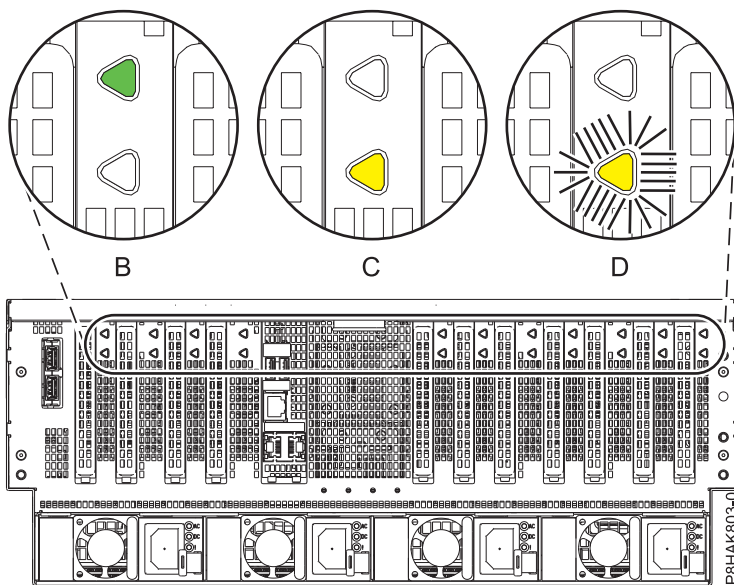

Figure 20. Location of the PCIe adapter LEDs in the 8408-44E or 8408-E8E system

9. Label and disconnect all cables and transceivers that are attached to the adapter you plan to remove. For instructions to remove transceivers, see “Removing and replacing the tailstock on a PCIe adapter” on page 44.
10. If you have not yet recorded the PCIe slot details, record the slot number and location of each adapter being removed.

Note: Adapter slots are numbered on the rear of the system.

11. If applicable, open the rack front door.

- Place the system into the service position. For instructions, see “Placing an 8408-44E or 8408-E8E system into the service position” on page 81.

CAUTION:

Do not place any object on top of a rack-mounted device unless that rack-mounted device is intended for use as a shelf. (R008)

(L012)



or



CAUTION: Pinch hazard. (L012)

- Remove the service access cover. For instructions, see “Removing the service access cover from an 8408-44E or 8408-E8E system” on page 75.

Removing a PCIe adapter from the 8408-44E or 8408-E8E system with the power turned on in AIX

To remove the Peripheral Component Interconnect (PCI) Express (PCIe) adapters from an AIX system or an AIX logical partition with the system power turned on, complete the steps in this procedure.

Procedure

- Ensure that you have the electrostatic discharge (ESD) wrist strap attached. If not, attach it now.
- Remove the PCIe adapter.

Attention:

- Left and right I/O retention brackets must be opened before you can access the rear slots.
 - You only need to open the I/O retention bracket for the side you are accessing.
 - A pin on the tailstock of the adapter resembles a removable screw. Do not remove this pin. It is required for correct alignment and seating.
- Unscrew the I/O retention bracket captive thumbscrew until fully loose. See **(A)** in Figure 21 on page 32.
 - Open the I/O retention bracket by rotating it up and away from the system. See **(B)** in Figure 21 on page 32.
 - Carefully grasp the adapter **(C)** by its top edge or tailstock, and remove adapter from the slot, as shown in Figure 21 on page 32.

Note: If you are removing a low-profile (short) PCIe adapter, disengage the adapter by pushing in the tailstock while you are lifting the adapter out of the slot.

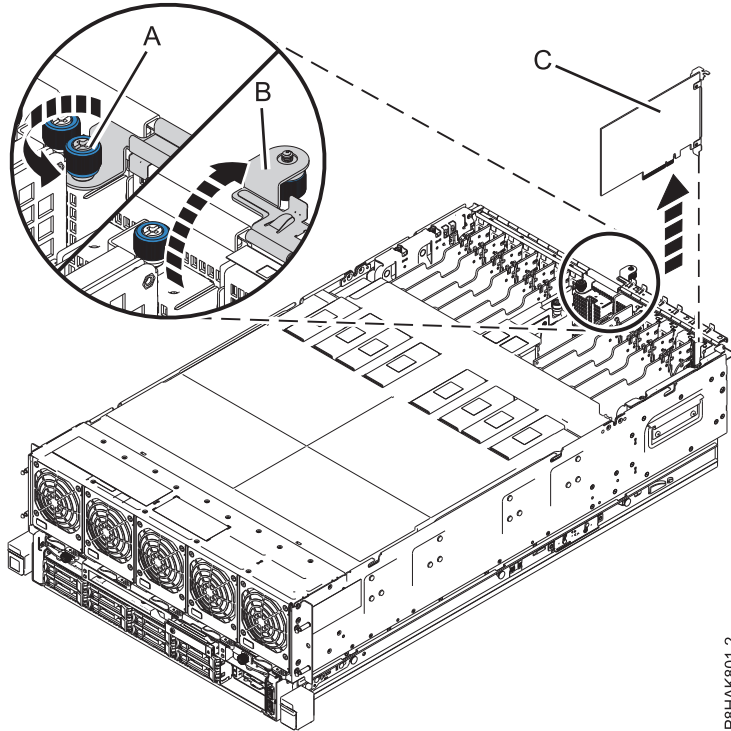

P8HAK801-2

Figure 21. Removing a PCIe adapter from the 8408-44E or 8408-E8E system

3. Place the removed adapter on an approved ESD surface.
 4. On the console, continue to follow the screen instructions until you receive a message that the adapter removal is successful. Successful removal is indicated by the OK message displayed next to the **Command** field at the top of the screen.
 5. If you have other adapters to remove, press the F3 key to return to the PCI Hot-Plug Manager menu and then follow the screen instructions until the adapter is placed in the action state. Then, complete the steps in this procedure to remove the adapter.
- or
- If you do not have other adapters to remove, continue with the next action.
6. Choose your next action from the following options:
 - If you are removing a PCIe adapter as part of another procedure, return to that procedure.
 - If you are replacing the failed adapter with a new adapter, go to the procedure for replacing a PCIe adapter.
 - If you are not replacing the PCIe adapter with a new one, you must install a PCIe tailstock filler in the empty slot. To install a PCIe tailstock filler, complete the following steps:
 - a. Carefully grasp the filler tailstock and align the filler with the slot and its connector on the system backplane, see (A) in Figure 22 on page 33.
 - b. Press the filler tailstock firmly into the slot.
 - c. Close the I/O retention bracket by rotating it down towards the system (B). See Figure 22 on page 33.
 - d. Screw the I/O retention bracket captive thumbscrew clockwise (C), as shown in Figure 22 on page 33.

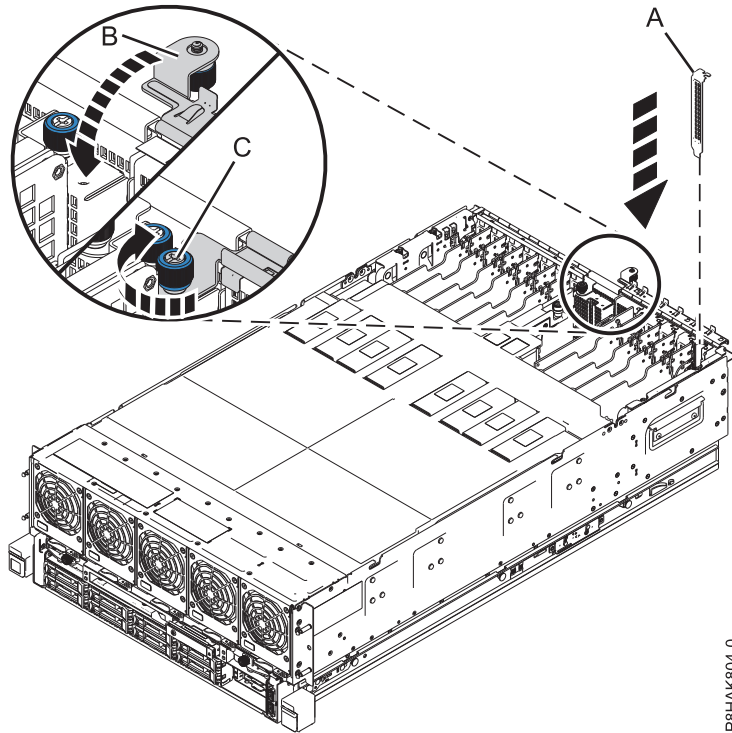

Figure 22. Installing a filler in a PCIe adapter slot in a 8408-44E or 8408-E8E system

Replacing a PCIe adapter in the 8408-44E or 8408-E8E system with the power turned on in AIX

To replace the Peripheral Component Interconnect (PCI) Express (PCIe) adapters in an AIX system or an AIX logical partition with the system power turned on, complete the steps in this procedure.

Procedure

1. Ensure that you have the electrostatic discharge (ESD) wrist strap attached. If not, attach it now.
2. Ensure that the target slot is empty.
3. If necessary, remove the adapter from the antistatic package.

Attention: Avoid touching the components and gold connectors on the adapter.

4. Place the adapter, component-side up, on a flat, antistatic surface.

Note: Some PCIe adapters are shipped from the manufacturer with a blue handle or support bracket along the back edge of the adapter. To use adapters of this type, you must remove the blue handle or the support bracket from the adapter.

Attention: A pin on the tailstock of the adapter resembles a removable screw. Do not remove this pin. It is required for correct alignment and seating.

5. Complete the following steps on the console:
 - a. Select **replace/remove PCI Hot Plug adapter** from the **Hot Plug Manager** menu.
 - b. Select the slot from where you removed the adapter.
 - c. Select **Replace**, and then press **Enter**. A fast-flashing amber LED at the rear of the system near the adapter indicates that the slot has been identified and is ready to receive the adapter.
6. Return to the system.

7. Carefully grasp the adapter by its top edge or tailstock, and align the adapter with the slot and its connector on the system backplane (A), as shown in Figure 23.
Attention: Before you insert the adapter in the PCIe slot, ensure that the adapter has no cables, protective shields, or transceivers that are attached to it. If the adapter has cables, protective shields, or transceivers that are attached, remove them. For instructions to remove protective shields or transceivers, see “Removing and replacing the tailstock on a PCIe adapter” on page 44. The cables, protective shields, or transceivers must be attached to the adapter after the adapter is inserted in the PCIe slot.
8. On the system, press the adapter firmly into its connector.
9. Ensure that the tailstock notch engages with the pin on the system's chassis. See (B) in Figure 23.
10. Close the I/O retention bracket (C) by rotating it down and then tighten the captive thumbscrew (D) until it is secured to the system's chassis. See Figure 23.

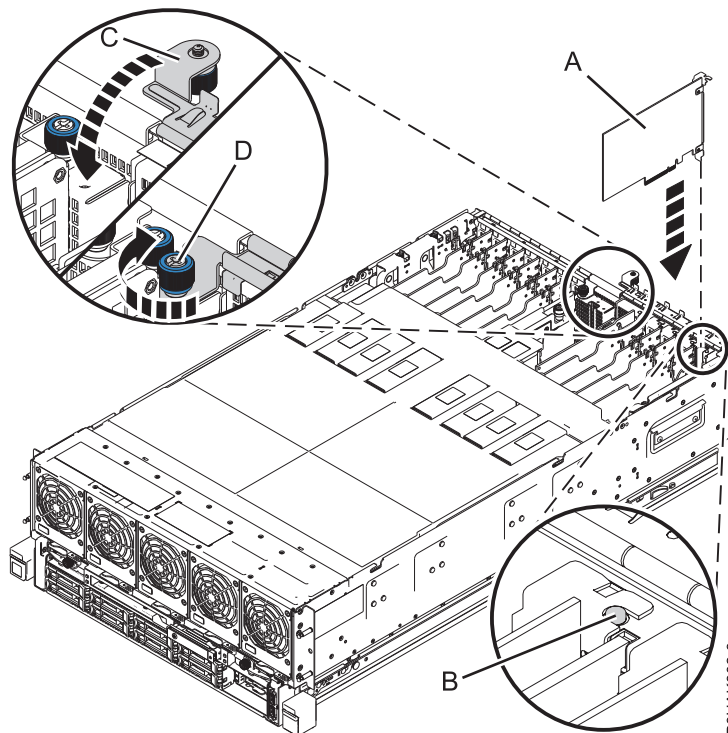

Figure 23. Installing or replacing a PCIe adapter in the 8408-44E or 8408-E8E system

11. On the console, continue to follow the screen instructions until you receive a message that the adapter replacement is successful. Successful replacement is indicated by the OK message displayed next to the **Command** field at the top of the screen.
12. If you have other adapters to replace, press the F3 key to return to the PCI Hot-Plug Manager menu and then follow the screen instructions until the adapter slot is placed in the action state. Then, complete the steps in this procedure to replace the adapter.
or
If you do not have other adapters to replace, continue with the next action.
13. If you replaced the PCIe adapter as part of another service procedure, return to that procedure.

Preparing the 8408-44E or 8408-E8E system for operation after removing and replacing a PCIe adapter with the power turned on in AIX

To prepare the system for operation after you replace the Peripheral Component Interconnect (PCI) Express (PCIe) adapters in the system, complete the steps in this procedure.

Procedure

1. Ensure that you have the electrostatic discharge (ESD) wrist strap attached. If not, attach it now.
2. Install the service access cover. For instructions, see “Installing the service access cover on an 8408-44E or 8408-E8E system” on page 76.
3. Place the system into the operating position. For instructions, see “Placing an 8408-44E or 8408-E8E system into the operating position” on page 82.

(L012)



or



CAUTION: Pinch hazard. (L012)

4. If applicable, close the rack front door.
5. If removed, connect the cables or transceivers to the adapter.
6. Route the cables through the cable-management arm.
7. Close the rack door at the rear of the system.
8. Complete the following steps on the console:
 - a. Press the **F3** (or **Esc+3**) key to return to the **PCI Hot-Plug Manager** menu.
 - b. Press the **F3** (or **Esc+3**) key to return to the **TASK** selection list.
 - c. Select **Log Repair Action**.
 - d. Select the resource just replaced, press **Enter**.
 - e. Press **Commit** (**F7** or **ESC 7**), and then press **Enter**.
 - f. Press **F3** (or **Esc+3**) to return to TASK Selection List.
 - g. Select **Hot Plug Task**, and then press **Enter**.
 - h. Select **PCI Hot Plug Manager > Configure a defined device**, and then press **Enter**.
 - i. Select the device just replaced from the list, and then press **Enter**. The device is now configured.
 - j. Press the **F10** key to exit the diagnostic program.
9. Verify the PCIe adapter replacement by using the following instructions:
 - a. Did you replace the adapter with the system power on?
 - **Yes** - Go to the next step.
 - **No** - Load the diagnostic program by doing the following actions:
 - If AIX is available, boot AIX, log in as root, and then enter the `diag` command.
 - b. Type the `diag` command if you are not already seeing the diagnostic menu.
 - c. Select **Advance Diagnostic Routines**, and then select **System Verification**.
 - d. Select the name of the resource just replaced from the menu. If the resource just replaced is not shown, choose the resource associated with it.
 - e. Press **Enter**, and then press **Commit** (**F7** or **Esc+7**).
 - f. Did the System Verification identify any problems?
 - **No**: Continue to the next step.
 - **Yes**: A problem is identified
 - If you are a customer, record the error information, and then contact your service provider.

- If you are an authorized service provider, return to map 210-5.
- g. Press the **F10** key to exit the diagnostic program.

You can install the device drivers for the installed adapter. For instructions, see “Installing the AIX device driver software” on page 50.

Removing and replacing a PCIe adapter in the 8408-44E or 8408-E8E system with the power turned on in Linux

Learn how to remove and replace the Peripheral Component Interconnect (PCI) Express (PCIe) adapters in a Linux system or a Linux logical partition with the system power turned on.

If your system is managed by the Hardware Management Console (HMC), use the HMC to repair a part in the system. For instructions, see “Repairing a part by using the HMC” on page 90.

If your system is not managed by an HMC, complete the following steps to remove and replace a PCIe adapter in the system:

1. “Preparing the 8408-44E or 8408-E8E system to remove and replace a PCIe adapter with the power turned on in Linux.”
2. “Removing a PCIe adapter from the 8408-44E or 8408-E8E system with the power turned on in Linux” on page 39.
3. “Replacing a PCIe adapter in the 8408-44E or 8408-E8E system with the power turned on in Linux” on page 40.
4. “Preparing the 8408-44E or 8408-E8E system for operation after removing and replacing a PCIe adapter with the power turned on in Linux” on page 41.

Preparing the 8408-44E or 8408-E8E system to remove and replace a PCIe adapter with the power turned on in Linux

To prepare the system to remove and replace the Peripheral Component Interconnect (PCI) Express (PCIe) adapters in the system, complete the steps in this procedure.

Procedure

1. Before you hot-plug an adapter, ensure that the server or partition is at the correct level of the Linux operating system.
2. Verify that the Linux, hot-plug PCI tools are installed. For instructions, see “Verifying that the hot-plug PCI tools are installed for Linux” on page 54.
3. Ensure that you have the POWER® Linux Service Aids installed on your system. These service aids enable system serviceability, as well to improve system management. If you are using a Linux on POWER distribution with Linux kernel version 2.6 or later, you can install the Service Aids that gives you access to more capabilities, which can help you diagnose problems on your system. This software is available at the Service and productivity tools for Linux on POWER website (<http://www14.software.ibm.com/webapp/set2/sas/f/lopdiags/home.html>).
4. You must take the PCIe adapter offline before removing and replacing a PCIe adapter with the system power turned on (hot-plugging). Before you take an adapter offline, the devices that are attached to the adapter must be taken offline as well. This action must be done by a system administrator. Taking the PCIe adapter offline prevents a service representative or user from causing an unexpected outage for other users of the system.
5. Before hot-plugging adapters for storage devices, ensure that the file systems on those devices are unmounted.
6. Familiarize yourself with the locations of the PCIe adapter slots. The PCIe adapters are installed in the rear of the system. Figure 24 on page 37 shows the locations of the PCIe adapters in an 8408-44E or 8408-E8E system.

Note: The number of the PCIe adapter slots that are available in the system depends on the number of system processors in the system. For the PCIe adapter placement information regarding the available slots in this system, see PCIe adapter placement rules and slot priorities for the 8408-44E or 8408-E8E system.

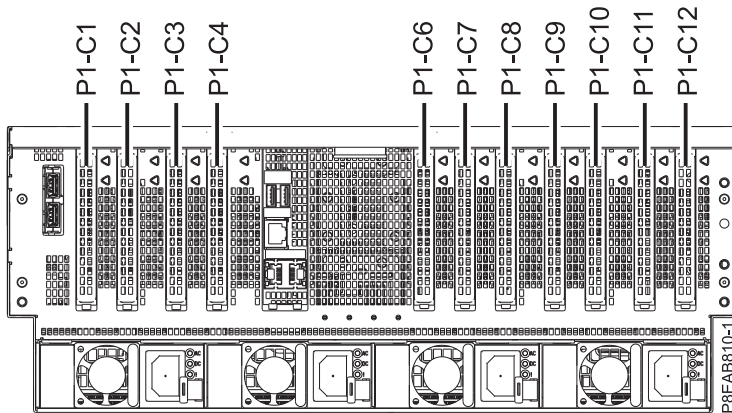

Figure 24. PCIe adapter slot locations in the 8408-44E or 8408-E8E system

7. Use the service indicator light-emitting diodes (LEDs) to help identify the part. For instructions, see “Identifying a part” on page 60.
8. Open the rack door at the rear of the system.
9. Attach the electrostatic discharge (ESD) wrist strap.

Attention:

- Attach an electrostatic discharge (ESD) wrist strap to the front ESD jack, to the rear ESD jack, or to an unpainted metal surface of your hardware to prevent the electrostatic discharge from damaging your hardware.
 - When you use an ESD wrist strap, follow all electrical safety procedures. An ESD wrist strap is used for static control. It does not increase or decrease your risk of receiving electric shock when using or working on electrical equipment.
 - If you do not have an ESD wrist strap, just prior to removing the product from ESD packaging and installing or replacing hardware, touch an unpainted metal surface of the system for a minimum of 5 seconds.
10. If you are removing the PCIe adapter as part of another service procedure, record the details about the PCIe adapter and its location code, and then go to the next step.

If you are servicing a failed PCIe adapter, look for the flashing amber LED for the failed PCIe adapter that you set to flash in the step to identify the failed part. Figure 25 on page 38 shows the state of the LEDs.

There are two LEDs associated with each PCIe adapter. The following LED states indicate the status of the PCIe adapter.

- **(B)** Indicates full power to the PCIe adapter. The green power LED (upper LED) is lit solid.
- **(C)** Indicates a failed PCIe adapter. The amber fault LED (lower LED) is lit solid.
- **(D)** Indicates a failed PCIe adapter that was selected by using the identify function. The amber fault LED (lower LED) is flashing.

Note: Do not attempt to remove a PCIe adapter with the green power LED (upper LED) is lit.

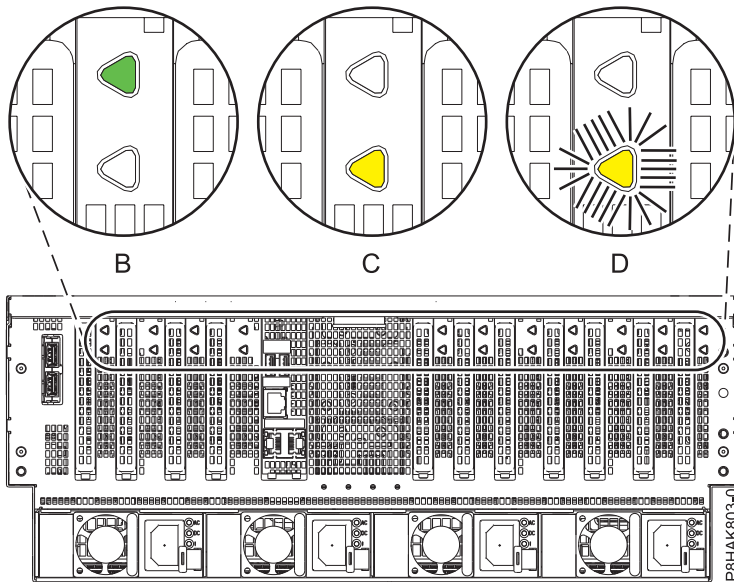

Figure 25. Location of the PCIe adapter LEDs in the 8408-44E or 8408-E8E system

11. Label and disconnect all cables and transceivers that are attached to the adapter you plan to remove. For instructions to remove transceivers, see “Removing and replacing the tailstock on a PCIe adapter” on page 44.
12. If you have not yet recorded the PCIe slot details, record the slot number and location of each adapter being removed.

Note: Adapter slots are numbered on the rear of the system.

13. If applicable, open the rack front door.
14. Place the system into the service position. For instructions, see “Placing an 8408-44E or 8408-E8E system into the service position” on page 81.

CAUTION:

Do not place any object on top of a rack-mounted device unless that rack-mounted device is intended for use as a shelf. (R008)

(L012)



or



CAUTION: Pinch hazard. (L012)

15. Remove the service access cover. For instructions, see “Removing the service access cover from an 8408-44E or 8408-E8E system” on page 75.
16. Enter **drmgr** on the console to enable an adapter to be removed:
For example, to remove the PCIe adapter in slot U7879.001.DQD014E-P1-C3 enter:
`drmgr -c pci -r -s locationcode`
Follow the instructions on the display to complete the task.

Removing a PCIe adapter from the 8408-44E or 8408-E8E system with the power turned on in Linux

To remove the Peripheral Component Interconnect (PCI) Express (PCIe) adapters from a Linux system or a Linux logical partition with the system power turned on, complete the steps in this procedure.

Procedure

1. Ensure that you have the electrostatic discharge (ESD) wrist strap attached. If not, attach it now.
2. Remove the PCIe adapter.

Attention:

- Left and right I/O retention brackets must be opened before you can access the rear slots.
 - You only need to open the I/O retention bracket for the side you are accessing.
 - A pin on the tailstock of the adapter resembles a removable screw. Do not remove this pin. It is required for correct alignment and seating.
- a. Unscrew the I/O retention bracket captive thumbscrew until fully loose. See **(A)** in Figure 26.
 - b. Open the I/O retention bracket by rotating it up and away from the system. See **(B)** in Figure 26.
 - c. Carefully grasp the adapter **(C)** by its top edge or tailstock, and remove adapter from the slot, as shown in Figure 26.

Note: If you are removing a low-profile (short) PCIe adapter, disengage the adapter by pushing in the tailstock while you are lifting the adapter out of the slot.

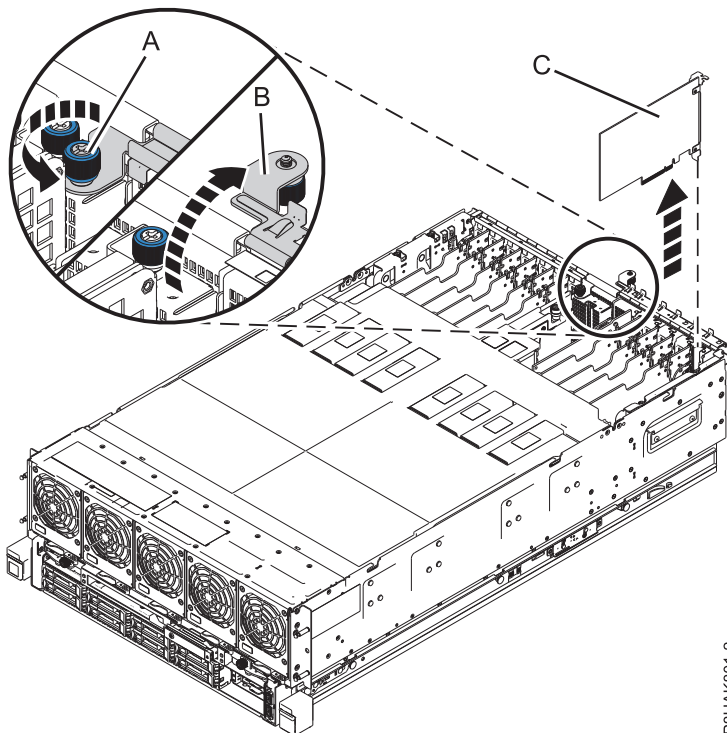

P8HAK801-2

Figure 26. Removing a PCIe adapter from the 8408-44E or 8408-E8E system

3. Place the removed adapter on an approved ESD surface.
4. Choose your next action from the following options:
 - If you are removing a PCIe adapter as part of another procedure, return to that procedure.

- If you are replacing the failed adapter with a new adapter, go to the procedure for replacing a PCIe adapter.
- If you are not replacing the PCIe adapter with a new one, you must install a PCIe tailstock filler in the empty slot. To install a PCIe tailstock filler, complete the following steps:
 - a. Carefully grasp the filler tailstock and align the filler with the slot and its connector on the system backplane, see (A) in Figure 27.
 - b. Press the filler tailstock firmly into the slot.
 - c. Close the I/O retention bracket by rotating it down towards the system (B). See Figure 27.
 - d. Screw the I/O retention bracket captive thumbscrew clockwise (C), as shown in Figure 27.

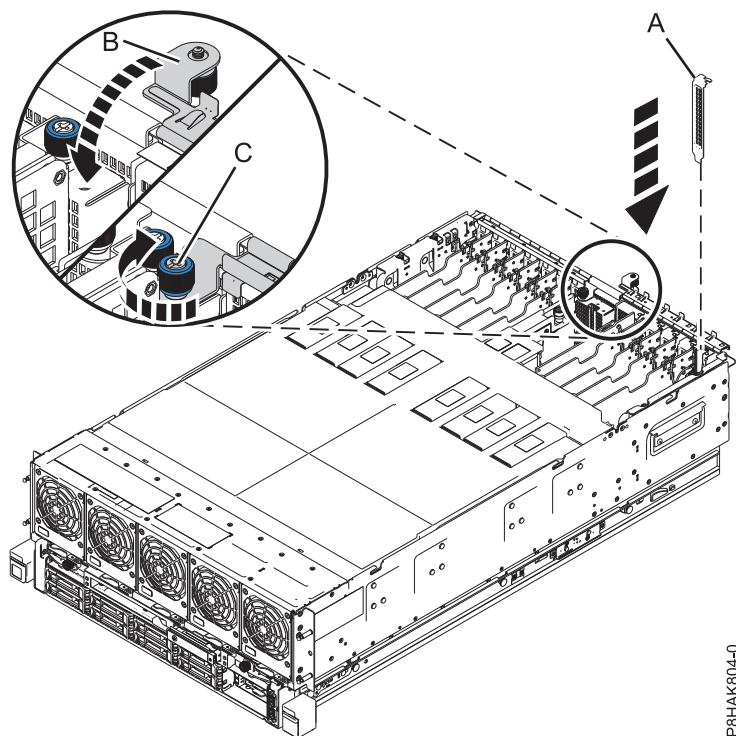

Figure 27. Installing a filler in a PCIe adapter slot in a 8408-44E or 8408-E8E system

Replacing a PCIe adapter in the 8408-44E or 8408-E8E system with the power turned on in Linux

To replace the Peripheral Component Interconnect (PCI) Express (PCIe) adapters in a Linux system or a Linux logical partition with the system power turned on, complete the steps in this procedure.

Procedure

1. Ensure that you have the electrostatic discharge (ESD) wrist strap attached. If not, attach it now.
2. Ensure that the target slot is empty.
3. If necessary, remove the adapter from the antistatic package.

Attention: Avoid touching the components and gold connectors on the adapter.

4. Place the adapter, component-side up, on a flat, antistatic surface.

Note: Some PCIe adapters are shipped from the manufacturer with a blue handle or support bracket along the back edge of the adapter. To use adapters of this type, you must remove the blue handle

or the support bracket from the adapter.

Attention: A pin on the tailstock of the adapter resembles a removable screw. Do not remove this pin. It is required for correct alignment and seating.

5. Enter `drmgr` on the console to enable an adapter to be replaced.

For example, to replace the PCIe adapter in slot U7879.001.DQD014E-P1-C3 enter: `drmgr -c pci -r -s locationcode`

Follow the instructions on the display to complete the task.

6. Return to the system.
7. Carefully grasp the adapter by its top edge or tailstock, and align the adapter with the slot and its connector on the system backplane (A), as shown in Figure 28.

Attention: Before you insert the adapter in the PCIe slot, ensure that the adapter has no cables, protective shields, or transceivers that are attached to it. If the adapter has cables, protective shields, or transceivers that are attached, remove them. For instructions to remove protective shields or transceivers, see "Removing and replacing the tailstock on a PCIe adapter" on page 44. The cables, protective shields, or transceivers must be attached to the adapter after the adapter is inserted in the PCIe slot.

8. On the system, press the adapter firmly into its connector.
9. Ensure that the tailstock notch engages with the pin on the system's chassis. See (B) in Figure 28.
10. Close the I/O retention bracket (C) by rotating it down and then tighten the captive thumbscrew (D) until it is secured to the system's chassis. See Figure 28.

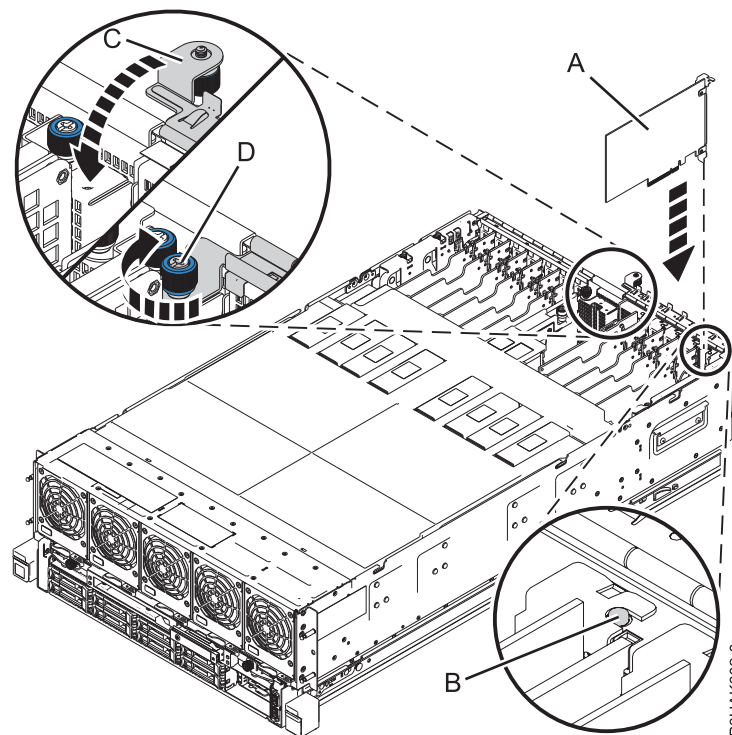

Figure 28. Installing or replacing a PCIe adapter in the 8408-44E or 8408-E8E system

11. If you replaced the PCIe adapter as part of another service procedure, return to that procedure.

Preparing the 8408-44E or 8408-E8E system for operation after removing and replacing a PCIe adapter with the power turned on in Linux

To prepare the system for operation after you replace the Peripheral Component Interconnect (PCI) Express (PCIe) adapters in the system, complete the steps in this procedure.

Procedure

1. Ensure that you have the electrostatic discharge (ESD) wrist strap attached. If not, attach it now.
2. Install the service access cover. For instructions, see “Installing the service access cover on an 8408-44E or 8408-E8E system” on page 76.
3. Place the system into the operating position. For instructions, see “Placing an 8408-44E or 8408-E8E system into the operating position” on page 82.

(L012)



or



CAUTION: Pinch hazard. (L012)

4. If applicable, close the rack front door.
5. If removed, connect the cables or transceivers to the adapter.
6. Route the cables through the cable-management arm.
7. Close the rack door at the rear of the system.
8. On the console, use the **lsslot** command to verify that you have installed the PCI adapter in the correct slot.

To verify the installation, complete the following steps:

- a. Enter **lsslot -c pci -a**. The information about the slots is displayed.
- b. Enter the slot information with the **lsslot** command, as shown in the following example.
For example, if the slot in which you installed the PCIe adapter was U7879.001.DQD014E-P1-C3
Enter **lsslot -c pci -s U7879.001.DQD014E-P1-C3**

The following screen is an example of the information that is displayed by this command:

```
# Slot          Description          Device(s)
U7879.001.DQD014E-P1-C3 PCI-X capable, 64 bit, 133MHz slot 0001:40:01.0
```

Related procedures for installing and removing PCIe adapters

Find procedures that are related to installing and removing PCIe adapters.

Avoiding electric shock

Learn about precautions you should take to avoid electric shock when working on or around a computer system.

DANGER: When working on or around the system, observe the following precautions:

Electrical voltage and current from power, telephone, and communication cables are hazardous. To avoid a shock hazard:

- If IBM supplied the power cord(s), connect power to this unit only with the IBM provided power cord. Do not use the IBM provided power cord for any other product.
- Do not open or service any power supply assembly.
- Do not connect or disconnect any cables or perform installation, maintenance, or reconfiguration of this product during an electrical storm.

- The product might be equipped with multiple power cords. To remove all hazardous voltages, disconnect all power cords.
 - For AC power, disconnect all power cords from their AC power source.
 - For racks with a DC power distribution panel (PDP), disconnect the customer’s DC power source to the PDP.
- When connecting power to the product ensure all power cables are properly connected.
 - For racks with AC power, connect all power cords to a properly wired and grounded electrical outlet. Ensure that the outlet supplies proper voltage and phase rotation according to the system rating plate.
 - For racks with a DC power distribution panel (PDP), connect the customer’s DC power source to the PDP. Ensure that the proper polarity is used when attaching the DC power and DC power return wiring.
- Connect any equipment that will be attached to this product to properly wired outlets.
- When possible, use one hand only to connect or disconnect signal cables.
- Never turn on any equipment when there is evidence of fire, water, or structural damage.
- Do not attempt to switch on power to the machine until all possible unsafe conditions are corrected.
- Assume that an electrical safety hazard is present. Perform all continuity, grounding, and power checks specified during the subsystem installation procedures to ensure that the machine meets safety requirements.
- Do not continue with the inspection if any unsafe conditions are present.
- Before you open the device covers, unless instructed otherwise in the installation and configuration procedures: Disconnect the attached AC power cords, turn off the applicable circuit breakers located in the rack power distribution panel (PDP), and disconnect any telecommunications systems, networks, and modems.

DANGER:

- Connect and disconnect cables as described in the following procedures when installing, moving, or opening covers on this product or attached devices.

To Disconnect:

1. Turn off everything (unless instructed otherwise).
2. For AC power, remove the power cords from the outlets.
3. For racks with a DC power distribution panel (PDP), turn off the circuit breakers located in the PDP and remove the power from the Customer's DC power source.
4. Remove the signal cables from the connectors.
5. Remove all cables from the devices.

To Connect:

1. Turn off everything (unless instructed otherwise).
2. Attach all cables to the devices.
3. Attach the signal cables to the connectors.
4. For AC power, attach the power cords to the outlets.
5. For racks with a DC power distribution panel (PDP), restore the power from the Customer's DC power source and turn on the circuit breakers located in the PDP.
6. Turn on the devices.

Sharp edges, corners and joints may be present in and around the system. Use care when handling equipment to avoid cuts, scrapes and pinching. (D005)

Handling static-sensitive devices

Learn about precautions you must take to prevent damage to electronic components from static electricity discharge.

Electronic boards, adapters, media drives, and disk drives are sensitive to static electricity discharge. These devices are wrapped in antistatic bags to prevent this damage. Take the following precautions to prevent damage to these devices from static electricity discharge.

- Attach a wrist strap to an unpainted metal surface of your hardware to prevent electrostatic discharge from damaging your hardware.
- When you are using a wrist strap, follow all electrical safety procedures. A wrist strap is for static control. It does not increase or decrease your risk of receiving electric shock when you are using or working on electrical equipment.
- If you do not have a wrist strap, before you remove the product from ESD packaging and installing or replacing hardware, touch an unpainted metal surface of the system for a minimum of 5 seconds.
- Do not remove the device from the antistatic bag until you are ready to install the device in the system.
- With the device still in its antistatic bag, touch it to the metal frame of the system.
- Grasp cards and boards by the edges. Avoid touching the components and gold connectors on the adapter.
- If you need to lay the device down while it is out of the antistatic bag, lay it on the antistatic bag. Before you pick it up again, touch the antistatic bag and the metal frame of the system at the same time.
- Handle the devices carefully to prevent permanent damage.

Updating the worldwide port name for a new 5735 IOA

If you exchange a 5735 Fibre Channel input/output adapter (IOA), the IBM external storage subsystem must be updated to use the worldwide port name (WWPN) of the new 5735 IOA. Any SAN hardware that uses the WWPN zoning might also need updating.

For instructions on how to update the external storage subsystem or SAN hardware configurations, see the documentation for those systems.

The WWPN for the Fibre Channel IOA can be found by using the Hardware Service Manager in SST or DST to display details about the 5735 IOA Logical Hardware Resource information, and use the port worldwide name field.

The 16-digit WWPN can also be determined by appending the digits 1000 to the beginning of the 12-digit IEEE address that is found on the tailstock label of the Fibre Channel IO adapter.

Removing and replacing the tailstock on a PCIe adapter

Find information about removing and replacing the tailstock on a PCIe adapter. You can replace the tailstock on an adapter if the adapter has a different tailstock.

You must have removed the PCIe adapter or the adapter filler from the system.

The tailstock for individual PCIe adapters can be either tall (high-profile) or short (low-profile). New systems ship with the correct tailstock on the cards already installed. Through unique feature codes, a miscellaneous equipment specification (MES) also ships with the correct sized tailstock. For repairs, however, replacement parts usually ship with high-profile tailstock. If the failed adapter was a low-profile adapter installed in the system, then you must exchange the tall tailstock that was shipped on the replacement card with the low-profile tailstock from the failed card.

Note: A Phillips screwdriver is required to complete the procedure.

To remove and replace a PCIe adapter tailstock, choose from the following options:

- Removing the tailstock from a failed adapter or adapter filler
- Removing the tailstock from a new adapter
- Replacing the tailstock in a new adapter

Removing the tailstock from a failed adapter or adapter filler

1. Ensure that you have the electrostatic discharge (ESD) wrist strap on and that the ESD clip is connected to an unpainted metal surface. If not, do so now.
2. Using a Phillips screwdriver, unscrew the two screws (A) that attach the tailstock (B) to the PCIe adapter, as shown in Figure 29.

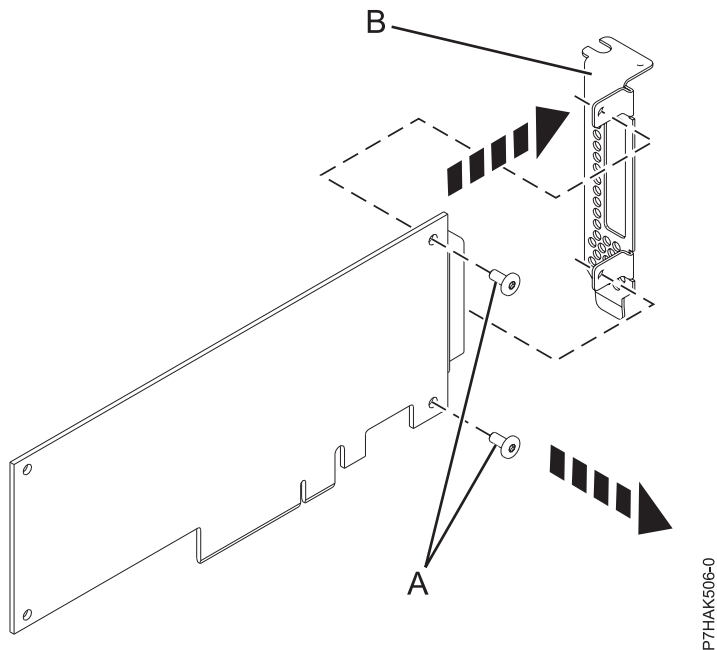

Figure 29. Removing the low-profile tailstock from a PCIe adapter

3. Detach the tailstock from the PCIe adapter and place the tailstock and the screws on a flat, static-protective surface.
4. If you are removing the tailstock from a 4-Port 10/100/1000 Base-TX PCIe adapter, there is only one screw to remove. After removing the screw, disengage the tabs from the card hardware and remove the tailstock.
5. If you are removing the tailstock from an Ethernet or Fibre Channel adapter that has small form-factor pluggable (SFP) transceivers, you must first remove the SFP transceivers. To remove the SFP transceivers, complete the following steps:
 - a. Place the card flat on a static-protective surface.
 - b. Open the latch (A) by rotating it down and away from the card as shown in Figure 30 on page 46.
 - c. Slide the transceiver (B) out of the adapter hardware.
 - d. Repeat for the other transceiver.

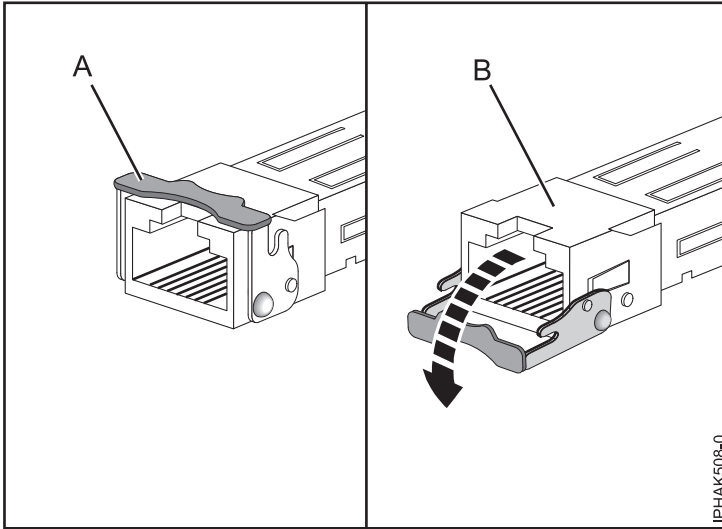

Figure 30. Removing SFP transceivers from adapters

6. If necessary, remove the adapter from the antistatic package.

Attention: Avoid touching the components and gold connectors on the adapter.

Removing the tailstock from a new adapter

7. Ensure that you have the electrostatic discharge (ESD) wrist strap on and that the ESD clip is connected to an unpainted metal surface. If not, do so now.
8. Using a Phillips screwdriver, unscrew the two retaining screws (A) that attach the high-profile tailstock (B) to the new PCIe adapter, as shown in Figure 31.

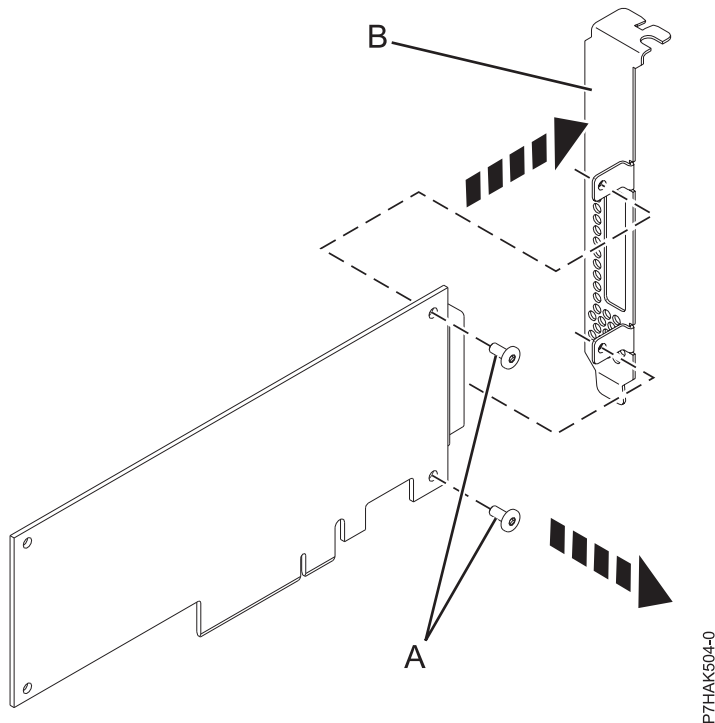

Figure 31. Removing the high-profile tailstock from a new PCIe adapter

9. If the new adapter is a 4-Port 10/100/1000 Base-TX PCIe adapter, see 4 on page 45 for removing the tailstock and then return here.
10. If the new adapter is an Ethernet or Fibre Channel adapter, see 5 on page 45 for removing the tailstock and then return here.
11. Detach the tailstock from the new PCIe adapter and store the tailstock and its screws in the antistatic package that the new adapter shipped in.

Replacing the tailstock in a new adapter

12. Ensure that you have the electrostatic discharge (ESD) wrist strap on and that the ESD clip is connected to an unpainted metal surface. If not, do so now.
13. Place the adapter, component-side up, on a flat, antistatic surface.

Note: Some PCIe adapters are shipped from the manufacturer with a blue handle or support bracket along the back edge of the adapter. To use adapters of this type, you must remove the blue handle or the support bracket from the adapter.

Attention: A pin on the tailstock of the adapter resembles a removable screw. Do not remove this pin. It is required for correct alignment and seating.

14. Using a Phillips screwdriver and the two retaining screws **(B)**, attach the tailstock **(A)** from the failed PCIe adapter onto the new PCIe adapter, as shown in Figure 32.

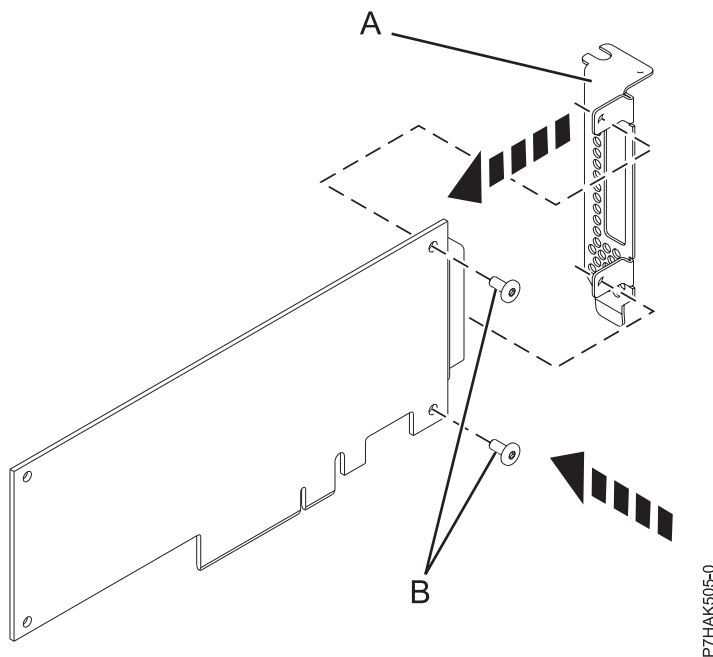

Figure 32. Attaching the low-profile tailstock to a PCIe adapter

15. If the new adapter is a 4-Port 10/100/1000 Base-TX PCI Express adapter, first engage the tailstock with the tabs on the card hardware. After the tailstock is attached, secure the tailstock with its screw.
16. If the new adapter is an Ethernet or Fibre Channel adapter, you must attach the SFP transceivers after you replace the tailstock. To attach the SFP transceivers, complete the following steps:
 - a. Place the card flat on a static-protective surface.
 - b. Slide the transceiver **(A)** into the adapter hardware.
 - c. With the latch **(B)** in the open position, push the latch by rotating it up and toward the card as shown in Figure 33 on page 48.

- d. Repeat for the other transceiver.

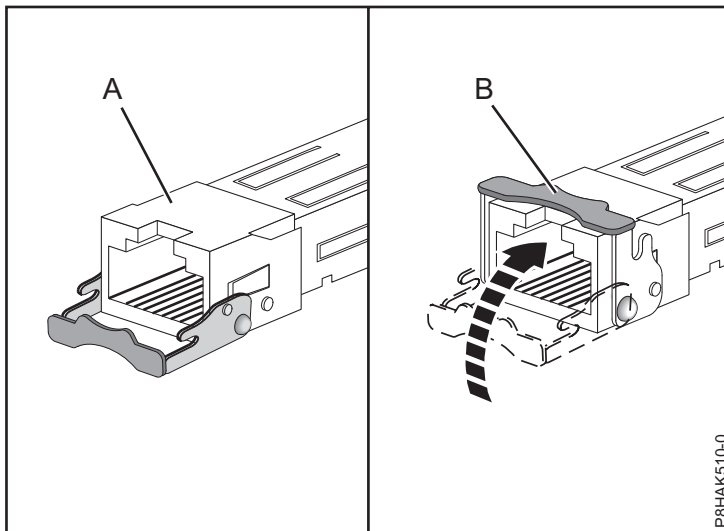

Figure 33. Replacing SFP transceivers in the adapter

17. Put the failed PCIe adapter in the shipping material and return it.

Return to the procedure that sent you here.

PCIe hot-plug manager access for AIX

You might need to service PCIe adapters with the system power on in AIX. Use the procedures in this section to perform this task.

The instructions for servicing PCIe adapters with the system power on in AIX refer you to these procedures when it is appropriate to perform them.

Note: For an adapter to be serviced with the system power on, both the adapter and the system unit must support hot-plug procedures. To identify adapters that are hot-pluggable in the system you are servicing, refer to the following placement information: PCI adapter placement.

Accessing hot-plug management functions

You can use the PCI hot-plug manager to service PCIe adapters with the system power turned on in AIX.

Note: Procedures that are completed with the system power turned on also known as hot-plug procedures. The hot-plug procedure for PCIe adapter in an AIX system requires the system administrator to take the PCIe adapter offline before starting the procedure. Before taking an adapter offline, the devices attached to the adapter must be taken offline as well. This action prevents a service representative or user from causing an unexpected outage for system users.

To access the hot-plug menus, complete the following steps:

1. Log in as root user.
2. At the command line, type `smitty`.
3. Select **Devices**.
4. Select **PCI Hot Plug Manager** and press Enter.

The PCI Hot-Plug Manager menu displays.

For details about the menu options in the PCI Hot-Plug Manager screen, see “PCI hot-plug manager menu” on page 49.

Return to the procedure that directed you here.

PCI hot-plug manager menu

You can use the PCI Hot Plug Manager to service PCI adapters with the system power on in AIX. The following options are available from the PCI Hot Plug Manager menu.

Note: For information about the PCI slot LED states, see “Component LEDs.”

Table 1. PCI Hot Plug Manager menu options

Menu option	Description
List PCI hot-plug slots	Provides a descriptive list of all slots that support PCI hot-plug capability. If the listing for a slot indicates it holds an unknown device, select the Install/configure Devices added after IPL to configure the adapter in that slot.
Add a PCI hot-plug adapter	Allows the user to add a new PCI hot-plug-capable adapter to the slot with the system turned on. You will be asked to identify the PCI slot that you have selected prior to the actual operation. The selected PCI slot will go into the Action state and finally into the On state. Note: The system will indicate the slot holds an unknown device until you perform the Install/configure devices added after IPL option to configure the adapter.
Replace/remove a PCI hot-plug adapter	Allows the user to remove an existing adapter, or replace an existing adapter with an identical one. For this option to work, the adapter must be in the Defined state (see the “Unconfigure a Device” option). You will be asked to identify the PCI slot prior to the actual operation. The selected PCI slot will go into the Action state.
Identify a PCI hot-plug slot	Allows the user to identify a PCI slot. The selected PCI slot will go into the Identify state. See “Component LEDs.”
Unconfigure a device	Allows the user to put an existing PCI adapter into the Defined state if the device is no longer in use. This step must be completed successfully before starting any removal or replacement operation. If this step fails, the customer must take action to release the device.
Configure a defined device	Allows a new PCI adapter to be configured into the system if software support is already available for the adapter. The selected PCI slot will go into the On state.
Install/configure devices added after IPL	The system attempts to configure any new devices and tries to find and install any required software from a user-selected source.

The add, remove, and replace functions return information to the user indicating whether the operation was successful. If additional instructions are provided on the screen, complete the recommended actions. If the instructions do not resolve the problem, do the following:

- If the adapter is listed as Unknown, perform the **Install/configure devices Added After IPL** option to configure the adapter.
- If you receive a warning indicating that needed device packages are not installed, the system administrator must install the specified packages before you can configure or diagnose the adapter.
- If you receive a failure message indicating a hardware error, the problem might be either the adapter or the PCI slot. Isolate the problem by retrying the operation in a different PCI slot, or trying a different adapter in the slot. If you determine that you have failing hardware, call your service representative.
- *Do not* use **Install/configure devices added after IPL** if your system is set up to run HACMP™ clustering. Consult with your system administrator or software support to determine the correct method to configure the replacement device.

Component LEDs

Individual LEDs are located on or near the failing components. Use the information in this section to interpret the LEDs.

The LEDs are located either on the component itself or on the carrier of the component (for example, memory card, fan, memory module, or processor). LEDs are either green or amber.

Green LEDs indicate either of the following:

- Electrical power is present.
- Activity is occurring on a link. (The system could be sending or receiving information.)

Amber LEDs indicate a fault or identify condition. If your system or one of the components on your system has an amber LED turned on or flashing, identify the problem and take the appropriate action to restore the system to normal.

Resetting the LEDs in AIX:

Individual LEDs are located on or near the failing components. You can use this procedure to reset the LEDs after you have completed a repair action.

After the repair action is completed, do the following:

1. Log in as root user.
2. At the command line, type `diag`.
3. Select **Task Selection**.
4. Select **Log Repair Action**.
5. Select the device that was repaired.
6. Press F10 to exit diagnostics.

If the Attention LED remains on after you have completed the repair action and reset the LEDs, call for service support.

Installing the AIX device driver software

Learn how to install the AIX device driver software for a PCI adapter.

If you are installing the AIX operating system at this time, install the adapter before you install the operating system. When you install AIX, the adapter device driver is automatically installed and the following procedure does not apply to your situation.

If you are installing only the device driver for a PCI adapter, perform these steps:

1. Log in to the system unit as root user.
2. Insert the media containing the device driver software (for example, the CD) into the media device. If your system does not have a CD-ROM drive, refer to your system documentation for performing a Network Installation Management (NIM) installation.
3. Type the following command at the System Management Interface Tool (SMIT) fast path: `smit devinst`.
4. Press **Enter**. The Install Additional Device Software window highlights the **INPUT device / directory for software** option.
5. Type the name of the input device that you are using, or press **F4** to select the input device from a list.
6. Press **Enter**. The Install Additional Device Software window highlights the **SOFTWARE to install** option.
7. Press **F4** to select List.
8. Type **/** to display the Find window.
9. Type the device package name, and press **Enter**. The system finds and highlights this device driver software.

10. Press **F7** to select the highlighted device driver software, and press **Enter**. The **INSTALL ADDITIONAL DEVICE SOFTWARE** window is displayed. The entry fields are automatically updated.
11. Press **Enter** to accept the information. The **ARE YOU SURE** window is displayed.
12. Press **Enter** to accept the information. The **COMMAND STATUS** window is displayed.
 - The message **RUNNING** is highlighted to indicate that the installation and configuration command is in progress.
 - When **RUNNING** changes to **OK**, scroll to the bottom of the page and locate the installation summary.
 - After a successful installation, **SUCCESS** is displayed in the **Result** column of the installation summary at the bottom of the page.
13. Remove the installation media from the drive.
14. Press **F10** to exit **SMIT**.

You can verify whether the AIX device driver software is installed. For instructions, see “Verifying the AIX device driver software.”

Verifying the AIX device driver software

Learn to verify the AIX device driver is installed for a PCI adapter.

To verify that the AIX device driver for an adapter is installed, complete the following steps:

1. If necessary, log in as root user.
2. At the command line, type `lslpp -l devices.xxxxxxxxx` where `xxxxxxxx` is the device package name.
3. Press **Enter**.

If the adapter device driver is installed, the following is an example of the data that is displayed on the window.

File set	Level	State	Description
Path: /usr/lib/objrepos devices.xxxxxxxxx	5.3.8.0	COMMITTED	<i>Adapter name</i> software

Verify that the file sets are installed at the AIX version level you are running. Level 5.3.8.0 is an example. If no data is displayed on your screen, the adapter device driver was not installed correctly. Try reinstalling the driver.

Installing or replacing a PCI adapter with the system power on in Virtual I/O Server

You can install or replace a PCI adapter in the Virtual I/O Server logical partition or in the Integrated Virtualization Manager management partition.

The Virtual I/O Server includes a PCI Hot Plug Manager that is similar to the PCI Hot Plug Manager in the AIX operating system. The PCI Hot Plug Manager allows you to hot plug PCI adapters into the system and then activate them for the logical partition without having to reboot the system. Use the PCI Hot Plug Manager for adding, identifying, or replacing PCI adapters in the system that are currently assigned to the Virtual I/O Server.

Getting started

Prerequisites:

- If you are installing a new adapter, an empty system slot must be assigned to the Virtual I/O Server logical partition. This task can be done through dynamic logical partitioning (DLPAR) operations.
 - If you are using a Hardware Management Console (HMC), you must also update the logical partition profile of the Virtual I/O Server so that the new adapter is configured to the Virtual I/O Server after you restart the system.
 - If you are using the Integrated Virtualization Manager, an empty slot is probably already assigned to the Virtual I/O Server logical partition because all slots are assigned to the Virtual I/O Server by default. You only need to assign an empty slot to the Virtual I/O Server logical partition if you previously assigned all empty slots to other logical partitions.
- If you are installing a new adapter, ensure that you have the software required to support the new adapter and determine whether there are any existing PTF prerequisites to install. For information about software prerequisites, see the IBM Prerequisite website (http://www-912.ibm.com/e_dir/eServerPrereq.nsf).
- If you need help determining the PCI slot in which to place a PCI adapter, see the PCI adapter placement.

Follow these steps to access the Virtual I/O Server, PCI Hot Plug Manager:

1. If you are using the Integrated Virtualization Manager, connect to the command-line interface.
2. Use the **diagmenu** command to open the Virtual I/O Server diagnostic menu. The menus are similar to the AIX diagnostic menus.
3. Select **Task Selection**, then press Enter.
4. At the Task Selection list, select **PCI Hot Plug Manager**.

Installing a PCI adapter

To install a PCI adapter with the system power on in Virtual I/O Server, complete the following steps:

1. From the PCI Hot Plug Manager, select **Add a PCI Hot Plug Adapter**, then press Enter. The Add a Hot-Plug Adapter window is displayed.
2. Select the appropriate empty PCI slot from those listed, and press Enter. A fast-blinking amber LED located at the back of the server near the adapter indicates that the slot has been identified.
3. Follow the instructions on the screen to install the adapter until the LED for the specified PCI slot is set to the Action state.
 - a. Set the adapter LED to the action state so that the indicator light for the adapter slot flashes
 - b. Physically install the adapter
 - c. Finish the adapter installation task in **diagmenu**.
4. Enter **cfgdev** to configure the device for the Virtual I/O Server.

If you are installing a PCI, Fibre Channel adapter, it is now ready to be attached to a SAN and have LUNs assigned to the Virtual I/O Server for virtualization.

Replacing a PCI adapter

Prerequisite: Before you can remove or replace a storage adapter, you must unconfigure that adapter. See “Unconfiguring storage adapters” on page 53 for instructions.

To replace a PCI adapter with the system power on in Virtual I/O Server, complete the following steps:

1. From the PCI Hot Plug Manager, select **Unconfigure a Device**, then press Enter.
2. Press F4 (or Esc +4) to display the **Device Names** menu.
3. Select the adapter you are removing in the **Device Names** menu.
4. In the **Keep Definition** field, use the Tab key to answer Yes. In the **Unconfigure Child Devices** field, use the Tab key again to answer YES, then press Enter.

5. Press Enter to verify the information on the **ARE YOU SURE** screen. Successful unconfiguration is indicated by the OK message displayed next to the Command field at the top of the screen.
6. Press F4 (or Esc +4) twice to return to the Hot Plug Manager.
7. Select **replace/remove PCI Hot Plug adapter**.
8. Select the slot that has the device to be removed from the system.
9. Select **replace**. A fast-blinking amber LED located at the back of the machine near the adapter indicates that the slot has been identified.
10. Press Enter which places the adapter in the action state, meaning it is ready to be removed from the system.

Unconfiguring storage adapters

Before you can remove or replace a storage adapter, you must unconfigure that adapter. Storage adapters are generally parent devices to media devices, such as disk drives or tape drives. Removing the parent requires that all attached child devices either be removed or placed in the define state.

Unconfiguring a storage adapter involves the following tasks:

- Closing all applications that are using the adapter you are removing, replacing, or moving
- Unmounting file systems
- Ensuring that all devices connected to the adapter are identified and stopped
- Listing all slots that are currently in use or a slot that is occupied by a specific adapter
- Identifying the adapter's slot location
- Making parent and child devices unavailable
- Making the adapter unavailable

If the adapter supports physical volumes that are in use by a client logical partition, then You can perform steps on the client logical partition before unconfiguring the storage adapter. For instructions, see "Preparing the client logical partitions." For example, the adapter might be in use because the physical volume was used to create a virtual target device, or it might be part of a volume group used to create a virtual target device.

To unconfigure SCSI, SSA, and Fibre Channel storage adapters, complete the following steps:

1. Connect to the Virtual I/O Server command-line interface.
2. Enter `oem_setup_env` to close all applications that are using the adapter you are unconfiguring.
3. Type `lsslot-c pci` to list all the hot plug slots in the system unit and display their characteristics.
4. Type `lsdev -C` to list the current state of all the devices in the system unit.
5. Type `umount` to unmount previously mounted file systems, directories, or files using this adapter.
6. Type `rmdev -l adapter -R` to make the adapter unavailable.

Attention: Do not use the `-d` flag with the `rmdev` command for hot plug operations because this action removes your configuration.

Preparing the client logical partitions

If the virtual target devices of the client logical partitions are not available, the client logical partitions can fail or they might be unable to perform I/O operations for a particular application. If you use the HMC to manage the system, you might have redundant Virtual I/O Server logical partitions, which allow for Virtual I/O Server maintenance and avoid downtime for client logical partitions. If you are replacing an adapter on the Virtual I/O Server and your client logical partition is dependent on one or more of the physical volumes accessed by that adapter, then You can take action on the client before you unconfigure the adapter.

The virtual target devices must be in the define state before the Virtual I/O Server adapter can be replaced. Do not remove the virtual devices permanently.

To prepare the client logical partitions so that you can unconfigure an adapter, complete the following steps depending on your situation.

Table 2. Situations and steps for preparing the client logical partitions

Situation	Steps
You have redundant hardware on the Virtual I/O Server for the adapter.	No action is required on the client logical partition.
HMC-managed systems only: You have redundant Virtual I/O Server logical partitions that, in conjunction with virtual client adapters, provide multiple paths to the physical volume on the client logical partition.	No action is required on the client logical partition. However, path errors might be logged on the client logical partition.
HMC-managed systems only: You have redundant Virtual I/O Server logical partitions that, in conjunction with virtual client adapters, provide multiple physical volumes that are used to mirror a volume group.	See the procedures for your client operating system. For example, for AIX, see Replacing a disk on the Virtual I/O Server in the IBM System p Advanced POWER Virtualization Best Practices Redpaper. The procedure for Linux is similar to this procedure for AIX.
You do not have redundant Virtual I/O Server logical partitions.	<p>Shut down the client logical partition.</p> <p>For instructions, see the following topics about shutting down logical partitions:</p> <ul style="list-style-type: none"> • For systems that are managed by the HMC, see “Shutting down AIX logical partitions using the HMC”, “Shutting down IBM i logical partitions using the HMC”, and “Shutting down Linux logical partitions using the HMC” in the Logical partitioning.¹ • For systems that are managed by the Integrated Virtualization Manager, see .
<p>¹The Logical partitioning can be found on the Hardware Information website http://publib.boulder.ibm.com/infocenter/systems/scope/hw/topic/p7hdx/power_systems.htm.</p>	

Verifying that the hot-plug PCI tools are installed for Linux

In the course of installing, removing, or replacing a PCI adapter with the system power on in Linux operating system you might need to use the hot-plug PCI tools. Learn to verify that you have the hot-plug PCI tools installed.

1. Enter the following command to verify that the hot-plug PCI tools are installed: `rpm -aq | grep powerpc-utils`. If the command does not list any `powerpc-utils` packages, the PCI Hot Plug tools are not installed.
2. Enter the following command to ensure that the `rpaphp` driver is loaded: `ls -l /sys/bus/pci/slots/`. The directory should contain data.
 - If the directory is empty, the driver is not loaded or the system does not contain hot-plug PCI slots. The following is an example of the information displayed by this command:

```
drwxr-xr-x 15 root root 0 Feb 16 23:31 .
drwxr-xr-x  5 root root 0 Feb 16 23:31 ..
drwxr-xr-x  2 root root 0 Feb 16 23:31 0000:00:02.0
drwxr-xr-x  2 root root 0 Feb 16 23:31 0000:00:02.2
drwxr-xr-x  2 root root 0 Feb 16 23:31 0000:00:02.4
drwxr-xr-x  2 root root 0 Feb 16 23:31 0001:00:02.0
drwxr-xr-x  2 root root 0 Feb 16 23:31 0001:00:02.2
drwxr-xr-x  2 root root 0 Feb 16 23:31 0001:00:02.4
drwxr-xr-x  2 root root 0 Feb 16 23:31 0001:00:02.6
drwxr-xr-x  2 root root 0 Feb 16 23:31 0002:00:02.0
drwxr-xr-x  2 root root 0 Feb 16 23:31 0002:00:02.2
drwxr-xr-x  2 root root 0 Feb 16 23:31 0002:00:02.4
drwxr-xr-x  2 root root 0 Feb 16 23:31 0002:00:02.6
```

- If the directory does not exist, run the following command to mount the filesystem: `mount -t sysfs sysfs /sys`
3. Ensure the following tools are available in the `/usr/sbin` directory.
 - `lsslot`
 - `drmgr -c pci`
 4. Return to the procedure that sent you here.

Common procedures for installing, removing, and replacing PCIe adapters

Find procedures that are common for installing, removing, and replacing PCIe adapters.

Before you begin

Observe these precautions when you are installing, removing, or replacing features and parts.

These precautions are intended to create a safe environment to service your system and do not provide steps for servicing your system. The installation, removal, and replacement procedures provide the step-by-step processes required to service your system.

DANGER: When working on or around the system, observe the following precautions:

Electrical voltage and current from power, telephone, and communication cables are hazardous. To avoid a shock hazard:

- If IBM supplied the power cord(s), connect power to this unit only with the IBM provided power cord. Do not use the IBM provided power cord for any other product.
- Do not open or service any power supply assembly.
- Do not connect or disconnect any cables or perform installation, maintenance, or reconfiguration of this product during an electrical storm.
- The product might be equipped with multiple power cords. To remove all hazardous voltages, disconnect all power cords.
 - For AC power, disconnect all power cords from their AC power source.
 - For racks with a DC power distribution panel (PDP), disconnect the customer's DC power source to the PDP.
- When connecting power to the product ensure all power cables are properly connected.
 - For racks with AC power, connect all power cords to a properly wired and grounded electrical outlet. Ensure that the outlet supplies proper voltage and phase rotation according to the system rating plate.
 - For racks with a DC power distribution panel (PDP), connect the customer's DC power source to the PDP. Ensure that the proper polarity is used when attaching the DC power and DC power return wiring.
- Connect any equipment that will be attached to this product to properly wired outlets.
- When possible, use one hand only to connect or disconnect signal cables.
- Never turn on any equipment when there is evidence of fire, water, or structural damage.
- Do not attempt to switch on power to the machine until all possible unsafe conditions are corrected.
- Assume that an electrical safety hazard is present. Perform all continuity, grounding, and power checks specified during the subsystem installation procedures to ensure that the machine meets safety requirements.
- Do not continue with the inspection if any unsafe conditions are present.
- Before you open the device covers, unless instructed otherwise in the installation and configuration procedures: Disconnect the attached AC power cords, turn off the applicable circuit breakers located in the rack power distribution panel (PDP), and disconnect any telecommunications systems, networks, and modems.

DANGER:

- Connect and disconnect cables as described in the following procedures when installing, moving, or opening covers on this product or attached devices.

To Disconnect:

1. Turn off everything (unless instructed otherwise).

2. For AC power, remove the power cords from the outlets.
3. For racks with a DC power distribution panel (PDP), turn off the circuit breakers located in the PDP and remove the power from the Customer's DC power source.
4. Remove the signal cables from the connectors.
5. Remove all cables from the devices.

To Connect:

1. Turn off everything (unless instructed otherwise).
2. Attach all cables to the devices.
3. Attach the signal cables to the connectors.
4. For AC power, attach the power cords to the outlets.
5. For racks with a DC power distribution panel (PDP), restore the power from the Customer's DC power source and turn on the circuit breakers located in the PDP.
6. Turn on the devices.

Sharp edges, corners and joints may be present in and around the system. Use care when handling equipment to avoid cuts, scrapes and pinching. (D005)

(R001 part 1 of 2):

DANGER: Observe the following precautions when working on or around your IT rack system:

- Heavy equipment—personal injury or equipment damage might result if mishandled.
- Always lower the leveling pads on the rack cabinet.
- Always install stabilizer brackets on the rack cabinet.
- To avoid hazardous conditions due to uneven mechanical loading, always install the heaviest devices in the bottom of the rack cabinet. Always install servers and optional devices starting from the bottom of the rack cabinet.
- Rack-mounted devices are not to be used as shelves or work spaces. Do not place objects on top of rack-mounted devices. In addition, do not lean on rack mounted devices and do not use them to stabilize your body position (for example, when working from a ladder).



- Each rack cabinet might have more than one power cord.
 - For AC powered racks, be sure to disconnect all power cords in the rack cabinet when directed to disconnect power during servicing.
 - For racks with a DC power distribution panel (PDP), turn off the circuit breaker that controls the power to the system unit(s), or disconnect the customer's DC power source, when directed to disconnect power during servicing.
- Connect all devices installed in a rack cabinet to power devices installed in the same rack cabinet. Do not plug a power cord from a device installed in one rack cabinet into a power device installed in a different rack cabinet.
- An electrical outlet that is not correctly wired could place hazardous voltage on the metal parts of the system or the devices that attach to the system. It is the responsibility of the customer to ensure that the outlet is correctly wired and grounded to prevent an electrical shock.

(R001 part 2 of 2):

CAUTION:

- Do not install a unit in a rack where the internal rack ambient temperatures will exceed the manufacturer's recommended ambient temperature for all your rack-mounted devices.
- Do not install a unit in a rack where the air flow is compromised. Ensure that air flow is not blocked or reduced on any side, front, or back of a unit used for air flow through the unit.

- Consideration should be given to the connection of the equipment to the supply circuit so that overloading of the circuits does not compromise the supply wiring or overcurrent protection. To provide the correct power connection to a rack, refer to the rating labels located on the equipment in the rack to determine the total power requirement of the supply circuit.
- (For sliding drawers.) Do not pull out or install any drawer or feature if the rack stabilizer brackets are not attached to the rack. Do not pull out more than one drawer at a time. The rack might become unstable if you pull out more than one drawer at a time.



- (For fixed drawers.) This drawer is a fixed drawer and must not be moved for servicing unless specified by the manufacturer. Attempting to move the drawer partially or completely out of the rack might cause the rack to become unstable or cause the drawer to fall out of the rack.

Before you begin a replacement or installation procedure, perform these tasks:

1. If you are installing a new feature, ensure that you have the software required to support the new feature. See IBM Prerequisite.
2. If you are performing an installation or replacement procedure that might put your data at risk, ensure, wherever possible, that you have a current backup of your system or logical partition (including operating systems, licensed programs, and data).
3. Review the installation or replacement procedure for the feature or part.
4. Note the significance of color on your system.

Blue or terra-cotta on a part of the hardware indicates a touch point where you can grip the hardware to remove it from or install it in the system, open or close a latch, and so on. Terra-cotta might also indicate that the part can be removed and replaced with the system or logical partition power on.

5. Ensure that you have access to a medium flat-blade screwdriver, a Phillips screwdriver, and a pair of scissors.
6. If parts are incorrect, missing, or visibly damaged, do the following:
 - If you are replacing a part, contact the provider of your parts or next level of support.
 - If you are installing a feature, contact one of the following service organizations:
 - The provider of your parts or next level of support.
 - In the United States, the IBM Rochester Manufacturing Automated Information Line (R-MAIL) at 1-800-300-8751.

In countries and regions outside of the United States, use the following website to locate your service and support telephone numbers:

<http://www.ibm.com/planetwide>

7. If you encounter difficulties during the installation, contact your service provider, your IBM reseller, or your next level of support.
8. If you are installing new hardware in a logical partition, you need to understand and plan for the implications of partitioning your system. For information, see Logical Partitioning.

Identifying a part

Learn how to identify the system or enclosure that contains a failing part, the location code and light-emitting diode (LED) status for a part, and how to activate and deactivate the identify part LED.

Note: If you are using PowerKVM, you must use the ASMI procedures to identify a part or enclosure.

Table 3. Tasks to identify a part

What you want to do	See the following information
Determine which server or enclosure contains the part	"Identifying the enclosure or server that contains the part"
Find the location of the part and determine whether the part has an identifying LED	"Finding the part location code and LED support status" on page 62
Turn on an identifying LED for a part	
If you are using PowerKVM:	"Identifying a part by using the ASMI" on page 66
If your system is in the runtime state:	"Identifying a part by using the operating system or VIOS" on page 63
If your system is in the standby power state:	"Identifying a part by using the ASMI" on page 66
If you have an HMC:	"Identifying a part by using the HMC" on page 67
Turn off an identify LED	"Deactivating an identify LED" on page 120
Turn off a check log indicator	"Deactivating a check log indicator (system information indicator) by using the ASMI" on page 122

Identifying the enclosure or server that contains the part

Learn how to determine which server or enclosure has the part you want to replace.

Enabling enclosure or server indicators with the ASMI

Find out how to enable enclosure or server indicators by using the Advanced System Management Interface (ASMI).

To perform this operation, you must have one of the following authority levels:

- Administrator
- Authorized service provider

To enable the enclosure or server indicator states, complete the following steps:

1. On the ASMI Welcome pane, specify your user ID and password, and click **Log In**.
2. In the navigation area, expand **System Configuration > Service Indicators > Enclosure Indicators**. A list of enclosures is displayed.
3. Select the enclosure and click **Continue**. A list of location codes is displayed. Alternatively, you can click **Indicators by Location Code** and type the location code in the **Location code** field.
4. In the **Identify indicator status** field, select **Identify**.
5. To save the changes made to the state of an indicator, click **Save settings**.

Control panel LEDs

Use this information as a guide to the control panel LEDs and buttons.

Use Figure 34 on page 61 with the control panel LED descriptions to understand the system status that is indicated by the control panel.

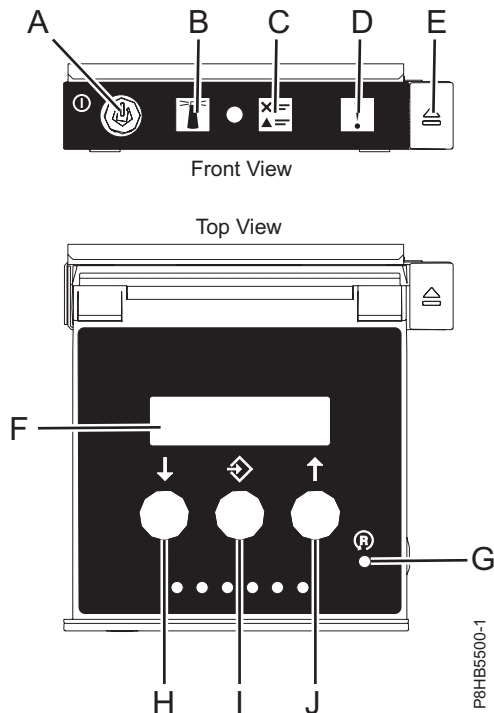

Figure 34. Control panel LEDs

Control panel LEDs and descriptions:

- **A:** Power-on button
 - A constant light indicates full system power to the unit.
 - A flashing light indicates standby power to the unit.
 - There is approximately a 30-second transition period from the time the power-on button is pressed to when the power LED goes from flashing to solid. During the transition period, the LED might flash faster.
- **B:** Enclosure identify light
 - A constant light indicates the identify state, which is used to identify a part.
 - No light indicates that the system is operating normally.
- **C:** Check log light
 - No light indicates that the system is operating normally.
 - Light on indicates that the system requires attention.
- **D:** Enclosure fault light
 - A constant light indicates a fault in the system unit.
 - No light indicates that the system is operating normally.
- **E:** Eject button
- **F:** Function/Data display
- **G:** Pinhole reset button
- **H:** Decrement button
- **I:** Enter button
- **J:** Increment button

Activating an identify LED for an enclosure or server by using the HMC

Learn how to activate an identify LED for an enclosure or server by using the Hardware Management Console (HMC).

The system provides several LEDs that help identify various components in the system, such as enclosures or field-replaceable units (FRUs). For this reason, they are called *identify LEDs*.

If you want to add a part to a specific enclosure or server, you need to know the machine type, model, and serial number (MTMS) of the enclosure or server. To determine whether you have the correct MTMS for the enclosure or server that needs the new part, you can activate the LED for an enclosure or server and verify that the MTMS corresponds to the enclosure or server that requires the new part.

1. Choose one of the following navigation options depending on the interface type of the HMC:
 - If you are using an HMC Classic or HMC Enhanced interface, complete the following steps:
 - a. In the navigation area, click **Systems Management > Servers**.
 - b. In the content pane, select the server.
 - c. Click **Tasks > Operations > LED Status > Identify LED**. The Identify LED, Select Enclosure window is displayed.
 - If you are using an HMC Enhanced + Tech Preview (Pre-GA) or HMC Enhanced+ interface, complete the following steps:



- a. In the navigation area, click the **Resources** icon  , and then click **All Systems**.
 - b. Click the server name for which you want to activate the identify LED.
 - c. Click **System Actions > Attention LED > Identify Attention LED**. The Identify Attention LED, Select Enclosure window is displayed.
2. To activate an identify LED for an enclosure or server, select an enclosure or server and then click **Activate LED**. The associated LED is turned on.

Finding the part location code and LED support status

You can use location codes for the server you are working with to find the part location code and whether there is Identify LED support.

To find the location code and to determine if there is identify LED support, complete the following steps:

1. Select the server you are working on to see the location codes:
 - 5148-21L, 5148-22L, 8247-21L, 8247-22L, 8284-21A, or 8284-22A locations (http://www.ibm.com/support/knowledgecenter/POWER8/p8ecs/p8ecs_83x_8rx_loccodes.htm)
 - 8247-42L, 8286-41A, or 8286-42A locations (http://www.ibm.com/support/knowledgecenter/POWER8/p8ecs/p8ecs_82x_84x_loccodes.htm)
 - 8408-44E or 8408-E8E locations(http://www.ibm.com/support/knowledgecenter/POWER8/p8ecs/p8ecs_85x_loccodes.htm)
 - 9080-MHE, 9080-MME, 9119-MHE, or 9119-MME locations(http://www.ibm.com/support/knowledgecenter/POWER8/p8ecs/p8ecs_87x_88x_loccodes.htm)
2. Record the location code.
3. Refer to the field replaceable unit (FRU) location table, Identify LED column to see if the word **Yes** (there is an identify LED) or **No** (there is not an identify LED) appears.
4. Select from the following options:
 - If the part has an identify LED, refer to the applicable procedure:
 - If you are using IBM PowerKVM, see “Identifying a part by using the ASMI” on page 66.
 - If your system is at runtime state, see “Identifying a part by using the operating system or VIOS” on page 63.
 - If your system is at standby power state, see “Identifying a part by using the ASMI” on page 66.
 - If the part does not have an identify LED, see Identifying the enclosure or server that contains the part.

Identifying a part by using the operating system or VIOS

Learn how to use AIX, IBM i, Linux, or the Virtual I/O Server (VIOS) to identify a part.

For IBM Power Systems™ that contain the POWER8® processor, the identify LEDs can be used to identify or verify the location of a part that you intend to install, remove, or replace. The identify function (flashing the amber LED) corresponds to the location code you are going to work with.

When you are removing a part, first verify whether you are working on the correct part by using the identify function in the management console or other user interface. When you remove a part by using the Hardware Management Console (HMC), the identify function is activated and deactivated automatically at the correct times.

The identify function causes the amber LED to flash. When you turn off the identify function, the LED returns to the state it was previously. For parts that have a blue service button, the identify function sets LED information for the service button so that when the button is pressed, the correct LEDs on that part flash.

Note: Use the enclosure locate LED to identify the enclosure that is being serviced. Then, confirm and verify the location of the FRU (to be serviced) in the enclosure by checking the active identify indicator (flashing LED) for the selected FRU. For some FRUs, you might need to remove the service access cover to be able to see the identify indicators.

Identifying a part in an AIX system or logical partition

Use these instructions to learn how to locate a part, activate the indicator light for the part, and deactivate the indicator light for the part on a system or logical partition running the AIX operating system.

Finding the location code for a part in an AIX system or logical partition:

You might need to use AIX tools, before activating the indicator light, to locate a part.

To configure the AIX system to locate a part, complete the following steps:

1. Log in as root user or celogin-.
2. At the command line, type `diag` and press Enter.
3. From the Function Selection menu, select **Task Selection** and press Enter.
4. Select **Display Previous Diagnostic Results** and press Enter.
5. From the Display Previous Diagnostic Results display, select **Display Diagnostic Log Summary**. The Display Diagnostic Log display shows a chronological list of events.
6. Look in the **T** column for the most recent **S** entry. Select this row in the table and press Enter.
7. Select **Commit**. The details of this log entry are shown.
8. Record the location information and the SRN value that is shown near the end of the entry.
9. Exit to the command line.

Use the location information for the part to activate the indicator light that identifies the part. See “Activating the indicator light for a part by using AIX diagnostics.”

Activating the indicator light for a part by using AIX diagnostics:

Use these instructions to help physically identify the location of a part you are servicing.

To activate the indicator light for a part, complete the following steps:

1. Log in as root user.
2. At the command line, type `diag` and press Enter.

3. From the **Function Selection** menu, select **Task Selection** and press Enter.
4. From the **Task Selection** menu, select **Identify and Attention Indicators** and press Enter.
5. From the list of lights, select the location code for the part and press Enter.
6. Select **Commit**. This turns on the system attention and indicator light for the part.

Important: A flashing amber LED indicates the location of the part and a solid amber LED indicates that the part is failing.

7. Exit to the command line.

Identifying a part in an IBM i system or logical partition

You can activate or deactivate the indicator light to locate a part in an IBM i system or logical partition.

Finding the location code and activating the indicator light for a part by using the IBM i operating system:

You can search the service action log for an entry that matches the time, reference code, or resource of a problem, and then activate the indicator light for a part.

1. Sign on to an IBM i session, **with at least service level authority**.
2. On the command line of the session, type `strsst` and press Enter.

Note: If you cannot get to the System Service Tools (SST) display, use function 21 from the control panel. Alternatively, if the system is managed by a Hardware Management Console (HMC), use the Service Focal Point utilities to get to the Dedicated Service Tools (DST) display.

3. Type your service tools user ID and service tools password on the System Service Tools (SST) Sign On display and press Enter.

Remember: The service tools password is case sensitive.

4. Select **Start a service tool** from the System Service Tools (SST) display and press Enter.
5. Select **Hardware service manager** from the Start a Service Tool display and press Enter.
6. Select **Work with service action log** from the Hardware Service Manager display and press Enter.
7. On the Select Timeframe display, change the **From: Date and Time** field to a date and time prior to when the problem occurred.
8. Search for an entry that matches one or more conditions of the problem:
 - System reference code
 - Resource
 - Date and time
 - Failing item list
9. Select option 2 (Display failing item information) to display the service action log entry.
10. Select option 2 (Display details) to display location information for the failing part to be replaced. The information displayed in the date and time fields is the date and time for the first occurrence of the specific system reference code for the resource displayed during the time range selected.
11. If location information is available, select option 6 (Indicator on) to turn on the indicator light for the part.

Tip: If the part does not contain a physical indicator light, a higher-level indicator light is activated. For example, the indicator light for the backplane or unit that contains the part might be lit. In this case, use the location information to locate the actual part.

12. Look for the enclosure indicator light to locate the enclosure that contains the part.

Important: A flashing amber LED indicates the location of the part and a solid amber LED indicates that the part is failing.

Identifying a part in a Linux system or logical partition

If the service aids have been installed on a system or logical partition, you can activate or deactivate the indicator lights to locate a part or complete a service action.

Finding the location code of a part in a Linux system or logical partition:

Use this procedure to retrieve the location code of the part to perform service operations.

To find the location code of a part in a Linux system or logical partition, complete the following steps:

1. Log in as root user.
2. At the command line, type `grep diagela /var/log/platform` and press Enter.
3. Look for the most recent entry that contains a system reference code (SRC).
4. Record the location information.

Related information:

 Service and productivity tools for PowerLinux servers from IBM
IBM provides hardware diagnostic aids and productivity tools, and installation aids for Linux operating systems on IBM Power Systems servers.

Activating the indicator light for a part by using the Linux operating system:

If you know the location code of a part, activate the indicator light to help locate the part the while performing service operations.

To activate the indicator light, complete the following steps:

1. Log in as root user.
2. At the command line, type `/usr/sbin/usysident -s identify -l location_code` and press Enter.
3. Look for the system attention light to identify the enclosure that contains the part.

Important: A flashing amber LED indicates the location of the part and a solid amber LED indicates that the part is failing.

Related information:

 Service and productivity tools for Linux on Power servers
IBM provides hardware diagnostic aids and productivity tools, and installation aids for Linux operating systems on IBM Power Systems servers.

Identifying a part in a VIOS system or logical partition

Learn how to find the location code and identify a part by using the Virtual I/O Server (VIOS) tools.

Finding the location code of a part in a VIOS system or logical partition:

You can use Virtual I/O Server (VIOS) tools to find the location code of a part before you activate the indicator light.

To configure the Virtual I/O Server system for identifying a part, complete the following steps:

1. Log in as root user or `celogin-`.
2. At the command line, type `diagmenu` and press Enter.
3. From the **Function Selection** menu, select **Task Selection** and press Enter.
4. Select **Display Previous Diagnostic Results** and press Enter.
5. From the **Display Previous Diagnostic Results** display, select **Display Diagnostic Log Summary**. A **Display Diagnostic Log** display appears. This display contains a chronological list of events.
6. Look in the **T** column for the most recent **S** entry. Select this row in the table and press Enter.

7. Choose **Commit**. The details of this log entry are shown.
8. Record the location information and the SRN value shown near the end of the entry.
9. Exit to the command line.

Use the location information for the part to activate the indicator light that identifies the part. For instructions, see “Activating the indicator light for a part by using the VIOS tools.”

Activating the indicator light for a part by using the VIOS tools:

You can use Virtual I/O Server (VIOS) tools to activate the indicator light to physically locate a part.

To turn on the indicator light for identifying a part, complete the following steps:

1. Log in as root user.
2. At the command line, type `diagmenu` and press Enter.
3. From the **Function Selection** menu, select **Task Selection** and press Enter.
4. From the **Task Selection** menu, select **Identify and Attention Indicators** and press Enter.
5. From the list of lights, select the location code for the failing part and press Enter.
6. Select **Commit**. This turns on the system attention and indicator light for the part.

Important: A flashing amber LED indicates the location of the part and a solid amber LED indicates that the part is failing.

7. Exit to the command line.

Identifying a part by using the ASMI

Learn how to activate or deactivate amber identify indicator light-emitting diodes (LEDs) by using the Advanced System Management Interface (ASMI).

You can access the ASMI by using a web browser. For more information, see [Accessing the ASMI using a PC or notebook and web browser](http://www.ibm.com/support/knowledgecenter/POWER8/p8hby/browser.htm)(<http://www.ibm.com/support/knowledgecenter/POWER8/p8hby/browser.htm>).

For IBM Power Systems that contain the POWER8 processor, the identify LEDs can be used to identify or verify the location of a part that you intend to install, remove, or replace. The identify function (flashing the amber LED) corresponds to the location code you are going to work with.

You can set the identify LED to flash and to stop flashing by using the ASMI.

Note: You can use the ASMI to turn on and turn off the identify indicators except for the adapters, disk drives, solid-state drives, and media devices.

Activating the identify LED by using the ASMI when you know the location code

Learn how to activate the identify LED by using the Advanced System Management Interface (ASMI) when you know the location code.

You can specify the location code of any indicator to view or modify its current state. If you provide the wrong location code, the ASMI attempts to go to the next higher level of the location code.

The next level is the base-level location code for that field replaceable unit (FRU). For example, a user types the location code for the FRU located on the second memory module slot of the third enclosure in the system. If the location code for the second memory module slot is incorrect (the FRU does not exist at this location), an attempt to set the indicator for the third enclosure is initiated. This process continues until a FRU is located or no other level is available.

To complete this operation, your authority level must be one of the following levels:

- Administrator
- Authorized service provider

To change the current state of an indicator, complete the following steps:

1. On the ASMI Welcome pane, specify your user ID and password, and click **Log In**.
2. In the navigation area, expand **System Configuration > Service Indicators > Indicators by Location code**.
3. In the **Location code** field, type the location code of the FRU and click **Continue**.
4. From the **Identify indicator status** list, select **Identify**.
5. Click **Save settings**.

Activating the identify LED by using the ASMI when you do not know the location code

Learn how to activate the identify LED by using the Advanced System Management Interface (ASMI) when you do not know the location code.

You can turn on the identify indicators in each enclosure.

To complete this operation, your authority level must be one of the following levels:

- Administrator
- Authorized service provider

To enable the enclosure indicator states, complete the following steps:

1. On the ASMI Welcome pane, specify your user ID and password, and click **Log In**.
2. In the navigation area, expand **System Configuration > Service Indicators > Enclosure Indicators**. All servers and enclosures managed by the ASMI will display.
3. Select the server or enclosure with the part that needs to be replaced and click **Continue**. The location code identifiers are listed.
4. Select the location code identifier and select **Identify**.
5. To save the changes made to the state of one or more FRU indicators, click **Save settings**.

Identifying a part by using the HMC

You can use the following procedures to activate light-emitting diodes (LEDs) by using the Hardware Management Console (HMC).

You can use the identify LED for a FRU associated with a specified enclosure to help you identify a part. For example, if you want to hook up a cable to a specific I/O adapter, you can activate the LED for the adapter, which is a field replaceable unit (FRU). Then, you can physically check to see where you should hook up the cable. This action is especially useful when you have several adapters with open ports.

1. Choose one of the following navigation options depending on the interface type of the HMC:
 - If you are using an HMC Classic or HMC Enhanced interface, complete the following steps:
 - a. In the navigation area, click **Systems Management > Servers**.
 - b. Select the server that you are working on.
 - c. In the **Tasks** menu, click **Operations > LED status > Identify LED**. The **Identify LED, Select Enclosure** window is displayed.
 - If you are using an HMC Enhanced + Tech Preview (Pre-GA) or HMC Enhanced+ interface, complete the following steps.



- a. In the navigation area, click the **Resources** icon  , and then click **All Systems**.
 - b. Click the system name for which you want to activate the attention LED.
 - c. In the navigation area, click **System Actions > Attention LED > Identify Attention LED**. The Identify LED, Select Enclosure window is displayed.
2. To activate an identify LED for the enclosure, select an enclosure and then click **Activate LED**. The associated LED is turned on and is flashing.
 3. To activate an identify LED for one or more FRUs in the enclosure, complete the following steps:
 - a. Select an enclosure and then click **List FRUs**.
 - b. Select the FRUs for which you want to activate the identify LED and click **Activate LED**. The associated LED is turned on and is flashing.

Starting the system or logical partition

Learn how to start a system or logical partition after performing a service action or system upgrade.

Starting a system that is not managed by an HMC

You can use the power button or the Advanced System Management Interface (ASMI) to start a system that is not managed by a Hardware Management Console (HMC).

Starting a system by using the control panel

You can use the power button on the control panel to start a system that is not managed by a Hardware Management Console (HMC).

To start a system by using the control panel, complete the following steps:

1. Open the front rack door, if necessary.
2. Before you press the power button on the control panel, ensure that power is connected to the system unit as follows:
 - All system power cables are connected to a power source.
 - The power LED, as shown in the following figure, is slowly flashing.
 - The top of the display, as shown in the following figure, shows 01 V=F.
3. Press the power button (**A**), as shown in the following figure, on the control panel.

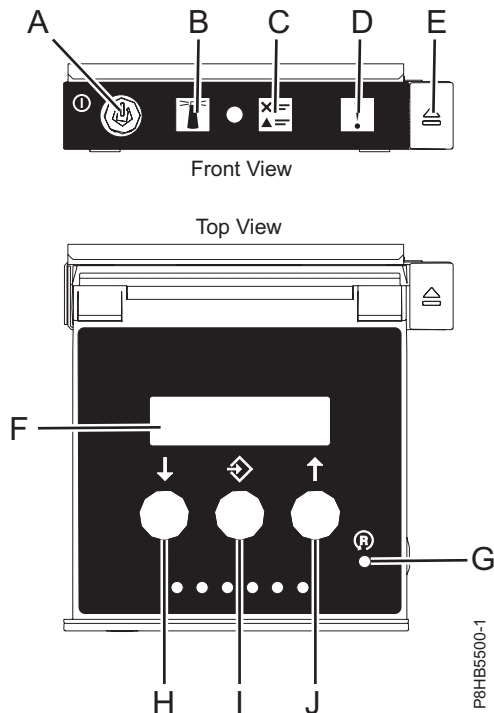

Figure 35. Control panel

- **A:** Power-on button
 - A constant light indicates full system power to the unit.
 - A flashing light indicates standby power to the unit.
 - There is approximately a 30-second transition period from the time the power-on button is pressed to when the power LED goes from flashing to solid. During the transition period, the LED might flash faster.
 - **B:** Enclosure identify light
 - A constant light indicates the identify state, which is used to identify a part.
 - No light indicates that the system is operating normally.
 - **C:** System information light
 - No light indicates that the system is operating normally.
 - Light on indicates that the system requires attention.
 - **D:** Enclosure fault roll-up light
 - A constant light indicates a fault in the enclosure.
 - No light indicates that the system is operating normally.
 - **E:** Eject button
 - **F:** Function/Data display
 - **G:** Pinhole reset button
 - **H:** Decrement button
 - **I:** Enter button
 - **J:** Increment button
4. Observe the following aspects after pressing the power button:
- The power-on light begins to flash faster.
 - The system cooling fans are activated after approximately 30 seconds and begin to accelerate to operating speed.

- Progress indicators, also referred to as checkpoints, appear on the control panel display while the system is being started. The power-on light on the control panel stops flashing and remains on, indicating that the system power is on.

Tip: If pressing the power button does not start the system, then contact your next level of support or your service provider.

Starting a system by using the ASMI

You can use the Advanced System Management Interface (ASMI) to start a system that is not managed by a Hardware Management Console (HMC).

To start a system by using the ASMI, complete the following steps:

1. On the ASMI Welcome pane, specify your user ID and password, and click **Log In**.
2. In the navigation area, click **Power/Restart Control > Power On/Off System**. The power state of the system is displayed.
3. Specify the settings as required and click **Save setting and power on**.

Starting a system or logical partition by using the HMC

You can use the Hardware Management Console (HMC) to start the system or logical partition after the required cables are installed and the power cables are connected to a power source.

Starting a system or logical partition by using the HMC Classic or HMC Enhanced interface

Learn how to start a system or logical partition by using the HMC Classic or HMC Enhanced interface.

To start the system by using the HMC Classic or HMC Enhanced interface, complete the following steps:

1. Verify that the logical partition start policy is set to **User-Initiated** by completing the following steps:
 - a. In the navigation area, expand **Systems Management > Servers**.
 - b. In the content pane, select the managed system.
 - c. In the Tasks area, click **Properties**.
 - d. Click the **Power-On Parameters** tab. Ensure that the **Partition start policy** field is set to **User-Initiated**.
2. Power on the managed system by completing the following steps:
 - a. In the navigation area, expand **Systems Management > Servers**.
 - b. In the content pane, select the managed system.
 - c. Click **Operations > Power on**.
 - d. Select the power-on option and click **OK**.

Starting a system or logical partition by using the HMC Enhanced + Tech Preview (Pre-GA) or HMC Enhanced+ interface

Learn how to start a system or logical partition by using the HMC Enhanced + Tech Preview (Pre-GA) or HMC Enhanced+ interface.

To start a system or logical partition by using the HMC Enhanced + Tech Preview (Pre-GA) or HMC Enhanced+ interface, complete the following steps:

1. To power on the managed system, complete the following steps:

- a. In the navigation area, click the **Resources** icon  , and then click **All Systems**.
- b. Select the system that you want to power on.
- c. In the content pane, click **Actions > View All Actions > Power On**.

- d. Click **OK**.
2. To activate a logical partition, complete the following steps:



- a. In the navigation area, click the **Resources** icon , and then click **All Partitions**.
 - b. Click the logical partition name that you want to activate.
 - c. In the navigation area, click **Partition Actions > Operations > Activate**.
 - d. Click **OK**.
3. To activate a logical partition for a specific system, complete the following steps:



- a. In the navigation area, click the **Resources** icon , and then click **All Systems**.
 - b. Click the system name in which you want to activate the logical partition.
 - c. Select logical partitions that you want to activate.
 - d. In the content pane, click **Actions > Activate**.
 - e. Click **OK**.
4. To verify that the logical partition start policy is set to **User-Initiated**, complete the following steps:



- a. In the navigation area, click the **Resources** icon , and then click **All Systems**.
- b. Click the system name to view details.
- c. In the navigation area, click **Properties > Other Properties**.
- d. Click the **Power-On Parameters** tab. Ensure that the **Partition start policy** field is set to **User-Initiated**.

Starting an IBM PowerKVM system

You can use the Intelligent Platform Management Interface (IPMI) to start an IBM PowerKVM system.

To start an IBM PowerKVM system, run the `ipmitool -I lanplus -H FSP IP -P ipmipassword chassis power on` command from a remote system.

Stopping a system or logical partition

Learn how to stop a system or logical partition as a part of a system upgrade or service action.

Attention: Using either the power-on button on the control panel or entering commands at the Hardware Management Console (HMC) to stop the system can cause unpredictable results in the data files. Also, the next time you start the system, it might take longer if all applications are not ended before stopping the system.

To stop the system or logical partition, select the appropriate procedure.

Stopping a system that is not managed by an HMC

You might need to stop the system to complete another task. If your system is not managed by the Hardware Management Console (HMC), use these instructions to stop the system by using the power button or the Advanced System Management Interface (ASMI).

Before you stop the system, follow these steps:

1. Ensure that all jobs are completed and end all applications.
2. If a Virtual I/O Server (VIOS) logical partition is running, ensure that all clients are shut down or that the clients have access to their devices by using an alternative method.

Stopping a system by using the control panel

You might need to stop the system to complete another task. If your system is not managed by the Hardware Management Console (HMC), use these instructions to stop the system by using the power button.

The following procedure describes how to stop a system that is not managed by the HMC.

1. Log in to the host partition as a user with the authority to run the **shutdown** or **pwrdownsys** (Power Down System) command.
2. At the command line, enter one of the following commands:
 - If your system is running the AIX operating system, type **shutdown**.
 - If your system is running the Linux operating system, type **shutdown -h now**.
 - If your system is running the IBM i operating system, type **PWRDOWNSYS**. If your system is partitioned, use the **PWRDOWNSYS** command to power down each of the secondary partitions. Then, use the **PWRDOWNSYS** command to power down the primary partition.

The command stops the operating system. The system power turns off, the power-on light begins to slowly flash, and the system goes into a standby state.

3. Record the IPL type and the IPL mode from the control panel display to help you return the system to this state when the installation or replacement procedure is completed.
4. Set the power switches of any devices that are connected to the system to off.

Stopping a system by using the ASMI

You might need to stop the system to complete another task. If your system is not managed by the Hardware Management Console (HMC), use these instructions to stop the system by using the Advanced System Management Interface (ASMI).

To stop a system by using the ASMI, complete the following steps:

1. On the ASMI Welcome pane, specify your user ID and password, and click **Log In**.
2. In the navigation area, click **Power/Restart Control > Power On/Off System**. The power state of the system is displayed.
3. Specify the settings as required and click **Save setting and power off**.

Stopping a system by using the HMC

You can use the Hardware Management Console (HMC) to stop the system or logical partition.

By default, the managed system is set to power off automatically when you shut down the last running logical partition on the managed system. If you set the managed system properties on the HMC so that the managed system does not power off automatically, you must use this procedure to power off your managed system.

Attention: Ensure that you shut down the running logical partitions on the managed system before you power off the managed system. Powering off the managed system without shutting down the logical partitions first causes the logical partitions to shut down abnormally and can cause data loss. If you use a Virtual I/O Server (VIOS) logical partition, ensure that all clients are shut down or that the clients have access to their devices by using an alternative method.

To power off a managed system, you must be a member of one of the following roles:

- Super administrator
- Service representative

- Operator
- Product engineer

Note: If you are a product engineer, verify that the customer has shut down all active partitions and has powered off the managed system. Continue with the procedure only after the status of the server changes to **Power Off**.

Stopping a system by using the HMC Classic or HMC Enhanced interface

Learn how to stop a system by using the HMC Classic or HMC Enhanced interface.

To stop the system or logical partition by using the HMC Classic or HMC Enhanced interface, complete the following steps:

1. In the navigation area, click **Systems Management > Servers**.
2. In the content pane, select the managed system.
3. In the Tasks area, click **Operations > Power Off**.
4. Select the appropriate power-off mode and click **OK**.

Related information:

 Shutting down and restarting logical partitions

Stopping a system by using the HMC Enhanced + Tech Preview (Pre-GA) or HMC Enhanced+ interface

Learn how to stop a system by using the HMC Enhanced + Tech Preview (Pre-GA) or HMC Enhanced+ interface.

To stop the system or logical partition by using the HMC Enhanced + Tech Preview (Pre-GA) or HMC Enhanced+ interface, complete the following steps:

1. You must deactivate all the active logical partitions before powering off the system. To deactivate logical partitions for a specific system, complete the following steps:

- a. In the navigation area, click the **Resources** icon  , and then click **All Systems**.
- b. Click the system name for which you want to deactivate partitions.
- c. Select the logical partitions that you want to deactivate.
- d. In the content pane, click **Actions > Deactivate**.
- e. Click **OK**.

2. To power off the system, complete the following steps:

- a. In the navigation area, click the **Resources** icon  , and then click **All Systems**.
- b. Select the system that you want to power off.
- c. In the content pane, click **Actions > View All Actions > Power Off**.
- d. Click **OK**.

Stopping an IBM PowerKVM system

You can use the Intelligent Platform Management Interface (IPMI) to stop an IBM PowerKVM system.

To stop an IBM PowerKVM system, complete the following steps:

1. Log in to the host as a root user or with sudo authority.
2. To power off each of the guests, complete the following steps.

- a. To obtain a list of all guests, type **virsh list**.
- b. For each guest in the list, type **virsh shutdown domain name** or type **virsh shutdown domain ID**.

Note:

Type **virsh list** to verify whether all the guests are powered off. If any guest is not powered off, type **virsh destroy domain name** or type **virsh destroy domain ID** to power off the guest.

3. Run the **ipmitool -I lanplus -H FSP IP -P ipmipassword chassis power off** command from a remote system.

Removing and replacing covers on an 8408-44E or 8408-E8E system

Use these instructions to remove and replace the covers in an 8408-44E or 8408-E8E system so that you can access the hardware parts or perform service.

Removing the front cover from an 8408-44E or 8408-E8E system

Use this procedure to remove the cover so that you can access the components or perform service.

To remove the front cover, complete the following steps:

1. If necessary, open the front rack door.
2. Ensure that you have the electrostatic discharge (ESD) wrist strap attached. If not, attach it now.
3. Place your fingers on the indentations and pull the latches (**B**) located on both sides of the cover.

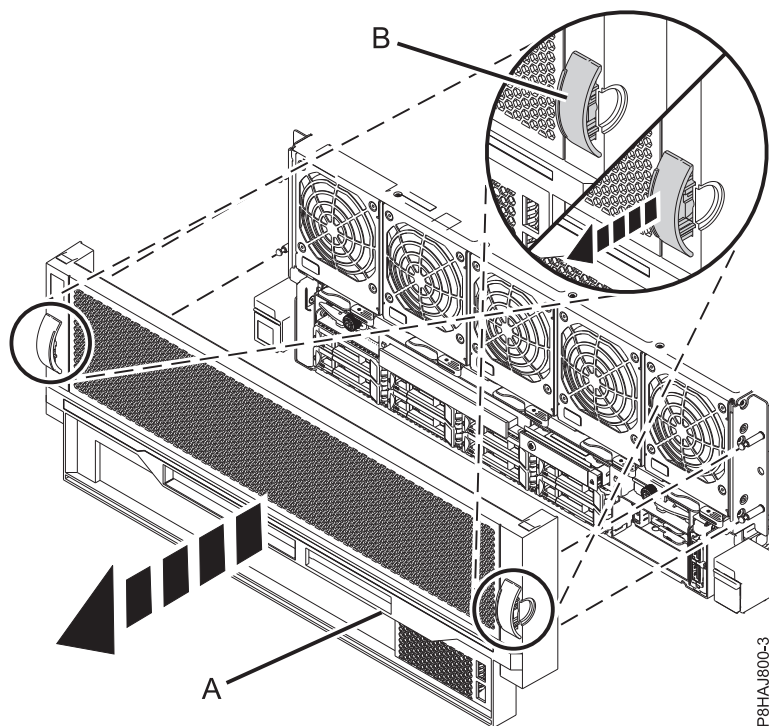

Figure 36. Removing the front cover

4. Pull the cover (**A**) away from the system.

Installing the front cover on an 8408-44E or 8408-E8E system

Use this procedure to install the cover after accessing the components or performing service.

To install the front cover, complete the following steps:

1. Ensure that you have the electrostatic discharge (ESD) wrist strap attached. If not, attach it now.
2. Position the cover (A) on the front of the system unit so that the four pins (B) on the system match the four holes at the rear of the cover.

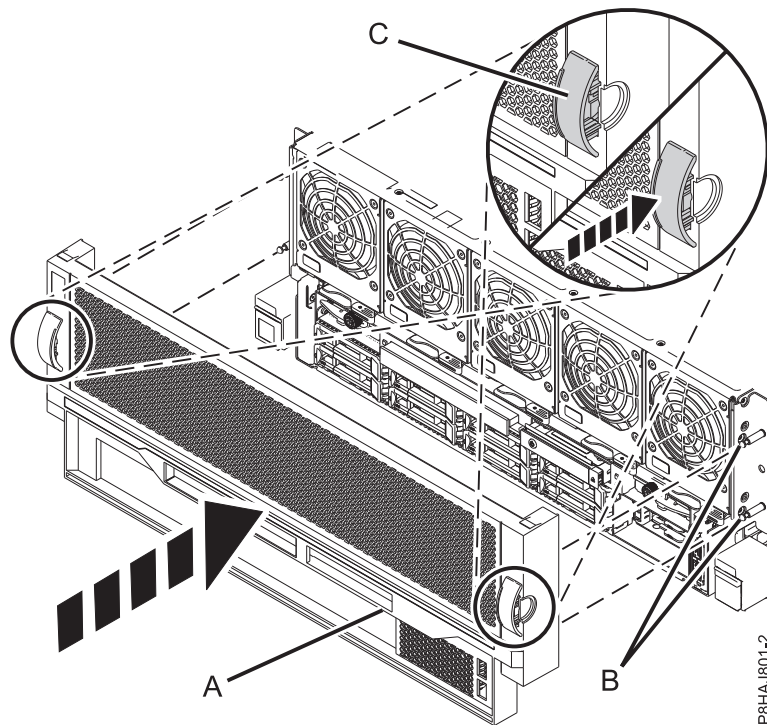

Figure 37. Installing the front cover

3. Press the tabs (C) to snap the cover into position.
4. Close the front door of the rack.

Removing the service access cover from an 8408-44E or 8408-E8E system

Use this procedure to remove the service access cover from an 8408-44E or 8408-E8E system.

To remove the service access cover, complete the following steps:

1. Ensure that you have the electrostatic discharge (ESD) wrist strap attached. If not, attach it now.
2. Push the release latches (A) in the direction shown.
3. Slide the cover (B) off the system unit. When the front of the service access cover has cleared the upper frame ledge, lift the cover up and off the system unit.

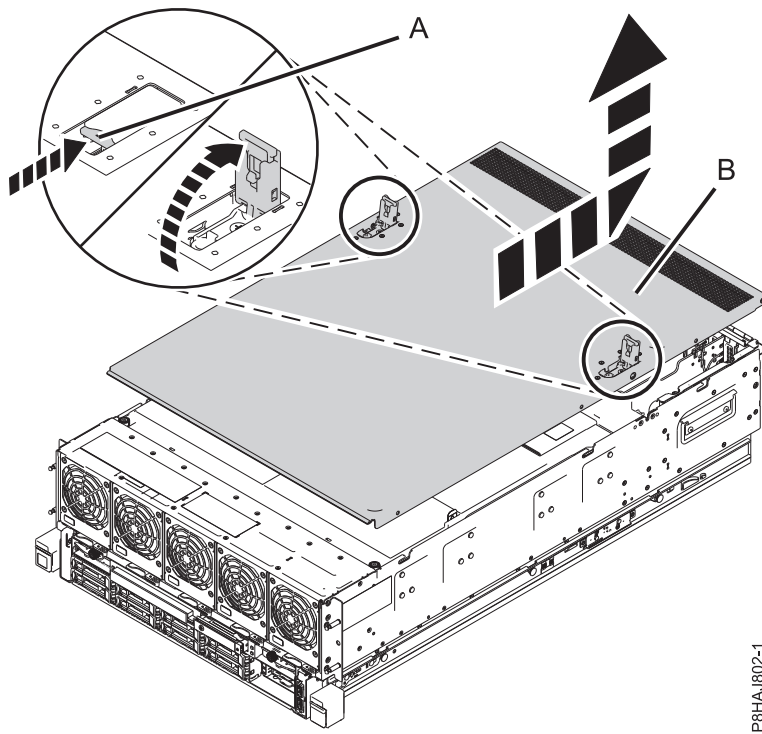

P8HAJ802-1

Figure 38. Removing the service access cover

Installing the service access cover on an 8408-44E or 8408-E8E system

Use this procedure to install the service access cover.

To install the service access cover, complete the following steps:

1. Ensure that you have the electrostatic discharge (ESD) wrist strap attached. If not, attach it now.
2. Slide the cover (**A**) onto the system unit.
3. Close the release latches (**B**) by pushing it in the direction shown.

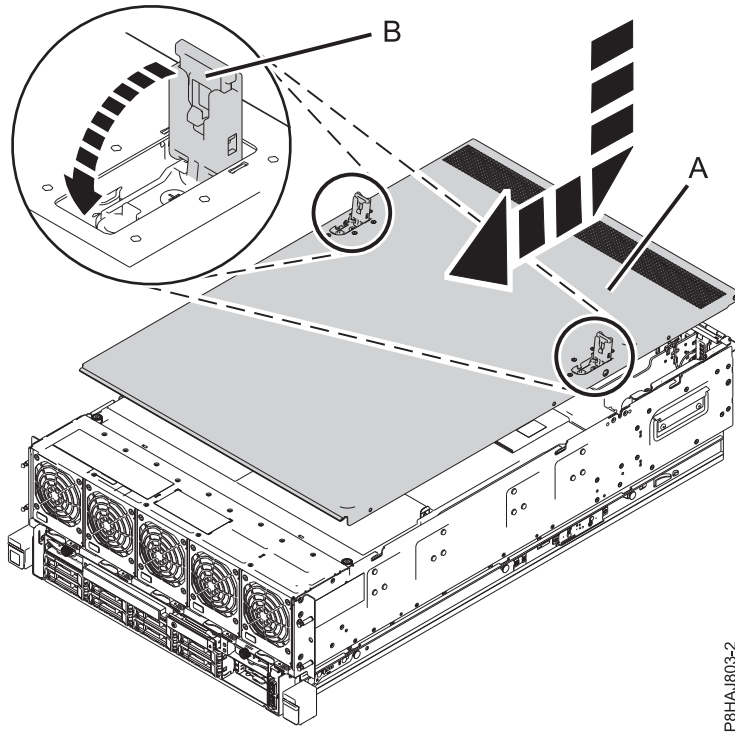

P8HAJ803-2

Figure 39. Installing the service access cover

Removing and replacing the safety cover in an 8408-44E or 8408-E8E system

Use these procedures to remove and replace the safety cover in an 8408-44E or 8408-E8E system.

Removing the safety cover from an 8408-44E or 8408-E8E system

Use this procedure to remove the safety cover from an 8408-44E or 8408-E8E system.

To remove the safety cover, complete the following steps:

1. Ensure that you have the electrostatic discharge (ESD) wrist strap attached. If not, attach it now.
2. Loosen the thumbscrew (A) located at the rear of the cover, by turning it in the direction shown in Figure 40 on page 78.
3. Slide the safety cover (B) toward the rear of the system. When the front of the cover has cleared the upper frame ledge, lift the cover up and off the system.

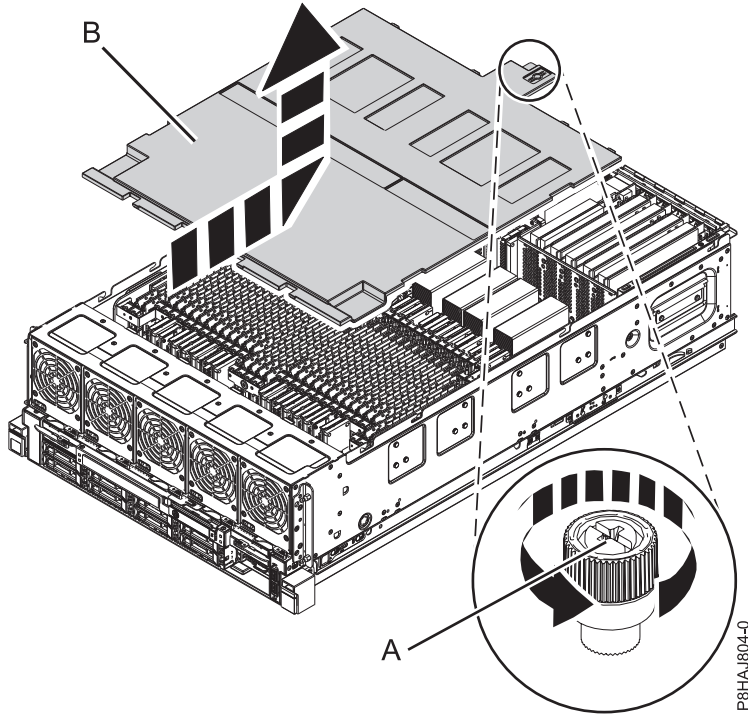

Figure 40. Removing the safety cover

Replacing the safety cover in an 8408-44E or 8408-E8E system

Use this procedure to replace the safety cover in an 8408-44E or 8408-E8E system.

To replace the safety cover, complete the following steps:

1. Ensure that you have the electrostatic discharge (ESD) wrist strap attached. If not, attach it now.
2. Push the safety cover (A) toward the chassis.
3. Tighten the thumbscrew (B) by turning it in the direction shown in Figure 41 on page 79 to fix the safety cover to the chassis.

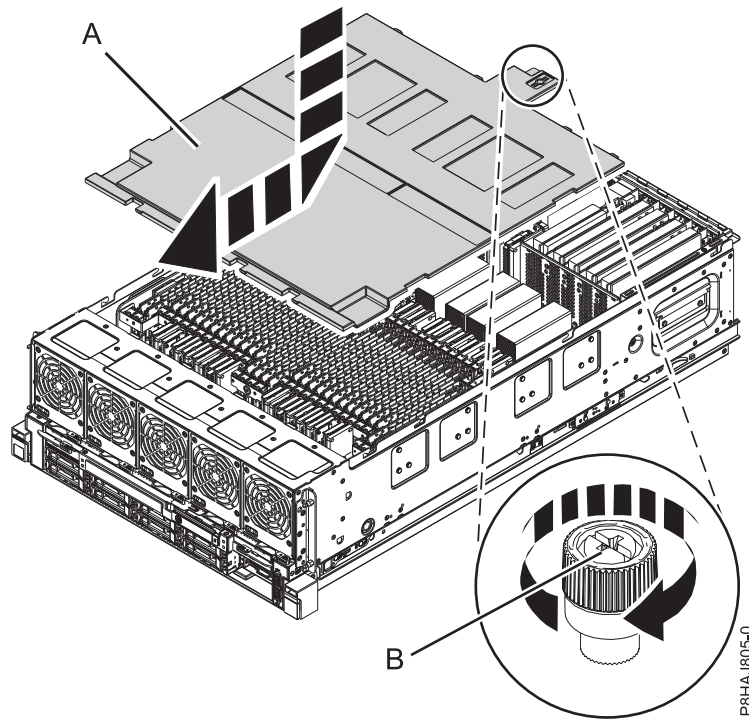

Figure 41. Replacing the safety cover

Opening and closing the I/O latch in an 8408-44E or 8408-E8E system

Use this procedure to open and close the I/O latch in an 8408-44E or 8408-E8E system.

The 8408-44E or 8408-E8E system is equipped with two I/O latches on either side of the system.

Opening the I/O latch in an 8408-44E or 8408-E8E system

Use this procedure to open the I/O latch in an 8408-44E or 8408-E8E system.

To open the I/O latch, complete the following steps:

1. Ensure that you have the electrostatic discharge (ESD) wrist strap attached. If not, attach it now.
2. Loosen the thumbscrew (A), by turning it in the direction shown in Figure 42 on page 80.
3. Move service access latch (B) to the open position, by pushing it in the direction shown in Figure 42 on page 80.

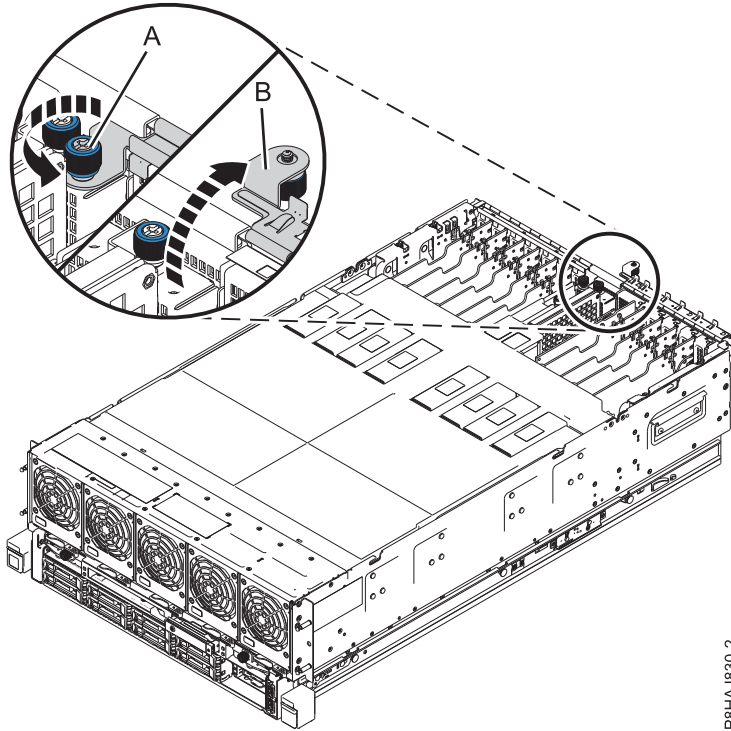

P8HAJ830-2

Figure 42. Opening the I/O latch

Closing the I/O latch in an 8408-44E or 8408-E8E system

Use this procedure to close the I/O latch in an 8408-44E or 8408-E8E system.

To close the I/O latch, complete the following steps:

1. Ensure that you have the electrostatic discharge (ESD) wrist strap attached. If not, attach it now.
2. Close the service access latch (**B**) by pushing it toward the chassis as shown in Figure 43 on page 81.
3. Tighten the thumbscrew (**A**) by turning it in the direction shown, to fix the latch to the chassis.

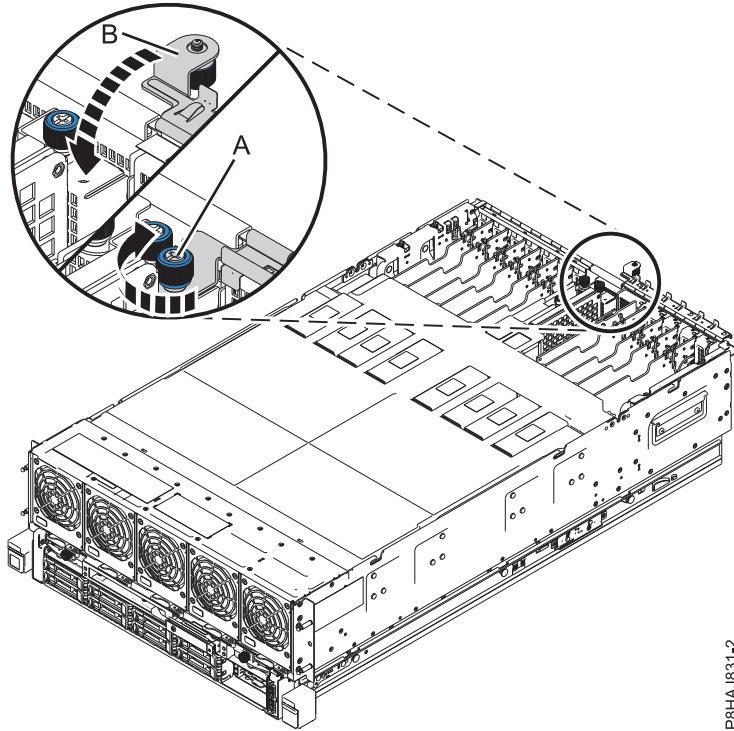

P8HAJ831-2

Figure 43. Closing the I/O latch

Service and operating positions for an 8408-44E or 8408-E8E system

Use these procedures to place an 8408-44E or 8408-E8E server into the service or operating position.

Placing an 8408-44E or 8408-E8E system into the service position

Use this procedure to place an 8408-44E or 8408-E8E system into the service position.

Notes:

- When placing the system into the service position, ensure that all stability plates are firmly in position to prevent the rack from toppling.
- Ensure that only one system unit is in the service position at a time.
- Ensure that the cables at the rear of the system unit do not catch or bind as you pull the system unit forward in the rack.
- When the rails are fully extended, the rail safety latches lock into place. This action prevents the system from being pulled out too far.

To place an 8408-44E or 8408-E8E system into the service position, complete the following steps:

1. Ensure that you have the electrostatic discharge (ESD) wrist strap attached. If not, attach it now.
2. If you have not already done so, remove the front cover from the system. For instructions, see “Removing the front cover from an 8408-44E or 8408-E8E system” on page 74.
3. Remove the shipping screws (A) by using a Phillips screwdriver, if they are not removed already.
4. Release the side latches (B) by pressing them downward and then outward as shown in the following figure.

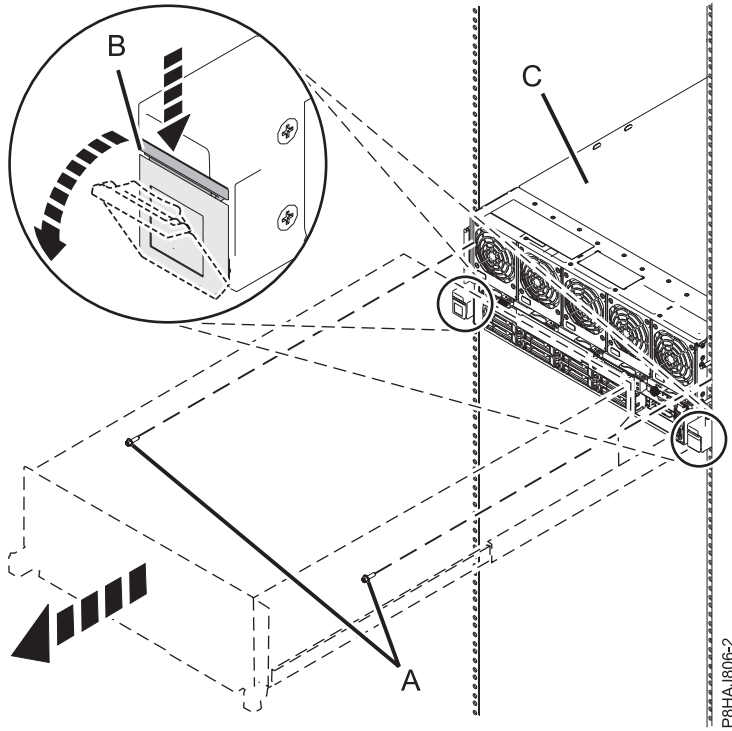

Figure 44. Placing the system in service position

5. Slide out the system unit (C) from the rack.

Placing an 8408-44E or 8408-E8E system into the operating position

Use this procedure to place an 8408-44E or 8408-E8E system into the operating position.

Note: When you place the system in the operating position, ensure that the cables at the rear of the system do not catch or bind as you push the system unit back into the rack.

To place an 8408-44E or 8408-E8E system in the operating position, complete the following steps:

1. Ensure that you have the electrostatic discharge (ESD) wrist strap attached. If not, attach it now.
2. Unlock the blue rail safety latches (A) by lifting them upward.
3. Push the system unit (B) back into the rack until both system unit release latches lock into position.

Note: Slide the system unit slowly into the rack to ensure that your fingers do not get caught in the side rails.

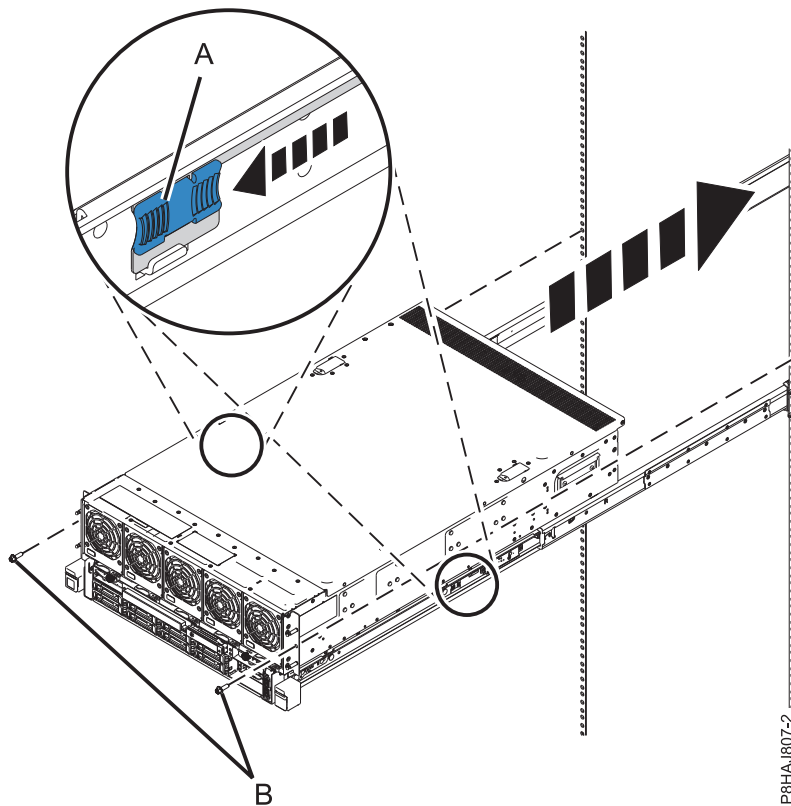

Figure 45. Placing the system into the operating position

4. Secure the server to the rack by using shipping screws.
5. If you have not already done so, replace the front cover. For instructions, see “Installing the front cover on an 8408-44E or 8408-E8E system” on page 74.

Power cords

Use these procedures to disconnect and connect the power cords on IBM Power Systems servers that contain the POWER8 processor.

Disconnecting the power cords from the system

Use this procedure to disconnect the power cords from the system.

To disconnect the power cords from the system, complete the following steps:

1. Open the rear rack door on the system unit that you are servicing.
2. Identify the system unit that you are servicing in the rack.
3. Disconnect the power cords (**B**) from the system unit. See Figure 49 on page 85, Figure 50 on page 85, or Figure 51 on page 86 or depending on the type of your system.

Notes:

- This system might be equipped with two or more power supplies. If the removing and replacing procedures require the power to be off, then ensure that all the power sources to the system have been completely disconnected.
- The power cord is fastened to the system using the hook-and-loop fastener (**A**). If you are placing the system in a service position after disconnecting the power cords, then ensure that you unstrap the fastener.

Figure 46 shows the supported alternate current (AC) and high voltage direct current (HVDC) connectors. Figure 47 and Figure 48 show the supported connectors and power distribution unit (PDU) for 8408-44E.

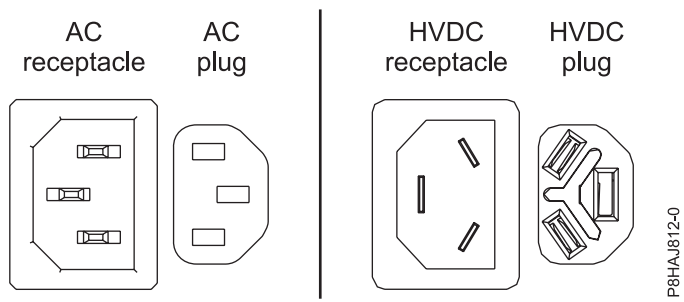

Figure 46. AC and HVDC connectors

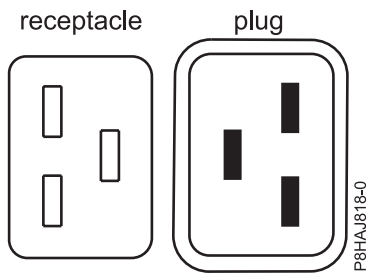

Figure 47. Connectors for the 8408-44E system

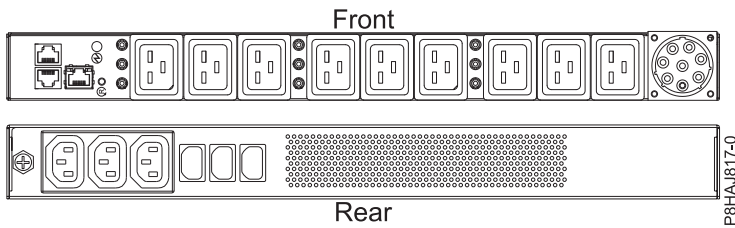

Figure 48. PDU for the 8408-44E system

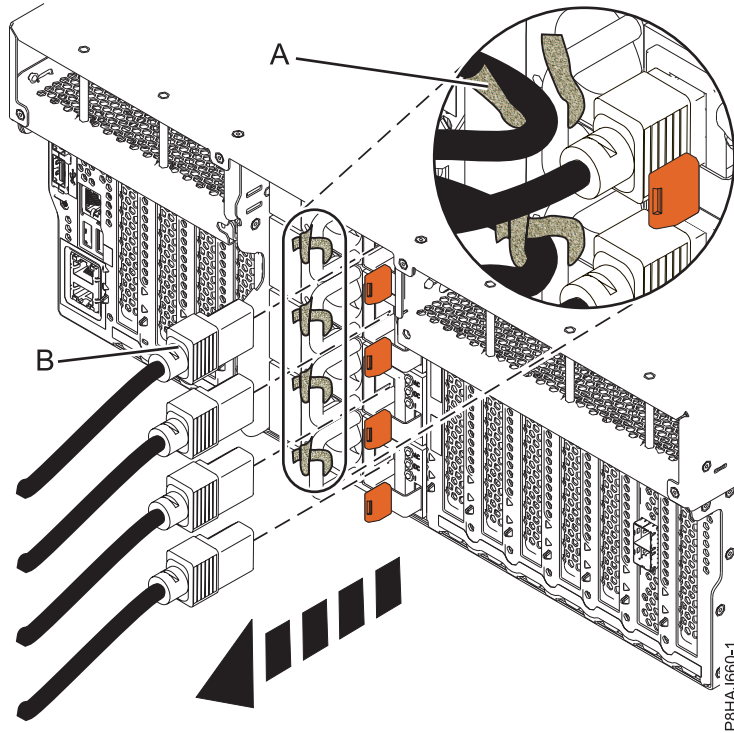

Figure 49. Removing the power cords from an 8247-42L, 8286-41A, or 8286-42A system

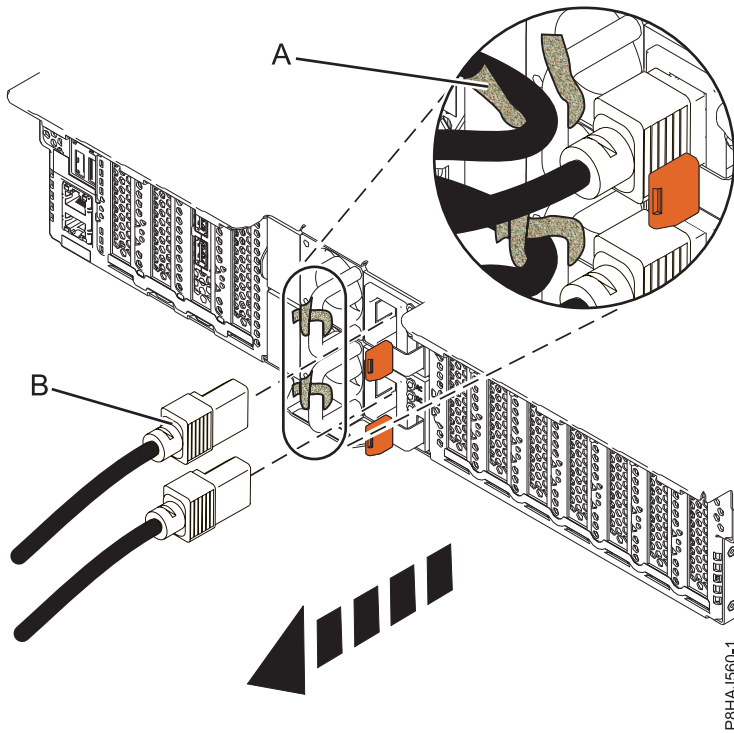

Figure 50. Removing the power cords from an 5148-21L, 5148-22L, 8247-21L, 8247-22L, 8284-21A, or 8284-22A system

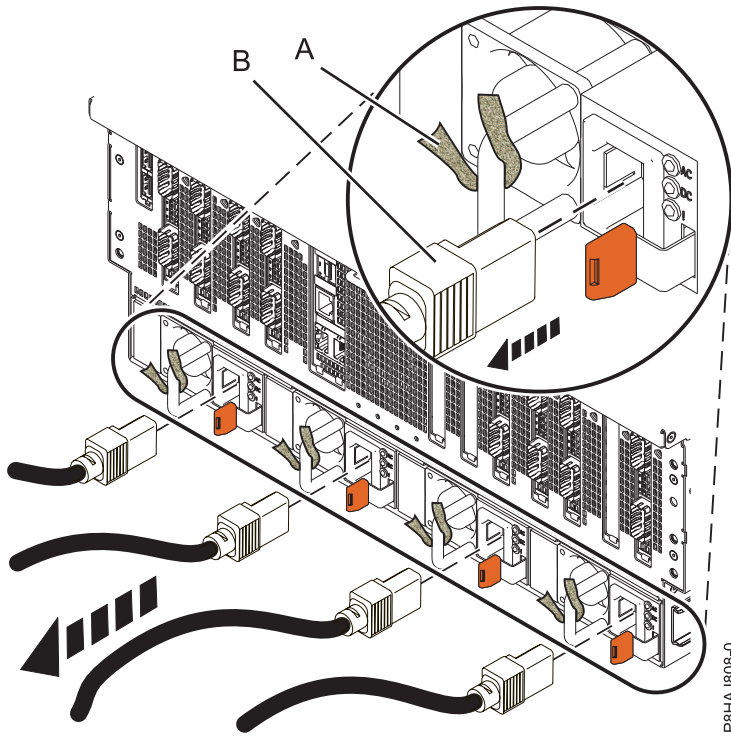

Figure 51. Removing the power cords from an 8408-44E or 8408-E8E system

Connecting the power cords to the system

Use this procedure to connect the power cords to the system.

To connect the power cords to the system, complete the following steps:

1. Open the rear rack door on the system unit that you are servicing.
2. Reconnect the power cords (A) to the system unit. See Figure 55 on page 87, Figure 56 on page 88, or Figure 57 on page 88 depending on the type of your system. Figure 52 shows the supported alternate current (AC) and high voltage direct current (HVDC) connectors. Figure 53 on page 87 and Figure 54 on page 87 show the supported connectors and power distribution unit (PDU) for 8408-44E.

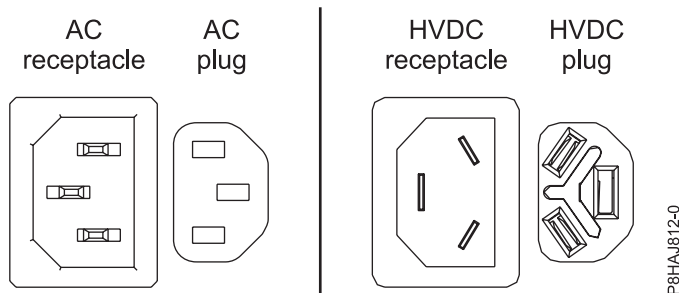

Figure 52. AC and HVDC connectors

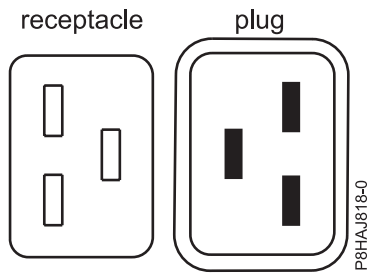

Figure 53. Connectors for the 8408-44E system

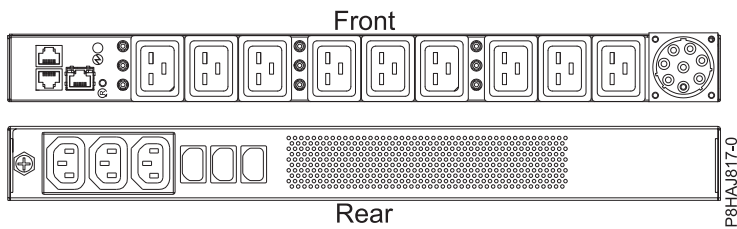

Figure 54. PDU for the 8408-44E system

3. Fasten the power cords to the system using the hook-and-loop fasteners **(B)**.

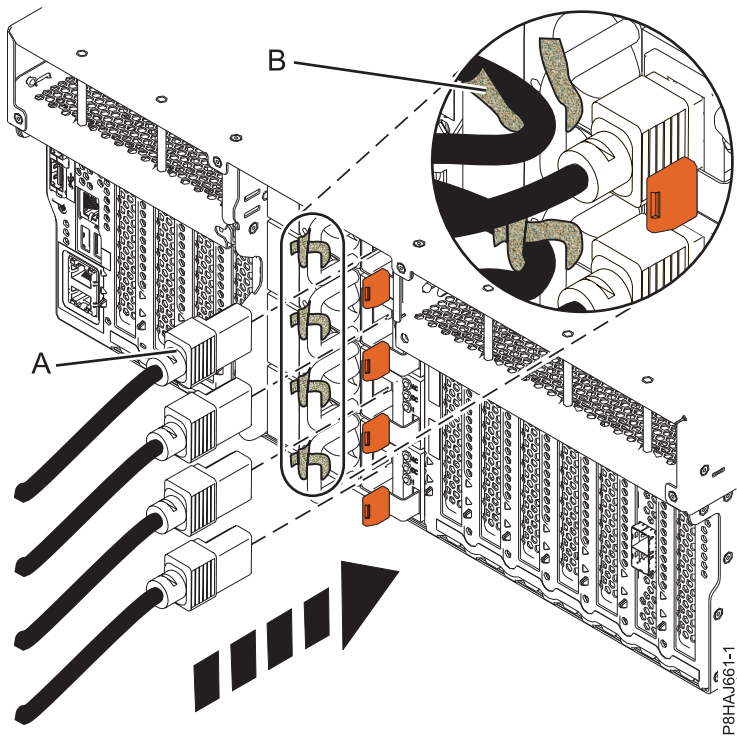

Figure 55. Connecting the power cords to an 8247-42L, 8286-41A, or 8286-42A system

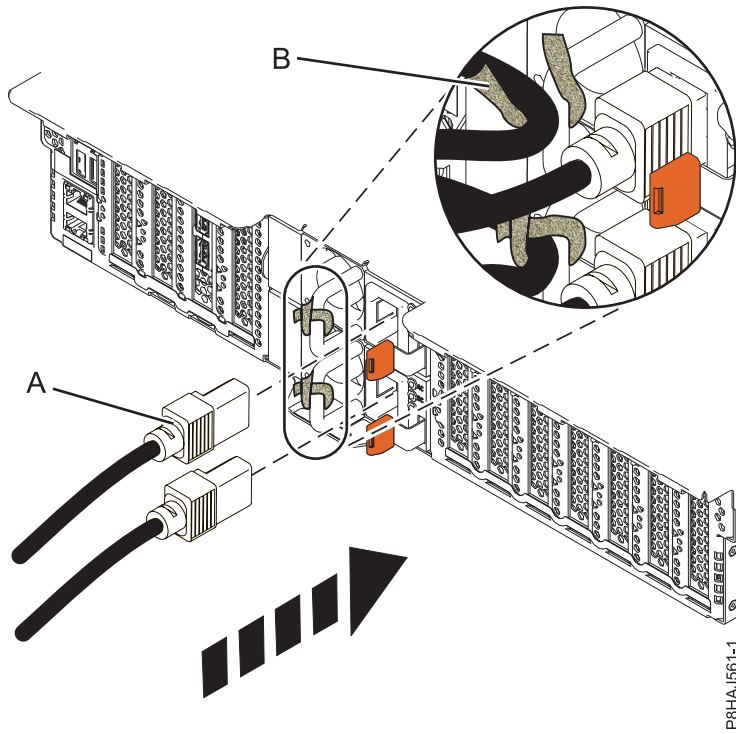

Figure 56. Connecting the power cords to a 5148-21L, 5148-22L, 8247-21L, 8247-22L, 8284-21A, or 8284-22A system

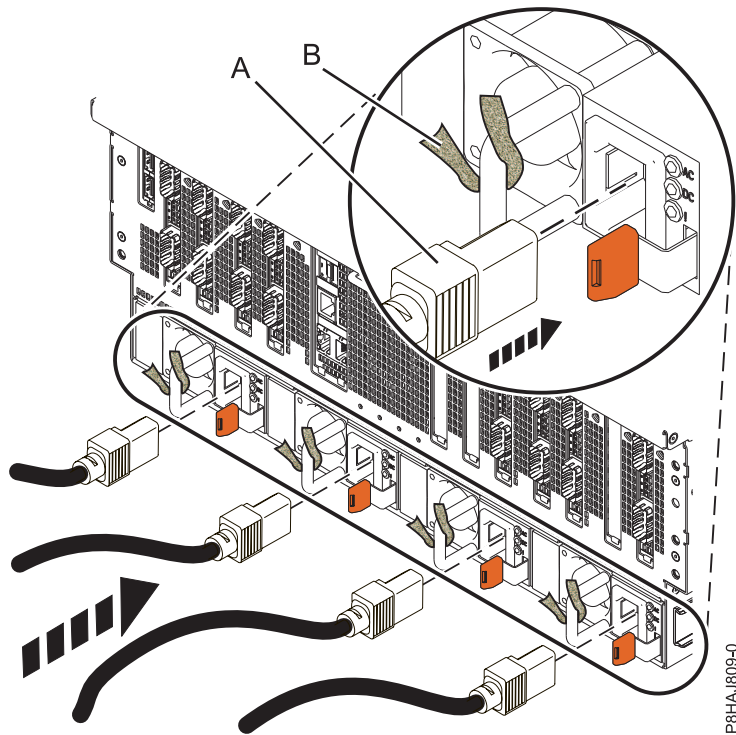

Figure 57. Connecting the power cords to an 8408-44E or 8408-E8E system

4. Close the rack door at the rear of the system.

Installing or replacing a part with an HMC

You can use the Hardware Management Console (HMC) to perform many service actions, including the installation of a new field-replaceable unit (FRU) or parts.

Installing a part by using the HMC

You can use the Hardware Management Console (HMC) to perform many service actions, including the installation of a new feature or part.

To install a feature or part into a system or an expansion unit by using the HMC, complete the following steps:

1. Choose one of the following navigation options depending on the interface type of the Hardware Management Console (HMC):

- If you are using an HMC Classic or HMC Enhanced interface, complete the following steps:
 - a. In the navigation area, expand **Systems Management > Servers**.
 - b. Select the managed system for which you want to install a part.

Note: If your part is in a miscellaneous equipment specification (MES), continue with step 1c. If your part is contained in the install that is done by the system services representative (SSR) or in a ship group, go to step 1h.

- c. In the Tasks area, expand **Serviceability > Hardware > MES Tasks > Open MES**.
 - d. Click **Add MES Order Number**.
 - e. Enter the number, and click **OK**.
 - f. Click the newly created order number, and click **Next**. The details of the order number are displayed.
 - g. Click **Cancel** to close the window.
 - h. In the Tasks area, expand **Serviceability > Hardware > MES Tasks**.
- If you are using an HMC Enhanced + Tech Preview (Pre-GA) or HMC Enhanced+ interface, complete the following steps:



- a. In the navigation area, click the **Resources** icon , and then click **All Systems**.
 - b. Click the system name for which you want to install the part.
 - c. In the navigation area, click **Serviceability**.
2. In the Serviceability window, click **Add FRU** (field replaceable unit).
 3. In the Add/Install/Remove Hardware-Add FRU, Select FRU Type window, select the system or enclosure into which you are installing the feature.
 4. Select the type of feature you are installing, and click **Next**.
 5. Select the location code where you will install the feature, and click **Add**.
 6. After the part is listed in the **Pending Actions** section, click **Launch Procedure** and follow the instructions to install the feature.

Note: The HMC might open external instructions for installing the feature. If so, follow those instructions to install the feature.

Removing a part by using the HMC

Learn how to remove a part by using the Hardware Management Console (HMC).

To remove a part in a system or an expansion unit by using the HMC, complete the following steps:

1. Choose one of the following navigation options depending on the interface type of the HMC:
 - If you are using an HMC Classic or HMC Enhanced interface, complete the following steps:
 - a. In the navigation area, expand **Systems Management > Servers**.
 - b. Select the managed system from which you are removing a part.
 - c. In the Tasks area, expand **Serviceability > Hardware > MES Tasks > Remove FRU**.
 - If you are using an HMC Enhanced + Tech Preview (Pre-GA) or HMC Enhanced+ interface, complete the following steps:



- a. In the navigation area, click the **Resources** icon  , and then click **All Systems**.
 - b. Click the system name for which you want to remove a part.
 - c. In the navigation area, click **Serviceability**.
 - d. In the Serviceability window, click **Remove FRU**.
2. In the Add/Install/Remove Hardware - Remove FRU, Select FRU Type window, select the system or enclosure from which you are removing the part.
 3. Select the type of part that you are removing, and click **Next**.
 4. Select the location of the part that you are removing, and click **Add**.
 5. After the part is listed in the **Pending Actions** section, click **Launch Procedure** and follow the instructions to remove the part.

Note: The HMC might display the IBM Knowledge Center instructions for removing the part. If so, follow those instructions to remove the part.

Repairing a part by using the HMC

You can use the Hardware Management Console (HMC) to complete many service actions, including repairing a field-replaceable unit (FRU) or part.

1. Choose one of the following navigation options depending on the interface type of the Hardware Management Console (HMC):
 - If you are using an HMC Classic or HMC Enhanced interface, complete the following steps:
 - a. In the navigation area, expand **Systems Management > Servers**.
 - b. Select the managed system for which you want to repair a part.
 - c. In the Tasks area, expand **Serviceability > Manage Serviceable Events**.
 - If you are using an HMC Enhanced + Tech Preview (Pre-GA) or HMC Enhanced+ interface, complete the following step:



- a. In the navigation area, click the **Resources** icon  , and then click **All Systems**.
 - b. Click the system name for which you want to remove a part.
 - c. In the navigation area, click **Serviceability**.
 - d. In the Serviceability window, click **Serviceable Events Manager**.
- Note:** You can also access **Serviceable Events Manager** option from the **Actions** list after selecting the system.
2. In the Manage Serviceable Events window, specify the event criteria, error criteria, and FRU criteria. If you do not want the results to be filtered, select **ALL**.
 3. Click **OK**. The Manage Serviceable Events - Serviceable Event Overview window displays all of the events that match your criteria. The information that is displayed in the compact table view includes the following details:

- Problem number
- PMH number
- Reference code - click the Reference code to display a description of the problem reported and actions that can be taken to fix the problem.
- Status of the problem
- Last reported time of the problem
- Failing MTMS of the problem

Note: The full table view includes more detailed information, including reporting MTMS, first reported time, and serviceable event text.

4. Select a serviceable event and use the **Selected** drop-down menu to select **Repair**.
5. Follow the instructions to repair the part.

Note: The HMC might open IBM Knowledge Center instructions for repairing the part. If so, follow those instructions to repair the part.

Verifying the installed part

You can verify a newly installed or replaced part on your system, logical partition, or expansion unit by using the operating system, stand-alone diagnostics, or the Hardware Management Console (HMC).

Verifying a part by using the operating system or VIOS

If you installed a new feature or replaced a part, you might want to use the tools in the operating system or Virtual I/O Server (VIOS) to verify that the feature or part is recognized by the system or logical partition.

Verifying an installed feature or replaced part by using an AIX system or logical partition

If you installed feature or replaced a part, you might want to use the tools in the AIX operating system to verify that the feature or part is recognized by the system or logical partition.

Verifying an installed feature by using the AIX operating system:

If you installed feature or replaced a part, you might want to use the tools in the AIX operating system to verify that the feature or part is recognized by the system or logical partition.

To verify the installed feature by using the AIX operating system, complete the following steps:

1. Log in as root user.
2. At the command line, type `diag` and press Enter.
3. Select **Advanced Diagnostics Routines** and press Enter.
4. From the **Diagnostic Mode Selection** menu, select **System Verification** and press Enter.
5. When the **Advanced Diagnostic Selection** menu appears, select one of the following options:
 - To test a single resource, select the resource that you installed from the list of resources and press Enter.
 - To test all the resources available to the operating system, select **All Resources** and press Enter.
6. Select **Commit**, and wait until the diagnostic programs run to completion, responding to any prompts that appear.
7. Did the diagnostics run to completion and display the message `No trouble was found?`
 - **No:** If a service request number (SRN) or other reference code is displayed, suspect a loose adapter or cable connection. Review the installation procedures to ensure that the new feature is installed correctly. If you cannot correct the problem, collect all SRNs or any other reference code

information that you see. If the system is running in logical partitioning (LPAR) mode, note the logical partition in which you installed the feature. Contact your service provider for assistance.

- **Yes:** The new device is installed correctly. Exit the diagnostic programs and return the system to normal operations.

Verifying a replaced part by using the AIX operating system:

If you replaced a part, you might want to use the tools in the AIX operating system to verify that the part is recognized by the system or logical partition.

To verify the operation of a replacement part, complete the following steps:

1. Did you use either the AIX operating system or the online diagnostics service aid concurrent (hot-swap) service to replace the part?
No: Go to step 2.
Yes: Go to step 5.
2. Is the system powered off?
No: Go to step 4.
Yes: Continue with the next step.
3. Start the system and wait until the AIX operating system login prompt is displayed or until apparent system activity on the operator panel or display has stopped.

Did the AIX login prompt display?

- **No:** If a service request number (SRN) or other reference code is displayed, suspect a loose adapter or cable connection. Review the procedures for the part that you replaced to ensure that the new part is installed correctly. If you cannot correct the problem, collect all SRNs or any other reference code information that you see. If the system does not start or you have no login prompt, see: Problems with loading and starting the operating system.

If the system is partitioned, note the logical partition in which you replaced the part. Contact your service provider for assistance.

- **Yes:** Go to step 4.
4. At the command prompt, type `diag -a` and press Enter to check for missing resources. If you see a command prompt, go to step 5.

If the **Diagnostic selection** menu is shown with **M** appearing next to any resource, follow these steps:

- a. Select the resource and press Enter.
 - b. Select **Commit**.
 - c. Follow any instructions that are shown.
 - d. If the *Do you want to review the previously displayed error?* message is shown, select **Yes** and press Enter.
 - e. If an SRN is shown, suspect a loose card or connection. If no obvious problem is shown, record the SRN and contact your service provider for assistance.
 - f. If no SRN is shown, go to step 5.
5. Test the part by doing the following steps:
 - a. At the command line, type `diag` and press Enter.
 - b. From the **Function Selection** menu, select **Advanced Diagnostics Routines** and press Enter.
 - c. From the **Diagnostic Mode Selection** menu, select **System Verification** and press Enter.
 - d. Select **All Resources**, or select the diagnostics for the individual part to test only the part you replaced and any devices that are attached to the part you replaced and press Enter.
Did the **Resource Repair Action** menu appear?
No: Go to step 6 on page 93.

Yes: Go to step 7.

6. Did the *Testing Complete, No trouble was found* message appear?
 - **No:** There is still a problem. Contact your service provider. **This ends the procedure.**
 - **Yes:** Select **Log Repair Action**, if not previously logged, from the **Task Selection** menu to update the AIX error log. If the repair action was reseating a cable or adapter, select the resource associated with that repair action. If the resource associated with your action is not displayed on the resource list, select **sysplanar0** and press Enter.

Tip: This action changes the indicator light for the part from the fault state to the normal state.

Go to step 9.

7. Select the resource for the replaced part from the **Resource Repair Action** menu. When a test is run on a resource in system verification mode, and that resource has an entry in the AIX error log, if the test on the resource was successful, the **Resource Repair Action** menu appears. Complete the following steps to update the AIX error log to indicate that a system-detectable part has been replaced.

Note: On systems with an indicator light for the failing part, this action changes the indicator light to the normal state.

- a. Select the resource that has been replaced from the **Resource Repair Action** menu. If the repair action was reseating a cable or adapter, select the resource associated with that repair action. If the resource associated with your action does not appear on the resource list, select **sysplanar0** and press Enter.
- b. Select **Commit** after you make your selections. Did another **Resource Repair Action** display appear?

No: If the **No Trouble Found** display appears, go to step 9

Yes: Go to step 8.

8. Select the parent or child of the resource for the replaced part from the **Resource Repair Action** menu if necessary. When a test is run on a resource in system verification mode, and that resource has an entry in the AIX error log, if the test on the resource was successful, the **Resource Repair Action** menu appears. Complete the following steps to update the AIX error log to indicate that a system-detectable part has been replaced.

Note: This action changes the indicator light for the part from the fault state to the normal state.

- a. From the **Resource Repair Action** menu, select the parent or child of the resource that has been replaced. If the repair action was to reseat a cable or adapter, select the resource associated with that repair action. If the resource associated with your action does not appear on the resource list, select **sysplanar0** and press Enter.
- b. Select **Commit** after you make your selections.
- c. If the **No Trouble Found** display appears, go to step 9.

9. If you changed the service processor or network settings, as instructed in previous procedures, restore the settings to the values they had prior to servicing the system.

10. Did you do any hot-plug procedures before doing this procedure?

No: Go to step 11.

Yes: Go to step 12.

11. Start the operating system, with the system or logical partition in normal mode. Were you able to start the operating system?

No: Contact your service provider. **This ends the procedure.**

Yes: Go to step 12.

12. Are the indicator lights still on?

- **No. This ends the procedure.**

- **Yes.** Turn off the lights. See the following for instructions: Changing service indicators (<http://www.ibm.com/support/knowledgecenter/POWER8/p8hby/serviceindicators.htm>).

Verifying the installed part by using an IBM i system or logical partition

If you have installed a new feature or part, verify that the system recognizes the feature or part by using the IBM i system service tools.

To verify the installed part, complete the following steps:

1. Deactivate the failing item indicator light. For instructions, see “Deactivating the indicator light by using the IBM i operating system” on page 120.
2. Sign on **with at least service level authority**.
3. On the command line of the IBM i session, type `strsst` and press Enter.

Note: If you cannot get to the System Service Tools display, use function 21 from the control panel. Alternatively, if the system is managed by Hardware Management Console (HMC), use the Service Focal Point Utilities to get to the Dedicated Service Tools (DST) display.

4. Type your service tools user ID and service tools password on the System Service Tools (SST) Sign On display and press Enter.

Note: The service tools password is case-sensitive.

5. Select **Start a service tool** from the System Service Tools (SST) display and press Enter.
6. Select **Hardware service manager** from the Start a Service Tool display and press Enter.
7. Select **Logical hardware resources (buses, IOPs, controllers)** from the Hardware Service Manager display and press Enter. This option allows you to display and work with logical resources. Logical hardware resources are the functional resources of the system used by the operating system.

With the Logical Hardware Resources display, you can show logical hardware resource status or information, and associated packaging hardware resources. Use the online Help information to better understand specific functions, fields, or symbols.

Verifying an installed part by using a Linux system or logical partition

Learn how to verify that the system recognizes a new or replacement part.

To verify the newly installed or replaced part, continue with “Verifying an installed part by using stand-alone diagnostics.”

Verifying an installed part by using stand-alone diagnostics

If you have installed or replaced a part, verify that the system recognizes the new part. You can use stand-alone diagnostics to verify an installed part in an AIX or Linux system, expansion unit, or logical partition.

- If this server is directly attached to another server or attached to a network, ensure communications with the other servers have stopped.
- The stand-alone diagnostics require use of all of the logical partition resources. No other activity can be running on the logical partition.
- The stand-alone diagnostics require access to the system console.

You access these diagnostics from a CD-ROM or from the Network Installation Management (NIM) server. This procedure describes how to use the diagnostics from a CD-ROM. For information on running diagnostics from the NIM server, see Running stand-alone diagnostics from a Network Installation Management server.

To use stand-alone diagnostics, follow these steps:

1. Stop all jobs and applications and then stop the operating system on the system or logical partition.

2. Remove all tapes, diskettes, and CD-ROM.
3. Turn off the system unit power. The next step boots the server or logical partition from the stand-alone diagnostics CD-ROM. If the optical drive is not available as a boot device on the server or logical partition on which you are working, follow these steps:
 - a. Access the ASMI. For information on using the ASMI, see *Managing the Advanced System Management Interface*.
 - b. On the ASMI main menu, click **Power/Restart Control**.
 - c. Click **Power On/Off System**.
 - d. Select the **Service mode boot from default boot list** option in the AIX or Linux logical partition mode boot drop-down menu.
 - e. Click **Save settings and power on**. When the optical drive is powered on, insert the stand-alone diagnostic CD-ROM.
 - f. Go to step 5.
4. Turn on the system unit power and immediately insert the diagnostics CD-ROM into the optical drive.
5. After the **keyboard** POST indicator displays on the system console and before the last POST indicator (**speaker**) displays, press the numeric 5 key on the system console to indicate that a service mode boot must be initiated by using the default-service mode boot list.
6. Enter any requested password.
7. At the **Diagnostic Operating Instructions** display, press Enter.

Tip: If a service request number (SRN) or other reference code is displayed, suspect a loose adapter or cable connection.

Note: If you received an SRN or any other reference code when you attempted to start the system, contact your service provider for assistance.

8. If the terminal type is requested, select the **Initialize Terminal** option on the Function Selection menu to initialize the operating system.
9. From the Function Selection menu, select **Advanced Diagnostics Routines** and press Enter.
10. From the Diagnostic Mode Selection menu, select **System Verification** and press Enter.
11. When the Advanced Diagnostic Selection menu appears, select **All Resources**, or test only the part you replaced, and any devices that are attached to the part you replaced, by selecting the diagnostics for the individual part and press Enter.
12. Did the Testing Complete, No trouble was found message appear?
 - **No:** There is still a problem. Contact your service provider.
 - **Yes:** Go to step 13.
13. If you changed the service processor or network settings, as instructed in previous procedures, restore the settings to the value they had prior to servicing the system.
14. If the indicator lights are still on, follow these steps:
 - a. Select **Identify and Attention Indicators** from the Task Selection menu to turn off the system attention and indicator lights and press Enter.
 - b. Select **Set System Attention Indicator to NORMAL** and press Enter.
 - c. Select **Set All Identify Indicators to NORMAL** and press Enter.
 - d. Choose **Commit**.

Note: This changes the system attention and identify indicators from the *Fault* state to the *Normal* state.

- e. Exit to the command line.

Verifying an installed part or replaced part on a system or logical partition by using Virtual I/O Server tools

If you installed or replaced a part, you might want to use the tools in Virtual I/O Server (VIOS) to verify that the part is recognized by the system or logical partition.

Verifying an installed part by using VIOS:

You can verify the operation of an installed part by using the VIOS.

To verify an installed part, complete the following steps:

1. Log in as root user.
2. At the command line, type `diagmenu` and press Enter.
3. Select **Advanced Diagnostics Routines** and press Enter.
4. From the **Diagnostic Mode Selection** menu, select **System Verification** and press Enter.
5. When the **Advanced Diagnostic Selection** menu appears, do one of the following steps:
 - To test a single resource, select the resource that you just installed from the list of resources and press Enter.
 - To test all the resources available to the operating system, select **All Resources** and press Enter.
6. Select **Commit**, and wait until the diagnostic programs run to completion, responding to any prompts that appear.
7. Did the diagnostics run to completion and display the message `No trouble was found`?
 - **No:** If a service request number (SRN) or other reference code is displayed, suspect a loose adapter or cable connection. Review the installation procedures to ensure that the new part is installed correctly. If you cannot correct the problem, collect all SRNs or any other reference code information that you see. If the system is running in LPAR mode, note the logical partition in which you installed the part. Contact your service provider for assistance.
 - **Yes:** The new device is installed correctly. Exit the diagnostic programs and return the system to normal operations.

Verify the replacement part by using VIOS:

You can verify the operation of a replacement part by using the VIOS.

To verify the operation of a replacement part, complete the following steps:

1. Did you replace the part by using either VIOS or the online diagnostics service aid's concurrent (hot-swap) service operation?
 - **No:** Go to step 2.
 - **Yes:** Go to step 5 on page 97.
2. Is the system powered off?
 - **No:** Go to step 4 on page 97.
 - **Yes:** Go to step 3.
3. Start the system and wait until the VIOS operating system login prompt displays or until apparent system activity on the operator panel or display has stopped. Did the VIOS login prompt display?
 - **No:** If an SRN or other reference code is displayed, suspect a loose adapter or cable connection. Review the procedures for the part that you replaced to ensure that the new part is installed correctly. If you cannot correct the problem, collect all SRNs or any other reference code information that you see. If the system does not start or you have no login prompt, see *Problems with loading and starting the operating system*.
If the system is partitioned, note the logical partition in which you replaced the part. Contact your service provider for assistance.
 - **Yes:** Go to step 4 on page 97.

4. At the command prompt, type `diag -a` and press Enter to check for missing resources. If you see a command prompt, go to step 5.

If the **Diagnostic selection** menu is shown with **M** appearing next to any resource, follow these steps:

- a. Select the resource and press Enter.
 - b. Select **Commit**.
 - c. Follow any instructions that are shown.
 - d. If a *Do you want to review the previously displayed error?* message is shown, select **Yes** and press Enter.
 - e. If an SRN is shown, suspect a loose card or connection. If no obvious problem is shown, record the SRN and contact your service provider for assistance.
 - f. If no SRN is shown, go to 5.
5. Test the part by doing the following:
 - a. At the command line, type `diagmenu` and press Enter.
 - b. From the **Function Selection** menu, select **Advanced Diagnostics Routines** and press Enter.
 - c. From the **Diagnostic Mode Selection** menu, select **System Verification** and press Enter.
 - d. Select **All Resources**, or select the diagnostics for the individual part to test only the part you replaced, and any devices that are attached to the part you replaced and press Enter.
Did the **Resource Repair Action** menu appear?
 - **No:** Go to step 6.
 - **Yes:** Go to step 7.
 6. Did the *Testing Complete, No trouble was found* message appear?
 - **No:** There is still a problem. Contact your service provider. **This ends the procedure.**
 - **Yes:** Select **Log Repair Action**, if not previously logged, from the **Task Selection** menu to update the error log. If the repair action was reseating a cable or adapter, select the resource associated with that repair action. If the resource associated with your action is not displayed on the Resource List, select `sysplanar0` and press Enter.

Tip: This action changes the indicator light for the part from the fault state to the normal state. Go to step 9 on page 98.
 7. Select the resource for the replaced part from the **Resource Repair Action** menu. When a test is run on a resource in system verification mode, and that resource has an entry in the error log, if the test on the resource was successful, the **Resource Repair Action** menu appears. Complete the following steps to update the error log to indicate that a system-detectable part has been replaced. On systems with a indicator light for the failing part, this changes the indicator light to the normal state.
 - a. Select the resource that has been replaced from the **Resource Repair Action** menu. If the repair action was reseating a cable or adapter, select the resource associated with that repair action. If the resource associated with your action does not appear on the Resource List, select `sysplanar0`. Press Enter.
 - b. Select **Commit** after you make your selections. Did another **Resource Repair Action** display appear?
 - **No:** If the **No Trouble Found** display appears, go to step 9 on page 98.
 - **Yes:** Go to step 8.
 8. Select the parent or child of the resource for the replaced part from the **Resource Repair Action** menu if necessary. When a test is run on a resource in system verification mode, and that resource has an entry in the error log, if the test on the resource was successful, the **Resource Repair Action** menu appears. Complete the following steps to update the error log to indicate that a system-detectable part has been replaced. This changes the indicator light for the part from the fault state to the normal state.

- a. From the **Resource Repair Action** menu, select the parent or child of the resource that has been replaced. If the repair action was to reseal a cable or adapter, select the resource associated with that repair action. If the resource associated with your action does not appear on the Resource List, select **sysplanar0**. Press Enter.
- b. Select **Commit** after you make your selections.
 - a. If the **No Trouble Found** display appears, go to step 9.
9. If you changed the service processor or network settings, as instructed in previous procedures, restore the settings to the values they had prior to servicing the system.
10. Did you do any hot-plug procedures before doing this procedure?
 - **No:** Go to step 11.
 - **Yes:** Go to step 12.
11. Start the operating system, with the system or logical partition in normal mode. Were you able to start the operating system?
 - **No:** Contact your service provider. **This ends the procedure.**
 - **Yes:** Go to step 12.
12. Are the indicator lights still on?
 - **No:** This ends the procedure.
 - **Yes.** Turn off the lights. For instructions, see Changing service indicators.

Verifying the installed part by using the HMC

If you have installed or replaced a part, use the Hardware Management Console (HMC) to update your HMC records after you have completed a service action on your server. If you have reference codes, symptoms, or location codes that you used during the service action, locate the records for use during this procedure.

To verify the installed part, complete the following steps:

1. At the HMC, examine the service action event log for any open service action events. See “Viewing serviceable events by using the HMC” on page 99 for details.
2. Are there any service action events that are open?
 - No:** If the system attention LED is still on, use the HMC to turn off the LED. See “Deactivating LEDs by using the HMC” on page 123. **This ends the procedure.**
 - Yes:** Continue with the next step.
3. Record the list of open service action events.
4. Examine the details of the open service action event. Is the error code associated with this service action event the same as you gathered earlier.
 - **No:** Select one of the following options:
 - Review the other serviceable events, find one that does match, and continue with the next step.
 - If the log does not match what you had gathered earlier, contact your service provider.
 - **Yes:** Continue with the next step.
5. Select and highlight the service action event from the Error Associated With This Serviceable Event window.
6. Click **Close Event**.
7. Add comments for the serviceable event. Include any unique additional information. Click **OK**.
8. Did you replace, add, or modify a field replaceable unit (FRU) of the open service action event?
 - **No:** Select the **No FRU Replaced for this Serviceable Event** option, and click **OK** to close the service action event.
 - **Yes:** Perform the following steps:
 - a. From the FRU list, select a FRU that you need to update.

- b. Double-click the FRU and update the FRU information.
 - c. Click **OK** to close the service action event.
9. If you continue to have problems, contact your service provider.

Viewing serviceable events by using the HMC

Use this procedure to view a serviceable event, including details, comments, and service history by using the Hardware Management Console (HMC).

To view serviceable events and other information about the events, you must be a member of one of the following roles:

- Super administrator
- Service representative
- Operator
- Product engineer
- Viewer

To view serviceable events, follow these steps:

1. Choose one of the following navigation options depending on the interface type of the HMC:
 - If you are using the HMC Classic or HMC Enhanced interface, in the navigation area, click **Service Management > Manage Serviceable Events**.
 - If you are using an HMC Enhanced + Tech Preview (Pre-GA) or HMC Enhanced+ interface, in the



navigation area, click the **Serviceability** icon , and then click **Serviceable Events Manager**.

2. Select the criteria for the serviceable events that you want to view, and click **OK**. The Serviceable Event Overview window opens. The list shows all serviceable events that match your selection criteria. You can use the menu options to complete actions on the serviceable events.
3. Select a line in the Serviceable Event Overview window, and select **Selected > View Details**. The Serviceable Event Details window opens, showing detailed information about the serviceable event. The upper table shows information, such as problem number and reference code. The lower table shows the field replaceable units (FRUs) associated with this event.
4. Select the error for which you want to view comments and history, and follow these steps:
 - a. Click **Actions > View Comments**.
 - b. When you are finished viewing the comments, click **Close**.
 - c. Click **Actions > View Service History**. The Service History window opens, showing service history that is associated with the selected error.
 - d. When you are finished viewing the service history, click **Close**.
5. When you are finished, click **Cancel** twice to close the Serviceable Event Details window and the Serviceable Event Overview window.

Verifying a repair

Use these procedures to verify hardware operation after making repairs to the system.

Choose from the following options:

- To verify the repair of a system that is currently powered off, go to step 1 on page 100.
- To verify the repair of a system that is currently powered on with no operating system loaded, go to step 3 on page 100.

- To verify the repair of a system that is currently powered on and that has an operating system loaded, go to step 5.
1. Power on the server and all attached I/O enclosures.

Did all the enclosures power on?

Yes: Go to step 3.

No: Continue with the next step.

2. Choose from the following options:

- If the original problem was that an enclosure would not power on and you have another FRU to replace, locate and replace the next field-replaceable unit (FRU).
 - If the next FRU in the FRU list is an isolation procedure, perform the isolation procedure.
 - If the original problem was that an enclosure would not power on and you have an isolation procedure to complete, perform the isolation procedure.
 - If the original problem was that an enclosure would not power on and there are no more FRUs or isolation procedures in the FRU list, contact your next level of support.
 - If you have a new problem, perform problem analysis and repair the new problem.
-

3. Load the operating system.

Did the operating system load successfully?

Yes: Go to step 5.

No: Continue with the next step.

4. Choose from the following options:

- If the original problem was a failing disk drive that contained the operating system software, go to step 5.
 - If the original problem was that the operating system would not load and you have another FRU to replace, go to your FRU locations section to locate the next FRU.
 - If the next FRU in the FRU list is an isolation procedure, perform the isolation procedure.
 - If the original problem was that the operating system would not load and you have an isolation procedure to complete, perform the isolation procedure.
 - If the original problem was that the operating system would not load and there are no more FRUs or isolation procedures in the FRU list, contact your next level of support.
 - If you have a new problem, perform problem analysis and repair the new problem.
-

5. Choose from the following options:

- “Verifying the repair in AIX”
- “Verifying the repair in Linux” on page 105
- “Verifying a repair by using an IBM i system or logical partition” on page 103
- “Verifying the repair on an IBM PowerKVM system” on page 105
- “Verifying the repair from the management console” on page 106

Verifying the repair in AIX

You can use this procedure to verify that a repair is complete using the AIX operating system.

Use this maintenance analysis procedure (MAP) to check out the server after a repair is completed.

1. Did you replace a disk drive in the root volume group?

No Go to step 3.

Yes Continue with the next step.

2. Run stand-alone diagnostics either from a CD or from a Network Installation Management (NIM) server.

Did you encounter any problems?

No Reinstall the operating system and continue with step 5.

Yes If the original problem still exists, replace the field-replaceable unit (FRU) or perform the isolation procedure that is next in the FRU list. If you have reached the end of the FRU list, contact your next level of support.

If a new problem has occurred, go to Beginning problem analysis.

3. Did you replace a FRU with the power turned on and concurrently with system operations?

No Go to step 5.

Yes Continue with the next step.

4. Did you use an AIX diagnostics service aid hot-swap operation to change the FRU?

No Go to step 7.

Yes Go to step 6.

Note: The AIX diagnostic service aid was used if a resource was removed by using the **Hot Plug** task.

5. If any FRUs have been removed that should be reinstalled, reinstall them now:

- a. If the system is not powered on, power it on now.

- b. Wait until the AIX operating system login prompt is displayed or until system activity on the operator panel or display has stopped.

- c. Did you encounter any problems?

No Continue at step 6.

Yes If the original problem still exists, replace the FRU or perform the isolation procedure that is next in the FRU list. If you have reached the end of the FRU list, contact your next level of support.

If a new problem occurs, go to Beginning problem analysis.

6. If the Resource Repair Action menu is already displayed, go to step 9 on page 102; otherwise, perform the following steps:

- a. Log into the operating system either with root authority (if needed, ask the customer to enter the password) or use the CE login.

- b. Enter `diag -a` command and check for missing resources. Follow any instructions that are displayed. If an SRN displays, suspect a loose card or connection. If no instructions are displayed, no resources were detected as missing. Continue with the next step.

7. Perform the following steps:

- a. Enter `diag` at the command prompt.

- b. Press Enter.

- c. Select the **Diagnostics Routines** option.

- d. When the Diagnostic Mode Selection menu is displayed, select **System verification**.

- e. When the Diagnostic Selection menu is displayed, select the **All Resources** option or test the FRUs you exchanged and any devices that are attached to the FRUs you exchanged by selecting the diagnostics for the individual FRU.

Did the Resource Repair Action menu (801015) display?

No Continue with the next step.

Yes Go to step 9.

8. Did the TESTING COMPLETE, no trouble was found menu (801010) display?

No If the original problem still exists, replace the FRU or perform the isolation procedure that is next in the FRU list. If you have reached the end of the FRU list, contact your next level of support.

If a new problem occurs go to Beginning problem analysis.

Yes Use the **Log Repair Action** option, if not previously logged, in the TASK SELECTION menu to update the AIX error log. If the repair action was reseating a cable or adapter, select the resource associated with that repair action.

If the resource associated with your action is not displayed on the resource list, select **sysplanar0**.

Note: If the check log indicator is on, this action will set it back to the normal state.

Go to step 11.

9. When a test is run on a resource in system verification mode, that resource has an entry in the AIX error log. If the test on that resource was successful, the Resource Repair Action menu is displayed. After replacing a FRU, you must select the resource for that FRU from the Resource Repair Action menu. This updates the AIX error log to indicate that a system-detectable FRU has been replaced.

Note: If the check log indicator is on, this action will set it back to the normal state.

Perform the following steps:

a. Select the resource that has been replaced from the Resource Repair Action menu. If the repair action was reseating a cable or adapter, select the resource associated with that repair action. If the resource associated with your action is not displayed on the resource list, select **sysplanar0**.

b. Press **Commit** after you make your selections.

Did another Resource Repair Action (801015) display?

No If the No Trouble Found menu displays, go to step 11.

Yes Continue with the next step.

10. The parent or child of the resource you just replaced might also require that you run the Resource Repair Action service aid on it.

When a test is run on a resource in system verification mode, that resource has an entry in the AIX error log. If the test on the resource was successful, the Resource Repair Action menu displays.

After replacing that FRU, you must select the resource for that FRU from the Resource Repair Action menu. This updates the AIX error log to indicate that a system-detectable FRU has been replaced.

Note: If the check log indicator is on, this action will set it back to the normal state.

Perform the following steps:

a. From the RESOURCE REPAIR ACTION menu, select the parent or child of the resource that has been replaced. If the repair action was reseating a cable or adapter, select the resource associated with that repair action. If the resource associated with your action is not displayed on the resource list, select **sysplanar0**.

b. Press **COMMIT** after you make your selections.

c. If the No Trouble Found menu is displayed, continue with the next step.

11. If you changed the service processor or network settings, as instructed in previous MAPs, restore the settings to the value they had prior to servicing the system. If you ran stand-alone diagnostics from CD-ROM, remove the stand-alone diagnostics CD-ROM from the system.

Did you perform service on a RAID subsystem that involved changing of the PCI RAID adapter cache card or changing the configuration?

Note: This information does not apply to the PCI-X RAID adapter or cache.

No Go to the close of call procedure.

Yes Continue with the next step.

12. Use the **Recover Options** selection to resolve the RAID configuration, by completing the following steps:
 - a. On the PCI SCSI Disk Array Manager display, select **Recovery options**.
 - b. If a previous configuration exists on the replacement adapter, this must be cleared. Select **Clear PCI SCSI Adapter Configuration** and press F3.
 - c. On the Recovery Options screen, select **Resolve PCI SCSI RAID Adapter Configuration**.
 - d. On the Resolve PCI SCSI RAID Adapter Configuration screen, select **Accept Configuration on Drives**.
 - e. On the PCI SCSI RAID Adapter selections menu, select the adapter that you changed.
 - f. On the next screen, press Enter.
 - g. When you see the Are You Sure selection menu, press Enter to continue.
 - h. If you see a Failed status message, verify that you selected the correct adapter, and then repeat this procedure. When the recovery is complete, exit the operating system.
 - i. Go to the Closing a service call procedure.

Verifying a repair by using an IBM i system or logical partition

Use this procedure to verify a repair by using the IBM i operating system.

1. Was the system powered off during the repair?

Yes: Continue with the next step.
No: Continue with step 3.
2. Perform the following tasks:
 - a. Verify that the power cable is plugged into the power outlet.
 - b. Verify that power is available at the customer's power outlet.
3. Was the partition powered off during the repair?

Yes: Continue with the next step.
No: Continue with step 6.
4. Select the IPL type and mode for the system or logical partition that the customer uses (see IPL type mode and speed options in the Service functions).
5. Start an IPL by powering on the system or partition (see Powering on and powering off). Did the system complete the IPL?

Yes: Continue with the next step.
No: This might be a new problem. Go to the Starting a repair action. **This ends the procedure.**
6. Did the system or partition remain running throughout the repair, and was the I/O processor, I/O adapter, or storage device replaced?

Yes: Continue with step 10.
No: Continue with the next step.
7. Use the service action log or serviceable event view (if the system is managed by an HMC) to look for any reference codes that are related to this IPL (see Searching the service action log). Are there any reference codes that are related to this IPL?

Yes: Continue with the next step.

- No:** If the problem was related to removable media or communications, perform the verification procedures in the Service functions to verify that the problem is corrected. Then return the system to the customer and have the customer verify the system date and time. **This ends the procedure.**
8. Is the new reference code the same as the original reference code?
 - Yes:** Continue with the next step.
 - No:** A new symptom might have occurred. Go to the Start of call procedure. **This ends the procedure.**
 9. Are there any other failing items that remain to be replaced?
 - Yes:** Replace the next failing item listed for this reference code. **This ends the procedure.**
 - No:** Contact your next level of support for assistance. **This ends the procedure.**
 10. Was concurrent maintenance performed on an optical storage unit?
 - Yes:** The product activity log and service action log, in most cases, contain a reference code for the optical storage unit when concurrent maintenance is performed. You can ignore this reference code. Perform the following:
 - Perform the verification procedures in the Service functions topic to verify that the problem is corrected.
 - Return the system to the customer and have the customer verify the system date and time. **This ends the procedure.**
 - No:** Continue with the next step.
 11. Use the service action log to look for any new reference codes (see Using the Service Action Log). Are there any new reference codes?
 - Yes:** Continue with the next step.
 - No:** Go to step 14.
 12. Is the new reference code the same as the original reference code?
 - Yes:** Continue with the next step.
 - No:** A new symptom might have occurred. Go to the Start of call procedure to determine the cause of the problem. **This ends the procedure.**
 13. Are there any other failing items that need to be replaced?
 - Yes:** Replace the next failing item listed for the reference code. **This ends the procedure..**
 - No:** Contact your next level of support for assistance. **This ends the procedure.**
 14. Are you working with a tape device?
 - Yes:** Perform the verification procedures in the Service functions to verify that the problem is corrected. After the verification test is complete, the tape device description will be set to the failed state because a resource change was detected. Perform the following tasks:
 - Vary the tape device description off and then on.
 - Return the system to the customer and have the customer verify the system date and time. Then go to Verifying the repair from the HMC. **This ends the procedure.**
 - No:** Continue with the next step.
 15. Are you working with an IOP or an IOA?
 - Yes:** Use the display hardware configuration service function to check for any missing or failed hardware:
 - On the command line, enter the STRSST (Start System Service Tools command). If you cannot get to SST, select DST. Do not IPL the system or partition to get to DST.
 - On the Start Service Tools Sign On display, enter the user ID with the service authority and password.
 - Select **Start a service tool > Hardware service manager > Logical hardware resources > System bus resources.**

- Select the function key for **Include nonreporting resources**.
 - If the IOP and IOA that you just replaced is a failed or nonreporting resource, the problem has not been fixed. Continue to the next failing item in the failing item list. **This ends the procedure.**
- No:** Perform the verification procedures in the Service functions topics to verify that the problem is corrected. Resources that usually vary on automatically during an IPL, or that were previously varied on manually, might need to be varied on again after the verification procedures are complete. Return the system to the customer and have the customer verify the system date and time. **This ends the procedure.**

Verifying the repair in Linux

You can use this procedure to verify that a repair is complete by using the Linux operating system.

1. Run stand-alone diagnostics from either a CD or from a Network Installation Management (NIM) server. See Running the stand-alone diagnostics from CD-ROM. **Did you encounter any problems?**

No Reboot the operating system and continue with the close of call procedure.

Yes If the original problem still exists, replace the field-replaceable unit (FRU) or perform the isolation procedure that is next in the FRU list. If you have reached the end of the FRU list, contact your next level of support.

If a new problem has occurs go to Beginning problem analysis and repair the new problem.

Verifying the repair on an IBM PowerKVM system

You can use the following procedure to verify whether a repair is complete on an IBM PowerKVM system.

1. Look for any new reference codes that might have occurred as a result of the service action that was performed. To locate the error information in a system running IBM PowerKVM, complete the following steps:

a. Log in as root user.

b. At the command line, type `opal-eelog-parse -s` and press **Enter**.

c. Look for the most recent entry that contains a reference code.

Did a new reference code occur as a result of the service action that was performed?

- **Yes:** Continue with the next step.
- **No:** Continue with step 4 on page 106.

2. The reference code description might provide information or an action that you can take to correct the failure.

Use the search function of IBM Knowledge Center to find the reference code details. The search function is located in the upper-left corner of IBM Knowledge Center. Read the reference code description and return here. Do not take any other action at this time.

For more information about reference codes, see Reference codes.

Was there a reference code description that enabled you to resolve the problem?

- **Yes: This ends the procedure.**
- **No:** Continue with the next step.

3. Service is required to resolve the error. Collect as much error data as possible and record it. You and your service provider will develop a corrective action to resolve the problem based on the following guidelines:

- If a field-replaceable unit (FRU) location code is provided, that location must be used to determine which FRU to replace.
- If an isolation procedure is listed for the reference code in the reference code lookup information, include it as a corrective action even if it is not listed in the serviceable event view or control panel.

- If any FRUs are marked for block replacement, replace all FRUs in the block replacement group at the same time.

Complete the following steps:

- Record the reference code if available.
- Record the error details.
- Run the `sosreport` command to collect debug data.
- Contact your service provider.

This ends the procedure.

- Was a disk drive, solid-state drive, media device, or I/O adapter replaced when the system was powered off?
 - **Yes:** Perform Running diagnostics on an IBM PowerKVM system. **This ends the procedure.**
 - **No:** Continue with the “Closing a service call” on page 107 procedure. **This ends the procedure.**

Verifying the repair from the management console

Perform these procedures to close problem numbers, clear hardware messages, and prepare the server to return to the customer by using the management console.

Follow this checklist before performing the procedures:

- You return the server to the state that the customer normally uses, such as IPL type, IPL mode, and the way the system is configured or partitioned.
 - While you were performing the problem analysis on the original serviceable event, other serviceable-event numbers might have been opened. Close all serviceable events that were opened as a result of your service activity.
 - Server verification has been performed and there are no problems that require additional service actions.
 - If the repair was done by using the HMC online repair procedures, ensure that the original serviceable event is now closed.
- Is a management console used to manage the server that you are servicing?
 - **Yes:** Continue with the next step.
 - **No:** Return to the “Verifying a repair” on page 99. **This ends the procedure.**
 - Are you closing a service event that was a repair on the management console personal computer?
 - **Yes:** Continue with the next step.
 - **No:** Go to step 4.
 - Power on the management console. Did the power-on process complete without errors?
 - **Yes:** Ensure that the management console can be used to perform server management tasks, and return the management console to normal operations. Go to “Closing a service call” on page 107. **This ends the procedure.**
 - **No:** Go to the *HMC isolation procedures*. **This ends the procedure.**
 - Log into the management console as the service representative. If invalid user or invalid password is displayed, get the correct login information from the system administrator.
 - If logged into the System Manager, select **Exit from the Console**, located in the System Manager window.
 - Log in to the System Manager with the following:
 - User identification - `service`
 - Password - `service mode`
 - View Serviceable Event Details.
 - In the navigation area, click **Service Applications**.
 - In the navigation area, click **Service Focal Point**.

- c. In the Contents area, click **Manage Serviceable Events**.
- d. Designate the set of Serviceable Events you want to view. When you are finished, click **OK**. The **Service Event Overview** window opens.

Note: Only the events that match all of the criteria you specify are shown.

6. Close open or delayed events.
 - a. Select the problem to close in the Service Event Overview window.
 - b. Select the **Selected** menu, located on the menu bar.
 - c. Click **Close Event**.
 - d. Enter your comments in the **Serviceable Event Comments** window, and click **Close Event**.
 - e. Close all events associated with the problem on which you were working.
7. Did the Service Event Overview window contain the event or events on which you were working?
 - **Yes:** Return the HMC to normal operations. Go to “Closing a service call.” **This ends the procedure.**
 - **No:** Go to Detecting problems. **This ends the procedure.**

Closing a service call

Perform these procedures to close serviceable events, clear hardware messages, and prepare the server to return to the customer.

Follow this checklist before performing the procedure:

- Return the server to the state that the customer normally uses such as IPL type, IPL mode, and the way the system is configured or partitioned.
 - While you were performing the problem analysis on the original serviceable event, other serviceable events might have been opened. Close all serviceable events that were opened as a result of your service activity.
 - Ensure that server verification has been performed and no problems require additional service actions.
 - If the repair was done using the management console online repair procedures, ensure that the original serviceable event is now closed.
1. Record the system reference code (SRC), or symptom, and the location code of the field-replaceable unit (FRU) you replaced, for future reference. Is the server managed by a management console?
 - **Yes:** Continue with the next step.
 - **No:** Do one of the following steps:
 - If the server is managed by Integrated Virtualization Manager (IVM), go to “Closing a service call by using Integrated Virtualization Manager” on page 114.
 - If the server is not partitioned and is running the AIX or Linux operating system, go to “Closing a service call by using AIX or Linux” on page 110.
 - If the server is running IBM PowerKVM, go to “Closing a service call by using IBM PowerKVM” on page 113.
 2. Choose one of the following navigation options depending on the interface type of the Hardware Management Console (HMC):
 - If you are using an HMC Classic or HMC Enhanced interface, complete the following steps:
 - a. In the navigation area, click **Systems management**.
 - b. In the content pane, click **Manage Serviceable Events**.
 - c. Examine the service action event log for any open service action events.
 - If you are using an HMC Enhanced+ interface, complete the following steps:



- a. In the navigation area, click the **Serviceability** icon  , and then click **Serviceable Events Manager**.
 - b. Examine the service action event log for any open service action events.
3. Are any service action events open?
 - **Yes:** Continue with the next step.
 - **No:** If the system attention LED is still on, turn off the LED as described in “Activating and deactivating LEDs” on page 117. Return the system to the customer. **This completes the repair.**
 4. Record the list of open service action events.
 5. From the list of serviceable events recorded in step 4, complete the following steps 6 - step 32 on page 109 for each open service action event.
 6. Determine the error class of the serviceable event. Record for future use.
 7. Examine the details of the open service action event.

Is the error code that is associated with this service action event the same as recorded in step 1 on page 107?

 - **Yes:** Go to step 11.
 - **No:** Continue with the next step.
 8. Examine the FRU list of the service action event. Are any FRUs listed for the service action event?
 - **Yes:** Continue with the next step.
 - **No:** Go to step 11.
 9. Is the FRU list identical that is, the same FRUs, same number of FRUs, and same order of FRUs) to the FRU list of the error code recorded in step 1 on page 107?
 - **Yes:** Go to step 11.
 - **No:** Continue with the next step.
 10. The FRU list is different. Is the FRU you replaced and recorded in step 1 on page 107 in the list of FRUs for this service action event?
 - **Yes:** Continue with the next step.
 - **No:** Go to step 32 on page 109.

Note: Some service action events will remain open when you leave this MAP. Further service actions might be required to complete the repair.
 11. Examine the details of this service action event, and record the partitions involved in this service action event for use in a later step.
 12. Is the error code associated with this service action event of the form A11-xxx or A01-xxx?
 - **Yes:** Continue with the next step.
 - **No:** Go to step 17 on page 109.
 13. Have you begun a list of Axx partitions from prior service action events that you processed in this MAP?
 - **Yes:** Go to step 15.
 - **No:** Continue with the next step.
 14. Begin a new list of Axx partitions by copying the list of partitions obtained in step 11. Go to step 16.
 15. Add the partition list obtained in step 11 to the existing list of Axx partitions obtained from processing previous service action events in this maintenance analysis procedure (MAP).
 16. Remove all entries in the list of all partitions you recorded in step 11. If you are referred to the list of partitions obtained in step 11 in future steps, the list is empty. Go to step 17 on page 109.

17. Select and highlight the service action event from the Error Associated With This Serviceable Event window.
18. Click **Close Event**.
19. Add comments for the serviceable event. Include any unique additional information. Click **OK**. The following steps will add or update FRU information.
20. Did you replace, add, or modify a FRU of the open service action event?
 - **Yes:** Continue with the next step.
 - **No:** Go to step 22.
21. From the FRU list, select a FRU that you need to update. Double-click the FRU, and update the FRU information. Go to step 23.
22. Select the **No FRU Replaced for this Serviceable Event** option.
23. Click **OK** to close the service action event.
24. Is the list of all partitions you recorded in step 11 on page 108 empty?
 - **Yes:** Go to step 32.
 - **No:** Continue with the next step.
25. Does the list of all partitions you recorded in step 11 on page 108 contain more than one entry?
 - **Yes:** Continue with the next step.
 - **No:** Go to step 32.
26. Is the error class recorded in step 25 AIX?
 - **Yes:** Continue with the next step.
 - **No:** Go to step 32.
27. Perform all the following steps for each entry in the list of all partitions you recorded in step 11 on page 108, except for the partition you were using to debug the original problem.
28. From the list of all partitions, open the HMC virtual terminal window of a partition, and then type `diag` at the AIX command prompt.
29. When the diagnostic operating instructions are displayed, complete the following steps:
 - a. Press Enter.
 - b. Select the **Task Selection** option.
 - c. Select the **Log Repair** option.
 - d. Select the resource associated with the repair action:
 - If the repair action was reseating a cable or adapter, select the resource associated with that repair action.
 - If the resource associated with your repair action is not displayed on the Resource List, select **sysplanar0**.
 - e. Click **Commit** after you make your selection.

Note: If the terminal type is not defined, you are prompted to define it before you can proceed.
30. Exit from diagnostics in this partition and return to the AIX command prompt.
31. Have all the partitions in the list of all the partitions you recorded in step 11 on page 108 been processed?
 - **Yes:** Continue with the next step.
 - **No:** Go to step 24 to process the next partition in the list you recorded in step 11 on page 108.
32. Have all the serviceable events recorded in step 4 on page 108 been processed?
 - **Yes:** Continue with the next step.
 - **No:** Go to step 5 on page 108 and process the next service action event in the list of serviceable events recorded in step 4 on page 108.
33. While processing all service action events, were you directed to step 14 on page 108?

- **Yes:** Continue with the next step.
- **No:** If the system attention LED is still on, turn off the LED as described in “Activating and deactivating LEDs” on page 117. Return the system to the customer. **This completes the repair.**

Note: If, during the processing of the list of open service action events, some service action events remained open, further service actions might be required to complete the repair.

34. Perform all the following steps for each entry in the list of Axx partitions you began recording in step 14 on page 108, except for the partition you were using to debug the original problem.
35. From the list of Axx partitions, open the management console virtual terminal window of a partition , and then type `diag` at the AIX command prompt.
36. When the diagnostic operating instructions are displayed, complete the following steps:
 - a. Press Enter.
 - b. Select the **Task Selection** option.

Note: If the terminal type is not defined, you are prompted to define it before you can proceed.

- c. Select the resource associated with the repair action:
 - If the repair action was reseating a cable or adapter, select the resource associated with that repair action.
 - If the resource associated with your repair action is not displayed on the Resource List, select **sysplanar0**.
 - d. Click **Commit** after you make your selection.
37. Exit from diagnostics in this partition and return to the AIX command prompt.
 38. Have all the partitions in the list of Axx partitions you began recording in step 14 on page 108 been processed?
 - **Yes:** Continue with the next step.
 - **No:** Go to step 34 to process the next partition in the list you recorded in step 14 on page 108.
 39. If the system attention LED is still on, turn off the LED as described in “Activating and deactivating LEDs” on page 117. **This completes the repair.** Return the system to the customer.

Note: If, during the processing of the list of open service action events, some service action events remained open, further service actions might be required to complete the repair.

Closing a service call by using AIX or Linux

If the server is not connected to a management console and not using Integrated Virtualization Manager (IVM), perform these procedures to close serviceable events, clear hardware messages, and prepare the server to return to the customer.

Follow this checklist before performing the procedure:

- Return the server to the state that the customer normally uses, such as IPL type, IPL mode, and the way the system is configured or partitioned.
- While you were performing the problem analysis on the original serviceable event, other serviceable-event numbers might have been opened. Close all serviceable events that were opened as a result of your service activity.
- Ensure that server verification has been performed and that no problems require additional service actions.
- If the repair was done by using the IVM online repair procedures, ensure that the original serviceable event is now closed.
 1. Did you use a hot-swap operation by using an AIX diagnostics service aid to change the FRU?
 - **Yes:** Go to step 4 on page 111
 - **No:** Continue with the next step.

2. Do you have any field-replaceable units (FRUs) (for example cards, adapters, cables, or devices) that were removed during problem analysis that you want to put back into the system?

Note: If the system backplane or battery has been replaced and you are loading diagnostics from a server over a network, it might be necessary for the customer to set the network boot information for this system before diagnostics can be loaded. Also, set the system time and date information after the repair is completed.

- **Yes:** Reinstall all of the FRUs that were removed during problem analysis. Go to step 3
- **No:** Continue with the next step.

3. Is the system or logical partition that you are performing a repair action on running the AIX operating system?

- **Yes:** Continue with the next step.
- **No:** Go to step 5.

4. Does the system or logical partition you are performing a repair action on have the AIX operating system installed?

Note: If you have just replaced a hard disk in the root volume group, answer no to this question.

- **Yes:** Go to step 7.
- **No:** Continue with the next step.

5. Run stand-alone diagnostics in problem determination mode from either a CD-ROM or from a Network Installation Management (NIM) server.

Note: For instructions about running stand-alone diagnostics from a CD and not by using an HMC, go to Running the stand-alone diagnostics from CD on a server without an HMC attached.

For instructions about running stand-alone diagnostics from a NIM server, go to Running the stand-alone diagnostics from a Network Installation Management server.

Did you encounter any problems?

- **Yes:** Go to Problem analysis.
- **No:** Continue with the next step.

6. The system hardware is functioning correctly.

If the system attention LED is still on, turn off the LED as described in “Activating and deactivating LEDs” on page 117.

This completes the repair.

Note: If, during the processing of the list of open service action events, some service action events remained open, further service actions might be required to complete the repair.

Return the server to the state that the customer normally uses, such as IPL type, IPL mode, and the way the system is configured or partitioned. This might require you to reboot the operating system.

7. Complete the following steps:

- a. Restart the system.
- b. Wait until the AIX operating system login prompt is displayed or until system activity on the operator panel or display has stopped.

Did the AIX Login Prompt display?

- **Yes:** Continue with the next step.
- **No:** Go to Problem analysis.

8. If the Resource Repair Action menu is already displayed, go to 12 on page 112; otherwise, complete the following steps:

- a. Log into the operating system, either with root authority (if needed, ask the customer to enter the password) or use the CE login.
- b. Enter the `diag -a` command and check for missing resources. Follow any instructions that are displayed. If a system request number (SRN) is displayed, suspect a loose card or connection. If no instructions are displayed, no resources were detected as missing. Continue with step 9.

9. Complete the following steps:

- a. Enter `diag` at the command prompt and press **Enter**.
- b. Select the **Diagnostics Routines** option.
- c. When the Diagnostic Mode Selection menu is displayed, select **Problem determination**.
- d. When the Advanced Diagnostic Selection menu is displayed, select the **All Resources** option. Alternatively, test the FRUs you exchanged and any devices that are attached to the FRUs you exchanged by selecting the diagnostics for the individual FRU.

Did the Resource Repair Action menu (801015) display?

- **Yes:** Go to step 13.
- **No:** Continue with the next step.

10. Did the TESTING COMPLETE, no trouble was found menu (801010) display?

- **Yes:** Continue with the next step.
- **No:** There is still a problem. Go to Problem analysis.

11. Select the **Log Repair Action** option, if not previously logged, in the TASK SELECTION menu to update the AIX error log. If the repair action was reseating a cable or adapter, select the resource associated with that repair action.

If the resource associated with your action is not displayed on the resource list, select **sysplanar0**.

Note: If the check log indicator is on, this will set it back to the normal state. Go to step 14 on page 113.

12. Run a test on a resource that has an entry in the AIX error log, in the system verification mode. If the test on the resource was successful, the Resource Repair Action menu is displayed.

After replacing a FRU, select the resource for that FRU from the Resource Repair Action menu. This updates the AIX error log to indicate that a system-detectable FRU has been replaced.

Note: If the check log indicator is on, this action will set it back to the normal state.

To select the resource for the replaced FRU, complete the following steps:

- a. Select the resource associated with the repair action:
 - If the repair action was reseating a cable or adapter, select the resource associated with that repair action.
 - If the resource associated with your repair action is not displayed on the Resource List, select **sysplanar0**.
- b. Click **Commit** after you make your selection.

Did another Resource Repair Action (801015) display?

- **Yes:** Continue with the next step.
- **No:** If the No Trouble Found menu is displayed, go to step 14 on page 113.

13. Run a test on a resource that has an entry in the AIX error log, in the system verification mode. If the test on the resource was successful, the Resource Repair Action menu is displayed.

Note: The parent or child of the resource you just replaced might also require that you run the Resource Repair Action service aid on it.

After replacing that FRU, select the resource for that FRU from the Resource Repair Action menu. This updates the AIX error log to indicate that a system-detectable FRU has been replaced.

Note: If the check log indicator is on, this action will set it back to the normal state.

To select the resource for the replaced FRU, complete the following steps:

- a. Select the resource associated with the repair action:
 - If the repair action was reseating a cable or adapter, select the resource associated with that repair action.
 - If the resource associated with your repair action is not displayed on the Resource List, select **sysplanar0**.
- b. Click **Commit** after you make your selection.

Did the No Trouble Found menu display?

- **Yes:** Continue with the next step.
- **No:** Go to Problem analysis.

14. If you changed the service processor or network settings, as instructed in previous MAPs, restore the settings to the value they had prior to servicing the system. If you ran stand-alone diagnostics from CD-ROM, remove the stand-alone diagnostics CD-ROM from the system.

Did you perform service on a RAID subsystem that involved changing the PCI RAID adapter cache card or changing the configuration?

Note: This does not refer to the PCI-X RAID adapter or cache.

- **Yes:** Continue with the next step.
- **No:** Go to step 16.

15. Use the **Recover Options** selection to resolve the RAID configuration, by completing the following steps:
 - a. On the PCI SCSI Disk Array Manager dialog, select **Recovery options**.
 - b. Select **Clear PCI SCSI Adapter Configuration** and press F3 to clear any previous configuration data that exists on the replacement adapter.
 - c. On the Recovery Options dialog, select **Resolve PCI SCSI RAID Adapter Configuration**.
 - d. On the Resolve PCI SCSI RAID Adapter Configuration dialog, select **Accept Configuration on Drives**.
 - e. On the PCI SCSI RAID Adapter selections menu, select the adapter that you changed.
 - f. On the next dialog, press Enter.
 - g. When you see the Are You Sure selection menu, press Enter to continue. When the recovery action is complete, the status message of **OK** is shown.
 - h. If you receive a status message of **Failed**, verify that you selected the correct adapter, and then repeat this procedure. When recovery is complete, exit the operating system.
 - i. Go to step 16.

16. The system hardware is functioning correctly. Return the server to the state that the customer normally uses, such as IPL type, IPL mode, and the way the system is configured or partitioned.

Closing a service call by using IBM PowerKVM

Perform the following steps to prepare the server to return to the customer.

Consider the following prerequisites before performing the procedure:

- Return the server to the state that the customer normally uses, such as IPL type, IPL mode, and the way the system is configured or partitioned.
 - Ensure that server verification has been performed and that no problems require additional service actions.
1. Do you have any field-replaceable units (FRUs) (for example, cards, adapters, cables, or devices) that were removed during problem analysis that you want to replace in the system?

- **Yes:** Reinstall all of the FRUs that were removed during problem analysis. Continue with the next step.
 - **No:** Continue with the next step.
2. Have you already performed “Verifying a repair” on page 99?
 - **Yes:** Continue with the next step.
 - **No:** Perform “Verifying a repair” on page 99. Then continue with the next step.
 3. The system hardware is functioning correctly.

If the check log LED is still on, turn off the LED as described in “Activating and deactivating LEDs” on page 117.

Closing a service call by using Integrated Virtualization Manager

Perform these procedures to close serviceable events, clear hardware messages, and prepare the server to return to the customer.

Follow this checklist before performing the procedure:

- Return the server to the state that the customer normally uses, such as IPL type, IPL mode, and the way the system is configured or partitioned.
- While you were performing the problem analysis on the original serviceable event, other serviceable-event numbers might have been opened. Close all serviceable events that were opened as a result of your service activity.
- Ensure that server verification has been performed and there are no problems that require additional service actions.
- If the repair was done by using the Integrated Virtualization Manager (IVM) online repair procedures, ensure that the original serviceable event is now closed.
 1. Record the system reference code (SRC), or symptom, and the location code of the field-replaceable unit (FRU) you replaced for future reference.
 2. On the IVM, open **Manage Serviceable Events** and look at existing serviceable events.
 3. Are there any service action events that are open?
 - **Yes:** Continue with the next step.
 - **No:** If the system attention LED is still on, turn off the LED as described in “Activating and deactivating LEDs” on page 117. Return the system to the customer. **This completes the repair.**
 4. Record the list of open service action events.
 5. From the list of serviceable events recorded in step 4, complete steps 6 - 30 on page 116 for each open service action event.
 6. Determine the error class of the serviceable event. Record it for future use.
 7. Examine the details of the open service action event.

Is the error code associated with this service action event the same as recorded in step 1?

 - **Yes:** Go to step 11 on page 115.
 - **No:** Continue with the next step.
 8. Examine the FRU list of the service action event. Are any FRUs listed for the service action event?
 - **Yes:** Continue with the next step.
 - **No:** Go to step 11 on page 115.
 9. Is the FRU list identical that is, the same FRUs, same number of FRUs, and same order of FRUs) to the FRU list of the error code recorded in step 1?
 - **Yes:** Go to step 11 on page 115.
 - **No:** Continue with the next step.
 10. Is the FRU you replaced and recorded in step 1 in the list of FRUs for this service action event?
 - **Yes:** Continue with the next step.

- **No:** Go to step 30 on page 116.

Note: Some service action events remain open when you leave this MAP. Further service actions might be required to complete the repair.

11. Examine the details of this service action event, and record the partitions involved in this service action event for use in a later step.
12. Is the error code associated with this service action event of the form A11-xxx or A01-xxx?
 - **Yes:** Continue with the next step.
 - **No:** Go to step 17.
13. Have you begun a list of Axx partitions from prior service action events that you processed in this maintenance analysis procedure (MAP)?
 - **Yes:** Go to step 15.
 - **No:** Continue with the next step.
14. Begin a new list of Axx partitions by copying the list of partitions obtained in step 11. Go to step 16.
15. Add the partition list obtained in step 11 to the existing list of Axx partitions obtained from processing previous service action events in this MAP.
16. Remove all entries in the list of all partitions you recorded in step 11. If you are referred to the list of partitions obtained in step 11 in future steps, the list is empty. Go to step 17.
17. Select and highlight the service action event from the Manage Serviceable Events window.
18. Click **Close Event**.
19. Add comments for the serviceable event. Include any unique additional information. Click **OK**.
20. Add or update the FRU information:
Did you replace, add, or modify a FRU of the open service action event?
 - **Yes:** Continue with the next step.
 - **No:** Go to step 22.
21. Click **OK** to close the service action event.
22. Is the list of all partitions you recorded in step 11 empty?
 - **Yes:** Go to step 30 on page 116.
 - **No:** Continue with the next step.
23. Does the list of all partitions you recorded in step 11 contain more than one entry?
 - **Yes:** Continue with the next step.
 - **No:** Go to step 30 on page 116.
24. Is the error class recorded in step 23?
 - **Yes:** Continue with the next step.
 - **No:** Go to step 30 on page 116.
25. Perform all the following steps for each entry in the list of all partitions you recorded in step 11, except for the partition you were using to debug the original problem.
26. From the list of all partitions, open the IVM virtual terminal window of a partition, and then type diag at the AIX command prompt.
27. When the diagnostic operating instructions are displayed, complete the following steps:
 - a. Press Enter.
 - b. Select the **Task Selection** option.
 - c. Select the **Log Repair** option.
 - d. Select the resource associated with the repair action:
 - If the repair action was reseating a cable or adapter, select the resource associated with that repair action.

- If the resource associated with your repair action is not displayed on the Resource List, select **sysplanar0**.

e. Click **Commit** after you make your selection.

Note: If the terminal type is not defined, you are prompted to define it before you can proceed.

28. Exit from diagnostics in this partition and return to the AIX command prompt.
29. Have all the partitions in the list of all partitions you recorded in step 11 on page 115 been processed?
 - **Yes:** Continue with the next step.
 - **No:** Go to step 25 on page 115 to process the next partition in the list you recorded in step 11 on page 115.
30. Have all the serviceable events recorded in step 4 on page 114 been processed?
 - **Yes:** Continue with the next step.
 - **No:** Go to step 5 on page 114 and process the next service action event in the list of serviceable events recorded in step 4 on page 114.
31. While processing all service action events, were you directed to step 14 on page 115?
 - **Yes:** Continue with the next step.
 - **No:** If the system attention LED is still on, turn off the LED as described in “Activating and deactivating LEDs” on page 117. Return the system to the customer. **This completes the repair.**

Note: If during the processing of the list of open service action events, some service action events remained open, further service actions might be required to complete the repair.

32. Complete all the following steps for each entry in the list of *Axx* partitions you began recording in step 14 on page 115, except for the partition you were using to debug the original problem.
33. From the list of *Axx* partitions, open the management console virtual terminal window of a partition , and then type `diag` at the AIX command prompt.
34. When the diagnostic operating instructions are displayed, complete the following steps:
 - a. Press Enter.
 - b. Select the **Task Selection** option.

Note: If the terminal type is not defined, you are prompted to define it before you can proceed.

- c. Select the **Log Repair** option.
- d. Select the resource associated with the repair action:
 - If the repair action was reseating a cable or adapter, select the resource associated with that repair action.
 - If the resource associated with your repair action is not displayed on the Resource List, select **sysplanar0**.
- e. Click **Commit** after you make your selection.
35. Exit from diagnostics in this partition and return to the AIX command prompt.
36. Have all the partitions in the list of *Axx* partitions you began recording in step 14 on page 115 been processed?
 - **Yes:** Continue with the next step.
 - **No:** Go to step 32 to process the next partition in the list you recorded in step 14 on page 115.
37. If the system attention LED is still on, turn off the LED as described in “Activating and deactivating LEDs” on page 117. **This completes the repair.** Return the system to the customer.

Note: If, during the processing of the list of open service action events, some service action events remained open, further service actions might be required to complete the repair.

Activating and deactivating LEDs

You can use these procedures to activate or deactivate light-emitting diodes (LEDs) by using the management console or the Advanced System Management Interface (ASMI).

The system attention LED is activated when an error that requires a service action is detected, but a fault LED is not activated. Such errors can include errors that generate a system reference code (SRC) or a service request number (SRN). On systems that support fault LEDs, a fault LED is activated for many problems that can be isolated to a specific hardware component. However, for some problems that require a service action, a fault LED might not be activated even if a problem can be isolated to a specific hardware component. For those problems, the system attention LED is activated instead.

For IBM Power Systems servers that contain the POWER8 processor, the LEDs can be used to identify or verify a part that you are servicing. The error and identify function (amber) LED indicates an error and corresponds to the location code in the system reference code (SRC). The LED is activated and deactivated automatically.

Additionally, the following procedures can also be used to activate and deactivate LEDs.

- “Deactivating a system attention LED or partition LED by using the management console”
- “Activating or deactivating an identify LED by using the management console” on page 118
- “Deactivating a system attention LED or logical partition LED by using the Advanced System Management Interface” on page 119
- “Activating or deactivating an identify LED by using the Advanced System Management Interface” on page 119

Deactivating a system attention LED or partition LED by using the management console

You can deactivate a system attention LED or a logical partition LED if you decide that a problem is not a high priority and you decide to repair the problem at a later time. You can do this task from the Hardware Management Console (HMC).

If you want to be alerted if another problem occurs, you must deactivate the system attention LED so that it can be activated again if another problem occurs.

To deactivate a system attention LED by using the HMC, choose one of the following navigation options depending on the interface type of the HMC:

- If you are using an HMC Classic or HMC Enhanced interface, complete the following steps:
 1. In the navigation area, click **Systems management > Servers**.
 2. To enable the tasks for that server, select the required server name.
 3. From the **Tasks** menu, click **Operations > LED Status**
 4. Click **Identify LED**. The Identify LED window opens. The selected system and its LED state are displayed in the upper part of the window. The logical partition and its LED state are displayed in the lower part of the window. From the Identify LED window, you can deactivate both the System attention LED and the logical partition LED.
 5. Click **Deactivate Attention LED**. A confirmation window is displayed that provides the following information:
 - A verification that the system attention LED was deactivated.
 - An indication that there still might be open problems within the system.
 - An indication that you cannot activate the system attention LED.
 6. Select one of the logical partitions in the lower table, and click **Deactivate partition LED**. A confirmation window is displayed that provides the following information:

- A verification that the logical partition LED was deactivated.
 - An indication that there still might be open problems within the logical partition.
 - An indication that you cannot activate the logical partition LED.
- If you are using an HMC Enhanced+ interface, complete the following steps:



1. In the navigation area, click the **Resources** icon , and then click **All Systems**.
2. To view the actions for that server, select the server name of the required server.
3. In the navigation area, click **System Actions > Attention LED**.
4. Click **Identify Attention LED**. The Identify LED window opens. The selected system and its LED state are displayed in the upper part of the window. The logical partition and its LED state are displayed in the lower part of the window. From the Identify LED window, you can deactivate both the System attention LED and the logical partition LED.
5. Click **Turn Attention LED Off**. A confirmation window is displayed that provides the following information:
 - A verification that the system attention LED was deactivated.
 - An indication that there still might be open problems within the system.
 - An indication that you cannot activate the system attention LED.
6. Select one of the logical partitions in the lower table, and click **Turn Attention LED Off**. A confirmation window is displayed that provides the following information:
 - A verification that the logical partition LED was deactivated.
 - An indication that there still might be open problems within the logical partition.
 - An indication that you cannot activate the logical partition LED.

Activating or deactivating an identify LED by using the management console

You can activate or deactivate an identify LED for components attached to the system from the Hardware Management Console (HMC).

The system provides several LEDs that help identify various components in the system, such as enclosures or field-replaceable units (FRUs). For this reason, they are called *identify LEDs*.

You can activate or deactivate the following types of identify LEDs:

- **Identify LED for an enclosure.** If you want to add an adapter to a specific drawer (enclosure), you need to know the machine type, model, and serial number (MTMS) of the drawer. To determine whether you have the correct MTMS for the drawer that needs the new adapter, you can activate the LED for a drawer and verify that the MTMS corresponds to the drawer that requires the new adapter.
- **Identify LED for a FRU associated with a specified enclosure.** If you want to hook up a cable to a specific I/O adapter, you can activate the LED for the adapter, which is a field replaceable unit (FRU), and then physically check to see where you should connect the cable. This is especially useful when you have several adapters with open ports.

To activate or deactivate an identify LED for an enclosure or FRU, choose one of the following navigation options depending on the interface type of the HMC:

- If you are using an HMC Classic or HMC Enhanced interface, complete the following steps:
 1. In the navigation area, click **Systems management > Servers**.
 2. To enable the tasks for that server, select the required server name.
 3. From the **Tasks** menu, click **Operations > LED Status > Identify LED**. The Identify LED, Select Enclosure window is displayed.

4. To activate or deactivate an identify LED for an enclosure, select an enclosure from the table, and click either **Activate LED** or **Deactivate LED**. The associated LED is either turned on or off.
 5. To activate or deactivate an identify LED for a FRU, select an enclosure from the table, and then click **Selected > List FRUs**.
 6. Select one or more FRUs from the table, and click either **Activate LED** or **Deactivate LED**. The associated LED is either turned on or off.
- If you are using an HMC Enhanced+ interface, complete the following steps:



1. In the navigation area, click the **Resources** icon , and then click **All Systems**.
2. To view the actions for that server, select the required server.
3. In the navigation area, click **System Actions > Attention LED > Identify Attention LED**. The Identify Attention LED, Select Enclosure window is displayed.
4. To activate or deactivate an identify LED for an enclosure, select an enclosure from the table, and click either **Activate LED** or **Deactivate LED**. The associated LED is either turned on or off.
5. To activate or deactivate an identify LED for a FRU, select an enclosure from the table, and then click **Selected > List FRUs**.
6. Select one or more FRUs from the table, and click either **Activate LED** or **Deactivate LED**. The associated LED is either turned on or off.

Deactivating a system attention LED or logical partition LED by using the Advanced System Management Interface

You can deactivate a system attention LED or a logical partition LED by using the Advanced System Management Interface (ASMI).

The check log indicator provides a visual signal that the system as a whole requires attention or service. Each system has a single check log indicator. When an event occurs that either needs your intervention or that of service and support, the check log indicator lights continuously. The check log indicator is turned on when an entry is made in the service processor error log. The error entry is transmitted to the system error log and to the operating system error log.

To perform this operation, your authority level must be one of the following levels:

- Administrator
- Authorized service provider

To turn off the check log indicator, do the following steps:

1. In the ASMI Welcome pane, specify your user ID and password, and click **Log In**.
2. In the navigation area, expand **System Configuration > Service Indicators > System Attention Indicator**.
3. In the right pane, click **Turn off system attention indicator**. If the attempt is unsuccessful, an error message is displayed.

Activating or deactivating an identify LED by using the Advanced System Management Interface

You can activate or deactivate an identify LED by using the Advanced System Management Interface (ASMI).

You can specify the location code of any indicator to view or modify its current state. If you provide the wrong location code, the advanced system manager attempts to go to the next higher level of the location code.

The next level is the base-level location code for that field replaceable unit (FRU). For example, a user types the location code for the FRU located on the second I/O slot of the third enclosure in the system. If the location code for the second I/O slot is incorrect (the FRU does not exist at this location), an attempt to set the indicator for the third enclosure is initiated. This process continues until a FRU is located or no other level is available.

To perform this operation, your authority level must be one of the following levels:

- Administrator
- Authorized service provider

To change the current state of an indicator, do the following steps:

1. On the ASMI Welcome pane, specify your user ID and password, and click **Log In**.
2. In the navigation area, expand **System Configuration > Service Indicators > Indicators by Location code**.
3. In the right pane, enter the location code of the FRU and click **Continue**.
4. Select the preferred state from the list.
5. Click **Save settings**.

Deactivating an identify LED

Learn how to deactivate an identifying LED for a part or enclosure.

Deactivating a system attention LED by using the operating system or VIOS tools

You can use the AIX, IBM i, or Linux operating system, or the Virtual I/O Server (VIOS) tools to deactivate a system attention LED.

Deactivating the indicator light for a part by using AIX diagnostics

Use this procedure to turn off any indicator light that you turned on as a part of a service action.

To deactivate the indicator light, complete the following steps:

1. Log in as root user.
2. At the command line, type `diag` and press Enter.
3. From the **Function Selection** menu, select **Task Selection** and press Enter.
4. From the **Task Selection** menu, select **Identify and Attention Indicators** and press Enter.
5. From the list of lights, select the location code for the part and press Enter. When a light is activated for a part, an I character precedes the location code.
6. Select **Commit**.
7. Exit to the command line.

Deactivating the indicator light by using the IBM i operating system

Use this procedure to turn off any indicator light that you turned on as a part of a service action.

To deactivate the indicator light, follow these steps:

1. Sign on to an IBM i session, **with at least service level authority**.
2. On the command line of the session, type `strsst` and press Enter.

Note: If you cannot get to the System Service Tools display, use function 21 from the control panel. Alternatively, if the system is managed by a Hardware Management Console (HMC), use the Service Focal Point utilities to get to the Dedicated Service Tools (DST) display.

3. Type your service tools user ID and service tools password on the System Service Tools (SST) Sign On display and press Enter.

Remember: The service tools password is case-sensitive.

4. Select **Start a service tool** from the System Service Tools (SST) display and press Enter.
5. Select **Hardware service manager** from the Start a Service Tool display and press Enter.
6. Select **Work with service action log** from the Hardware Service Manager display and press Enter.
7. On the Select Timeframe display, change the **From: Date and Time** field to a date and time prior to when the problem occurred.
8. Search for an entry that matches one or more conditions of the problem:
 - System reference code
 - Resource
 - Date and time
 - Failing item list
9. Select option 2 (Display failing item information) to display the service action log entry.
10. Select option 2 (Display details) to display location information for the failing part to be replaced. The information displayed in the date and time fields is the date and time for the first occurrence of the specific system reference code for the resource displayed during the time range selected.
11. Select option 7 (Indicator off) to turn off the indicator light.
12. Select the **Acknowledge all errors** function at the bottom of the Service Action Log display, if all problems have been resolved.
13. Close the log entry by selecting option 8 (Close new entry) on the Service Action Log Report display.

Deactivating the indicator light by using the Linux operating system

After you complete a removal and replacement procedure, you can deactivate the indicator light.

To deactivate the indicator light, complete the following steps:

1. Log in as root user.
2. At the command line, type `/usr/sbin/usysident -s normal -l location_code` and press Enter.

Related information:

 [Service and productivity tools for Linux on Power servers](#)

IBM provides hardware diagnostic aids and productivity tools, and installation aids for Linux operating systems on IBM Power Systems servers.

Deactivating the indicator light for a part by using the VIOS tools

Use this procedure to turn off any indicator light that you turned on as a part of a service action.

To deactivate the indicator light, complete the following steps:

1. Log in as root user.
2. At the command line, type `diagmenu` and press Enter.
3. From the **Function Selection** menu, select **Task Selection** and press Enter.
4. From the **Task Selection** menu, select **Identify and Attention Indicators** and press Enter.
5. From the list of lights, select the location code for the part and press Enter. When a light is activated for a part, an I character precedes the location code.
6. Select **Commit**.
7. Exit to the command line.

Deactivating a system attention LED by using the ASMI

You can use the Advanced System Management Interface (ASMI) to deactivate a system attention LED.

Deactivating the identify LED by using the ASMI when you know the location code

Learn how to deactivate the identify LED by using the Advanced System Management Interface (ASMI) when you know the location code.

You can specify the location code of any indicator to view or modify its current state. If you provide the wrong location code, the ASMI attempts to go to the next higher level of the location code.

The next level is the base-level location code for that field replaceable unit (FRU). For example, a user types the location code for the FRU located on the second memory module slot of the third enclosure in the system. If the location code for the second memory module slot is incorrect (the FRU does not exist at this location), an attempt to set the indicator for the third enclosure is initiated. This process continues until a FRU is located or no other level is available.

To complete this operation, your authority level must be one of the following levels:

- Administrator
- Authorized service provider

To change the current state of an indicator, complete the following steps:

1. On the ASMI Welcome pane, specify your user ID and password, and click **Log In**.
2. In the navigation area, expand **System Configuration > Service Indicators > Indicators by Location code**.
3. In the **Location code** field, type the location code of the FRU and click **Continue**.
4. From the **Identify indicator status** list, select **Off**.
5. Click **Save settings**.

Deactivating the identify LED by using the ASMI when you do not know the location code

Learn how to deactivate the identify LED by using the Advanced System Management Interface (ASMI) when you do not know the location code.

You can turn off the identify indicators in each enclosure.

To complete this operation, your authority level must be one of the following levels:

- Administrator
- Authorized service provider

To disable the enclosure indicator states, complete the following steps:

1. On the ASMI Welcome pane, specify your user ID and password, and click **Log In**.
2. In the navigation area, expand **System Configuration > Service Indicators > Enclosure Indicators**. All servers and enclosures managed by the ASMI will display.
3. Select the server or enclosure with the part that needs to be replaced and click **Continue**. The location code identifiers are listed.
4. Select the location code identifier and select **Off**.
5. To save the changes made to the state of one or more FRU indicators, click **Save settings**.

Deactivating a check log indicator (system information indicator) by using the ASMI

You can deactivate a check log indicator (system information indicator) or logical partition check log indicator by using the ASMI.

The check log indicator provides a visual signal that the system as a whole requires attention or service. Each system has a single check log indicator. When an event occurs that either needs your intervention or

that of service and support, the check log indicator lights continuously. The check log indicator is turned on when an entry is made in the service processor error log. The error entry is transmitted to the system error log and to the operating system error log.

To complete this operation, your authority level must be one of the following levels:

- Administrator
- Authorized service provider

To turn off the check log indicator, do the following steps:

1. In the ASMI Welcome pane, specify your user ID and password, and click **Log In**.
2. In the navigation area, expand **System Configuration > Service Indicators > System Information Indicator**.
3. In the right pane, click **Turn off system information indicator**. If the attempt is unsuccessful, an error message is displayed.

Deactivating LEDs by using the HMC

Use this procedure to deactivate LEDs by using the Hardware Management Console (HMC).

Deactivating a system attention LED or partition LED by using the HMC

Use this procedure to deactivate a system attention LED or partition LED by using the Hardware Management Console (HMC).

To deactivate an LED by using the HMC, complete the following steps:

Choose one of the following navigation options depending on the interface type of the HMC:

- If you are using an HMC Classic or HMC Enhanced interface, complete the following steps:
 1. In the navigation area, click **Systems Management > Servers**.
 2. In the content pane, select the system.
 3. From the **Tasks** menu, click **Operations > LED Status**.
 4. Click **Identify LED**. The Identify LED window opens. The selected system and its LED state are displayed in the upper part of the window. The logical partition and its LED state are displayed in the lower part of the window. From the Identify LED window, you can deactivate both the system attention LED and the logical partition LED.
 5. Click **Deactivate Attention LED**. A confirmation window is displayed that provides the following information:
 - A verification that the system attention LED was deactivated.
 - An indication that there still might be open problems within the system.
 - An indication that you cannot deactivate the system attention LED.
 6. Select one of the logical partitions in the lower table, and click **Deactivate partition LED**. A confirmation window is displayed that provides the following information:
 - A verification that the logical partition attention LED was deactivated.
 - An indication that there still might be open problems within the logical partition.
 - An indication that you cannot deactivate the logical partition attention LED.
- If you are using an HMC Enhanced + Tech Preview (Pre-GA) or HMC Enhanced+ interface, complete the following steps:



1. In the navigation area, click the **Resources** icon  , and then click **All Systems**.
2. Click the server name for which you want to deactivate the attention LED.

3. In the navigation area, click **System Actions** > **Attention LED**.
4. Click **Turn Attention LED Off**. A confirmation window that provides the following information is displayed.
 - A verification that the system attention LED was deactivated.
 - An indication that there still might be open problems within the system.
5. Click **OK**.

Deactivating an identify LED for a FRU by using the HMC

Learn how to deactivate an identify LED by using the Hardware Management Console (HMC).

To deactivate an identify LED for a FRU by using the HMC, complete the following steps:

1. Choose one of the following navigation options depending on the interface type of the HMC:
 - If you are using an HMC Classic or HMC Enhanced interface, complete the following steps:
 - a. In the navigation area, click **Systems Management** > **Servers**.
 - b. In the content pane, select the system.
 - c. Click **Tasks** > **Operations** > **LED Status** > **Identify LED**. The Identify LED, Select Enclosure window is displayed.
 - If you are using an HMC Enhanced + Tech Preview (Pre-GA) or HMC Enhanced+ interface, complete the following steps.



- a. In the navigation area, click the **Resources** icon , and then click **All Systems**.
 - b. To view the actions for that server, click the name of the required server.
 - c. In the navigation area, click **System Actions** > **Attention LED** > **Identify Attention LED**. The Identify LED, Select Enclosure window is displayed.
2. To deactivate an identify LED for a FRU, select an enclosure from the table, and then click **Selected** > **List FRUs**.
3. Select one or more FRUs from the table, and click **Deactivate LED**. The associated LED is turned off.

Deactivating an identify LED for an enclosure by using the HMC

Learn how to deactivate an identify LED by using the Hardware Management Console (HMC).

To deactivate an identify LED for an enclosure by using the HMC, complete the following steps:

1. Choose one of the following navigation options depending on the interface type of the HMC:
 - If you are using an HMC Classic or HMC Enhanced interface, complete the following steps:
 - a. In the navigation area, click **Systems Management** > **Servers**.
 - b. In the content pane, select the system.
 - c. Click **Tasks** > **Operations** > **LED Status** > **Identify LED**.
 - If you are using an HMC Enhanced + Tech Preview (Pre-GA) or HMC Enhanced+ interface, complete the following steps.



- a. In the navigation area, click the **Resources** icon , and then click **All Systems**.
 - b. To view the actions for that server, click the name of the required server.
 - c. In the navigation area, click **System Actions** > **Attention LED** > **Identify Attention LED**.
2. To deactivate an identify LED for an enclosure, select an enclosure from the table, and click **Deactivate LED**. The associated LED is turned off.

Notices

This information was developed for products and services offered in the US.

IBM may not offer the products, services, or features discussed in this document in other countries. Consult your local IBM representative for information on the products and services currently available in your area. Any reference to an IBM product, program, or service is not intended to state or imply that only that IBM product, program, or service may be used. Any functionally equivalent product, program, or service that does not infringe any IBM intellectual property right may be used instead. However, it is the user's responsibility to evaluate and verify the operation of any non-IBM product, program, or service.

IBM may have patents or pending patent applications covering subject matter described in this document. The furnishing of this document does not grant you any license to these patents. You can send license inquiries, in writing, to:

*IBM Director of Licensing
IBM Corporation
North Castle Drive, MD-NC119
Armonk, NY 10504-1785
US*

INTERNATIONAL BUSINESS MACHINES CORPORATION PROVIDES THIS PUBLICATION "AS IS" WITHOUT WARRANTY OF ANY KIND, EITHER EXPRESS OR IMPLIED, INCLUDING, BUT NOT LIMITED TO, THE IMPLIED WARRANTIES OF NON-INFRINGEMENT, MERCHANTABILITY OR FITNESS FOR A PARTICULAR PURPOSE. Some jurisdictions do not allow disclaimer of express or implied warranties in certain transactions, therefore, this statement may not apply to you.

This information could include technical inaccuracies or typographical errors. Changes are periodically made to the information herein; these changes will be incorporated in new editions of the publication. IBM may make improvements and/or changes in the product(s) and/or the program(s) described in this publication at any time without notice.

Any references in this information to non-IBM websites are provided for convenience only and do not in any manner serve as an endorsement of those websites. The materials at those websites are not part of the materials for this IBM product and use of those websites is at your own risk.

IBM may use or distribute any of the information you provide in any way it believes appropriate without incurring any obligation to you.

The performance data and client examples cited are presented for illustrative purposes only. Actual performance results may vary depending on specific configurations and operating conditions.

Information concerning non-IBM products was obtained from the suppliers of those products, their published announcements or other publicly available sources. IBM has not tested those products and cannot confirm the accuracy of performance, compatibility or any other claims related to non-IBM products. Questions on the capabilities of non-IBM products should be addressed to the suppliers of those products.

Statements regarding IBM's future direction or intent are subject to change or withdrawal without notice, and represent goals and objectives only.

All IBM prices shown are IBM's suggested retail prices, are current and are subject to change without notice. Dealer prices may vary.

This information is for planning purposes only. The information herein is subject to change before the products described become available.

This information contains examples of data and reports used in daily business operations. To illustrate them as completely as possible, the examples include the names of individuals, companies, brands, and products. All of these names are fictitious and any similarity to actual people or business enterprises is entirely coincidental.

If you are viewing this information in softcopy, the photographs and color illustrations may not appear.

The drawings and specifications contained herein shall not be reproduced in whole or in part without the written permission of IBM.

IBM has prepared this information for use with the specific machines indicated. IBM makes no representations that it is suitable for any other purpose.

IBM's computer systems contain mechanisms designed to reduce the possibility of undetected data corruption or loss. This risk, however, cannot be eliminated. Users who experience unplanned outages, system failures, power fluctuations or outages, or component failures must verify the accuracy of operations performed and data saved or transmitted by the system at or near the time of the outage or failure. In addition, users must establish procedures to ensure that there is independent data verification before relying on such data in sensitive or critical operations. Users should periodically check IBM's support websites for updated information and fixes applicable to the system and related software.

Homologation statement

This product may not be certified in your country for connection by any means whatsoever to interfaces of public telecommunications networks. Further certification may be required by law prior to making any such connection. Contact an IBM representative or reseller for any questions.

Accessibility features for IBM Power Systems servers

Accessibility features assist users who have a disability, such as restricted mobility or limited vision, to use information technology content successfully.

Overview

The IBM Power Systems servers include the following major accessibility features:

- Keyboard-only operation
- Operations that use a screen reader

The IBM Power Systems servers use the latest W3C Standard, WAI-ARIA 1.0 (www.w3.org/TR/wai-aria/), to ensure compliance with US Section 508 (www.access-board.gov/guidelines-and-standards/communications-and-it/about-the-section-508-standards/section-508-standards) and Web Content Accessibility Guidelines (WCAG) 2.0 (www.w3.org/TR/WCAG20/). To take advantage of accessibility features, use the latest release of your screen reader and the latest web browser that is supported by the IBM Power Systems servers.

The IBM Power Systems servers online product documentation in IBM Knowledge Center is enabled for accessibility. The accessibility features of IBM Knowledge Center are described in the Accessibility section of the IBM Knowledge Center help (www.ibm.com/support/knowledgcenter/doc/kc_help.html#accessibility).

Keyboard navigation

This product uses standard navigation keys.

Interface information

The IBM Power Systems servers user interfaces do not have content that flashes 2 - 55 times per second.

The IBM Power Systems servers web user interface relies on cascading style sheets to render content properly and to provide a usable experience. The application provides an equivalent way for low-vision users to use system display settings, including high-contrast mode. You can control font size by using the device or web browser settings.

The IBM Power Systems servers web user interface includes WAI-ARIA navigational landmarks that you can use to quickly navigate to functional areas in the application.

Vendor software

The IBM Power Systems servers include certain vendor software that is not covered under the IBM license agreement. IBM makes no representation about the accessibility features of these products. Contact the vendor for accessibility information about its products.

Related accessibility information

In addition to standard IBM help desk and support websites, IBM has a TTY telephone service for use by deaf or hard of hearing customers to access sales and support services:

TTY service
800-IBM-3383 (800-426-3383)
(within North America)

For more information about the commitment that IBM has to accessibility, see IBM Accessibility (www.ibm.com/able).

Privacy policy considerations

IBM Software products, including software as a service solutions, (“Software Offerings”) may use cookies or other technologies to collect product usage information, to help improve the end user experience, to tailor interactions with the end user, or for other purposes. In many cases no personally identifiable information is collected by the Software Offerings. Some of our Software Offerings can help enable you to collect personally identifiable information. If this Software Offering uses cookies to collect personally identifiable information, specific information about this offering’s use of cookies is set forth below.

This Software Offering does not use cookies or other technologies to collect personally identifiable information.

If the configurations deployed for this Software Offering provide you as the customer the ability to collect personally identifiable information from end users via cookies and other technologies, you should seek your own legal advice about any laws applicable to such data collection, including any requirements for notice and consent.

For more information about the use of various technologies, including cookies, for these purposes, see IBM’s Privacy Policy at <http://www.ibm.com/privacy> and IBM’s Online Privacy Statement at <http://www.ibm.com/privacy/details> the section entitled “Cookies, Web Beacons and Other Technologies” and the “IBM Software Products and Software-as-a-Service Privacy Statement” at <http://www.ibm.com/software/info/product-privacy>.

Trademarks

IBM, the IBM logo, and ibm.com are trademarks or registered trademarks of International Business Machines Corp., registered in many jurisdictions worldwide. Other product and service names might be trademarks of IBM or other companies. A current list of IBM trademarks is available on the web at Copyright and trademark information at www.ibm.com/legal/copytrade.shtml.

Linux is a registered trademark of Linus Torvalds in the United States, other countries, or both.

Electronic emission notices

When attaching a monitor to the equipment, you must use the designated monitor cable and any interference suppression devices supplied with the monitor.

Class A Notices

The following Class A statements apply to the IBM servers that contain the POWER8 processor and its features unless designated as electromagnetic compatibility (EMC) Class B in the feature information.

Federal Communications Commission (FCC) Statement

Note: This equipment has been tested and found to comply with the limits for a Class A digital device, pursuant to Part 15 of the FCC Rules. These limits are designed to provide reasonable protection against harmful interference when the equipment is operated in a commercial environment. This equipment generates, uses, and can radiate radio frequency energy and, if not installed and used in accordance with the instruction manual, may cause harmful interference to radio communications. Operation of this equipment in a residential area is likely to cause harmful interference, in which case the user will be required to correct the interference at his own expense.

Properly shielded and grounded cables and connectors must be used in order to meet FCC emission limits. IBM is not responsible for any radio or television interference caused by using other than recommended cables and connectors or by unauthorized changes or modifications to this equipment. Unauthorized changes or modifications could void the user's authority to operate the equipment.

This device complies with Part 15 of the FCC rules. Operation is subject to the following two conditions: (1) this device may not cause harmful interference, and (2) this device must accept any interference received, including interference that may cause undesired operation.

Industry Canada Compliance Statement

CAN ICES-3 (A)/NMB-3(A)

European Community Compliance Statement

This product is in conformity with the protection requirements of EU Council Directive 2014/30/EU on the approximation of the laws of the Member States relating to electromagnetic compatibility. IBM cannot accept responsibility for any failure to satisfy the protection requirements resulting from a non-recommended modification of the product, including the fitting of non-IBM option cards.

European Community contact:

IBM Deutschland GmbH

Technical Regulations, Abteilung M456

IBM-Allee 1, 71139 Ehningen, Germany

Tel: +49 800 225 5426

email: halloibm@de.ibm.com

Warning: This is a Class A product. In a domestic environment, this product may cause radio interference, in which case the user may be required to take adequate measures.

VCCI Statement - Japan

この装置は、クラスA 情報技術装置です。この装置を家庭環境で使用すると電波妨害を引き起こすことがあります。この場合には使用者が適切な対策を講ずるよう要求されることがあります。 VCCI-A

The following is a summary of the VCCI Japanese statement in the box above:

This is a Class A product based on the standard of the VCCI Council. If this equipment is used in a domestic environment, radio interference may occur, in which case, the user may be required to take corrective actions.

Japan Electronics and Information Technology Industries Association Statement

This statement explains the Japan JIS C 61000-3-2 product wattage compliance.

(一社) 電子情報技術産業協会 高調波電流抑制対策実施
要領に基づく定格入力電力値 : Knowledge Centerの各製品の
仕様ページ参照

This statement explains the Japan Electronics and Information Technology Industries Association (JEITA) statement for products less than or equal to 20 A per phase.

高調波電流規格 JIS C 61000-3-2 適合品

This statement explains the JEITA statement for products greater than 20 A, single phase.

高調波電流規格 JIS C 61000-3-2 準用品

本装置は、「高圧又は特別高圧で受電する需要家の高調波抑制対策ガイドライン」対象機器（高調波発生機器）です。

- 回路分類 : 6 (単相、PFC回路付)
- 換算係数 : 0

This statement explains the JEITA statement for products greater than 20 A per phase, three-phase.

高調波電流規格 JIS C 61000-3-2 準用品

本装置は、「高圧又は特別高圧で受電する需要家の高調波抑制対策ガイドライン」対象機器（高調波発生機器）です。

- 回路分類 : 5 (3相、PFC回路付)
- 換算係数 : 0

Electromagnetic Interference (EMI) Statement - People's Republic of China

声 明

此为 A 级产品, 在生活环境中, 该产品可能会造成无线电干扰。在这种情况下, 可能需要用户对其干扰采取切实可行的措施。

Declaration: This is a Class A product. In a domestic environment this product may cause radio interference in which case the user may need to perform practical action.

Electromagnetic Interference (EMI) Statement - Taiwan

警告使用者：

這是甲類的資訊產品，在居住的環境中使用時，可能會造成射頻干擾，在這種情況下，使用者會被要求採取某些適當的對策。

The following is a summary of the EMI Taiwan statement above.

Warning: This is a Class A product. In a domestic environment this product may cause radio interference in which case the user will be required to take adequate measures.

IBM Taiwan Contact Information:

台灣IBM 產品服務聯絡方式：
台灣國際商業機器股份有限公司
台北市松仁路7號3樓
電話：0800-016-888

Electromagnetic Interference (EMI) Statement - Korea

이 기기는 업무용 환경에서 사용할 목적으로 적합성평가를 받은 기기로서 가정용 환경에서 사용하는 경우 전파간섭의 우려가 있습니다.

Germany Compliance Statement

Deutschsprachiger EU Hinweis: Hinweis für Geräte der Klasse A EU-Richtlinie zur Elektromagnetischen Verträglichkeit

Dieses Produkt entspricht den Schutzanforderungen der EU-Richtlinie 2014/30/EU zur Angleichung der Rechtsvorschriften über die elektromagnetische Verträglichkeit in den EU-Mitgliedsstaaten und hält die Grenzwerte der EN 55022 / EN 55032 Klasse A ein.

Um dieses sicherzustellen, sind die Geräte wie in den Handbüchern beschrieben zu installieren und zu betreiben. Des Weiteren dürfen auch nur von der IBM empfohlene Kabel angeschlossen werden. IBM übernimmt keine Verantwortung für die Einhaltung der Schutzanforderungen, wenn das Produkt ohne Zustimmung von IBM verändert bzw. wenn Erweiterungskomponenten von Fremdherstellern ohne Empfehlung von IBM gesteckt/eingebaut werden.

EN 55022 / EN 55032 Klasse A Geräte müssen mit folgendem Warnhinweis versehen werden:
"Warnung: Dieses ist eine Einrichtung der Klasse A. Diese Einrichtung kann im Wohnbereich Funk-Störungen verursachen; in diesem Fall kann vom Betreiber verlangt werden, angemessene Maßnahmen zu ergreifen und dafür aufzukommen."

Deutschland: Einhaltung des Gesetzes über die elektromagnetische Verträglichkeit von Geräten

Dieses Produkt entspricht dem "Gesetz über die elektromagnetische Verträglichkeit von Geräten (EMVG)". Dies ist die Umsetzung der EU-Richtlinie 2014/30/EU in der Bundesrepublik Deutschland.

Zulassungsbescheinigung laut dem Deutschen Gesetz über die elektromagnetische Verträglichkeit von Geräten (EMVG) (bzw. der EMC Richtlinie 2014/30/EU) für Geräte der Klasse A

Dieses Gerät ist berechtigt, in Übereinstimmung mit dem Deutschen EMVG das EG-Konformitätszeichen - CE - zu führen.

Verantwortlich für die Einhaltung der EMV Vorschriften ist der Hersteller:
International Business Machines Corp.
New Orchard Road
Armonk, New York 10504
Tel: 914-499-1900

Der verantwortliche Ansprechpartner des Herstellers in der EU ist:
IBM Deutschland GmbH
Technical Relations Europe, Abteilung M456
IBM-Allee 1, 71139 Ehningen, Germany
Tel: +49 (0) 800 225 5426
email: HalloIBM@de.ibm.com

Generelle Informationen:

Das Gerät erfüllt die Schutzanforderungen nach EN 55024 und EN 55022 / EN 55032 Klasse A.

Electromagnetic Interference (EMI) Statement - Russia

ВНИМАНИЕ! Настоящее изделие относится к классу А.
В жилых помещениях оно может создавать
радиопомехи, для снижения которых необходимы
дополнительные меры

Class B Notices

The following Class B statements apply to features designated as electromagnetic compatibility (EMC) Class B in the feature installation information.

Federal Communications Commission (FCC) Statement

This equipment has been tested and found to comply with the limits for a Class B digital device, pursuant to Part 15 of the FCC Rules. These limits are designed to provide reasonable protection against harmful interference in a residential installation.

This equipment generates, uses, and can radiate radio frequency energy and, if not installed and used in accordance with the instructions, may cause harmful interference to radio communications. However, there is no guarantee that interference will not occur in a particular installation.

If this equipment does cause harmful interference to radio or television reception, which can be determined by turning the equipment off and on, the user is encouraged to try to correct the interference by one or more of the following measures:

- Reorient or relocate the receiving antenna.
- Increase the separation between the equipment and receiver.
- Connect the equipment into an outlet on a circuit different from that to which the receiver is connected.
- Consult an IBM-authorized dealer or service representative for help.

Properly shielded and grounded cables and connectors must be used in order to meet FCC emission limits. Proper cables and connectors are available from IBM-authorized dealers. IBM is not responsible for any radio or television interference caused by unauthorized changes or modifications to this equipment. Unauthorized changes or modifications could void the user's authority to operate this equipment.

This device complies with Part 15 of the FCC rules. Operation is subject to the following two conditions: (1) this device may not cause harmful interference, and (2) this device must accept any interference received, including interference that may cause undesired operation.

Industry Canada Compliance Statement

CAN ICES-3 (B)/NMB-3(B)

European Community Compliance Statement

This product is in conformity with the protection requirements of EU Council Directive 2014/30/EU on the approximation of the laws of the Member States relating to electromagnetic compatibility. IBM cannot accept responsibility for any failure to satisfy the protection requirements resulting from a non-recommended modification of the product, including the fitting of non-IBM option cards.

European Community contact:
IBM Deutschland GmbH
Technical Regulations, Abteilung M456
IBM-Allee 1, 71139 Ehningen, Germany
Tel: +49 800 225 5426
email: halloibm@de.ibm.com

VCCI Statement - Japan

この装置は、クラスB情報技術装置です。この装置は、家庭環境で使用することを目的としていますが、この装置がラジオやテレビジョン受信機に近接して使用されると、受信障害を引き起こすことがあります。

取扱説明書に従って正しい取り扱いをして下さい。 VCCI-B

Japan Electronics and Information Technology Industries Association Statement

This statement explains the Japan JIS C 61000-3-2 product wattage compliance.

(一社) 電子情報技術産業協会 高調波電流抑制対策実施
要領に基づく定格入力電力値 : Knowledge Centerの各製品の
仕様ページ参照

This statement explains the Japan Electronics and Information Technology Industries Association (JEITA) statement for products less than or equal to 20 A per phase.

高調波電流規格 JIS C 61000-3-2 適合品

This statement explains the JEITA statement for products greater than 20 A, single phase.

高調波電流規格 JIS C 61000-3-2 準用品

本装置は、「高圧又は特別高圧で受電する需要家の高調波抑制対策ガイドライン」対象機器（高調波発生機器）です。

- 回路分類 : 6 (単相、PFC回路付)
- 換算係数 : 0

This statement explains the JEITA statement for products greater than 20 A per phase, three-phase.

高調波電流規格 JIS C 61000-3-2 準用品

本装置は、「高圧又は特別高圧で受電する需要家の高調波抑制対策ガイドライン」対象機器（高調波発生機器）です。

- 回路分類 : 5 (3相、PFC回路付)
- 換算係数 : 0

IBM Taiwan Contact Information

台灣IBM 產品服務聯絡方式：
台灣國際商業機器股份有限公司
台北市松仁路7號3樓
電話：0800-016-888

Germany Compliance Statement

Deutschsprachiger EU Hinweis: Hinweis für Geräte der Klasse B EU-Richtlinie zur Elektromagnetischen Verträglichkeit

Dieses Produkt entspricht den Schutzanforderungen der EU-Richtlinie 2014/30/EU zur Angleichung der Rechtsvorschriften über die elektromagnetische Verträglichkeit in den EU-Mitgliedsstaaten und hält die Grenzwerte der EN 55022/ EN 55032 Klasse B ein.

Um dieses sicherzustellen, sind die Geräte wie in den Handbüchern beschrieben zu installieren und zu betreiben. Des Weiteren dürfen auch nur von der IBM empfohlene Kabel angeschlossen werden. IBM übernimmt keine Verantwortung für die Einhaltung der Schutzanforderungen, wenn das Produkt ohne Zustimmung von IBM verändert bzw. wenn Erweiterungskomponenten von Fremdherstellern ohne Empfehlung von IBM gesteckt/eingebaut werden.

Deutschland: Einhaltung des Gesetzes über die elektromagnetische Verträglichkeit von Geräten

Dieses Produkt entspricht dem "Gesetz über die elektromagnetische Verträglichkeit von Geräten (EMVG)". Dies ist die Umsetzung der EU-Richtlinie 2014/30/EU in der Bundesrepublik Deutschland.

Zulassungsbescheinigung laut dem Deutschen Gesetz über die elektromagnetische Verträglichkeit von Geräten (EMVG) (bzw. der EMC Richtlinie 2014/30/EU) für Geräte der Klasse B

Dieses Gerät ist berechtigt, in Übereinstimmung mit dem Deutschen EMVG das EG-Konformitätszeichen - CE - zu führen.

Verantwortlich für die Einhaltung der EMV Vorschriften ist der Hersteller:
International Business Machines Corp.
New Orchard Road
Armonk, New York 10504

Tel: 914-499-1900

Der verantwortliche Ansprechpartner des Herstellers in der EU ist:

IBM Deutschland GmbH
Technical Relations Europe, Abteilung M456
IBM-Allee 1, 71139 Ehningen, Germany
Tel: +49 (0) 800 225 5426
email: HalloIBM@de.ibm.com

Generelle Informationen:

Das Gerät erfüllt die Schutzanforderungen nach EN 55024 und EN 55022/ EN 55032 Klasse B.

Terms and conditions

Permissions for the use of these publications are granted subject to the following terms and conditions.

Applicability: These terms and conditions are in addition to any terms of use for the IBM website.

Personal Use: You may reproduce these publications for your personal, noncommercial use provided that all proprietary notices are preserved. You may not distribute, display or make derivative works of these publications, or any portion thereof, without the express consent of IBM.

Commercial Use: You may reproduce, distribute and display these publications solely within your enterprise provided that all proprietary notices are preserved. You may not make derivative works of these publications, or reproduce, distribute or display these publications or any portion thereof outside your enterprise, without the express consent of IBM.

Rights: Except as expressly granted in this permission, no other permissions, licenses or rights are granted, either express or implied, to the publications or any information, data, software or other intellectual property contained therein.

IBM reserves the right to withdraw the permissions granted herein whenever, in its discretion, the use of the publications is detrimental to its interest or, as determined by IBM, the above instructions are not being properly followed.

You may not download, export or re-export this information except in full compliance with all applicable laws and regulations, including all United States export laws and regulations.

IBM MAKES NO GUARANTEE ABOUT THE CONTENT OF THESE PUBLICATIONS. THE PUBLICATIONS ARE PROVIDED "AS-IS" AND WITHOUT WARRANTY OF ANY KIND, EITHER EXPRESSED OR IMPLIED, INCLUDING BUT NOT LIMITED TO IMPLIED WARRANTIES OF MERCHANTABILITY, NON-INFRINGEMENT, AND FITNESS FOR A PARTICULAR PURPOSE.

