

Power Systems

*Problem Determination and Service
Guide for the IBM PS703 (7891-73X)
and PS704 (7891-74X)*



Power Systems

*Problem Determination and Service
Guide for the IBM PS703 (7891-73X)
and PS704 (7891-74X)*



Note

Before using this information and the product it supports, read the information in "Notices," on page 275, "Safety notices" on page v, the *IBM Systems Safety Notices* manual, G229-9054, and the *IBM Environmental Notices and User Guide*, Z125-5823.

This edition applies to IBM Power Systems servers that contain the POWER7 processor and to all associated models.

© Copyright IBM Corporation 2011.

US Government Users Restricted Rights – Use, duplication or disclosure restricted by GSA ADP Schedule Contract with IBM Corp.

Contents

Safety notices v

Chapter 1. Introduction 1

Related documentation	1
Notices and statements	2
Features and specifications.	2
Supported DIMMs	4
Blade server control panel buttons and LEDs	6
Turning on the blade server	7
Turning off the blade server	8
System-board layouts	8
System-board connectors	9
System-board LEDs.	12

Chapter 2. Diagnostics 15

Diagnostic tools	15
Collecting dump data	17
Location codes	17
Reference codes	20
System reference codes (SRCs)	21
1xxxxxxx SRCs	22
6xxxxxxx SRCs	33
A1xxxxxx service processor SRCs	36
AA00E1A8 to AA260005 Partition firmware attention codes	37
B1xxxxxx service processor SRCs	40
B200xxxx Logical partition SRCs	40
B7xxxxxx Licensed internal code SRCs	50
BA000010 to BA400002 Partition firmware SRCs	61
POST progress codes (checkpoints)	97
C1001F00 to C1645300 Service processor checkpoints	98
C2001000 to C20082FF Virtual service processor checkpoints	106
IPL status progress codes	115
C700xxxx Server firmware IPL status checkpoints	115
CA000000 to CA2799FF Partition firmware checkpoints	115
D1001xxx to D1xx3FFF Service processor dump codes	133
D1xx3y01 to D1xx3yF2 Service processor dump codes	138
D1xx900C to D1xxC003 Service processor power-off checkpoints	141
Service request numbers (SRNs)	142
Using the SRN tables.	142
101-711 through FFC-725 SRNs	142
A00-FF0 through A24-xxx SRNs	169
SCSD Devices SRNs (ssss-102 to ssss-640)	169
Failing function codes	173
Error logs	176
Checkout procedure	176
About the checkout procedure.	176

Performing the checkout procedure	177
Verifying the partition configuration.	179
Running the diagnostics program	179
Starting AIX concurrent diagnostics	179
Starting stand-alone diagnostics from a CD	179
Starting stand-alone diagnostics from a NIM server	180
Using the diagnostics program	181
Boot problem resolution.	182
Troubleshooting tables	183
General problems	183
Drive problems.	184
Intermittent problems	184
Management module service processor problems	185
Memory problems.	185
Microprocessor problems	186
Network connection problems.	186
PCI expansion card (PIOCARD) problem isolation procedure	186
Optional device problems	188
Power problems	188
Hypervisor problems.	190
Service processor problems.	193
Software problems.	209
Universal Serial Bus (USB) port problems	210
Light path diagnostics	210
Viewing the light path diagnostic LEDs	210
Light path diagnostics LEDs	213
Isolating firmware problems	216
Recovering the system firmware	217
Starting the PERM image	217
Starting the TEMP image	217
Recovering the TEMP image from the PERM image	218
Verifying the system firmware levels	218
Committing the TEMP system firmware image	219
Solving shared BladeCenter resource problems	219
Solving shared media tray problems.	220
Solving shared network connection problems	221
Solving shared power problems	222
Solving undetermined problems	223
Calling IBM for service	224

Chapter 3. Parts listing, type 7891 . . . 225

Chapter 4. Removing and replacing blade server components 229

Installation guidelines	229
System reliability guidelines	230
Handling static-sensitive devices	230
Returning a device or component	230
Removing the blade server from a BladeCenter unit	231
Installing the blade server in a BladeCenter unit	232

Removing and replacing tier 1 CRUs	233
Removing the blade server cover	233
Installing and closing the blade server cover	235
Removing the expansion unit for a PS704 blade server	237
Replacing the expansion unit in a PS704 blade server	238
Removing the bezel assembly	240
Installing the bezel assembly	241
Removing a hard-disk drive	242
Installing a hard-disk drive	243
Removing an SSD carrier	244
Replacing an SSD carrier	245
Removing an SSD	246
Installing an SSD	248
Removing a memory module	249
Installing a memory module	251
Removing and installing an I/O expansion card	253
Removing a CIOv form-factor expansion card	254
Installing a CIOv form-factor expansion card	255
Removing a combination-form-factor expansion card	256
Installing a combination-form-factor expansion card	257
Removing the battery	258
Installing the battery	258
Removing the disk drive tray	260

Installing the disk drive tray	261
Removing the tier 2 management card	262
Installing the tier 2 management card	263
Replacing the FRU system-board and chassis assembly	264

Chapter 5. Configuring 267

Updating the firmware	267
Configuring the blade server	269
Using the SMS utility	269
Starting the SMS utility	269
SMS utility menu choices	270
Creating a CE login	270
Configuring the Gigabit Ethernet controllers	270
Blade server Ethernet controller enumeration	271
MAC addresses for integrated Ethernet controllers	272
Configuring a RAID array	273
Updating IBM Director	273

Appendix. Notices 275

Trademarks	276
Electronic emission notices	277
Class A Notices	277
Class B Notices	281
Terms and conditions	284

Safety notices

Safety notices may be printed throughout this guide:

- **DANGER** notices call attention to a situation that is potentially lethal or extremely hazardous to people.
- **CAUTION** notices call attention to a situation that is potentially hazardous to people because of some existing condition.
- **Attention** notices call attention to the possibility of damage to a program, device, system, or data.

World Trade safety information

Several countries require the safety information contained in product publications to be presented in their national languages. If this requirement applies to your country, a safety information booklet is included in the publications package shipped with the product. The booklet contains the safety information in your national language with references to the U.S. English source. Before using a U.S. English publication to install, operate, or service this product, you must first become familiar with the related safety information in the booklet. You should also refer to the booklet any time you do not clearly understand any safety information in the U.S. English publications.

German safety information

Das Produkt ist nicht für den Einsatz an Bildschirmarbeitsplätzen im Sinne § 2 der Bildschirmarbeitsverordnung geeignet.

Laser safety information

IBM® servers can use I/O cards or features that are fiber-optic based and that utilize lasers or LEDs.

Laser compliance

IBM servers may be installed inside or outside of an IT equipment rack.

DANGER

When working on or around the system, observe the following precautions:

Electrical voltage and current from power, telephone, and communication cables are hazardous. To avoid a shock hazard:

- Connect power to this unit only with the IBM provided power cord. Do not use the IBM provided power cord for any other product.
- Do not open or service any power supply assembly.
- Do not connect or disconnect any cables or perform installation, maintenance, or reconfiguration of this product during an electrical storm.
- The product might be equipped with multiple power cords. To remove all hazardous voltages, disconnect all power cords.
- Connect all power cords to a properly wired and grounded electrical outlet. Ensure that the outlet supplies proper voltage and phase rotation according to the system rating plate.
- Connect any equipment that will be attached to this product to properly wired outlets.
- When possible, use one hand only to connect or disconnect signal cables.
- Never turn on any equipment when there is evidence of fire, water, or structural damage.
- Disconnect the attached power cords, telecommunications systems, networks, and modems before you open the device covers, unless instructed otherwise in the installation and configuration procedures.
- Connect and disconnect cables as described in the following procedures when installing, moving, or opening covers on this product or attached devices.

To Disconnect:

1. Turn off everything (unless instructed otherwise).
2. Remove the power cords from the outlets.
3. Remove the signal cables from the connectors.
4. Remove all cables from the devices

To Connect:

1. Turn off everything (unless instructed otherwise).
2. Attach all cables to the devices.
3. Attach the signal cables to the connectors.
4. Attach the power cords to the outlets.
5. Turn on the devices.

(D005)

DANGER

Observe the following precautions when working on or around your IT rack system:

- Heavy equipment—personal injury or equipment damage might result if mishandled.
- Always lower the leveling pads on the rack cabinet.
- Always install stabilizer brackets on the rack cabinet.
- To avoid hazardous conditions due to uneven mechanical loading, always install the heaviest devices in the bottom of the rack cabinet. Always install servers and optional devices starting from the bottom of the rack cabinet.
- Rack-mounted devices are not to be used as shelves or work spaces. Do not place objects on top of rack-mounted devices.



- Each rack cabinet might have more than one power cord. Be sure to disconnect all power cords in the rack cabinet when directed to disconnect power during servicing.
- Connect all devices installed in a rack cabinet to power devices installed in the same rack cabinet. Do not plug a power cord from a device installed in one rack cabinet into a power device installed in a different rack cabinet.
- An electrical outlet that is not correctly wired could place hazardous voltage on the metal parts of the system or the devices that attach to the system. It is the responsibility of the customer to ensure that the outlet is correctly wired and grounded to prevent an electrical shock.

CAUTION

- Do not install a unit in a rack where the internal rack ambient temperatures will exceed the manufacturer's recommended ambient temperature for all your rack-mounted devices.
- Do not install a unit in a rack where the air flow is compromised. Ensure that air flow is not blocked or reduced on any side, front, or back of a unit used for air flow through the unit.
- Consideration should be given to the connection of the equipment to the supply circuit so that overloading of the circuits does not compromise the supply wiring or overcurrent protection. To provide the correct power connection to a rack, refer to the rating labels located on the equipment in the rack to determine the total power requirement of the supply circuit.
- *(For sliding drawers.)* Do not pull out or install any drawer or feature if the rack stabilizer brackets are not attached to the rack. Do not pull out more than one drawer at a time. The rack might become unstable if you pull out more than one drawer at a time.
- *(For fixed drawers.)* This drawer is a fixed drawer and must not be moved for servicing unless specified by the manufacturer. Attempting to move the drawer partially or completely out of the rack might cause the rack to become unstable or cause the drawer to fall out of the rack.

(R001)

CAUTION:

Removing components from the upper positions in the rack cabinet improves rack stability during relocation. Follow these general guidelines whenever you relocate a populated rack cabinet within a room or building:

- Reduce the weight of the rack cabinet by removing equipment starting at the top of the rack cabinet. When possible, restore the rack cabinet to the configuration of the rack cabinet as you received it. If this configuration is not known, you must observe the following precautions:
 - Remove all devices in the 32U position and above.
 - Ensure that the heaviest devices are installed in the bottom of the rack cabinet.
 - Ensure that there are no empty U-levels between devices installed in the rack cabinet below the 32U level.
- If the rack cabinet you are relocating is part of a suite of rack cabinets, detach the rack cabinet from the suite.
- Inspect the route that you plan to take to eliminate potential hazards.
- Verify that the route that you choose can support the weight of the loaded rack cabinet. Refer to the documentation that comes with your rack cabinet for the weight of a loaded rack cabinet.
- Verify that all door openings are at least 760 x 230 mm (30 x 80 in.).
- Ensure that all devices, shelves, drawers, doors, and cables are secure.
- Ensure that the four leveling pads are raised to their highest position.
- Ensure that there is no stabilizer bracket installed on the rack cabinet during movement.
- Do not use a ramp inclined at more than 10 degrees.
- When the rack cabinet is in the new location, complete the following steps:
 - Lower the four leveling pads.
 - Install stabilizer brackets on the rack cabinet.
 - If you removed any devices from the rack cabinet, repopulate the rack cabinet from the lowest position to the highest position.
- If a long-distance relocation is required, restore the rack cabinet to the configuration of the rack cabinet as you received it. Pack the rack cabinet in the original packaging material, or equivalent. Also lower the leveling pads to raise the casters off of the pallet and bolt the rack cabinet to the pallet.

(R002)

(L001)



(L002)



(L003)



or



All lasers are certified in the U.S. to conform to the requirements of DHHS 21 CFR Subchapter J for class 1 laser products. Outside the U.S., they are certified to be in compliance with IEC 60825 as a class 1 laser product. Consult the label on each part for laser certification numbers and approval information.

CAUTION:

This product might contain one or more of the following devices: CD-ROM drive, DVD-ROM drive, DVD-RAM drive, or laser module, which are Class 1 laser products. Note the following information:

- Do not remove the covers. Removing the covers of the laser product could result in exposure to hazardous laser radiation. There are no serviceable parts inside the device.
- Use of the controls or adjustments or performance of procedures other than those specified herein might result in hazardous radiation exposure.

(C026)

CAUTION:

Data processing environments can contain equipment transmitting on system links with laser modules that operate at greater than Class 1 power levels. For this reason, never look into the end of an optical fiber cable or open receptacle. (C027)

CAUTION:

This product contains a Class 1M laser. Do not view directly with optical instruments. (C028)

CAUTION:

Some laser products contain an embedded Class 3A or Class 3B laser diode. Note the following information: laser radiation when open. Do not stare into the beam, do not view directly with optical instruments, and avoid direct exposure to the beam. (C030)

Power and cabling information for NEBS (Network Equipment-Building System) GR-1089-CORE

The following comments apply to the IBM servers that have been designated as conforming to NEBS (Network Equipment-Building System) GR-1089-CORE:

The equipment is suitable for installation in the following:

- Network telecommunications facilities
- Locations where the NEC (National Electrical Code) applies

The intrabuilding ports of this equipment are suitable for connection to intrabuilding or unexposed wiring or cabling only. The intrabuilding ports of this equipment *must not* be metallically connected to the interfaces that connect to the OSP (outside plant) or its wiring. These interfaces are designed for use as intrabuilding interfaces only (Type 2 or Type 4 ports as described in GR-1089-CORE) and require isolation from the exposed OSP cabling. The addition of primary protectors is not sufficient protection to connect these interfaces metallically to OSP wiring.

Note: All Ethernet cables must be shielded and grounded at both ends.

The ac-powered system does not require the use of an external surge protection device (SPD).

The dc-powered system employs an isolated DC return (DC-I) design. The DC battery return terminal *shall not* be connected to the chassis or frame ground.

Chapter 1. Introduction

This problem determination and service information helps you solve problems that might occur in your IBM BladeCenter® PS703 or PS704 blade server. The information describes the diagnostic tools that come with the blade server, error codes and suggested actions, and instructions for replacing failing components.

Replaceable components are of three types:

- **Tier 1 customer replaceable unit (CRU):** Replacement of tier 1 CRUs is your responsibility. If IBM installs a tier 1 CRU at your request, you are charged for the installation.
- **Tier 2 customer replaceable unit:** You can install a tier 2 CRU yourself or request IBM to install it, at no additional charge, under the type of warranty service that is designated for your blade server.
- **Field replaceable unit (FRU):** FRUs must be installed only by trained service technicians.

The serial number for the PS703 or PS704 blade server can be found in the following locations:

- The bottom front of the blade server in the right corner on the 1S label.
- The bottom rear of the blade server in the right corner.
- Under the front cover door.

For information about the terms of the warranty and getting service and assistance, see the information center or the *Warranty and Support Information* document on the IBM *BladeCenter Documentation CD*.

Related documentation

Documentation for the PS703 or PS704 blade server includes PDF files on the IBM *BladeCenter Documentation CD* and the information center.

The most recent version of all BladeCenter documentation is in the BladeCenter information center.

The online BladeCenter information center is available in the IBM BladeCenter Information Center at <http://publib.boulder.ibm.com/infocenter/bladectr/documentation/index.jsp>.

PDF versions of the following documents are on the IBM *BladeCenter Documentation CD* and in the information center:

- *Installation and User's Guide*

This document contains general information about the blade server, including how to install supported options and how to configure the blade server.

- *Safety Information*

This document contains translated caution and danger statements. Each caution and danger statement that appears in the documentation has a number that you can use to locate the corresponding statement in your language in the *Safety Information* document.

- *Warranty and Support Information*

This document contains information about the terms of the warranty and about getting service and assistance.

Additional documents might be included in the information center and on the IBM *BladeCenter Documentation CD*.

The blade server might have features that are not described in the documentation that comes with the blade server. Occasional updates to the documentation might include information about those features, or technical updates might be available to provide additional information that is not included in the documentation that comes with the blade server.

Review the online information or the *Planning Guide* and the *Installation Guide* for your IBM BladeCenter unit. The information can help you prepare for system installation and configuration. The most current version of each document is available in the BladeCenter information center.

Notices and statements

The caution and danger statements in this document are also in the multilingual *Safety Information*. Each statement is numbered for reference to the corresponding statement in your language in the *Safety Information* document.

The following notices and statements are used in this document:

- **Note:** These notices provide important tips, guidance, or advice.
- **Important:** These notices provide information or advice that might help you avoid inconvenient or problem situations.
- **Attention:** These notices indicate potential damage to programs, devices, or data. An attention notice is placed just before the instruction or situation in which damage might occur.
- **Caution:** These statements indicate situations that can be potentially hazardous to you. A caution statement is placed just before the description of a potentially hazardous procedure step or situation.
- **Danger:** These statements indicate situations that can be potentially lethal or extremely hazardous to you. A danger statement is placed just before the description of a potentially lethal or extremely hazardous procedure step or situation.

Features and specifications

Features and specifications of the IBM BladeCenter PS703 or PS704 blade server are summarized in this overview.

The PS703 is a single-wide blade server. The PS704 is the double-wide symmetric multiprocessing (SMP) unit. They are used in an IBM BladeCenter H (8852 and 7989), BladeCenter HT (8740 and 8750), or BladeCenter S (8886 and 7779) chassis unit.

Notes:

- Power, cooling, removable-media drives, external ports, and advanced system management are provided by the BladeCenter unit.
- The operating system in the blade server must provide support for the Universal Serial Bus (USB) to enable the blade server to recognize and communicate internally with the removable-media drives and front-panel USB ports.

<p>Core electronics:</p> <p>64-bit 2 x POWER7[®] processors (12S technology)</p> <p>PS703 single-wide model:</p> <ul style="list-style-type: none"> • 16-way single-wide blade: 2 socket 8-core at 2.4 GHz • 16 very low profile (VLP) DIMM slots. Maximum capacity is 128 GB. Supports 4 GB DDR3 and 8 GB DDR3 at 1066 MHz <p>PS704 double-wide model:</p> <ul style="list-style-type: none"> • 32-way double-wide: 2x8-way base with 2x8-way expansion • 32 very low profile (VLP) DIMM slots. Maximum capacity is 256 GB. Supports 4 GB DDR3 and 8 GB DDR3 at 1066 MHz <p>P7I/O I/O hub</p> <p>On-board, integrated features:</p> <ul style="list-style-type: none"> • FSP1 Service Processor - IPMI, SOL • Two 1 Gb Ethernet ports using 5709S Ethernet controller (two on PS703 , four on PS704) • SAS controller • USB 2.0 • 1 Serial over LAN (SOL) console using BMC Ethernet port <p>Local storage:</p> <ul style="list-style-type: none"> • PS703 : Maximum of one SAS 2.5 in. hard disk drive (HDD) or maximum of two SATA 1.8 in. solid-state drives (SSDs) or none • PS704: <ul style="list-style-type: none"> - Maximum of two SAS 2.5 in. HDDs or maximum of four SATA 1.8 in. SSDs or none - Valid options: <ul style="list-style-type: none"> - None - 1 HDD - 2 HDDs - 1 HDD and 1 SSD - 1 HDD and 2 SSDs - 2 SSDs, 3 SSDs, or 4 SSDs • SSDs are 200 GB • HDDs are 300 GB and 600 GB • RAID functions supported 	<p>Daughter card I/O options:</p> <ul style="list-style-type: none"> • in the PS703 : <ul style="list-style-type: none"> - Supports one expansion card (CIOv) - Supports one CFFh expansion card (combination form factor horizontal high-speed data card) - Supports one SAS passthrough using CIOv • PS704: <ul style="list-style-type: none"> - Supports two expansion cards (CIOv) - Supports two CFFh expansion cards - Supports up to two SAS passthroughs using CIOv <p>Integrated functions:</p> <ul style="list-style-type: none"> • RS-485 interface for communication with the management module • Automatic server restart (ASR) • SOL through service processor • Two Universal Serial Buses (USB 2.0) on base system board for communication with removable-media drives • Optical media available by shared chassis feature <p>Environment:</p> <ul style="list-style-type: none"> • Air temperature: <ul style="list-style-type: none"> - Blade server with power on: 10° - 35°C (50° - 95°F). Altitude: 0 - 914 m (3000 ft) - Blade server with power on: 10° - 32°C (50° - 90°F). Altitude: 914 m - 2133 m (3000 ft - 7000 ft) - Blade server with power off: -40° - 60°C (-40° - 140°F) • Humidity: <ul style="list-style-type: none"> - Blade server with power on: 8% - 80% - Blade server with power off: 8% - 80% <p>PS703 or PS704 size:</p> <ul style="list-style-type: none"> • Height: 24.5 cm (9.7 in.) • Depth: 44.6 cm (17.6 in.) • PS703: Width: 30 mm (1.14 in.) • PS704: 60 mm (2.28 in.) 	<p>Systems management:</p> <ul style="list-style-type: none"> • Supported by BladeCenter chassis management module • Front panel LEDs • IBM Director • Energy scale thermal management for power management, power oversubscription (throttling), and environmental sensing • Active Energy Manager • Concurrent Code Update via Director Update Manager, Inventory Collection, Multiple VIOS, and PowerVM[™] Enterprise <p>Clusters support for:</p> <ul style="list-style-type: none"> • IBM Director • xCat <p>Virtualization support for:</p> <p>PowerVM Standard Edition hardware feature, which provides the Integrated Virtualization Manager, Virtual I/O Server, and IBM Systems Director Management Console (SDMC).</p> <p>No HMC support</p> <p>Reliability and service features:</p> <ul style="list-style-type: none"> • Dual alternating current power supply • BladeCenter chassis redundant and hot-plug power and cooling modules • Boot-time processor deallocation • Blade server hot plug • Customer setup and expansion • Automatic reboot on power loss • Internal and ambient temperature monitors • ECC, chipkill memory • System management alerts • Light path diagnostics • Electronic Service Agent[™] call home capability <p>Electrical input: 12 V DC</p>
--	--	--

See the ServerProven website for information about supported operating-system versions and all blade server optional devices.

Supported DIMMs

Your blade server contains connectors for registered dual inline memory modules (RDIMMs).

Each system board in the PS703 or PS704 blade server contains 16 very low profile (VLP) memory connectors for DIMMs. The PS704 supports up to 32 DIMMs. The maximum size for a single DIMM is 8 GB. The maximum memory capacity for a PS703 server is 128 GB. The maximum memory capacity for a PS704 server is 256 GB.

See Chapter 3, “Parts listing, type 7891,” on page 225 for memory modules that you can order from IBM.

Memory module rules:

- Install DIMM fillers in unused DIMM slots for proper cooling.
- Install DIMMs in pairs (1 and 4, 5 and 8, 9 and 12, 13 and 16, 2 and 3, 6 and 7, 10 and 11, and 14 and 15).
- Both DIMMs in a pair must be the same size, speed, type, and technology. You can mix compatible DIMMs from different manufacturers.
- Each DIMM within a processor-support group (1-4, 5-8, 9-12, 13-16) must be the same size and speed.
- Install only supported DIMMs, as described on the ServerProven[®] website. See <http://www-03.ibm.com/servers/eserver/serverproven/compat/us/>.
- Installing or removing DIMMs changes the configuration of the blade server. After you install or remove a DIMM, the blade server is automatically reconfigured, and the new configuration information is stored.
- See “System-board connectors” on page 9 for DIMM connector locations.

Table 1 shows allowable placements of DIMM modules for the PS703 blade server. Table 2 on page 5 shows allowable placements of DIMM modules for the PS704 blade server.

Table 1. Memory module combinations for the PS703 blade server

DIMM count	PS703 DIMM slots															
	1	2	3	4	5	6	7	8	9	10	11	12	13	14	15	16
2	X			X												
4	X			X					X			X				
6	X			X	X			X	X			X				
8	X			X	X			X	X			X	X			X
10	X	X	X	X	X			X	X			X	X			X
12	X	X	X	X	X			X	X	X	X	X	X			X
14	X	X	X	X	X	X	X	X	X	X	X	X	X			X
16	X	X	X	X	X	X	X	X	X	X	X	X	X	X	X	X

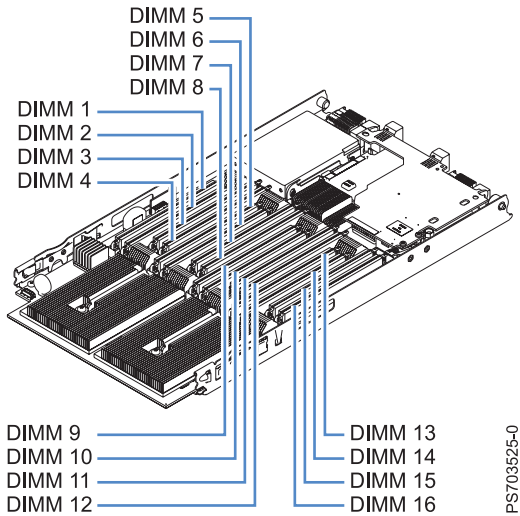

Figure 1. DIMM connectors for the PS703

Table 2. Memory module combinations for the PS704 blade server

DIMM count	PS704 base blade unit (P1) DIMM slots and expansion unit (P2) DIMM slots															
	1 (17)	2 (18)	3 (19)	4 (20)	5 (21)	6 (22)	7 (23)	8 (24)	9 (25)	10 (26)	11 (27)	12 (28)	13 (29)	14 (30)	15 (31)	16 (32)
2	X			X												
4	X			X					X			X				
6	X			X	X			X	X			X				
8	X			X	X			X	X			X	X			X
10	X	X	X	X	X			X	X			X	X			X
12	X	X	X	X	X			X	X	X	X	X	X			X
14	X	X	X	X	X	X	X	X	X	X	X	X	X			X
16	X	X	X	X	X	X	X	X	X	X	X	X	X	X	X	X

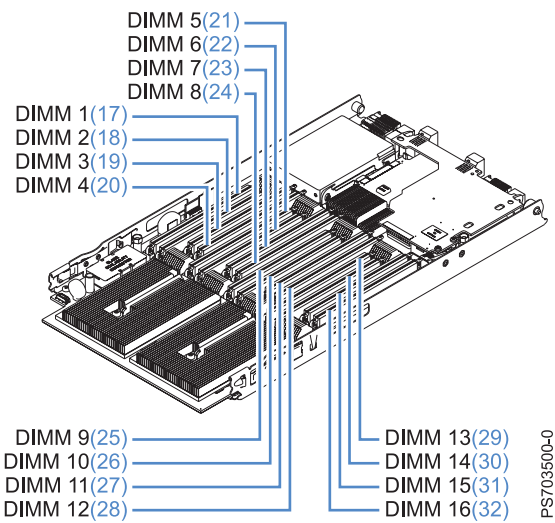

Figure 2. DIMM connectors for the PS704

Blade server control panel buttons and LEDs

Blade server control panel buttons and LEDs provide operational controls and status indicators.

Note: Figure 3 shows the control-panel door in the closed (normal) position. To access the power-control button, you must open the control-panel door.

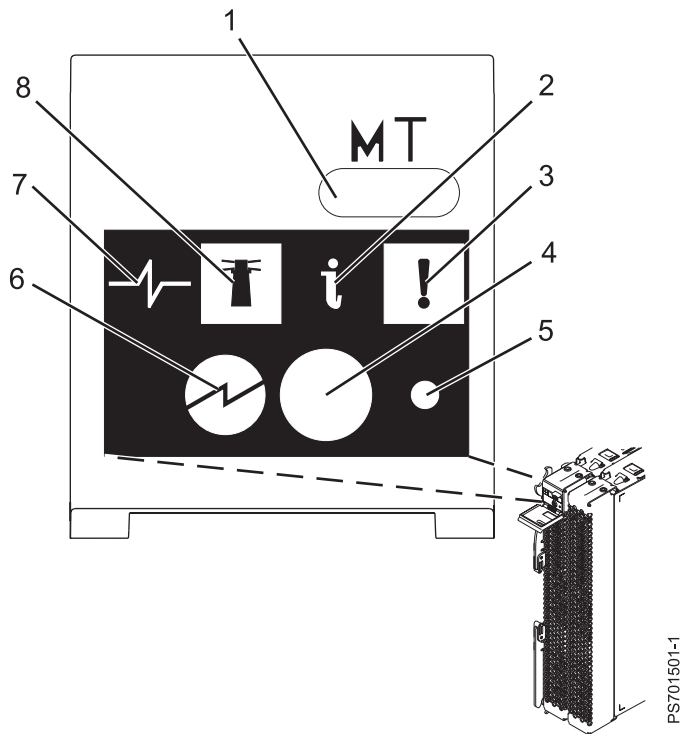

Figure 3. Blade server control panel buttons and LEDs

- 1 Media-tray select button:** Press this button to associate the shared BladeCenter unit media tray (removable-media drives and front-panel USB ports) with the blade server. The LED on the button flashes while the request is being processed, then is lit when the ownership of the media tray has been transferred to the blade server. It can take approximately 20 seconds for the operating system in the blade server to recognize the media tray.

If there is no response when you press the media-tray select button, use the management module to determine whether local control has been disabled on the blade server.

Note: The operating system in the blade server must provide USB support for the blade server to recognize and use the removable-media drives and USB ports.

- 2 Information LED:** When this amber LED is lit, it indicates that information about a system error for the blade server has been placed in the management-module event log. The information LED can be turned off through the Web interface of the management module or through IBM Director Console.
- 3 Blade-error LED:** When this amber LED is lit, it indicates that a system error has occurred in the blade server. The blade-error LED will turn off after one of the following events:
 - Correcting the error
 - Reseating the blade server in the BladeCenter unit
 - Cycling the BladeCenter unit power

- 4 Power-control button:** This button is behind the control panel door. Press this button to turn on or turn off the blade server.

The power-control button has effect only if local power control is enabled for the blade server. Local power control is enabled and disabled through the Web interface of the management module.

Press the power button for 5 seconds to begin powering down the blade server.

- 5 NMI reset (recessed):** The nonmaskable interrupt (NMI) reset dumps the partition. Use this recessed button only as directed by IBM Support.

- 6 Power-on LED:** This green LED indicates the power status of the blade server in the following manner:

- Flashing rapidly: The service processor is initializing the blade server.
- Flashing slowly: The blade server has completed initialization and is waiting for a power-on command.
- Lit continuously: The blade server has power and is turned on.

Note: The enhanced service processor can take as long as three minutes to initialize after you install the blade server, at which point the LED begins to flash slowly.

- 7 Activity LED:** When this green LED is lit, it indicates that there is activity on the hard disk drive or network.

- 8 Location LED:** When this blue LED is lit, it has been turned on by the system administrator to aid in visually locating the blade server. The location LED can be turned off through the Web interface of the management module or through IBM Director Console.

Turning on the blade server

After you connect the blade server to power through the BladeCenter unit, you can start the blade server after the discovery and initialization process is complete.

You can start the blade server in any of the following ways.

- Start the blade server by pressing the power-control button on the front of the blade server.

The power-control button is behind the control panel door, as described in “Blade server control panel buttons and LEDs” on page 6.

After you push the power-control button, the power-on LED continues to blink slowly for about 15 seconds, then is lit solidly when the power-on process is complete.

Wait until the power-on LED on the blade server flashes slowly before you press the blade server power-control button. If the power-on LED is flashing rapidly, the service processor is initializing the blade server. The power-control button does not respond during initialization.

Note: The enhanced service processor can take as long as three minutes to initialize after you install the blade server, at which point the LED begins to flash slowly.

- Start the blade server automatically when power is restored after a power failure.
If a power failure occurs, the BladeCenter unit and then the blade server can start automatically when power is restored. You must configure the blade server to restart through the management module.
- Start the blade server remotely using the management module.
After you initiate the power-on process, the power-on LED blinks slowly for about 15 seconds, then is lit solidly when the power-on process is complete.

Turning off the blade server

When you turn off the blade server, it is still connected to power through the BladeCenter unit. The blade server can respond to requests from the service processor, such as a remote request to turn on the blade server. To remove all power from the blade server, you must remove it from the BladeCenter unit.

Shut down the operating system before you turn off the blade server. See the operating-system documentation for information about shutting down the operating system.

You can turn off the blade server in one of the following ways.

- Turn off the blade server by pressing the power-control button for at least 5 seconds.
The power-control button is on the blade server behind the control panel door. See “Blade server control panel buttons and LEDs” on page 6 for the location.

Note: The power-control LED can remain on solidly for up to 1 minute after you push the power-control button. After you turn off the blade server, wait until the power-control LED is blinking slowly before you press the power-control button to turn on the blade server again.

If the operating system stops functioning, press and hold the power-control button for more than 5 seconds to force the blade server to turn off.

- Use the management module to turn off the blade server.

The power-control LED can remain on solidly for up to 1 minute after you initiate the power-off process. After you turn off the blade server, wait until the power-control LED is blinking slowly before you initiate the power-on process from the AMM to turn on the blade server again.

Use the management-module Web interface to configure the management module to turn off the blade server if the system is not operating correctly.

For additional information, see the online documentation or the *User's Guide* for the management module.

System-board layouts

Illustrations show the connectors and LEDs on the system board. The illustrations might differ slightly from your hardware.

System-board connectors

Blade server components attach to the connectors on the system board.

The following figure shows the connectors on the base-unit system board in the PS703 blade server.

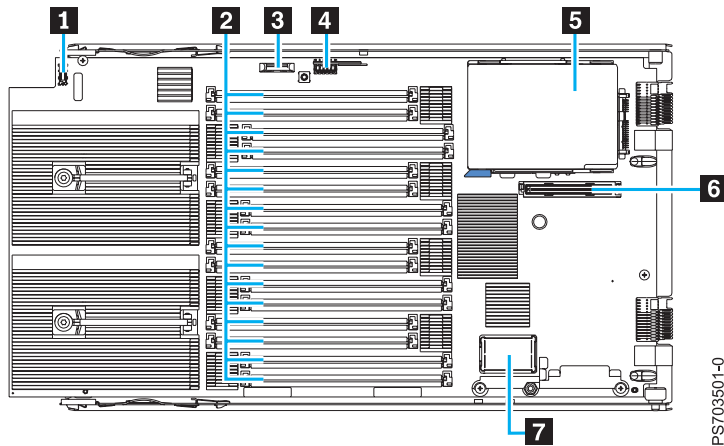

Figure 4. PS703 system-board connectors

The following table identifies and describes the connectors for the PS703 blade server.

Table 3. PS703 connectors

Callout	PS703 blade server connectors
1	Operator panel connector
2	DIMM connectors (See Figure 7 on page 11 for individual connectors.)
3	3 V lithium battery connector (P1-E1)
4	Management card connector (P1-C17)
5	2.5" SAS HDD (P1-D1) or 1.8" SATA SSD (P1-C18, P1-C18-D1, P1-C18-D2) carrier
6	CIOv expansion card connector (P1-C19)
7	High-speed (CFFh) expansion card connector (P1-C20)

The following figure shows the connectors on the base-unit system board in the PS704 blade server.

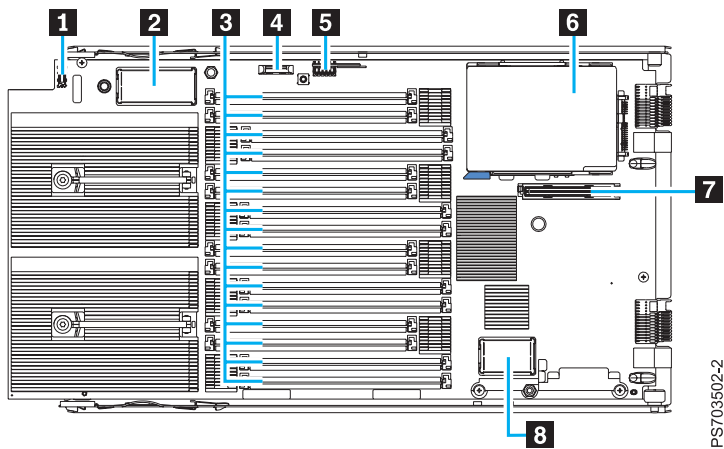

Figure 5. PS704 system base-unit connectors

The following figure shows the connectors on the expansion-unit system board in the PS704 blade server.

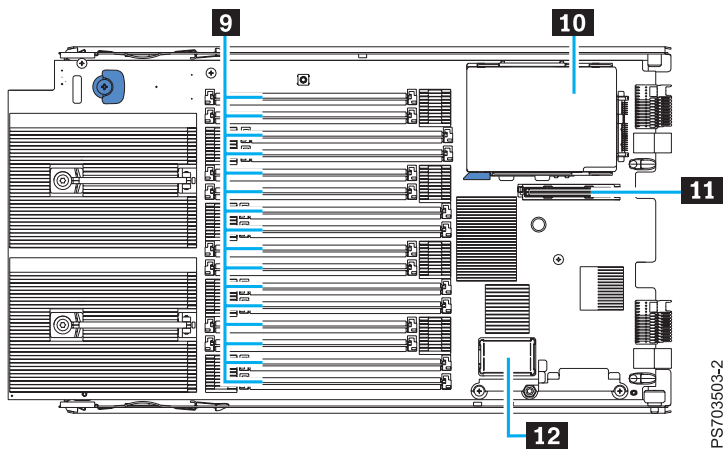

Figure 6. PS704 system expansion-unit connectors

The following table identifies and describes the connectors for the PS704 blade server.

Table 4. PS704 connectors

Callout	PS704 blade server connectors
1	Operator panel connector
2	Expansion connector
3	DIMM connectors (See Figure 8 on page 11 for individual connectors.)
4	3 V lithium battery connector (P1-E1)
5	Management card connector
6	2.5" SAS HDD (P1-D1) or 1.8" SATA SSD (P1-C18, P1-C18-D1, P1-C18-D2) carrier
7	CIOv expansion card connector (P1-C19)
8	High-speed (CFFh) expansion card connector (P1-C20)
9	DIMM connectors (See Figure 8 on page 11 for individual connectors.)
10	2.5" SAS HDD (P2-D1) or 1.8" SATA SSD (P2-C18, P2-C18-D1, P2-C18-D2) carrier
11	CIOv expansion card connector (P2-C19)

Table 4. PS704 connectors (continued)

Callout	PS704 blade server connectors
12	High-speed (CFFh) expansion card connector (P2-C20)

Figure 7 shows individual DIMM connectors for the PS703 system board.

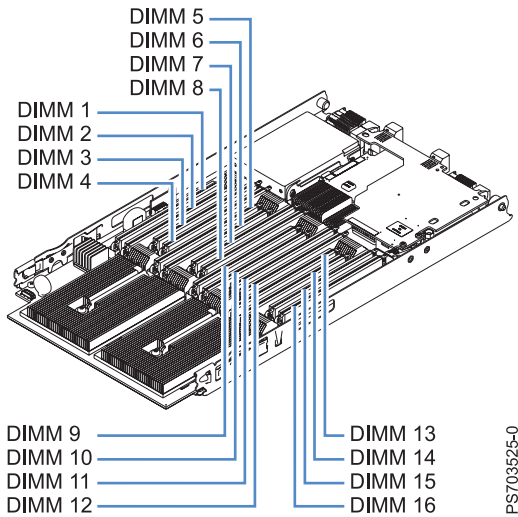

Figure 7. DIMM connectors for the PS703

Figure 8 shows individual DIMM connectors for the PS704 system board. The numbers in parentheses are for the PS704 expansion-unit system board.

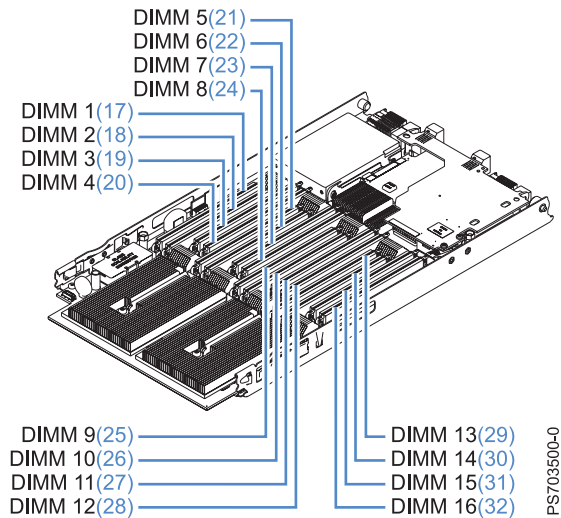

Figure 8. DIMM connectors for the PS704

System-board LEDs

Use the illustration of the LEDs on the system board to identify a light emitting diode (LED).

Remove the blade server from the BladeCenter unit, open the cover, press the blue button to see any error LEDs that were turned on during error processing. Use Figure 9 to identify the failing component.

If the "Check card below LED" is lit on the PS704 expansion-unit system board, remove the expansion unit and push the blue button on the base-unit system board to view LEDs on the system board of the base unit.

The following figure shows LEDs on the PS703 blade server.

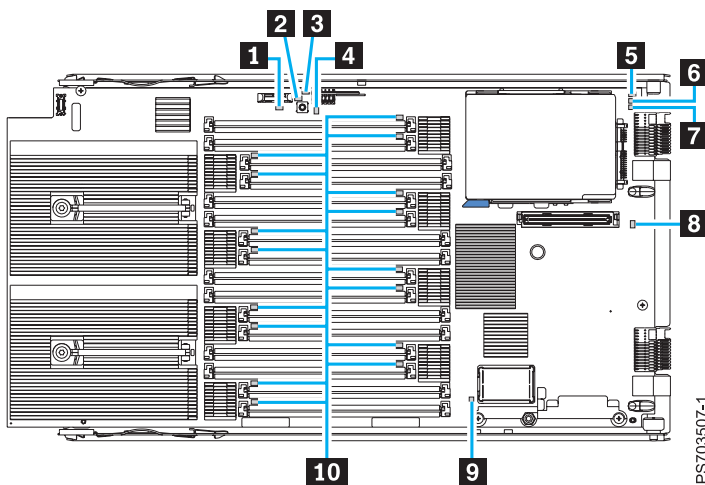

Figure 9. LED locations on the system board of the PS703 blade server

The following figure shows LEDs on the base system board of the PS704 blade server.

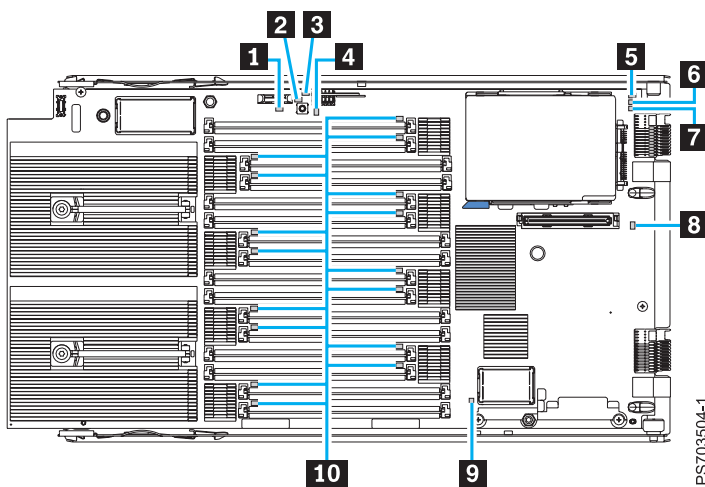

Figure 10. LED locations on the base system board of the PS704 blade server

The following figure shows LEDs on the expansion-unit board of the PS704 blade server.

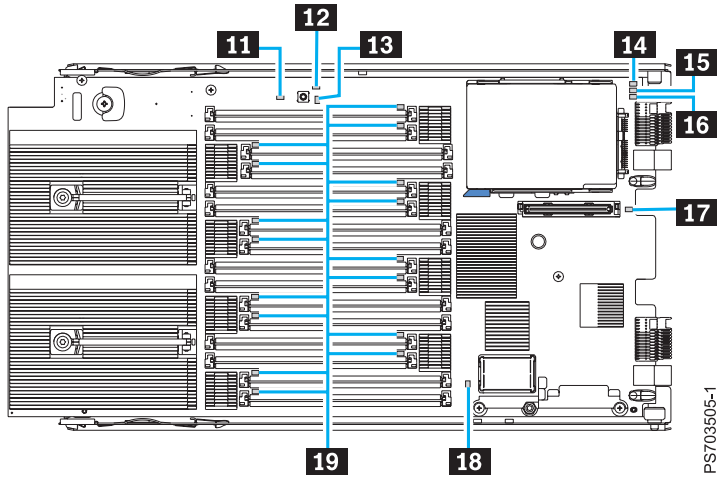

Figure 11. LED locations on the board of the PS704 expansion unit

The following table identifies and describes the LEDs.

Table 5. PS704 and PS703 LEDs

Callout	Unit LEDs
1	3 V lithium battery LED
2	Light path power LED
3	Management card LED
4	System board LED
5	DRV1 LED (HDD or SSD1)
6	DRV2 LED (SSD2)
7	SSD carrier LED
8	CIOv LED
9	CFFh LED
10	DIMM error LEDs
11	Check card below LED
12	Light path LED
13	System board LED
14	DVR1 LED (HDD or SSD1)
15	DVR2 LED (SSD2)
16	SSD carrier LED
17	CIOv LED
18	CFFh LED
19	DIMM error LEDs

Chapter 2. Diagnostics

Use the available diagnostic tools to help solve any problems that might occur in the blade server.

The first and most crucial component of a solid serviceability strategy is the ability to accurately and effectively detect errors when they occur. While not all errors are a threat to system availability, those that go undetected are dangerous because the system does not have the opportunity to evaluate and act if necessary. POWER7 processor-based systems are specifically designed with error-detection mechanisms that extend from processor cores and memory to power supplies and hard drives.

POWER7 processor-based systems contain specialized hardware detection circuitry for detecting erroneous hardware operations. Error checking hardware ranges from parity error detection coupled with processor instruction retry and bus retry, to ECC correction on caches and system buses.

IBM hardware error checkers have these distinct attributes:

- Continuous monitoring of system operations to detect potential calculation errors
- Attempted isolation of physical faults based on runtime detection of each unique failure
- Initiation of a wide variety of recovery mechanisms designed to correct a problem

POWER7 processor-based systems include extensive hardware and firmware recovery logic.

Machine check handling

Machine checks are handled by firmware. When a machine check occurs, the firmware analyzes the error to identify the failing device and creates an error log entry.

If the system degrades to the point that the service processor cannot reach standby state, the ability to analyze the error does not exist. If the error occurs during hypervisor activities, the hypervisor initiates a system reboot.

In partitioned mode, an error that occurs during partition activity is reported to the operating system in the partition.

Diagnostic tools

Tools are available to help you diagnose and solve hardware-related problems.

- **Power-on self-test (POST) progress codes (checkpoints), error codes, and isolation procedures**

The POST checks out the hardware at system initialization. IPL diagnostic functions test some system components and interconnections. The POST generates eight-digit checkpoints to mark the progress of powering up the blade server.

Use the management module to view progress codes.

The documentation of a progress code includes recovery actions for system hangs. See “POST progress codes (checkpoints)” on page 97 for more information.

If the service processor detects a problem during POST, an error code is logged in the management module event log. Error codes are also logged in the Linux `syslog` or AIX[®] diagnostic log, if possible. See “System reference codes (SRCs)” on page 21.

The service processor can generate codes that point to specific isolation procedures. See “Service processor problems” on page 193.

- **Light path diagnostics**

Use the light path diagnostic LEDs on the system board to identify failing hardware. If the system error LED on the system LED panel on the front or rear of the BladeCenter unit is lit, one or more error LEDs on the BladeCenter unit components also might be lit.

Light path diagnostics help identify failing customer replaceable unit (CRUs). CRU location codes are included in error codes and the event log.

LED locations

See “System-board LEDs” on page 12.

Front panel

See “Blade server control panel buttons and LEDs” on page 6.

- **Troubleshooting tables**

Use the troubleshooting tables to find solutions to problems that have identifiable symptoms.

See “Troubleshooting tables” on page 183.

- **Dump data collection**

In some circumstances, an error might require a dump to show more data. The Integrated Virtual Manager (IVM) sets up a dump area. Specific IVM information is included as part of the information that can optionally be sent to IBM support for analysis.

See “Collecting dump data” on page 17 for more information.

- **Stand-alone diagnostics**

The AIX-based stand-alone diagnostics CD is in the ship package and is also available from the IBM Web site. Boot the diagnostics from a CD drive or from an AIX network installation manager (NIM) server if the blade server cannot boot to an operating system, no matter which operating system is installed.

Functions provided by the stand-alone diagnostics include:

- Analysis of errors reported by the platform, such as microprocessor and memory errors
- Testing of resources, such as I/O adapters and devices
- Service aids, such as firmware update, format disk, and Raid Manager

- **Diagnostic utilities for the AIX operating system**

Run AIX concurrent diagnostics if AIX is functioning instead of the stand-alone diagnostics. Functions provided by disk-based AIX diagnostics include:

- Automatic error log analysis
- Analysis of errors reported by the platform, such as microprocessor and memory errors
- Testing of resources, such as I/O adapters and devices
- Service aids, such as firmware update, format disk, and Raid Manager

- **Diagnostic utilities for Linux operating systems**

Linux service and productivity tools include hardware diagnostic aids and productivity tools, and installation aids. The installation aids are provided in the IBM Installation Toolkit for Linux, a set of tools that aids the installation of Linux on IBM servers with POWER® architecture. You can also use the tools to update the PS703 or PS704 blade server firmware.

Diagnostic utilities for the Linux operating system are available from IBM at <https://www14.software.ibm.com/webapp/set2/sas/f/lopdiags/home.html>.

- **Diagnostic utilities for other operating systems**

You can use the stand-alone diagnostics CD to perform diagnostics on the PS703 or PS704 blade server, no matter which operating system is loaded on the blade server. However, other supported operating systems might have diagnostic tools that are available through the operating system. See the documentation for your operating system for more information.

Collecting dump data

A dump might be critical for fault isolation when the built-in First Failure Data Capture (FFDC) mechanisms are not capturing sufficient fault data. Even when a fault is identified, dump data can provide additional information that is useful in problem determination.

All hardware state information is part of the dump if a hardware checkstop occurs. When a checkstop occurs, the service processor attempts to dump data that is necessary to analyze the error from appropriate parts of the system.

Note: If you power off the blade through the management module while the service processor is performing a dump, platform dump data is lost.

You might be asked to retrieve a dump to send it to IBM Support for analysis. The location of the dump data varies by operating system.

- For an AIX operating system, collect the dump from the `/var/adm/platform` directory.
- For a Linux operating system, collect the dump from the `/var/log/dump` directory.
- For a PS703 or PS704 blade server that is managed by the Integrated Virtualization Manager (IVM), collect the dump using the **Manage Dumps** task in the IVM console.

Location codes

Location codes identify components of the blade server. Location codes are displayed with some error codes to identify the blade server component that is causing the error.

See “System-board connectors” on page 9 for component locations.

Notes:

1. Location codes do not indicate the location of the blade server within the BladeCenter unit. The codes identify components of the blade server only.
2. For checkpoints with no associated location code, see “Light path diagnostics” on page 210 to identify the failing component when there is a hang condition.
3. For checkpoints with location codes, use the following table to identify the failing component when there is a hang condition.
4. For 8-digit codes not listed in Table 6 on page 18, see the “Checkout procedure” on page 176.

Table 6. Location codes for PS703.

Components	Physical location code	CRU LED
<p>U_n location codes are for enclosure and VPD locations.</p> <p>$U_n = U_{tttt}.mmm.ssssss$</p> <p>$tttt$ = system machine type mmm = system model number $ssssss$ = system serial number</p>		
DIMM 1	U_n -P1-C1	Yes
DIMM 2	U_n -P1-C2	Yes
DIMM 3	U_n -P1-C3	Yes
DIMM 4	U_n -P1-C4	Yes
DIMM 5	U_n -P1-C5	Yes
DIMM 6	U_n -P1-C6	Yes
DIMM 7	U_n -P1-C7	Yes
DIMM 8	U_n -P1-C8	Yes
DIMM 9	U_n -P1-C9	Yes
DIMM 10	U_n -P1-C10	Yes
DIMM 11	U_n -P1-C11	Yes
DIMM 12	U_n -P1-C12	Yes
DIMM 13	U_n -P1-C13	Yes
DIMM 14	U_n -P1-C14	Yes
DIMM 15	U_n -P1-C15	Yes
DIMM 16	U_n -P1-C16	Yes
2.5" SAS disk drive	U_n -P1-D1	Yes
Management card	U_n -P1-C17	Yes
Solid-state drive carrier	U_n -P1-C18	Yes
Solid-state drive 1 (top drive)	U_n -P1-C18-D1	Yes
Solid-state drive 2 (bottom drive)	U_n -P1-C18-D2	Yes
Battery	U_n -P1-E1	Yes
CFFh expansion card	U_n -P1-C20	Yes
CIOv form-factor expansion card	U_n -P1-C19	Yes
USB port 1 (CDROM/FDD)	U_n -P1-T1	No
USB port 2 (CDROM/FDD)	U_n -P1-T2	No
Ethernet port 0	U_n -P1-T3	No
Ethernet port 1	U_n -P1-T4	No
Integrated SAS controller	U_n -P1-T5	No
Machine location code	$U_{tttt}.mmm.ssssss$	No
<p>U_m codes are for firmware. The format is the same as for a U_n location code.</p> <p>$U_m = U_{tttt}.mmm.ssssss$</p>		
Firmware version		U_m -Y1

Table 7. Location codes for PS704

Components	Physical location code	CRU LED
<p><i>Un</i> location codes are for enclosure and VPD locations.</p> <p>$Un = U\text{tttt}.mmm.ssssss$</p> <p><i>tttt</i> = system machine type <i>mmm</i> = system model number <i>ssssss</i> = system serial number</p>		
DIMM 1	<i>Un</i> -P1-C1	Yes
DIMM 2	<i>Un</i> -P1-C2	Yes
DIMM 3	<i>Un</i> -P1-C3	Yes
DIMM 4	<i>Un</i> -P1-C4	Yes
DIMM 5	<i>Un</i> -P1-C5	Yes
DIMM 6	<i>Un</i> -P1-C6	Yes
DIMM 7	<i>Un</i> -P1-C7	Yes
DIMM 8	<i>Un</i> -P1-C8	Yes
DIMM 9	<i>Un</i> -P1-C9	Yes
DIMM 10	<i>Un</i> -P1-C10	Yes
DIMM 11	<i>Un</i> -P1-C11	Yes
DIMM 12	<i>Un</i> -P1-C12	Yes
DIMM 13	<i>Un</i> -P1-C13	Yes
DIMM 14	<i>Un</i> -P1-C14	Yes
DIMM 15	<i>Un</i> -P1-C15	Yes
DIMM 16	<i>Un</i> -P1-C16	Yes
2.5" SAS disk drive	<i>Un</i> -P1-D1	Yes
Management card	<i>Un</i> -P1-C17	Yes
Solid-state drive carrier	<i>Un</i> -P1-C18	Yes
Solid-state drive 1 (top drive)	<i>Un</i> -P1-C18-D1	Yes
Solid-state drive 2 (bottom drive)	<i>Un</i> -P1-C18-D2	Yes
Battery	<i>Un</i> -P1-E1	Yes
CFFh expansion card	<i>Un</i> -P1-C20	Yes
CIOv form-factor expansion card	<i>Un</i> -P1-C19	Yes
USB port 1 (CDROM/FDD)	<i>Un</i> -P1-T1	No
USB port 2 (CDROM/FDD)	<i>Un</i> -P1-T2	No
Ethernet port 0	<i>Un</i> -P1-T3	No
Ethernet port 1	<i>Un</i> -P1-T4	No
Integrated SAS controller	<i>Un</i> -P1-T5	No
DIMM 17	<i>Un</i> -P2-C1	Yes
DIMM 18	<i>Un</i> -P2-C2	Yes
DIMM 19	<i>Un</i> -P2-C3	Yes
DIMM 20	<i>Un</i> -P2-C4	Yes
DIMM 21	<i>Un</i> -P2-C5	Yes
DIMM 22	<i>Un</i> -P2-C6	Yes

Table 7. Location codes for PS704 (continued)

Components	Physical location code	CRU LED
DIMM 23	Un-P2-C7	Yes
DIMM 24	Un-P2-C8	Yes
DIMM 25	Un-P2-C9	Yes
DIMM 26	Un-P2-C10	Yes
DIMM 27	Un-P2-C11	Yes
DIMM 28	Un-P2-C12	Yes
DIMM 29	Un-P2-C13	Yes
DIMM 30	Un-P2-C14	Yes
DIMM 31	Un-P2-C15	Yes
DIMM 32	Un-P2-C16	Yes
2.5" SAS disk drive	Un-P2-D1	Yes
Solid-state drive carrier	Un-P2-C18	Yes
Solid-state drive 1 (top drive)	Un-P2-C18-D1	Yes
Solid-state drive 2 (bottom drive)	Un-P2-C18-D2	Yes
CFFh expansion card	Un-P2-C20	Yes
CIOv form-factor expansion card	Un-P2-C19	Yes
Ethernet port 0	Un-P2-T3	No
Ethernet port 1	Un-P2-T4	No
Integrated SAS controller	Un-P2-T5	No
Machine location code	Utttt.mmm.ssssss	No
Um codes are for firmware. The format is the same as for a Un location code.		
Um = Utttt.mmm.ssssss		
Firmware version		Um-Y1

Reference codes

Reference codes are diagnostic aids that help you determine the source of a hardware or operating system problem. To use reference codes effectively, use them in conjunction with other service and support procedures.

The PS703 or PS704 blade server produces several types of codes.

Progress codes: The power-on self-test (POST) generates eight-digit status codes that are known as *checkpoints* or *progress codes*, which are recorded in the management-module event log. The checkpoints indicate which blade server resource is initializing.

Error codes: The First Failure Data Capture (FFDC) error checkers capture fault data, which the service processor then analyzes. For unrecoverable errors (UEs), for recoverable events that meet or exceed their service thresholds, and for fatal system errors, an unrecoverable checkstop service event triggers the service processor to analyze the error, log the system reference code (SRC), and turn on the system attention LED.

The service processor logs the nine-word, eight-digit per word error code in the BladeCenter management-module event log. Error codes are either *system reference codes (SRCs)* or *service request numbers (SRNs)*. A location code might also be included.

Isolation procedures: If the fault analysis does not determine a definitive cause, the service processor might indicate a fault isolation procedure that you can use to isolate the failing component.

Viewing the codes

The PS703 or PS704 blade server does not display checkpoints or error codes on the remote console.

If the POST detects a problem, a 9-word, 8-digit error code is logged in the BladeCenter management-module event log. A location code that identifies a component might also be included. See “Error logs” on page 176 for information about viewing the management-module event log.

Service request numbers can be viewed using the AIX diagnostics CD, or various operating system utilities such as AIX diagnostics or the Linux service aid “diagela”, if it is installed.

System reference codes (SRCs)

System reference codes indicate a server hardware or software problem that can originate in hardware, in firmware, or in the operating system.

A blade server component generates an error code when it detects a problem. An SRC identifies the component that generated the error code and describes the error. Use the SRC information to identify a list of possibly failing items and to find information about any additional isolation procedures.

The following table shows the syntax of a nine-word B700xxxx SRC as it might be displayed in the event log of the management module.

The first word of the SRC in this example is the message identifier, **B7001111**. This example numbers each word after the first word to show relative word positions. The seventh word is the direct select address, which is **77777777** in the example.

Table 8. Nine-word system reference code in the management-module event log

Index	Sev	Source	Date/Time	Text
1	E	Blade_05	01/21/2008, 17:15:14	(PS700-BC1BLD5E) SYS F/W: Error. Replace UNKNOWN (5008FECF B7001111 22222222 33333333 44444444 55555555 66666666 77777777 88888888 99999999)

Depending on your operating system and the utilities you have installed, error messages might also be stored in an operating system log. See the documentation that comes with the operating system for more information.

The management module can display the most recent 32 SRCs and time stamps. Manually refresh the list to update it.

Select **Blade Service Data** → *blade_name* in the management module to see a list of the 32 most recent SRCs.

Table 9. Management module reference code listing

Unique ID	System Reference Code	Timestamp
00040001	D1513901	2005-11-13 19:30:20
00000016	D1513801	2005-11-13 19:30:16

Any message with more detail is highlighted as a link in the System Reference Code column. Click the message to cause the management module to present the additional message detail:

D1513901
Created at: 2007-11-13 19:30:20
SRC Version: 0x02
Hex Words 2-5: 020110F0 52298910 C1472000 200000FF

SRC formats

SRCs are strings of either six or eight alphanumeric characters. The first two characters designate the reference code type.

The first character indicates the type of error. In a few cases, the first two characters indicate the type of error:

- 1xxxxxxx - System power control network (SPCN) error
- 6xxxxxxx - Virtual optical device error
- A1xxxxxx - Attention required (Service processor)
- AAxxxxxx - Attention required (Partition firmware)
- B1xxxxxx - Service processor error, such as a boot problem
- B6xxxxxx - Licensed Internal Code or hardware event error
- B9xxxxxx - Software installation error or IBM i IPL error. See "Recovering from IPL or system failures" in the IBM i Information Center at http://publib.boulder.ibm.com/infocenter/systems/scope/hw/index.jsp?topic=/ipha5_p5/iplprocedure.htm.
- BAxxxxxx - Partition firmware error
- Cxxxxxxx - Checkpoint (must hang to indicate an error)
- Dxxxxxxx - Dump checkpoint (must hang to indicate an error)

To find a description of an SRC that is not listed in this PS703 or PS704 blade server documentation, refer to the POWER7 Reference Code Lookup page at <http://publib.boulder.ibm.com/infocenter/systems/scope/hw/index.jsp?topic=/ipha8/codefinder.htm>.

1xxxyyyy SRCs

The 1xxxyyyy system reference codes are system power control network (SPCN) reference codes.

Look for the rightmost 4 characters (*yyyy* in 1xxxyyyy) in the error code; this is the reference code. Find the reference code in Table 10 on page 23.

Perform all actions before exchanging failing items.

Table 10. 1xxxxxxx SRCs

<ul style="list-style-type: none"> Follow the suggested actions in the order in which they are listed in the Action column until the problem is solved. If an action solves the problem, then you can stop performing the remaining actions. See Chapter 3, "Parts listing, type 7891," on page 225 to determine which components are CRUs and which components are FRUs. 		
1xxxxxxx Error Codes	Description	Action
00AC	Informational message: AC loss was reported	No action is required.
00AD	Informational message: A service processor reset caused the blade server to power off	No action is required.
1F02	Informational message: The trace logs reached 1K of data.	No action is required.
1F03	Informational message: Invalid TMS of location code.	No action is required.
2600	Power good (pGood) master fault	<ol style="list-style-type: none"> Go to "Checkout procedure" on page 176. Replace the base system-board (Un-P1) and chassis assembly, as described in "Replacing the FRU system-board and chassis assembly" on page 264.
2610	pGood fault	<ol style="list-style-type: none"> Go to "Checkout procedure" on page 176. Perform one of the following: <ol style="list-style-type: none"> If the location code reported with this SRC is Un-P2, replace the expansion system-board assembly, as described in "Removing the expansion unit for a PS704 blade server" on page 237. If the location code reported with this SRC is Un-P1, replace the base system-board and chassis assembly, as described in "Replacing the FRU system-board and chassis assembly" on page 264.
2620	12V dc pGood input fault	<ol style="list-style-type: none"> Go to "Checkout procedure" on page 176. Perform one of the following: <ol style="list-style-type: none"> If the location code reported with this SRC is Un-P2, replace the expansion system-board assembly, as described in "Removing the expansion unit for a PS704 blade server" on page 237. If the location code reported with this SRC is Un-P1, replace the base system-board and chassis assembly, as described in "Replacing the FRU system-board and chassis assembly" on page 264.
2622	Expansion_Comp_pGood_fault	<ol style="list-style-type: none"> Go to "Checkout procedure" on page 176. Replace the expansion system-board (Un-P2) assembly, as described in "Removing the expansion unit for a PS704 blade server" on page 237. Replace the base system-board (Un-P1) and chassis assembly, as described in "Replacing the FRU system-board and chassis assembly" on page 264.

Table 10. 1xxxxxxx SRCs (continued)

<ul style="list-style-type: none"> Follow the suggested actions in the order in which they are listed in the Action column until the problem is solved. If an action solves the problem, then you can stop performing the remaining actions. See Chapter 3, "Parts listing, type 7891," on page 225 to determine which components are CRUs and which components are FRUs. 		
1xxxxxxx Error Codes	Description	Action
2629	1.5V reg_pgood fault	<ol style="list-style-type: none"> Go to "Checkout procedure" on page 176. Perform one of the following: <ol style="list-style-type: none"> If the location code reported with this SRC is Un-P2, replace the expansion system-board assembly, as described in "Removing the expansion unit for a PS704 blade server" on page 237. If the location code reported with this SRC is Un-P1, replace the base system-board and chassis assembly, as described in "Replacing the FRU system-board and chassis assembly" on page 264.
262B	1.8V reg_pgood fault	<ol style="list-style-type: none"> Go to "Checkout procedure" on page 176. Perform one of the following: <ol style="list-style-type: none"> If the location code reported with this SRC is Un-P2, replace the expansion system-board assembly, as described in "Removing the expansion unit for a PS704 blade server" on page 237. If the location code reported with this SRC is Un-P1, replace the base system-board and chassis assembly, as described in "Replacing the FRU system-board and chassis assembly" on page 264.
262C	5V reg_pgood fault	<ol style="list-style-type: none"> Go to "Checkout procedure" on page 176. Perform one of the following: <ol style="list-style-type: none"> If the location code reported with this SRC is Un-P2, replace the expansion system-board assembly, as described in "Removing the expansion unit for a PS704 blade server" on page 237. If the location code reported with this SRC is Un-P1, replace the base system-board and chassis assembly, as described in "Replacing the FRU system-board and chassis assembly" on page 264.
262D	3.3V reg_pgood fault	<ol style="list-style-type: none"> Go to "Checkout procedure" on page 176. Perform one of the following: <ol style="list-style-type: none"> If the location code reported with this SRC is Un-P2, replace the expansion system-board assembly, as described in "Removing the expansion unit for a PS704 blade server" on page 237. If the location code reported with this SRC is Un-P1, replace the base system-board and chassis assembly, as described in "Replacing the FRU system-board and chassis assembly" on page 264.

Table 10. 1xxxxxxx SRCs (continued)

<ul style="list-style-type: none"> Follow the suggested actions in the order in which they are listed in the Action column until the problem is solved. If an action solves the problem, then you can stop performing the remaining actions. See Chapter 3, "Parts listing, type 7891," on page 225 to determine which components are CRUs and which components are FRUs. 		
1xxxxxxx Error Codes	Description	Action
262E	2.5V reg_pgood fault	<ol style="list-style-type: none"> Go to "Checkout procedure" on page 176. Perform one of the following: <ol style="list-style-type: none"> If the location code reported with this SRC is Un-P2, replace the expansion system-board assembly, as described in "Removing the expansion unit for a PS704 blade server" on page 237. If the location code reported with this SRC is Un-P1, replace the base system-board and chassis assembly, as described in "Replacing the FRU system-board and chassis assembly" on page 264.
262F	1.0V fault	<ol style="list-style-type: none"> Go to "Checkout procedure" on page 176. Perform one of the following: <ol style="list-style-type: none"> If the location code reported with this SRC is Un-P2, replace the expansion system-board assembly, as described in "Removing the expansion unit for a PS704 blade server" on page 237. If the location code reported with this SRC is Un-P1, replace the base system-board and chassis assembly, as described in "Replacing the FRU system-board and chassis assembly" on page 264.
2630	VRM CP0 core pGood fault	<ol style="list-style-type: none"> Go to "Checkout procedure" on page 176. Perform one of the following: <ol style="list-style-type: none"> If the location code reported with this SRC is Un-P2, replace the expansion system-board assembly, as described in "Removing the expansion unit for a PS704 blade server" on page 237. If the location code reported with this SRC is Un-P1, replace the base system-board and chassis assembly, as described in "Replacing the FRU system-board and chassis assembly" on page 264.
2632	VRM CP0 cache pGood fault	<ol style="list-style-type: none"> Go to "Checkout procedure" on page 176. Perform one of the following: <ol style="list-style-type: none"> If the location code reported with this SRC is Un-P2, replace the expansion system-board assembly, as described in "Removing the expansion unit for a PS704 blade server" on page 237. If the location code reported with this SRC is Un-P1, replace the base system-board and chassis assembly, as described in "Replacing the FRU system-board and chassis assembly" on page 264.

Table 10. 1xxxxxxx SRCs (continued)

<ul style="list-style-type: none"> Follow the suggested actions in the order in which they are listed in the Action column until the problem is solved. If an action solves the problem, then you can stop performing the remaining actions. See Chapter 3, "Parts listing, type 7891," on page 225 to determine which components are CRUs and which components are FRUs. 		
1xxxxxxx Error Codes	Description	Action
2640	VRM CP1 core pGood fault	<ol style="list-style-type: none"> Go to "Checkout procedure" on page 176. Perform one of the following: <ol style="list-style-type: none"> If the location code reported with this SRC is Un-P2, replace the expansion system-board assembly, as described in "Removing the expansion unit for a PS704 blade server" on page 237. If the location code reported with this SRC is Un-P1, replace the base system-board and chassis assembly, as described in "Replacing the FRU system-board and chassis assembly" on page 264.
2642	VRM CP1 array pGood fault	<ol style="list-style-type: none"> Go to "Checkout procedure" on page 176. Perform one of the following: <ol style="list-style-type: none"> If the location code reported with this SRC is Un-P2, replace the expansion system-board assembly, as described in "Removing the expansion unit for a PS704 blade server" on page 237. If the location code reported with this SRC is Un-P1, replace the base system-board and chassis assembly, as described in "Replacing the FRU system-board and chassis assembly" on page 264.
2647	12V "or-ing" FET short	<ol style="list-style-type: none"> Go to "Checkout procedure" on page 176. Perform one of the following: <ol style="list-style-type: none"> If the location code reported with this SRC is Un-P2, replace the expansion system-board assembly, as described in "Removing the expansion unit for a PS704 blade server" on page 237. If the location code reported with this SRC is Un-P1, replace the base system-board and chassis assembly, as described in "Replacing the FRU system-board and chassis assembly" on page 264.
2648	Blade power latch fault	<ol style="list-style-type: none"> Go to "Checkout procedure" on page 176. Perform one of the following: <ol style="list-style-type: none"> If the location code reported with this SRC is Un-P2, replace the expansion system-board assembly, as described in "Removing the expansion unit for a PS704 blade server" on page 237. If the location code reported with this SRC is Un-P1, replace the base system-board and chassis assembly, as described in "Replacing the FRU system-board and chassis assembly" on page 264.

Table 10. 1xxxxxxx SRCs (continued)

<ul style="list-style-type: none"> Follow the suggested actions in the order in which they are listed in the Action column until the problem is solved. If an action solves the problem, then you can stop performing the remaining actions. See Chapter 3, "Parts listing, type 7891," on page 225 to determine which components are CRUs and which components are FRUs. 		
1xxxxxxx Error Codes	Description	Action
2649	Blade power fault	<ol style="list-style-type: none"> Go to "Checkout procedure" on page 176. Perform one of the following: <ol style="list-style-type: none"> If the location code reported with this SRC is Un-P2, replace the expansion system-board assembly, as described in "Removing the expansion unit for a PS704 blade server" on page 237. If the location code reported with this SRC is Un-P1, replace the base system-board and chassis assembly, as described in "Replacing the FRU system-board and chassis assembly" on page 264.
265A	1.2VA pGood fault	<ol style="list-style-type: none"> Go to "Checkout procedure" on page 176. Perform one of the following: <ol style="list-style-type: none"> If the location code reported with this SRC is Un-P2, replace the expansion system-board assembly, as described in "Removing the expansion unit for a PS704 blade server" on page 237. If the location code reported with this SRC is Un-P1, replace the base system-board and chassis assembly, as described in "Replacing the FRU system-board and chassis assembly" on page 264.
2671	12V power fault in the blade server	<ol style="list-style-type: none"> Go to "Checkout procedure" on page 176. Perform one of the following: <ol style="list-style-type: none"> If the location code reported with this SRC is Un-P2, replace the expansion system-board assembly, as described in "Removing the expansion unit for a PS704 blade server" on page 237. If the location code reported with this SRC is Un-P1, replace the base system-board and chassis assembly, as described in "Replacing the FRU system-board and chassis assembly" on page 264.
2672	CFFh expansion card voltage alert	<p>Perform the DTRCARD symbolic CRU isolation procedure by completing the following steps:</p> <ol style="list-style-type: none"> Reseat the PCIe expansion card. If the problem persists, replace the expansion card. If the problem persists, go to the "Checkout procedure" on page 176. If the problem persists, replace the base system-board (Un-P1) and chassis assembly, as described in "Replacing the FRU system-board and chassis assembly" on page 264. <p>The DTRCARD symbolic CRU isolation procedure is in "Service processor problems" on page 193</p>

Table 10. 1xxxxxxx SRCs (continued)

<ul style="list-style-type: none"> Follow the suggested actions in the order in which they are listed in the Action column until the problem is solved. If an action solves the problem, then you can stop performing the remaining actions. See Chapter 3, "Parts listing, type 7891," on page 225 to determine which components are CRUs and which components are FRUs. 		
1xxxxxxx Error Codes	Description	Action
2673	Standby power fault on the expansion blade	<ol style="list-style-type: none"> 1. Check the management-module event log for entries that indicate a power problem with the BladeCenter unit. 2. Resolve any problems. 3. Remove the blade from the BladeCenter unit and then reinsert the blade server. 4. Power on the blade server. 5. Monitor the blade server operation to verify that the problem is solved. 6. If the BladeCenter unit is functioning normally, but the problem persists, replace the system board and chassis assembly, as described in "Replacing the FRU system-board and chassis assembly" on page 264.
2674	Expansion blade pGood fault at standby	<ol style="list-style-type: none"> 1. Go to "Checkout procedure" on page 176. 2. Replace the expansion system-board (Un-P2) assembly, as described in "Removing the expansion unit for a PS704 blade server" on page 237.
2675	1.1 Reg_CPU0_P5IO2C_Vio_pGood fault	<ol style="list-style-type: none"> 1. Go to "Checkout procedure" on page 176. 2. Perform one of the following: <ol style="list-style-type: none"> a. If the location code reported with this SRC is Un-P2, replace the expansion system-board assembly, as described in "Removing the expansion unit for a PS704 blade server" on page 237. b. If the location code reported with this SRC is Un-P1, replace the base system-board and chassis assembly, as described in "Replacing the FRU system-board and chassis assembly" on page 264.
2676	VTTA/B pGood fault	<ol style="list-style-type: none"> 1. Go to "Checkout procedure" on page 176. 2. Perform one of the following: <ol style="list-style-type: none"> a. If the location code reported with this SRC is Un-P2, replace the expansion system-board assembly, as described in "Removing the expansion unit for a PS704 blade server" on page 237. b. If the location code reported with this SRC is Un-P1, replace the base system-board and chassis assembly, as described in "Replacing the FRU system-board and chassis assembly" on page 264.

Table 10. 1xxxxxxx SRCs (continued)

<ul style="list-style-type: none"> Follow the suggested actions in the order in which they are listed in the Action column until the problem is solved. If an action solves the problem, then you can stop performing the remaining actions. See Chapter 3, "Parts listing, type 7891," on page 225 to determine which components are CRUs and which components are FRUs. 		
1xxxxxxx Error Codes	Description	Action
2678	PROC Vmem controller pGood 1.0V fault	<ol style="list-style-type: none"> Go to "Checkout procedure" on page 176. Perform one of the following: <ol style="list-style-type: none"> If the location code reported with this SRC is Un-P2, replace the expansion system-board assembly, as described in "Removing the expansion unit for a PS704 blade server" on page 237. If the location code reported with this SRC is Un-P1, replace the base system-board and chassis assembly, as described in "Replacing the FRU system-board and chassis assembly" on page 264.
2679	Vmem_controller_pGood 1.5V reg fault	<ol style="list-style-type: none"> Go to "Checkout procedure" on page 176. Perform one of the following: <ol style="list-style-type: none"> If the location code reported with this SRC is Un-P2, replace the expansion system-board assembly, as described in "Removing the expansion unit for a PS704 blade server" on page 237. If the location code reported with this SRC is Un-P1, replace the base system-board and chassis assembly, as described in "Replacing the FRU system-board and chassis assembly" on page 264.
267A	CFFh expansion card A0 pGood fault	<p>Perform the DTRCARD symbolic CRU isolation procedure by completing the following steps:</p> <ol style="list-style-type: none"> Reseat the PCIe expansion card. If the problem persists, replace the expansion card. If the problem persists, go to the "Checkout procedure" on page 176. Perform one of the following: <ol style="list-style-type: none"> If the location code reported with this SRC is Un-P2-C20, replace the expansion system-board assembly, as described in "Removing the expansion unit for a PS704 blade server" on page 237. If the location code reported with this SRC is Un-P1-C20, replace the base system-board and chassis assembly, as described in "Replacing the FRU system-board and chassis assembly" on page 264. <p>The DTRCARD symbolic CRU isolation procedure is in "Service processor problems" on page 193</p>

Table 10. 1xxxxxxx SRCs (continued)

<ul style="list-style-type: none"> Follow the suggested actions in the order in which they are listed in the Action column until the problem is solved. If an action solves the problem, then you can stop performing the remaining actions. See Chapter 3, "Parts listing, type 7891," on page 225 to determine which components are CRUs and which components are FRUs. 		
1xxxxxxx Error Codes	Description	Action
267B	CFFh expansion card B0 pGood fault	<p>Perform the DTRCARD symbolic CRU isolation procedure by completing the following steps:</p> <ol style="list-style-type: none"> Reseat the PCIe expansion card. If the problem persists, replace the expansion card. If the problem persists, go to the "Checkout procedure" on page 176. Perform one of the following: <ol style="list-style-type: none"> If the location code reported with this SRC is Un-P2-C20, replace the expansion system-board assembly, as described in "Removing the expansion unit for a PS704 blade server" on page 237. If the location code reported with this SRC is Un-P1-C20, replace the base system-board and chassis assembly, as described in "Replacing the FRU system-board and chassis assembly" on page 264. <p>The DTRCARD symbolic CRU isolation procedure is in "Service processor problems" on page 193</p>
267C	REG_P5IO2C_core 1.2V pGood fault	<ol style="list-style-type: none"> Go to "Checkout procedure" on page 176. Perform one of the following: <ol style="list-style-type: none"> If the location code reported with this SRC is Un-P2, replace the expansion system-board assembly, as described in "Removing the expansion unit for a PS704 blade server" on page 237. If the location code reported with this SRC is Un-P1, replace the base system-board and chassis assembly, as described in "Replacing the FRU system-board and chassis assembly" on page 264.
267D	2.0_PLL_pGood fault	<ol style="list-style-type: none"> Go to "Checkout procedure" on page 176. Perform one of the following: <ol style="list-style-type: none"> If the location code reported with this SRC is Un-P2, replace the expansion system-board assembly, as described in "Removing the expansion unit for a PS704 blade server" on page 237. If the location code reported with this SRC is Un-P1, replace the base system-board and chassis assembly, as described in "Replacing the FRU system-board and chassis assembly" on page 264.
26DA	pGood fault	Replace the expansion system-board (Un-P2).
2900	SSD interposer card or SSD 3.3V pGood fault on the base system board	<p>Replace the following, one at a time, until the failure is no longer detected:</p> <ol style="list-style-type: none"> The SSD interposer card, Un-P1-C18. The first SSD drive, Un-P1-C18-D1. The second SSD drive, Un-P1-C18-D2.

Table 10. 1xxxxxxx SRCs (continued)

<ul style="list-style-type: none"> • Follow the suggested actions in the order in which they are listed in the Action column until the problem is solved. If an action solves the problem, then you can stop performing the remaining actions. • See Chapter 3, “Parts listing, type 7891,” on page 225 to determine which components are CRUs and which components are FRUs. 		
1xxxxxxx Error Codes	Description	Action
2901	SSD interposer card pGood fault	Replace the interposer card on the base system planar, Un-P1-C18.
2902	SSD drive power-on self-test failure	Perform one of the following actions: <ul style="list-style-type: none"> • If the location code reported with this SRC is Un-P1-C18-D1, replace the first SSD drive on the base system board. • If the location code reported with this SRC is Un-P1-C18-D2, replace the second SSD drive on the base system board.
2910	SSD interposer card or SSD 3.3V pGood fault on the expansion system board	Replace the following, one at a time, until the failure is no longer detected: <ol style="list-style-type: none"> 1. The SSD interposer card, Un-P2-C18. 2. The first SSD drive, Un-P2-C18-D1. 3. The second SSD drive, Un-P2-C18-D2.
2911	SSD interposer card pGood fault	Replace the interposer card on the expansion system board at Un-P2-C18.
2912	SSD drive power-on self-test failure	Perform one of the following actions: <ul style="list-style-type: none"> • If the location code reported with this SRC is Un-P2-C18-D1, replace the first SSD drive on the expansion system board. • If the location code reported with this SRC is Un-P2-C18-D2, replace the second SSD drive on the expansion system board.
3120	Voltage adjustment failure on a VMR	<ol style="list-style-type: none"> 1. Go to “Checkout procedure” on page 176. 2. Perform one of the following: <ol style="list-style-type: none"> a. If the location code reported with this SRC is Un-P2, replace the expansion system-board assembly, as described in “Removing the expansion unit for a PS704 blade server” on page 237. b. If the location code reported with this SRC is Un-P1, replace the base system-board and chassis assembly, as described in “Replacing the FRU system-board and chassis assembly” on page 264.

Table 10. 1xxxxxxx SRCs (continued)

<ul style="list-style-type: none"> Follow the suggested actions in the order in which they are listed in the Action column until the problem is solved. If an action solves the problem, then you can stop performing the remaining actions. See Chapter 3, "Parts listing, type 7891," on page 225 to determine which components are CRUs and which components are FRUs. 		
1xxxxxxx Error Codes	Description	Action
3134	Fault on the hardware monitoring chip	<p>Perform the DTRCARD symbolic CRU isolation procedure by completing the following steps:</p> <ol style="list-style-type: none"> Reseat the PCIe expansion card. If the problem persists, replace the expansion card. If the problem persists, go to the "Checkout procedure" on page 176. Perform one of the following: <ol style="list-style-type: none"> If the location code reported with this SRC is Un-P2-C20, replace the expansion system-board assembly, as described in "Removing the expansion unit for a PS704 blade server" on page 237. If the location code reported with this SRC is Un-P1-C20, replace the base system-board and chassis assembly, as described in "Replacing the FRU system-board and chassis assembly" on page 264. <p>The DTRCARD symbolic CRU isolation procedure is in "Service processor problems" on page 193</p>
8400	Invalid configuration decode	<ol style="list-style-type: none"> Check for server firmware updates. Apply any available updates. If the problem persists: <ol style="list-style-type: none"> Go to "Checkout procedure" on page 176. Replace the system-board, as described in "Replacing the FRU system-board and chassis assembly" on page 264.
8402	Unable to get VPD from the concentrator	<ol style="list-style-type: none"> Go to "Checkout procedure" on page 176. Replace the base system-board (Un-P1) and chassis assembly, as described in "Replacing the FRU system-board and chassis assembly" on page 264.
8413	Invalid processor 1 VPD	<ol style="list-style-type: none"> Go to "Checkout procedure" on page 176. Perform one of the following: <ol style="list-style-type: none"> If the location code reported with this SRC is Un-P2, replace the expansion system-board assembly, as described in "Removing the expansion unit for a PS704 blade server" on page 237. If the location code reported with this SRC is Un-P1, replace the base system-board and chassis assembly, as described in "Replacing the FRU system-board and chassis assembly" on page 264.

Table 10. 1xxxxxxx SRCs (continued)

<ul style="list-style-type: none"> Follow the suggested actions in the order in which they are listed in the Action column until the problem is solved. If an action solves the problem, then you can stop performing the remaining actions. See Chapter 3, "Parts listing, type 7891," on page 225 to determine which components are CRUs and which components are FRUs. 		
1xxxxxxx Error Codes	Description	Action
8414	Invalid processor 2 VPD	<ol style="list-style-type: none"> Go to "Checkout procedure" on page 176. Perform one of the following: <ol style="list-style-type: none"> If the location code reported with this SRC is Un-P2, replace the expansion system-board assembly, as described in "Removing the expansion unit for a PS704 blade server" on page 237. If the location code reported with this SRC is Un-P1, replace the base system-board and chassis assembly, as described in "Replacing the FRU system-board and chassis assembly" on page 264.
8423	No processor VPD was found	<ol style="list-style-type: none"> Go to "Checkout procedure" on page 176. Replace the base system-board (Un-P1) and chassis assembly, as described in "Replacing the FRU system-board and chassis assembly" on page 264.
8447	SSD interposer card pGood fault	Replace the interposer card on the base system planar, Un-P1-C18.
8480	Bad or missing memory controller VID	<ol style="list-style-type: none"> Go to "Checkout procedure" on page 176. Perform one of the following: <ol style="list-style-type: none"> If the location code reported with this SRC is Un-P2, replace the expansion system-board assembly, as described in "Removing the expansion unit for a PS704 blade server" on page 237. If the location code reported with this SRC is Un-P1, replace the base system-board and chassis assembly, as described in "Replacing the FRU system-board and chassis assembly" on page 264.

6xxxxxxx SRCs

The 6xxxxxxx system reference codes are virtual optical reference codes.

Look for the rightmost 4 characters (yyyy in 6xxxxxxx) in the error code; this is the reference code. Find the reference code in Table 11.

Table 11. 6xxxxxxx SRCs

<ul style="list-style-type: none"> Follow the suggested actions in the order in which they are listed in the Action column until the problem is solved. If an action solves the problem, then you can stop performing the remaining actions. See Chapter 3, "Parts listing, type 7891," on page 225 to determine which components are CRUs and which components are FRUs. 		
6xxxxxxx Error Codes	Description	Action
632Byyyy codes are Network File System (NFS) virtual optical SRCs		

Table 11. 6xxxxxxx SRCs (continued)

<ul style="list-style-type: none"> Follow the suggested actions in the order in which they are listed in the Action column until the problem is solved. If an action solves the problem, then you can stop performing the remaining actions. See Chapter 3, "Parts listing, type 7891," on page 225 to determine which components are CRUs and which components are FRUs. 		
6xxxxxxx Error Codes	Description	Action
632BCFC1	A virtual optical device cannot access the file containing the list of volumes.	On this partition and on the Network File System server, verify that the proper file is specified and that the proper authority is granted.
632BCFC2	A non-recoverable error was detected while reading the list of volumes.	Resolve any errors on the Network File System server.
632BCFC3	The data in the list of volumes is not valid.	On the Network File System server, verify that the proper file is specified, that all files are entered correctly, that there are no blank lines, and that the character set used is valid.
632BCFC4	A virtual optical device cannot access the file containing the specified optical volume.	On the Network File System server, verify that the proper file is specified in the list of volumes, and that the proper authority is granted.
632BCFC5	A non-recoverable error was detected while reading a virtual optical volume.	Resolve any errors on the Network File System server.
632BCFC6	The file specified does not contain data that can be processed as a virtual optical volume.	On the Network File System server, verify that all the files specified in the list of optical volumes are correct.
632BCFC7	A virtual optical device detected an error reported by the Network File System server that cannot be recovered.	Resolve any errors on the Network File System server.
632BCFC8	A virtual optical device encountered a non-recoverable error.	Install any available operating system updates.
632Cyyyy codes are virtual optical SRCs		
632CC000	Informational system log entry only.	No corrective action is required.
632CC002	self configuring SCSI device (SCSD) selection or reselection timeout occurred.	Refer to the hosting partition for problem analysis.
632CC010	Undefined sense key returned by device.	Refer to the hosting partition for problem analysis.
632CC020	Configuration error.	Refer to the hosting partition for problem analysis.
632CC100	SCSD bus error occurred.	Refer to the hosting partition for problem analysis.
632CC110	SCSD command timeout occurred.	Refer to the hosting partition for problem analysis.
632CC210	Informational system log entry only.	No corrective action is required.
632CC300	Media or device error occurred.	Refer to the hosting partition for problem analysis.

Table 11. 6xxxxxxx SRCs (continued)

<ul style="list-style-type: none"> Follow the suggested actions in the order in which they are listed in the Action column until the problem is solved. If an action solves the problem, then you can stop performing the remaining actions. See Chapter 3, "Parts listing, type 7891," on page 225 to determine which components are CRUs and which components are FRUs. 		
6xxxxxxx Error Codes	Description	Action
632CC301	Media or device error occurred.	Refer to the hosting partition for problem analysis.
632CC302	Media or device error occurred.	Refer to the hosting partition for problem analysis.
632CC303	Media has an unknown format.	No corrective action is required.
632CC333	Incompatible media.	<ol style="list-style-type: none"> Verify that the disk has a supported format. If the format is supported, clean the disk and attempt the failing operation again. If the operation fails again with the same system reference code, ask your media source for a replacement disk.
632CC400	Physical link error detected by device.	Refer to the hosting partition for problem analysis.
632CC402	An internal program error occurred.	Install any available operating system updates.
632CCFF2	Informational system log entry only.	No corrective action is required.
632CCFF4	Internal device error occurred.	Refer to the hosting partition for problem analysis.
632CCFF6	Informational system log entry only.	No corrective action is required.
632CCFF7	Informational system log entry only.	No corrective action is required.
632CCFFE	Informational system log entry only.	No corrective action is required.
632CFF3D	Informational system log entry only.	No corrective action is required.
632CFF6D	Informational system log entry only.	No corrective action is required.

A1xyyyy service processor SRCs

An A1xyyyy system reference code (SRC) is an attention code that offers information about a platform or service processor dump or confirms a control panel function request. Take the steps in the Action column only if the BladeSystem appears to hang on an attention code.

Table 12 shows A1xyyyy SRCs.

Table 12. A1xyyyy service processor SRCs

Attention code	Description	Action
A1xyyyy	Attention code	<ol style="list-style-type: none">1. Go to "Checkout procedure" on page 176.2. Replace the system board and chassis assembly, as described in "Replacing the FRU system-board and chassis assembly" on page 264.

A2xyyyy Logical partition SRCs

An A2xyyyy SRC is a logical partition reference code that is related to logical partitioning.

Table 13. A2xyyyy Logical partition SRCs

Reference Code	Description	Action
A2xyyyy	See the description for the B200yyyy error code with the same yyyy value.	Perform the action described in the B200yyyy error code with the same yyyy value.
A2D03000	User-initiated immediate termination and MSD of a partition.	No corrective action is required.
A2D03001	User-initiated RSCDUMP of RPA partition's PFW content.	No corrective action is required.
A2D03002	User-initiated RSCDUMP of IBM i partition's SLIC bootloader and PFW content.	No corrective action is required.

A700yyyy Licensed internal code SRCs

An A700xxxx system reference code (SRC) is an error/event code that is related to licensed internal code.

Table 14. A700yyyy Licensed internal code SRCs

Reference Code	Description	Action
A700173C	Informational system log entry only.	No corrective action is required.
A7003000	A user-initiated platform dump occurred.	No service action required.
A7004700	Informational system log entry only.	No corrective action is required.
A7004712	A problem occurred when initializing, reading, or using system VPD.	Replace the management card, as described in "Removing the tier 2 management card" on page 262 and "Installing the tier 2 management card" on page 263.
A7004713	A problem occurred when initializing, reading, or using system VPD.	Replace the management card, as described in "Removing the tier 2 management card" on page 262 and "Installing the tier 2 management card" on page 263.
A7004715	A problem occurred when initializing, reading, or using system VPD.	Replace the management card, as described in "Removing the tier 2 management card" on page 262 and "Installing the tier 2 management card" on page 263.

Table 14. A700yyyy Licensed internal code SRCs (continued)

Reference Code	Description	Action
A7004721	The World Wide Port Name (WWPN) Prefix is not valid.	https://www-912.ibm.com/supporthome.nsf/document/51455410
A7004730	Informational system log entry only.	No corrective action is required.
A7004740	Informational system log entry only.	No corrective action is required.
A7004741	Informational system log entry only.	No corrective action is required.
A7004788	Informational system log entry only.	No corrective action is required.
A70047FF	Informational system log entry only.	No corrective action is required.
A7013003	Partition-initiated PHYP-content RSCDUMP.	No corrective action is required.
A700yyyy	For any other A7xyyyyy SRC not listed here, see the description for the B7xyyyyy error code with the same xyyyyy value.	Perform the action in the B7xyyyyy error code with the same xyyyyy value.

AA00E1A8 to AA260005 Partition firmware attention codes

AAxx attention codes provide information about the next target state for the platform firmware. These codes might indicate that you need to perform an action.

Table 15 describes the partition firmware codes that might be displayed if the POST detects a problem. Each message description includes a suggested action to correct the problem.

Table 15. AA00E1A8 to AA260005 Partition firmware attention codes

<ul style="list-style-type: none"> Follow the suggested actions in the order in which they are listed in the Action column until the problem is solved. If an action solves the problem, then you can stop performing the remaining actions. See Chapter 3, "Parts listing, type 7891," on page 225 to determine which components are CRUs and which components are FRUs. 		
Attention code	Description	Action
AA00E1A8	The system is booting to the open firmware prompt.	At the open firmware prompt, type <code>dev/packages/gui obe</code> and press Enter ; then, type 1 to select SMS Menu .
AA00E1A9	The system is booting to the System Management Services (SMS) menus.	<ol style="list-style-type: none"> If the system or partition returns to the SMS menus after a boot attempt failed, use the SMS menus to check the progress indicator history for a <code>BAxx xxxx</code> error, which may indicate why the boot attempt failed. Follow the actions for that error code to resolve the boot problem. Use the SMS menus to establish the boot list and restart the blade server.
AA00E1B0	Waiting for the user to select the language and keyboard. The menu should be visible on the console.	<ol style="list-style-type: none"> Check for server firmware updates. Apply any available updates. If the problem persists: <ol style="list-style-type: none"> Go to "Checkout procedure" on page 176. Replace the system-board, as described in "Replacing the FRU system-board and chassis assembly" on page 264.

Table 15. AA00E1A8 to AA260005 Partition firmware attention codes (continued)

<ul style="list-style-type: none"> Follow the suggested actions in the order in which they are listed in the Action column until the problem is solved. If an action solves the problem, then you can stop performing the remaining actions. See Chapter 3, "Parts listing, type 7891," on page 225 to determine which components are CRUs and which components are FRUs. 		
Attention code	Description	Action
AA00E1B1	Waiting for the user to accept or decline the license	<ol style="list-style-type: none"> Check for server firmware updates. Apply any available updates. If the problem persists: <ol style="list-style-type: none"> Go to "Checkout procedure" on page 176. Replace the system-board, as described in "Replacing the FRU system-board and chassis assembly" on page 264.
AA060007	A keyboard was not found.	Verify that a keyboard is attached to the USB port that is assigned to the partition.
AA06000B	The system or partition was not able to find an operating system on any of the devices in the boot list.	<ol style="list-style-type: none"> Use the SMS menus to modify the boot list so that it includes devices that have a known-good operating system and restart the blade server. If the problem remains, go to "Boot problem resolution" on page 182.
AA06000C	The media in a device in the boot list was not bootable.	<ol style="list-style-type: none"> Replace the media in the device with known-good media or modify the boot list to boot from another bootable device. If the problem remains, go to "Boot problem resolution" on page 182.
AA06000D	The media in the device in the bootlist was not found under the I/O adapter specified by the bootlist.	<ol style="list-style-type: none"> Verify that the media from which you are trying to boot is bootable or modify the boot list to boot from another bootable device. If the problem remains, go to "Boot problem resolution" on page 182.
AA06000E	The adapter specified in the boot list is not present or is not functioning.	<ul style="list-style-type: none"> For an AIX operating system: <ol style="list-style-type: none"> Try booting the blade server from another bootable device; then, run AIX online diagnostics against the failing adapter. If AIX cannot be booted from another device, boot the blade server using the stand-alone <i>diagnostics</i> CD or a NIM server; then, run diagnostics against the failing adapter. For a Linux operating system, boot the blade server using the stand-alone <i>diagnostics</i> CD or a NIM server; then, run diagnostics against the failing adapter.

Table 15. AA00E1A8 to AA260005 Partition firmware attention codes (continued)

<ul style="list-style-type: none"> Follow the suggested actions in the order in which they are listed in the Action column until the problem is solved. If an action solves the problem, then you can stop performing the remaining actions. See Chapter 3, "Parts listing, type 7891," on page 225 to determine which components are CRUs and which components are FRUs. 		
Attention code	Description	Action
AA060011	The firmware did not find an operating system image and at least one hard disk in the boot list was not detected by the firmware. The firmware is retrying the entries in the boot list.	This might occur if a disk enclosure that contains the boot disk is not fully initialized or if the boot disk belongs to another partition. Verify that: <ul style="list-style-type: none"> The boot disk belongs to the partition from which you are trying to boot. The boot list in the SMS menus is correct.
AA130013	Bootable media is missing from a USB CD-ROM	Verify that a bootable CD is properly inserted in the CD or DVD drive and retry the boot operation.
AA130014	The media in a USB CD-ROM has changed.	<ol style="list-style-type: none"> Retry the operation. Check for server firmware updates; then, install the updates if available and retry the operation.
AA170210	Setenv/\$setenv parameter error - the name contains a null character.	<ol style="list-style-type: none"> Go to "Checkout procedure" on page 176. Replace the system-board, as described in "Replacing the FRU system-board and chassis assembly" on page 264.
AA170211	Setenv/\$setenv parameter error - the value contains a null character.	<ol style="list-style-type: none"> Go to "Checkout procedure" on page 176. Replace the system-board, as described in "Replacing the FRU system-board and chassis assembly" on page 264.
AA190001	The hypervisor function to get or set the time-of-day clock reported an error.	<ol style="list-style-type: none"> Use the operating system to set the system clock. If the problem persists, check for server firmware updates. Install any available updates and retry the operation.
AA260001	Enter the Type Model Number (Must be 8 characters)	Enter the machine type and model of the blade server at the prompt.
AA260002	Enter the Serial Number (Must be 7 characters)	Enter the serial number of the blade server at the prompt.
AA260003	Enter System Unique ID (Must be 12 characters)	Enter the system unique ID number at the prompt.
AA260004	Enter WorldWide Port Number (Must be 12 characters)	Enter the worldwide port number of the blade server at the prompt.
AA260005	Enter Brand (Must be 2 characters)	Enter the brand number of the blade server at the prompt.

B1xyyyy service processor SRCs

A B1xyyyy system reference code (SRC) is an error code that is related to an event or exception that occurred in the service processor firmware.

To find a description of an SRC that is not listed in this PS703 or PS704 blade server documentation, refer to the POWER7 Reference Code Lookup page at <http://publib.boulder.ibm.com/infocenter/systems/scope/hw/index.jsp?topic=/ipha8/codefinder.htm>.

Note: For problems persisting after completing the suggested actions, see “Solving undetermined problems” on page 223.

B200xxxx Logical partition SRCs

A B200xxxx SRC is a logical partition reference code that is related to logical partitioning.

Table 16 describes system reference codes that might be displayed if system firmware detects a problem. Suggested actions to correct the problem are also listed.

Note: For problems persisting after completing the suggested actions, see “Checkout procedure” on page 176 and “Solving undetermined problems” on page 223.

Table 16. B2xyyyy Logical partition SRCs

Reference Code	Description	Action
	<ul style="list-style-type: none">• Follow the suggested actions in the order in which they are listed in the Action column until the problem is solved. If an action solves the problem, then you can stop performing the remaining actions.• See Chapter 3, “Parts listing, type 7891,” on page 225 to determine which components are CRUs and which components are FRUs.	
B2001130	A problem occurred during the migration of a partition You attempted to migrate a partition to a system that has a power or thermal problem. The migration will not continue.	Look for and fix power or thermal problems and then retry the migration.
B2001131	A problem occurred during the migration of a partition. The migration of a partition did not complete.	Check for server firmware updates; then, install the updates if available.
B2001132	A problem occurred during the startup of a partition. A platform firmware error occurred while it was trying to allocate memory. The startup will not continue.	Collect a platform dump and then go to “Isolating firmware problems” on page 216.
B2001133	A problem occurred during the migration of a partition. The migration of a partition did not complete.	Check for server firmware updates; then, install the updates if available.
B2001134	A problem occurred during the migration of a partition. The migration of a partition did not complete.	Check for server firmware updates; then, install the updates if available.

Table 16. B2xyyyy Logical partition SRCs (continued)

<ul style="list-style-type: none"> Follow the suggested actions in the order in which they are listed in the Action column until the problem is solved. If an action solves the problem, then you can stop performing the remaining actions. See Chapter 3, “Parts listing, type 7891,” on page 225 to determine which components are CRUs and which components are FRUs. 		
Reference Code	Description	Action
B2001140	A problem occurred during the migration of a partition. The migration of a partition did not complete.	Check for server firmware updates; then, install the updates if available.
B2001141	A problem occurred during the migration of a partition. The migration of a partition did not complete.	Check for server firmware updates; then, install the updates if available.
B2001142	A problem occurred during the migration of a partition. The migration of a partition did not complete.	Check for server firmware updates; then, install the updates if available.
B2001143	A problem occurred during the migration of a partition. The migration of a partition did not complete.	Check for server firmware updates; then, install the updates if available.
B2001144	A problem occurred during the migration of a partition. The migration of a partition did not complete.	Check for server firmware updates; then, install the updates if available.
B2001148	A problem occurred during the migration of a partition. The migration of a partition did not complete.	Check for server firmware updates; then, install the updates if available.
B2001150	During the startup of a partition, a partitioning configuration problem occurred.	Go to “Verifying the partition configuration” on page 179.
B2001151	A problem occurred during the migration of a partition. The migration of a partition did not complete.	Check for server firmware updates; then, install the updates if available.
B2001170	During the startup of a partition, a failure occurred due to a validation error.	Go to “Verifying the partition configuration” on page 179.
B2001225	A problem occurred during the startup of a partition. The partition attempted to start up prior to the platform fully initializing. Restart the partition after the platform has fully completed and the platform is not in standby mode.	Restart the partition.

Table 16. B2xyyyy Logical partition SRCs (continued)

Reference Code	Description	Action
	<ul style="list-style-type: none"> Follow the suggested actions in the order in which they are listed in the Action column until the problem is solved. If an action solves the problem, then you can stop performing the remaining actions. See Chapter 3, "Parts listing, type 7891," on page 225 to determine which components are CRUs and which components are FRUs. 	
B2001230	During the startup of a partition, a partitioning configuration problem occurred; the partition is lacking the necessary resources to start up.	Go to "Verifying the partition configuration" on page 179.
B2001260	<p>A problem occurred during the startup of a partition.</p> <p>The partition could not start at the Timed Power On setting because the partition was not set to Normal.</p>	Set the partition to Normal.
B2001265	The partition could not start up. An operating system Main Storage Dump startup was attempted with the startup side on D-mode, which is not a valid operating system startup scenario. The startup will be halted. This SRC can occur when a D-mode SLIC installation fails and attempts a Main Storage Dump.	Correct the startup settings.
B2001266	The partition could not start up. You are attempting to start up an operating system that is not supported.	Install a supported operating system and restart the partition.
B2001280	A problem occurred during a partition Main Storage Dump. A mainstore dump startup did not complete due to a configuration mismatch.	Go to "Isolating firmware problems" on page 216.
B2001281	A partition memory error occurred. The failed memory will no longer be used.	Restart the partition.
B2001282	A problem occurred during the startup of a partition.	Go to "Isolating firmware problems" on page 216.
B2001320	<p>A problem occurred during the startup of a partition.</p> <p>No default load source was selected. The startup will attempt to continue, but there may not be enough information to find the correct load source.</p>	Configure a load source for the partition. Then restart the partition.
B2001321	A problem occurred during the startup of a partition.	Verify that the correct slot is specified for the load source. Then restart the partition.
B2001322	In the partition startup, code failed during a check of the load source path.	Verify that the path for the load source is specified correctly. Then restart the partition.

Table 16. B2xyyyy Logical partition SRCs (continued)

<ul style="list-style-type: none"> Follow the suggested actions in the order in which they are listed in the Action column until the problem is solved. If an action solves the problem, then you can stop performing the remaining actions. See Chapter 3, “Parts listing, type 7891,” on page 225 to determine which components are CRUs and which components are FRUs. 		
Reference Code	Description	Action
B2002048	A problem occurred during a partition Main Storage Dump. A mainstore dump startup did not complete due to a copy error.	Go to “Isolating firmware problems” on page 216.
B2002054	A problem occurred during a partition Main Storage Dump. A mainstore dump IPL did not complete due to a configuration mismatch.	Go to “Isolating firmware problems” on page 216.
B2002058	A problem occurred during a partition Main Storage Dump. A mainstore dump startup did not complete due to a copy error.	Go to “Isolating firmware problems” on page 216.
B2002210	Informational system log entry only.	No corrective action is required.
B2002220	Informational system log entry only.	No corrective action is required.
B2002250	During the startup of a partition, an attempt to toggle the power state of a slot has failed.	Check for server firmware updates; then, install the updates if available.
B2002260	During the startup of a partition, the partition firmware attempted an operation that failed.	Go to “Isolating firmware problems” on page 216.
B2002300	During the startup of a partition, an attempt to toggle the power state of a slot has failed.	Check for server firmware updates; then, install the updates if available.
B2002310	During the startup of a partition, the partition firmware attempted an operation that failed.	Go to “Isolating firmware problems” on page 216.
B2002320	During the startup of a partition, the partition firmware attempted an operation that failed.	Go to “Isolating firmware problems” on page 216.
B2002425	During the startup of a partition, the partition firmware attempted an operation that failed.	Go to “Isolating firmware problems” on page 216.
B2002426	During the startup of a partition, the partition firmware attempted an operation that failed.	Go to “Isolating firmware problems” on page 216.
B2002475	During the startup of a partition, a slot that was needed for the partition was either empty or the device in the slot has failed.	Check for server firmware updates; then, install the updates if available.
B2002485	During the startup of a partition, the partition firmware attempted an operation that failed.	Go to “Isolating firmware problems” on page 216.
B2003000	Informational system log entry only.	No corrective action is required.

Table 16. B2xyyyy Logical partition SRCs (continued)

<ul style="list-style-type: none"> Follow the suggested actions in the order in which they are listed in the Action column until the problem is solved. If an action solves the problem, then you can stop performing the remaining actions. See Chapter 3, "Parts listing, type 7891," on page 225 to determine which components are CRUs and which components are FRUs. 		
Reference Code	Description	Action
B2003081	During the startup of a partition, the startup did not complete due to a copy error.	Check for server firmware updates; then, install the updates if available.
B2003084	A problem occurred during the startup of a partition. The adapter type might not be supported.	Verify that the adapter type is supported.
B2003088	Informational system log entry only.	No corrective action is required.
B200308C	A problem occurred during the startup of a partition. The adapter type cannot be determined.	Verify that a valid I/O Load Source is tagged.
B2003090	A problem occurred during the startup of a partition.	Go to "Isolating firmware problems" on page 216.
B2003110	A problem occurred during the startup of a partition.	Go to "Isolating firmware problems" on page 216.
B2003113	A problem occurred during the startup of a partition.	Look for B7xx xxxx errors and resolve them.
B2003114	A problem occurred during the startup of a partition.	Look for other errors and resolve them.
B2003120	Informational system log entry only.	No corrective action is required.
B2003123	Informational system log entry only.	No corrective action is required.
B2003125	During the startup of a partition, the blade server firmware could not obtain a segment of main storage within the blade server to use for managing the creation of a partition.	Check for server firmware updates; then, install the updates if available.
B2003128	A problem occurred during the startup of a partition. A return code for an unexpected failure was returned when attempting to query the load source path.	Look for and resolve B700 69xx errors.
B2003130	A problem occurred during the startup of a partition.	Check for server firmware updates; then, install the updates if available.
B2003135	A problem occurred during the startup of a partition.	Check for server firmware updates; then, install the updates if available.
B2003140	A problem occurred during the startup of a partition. This is a configuration problem in the partition.	Reconfigure the partition to include the intended load source path.
B2003141	Informational system log entry only.	No corrective action is required.
B2003142	Informational system log entry only.	No corrective action is required.
B2003143	Informational system log entry only.	No corrective action is required.

Table 16. B2xyyyy Logical partition SRCs (continued)

<ul style="list-style-type: none"> Follow the suggested actions in the order in which they are listed in the Action column until the problem is solved. If an action solves the problem, then you can stop performing the remaining actions. See Chapter 3, "Parts listing, type 7891," on page 225 to determine which components are CRUs and which components are FRUs. 		
Reference Code	Description	Action
B2003144	Informational system log entry only.	No corrective action is required.
B2003145	Informational system log entry only.	No corrective action is required.
B2003200	Informational system log entry only.	No corrective action is required.
B2004158	Informational system log entry only.	No corrective action is required.
B2004400	A problem occurred during the startup of a partition.	Check for server firmware updates; then, install the updates if available.
B2005106	A problem occurred during the startup of a partition. There is not enough space to contain the partition main storage dump. The startup will not continue.	Verify that there is sufficient memory available to start the partition as it is configured. If there is already enough memory, then go to "Isolating firmware problems" on page 216.
B2005109	A problem occurred during the startup of a partition. There was a partition main storage dump problem. The startup will not continue.	Go to "Isolating firmware problems" on page 216.
B2005114	A problem occurred during the startup of a partition. There is not enough space to contain the partition main storage dump. The startup will not continue.	Go to "Isolating firmware problems" on page 216.
B2005115	A problem occurred during the startup of a partition. There was an error reading the partition main storage dump from the partition load source into main storage. The startup will attempt to continue.	If the startup does not continue, look for and resolve other errors.
B2005117	A problem occurred during the startup of a partition. A partition main storage dump has occurred but cannot be written to the load source device because a valid dump already exists.	Use the Main Storage Dump Manager to rename or copy the current main storage dump.
B2005121	A problem occurred during the startup of a partition. There was an error writing the partition main storage dump to the partition load source. The startup will not continue.	Look for related errors in the "Product Activity Log" and fix any problems found. Use virtual control panel function 34 to retry the current Main Store Dump startup while the partition is still in the failed state.
B2005122	Informational system log entry only.	No corrective action is required.
B2005123	Informational system log entry only.	No corrective action is required.
B2005135	A problem occurred during the startup of a partition. There was an error writing the partition main storage dump to the partition load source. The main store dump startup will continue.	Look for other errors and resolve them.

Table 16. B2xyyyy Logical partition SRCs (continued)

<ul style="list-style-type: none"> • Follow the suggested actions in the order in which they are listed in the Action column until the problem is solved. If an action solves the problem, then you can stop performing the remaining actions. • See Chapter 3, “Parts listing, type 7891,” on page 225 to determine which components are CRUs and which components are FRUs. 		
Reference Code	Description	Action
B2005137	A problem occurred during the startup of a partition. There was an error writing the partition main storage dump to the partition load source. The main store dump startup will continue.	Look for other errors and resolve them.
B2005145	A problem occurred during the startup of a partition. There was an error writing the partition main storage dump to the partition load source. The main store dump startup will continue.	Look for other errors and resolve them.
B2005148	A problem occurred during the startup of a partition. An error occurred while doing a main storage dump that would have caused another main storage dump. The startup will not continue.	Go to “Isolating firmware problems” on page 216.
B2005149	A problem occurred during the startup of a partition while doing a Firmware Assisted Dump that would have caused another Firmware Assisted Dump.	Check for server firmware updates; then, install the updates if available.
B200514A	A Firmware Assisted Dump did not complete due to a copy error.	Check for server firmware updates; then, install the updates if available.
B200542A	A Firmware Assisted Dump did not complete due to a read error.	Check for server firmware updates; then, install the updates if available.
B200542B	A Firmware Assisted Dump did not complete due to a copy error.	Check for server firmware updates; then, install the updates if available.
B200543A	A Firmware Assisted Dump did not complete due to a copy error.	Check for server firmware updates; then, install the updates if available.
B200543B	A Firmware Assisted Dump did not complete due to a copy error.	Check for server firmware updates; then, install the updates if available.
B200543C	Informational system log entry only.	No corrective action is required.
B200543D	A Firmware Assisted Dump did not complete due to a copy error.	Check for server firmware updates; then, install the updates if available.
B2006006	During the startup of a partition, a system firmware error occurred when the partition memory was being initialized; the startup will not continue.	Go to “Isolating firmware problems” on page 216.
B200600A	A problem occurred during the startup of a partition. The partition could not reserve the memory required for IPL.	Contact IBM support.

Table 16. B2xyyyy Logical partition SRCs (continued)

Reference Code	Description	Action
<ul style="list-style-type: none"> Follow the suggested actions in the order in which they are listed in the Action column until the problem is solved. If an action solves the problem, then you can stop performing the remaining actions. See Chapter 3, "Parts listing, type 7891," on page 225 to determine which components are CRUs and which components are FRUs. 		
B2006012	During the startup of a partition, the partition LID failed to completely load into the partition main storage area.	Go to "Isolating firmware problems" on page 216.
B2006015	A problem occurred during the startup of a partition. The load source media is corrupted or not valid.	Replace the load source media.
B2006025	A problem occurred during the startup of a partition. This is a problem with the load source media being corrupt or not valid.	Replace the load source media.
B2006027	During the startup of a partition, a failure occurred when allocating memory for an internal object used for firmware module load operations.	<ol style="list-style-type: none"> Make sure that enough main storage was allocated to the partition. Retry the operation.
B2006110	A problem occurred during the startup of a partition. There was an error on the load source device. The startup will attempt to continue.	Look for other errors and resolve them.
B200690A	During the startup of a partition, an error occurred while copying open firmware into the partition load area.	Go to "Isolating firmware problems" on page 216.
B2007200	Informational system log entry only.	No corrective action is required.
B2008080	Informational system log entry only.	No corrective action is required.
B2008081	During the startup of a partition, an internal firmware time-out occurred; the partition might continue to start up but it can experience problems while running.	Check for server firmware updates; then, install the updates if available.
B2008105	During the startup of a partition, there was a failure loading the VPD areas of the partition; the load source media has been corrupted or is unsupported on this server.	Check for server firmware updates; then, install the updates if available.
B2008106	A problem occurred during the startup of a partition. The startup will not continue.	Replace the load source media.
B2008107	During the startup of a partition, there was a problem getting a segment of main storage in the blade server main storage.	Check for server firmware updates; then, install the updates if available.
B2008109	During the startup of a partition, a failure occurred. The startup will not continue.	<ol style="list-style-type: none"> Make sure that there is enough memory to start up the partition. Check for server firmware updates; then, install the updates if available.

Table 16. B2xyyyy Logical partition SRCs (continued)

<ul style="list-style-type: none"> Follow the suggested actions in the order in which they are listed in the Action column until the problem is solved. If an action solves the problem, then you can stop performing the remaining actions. See Chapter 3, "Parts listing, type 7891," on page 225 to determine which components are CRUs and which components are FRUs. 		
Reference Code	Description	Action
B2008111	A problem occurred during the startup of a partition.	Check for server firmware updates; then, install the updates if available.
B2008112	During the startup of a partition, a failure occurred; the startup will not continue.	Check for server firmware updates; then, install the updates if available.
B2008113	During the startup of a partition, an error occurred while mapping memory for the partition startup.	Check for server firmware updates; then, install the updates if available.
B2008114	During the startup of a partition, there was a failure verifying the VPD for the partition resources during startup.	Check for server firmware updates; then, install the updates if available.
B2008115	During the startup of a partition, there was a low level partition-to-partition communication failure.	Check for server firmware updates; then, install the updates if available.
B2008117	During the startup of a partition, the partition did not start up due to a system firmware error.	Check for server firmware updates; then, install the updates if available.
B2008121	During the startup of a partition, the partition did not start up due to a system firmware error.	Go to "Isolating firmware problems" on page 216.
B2008123	During the startup of a partition, the partition did not start up due to a system firmware error.	Go to "Isolating firmware problems" on page 216.
B2008125	During the startup of a partition, the partition did not start up due to a system firmware error.	Go to "Isolating firmware problems" on page 216.
B2008127	During the startup of a partition, the partition did not start up due to a system firmware error.	Go to "Isolating firmware problems" on page 216.
B2008129	During the startup of a partition, the partition did not start up due to a system firmware error.	Go to "Isolating firmware problems" on page 216.
B200813A	There was a problem establishing a console.	Go to "Isolating firmware problems" on page 216.
B2008140	Informational system log entry only.	No corrective action is required.
B2008141	Informational system log entry only.	No corrective action is required.
B2008142	Informational system log entry only.	No corrective action is required.
B2008143	Informational system log entry only.	No corrective action is required.
B2008144	Informational system log entry only.	No corrective action is required.
B2008145	Informational system log entry only.	No corrective action is required.
B2008150	System firmware detected an error.	Collect a platform dump and then go to "Isolating firmware problems" on page 216.

Table 16. B2xyyyy Logical partition SRCs (continued)

Reference Code	Description	Action
<ul style="list-style-type: none"> Follow the suggested actions in the order in which they are listed in the Action column until the problem is solved. If an action solves the problem, then you can stop performing the remaining actions. See Chapter 3, "Parts listing, type 7891," on page 225 to determine which components are CRUs and which components are FRUs. 		
B2008151	System firmware detected an error.	Use the Integrated Virtual Manager (IVM) to increase the Logical Memory Block (LMB) size, and to reduce the number of virtual devices for the partition.
B2008152	No active system processors.	Verify that processor resources are assigned to the partition.
B2008160	A problem occurred during the migration of a partition.	Contact IBM support.
B2008161	A problem occurred during the migration of a partition.	Contact IBM support.
B200A100	A partition ended abnormally; the partition could not stay running and shut itself down.	<ol style="list-style-type: none"> Check the error logs and take the actions for the error codes that are found. Go to "Isolating firmware problems" on page 216.
B200A101	A partition ended abnormally; the partition could not stay running and shut itself down.	<ol style="list-style-type: none"> Check the error logs and take the actions for the error codes that are found. Go to "Isolating firmware problems" on page 216.
B200A140	A lower priority partition lost a usable processor to supply it to a higher priority partition with a bad processor.	Evaluate the entire LPAR configuration. Adjust partition profiles with the new number of processors available in the system.
B200B07B	Informational system log entry only.	No corrective action is required.
B200B215	<p>A problem occurred after a partition ended abnormally.</p> <p>There was a communications problem between this partition's service processor and the platform's service processor.</p>	Restart the platform.
B2005127	Timeout occurred during a main store dump IPL.	There was not enough memory available for the dump to complete before the timeout occurred. Retry the main store dump IPL, or else power on the partition normally.
B2D03001	Informational system log entry only.	No corrective action is required.
B2D03002	Informational system log entry only.	No corrective action is required.
B200C1F0	An internal system firmware error occurred during a partition shutdown or a restart.	Go to "Isolating firmware problems" on page 216.
B200D150	A partition ended abnormally; there was a communications problem between this partition and the code that handles resource allocation.	Check for server firmware updates; then, install the updates if available.
B200E0AA	A problem occurred during the power off of a partition.	Go to "Isolating firmware problems" on page 216.
B200F001	A problem occurred during the startup of a partition. An operation has timed out.	Look for other errors and resolve them.

Table 16. B2xyyyy Logical partition SRCs (continued)

<ul style="list-style-type: none"> Follow the suggested actions in the order in which they are listed in the Action column until the problem is solved. If an action solves the problem, then you can stop performing the remaining actions. See Chapter 3, "Parts listing, type 7891," on page 225 to determine which components are CRUs and which components are FRUs. 		
Reference Code	Description	Action
B200F003	During the startup of a partition, the partition processor(s) did not start the firmware within the time-out window.	Collect the partition dump information; then, go to "Isolating firmware problems" on page 216.
B200F004	Informational system log entry only.	No corrective action is required.
B200F005	Informational system log entry only.	No corrective action is required.
B200F006	During the startup of a partition, the code load operation for the partition startup timed out.	<ol style="list-style-type: none"> Check the error logs and take the actions for the error codes that are found. Go to "Isolating firmware problems" on page 216.
B200F007	During a shutdown of the partition, a time-out occurred while trying to stop a partition.	Check for server firmware updates; then, install the updates if available.
B200F008	Informational system log entry only.	No corrective action is required.
B200F009	Informational system log entry only.	No corrective action is required.
B200F00A	Informational system log entry only.	No corrective action is required.
B200F00B	Informational system log entry only.	No corrective action is required.
B200F00C	Informational system log entry only.	No corrective action is required.
B200F00D	Informational system log entry only.	No corrective action is required.

B7xyyyy Licensed internal code SRCs

A B7xyyyy system reference code (SRC) is an error code or event code that is related to licensed internal code.

Table 17 describes the system reference codes that might be displayed if system firmware detects a problem. Suggested actions to correct the problem are also listed.

Note: For problems persisting after completing the suggested actions, see "Checkout procedure" on page 176 and "Solving undetermined problems" on page 223.

Table 17. B7xyyyy Licensed internal code SRCs

<ul style="list-style-type: none"> Follow the suggested actions in the order in which they are listed in the Action column until the problem is solved. If an action solves the problem, then you can stop performing the remaining actions. See Chapter 3, "Parts listing, type 7891," on page 225 to determine which components are CRUs and which components are FRUs. 		
B700 xxxx Error Codes	Description	Action
0102	System firmware detected an error. A machine check occurred during startup.	<ol style="list-style-type: none"> Collect the event log information. Go to "Isolating firmware problems" on page 216.
0103	System firmware detected a failure	<ol style="list-style-type: none"> Collect the event log information. Collect the platform dump information. Go to "Isolating firmware problems" on page 216.

Table 17. B7xyyy Licensed internal code SRCs (continued)

<ul style="list-style-type: none"> Follow the suggested actions in the order in which they are listed in the Action column until the problem is solved. If an action solves the problem, then you can stop performing the remaining actions. See Chapter 3, "Parts listing, type 7891," on page 225 to determine which components are CRUs and which components are FRUs. 		
B700 xxxx Error Codes	Description	Action
0104	System firmware failure. Machine check, undefined error occurred.	<ol style="list-style-type: none"> Check for server firmware updates. Update the firmware.
0105	System firmware detected an error. More than one request to terminate the system was issued.	Go to "Isolating firmware problems" on page 216.
0106	System firmware failure.	<ol style="list-style-type: none"> Collect the event log information. Collect the platform dump information. Go to "Isolating firmware problems" on page 216.
0107	System firmware failure. The system detected an unrecoverable machine check condition.	<ol style="list-style-type: none"> Collect the event log information. Collect the platform dump information. Go to "Isolating firmware problems" on page 216.
0200	System firmware has experienced a low storage condition	<p>No immediate action is necessary.</p> <p>Continue running the system normally. At the earliest convenient time or service window, work with IBM Support to collect a platform dump and restart the system; then, go to "Isolating firmware problems" on page 216.</p>
0201	System firmware detected an error.	<p>No immediate action is necessary.</p> <p>Continue running the system normally. At the earliest convenient time or service window, work with IBM Support to collect a platform dump and restart the system; then, go to "Isolating firmware problems" on page 216.</p>
0202	Informational system log entry only.	No corrective action is required.
0302	System firmware failure	<ol style="list-style-type: none"> Collect the platform dump information. Go to "Isolating firmware problems" on page 216.
0441	Service processor failure. The platform encountered an error early in the startup or termination process.	Replace the system-board and chassis assembly, as described in "Replacing the FRU system-board and chassis assembly" on page 264.
0443	Service processor failure.	Replace the system-board and chassis assembly, as described in "Replacing the FRU system-board and chassis assembly" on page 264.
0601	Informational system log entry only.	<p>No corrective action is required.</p> <p>Note: This code and associated data can be used to determine why the time of day for a partition was lost.</p>

Table 17. B7xyyy Licensed internal code SRCs (continued)

<ul style="list-style-type: none"> Follow the suggested actions in the order in which they are listed in the Action column until the problem is solved. If an action solves the problem, then you can stop performing the remaining actions. See Chapter 3, "Parts listing, type 7891," on page 225 to determine which components are CRUs and which components are FRUs. 		
B700 xxxx Error Codes	Description	Action
0602	System firmware detected an error condition.	<ol style="list-style-type: none"> Collect the event log information. Go to "Isolating firmware problems" on page 216.
0611	There is a problem with the system hardware clock; the clock time is invalid.	Use the operating system to set the system clock.
0621	Informational system log entry only.	No corrective action is required.
0641	System firmware detected an error.	<ol style="list-style-type: none"> Collect the platform dump information. Go to "Isolating firmware problems" on page 216.
0650	System firmware detected an error. Resource management was unable to allocate main storage. A platform dump was initiated.	<ol style="list-style-type: none"> Collect the event log. Collect the platform dump data. Collect the partition configuration information. Go to "Isolating firmware problems" on page 216.
0651	The system detected an error in the system clock hardware	Replace the system-board and chassis assembly, as described in "Replacing the FRU system-board and chassis assembly" on page 264.
0803	Informational system log entry only.	No corrective action is required.
0804	Informational system log entry only.	No corrective action is required.
0A00	Informational system log entry only.	No corrective action is required.
0A01	Informational system log entry only.	No corrective action is required.
0A10	Informational system log entry only.	No corrective action is required.
1150	Informational system log entry only.	No corrective action is required.
1151	Informational system log entry only.	No corrective action is required.
1152	Informational system log entry only.	No corrective action is required.
1160	Service processor failure	<ol style="list-style-type: none"> Go to "Isolating firmware problems" on page 216. Replace the system-board, as described in "Replacing the FRU system-board and chassis assembly" on page 264.
1161	Informational system log entry only.	No corrective action is required.
1730	The VPD for the system is not what was expected at startup.	Replace the management card, as described in "Removing the tier 2 management card" on page 262 and "Installing the tier 2 management card" on page 263.
1731	The VPD on a memory DIMM is not correct and the memory on the DIMM cannot be used, resulting in reduced memory.	Replace the MEMDIMM symbolic CRU, as described in "Service processor problems" on page 193.

Table 17. B7xyyy Licensed internal code SRCs (continued)

<ul style="list-style-type: none"> Follow the suggested actions in the order in which they are listed in the Action column until the problem is solved. If an action solves the problem, then you can stop performing the remaining actions. See Chapter 3, "Parts listing, type 7891," on page 225 to determine which components are CRUs and which components are FRUs. 		
B700 xxxx Error Codes	Description	Action
1732	The VPD on a processor card is not correct and the processor card cannot be used, resulting in reduced processing power.	Replace the system-board and chassis assembly, as described in "Replacing the FRU system-board and chassis assembly" on page 264.
1733	System firmware failure. The startup will not continue.	<p>Look for and correct B1xxxxxx errors. If there are no serviceable B1xxxxxx errors, or if correcting the errors does not correct the problem, contact IBM support to reset the server firmware settings.</p> <p>Attention: Resetting the server firmware settings results in the loss of all of the partition data that is stored on the service processor. Before continuing with this operation, manually record all settings that you intend to preserve.</p> <p>The service processor reboots after IBM Support resets the server firmware settings.</p> <p>If the problem persists, Replace the system-board, as described in "Replacing the FRU system-board and chassis assembly" on page 264.</p>
173A	A VPD collection overflow occurred.	<ol style="list-style-type: none"> Look for and resolve other errors. If there are no other errors: <ol style="list-style-type: none"> Update the firmware to the current level, as described in "Updating the firmware" on page 267. You might also have to update the management module firmware to a compatible level.
173B	A system firmware failure occurred during VPD collection.	Look for and correct other B1xxxxxx errors.
4091	Informational system log entry only.	No corrective action is required.
4400	There is a platform dump to collect	<ol style="list-style-type: none"> Collect the platform dump information. Go to "Isolating firmware problems" on page 216.
4401	System firmware failure. The system firmware detected an internal problem.	Go to "Isolating firmware problems" on page 216.
4402	A system firmware error occurred while attempting to allocate the memory necessary to create a platform dump.	Go to "Isolating firmware problems" on page 216.
4705	System firmware failure. A problem occurred when initializing, reading, or using the system VPD. The Capacity on Demand function is not available.	Restart the system.

Table 17. B7xyyy Licensed internal code SRCs (continued)

<ul style="list-style-type: none"> Follow the suggested actions in the order in which they are listed in the Action column until the problem is solved. If an action solves the problem, then you can stop performing the remaining actions. See Chapter 3, "Parts listing, type 7891," on page 225 to determine which components are CRUs and which components are FRUs. 		
B700 xxxx Error Codes	Description	Action
4710	Informational system log entry only.	No corrective action is required.
4714	Informational system log entry only.	No corrective action is required.
4715	A problem occurred when initializing, reading, or using system VPD.	Replace the management card, as described in "Removing the tier 2 management card" on page 262 and "Installing the tier 2 management card" on page 263.
4750	Informational system log entry only.	No corrective action is required.
4788	Informational system log entry only.	No corrective action is required.
47CB	Informational system log entry only.	No corrective action is required.
5120	System firmware detected an error	If the system is not exhibiting problematic behavior, you can ignore this error. Otherwise, go to "Isolating firmware problems" on page 216.
5121	System firmware detected a programming problem for which a platform dump may have been initiated.	<ol style="list-style-type: none"> 1. Collect the event log information. 2. Collect the platform dump information. 3. Go to "Isolating firmware problems" on page 216.
5122	An error occurred during a search for the load source.	If the partition fails to startup, go to "Isolating firmware problems" on page 216. Otherwise, no corrective action is required.
5123	Informational system log entry only.	No corrective action is required.
5190	Operating system error. The server firmware detected a problem in an operating system.	Check for error codes in the partition that is reporting the error and take the appropriate actions for those error codes.
5191	System firmware detected a virtual I/O configuration error.	<ol style="list-style-type: none"> 1. Use the Integrated Virtual Manager (IVM) to verify or reconfigure the invalid virtual I/O configuration. 2. Check for server firmware updates; then, install the updates if available.
5209	Informational system log entry only.	No corrective action is required.
5219	Informational system log entry only.	No corrective action is required.
5300	System firmware detected a failure while partitioning resources. The platform partitioning code encountered an error.	Check the management-module event log for error codes; then, take the actions associated with those error codes.
5301	User intervention required. The system detected a problem with the partition configuration.	Use the Integrated Virtual Manager (IVM) to reallocate the system resources.
5302	<p>An unsupported Preferred Operating System was detected.</p> <p>The Preferred Operating System specified is not supported. The IPL will not continue.</p>	Work with IBM support to select a supported Preferred Operating System; then, re-IPL the system.

Table 17. B7xyyy Licensed internal code SRCs (continued)

<ul style="list-style-type: none"> Follow the suggested actions in the order in which they are listed in the Action column until the problem is solved. If an action solves the problem, then you can stop performing the remaining actions. See Chapter 3, "Parts listing, type 7891," on page 225 to determine which components are CRUs and which components are FRUs. 		
B700 xxxx Error Codes	Description	Action
5303	An unsupported Preferred Operating System was detected. The Preferred Operating System specified is not supported. The IPL will continue.	Work with IBM support to select a supported Preferred Operating System; then, re-IPL the system.
5304	The number of available World Wide Port Names (WWPN) is low.	https://www-912.ibm.com/supporthome.nsf/document/51455410
5305	The number of available World Wide Port Names (WWPN) is low.	https://www-912.ibm.com/supporthome.nsf/document/51455410
5400	System firmware detected a problem with a processor.	Replace the system-board and chassis assembly, as described in "Replacing the FRU system-board and chassis assembly" on page 264.
5442	System firmware detected an error.	Replace the system-board and chassis assembly, as described in "Replacing the FRU system-board and chassis assembly" on page 264.
54DD	Informational system log entry only.	No corrective action is required.
5600	Informational system log entry only.	No corrective action is required.
5601	System firmware failure. There was a problem initializing, reading, or using system location codes.	Go to "Isolating firmware problems" on page 216.
5602	The system has out-of-date VPD LIDs.	Check for server firmware updates; then, install the updates if available.
5603	Enclosure feature code and/or serial number not valid.	Verify that the machine type, model, and serial number are correct for this server.
6900	PCI host bridge failure	<ol style="list-style-type: none"> Replace the system-board, as described in "Replacing the FRU system-board and chassis assembly" on page 264. If the problem persists, use the "PCI expansion card (PIOCARD) problem isolation procedure" on page 186 to determine the failing component.
6906	System bus error	Replace the system-board and chassis assembly, as described in "Replacing the FRU system-board and chassis assembly" on page 264.
6907	System bus error	<ol style="list-style-type: none"> Replace the system-board, as described in "Replacing the FRU system-board and chassis assembly" on page 264. Go to "Isolating firmware problems" on page 216.

Table 17. B7xyyy Licensed internal code SRCs (continued)

<ul style="list-style-type: none"> Follow the suggested actions in the order in which they are listed in the Action column until the problem is solved. If an action solves the problem, then you can stop performing the remaining actions. See Chapter 3, "Parts listing, type 7891," on page 225 to determine which components are CRUs and which components are FRUs. 		
B700 xxxx Error Codes	Description	Action
6908	System bus error	Replace the system-board and chassis assembly, as described in "Replacing the FRU system-board and chassis assembly" on page 264.
6909	System bus error	<ol style="list-style-type: none"> Replace the system-board, as described in "Replacing the FRU system-board and chassis assembly" on page 264. Go to "Isolating firmware problems" on page 216.
6911	Platform LIC unable to find or retrieve VPD LID file.	Check for server firmware updates; then, install the updates if available.
6912	Platform LIC unable to find or retrieve VPD LID file.	Check for server firmware updates; then, install the updates if available.
6944	Informational system log entry only.	No corrective action is required.
6950	A platform dump has occurred.	<ol style="list-style-type: none"> Collect the platform dump information. Go to "Isolating firmware problems" on page 216.
6951	An error occurred because a partition needed more NVRAM than was available.	Use the Integrated Virtualization Manager (IVM) to delete one or more partitions.
6952	Informational system log entry only.	No corrective action is required.
6953	PHYP NVRAM is unavailable after a service processor reset and reload.	Go to "Isolating firmware problems" on page 216.
6954	Informational system log entry only.	No corrective action is required.
6955	Informational system log entry only.	No corrective action is required.
6956	An NVRAM failure was detected.	Go to "Isolating firmware problems" on page 216.
6965	Informational system log entry only.	No corrective action is required.
6970	PCI host bridge failure	<ol style="list-style-type: none"> Replace the system-board, as described in "Replacing the FRU system-board and chassis assembly" on page 264. If the problem persists, use the "PCI expansion card (PIOCARD) problem isolation procedure" on page 186 to determine the failing component.
6971	PCI bus failure	<ol style="list-style-type: none"> Use the "PCI expansion card (PIOCARD) problem isolation procedure" on page 186 to determine the failing component. If the problem persists, replace the system-board and chassis assembly, as described in "Replacing the FRU system-board and chassis assembly" on page 264.

Table 17. B7xyyy Licensed internal code SRCs (continued)

<ul style="list-style-type: none"> Follow the suggested actions in the order in which they are listed in the Action column until the problem is solved. If an action solves the problem, then you can stop performing the remaining actions. See Chapter 3, "Parts listing, type 7891," on page 225 to determine which components are CRUs and which components are FRUs. 		
B700 xxxx Error Codes	Description	Action
6972	System bus error	Replace the system-board and chassis assembly, as described in "Replacing the FRU system-board and chassis assembly" on page 264.
6973	System bus error	<ol style="list-style-type: none"> Use the "PCI expansion card (PIOCARD) problem isolation procedure" on page 186 to determine the failing component. If the problem persists, replace the system-board and chassis assembly, as described in "Replacing the FRU system-board and chassis assembly" on page 264.
6974	Informational system log entry only.	No corrective action is required.
6978	Informational system log entry only.	No corrective action is required.
6979	Informational system log entry only.	No corrective action is required.
697C	Connection from service processor to system processor failed.	Replace the system-board and chassis assembly, as described in "Replacing the FRU system-board and chassis assembly" on page 264.
6980	RIO, HSL or 12X controller failure	Replace the system-board and chassis assembly, as described in "Replacing the FRU system-board and chassis assembly" on page 264.
6981	System bus error.	Replace the system-board and chassis assembly, as described in "Replacing the FRU system-board and chassis assembly" on page 264.
6984	Informational system log entry only.	No corrective action is required.
6985	Remote I/O (RIO), high-speed link (HSL), or 12X loop status message.	Replace the system-board and chassis assembly, as described in "Replacing the FRU system-board and chassis assembly" on page 264.
6987	Remote I/O (RIO), high-speed link (HSL), or 12X connection failure.	Replace the system-board and chassis assembly, as described in "Replacing the FRU system-board and chassis assembly" on page 264.
6990	Service processor failure.	Replace the system-board and chassis assembly, as described in "Replacing the FRU system-board and chassis assembly" on page 264.
6991	System firmware failure	Go to "Isolating firmware problems" on page 216.

Table 17. B7xyyy Licensed internal code SRCs (continued)

<ul style="list-style-type: none"> Follow the suggested actions in the order in which they are listed in the Action column until the problem is solved. If an action solves the problem, then you can stop performing the remaining actions. See Chapter 3, "Parts listing, type 7891," on page 225 to determine which components are CRUs and which components are FRUs. 		
B700 xxxx Error Codes	Description	Action
6993	Service processor failure	<ol style="list-style-type: none"> Replace the system-board, as described in "Replacing the FRU system-board and chassis assembly" on page 264. Go to "Isolating firmware problems" on page 216.
6994	Service processor failure.	Replace the system-board and chassis assembly, as described in "Replacing the FRU system-board and chassis assembly" on page 264.
6995	Informational system log entry only.	No corrective action is required.
69C2	Informational system log entry only.	No corrective action is required.
69C3	Informational system log entry only.	No corrective action is required.
6A21	PCI-E switch had a permanent unrecoverable (internal) chip failure. All downstream I/O is failed.	<ol style="list-style-type: none"> Collect error logs and info logs. Replace the system-board and chassis assembly, as described in "Replacing the FRU system-board and chassis assembly" on page 264. Send the failed FRU and the data to IBM for fault analysis.
6A22	PCI-E switch had a recoverable failure, however, all downstream I/O had to be failed during recovery. Recovery for the PCI-E switch failure is being attempted. If the recovery is successful, no other SRC is logged.	Once the PCI-E switch is recovered, the downstream I/O adapters should recover. The partition or application associated with the failed downstream I/O might have to be restarted.
6A23	PCI-E switch recovery failure. All downstream I/O is failed.	<p>If there are any AIX or Linux errors logged against I/O adapters on this switch, do not replace any I/O adapter hardware. This PCI-E switch failure is the root cause.</p> <ol style="list-style-type: none"> Collect error logs and info logs. Collect the configuration data for the IOAs downstream of the PCI-E switch. Replace the system-board and chassis assembly, as described in "Replacing the FRU system-board and chassis assembly" on page 264. Although the partition or application might have continued to run after the I/O adapter failures, it might need to be restarted to recover.

Table 17. B7xyyy Licensed internal code SRCs (continued)

<ul style="list-style-type: none"> Follow the suggested actions in the order in which they are listed in the Action column until the problem is solved. If an action solves the problem, then you can stop performing the remaining actions. See Chapter 3, "Parts listing, type 7891," on page 225 to determine which components are CRUs and which components are FRUs. 		
B700 xxxx Error Codes	Description	Action
6A24	PCI-E switch had an unrecoverable failure. All downstream I/O is failed.	<ol style="list-style-type: none"> 1. Collect error logs and info logs. 2. Collect the configuration data for the IOAs downstream of the PCI-E switch. 3. Replace the system-board and chassis assembly, as described in "Replacing the FRU system-board and chassis assembly" on page 264. Send the failed FRU and the data to IBM for fault analysis.
6A25	PCI-E switch has detected a firmware action that was not valid. All downstream I/O is failed.	<ol style="list-style-type: none"> 1. Collect error logs and info logs. 2. Collect the configuration data for the IOAs downstream of the PCI-E switch. 3. Update the firmware to the current level, as described in "Updating the firmware" on page 267. 4. If the problem persists, replace the system-board and chassis assembly, as described in "Replacing the FRU system-board and chassis assembly" on page 264. Send the failed FRU and the data to IBM for fault analysis.
6A28	PCI-E switch had a correctable error. Downstream I/O is not affected.	No corrective action is required.
6A2A	PCI-E switch downstream I/O bus had a recoverable failure. The downstream IOA might be failed.	Look for and resolve other errors. If there were no other errors, then the PCI-E switch recovery was successful. In either case, determine if any downstream I/O adapters are in failed states and to which partitions they belong. The partition or application associated with the failed downstream I/O might have to be restarted.
6A2B	PCI-E switch downstream bus had recoverable failure, but has reached the threshold of recovery attempts. The downstream IOA is failed.	<ol style="list-style-type: none"> 1. Collect error logs and info logs. 2. Collect the configuration data for the IOAs downstream of the PCI-E switch. 3. Replace the system-board and chassis assembly, as described in "Replacing the FRU system-board and chassis assembly" on page 264. Send the failed FRU and the data to IBM for fault analysis. 4. After the FRU has been replaced, the partition or application associated with the failed downstream I/O might have to be restarted.

Table 17. B7xyyy Licensed internal code SRCs (continued)

<ul style="list-style-type: none"> Follow the suggested actions in the order in which they are listed in the Action column until the problem is solved. If an action solves the problem, then you can stop performing the remaining actions. See Chapter 3, "Parts listing, type 7891," on page 225 to determine which components are CRUs and which components are FRUs. 		
B700 xxxx Error Codes	Description	Action
6A30	A PCI-E bus internal connection initialized to a lower bus configuration than expected. The bus is operational, but operating at a bandwidth below its rated capacity. This might lead to degraded I/O throughput.	Replace the system-board and chassis assembly, as described in "Replacing the FRU system-board and chassis assembly" on page 264.
BA01	During analysis of a previous serviceable error, a request to activate a FRU fault indicator was not successful.	Replace the system-board and chassis assembly, as described in "Replacing the FRU system-board and chassis assembly" on page 264.
BAD1	The platform firmware detected an error.	Go to "Isolating firmware problems" on page 216.
BAD2	System firmware detected an error.	<ol style="list-style-type: none"> Collect the event log information. Go to "Isolating firmware problems" on page 216.
F103	System firmware failure	<ol style="list-style-type: none"> Collect the event log information. Collect the platform dump information. Go to "Isolating firmware problems" on page 216.
F104	Operating system error. System firmware terminated a partition.	Check the management-module event log for partition firmware error codes (especially BA00F104); then, take the appropriate actions for those error codes.
F105	System firmware detected an internal error	<ol style="list-style-type: none"> Collect the event log information. Collect the platform dump information. Go to "Isolating firmware problems" on page 216.
F106	System firmware detected an error	Replace the system-board and chassis assembly, as described in "Replacing the FRU system-board and chassis assembly" on page 264.
F107	System firmware detected an error.	<ol style="list-style-type: none"> Collect the event log information. Go to "Isolating firmware problems" on page 216.
F108	A firmware error caused the system to terminate.	<ol style="list-style-type: none"> Collect the event log information. Go to "Isolating firmware problems" on page 216.
F10A	System firmware detected an error	Look for and correct B1xxxxxx errors.
F10B	A processor resource has been disabled due to hardware problems	Replace the system-board and chassis assembly, as described in "Replacing the FRU system-board and chassis assembly" on page 264.

Table 17. B7xyyy Licensed internal code SRCs (continued)

<ul style="list-style-type: none"> Follow the suggested actions in the order in which they are listed in the Action column until the problem is solved. If an action solves the problem, then you can stop performing the remaining actions. See Chapter 3, “Parts listing, type 7891,” on page 225 to determine which components are CRUs and which components are FRUs. 		
B700 xxxx Error Codes	Description	Action
F10C	The platform LIC detected an internal problem performing Partition Mobility.	<ol style="list-style-type: none"> Collect the event log information. Go to “Isolating firmware problems” on page 216.
F120	Informational system log entry only.	No corrective action is required.
F130	Thermal Power Management Device firmware error was detected.	Check for server firmware updates; then, install the updates if available.

BA000010 to BA400002 Partition firmware SRCs

The power-on self-test (POST) might display an error code that the partition firmware detects. Try to correct the problem with the suggested action.

Table 18 describes error codes that might be displayed if POST detects a problem. The description also includes suggested actions to correct the problem.

Note: For problems persisting after completing the suggested actions, see “Checkout procedure” on page 176 and “Solving undetermined problems” on page 223.

Table 18. BA000010 to BA400002 Partition firmware SRCs

<ul style="list-style-type: none"> Follow the suggested actions in the order in which they are listed in the Action column until the problem is solved. If an action solves the problem, then you can stop performing the remaining actions. See Chapter 3, “Parts listing, type 7891,” on page 225 to determine which components are CRUs and which components are FRUs. 		
Error code	Description	Action
BA000010	The device data structure is corrupted	<ol style="list-style-type: none"> Go to “Checkout procedure” on page 176. Replace the system-board, as described in “Replacing the FRU system-board and chassis assembly” on page 264.
BA000020	Incompatible firmware levels were found	<ol style="list-style-type: none"> Reboot the blade server. If the problem persists: <ol style="list-style-type: none"> Go to “Checkout procedure” on page 176. Replace the system-board, as described in “Replacing the FRU system-board and chassis assembly” on page 264.
BA000030	An lpevent communication failure occurred	<ol style="list-style-type: none"> Go to “Checkout procedure” on page 176. Replace the system-board, as described in “Replacing the FRU system-board and chassis assembly” on page 264.
BA000031	An lpevent communication failure occurred	<ol style="list-style-type: none"> Go to “Checkout procedure” on page 176. Replace the system-board, as described in “Replacing the FRU system-board and chassis assembly” on page 264.

Table 18. BA000010 to BA400002 Partition firmware SRCs (continued)

<ul style="list-style-type: none"> Follow the suggested actions in the order in which they are listed in the Action column until the problem is solved. If an action solves the problem, then you can stop performing the remaining actions. See Chapter 3, "Parts listing, type 7891," on page 225 to determine which components are CRUs and which components are FRUs. 		
Error code	Description	Action
BA000032	The firmware failed to register the lpevent queues	<ol style="list-style-type: none"> 1. Reboot the blade server. 2. If the problem persists: <ol style="list-style-type: none"> a. Go to "Checkout procedure" on page 176. b. Replace the system-board, as described in "Replacing the FRU system-board and chassis assembly" on page 264.
BA000034	The firmware failed to exchange capacity and allocate lpevents	<ol style="list-style-type: none"> 1. Reboot the blade server. 2. If the problem persists: <ol style="list-style-type: none"> a. Go to "Checkout procedure" on page 176. b. Replace the system-board, as described in "Replacing the FRU system-board and chassis assembly" on page 264.
BA000038	The firmware failed to exchange virtual continuation events	<ol style="list-style-type: none"> 1. Reboot the blade server. 2. If the problem persists: <ol style="list-style-type: none"> a. Go to "Checkout procedure" on page 176. b. Replace the system-board, as described in "Replacing the FRU system-board and chassis assembly" on page 264.
BA000040	The firmware was unable to obtain the RTAS code lid details	<ol style="list-style-type: none"> 1. Reboot the blade server. 2. If the problem persists: <ol style="list-style-type: none"> a. Go to "Checkout procedure" on page 176. b. Replace the system-board, as described in "Replacing the FRU system-board and chassis assembly" on page 264.
BA000050	The firmware was unable to load the RTAS code lid	<ol style="list-style-type: none"> 1. Reboot the blade server. 2. If the problem persists: <ol style="list-style-type: none"> a. Go to "Checkout procedure" on page 176. b. Replace the system-board, as described in "Replacing the FRU system-board and chassis assembly" on page 264.
BA000060	The firmware was unable to obtain the open firmware code lid details	<ol style="list-style-type: none"> 1. Reboot the blade server. 2. If the problem persists: <ol style="list-style-type: none"> a. Go to "Checkout procedure" on page 176. b. Replace the system-board, as described in "Replacing the FRU system-board and chassis assembly" on page 264.

Table 18. BA000010 to BA400002 Partition firmware SRCs (continued)

<ul style="list-style-type: none"> Follow the suggested actions in the order in which they are listed in the Action column until the problem is solved. If an action solves the problem, then you can stop performing the remaining actions. See Chapter 3, "Parts listing, type 7891," on page 225 to determine which components are CRUs and which components are FRUs. 		
Error code	Description	Action
BA000070	The firmware was unable to load the open firmware code lid	<ol style="list-style-type: none"> Reboot the blade server. If the problem persists: <ol style="list-style-type: none"> Go to "Checkout procedure" on page 176. Replace the system-board, as described in "Replacing the FRU system-board and chassis assembly" on page 264.
BA000080	The user did not accept the license agreement	Accept the license agreement and restart the blade server. If the problem persists: <ol style="list-style-type: none"> Go to "Checkout procedure" on page 176. Replace the system-board, as described in "Replacing the FRU system-board and chassis assembly" on page 264.
BA000081	Failed to get the firmware license policy	<ol style="list-style-type: none"> Reboot the blade server. If the problem persists: <ol style="list-style-type: none"> Go to "Checkout procedure" on page 176. Replace the system-board, as described in "Replacing the FRU system-board and chassis assembly" on page 264.
BA000082	Failed to set the firmware license policy	<ol style="list-style-type: none"> Reboot the blade server. If the problem persists: <ol style="list-style-type: none"> Go to "Checkout procedure" on page 176. Replace the system-board, as described in "Replacing the FRU system-board and chassis assembly" on page 264.
BA000091	Unable to load a firmware code update module	<ol style="list-style-type: none"> Reboot the blade server. If the problem persists: <ol style="list-style-type: none"> Go to "Checkout procedure" on page 176. Replace the system-board, as described in "Replacing the FRU system-board and chassis assembly" on page 264.
BA00E820	An lpevent communication failure occurred	<ol style="list-style-type: none"> Go to "Checkout procedure" on page 176. Replace the system-board, as described in "Replacing the FRU system-board and chassis assembly" on page 264.
BA00E830	Failure when initializing ibm,event-scan	<ol style="list-style-type: none"> Go to "Checkout procedure" on page 176. Replace the system-board, as described in "Replacing the FRU system-board and chassis assembly" on page 264.

Table 18. BA000010 to BA400002 Partition firmware SRCs (continued)

<ul style="list-style-type: none"> Follow the suggested actions in the order in which they are listed in the Action column until the problem is solved. If an action solves the problem, then you can stop performing the remaining actions. See Chapter 3, "Parts listing, type 7891," on page 225 to determine which components are CRUs and which components are FRUs. 		
Error code	Description	Action
BA00E840	Failure when initializing PCI hot-plug	<ol style="list-style-type: none"> Go to "Checkout procedure" on page 176. Replace the system-board, as described in "Replacing the FRU system-board and chassis assembly" on page 264.
BA00E843	Failure when initializing the interface to AIX or Linux	<ol style="list-style-type: none"> Go to "Checkout procedure" on page 176. Replace the system-board, as described in "Replacing the FRU system-board and chassis assembly" on page 264.
BA00E850	Failure when initializing dynamic reconfiguration	<ol style="list-style-type: none"> Go to "Checkout procedure" on page 176. Replace the system-board, as described in "Replacing the FRU system-board and chassis assembly" on page 264.
BA00E860	Failure when initializing sensors	<ol style="list-style-type: none"> Go to "Checkout procedure" on page 176. Replace the system-board, as described in "Replacing the FRU system-board and chassis assembly" on page 264.
BA010000	There is insufficient information to boot the systems	<ol style="list-style-type: none"> Go to "Checkout procedure" on page 176. Replace the system-board, as described in "Replacing the FRU system-board and chassis assembly" on page 264.
BA010001	The client IP address is already in use by another network device	Verify that all of the IP addresses on the network are unique; then, retry the operation.
BA010002	Cannot get gateway IP address	Perform the following actions that checkpoint CA00E174 describes: <ol style="list-style-type: none"> Verify that: <ul style="list-style-type: none"> The bootp server is correctly configured; then, retry the operation. The network connections are correct; then, retry the operation. If the problem persists: <ol style="list-style-type: none"> Go to "Checkout procedure" on page 176. Replace the system-board, as described in "Replacing the FRU system-board and chassis assembly" on page 264.

Table 18. BA000010 to BA400002 Partition firmware SRCs (continued)

Error code	Description	Action
BA010003	Cannot get server hardware address	Perform the following actions that checkpoint CA00E174 describes: <ol style="list-style-type: none"> 1. Verify that: <ul style="list-style-type: none"> • The bootp server is correctly configured; then, retry the operation. • The network connections are correct; then, retry the operation. 2. If the problem persists: <ol style="list-style-type: none"> a. Go to “Checkout procedure” on page 176. b. Replace the system-board, as described in “Replacing the FRU system-board and chassis assembly” on page 264.
BA010004	Bootp failed	Perform the following actions that checkpoint CA00E174 describes: <ol style="list-style-type: none"> 1. Verify that: <ul style="list-style-type: none"> • The bootp server is correctly configured; then, retry the operation. • The network connections are correct; then, retry the operation. 2. If the problem persists: <ol style="list-style-type: none"> a. Go to “Checkout procedure” on page 176. b. Replace the system-board, as described in “Replacing the FRU system-board and chassis assembly” on page 264.
BA010005	File transmission (TFTP) failed	Perform the following actions that checkpoint CA00E174 describes: <ol style="list-style-type: none"> 1. Verify that: <ul style="list-style-type: none"> • The bootp server is correctly configured; then, retry the operation. • The network connections are correct; then, retry the operation. 2. If the problem persists: <ol style="list-style-type: none"> a. Go to “Checkout procedure” on page 176. b. Replace the system-board, as described in “Replacing the FRU system-board and chassis assembly” on page 264.
BA010006	The boot image is too large	Start up from another device with a bootable image.

Table 18. BA000010 to BA400002 Partition firmware SRCs (continued)

<ul style="list-style-type: none"> Follow the suggested actions in the order in which they are listed in the Action column until the problem is solved. If an action solves the problem, then you can stop performing the remaining actions. See Chapter 3, "Parts listing, type 7891," on page 225 to determine which components are CRUs and which components are FRUs. 		
Error code	Description	Action
BA010007	The device does not have the required device_type property.	<ol style="list-style-type: none"> Reboot the blade server. If the problem persists: <ol style="list-style-type: none"> Go to "Checkout procedure" on page 176. Replace the system-board, as described in "Replacing the FRU system-board and chassis assembly" on page 264.
BA010008	The device_type property for this device is not supported by the iSCSI initiator configuration specification.	<ol style="list-style-type: none"> Reboot the blade server. If the problem persists: <ol style="list-style-type: none"> Go to "Checkout procedure" on page 176. Replace the system-board, as described in "Replacing the FRU system-board and chassis assembly" on page 264.
BA010009	The arguments specified for the ping function are invalid.	The embedded host Ethernet adapters (HEAs) help provide iSCSI, which is supported by iSCSI software device drivers on either AIX or Linux. Verify that all of the iSCSI configuration arguments on the operating system comply with the configuration for the iSCSI Host Bus Adapter (HBA), which is the <i>iSCSI initiator</i> .
BA01000A	The itname parameter string exceeds the maximum length allowed.	The embedded host Ethernet adapters (HEAs) help provide iSCSI, which is supported by iSCSI software device drivers on either AIX or Linux. Verify that all of the iSCSI configuration arguments on the operating system comply with the configuration for the iSCSI Host Bus Adapter (HBA), which is the <i>iSCSI initiator</i> .
BA01000B	The ichapid parameter string exceeds the maximum length allowed.	The embedded host Ethernet adapters (HEAs) help provide iSCSI, which is supported by iSCSI software device drivers on either AIX or Linux. Verify that all of the iSCSI configuration arguments on the operating system comply with the configuration for the iSCSI Host Bus Adapter (HBA), which is the <i>iSCSI initiator</i> .
BA01000C	The ichappw parameter string exceeds the maximum length allowed.	The embedded host Ethernet adapters (HEAs) help provide iSCSI, which is supported by iSCSI software device drivers on either AIX or Linux. Verify that all of the iSCSI configuration arguments on the operating system comply with the configuration for the iSCSI Host Bus Adapter (HBA), which is the <i>iSCSI initiator</i> .

Table 18. BA000010 to BA400002 Partition firmware SRCs (continued)

Error code	Description	Action
<ul style="list-style-type: none"> Follow the suggested actions in the order in which they are listed in the Action column until the problem is solved. If an action solves the problem, then you can stop performing the remaining actions. See Chapter 3, "Parts listing, type 7891," on page 225 to determine which components are CRUs and which components are FRUs. 		
BA01000D	The iname parameter string exceeds the maximum length allowed.	The embedded host Ethernet adapters (HEAs) help provide iSCSI, which is supported by iSCSI software device drivers on either AIX or Linux. Verify that all of the iSCSI configuration arguments on the operating system comply with the configuration for the iSCSI Host Bus Adapter (HBA), which is the <i>iSCSI initiator</i> .
BA01000E	The LUN specified is not valid.	The embedded host Ethernet adapters (HEAs) help provide iSCSI, which is supported by iSCSI software device drivers on either AIX or Linux. Verify that all of the iSCSI configuration arguments on the operating system comply with the configuration for the iSCSI Host Bus Adapter (HBA), which is the <i>iSCSI initiator</i> .
BA01000F	The chapid parameter string exceeds the maximum length allowed.	The embedded host Ethernet adapters (HEAs) help provide iSCSI, which is supported by iSCSI software device drivers on either AIX or Linux. Verify that all of the iSCSI configuration arguments on the operating system comply with the configuration for the iSCSI Host Bus Adapter (HBA), which is the <i>iSCSI initiator</i> .
BA010010	The chappw parameter string exceeds the maximum length allowed.	The embedded host Ethernet adapters (HEAs) help provide iSCSI, which is supported by iSCSI software device drivers on either AIX or Linux. Verify that all of the iSCSI configuration arguments on the operating system comply with the configuration for the iSCSI Host Bus Adapter (HBA), which is the <i>iSCSI initiator</i> .
BA010011	SET-ROOT-PROP could not find / (root) package	<ol style="list-style-type: none"> Reboot the blade server. If the problem persists: <ol style="list-style-type: none"> Go to "Checkout procedure" on page 176. Replace the system-board, as described in "Replacing the FRU system-board and chassis assembly" on page 264.
BA010013	The information in the error log entry for this SRC provides network trace data.	Informational message. No action is required.
BA010014	The information in the error log entry for this SRC provides network trace data.	Informational message. No action is required.
BA010015	The information in the error log entry for this SRC provides network trace data.	Informational message. No action is required.

Table 18. BA000010 to BA400002 Partition firmware SRCs (continued)

<ul style="list-style-type: none"> Follow the suggested actions in the order in which they are listed in the Action column until the problem is solved. If an action solves the problem, then you can stop performing the remaining actions. See Chapter 3, "Parts listing, type 7891," on page 225 to determine which components are CRUs and which components are FRUs. 		
Error code	Description	Action
BA010020	A trace entry addition failed because of a bad trace type.	<ol style="list-style-type: none"> Reboot the blade server. If the problem persists: <ol style="list-style-type: none"> Go to "Checkout procedure" on page 176. Replace the system-board, as described in "Replacing the FRU system-board and chassis assembly" on page 264.
BA012010	Opening the TCP node failed.	<ol style="list-style-type: none"> Reboot the blade server. If the problem persists: <ol style="list-style-type: none"> Go to "Checkout procedure" on page 176. Replace the system-board, as described in "Replacing the FRU system-board and chassis assembly" on page 264.
BA012011	TCP failed to read from the network	<ol style="list-style-type: none"> Reboot the blade server. If the problem persists: <ol style="list-style-type: none"> Go to "Checkout procedure" on page 176. Replace the system-board, as described in "Replacing the FRU system-board and chassis assembly" on page 264.
BA012012	TCP failed to write to the network.	<ol style="list-style-type: none"> Reboot the blade server. If the problem persists: <ol style="list-style-type: none"> Go to "Checkout procedure" on page 176. Replace the system-board, as described in "Replacing the FRU system-board and chassis assembly" on page 264.
BA012013	Closing TCP failed.	<ol style="list-style-type: none"> Reboot the blade server. If the problem persists: <ol style="list-style-type: none"> Go to "Checkout procedure" on page 176. Replace the system-board, as described in "Replacing the FRU system-board and chassis assembly" on page 264.
BA017020	Failed to open the TFTP package	Verify that the Trivial File Transfer Protocol (TFTP) parameters are correct.
BA017021	Failed to load the TFTP file	Verify that the TFTP server and network connections are correct.

Table 18. BA000010 to BA400002 Partition firmware SRCs (continued)

<ul style="list-style-type: none"> Follow the suggested actions in the order in which they are listed in the Action column until the problem is solved. If an action solves the problem, then you can stop performing the remaining actions. See Chapter 3, "Parts listing, type 7891," on page 225 to determine which components are CRUs and which components are FRUs. 		
Error code	Description	Action
BA01B010	Opening the BOOTP node failed.	<ol style="list-style-type: none"> Reboot the blade server. If the problem persists: <ol style="list-style-type: none"> Go to "Checkout procedure" on page 176. Replace the system-board, as described in "Replacing the FRU system-board and chassis assembly" on page 264.
BA01B011	BOOTP failed to read from the network	<p>Perform the following actions that checkpoint CA00E174 describes:</p> <ol style="list-style-type: none"> Verify that: <ul style="list-style-type: none"> The bootp server is correctly configured; then, retry the operation. The network connections are correct; then, retry the operation. If the problem persists: <ol style="list-style-type: none"> Go to "Checkout procedure" on page 176. Replace the system-board, as described in "Replacing the FRU system-board and chassis assembly" on page 264.
BA01B012	BOOTP failed to write to the network	<p>Perform the following actions that checkpoint CA00E174 describes:</p> <ol style="list-style-type: none"> Verify that: <ul style="list-style-type: none"> The bootp server is correctly configured; then, retry the operation. The network connections are correct; then, retry the operation. If the problem persists: <ol style="list-style-type: none"> Go to "Checkout procedure" on page 176. Replace the system-board, as described in "Replacing the FRU system-board and chassis assembly" on page 264.
BA01B013	The discover mode is invalid	<ol style="list-style-type: none"> Reboot the blade server. If the problem persists: <ol style="list-style-type: none"> Go to "Checkout procedure" on page 176. Replace the system-board, as described in "Replacing the FRU system-board and chassis assembly" on page 264.

Table 18. BA000010 to BA400002 Partition firmware SRCs (continued)

<ul style="list-style-type: none"> Follow the suggested actions in the order in which they are listed in the Action column until the problem is solved. If an action solves the problem, then you can stop performing the remaining actions. See Chapter 3, "Parts listing, type 7891," on page 225 to determine which components are CRUs and which components are FRUs. 		
Error code	Description	Action
BA01B014	Closing the BOOTP node failed	<ol style="list-style-type: none"> Reboot the blade server. If the problem persists: <ol style="list-style-type: none"> Go to "Checkout procedure" on page 176. Replace the system-board, as described in "Replacing the FRU system-board and chassis assembly" on page 264.
BA01B015	The BOOTP discover server timed out	Perform the following actions that checkpoint CA00E174 describes: <ol style="list-style-type: none"> Verify that: <ul style="list-style-type: none"> The bootp server is correctly configured; then, retry the operation. The network connections are correct; then, retry the operation. If the problem persists: <ol style="list-style-type: none"> Go to "Checkout procedure" on page 176. Replace the system-board, as described in "Replacing the FRU system-board and chassis assembly" on page 264.
BA01D001	Opening the DHCP node failed	<ol style="list-style-type: none"> Reboot the blade server. If the problem persists: <ol style="list-style-type: none"> Go to "Checkout procedure" on page 176. Replace the system-board, as described in "Replacing the FRU system-board and chassis assembly" on page 264.
BA01D020	DHCP failed to read from the network	<ol style="list-style-type: none"> Verify that the network cable is connected, and that the network is active. If the problem persists: <ol style="list-style-type: none"> Go to "Checkout procedure" on page 176. Replace the system-board, as described in "Replacing the FRU system-board and chassis assembly" on page 264.
BA01D030	DHCP failed to write to the network	<ol style="list-style-type: none"> Verify that the network cable is connected, and that the network is active. If the problem persists: <ol style="list-style-type: none"> Go to "Checkout procedure" on page 176. Replace the system-board, as described in "Replacing the FRU system-board and chassis assembly" on page 264.

Table 18. BA000010 to BA400002 Partition firmware SRCs (continued)

Error code	Description	Action
BA01D040	The DHCP discover server timed out	<ol style="list-style-type: none"> 1. Verify that the DHCP server has addresses available. 2. Verify that the DHCP server configuration file is not overly constrained. An over-constrained file might prevent a server from meeting the configuration requested by the client. 3. Perform the following actions that checkpoint CA00E174 describes: <ol style="list-style-type: none"> a. Verify that: <ul style="list-style-type: none"> • The bootp server is correctly configured; then, retry the operation. • The network connections are correct; then, retry the operation. b. If the problem persists: <ol style="list-style-type: none"> 1) Go to "Checkout procedure" on page 176. 2) Replace the system-board, as described in "Replacing the FRU system-board and chassis assembly" on page 264.
BA01D050	DHCP::discover no good offer	<p>DHCP discovery did not receive any DHCP offers from the servers that meet the client requirements.</p> <p>Verify that the DHCP server configuration file is not overly constrained. An over-constrained file might prevent a server from meeting the configuration requested by the client.</p>
BA01D051	DHCP::discover DHCP request timed out	<p>DHCP discovery did receive a DHCP offer from a server that met the client requirements, but the server did not send the DHCP acknowledgement (DHCP ack) to the client DHCP request.</p> <p>Another client might have used the address that was served.</p> <p>Verify that the DHCP server has addresses available.</p>
BA01D052	DHCP::discover: 10 incapable servers were found	<p>Ten DHCP servers have sent DHCP offers, none of which met the requirements of the client. Check the compatibility of the configuration that the client is requesting and the server DHCP configuration files.</p>
BA01D053	DHCP::discover received a reply, but without a message type	<p>Verify that the DHCP server is properly configured.</p>

Table 18. BA000010 to BA400002 Partition firmware SRCs (continued)

Error code	Description	Action
BA01D054	DHCP::discover: DHCP nak received	<p>DHCP discovery did receive a DHCP offer from a server that meets the client requirements, but the server sent a DHCP not acknowledged (DHCP nak) to the client DHCP request.</p> <p>Another client might be using the address that was served.</p> <p>This situation can occur when there are multiple DHCP servers on the same network, and server A does not know the subnet configuration of server B, and vice-versa.</p> <p>This situation can also occur when the pool of addresses is not truly divided.</p> <p>Set the DHCP server configuration file to "authoritative".</p> <p>Verify that the DHCP server is functioning properly.</p>
BA01D055	DHCP::discover: DHCP decline	<p>DHCP discovery did receive a DHCP offer from one or more servers that meet the client requirements. However, the client performed an ARP test on the address and found that another client was using the address.</p> <p>The client sent a DHCP decline to the server, but the client did not receive an additional DHCP offer from a server. The client still does not have a valid address.</p> <p>Verify that the DHCP server is functioning properly.</p>
BA01D056	DHCP::discover: unknown DHCP message	<p>DHCP discovery received an unknown DHCP message type. Verify that the DHCP server is functioning properly.</p>
BA01D0FF	Closing the DHCP node failed.	<ol style="list-style-type: none"> 1. Reboot the blade server. 2. If the problem persists: <ol style="list-style-type: none"> a. Go to "Checkout procedure" on page 176. b. Replace the system-board, as described in "Replacing the FRU system-board and chassis assembly" on page 264.
BA030011	RTAS attempt to allocate memory failed	<ol style="list-style-type: none"> 1. Go to "Checkout procedure" on page 176. 2. Replace the system-board, as described in "Replacing the FRU system-board and chassis assembly" on page 264.

Table 18. BA000010 to BA400002 Partition firmware SRCs (continued)

<ul style="list-style-type: none"> Follow the suggested actions in the order in which they are listed in the Action column until the problem is solved. If an action solves the problem, then you can stop performing the remaining actions. See Chapter 3, "Parts listing, type 7891," on page 225 to determine which components are CRUs and which components are FRUs. 		
Error code	Description	Action
BA04000F	Self test failed on device; no error or location code information available	<ol style="list-style-type: none"> If a location code is identified with the error, replace the device specified by the location code. If the problem persists: <ol style="list-style-type: none"> Go to "Checkout procedure" on page 176. Replace the system-board, as described in "Replacing the FRU system-board and chassis assembly" on page 264.
BA040010	Self test failed on device; can't locate package.	<ol style="list-style-type: none"> If a location code is identified with the error, replace the device specified by the location code. If the problem persists: <ol style="list-style-type: none"> Go to "Checkout procedure" on page 176. Replace the system-board, as described in "Replacing the FRU system-board and chassis assembly" on page 264.
BA040020	The machine type and model are not recognized by the blade server firmware.	<ol style="list-style-type: none"> Reboot the blade server. If the problem persists: <ol style="list-style-type: none"> Go to "Checkout procedure" on page 176. Replace the system-board, as described in "Replacing the FRU system-board and chassis assembly" on page 264.
BA040030	The firmware was not able to build the UID properly for this system. As a result, problems may occur with the licensing of the AIX operating system.	<ol style="list-style-type: none"> Go to "Checkout procedure" on page 176. Replace the system-board, as described in "Replacing the FRU system-board and chassis assembly" on page 264.
BA040035	The firmware was unable to find the "plant of manufacture" in the VPD. This may cause problems with the licensing of the AIX operating system.	Verify that the machine type, model, and serial number are correct for this server. If this is a new server, check for server firmware updates; then, install the updates if available.
BA040040	Setting the machine type, model, and serial number failed.	<ol style="list-style-type: none"> Go to "Checkout procedure" on page 176. Replace the system-board, as described in "Replacing the FRU system-board and chassis assembly" on page 264.
BA040050	The h-call to switch off the boot watchdog timer failed.	<ol style="list-style-type: none"> Go to "Checkout procedure" on page 176. Replace the system-board, as described in "Replacing the FRU system-board and chassis assembly" on page 264.

Table 18. BA000010 to BA400002 Partition firmware SRCs (continued)

<ul style="list-style-type: none"> Follow the suggested actions in the order in which they are listed in the Action column until the problem is solved. If an action solves the problem, then you can stop performing the remaining actions. See Chapter 3, "Parts listing, type 7891," on page 225 to determine which components are CRUs and which components are FRUs. 		
Error code	Description	Action
BA040060	Setting the firmware boot side for the next boot failed.	<ol style="list-style-type: none"> Go to "Checkout procedure" on page 176. Replace the system-board, as described in "Replacing the FRU system-board and chassis assembly" on page 264.
BA050001	Failed to reboot a partition in logical partition mode	<ol style="list-style-type: none"> Go to "Checkout procedure" on page 176. Replace the system-board, as described in "Replacing the FRU system-board and chassis assembly" on page 264.
BA050004	Failed to locate service processor device tree node.	<ol style="list-style-type: none"> Go to "Checkout procedure" on page 176. Replace the system-board, as described in "Replacing the FRU system-board and chassis assembly" on page 264.
BA05000A	Failed to send boot failed message	<ol style="list-style-type: none"> Go to "Checkout procedure" on page 176. Replace the system-board, as described in "Replacing the FRU system-board and chassis assembly" on page 264.
BA060008	No configurable adapters found by the Remote IPL menu in the SMS utilities	This error occurs when the firmware cannot locate any LAN adapters that are supported by the remote IPL function. Verify that the devices in the remote IPL device list are correct using the SMS menus.
BA06000B	The system was not able to find an operating system on the devices in the boot list.	Go to "Boot problem resolution" on page 182.
BA06000C	A pointer to the operating system was found in non-volatile storage.	<ol style="list-style-type: none"> Go to "Checkout procedure" on page 176. Replace the system-board, as described in "Replacing the FRU system-board and chassis assembly" on page 264.
BA060020	The environment variable "boot-device" exceeded the allowed character limit.	<ol style="list-style-type: none"> Go to "Checkout procedure" on page 176. Replace the system-board, as described in "Replacing the FRU system-board and chassis assembly" on page 264.
BA060021	The environment variable "boot-device" contained more than five entries.	<ol style="list-style-type: none"> Go to "Checkout procedure" on page 176. Replace the system-board, as described in "Replacing the FRU system-board and chassis assembly" on page 264.

Table 18. BA000010 to BA400002 Partition firmware SRCs (continued)

<ul style="list-style-type: none"> Follow the suggested actions in the order in which they are listed in the Action column until the problem is solved. If an action solves the problem, then you can stop performing the remaining actions. See Chapter 3, "Parts listing, type 7891," on page 225 to determine which components are CRUs and which components are FRUs. 		
Error code	Description	Action
BA060022	The environment variable "boot-device" contained an entry that exceeded 255 characters in length	<ol style="list-style-type: none"> Using the SMS menus, set the boot list to the default boot list. Shut down; then, start up the blade server. Use SMS menus to customize the boot list as required. If the problem persists: <ol style="list-style-type: none"> Go to "Checkout procedure" on page 176. Replace the system-board, as described in "Replacing the FRU system-board and chassis assembly" on page 264.
BA060030	Logical partitioning with shared processors is enabled and the operating system does not support it.	<ol style="list-style-type: none"> Install or boot a level of the operating system that supports shared processors. Disable logical partitioning with shared processors in the operating system. If the problem remains: <ol style="list-style-type: none"> Go to "Checkout procedure" on page 176. Replace the system-board, as described in "Replacing the FRU system-board and chassis assembly" on page 264.
BA060060	The operating system expects an IOSPP partition, but it failed to make the transition to alpha mode.	<ol style="list-style-type: none"> Verify that: <ul style="list-style-type: none"> The alpha-mode operating system image is intended for this partition. The configuration of the partition supports an alpha-mode operating system. If the problem remains: <ol style="list-style-type: none"> Go to "Checkout procedure" on page 176. Replace the system-board, as described in "Replacing the FRU system-board and chassis assembly" on page 264.
BA060061	The operating system expects a non-IOSPP partition, but it failed to make the transition to MGC mode.	<ol style="list-style-type: none"> Verify that: <ul style="list-style-type: none"> The alpha-mode operating system image is intended for this partition. The configuration of the partition supports an alpha-mode operating system. If the problem remains: <ol style="list-style-type: none"> Go to "Checkout procedure" on page 176. Replace the system-board, as described in "Replacing the FRU system-board and chassis assembly" on page 264.

Table 18. BA000010 to BA400002 Partition firmware SRCs (continued)

<ul style="list-style-type: none"> Follow the suggested actions in the order in which they are listed in the Action column until the problem is solved. If an action solves the problem, then you can stop performing the remaining actions. See Chapter 3, "Parts listing, type 7891," on page 225 to determine which components are CRUs and which components are FRUs. 		
Error code	Description	Action
BA060070	The operating system does not support this system's processor(s)	Boot a supported version of the operating system.
BA060071	An invalid number of vectors was received from the operating system	Boot a supported version of the operating system.
BA060072	Client-arch-support hcall error	<ol style="list-style-type: none"> Go to "Checkout procedure" on page 176. Replace the system-board, as described in "Replacing the FRU system-board and chassis assembly" on page 264.
BA060075	Client-arch-support firmware error	<ol style="list-style-type: none"> Go to "Checkout procedure" on page 176. Replace the system-board, as described in "Replacing the FRU system-board and chassis assembly" on page 264.
BA060200	Failed to set the operating system boot list from the management module boot list	<ol style="list-style-type: none"> Using the SMS menus, set the boot list to the default boot list. Shut down; then, start up the blade server. Use SMS menus to customize the boot list as required. If the problem persists: <ol style="list-style-type: none"> Go to "Checkout procedure" on page 176. Replace the system-board, as described in "Replacing the FRU system-board and chassis assembly" on page 264.
BA060201	Failed to read the VPD "boot path" field value	<ol style="list-style-type: none"> Go to "Checkout procedure" on page 176. Replace the system-board, as described in "Replacing the FRU system-board and chassis assembly" on page 264.
BA060202	Failed to update the VPD with the new "boot path" field value	<ol style="list-style-type: none"> Go to "Checkout procedure" on page 176. Replace the system-board, as described in "Replacing the FRU system-board and chassis assembly" on page 264.
BA060300	An I/O error on the adapter from which the boot was attempted prevented the operating system from being booted.	<ol style="list-style-type: none"> Using the SMS menus, select another adapter from which to boot the operating system, and reboot the system. Attempt to reboot the system. Go to "Boot problem resolution" on page 182.
BA07xxxx	self configuring SCSI device (SCSD) controller failure	<ol style="list-style-type: none"> Go to "Checkout procedure" on page 176. Replace the system-board, as described in "Replacing the FRU system-board and chassis assembly" on page 264.

Table 18. BA000010 to BA400002 Partition firmware SRCs (continued)

<ul style="list-style-type: none"> Follow the suggested actions in the order in which they are listed in the Action column until the problem is solved. If an action solves the problem, then you can stop performing the remaining actions. See Chapter 3, "Parts listing, type 7891," on page 225 to determine which components are CRUs and which components are FRUs. 		
Error code	Description	Action
BA090001	SCSD DASD: test unit ready failed; hardware error	<ol style="list-style-type: none"> Go to "Checkout procedure" on page 176. Replace the system-board, as described in "Replacing the FRU system-board and chassis assembly" on page 264.
BA090002	SCSD DASD: test unit ready failed; sense data available	<ol style="list-style-type: none"> Go to "Checkout procedure" on page 176. Replace the system-board, as described in "Replacing the FRU system-board and chassis assembly" on page 264.
BA090003	SCSD DASD: send diagnostic failed; sense data available	<ol style="list-style-type: none"> Go to "Checkout procedure" on page 176. Replace the system-board, as described in "Replacing the FRU system-board and chassis assembly" on page 264.
BA090004	SCSD DASD: send diagnostic failed: devofl cmd	<ol style="list-style-type: none"> Go to "Checkout procedure" on page 176. Replace the system-board, as described in "Replacing the FRU system-board and chassis assembly" on page 264.
BA09000A	There was a vendor specification error.	<ol style="list-style-type: none"> Check the vendor specification for additional information. If the problem persists: <ol style="list-style-type: none"> Go to "Checkout procedure" on page 176. Replace the system-board, as described in "Replacing the FRU system-board and chassis assembly" on page 264.
BA09000B	Generic SCSD sense error	<ol style="list-style-type: none"> Verify that the SCSD cables and devices are properly plugged. Correct any problems that are found. If the problem persists: <ol style="list-style-type: none"> Go to "Checkout procedure" on page 176. Replace the system-board, as described in "Replacing the FRU system-board and chassis assembly" on page 264.
BA09000C	The media is write-protected	<ol style="list-style-type: none"> Change the setting of the media to allow writing, then retry the operation. Insert new media of the correct type. If the problem persists: <ol style="list-style-type: none"> Go to "Checkout procedure" on page 176. Replace the system-board, as described in "Replacing the FRU system-board and chassis assembly" on page 264.

Table 18. BA000010 to BA400002 Partition firmware SRCs (continued)

<ul style="list-style-type: none"> Follow the suggested actions in the order in which they are listed in the Action column until the problem is solved. If an action solves the problem, then you can stop performing the remaining actions. See Chapter 3, "Parts listing, type 7891," on page 225 to determine which components are CRUs and which components are FRUs. 		
Error code	Description	Action
BA09000D	The media is unsupported or not recognized.	<ol style="list-style-type: none"> 1. Insert new media of the correct type. 2. If the problem persists: <ol style="list-style-type: none"> a. Go to "Checkout procedure" on page 176. b. Replace the system-board, as described in "Replacing the FRU system-board and chassis assembly" on page 264.
BA09000E	The media is not formatted correctly.	<ol style="list-style-type: none"> 1. Insert the media. 2. Insert new media of the correct type. 3. If the problem persists: <ol style="list-style-type: none"> a. Go to "Checkout procedure" on page 176. b. Replace the system-board, as described in "Replacing the FRU system-board and chassis assembly" on page 264.
BA09000F	Media is not present	<ol style="list-style-type: none"> 1. Insert new media with the correct format. 2. If the problem persists: <ol style="list-style-type: none"> a. Go to "Checkout procedure" on page 176. b. Replace the system-board, as described in "Replacing the FRU system-board and chassis assembly" on page 264.
BA090010	The request sense command failed.	<ol style="list-style-type: none"> 1. Troubleshoot the SCSD devices. 2. Verify that the SCSD cables and devices are properly plugged. Correct any problems that are found. 3. Replace the SCSD cables and devices. 4. If the problem persists: <ol style="list-style-type: none"> a. Go to "Checkout procedure" on page 176. b. Replace the system-board, as described in "Replacing the FRU system-board and chassis assembly" on page 264.
BA090011	The retry limit has been exceeded.	<ol style="list-style-type: none"> 1. Troubleshoot the SCSD devices. 2. Verify that the SCSD cables and devices are properly plugged. Correct any problems that are found. 3. Replace the SCSD cables and devices. 4. If the problem persists: <ol style="list-style-type: none"> a. Go to "Checkout procedure" on page 176. b. Replace the system-board, as described in "Replacing the FRU system-board and chassis assembly" on page 264.

Table 18. BA000010 to BA400002 Partition firmware SRCs (continued)

<ul style="list-style-type: none"> Follow the suggested actions in the order in which they are listed in the Action column until the problem is solved. If an action solves the problem, then you can stop performing the remaining actions. See Chapter 3, "Parts listing, type 7891," on page 225 to determine which components are CRUs and which components are FRUs. 		
Error code	Description	Action
BA090012	There is a SCSD device that is not supported.	<ol style="list-style-type: none"> Replace the SCSD device that is not supported with a supported device. If the problem persists: <ol style="list-style-type: none"> Troubleshoot the SCSD devices. Verify that the SCSD cables and devices are properly plugged. Correct any problems that are found. Replace the SCSD cables and devices. If the problem persists: <ol style="list-style-type: none"> Go to "Checkout procedure" on page 176. Replace the system-board, as described in "Replacing the FRU system-board and chassis assembly" on page 264.
BA120001	On an undetermined SCSD device, test unit ready failed; hardware error	<ol style="list-style-type: none"> Troubleshoot the SCSD devices. Verify that the SCSD cables and devices are properly plugged. Correct any problems that are found. Replace the SCSD cables and devices. If the problem persists: <ol style="list-style-type: none"> Go to "Checkout procedure" on page 176. Replace the system-board, as described in "Replacing the FRU system-board and chassis assembly" on page 264.
BA120002	On an undetermined SCSD device, test unit ready failed; sense data available	<ol style="list-style-type: none"> Troubleshoot the SCSD devices. Verify that the SCSD cables and devices are properly plugged. Correct any problems that are found. Replace the SCSD cables and devices. If the problem persists: <ol style="list-style-type: none"> Go to "Checkout procedure" on page 176. Replace the system-board, as described in "Replacing the FRU system-board and chassis assembly" on page 264.

Table 18. BA000010 to BA400002 Partition firmware SRCs (continued)

<ul style="list-style-type: none"> Follow the suggested actions in the order in which they are listed in the Action column until the problem is solved. If an action solves the problem, then you can stop performing the remaining actions. See Chapter 3, "Parts listing, type 7891," on page 225 to determine which components are CRUs and which components are FRUs. 		
Error code	Description	Action
BA120003	On an undetermined SCSD device, send diagnostic failed; sense data available	<ol style="list-style-type: none"> Troubleshoot the SCSD devices. Verify that the SCSD cables and devices are properly plugged. Correct any problems that are found. Replace the SCSD cables and devices. If the problem persists: <ol style="list-style-type: none"> Go to "Checkout procedure" on page 176. Replace the system-board, as described in "Replacing the FRU system-board and chassis assembly" on page 264.
BA120004	On an undetermined SCSD device, send diagnostic failed; devofl command	<ol style="list-style-type: none"> Troubleshoot the SCSD devices. Verify that the SCSD cables and devices are properly plugged. Correct any problems that are found. Replace the SCSD cables and devices. If the problem persists: <ol style="list-style-type: none"> Go to "Checkout procedure" on page 176. Replace the system-board, as described in "Replacing the FRU system-board and chassis assembly" on page 264.
BA120010	Failed to generate the SAS device physical location code. The event log entry has the details.	<ol style="list-style-type: none"> Reboot the blade server. If the problem persists: <ol style="list-style-type: none"> Go to "Checkout procedure" on page 176. Replace the system-board, as described in "Replacing the FRU system-board and chassis assembly" on page 264.
BA130010	USB CD-ROM in the media tray: device remained busy longer than the time-out period	<ol style="list-style-type: none"> Retry the operation. Reboot the blade server. Troubleshoot the media tray and CD-ROM drive. Replace the USB CD or DVD drive. If the problem persists: <ol style="list-style-type: none"> Go to "Checkout procedure" on page 176. Replace the system-board, as described in "Replacing the FRU system-board and chassis assembly" on page 264.

Table 18. BA000010 to BA400002 Partition firmware SRCs (continued)

<ul style="list-style-type: none"> Follow the suggested actions in the order in which they are listed in the Action column until the problem is solved. If an action solves the problem, then you can stop performing the remaining actions. See Chapter 3, "Parts listing, type 7891," on page 225 to determine which components are CRUs and which components are FRUs. 		
Error code	Description	Action
BA130011	USB CD-ROM in the media tray: execution of ATA/ATAPI command was not completed with the allowed time.	<ol style="list-style-type: none"> 1. Retry the operation. 2. Reboot the blade server. 3. Troubleshoot the media tray and CD-ROM drive. 4. Replace the USB CD or DVD drive. 5. If the problem persists: <ol style="list-style-type: none"> a. Go to "Checkout procedure" on page 176. b. Replace the system-board, as described in "Replacing the FRU system-board and chassis assembly" on page 264.
BA130012	USB CD-ROM in the media tray: execution of ATA/ATAPI command failed.	<ol style="list-style-type: none"> 1. Retry the operation. 2. Reboot the blade server. 3. Troubleshoot the media tray and CD-ROM drive. 4. Replace the USB CD or DVD drive. 5. If the problem persists: <ol style="list-style-type: none"> a. Go to "Checkout procedure" on page 176. b. Replace the system-board, as described in "Replacing the FRU system-board and chassis assembly" on page 264.
BA130013	USB CD-ROM in the media tray: bootable media is missing from the drive	<ol style="list-style-type: none"> 1. Insert a bootable CD in the drive and retry the operation. 2. If the problem persists: <ol style="list-style-type: none"> a. Retry the operation. b. Reboot the blade server. c. Troubleshoot the media tray and CD-ROM drive. d. Replace the USB CD or DVD drive. e. If the problem persists: <ol style="list-style-type: none"> 1) Go to "Checkout procedure" on page 176. 2) Replace the system-board, as described in "Replacing the FRU system-board and chassis assembly" on page 264.

Table 18. BA000010 to BA400002 Partition firmware SRCs (continued)

<ul style="list-style-type: none"> Follow the suggested actions in the order in which they are listed in the Action column until the problem is solved. If an action solves the problem, then you can stop performing the remaining actions. See Chapter 3, "Parts listing, type 7891," on page 225 to determine which components are CRUs and which components are FRUs. 		
Error code	Description	Action
BA130014	USB CD-ROM in the media tray: the media in the USB CD-ROM drive has been changed.	<ol style="list-style-type: none"> 1. Retry the operation. 2. Reboot the blade server. 3. Troubleshoot the media tray and CD-ROM drive. 4. Replace the USB CD or DVD drive. 5. If the problem persists: <ol style="list-style-type: none"> a. Go to "Checkout procedure" on page 176. b. Replace the system-board, as described in "Replacing the FRU system-board and chassis assembly" on page 264.
BA130015	USB CD-ROM in the media tray: ATA/ATAPI packet command execution failed.	<ol style="list-style-type: none"> 1. Remove the CD or DVD in the drive and replace it with a known-good disk. 2. If the problem persists: <ol style="list-style-type: none"> a. Retry the operation. b. Reboot the blade server. c. Troubleshoot the media tray and CD-ROM drive. d. Replace the USB CD or DVD drive. e. If the problem persists: <ol style="list-style-type: none"> 1) Go to "Checkout procedure" on page 176. 2) Replace the system-board, as described in "Replacing the FRU system-board and chassis assembly" on page 264.
BA131010	The USB keyboard has been removed.	<ol style="list-style-type: none"> 1. Reseat the keyboard cable in the management module USB port. 2. Check for server firmware updates; then, install the updates if available.
BA140001	The SCSD read/write optical test unit ready failed; hardware error.	<ol style="list-style-type: none"> 1. Troubleshoot the SCSD devices. 2. Verify that the SCSD cables and devices are properly plugged. Correct any problems that are found. 3. Replace the SCSD cables and devices. 4. If the problem persists: <ol style="list-style-type: none"> a. Go to "Checkout procedure" on page 176. b. Replace the system-board, as described in "Replacing the FRU system-board and chassis assembly" on page 264.

Table 18. BA000010 to BA400002 Partition firmware SRCs (continued)

<ul style="list-style-type: none"> Follow the suggested actions in the order in which they are listed in the Action column until the problem is solved. If an action solves the problem, then you can stop performing the remaining actions. See Chapter 3, "Parts listing, type 7891," on page 225 to determine which components are CRUs and which components are FRUs. 		
Error code	Description	Action
BA140002	The SCSD read/write optical test unit ready failed; sense data available.	<ol style="list-style-type: none"> Troubleshoot the SCSD devices. Verify that the SCSD cables and devices are properly plugged. Correct any problems that are found. Replace the SCSD cables and devices. If the problem persists: <ol style="list-style-type: none"> Go to "Checkout procedure" on page 176. Replace the system-board, as described in "Replacing the FRU system-board and chassis assembly" on page 264.
BA140003	The SCSD read/write optical send diagnostic failed; sense data available.	<ol style="list-style-type: none"> Troubleshoot the SCSD devices. Verify that the SCSD cables and devices are properly plugged. Correct any problems that are found. Replace the SCSD cables and devices. If the problem persists: <ol style="list-style-type: none"> Go to "Checkout procedure" on page 176. Replace the system-board, as described in "Replacing the FRU system-board and chassis assembly" on page 264.
BA140004	The SCSD read/write optical send diagnostic failed; devofl command.	<ol style="list-style-type: none"> Troubleshoot the SCSD devices. Verify that the SCSD cables and devices are properly plugged. Correct any problems that are found. Replace the SCSD cables and devices. If the problem persists: <ol style="list-style-type: none"> Go to "Checkout procedure" on page 176. Replace the system-board, as described in "Replacing the FRU system-board and chassis assembly" on page 264.
BA150001	PCI Ethernet BNC/RJ-45 or PCI Ethernet AUI/RJ-45 adapter: internal wrap test failure	Replace the adapter specified by the location code.
BA151001	10/100 Mbps Ethernet PCI adapter: internal wrap test failure	Replace the adapter specified by the location code.
BA151002	10/100 Mbps Ethernet card failure	<ol style="list-style-type: none"> Go to "Checkout procedure" on page 176. Replace the system-board, as described in "Replacing the FRU system-board and chassis assembly" on page 264.
BA153002	Gigabit Ethernet adapter failure	Verify that the MAC address programmed in the FLASH/EEPROM is correct.

Table 18. BA000010 to BA400002 Partition firmware SRCs (continued)

<ul style="list-style-type: none"> Follow the suggested actions in the order in which they are listed in the Action column until the problem is solved. If an action solves the problem, then you can stop performing the remaining actions. See Chapter 3, "Parts listing, type 7891," on page 225 to determine which components are CRUs and which components are FRUs. 		
Error code	Description	Action
BA153003	Gigabit Ethernet adapter failure	<ol style="list-style-type: none"> 1. Check for server firmware updates; then, install the updates if available. 2. Replace the Gigabit Ethernet adapter.
BA154010	HEA software error	<ol style="list-style-type: none"> 1. Go to "Checkout procedure" on page 176. 2. Replace the system-board, as described in "Replacing the FRU system-board and chassis assembly" on page 264.
BA154020	The required open firmware property was not found.	<ol style="list-style-type: none"> 1. Reboot the blade server. 2. If the problem persists: <ol style="list-style-type: none"> a. Go to "Checkout procedure" on page 176. b. Replace the system-board, as described in "Replacing the FRU system-board and chassis assembly" on page 264.
BA154030	Invalid parameters were passed to the HEA device driver.	<ol style="list-style-type: none"> 1. Reboot the blade server. 2. If the problem persists: <ol style="list-style-type: none"> a. Go to "Checkout procedure" on page 176. b. Replace the system-board, as described in "Replacing the FRU system-board and chassis assembly" on page 264.
BA154040	The TFTP package open failed	<ol style="list-style-type: none"> 1. Reboot the blade server. 2. If the problem persists: <ol style="list-style-type: none"> a. Go to "Checkout procedure" on page 176. b. Replace the system-board, as described in "Replacing the FRU system-board and chassis assembly" on page 264.
BA154050	The transmit operation failed.	<ol style="list-style-type: none"> 1. Reboot the blade server. 2. If the problem persists: <ol style="list-style-type: none"> a. Go to "Checkout procedure" on page 176. b. Replace the system-board, as described in "Replacing the FRU system-board and chassis assembly" on page 264.
BA154060	Failed to initialize the HEA port or queue	<ol style="list-style-type: none"> 1. Reboot the blade server. 2. If the problem persists: <ol style="list-style-type: none"> a. Go to "Checkout procedure" on page 176. b. Replace the system-board, as described in "Replacing the FRU system-board and chassis assembly" on page 264.

Table 18. BA000010 to BA400002 Partition firmware SRCs (continued)

<ul style="list-style-type: none"> Follow the suggested actions in the order in which they are listed in the Action column until the problem is solved. If an action solves the problem, then you can stop performing the remaining actions. See Chapter 3, "Parts listing, type 7891," on page 225 to determine which components are CRUs and which components are FRUs. 		
Error code	Description	Action
BA154070	The receive operation failed.	<ol style="list-style-type: none"> 1. Reboot the blade server. 2. If the problem persists: <ol style="list-style-type: none"> a. Go to "Checkout procedure" on page 176. b. Replace the system-board, as described in "Replacing the FRU system-board and chassis assembly" on page 264.
BA170000	NVRAMRC initialization failed; device test failed	<ol style="list-style-type: none"> 1. Go to "Checkout procedure" on page 176. 2. Replace the system-board, as described in "Replacing the FRU system-board and chassis assembly" on page 264.
BA170100	NVRAM data validation check failed	<ol style="list-style-type: none"> 1. Shut down the blade server; then, restart it. 2. If the problem persists: <ol style="list-style-type: none"> a. Go to "Checkout procedure" on page 176. b. Replace the system-board, as described in "Replacing the FRU system-board and chassis assembly" on page 264.
BA170201	The firmware was unable to expand target partition - saving configuration variable	<ol style="list-style-type: none"> 1. Reboot the blade server. 2. If the problem persists: <ol style="list-style-type: none"> a. Go to "Checkout procedure" on page 176. b. Replace the system-board, as described in "Replacing the FRU system-board and chassis assembly" on page 264.
BA170202	The firmware was unable to expand target partition - writing event log entry	<ol style="list-style-type: none"> 1. Reboot the blade server. 2. If the problem persists: <ol style="list-style-type: none"> a. Go to "Checkout procedure" on page 176. b. Replace the system-board, as described in "Replacing the FRU system-board and chassis assembly" on page 264.
BA170203	The firmware was unable to expand target partition - writing VPD data	<ol style="list-style-type: none"> 1. Reboot the blade server. 2. If the problem persists: <ol style="list-style-type: none"> a. Go to "Checkout procedure" on page 176. b. Replace the system-board, as described in "Replacing the FRU system-board and chassis assembly" on page 264.
BA170210	Setenv/\$Setenv parameter error - name contains a null character	<ol style="list-style-type: none"> 1. Go to "Checkout procedure" on page 176. 2. Replace the system-board, as described in "Replacing the FRU system-board and chassis assembly" on page 264.

Table 18. BA000010 to BA400002 Partition firmware SRCs (continued)

<ul style="list-style-type: none"> Follow the suggested actions in the order in which they are listed in the Action column until the problem is solved. If an action solves the problem, then you can stop performing the remaining actions. See Chapter 3, "Parts listing, type 7891," on page 225 to determine which components are CRUs and which components are FRUs. 		
Error code	Description	Action
BA170211	Setenv/\$Setenv parameter error - value contains a null character	<ol style="list-style-type: none"> Go to "Checkout procedure" on page 176. Replace the system-board, as described in "Replacing the FRU system-board and chassis assembly" on page 264.
BA170220	Unable to write a variable value to NVRAM due to lack of free memory in NVRAM.	<ol style="list-style-type: none"> Reduce the number of partitions, if possible, to add more NVRAM memory to this partition. If the problem persists: <ol style="list-style-type: none"> Go to "Checkout procedure" on page 176. Replace the system-board, as described in "Replacing the FRU system-board and chassis assembly" on page 264.
BA170221	Setenv/\$setenv had to delete stored firmware network boot settings to free memory in NVRAM.	Enter the adapter and network parameters again for the network boot or network installation.
BA170998	NVRAMRC script evaluation error - command line execution error.	<ol style="list-style-type: none"> Go to "Checkout procedure" on page 176. Replace the system-board, as described in "Replacing the FRU system-board and chassis assembly" on page 264.
BA180008	PCI device Fcode evaluation error	<ol style="list-style-type: none"> Go to "Checkout procedure" on page 176. Replace the system-board, as described in "Replacing the FRU system-board and chassis assembly" on page 264.
BA180009	The Fcode on a PCI adapter left a data stack imbalance	<ol style="list-style-type: none"> Reseat the PCI adapter card. Check for adapter firmware updates; then, install the updates if available. Check for server firmware updates; then, install the updates if available. Replace the PCI adapter card. If the problem persists: <ol style="list-style-type: none"> Go to "Checkout procedure" on page 176. Replace the system-board, as described in "Replacing the FRU system-board and chassis assembly" on page 264.
BA180010	PCI probe error, bridge in freeze state	<ol style="list-style-type: none"> Go to "Checkout procedure" on page 176. Replace the system-board, as described in "Replacing the FRU system-board and chassis assembly" on page 264.
BA180011	PCI bridge probe error, bridge is not usable	<ol style="list-style-type: none"> Go to "Checkout procedure" on page 176. Replace the system-board, as described in "Replacing the FRU system-board and chassis assembly" on page 264.

Table 18. BA000010 to BA400002 Partition firmware SRCs (continued)

<ul style="list-style-type: none"> Follow the suggested actions in the order in which they are listed in the Action column until the problem is solved. If an action solves the problem, then you can stop performing the remaining actions. See Chapter 3, "Parts listing, type 7891," on page 225 to determine which components are CRUs and which components are FRUs. 		
Error code	Description	Action
BA180012	PCI device runtime error, bridge in freeze state	<ol style="list-style-type: none"> Go to "Checkout procedure" on page 176. Replace the system-board, as described in "Replacing the FRU system-board and chassis assembly" on page 264.
BA180014	MSI software error	<ol style="list-style-type: none"> Reboot the blade server. If the problem persists: <ol style="list-style-type: none"> Go to "Checkout procedure" on page 176. Replace the system-board, as described in "Replacing the FRU system-board and chassis assembly" on page 264.
BA180020	No response was received from a slot during PCI probing.	<ol style="list-style-type: none"> Reboot the blade server. If the problem persists: <ol style="list-style-type: none"> Go to "Checkout procedure" on page 176. Replace the system-board, as described in "Replacing the FRU system-board and chassis assembly" on page 264.
BA180099	PCI probe error; bridge in freeze state, slot in reset state	<ol style="list-style-type: none"> Reseat the PCI adapter card. Check for adapter firmware updates; then, install the updates if available. Check for server firmware updates; then, install the updates if available. Replace the PCI adapter card. If the problem persists: <ol style="list-style-type: none"> Go to "Checkout procedure" on page 176. Replace the system-board, as described in "Replacing the FRU system-board and chassis assembly" on page 264.
BA180100	The FDDI adapter Fcode driver is not supported on this server.	IBM may produce a compatible driver in the future, but does not guarantee one.
BA180101	Stack underflow from fibre-channel adapter	<ol style="list-style-type: none"> Go to "Checkout procedure" on page 176. Replace the system-board, as described in "Replacing the FRU system-board and chassis assembly" on page 264.
BA190001	Firmware function to get/set time-of-day reported an error	<ol style="list-style-type: none"> Go to "Checkout procedure" on page 176. Replace the system-board, as described in "Replacing the FRU system-board and chassis assembly" on page 264.

Table 18. BA000010 to BA400002 Partition firmware SRCs (continued)

<ul style="list-style-type: none"> Follow the suggested actions in the order in which they are listed in the Action column until the problem is solved. If an action solves the problem, then you can stop performing the remaining actions. See Chapter 3, "Parts listing, type 7891," on page 225 to determine which components are CRUs and which components are FRUs. 		
Error code	Description	Action
BA201001	The serial interface dropped data packets	<ol style="list-style-type: none"> Go to "Checkout procedure" on page 176. Replace the system-board, as described in "Replacing the FRU system-board and chassis assembly" on page 264.
BA201002	The serial interface failed to open	<ol style="list-style-type: none"> Go to "Checkout procedure" on page 176. Replace the system-board, as described in "Replacing the FRU system-board and chassis assembly" on page 264.
BA201003	The firmware failed to handshake properly with the serial interface	<ol style="list-style-type: none"> Reboot the blade server. If the problem persists: <ol style="list-style-type: none"> Go to "Checkout procedure" on page 176. Replace the system-board, as described in "Replacing the FRU system-board and chassis assembly" on page 264.
BA210000	Partition firmware reports a default catch	<ol style="list-style-type: none"> Reboot the blade server. If the problem persists: <ol style="list-style-type: none"> Go to "Checkout procedure" on page 176. Replace the system-board, as described in "Replacing the FRU system-board and chassis assembly" on page 264.
BA210001	Partition firmware reports a stack underflow was caught	<ol style="list-style-type: none"> Reboot the blade server. If the problem persists: <ol style="list-style-type: none"> Go to "Checkout procedure" on page 176. Replace the system-board, as described in "Replacing the FRU system-board and chassis assembly" on page 264.
BA210002	Partition firmware was ready before standout was ready	<ol style="list-style-type: none"> Reboot the blade server. If the problem persists: <ol style="list-style-type: none"> Go to "Checkout procedure" on page 176. Replace the system-board, as described in "Replacing the FRU system-board and chassis assembly" on page 264.

Table 18. BA000010 to BA400002 Partition firmware SRCs (continued)

Error code	Description	Action
BA210003	A data storage error was caught by partition firmware	<ol style="list-style-type: none"> 1. If the location code reported with the error points to an adapter, check for adapter firmware updates. 2. Apply any available updates. 3. Check for server firmware updates. 4. Apply any available updates. 5. If the problem persists: <ol style="list-style-type: none"> a. Go to "Checkout procedure" on page 176. b. Replace the system-board, as described in "Replacing the FRU system-board and chassis assembly" on page 264.
BA210004	An open firmware stack-depth assert failed.	<ol style="list-style-type: none"> 1. Reboot the blade server. 2. If the problem persists: <ol style="list-style-type: none"> a. Go to "Checkout procedure" on page 176. b. Replace the system-board, as described in "Replacing the FRU system-board and chassis assembly" on page 264.
BA210010	The transfer of control to the SLIC loader failed	<ol style="list-style-type: none"> 1. Go to "Checkout procedure" on page 176. 2. Replace the system-board, as described in "Replacing the FRU system-board and chassis assembly" on page 264.
BA210011	The transfer of control to the IO Reporter failed	<ol style="list-style-type: none"> 1. Go to "Checkout procedure" on page 176. 2. Replace the system-board, as described in "Replacing the FRU system-board and chassis assembly" on page 264.
BA210012	There was an NVRAMRC forced-boot problem; unable to load the previous boot's operating system image	<ol style="list-style-type: none"> 1. Use the SMS menus to verify that the partition firmware can still detect the operating system image. 2. If the problem persists: <ol style="list-style-type: none"> a. Go to "Checkout procedure" on page 176. b. Replace the system-board, as described in "Replacing the FRU system-board and chassis assembly" on page 264.
BA210013	There was a partition firmware error when in the SMS menus.	<ol style="list-style-type: none"> 1. Reboot the blade server. 2. If the problem persists: <ol style="list-style-type: none"> a. Go to "Checkout procedure" on page 176. b. Replace the system-board, as described in "Replacing the FRU system-board and chassis assembly" on page 264.

Table 18. BA000010 to BA400002 Partition firmware SRCs (continued)

<ul style="list-style-type: none"> Follow the suggested actions in the order in which they are listed in the Action column until the problem is solved. If an action solves the problem, then you can stop performing the remaining actions. See Chapter 3, "Parts listing, type 7891," on page 225 to determine which components are CRUs and which components are FRUs. 		
Error code	Description	Action
BA210020	I/O configuration exceeded the maximum size allowed by partition firmware.	<ol style="list-style-type: none"> Increase the logical memory block size to 256 MB and restart the blade server. If the problem persists: <ol style="list-style-type: none"> Go to "Checkout procedure" on page 176. Replace the system-board, as described in "Replacing the FRU system-board and chassis assembly" on page 264.
BA210100	An error may not have been sent to the management module event log.	<ol style="list-style-type: none"> Reboot the blade server. If the problem persists: <ol style="list-style-type: none"> Go to "Checkout procedure" on page 176. Replace the system-board, as described in "Replacing the FRU system-board and chassis assembly" on page 264.
BA210101	The partition firmware event log queue is full	<ol style="list-style-type: none"> Reboot the blade server. If the problem persists: <ol style="list-style-type: none"> Go to "Checkout procedure" on page 176. Replace the system-board, as described in "Replacing the FRU system-board and chassis assembly" on page 264.
BA210102	There was a communication failure between partition firmware and the hypervisor. The lpevent that was expected from the hypervisor was not received.	<ol style="list-style-type: none"> Review the event log for errors that occurred around the time of this error. Correct any errors that are found and reboot the blade server. If the problem persists: <ol style="list-style-type: none"> Reboot the blade server. If the problem persists: <ol style="list-style-type: none"> Go to "Checkout procedure" on page 176. Replace the system-board, as described in "Replacing the FRU system-board and chassis assembly" on page 264.

Table 18. BA000010 to BA400002 Partition firmware SRCs (continued)

<ul style="list-style-type: none"> Follow the suggested actions in the order in which they are listed in the Action column until the problem is solved. If an action solves the problem, then you can stop performing the remaining actions. See Chapter 3, "Parts listing, type 7891," on page 225 to determine which components are CRUs and which components are FRUs. 		
Error code	Description	Action
BA210103	There was a communication failure between partition firmware and the hypervisor. There was a failing return code with the lpevent acknowledgement from the hypervisor.	<ol style="list-style-type: none"> Review the event log for errors that occurred around the time of this error. Correct any errors that are found and reboot the blade server. If the problem persists: <ol style="list-style-type: none"> Reboot the blade server. If the problem persists: <ol style="list-style-type: none"> Go to "Checkout procedure" on page 176. Replace the system-board, as described in "Replacing the FRU system-board and chassis assembly" on page 264.
BA220010	There was a partition firmware error during a USB hotplug probing. USB hotplug may not work properly on this partition.	<ol style="list-style-type: none"> Look for EEH-related errors in the event log. Resolve any EEH event log entries that are found. Correct any errors that are found and reboot the blade server. If the problem persists: <ol style="list-style-type: none"> Go to "Checkout procedure" on page 176. Replace the system-board, as described in "Replacing the FRU system-board and chassis assembly" on page 264.
BA220020	CRQ registration error; partner vslot may not be valid	Verify that this client virtual slot device has a valid server virtual slot device in a hosting partition.
BA278001	Failed to flash firmware: invalid image file	Download a new firmware update image and retry the update.
BA278002	Flash file is not designed for this platform	Download a new firmware update image and retry the update.
BA278003	Unable to lock the firmware update lid manager	<ol style="list-style-type: none"> Restart the blade server. Verify that the operating system is authorized to update the firmware. If the system is running multiple partitions, verify that this partition has service authority.
BA278004	An invalid firmware update lid was requested	Download a new firmware update image and retry the update.
BA278005	Failed to flash a firmware update lid	Download a new firmware update image and retry the update.
BA278006	Unable to unlock the firmware update lid manager	Restart the blade server.

Table 18. BA000010 to BA400002 Partition firmware SRCs (continued)

<ul style="list-style-type: none"> Follow the suggested actions in the order in which they are listed in the Action column until the problem is solved. If an action solves the problem, then you can stop performing the remaining actions. See Chapter 3, "Parts listing, type 7891," on page 225 to determine which components are CRUs and which components are FRUs. 		
Error code	Description	Action
BA278007	Failed to reboot the system after a firmware flash update	Restart the blade server.
BA278009	The operating system's server firmware update management tools are incompatible with this system.	Go to the IBM download site at www14.software.ibm.com/webapp/set2/sas/f/lopdiags/home.html to download the latest version of the service aids package for Linux.
BA27800A	The firmware installation failed due to a hardware error that was reported.	<ol style="list-style-type: none"> Look for hardware errors in the event log. Resolve any hardware errors that are found. If the problem persists: <ol style="list-style-type: none"> Go to "Checkout procedure" on page 176. Replace the system-board, as described in "Replacing the FRU system-board and chassis assembly" on page 264.
BA280000	RTAS discovered an invalid operation that may cause a hardware error	<ol style="list-style-type: none"> Go to "Checkout procedure" on page 176. Replace the system-board, as described in "Replacing the FRU system-board and chassis assembly" on page 264.
BA290000	RTAS discovered an internal stack overflow	<ol style="list-style-type: none"> Go to "Checkout procedure" on page 176. Replace the system-board, as described in "Replacing the FRU system-board and chassis assembly" on page 264.
BA290001	RTAS low memory corruption was detected	<ol style="list-style-type: none"> Reboot the blade server. If the problem persists: <ol style="list-style-type: none"> Go to "Checkout procedure" on page 176. Replace the system-board, as described in "Replacing the FRU system-board and chassis assembly" on page 264.
BA290002	RTAS low memory corruption was detected	<ol style="list-style-type: none"> Reboot the blade server. If the problem persists: <ol style="list-style-type: none"> Go to "Checkout procedure" on page 176. Replace the system-board, as described in "Replacing the FRU system-board and chassis assembly" on page 264.
BA310010	Unable to obtain the SRC history	<ol style="list-style-type: none"> Reboot the blade server. If the problem persists: <ol style="list-style-type: none"> Go to "Checkout procedure" on page 176. Replace the system-board, as described in "Replacing the FRU system-board and chassis assembly" on page 264.

Table 18. BA000010 to BA400002 Partition firmware SRCs (continued)

<ul style="list-style-type: none"> • Follow the suggested actions in the order in which they are listed in the Action column until the problem is solved. If an action solves the problem, then you can stop performing the remaining actions. • See Chapter 3, “Parts listing, type 7891,” on page 225 to determine which components are CRUs and which components are FRUs. 		
Error code	Description	Action
BA310020	An invalid SRC history was obtained.	<ol style="list-style-type: none"> 1. Reboot the blade server. 2. If the problem persists: <ol style="list-style-type: none"> a. Go to “Checkout procedure” on page 176. b. Replace the system-board, as described in “Replacing the FRU system-board and chassis assembly” on page 264.
BA310030	Writing the MAC address to the VPD failed.	<ol style="list-style-type: none"> 1. Reboot the blade server. 2. If the problem persists: <ol style="list-style-type: none"> a. Go to “Checkout procedure” on page 176. b. Replace the system-board, as described in “Replacing the FRU system-board and chassis assembly” on page 264.
BA330000	Memory allocation error.	<ol style="list-style-type: none"> 1. Reboot the blade server. 2. If the problem persists: <ol style="list-style-type: none"> a. Go to “Checkout procedure” on page 176. b. Replace the system-board, as described in “Replacing the FRU system-board and chassis assembly” on page 264.
BA330001	Memory allocation error.	<ol style="list-style-type: none"> 1. Reboot the blade server. 2. If the problem persists: <ol style="list-style-type: none"> a. Go to “Checkout procedure” on page 176. b. Replace the system-board, as described in “Replacing the FRU system-board and chassis assembly” on page 264.
BA330002	Memory allocation error.	<ol style="list-style-type: none"> 1. Reboot the blade server. 2. If the problem persists: <ol style="list-style-type: none"> a. Go to “Checkout procedure” on page 176. b. Replace the system-board, as described in “Replacing the FRU system-board and chassis assembly” on page 264.
BA330003	Memory allocation error.	<ol style="list-style-type: none"> 1. Reboot the blade server. 2. If the problem persists: <ol style="list-style-type: none"> a. Go to “Checkout procedure” on page 176. b. Replace the system-board, as described in “Replacing the FRU system-board and chassis assembly” on page 264.

Table 18. BA000010 to BA400002 Partition firmware SRCs (continued)

<ul style="list-style-type: none"> Follow the suggested actions in the order in which they are listed in the Action column until the problem is solved. If an action solves the problem, then you can stop performing the remaining actions. See Chapter 3, "Parts listing, type 7891," on page 225 to determine which components are CRUs and which components are FRUs. 		
Error code	Description	Action
BA330004	Memory allocation error.	<ol style="list-style-type: none"> 1. Reboot the blade server. 2. If the problem persists: <ol style="list-style-type: none"> a. Go to "Checkout procedure" on page 176. b. Replace the system-board, as described in "Replacing the FRU system-board and chassis assembly" on page 264.
BA340001	There was a logical partition event communication failure reading the BladeCenter open fabric manager parameter data structure from the service processor.	<ol style="list-style-type: none"> 1. Reboot the blade server. 2. If the problem persists: <ol style="list-style-type: none"> a. Go to "Checkout procedure" on page 176. b. Replace the system-board, as described in "Replacing the FRU system-board and chassis assembly" on page 264.
BA340002	There was a logical partition event communication failure reading the BladeCenter open fabric manager location code mapping data from the service processor.	<ol style="list-style-type: none"> 1. Reboot the blade server. 2. If the problem persists: <ol style="list-style-type: none"> a. Go to "Checkout procedure" on page 176. b. Replace the system-board, as described in "Replacing the FRU system-board and chassis assembly" on page 264.
BA340003	An internal firmware error occurred; unable to allocate memory for the open fabric manager location code mapping data.	<ol style="list-style-type: none"> 1. Reboot the blade server. 2. If the problem persists: <ol style="list-style-type: none"> a. Go to "Checkout procedure" on page 176. b. Replace the system-board, as described in "Replacing the FRU system-board and chassis assembly" on page 264.
BA340004	An internal firmware error occurred; the open fabric manager parameter data was corrupted.	<ol style="list-style-type: none"> 1. Reboot the blade server. 2. If the problem persists: <ol style="list-style-type: none"> a. Go to "Checkout procedure" on page 176. b. Replace the system-board, as described in "Replacing the FRU system-board and chassis assembly" on page 264.
BA340005	An internal firmware error occurred; the location code mapping table was corrupted.	<ol style="list-style-type: none"> 1. Reboot the blade server. 2. If the problem persists: <ol style="list-style-type: none"> a. Go to "Checkout procedure" on page 176. b. Replace the system-board, as described in "Replacing the FRU system-board and chassis assembly" on page 264.

Table 18. BA000010 to BA400002 Partition firmware SRCs (continued)

<ul style="list-style-type: none"> Follow the suggested actions in the order in which they are listed in the Action column until the problem is solved. If an action solves the problem, then you can stop performing the remaining actions. See Chapter 3, "Parts listing, type 7891," on page 225 to determine which components are CRUs and which components are FRUs. 		
Error code	Description	Action
BA340006	An LP event communication failure occurred reading the system initiator capability data from the service processor.	<ol style="list-style-type: none"> 1. Reboot the blade server. 2. If the problem persists: <ol style="list-style-type: none"> a. Go to "Checkout procedure" on page 176. b. Replace the system-board, as described in "Replacing the FRU system-board and chassis assembly" on page 264.
BA340007	An internal firmware error occurred; the open fabric manager system initiator capability data was corrupted.	<ol style="list-style-type: none"> 1. Reboot the blade server. 2. If the problem persists: <ol style="list-style-type: none"> a. Go to "Checkout procedure" on page 176. b. Replace the system-board, as described in "Replacing the FRU system-board and chassis assembly" on page 264.
BA340008	An internal firmware error occurred; the open fabric manager system initiator capability data version was not correct.	<ol style="list-style-type: none"> 1. Reboot the blade server. 2. If the problem persists: <ol style="list-style-type: none"> a. Go to "Checkout procedure" on page 176. b. Replace the system-board, as described in "Replacing the FRU system-board and chassis assembly" on page 264.
BA340009	An internal firmware error occurred; the open fabric manager system initiator capability processing encountered an unexpected error.	<ol style="list-style-type: none"> 1. Reboot the blade server. 2. If the problem persists: <ol style="list-style-type: none"> a. Go to "Checkout procedure" on page 176. b. Replace the system-board, as described in "Replacing the FRU system-board and chassis assembly" on page 264.
BA340010	An internal firmware error was detected during open fabric manager processing.	<ol style="list-style-type: none"> 1. Reboot the blade server. 2. If the problem persists: <ol style="list-style-type: none"> a. Go to "Checkout procedure" on page 176. b. Replace the system-board, as described in "Replacing the FRU system-board and chassis assembly" on page 264.
BA340011	Assignment of fabric ID to the I/O adapter failed.	<ol style="list-style-type: none"> 1. Reboot the blade server. 2. If the problem persists: <ol style="list-style-type: none"> a. Go to "Checkout procedure" on page 176. b. Replace the system-board, as described in "Replacing the FRU system-board and chassis assembly" on page 264.

Table 18. BA000010 to BA400002 Partition firmware SRCs (continued)

<ul style="list-style-type: none"> Follow the suggested actions in the order in which they are listed in the Action column until the problem is solved. If an action solves the problem, then you can stop performing the remaining actions. See Chapter 3, "Parts listing, type 7891," on page 225 to determine which components are CRUs and which components are FRUs. 		
Error code	Description	Action
BA340020	A logical partition event communication failure occurred when writing the BladeCenter open fabric manager parameter data to the service processor.	<ol style="list-style-type: none"> 1. Reboot the blade server. 2. If the problem persists: <ol style="list-style-type: none"> a. Go to "Checkout procedure" on page 176. b. Replace the system-board, as described in "Replacing the FRU system-board and chassis assembly" on page 264.
BA340021	A logical partition event communication failure occurred when writing the BladeCenter open fabric manager system initiator capabilities data to the service processor.	<ol style="list-style-type: none"> 1. Reboot the blade server. 2. If the problem persists: <ol style="list-style-type: none"> a. Go to "Checkout procedure" on page 176. b. Replace the system-board, as described in "Replacing the FRU system-board and chassis assembly" on page 264.
BA400001	Informational message: DMA trace buffer full.	<ol style="list-style-type: none"> 1. Reboot the blade server. 2. If the problem persists: <ol style="list-style-type: none"> a. Go to "Checkout procedure" on page 176. b. Replace the system-board, as described in "Replacing the FRU system-board and chassis assembly" on page 264.
BA400002	Informational message: DMA map-out size mismatch.	<ol style="list-style-type: none"> 1. Reboot the blade server. 2. If the problem persists: <ol style="list-style-type: none"> a. Go to "Checkout procedure" on page 176. b. Replace the system-board, as described in "Replacing the FRU system-board and chassis assembly" on page 264.

POST progress codes (checkpoints)

When you turn on the blade server, the power-on self-test (POST) performs a series of tests to check the operation of the blade server components. Use the management module to view progress codes that offer information about the stages involved in powering on and performing an initial program load (IPL).

Progress codes do not indicate an error, although in some cases, the blade server can pause indefinitely (hang). Progress codes for blade servers are 9-word, 8-digit hexadecimal numbers that start with C and D.

Checkpoints are generated by various components. The baseboard management controller (BMC) service processor and the partitioning firmware are key contributors. The service processor provides additional isolation procedure codes for troubleshooting.

A checkpoint might have an associated location code as part of the message. The location code provides information that identifies the failing component when there is a hang condition.

Notes:

1. For checkpoints with no associated location code, see “Light path diagnostics” on page 210 to identify the failing component when there is a hang condition.
2. For checkpoints with location codes, see “Location codes” on page 17 to identify the failing component when there is a hang condition.
3. For eight-digit codes not listed here, see “Checkout procedure” on page 176 for information.

The management module can display the most recent 32 SRCs and time stamps. Manually refresh the list to update it.

Select **Blade Service Data** → *blade_name* in the management module to see a list of the 32 most recent SRCs.

Table 19. Management module reference code listing

Unique ID	System Reference Code	Timestamp
00040001	D1513901	2005-11-13 19:30:20
00000016	D1513801	2005-11-13 19:30:16

Any message with more detail is highlighted as a link in the System Reference Code column. Click the message to cause the management module to present the additional message detail:

```
D1513901
Created at: 2007-11-13 19:30:20
SRC Version: 0x02
Hex Words 2-5: 020110F0 52298910 C1472000 200000FF
```

C1001F00 to C1645300 Service processor checkpoints

The C1xx progress codes, or checkpoints, offer information about the initialization of both the service processor and the server. Service processor checkpoints are typical reference codes that occur during the initial program load (IPL) of the server.

Table 20 lists the progress codes that might be displayed during the power-on self-test (POST), along with suggested actions to take if the system hangs on the progress code. Only when you experience a hang condition should you take any of the actions described for a progress code.

In the following progress codes, *x* can be any number or letter.

Table 20. C1001F00 to C1645300 checkpoints

Progress code	Description	Action
C10010xx	Pre-standby	<ol style="list-style-type: none"> 1. Go to "Checkout procedure" on page 176. 2. Replace the system-board, as described in "Replacing the FRU system-board and chassis assembly" on page 264.
C1001F00	Pre-standby: starting initial transition file	<ol style="list-style-type: none"> 1. Go to "Checkout procedure" on page 176. 2. Replace the system-board, as described in "Replacing the FRU system-board and chassis assembly" on page 264.
C1001F0D	<p>Pre-standby: discovery completed in initial transition file</p> <p>While the blade server displays this checkpoint, the service processor reads the system vital product data (VPD). The service processor must complete reading the system VPD before the system displays the next progress code.</p>	<ol style="list-style-type: none"> 1. Wait at least 15 minutes for this checkpoint to change before you decide that the system is hung. Reading the system VPD might take as long as 15 minutes on systems with maximum configurations or many disk drives. 2. Go to "Checkout procedure" on page 176. 3. Replace the system-board, as described in "Replacing the FRU system-board and chassis assembly" on page 264.
C1001F0F	Pre-standby: waiting for standby synchronization from initial transition file	<ol style="list-style-type: none"> 1. Go to "Checkout procedure" on page 176. 2. Replace the system-board, as described in "Replacing the FRU system-board and chassis assembly" on page 264.
C1001FFF	Pre-standby: completed initial transition file	<ol style="list-style-type: none"> 1. Go to "Checkout procedure" on page 176. 2. Replace the system-board, as described in "Replacing the FRU system-board and chassis assembly" on page 264.
C1009x01	Hardware object manager: (HOM): the cancontinue flag is being cleared	<ol style="list-style-type: none"> 1. Go to "Checkout procedure" on page 176. 2. Replace the system-board, as described in "Replacing the FRU system-board and chassis assembly" on page 264.

Table 20. C1001F00 to C1645300 checkpoints (continued)

<ul style="list-style-type: none"> • If the system hangs on a progress code, follow the suggested actions in the order in which they are listed in the Action column until the problem is solved. If an action solves the problem, you can stop performing the remaining actions. • See Chapter 3, “Parts listing, type 7891,” on page 225 to determine which components are CRUs and which components are FRUs. 		
Progress code	Description	Action
C1009x02	Hardware object manager: (HOM): erase HOM IPL step in progress	<ol style="list-style-type: none"> 1. Go to “Checkout procedure” on page 176. 2. Replace the system-board, as described in “Replacing the FRU system-board and chassis assembly” on page 264.
C1009x04	Hardware object manager: (HOM): build cards IPL step in progress	<ol style="list-style-type: none"> 1. Go to “Checkout procedure” on page 176. 2. Replace the system-board, as described in “Replacing the FRU system-board and chassis assembly” on page 264.
C1009x08	Hardware object manager: (HOM): build processors IPL step in progress	<ol style="list-style-type: none"> 1. Go to “Checkout procedure” on page 176. 2. Replace the system-board, as described in “Replacing the FRU system-board and chassis assembly” on page 264.
C1009x0C	Hardware object manager: (HOM): build chips IPL step in progress	<ol style="list-style-type: none"> 1. Go to “Checkout procedure” on page 176. 2. Replace the system-board, as described in “Replacing the FRU system-board and chassis assembly” on page 264.
C1009x10	Hardware object manager: (HOM): initialize HOM	<ol style="list-style-type: none"> 1. Go to “Checkout procedure” on page 176. 2. Replace the system-board, as described in “Replacing the FRU system-board and chassis assembly” on page 264.
C1009x14	Hardware object manager: (HOM): validate HOM	<ol style="list-style-type: none"> 1. Go to “Checkout procedure” on page 176. 2. Replace the system-board, as described in “Replacing the FRU system-board and chassis assembly” on page 264.
C1009x18	Hardware object manager: (HOM): GARD in progress	<ol style="list-style-type: none"> 1. Go to “Checkout procedure” on page 176. 2. Replace the system-board, as described in “Replacing the FRU system-board and chassis assembly” on page 264.
C1009x1C	Hardware object manager: (HOM): clock test in progress	<ol style="list-style-type: none"> 1. Go to “Checkout procedure” on page 176. 2. Replace the system-board, as described in “Replacing the FRU system-board and chassis assembly” on page 264.
C1009x20	Frequency control IPL step in progress	<ol style="list-style-type: none"> 1. Go to “Checkout procedure” on page 176. 2. Replace the system-board, as described in “Replacing the FRU system-board and chassis assembly” on page 264.
C1009x24	Asset protection IPL step in progress	<ol style="list-style-type: none"> 1. Go to “Checkout procedure” on page 176. 2. Replace the system-board, as described in “Replacing the FRU system-board and chassis assembly” on page 264.

Table 20. C1001F00 to C1645300 checkpoints (continued)

<ul style="list-style-type: none"> • If the system hangs on a progress code, follow the suggested actions in the order in which they are listed in the Action column until the problem is solved. If an action solves the problem, you can stop performing the remaining actions. • See Chapter 3, “Parts listing, type 7891,” on page 225 to determine which components are CRUs and which components are FRUs. 		
Progress code	Description	Action
C1009x28	Memory configuration IPL step in progress	<ol style="list-style-type: none"> 1. Go to “Checkout procedure” on page 176. 2. Replace the system-board, as described in “Replacing the FRU system-board and chassis assembly” on page 264.
C1009x2C	Processor CFAM initialization in progress	<ol style="list-style-type: none"> 1. Go to “Checkout procedure” on page 176. 2. Replace the system-board, as described in “Replacing the FRU system-board and chassis assembly” on page 264.
C1009x30	Processor self-synchronization in progress	<ol style="list-style-type: none"> 1. Go to “Checkout procedure” on page 176. 2. Replace the system-board, as described in “Replacing the FRU system-board and chassis assembly” on page 264.
C1009034	Processor mask attentions being initialized	<ol style="list-style-type: none"> 1. Go to “Checkout procedure” on page 176. 2. Replace the system-board, as described in “Replacing the FRU system-board and chassis assembly” on page 264.
C1009x38	Processor check ring IPL step in progress	<ol style="list-style-type: none"> 1. Go to “Checkout procedure” on page 176. 2. Replace the system-board, as described in “Replacing the FRU system-board and chassis assembly” on page 264.
C1009x39	Processor L2 line delete in progress	<ol style="list-style-type: none"> 1. Go to “Checkout procedure” on page 176. 2. Replace the system-board, as described in “Replacing the FRU system-board and chassis assembly” on page 264.
C1009x3A	Load processor gpnr IPL step in progress	<ol style="list-style-type: none"> 1. Go to “Checkout procedure” on page 176. 2. Replace the system-board, as described in “Replacing the FRU system-board and chassis assembly” on page 264.
C1009x3C	Processor ABIST step in progress	<ol style="list-style-type: none"> 1. Go to “Checkout procedure” on page 176. 2. Replace the system-board, as described in “Replacing the FRU system-board and chassis assembly” on page 264.
C1009x40	Processor LBIST step in progress	<ol style="list-style-type: none"> 1. Go to “Checkout procedure” on page 176. 2. Replace the system-board, as described in “Replacing the FRU system-board and chassis assembly” on page 264.
C1009x44	Processor array initialization step in progress	<ol style="list-style-type: none"> 1. Go to “Checkout procedure” on page 176. 2. Replace the system-board, as described in “Replacing the FRU system-board and chassis assembly” on page 264.

Table 20. C1001F00 to C1645300 checkpoints (continued)

<ul style="list-style-type: none"> • If the system hangs on a progress code, follow the suggested actions in the order in which they are listed in the Action column until the problem is solved. If an action solves the problem, you can stop performing the remaining actions. • See Chapter 3, “Parts listing, type 7891,” on page 225 to determine which components are CRUs and which components are FRUs. 		
Progress code	Description	Action
C1009x46	Processor AVP initialization step in progress	<ol style="list-style-type: none"> 1. Go to “Checkout procedure” on page 176. 2. Replace the system-board, as described in “Replacing the FRU system-board and chassis assembly” on page 264.
C1009x48	Processor flush IPL step in progress	<ol style="list-style-type: none"> 1. Go to “Checkout procedure” on page 176. 2. Replace the system-board, as described in “Replacing the FRU system-board and chassis assembly” on page 264.
C1009x4C	Processor wiretest IPL step in progress	<ol style="list-style-type: none"> 1. Go to “Checkout procedure” on page 176. 2. Replace the system-board, as described in “Replacing the FRU system-board and chassis assembly” on page 264.
C1009x50	Processor long scan IPL step in progress	<ol style="list-style-type: none"> 1. Go to “Checkout procedure” on page 176. 2. Replace the system-board, as described in “Replacing the FRU system-board and chassis assembly” on page 264.
C1009x54	Start processor clocks IPL step in progress	<ol style="list-style-type: none"> 1. Go to “Checkout procedure” on page 176. 2. Replace the system-board, as described in “Replacing the FRU system-board and chassis assembly” on page 264.
C1009x58	Processor SCOM initialization step in progress	<ol style="list-style-type: none"> 1. Go to “Checkout procedure” on page 176. 2. Replace the system-board, as described in “Replacing the FRU system-board and chassis assembly” on page 264.
C1009x5C	Processor interface alignment procedure in progress	<ol style="list-style-type: none"> 1. Go to “Checkout procedure” on page 176. 2. Replace the system-board, as described in “Replacing the FRU system-board and chassis assembly” on page 264.
C1009x5E	Processor AVP L2 test case in progress	<ol style="list-style-type: none"> 1. Go to “Checkout procedure” on page 176. 2. Replace the system-board, as described in “Replacing the FRU system-board and chassis assembly” on page 264.
C1009x60	Processor random data test in progress	<ol style="list-style-type: none"> 1. Go to “Checkout procedure” on page 176. 2. Replace the system-board, as described in “Replacing the FRU system-board and chassis assembly” on page 264.
C1009x64	Processor enable machine check test in progress	<ol style="list-style-type: none"> 1. Go to “Checkout procedure” on page 176. 2. Replace the system-board, as described in “Replacing the FRU system-board and chassis assembly” on page 264.

Table 20. C1001F00 to C1645300 checkpoints (continued)

<ul style="list-style-type: none"> • If the system hangs on a progress code, follow the suggested actions in the order in which they are listed in the Action column until the problem is solved. If an action solves the problem, you can stop performing the remaining actions. • See Chapter 3, “Parts listing, type 7891,” on page 225 to determine which components are CRUs and which components are FRUs. 		
Progress code	Description	Action
C1009x66	Concurrent initialization in progress	<ol style="list-style-type: none"> 1. Go to “Checkout procedure” on page 176. 2. Replace the system-board, as described in “Replacing the FRU system-board and chassis assembly” on page 264.
C1009x68	Processor fabric initialization step in progress	<ol style="list-style-type: none"> 1. Go to “Checkout procedure” on page 176. 2. Replace the system-board, as described in “Replacing the FRU system-board and chassis assembly” on page 264.
C1009x6C	Processor PSI initialization step in progress	<ol style="list-style-type: none"> 1. Go to “Checkout procedure” on page 176. 2. Replace the system-board, as described in “Replacing the FRU system-board and chassis assembly” on page 264.
C1009x70	ASIC CFAM initialization step in progress	<ol style="list-style-type: none"> 1. Go to “Checkout procedure” on page 176. 2. Replace the system-board, as described in “Replacing the FRU system-board and chassis assembly” on page 264.
C1009x74	ASIC mask attentions being set up	<ol style="list-style-type: none"> 1. Go to “Checkout procedure” on page 176. 2. Replace the system-board, as described in “Replacing the FRU system-board and chassis assembly” on page 264.
C1009x78	ASIC check rings being set up	<ol style="list-style-type: none"> 1. Go to “Checkout procedure” on page 176. 2. Replace the system-board, as described in “Replacing the FRU system-board and chassis assembly” on page 264.
C1009x7C	ASIC ABIST test being run	<ol style="list-style-type: none"> 1. Go to “Checkout procedure” on page 176. 2. Replace the system-board, as described in “Replacing the FRU system-board and chassis assembly” on page 264.
C1009x80	ASIC LBIST test being run	<ol style="list-style-type: none"> 1. Go to “Checkout procedure” on page 176. 2. Replace the system-board, as described in “Replacing the FRU system-board and chassis assembly” on page 264.
C1009x82	ASIC RGC being reset	<ol style="list-style-type: none"> 1. Go to “Checkout procedure” on page 176. 2. Replace the system-board, as described in “Replacing the FRU system-board and chassis assembly” on page 264.
C1009x84	ASIC being flushed	<ol style="list-style-type: none"> 1. Go to “Checkout procedure” on page 176. 2. Replace the system-board, as described in “Replacing the FRU system-board and chassis assembly” on page 264.

Table 20. C1001F00 to C1645300 checkpoints (continued)

<ul style="list-style-type: none"> • If the system hangs on a progress code, follow the suggested actions in the order in which they are listed in the Action column until the problem is solved. If an action solves the problem, you can stop performing the remaining actions. • See Chapter 3, “Parts listing, type 7891,” on page 225 to determine which components are CRUs and which components are FRUs. 		
Progress code	Description	Action
C1009x88	ASIC long scan initialization in progress	<ol style="list-style-type: none"> 1. Go to “Checkout procedure” on page 176. 2. Replace the system-board, as described in “Replacing the FRU system-board and chassis assembly” on page 264.
C1009x8C	ASIC start clocks in progress	<ol style="list-style-type: none"> 1. Go to “Checkout procedure” on page 176. 2. Replace the system-board, as described in “Replacing the FRU system-board and chassis assembly” on page 264.
C1009x90	Wire test in progress	<ol style="list-style-type: none"> 1. Go to “Checkout procedure” on page 176. 2. Replace the system-board, as described in “Replacing the FRU system-board and chassis assembly” on page 264.
C1009x92	ASIC restore erepair in progress	<ol style="list-style-type: none"> 1. Go to “Checkout procedure” on page 176. 2. Replace the system-board, as described in “Replacing the FRU system-board and chassis assembly” on page 264.
C1009x94	ASIC transmit/receive initialization step in progress	<ol style="list-style-type: none"> 1. Go to “Checkout procedure” on page 176. 2. Replace the system-board, as described in “Replacing the FRU system-board and chassis assembly” on page 264.
C1009x98	ASIC wrap test in progress	<ol style="list-style-type: none"> 1. Go to “Checkout procedure” on page 176. 2. Replace the system-board, as described in “Replacing the FRU system-board and chassis assembly” on page 264.
C1009x9C	ASIC SCOM initialization step in progress	<ol style="list-style-type: none"> 1. Go to “Checkout procedure” on page 176. 2. Replace the system-board, as described in “Replacing the FRU system-board and chassis assembly” on page 264.
C1009x9E	ASIC HSS set up in progress	<ol style="list-style-type: none"> 1. Go to “Checkout procedure” on page 176. 2. Replace the system-board, as described in “Replacing the FRU system-board and chassis assembly” on page 264.
C1009xA0	ASIC onyx BIST in progress	<ol style="list-style-type: none"> 1. Go to “Checkout procedure” on page 176. 2. Replace the system-board, as described in “Replacing the FRU system-board and chassis assembly” on page 264.
C1009xA4	ASIC interface alignment step in progress	<ol style="list-style-type: none"> 1. Go to “Checkout procedure” on page 176. 2. Replace the system-board, as described in “Replacing the FRU system-board and chassis assembly” on page 264.

Table 20. C1001F00 to C1645300 checkpoints (continued)

<ul style="list-style-type: none"> • If the system hangs on a progress code, follow the suggested actions in the order in which they are listed in the Action column until the problem is solved. If an action solves the problem, you can stop performing the remaining actions. • See Chapter 3, “Parts listing, type 7891,” on page 225 to determine which components are CRUs and which components are FRUs. 		
Progress code	Description	Action
C1009xA8	ASIC random data test in progress	<ol style="list-style-type: none"> 1. Go to “Checkout procedure” on page 176. 2. Replace the system-board, as described in “Replacing the FRU system-board and chassis assembly” on page 264.
C1009xAC	ASIC enable machine check step in progress	<ol style="list-style-type: none"> 1. Go to “Checkout procedure” on page 176. 2. Replace the system-board, as described in “Replacing the FRU system-board and chassis assembly” on page 264.
C1009xB0	ASIC I/O initialization step in progress	<ol style="list-style-type: none"> 1. Go to “Checkout procedure” on page 176. 2. Replace the system-board, as described in “Replacing the FRU system-board and chassis assembly” on page 264.
C1009xB4	ASIC DRAM initialization step in progress	<ol style="list-style-type: none"> 1. Go to “Checkout procedure” on page 176. 2. Replace the system-board, as described in “Replacing the FRU system-board and chassis assembly” on page 264.
C1009xB8	ASIC memory diagnostic step in progress	<ol style="list-style-type: none"> 1. Go to “Checkout procedure” on page 176. 2. Replace the system-board, as described in “Replacing the FRU system-board and chassis assembly” on page 264.
C1009xB9	PSI diagnostic step in progress	<ol style="list-style-type: none"> 1. Go to “Checkout procedure” on page 176. 2. Replace the system-board, as described in “Replacing the FRU system-board and chassis assembly” on page 264.
C1009xBB	Restore L3 line delete step in progress	<ol style="list-style-type: none"> 1. Go to “Checkout procedure” on page 176. 2. Replace the system-board, as described in “Replacing the FRU system-board and chassis assembly” on page 264.
C1009xBD	AVP memory test case in progress	<ol style="list-style-type: none"> 1. Go to “Checkout procedure” on page 176. 2. Replace the system-board, as described in “Replacing the FRU system-board and chassis assembly” on page 264.
C1009xC0	Node interface alignment procedure in progress	<ol style="list-style-type: none"> 1. Go to “Checkout procedure” on page 176. 2. Replace the system-board, as described in “Replacing the FRU system-board and chassis assembly” on page 264.
C1009xC4	Dump initialization step in progress	<ol style="list-style-type: none"> 1. Go to “Checkout procedure” on page 176. 2. Replace the system-board, as described in “Replacing the FRU system-board and chassis assembly” on page 264.

Table 20. C1001F00 to C1645300 checkpoints (continued)

<ul style="list-style-type: none"> • If the system hangs on a progress code, follow the suggested actions in the order in which they are listed in the Action column until the problem is solved. If an action solves the problem, you can stop performing the remaining actions. • See Chapter 3, “Parts listing, type 7891,” on page 225 to determine which components are CRUs and which components are FRUs. 		
Progress code	Description	Action
C1009xC8	Start PRD step in progress	<ol style="list-style-type: none"> 1. Go to “Checkout procedure” on page 176. 2. Replace the system-board, as described in “Replacing the FRU system-board and chassis assembly” on page 264.
C1009xCC	Message passing waiting period has begun	<ol style="list-style-type: none"> 1. Go to “Checkout procedure” on page 176. 2. Replace the system-board, as described in “Replacing the FRU system-board and chassis assembly” on page 264.
C1009xD0	Message passing waiting period has begun	<ol style="list-style-type: none"> 1. Go to “Checkout procedure” on page 176. 2. Replace the system-board, as described in “Replacing the FRU system-board and chassis assembly” on page 264.
C1009xD4	Starting elastic interface calibration	<ol style="list-style-type: none"> 1. Go to “Checkout procedure” on page 176. 2. Replace the system-board, as described in “Replacing the FRU system-board and chassis assembly” on page 264.
C103A1xx	Hypervisor code modules are being transferred to system storage	<ol style="list-style-type: none"> 1. Go to “Checkout procedure” on page 176. 2. Replace the system-board, as described in “Replacing the FRU system-board and chassis assembly” on page 264.
C103A2xx	Hypervisor data areas are being built in system storage	<ol style="list-style-type: none"> 1. Go to “Checkout procedure” on page 176. 2. Replace the system-board, as described in “Replacing the FRU system-board and chassis assembly” on page 264.
C103A3xx	Hypervisor data structures are being transferred to system storage	<ol style="list-style-type: none"> 1. Go to “Checkout procedure” on page 176. 2. Replace the system-board, as described in “Replacing the FRU system-board and chassis assembly” on page 264.
C103A400	Special purpose registers are loaded and instructions are started on the system processors	<ol style="list-style-type: none"> 1. Go to “Checkout procedure” on page 176. 2. Replace the system-board, as described in “Replacing the FRU system-board and chassis assembly” on page 264.
C103A401	Instructions have been started on the system processors	<ol style="list-style-type: none"> 1. Go to “Checkout procedure” on page 176. 2. Replace the system-board, as described in “Replacing the FRU system-board and chassis assembly” on page 264.
C116C2xx	System power interface is listening for power fault events from SPCN. The last byte (xx) will increment up from 00 to 1F every second while it waits.	<ol style="list-style-type: none"> 1. Go to “Checkout procedure” on page 176. 2. Replace the system-board, as described in “Replacing the FRU system-board and chassis assembly” on page 264.

Table 20. C1001F00 to C1645300 checkpoints (continued)

<ul style="list-style-type: none"> • If the system hangs on a progress code, follow the suggested actions in the order in which they are listed in the Action column until the problem is solved. If an action solves the problem, you can stop performing the remaining actions. • See Chapter 3, “Parts listing, type 7891,” on page 225 to determine which components are CRUs and which components are FRUs. 		
Progress code	Description	Action
C162E4xyy	VPD is being collected; yy indicates the type of device from which VPD is being collected	<ol style="list-style-type: none"> 1. Go to “Checkout procedure” on page 176. 2. Replace the system-board, as described in “Replacing the FRU system-board and chassis assembly” on page 264.
C1645300	Starting a data synchronization operation between the primary service processor and the secondary service processor.	<ol style="list-style-type: none"> 1. Go to “Checkout procedure” on page 176. 2. Replace the system-board, as described in “Replacing the FRU system-board and chassis assembly” on page 264.

C2001000 to C20082FF Virtual service processor checkpoints

The C2xx progress codes indicate the progress of a partition IPL that is controlled by the virtual service processor. The virtual service processor progress codes end after the environment setup completes and the specific operating system code continues the IPL.

The virtual service processor can start a variety of operating systems. Some codes are specific to an operating system and therefore, do not apply to all operating systems.

Table 21 lists the progress codes that might be displayed during the power-on self-test (POST), along with suggested actions to take if the system hangs on the progress code. Only when you experience a hang condition should you take any of the actions described for a progress code.

In the following progress codes, *x* can be any number or letter.

Table 21. C2001000 to C20082FF checkpoints

<ul style="list-style-type: none"> • If the system hangs on a progress code, follow the suggested actions in the order in which they are listed in the Action column until the problem is solved. If an action solves the problem, you can stop performing the remaining actions. • See Chapter 3, “Parts listing, type 7891,” on page 225 to determine which components are CRUs and which components are FRUs. 		
Progress code	Description	Action
C2001000	Partition auto-startup during a platform startup	<ol style="list-style-type: none"> 1. Go to “Recovering the system firmware” on page 217. 2. Replace the system-board, as described in “Replacing the FRU system-board and chassis assembly” on page 264.
C2001010	Startup source	<ol style="list-style-type: none"> 1. Go to “Recovering the system firmware” on page 217. 2. Replace the system-board, as described in “Replacing the FRU system-board and chassis assembly” on page 264.

Table 21. C2001000 to C20082FF checkpoints (continued)

Progress code	Description	Action
C2001100	Adding partition resources to the secondary configuration	<ol style="list-style-type: none"> 1. Go to "Recovering the system firmware" on page 217. 2. Replace the system-board, as described in "Replacing the FRU system-board and chassis assembly" on page 264.
C20011FF	Partition resources added successfully	<ol style="list-style-type: none"> 1. Go to "Recovering the system firmware" on page 217. 2. Replace the system-board, as described in "Replacing the FRU system-board and chassis assembly" on page 264.
C2001200	Checking if startup is allowed	<ol style="list-style-type: none"> 1. Go to "Recovering the system firmware" on page 217. 2. Replace the system-board, as described in "Replacing the FRU system-board and chassis assembly" on page 264.
C20012FF	Partition startup is allowed to proceed	<ol style="list-style-type: none"> 1. Go to "Recovering the system firmware" on page 217. 2. Replace the system-board, as described in "Replacing the FRU system-board and chassis assembly" on page 264.
C2001300	Initializing ISL roadmap	<ol style="list-style-type: none"> 1. Go to "Recovering the system firmware" on page 217. 2. Replace the system-board, as described in "Replacing the FRU system-board and chassis assembly" on page 264.
C20013FF	ISL roadmap initialized successfully	<ol style="list-style-type: none"> 1. Go to "Recovering the system firmware" on page 217. 2. Replace the system-board, as described in "Replacing the FRU system-board and chassis assembly" on page 264.
C2001400	Initializing SP Communication Area #1	<ol style="list-style-type: none"> 1. Go to "Recovering the system firmware" on page 217. 2. Replace the system-board, as described in "Replacing the FRU system-board and chassis assembly" on page 264.
C2001410	Initializing startup parameters	<ol style="list-style-type: none"> 1. Go to "Recovering the system firmware" on page 217. 2. Replace the system-board, as described in "Replacing the FRU system-board and chassis assembly" on page 264.

Table 21. C2001000 to C20082FF checkpoints (continued)

Progress code	Description	Action
C20014FF	Startup parameters initialized successfully	<ol style="list-style-type: none"> 1. Go to "Recovering the system firmware" on page 217. 2. Replace the system-board, as described in "Replacing the FRU system-board and chassis assembly" on page 264.
C2002100	Power on racks	<ol style="list-style-type: none"> 1. Go to "Recovering the system firmware" on page 217. 2. Replace the system-board, as described in "Replacing the FRU system-board and chassis assembly" on page 264.
C2002110	Issuing a power on command	<ol style="list-style-type: none"> 1. Go to "Recovering the system firmware" on page 217. 2. Replace the system-board, as described in "Replacing the FRU system-board and chassis assembly" on page 264.
C200211F	Power on command successful	<ol style="list-style-type: none"> 1. Go to "Recovering the system firmware" on page 217. 2. Replace the system-board, as described in "Replacing the FRU system-board and chassis assembly" on page 264.
C20021FF	Power on phase complete	<ol style="list-style-type: none"> 1. Go to "Recovering the system firmware" on page 217. 2. Replace the system-board, as described in "Replacing the FRU system-board and chassis assembly" on page 264.
C2002200	Begin acquiring slot locks	<ol style="list-style-type: none"> 1. Go to "Recovering the system firmware" on page 217. 2. Replace the system-board, as described in "Replacing the FRU system-board and chassis assembly" on page 264.
C20022FF	End acquiring slot locks	<ol style="list-style-type: none"> 1. Go to "Recovering the system firmware" on page 217. 2. Replace the system-board, as described in "Replacing the FRU system-board and chassis assembly" on page 264.
C2002300	Begin acquiring VIO slot locks	<ol style="list-style-type: none"> 1. Go to "Recovering the system firmware" on page 217. 2. Replace the system-board, as described in "Replacing the FRU system-board and chassis assembly" on page 264.

Table 21. C2001000 to C20082FF checkpoints (continued)

<ul style="list-style-type: none"> • If the system hangs on a progress code, follow the suggested actions in the order in which they are listed in the Action column until the problem is solved. If an action solves the problem, you can stop performing the remaining actions. • See Chapter 3, “Parts listing, type 7891,” on page 225 to determine which components are CRUs and which components are FRUs. 		
Progress code	Description	Action
C20023FF	End acquiring VIO slot locks	<ol style="list-style-type: none"> 1. Go to “Recovering the system firmware” on page 217. 2. Replace the system-board, as described in “Replacing the FRU system-board and chassis assembly” on page 264.
C2002400	Begin powering on slots	<ol style="list-style-type: none"> 1. Go to “Recovering the system firmware” on page 217. 2. Replace the system-board, as described in “Replacing the FRU system-board and chassis assembly” on page 264.
C2002450	Waiting for power on of slots to complete	<ol style="list-style-type: none"> 1. Go to “Recovering the system firmware” on page 217. 2. Replace the system-board, as described in “Replacing the FRU system-board and chassis assembly” on page 264.
C20024FF	End powering on slots	<ol style="list-style-type: none"> 1. Go to “Recovering the system firmware” on page 217. 2. Replace the system-board, as described in “Replacing the FRU system-board and chassis assembly” on page 264.
C2002500	Begin power on VIO slots	<ol style="list-style-type: none"> 1. Go to “Recovering the system firmware” on page 217. 2. Replace the system-board, as described in “Replacing the FRU system-board and chassis assembly” on page 264.
C20025FF	End powering on VIO slots	<ol style="list-style-type: none"> 1. Go to “Recovering the system firmware” on page 217. 2. Replace the system-board, as described in “Replacing the FRU system-board and chassis assembly” on page 264.
C2003100	Validating ISL command parameters	<ol style="list-style-type: none"> 1. Go to “Recovering the system firmware” on page 217. 2. Replace the system-board, as described in “Replacing the FRU system-board and chassis assembly” on page 264.
C2003111	Waiting for bus object to become operational	<ol style="list-style-type: none"> 1. Go to “Recovering the system firmware” on page 217. 2. Replace the system-board, as described in “Replacing the FRU system-board and chassis assembly” on page 264.

Table 21. C2001000 to C20082FF checkpoints (continued)

Progress code	Description	Action
		<ul style="list-style-type: none"> • If the system hangs on a progress code, follow the suggested actions in the order in which they are listed in the Action column until the problem is solved. If an action solves the problem, you can stop performing the remaining actions. • See Chapter 3, “Parts listing, type 7891,” on page 225 to determine which components are CRUs and which components are FRUs.
C2003112	Waiting for bus unit to become disabled	<ol style="list-style-type: none"> 1. Go to “Recovering the system firmware” on page 217. 2. Replace the system-board, as described in “Replacing the FRU system-board and chassis assembly” on page 264.
C2003115	Waiting for creation of bus object	<ol style="list-style-type: none"> 1. Go to “Recovering the system firmware” on page 217. 2. Replace the system-board, as described in “Replacing the FRU system-board and chassis assembly” on page 264.
C2003150	Sending ISL command to bus unit	<ol style="list-style-type: none"> 1. Go to “Recovering the system firmware” on page 217. 2. Replace the system-board, as described in “Replacing the FRU system-board and chassis assembly” on page 264.
C20031FF	Waiting for ISL command completion	<ol style="list-style-type: none"> 1. Go to “Recovering the system firmware” on page 217. 2. Replace the system-board, as described in “Replacing the FRU system-board and chassis assembly” on page 264.
C20032FF	ISL command complete successfully	<ol style="list-style-type: none"> 1. Go to “Recovering the system firmware” on page 217. 2. Replace the system-board, as described in “Replacing the FRU system-board and chassis assembly” on page 264.
C2003300	Start SoftPOR of a failed ISL slot	<ol style="list-style-type: none"> 1. Go to “Recovering the system firmware” on page 217. 2. Replace the system-board, as described in “Replacing the FRU system-board and chassis assembly” on page 264.
C2003350	Waiting for SoftPOR of a failed ISL slot	<ol style="list-style-type: none"> 1. Go to “Recovering the system firmware” on page 217. 2. Replace the system-board, as described in “Replacing the FRU system-board and chassis assembly” on page 264.
C20033FF	Finish SoftPOR of a failed ISL slot	<ol style="list-style-type: none"> 1. Go to “Recovering the system firmware” on page 217. 2. Replace the system-board, as described in “Replacing the FRU system-board and chassis assembly” on page 264.

Table 21. C2001000 to C20082FF checkpoints (continued)

<ul style="list-style-type: none"> • If the system hangs on a progress code, follow the suggested actions in the order in which they are listed in the Action column until the problem is solved. If an action solves the problem, you can stop performing the remaining actions. • See Chapter 3, “Parts listing, type 7891,” on page 225 to determine which components are CRUs and which components are FRUs. 		
Progress code	Description	Action
C2004100	Waiting for load source device to enlist	<ol style="list-style-type: none"> 1. Go to “Recovering the system firmware” on page 217. 2. Replace the system-board, as described in “Replacing the FRU system-board and chassis assembly” on page 264.
C2004200	Load source device has enlisted	<ol style="list-style-type: none"> 1. Go to “Recovering the system firmware” on page 217. 2. Replace the system-board, as described in “Replacing the FRU system-board and chassis assembly” on page 264.
C2004300	Preparing connection to load source device	<ol style="list-style-type: none"> 1. Go to “Recovering the system firmware” on page 217. 2. Replace the system-board, as described in “Replacing the FRU system-board and chassis assembly” on page 264.
C20043FF	Load source device is connected	<ol style="list-style-type: none"> 1. Go to “Recovering the system firmware” on page 217. 2. Replace the system-board, as described in “Replacing the FRU system-board and chassis assembly” on page 264.
C2006000	Locating first LID information on the load source	<ol style="list-style-type: none"> 1. Go to “Recovering the system firmware” on page 217. 2. Replace the system-board, as described in “Replacing the FRU system-board and chassis assembly” on page 264.
C2006005	Clearing all partition main store	<ol style="list-style-type: none"> 1. Go to “Recovering the system firmware” on page 217. 2. Replace the system-board, as described in “Replacing the FRU system-board and chassis assembly” on page 264.
C2006010	Locating next LID information on the load source	<ol style="list-style-type: none"> 1. Go to “Recovering the system firmware” on page 217. 2. Replace the system-board, as described in “Replacing the FRU system-board and chassis assembly” on page 264.
C2006020	Verifying LID information	<ol style="list-style-type: none"> 1. Go to “Recovering the system firmware” on page 217. 2. Replace the system-board, as described in “Replacing the FRU system-board and chassis assembly” on page 264.

Table 21. C2001000 to C20082FF checkpoints (continued)

<ul style="list-style-type: none"> • If the system hangs on a progress code, follow the suggested actions in the order in which they are listed in the Action column until the problem is solved. If an action solves the problem, you can stop performing the remaining actions. • See Chapter 3, “Parts listing, type 7891,” on page 225 to determine which components are CRUs and which components are FRUs. 		
Progress code	Description	Action
C2006030	Priming LP configuration LID	<ol style="list-style-type: none"> 1. Go to “Recovering the system firmware” on page 217. 2. Replace the system-board, as described in “Replacing the FRU system-board and chassis assembly” on page 264.
C2006040	Preparing to initiate LID load from load source	<ol style="list-style-type: none"> 1. Go to “Recovering the system firmware” on page 217. 2. Replace the system-board, as described in “Replacing the FRU system-board and chassis assembly” on page 264.
C2006050	LP configuration LID primed successfully	<ol style="list-style-type: none"> 1. Go to “Recovering the system firmware” on page 217. 2. Replace the system-board, as described in “Replacing the FRU system-board and chassis assembly” on page 264.
C2006060	Waiting for LID load to complete	<ol style="list-style-type: none"> 1. Go to “Recovering the system firmware” on page 217. 2. Replace the system-board, as described in “Replacing the FRU system-board and chassis assembly” on page 264.
C2006100	LID load completed successfully	<ol style="list-style-type: none"> 1. Go to “Recovering the system firmware” on page 217. 2. Replace the system-board, as described in “Replacing the FRU system-board and chassis assembly” on page 264.
C2006200	Loading raw kernel memory image	<ol style="list-style-type: none"> 1. Go to “Recovering the system firmware” on page 217. 2. Replace the system-board, as described in “Replacing the FRU system-board and chassis assembly” on page 264.
C20062FF	Loading raw kernel memory image completed successfully	<ol style="list-style-type: none"> 1. Go to “Recovering the system firmware” on page 217. 2. Replace the system-board, as described in “Replacing the FRU system-board and chassis assembly” on page 264.
C2008040	Begin transfer slot locks to partition	<ol style="list-style-type: none"> 1. Go to “Recovering the system firmware” on page 217. 2. Replace the system-board, as described in “Replacing the FRU system-board and chassis assembly” on page 264.

Table 21. C2001000 to C20082FF checkpoints (continued)

Progress code	Description	Action
C2008060	End transfer slot locks to partition	<ol style="list-style-type: none"> 1. Go to "Recovering the system firmware" on page 217. 2. Replace the system-board, as described in "Replacing the FRU system-board and chassis assembly" on page 264.
C2008080	Begin transfer VIO slot locks to partition	<ol style="list-style-type: none"> 1. Go to "Recovering the system firmware" on page 217. 2. Replace the system-board, as described in "Replacing the FRU system-board and chassis assembly" on page 264.
C20080A0	End transfer VIO slot locks to partition	<ol style="list-style-type: none"> 1. Go to "Recovering the system firmware" on page 217. 2. Replace the system-board, as described in "Replacing the FRU system-board and chassis assembly" on page 264.
C20080FF	Hypervisor low-level session manager object is ready	<ol style="list-style-type: none"> 1. Go to "Recovering the system firmware" on page 217. 2. Replace the system-board, as described in "Replacing the FRU system-board and chassis assembly" on page 264.
C2008100	Initializing service processor communication area #2	<ol style="list-style-type: none"> 1. Go to "Recovering the system firmware" on page 217. 2. Replace the system-board, as described in "Replacing the FRU system-board and chassis assembly" on page 264.
C2008104	Loading data structures into main store	<ol style="list-style-type: none"> 1. Go to "Recovering the system firmware" on page 217. 2. Replace the system-board, as described in "Replacing the FRU system-board and chassis assembly" on page 264.
C2008110	Initializing event paths	<ol style="list-style-type: none"> 1. Go to "Recovering the system firmware" on page 217. 2. Replace the system-board, as described in "Replacing the FRU system-board and chassis assembly" on page 264.
C2008120	Starting processor(s)	<ol style="list-style-type: none"> 1. Go to "Recovering the system firmware" on page 217. 2. Replace the system-board, as described in "Replacing the FRU system-board and chassis assembly" on page 264.

- If the system hangs on a progress code, follow the suggested actions in the order in which they are listed in the Action column until the problem is solved. If an action solves the problem, you can stop performing the remaining actions.
- See Chapter 3, "Parts listing, type 7891," on page 225 to determine which components are CRUs and which components are FRUs.

Table 21. C2001000 to C20082FF checkpoints (continued)

Progress code	Description	Action
C2008130	Begin associate of system ports	<ol style="list-style-type: none"> 1. Go to "Recovering the system firmware" on page 217. 2. Replace the system-board, as described in "Replacing the FRU system-board and chassis assembly" on page 264.
C2008138	Associating system ports to the partition	<ol style="list-style-type: none"> 1. Go to "Recovering the system firmware" on page 217. 2. Replace the system-board, as described in "Replacing the FRU system-board and chassis assembly" on page 264.
C200813F	End associate of system ports	<ol style="list-style-type: none"> 1. Go to "Recovering the system firmware" on page 217. 2. Replace the system-board, as described in "Replacing the FRU system-board and chassis assembly" on page 264.
C20081FF	Processors started successfully, now waiting to receive the continue acknowledgement from system firmware	<ol style="list-style-type: none"> 1. Go to "Recovering the system firmware" on page 217. 2. Replace the system-board, as described in "Replacing the FRU system-board and chassis assembly" on page 264.
C2008200	Continue acknowledgement received from system firmware	<ol style="list-style-type: none"> 1. Go to "Recovering the system firmware" on page 217. 2. Replace the system-board, as described in "Replacing the FRU system-board and chassis assembly" on page 264.
C20082FF	VSP startup complete successfully	<ol style="list-style-type: none"> 1. Go to "Recovering the system firmware" on page 217. 2. Replace the system-board, as described in "Replacing the FRU system-board and chassis assembly" on page 264.

IPL status progress codes

A server that stalls during an initial program load (IPL) of the operating system indicates a problem with the operating system code or hardware configuration.

The Systems Hardware Information center at <http://publib.boulder.ibm.com/infocenter/systems/scope/hw/index.jsp> describes IPL status progress codes C3yx, C500, C5yx, C600, and C6xx.

C700xxxx Server firmware IPL status checkpoints:

A server that stalls during an initial program load (IPL) of the server firmware indicates a problem with the server firmware code. If the C700 progress that you see is not C700 4091, your only service action is to collect information on words 3 and 4 of the SRC, and to call your next level of support.

Table 22 shows the form of the C700xxxx progress codes, where xxxx can be any number or letter.

- If the system hangs on a progress code, follow the suggested actions in the order in which they are listed in the Action column until the problem is solved. If an action solves the problem, you can stop performing the remaining actions.
- See Chapter 3, “Parts listing, type 7891,” on page 225 to determine which components are CRUs and which components are FRUs.

Table 22. C700xxxx Server firmware IPL status checkpoints

Progress code	Description	Action
C700xxxx	A problem has occurred with the system firmware during startup.	<ol style="list-style-type: none">1. Shutdown and restart the blade server from the permanent-side image.2. Check for updates to the system firmware.3. Update the firmware.4. Go to “Checkout procedure” on page 176.5. Replace the system-board, as described in “Replacing the FRU system-board and chassis assembly” on page 264. assembly.

CA000000 to CA2799FF Partition firmware checkpoints

The CAxx partition firmware progress codes provide information about the progress of partition firmware as it is initializing. In some cases, a server might hang (or stall) at one of these progress codes without displaying an 8-character system reference code (SRC).

Table 23 lists the progress codes that might be displayed during the power-on self-test (POST), along with suggested actions to take if the system hangs on the progress code. Only when you experience a hang condition should you take any of the actions described for a progress code.

In the following progress codes, *x* can be any number or letter.

Table 23. CA000000 to CA2799FF checkpoints

Progress code	Description	Action
CA000000	Process control now owned by partition firmware	<ol style="list-style-type: none"> 1. Go to "Checkout procedure" on page 176. 2. Replace the system-board, as described in "Replacing the FRU system-board and chassis assembly" on page 264.
CA000020	Checking firmware levels	<ol style="list-style-type: none"> 1. Go to "Checkout procedure" on page 176. 2. Replace the system-board, as described in "Replacing the FRU system-board and chassis assembly" on page 264.
CA000030	Attempting to establish a communication link by using lpevents	<ol style="list-style-type: none"> 1. Go to "Checkout procedure" on page 176. 2. Replace the system-board, as described in "Replacing the FRU system-board and chassis assembly" on page 264.
CA000032	Attempting to register lpevent queues	<ol style="list-style-type: none"> 1. Go to "Checkout procedure" on page 176. 2. Replace the system-board, as described in "Replacing the FRU system-board and chassis assembly" on page 264.
CA000034	Attempting to exchange cap and allocate lpevents	<ol style="list-style-type: none"> 1. Go to "Checkout procedure" on page 176. 2. Replace the system-board, as described in "Replacing the FRU system-board and chassis assembly" on page 264.
CA000038	Attempting to exchange virtual continue events	<ol style="list-style-type: none"> 1. Go to "Checkout procedure" on page 176. 2. Replace the system-board, as described in "Replacing the FRU system-board and chassis assembly" on page 264.
CA000040	Attempting to obtain RTAS firmware details	<ol style="list-style-type: none"> 1. Go to "Checkout procedure" on page 176. 2. Replace the system-board, as described in "Replacing the FRU system-board and chassis assembly" on page 264.
CA000050	Attempting to load RTAS firmware	<ol style="list-style-type: none"> 1. Go to "Checkout procedure" on page 176. 2. Replace the system-board, as described in "Replacing the FRU system-board and chassis assembly" on page 264.
CA000060	Attempting to obtain open firmware details	<ol style="list-style-type: none"> 1. Go to "Checkout procedure" on page 176. 2. Replace the system-board, as described in "Replacing the FRU system-board and chassis assembly" on page 264.

Table 23. CA000000 to CA2799FF checkpoints (continued)

<ul style="list-style-type: none"> • If the system hangs on a progress code, follow the suggested actions in the order in which they are listed in the Action column until the problem is solved. If an action solves the problem, you can stop performing the remaining actions. • See Chapter 3, “Parts listing, type 7891,” on page 225 to determine which components are CRUs and which components are FRUs. 		
Progress code	Description	Action
CA000070	Attempting to load open firmware	<ol style="list-style-type: none"> 1. Go to “Checkout procedure” on page 176. 2. Replace the system-board, as described in “Replacing the FRU system-board and chassis assembly” on page 264.
CA000080	Preparing to start open firmware	<ol style="list-style-type: none"> 1. Go to “Checkout procedure” on page 176. 2. Replace the system-board, as described in “Replacing the FRU system-board and chassis assembly” on page 264.
CA000090	Open firmware package corrupted (phase 1)	<ol style="list-style-type: none"> 1. Reboot the blade server. 2. If the problem persists: <ol style="list-style-type: none"> a. Go to “Checkout procedure” on page 176. b. Replace the system-board, as described in “Replacing the FRU system-board and chassis assembly” on page 264.
CA000091	Attempting to load the second pass of C code	<ol style="list-style-type: none"> 1. Go to “Checkout procedure” on page 176. 2. Replace the system-board, as described in “Replacing the FRU system-board and chassis assembly” on page 264.
CA0000A0	Open firmware package corrupted (phase 2)	<ol style="list-style-type: none"> 1. Go to “Checkout procedure” on page 176. 2. Replace the system-board, as described in “Replacing the FRU system-board and chassis assembly” on page 264.
CA00D001	PCI probe process completed, create PCI bridge interrupt routing properties	<ol style="list-style-type: none"> 1. Go to “Checkout procedure” on page 176. 2. Replace the system-board, as described in “Replacing the FRU system-board and chassis assembly” on page 264.
CA00D002	PCI adapter NVRAM hint created; system is rebooting	<ol style="list-style-type: none"> 1. Go to “Checkout procedure” on page 176. 2. Replace the system-board, as described in “Replacing the FRU system-board and chassis assembly” on page 264.
CA00D003	PCI probing complete	<ol style="list-style-type: none"> 1. Go to “Checkout procedure” on page 176. 2. Replace the system-board, as described in “Replacing the FRU system-board and chassis assembly” on page 264.
CA00D004	Beginning of install-console, loading GUI package	<ol style="list-style-type: none"> 1. Go to “Checkout procedure” on page 176. 2. Replace the system-board, as described in “Replacing the FRU system-board and chassis assembly” on page 264.

Table 23. CA000000 to CA2799FF checkpoints (continued)

<ul style="list-style-type: none"> • If the system hangs on a progress code, follow the suggested actions in the order in which they are listed in the Action column until the problem is solved. If an action solves the problem, you can stop performing the remaining actions. • See Chapter 3, “Parts listing, type 7891,” on page 225 to determine which components are CRUs and which components are FRUs. 		
Progress code	Description	Action
CA00D008	Initialize console and flush queues	<ol style="list-style-type: none"> 1. Go to “Checkout procedure” on page 176. 2. Replace the system-board, as described in “Replacing the FRU system-board and chassis assembly” on page 264.
CA00D00C	The partition firmware is about to search for an NVRAM script	<ol style="list-style-type: none"> 1. Go to “Checkout procedure” on page 176. 2. Replace the system-board, as described in “Replacing the FRU system-board and chassis assembly” on page 264.
CA00D00D	Evaluating NVRAM script	<ol style="list-style-type: none"> 1. Go to “Checkout procedure” on page 176. 2. Replace the system-board, as described in “Replacing the FRU system-board and chassis assembly” on page 264.
CA00D010	First pass open firmware initialization complete; establish parameters for restart	<ol style="list-style-type: none"> 1. Go to “Checkout procedure” on page 176. 2. Replace the system-board, as described in “Replacing the FRU system-board and chassis assembly” on page 264.
CA00D011	First pass open firmware initialization complete; control returned to initialization firmware	<ol style="list-style-type: none"> 1. Go to “Checkout procedure” on page 176. 2. Replace the system-board, as described in “Replacing the FRU system-board and chassis assembly” on page 264.
CA00D012	Second pass open firmware initialization complete; control returned to initialization firmware	<ol style="list-style-type: none"> 1. Go to “Checkout procedure” on page 176. 2. Replace the system-board, as described in “Replacing the FRU system-board and chassis assembly” on page 264.
CA00D013	Runtime open firmware initialization complete; control returned to initialization firmware	<ol style="list-style-type: none"> 1. Go to “Checkout procedure” on page 176. 2. Replace the system-board, as described in “Replacing the FRU system-board and chassis assembly” on page 264.
CA00D020	About to download the run the SLIC loader (IOP-less boot)	<ol style="list-style-type: none"> 1. Go to “Checkout procedure” on page 176. 2. Replace the system-board, as described in “Replacing the FRU system-board and chassis assembly” on page 264.
CA00D021	About to download the run the IO Reporter (for VPD collection)	<ol style="list-style-type: none"> 1. Go to “Checkout procedure” on page 176. 2. Replace the system-board, as described in “Replacing the FRU system-board and chassis assembly” on page 264.
CA00E101	Create RTAS node	<ol style="list-style-type: none"> 1. Go to “Checkout procedure” on page 176. 2. Replace the system-board, as described in “Replacing the FRU system-board and chassis assembly” on page 264.

Table 23. CA000000 to CA2799FF checkpoints (continued)

<ul style="list-style-type: none"> • If the system hangs on a progress code, follow the suggested actions in the order in which they are listed in the Action column until the problem is solved. If an action solves the problem, you can stop performing the remaining actions. • See Chapter 3, “Parts listing, type 7891,” on page 225 to determine which components are CRUs and which components are FRUs. 		
Progress code	Description	Action
CA00E102	Load and initialize RTAS	<ol style="list-style-type: none"> 1. Go to “Checkout procedure” on page 176. 2. Replace the system-board, as described in “Replacing the FRU system-board and chassis assembly” on page 264.
CA00E105	Transfer control to operating system (normal mode boot)	Go to “Boot problem resolution” on page 182.
CA00E10A	Load RTAS device tree	<ol style="list-style-type: none"> 1. Go to “Checkout procedure” on page 176. 2. Replace the system-board, as described in “Replacing the FRU system-board and chassis assembly” on page 264.
CA00E10B	Set RTAS device properties	<ol style="list-style-type: none"> 1. Go to “Checkout procedure” on page 176. 2. Replace the system-board, as described in “Replacing the FRU system-board and chassis assembly” on page 264.
CA00E110	Create KDUMP properties	<ol style="list-style-type: none"> 1. Reboot the blade server. 2. If the problem persists: <ol style="list-style-type: none"> a. Go to “Checkout procedure” on page 176. b. Replace the system-board, as described in “Replacing the FRU system-board and chassis assembly” on page 264.
CA00E130	Build device tree	<ol style="list-style-type: none"> 1. Go to “Checkout procedure” on page 176. 2. Replace the system-board, as described in “Replacing the FRU system-board and chassis assembly” on page 264.
CA00E131	Create root node properties	<ol style="list-style-type: none"> 1. Reboot the blade server. 2. If the problem persists: <ol style="list-style-type: none"> a. Go to “Checkout procedure” on page 176. b. Replace the system-board, as described in “Replacing the FRU system-board and chassis assembly” on page 264.
CA00E134	Create memory node	<ol style="list-style-type: none"> 1. Go to “Checkout procedure” on page 176. 2. Replace the system-board, as described in “Replacing the FRU system-board and chassis assembly” on page 264.
CA00E135	Create HCA node	<ol style="list-style-type: none"> 1. Go to “Checkout procedure” on page 176. 2. Replace the system-board, as described in “Replacing the FRU system-board and chassis assembly” on page 264.

Table 23. CA000000 to CA2799FF checkpoints (continued)

Progress code	Description	Action
<ul style="list-style-type: none"> • If the system hangs on a progress code, follow the suggested actions in the order in which they are listed in the Action column until the problem is solved. If an action solves the problem, you can stop performing the remaining actions. • See Chapter 3, “Parts listing, type 7891,” on page 225 to determine which components are CRUs and which components are FRUs. 		
CA00E136	Create BSR node	<ol style="list-style-type: none"> 1. Go to “Checkout procedure” on page 176. 2. Replace the system-board, as described in “Replacing the FRU system-board and chassis assembly” on page 264.
CA00E137	Create integrated Ethernet port node	<ol style="list-style-type: none"> 1. Reboot the blade server. 2. If the problem persists: <ol style="list-style-type: none"> a. Go to “Checkout procedure” on page 176. b. Replace the system-board, as described in “Replacing the FRU system-board and chassis assembly” on page 264.
CA00E138	Create options node	<ol style="list-style-type: none"> 1. Go to “Checkout procedure” on page 176. 2. Replace the system-board, as described in “Replacing the FRU system-board and chassis assembly” on page 264.
CA00E139	Create aliases node and system aliases	<ol style="list-style-type: none"> 1. Go to “Checkout procedure” on page 176. 2. Replace the system-board, as described in “Replacing the FRU system-board and chassis assembly” on page 264.
CA00E13A	Create packages node	<ol style="list-style-type: none"> 1. Go to “Checkout procedure” on page 176. 2. Replace the system-board, as described in “Replacing the FRU system-board and chassis assembly” on page 264.
CA00E13B	Create integrated Ethernet port node	<ol style="list-style-type: none"> 1. Reboot the blade server. 2. If the problem persists: <ol style="list-style-type: none"> a. Go to “Checkout procedure” on page 176. b. Replace the system-board, as described in “Replacing the FRU system-board and chassis assembly” on page 264.
CA00E13C	Create integrated Ethernet port node	<ol style="list-style-type: none"> 1. Reboot the blade server. 2. If the problem persists: <ol style="list-style-type: none"> a. Go to “Checkout procedure” on page 176. b. Replace the system-board, as described in “Replacing the FRU system-board and chassis assembly” on page 264.
CA00E140	Loading operating system	Go to “Boot problem resolution” on page 182.

Table 23. CA000000 to CA2799FF checkpoints (continued)

<ul style="list-style-type: none"> • If the system hangs on a progress code, follow the suggested actions in the order in which they are listed in the Action column until the problem is solved. If an action solves the problem, you can stop performing the remaining actions. • See Chapter 3, “Parts listing, type 7891,” on page 225 to determine which components are CRUs and which components are FRUs. 		
Progress code	Description	Action
CA00E141	Synchronizing the operating system bootlist to the management module bootlist	<ol style="list-style-type: none"> 1. Reboot the blade server. 2. If the problem persists: <ol style="list-style-type: none"> a. Go to “Checkout procedure” on page 176. b. Replace the system-board, as described in “Replacing the FRU system-board and chassis assembly” on page 264.
CA00E142	The management module bootlist is being set from the operating system bootlist	<ol style="list-style-type: none"> 1. Reboot the blade server. 2. If the problem persists: <ol style="list-style-type: none"> a. Go to “Checkout procedure” on page 176. b. Replace the system-board, as described in “Replacing the FRU system-board and chassis assembly” on page 264.
CA00E143	The operating system bootlist is being set from the management module bootlist	<ol style="list-style-type: none"> 1. Reboot the blade server. 2. If the problem persists: <ol style="list-style-type: none"> a. Go to “Checkout procedure” on page 176. b. Replace the system-board, as described in “Replacing the FRU system-board and chassis assembly” on page 264.
CA00E149	Create boot manager node	<ol style="list-style-type: none"> 1. Go to “Checkout procedure” on page 176. 2. Replace the system-board, as described in “Replacing the FRU system-board and chassis assembly” on page 264.
CA00E14C	Create terminal emulator node	<ol style="list-style-type: none"> 1. Go to “Checkout procedure” on page 176. 2. Replace the system-board, as described in “Replacing the FRU system-board and chassis assembly” on page 264.
CA00E14D	Load boot image	Go to “Boot problem resolution” on page 182.
CA00E150	Create host (primary) node	<ol style="list-style-type: none"> 1. Go to “Checkout procedure” on page 176. 2. Replace the system-board, as described in “Replacing the FRU system-board and chassis assembly” on page 264.
CA00E151	Probing PCI bus	<ol style="list-style-type: none"> 1. Go to “Checkout procedure” on page 176. 2. Replace the system-board, as described in “Replacing the FRU system-board and chassis assembly” on page 264.
CA00E152	Probing for adapter FCODE; evaluate if present	<ol style="list-style-type: none"> 1. Go to “Checkout procedure” on page 176. 2. Replace the system-board, as described in “Replacing the FRU system-board and chassis assembly” on page 264.

Table 23. CA000000 to CA2799FF checkpoints (continued)

Progress code	Description	Action
CA00E153	End adapter FCODE probing and evaluation	<ol style="list-style-type: none"> 1. Go to "Checkout procedure" on page 176. 2. Replace the system-board, as described in "Replacing the FRU system-board and chassis assembly" on page 264.
CA00E154	Create PCI bridge node	<ol style="list-style-type: none"> 1. Go to "Checkout procedure" on page 176. 2. Replace the system-board, as described in "Replacing the FRU system-board and chassis assembly" on page 264.
CA00E155	Probing PCI bridge secondary bus	<ol style="list-style-type: none"> 1. Go to "Checkout procedure" on page 176. 2. Replace the system-board, as described in "Replacing the FRU system-board and chassis assembly" on page 264.
CA00E156	Create plug-in PCI bridge node	<ol style="list-style-type: none"> 1. Go to "Checkout procedure" on page 176. 2. Replace the system-board, as described in "Replacing the FRU system-board and chassis assembly" on page 264.
CA00E15B	Transfer control to operating system (service mode boot)	Go to "Boot problem resolution" on page 182.
CA00E15F	Adapter VPD evaluation	<ol style="list-style-type: none"> 1. Go to "Checkout procedure" on page 176. 2. Replace the system-board, as described in "Replacing the FRU system-board and chassis assembly" on page 264.
CA00E170	Start of PCI bus probe	<ol style="list-style-type: none"> 1. Go to "Checkout procedure" on page 176. 2. Replace the system-board, as described in "Replacing the FRU system-board and chassis assembly" on page 264.
CA00E172	First pass of PCI device probe	<ol style="list-style-type: none"> 1. Go to "Checkout procedure" on page 176. 2. Replace the system-board, as described in "Replacing the FRU system-board and chassis assembly" on page 264.
CA00E174	Establishing host connection	<ol style="list-style-type: none"> 1. Verify that: <ul style="list-style-type: none"> • The bootp server is correctly configured; then, retry the operation. • The network connections are correct; then, retry the operation. 2. If the problem persists: <ol style="list-style-type: none"> a. Go to "Checkout procedure" on page 176. b. Replace the system-board, as described in "Replacing the FRU system-board and chassis assembly" on page 264.

Table 23. CA000000 to CA2799FF checkpoints (continued)

<ul style="list-style-type: none"> • If the system hangs on a progress code, follow the suggested actions in the order in which they are listed in the Action column until the problem is solved. If an action solves the problem, you can stop performing the remaining actions. • See Chapter 3, “Parts listing, type 7891,” on page 225 to determine which components are CRUs and which components are FRUs. 		
Progress code	Description	Action
CA00E175	Bootp request	<ol style="list-style-type: none"> 1. Verify that: <ul style="list-style-type: none"> • The bootp server is correctly configured; then, retry the operation. • The network connections are correct; then, retry the operation. 2. If the problem persists: <ol style="list-style-type: none"> a. Go to “Checkout procedure” on page 176. b. Replace the system-board, as described in “Replacing the FRU system-board and chassis assembly” on page 264.
CA00E176	TFTP file transfer	<ol style="list-style-type: none"> 1. Verify that: <ul style="list-style-type: none"> • The bootp server is correctly configured; then, retry the operation. • The network connections are correct; then, retry the operation. 2. If the problem persists: <ol style="list-style-type: none"> a. Go to “Checkout procedure” on page 176. b. Replace the system-board, as described in “Replacing the FRU system-board and chassis assembly” on page 264.
CA00E177	Transfer failure due to TFTP error condition	<ol style="list-style-type: none"> 1. Verify that: <ul style="list-style-type: none"> • The bootp server is correctly configured; then, retry the operation. • The network connections are correct; then, retry the operation. 2. If the problem persists: <ol style="list-style-type: none"> a. Go to “Checkout procedure” on page 176. b. Replace the system-board, as described in “Replacing the FRU system-board and chassis assembly” on page 264.
CA00E178	Initiating TFTP file transfer	<ol style="list-style-type: none"> 1. Verify that: <ul style="list-style-type: none"> • The bootp server is correctly configured; then, retry the operation. • The network connections are correct; then, retry the operation. 2. If the problem persists: <ol style="list-style-type: none"> a. Go to “Checkout procedure” on page 176. b. Replace the system-board, as described in “Replacing the FRU system-board and chassis assembly” on page 264.

Table 23. CA000000 to CA2799FF checkpoints (continued)

<ul style="list-style-type: none"> • If the system hangs on a progress code, follow the suggested actions in the order in which they are listed in the Action column until the problem is solved. If an action solves the problem, you can stop performing the remaining actions. • See Chapter 3, “Parts listing, type 7891,” on page 225 to determine which components are CRUs and which components are FRUs. 		
Progress code	Description	Action
CA00E179	Closing BOOTP	<ol style="list-style-type: none"> 1. Verify that: <ul style="list-style-type: none"> • The bootp server is correctly configured; then, retry the operation. • The network connections are correct; then, retry the operation. 2. If the problem persists: <ol style="list-style-type: none"> a. Go to “Checkout procedure” on page 176. b. Replace the system-board, as described in “Replacing the FRU system-board and chassis assembly” on page 264.
CA00E17B	Microprocessor clock speed measurement	<ol style="list-style-type: none"> 1. Go to “Checkout procedure” on page 176. 2. Replace the system-board, as described in “Replacing the FRU system-board and chassis assembly” on page 264.
CA00E198	The system is rebooting to enact changes that were specified in ibm,client-architecture-support	Go to “Boot problem resolution” on page 182.
CA00E199	The system is rebooting to enact changes that were specified in the boot image ELF header	<ol style="list-style-type: none"> 1. Verify that: <ul style="list-style-type: none"> • The bootp server is correctly configured; then, retry the operation. • The network connections are correct; then, retry the operation. 2. If the problem persists: <ol style="list-style-type: none"> a. Go to “Checkout procedure” on page 176. b. Replace the system-board, as described in “Replacing the FRU system-board and chassis assembly” on page 264.
CA00E19A	NVRAM auto-boot? variable not found - assume FALSE	<ol style="list-style-type: none"> 1. Go to “Checkout procedure” on page 176. 2. Replace the system-board, as described in “Replacing the FRU system-board and chassis assembly” on page 264.
CA00E19B	NVRAM menu? variable not found - assume FALSE	<ol style="list-style-type: none"> 1. Go to “Checkout procedure” on page 176. 2. Replace the system-board, as described in “Replacing the FRU system-board and chassis assembly” on page 264.
CA00E19D	Create NVRAM node	<ol style="list-style-type: none"> 1. Go to “Checkout procedure” on page 176. 2. Replace the system-board, as described in “Replacing the FRU system-board and chassis assembly” on page 264.

Table 23. CA000000 to CA2799FF checkpoints (continued)

<ul style="list-style-type: none"> • If the system hangs on a progress code, follow the suggested actions in the order in which they are listed in the Action column until the problem is solved. If an action solves the problem, you can stop performing the remaining actions. • See Chapter 3, “Parts listing, type 7891,” on page 225 to determine which components are CRUs and which components are FRUs. 		
Progress code	Description	Action
CA00E1A0	User requested boot to SMS menus using keyboard entry	<ol style="list-style-type: none"> 1. Go to “Checkout procedure” on page 176. 2. Replace the system-board, as described in “Replacing the FRU system-board and chassis assembly” on page 264.
CA00E1A1	User requested boot to open firmware prompt using keyboard entry	<ol style="list-style-type: none"> 1. Go to “Checkout procedure” on page 176. 2. Replace the system-board, as described in “Replacing the FRU system-board and chassis assembly” on page 264.
CA00E1A2	User requested boot using default service mode boot list using keyboard entry	<ol style="list-style-type: none"> 1. Go to “Checkout procedure” on page 176. 2. Replace the system-board, as described in “Replacing the FRU system-board and chassis assembly” on page 264.
CA00E1A3	User requested boot using customized service mode boot list using keyboard entry	<ol style="list-style-type: none"> 1. Go to “Checkout procedure” on page 176. 2. Replace the system-board, as described in “Replacing the FRU system-board and chassis assembly” on page 264.
CA00E1A4	User requested boot to SMS menus	<ol style="list-style-type: none"> 1. Go to “Checkout procedure” on page 176. 2. Replace the system-board, as described in “Replacing the FRU system-board and chassis assembly” on page 264.
CA00E1A5	User requested boot to open firmware prompt	<ol style="list-style-type: none"> 1. Go to “Checkout procedure” on page 176. 2. Replace the system-board, as described in “Replacing the FRU system-board and chassis assembly” on page 264.
CA00E1A6	User requested boot using default service mode boot list	<ol style="list-style-type: none"> 1. Go to “Checkout procedure” on page 176. 2. Replace the system-board, as described in “Replacing the FRU system-board and chassis assembly” on page 264.
CA00E1A7	User requested boot using customized service mode boot list	<ol style="list-style-type: none"> 1. Go to “Checkout procedure” on page 176. 2. Replace the system-board, as described in “Replacing the FRU system-board and chassis assembly” on page 264.
CA00E1AA	System boot check for NVRAM settings	<ol style="list-style-type: none"> 1. Go to “Checkout procedure” on page 176. 2. Replace the system-board, as described in “Replacing the FRU system-board and chassis assembly” on page 264.
CA00E1AB	System booting using default service mode boot list	<ol style="list-style-type: none"> 1. Go to “Checkout procedure” on page 176. 2. Replace the system-board, as described in “Replacing the FRU system-board and chassis assembly” on page 264.

Table 23. CA000000 to CA2799FF checkpoints (continued)

<ul style="list-style-type: none"> • If the system hangs on a progress code, follow the suggested actions in the order in which they are listed in the Action column until the problem is solved. If an action solves the problem, you can stop performing the remaining actions. • See Chapter 3, "Parts listing, type 7891," on page 225 to determine which components are CRUs and which components are FRUs. 		
Progress code	Description	Action
CA00E1AC	System booting using customized service mode boot list	<ol style="list-style-type: none"> 1. Go to "Checkout procedure" on page 176. 2. Replace the system-board, as described in "Replacing the FRU system-board and chassis assembly" on page 264.
CA00E1AD	System booting to the operating system	<ol style="list-style-type: none"> 1. Go to "Checkout procedure" on page 176. 2. Replace the system-board, as described in "Replacing the FRU system-board and chassis assembly" on page 264.
CA00E1AE	System booted to SMS multiboot menu using NVRAM settings	<ol style="list-style-type: none"> 1. Go to "Checkout procedure" on page 176. 2. Replace the system-board, as described in "Replacing the FRU system-board and chassis assembly" on page 264.
CA00E1AF	System booted to SMS utilities menu using NVRAM settings	<ol style="list-style-type: none"> 1. Go to "Checkout procedure" on page 176. 2. Replace the system-board, as described in "Replacing the FRU system-board and chassis assembly" on page 264.
CA00E1B1	System booting system-directed boot-device repair	<ol style="list-style-type: none"> 1. Go to "Checkout procedure" on page 176. 2. Replace the system-board, as described in "Replacing the FRU system-board and chassis assembly" on page 264.
CA00E1B2	XOFF received, waiting for XON	<ol style="list-style-type: none"> 1. Go to "Checkout procedure" on page 176. 2. Replace the system-board, as described in "Replacing the FRU system-board and chassis assembly" on page 264.
CA00E1B3	XON received	<ol style="list-style-type: none"> 1. Go to "Checkout procedure" on page 176. 2. Replace the system-board, as described in "Replacing the FRU system-board and chassis assembly" on page 264.
CA00E1B4	System-directed boot-string didn't load an operating system	<ol style="list-style-type: none"> 1. Go to "Checkout procedure" on page 176. 2. Replace the system-board, as described in "Replacing the FRU system-board and chassis assembly" on page 264.
CA00E1B5	Checking for iSCSI disk aliases	<ol style="list-style-type: none"> 1. Go to "Checkout procedure" on page 176. 2. Replace the system-board, as described in "Replacing the FRU system-board and chassis assembly" on page 264.
CA00E1D0	Create PCI self configuring SCSI device (SCSD) node	<ol style="list-style-type: none"> 1. Go to "Checkout procedure" on page 176. 2. Replace the system-board, as described in "Replacing the FRU system-board and chassis assembly" on page 264.

Table 23. CA000000 to CA2799FF checkpoints (continued)

<ul style="list-style-type: none"> • If the system hangs on a progress code, follow the suggested actions in the order in which they are listed in the Action column until the problem is solved. If an action solves the problem, you can stop performing the remaining actions. • See Chapter 3, “Parts listing, type 7891,” on page 225 to determine which components are CRUs and which components are FRUs. 		
Progress code	Description	Action
CA00E1D3	Create SCSD block device node (SD)	<ol style="list-style-type: none"> 1. Go to “Checkout procedure” on page 176. 2. Replace the system-board, as described in “Replacing the FRU system-board and chassis assembly” on page 264.
CA00E1D4	Create SCSD byte device node (ST)	<ol style="list-style-type: none"> 1. Go to “Checkout procedure” on page 176. 2. Replace the system-board, as described in “Replacing the FRU system-board and chassis assembly” on page 264.
CA00E1DC	Dynamic console selection	<ol style="list-style-type: none"> 1. Verify the video session and the SOL session. The console might be redirected to the video controller. 2. Start a remote control session to see the status. 3. Go to “Checkout procedure” on page 176. 4. Replace the system-board, as described in “Replacing the FRU system-board and chassis assembly” on page 264.
CA00E1DD	A graphics adapter has been selected as the firmware console, but the USB keyboard is not attached.	<ol style="list-style-type: none"> 1. Verify that there is a USB keyboard attached to a USB port that is assigned to the partition. 2. If the problem persists: <ol style="list-style-type: none"> a. Go to “Checkout procedure” on page 176. b. Replace the system-board, as described in “Replacing the FRU system-board and chassis assembly” on page 264.
CA00E1F0	Start out-of-box experience	<ol style="list-style-type: none"> 1. Go to “Checkout procedure” on page 176. 2. Replace the system-board, as described in “Replacing the FRU system-board and chassis assembly” on page 264.
CA00E1F1	Start self test sequence on one or more devices	<ol style="list-style-type: none"> 1. Go to “Checkout procedure” on page 176. 2. Replace the system-board, as described in “Replacing the FRU system-board and chassis assembly” on page 264.
CA00E1F2	Power on password prompt	<ol style="list-style-type: none"> 1. Go to “Checkout procedure” on page 176. 2. Replace the system-board, as described in “Replacing the FRU system-board and chassis assembly” on page 264.
CA00E1F3	Privileged-access password prompt	<ol style="list-style-type: none"> 1. Go to “Checkout procedure” on page 176. 2. Replace the system-board, as described in “Replacing the FRU system-board and chassis assembly” on page 264.

Table 23. CA000000 to CA2799FF checkpoints (continued)

<ul style="list-style-type: none"> • If the system hangs on a progress code, follow the suggested actions in the order in which they are listed in the Action column until the problem is solved. If an action solves the problem, you can stop performing the remaining actions. • See Chapter 3, “Parts listing, type 7891,” on page 225 to determine which components are CRUs and which components are FRUs. 		
Progress code	Description	Action
CA00E1F4	End self-test sequence on one or more boot devices; begin system management services	<ol style="list-style-type: none"> 1. Go to “Checkout procedure” on page 176. 2. Replace the system-board, as described in “Replacing the FRU system-board and chassis assembly” on page 264.
CA00E1F5	Build boot device list	<ol style="list-style-type: none"> 1. Go to “Checkout procedure” on page 176. 2. Replace the system-board, as described in “Replacing the FRU system-board and chassis assembly” on page 264.
CA00E1F6	Determine boot device sequence	<ol style="list-style-type: none"> 1. Go to “Checkout procedure” on page 176. 2. Replace the system-board, as described in “Replacing the FRU system-board and chassis assembly” on page 264.
CA00E1F7	No boot image located	Go to “Boot problem resolution” on page 182.
CA00E1F8	Build boot device list for SCSD adapters. (The location code of the SCSD adapter being scanned is also displayed.)	<ol style="list-style-type: none"> 1. Go to “Checkout procedure” on page 176. 2. Replace the system-board, as described in “Replacing the FRU system-board and chassis assembly” on page 264.
CA00E1F9	Build boot device list for fibre-channel adapters. (The location code of the SAN adapter being scanned is also displayed.)	<ol style="list-style-type: none"> 1. Go to “Checkout procedure” on page 176. 2. Replace the system-board, as described in “Replacing the FRU system-board and chassis assembly” on page 264.
CA00E1FA	Building device list for SCSD adapters. (The device ID and device LUN of the device being scanned is also displayed.)	<ol style="list-style-type: none"> 1. Go to “Checkout procedure” on page 176. 2. Replace the system-board, as described in “Replacing the FRU system-board and chassis assembly” on page 264.
CA00E1FB	Scan SCSD bus for attached devices	<ol style="list-style-type: none"> 1. Go to “Checkout procedure” on page 176. 2. Replace the system-board, as described in “Replacing the FRU system-board and chassis assembly” on page 264.
CA00E1FC	Build boot device list for SSA adapters. (The location code of the SSA adapter being scanned is also displayed.)	<ol style="list-style-type: none"> 1. Go to “Checkout procedure” on page 176. 2. Replace the system-board, as described in “Replacing the FRU system-board and chassis assembly” on page 264.
CA00E1FE	Building device list for fibre-channel (SAN) adapters. (The WWPN of the SAN adapter being scanned is also displayed.)	<ol style="list-style-type: none"> 1. Go to “Checkout procedure” on page 176. 2. Replace the system-board, as described in “Replacing the FRU system-board and chassis assembly” on page 264.
CA00E1FF	Build device list for fibre-channel (SAN) adapters. (The LUN of the SAN adapter being scanned is also displayed.)	<ol style="list-style-type: none"> 1. Go to “Checkout procedure” on page 176. 2. Replace the system-board, as described in “Replacing the FRU system-board and chassis assembly” on page 264.

Table 23. CA000000 to CA2799FF checkpoints (continued)

Progress code	Description	Action
CA00E440	Validate NVRAM, initialize partitions as needed	<ol style="list-style-type: none"> 1. Go to "Checkout procedure" on page 176. 2. Replace the system-board, as described in "Replacing the FRU system-board and chassis assembly" on page 264.
CA00E441	Generate /options node NVRAM configuration variable properties	<ol style="list-style-type: none"> 1. Go to "Checkout procedure" on page 176. 2. Replace the system-board, as described in "Replacing the FRU system-board and chassis assembly" on page 264.
CA00E442	Validate NVRAM partitions	<ol style="list-style-type: none"> 1. Go to "Checkout procedure" on page 176. 2. Replace the system-board, as described in "Replacing the FRU system-board and chassis assembly" on page 264.
CA00E443	Generate NVRAM configuration variable dictionary words	<ol style="list-style-type: none"> 1. Go to "Checkout procedure" on page 176. 2. Replace the system-board, as described in "Replacing the FRU system-board and chassis assembly" on page 264.
CA00E444	The NVRAM size is less than 8K bytes	<ol style="list-style-type: none"> 1. Reboot the blade server. 2. If the problem persists: <ol style="list-style-type: none"> a. Go to "Checkout procedure" on page 176. b. Replace the system-board, as described in "Replacing the FRU system-board and chassis assembly" on page 264.
CA00E701	Create memory VPD	<ol style="list-style-type: none"> 1. Go to "Checkout procedure" on page 176. 2. Replace the system-board, as described in "Replacing the FRU system-board and chassis assembly" on page 264.
CA00E800	Initialize RTAS	<ol style="list-style-type: none"> 1. Go to "Checkout procedure" on page 176. 2. Replace the system-board, as described in "Replacing the FRU system-board and chassis assembly" on page 264.
CA00E810	Initializing ioconfig plds	<ol style="list-style-type: none"> 1. Go to "Checkout procedure" on page 176. 2. Replace the system-board, as described in "Replacing the FRU system-board and chassis assembly" on page 264.
CA00E820	Initializing lpevent	<ol style="list-style-type: none"> 1. Go to "Checkout procedure" on page 176. 2. Replace the system-board, as described in "Replacing the FRU system-board and chassis assembly" on page 264.

Table 23. CA000000 to CA2799FF checkpoints (continued)

Progress code	Description	Action
CA00E830	Initializing event scan	<ol style="list-style-type: none"> 1. Go to "Checkout procedure" on page 176. 2. Replace the system-board, as described in "Replacing the FRU system-board and chassis assembly" on page 264.
CA00E840	Initializing hot plug	<ol style="list-style-type: none"> 1. Go to "Checkout procedure" on page 176. 2. Replace the system-board, as described in "Replacing the FRU system-board and chassis assembly" on page 264.
CA00E843	Initializing interface/AIX access	<ol style="list-style-type: none"> 1. Go to "Checkout procedure" on page 176. 2. Replace the system-board, as described in "Replacing the FRU system-board and chassis assembly" on page 264.
CA00E850	Initializing dynamic reconfiguration	<ol style="list-style-type: none"> 1. Go to "Checkout procedure" on page 176. 2. Replace the system-board, as described in "Replacing the FRU system-board and chassis assembly" on page 264.
CA00E860	Initializing sensors	<ol style="list-style-type: none"> 1. Go to "Checkout procedure" on page 176. 2. Replace the system-board, as described in "Replacing the FRU system-board and chassis assembly" on page 264.
CA00E865	Initializing VPD	<ol style="list-style-type: none"> 1. Go to "Checkout procedure" on page 176. 2. Replace the system-board, as described in "Replacing the FRU system-board and chassis assembly" on page 264.
CA00E870	Initializing pfd's memory manager	<ol style="list-style-type: none"> 1. Go to "Checkout procedure" on page 176. 2. Replace the system-board, as described in "Replacing the FRU system-board and chassis assembly" on page 264.
CA00E875	Initializing rtas_last_error	<ol style="list-style-type: none"> 1. Go to "Checkout procedure" on page 176. 2. Replace the system-board, as described in "Replacing the FRU system-board and chassis assembly" on page 264.
CA00E876	Initializing rtas_error_inject	<ol style="list-style-type: none"> 1. Go to "Checkout procedure" on page 176. 2. Replace the system-board, as described in "Replacing the FRU system-board and chassis assembly" on page 264.
CA00E877	Initializing dump interface	<ol style="list-style-type: none"> 1. Go to "Checkout procedure" on page 176. 2. Replace the system-board, as described in "Replacing the FRU system-board and chassis assembly" on page 264.

Table 23. CA000000 to CA2799FF checkpoints (continued)

Progress code	Description	Action
CA00E879	Initializing the platform-assisted kdump interface	<ol style="list-style-type: none"> 1. Go to "Checkout procedure" on page 176. 2. Replace the system-board, as described in "Replacing the FRU system-board and chassis assembly" on page 264.
CA00E885	Initializing set-power-level	<ol style="list-style-type: none"> 1. Go to "Checkout procedure" on page 176. 2. Replace the system-board, as described in "Replacing the FRU system-board and chassis assembly" on page 264.
CA00E886	Initializing exit2c	<ol style="list-style-type: none"> 1. Go to "Checkout procedure" on page 176. 2. Replace the system-board, as described in "Replacing the FRU system-board and chassis assembly" on page 264.
CA00E887	Initialize gdata for activate_firmware	<ol style="list-style-type: none"> 1. Go to "Checkout procedure" on page 176. 2. Replace the system-board, as described in "Replacing the FRU system-board and chassis assembly" on page 264.
CA00E890	Starting to initialize open firmware	<ol style="list-style-type: none"> 1. Go to "Checkout procedure" on page 176. 2. Replace the system-board, as described in "Replacing the FRU system-board and chassis assembly" on page 264.
CA00E891	Finished initializing open firmware	<ol style="list-style-type: none"> 1. Go to "Checkout procedure" on page 176. 2. Replace the system-board, as described in "Replacing the FRU system-board and chassis assembly" on page 264.
CA00EAA1	Probe PCI-PCI bridge bus	<ol style="list-style-type: none"> 1. Go to "Checkout procedure" on page 176. 2. Replace the system-board, as described in "Replacing the FRU system-board and chassis assembly" on page 264.
CA060203	An alias was modified or created	<ol style="list-style-type: none"> 1. Go to "Checkout procedure" on page 176. 2. Replace the system-board, as described in "Replacing the FRU system-board and chassis assembly" on page 264.
CA26ttss	Waiting for lpevent of type <i>tt</i> and subtype <i>ss</i> .	<ol style="list-style-type: none"> 1. Reboot the blade server. 2. If the problem persists: <ol style="list-style-type: none"> a. Go to "Checkout procedure" on page 176. b. Replace the system-board, as described in "Replacing the FRU system-board and chassis assembly" on page 264.

Table 23. CA000000 to CA2799FF checkpoints (continued)

Progress code	Description	Action
CA26FFFF	An extended item was required for Ipevent to complete.	<ol style="list-style-type: none"> 1. Go to "Checkout procedure" on page 176. 2. Replace the system-board, as described in "Replacing the FRU system-board and chassis assembly" on page 264.
CA279001	The firmware update image contains an update module that is not already on the system.	<ol style="list-style-type: none"> 1. Look at the event log for a BA27xxxx error code to determine if a firmware installation error occurred. 2. If a firmware installation error did occur, resolve the problem. 3. Retry the firmware update. 4. If the problem persists: <ol style="list-style-type: none"> a. Go to "Checkout procedure" on page 176. b. Replace the system-board, as described in "Replacing the FRU system-board and chassis assembly" on page 264.
CA2799FD	A firmware update module is being read.	<p>This checkpoint alternates in the control panel with CA2799FF.</p> <p>This pair of checkpoints might stay in the display for up to 30 minutes with no indication of activity other than the alternating codes. Do not assume that the system is hung until the alternation stops and only one of the checkpoints remains in the control panel for at least 30 minutes, with no other indication of activity.</p> <p>If the system is hung on this checkpoint, then CA2799FD and CA2799FF are not alternating and you must perform the following procedure:</p> <ol style="list-style-type: none"> 1. Shut down the blade server. 2. Restart the blade server using the permanent boot image, as described in "Starting the PERM image" on page 217. 3. Use the Update and Manage System Flash menu to reject the temporary image.

Table 23. CA000000 to CA2799FF checkpoints (continued)

<ul style="list-style-type: none"> • If the system hangs on a progress code, follow the suggested actions in the order in which they are listed in the Action column until the problem is solved. If an action solves the problem, you can stop performing the remaining actions. • See Chapter 3, “Parts listing, type 7891,” on page 225 to determine which components are CRUs and which components are FRUs. 		
Progress code	Description	Action
CA2799FF	A firmware update module is being written.	<p>This checkpoint alternates in the control panel with CA2799FD.</p> <p>This pair of checkpoints might stay in the display for up to 30 minutes with no indication of activity other than the alternating codes. Do not assume that the system is hung until the alternation stops and only one of the checkpoints remains in the control panel for at least 30 minutes, with no other indication of activity.</p> <p>If the system is hung on this checkpoint, then CA2799FD and CA2799FF are not alternating and you must perform the following procedure:</p> <ol style="list-style-type: none"> 1. Shut down the blade server. 2. Restart the blade server using the permanent boot image, as described in “Starting the PERM image” on page 217. 3. Use the Update and Manage System Flash menu to reject the temporary image.

D1001xxx to D1xx3FFF Service processor dump codes

D1xx service processor dump status codes indicate the cage or node ID that the dump component is processing, the node from which the hardware data is collected, and a counter that increments each time that the dump processor stores 4K of dump data.

Service processor dump status codes use the format, D1yy1xxx, where yy and xxx can be any number or letter.

The yy part of the code indicates the cage or node ID that the dump component is processing. The node varies depending on the node from which the hardware data is collected. The node is 0xFF when collecting the mainstore memory data.

The xxx part of the code is a counter that increments each time that the dump processor stores 4K of dump data.

Table 24 on page 134 lists the progress codes that might be displayed during the power-on self-test (POST), along with suggested actions to take if the system hangs on the progress code. Only when you experience a hang condition should you take any of the actions described for a progress code.

Table 24. D1001xxx to D1xx3FFF dump codes

<ul style="list-style-type: none"> • If the system hangs on a progress code, follow the suggested actions in the order in which they are listed in the Action column until the problem is solved. If an action solves the problem, you can stop performing the remaining actions. • See Chapter 3, “Parts listing, type 7891,” on page 225 to determine which components are CRUs and which components are FRUs. 		
Progress code	Description	Action
D1001xxx	Dump error data	<ol style="list-style-type: none"> 1. Go to “Checkout procedure” on page 176. 2. Replace the system-board, as described in “Replacing the FRU system-board and chassis assembly” on page 264.
D1011xxx	Dump dump header	<ol style="list-style-type: none"> 1. Go to “Checkout procedure” on page 176. 2. Replace the system-board, as described in “Replacing the FRU system-board and chassis assembly” on page 264.
D101C00F	No power off to allow debugging for CPU controls	<ol style="list-style-type: none"> 1. Go to “Checkout procedure” on page 176. 2. Replace the system-board, as described in “Replacing the FRU system-board and chassis assembly” on page 264.
D1021xxx	Dump dump header directory	<ol style="list-style-type: none"> 1. Go to “Checkout procedure” on page 176. 2. Replace the system-board, as described in “Replacing the FRU system-board and chassis assembly” on page 264.
D1031xxx	Dump dump header fips header	<ol style="list-style-type: none"> 1. Go to “Checkout procedure” on page 176. 2. Replace the system-board, as described in “Replacing the FRU system-board and chassis assembly” on page 264.
D1041xxx	Dump dump header entry header	<ol style="list-style-type: none"> 1. Go to “Checkout procedure” on page 176. 2. Replace the system-board, as described in “Replacing the FRU system-board and chassis assembly” on page 264.
D1051xxx	Dump core file for failing component	<ol style="list-style-type: none"> 1. Go to “Checkout procedure” on page 176. 2. Replace the system-board, as described in “Replacing the FRU system-board and chassis assembly” on page 264.
D1061xxx	Dump all NVRAM	<ol style="list-style-type: none"> 1. Go to “Checkout procedure” on page 176. 2. Replace the system-board, as described in “Replacing the FRU system-board and chassis assembly” on page 264.
D1071xxx	Dump component trace for failing component	<ol style="list-style-type: none"> 1. Go to “Checkout procedure” on page 176. 2. Replace the system-board, as described in “Replacing the FRU system-board and chassis assembly” on page 264.
D1081xxx	Dump component data from /opt/p0	<ol style="list-style-type: none"> 1. Go to “Checkout procedure” on page 176. 2. Replace the system-board, as described in “Replacing the FRU system-board and chassis assembly” on page 264.

Table 24. D1001xxx to D1xx3FFF dump codes (continued)

<ul style="list-style-type: none"> • If the system hangs on a progress code, follow the suggested actions in the order in which they are listed in the Action column until the problem is solved. If an action solves the problem, you can stop performing the remaining actions. • See Chapter 3, “Parts listing, type 7891,” on page 225 to determine which components are CRUs and which components are FRUs. 		
Progress code	Description	Action
D1091xxx	Dump /opt/p1/**	<ol style="list-style-type: none"> 1. Go to “Checkout procedure” on page 176. 2. Replace the system-board, as described in “Replacing the FRU system-board and chassis assembly” on page 264.
D1111xxx	Dump /opt/p0/**	<ol style="list-style-type: none"> 1. Go to “Checkout procedure” on page 176. 2. Replace the system-board, as described in “Replacing the FRU system-board and chassis assembly” on page 264.
D1121xxx	Dump /opt/p1/**	<ol style="list-style-type: none"> 1. Go to “Checkout procedure” on page 176. 2. Replace the system-board, as described in “Replacing the FRU system-board and chassis assembly” on page 264.
D1131xxx	Dump all traces	<ol style="list-style-type: none"> 1. Go to “Checkout procedure” on page 176. 2. Replace the system-board, as described in “Replacing the FRU system-board and chassis assembly” on page 264.
D1141xxx	Dump code version	<ol style="list-style-type: none"> 1. Go to “Checkout procedure” on page 176. 2. Replace the system-board, as described in “Replacing the FRU system-board and chassis assembly” on page 264.
D1151xxx	Dump all /opt/p3 except rtbl	<ol style="list-style-type: none"> 1. Go to “Checkout procedure” on page 176. 2. Replace the system-board, as described in “Replacing the FRU system-board and chassis assembly” on page 264.
D1161xxx	Dump pddcustomize -r command	<ol style="list-style-type: none"> 1. Go to “Checkout procedure” on page 176. 2. Replace the system-board, as described in “Replacing the FRU system-board and chassis assembly” on page 264.
D1171xxx	Dump registry -l command	<ol style="list-style-type: none"> 1. Go to “Checkout procedure” on page 176. 2. Replace the system-board, as described in “Replacing the FRU system-board and chassis assembly” on page 264.
D1181xxx	Dump all /core/core.* files	<ol style="list-style-type: none"> 1. Go to “Checkout procedure” on page 176. 2. Replace the system-board, as described in “Replacing the FRU system-board and chassis assembly” on page 264.
D1191xxx	Dump BDMP component trace (after dump if enough space)	<ol style="list-style-type: none"> 1. Go to “Checkout procedure” on page 176. 2. Replace the system-board, as described in “Replacing the FRU system-board and chassis assembly” on page 264.

Table 24. D1001xxx to D1xx3FFF dump codes (continued)

<ul style="list-style-type: none"> • If the system hangs on a progress code, follow the suggested actions in the order in which they are listed in the Action column until the problem is solved. If an action solves the problem, you can stop performing the remaining actions. • See Chapter 3, “Parts listing, type 7891,” on page 225 to determine which components are CRUs and which components are FRUs. 		
Progress code	Description	Action
D11A1xxx	Dump any state information before dumping starts	<ol style="list-style-type: none"> 1. Go to “Checkout procedure” on page 176. 2. Replace the system-board, as described in “Replacing the FRU system-board and chassis assembly” on page 264.
D11B1xxx	Dump /proc filesystem	<ol style="list-style-type: none"> 1. Go to “Checkout procedure” on page 176. 2. Replace the system-board, as described in “Replacing the FRU system-board and chassis assembly” on page 264.
D11C1xxx	Dump mounted filesystem statistics	<ol style="list-style-type: none"> 1. Go to “Checkout procedure” on page 176. 2. Replace the system-board, as described in “Replacing the FRU system-board and chassis assembly” on page 264.
D11D1xxx	Dump environment	<ol style="list-style-type: none"> 1. Go to “Checkout procedure” on page 176. 2. Replace the system-board, as described in “Replacing the FRU system-board and chassis assembly” on page 264.
D1231xxx	Dump update dump headers	<ol style="list-style-type: none"> 1. Go to “Checkout procedure” on page 176. 2. Replace the system-board, as described in “Replacing the FRU system-board and chassis assembly” on page 264.
D1241xxx	Dump CRC1 calculation off	<ol style="list-style-type: none"> 1. Go to “Checkout procedure” on page 176. 2. Replace the system-board, as described in “Replacing the FRU system-board and chassis assembly” on page 264.
D1251xxx	Dump CRC1 calculation on	<ol style="list-style-type: none"> 1. Go to “Checkout procedure” on page 176. 2. Replace the system-board, as described in “Replacing the FRU system-board and chassis assembly” on page 264.
D1261xxx	Dump CRC2 calculation off	<ol style="list-style-type: none"> 1. Go to “Checkout procedure” on page 176. 2. Replace the system-board, as described in “Replacing the FRU system-board and chassis assembly” on page 264.
D1271xxx	Dump CRC2 calculation on	<ol style="list-style-type: none"> 1. Go to “Checkout procedure” on page 176. 2. Replace the system-board, as described in “Replacing the FRU system-board and chassis assembly” on page 264.
D1281xxx	Dump output the calculated CRC1 (dump headers)	<ol style="list-style-type: none"> 1. Go to “Checkout procedure” on page 176. 2. Replace the system-board, as described in “Replacing the FRU system-board and chassis assembly” on page 264.

Table 24. D1001xxx to D1xx3FFF dump codes (continued)

<ul style="list-style-type: none"> • If the system hangs on a progress code, follow the suggested actions in the order in which they are listed in the Action column until the problem is solved. If an action solves the problem, you can stop performing the remaining actions. • See Chapter 3, “Parts listing, type 7891,” on page 225 to determine which components are CRUs and which components are FRUs. 		
Progress code	Description	Action
D1291xxx	Dump output the calculated CRC2 (data and data headers)	<ol style="list-style-type: none"> 1. Go to “Checkout procedure” on page 176. 2. Replace the system-board, as described in “Replacing the FRU system-board and chassis assembly” on page 264.
D12A1xxx	Jump to the position in dump directly after CRC1	<ol style="list-style-type: none"> 1. Go to “Checkout procedure” on page 176. 2. Replace the system-board, as described in “Replacing the FRU system-board and chassis assembly” on page 264.
D12B1xxx	Initialize the headers dump time and serial numbers	<ol style="list-style-type: none"> 1. Go to “Checkout procedure” on page 176. 2. Replace the system-board, as described in “Replacing the FRU system-board and chassis assembly” on page 264.
D12C1xxx	Display final SRC to panel	<ol style="list-style-type: none"> 1. Go to “Checkout procedure” on page 176. 2. Replace the system-board, as described in “Replacing the FRU system-board and chassis assembly” on page 264.
D12D1xxx	Rmve /core/core.app.time.pid	<ol style="list-style-type: none"> 1. Go to “Checkout procedure” on page 176. 2. Replace the system-board, as described in “Replacing the FRU system-board and chassis assembly” on page 264.
D12E1xxx	Remove /core/core.*	<ol style="list-style-type: none"> 1. Go to “Checkout procedure” on page 176. 2. Replace the system-board, as described in “Replacing the FRU system-board and chassis assembly” on page 264.
D12F1xxx	Display beginning SRC to panel	<ol style="list-style-type: none"> 1. Go to “Checkout procedure” on page 176. 2. Replace the system-board, as described in “Replacing the FRU system-board and chassis assembly” on page 264.
D1301xxx	Turn off error log capture into dump	<ol style="list-style-type: none"> 1. Go to “Checkout procedure” on page 176. 2. Replace the system-board, as described in “Replacing the FRU system-board and chassis assembly” on page 264.
D1311xxx	Turn on error log capture into dump	<ol style="list-style-type: none"> 1. Go to “Checkout procedure” on page 176. 2. Replace the system-board, as described in “Replacing the FRU system-board and chassis assembly” on page 264.
D1321xxx	Store information about existing core files	<ol style="list-style-type: none"> 1. Go to “Checkout procedure” on page 176. 2. Replace the system-board, as described in “Replacing the FRU system-board and chassis assembly” on page 264.

Table 24. D1001xxx to D1xx3FFF dump codes (continued)

Progress code	Description	Action
D1381xxx	Invalidate the dump	<ol style="list-style-type: none"> 1. Go to "Checkout procedure" on page 176. 2. Replace the system-board, as described in "Replacing the FRU system-board and chassis assembly" on page 264.
D1391xxx	Check for valid dump sequence	<ol style="list-style-type: none"> 1. Go to "Checkout procedure" on page 176. 2. Replace the system-board, as described in "Replacing the FRU system-board and chassis assembly" on page 264.
D13A1xxx	Get dump identity sequence	<ol style="list-style-type: none"> 1. Go to "Checkout procedure" on page 176. 2. Replace the system-board, as described in "Replacing the FRU system-board and chassis assembly" on page 264.
D13B1xxx	Get dump length sequence	<ol style="list-style-type: none"> 1. Go to "Checkout procedure" on page 176. 2. Replace the system-board, as described in "Replacing the FRU system-board and chassis assembly" on page 264.
D1FF1xxx	Dump complete	<ol style="list-style-type: none"> 1. Go to "Checkout procedure" on page 176. 2. Replace the system-board, as described in "Replacing the FRU system-board and chassis assembly" on page 264.
D1xx3000 - D1xx3FFF	Platform dump status codes are described in "D1xx3y01 to D1xx3yF2 Service processor dump codes"	

D1xx3y01 to D1xx3yF2 Service processor dump codes:

These D1xx3yxx service processor dump codes use the format: D1xx3yzz, where xx indicates the cage or node ID that the dump component is processing, y increments from 0 to F to indicate that the system is not hung, and zz indicates the command being processed.

Table 25 lists the progress codes that might be displayed during the power-on self-test (POST), along with suggested actions to take if the system hangs on the progress code. Only when you experience a hang condition should you take any of the actions described for a progress code.

Table 25. D1xx3y01 to D1xx3yF2 checkpoints

Progress code	Description (Command Being Processed)	Action
D1xx3y01	Get SCOM	<ol style="list-style-type: none"> 1. Go to "Checkout procedure" on page 176. 2. Replace the system-board, as described in "Replacing the FRU system-board and chassis assembly" on page 264.
D1xx3y02	Get scan ring	<ol style="list-style-type: none"> 1. Go to "Checkout procedure" on page 176. 2. Replace the system-board, as described in "Replacing the FRU system-board and chassis assembly" on page 264.
D1xx3y03	Get array values	<ol style="list-style-type: none"> 1. Go to "Checkout procedure" on page 176. 2. Replace the system-board, as described in "Replacing the FRU system-board and chassis assembly" on page 264.
D1xx3y04	Stop the clocks	<ol style="list-style-type: none"> 1. Go to "Checkout procedure" on page 176. 2. Replace the system-board, as described in "Replacing the FRU system-board and chassis assembly" on page 264.
D1xx3y05	Flush the cache	<ol style="list-style-type: none"> 1. Go to "Checkout procedure" on page 176. 2. Replace the system-board, as described in "Replacing the FRU system-board and chassis assembly" on page 264.
D1xx3y06	Get CFAM	<ol style="list-style-type: none"> 1. Go to "Checkout procedure" on page 176. 2. Replace the system-board, as described in "Replacing the FRU system-board and chassis assembly" on page 264.
D1xx3y07	Put SCOM	<ol style="list-style-type: none"> 1. Go to "Checkout procedure" on page 176. 2. Replace the system-board, as described in "Replacing the FRU system-board and chassis assembly" on page 264.
D1xx3y08	Send command	<ol style="list-style-type: none"> 1. Go to "Checkout procedure" on page 176. 2. Replace the system-board, as described in "Replacing the FRU system-board and chassis assembly" on page 264.
D1xx3y09	Get optimized cache	<ol style="list-style-type: none"> 1. Go to "Checkout procedure" on page 176. 2. Replace the system-board, as described in "Replacing the FRU system-board and chassis assembly" on page 264.

Table 25. D1xx3y01 to D1xx3yF2 checkpoints (continued)

<ul style="list-style-type: none"> • If the system hangs on a progress code, follow the suggested actions in the order in which they are listed in the Action column until the problem is solved. If an action solves the problem, you can stop performing the remaining actions. • See Chapter 3, “Parts listing, type 7891,” on page 225 to determine which components are CRUs and which components are FRUs. 		
Progress code	Description (Command Being Processed)	Action
D1xx3y0A	Get general purpose (GP) register	<ol style="list-style-type: none"> 1. Go to “Checkout procedure” on page 176. 2. Replace the system-board, as described in “Replacing the FRU system-board and chassis assembly” on page 264.
D1xx3y0B	Processor clean-up	<ol style="list-style-type: none"> 1. Go to “Checkout procedure” on page 176. 2. Replace the system-board, as described in “Replacing the FRU system-board and chassis assembly” on page 264.
D1xx3y0C	Get JTAG register	<ol style="list-style-type: none"> 1. Go to “Checkout procedure” on page 176. 2. Replace the system-board, as described in “Replacing the FRU system-board and chassis assembly” on page 264.
D1xx3y0D	Stop clocks without quiescing	<ol style="list-style-type: none"> 1. Go to “Checkout procedure” on page 176. 2. Replace the system-board, as described in “Replacing the FRU system-board and chassis assembly” on page 264.
D1xx3yF0	Memory collection set-up	<ol style="list-style-type: none"> 1. Go to “Checkout procedure” on page 176. 2. Replace the system-board, as described in “Replacing the FRU system-board and chassis assembly” on page 264.
D1xx3yF1	Memory collection DMA step	<ol style="list-style-type: none"> 1. Go to “Checkout procedure” on page 176. 2. Replace the system-board, as described in “Replacing the FRU system-board and chassis assembly” on page 264.
D1xx3yF2	Memory collection cleanup	<ol style="list-style-type: none"> 1. Go to “Checkout procedure” on page 176. 2. Replace the system-board, as described in “Replacing the FRU system-board and chassis assembly” on page 264.

D1xx900C to D1xxC003 Service processor power-off checkpoints

These D1xx service processor power-off status codes offer information about the status of the service processor during a power-off operation.

Table 26 lists the progress codes that might be displayed during the power-on self-test (POST), along with suggested actions to take if the system hangs on the progress code. Only when you experience a hang condition should you take any of the actions described for a progress code.

Table 26. D1xx900C to D1xxC003 checkpoints

Progress code	Description (Command Being Processed)	Action
D1xx900C	Breakpoint set in CPU controls has been hit	<ol style="list-style-type: none"> Go to “Checkout procedure” on page 176. Replace the system-board, as described in “Replacing the FRU system-board and chassis assembly” on page 264.
D1xxB0FF	Request to initiate power-off program has been sent	<ol style="list-style-type: none"> Go to “Checkout procedure” on page 176. Replace the system-board, as described in “Replacing the FRU system-board and chassis assembly” on page 264.
D1xxC000	Indicates a message is ready to send to the hypervisor to power off	<ol style="list-style-type: none"> Go to “Checkout procedure” on page 176. Replace the system-board, as described in “Replacing the FRU system-board and chassis assembly” on page 264.
D1xxC001	Waiting for the hypervisor to acknowledge the delayed power off notification	<ol style="list-style-type: none"> Go to “Checkout procedure” on page 176. Replace the system-board, as described in “Replacing the FRU system-board and chassis assembly” on page 264.
D1xxC002	Waiting for the hypervisor to send the power off message	<ol style="list-style-type: none"> Go to “Checkout procedure” on page 176. Replace the system-board, as described in “Replacing the FRU system-board and chassis assembly” on page 264.
D1xxC003	Hypervisor handshaking is complete	<ol style="list-style-type: none"> Go to “Checkout procedure” on page 176. Replace the system-board, as described in “Replacing the FRU system-board and chassis assembly” on page 264.

- If the system hangs on a progress code, follow the suggested actions in the order in which they are listed in the Action column until the problem is solved. If an action solves the problem, you can stop performing the remaining actions.
- See Chapter 3, “Parts listing, type 7891,” on page 225 to determine which components are CRUs and which components are FRUs.

Service request numbers (SRNs)

Service request numbers (SRNs) are error codes that the operating system generates. The codes have three or four digits, a hyphen, and three or four digits after the hyphen. SRNs can be viewed using the AIX diagnostics or the Linux service aid “diagela” if it is installed.

Note: The “diagela” service aid is part of the Linux service aids for hardware diagnostics. The service aids are separate from the operating system and are available for download from the Service and productivity tools for Linux systems site.

Using the SRN tables

The service request number (SRN) list is in numerical sequence. The failing function codes (FFCs) are provided to aid in locating a failing component.

1. Look up a service request number when you see an error code with a hyphen.

The SRN is in the first column of the SRN table in numerical order.

The SRN might have an associated FFC number. Possible FFC values for SRNs are displayed in the second column of the table. FFC numbers might be the first three digits of the SRN or the last three digits, or might not be in the SRN.

The third column describes the problem and an action to take to try to fix the problem. The description also includes how to find the FFC number for an SRN if one exists.

2. See “Failing function codes” on page 173 for a description of each FFC value.
3. If the SRN does not appear in the table, see “Solving undetermined problems” on page 223.
4. After replacing a component, verify the replacement part and perform a log-repair action using the AIX diagnostics.

101-711 through FFC-725 SRNs

AIX might generate service request numbers (SRNs) from 101-711 to FFC-725.

Replace any parts in the order that the codes are listed in Table 27.

Note: An *x* in the following SRNs represents a digit or character that might have any value.

Table 27. 101-711 through FFC-725 SRNs

SRN	FFC	Description and Action
101-711 to 101-726	711 to 726	The system hung while trying to configure an unknown resource. 1. Run the stand-alone diagnostics problem determination procedure. 2. If the problem remains, refer to “Failing function codes” on page 173 to find the FFC that matches the last three digits of the SRN. 3. Suspect the device adapter or device itself.
101-888	210 227	The system does not IPL. Go to “Performing the checkout procedure” on page 177 or undetermined problem procedure.
101-2020		The system hung while trying to configure the InfiniBand Communication Manager. This problem may be attributed to software. Report this problem to the AIX Support Center.
101-2021		The system hung while trying to configure the InfiniBand TCP/IP Interface. This problem may be attributed to software. Report this problem to the AIX Support Center.
101-xxxx	xxxx	The system hung while configuring a resource. The last three or four digits after the dash (-) identify the failing function code for the resource being configured. Go to undetermined problem procedure.

Table 27. 101-711 through FFC-725 SRNs (continued)

SRN	FFC	Description and Action
103-151	151	The time-of-day battery failed. <ol style="list-style-type: none"> Go to "Removing the battery" on page 258 to start the battery replacement procedure. Go to "Installing the battery" on page 258 to complete the procedure.
109-200		The system crashed while you running it. <ol style="list-style-type: none"> Go to "Performing the checkout procedure" on page 177. If the 8-digit error and location codes were NOT reported, run AIX diagnostics in problem determination procedure and record and report the 8-digit error and location codes for this SRN.
110-101		The diagnostics did not detect an installed resource. If this SRN appeared when running concurrent diagnostics, then run concurrent diagnostics using the diag -a command.
110-921 to 110-926	812 xxx	The system halted while diagnostics were executing. Go to "Performing the checkout procedure" on page 177 or problem resolution. Note: xxx corresponds to the last three digits of the SRN.
110-935	812	The system halted while diagnostics were executing. Use the problem determination procedure.
110-xxxx	xxxx 221	The system halted while diagnostics were executing. Note: xxxx corresponds to the last three or four digits of the SRN following the dash (-). <ol style="list-style-type: none"> If your 110 SRN is not listed, substitute the last three or four digits of the SRN for xxxx and go to "Failing function codes" on page 173 to identify the failing feature. Run stand-alone diagnostics and the problem determination procedure for your operating system.
111-107		A machine check occurred. Go to "Performing the checkout procedure" on page 177.
111-108		An encoded SRN was displayed. Go to "Performing the checkout procedure" on page 177.
111-121		There is a display problem. Go to "Performing the checkout procedure" on page 177.
111-78C	227	PCI adapter I/O bus problem. Go to "Performing the checkout procedure" on page 177. Perform "Solving undetermined problems" on page 223.
111-999	210	System does not perform a soft reset. Go to "Performing the checkout procedure" on page 177.
650-xxx	650	Disk drive configuration failed. <ol style="list-style-type: none"> Check the BladeCenter management-module event log. If an error was recorded by the system, see "POST progress codes (checkpoints)" on page 97. Replace any parts reported by the diagnostic program. Update the disk drive firmware. Troubleshoot the disk drive. Replace the system-board
651-140	221	Display Character test failed. Note: Diagnostic will provide this SRN but there is no action to be taken. Do not perform operator panel test from diagnostics.

Table 27. 101-711 through FFC-725 SRNs (continued)

SRN	FFC	Description and Action
950-2506	2506 221	Missing options resolution for 3Gb SAS Adapter card. Try each of the following steps. After reseating, removing, or replacing a part, retry the operation. 1. Check the BladeCenter management-module event log. If an error was recorded by the system, see "POST progress codes (checkpoints)" on page 97. 2. Replace any parts reported by the diagnostic program. 3. Reseat the 3Gb SAS Adapter card. 4. Replace the 3Gb SAS Adapter card. 5. Replace the system-board
2506-102E	722	Out of alternate disk storage for storage. Go to "Performing the checkout procedure" on page 177.
2506-3002	722	Addressed device failed to respond to selection. Go to "Performing the checkout procedure" on page 177.
2506-3010	722	Disk returned wrong response to adapter. Go to "Performing the checkout procedure" on page 177.
2506-3020	-	Storage subsystem configuration error. Go to "Performing the checkout procedure" on page 177.
2506-3100	-	Controller detected device bus interface error. Go to "Performing the checkout procedure" on page 177.
2506-3109	-	Controller timed out a device command. Go to "Performing the checkout procedure" on page 177.
2506-3110	-	Device bus interface error. Go to "Performing the checkout procedure" on page 177.
2506-4010	-	Configuration error, incorrect connection between cascaded enclosures. Go to "Performing the checkout procedure" on page 177.
2506-4020	-	Configuration error, connections exceed IOA design limits. Go to "Performing the checkout procedure" on page 177.
2506-4030	-	Configuration error, incorrect multipath connection. Go to "Performing the checkout procedure" on page 177.
2506-4040	-	Configuration error, incomplete multipath connection between controller and enclosure detected. Go to "Performing the checkout procedure" on page 177.
2506-4041	-	Configuration error, incomplete multipath connection between enclosure and device detected. Go to "Performing the checkout procedure" on page 177.
2506-4050	-	Attached enclosure does not support required multipath function. Go to "Performing the checkout procedure" on page 177.
2506-4060	-	Multipath redundancy level got worse. Go to "Performing the checkout procedure" on page 177.
2506-4100	-	Device bus fabric error. Go to "Performing the checkout procedure" on page 177.
2506-4101	-	Temporary device bus fabric error. Go to "Performing the checkout procedure" on page 177.
2506-4110	-	Unsupported enclosure function detected. Go to "Performing the checkout procedure" on page 177.
2506-4150	2506	PCI bus error detected by controller. Go to "Performing the checkout procedure" on page 177.
2506-4160	2506	PCI bus error detected by controller. Go to "Performing the checkout procedure" on page 177.
2506-7001	722	Temporary disk data error. Go to "Performing the checkout procedure" on page 177.

Table 27. 101-711 through FFC-725 SRNs (continued)

SRN	FFC	Description and Action
2506-8008	BAT	A permanent Cache Battery Pack failure occurred. Go to "Performing the checkout procedure" on page 177.
2506-8009	BAT	Impending Cache Battery Pack failure. Go to "Performing the checkout procedure" on page 177.
2506-8150	2506	Controller failure. Go to "Performing the checkout procedure" on page 177.
2506-8157	2506	Temporary controller failure. Go to "Performing the checkout procedure" on page 177.
2506-9000	-	Controller detected device error during configuration discovery. Go to "Performing the checkout procedure" on page 177.
2506-9001	-	Controller detected device error during configuration discovery. Go to "Performing the checkout procedure" on page 177.
2506-9002	-	Controller detected device error during configuration discovery. Go to "Performing the checkout procedure" on page 177.
2506-9008	-	Controller does not support function expected for one or more disks. Go to "Performing the checkout procedure" on page 177.
2506-9010	-	Cache data associated with attached disks cannot be found. Go to "Performing the checkout procedure" on page 177.
2506-9011	-	Cache data belongs to disks other than those attached. Go to "Performing the checkout procedure" on page 177.
2506-9020	-	Two or more disks are missing from a RAID-5 or RAID 6 Disk Array. Go to "Performing the checkout procedure" on page 177.
2506-9021	-	Two or more disks are missing from a RAID-5 or RAID 6 Disk Array. Go to "Performing the checkout procedure" on page 177.
2506-9022	-	Two or more disks are missing from a RAID-5 or RAID 6 Disk Array. Go to "Performing the checkout procedure" on page 177.
2506-9023	-	One or more Disk Array members are not at required physical locations. Go to "Performing the checkout procedure" on page 177.
2506-9024	-	Physical location of Disk Array members conflict with another Disk Array. Go to "Performing the checkout procedure" on page 177.
2506-9025	-	Incompatible disk installed at degraded disk location in Disk Array. Go to "Performing the checkout procedure" on page 177.
2506-9026	-	Previously degraded disk in Disk Array not found at required physical location. Go to "Performing the checkout procedure" on page 177.
2506-9027	-	Disk Array is or would become degraded and parity data is out of synchronization. Go to "Performing the checkout procedure" on page 177.
2506-9028	-	Maximum number of functional Disk Arrays has been exceeded. Go to "Performing the checkout procedure" on page 177.
2506-9029	-	Maximum number of functional Disk Arrays disks has been exceeded. Go to "Performing the checkout procedure" on page 177.
2506-9030	-	Disk Array is degraded due to missing/failed disk. Go to "Performing the checkout procedure" on page 177.
2506-9031	-	Automatic reconstruction initiated for Disk Array. Go to "Performing the checkout procedure" on page 177.
2506-9032	-	Disk Array is degraded due to missing/failed disk. Go to "Performing the checkout procedure" on page 177.
2506-9041	-	Background Disk Array parity checking detected and corrected errors. Go to "Performing the checkout procedure" on page 177.

Table 27. 101-711 through FFC-725 SRNs (continued)

SRN	FFC	Description and Action
2506-9042	-	Background Disk Array parity checking detected and corrected errors on specified disk. Go to "Performing the checkout procedure" on page 177.
2506-9050	-	Required cache data can not be located for one or more disks. Go to "Performing the checkout procedure" on page 177.
2506-9051	-	Cache data exists for one or more missing/failed disks. Go to "Performing the checkout procedure" on page 177.
2506-9052	-	Cache data exists for one or more modified disks. Go to "Performing the checkout procedure" on page 177.
2506-9054	-	RAID controller resources not available due to previous problems. Go to "Performing the checkout procedure" on page 177.
2506-9060	-	One or more disk pairs are missing from a RAID-10 Disk Array. Go to "Performing the checkout procedure" on page 177.
2506-9061	-	One or more disks are missing from a RAID-0 Disk Array. Go to "Performing the checkout procedure" on page 177.
2506-9062	-	One or more disks are missing from a RAID-0 Disk Array. Go to "Performing the checkout procedure" on page 177.
2506-9063	-	Maximum number of functional Disk Arrays has been exceeded. Go to "Performing the checkout procedure" on page 177.
2506-9073	-	Multiple controllers connected in an invalid configuration. Go to "Performing the checkout procedure" on page 177.
2506-9074	-	Multiple controllers not capable of similar functions or controlling same set of devices. Go to "Performing the checkout procedure" on page 177.
2506-9075	-	Incomplete multipath connection between controller and remote controller. Go to "Performing the checkout procedure" on page 177.
2506-9076	-	Missing remote controller. Go to "Performing the checkout procedure" on page 177.
2506-9081	-	Controller detected device error during internal media recovery. Go to "Performing the checkout procedure" on page 177.
2506-9082	-	Controller detected device error during internal media recovery. Go to "Performing the checkout procedure" on page 177.
2506-9090	-	Disk has been modified after last known status. Go to "Performing the checkout procedure" on page 177.
2506-9091	-	Incorrect disk configuration change has been detected. Go to "Performing the checkout procedure" on page 177.
2506-9092	-	Disk requires Format before use. Format the disk and retry the operation.
2506-FF3D	2506	Temporary controller failure. Retry the operation.
2506-FFF3	-	Disk media format bad. Reformat the disk and retry the operation.
2506-FFF4	722	Device problem. Perform diagnostics on the device and retry the operation.
2506-FFF6	722	Device detected recoverable error. Retry the operation.
2506-FFFA	722	Temporary device bus error. Retry the operation.
2506-FFFE	-	Temporary device bus error. Retry the operation.
252B-101	252B	<p>Adapter configuration error.</p> <ol style="list-style-type: none"> 1. Check the BladeCenter management-module event log. If an error was recorded by the system, see "POST progress codes (checkpoints)" on page 97. 2. Replace any parts reported by the diagnostic program. 3. Replace the system-board

Table 27. 101-711 through FFC-725 SRNs (continued)

SRN	FFC	Description and Action
252B-710	252B	Permanent adapter failure. <ol style="list-style-type: none"> 1. Check the BladeCenter management-module event log. If an error was recorded by the system, see "POST progress codes (checkpoints)" on page 97. 2. Replace any parts reported by the diagnostic program. 3. Replace the system-board
252B-711	252B	Adapter failure. <ol style="list-style-type: none"> 1. Check the BladeCenter management-module event log. If an error was recorded by the system, see "POST progress codes (checkpoints)" on page 97. 2. Replace any parts reported by the diagnostic program. 3. Replace the system-board
252B-712	252B	Adapter failure. <ol style="list-style-type: none"> 1. Check the BladeCenter management-module event log. If an error was recorded by the system, see "POST progress codes (checkpoints)" on page 97. 2. Replace any parts reported by the diagnostic program. 3. Replace the system-board
252B-713	252B	Adapter failure. <ol style="list-style-type: none"> 1. Check the BladeCenter management-module event log. If an error was recorded by the system, see "POST progress codes (checkpoints)" on page 97. 2. Replace any parts reported by the diagnostic program. 3. Replace the system-board
252B-714	252B	Temporary adapter failure. <ol style="list-style-type: none"> 1. Check the BladeCenter management-module event log. If an error was recorded by the system, see "POST progress codes (checkpoints)" on page 97. 2. Replace any parts reported by the diagnostic program. 3. Replace the system-board
252B-715	252B	Temporary adapter failure. <ol style="list-style-type: none"> 1. Check the BladeCenter management-module event log. If an error was recorded by the system, see "POST progress codes (checkpoints)" on page 97. 2. Replace any parts reported by the diagnostic program. 3. Replace the system-board
252B-716	252B 293	PCI bus error detected by EEH. <ol style="list-style-type: none"> 1. Check the BladeCenter management-module event log. If an error was recorded by the system, see "POST progress codes (checkpoints)" on page 97. 2. Replace any parts reported by the diagnostic program. 3. Replace the system-board
252B-717	252B 293	PCI bus error detected by adapter. <ol style="list-style-type: none"> 1. Check the BladeCenter management-module event log. If an error was recorded by the system, see "POST progress codes (checkpoints)" on page 97. 2. Replace any parts reported by the diagnostic program. 3. Replace the system-board
252B-718	252B 293	Temporary PCI bus error detected by adapter. <ol style="list-style-type: none"> 1. Check the BladeCenter management-module event log. If an error was recorded by the system, see "POST progress codes (checkpoints)" on page 97. 2. Replace any parts reported by the diagnostic program. 3. Replace the system-board

Table 27. 101-711 through FFC-725 SRNs (continued)

SRN	FFC	Description and Action
252B-719	252B	Device bus termination power lost or not detected. <ol style="list-style-type: none"> 1. Check the BladeCenter management-module event log. If an error was recorded by the system, see "POST progress codes (checkpoints)" on page 97. 2. Replace any parts reported by the diagnostic program. 3. Replace the system-board
252B-720	252B	Adapter detected device bus failure. <ol style="list-style-type: none"> 1. Check the BladeCenter management-module event log. If an error was recorded by the system, see "POST progress codes (checkpoints)" on page 97. 2. Replace any parts reported by the diagnostic program. 3. Replace the system-board
252B-721	252B	Temporary adapter detected device bus failure. <ol style="list-style-type: none"> 1. Check the BladeCenter management-module event log. If an error was recorded by the system, see "POST progress codes (checkpoints)" on page 97. 2. Replace any parts reported by the diagnostic program. 3. Replace the system-board
252B-722	252B	Device bus interface problem. <ol style="list-style-type: none"> 1. Check the BladeCenter management-module event log. If an error was recorded by the system, see "POST progress codes (checkpoints)" on page 97. 2. Replace any parts reported by the diagnostic program. 3. Replace the system-board
252B-723	252B	Device bus interface problem. <ol style="list-style-type: none"> 1. Check the BladeCenter management-module event log. If an error was recorded by the system, see "POST progress codes (checkpoints)" on page 97. 2. Replace any parts reported by the diagnostic program. 3. Replace the system-board
254E-201	254E 221	Adapter configuration error. Go to "Performing the checkout procedure" on page 177.
254E-601	254	Error log analysis indicates adapter failure. Go to "Performing the checkout procedure" on page 177.
254E-602	254	Error log analysis indicates an error attention condition. Go to "Performing the checkout procedure" on page 177.
254E-603	254	Error log analysis indicates that the microcode could not be loaded on the adapter. Go to "Performing the checkout procedure" on page 177.
254E-604	254	Error log analysis indicates a permanent adapter failure. Go to "Performing the checkout procedure" on page 177.
254E-605	254	Error log analysis indicates permanent adapter failure is reported on the other port of this adapter. Go to "Performing the checkout procedure" on page 177.
254E-606	254	Error log analysis indicates adapter failure. Go to "Performing the checkout procedure" on page 177.
254E-701	254E 221	Error log analysis indicates permanent adapter failure. Go to "Performing the checkout procedure" on page 177.
254E-702	254E 221	Error log analysis indicates permanent adapter failure is reported on the other port of this adapter. Go to "Performing the checkout procedure" on page 177.
2567-xxx	2567	USB integrated system-board and chassis assembly. Go to "Performing the checkout procedure" on page 177.

Table 27. 101-711 through FFC-725 SRNs (continued)

SRN	FFC	Description and Action
256D-201	256D 221	Adapter configuration error. <ol style="list-style-type: none"> 1. Check the BladeCenter management-module event log. If an error was recorded by the system, see "POST progress codes (checkpoints)" on page 97. 2. Replace any parts reported by the diagnostic program. 3. Replace the system-board
256D-601	256D	Error log analysis indicates adapter. <ol style="list-style-type: none"> 1. Check the BladeCenter management-module event log. If an error was recorded by the system, see "POST progress codes (checkpoints)" on page 97. 2. Replace any parts reported by the diagnostic program. 3. Replace the system-board
256D-602	256D	Error log analysis indicates an error attention condition. <ol style="list-style-type: none"> 1. Check the BladeCenter management-module event log. If an error was recorded by the system, see "POST progress codes (checkpoints)" on page 97. 2. Replace any parts reported by the diagnostic program. 3. Replace the system-board
256D-603	256D	Error Log Analysis indicates that the microcode could not be loaded on the adapter. <ol style="list-style-type: none"> 1. Check the BladeCenter management-module event log. If an error was recorded by the system, see "POST progress codes (checkpoints)" on page 97. 2. Replace any parts reported by the diagnostic program. 3. Replace the system-board
256D-604	256D 210	Error Log Analysis indicates a permanent adapter failure. <ol style="list-style-type: none"> 1. Check the BladeCenter management-module event log. If an error was recorded by the system, see "POST progress codes (checkpoints)" on page 97. 2. Replace any parts reported by the diagnostic program. 3. Replace the system-board
256D-605	256D	Error Log Analysis indicates permanent adapter failure is reported on the other port of this adapter. <ol style="list-style-type: none"> 1. Check the BladeCenter management-module event log. If an error was recorded by the system, see "POST progress codes (checkpoints)" on page 97. 2. Replace any parts reported by the diagnostic program. 3. Replace the system-board
256D-606	256D	Error Log Analysis indicates adapter failure. <ol style="list-style-type: none"> 1. Check the BladeCenter management-module event log. If an error was recorded by the system, see "POST progress codes (checkpoints)" on page 97. 2. Replace any parts reported by the diagnostic program. 3. Replace the system-board
256D-701	256D 221	Error Log Analysis indicates permanent adapter failure. <ol style="list-style-type: none"> 1. Check the BladeCenter management-module event log. If an error was recorded by the system, see "POST progress codes (checkpoints)" on page 97. 2. Replace any parts reported by the diagnostic program. 3. Replace the system-board
256D-702	256D 221	Error Log Analysis indicates permanent adapter failure is reported on the other port of this adapter. <ol style="list-style-type: none"> 1. Check the BladeCenter management-module event log. If an error was recorded by the system, see "POST progress codes (checkpoints)" on page 97. 2. Replace any parts reported by the diagnostic program. 3. Replace the system-board

Table 27. 101-711 through FFC-725 SRNs (continued)

SRN	FFC	Description and Action
25C4-xxx	25C4	Generic reference for Broadcom adapter. Go to "Performing the checkout procedure" on page 177.
25C4-201	25C4	Configuration error. Go to "Performing the checkout procedure" on page 177.
25C4-701	25C4	Permanent adapter failure. Go to "Performing the checkout procedure" on page 177.
25C4-601	25C4	Download firmware error. Go to "Performing the checkout procedure" on page 177.
25C4-602	25C4	EEPROM read error. Go to "Performing the checkout procedure" on page 177.
2604-xxx	2604	Generic reference for 4Gb Fibre Channel Adapter card. Go to "Performing the checkout procedure" on page 177.
2604-102	2604	Reset Test failure for the Fibre Channel adapter card. Replace the 4Gb Fibre Channel Adapter card.
2604-103	2604	Register Test failure for the Fibre Channel adapter card. Replace the 4Gb Fibre Channel Adapter card.
2604-104	2604	SRAM Test failure for the Fibre Channel adapter card. Replace the 4Gb Fibre Channel Adapter card.
2604-105	2604	Internal Wrap Test failure for the Fibre Channel adapter card. Replace the 4Gb Fibre Channel Adapter card.
2604-106	2604	Gigabit Link Module (GLM) Wrap Test failure for the Fibre Channel adapter card. Replace the 4Gb Fibre Channel Adapter card.
2604-108	2604 221	Enhanced Error Handling Failure on the bus for the Fibre Channel adapter card. Go to "Performing the checkout procedure" on page 177.
2604-110	2604	Enhanced Error Handling Failure on the Fibre Channel adapter card. Replace the 4Gb Fibre Channel Adapter card.
2604-201	2604 221	Configuration Register Test Failure for the Fibre Channel adapter card. Go to "Performing the checkout procedure" on page 177.
2604-203	2604	PCI Wrap Test Failure for the Fibre Channel adapter card. Replace the 4Gb Fibre Channel Adapter card.
2604-204	2604 221	DMA Test Failure for the Fibre Channel adapter card. Go to "Performing the checkout procedure" on page 177.
2604-205	2604 221	Error on Read/Write Operation for the Fibre Channel adapter card. Go to "Performing the checkout procedure" on page 177.
2604-701	2604	Error Log Analysis indicates that the adapter self-test failed for the Fibre Channel adapter card. Go to "Performing the checkout procedure" on page 177.
2604-703	2604	Error Log Analysis indicates that an unknown adapter error has occurred for the Fibre Channel adapter card. Go to "Performing the checkout procedure" on page 177.
2604-704	2604	Error Log Analysis indicates that an adapter error has occurred for the Fibre Channel adapter card. Go to "Performing the checkout procedure" on page 177.
2604-705	2604	Error Log Analysis indicates that a parity error has been detected for the Fibre Channel adapter card. The adapter must be replaced immediately. Failure to do so could result in data being read or written incorrectly.
2604-706	2604	Error Log Analysis indicates that a fatal hardware error has occurred for the Fibre Channel adapter card. This adapter was successfully taken off-line. It will remain off-line until reconfigured or the system is rebooted. This adapter must be replaced and not brought back on-line. Failure to adhere to this action could result in data being read or written incorrectly or in the loss of data.

Table 27. 101-711 through FFC-725 SRNs (continued)

SRN	FFC	Description and Action
2607-xxx	2607	Generic reference for 8Gb PCIe Fibre Channel Expansion Card. Go to “Performing the checkout procedure” on page 177.
2607-102	2607	Reset Test failure for the Fibre Channel adapter card. Replace the 8Gb PCIe Fibre Channel Expansion Card.
2607-103	2607	Register Test failure for the Fibre Channel adapter card. Replace the 8Gb PCIe Fibre Channel Expansion Card.
2607-104	2607	SRAM Test failure for the Fibre Channel adapter card. Replace the 8Gb PCIe Fibre Channel Expansion Card.
2607-105	2607	Internal Wrap Test failure for the Fibre Channel adapter card. Replace the 8Gb PCIe Fibre Channel Expansion Card.
2607-106	2607	Gigabit Link Module (GLM) Wrap Test failure for the Fibre Channel adapter card. Replace the 8Gb PCIe Fibre Channel Expansion Card.
2607-108	2607 221	Enhanced Error Handling Failure on the bus for the Fibre Channel adapter card. Go to “Performing the checkout procedure” on page 177.
2607-110	2607	Enhanced Error Handling Failure on the Fibre Channel adapter card. Replace the 8Gb PCIe Fibre Channel Expansion Card.
2607-201	2607 221	Configuration Register Test Failure for the Fibre Channel adapter card. Go to “Performing the checkout procedure” on page 177.
2607-203	2607	PCI Wrap Test Failure for the Fibre Channel adapter card. Replace the 8Gb PCIe Fibre Channel Expansion Card.
2607-204	2607 221	DMA Test Failure for the Fibre Channel adapter card. Go to “Performing the checkout procedure” on page 177.
2607-205	2607 221	Error on Read/Write Operation for the Fibre Channel adapter card. Go to “Performing the checkout procedure” on page 177.
2607-701	2607	Error Log Analysis indicates that the adapter self-test failed for the Fibre Channel adapter card. Go to “Performing the checkout procedure” on page 177.
2607-703	2607	Error Log Analysis indicates that an unknown adapter error has occurred for the Fibre Channel adapter card. Go to “Performing the checkout procedure” on page 177.
2607-704	2607	Error Log Analysis indicates that an adapter error has occurred for the Fibre Channel adapter card. Go to “Performing the checkout procedure” on page 177.
2607-705	2607	Error Log Analysis indicates that a parity error has been detected for the Fibre Channel adapter card. The adapter must be replaced immediately. Failure to do so could result in data being read or written incorrectly.
2607-706	2607	Error Log Analysis indicates that a fatal hardware error has occurred for the Fibre Channel adapter card. This adapter was successfully taken off-line. It will remain off-line until reconfigured or the system is rebooted. This adapter must be replaced and not brought back on-line. Failure to adhere to this action could result in data being read or written incorrectly or in the loss of data.
2624-xxx	2624	Generic reference for 4X PCI-E DDR InfiniBand Host Channel Adapter. Go to “Performing the checkout procedure” on page 177.
2624-101	2624	Configuration failure. Replace the 4X PCI-E DDR InfiniBand Host Channel Adapter.
2624-102	2624	Queue pair create failure. Replace the 4X PCI-E DDR InfiniBand Host Channel Adapter.
2624-103	2624	Loop back test failure. Replace the 4X PCI-E DDR InfiniBand Host Channel Adapter.

Table 27. 101-711 through FFC-725 SRNs (continued)

SRN	FFC	Description and Action
2624-201	cable network	Loop back test failure. Do the following steps one at a time, in order, and rerun the test after each step: <ol style="list-style-type: none"> 1. Reseat the cable. 2. Replace the cable. 3. Verify that the network is functional. 4. Verify that the network switch is functional.
2624-301	cable network 2624	Loop back test failure. Do the following steps one at a time, in order, and rerun the test after each step: <ol style="list-style-type: none"> 1. Reseat the cable. 2. Replace the cable. 3. Verify that the network is functional. 4. Verify that the network switch is functional. 5. Go to "Performing the checkout procedure" on page 177.
2624-701	2624	Error Log Analysis indicates that this adapter has failed due to an internal error. Replace the 4X PCI-E DDR InfiniBand Host Channel Adapter.
2624-702	2624	Error Log Analysis indicates that this adapter has failed due to a failure with the uplink interface used to connect this device to the host processor. Replace the 4X PCI-E DDR InfiniBand Host Channel Adapter.
2624-703	2624	Error Log Analysis indicates that this adapter has failed due to a memory error. Replace the 4X PCI-E DDR InfiniBand Host Channel Adapter.
2624-704	2624	Error Log Analysis indicates that this adapter has failed due to a unrecoverable internal parity error Replace the 4X PCI-E DDR InfiniBand Host Channel Adapter.
2624-705	2624	Error Log Analysis indicates that this adapter has failed due to a internal error. Replace the 4X PCI-E DDR InfiniBand Host Channel Adapter.
2624-706	2624	Error Log Analysis indicates that this adapter has failed due to a memory error. Replace the 4X PCI-E DDR InfiniBand Host Channel Adapter.
2625-xxx	2625	Generic reference for 2-port QDR 40 GB/S InfiniBand expansion card (CFFh). Go to "Performing the checkout procedure" on page 177.
2625-101	2625	Configuration failure. Replace the 2-port QDR 40 GB/S InfiniBand expansion card (CFFh).
2625-102	2625	Queue pair create failure. Replace the 2-port QDR 40 GB/S InfiniBand expansion card (CFFh).
2625-103	2625	Loop back test failure. Replace the 2-port QDR 40 GB/S InfiniBand expansion card (CFFh).
2625-201	cable network	Loop back test failure. Do the following steps one at a time, in order, and rerun the test after each step: <ol style="list-style-type: none"> 1. Reseat the cable. 2. Replace the cable. 3. Verify that the network is functional. 4. Verify that the network switch is functional.
2625-301	cable network 2625	Loop back test failure. Do the following steps one at a time, in order, and rerun the test after each step: <ol style="list-style-type: none"> 1. Reseat the cable. 2. Replace the cable. 3. Verify that the network is functional. 4. Verify that the network switch is functional. 5. Go to "Performing the checkout procedure" on page 177.

Table 27. 101-711 through FFC-725 SRNs (continued)

SRN	FFC	Description and Action
2625-701	2625	Error Log Analysis indicates that this adapter has failed due to an internal error. Replace the 2-port QDR 40 GB/S InfiniBand expansion card (CFFh).
2625-702	2625	Error Log Analysis indicates that this adapter has failed due to a failure with the uplink interface used to connect this device to the host processor. Replace the 2-port QDR 40 GB/S InfiniBand expansion card (CFFh).
2625-703	2625	Error Log Analysis indicates that this adapter has failed due to a memory error. Replace the 2-port QDR 40 GB/S InfiniBand expansion card (CFFh).
2625-704	2625	Error Log Analysis indicates that this adapter has failed due to a unrecoverable internal parity error. Replace the 2-port QDR 40 GB/S InfiniBand expansion card (CFFh).
2625-705	2625	Error Log Analysis indicates that this adapter has failed due to a internal error. Replace the 2-port QDR 40 GB/S InfiniBand expansion card (CFFh).
2625-706	2625	Error Log Analysis indicates that this adapter has failed due to a memory error. Replace the 2-port QDR 40 GB/S InfiniBand expansion card (CFFh).
2640-121	2640	Physical volume hardware error. Go to "Performing the checkout procedure" on page 177.
2640-131	2640	Smart status threshold exceeded. Go to "Performing the checkout procedure" on page 177.
2640-132	2640	Command timeouts threshold exceeded. Go to "Performing the checkout procedure" on page 177.
2640-133	2640	Command timeout with error condition. Go to "Performing the checkout procedure" on page 177.
2640-134	2640	Hardware command or DMA failure. Go to "Performing the checkout procedure" on page 177.
2640-136	2640 2631	Timeout waiting for controller or drive with no busy status. Go to "Performing the checkout procedure" on page 177.
268B-102	268B	An unrecoverable media error occurred. <ol style="list-style-type: none"> 1. Check the BladeCenter management-module event log. If an error was recorded by the system, see "POST progress codes (checkpoints)" on page 97. 2. Replace any parts reported by the diagnostic program. 3. Replace the system board and chassis assembly, as described in Replacing the Tier 2 system-board and chassis assembly.
268B-104	268B	The motor failed to restart. <ol style="list-style-type: none"> 1. Check the BladeCenter management-module event log. If an error was recorded by the system, see "POST progress codes (checkpoints)" on page 97. 2. Replace any parts reported by the diagnostic program. 3. Replace the system board and chassis assembly, as described in Replacing the Tier 2 system-board and chassis assembly.
268B-105	268B	The drive did not become ready. <ol style="list-style-type: none"> 1. Check the BladeCenter management-module event log. If an error was recorded by the system, see "POST progress codes (checkpoints)" on page 97. 2. Replace any parts reported by the diagnostic program. 3. Replace the system board and chassis assembly, as described in Replacing the Tier 2 system-board and chassis assembly.

Table 27. 101-711 through FFC-725 SRNs (continued)

SRN	FFC	Description and Action
268B-106	268B	The electronics card test failed. <ol style="list-style-type: none"> 1. Check the BladeCenter management-module event log. If an error was recorded by the system, see "POST progress codes (checkpoints)" on page 97. 2. Replace any parts reported by the diagnostic program. 3. Replace the system board and chassis assembly, as described in Replacing the Tier 2 system-board and chassis assembly.
268B-108	268B	The bus test failed. <ol style="list-style-type: none"> 1. Check the BladeCenter management-module event log. If an error was recorded by the system, see "POST progress codes (checkpoints)" on page 97. 2. Replace any parts reported by the diagnostic program. 3. Replace the system board and chassis assembly, as described in Replacing the Tier 2 system-board and chassis assembly.
268B-110	268B	The media format is corrupted. <ol style="list-style-type: none"> 1. Check the BladeCenter management-module event log. If an error was recorded by the system, see "POST progress codes (checkpoints)" on page 97. 2. Replace any parts reported by the diagnostic program. 3. Replace the system board and chassis assembly, as described in Replacing the Tier 2 system-board and chassis assembly.
268B-112	268B	The diagnostic test failed. <ol style="list-style-type: none"> 1. Check the BladeCenter management-module event log. If an error was recorded by the system, see "POST progress codes (checkpoints)" on page 97. 2. Replace any parts reported by the diagnostic program. 3. Replace the system board and chassis assembly, as described in Replacing the Tier 2 system-board and chassis assembly.
268B-114	268B	An unrecoverable hardware error. <ol style="list-style-type: none"> 1. Check the BladeCenter management-module event log. If an error was recorded by the system, see "POST progress codes (checkpoints)" on page 97. 2. Replace any parts reported by the diagnostic program. 3. Replace the system board and chassis assembly, as described in Replacing the Tier 2 system-board and chassis assembly.
268B-116	268B	A protocol error. <ol style="list-style-type: none"> 1. Make sure that the device, adapter and diagnostic firmware, and the application software levels are compatible. 2. If you do not find a problem, call your operating-system support person.
268B-117	268B	A write-protect error occurred. <ol style="list-style-type: none"> 1. Check the BladeCenter management-module event log. If an error was recorded by the system, see "POST progress codes (checkpoints)" on page 97. 2. Replace any parts reported by the diagnostic program. 3. Replace the system board and chassis assembly, as described in Replacing the Tier 2 system-board and chassis assembly.
268B-118	268B 252B	A SCSD command time-out occurred. <ol style="list-style-type: none"> 1. Check the BladeCenter management-module event log. If an error was recorded by the system, see "POST progress codes (checkpoints)" on page 97. 2. Replace any parts reported by the diagnostic program. 3. Replace the system board and chassis assembly, as described in Replacing the Tier 2 system-board and chassis assembly.

Table 27. 101-711 through FFC-725 SRNs (continued)

SRN	FFC	Description and Action
268B-120	268B	<p>A SCSD busy or command error.</p> <ol style="list-style-type: none"> 1. Check the BladeCenter management-module event log. If an error was recorded by the system, see “POST progress codes (checkpoints)” on page 97. 2. Replace any parts reported by the diagnostic program. 3. Replace the system board and chassis assembly, as described in Replacing the Tier 2 system-board and chassis assembly.
268B-122	268B	<p>A SCSD reservation conflict error.</p> <ol style="list-style-type: none"> 1. Check the BladeCenter management-module event log. If an error was recorded by the system, see “POST progress codes (checkpoints)” on page 97. 2. Replace any parts reported by the diagnostic program. 3. Replace the system board and chassis assembly, as described in Replacing the Tier 2 system-board and chassis assembly.
268B-124	268B	<p>A SCSD check condition error occurred.</p> <ol style="list-style-type: none"> 1. Check the BladeCenter management-module event log. If an error was recorded by the system, see “POST progress codes (checkpoints)” on page 97. 2. Replace any parts reported by the diagnostic program. 3. Replace the system board and chassis assembly, as described in Replacing the Tier 2 system-board and chassis assembly.
268B-126	268B 252B	<p>A software error was caused by a hardware failure.</p> <ol style="list-style-type: none"> 1. Check the BladeCenter management-module event log. If an error was recorded by the system, see “POST progress codes (checkpoints)” on page 97. 2. Replace any parts reported by the diagnostic program. 3. Replace the system board and chassis assembly, as described in Replacing the Tier 2 system-board and chassis assembly.
268B-128	252B 268B Software	<p>The error log analysis indicates a hardware failure.</p> <ol style="list-style-type: none"> 1. Check the BladeCenter management-module event log. If an error was recorded by the system, see “POST progress codes (checkpoints)” on page 97. 2. Replace any parts reported by the diagnostic program. 3. Replace the system board and chassis assembly, as described in Replacing the Tier 2 system-board and chassis assembly.
268B-129	252B 268B Software	<p>Error log analysis indicates a SCSD bus problem.</p> <ol style="list-style-type: none"> 1. Check the BladeCenter management-module event log. If an error was recorded by the system, see “POST progress codes (checkpoints)” on page 97. 2. Replace any parts reported by the diagnostic program. 3. Replace the system board and chassis assembly, as described in Replacing the Tier 2 system-board and chassis assembly.
268B-130	268B	<p>Error log analysis indicates a problem reported by the disk drive's self-monitoring function.</p> <ol style="list-style-type: none"> 1. Check the BladeCenter management-module event log. If an error was recorded by the system, see “POST progress codes (checkpoints)” on page 97. 2. Replace any parts reported by the diagnostic program. 3. Replace the system board and chassis assembly, as described in Replacing the Tier 2 system-board and chassis assembly.

Table 27. 101-711 through FFC-725 SRNs (continued)

SRN	FFC	Description and Action
268B-132	268B	<p>A disk drive hardware error occurred.</p> <ol style="list-style-type: none"> 1. Check the BladeCenter management-module event log. If an error was recorded by the system, see “POST progress codes (checkpoints)” on page 97. 2. Replace any parts reported by the diagnostic program. 3. Replace the system board and chassis assembly, as described in Replacing the Tier 2 system-board and chassis assembly.
268B-134	252B Software	<p>The adapter failed to configure.</p> <ol style="list-style-type: none"> 1. Check the BladeCenter management-module event log. If an error was recorded by the system, see “POST progress codes (checkpoints)” on page 97. 2. Replace any parts reported by the diagnostic program. 3. Replace the system board and chassis assembly, as described in Replacing the Tier 2 system-board and chassis assembly.
268B-135	268B 252B Software	<p>The device failed to configure.</p> <ol style="list-style-type: none"> 1. Check the BladeCenter management-module event log. If an error was recorded by the system, see “POST progress codes (checkpoints)” on page 97. 2. Replace any parts reported by the diagnostic program. 3. Replace the system board and chassis assembly, as described in Replacing the Tier 2 system-board and chassis assembly.
268B-136	268B	<p>The certify operation failed.</p> <ol style="list-style-type: none"> 1. Check the BladeCenter management-module event log. If an error was recorded by the system, see “POST progress codes (checkpoints)” on page 97. 2. Replace any parts reported by the diagnostic program. 3. Replace the system board and chassis assembly, as described in Replacing the Tier 2 system-board and chassis assembly.
268B-137	268B 252B	<p>Unit attention condition has occurred on the Send Diagnostic command.</p> <ol style="list-style-type: none"> 1. Check the BladeCenter management-module event log. If an error was recorded by the system, see “POST progress codes (checkpoints)” on page 97. 2. Replace any parts reported by the diagnostic program. 3. Replace the system board and chassis assembly, as described in Replacing the Tier 2 system-board and chassis assembly.
268B-138	268B	<p>Error log analysis indicates that the disk drive is operating at a higher than recommended temperature.</p> <ul style="list-style-type: none"> • Make sure that: <ul style="list-style-type: none"> – The ventilation holes in the blade server bezel are not blocked. – The management-module event log is not reporting any system environmental warnings. • If the problem remains, call IBM support.
268B-140	199 252B 268B	<p>Error log analysis indicates poor signal quality.</p> <ol style="list-style-type: none"> 1. Check the BladeCenter management-module event log. If an error was recorded by the system, see “POST progress codes (checkpoints)” on page 97. 2. Replace any parts reported by the diagnostic program. 3. Replace the system board and chassis assembly, as described in Replacing the Tier 2 system-board and chassis assembly.

Table 27. 101-711 through FFC-725 SRNs (continued)

SRN	FFC	Description and Action
268B-640	268B	Error log analysis indicates a path error. 1. Check the BladeCenter management-module event log. If an error was recorded by the system, see “POST progress codes (checkpoints)” on page 97. 2. Replace any parts reported by the diagnostic program. 3. Replace the system board and chassis assembly, as described in Replacing the Tier 2 system-board and chassis assembly.
26B4-102	26B4	An unrecoverable media error occurred.
26B4-104	26B4	The motor failed to restart.
26B4-105	26B4	The drive did not become ready.
26B4-106	26B4	The electronics card test failed.
26B4-108	26B4	The bus test failed.
26B4-110	26B4	The media format is corrupted.
26B4-112	26B4	The diagnostic test failed.
26B4-114	26B4	An unrecoverable hardware error.
26B4-116	26B4 26BD	A protocol error. Check the levels of the device, adapter, diagnostic software, and application software to be sure they are all compatible. If you do not find a problem, call your support person.
26B4-117	26B4	A write-protect error occurred.
26B4-118	26B4 26BD 252B	A SCSI command time-out occurred.
26B4-120	26B4 26BD	A SCSI busy or command error.
26B4-122	26B4 26BD	A SCSI reservation conflict error.
26B4-124	26B4 26BD	A SCSI check condition error occurred.
26B4-126	26B4 26BD 252B	A software error was caused by a hardware failure.
26B4-128	26BD 252B 26B4 Software	The error log analysis indicates a hardware failure.
26B4-129	26BD 252B 26B4 Software	Error log analysis indicates a SCSI bus problem.

Table 27. 101-711 through FFC-725 SRNs (continued)

SRN	FFC	Description and Action
26B4-130	26B4	Error log analysis indicates a problem reported by the disk drive's self-monitoring function.
26B4-132	26B4 26BD	A disk drive hardware error occurred.
26B4-134	252B Software	The adapter failed to configure.
26B4-135	26B4 26BD 252B Software	The device failed to configure.
26B4-136	26B4	The certify operation failed.
26B4-137	26B4 26BD 252B	Unit attention condition has occurred on the Send Diagnostic command.
26B4-138	26B4	Error log analysis indicates that the disk drive is operating at a higher than recommended temperature. Check to be sure none of the air passages in the system covers are blocked, that no other system environmental warnings are occurring.
26B4-140	26BD 252B 26B4	Error log analysis indicates poor signal quality.
26B4-640		Error log analysis indicates a path error.
26D2-102	26D2	An unrecoverable media error occurred.
26D2-104	26D2	The motor failed to restart.
26D2-105	26D2	The drive did not become ready.
26D2-106	26D2	The electronics card test failed.
26D2-108	26D2	The bus test failed.
26D2-110	26D2	The media format is corrupted.
26D2-112	26D2	The diagnostic test failed.
26D2-114	26D2	An unrecoverable hardware error.
26D2-116	26D2	A protocol error. Check the levels of the device, adapter, diagnostic software, and application software to be sure they are all compatible. If you do not find a problem, call your support person.
26D2-117	26D2	A write-protect error occurred.
26D2-118	26D2 252B	A SCSI command time-out occurred.
26D2-120	26D2	A SCSI busy or command error.
26D2-122	26D2	A SCSI reservation conflict error.

Table 27. 101-711 through FFC-725 SRNs (continued)

SRN	FFC	Description and Action
26D2-124	26D2	A SCSI check condition error occurred.
26D2-126	26D2 252B	A software error was caused by a hardware failure.
26D2-128	252B 26D2 Software	The error log analysis indicates a hardware failure.
26D2-129	252B 26D2 Software	Error log analysis indicates a SCSI bus problem.
26D2-130	26D2	Error log analysis indicates a problem reported by the disk drive's self-monitoring function.
26D2-132	26D2	A disk drive hardware error occurred.
26D2-134	252B Software	The adapter failed to configure.
26D2-135	26D2 252B Software	The device failed to configure.
26D2-136	26D2	The certify operation failed.
26D2-137	26D2 252B	Unit attention condition has occurred on the Send Diagnostic command.
26D2-138	26D2	Error log analysis indicates that the disk drive is operating at a higher than recommended temperature. Check to be sure none of the air passages in the system covers are blocked, that no other system environmental warnings are occurring.
26D2-140	199 252B 26D2	Error log analysis indicates poor signal quality.
26D2-640		Error log analysis indicates a path error.
2D02-xxx	2631	Generic reference for USB controller/adaptor - system-board and chassis assembly. Go to "Performing the checkout procedure" on page 177.
2E00-201	2E00 221	Configuration error. 1. Check the BladeCenter management-module event log. If an error was recorded by the system, see "POST progress codes (checkpoints)" on page 97. 2. Replace any parts reported by the diagnostic program. 3. Replace the system-board

Table 27. 101-711 through FFC-725 SRNs (continued)

SRN	FFC	Description and Action
2E00-601	2E00	EEPROM read error <ol style="list-style-type: none"> 1. Check the BladeCenter management-module event log. If an error was recorded by the system, see "POST progress codes (checkpoints)" on page 97. 2. Replace any parts reported by the diagnostic program. 3. Replace the system-board
2E00-701	2E00 221	Permanent adapter failure. <ol style="list-style-type: none"> 1. Check the BladeCenter management-module event log. If an error was recorded by the system, see "POST progress codes (checkpoints)" on page 97. 2. Replace any parts reported by the diagnostic program. 3. Replace the system-board
2E10-201	2E10 221	Adapter configuration error. <ol style="list-style-type: none"> 1. Check the BladeCenter management-module event log. If an error was recorded by the system, see "POST progress codes (checkpoints)" on page 97. 2. Replace any parts reported by the diagnostic program. 3. Replace the system-board
2E10-601	2E10	Error Log Analysis indicates adapter failure. <ol style="list-style-type: none"> 1. Check the BladeCenter management-module event log. If an error was recorded by the system, see "POST progress codes (checkpoints)" on page 97. 2. Replace any parts reported by the diagnostic program. 3. Replace the system-board
2E10-602	2E10	Error Log Analysis indicates an Error Attention condition. <ol style="list-style-type: none"> 1. Check the BladeCenter management-module event log. If an error was recorded by the system, see "POST progress codes (checkpoints)" on page 97. 2. Replace any parts reported by the diagnostic program. 3. Replace the system-board
2E10-603	2E10	Error Log Analysis indicates that the microcode could not be loaded on the adapter. <ol style="list-style-type: none"> 1. Check the BladeCenter management-module event log. If an error was recorded by the system, see "POST progress codes (checkpoints)" on page 97. 2. Replace any parts reported by the diagnostic program. 3. Replace the system-board
2E10-604	2E10	Error Log Analysis indicates a permanent adapter failure. <ol style="list-style-type: none"> 1. Check the BladeCenter management-module event log. If an error was recorded by the system, see "POST progress codes (checkpoints)" on page 97. 2. Replace any parts reported by the diagnostic program. 3. Replace the system-board
2E10-605	2E10	Error Log Analysis indicates permanent adapter failure is reported on the other port of this adapter. <ol style="list-style-type: none"> 1. Check the BladeCenter management-module event log. If an error was recorded by the system, see "POST progress codes (checkpoints)" on page 97. 2. Replace any parts reported by the diagnostic program. 3. Replace the system-board
2E10-606	2E10	Error Log Analysis indicates adapter failure. <ol style="list-style-type: none"> 1. Check the BladeCenter management-module event log. If an error was recorded by the system, see "POST progress codes (checkpoints)" on page 97. 2. Replace any parts reported by the diagnostic program. 3. Replace the system-board

Table 27. 101-711 through FFC-725 SRNs (continued)

SRN	FFC	Description and Action
2E10-701	2E10 221	Error Log Analysis indicates permanent adapter failure. <ol style="list-style-type: none"> 1. Check the BladeCenter management-module event log. If an error was recorded by the system, see "POST progress codes (checkpoints)" on page 97. 2. Replace any parts reported by the diagnostic program. 3. Replace the system-board
2E10-702	2E10 221	Error Log Analysis indicates permanent adapter failure. <ol style="list-style-type: none"> 1. Check the BladeCenter management-module event log. If an error was recorded by the system, see "POST progress codes (checkpoints)" on page 97. 2. Replace any parts reported by the diagnostic program. 3. Replace the system-board
2E13-201	2E13 221	Adapter configuration error. <ol style="list-style-type: none"> 1. Check the BladeCenter management-module event log. If an error was recorded by the system, see "POST progress codes (checkpoints)" on page 97. 2. Replace any parts reported by the diagnostic program. 3. Replace the system-board
2E13-601	2E13	Error Log Analysis indicates adapter failure. <ol style="list-style-type: none"> 1. Check the BladeCenter management-module event log. If an error was recorded by the system, see "POST progress codes (checkpoints)" on page 97. 2. Replace any parts reported by the diagnostic program. 3. Replace the system-board
2E13-602	2E13	Error Log Analysis indicates an Error Attention condition. <ol style="list-style-type: none"> 1. Check the BladeCenter management-module event log. If an error was recorded by the system, see "POST progress codes (checkpoints)" on page 97. 2. Replace any parts reported by the diagnostic program. 3. Replace the system-board
2E13-603	2E13	Error Log Analysis indicates that the microcode could not be loaded on the adapter. <ol style="list-style-type: none"> 1. Check the BladeCenter management-module event log. If an error was recorded by the system, see "POST progress codes (checkpoints)" on page 97. 2. Replace any parts reported by the diagnostic program. 3. Replace the system-board
2E13-604	2E13	Error Log Analysis indicates a permanent adapter failure. <ol style="list-style-type: none"> 1. Check the BladeCenter management-module event log. If an error was recorded by the system, see "POST progress codes (checkpoints)" on page 97. 2. Replace any parts reported by the diagnostic program. 3. Replace the system-board
2E13-605	2E13	Error Log Analysis indicates permanent adapter failure is reported on the other port of this adapter. <ol style="list-style-type: none"> 1. Check the BladeCenter management-module event log. If an error was recorded by the system, see "POST progress codes (checkpoints)" on page 97. 2. Replace any parts reported by the diagnostic program. 3. Replace the system-board
2E13-606	2E13	Error Log Analysis indicates adapter failure. <ol style="list-style-type: none"> 1. Check the BladeCenter management-module event log. If an error was recorded by the system, see "POST progress codes (checkpoints)" on page 97. 2. Replace any parts reported by the diagnostic program. 3. Replace the system-board

Table 27. 101-711 through FFC-725 SRNs (continued)

SRN	FFC	Description and Action
2E13-701	2E13 221	Error Log Analysis indicates permanent adapter failure. <ol style="list-style-type: none"> 1. Check the BladeCenter management-module event log. If an error was recorded by the system, see "POST progress codes (checkpoints)" on page 97. 2. Replace any parts reported by the diagnostic program. 3. Replace the system-board
2E13-702	2E13 221	Error Log Analysis indicates permanent adapter failure is reported <ol style="list-style-type: none"> 1. Check the BladeCenter management-module event log. If an error was recorded by the system, see "POST progress codes (checkpoints)" on page 97. 2. Replace any parts reported by the diagnostic program. 3. Replace the system-board
2E14-201	2E14 221	Adapter configuration error. <ol style="list-style-type: none"> 1. Check the BladeCenter management-module event log. If an error was recorded by the system, see "POST progress codes (checkpoints)" on page 97. 2. Replace any parts reported by the diagnostic program. 3. Replace the system-board
2E14-601	2E14	Error Log Analysis indicates adapter failure. <ol style="list-style-type: none"> 1. Check the BladeCenter management-module event log. If an error was recorded by the system, see "POST progress codes (checkpoints)" on page 97. 2. Replace any parts reported by the diagnostic program. 3. Replace the system-board
2E14-602	2E14	Error Log Analysis indicates an Error Attention condition. <ol style="list-style-type: none"> 1. Check the BladeCenter management-module event log. If an error was recorded by the system, see "POST progress codes (checkpoints)" on page 97. 2. Replace any parts reported by the diagnostic program. 3. Replace the system-board
2E14-603	2E14	Error Log Analysis indicates that the microcode could not be loaded on the adapter. <ol style="list-style-type: none"> 1. Check the BladeCenter management-module event log. If an error was recorded by the system, see "POST progress codes (checkpoints)" on page 97. 2. Replace any parts reported by the diagnostic program. 3. Replace the system-board
2E14-604	2E14	Error Log Analysis indicates a permanent adapter failure. <ol style="list-style-type: none"> 1. Check the BladeCenter management-module event log. If an error was recorded by the system, see "POST progress codes (checkpoints)" on page 97. 2. Replace any parts reported by the diagnostic program. 3. Replace the system-board
2E14-605	2E14	Error Log Analysis indicates permanent adapter failure is reported on the other port of this adapter. <ol style="list-style-type: none"> 1. Check the BladeCenter management-module event log. If an error was recorded by the system, see "POST progress codes (checkpoints)" on page 97. 2. Replace any parts reported by the diagnostic program. 3. Replace the system-board
2E14-606	2E14	Error Log Analysis indicates adapter failure. <ol style="list-style-type: none"> 1. Check the BladeCenter management-module event log. If an error was recorded by the system, see "POST progress codes (checkpoints)" on page 97. 2. Replace any parts reported by the diagnostic program. 3. Replace the system-board

Table 27. 101-711 through FFC-725 SRNs (continued)

SRN	FFC	Description and Action
2E14-701	2E14 221	Error Log Analysis indicates permanent adapter failure. <ol style="list-style-type: none"> 1. Check the BladeCenter management-module event log. If an error was recorded by the system, see "POST progress codes (checkpoints)" on page 97. 2. Replace any parts reported by the diagnostic program. 3. Replace the system-board
2E14-702	2E14 221	Error Log Analysis indicates permanent adapter failure is reported <ol style="list-style-type: none"> 1. Check the BladeCenter management-module event log. If an error was recorded by the system, see "POST progress codes (checkpoints)" on page 97. 2. Replace any parts reported by the diagnostic program. 3. Replace the system-board
2E15-201	2E15 221	Adapter configuration error. <ol style="list-style-type: none"> 1. Check the BladeCenter management-module event log. If an error was recorded by the system, see "POST progress codes (checkpoints)" on page 97. 2. Replace any parts reported by the diagnostic program. 3. Replace the system-board
2E15-601	2E15	Error Log Analysis indicates adapter failure. <ol style="list-style-type: none"> 1. Check the BladeCenter management-module event log. If an error was recorded by the system, see "POST progress codes (checkpoints)" on page 97. 2. Replace any parts reported by the diagnostic program. 3. Replace the system-board
2E15-602	2E15	Error Log Analysis indicates an Error Attention condition. <ol style="list-style-type: none"> 1. Check the BladeCenter management-module event log. If an error was recorded by the system, see "POST progress codes (checkpoints)" on page 97. 2. Replace any parts reported by the diagnostic program. 3. Replace the system-board
2E15-603	2E15	Error Log Analysis indicates that the microcode could not be loaded on the adapter. <ol style="list-style-type: none"> 1. Check the BladeCenter management-module event log. If an error was recorded by the system, see "POST progress codes (checkpoints)" on page 97. 2. Replace any parts reported by the diagnostic program. 3. Replace the system-board
2E15-604	2E15	Error Log Analysis indicates a permanent adapter failure. <ol style="list-style-type: none"> 1. Check the BladeCenter management-module event log. If an error was recorded by the system, see "POST progress codes (checkpoints)" on page 97. 2. Replace any parts reported by the diagnostic program. 3. Replace the system-board
2E15-605	2E15	Error Log Analysis indicates permanent adapter failure is reported on the other port of this adapter. <ol style="list-style-type: none"> 1. Check the BladeCenter management-module event log. If an error was recorded by the system, see "POST progress codes (checkpoints)" on page 97. 2. Replace any parts reported by the diagnostic program. 3. Replace the system-board
2E15-606	2E15	Error Log Analysis indicates adapter failure. <ol style="list-style-type: none"> 1. Check the BladeCenter management-module event log. If an error was recorded by the system, see "POST progress codes (checkpoints)" on page 97. 2. Replace any parts reported by the diagnostic program. 3. Replace the system-board

Table 27. 101-711 through FFC-725 SRNs (continued)

SRN	FFC	Description and Action
2E15-701	2E15 221	Error Log Analysis indicates permanent adapter failure. <ol style="list-style-type: none"> 1. Check the BladeCenter management-module event log. If an error was recorded by the system, see "POST progress codes (checkpoints)" on page 97. 2. Replace any parts reported by the diagnostic program. 3. Replace the system-board
2E15-702	2E15 221	Error Log Analysis indicates permanent adapter failure is reported. <ol style="list-style-type: none"> 1. Check the BladeCenter management-module event log. If an error was recorded by the system, see "POST progress codes (checkpoints)" on page 97. 2. Replace any parts reported by the diagnostic program. 3. Replace the system-board
2E21-201	2E21 221	Adapter configuration error. <ol style="list-style-type: none"> 1. Check the BladeCenter management-module event log. If an error was recorded by the system, see "POST progress codes (checkpoints)" on page 97. 2. Replace any parts reported by the diagnostic program. 3. Replace the system-board
2E21-601	2E21	Error Log Analysis indicates adapter failure. <ol style="list-style-type: none"> 1. Check the BladeCenter management-module event log. If an error was recorded by the system, see "POST progress codes (checkpoints)" on page 97. 2. Replace any parts reported by the diagnostic program. 3. Replace the system-board
2E21-602	2E21	Error Log Analysis indicates an Error Attention condition. <ol style="list-style-type: none"> 1. Check the BladeCenter management-module event log. If an error was recorded by the system, see "POST progress codes (checkpoints)" on page 97. 2. Replace any parts reported by the diagnostic program. 3. Replace the system-board
2E21-603	2E21	Error Log Analysis indicates that the microcode could not be loaded on the adapter. <ol style="list-style-type: none"> 1. Check the BladeCenter management-module event log. If an error was recorded by the system, see "POST progress codes (checkpoints)" on page 97. 2. Replace any parts reported by the diagnostic program. 3. Replace the system-board
2E21-604	2E21	Error Log Analysis indicates a permanent adapter failure. <ol style="list-style-type: none"> 1. Check the BladeCenter management-module event log. If an error was recorded by the system, see "POST progress codes (checkpoints)" on page 97. 2. Replace any parts reported by the diagnostic program. 3. Replace the system-board
2E21-605	2E21	Error Log Analysis indicates permanent adapter failure is reported on the other port of this adapter. <ol style="list-style-type: none"> 1. Check the BladeCenter management-module event log. If an error was recorded by the system, see "POST progress codes (checkpoints)" on page 97. 2. Replace any parts reported by the diagnostic program. 3. Replace the system-board
2E21-606	2E21	Error Log Analysis indicates adapter failure. <ol style="list-style-type: none"> 1. Check the BladeCenter management-module event log. If an error was recorded by the system, see "POST progress codes (checkpoints)" on page 97. 2. Replace any parts reported by the diagnostic program. 3. Replace the system-board

Table 27. 101-711 through FFC-725 SRNs (continued)

SRN	FFC	Description and Action
2E21-701	2E21 221	Error Log Analysis indicates permanent adapter failure. <ol style="list-style-type: none"> 1. Check the BladeCenter management-module event log. If an error was recorded by the system, see "POST progress codes (checkpoints)" on page 97. 2. Replace any parts reported by the diagnostic program. 3. Replace the system-board
2E21-702	2E21 221	Error Log Analysis indicates permanent adapter failure is reported on the other port of this adapter. <ol style="list-style-type: none"> 1. Check the BladeCenter management-module event log. If an error was recorded by the system, see "POST progress codes (checkpoints)" on page 97. 2. Replace any parts reported by the diagnostic program. 3. Replace the system-board
2E23-101	2E23	Register Test Failure <ol style="list-style-type: none"> 1. Check the BladeCenter management-module event log. If an error was recorded by the system, see "POST progress codes (checkpoints)" on page 97. 2. Replace any parts reported by the diagnostic program. 3. Replace the system-board
2E23-102	2E23	VPD Checksum Test Failure <ol style="list-style-type: none"> 1. Check the BladeCenter management-module event log. If an error was recorded by the system, see "POST progress codes (checkpoints)" on page 97. 2. Replace any parts reported by the diagnostic program. 3. Replace the system-board
2E23-103	2E23	Flash Test Failure <ol style="list-style-type: none"> 1. Check the BladeCenter management-module event log. If an error was recorded by the system, see "POST progress codes (checkpoints)" on page 97. 2. Replace any parts reported by the diagnostic program. 3. Replace the system-board
2E23-104	2E23	Internal Wrap Test Failure <ol style="list-style-type: none"> 1. Check the BladeCenter management-module event log. If an error was recorded by the system, see "POST progress codes (checkpoints)" on page 97. 2. Replace any parts reported by the diagnostic program. 3. Replace the system-board
2E23-105	2E23	External Wrap Test Failure <ol style="list-style-type: none"> 1. Check the BladeCenter management-module event log. If an error was recorded by the system, see "POST progress codes (checkpoints)" on page 97. 2. Replace any parts reported by the diagnostic program. 3. Replace the system-board
2E23-106	2E23	External Wrap with IP Checksum Test Failure <ol style="list-style-type: none"> 1. Check the BladeCenter management-module event log. If an error was recorded by the system, see "POST progress codes (checkpoints)" on page 97. 2. Replace any parts reported by the diagnostic program. 3. Replace the system-board
2E23-107	2E23	External Wrap with TCP Checksum Test Failure <ol style="list-style-type: none"> 1. Check the BladeCenter management-module event log. If an error was recorded by the system, see "POST progress codes (checkpoints)" on page 97. 2. Replace any parts reported by the diagnostic program. 3. Replace the system-board

Table 27. 101-711 through FFC-725 SRNs (continued)

SRN	FFC	Description and Action
2E23-108	2E23	External Wrap with UDP Checksum Test Failure <ol style="list-style-type: none"> 1. Check the BladeCenter management-module event log. If an error was recorded by the system, see "POST progress codes (checkpoints)" on page 97. 2. Replace any parts reported by the diagnostic program. 3. Replace the system-board
2E23-109	241	Network link test failure. <ol style="list-style-type: none"> 1. Check the BladeCenter management-module event log. If an error was recorded by the system, see "POST progress codes (checkpoints)" on page 97. 2. Replace any parts reported by the diagnostic program. 3. Replace the system-board
2E23-201	2E23 221	Enhanced Error Handling Failure <ol style="list-style-type: none"> 1. Check the BladeCenter management-module event log. If an error was recorded by the system, see "POST progress codes (checkpoints)" on page 97. 2. Replace any parts reported by the diagnostic program. 3. Replace the system-board
2E23-202	241 2E23	Network link test failure. <ol style="list-style-type: none"> 1. Check the BladeCenter management-module event log. If an error was recorded by the system, see "POST progress codes (checkpoints)" on page 97. 2. Replace any parts reported by the diagnostic program. 3. Replace the system-board
2E23-601	2E23	Error log analysis indicates a hardware error. <ol style="list-style-type: none"> 1. Check the BladeCenter management-module event log. If an error was recorded by the system, see "POST progress codes (checkpoints)" on page 97. 2. Replace any parts reported by the diagnostic program. 3. Replace the system-board
2E23-602	2E23	Error log analysis indicates an EEH error. <ol style="list-style-type: none"> 1. Check the BladeCenter management-module event log. If an error was recorded by the system, see "POST progress codes (checkpoints)" on page 97. 2. Replace any parts reported by the diagnostic program. 3. Replace the system-board
2E23-603	2E23	Error log analysis indicates an EEPROM error. <ol style="list-style-type: none"> 1. Check the BladeCenter management-module event log. If an error was recorded by the system, see "POST progress codes (checkpoints)" on page 97. 2. Replace any parts reported by the diagnostic program. 3. Replace the system-board
2E23-604	2E23	Error log analysis indicates transmission errors. <ol style="list-style-type: none"> 1. Check the BladeCenter management-module event log. If an error was recorded by the system, see "POST progress codes (checkpoints)" on page 97. 2. Replace any parts reported by the diagnostic program. 3. Replace the system-board
2E33-201	2E33 221	Adapter configuration error. <ol style="list-style-type: none"> 1. Check the BladeCenter management-module event log. If an error was recorded by the system, see "POST progress codes (checkpoints)" on page 97. 2. Replace any parts reported by the diagnostic program. 3. Replace the system-board

Table 27. 101-711 through FFC-725 SRNs (continued)

SRN	FFC	Description and Action
2E33-601	2E33	Download firmware error. <ol style="list-style-type: none"> 1. Check the BladeCenter management-module event log. If an error was recorded by the system, see "POST progress codes (checkpoints)" on page 97. 2. Replace any parts reported by the diagnostic program. 3. Replace the system-board
2E33-602	2E33	EEPROM read error. <ol style="list-style-type: none"> 1. Check the BladeCenter management-module event log. If an error was recorded by the system, see "POST progress codes (checkpoints)" on page 97. 2. Replace any parts reported by the diagnostic program. 3. Replace the system-board
2E33-701	2E33 221	Permanent adapter failure. <ol style="list-style-type: none"> 1. Check the BladeCenter management-module event log. If an error was recorded by the system, see "POST progress codes (checkpoints)" on page 97. 2. Replace any parts reported by the diagnostic program. 3. Replace the system-board
2E34-201	2E34 221	Adapter configuration error. <ol style="list-style-type: none"> 1. Check the BladeCenter management-module event log. If an error was recorded by the system, see "POST progress codes (checkpoints)" on page 97. 2. Replace any parts reported by the diagnostic program. 3. Replace the system-board
2E34-601	2E34	Download firmware error. <ol style="list-style-type: none"> 1. Check the BladeCenter management-module event log. If an error was recorded by the system, see "POST progress codes (checkpoints)" on page 97. 2. Replace any parts reported by the diagnostic program. 3. Replace the system-board
2E34-602	2E34	EEPROM read error. <ol style="list-style-type: none"> 1. Check the BladeCenter management-module event log. If an error was recorded by the system, see "POST progress codes (checkpoints)" on page 97. 2. Replace any parts reported by the diagnostic program. 3. Replace the system-board
2E34-701	2E34 221	Permanent adapter failure. <ol style="list-style-type: none"> 1. Check the BladeCenter management-module event log. If an error was recorded by the system, see "POST progress codes (checkpoints)" on page 97. 2. Replace any parts reported by the diagnostic program. 3. Replace the system-board
2E35-201	2E35 221	Adapter configuration error. <ol style="list-style-type: none"> 1. Check the BladeCenter management-module event log. If an error was recorded by the system, see "POST progress codes (checkpoints)" on page 97. 2. Replace any parts reported by the diagnostic program. 3. Replace the system-board
2E35-601	2E35	Download firmware error. <ol style="list-style-type: none"> 1. Check the BladeCenter management-module event log. If an error was recorded by the system, see "POST progress codes (checkpoints)" on page 97. 2. Replace any parts reported by the diagnostic program. 3. Replace the system-board

Table 27. 101-711 through FFC-725 SRNs (continued)

SRN	FFC	Description and Action
2E35-602	2E35	EEPROM read error. <ol style="list-style-type: none"> 1. Check the BladeCenter management-module event log. If an error was recorded by the system, see "POST progress codes (checkpoints)" on page 97. 2. Replace any parts reported by the diagnostic program. 3. Replace the system-board
2E35-701	2E35 221	Permanent adapter failure. <ol style="list-style-type: none"> 1. Check the BladeCenter management-module event log. If an error was recorded by the system, see "POST progress codes (checkpoints)" on page 97. 2. Replace any parts reported by the diagnostic program. 3. Replace the system-board
2E36-201	2E36 221	Adapter configuration error. <ol style="list-style-type: none"> 1. Check the BladeCenter management-module event log. If an error was recorded by the system, see "POST progress codes (checkpoints)" on page 97. 2. Replace any parts reported by the diagnostic program. 3. Replace the system-board
2E36-601	2E36	Download firmware error. <ol style="list-style-type: none"> 1. Check the BladeCenter management-module event log. If an error was recorded by the system, see "POST progress codes (checkpoints)" on page 97. 2. Replace any parts reported by the diagnostic program. 3. Replace the system-board
2E36-602	2E36	EEPROM read error. <ol style="list-style-type: none"> 1. Check the BladeCenter management-module event log. If an error was recorded by the system, see "POST progress codes (checkpoints)" on page 97. 2. Replace any parts reported by the diagnostic program. 3. Replace the system-board
2E36-701	2E36 221	Permanent adapter failure. <ol style="list-style-type: none"> 1. Check the BladeCenter management-module event log. If an error was recorded by the system, see "POST progress codes (checkpoints)" on page 97. 2. Replace any parts reported by the diagnostic program. 3. Replace the system-board
FFC-724	FFC	Temporary device bus interface problem. <ol style="list-style-type: none"> 1. Check the BladeCenter management-module event log. If an error was recorded by the system, see "POST progress codes (checkpoints)" on page 97. 2. Replace any parts reported by the diagnostic program. 3. Go to "Performing the checkout procedure" on page 177.
FFC-725	FFC	Temporary device bus interface problem. <ol style="list-style-type: none"> 1. Check the BladeCenter management-module event log. If an error was recorded by the system, see "POST progress codes (checkpoints)" on page 97. 2. Replace any parts reported by the diagnostic program. 3. Go to "Performing the checkout procedure" on page 177.

A00-FF0 through A24-xxx SRNs

AIX might generate service request numbers (SRNs) from A00-FF0 to A24-xxx.

Note: Some SRNs in this sequence might have 4 rather than 3 digits after the dash (-).

Table 28 shows the meaning of an *x* in any of the following SRNs, such as A01-00*x*.

Table 28. Meaning of the last character (*x*) after the hyphen

Number	Meaning
1	Replace all FRUs listed
2	Hot swap supported
4	Software might be the cause
8	Reserved

Table 29 describes each SRN and provides a recommended corrective action.

Table 29. A00-FF0 through A24-xxx SRNs

SRN	Description	FRU/action
A24-000	Spurious interrupts on shared interrupt level have exceeded threshold	<ol style="list-style-type: none">1. Check the BladeCenter management-module event log. If an error was recorded by the system, see "POST progress codes (checkpoints)" on page 97.2. Replace part numbers reported by the diagnostic program.3. If no entry is found, Replace the system-board
A24-xxx	Spurious interrupts have exceeded threshold.	<ol style="list-style-type: none">1. Check the BladeCenter management-module event log; if an error was recorded by the system, see "POST progress codes (checkpoints)" on page 97.2. Replace part numbers reported by the diagnostic program.3. If no entry is found, Replace the system-board

SCSD Devices SRNs (ssss-102 to ssss-640)

These service request numbers (SRNs) identify a Self-Configuring SCSI Device (SCSD) problem.

Use Table 30 on page 170 to identify an SRN when you suspect a SAS hard disk device problem. Replace the parts in the order that the failing function codes (FFCs) are listed.

Notes:

1. Some SRNs might have 4 digits rather than 3 digits after the dash (-).
2. The *ssss* before the dash (-) represents the 3 digit or 4 digit SCSD SRN.

Table 30. ssss-102 through ssss-640 SRNs

SRN	FFC	Description and action
sss-102	sss	An unrecoverable media error occurred. <ol style="list-style-type: none"> 1. Check the BladeCenter management-module event log. If an error was recorded by the system, see "POST progress codes (checkpoints)" on page 97. 2. Replace any parts reported by the diagnostic program. 3. Replace the system board and chassis assembly, as described in "Replacing the FRU system-board and chassis assembly" on page 264.
sss-104	sss	The motor failed to restart. <ol style="list-style-type: none"> 1. Check the BladeCenter management-module event log. If an error was recorded by the system, see "POST progress codes (checkpoints)" on page 97. 2. Replace any parts reported by the diagnostic program. 3. Replace the system board and chassis assembly, as described in "Replacing the FRU system-board and chassis assembly" on page 264.
sss-105	sss	The drive did not become ready. <ol style="list-style-type: none"> 1. Check the BladeCenter management-module event log. If an error was recorded by the system, see "POST progress codes (checkpoints)" on page 97. 2. Replace any parts reported by the diagnostic program. 3. Replace the system board and chassis assembly, as described in "Replacing the FRU system-board and chassis assembly" on page 264.
sss-106	sss	The electronics card test failed. <ol style="list-style-type: none"> 1. Check the BladeCenter management-module event log. If an error was recorded by the system, see "POST progress codes (checkpoints)" on page 97. 2. Replace any parts reported by the diagnostic program. 3. Replace the system board and chassis assembly, as described in "Replacing the FRU system-board and chassis assembly" on page 264.
sss-108	sss	The bus test failed. <ol style="list-style-type: none"> 1. Check the BladeCenter management-module event log. If an error was recorded by the system, see "POST progress codes (checkpoints)" on page 97. 2. Replace any parts reported by the diagnostic program. 3. Replace the system board and chassis assembly, as described in "Replacing the FRU system-board and chassis assembly" on page 264.
sss-110	sss	The media format is corrupted. <ol style="list-style-type: none"> 1. Check the BladeCenter management-module event log. If an error was recorded by the system, see "POST progress codes (checkpoints)" on page 97. 2. Replace any parts reported by the diagnostic program. 3. Replace the system board and chassis assembly, as described in "Replacing the FRU system-board and chassis assembly" on page 264.
sss-112	sss	The diagnostic test failed. <ol style="list-style-type: none"> 1. Check the BladeCenter management-module event log. If an error was recorded by the system, see "POST progress codes (checkpoints)" on page 97. 2. Replace any parts reported by the diagnostic program. 3. Replace the system board and chassis assembly, as described in "Replacing the FRU system-board and chassis assembly" on page 264.
sss-114	sss	An unrecoverable hardware error. <ol style="list-style-type: none"> 1. Check the BladeCenter management-module event log. If an error was recorded by the system, see "POST progress codes (checkpoints)" on page 97. 2. Replace any parts reported by the diagnostic program. 3. Replace the system board and chassis assembly, as described in "Replacing the FRU system-board and chassis assembly" on page 264.

Table 30. ssss-102 through ssss-640 SRNs (continued)

SRN	FFC	Description and action
sss-116	sss	A protocol error. <ol style="list-style-type: none"> 1. Make sure that the device, adapter and diagnostic firmware, and the application software levels are compatible. 2. If you do not find a problem, call your operating-system support person.
sss-117	sss	A write-protect error occurred. <ol style="list-style-type: none"> 1. Check the BladeCenter management-module event log. If an error was recorded by the system, see "POST progress codes (checkpoints)" on page 97. 2. Replace any parts reported by the diagnostic program. 3. Replace the system board and chassis assembly, as described in "Replacing the FRU system-board and chassis assembly" on page 264.
sss-118	sss 252B	A SCSD command time-out occurred. <ol style="list-style-type: none"> 1. Check the BladeCenter management-module event log. If an error was recorded by the system, see "POST progress codes (checkpoints)" on page 97. 2. Replace any parts reported by the diagnostic program. 3. Replace the system board and chassis assembly, as described in "Replacing the FRU system-board and chassis assembly" on page 264.
sss-120	sss	A SCSD busy or command error. <ol style="list-style-type: none"> 1. Check the BladeCenter management-module event log. If an error was recorded by the system, see "POST progress codes (checkpoints)" on page 97. 2. Replace any parts reported by the diagnostic program. 3. Replace the system board and chassis assembly, as described in "Replacing the FRU system-board and chassis assembly" on page 264.
sss-122	sss	A SCSD reservation conflict error. <ol style="list-style-type: none"> 1. Check the BladeCenter management-module event log. If an error was recorded by the system, see "POST progress codes (checkpoints)" on page 97. 2. Replace any parts reported by the diagnostic program. 3. Replace the system board and chassis assembly, as described in "Replacing the FRU system-board and chassis assembly" on page 264.
sss-124	sss	A SCSD check condition error occurred. <ol style="list-style-type: none"> 1. Check the BladeCenter management-module event log. If an error was recorded by the system, see "POST progress codes (checkpoints)" on page 97. 2. Replace any parts reported by the diagnostic program. 3. Replace the system board and chassis assembly, as described in "Replacing the FRU system-board and chassis assembly" on page 264.
sss-126	sss 252B	A software error was caused by a hardware failure. <ol style="list-style-type: none"> 1. Check the BladeCenter management-module event log. If an error was recorded by the system, see "POST progress codes (checkpoints)" on page 97. 2. Replace any parts reported by the diagnostic program. 3. Replace the system board and chassis assembly, as described in "Replacing the FRU system-board and chassis assembly" on page 264.
sss-128	252B ssss software	The error log analysis indicates a hardware failure. <ol style="list-style-type: none"> 1. Check the BladeCenter management-module event log. If an error was recorded by the system, see "POST progress codes (checkpoints)" on page 97. 2. Replace any parts reported by the diagnostic program. 3. Replace the system board and chassis assembly, as described in "Replacing the FRU system-board and chassis assembly" on page 264.

Table 30. ssss-102 through ssss-640 SRNs (continued)

SRN	FFC	Description and action
sss-129	252B ssss software	Error log analysis indicates a SCSD bus problem. <ol style="list-style-type: none"> 1. Check the BladeCenter management-module event log. If an error was recorded by the system, see "POST progress codes (checkpoints)" on page 97. 2. Replace any parts reported by the diagnostic program. 3. Replace the system board and chassis assembly, as described in "Replacing the FRU system-board and chassis assembly" on page 264.
sss-130	sss	Error log analysis indicates a problem reported by the disk drive's self-monitoring function. <ol style="list-style-type: none"> 1. Check the BladeCenter management-module event log. If an error was recorded by the system, see "POST progress codes (checkpoints)" on page 97. 2. Replace any parts reported by the diagnostic program. 3. Replace the system board and chassis assembly, as described in "Replacing the FRU system-board and chassis assembly" on page 264.
sss-132	sss	A disk drive hardware error occurred. <ol style="list-style-type: none"> 1. Check the BladeCenter management-module event log. If an error was recorded by the system, see "POST progress codes (checkpoints)" on page 97. 2. Replace any parts reported by the diagnostic program. 3. Replace the system board and chassis assembly, as described in "Replacing the FRU system-board and chassis assembly" on page 264.
sss-134	252B software	The adapter failed to configure. <ol style="list-style-type: none"> 1. Check the BladeCenter management-module event log. If an error was recorded by the system, see "POST progress codes (checkpoints)" on page 97. 2. Replace any parts reported by the diagnostic program. 3. Replace the system board and chassis assembly, as described in "Replacing the FRU system-board and chassis assembly" on page 264.
sss-135	sss 252B software	The device failed to configure. <ol style="list-style-type: none"> 1. Check the BladeCenter management-module event log. If an error was recorded by the system, see "POST progress codes (checkpoints)" on page 97. 2. Replace any parts reported by the diagnostic program. 3. Replace the system board and chassis assembly, as described in "Replacing the FRU system-board and chassis assembly" on page 264.
sss-136	sss	The certify operation failed. <ol style="list-style-type: none"> 1. Check the BladeCenter management-module event log. If an error was recorded by the system, see "POST progress codes (checkpoints)" on page 97. 2. Replace any parts reported by the diagnostic program. 3. Replace the system board and chassis assembly, as described in "Replacing the FRU system-board and chassis assembly" on page 264.
sss-137	sss 252B	Unit attention condition has occurred on the <i>Send Diagnostic</i> command. <ol style="list-style-type: none"> 1. Check the BladeCenter management-module event log. If an error was recorded by the system, see "POST progress codes (checkpoints)" on page 97. 2. Replace any parts reported by the diagnostic program. 3. Replace the system board and chassis assembly, as described in "Replacing the FRU system-board and chassis assembly" on page 264.

Table 30. ssss-102 through ssss-640 SRNs (continued)

SRN	FFC	Description and action
sss-138	sss	Error log analysis indicates that the disk drive is operating at a higher than recommended temperature. <ol style="list-style-type: none"> Make sure that: <ul style="list-style-type: none"> The ventilation holes in the blade server bezel are not blocked. The management-module event log is not reporting any system environmental warnings. If the problem remains, call IBM support.
sss-140	199 252B sss	Error log analysis indicates poor signal quality. <ol style="list-style-type: none"> Check the BladeCenter management-module event log. If an error was recorded by the system, see "POST progress codes (checkpoints)" on page 97. Replace any parts reported by the diagnostic program. Replace the system board and chassis assembly, as described in "Replacing the FRU system-board and chassis assembly" on page 264.
sss-640	sss	Error log analysis indicates a path error. <ol style="list-style-type: none"> Check the BladeCenter management-module event log. If an error was recorded by the system, see "POST progress codes (checkpoints)" on page 97. Replace any parts reported by the diagnostic program. Replace the system board and chassis assembly, as described in "Replacing the FRU system-board and chassis assembly" on page 264.

Failing function codes

Failing function codes (FFCs) identify a function within the system unit that is failing.

Table 31 describes the component that each function code identifies.

Note: When replacing a component, perform system verification for the component. See "Using the diagnostics program" on page 181.

Table 31. Failing function codes

FFC	Description and notes
151	<ol style="list-style-type: none"> Battery Note: After replacing the battery: <ol style="list-style-type: none"> Set the time and date. Set the Network IP addresses (for blade servers that start up from a network). System-board and chassis assembly
152	System-board and chassis assembly
166	Check management-module event log for a BladeCenter blower or fan fault. See the documentation that comes with the BladeCenter unit.
199	System-board and chassis assembly
210	System-board and chassis assembly
212	System-board and chassis assembly (cache problem)
214	System-board and chassis assembly
217	System-board and chassis assembly

Table 31. Failing function codes (continued)

FFC	Description and notes
219	Common Memory Logic problem for memory DIMMs. Note: If more than one pair of memory DIMMs are reported missing: 1. Replace the memory DIMM at the physical location code that is reported 2. Replace the system-board
221	System-board and chassis assembly
226	System-board and chassis assembly
227	System-board and chassis assembly
241	Ethernet network problem
282	System-board and chassis assembly
292	System-board and chassis assembly (Host – PCI bridge problem)
293	System-board and chassis assembly (PCI – PCI bridge problem)
294	System-board and chassis assembly (MPIC interrupt controller problem)
296	PCI device or adapter problem. Note: The replacement part can only be identified by the location code reported by diagnostics.
2C4	System-board and chassis assembly
2C7	System-board and chassis assembly (Memory controller)
2C8	System-board and chassis assembly
2C9	System-board and chassis assembly
2D2	System-board and chassis assembly (Bus arbiter problem)
2D3	System-board and chassis assembly
2D4	System-board and chassis assembly (System/SP interface logic problem)
2D5	System-board and chassis assembly (I2C primary)
2D6	System-board and chassis assembly (I2C secondary)
2D7	System-board and chassis assembly (VPD module)
2D9	System-board and chassis assembly (Power controller)
2E0	System-board and chassis assembly (Fan sensor problem)
2E1	System-board and chassis assembly (Thermal sensor problem)
2E2	System-board and chassis assembly (Voltage sensor problem)
2E3	System-board and chassis assembly (Serial port controller problem)
2E4	System-board and chassis assembly (JTAG/COP controller problem)
2E8	System-board and chassis assembly (Cache controller)
308	System-board and chassis assembly (I/O bridge problem)
650	Unknown hard disk drive. Note: This FFC indicates that the hard disk drive could not configure properly.
711	Unknown adapter
722	Unknown disk drive
7C0	System-board and chassis assembly (microprocessor/system interface)
812	System-board and chassis assembly (Common standard adapter logic problem)
814	System-board and chassis assembly (NVRAM problem)
815	System-board and chassis assembly (floating point processor problem)
817	System-board and chassis assembly (time-of-day logic)

Table 31. Failing function codes (continued)

FFC	Description and notes
820	System-board and chassis assembly (interprocessor related testing problem)
887	System-board and chassis assembly (integrated Ethernet adapter)
893	LAN adapter
D01	System-board and chassis assembly (cache problem)
E19	System-board and chassis assembly (power supply sensor failed)
2506	3Gb SAS pass-through expansion card 2506-101 Adapter configuration error indicated by test failures. Reconfigure the adapter. If the problem persists, replace the adapter. 2506-710 Error log analysis reveals a permanent controller failure. Replace the adapter. 2506-713 Error log analysis reveals a controller failure. Replace the adapter. 2506-720 Error log analysis reveals a controller device bus configuration error. Replace the adapter. If the problem persists, replace the system board and chassis assembly.
252B	System-board and chassis assembly (SAS controller)
2567	System-board and chassis assembly (USB integrated adapter)
25A0	System-board and chassis assembly
25C4	Broadcom Ethernet adapter
2607	Emulex 8 Gb Fibre Channel expansion card (CIOv)
2624	4x InfiniBand DDR expansion card (CFFh)
2625	4x InfiniBand QDR expansion card (CFFh)
2631	System-board and chassis assembly
268B	300 GB SAS small form factor disk drive
26B4	200 GB solid-state drive
26BD	Solid-state drive carrier (holds up to two solid-state drives)
26D2	600 GB SAS small form factor disk drive
2D02	System-board and chassis assembly (generic USB reference to controller/adapter)
2E00	QLogic 4 Gb Fibre Channel and Broadcom 1 Gb Ethernet expansion card (CFFh)
2E10	QLogic 4 Gb Fibre Channel and Broadcom 1 Gb Ethernet expansion card (CFFh)
2E13	QLogic 4 Gb Fibre Channel expansion card (CIOv)
2E14	QLogic 8 Gb Fibre Channel expansion card (CIOv)
2E15	QLogic 8 Gb and Broadcom 1 Gb Ethernet expansion card (CFFh)
2E21	QLogic 10 Gb FCoCEE daughtercard
2E23	QLogic 10 Gb FCoCEE daughtercard
2E33	Broadcom 4 port 1 Gb Ethernet expansion card (CFFh)
2E34	Broadcom 2 port 1 Gb Ethernet expansion card (CIOv)
2E35	QLogic 8 Gb Fibre Channel and 1 Gb Ethernet expansion card (CFFh)
2E36	System-board and chassis assembly (integrated Ethernet adapter)

Error logs

The power-on self-test (POST), the hypervisor, and the service processor write errors to the BladeCenter management module event log.

Select the **Monitors** → **Event Log** option in the management module Web interface to view entries that are currently stored in the management-module event log. This log includes entries for events that are detected by the blade servers. The log displays the most recent entries first.

The following table shows the syntax of a nine-word B700xxxx SRC as it might be displayed in the event log of the management module.

The first word of the SRC in this example is the message identifier, **B7001111**. This example numbers each word after the first word to show relative word positions. The seventh word is the direct select address, which is **77777777** in the example.

Table 32. Nine-word system reference code in the management-module event log

Index	Sev	Source	Date/Time	Text
1	E	Blade_05	01/21/2008, 17:15:14	(PS700-BC1BLD5E) SYS F/W: Error. Replace UNKNOWN (5008FECF B7001111 22222222 33333333 44444444 55555555 66666666 77777777 88888888 99999999)

Depending on your operating system and the utilities you have installed, error messages might also be stored in an operating system log. See the documentation that comes with the operating system for more information.

See the online information or the *BladeCenter Management Module User's Guide* for more information about the event log.

Checkout procedure

The checkout procedure is the sequence of tasks that you should follow to diagnose a problem in the blade server.

About the checkout procedure

Review this information before performing the checkout procedure.

- Read the Safety topic and the “Installation guidelines” on page 229.
- The firmware diagnostic program provides the primary methods of testing the major components of the blade server. If you are not sure whether a problem is caused by the hardware or by the software, you can use the firmware diagnostic program to confirm that the hardware is working correctly. The firmware diagnostic program runs automatically when the blade server is turned on.
- A single problem might cause more than one error message. When this happens, correct the cause of the first error message. The other error messages usually will not occur the next time you run the diagnostic programs.

Exception: If there are multiple error codes or light path diagnostic LEDs that indicate a microprocessor error, the error might be in a microprocessor or in a microprocessor socket. See “Microprocessor problems” on page 186 for information about diagnosing microprocessor problems.

- If the blade server hangs on a POST checkpoint, see “POST progress codes (checkpoints)” on page 97. If the blade server is halted and no error message is displayed, see “Troubleshooting tables” on page 183 and “Solving undetermined problems” on page 223.
- For intermittent problems, check the management-module event log and “POST progress codes (checkpoints)” on page 97.

- If the blade server front panel shows no LEDs, verify the blade server status and errors in the BladeCenter Web interface; also see “Solving undetermined problems” on page 223.
- If device errors occur, see “Troubleshooting tables” on page 183.

Performing the checkout procedure

Follow this procedure to perform the checkout.

Step 001

Perform the following steps:

1. Update the firmware to the current level, as described in “Updating the firmware” on page 267.
2. You might also have to update the management module firmware.
3. If you did not update the firmware for some reason, power off the blade server for 45 seconds before powering it back on.
4. Establish an SOL session; then continue to Step 002. If the blade server does not start, see “Troubleshooting tables” on page 183.

Step 002

Verify that you have looked up each error code or hung checkpoint and attempted the corrective action before going to Step 003:

1. If the firmware hangs on an eight-digit progress code, see “POST progress codes (checkpoints)” on page 97.
2. If the firmware records an eight-digit error code, see “System reference codes (SRCs)” on page 21.
3. If the AIX operating system records a service request number (SRN), see “Service request numbers (SRNs)” on page 142.
4. Check the BladeCenter management-module event log. If an error was recorded by the system, see “POST progress codes (checkpoints)” on page 97 or “System reference codes (SRCs)” on page 21.
5. If no error was recorded, or if the login prompt appears and you still suspect a problem, continue to Step 003.

Step 003

Is the operating system AIX?

Yes Record any information or messages that may be in the management module event log; then go to Step 005.

No Go to Step 004.

Step 004

Is the operating system Linux?

Yes Record any information or messages that may be in the management module event log; then go to Step 007. If you cannot load the stand-alone diagnostics CD, answer this question *No*.

No Go to “Solving undetermined problems” on page 223.

Step 005

Perform the following steps:

Note: When possible, run AIX online diagnostics in concurrent mode. AIX online diagnostics perform more functions than the stand-alone diagnostics.

1. Perform the AIX online diagnostics, see “Starting AIX concurrent diagnostics” on page 179. Record any diagnostic results and see the “Service request numbers (SRNs)” on page 142 to identify the failing component.

Note: When replacing a component, perform system verification for the component. See “Using the diagnostics program” on page 181.

2. If you cannot perform AIX concurrent online diagnostics, continue to Step **006**.

Step 006

Perform the following steps:

1. Use the management-module Web interface to make sure that the device from which you load the stand-alone diagnostics is set as the first device in the blade server boot sequence.
2. Turn off the system unit power and wait 45 seconds before proceeding.
3. Turn on the blade server and establish an SOL session.
4. Check for the following responses:
 - a. Progress codes are recorded in the management-module event log.
 - b. Record any messages or diagnostic information that might be in the log.
5. Load the stand-alone diagnostics. Go to “Starting stand-alone diagnostics from a CD” on page 179 or “Starting stand-alone diagnostics from a NIM server” on page 180.
6. If you have replaced the failing component, perform system verification for the component. See “Using the diagnostics program” on page 181

This ends the AIX procedure.

Step 007

Perform the following steps:

1. Use the management-module Web interface to make sure that the device from which you load the stand-alone diagnostics is set as the first device in the blade server boot sequence.
2. Turn off the blade server and wait 45 seconds before proceeding.
3. Turn on the blade server and establish an SOL session.
4. Check for the following responses:
 - a. Progress codes are recorded in the management-module event log.
 - b. Record any messages or diagnostic information that might be in the log.Continue with step **008**.

Step 008

Load the stand-alone diagnostics. Go to “Starting stand-alone diagnostics from a CD” on page 179 or “Starting stand-alone diagnostics from a NIM server” on page 180.

Can you load the stand-alone diagnostics?

No Go to “Solving undetermined problems” on page 223.

Yes Select the resources to be tested and record any SRNs; then go to “Service request numbers (SRNs)” on page 142.

This ends the Linux procedure.

For more information about installing and using all supported operating systems, search the IBM Support Site.

Verifying the partition configuration

Perform this procedure if there is a configuration problem with the system or a logical partition.

1. Check the processor and memory allocations of the system or the partition. Processor or memory resources that fail during system startup could cause the startup problem in the partition. Make sure that there are enough functioning processor and memory resources in the system for all the partitions.
2. Check the bus and virtual adapter allocations for the partition. Make sure that the partition has load source and console I/O resources.
3. Make sure that the Boot Mode partition properties are set to Normal.
4. If the problem remains, contact your software service provider for further assistance.

Running the diagnostics program

You can start or run the diagnostics program from the AIX operating system, from a CD, or from a management server.

Starting AIX concurrent diagnostics

Perform this procedure to start AIX concurrent diagnostics from the AIX operating system.

1. Log in to the AIX operating system as root user, or use the CE login. See “Creating a CE login” on page 270 for more information. If you need help, contact the system operator.
2. Type `diag` and press **Enter** at the operating system prompt to start the diagnostics program and display its Function Selection menu. See “Using the diagnostics program” on page 181 for more information about running the diagnostics program.
3. When testing is complete, press **F3** until the Diagnostic Operating Instructions panel is displayed, then press **F3** to exit the diagnostic program.

Starting stand-alone diagnostics from a CD

Perform these procedures to start the stand-alone diagnostics from a CD. These procedures can be used if the blade server is running a Linux operating system or if an AIX operating system cannot start the concurrent diagnostics program.

You can download the latest version of the stand-alone diagnostics from the Standalone Diagnostics CD page.

1. Verify with the system administrator and systems users that the blade server may be shut down. Stop all programs; then, shut down the operating system and shut down the blade server. Refer to the documentation that comes with your operating system documentation for information about shutting down the operating system.
2. Press the CD button on the front of the blade server to give it ownership of the BladeCenter media tray.
3. Using the management module Web interface, make sure that:
 - The blade server firmware is at the latest version.
 - SOL is enabled for the blade server.
 - The CD or DVD drive is selected as the first boot device for the blade server.

4. Insert the stand-alone diagnostics CD into the CD or DVD drive.
5. Turn on the blade server and establish an SOL session.

Note: It can take from 3 to 5 minute to load the stand-alone diagnostics from the CD. Please be patient.

The screen will display “Please define the System Console.”

6. Type **1** and press **Enter** to continue.

The Diagnostic Operating Instructions screen will display.

7. Press **Enter** to continue.

The Function Selection screen will display. See “Using the diagnostics program” on page 181 for more information about running the diagnostics program.

Note: If the Define Terminal screen is displayed, type the terminal type and press Enter. The use of “vs100” as the terminal type is recommended; however, the function keys (F#) may not work. In this case, press Esc and the number in the screen menus. For example, instead of **F3** you can press **Esc** and **3**.

8. When testing is complete, press **F3** until the Diagnostic Operating Instructions screen is displayed; then press **F3** again to exit the diagnostic program.
9. Remove the CD from the CD or DVD drive.

Starting stand-alone diagnostics from a NIM server

Perform this procedure to start the stand-alone diagnostics from a network installation management (NIM) server.

Note: See Network Installation Management in the AIX Information Center for information about configuring the blade server as a NIM server client. Also see the Configuring the NIM Master and Creating Basic Installation Resources Web page.

1. Verify with the system administrator and systems users that the blade server can be shut down. Stop all programs; then, shut down the operating system and shut down the blade server. Refer to the documentation that comes with your operating system for information about shutting down the operating system.
2. If the system is running in a full-machine partition, turn on the blade server and establish an SOL session.
3. Perform the following steps to check the NIM server boot settings:
 - a. When the POST menu is displayed, press **1** to start the SMS utility.
 - b. From the SMS main menu, select **Setup Remote IPL (Initial Program Load)**.
 - c. From the NIC Adapters menu, select the network adapter that is attached to the NIM server.
 - d. From the Network Parameters menu, select **IP Parameters**.
 - e. Enter the client, server, and gateway IP addresses (if applicable), and enter the subnet mask. If there is no gateway between the NIM server and the client, set the gateway address to 0.0.0.0 See your network administrator to determine if there is a gateway.
 - f. If the NIM server is set up to allow pingging the client system, use the Ping Test option on the Network Parameters menu to verify that the client system can ping the NIM server.

Note: If the ping fails, see “Boot problem resolution” on page 182; then, follow the steps for network boot problems.

4. When the ping is successful, start the blade server from the NIM server.
5. Establish an SOL session.

If the Diagnostic Operating Instructions screen is displayed, the diagnostics program has started successfully.

Note: If the AIX login prompt is displayed, the diagnostics program did not load. See “Boot problem resolution” on page 182; then, follow the steps for network boot problems.

6. Press **Enter** to continue.

The Function Selection screen will display. See “Using the diagnostics program” for more information about running the diagnostics program.

Note: If the Define Terminal screen is displayed, type the terminal type and press Enter. The use of “vs100” as the terminal type is recommended; however, the function keys (F#) may not work. In this case, press Esc and the number in the screen menus. For example, instead of **F3** you can press **Esc** and **3**.

7. When testing is complete, press **F3** until the Diagnostic Operating Instructions screen is displayed; then press **F3** again to exit the diagnostic program.

Using the diagnostics program

Follow the basic procedures for running the diagnostics program.

1. Start the diagnostics from the AIX operating system, from a CD, or from a management server. See “Starting AIX concurrent diagnostics” on page 179, “Starting stand-alone diagnostics from a CD” on page 179, or “Starting stand-alone diagnostics from a NIM server” on page 180.
2. The Function Selection menu is displayed. Use the steps listed to perform one of the following tasks:

- **Problem Determination**

- a. From the Function Selection menu, select **Diagnostic Routines** and press Enter.
- b. From the Diagnostic Mode Selection menu, select **Problem Determination**
- c. Select the resource to be tested and press **F7=Commit**.
- d. Record any results provided and go to “Service request numbers (SRNs)” on page 142 to identify the failure and perform the action(s).
- e. When testing is complete, press **F3** to return to the Diagnostic Selection menu. If you want to run another test, press **F3** again to return to the Function Selection menu.

- **System Verification**

- a. From the Function Selection menu, select **Diagnostic Routines** and press Enter.
- b. From the Diagnostic Mode Selection menu, select **System Verification**.
- c. Select the resource to be tested and press **F7=Commit**.
- d. Record any results provided and go to “Service request numbers (SRNs)” on page 142 to identify the failure and perform the action(s).
- e. When testing is complete, press **F3** to return to the Diagnostic Selection menu. If you want to run another test, press **F3** again to return to the Function Selection menu.

- **Task selection**

- a. From the Function Selection menu, select **Task Selection** and press Enter.
- b. Select the task to be run and press **Enter**.
- c. If the Resource Selection List menu is displayed, select the resource on which the task is to be run and press **F7=Commit**.
- d. Follow the instruction for the selected task.
- e. When the task is complete, press **F3** to return to the Task Selection List menu. If you want to run another test, press **F3** again to return to the Function Selection menu.

3. When testing is complete, press **F3** until the Diagnostic Operating Instructions screen is displayed; then press **F3** again to exit the diagnostic program.

Boot problem resolution

Depending on the boot device, a checkpoint might be displayed in the list of checkpoints in the management module for an extended period of time while the boot image is retrieved from the device.

This situation is particularly true for CD and network boot attempts. When booting from a CD, watch for a blinking activity LED on the CD or DVD drive. A blinking activity LED indicates that the loading of either the boot image, or additional information required by the operating system being booted, is still in progress. If the checkpoint is displayed for an extended period of time and the CD-drive or DVD-drive activity LED is not blinking, there might be a problem loading the boot image from the device.

Note: For network boot attempts, if the system is not connected to an active network, or if there is no server configured to respond to the system's boot request, the system will still attempt to boot. Because time-out durations are necessarily long to accommodate retries, the system might appear to be hung.

If you suspect a problem loading the boot image, complete the following steps.

1. Make sure that your boot list is correct.
 - a. From the BladeCenter management-module Web interface, display the boot sequences for the blade servers in your BladeCenter unit: **Blade Tasks** → **Configuration** → **Boot Sequence**.
 - b. Find your blade server on the list that is displayed and make sure that the device from which you are attempting to boot is the first device in the boot sequence. If it is not, select your blade server from the list of servers and modify the boot sequence. Cycle power on your blade server to retry the boot.

Note: If **Network** is selected, the blade server will try to boot from both Ethernet ports on the system board.

- c. If this boot attempt fails, do the following:
 - 1) If you are attempting to boot from the network, go to Step **002**.
 - 2) If you are attempting to boot from the CD or DVD drive, go to Step **003**.
 - 3) If you are attempting to boot from a hard disk drive, go to Step **004**.
2. If you are attempting to boot from the network:
 - a. Make sure that the network cabling to the BladeCenter network switch is correct.
 - b. Check with the network administrator to make sure that the network is up.
 - c. Verify that the blade server for your system is running and configured to respond to your system.
 - d. Turn the blade server power off; then, turn it on and retry the boot operation.
 - e. If the boot still fails, replace the system-board and chassis assembly.
 3. If you are attempting to boot from the CD or DVD drive:
 - a. From the BladeCenter management-module Web interface, make sure that the media tray is assigned to your blade server: **Blade Tasks** → **Remote Control**.
 - b. Turn the blade server power off; then, turn it on and retry the boot operation.
 - c. If the boot fails, try a known-good bootable CD.
 - d. If possible, try to boot another blade server in the BladeCenter unit to verify that the CD or DVD drive is functional.
 - If the CD boots on the second server, replace the system-board and chassis assembly in the PS703 or PS704 blade server that you were originally trying to boot.
 - If the CD fails on the second server, replace the CD or DVD drive in the media tray.
 - e. If replacing the CD or DVD drive does not resolve the problem, replace the media tray.

- f. If booting on all servers fails using the new media tray, replace the following in the BladeCenter unit:
 - Management module
 - Midplane
4. If you are attempting to boot from a hard disk drive.
 - a. Verify that the hard disk drive is installed.
 - b. Select the CD or DVD drive as the boot device.
 - c. Go to “Performing the checkout procedure” on page 177.
 - d. Reload the operating system onto the hard disk drive if the boot attempts from that disk continue to fail.
 - e. Replace the suspect hard disk drive if you are not able to load the operating system.
 - f. Replace the system-board; then, retry loading the operating system.

Troubleshooting tables

Use the troubleshooting tables to find solutions to problems that have identifiable symptoms.

If these symptoms relate to shared BladeCenter unit resources, see “Solving shared BladeCenter resource problems” on page 219. If you cannot find the problem in these tables, see “Running the diagnostics program” on page 179 for information about testing the blade server.

If you have just added new software or a new optional device and the blade server is not working, complete the following steps before using the troubleshooting tables:

1. Remove the software or device that you just added.
2. Run the diagnostic tests to determine whether the blade server is running correctly.
3. Reinstall the new software or new device.

General problems

Identify general problem symptoms and corrective actions.

<ul style="list-style-type: none"> • Follow the suggested actions in the order in which they are listed in the Action column until the problem is solved. • See Chapter 3, “Parts listing, type 7891,” on page 225 to determine which components are CRUs and which components are FRUs. • If an action step is preceded by “(Trained service technician only),” that step must be performed only by a trained service technician. 	
Symptom	Action
An LED is not working or a similar problem has occurred.	If the part is a CRU, replace it. If the part is a FRU, the part must be replaced by a trained service technician.

Drive problems

Identify hard disk drive problem symptoms and what corrective actions to take.

<ul style="list-style-type: none"> • Follow the suggested actions in the order in which they are listed in the Action column until the problem is solved. • See Chapter 3, “Parts listing, type 7891,” on page 225 to determine which components are CRUs and which components are FRUs. • If an action step is preceded by “(Trained service technician only),” that step must be performed only by a trained service technician. 	
Symptom	Action
Not all drives are recognized by the disk drive firmware or operating system.	<ol style="list-style-type: none"> 1. Run diagnostics 2. Reseat the drive 3. Run the diagnostics again 4. If the remaining drives are recognized, replace the drive that you removed with a new one.
System stops responding during drive operating system commands to test or look for bad blocks.	<ol style="list-style-type: none"> 1. Run diagnostics 2. Reseat the drive 3. Run the diagnostics again 4. If the drive diagnostic test runs successfully, replace the drive you removed with a new one.

Intermittent problems

Identify intermittent problem symptoms and corrective actions.

<ul style="list-style-type: none"> • Follow the suggested actions in the order in which they are listed in the Action column until the problem is solved. • See Chapter 3, “Parts listing, type 7891,” on page 225 to determine which components are CRUs and which components are FRUs. • If an action step is preceded by “(Trained service technician only),” that step must be performed only by a trained service technician. 	
Symptom	Action
A problem occurs only occasionally and is difficult to diagnose.	<ol style="list-style-type: none"> 1. Check the Advanced Management Module event log for errors 2. Make sure that: <ul style="list-style-type: none"> • When the blade server is turned on, air is flowing from the rear of the blade server at the blower grill. If there is no airflow, the blower is not working. This causes the blade server to overheat and shut down. • Ensure that the self configuring SCSI device (SCSD) bus and devices are configured correctly.

Management module service processor problems

Determine if a problem is a management module service processor problem and, if so, the corrective action to take.

<ul style="list-style-type: none"> • Follow the suggested actions in the order in which they are listed in the Action column until the problem is solved. • See Chapter 3, “Parts listing, type 7891,” on page 225 to determine which components are CRUs and which components are FRUs. • If an action step is preceded by “(Trained service technician only),” that step must be performed only by a trained service technician. 	
Symptom	Action
Service processor in the management module reports a general monitor failure.	<p>Disconnect the BladeCenter unit from all electrical sources, wait for 30 seconds, reconnect the BladeCenter unit to the electrical sources, and restart the blade server.</p> <p>If the problem remains, see “Solving undetermined problems” on page 223, or the Advanced Management Module Guide</p>

Memory problems

Identify memory problem symptoms and the corrective actions to take.

<ul style="list-style-type: none"> • Follow the suggested actions in the order in which they are listed in the Action column until the problem is solved. • See Chapter 3, “Parts listing, type 7891,” on page 225 to determine which components are CRUs and which components are FRUs. • If an action step is preceded by “(Trained service technician only),” that step must be performed only by a trained service technician. 	
Symptom	Action
The amount of system memory displayed is less than the amount of physical memory installed.	<ol style="list-style-type: none"> 1. Make sure that: <ul style="list-style-type: none"> • All installed memory is listed in the output of the <code>lscfg -vp</code> command. • The memory modules are seated properly. • You have installed the correct type of memory. • All banks of memory on the DIMMs are enabled. The blade server might have automatically disabled a DIMM bank when it detected a problem or a DIMM bank could have been manually disabled. 2. Check the Advanced Management Module event log for an error message. <ul style="list-style-type: none"> • If the DIMM was disabled by a system-management interrupt (SMI), replace the DIMM. • If the DIMM was disabled by the POST, obtain the eight-digit error code and location code and replace the failing DIMM. 3. Reseat the DIMM. 4. Replace the DIMM. 5. Replace the system-board

Microprocessor problems

Identify microprocessor problem symptoms and the corrective actions to take.

<ul style="list-style-type: none">• Follow the suggested actions in the order in which they are listed in the Action column until the problem is solved.• See Chapter 3, "Parts listing, type 7891," on page 225 to determine which components are CRUs and which components are FRUs.• If an action step is preceded by "(Trained service technician only)," that step must be performed only by a trained service technician.	
Symptom	Action
The blade server will not boot or a checkpoint or firmware error code is logged in the management-module event log (the startup microprocessor is not working correctly)	<ol style="list-style-type: none">1. If a checkpoint or firmware error was logged in the Advanced Management Module event log, correct that error.2. If no error was logged, restart the blade server and check the management module event log again for error codes.3. Replace the system-board

Network connection problems

Identify network connection problem symptoms and the corrective actions to take.

<ul style="list-style-type: none">• Follow the suggested actions in the order in which they are listed in the Action column until the problem is solved.• See Chapter 3, "Parts listing, type 7891," on page 225 to determine which components are CRUs and which components are FRUs.• If an action step is preceded by "(Trained service technician only)," that step must be performed only by a trained service technician.	
Symptom	Action
One or more blade servers are unable to communicate with the network.	<ol style="list-style-type: none">1. Verify that the I/O module is a switch or pass thru module. Ppass thru modules require an upstream switch for network traffic to pass.2. Ensure the correct device drivers are installed.3. Verify that the optional I/O expansion cards are correctly installed and configured, see "Removing and installing an I/O expansion card" on page 253

PCI expansion card (PIOCARD) problem isolation procedure

The hardware that controls PCI adapters and PCI card slots detected an error. The direct select address (DSA) portion of the system reference code (SRC) identifies the location code of the failing component.

The following table shows the syntax of a nine-word B700xxxx SRC as it might be displayed in the event log of the management module.

The first word of the SRC in this example is the message identifier, **B7001111**. This example numbers each word after the first word to show relative word positions. The seventh word is the direct select address, which is **77777777** in the example.

Table 33. Nine-word system reference code in the management-module event log

Index	Sev	Source	Date/Time	Text
1	E	Blade_05	01/21/2008, 17:15:14	(PS700-BC1BLD5E) SYS F/W: Error. Replace UNKNOWN (5008FECF B7001111 22222222 33333333 44444444 55555555 66666666 77777777 88888888 99999999)

Depending on your operating system and the utilities you have installed, error messages might also be stored in an operating system log. See the documentation that comes with the operating system for more information.

Table 34 shows the procedure for isolating which PCI expansion card is failing.

Table 34. PCI expansion card problem isolation procedure

<ul style="list-style-type: none"> • Follow the suggested actions in the order in which they are listed in the Action column until the problem is solved. • See Chapter 3, “Parts listing, type 7891,” on page 225 to determine which components are CRUs and which components are FRUs. • If an action step is preceded by “(Trained service technician only),” that step must be performed only by a trained service technician. 	
Symptom	Action
A B700xxxx error message indicates a problem with a PCI expansion card.	<ol style="list-style-type: none"> 1. Collect the error log information. 2. Get the DSA, which is word 7 of the associated B700xxxx SRC. 3. Use the hexadecimal value of the DSA to determine the location code of the failing CRU. <ul style="list-style-type: none"> • If the value is 05120010, the location code is P1-C19 or P2-C19. • If the value is xxxx 0100, the location code is P1-C20 or P2-C20. 4. Reseat the device that you just installed. 5. Replace the device that you just installed.

Optional device problems

Identify optional device problem symptoms and the corrective actions to take.

<ul style="list-style-type: none">• Follow the suggested actions in the order in which they are listed in the Action column until the problem is solved.• See Chapter 3, "Parts listing, type 7891," on page 225 to determine which components are CRUs and which components are FRUs.• If an action step is preceded by "(Trained service technician only)," that step must be performed only by a trained service technician.	
Symptom	Action
An IBM optional device that was just installed does not work.	<ol style="list-style-type: none">1. Make sure that:<ul style="list-style-type: none">• The option is designed for the blade server. See the ServerProven list at www.ibm.com/servers/eserver/serverproven/compat/us/.• You followed the installation instructions that came with the option.• The option is installed correctly.• You have not loosened any other installed devices or cables.2. If the option comes with its own test instructions, use those instructions to test the option.3. Reseat the device that you just installed.4. Replace the device that you just installed.

Power problems

Identify power problem symptoms and the corrective actions to take.

<ul style="list-style-type: none">• Follow the suggested actions in the order in which they are listed in the Action column until the problem is solved.• See Chapter 3, "Parts listing, type 7891," on page 225 to determine which components are CRUs and which components are FRUs.• If an action step is preceded by "(Trained service technician only)," that step must be performed only by a trained service technician.	
Symptom	Action
Power button does not work.	<ol style="list-style-type: none">1. Use the BladeCenter management module to verify that local power control for the blade server is enabled.2. Reseat the control-panel connector.3. Replace the bezel assembly.4. Replace the system-board

- Follow the suggested actions in the order in which they are listed in the Action column until the problem is solved.
- See Chapter 3, “Parts listing, type 7891,” on page 225 to determine which components are CRUs and which components are FRUs.
- If an action step is preceded by “(Trained service technician only),” that step must be performed only by a trained service technician.

Symptom	Action
The blade server does not turn on.	<ol style="list-style-type: none"> 1. Make sure that: <ol style="list-style-type: none"> a. The power LED on the front of the BladeCenter unit is on. b. The LEDs on all the BladeCenter power modules are on. c. The blade server is in a blade bay that is supported by the power modules installed in the BladeCenter unit. d. If the power LED is flashing rapidly , and continues to flash rapidly, the blade server is not communicating with the management module; reseal the blade server by following these procedures: <ul style="list-style-type: none"> • “Removing the tier 2 management card” on page 262 • “Installing the tier 2 management card” on page 263 • If reseating the blade server or the management card does not resolve the problem, go to step 3. e. If the power LED is off instead of flashing slowly or rapidly, the blade bay is not receiving power, the blade server is defective, or the LED information panel is loose or defective. f. Local power control for the blade server is enabled (use the BladeCenter Advanced Management Module Web interface to erify), or the blade server was instructed through the management module Web interface to start. 2. If you just installed a device in the blade server, remove it, and restart the blade server. If the blade server now starts, you might have installed more devices than the power to that blade bay supports. 3. Try another blade server in the blade bay; if it works, replace the faulty blade server. 4. See “Solving undetermined problems” on page 223.
The blade server turns off for no apparent reason	<ol style="list-style-type: none"> 1. Make sure that each blade bay has a blade server, expansion unit, or blade filler correctly installed. If these components are missing or incorrectly installed, an over-temperature condition might result in shutdown. 2. Check the Advanced Management Module event log for error messages. 3. Check the blade server light path. See “Light path diagnostics LEDs” on page 213 4. If the system board error LED is lit, replace the system board.
The blade server does not turn off.	<ol style="list-style-type: none"> 1. Verify whether you are using an ACPI or non-ACPI operating system. If you are using a non-ACPI operating system: <ol style="list-style-type: none"> a. Press Ctrl+Alt+Delete. b. Turn off the system by holding the power-control button for 4 seconds. c. If the blade server fails during POST and the power-control button does not work, remove the blade server from the bay and reseal it. 2. If the problem remains or if you are using an ACPI-aware operating system, suspect the system board. 3. Verify the Power button is working correctly. 4. Ensure local power control for the blade server is enabled.

Hypervisor problems

The hypervisor provides error diagnostics with associated error codes and fault isolation procedures for troubleshooting.

When the hypervisor error analysis determines a specific fault, the hypervisor logs an error code that identifies a failing component. When the analysis is not definitive, the hypervisor logs one or more isolation procedures for you to run to identify and correct the problem.

Table 35 describes the isolation procedures.

Table 35. Hypervisor isolation procedures

<ul style="list-style-type: none"> • Follow the suggested actions in the order in which they are listed in the Action column until the problem is solved. • See Chapter 3, “Parts listing, type 7891,” on page 225 to determine which components are CRUs and which components are FRUs. • If an action step is preceded by “(Trained service technician only),” that step must be performed only by a trained service technician. 		
Isolation Procedure Code	Symptom	Action
LPARCFG Symbolic CRU	There is a configuration problem with the system or a logical partition.	<ol style="list-style-type: none"> 1. Perform the procedure associated with the SRC code that is called out after the LPARCFG call. 2. Check processor and memory allocations of the system or the partitions. Verify that there are enough functioning processor and memory resources in the system for all of the partitions. Processor or memory resources that failed or were Garded during system IPL could cause the IPL problem in the partition. 3. Check the bus and I/O adapter allocations for the partition. Verify that the partition has load source and console I/O resources. 4. Check the IPL mode of the system or failing partition. 5. For further assistance, contact IBM Support.

Table 35. Hypervisor isolation procedures (continued)

<ul style="list-style-type: none"> • Follow the suggested actions in the order in which they are listed in the Action column until the problem is solved. • See Chapter 3, “Parts listing, type 7891,” on page 225 to determine which components are CRUs and which components are FRUs. • If an action step is preceded by “(Trained service technician only),” that step must be performed only by a trained service technician. 		
Isolation Procedure Code	Symptom	Action
MEMDIMM Symbolic CRU	The failing component is one of the memory DIMMs.	<ol style="list-style-type: none"> 1. Replace the failing CRU: <ul style="list-style-type: none"> DIMM 1 or 17 (Px-C1) P1-C1 is memory module 1; P2-C1 is memory module 17. DIMM 2 or 18 (Px-C2) P1-C2 is memory module 2; P2-C2 is memory module 18. DIMM 3 or 19 (Px-C3) P1-C3 is memory module 3; P2-C3 is memory module 19. DIMM 4 or 20 (Px-C4) P1-C4 is memory module 4; P2-C4 is memory module 20. DIMM 5 or 21 (Px-C5) P1-C5 is memory module 5; P2-C5 is memory module 21. DIMM 6 or 22 (Px-C6) P1-C6 is memory module 6; P2-C6 is memory module 22. DIMM 7 or 23 (Px-C7) P1-C7 is memory module 7; P2-C7 is memory module 23. DIMM 8 or 24 (Px-C8) P1-C8 is memory module 8; P2-C8 is memory module 24. DIMM 9 or 25 (Px-C9) P1-C9 is memory module 9; P2-C9 is memory module 25. 2. See “Removing a memory module” on page 249 for location information and the removal procedure. 3. Install new memory DIMMs, as described in “Installing a memory module” on page 251. <p>See “Supported DIMMs” on page 4 for more information.</p>

Table 35. Hypervisor isolation procedures (continued)

<ul style="list-style-type: none"> • Follow the suggested actions in the order in which they are listed in the Action column until the problem is solved. • See Chapter 3, “Parts listing, type 7891,” on page 225 to determine which components are CRUs and which components are FRUs. • If an action step is preceded by “(Trained service technician only),” that step must be performed only by a trained service technician. 		
Isolation Procedure Code	Symptom	Action
MEMDIMM Symbolic CRU	The failing component is one of the memory DIMMs.	<ol style="list-style-type: none"> 1. Replace the failing CRU: <ul style="list-style-type: none"> DIMM 10 or 26 (Px-C10) P1-C10 is memory module 10; P2-C10 is memory module 26. DIMM 11 or 27 (Px-C11) P1-C11 is memory module 11; P2-C11 is memory module 27. DIMM 12 or 28 (Px-C12) P1-C12 is memory module 12; P2-C12 is memory module 28. DIMM 13 or 29 (Px-C13) P1-C13 is memory module 13; P2-C13 is memory module 29. DIMM 14 or 30 (Px-C14) P1-C14 is memory module 14; P2-C14 is memory module 30. DIMM 15 or 31 (Px-C15) P1-C15 is memory module 15; P2-C15 is memory module 31. DIMM 16 or 32 (Px-C16) P1-C16 is memory module 16; P2-C16 is memory module 32. 2. See “Removing a memory module” on page 249 for location information and the removal procedure. 3. Install new memory DIMMs, as described in “Installing a memory module” on page 251. <p>See “Supported DIMMs” on page 4 for more information.</p>
NEXTLVL Symbolic CRU	Contact IBM Support.	
PIOCARD Symbolic CRU	The hardware that controls PCI adapters and PCI card slots detected an error. The direct select address (DSA) portion of the system reference code (SRC) identifies the location code of the failing component.	<ol style="list-style-type: none"> 1. Collect the error log information. 2. Get the DSA, which is word 7 of the associated B700xxxx SRC. 3. Use the hexadecimal value of the DSA to determine the location code of the failing CRU. <ul style="list-style-type: none"> • If the value is 05120010, the location code is P1-C19 or P2-C19. • If the value is xxxx 0100, the location code is P1-C20 or P2-C20. 4. Reseat the device that you just installed. 5. Replace the device that you just installed.

Service processor problems

The baseboard management controller (BMC) is a flexible service processor that provides error diagnostics with associated error codes, and fault isolation procedures for troubleshooting.

Note: Resetting the service processor causes a POWER7 reset/reload, which generates a dump. The dump is recorded in the management module event log. The reset/reload dump occurs whenever the service processor resets, such as when resetting the service processor through the management module Web interface or through the management module command line interface.

When the advanced POWER7 service processor error analysis determines a specific fault, the service processor logs an error code to identify the failing component. When the analysis is not definitive, the service processor logs one or more isolation procedures for you to run to identify and correct the problem.

The service processor reports fault isolation procedure codes to identify a specific service action. The isolation procedure code is recorded in the management-module event log.

A message with three procedures might be similar to the following example, except that the entry would be on one line in the event log:

```
(SN#YL31W7120029) SYS F/W: CEC Hardware VPD.  
See procedure FSPSP07, FSPSP28 then FSP0200  
(5000004C B15A3303 22222222 33333333 44444444 55555555  
66666666 77777777 88888888 99999999)
```

B15A3303 is the identifier word of the associated SRC. The rest of the nine words in the SRC are shown in sequence.

A message that identifies customer replaceable units (CRUs) might be similar to the following example:

```
(SN#YL31W7120029) SYS F/W: Error. Replace PIOCARD then Sys Brd  
(500213A0 B7006973 22222222 33333333 44444444 55555555  
66666666 77777777 88888888 99999999)
```

A message with multiple replacement callouts might be too long to display. In such a case, the message removes SRC words starting with word 2 and inserts an X for every removed word. The following example shows an error log entry that did not have enough room for words 2 and 3:

```
(SN#YL31W7120029) SYS F/W: CEC Hardware VPD.  
See procedure FSPSP07, FSPSP28 then FSP0200  
(50000014 B15A3303 XX 44444444 55555555 66666666  
77777777 88888888 99999999)
```

<ul style="list-style-type: none"> • Follow the suggested actions in the order in which they are listed in the Action column until the problem is solved. • See Chapter 3, “Parts listing, type 7891,” on page 225 to determine which components are CRUs and which components are FRUs. • If an action step is preceded by “(Trained service technician only),” that step must be performed only by a trained service technician. 		
Isolation Procedure Code	Symptom	Action
ANYPROC Symbolic CRU	The failing component is one of the system processors.	Replace the system board and chassis assembly, as described in “Replacing the FRU system-board and chassis assembly” on page 264.
BCPROB Symbolic CRU	Error code 1xxx2670 indicates that the BladeCenter encountered a problem, and the blade server was automatically shut down as a result.	<ol style="list-style-type: none"> 1. Check the management-module event log for entries that were made around the time that the PS703 or PS704 blade server shut down. 2. Resolve any problems. 3. Remove the blade from the BladeCenter unit and then reinsert the blade server. 4. Power on the blade server. 5. Monitor the blade server operation to verify that the problem is solved. 6. If the BladeCenter unit is functioning normally, but the 1xxx2670 problem persists, replace the system board and chassis assembly, as described in “Replacing the FRU system-board and chassis assembly” on page 264.
CAPACTY Symbolic CRU	The failing component is the management card.	<ol style="list-style-type: none"> 1. Replace the management card, as described in “Removing the tier 2 management card” on page 262 and “Installing the tier 2 management card” on page 263. 2. After replacing the card and installing the blade server in the chassis unit and before rebooting the blade server or performing other operations, ensure that the initialization of the management card VPD occurs by waiting for the management module to discover the blade server. Otherwise, the system might fail to IPL.
CLCKMOD Symbolic CRU	The logic oscillator is failing.	Replace the system board and chassis assembly, as described in “Replacing the FRU system-board and chassis assembly” on page 264.
DTRCARD Symbolic CRU	Error code 1xxx2625, 2626, or 2527 indicates that the blade server is reporting a problem with the PCIe expansion card.	<ol style="list-style-type: none"> 1. Reseat the PCIe expansion card. 2. If the problem persists, replace the expansion card. 3. If the problem persists, go to “Checkout procedure” on page 176. 4. If the problem persists, replace the system board and chassis assembly, as described in “Replacing the FRU system-board and chassis assembly” on page 264.

- Follow the suggested actions in the order in which they are listed in the Action column until the problem is solved.
- See Chapter 3, “Parts listing, type 7891,” on page 225 to determine which components are CRUs and which components are FRUs.
- If an action step is preceded by “(Trained service technician only),” that step must be performed only by a trained service technician.

Isolation Procedure Code	Symptom	Action
FSPSP01	A part vital to system function has been deconfigured. Review the system error logs for errors that call out CRUs that are relevant to each reason code.	<p>If replacing parts does not resolve the error, perform one of the following procedures, based on the SRC code that is called out after the FSPSP01 call.</p> <p>If the SRC is B1xxB10C or B1xxB10D</p> <p>The system has detected a deconfigured memory controller that is required for the system to function, or it has detected that there is not enough memory or that the memory is plugged incorrectly.</p> <ol style="list-style-type: none"> 1. Reseat all of the memory DIMMs in the system enclosure but do not replace any memory DIMMs at this time. Reseat the memory DIMMs as described in “Installing a memory module” on page 251. 2. If the problem persists, replace each memory DIMM, by following the action for symbolic FRU MEMDIMM. 3. Install the blade server into the BladeCenter unit after each DIMM replacement and restart the blade to verify if the problem is solved. 4. If the problem persists after replacing all DIMMs, replace the system board and chassis assembly, as described in “Replacing the FRU system-board and chassis assembly” on page 264. <p>If the SRC is B1xxB107 or B1xxB108</p> <p>The system has detected a problem with a clock card.</p> <ol style="list-style-type: none"> 1. Replace the system board and chassis assembly, as described in “Replacing the FRU system-board and chassis assembly” on page 264. <p>If the SRC is B1xxB106</p> <p>The system has detected that the planars are deconfigured.</p> <ol style="list-style-type: none"> 1. Replace the system board and chassis assembly, as described in “Replacing the FRU system-board and chassis assembly” on page 264. <p>If the SRC is B1xxB110 or B1xxB111</p> <p>The system has detected that all of the I/O bridges are deconfigured.</p> <ol style="list-style-type: none"> 1. Replace the system board and chassis assembly, as described in “Replacing the FRU system-board and chassis assembly” on page 264.
FSPSP02	This procedure is for boot failures that terminate very early in the boot process or when the management card or the VPD data on the management card is not operational or is not present.	<ol style="list-style-type: none"> 1. Replace the management card, as described in “Removing the tier 2 management card” on page 262 and “Installing the tier 2 management card” on page 263. 2. After replacing the card and installing the blade server in the chassis unit and before rebooting the blade server or performing other operations, ensure that the initialization of the management card VPD occurs by waiting for the management module to discover the blade server. Otherwise, the system might fail to IPL. 3. If the problem persists, replace the system board and chassis assembly, as described in “Replacing the FRU system-board and chassis assembly” on page 264.

<ul style="list-style-type: none"> • Follow the suggested actions in the order in which they are listed in the Action column until the problem is solved. • See Chapter 3, “Parts listing, type 7891,” on page 225 to determine which components are CRUs and which components are FRUs. • If an action step is preceded by “(Trained service technician only),” that step must be performed only by a trained service technician. 		
Isolation Procedure Code	Symptom	Action
FSPSP03	A system operator or user error has occurred.	Refer to the documentation for the function you were attempting to perform.
FSPSP04	A problem has been detected in the service processor firmware.	<ol style="list-style-type: none"> 1. Verify that the operating system is running. If it is running, perform an in-band firmware update, as described in “Updating the firmware” on page 267. 2. If the problem persists, replace the system board and chassis assembly, as described in “Replacing the FRU system-board and chassis assembly” on page 264.
FSPSP05	The service processor has detected a problem in the platform firmware.	<ol style="list-style-type: none"> 1. Verify that the operating system is running. If it is running, perform an in-band firmware update, as described in “Updating the firmware” on page 267. 2. If the problem persists, replace the system board and chassis assembly, as described in “Replacing the FRU system-board and chassis assembly” on page 264.
FSPSP06	The service processor reported a suspected intermittent problem.	Contact IBM Support.
FSPSP07	The time of day has been reset to the default value.	<ol style="list-style-type: none"> 1. Use the chdate command to set the Virtual I/O Server date and time, using one of the following syntaxes: <pre>chdate [-year YYyy] [-month mm] [-day dd] [-hour HH] [-minute MM] [-timezone TZ] chdate mmddHHMM[YYyy yy] [-timezone TZ]</pre> 2. If the problem persists, replace the battery, as described in “Removing the battery” on page 258 and “Installing the battery” on page 258.

- Follow the suggested actions in the order in which they are listed in the Action column until the problem is solved.
- See Chapter 3, “Parts listing, type 7891,” on page 225 to determine which components are CRUs and which components are FRUs.
- If an action step is preceded by “(Trained service technician only),” that step must be performed only by a trained service technician.

Isolation Procedure Code	Symptom	Action
FSPSP09	A problem has been detected with a memory DIMM, but it cannot be isolated to a specific memory DIMM.	<p>Replace the CRU called out after this FSPSP call. If the CRU that is called out is a DIMM CRU, perform the following procedure:</p> <ol style="list-style-type: none"> 1. Replace both memory DIMMs of the pair on the microprocessor that contains the failing CRU: <ul style="list-style-type: none"> DIMM 1 (Px-C1) For P1-C1, replace DIMMs 1 and 3; for P2-C1, replace DIMMs 17 and 19. DIMM 2 (Px-C2) Replace DIMMs 2 and 4, or DIMMs 18 and 20. DIMM 3 (Px-C3) Replace DIMMs 1 and 3, or DIMMs 17 and 19. DIMM 4 (Px-C4) Replace DIMMs 2 and 4, or DIMMs 18 and 20. DIMM 5 (Px-C5) Replace DIMMs 5 and 7, or DIMMs 21 and 23. DIMM 6 (Px-C6) Replace DIMMs 6 and 8, or DIMMs 22 and 24. DIMM 7 (Px-C7) Replace DIMMs 5 and 7, or DIMMs 21 and 23. DIMM 8 (Px-C8) Replace DIMMs 6 and 8, or DIMMs 22 and 24. DIMM 9 (Px-C9) Replace DIMMs 9 and 11, or DIMMs 25 and 27. DIMM 10 (Px-C10) Replace DIMMs 10 and 12, or DIMMs 26 and 28. DIMM 11 (Px-C11) Replace DIMMs 9 and 11, or DIMMs 25 and 27. DIMM 12 (Px-C12) Replace DIMMs 10 and 12, or DIMMs 26 and 28. DIMM 13 (Px-C13) Replace DIMMs 13 and 15, or DIMMs 29 and 31. DIMM 14 (Px-C14) Replace DIMMs 14 and 16, or DIMMs 30 and 32. DIMM 15 (Px-C15) Replace DIMMs 13 and 15, or DIMMs 29 and 31. DIMM 16 (Px-C16) Replace DIMMs 14 and 16, or DIMMs 30 and 32. 2. See “Removing a memory module” on page 249 for location information and the removal procedure. 3. Install new memory DIMMs, as described in “Installing a memory module” on page 251.

<ul style="list-style-type: none"> • Follow the suggested actions in the order in which they are listed in the Action column until the problem is solved. • See Chapter 3, “Parts listing, type 7891,” on page 225 to determine which components are CRUs and which components are FRUs. • If an action step is preceded by “(Trained service technician only),” that step must be performed only by a trained service technician. 		
Isolation Procedure Code	Symptom	Action
FSPSP10	The part indicated in the CRU callout that follows this procedure is invalid or missing for this system's configuration.	<ol style="list-style-type: none"> 1. If there is only one CRU called out after this FSPSP10 call: <ol style="list-style-type: none"> a. Verify that the CRU is installed, connected, and seated properly. b. If the CRU is seated properly and the problem persists, replace the CRU. c. If the CRU is missing, add the CRU. 2. If multiple CRUs are called out, they have identical serial numbers. Remove all but one of the CRUs.
FSPSP11	The service processor has detected an error on the RIO/HSL port in the system unit.	<ol style="list-style-type: none"> 1. Verify that the operating system is running. If it is running, perform an in-band firmware update, as described in “Updating the firmware” on page 267. 2. If the problem persists, replace the system board and chassis assembly, as described in “Replacing the FRU system-board and chassis assembly” on page 264.
FSPSP12	The DIMM CRU that was called out failed to correct the memory error.	Replace the system board and chassis assembly, as described in “Replacing the FRU system-board and chassis assembly” on page 264.
FSPSP14	The service processor cannot establish communication with the server firmware. The server firmware will continue to run the system and partitions while it attempts to recover the communications. Server firmware recovery actions will continue for approximately 30 to 40 minutes.	<ol style="list-style-type: none"> 1. View the event log in the management module to locate the system reference code (SRC) and the time that the event was logged. See “Error logs” on page 176. If progress codes are being displayed, the server firmware was able to reset the service processor and solve the problem. 2. Record the time the log was created or when you first noticed this SRC. 3. If progress codes are not being displayed, examine the management module event log to see if an A7006995 SRC has been displayed. If an A7006995 SRC has been displayed, the blade server is powering off partitions and attempting a server dump. Follow the action in the A7006995 SRC description if the partitions do not terminate as requested. 4. If an A7006995 SRC has not been displayed, has the A1xx SRC remained for more than 40 minutes? If so, the server firmware could not begin terminating the partitions. Contact your next level of support to assist in attempting to terminate any remaining partitions and forcing a server dump. Collect the dump for support and power off and power on the blade server. 5. If an A1xx SRC has not remained more than 40 minutes, call IBM Support.
FSPSP16	Save any error log and dump data and contact your next level of support for assistance.	Contact IBM Support.

<ul style="list-style-type: none"> • Follow the suggested actions in the order in which they are listed in the Action column until the problem is solved. • See Chapter 3, “Parts listing, type 7891,” on page 225 to determine which components are CRUs and which components are FRUs. • If an action step is preceded by “(Trained service technician only),” that step must be performed only by a trained service technician. 		
Isolation Procedure Code	Symptom	Action
FSPSP17	A system uncorrectable error has occurred.	<ul style="list-style-type: none"> • Look for other serviceable events. • Use the SRCs that those events call out to determine and fix any problems.
FSPSP18	A problem has been detected in the platform licensed internal code (LIC).	<ol style="list-style-type: none"> 1. Verify that the operating system is running. If it is running, perform an in-band firmware update, as described in “Updating the firmware” on page 267. 2. If the problem persists, replace the system board and chassis assembly, as described in “Replacing the FRU system-board and chassis assembly” on page 264.
FSPSP20	A failing item has been detected by a hardware procedure.	Call IBM Support.
FSPSP22	The system has detected that a processor chip is missing from the system configuration because JTAG lines are not working.	Replace the system board and chassis assembly, as described in “Replacing the FRU system-board and chassis assembly” on page 264.
FSPSP23	The system needs to perform a service processor dump.	<ol style="list-style-type: none"> 1. Save the service processor dump to storage by using the partition dump pin control on the control panel. 2. Once the dump is complete, attempt to re-IPL the system. 3. Call IBM Support.
FSPSP24	The system is running in a degraded mode. Array bit steering might be able to correct this problem without replacing hardware.	<ol style="list-style-type: none"> 1. Power off the blade server, as described in “Turning off the blade server” on page 8. 2. Remove the blade server from the BladeCenter unit and reinsert the blade server into the BladeCenter unit. 3. Power on the blade server, as described in “Turning on the blade server” on page 7. 4. If the problem persists, replace the CRU that is called out after this procedure.
FSPSP27	An attention line has been detected as having a problem.	Replace the CRU that is called out before this FSPSP27 call. If the CRU does not correct the problem, call IBM Support.
FSPSP28	The resource ID (RID) of the CRU could not be found in the Vital Product Data (VPD) table.	<ol style="list-style-type: none"> 1. Find another callout that reads “FSPxxxx” where xxxx is a 4-digit hex number that represents the resource ID. Record the resource ID and the model of the system. 2. Call IBM Support to find out what CRU the resource ID represents. 3. Replace the CRU that the resource ID represents.

<ul style="list-style-type: none"> • Follow the suggested actions in the order in which they are listed in the Action column until the problem is solved. • See Chapter 3, “Parts listing, type 7891,” on page 225 to determine which components are CRUs and which components are FRUs. • If an action step is preceded by “(Trained service technician only),” that step must be performed only by a trained service technician. 		
Isolation Procedure Code	Symptom	Action
FSPSP29	The system has detected that all I/O bridges are missing from the system configuration.	Replace the system board and chassis assembly, as described in “Replacing the FRU system-board and chassis assembly” on page 264.
FSPSP30	<p>A problem has been encountered accessing the management card or the VPD data found on the management card has been corrupted.</p> <p>This error occurred before VPD collection was completed, so no location codes have been created.</p>	<ol style="list-style-type: none"> 1. Replace the management card, as described in “Removing the tier 2 management card” on page 262 and “Installing the tier 2 management card” on page 263. 2. After replacing the card and installing the blade server in the chassis unit and before rebooting the blade server or performing other operations, ensure that the initialization of the management card VPD occurs by waiting for the management module to discover the blade server. Otherwise, the system might fail to IPL. 3. If the problem persists, replace the system board and chassis assembly, as described in “Replacing the FRU system-board and chassis assembly” on page 264.
FSPSP31	The service processor has detected that one or more of the required fields in the system VPD has not initialized.	<ol style="list-style-type: none"> 1. When the system reaches the SMS, set the system VPD values that are required, which automatically resets the service processor. 2. Power on the blade server, as described in “Turning on the blade server” on page 7.
FSPSP32	<p>A problem with the enclosure has been found.</p> <p>The problem is one of the following problems:</p> <ul style="list-style-type: none"> • The enclosure VPD cannot be found. • The enclosure serial number is not programmed. • The enclosure feature code is not programmed. 	<p>Record the reason code, which is the last four digits of the first word from the SRC. Perform one of the following procedures based upon the value of the reason code:</p> <ul style="list-style-type: none"> • Reason code A46F <ol style="list-style-type: none"> 1. Verify that the operating system is running. If it is running, perform an in-band firmware update. 2. If the problem persists, replace the system board and chassis assembly, as described in “Replacing the FRU system-board and chassis assembly” on page 264. 3. If the problem persists, call IBM Support. • Reason code A460 <ol style="list-style-type: none"> 1. Set the enclosure serial number using SMS, which automatically resets the service processor. 2. If the problem persists, call IBM Support. • Reason code A45F <ol style="list-style-type: none"> 1. Set the enclosure feature code using SMS, which automatically resets the service processor. 2. If the problem persists, call IBM Support. <p>If you do not see your reason code listed, call IBM Support.</p>

- Follow the suggested actions in the order in which they are listed in the Action column until the problem is solved.
- See Chapter 3, “Parts listing, type 7891,” on page 225 to determine which components are CRUs and which components are FRUs.
- If an action step is preceded by “(Trained service technician only),” that step must be performed only by a trained service technician.

Isolation Procedure Code	Symptom	Action
FSPSP34	The memory cards are plugged in an invalid configuration and cannot be used by the system.	<p>Install a DIMM for each of the dual processors on the BladeCenter PS703 or PS704 blade server. Install the first pair in DIMM connectors 2 and 4.</p> <p>Look for the following error codes in order. Follow the procedure for the first code you find.</p> <p>SRC B1xx C02A A memory card is missing from the system.</p> <p>The additional parts in the CRU callout list include all memory cards in the group with the missing card. To correct the error, visually check the system to determine which card is missing, and add the card.</p> <p>SRC B1xx C029 A memory card is a different type than the other memory cards in the same group.</p> <p>The additional parts in the CRU callout list include all memory cards in the group that contain the error. To correct the error, exchange the memory cards of the incorrect type with those of the correct type.</p> <p>SRC B1xx C02B A group of memory cards are missing and are required so that other memory cards on the board can be configured.</p> <p>The additional parts in the CRU callout list include all the missing memory cards in the group. To correct the error, add or move the memory cards to the correct locations.</p> <p>SRC B1xx C036 A memory card is not supported in this system.</p> <p>The additional parts in the CRU callout list include all memory cards in the group that contain the unsupported cards. To correct the error, remove the unsupported cards from the system or replace them with the correct type.</p>
FSPSP35	The system has detected a problem with a memory controller.	<p>Enable redundant utilization by performing the following procedure:</p> <ol style="list-style-type: none"> 1. Power off the blade server, as described in “Turning off the blade server” on page 8. 2. Remove the blade server from the BladeCenter unit and reinsert the blade server. 3. Power on the blade server, as described in “Turning on the blade server” on page 7.
FSPSP38	The system has detected an error within the JTAG path.	Replace the CRU that is called out before this FSPSP38 call. If the CRU that you replace does not correct the problem, call IBM Support.
FSPSP42	An error communicating between two system processors was detected.	Contact IBM Support.

- Follow the suggested actions in the order in which they are listed in the Action column until the problem is solved.
- See Chapter 3, “Parts listing, type 7891,” on page 225 to determine which components are CRUs and which components are FRUs.
- If an action step is preceded by “(Trained service technician only),” that step must be performed only by a trained service technician.

Isolation Procedure Code	Symptom	Action
FSPSP45	The system has detected an error within the FSI path.	Replace the system board and chassis assembly, as described in “Replacing the FRU system-board and chassis assembly” on page 264.
FSPSP46	Some corrupt areas of flash or RAM have been detected on the Service Processor.	Replace the system board and chassis assembly, as described in “Replacing the FRU system-board and chassis assembly” on page 264.
FSPSP47	The system has detected an error within the PSI link.	Replace the system board and chassis assembly, as described in “Replacing the FRU system-board and chassis assembly” on page 264.
FSPSP48	A diagnostics function detects an external processor interface problem.	If the CRUs called out before this procedure do not fix the problem, contact IBM Support.
FSPSP49	A diagnostic function detects an internal processor interface problem.	If the CRUs called out before this procedure do not fix the problem, contact IBM Support.
FSPSP50	A diagnostic function detects a connection problem between a processor chip and a GX chip.	If the CRUs called out before this procedure do not fix the problem, contact IBM Support.

- Follow the suggested actions in the order in which they are listed in the Action column until the problem is solved.
- See Chapter 3, “Parts listing, type 7891,” on page 225 to determine which components are CRUs and which components are FRUs.
- If an action step is preceded by “(Trained service technician only),” that step must be performed only by a trained service technician.

Isolation Procedure Code	Symptom	Action
FSPSP51	Runtime diagnostics has detected a memory bus correctable error that is exceeding threshold. The memory bus correctable error does not threaten the system operation at the moment. However, the system is operating under degraded mode.	<p>Replace the CRU called out after this FSPSP call. If the CRU that is called out is a DIMM CRU, perform the following procedure:</p> <ol style="list-style-type: none"> 1. Replace both memory DIMMs of the pair on the microprocessor that contains the failing CRU: <ul style="list-style-type: none"> DIMM 1 (Px-C1) For P1-C1, replace DIMMs 1 and 3; for P2-C1, replace DIMMs 17 and 19. DIMM 2 (Px-C2) Replace DIMMs 2 and 4, or DIMMs 18 and 20. DIMM 3 (Px-C3) Replace DIMMs 1 and 3, or DIMMs 17 and 19. DIMM 4 (Px-C4) Replace DIMMs 2 and 4, or DIMMs 18 and 20. DIMM 5 (Px-C5) Replace DIMMs 5 and 7, or DIMMs 21 and 23. DIMM 6 (Px-C6) Replace DIMMs 6 and 8, or DIMMs 22 and 24. DIMM 7 (Px-C7) Replace DIMMs 5 and 7, or DIMMs 21 and 23. DIMM 8 (Px-C8) Replace DIMMs 6 and 8, or DIMMs 22 and 24. DIMM 9 (Px-C9) Replace DIMMs 9 and 11, or DIMMs 25 and 27. DIMM 10 (Px-C10) Replace DIMMs 10 and 12, or DIMMs 26 and 28. DIMM 11 (Px-C11) Replace DIMMs 9 and 11, or DIMMs 25 and 27. DIMM 12 (Px-C12) Replace DIMMs 10 and 12, or DIMMs 26 and 28. DIMM 13 (Px-C13) Replace DIMMs 13 and 15, or DIMMs 29 and 31. DIMM 14 (Px-C14) Replace DIMMs 14 and 16, or DIMMs 30 and 32. DIMM 15 (Px-C15) Replace DIMMs 13 and 15, or DIMMs 29 and 31. DIMM 16 (Px-C16) Replace DIMMs 14 and 16, or DIMMs 30 and 32. 2. See “Removing a memory module” on page 249 for location information and the removal procedure. 3. Install new memory DIMMs, as described in “Installing a memory module” on page 251.

- Follow the suggested actions in the order in which they are listed in the Action column until the problem is solved.
- See Chapter 3, “Parts listing, type 7891,” on page 225 to determine which components are CRUs and which components are FRUs.
- If an action step is preceded by “(Trained service technician only),” that step must be performed only by a trained service technician.

Isolation Procedure Code	Symptom	Action
FSPSP53	A network error has occurred between the service processor and the network switch that is on the blade server.	Replace the system board and chassis assembly, as described in “Replacing the FRU system-board and chassis assembly” on page 264.
FSPSP54	A processor over-temperature has been detected. Check for any environmental issues before replacing any parts.	<ol style="list-style-type: none"> 1. Measure the ambient room temperature to see if it is within the upper limit of the normal operating range. The upper limit is less than 35 degrees C or 95 degrees F. If the temperature exceeds this limit, you must bring down the room temperature until it is within the limit. When the temperature is within range, retry the operation. 2. If the temperature is within the acceptable range, check the front and rear of the BladeCenter unit to verify that each is free of obstructions that would impede the airflow. If there are obstructions, you must clear the obstructions. Also clean the air inlets and exits in the BladeCenter unit drawer as required. If you cleared obstructions, retry the operation. 3. Verify that the fans in the BladeCenter unit are working correctly. If not, replace fans that are not turning or that are turning slowly. If you replace fans, wait for the unit to cool and retry the operation. 4. If the cooling components are functioning correctly, replace the system board and chassis assembly, as described in “Replacing the FRU system-board and chassis assembly” on page 264.

- Follow the suggested actions in the order in which they are listed in the Action column until the problem is solved.
- See Chapter 3, “Parts listing, type 7891,” on page 225 to determine which components are CRUs and which components are FRUs.
- If an action step is preceded by “(Trained service technician only),” that step must be performed only by a trained service technician.

Isolation Procedure Code	Symptom	Action
FSPSP72	The network sideband interface controller (NSIC) has detected that the physical Ethernet link is down.	<ol style="list-style-type: none"> Using SRC word 6, determine which I/O module has been identified as having a problem: <ul style="list-style-type: none"> 0x00000003 Blade center I/O slot 3 0x00000004 Blade center I/O slot 4 0x00000005 Blade center I/O slot 7 0x00000006 Blade center I/O slot 8 0x00000007 Blade center I/O slot 9 0x00000008 Blade center I/O slot 10 Verify that the I/O module installed in the blade center I/O slot identified by word 6 of the SRC is marked compatible in the blade center advanced management module (AMM) interface. Click System Status > I/O Compatibility. If the I/O module is marked as compatible, continue with the next step. If the I/O module is not marked as compatible, select an I/O module slot that is compatible with the current blade configuration as identified by the AMM. Select the I/O module for Ethernet traffic by clicking Blade Tasks > Configuration > Interface Management > blade > Management Network > Route Traffic Through. This ends the procedure. Reseat the I/O module identified in step 1. If the problem persists, continue with the next step. Reseat the blade system. If the problem persists, continue with the next step. Using SRC word 7, determine the FRU to replace: <ul style="list-style-type: none"> 0x00000001 CIOv form-factor expansion card 0x00000002 CFFh expansion card 0x00000003 Blade system This ends the procedure.
IOHUB Symbolic CRU	The failing component is the RIO/HSL NIC on the IPL path.	Replace the system board and chassis assembly, as described in “Replacing the FRU system-board and chassis assembly” on page 264.

- Follow the suggested actions in the order in which they are listed in the Action column until the problem is solved.
- See Chapter 3, "Parts listing, type 7891," on page 225 to determine which components are CRUs and which components are FRUs.
- If an action step is preceded by "(Trained service technician only)," that step must be performed only by a trained service technician.

Isolation Procedure Code	Symptom	Action
IOBRDG Symbolic CRU	The failing component is the RIO/HSL I/O bridge on the IPL path.	Replace the system board and chassis assembly, as described in "Replacing the FRU system-board and chassis assembly" on page 264.
MEMBRD Symbolic CRU	The failing component is the board the memory DIMMs plug into.	Replace the system board and chassis assembly, as described in "Replacing the FRU system-board and chassis assembly" on page 264.
MEMCTLR Symbolic CRU	The failing component is one of the memory controllers.	Replace the system board and chassis assembly, as described in "Replacing the FRU system-board and chassis assembly" on page 264.

- Follow the suggested actions in the order in which they are listed in the Action column until the problem is solved.
- See Chapter 3, “Parts listing, type 7891,” on page 225 to determine which components are CRUs and which components are FRUs.
- If an action step is preceded by “(Trained service technician only),” that step must be performed only by a trained service technician.

Isolation Procedure Code	Symptom	Action
MEMDIMM Symbolic CRU	The failing component is one of the memory DIMMs.	<p>1. Replace the failing CRU:</p> <p>DIMM 1 or 17 (Px-C1) P1-C1 is memory module 1; P2-C1 is memory module 17.</p> <p>DIMM 2 or 18 (Px-C2) P1-C2 is memory module 2; P2-C2 is memory module 18.</p> <p>DIMM 3 or 19 (Px-C3) P1-C3 is memory module 3; P2-C3 is memory module 19.</p> <p>DIMM 4 or 20 (Px-C4) P1-C4 is memory module 4; P2-C4 is memory module 20.</p> <p>DIMM 5 or 21 (Px-C5) P1-C5 is memory module 5; P2-C5 is memory module 21.</p> <p>DIMM 6 or 22 (Px-C6) P1-C6 is memory module 6; P2-C6 is memory module 22.</p> <p>DIMM 7 or 23 (Px-C7) P1-C7 is memory module 7; P2-C7 is memory module 23.</p> <p>DIMM 8 or 24 (Px-C8) P1-C8 is memory module 8; P2-C8 is memory module 24.</p> <p>DIMM 9 or 25 (Px-C9) P1-C9 is memory module 9; P2-C9 is memory module 25.</p> <p>2. See “Removing a memory module” on page 249 for location information and the removal procedure.</p> <p>3. Install new memory DIMMs, as described in “Installing a memory module” on page 251.</p> <p>See “Supported DIMMs” on page 4 for more information.</p>

- Follow the suggested actions in the order in which they are listed in the Action column until the problem is solved.
- See Chapter 3, “Parts listing, type 7891,” on page 225 to determine which components are CRUs and which components are FRUs.
- If an action step is preceded by “(Trained service technician only),” that step must be performed only by a trained service technician.

Isolation Procedure Code	Symptom	Action
MEMDIMM Symbolic CRU	The failing component is one of the memory DIMMs.	<ol style="list-style-type: none"> 1. Replace the failing CRU: <ul style="list-style-type: none"> DIMM 10 or 26 (Px-C10) P1-C10 is memory module 10; P2-C10 is memory module 26. DIMM 11 or 27 (Px-C11) P1-C11 is memory module 11; P2-C11 is memory module 27. DIMM 12 or 28 (Px-C12) P1-C12 is memory module 12; P2-C12 is memory module 28. DIMM 13 or 29 (Px-C13) P1-C13 is memory module 13; P2-C13 is memory module 29. DIMM 14 or 30 (Px-C14) P1-C14 is memory module 14; P2-C14 is memory module 30. DIMM 15 or 31 (Px-C15) P1-C15 is memory module 15; P2-C15 is memory module 31. DIMM 16 or 32 (Px-C16) P1-C16 is memory module 16; P2-C16 is memory module 32. 2. See “Removing a memory module” on page 249 for location information and the removal procedure. 3. Install new memory DIMMs, as described in “Installing a memory module” on page 251. <p>See “Supported DIMMs” on page 4 for more information.</p>
NO12VDC Symbolic CRU	Error code 1xxx2647 indicates that the blade server is reporting that 12V dc is not present on the BladeCenter midplane.	<ol style="list-style-type: none"> 1. Check the management-module event log for entries that indicate a power problem with the BladeCenter unit. 2. Resolve any problems. 3. Remove the blade from the BladeCenter unit and then reinsert the blade server. 4. Power on the blade server. 5. Monitor the blade server operation to verify that the problem is solved. 6. If the BladeCenter unit is functioning normally, but the 1xxx2647 problem persists, replace the system board and chassis assembly, as described in “Replacing the FRU system-board and chassis assembly” on page 264.

<ul style="list-style-type: none"> • Follow the suggested actions in the order in which they are listed in the Action column until the problem is solved. • See Chapter 3, “Parts listing, type 7891,” on page 225 to determine which components are CRUs and which components are FRUs. • If an action step is preceded by “(Trained service technician only),” that step must be performed only by a trained service technician. 		
Isolation Procedure Code	Symptom	Action
NODEPL Symbolic CRU	The failing component is the node midplane.	Replace the system board and chassis assembly, as described in “Replacing the FRU system-board and chassis assembly” on page 264.
TOD_BAT Symbolic CRU	The battery for the time-of-day battery is low or failing.	Replace the battery, as described in “Removing the battery” on page 258 and “Installing the battery” on page 258.

Software problems

Use this information to recognize software problem symptoms and to take corrective actions.

<ul style="list-style-type: none"> • Follow the suggested actions in the order in which they are listed in the Action column until the problem is solved. • See Chapter 3, “Parts listing, type 7891,” on page 225 to determine which components are CRUs and which components are FRUs. • If an action step is preceded by “(Trained service technician only),” that step must be performed only by a trained service technician. 	
Symptom	Action
You suspect a software problem.	<ol style="list-style-type: none"> 1. To determine whether the problem is caused by the software, make sure that: <ul style="list-style-type: none"> • The server has the minimum memory that is needed to use the software. For memory requirements, see the information that comes with the software. Note: If you have just installed an adapter or memory, the blade server might have a memory-address conflict. • The software is designed to operate on the blade server. • Other software works on the blade server. • The software works on another server. 2. If you received any error messages when using the software, see the information that comes with the software for a description of the messages and suggested solutions to the problem. 3. Contact your place of purchase of the software.

Universal Serial Bus (USB) port problems

This topic describes USB port problem symptoms and corrective actions.

<ul style="list-style-type: none">• Follow the suggested actions in the order in which they are listed in the Action column until the problem is solved.• See Chapter 3, "Parts listing, type 7891," on page 225 to determine which components are CRUs and which components are FRUs.• If an action step is preceded by "(Trained service technician only)," that step must be performed only by a trained service technician.	
Symptom	Action
A USB device does not work.	Make sure that: <ul style="list-style-type: none">• The correct USB device driver is installed.• The operating system supports USB devices.

Light path diagnostics

Light path diagnostics is a system of LEDs on the control panel and on the system board of the blade server. When an error occurs, LEDs are lit throughout the blade server. If the control panel indicates an error, use the descriptions of the LEDs to diagnose the problem and take corrective action.

LEDs are available for the following components:

- Battery (base unit only)
- SAS disk drive on both the base unit and the expansion unit
- SSD on both the base unit and the expansion unit
- SSD carrier on both the base unit and the expansion unit
- Management card on the base unit only
- Memory modules (DIMMs) on both the base unit and the expansion unit
- CFFh expansion card option on both the base unit and the expansion unit
- CIOv form-factor expansion card option on both the base unit and the expansion unit
- System board and chassis assembly on both the base unit and the expansion unit
- A "check card below" LED on the expansion unit only

Viewing the light path diagnostic LEDs

After reading required safety information, look at the control panel to determine if the LEDs indicate a sub-optimal condition or an error.

View the system LEDs remotely through the Advanced Management Module Web interface. The main LED page shows the external LEDs on the blade server. The internal blade LEDs are also available through a blade hyperlink from the LED page. This enables you to see the status of the internal LEDs on the blade server without having to turn off the blade server, remove it from the chassis, and activate the light path indications.

Before working inside the blade server to view light path diagnostic LEDs, see the *Safety* topic and the “Handling static-sensitive devices” on page 230 guidelines.

If an error occurs, view the light path diagnostic LEDs in the following order:

1. Look at the control panel on the front of the blade server. See “Blade server control panel buttons and LEDs” on page 6.
 - If the information LED is lit, it indicates that information about a suboptimal condition in the blade server is available in the management-module event log.
 - If the blade-error LED is lit, it indicates that an error has occurred and you should proceed to the next step.
2. If an error has occurred, view the light path diagnostics panel and LEDs:
 - a. Remove the blade server from the BladeCenter unit.
 - b. Place the blade server on a flat, static-protective surface.
 - c. Remove the cover from the blade server.
 - d. Press and hold the light path diagnostics switch (blue button) to relight the LEDs on the expansion unit if you are examining a PS704 blade server. If the “Check card below” LED is lit, remove the expansion unit and examine the base unit LEDs.
 - e. Press and hold the light path diagnostics switch to relight the LEDs that were lit before you removed the blade server from the BladeCenter unit. The LEDs will remain lit for as long as you press the switch, to a maximum of 25 seconds.

The following figure shows LEDs on the PS703 blade server.

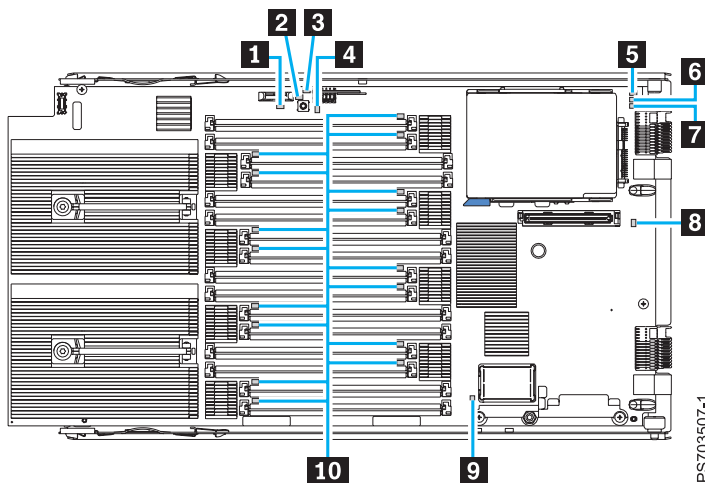

Figure 12. LED locations on the system board of the PS703 blade server

The following figure shows LEDs on the base system board of the PS704 blade server.

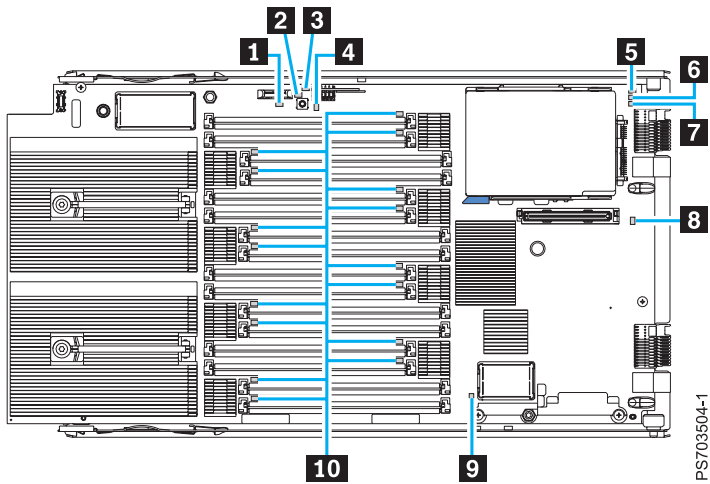

Figure 13. LED locations on the base system board of the PS704 blade server

The following figure shows LEDs on the expansion-unit board of the PS704 blade server.

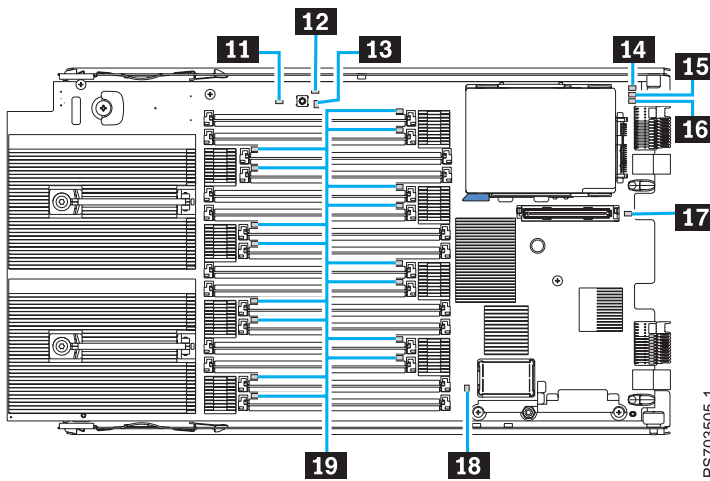

Figure 14. LED locations on the board of the PS704 expansion unit

Light path diagnostics LEDs

Light path diagnostics is a system of LEDs on the control panel and on the system board of the blade server. When an error occurs, LEDs are lit throughout the blade server. If the control panel indicates an error, use the descriptions of the LEDs to diagnose the problem and take corrective action.

Table 36 describes the LEDs on the system board and suggested actions for correcting any detected problems.

Table 36. Light path diagnostic LED descriptions

<ul style="list-style-type: none"> • Follow the suggested actions in the order in which they are listed in the Action column until the problem is solved. • See Chapter 3, “Parts listing, type 7891,” on page 225 to determine which components are CRUs and which components are FRUs. • If an action step is preceded by “(Trained service technician only),” that step must be performed only by a trained service technician. 		
Lit light path diagnostics LED	Description	Action
None	An error has occurred and cannot be isolated, or the service processor has failed.	An error has occurred that is not represented by a light path diagnostics LED. Check the management-module event log for information about the error.
Battery error P1-E1	A battery error occurred.	<ol style="list-style-type: none"> 1. Reseat the battery, as described in “Installing the battery” on page 258. 2. Replace the battery, as described in “Removing the battery” on page 258 and “Installing the battery” on page 258.
Check card below	No error was detected on the expansion unit.	Check the PS704 LEDs. The Check card below LED only confirms no errors are identified on the PS704 expansion unit. It does not guarantee there is an error on the PS704 base unit.

Table 36. Light path diagnostic LED descriptions (continued)

<ul style="list-style-type: none"> Follow the suggested actions in the order in which they are listed in the Action column until the problem is solved. See Chapter 3, "Parts listing, type 7891," on page 225 to determine which components are CRUs and which components are FRUs. If an action step is preceded by "(Trained service technician only)," that step must be performed only by a trained service technician. 		
Lit light path diagnostics LED	Description	Action
DIMM x error P1-C1 DIMM 1 P1-C2 DIMM 2 P1-C3 DIMM 3 P1-C1 DIMM 1 P1-C2 DIMM 2 P1-C3 DIMM 3 P1-C4 DIMM 4 P1-C5 DIMM 5 P1-C6 DIMM 6 P1-C7 DIMM 7 P1-C8 DIMM 8 P1-C9 DIMM 9 P1-C10 DIMM 10 P1-C11 DIMM 11 P1-C12 DIMM 12 P1-C13 DIMM 13 P1-C14 DIMM 14 P1-C15 DIMM 15 P1-C16 DIMM 16 P2-C1 DIMM 17 P2-C2 DIMM 18 P2-C3 DIMM 19 P2-C4 DIMM 20 P2-C5 DIMM 21 P2-C6 DIMM 22 P2-C7 DIMM 23 P2-C8 DIMM 24 P2-C9 DIMM 25 P2-C10 DIMM 26 P2-C11 DIMM 27 P2-C12 DIMM 28 P2-C13 DIMM 29 P2-C14 DIMM 30 P2-C15 DIMM 31 P2-C16 DIMM 32	A memory error occurred.	<ol style="list-style-type: none"> Verify that the DIMM indicated by the lit LED is a supported memory module, as described on the ServerProven website. Reseat the DIMM indicated by the lit LED, as described in "Installing a memory module" on page 251. Replace the DIMM indicated by the lit LED, as described in "Removing a memory module" on page 249 and "Installing a memory module" on page 251. <p>Note: Multiple DIMM LEDs do not necessarily indicate multiple DIMM failures. If more than one DIMM LED is lit, reseat or replace one DIMM at a time until the error goes away. See the online information or the <i>Hardware Maintenance Manual and Troubleshooting Guide</i> or <i>Problem Determination and Service Guide</i> for your BladeCenter unit for further isolation.</p>
Drive 1 error P1-D1 P1-C18-D1 P2-D1 P2-C18-D1	An error occurred on drive 1.	Reseat the disk drive or solid-state drive. If that does not correct the problem, replace the disk drive or solid-state drive. See "Removing a hard-disk drive" on page 242 or "Removing an SSD" on page 246.

Table 36. Light path diagnostic LED descriptions (continued)

<ul style="list-style-type: none"> • Follow the suggested actions in the order in which they are listed in the Action column until the problem is solved. • See Chapter 3, “Parts listing, type 7891,” on page 225 to determine which components are CRUs and which components are FRUs. • If an action step is preceded by “(Trained service technician only),” that step must be performed only by a trained service technician. 		
Lit light path diagnostics LED	Description	Action
Drive 2 error P1-C18-D2 P2-C18-D2	An error occurred on drive 2.	Reseat the solid-state drive. If that does not correct the problem, replace the solid-state drive. See “Removing an SSD” on page 246.
Solid-state drive carrier error P1-C18 P2-C18	A solid-state drive carrier error occurred.	Reseat the solid-state drive carrier. If that does not correct the problem, replace the solid-state drive carrier. See “Removing an SSD carrier” on page 244.
CFFh expansion card error P1-C20 P2-C20	An I/O expansion card option error occurred.	<ol style="list-style-type: none"> 1. Make sure that the I/O expansion option is supported. 2. Reseat the I/O expansion option, as described in “Removing and installing an I/O expansion card” on page 253. 3. Replace the I/O expansion option. <p>If you are still having problems, see theServerProven website.</p>
Management card error P1-C17	A system board error occurred.	<ol style="list-style-type: none"> 1. Replace the blade server cover, reinsert the blade server in the BladeCenter unit, and then restart the blade server. 2. Check the management-module event log for information about the error. 3. Replace the management card assembly, as described in “Removing the tier 2 management card” on page 262 and “Installing the tier 2 management card” on page 263. 4. Replace the system board and chassis assembly, as described in “Replacing the FRU system-board and chassis assembly” on page 264.

Table 36. Light path diagnostic LED descriptions (continued)

<ul style="list-style-type: none"> Follow the suggested actions in the order in which they are listed in the Action column until the problem is solved. See Chapter 3, "Parts listing, type 7891," on page 225 to determine which components are CRUs and which components are FRUs. If an action step is preceded by "(Trained service technician only)," that step must be performed only by a trained service technician. 		
Lit light path diagnostics LED	Description	Action
CIOv form-factor expansion card error P1-C19 P2-C19	An I/O expansion card option error occurred.	<ol style="list-style-type: none"> Make sure that the I/O expansion option is supported, as described on the ServerProven Web site. See http://www.ibm.com/servers/eserver/serverproven/compat/us/. Reseat the I/O expansion option, as described in "Removing and installing an I/O expansion card" on page 253. Replace the I/O expansion option. See "PCI expansion card (PIOCARD) problem isolation procedure" on page 186 for more information.
System board error P1 P2	A system board and chassis assembly error has occurred. A microprocessor failure shows up as a system board and chassis assembly error.	<ol style="list-style-type: none"> Replace the blade server cover, reinsert the blade server in the BladeCenter unit, and then restart the blade server. Check the management-module event log for information about the error. Replace the system board and chassis assembly, as described in "Replacing the FRU system-board and chassis assembly" on page 264.

Isolating firmware problems

You can use this procedure to isolate firmware problems.

To isolate a firmware problem, follow the procedure until the problem is solved.

- If the blade server is operating, shut down the operating system and turn off the blade server.
- Turn on the blade server.

If the problem no longer occurs, no further action is necessary. You are finished with this procedure.

- If the blade server boots up far enough to allow the installation of server firmware updates, check for appropriate updates and install them.

If you install updates, reboot the server and see if the problem still exists. If not, you are finished with this procedure.

4. Recover the system firmware, as described in “Recovering the system firmware.”
5. After recovering the system firmware, check for and install any server firmware updates.

Recovering the system firmware

The system firmware is contained in separate temporary and permanent images in the flash memory of the blade server. These images are referred to as TEMP and PERM, respectively. The blade server normally starts from the TEMP image, and uses the PERM image as a backup. If the TEMP image becomes damaged, such as from a power failure during a firmware update, you can recover the TEMP image from the PERM image.

If your system hangs, access the management module and click **Blade Tasks** → **Configuration** → **Boot Mode** to show the PS703 or PS704 blade server in the list of blade servers in the BladeCenter unit. Click the appropriate blade server and select **Permanent** to force the system to start from the PERM image.

See the documentation for the management module to learn more.

Starting the PERM image

You can force the blade server to start the PERM (permanent) image.

To force the blade server to start the PERM (permanent) image, complete the following procedure.

1. Access the Advanced Management Module menus.
2. Click **Blade Tasks** → **Configuration** → **Boot Mode**.
3. Click the appropriate PS703 or PS704 blade server in the list of blade servers in the BladeCenter unit.
4. Select **Permanent** to force the system to start from the PERM image.

See the documentation for the management module to learn more.

Starting the TEMP image

Start the TEMP image before you update the firmware.

Perform the following procedure to start the TEMP image.

1. Access the advanced management module.
See the *BladeCenter Management Module Command-Line Interface Reference Guide* or the *BladeCenter Serial-Over-LAN Setup Guide* for more information.
2. Click **Blade Tasks** → **Configuration** → **Boot Mode**.
3. Click the applicable PS703 or PS704 blade server in the list of blade servers in the BladeCenter unit.
4. Select **Temporary** to force the system to start from the TEMP image.
5. Restart the blade server.
6. Verify that the system starts from the TEMP image, as described in “Verifying the system firmware levels” on page 218.

Recovering the TEMP image from the PERM image

To recover the TEMP image from the PERM image, you must perform the reject function. The reject function copies the PERM image into the TEMP image.

To perform the reject function, complete the following procedure.

1. If you have not started the system from the PERM image, do so now. See “Starting the PERM image” on page 217.
2. Issue the appropriate command for your operating system to reject the TEMP image.
 - If you are using the Red Hat Linux or SUSE Linux operating system, type the following command:
`update_flash -r`
 - If you are using the AIX operating system, type the following command:
`/usr/lpp/diagnostics/bin/update_flash -r`
3. Start the TEMP image, as described in “Starting the TEMP image” on page 217.

You might need to update the firmware code to the latest version. See “Updating the firmware” on page 267 for more information about how to update the firmware code.

Verifying the system firmware levels

The diagnostics program displays the current system firmware levels for the TEMP and PERM images. This function also displays which image the blade server used to start up.

1. Start the diagnostics program.

See “Running the diagnostics program” on page 179.

The online BladeCenter information center is available in the IBM BladeCenter Information Center at <http://publib.boulder.ibm.com/infocenter/bladectr/documentation/index.jsp>.
2. From the **Function Selection** menu, select **Task Selection** and press Enter.
3. From the **Tasks Selection List** menu, select **Update and Manage System Flash** and press Enter.

The **Update and Manage System Flash** menu is displayed. The top of the window displays the system firmware level for the PERM and the TEMP images and the image that the blade server used to start.

Note: If the TEMP image level is more current than the PERM image, commit the TEMP image.

See “Committing the TEMP system firmware image” on page 219.

4. When you have verified the firmware levels, press F3 until the Diagnostic Operating Instructions window is displayed; then press F3 again to exit the diagnostic program.

Committing the TEMP system firmware image

After updating the system firmware and successfully starting up the blade server from the TEMP image, copy the TEMP image to the PERM image using the diagnostics program commit function.

Note: If you install the server firmware update permanently by committing the temporary firmware level from the temporary side to the permanent side, the temporary and permanent sides contain the same level of firmware. You cannot return to the level that was previously on the permanent side.

1. Load the diagnostics program. See “Running the diagnostics program” on page 179.
2. From the Function Selection menu, select **Task Selection** and press **Enter**.
3. From the Tasks Selection List menu, select **Update and Manage System Flash** and press **Enter**.
4. From the Update and Manage System Flash menu, select **Commit the Temporary Image** and press **Enter**.
5. When the commit function is complete, press **F3** until the Diagnostic Operating Instructions screen is displayed; then press **F3** again to exit the diagnostic program.

Solving shared BladeCenter resource problems

Problems with BladeCenter shared resources might appear to be in the blade server, but might actually be a problem in a BladeCenter unit component.

This information provides procedures to help you isolate blade server problems from shared BladeCenter resource problems.

If the problem is thought to be with a shared resource, see the online information center or the *Problem Determination and Service Guide* or the *Hardware Maintenance Manual and Troubleshooting Guide* for your BladeCenter unit, or see the documentation for BladeCenter unit components for additional information. If the problem cannot be solved, see “Solving undetermined problems” on page 223.

To check the general function of shared BladeCenter resources, complete the following operations.

1. Verify that the BladeCenter unit has the required power modules installed and is connected to a working power source.
2. Verify that power management is set correctly for your BladeCenter unit configuration.
3. Verify whether the problem is being experienced on more than one blade server.
4. Perform a test of the failing function on a blade server that is known to be operational.
5. Try the blade server in a different blade bay.
6. Try a blade server that is known to be operational in the blade bay with the failing blade server.
7. Verify that the blade server and the monitor are powered on.
8. Check for problems with the media tray (removable media drives and USB ports), as described in “Solving shared media tray problems” on page 220.
9. Check for network connection problems, as described in “Solving shared network connection problems” on page 221.

10. Check for power problems, as described in “Solving shared power problems” on page 222.

Solving shared media tray problems

Problems with BladeCenter shared resources might appear to be in the blade server, but might actually be a problem in a BladeCenter unit media tray component.

To check the general function of shared BladeCenter media tray resources, perform the following procedure.

1. Verify that the media-tray select button LED on the front of the blade server is lit.
A lit media-tray select button LED shows that the blade server is connected to the shared media tray.
2. Verify that the media tray devices work with another blade server.
3. Verify which components of the media tray are affected.
Components include:
 - USB ports
 - Diskette drive
 - CD or DVD drive
4. Troubleshoot USB port problems if USB ports are the only failing component.
 - a. Make sure that the USB device is operational.
 - b. If using a USB hub, make sure that the hub is operating correctly and that any software the hub requires is installed.
 - c. Plug the USB device directly into the USB port, bypassing the hub, to check its operation.
 - d. Reseat the following components:
 - USB device cable
 - Media tray cable (if applicable)
 - Media tray
 - e. Replace the following components one at a time, in the order shown, restarting the blade server each time:
 - 1) USB cable (if applicable)
 - 2) Media tray cable (if applicable)
 - 3) Media tray
5. Troubleshoot the diskette drive if it is the only failing component. If there is a diskette in the drive, make sure that:
 - The diskette is inserted correctly in the drive.
 - The diskette is good and not damaged; the drive LED light flashes once per second when the diskette is inserted. (Try another diskette if you have one.)
 - The diskette contains the necessary files to start the blade server.
 - The software program is working properly.
 - The distance between monitors and diskette drives is at least 76 mm (3 in).

6. Troubleshoot the CD or DVD drive if it is the only failing component.
 - Verify that the CD or DVD is inserted correctly in the drive. If necessary, insert the end of a straightened paper clip into the manual tray-release opening to eject the CD or DVD. The drive LED light flashes once per second when the CD or DVD is inserted.
 - Verify that the CD or DVD is clean and not damaged. (Try another CD or DVD if you have one.)
 - Verify that the software program is working properly.
7. Troubleshoot one or more of the removable media drives if they are the only failing components.
 - a. Reseat the following components:
 - Removable-media drive cable (if applicable)
 - Removable-media drive
 - Media tray cable (if applicable)
 - Media tray
8. Replace the following components one at a time, in the order shown, restarting the blade server each time:
 - a. Removable-media drive cable (if applicable)
 - b. Media tray cable (if applicable)
 - c. Removable-media drive
 - d. Media tray
9. Verify that the management module is operating correctly.

See the online information center or the *Problem Determination and Service Guide* or the *Hardware Maintenance Manual and Troubleshooting Guide* for your BladeCenter unit.

Some BladeCenter unit types have several management-module components that you might test or replace. See the online information or the *Installation Guide* for your management module for more information.
10. Replace the management module.

See the online information center or the *Problem Determination and Service Guide* or the *Hardware Maintenance Manual and Troubleshooting Guide* for your BladeCenter unit.

If these steps do not resolve the problem, it is likely a problem with the blade server. See “Universal Serial Bus (USB) port problems” on page 210 for more information.

Solving shared network connection problems

Problems with BladeCenter shared resources might appear to be in the blade server, but might actually be a problem in a BladeCenter unit network connection resource.

To check the general function of shared BladeCenter network connection resources, perform the following procedure.

1. Verify that the network cables are securely connected to the I/O module.
2. Verify that the network cables are securely connected to the I/O module.
3. Verify that the power configuration of the BladeCenter unit supports the I/O module configuration.
4. Verify that the installation of the I/O-module type is supported by the BladeCenter unit and blade server hardware.
5. Verify that the I/O modules for the network interface are installed in the correct BladeCenter bays.
6. Verify that the I/O modules for the network interface are configured correctly.
7. Verify that the settings in the I/O module are correct for the blade server. Some settings in the I/O module are specifically for each blade server.
8. Verify that the I/O modules for the network interface are operating correctly.
Troubleshoot and replace the I/O module as indicated in the documentation for the I/O module.
9. Verify that the management module is operating correctly.
See the online information center or the *Problem Determination and Service Guide* or the *Hardware Maintenance Manual and Troubleshooting Guide* for your BladeCenter unit.
Some BladeCenter unit types have several management-module components that you might test or replace. See the online information or the *Installation Guide* for your management module for more information.
10. Replace the management module.
See the online information center or the *Problem Determination and Service Guide* or the *Hardware Maintenance Manual and Troubleshooting Guide* for your BladeCenter unit.

If these steps do not resolve the problem, it is likely a problem with the blade server. See “Network connection problems” on page 186 for more information.

Solving shared power problems

Problems with BladeCenter shared resources might appear to be in the blade server, but might actually be a problem in a BladeCenter unit power component.

To check the general function of shared BladeCenter power resources, perform the following procedure.

1. Verify that the LEDs on all the BladeCenter power modules are lit.
2. Verify that power is being supplied to the BladeCenter unit.
3. Verify that the installation of the blade server type is supported by the BladeCenter unit.
4. Verify that the power configuration of the BladeCenter unit supports the blade bay where your blade server is installed. See the online documentation for your BladeCenter unit.
5. Verify that the BladeCenter unit power management configuration and status support blade server operation.
See the online information for your management module or the *Management Module User's Guide* or the *Management Module Command-Line Interface Reference Guide* for more information.

6. Verify that the local power control for the blade server is set correctly.
See the online information for your management module or the *Management Module User's Guide* or the *Management Module Command-Line Interface Reference Guide* for more information.
7. Verify that the BladeCenter unit blowers are correctly installed and operational.

If these steps do not resolve the problem, it is likely a problem with the blade server. See “Power problems” on page 188 for more information.

Solving undetermined problems

When you are diagnosing a problem in the PS703 or PS704 blade server, you must determine whether the problem is in the blade server or in the BladeCenter unit.

- If all of the blade servers have the same symptom, it is probably a BladeCenter unit problem; for more information, See the online information or the *Hardware Maintenance Manual and Troubleshooting Guide* or *Problem Determination and Service Guide* for your BladeCenter unit.
- If the BladeCenter unit contains more than one blade server and only one of the blade servers has the problem, troubleshoot the blade server that has the problem.

Check the LEDs on all the power supplies of the BladeCenter unit where the blade server is installed. If the LEDs indicate that the power supplies are working correctly, and reseating the blade server does not correct the problem, complete the following steps:

1. Make sure that the control panel connector is correctly seated on the system board. See “System-board connectors” on page 9 for the location of the connector.
2. If no LEDs on the control panel are working, replace the bezel assembly; then, try to power-on the blade server from the BladeCenter Web interface. See the online information or the *BladeCenter Management Module User's Guide* for more information.
3. Turn off the blade server.
4. Remove the blade server from the BladeCenter unit and remove the cover.
5. Remove or disconnect the following devices, one at a time, until you find the failure. Reinstall, turn on, and reconfigure the blade server each time.
 - I/O expansion option.
 - Hard disk drives.
 - Memory modules. The minimum configuration requirement is 2 GB (two 1 GB DIMMs).

The following minimum configuration is required for the blade server to start:

- System-board and chassis assembly (with two microprocessors)
 - Two 2 GB DIMMs
 - A functioning BladeCenter unit
6. Install and turn on the blade server. If the problem remains, suspect the following components in order:
 - a. DIMM
 - b. System-board and chassis assembly

If the problem is solved when you remove an I/O expansion option from the blade server but the problem recurs when you reinstall the same expansion option, suspect the expansion option; if the problem recurs when you replace the expansion option with a different one, suspect the System-board and chassis assembly.

If you suspect a networking problem and the blade server passes all the system tests, suspect a network cabling problem that is external to the system.

Calling IBM for service

Call IBM for service after you collect as much as possible of the following information.

Before calling for service, collect as much as possible of the following available information:

- Machine type and model
- Hard disk drive upgrades
- Failure symptoms:
 - Does the blade server fail the diagnostic programs? If so, what are the error codes?
 - What occurs? When? Where?
 - Is the failure repeatable?
 - Has the current server configuration ever worked?
 - What changes, if any, were made before it failed?
 - Is this the original reported failure, or has this failure been reported before?
- Diagnostic program type and version level
- Hardware configuration (print screen of the system summary)
- Firmware level
- Operating-system type and version level
- Advanced Management Module service data. See Advanced Management Module Messages Guide.
- SNAP data. See Blade server Data Collection Guide

You can solve some problems by comparing the configuration and software setups between working and nonworking blade server. When you compare blade servers to each other for diagnostic purposes, consider them identical only if all the following factors are exactly the same in all of the blade servers:

- Machine type and model
- Firmware level
- Adapters and attachments, in the same locations
- Software versions and levels
- Diagnostic program type and version level
- Configuration option settings
- Operating-system control-file setup

Chapter 3. Parts listing, type 7891

The parts listing identifies each replaceable part and its part number.

Figure 15 shows replaceable components that are available for the PS703 and PS704 blade server.

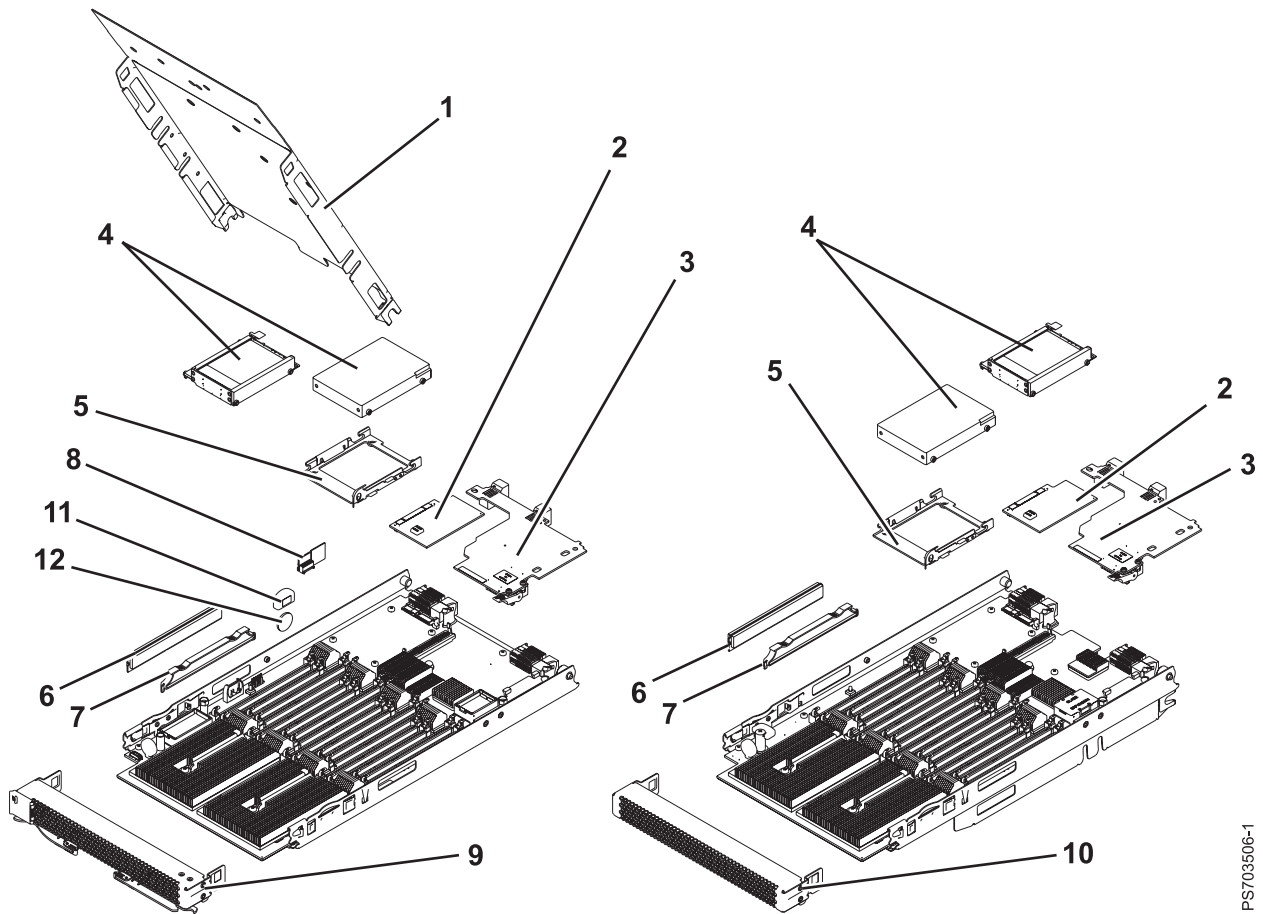

Figure 15. Parts illustration, type 7891. PS703 and PS704 with cover.

PS703506-1

Replaceable components are of three types:

- **Tier 1 customer replaceable unit (CRU):** Replacement of tier 1 CRUs is your responsibility. If IBM installs a tier 1 CRU at your request, you will be charged for the installation.
- **Tier 2 customer replaceable unit:** You may install a tier 2 CRU yourself or request IBM to install it, at no additional charge, under the type of warranty service that is designated for your blade server.
- **Field replaceable unit (FRU):** FRUs must be installed only by trained service technicians.

For information about the terms of the warranty and getting service and assistance, see the information center or the *Warranty and Support Information* document on the IBM *BladeCenter Documentation CD*.

Table 37. Parts listing, type 7891

Index	Description	CRU part number		FRU part number	Failing function code (FFC)
		(Tier 1)	(Tier 2)		
	Base system-board and chassis assembly: <ul style="list-style-type: none"> • PS703 with two eight-core POWER7 microprocessors • PS704 with two eight-core POWER7 microprocessors 			<ul style="list-style-type: none"> • 74Y3188 • 74Y3197 	Various, see "Failing function codes" on page 173
	Expansion system-board and chassis assembly: <ul style="list-style-type: none"> • PS704 with two eight-core POWER7 microprocessors 			74Y3206	Various, see "Failing function codes" on page 173
1	Cover	46C7341			
2	3 Gb SAS pass-through expansion card (CIOv) (option)	46C4069			2506
2	Emulex 8 Gb Fibre Channel expansion card (CIOv) (option)	46M6138			2607
2	QLogic 4 Gb Fibre Channel expansion card (CIOv) (option)	49Y4237			2E13
2	QLogic 8 Gb Fibre Channel expansion card (CIOv) (option)	44X1948			2E14
2	Broadcom 2 port 1 Gb Ethernet expansion card (CIOv) (option)	46M6138			2E34
3	4x InfiniBand DDR expansion card (CFFh) (option)	49Y9976			2624
3	4x InfiniBand QDR expansion card (CFFh) (option)	60Y0927			2625
3	4 Gb Fibre Channel and 1 Gb Ethernet expansion card (CFFh) (option)	39Y9304			2E00, 2E10
3	QLogic 8 Gb Fibre Channel and 1 Gb Ethernet expansion card (CFFh) (option)	44X1943			2E15, 2E35
3	QLogic 2 port 10 Gb Ethernet FCoCEE expansion card (CFFh) (option)	42C1832			2E21, 2E23
3	Broadcom 4 port 1 Gb Ethernet expansion card (CFFh) (option)	44W4488			2E33
4	300 GB SAS small form factor disk drive and screws (4) (option)	42D0628			268B
4	600 GB SAS small form factor disk drive and screws (4) (option)	49Y2023			26D2
4	Hard drive filler	40K5928			

Table 37. Parts listing, type 7891 (continued)

Index	Description	CRU part number		FRU part number	Failing function code (FFC)
		(Tier 1)	(Tier 2)		
4	Solid-state drive: <ul style="list-style-type: none"> • Solid-state drive carrier (holds up to two solid-state drives) • 200 GB solid-state drive 	<ul style="list-style-type: none"> • 74Y1760 • 74Y9115 			<ul style="list-style-type: none"> • 26BD • 26B4
5	Tray, SAS hard disk drive	31R2239			
6	Memory, 4 GB DDR3, 1066 MHz DIMM	78P0501			
6	Memory, 8 GB DDR3, 1066 MHz DIMM	78P0502			
7	DIMM filler	60H2962			
8	Management card: <ul style="list-style-type: none"> • PS703 • PS704 		<ul style="list-style-type: none"> • 74Y2681 • 74Y2681 		
9	Bezel assembly with control panel: <ul style="list-style-type: none"> • PS703 • PS704 	<ul style="list-style-type: none"> • 74Y6131 • 74Y6129 			
9	OEM bezel assembly with control panel	74Y6130			
10	Bezel assembly for expansion unit (PS704)	74Y6144			
	Service label: <ul style="list-style-type: none"> • PS703 • PS704 	<ul style="list-style-type: none"> • 74Y7457 • 74Y7458 			
	FRU and CRU label: <ul style="list-style-type: none"> • PS703 • PS704 	<ul style="list-style-type: none"> • 74Y7599 • 74Y7600 			
	Cover warning label	90P4799			
	Miscellaneous parts kit	74Y7699			
	3.0V battery	33F8354			
	RFID tag for North America, Latin America, Asia Pacific	46K5362			
	RFID tag for Europe	74Y7652			
	RFID tag for Japan	46K5364			

Chapter 4. Removing and replacing blade server components

Use this information to remove and replace components of the PS703 or PS704 blade server that are replaceable.

Replaceable components are of three types:

- **Tier 1 customer replaceable unit (CRU):** Replacement of tier 1 CRUs is your responsibility. If IBM installs a tier 1 CRU at your request, you will be charged for the installation.
- **Tier 2 customer replaceable unit:** You may install a tier 2 CRU yourself or request IBM to install it, at no additional charge, under the type of warranty service that is designated for your blade server.
- **Field replaceable unit (FRU):** FRUs must be installed only by trained service technicians.

See Chapter 3, “Parts listing, type 7891,” on page 225 to determine whether a part is a tier 1 CRU, tier 2 CRU, or FRU component.

For information about the terms of the warranty and getting service and assistance, see the *Warranty and Support Information* document.

Installation guidelines

Follow these guidelines to remove and replace blade server components.

- Read the safety information in the Safety topic and the guidelines in “Handling static-sensitive devices” on page 230. This information will help you work safely.
- When you install a new blade server, download and apply the most recent firmware updates.

Download and install updated device drivers and the blade server firmware. Go to the IBM Support site to download the updates. Select your product, type, model, and operating system, and then click **Go**. Click the **Download** tab, if necessary, for device driver and firmware updates.

Note: Changes are made periodically to the IBM website. Procedures for locating firmware and documentation might vary slightly from what is described in this documentation.

- Observe good housekeeping in the area where you are working. Place removed covers and other parts in a safe place.
- Back up all important data before you make changes to disk drives.
- Before you remove a hot-swap blade server from the BladeCenter unit, you must shut down the operating system and turn off the blade server. You do not have to shut down the BladeCenter unit itself.
- Blue on a component indicates touch points, where you can grip the component to remove it from or install it in the blade server, open or close a latch, and so on.
- Orange on a component or an orange label on or near a component indicates that the component can be hot-swapped, which means that if the blade server and operating system support hot-swap capability, you can remove or install the component while the blade server is running. (Orange can also indicate touch points on hot-swap components.) See the instructions for removing or installing a specific hot-swap component for any additional procedures that you might have to perform before you remove or install the component.
- When you are finished working on the blade server, reinstall all safety shields, guards, labels, and ground wires.

See the ServerProven website for information about supported operating-system versions and all blade server optional devices.

System reliability guidelines

Follow these guidelines to help ensure proper cooling and system reliability.

- Verify that the ventilation holes on the blade server are not blocked.
- Verify that you are maintaining proper system cooling in the unit.
Do not operate the BladeCenter unit without a blade server, expansion unit, or filler blade installed in each blade bay. See the documentation for your BladeCenter unit for additional information.
- Verify that you have followed the reliability guidelines for the BladeCenter unit.
- Verify that the blade server battery is operational. If the battery becomes defective, replace it immediately, as described in “Removing the battery” on page 258 and “Installing the battery” on page 258.

Handling static-sensitive devices

Static electricity can damage the blade server and other electronic devices. To avoid damage, keep static-sensitive devices in their static-protective packages until you are ready to install them.

Attention:

To reduce the possibility of damage from electrostatic discharge, observe the following precautions:

- Limit your movement. Movement can cause static electricity to build up around you.
- Handle the device carefully, holding it by its edges or its frame.
- Do not touch solder joints, pins, or exposed circuitry.
- Do not leave the device where others can handle and damage it.
- While the device is still in its static-protective package, touch it to an unpainted metal part of the BladeCenter unit or any unpainted metal surface on any other grounded rack component in the rack you are installing the device in for at least 2 seconds. This drains static electricity from the package and from your body.
- Remove the device from its package and install it directly into the blade server without setting down the device. If it is necessary to set down the device, put it back into its static-protective package. Do not place the device on the blade server cover or on a metal surface.
- Take additional care when handling devices during cold weather. Heating dry winter air further reduces its humidity and increases static electricity.

Returning a device or component

If you are instructed to return a device or component, follow all packaging instructions, and use any packaging materials for shipping that are supplied to you.

Removing the blade server from a BladeCenter unit

Remove the blade server from the BladeCenter unit to access options, connectors, and system-board indicators.

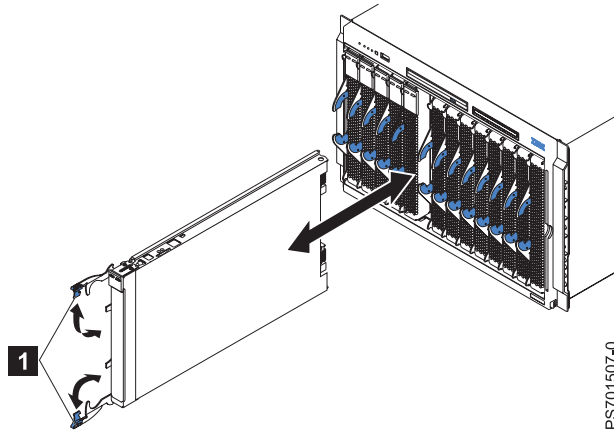

Figure 16. Removing the blade server from the BladeCenter unit

Attention:

- To maintain proper system cooling, do not operate the BladeCenter unit without a blade server, expansion unit, or blade filler installed in each blade bay.
- When you remove the blade server, note the bay number. Reinstalling a blade server into a different bay from the one where it was removed might have unintended consequences. Some configuration information and update options are established according to bay numbers. If you reinstall the blade server into a different bay, you might have to reconfigure the blade server.

Perform the following procedure to remove the blade server.

1. Read the Safety topic and the “Installation guidelines” on page 229.
2. If the blade server is operating, shut down the operating system.
3. Press the power-control button (behind the control-panel door) to turn off the blade server. See “Turning off the blade server” on page 8.
4. Wait at least 30 seconds for the hard disk drive to stop spinning.
5. Open the two release handles, as shown by **1** in Figure 16. The blade server moves out of the bay approximately 0.6 cm (0.25 inch).
6. Pull the blade server out of the bay. Spring-loaded doors that are farther back in the bay will move into place to cover the bay temporarily.
7. Carefully lay the blade server on a flat, static-protective surface, with the cover side up.
8. Place either a blade filler or another blade server in the bay within 1 minute. The recessed spring-loaded doors move out of the way as you insert the blade server or filler blade.

Installing the blade server in a BladeCenter unit

Install the blade server in a BladeCenter unit to use the blade server.

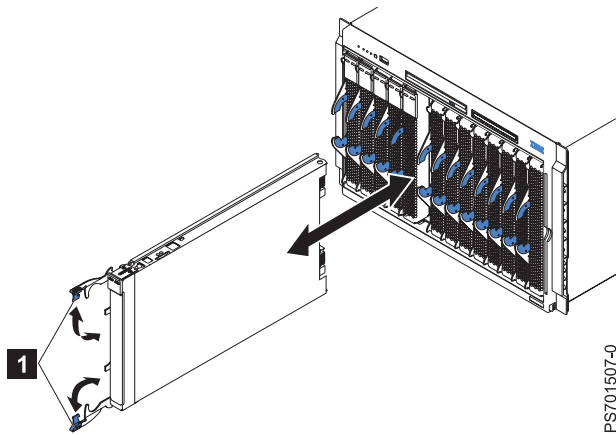

Figure 17. Installing the blade server in a BladeCenter unit

Statement 21



CAUTION:

Hazardous energy is present when the blade server is connected to the power source. Always replace the blade server cover before installing the blade server.

Perform the following procedure to install a blade server in a BladeCenter unit.

1. Go to <http://www.ibm.com/systems/support/> to download the latest firmware for the blade server. Download the firmware so that you can use it later to update the blade server after you start it.
2. Read the Safety topic and the “Installation guidelines” on page 229.
3. If you have not done so already, install any optional devices that you want, such as a SAS drive or memory modules.
4. Select the bay for the blade server.
 - See the online information or the *Installation and User’s Guide* that comes with your BladeCenter unit to verify that the bay you choose is powered.
 - Ensure proper cooling, performance, and system reliability by installing a blade server, expansion unit, or blade filler in each blade bay.
 - Reinstall a blade server in the same blade bay to preserve configuration information and update options that are established by blade bay. Reinstalling into a different blade bay can have unintended consequences, which might include re-configuring the blade server.

5. Verify that the release handles on the blade server are in the open position (perpendicular to the blade server, as shown in **1** in Figure 17 on page 232).
6. If you installed a filler blade or another blade server in the bay from which you removed the blade server, remove it from the bay.
7. Slide the blade server into the blade bay from which you removed it until the blade server stops. The spring-loaded doors farther back in the bay that cover the bay opening move out of the way as you insert the blade server.
8. Push the release handles on the front of the blade server to close and lock them. The discovery and initialization process can take up to three minutes to complete. The discovery and initialization process is complete when the green LED stops flashing rapidly and begins to flash slowly. At this point, you can power on the blade server.
9. Turn on the blade server. See "Turning on the blade server" on page 7.
10. Verify that the power-on LED on the blade server control panel is lit continuously. The continuous light indicates that the blade server is receiving power and is turned on.
11. Optional: Write identifying information on one of the user labels that come with the blade servers and place the label on the BladeCenter unit bezel.
Important: Do not place the label on the blade server or in any way block the ventilation holes on the blade server. See the online information or the documentation that comes with your BladeCenter unit for information about label placement.
12. Use the SMS Utility program to configure the blade server. See "Using the SMS utility" on page 269.
13. Also use the management module to configure the blade server. See the documentation for the management module to understand the functions that the management module provides.

If you have changed the configuration of the blade server or if this is a different blade server than the one you removed, you must configure the blade server. You might also have to install the blade server operating system.

See the "Installing the operating system" in the online information or the *Installation and User's Guide* PDF for detailed information about these tasks.

Removing and replacing tier 1 CRUs

Replacement of tier 1 customer-replaceable units (CRUs) is your responsibility.

If IBM installs a tier 1 CRU at your request, you will be charged for the installation.

The illustrations in this documentation might differ slightly from your hardware.

Removing the blade server cover

Remove the blade server from the chassis unit and press the blade server cover releases to open and remove the blade server cover.

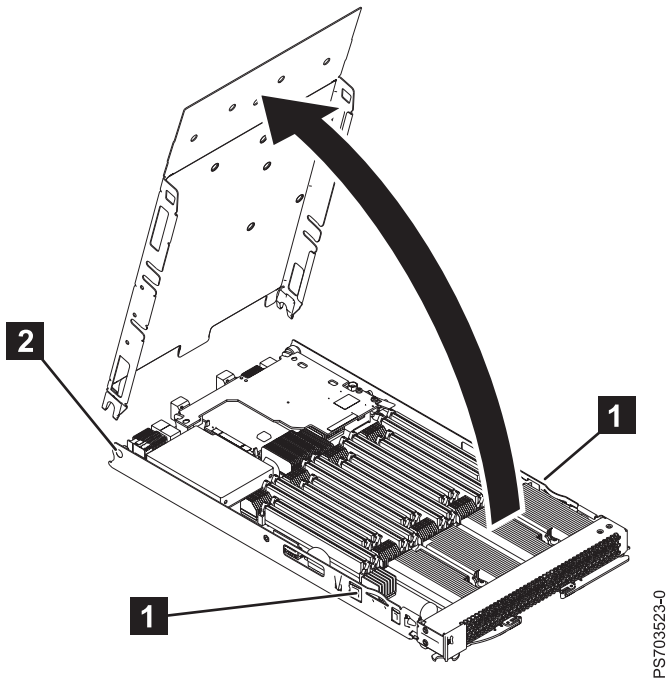

Figure 18. Removing the cover from a PS703 blade server

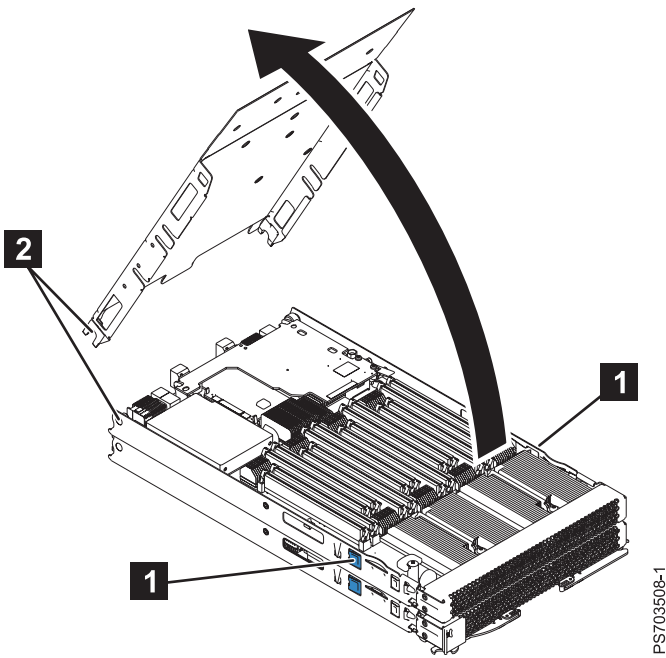

Figure 19. Removing the cover from a PS704 blade server

Perform the following procedure to open and remove the blade server cover.

1. Read the Safety topic and the “Installation guidelines” on page 229.
2. Shut down the operating system, turn off the blade server, and remove the blade server from the BladeCenter unit. See “Removing the blade server from a BladeCenter unit” on page 231.
3. Carefully lay the blade server on a flat, static-protective surface, with the cover side up.
4. Press the blade-cover release (as shown by **1**) on each side of the blade server, rotate the cover on the cover pins (**2**) and lift the cover open.
5. Lay the cover flat, or lift it from the cover pins on the blade server and store the cover for future use.

Statement 21



CAUTION:

Hazardous energy is present when the blade server is connected to the power source. Always replace the blade server cover before installing the blade server.

Installing and closing the blade server cover

Install and close the cover of the blade server before you insert the blade server into the BladeCenter unit. Do not attempt to override this important protection.

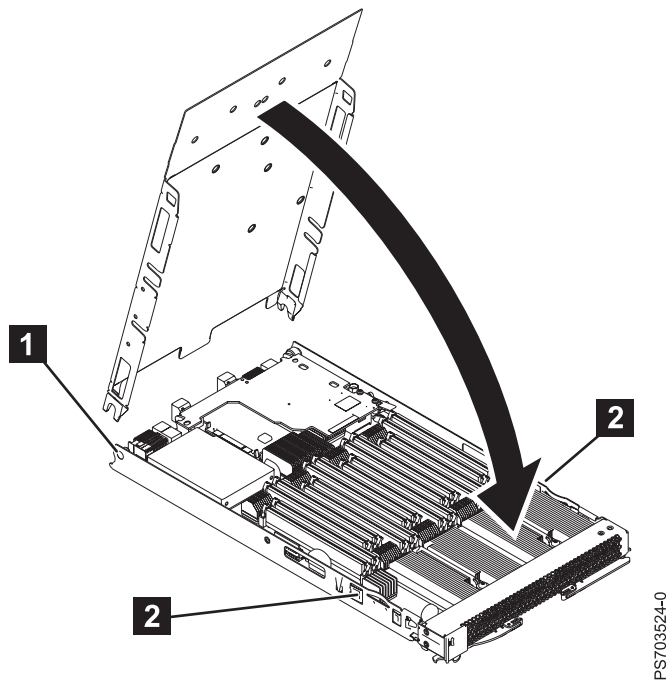

Figure 20. Installing the cover for a PS703 blade server

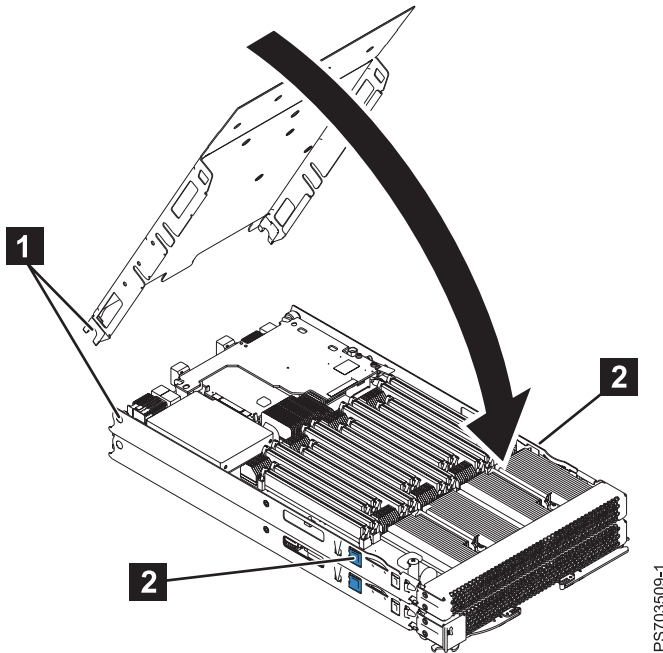

Figure 21. Installing the cover for a PS704 blade server

Statement 21



CAUTION:

Hazardous energy is present when the blade server is connected to the power source. Always replace the blade server cover before installing the blade server.

Perform the following procedure to replace and close the blade server cover.

1. Read the Safety topic and the "Installation guidelines" on page 229.
2. Lower the cover so that the slots at the rear slide down onto the pins (**1** in Figure 20 on page 235) at the rear of the blade server. Before you close the cover, verify that all components are installed and seated correctly and that you have not left loose tools or parts inside the blade server.
3. Pivot the cover to the closed position until the releases (**2**) click into place in the cover.
4. Install the blade server into the BladeCenter unit. See "Installing the blade server in a BladeCenter unit" on page 232.

Removing the expansion unit for a PS704 blade server

To replace an expansion unit in a PS704 blade server, you must first remove the expansion unit.

1. Read the Safety topic and the “Installation guidelines” on page 229.
2. Shut down the operating system, turn off the blade server, and remove the blade server from the BladeCenter unit. See “Removing the blade server from a BladeCenter unit” on page 231.
3. Carefully lay the blade server on a flat, static-protective surface, with the cover side up.
4. Open and remove the blade server cover. See “Removing the blade server cover” on page 233.

Note: If you are servicing the base unit of a PS704 blade server, you must first remove the expansion unit. For more information, see “Removing the expansion unit for a PS704 blade server.”

5. Use your thumb to back out the expansion blade retention thumb screw (**4**) by rotating the screw counterclockwise until the connection between the expansion unit and the base unit is loose and the expansion unit is fully separated from the base unit.

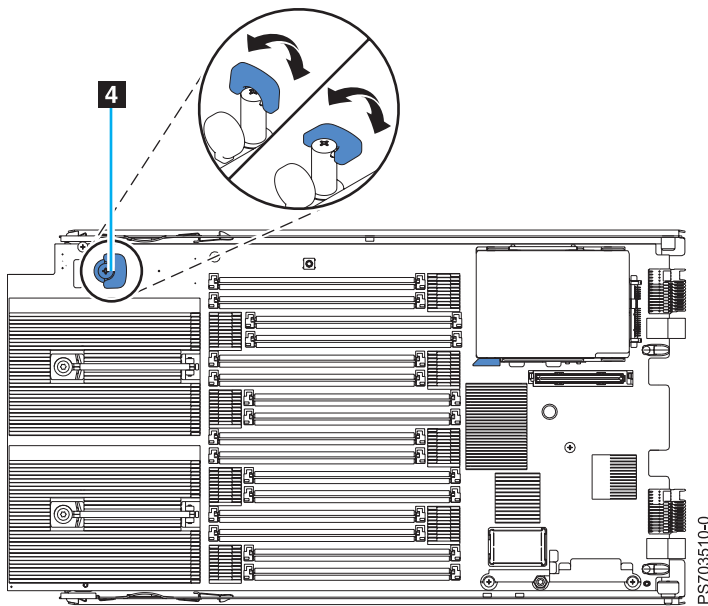

Figure 22. Removing the expansion unit

6. Pivot the expansion unit (**1** in Figure 23 on page 238) up on the cover pins of the base unit (**2**).

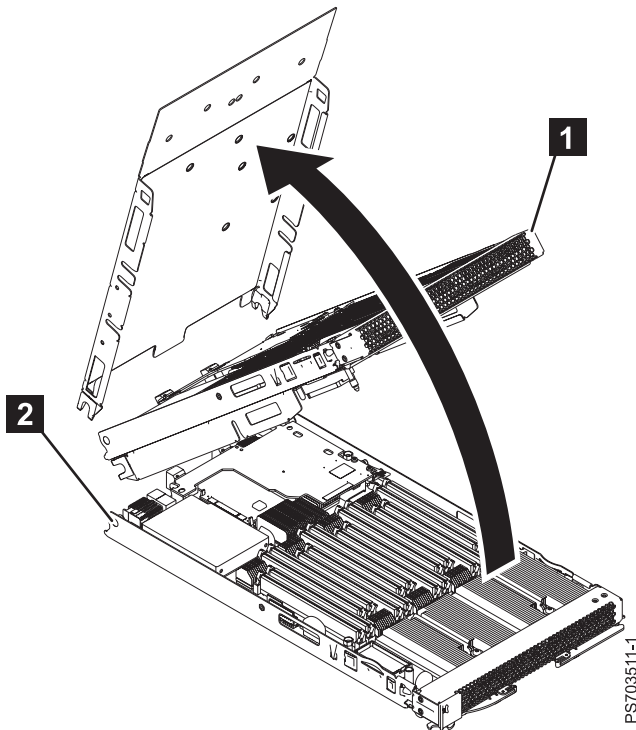

Figure 23. Removing the expansion unit

7. Lift the expansion unit (**1** in Figure 23) from the blade-server base unit and lay it on a flat, static-protective surface.
8. If you are replacing the expansion unit with a new expansion unit, see “Replacing the expansion unit in a PS704 blade server.” If you are removing the expansion unit as part of another procedure, return to that procedure now.
9. If you are instructed to return the expansion unit, follow all packaging instructions, and use any packaging materials for shipping that are supplied to you.

Replacing the expansion unit in a PS704 blade server

Install a new expansion unit on the PS704 double-wide blade server.

You must have already completed the procedure “Removing the expansion unit for a PS704 blade server” on page 237.

1. Lift the expansion unit above the blade server base unit and engage the circular pivot bearings onto the cover pins (as shown by **1** in Figure 24 on page 239) of the base unit.
The expansion unit of the PS704 blade server fits on top of the PS704 base unit, with the DIMM slots and expansion card slots on top.

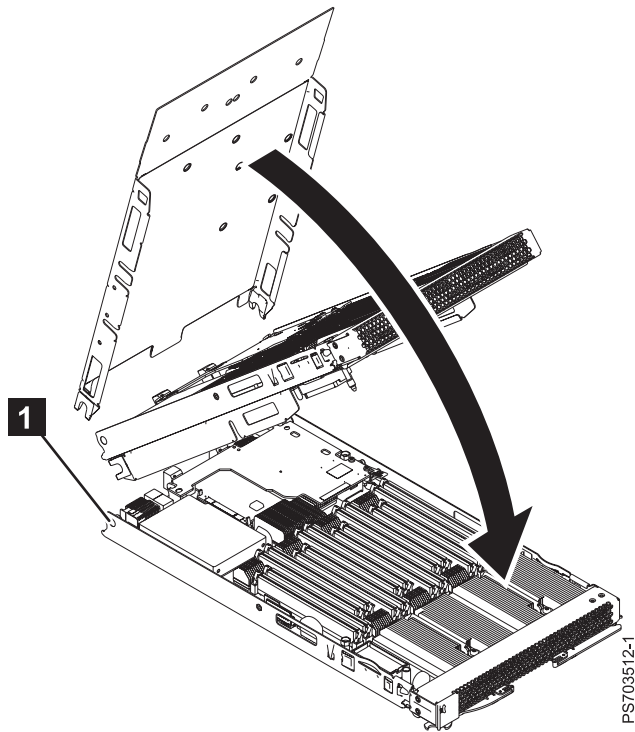

Figure 24. Replacing the expansion unit

2. Pivot the expansion unit on the cover pins of the PS704 base unit and lower the expansion unit until it lies flat on the PS704 base unit.
3. To access the expansion-blade retention thumb screw, see **4** in Figure 25.

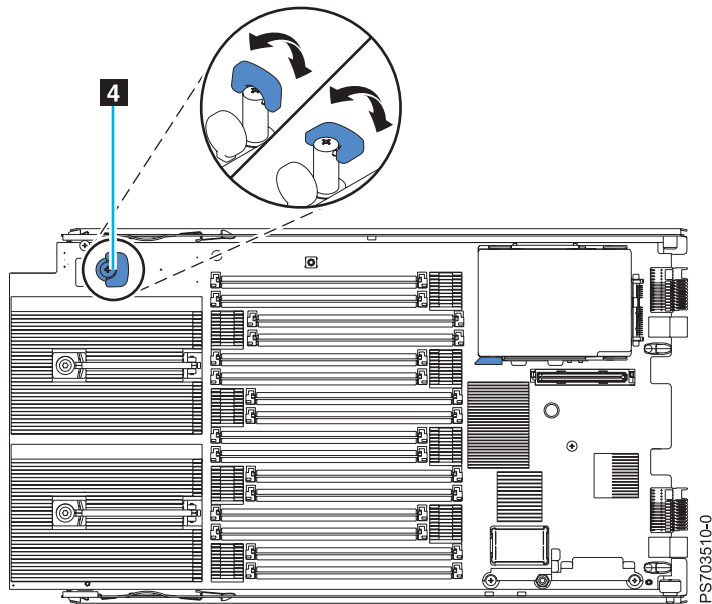

Figure 25. Expansion blade retention screw

4. Lift the wing on the expansion-blade retention thumb screw as shown in the preceding figure.
5. Tighten the thumb screw (**4**) by rotating the screw clockwise until the connection between the expansion unit and the PS704 base unit is secure. Stop tightening when firm resistance is detected. Ensure that the thumb screw wing is down.

Note: You can optionally use a Phillips screwdriver to tighten the retention thumb screw.

6. Install and close the blade server cover. See “Installing and closing the blade server cover” on page 235.

Statement 21



CAUTION:

Hazardous energy is present when the blade server is connected to the power source. Always replace the blade server cover before installing the blade server.

7. Install the blade server into the BladeCenter unit. See “Installing the blade server in a BladeCenter unit” on page 232.

Removing the bezel assembly

You can remove a bezel from a PS703 blade server, or from either the base unit or the expansion unit of a PS704 blade server.

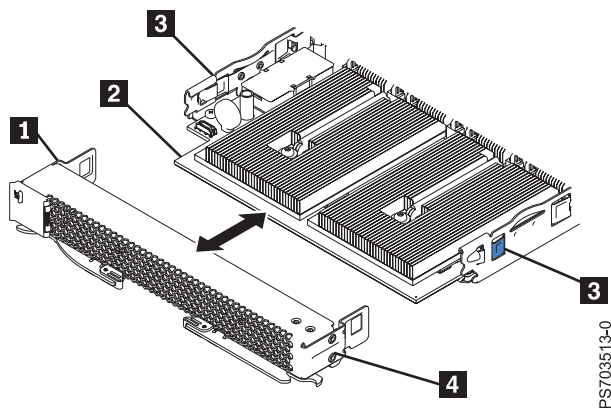

Figure 26. Removing the bezel assembly

1. Read the Safety topic and the “Installation guidelines” on page 229.
2. Shut down the operating system, turn off the blade server, and remove the blade server from the BladeCenter unit. See “Removing the blade server from a BladeCenter unit” on page 231.
3. Carefully lay the blade server on a flat, static-protective surface, with the cover side up.

4. Open and remove the blade server cover. See “Removing the blade server cover” on page 233.

Note: If you are servicing the base unit of a PS704 blade server, you must first remove the expansion unit. For more information, see “Removing the expansion unit for a PS704 blade server” on page 237.

5. Press the cover-assembly release (as shown by **3** in Figure 26 on page 240) on each side of the blade server and pull the bezel assembly (**4**) away from the blade server approximately 1.2 cm (0.5 inch).
6. If you are servicing a base unit and not an expansion unit, disconnect the control-panel (**1**) from the control-panel connector (**2**).
7. Pull the bezel assembly away from the blade server.
8. If you are instructed to return the bezel assembly, follow all packaging instructions, and use any packaging materials for shipping that are supplied to you.

Installing the bezel assembly

You can install a bezel on a PS703 blade server, or on either the base unit or the expansion unit of a PS704 blade server.

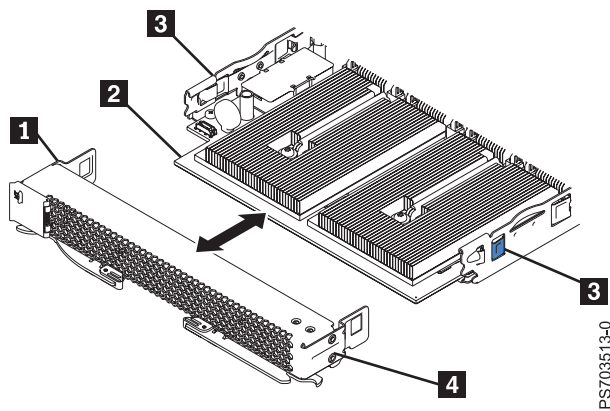

Figure 27. Installing the bezel assembly

1. If you are servicing a base unit and not an expansion unit, connect the control-panel cable (**1** in Figure 27) to the control-panel connector (**2**) on the system board.
2. Carefully slide the bezel assembly (**4**) onto the blade server until the two bezel-assembly releases (**3**) click into place in the bezel assembly.
3. Install and close the blade server cover. See “Installing and closing the blade server cover” on page 235.

Statement 21



CAUTION:

Hazardous energy is present when the blade server is connected to the power source. Always replace the blade server cover before installing the blade server.

4. Install the blade server into the BladeCenter unit. See “Installing the blade server in a BladeCenter unit” on page 232.

Removing a hard-disk drive

You can remove the serial-attached SCSI (SAS) hard disk drive from a PS703 blade server, or from either the base unit or the expansion unit of a PS704 blade server.

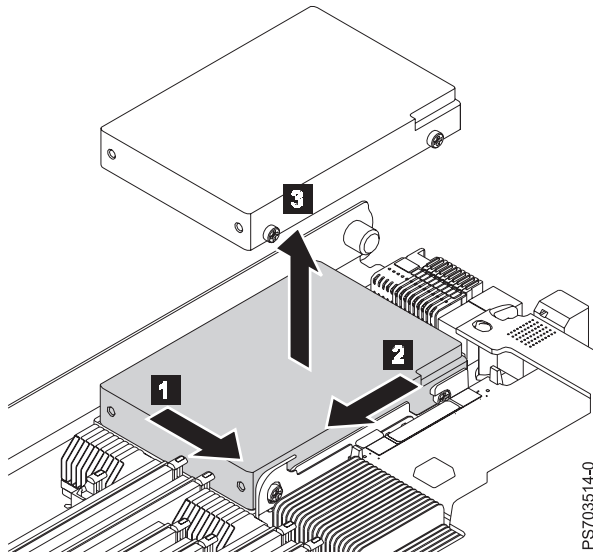

Figure 28. Removing a hard-disk drive

To remove the hard disk drive, complete the following steps:

1. Back up the data from the drive to another storage device.
2. Read the Safety topic and the “Installation guidelines” on page 229.
3. Shut down the operating system, turn off the blade server, and remove the blade server from the BladeCenter unit. See “Removing the blade server from a BladeCenter unit” on page 231.
4. Carefully lay the blade server on a flat, static-protective surface, with the cover side up.
5. Open and remove the blade server cover. See “Removing the blade server cover” on page 233.

Note: If you are servicing the base unit of a PS704 blade server, you must first remove the expansion unit. For more information, see “Removing the expansion unit for a PS704 blade server” on page 237.

6. Remove the drive:
 - a. Pull and hold the blue release lever **1** at the front of the drive tray.
 - b. Slide the drive forward **2** to disengage the connector.
 - c. Lift the drive **3** out of the drive tray.

7. If you are instructed to return the hard-disk drive, follow all packaging instructions, and use any packaging materials for shipping that are supplied to you.

Installing a hard-disk drive

You can install a hard disk drive in a PS703 blade server, or in either the base unit or the expansion unit of a PS704 blade server.

Figure 29 shows how to install the hard-disk drive.

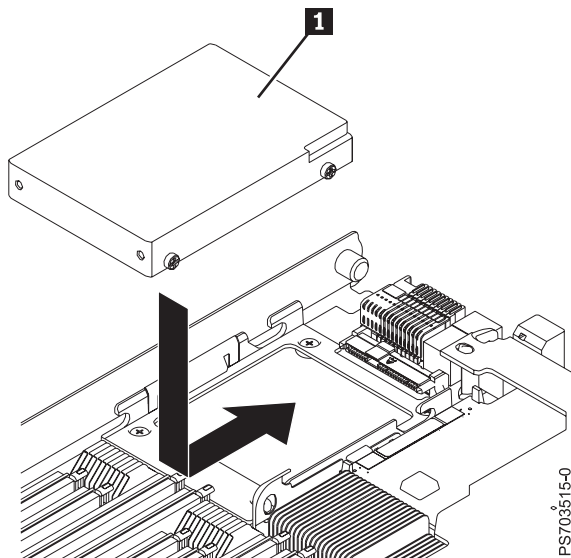

Figure 29. Installing a hard-disk drive

All drive connectors are from the same controller. Both PS703PS704 blade servers can be used to implement RAID functions. See “Configuring a RAID array” on page 273 for information about RAID configuration.

To install a hard-disk drive, complete the following steps.

1. Read the Safety topic and the “Installation guidelines” on page 229.
2. Shut down the operating system, turn off the blade server, and remove the blade server from the BladeCenter unit. See “Removing the blade server from a BladeCenter unit” on page 231.
3. Carefully lay the blade server on a flat, static-protective surface, with the cover side up.
4. Open and remove the blade server cover. See “Removing the blade server cover” on page 233.

Note: If you are servicing the base unit of a PS704 blade server, you must first remove the expansion unit. For more information, see “Removing the expansion unit for a PS704 blade server” on page 237.

5. Locate the connector for the drive.
6. Place the drive **1** into the drive tray and push it toward the rear of the blade, into the connector until the drive moves past the lever at the front of the tray.
Attention: Do not press on the top of the drive. Pressing the top might damage the drive.
7. Install and close the blade server cover. See “Installing and closing the blade server cover” on page 235.

Statement 21



CAUTION:

Hazardous energy is present when the blade server is connected to the power source. Always replace the blade server cover before installing the blade server.

8. Install the blade server into the BladeCenter unit. See “Installing the blade server in a BladeCenter unit” on page 232.

Removing an SSD carrier

You can remove an SSD carrier from a PS703 blade server, or from either the base unit or the expansion unit of a PS704 blade server.

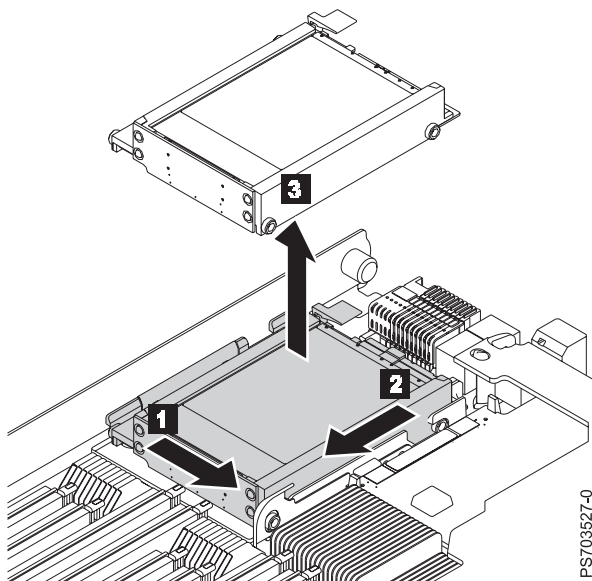

Figure 30. Removing an SSD carrier

Perform the following procedure to remove the drive.

1. Back up the data from the drive to another storage device.
2. Read the Safety topic and the “Installation guidelines” on page 229.
3. Shut down the operating system, turn off the blade server, and remove the blade server from the BladeCenter unit. See “Removing the blade server from a BladeCenter unit” on page 231.
4. Carefully lay the blade server on a flat, static-protective surface, with the cover side up.
5. Open and remove the blade server cover. See “Removing the blade server cover” on page 233.

Note: If you are servicing the base unit of a PS704 blade server, you must first remove the expansion unit. For more information, see “Removing the expansion unit for a PS704 blade server” on page 237.

6. Remove the drive:
 - a. Pull and hold the blue release lever **1** at the front of the drive tray.
 - b. Slide the carrier case forward **2** to disengage the connector.
 - c. Lift the carrier case **3** out of the drive tray.
7. Remove any SSDs from the carrier case. See “Removing an SSD” on page 246.
8. If you are instructed to return the SSD carrier, follow all packaging instructions, and use any packaging materials for shipping that are supplied to you.

Replacing an SSD carrier

You can replace a solid-state drive carrier in a PS703 blade server, or in either the base unit or the expansion unit of a PS704 blade server.

Figure 31 shows how to install the disk drive.

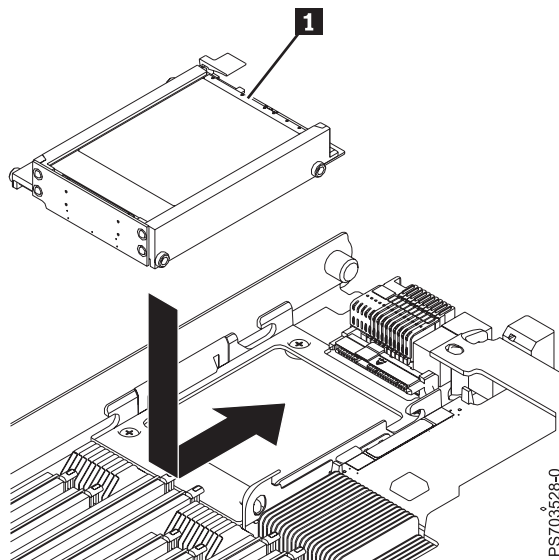

Figure 31. Replacing an SSD carrier

To replace an SSD carrier, complete the following steps.

1. Read the Safety topic and the “Installation guidelines” on page 229.
2. Shut down the operating system, turn off the blade server, and remove the blade server from the BladeCenter unit. See “Removing the blade server from a BladeCenter unit” on page 231.
3. Carefully lay the blade server on a flat, static-protective surface, with the cover side up.
4. Open and remove the blade server cover. See “Removing the blade server cover” on page 233.

Note: If you are servicing the base unit of a PS704 blade server, you must first remove the expansion unit. For more information, see “Removing the expansion unit for a PS704 blade server” on page 237.

5. Locate the connector for the drive.

Note: The SSD carrier case plugs in to the 2.5" SAS HDD connector.

6. Install SSDs into the carrier case. See “Installing an SSD” on page 248.
7. Place the carrier case **1** into the drive tray and push it toward the rear of the blade, into the connector until the drive moves past the lever at the front of the tray.

Attention: Do not press the top of the carrier case. Pressing the top might damage the drive.

8. Install and close the blade server cover. See “Installing and closing the blade server cover” on page 235.

Statement 21



CAUTION:

Hazardous energy is present when the blade server is connected to the power source. Always replace the blade server cover before installing the blade server.

9. Install the blade server into the BladeCenter unit. See “Installing the blade server in a BladeCenter unit” on page 232.

Removing an SSD

You can remove a solid state drive (SSD) from a PS703 blade server, or from either the base unit or the expansion unit of a PS704 blade server.

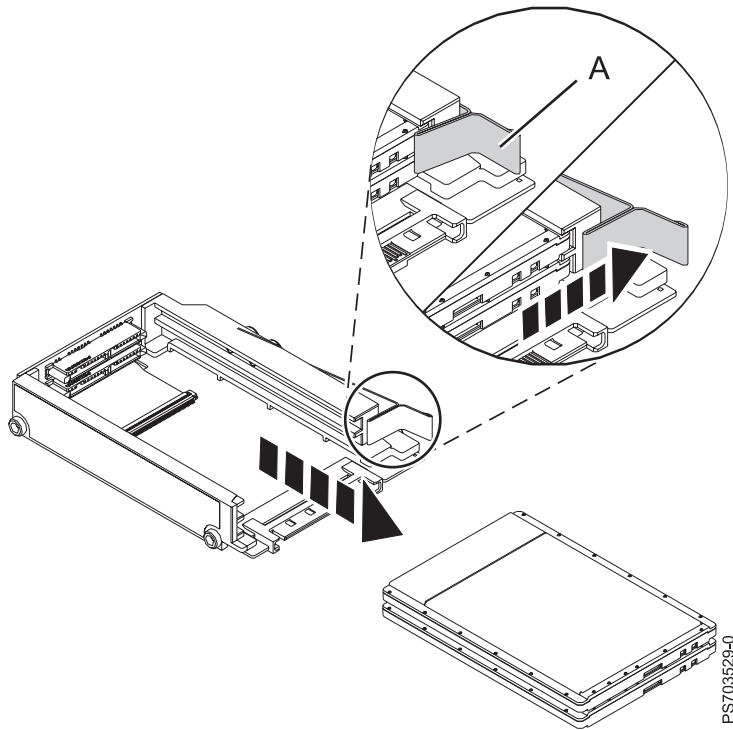

Figure 32. Removing a drive

Perform the following procedure to remove the drive.

1. Back up the data from the drive to another storage device.
2. Read the Safety topic and the “Installation guidelines” on page 229.
3. Shut down the operating system, turn off the blade server, and remove the blade server from the BladeCenter unit. See “Removing the blade server from a BladeCenter unit” on page 231.
4. Carefully lay the blade server on a flat, static-protective surface, with the cover side up.
5. Open and remove the blade server cover. See “Removing the blade server cover” on page 233.

Note: If you are servicing the base unit of a PS704 blade server, you must first remove the expansion unit. For more information, see “Removing the expansion unit for a PS704 blade server” on page 237.

6. Remove the SSD carrier from the drive tray. See “Removing an SSD carrier” on page 244.
7. Remove the SSD:
 - a. Pull and hold the blue release lever **A** at the front of the carrier case.
 - b. Slide the SSD that you want to remove forward to disengage the connector.

Note: If the case contains two SSDs and you want to remove the bottom one, you must first remove the top SSD.

- c. Lift the SSD out of the carrier case.

8. If you are instructed to return the drive, follow all packaging instructions, and use any packaging materials for shipping that are supplied to you.

Installing an SSD

You can install a hard disk drive in a PS703 blade server, or in either the base unit or the expansion unit of a PS704 blade server.

Figure 33 shows how to install the disk drive.

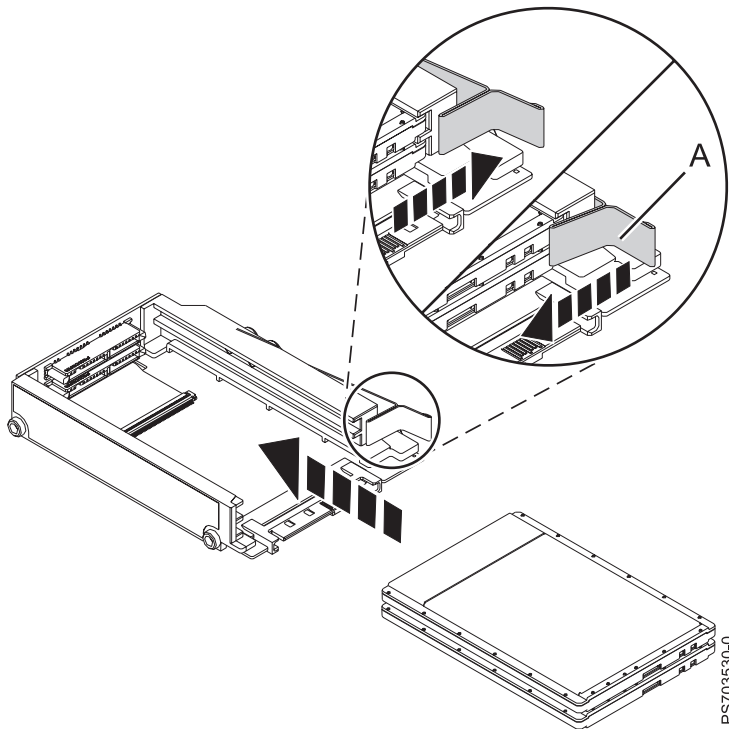

Figure 33. Installing an SSD

To install a drive, complete the following steps.

1. Read the Safety topic and the “Installation guidelines” on page 229.
2. Shut down the operating system, turn off the blade server, and remove the blade server from the BladeCenter unit. See “Removing the blade server from a BladeCenter unit” on page 231.
3. Carefully lay the blade server on a flat, static-protective surface, with the cover side up.
4. Open and remove the blade server cover. See “Removing the blade server cover” on page 233.

Note: If you are servicing the base unit of a PS704 blade server, you must first remove the expansion unit. For more information, see “Removing the expansion unit for a PS704 blade server” on page 237.

5. Locate the connector for the drive.
6. Remove the SSD carrier case from the drive tray. See “Removing an SSD carrier” on page 244.
7. Place the SSD into the carrier:
 - a. Pull and hold the blue release lever **A** at the front of the carrier case.
 - b. Slide the SSD that you want to install into the case until it engages the connector.

Note: SSDs can be installed in any order. It is recommended, however, that you install a solitary SSD into the top slot of the carrier. If you have two SSDs, it is recommended that you install the higher capacity SSD in the top slot of the carrier.

8. Replace the carrier case in the drive tray. See “Replacing an SSD carrier” on page 245.
Attention: Do not press the top of the drive. Pressing the top might damage the drive.
9. Install and close the blade server cover. See “Installing and closing the blade server cover” on page 235.

Statement 21



CAUTION:

Hazardous energy is present when the blade server is connected to the power source. Always replace the blade server cover before installing the blade server.

10. Install the blade server into the BladeCenter unit. See “Installing the blade server in a BladeCenter unit” on page 232.

Removing a memory module

You can remove a very low profile (VLP) dual-inline memory module (DIMM) from a PS703 blade server, or from either the base unit or the expansion unit of a PS704 blade server.

1. Read the Safety topic and the “Installation guidelines” on page 229.
2. Shut down the operating system, turn off the blade server, and remove the blade server from the BladeCenter unit. See “Removing the blade server from a BladeCenter unit” on page 231.
3. Carefully lay the blade server on a flat, static-protective surface, with the cover side up.
4. Open and remove the blade server cover. See “Removing the blade server cover” on page 233.

Note: If you are servicing the base unit of a PS704 blade server, you must first remove the expansion unit. For more information, see “Removing the expansion unit for a PS704 blade server” on page 237.

5. Locate the DIMM connector that contains the DIMM being replaced.

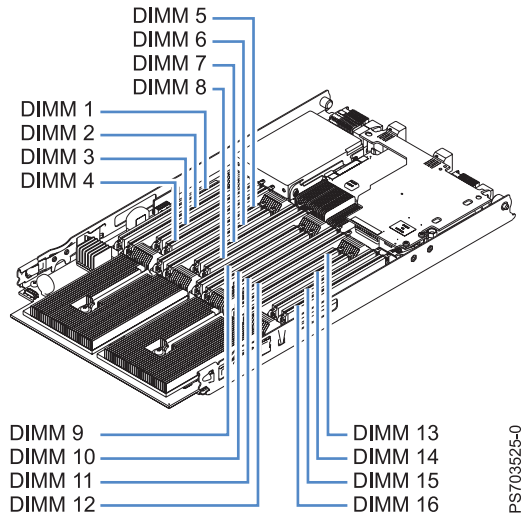

Figure 34. DIMM connectors for the PS703

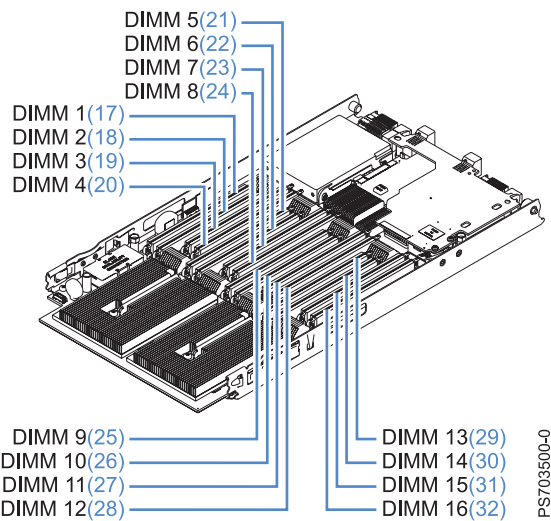

Figure 35. DIMM connectors for the PS704

Attention: To avoid breaking the DIMM retaining clips or damaging the DIMM connectors, open and close the clips gently.

6. Carefully open the retaining clips on each end of the DIMM connector and remove the DIMM.

Note: When replacing DIMM 16 in the PS703 server and DIMM 16 or DIMM 32 in the PS704 server, and if a combination form factor horizontal card (CFFh) is present, lift the blue cam mechanism so that you can maneuver your finger under the blue tab and open the retaining clip.

7. Install a DIMM filler in any location where a DIMM is not present to avoid machine damage.
8. If you are instructed to return the DIMM, follow all packaging instructions, and use any packaging materials for shipping that are supplied to you.

Installing a memory module

Install dual inline memory modules (DIMMs) in the PS703 blade server, or in either the base unit or the expansion unit of a PS704 blade server.

Table 38 shows allowable placements of DIMM modules for the PS703 blade server. Table 39 shows allowable placements of DIMM modules for the PS704 blade server.

Table 38. Memory module combinations for the PS703 blade server

DIMM count	PS703 DIMM slots															
	1	2	3	4	5	6	7	8	9	10	11	12	13	14	15	16
2	X			X												
4	X			X				X			X					
6	X			X	X			X	X		X					
8	X			X	X			X	X		X	X				X
10	X	X	X	X	X			X	X		X	X				X
12	X	X	X	X	X			X	X	X	X	X	X			X
14	X	X	X	X	X	X	X	X	X	X	X	X	X			X
16	X	X	X	X	X	X	X	X	X	X	X	X	X	X	X	X

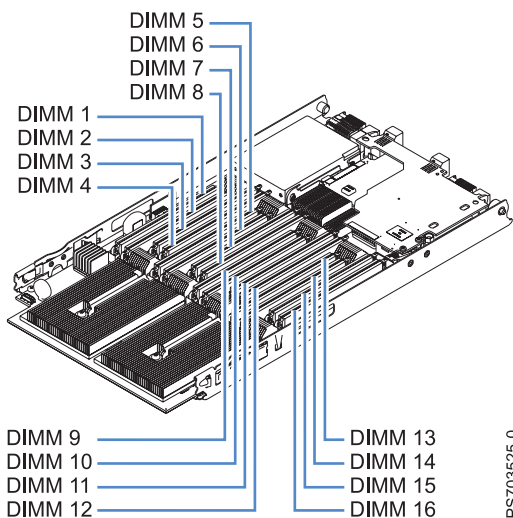

Figure 36. DIMM connectors for the PS703

Table 39. Memory module combinations for the PS704 blade server

DIMM count	PS704 base blade unit (P1) DIMM slots and expansion unit (P2) DIMM slots															
	1 (17)	2 (18)	3 (19)	4 (20)	5 (21)	6 (22)	7 (23)	8 (24)	9 (25)	10 (26)	11 (27)	12 (28)	13 (29)	14 (30)	15 (31)	16 (32)
2	X			X												
4	X			X				X		X	X					
6	X			X	X			X	X		X					
8	X			X	X			X	X		X	X				X

Table 39. Memory module combinations for the PS704 blade server (continued)

DIMM count	PS704 base blade unit (P1) DIMM slots and expansion unit (P2) DIMM slots															
10	X	X	X	X	X			X	X			X	X			X
12	X	X	X	X	X			X	X	X	X	X	X			X
14	X	X	X	X	X	X	X	X	X	X	X	X	X			X
16	X	X	X	X	X	X	X	X	X	X	X	X	X	X	X	X

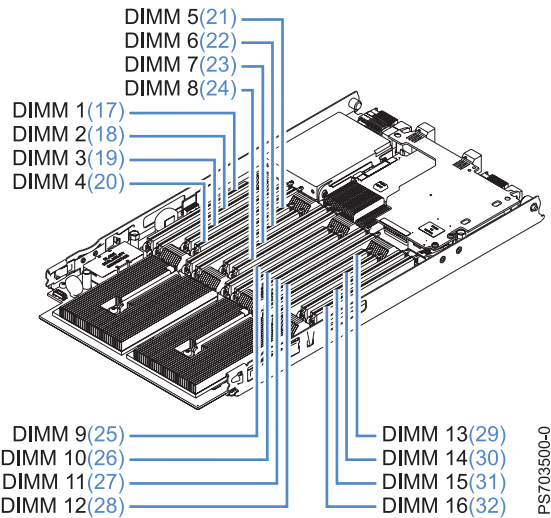

Figure 37. DIMM connectors for the PS704

See “Supported DIMMs” on page 4 for additional information about the type of memory that is compatible with the blade server.

To install a DIMM, complete the following steps:

1. Read the Safety and the “Installation guidelines” on page 229.
2. Read the documentation that comes with the DIMMs.
3. Shut down the operating system, turn off the blade server, and remove the blade server from the BladeCenter unit. See “Removing the blade server from a BladeCenter unit” on page 231.
4. Carefully lay the blade server on a flat, static-protective surface, with the cover side up.
5. Open and remove the blade server cover. See “Removing the blade server cover” on page 233.

Note: If you are servicing the base unit of a PS704 blade server, you must first remove the expansion unit. For more information, see “Removing the expansion unit for a PS704 blade server” on page 237.

6. Locate the DIMM connectors on the system board. See the illustration in “System-board connectors” on page 9. Determine the connector into which you will install the DIMM.
7. Touch the static-protective package that contains the part to any *unpainted* metal surface on the BladeCenter unit or any *unpainted* metal surface on any other grounded rack component; then, remove the part from its package.
8. Verify that both of the connector retaining clips are in the fully open position.
9. Turn the DIMM so that the DIMM keys align correctly with the connector on the system board.
Attention: To avoid breaking the DIMM retaining clips or damaging the DIMM connectors, handle the clips gently.
10. Insert the DIMM by pressing the DIMM along the guides into the connector.
Verify that each retaining clip snaps into the closed position.

Important: If there is a gap between the DIMM and the retaining clips, the DIMM is not correctly installed. Open the retaining clips to remove and reinsert the DIMM. Install a DIMM filler in any location where a DIMM is not present to avoid machine damage.

11. Ensure that the CFFh card is fully seated by pushing down on it. This card can become unseated when accessing DIMM 16 in the PS703 server and DIMM 16 or DIMM 32 in the PS704 server.
12. Install and close the blade server cover. See “Installing and closing the blade server cover” on page 235.

Statement 21



CAUTION:

Hazardous energy is present when the blade server is connected to the power source. Always replace the blade server cover before installing the blade server.

13. Install the blade server into the BladeCenter unit. See “Installing the blade server in a BladeCenter unit” on page 232.

Removing and installing an I/O expansion card

Add an I/O expansion card to the blade server to provide additional connections for communicating on a network.

The blade server supports various types of I/O expansion cards, including Gigabit Ethernet and Fibre Channel expansion cards.

Verify that any expansion card that you are using is listed on the ServerProven website in the list of supported expansion cards for the PS703 or PS704 blade server. For example, the following expansion cards are not supported by the PS703 or PS704 blade server:

- BladeCenter SFF Gb Ethernet
- Cisco 1X InfiniBand
- QLogic iSCSI TOE Expansion Card (LFF)

See the ServerProven website for information about supported operating-system versions and all blade server optional devices.

Removing a CIOv form-factor expansion card

You can remove a CIOv form-factor expansion card from the CIOv connector from a PS703 blade server, or from either the base unit or the expansion unit of a PS704 blade server.

Note: If a CFFh card is present, remove it before installing the CIOv card.

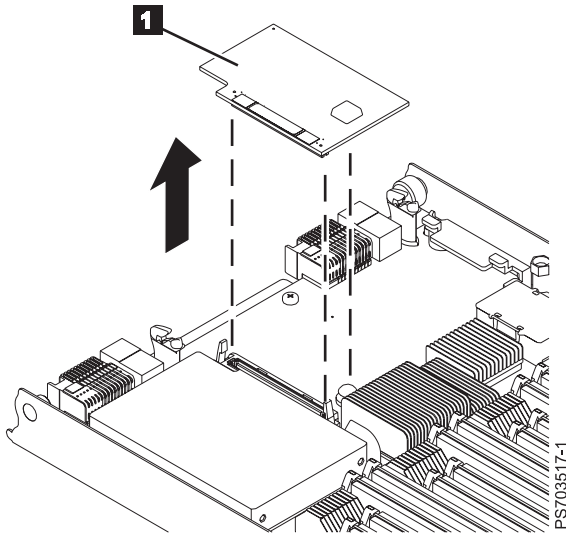

Figure 38. Removing a CIOv form factor expansion card from the CIOv connector

1. Read the Safety topic and the “Installation guidelines” on page 229.
2. Shut down the operating system, turn off the blade server, and remove the blade server from the BladeCenter unit. See “Removing the blade server from a BladeCenter unit” on page 231.
3. Carefully lay the blade server on a flat, static-protective surface, with the cover side up.
4. Open and remove the blade server cover. See “Removing the blade server cover” on page 233.

Note: If you are servicing the base unit of a PS704 blade server, you must first remove the expansion unit. For more information, see “Removing the expansion unit for a PS704 blade server” on page 237.

5. If your server has a combination-form-factor (CFFh) card, remove that card before you attempt to remove the CIOv form-factor expansion card. For more information, see “Removing a combination-form-factor expansion card” on page 256.
6. Lift the expansion card **1** up and away from the CIOv connector and out of the blade server.
7. If you are instructed to return the expansion card, follow all packaging instructions, and use any packaging materials for shipping that are supplied to you.

Installing a CIOv form-factor expansion card

You can install a CIOv form-factor expansion card on the CIOv connector to expand the I/O capabilities of the blade server.

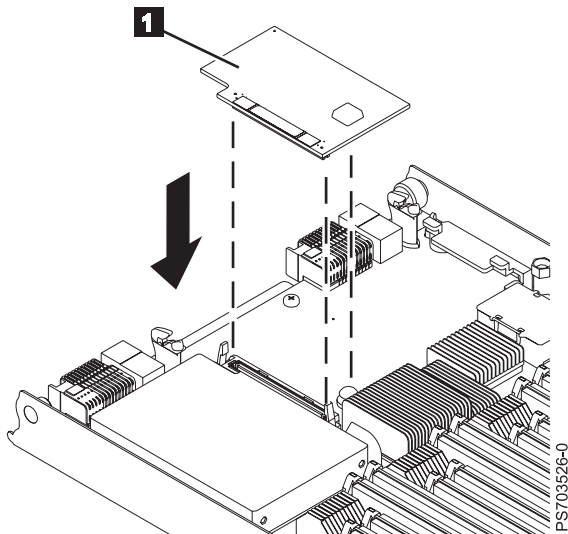

Figure 39. Installing a CIOv form-factor expansion card on the CIOv connector

To install a CIOv form-factor expansion card, complete the following steps:

1. Read the Safety topic and the “Installation guidelines” on page 229.
2. Shut down the operating system, turn off the blade server, and remove the blade server from the BladeCenter unit. See “Removing the blade server from a BladeCenter unit” on page 231.
3. Open and remove the blade server cover. See “Removing the blade server cover” on page 233.

Note: If you are servicing the base unit of a PS704 blade server, you must first remove the expansion unit. For more information, see “Removing the expansion unit for a PS704 blade server” on page 237.

4. Touch the static-protective package that contains the part to any *unpainted* metal surface on the BladeCenter unit or any *unpainted* metal surface on any other grounded rack component; then, remove the part from its package.
5. Orient the expansion card **1** over the system board.
6. Lower the card to the system board, aligning the connectors on the card with the CIOv connector on the system board.
7. Install and close the blade server cover. See “Installing and closing the blade server cover” on page 235.

Statement 21



CAUTION:

Hazardous energy is present when the blade server is connected to the power source. Always replace the blade server cover before installing the blade server.

8. Install the blade server into the BladeCenter unit. See “Installing the blade server in a BladeCenter unit” on page 232.
9. Use the documentation that comes with the expansion card to install device drivers and to perform any configuration that the expansion card requires.

Removing a combination-form-factor expansion card

Complete this procedure to remove a combination-form-factor (CFFh) expansion card from a PS703 blade server, or from either the base unit or the expansion unit of a PS704 blade server.

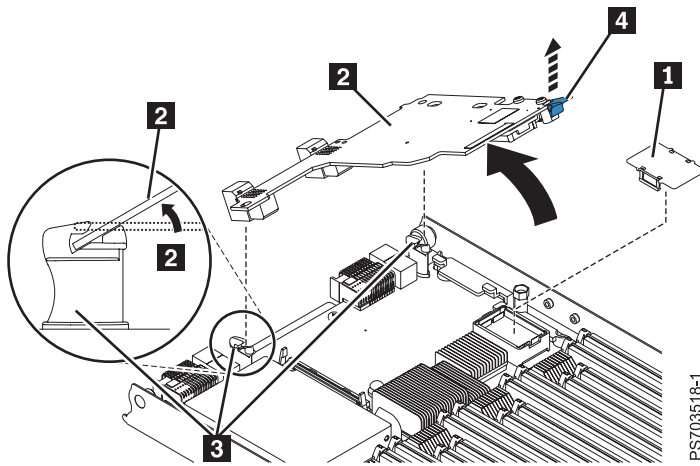

Figure 40. Removing a combination-form-factor expansion card

1. Read the Safety topic and the “Installation guidelines” on page 229.
2. Shut down the operating system, turn off the blade server, and remove the blade server from the BladeCenter unit. See “Removing the blade server from a BladeCenter unit” on page 231.
3. Open and remove the blade server cover. See “Removing the blade server cover” on page 233.

Note: If you are servicing the base unit of a PS704 blade server, you must first remove the expansion unit. For more information, see “Removing the expansion unit for a PS704 blade server” on page 237.

4. Remove the horizontal (CFFh) CFFe expansion card **2**.
 - a. Pull all the way up on the cam lever **4** until it disengages the card from the high-speed PCI Express® (PCIe) connector.
 - b. Gently pivot the card up and out of the expansion card standoffs **3** on the system board.
 - c. Lift the card out of the blade server.
 - d. Optional: Reattach the plastic cover **1** for the PCIe connector, if it is available.
5. If you are instructed to return the expansion card, follow all packaging instructions, and use any packaging materials for shipping that are supplied to you.

Installing a combination-form-factor expansion card

Install a combination-form-factor (CFFh) expansion card to expand the I/O capabilities of the blade server.

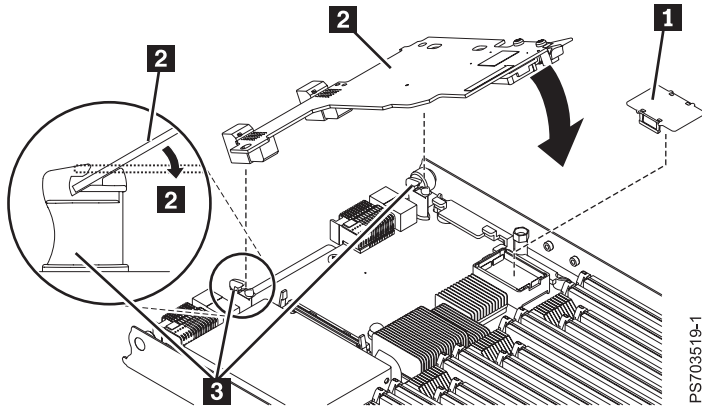

Figure 41. Installing a combination-form-factor expansion card

To install a combination-form-factor expansion card, complete the following steps:

1. Read the Safety topic and the “Installation guidelines” on page 229.
2. Shut down the operating system, turn off the blade server, and remove the blade server from the BladeCenter unit. See “Removing the blade server from a BladeCenter unit” on page 231.
3. Open and remove the blade server cover. See “Removing the blade server cover” on page 233.

Note: If you are servicing the base unit of a PS704 blade server, you must first remove the expansion unit. For more information, see “Removing the expansion unit for a PS704 blade server” on page 237.

4. Remove the plastic cover for the PCI Express (PCI-e) connector **1**.
5. Touch the static-protective package that contains the part to any *unpainted* metal surface on the BladeCenter unit or any *unpainted* metal surface on any other grounded rack component; then, remove the part from its package.
6. Install the expansion card **2**.
 - a. Slide the card into the expansion card standoffs **3** on the system board.
 - b. Gently pivot down the card and attach it to the high-speed PCIe connector.
 - c. Press down on the “PRESS TO INSTALL” label to secure the card in its slot.
7. Install and close the blade server cover. See “Installing and closing the blade server cover” on page 235.

Statement 21



CAUTION:

Hazardous energy is present when the blade server is connected to the power source. Always replace the blade server cover before installing the blade server.

8. Install the blade server into the BladeCenter unit. See “Installing the blade server in a BladeCenter unit” on page 232.
9. Use the documentation that comes with the expansion card to install device drivers and to perform any configuration that the expansion card requires.

Removing the battery

You can remove and replace the battery.

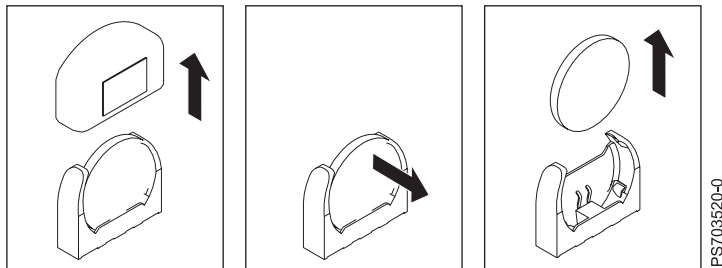

Figure 42. Removing the battery

To remove the battery, complete the following steps:

1. Read the Safety topic and the “Installation guidelines” on page 229.
2. Shut down the operating system, turn off the blade server, and remove the blade server from the BladeCenter unit. See “Removing the blade server from a BladeCenter unit” on page 231.
3. Carefully lay the blade server on a flat, static-protective surface, with the cover side up.
4. Open and remove the blade server cover. See “Removing the blade server cover” on page 233.

Note: If you are servicing the base unit of a PS704 blade server, you must first remove the expansion unit. For more information, see “Removing the expansion unit for a PS704 blade server” on page 237.

5. Locate the battery on the system board. See “System-board connectors” on page 9 for the location of the battery connector.
6. Remove the battery cover.
7. Press the battery toward the DIMMs.
8. Remove the battery.

Installing the battery

You can install the battery.

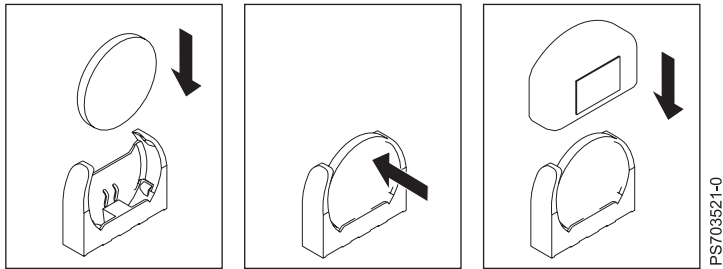

Figure 43. Installing the battery

The following notes describe information that you must consider when replacing the battery in the blade server.

- When replacing the battery, you must replace it with a lithium battery of the same type from the same manufacturer.
- To order replacement batteries, call 1-800-426-7378 within the United States, and 1-800-465-7999 or 1-800-465-6666 within Canada. Outside the U.S. and Canada, call your IBM marketing representative or authorized reseller.
- After you replace the battery:
 1. Set the time and date.
 2. Set the Network IP addresses (for blade servers that start up from a network).
 3. Reconfigure any other blade server settings.
- To avoid possible danger, read and follow the following safety statement.

Statement 2:



CAUTION:

When replacing the lithium battery, use only IBM Part Number 33F8354 or an equivalent type battery recommended by the manufacturer. If your system has a module containing a lithium battery, replace it only with the same module type made by the same manufacturer. The battery contains lithium and can explode if not properly used, handled, or disposed of.

Do not:

- Throw or immerse into water
- Heat to more than 100°C (212°F)
- Repair or disassemble

Dispose of the battery as required by local ordinances or regulations.

To install the battery, complete the following steps:

1. Follow any special handling and installation instructions that come with the battery.
2. Tilt the battery so that you can insert it into the socket. Make sure that the side with the positive (+) symbol is facing the correct direction.
3. Press the battery away from the DIMMs until fully inserted into the battery holder.
4. Install the battery cover.
5. Install and close the blade server cover. See “Installing and closing the blade server cover” on page 235.

Statement 21



CAUTION:

Hazardous energy is present when the blade server is connected to the power source. Always replace the blade server cover before installing the blade server.

6. Install the blade server into the BladeCenter unit. See “Installing the blade server in a BladeCenter unit” on page 232.
7. Turn on the blade server and reset the system date and time through the operating system that you installed. For additional information, see your operating-system documentation.
8. Make sure that the boot list is correct using the management module Web interface. See the management module documentation for more information) or the SMS Utility. See “Using the SMS utility” on page 269 for more information.

Removing the disk drive tray

You can remove the disk drive tray.

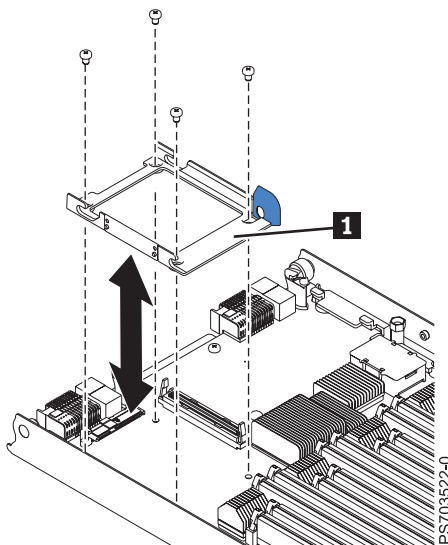

Figure 44. Removing the disk drive tray

To remove the disk drive tray, complete the following steps:

1. Read the Safety topic and the “Installation guidelines” on page 229.
2. Shut down the operating system, turn off the blade server, and remove the blade server from the BladeCenter unit. See “Removing the blade server from a BladeCenter unit” on page 231.
3. Carefully lay the blade server on a flat, static-protective surface, with the cover side up.
4. Open and remove the blade server cover. See “Removing the blade server cover” on page 233.

Note: If you are servicing the base unit of a PS704 blade server, you must first remove the expansion unit. For more information, see “Removing the expansion unit for a PS704 blade server” on page 237.

5. Remove the disk drive if one is installed. See “Removing a hard-disk drive” on page 242.
6. Remove the four screws that secure the drive tray (**1** in Figure 44 on page 260) to the system board and remove the drive tray.

Installing the disk drive tray

You can install the disk drive tray.

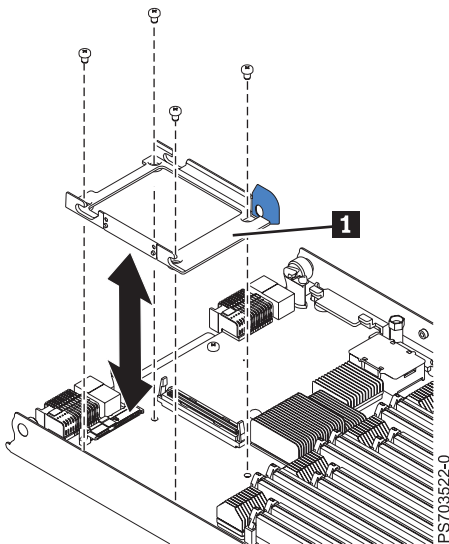

Figure 45. Installing the disk drive tray

To install the disk drive tray, complete the following steps:

1. Place the drive tray (**1** in Figure 45) into position on the system board and install the four screws to secure it.
2. Install the disk drive that was removed from the drive tray. See “Installing a hard-disk drive” on page 243 for instructions.
3. Install and close the blade server cover. See “Installing and closing the blade server cover” on page 235.

Statement 21



CAUTION:

Hazardous energy is present when the blade server is connected to the power source. Always replace the blade server cover before installing the blade server.

4. Install the blade server into the BladeCenter unit. See “Installing the blade server in a BladeCenter unit” on page 232.

Removing the tier 2 management card

You can remove this tier 2 CRU yourself or request IBM to install it, at no additional charge, under the type of warranty service that is designated for the blade server. Remove the management card to replace the card or to reuse the card in a new system board and chassis assembly.

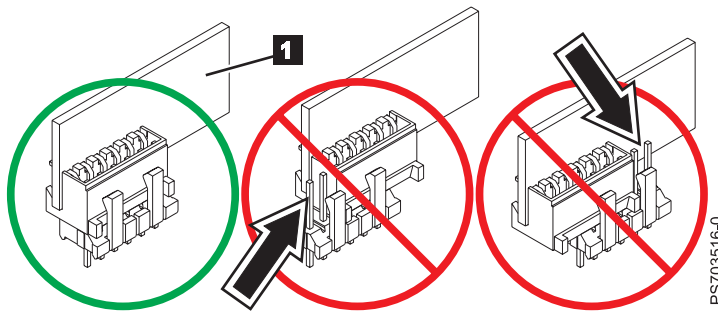

Figure 46. Removing the management card

To remove the management card, which is shown by **1** in Figure 46, complete the following steps:

1. Read the Safety topic and the “Installation guidelines” on page 229.
2. Shut down the operating system, turn off the blade server, and remove the blade server from the BladeCenter unit. See “Removing the blade server from a BladeCenter unit” on page 231.
3. Carefully lay the blade server on a flat, static-protective surface, with the cover side up.
4. Open and remove the blade server cover. See “Removing the blade server cover” on page 233.

Note: If you are servicing the base unit of a PS704 blade server, you must first remove the expansion unit. For more information, see “Removing the expansion unit for a PS704 blade server” on page 237.

5. Grasp the management card and pull it vertically out of unit to disengage the connectors.
6. If you are instructed to return the management card, follow all packaging instructions, and use any packaging materials for shipping that are supplied to you.
7. Move the management card to the new system board and chassis assembly.

If you are directed to move the management card to a new system board and chassis assembly, perform the following procedure.

- a. Replace the system board and chassis assembly, as described in “Replacing the FRU system-board and chassis assembly” on page 264.
- b. Replace the management card, as described in “Installing the tier 2 management card” on page 263.

Installing the tier 2 management card

You can install this tier 2 CRU yourself or request IBM to install it, at no additional charge, under the type of warranty service that is designated for the blade server. Use this procedure to install the management card into the currently installed system board. If you are also installing a new system board, you must complete this procedure before installing the new system board.

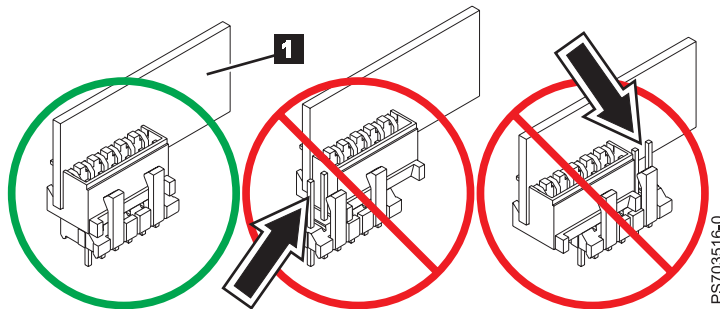

Figure 47. Installing the management card

To install the management card, which is shown by **1** in Figure 47, complete the following steps:

1. Read the documentation that comes with the management card, if you ordered a replacement card.
2. Locate the connector on the currently installed system board into which the management card will be installed. See “System-board connectors” on page 9 for the location.
3. Touch the static-protective package that contains the management card to any *unpainted* metal surface on the BladeCenter unit or any *unpainted* metal surface on any other grounded rack component; then, remove the management card from its package.
4. Insert the management card (as shown by **1** in Figure 47) and verify that the card is securely on the connector and pushed down all the way to the main board.
5. Install and close the blade server cover. See “Installing and closing the blade server cover” on page 235.

Statement 21



CAUTION:

Hazardous energy is present when the blade server is connected to the power source. Always replace the blade server cover before installing the blade server.

6. Install the blade server into the BladeCenter unit. See “Installing the blade server in a BladeCenter unit” on page 232.

Because the system board and chassis assembly has not changed, the firmware initializes the management card VPD using data that the blade server cached. To ensure that you give the initialization enough time to complete, access the management module and wait for the management module to discover the blade server.

Attention: If the management card was not properly installed, the power-on LED blinks rapidly and a communication error is reported to the management module. If this occurs, remove the blade server from the BladeCenter, as described in “Removing the tier 2 management card” on page 262. Reseat the management card, then reinstall the blade server in the BladeCenter.

7. Complete this procedure before installing a new system board. Then, you can install the new system board by performing the following procedure:
 - a. Shut down the operating system, turn off the blade server, and remove the blade server from the BladeCenter unit. See “Removing the blade server from a BladeCenter unit” on page 231.
 - b. Perform the procedure for replacing the system board to install the new system board. See “Replacing the FRU system-board and chassis assembly.”

Replacing the FRU system-board and chassis assembly

FRUs must be replaced only by trained service technicians. Replace the system board and chassis assembly. When replacing the system board, you will replace the system board, blade base (chassis), microprocessors, and heat sinks as one assembly. After replacement, you must either update the system with the latest firmware or restore the pre-existing firmware that the customer provides on a diskette or CD image.

Note: See “System-board layouts” on page 8 for more information on the locations of the connectors and LEDs on the system board.

To replace the system-board and chassis assembly, complete the following steps:

1. Read the Safety topic and the “Installation guidelines” on page 229.
2. Shut down the operating system, turn off the blade server, and remove the blade server from the BladeCenter unit. See “Removing the blade server from a BladeCenter unit” on page 231.
3. Carefully lay the blade server on a flat, static-protective surface, with the cover side up.
4. Open and remove the blade server cover. See “Removing the blade server cover” on page 233.

Note: If you are servicing the base unit of a PS704 blade server, you must first remove the expansion unit. For more information, see “Removing the expansion unit for a PS704 blade server” on page 237.

5. If you are servicing a base unit and not an expansion unit, remove the bezel assembly. See “Removing the bezel assembly” on page 240.
6. Remove any of the installed components listed below from the system board; then, place them on a non-conductive surface or install them on the new system board and chassis assembly.
 - I/O expansion card. See “Removing and installing an I/O expansion card” on page 253.
 - Hard disk drives. See “Removing a hard-disk drive” on page 242.
 - DIMMs. See “Removing a memory module” on page 249.
 - Management card. See “Removing the tier 2 management card” on page 262.
 - Battery. See “Removing the battery” on page 258.
7. Touch the static-protective package that contains the system-board and chassis assembly to any *unpainted* metal surface on the BladeCenter unit or any *unpainted* metal surface on any other grounded rack component; then, remove the assembly from its package.
8. Install any of the components listed below that were removed from the old system-board and chassis assembly.
 - I/O expansion card. See “Removing and installing an I/O expansion card” on page 253.
 - Hard disk drives. See “Installing a hard-disk drive” on page 243.
 - DIMMs. See “Installing a memory module” on page 251.
 - Management card. See “Installing the tier 2 management card” on page 263.
 - Battery. See “Installing the battery” on page 258.

Note: Install a DIMM filler or a hard drive filler in any location where a DIMM or hard drive is not present to avoid machine damage.

9. If you are servicing a base unit and not an expansion unit, install the bezel assembly. See “Installing the bezel assembly” on page 241 for instructions.
10. Install and close the blade server cover. See “Installing and closing the blade server cover” on page 235.

Statement 21



CAUTION:

Hazardous energy is present when the blade server is connected to the power source. Always replace the blade server cover before installing the blade server.

11. Write the machine type, model number, and serial number of the blade server on the repair identification (RID) tag that comes with the replacement system-board and chassis assembly. This information is on the identification label that is behind the control-panel door on the front of the blade server.

Important: Completing the information on the RID tag ensures future entitlement for service.

12. Place the RID tag on the bottom of the blade server chassis.
13. Install the blade server into the BladeCenter unit. See “Installing the blade server in a BladeCenter unit” on page 232.
14. Turn on the blade server.
15. Reset the system date and time through the operating system that you installed.
For additional information, see the documentation for your operating system.

Chapter 5. Configuring

Update the firmware and use the management module and the system management services (SMS) to configure the PS703 or PS704 blade server.

Updating the firmware

IBM periodically makes firmware updates available for you to install on the blade server, the management module, or expansion cards in the blade server.

Important: To avoid problems and to maintain proper system performance, always verify that the blade server BIOS, service processor, and diagnostic firmware levels are consistent for all blade servers within the BladeCenter unit. See “Verifying the system firmware levels” on page 218 for more information.

Plan to use a method of applying blade server firmware updates other than the management module. The enhanced service processor has a larger firmware image that makes it impractical to download and install over the RS-485 bus of the management module. Therefore, a firmware update for the blade server is not supported from the management module.

You can still use the other methods of performing firmware updates for the blade server:

- In-band operating system capabilities, such as the **update_flash** command for Linux and AIX or the **ldfware** command for Virtual I/O Server
- The firmware update function of AIX diagnostics
- The firmware update function of the stand-alone *diagnostics CD*
- If the blade server is managed by the IBM Systems Director Management Console (SDMC), an out-of-band update can be made using the SDMC.

Attention: Before the installation of the new firmware to the temporary side begins, the contents of the temporary side are copied into the permanent side. After the firmware installation begins, the previous level of firmware on the permanent side is no longer available.

To install blade server firmware using an in-band method, complete the following steps:

1. Start the TEMP image as described in “Starting the TEMP image” on page 217.
2. Download the PS703 single-wide blade firmware or the PS704 double-wide blade firmware.
 - a. Go to the IBM Support website (<http://www-947.ibm.com/systems/support/>) to download the updates.
 - b. Select your product, type, model, and operating system, and then click **Go**.
 - c. Click the **Download** tab, if necessary, for device driver and firmware updates.
 - d. Download the firmware to the /tmp/fwupdate directory.

3. Log on to the AIX or Linux system as root, or log on to the Virtual I/O Server/IVM alpha partition as padmin.
4. Type `ls /tmp/fwupdate` to identify the name of the firmware.
The result of the command lists any firmware updates that you downloaded to the directory, such as the following update, for example:

```
01AA7xx_yyy_zzz
```

5. Install the firmware update with one of the following methods:
 - Install the firmware with the in-band diagnostics of your AIX system, as described in Using the AIX diagnostics to install the server firmware update through AIX.
 - Install the firmware with the **update_flash** command on AIX:

```
cd /tmp/fwupdate
/usr/lpp/diagnostics/bin/update_flash -f 01EA3xx_yyy_zzz
```
 - Install the firmware with the **update_flash** command on Linux:

```
cd /tmp/fwupdate
/usr/sbin/update_flash -f 01EA3xx_yyy_zzz
```
 - Install the firmware with the **ldfware** command on Virtual I/O Server:

```
cd /tmp/fwupdate
ldfware -file 01EA3xx_yyy_zzz
```

Reference codes CA2799FD and CA2799FF are displayed alternately on the control panel during the server firmware installation process. The system automatically powers off and on when the installation is complete.

To install firmware using the SDMC, complete the following steps:

- a. Log on to the SDMC console.
- b. Under **Welcome to IBM Systems Director**, click on the **Manage** tab.
- c. Click on **Update Manager**.

The **Update Manager** guides you through the steps to update the firmware. For more information, see the *SDMC User's Guide*.

6. Verify that the update installed correctly, as described in "Verifying the system firmware levels" on page 218.
7. Optional: After testing the updated server, you might decide to install the firmware update permanently, as described in "Committing the TEMP system firmware image" on page 219.
You can also install an update permanently on either AIX or Linux, as described in:
 - Using AIX commands to install a firmware update permanently
 - Using Linux commands to install a firmware update permanently

Configuring the blade server

While the firmware is running POST and before the operating system starts, a POST menu with POST indicators is displayed. The POST indicators are the words *Memory*, *Keyboard*, *Network*, *SCSI*, and *Speaker* that are displayed as each component is tested. You can then select configuration utilities from the POST menu.

- **System management services (SMS)**

Use the system management services (SMS) utility to view information about your system or partition and to perform tasks such as setting up remote IPL, changing self configuring SCSI device (SCSD) settings, and selecting boot options. The SMS utility can be used for AIX or Linux partitions. See “Using the SMS utility” for more information.

- **Default boot list**

Use this utility to initiate a system boot in service mode through the default service mode boot list. This mode attempts to boot from the first device of each type that is found in the list.

Note: This is the preferred method of starting the stand-alone AIX diagnostics from CD.

- **Stored boot list**

Use this utility to initiate a system boot in service mode, using the customized service mode boot list that was set up by AIX when AIX was first booted, or manually using the AIX service aids.

- **Open firmware prompt**

This utility is for advanced users of the IEEE 1275 specifications only.

- **Management module**

Use the management module to change the boot list, determine which firmware image to boot, and perform other configuration tasks.

Using the SMS utility

Use the System Management Services (SMS) utility to perform various configuration tasks on the PS703 and PS704 blade servers.

Starting the SMS utility

Start the SMS utility to configure the blade server.

1. Turn on or restart the blade server, and establish an SOL session with it.

See the *BladeCenter Management Module Command-Line Interface Reference Guide* or the *BladeCenter Serial-Over-LAN Setup Guide* for more information.

2. When the POST menu and indicators are displayed, press the 1 key after the word *Keyboard* is displayed and before the word *Speaker* is displayed.
3. Follow the instructions on the screen.

SMS utility menu choices

Select SMS tasks from the SMS utility main menu. Choices on the SMS utility main menu depend on the version of the firmware in the blade server. Some menu choices might differ slightly from these descriptions.

- **Select Language**
Select this choice to change the language that is used to display the SMS menus.
- **Setup Remote IPL (Initial Program Load)**
Select this choice to enable and set up the remote startup capability of the blade server or partition.
- **Change SCSD Settings**
Select this choice to view and change the addresses of the self configuring SCSI device (SCSD) controllers that are attached to the blade server.
- **Select Console**
Select this choice to select the console on which the SMS menus are displayed.
- **Select Boot Options**
Select this choice to view and set various options regarding the installation devices and boot devices.

Note: If a device that you are trying to select (such as a USB CD drive in the BladeCenter media tray) is not displayed in the **Select Device Type** menu, select **List all Devices** and select the device from that menu.

Creating a CE login

If the blade server is running an AIX operating system, you can create a customer engineer (CE) login to perform operating system commands that are required to service the system without being logged in as a root user.

The CE login must have a role of Run Diagnostics and be a primary group of System. This enables the CE login to perform the following tasks:

- Run the diagnostics, including the service aids, certify, and format.
- Run all the operating-system commands that are run by system group users.
- Configure and unconfigure devices that are not in use.

In addition, this login can have Shutdown Group enabled to allow use of the Update System Microcode service aid and the shutdown and reboot operations.

The recommended CE login user name is qserv.

Configuring the Gigabit Ethernet controllers

An Ethernet controller is integrated on each blade server system board. You must install a device driver to enable the blade server operating system to address the Ethernet controller.

Each controller provides two 1 Gb full-duplex interfaces for connecting to one of the Ethernet-compatible I/O modules in I/O-module bays 1 and 2, which enables simultaneous transmission and reception of data on the Ethernet local area network (LAN).

The routing from an Ethernet controller to an I/O-module bay varies, depending on the type of BladeCenter that the blade is installed in. For example, each Ethernet controller on the system board is routed to a different I/O module in I/O module bay 1 or module bay 2 of the BladeCenter H or HT.

See “Blade server Ethernet controller enumeration” for information about how to determine the routing from an Ethernet controller to an I/O-module bay for the blade server.

Note: Other types of blade servers, such as the BladeCenter HS20 Type 8678 blade server, in the same BladeCenter unit as the PS703 and PS704 blade servers might have different Ethernet controller routing. See the documentation for a blade server for information.

You must install a device driver for the blade server operating system to address the Ethernet controllers. For device drivers and information about configuring Ethernet controllers, see the *Broadcom NetXtreme Gigabit Ethernet Software* CD that comes with the blade server. For updated information about configuring the controllers, see <http://www.ibm.com/systems/support/>.

The Ethernet controllers in your blade server support failover, which provides automatic redundancy for the Ethernet controllers. Failover capabilities vary per BladeCenter unit.

Without failover, only one Ethernet controller can be connected from each server to each virtual LAN or subnet. With failover, you can configure more than one Ethernet controller from each server to attach to the same virtual LAN or subnet. Either one of the integrated Ethernet controllers can be configured as the primary Ethernet controller. If you have configured the controllers for failover and the primary link fails, the secondary controller takes over. When the primary link is restored, the Ethernet traffic switches back to the primary Ethernet controller. See the operating-system device-driver documentation for information about configuring for failover.

Important: To support failover on the blade server Ethernet controllers, the Ethernet switch modules in the BladeCenter unit must have identical configurations.

Blade server Ethernet controller enumeration

The enumeration of the Ethernet controllers in a blade server is operating-system dependent. You can verify the Ethernet controller designations that a blade server uses through the operating-system settings.

The routing of an Ethernet controller to a particular I/O-module bay depends on the type of blade server. You can verify which Ethernet controller is routed to which I/O-module bay by using the following test:

1. Install only one Ethernet switch module or pass-thru module in I/O-module bay 1.
2. Make sure that the ports on the switch module or pass-thru module are enabled. Click **I/O Module Tasks** → **Admin/Power/Restart** in the management-module Web interface.
3. Enable only one of the Ethernet controllers on the blade server. Note the designation that the blade server operating system has for the controller.
4. Ping an external computer on the network that is connected to the switch module or pass-thru module. If you can ping the external computer, the Ethernet controller that you enabled is associated with the switch module or pass-thru module in I/O-module bay 1. The other Ethernet controller in the blade server is associated with the switch module or pass-thru module in I/O-module bay 2.

If you have installed an I/O expansion card in the blade server, communication from the expansion card should be routed to I/O-module bays 3 and 4, if these bays are supported by your BladeCenter unit. You can verify which controller on the card is routed to which I/O-module bay by performing the same test and using a controller on the expansion card and a compatible switch module or pass-thru module in I/O-module bay 3 or 4.

MAC addresses for integrated Ethernet controllers

The Ethernet controllers in the PS703 and PS704 blade servers provide the physical Ethernet ports that, when used with a virtual I/O server (VIOS), provide virtual *logical Ethernet* to client logical partitions (LPARs). The VIOS software uses the logical Ethernet as if they were real physical ports.

The logical Ethernet ports connect directly to the integrated Ethernet controller and from there to the I/O modules in the BladeCenter unit. See *Locating the installation instructions* for more information on installing VIOS for the virtual Ethernet ports.

The PS703 blade server has two physical integrated Ethernet ports and the PS704 has four physical integrated Ethernet ports.

The medium access control (MAC) addresses of the integrated Ethernet ports are listed on a label on the blade server. The blade server label lists four MAC addresses:

- The first two indicate the BMC service processor built-in Ethernet ports.
- The next two indicate the two integrated Ethernet ports.

The MAC addresses of the integrated Ethernet ports are displayed in the BladeCenter Advanced Management Module. The logical ports MAC addresses are generated by VIOS.

Table 40 shows the relative addressing scheme.

Table 40. MAC addressing scheme for physical and logical integrated Ethernet controllers

Node	Name in management module	Relation to the MAC that is listed on the PS703 and PS704 label	Example
BMC built-in Enet0		Same as first MAC address	00:1A:64:44:0e:c4
BMC built-in Enet1		MAC + 1	00:1A:64:44:0e:c5
Integrated Ethernet port 0	MAC address 1	MAC + 2	00:1A:64:44:0e:c6
Integrated Ethernet port 1	MAC address 2	MAC + 3	00:1A:64:44:0e:c7
Logical Ethernet ports		Generated by VIOS	

For more information about planning, deploying, and managing the use of integrated Ethernet controllers, see the *Configuring* section of the PowerVM Information Roadmap.

Configuring a RAID array

Configuring a RAID array applies to a blade server in which disk drives or solid-state drives are installed.

Disk drives and solid-state drives in the PS703 or PS704 blade server can be used to implement and manage various types of RAID arrays in operating systems that are on the ServerProven list. For the blade server, you must configure the RAID array through "smit sasdam," which is the SAS RAID Disk Array Manager for AIX. The AIX Disk Array Manager is packaged with the Diagnostics utilities on the Diagnostics CD. Use "smit sasdam" to configure the disk drives for use with the SAS controller. For more information, see "Using the Disk Array Manager" in the Systems Hardware Information Center at <http://publib.boulder.ibm.com/infocenter/systems/scope/hw/index.jsp?topic=/p7ebj/sasusingthesasdiskarraymanager.htm>.

Important: Depending on your RAID configuration, you might have to create the array *before* you install the operating system in the blade server.

Before you can create a RAID array, you must reformat the drives so that the sector size of the drives changes from 512 bytes to 528 bytes. If you later decide to remove the drives, delete the RAID array before you remove the drives. If you decide to delete the RAID array and reuse the drives, you might need to reformat the drives so that the sector size of the drives changes from 528 bytes to 512 bytes.

Updating IBM Director

If you plan to use IBM Director to manage the blade server, you must check for the latest applicable IBM Director updates and interim fixes.

To install the IBM Director updates and any other applicable updates and interim fixes, complete the following steps.

Note: Changes are made periodically to the IBM Web site. The actual procedure might vary slightly from what is described in this procedure.

1. Check for the latest version of IBM Director:
 - a. Go to the IBM Director download site at <http://www.ibm.com/systems/management/director/downloads.html>.
 - b. If the drop-down list shows a newer version of IBM Director than the version that comes with the blade server, follow the instructions on the Web page to download the latest version.
2. Install IBM Director.
3. Download and install any applicable updates or interim fixes for the blade server:
 - a. Go to the IBM Support site at <http://www.ibm.com/systems/support/>.
 - b. Under **Product support**, click **BladeCenter**.
 - c. Under **Popular links**, click **Software and device drivers**.
 - d. Click **BladeCenter PS704 and PS703** to display the list of downloadable files for the blade server.

Appendix. Notices

This information was developed for products and services offered in the U.S.A.

The manufacturer may not offer the products, services, or features discussed in this document in other countries. Consult the manufacturer's representative for information on the products and services currently available in your area. Any reference to the manufacturer's product, program, or service is not intended to state or imply that only that product, program, or service may be used. Any functionally equivalent product, program, or service that does not infringe any intellectual property right of the manufacturer may be used instead. However, it is the user's responsibility to evaluate and verify the operation of any product, program, or service.

The manufacturer may have patents or pending patent applications covering subject matter described in this document. The furnishing of this document does not grant you any license to these patents. You can send license inquiries, in writing, to the manufacturer.

The following paragraph does not apply to the United Kingdom or any other country where such provisions are inconsistent with local law: THIS INFORMATION IS PROVIDED "AS IS" WITHOUT WARRANTY OF ANY KIND, EITHER EXPRESS OR IMPLIED, INCLUDING, BUT NOT LIMITED TO, THE IMPLIED WARRANTIES OF NON-INFRINGEMENT, MERCHANTABILITY OR FITNESS FOR A PARTICULAR PURPOSE. Some states do not allow disclaimer of express or implied warranties in certain transactions, therefore, this statement may not apply to you.

This information could include technical inaccuracies or typographical errors. Changes are periodically made to the information herein; these changes will be incorporated in new editions of the publication. The manufacturer may make improvements and/or changes in the product(s) and/or the program(s) described in this publication at any time without notice.

Any references in this information to websites not owned by the manufacturer are provided for convenience only and do not in any manner serve as an endorsement of those websites. The materials at those websites are not part of the materials for this product and use of those websites is at your own risk.

The manufacturer may use or distribute any of the information you supply in any way it believes appropriate without incurring any obligation to you.

Any performance data contained herein was determined in a controlled environment. Therefore, the results obtained in other operating environments may vary significantly. Some measurements may have been made on development-level systems and there is no guarantee that these measurements will be the same on generally available systems. Furthermore, some measurements may have been estimated through extrapolation. Actual results may vary. Users of this document should verify the applicable data for their specific environment.

Information concerning products not produced by this manufacturer was obtained from the suppliers of those products, their published announcements or other publicly available sources. This manufacturer has not tested those products and cannot confirm the accuracy of performance, compatibility or any other claims related to products not produced by this manufacturer. Questions on the capabilities of products not produced by this manufacturer should be addressed to the suppliers of those products.

All statements regarding the manufacturer's future direction or intent are subject to change or withdrawal without notice, and represent goals and objectives only.

The manufacturer's prices shown are the manufacturer's suggested retail prices, are current and are subject to change without notice. Dealer prices may vary.

This information is for planning purposes only. The information herein is subject to change before the products described become available.

This information contains examples of data and reports used in daily business operations. To illustrate them as completely as possible, the examples include the names of individuals, companies, brands, and products. All of these names are fictitious and any similarity to the names and addresses used by an actual business enterprise is entirely coincidental.

If you are viewing this information in softcopy, the photographs and color illustrations may not appear.

The drawings and specifications contained herein shall not be reproduced in whole or in part without the written permission of the manufacturer.

The manufacturer has prepared this information for use with the specific machines indicated. The manufacturer makes no representations that it is suitable for any other purpose.

The manufacturer's computer systems contain mechanisms designed to reduce the possibility of undetected data corruption or loss. This risk, however, cannot be eliminated. Users who experience unplanned outages, system failures, power fluctuations or outages, or component failures must verify the accuracy of operations performed and data saved or transmitted by the system at or near the time of the outage or failure. In addition, users must establish procedures to ensure that there is independent data verification before relying on such data in sensitive or critical operations. Users should periodically check the manufacturer's support websites for updated information and fixes applicable to the system and related software.

Ethernet connection usage restriction

This product is not intended to be connected directly or indirectly by any means whatsoever to interfaces of public telecommunications networks.

Trademarks

IBM, the IBM logo, and ibm.com are trademarks or registered trademarks of International Business Machines Corp., registered in many jurisdictions worldwide. Other product and service names might be trademarks of IBM or other companies. A current list of IBM trademarks is available on the Web at Copyright and trademark information at www.ibm.com/legal/copytrade.shtml.

Adobe, the Adobe logo, PostScript, and the PostScript logo are either registered trademarks or trademarks of Adobe Systems Incorporated in the United States, and/or other countries.

INFINIBAND, InfiniBand Trade Association, and the INFINIBAND design marks are trademarks and/or service marks of the INFINIBAND Trade Association.

Linux is a registered trademark of Linus Torvalds in the United States, other countries, or both.

Microsoft and Windows are trademarks of Microsoft Corporation in the United States, other countries, or both.

Red Hat, the Red Hat "Shadow Man" logo, and all Red Hat-based trademarks and logos are trademarks or registered trademarks of Red Hat, Inc., in the United States and other countries.

Other product or service names might be trademarks of IBM or other companies.

Electronic emission notices

When attaching a monitor to the equipment, you must use the designated monitor cable and any interference suppression devices supplied with the monitor.

Class A Notices

The following Class A statements apply to the IBM servers that contain the POWER7 processor and its features unless designated as electromagnetic compatibility (EMC) Class B in the feature information.

Federal Communications Commission (FCC) statement

Note: This equipment has been tested and found to comply with the limits for a Class A digital device, pursuant to Part 15 of the FCC Rules. These limits are designed to provide reasonable protection against harmful interference when the equipment is operated in a commercial environment. This equipment generates, uses, and can radiate radio frequency energy and, if not installed and used in accordance with the instruction manual, may cause harmful interference to radio communications. Operation of this equipment in a residential area is likely to cause harmful interference, in which case the user will be required to correct the interference at his own expense.

Properly shielded and grounded cables and connectors must be used in order to meet FCC emission limits. IBM is not responsible for any radio or television interference caused by using other than recommended cables and connectors or by unauthorized changes or modifications to this equipment. Unauthorized changes or modifications could void the user's authority to operate the equipment.

This device complies with Part 15 of the FCC rules. Operation is subject to the following two conditions: (1) this device may not cause harmful interference, and (2) this device must accept any interference received, including interference that may cause undesired operation.

Industry Canada Compliance Statement

This Class A digital apparatus complies with Canadian ICES-003.

Avis de conformité à la réglementation d'Industrie Canada

Cet appareil numérique de la classe A est conforme à la norme NMB-003 du Canada.

European Community Compliance Statement

This product is in conformity with the protection requirements of EU Council Directive 2004/108/EC on the approximation of the laws of the Member States relating to electromagnetic compatibility. IBM cannot accept responsibility for any failure to satisfy the protection requirements resulting from a non-recommended modification of the product, including the fitting of non-IBM option cards.

This product has been tested and found to comply with the limits for Class A Information Technology Equipment according to European Standard EN 55022. The limits for Class A equipment were derived for commercial and industrial environments to provide reasonable protection against interference with licensed communication equipment.

European Community contact:
IBM Deutschland GmbH
Technical Regulations, Department M456
IBM-Allee 1, 71139 Ehningen, Germany
Tele: +49 7032 15-2937
email: tjahn@de.ibm.com

Warning: This is a Class A product. In a domestic environment, this product may cause radio interference, in which case the user may be required to take adequate measures.

VCCI Statement - Japan

この装置は、クラスA 情報技術装置です。この装置を家庭環境で使用すると電波妨害を引き起こすことがあります。この場合には使用者が適切な対策を講ずるよう要求されることがあります。 VCCI-A

The following is a summary of the VCCI Japanese statement in the box above:

This is a Class A product based on the standard of the VCCI Council. If this equipment is used in a domestic environment, radio interference may occur, in which case, the user may be required to take corrective actions.

Japanese Electronics and Information Technology Industries Association (JEITA) Confirmed Harmonics Guideline (products less than or equal to 20 A per phase)

高調波ガイドライン適合品

Japanese Electronics and Information Technology Industries Association (JEITA) Confirmed Harmonics Guideline with Modifications (products greater than 20 A per phase)

高調波ガイドライン準用品

Electromagnetic Interference (EMI) Statement - People's Republic of China

声 明

此为 A 级产品, 在生活环境中, 该产品可能会造成无线电干扰。在这种情况下, 可能需要用户对其干扰采取切实可行的措施。

Declaration: This is a Class A product. In a domestic environment this product may cause radio interference in which case the user may need to perform practical action.

Electromagnetic Interference (EMI) Statement - Taiwan

警告使用者：
這是甲類的資訊產品，在居住的環境中使用時，可能會造成射頻干擾，在這種情況下，使用者會被要求採取某些適當的對策。

The following is a summary of the EMI Taiwan statement above.

Warning: This is a Class A product. In a domestic environment this product may cause radio interference in which case the user will be required to take adequate measures.

IBM Taiwan Contact Information:

台灣IBM 產品服務聯絡方式：
台灣國際商業機器股份有限公司
台北市松仁路7號3樓
電話：0800-016-888

Electromagnetic Interference (EMI) Statement - Korea

이 기기는 업무용(A급)으로 전자파적합기기로서 판매자 또는 사용자는 이 점을 주의하시기 바라며, 가정외의 지역에서 사용하는 것을 목적으로 합니다.

Germany Compliance Statement

Deutschsprachiger EU Hinweis: Hinweis für Geräte der Klasse A EU-Richtlinie zur Elektromagnetischen Verträglichkeit

Dieses Produkt entspricht den Schutzanforderungen der EU-Richtlinie 2004/108/EG zur Angleichung der Rechtsvorschriften über die elektromagnetische Verträglichkeit in den EU-Mitgliedsstaaten und hält die Grenzwerte der EN 55022 Klasse A ein.

Um dieses sicherzustellen, sind die Geräte wie in den Handbüchern beschrieben zu installieren und zu betreiben. Des Weiteren dürfen auch nur von der IBM empfohlene Kabel angeschlossen werden. IBM übernimmt keine Verantwortung für die Einhaltung der Schutzanforderungen, wenn das Produkt ohne Zustimmung von IBM verändert bzw. wenn Erweiterungskomponenten von Fremdherstellern ohne Empfehlung von IBM gesteckt/eingebaut werden.

EN 55022 Klasse A Geräte müssen mit folgendem Warnhinweis versehen werden:
"Warnung: Dieses ist eine Einrichtung der Klasse A. Diese Einrichtung kann im Wohnbereich Funk-Störungen verursachen; in diesem Fall kann vom Betreiber verlangt werden, angemessene Maßnahmen zu ergreifen und dafür aufzukommen."

Deutschland: Einhaltung des Gesetzes über die elektromagnetische Verträglichkeit von Geräten

Dieses Produkt entspricht dem "Gesetz über die elektromagnetische Verträglichkeit von Geräten (EMVG)". Dies ist die Umsetzung der EU-Richtlinie 2004/108/EG in der Bundesrepublik Deutschland.

Zulassungsbescheinigung laut dem Deutschen Gesetz über die elektromagnetische Verträglichkeit von Geräten (EMVG) (bzw. der EMC EG Richtlinie 2004/108/EG) für Geräte der Klasse A

Dieses Gerät ist berechtigt, in Übereinstimmung mit dem Deutschen EMVG das EG-Konformitätszeichen - CE - zu führen.

Verantwortlich für die Einhaltung der EMV Vorschriften ist der Hersteller:
International Business Machines Corp.
New Orchard Road
Armonk, New York 10504
Tel: 914-499-1900

Der verantwortliche Ansprechpartner des Herstellers in der EU ist:
IBM Deutschland GmbH
Technical Regulations, Abteilung M456
IBM-Allee 1, 71139 Ehningen, Germany
Tel: +49 7032 15-2937
email: tjahn@de.ibm.com

Generelle Informationen:

Das Gerät erfüllt die Schutzanforderungen nach EN 55024 und EN 55022 Klasse A.

Electromagnetic Interference (EMI) Statement - Russia

ВНИМАНИЕ! Настоящее изделие относится к классу А.
В жилых помещениях оно может создавать радиопомехи, для снижения которых необходимы дополнительные меры

Class B Notices

The following Class B statements apply to features designated as electromagnetic compatibility (EMC) Class B in the feature installation information.

Federal Communications Commission (FCC) statement

This equipment has been tested and found to comply with the limits for a Class B digital device, pursuant to Part 15 of the FCC Rules. These limits are designed to provide reasonable protection against harmful interference in a residential installation.

This equipment generates, uses, and can radiate radio frequency energy and, if not installed and used in accordance with the instructions, may cause harmful interference to radio communications. However, there is no guarantee that interference will not occur in a particular installation.

If this equipment does cause harmful interference to radio or television reception, which can be determined by turning the equipment off and on, the user is encouraged to try to correct the interference by one or more of the following measures:

- Reorient or relocate the receiving antenna.
- Increase the separation between the equipment and receiver.
- Connect the equipment into an outlet on a circuit different from that to which the receiver is connected.
- Consult an IBM-authorized dealer or service representative for help.

Properly shielded and grounded cables and connectors must be used in order to meet FCC emission limits. Proper cables and connectors are available from IBM-authorized dealers. IBM is not responsible for any radio or television interference caused by unauthorized changes or modifications to this equipment. Unauthorized changes or modifications could void the user's authority to operate this equipment.

This device complies with Part 15 of the FCC rules. Operation is subject to the following two conditions: (1) this device may not cause harmful interference, and (2) this device must accept any interference received, including interference that may cause undesired operation.

Industry Canada Compliance Statement

This Class B digital apparatus complies with Canadian ICES-003.

Avis de conformité à la réglementation d'Industrie Canada

Cet appareil numérique de la classe B est conforme à la norme NMB-003 du Canada.

European Community Compliance Statement

This product is in conformity with the protection requirements of EU Council Directive 2004/108/EC on the approximation of the laws of the Member States relating to electromagnetic compatibility. IBM cannot accept responsibility for any failure to satisfy the protection requirements resulting from a non-recommended modification of the product, including the fitting of non-IBM option cards.

This product has been tested and found to comply with the limits for Class B Information Technology Equipment according to European Standard EN 55022. The limits for Class B equipment were derived for typical residential environments to provide reasonable protection against interference with licensed communication equipment.

European Community contact:
IBM Deutschland GmbH
Technical Regulations, Department M456
IBM-Allee 1, 71139 Ehningen, Germany
Tele: +49 7032 15-2937
email: tjahn@de.ibm.com

VCCI Statement - Japan

この装置は、クラスB情報技術装置です。この装置は、家庭環境で使用することを目的としていますが、この装置がラジオやテレビジョン受信機に近接して使用されると、受信障害を引き起こすことがあります。

取扱説明書に従って正しい取り扱いをして下さい。 VCCI-B

Japanese Electronics and Information Technology Industries Association (JEITA) Confirmed Harmonics Guideline (products less than or equal to 20 A per phase)

高調波ガイドライン適合品

**Japanese Electronics and Information Technology Industries Association (JEITA)
Confirmed Harmonics Guideline with Modifications (products greater than 20 A per
phase)**

高調波ガイドライン準用品

IBM Taiwan Contact Information

台灣IBM 產品服務聯絡方式：
台灣國際商業機器股份有限公司
台北市松仁路7號3樓
電話：0800-016-888

Electromagnetic Interference (EMI) Statement - Korea

이 기기는 가정용(B급)으로 전자파적합기기로서 주로 가정에서 사용하는 것을 목적으로 하며, 모든 지역에서 사용할 수 있습니다.

Germany Compliance Statement

**Deutschsprachiger EU Hinweis: Hinweis für Geräte der Klasse B EU-Richtlinie zur
Elektromagnetischen Verträglichkeit**

Dieses Produkt entspricht den Schutzanforderungen der EU-Richtlinie 2004/108/EG zur Angleichung der Rechtsvorschriften über die elektromagnetische Verträglichkeit in den EU-Mitgliedsstaaten und hält die Grenzwerte der EN 55022 Klasse B ein.

Um dieses sicherzustellen, sind die Geräte wie in den Handbüchern beschrieben zu installieren und zu betreiben. Des Weiteren dürfen auch nur von der IBM empfohlene Kabel angeschlossen werden. IBM übernimmt keine Verantwortung für die Einhaltung der Schutzanforderungen, wenn das Produkt ohne Zustimmung von IBM verändert bzw. wenn Erweiterungskomponenten von Fremdherstellern ohne Empfehlung von IBM gesteckt/eingebaut werden.

Deutschland: Einhaltung des Gesetzes über die elektromagnetische Verträglichkeit von Geräten

Dieses Produkt entspricht dem "Gesetz über die elektromagnetische Verträglichkeit von Geräten (EMVG)". Dies ist die Umsetzung der EU-Richtlinie 2004/108/EG in der Bundesrepublik Deutschland.

**Zulassungsbescheinigung laut dem Deutschen Gesetz über die elektromagnetische Verträglichkeit von
Geräten (EMVG) (bzw. der EMC EG Richtlinie 2004/108/EG) für Geräte der Klasse B**

Dieses Gerät ist berechtigt, in Übereinstimmung mit dem Deutschen EMVG das EG-Konformitätszeichen - CE - zu führen.

Verantwortlich für die Einhaltung der EMV Vorschriften ist der Hersteller:

International Business Machines Corp.

New Orchard Road

Armonk, New York 10504

Tel: 914-499-1900

Der verantwortliche Ansprechpartner des Herstellers in der EU ist:

IBM Deutschland GmbH

Technical Regulations, Abteilung M456

IBM-Allee 1, 71139 Ehningen, Germany

Tel: +49 7032 15-2937

email: tjahn@de.ibm.com

Generelle Informationen:

Das Gerät erfüllt die Schutzanforderungen nach EN 55024 und EN 55022 Klasse B.

Terms and conditions

Permissions for the use of these publications is granted subject to the following terms and conditions.

Personal Use: You may reproduce these publications for your personal, noncommercial use provided that all proprietary notices are preserved. You may not distribute, display or make derivative works of these publications, or any portion thereof, without the express consent of the manufacturer.

Commercial Use: You may reproduce, distribute and display these publications solely within your enterprise provided that all proprietary notices are preserved. You may not make derivative works of these publications, or reproduce, distribute or display these publications or any portion thereof outside your enterprise, without the express consent of the manufacturer.

Except as expressly granted in this permission, no other permissions, licenses or rights are granted, either express or implied, to the publications or any information, data, software or other intellectual property contained therein.

The manufacturer reserves the right to withdraw the permissions granted herein whenever, in its discretion, the use of the publications is detrimental to its interest or, as determined by the manufacturer, the above instructions are not being properly followed.

You may not download, export or re-export this information except in full compliance with all applicable laws and regulations, including all United States export laws and regulations.

THE MANUFACTURER MAKES NO GUARANTEE ABOUT THE CONTENT OF THESE PUBLICATIONS. THESE PUBLICATIONS ARE PROVIDED "AS-IS" AND WITHOUT WARRANTY OF ANY KIND, EITHER EXPRESSED OR IMPLIED, INCLUDING BUT NOT LIMITED TO IMPLIED WARRANTIES OF MERCHANTABILITY, NON-INFRINGEMENT, AND FITNESS FOR A PARTICULAR PURPOSE.



Printed in USA

GI11-9841-00

