

Power Systems

Racks and rack features

IBM

Power Systems

Racks and rack features

IBM

Note

Before using this information and the product it supports, read the information in “Safety notices” on page v, “Notices” on page 51, the *IBM Systems Safety Notices* manual, G229-9054, and the *IBM Environmental Notices and User Guide*, Z125-5823.

This edition applies to IBM Power Systems™ servers that contain the POWER7 processor and to all associated models.

© Copyright IBM Corporation 2012, 2013.

US Government Users Restricted Rights – Use, duplication or disclosure restricted by GSA ADP Schedule Contract with IBM Corp.

Contents

Safety notices	v
Racks and rack features	1
What's new in Racks and rack features	1
Installing the rack	1
7014-T00 and 7014-T42 racks	1
Installing the 7014-T00 and 7014-T42 racks	1
Completing a parts inventory	1
Positioning the rack	2
Leveling the rack	2
Attaching the stabilizer brackets	3
Attaching the rack to a concrete floor	4
Attaching the rack to the concrete floor beneath a raised floor	9
Connecting the power distribution system	13
Checking the ac outlets	13
Attaching the front or back ac electrical outlet	14
Connecting a dc power source	17
Removing and replacing 7014-T00 or 7014-T42 side panels	21
Removing a 7014-T00 or 7014-T42 side panel	21
Replacing a 7014-T00 or 7014-T42 side panel	22
Removing and replacing 7014-T00 or 7014-T42 trim panels	22
Removing the 7014-T00 or 7014-T42 trim panels	22
Replacing the 7014-T00 or 7014-T42 trim panels	23
Attaching the rack doors	24
Attaching a high-perforation front door	25
Rack safety notices	26
Installing the rack security kit	28
Ruggedized kit	30
Releasing the ruggedized brace	31
Releasing the side panel with a ruggedized kit	32
Connecting multiple racks with rack-to-rack attachment kit	33
Removing and replacing the rack top cover	35
Removing the rack top cover	35
Replacing the rack top cover	37
Power distribution unit	39
Installing the PDU or PDU+ in the side of a rack	39
Setting up power monitoring using the PDU+	45
Notices	51
Trademarks	52
Electronic emission notices	52
Class A Notices	52
Class B Notices	56
Terms and conditions	59

Safety notices

Safety notices may be printed throughout this guide:

- **DANGER** notices call attention to a situation that is potentially lethal or extremely hazardous to people.
- **CAUTION** notices call attention to a situation that is potentially hazardous to people because of some existing condition.
- **Attention** notices call attention to the possibility of damage to a program, device, system, or data.

World Trade safety information

Several countries require the safety information contained in product publications to be presented in their national languages. If this requirement applies to your country, safety information documentation is included in the publications package (such as in printed documentation, on DVD, or as part of the product) shipped with the product. The documentation contains the safety information in your national language with references to the U.S. English source. Before using a U.S. English publication to install, operate, or service this product, you must first become familiar with the related safety information documentation. You should also refer to the safety information documentation any time you do not clearly understand any safety information in the U.S. English publications.

Replacement or additional copies of safety information documentation can be obtained by calling the IBM Hotline at 1-800-300-8751.

German safety information

Das Produkt ist nicht für den Einsatz an Bildschirmarbeitsplätzen im Sinne § 2 der Bildschirmarbeitsverordnung geeignet.

Laser safety information

IBM® servers can use I/O cards or features that are fiber-optic based and that utilize lasers or LEDs.

Laser compliance

IBM servers may be installed inside or outside of an IT equipment rack.

DANGER

When working on or around the system, observe the following precautions:

Electrical voltage and current from power, telephone, and communication cables are hazardous. To avoid a shock hazard:

- Connect power to this unit only with the IBM provided power cord. Do not use the IBM provided power cord for any other product.
- Do not open or service any power supply assembly.
- Do not connect or disconnect any cables or perform installation, maintenance, or reconfiguration of this product during an electrical storm.
- The product might be equipped with multiple power cords. To remove all hazardous voltages, disconnect all power cords.
- Connect all power cords to a properly wired and grounded electrical outlet. Ensure that the outlet supplies proper voltage and phase rotation according to the system rating plate.
- Connect any equipment that will be attached to this product to properly wired outlets.
- When possible, use one hand only to connect or disconnect signal cables.
- Never turn on any equipment when there is evidence of fire, water, or structural damage.
- Disconnect the attached power cords, telecommunications systems, networks, and modems before you open the device covers, unless instructed otherwise in the installation and configuration procedures.
- Connect and disconnect cables as described in the following procedures when installing, moving, or opening covers on this product or attached devices.

To Disconnect:

1. Turn off everything (unless instructed otherwise).
2. Remove the power cords from the outlets.
3. Remove the signal cables from the connectors.
4. Remove all cables from the devices.

To Connect:

1. Turn off everything (unless instructed otherwise).
2. Attach all cables to the devices.
3. Attach the signal cables to the connectors.
4. Attach the power cords to the outlets.
5. Turn on the devices.

(D005)

DANGER

Observe the following precautions when working on or around your IT rack system:

- Heavy equipment—personal injury or equipment damage might result if mishandled.
- Always lower the leveling pads on the rack cabinet.
- Always install stabilizer brackets on the rack cabinet.
- To avoid hazardous conditions due to uneven mechanical loading, always install the heaviest devices in the bottom of the rack cabinet. Always install servers and optional devices starting from the bottom of the rack cabinet.
- Rack-mounted devices are not to be used as shelves or work spaces. Do not place objects on top of rack-mounted devices.



- Each rack cabinet might have more than one power cord. Be sure to disconnect all power cords in the rack cabinet when directed to disconnect power during servicing.
- Connect all devices installed in a rack cabinet to power devices installed in the same rack cabinet. Do not plug a power cord from a device installed in one rack cabinet into a power device installed in a different rack cabinet.
- An electrical outlet that is not correctly wired could place hazardous voltage on the metal parts of the system or the devices that attach to the system. It is the responsibility of the customer to ensure that the outlet is correctly wired and grounded to prevent an electrical shock.

CAUTION

- Do not install a unit in a rack where the internal rack ambient temperatures will exceed the manufacturer's recommended ambient temperature for all your rack-mounted devices.
- Do not install a unit in a rack where the air flow is compromised. Ensure that air flow is not blocked or reduced on any side, front, or back of a unit used for air flow through the unit.
- Consideration should be given to the connection of the equipment to the supply circuit so that overloading of the circuits does not compromise the supply wiring or overcurrent protection. To provide the correct power connection to a rack, refer to the rating labels located on the equipment in the rack to determine the total power requirement of the supply circuit.
- *(For sliding drawers.)* Do not pull out or install any drawer or feature if the rack stabilizer brackets are not attached to the rack. Do not pull out more than one drawer at a time. The rack might become unstable if you pull out more than one drawer at a time.
- *(For fixed drawers.)* This drawer is a fixed drawer and must not be moved for servicing unless specified by the manufacturer. Attempting to move the drawer partially or completely out of the rack might cause the rack to become unstable or cause the drawer to fall out of the rack.

(R001)

CAUTION:

Removing components from the upper positions in the rack cabinet improves rack stability during relocation. Follow these general guidelines whenever you relocate a populated rack cabinet within a room or building:

- Reduce the weight of the rack cabinet by removing equipment starting at the top of the rack cabinet. When possible, restore the rack cabinet to the configuration of the rack cabinet as you received it. If this configuration is not known, you must observe the following precautions:
 - Remove all devices in the 32U position and above.
 - Ensure that the heaviest devices are installed in the bottom of the rack cabinet.
 - Ensure that there are no empty U-levels between devices installed in the rack cabinet below the 32U level.
- If the rack cabinet you are relocating is part of a suite of rack cabinets, detach the rack cabinet from the suite.
- Inspect the route that you plan to take to eliminate potential hazards.
- Verify that the route that you choose can support the weight of the loaded rack cabinet. Refer to the documentation that comes with your rack cabinet for the weight of a loaded rack cabinet.
- Verify that all door openings are at least 760 x 230 mm (30 x 80 in.).
- Ensure that all devices, shelves, drawers, doors, and cables are secure.
- Ensure that the four leveling pads are raised to their highest position.
- Ensure that there is no stabilizer bracket installed on the rack cabinet during movement.
- Do not use a ramp inclined at more than 10 degrees.
- When the rack cabinet is in the new location, complete the following steps:
 - Lower the four leveling pads.
 - Install stabilizer brackets on the rack cabinet.
 - If you removed any devices from the rack cabinet, repopulate the rack cabinet from the lowest position to the highest position.
- If a long-distance relocation is required, restore the rack cabinet to the configuration of the rack cabinet as you received it. Pack the rack cabinet in the original packaging material, or equivalent. Also lower the leveling pads to raise the casters off of the pallet and bolt the rack cabinet to the pallet.

(R002)

(L001)



(L002)



(L003)



or



All lasers are certified in the U.S. to conform to the requirements of DHHS 21 CFR Subchapter J for class 1 laser products. Outside the U.S., they are certified to be in compliance with IEC 60825 as a class 1 laser product. Consult the label on each part for laser certification numbers and approval information.

CAUTION:

This product might contain one or more of the following devices: CD-ROM drive, DVD-ROM drive, DVD-RAM drive, or laser module, which are Class 1 laser products. Note the following information:

- Do not remove the covers. Removing the covers of the laser product could result in exposure to hazardous laser radiation. There are no serviceable parts inside the device.
- Use of the controls or adjustments or performance of procedures other than those specified herein might result in hazardous radiation exposure.

(C026)

CAUTION:

Data processing environments can contain equipment transmitting on system links with laser modules that operate at greater than Class 1 power levels. For this reason, never look into the end of an optical fiber cable or open receptacle. (C027)

CAUTION:

This product contains a Class 1M laser. Do not view directly with optical instruments. (C028)

CAUTION:

Some laser products contain an embedded Class 3A or Class 3B laser diode. Note the following information: laser radiation when open. Do not stare into the beam, do not view directly with optical instruments, and avoid direct exposure to the beam. (C030)

CAUTION:

The battery contains lithium. To avoid possible explosion, do not burn or charge the battery.

Do Not:

- ___ Throw or immerse into water
- ___ Heat to more than 100°C (212°F)
- ___ Repair or disassemble

Exchange only with the IBM-approved part. Recycle or discard the battery as instructed by local regulations. In the United States, IBM has a process for the collection of this battery. For information, call 1-800-426-4333. Have the IBM part number for the battery unit available when you call. (C003)

Power and cabling information for NEBS (Network Equipment-Building System) GR-1089-CORE

The following comments apply to the IBM servers that have been designated as conforming to NEBS (Network Equipment-Building System) GR-1089-CORE:

The equipment is suitable for installation in the following:

- Network telecommunications facilities
- Locations where the NEC (National Electrical Code) applies

The intrabuilding ports of this equipment are suitable for connection to intrabuilding or unexposed wiring or cabling only. The intrabuilding ports of this equipment *must not* be metallically connected to the interfaces that connect to the OSP (outside plant) or its wiring. These interfaces are designed for use as intrabuilding interfaces only (Type 2 or Type 4 ports as described in GR-1089-CORE) and require isolation from the exposed OSP cabling. The addition of primary protectors is not sufficient protection to connect these interfaces metallically to OSP wiring.

Note: All Ethernet cables must be shielded and grounded at both ends.

The ac-powered system does not require the use of an external surge protection device (SPD).

The dc-powered system employs an isolated DC return (DC-I) design. The DC battery return terminal *shall not* be connected to the chassis or frame ground.

Racks and rack features

Learn about the procedures used to install racks and rack features.

You can perform these tasks or contact a service provider to perform the tasks for you. You might be charged a fee by the service provider for this service.

What's new in Racks and rack features

Read about new or significantly changed information in Racks and rack features since the previous update of this topic collection.

November 2013

- Removed reference to 7953-94Y racks.

March 2013

Content updates include the following:

- Miscellaneous changes were made to the Installing the PDU or PDU+ in the side of a rack topic.

October 2012

Content updates include the following:

- Added link to information about planning and installing the IBM PureFlex™ System 42U Rack (7953-94X) and the IBM 42U Slim Rack (7953-94Y).

Installing the rack

Use this information to find the planning and installation procedures for the 7014-T00 and 7014-T42 racks and the 7953-94X rack.

7014-T00 and 7014-T42 racks

Use this information to install the 7014-T00 and 7014-T42 racks and to install the related components of the racks system.

Installing the 7014-T00 and 7014-T42 racks

Use this information to install the 7014-T00 and 7014-T42 racks.

If you are installing a rack security kit in this rack, see “Installing the rack security kit” on page 28 after you have installed the rack.

Before installing a rack, read the “Rack safety notices” on page 26.

Completing a parts inventory:

Before beginning the rack installation it is a good idea to do a parts inventory. This section guides you in performing this task.

If you have not done so, complete a parts inventory before installing the unit in the rack:

1. Locate the kitting report in an accessory box.
2. Ensure that you received all of the features that you ordered and all of the parts on the kitting report.

If there are incorrect, missing, or damaged parts, contact:

- Your IBM reseller
- IBM support (see Directory of worldwide contacts website at IBM Directory of worldwide contacts - Country/region for contact information for your country)
- IBM Rochester Manufacturing Automated Information Line at 1-800-300-8751 (United States only)

Positioning the rack:

Proper rack positioning is needed to comply with safety and regulatory requirements. Use the procedure in this section to perform this task.

After the rack has been placed into its location on the floor, lock each caster by tightening the locking screw. See the following illustration for the locking screw location (2). Remove all the tape and packing materials from the rack.

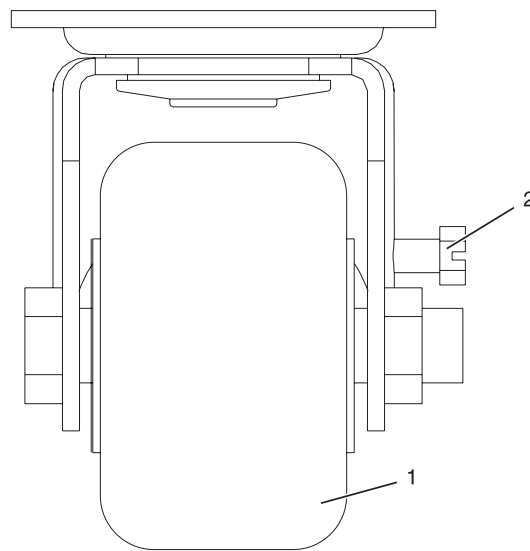

- 1 Caster
- 2 Locking screw

Figure 1. Tightening the locking screw

Use the following to determine the next step:

- To bolt the rack to a concrete floor, go to “Attaching the rack to a concrete floor” on page 4.
- To bolt the rack to a concrete floor beneath a raised floor, go to “Attaching the rack to the concrete floor beneath a raised floor” on page 9.
- To attach the rack to the floor, go to “Leveling the rack.”

Leveling the rack:

If you need to level the rack, use the procedure described in this section.

To level the rack, complete the following steps:

1. Loosen the jam nut on each leveling foot.
2. Rotate each leveling foot downward until it contacts the surface on which the rack is placed.

3. Adjust the leveling feet downward as needed until the rack is level. When the rack is level, tighten the jam nuts against the base.

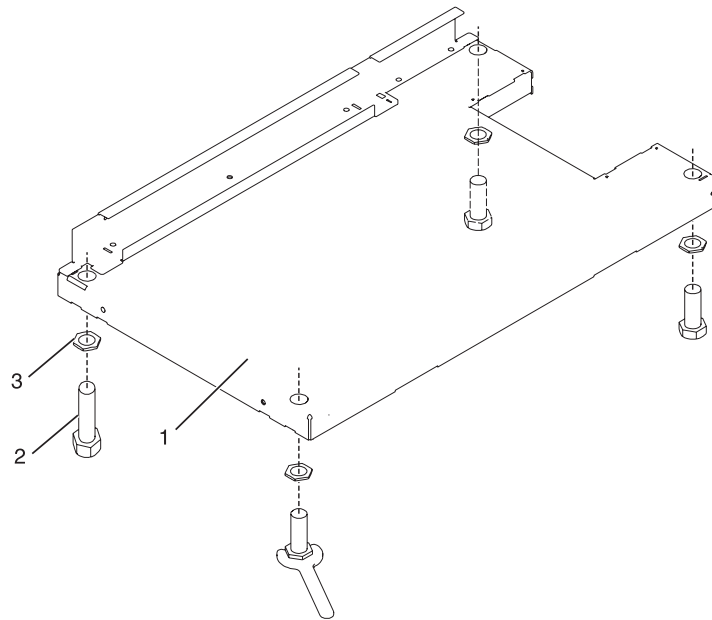

- 1 Rack Front (base)
- 2 Leveling Foot (quantity 4)
- 3 Jam Nut (quantity 4)

Figure 2. Adjusting the leveling feet

Attaching the stabilizer brackets:

You might need to attach the stabilizer brackets to the rack. This section helps you determine whether stabilizer brackets are necessary and describes how to attach them if needed.

If the front or back ac electrical outlets are going to be installed in the rack, you cannot attach the stabilizer brackets. The rack must be bolted to the floor. Stabilizer brackets are used only if you will not be bolting the rack to the floor. If you are going to bolt the rack to the floor, go to “Attaching the rack to a concrete floor” on page 4.

To attach the stabilizer brackets to the bottom of the rack, complete the following steps:

Note: Before installing the stabilizer brackets, see “Attaching the front or back ac electrical outlet” on page 14 for instruction about installing the ac outlet-mounting plates.

1. Align the slots of one of the stabilizer brackets with the mounting holes at the bottom front of the rack.
2. Install the two mounting screws.
3. Ensure that the base of the stabilizer bracket rests firmly on the floor. Use the Allen wrench that was supplied with the rack to tighten the mounting screws alternately until they are tight.

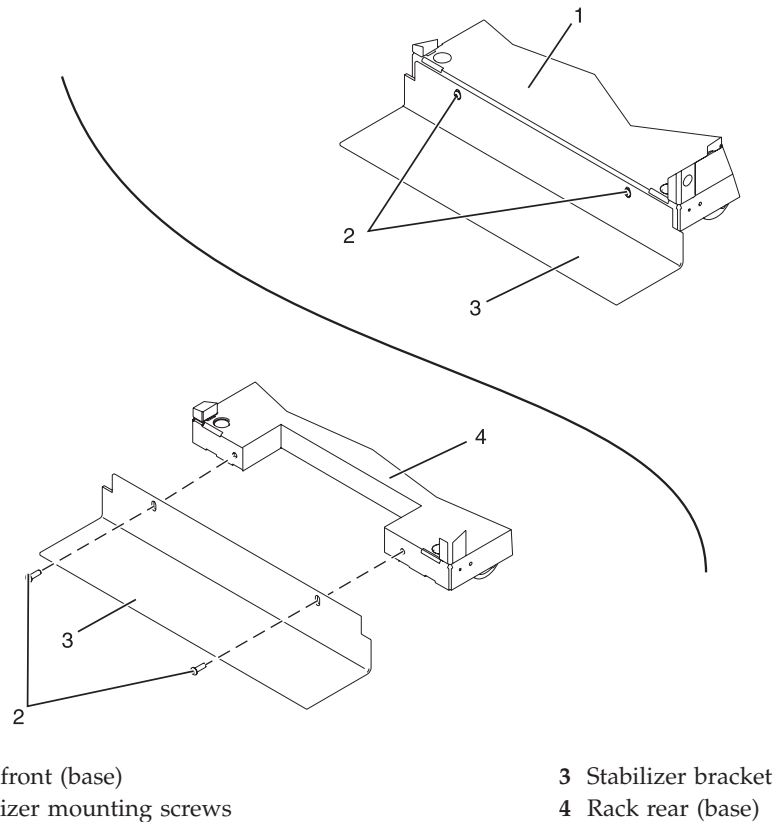

Figure 3. Attaching the stabilizer brackets

- To install the second stabilizer bracket on the back of the rack, repeat steps 1 - 3.

Attaching the rack to a concrete floor:

If you plan to install the front or back ac electrical outlets in the rack, the rack must be bolted to the floor. This section describes how to perform this task for a concrete floor.

Obtain the services of a mechanical contractor to attach the rack-mounting plates to the concrete floor. The mechanical contractor must determine that the hardware being used to secure the rack-mounting plates to the concrete floor is sufficient to meet the requirements for the installation.

To attach the rack to a concrete floor, complete the following step:

- Put the rack in its predetermined location, and tighten the locking screws on the casters.
- If they are installed, remove the top, left, and right trim panels. The trim panels are held in place with spring clips. See the following illustration.

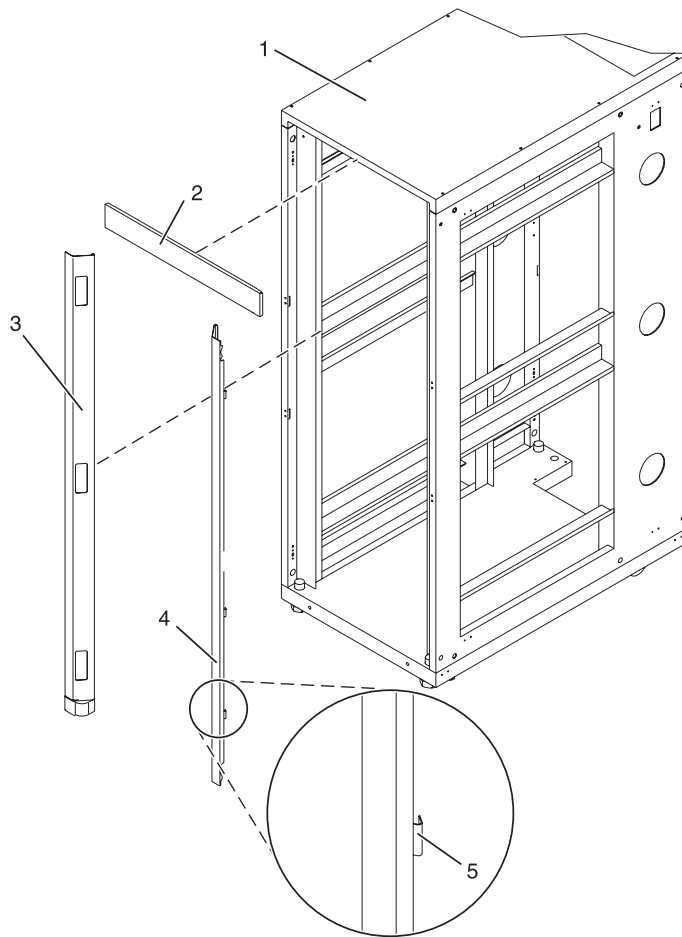

- | | |
|--|--|
| <ul style="list-style-type: none"> 1 Rack chassis 2 Top trim panel 3 Left-side trim panel | <ul style="list-style-type: none"> 4 Right-side trim panel 5 Spring clip |
|--|--|

Figure 4. Removing the trim panels

3. If they are installed, remove the front and rear doors. After the rack doors have been removed, go to the next substep. To remove a rack door, complete the following steps:
 - a. Unlock and open the door.
 - b. Grasp the door firmly with both hands and pull it away from the hinges.
4. Locate the hardware mounting kit and the two mounting plates. Refer to the following illustration when reviewing the contents of the hardware mounting kit. The hardware mounting kit contains the following items:
 - 4 Rack-mounting bolts
 - 4 Thin washers
 - 8 Plastic isolator bushings
 - 4 Thick washers
 - 4 Spacers
5. If you are installing an ac-powered rack, temporarily install the lower plastic isolator bushings to help you locate the mounting locations for the stabilizer bracket. After the stabilizer bracket has been

correctly located, remove the lower plastic isolator bushings.

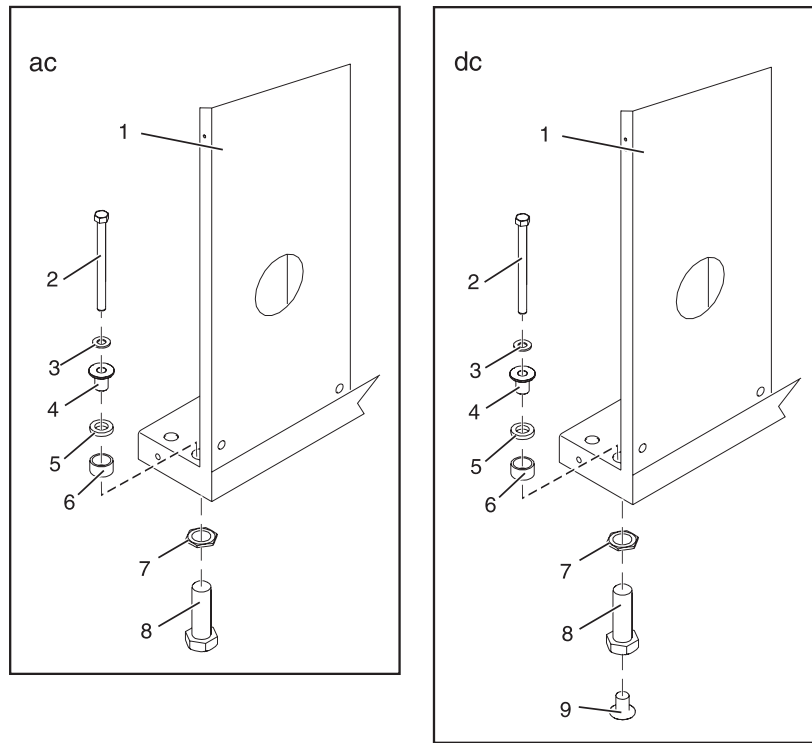
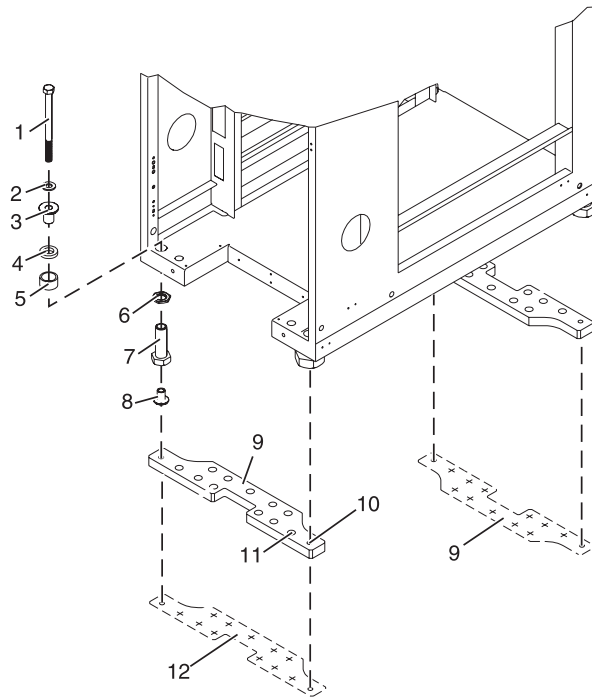

Figure 5. Installing ac-power mounting plates

- | | |
|--------------------------------|--|
| 1 Rack chassis | 7 Jam nut |
| 2 Rack-mounting bolt | 8 Leveling foot |
| 3 Thin washer | 9 Lower plastic isolator bushing (used only on dc powered systems) |
| 4 Top plastic isolator bushing | ac Typical leveling foot installation for an ac-powered rack |
| 5 Thick washer | dc Typical leveling foot installation for a dc-powered rack |
| 6 Spacer | |

6. Position the two mounting plates in the approximate mounting location under the rack.
7. Create a rack-mounting bolt assembly by adding the following items, in the order listed, to each rack-mounting bolt.
 - a. Thin washer
 - b. Top plastic isolator bushing
 - c. Thick flat washer
 - d. Spacer
8. Insert a rack-mounting bolt assembly through each of the leveling feet.
9. Reposition the rack-mounting plates under the four rack-mounting bolts so that the mounting bolts are centered directly over the threaded bolt holes.
10. Turn the rack-mounting bolts four complete turns into the mounting plate's threaded bolt holes.



- | | |
|--------------------------------|--|
| 1 Rack-mounting bolt | 7 Leveling foot |
| 2 Thin washer | 8 Lower plastic isolator bushing (Used only on dc powered systems) |
| 3 Top plastic isolator bushing | 9 Mounting plate |
| 4 Thick washer | 10 Threaded hole (Used to secure the rack to stabilizer bracket.) |
| 5 Spacer | 11 Anchor bolt hole |
| 6 Jam nut | 12 Traced pattern (Pattern to be traced onto the floor using the stabilizer bracket as a template) |

Figure 6. Securing the rack to the floor

11. Mark the floor around the edges of both stabilizer brackets.
12. Mark the plate bolt-down holes that are accessible through the opening in the rear of the rack.
13. Remove the rack-mounting bolt assemblies.
14. If you are installing an ac-powered rack, remove the bottom isolator bushing from each of the leveling feet.
15. Remove the stabilizer brackets from the marked locations.
16. Loosen each of the locking screws on the casters.
17. Move the rack so that it is clear of both areas that were marked on the floor for the stabilizer bracket locations.
18. Reposition the stabilizer brackets within the marked areas.
19. Mark the floor at the center of all holes in both stabilizer brackets.
20. Remove the two rack-mounting plates from the marked areas.
21. At the marked location of the threaded rack-mounting bolt holes, drill four clearance holes into the concrete floor. Each clearance hole should be approximately 1-inch deep. This depth allows the rack-mounting bolts enough room to protrude past the thickness of the stabilizer brackets.

Note: You *must* use a minimum of two anchor bolts for each rack-mounting plate to securely attach the plate to the concrete floor. Because some of the holes in each rack-mounting plate might align with concrete reinforcement rods embedded in the concrete, some of the rack-mounting plate holes might not be usable.

22. Select at least two suitable hole locations for each stabilizer bracket bolt. The selected locations should be as close to the threaded bolt holes as possible. Be sure that the holes selected at the back of the rack are accessible. Drill holes at the selected locations into the concrete floor.
23. Position the stabilizer brackets over the concrete anchors.
24. Securely bolt the front stabilizer bracket to the concrete floor.
25. Position the stabilizer bracket over the concrete anchors.
26. Securely bolt the back stabilizer bracket to the concrete floor.

Note: The size of the anchor bolts and concrete anchors *must* be determined by the mechanical contractor who will be installing the rack-mounting plate.

27. Position the rack over the stabilizer bracket.
28. Insert each of the stabilizer bracket bolts through a flat washer, a plastic isolator bushing and a thick washer, and through a leveling foot.
29. Align the four stabilizer brackets bolts with the four tapped holes in the two mounting plates and turn three to four rotations.
30. Tighten the locking screw on each caster.
31. Adjust the leveling feet downward as needed until the rack is level. When the rack is level, tighten the jam nuts against the base of the rack.

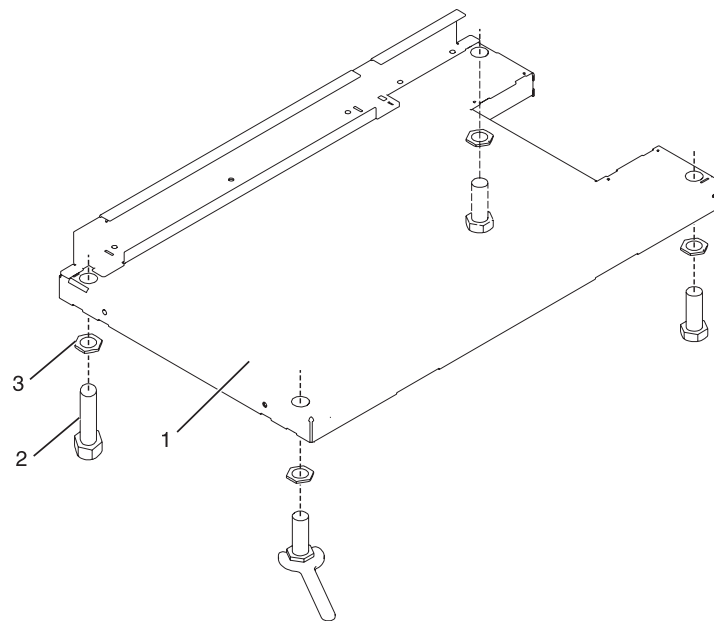

- 1 Rack front (base)
- 2 Leveling foot (quantity 4)
- 3 Jam nut (quantity 4)

Figure 7. Adjusting the leveling feet

32. If you have multiple racks that are connected in a suite (bolted to each other), go to “Connecting multiple racks with rack-to-rack attachment kit” on page 33. Otherwise, torque the four bolts to 54 - 67 newton-meters (40 - 50 foot-pounds).

33. If you are not installing doors on your rack, install the top, left, and right trim panel.
34. Connect the power distribution system as described in “Connecting the power distribution system” on page 13.
35. After all racks are bolted down, go to “Attaching the front or back ac electrical outlet” on page 14.
36. If you are not going to attach a front electrical outlet and you are installing rack doors, go to “Attaching the rack doors” on page 24

Attaching the rack to the concrete floor beneath a raised floor:

If you plan to install front or back ac electrical outlets in the rack, the rack must be bolted to the floor. When you attach the rack to a concrete floor, which lays beneath a raised floor, follow the procedure described in this section.

Obtain the services of a mechanical contractor to attach the rack-mounting plates to the concrete floor. The mechanical contractor needs to determine that the hardware being used to secure the rack-mounting plates to the concrete floor is sufficient to meet the requirements for the installation.

To attach the rack to a concrete floor beneath a raised floor, complete the following steps:

1. Put your rack in its predetermined location and tighten the locking screws on the casters.
2. If installed, remove the top, left and right trim panels. The trim panels are held in place with spring clips. See the following illustration.

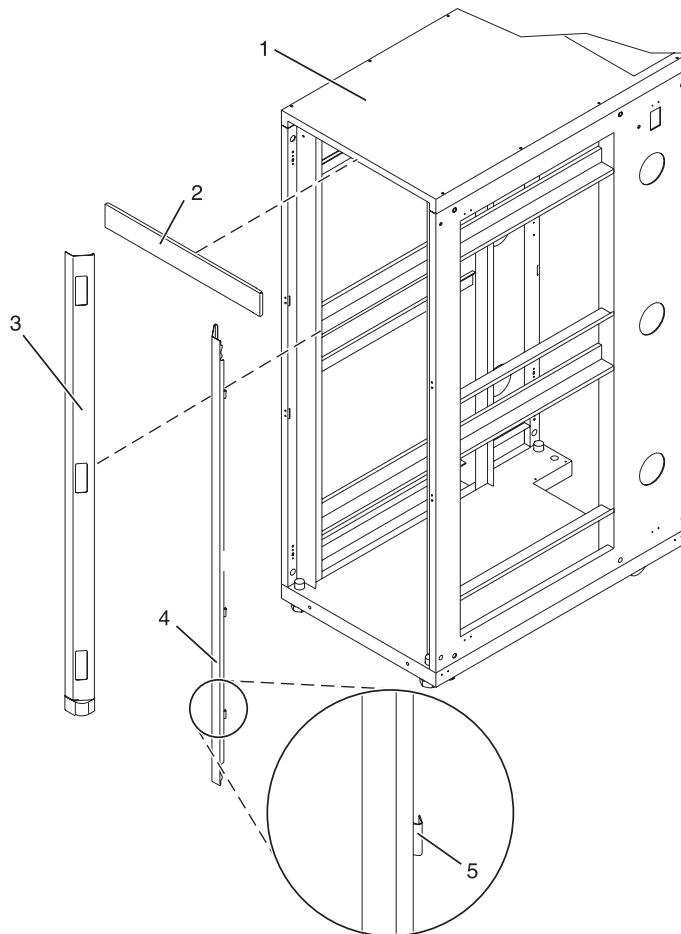

1 Rack chassis
2 Top trim panel

4 Right-side trim panel
5 Spring clip

3 Left-side trim panel

Figure 8. Removing the trim panels

3. If installed, remove the front and rear doors. For instructions, see “Attaching the rack doors” on page 24. After the rack doors have been removed, go to the next step.
4. Locate the hardware mounting kit and the two mounting plates. Refer to the following illustration when reviewing the contents of the hardware mounting kit. The hardware mounting kit contains the following items:
 - Four rack-mounting bolts
 - Four thin washers
 - Eight plastic isolator bushings
 - Four thick washers
 - Four spacers
5. If you are installing an ac-powered rack, temporarily install the lower plastic isolator bushings to help you locate the rack-mounting plate. After the mounting plate has been correctly located, remove the lower plastic isolator bushings.

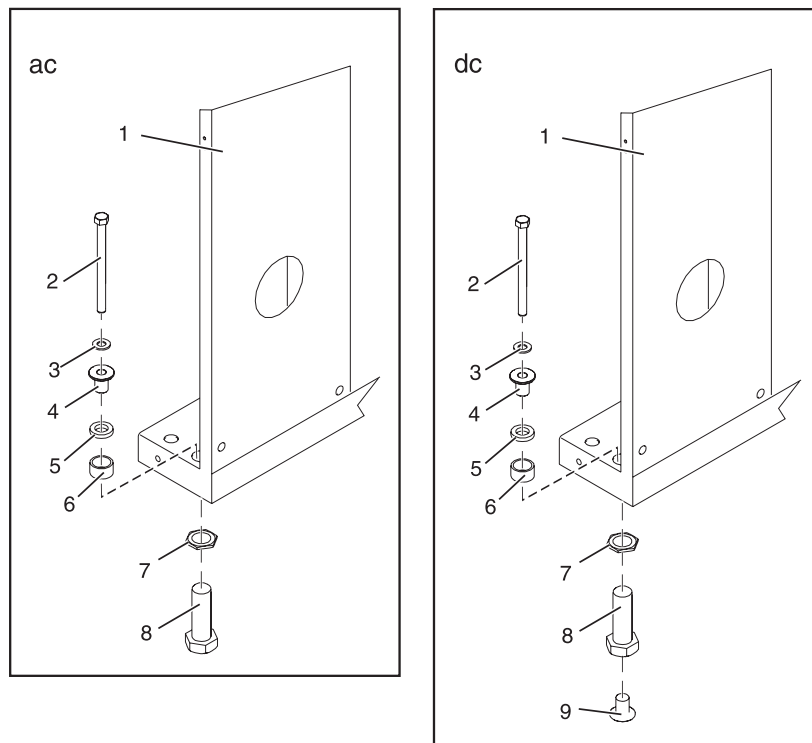

Figure 9. Installing the ac power-mounting plates

- 1 Rack chassis
- 2 Rack-mounting bolt
- 3 Thin washer
- 4 Top plastic isolator bushing
- 5 Thick washer

- 7 Jam nut
- 8 Leveling foot
- 9 Lower plastic isolator bushing (used only on dc powered systems)
- ac Typical leveling foot installation for an ac-powered rack
- dc Typical leveling foot installation for a dc-powered rack

6 Spacer

6. Position the two mounting plates in the approximate mounting location under the rack.
7. Create a rack-mounting bolt assembly by adding the following items, in the order listed, to each rack-mounting bolt.
 - a. Thin washer
 - b. Top plastic isolator bushing
 - c. Thick flat washer
 - d. Spacer
8. Insert a rack-mounting bolt assembly through each of the leveling feet.
9. Reposition the rack-mounting plates under the four rack-mounting bolts so that the mounting bolts are centered directly over the threaded bolt holes.
10. Turn the rack-mounting bolts four complete turns into the mounting plate's threaded bolt holes.
11. Mark the raised-floor panel around the edges of front and rear rack-mounting plates.
12. Mark the plate bolt-down holes that are accessible through the opening in the rear of the rack.
13. Remove the rack-mounting bolt assemblies.
14. If you are installing an ac-powered rack, remove the bottom isolator bushing from each of the leveling feet.
15. Remove the rack-mounting plates from the marked locations.
16. Loosen each of the locking screws on the casters.
17. Move the rack so that it is clear of both areas that were marked on the floor for the rack-mounting plate locations.
18. Reposition the mounting plates within the marked areas.
19. Mark the raised-floor panel at the center of each hole in the rack-mounting plates (including the tapped holes).
20. Remove the two rack-mounting plates from the marked locations on the raised floor panel.
21. Drill two clearance holes on each end of each rack-mounting plate. The drilled holes should be approximately 1-inch deep. This depth will accommodate any rack-mounting bolt extending past the rack-mounting plate when securing the rack to the rack-mounting plate.
22. For each rack-mounting plate, select at least two suitable hole locations. Select the hole locations as close to the threaded hole areas as possible. Be sure the hole locations selected at the back of the rack are accessible.
23. Drill pass-through holes in the raised-floor panel. The pass-through holes allow the anchor bolts to be inserted into the rack-mounting plate and pass through the raised floor panel to the concrete floor.

Note: You *must* use a minimum of two anchor bolts for each rack-mounting plate to securely attach the rack-mounting plate through the raised-floor panel to the concrete floor. Because some of the holes in each rack-mounting plate may align with concrete reinforcement rods imbedded in the concrete, some of the rack-mounting plate holes might not be usable.

24. Transfer the locations of the anchor bolt holes (exclude the clearance holes drilled for the rack-mounting bolts) from the raised-floor panel to the concrete floor directly beneath, and mark the hole locations on the concrete floor.
25. Drill holes in the concrete floor to secure the anchor bolts.
26. Position the raised-floor panel back into position over the anchor bolt holes.
27. Position the front stabilizer bracket within the marked area on the raised-floor panel.
28. Using your anchor bolts, secure the front stabilizer brackets on top of the raised floor and through to the concrete floor.
29. Position the rear stabilizer brackets within the marked area on the raised-floor panel.

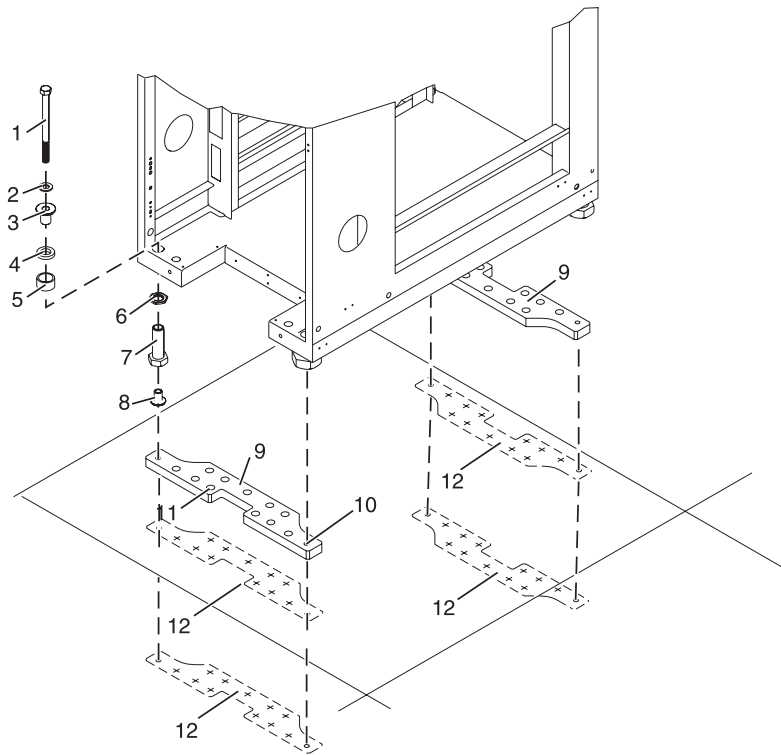

- | | |
|--------------------------------|--|
| 1 Rack-mounting bolt | 7 Leveling foot |
| 2 Thin washer | 8 Lower plastic isolator bushing (used only on dc-powered systems) |
| 3 Top plastic isolator bushing | 9 Stabilizer brackets |
| 4 Thick washer | 10 Threaded hole (used to secure the rack to mounting plate.) |
| 5 Spacer | 11 Anchor bolt hole |
| 6 Jam nut | 12 Traced pattern (pattern to be traced onto the floor using the mounting plate as a template) |

Figure 10. Securing the rack to the floor

30. Using your anchor bolts, secure the back stabilizer bracket on top of the raised floor and through to the concrete floor.
31. Replace all raised-floor panels that may have been removed when aligning and securing the anchor bolts to the concrete floor.
32. Align the rack over the front and rear stabilizer brackets.
33. Insert each of the bolt assemblies through a leveling foot.
34. Align the rack-mounting bolts with the threaded holes in each stabilizer bracket. Turn each bolt three to four rotations.
35. Tighten the locking screw on each caster.
36. Adjust the leveling feet downward as needed until the rack is level. When the rack is level, tighten the jam nuts against the base of the rack.
37. If you have multiple racks that are connected as a suite (bolted to each other), go to “Connecting multiple racks with rack-to-rack attachment kit” on page 33. Otherwise, torque the four bolts to 54 - 67 newton-meters (40 - 50 foot-pounds).
38. If you are not installing doors on your rack, install the top, left, and right trim panel.

39. Connect the power distribution system. For instructions, see “Connecting the power distribution system.”
40. After the rack is bolted down and you are going to attach a front electrical outlet, go to “Attaching the front or back ac electrical outlet” on page 14.
41. If you are not going to attach a front electrical outlet and you are installing rack doors, go to “Attaching the rack doors” on page 24.

Connecting the power distribution system:

You can use a power distribution system to monitor the individual power loads of the devices that are plugged into it. Use the procedure in this section to connect this system.

To connect a power distribution unit, see “Power distribution unit” on page 39.

Checking the ac outlets:

To help ensure safety and reliable operation, you should check the ac outlets. Use the procedure in this section to perform this task.

Before you begin, ensure that you have a multimeter to check voltages and an appropriately approved ground-impedance tester to test the grounding resistances.

Note: Use only an appropriately approved ground-impedance tester to test the grounding resistances. Do not use a multimeter to measure grounding resistance.

Before plugging the rack into the ac power source, complete the following checks on the ac power source:

1. Turn off the branch circuit breaker for the ac power outlet that the rack will plug into. To the circuit breaker switch, attach tag S229-0237, which reads Do Not Operate.

Note: All measurements are made with the receptacle faceplate in the usual installed position.

2. Some receptacles are enclosed in metal housings. For this type of receptacle, complete the following steps:
 - a. Using a multimeter, check for less than 1 volt from the receptacle case to any grounded metal structure in the building, such as a raised-floor metal structure, water pipe, building steel, or similar structure.
 - b. Using a multimeter, check for less than 1 volt from the receptacle ground pin to a grounded point in the building.

Note: If the receptacle case or faceplate is painted, be sure the probe tip penetrates the paint and makes good electrical contact with the metal.

- c. Using a multimeter, check the resistance from the receptacle ground pin to the receptacle case. Check resistance from the ground pin to the building ground. The readings should be less than 1.0 ohm, which indicates the presence of a continuous grounding conductor.
3. If any of the checks made in step 2 are not correct, remove the power from the branch circuit and make the wiring corrections. Recheck the receptacle after the wiring is corrected.
4. Using a ground-impedance tester, check for infinite resistance between the ground pin of the receptacle and each of the phase pins. This is a check for a wiring short to ground or a wiring reversal.
5. Using a ground-impedance tester, check for infinite resistance between the phase pins. This is a check for a wiring short.
6. Turn on the branch circuit breaker.
7. Using a multimeter, measure for the appropriate voltages between phases. If no voltage is present on the receptacle case or grounded pin, the receptacle is safe to touch.

8. Using a multimeter, verify that the voltage at the ac outlet is correct.

Attaching the front or back ac electrical outlet:

If you need to attach an ac outlet, you can use the procedure in this section to perform this task.

Attention: The front and rear ac outlet-mounting plates mount through the same mounting holes in that secure the stabilizer brackets to the rack chassis. Therefore, if the rack must be bolted to the floor, the stabilizer brackets must be removed.

Install the ac outlet-mounting plates only after the rack has been bolted to the floor and the stabilizer brackets have been removed.

The following items are installed at the customer's site:

- The ac outlet-mounting plates for installing customer-supplied ac electrical outlets on the front or rear of the rack. The ac outlet-mounting plate provides the mounting location for an ac electrical outlet.
- The brass ground lug for an electrostatic discharge (ESD) connection.

Note: The customer is responsible for providing both the outlets and the power cables that attach to the power source. The customer is also responsible for connecting the ac outlet correctly. These items are not field-replaceable units (FRUs).

Installing the ac outlet-mounting plates with ac outlets:

If you choose to install ac mounting plates, you can follow the procedure detailed in this section to perform this task. This section also includes illustrations of the related hardware components and shows how these components relate to each other.

If you do not want ac outlets installed on the rack, go to “Installing the ac outlet-mounting plate without ac outlets” on page 17.

If you want ac outlets installed on the front or rear ac outlet-mounting plate, complete the following steps:

1. Determine the number of ac outlets that you are installing.
2. Confirm with your contractor that the number and location of ac outlets to be installed are correct.
3. Remove the blank filler plates from the ac outlet-mounting plates for the number of ac outlets being installed.
4. Install the ac outlets on the ac outlet-mounting plate.
5. Install the ground lug in the ac outlet-mounting plate using only one nut, as shown in the following illustration.
6. Securely tighten the one nut on the ground lug.
7. Locate the Y-shaped ground cable supplied with the mounting plate.

Note: The remaining steps can be used to install ac outlets on the front or the rear of the rack.

8. Place the star washer onto the ground lug of the front ac outlet-mounting plate.
9. Place the lug on the long end of the ground cable onto the ground lug.
10. Place a ground lug nut onto the ground lug and securely tighten it.
11. Position the front ac outlet-mounting plate onto the rack frame with the ground lug fully inserted through the mounting holes in the rack.
12. Route the cable under the rack.
13. Place the star washer onto the ground lug of the rear ac outlet-mounting plate.
14. Place the lug on the short end of the ground cable onto the ground lug.

15. Place a ground lug nut onto the ground lug and securely tighten it.

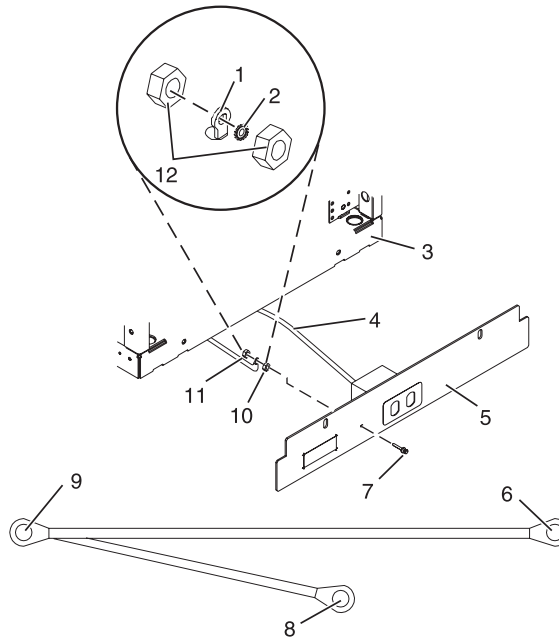

- | | |
|-------------------------------------|--|
| 1 Ground cable lug | 7 Ground lug |
| 2 Star washer | 8 Ground connector (short end of ground cable) |
| 3 Front of rack | 9 "Y" end of ground cable |
| 4 Power cable from the power source | 10 Ground lug nut (quantity 2) |
| 5 Mounting plate | 11 Long end of ground cable |
| 6 Long end of ground cable | 12 Ground lug nut (quantity 2) |

Figure 11. Installing the ground lug

16. Position the rear ac outlet-mounting plate onto the rack frame with the ground lug fully inserted through the mounting holes in the rack.
17. Install the front ac outlet-mounting plate screws (stabilizer mounting screws) into the mounting plate and through the mounting holes in the rack. Securely tighten the screws.

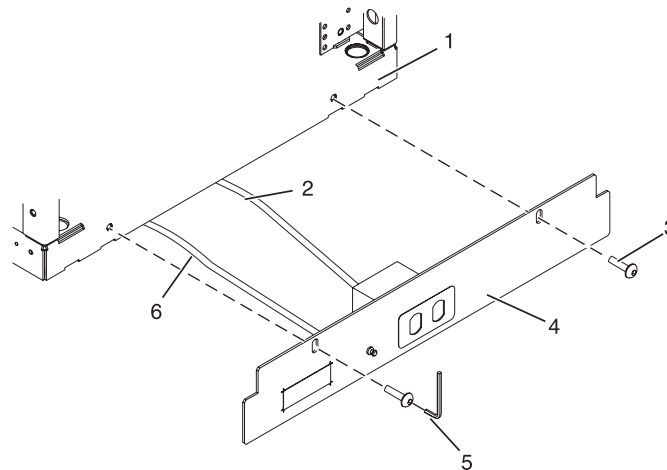

- | | |
|---|------------------|
| 1 Front or rear of rack (as applicable) | 4 Mounting plate |
|---|------------------|

- 2 Power cable from power source
- 3 Button-head screw

- 5 Allen wrench
- 6 Long end of ground cable

Figure 12. Installing the front mounting plate

- 18. Connect the Y-shaped end of the ground cable to the rack frame, either near the center in the back of the rack or to the ground bus bar at the rear of the rack.
- 19. Install the rear ac outlet-mounting plate screws (stabilizer mounting screws) into the mounting plate and through the mounting holes in the rack. Securely tighten the screws.

Note: The bus bar might be located at either the top or bottom of the rack.

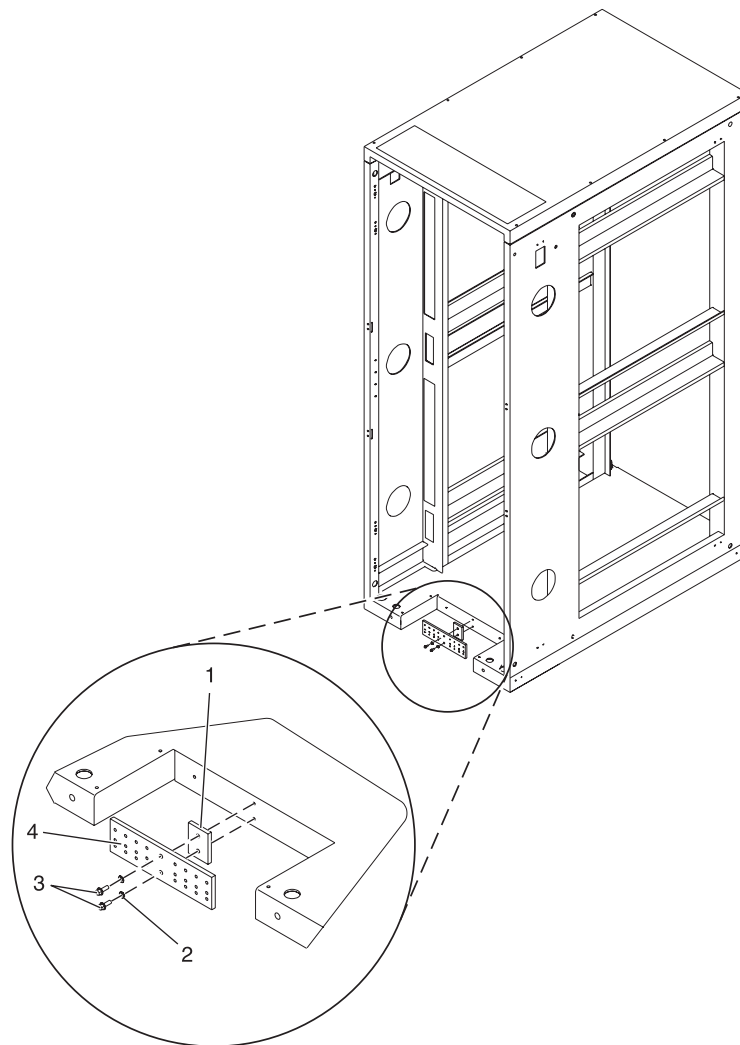

- 1 Bus bar mounting plate
- 2 Lock washer (quantity 2)

- 3 Hex screws (M5 x 20) (quantity 2)
- 4 Ground bus bar

Figure 13. Installing the back mounting plate

Installing the ac outlet-mounting plate without ac outlets:

If you choose to install an outlet plate without the outlets, use the procedure in this section to perform this task.

If you do not want any ac outlets installed on the front or rear ac outlet-mounting plate, perform only “Attaching the rack to the concrete floor beneath a raised floor” on page 9 through “Connecting the power distribution system” on page 13.

For instructions to install front or rear ac outlet-mounting plates, see “Installing the ac outlet-mounting plates with ac outlets” on page 14.

Connecting a dc power source:

Some rack models (such as the 7014-T00) can support a dc power configuration for systems that require dc power. If you decide to connect a dc power source to the rack, you can use the procedure in this section to perform this task. This section also includes illustrations of the related hardware components and shows how these components relate to each other.

Note: The customer is responsible for providing and connecting the -48 V dc power source and -48 V dc power return cables from the customer's source -48 V dc to the bus bars in the power distribution panel. The customer is also responsible for connecting the ground cable to the rack frame. This procedure provides information about accessing the power distribution panel.

1. Remove the six mounting screws from the top cover of the dc power distribution panel and remove the top cover.
2. If they are installed, remove the four screws from the cable channel cover.
3. Remove the cable channel cover.

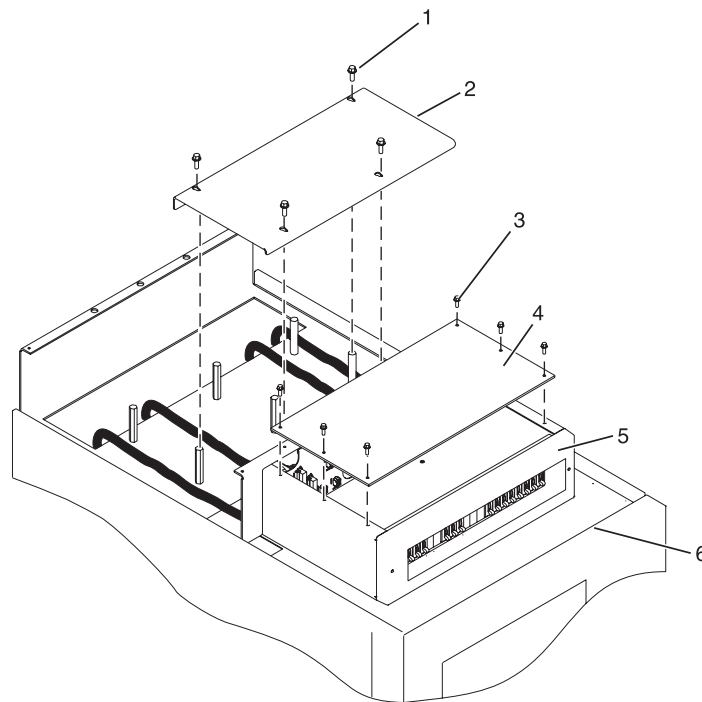

- | | |
|---|----------------------------|
| 1 Cable channel cover retaining screw | 5 Shield |
| 2 Cable channel cover | 6 Power distribution panel |
| 3 Power distribution panel top cover retaining screws | |

4 Power distribution panel top cover

Figure 14. Removing the cable channel cover

4. Remove the -48 V dc bus bar shield from the power distribution panel.
Attention: The bus bar shield must be correctly reinstalled over the -48 V dc return bus bars to protect against injury while servicing the power distribution panel.

5. Ensure that the following steps are performed when connecting the dc power source.
 - a. At -48 V dc power source, turn off any -48 V dc power sources that will be connected to the power distribution panel.
 - b. After the -48 V dc power sources are turned off, be sure there is a tag or label over the power source switches or fuses (lock-out/tag-out) to indicate that the power source is turned off intentionally.

Note: Ensure that any oxidation on the copper bus bars is removed.

- c. If this is a raised-floor installation and you are working at the back of the rack, route the power cables up the rack's right side.
- d. Ensure that the external -48 V dc power cable is connected correctly to the -48 V dc bus bar.
- e. Ensure that the external -48 V dc return cable is routed correctly and installed on the return bus bar.

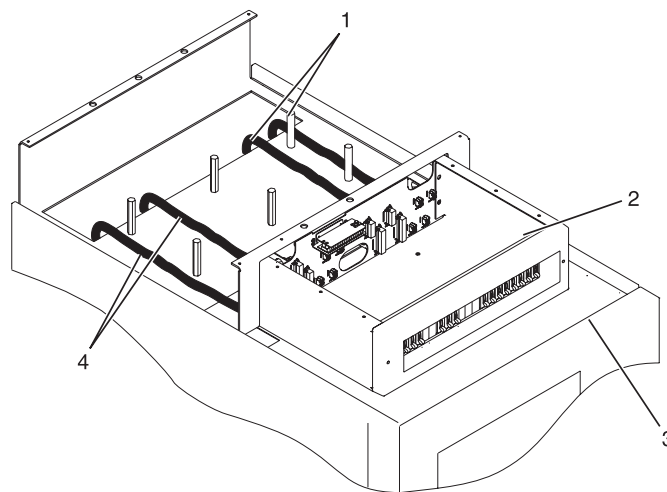

- 1 -48 V dc power cable and return power cable
- 2 Power distribution panel
- 3 Front of rack
- 4 -48 V dc power cable and return power cable

Figure 15. Routing the power cables

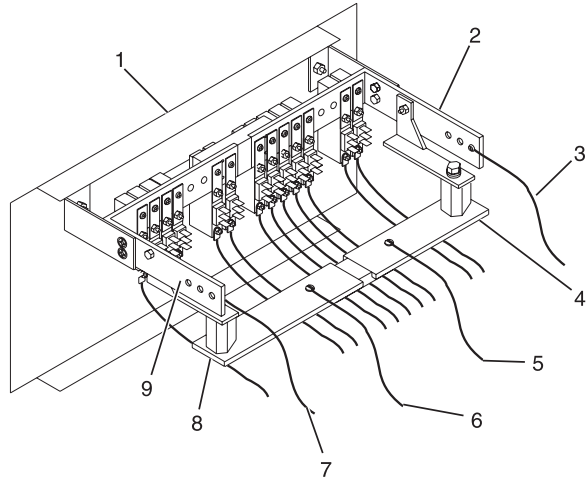

- | | |
|-------------------------------------|--------------------------------|
| 1 Front of power distribution panel | 6 (B) Return (-) power cable |
| 2 (A) -48 V dc (-) bus bar | 7 (B) -48 V dc (-) power cable |
| 3 (A) -48 V dc (-) power cable | 8 (B) Return (-) bus bar |
| 4 (A) Return (-) bus bar | 9 (B) -48 V dc (-) bus bar |
| 5 (A) Return (-) power cable | |

Figure 16. Return bus bar

- f. If you want to install a power status alarm, connect the alarm cable to the terminal board on the back cover of the dc power distribution panel.

Note: Ensure that you remove the oxidation on the copper bus bars.

- g. Ensure that the power-source ground cable is routed correctly and connects the power-source ground cable to the copper bar at the lower-back or upper-back center of the rack.
- h. If the rack is on a raised floor, attach the -48 V dc power source cables to the rear of the rack with cable-restraint straps.

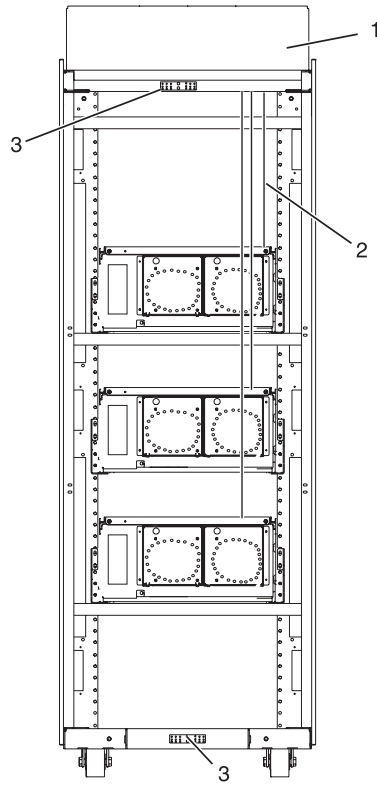

- 1 Rear view of rack (dc)
- 2 Power cable, power return cable, and ground
- 3 Ground cable (Install at either top or bottom of the rack)

Figure 17. Cable locations

- 6. Reinstall the -48 V dc bus bar shield.
- 7. Reinstall the top cover on the dc power distribution panel.
- 8. Reinstall the cable channel cover.

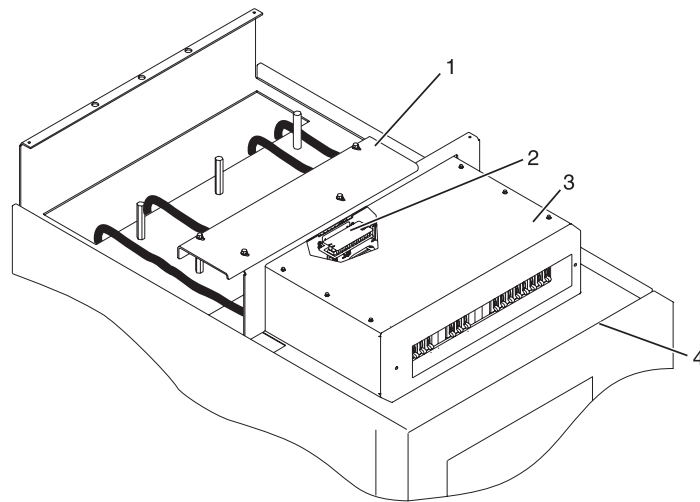

- 1 Cable channel cover

- 2 Terminal block (both sides)
- 3 Power distribution panel
- 4 Front of rack

Figure 18. Reinstalling the cable channel cover

Removing and replacing 7014-T00 or 7014-T42 side panels

Learn how to remove and replace a side panel on a rack. Use the procedures in this section to perform this task.

Removing a 7014-T00 or 7014-T42 side panel:

Use the procedure in this section to remove a side panel on a rack.

To remove a side panel, complete the following steps:

1. Unlock the side panels by pressing down on both locking latches to release the latches.

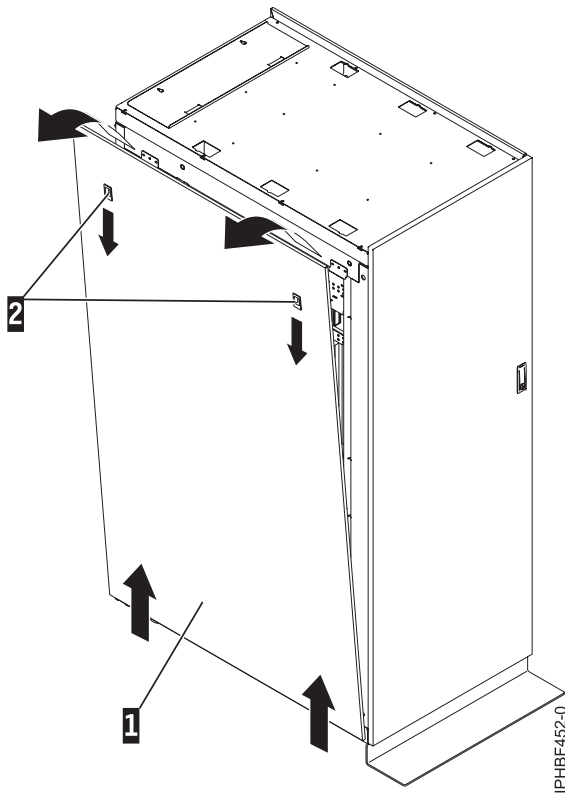

Figure 19. Removing the side panel

Note: If your rack uses a ruggedized kit, you must remove the securing screw to allow each side panel to be removed. See “Releasing the side panel with a ruggedized kit” on page 32.

2. Tilt the top of the side panel slightly toward you.
3. Lift the side panel away from the ridge on the bottom of the rack.
4. Repeat this procedure for the other side panel.

Replacing a 7014-T00 or 7014-T42 side panel:

Use the procedure in this section to replace a side panel on a rack.

To replace a side panel, complete the following steps:

1. Tilt the top of the side panel slightly toward you.
2. Place the bottom of the side panel onto the ridge on the bottom of the rack.

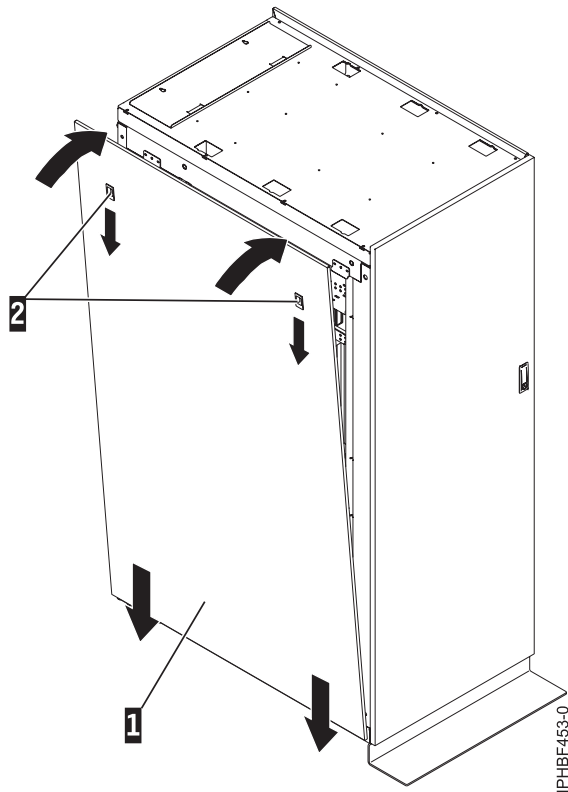

Figure 20. Replacing the side panel

3. Slide the top of the side panel into place and close the locking latches.

Note: If your rack uses ruggedized kit, you must install a securing screw into each side panel that was installed. See “Ruggedized kit” on page 30.

Removing and replacing 7014-T00 or 7014-T42 trim panels

Racks that are installed with multiple processor drawer systems can use front trim panels instead of doors. For racks that use trim panels, a reduced-interference panel type must be installed when certain expansion unit models are present. Use the procedures in this section to remove the existing trim panels from the rack and replace them with the reduced-interference panel type.

Removing the 7014-T00 or 7014-T42 trim panels:

For racks that use trim panels instead of doors, a reduced-interference panel type must be installed when certain expansion unit models are present. Use the procedure in this section to remove the trim panels.

To remove the existing rack trim panels, complete the following steps:

1. Place both hands on the center of the right side trim panel.

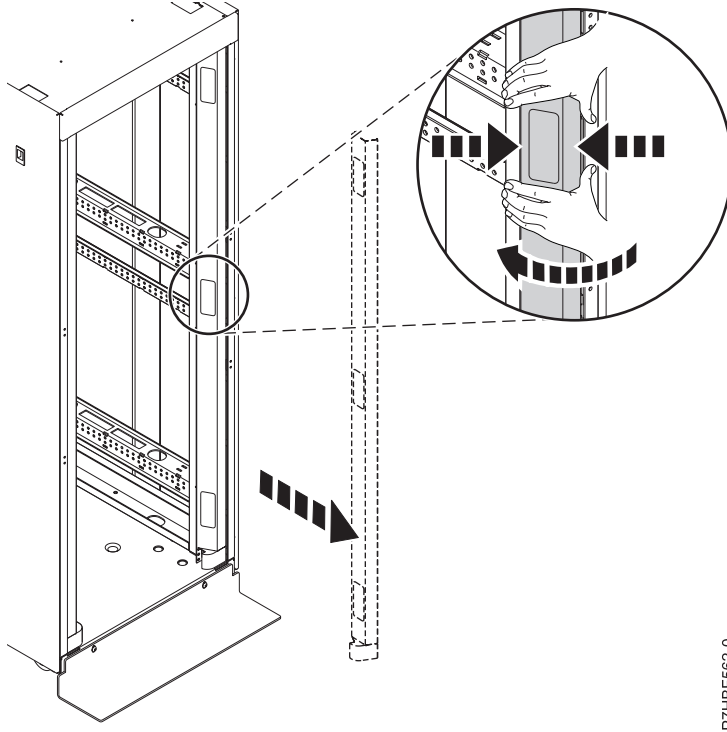

P7HBF562-0

Figure 21. Removing the rack trim panel

2. Squeeze inward firmly with your fingertips to release the spring clips that hold the panel in place.
3. Rotate your hands in slightly until the panel is disengaged.
4. Lift the panel out and set it aside.
5. Repeat this procedure to remove the left side trim panel.

Replacing the 7014-T00 or 7014-T42 trim panels:

For racks that use trim panels instead of doors, a reduced-interference panel type must be installed when certain expansion unit models are present. Use the procedure in this section to replace the trim panels.

To install the trim panels, complete the following steps:

1. Align the bottom plate (A) of the right side trim panel to the bottom of the rack.

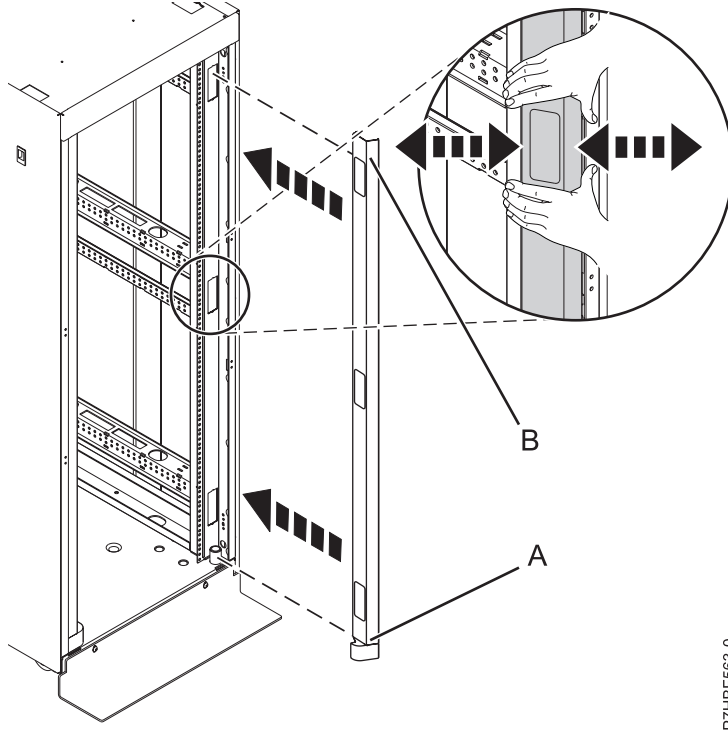

P7HBF563-0

Figure 22. Installing the rack trim panel

2. Align the top of the trim panel (B) and squeeze slightly with your fingertips.
3. After the trim panel is in the correct location, release the pressure to allow the spring clips to hold the panel in place.
4. Repeat this procedure to install the left side trim panel.

Attaching the rack doors

Learn how to attach the rack doors. Use this procedure to perform this task.

Depending on the model of the rack, the front door of a rack might be an optional feature. If your system already has the front door installed, or does not have a front door to install, skip this step.

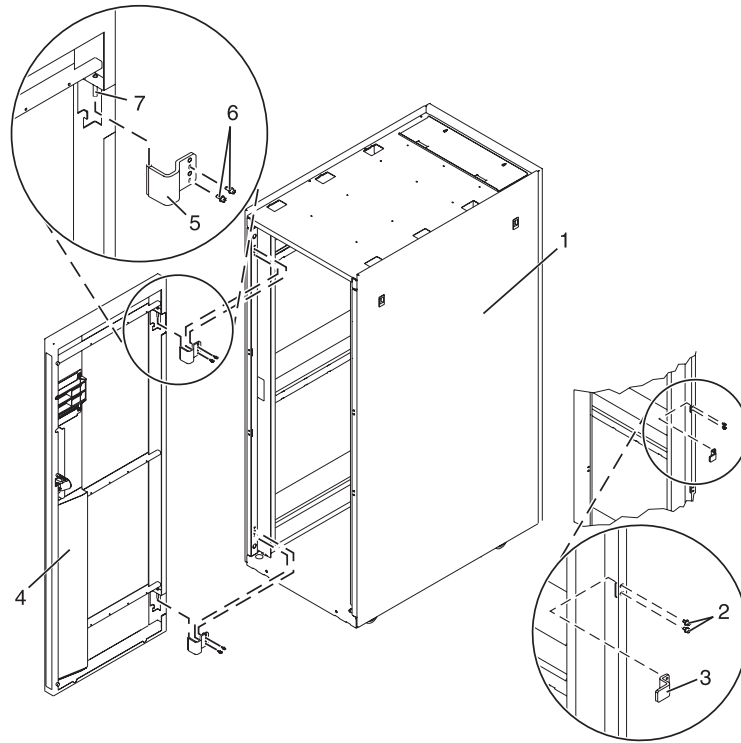

Figure 23. Attaching the rack door

Attaching a high-perforation front door:

You might need to attach a front door to the rack. Use the procedure in this section to perform this task.

To install the high-perforation front door, complete the following steps:

1. Read the “Rack safety notices” on page 26.
2. Remove the top, left, and right trim panels. For details about removing the left and right trim panels from a 7014-T00 or 7014-T42 rack, see “Removing and replacing 7014-T00 or 7014-T42 trim panels” on page 22.

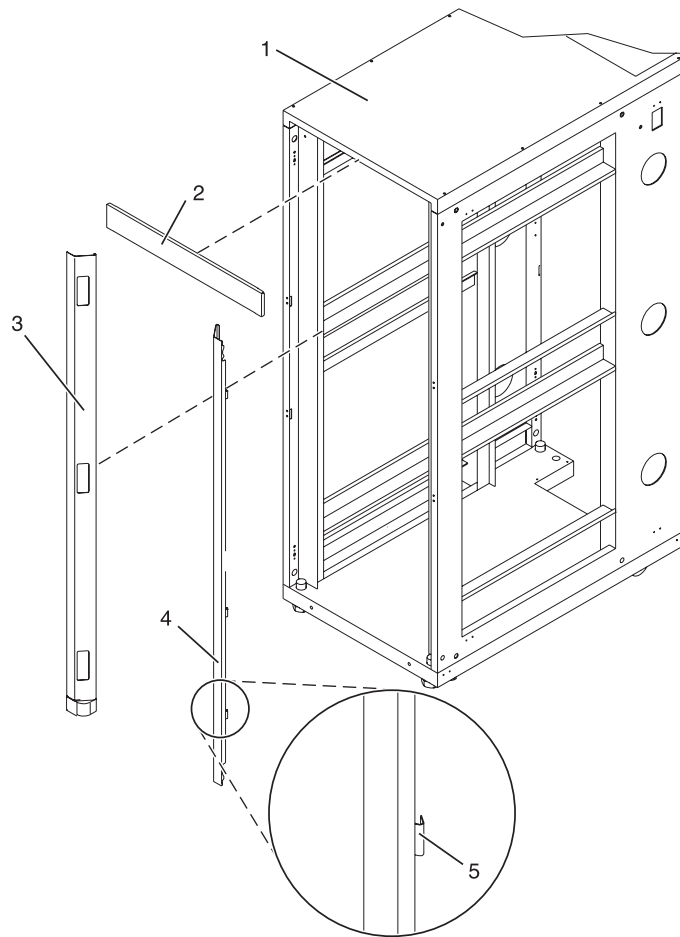

Figure 24. Removing the trim panels

- | | |
|------------------------|-------------------------|
| 1 Rack chassis | 4 Right-side trim panel |
| 2 Top trim panel | 5 Spring clip |
| 3 Left-side trim panel | |

3. Install the door latch on the right and the door hinges on the left.
4. For a high-perforation front door, align the door over the rack hinge, then move up the hinge pin on the door, and lower the hinge pin into the hinge.
5. Adjust the latch so the door latches securely.

Rack safety notices:

You need to read the rack safety notices before installing equipment.

Before installing a rack, rack features, or a system or expansion unit into a rack, read the following safety information.

Attention: If you are installing equipment into a non-IBM rack, the rack must comply with the Electronics Industries Association (EIA) 310D specifications. If you do not have a rail kit designed for the equipment in the non-IBM rack, do not install the equipment into the rack as damage to the equipment or personal injury could occur.

DANGER

Observe the following precautions when working on or around your IT rack system:

- Heavy equipment—personal injury or equipment damage might result if mishandled.
- Always lower the leveling pads on the rack cabinet.
- Always install stabilizer brackets on the rack cabinet.
- To avoid hazardous conditions due to uneven mechanical loading, always install the heaviest devices in the bottom of the rack cabinet. Always install servers and optional devices starting from the bottom of the rack cabinet.
- Rack-mounted devices are not to be used as shelves or work spaces. Do not place objects on top of rack-mounted devices.



- Each rack cabinet might have more than one power cord. Be sure to disconnect all power cords in the rack cabinet when directed to disconnect power during servicing.
- Connect all devices installed in a rack cabinet to power devices installed in the same rack cabinet. Do not plug a power cord from a device installed in one rack cabinet into a power device installed in a different rack cabinet.
- An electrical outlet that is not correctly wired could place hazardous voltage on the metal parts of the system or the devices that attach to the system. It is the responsibility of the customer to ensure that the outlet is correctly wired and grounded to prevent an electrical shock.

CAUTION

- Do not install a unit in a rack where the internal rack ambient temperatures will exceed the manufacturer's recommended ambient temperature for all your rack-mounted devices.
- Do not install a unit in a rack where the air flow is compromised. Ensure that air flow is not blocked or reduced on any side, front, or back of a unit used for air flow through the unit.
- Consideration should be given to the connection of the equipment to the supply circuit so that overloading of the circuits does not compromise the supply wiring or overcurrent protection. To provide the correct power connection to a rack, refer to the rating labels located on the equipment in the rack to determine the total power requirement of the supply circuit.
- *(For sliding drawers.)* Do not pull out or install any drawer or feature if the rack stabilizer brackets are not attached to the rack. Do not pull out more than one drawer at a time. The rack might become unstable if you pull out more than one drawer at a time.
- *(For fixed drawers.)* This drawer is a fixed drawer and must not be moved for servicing unless specified by the manufacturer. Attempting to move the drawer partially or completely out of the rack might cause the rack to become unstable or cause the drawer to fall out of the rack.

(R001)

Lift precautions:



18-32 kg (39.7-70.5 lbs)



32-55 kg (70.5-121.2 lbs)



≥55 kg (≥121.2 lbs)

IPHBF443-0

Installing the rack security kit

You might need to install the rack security kit. Use the procedure in this section to perform this task. This section also includes illustrations of the related hardware components and shows how these components relate to each other.

To install a rack security kit (feature 6580) that consists of the security lock and security slide bars, complete the following steps:

1. Read the “Rack safety notices” on page 26.
2. Verify the inventory in the rack security kit.

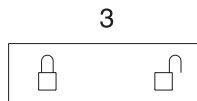
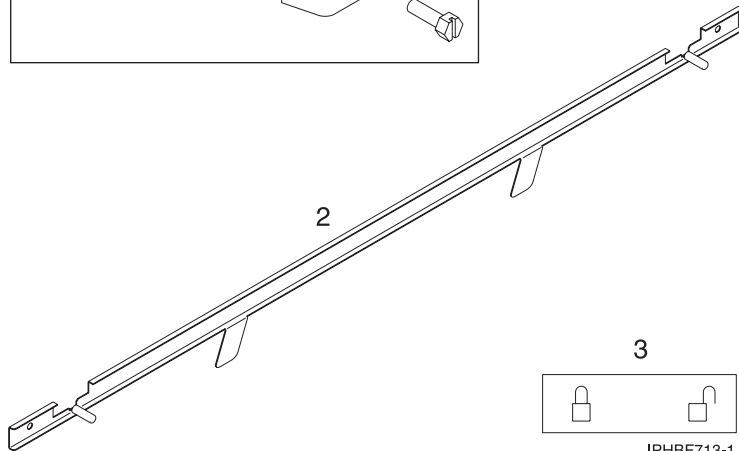
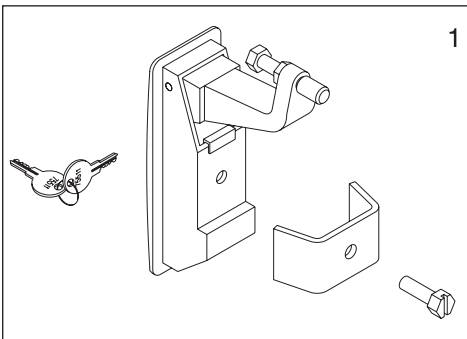

IPHBF713-1

- 1** Two lock hardware kits. Each kit contains:
 - Rack lock
 - Bracket
 - Screw
 - Two keys
- 2** Two security slide bars

3 Two locked/unlocked stickers

Figure 25. Rack security kit inventory

3. Remove the existing door latch.
 - a. Open the front rack door.
 - b. On the inside of the door, remove the screw (4) in Figure 26 that secures the lock to the rack door.

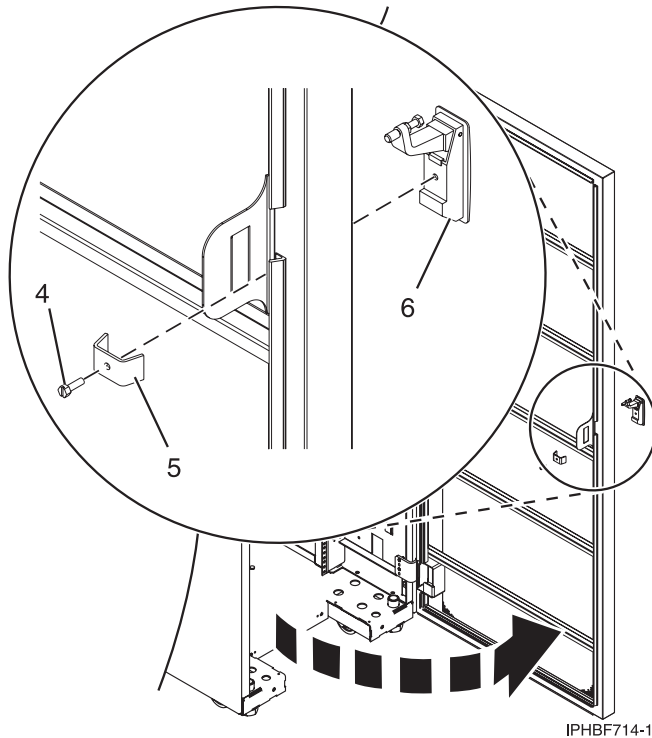

Figure 26. Removing the existing door latch

- c. Remove the bracket (5).
 - d. From the outside of the door, remove the door latch (6).
4. Install the locking latch.
 - a. Insert the keyed rack lock into the latch slot on the front of the door (6) in Figure 26.
 - b. Secure the lock by attaching the lock bracket (5) with the screw (4), on the inside of the door.
5. Repeat steps 3 and 4 to install the second lock on the back rack door.
6. Install a security slide bar on the right side of the rack.

Note: If the rack is equipped with the ruggedized kit, remove the jam nut and hex nut from the existing door latch and reinstall both nuts on the new door lock latch.

- a. Unlatch right-side cover panel and lean the panel back so that you can access the top of the panel.
 - b. With the flat side of the slide bar rail (7) in Figure 27 on page 30, facing the inside of the cover panel (8), insert the two tabs (9), on the slide bar rail into the two vertical support channels (10) on the side cover panel.

Note: When installed correctly, the slide rail moves from front to back.

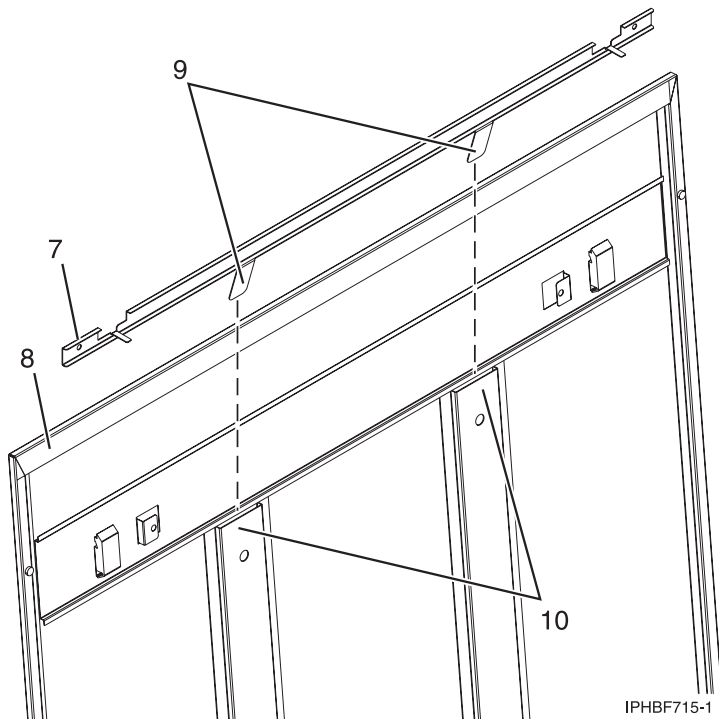

Figure 27. Installing a security slide bar

- c. Reinstall the side panel cover on to the rack.
- d. Lock the side panel covers by sliding the bars to the front of the rack.
- e. Place a locked/unlocked sticker on the inside of the cover panel so that when the slide bar is in the locked position, the tab is over the locked symbol (11), and over the unlocked symbol (12), when the slide bar is unlocked.

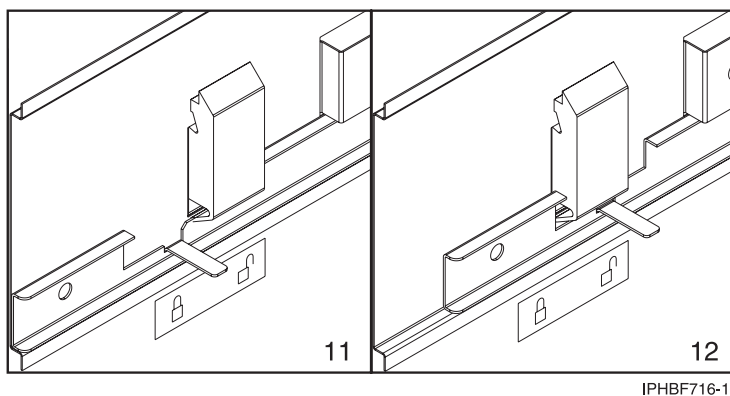

Figure 28. Placing the locked/unlocked sticker on the cover panel

- f. Repeat the procedure for the left side of the rack.

Ruggedized kit

You might need to remove or replace a part in the ruggedized kit. This section includes procedures so that you can perform these tasks.

The ruggedized kit, feature code 6080, should be ordered at the same time the rack is ordered. The ruggedized kit brackets are installed at the manufacturer.

Note: If you are installing a rack with the ruggedized kit and need to secure the rack to the floor, see “Installing the rack” on page 1.

The following illustration highlights the contents of the kit and the approximate location of each bracket and hinges in the event that you need to uninstall and reinstall a part.

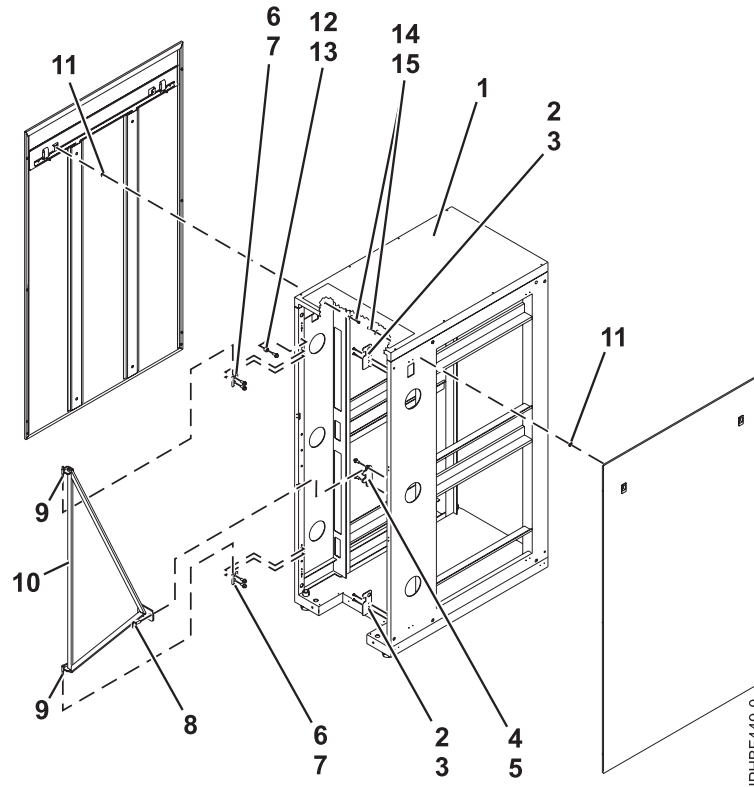

Figure 29. Ruggedized kit parts

- | | |
|------------------------------|--|
| 1 Rack | 9 Brace hinges |
| 2 Spacer | 10 Brace |
| 3 Brace hinge | 11 Side-door securing screw mount |
| 4 Hinge pivot studs | 12 Spacer |
| 5 Brace latch bracket | 13 Screw |
| 6 Spacer | 14 Washer |
| 7 Screw | 15 Side door securing screw |
| 8 Brace thumbscrew | |

Releasing the ruggedized brace:

You might need to release the ruggedized brace. Use the procedure in this section to perform this task.

To access the back of a system that is installed in a rack with a ruggedized kit, complete the following steps to release the ruggedized brace:

1. Remove the brace thumbscrew (8).

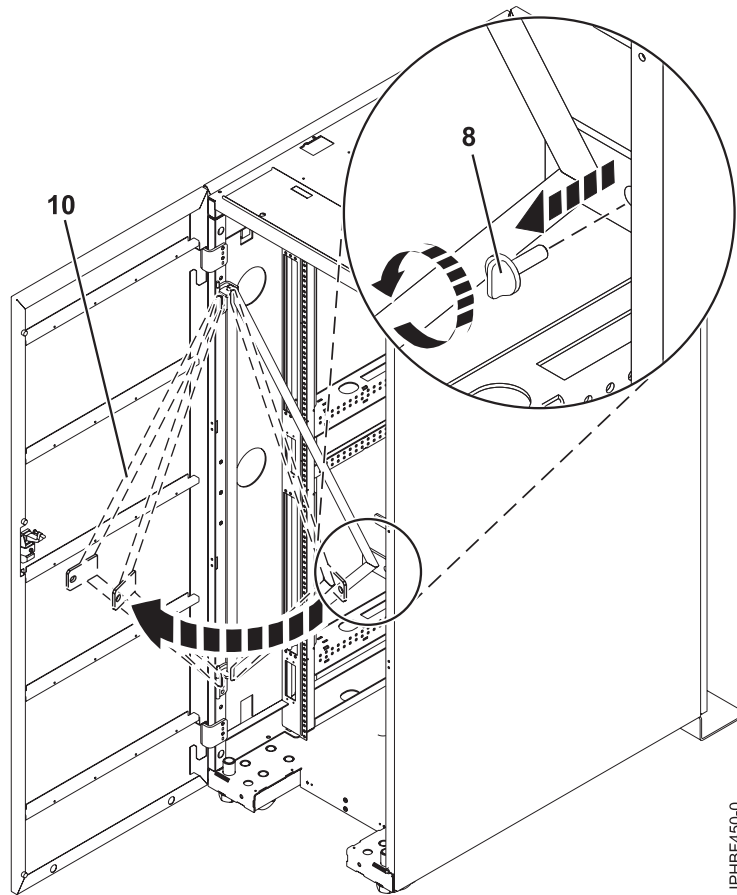

IPHBF450-0

Figure 30. Releasing the brace to access systems

2. Swing the brace (10) out of the rack.
3. Access the system and reinstall the brace.

Releasing the side panel with a ruggedized kit:

You might need to release the side panel on the rack. Use this procedure to perform this task.

The ruggedized kit contains securing screws that secure the side panels to the rack. To remove a securing screw, complete the following steps:

1. If necessary, open or remove the back rack door.
2. Locate the securing screw mount (11) for the side door that will be removed.

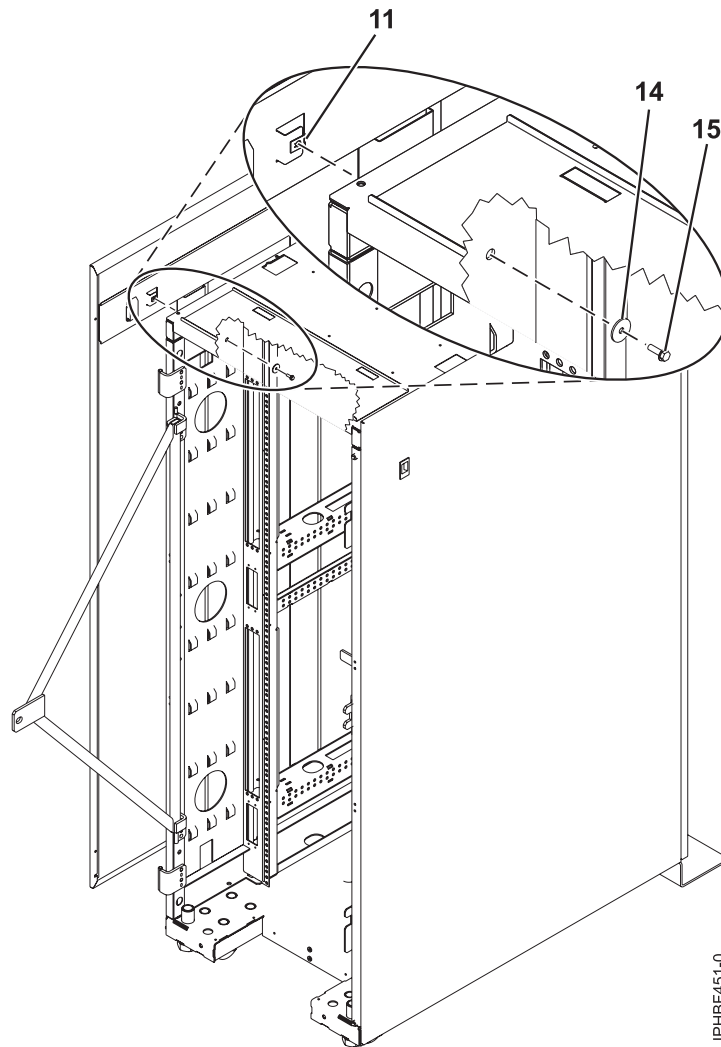

Figure 31. Removing the securing screws on the side panel

3. Using a screwdriver, remove the securing screw (15) and washer (14) from the side panel. To remove the side panel, see “Removing and replacing 7014-T00 or 7014-T42 side panels” on page 21.

Connecting multiple racks with rack-to-rack attachment kit

You might need to connect multiple racks together. Use the procedure in this section to perform this task.

This topic describes how to connect multiple racks to each other using a rack-to-rack attachment kit. To do this, you will need the rack-to-rack attachment kit (feature 7840).

To connect multiple racks with the rack-to-rack attachment kit, complete the following steps:

1. Read the “Rack safety notices” on page 26.
2. If they are installed, remove the side panels from each rack. Remove side panels only from the sides that will be attached to each other by completing the following steps:
 - a. Lift up the two panel-release tabs.
 - b. Pull the panel up and away from the rack chassis. This motion will release the panel from the two lower J brackets.
 - c. Store the side panels.
3. Remove the two Z brackets and the two J brackets. These brackets are used to hang the side panels.

4. Install the first two standoffs in the upper-left and lower-right corners of the first rack as shown in Figure 32.

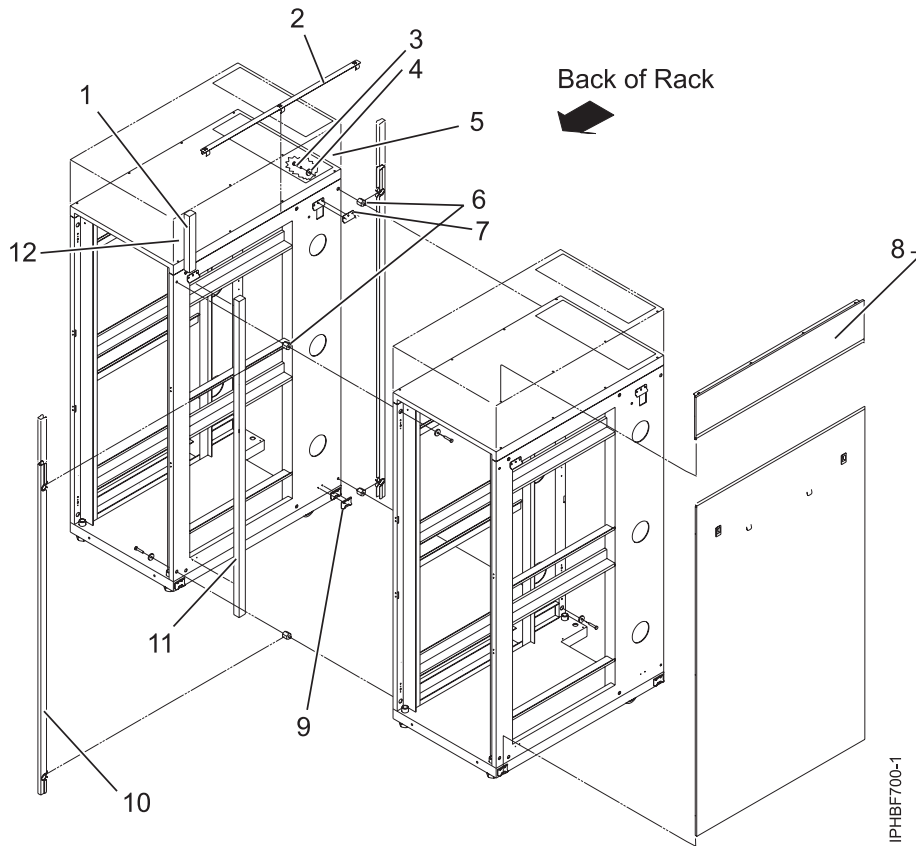

Figure 32. Removing the side panels, Z and J brackets, and installing standoffs and long foam to connect multiple racks

5. Install the second two standoffs in the upper-left and lower-right corners of the second rack as shown in Figure 32.
6. Attach the long foam as shown in Figure 32. For a model T42 rack, join the short foam to the end of the long foam, and adhere it to the frame length of the rack.

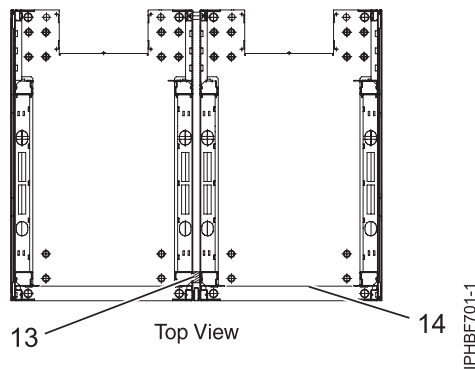

Figure 33. Location of foam strips (top view)

7. Position the racks together.
8. Align the standoff holes. You might need to adjust the leveling feet to do this.

9. Install a screw and washer into all four positions, but do not tighten.
10. After all racks are bolted together, level the racks.
11. Tighten all four screws.
12. Snap on the trim pieces that go between the front and back racks.
13. Snap on the trim piece that goes on top and between the racks.
14. Install rack filler panels to cover the open areas at the front of the racks. All the gaps in the front of the rack must also be sealed, including the gaps between equipment. This step ensures that proper airflow within the rack is maintained.
15. Connect the cables that go between the racks.
16. If you are installing tip plates, go to step 5 in “Installing the rack” on page 1.

Removing and replacing the rack top cover

You might need to remove or replace the rack top cover. Use these procedures to perform these tasks.

Removing the rack top cover:

You might need to remove the rack top cover. Use this procedure to perform this task.

Note: A 10 mm box socket with an extension bar is required to remove the screws from the top cover. Other tools might cause the screw heads to become rounded and unremovable.

To remove the rack cover from the rack, complete the following steps:

1. Remove the front door.

Note: If the rack is locked, unlock the doors. Then unlock the side panels by removing the locking bars from both sides of the top rear of the rack. Slide the locking bars out from the rack at the top of each side of the rack from the rear. The locking bars can be removed from each side of the front of the rack if the rack space in the locking bars area is open and the bars are easily accessible.

2. Remove the top, left, and right trim panels.
3. Remove the side panels. For more information, see “Removing and replacing 7014-T00 or 7014-T42 side panels” on page 21.
4. Remove one screw from the right side of the top cover and one screw from the left side of the top cover. Do for both front and rear covers.
5. Locate the front **(A)** and back **(C)** rack braces that were provided in the shipping container. Fasten each rack brace at the top of the front and rear of the rack, just below the top cover.
6. Use the four screws **(B)** that were removed from the top cover to secure each rack brace to the rack, as shown in Figure 34 on page 36.

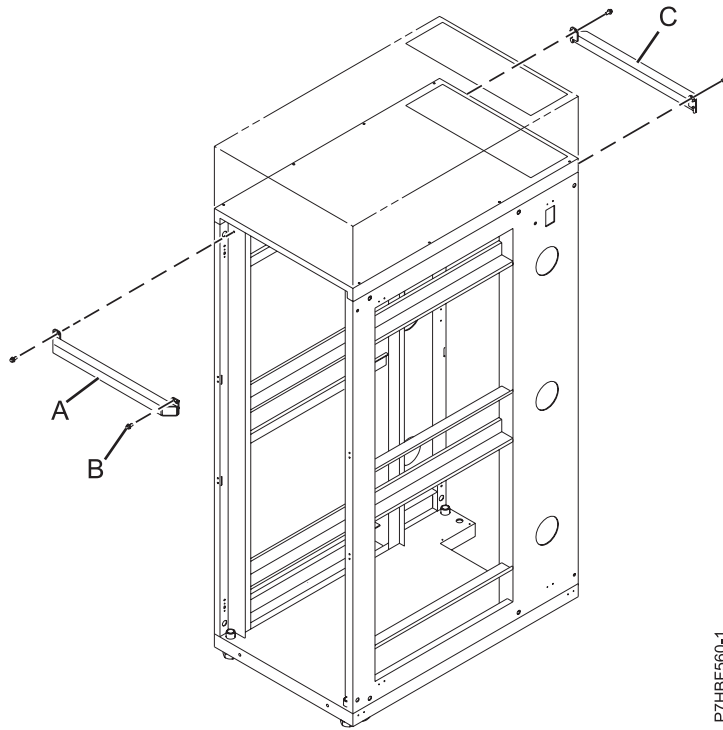

Figure 34. Securing the rack brace

- A Front rack brace
- B Retaining screws (2 screws for each brace)
- C Rear rack brace

7. Remove the remaining six screws from the left and right sides of the top cover (D).

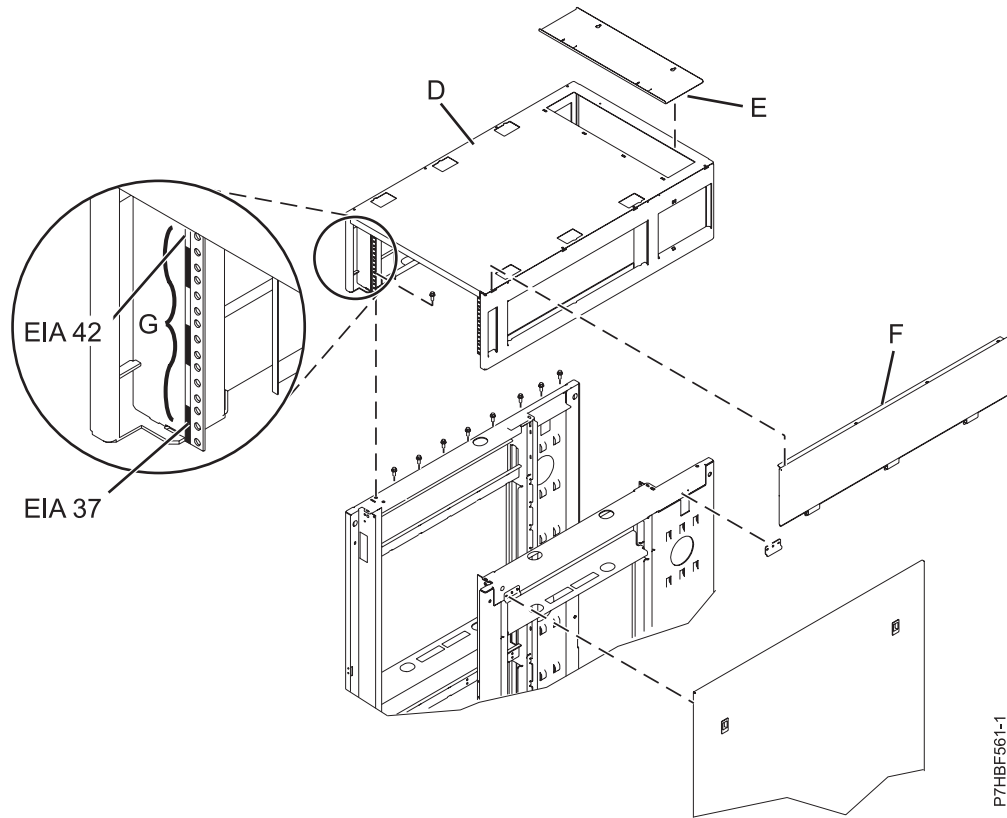

Figure 35. Removing the top cover

- D Top cover
- E Cable access cover
- F Side cover (quantity 2)
- G EIA label

8. Lift off the top cover.

Replacing the rack top cover:

You might need to replace the rack top cover. Use this procedure to perform this task.

Note: A 10 mm box socket with an extension bar is required to replace the screws into the rack top cover. Other tools might cause the screw heads to become rounded and unable to be removed again.

To replace the rack top cover onto the rack, complete the following steps:

1. Position the rack top cover (D) on the rack.
2. Install the six screws at the left and right sides of the rack top cover.

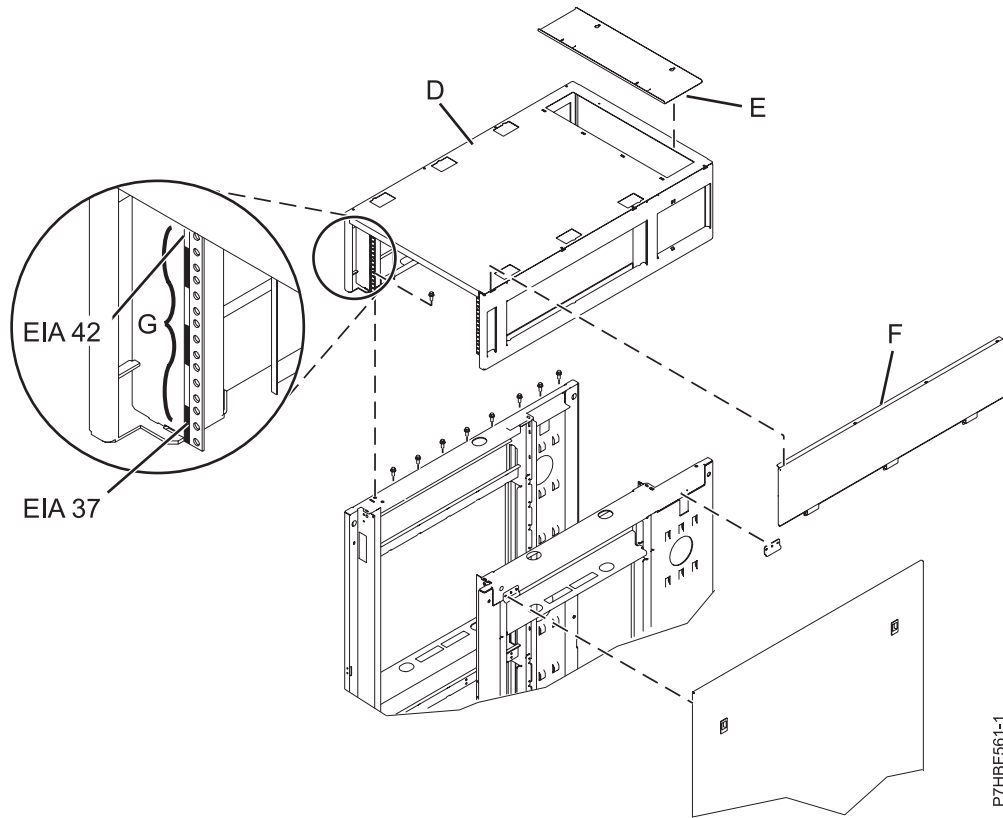

P7HBF561-1

Figure 36. Removing the top cover

- D Top cover
- E Cable access cover
- F Side cover (quantity 2)
- G EIA label

Note: A 10 mm box socket with an extension bar is required to replace the screws into the rack top cover. Other tools might cause the screw heads to become rounded and unable to be removed again.

3. Remove the rack braces (A) and (C) by unfastening them at the top of the rack, just below the top cover. Remove the braces at the front and rear of the rack.

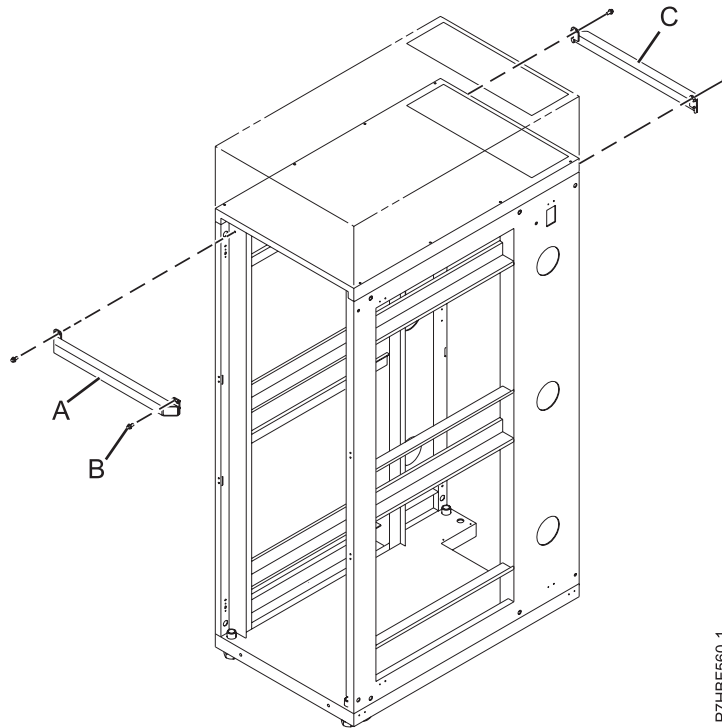

P7HBF560-1

Figure 37. Removing the top cover

- A Front rack brace
- B Retaining screws (quantity 2 for each brace)
- C Rear rack brace

4. Install the screws (**B**) you removed from the rack braces at the right and left side of the top cover. Install the screws for both the front and rear of the rack.
5. Install rack filler panels to cover open areas at the front of the rack. Seal all gaps in the front of the rack, including the gaps between pieces of equipment. This step ensures that proper airflow within the rack is maintained.

Power distribution unit

The power distribution unit (PDU) or power distribution unit plus (PDU+) can be installed in the 7014-T00 and 7014-T42 racks. It allows you to monitor the individual power loads of the devices that are plugged into it.

Installing the PDU or PDU+ in the side of a rack:

Learn how to install the power distribution unit (PDU) or power distribution unit plus (PDU+) vertically in the side of a rack.

Tip: Removing the rack doors and side panels might make installation easier.

To install the PDU model in a single EIA vertical mounting space in the side of the rack, complete the following steps:

1. Read the “Rack safety notices” on page 26.
2. Choose one of the following options to install your PDU model:
 - To install the PDU, go to step 5 on page 40.
 - To install the PDU+, continue with step 3 on page 40.

- Align the vertical-mounting brackets (**A**) to the front of the PDU+. Make sure that you attach the brackets so that the power outlets face the rear of the rack.

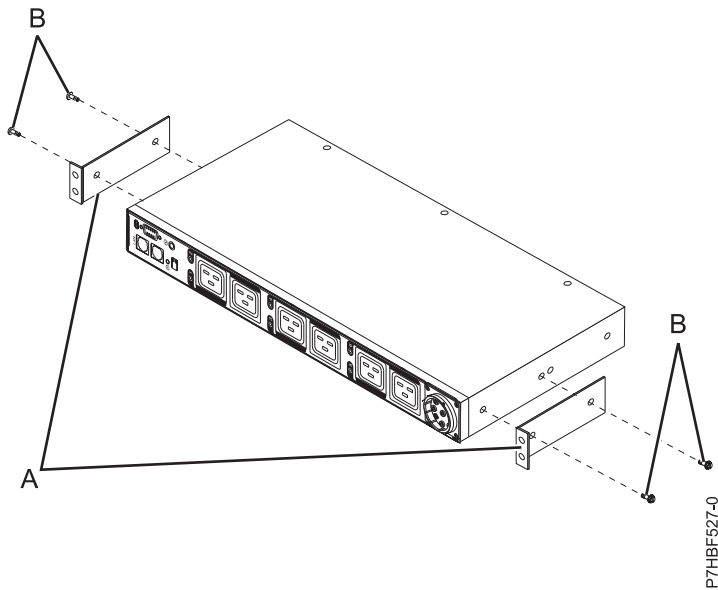

Figure 38. Aligning the vertical-mounting brackets to the front of the PDU+

- Attach the brackets (**A**) to the PDU+ with two M3x5 screws (**B**) per bracket. Use screws that were provided with the rack mounting kit.
- Attach nut clips (**A**) to the four locations on the rack mounting flanges where the PDU model will be attached. Use nut clips that were provided with the rack mounting kit. See the following figure.

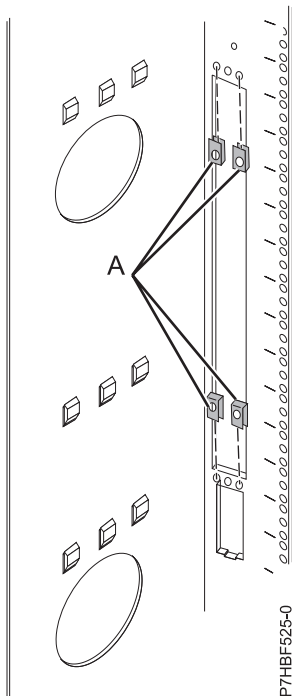

Figure 39. Attaching nut clips to the rack mounting flanges

- Align the PDU model with the opening in the side of the rack. Then, while holding the PDU model in place, attach the brackets to the nut clips in the rack mounting flanges with four M5 screws (**A**) as shown in the following figure. Use screws that were provided with the rack mounting kit.

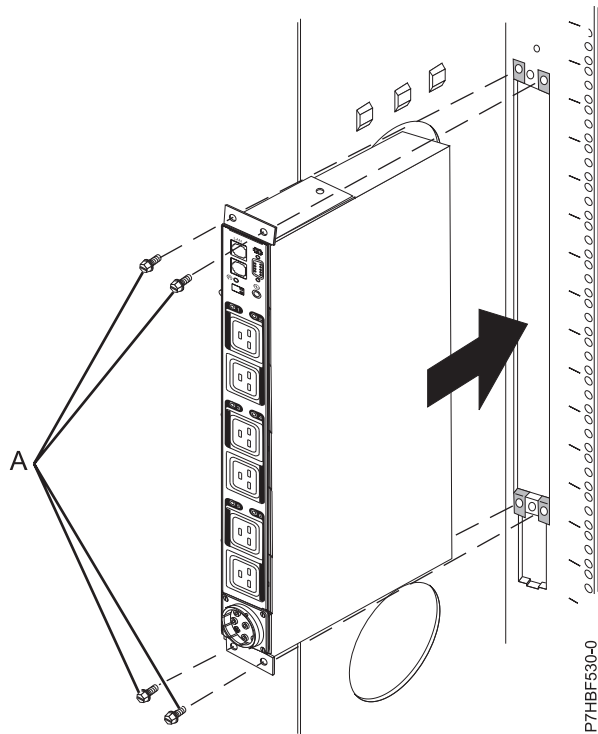

Figure 40. Aligning the PDU+ with the opening in the side of the rack

Attention: You must disconnect the main input power before connecting or disconnecting the input power cord from the PDU model.

7. If the PDU model was provided with a detached power cord, connect the power cord now. Align the connector on the power cord (A) that was provided with the PDU model with the connector on the front of the unit (A), turning as necessary for key alignment. Then, turn the connector twist-lock (B) clockwise until it locks into place.

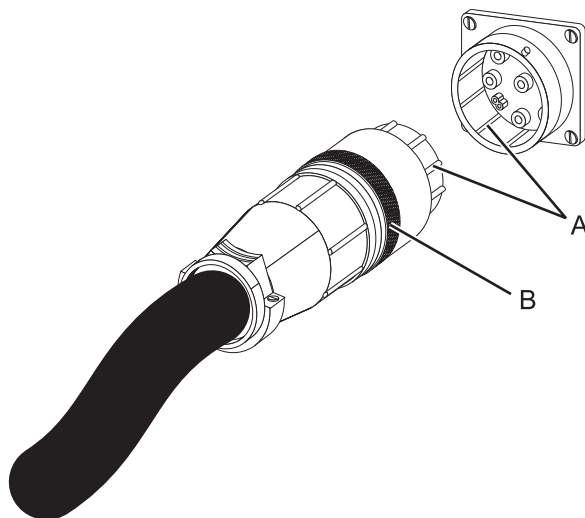

Figure 41. Aligning the connector on the power cord with the PDU model

8. Route the power cord from the PDU model toward the rack side braces. Then, route the power cord along a side brace toward the rear of the rack and secure the power cord with the cable straps that are provided with the PDU model.

- Route the power cord toward a dedicated power source. Use the provided cable straps to secure the power cord along the way. Use the openings in the rack, if the power cord must exit the rack to connect to a power source.

Attention: To prevent damage to a power device and other connected devices, always connect the power device to an authorized power source for that device.

- Connect the power cord to a properly wired and grounded dedicated power source. Then, connect the servers or rack PDUs in the rack to the power outlets on the PDU model.
- Route all of the other power cables neatly, and secure the power cables with cable straps.

Related concepts:

“Setting up power monitoring using the PDU+” on page 45

You can monitor the power status for any device that is connected to the power distribution unit plus (PDU+), either manually or remotely, through the PDU+ web interface.

Installing the PDU or PDU+ horizontally in a rack:

Learn how to install the power distribution unit (PDU) or power distribution unit plus (PDU+) horizontally in the side of a rack.

Tip: Removing the rack doors and side panels might make installation easier.

To install the PDU model in a single EIA horizontal mounting space in the rack, complete the following steps:

- Read the “Rack safety notices” on page 26.
- Choose one of the following options to install your PDU model:
 - To install the PDU, go to step 5.
 - To install the PDU+, continue with step 3.
- Align the vertical-mounting brackets **(A)** to the front of the PDU+ as shown in the following figure. Make sure that you attach the brackets so that the power outlets face the rear of the rack.

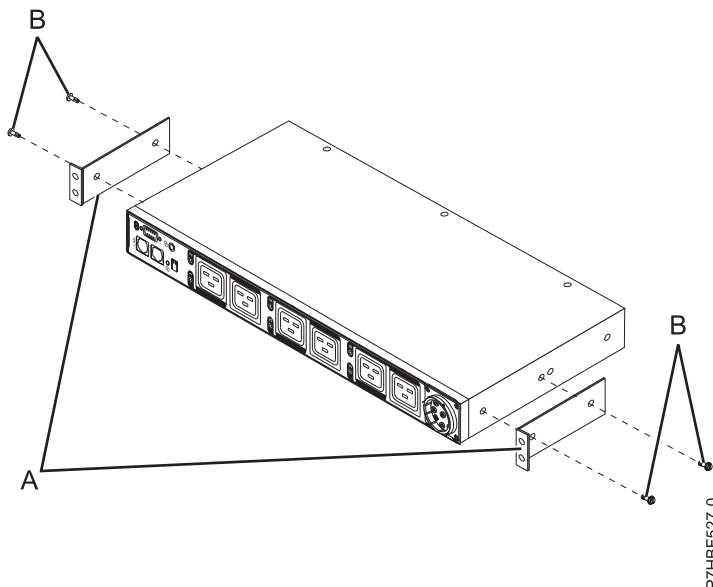
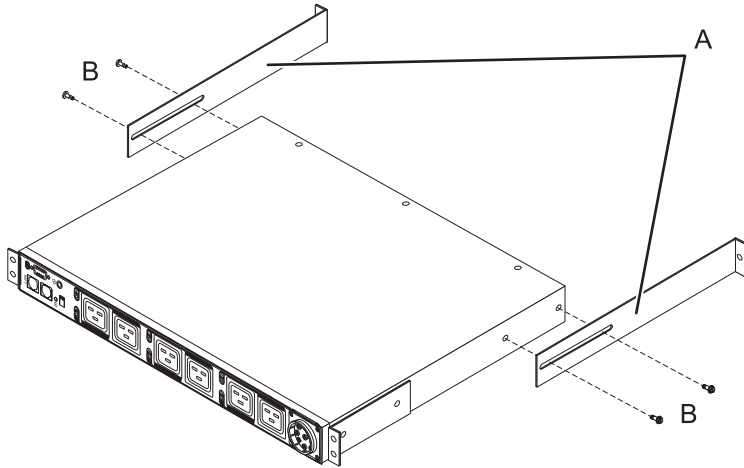

Figure 42. Aligning the vertical-mounting brackets to the front of the PDU+

- Attach the brackets **(A)** to the PDU+ with two M3x5 screws **(B)** per bracket. Use screws that were provided with the rack mounting kit.
- Align the long mounting brackets **(A)** with the holes in the rear of the PDU model, and attach the brackets to the PDU model with two M3 pan-head screws **(B)** with captive lock washers per bracket.

Use screws that were provided with the rack mounting kit.



P7HBF528-0

Figure 43. Attaching the long mounting brackets

6. Identify an open mounting space that is the size of a single EIA in the rack where you will install the PDU model. At the rear of the rack, attach nut clips to the top and bottom holes of the EIA on each side of the rack. Use nut clips that were provided with the rack mounting kit.

Note: If your rack has square mounting holes, attach cage nuts instead of nut clips to the specified EIA locations. Use cage nuts that were provided with the rack mounting kit.

7. Hold the PDU model at a slight angle and carefully insert it into a mounting space that is a single EIA in height within the rack cabinet. Pushing in slightly on both of the long mounting brackets helps clear the brackets from the rack flanges.
8. Align the end of the PDU model with the short mounting brackets with the outside of the rack flanges. Use two M6 screws (A) if cage nuts are used or M5 screws if nut clips are used per bracket to attach the brackets to the nut clips or cage nuts on the rack flanges. Use screws that were provided with the rack mounting kit.

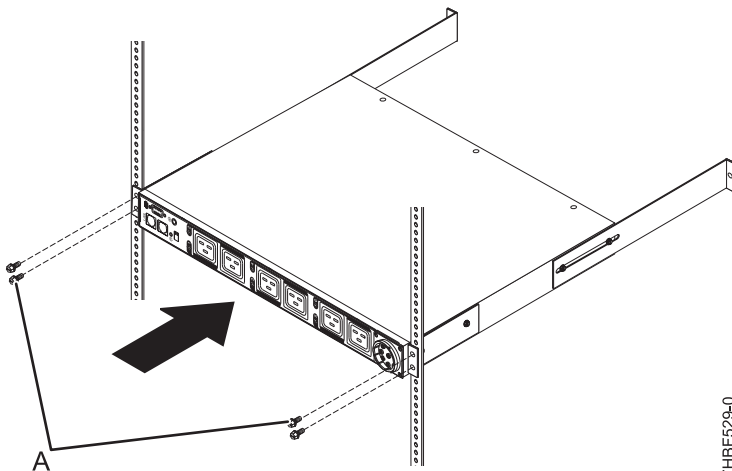

P7HBF529-0

Figure 44. Attaching the front of the PDU+ in the rack

- Secure the long mounting brackets and the blank filler panel (A) to the rack cabinet by completing the following steps:

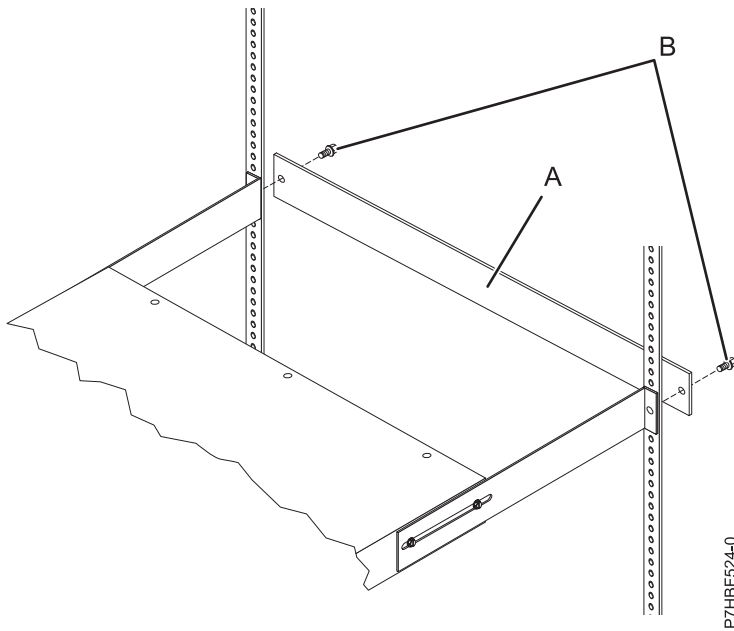
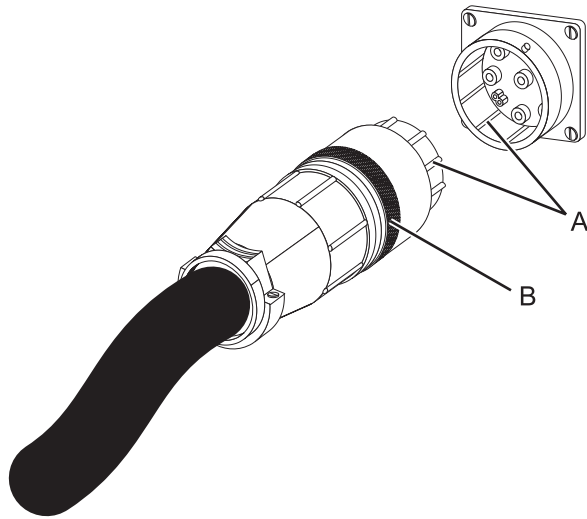

Figure 45. Attaching the brackets and filler panel to the rack

- Adjust the long mounting brackets (A) to fit the depth of the rack cabinet.
 - Tighten the M3 pan-head screws (D) that secure the long mounting brackets to the PDU model.
 - Make sure that the long mounting brackets are aligned with the inside of the rack flanges.
 - Align the blank filler panel (B) on the outside of the rack flanges.
 - Attach the filler panel to the rack flanges and then to the long mounting bracket with one M6 screw (C) per bracket. Use screws that were provided with the rack mounting kit.
- If the PDU model was provided with a detached power cord, connect the power cord now. Align the connector on the power cord (A) that was provided with the PDU model with the connector on the front of the unit (A), turning as necessary for key alignment. Then, turn the twist-lock (B) on the connector clockwise until it locks into place.

Attention: You must disconnect the main input power before connecting or disconnecting the input power cord from the PDU model.



P7HBF521-0

Figure 46. Aligning the connector on the power cord with the PDU model

11. Route the power cord from the PDU model toward the rack side braces. Then, route the power cord along a side brace toward the back of the rack and secure the power cord with the cable straps that are provided with the PDU model.
12. Route the power cord toward a dedicated power source. Use the provided cable straps to secure the power cord along the way. Use the openings in the rack if the power cord must exit the rack to connect to a power source.
Attention: To prevent damage to a power device and other connected devices, always connect the power device to an authorized power source for that device.
13. Connect the power cord to a properly wired and grounded dedicated power source. Then, you can connect the servers or rack PDUs in the rack to the power outlets on the PDU model.
14. Route all of the other power cables neatly, and secure the power cables with cable straps.

Setting up power monitoring using the PDU+:

You can monitor the power status for any device that is connected to the power distribution unit plus (PDU+), either manually or remotely, through the PDU+ web interface.

Note: All of the Configuration Utility configuration options are available through the web interface after the PDU+ is set up on the local network.

Related tasks:

“Installing the PDU or PDU+ in the side of a rack” on page 39

Learn how to install the power distribution unit (PDU) or power distribution unit plus (PDU+) vertically in the side of a rack.

Using the IBM DPI Configuration Utility:

Learn how to use the IBM Distributed power interconnect (DPI) Configuration Utility to configure the power distribution unit plus (PDU+) settings, such as the IP address, network parameters, access control table, and trap receivers table.

Connecting the console:

You can configure the PDU+ by using a workstation or notebook computer that is connected to the PDU+. Connect the DB9-to-RJ-45 cable that is shipped with the PDU+ to the RJ-45 console connector on the PDU+, and to a RS-232 serial (COM) connector on a workstation or notebook computer.

Using HyperTerminal:

HyperTerminal is a terminal program in a Microsoft Windows operating system that enables you to configure or control a device using command line parameters. You can configure the PDU+ parameters and its outlets using numeric commands from a keyboard. You can also use Telnet or any other terminal program to configure the PDU+ after the IP address is set.

To start HyperTerminal and communicate with the PDU+, complete the following steps:

1. Click **Start > Programs > Accessories > Communications > HyperTerminal**. The Connection Description window is displayed.
2. Type the name for the connection in the **Name** field and select an icon for the connection.
3. Click **OK**. The Connect To window is displayed.
4. In the **Connect using** field, select the COM port that is connected to the PDU+.
5. Click **OK**. The Properties window is displayed.
6. Click **Restore Defaults** to use the default settings. Make sure that the **Bits per second** field is 9600 and that the **Flow control** field is None.
7. Click **OK**.
8. Press any key. The Configuration Utility main menu is displayed.
9. Type the default password, passw0rd (all lowercase letters with a zero, not O), and press Enter.
10. Enter the menu option that you want. For descriptions of the options, see "Configuration Utility menu options."

Configuration Utility menu options:

The following options are shown on the Configuration Utility main menu:

IBM DPI Settings

When you select IBM DPI Settings, the IBM DPI Configuration Utility window is displayed with the following options:

Set the IP Address, Gateway Address and MIB System Group

View and change the IP address, date, time, and MIB system information.

Set IBM DPI Control Group

Set the administrator user name, password, and access protocols.

Set Write Access Managers

Set up a list of users who can access and control the PDU+.

Set Trap Receivers

Configure remote network management system (NMS) servers to receive traps.

Set Date and Time

Adjust the date and time information for the PDU+.

Set Superuser Name and Password

Set the user name and password of the administrator who will use a web browser to configure the PDU+.

E-mail Notification

Set up a list of users who will be alerted with event messages if an unusual event is triggered on the PDU+ system.

Set Multi-Users

Configure other user and password logins and the read and write access levels.

Set IBM DPI Information

Configure the PDU+ logging interval, refresh rate, and custom name fields for the load groups.

Settings and Event Log Summary

View all PDU+ configuration settings.

Reset Configuration to Default

Reset all system settings to their factory default values.

Restart HD-PDU

Restart the PDU+.

Setting the IP address:

Important: You must set the IP address before you can use the web interface or access the PDU+ in an IP network (LAN/WAN). Contact your system administrator if you do not know the IP address.

To set the IP address, complete the following steps:

1. In the Configuration Utility main menu, enter the menu option for **IBM DPI Settings**.
2. Enter the menu option for **Set the IP Address, Gateway Address and MIB System Group**.

Using the web interface to configure the PDU+:

Learn how to use the web interface to configure and monitor the power distribution unit plus (PDU+) remotely. The PDU+ provides a graphical user interface that you can view from a web browser. Using a web browser, you can access and monitor the PDU+ power outlets and output devices remotely from a workstation or notebook computer.

Starting the web interface:

To start the web interface, complete the following steps:

1. Start a web browser from a workstation or notebook computer, and enter the IP address of the PDU+ in the **address** field. The **Connect to** window is displayed.

Note: For more information about setting the IP address of the system, see “Setting the IP address.”

2. In the **User name** field, type USERID (all uppercase letters).
3. In the **Password** field, type passwd (all lowercase letters with a zero, not O).
4. Click **OK**. The main status page is displayed.

The main status page displays a graphical representation of the PDU+ power outlets and input status:

- The left pane displays the menus and submenus for the PDU+. Click a menu to display the menu options, expand the menu items, and modify the menu options as required.
- The graphic displayed in the right pane shows the status of the outlets, input voltage, output voltage, frequency, current and power, watt-hour consumption, and cumulative kilowatt hour power consumption. If you connect an optional environmental monitored probe, the temperature and humidity environment conditions are displayed.

Each menu page provides online help to assist you with configuring the PDU+. Click the **Help** icon at the top of each page to view the help.

Changing the basic settings:

Use the System menu to configure the PDU+ system parameters such as the superuser name, password, IP address, date, and time.

Changing the superuser name and password:

You can set the user name and password of the administrator who will use a web browser to configure the PDU+ on the Configuration Utility page.

To change the superuser name and password, complete the following steps:

1. From the main status page, in the left navigation pane, click **System**.

2. Click **Configuration** to view and modify the system configuration and superuser user name and password.

Identifying the PDU+ and Web/SNMP card:

You can view the PDU+ and Web/SNMP card information on the Identification of Power Management page.

To view the power management information of the PDU+ and Web/SNMP card, complete the following steps:

1. From the main status page, in the left navigation pane, click **System**.
2. Click **Identification** to view the PDU+ and Web/SNMP card information.

Adding users:

You can add users who can access and control the PDU+ on the Multi-User Configuration page.

To create a list of users who can access and control the PDU+, complete the following steps:

1. From the main status page, in the left navigation pane, click **System**.
2. Click **Multi-User** to add users who can only view the PDU+ status or users who can change the PDU+ settings.

Changing the date and time:

You can change the date and time of the PDU+ on the Date and Time page.

Important: Changing the PDU+ date and time affects other system settings such as e-mail, traps, and logs.

To change the date and time, complete the following steps:

1. From the main status page, in the left navigation pane, click **System**.
2. Click **Date and Time** to view and modify the system date and time. You can set the date and time manually, synchronize it with the computer time, or synchronize it with an NTP server.

Changing event alerts:

You can change event alerts on the SNMP Trap Receivers page.

To configure the PDU+ to send e-mail or SNMP trap alerts to specified users when specific events occur, complete the following steps:

1. From the main status page, in the left navigation pane, click **System**.
2. Click **Trap Receivers** to create a list of users or workstations who will be alerted with an SNMP trap message. You can specify the IP addresses of up to eight trap receivers, the community information, type of trap, severity of trap, and description of the events that cause the traps.
3. Click **Email Notification** under **System** to create a list of up to four users who will be alerted with an e-mail. Use this menu to specify the mail server, user account, DNS, and other information necessary to set up a mail server for sending mail alerts. Use the Email Receivers Table to add the e-mail addresses.

Changing the network information:

Use the Network menu to change the network information for the PDU+, for example, the IP address.

Changing the network configuration:

You can view or change the network configuration on the Network Configuration page.

To view or change the network configuration of the PDU+, complete the following steps:

1. From the main status page, in the left navigation pane, click **Network**.
2. Click **Configuration** to set the PDU+ IP address, gateway address, subnet mask, and Domain Name System (DNS) address.
3. Click **Control** to configure TCP/IP settings.
4. Click **Access Control** to set access control to prevent unauthorized users from accessing the PDU+.

History and event log summaries:

The Logs menu provides a detailed description of all events and a record of the PDU+ status. System administrators can use this page to analyze problems with network equipment.

Viewing the history log:

You can view the complete history of the PDU+ inputs and outputs on the History Log page.

To view the history of the PDU+, complete the following steps:

1. From the main status page, in the left navigation pane, click **Logs**.
2. Click **History**. Each event log file shows the time, date, and description of all the events occurring on the PDU+.

Viewing the event log:

You can view the complete record of the PDU+ events on the Event Log page.

To view the complete record of the PDU+ events, complete the following steps:

1. From the main status page, in the left navigation pane, click **Logs**.
2. Click **Events**. Each log file shows a record of the input power and output power of each outlet.

Notices

This information was developed for products and services offered in the U.S.A.

The manufacturer may not offer the products, services, or features discussed in this document in other countries. Consult the manufacturer's representative for information on the products and services currently available in your area. Any reference to the manufacturer's product, program, or service is not intended to state or imply that only that product, program, or service may be used. Any functionally equivalent product, program, or service that does not infringe any intellectual property right of the manufacturer may be used instead. However, it is the user's responsibility to evaluate and verify the operation of any product, program, or service.

The manufacturer may have patents or pending patent applications covering subject matter described in this document. The furnishing of this document does not grant you any license to these patents. You can send license inquiries, in writing, to the manufacturer.

The following paragraph does not apply to the United Kingdom or any other country where such provisions are inconsistent with local law: THIS PUBLICATION IS PROVIDED "AS IS" WITHOUT WARRANTY OF ANY KIND, EITHER EXPRESS OR IMPLIED, INCLUDING, BUT NOT LIMITED TO, THE IMPLIED WARRANTIES OF NON-INFRINGEMENT, MERCHANTABILITY OR FITNESS FOR A PARTICULAR PURPOSE. Some states do not allow disclaimer of express or implied warranties in certain transactions, therefore, this statement may not apply to you.

This information could include technical inaccuracies or typographical errors. Changes are periodically made to the information herein; these changes will be incorporated in new editions of the publication. The manufacturer may make improvements and/or changes in the product(s) and/or the program(s) described in this publication at any time without notice.

Any references in this information to websites not owned by the manufacturer are provided for convenience only and do not in any manner serve as an endorsement of those websites. The materials at those websites are not part of the materials for this product and use of those websites is at your own risk.

The manufacturer may use or distribute any of the information you supply in any way it believes appropriate without incurring any obligation to you.

Any performance data contained herein was determined in a controlled environment. Therefore, the results obtained in other operating environments may vary significantly. Some measurements may have been made on development-level systems and there is no guarantee that these measurements will be the same on generally available systems. Furthermore, some measurements may have been estimated through extrapolation. Actual results may vary. Users of this document should verify the applicable data for their specific environment.

Information concerning products not produced by this manufacturer was obtained from the suppliers of those products, their published announcements or other publicly available sources. This manufacturer has not tested those products and cannot confirm the accuracy of performance, compatibility or any other claims related to products not produced by this manufacturer. Questions on the capabilities of products not produced by this manufacturer should be addressed to the suppliers of those products.

All statements regarding the manufacturer's future direction or intent are subject to change or withdrawal without notice, and represent goals and objectives only.

The manufacturer's prices shown are the manufacturer's suggested retail prices, are current and are subject to change without notice. Dealer prices may vary.

This information is for planning purposes only. The information herein is subject to change before the products described become available.

This information contains examples of data and reports used in daily business operations. To illustrate them as completely as possible, the examples include the names of individuals, companies, brands, and products. All of these names are fictitious and any similarity to the names and addresses used by an actual business enterprise is entirely coincidental.

If you are viewing this information in softcopy, the photographs and color illustrations may not appear.

The drawings and specifications contained herein shall not be reproduced in whole or in part without the written permission of the manufacturer.

The manufacturer has prepared this information for use with the specific machines indicated. The manufacturer makes no representations that it is suitable for any other purpose.

The manufacturer's computer systems contain mechanisms designed to reduce the possibility of undetected data corruption or loss. This risk, however, cannot be eliminated. Users who experience unplanned outages, system failures, power fluctuations or outages, or component failures must verify the accuracy of operations performed and data saved or transmitted by the system at or near the time of the outage or failure. In addition, users must establish procedures to ensure that there is independent data verification before relying on such data in sensitive or critical operations. Users should periodically check the manufacturer's support websites for updated information and fixes applicable to the system and related software.

Homologation statement

This product may not be certified in your country for connection by any means whatsoever to interfaces of public telecommunications networks. Further certification may be required by law prior to making any such connection. Contact an IBM representative or reseller for any questions.

Trademarks

IBM, the IBM logo, and ibm.com are trademarks or registered trademarks of International Business Machines Corp., registered in many jurisdictions worldwide. Other product and service names might be trademarks of IBM or other companies. A current list of IBM trademarks is available on the web at www.ibm.com/legal/copytrade.shtml.

Microsoft and Windows are trademarks of Microsoft Corporation in the United States, other countries, or both.

Electronic emission notices

When attaching a monitor to the equipment, you must use the designated monitor cable and any interference suppression devices supplied with the monitor.

Class A Notices

The following Class A statements apply to the IBM servers that contain the POWER7[®] processor and its features unless designated as electromagnetic compatibility (EMC) Class B in the feature information.

Federal Communications Commission (FCC) statement

Note: This equipment has been tested and found to comply with the limits for a Class A digital device, pursuant to Part 15 of the FCC Rules. These limits are designed to provide reasonable protection against harmful interference when the equipment is operated in a commercial environment. This equipment

generates, uses, and can radiate radio frequency energy and, if not installed and used in accordance with the instruction manual, may cause harmful interference to radio communications. Operation of this equipment in a residential area is likely to cause harmful interference, in which case the user will be required to correct the interference at his own expense.

Properly shielded and grounded cables and connectors must be used in order to meet FCC emission limits. IBM is not responsible for any radio or television interference caused by using other than recommended cables and connectors or by unauthorized changes or modifications to this equipment. Unauthorized changes or modifications could void the user's authority to operate the equipment.

This device complies with Part 15 of the FCC rules. Operation is subject to the following two conditions: (1) this device may not cause harmful interference, and (2) this device must accept any interference received, including interference that may cause undesired operation.

Industry Canada Compliance Statement

This Class A digital apparatus complies with Canadian ICES-003.

Avis de conformité à la réglementation d'Industrie Canada

Cet appareil numérique de la classe A est conforme à la norme NMB-003 du Canada.

European Community Compliance Statement

This product is in conformity with the protection requirements of EU Council Directive 2004/108/EC on the approximation of the laws of the Member States relating to electromagnetic compatibility. IBM cannot accept responsibility for any failure to satisfy the protection requirements resulting from a non-recommended modification of the product, including the fitting of non-IBM option cards.

This product has been tested and found to comply with the limits for Class A Information Technology Equipment according to European Standard EN 55022. The limits for Class A equipment were derived for commercial and industrial environments to provide reasonable protection against interference with licensed communication equipment.

European Community contact:
IBM Deutschland GmbH
Technical Regulations, Department M372
IBM-Allee 1, 71139 Ehningen, Germany
Tele: +49 7032 15 2941
email: lugi@de.ibm.com

Warning: This is a Class A product. In a domestic environment, this product may cause radio interference, in which case the user may be required to take adequate measures.

VCCI Statement - Japan

この装置は、クラスA情報技術装置です。この装置を家庭環境で使用すると電波妨害を引き起こすことがあります。この場合には使用者が適切な対策を講ずるよう要求されることがあります。

VCCI-A

The following is a summary of the VCCI Japanese statement in the box above:

This is a Class A product based on the standard of the VCCI Council. If this equipment is used in a domestic environment, radio interference may occur, in which case, the user may be required to take corrective actions.

Japanese Electronics and Information Technology Industries Association (JEITA) Confirmed Harmonics Guideline (products less than or equal to 20 A per phase)

高調波ガイドライン適合品

Japanese Electronics and Information Technology Industries Association (JEITA) Confirmed Harmonics Guideline with Modifications (products greater than 20 A per phase)

高調波ガイドライン準用品

Electromagnetic Interference (EMI) Statement - People's Republic of China

声 明

此为 A 级产品,在生活环境中,
该产品可能会造成无线电干扰。
在这种情况下,可能需要用户对其
干扰采取切实可行的措施。

Declaration: This is a Class A product. In a domestic environment this product may cause radio interference in which case the user may need to perform practical action.

Electromagnetic Interference (EMI) Statement - Taiwan

警告使用者：

這是甲類的資訊產品，在
居住的環境中使用時，可
能會造成射頻干擾，在這
種情況下，使用者會被要
求採取某些適當的對策。

The following is a summary of the EMI Taiwan statement above.

Warning: This is a Class A product. In a domestic environment this product may cause radio interference in which case the user will be required to take adequate measures.

IBM Taiwan Contact Information:

台灣IBM 產品服務聯絡方式：
台灣國際商業機器股份有限公司
台北市松仁路7號3樓
電話：0800-016-888

Electromagnetic Interference (EMI) Statement - Korea

이 기기는 업무용(A급)으로 전자파적합기기로서 판매자 또는 사용자는 이 점을 주의하시기 바라며, 가정외의 지역에서 사용하는 것을 목적으로 합니다.

Germany Compliance Statement

Deutschsprachiger EU Hinweis: Hinweis für Geräte der Klasse A EU-Richtlinie zur Elektromagnetischen Verträglichkeit

Dieses Produkt entspricht den Schutzanforderungen der EU-Richtlinie 2004/108/EG zur Angleichung der Rechtsvorschriften über die elektromagnetische Verträglichkeit in den EU-Mitgliedsstaaten und hält die Grenzwerte der EN 55022 Klasse A ein.

Um dieses sicherzustellen, sind die Geräte wie in den Handbüchern beschrieben zu installieren und zu betreiben. Des Weiteren dürfen auch nur von der IBM empfohlene Kabel angeschlossen werden. IBM übernimmt keine Verantwortung für die Einhaltung der Schutzanforderungen, wenn das Produkt ohne Zustimmung von IBM verändert bzw. wenn Erweiterungskomponenten von Fremdherstellern ohne Empfehlung von IBM gesteckt/eingebaut werden.

EN 55022 Klasse A Geräte müssen mit folgendem Warnhinweis versehen werden:

"Warnung: Dieses ist eine Einrichtung der Klasse A. Diese Einrichtung kann im Wohnbereich Funk-Störungen verursachen; in diesem Fall kann vom Betreiber verlangt werden, angemessene Maßnahmen zu ergreifen und dafür aufzukommen."

Deutschland: Einhaltung des Gesetzes über die elektromagnetische Verträglichkeit von Geräten

Dieses Produkt entspricht dem "Gesetz über die elektromagnetische Verträglichkeit von Geräten (EMVG)". Dies ist die Umsetzung der EU-Richtlinie 2004/108/EG in der Bundesrepublik Deutschland.

Zulassungsbescheinigung laut dem Deutschen Gesetz über die elektromagnetische Verträglichkeit von Geräten (EMVG) (bzw. der EMC EG Richtlinie 2004/108/EG) für Geräte der Klasse A

Dieses Gerät ist berechtigt, in Übereinstimmung mit dem Deutschen EMVG das EG-Konformitätszeichen - CE - zu führen.

Verantwortlich für die Einhaltung der EMV Vorschriften ist der Hersteller:
International Business Machines Corp.
New Orchard Road
Armonk, New York 10504
Tel: 914-499-1900

Der verantwortliche Ansprechpartner des Herstellers in der EU ist:
IBM Deutschland GmbH
Technical Regulations, Abteilung M372
IBM-Allee 1, 71139 Ehningen, Germany
Tel: +49 7032 15 2941
email: lugi@de.ibm.com

Generelle Informationen:

Das Gerät erfüllt die Schutzanforderungen nach EN 55024 und EN 55022 Klasse A.

Electromagnetic Interference (EMI) Statement - Russia

ВНИМАНИЕ! Настоящее изделие относится к классу А.
В жилых помещениях оно может создавать
радиопомехи, для снижения которых необходимы
дополнительные меры

Class B Notices

The following Class B statements apply to features designated as electromagnetic compatibility (EMC) Class B in the feature installation information.

Federal Communications Commission (FCC) statement

This equipment has been tested and found to comply with the limits for a Class B digital device, pursuant to Part 15 of the FCC Rules. These limits are designed to provide reasonable protection against harmful interference in a residential installation.

This equipment generates, uses, and can radiate radio frequency energy and, if not installed and used in accordance with the instructions, may cause harmful interference to radio communications. However, there is no guarantee that interference will not occur in a particular installation.

If this equipment does cause harmful interference to radio or television reception, which can be determined by turning the equipment off and on, the user is encouraged to try to correct the interference by one or more of the following measures:

- Reorient or relocate the receiving antenna.
- Increase the separation between the equipment and receiver.
- Connect the equipment into an outlet on a circuit different from that to which the receiver is connected.
- Consult an IBM-authorized dealer or service representative for help.

Properly shielded and grounded cables and connectors must be used in order to meet FCC emission limits. Proper cables and connectors are available from IBM-authorized dealers. IBM is not responsible for

any radio or television interference caused by unauthorized changes or modifications to this equipment. Unauthorized changes or modifications could void the user's authority to operate this equipment.

This device complies with Part 15 of the FCC rules. Operation is subject to the following two conditions: (1) this device may not cause harmful interference, and (2) this device must accept any interference received, including interference that may cause undesired operation.

Industry Canada Compliance Statement

This Class B digital apparatus complies with Canadian ICES-003.

Avis de conformité à la réglementation d'Industrie Canada

Cet appareil numérique de la classe B est conforme à la norme NMB-003 du Canada.

European Community Compliance Statement

This product is in conformity with the protection requirements of EU Council Directive 2004/108/EC on the approximation of the laws of the Member States relating to electromagnetic compatibility. IBM cannot accept responsibility for any failure to satisfy the protection requirements resulting from a non-recommended modification of the product, including the fitting of non-IBM option cards.

This product has been tested and found to comply with the limits for Class B Information Technology Equipment according to European Standard EN 55022. The limits for Class B equipment were derived for typical residential environments to provide reasonable protection against interference with licensed communication equipment.

European Community contact:
IBM Deutschland GmbH
Technical Regulations, Department M372
IBM-Allee 1, 71139 Ehningen, Germany
Tele: +49 7032 15 2941
email: lugi@de.ibm.com

VCCI Statement - Japan

この装置は、クラスB情報技術装置です。この装置は、家庭環境で使用することを目的としていますが、この装置がラジオやテレビジョン受信機に近接して使用されると、受信障害を引き起こすことがあります。

取扱説明書に従って正しい取り扱いをして下さい。 VCCI-B

Japanese Electronics and Information Technology Industries Association (JEITA) Confirmed Harmonics Guideline (products less than or equal to 20 A per phase)

高調波ガイドライン適合品

**Japanese Electronics and Information Technology Industries Association (JEITA)
Confirmed Harmonics Guideline with Modifications (products greater than 20 A per
phase)**

高調波ガイドライン準用品

IBM Taiwan Contact Information

台灣IBM 產品服務聯絡方式：
台灣國際商業機器股份有限公司
台北市松仁路7號3樓
電話：0800-016-888

Electromagnetic Interference (EMI) Statement - Korea

이 기기는 가정용(B급)으로 전자파적합기기로서 주로 가정에서 사용하는 것을 목적으로 하며, 모든 지역에서 사용할 수 있습니다.

Germany Compliance Statement

**Deutschsprachiger EU Hinweis: Hinweis für Geräte der Klasse B EU-Richtlinie zur
Elektromagnetischen Verträglichkeit**

Dieses Produkt entspricht den Schutzanforderungen der EU-Richtlinie 2004/108/EG zur Angleichung der Rechtsvorschriften über die elektromagnetische Verträglichkeit in den EU-Mitgliedsstaaten und hält die Grenzwerte der EN 55022 Klasse B ein.

Um dieses sicherzustellen, sind die Geräte wie in den Handbüchern beschrieben zu installieren und zu betreiben. Des Weiteren dürfen auch nur von der IBM empfohlene Kabel angeschlossen werden. IBM übernimmt keine Verantwortung für die Einhaltung der Schutzanforderungen, wenn das Produkt ohne Zustimmung von IBM verändert bzw. wenn Erweiterungskomponenten von Fremdherstellern ohne Empfehlung von IBM gesteckt/eingebaut werden.

Deutschland: Einhaltung des Gesetzes über die elektromagnetische Verträglichkeit von Geräten

Dieses Produkt entspricht dem "Gesetz über die elektromagnetische Verträglichkeit von Geräten (EMVG)". Dies ist die Umsetzung der EU-Richtlinie 2004/108/EG in der Bundesrepublik Deutschland.

**Zulassungsbescheinigung laut dem Deutschen Gesetz über die elektromagnetische Verträglichkeit von
Geräten (EMVG) (bzw. der EMC EG Richtlinie 2004/108/EG) für Geräte der Klasse B**

Dieses Gerät ist berechtigt, in Übereinstimmung mit dem Deutschen EMVG das EG-Konformitätszeichen - CE - zu führen.

Verantwortlich für die Einhaltung der EMV Vorschriften ist der Hersteller:
International Business Machines Corp.
New Orchard Road
Armonk, New York 10504
Tel: 914-499-1900

Der verantwortliche Ansprechpartner des Herstellers in der EU ist:
IBM Deutschland GmbH
Technical Regulations, Abteilung M372
IBM-Allee 1, 71139 Ehningen, Germany
Tel: +49 7032 15 2941
email: lugi@de.ibm.com

Generelle Informationen:

Das Gerät erfüllt die Schutzanforderungen nach EN 55024 und EN 55022 Klasse B.

Terms and conditions

Permissions for the use of these publications are granted subject to the following terms and conditions.

Applicability: These terms and conditions are in addition to any terms of use for the IBM website.

Personal Use: You may reproduce these publications for your personal, noncommercial use provided that all proprietary notices are preserved. You may not distribute, display or make derivative works of these publications, or any portion thereof, without the express consent of IBM.

Commercial Use: You may reproduce, distribute and display these publications solely within your enterprise provided that all proprietary notices are preserved. You may not make derivative works of these publications, or reproduce, distribute or display these publications or any portion thereof outside your enterprise, without the express consent of IBM.

Rights: Except as expressly granted in this permission, no other permissions, licenses or rights are granted, either express or implied, to the Publications or any information, data, software or other intellectual property contained therein.

IBM reserves the right to withdraw the permissions granted herein whenever, in its discretion, the use of the publications is detrimental to its interest or, as determined by IBM, the above instructions are not being properly followed.

You may not download, export or re-export this information except in full compliance with all applicable laws and regulations, including all United States export laws and regulations.

IBM MAKES NO GUARANTEE ABOUT THE CONTENT OF THESE PUBLICATIONS. THE PUBLICATIONS ARE PROVIDED "AS-IS" AND WITHOUT WARRANTY OF ANY KIND, EITHER EXPRESSED OR IMPLIED, INCLUDING BUT NOT LIMITED TO IMPLIED WARRANTIES OF MERCHANTABILITY, NON-INFRINGEMENT, AND FITNESS FOR A PARTICULAR PURPOSE.



Printed in USA