



IBM Storwize V7000
Quick Installation Guide

Version 6.1.0

GC27-2290-00





IBM Storwize V7000
Quick Installation Guide

Version 6.1.0

GC27-2290-00

Note

Before using this information and the product it supports, read the general information in “Notices” on page 29, the information in the “Safety and environmental notices” on page ix, as well as the information in the *IBM Environmental Notices and User Guide* on the documentation CD.

This edition applies to the IBM Storwize V7000 , Version 6.1.0, and to all subsequent releases and modifications until otherwise indicated in new editions.

This edition applies to GC27-2290-00.

© **Copyright IBM Corporation 2010.**

US Government Users Restricted Rights – Use, duplication or disclosure restricted by GSA ADP Schedule Contract with IBM Corp.

Contents

Figures	v
Tables	vii
Safety and environmental notices	ix
Chapter 1. Before you begin the installation	1
Step 1. Reviewing your packing slip	2
Step 2. Identifying the hardware components	3
Step 3. Verifying environmental requirements	6
Step 4. Reviewing enclosure location guidelines	7
Chapter 2. Performing the hardware installation	9
Step 5. Installing the support rails	9
Step 6. Installing the enclosures.	11
Step 7. Connecting the SAS cables to the expansion enclosures	13
Step 8. Attaching the Ethernet cables	18
Step 9. Attaching the longwave SFP transceivers	18
Step 10. Attaching the Fibre Channel cables.	18
Step 11. Connecting the power cords	19
Step 12. Powering on the system	21
Chapter 3. Configuring the system.	25
Step 13. Configuring the system	25

Notices	29
Trademarks	31
Electronic emission notices	31
Federal Communications Commission (FCC) statement	31
Industry Canada compliance statement	32
Avis de conformité à la réglementation d'Industrie Canada	32
Australia and New Zealand Class A Statement	32
European Union Electromagnetic Compatibility Directive	32
Germany Electromagnetic compatibility directive	32
Japan VCCI Council Class A statement	33
People's Republic of China Class A Electronic Emission Statement.	33
International Electrotechnical Commission (IEC) statement	34
United Kingdom telecommunications requirements	34
Korean Communications Commission (KCC) Class A Statement	34
Russia Electromagnetic Interference (EMI) Class A Statement	34
Taiwan Class A compliance statement	34
European Contact Information	34
Taiwan Contact Information	35

Figures

1.	24 drives and two end caps	3	12.	Attaching an expansion enclosure to the control enclosure.	15
2.	12 drives and two end caps	3	13.	Adding a second expansion enclosure.	16
3.	Rear view of a control enclosure	4	14.	Attaching SAS cables to the enclosures	17
4.	Data ports and LEDs in the rear of the control enclosure.	4	15.	Unlocking the cable retention bracket	20
5.	Rear view of an expansion enclosure	5	16.	Sliding the cable retention bracket directly behind the power cord.	21
6.	SAS ports and LEDs in rear of expansion enclosure.	6	17.	LEDs on the power supply units of the expansion enclosure.	22
7.	Hole locations in the front of the rack	9	18.	LEDs on the power supply units of the control enclosure	23
8.	Attaching a rail assembly to a rack cabinet	10	19.	Initialization tool welcome panel	26
9.	Hole locations in the back of the rack	10			
10.	Removing the enclosure end cap	12			
11.	Securing an enclosure to a rack cabinet	13			

Tables

1. Cabling guide.	14	3. LED status when control enclosure is powered on.	23
2. LED status when expansion enclosures are powered on	22		

Safety and environmental notices

Review the multilingual safety notices for the IBM® Storwize® V7000 system before you install and use the product.

Suitability for telecommunication environment: This product is not intended to connect directly or indirectly by any means whatsoever to interfaces of public telecommunications networks.

To find the translated text for a caution or danger notice:

1. Look for the identification number at the end of each caution notice or each danger notice. In the following examples, the numbers (C001) and (D002) are the identification numbers.

CAUTION:

A caution notice indicates the presence of a hazard that has the potential of causing moderate or minor personal injury. (C001)

DANGER

A danger notice indicates the presence of a hazard that has the potential of causing death or serious personal injury. (D002)

2. Locate *IBM Systems Safety Notices* with the user publications that were provided with the Storwize V7000 hardware.
3. Find the matching identification number in the *IBM Systems Safety Notices*. Then review the topics concerning the safety notices to ensure that you are in compliance.
4. Optionally, read the multilingual safety instructions on the Storwize V7000 website. Go to Support for Storwize V7000 website at www.ibm.com/storage/support/storwize/v7000, click the current product documentation link, and then click **Multi-language**.

Chapter 1. Before you begin the installation

The *Quick Installation Guide* contains a set of instructions to help you unpack your shipping order and install your system. The guide is divided into three chapters. The steps in the first chapter involve verifying your order, becoming familiar with the hardware component terminology, and ensuring that you have met the environmental requirements. The steps in the second chapter involve installing the hardware and attaching the data cables and power cords. The final chapter helps you create your configuration file and access the management GUI. The management GUI guides you through the initial configuration process.

See the following website for the available translated versions of the *Quick Installation Guide*:

Support for Storwize V7000 website at www.ibm.com/storage/support/storwize/v7000

Occasionally you are referred to topics in the Storwize V7000 Information Center. A copy of the Storwize V7000 Information Center is on the DVD that is included in your shipping order.

Note: The guide assumes that you have read the planning information regarding your physical environment that is available from the Storwize V7000 Information Center.

Depending on your order, this documentation steps you through setting up your system for the following scenarios

- Setting up a new system that consists of installing a control enclosure only. In this case, you are not installing any expansion enclosures.
- Setting up a new system that consists of installing a control enclosure and installing one or more expansion enclosures.
- Adding an expansion enclosure to an existing system. In this case, you initially installed a control enclosure or installed a control enclosure and one or more expansion enclosures. You want to add an expansion enclosure to your existing system.

Be familiar with the following information

- Where it is applicable, a CAUTION notice indicates situations that can be potentially hazardous to you. Before doing a step that contains a caution notice, read and understand the statement that accompanies it.
- Use safe practices when lifting. The fully populated enclosure weighs about 57.2 lbs (26 kg). At least two people are required to lift and install the enclosure into the rack or to remove an enclosure from the rack.

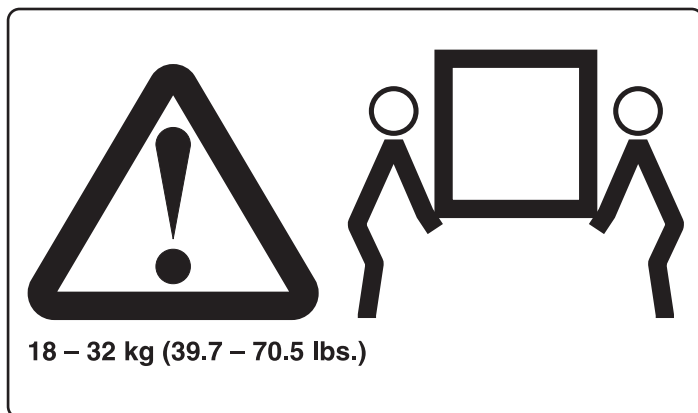

- Rack-mounted devices are not to be used as a shelf or workspace. Do not place any object on top of rack-mounted devices.

Tools needed

A screwdriver is the only tool needed for the system installation. The screwdriver can be either a flat-blade screwdriver or a crosshead screwdriver.

Step 1. Reviewing your packing slip

After you open your box or boxes, locate your packing slip. Ensure that the items that are listed in your packing slip match what is in the box. Ensure that any optional items that you ordered are included in the list. Your shipment might contain additional items depending on the order.

Standard ship group contents:

- ___ • Control enclosure (model 2076-112 or 2076-124) or expansion enclosure (model 2076-212 or 2076-224). The last two digits of the model number identify the number of drive slots. The last two digits are either 12 or 24.
- ___ • Rack-mounting hardware kit, including:
 - ___ – Two rails (right and left assembly)
 - ___ – Two M5 x 15 Hex Phillips screws per rail (two rails)
 - ___ – Two M5 x 15 Hex Phillips screws per chassis
- Note:** Two parts of the rail kit are attached to each side of the enclosure.
- ___ • Two power cords
- ___ • Drive assemblies or blank carriers (installed in the enclosure).
Verify the number of drives and the size of the drives.
- ___ • Environmental Notices flyer
- ___ • Limited Warranty information
- ___ • Software DVD that contains the environmental notices, the publication PDFs, and the information center content. One DVD is shipped per enclosure.
- ___ • License Function authorization document
- ___ • Code Reference flyer
- ___ • *IBM Storwize V7000 Quick Installation Guide, GC27-2290-00*

Additional components for control enclosures:

- ___ • USB key, also known as a flash drive, is located with the publications.

- __ • Fibre Channel cables, if ordered
- __ • Small form-factor pluggable (SFP) transceivers that are preinstalled in the enclosure
- __ • Longwave SFP transceivers, if ordered

Additional components for expansion enclosures:

- __ • Two SAS cables for each expansion enclosure

Step 2. Identifying the hardware components

The following graphics and descriptions identify the various hardware components and port locations for the control enclosure and the expansion enclosure. Each enclosure contains two canisters, two power supply units, drives, and a chassis. The power supply units for the control enclosure each contain a battery. Each enclosure takes up the full 2U height in the rack.

See the *IBM Storwize V7000 Troubleshooting, Recovery, and Maintenance Guide* PDF on the DVD for the full descriptions of the hardware components.

Each enclosure has drives that are located on the front. Figure 1 and Figure 2 show the front of an enclosure that has space for up to 12 or 24 drives **2**, depending on the model, and a left end cap **1** and a right end cap **3**.



Figure 1. 24 drives and two end caps

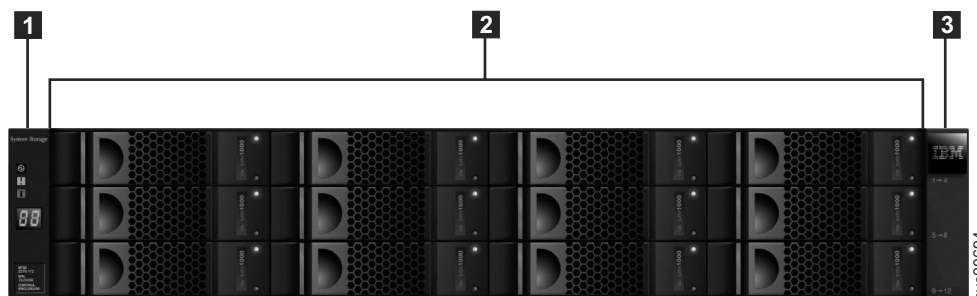

Figure 2. 12 drives and two end caps

Control enclosure components

Figure 3 on page 4 shows the rear view of a control enclosure and identifies the location of the power supply units and the canisters.

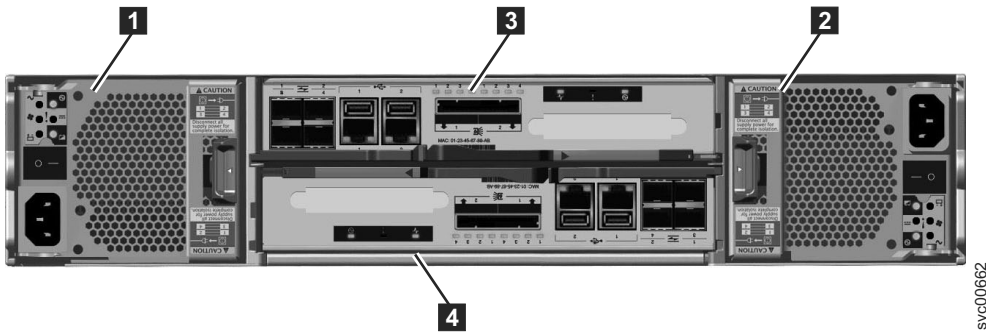

Figure 3. Rear view of a control enclosure

- Power supply units are located on the left and right of the canisters. Each unit contains a battery. Power supply 1 **1** is located on the left. Power supply 2 **2** is located on the right. Power supply 1 is inserted top side up, and power supply 2 is inverted, or top side down.

Important: The power supply units for the control enclosure and expansion enclosure are not interchangeable.

- Two canisters are housed in the middle of the enclosure. Each canister is known as a node canister. The upper canister is canister 1 **3**, and the lower canister is canister 2 **4**. Canister 1 is top side up, and canister 2 is inverted, or top side down.

Figure 4 shows the rear view of a control enclosure and identifies the location of the ports.

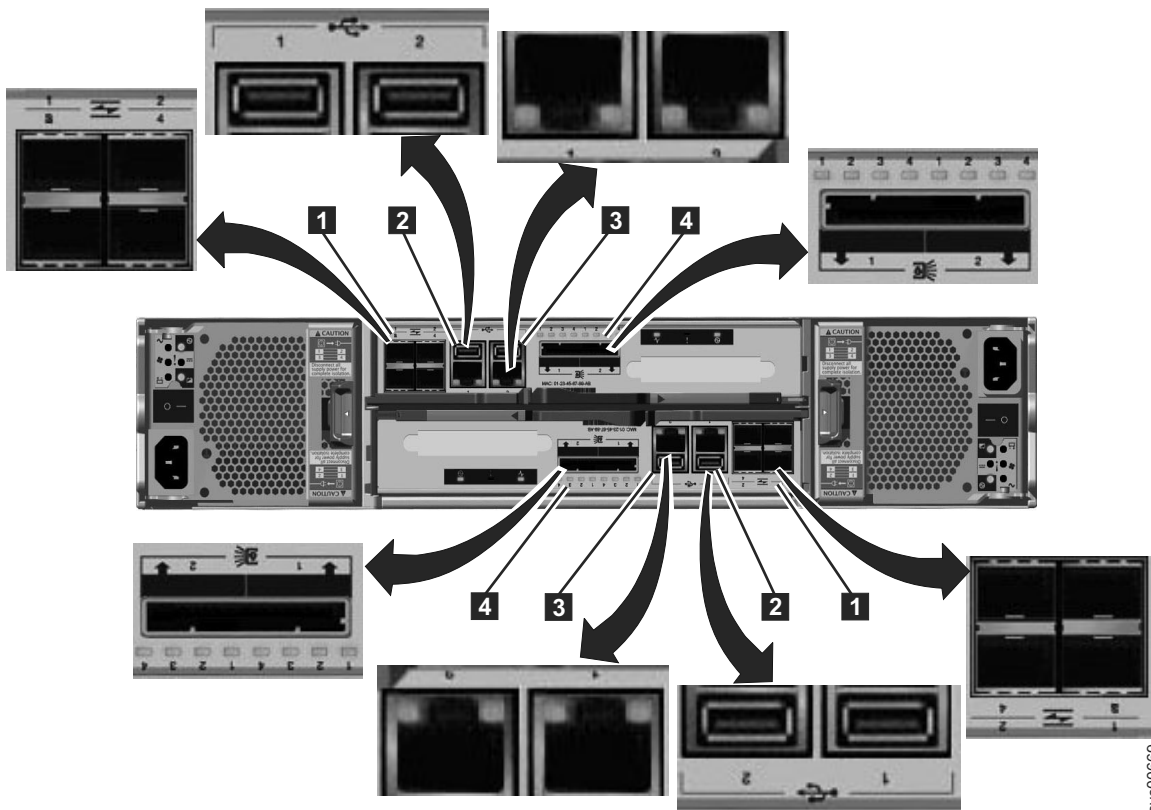

Figure 4. Data ports and LEDs in the rear of the control enclosure

- **1** Fibre Channel ports. Each canister has four Fibre Channel ports. They are in a block of four in two rows of two connectors. The ports are numbered 1 - 4 from left to right, top to bottom. Their use is optional.
- **2** USB ports. Each canister has two USB ports. The ports are side by side on the canister and are numbered 1 on the left and 2 on the right. One port is used during installation.
- **3** Ethernet ports. Each canister has two Ethernet ports. The ports are side by side on the canister. They are numbered 1 on the left and 2 on the right. Port 1 must be connected; the use of port 2 is optional.
- **4** Serial-attached SCSI (SAS) ports. Each canister has two SAS ports. The ports are side by side on the canister. They are numbered 1 on the left and 2 on the right. Port 1 must be connected if you are adding one expansion enclosure. Port 2 must be connected if you are adding a second expansion enclosure.

Note: The reference to the left and right locations applies to canister 1, which is the upper canister. The port locations are inverted for canister 2, which is the lower canister.

Expansion enclosure components

Figure 5 shows the rear view of an expansion enclosure and identifies the location of the power supply units and the canisters. The ports and their use are described later in this section.

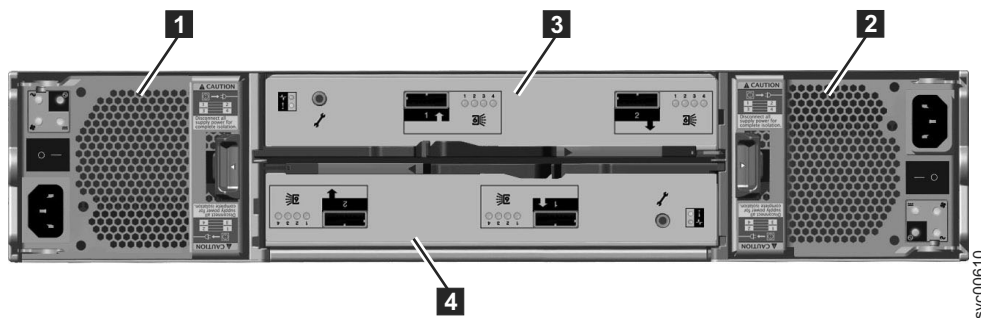

Figure 5. Rear view of an expansion enclosure

- Power supply units are on the left and right of the canisters. Power supply 1 **1** is located on the left. Power supply 2 **2** is located on the right. Power supply 1 is inserted top side up, and power supply 2 is inverted, or top side down.

Important: The power supply units for the control enclosure and expansion enclosure are not interchangeable.

- Two canisters are housed in the middle of the enclosure. Each canister is known as an expansion canister. The upper canister is canister 1 **3**, and the lower canister is canister 2 **4**. Canister 1 is top side up, and canister 2 is inverted, or top side down.

Figure 6 on page 6 shows the rear view of an expansion enclosure and identifies the SAS port locations.

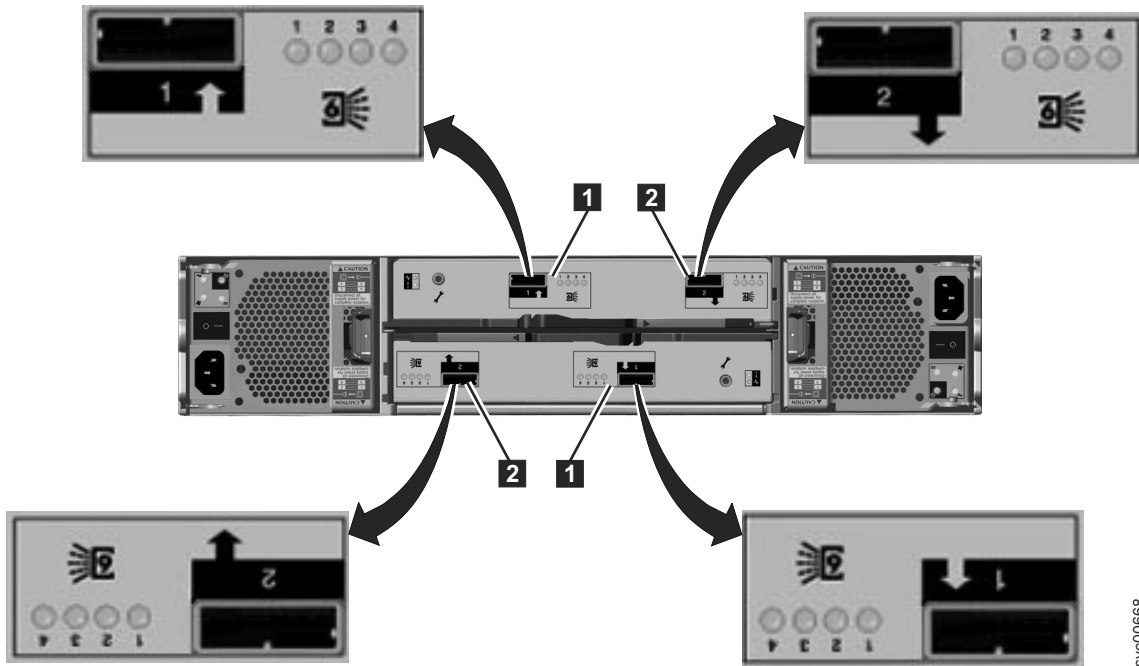

Figure 6. SAS ports and LEDs in rear of expansion enclosure

Each canister has two SAS ports that are numbered 1 on the left **1** and 2 on the right **2**. Port 1 must be connected if you are adding one expansion enclosure. Port 2 must be connected if you are adding a second expansion enclosure.

Note: The reference to the left and right locations applies to canister 1, which is the upper canister. The port locations are inverted for canister 2, which is the lower canister.

Miscellaneous hardware

The USB key (also known as a USB flash drive) is packaged with the publications and contains the initialization tool for performing the initial system configuration.

Step 3. Verifying environmental requirements

Certain requirements for the physical site must be met before your system works reliably. This step includes verifying that adequate space in a suitable rack is available and that requirements for power and environmental conditions are met. You must also verify that you are using a supported browser. This documentation assumes that you have completed the physical planning for the environment of your system.

If you have not done the environmental planning for your system, see the "Storwize V7000 physical installation planning" topic in the Storwize V7000 Information Center.

You must use a supported browser. Verify that you are using a supported browser from the following website:

Support for Storwize V7000 website at www.ibm.com/storage/support/storwize/v7000

Step 4. Reviewing enclosure location guidelines

Use these guidelines to create a plan that identifies an appropriate location in the rack for the enclosure or enclosures that you are installing now or in the future. An enclosure requires two standard rack units of space in a rack. See Figure 9 on page 10 for a sample template of two rack units. For example, position the control enclosure in the middle of the rack beginning at rack numbers 18 and 19.

If you are installing a control enclosure only, follow these guidelines:

Position the enclosure in the rack so that you can easily view it and access it for servicing. This action helps the rack to remain stable and provides a way for two or more people to install and remove the enclosure.

Note: If you plan to add expansion enclosures in the future, review the guidelines for "If you are installing an expansion enclosure only."

If you are installing a control enclosure plus one or more expansion enclosures, follow these guidelines:

If you have one or more expansion enclosures, position the control enclosure in the center of the rack. Balance the expansion enclosures above and below the control enclosure.

For example, position the control enclosure in the middle of the rack for ease of cabling.

- You can have no more than five expansion enclosures attached to SAS port 1 of the control enclosure.
- You can have no more than four expansion enclosures attached to SAS port 2 of the control enclosure.
- Position the enclosures together; avoid adding other equipment between enclosures.
- When you add the first expansion enclosure to a control enclosure, it is preferable to add the enclosure directly below the control enclosure.
- When you add a second expansion enclosure, it is preferable to add the enclosure directly above the control enclosure. For each additional expansion enclosure that you add, alternately add it below or above the control enclosure.
- Position the enclosures in the rack so that you can easily view them and access them for servicing. This action helps the rack to remain stable and provides a way for two or more people to install and remove the enclosures.

If you are installing an expansion enclosure only, follow these guidelines:

When you add the first expansion enclosure to a control enclosure, it is preferable to add the enclosure directly below the control enclosure. When you add a second expansion enclosure, it is preferable to add the enclosure directly above the control enclosure. For each expansion enclosure that you add, alternately add it below or above the control enclosure.

Chapter 2. Performing the hardware installation

You have completed the initial steps of verifying the shipping contents and becoming familiar with the hardware components. You have verified that the power and environmental requirements are met and have planned the location of the enclosures. You are now ready to begin installing the hardware components and connecting the data cables and power cords.

Step 5. Installing the support rails

To install the support rails, perform the following steps:

1. Locate the rack mounting rails and screws.

The rail assembly is made up of two sets of rails. One set of rails is already installed, or preinstalled, on the sides of the enclosures. The other set of rails must be installed in the rack cabinet. The rails on the sides of the enclosures slide into the rails that are installed in the rack cabinet.

2. Working at the front of the rack cabinet, identify the two standard rack units of space in the rack into which you want to install the support rails.

Figure 7 shows two rack units with the front mounting holes identified.

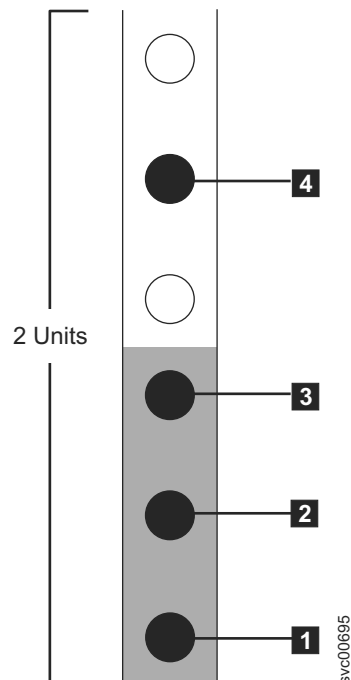
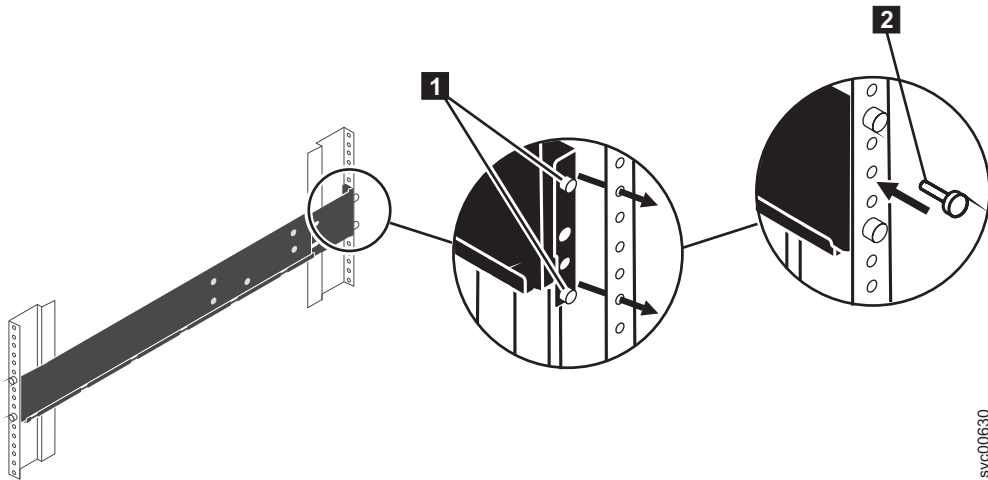

Figure 7. Hole locations in the front of the rack

- **1** Bottom rail location pin hole
- **2** Enclosure mounting screw hole
- **3** Rack mounting screw hole
- **4** Top rail location pin hole

Figure 8 on page 10 shows the alignment of the rail location pins to the rack and the alignment of the clamping screw to the rack.



svc00630

Figure 8. Attaching a rail assembly to a rack cabinet

3. Align the bottom of the rail with the bottom of the two rack units. Insert the rail location pins **1** through the holes in the rack cabinet.
4. Insert a clamping screw into the rack mounting hole **2** between the rail location pins.
5. Tighten the screw to secure the rail to the rack.
6. Working from the rear of the rack cabinet, extend the rail that you secured to the front to align the bottom of the rail with the bottom of the two rack units.

Note: Ensure that the rail is level between the front and the back.

Figure 9 shows two rack units with the back mounting holes identified.

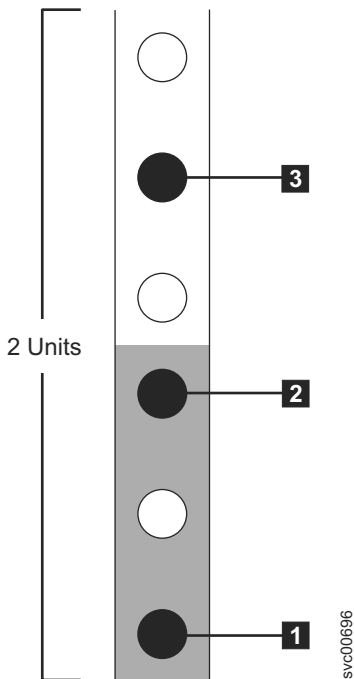

svc00696

Figure 9. Hole locations in the back of the rack

- **1** Bottom rail location pin hole
- **2** Rack mounting screw hole

- **3** Top rail location pin hole
7. Insert the rail location pins through the holes in the rack cabinet.
 8. Insert a clamping screw into the rack mounting hole between the rail location pins.
 9. Tighten the screw to secure the rail to the rack from the back side.
 10. Repeat the steps to secure the opposite rail to the rack cabinet.
 11. Repeat the procedure for each additional enclosure.

Step 6. Installing the enclosures

CAUTION:

- 1. To lift and install the enclosure into the rack requires at least two people.**
- 2. Load the rack from the bottom to ensure rack stability. Empty the rack from the top down.**

Following your enclosure location plan, install the correct type of enclosure starting from the bottom.

1. On either side of the drive assemblies, remove the enclosure end caps by squeezing the middle of the cap and pulling it away from the front of the enclosure as shown in Figure 10 on page 12. You can also use a flat-blade screwdriver to remove the cap.



Figure 10. Removing the enclosure end cap

2. Align the enclosure with the front of the rack cabinet.
3. Carefully slide the enclosure into the rack along the rails until the enclosure is fully inserted.

Notes:

- a. The preinstalled rails on the sides of the enclosure must fit into the rack-mounted rails that you previously installed.
 - b. The rails are not designed to hold an enclosure that is partially inserted. The enclosure must always be in a fully inserted position.
 - c. Do not have more than one enclosure extended out of the rack at the same time to avoid the danger of the rack toppling over.
4. Insert a screw into the hole behind the enclosure end cap and tighten the screw as shown in Figure 11 on page 13.



Figure 11. Securing an enclosure to a rack cabinet

5. Push the end caps back into position.
6. Repeat this procedure for each additional enclosure that you install.

Step 7. Connecting the SAS cables to the expansion enclosures

This task applies if you are installing one or more expansion enclosures.

Note: The enclosure terminology that is used in this topic is described fully in “Step 2. Identifying the hardware components” on page 3.

Be aware of these guidelines when you begin to attach the cables to the SAS ports:

- No more than five expansion enclosures can be chained to port 1 (below the control enclosure). The connecting sequence from port 1 of the node canister is called chain 1.
- No more than four expansion enclosures can be chained to port 2 (above the control enclosure). The connecting sequence from port 2 of the node canister is called chain 2.
- No cable can be connected between a port on an upper canister and a port on a lower canister.
- Attach cables serially between enclosures; do not skip an enclosure.
- The last enclosure in a chain must not have cables in port 2 of canister 1 and port 2 of canister 2.
- Ensure that cables are installed in a tidy manner to reduce the risk of cable damage when Storwize V7000 replaceable units are removed or inserted.
- Arrange your cables to provide access to:
 - The USB ports. Access is required to this port when you use the USB key to configure the system.
 - The enclosures themselves. Access is required to the hardware for servicing and for safely removing and replacing components using two or more people.
- Ensure that each SAS cable is fully inserted. A click is heard when the cable is successfully inserted.

Note: If you make a mistake during cabling and must unplug a SAS cable, pull the blue tag to release the cable.

1. Review Table 1 and the following figures before attaching the SAS cables.

Table 1 provides a summary of how to attach the SAS cables.

Table 1. Cabling guide

From:	To:
1 Port 1 of upper canister, control enclosure	2 Port 1 of upper canister, expansion enclosure 1
3 Port 1 of lower canister, control enclosure	4 Port 1 of lower canister, expansion enclosure 1
5 Port 2 of upper canister, control enclosure	6 Port 1 of upper canister, expansion enclosure 2
7 Port 2 of lower canister, control enclosure	8 Port 1 of lower canister, expansion enclosure 2
9 Port 2 of upper canister, expansion enclosure 1	10 Port 1 of upper canister, expansion enclosure 3
11 Port 2 of lower canister, expansion enclosure 1	12 Port 1 of lower canister, expansion enclosure 3

2. Attach the SAS cables from the control enclosure to the first expansion enclosure as shown in Figure 12 on page 15. Remove the protective end covers, if necessary. The first expansion enclosure is below the control enclosure.

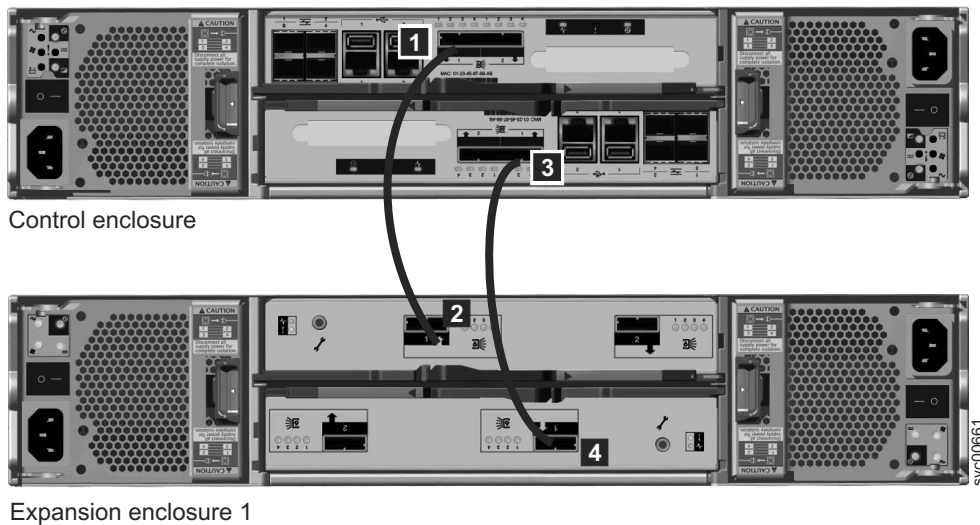

Figure 12. Attaching an expansion enclosure to the control enclosure

- a. Port 1 **1** of the upper canister, control enclosure, attaches to Port 1 **2** of the upper canister, expansion enclosure 1.
- b. Port 1 **3** of the lower canister, control enclosure, attaches to Port 1 **4** of the lower canister, expansion enclosure 1. The port locations on the lower canister are inverted from the port locations on the upper canister. Port 1 on the lower canister is opposite port 1 on the upper canister.

Note: The connecting sequence from port 1 of the node canister is called chain 1.

3. Attach the SAS cables from the control enclosure to the second expansion enclosure as shown in Figure 13 on page 16. The second expansion enclosure is above the control enclosure.

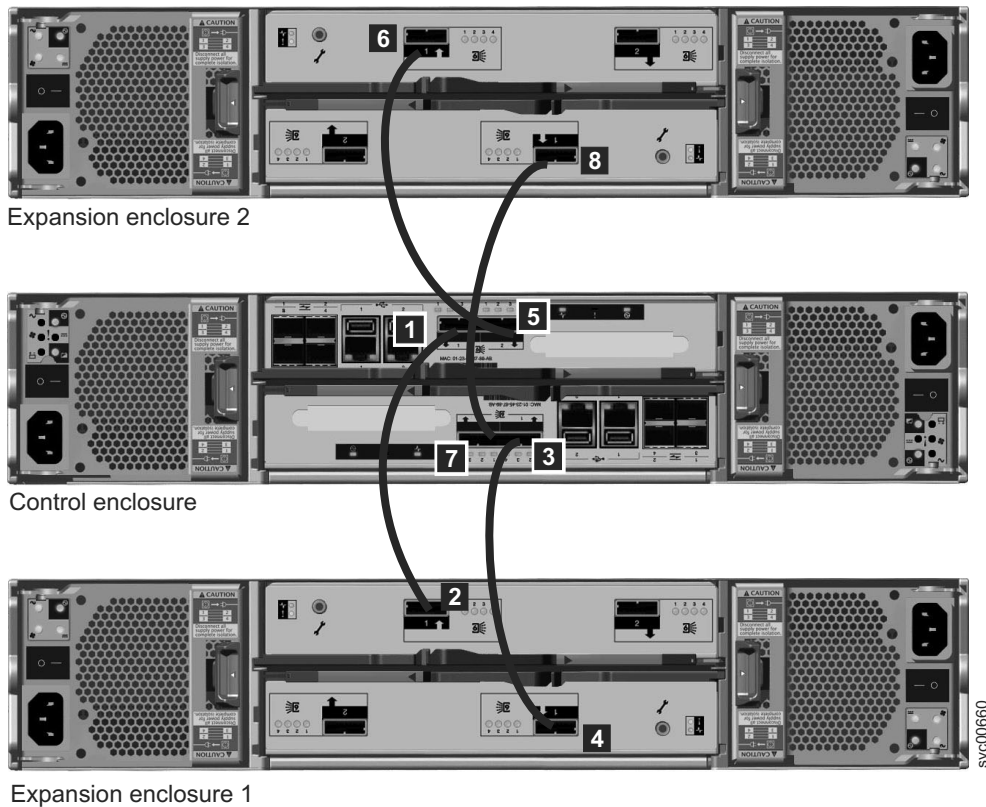

Figure 13. Adding a second expansion enclosure

- a. Port 2 **5** of the upper canister, control enclosure, attaches to Port 1 **6** of the upper canister, expansion enclosure 2.
- b. Port 2 **7** of the lower canister, control enclosure, attaches to Port 1 **8** of the lower canister, expansion enclosure 2. The port locations on the lower canister are inverted from the port locations on the upper canister. Port 1 on the lower canister is opposite port 1 on the upper canister.

Note: The connecting sequence from port 2 of the node canister is called chain 2.

4. Attach the SAS cables from the first expansion enclosure to the third expansion enclosure.

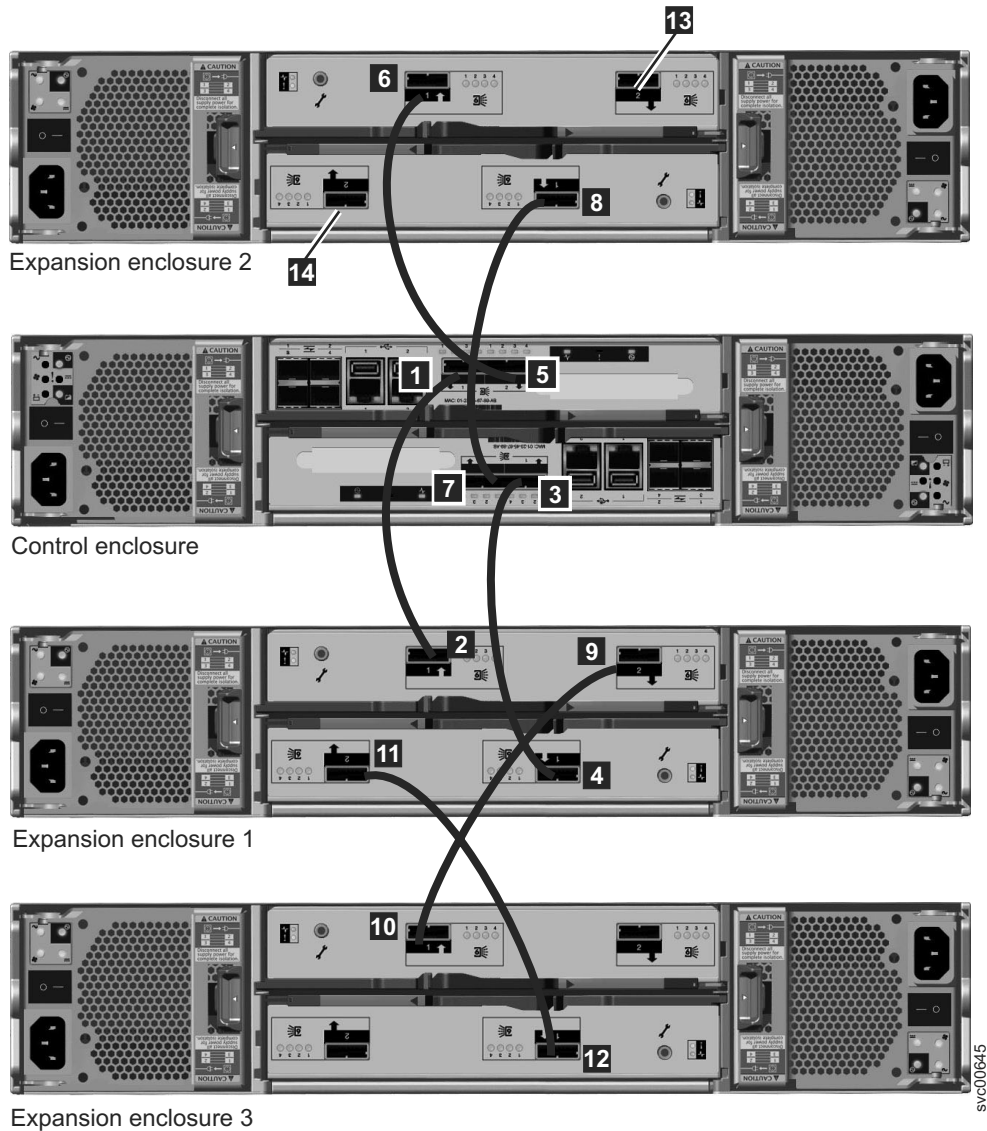

Figure 14. Attaching SAS cables to the enclosures

- a. Port 2 **9** of the upper canister, expansion enclosure 1, attaches to Port 1 **10** of the upper canister, expansion enclosure 3.
- b. Port 2 **11** of the lower canister, expansion enclosure 1, attaches to Port 1 **12** of the lower canister, expansion enclosure 3.
5. Attach SAS cables for additional expansion enclosures. You can add up to nine expansion enclosures. You add a fourth expansion enclosure at **13** and **14** on expansion enclosure 2.
 - a. Add the enclosures alternately to chain 1, and then chain 2.
 - b. Use port 2 on the canisters that are already connected to attach to port 1 on the canisters of the enclosures that you want to add.
 - c. Connect the SAS cables from canister 1 to canister 1.
 - d. Connect the SAS cables from canister 2 to canister 2.
6. Verify your cabling.

Step 8. Attaching the Ethernet cables

This task applies if you are installing a control enclosure only or a control enclosure plus one or more expansion enclosures.

This task assumes that your initial planning has determined where the Ethernet cables are to be located.

Attention: The IP address 192.168.70.121 is preconfigured as the service address on Ethernet port 1 on canister 1. The IP address 192.168.70.122 is preconfigured as the service address on Ethernet port 1 of canister 2. Do not attach Ethernet cables to the network if a conflict exists with these IP addresses. If these IP addresses conflict with any devices in your network, use the **Set or reset service IP address** option of the initialization tool that is described in step "Step 13. Configuring the system" on page 25 to set the service IP addresses on any node that has a conflict before continuing. If necessary, perform the procedure on both nodes. See the *IBM Storwize V7000 Troubleshooting, Recovery, and Maintenance Guide* PDF on the DVD for further information about setting service IP addresses using a USB key.

1. For each node canister in the control enclosure, connect an Ethernet cable between Ethernet port 1 of the canister and an enabled port on your Ethernet switch or router. Port 1 can be used for management, service, and iSCSI.

Note: Ethernet cables are not supplied as part of your order. A CAT 5 unshielded twisted pair (UTP) is the minimum requirement for an Ethernet cable.

Ensure that cables are installed in a tidy manner to reduce the risk of cable damage when Storwize V7000 replaceable units are removed or inserted.

2. Optionally attach Ethernet cables between Ethernet port 2 on each node canister and your Ethernet network. Port 2 can be used for management and iSCSI.

Step 9. Attaching the longwave SFP transceivers

This task applies if you are using longwave SFP transceivers and have ordered longwave SFP transceivers.

Attention: The shortwave SFP transceivers are preinstalled in the control enclosure. No further action is required if you are using the shortwave SFP transceivers.

1. For both node canisters in the control enclosure, identify which of the four shortwave SFP transceivers must be replaced with longwave SFP transceivers.
2. Remove the shortwave SFP transceivers.
3. Plug the longwave SFP transceivers into ports 1-4, as needed.

For more information about removing and replacing hardware components, see the "Removing and replacing parts" topics in the Storwize V7000 Information Center to find out how to perform these procedures.

Step 10. Attaching the Fibre Channel cables

This task applies if you are installing a control enclosure and are connecting it to your Fibre Channel network.

This task assumes that your initial planning has determined where the Fibre Channel cables are to be located.

1. Remove any protective end covers from the cables or the SFP transceivers.
2. Attach the Fibre Channel cables to a Fibre Channel switch.

Ensure that cables are installed in a tidy manner to reduce the risk of cable damage when Storwize V7000 replaceable units are removed or inserted.

3. Attach the other ends of the Fibre Channel cables to the Fibre Channel ports on the node canisters.

Note: If you use fewer than eight Fibre Channel cables, it does not matter which Fibre Channel ports you use. Ensure that you attach the Fibre Channel cables evenly between the two node canisters.

Be sure to configure your Fibre Channel zoning to match the guidelines in the "Zoning details" topic in the Storwize V7000 Information Center. You must configure your zoning before the system is fully operational.

Notes:

1. Ensure that Storwize V7000 ports with shortwave SFP transceivers are connected to shortwave SFP transceivers on the Fibre Channel switch. The same requirement applies to longwave SFP transceivers.
2. The cable types are different between longwave and shortwave connections. Ensure that the correct cable type is used.

Step 11. Connecting the power cords

Two power supply units are located in each enclosure. Ensure that the power switches for each power supply unit are off.

Perform the following steps when you attach the power cord to each power supply unit.

Note: Each power supply unit comes with an attached cable retention bracket that fastens around the power cord to prevent the cord from being removed accidentally.

1. Straighten the cable tie on the cable retention bracket. The cable retention bracket is attached to the power supply unit.
2. Open the cable retention bracket.



Figure 15. Unlocking the cable retention bracket

3. Slide the cable retention bracket away from the power supply unit until there is enough room to attach the cable retention bracket to the cable. When sliding the bracket away from the cable plugin, pull the lever on the bracket that controls the cable tie towards you. You do not need to pull the lever to slide the bracket towards the cable plugin.
4. Attach a power cord to each of the two power supply units in each enclosure.
Ensure that cables are installed in a tidy manner to reduce the risk of cable damage when Storwize V7000 replaceable units are removed or inserted.
5. Place the cable retention bracket around the end of the cable that plugs into the power supply unit.
6. Slide the cable retention bracket along the cord until it fits snugly against the plug end of the cable.

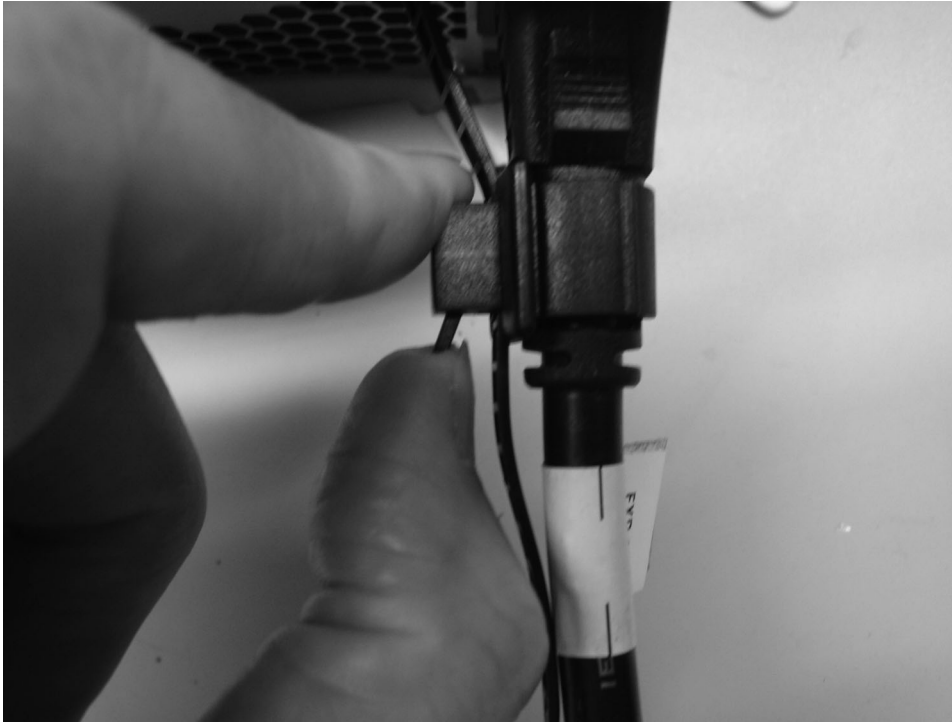

svc00644

Figure 16. Sliding the cable retention bracket directly behind the power cord

7. Tighten the fastener around the plug.
8. Repeat the steps for each additional power cord.
9. Plug the power cords into a properly grounded electrical outlet. To provide power failure redundancy, plug the power cords for the individual power supply units for each enclosure into separate power distribution circuits, if possible.

Step 12. Powering on the system

Attention: Do not operate the system when the drive assemblies are missing. Drive assemblies that are missing disrupt the airflow; the drives do not receive sufficient cooling. You must insert blank carriers into unused drive bays.

1. Power on all expansion enclosures. Use the power switch on each of the two power supply units in the back of the expansion enclosure.
2. Use the information in Table 2 on page 22 to verify the state of the LEDs on the system. Verify that no faults are detected. See the *IBM Storwize V7000 Troubleshooting, Recovery, and Maintenance Guide* PDF on the DVD if problems are encountered.

Figure 17 on page 22 shows the location of the LEDs on the power supply units in the rear of the expansion enclosure.

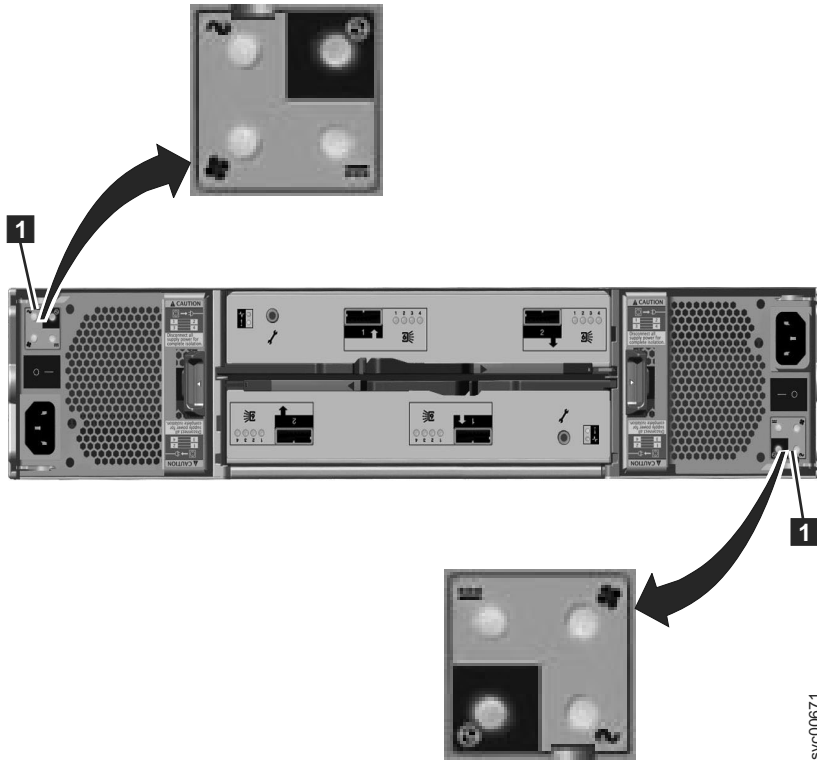











Figure 17. LEDs on the power supply units of the expansion enclosure

Table 2. LED status when expansion enclosures are powered on

Hardware component	LED name and symbol	If power on and no fault is detected
Left enclosure end cap, front of enclosure	Power, top 	LED is on.
	Fault, middle 	LED is off.
	Identify, bottom 	LED is off.
Expansion canister, rear. The reference to the top and bottom locations applies to canister 1, which is the upper canister. The LED locations are inverted for canister 2, which is the lower canister.	Canister status, top 	LED is on.
	Fault status, bottom 	LED is off.
Power supply unit, expansion enclosure. The reference to the left and right locations applies to power supply unit 1, which is the left power supply. The LED locations are inverted for power supply unit 2, which is the right power supply.	Power supply, upper right 	LED is on.
	Fan failure 	LED is off.
	dc power failure 	LED is off.
	ac power failure, upper left 	LED is off.

3. Power on the control enclosure by using the power switch on each of the two power supply units in the back of the enclosure.
4. Use the Table 3 on page 23 to verify the state of the LEDs on the system. Verify that no faults are detected.

Figure 18 on page 23 shows the location of the LEDs on the power supply units in the rear of the control enclosure.

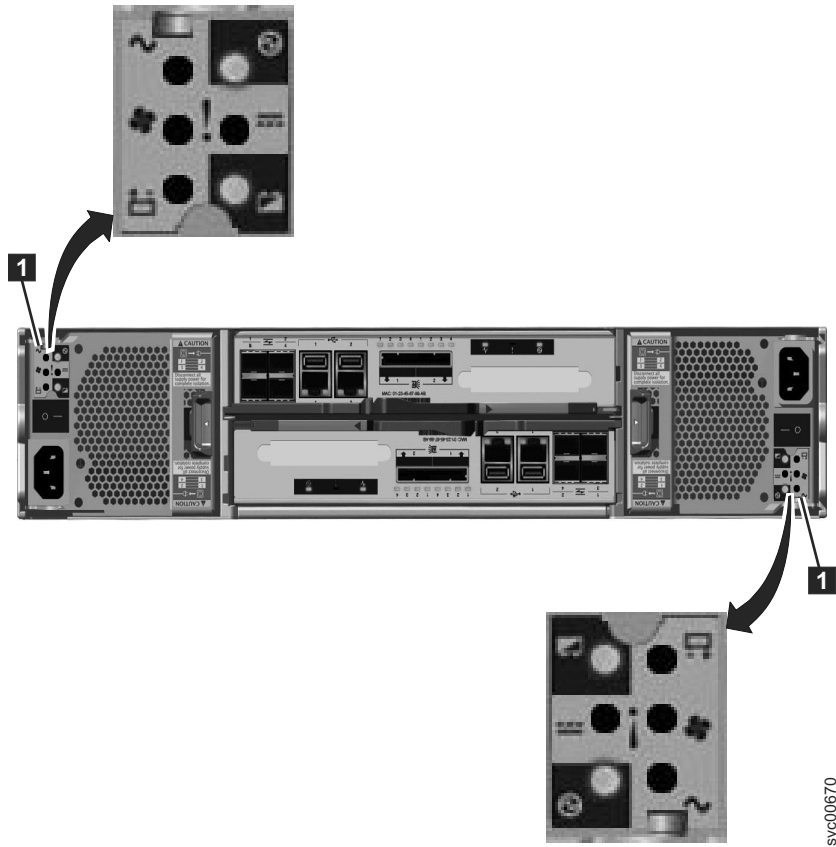

svc00670

Figure 18. LEDs on the power supply units of the control enclosure

Table 3. LED status when control enclosure is powered on













Hardware component	LED name	If power on and no fault is detected
Left enclosure end cap, front of enclosure	Power, top 	LED is on.
	Fault, middle 	LED is off.
	Identify, bottom 	LED is off.

Table 3. LED status when control enclosure is powered on (continued)

Hardware component	LED name	If power on and no fault is detected
Node canister, rear. The reference to the top and bottom locations applies to canister 1, which is the upper canister. The LED locations are inverted for canister 2, which is the lower canister.	Fibre Channel port, if used	One or more LEDs are on or flashing per port. The LEDs are located between the Fibre Channel ports. The arrow-shaped LEDs point toward the affected port.
	Ethernet port, if used	One or more LEDs are on per port.
	SAS ports	Four LEDs are on per connected port.
	Cluster status, left 	LED is flashing or on. The cluster status is on if the node canister is an active member of a cluster. The cluster status is flashing if the node canister is in service or candidate state. If the cluster status is off, the node canister might still be booting up.
	Fault status, middle 	LED is off.
	Power status, right 	LED is on.
Power supply unit, control enclosure. The reference to the left and right locations applies to power supply unit 1, which is the left power supply. The LED locations are inverted for power supply unit 2, which is the right power supply.	Power supply, upper right 	LED is on.
	ac power failure, upper left 	LED is off.
	dc power failure 	LED is off.
	Fan failure 	LED is off.
	Battery failure 	LED is off
	Battery good, lower right 	LED is on or flashing.

See the *IBM Storwize V7000 Troubleshooting, Recovery, and Maintenance Guide* PDF on the DVD if problems are encountered.

Chapter 3. Configuring the system

In the previous steps, you installed the enclosures in the rack, connected all cables, powered the system on, and checked the LED status for the system. When you have completed all these steps, continue with the last step to configure the system.

The last step for configuring your system provides instructions for two scenarios. Follow the first set of instructions when you are setting up your system for the first time. Follow the second set of instructions when you have an existing system and are now adding one or more expansion enclosures to the existing system.

Step 13. Configuring the system

To complete this step, you must use a supported browser. Verify that you are using a supported browser from the following website:

Support for Storwize V7000 website at www.ibm.com/storage/support/storwize/v7000

- **Scenario 1: Setting up your system for the first time with a control enclosure or a control enclosure and one or more expansion enclosures.**

You must initialize the system by creating a cluster and configuring it. The first stage is to create the cluster using the initialization tool and the USB key. You must know the required cluster management IP address before continuing.

1. Locate the USB key that was shipped with your order in the documentation package.
2. Insert the USB key into a USB port in a personal computer that is running Microsoft Windows XP Professional or higher.

Start the initialization tool.

If the system is configured to autorun for USB keys, the initialization tool starts automatically. Otherwise, open the USB key from **My Computer** and double-click the `InitTool.exe`.



Figure 19. Initialization tool welcome panel

If you are running a non-Windows operating system, you must create the files manually on the USB key. See the *IBM Storwize V7000 Troubleshooting, Recovery, and Maintenance Guide* PDF on the DVD to learn more about using the USB key to manage or service the system.

3. Follow the on-screen instructions to configure the system by selecting the **Initialize a new system using the USB key** option from the Welcome panel of the initialization tool. The initialization tool guides you through the configuration process:
 - a. Entering the management IP address.
 - b. Transferring the USB key to the powered-on control enclosure to create the cluster.

While the cluster is being created, the amber fault LED on the node canister flashes. When the amber fault LED stops flashing, remove the USB key and reinsert it in your personal computer to restart the initialization tool. The results of the create cluster operation are shown. Check that the cluster create succeeded.

The cluster cannot become active until there is sufficient battery power to safeguard the system in the event of a power failure. If the batteries do not have sufficient charge, the cluster cannot start immediately. An estimated time for when the cluster is available is shown. When you receive the batteries, they normally contain sufficient power for the cluster to start.

The LED status on the node canisters in the control enclosure change when a cluster starts. The cluster status LED on the node canister that you created the cluster on changes from flashing to fully on when the cluster is created and there is sufficient battery power to safeguard the system. After a short wait, the cluster status LED on the other node canister changes from flashing to fully on. For information about the LEDs, see “Step 12. Powering on the system” on page 21.

If necessary, wait until the cluster has started.

If you are unable to create the cluster, see the *IBM Storwize V7000 Troubleshooting, Recovery, and Maintenance Guide* PDF on the DVD that is shipped with the system. Remove hardware components only when directed to do so by the service procedures. Failure to follow the procedures can result in loss of access to data or loss of data.

If you are unable to start the management GUI, see the *IBM Storwize V7000 Troubleshooting, Recovery, and Maintenance Guide* PDF on the DVD that is shipped with the system.

4. If the personal computer from which you are using the initialization tool has a supported browser and an Ethernet connection to the cluster IP address, click **Launch the management GUI** on the results window. Otherwise, go to a personal computer that has an Ethernet connection to the cluster IP address and point a supported browser to the management IP address to start the management GUI. You see the management GUI logon panel.

For assistance in troubleshooting a problem, see the *IBM Storwize V7000 Troubleshooting, Recovery, and Maintenance Guide* PDF on the DVD that is shipped with the system.

5. Log in as superuser. Use `passwd` for the password.

Note: Change the password to a secure value as soon as possible.

6. Review the International Program License Agreement (IPLA).
You must accept the agreement before you can continue to use the product.
7. The Setup wizard starts and guides you through the initial configuration and verification of the system.

If you are not ready to complete any of the configuration steps now, use the configuration tasks in the management GUI to complete the configuration at a later time.

8. When you are finished using the USB key, store it in a safe location. You can use it to do other tasks.
- **Scenario 2: Adding an expansion enclosure into an existing system.**
 1. Start the management GUI.
 2. Go to **Home** → **Manage Device**.
 3. Select the system name in the tree.
 4. Go to **Actions** → **Add Enclosure**.
 5. Continue to follow the on-screen instructions.

This step completes the quick installation procedures. If you are setting up for the first time, see the configuring topics in the Storwize V7000 Information Center and continue to follow the tasks available in **Getting Started** from the management GUI. If you added an expansion enclosure into an existing system, continue to perform your standard tasks.

Notices

This information was developed for products and services offered in the U.S.A.

IBM may not offer the products, services, or features discussed in this document in other countries. Consult your local IBM representative for information on the products and services currently available in your area. Any reference to an IBM product, program, or service is not intended to state or imply that only that IBM product, program, or service may be used. Any functionally equivalent product, program, or service that does not infringe any IBM intellectual property right may be used instead. However, it is the user's responsibility to evaluate and verify the operation of any non-IBM product, program, or service.

IBM may have patents or pending patent applications covering subject matter described in this document. The furnishing of this document does not give you any license to these patents. You can send license inquiries, in writing, to:

*IBM Director of Licensing
IBM Corporation
North Castle Drive
Armonk, NY 10504-1785
U.S.A.*

For license inquiries regarding double-byte (DBCS) information, contact the IBM Intellectual Property Department in your country or send inquiries, in writing, to:

*Intellectual Property Licensing
Legal and Intellectual Property Law
IBM Japan, Ltd.
1623-14, Shimotsuruma, Yamato-shi
Kanagawa 242-8502 Japan*

The following paragraph does not apply to the United Kingdom or any other country where such provisions are inconsistent with local law: INTERNATIONAL BUSINESS MACHINES CORPORATION PROVIDES THIS PUBLICATION "AS IS" WITHOUT WARRANTY OF ANY KIND, EITHER EXPRESS OR IMPLIED, INCLUDING, BUT NOT LIMITED TO, THE IMPLIED WARRANTIES OF NON-INFRINGEMENT, MERCHANTABILITY OR FITNESS FOR A PARTICULAR PURPOSE. Some states do not allow disclaimer of express or implied warranties in certain transactions, therefore, this statement may not apply to you.

This information could include technical inaccuracies or typographical errors. Changes are periodically made to the information herein; these changes will be incorporated in new editions of the publication. IBM may make improvements and/or changes in the product(s) and/or the program(s) described in this publication at any time without notice.

Any references in this information to non-IBM websites are provided for convenience only and do not in any manner serve as an endorsement of those websites. The materials at those websites are not part of the materials for this IBM product and use of those websites is at your own risk.

IBM may use or distribute any of the information you supply in any way it believes appropriate without incurring any obligation to you.

Licensees of this program who wish to have information about it for the purpose of enabling: (i) the exchange of information between independently created programs and other programs (including this one) and (ii) the mutual use of the information which has been exchanged, should contact:

*IBM Corporation
Almaden Research
650 Harry Road
Bldg 80, D3-304, Department 277
San Jose, CA 95120-6099
U.S.A.*

Such information may be available, subject to appropriate terms and conditions, including in some cases, payment of a fee.

The licensed program described in this document and all licensed material available for it are provided by IBM under terms of the IBM Customer Agreement, IBM International Program License Agreement or any equivalent agreement between us.

Any performance data contained herein was determined in a controlled environment. Therefore, the results obtained in other operating environments may vary significantly. Some measurements may have been made on development-level systems and there is no guarantee that these measurements will be the same on generally available systems. Furthermore, some measurement may have been estimated through extrapolation. Actual results may vary. Users of this document should verify the applicable data for their specific environment.

Information concerning non-IBM products was obtained from the suppliers of those products, their published announcements or other publicly available sources. IBM has not tested those products and cannot confirm the accuracy of performance, compatibility or any other claims related to non-IBM products. Questions on the capabilities of non-IBM products may be addressed to the suppliers of those products.

All statements regarding IBM's future direction or intent are subject to change or withdrawal without notice, and represent goals and objectives only.

This information is for planning purposes only. The information herein is subject to change before the products described become available.

This information contains examples of data and reports used in daily business operations. To illustrate them as completely as possible, the examples include the names of individuals, companies, brands, and products. All of these names are fictitious and any similarity to the names and addresses used by an actual business enterprise is entirely coincidental.

COPYRIGHT LICENSE:

This information contains sample application programs in source language, which illustrate programming techniques on various operating platforms. You may copy, modify, and distribute these sample programs in any form without payment to IBM, for the purposes of developing, using, marketing or distributing application programs conforming to the application programming interface for the operating platform for which the sample programs are written. These examples have not been thoroughly tested under all conditions. IBM, therefore, cannot guarantee or imply reliability, serviceability, or function of these programs. The sample programs are provided "AS IS", without warranty of any kind. IBM shall not be liable for any damages arising out of your use of the sample programs.

If you are viewing this information softcopy, the photographs and color illustrations may not appear.

Trademarks

IBM, the IBM logo, and ibm.com are trademarks or registered trademarks of International Business Machines Corp., registered in many jurisdictions worldwide. Other product and service names might be trademarks of IBM or other companies. A current list of IBM trademarks is available on the web at Copyright and trademark information at www.ibm.com/legal/copytrade.shtml.

Adobe and the Adobe logo are either registered trademarks or trademarks of Adobe Systems Incorporated in the United States, and/or other countries.

Intel, Intel logo, Intel Xeon, and Pentium are trademarks or registered trademarks of Intel Corporation or its subsidiaries in the United States and other countries.

Java and all Java-based trademarks and logos are trademarks of Sun Microsystems, Inc. in the United States, other countries, or both.

Linux is a registered trademark of Linus Torvalds in the United States, other countries, or both.

Microsoft, Windows, Windows NT, and the Windows logo are trademarks of Microsoft Corporation in the United States, other countries, or both.

UNIX is a registered trademark of The Open Group in the United States and other countries.

Other company, product, or service names may be trademarks or service marks of others.

Electronic emission notices

The following electronic emission statements apply to this product. The statements for other products that are intended for use with this product are included in their accompanying documentation.

Federal Communications Commission (FCC) statement

This explains the Federal Communications Commission's (FCC) statement.

This equipment has been tested and found to comply with the limits for a Class A digital device, pursuant to Part 15 of the FCC Rules. These limits are designed to provide reasonable protection against harmful interference when the equipment is operated in a commercial environment. This equipment generates, uses, and can radiate radio frequency energy and, if not installed and used in accordance with the instruction manual, might cause harmful interference to radio communications. Operation of this equipment in a residential area is likely to cause harmful interference, in which case the user will be required to correct the interference at his own expense.

Properly shielded and grounded cables and connectors must be used in order to meet FCC emission limits. IBM is not responsible for any radio or television interference caused by using other than recommended cables and connectors, or by unauthorized changes or modifications to this equipment. Unauthorized changes or modifications could void the user's authority to operate the equipment.

This device complies with Part 15 of the FCC Rules. Operation is subject to the following two conditions: (1) this device might not cause harmful interference, and (2) this device must accept any interference received, including interference that might cause undesired operation.

Industry Canada compliance statement

This Class A digital apparatus complies with ICES-003.

Cet appareil numérique de la classe A est conforme à la norme NMB-003 du Canada.

Avis de conformité à la réglementation d'Industrie Canada

Cet appareil numérique de la classe A est conforme à la norme NMB-003 du Canada.

Australia and New Zealand Class A Statement

Attention: This is a Class A product. In a domestic environment this product might cause radio interference in which case the user might be required to take adequate measures.

European Union Electromagnetic Compatibility Directive

This product is in conformity with the protection requirements of European Union (EU) Council Directive 2004/108/EC on the approximation of the laws of the Member States relating to electromagnetic compatibility. IBM cannot accept responsibility for any failure to satisfy the protection requirements resulting from a non-recommended modification of the product, including the fitting of non-IBM option cards.

Attention: This is an EN 55022 Class A product. In a domestic environment this product might cause radio interference in which case the user might be required to take adequate measures.

Responsible Manufacturer:

International Business Machines Corp.
New Orchard Road
Armonk, New York 10504
914-499-1900

European community contact:

IBM Technical Regulations, Department M456
IBM-Allee 1, 71137 Ehningen, Germany
Tel: +49 7032 15-2937
E-mail: tjahn@de.ibm.com

Germany Electromagnetic compatibility directive

Deutschsprachiger EU Hinweis: Hinweis für Geräte der Klasse A EU-Richtlinie zur Elektromagnetischen Verträglichkeit

Dieses Produkt entspricht den Schutzanforderungen der EU-Richtlinie 2004/108/EG zur Angleichung der Rechtsvorschriften über die elektromagnetische Verträglichkeit in den EU-Mitgliedsstaaten und hält die Grenzwerte der EN 55022 Klasse A ein.

Um dieses sicherzustellen, sind die Geräte wie in den Handbüchern beschrieben zu installieren und zu betreiben. Des Weiteren dürfen auch nur von der IBM empfohlene Kabel angeschlossen werden. IBM übernimmt keine Verantwortung für die Einhaltung der Schutzanforderungen, wenn das Produkt ohne Zustimmung der IBM verändert bzw. wenn Erweiterungskomponenten von Fremdherstellern ohne Empfehlung der IBM gesteckt/eingebaut werden.

EN 55022 Klasse A Geräte müssen mit folgendem Warnhinweis versehen werden:

"Warnung: Dieses ist eine Einrichtung der Klasse A. Diese Einrichtung kann im Wohnbereich Funk-Störungen verursachen; in diesem Fall kann vom Betreiber verlangt werden, angemessene Maßnahmen zu ergreifen und dafür aufzukommen."

Deutschland: Einhaltung des Gesetzes über die elektromagnetische Verträglichkeit von Geräten

Dieses Produkt entspricht dem "Gesetz über die elektromagnetische Verträglichkeit von Geräten (EMVG)." Dies ist die Umsetzung der EU-Richtlinie 2004/108/EG in der Bundesrepublik Deutschland.

Zulassungsbescheinigung laut dem Deutschen Gesetz über die elektromagnetische Verträglichkeit von Geräten (EMVG) (bzw. der EMC EG Richtlinie 2004/108/EG) für Geräte der Klasse A

Dieses Gerät ist berechtigt, in Übereinstimmung mit dem Deutschen EMVG das EG-Konformitätszeichen - CE - zu führen.

Verantwortlich für die Einhaltung der EMV Vorschriften ist der Hersteller:

International Business Machines Corp.
New Orchard Road
Armonk, New York 10504
Tel: 914-499-1900

Der verantwortliche Ansprechpartner des Herstellers in der EU ist:

IBM Deutschland
Technical Regulations, Department M456
IBM-Allee 1, 71137 Ehningen, Germany
Tel: +49 7032 15-2937
e-mail: tjahn@de.ibm.com

Generelle Informationen: Das Gerät erfüllt die Schutzanforderungen nach EN 55024 und EN 55022 Klasse A.

Japan VCCI Council Class A statement

この装置は、クラス A 情報技術装置です。この装置を家庭環境で使用する
と電波妨害を引き起こすことがあります。この場合には使用者が適切な対策
を講ずるよう要求されることがあります。 VCCI-A

People's Republic of China Class A Electronic Emission Statement

中华人民共和国“A类”警告声明

声明

此为A级产品，在生活环境中，该产品可能会造成无线电干扰。在这种情况下，可能需要用户对其干扰采取切实可行的措施。

International Electrotechnical Commission (IEC) statement

This product has been designed and built to comply with (IEC) Standard 950.

United Kingdom telecommunications requirements

This apparatus is manufactured to the International Safety Standard EN60950 and as such is approved in the U.K. under approval number NS/G/1234/J/100003 for indirect connection to public telecommunications systems in the United Kingdom.

Korean Communications Commission (KCC) Class A Statement

이기는 업무용으로 전자파 적합등록을 받은 기기
이오니, 판매자 또는 사용자는 이점을 주의하시기
바라며, 만약 잘못 구입하셨을 때에는 구입한 곳에
서 비업무용으로 교환하시기 바랍니다.

Russia Electromagnetic Interference (EMI) Class A Statement

ВНИМАНИЕ! Настоящее изделие относится к классу А.
В жилых помещениях оно может создавать
радиопомехи, для снижения которых необходимы
дополнительные меры

rusemi

Taiwan Class A compliance statement

警告使用者：
這是甲類的資訊產品，在
居住的環境中使用時，可
能會造成射頻干擾，在這
種情況下，使用者會被要
求採取某些適當的對策。

taieimi

European Contact Information

This topic contains the product service contact information for Europe.

European Community contact:
IBM Technical Regulations
Pascalstr. 100, Stuttgart, Germany 70569
Tele: 0049 (0)711 785 1176
Fax: 0049 (0)711 785 1283
Email: <mailto:tjahn@de.ibm.com>

Taiwan Contact Information

This topic contains the product service contact information for Taiwan.

IBM Taiwan Product Service Contact Information:
IBM Taiwan Corporation
3F, No 7, Song Ren Rd., Taipei Taiwan
Tel: 0800-016-888

台灣IBM 產品服務聯絡方式：
台灣國際商業機器股份有限公司
台北市松仁路7號3樓
電話：0800-016-888

f2c00790



Part Number: 85Y5979

Printed in USA

GC27-2290-00



(1P) P/N: 85Y5979

