

IBM System Storage SAN Volume Controller



Hardware Maintenance Guide

Version 5.1.0

IBM System Storage SAN Volume Controller



Hardware Maintenance Guide

Version 5.1.0

Note:

Before using this information and the product it supports, read the information in the **Safety and environmental notices and Notices**, as well as the information in the **IBM Environmental Notices and User Guide** on the documentation CD.

This edition applies to the IBM System Storage SAN Volume Controller, release 5.1.0, and to all subsequent releases and modifications until otherwise indicated in new editions. This edition replaces GC27-2226-01.

© **Copyright International Business Machines Corporation 2003, 2009.**

US Government Users Restricted Rights – Use, duplication or disclosure restricted by GSA ADP Schedule Contract with IBM Corp.

Contents

Figures	vii
Tables	xv
Safety and environmental notices	xvii
General safety	xvii
Electrical safety	xviii
Inspecting the SAN Volume Controller for unsafe conditions	xix
External device check	xx
Internal device checks	xxi
Checking the grounding of a SAN Volume Controller, the uninterruptible power supply, and the redundant ac-power switch	xxi
Inspecting the uninterruptible power supply for unsafe conditions	xxiii
Uninterruptible power-supply requirements	xxiii
Emergency power-off shutdown	xxiv
Handling static-sensitive devices	xxiv
Environmental notices and statements	xxiv
Product recycling and disposal	xxiv
About this guide	xxv
Who should use this guide	xxv
Summary of changes	xxv
Summary of changes for GC27-2226-01 and GC27-2226-02 SAN Volume Controller Hardware Maintenance Guide	xxv
Emphasis	xxvi
SAN Volume Controller library and related publications	xxvii
Related Web sites	xxx
How to order IBM publications	xxxi
How to send your comments	xxxi
Chapter 1. Parts listing	1
SAN Volume Controller 2145-CF8 parts	1
SAN Volume Controller 2145-8A4 parts	6
SAN Volume Controller 2145-8G4 parts	9
SAN Volume Controller 2145-8F4 parts	13
SAN Volume Controller 2145-8F2 parts	15
Redundant ac-power switch parts	18
2145 UPS-1U parts	18
Power cables for the 2145 UPS-1U	20
Chapter 2. Removing and replacing parts	23
Enabling concurrent maintenance	23
Preparing to remove and replace parts	24
Working inside the node with the power on	24
Removing and replacing SAN Volume Controller parts	25
Removing the cable-management arm	25
Replacing the cable-management arm	30
Removing the cable-retention bracket	34
Replacing the cable-retention bracket	40
Removing the SAN Volume Controller from a rack	48
Replacing the SAN Volume Controller in a rack	59
Removing the support rails for a SAN Volume Controller	66
Installing the support rails for a SAN Volume Controller	70

Removing the top cover	81
Replacing the top cover	86
Removing the service controller.	90
Replacing the service controller	102
Replacing a disk drive and a service controller on the SAN Volume Controller.	110
Removing and replacing the SAN Volume Controller power-cable assembly	110
Removing the memory modules (DIMM)	112
Replacing the memory modules (DIMM)	116
Removing the disk drive	118
Replacing the disk drive	126
Removing a solid-state drive (SSD)	131
Replacing a solid-state drive (SSD)	134
Removing the disk-drive backplane	136
Replacing the disk-drive backplane	143
Removing the CMOS battery	151
Replacing the CMOS battery	157
Removing the power supply.	165
Replacing the power supply.	172
Removing the power backplane	181
Replacing the power backplane	183
Removing and replacing the frame assembly	185
Removing and replacing the fibre-channel SFP connector on a SAN Volume Controller node	187
Removing the fibre-channel adapter assembly	189
Replacing the fibre-channel adapter assembly	197
Removing the high-speed SAS adapter	202
Replacing the high-speed SAS adapter	204
Removing the high-speed SAS adapter, the adapter cable, and the solid-state drive (SSD).	206
Replacing the high-speed SAS adapter, the adapter cable, and the solid-state drive (SSD).	209
Removing the disk-controller and USB riser-card assembly	212
Replacing the disk-controller and USB riser-card assembly	214
Removing the PCI express riser card assembly	219
Replacing the PCI express riser-card assembly	220
Removing the operator-information panel assembly	220
Replacing the operator-information panel assembly	229
Removing the operator-information panel cable	237
Replacing the operator-information panel cable	241
Removing the fans	244
Replacing the fans	250
Removing the SAN Volume Controller 2145-8F2 or SAN Volume Controller 2145-8F4 fan holder and fan backplanes	258
Replacing the SAN Volume Controller 2145-8F2 or SAN Volume Controller 2145-8F4 fan holder and fan backplanes	258
Removing the microprocessor	259
Replacing the microprocessor	266
Removing the SAN Volume Controller 2145-8F4 or SAN Volume Controller 2145-8F2 VRM	278
Replacing the SAN Volume Controller 2145-8F2 or SAN Volume Controller 2145-8F4 VRM	280
Removing the SAN Volume Controller system board	280
Replacing the SAN Volume Controller system board.	296
Removing the redundant ac-power switch	311
Replacing the redundant ac-power switch	312

Removing and replacing 2145 UPS-1U parts	314
Removing and replacing the 2145 UPS-1U power cable-retention bracket	314
Removing the 2145 UPS-1U	315
Replacing the 2145 UPS-1U	319
Removing the support rails for a 2145 UPS-1U	324
Installing the support rails for the 2145 UPS-1U	325
Removing the power cable from the 2145 UPS-1U	327
Removing the 2145 UPS-1U battery	329
Replacing the 2145 UPS-1U battery	331
Appendix. Accessibility.	335
Notices	337
Trademarks.	339
Electronic emission notices	339
Federal Communications Commission (FCC) statement	339
Industry Canada compliance statement	340
Avis de conformité à la réglementation d'Industrie Canada	340
New Zealand compliance statement.	340
European Union EMC Directive conformance statement	340
Germany compliance statement	341
Japanese Voluntary Control Council for Interference (VCCI) statement	341
People's Republic of China Class A Electronic Emission Statement	342
International Electrotechnical Commission (IEC) statement	342
United Kingdom telecommunications requirements	342
Korean Class A Electronic Emission Statement	342
Taiwan Class A compliance statement	342
European Contact Information	342
Taiwan Contact Information	343
Index	345

Figures

1. Exploded view of the SAN Volume Controller 2145-CF8 node	2
2. Exploded view of the SAN Volume Controller 2145-8A4 node	6
3. Exploded view of the SAN Volume Controller 2145-8G4 node	10
4. Exploded view of the SAN Volume Controller 2145-8F4 node	14
5. Exploded view of the SAN Volume Controller 2145-8F2 node	16
6. View of the redundant ac-power switch FRU.	18
7. Exploded view of the 2145 UPS-1U hardware	19
8. SAN Volume Controller 2145-CF8 cable-management arm, support rails, and associated parts	25
9. SAN Volume Controller 2145-CF8 release latches and mounting screws	26
10. SAN Volume Controller 2145-CF8 cables in the cable-management arm	27
11. SAN Volume Controller 2145-CF8 cable-management arm on the support arm	28
12. Removing the SAN Volume Controller 2145-CF8 cable-management arm mounting bracket	29
13. Freeing the swing end of the SAN Volume Controller 2145-CF8 support arm	29
14. Removing the SAN Volume Controller 2145-CF8 cable-management stop bracket	30
15. Detaching the SAN Volume Controller 2145-CF8 cable-management support arm	30
16. Rack rear: Attaching the SAN Volume Controller 2145-CF8 cable-management support arm	31
17. Rack rear: Installing the SAN Volume Controller 2145-CF8 cable-management stop bracket	31
18. Attaching the free end of the SAN Volume Controller 2145-CF8 support arm	32
19. Rack rear: Installing the SAN Volume Controller 2145-CF8 cable-management arm mounting bracket	32
20. SAN Volume Controller 2145-CF8 cable-management arm on the support arm	33
21. SAN Volume Controller 2145-CF8 cables in the cable-management arm	34
22. SAN Volume Controller 2145-CF8 cable-retention brackets	35
23. SAN Volume Controller 2145-8A4 with the cable-retention bracket installed	37
24. SAN Volume Controller 2145-8G4 cable retention bracket - type A	38
25. SAN Volume Controller 2145-8G4 cable retention bracket - type B	38
26. The SAN Volume Controller 2145-8G4 with the cable-retention bracket attached	39
27. The SAN Volume Controller 2145-8G4 with cable-retention bracket type B attached	40
28. SAN Volume Controller 2145-CF8 cable-retention brackets	41
29. Raising the SAN Volume Controller 2145-CF8 locking levers of the slide rails of the rack	42
30. Retaining screw on the SAN Volume Controller 2145-8A4 node	43
31. Installing the SAN Volume Controller 2145-8A4 cable retention bracket	44
32. SAN Volume Controller 2145-8G4 cable retention bracket - type A	45
33. SAN Volume Controller 2145-8G4 cable retention bracket - type B	45
34. The SAN Volume Controller 2145-8G4 before you attach the cable-retention bracket	46
35. The SAN Volume Controller 2145-8G4 with cable-retention bracket type B attached	47
36. Attaching the cable retention bracket to the SAN Volume Controller 2145-8F4 power cable	48
37. Removing the SAN Volume Controller 2145-CF8 from the rack	51
38. The captive thumbscrews that secure the node and the shipping brackets	54
39. Removing the SAN Volume Controller 2145-8G4 from the rack	57
40. Installing the SAN Volume Controller 2145-CF8 node in the slide rails of the rack	62
41. Raising the SAN Volume Controller 2145-CF8 locking levers of the slide rails of the rack	62
42. The captive thumbscrews that secure the node and the shipping brackets	63
43. The captive thumbscrews that secure the node and the shipping brackets	64
44. Aligning the SAN Volume Controller 2145-8G4 with the rack slides	65
45. Sliding the SAN Volume Controller 2145-8F4 into the rack	66
46. Disengaging the SAN Volume Controller 2145-CF8 slide rails from the rear of the rack	67
47. Removing the SAN Volume Controller 2145-CF8 slide rails from the rack	67
48. The rail-adjustment bracket and the release tab on the rear rail-locking carrier	68
49. Removing the latch strike from the front of the slide rail	69
50. Removing the right slide rail from the front of the rack	69
51. The left support rail for the SAN Volume Controller	70
52. Installing the SAN Volume Controller 2145-CF8 slide rails on the rack	71

I	53. Installing the rear of a SAN Volume Controller 2145-CF8 slide rail in the rear of the rack	71
I	54. Installing the front of a SAN Volume Controller 2145-CF8 slide rail in the front of the rack	72
	55. SAN Volume Controller 2145-8A4 support-rails installation kit	72
	56. A closed rail-locking carrier at the front of the support rail for the SAN Volume Controller 2145-8A4	73
	57. An open rail-locking carrier at the rear of the support rail for the SAN Volume Controller 2145-8A4	74
	58. Aligning the pins on the left front support rail for the SAN Volume Controller 2145-8A4 with the front mounting flange	75
	59. SAN Volume Controller 2145-8G4 support rails installation kit	76
	60. Inserting the right slide rail into the rear rack mounting flange	76
	61. Extending the right slide rail.	77
	62. Attaching the latch strike to the front of the slide rail.	77
	63. Retracting the latch-lock carrier	78
	64. Opening the front latch-lock carrier assembly	79
	65. Opening the back latch-lock carrier assembly	79
	66. Installing the front end of the rail	80
	67. Closing the latch-lock carrier assembly.	81
I	68. Removing the SAN Volume Controller 2145-CF8 cover.	83
	69. Removing the SAN Volume Controller 2145-8A4 cover.	84
	70. The SAN Volume Controller 2145-8G4 with fan door open	85
	71. SAN Volume Controller 2145-8F2 or SAN Volume Controller 2145-8F4 with fan doors open	86
I	72. Replacing the SAN Volume Controller 2145-CF8 cover.	87
I	73. Raising the SAN Volume Controller 2145-CF8 locking levers of the slide rails of the rack	88
	74. SAN Volume Controller 2145-8G4 with the fan door open.	89
	75. SAN Volume Controller 2145-8F2 with the access doors open	90
I	76. Left release button of a SAN Volume Controller 2145-CF8 service controller	92
I	77. Service controller for the SAN Volume Controller 2145-CF8 with attached USB cable	93
I	78. SAN Volume Controller 2145-CF8 service controller	93
I	79. Removing and replacing the USB cable in the SAN Volume Controller 2145-CF8 service controller	95
I	80. USB service-controller cable connected to the disk controller and USB riser card in the SAN Volume Controller 2145-CF8	96
I	81. USB service-controller cable connector on the USB riser card	97
	82. SAN Volume Controller 2145-8A4 service controller release button	98
	83. SAN Volume Controller 2145-8G4 service controller release button	99
	84. Removing the service controller from the SAN Volume Controller 2145-8G4	100
	85. SAN Volume Controller 2145-8F2 or SAN Volume Controller 2145-8F4 with fan doors open	101
	86. SAN Volume Controller 2145-8F2 or SAN Volume Controller 2145-8F4 service controller	101
I	87. SAN Volume Controller 2145-CF8 service controller	103
I	88. Raising the SAN Volume Controller 2145-CF8 locking levers of the slide rails of the rack	104
	89. SAN Volume Controller 2145-8A4 service controller	105
	90. SAN Volume Controller 2145-8G4 service controller	107
	91. SAN Volume Controller 2145-8F2 or SAN Volume Controller 2145-8F4 service controller	108
	92. SAN Volume Controller 2145-8F2 or SAN Volume Controller 2145-8F4 with fan doors open	109
I	93. Power LED on the SAN Volume Controller models 2145-CF8, 2145-8A4, 2145-8G4, and 2145-8F4 or 2145-8F2 operator-information panel	111
I	94. SAN Volume Controller models 2145-CF8, 2145-8A4, 2145-8G4, and 2145-8F4 or 2145-8F2 power-control button	111
I	95. Locating the SAN Volume Controller 2145-CF8 memory modules	113
I	96. Locating the SAN Volume Controller 2145-8A4 memory modules.	114
	97. Locating the SAN Volume Controller 2145-8G4 memory modules	114
	98. Locating the SAN Volume Controller 2145-8F2 or SAN Volume Controller 2145-8F4 memory modules	115
	99. Removing the memory modules	116
I	100. Replacing a memory module	117
	101. SAN Volume Controller 2145-8A4 SATA disk drive	119
	102. Removing the SATA disk drive	120

103.	SAN Volume Controller 2145-4F2 disk drive and front panel	121
104.	Attaching the rails to the SAN Volume Controller 2145-4F2 disk drive	121
105.	Boot drive for the SAN Volume Controller 2145-CF8	123
106.	Drive-bay filler panel and disk-drive handle for the SAN Volume Controller 2145-CF8	123
107.	Drive IDs for SAN Volume Controller 2145-CF8	124
108.	SAN Volume Controller 2145-8A4 SATA disk drive	125
109.	Removing the SATA disk drive	126
110.	Drive-bay filler panel and disk-drive handle for the SAN Volume Controller 2145-CF8	128
111.	Raising the SAN Volume Controller 2145-CF8 locking levers of the slide rails of the rack	129
112.	Attaching the rails assembly to the SATA disk drive for the SAN Volume Controller 2145-8A4 and the SAN Volume Controller 2145-8G4.	130
113.	Service controller for the SAN Volume Controller 2145-CF8 with attached USB cable	133
114.	Solid-state drive (SSD) for the SAN Volume Controller 2145-CF8	133
115.	SAN Volume Controller 2145-CF8 drive and drive-bay filler.	135
116.	Raising the SAN Volume Controller 2145-CF8 locking levers of the slide rails of the rack	136
117.	Boot-disk SAS cable and the high-speed SAS cable connected to the disk backplane in the SAN Volume Controller 2145-CF8	138
118.	The SAN Volume Controller 2145-CF8 disk backplane	139
119.	SAN Volume Controller 2145-8A4 SATA cable connectors	140
120.	Air deflector for the SAN Volume Controller 2145-8A4 power supply	140
121.	SAN Volume Controller 2145-8A4 power supply connectors	141
122.	The SAN Volume Controller 2145-8G4 disk-drive backplane connectors	142
123.	The SAN Volume Controller 2145-8G4 SATA disk drive and back plate	142
124.	The SAN Volume Controller 2145-CF8 disk backplane	144
125.	Boot-disk SAS cable and the high-speed SAS cable connected to the disk backplane in the SAN Volume Controller 2145-CF8	145
126.	Boot-disk SAS cable routed through the blue bulkhead clip and connected to the SAS disk controller in the SAN Volume Controller 2145-CF8	146
127.	Raising the SAN Volume Controller 2145-CF8 locking levers of the slide rails of the rack	147
128.	Air deflector for the SAN Volume Controller 2145-8A4 power supply	147
129.	SAN Volume Controller 2145-8A4 power supply connectors	148
130.	SAN Volume Controller 2145-8A4 SATA cables	149
131.	The SAN Volume Controller 2145-8G4 SATA disk drive and back plate	150
132.	The SAN Volume Controller 2145-8G4 disk-drive backplane connectors	150
133.	Location of the SAN Volume Controller 2145-CF8 CMOS battery holder	153
134.	SAN Volume Controller 2145-CF8 CMOS battery holder	153
135.	Locating the SAN Volume Controller 2145-8A4 CMOS battery.	154
136.	Removing the SAN Volume Controller 2145-8A4 CMOS battery	154
137.	Location of the SAN Volume Controller 2145-8G4 CMOS battery holder	155
138.	SAN Volume Controller 2145-8G4 CMOS battery holder	156
139.	Location of the CMOS battery on the SAN Volume Controller 2145-8F2 or the SAN Volume Controller 2145-8F4	157
140.	SAN Volume Controller 2145-8F2 or the SAN Volume Controller 2145-8F4 CMOS battery holder	157
141.	Location of the SAN Volume Controller 2145-CF8 CMOS battery holder	159
142.	SAN Volume Controller 2145-CF8 CMOS battery holder	159
143.	Raising the SAN Volume Controller 2145-CF8 locking levers of the slide rails of the rack	160
144.	Locating the SAN Volume Controller 2145-8A4 CMOS battery.	161
145.	Installing the SAN Volume Controller 2145-8A4 CMOS battery	161
146.	Location of the SAN Volume Controller 2145-8G4 CMOS battery holder	163
147.	SAN Volume Controller 2145-8G4 CMOS battery holder	163
148.	Location of the CMOS battery on the SAN Volume Controller 2145-8F2 or the SAN Volume Controller 2145-8F4	164
149.	CMOS battery socket.	165
150.	SAN Volume Controller 2145-CF8 power supply	167
151.	SATA connectors on the SAN Volume Controller 2145-8A4 system board	168
152.	Power P5 connector on the SAN Volume Controller 2145-8A4 power supply	169

153.	The retention clip for the SAN Volume Controller 2145-8A4 power-supply cables	169
154.	The SAN Volume Controller 2145-8A4 power-supply	170
155.	SAN Volume Controller 2145-8G4 power supply	171
156.	Removing the SAN Volume Controller 2145-8F2 power supply	172
I 157.	SAN Volume Controller 2145-CF8 power supply	174
I 158.	SAN Volume Controller 2145-CF8 ac, dc, and power-error LEDs	175
159.	Air deflector for the SAN Volume Controller 2145-8A4 power supply	176
160.	SATA connectors on the SAN Volume Controller 2145-8A4 system board	176
161.	The retention clip for the SAN Volume Controller 2145-8A4 power-supply cables	177
162.	SAN Volume Controller 2145-8G4 power supply	178
163.	SAN Volume Controller 2145-8G4 ac and dc LEDs	179
164.	SAN Volume Controller 2145-8F2 power supply	180
165.	SAN Volume Controller 2145-8F2 or SAN Volume Controller 2145-8F4 ac and dc power LEDs	181
166.	SAN Volume Controller 2145-8G4 power backplane	182
167.	SAN Volume Controller 2145-8F4 or SAN Volume Controller 2145-8F2 power backplane	183
168.	SAN Volume Controller 2145-8G4 power backplane	184
169.	Replacing the SAN Volume Controller 2145-8F4 or SAN Volume Controller 2145-8F2 power backplane	185
I 170.	Fibre-channel SFP connector	189
I 171.	Connectors on the rear of the SAN Volume Controller 2145-CF8	190
I 172.	The SAN Volume Controller 2145-CF8 fibre-channel adapter	191
I 173.	Removing the fibre-channel riser-card assembly for the SAN Volume Controller 2145-CF8	192
174.	SAN Volume Controller 2145-8A4 riser-card assembly	193
175.	Fibre-channel SFP connector	193
176.	The physical port numbers for the SAN Volume Controller 2145-8G4	194
177.	Removing the riser-card assembly from the SAN Volume Controller 2145-8G4	194
178.	Rear view of the SAN Volume Controller 2145-8F2 with fibre-channel ports indicated	195
179.	Rear view of the SAN Volume Controller 2145-8F4	195
180.	SAN Volume Controller 2145-8F2 or SAN Volume Controller 2145-8F4 PCI slot 1 card retainer	196
181.	SAN Volume Controller 2145-8F2 riser card and low profile adapter	196
182.	SAN Volume Controller 2145-8F2 or SAN Volume Controller 2145-8F4 slot 2 adapter	197
I 183.	Replacing the riser-card assembly for the SAN Volume Controller 2145-8G4	198
I 184.	The SAN Volume Controller 2145-CF8 fibre-channel adapter	199
185.	SAN Volume Controller 2145-8A4 riser-card assembly	200
186.	Replacing the riser-card assembly for the SAN Volume Controller 2145-8G4	201
187.	SAN Volume Controller 2145-8F2 or SAN Volume Controller 2145-8F4 PCI slot 1 card retainer	202
I 188.	High-speed SAS adapter assembly mounted in the back rail of the SAN Volume Controller 2145-CF8	203
I 189.	Removing the high-speed SAS riser-card assembly for the SAN Volume Controller 2145-CF8	204
I 190.	Replacing the high-speed SAS riser-card assembly for the SAN Volume Controller 2145-CF8	205
I 191.	High-speed SAS adapter assembly mounted in the back rail of the SAN Volume Controller 2145-CF8	206
I 192.	High-speed SAS adapter assembly and high-speed SAS cable in the SAN Volume Controller 2145-CF8	207
I 193.	Boot-disk SAS cable routed through the blue bulkhead clip and connected to the SAS disk controller in the SAN Volume Controller 2145-CF8	208
I 194.	Boot-disk SAS cable and the high-speed SAS cable connected to the disk backplane in the SAN Volume Controller 2145-CF8	209
I 195.	High-speed SAS adapter assembly and high-speed SAS cable in the SAN Volume Controller 2145-CF8	210
I 196.	Boot-disk SAS cable and the high-speed SAS cable connected to the disk backplane in the SAN Volume Controller 2145-CF8	211
I 197.	Boot-disk SAS cable routed through the blue bulkhead clip and connected to the SAS disk controller in the SAN Volume Controller 2145-CF8	212
I 198.	USB riser-card assembly for the SAN Volume Controller 2145-CF8	213

	199. Disengaging the disk-controller front-retention bracket and removing the riser assembly and disk controller	214
	200. Engaging the disk-controller front-retention bracket and replacing the riser assembly and disk controller	215
	201. USB riser-card assembly for the SAN Volume Controller 2145-CF8	216
	202. USB service-controller cable connected to the disk controller and USB riser card in the SAN Volume Controller 2145-CF8	217
	203. Boot-disk SAS cable and the high-speed SAS cable connected to the disk backplane in the SAN Volume Controller 2145-CF8	218
	204. Boot-disk SAS cable routed through the blue bulkhead clip and connected to the SAS disk controller in the SAN Volume Controller 2145-CF8	219
	205. Using the release tab to remove the SAN Volume Controller 2145-CF8 operator-information panel.	222
	206. SAN Volume Controller 2145-8A4 operator-information panel	223
	207. SAN Volume Controller 2145-8G4 dummy CD/DVD drive	224
	208. Removing the CD interposer card	224
	209. SAN Volume Controller 2145-8G4 fan 3	225
	210. SAN Volume Controller 2145-8G4 air baffle	226
	211. SAN Volume Controller 2145-8G4 video, USB, and the CD/DVD cables	227
	212. SAN Volume Controller 2145-8G4 operator-information panel	228
	213. Removing the SAN Volume Controller 2145-8G4 operator-information panel	228
	214. SAN Volume Controller 2145-8F4 operator-information panel	229
	215. SAN Volume Controller 2145-8F2 with exposed operator-information panel	229
	216. Replacing the SAN Volume Controller 2145-CF8 operator-information panel	231
	217. Connecting the SAN Volume Controller 2145-CF8 operator-information panel cable	231
	218. Raising the SAN Volume Controller 2145-CF8 locking levers of the slide rails of the rack	232
	219. SAN Volume Controller 2145-8A4 operator-information panel	233
	220. SAN Volume Controller 2145-8G4 operator-information panel	234
	221. SAN Volume Controller 2145-8G4 video, USB, and the CD/DVD cables	234
	222. SAN Volume Controller 2145-8G4 air baffle	235
	223. SAN Volume Controller 2145-8G4 fan 3	236
	224. SAN Volume Controller 2145-8G4 dummy CD/DVD drive	236
	225. Replacing the operator-information panel	237
	226. Disconnecting the SAN Volume Controller 2145-CF8 operator-information panel cable	239
	227. SAN Volume Controller 2145-8A4 operator-information panel	240
	228. Connectors for the operator-information panel on the SAN Volume Controller 2145-8A4 system board	241
	229. Connecting the SAN Volume Controller 2145-CF8 operator-information panel cable	242
	230. Raising the SAN Volume Controller 2145-CF8 locking levers of the slide rails of the rack	243
	231. Connectors for the operator-information panel on the SAN Volume Controller 2145-8A4 system board	244
	232. SAN Volume Controller 2145-CF8 fan locations and connectors	246
	233. Removing or replacing a fan in the SAN Volume Controller 2145-CF8 node.	247
	234. Connectors for the SAN Volume Controller 2145-8A4 heat exchange fans	248
	235. SAN Volume Controller 2145-8G4 fan doors, locations, and connectors	249
	236. SAN Volume Controller 2145-8F2 with the access doors open.	250
	237. SAN Volume Controller 2145-8F2 fan locations	250
	238. SAN Volume Controller 2145-CF8 fan locations and connectors	252
	239. Removing or replacing a fan in the SAN Volume Controller 2145-CF8 node.	253
	240. Raising the SAN Volume Controller 2145-CF8 locking levers of the slide rails of the rack	254
	241. A close up of the SAN Volume Controller 2145-8A4 fan	255
	242. Routing the SAN Volume Controller 2145-8A4 fan cable	255
	243. SAN Volume Controller 2145-8G4 fan doors, locations, and connectors	257
	244. Removing the heat sink from the SAN Volume Controller 2145-CF8 microprocessor	261
	245. Opening the SAN Volume Controller 2145-CF8 microprocessor-bracket frame	261
	246. SAN Volume Controller 2145-8A4 air baffle and heat-exchanger assembly	262

247. The SAN Volume Controller 2145-8A4 microprocessor bracket frame fully opened	263
248. Removing the heat sink from the microprocessor	264
249. The microprocessor release lever and bracket frame fully opened	265
250. Location of the microprocessor and VRM sockets	265
I 251. Opening the SAN Volume Controller 2145-CF8 microprocessor-bracket frame	268
I 252. Closing the SAN Volume Controller 2145-CF8 microprocessor-bracket frame	269
I 253. Applying thermal grease to the SAN Volume Controller 2145-CF8 microprocessor	270
I 254. Installing the heat sink on the SAN Volume Controller 2145-CF8 microprocessor	270
I 255. Raising the SAN Volume Controller 2145-CF8 locking levers of the slide rails of the rack	271
256. SAN Volume Controller 2145-8A4 microprocessor	272
257. Complete set of nine thermal grease dots on the SAN Volume Controller 2145-8A4 microprocessor	273
258. Alignment pins on the SAN Volume Controller 2145-8A4 heat-exchanger assembly	274
259. Aligning the microprocessor with the socket	275
260. Installing the heat sink	276
261. Microprocessor locking lever in open position	277
262. Microprocessor and heat sink locations	278
263. Location of the microprocessor and VRM sockets	279
I 264. Removing and replacing the SAN Volume Controller 2145-CF8 system board	283
265. Connectors that are used on the SAN Volume Controller 2145-8A4 system board	285
266. SAN Volume Controller 2145-8A4 SATA cable connectors	286
267. SAN Volume Controller 2145-8A4 power supply connectors	286
268. The IDE connector on the SAN Volume Controller 2145-8A4 system board	287
269. Connectors for the SAN Volume Controller 2145-8A4 heat exchange fans	288
270. SAN Volume Controller 2145-8A4 system board and microprocessor retention module	289
271. Connectors on the SAN Volume Controller 2145-8G4 system board	291
272. Left air baffle on the SAN Volume Controller 2145-8G4	291
273. Connectors on the right front side of the SAN Volume Controller 2145-8G4 system board	292
274. Disk power cable connector and power backplane on the SAN Volume Controller 2145-8G4 system board	293
275. Right air baffle on the SAN Volume Controller 2145-8G4 system board	293
276. Removing thermal grease from the SAN Volume Controller 2145-8G4 microprocessor	294
277. Serial and video ports on the SAN Volume Controller 2145-8G4	295
278. The placement of the screws that secure the SAN Volume Controller 2145-8G4 system board	295
279. SAN Volume Controller 2145-8G4 system board	296
I 280. Removing and replacing the SAN Volume Controller 2145-CF8 system board	297
I 281. Raising the SAN Volume Controller 2145-CF8 locking levers of the slide rails of the rack	298
282. The SAN Volume Controller 2145-8A4 microprocessor bracket frame fully opened	300
283. SAN Volume Controller 2145-8G4 system board	303
284. The placement of the screws that secure the SAN Volume Controller 2145-8G4 system board	304
285. Serial and video ports on the SAN Volume Controller 2145-8G4	304
286. Installing the microprocessor	305
287. Estimating the position of the thermal grease dots	306
288. Complete set of nine thermal grease dots on the microprocessor	306
289. Right air baffle on the SAN Volume Controller 2145-8G4 system board	307
290. Connectors on the right front side of the SAN Volume Controller 2145-8G4 system board	308
291. Left air baffle on the SAN Volume Controller 2145-8G4	309
292. Connectors on the SAN Volume Controller 2145-8G4 system board	309
293. Attaching the mounting plates	312
294. Power cable clips	313
295. 2145 UPS-1U power cable-retention bracket hardware	314
296. 2145 UPS-1U power cable-retention bracket	315
297. 2145 UPS-1U power cable-retention bracket	315
298. The 2145 UPS-1U front-panel assembly	316
299. 2145 UPS-1U (rear view)	317
300. Removing the 2145 UPS-1U front panel	317

301. The 2145 UPS-1U internal-battery connector	318
302. The 2145 UPS-1U internal battery connector with protective tape	318
303. Mounting screws for the 2145 UPS-1U	319
304. Installing the support rails for a 2145 UPS-1U into the rack.	320
305. Mounting screws for the 2145 UPS-1U	321
306. Removing the 2145 UPS-1U front panel.	321
307. The 2145 UPS-1U internal battery connector with protective tape	322
308. The 2145 UPS-1U with internal battery connectors in place.	322
309. The 2145 UPS-1U cable retention bracket connected to the 2145 UPS-1U	323
310. 2145 UPS-1U (rear view)	323
311. 2145 UPS-1U front-panel assembly	323
312. Removing the front screws from the 2145 UPS-1U	324
313. Removing the front rail on the 2145 UPS-1U	325
314. Removing the rear rail on the 2145 UPS-1U	325
315. Installing the support rails for a 2145 UPS-1U into the rack.	326
316. Adjusting the rail depth on the 2145 UPS-1U	326
317. Securing the rear rail on the 2145 UPS-1U.	327
318. Securing the front rail on the 2145 UPS-1U	327
319. Front and back panels for the 2145 UPS-1U	328
320. Removing the 2145 UPS-1U front panel.	330
321. The 2145 UPS-1U internal battery connector with protective tape	330
322. Removing the 2145 UPS-1U battery	331
323. Replacing the 2145 UPS-1U battery	332
324. The 2145 UPS-1U internal-battery connector	332
325. Replacing the 2145 UPS-1U front panel	333

Tables

1.	SAN Volume Controller library	xxvii
2.	Other IBM publications	xxix
3.	IBM documentation and related Web sites	xxx
4.	FRUs in the SAN Volume Controller 2145-CF8 parts assembly	3
5.	FRUs to which SAN Volume Controller 2145-CF8 service procedures do not refer	5
6.	FRU parts for the solid-state drive (SSD) features	5
7.	FRU parts for the long-wave small form-factor pluggable (SFP) transceiver feature	5
8.	FRUs that are exchanged within SAN Volume Controller 2145-8A4 service procedures	7
9.	FRUs that are not exchanged within SAN Volume Controller 2145-8A4 service procedures	8
10.	Distinctive characteristics of the SAN Volume Controller 2145-8G4 versions	10
11.	FRU part numbers that are unique for the SAN Volume Controller 2145-8G4 Rev 1 version	11
12.	FRU part numbers that are unique for the SAN Volume Controller 2145-8G4 Rev 2 version	11
13.	FRUs in the SAN Volume Controller 2145-8G4 parts assembly	11
14.	FRUs that are not referenced by SAN Volume Controller 2145-8G4 service procedures	13
15.	SAN Volume Controller 2145-8F4 frame assembly	14
16.	Items not included in the SAN Volume Controller 2145-8F4 frame assembly	15
17.	SAN Volume Controller 2145-8F2 frame assembly	16
18.	Items not included in the SAN Volume Controller 2145-8F2 frame assembly	17
19.	Redundant ac-power switch	18
20.	2145 UPS-1U part numbers	19
21.	Cable-management arm and associated parts descriptions and quantities	25
22.	Instructions for removing the SFP connector	188

Safety and environmental notices

Review the multilingual safety notices for the IBM® System Storage™ SAN Volume Controller, redundant ac-power switch, and the uninterruptible power supply before you install and use the product.

To find the translated text for a caution or danger notice:

1. Look for the identification number at the end of each caution notice or each danger notice. In the following examples, the numbers (C001) and (D002) are the identification numbers.

CAUTION:

A caution notice indicates the presence of a hazard that has the potential of causing moderate or minor personal injury. (C001)

DANGER

<p>A danger notice indicates the presence of a hazard that has the potential of causing death or serious personal injury. (D002)</p>

2. Locate *IBM Systems Safety Notices* with the user publications that were provided with the SAN Volume Controller hardware.
3. Find the matching identification number in the *IBM Systems Safety Notices*. Then review the topics concerning the safety notices to ensure that you are in compliance.
4. Optionally, read the multilingual safety instructions on the SAN Volume Controller Web site. Go to www.ibm.com/storage/support/2145, click the current product documentation link, and then click **Multi-language**.

General safety

When you service the SAN Volume Controller, redundant ac-power switch, or the uninterruptible power supply, follow general safety guidelines.

Use the following general rules to ensure safety to yourself and others:

- Observe good housekeeping in the area where the devices are kept during and after maintenance.
- Follow the guidelines when lifting any heavy object:
 1. Ensure that you can stand safely without slipping.
 2. Distribute the weight of the object equally between your feet.
 3. Use a slow lifting force. Never move suddenly or twist when you attempt to lift.
 4. Lift by standing or by pushing up with your leg muscles; this action removes the strain from the muscles in your back. *Do not attempt to lift any objects that weigh more than 18 kg (40 lb) or objects that you think are too heavy for you.*
- Do not perform any action that causes a hazard to the customer, or that makes the equipment unsafe.
- Before you start the device, ensure that other service representatives and customer's personnel are not in a hazardous position.
- Place removed covers and other parts in a safe place, away from all personnel, while you are servicing the unit.

- Keep your tool case away from walk areas so that other people will not trip over it.
- Do not wear loose clothing that can be trapped in the moving parts of a device. Ensure that your sleeves are fastened or rolled up above your elbows. If your hair is long, fasten it.
- Insert the ends of your necktie or scarf inside clothing or fasten it with a nonconducting clip, approximately 8 cm (3 in.) from the end.
- Do not wear jewelry, chains, metal-frame eyeglasses, or metal fasteners for your clothing.

Remember: Metal objects are good electrical conductors.

- Wear safety glasses when you are: hammering, drilling, soldering, cutting wire, attaching springs, using solvents, or working in any other conditions that might be hazardous to your eyes.
- After service, reinstall all safety shields, guards, labels, and ground wires. Replace any safety device that is worn or defective.
- Reinstall all covers correctly after you have finished servicing the unit.

Electrical safety

Observe these rules when working on electrical equipment.

CAUTION:

Electrical current from power, telephone, and communication cables can be hazardous. To avoid personal injury or equipment damage, disconnect the attached power cords, telecommunication systems, networks, and modems before you open the machine covers, unless instructed otherwise in the installation and configuration procedures. (26)

Important: Use only approved tools and test equipment. Some hand tools have handles covered with a soft material that does not insulate you when working with live electrical currents. Many customers have, near their equipment, rubber floor mats that contain small conductive fibers to decrease electrostatic discharges. Do not use this type of mat to protect yourself from electrical shock.

- Find the room emergency power-off (EPO) switch, disconnecting switch, or electrical outlet. If an electrical accident occurs, you can then operate the switch or unplug the power cord quickly.
- Do not work alone under hazardous conditions or near equipment that has hazardous voltages.
- Disconnect all power before the following activities:
 - Performing a mechanical inspection
 - Working near power supplies
 - Removing or installing main units
- Before you start to work on the unit, unplug the power cord. If you cannot unplug it, ask the customer to power off the wall box that supplies power to the device and to lock the wall box in the off position.
- If you need to work on a device that has exposed electrical circuits, observe the following precautions:
 - Ensure that another person, familiar with the power-off controls, is near you.

Remember: Another person must be there to switch off the power, if necessary.

- Use only one hand when working with electrical equipment that has the power turned on; keep the other hand in your pocket or behind your back.

Remember: There must be a complete circuit to cause electrical shock. By observing the previous rule, you might prevent a current from passing through your body.

- When using testers, set the controls correctly and use the approved probe leads and accessories for that tester.
- Stand on suitable rubber mats (obtained locally, if necessary) to insulate you from grounds such as metal floor strips and machine frames.

Observe the special safety precautions when you work with very high voltages; these instructions are in the safety sections of maintenance information. Use extreme care when measuring high voltages.

- Regularly inspect and maintain your electrical hand tools for safe operational condition.
- Do not use worn or broken tools and testers.
- *Never assume* that power has been disconnected from a circuit. First, *check* that power has been powered off.
- Always look carefully for possible hazards in your work area. Examples of these hazards are moist floors, nongrounded power extension cables, power surges, and missing safety grounds.
- Do not touch live electrical circuits with the reflective surface of a plastic dental mirror. The surface is conductive; such touching can cause personal injury and device damage.
- Do not service the following parts with the power on when they are removed from their normal operating places in a device. (This practice ensures correct grounding of the units.)
 - Power supply units
 - Pumps
 - Blowers and fans
 - Motor generators
 - And similar units
- If an electrical accident occurs:
 - Use caution; do not become a victim yourself.
 - Switch off power.
 - Send another person to get medical aid.

Inspecting the SAN Volume Controller for unsafe conditions

Use caution when working in any potential safety hazardous situation that is not covered in the safety checks. If unsafe conditions are present, determine how serious the hazards are and whether you can continue before you correct the problem.

Before you start the safety inspection, make sure that the power is off, and that the power cord is disconnected.

Each device has required safety items installed to protect users and IBM service personnel from injury. This guide addresses only those items.

Important: Good judgment must also be used to identify potential safety hazards due to the attachment of non-IBM features or options not covered by this inspection guide.

If any unsafe conditions are present, you must determine how serious the apparent hazard could be and whether you can continue without first correcting the problem. For example, consider the following conditions and their potential safety hazards:

Electrical hazards (especially primary power)

Primary voltage on the frame can cause serious or lethal electrical shock.

Explosive hazards

A damaged CRT face or a bulging capacitor can cause serious injury.

Mechanical hazards

Loose or missing items (for example, nuts and screws) can cause serious injury.

To inspect each SAN Volume Controller node for unsafe conditions, perform the following steps. If necessary, see any suitable safety publications.

1. Turn off the SAN Volume Controller and disconnect the power cord.
2. Check the frame for damage (loose, broken, or sharp edges).
3. Check the power cables using the following steps:
 - a. Ensure that the third-wire ground connector is in good condition. Use a meter to check that the third-wire ground continuity is 0.1 ohm or less between the external ground pin and the frame ground.
 - b. Ensure that the power cord is the appropriate type, as specified in the parts listings.
 - c. Ensure that the insulation is not worn or damaged.
4. Check for any obvious nonstandard changes, both inside and outside the unit. Use good judgment about the safety of any such changes.
5. Check inside the SAN Volume Controller for any obvious unsafe conditions, such as metal particles, contamination, water or other fluids, or marks of overheating, fire, or smoke damage.
6. Check for worn, damaged, or pinched cables.
7. Ensure that the voltage that is specified on the product-information label matches the specified voltage of the electrical power outlet. If necessary, verify the voltage.
8. Inspect the power-supply assemblies and check that the fasteners (screws or rivets) in the cover of the power-supply unit have not been removed or disturbed.
9. Before connecting the SAN Volume Controller to the storage area network (SAN), check the grounding.

Related tasks

“Checking the grounding of a SAN Volume Controller, the uninterruptible power supply, and the redundant ac-power switch” on page xxi

Ensure that you understand how to check the grounding of a SAN Volume Controller, the uninterruptible power supply, and the optional redundant ac-power switch feature.

External device check

Ensure that you perform an external device check before you install or service the SAN Volume Controller.

To conduct an external device check, perform the following steps:

1. Verify that all external covers are present and are not damaged.
2. Ensure that all latches and hinges are in the correct operating condition.
3. If the SAN Volume Controller is not installed in a rack cabinet, check for loose or broken feet.
4. Check the power cord for damage.
5. Check the external signal cable for damage.
6. Check the cover for sharp edges, damage, or alterations that expose the internal parts of the device.
7. Correct any problems that you find.

Internal device checks

Ensure that you perform an internal device check before you install or service the SAN Volume Controller.

To conduct the internal device check, perform the following steps:

1. Check for any non-IBM changes that might have been made to the device. If any are present, obtain the “Non-IBM Alteration Attachment Survey,” form number R009, from the IBM branch office. Complete the form and return it to the branch office.
2. Check the condition of the inside of the device for any metal or other contaminants, or any indications of water, other fluid, fire, or smoke damage.
3. Check for any obvious mechanical problems, such as loose components.
4. Check any exposed cables and connectors for wear, cracks, or pinching.

Checking the grounding of a SAN Volume Controller, the uninterruptible power supply, and the redundant ac-power switch

Ensure that you understand how to check the grounding of a SAN Volume Controller, the uninterruptible power supply, and the optional redundant ac-power switch feature.

To test the grounding of a SAN Volume Controller node, perform the following steps. Follow the steps for the SAN Volume Controller configuration that you are using. Before you start, confirm that you know the SAN Volume Controller model type, the uninterruptible power-supply type, and whether you are using redundant ac power. Determine the location of the signal cables that are attached to the SAN Volume Controller.

When you are asked to test the grounding continuity, use your local procedures to perform the test. The test is successful if the measured resistance is 0.1 ohm or less.

Attention: Some electrical circuits can be damaged if the external signal cables are present at the SAN Volume Controller while it is undergoing a grounding test.

1. Ensure that the SAN Volume Controller node is powered off. See MAP 5350: Powering off a SAN Volume Controller node in the *IBM System Storage SAN Volume Controller Troubleshooting Guide*.
2. If the uninterruptible power supply is a 2145 UPS, ensure that other SAN Volume Controller nodes that are powered from the uninterruptible power supply are powered off.

3. Use the power button to power off the uninterruptible power supply.
4. Disconnect all signal cables from the SAN Volume Controller node, which includes the following cables:
 - The fibre-channel cables
 - The Ethernet cable or cables
 - The serial cable that is connected to the uninterruptible power supply
5. Disconnect all signal cables from the uninterruptible power supply. If the uninterruptible power supply is a 2145 UPS, there might be multiple signal cables.
6. If the uninterruptible power supply is a 2145 UPS, disconnect any power cables that are connected to SAN Volume Controller nodes, except the one that is being tested.
7. If redundant ac power is not used, disconnect the uninterruptible power-supply power cable from the site power-distribution unit.
8. If redundant ac power is used, turn off any SAN Volume Controller that is being supplied from the redundant ac-power switch, and remove the power cable to this system from the redundant ac-power switch.
9. If redundant ac power is used, disconnect **both** input power leads from the site power distribution units.
10. If redundant ac power is not used, test the grounding continuity between a conductive area on the SAN Volume Controller frame and the ground pin on the plug of the uninterruptible power-supply input-power cable.
11. If redundant ac power is used, test the grounding continuity between a conductive area on the SAN Volume Controller frame and the ground pin on the plug of the main power cable of the redundant ac-power switch. If the test is successful, test the grounding continuity between a conductive area on the SAN Volume Controller frame and the ground pin on the plug of the backup power cable of the redundant ac-power switch. Both tests must be successful.
12. After you have completed testing the grounding continuity, perform one of the following procedures, depending on the outcome of the test.
 - If the test is successful, reconnect any cables that were removed, and power on any uninterruptible power-supply units and SAN Volume Controller nodes that were powered off.
 - If the test was not successful, ensure that all cables are securely connected. If the test still fails, test the individual system components. Before you test the individual components, remove all cables from the components. If any component test fails, replace the component. After each component has been tested and the failing ones have been replaced, repeat the complete system test by returning to step 1 on page xxi.

Test the components in the following order:

 - a. The SAN Volume Controller node, from the frame to the ground pin of the input power receptacle
 - b. The uninterruptible power supply from the ground pin of the input power receptacle to the ground conductor of the output power receptacle
 - c. If used, the redundant ac-power switch from the ground pin of the main input power receptacle to the ground conductor of the output power receptacle, and from the ground pin of the backup input power receptacle to the ground conductor of the output power receptacle
 - d. The SAN Volume Controller node to uninterruptible power-supply power-cable assembly, between the two ground conductors of the power cable

- e. The uninterruptible power-supply input-power cable, between the two ground conductors of the power cable
- f. If used, the redundant ac-power switch main input-power cable, between the two ground conductors of the cable
- g. If used, the redundant ac-power switch backup input-power cable, between the two ground conductors of the cable

Inspecting the uninterruptible power supply for unsafe conditions

Ensure that you take the time to inspect the uninterruptible power supply for unsafe conditions.

Consider the following conditions and their potential safety hazards:

Electrical hazards (especially primary power)

Primary voltage on the frame can cause serious or lethal electrical shock.

Explosive hazards

A bulging capacitor can cause serious injury.

Mechanical hazards

Loose or missing items (for example, nuts and screws) can cause serious injury.

Use caution when working in a potential safety hazard that is not covered in the safety checks. If unsafe conditions are present, determine how serious the hazards are and whether you can continue before you correct the problem.

Using the following inspection checklist as a guide, inspect the uninterruptible power supply for unsafe conditions. If necessary, see any suitable safety publications.

1. If any equipment has been damaged during the shipment, keep the shipping cartons and packing materials.
2. To file a claim for the shipping damage, perform the following steps:
 - a. File with the carrier within fifteen days of receipt of the equipment.
 - b. Send a copy of the damage claim within fifteen days to your service support representative.

Uninterruptible power-supply requirements

Ensure that you comply with the requirements for the uninterruptible power supply.

The following list describes requirements for the 2145 UPS-1U:

- The voltage that is supplied to the 2145 UPS-1U must be 200-240 V single phase.
- The frequency that is supplied must be 50 or 60 Hz.

Note: The 2145 UPS-1U has an integrated circuit breaker and does not need external protection.

Attention:

- If the uninterruptible power supply is cascaded from another uninterruptible power supply, the source uninterruptible power supply must have at least three times the capacity per phase and the total harmonic distortion must be less than 5%.
- The uninterruptible power supply also must have input voltage capture that has a slew rate of no more than 3 Hz per second.

Emergency power-off shutdown

The SAN Volume Controller and each uninterruptible power supply support emergency power-off (EPO) shutdowns.

Handling static-sensitive devices

Ensure that you understand how to handle devices that are sensitive to static electricity.

Attention: Static electricity can damage electronic devices and your system. To avoid damage, keep static-sensitive devices in their static-protective bags until you are ready to install them.

To reduce the possibility of electrostatic discharge, observe the following precautions:

- Limit your movement. Movement can cause static electricity to build up around you.
- Handle the device carefully, holding it by its edges or frame.
- Do not touch solder joints, pins, or exposed printed circuitry.
- Do not leave the device where others can handle and possibly damage the device.
- While the device is still in its antistatic bag, touch it to an unpainted metal part of the system unit for at least two seconds. (This action removes static electricity from the package and from your body.)
- Remove the device from its package and install it directly into your SAN Volume Controller, without putting it down. If it is necessary to put the device down, place it onto its static-protective bag. (If your device is an adapter, place it component-side up.) Do not place the device onto the cover of the SAN Volume Controller or onto a metal table.
- Take additional care when you handle devices during cold weather because heating reduces indoor humidity and increases static electricity.

Environmental notices and statements

You must become familiar with the environmental notices and statements.

The following topics describe the environmental notices and statements that are applicable to this product.

Product recycling and disposal

Ensure that you are aware of the materials that must be recycled. Before using this information and the product that it supports, read the *IBM Environmental Notices and User Guide* on the SAN Volume Controller Documentation CD.

About this guide

This guide describes how to service the IBM System Storage SAN Volume Controller.

The chapter that follows shows you the parts assembly for each SAN Volume Controller model, the redundant ac-power switch, and the uninterruptible power supply.

You are also provided with step-by-step procedures to remove and replace parts for the SAN Volume Controller and the uninterruptible power supply.

Note: The *IBM System Storage SAN Volume Controller Hardware Maintenance Guide* and the *IBM System Storage SAN Volume Controller Troubleshooting Guide* were formerly combined in one book that was titled *IBM System Storage SAN Volume Controller Service Guide*.

Who should use this guide

This guide is intended for the systems services representative who is responsible for the service of the SAN Volume Controller, the redundant ac-power switch, and the uninterruptible power supply.

Summary of changes

This document contains terminology, maintenance, and editorial changes.

Technical changes or additions to the text and illustrations are indicated by a vertical line to the left of the change. This summary of changes describes new functions that have been added to this release.

Summary of changes for GC27-2226-01 and GC27-2226-02 SAN Volume Controller Hardware Maintenance Guide

The summary of changes provides a list of new and changed information since the last version of the guide.

New information

This topic describes the changes to this guide since the GC27-2226-00 edition. The following sections summarize changes that have been implemented.

This version includes the following new information:

- New removals and replacements for components of the new SAN Volume Controller 2145-CF8 node are included.
- Replacement disk drives for nodes can now be a compatible drive of at least the same size.
- The SAN Volume Controller 2145-CF8 node supports solid-state drives (SSDs).
- The SAN Volume Controller 2145-CF8 node has redundant hot-swap power supplies.
- The SAN Volume Controller 2145-CF8 node uses a cable-management arm at the rear of the node. The arm extends into the rack as you slide the node out of the rack.

- The SAN Volume Controller 2145-CF8 node has slide rails that extend outside of the rack to a position where you can perform maintenance without removing the node from the rack.
- The SAN Volume Controller 2145-CF8 node has a service controller that is attached with a USB cable.
- The SAN Volume Controller 2145-CF8 node offers optional features that support up to four SSDs that provide space for virtual disks.
- All of the nodes supported by SAN Volume Controller 5.1.0 are capable of having two Ethernet connections rather than one.

Changed information

This version includes edits for usability and writing style.

Removed information

The removal and replacement procedures for components of the SAN Volume Controller 2145-4F2 node are no longer in the book, because the SAN Volume Controller 2145-4F2 node is not supported in version 5.1.0 of SAN Volume Controller.

However, the information center does include the SAN Volume Controller 2145-4F2 information.

For information about replacing a SAN Volume Controller 2145-4F2 node with a SAN Volume Controller 2145-CF8 node, see *Procedures for Replacing SAN Volume Controller 2145-4F2 Nodes with SAN Volume Controller 2145-CF8 Nodes* on the Support for SAN Volume Controller (2145) Web site:

www.ibm.com/storage/support/2145

The link to the procedures is located under **Related Reading** on the page that contains the V5.1.x *IBM System Storage SAN Volume Controller Software Installation and Configuration Guide*.

Emphasis

Different typefaces are used in this guide to show emphasis.

The following typefaces are used to show emphasis:

Boldface	Text in boldface represents menu items and command names.
<i>Italics</i>	Text in <i>italics</i> is used to emphasize a word. In command syntax, it is used for variables for which you supply actual values, such as a default directory or the name of a cluster.
Monospace	Text in monospace identifies the data or commands that you type, samples of command output, examples of program code or messages from the system, or names of command flags, parameters, arguments, and name-value pairs.

SAN Volume Controller library and related publications

Product manuals, other publications, and Web sites contain information that relates to SAN Volume Controller.

SAN Volume Controller Information Center

The IBM System Storage SAN Volume Controller Information Center contains all of the information that is required to install, configure, and manage the SAN Volume Controller. The information center is updated between SAN Volume Controller product releases to provide the most current documentation. The information center is available at the following Web site:

<http://publib.boulder.ibm.com/infocenter/svcic/v3r1m0/index.jsp>

SAN Volume Controller library

Table 1 lists and describes the publications that make up the SAN Volume Controller library. Unless otherwise noted, these publications are available in Adobe® portable document format (PDF) from the following Web site:

www.ibm.com/storage/support/2145

Table 1. SAN Volume Controller library

Title	Description	Order number
<i>IBM System Storage SAN Volume Controller Planning Guide</i>	This guide introduces the SAN Volume Controller and lists the features that you can order. It also provides guidelines for planning the installation and configuration of the SAN Volume Controller.	GA32-0551
<i>IBM System Storage SAN Volume Controller Model 2145-CF8 Hardware Installation Guide</i>	This guide provides the instructions that the IBM service representative uses to install the hardware for SAN Volume Controller model 2145-CF8.	GC52-1356
<i>IBM System Storage SAN Volume Controller Model 2145-8A4 Hardware Installation Guide</i>	This guide provides the instructions that the IBM service representative uses to install the hardware for SAN Volume Controller model 2145-8A4.	GC27-2219
<i>IBM System Storage SAN Volume Controller Model 2145-8G4 Hardware Installation Guide</i>	This guide provides the instructions that the IBM service representative uses to install the hardware for SAN Volume Controller model 2145-8G4.	GC27-2220

Table 1. SAN Volume Controller library (continued)

Title	Description	Order number
<i>IBM System Storage SAN Volume Controller Models 2145-8F2 and 2145-8F4 Hardware Installation Guide</i>	This guide provides the instructions that the IBM service representative uses to install the hardware for SAN Volume Controller models 2145-8F2 and 2145-8F4.	GC27-2221
<i>IBM System Storage SAN Volume Controller Software Installation and Configuration Guide</i>	This guide provides guidelines for configuring your SAN Volume Controller. Instructions for backing up and restoring the cluster configuration, using and upgrading the SAN Volume Controller Console, using the CLI, upgrading the SAN Volume Controller software, and replacing or adding nodes to a cluster are included.	SC23-6628
<i>IBM System Storage SAN Volume Controller CIM Agent Developer's Guide</i>	This guide describes the concepts of the Common Information Model (CIM) environment. Steps about using the CIM agent object class instances to complete basic storage configuration tasks, establishing new Copy Services relationships, and performing CIM agent maintenance and diagnostic tasks are included.	SC23-6665
<i>IBM System Storage SAN Volume Controller Command-Line Interface User's Guide</i>	This guide describes the commands that you can use from the SAN Volume Controller command-line interface (CLI).	SC26-7903
<i>IBM System Storage SAN Volume Controller Host Attachment Guide</i>	This guide provides guidelines for attaching the SAN Volume Controller to your host system.	SC26-7905
<i>IBM System Storage SAN Volume Controller Troubleshooting Guide</i>	This guide describes the features of each SAN Volume Controller model, explains how to use the front panel, and provides maintenance analysis procedures to help you diagnose and solve problems with the SAN Volume Controller.	GC27-2227

Table 1. SAN Volume Controller library (continued)

Title	Description	Order number
<i>IBM System Storage SAN Volume Controller Hardware Maintenance Guide</i>	This guide provides the instructions that the IBM service representative uses to service the SAN Volume Controller hardware, including the removal and replacement of parts.	GC27-2226
<i>IBM System Storage SAN Volume Controller Master Console Guide</i>	This guide describes how to install, maintain, and service the master console.	GC27-2223
<i>IBM Systems Safety Notices</i>	This guide contains translated caution and danger statements. Each caution and danger statement in the SAN Volume Controller documentation has a number that you can use to locate the corresponding statement in your language in the <i>IBM Systems Safety Notices</i> document.	G229-9054

Other IBM publications

Table 2 lists IBM publications that contain information related to the SAN Volume Controller.

Table 2. Other IBM publications

Title	Description	Order number
<i>IBM System Storage Productivity Center Introduction and Planning Guide</i>	This guide introduces the IBM System Storage Productivity Center hardware and software.	SC23-8824
<i>Read This First: Installing the IBM System Storage Productivity Center</i>	This guide describes how to install the IBM System Storage Productivity Center hardware.	GI11-8938
<i>IBM System Storage Productivity Center User's Guide</i>	This guide describes how to configure the IBM System Storage Productivity Center software.	SC27-2336
<i>IBM System Storage Multipath Subsystem Device Driver User's Guide</i>	This guide describes the IBM System Storage Multipath Subsystem Device Driver for IBM System Storage products and how to use it with the SAN Volume Controller.	GC52-1309

Table 2. Other IBM publications (continued)

Title	Description	Order number
<i>Implementing the IBM System Storage SAN Volume Controller V4.3</i>	This IBM Redbooks® publication is a detailed technical guide to the IBM System Storage SAN Volume Controller. It provides a high-level overview of storage virtualization and the SAN Volume Controller architecture, discusses implementing and configuring the SAN Volume Controller, tells you how to migrate existing storage to the SAN Volume Controller, and discusses different supported migration activities.	SG24-6423

IBM documentation and related Web sites

Table 3 lists Web sites that provide publications and other information about the SAN Volume Controller or related products or technologies.

Table 3. IBM documentation and related Web sites

Web site	Address
Support for SAN Volume Controller (2145)	www.ibm.com/storage/support/2145
Support for IBM System Storage and IBM TotalStorage® products	www.ibm.com/storage/support/
IBM Publications Center	www.ibm.com/shop/publications/order/
IBM Redbooks publications	www.redbooks.ibm.com/

Related accessibility information

To view a PDF file, you need Adobe Acrobat Reader, which can be downloaded from the Adobe Web site:

www.adobe.com/support/downloads/main.html

Related Web sites

The following Web sites provide information about the SAN Volume Controller or related products or technologies:

Type of information	Web site
SAN Volume Controller support	www.ibm.com/storage/support/2145
Technical support for IBM storage products	www.ibm.com/storage/support/

How to order IBM publications

The IBM Publications Center is a worldwide central repository for IBM product publications and marketing material.

The IBM Publications Center offers customized search functions to help you find the publications that you need. Some publications are available for you to view or download at no charge. You can also order publications. The publications center displays prices in your local currency. You can access the IBM Publications Center through the following Web site:

www.ibm.com/shop/publications/order/

How to send your comments

Your feedback is important to help us provide the highest quality information. If you have any comments about this book or any other documentation, you can submit them in one of the following ways:

- E-mail

Submit your comments electronically to the following e-mail address:
starpubs@us.ibm.com

Be sure to include the name and order number of the book and, if applicable, the specific location of the text you are commenting on, such as a page number or table number.

- Mail

Fill out the Readers' Comments form (RCF) at the back of this book. If the RCF has been removed, you can address your comments to:

International Business Machines Corporation
RCF Processing Department
Department 61C
9032 South Rita Road
Tucson, Arizona 85775-4401
U.S.A.

Chapter 1. Parts listing

Part numbers are available for the different parts and field-replaceable units (FRUs) of the SAN Volume Controller nodes, the redundant ac-power switch, and the uninterruptible power-supply unit.

SAN Volume Controller supports five different node types. A label on the front of the node indicates the SAN Volume Controller node type, hardware revision (if appropriate), and serial number.

Related information

“SAN Volume Controller 2145-CF8 parts”

You might have to replace a SAN Volume Controller 2145-CF8 field-replaceable unit (FRU).

“SAN Volume Controller 2145-8A4 parts” on page 6

You might need to replace a SAN Volume Controller 2145-8A4 field replaceable unit (FRU).

“SAN Volume Controller 2145-8G4 parts” on page 9

You might need to replace a SAN Volume Controller 2145-8G4 field replaceable unit (FRU).

“SAN Volume Controller 2145-8F4 parts” on page 13

You might need to replace a SAN Volume Controller 2145-8F4 field replaceable unit (FRU).

“SAN Volume Controller 2145-8F2 parts” on page 15

You might need to replace a SAN Volume Controller 2145-8F2 field replaceable unit (FRU).

“Redundant ac-power switch parts” on page 18

There is a single field-replaceable unit (FRU) assembly for the redundant ac power feature. It consists of the switch and two input-power cables.

“2145 UPS-1U parts” on page 18

The 2145 UPS-1U is assembled from four separate parts.

SAN Volume Controller 2145-CF8 parts

You might have to replace a SAN Volume Controller 2145-CF8 field-replaceable unit (FRU).

Figure 1 on page 2 shows how the different parts of the SAN Volume Controller 2145-CF8 are assembled.

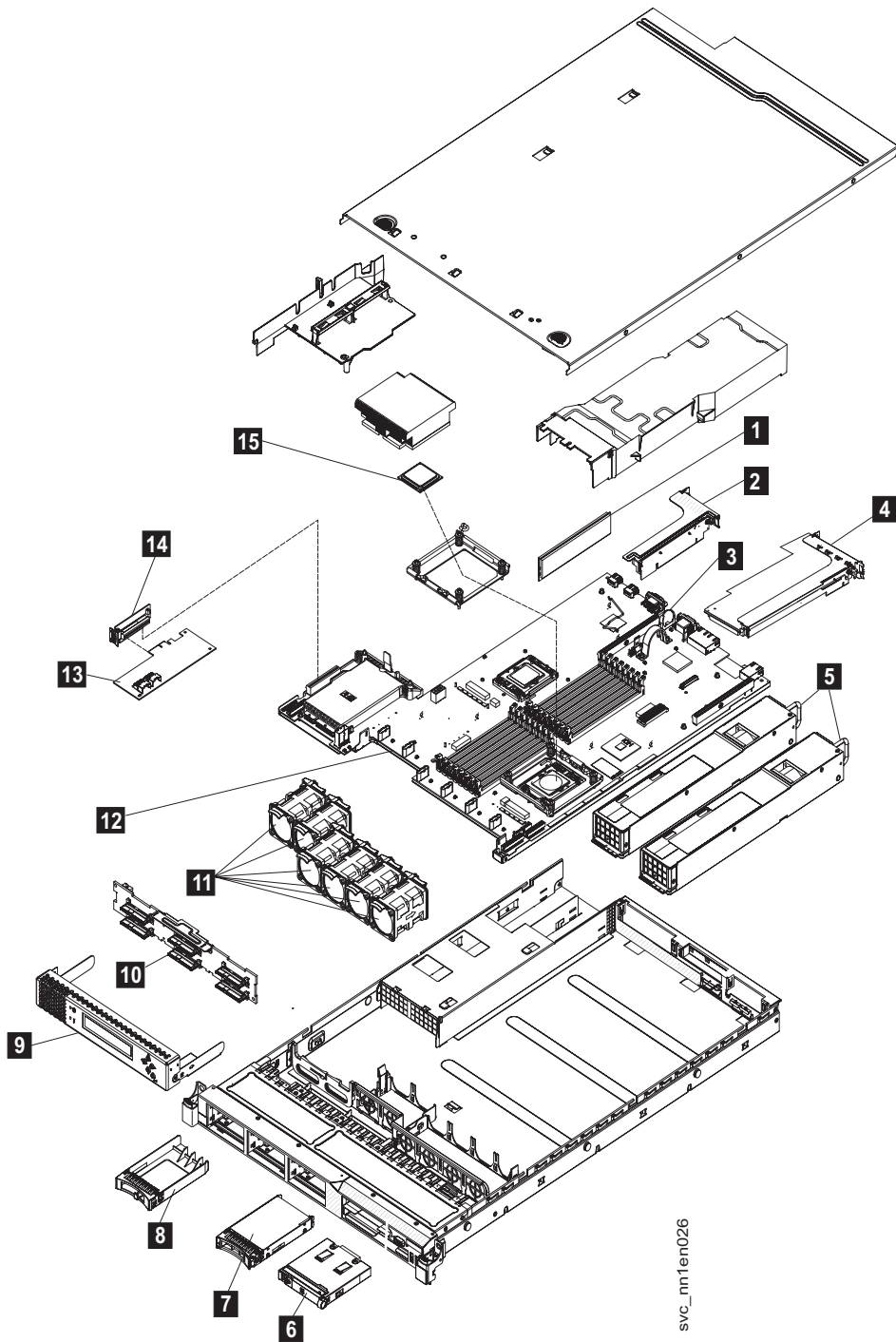

Figure 1. Exploded view of the SAN Volume Controller 2145-CF8 node

The following tables identify part numbers and provide brief descriptions of the SAN Volume Controller 2145-CF8 parts. Use the assembly index number to locate and identify the parts that are shown in Figure 1.

- Table 4 on page 3 calls out the FRUs that are referred to in service procedures.
- Table 5 on page 5 lists the FRUs that are not referred to by any SAN Volume Controller 2145-CF8 service procedure, but that might be replaced in some circumstances.

- Table 6 on page 5 lists the FRUs that are related to the optional solid-state drive (SSD) features.

Table 4. FRUs in the SAN Volume Controller 2145-CF8 parts assembly

Assembly index	Part number	Units	Description
-1	44T1493	6	Memory module 4 GB memory module, DDR3-1333 2RX4 LP RDIMM
-2	31P1340	1	Optional: High speed SAS adapter An assembly that includes a high speed SAS adapter card that provides connectivity for up to four solid-state drives (SSDs), a riser card, a blanking plate, and screws.
-3	33F8354	1	CMOS battery 3.0 volt battery on the system board that maintains power to back up system BIOS settings.
-4	31P1337	1	4-port fibre-channel adapter A fibre-channel host bus adapter (HBA) assembly that connects the SVC CF8 to the fibre-channel fabric. It is located in PCI slot 1. The adapter assembly includes the fibre-channel PCI Express adapter, four short-wave SFPs, the riser card, and the bracket. Note: If the system is using alternative SFPs, replace the SFPs on the FRU part with the SFPs from the fibre-channel adapter that is being replaced.
-5	39Y7201	2	Power supply unit Ac power supply, 675 Watt
-6	44E4372	1	Operator-information panel This assembly includes the information panel that contains the power-control button and diagnostics LEDs.
-7	42D0673	1	Disk drive The serial-attached SCSI (SAS) 2.5 inch disk drive, which, when ordered as a replacement, might be a supported compatible drive of at least the same capacity as the one being replaced.
-8	44T2248	4	Drive bay blank EMC filler assembly
-9	31P1339	1	Service controller The service controller includes the front-panel display, buttons, and associated electronics.
-10	43V7071	1	Disk backplane Hot-swap SAS 2.5" disk-drive backplane
-11	43V6929	6	Fan assembly The fan assembly is used in each of the six fan positions.
-12	43V7072	1	System board The system board is also called the <i>planar</i> . Note: This part is the system board only. When replaced, you must also have alcohol wipes and thermal grease.

Table 4. FRUs in the SAN Volume Controller 2145-CF8 parts assembly (continued)

Assembly index	Part number	Units	Description
-13	44E8690	1	Disk controller SAS controller card for the SAS 2.5 inch disk drive that also includes the riser card.
-14	44E8690	1	Disk controller / USB riser card Riser card that connects the disk controller to the system board and provides the USB port to which the service controller cable connects.
-15	46D1266	1	Microprocessor 2.40 GHz Quad-core microprocessor Note: This part is the microprocessor only. When replaced, you must also have alcohol wipes and thermal grease.
-	31P1338	4	Short-wave SFP Small form-factor pluggable (SFP) transceiver that provides an auto-negotiating 2, 4, or 8 gigabits-per-second short-wave optical connection on the 4-port fibre-channel adapter. Note: It is possible that SFPs other than those shipped with the product are in use on the fibre-channel host bus adapter. It is a customer responsibility to obtain replacement parts for such SFPs. The FRU part number is shown as "Non standard - supplied by customer" in the vital product data.
-	31P1206	1	Service controller cable The USB cable used to connect the service controller to the system board.
-	43V6922	1	Disk signal cable 200 mm SAS disk signal cable
-	46C4148	1	Disk power cable SAS disk power cable
-	31P1294	1	Power cable assembly The cable assembly that connects the SAN Volume Controller and the 2145 UPS-1U. The assembly consists of two power cables bundled with a serial cable.
-	49Y4817	1	Cable-management arm
-	46C4139	1	Operator information panel cable Cable that connects the operator information panel to the system board
-	41Y9292	-	Thermal grease Grease that helps provide a thermal seal between the processor and the heat sink
-	59P4739	-	Alcohol wipe Cleaning wipe

Table 5. FRUs to which SAN Volume Controller 2145-CF8 service procedures do not refer

Description	Part number	Quantity
Top cover	43V6933	1
Front panel moulding that surrounds the operator information panel	49Y4818	1
Air baffle kit (microprocessor and memory)	43V6931	1
Heat sink	49Y4820	1
Base chassis	49Y4813	1
Rail kit used to install the node in a rack	49Y4816	1
Cable management arm assembly	49Y4817	1
Cable retention bracket	31P1243	1
Front panel USB cable	43V6920	1
Front bezel assembly	49Y4818	1
DVD drive bay filler	49Y4824	1
240VA safety cover	49Y4823	1
HDD I2C signal cable	43V7023	1

Table 6. FRU parts for the solid-state drive (SSD) features

Description	Part number	Quantity	Feature Code
High-speed SAS adapter An assembly that includes a high speed SAS adapter card that provides connectivity for up to four solid-state drive (SSD). The assembly includes a riser card, a blanking plate, and two M3 screws.	31P1340	1	4500
High-speed SAS cable This cable connects the high-speed SAS adapter to the disk backplane.	41Y3884	1	
146 GB Solid-state drive (SSD)	31P1342	1 to 4	4601

Table 7. FRU parts for the long-wave small form-factor pluggable (SFP) transceiver feature

Description	Part number	Quantity	Feature Code
Long-wave SFP FRU Long-wave SFP transceiver that provides an auto-negotiating 2, 4, or 8 gigabits-per-second 10 kilometer (km) long-wave optical connection on the 4-port fibre-channel adapter. Note: It is possible that SFPs other than those shipped with the product are in use on the fibre-channel host bus adapter. It is a customer responsibility to obtain replacement parts for such SFPs. The FRU part number is shown as "Non standard - supplied by customer" in the vital product data.	31P1345	1 to 4	5608

SAN Volume Controller 2145-8A4 parts

You might need to replace a SAN Volume Controller 2145-8A4 field replaceable unit (FRU).

Figure 2 shows how the different parts of the SAN Volume Controller 2145-8A4 are assembled.

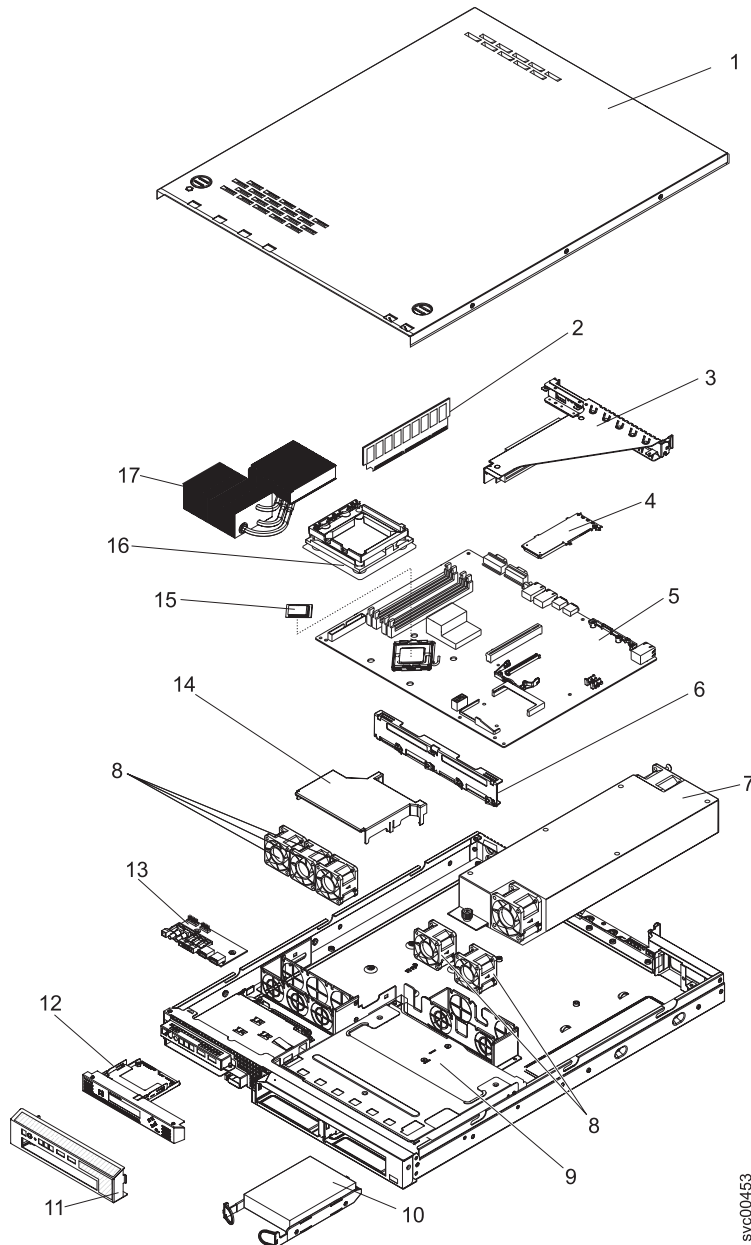

Figure 2. Exploded view of the SAN Volume Controller 2145-8A4 node

- Table 8 on page 7 provides the part numbers and a brief description for parts that are exchanged within SAN Volume Controller 2145-8A4 service procedures.
- Table 9 on page 8 provides the part numbers and a brief description for parts that are not exchanged within SAN Volume Controller 2145-8A4 service procedures.

Use the assembly index number to locate and identify the parts that are shown in Figure 2 on page 6.

Table 8. FRUs that are exchanged within SAN Volume Controller 2145-8A4 service procedures

Assembly index	Part number	Units	Description
-2	41Y2854	4	Memory, 2 GB PC2-5300 ECC
-3	43W5112	1	Riser card, PCI Express
-4	31P0937	1	4-port fibre-channel host bus adapter
-	23R2770	4	Fibre-channel SFP connector
-5	43W5103	1	System board (You need 1 alcohol wipe and 1 thermal grease syringe when you replace this FRU. If you do not already have these, order them before you begin to replace the part.)
-6	39M4347	1	Disk cable assembly (A SATA disk drive back plate with 2 SATA cables)
-7	39Y7289	1	Power supply, 351 watt
-8	39M4322	5	Fan (40 mm)
-10	41Y8247	1	Hard disk drive, 3.5 in, simple-swap SATA This disk drive, when ordered as a replacement, will be a supported compatible drive of at least the same capacity as the one being replaced.
-12	31P1157	1	Service controller, including the front-panel display and the display and control buttons
-13	42C1513	1	Operator-information panel
-	39M6266	1	Operator-information panel cable

|
|
|
|
|
|
|

Table 8. FRUs that are exchanged within SAN Volume Controller 2145-8A4 service procedures (continued)

Assembly index	Part number	Units	Description
-15	44X0204	1	Microprocessor, 3.0 GHz 6 MB dual core (You need 1 alcohol wipe and 1 thermal grease syringe when you replace this FRU. If you do not already have these, order them before you begin to replace the part.)
-	33F8354	1	Battery, 3.0V
-	31P1177	1	Power cable assembly (SAN Volume Controller to the 2145 UPS-1U). The SAN Volume Controller 2145-8A4 does not work with previous versions of the power cable assembly. The correct power cable assembly is indicated by the red tape that is used to bind the cables together.
-	12R9914	1	External fibre-channel cable, LC-LC, 5.0 m (16.4 ft)
-	12R9915	1	External fibre-channel cable, LC-LC, 25.0 m (82 ft)
-	59P4739	1	Alcohol wipe
-	41Y9292	1	Thermal grease

Table 9. FRUs that are not exchanged within SAN Volume Controller 2145-8A4 service procedures

Assembly index	Part number	Quantity	Description
-	32P9107	1	Support rail kit
-	31P1171	1	Cable retention bracket
-	43W5119	1	Chassis
1	42C1284	1	Top cover
9	42C1286	1	Drive cage
11	43W5115	1	Front bezel
14	39M6296	1	Air baffle
16	43W5117	1	Heat-sink assembly retention module

Table 9. FRUs that are not exchanged within SAN Volume Controller 2145-8A4 service procedures (continued)

Assembly index	Part number	Quantity	Description
17	43W5116	1	Heat-sink assembly
-	42C1282	1	3.5 in. SATA service label
-	43W5113	1	Service label
-	43W5114	1	CRU/FRU label
-	39M4351	2	Bracket ear

SAN Volume Controller 2145-8G4 parts

You might need to replace a SAN Volume Controller 2145-8G4 field replaceable unit (FRU).

Figure 3 on page 10 shows how the different parts of the SAN Volume Controller 2145-8G4 are assembled.

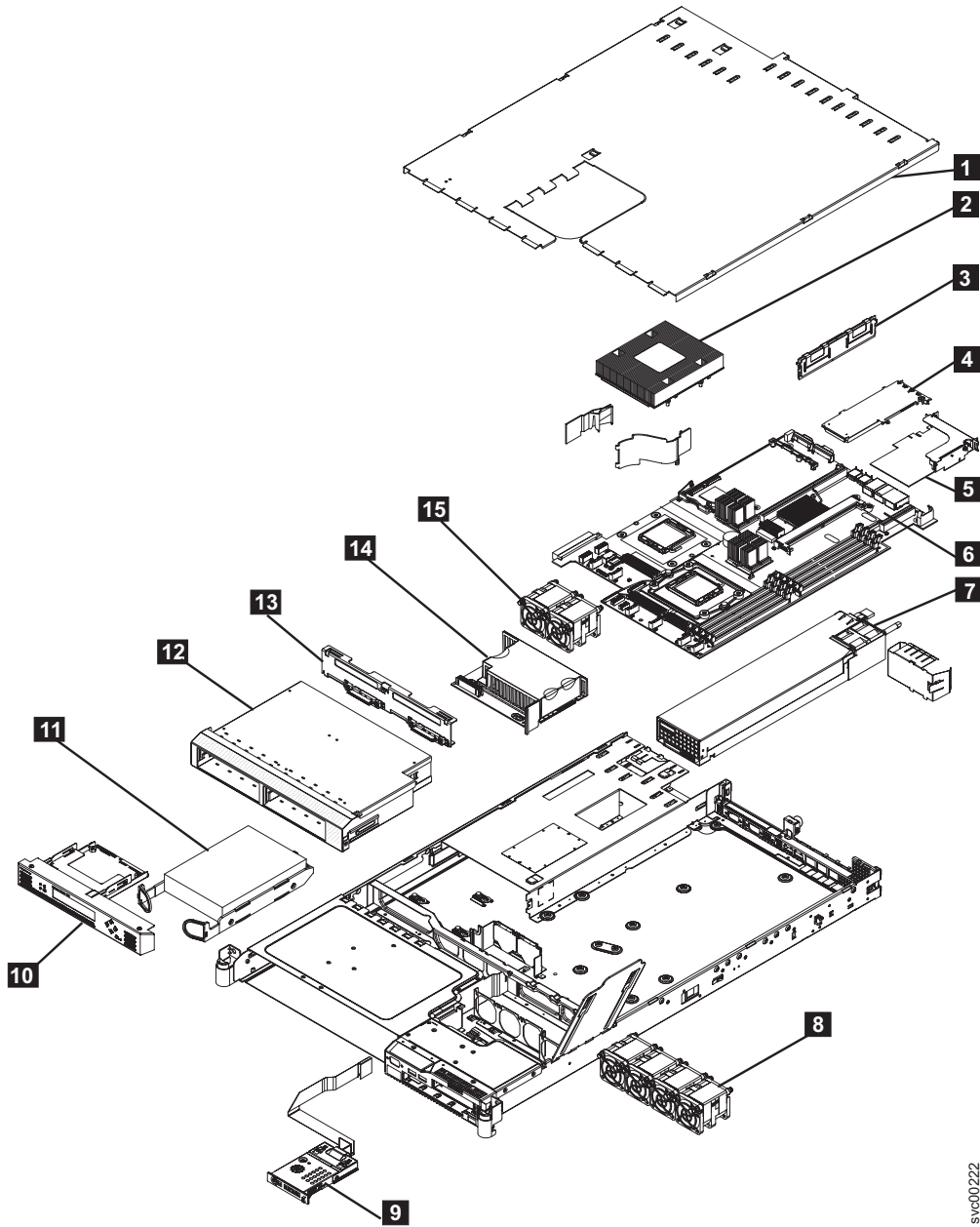

svc00222

Figure 3. Exploded view of the SAN Volume Controller 2145-8G4 node

There are two versions of the SAN Volume Controller 2145-8G4 node: Rev 1 and Rev 2. The differences between these two versions are in the memory and processor configuration. See Table 10 to determine which version you have. In addition, the vital product data (VPD) for the node indicates the correct part numbers for nodes that are working in a cluster.

Table 10. Distinctive characteristics of the SAN Volume Controller 2145-8G4 versions

Rev 1 version	Rev 2 version
There is one label on the front of the node and it does not include a revision number	There are two labels on the front of the node; the larger label is positioned on the optical drive filler panel and includes the revision number
Has two microprocessors	Has one microprocessor

Table 10. Distinctive characteristics of the SAN Volume Controller 2145-8G4 versions (continued)

Rev 1 version	Rev 2 version
Has eight memory modules	Has four memory modules
Has a serial number in the format <i>mm-Fxxxx</i>	Has a serial number in the format <i>mm-Gxxxx</i>

The following tables identify part numbers and provide brief descriptions of the SAN Volume Controller 2145-8G4 parts. Use the assembly index number to locate and identify the parts that are shown in Figure 3 on page 10.

- Table 11 lists the parts that are unique for the Rev 1 version.
- Table 12 lists the parts that are unique for the Rev 2 version.
- Table 13 lists the parts that are used with both versions.
- Table 14 on page 13 lists the FRUs that are not referred to by any SAN Volume Controller 2145-8G4 service procedure.

Table 11. FRU part numbers that are unique for the SAN Volume Controller 2145-8G4 Rev 1 version

Assembly index	Part number	Units	Description
-2	42C4228	2	Microprocessor, 2.33 GHz with heat sink
-3	39M5784	8	Memory, 1 GB ECC DRR2

Table 12. FRU part numbers that are unique for the SAN Volume Controller 2145-8G4 Rev 2 version

Assembly index	Part number	Units	Description
-2	44R5646	1	Microprocessor, 2.5 GHz (You need 1 alcohol wipe and 1 thermal grease syringe when you replace this FRU. If you do not already have these, order them before you begin to replace the part.)
-3	39M5790	4	Memory, 2 GB ECC DRR2

Table 13. FRUs in the SAN Volume Controller 2145-8G4 parts assembly

Assembly index	Part number	Units	Description
-1	43W0609	1	Top cover
-4	31P0937	1	4-port fibre-channel host bus adapter
-5	32R2883	1	Riser card, PCI Express (Slot 1)

Table 13. FRUs in the SAN Volume Controller 2145-8G4 parts assembly (continued)

Assembly index	Part number	Units	Description
-6	31P1090	1	System board (You need 2 alcohol wipes and 2 thermal grease syringes when you replace this FRU. If you do not already have these, order them before you begin to replace the part.)
-7	39Y7189	1	Power supply, 670 watt
-8 and -15	26K8083	6	Fan assembly
-	33F8354	1	Battery, 3.0V
-9	43W0625	1	Operator-information panel
-10	31P0908	1	Service controller
-11	41Y8247	1	Hard disk drive, 3.5 in, simple-swap SATA (beginning with SAN Volume Controller 4.3.1) This disk drive, when ordered as a replacement, will be a supported compatible drive of at least the same capacity as the one being replaced.
-12	32R2823	1	Simple-swap SATA disk drive cage
-13	26K8060	1	Disk-drive backplane
-14	39Y6972	1	Power back plane
-	23R2770	1	Fibre-channel SFP connector
-	31P1063	1	Power cable assembly (SAN Volume Controller to 2145 UPS-1U)
-	39M5700	1	External fibre-channel cable, LC-LC, 5.0 m (16.4 ft)
-	39M5701	1	External fibre-channel cable, LC-LC, 25.0 m (82 ft)
-	59P4739	1	Alcohol wipe
-	41Y9292	1	Thermal grease

Table 14. FRUs that are not referenced by SAN Volume Controller 2145-8G4 service procedures

Part number	Quantity	Description
39Y9510	1	Kit, toolless rail
31P1045	1	Cable retainer assembly
26K8058	2	Front panel USB cable
32R2820	1	3.5 in. SATA service label
39Y9420	1	Air flow parts
39Y9423	2	Heat sink assembly
39Y9507	1	Media bezel assembly
43W0610	1	Service labels assembly
39Y9522	1	Main panel weldment
42C3983	1	Optical interposer card
43V4869	1	CRU/FRU label
39Y9507	1	Media bezel assembly
32R2823	1	3.5 in. SATA cartridge assembly

SAN Volume Controller 2145-8F4 parts

You might need to replace a SAN Volume Controller 2145-8F4 field replaceable unit (FRU).

Figure 4 on page 14 shows how the different parts of the SAN Volume Controller 2145-8F4 are assembled.

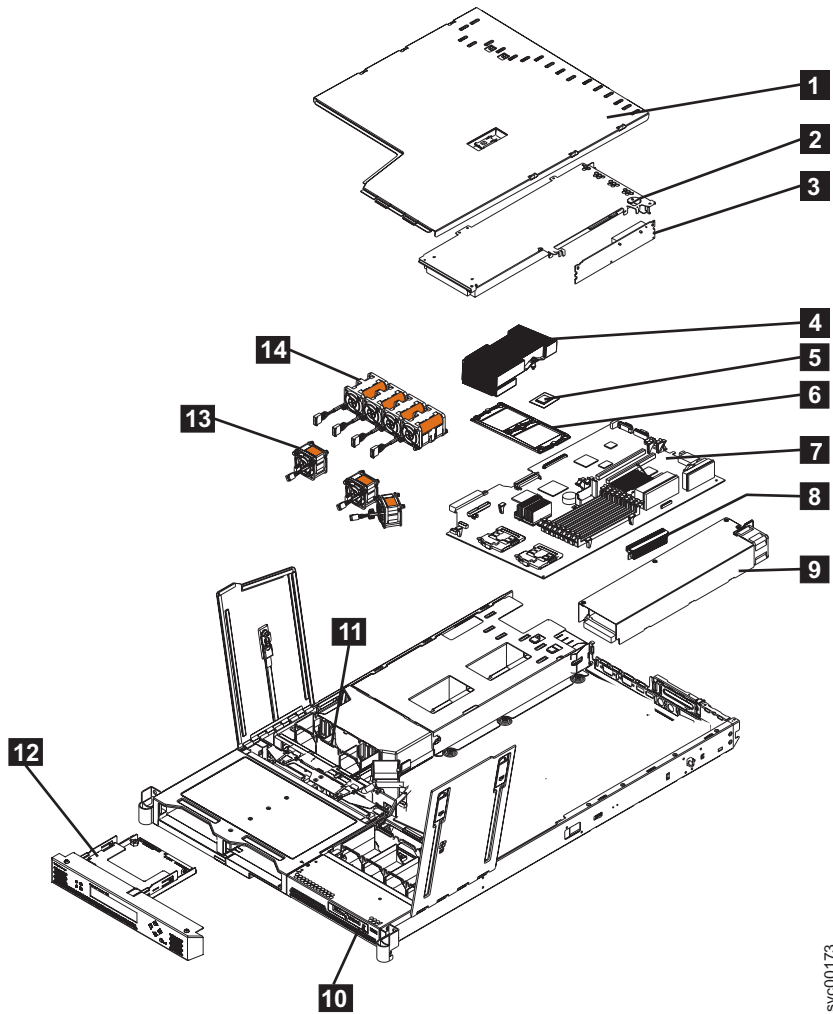

svc00173

Figure 4. Exploded view of the SAN Volume Controller 2145-8F4 node

Table 15 provides the part numbers and a brief description of the frame assembly parts that are labeled in Figure 4. The frame assembly comprises all the parts except the service controller and fibre-channel cards. These parts are listed in Table 16 on page 15.

Table 15. SAN Volume Controller 2145-8F4 frame assembly

Assembly index	Part number	Units	Description
	31P0705	1	Frame assembly
-	31P0769	1	80GB SATA HDD This disk drive, when ordered as a replacement, will be a supported compatible drive of at least the same capacity as the one being replaced.
-1	23K4219	1	Top cover
-3	90P1956	1	Riser card, PCI Express
-4	39R9058	2	Heat sink
-5	13M8293	2	Microprocessor, 3.0 GHz
-6	90P5282	1	Heat sink retention module

Table 15. SAN Volume Controller 2145-8F4 frame assembly (continued)

Assembly index	Part number	Units	Description
-	90P5284	1	Chassis
-	23K4209	1	Cage assembly
-7	39Y6958	1	System board
-8	39Y7261	2	Voltage regulator module (VRM), 1U/75A
-9	39Y7169	1	Power supply, 585 watt
-	40K8157	1	Power backplane
-	33F8354	1	Battery, 3.0V
-	40K8160	1	Cable, fan power
-	40K8159	1	Cable, signal, front panel
-10	42C9719	1	Operator information panel
-11	40K8156	1	Fan holder with fan backplanes
-13	40K8139	3	Fan, 40×40×28
-14	40K8140	4	Fan, 40×40×56
-	73P2870	8	Memory, 1 GB ECC DRR2

Table 16. Items not included in the SAN Volume Controller 2145-8F4 frame assembly

Assembly index	Part number	Units	Description
-2	31P0714	1	4-port fibre-channel host bus adapter
-	23R2770	1	Fibre-channel SFP connector
-12	31P0708	1	Service controller
-	23K4218	1	Kit, toolless rail
-	31P1063	1	Power cable assembly (SAN Volume Controller to the 2145 UPS-1U)
-	31P0715	1	Cable retainer
-	39M5699		External Fibre Channel cable, LC–LC, 1.0 m (3.3 ft)
-	39M5700		External Fibre Channel cable, LC–LC, 5.0 m (16.4 ft)
-	39M5701		External Fibre Channel cable, LC–LC, 25.0 m (82 ft)
-	12R9321		External Fibre Channel cable, LC–SC/LC, 1.0 m (3.3 ft)

SAN Volume Controller 2145-8F2 parts

You might need to replace a SAN Volume Controller 2145-8F2 field replaceable unit (FRU).

Figure 5 on page 16 shows how the different parts for the SAN Volume Controller 2145-8F2 are assembled.

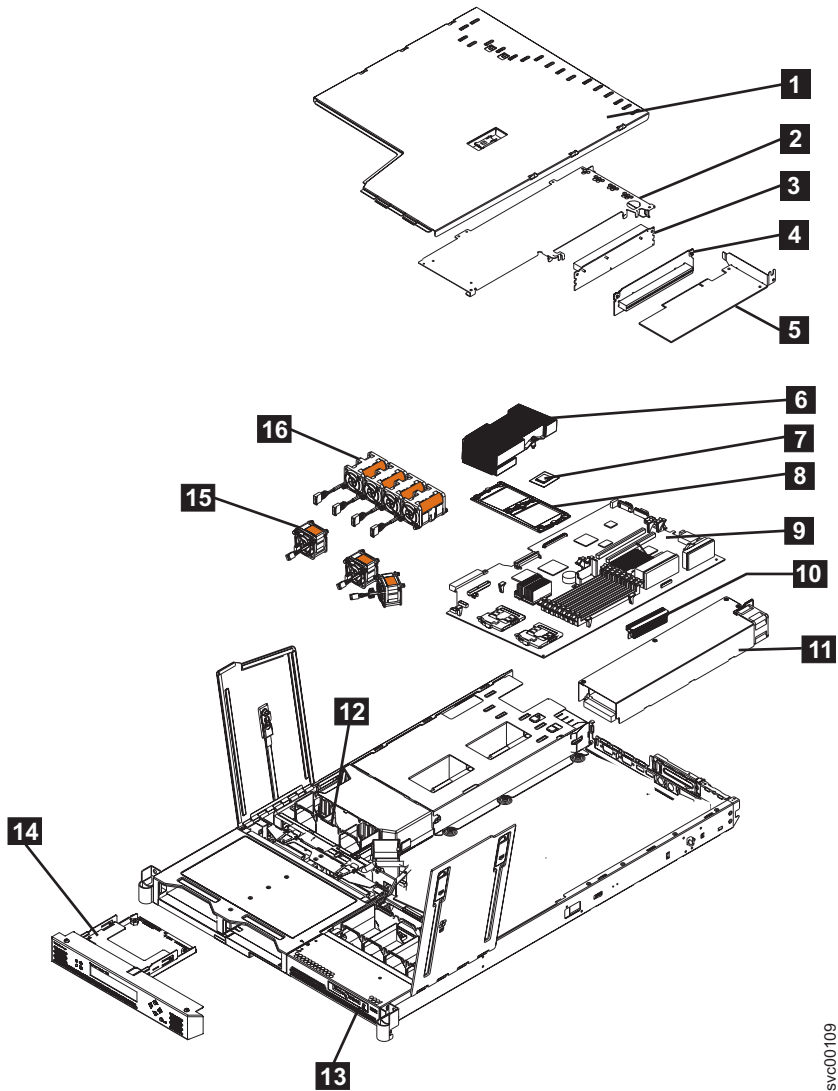

svc00109

Figure 5. Exploded view of the SAN Volume Controller 2145-8F2 node

Table 17 provides the part numbers and a brief description of the frame assembly parts that are labeled in Figure 5. The frame assembly comprises all of the parts except the service controller and fibre-channel cards. These parts are listed in Table 18 on page 17.

Table 17. SAN Volume Controller 2145-8F2 frame assembly

Assembly index	Part number	Units	Description
	64P7934	1	Frame assembly
-1	23K4219	1	Top cover
-	64P8332	1	80GB SATA HDD
-3	23K4211	1	Riser card, PCI (full height)
-4	90P1957	1	Riser card, PCI (low profile)
-6	90P5281	2	Heat sink

Table 17. SAN Volume Controller 2145-8F2 frame assembly (continued)

Assembly index	Part number	Units	Description
-7	13M8293	2	Microprocessor, 3.0 GHz
-8	90P5282	1	Heat sink retention module
-	90P5284	1	Chassis
-	23K4209	1	Cage assembly
-9	32R1730	1	System board
-10	24R2698	2	VRM, 1U/75A
-11	24R2640	1	Power supply assembly
-	23K4515	1	Power backplane
-	33F8354	1	Battery, 3.0V
-	33P2352	1	Cable, fan power
-	25R4052	1	Cable, signal, front panel
-12	23K4992	1	Fan holder with fan backplanes
-13	23K4490	1	Operator information panel
-15	23K4217	3	Fan, 40×40×28
-16	33P2335	4	Fan, 40×40×56
-	73P2870	8	Memory, 1 GB ECC DRR2

Table 18. Items not included in the SAN Volume Controller 2145-8F2 frame assembly

Assembly index	Part number	Units	Description
-2	64P7783	1	Fibre-channel HBA (full height)
-5	64P7813	1	Fibre-channel HBA (low profile)
-	23R2770	1	Fibre-channel SFP connector
-14	64P7874	1	Service controller
-	64P7940	1	Input power cable assembly, (SAN Volume Controller 2145-8F2 to the 2145 UPS-1U)
-	23K4218	1	Kit, toolless rail
-	39M5699		External fibre-channel cable, LC–LC, 1.0 m (3.3 ft)
-	39M5700		External fibre-channel cable, LC–LC, 5.0 m (16.4 ft)

Table 18. Items not included in the SAN Volume Controller 2145-8F2 frame assembly (continued)

Assembly index	Part number	Units	Description
-	39M5701		External fibre-channel cable, LC–LC, 25.0 m (82 ft)
-	12R9321		External fibre-channel cable, LC–SC/LC, 1.0 m (3.3 ft)

Redundant ac-power switch parts

There is a single field-replaceable unit (FRU) assembly for the redundant ac power feature. It consists of the switch and two input-power cables.

The redundant ac-power switch is an optional feature that makes the SAN Volume Controller nodes resilient to the failure of a single power circuit. The redundant ac-power switch is not a replacement for an uninterruptible power supply. You must still use a uninterruptible power supply for each node.

Figure 6 shows the redundant ac-power switch.

Table 19 lists the part numbers for the redundant ac-power switch.



Figure 6. View of the redundant ac-power switch FRU

Table 19. Redundant ac-power switch

Part number	Units	Description
31P0896	1	Redundant ac-power switch assembly

2145 UPS-1U parts

The 2145 UPS-1U is assembled from four separate parts.

A 2145 UPS-1U powers one SAN Volume Controller node. Figure 7 on page 19 shows the parts that make up the 2145 UPS-1U.

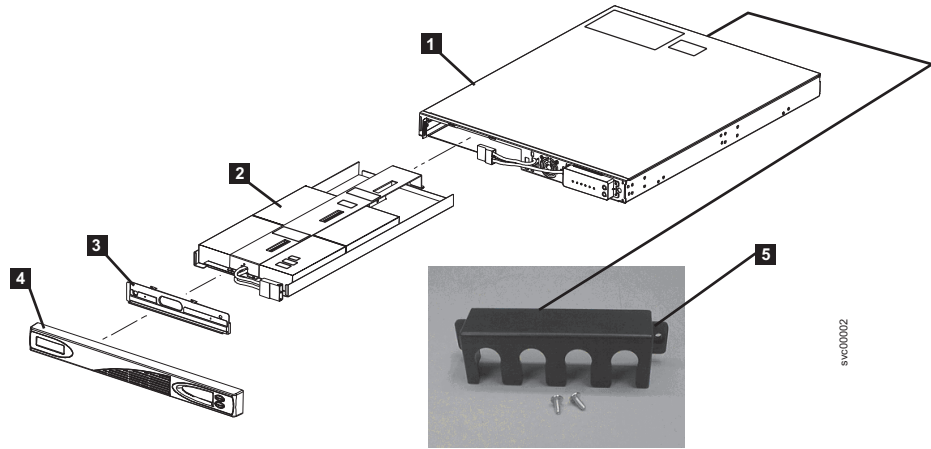

Figure 7. Exploded view of the 2145 UPS-1U hardware

Table 20 lists the different parts that are labeled in Figure 7.

Table 20. 2145 UPS-1U part numbers

Assembly index	Part number	Units	Description
	31P1318	1	2145 UPS-1U assembly Uninterruptible power supply assembly for use with 2145-CF8
	31P0875	1	2145 UPS-1U assembly Uninterruptible power supply assembly for use with 2145-8F2, 2145-8F4, 2145-8G4, and 2145-8A4. The 31P1318 FRU part might be substituted for this FRU.
-1	Not available	1	Chassis assembly This item cannot be ordered and is supplied as part of the 2145 UPS-1U assembly.
-2	31P0710	1	Battery pack assembly
-3	Not available	1	Battery plate This item cannot be ordered and is supplied as part of the 2145 UPS-1U assembly.
-4	31P0709	1	Front panel
-5	31P1060	1	2145 UPS-1U cable retention bracket kit
-	31P0711	1	Support rail kit, contains rails, nut clips, and screws
-	39M5376	1	Input-power cable, power distribution unit to the 2145 UPS-1U.
-	39M5116	1	Main power cable for the United States.

Related reference

“Power cables for the 2145 UPS-1U”

If you do not connect the 2145 UPS-1U to a rack power-distribution unit (PDU) or redundant ac-power switch, you must follow your country or region’s power requirements to choose the appropriate power cable for the 2145 UPS-1U.

Power cables for the 2145 UPS-1U

If you do not connect the 2145 UPS-1U to a rack power-distribution unit (PDU) or redundant ac-power switch, you must follow your country or region’s power requirements to choose the appropriate power cable for the 2145 UPS-1U.

The 2145 UPS-1U is supplied with an IEC 320-C13 to C14 jumper to connect it to a rack PDU. You can also use this cable to connect the 2145 UPS-1U to the redundant ac-power switch.

The following table lists the power cable options for your country or region.

Country or region	Length	Connection type (attached plug designed for 200 - 240 V ac input)	Part number
United States of America (Chicago), Canada, Mexico	1.8 m (6 ft)	NEMA L6-15P	39M5115
Bahamas, Barbados, Bermuda, Bolivia, Brazil, Canada, Cayman Islands, Colombia, Costa Rica, Dominican Republic, Ecuador, El Salvador, Guatemala, Guyana, Haiti, Honduras, Jamaica, Japan, Korea (South), Liberia, Mexico, Netherlands Antilles, Nicaragua, Panama, Peru, Philippines, Saudi Arabia, Suriname, Taiwan, Trinidad (West Indies), United States of America, Venezuela	2.8 m (9 ft)	NEMA L6-15P	39M5116
Afghanistan, Algeria, Andorra, Angola, Austria, Belgium, Benin, Bulgaria, Burkina Faso, Burundi, Cameroon, Central African Republic, Chad, Czech Republic, Egypt, Finland, France, French Guiana, Germany, Greece, Guinea, Hungary, Iceland, Indonesia, Iran, Ivory Coast, Jordan, Lebanon, Luxembourg, Macao S.A.R. of China, Malagasy, Mali, Martinique, Mauritania, Mauritius, Monaco, Morocco, Mozambique, Netherlands, New Caledonia, Niger, Norway, Poland, Portugal, Romania, Senegal, Slovakia, Spain, Sudan, Sweden, Syria, Togo, Tunisia, Turkey, former USSR, Vietnam, former Yugoslavia, Zaire, Zimbabwe	2.8 m (9 ft)	CEE 7-VII	39M5123

Country or region	Length	Connection type (attached plug designed for 200 - 240 V ac input)	Part number
Antigua, Bahrain, Brunei, Channel Islands, Hong Kong S.A.R. of China, Cyprus, Dubai, Fiji, Ghana, India, Iraq, Ireland, Kenya, Kuwait, Malawi, Malaysia, Malta, Nepal, Nigeria, Polynesia, Qatar, Sierra Leone, Singapore, Tanzania, Uganda, United Kingdom, Yemen, Zambia	2.8 m (9 ft)	BS 1363/A	39M5151
Argentina	2.8 m (9 ft)	IRAM 2073	39M5068
Argentina, Australia, New Zealand, Papua New Guinea, Paraguay, Uruguay, Western Samoa	2.8 m (9 ft)	AS/NZS 3112/2000	39M5102
Bangladesh, Burma, Pakistan, South Africa, Sri Lanka	2.8 m (9 ft)	SABS 164	39M5144
Chile, Ethiopia, Italy, Libya, Somalia	2.8 m (9 ft)	CEI 23-16	39M5165
People's Republic of China	2.8 m (9 ft)	GB 2099.1	39M5206
Denmark	2.8 m (9 ft)	DK2-5a	39M5130
Israel	2.8 m (9 ft)	SI 32	39M5172
Liechtenstein, Switzerland	2.8 m (9 ft)	IEC 60884 Stnd. Sheet 416534?2 (CH Type 12)	39M5158
Thailand	2.8 m (9 ft)	NEMA 6-15P	39M5095

Chapter 2. Removing and replacing parts

You can remove and replace field-replaceable units (FRUs) from the SAN Volume Controller, redundant ac-power switch, and uninterruptible power supply.

Each FRU has its own removal procedure. Sometimes you can find that a step within a procedure might refer you to a different remove/replace procedure. You might want to complete the new procedure before you continue with the first procedure that you started.

Remove or replace parts only when you are directed to do so by the *IBM System Storage SAN Volume Controller Troubleshooting Guide*. Start all problem determination and repair procedures with MAP 5000.

Related information

“Removing and replacing SAN Volume Controller parts” on page 25

The remove and replace procedures for the SAN Volume Controller field replaceable units are described in the topics that follow.

“Removing and replacing 2145 UPS-1U parts” on page 314

The remove and replace procedures for the 2145 UPS-1U field replaceable units are described in the topics which follow.

Enabling concurrent maintenance

To allow concurrent maintenance, SAN Volume Controllers must be configured in pairs.

While one SAN Volume Controller is being serviced, the other keeps the I/O group operational. With concurrent maintenance, all field-replaceable units (FRUs) can be removed, replaced, and tested on one SAN Volume Controller while the SAN and host systems are powered on and doing productive work.

Attention: Do not remove the power from both SAN Volume Controllers unless the procedures instruct you to do so.

Perform the following checks to verify that concurrent maintenance is enabled. It is particularly important to perform these checks if a node contains solid-state drives (SSDs) because virtual disks (VDisks) on the SSDs might not be mirrored:

1. Confirm that no hosts have dependencies on the node.

When shutting down a node that is part of a cluster, or when deleting the node from a cluster, use the Show Dependent VDisks menu option on the Viewing Nodes panel in the SAN Volume Controller Console to display all the VDisks that are dependent on a node, or use the `svcinfo lsnode dependentvdisk` command to view dependent VDisks.

If dependent VDisks exist, determine if the VDisks are being used. If the VDisks are being used, either restore the redundant configuration or suspend the host application. If a dependent quorum disk is reported, repair the access to the quorum disk or modify the quorum disk configuration.

2. Ensure that the host multipathing device drivers can fail over to the partner node.

Some host multipathing device drivers take a while to update after changes are made on the fabric. Do not shut down a node or delete the node from a cluster if the partner node in the I/O group to which the node belongs has not been online for more than 30 minutes.

If possible, check the status of the host multipathing device drivers before shutting down a node to ensure that the device drivers can fail over to the partner node.

When shutting down the node, see MAP 5350 in the *IBM System Storage SAN Volume Controller Troubleshooting Guide* for a description of how to check for dependencies on the node during the procedure to turn off the node.

When deleting a node from the cluster, see "Deleting a node from a cluster using the SAN Volume Controller Console" in the *IBM System Storage SAN Volume Controller Troubleshooting Guide* for a description of node information to retain to avoid data corruption when adding the node back to the cluster, how to ensure that the multipathing device driver does not rediscover any paths that are manually removed, and for other considerations regarding dependent VDisks.

For more information about working with dependent VDisks, see the following topics:

- "Listing node-dependent VDisks using the CLI" in the *IBM System Storage SAN Volume Controller Troubleshooting Guide*
- "Isnodependentvdisks" command description in the *IBM System Storage SAN Volume Controller Command-Line Interface User's Guide*

Preparing to remove and replace parts

Before you remove and replace parts, you must be aware of all safety issues.

First, read the safety precautions in the *IBM Systems Safety Notices*. These guidelines help you safely work with the SAN Volume Controller, redundant ac-power switch, and uninterruptible power supply.

Working inside the node with the power on

When you are servicing the SAN Volume Controller node, you might need to turn on the node while the cover is off.

Attention: Static electricity that is released to internal components when the node is turned on might cause the node to halt, which might result in the loss of data. To avoid this potential problem, always use an electrostatic-discharge wrist strap or other grounding system when you work inside the node with the power on.

You might be instructed to turn on the node and look at system-board LEDs while the cover is off. Follow these guidelines when you work inside a node that is turned on:

- Avoid wearing loose-fitting clothing on your forearms. Button long-sleeved shirts before working inside the server; do not wear cuff links while you are working inside the node.
- Do not allow your necktie or scarf to hang inside the node.
- Remove jewelry, such as bracelets, necklaces, rings, and loose-fitting wrist watches.
- Remove items from your shirt pocket, such as pens and pencils, that could fall into the node as you lean over it.
- Avoid dropping any metallic objects, such as paper clips, hairpins, and screws, into the node.

Removing and replacing SAN Volume Controller parts

The remove and replace procedures for the SAN Volume Controller field replaceable units are described in the topics that follow.

Removing the cable-management arm

You can remove the SAN Volume Controller 2145-CF8 cable-management arm from the rack.

Removing the SAN Volume Controller 2145-CF8 cable-management arm

Remove the SAN Volume Controller 2145-CF8 cable-management arm that routes and secures the power cables and other cables.

The parts involved in removing the cable-management arm are shown in Figure 8.

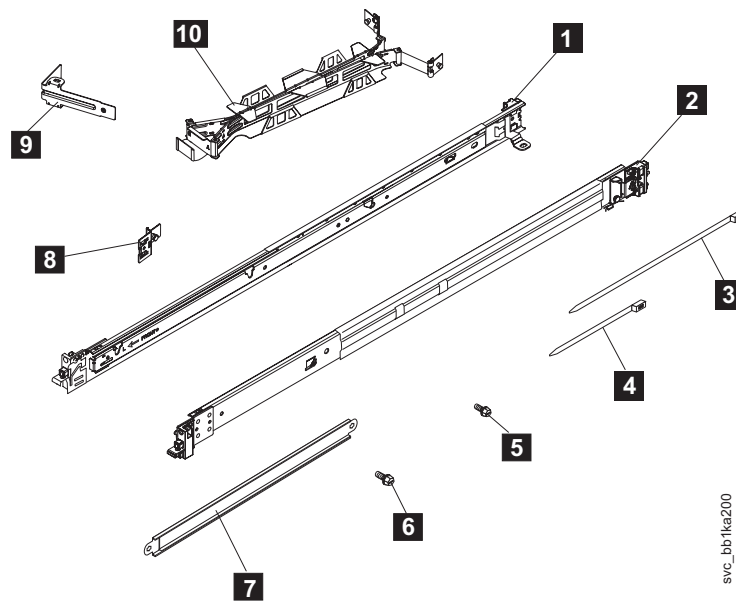

Figure 8. SAN Volume Controller 2145-CF8 cable-management arm, support rails, and associated parts

Table 21. Cable-management arm and associated parts descriptions and quantities

Reference	Description	Quantity
1	Slide rail (left)	1
2	Slide rail (right)	1
3	Large cable tie	1
4	Cable ties	5
5	M6 screws	4
6	10-32 screws	2
7	Cable-management support arm	1
8	Cable-management arm mounting bracket	1
9	Cable-management arm stop bracket	1
10	Cable-management arm assembly	1

The cable-management arm is installed to pivot from the left side of the SAN Volume Controller 2145-CF8 rack.

To remove the cable-management arm, perform the following steps:

1. Remove all power from the node, as described in MAP 5350 in the *IBM System Storage SAN Volume Controller Troubleshooting Guide*.
2. Disconnect all cables from the back of the SAN Volume Controller 2145-CF8 node.
3. Slide the SAN Volume Controller 2145-CF8 away from the back of the rack.
 - a. Remove any optional M6 screws, as shown by **1** in Figure 9, from the front of the node.
 - b. To release the node from the rack, press the orange release latches **2** and slide the SAN Volume Controller 2145-CF8 node forward until it latches in the service position.

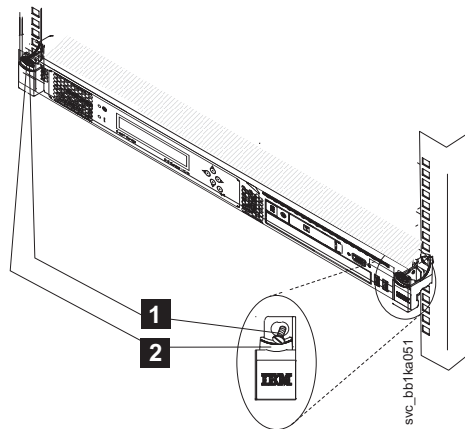
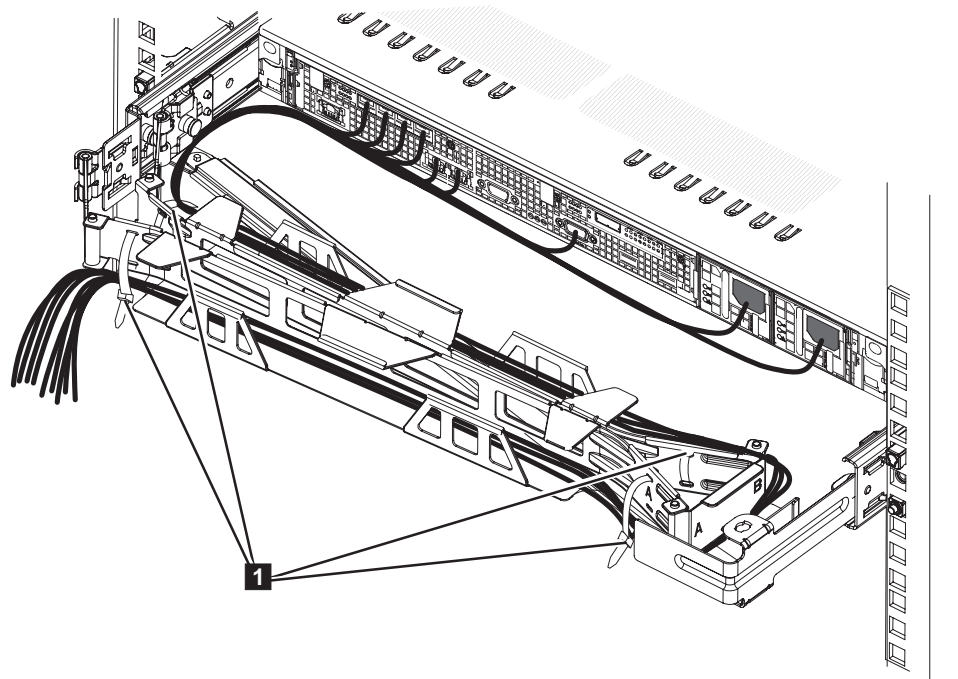

Figure 9. SAN Volume Controller 2145-CF8 release latches and mounting screws

4. Disconnect the power cords and other cables from the cable-management arm.
 - a. Remove the cable ties or hook-and-loop fasteners.
 - b. Free the cables and power cords from the cable-management arm, as shown by **1** in Figure 10 on page 27.



svc00547

Figure 10. SAN Volume Controller 2145-CF8 cables in the cable-management arm

5. Remove the cable-management arm from the support arm.
 - a. Pull out the cable-management arm pin, as shown by **3** in Figure 11 on page 28, then slide the cable-management arm tab **4** on the outside of the slide rail.
 - b. Pull the tab until it is free.
 - c. Pull out the other cable-management arm pin **1**, then slide the cable-management arm tab **2** out of the slot on the inside of the slide rail.
 - d. Pull the tab until it is free.

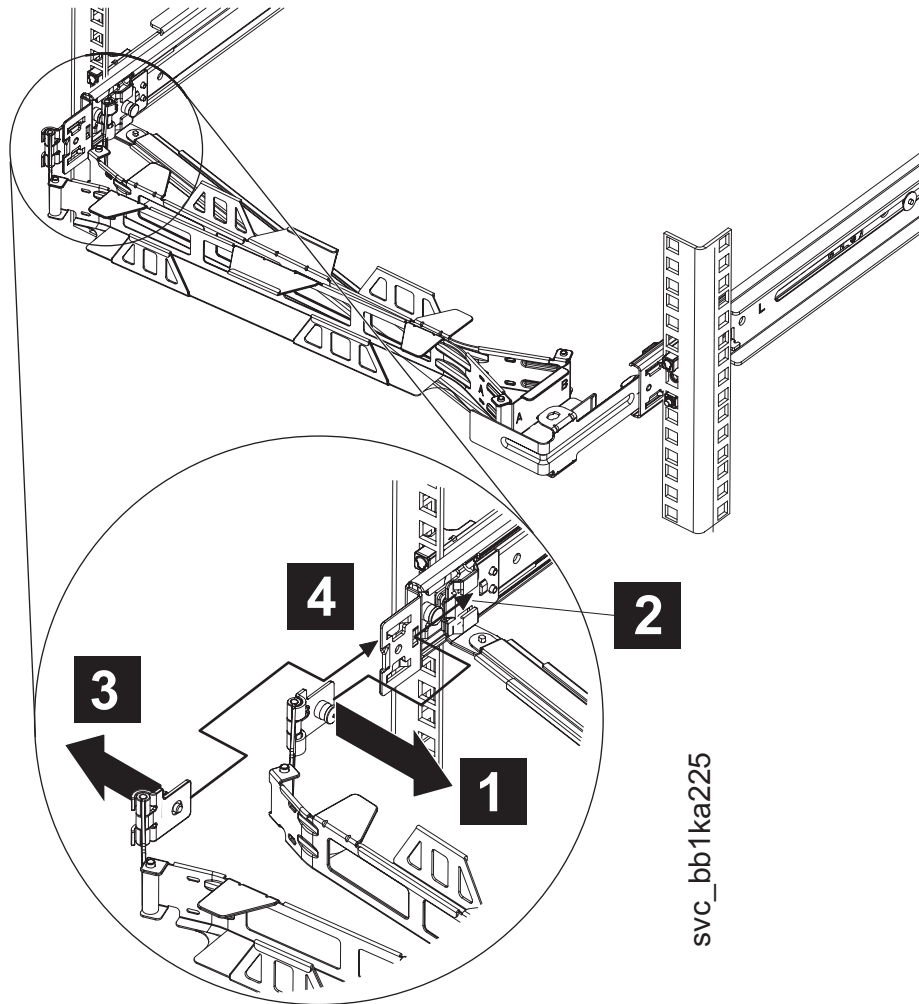

Figure 11. SAN Volume Controller 2145-CF8 cable-management arm on the support arm

6. Remove the cable-management mounting bracket from the same slide rail onto which the cable-management arm was installed.

The cable-management support arm is not shown in Figure 12 on page 29.

Pull out the mounting bracket pin **1** and slide the mounting bracket **2** out of the left slide rail. Pull the bracket from the slide rail until it is free.

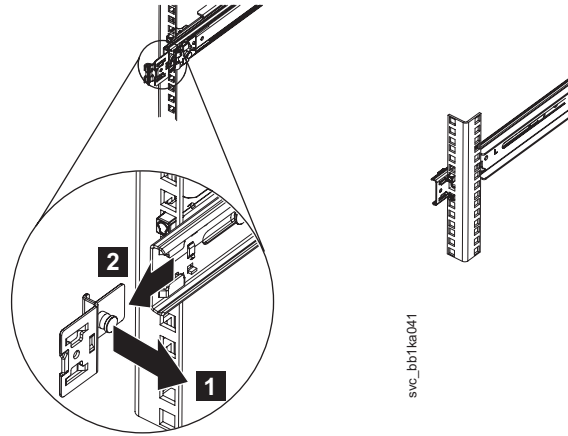

Figure 12. Removing the SAN Volume Controller 2145-CF8 cable-management arm mounting bracket

7. To free the swing end of the support arm from the backside of the slide rail, push the blue latch on the cable-support-arm stop bracket on the right rail to open the cable-management arm, pivoting the arm on the left rail, as shown by **1** in Figure 13, and then slide the bracket **2** from the slide rail.

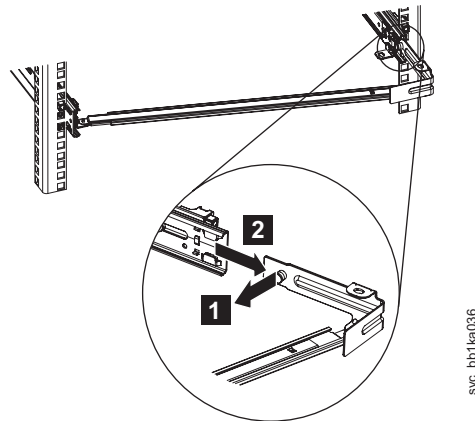

Figure 13. Freeing the swing end of the SAN Volume Controller 2145-CF8 support arm

8. Remove the L-shaped cable-management stop bracket on the unattached end of the support arm. Turn the bracket, as shown by **1** in Figure 14 on page 30 to free it from the support arm. Then lift the cable-management stop bracket **2** from the support arm.

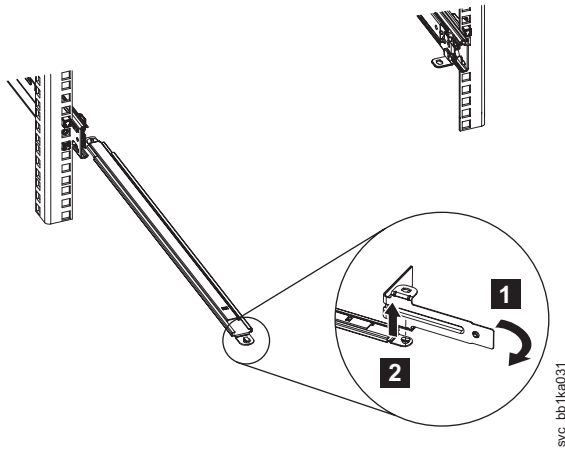

Figure 14. Removing the SAN Volume Controller 2145-CF8 cable-management stop bracket

9. Disconnect the attached end of the support arm, as shown by **1** in Figure 15, from the same slide rail from which you detached the cable-management arm.

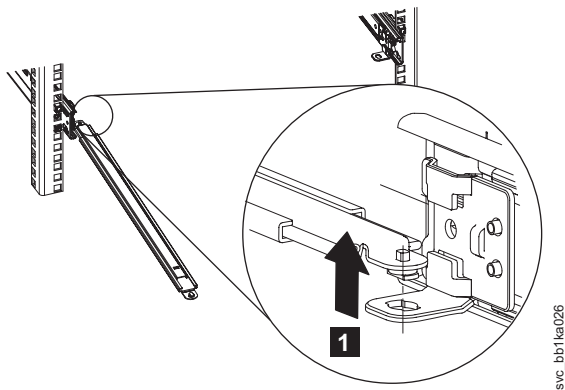

Figure 15. Detaching the SAN Volume Controller 2145-CF8 cable-management support arm

Related tasks

“Removing the support rails for the SAN Volume Controller 2145-CF8” on page 66
 This topic describes how to remove the SAN Volume Controller 2145-CF8 support rails.

Replacing the cable-management arm

Replace the cable-management arm after you install the SAN Volume Controller 2145-CF8 node into the rack.

Replacing the SAN Volume Controller 2145-CF8 cable-management arm

The SAN Volume Controller 2145-CF8 uses a cable-management arm to route and secure power cables and other cables.

Replace the SAN Volume Controller 2145-CF8 cable-management arm after you replace the node in the rack.

The cable-management arm is installed to pivot from the left side of the SAN Volume Controller 2145-CF8 rack, when viewed from the rear of the rack.

To attach the cable-management arm, perform the following steps:

1. At the rear of the rack, connect one end of the support arm, as shown by **1** in Figure 16, to the same slide rail to which you plan to attach the cable-management arm so that you can swing the other end of the support arm **2** toward the rack.

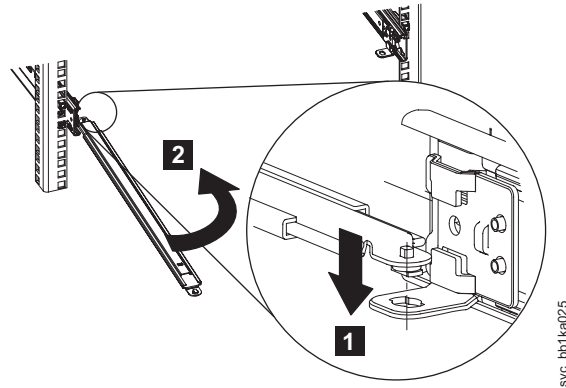

Figure 16. Rack rear: Attaching the SAN Volume Controller 2145-CF8 cable-management support arm

2. Install the L-shaped cable-management stop bracket, as shown by **1** in Figure 17 on the unattached end of the support arm. Turn the bracket **2** to secure it to the support arm.

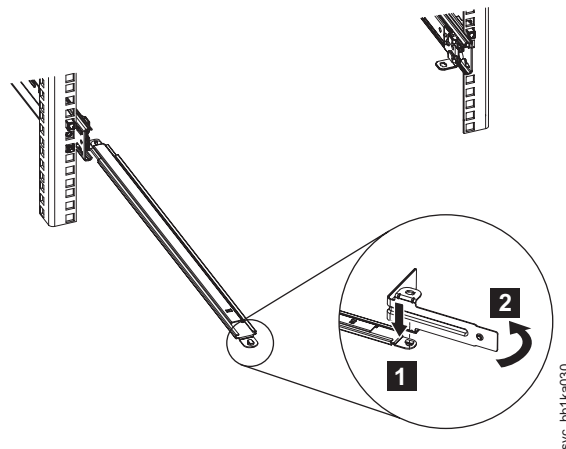

Figure 17. Rack rear: Installing the SAN Volume Controller 2145-CF8 cable-management stop bracket

3. To attach the other side of the support arm to the backside of the slide rail, push the blue latch on the cable-support-arm stop bracket, as shown by **1** in Figure 18 on page 32, to slide the bracket **2** into the slide rail.

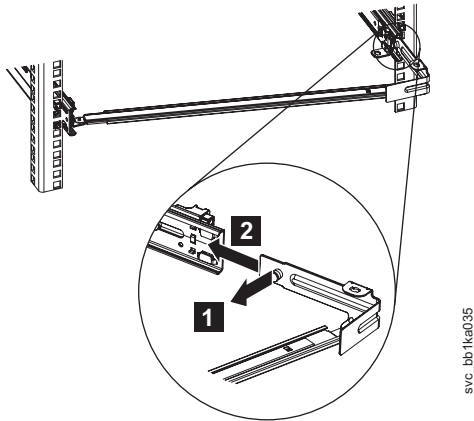

Figure 18. Attaching the free end of the SAN Volume Controller 2145-CF8 support arm

4. To install the cable-management arm assembly, you must place the cable-management arm mounting bracket into the same slide rail onto which you installed the cable-management support arm.

The cable-management support arm is not shown in Figure 19.

Push the blue latch on the cable-support-arm stop bracket **1** to slide the mounting bracket **2** into the left slide rail. Push the bracket into the slide rail until the bracket snaps into place.

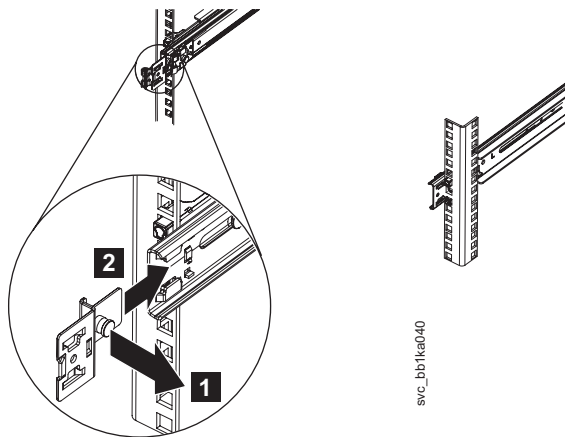

Figure 19. Rack rear: Installing the SAN Volume Controller 2145-CF8 cable-management arm mounting bracket

5. Place the cable-management arm on the support arm.
 - a. Pull out the cable-management arm pin, as shown by **1** in Figure 20 on page 33, then slide the cable-management arm tab **2** into the slot on the inside of the slide rail.
 - b. Push the tab until it snaps into place.
 - c. Pull out the other cable-management arm pin **3**, then slide the cable-management arm tab into the slot **4** on the outside of the slide rail.
 - d. Push the tab until it snaps into place.

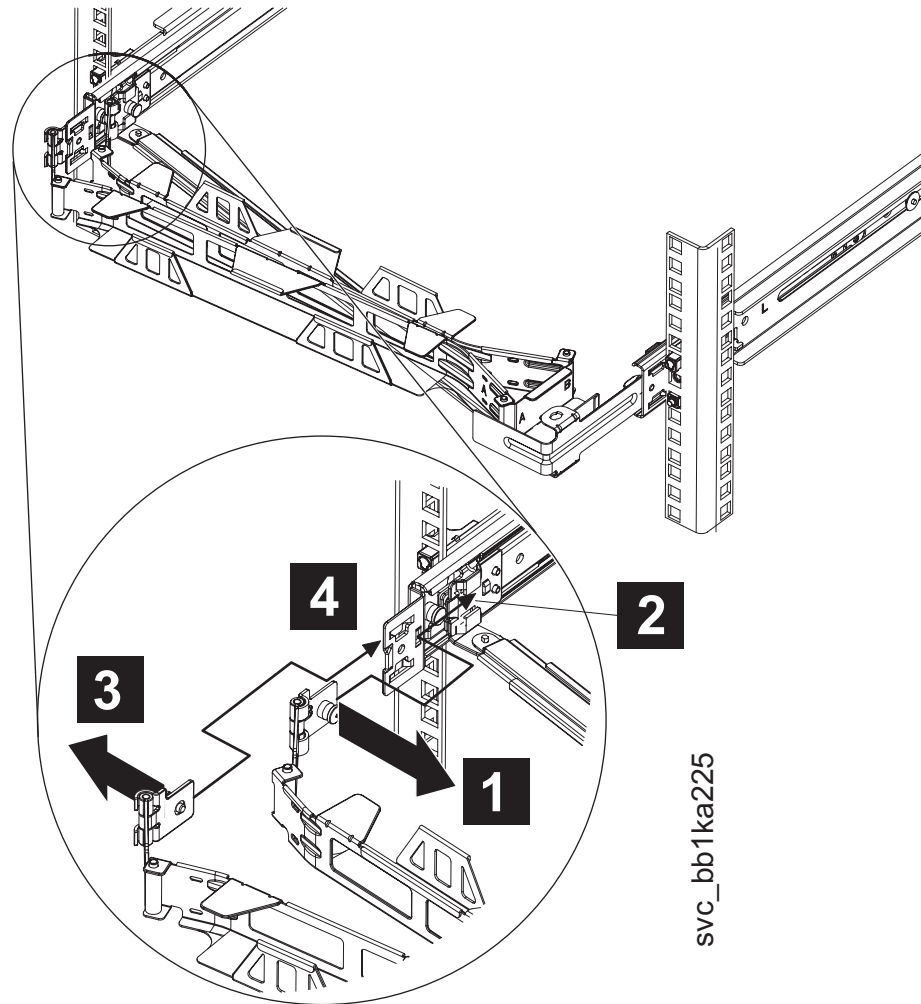

Figure 20. SAN Volume Controller 2145-CF8 cable-management arm on the support arm

6. Attach the power cords and data cables to the rear of the node.
 - a. Route the cables and power cords on the cable-management arm, as shown by **1** in Figure 21 on page 34.

If you attach the arm properly and route the cables properly, the arm swings into the rack as you pull the node forward in the rack, opening to allow the cables to follow the node toward the front of the rack. You can perform some service procedures from the fully extended rail position without disconnecting the fibre-channel cables and the Ethernet cables. You can also perform some service procedures without turning off the node or disconnecting the power cables.

- b. Secure the cables with cable ties or hook-and-loop fasteners.

Note: Leave some slack in all of the cables to avoid tension in the cables as the cable-management arm moves.

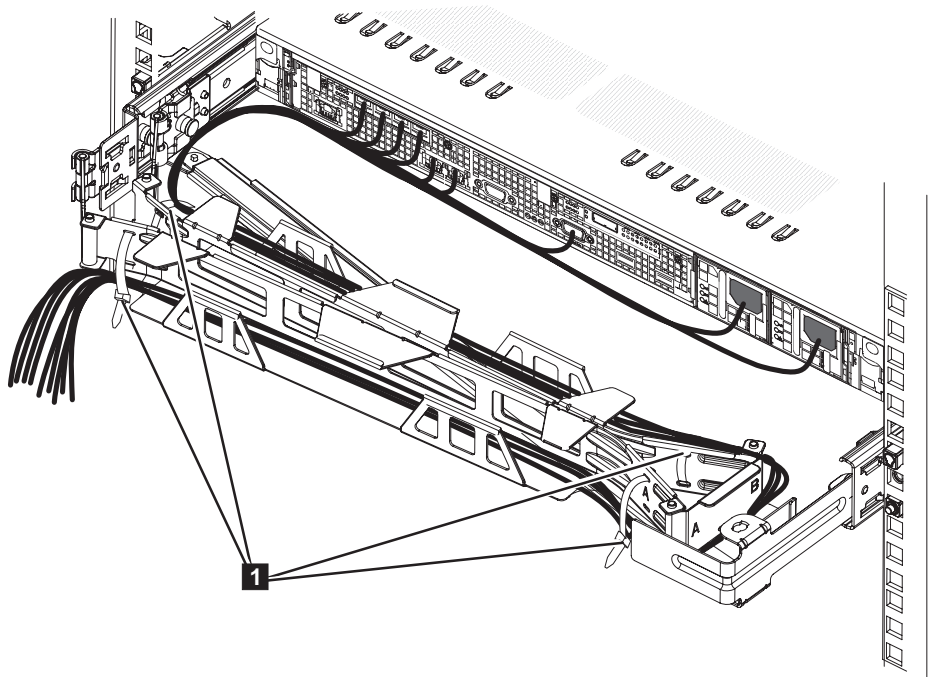

svc00547

Figure 21. SAN Volume Controller 2145-CF8 cables in the cable-management arm

7. Slide the SAN Volume Controller 2145-CF8 into the rack until it snaps into place.
8. Connect all cables to the back of the SAN Volume Controller 2145-CF8 node.

Removing the cable-retention bracket

The SAN Volume Controller models 2145-CF8, 2145-8A4, 2145-8G4, 2145-8F4, and 2145-8F2 provide a cable-retention bracket, which ensures that the node does not mistakenly become unplugged from the uninterruptible power supply.

Related tasks

“Removing the SAN Volume Controller 2145-CF8 cable-retention brackets”

You can remove the two SAN Volume Controller 2145-CF8 cable-retention brackets when removing the power cords from the node.

“Removing the SAN Volume Controller 2145-8A4 cable retention bracket” on page 36

The cable-retention bracket attaches to the back of the SAN Volume Controller 2145-8A4 node. It is connected with one screw that already holds the rear plate of the power supply in place.

“Removing the SAN Volume Controller 2145-8G4 cable retention bracket” on page 37

“Removing the SAN Volume Controller 2145-8F4 cable retention bracket” on page 40

The cable-retention bracket attaches to the back of the SAN Volume Controller 2145-8F4 node. It is connected with one screw that already holds the rear plate of the power supply in place.

“Replacing the cable-retention bracket” on page 40

Replace the cable-retention bracket after you install SAN Volume Controller model 2145-8A4, 2145-8G4, or 2145-8F4 into the rack.

Removing the SAN Volume Controller 2145-CF8 cable-retention brackets

You can remove the two SAN Volume Controller 2145-CF8 cable-retention brackets when removing the power cords from the node.

DANGER

Multiple power cords. The product might be equipped with multiple power cords. To remove all hazardous voltages, disconnect all power cords.

The SAN Volume Controller 2145-CF8 uses two toolless cable-retention brackets, one to retain each cable from the uninterruptible power-supply to one of the two SAN Volume Controller 2145-CF8 power supplies, as shown in Figure 22.

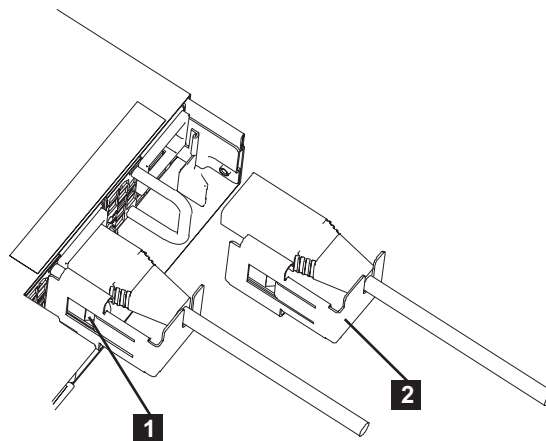

Figure 22. SAN Volume Controller 2145-CF8 cable-retention brackets

Each cable-retention bracket attaches to the back of the SAN Volume Controller 2145-CF8 node. The brackets connect without screws.

This service action requires you to:

- Optionally, turn off the node.
- Disconnect the power cable that the retention bracket is on.

To remove a cable-retention bracket, perform these steps:

1. Read the safety information to which “Preparing to remove and replace parts” on page 24 refers.
2. Optional: Follow the procedure in MAP 5350 in the *IBM System Storage SAN Volume Controller Troubleshooting Guide* to verify that the node data is mirrored and synchronized, and that there are no dependent virtual disks (VDisks) before turning off the node.

Important: If you decide to hot swap a power supply, and that is why you are removing the cable retention bracket, use MAP 5350 to make all of the necessary checks that ensure that the partner node in the I/O group can take over all I/O group operations, if necessary, and that there are no dependent VDisks on the node. With the partner node available and no dependent VDisks on the node, you do not lose access to data if this node accidentally powers off.

3. Pull back the cable-management arm if you are working from the rear of the rack, or slide the node out of the rack to the fully extended rail position if you are working from the front.
4. When the node is completely turned off, from under the cable, carefully push the spring clip away from the cable to free the cable-retention bracket from the handle on the power supply.
The spring clip is shown by **1** in Figure 22 on page 35.
5. Pull both the bracket and the cable (**2**) away from the SAN Volume Controller 2145-CF8 power supply.
6. Remove the cable-retention bracket from the power cord.

Related tasks

“Removing the cable-retention bracket” on page 34

The SAN Volume Controller models 2145-CF8, 2145-8A4, 2145-8G4, 2145-8F4, and 2145-8F2 provide a cable-retention bracket, which ensures that the node does not mistakenly become unplugged from the uninterruptible power supply.

Removing the SAN Volume Controller 2145-8A4 cable retention bracket

The cable-retention bracket attaches to the back of the SAN Volume Controller 2145-8A4 node. It is connected with one screw that already holds the rear plate of the power supply in place.

Remove the cable-retention bracket before you remove the SAN Volume Controller 2145-8A4 node from the rack.

To remove the bracket from the node, perform the following steps:

1. With the node turned off, unscrew the retaining screw **1**, shown in Figure 23 on page 37, half a turn, but do not fully loosen or remove it.

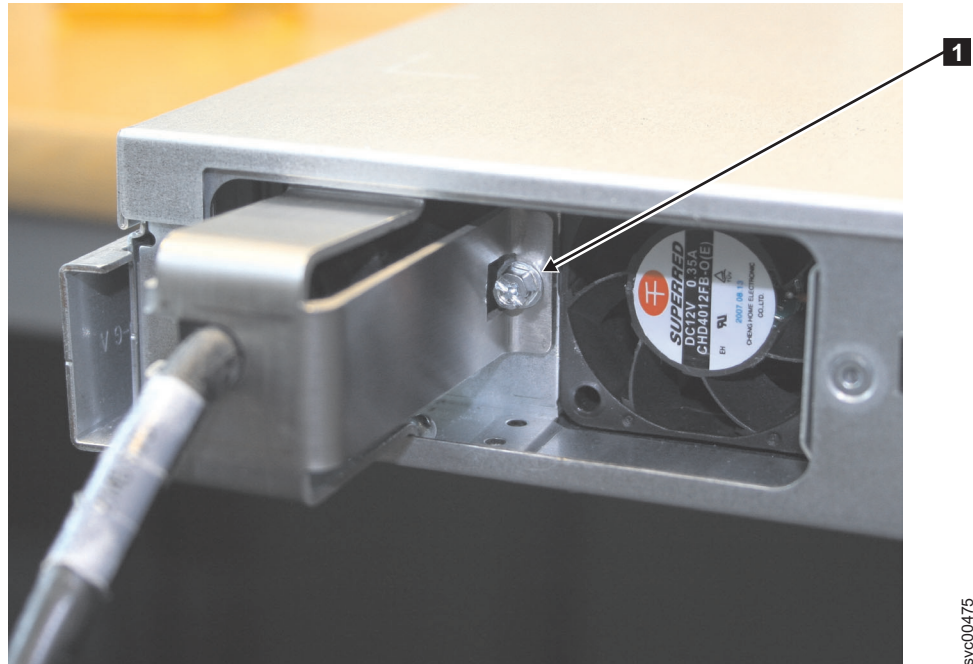

svc00475

Figure 23. SAN Volume Controller 2145-8A4 with the cable-retention bracket installed

2. Slide the bracket to the right just enough to disengage the screw.
3. Squeeze the top and bottom of the bracket together slightly and turn the bracket at a slight angle to remove both lips of the bracket from the node frame.
4. Slide the bracket back onto the power cable and then slide it off the cable.
5. Remove the power cable.

Related tasks

“Removing the cable-retention bracket” on page 34

The SAN Volume Controller models 2145-CF8, 2145-8A4, 2145-8G4, 2145-8F4, and 2145-8F2 provide a cable-retention bracket, which ensures that the node does not mistakenly become unplugged from the uninterruptible power supply.

Removing the SAN Volume Controller 2145-8G4 cable retention bracket

The SAN Volume Controller 2145-8G4 uses one of two different cable-retention brackets. Depending on which bracket you have, use the appropriate instructions to remove and replace the cable-retention bracket.

- If your cable-retention bracket looks like the bracket in Figure 24 on page 38, go to “Removing the SAN Volume Controller 2145-8G4 cable retention bracket - option A” on page 39.



Figure 24. SAN Volume Controller 2145-8G4 cable retention bracket - type A

- If your cable-retention bracket looks like the bracket in Figure 25, go to “Removing the SAN Volume Controller 2145-8G4 cable retention bracket - option B” on page 39.



Figure 25. SAN Volume Controller 2145-8G4 cable retention bracket - type B

Related tasks

“Removing the cable-retention bracket” on page 34

The SAN Volume Controller models 2145-CF8, 2145-8A4, 2145-8G4, 2145-8F4, and 2145-8F2 provide a cable-retention bracket, which ensures that the node does not mistakenly become unplugged from the uninterruptible power supply.

Removing the SAN Volume Controller 2145-8G4 cable retention bracket - option A:

The cable-retention bracket attaches to the back of the SAN Volume Controller 2145-8G4 node. It is connected with the screws that already hold the rear plate of the power supply in place.

Remove the cable-retention bracket before you remove the SAN Volume Controller 2145-8G4 node from the rack.

To remove the cable-retention bracket, perform these steps:

1. Carefully remove the two retaining screws on the right side of the power supply rear plate shown in Figure 26.



Figure 26. The SAN Volume Controller 2145-8G4 with the cable-retention bracket attached

2. Remove the bracket.
3. Replace the screws in the power supply rear plate.

Removing the SAN Volume Controller 2145-8G4 cable retention bracket - option B:

Remove the cable-retention bracket before you remove the SAN Volume Controller 2145-8G4 from the rack.

To remove the cable-retention bracket, perform these steps:

1. Remove the securing bolt from the node side rail (shown in Figure 27 on page 40) next to the power supply.

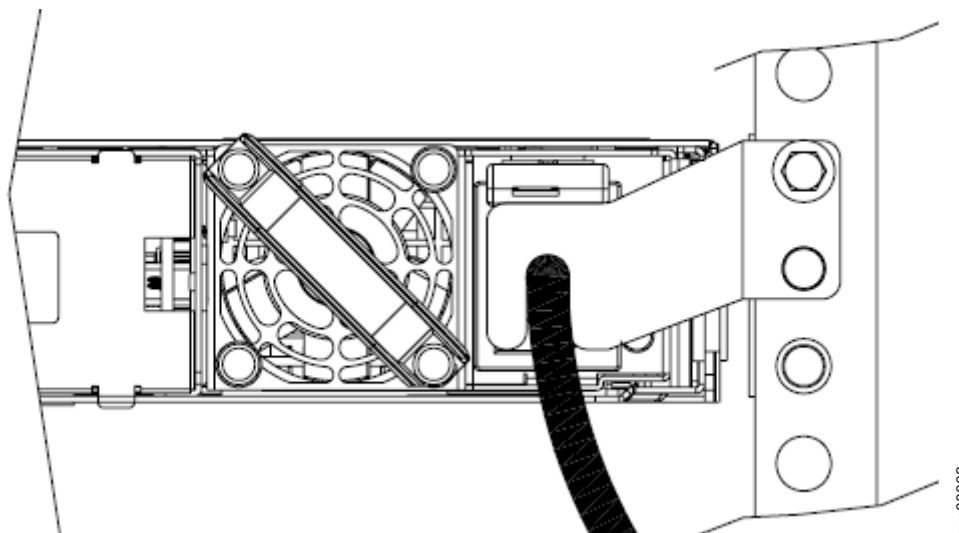

Figure 27. The SAN Volume Controller 2145-8G4 with cable-retention bracket type B attached

2. Remove the bracket.
3. Replace the bolt in the node side rail.

Removing the SAN Volume Controller 2145-8F4 cable retention bracket

The cable-retention bracket attaches to the back of the SAN Volume Controller 2145-8F4 node. It is connected with one screw that already holds the rear plate of the power supply in place.

Remove the cable-retention bracket before you remove the SAN Volume Controller 2145-8F4 node from the rack.

To remove the bracket from the node, perform the following steps:

1. With the node turned off, pull the cable-retention bracket backward slightly to disengage the bracket from the slot at the rear of the support rail.
2. Slide the bracket out of the support rail and then move it to the right away from the cable.
3. Remove the power cable.

Related tasks

“Removing the cable-retention bracket” on page 34

The SAN Volume Controller models 2145-CF8, 2145-8A4, 2145-8G4, 2145-8F4, and 2145-8F2 provide a cable-retention bracket, which ensures that the node does not mistakenly become unplugged from the uninterruptible power supply.

Replacing the cable-retention bracket

Replace the cable-retention bracket after you install SAN Volume Controller model 2145-8A4, 2145-8G4, or 2145-8F4 into the rack.

Related tasks

“Removing the cable-retention bracket” on page 34

The SAN Volume Controller models 2145-CF8, 2145-8A4, 2145-8G4, 2145-8F4, and 2145-8F2 provide a cable-retention bracket, which ensures that the node does not mistakenly become unplugged from the uninterruptible power supply.

“Replacing the SAN Volume Controller 2145-CF8 cable-retention brackets”

Replace one of the two cable-retention brackets on the back of the SAN Volume Controller 2145-CF8 to anchor the power cord that runs from the uninterruptible power-supply to one of the two SAN Volume Controller 2145-CF8 power supplies.

“Replacing the SAN Volume Controller 2145-8A4 cable retention bracket” on page 42

“Replacing the SAN Volume Controller 2145-8G4 cable retention bracket” on page 44

The SAN Volume Controller 2145-8G4 uses one of two different cable-retention brackets. Depending on which bracket you have, use the appropriate instructions to remove and replace the cable-retention bracket.

“Replacing the SAN Volume Controller 2145-8F4 cable retention bracket” on page 47

Replacing the SAN Volume Controller 2145-CF8 cable-retention brackets

Replace one of the two cable-retention brackets on the back of the SAN Volume Controller 2145-CF8 to anchor the power cord that runs from the uninterruptible power-supply to one of the two SAN Volume Controller 2145-CF8 power supplies.

DANGER

Multiple power cords. The product might be equipped with multiple power cords. To remove all hazardous voltages, disconnect all power cords.

The SAN Volume Controller 2145-CF8 uses two toolless cable-retention brackets, one to retain each cable from the uninterruptible power-supply to one of the two SAN Volume Controller 2145-CF8 power supplies, as shown in Figure 28.

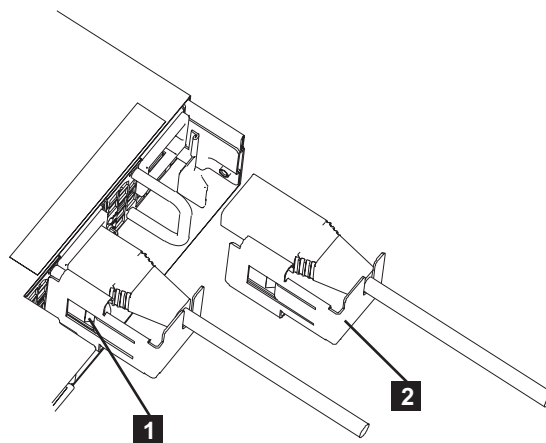

Figure 28. SAN Volume Controller 2145-CF8 cable-retention brackets

Each cable-retention bracket attaches to the back of the SAN Volume Controller 2145-CF8 node. The brackets connect without screws.

To replace each cable-retention bracket, perform these steps:

1. If you removed the node from the rack, replace the node in the rack, as described in “Replacing the SAN Volume Controller in a rack” on page 59.
2. If you removed any fibre-channel or Ethernet cables, use the labels you placed on each cable to replace all fibre-channel and Ethernet cables in the same ports from which they were removed.
3. Loosely install the cable-retention bracket on a power cord by slipping the power cord into the notch on the rear of the bracket.
4. Align the cable-retention bracket on the power cord so that the bracket is to the left of the cord, as shown by **2** in Figure 28 on page 41.
5. Align the power cord with the power connector on the power supply and the bracket with the power-supply handle.
6. Push the power cord into the power connector on the power supply.
7. Carefully push the bracket against the power-supply handle to force the spring clip (**1**) over the leading edge of the handle.
8. Lift the locking levers (**1** in Figure 29) on the slide rails and push the server **2** all the way into the rack until it clicks into place.

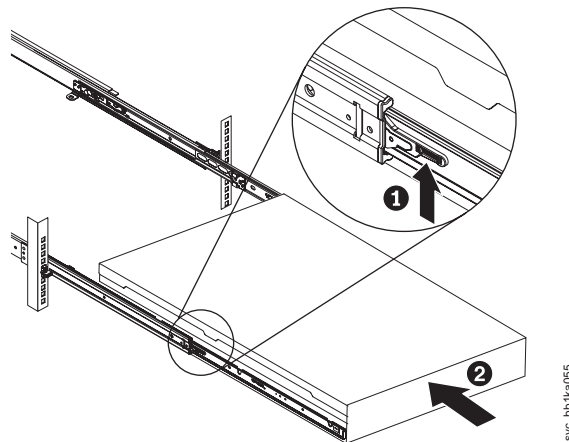

Figure 29. Raising the SAN Volume Controller 2145-CF8 locking levers of the slide rails of the rack

9. Turn on the node.

Related tasks

“Replacing the cable-retention bracket” on page 40

Replace the cable-retention bracket after you install SAN Volume Controller model 2145-8A4, 2145-8G4, or 2145-8F4 into the rack.

Replacing the SAN Volume Controller 2145-8A4 cable retention bracket

The cable-retention bracket attaches to the back of the SAN Volume Controller 2145-8A4 node. It is connected to the back of the node with the screw that already holds the rear plate of the power supply in place.

To attach the bracket, perform the following steps:

1. Insert the power cable in the node.
2. Unscrew the retaining screw **1** that is located next to the power cable socket three full turns, but do not fully remove the screw, as shown in Figure 30.

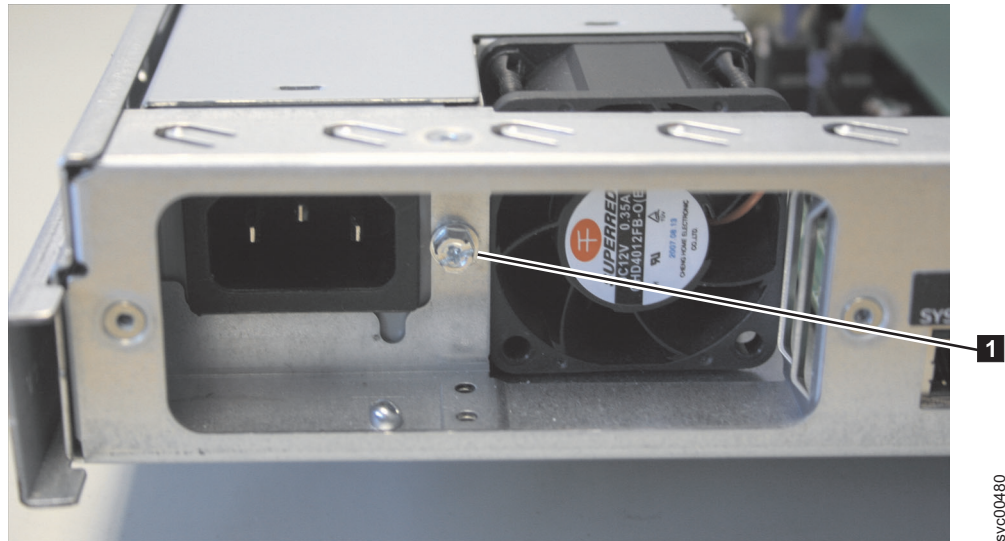

Figure 30. Retaining screw on the SAN Volume Controller 2145-8A4 node

3. Slide the bracket jaw over the power cable.
4. Slide the bracket down the cable until it is next to the power plug and slightly to the right of where it needs to be.
5. Place the bottom lip of the retention bracket in the node chassis as shown in Figure 31 on page 44. Turn the bracket at a slight angle, squeeze the top and bottom together, and position the top lip in place behind the chassis back plate.

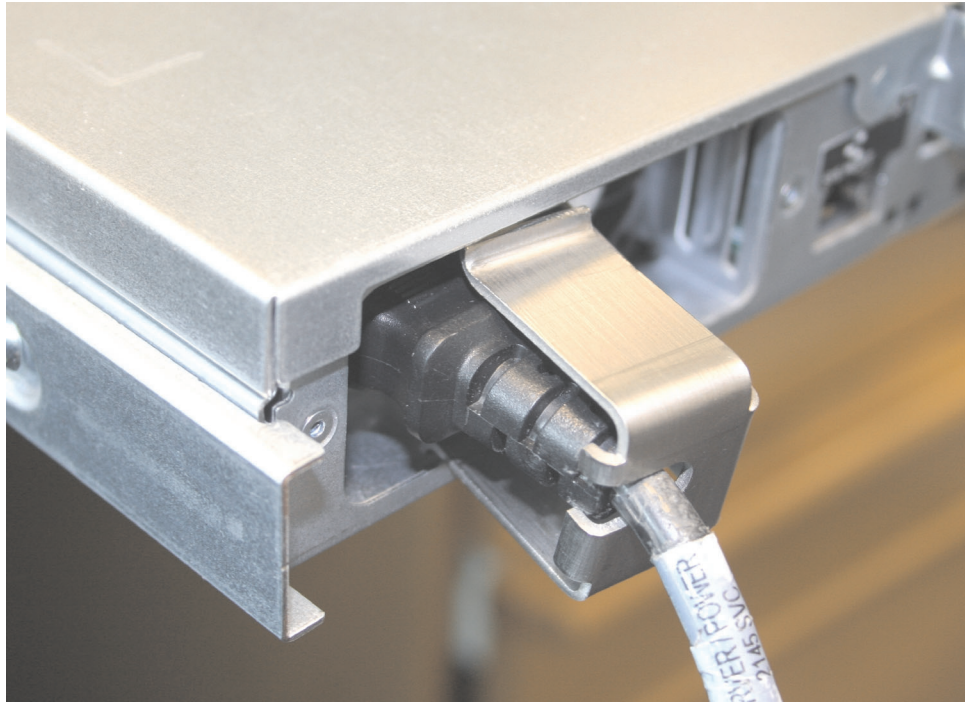

Figure 31. Installing the SAN Volume Controller 2145-8A4 cable retention bracket

6. Slide the bracket to the left until the side lip of the retention bracket goes behind the screw. Tighten the screw.

Related tasks

“Replacing the cable-retention bracket” on page 40

Replace the cable-retention bracket after you install SAN Volume Controller model 2145-8A4, 2145-8G4, or 2145-8F4 into the rack.

Replacing the SAN Volume Controller 2145-8G4 cable retention bracket

The SAN Volume Controller 2145-8G4 uses one of two different cable-retention brackets. Depending on which bracket you have, use the appropriate instructions to remove and replace the cable-retention bracket.

- If your cable-retention bracket looks like the following, go to “Replacing the cable-retention bracket - option A” on page 45.



Figure 32. SAN Volume Controller 2145-8G4 cable retention bracket - type A

I

- If your cable-retention bracket looks like the following, go to “Replacing the cable-retention bracket - option B” on page 46.



Figure 33. SAN Volume Controller 2145-8G4 cable retention bracket - type B

Related tasks

“Replacing the cable-retention bracket” on page 40

Replace the cable-retention bracket after you install SAN Volume Controller model 2145-8A4, 2145-8G4, or 2145-8F4 into the rack.

Replacing the cable-retention bracket - option A:

The cable-retention bracket attaches to the back of the SAN Volume Controller 2145-8G4 node. It is connected with the screws that already hold the rear plate of the power supply in place.

Replace the SAN Volume Controller 2145-8G4 cable retention bracket after you replace the node in the rack.

To attach the bracket to the rack rail, perform the following steps:

1. With the node powered off and the power cable removed, loosen and remove the two screws **1** on the right side of the rear plate that covers the power supply fan unit, as shown in Figure 34.

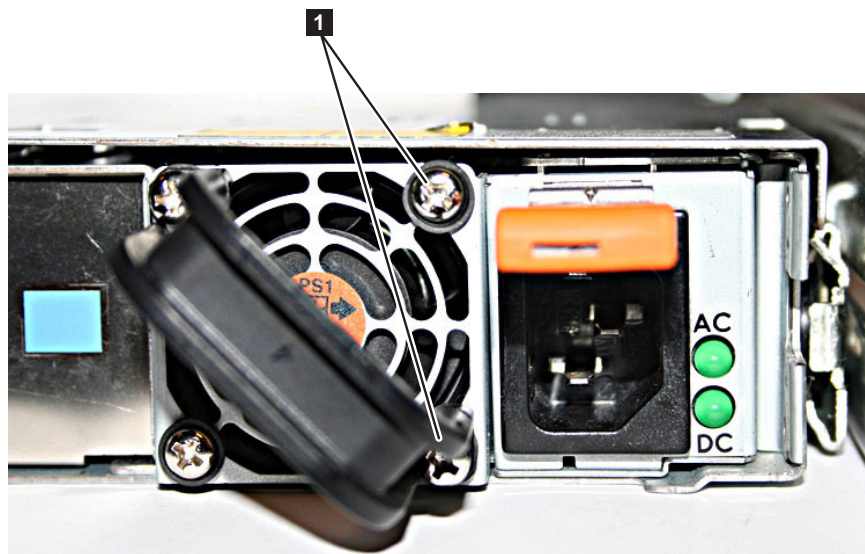

Figure 34. The SAN Volume Controller 2145-8G4 before you attach the cable-retention bracket

2. Rotate the power supply handle out of the way.
3. Insert the power cable.
4. Position the cable-retention bracket so that the power cable runs through the slot in the bracket. Align the screw holes in the bracket with the holes that are in the rear plate where you removed the two screws.
5. Replace the top screw.
6. Move the power supply handle back into place over the retention bracket, and replace the lower screw so that it holds the power supply handle, cable-retention bracket, and power supply rear plate in place.

Replacing the cable-retention bracket - option B:

Replace the SAN Volume Controller 2145-8G4 cable retention bracket after you replace the node in the rack.

Install the SAN Volume Controller 2145-8G4 cable retention bracket after you install the node in the rack.

To attach the bracket to the rack rail, perform the following steps:

1. Install the power cable into the power supply.
2. At the back of the cabinet, remove the securing bolt from the node side rail next to the power supply, as shown in Figure 35.

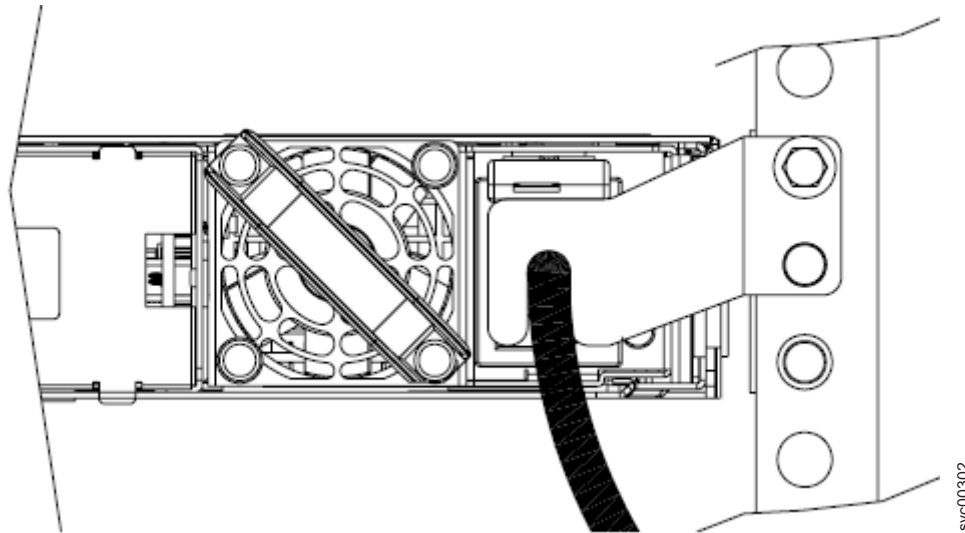

Figure 35. The SAN Volume Controller 2145-8G4 with cable-retention bracket type B attached

3. Slide the cable-retention bracket over the cable and position it over the side rail. Secure it in place using the original bolt.

Replacing the SAN Volume Controller 2145-8F4 cable retention bracket

The cable-retention bracket attaches to the support rail at the back of the SAN Volume Controller 2145-8F4 node.

To attach the bracket, perform the following steps:

1. Insert the power cable in the node.
2. Insert the bracket onto the power cable so that the power cable is held by the slot on the end of the bracket. Figure 36 on page 48 provides a view of how to align the cable-retention bracket with the cable.



Figure 36. Attaching the cable retention bracket to the SAN Volume Controller 2145-8F4 power cable

3. Position the cable-retention bracket against the support rail and attach the bracket onto the slot in the rear of the rail.

Related tasks

“Replacing the cable-retention bracket” on page 40

Replace the cable-retention bracket after you install SAN Volume Controller model 2145-8A4, 2145-8G4, or 2145-8F4 into the rack.

Removing the SAN Volume Controller from a rack

During some service procedures, you might need to remove the SAN Volume Controller from a rack.

Related tasks

“Removing the fibre-channel adapter assembly” on page 189

Use the information in this topic when you need to remove a fibre channel adapter or fibre-channel adapter assemblies.

Related reference

“Handling static-sensitive devices” on page xxiv

Ensure that you understand how to handle devices that are sensitive to static electricity.

Turning off the SAN Volume Controller node

When instructed to do so, shut down and turn off the SAN Volume Controller node before you remove and replace parts.

For information about how to turn off the SAN Volume Controller and retain access to its data, see MAP 5350 in the *IBM System Storage SAN Volume Controller Troubleshooting Guide*.

Attention: Unless host systems or fibre-channel switches must be switched off for another reason, do not turn them off when you are servicing the SAN Volume Controller. Shut down the SAN Volume Controller before you remove the power cables. You can connect or disconnect Ethernet and fibre-channel cables at any time.

Removing the SAN Volume Controller 2145-CF8 from a rack

Use these instructions when you are prompted to remove a SAN Volume Controller 2145-CF8 from a rack.

DANGER

Multiple power cords. The product might be equipped with multiple power cords. To remove all hazardous voltages, disconnect all power cords.

Attention: Do not touch the power control switches on adjacent SAN Volume Controller nodes when you remove or install SAN Volume Controller nodes in a rack. Touching these switches on adjacent SAN Volume Controller nodes might cause those devices to turn off and make customer data inaccessible.

Use the reference numbers in parentheses at the end of each notice, such as (C003) for example, to find the matching translated notice in *IBM Systems Safety Notices*.

DANGER

Observe the following precautions when working on or around your IT rack system:

- **Heavy equipment—personal injury or equipment damage might result if mishandled.**
- **Always lower the leveling pads on the rack cabinet.**
- **Always install stabilizer brackets on the rack cabinet.**
- **To avoid hazardous conditions due to uneven mechanical loading, always install the heaviest devices in the bottom of the rack cabinet. Always install servers and optional devices starting from the bottom of the rack cabinet.**
- **Rack-mounted devices are not to be used as shelves or work spaces. Do not place objects on top of rack-mounted devices.**



f2c00064

- **Each rack cabinet might have more than one power cord. Be sure to disconnect all power cords in the rack cabinet when directed to disconnect power during servicing.**
- **Connect all devices installed in a rack cabinet to power devices installed in the same rack cabinet. Do not plug a power cord from a device installed in one rack cabinet into a power device installed in a different rack cabinet.**
- **An electrical outlet that is not correctly wired could place hazardous voltage on the metal parts of the system or the devices that attach to the system. It is the responsibility of the customer to ensure that the outlet is correctly wired and grounded to prevent an electrical shock.**

(R001 part 1 of 2)

DANGER

- Do not install a unit in a rack where the internal rack ambient temperatures will exceed the manufacturer's recommended ambient temperature for all your rack-mounted devices.
- Do not install a unit in a rack where the air flow is compromised. Ensure that air flow is not blocked or reduced on any side, front, or back of a unit used for air flow through the unit.
- Consideration should be given to the connection of the equipment to the supply circuit so that overloading of the circuits does not compromise the supply wiring or overcurrent protection. To provide the correct power connection to a rack, refer to the rating labels located on the equipment in the rack to determine the total power requirement of the supply circuit.
- (For sliding drawers) Do not pull out or install any drawer or feature if the rack stabilizer brackets are not attached to the rack. Do not pull out more than one drawer at a time. The rack might become unstable if you pull out more than one drawer at a time.
- (For fixed drawers) This drawer is a fixed drawer and must not be moved for servicing unless specified by the manufacturer. Attempting to move the drawer partially or completely out of the rack might cause the rack to become unstable or cause the drawer to fall out of the rack.

(R001 part 2 of 2)

Important:

You can perform most service actions when the node is fully extended from the rack on its slide rails.

To remove the SAN Volume Controller 2145-CF8 from the rack, complete these steps:

1. Follow the procedure in MAP 5350 in the *IBM System Storage SAN Volume Controller Troubleshooting Guide* to verify that the node data is mirrored and synchronized, and that there are no dependent virtual disks (VDisks) before turning off the node..
2. Pull back the cable-management arm if you are working from the rear of the rack, or slide the node out of the rack to the fully extended rail position if you are working from the front.
3. To make sure that you can replace all cables in the same ports from which they were removed, record the position of all fibre-channel and Ethernet cables; then remove all cables from the back of the node.
4. Pull forward the two white catches (**1** in Figure 37 on page 51) on the side of the rails, and lift up the front of the node very slightly.
5. Support the node from the front and the back and pull the node forward slightly and lift to remove the node from the back of the rails (**3**).

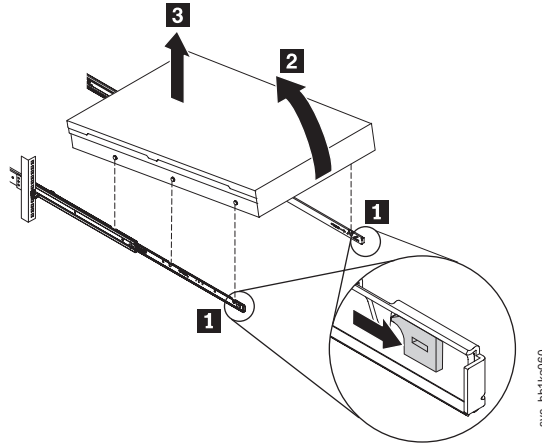

Figure 37. Removing the SAN Volume Controller 2145-CF8 from the rack

Related tasks

“Removing the support rails for the SAN Volume Controller 2145-CF8” on page 66
 This topic describes how to remove the SAN Volume Controller 2145-CF8 support rails.

Removing the SAN Volume Controller 2145-8A4 from a rack

Use these instructions when you are prompted to remove a SAN Volume Controller 2145-8A4 from a rack.

If the SAN Volume Controller is not already turned off, see “Turning off the SAN Volume Controller node” in the *IBM System Storage SAN Volume Controller Troubleshooting Guide*.

Attention: Do not touch the power control switches on adjacent SAN Volume Controller nodes when you remove or install SAN Volume Controller nodes in a rack. Touching these switches on adjacent SAN Volume Controller nodes might cause those devices to turn off and make customer data inaccessible.

Use the reference numbers in parentheses at the end of each notice, such as (C003) for example, to find the matching translated notice in *IBM Systems Safety Notices*.

DANGER

Observe the following precautions when working on or around your IT rack system:

- Heavy equipment—personal injury or equipment damage might result if mishandled.
- Always lower the leveling pads on the rack cabinet.
- Always install stabilizer brackets on the rack cabinet.
- To avoid hazardous conditions due to uneven mechanical loading, always install the heaviest devices in the bottom of the rack cabinet. Always install servers and optional devices starting from the bottom of the rack cabinet.
- Rack-mounted devices are not to be used as shelves or work spaces. Do not place objects on top of rack-mounted devices.



- Each rack cabinet might have more than one power cord. Be sure to disconnect all power cords in the rack cabinet when directed to disconnect power during servicing.
- Connect all devices installed in a rack cabinet to power devices installed in the same rack cabinet. Do not plug a power cord from a device installed in one rack cabinet into a power device installed in a different rack cabinet.
- An electrical outlet that is not correctly wired could place hazardous voltage on the metal parts of the system or the devices that attach to the system. It is the responsibility of the customer to ensure that the outlet is correctly wired and grounded to prevent an electrical shock.

(R001 part 1 of 2)

DANGER

- Do not install a unit in a rack where the internal rack ambient temperatures will exceed the manufacturer's recommended ambient temperature for all your rack-mounted devices.
- Do not install a unit in a rack where the air flow is compromised. Ensure that air flow is not blocked or reduced on any side, front, or back of a unit used for air flow through the unit.
- Consideration should be given to the connection of the equipment to the supply circuit so that overloading of the circuits does not compromise the supply wiring or overcurrent protection. To provide the correct power connection to a rack, refer to the rating labels located on the equipment in the rack to determine the total power requirement of the supply circuit.
- (For sliding drawers) Do not pull out or install any drawer or feature if the rack stabilizer brackets are not attached to the rack. Do not pull out more than one drawer at a time. The rack might become unstable if you pull out more than one drawer at a time.
- (For fixed drawers) This drawer is a fixed drawer and must not be moved for servicing unless specified by the manufacturer. Attempting to move the drawer partially or completely out of the rack might cause the rack to become unstable or cause the drawer to fall out of the rack.

(R001 part 2 of 2)

To remove the SAN Volume Controller 2145-8A4 from a rack, complete these steps:

1. Remove the cable-retention bracket and disconnect the power cable from the node. See "Removing the cable-retention bracket" on page 34.
2. To make sure that you can replace all cables in the same ports from which they were removed, record the position of all fibre-channel and Ethernet cables; then remove all cables from the back of the node.
3. Loosen the captive thumbscrews (**1** in Figure 38 on page 54) that secure the node to the front mounting flanges.

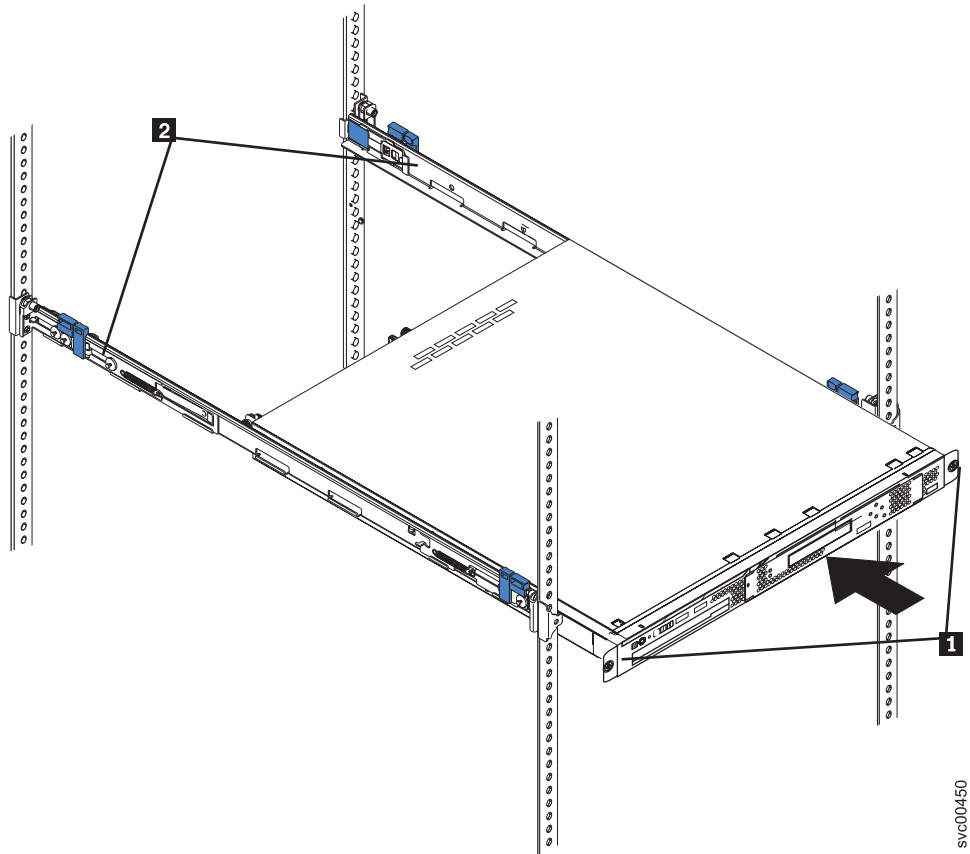

Figure 38. The captive thumbscrews that secure the node and the shipping brackets

4. Pull the SAN Volume Controller 2145-8A4 node completely out of the slides.

Removing the SAN Volume Controller 2145-8G4 from a rack

Use these instructions when you are prompted to remove a SAN Volume Controller 2145-8G4 from a rack.

If the SAN Volume Controller is not already turned off, see "Turning off the SAN Volume Controller node" in the *IBM System Storage SAN Volume Controller Troubleshooting Guide*.

Attention: Do not touch the power control switches on adjacent SAN Volume Controller nodes when you remove or install SAN Volume Controller nodes in a rack. Touching these switches on adjacent SAN Volume Controller nodes might cause those devices to turn off and make customer data inaccessible.

Use the reference numbers in parentheses at the end of each notice, such as (C003) for example, to find the matching translated notice in *IBM Systems Safety Notices*.

DANGER

Observe the following precautions when working on or around your IT rack system:

- Heavy equipment—personal injury or equipment damage might result if mishandled.
- Always lower the leveling pads on the rack cabinet.
- Always install stabilizer brackets on the rack cabinet.
- To avoid hazardous conditions due to uneven mechanical loading, always install the heaviest devices in the bottom of the rack cabinet. Always install servers and optional devices starting from the bottom of the rack cabinet.
- Rack-mounted devices are not to be used as shelves or work spaces. Do not place objects on top of rack-mounted devices.



- Each rack cabinet might have more than one power cord. Be sure to disconnect all power cords in the rack cabinet when directed to disconnect power during servicing.
- Connect all devices installed in a rack cabinet to power devices installed in the same rack cabinet. Do not plug a power cord from a device installed in one rack cabinet into a power device installed in a different rack cabinet.
- An electrical outlet that is not correctly wired could place hazardous voltage on the metal parts of the system or the devices that attach to the system. It is the responsibility of the customer to ensure that the outlet is correctly wired and grounded to prevent an electrical shock.

(R001 part 1 of 2)

DANGER

- Do not install a unit in a rack where the internal rack ambient temperatures will exceed the manufacturer's recommended ambient temperature for all your rack-mounted devices.
- Do not install a unit in a rack where the air flow is compromised. Ensure that air flow is not blocked or reduced on any side, front, or back of a unit used for air flow through the unit.
- Consideration should be given to the connection of the equipment to the supply circuit so that overloading of the circuits does not compromise the supply wiring or overcurrent protection. To provide the correct power connection to a rack, refer to the rating labels located on the equipment in the rack to determine the total power requirement of the supply circuit.
- (For sliding drawers) Do not pull out or install any drawer or feature if the rack stabilizer brackets are not attached to the rack. Do not pull out more than one drawer at a time. The rack might become unstable if you pull out more than one drawer at a time.
- (For fixed drawers) This drawer is a fixed drawer and must not be moved for servicing unless specified by the manufacturer. Attempting to move the drawer partially or completely out of the rack might cause the rack to become unstable or cause the drawer to fall out of the rack.

(R001 part 2 of 2)

To remove the SAN Volume Controller 2145-8G4 from a rack, complete these steps:

1. Remove the cable-retention bracket and disconnect the power cable from the node. See "Removing the cable-retention bracket" on page 34.
2. To make sure that you can replace all cables in the same ports from which they were removed, record the position of all fibre-channel and Ethernet cables; then remove all cables from the back of the node.
3. Slide the SAN Volume Controller 2145-8G4 node forward until it latches in the service position.
4. Position yourself to support the weight of the node when it is no longer held by the slides and then press the rear slide release latches (**1** in Figure 39 on page 57) on both sides of the SAN Volume Controller 2145-8G4 node.
5. Pull the node forward and remove it from the rack.

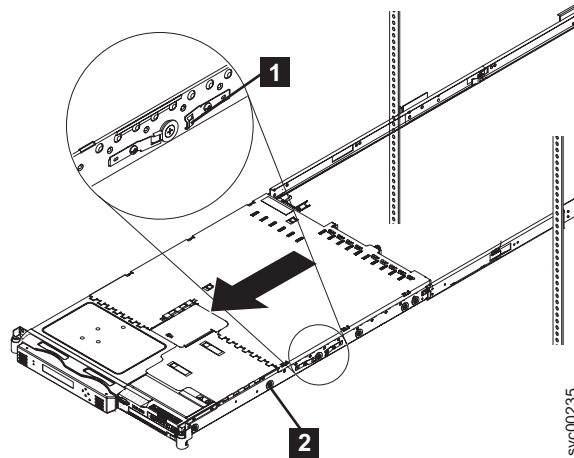

Figure 39. Removing the SAN Volume Controller 2145-8G4 from the rack

Removing the SAN Volume Controller 2145-8F4 or SAN Volume Controller 2145-8F2 from a rack

Use these instructions when you are directed to remove a SAN Volume Controller 2145-8F4 or SAN Volume Controller 2145-8F2 from a rack.

If the SAN Volume Controller is not already turned off, see "Turning off the SAN Volume Controller node" in the *IBM System Storage SAN Volume Controller Troubleshooting Guide*.

Attention: Do not touch the power control switches on adjacent SAN Volume Controller nodes when you remove or install SAN Volume Controller nodes in a rack. Touching these switches on adjacent SAN Volume Controller nodes might cause those devices to turn off and make customer data inaccessible.

Use the reference numbers in parentheses at the end of each notice, such as (C003) for example, to find the matching translated notice in *IBM Systems Safety Notices*.

DANGER

Observe the following precautions when working on or around your IT rack system:

- Heavy equipment—personal injury or equipment damage might result if mishandled.
- Always lower the leveling pads on the rack cabinet.
- Always install stabilizer brackets on the rack cabinet.
- To avoid hazardous conditions due to uneven mechanical loading, always install the heaviest devices in the bottom of the rack cabinet. Always install servers and optional devices starting from the bottom of the rack cabinet.
- Rack-mounted devices are not to be used as shelves or work spaces. Do not place objects on top of rack-mounted devices.



- Each rack cabinet might have more than one power cord. Be sure to disconnect all power cords in the rack cabinet when directed to disconnect power during servicing.
- Connect all devices installed in a rack cabinet to power devices installed in the same rack cabinet. Do not plug a power cord from a device installed in one rack cabinet into a power device installed in a different rack cabinet.
- An electrical outlet that is not correctly wired could place hazardous voltage on the metal parts of the system or the devices that attach to the system. It is the responsibility of the customer to ensure that the outlet is correctly wired and grounded to prevent an electrical shock.

(R001 part 1 of 2)

DANGER

- Do not install a unit in a rack where the internal rack ambient temperatures will exceed the manufacturer's recommended ambient temperature for all your rack-mounted devices.
- Do not install a unit in a rack where the air flow is compromised. Ensure that air flow is not blocked or reduced on any side, front, or back of a unit used for air flow through the unit.
- Consideration should be given to the connection of the equipment to the supply circuit so that overloading of the circuits does not compromise the supply wiring or overcurrent protection. To provide the correct power connection to a rack, refer to the rating labels located on the equipment in the rack to determine the total power requirement of the supply circuit.
- (For sliding drawers) Do not pull out or install any drawer or feature if the rack stabilizer brackets are not attached to the rack. Do not pull out more than one drawer at a time. The rack might become unstable if you pull out more than one drawer at a time.
- (For fixed drawers) This drawer is a fixed drawer and must not be moved for servicing unless specified by the manufacturer. Attempting to move the drawer partially or completely out of the rack might cause the rack to become unstable or cause the drawer to fall out of the rack.

(R001 part 2 of 2)

To remove the SAN Volume Controller 2145-8F4 or the SAN Volume Controller 2145-8F2 node from a rack, complete these steps:

1. To make sure that you can replace all cables in the same ports from which they were removed, record the position of all fibre-channel and Ethernet cables; then remove all cables from the back of the node.
2. Unlatch the two latches on the front of the rack.
3. Pull the node forward and remove it from the rack.

Replacing the SAN Volume Controller in a rack

You must use caution when you replace the SAN Volume Controller in a rack.

Note: If you have recently replaced a field-replaceable unit (FRU) in the node, the repaired node normally rejoins the cluster as soon as it is powered-on and has completed its self-tests. There are some exceptions to this, such as when a disk drive has been replaced, or when for some other reason the node has lost its identity or the integrity of its cluster metadata. Under these circumstances, the node goes offline. If you are performing this repair under directed maintenance procedures, those procedures will automatically restore the node to the cluster. If you are not performing the repair under directed maintenance procedures, you might be required to delete and add the node back into the cluster.

DANGER

Observe the following precautions when working on or around your IT rack system:

- Heavy equipment—personal injury or equipment damage might result if mishandled.
- Always lower the leveling pads on the rack cabinet.
- Always install stabilizer brackets on the rack cabinet.
- To avoid hazardous conditions due to uneven mechanical loading, always install the heaviest devices in the bottom of the rack cabinet. Always install servers and optional devices starting from the bottom of the rack cabinet.
- Rack-mounted devices are not to be used as shelves or work spaces. Do not place objects on top of rack-mounted devices.



f2c00064

- Each rack cabinet might have more than one power cord. Be sure to disconnect all power cords in the rack cabinet when directed to disconnect power during servicing.
- Connect all devices installed in a rack cabinet to power devices installed in the same rack cabinet. Do not plug a power cord from a device installed in one rack cabinet into a power device installed in a different rack cabinet.
- An electrical outlet that is not correctly wired could place hazardous voltage on the metal parts of the system or the devices that attach to the system. It is the responsibility of the customer to ensure that the outlet is correctly wired and grounded to prevent an electrical shock.

(R001 part 1 of 2)

DANGER

- **Do not install a unit in a rack where the internal rack ambient temperatures will exceed the manufacturer’s recommended ambient temperature for all your rack-mounted devices.**
- **Do not install a unit in a rack where the air flow is compromised. Ensure that air flow is not blocked or reduced on any side, front, or back of a unit used for air flow through the unit.**
- **Consideration should be given to the connection of the equipment to the supply circuit so that overloading of the circuits does not compromise the supply wiring or overcurrent protection. To provide the correct power connection to a rack, refer to the rating labels located on the equipment in the rack to determine the total power requirement of the supply circuit.**
- **(For sliding drawers) Do not pull out or install any drawer or feature if the rack stabilizer brackets are not attached to the rack. Do not pull out more than one drawer at a time. The rack might become unstable if you pull out more than one drawer at a time.**
- **(For fixed drawers) This drawer is a fixed drawer and must not be moved for servicing unless specified by the manufacturer. Attempting to move the drawer partially or completely out of the rack might cause the rack to become unstable or cause the drawer to fall out of the rack.**

(R001 part 2 of 2)

Related tasks

“Replacing the disk-drive backplane” on page 143

You might have to replace the disk-drive backplane, which includes the simple-swap SAS backplane in the SAN Volume Controller 2145-CF8 or the hot-swap SATA backplane for a SAN Volume Controller 2145-8A4 or SAN Volume Controller 2145-8G4.

Replacing the SAN Volume Controller 2145-CF8 in a rack

Follow these instructions when you are prompted to replace the SAN Volume Controller 2145-CF8.

Attention: Do not touch the power control switches on adjacent SAN Volume Controller nodes when you remove or install SAN Volume Controller nodes in a rack. Touching these switches on adjacent SAN Volume Controller nodes might cause those devices to turn off and make customer data inaccessible.

Use the reference numbers in parentheses at the end of each notice, such as (C003) for example, to find the matching translated notice in *IBM Systems Safety Notices*.

Perform the following steps to replace the SAN Volume Controller 2145-CF8 in a rack:

1. Place the SAN Volume Controller 2145-CF8 in the rails on the rack.
 - a. Pull the slide rails forward (**1** in Figure 40 on page 62) until they click twice into place.
 - b. Carefully lift the server and tilt it into position over the slide rails so that the rear nail heads **2** on the server line up with the rear slots **3** on the slide rails.

- c. Slide the server down until the rear nail heads slip into the two rear slots; then slowly lower the front of the server **4** until the other nail heads slip into the other slots on the slide rails.
- d. Verify that the front latch **5** slides over the nail heads.

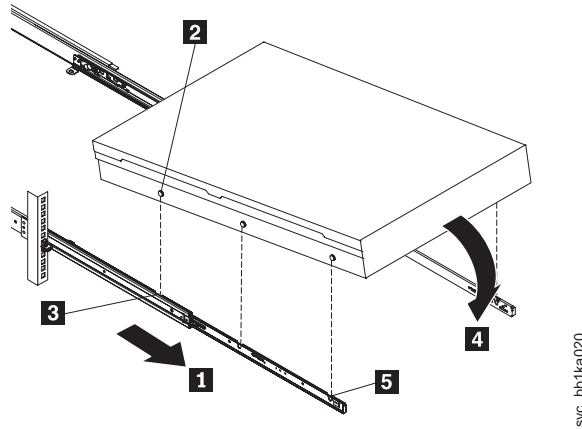

Figure 40. Installing the SAN Volume Controller 2145-CF8 node in the slide rails of the rack

- 2. Lift the locking levers (**1** in Figure 41) on the slide rails and push the server **2** all the way into the rack until it clicks into place.

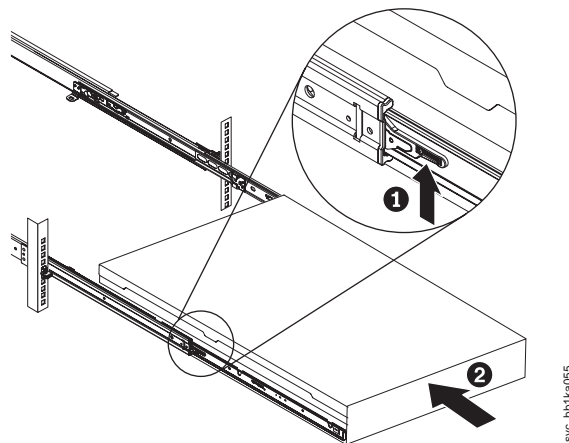

Figure 41. Raising the SAN Volume Controller 2145-CF8 locking levers of the slide rails of the rack

- 3. Replace the cable-management arm. See “Replacing the cable-management arm” on page 30.
- 4. Reconnect the fibre-channel and Ethernet cables. Ensure that you replace the fibre-channel and Ethernet cables in the same ports from which they were removed.
- 5. Connect the power cable to the node and replace the cable-retention bracket. See “Replacing the cable-retention bracket” on page 40.
- 6. Replace the cable-management arm, as described in “Replacing the cable-management arm” on page 30.
- 7. Turn on the node.

Replacing the SAN Volume Controller 2145-8A4 in a rack

Follow these instructions when you are prompted to replace the SAN Volume Controller 2145-8A4.

Attention: Do not touch the power control switches on adjacent SAN Volume Controller nodes when you remove or install SAN Volume Controller nodes in a rack. Touching these switches on adjacent SAN Volume Controller nodes might cause those devices to turn off and make customer data inaccessible.

Perform the following steps to replace the SAN Volume Controller 2145-8A4 node in a rack:

1. Align the node on the slide rails and push the node fully into the rack. Secure the node to the front mounting flanges with the captive thumbscrews (**1** in Figure 42).

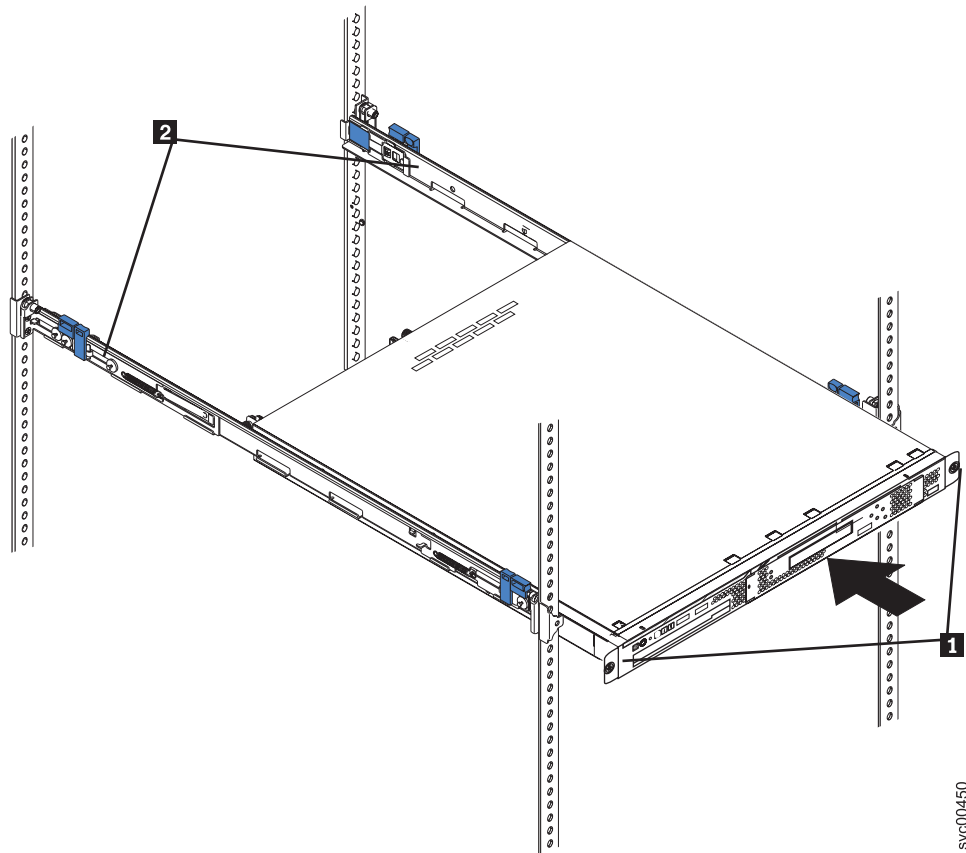

Figure 42. The captive thumbscrews that secure the node and the shipping brackets

2. Reconnect the fibre-channel and Ethernet cables. Ensure that you replace the fibre-channel and Ethernet cables in the same ports from which they were removed.
3. Replace the cable-retention bracket. See “Replacing the cable-retention bracket” on page 40.

Replacing the SAN Volume Controller 2145-8G4 in a rack

Follow these instructions when you are prompted to replace the SAN Volume Controller 2145-8G4.

Attention: Do not touch the power control switches on adjacent SAN Volume Controller nodes when you remove or install SAN Volume Controller nodes in a rack. Touching these switches on adjacent SAN Volume Controller nodes might cause those devices to turn off and make customer data inaccessible.

Perform the following steps to replace the SAN Volume Controller 2145-8G4 in a rack:

1. Fully extend the support slides.
2. Align the node on the slide rails and push the node fully into the rack. Secure the node to the front mounting flanges with the captive thumbscrews (**1** in Figure 43).

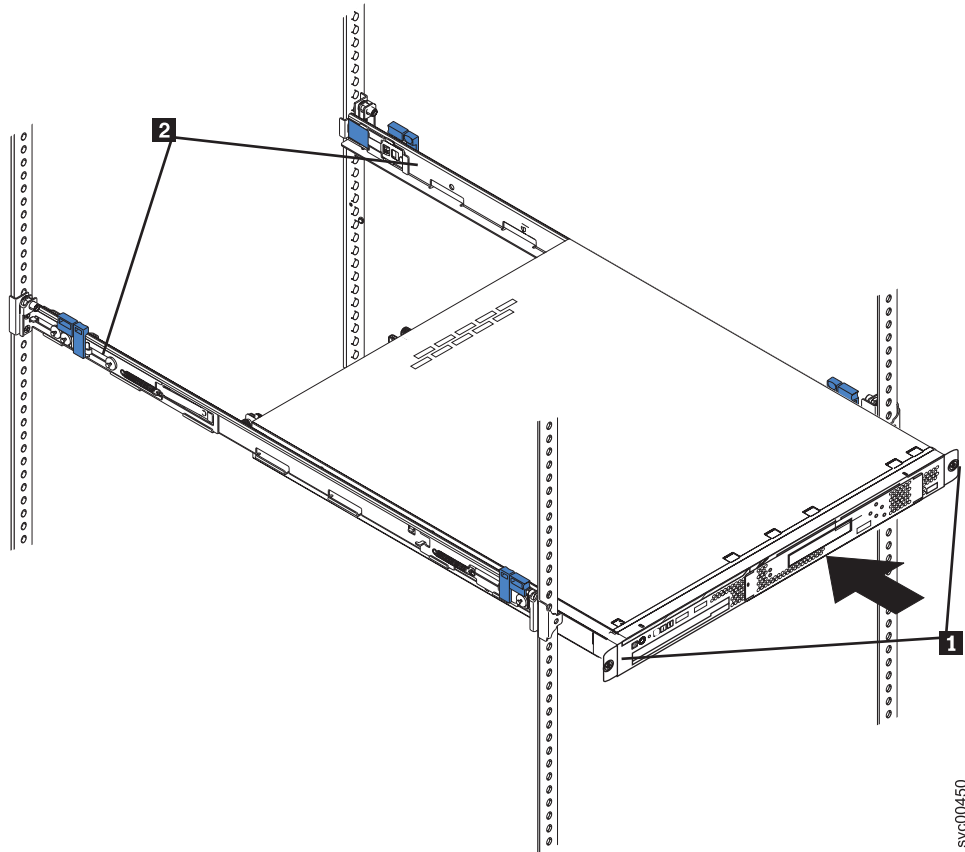

Figure 43. The captive thumbscrews that secure the node and the shipping brackets

3. Align the two rear wheels on the node with the opening in the slides and then push the node into the slides until the rear slide release latches (**2** in Figure 44 on page 65) click into place, locking the node in the slides.

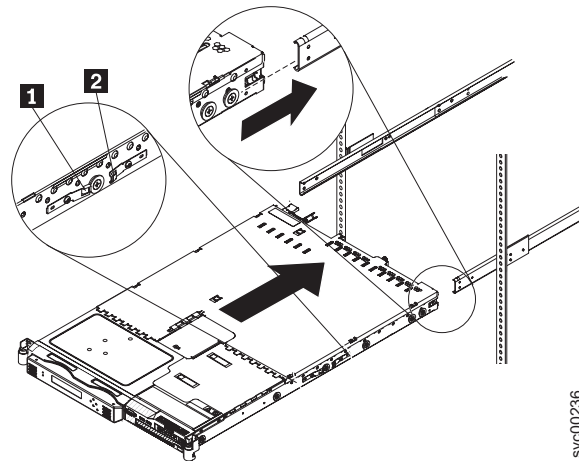

Figure 44. Aligning the SAN Volume Controller 2145-8G4 with the rack slides

4. Reconnect the fibre-channel and Ethernet cables. Ensure that you replace the fibre-channel and Ethernet cables in the same ports from which they were removed.
5. Connect the power cable to the node and replace the cable-retention bracket. See “Replacing the cable-retention bracket” on page 40.
6. Turn on the node.

Replacing the SAN Volume Controller 2145-8F4 or SAN Volume Controller 2145-8F2 in a rack

Follow these instructions when you are prompted to replace the SAN Volume Controller 2145-8F4 or the SAN Volume Controller 2145-8F2 in a rack.

Attention: Do not touch the power control switches on adjacent SAN Volume Controller nodes when you remove or install SAN Volume Controller nodes in a rack. Touching these switches on adjacent SAN Volume Controller nodes might cause those devices to turn off and make customer data inaccessible.

Perform the following steps to replace the SAN Volume Controller 2145-8F4 or the SAN Volume Controller 2145-8F2 in the rack:

1. Slide the SAN Volume Controller 2145-8F4 or the SAN Volume Controller 2145-8F2 node into the rack.
2. Latch the two latches on the front of the rack to attach the node to the rack. (**1** in Figure 45 on page 66).

Note: The front of the rail assembly looks different from the front, as you can see in Figure 45 on page 66.

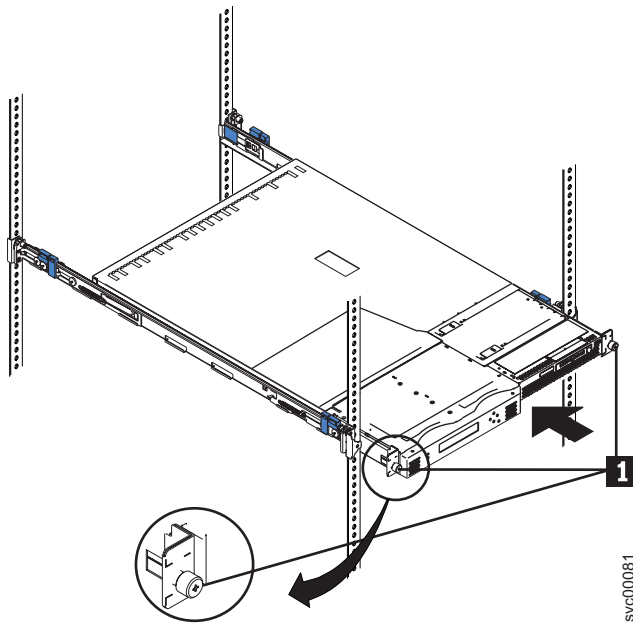

Figure 45. Sliding the SAN Volume Controller 2145-8F4 into the rack

3. Reconnect the fibre-channel and Ethernet cables. Ensure that you replace the fibre-channel and Ethernet cables in the same ports from which they were removed.
4. Connect the power cable to the node and replace the cable-retention bracket. See “Replacing the cable-retention bracket” on page 40.
5. Turn on the node.

Removing the support rails for a SAN Volume Controller

The SAN Volume Controller support rails can be removed if you need to move the SAN Volume Controller.

Related tasks

“Installing the support rails for a SAN Volume Controller” on page 70
 You must install the support rails that hold the SAN Volume Controller.

Removing the support rails for the SAN Volume Controller 2145-CF8

This topic describes how to remove the SAN Volume Controller 2145-CF8 support rails.

Perform the following steps to remove the SAN Volume Controller 2145-CF8 support rails:

1. Remove the SAN Volume Controller 2145-CF8 node, as described in “Removing the SAN Volume Controller 2145-CF8 from a rack” on page 48.
2. Remove the cable-management arm, as described in “Removing the SAN Volume Controller 2145-CF8 cable-management arm” on page 25.
3. Disengage the slide rails from the rear of the rack.
 - a. Push in the pins in the order shown by **1** and **2** in Figure 46 on page 67.
 - b. Lift slightly; then push back on the rail **3**.

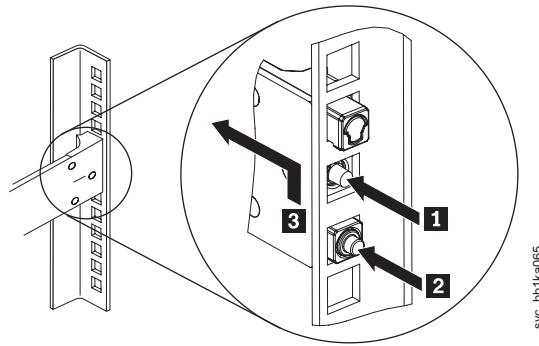

Figure 46. Disengaging the SAN Volume Controller 2145-CF8 slide rails from the rear of the rack

4. Remove the side rails from the front of the rack and remove the rails.
 - a. To remove the slide rails from the front of the rack, push up the front tab (**1** in Figure 47) and slide out the front latch **2** .
 - b. Lift up slightly (**3**); then slide the rail backward **4** . Remove the slide rail from the rack.

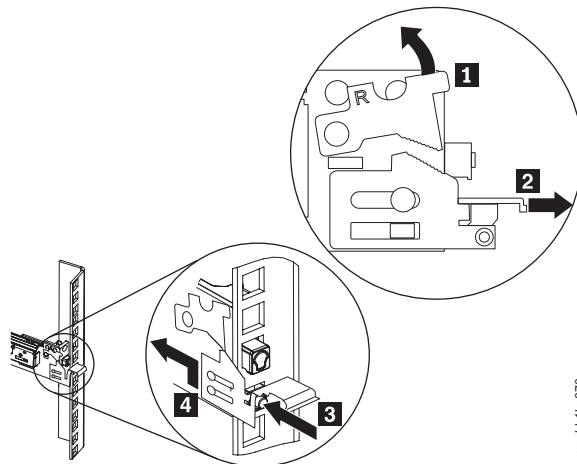

Figure 47. Removing the SAN Volume Controller 2145-CF8 slide rails from the rack

Related tasks

“Removing the SAN Volume Controller 2145-CF8 cable-management arm” on page 25

Remove the SAN Volume Controller 2145-CF8 cable-management arm that routes and secures the power cables and other cables.

“Removing the SAN Volume Controller 2145-CF8 from a rack” on page 48

Use these instructions when you are prompted to remove a SAN Volume Controller 2145-CF8 from a rack.

Removing the support rails for the SAN Volume Controller 2145-8A4

You can remove the support rails that hold the SAN Volume Controller 2145-8A4 node.

To remove the SAN Volume Controller 2145-8A4 support rails, perform the following steps:

1. Remove the M6 screw **1** from the front and rear brackets.

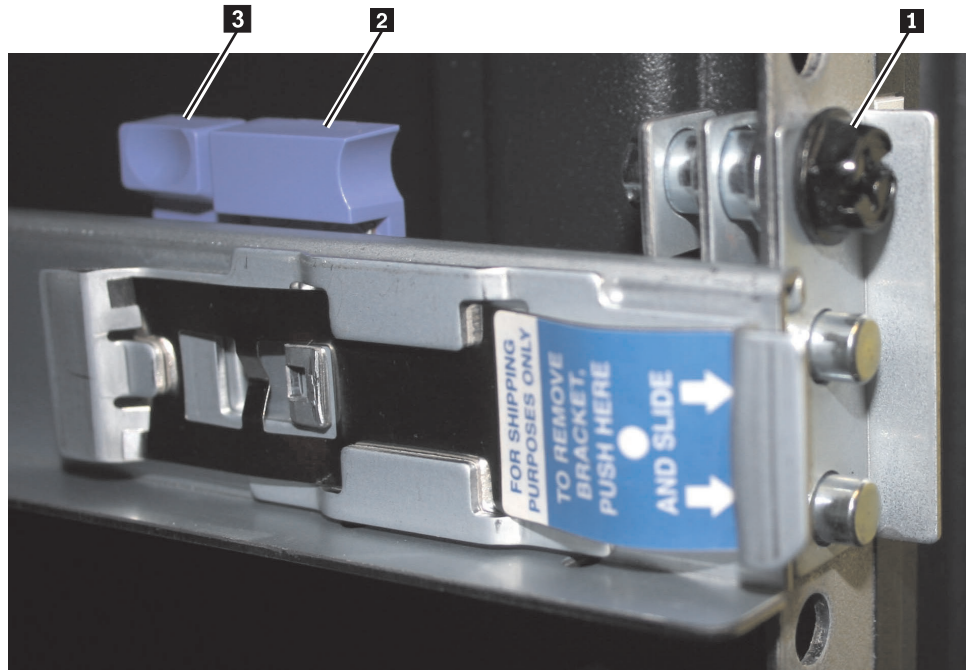

Figure 48. The rail-adjustment bracket and the release tab on the rear rail-locking carrier

2. Starting from the rear, press the release tab **3** backwards, away from the rail. Push the rail-adjustment bracket **2** toward the center of the rack until it snaps into place. Lift the tab that secures the rear of the slide rail to the rear mounting flange.
3. Repeat step 2 to remove the front bracket and then remove the support rail from the rack.
4. Repeat steps 1 through 3 for the other support rail.

Removing the support rails for the SAN Volume Controller 2145-8G4

This topic describes how to remove the SAN Volume Controller 2145-8G4 support rails.

Perform the following steps to remove the SAN Volume Controller 2145-8G4 support rails:

1. Loosen and remove the captive screw **3** and latch strike **1** from the left rear mounting flange, as shown in Figure 49 on page 69, to release the slide rail **2**. Loosen and remove the captive screw from the right rear mounting flange and release the other slide rail in the same way.

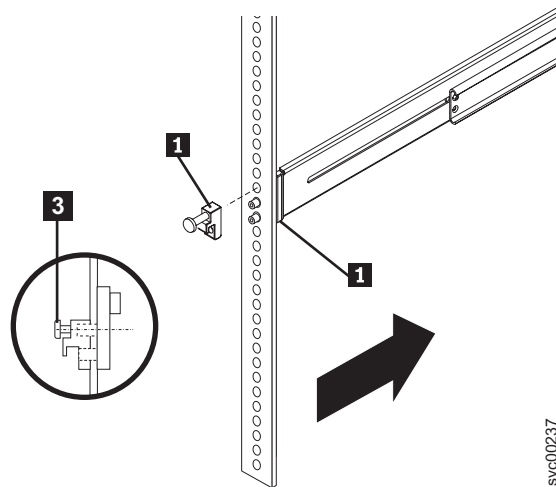

Figure 49. Removing the latch strike from the front of the slide rail

2. Loosen and remove the captive screw from the front of the right rail and then remove the latch strike. Remove the captive screw and latch strike from the front of the left rail in the same way.
3. Push the rail pins **1** out of the front rack mounting flange, as shown in Figure 50, to shorten the right slide rail and remove it from the front flange. Then pull the right slide rail forward to remove the slide rail from the rear rack mounting flange. Remove the left slide rail in the same way.

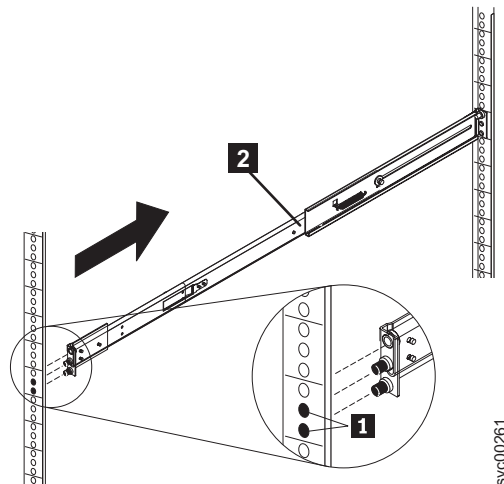

Figure 50. Removing the right slide rail from the front of the rack

Removing the support rails for the SAN Volume Controller 2145-8F4 or SAN Volume Controller 2145-8F2

This topic describes how to remove the SAN Volume Controller 2145-8F4 or SAN Volume Controller 2145-8F2 support rails.

Perform the following steps to remove the SAN Volume Controller support rails:

1. Go to the front of the left support rail.
2. Put your left index finger onto the back edge of the latch lever **2** and your left thumb on the front edge of the latch lock **1**, as shown in Figure 51 on page 70

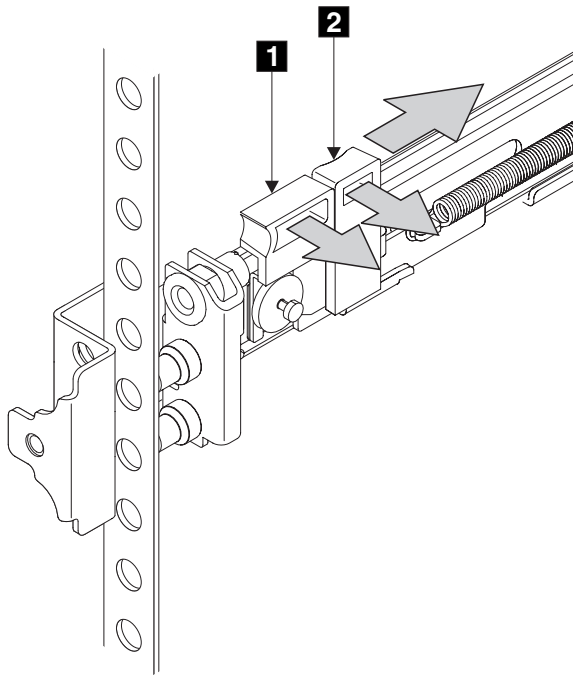

Figure 51. The left support rail for the SAN Volume Controller

3. Gently move the latch lock inward and push the latch-lock carrier toward the back of the rack until it latches onto the rail.
4. Pull the rail out from the front rack-mounting flange.
5. Repeat the action at the back of the rail.
6. Remove the rail from the rack.
7. Repeat steps 2 on page 69 through 6 for the right support rail.

Installing the support rails for a SAN Volume Controller

You must install the support rails that hold the SAN Volume Controller.

The instructions for installing the SAN Volume Controller are found in the topics that follow.

Related tasks

“Removing the support rails for a SAN Volume Controller” on page 66

The SAN Volume Controller support rails can be removed if you need to move the SAN Volume Controller.

Installing the support rails for the SAN Volume Controller 2145-CF8

Install the support rails that hold the SAN Volume Controller 2145-CF8 in the rack.

When you are ready to install the support rails, use the hardware-location chart of the customer and the Electronic Industries Alliance (EIA) positions on the rack to determine where in the rack that the SAN Volume Controller 2145-CF8 node is to be installed.

Perform the following steps to install the support rails for the SAN Volume Controller 2145-CF8:

1. Optional: You might find it helpful, with some types of racks, to remove the rack doors and side panels to provide easier access during installation.
2. Prepare each slide rail for installation.
 - a. Select one of the slide rails that is marked with either an R (right) or an L (left), as shown in Figure 52.
 - b. Push up on the front moveable tab **1**.
 - c. Pull out the front latch **2** and slide out the front side rail.
 - d. If a thumbscrew is installed in the slide rail **3**, remove it.

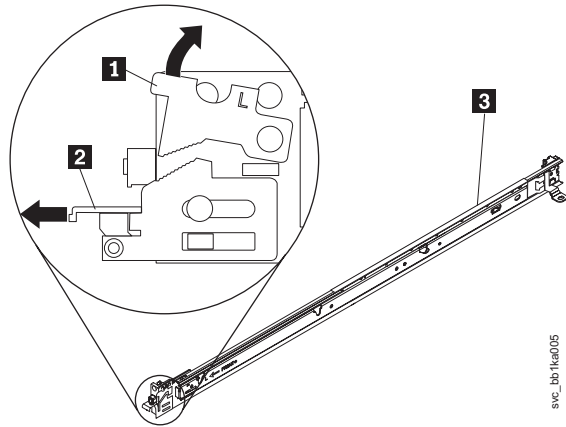

Figure 52. Installing the SAN Volume Controller 2145-CF8 slide rails on the rack

3. Install the rear of the rail into the rear of the rack.
 - a. Line up the three pins on the rear of the slide rail with the three holes in the selected U on the rear of the rack.
 - b. Push the rails so that the pins go into the holes, as shown by **1** in Figure 53.
 - c. Drop the slide rail down **2** until it latches into place.

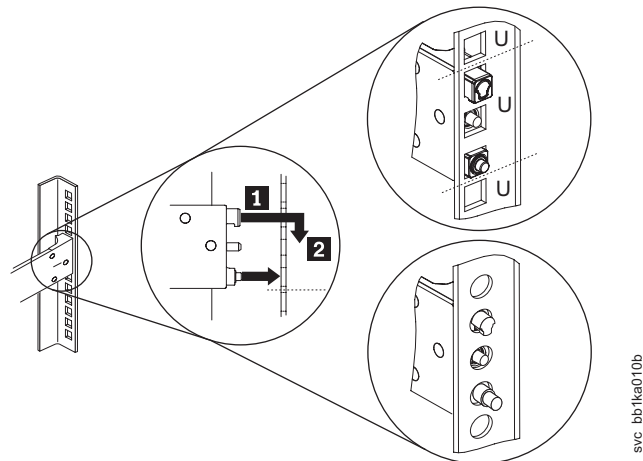

Figure 53. Installing the rear of a SAN Volume Controller 2145-CF8 slide rail in the rear of the rack

4. Install the front of the rail into the front of the rack.
 - a. Pull the slide rail forward and insert the metal of the rack between the front latch and the pins, as shown by **1** in Figure 54.
Insert the two pins into the two lower holes in the U on the front of the rack.
 - b. Drop the rail into place until it clicks.
 - c. Push the front latch **2** in all the way.

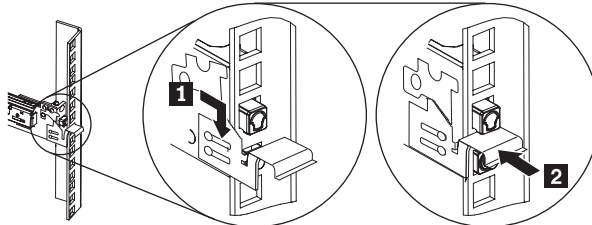

Figure 54. Installing the front of a SAN Volume Controller 2145-CF8 slide rail in the front of the rack

5. Install the other rail in the same manner.

The installation of the support rails for the SAN Volume Controller 2145-CF8 is complete.

Installing the support rails for the SAN Volume Controller 2145-8A4

You must install the support rails that hold the SAN Volume Controller 2145-8A4 node.

Figure 55 shows the items that you need to install the SAN Volume Controller 2145-8A4 node in a rack.

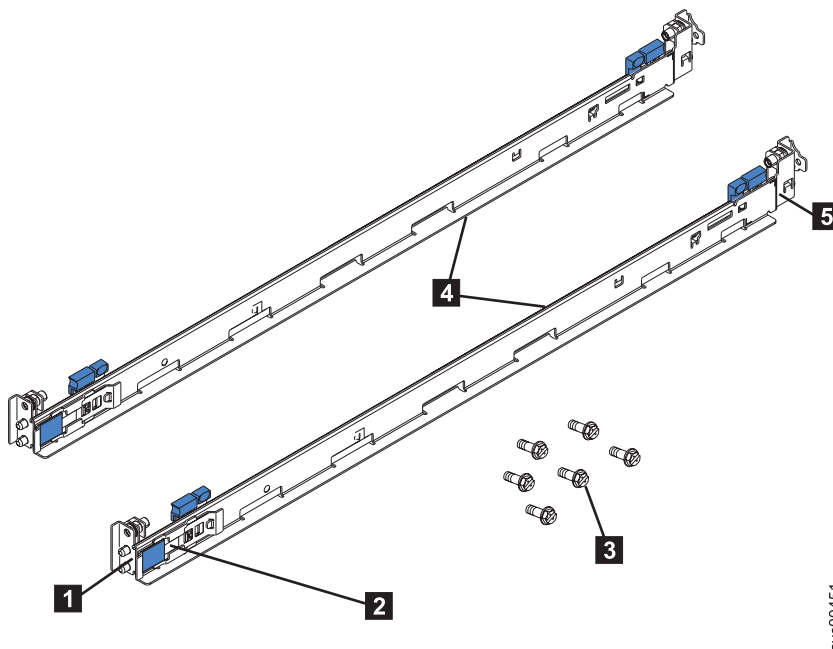

Figure 55. SAN Volume Controller 2145-8A4 support-rails installation kit

- 1** Rear of rail
- 2** Shipping bracket
- 3** M6 screws (6)
- 4** Rack mounting rails
- 5** Front of rail

Notes:

- With some types of racks, you might find it helpful to remove the rack doors and side panels to provide easier access during installation.
- The slide rails are marked (RIGHT / FRONT and LEFT / FRONT) for proper placement on the rack flanges.
- The front and back of each rail has a spring-loaded rail-locking carrier, which can be locked in the open position and then released when the rail is in the rack.

When you are ready to install the support rails, use the customer's hardware-location chart and the Electronic Industries Alliance (EIA) positions on the rack to determine where in the rack that the SAN Volume Controller node is to be installed.

Perform the following steps to install the support rails:

1. Ensure that the rail-locking carriers at the front and rear of each support rail are open. The mechanism to open is similar at each end. If a locking mechanism is closed, as shown in Figure 56 (for a front bracket), open it.

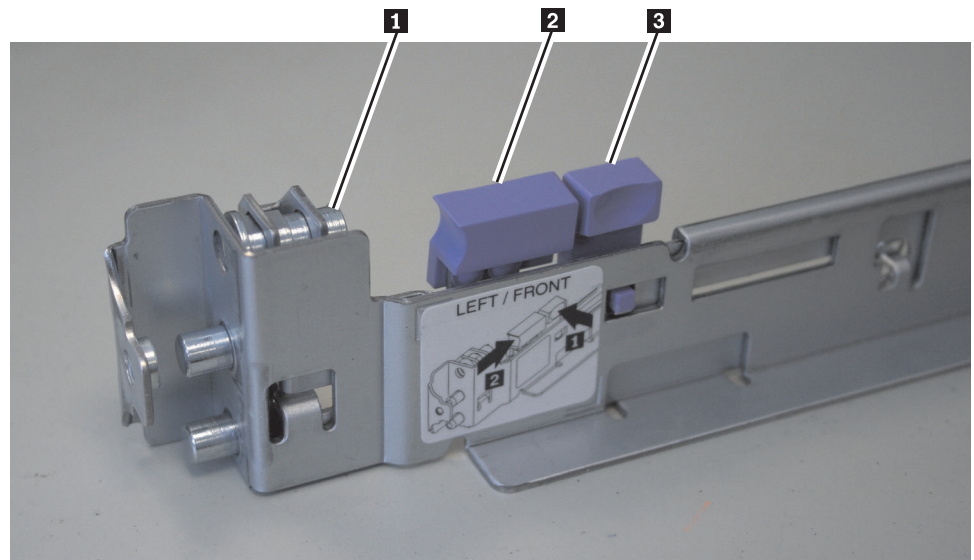

Figure 56. A closed rail-locking carrier at the front of the support rail for the SAN Volume Controller 2145-8A4

To open the rail-locking carrier, push the small tab **3** back away from the rail and slide the larger tab **2** toward the center of the slide rail. Slide the rail-locking carrier approximately 15 mm toward the end of the slide rail until the rail-locking carrier locks in the open position, as shown in Figure 57 on page 74 (which shows the rear bracket).

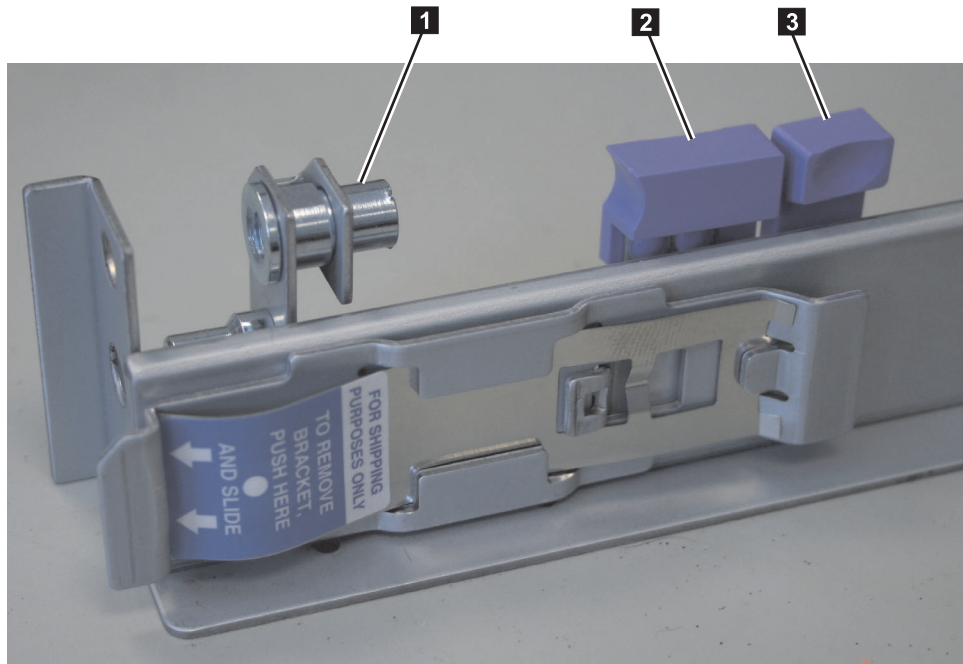
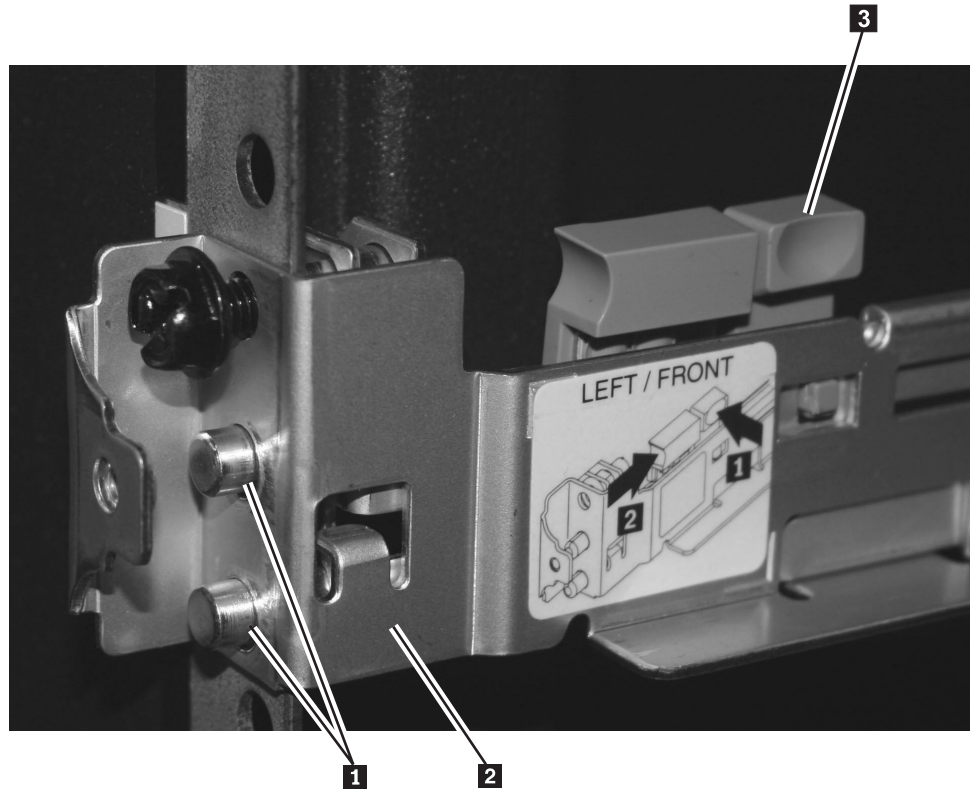

Figure 57. An open rail-locking carrier at the rear of the support rail for the SAN Volume Controller 2145-8A4

2. Position the rail at the correct height in the rack.
 - a. Start from the front and align the pins (**1** in Figure 58 on page 75) on the front rail-locking carrier with the holes on the rack mounting flange **2** .
 - b. Release the rail-locking latch by pushing the smaller blue tab **3** away from the rail. The pins spring into the closed position. Ensure that the pins go fully through the holes in the mounting flange, as shown in Figure 58 on page 75.
 - c. At the rear of the rack, align the pins on the rear rail-locking carrier with the holes on the rack mounting flange.



svc00445

Figure 58. Aligning the pins on the left front support rail for the SAN Volume Controller 2145-8A4 with the front mounting flange

3. Insert one of the M6 screws into the front and rear locking latches and tighten.
4. Repeat the instructions in steps 1 on page 73 through 3 with the right support rail.

Installing the support rails for the SAN Volume Controller 2145-8G4

You must install the support rails that hold the SAN Volume Controller 2145-8G4.

When you are ready to install the support rails, use the customer's hardware-location chart and the Electronic Industries Alliance (EIA) positions on the rack to determine where in the rack that the SAN Volume Controller node is to be installed.

Perform the following steps to install the support rails (shown in Figure 59 on page 76) for the SAN Volume Controller 2145-8G4:

1. Make sure you have all the items that you need for installing the support rails.

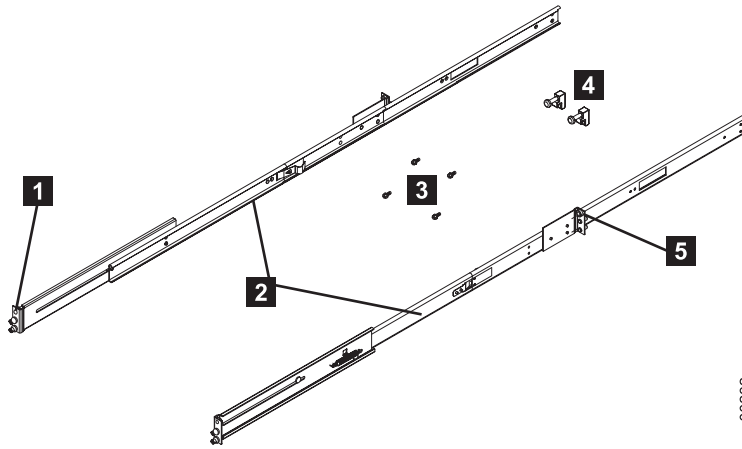

Figure 59. SAN Volume Controller 2145-8G4 support rails installation kit

- 1** Rear of rail
- 2** Rack mounting rails
- 3** M6 screws
- 4** Latches
- 5** Front of rail

Note: You might find it helpful, with some types of racks, to remove the rack doors and side panels to provide easier access during installation.

2. Check the labels on the support rails. Each rail has a label that indicates which is the front end of the rail and whether the rail is for the left or right side of the rack. Perform this procedure for both rails.
3. Insert the right slide rail **2** into the rear rack mounting flange, as shown in Figure 60, with the rail pins **1** protruding through the flange.

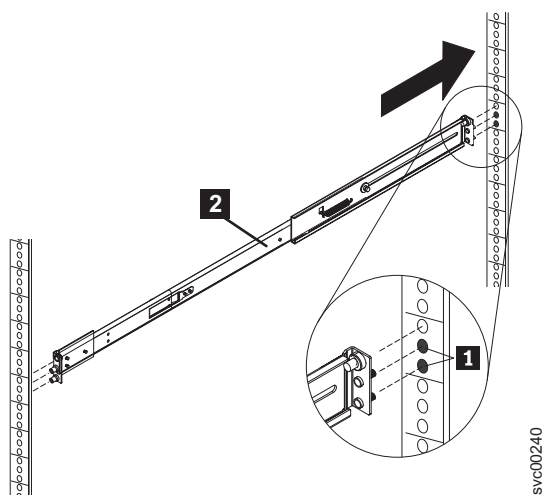

Figure 60. Inserting the right slide rail into the rear rack mounting flange

4. Extend the right slide rail **2** and insert it into the front rack mounting flange, as shown in Figure 61 on page 77, with the rail pins **1** protruding through the

flange. Insert the left slide rail in the same way.

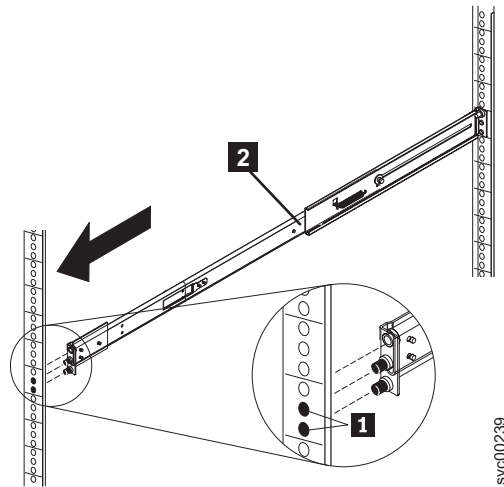

Figure 61. Extending the right slide rail

5. Attach one latch strike **1** to the front of the right rail **2**, as shown in Figure 62, using the captive screw **3**. Turn the screw only finger tight. Attach the other latch strike to the front of the left rail in the same way.

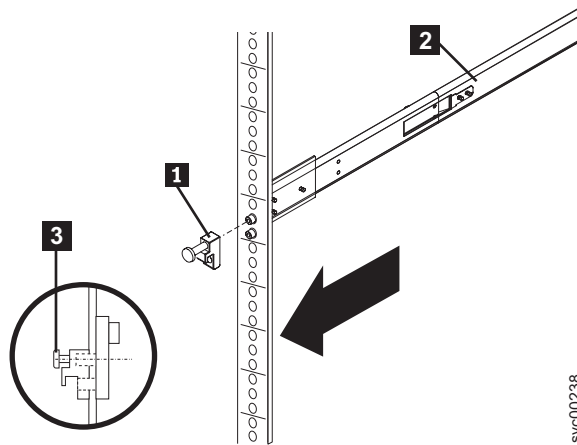

Figure 62. Attaching the latch strike to the front of the slide rail

6. Attach the slide rail to the left rear mounting flange with a single screw and latch strike. The screw should be only finger tight. Likewise, attach the other slide rail to the right rear mounting flange. The installation of the support rails for the SAN Volume Controller 2145-8G4 is complete.

Installing the support rails for the SAN Volume Controller 2145-8F4 or the SAN Volume Controller 2145-8F2

You must install the support rails that hold the SAN Volume Controller 2145-8F4 or the SAN Volume Controller 2145-8F2.

When you are ready to install the support rails, use the customer's hardware-location chart and the Electronic Industries Alliance (EIA) positions on the rack to determine where in the rack that the SAN Volume Controller node is to be installed.

Perform the following steps to install the support rails:

1. Check the labels on the support rails. Each rail has a label that indicates which is the front end of the rail and whether the rail is for the left or right side of the rack. Perform this procedure for both rails.
2. Put your index finger against the side of the latch-lever, **1** in Figure 63, and put your thumb against the front of the latch-lock **2**.

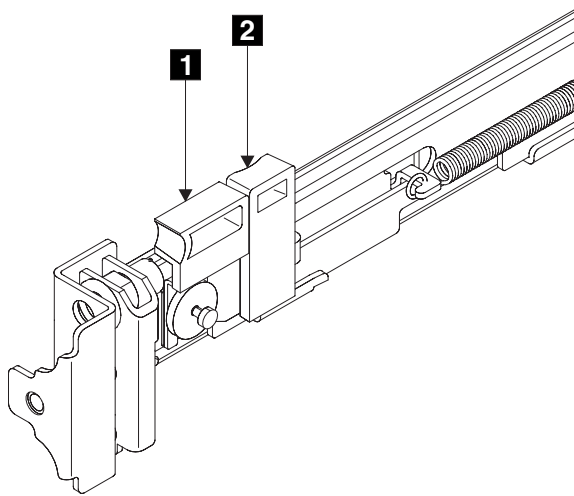

Figure 63. Retracting the latch-lock carrier

- 1** Latch lever
- 2** Latch lock

3. Gently push the latch lock **2** away from the rail as you move the latch lever **1** toward the far end of the rail (Figure 64 on page 79). The latch-lock carrier assembly slides against the spring tension.

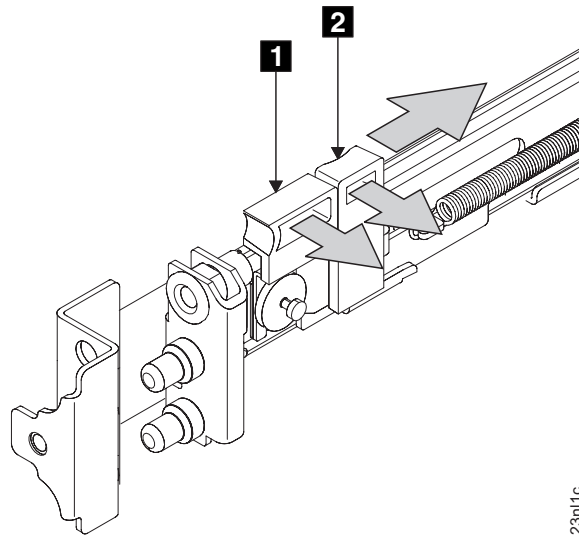

Figure 64. Opening the front latch-lock carrier assembly

- 1** Latch lever
- 2** Latch lock

4. Continue to slide the latch-lock carrier for approximately 13 mm (0.5 in). The latch-lever engages a hole in the back bracket assembly and holds the latch-lock carrier in the retracted position.
5. Push the back rail bracket **1** (Figure 65) toward the front of the rail until it stops. The rail is now at its shortest adjustment.

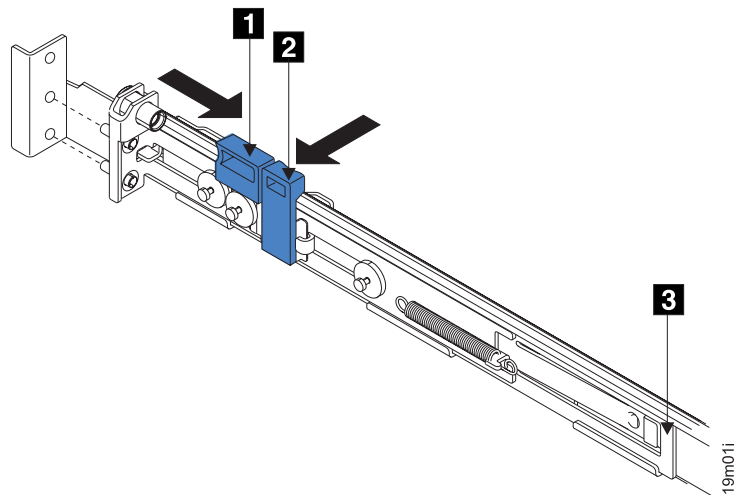

Figure 65. Opening the back latch-lock carrier assembly

- 1** Latch-lever
- 2** Latch-lock
- 3** Back rail bracket

6. Place the front end of the left rail in the rack cabinet. Align the top of the front bracket **1** (Figure 66 on page 80) with the required EIA marking that is on the rack.

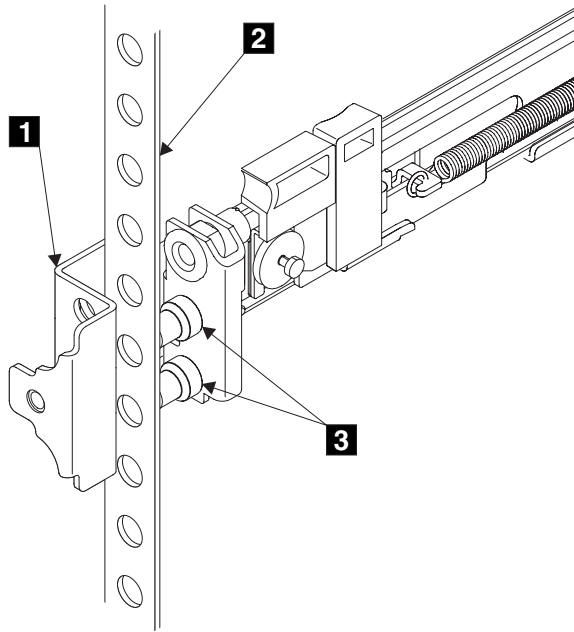

Figure 66. Installing the front end of the rail

- 1** Front bracket
- 2** Rack-mounting flange
- 3** Locating pins

7. Align the locating pins **3** with the holes that are in the rack-mounting flange.
8. Push the latch lock **2** (Figure 67 on page 81) away from the rail to release the carrier. The latch-lock carrier slides toward the front of the rack and the locating pins project through the holes that are in the front flange and in the front rail bracket.

Important: Ensure that the locating pins are fully extended through the front rail bracket.

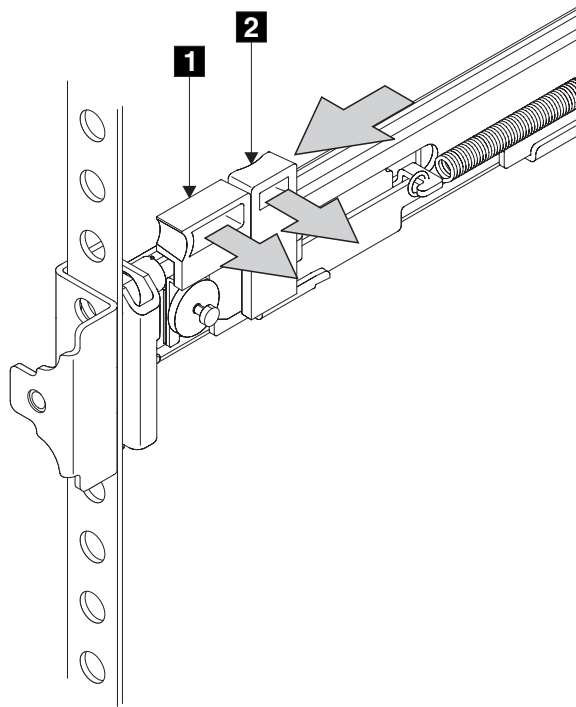

Figure 67. Closing the latch-lock carrier assembly

1 Latch-lever

2 Latch-lock

9. Push the back rail bracket toward the rear of the rack and align the locating pins with the rack-mounting flange.
10. Push the latch lock **2** away from the rail to release the carrier. The latch-lock carrier slides toward the rear of the rack, and the locating pins project through the holes that are in the rear flange and in the rear rail bracket.

Important: Ensure that the locating pins are fully extended through the rear rail bracket.

11. On the rear of each rail, press the blue release tab and slide the shipping bracket off the slide rail. Store the shipping bracket for further use.

Removing the top cover

You can remove the top cover of the SAN Volume Controller node if maintenance is necessary.

Related tasks

“Removing the SAN Volume Controller from a rack” on page 48
During some service procedures, you might need to remove the SAN Volume Controller from a rack.

“Removing the power cable from the 2145 UPS-1U” on page 327

You can remove the power cable from the 2145 UPS-1U if you are having problems with the power supply and suspect that the power cable is defective.

“Replacing the top cover” on page 86

You must replace the top cover on the SAN Volume Controller node after maintenance is completed.

“Removing and replacing the SAN Volume Controller power-cable assembly” on page 110

Make sure that power to the SAN Volume Controller is turned off before you remove the power-cable assembly. Turn off the node while ensuring that its data is mirrored and synchronized, as described in MAP 5350 in the *IBM System Storage SAN Volume Controller Troubleshooting Guide*.

“Removing the fibre-channel adapter assembly” on page 189

Use the information in this topic when you need to remove a fibre channel adapter or fibre-channel adapter assemblies.

Removing the SAN Volume Controller 2145-CF8 top cover

Remove the SAN Volume Controller 2145-CF8 top cover to gain access to node components.

Important: Before you turn on the node, replace the cover for proper cooling and airflow. Operating the node for extended periods of time (more than 30 minutes) with the cover removed might damage components.

DANGER

Multiple power cords. The product might be equipped with multiple power cords. To remove all hazardous voltages, disconnect all power cords.

To remove the SAN Volume Controller 2145-CF8 cover, complete the following steps:

1. Read the safety information to which “Preparing to remove and replace parts” on page 24 refers.
2. Optional: Follow the procedure in MAP 5350 in the *IBM System Storage SAN Volume Controller Troubleshooting Guide* to verify that the node data is mirrored and synchronized, and that there are no dependent virtual disks (VDisks) before turning off the node.

Most maintenance procedures that require you to remove the cover are performed with:

- The node turned off
- The power cables disconnected
- The data cables connected

Depending on the part that you are removing or replacing, you might be able to leave the power cords and the data cables connected. The removal or replacement procedure for each part describes what to do about power, the power cords, and the data cables.

If you are removing or replacing a hot-swap fan, for example, you can leave the node turned on, the power cords connected, and the data cables connected.

However, do not run the node for longer than thirty minutes without the cover. If you must take a longer time, turn off the node as directed in MAP 5350.

3. Pull back the cable-management arm if you are working from the rear of the rack, or slide the node out of the rack to the fully extended rail position if you are working from the front.

You can perform most service actions when the node is fully extended from the rack on its slide rails.

4. Optional: When the node is completely turned off, remove the cable-retention brackets and disconnect the power cables, as described in “Removing the cable-retention bracket” on page 34.
5. Optional: To make sure that you can replace all cables in the same ports from which they were removed, label the port position of each fibre-channel and Ethernet cable; then remove all cables from the back of the node.
6. Optional: Remove the node from the rack and place it on a flat, static-protective surface. See “Removing the SAN Volume Controller from a rack” on page 48.
7. Press down firmly on the blue tab (**2** in Figure 68) that secures the cover (**1**) and slide the cover toward the rear of the node until the cover disengages the chassis.

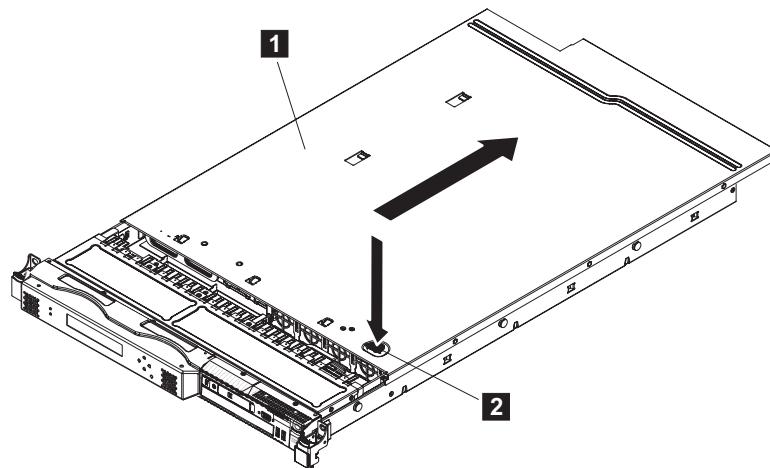

Figure 68. Removing the SAN Volume Controller 2145-CF8 cover

- 1** Cover
- 2** Blue locking tab

8. Lift the cover off the SAN Volume Controller 2145-CF8 and set it aside.

Removing the SAN Volume Controller 2145-8A4 top cover

This topic describes how to remove the top cover of the SAN Volume Controller 2145-8A4 node.

Attention: Never remove the top cover with power applied. To remove all power from the node, see MAP 5350 in the *IBM System Storage SAN Volume Controller Troubleshooting Guide*.

To remove the SAN Volume Controller 2145-8A4 cover, complete the following steps.

1. Read the safety information that is referenced in “Preparing to remove and replace parts” on page 24.

2. Remove the node from the rack and place it on a flat, static-protective surface. See “Removing the SAN Volume Controller from a rack” on page 48.
3. Press the cover-release button **1**, which is shown in Figure 69.

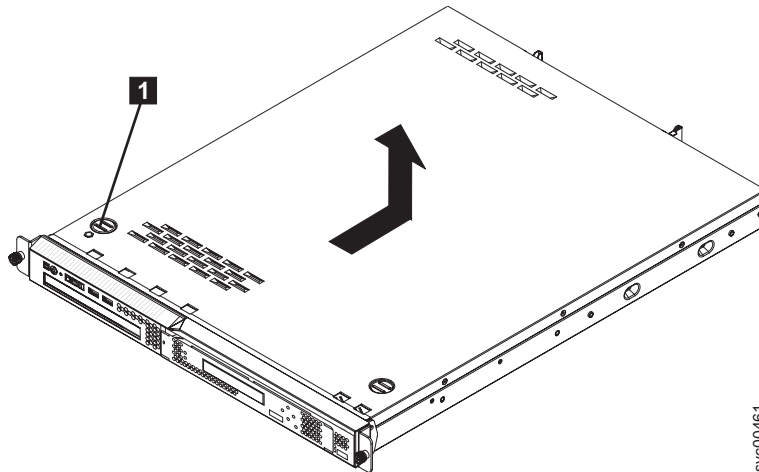

Figure 69. Removing the SAN Volume Controller 2145-8A4 cover

4. Slide the cover back approximately 1.3 cm (0.5 in); then, lift it off the node.

Removing the SAN Volume Controller 2145-8G4 top cover

This topic describes how to remove the SAN Volume Controller 2145-8G4 top cover.

Important: Before you turn on the node, replace the cover for proper cooling and airflow. Operating the node for extended periods of time (more than 30 minutes) with the cover removed might damage components.

To remove the SAN Volume Controller 2145-8G4 cover, complete the following steps.

Attention: Never remove the top cover with power applied. To remove all power from the node, see MAP 5350 in the *IBM System Storage SAN Volume Controller Troubleshooting Guide*.

1. Read the safety information that is referenced in “Preparing to remove and replace parts” on page 24.
2. Remove the node from the rack and place it on a flat, static-protective surface. See “Removing the SAN Volume Controller from a rack” on page 48.
3. Loosen the thumbscrew (**1** in Figure 70 on page 85) that secures the cover at the rear of the SAN Volume Controller 2145-8G4.

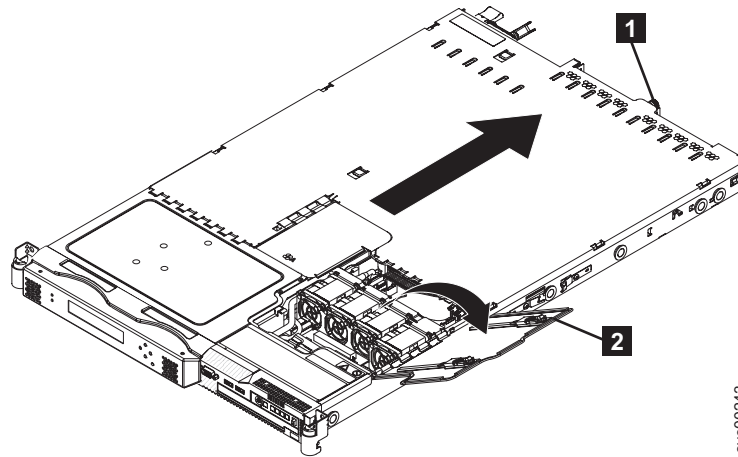

Figure 70. The SAN Volume Controller 2145-8G4 with fan door open

4. Open the fan door **2**. To open the fan door, slide the two latches to the right, and raise the door panel.
5. Remove the SAN Volume Controller 2145-8G4 cover:
 - a. Slide the cover slightly toward the rear of the SAN Volume Controller 2145-8G4 until it comes free. Make sure that the cover tabs all slide away from the insets that are on the front, rear, and sides of the SAN Volume Controller 2145-8G4.
 - b. Lift the cover off the SAN Volume Controller 2145-8G4 and set the cover aside.

Removing the SAN Volume Controller 2145-8F4 or SAN Volume Controller 2145-8F2 top cover

This topic describes how to remove the SAN Volume Controller 2145-8F4 or SAN Volume Controller 2145-8F2 top cover.

Important: Before you turn on the node, replace the cover for proper cooling and airflow. Operating the node for extended periods of time (more than 30 minutes) with the cover removed might damage components.

Before you remove the cover, you must remove all power from the node. To remove all power from the node, see MAP 5350 in the *IBM System Storage SAN Volume Controller Troubleshooting Guide*.

Perform the following steps to remove the SAN Volume Controller 2145-8F4 or SAN Volume Controller 2145-8F2 top cover:

1. Remove the server from the rack:
 - a. Pull the node out, about a third of the way, until it stops.
 - b. Slide both side release latches (left and right) toward the front of the node. Make sure that both rail-lock pins (**2** in Figure 71 on page 86) are in a vertical position, pull the node out, and remove it from the rack.

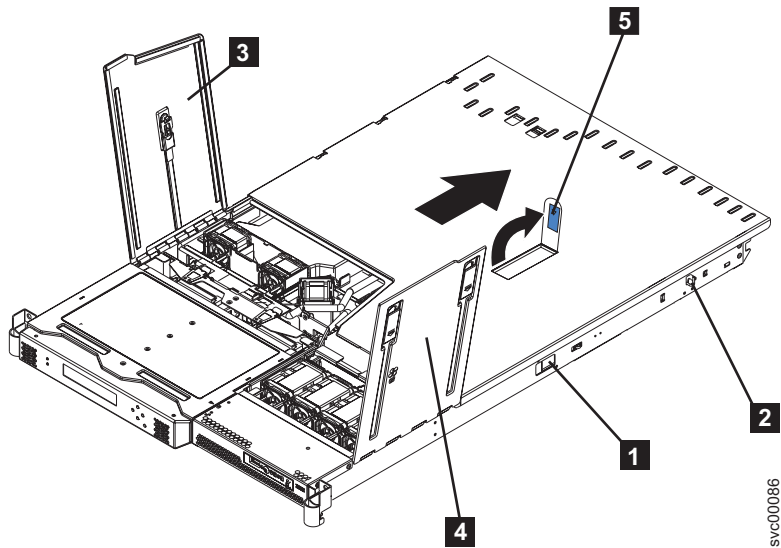

Figure 71. SAN Volume Controller 2145-8F2 or SAN Volume Controller 2145-8F4 with fan doors open

- 1** Side release latch
- 2** Rail lock pin
- 3** Fan door A
- 4** Fan door B
- 5** Cover release latch

2. Open fan door A **3** and fan door B **4**. To open fan door A, slide the slide latch to the left and lift up the door panel. To open fan door B, slide the two slide latches to the right and lift up the door panel.
3. Perform the following steps to remove the SAN Volume Controller 2145-8F4 or SAN Volume Controller 2145-8F2 cover:
 - a. Lift up the cover release latch **5** and slide the cover to the rear of the node.
 - b. Make sure that the SAN Volume Controller 2145-8F4 or SAN Volume Controller 2145-8F2 cover slides away from the insets that are on the front, rear, and sides of the SAN Volume Controller 2145-8F4 or SAN Volume Controller 2145-8F2 cover.
 - c. Lift the cover off the node and set the cover aside.

Replacing the top cover

You must replace the top cover on the SAN Volume Controller node after maintenance is completed.

Related tasks

“Removing the top cover” on page 81

You can remove the top cover of the SAN Volume Controller node if maintenance is necessary.

“Replacing the SAN Volume Controller in a rack” on page 59

You must use caution when you replace the SAN Volume Controller in a rack.

Replacing the SAN Volume Controller 2145-CF8 top cover

This topic describes how to replace the SAN Volume Controller 2145-CF8 top cover.

Important: Before you slide the cover forward, make sure that all the tabs on both the front, rear, and side of the cover engage the chassis correctly. If all the tabs do not engage the chassis correctly, it will be very difficult to remove the cover later.

To replace the top cover on the SAN Volume Controller 2145-CF8, complete the following steps:

1. If you removed the node from the rack, replace the node in the rack, as described in “Replacing the SAN Volume Controller in a rack” on page 59.
2. Make sure that all cables, adapters, and other components are installed and seated correctly and that you have not left loose tools or parts inside the node. Make sure that all internal cables are correctly routed. If you disconnected the fibre-channel and Ethernet cables, make sure that each cable is reconnected to the same port from which it was removed.
3. If you removed the power cords, replace the power cords and the cable-retention brackets, as described in “Replacing the cable-retention bracket” on page 40.
4. Position the cover on top of the SAN Volume Controller 2145-CF8.

Important: Before you slide the cover forward, make sure that all the tabs on both the front, rear, and side of the cover engage the chassis correctly. If all the tabs do not engage the chassis correctly, it will be very difficult to remove the cover later.

5. Slide the cover toward the front of the node, as shown in Figure 72.

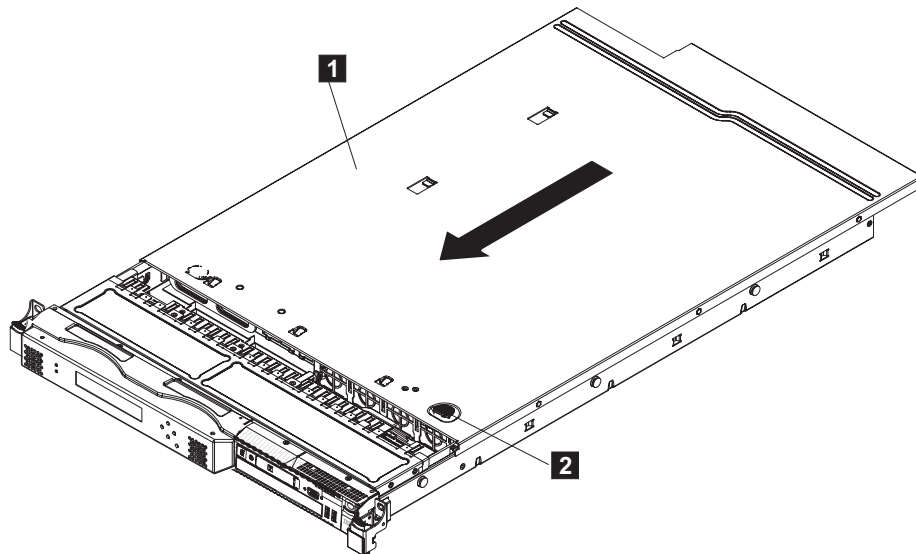

Figure 72. Replacing the SAN Volume Controller 2145-CF8 cover

- 1** Cover
- 2** Blue locking tab

6. Verify that the cover correctly engages all the inset tabs on the node.
7. Lift the locking levers (**1** in Figure 73 on page 88) on the slide rails and push the server **2** all the way into the rack until it clicks into place.

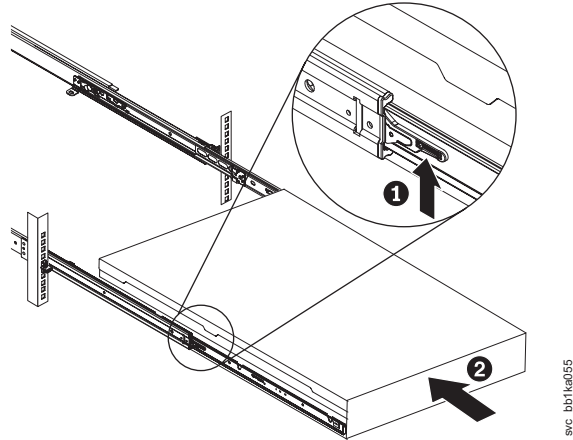

Figure 73. Raising the SAN Volume Controller 2145-CF8 locking levers of the slide rails of the rack

8. If you turned off the node during the service procedure, turn on the node.

Replacing the SAN Volume Controller 2145-8A4 top cover

This topic describes how to replace the SAN Volume Controller 2145-8A4 top cover.

To replace the top cover on the SAN Volume Controller 2145-8A4, complete the following steps:

1. Make sure that all internal cables are correctly routed so that they do not interfere with the cover installation.
2. Set the cover on top of the node so that approximately 1.3 cm (0.5 in) extends from the rear.
3. Slide the cover forward and into position.
4. Replace the node in the rack.

Replacing the SAN Volume Controller 2145-8G4 top cover

This topic describes how to replace the SAN Volume Controller 2145-8G4 top cover.

Important: Before you slide the cover forward, make sure that all the tabs on both the front, rear, and side of the cover engage the chassis correctly. If all the tabs do not engage the chassis correctly, it will be very difficult to remove the cover later.

To replace the top cover on the SAN Volume Controller 2145-8G4, complete the following steps:

1. Position the internal cables so that they do not interfere with the cover installation.
2. Position the cover on top of the SAN Volume Controller 2145-8G4 and open the fan door.
3. Tighten the thumbscrew **1**, which is shown in Figure 74 on page 89, until the cover correctly engages all the inset tabs on the SAN Volume Controller 2145-8G4.

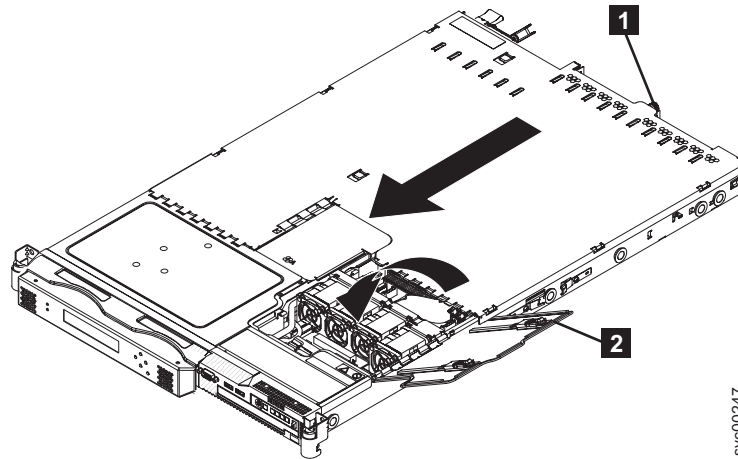

Figure 74. SAN Volume Controller 2145-8G4 with the fan door open

4. Close the fan door **2**.
5. Replace the node in the rack.

Replacing the SAN Volume Controller 2145-8F4 or SAN Volume Controller 2145-8F2 top cover

This topic describes how to replace the SAN Volume Controller 2145-8F4 or SAN Volume Controller 2145-8F2 top cover.

Important: Before you turn on the node, replace the cover for proper cooling and airflow. Operating the node for extended periods of time (more than 30 minutes) with the cover removed might damage components.

Important: Before you slide the cover forward, make sure that all the tabs on both the front, rear, and side of the cover engage the chassis correctly. If all the tabs do not engage the chassis correctly, it will be very difficult to remove the cover later.

Perform the following steps to replace the SAN Volume Controller 2145-8F4 or SAN Volume Controller 2145-8F2 top cover:

1. Position the internal cables so that they do not interfere with the cover installation.
2. Position the cover on top of the node and slide it forward.
3. Press down on the cover release latch **3**, which is shown in Figure 75 on page 90, until the cover properly engages all the inset tabs on the SAN Volume Controller 2145-8F2.

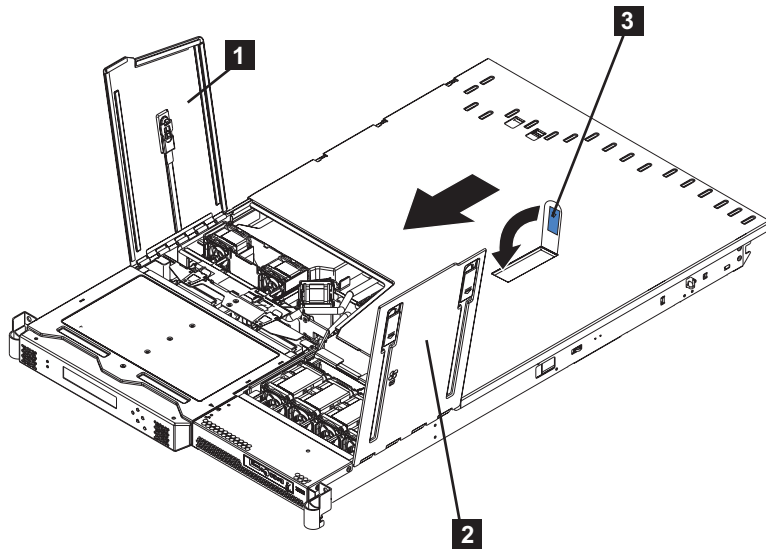

svc00087

Figure 75. SAN Volume Controller 2145-8F2 with the access doors open

- 1** Fan door A
 - 2** Fan door B
 - 3** Cover release latch
4. Close the fan doors.
 5. Replace the node in the rack.

Removing the service controller

You can remove the service controller from the SAN Volume Controller.

Related tasks

“Removing the SAN Volume Controller from a rack” on page 48
During some service procedures, you might need to remove the SAN Volume Controller from a rack.

“Removing and replacing the SAN Volume Controller power-cable assembly” on page 110

Make sure that power to the SAN Volume Controller is turned off before you remove the power-cable assembly. Turn off the node while ensuring that its data is mirrored and synchronized, as described in MAP 5350 in the *IBM System Storage SAN Volume Controller Troubleshooting Guide*.

“Removing the top cover” on page 81

You can remove the top cover of the SAN Volume Controller node if maintenance is necessary.

Related reference

“Replacing a disk drive and a service controller on the SAN Volume Controller” on page 110

When you replace a service controller at the same time that you replace the disk drive, you might not be able to perform a node rescue because the nonvolatile memory in the “new” service controller does not contain the operating system software required to do so.

Removing the SAN Volume Controller 2145-CF8 service controller

DANGER

Multiple power cords. The product might be equipped with multiple power cords. To remove all hazardous voltages, disconnect all power cords.

This service action is used in two separate removal and replacement procedures, which each have unique power requirements:

- If you are replacing the service controller, this service action requires you to turn off the node and disconnect the USB service-controller cable.
- If you are replacing a hot-swap drive, you do not have to turn off the node, and you can leave the service-controller cable attached to the service controller.

To remove the service controller, perform the following steps:

1. Read the safety information to which “Preparing to remove and replace parts” on page 24 refers.
2. If you are intending to replace the service controller field-replaceable unit (FRU), use one of the following methods to read and record the WWNN of the node.
 - From the front panel, press the down button until Node: xxxx shows in the display. Press the right button until Node WWNN: nnnn is displayed and record the five-digit number.
 - From the cluster vital product data (VPD), record the last five digits of the WWNN or the WWPN of the fibre-channel ports.

If you cannot obtain the WWNN with either method, obtain the information from your storage-attached network (SAN) switch.

3. If you are intending to replace the service controller FRU, verify that the node data is mirrored and synchronized, and that there are no dependent virtual disks before turning off the node.

Follow the procedure in MAP 5350 in the *IBM System Storage SAN Volume Controller Troubleshooting Guide* to verify that the node data is mirrored and synchronized, and that there are no dependent virtual disks (VDisks) before turning off the node.

4. Optional: Slide the node out on its slide rails to the fully extended position. You can leave the fibre-channel and Ethernet cables connected, if you are using the cable-management arm and if you are not removing the node from the rack. If the location of the node in the rack is too high or too low to work comfortably, you can remove the node from the rack.

Fast path: You can perform this service procedure with the node in place.

5. If you must remove the node from the rack to work on it, perform the following procedure to turn off the node, remove all cables, and remove the node from the rack:
 - a. If you have not yet done so, verify that the node data is mirrored and synchronized, and that there are no dependent virtual disks before turning off the node.

Follow the procedure in MAP 5350 in the *IBM System Storage SAN Volume Controller Troubleshooting Guide* to verify that the node data is mirrored and synchronized, and that there are no dependent virtual disks (VDisks) before turning off the node.
 - b. Pull back the cable-management arm if you are working from the rear of the rack, or slide the node out of the rack to the fully extended rail position if you are working from the front.
 - c. When the node is completely turned off, remove the cable-retention brackets and disconnect the power cables, as described in “Removing the cable-retention bracket” on page 34.
 - d. To make sure that you can replace all cables in the same ports from which they were removed, label the port position of each fibre-channel and Ethernet cable; then remove all cables from the back of the node.
 - e. Remove the node from the rack and place it on a flat, static-protective surface. See “Removing the SAN Volume Controller from a rack” on page 48.
6. Locate the recessed, blue service-controller release buttons on each side of the controller. See Figure 76.

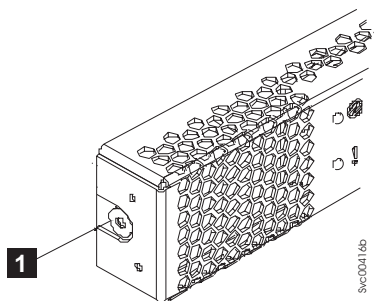

Figure 76. Left release button of a SAN Volume Controller 2145-CF8 service controller

7. Gently press both release buttons, shown by **2** in Figure 77 on page 93, and release the catch while pulling gently forward on the service controller. The service controller moves slightly forward.

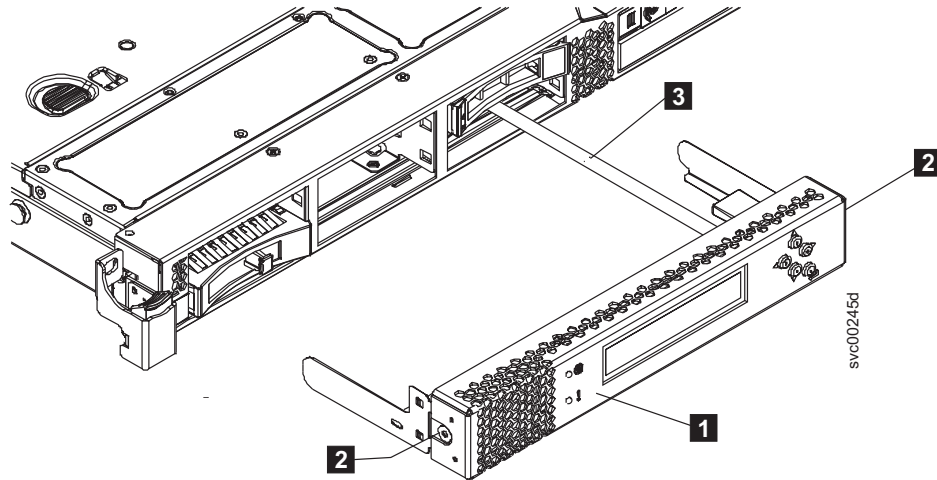

Figure 77. Service controller for the SAN Volume Controller 2145-CF8 with attached USB cable

- 1 Service controller
- 2 Service-controller release buttons
- 3 USB service-controller cable

Attention: If you meet any resistance, do not pull harder, or you might damage the release mechanism.

Stop pressing the release buttons once the service-controller locking mechanism clears the SAN Volume Controller 2145-CF8.

8. Pull the service controller fully out of the frame.

If you are replacing a hot-swap drive, you can leave the service-controller cable attached to the service controller. You can suspend the service controller by its cable, or rest it on another surface while removing and replacing the drive.

9. If you are intending to replace the service controller FRU, detach the USB cable, shown by 3 in Figure 78, from the service controller.

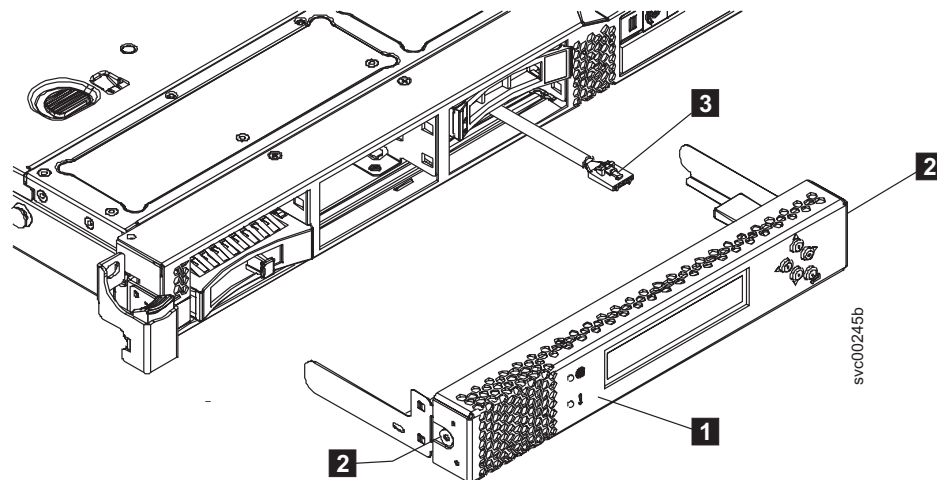

Figure 78. SAN Volume Controller 2145-CF8 service controller

10. If you are intending to replace the service controller FRU, label the one that you are removing to avoid a possible worldwide node name (WWNN) conflict if the service controller is ever reused.

Note: When you replace a service controller, it is normal to change the worldwide node name (WWNN) of the new service controller to match the one that is being replaced. In this case, you will have two service controllers with the same WWNN. Clearly label the service controller that you are removing and indicate that its WWNN is now a duplicate and that it must not be connected to a SAN before its WWNN is reset.

Removing and replacing the SAN Volume Controller 2145-CF8 service controller cable

You can remove and replace the USB service-controller cable in the SAN Volume Controller 2145-CF8.

DANGER

Multiple power cords. The product might be equipped with multiple power cords. To remove all hazardous voltages, disconnect all power cords.

This service action requires you to remove the cover and:

- Turn the node off.
- Disconnect the power cables.
- Disconnect or reconnect the USB service-controller data cable.

Perform the following steps to remove or replace the service controller cable.

1. Read the safety information to which “Preparing to remove and replace parts” on page 24 refers.
2. Follow the procedure in MAP 5350 in the *IBM System Storage SAN Volume Controller Troubleshooting Guide* to verify that the node data is mirrored and synchronized, and that there are no dependent virtual disks (VDisks) before turning off the node.
3. Slide the node out on its slide rails to the fully extended position.
You can perform most service actions when the node is fully extended from the rack on its slide rails. If the location of the node in the rack is too high or too low to work comfortably, you can remove the node from the rack.
4. When the node is completely turned off, remove the cable-retention brackets and disconnect the power cables, as described in “Removing the cable-retention bracket” on page 34.
5. Optional: If you must remove the node from the rack to work on it, perform the following procedure to remove all cables and remove the node from the rack:
 - a. To make sure that you can replace all cables in the same ports from which they were removed, label the port position of each fibre-channel and Ethernet cable; then remove all cables from the back of the node.
 - b. Remove the node from the rack and place it on a flat, static-protective surface. See “Removing the SAN Volume Controller from a rack” on page 48.
6. Remove the top cover. See “Removing the top cover” on page 81.
7. Remove the service controller from the SAN Volume Controller 2145-CF8, as described in “Removing the SAN Volume Controller 2145-CF8 service controller” on page 91.

8. Remove or replace the USB service-controller cable.

To remove the USB service-controller cable, perform the following procedure:

- a. Disconnect the USB cable (**1** in Figure 79) from the service controller (**2**).

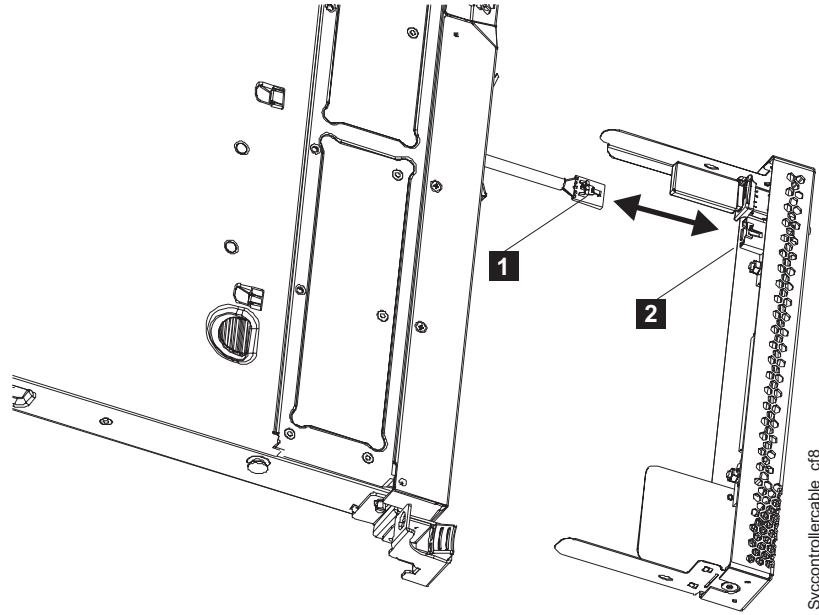

Figure 79. Removing and replacing the USB cable in the SAN Volume Controller 2145-CF8 service controller

- 1** USB cable
- 2** USB connector

- b. Locate the USB connector (**1** in Figure 80 on page 96) on the left side of the SAN Volume Controller 2145-CF8.



Figure 80. USB service-controller cable connected to the disk controller and USB riser card in the SAN Volume Controller 2145-CF8

1 USB connector on the disk controller and USB riser card

2 USB cable

- c. Grasp the blue lockbar (**2** in Figure 81 on page 97) and slide it toward the USB riser-card assembly (**3**) to the unlock position and remove the USB cable (**1**) from the connector.

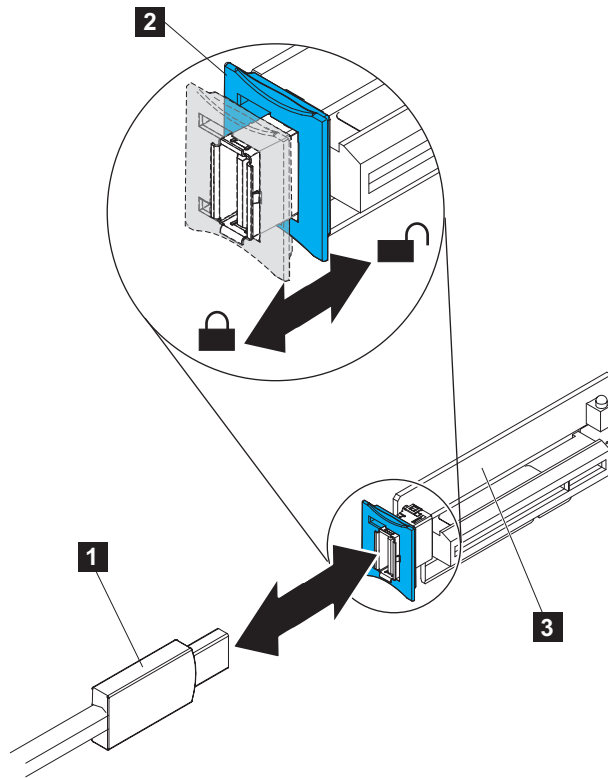

Figure 81. USB service-controller cable connector on the USB riser card

d. Remove the cable from the node.

To replace the USB service-controller cable, perform the following procedure:

a. To reinstall the cable, *carefully* thread the USB cable through disk-drive bay 5, routing the larger connector of the cable to the USB connector (**1** in Figure 80 on page 96) on the USB riser card.

Route the cable beneath any red SAS cables that are attached to the disk backplane.

b. Align the USB service-controller cable (**1** in Figure 81) with the connector on the USB riser-card assembly (**3**) and push it into the connector until it is firmly seated.

c. Slide the blue lockbar (**2**) toward the USB service-controller cable to the locked position until it is seated firmly.

d. Install the other end of the USB cable in the USB connector (**2** in Figure 79 on page 95) on the rear of the service controller.

e. Carefully install the service controller, as described in “Replacing the SAN Volume Controller 2145-CF8 service controller” on page 102.

Important: Ensure that the USB cable is pushed back into the empty drive bay, and ensure that the cable is not trapped above or below the bay.

9. After replacing the cable and the service controller, perform the procedure to replace the top cover, as described in “Replacing the top cover” on page 86.

After performing the procedure, the node is reinstalled in the rack with the power on.

Removing the SAN Volume Controller 2145-8A4 service controller

To remove the service controller, perform the following steps:

1. Turn off the node while ensuring that its data is mirrored and synchronized. See MAP 5350 in the *IBM System Storage SAN Volume Controller Troubleshooting Guide* for more information.
2. Remove the cable-retention bracket and disconnect the power cable from the node. See “Removing the cable-retention bracket” on page 34.
3. Locate the recessed service controller release button on the left side of the controller, which is marked in blue, as shown in Figure 82.



Figure 82. SAN Volume Controller 2145-8A4 service controller release button

4. Use a small screwdriver to gently press the release button and release the catch while pulling gently forward on the service controller. The service controller will move slightly forward.

Note: If you meet any resistance, do not press harder, or you might damage the release mechanism.

5. You can stop pressing the release button and pull the service controller fully out of the frame

Note: When you replace a service controller, it is normal to change the worldwide node name (WWNN) of the new service controller to match the one that is being replaced. In this case, you will have two service controllers with the same WWNN. Clearly label the service controller that you are removing and indicate that its WWNN is now a duplicate and that it must not be connected to a SAN before its WWNN is reset.

Removing the SAN Volume Controller 2145-8G4 service controller

To remove the service controller, perform the following steps:

1. Turn off the node while ensuring that its data is mirrored and synchronized. See MAP 5350 in the *IBM System Storage SAN Volume Controller Troubleshooting Guide* for more information..
2. Remove the cable-retention bracket and disconnect the power cable from the node. See “Removing the cable-retention bracket” on page 34.

3. After ensuring that there is enough slack in the cables connected to the rear of the SAN Volume Controller 2145-8G4 node, slide the node forward in the rack by approximately 10 cm (4 in).
4. Locate the recessed service controller release button on the left side of the controller, which is marked in blue, as shown in Figure 83.



Figure 83. SAN Volume Controller 2145-8G4 service controller release button

5. Use a small screwdriver to gently press the release button and release the catch while pulling gently forward on the service controller. The service controller will move slightly forward.

Note: If you meet any resistance, do not press harder, or you might damage the release mechanism.

6. You can stop pressing the release button and pull the service controller fully out of the frame, as shown in Figure 84 on page 100

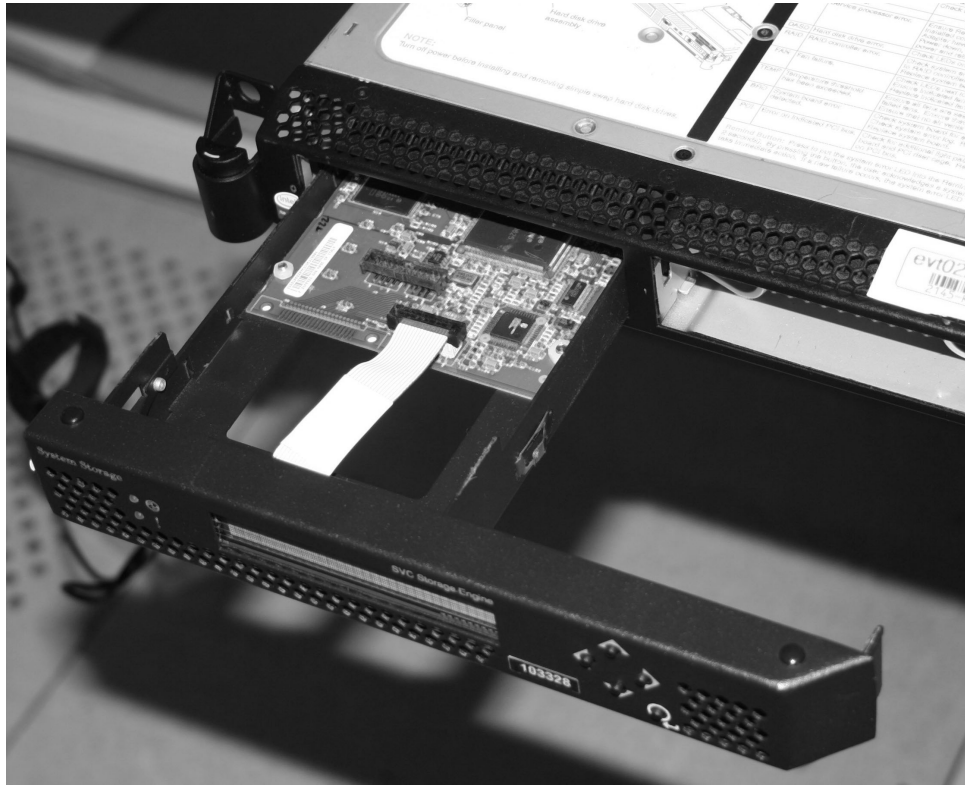

Figure 84. Removing the service controller from the SAN Volume Controller 2145-8G4

Note: When you replace a service controller, it is normal to change the worldwide node name (WWNN) of the new service controller to match the one that is being replaced. In this case, you will have two service controllers with the same WWNN. Clearly label the service controller that you are removing and indicate that its WWNN is now a duplicate and that it must not be connected to a SAN before its WWNN is reset.

Removing the SAN Volume Controller 2145-8F4 or SAN Volume Controller 2145-8F2 service controller

To remove the service controller, perform the following steps:

1. Turn off the node while ensuring that its data is mirrored and synchronized. See MAP 5350 in the *IBM System Storage SAN Volume Controller Troubleshooting Guide* for more information.
2. Remove the node from the rack and place it on a flat, static-protective surface. See “Removing the SAN Volume Controller from a rack” on page 48.
3. Open fan door A (1 in Figure 85 on page 101) of the node.

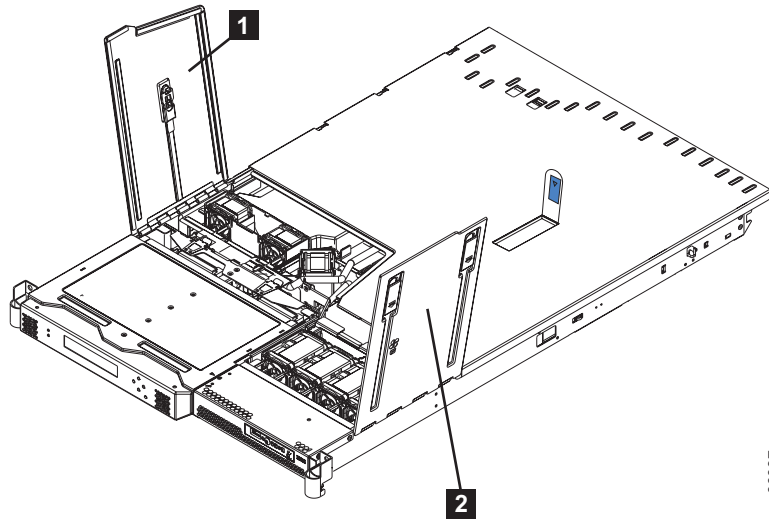

svc00097

Figure 85. SAN Volume Controller 2145-8F2 or SAN Volume Controller 2145-8F4 with fan doors open

1 Fan door A

2 Fan door B

4. Lift the two blue levers on the rear of the cage assembly to release it from the frame.
5. Lift the cage assembly until the blue release latch (**1** in Figure 86) on the left side of the service controller assembly is accessible.

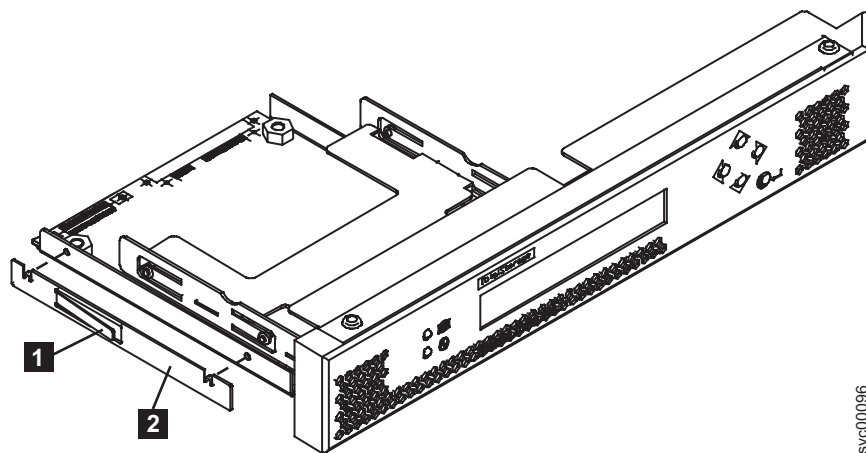

svc00096

Figure 86. SAN Volume Controller 2145-8F2 or SAN Volume Controller 2145-8F4 service controller

1 Release latch

2 Retention clip

6. Press the release latch **1** and then pull the service controller forward and out of the cage assembly.

Note: When you replace a service controller, it is normal to change the worldwide node name (WWNN) of the new service controller to match the one that is being replaced. In this case, you will have two service controllers with the same WWNN. Clearly label the service controller that you are removing and indicate that its WWNN is now a duplicate and that it must not be connected to a SAN before its WWNN is reset.

7. Remove the retention clip **2**. Make sure to save the retention clip for when you reinstall the node.

Replacing the service controller

You can replace the SAN Volume Controller service controller.

Related tasks

“Replacing the SAN Volume Controller in a rack” on page 59

You must use caution when you replace the SAN Volume Controller in a rack.

“Removing and replacing the SAN Volume Controller power-cable assembly” on page 110

Make sure that power to the SAN Volume Controller is turned off before you remove the power-cable assembly. Turn off the node while ensuring that its data is mirrored and synchronized, as described in MAP 5350 in the *IBM System Storage SAN Volume Controller Troubleshooting Guide*.

“Replacing the top cover” on page 86

You must replace the top cover on the SAN Volume Controller node after maintenance is completed.

“Replacing the disk-drive backplane” on page 143

You might have to replace the disk-drive backplane, which includes the simple-swap SAS backplane in the SAN Volume Controller 2145-CF8 or the hot-swap SATA backplane for a SAN Volume Controller 2145-8A4 or SAN Volume Controller 2145-8G4.

Related reference

“Handling static-sensitive devices” on page xxiv

Ensure that you understand how to handle devices that are sensitive to static electricity.

“Replacing a disk drive and a service controller on the SAN Volume Controller” on page 110

When you replace a service controller at the same time that you replace the disk drive, you might not be able to perform a node rescue because the nonvolatile memory in the “new” service controller does not contain the operating system software required to do so.

Replacing the SAN Volume Controller 2145-CF8 service controller

Use the following information to replace the SAN Volume Controller 2145-CF8 service controller.

To replace the service controller, perform the following steps:

1. When the service controller, as shown by **1** in Figure 87 on page 103, is close enough to the USB cable (**3**), attach the cable to the service controller, if necessary.

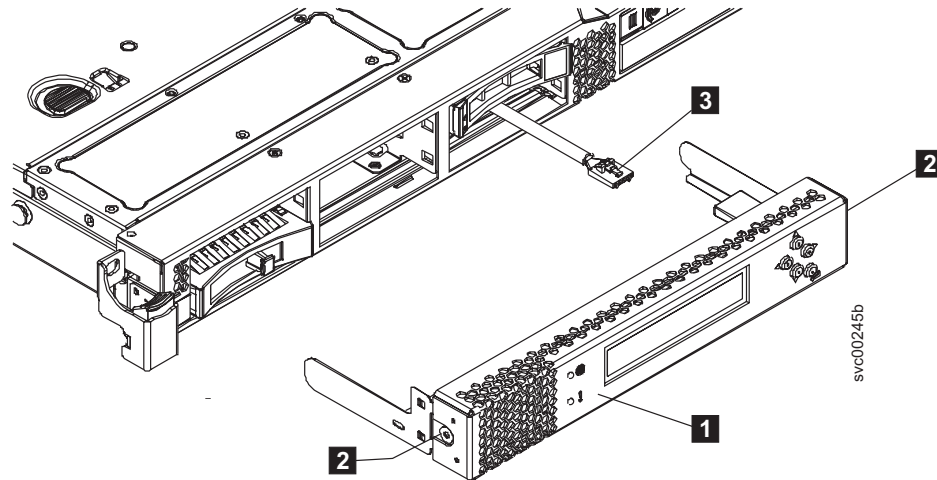

Figure 87. SAN Volume Controller 2145-CF8 service controller

- 1** Service controller
- 2** Service-controller release buttons
- 3** USB service-controller cable

2. Align the service controller with the service controller bay on the SAN Volume Controller 2145-CF8 node, and gently begin to push the service controller into the node.
3. Continue gently pushing the service controller into the frame until the rear connectors are fully seated and the front metal work of the service controller is up to the frame.

Important: Ensure that the USB cable is pushed back into the empty drive bay, and ensure that the cable is not trapped above or below the bay.

4. If you removed the node from the rack, replace the node in the rack, as described in “Replacing the SAN Volume Controller in a rack” on page 59.
5. If you removed any fibre-channel or Ethernet cables, use the labels you placed on each cable to replace all fibre-channel and Ethernet cables in the same ports from which they were removed.
6. If you removed the power cords, replace the power cords and the cable-retention brackets, as described in “Replacing the cable-retention bracket” on page 40.
7. If you pulled out the node to the fully-extended position on the rack, lift the locking levers (**1** in Figure 88 on page 104) on the slide rails and push the server **2** all the way into the rack until it clicks into place.

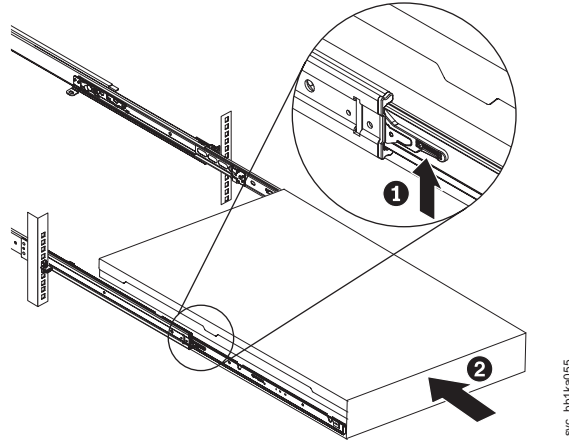

Figure 88. Raising the SAN Volume Controller 2145-CF8 locking levers of the slide rails of the rack

8. Turn on the node.

Note: The worldwide port names (WWPNs) of the fibre-channel ports are derived from the worldwide node name (WWNN) of the service controller. If you do not perform step 9, you might have to rezone the fibre-channel switches if the switch zoning uses WWPN. You must restart the host systems before they are able to access disks through this node.

9. If you replaced the service controller as part of concurrent maintenance, you must rewrite the WWNN on the new service controller. If you do not, and the fibre-channel switch zoning uses WWPNs, you cannot add the node back into the cluster until the fibre-channel switches in the SAN are rezoned. Also, the host systems cannot access the fibre-channel ports on that node until the host systems are reconfigured.

The node finally stops with `Validate WWNN` in the front panel. Press **select** and use the left and right buttons until either `Disk WWNN` or `Panel WWNN` is displayed. If you use `Disk WWNN`, which is what the node was using before the service controller was changed, you do not have to reconfigure SAN switches and applications.

Press and release the down button until `Use Disk WWNN` is displayed. If your selection is correct, press **Select** to verify that the WWNN that you set matches the WWNN that you recorded when you removed the service controller.

If the WWNN for the node is not correct, restore the WWNN by performing the following steps:

- a. Determine the WWNN for the node by examining the vital product data (VPD) of the node or the zoning that is defined in the SAN switch. Record the last five numbers of the WWNN for the node that you are working on.
- b. Start the node by performing a node rescue.
- c. Change the node WWNN by performing the following steps:
 - 1) On the front-panel display, press and release the down button until the `Node panel` is displayed. Then press and release the right button until the `Node WWNN: panel` is displayed.
 - 2) Press and hold the down button, press and release the select button, and then release the down button. The display switches into edit mode. `Edit WWNN` is displayed on line 1. Line 2 of the display shows the last five numbers of the WWNN that is currently set. The first number is highlighted.

- 3) Change the highlighted number to match the number from the VPD or from customer zoning. Use the up and down buttons to increase or decrease the numbers. The numbers wrap F to 0 or 0 to F. Use the left and right buttons to move between the numbers.
- 4) When the displayed value matches the numbers in the VPD or customer zoning, press and release the select button to accept the numbers. The Node WWNN: panel is displayed and the second line shows the last five numbers of the restored WWNN.

Wait one minute. If `Cluster: cluster_name` is displayed, the node has rejoined the cluster. If `Cluster:` does not display, see "MAP 5000" in the *IBM System Storage SAN Volume Controller Troubleshooting Guide* to determine how to solve this problem or contact the IBM support center.

Replacing the SAN Volume Controller 2145-8A4 service controller

Use the following information to replace the SAN Volume Controller 2145-8A4 service controller.

To replace the service controller, perform the following steps:

1. Gently push the service controller (shown in Figure 89) into the frame until the rear connectors are fully seated and the service controller front metal work is up to the frame.

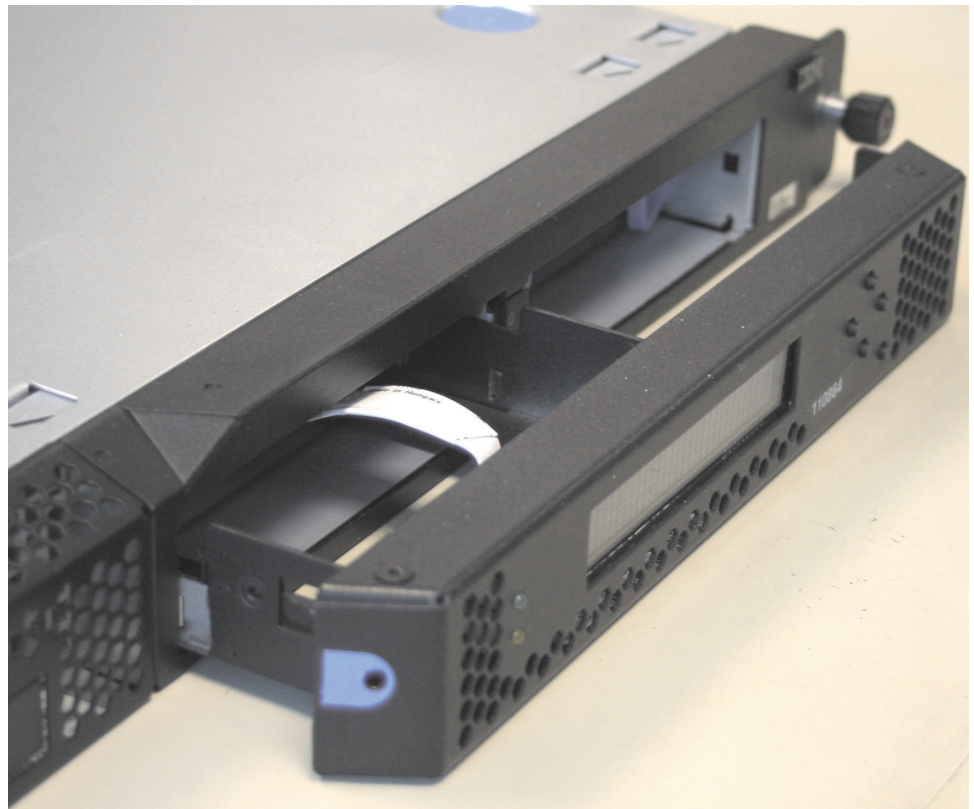

Figure 89. SAN Volume Controller 2145-8A4 service controller

2. Connect the power cable to the node and replace the cable-retention bracket. See "Replacing the cable-retention bracket" on page 40.

Note: If you replaced the service controller as part of concurrent maintenance, you must rewrite the WWNN on the new service controller. If you do not, and the fibre-channel switch zoning uses WWPNs, you cannot add the node back into the cluster until the fibre-channel switches in the SAN are re-zoned. Also, the host systems cannot access the fibre-channel ports on that node until the host systems are rebooted.

To restore the WWNN, perform the following steps:

- a. Determine the WWNN for the node by examining the vital product data (VPD) of the node or the zoning that is defined in the SAN switch. Record the last five numbers of the WWNN for the node that you are working on.
- b. Start the node by performing a node rescue.
- c. Change the node WWNN by performing the following steps:
 - 1) On the front-panel display, press and release the down button until the Node panel is displayed. Then press and release the right button until the Node WWNN: panel is displayed.
 - 2) Press and hold the down button, press and release the select button, and then release the down button. The display switches into edit mode. Edit WWNN is displayed on line 1. Line 2 of the display shows the last five numbers of the WWNN that is currently set. The first number is highlighted.
 - 3) Change the highlighted number to match the number from the VPD or from customer zoning. Use the up and down buttons to increase or decrease the numbers. The numbers wrap F to 0 or 0 to F. Use the left and right buttons to move between the numbers.
 - 4) When the displayed value matches the numbers in the VPD or customer zoning, press and release the select button to accept the numbers. The Node WWNN: panel is displayed and the second line shows the last five numbers of the restored WWNN.

Wait one minute. If `Cluster:` is displayed on the front panel, this indicates that the node is ready to be added to the cluster. If `Cluster:` does not display, see MAP 5000 in the *IBM System Storage SAN Volume Controller Troubleshooting Guide* to determine how to solve this problem or contact the IBM support center.

Replacing the SAN Volume Controller 2145-8G4 service controller

Use the following information to replace the SAN Volume Controller 2145-8G4 service controller.

To replace the service controller, perform the following steps:

1. Gently push the service controller (shown in Figure 90 on page 107) into the frame until the rear connectors are fully seated and the service controller front metal work is up to the frame.



Figure 90. SAN Volume Controller 2145-8G4 service controller

2. Slide the SAN Volume Controller 2145-8G4 back into the rack and check that all cables are still firmly in place.
3. Connect the power cable to the node and replace the cable-retention bracket. See “Replacing the cable-retention bracket” on page 40.

Note: The worldwide port names (WWPNs) of the fibre-channel ports are derived from the worldwide node name (WWNN) of the service controller. If you do not perform step 4, you might have to re-zone the fibre-channel switches if the switch zoning uses WWPN. You must restart the host systems before they are able to access disks through this node.

4. If you replaced the service controller as part of concurrent maintenance, you must rewrite the WWNN on the new service controller. If you do not, and the fibre-channel switch zoning uses WWPNs, you cannot add the node back into the cluster until the fibre-channel switches in the SAN are re-zoned. Also, the host systems cannot access the fibre-channel ports on that node until the host systems are rebooted.

To restore the WWNN, perform the following steps:

- a. Determine the WWNN for the node by examining the vital product data (VPD) of the node or the zoning that is defined in the SAN switch. Record the last five numbers of the WWNN for the node that you are working on.
- b. Start the node by performing a node rescue.
- c. Change the node WWNN by performing the following steps:
 - 1) On the front-panel display, press and release the down button until the Node panel is displayed. Then press and release the right button until the Node WWNN: panel is displayed.
 - 2) Press and hold the down button, press and release the select button, and then release the down button. The display switches into edit mode. Edit WWNN is displayed on line 1. Line 2 of the display shows the last five numbers of the WWNN that is currently set. The first number is highlighted.
 - 3) Change the highlighted number to match the number from the VPD or from customer zoning. Use the up and down buttons to increase or decrease the numbers. The numbers wrap F to 0 or 0 to F. Use the left and right buttons to move between the numbers.

- 4) When the displayed value matches the numbers in the VPD or customer zoning, press and release the select button to accept the numbers. The Node WWNN: panel is displayed and the second line shows the last five numbers of the restored WWNN.

Wait one minute. If `C1uster:` is displayed on the front panel, this indicates that the node is ready to be added to the cluster. If `C1uster:` does not display, see "MAP 5000" in the *IBM System Storage SAN Volume Controller Troubleshooting Guide* to determine how to solve this problem or contact the IBM support center.

Replacing the SAN Volume Controller 2145-8F4 or SAN Volume Controller 2145-8F2 service controller

Use the following information to replace the SAN Volume Controller 2145-8F4 or SAN Volume Controller 2145-8F2 service controller.

To replace the service controller, perform the following steps:

1. Place the retention clip (2 in Figure 91) over the locating holes on the left side of the service controller.

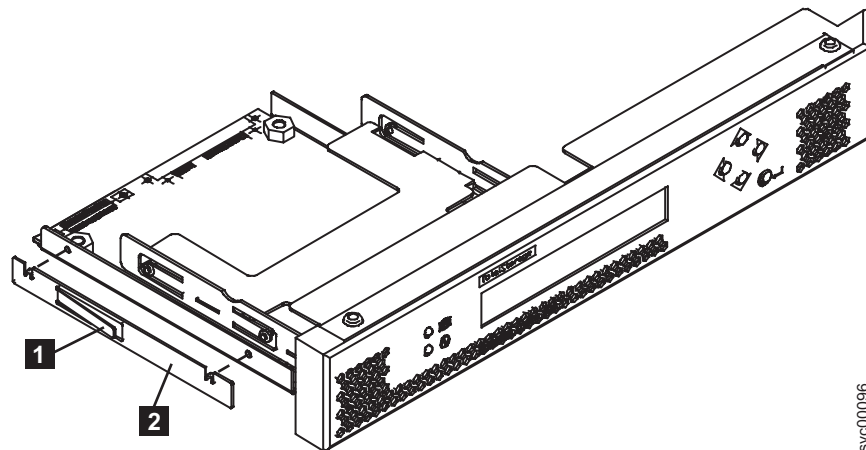

Figure 91. SAN Volume Controller 2145-8F2 or SAN Volume Controller 2145-8F4 service controller

2. Push the service controller into the cage until the retention clip engages.
3. Relocate the cage assembly and close the blue levers to secure the cage assembly to the frame.
4. Close the fan door (1 in Figure 92 on page 109) and replace the node in the rack.

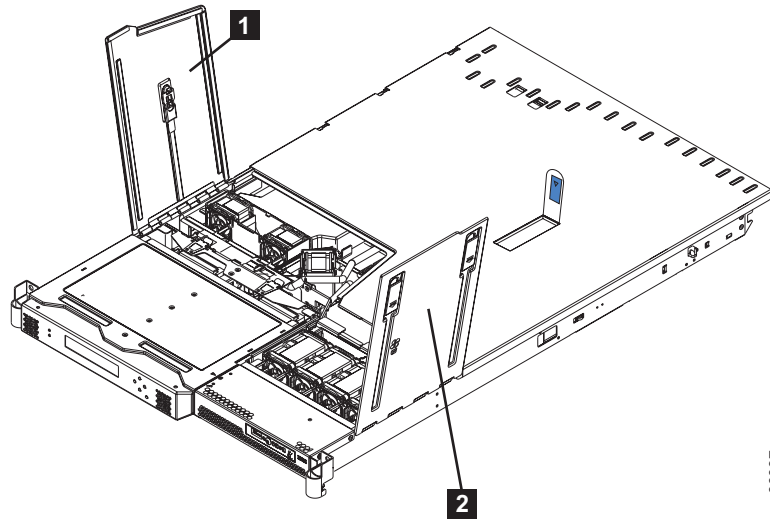

Figure 92. SAN Volume Controller 2145-8F2 or SAN Volume Controller 2145-8F4 with fan doors open

Note: The worldwide port names (WWPNs) of the fibre-channel ports are derived from the worldwide node name (WWNN) of the service controller. If you do not perform step 5, you might have to re-zone the fibre-channel switches if the switch zoning uses WWPN. You must restart the host systems before they are able to access disks through this node.

5. If you replaced the service controller as part of concurrent maintenance, you must rewrite the WWNN on the new service controller. If you do not, and the fibre-channel switch zoning uses WWPNs, you cannot add the node back into the cluster until the fibre-channel switches in the SAN are re-zoned. Also, the host systems cannot access the fibre-channel ports on that node until the host systems are rebooted.

To restore the WWNN, perform the following steps:

- a. Determine the WWNN for the node by examining the vital product data (VPD) of the node or the zoning that is defined in the SAN switch. Record the last five numbers of the WWNN for the node that you are working on.
- b. Start the node by performing a node rescue.
- c. Change the node WWNN by performing the following steps:
 - 1) On the front-panel display, press and release the down button until the Node panel is displayed. Then press and release the right button until the Node WWNN: panel is displayed.
 - 2) Press and hold the down button, press and release the select button, and then release the down button. The display switches into edit mode. Edit WWNN is displayed on line 1. Line 2 of the display shows the last five numbers of the WWNN that is currently set. The first number is highlighted.
 - 3) Change the highlighted number to match the number from the VPD or from customer zoning. Use the up and down buttons to increase or decrease the numbers. The numbers wrap F to 0 or 0 to F. Use the left and right buttons to move between the numbers.
 - 4) When the displayed value matches the numbers in the VPD or customer zoning, press and release the select button to accept the numbers. The Node WWNN: panel is displayed and the second line shows the last five numbers of the restored WWNN.

Wait one minute. If Cluster: is displayed on the front panel, this indicates that the node is ready to be added to the cluster. If Cluster: does not display, see "MAP 5000" in the *IBM System Storage SAN Volume Controller Troubleshooting Guide* to determine how to solve this problem or contact the IBM support center.

Replacing a disk drive and a service controller on the SAN Volume Controller

When you replace a service controller at the same time that you replace the disk drive, you might not be able to perform a node rescue because the nonvolatile memory in the "new" service controller does not contain the operating system software required to do so.

Also, if you must replace the hard disk and the service controller at the same time, you cannot boot the node to perform node rescue. If you find that you cannot run node rescue, then use the following procedure to perform the rescue:

- Swap the service controller with a service controller from a working node. The results are the following:
 - The "new" service controller that is swapped into the working node has its nonvolatile memory updated when the node is booted from the hard disk.
 - The service controller that is swapped into the failed node from the working node contains the operating system that is required to perform node rescue on that failed node.
- When all updates are complete, swap the service controllers again, returning them to their original nodes.

Related tasks

"Removing the service controller" on page 90

You can remove the service controller from the SAN Volume Controller.

"Removing the disk drive" on page 118

You might have to remove the disk drive for a service action.

Removing and replacing the SAN Volume Controller power-cable assembly

Make sure that power to the SAN Volume Controller is turned off before you remove the power-cable assembly. Turn off the node while ensuring that its data is mirrored and synchronized, as described in MAP 5350 in the *IBM System Storage SAN Volume Controller Troubleshooting Guide*.

The power-cable assembly is composed of a power cable (two power cables in the SAN Volume Controller model 2145-CF8) and a signal cable that are bound together. You can remove the power-cable assembly if you have problems with the power supply and suspect that a power or signal cable is defective. When removing the power-cable assembly, ensure that you also remove it from the uninterruptible power supply.

Perform the following steps to remove the power-cable assembly:

1. Check the SAN Volume Controller models 2145-CF8, 2145-8A4, 2145-8G4, 2145-8F4, and 2145-8F2 power LED (**1** in Figure 93 on page 111).
 - If the light is on, go to step 2 on page 111.
 - If the light is either off or flashing, power has already been removed from the SAN Volume Controller. Go to step 7 on page 112.

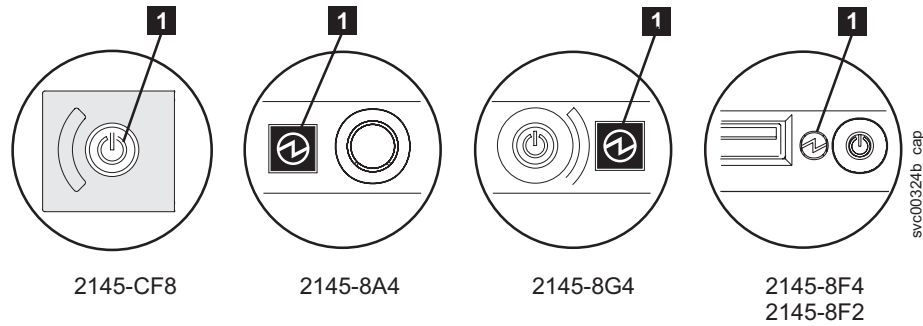

Figure 93. Power LED on the SAN Volume Controller models 2145-CF8, 2145-8A4, 2145-8G4, and 2145-8F4 or 2145-8F2 operator-information panel

1 Power LED

Important: SAN Volume Controller nodes operate in pairs. Both SAN Volume Controller nodes are in the same I/O group. One SAN Volume Controller must be operational if you are servicing the other SAN Volume Controller. If both SAN Volume Controller nodes are not functioning, you cannot access any of the disks in that I/O group.

- Turn off the node while ensuring that its data is mirrored and synchronized. See MAP 5350 in the *IBM System Storage SAN Volume Controller Troubleshooting Guide* for more information.

Attention: If both SAN Volume Controller nodes are online, removing the power from one SAN Volume Controller causes some performance degradation because I/O operations are automatically rerouted through the other SAN Volume Controller. You must obtain customer agreement before you continue with this procedure.

- Press and release the SAN Volume Controller models 2145-CF8, 2145-8A4, 2145-8G4, 2145-8F4, and 2145-8F2 power-control button **1**, as shown in Figure 94. Wait one minute for the SAN Volume Controller to turn off. The other SAN Volume Controller nodes in the cluster might display an error code indicating that a node is missing from the cluster. Ignore this error code; it is automatically resolved when the repair is complete.

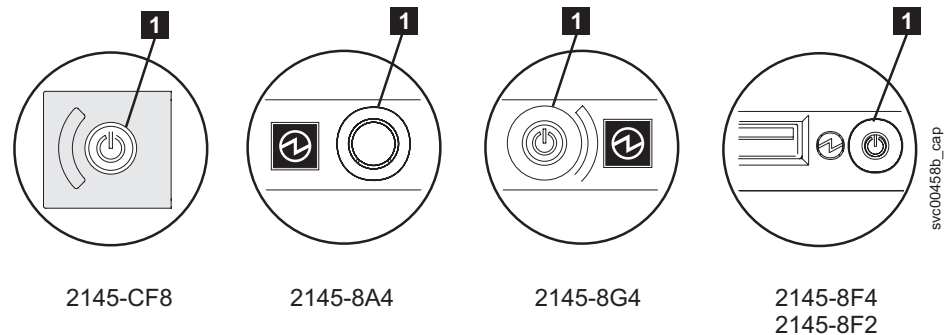

Figure 94. SAN Volume Controller models 2145-CF8, 2145-8A4, 2145-8G4, and 2145-8F4 or 2145-8F2 power-control button

1 Power-control button

- For the SAN Volume Controller model 2145-CF8, pull back the cable-management arm, remove any cable ties or hook-and-loop fasteners that might be securing the power cords, and free the power cords from the cable-management arm.

5. For the SAN Volume Controller model 2145-CF8, 2145-8A4, 2145-8G4, or 2145-8F4, remove the cable-retention bracket, as described in “Removing the cable-retention bracket” on page 34.
6. Remove the cable-retention bracket from the 2145 UPS-1U, as described in “Removing and replacing the 2145 UPS-1U power cable-retention bracket” on page 314.
7. Remove the power cord from the back of the SAN Volume Controller node (or both power cords from the back of the SAN Volume Controller 2145-CF8).
8. Replace the power cord (or both power cords for the SAN Volume Controller 2145-CF8) and verify that the cord is seated (or that both power cords are seated).
9. Replace the SAN Volume Controller model 2145-CF8, 2145-8A4, 2145-8G4, or 2145-8F4 cable-retention bracket and the 2145 UPS-1U cable-retention bracket.
10. For the SAN Volume Controller model 2145-CF8, route the power cords on the cable-management arm, secure the power cords with cable ties or hook-and-loop fasteners, and close the cable-management arm.
11. If the SAN Volume Controller does not turn on automatically, press and release the power-control button or switch.

Related tasks

“Removing the fibre-channel adapter assembly” on page 189

Use the information in this topic when you need to remove a fibre channel adapter or fibre-channel adapter assemblies.

Removing the memory modules (DIMM)

You can remove a memory module.

The memory modules are electrostatic-discharge (ESD) sensitive. Take precautions to avoid damage from static electricity.

Related tasks

“Removing and replacing the SAN Volume Controller power-cable assembly” on page 110

Make sure that power to the SAN Volume Controller is turned off before you remove the power-cable assembly. Turn off the node while ensuring that its data is mirrored and synchronized, as described in MAP 5350 in the *IBM System Storage SAN Volume Controller Troubleshooting Guide*.

“Removing the SAN Volume Controller from a rack” on page 48

During some service procedures, you might need to remove the SAN Volume Controller from a rack.

“Removing the top cover” on page 81

You can remove the top cover of the SAN Volume Controller node if maintenance is necessary.

Related reference

“Handling static-sensitive devices” on page xxiv

Ensure that you understand how to handle devices that are sensitive to static electricity.

Locating memory modules

If you do not need to remove all of the memory modules, use this information to locate a specific memory module for the SAN Volume Controller model.

After you find the location of the faulty memory module, go to “Removing memory modules” on page 115.

- SAN Volume Controller 2145-CF8: The SAN Volume Controller 2145-CF8 node uses six modules in DIMM slots **2**, **3**, **5**, **6**, **7**, and **8**, as shown in Figure 95.

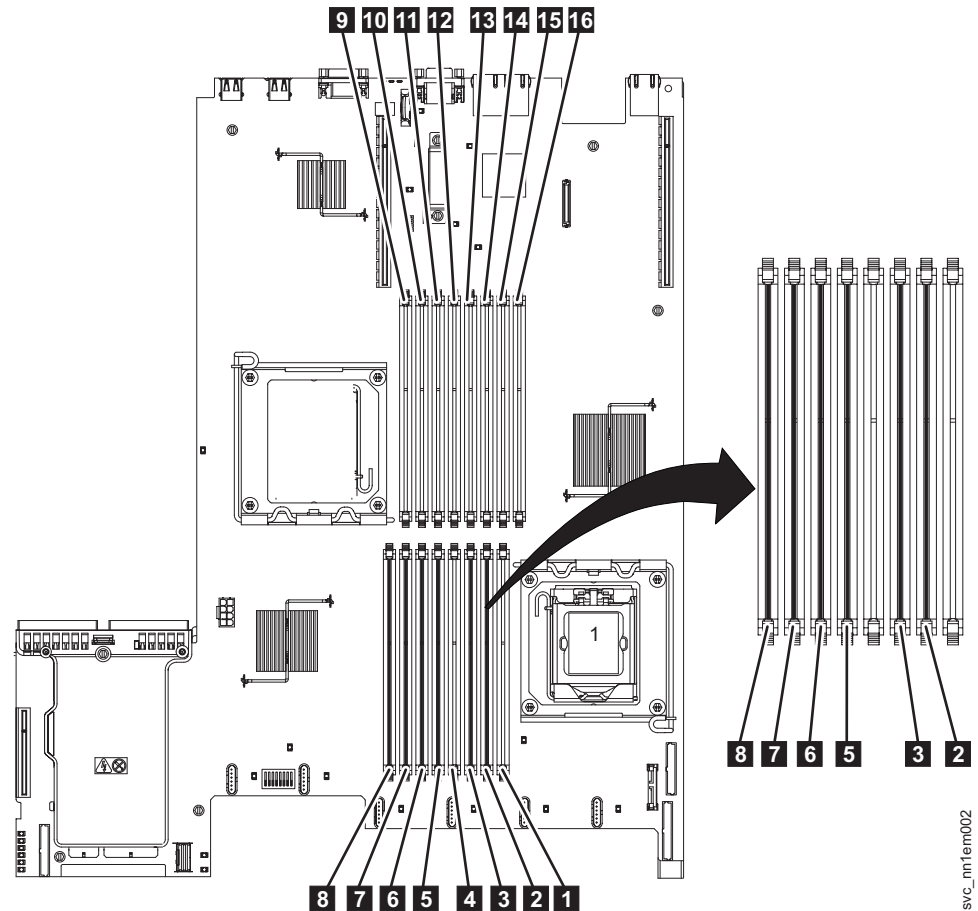

Figure 95. Locating the SAN Volume Controller 2145-CF8 memory modules

- SAN Volume Controller 2145-8A4: These modules are numbered **1** through **4**, as shown in Figure 96 on page 114.

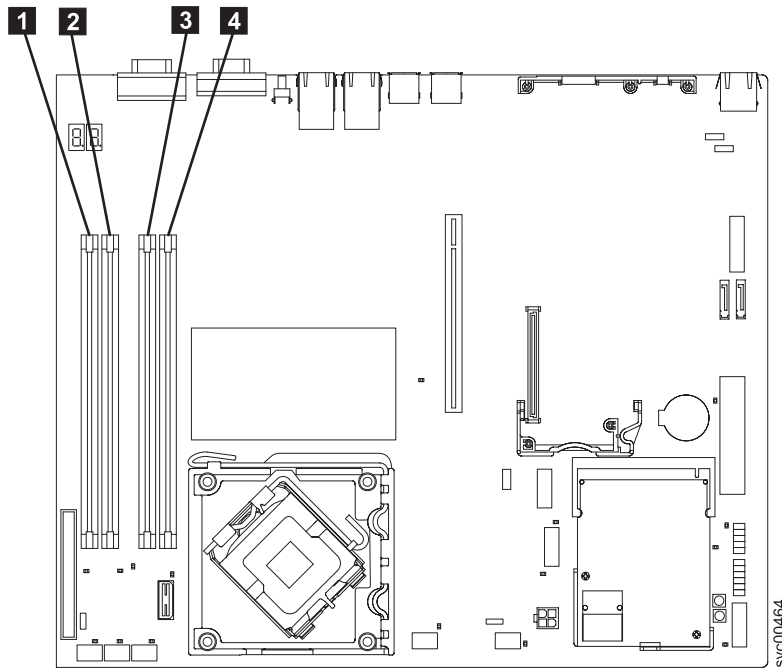

Figure 96. Locating the SAN Volume Controller 2145-8A4 memory modules

- SAN Volume Controller 2145-8G4: There are two versions of this node.
 - The original version (Rev 1) uses eight 1 GB memory modules in slots **1** through **8**, which are shown in Figure 97.
 - The second version of this node (Rev 2) uses four 2 GB memory modules in slots **1**, **3**, **5**, and **7**.

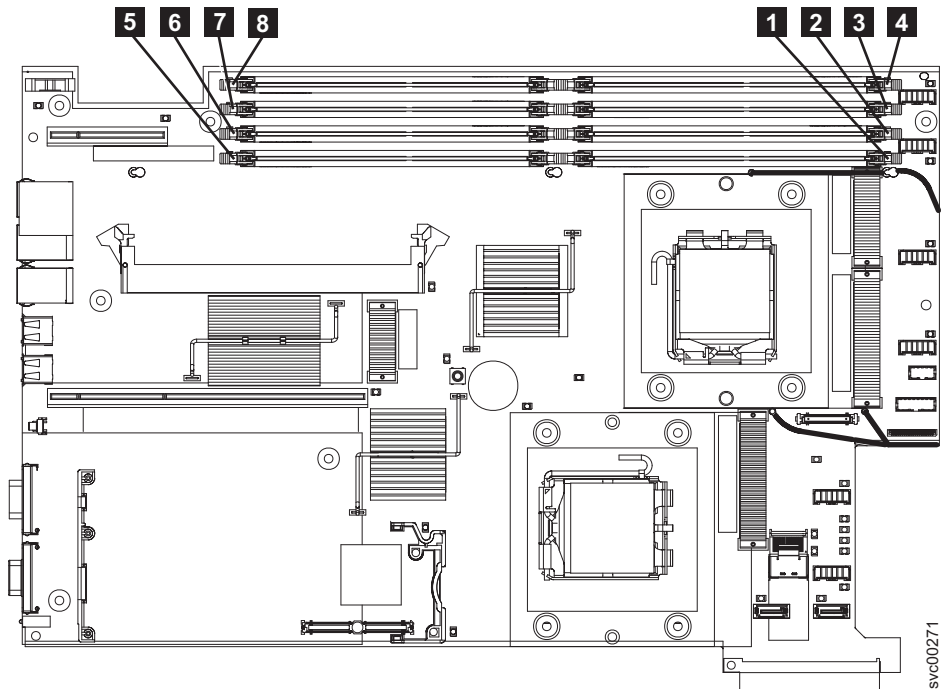

Figure 97. Locating the SAN Volume Controller 2145-8G4 memory modules

- SAN Volume Controller 2145-8F4 or SAN Volume Controller 2145-8F2: These modules are numbered **1** through **8**, as shown in Figure 98.

Note: If more than one SAN Volume Controller 2145-8G4, SAN Volume Controller 2145-8F4, or SAN Volume Controller 2145-8F2 DIMM is indicated by the light path diagnostics, replace the DIMMs one-at-a-time, starting at the lowest numbered DIMM slot that is indicated by the diagnostics.

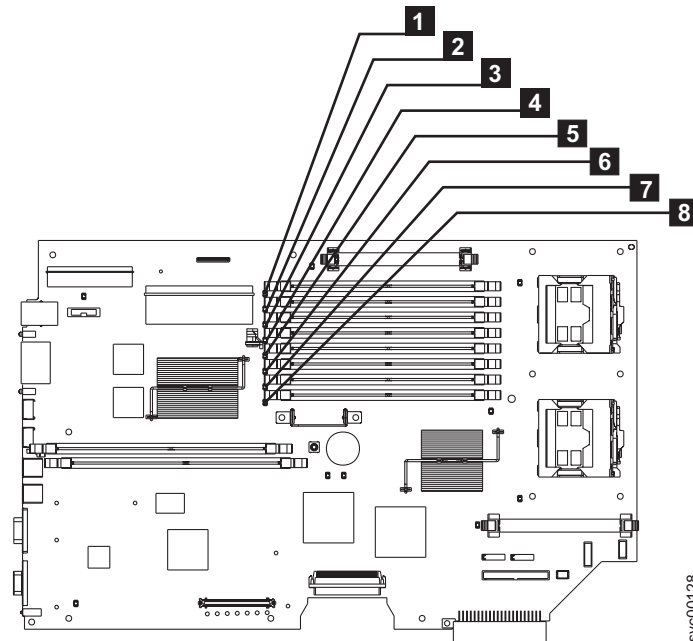

Figure 98. Locating the SAN Volume Controller 2145-8F2 or SAN Volume Controller 2145-8F4 memory modules

Removing memory modules

This topic describes how to remove the memory modules.

Perform the following steps to remove the memory modules:

1. Follow the procedure in MAP 5350 in the *IBM System Storage SAN Volume Controller Troubleshooting Guide* to verify that the node data is mirrored and synchronized, and that there are no dependent virtual disks (VDisks) before turning off the node.
2. Remove the node from the rack and place it on a flat, static-protective surface. See “Removing the SAN Volume Controller from a rack” on page 48.
3. Remove the top cover. See “Removing the top cover” on page 81.

Attention: If the fault has been isolated only to the bank of modules instead of to a particular module, exchange both modules of the bank. Otherwise, if you need to remove fewer memory modules, see “Locating memory modules” on page 112. If more than one SAN Volume Controller 2145-8G4, SAN Volume Controller 2145-8F4, or SAN Volume Controller 2145-8F2 DIMM is indicated by the light path diagnostics, replace the DIMMs one-at-a-time, starting at the lowest numbered DIMM slot that is indicated by the diagnostics.

4. Open the clips **2** by pressing them outward, as shown in Figure 99 on page 116. This action pulls the memory module **3** out of the connector.

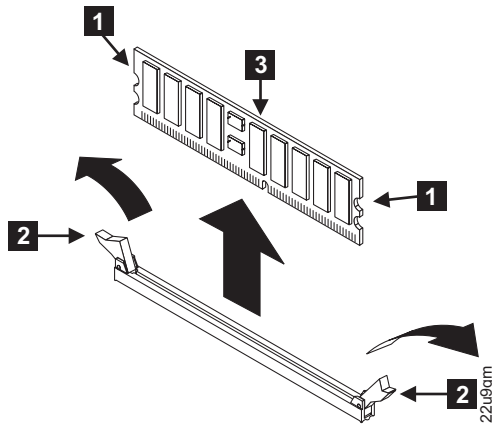

Figure 99. Removing the memory modules

- 1 Side connector latch
- 2 Memory clips
- 3 Memory module

5. If you have other tasks to complete inside the SAN Volume Controller, do those tasks now.

Replacing the memory modules (DIMM)

The memory modules are electrostatic-discharge (ESD) sensitive. Take precautions to avoid damage from static electricity.

There are two versions of the SAN Volume Controller 2145-8G4 node: Rev 1 and Rev 2. One difference between these two versions is in the memory configuration. The original version (Rev 1) has eight 1 GB memory modules, while the second version (Rev 2) has four 2 GB memory modules. The label on the Rev 1 node does not include a version number. An additional label on the front of the Rev 2 node includes the version number. Ensure that you have the correct memory modules for the node that you are servicing.

Perform the following steps to replace the memory modules:

Attention: To avoid breaking the retaining clips or damaging the memory module connectors, open and close the clips gently.

1. With the clips **2** open, lower the memory module **3** into the connector, as shown in Figure 100 on page 117. Insert the DIMM fully to close the clips.

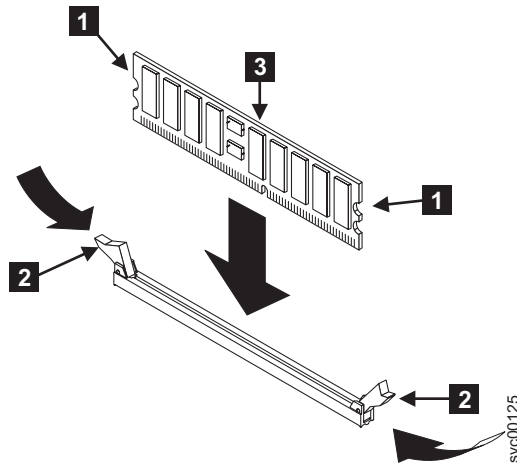

Figure 100. Replacing a memory module

2. Replace the top cover on the node.
3. Replace the node in the rack.
4. Restore all power to the node.

If a node error between 511 and 515 displays on the SAN Volume Controller model 2145-CF8, 2145-8G4, 2145-8F4, 2145-8F2 front panel, complete the following steps:

- a. Use the power button to turn off the node.
 - b. Remove the power cable from the node.
 - c. Wait 20 seconds and then replace the power cable.
 - d. Turn on the node.
 - e. If the error displays again, the memory bank might be disabled.
 - For the SAN Volume Controller 2145-CF8, 2145-8A4, 2145-8G4, 2145-8F4, or 2145-8F2 node, complete the following steps to enable a disabled memory bank:
 - 1) Use the power button to turn off the node.
 - 2) Attach the display and keyboard to the rear panel connectors. No special cables are required.
 - 3) Turn on the node and press F1 until you the setup menu displays.
 - 4) Go to the configuration menu, select **Memory**, and enable the disabled memory bank.
 - 5) Save the settings, exit the configuration program, and then restart the node.
 - f. If the error displays again, remove and replace the memory module again to ensure that it is seated correctly. If that does not resolve the error, the memory module connector might be the problem. Replace the system board on the SAN Volume Controller models 2145-CF8, 2145-8A4, 2145-8G4, or replace the frame assembly on the SAN Volume Controller 2145-8F4 and SAN Volume Controller 2145-8F2.
5. Make sure that all cables, adapters, and other components are installed and seated correctly and that you have not left loose tools or parts inside the node. Make sure that all internal cables are correctly routed. If you disconnected the fibre-channel and Ethernet cables, make sure that each cable is reconnected to the same port from which it was removed.
 6. Replace the top cover. See “Replacing the top cover” on page 86.

The procedure to replace the top cover also installs the node in the rack and turns on the node.

Related reference

“Handling static-sensitive devices” on page xxiv

Ensure that you understand how to handle devices that are sensitive to static electricity.

Removing the disk drive

You might have to remove the disk drive for a service action.

Related tasks

“Replacing the disk drive” on page 126

You might have to replace the disk drive for a service action.

“Removing the service controller” on page 90

You can remove the service controller from the SAN Volume Controller.

“Removing and replacing the SAN Volume Controller power-cable assembly” on page 110

Make sure that power to the SAN Volume Controller is turned off before you remove the power-cable assembly. Turn off the node while ensuring that its data is mirrored and synchronized, as described in MAP 5350 in the *IBM System Storage SAN Volume Controller Troubleshooting Guide*.

Related reference

“Replacing a disk drive and a service controller on the SAN Volume Controller” on page 110

When you replace a service controller at the same time that you replace the disk drive, you might not be able to perform a node rescue because the nonvolatile memory in the “new” service controller does not contain the operating system software required to do so.

“Handling static-sensitive devices” on page xxiv

Ensure that you understand how to handle devices that are sensitive to static electricity.

Removing the SATA disk drive for the SAN Volume Controller 2145-8A4 and the SAN Volume Controller 2145-8G4

This topic describes how to remove the SATA disk drive for the SAN Volume Controller 2145-8A4 and the SAN Volume Controller 2145-8G4.

You can remove the disk drive after you shut down the node.

To remove the SAN Volume Controller 2145-8A4 or the SAN Volume Controller 2145-8G4 disk drive, perform the following steps:

1. Make sure that the cover is in place and fully closed.

Attention: To avoid damage to the hard disk drive connectors, make sure that the cover is in place and fully closed whenever you install or remove a hard disk drive.

2. Turn off the node while ensuring that its data is mirrored and synchronized. See MAP 5350 in the *IBM System Storage SAN Volume Controller Troubleshooting Guide* for more information.
3. Remove the cable-retention bracket and disconnect the power cable from the node. See “Removing the cable-retention bracket” on page 34.
4. Remove the service controller. See “Removing the service controller” on page 90.

5. Pull the loops of the drive tray (shown in Figure 101) toward each other and pull the tray out of the bay.



Figure 101. SAN Volume Controller 2145-8A4 SATA disk drive

Removing the SAN Volume Controller 2145-8F2 or SAN Volume Controller 2145-8F4 SATA disk drive

You can remove the disk drive after you shut down the node.

To remove the SAN Volume Controller 2145-8F2 or SAN Volume Controller 2145-8F4 disk drive, perform the following steps:

1. Turn off the node while ensuring that its data is mirrored and synchronized. See MAP 5350 in the *IBM System Storage SAN Volume Controller Troubleshooting Guide* for more information.
2. Remove the SAN Volume Controller 2145-8F4 cable retention bracket.
3. To make sure that you can replace all cables in the same ports from which they were removed, record the position of all fibre-channel and Ethernet cables; then remove all cables from the back of the node.
4. Remove the node from the rack and place it on a flat, static-protective surface. See “Removing the SAN Volume Controller from a rack” on page 48.
5. Open fan door A (1 in Figure 102 on page 120).
6. Remove the service controller. See “Removing the service controller” on page 90.
7. Pull the disk drive out of the bay.

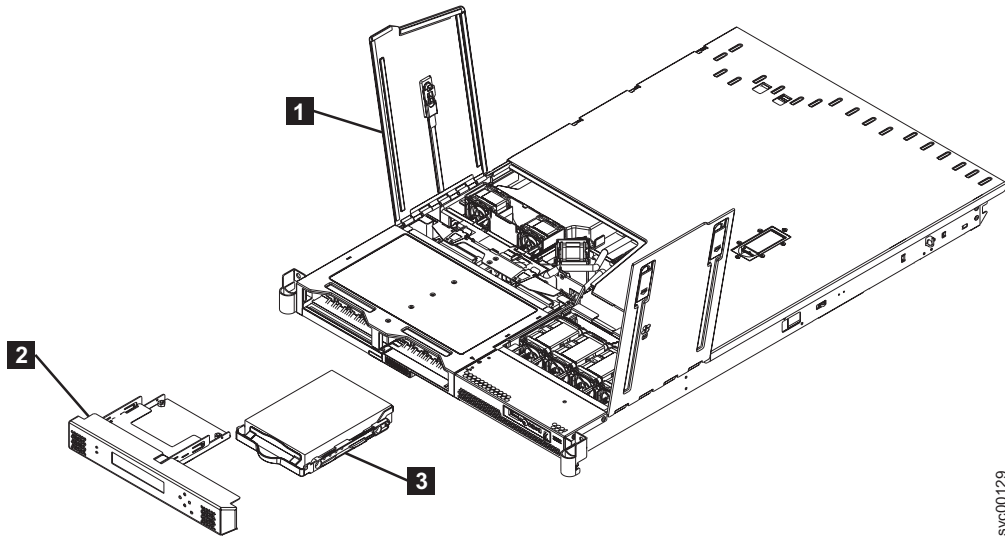

svc00129

Figure 102. Removing the SATA disk drive

- 1** Fan door A
- 2** Service controller
- 3** SATA disk drive

You can now replace the SAN Volume Controller 2145-8F2 or SAN Volume Controller 2145-8F4 disk drive.

Removing the SAN Volume Controller 2145-4F2 disk drive

Attention:

- Handle the disk drive with care and keep it away from strong magnetic fields.
- The disk drive is electrostatic-discharge (ESD) sensitive. Take precautions to avoid damage from static electricity. Wear an anti-static wrist strap and use a static-protected mat or surface. For more information, see “Handling static-sensitive devices” on page xxiv.

To remove the disk drive and cables, perform the following steps:

1. Verify that all operations between the node and the host system have been stopped.
2. Turn off the node while ensuring that its data is mirrored and synchronized. See MAP 5350 in the *IBM System Storage SAN Volume Controller Troubleshooting Guide* for more information.
3. Remove the node from the rack and place it on a flat, static-protective surface. See “Removing the SAN Volume Controller from a rack” on page 48.
4. Remove the top cover. See “Removing the top cover” on page 81.
5. Disconnect the SCSI signal connector **1** and the power connector **2** from the back of the disk drive.

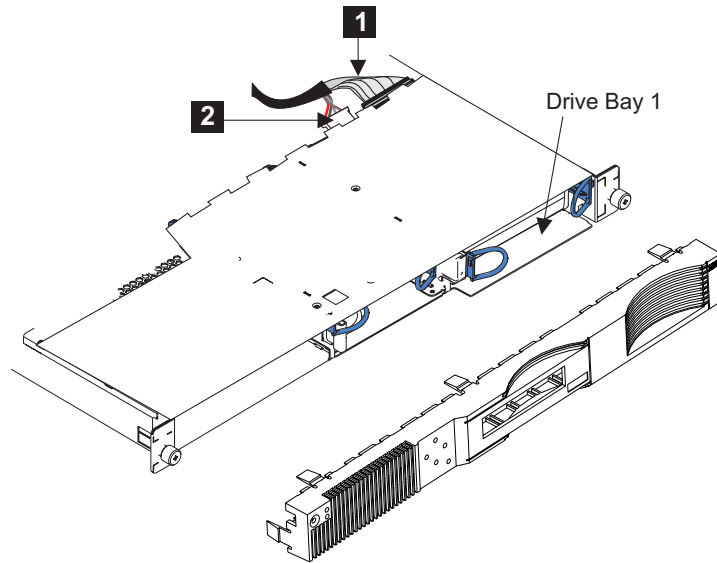

Figure 103. SAN Volume Controller 2145-4F2 disk drive and front panel

6. Remove the front panel.
7. Remove the service controller. See “Removing the service controller” on page 90.
8. Pull the two handles to release the latches, and pull the disk drive forward and out of the node.
9. If you are exchanging the disk drive for another, locate the rails and screws that are shipped with the new disk drive. Attach the rails to the disk drive, as shown in Figure 104.

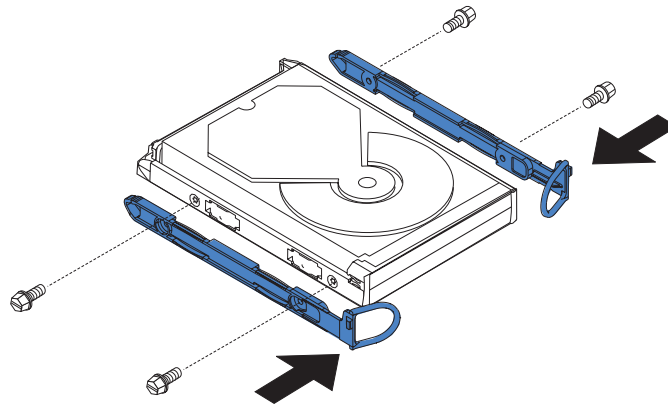

Figure 104. Attaching the rails to the SAN Volume Controller 2145-4F2 disk drive

10. Keep the disk drive that you removed if it has any jumpers installed, because you will need to set the same jumpers on the replacement disk drive.
If you have any tasks that you need to perform while the service controller is removed, do them now.

You can now replace the SAN Volume Controller 2145-4F2 disk drive.

Removing the SAS boot drive from the SAN Volume Controller 2145-CF8

You can remove the SAS boot drive from the SAN Volume Controller 2145-CF8.

DANGER

Multiple power cords. The product might be equipped with multiple power cords. To remove all hazardous voltages, disconnect all power cords.

This service action requires you to turn off the node.

To remove the SAN Volume Controller 2145-CF8 disk drive, perform the following steps:

1. Read the safety information to which “Preparing to remove and replace parts” on page 24 refers.
2. Follow the procedure in MAP 5350 in the *IBM System Storage SAN Volume Controller Troubleshooting Guide* to verify that the node data is mirrored and synchronized, and that there are no dependent virtual disks (VDisks) before turning off the node.
3. Slide the node out on its slide rails to the fully extended position.

Fast path: You can perform this service procedure with the node in place. Slide the node out six inches to verify that the cover is in place, then return the node to its locked position.

You can perform most service actions when the node is fully extended from the rack on its slide rails. You can leave the fibre-channel and Ethernet cables connected, if you are using the cable-management arm and if you are not removing the node from the rack. If the location of the node in the rack is too high or too low to work comfortably, you can remove the node from the rack.

4. Optional: If you must remove the node from the rack to work on it, perform the following procedure to remove all cables and remove the node from the rack:
 - a. Pull back the cable-management arm if you are working from the rear of the rack, or slide the node out of the rack to the fully extended rail position if you are working from the front.
 - b. When the node is completely turned off, remove the cable-retention brackets and disconnect the power cables, as described in “Removing the cable-retention bracket” on page 34.
 - c. To make sure that you can replace all cables in the same ports from which they were removed, label the port position of each fibre-channel and Ethernet cable; then remove all cables from the back of the node.
 - d. Remove the node from the rack and place it on a flat, static-protective surface. See “Removing the SAN Volume Controller from a rack” on page 48.
5. Make sure that the cover is in place and fully closed.

Attention: To avoid damage to the disk drive connectors, make sure that the cover is in place and fully closed whenever you install or remove the hard-disk drive.

6. Remove the service controller. See “Removing the service controller” on page 90.

You do not have to disconnect the service controller cable. You can suspend the service controller by its cable or rest the service controller on another surface while removing and replacing the drive.

7. Slide the orange release latch (**1** in Figure 105) gently to the left to unlock the drive handle of the boot drive in drive bay 4, which is the top, right drive bay.

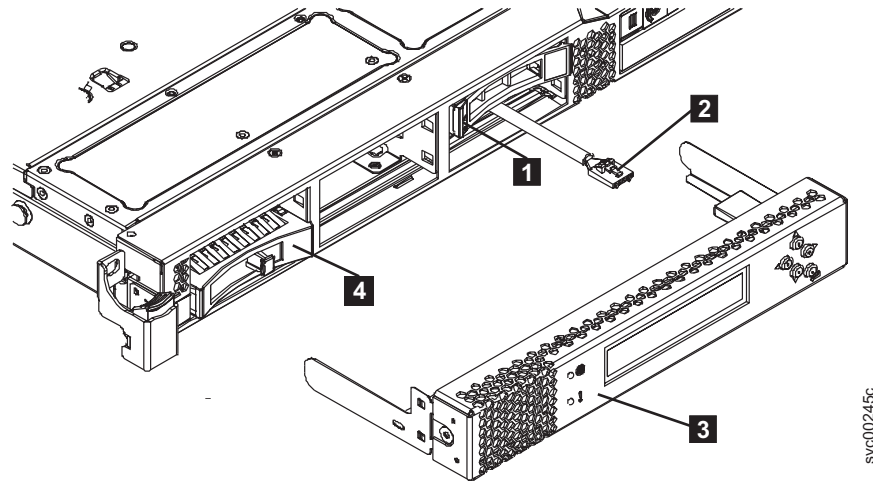

Figure 105. Boot drive for the SAN Volume Controller 2145-CF8

- 1** Boot-drive release latch (in drive bay 4)
 - 2** Service-controller USB cable (in drive bay 5)
 - 3** Service controller
 - 4** Drive bay filler panel (shown in drive bay 1, but also in all other unused drive bays)
8. Grasp the open drive handle and slide the drive out of the drive bay.

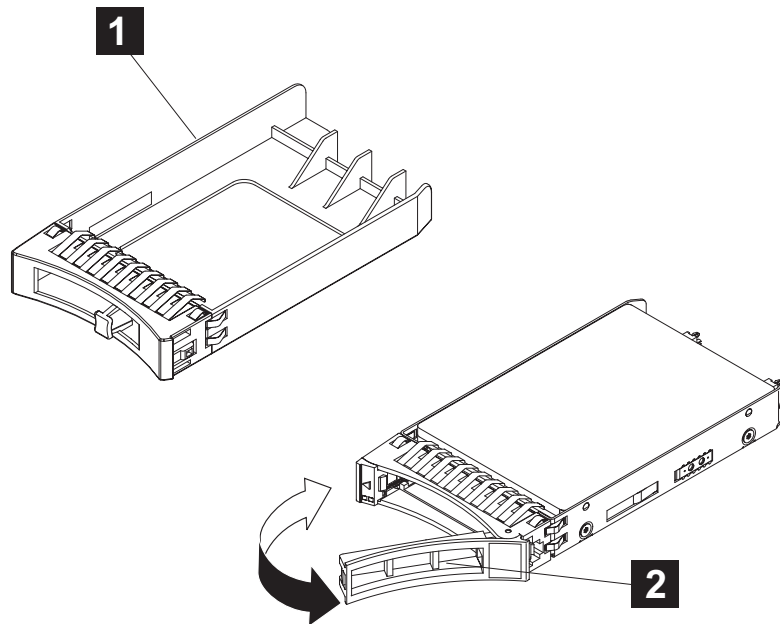

Figure 106. Drive-bay filler panel and disk-drive handle for the SAN Volume Controller 2145-CF8

- 1** Drive bay blank EMC filler assembly (used in all empty drive bays)

2 Handle of SAS disk drive

9. If you are instructed to return the drive assembly, follow all packaging instructions, and use any packaging materials for shipping that are supplied to you.

IDs for SAN Volume Controller 2145-CF8 disk drives

The hot-swap-drive ID that is assigned to each drive is printed on the front of the node, but is covered by the service controller.

Figure 107 shows the location of the disk drives by drive ID. The ID numbers and the drive-bay numbers are the same.

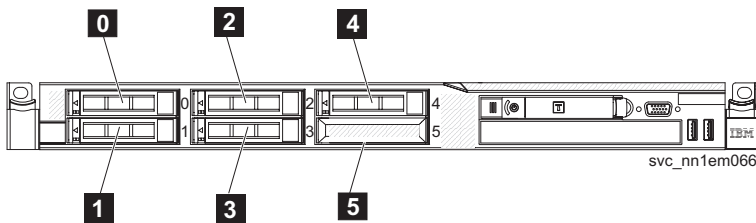

Figure 107. Drive IDs for SAN Volume Controller 2145-CF8

- 0 Drive bay 0
- 1 Drive bay 1
- 2 Drive bay 2
- 3 Drive bay 3
- 4 Drive bay 4 (reserved for the node boot disk)
- 5 Drive bay 5 (reserved for service controller)

Removing the SATA disk drive for the SAN Volume Controller 2145-8A4 and the SAN Volume Controller 2145-8G4

This topic describes how to remove the SATA disk drive for the SAN Volume Controller 2145-8A4 and the SAN Volume Controller 2145-8G4.

You can remove the disk drive after you shut down the node.

To remove the SAN Volume Controller 2145-8A4 or the SAN Volume Controller 2145-8G4 disk drive, perform the following steps:

1. Make sure that the cover is in place and fully closed.
Attention: To avoid damage to the hard disk drive connectors, make sure that the cover is in place and fully closed whenever you install or remove a hard disk drive.
2. Turn off the node while ensuring that its data is mirrored and synchronized. See MAP 5350 in the *IBM System Storage SAN Volume Controller Troubleshooting Guide* for more information.
3. Remove the cable-retention bracket and disconnect the power cable from the node. See “Removing the cable-retention bracket” on page 34.
4. Remove the service controller. See “Removing the service controller” on page 90.
5. Pull the loops of the drive tray (shown in Figure 108 on page 125) toward each other and pull the tray out of the bay.



Figure 108. SAN Volume Controller 2145-8A4 SATA disk drive

Removing the SAN Volume Controller 2145-8F4 or SAN Volume Controller 2145-8F2 SATA disk drive

You can remove the disk drive after you shut down the node.

To remove the SAN Volume Controller 2145-8F4 or SAN Volume Controller 2145-8F2 disk drive, perform the following steps:

1. Turn off the node while ensuring that its data is mirrored and synchronized. See MAP 5350 in the *IBM System Storage SAN Volume Controller Troubleshooting Guide* for more information.
2. Remove the SAN Volume Controller 2145-8F4 cable retention bracket.
3. To make sure that you can replace all cables in the same ports from which they were removed, record the position of all fibre-channel and Ethernet cables; then remove all cables from the back of the node.
4. Remove the node from the rack and place it on a flat, static-protective surface. See “Removing the SAN Volume Controller from a rack” on page 48.
5. Open fan door A (1 in Figure 109 on page 126).
6. Remove the service controller. See “Removing the service controller” on page 90.
7. Pull the disk drive out of the bay.

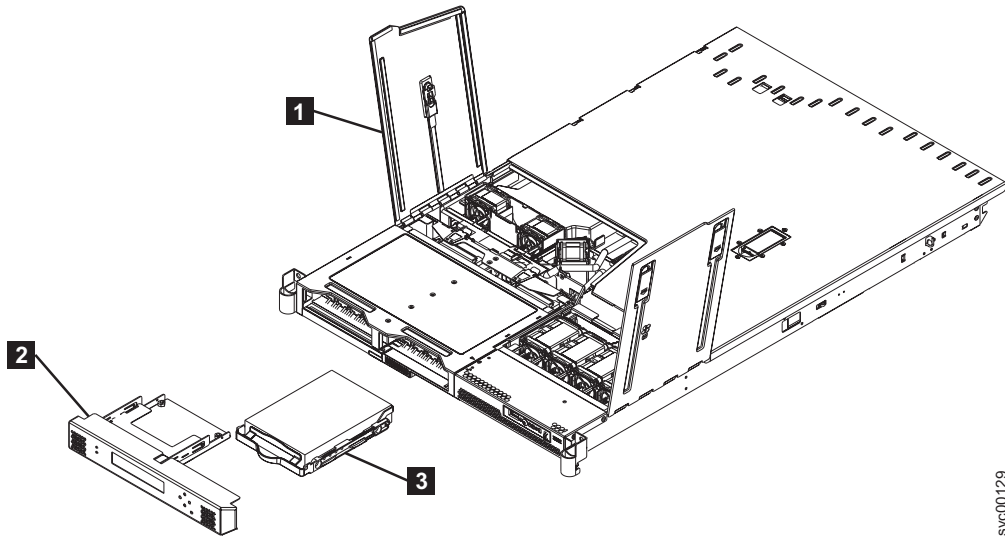

svc00129

Figure 109. Removing the SATA disk drive

- 1** Fan door A
- 2** Service controller
- 3** SATA disk drive

You can now replace the SAN Volume Controller 2145-8F4 or SAN Volume Controller 2145-8F2 disk drive.

Replacing the disk drive

You might have to replace the disk drive for a service action.

Related tasks

“Removing the disk drive” on page 118

You might have to remove the disk drive for a service action.

“Replacing the top cover” on page 86

You must replace the top cover on the SAN Volume Controller node after maintenance is completed.

“Replacing the service controller” on page 102

You can replace the SAN Volume Controller service controller.

“Replacing the SAN Volume Controller in a rack” on page 59

You must use caution when you replace the SAN Volume Controller in a rack.

“Replacing the disk-drive backplane” on page 143

You might have to replace the disk-drive backplane, which includes the simple-swap SAS backplane in the SAN Volume Controller 2145-CF8 or the hot-swap SATA backplane for a SAN Volume Controller 2145-8A4 or SAN Volume Controller 2145-8G4.

Replacing the SAN Volume Controller 2145-CF8 SAS boot drive

You can replace the serial attached SCSI (SAS) boot drive for the SAN Volume Controller 2145-CF8 node.

DANGER

Multiple power cords. The product might be equipped with multiple power cords. To remove all hazardous voltages, disconnect all power cords.

The following notes describe information that you must consider when you install a hard-disk drive.

- Locate the documentation that comes with the disk drive and follow those instructions in addition to the instructions in this topic.
- Make sure that you have all the cables and other equipment that are specified in the documentation that comes with the drive.
- Install the boot drive in drive bay 4. Drive bays 0,1,2, and 3 are available for solid-state drives (SSDs).
- Check the instructions that come with the drive to determine whether you have to set any switches or jumpers on the drive. Set the SAS ID for the device, if necessary.

To replace a SAN Volume Controller 2145-CF8 disk drive, perform the following steps:

1. Read the safety information to which “Preparing to remove and replace parts” on page 24 refers.
2. Make sure that the node cover is in place and fully closed.
Attention: To avoid damage to the disk-drive connectors, make sure that the node cover is in place and fully closed whenever you remove or replace a disk drive.
3. Touch the static-protective package that contains the drive to any unpainted metal surface on the node; then, remove the drive from the package and place it on a static-protective surface.
4. Make sure that the disk-drive handle is in the open (unlocked) position.

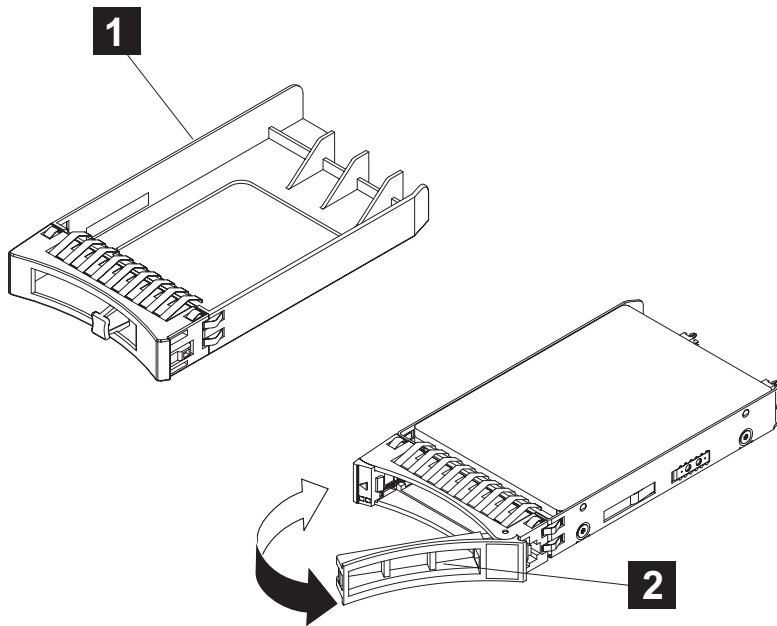

Figure 110. Drive-bay filler panel and disk-drive handle for the SAN Volume Controller 2145-CF8

- 1** Drive bay filler panel (used in all empty drive bays)
 - 2** SAS disk drive with handle extended
5. Align the drive assembly with the guide rails in drive bay 4, which is the top bay on the right of the node when viewed from the front.
 6. Gently push the drive assembly into the bay until the drive stops.
 7. Rotate the tray handle to the closed (locked) position.
 8. Install the service controller. See “Replacing the service controller” on page 102.
 9. If you removed the node from the rack, replace the node in the rack, as described in “Replacing the SAN Volume Controller in a rack” on page 59.
 10. Make sure that all cables, adapters, and other components are installed and seated correctly and that you have not left loose tools or parts inside the node. Make sure that all internal cables are correctly routed. If you disconnected the fibre-channel and Ethernet cables, make sure that each cable is reconnected to the same port from which it was removed.
 11. If you removed the power cords, replace the power cords and the cable-retention brackets, as described in “Replacing the cable-retention bracket” on page 40.
 12. Lift the locking levers (**1** in Figure 111 on page 129) on the slide rails and push the server **2** all the way into the rack until it clicks into place.

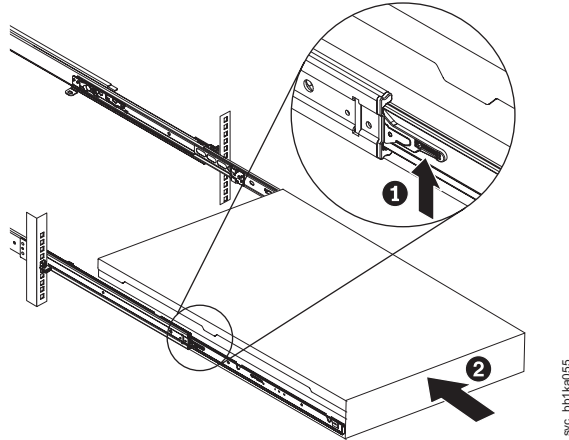

Figure 111. Raising the SAN Volume Controller 2145-CF8 locking levers of the slide rails of the rack

13. Turn on the node. When you turn on the node, use the node rescue procedure to install the SAN Volume Controller software on the new disk. Then add the node back into the cluster. See "Performing the node rescue" in the *IBM System Storage SAN Volume Controller Troubleshooting Guide*.

Note: If you must replace the hard disk and the service controller at the same time, you might not be able to start the node to perform node rescue. See "Replacing a disk drive and a service controller on the SAN Volume Controller" on page 110.

Replacing the SAN Volume Controller 2145-8A4 and the SAN Volume Controller 2145-8G4 SATA disk drive

This topic describes how to replace the SATA disk drive for the SAN Volume Controller 2145-8A4 and the SAN Volume Controller 2145-8G4 nodes.

You can replace the SATA (serial advanced technology attachment) disk drive after you remove the existing disk drive.

To replace the SAN Volume Controller 2145-8A4 and the SAN Volume Controller 2145-8G4 disk drive, perform the following steps:

1. Make sure that the node cover is in place and fully closed.

Attention: To avoid damage to the hard disk drive connectors, make sure that the node cover is in place and fully closed whenever you remove or replace a hard disk drive.

2. Find the rails assembly and screws that are shipped with the new disk drive. Attach the rails assembly to the disk drive with four screws, as shown in Figure 112 on page 130, using two on each side of the disk.



Figure 112. Attaching the rails assembly to the SATA disk drive for the SAN Volume Controller 2145-8A4 and the SAN Volume Controller 2145-8G4

3. Pull the loops of the rails toward each other and slide the drive into the node until the drive connects to the backplate.
4. Release the loops of the drive tray.
5. Install the service controller. See “Replacing the service controller” on page 102.
6. Reconnect the power cords and the fibre-channel and Ethernet cables. Ensure that you replace the fibre-channel and Ethernet cables in the same ports from which they were removed.
7. Turn on the node. When you turn on the node, use the node rescue procedure to install the SAN Volume Controller software on the new disk. Then add the node back into the cluster. See “Performing the node rescue” in the *IBM System Storage SAN Volume Controller Troubleshooting Guide*.

Note: If you must replace the hard disk and the service controller at the same time, you cannot start the node to perform node rescue. See “Replacing a disk drive and a service controller on the SAN Volume Controller” on page 110.

Replacing the SAN Volume Controller 2145-8F4 or SAN Volume Controller 2145-8F2 SATA disk drive

This topic describes how to replace the SATA (serial advanced technology attachment) disk drive for the SAN Volume Controller 2145-8F2 and the SAN Volume Controller 2145-8F4 nodes.

The SAN Volume Controller 2145-8F4 or SAN Volume Controller 2145-8F2 SATA disk drive can be replaced after you remove the existing disk drive.

To replace the SAN Volume Controller 2145-8F4 or SAN Volume Controller 2145-8F2 disk drive, perform the following steps:

1. Slide the disk drive into the bay until the rear of the drive snaps into place with the rear panel-mount connector.
2. Install the service controller. See “Replacing the service controller” on page 102.

3. Place the node in the rack. See “Replacing the SAN Volume Controller in a rack” on page 59.
4. Reconnect the power cords and the fibre-channel and Ethernet cables. Ensure that you replace the fibre-channel and Ethernet cables in the same ports from which they were removed.
5. Turn on the node. When you turn on the node, use the node rescue procedure to install the SAN Volume Controller software on the new disk. Then add the node back into the cluster. See “Performing the node rescue” in the *IBM System Storage SAN Volume Controller Troubleshooting Guide*.

Note: If you must replace the hard disk and the service controller at the same time, you cannot start the node to perform node rescue. See “Replacing a disk drive and a service controller on the SAN Volume Controller” on page 110.

Removing a solid-state drive (SSD)

You can remove solid-state drives (SSDs) in the SAN Volume Controller 2145-CF8.

Removing a SAN Volume Controller 2145-CF8 solid-state drive (SSD)

You can remove an installed solid-state drive (SSD) from a SAN Volume Controller 2145-CF8 node.

DANGER

Multiple power cords. The product might be equipped with multiple power cords. To remove all hazardous voltages, disconnect all power cords.

If you are installing a high-speed SAS adapter (feature code 4500) and one or more solid-state drives (SSDs) (feature code 4601), use the instructions that come with each MES upgrade to install and configure the high-speed SAS adapter and each solid-state drive (SSD).

This topic describes how to remove a solid-state drive (SSD) that was installed and configured, but that must now be removed from a SAN Volume Controller 2145-CF8 node.

The SAN Volume Controller 2145-CF8 node supports from one to four optional 2.5-inch SSDs in addition to the one required boot drive that ships with the node.

You do not have to turn off the node to perform this service action. You can leave the node turned on, the power cords connected, and the data cables connected to perform this service action from the fully extended rail position.

Although you do not have to turn off the node, SSDs require some planning before you can simply swap one drive for another.

See MAP 5350 in the *IBM System Storage SAN Volume Controller Troubleshooting Guide* for information about ensuring that data is mirrored and synchronized, and that there are no dependent virtual disks (VDisks) on the node before removing an SSD, whether you are turning off the node or swapping the drive while the node is turned on.

To remove the SAN Volume Controller 2145-CF8 solid-state drive (SSD), perform the following steps:

1. Read the safety information to which “Preparing to remove and replace parts” on page 24 refers.
2. Slide the node out on its slide rails to the fully extended position.

Fast path: You can perform this service procedure with the node in place. Slide the node out six inches to verify that the cover is in place, then return the node to its locked position.

You can perform most service actions when the node is fully extended from the rack on its slide rails. If the location of the node in the rack is too high or too low to work comfortably, you can remove the node from the rack.

3. Optional: If you must remove the node from the rack to work on it, perform the following procedure to turn off the node, remove all cables, and remove the node from the rack:
 - a. Follow the procedure in MAP 5350 in the *IBM System Storage SAN Volume Controller Troubleshooting Guide* to verify that the node data is mirrored and synchronized, and that there are no dependent virtual disks (VDisks) before turning off the node.
 - b. Pull back the cable-management arm if you are working from the rear of the rack, or slide the node out of the rack to the fully extended rail position if you are working from the front.
 - c. When the node is completely turned off, remove the cable-retention brackets and disconnect the power cables, as described in “Removing the cable-retention bracket” on page 34.
 - d. To make sure that you can replace all cables in the same ports from which they were removed, label the port position of each fibre-channel and Ethernet cable; then remove all cables from the back of the node.
 - e. Remove the node from the rack and place it on a flat, static-protective surface. See “Removing the SAN Volume Controller from a rack” on page 48.
4. Make sure that the node top cover is in place and fully closed.

Attention: To avoid damage to the disk drive connectors, make sure that the node cover is in place and fully closed whenever you remove or replace a disk drive.

5. If the service controller (**1** in Figure 113 on page 133) is in place, press the release buttons (**2**) on each side of the service controller assembly to release the service controller from the node, but do not disconnect the USB service controller cable. Slide the service controller from the node and support it somewhere, if possible, or gently suspend the service controller from the service controller cable.

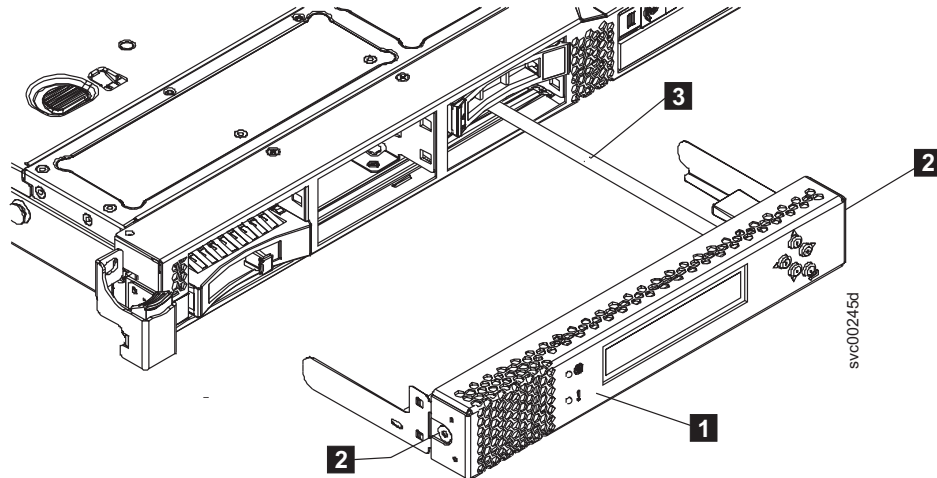

Figure 113. Service controller for the SAN Volume Controller 2145-CF8 with attached USB cable

- 1** Service controller
- 2** Service-controller release buttons
- 3** Service controller USB cable

6. Remove the drive from the drive bay:
 - a. Slide the orange release latch at the left end of the handle gently to the left to unlock the drive handle.
 - b. Rotate the drive handle to the open (unlocked) position, as shown in Figure 114.
 - c. Gently slide out the drive assembly along the guide rails until the drive is free of the drive bay.

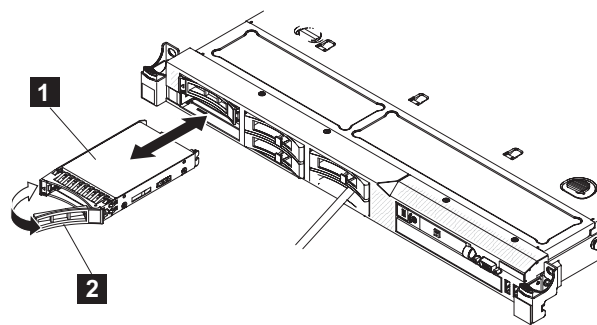

Figure 114. Solid-state drive (SSD) for the SAN Volume Controller 2145-CF8

- 1** Solid-state drive (SSD)
- 2** Drive handle

The system error LED and the DASD diagnostics panel LED turn on when a solid-state drive (SSD) is removed from a drive bay. The system error LED and the DASD diagnostics panel LED turn off when the SSD is replaced in the drive bay. If you do not replace the SSD in the same drive bay, the system error LED and the DASD diagnostics panel LED remain lit. To clear the system error LED and the DASD diagnostics panel LED, turn

off the node using the instructions given in MAP 5350 in the *IBM System Storage SAN Volume Controller Troubleshooting Guide* and remove both power cables.

7. If you are not replacing the drive right away, install a drive-bay blank electromagnetic compatibility (EMC) filler assembly into the empty drive bay. The electromagnetic interference (EMI) integrity and cooling of the node are protected by having all bays and PCI slots covered or occupied. When you install a drive, save the drive bay blank EMC filler assembly from the drive bay to cover any later removal of the device.
8. If you are removing additional hot-swap solid-state drives (SSDs), do so now.
9. If you are replacing drives, replace them now, as described in “Replacing a SAN Volume Controller 2145-CF8 solid-state drive (SSD).”
10. If you are instructed to return the drive assembly, follow all packaging instructions, and use any packaging materials for shipping that are supplied to you.

Replacing a solid-state drive (SSD)

You can replace solid-state drives (SSDs) in the SAN Volume Controller 2145-CF8.

Replacing a SAN Volume Controller 2145-CF8 solid-state drive (SSD)

You can replace an installed solid-state drive (SSD) on a SAN Volume Controller 2145-CF8 node.

If you are installing a high-speed SAS adapter (feature code 4500) and one or more solid-state drives (SSDs) (feature code 4601), use the instructions that come with each MES upgrade to install and configure the high-speed SAS adapter and each solid-state drive (SSD).

This procedure describes how to replace a solid-state drive (SSD) that was installed and configured, but then removed.

The SAN Volume Controller 2145-CF8 node supports from one to four 2.5-inch SSDs in addition to the required boot drive that ships with the node.

To replace the SAN Volume Controller 2145-CF8 disk drive, perform the following steps:

1. Read the safety information to which “Preparing to remove and replace parts” on page 24 refers.
2. Make sure that the node cover is in place and fully closed.
Attention: To avoid damage to the disk-drive connectors, make sure that the node cover is in place and fully closed whenever you remove or replace a disk drive.
3. If the service controller is in place, press the release button on the side of the service controller assembly to release it from the node, but do not disconnect the USB service controller cable. Slide the service controller from the node and support it somewhere, if possible, or gently suspend the service controller from the service controller cable.
4. If the drive bay contains a drive-bay blank electromagnetic compatibility (EMC) filler assembly, remove the filler from the drive bay.
The electromagnetic interference (EMI) integrity and cooling of the node are protected by having all bays and PCI slots covered or occupied. When you

install a drive, save the drive bay blank EMC filler assembly from the drive bay to cover any later removal of the device.

5. Touch the static-protective package that contains a new drive to any unpainted metal surface on the node; then, remove the drive from the package and place it on a static-protective surface.
6. Install the drive in the drive bay:
 - a. Make sure that the tray handle is in the open (unlocked) position.
 - b. Align the drive assembly with the guide rails in the bay, as shown in Figure 115.

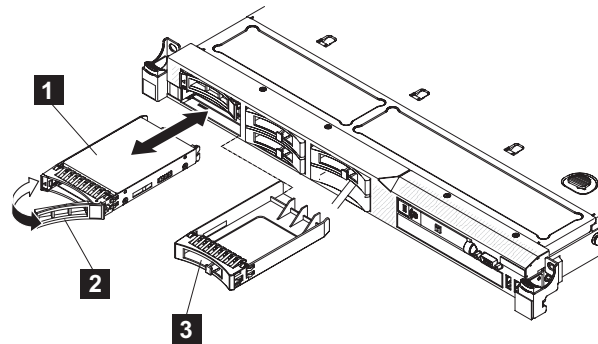

Figure 115. SAN Volume Controller 2145-CF8 drive and drive-bay filler

1 Solid-state drive (SSD)

2 Drive handle

3 Drive-bay blank electromagnetic compatibility (EMC) filler assembly

- c. Gently push the drive assembly into the bay until the drive stops.
- d. Rotate the tray handle to the closed (locked) position.

The system error LED and the DAsD diagnostics panel LED turn on when a solid-state drive (SSD) is removed from a drive bay. The system error LED and the DAsD diagnostics panel LED turn off when the SSD is replaced in the drive bay. If you do not replace the SSD in the same drive bay, the system error LED and the DAsD diagnostics panel LED remain lit. To clear the system error LED and the DAsD diagnostics panel LED, turn off the node using the instructions given in MAP 5350 in the *IBM System Storage SAN Volume Controller Troubleshooting Guide* and remove both power cables.

7. If you are installing additional hot-swap solid-state drives (SSDs), do so now.
8. Install the service controller. See “Replacing the service controller” on page 102.
9. If you removed the node from the rack, replace the node in the rack, as described in “Replacing the SAN Volume Controller in a rack” on page 59.
10. Make sure that all cables, adapters, and other components are installed and seated correctly and that you have not left loose tools or parts inside the node. Make sure that all internal cables are correctly routed. If you disconnected the fibre-channel and Ethernet cables, make sure that each cable is reconnected to the same port from which it was removed.
11. If you removed the power cords, replace the power cords and the cable-retention brackets, as described in “Replacing the cable-retention bracket” on page 40.
12. Lift the locking levers (**1** in Figure 116 on page 136) on the slide rails and push the server **2** all the way into the rack until it clicks into place.

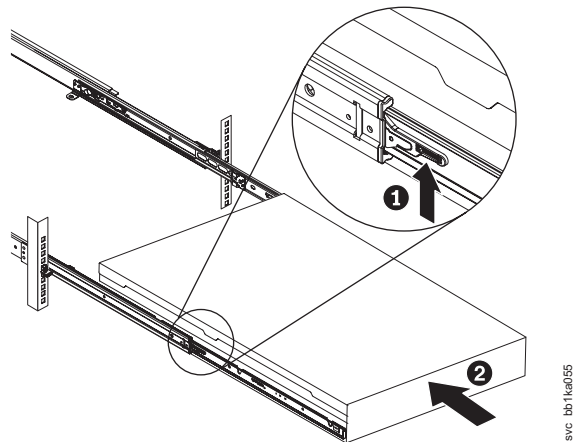

Figure 116. Raising the SAN Volume Controller 2145-CF8 locking levers of the slide rails of the rack

13. If you turned off the node during the service procedure, turn on the node.

Removing the disk-drive backplane

You might have to remove the disk-drive backplane, which includes the simple-swap SAS back plate in the SAN Volume Controller 2145-CF8 or the SATA back plate for a SAN Volume Controller 2145-8A4 or SAN Volume Controller 2145-8G4.

Related tasks

“Replacing the disk-drive backplane” on page 143

You might have to replace the disk-drive backplane, which includes the simple-swap SAS backplane in the SAN Volume Controller 2145-CF8 or the hot-swap SATA backplane for a SAN Volume Controller 2145-8A4 or SAN Volume Controller 2145-8G4.

“Removing the SAN Volume Controller from a rack” on page 48

During some service procedures, you might need to remove the SAN Volume Controller from a rack.

“Removing the service controller” on page 90

You can remove the service controller from the SAN Volume Controller.

“Removing the disk drive” on page 118

You might have to remove the disk drive for a service action.

Removing the SAN Volume Controller 2145-CF8 disk-drive backplane

Use the following information to remove the SAN Volume Controller 2145-CF8 disk-drive backplane.

DANGER

Multiple power cords. The product might be equipped with multiple power cords. To remove all hazardous voltages, disconnect all power cords.

This service action requires you to remove the cover and:

- Turn the node off.
- Disconnect the power cables.

- Disconnect the internal SAS data cables.

To remove the SAN Volume Controller 2145-CF8 disk-drive backplane, complete the following steps:

1. Read the safety information to which “Preparing to remove and replace parts” on page 24 refers.
2. Follow the procedure in MAP 5350 in the *IBM System Storage SAN Volume Controller Troubleshooting Guide* to verify that the node data is mirrored and synchronized, and that there are no dependent virtual disks (VDisks) before turning off the node.
3. Slide the node out on its slide rails to the fully extended position.
4. When the node is completely turned off, remove the cable-retention brackets and disconnect the power cables, as described in “Removing the cable-retention bracket” on page 34.
5. Optional: To make sure that you can replace all cables in the same ports from which they were removed, label the port position of each fibre-channel and Ethernet cable; then remove all cables from the back of the node.
You can leave the fibre-channel and Ethernet cables connected, if you are using the cable-management arm and if you are not removing the node from the rack.
6. Optional: Remove the node from the rack and place it on a flat, static-protective surface. See “Removing the SAN Volume Controller from a rack” on page 48.
You can perform most service actions when the node is fully extended from the rack on its slide rails. If the location of the node in the rack is too high or too low to work comfortably, you can remove the node from the rack.
7. Remove the service controller. See “Removing the service controller” on page 90.
8. Pull the disk drives and filler panels out of the node slightly to disengage them from the back plate. See “Removing the disk drive” on page 118.
9. Remove the top cover. See “Removing the top cover” on page 81.
10. Remove fans 4, 5, and 6, as described in “Removing the SAN Volume Controller 2145-CF8 fans” on page 245.
11. Disconnect all cables from the disk-drive backplane.

Note: You can also choose to disconnect the cables after removing the backplane from the brackets, if that is easier for you.

The high-speed SAS cable and the boot-disk SAS cable are shown in Figure 117 on page 138.

The boot-disk cable is shown after disconnecting the cable from the disk controller so that you can see the connectors more clearly.

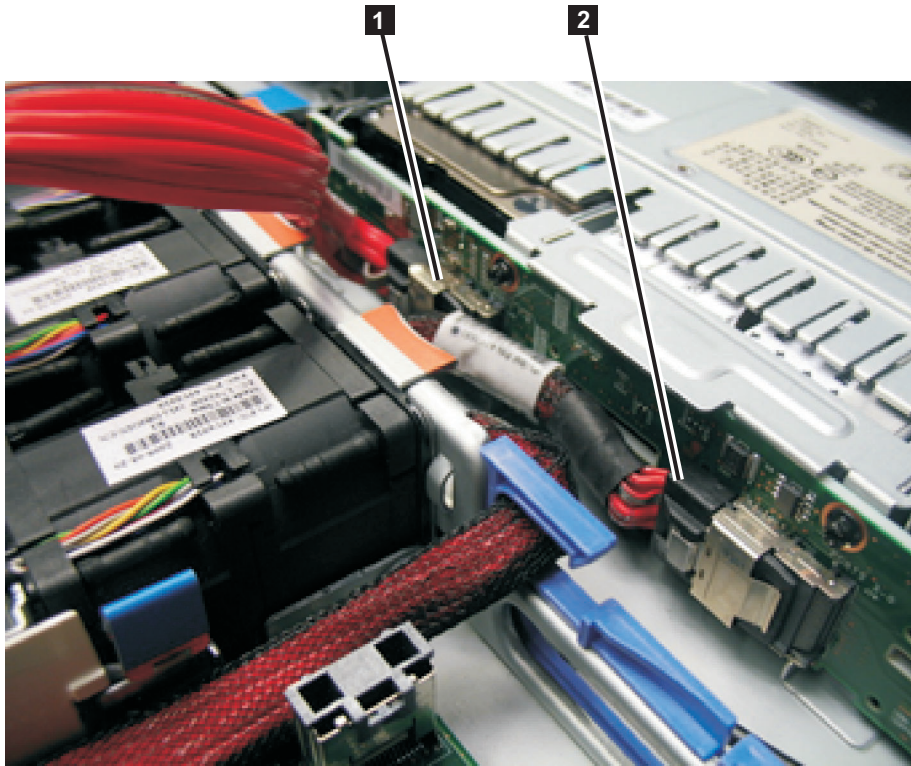

Figure 117. Boot-disk SAS cable and the high-speed SAS cable connected to the disk backplane in the SAN Volume Controller 2145-CF8

- 1** Boot-disk SAS cable that is plugged into the disk-drive backplane to support drive bay 4
 - 2** High-speed SAS-adapter cable that is plugged into the middle of the backplane to support drive bays 0, 1, 2, and 3
12. Lift up the disk-drive backplane (**1** in Figure 118 on page 139) to disengage the backplane tabs (**2**) from the slots (**3**) on the backplane bracket; then, push the backplane backwards until it is clear of the slots on the bracket and remove it from the node.

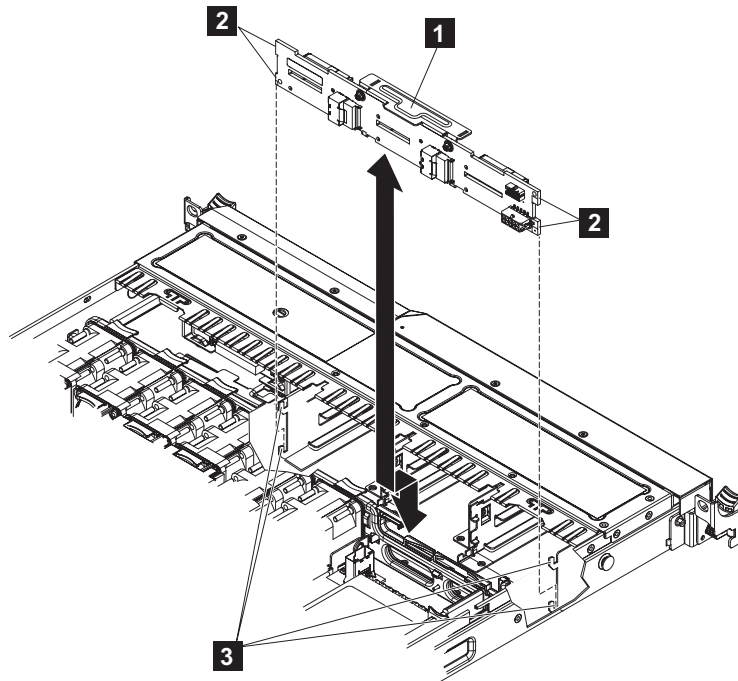

Figure 118. The SAN Volume Controller 2145-CF8 disk backplane

- 1** Disk-drive backplane
- 2** Backplane tabs
- 3** Backplane-bracket slots

13. If you are instructed to return the disk-drive backplane, follow all packaging instructions, and use any packaging materials for shipping that are supplied to you.

Removing the SAN Volume Controller 2145-8A4 disk-drive backplane

Use the following information to remove the SAN Volume Controller 2145-8A4 disk-drive backplane.

To remove the SAN Volume Controller 2145-8A4 disk-drive backplane, including the SATA back plate, complete the following steps.

1. Read the safety precautions in “Safety and environmental notices” on page xvii.
2. Turn off the node while ensuring that its data is mirrored and synchronized. See MAP 5350 in the *IBM System Storage SAN Volume Controller Troubleshooting Guide* for more information.
3. Remove the cable-retention bracket and disconnect the power cable from the node. See “Removing the cable-retention bracket” on page 34.
4. Remove the node from the rack and place it on a flat, static-protective surface. See “Removing the SAN Volume Controller from a rack” on page 48.
5. Remove the service controller. See “Removing the service controller” on page 90.
6. Pull the hard disk drive out of the node slightly to disengage it from the back plate.
7. Remove the top cover. See “Removing the top cover” on page 81.

8. Notice where the two SATA cables that are connected to the back plate are connected to the system board, as shown in Figure 119. Then disconnect the two SATA cables from the system board.

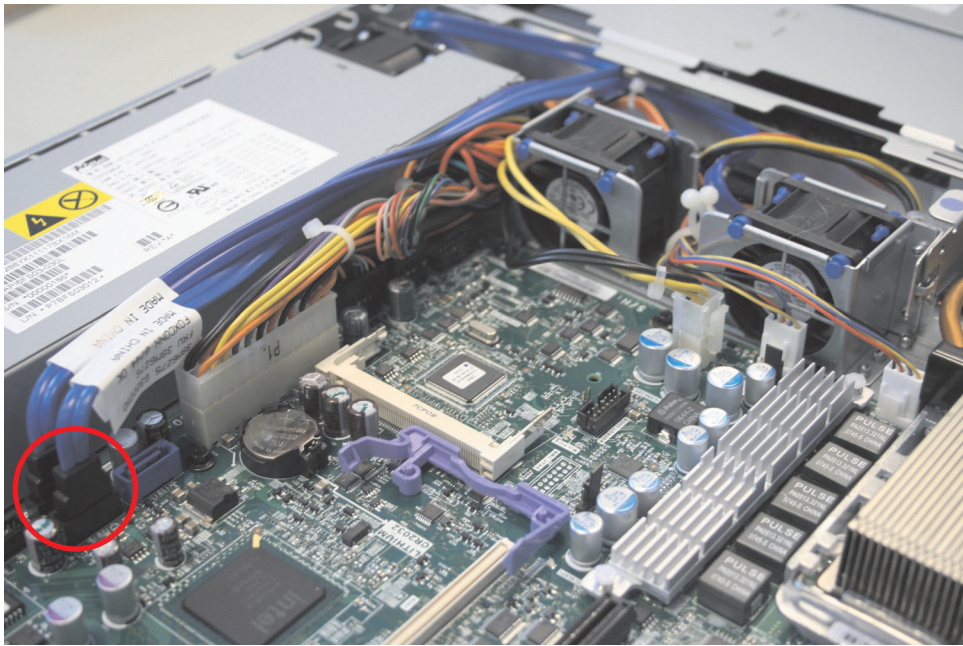

Figure 119. SAN Volume Controller 2145-8A4 SATA cable connectors

9. Rotate (lift) the air deflector **1** out of the way, as shown in Figure 120.

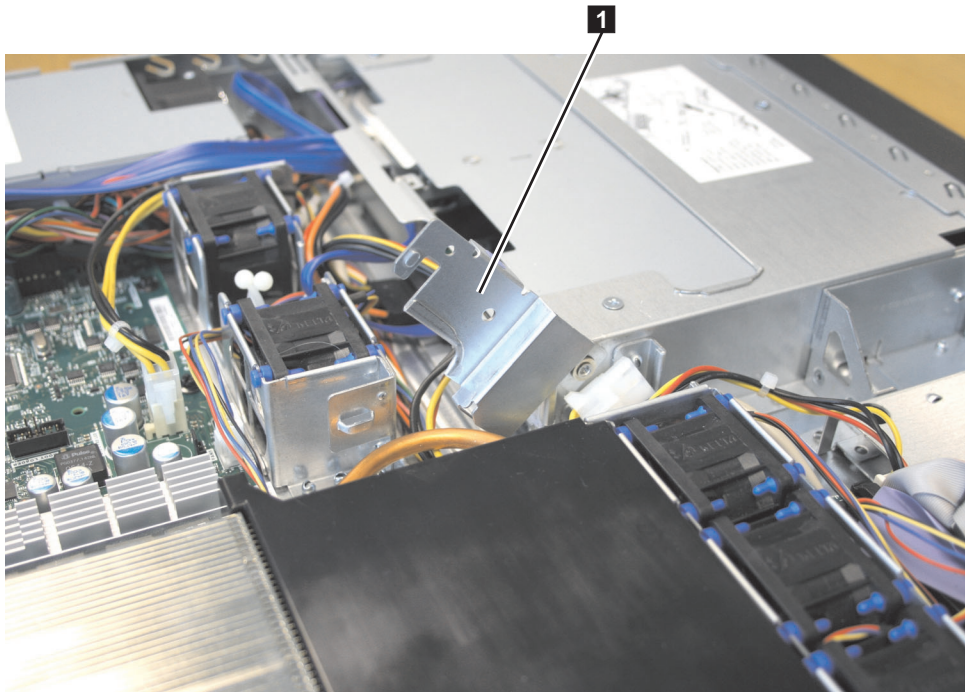

Figure 120. Air deflector for the SAN Volume Controller 2145-8A4 power supply

10. Slightly lift the back plate out of the node. Disconnect power cable connectors P2 **1** and P3 **2**, shown in Figure 121, and remove the back plate.

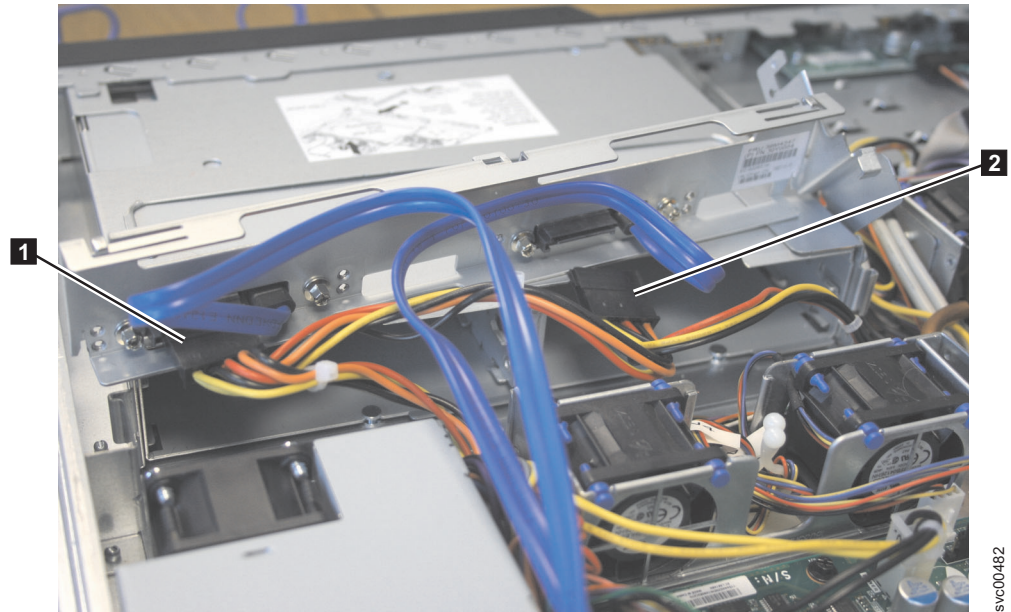

Figure 121. SAN Volume Controller 2145-8A4 power supply connectors

Removing the SAN Volume Controller 2145-8G4 disk-drive backplane

Use the following information to remove the SAN Volume Controller 2145-8G4 disk-drive backplane.

To remove the SAN Volume Controller 2145-8G4 disk-drive backplane, including the SATA back plate, complete the following steps:

1. Read the safety precautions in “Safety and environmental notices” on page xvii.
2. Turn off the node while ensuring that its data is mirrored and synchronized. See MAP 5350 in the *IBM System Storage SAN Volume Controller Troubleshooting Guide* for more information.
3. Remove the cable-retention bracket and disconnect the power cable from the node. See “Removing the cable-retention bracket” on page 34.
4. Remove the node from the rack and place it on a flat, static-protective surface. See “Removing the SAN Volume Controller from a rack” on page 48.
5. Remove the service controller. See “Removing the service controller” on page 90.
6. Pull the hard disk drive out of the node slightly to disengage it from the back plate.
7. Remove the top cover. See “Removing the top cover” on page 81.
8. Disconnect the two blue signal cables from the system board, shown in Figure 122 on page 142, and disconnect the power cable from the power supply backplane card.

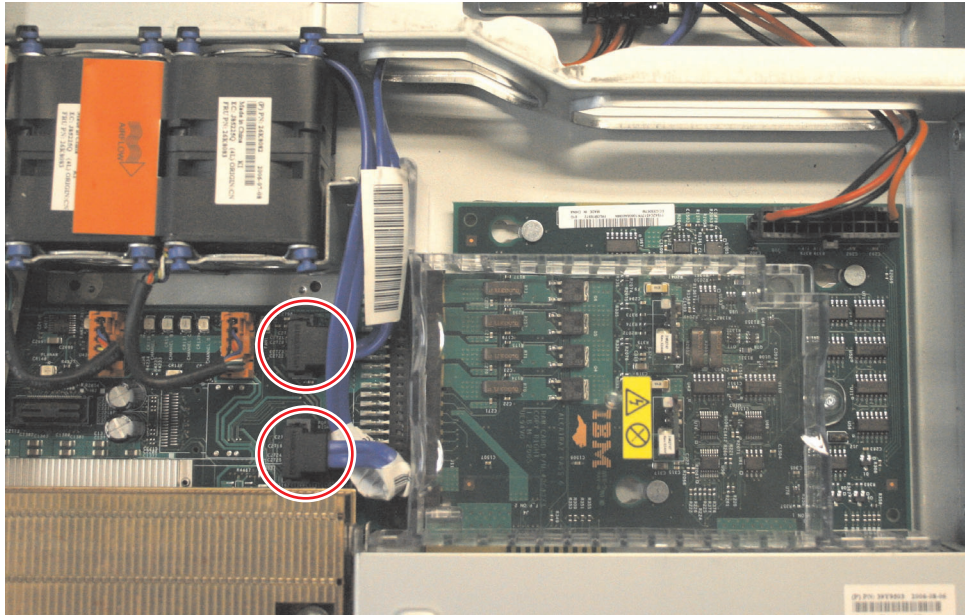

Figure 122. The SAN Volume Controller 2145-8G4 disk-drive backplane connectors

9. Press the locking tab **1**, which is shown in Figure 123, and lift the back plate out of the node slightly. Disconnect the power cable and remove the back plate.

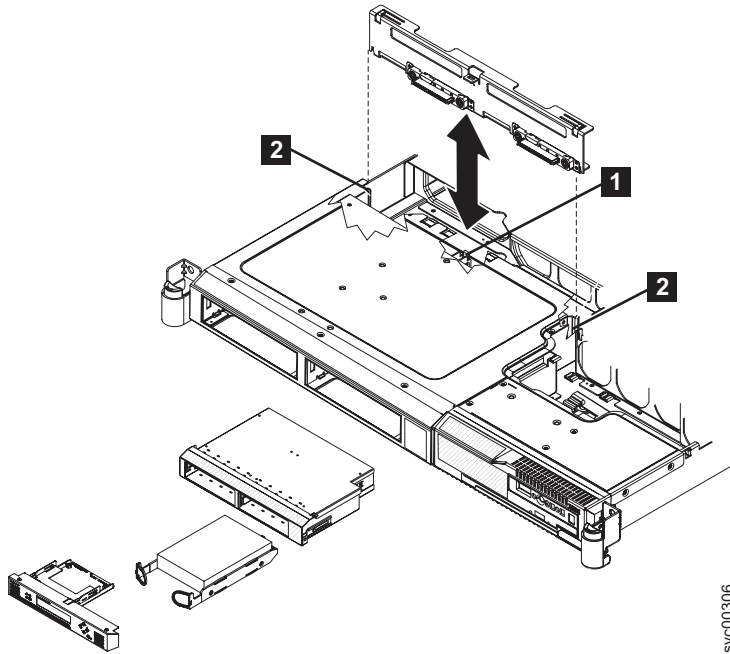

Figure 123. The SAN Volume Controller 2145-8G4 SATA disk drive and back plate

- 1** Locking tab
- 2** Mounting channel

Replacing the disk-drive backplane

You might have to replace the disk-drive backplane, which includes the simple-swap SAS backplane in the SAN Volume Controller 2145-CF8 or the hot-swap SATA backplane for a SAN Volume Controller 2145-8A4 or SAN Volume Controller 2145-8G4.

Related tasks

“Removing the disk-drive backplane” on page 136

You might have to remove the disk-drive backplane, which includes the simple-swap SAS back plate in the SAN Volume Controller 2145-CF8 or the SATA back plate for a SAN Volume Controller 2145-8A4 or SAN Volume Controller 2145-8G4.

“Replacing the SAN Volume Controller in a rack” on page 59

You must use caution when you replace the SAN Volume Controller in a rack.

“Replacing the service controller” on page 102

You can replace the SAN Volume Controller service controller.

“Replacing the disk drive” on page 126

You might have to replace the disk drive for a service action.

Replacing the SAN Volume Controller 2145-CF8 disk-drive backplane

You can replace the SAN Volume Controller 2145-CF8 disk-drive backplane, which includes the SAS back plate.

DANGER

Multiple power cords. The product might be equipped with multiple power cords. To remove all hazardous voltages, disconnect all power cords.

To replace the SAN Volume Controller 2145-CF8 disk-drive backplane, complete the following steps:

1. Align the tabs on the disk-drive backplane with the slots on the backplane bracket.
2. Insert the disk-drive backplane tabs into slots on the backplane bracket and push the disk-drive backplane down until the backplane is fully seated and the tabs locked in place.

You can reconnect the boot-disk cable to the connector on the left side (when viewed from the rear) of the back of the disk-drive backplane before installing the backplane onto the brackets, or you can connect the cable after you install the backplane, if that is easier for you.

The other end of this cable attaches to the disk-controller and USB riser card assembly, as shown in Figure 125 on page 145.

If you are using solid-state drives (SSDs), you can connect the labelled end of the high-speed SAS cable to the connector in the middle of the back of the disk-drive backplane. The other end of this cable attaches to the high-speed SAS adapter at the rear of the node.

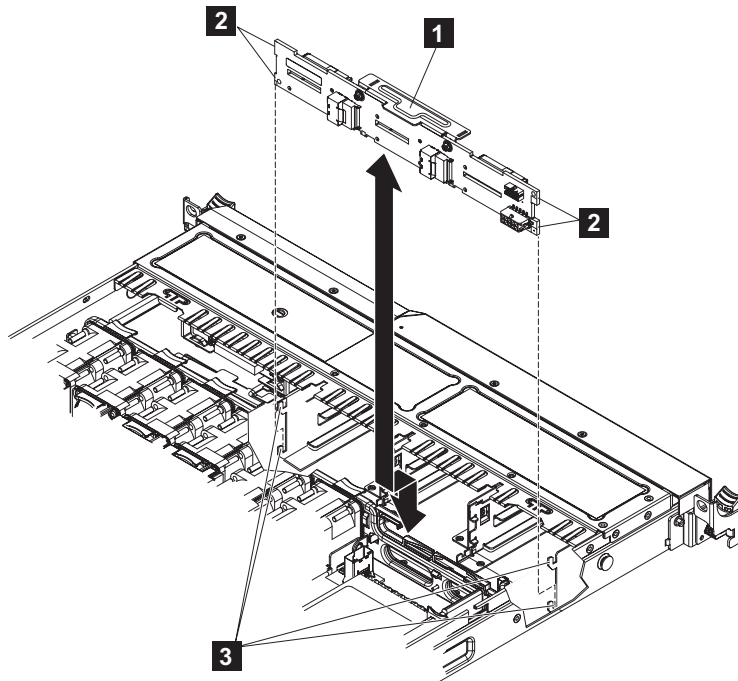

Figure 124. The SAN Volume Controller 2145-CF8 disk backplane

- 1** Disk-drive backplane
- 2** Backplane tabs
- 3** Backplane-bracket slots

3. Reconnect the cables to the disk-drive backplane.
The boot-drive cable and the high-speed SAS-adapter cable are shown in Figure 125 on page 145.

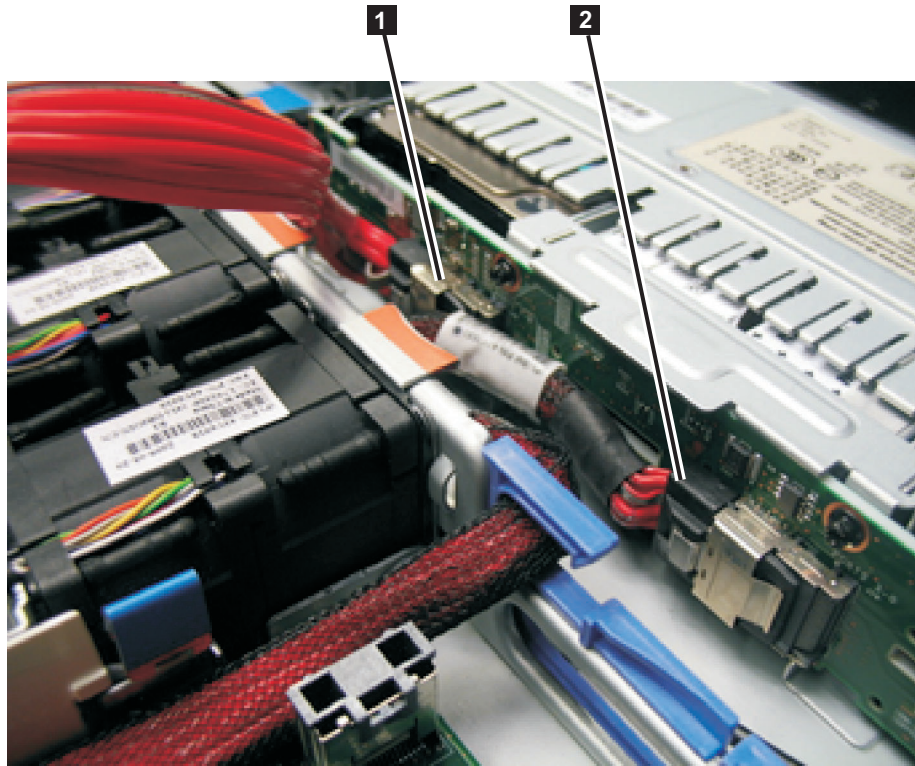

Figure 125. Boot-disk SAS cable and the high-speed SAS cable connected to the disk backplane in the SAN Volume Controller 2145-CF8

- 1** Boot-disk SAS cable that is plugged into the disk-drive backplane to support drive bay 4
 - 2** High-speed SAS-adapter cable that is plugged into the middle of the backplane to support drive bays 0, 1, 2, and 3
4. Reconnect the boot-disk SAS cable to the SAS disk controller.
The boot-drive cable and the high-speed SAS-adapter cable are shown in Figure 126 on page 146.

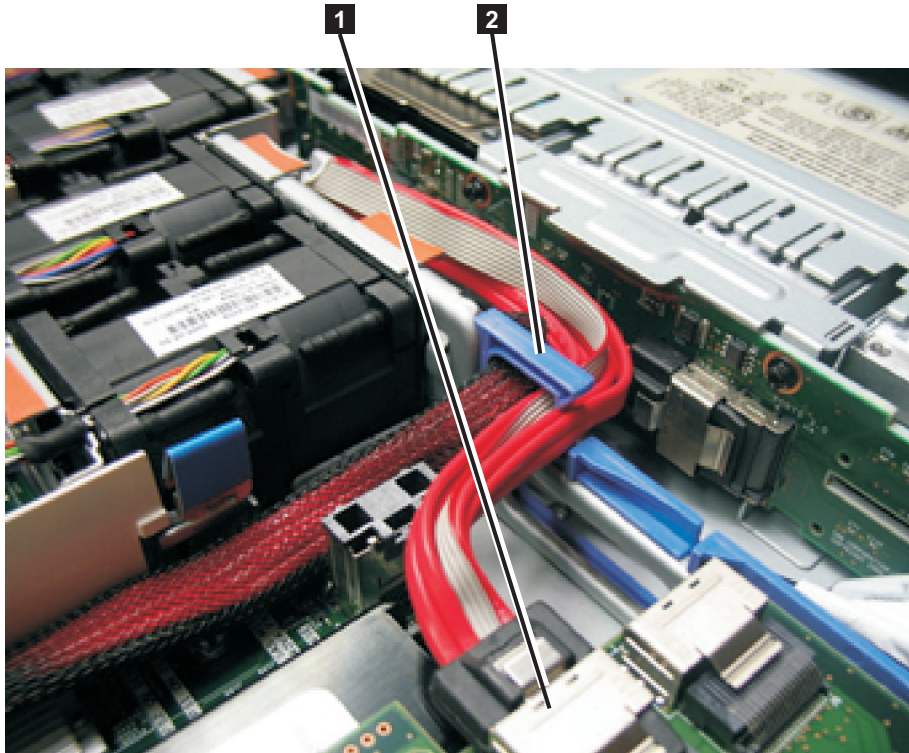

Figure 126. Boot-disk SAS cable routed through the blue bulkhead clip and connected to the SAS disk controller in the SAN Volume Controller 2145-CF8

- 1 Boot-disk SAS cable that is plugged into the disk-controller-and-USB-riser-card assembly
 - 2 Blue bulkhead clip with the high-speed SAS-adapter cable and the boot-disk SAS cable
5. Reinstall the fans, as described in “Replacing the fans” on page 250.
 6. Reinstall the cover, as described in “Replacing the top cover” on page 86.
 7. Reinstall the disk drives and drive-bay blank electromagnetic compatibility (EMC) filler assemblies, as described in “Replacing the disk drive” on page 126.
 8. Replace the service controller, as described in “Replacing the service controller” on page 102.
 9. If you removed the node from the rack, replace the node in the rack, as described in “Replacing the SAN Volume Controller in a rack” on page 59.
 10. If you removed any fibre-channel or Ethernet cables, use the labels you placed on each cable to replace all fibre-channel and Ethernet cables in the same ports from which they were removed.
 11. If you removed the power cords, replace the power cords and the cable-retention brackets, as described in “Replacing the cable-retention bracket” on page 40.
 12. Lift the locking levers (1 in Figure 127 on page 147) on the slide rails and push the server 2 all the way into the rack until it clicks into place.

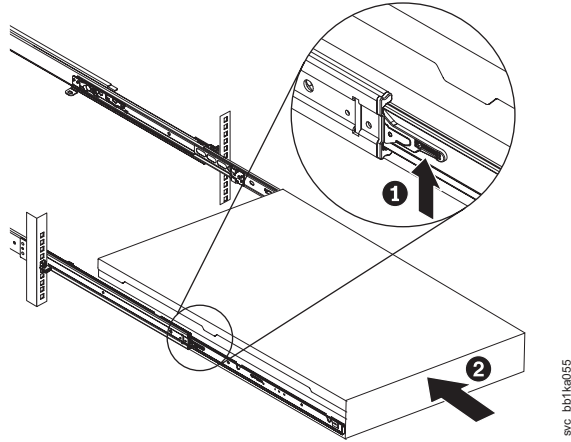

Figure 127. Raising the SAN Volume Controller 2145-CF8 locking levers of the slide rails of the rack

13. Turn on the node.

Replacing the SAN Volume Controller 2145-8A4 disk-drive backplane

To replace the SAN Volume Controller 2145-8A4 disk-drive backplane, including the SATA back plate, complete the following steps.

1. Make sure that the air deflector **1**, which is shown in Figure 128, is in the open position.

Note: The air deflector also functions as the back plate latch. In this procedure, you must lift the air deflector to access some of the cables.

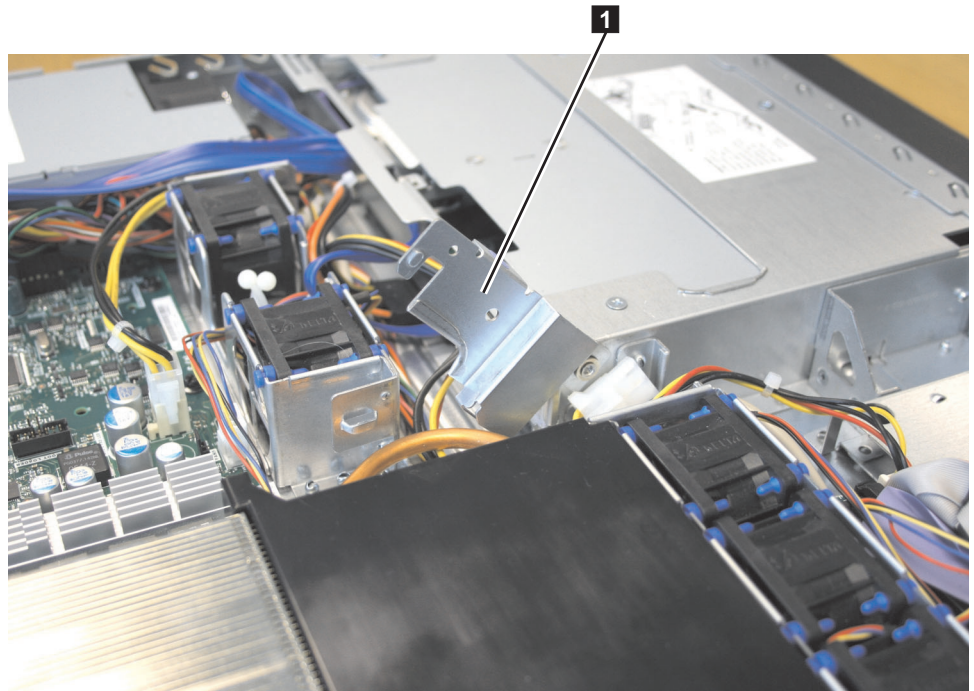

Figure 128. Air deflector for the SAN Volume Controller 2145-8A4 power supply

2. Connect power cable connectors P2 **1** and P3 **2** to the replacement back plate, as shown in Figure 129.

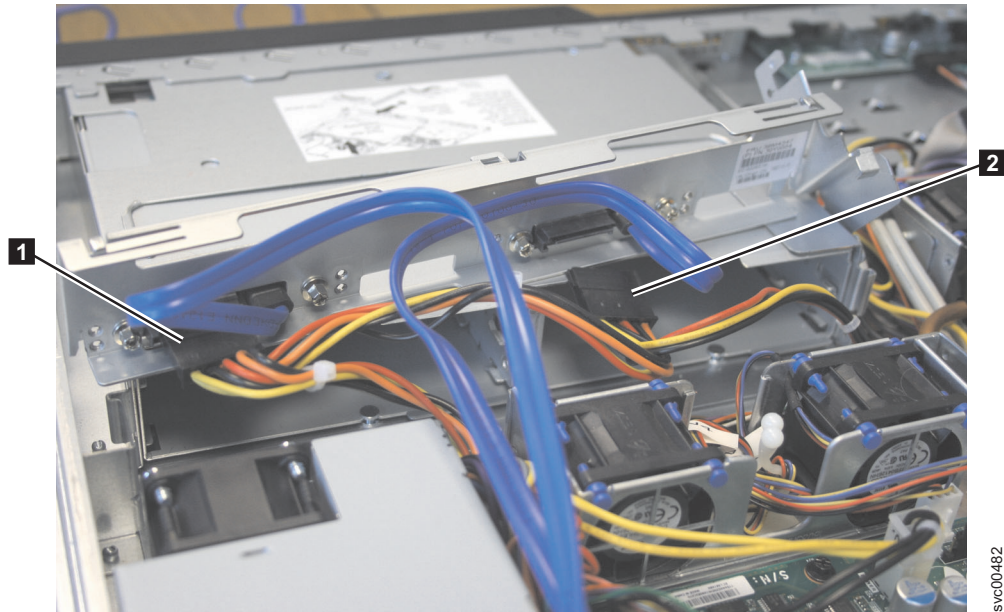

Figure 129. SAN Volume Controller 2145-8A4 power supply connectors

3. Slide the back plate into the card guides, making sure not to trap or pinch any nearby wires or cables.
4. Press firmly until the back plate is fully seated.
5. Rotate the air deflector (**1** in Figure 128 on page 147) into place, making sure not to pinch any cables beneath it, and press it down firmly.
6. Reconnect the SATA cables to the system board. When you look from the front, SATA 0 is the drive number for the left bay and SATA 2 is the drive number for the right bay.

Note: Make sure that the cable drive number matches the connector number on the system board. The cables will cross over each other, as shown in Figure 130 on page 149.

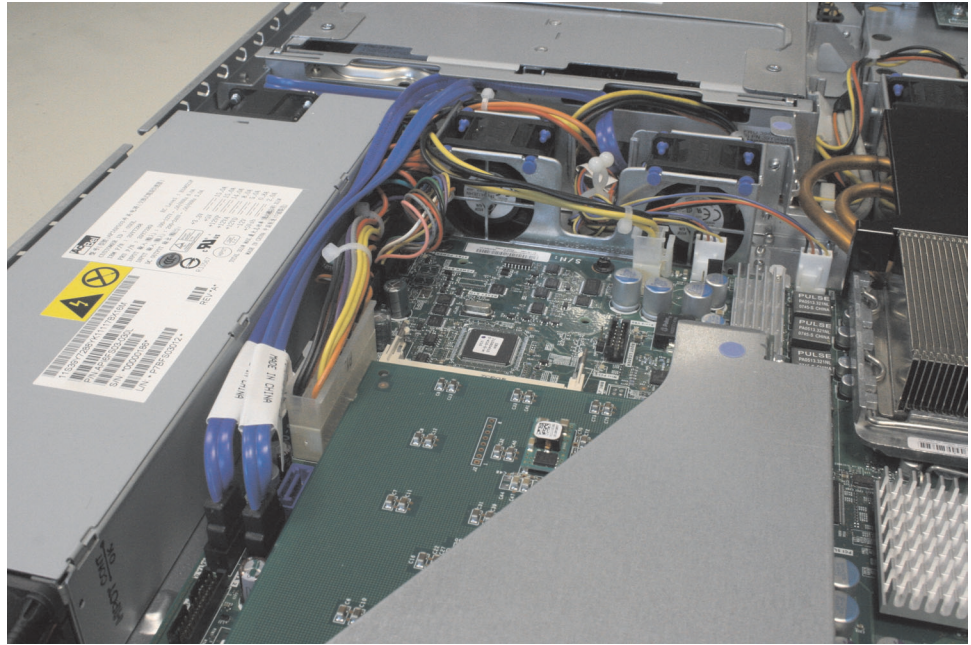

Figure 130. SAN Volume Controller 2145-8A4 SATA cables

7. Install the hard disk drive. See “Replacing the disk drive” on page 126.
8. Install the service controller. See “Replacing the service controller” on page 102.
9. Replace the top cover. See “Replacing the top cover” on page 86.
10. Place the node in the rack. See “Replacing the SAN Volume Controller in a rack” on page 59.
11. Reconnect the fibre-channel and Ethernet cables. Ensure that you replace the fibre-channel and Ethernet cables in the same ports from which they were removed.
12. Turn on the node.

Replacing the SAN Volume Controller 2145-8G4 disk-drive backplane

To replace the SAN Volume Controller 2145-8G4 disk-drive backplane, including the SATA back plate, complete the following steps.

1. Connect the power cable to the replacement back plate.
2. Slide the back plate into the mounting channels **2**, which are shown in Figure 131 on page 150, making sure not to trap or pinch any nearby wires or cables.

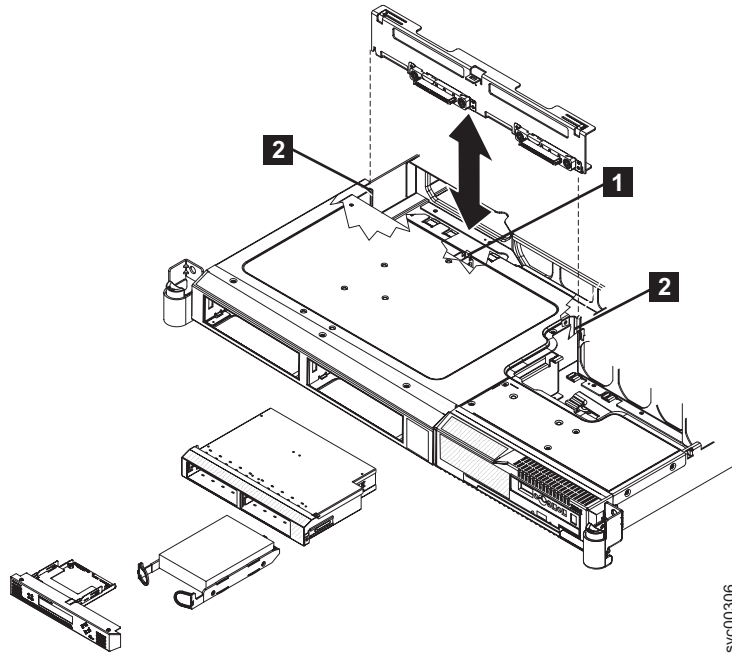

Figure 131. The SAN Volume Controller 2145-8G4 SATA disk drive and back plate

3. Press firmly until the back plate is fully seated and the locking tab **1** snaps into place.
4. Reconnect the power cable to the power supply backplane card. Then reconnect the two blue signal cables to the system board. The left cable goes to the front system board connector and the right cable goes to the rear system board connector, as shown in Figure 132.

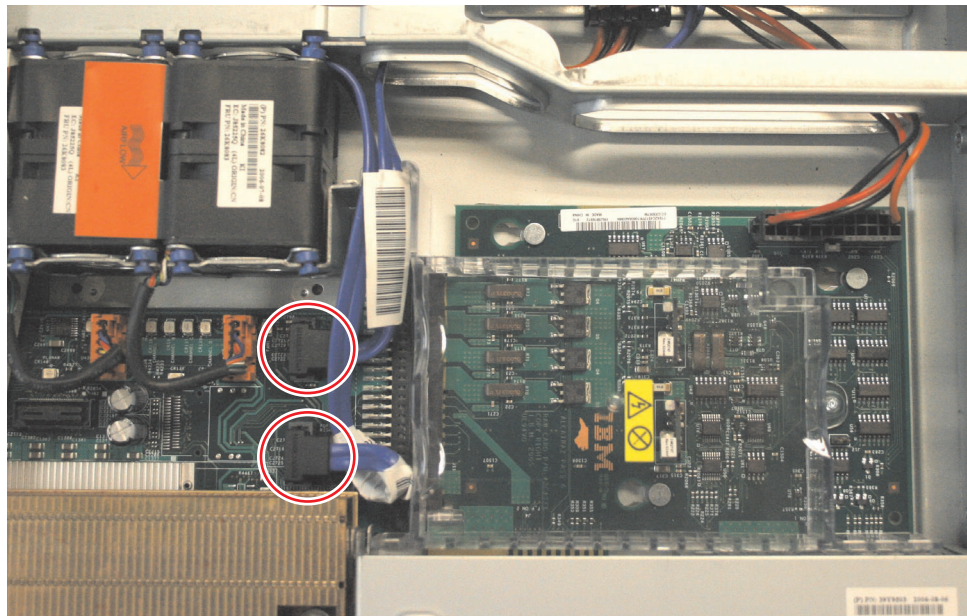

Figure 132. The SAN Volume Controller 2145-8G4 disk-drive backplane connectors

5. Install the hard disk drive. See “Replacing the disk drive” on page 126.

6. Install the service controller. See “Replacing the service controller” on page 102.
7. Replace the top cover. See “Replacing the top cover” on page 86.
8. Place the node in the rack. See “Replacing the SAN Volume Controller in a rack” on page 59.
9. Reconnect the fibre-channel and Ethernet cables. Ensure that you replace the fibre-channel and Ethernet cables in the same ports from which they were removed.
10. Turn on the node.

Removing the CMOS battery

You must remove the system board complementary metal-oxide semiconductor (CMOS), or system-board, battery to replace it or to perform routine maintenance.

This product was designed with your safety in mind. The lithium battery must be handled correctly to avoid possible danger. If you replace the battery, you must adhere to all safety instructions.

Use the reference numbers in parentheses at the end of each notice, such as (C003) for example, to find the matching translated notice in *IBM Systems Safety Notices*.

Related tasks

“Removing the top cover” on page 81

You can remove the top cover of the SAN Volume Controller node if maintenance is necessary.

“Removing and replacing the SAN Volume Controller power-cable assembly” on page 110

Make sure that power to the SAN Volume Controller is turned off before you remove the power-cable assembly. Turn off the node while ensuring that its data is mirrored and synchronized, as described in MAP 5350 in the *IBM System Storage SAN Volume Controller Troubleshooting Guide*.

“Removing the SAN Volume Controller from a rack” on page 48

During some service procedures, you might need to remove the SAN Volume Controller from a rack.

Related reference

“Handling static-sensitive devices” on page xxiv

Ensure that you understand how to handle devices that are sensitive to static electricity.

Removing the SAN Volume Controller 2145-CF8 CMOS battery

This topic describes how to remove the SAN Volume Controller 2145-CF8 CMOS battery.

DANGER

Multiple power cords. The product might be equipped with multiple power cords. To remove all hazardous voltages, disconnect all power cords.

CAUTION:

The battery contains lithium. To avoid possible explosion, do not burn or charge the battery.

Do not:

- Throw or immerse into water
- Heat to more than 100°C (212°F)
- Repair or disassemble

Exchange only with the IBM-approved part. Recycle or discard the battery as instructed by local regulations. In the United States, IBM has a process for the collection of this battery. For information, call 1-800-426-4333. Have the IBM part number for the battery unit available when you call. (C003)

This service action requires you to remove the cover and:

- Turn the node off.
- Disconnect the power cables.
- Optionally disconnect the fibre-channel and Ethernet data cables.

To remove the CMOS battery, perform the following steps:

1. Read the safety information to which “Preparing to remove and replace parts” on page 24 refers.
2. Follow the procedure in MAP 5350 in the *IBM System Storage SAN Volume Controller Troubleshooting Guide* to verify that the node data is mirrored and synchronized, and that there are no dependent virtual disks (VDisks) before turning off the node.
3. Slide the node out on its slide rails to the fully extended position.
You can perform most service actions when the node is fully extended from the rack on its slide rails. You can leave the fibre-channel and Ethernet cables connected, if you are using the cable-management arm and if you are not removing the node from the rack. If the location of the node in the rack is too high or too low to work comfortably, you can remove the node from the rack.
4. When the node is completely turned off, remove the cable-retention brackets and disconnect the power cables, as described in “Removing the cable-retention bracket” on page 34.
5. Optional: If you must remove the node from the rack to work on it, perform the following procedure to remove all cables and remove the node from the rack:
 - a. To make sure that you can replace all cables in the same ports from which they were removed, label the port position of each fibre-channel and Ethernet cable; then remove all cables from the back of the node.
 - b. Remove the node from the rack and place it on a flat, static-protective surface. See “Removing the SAN Volume Controller from a rack” on page 48.
6. Remove the top cover. See “Removing the top cover” on page 81.
7. Locate the battery **1** on the system board. Figure 133 on page 153 shows the location of the battery.

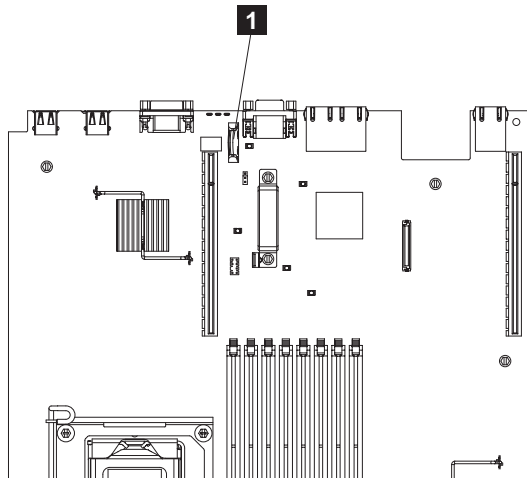

Figure 133. Location of the SAN Volume Controller 2145-CF8 CMOS battery holder

8. Remove the CMOS battery, as shown in Figure 134:

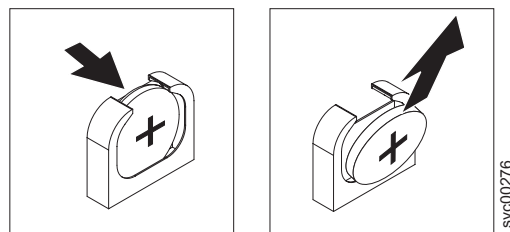

Figure 134. SAN Volume Controller 2145-CF8 CMOS battery holder

- a. Use a fingernail to press the top of the battery clip away from the battery. The battery pops up when released.
 - b. Use your thumb and index finger to lift the battery from the socket.
9. Recycle or discard the battery as instructed by local regulations. See the warning at the beginning of this topic for further instructions regarding handling the battery.

Removing the SAN Volume Controller 2145-8A4 CMOS battery

This topic describes how to remove the SAN Volume Controller 2145-8A4 CMOS battery.

CAUTION:

The battery contains lithium. To avoid possible explosion, do not burn or charge the battery.

Do not:

- Throw or immerse into water
- Heat to more than 100°C (212°F)
- Repair or disassemble

Exchange only with the IBM-approved part. Recycle or discard the battery as instructed by local regulations. In the United States, IBM has a process for the collection of this battery. For information, call 1-800-426-4333. Have the IBM part number for the battery unit available when you call. (C003)

To remove the CMOS battery, perform the following steps:

1. Read the safety precautions in “Safety and environmental notices” on page xvii.
2. Turn off the node while ensuring that its data is mirrored and synchronized. See MAP 5350 in the *IBM System Storage SAN Volume Controller Troubleshooting Guide* for more information.
3. Remove the node from the rack and place it on a flat, static-protective surface. See “Removing the SAN Volume Controller from a rack” on page 48.
4. Remove the top cover. See “Removing the top cover” on page 81.
5. Lift the riser-card assembly out of the way. You do not need to separate the riser-card assembly and the fibre-channel adapter. See “Removing the PCI express riser card assembly” on page 219.
6. Locate the battery on the system board.

1 in Figure 135 shows the location of the battery.

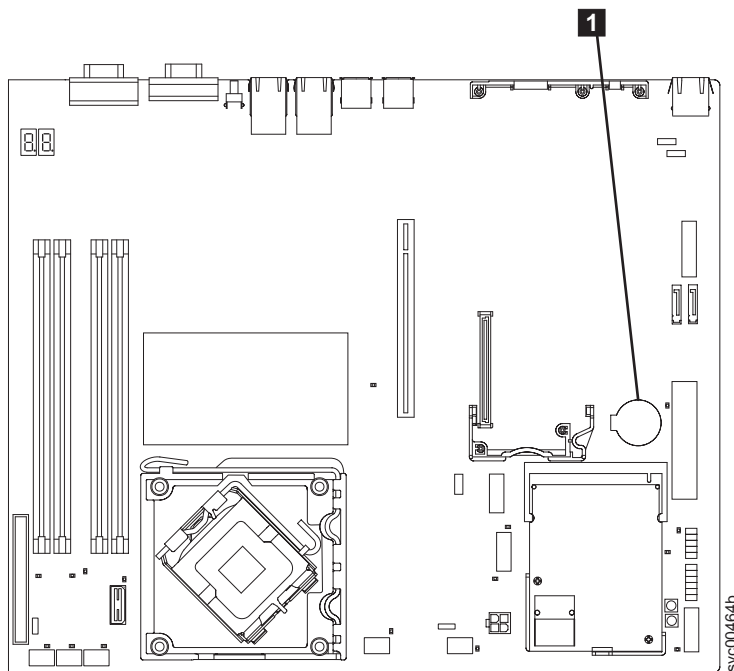

Figure 135. Locating the SAN Volume Controller 2145-8A4 CMOS battery

7. Remove the CMOS battery, as shown in Figure 136:

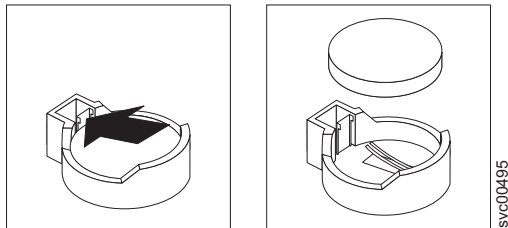

Figure 136. Removing the SAN Volume Controller 2145-8A4 CMOS battery

- a. Use a fingernail to press the top of the battery clip away from the battery. The battery pops up when released.
- b. Use your thumb and index finger to lift the battery from the socket.

Removing the SAN Volume Controller 2145-8G4 CMOS battery

This topic describes how to remove the SAN Volume Controller 2145-8G4 CMOS battery.

CAUTION:

The battery contains lithium. To avoid possible explosion, do not burn or charge the battery.

Do not:

- Throw or immerse into water
- Heat to more than 100°C (212°F)
- Repair or disassemble

Exchange only with the IBM-approved part. Recycle or discard the battery as instructed by local regulations. In the United States, IBM has a process for the collection of this battery. For information, call 1-800-426-4333. Have the IBM part number for the battery unit available when you call. (C003)

To remove the CMOS battery, perform the following steps:

1. Turn off the node while ensuring that its data is mirrored and synchronized. See MAP 5350 in the *IBM System Storage SAN Volume Controller Troubleshooting Guide* for more information.
2. Remove the cable-retention bracket and disconnect the power cable from the node. See “Removing the cable-retention bracket” on page 34.
3. Remove the top cover. See “Removing the top cover” on page 81.
4. Locate the battery **1** on the system board. Figure 137 shows the location of the battery.

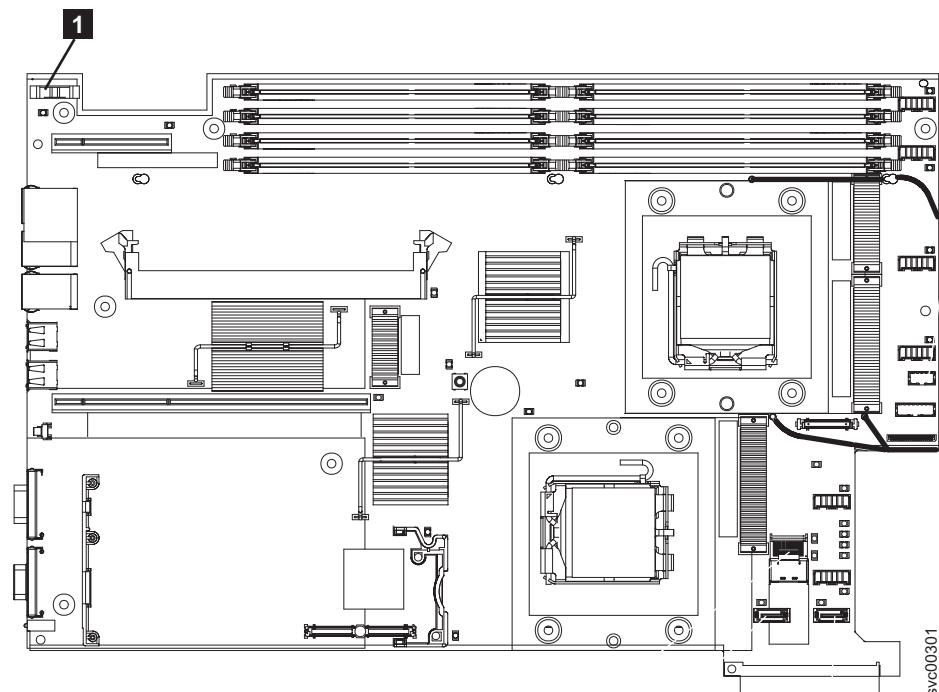

Figure 137. Location of the SAN Volume Controller 2145-8G4 CMOS battery holder

5. Remove the CMOS battery, as shown in Figure 138:

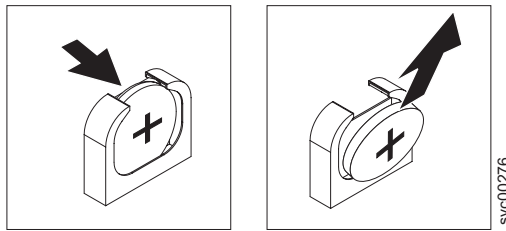

Figure 138. SAN Volume Controller 2145-8G4 CMOS battery holder

- a. Use a fingernail to press the top of the battery clip away from the battery. The battery pops up when released.
- b. Use your thumb and index finger to lift the battery from the socket.

Removing the SAN Volume Controller 2145-8F4 or SAN Volume Controller 2145-8F2 CMOS battery

This topic describes how to remove the SAN Volume Controller 2145-8F4 and SAN Volume Controller 2145-8F2 CMOS battery.

CAUTION:

The battery contains lithium. To avoid possible explosion, do not burn or charge the battery.

Do not:

- Throw or immerse into water
- Heat to more than 100°C (212°F)
- Repair or disassemble

Exchange only with the IBM-approved part. Recycle or discard the battery as instructed by local regulations. In the United States, IBM has a process for the collection of this battery. For information, call 1-800-426-4333. Have the IBM part number for the battery unit available when you call. (C003)

To remove the CMOS battery, perform the following steps:

1. Follow any special handling and installation instructions supplied with the battery.
2. Turn off the node while ensuring that its data is mirrored and synchronized. See MAP 5350 in the *IBM System Storage SAN Volume Controller Troubleshooting Guide* for more information.
3. Remove the node from the rack and place it on a flat, static-protective surface. See “Removing the SAN Volume Controller from a rack” on page 48.
4. Remove the top cover. See “Removing the top cover” on page 81.
5. Locate the battery **1** on the system board. Figure 139 on page 157 shows the location of the battery.

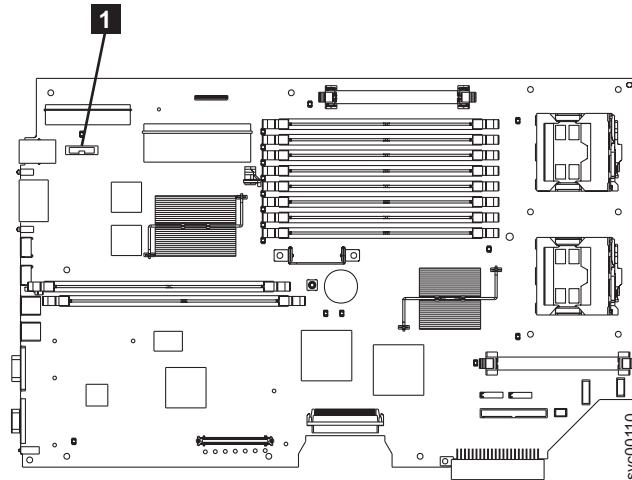

Figure 139. Location of the CMOS battery on the SAN Volume Controller 2145-8F2 or the SAN Volume Controller 2145-8F4

6. Remove the battery:
 - a. Use one finger to pull the retainer tab, which is shown in Figure 140, that secures the battery to its housing.

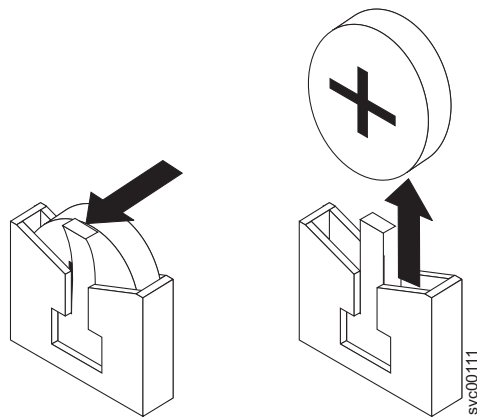

Figure 140. SAN Volume Controller 2145-8F2 or the SAN Volume Controller 2145-8F4 CMOS battery holder

- b. Use one finger to slide the battery up and out from its socket.

Replacing the CMOS battery

You must replace the system board complementary metal-oxide semiconductor (CMOS) battery after you perform routine maintenance.

The lithium battery must be handled correctly to avoid possible danger. If you replace the battery, you must adhere to all safety instructions.

Use the reference numbers in parentheses at the end of each notice, such as (C003) for example, to find the matching translated notice in *IBM Systems Safety Notices*.

Related tasks

“Replacing the top cover” on page 86

You must replace the top cover on the SAN Volume Controller node after maintenance is completed.

“Replacing the SAN Volume Controller in a rack” on page 59

You must use caution when you replace the SAN Volume Controller in a rack.

“Removing and replacing the SAN Volume Controller power-cable assembly” on page 110

Make sure that power to the SAN Volume Controller is turned off before you remove the power-cable assembly. Turn off the node while ensuring that its data is mirrored and synchronized, as described in MAP 5350 in the *IBM System Storage SAN Volume Controller Troubleshooting Guide*.

Related reference

“Handling static-sensitive devices” on page xxiv

Ensure that you understand how to handle devices that are sensitive to static electricity.

Replacing the SAN Volume Controller 2145-CF8 system-board CMOS battery

This topic describes how to replace the system-board SAN Volume Controller 2145-CF8 CMOS battery.

DANGER

Multiple power cords. The product might be equipped with multiple power cords. To remove all hazardous voltages, disconnect all power cords.

CAUTION:

The battery contains lithium. To avoid possible explosion, do not burn or charge the battery.

Do not:

- **Throw or immerse into water**
- **Heat to more than 100°C (212°F)**
- **Repair or disassemble**

Exchange only with the IBM-approved part. Recycle or discard the battery as instructed by local regulations. In the United States, IBM has a process for the collection of this battery. For information, call 1-800-426-4333. Have the IBM part number for the battery unit available when you call. (C003)

This service action assumes that:

- The node is turned off.
- The power cables are disconnected.
- The battery is removed from the node.
- The top cover is off.

Perform the following steps to replace the SAN Volume Controller 2145-CF8 system-board CMOS battery:

1. Follow any special handling and installation instructions that come with the replacement battery.

2. Locate the battery on the system board. Figure 141 shows the location (**1**) of the battery on the system board.

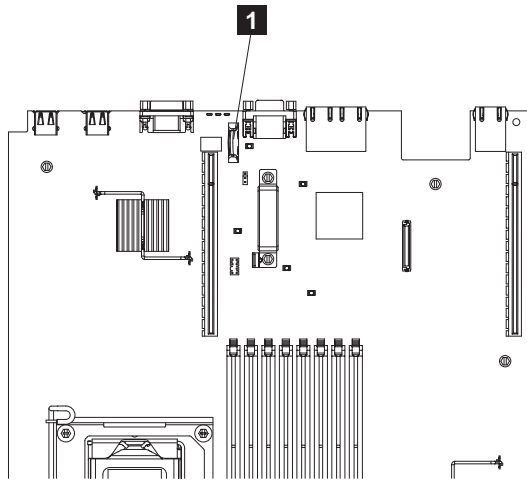

Figure 141. Location of the SAN Volume Controller 2145-CF8 CMOS battery holder

3. Insert the new battery:
 - a. Tilt the battery so that you can insert it into the socket on the side opposite the battery clip.
 - b. Press the battery across into the socket until it clicks into place. Make sure that the battery clip holds the battery securely, as shown in Figure 142.

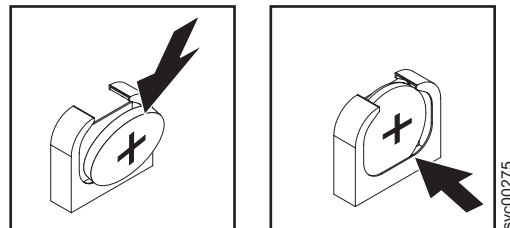

Figure 142. SAN Volume Controller 2145-CF8 CMOS battery holder

4. Make sure that all cables, adapters, and other components are installed and seated correctly and that you have not left loose tools or parts inside the node. Make sure that all internal cables are correctly routed. If you disconnected the fibre-channel and Ethernet cables, make sure that each cable is reconnected to the same port from which it was removed.
5. Replace the top cover. See “Replacing the top cover” on page 86.
6. If you removed the node from the rack, replace the node in the rack, as described in “Replacing the SAN Volume Controller in a rack” on page 59.
7. If you removed any fibre-channel or Ethernet cables, use the labels you placed on each cable to replace all fibre-channel and Ethernet cables in the same ports from which they were removed.
8. If you removed the power cords, replace the power cords and the cable-retention brackets, as described in “Replacing the cable-retention bracket” on page 40.
9. Lift the locking levers (**1** in Figure 143 on page 160) on the slide rails and push the server **2** all the way into the rack until it clicks into place.

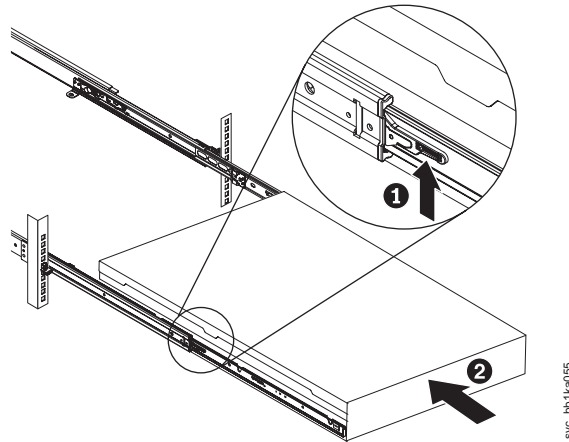

Figure 143. Raising the SAN Volume Controller 2145-CF8 locking levers of the slide rails of the rack

10. Turn on the node.
11. If there is a problem restarting the node, see MAP 5900 in the *IBM System Storage SAN Volume Controller Troubleshooting Guide*; then connect a monitor and keyboard to the system and reset the BIOS date and time.

Replacing the SAN Volume Controller 2145-8A4 system-board CMOS battery

This topic describes how to replace the system-board SAN Volume Controller 2145-8A4 CMOS battery.

Consider the following notice when you replace the battery in the node:

CAUTION:

The battery contains lithium. To avoid possible explosion, do not burn or charge the battery.

Do not:

- Throw or immerse into water
- Heat to more than 100°C (212°F)
- Repair or disassemble

Exchange only with the IBM-approved part. Recycle or discard the battery as instructed by local regulations. In the United States, IBM has a process for the collection of this battery. For information, call 1-800-426-4333. Have the IBM part number for the battery unit available when you call. (C003)

To replace the SAN Volume Controller 2145-8A4 system-board CMOS battery, perform the following steps:

1. Follow any special handling and installation instructions that come with the replacement battery.
2. Locate the battery on the system board.

1 in Figure 144 on page 161 shows the location of the battery.

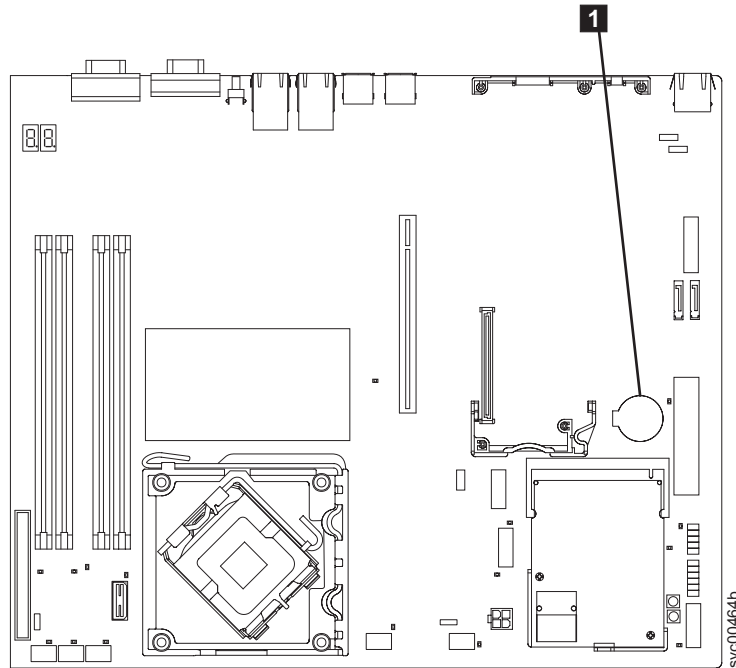

Figure 144. Locating the SAN Volume Controller 2145-8A4 CMOS battery

3. Insert the new battery:
 - a. Orient the battery so that the positive side faces up.
 - b. Tilt the battery so that you can insert it into the socket on the side opposite the battery clip.
 - c. Press the battery down into the socket, as shown in Figure 145, until it clicks into place. Make sure that the battery clip holds the battery securely.

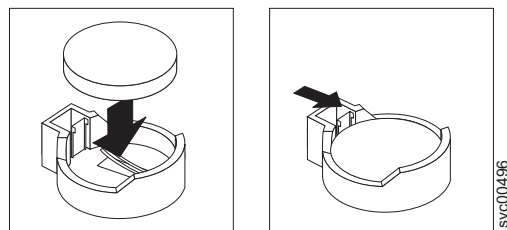

Figure 145. Installing the SAN Volume Controller 2145-8A4 CMOS battery

4. Replace the riser-card assembly and ensure that it is fully seated in the connectors on the system board. See “Replacing the PCI express riser-card assembly” on page 220.
5. Replace the top cover. See “Replacing the top cover” on page 86.
6. Place the node in the rack. See “Replacing the SAN Volume Controller in a rack” on page 59.
7. Reconnect the external cables, and then reconnect the power cords and the node.

Note: You must wait approximately 20 seconds after you connect power to the node before the power-control button becomes active.

8. Turn on the node.

9. If there is a problem restarting the node, see “MAP 5900” and then connect a monitor and keyboard to the system and reset the system date and time.

Replacing the SAN Volume Controller 2145-8G4 system-board CMOS battery

This topic describes how to replace the system-board SAN Volume Controller 2145-8G4 CMOS battery.

If you are exchanging the battery for a new one, use only IBM Part Number 33F8354 or a similar type of battery that the manufacturer recommends.

CAUTION:

The battery contains lithium. To avoid possible explosion, do not burn or charge the battery.

Do not:

- **Throw or immerse into water**
- **Heat to more than 100°C (212°F)**
- **Repair or disassemble**

Exchange only with the IBM-approved part. Recycle or discard the battery as instructed by local regulations. In the United States, IBM has a process for the collection of this battery. For information, call 1-800-426-4333. Have the IBM part number for the battery unit available when you call. (C003)

Use the reference numbers in parentheses at the end of each notice, such as (C003) for example, to find the matching translated notice in *IBM Systems Safety Notices*.

Perform the following steps to replace the SAN Volume Controller 2145-8G4 system-board CMOS battery:

1. Follow any special handling and installation instructions that come with the replacement battery.
2. Locate the battery on the system board. Figure 146 on page 163 shows the location () of the battery.

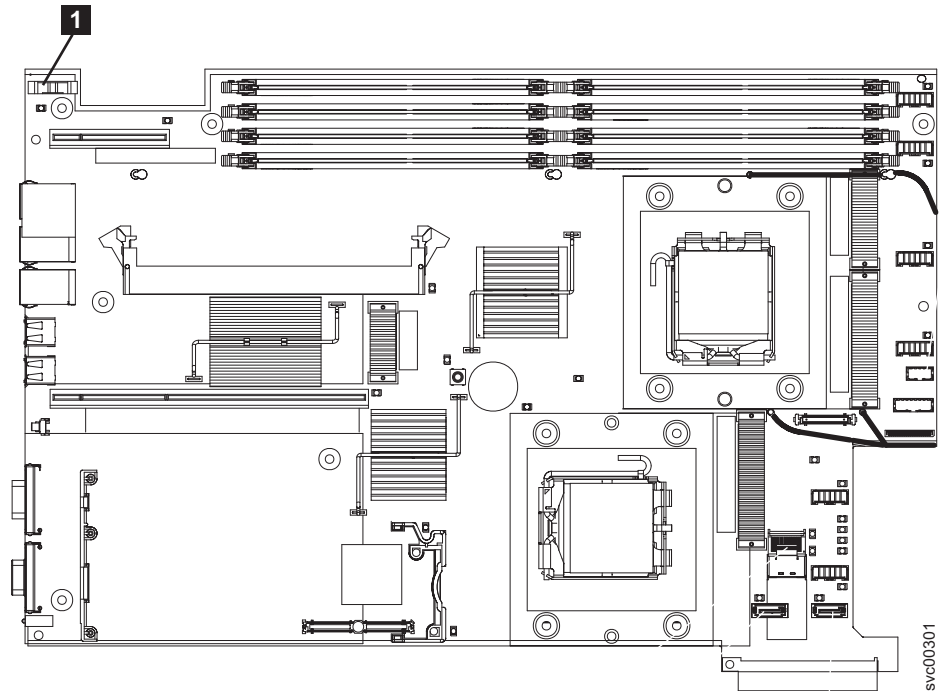

Figure 146. Location of the SAN Volume Controller 2145-8G4 CMOS battery holder

3. Insert the new battery:
 - a. Tilt the battery so that you can insert it into the socket on the side opposite the battery clip.
 - b. Press the battery down into the socket until it clicks into place. Make sure that the battery clip holds the battery securely, as shown in Figure 147.

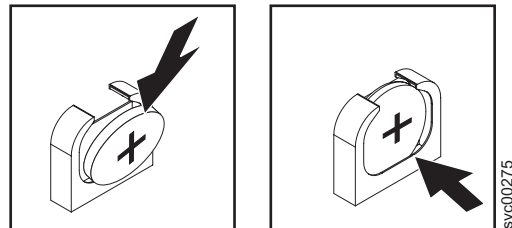

Figure 147. SAN Volume Controller 2145-8G4 CMOS battery holder

4. Replace the top cover. See “Replacing the top cover” on page 86.
5. Place the node in the rack. See “Replacing the SAN Volume Controller in a rack” on page 59.
6. Reconnect the external cables, and then reconnect the power cords and the node.
7. If there is a problem restarting the node, see MAP 5900 and then connect a monitor and keyboard to the system and reset the BIOS date and time.

Replacing the SAN Volume Controller 2145-8F4 or SAN Volume Controller 2145-8F2 CMOS battery

This product was designed with your safety in mind. The lithium battery must be handled correctly to avoid possible danger. If you replace the battery, you must adhere to all safety instructions.

CAUTION:

The battery contains lithium. To avoid possible explosion, do not burn or charge the battery.

Do not:

- Throw or immerse into water
- Heat to more than 100°C (212°F)
- Repair or disassemble

Exchange only with the IBM-approved part. Recycle or discard the battery as instructed by local regulations. In the United States, IBM has a process for the collection of this battery. For information, call 1-800-426-4333. Have the IBM part number for the battery unit available when you call. (C003)

Use the reference numbers in parentheses at the end of each notice, such as (C003) for example, to find the matching translated notice in *IBM Systems Safety Notices*.

Perform the following steps to replace the SAN Volume Controller 2145-8F2 or SAN Volume Controller 2145-8F4 CMOS battery:

1. Insert the new battery in the battery socket. Figure 148 shows the location (**1**) of the battery socket.

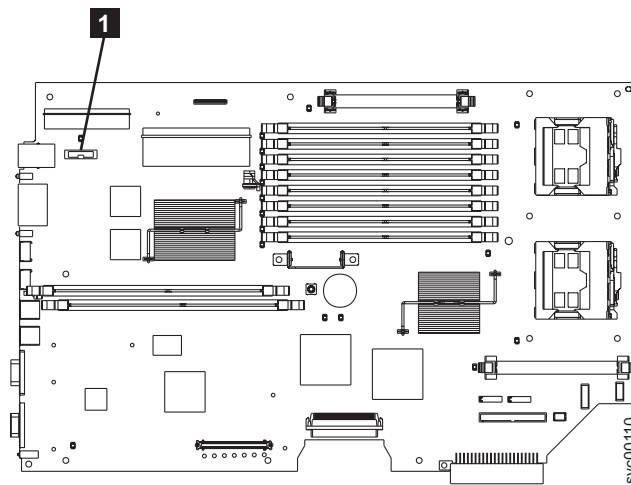

Figure 148. Location of the CMOS battery on the SAN Volume Controller 2145-8F2 or the SAN Volume Controller 2145-8F4

- a. Hold the battery so that the positive (+) side of the battery is facing toward the center of the server.
- b. Pull the retainer tab out of the way so that you can slide the battery into its socket.

- c. Slide the battery down until it snaps into place, as shown in Figure 149.

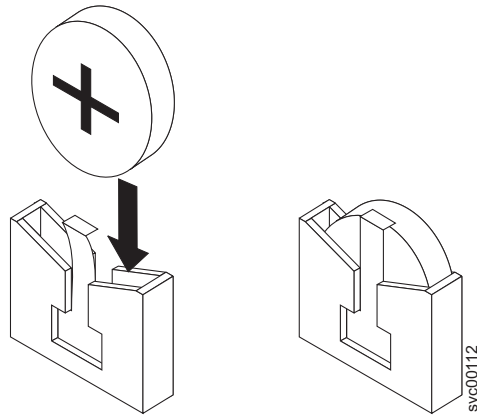

Figure 149. CMOS battery socket

2. Replace the top cover. See “Replacing the top cover” on page 86.
3. Place the node in the rack. See “Replacing the SAN Volume Controller in a rack” on page 59.

Removing the power supply

You must remove the SAN Volume Controller power supply if you intend to replace it.

Use the reference numbers in parentheses at the end of each notice, such as (C003) for example, to find the matching translated notice in *IBM Systems Safety Notices*.

DANGER

Do not open or service any power supply assembly. (D005a)

Related tasks

“Removing the SAN Volume Controller from a rack” on page 48

During some service procedures, you might need to remove the SAN Volume Controller from a rack.

“Removing the top cover” on page 81

You can remove the top cover of the SAN Volume Controller node if maintenance is necessary.

Related reference

“Handling static-sensitive devices” on page xxiv

Ensure that you understand how to handle devices that are sensitive to static electricity.

Removing a SAN Volume Controller 2145-CF8 power supply

You can remove and replace either of the two 675-watt hot-swap redundant power supplies in the SAN Volume Controller 2145-CF8. These redundant power supplies operate in parallel, one continuing to power the node if the other fails.

DANGER

Multiple power cords. The product might be equipped with multiple power cords. To remove all hazardous voltages, disconnect all power cords.

Ensure that you are aware of the procedures for handling static-sensitive devices before you remove the power supply.

This service action requires you to:

- Optionally, turn the node off.
- Disconnect the power cable on each power supply that you are removing.

Important: You can hot swap the power supply. However, using MAP 5350 to power off the node through proven methods avoids risking an abrupt power failure on the node, which avoids the possible corruption of data.

To remove the SAN Volume Controller 2145-CF8 power supply, perform the following steps:

1. Read the safety information to which “Preparing to remove and replace parts” on page 24 refers.
2. Optional: Follow the procedure in MAP 5350 in the *IBM System Storage SAN Volume Controller Troubleshooting Guide* to verify that the node data is mirrored and synchronized, and that there are no dependent virtual disks (VDisks) before turning off the node.

Important: If you decide to hot swap the power supply, use MAP 5350 to make all of the necessary checks that ensure that the partner node in the I/O group can take over all I/O group operations, if necessary, and that there are no dependent VDisks on the node. With the partner node available and no dependent VDisks on the node, you do not lose access to data if this node accidentally powers off.

3. Pull back the cable-management arm if you are working from the rear of the rack, or slide the node out of the rack to the fully extended rail position if you are working from the front.
4. Optional: Wait for the node to turn off completely if you are not hot-swapping the drive.
5. Remove the cable-retention bracket and the power cord from the power supply that you are replacing, as described in “Removing the SAN Volume Controller 2145-CF8 cable-retention brackets” on page 35.
6. To remove the power supply, press and hold the release tab **2** to the left. Grasp the handle **3** on the rear of the power supply, as shown in Figure 150 on page 167, and pull the power supply out of the node.

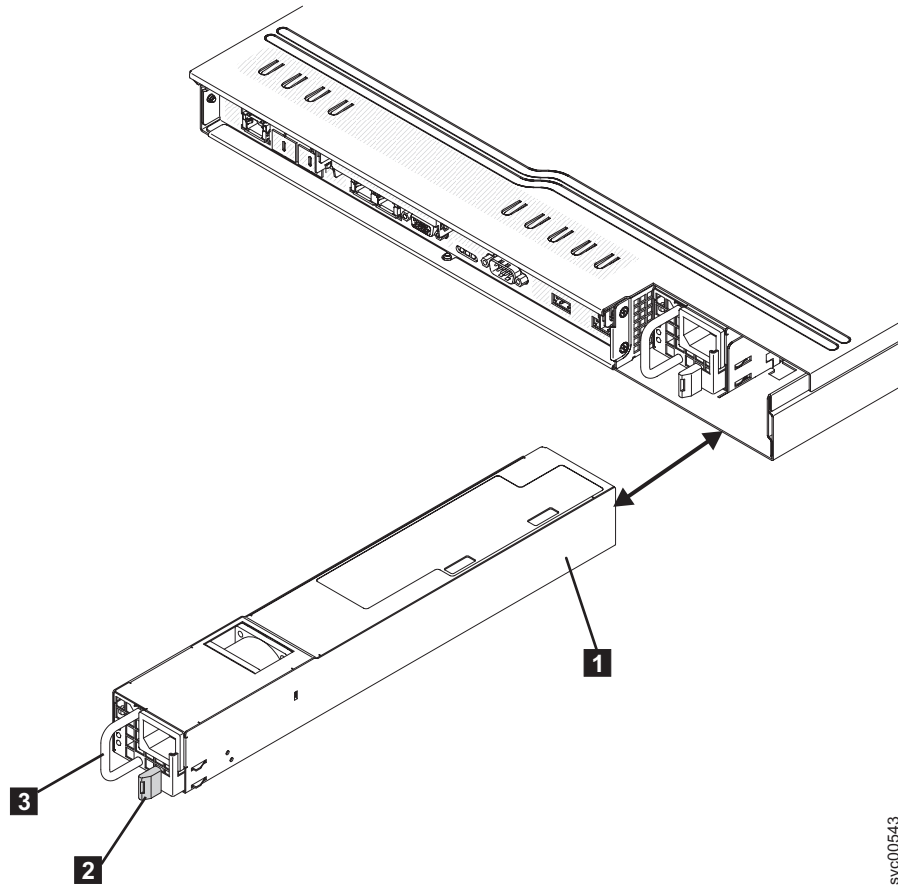

svc00543

Figure 150. SAN Volume Controller 2145-CF8 power supply

- 1** Power supply
- 2** Power-supply release tab
- 3** Power-supply handle

7. If you are instructed to return the power supply, follow all packaging instructions, and use any packaging materials for shipping that are supplied to you.

Removing a SAN Volume Controller 2145-8A4 power supply

This topic describes how to remove a SAN Volume Controller 2145-8G4 power supply.

Take precautions to avoid damage from static electricity. Wear an anti-static wrist strap and use a static-protected mat or surface. For more information, see “Handling static-sensitive devices” on page xxiv.

To remove the power supply, perform the following steps:

Notes:

- The air deflector also functions as the back plate latch. In this procedure, you must lift the air deflector to access some of the cables.
 - Notice the routing of all power-supply cables. You will route the power-supply cables the same way when you install the power supply.
1. Read the safety precautions in “Safety and environmental notices” on page xvii.

2. Turn off the node while ensuring that its data is mirrored and synchronized. See MAP 5350 in the *IBM System Storage SAN Volume Controller Troubleshooting Guide* for more information.
3. Remove the cable-retention bracket and disconnect the power cable from the node. See “Removing the cable-retention bracket” on page 34.
4. Remove the node from the rack and place it on a flat, static-protective surface. See “Removing the SAN Volume Controller from a rack” on page 48.
5. Remove the top cover. See “Removing the top cover” on page 81.
6. Remove the SATA back plate far enough to disconnect the two power cables from it. See “Removing the disk-drive backplane” on page 136.
7. Disconnect the power-supply cables from the 24 PIN POWER connector **1** and the POWER connector **2** on the system board, as shown in Figure 151.



Figure 151. SATA connectors on the SAN Volume Controller 2145-8A4 system board

8. Disconnect the power cable, connector P5, which is shown in Figure 152 on page 169, from the CD/DVD interface card.

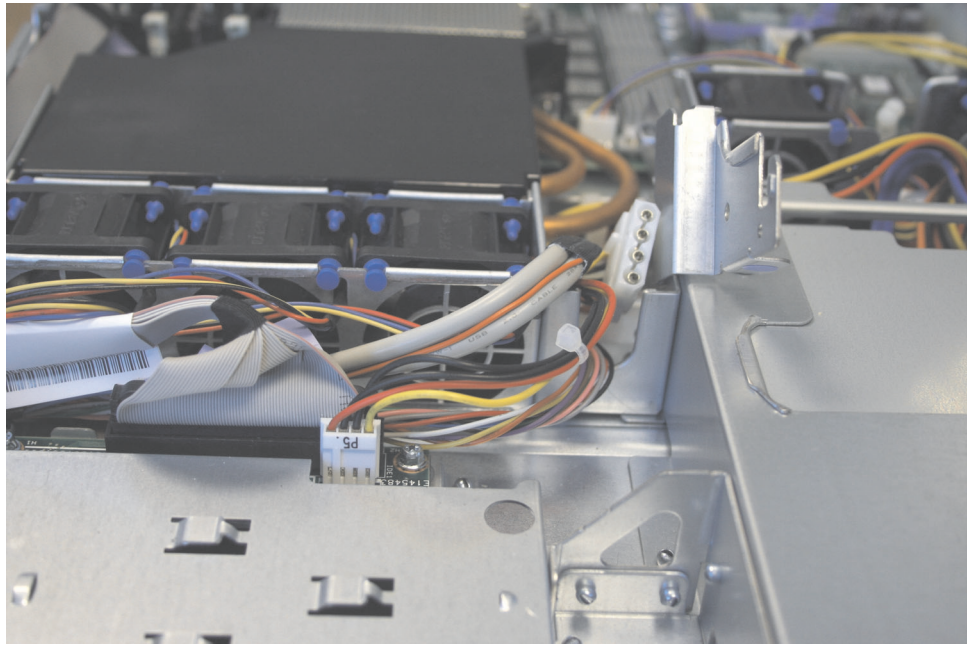

svc00483

Figure 152. Power P5 connector on the SAN Volume Controller 2145-8A4 power supply

9. Disengage the power cable, which terminates in connector P5, from the retention-clip **1**, which is shown in Figure 153.

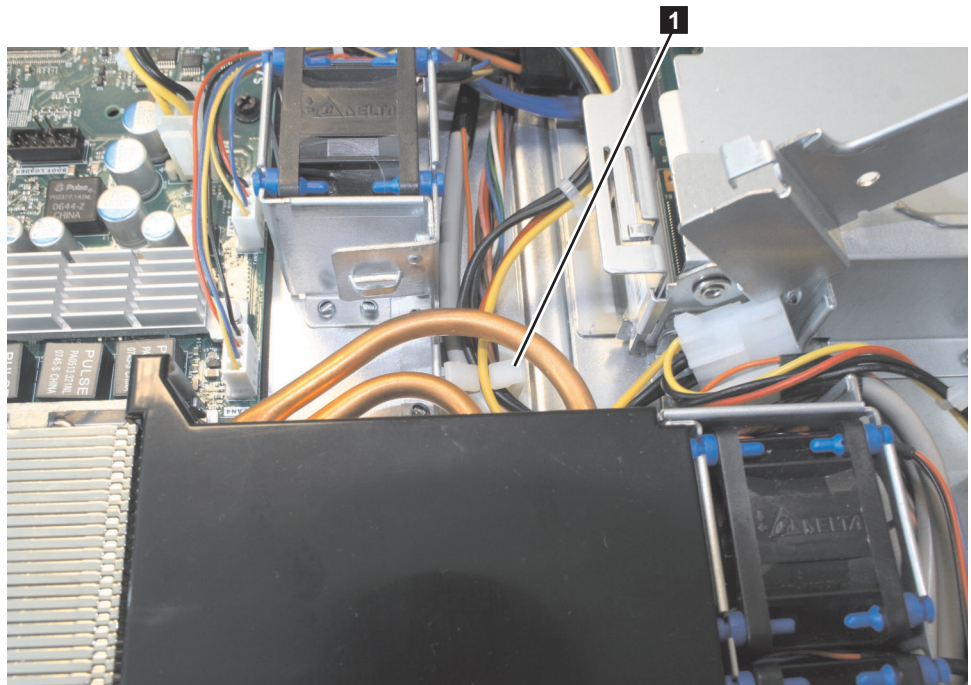

svc00486

Figure 153. The retention clip for the SAN Volume Controller 2145-8A4 power-supply cables

10. Remove the screw **3**, shown in Figure 154 on page 170, that holds the power supply to the rear of the chassis.

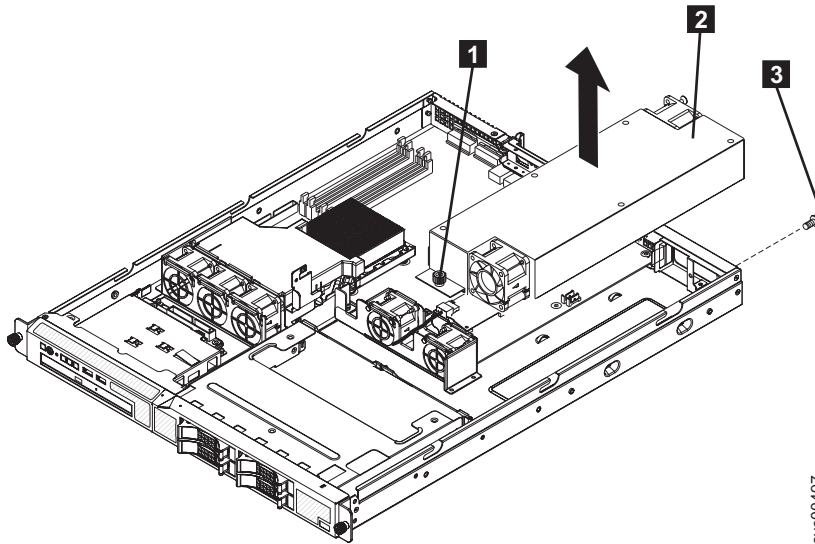

svc00497

Figure 154. The SAN Volume Controller 2145-8A4 power-supply

11. Loosen the captive thumbscrew **1** that secures the rear of the power supply to the chassis bottom.
12. Lift the power supply **2** out of the bay.

Removing a SAN Volume Controller 2145-8G4 power supply

This topic describes how to remove a SAN Volume Controller 2145-8G4 power supply.

Ensure that you are aware of the procedures for handling static-sensitive devices before you remove the SAN Volume Controller 2145-8G4 power supply.

Perform the following steps to remove the power supply:

1. Turn off the node while ensuring that its data is mirrored and synchronized. See MAP 5350 in the *IBM System Storage SAN Volume Controller Troubleshooting Guide* for more information.
2. At the back of the node, remove the cable restraint bracket to gain access to the rear of the node and the power supply **1**.
3. Press and hold down the orange release tab **2**, which is shown in Figure 155 on page 171, and pull the power supply out of the node.

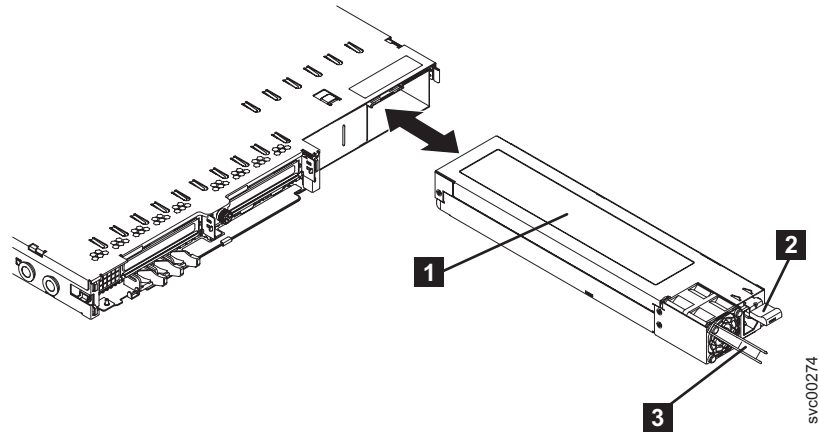

Figure 155. SAN Volume Controller 2145-8G4 power supply

- 1** Power supply
- 2** Power supply release tab
- 3** Power supply handle

Removing a SAN Volume Controller 2145-8F2 or SAN Volume Controller 2145-8F4 power supply

Ensure that you are aware of the procedures for handling static-sensitive devices before you remove the SAN Volume Controller 2145-8F2 or SAN Volume Controller 2145-8F4 power supply.

Perform the following steps to remove the power supply:

1. Turn off the node while ensuring that its data is mirrored and synchronized. See MAP 5350 in the *IBM System Storage SAN Volume Controller Troubleshooting Guide* for more information.
2. Turn off the 2145 UPS-1U that is supplying this node.
3. Remove the SAN Volume Controller 2145-8F4 cable retention bracket.
4. From the rear of the node, as shown in Figure 156 on page 172, push the orange release lever to the left and then push down on it to release the power-supply assembly. This will move the power supply back, slightly, for easy removal.

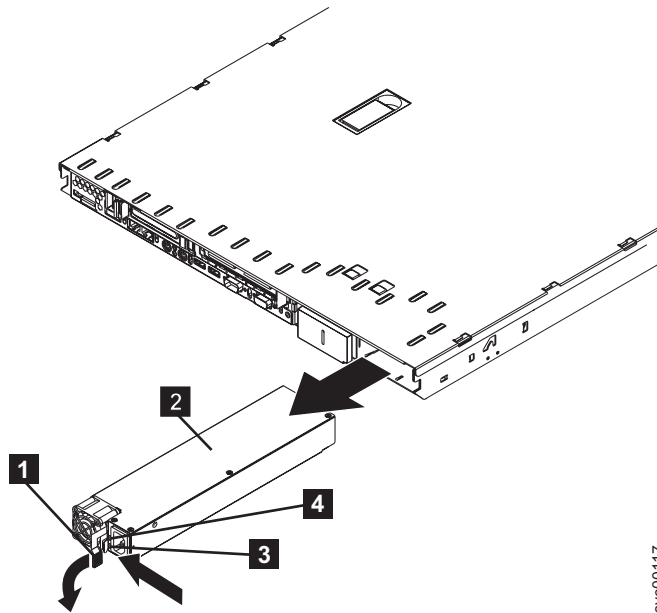

Figure 156. Removing the SAN Volume Controller 2145-8F2 power supply

- 1** Handle
- 2** Power supply
- 3** dc power LED
- 4** ac power LED

5. Pull the power supply out of the power-supply bay.

Replacing the power supply

You might need to replace the SAN Volume Controller power supply for a service action.

Note: For a translation of the following notice, see *IBM Systems Safety Notices*.

DANGER

Do not open or service any power supply assembly. (D005a)

Related reference

“Handling static-sensitive devices” on page xxiv

Ensure that you understand how to handle devices that are sensitive to static electricity.

Replacing a SAN Volume Controller 2145-CF8 power supply

You can replace either of the two 675-watt hot-swap redundant power supplies in the SAN Volume Controller 2145-CF8 node. These redundant power supplies operate in parallel, one continuing to power the node if the other fails.

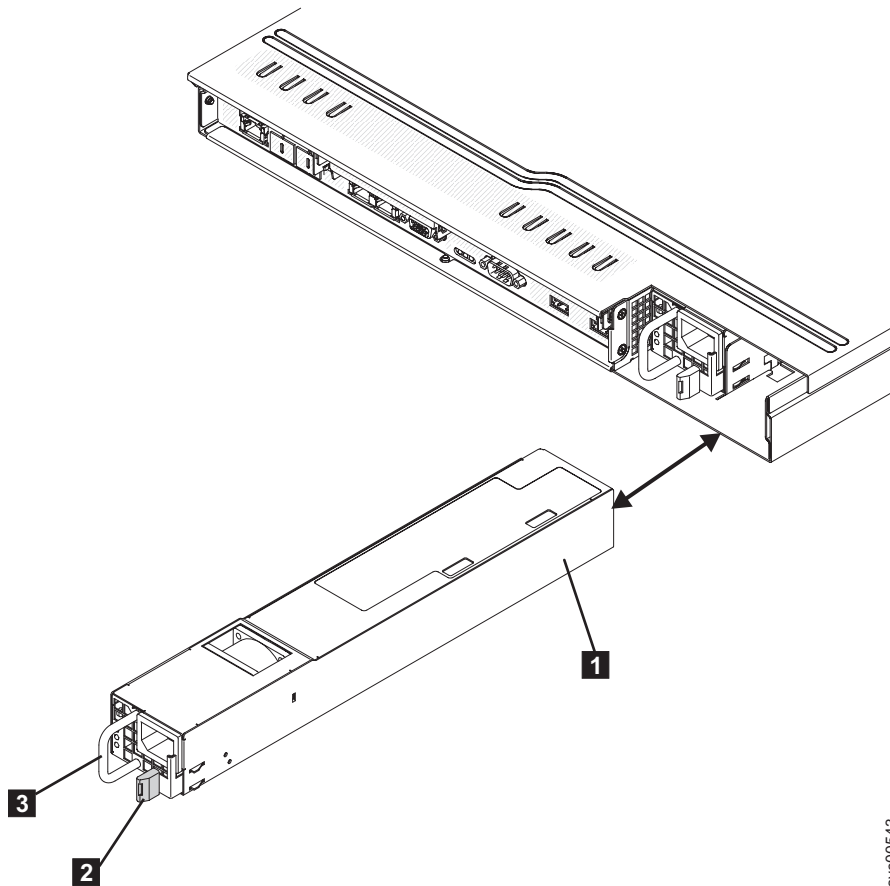

svc00543

Figure 157. SAN Volume Controller 2145-CF8 power supply

- 1** Power supply
- 2** Power-supply release tab
- 3** Power-supply handle

3. Attach the cable-retention bracket to the power cord from the 2145 UPS-1U and connect the cord to the power-cord connector on the power supply, as described in “Replacing the SAN Volume Controller 2145-CF8 cable-retention brackets” on page 41.
4. If necessary, turn on the node.
5. To the left of the power-cord connector on each power supply, verify that the ac power LED, as shown by **1** in Figure 158 on page 175, and the dc power LED (**2**) are lit.

The green power LEDs indicate that the power supply is operating correctly. A power-supply error is indicated by the amber power-supply error LED (**3**).

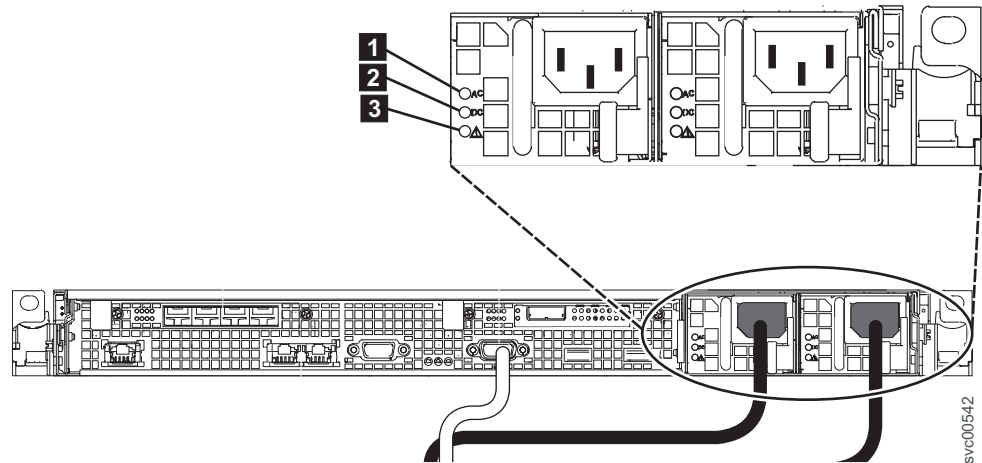

Figure 158. SAN Volume Controller 2145-CF8 ac, dc, and power-error LEDs

Replacing a SAN Volume Controller 2145-8A4 power supply

Take precautions to avoid damage from static electricity. Wear an anti-static wrist strap and use a static-protected mat or surface. For more information, see “Handling static-sensitive devices” on page xxiv.

To replace the SAN Volume Controller 2145-8A4 power supply, perform the following steps:

1. Place the new power supply into the bay.
2. Tighten the captive thumbscrew that secures the rear of the power supply to the chassis bottom.
3. Replace the screw that holds the power supply to the rear of the chassis.
4. Make sure that the air deflector **1** is in the open position, as shown in Figure 159 on page 176.

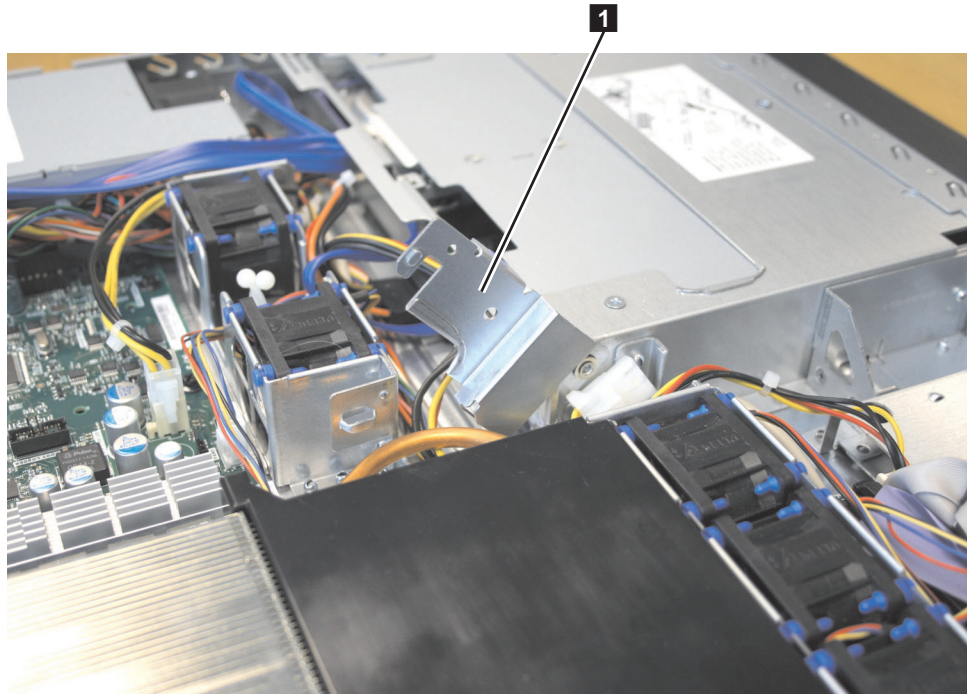

svc00485

Figure 159. Air deflector for the SAN Volume Controller 2145-8A4 power supply

5. There are two cables to connect to the system board, as shown in Figure 160. Connect the cable labeled P1 **1** to the position marked 24 PIN POWER CONN. Connect the cable labeled P6 **2** to the position marked POWER.



svc00484

Figure 160. SATA connectors on the SAN Volume Controller 2145-8A4 system board

6. Route the power-supply cable with the P5 connector to the CD/DVD interface card and secure it under the retention-clip **1**, as shown in Figure 161 on page 177

page 177, on the chassis.

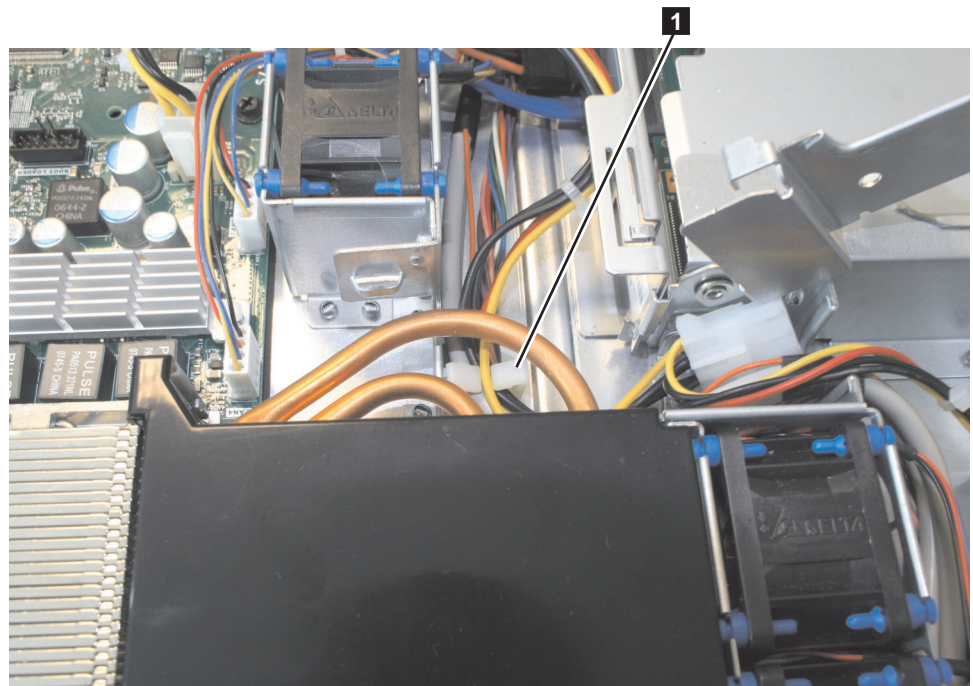

Figure 161. The retention clip for the SAN Volume Controller 2145-8A4 power-supply cables

7. Reconnect the cable to the CD/DVD interface card.
8. Connect the power connectors P2 and P3 to the SATA disk back plate and slide the back plate back into position.
9. Rotate the air deflector into place, making sure that no cables are pinched beneath it, and press it down firmly.
10. Test the power supply:
 - a. For testing on the bench, only connect the ac power cord from the connector on the back of the power supply to a properly grounded electrical outlet. If you are using the combined power/serial cable, do not connect the serial port.
 - b. Make sure that the standby power LED on the system board is lit. If the standby power LED is not lit, discontinue this procedure and obtain a new power supply.
 - c. Press the power-control button. Make sure that the power LED on the front of the node is lit.
 - If the node starts, it will go through the boot sequence and then stop and display boot code Failed 181. This is expected, because the uninterruptible power supply is not connected. Proceed to the next step.
 - If the node does not start, disconnect the ac power cord and contact the IBM Support Center.
 - d. Turn off the node using the power-control button and then disconnect the ac power cord.
11. Replace the top cover. See “Replacing the top cover” on page 86.
12. Place the node in the rack. See “Replacing the SAN Volume Controller in a rack” on page 59.

13. Reconnect the ac power cord into the connector on the back of the power supply, being sure to route the cable through the cable retention bracket in order to minimize mechanical strain on the cable.
14. Connect all external cables that you disconnected before you could remove the power supply.
15. Reconnect the power cord and turn on the 2145 UPS-1U.
16. Turn on the node.
17. Make sure that the power LED on the front of the node is lit.

Replacing a SAN Volume Controller 2145-8G4 power supply

This topic describes how to replace a SAN Volume Controller 2145-8G4 power supply.

Ensure that you are aware of the procedures for handling static-sensitive devices before you remove the power supply.

To replace the SAN Volume Controller 2145-8G4 power supply, perform the following steps:

1. Grasp the handle on the rear of the power supply (shown in Figure 162) and slide the power supply forward fully into the node until it clicks in place.

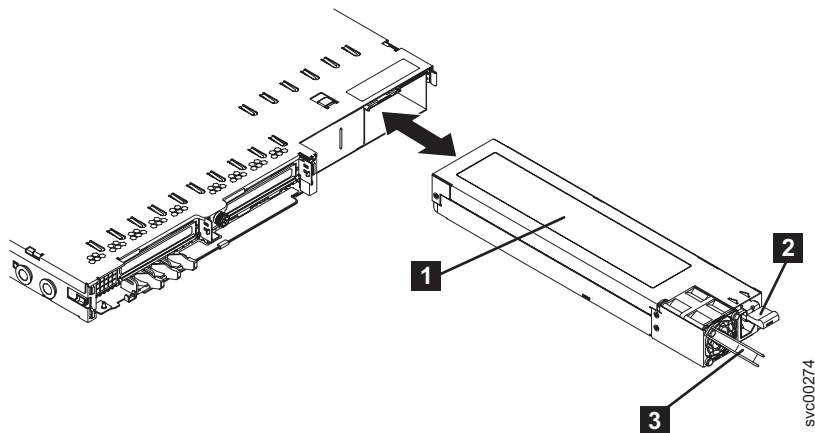

Figure 162. SAN Volume Controller 2145-8G4 power supply

- 1** Power supply
 - 2** Power supply release tab
 - 3** Power supply handle
2. Connect the power cord to the power-cord connector on the power supply, being sure to route the cord through the cable restraint bracket in order to minimize mechanical strain on the cord.
 3. Reconnect the power cord and turn on the 2145 UPS-1U.
 4. Make sure that the ac power LED **1** and the dc power LED **2** (shown in Figure 163 on page 179) on the power supply are lit, indicating that the power supply is operating correctly. The two green LEDs are next to the power-cord connector.

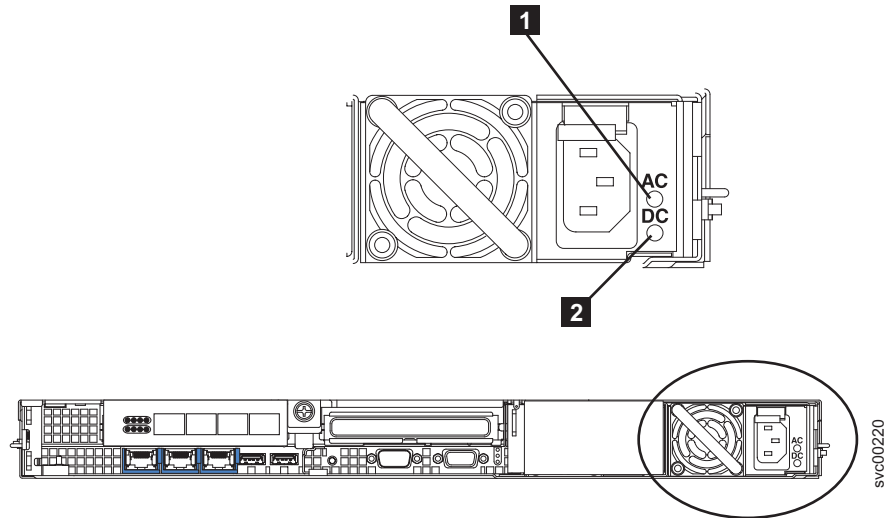

Figure 163. SAN Volume Controller 2145-8G4 ac and dc LEDs

5. Turn on the node.

Replacing the SAN Volume Controller 2145-8F4 or SAN Volume Controller 2145-8F2 power supply

Ensure that you are aware of the procedures for handling static-sensitive devices before you remove the power supply.

To replace the SAN Volume Controller 2145-8F4 or SAN Volume Controller 2145-8F2 power supply, perform the following steps:

1. Install the power supply in the empty power supply bay:
 - a. Rotate the handle **1** down on the rear of the power supply to the open position, and then slide the power supply forward into the power-supply bay, as shown in Figure 164 on page 180.

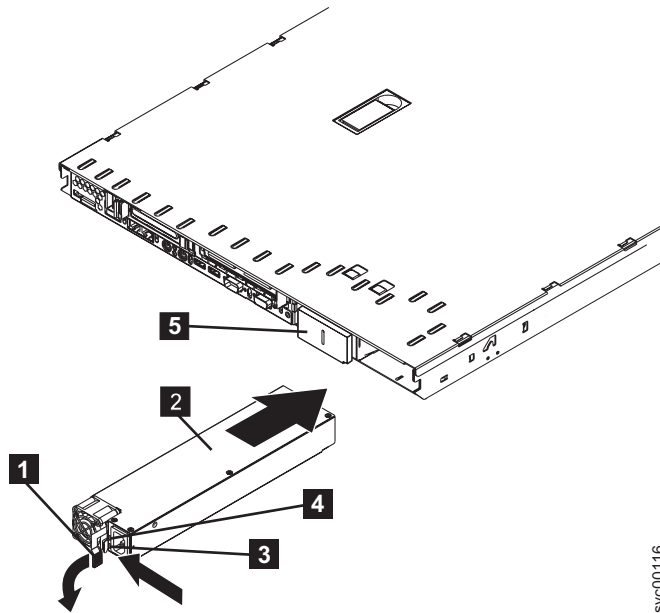

svc00116

Figure 164. SAN Volume Controller 2145-8F2 power supply

- 1** Handle
- 2** Power supply
- 3** Dc power LED
- 4** Ac power LED

- b. Gently lift the handle up until it clicks. This signals that the power supply is securely seated in the bay.
2. Connect the power cord for the new power supply to the power-cord connector on the power supply.
3. Reconnect the power cord and turn on the 2145 UPS-1U.
4. Turn on the node.
5. Make sure that the power-supply fan starts and the ac power LED **1** and dc power LED **2** (shown in Figure 165 on page 181) on the power supply are lit, indicating that the power supply is operating correctly.

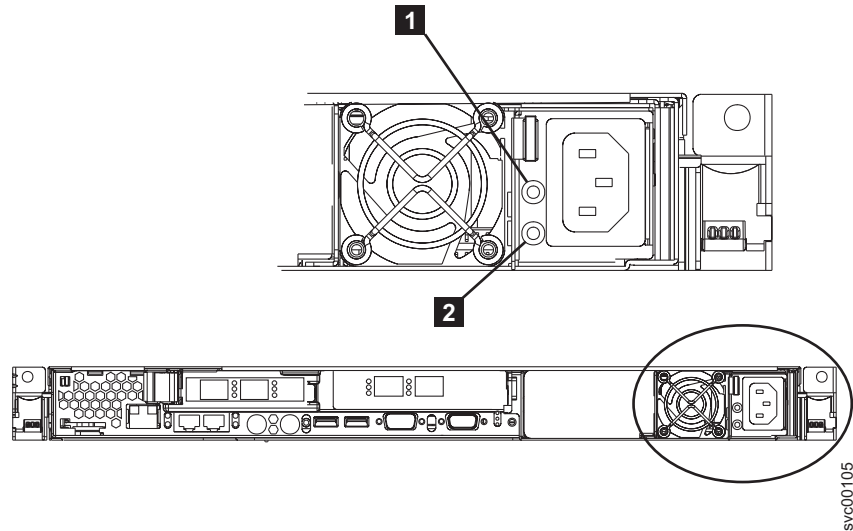

Figure 165. SAN Volume Controller 2145-8F2 or SAN Volume Controller 2145-8F4 ac and dc power LEDs

Removing the power backplane

The SAN Volume Controller power backplane might have to be removed.

Related tasks

“Removing the SAN Volume Controller from a rack” on page 48

During some service procedures, you might need to remove the SAN Volume Controller from a rack.

“Removing the top cover” on page 81

You can remove the top cover of the SAN Volume Controller node if maintenance is necessary.

“Removing the power supply” on page 165

You must remove the SAN Volume Controller power supply if you intend to replace it.

Related reference

“Handling static-sensitive devices” on page xxiv

Ensure that you understand how to handle devices that are sensitive to static electricity.

Removing the SAN Volume Controller 2145-8G4 power backplane

This topic describes how to remove the SAN Volume Controller 2145-8G4 power backplane.

Take precautions to avoid damage from static electricity. Wear an anti-static wrist strap and use a static-protected mat or surface. For more information, see “Handling static-sensitive devices” on page xxiv.

Perform the following steps to remove the power backplane:

1. Turn off the node while ensuring that its data is mirrored and synchronized. See MAP 5350 in the *IBM System Storage SAN Volume Controller Troubleshooting Guide* for more information.
2. Remove the cable-retention bracket and disconnect the power cable from the node. See “Removing the cable-retention bracket” on page 34.

3. Remove the node from the rack and place it on a flat, static-protective surface. See “Removing the SAN Volume Controller from a rack” on page 48.
4. Remove the top cover. See “Removing the top cover” on page 81.
5. Disconnect the power supplies from the power-supply backplane, as shown in Figure 166.

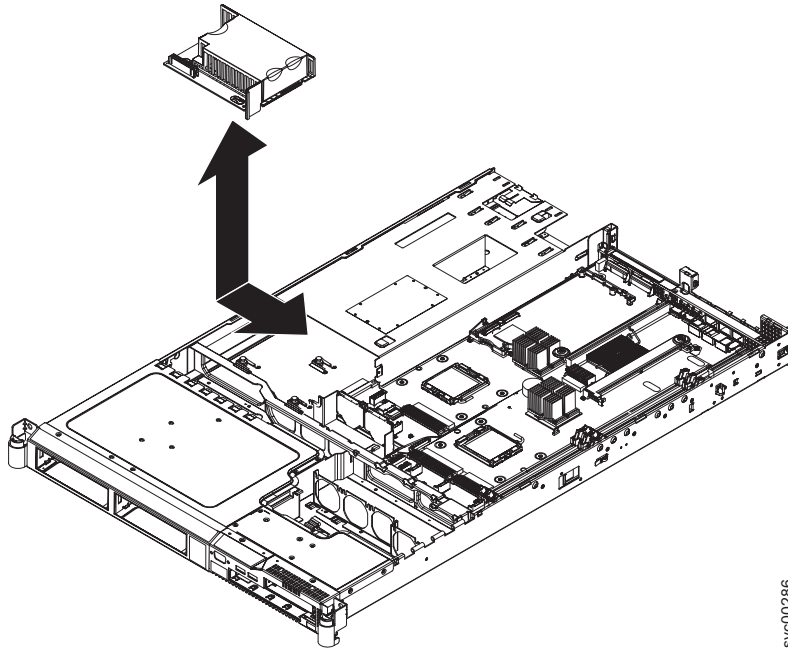

svc00286

Figure 166. SAN Volume Controller 2145-8G4 power backplane

6. Disconnect the cable connected to the power-supply backplane.
7. Slide the power-supply backplane to the left, disconnecting it from the system board.
8. Lift the power-supply backplane to remove it from the node.

Removing the SAN Volume Controller 2145-8F4 or SAN Volume Controller 2145-8F2 power backplane

The SAN Volume Controller 2145-8F4 or SAN Volume Controller 2145-8F2 power backplane might have to be replaced.

Take precautions to avoid damage from static electricity. Wear an anti-static wrist strap and use a static-protected mat or surface. For more information, see “Handling static-sensitive devices” on page xxiv.

Perform the following steps to remove the power backplane:

1. Turn off the node while ensuring that its data is mirrored and synchronized. See MAP 5350 in the *IBM System Storage SAN Volume Controller Troubleshooting Guide* for more information.
2. Remove the SAN Volume Controller 2145-8F4 cable retention bracket.
3. To make sure that you can replace all cables in the same ports from which they were removed, record the position of all fibre-channel and Ethernet cables; then remove all cables from the back of the node.
4. Remove the node from the rack and place it on a flat, static-protective surface. See “Removing the SAN Volume Controller from a rack” on page 48.

5. Remove the top cover. See “Removing the top cover” on page 81.
6. Disconnect the power supply from the power backplane.
7. Slide the power backplane to the left, as shown in Figure 167, and disconnect it from the system board.

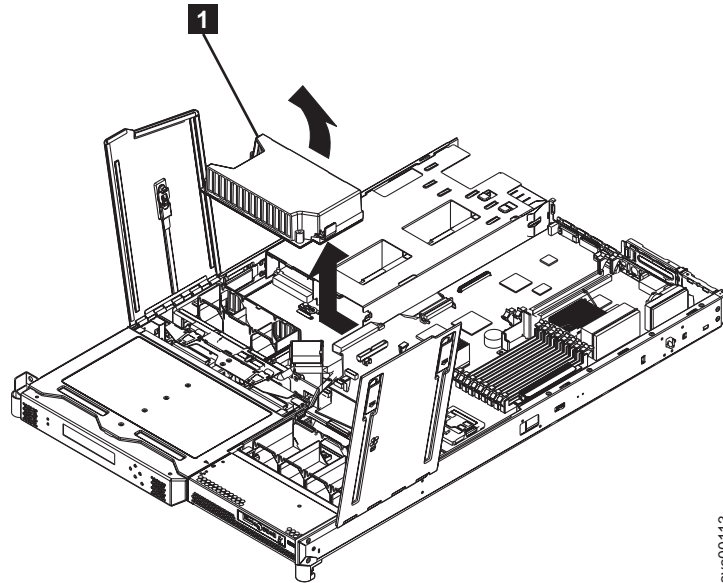

Figure 167. SAN Volume Controller 2145-8F4 or SAN Volume Controller 2145-8F2 power backplane

8. Remove the power backplane from the node.

Replacing the power backplane

The power backplane might have to be replaced for a service action.

Related tasks

“Replacing the power supply” on page 172

You might need to replace the SAN Volume Controller power supply for a service action.

“Replacing the SAN Volume Controller in a rack” on page 59

You must use caution when you replace the SAN Volume Controller in a rack.

“Replacing the top cover” on page 86

You must replace the top cover on the SAN Volume Controller node after maintenance is completed.

Related reference

“Handling static-sensitive devices” on page xxiv

Ensure that you understand how to handle devices that are sensitive to static electricity.

Replacing the SAN Volume Controller 2145-8G4 power backplane

This topic describes how to replace the SAN Volume Controller 2145-8G4 power backplane.

Take precautions to avoid damage from static electricity. Wear an anti-static wrist strap and use a static-protected mat or surface. For more information, see “Handling static-sensitive devices” on page xxiv.

Perform the following steps to replace the power backplane:

1. Align the keyhole slots in the power-supply backplane with the mounting pins in the node.
2. Slide the power-supply backplane toward the right side of the node until the edge-connectors are fully connected.
3. Reconnect the cables to the power-supply backplane.
4. Install the power supply into the power-supply bay as shown in Figure 168.

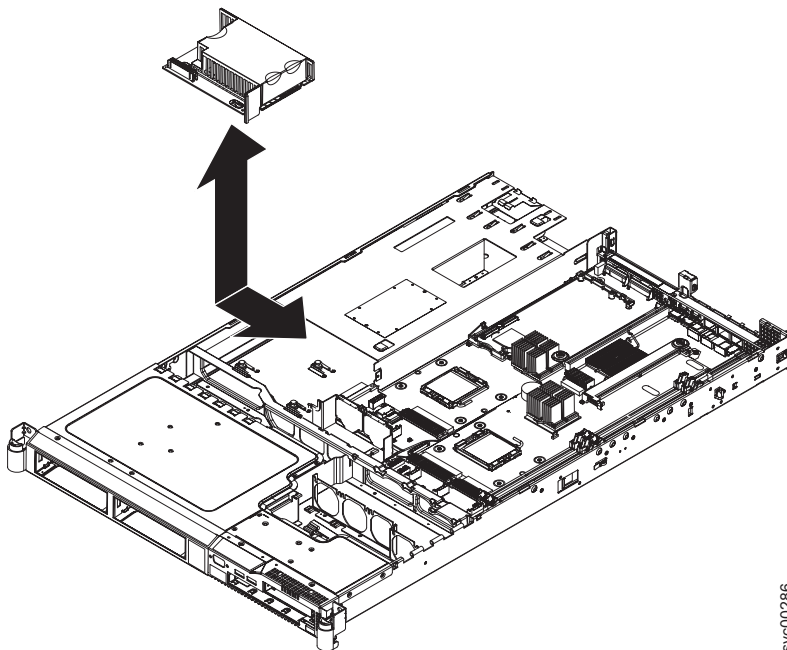

Figure 168. SAN Volume Controller 2145-8G4 power backplane

5. Replace the top cover. See “Replacing the top cover” on page 86.
6. Place the node in the rack. See “Replacing the SAN Volume Controller in a rack” on page 59.
7. Reconnect the fibre-channel and Ethernet cables. Ensure that you replace the fibre-channel and Ethernet cables in the same ports from which they were removed.
8. Turn on the node.

Replacing the SAN Volume Controller 2145-8F4 or SAN Volume Controller 2145-8F2 power backplane

The SAN Volume Controller 2145-8F4 or SAN Volume Controller 2145-8F2 power backplane might have to be replaced.

Take precautions to avoid damage from static electricity. Wear an anti-static wrist strap and use a static-protected mat or surface. For more information, see “Handling static-sensitive devices” on page xxiv.

Perform the following steps to replace the power backplane:

1. Lower the power backplane into position on the SAN Volume Controller 2145-8F4 or SAN Volume Controller 2145-8F2 and slide it to the right to connect it to the system board. See Figure 169 on page 185.

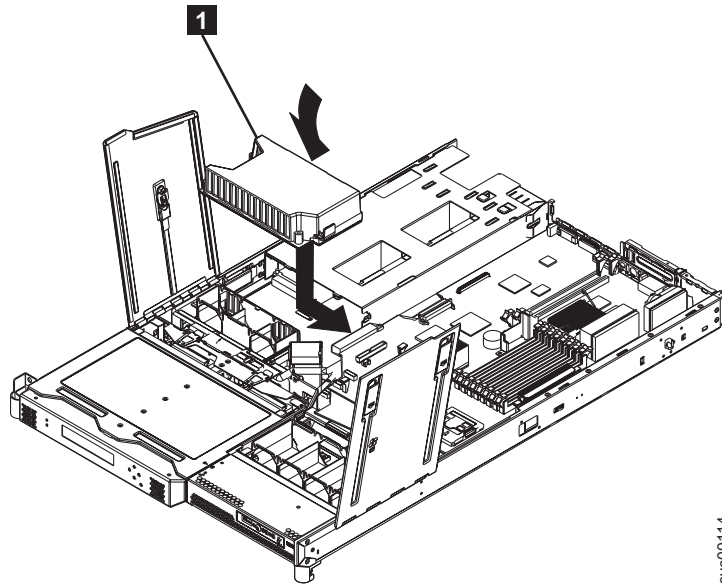

Figure 169. Replacing the SAN Volume Controller 2145-8F4 or SAN Volume Controller 2145-8F2 power backplane

2. Connect the power supply to the power backplane.
3. Replace the top cover. See “Replacing the top cover” on page 86.
4. Place the node in the rack. See “Replacing the SAN Volume Controller in a rack” on page 59.
5. Reconnect the fibre-channel and Ethernet cables. Ensure that you replace the fibre-channel and Ethernet cables in the same ports from which they were removed.
6. Turn on the node.

Removing and replacing the frame assembly

This topic describes how to replace the SAN Volume Controller 2145-8F2 and SAN Volume Controller 2145-8F4 frame assembly.

The SAN Volume Controller 2145-8F2 and SAN Volume Controller 2145-8F4 frame assembly must be replaced when the system board fails or when replacing other system board components does not isolate the error.

Note: If you are replacing the frame assembly after you replaced the service controller, you must ensure that the node can be added back to the cluster. Use the following choices, which are based on the actions that you must take or have already taken, to determine how the node can be added back to the cluster:

- If you are replacing the node because the new service controller did not fix the original problem and you could not update the WWNN of the service controller, use the original service controller when you perform the frame replacement. This ensures that the WWNN is correct.
- If you have already made any required updates to the worldwide node name (WWNN) and the updates are stored in the service controller, continue with the following instructions to replace the frame assembly.

- If you must use a new service controller when you replace the frame assembly, use the following instructions to replace the frame assembly and make sure that you follow the special instructions in step 11.

Perform the following steps to replace the frame assembly:

1. Write down the 7-character serial number from the serial number label that is on the front of the node.
For the SAN Volume Controller 2145-8F2 and SAN Volume Controller 2145-8F4 models only: If you cannot read the serial number or if you want to verify that it is correct, you can also find it on the node vital product data (VPD).
Perform the following steps to find the serial number in the VPD:
 - a. Start the SAN Volume Controller Console application.
 - b. Display the VPD for the failed node.
 - c. Note the system serial number.
2. Turn off the node while ensuring that its data is mirrored and synchronized. See MAP 5350 in the *IBM System Storage SAN Volume Controller Troubleshooting Guide* for more information.
3. Remove the node from the rack and place it on a flat, static-protective surface. See “Removing the SAN Volume Controller from a rack” on page 48.
4. Remove the top cover. See “Removing the top cover” on page 81.
5. Remove the fibre-channel adapter cards from the frame assembly that you are replacing.
6. Remove the service controller from the frame assembly you are replacing.
7. Install the fibre-channel adapter cards into the new frame assembly.
8. Install the service controller into the new frame assembly.
9. Replace the top cover. See “Replacing the top cover” on page 86.
10. Place the node in the rack. See “Replacing the SAN Volume Controller in a rack” on page 59.
11. Start the node using the node rescue procedure.

Note: If you have to install a new service controller in the frame assembly, you must perform the next steps to allow the node rescue to find a suitable donor node.
 - a. Turn on the node. Use your SAN monitoring tools to determine the WWNN of the node.
 - b. Rezone the switch to allow at least one port of the replaced node to connect to at least one port of an existing node.
 - c. Perform a node rescue.
 - d. Set the WWNN of the replacement node to match the node that it replaced. See “Node WWNN” in the *IBM System Storage SAN Volume Controller Troubleshooting Guide* for more information.
 - e. Rezone the switch to its original settings.
 - f. Add the node back into the cluster.
 - g. Clearly label the original service controller to indicate that its WWNN has been re-used, and that the part cannot be used without first changing the WWNN.

Attention: It is essential that you perform all the stages of the next step to ensure that the replacement system is set to the serial number of the original machine.

12. If you are performing this repair as part of a directed maintenance procedure, you will be prompted to type the machine serial number that you noted above. Otherwise, perform the following steps:
 - a. Delete the failed node from the cluster.
 - b. Add the repaired node to the cluster.
 - c. Start the command-line interface (CLI). See "Accessing the SAN Volume Controller CLI" in the *IBM System Storage SAN Volume Controller Troubleshooting Guide*.
 - d. Issue the following command:

```
svctask writesernum -sernum nodeserialnumber nodename
```

where *nodeserialnumber* is the number that you noted previously and *nodename* is the name of the repaired node that you added in this step.
For example, to write the machine serial number to the system board when the serial number is "13-FEDCB" and the node name is "ZYXW3," you would issue the following command:

```
svctask writesernum -sernum 13FEDCB ZYXW3
```

Note: The node will restart as soon as the serial number has been written to it.
 - e. Write the serial number that you noted previously on the blank serial number label on the front of the node.

Related tasks

"Removing the SAN Volume Controller from a rack" on page 48

During some service procedures, you might need to remove the SAN Volume Controller from a rack.

"Replacing the SAN Volume Controller in a rack" on page 59

You must use caution when you replace the SAN Volume Controller in a rack.

"Removing the top cover" on page 81

You can remove the top cover of the SAN Volume Controller node if maintenance is necessary.

"Replacing the top cover" on page 86

You must replace the top cover on the SAN Volume Controller node after maintenance is completed.

"Removing the fibre-channel adapter assembly" on page 189

Use the information in this topic when you need to remove a fibre channel adapter or fibre-channel adapter assemblies.

"Replacing the fibre-channel adapter assembly" on page 197

Use these instructions when you need to replace the adapter assemblies.

"Removing the service controller" on page 90

You can remove the service controller from the SAN Volume Controller.

"Replacing the service controller" on page 102

You can replace the SAN Volume Controller service controller.

Removing and replacing the fibre-channel SFP connector on a SAN Volume Controller node

When a failure occurs on a single fibre-channel link, the SFP connector might need to be replaced.

The SFP connector is designed to be hot-plugged, so that you do not need to power off the SAN Volume Controller node.

CAUTION:

Some laser products contain an embedded Class 3A or Class 3B laser diode. Note the following information: laser radiation when open. Do not stare into the beam, do not view directly with optical instruments, and avoid direct exposure to the beam. (C030)

Perform the following steps to remove and then replace the SFP connector:

1. Carefully determine the failing physical port connection. See the *IBM System Storage SAN Volume Controller Troubleshooting Guide* for illustrations of the fibre-channel port locations.

Important: SAN Volume Controller nodes are now supported with both long-wave SFPs and short-wave SFPs. A long-wave SFP has some blue components that are visible even when the SFP is plugged in. You must replace an SFP with the same type of SFP that you are replacing. If the SFP to replace is a long wave SFP, for example, you must provide a suitable replacement. Removing the wrong SFP connector could result in loss of data access.

2. Remove the fibre-channel cable by pressing the release tab and pulling the cable out. Be careful to exert pressure only on the connector and do not pull on the fibre-channel cables.
3. Remove the SFP. There are a number of different handling or locking mechanisms that are used on the SFP connectors. Table 22 describes the usual type of mechanisms that are found on a SAN Volume Controller model. It is possible, however, that the installed SFP connectors have a different mechanism than is indicated.

Table 22. Instructions for removing the SFP connector

SAN Volume Controller model	Removal instructions
SAN Volume Controller models 2145-CF8, 2145-8A4, 2145-8G4, and 2145-8F4	Locate the release handle that is incorporated into the SFP connector, unclip the handle, and then use the handle to pull out the SFP connector.
SAN Volume Controller 2145-8F2	Locate the small black locking tag on the bottom of the SFP connector, push it back, and then pull out the SFP connector.
Note: Other SFP connectors might have a plastic tag. If so, pull the tag to remove the SFP connector.	

Important: The customer might be using a non-standard SFP connector. If so, the customer should alert you as to the SFP connector to use, and provide the SFP connector to you. Always check that the SFP connector that you replace matches the SFP connector that you remove.

4. Push the new SFP connector into the aperture and ensure it is securely pushed home. The SFP usually locks into place without having to swing the release handle until it locks flush with the SFP connector. Figure 170 on page 189 illustrates an SFP connector and its release handle.



Figure 170. Fibre-channel SFP connector

5. Reconnect the fibre-channel cable.
6. Confirm that the error is now fixed. Check the fibre-channel port status using the front-panel display. If possible, check the status given by the customer's SAN monitoring tools. Either mark the error as fixed or restart the node depending on the failure indication that you originally noted.

Removing the fibre-channel adapter assembly

Use the information in this topic when you need to remove a fibre channel adapter or fibre-channel adapter assemblies.

Take precautions to avoid damage from static electricity. Wear an anti-static wrist strap and use a static-protected mat or surface. For more information, see "Handling static-sensitive devices" on page xxiv.

Related tasks

"Removing the SAN Volume Controller from a rack" on page 48

During some service procedures, you might need to remove the SAN Volume Controller from a rack.

"Removing the top cover" on page 81

You can remove the top cover of the SAN Volume Controller node if maintenance is necessary.

"Removing and replacing the SAN Volume Controller power-cable assembly" on page 110

Make sure that power to the SAN Volume Controller is turned off before you remove the power-cable assembly. Turn off the node while ensuring that its data is mirrored and synchronized, as described in MAP 5350 in the *IBM System Storage SAN Volume Controller Troubleshooting Guide*.

Related reference

"Handling static-sensitive devices" on page xxiv

Ensure that you understand how to handle devices that are sensitive to static electricity.

Removing the SAN Volume Controller 2145-CF8 fibre-channel adapter assembly

To remove the SAN Volume Controller 2145-CF8 fibre-channel adapter assembly, perform the following steps:

DANGER

Multiple power cords. The product might be equipped with multiple power cords. To remove all hazardous voltages, disconnect all power cords.

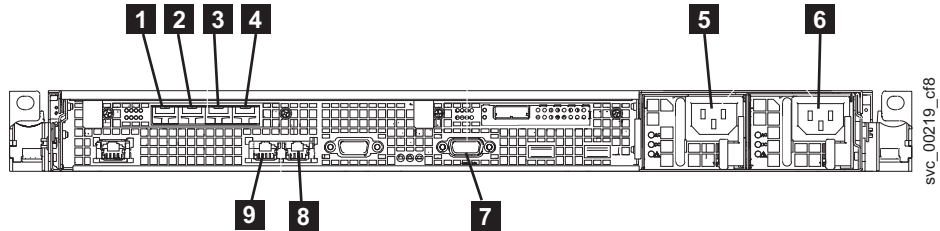

Figure 171. Connectors on the rear of the SAN Volume Controller 2145-CF8

- 1** Fibre-channel port 1
- 2** Fibre-channel port 2
- 3** Fibre-channel port 3
- 4** Fibre-channel port 4
- 5** Power connector 1
- 6** Power connector 2
- 7** Serial port for UPS communications (RS232)
- 8** Ethernet port 2
- 9** Ethernet port 1

This service action requires you to remove the cover and:

- Turn the node off.
- Disconnect the power cables.
- Disconnect the data cables.

To remove the SAN Volume Controller 2145-CF8 fibre-channel adapter assembly, perform the following steps:

1. Read the safety information to which “Preparing to remove and replace parts” on page 24 refers.
2. Follow the procedure in MAP 5350 in the *IBM System Storage SAN Volume Controller Troubleshooting Guide* to verify that the node data is mirrored and synchronized, and that there are no dependent virtual disks (VDisks) before turning off the node.
3. Slide the node out on its slide rails to the fully extended position.
4. When the node is completely turned off, remove the cable-retention brackets and disconnect the power cables, as described in “Removing the cable-retention bracket” on page 34.
5. To make sure that you can replace all cables in the same ports from which they were removed, label the port position of each fibre-channel and Ethernet cable; then remove all cables from the back of the node.
6. Optional: Remove the node from the rack and place it on a flat, static-protective surface. See “Removing the SAN Volume Controller from a rack” on page 48.

You can perform most service actions when the node is fully extended from the rack on its slide rails. If the location of the node in the rack is too high or too low to work comfortably, you can remove the node from the rack.

7. Remove the top cover. See “Removing the top cover” on page 81.
8. Remove all SFPs before removing the adapter, as described in “Removing and replacing the fibre-channel SFP connector on a SAN Volume Controller node” on page 187.
9. Remove the two M3 screws that attach the adapter assembly to the back rail. The fibre-channel adapter assembly and the high-speed SAS adapter assembly each attach to the back rail with two screws, as shown in the partial view of the rail with the fibre-channel adapter assembly attached in Figure 172.

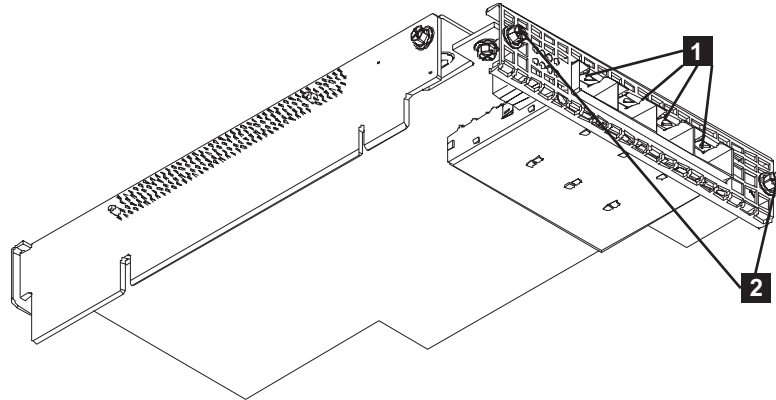

Figure 172. The SAN Volume Controller 2145-CF8 fibre-channel adapter

- 1** Fibre-channel ports 1 - 4
- 2** Back-rail retaining screws

10. After removing the back-rail retaining screws for the adapter assembly, grasp the riser-card assembly at either end and pull up out of the slot 1 riser-card connector, as shown in Figure 173 on page 192. Once the riser card clears the connector, gently twist the card assembly to separate the assembly from the node.

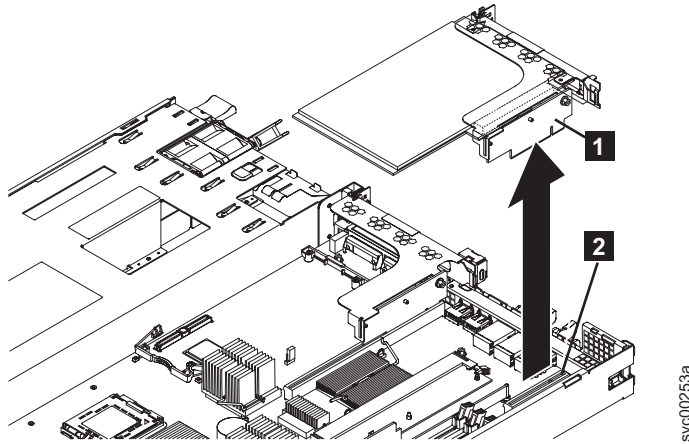

Figure 173. Removing the fibre-channel riser-card assembly for the SAN Volume Controller 2145-CF8

When looking from the back, the slot 1 connector is the connector on the left. The high-speed SAS riser-card assembly, if present, attaches to the slot 2 connector on the left side of the system board, when looking from the back. If there is no high-speed SAS adapter riser-card assembly, a riser-card adapter is present in slot 2.

11. Place the riser-card assembly on a flat, static-protective surface.
12. If you are instructed to return the fibre-channel adapter assembly, follow all packaging instructions, and use any packaging materials for shipping that are supplied to you.

Removing the SAN Volume Controller 2145-8A4 fibre-channel adapter assembly

You need to remove the riser-card assembly from the SAN Volume Controller 2145-8A4 node and then remove the fibre-channel adapter assembly from the riser-card assembly.

Perform the following steps to remove a fibre-channel adapter assembly:

1. Turn off the node while ensuring that its data is mirrored and synchronized. See MAP 5350 in the *IBM System Storage SAN Volume Controller Troubleshooting Guide* for more information.
2. Remove the cable-retention bracket and disconnect the power cable from the node. See “Removing the cable-retention bracket” on page 34.
3. Remove the node from the rack and place it on a flat, static-protective surface. See “Removing the SAN Volume Controller from a rack” on page 48.
4. Remove the top cover. See “Removing the top cover” on page 81.
5. Grasp the riser-card assembly at the front and rear edges and lift to remove it from the node. Place the riser-card assembly shown in Figure 174 on page 193 on a flat, static-protective surface.

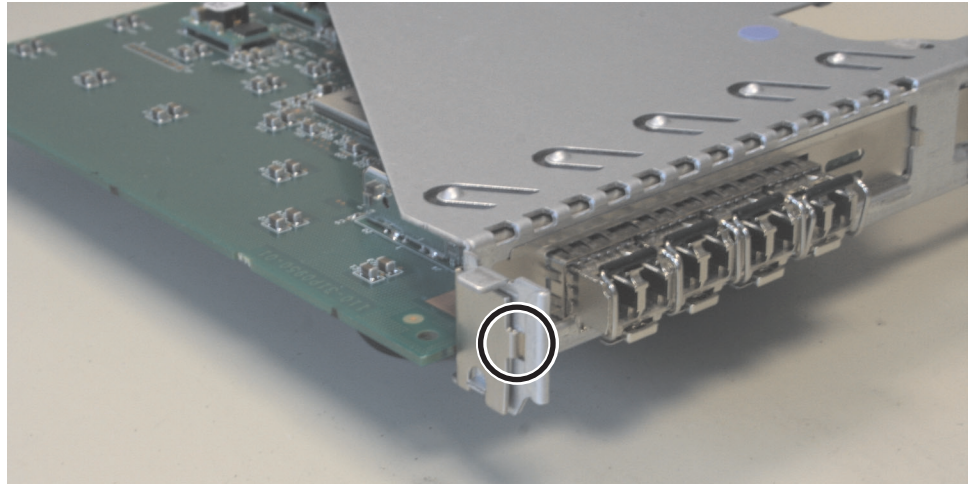

svc00500

Figure 174. SAN Volume Controller 2145-8A4 riser-card assembly

6. Remove the four SFP connectors from the adapter. To do this, unclip the release handle shown in Figure 175 and then use the handle to pull out each SFP connector.



svc00418

Figure 175. Fibre-channel SFP connector

7. Slide the adapter straight back from the connector and out of the riser-card assembly. Do not try to slide the adapter at an angle.

Removing the SAN Volume Controller 2145-8G4 fibre-channel adapter assembly

Perform the following steps to remove the SAN Volume Controller 2145-8G4 fibre-channel adapter assembly:

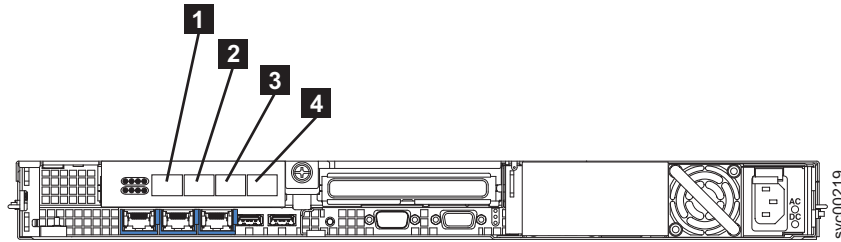

Figure 176. The physical port numbers for the SAN Volume Controller 2145-8G4

1. Turn off the node while ensuring that its data is mirrored and synchronized. See MAP 5350 in the *IBM System Storage SAN Volume Controller Troubleshooting Guide* for more information.

Attention: When you install an adapter, make sure that the adapter is correctly seated in the connector before you turn on the server. An incorrectly seated adapter might cause damage to the system board, the riser-card assembly, or the adapter.

2. When the node is completely turned off, remove the main power cable-retention bracket and remove the power cable from the rear of the node.
3. After writing down their locations, remove all other cables from the node.
4. Remove the node from the rack and place it on a flat, static-protective surface. See “Removing the SAN Volume Controller from a rack” on page 48.
5. Remove the top cover. See “Removing the top cover” on page 81.
6. Grasp the riser-card assembly (2 in Figure 177) at the rear edge and lift to remove the riser-card assembly.

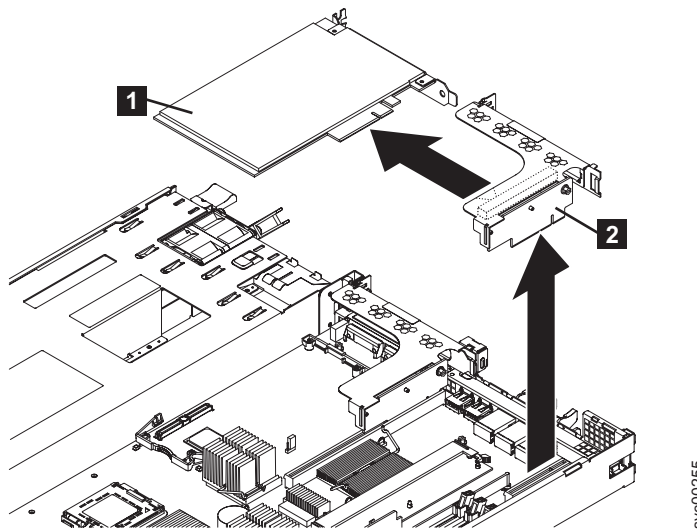

Figure 177. Removing the riser-card assembly from the SAN Volume Controller 2145-8G4

7. Place the riser-card assembly on a flat, static-protective surface.
8. Carefully grasp the adapter (1) by its top edge or upper corners, and pull the adapter from the riser-card assembly (2).

Removing the SAN Volume Controller 2145-8F4 or SAN Volume Controller 2145-8F2 adapter assemblies

The SAN Volume Controller 2145-8F2 contains two types of fibre-channel adapters that are functionally identical but not interchangeable. The SAN Volume Controller 2145-8F4 contains a single 4-Port adapter in PCI slot 2.

Figure 178 shows the rear view of the SAN Volume Controller 2145-8F2 with the two fibre-channel ports identified:

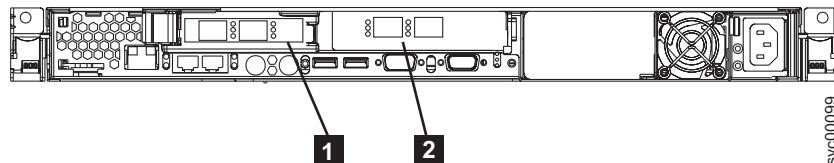

Figure 178. Rear view of the SAN Volume Controller 2145-8F2 with fibre-channel ports indicated

- 1** PCI slot 1 - contains a dual port fibre-channel host bus adapter (HBA) in a low profile
- 2** PCI slot 2 - contains a dual port fibre-channel HBA at full height

Figure 179 shows the rear view of the SAN Volume Controller 2145-8F4 with the 4-port fibre-channel HBA identified:

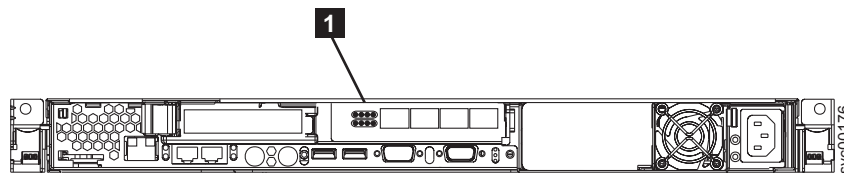

Figure 179. Rear view of the SAN Volume Controller 2145-8F4

- 1** PCI slot 2 - contains a 4-port fibre-channel HBA

Perform the following steps to remove a fibre-channel adapter assembly:

1. Turn off the node while ensuring that its data is mirrored and synchronized. See MAP 5350 in the *IBM System Storage SAN Volume Controller Troubleshooting Guide* for more information.
2. Remove the node from the rack and place it on a flat, static-protective surface. See “Removing the SAN Volume Controller from a rack” on page 48.
3. Remove the top cover. See “Removing the top cover” on page 81.
4. Perform the following steps to remove the PCI card from PCI slot 1 (low profile):
 - a. Pull the blue PCI card retainer **1** from the rear of the node, shown in Figure 180 on page 196.

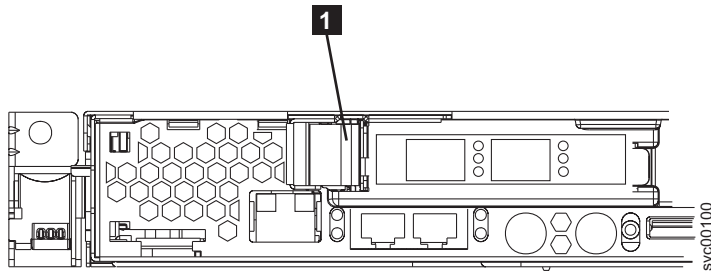

Figure 180. SAN Volume Controller 2145-8F2 or SAN Volume Controller 2145-8F4 PCI slot 1 card retainer

1 Slot 1 card retainer

- b. Hold the blue adapter support away from the card and pull it away from the edge connector on the riser card assembly, as shown in Figure 181.

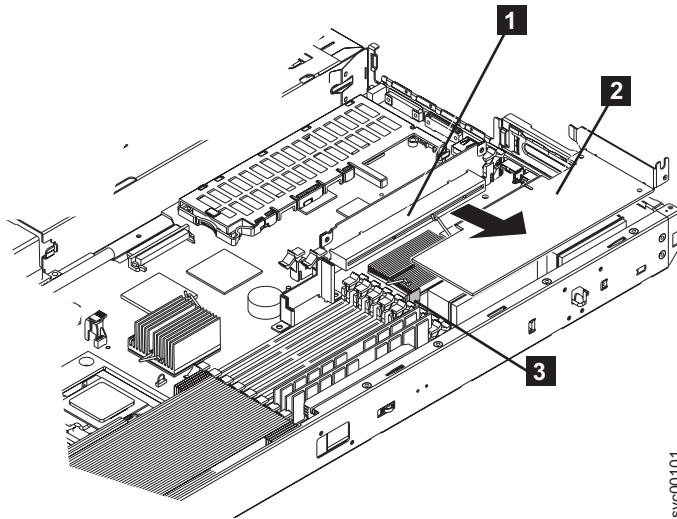

Figure 181. SAN Volume Controller 2145-8F2 riser card and low profile adapter

1 Riser card

2 Low-profile adapter

3 Low-profile adapter support

5. Perform the following steps to remove the PCI card from PCI slot 2:
 - a. Open the retaining clips on both sides of the slot 2 riser card (**2** in Figure 182 on page 197) by pushing the clips down and away from the riser card until the clips are no longer attached to the riser card.

Note: Insert your finger into the access hole on the slot 2 adapter cover to open the retention latch at the rear of the node.

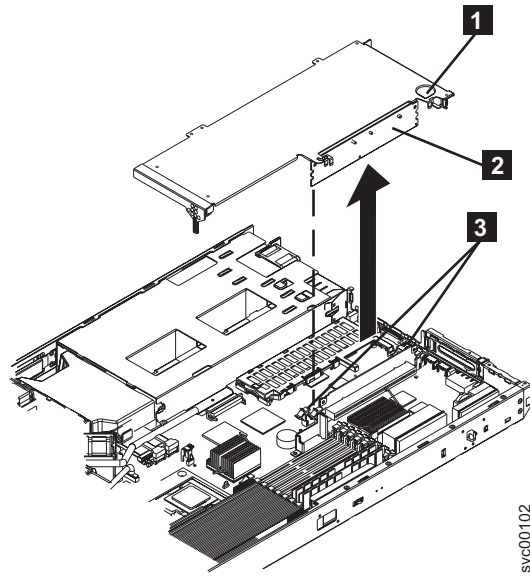

Figure 182. SAN Volume Controller 2145-8F2 or SAN Volume Controller 2145-8F4 slot 2 adapter

- 1** Access hole to retention latch
 - 2** Riser card
 - 3** Riser-card retention latches
- b. Unlatch the PCI slot 2 riser card **2** and pull it clear of the system-board edge connector.
 - c. Lift the riser card clear of the frame and pull the fibre-channel card from the riser-card edge connector.

Replacing the fibre-channel adapter assembly

Use these instructions when you need to replace the adapter assemblies.

Related tasks

“Replacing the SAN Volume Controller in a rack” on page 59

You must use caution when you replace the SAN Volume Controller in a rack.

“Removing the fibre-channel adapter assembly” on page 189

Use the information in this topic when you need to remove a fibre channel adapter or fibre-channel adapter assemblies.

Related reference

“Handling static-sensitive devices” on page xxiv

Ensure that you understand how to handle devices that are sensitive to static electricity.

Replacing the SAN Volume Controller 2145-CF8 fibre-channel adapter assembly

Perform the following steps to replace the SAN Volume Controller 2145-CF8 fibre-channel adapter assembly:

|
|
|
|

DANGER

Multiple power cords. The product might be equipped with multiple power cords. To remove all hazardous voltages, disconnect all power cords.

1. Remove all SFPs, as described in “Removing and replacing the fibre-channel SFP connector on a SAN Volume Controller node” on page 187.
2. Grasp each end of the riser card, tilt the adapter card so that the side with the PCI riser card is higher than the opposite side, and the back is higher than the front.
3. Locate the cage which houses the SFPs through the hole in the back of the node.
4. Align the fibre-channel adapter riser-card connector with the connector on the system board.

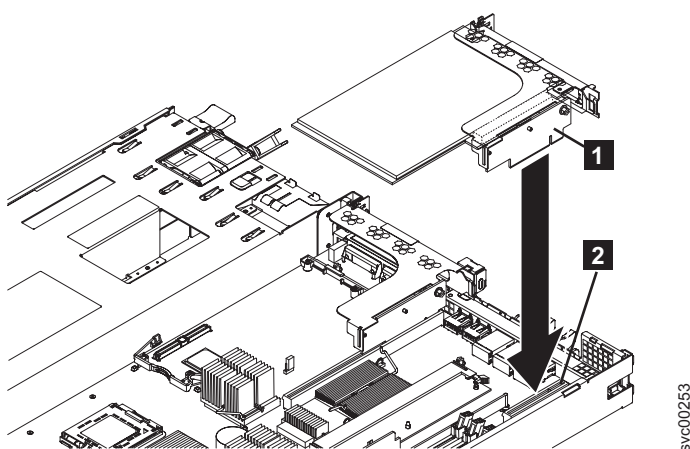

Figure 183. Replacing the riser-card assembly for the SAN Volume Controller 2145-8G4

- 1** Fibre-channel riser-card assembly
- 2** System-board-riser-card connector

5. Press down on the top of the riser card until the card settles in the slot.
6. Anchor the adapter card assembly using two fastening screws from the back of the node.

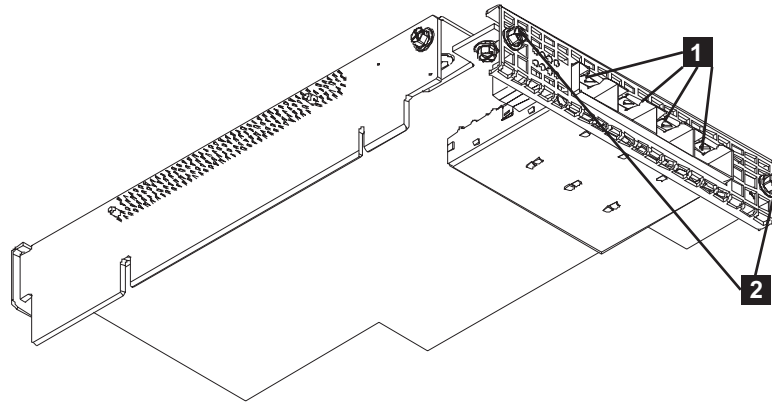

Figure 184. The SAN Volume Controller 2145-CF8 fibre-channel adapter

- 1 Fibre-channel ports 1 - 4
- 2 Back-rail retaining screws

7. Install all of the SFPs into the adapter card, as described in “Removing and replacing the fibre-channel SFP connector on a SAN Volume Controller node” on page 187.
8. Make sure that all cables, adapters, and other components are installed and seated correctly and that you have not left loose tools or parts inside the node. Make sure that all internal cables are correctly routed. If you disconnected the fibre-channel and Ethernet cables, make sure that each cable is reconnected to the same port from which it was removed.
9. Replace the top cover. See “Replacing the top cover” on page 86.
10. Place the node in the rack. See “Replacing the SAN Volume Controller in a rack” on page 59.
11. Replace the cable-retention brackets and reconnect the power cables, as described in “Replacing the SAN Volume Controller 2145-CF8 cable-retention brackets” on page 41.
12. Turn on the node.

Replacing the SAN Volume Controller 2145-8A4 fibre-channel adapter assembly

Before you can replace the fibre-channel adapter assembly, it must be installed in the riser-card assembly.

Perform the following steps to replace the SAN Volume Controller 2145-8A4 fibre-channel adapter assembly:

1. Remove the SFP connectors if they are in the new fibre-channel adapter assembly. To do this, unclip the release handle and then use the handle to pull out each SFP connector.
2. Slide the fibre-channel adapter into position, keeping it close and parallel to the back edge of the riser card. Push the adapter securely into the connector. Ensure that the positioning clip on the adapter goes into the locating hole on the

riser card, as shown in Figure 185.

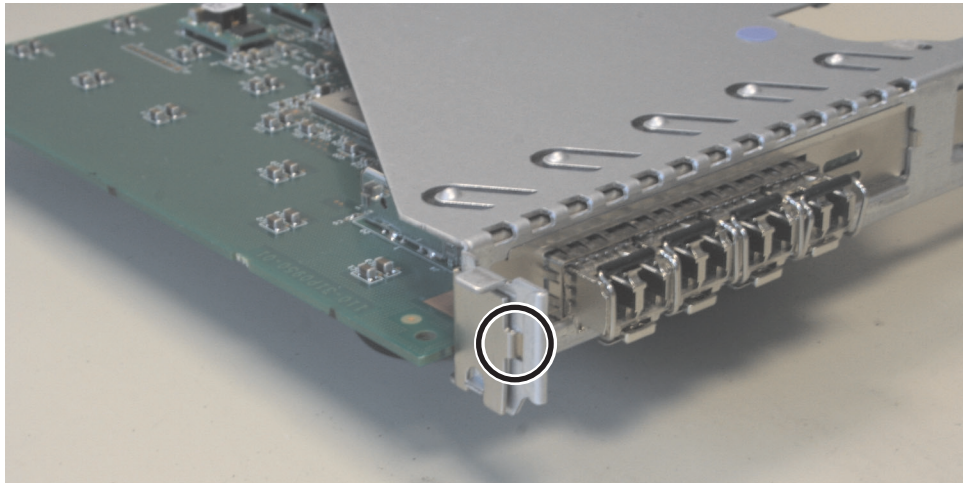

Figure 185. SAN Volume Controller 2145-8A4 riser-card assembly

3. Replace the SFP connectors in the fibre-channel adapter assembly.
4. Carefully align the riser-card assembly with the guides on the rear of the node and with the riser-card connectors on the system board. Press down on the assembly and make sure that the riser-card assembly is fully seated in the riser-card connectors on the system board.
5. Replace the top cover. See “Replacing the top cover” on page 86.
6. Place the node in the rack. See “Replacing the SAN Volume Controller in a rack” on page 59.
7. Replace the cables that were removed from the node, and make sure that you replace the fibre-channel cables in the same ports from which they were removed.
8. Replace the cable-retention bracket. See “Replacing the cable-retention bracket” on page 40.

Replacing the SAN Volume Controller 2145-8G4 fibre-channel adapter assembly

Perform the following steps to replace the SAN Volume Controller 2145-8G4 fibre-channel adapter assembly:

1. As you start inserting the adapter, align the edge connector on the low-profile adapter **1** with the connector **3** on the riser-card assembly **4**. Make sure that the adapter snaps into the riser-card securely. Press the riser-card edge connector firmly into the system-board connector. **5**, as shown in Figure 186 on page 201.

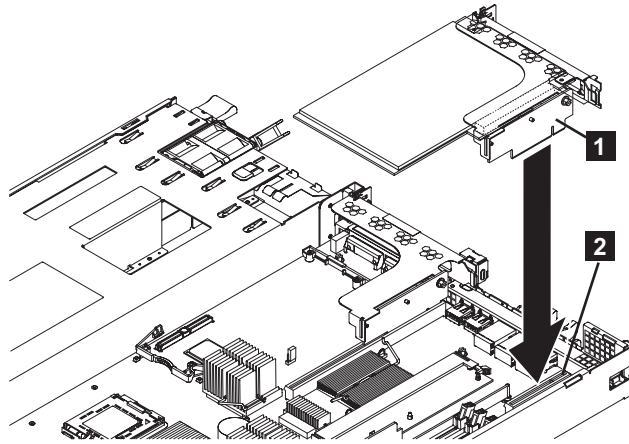

svc00253

Figure 186. Replacing the riser-card assembly for the SAN Volume Controller 2145-8G4

- 1** Fibre-channel adapter
- 2** Adapter support bracket
- 3** Riser-card-adapter connector
- 4** Riser-card assembly
- 5** System-board-riser-card connector

2. Replace the top cover. See “Replacing the top cover” on page 86.
3. Place the node in the rack. See “Replacing the SAN Volume Controller in a rack” on page 59.
4. Replace the cables that were removed from the node, and make sure that you replace the fibre-channel cables in the same ports from which they were removed.
5. Replace the cable-retention bracket. See “Replacing the cable-retention bracket” on page 40.

Replacing the SAN Volume Controller 2145-8F4 or SAN Volume Controller 2145-8F2 adapter assemblies

Perform the following steps to install the fibre-channel card into the riser-card assembly:

Note: The adapter assemblies are electrostatic-discharge sensitive. Take precautions to avoid damage from static electricity. Wear an anti-static wrist strap and use a static-protected mat or surface. For more information, see “Handling static-sensitive devices” on page xxiv.

1. Install the fibre-channel card in slot 1, which is shown in Figure 187 on page 202.

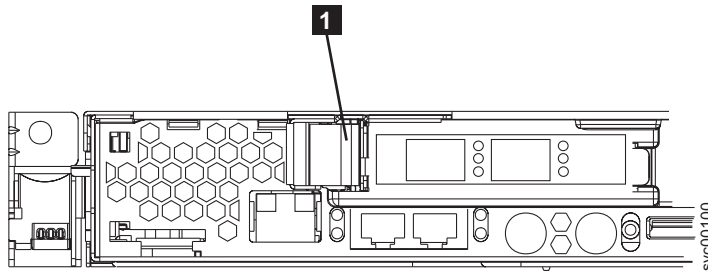

Figure 187. SAN Volume Controller 2145-8F2 or SAN Volume Controller 2145-8F4 PCI slot 1 card retainer

- a. Slide the I/O connector portion of the adapter through the slot 1 opening and align the edge connector on the low-profile adapter with the connector on the riser card. Press the edge connector firmly into the riser-card connector. Make sure that the adapter snaps into the riser card securely and the adapter is lying on top of the low-profile adapter support.
 - b. Push the adapter down past the tab so that the adapter snaps into place on the support.
 - c. Check the retention latches on the riser card and make sure that they are still securely in place.
 - d. Close the fibre-channel card retainer to secure the card.
2. Install the fibre-channel card in slot 2.
 - a. Align the edge connector on the fibre-channel adapter with the connector on the riser card. Press the edge connector firmly into the riser-card connector. The card is fully installed when the gold connectors on the edge of the fibre-channel cards are no longer visible.
 - b. Grasp the riser card assembly by its top edge or upper corners and align the riser card with the guides for the riser-card connector.
 - c. Press the riser card edge connector firmly into the slot 2 riser-card edge connector on the system board. Make sure that the retention latches snap into place to secure the riser card into the slot 2 riser-card connector.
 3. Replace the top cover. See “Replacing the top cover” on page 86.
 4. Place the node in the rack. See “Replacing the SAN Volume Controller in a rack” on page 59.

Removing the high-speed SAS adapter

You can remove the high-speed adapter assembly in the SAN Volume Controller 2145-CF8.

Removing the SAN Volume Controller 2145-CF8 high-speed SAS adapter assembly

You can remove the SAN Volume Controller 2145-CF8 high-speed SAS adapter assembly.

DANGER

Multiple power cords. The product might be equipped with multiple power cords. To remove all hazardous voltages, disconnect all power cords.

This service action requires you to remove the cover and:

- Turn the node off.

- Disconnect the power cables.
- Disconnect the data cables.

To remove the SAN Volume Controller 2145-CF8 high-speed SAS adapter assembly, perform the following steps:

1. Read the safety information to which “Preparing to remove and replace parts” on page 24 refers.
2. Follow the procedure in MAP 5350 in the *IBM System Storage SAN Volume Controller Troubleshooting Guide* to verify that the node data is mirrored and synchronized, and that there are no dependent virtual disks (VDisks) before turning off the node.
3. Slide the node out on its slide rails to the fully extended position.
You can perform most service actions when the node is fully extended from the rack on its slide rails. You can leave the fibre-channel and Ethernet cables connected, if you are using the cable-management arm and if you are not removing the node from the rack. If the location of the node in the rack is too high or too low to work comfortably, you can remove the node from the rack.
4. When the node is completely turned off, remove the cable-retention brackets and disconnect the power cables, as described in “Removing the cable-retention bracket” on page 34.
5. To make sure that you can replace all cables in the same ports from which they were removed, label the port position of each fibre-channel and Ethernet cable; then remove all cables from the back of the node.
6. Optional: Remove the node from the rack and place it on a flat, static-protective surface. See “Removing the SAN Volume Controller from a rack” on page 48.
7. Remove the top cover. See “Removing the top cover” on page 81.
8. Remove the two M3 screws that attach the adapter assembly to the back rail.
The high-speed SAS adapter assembly and the fibre-channel adapter assembly each attach to the back rail with two screws, as shown in the partial view of the rail with the high-speed SAS adapter assembly attached in Figure 188.

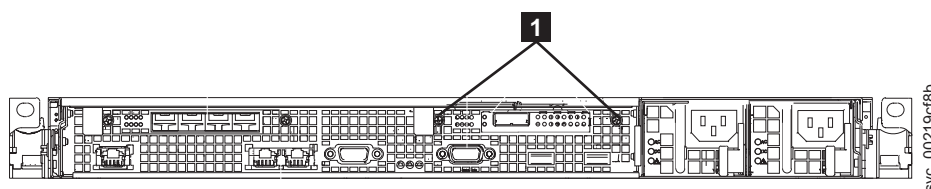

Figure 188. High-speed SAS adapter assembly mounted in the back rail of the SAN Volume Controller 2145-CF8

9. After removing the back-rail retaining screws for the adapter assembly, grasp the riser-card assembly at the rear edge and lift to remove the assembly, as shown in Figure 189 on page 204.

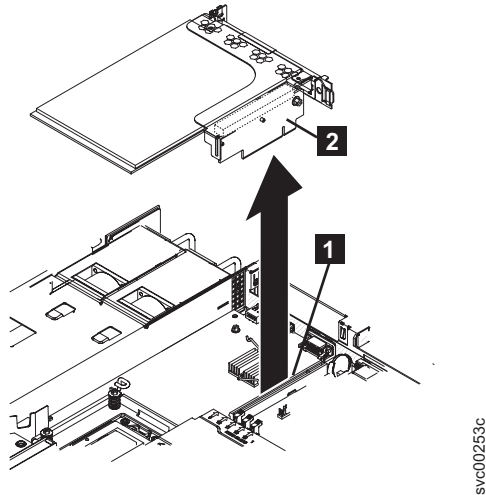

Figure 189. Removing the high-speed SAS riser-card assembly for the SAN Volume Controller 2145-CF8

10. Grasp the high-speed SAS adapter riser-card assembly by its top edge or upper corners and pull the card up out of the slot 2 riser-card connector.
When looking from the back, the slot 2 connector is the connector on the right. The 4-port fibre-channel adapter attaches to the slot 1 connector on the left side of the system board, when looking from the back.
11. Remove the high-speed SAS adapter cable from the adapter.
12. Place the high-speed SAS adapter riser-card assembly on a flat, static-protective surface.
13. If you are instructed to return the high-speed SAS adapter riser-card assembly, follow all packaging instructions, and use any packaging materials for shipping that are supplied to you.

Replacing the high-speed SAS adapter

You can replace the high-speed SAS adapter in the SAN Volume Controller 2145-CF8.

Replacing the SAN Volume Controller 2145-CF8 high-speed SAS adapter assembly

You can replace a high-speed SAS adapter that was installed and configured, but then removed.

If you are installing a high-speed SAS adapter assembly (feature code 4500) and one or more solid-state drives (SSDs) (feature code 4601), use the instructions that come with each MES upgrade to install and configure the high-speed SAS adapter and each solid-state drive (SSD).

DANGER

Multiple power cords. The product might be equipped with multiple power cords. To remove all hazardous voltages, disconnect all power cords.

Perform the following steps to replace the SAN Volume Controller 2145-CF8 high-speed SAS adapter assembly, after removing an adapter that was already configured:

1. Read the safety information to which “Preparing to remove and replace parts” on page 24 refers.
2. Attach the high-speed SAS cable to the connector on the bottom of the high-speed SAS adapter, as described in “Replacing the SAN Volume Controller 2145-CF8 high-speed SAS cable” on page 209.
Attach the cable so that the end with the label is to the front of the node and the end without the label attaches to the adapter.
3. As you start inserting the adapter, align the edge connector on the low-profile adapter **1** with the connector **3** on the riser-card assembly **4**. Make sure that the adapter snaps into the riser-card securely. Press the riser-card edge connector firmly into the system-board connector **5**, as shown in Figure 190.

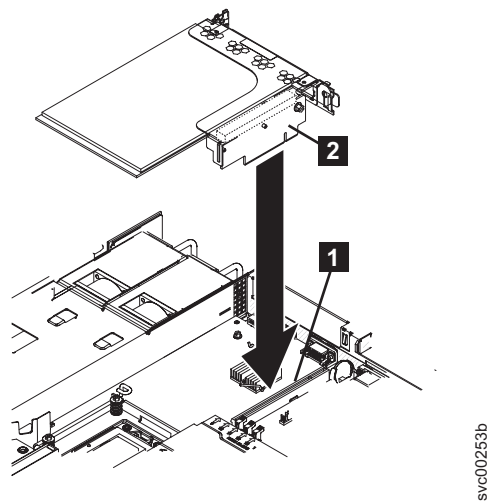

Figure 190. Replacing the high-speed SAS riser-card assembly for the SAN Volume Controller 2145-CF8

- 1** High-speed SAS adapter
 - 2** Adapter support bracket
 - 3** Riser-card-adapter connector
 - 4** Riser-card assembly
 - 5** System-board-riser-card connector
4. Grasp the high-speed SAS adapter assembly to steady it while you align and attach the adapter assembly to the back rail with the two M3 screws that were removed during the removal of the adapter.
The high-speed SAS adapter assembly and the fibre-channel adapter assembly each attach to the back rail with two screws, as shown in the view of the rail with the high-speed SAS adapter assembly attached in Figure 191 on page 206.

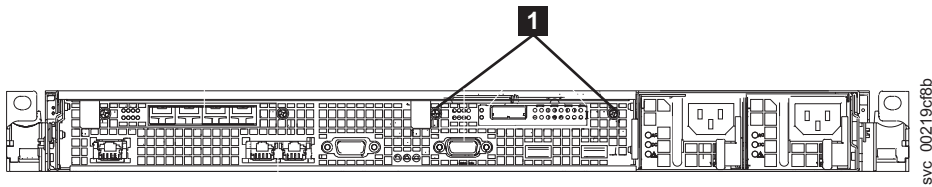

Figure 191. High-speed SAS adapter assembly mounted in the back rail of the SAN Volume Controller 2145-CF8

5. Make sure that all cables, adapters, and other components are installed and seated correctly and that you have not left loose tools or parts inside the node. Make sure that all internal cables are correctly routed. If you disconnected the fibre-channel and Ethernet cables, make sure that each cable is reconnected to the same port from which it was removed.
6. Replace the top cover. See “Replacing the top cover” on page 86.
After following the procedure to replace the top cover, the node is installed in the rack and is turned on.

Removing the high-speed SAS adapter, the adapter cable, and the solid-state drive (SSD)

You can remove the high-speed adapter assembly, the adapter cable, and the serial attached SCSI (SAS) solid-state drives (SSDs) in the SAN Volume Controller 2145-CF8.

Removing the SAN Volume Controller 2145-CF8 high-speed SAS cable

You can remove the SAN Volume Controller 2145-CF8 high-speed SAS cable.

DANGER

Multiple power cords. The product might be equipped with multiple power cords. To remove all hazardous voltages, disconnect all power cords.

This service action requires you to remove the cover and:

- Turn the node off.
- Disconnect the power cables.
- Disconnect the data cables.

To remove the SAN Volume Controller 2145-CF8 high-speed SAS adapter cable, perform the following steps :

1. Read the safety information to which “Preparing to remove and replace parts” on page 24 refers.
2. Follow the procedure in MAP 5350 in the *IBM System Storage SAN Volume Controller Troubleshooting Guide* to verify that the node data is mirrored and synchronized, and that there are no dependent virtual disks (VDisks) before turning off the node.
3. Slide the node out on its slide rails to the fully extended position.
4. When the node is completely turned off, remove the cable-retention brackets and disconnect the power cables, as described in “Removing the cable-retention bracket” on page 34.

5. To make sure that you can replace all cables in the same ports from which they were removed, label the port position of each fibre-channel and Ethernet cable; then remove all cables from the back of the node.

6. Optional: Remove the node from the rack and place it on a flat, static-protective surface. See “Removing the SAN Volume Controller from a rack” on page 48.

You can perform most service actions when the node is fully extended from the rack on its slide rails. If the location of the node in the rack is too high or too low to work comfortably, you can remove the node from the rack.

7. Remove the top cover. See “Removing the top cover” on page 81.

8. Remove the high-speed SAS adapter from the slot 2 riser-card connector at the rear of the system board, as described in “Removing the SAN Volume Controller 2145-CF8 high-speed SAS adapter assembly” on page 202.

The high-speed SAS cable is shown in Figure 192.

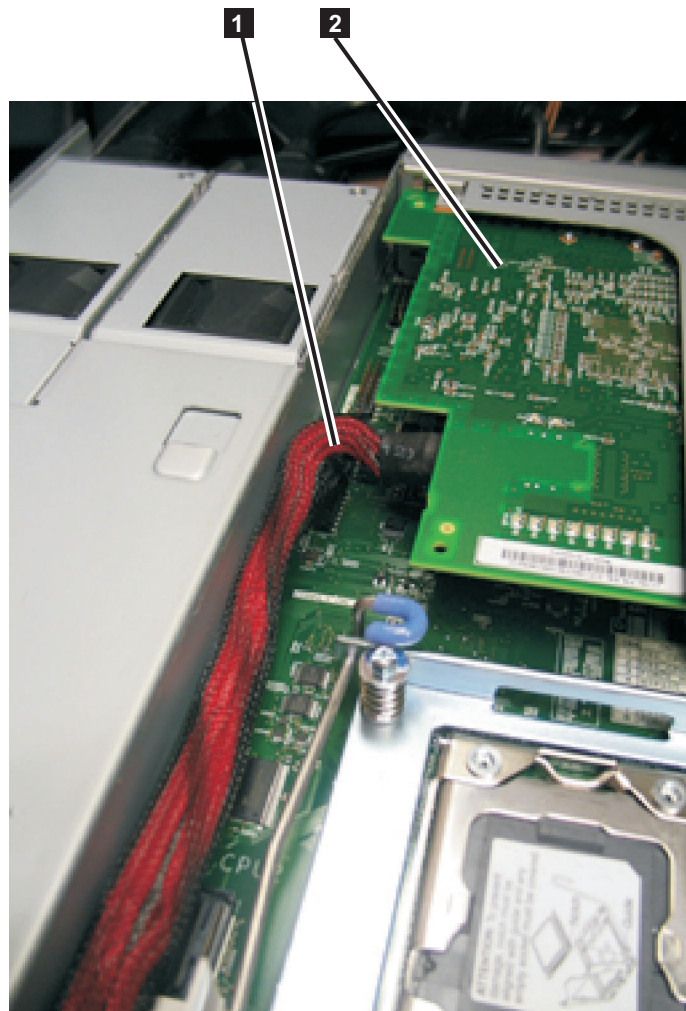

Figure 192. High-speed SAS adapter assembly and high-speed SAS cable in the SAN Volume Controller 2145-CF8

1 High-speed SAS cable plugged into the high-speed SAS adapter assembly

2 High-speed SAS adapter assembly

9. Disconnect the high-speed SAS cable from the high-speed SAS adapter.

10. Remove the cable from the blue bulkhead clip behind the disk backplane, as shown in Figure 193.

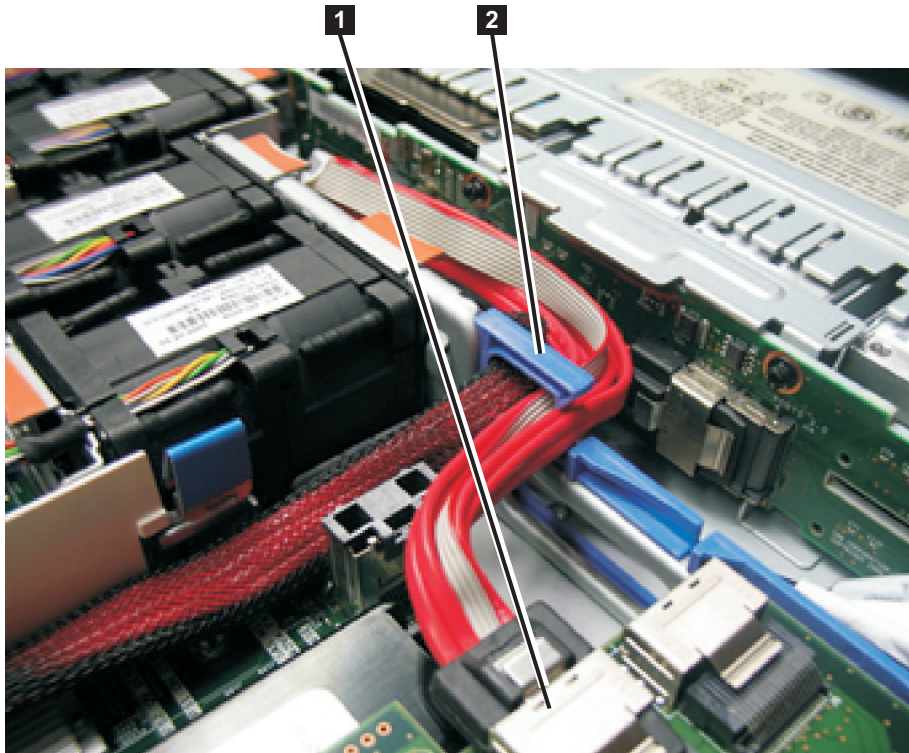

Figure 193. Boot-disk SAS cable routed through the blue bulkhead clip and connected to the SAS disk controller in the SAN Volume Controller 2145-CF8

1 Boot-disk SAS cable that is plugged into the disk-controller-and-USB-riser-card assembly

2 Blue bulkhead clip with the high-speed SAS-adapter cable and the boot-disk SAS cable

Remove the boot-disk SAS cable from the blue bulkhead clip if necessary, before removing the high-speed SAS adapter cable from the clip.

11. Disconnect the high-speed SAS cable from the SAS connector in the center of the back of the disk backplane, as shown in Figure 194 on page 209.

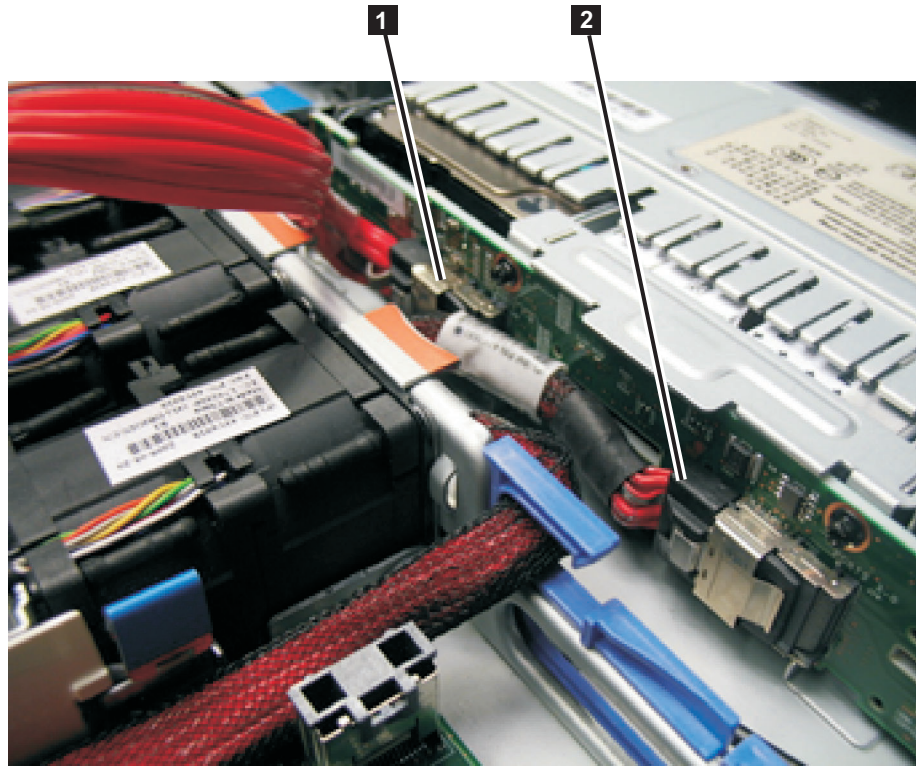

Figure 194. Boot-disk SAS cable and the high-speed SAS cable connected to the disk backplane in the SAN Volume Controller 2145-CF8

- 1 Boot-disk SAS cable that is plugged into the disk-drive backplane to support drive bay 4
- 2 High-speed SAS-adapter cable that is plugged into the middle of the backplane to support drive bays 0, 1, 2, and 3

12. Remove the cable from the SAN Volume Controller 2145-CF8.

Replacing the high-speed SAS adapter, the adapter cable, and the solid-state drive (SSD)

You can replace the high-speed SAS adapter, the adapter cable, and the serial attached SCSI (SAS) solid-state drives (SSDs) in the SAN Volume Controller 2145-CF8.

Replacing the SAN Volume Controller 2145-CF8 high-speed SAS cable

You can replace the SAN Volume Controller 2145-CF8 high-speed SAS cable.

Perform the following steps to replace the SAN Volume Controller 2145-CF8 high-speed cable:

1. Remove the high-speed SAS adapter from the slot 2 riser-card connector at the rear of the system board, as described in “Removing the SAN Volume Controller 2145-CF8 high-speed SAS adapter assembly” on page 202.

The high-speed SAS cable is shown in Figure 195 on page 210.

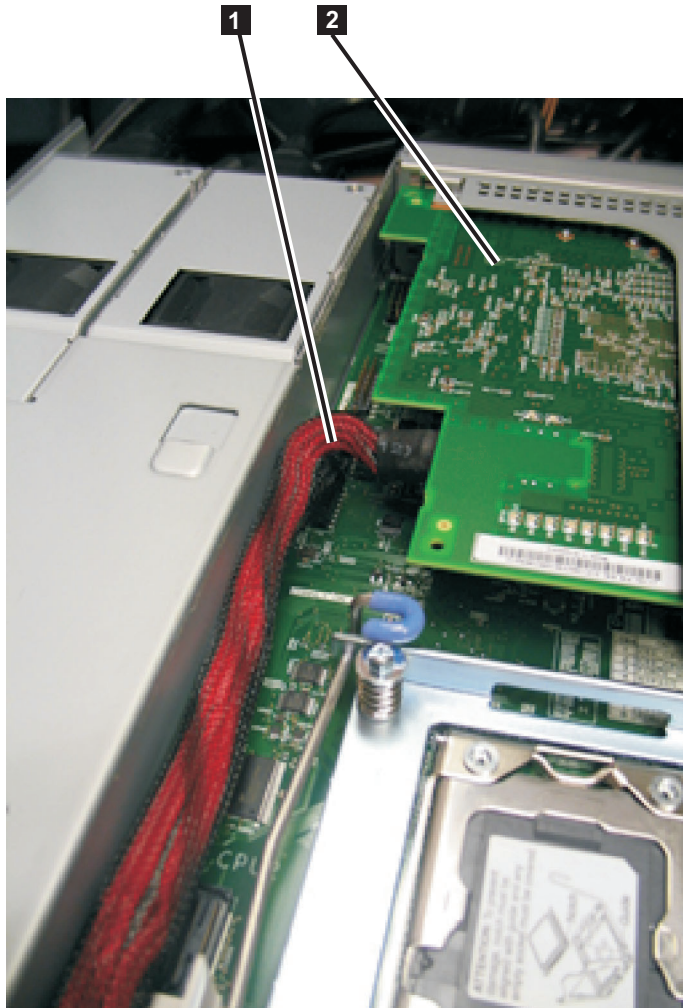

Figure 195. High-speed SAS adapter assembly and high-speed SAS cable in the SAN Volume Controller 2145-CF8

- 1 High-speed SAS cable plugged into the high-speed SAS adapter assembly
 - 2 High-speed SAS adapter assembly
2. Attach the high-speed SAS cable to the high-speed SAS adapter.
Attach the cable so that the end with the label is to the front of the node and the end without the label attaches to the adapter.
 3. Replace the high-speed SAS adapter card, as described in “Replacing the SAN Volume Controller 2145-CF8 high-speed SAS adapter assembly” on page 204.
 4. Disconnect the boot-disk SAS cable from the disk controller and move it out of the blue bulkhead clip.
 5. Route the cable from the high-speed SAS adapter through the blue bulkhead clip behind the drive backplane.
 6. Attach the high-speed SAS cable to the SAS connector in the center of the back of the SAS drive back plane. Use the connector that connects to drive bays 0, 1, 2, and 3.
The high-speed SAS cable is shown in Figure 196 on page 211.

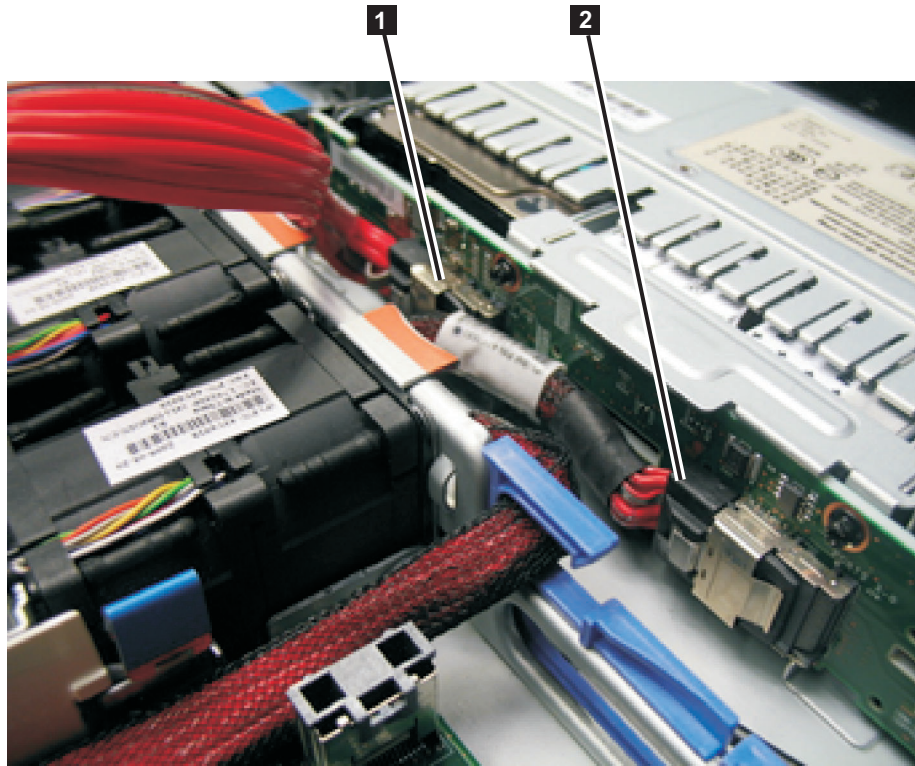

Figure 196. Boot-disk SAS cable and the high-speed SAS cable connected to the disk backplane in the SAN Volume Controller 2145-CF8

- 1** Boot-disk SAS cable that is plugged into the disk-drive backplane to support drive bay 4
 - 2** High-speed SAS-adapter cable that is plugged into the middle of the backplane to support drive bays 0, 1, 2, and 3
7. Reroute the boot-disk SAS cable through the blue bulkhead clip and reconnect the cable to the disk controller.
- The high-speed SAS cable is shown in Figure 197 on page 212.

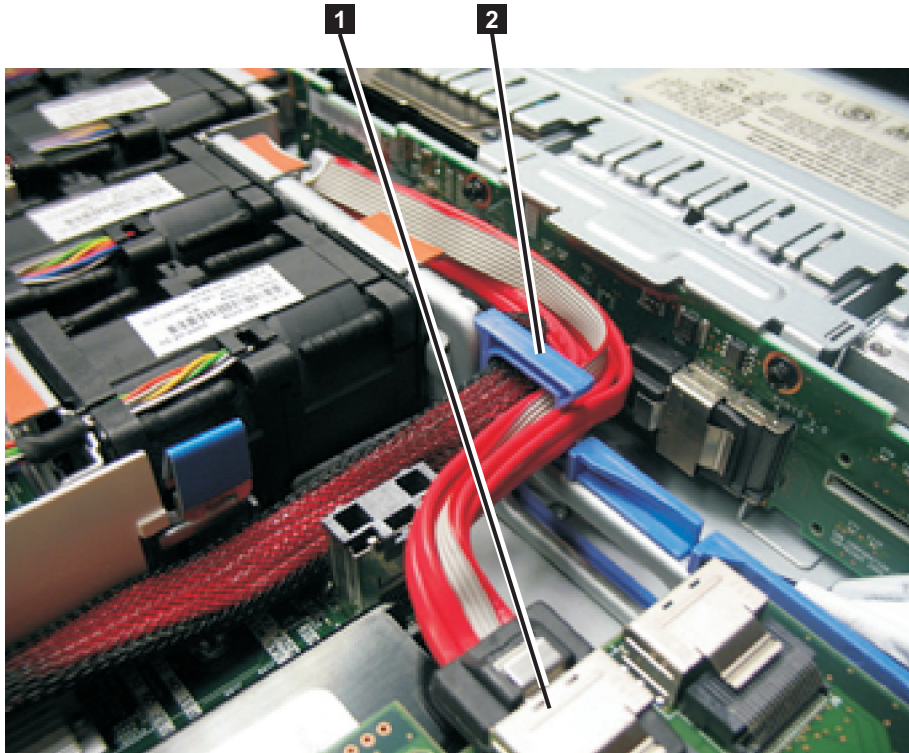

Figure 197. Boot-disk SAS cable routed through the blue bulkhead clip and connected to the SAS disk controller in the SAN Volume Controller 2145-CF8

- 1** Boot-disk SAS cable that is plugged into the disk-controller-and-USB-riser-card assembly
- 2** Blue bulkhead clip with the high-speed SAS-adapter cable and the boot-disk SAS cable

Removing the disk-controller and USB riser-card assembly

You can remove the disk-controller and USB riser-card assembly.

Take precautions to avoid damage from static electricity. Wear an anti-static wrist strap and use a static-protected mat or surface. For more information, see “Handling static-sensitive devices” on page xxiv.

Removing the SAN Volume Controller 2145-CF8 disk-controller and USB riser-card assembly

You can remove the SAN Volume Controller 2145-CF8 disk-controller and USB riser-card assembly.

DANGER

Multiple power cords. The product might be equipped with multiple power cords. To remove all hazardous voltages, disconnect all power cords.

This service action requires you to remove the cover and:

- Turn off the node.
- Disconnect the power cables.
- Disconnect the service-controller USB cable, the SAS boot-disk cable, and the SAS cable to disk bays 0, 1, 2, and 3, if the cable is still installed.

To remove the disk-controller and USB riser-card assembly, complete the following steps:

1. Read the safety information to which “Preparing to remove and replace parts” on page 24 refers.
2. Follow the procedure in MAP 5350 in the *IBM System Storage SAN Volume Controller Troubleshooting Guide* to verify that the node data is mirrored and synchronized, and that there are no dependent virtual disks (VDisks) before turning off the node.
3. Slide the node out on its slide rails to the fully extended position.
You can perform most service actions when the node is fully extended from the rack on its slide rails. You can leave the fibre-channel and Ethernet cables connected, if you are using the cable-management arm and if you are not removing the node from the rack. If the location of the node in the rack is too high or too low to work comfortably, you can remove the node from the rack.
4. When the node is completely turned off, remove the cable-retention brackets and disconnect the power cables, as described in “Removing the cable-retention bracket” on page 34.
5. Optional: If you must remove the node from the rack to work on it, perform the following procedure to remove all cables and remove the node from the rack:
 - a. To make sure that you can replace all cables in the same ports from which they were removed, label the port position of each fibre-channel and Ethernet cable; then remove all cables from the back of the node.
 - b. Remove the node from the rack and place it on a flat, static-protective surface. See “Removing the SAN Volume Controller from a rack” on page 48.
6. Remove the top cover. See “Removing the top cover” on page 81.
7. Remove the USB service-controller cable from the USB connection (**1** in Figure 198) on the disk-controller and USB riser-card assembly (**3**), as described in “Removing and replacing the SAN Volume Controller 2145-CF8 service controller cable” on page 94.

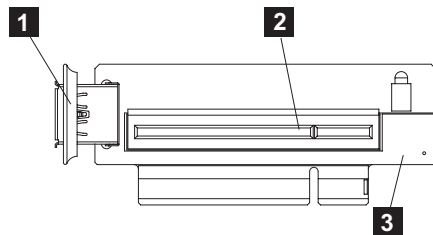

Figure 198. USB riser-card assembly for the SAN Volume Controller 2145-CF8

- 1** USB connector
 - 2** Disk-controller connector
 - 3** USB riser-card assembly (shown without the disk controller)
8. Remove the SAS cable that runs to the boot-drive-bay connector on the left side of the back of the disk backplane, when viewed from the rear, from the connector on the disk-controller and USB riser-card assembly that is closer to the power supply.
 9. If present, remove the SAS cable that runs to disk-drive-bay connector in the center of the back of the disk backplane, when viewed from the rear, from the connector on the disk-controller and USB riser-card assembly that is closer to the front of the node.

10. Grasp the disk controller near the end next to the power-supply cage while you press the black plastic tab (next to the power supply) toward the power supply.

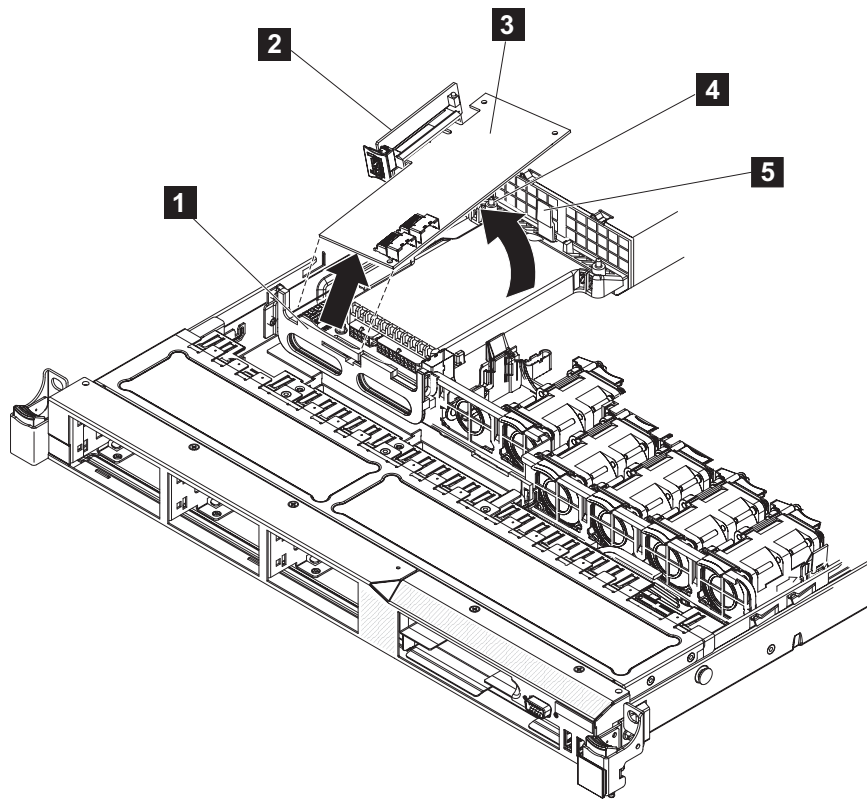

Figure 199. Disengaging the disk-controller front-retention bracket and removing the riser assembly and disk controller

- 1 Disk-controller front-retention bracket
- 2 Disk-controller and USB riser-card assembly
- 3 Disk controller
- 4 Alignment post
- 5 Plastic tab

11. Pull up on the disk controller (**3** in Figure 199) until the disk-controller and USB riser-card assembly (**2**) disengages from the connector on the system board.
12. Place the disk-controller and USB riser-card assembly on a flat, static-protective surface.
13. If you are instructed to return the disk-controller and USB riser-card assembly, follow all packaging instructions, and use any packaging materials for shipping that are supplied to you.

Replacing the disk-controller and USB riser-card assembly

You can replace the disk-controller and USB riser-card assembly.

Take precautions to avoid damage from static electricity. Wear an anti-static wrist strap and use a static-protected mat or surface. For more information, see “Handling static-sensitive devices” on page xxiv.

Replacing the SAN Volume Controller 2145-CF8 disk-controller and USB riser-card assembly

You can replace the SAN Volume Controller 2145-CF8 disk-controller and USB riser-card assembly.

To replace the disk-controller and USB riser-card assembly, complete the following steps:

1. Turn off the node while ensuring that its data is mirrored and synchronized. See MAP 5350 in the *IBM System Storage SAN Volume Controller Troubleshooting Guide* for more information.
2. When the node is completely turned off, remove the power cable-retention brackets and remove the power cables from the rear of the node.
3. After labeling the fibre-channel cables and the Ethernet cables with their locations, remove all of the cables from the node.
4. Optional: Remove the node from the rack and place it on a flat, static-protective surface. See “Removing the SAN Volume Controller from a rack” on page 48.
5. Remove the top cover. See “Removing the top cover” on page 81.
6. Remove the disk-controller and USB riser-card assembly from its packaging and place the riser-card assembly on a flat, static-protective surface.
7. Install the disk-controller and USB riser-card assembly.
 - a. Tilt the SAS riser-card assembly slightly and insert the end of the disk controller in the slot on the retention bracket as shown in the following illustration.

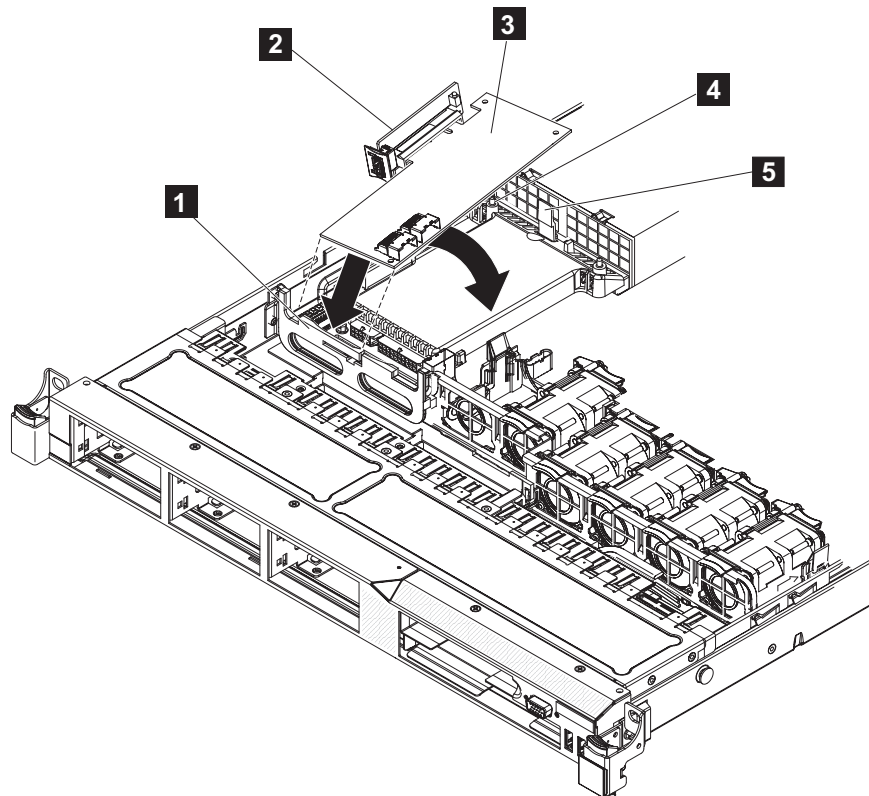

Figure 200. Engaging the disk-controller front-retention bracket and replacing the riser assembly and disk controller

- 1** Disk-controller front-retention bracket
- 2** Disk-controller and USB riser-card assembly
- 3** Disk controller
- 4** Alignment post
- 5** Plastic tab

- b. Align the riser-card assembly keys correctly with the connector on the system board and press down on the assembly until it is seated firmly into the connector on the system board.
8. Connect the USB service-controller cable to the USB connector on the USB riser-card assembly, if the cable is not connected, as described in “Removing and replacing the SAN Volume Controller 2145-CF8 service controller cable” on page 94.

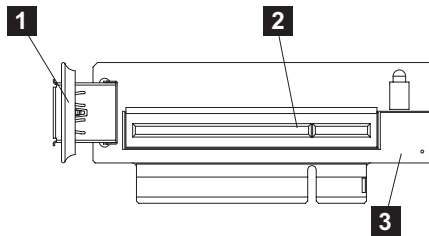

Figure 201. USB riser-card assembly for the SAN Volume Controller 2145-CF8

- 1** USB connector
- 2** Disk-controller connector
- 3** Disk-controller and USB riser-card assembly

Figure 202 on page 217 shows the USB service-controller cable connected to the disk-controller and USB riser-card assembly.

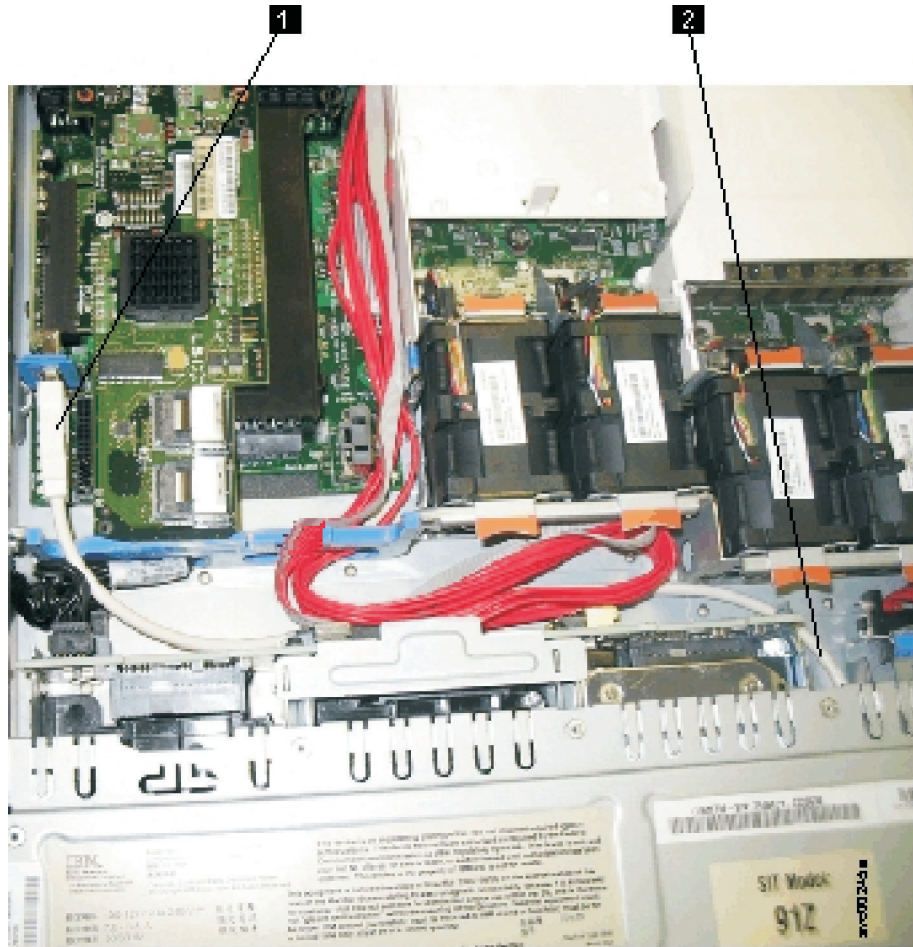

Figure 202. USB service-controller cable connected to the disk controller and USB riser card in the SAN Volume Controller 2145-CF8

- 1 USB service-controller cable attached to the USB riser card
 - 2 Service controller cable
9. Connect the SAS boot-drive cable (the cable to drive bays 4 and 5) to the connector on the disk controller that is closer to the power supplies. Figure 203 on page 218 shows the boot-disk SAS cable connected to the disk backplane.

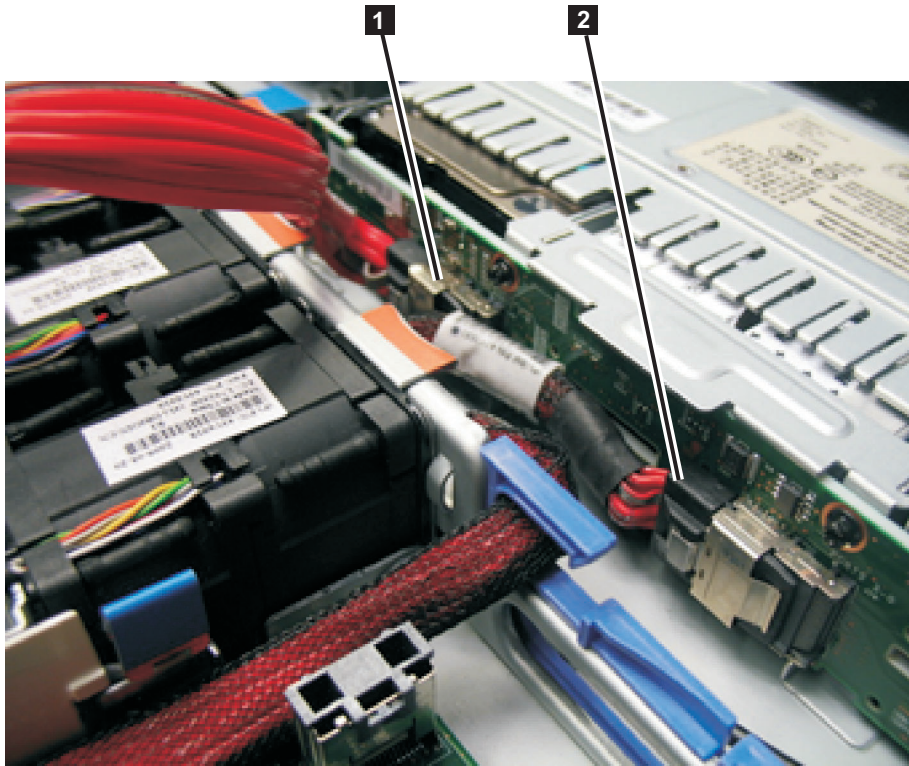

Figure 203. Boot-disk SAS cable and the high-speed SAS cable connected to the disk backplane in the SAN Volume Controller 2145-CF8

The boot-disk cable is shown disconnected from the disk controller so that you can see the connectors on the back of the disk backplane more clearly.

1 Boot-disk SAS cable that is plugged into the disk-drive backplane to support drive bay 4

2 High-speed SAS-adapter cable that is plugged into the middle of the backplane to support drive bays 0, 1, 2, and 3

Figure 204 on page 219 shows the boot-disk SAS cable connected to the disk controller.

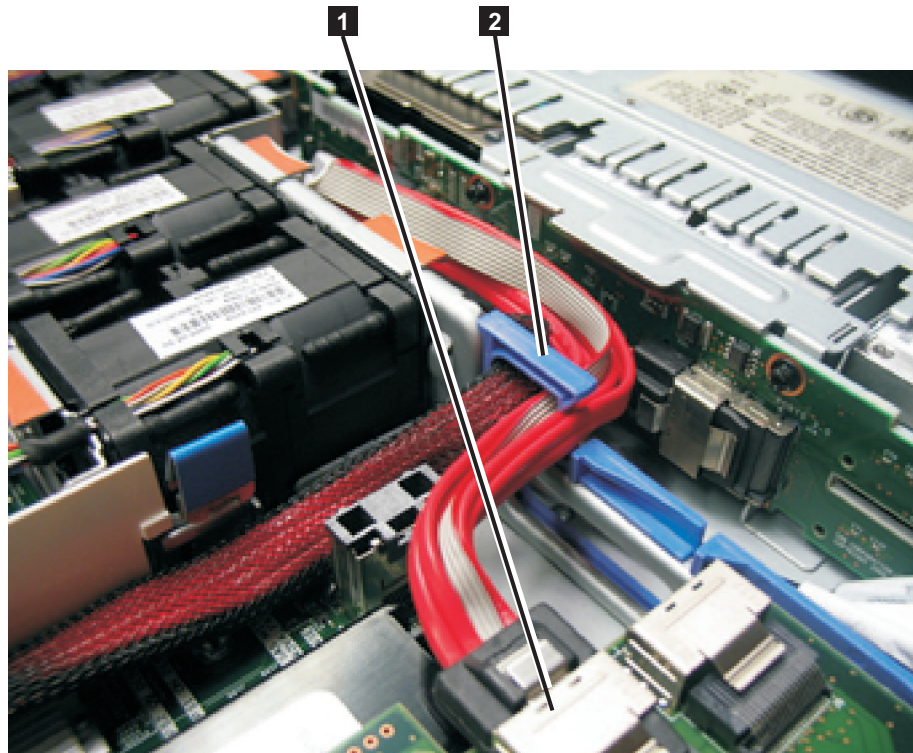

Figure 204. Boot-disk SAS cable routed through the blue bulkhead clip and connected to the SAS disk controller in the SAN Volume Controller 2145-CF8

- 1 Disk-controller cable connected to the disk-controller connector that is closer to the power supplies
 - 2 Blue bulkhead clip with the boot-disk SAS cable and the underlying high-speed SAS adapter cable for solid-state drives (SSDs), if present
10. Replace the top cover. See “Replacing the top cover” on page 86.
 11. Place the node in the rack. See “Replacing the SAN Volume Controller in a rack” on page 59.
 12. Slide the node into the rack.
 13. Reconnect the power cords and the fibre-channel and Ethernet cables. Ensure that you replace the fibre-channel and Ethernet cables in the same ports from which they were removed.
 14. Replace the cable-retention bracket. See “Replacing the cable-retention bracket” on page 40.
 15. Replace the cable-management arm. See “Replacing the cable-management arm” on page 30.
 16. Turn on the node.

Removing the PCI express riser card assembly

Use these instructions when you are prompted to remove the SAN Volume Controller PCI express riser card assembly.

Removing the SAN Volume Controller 2145-8A4 PCI express riser card assembly

Use these instructions when you are prompted to remove the SAN Volume Controller 2145-8A4 PCI express riser card assembly.

Note: Take precautions to avoid damage from static electricity. Wear an anti-static wrist strap and use a static-protected mat or surface. For more information, see “Handling static-sensitive devices” on page xxiv.

To remove the SAN Volume Controller 2145-8A4 PCI express riser card assembly, follow the instructions in “Removing the SAN Volume Controller 2145-8A4 fibre-channel adapter assembly” on page 192.

Removing the SAN Volume Controller 2145-8G4 PCI express riser card assembly

Use these instructions when you are prompted to remove the SAN Volume Controller 2145-8G4 PCI express riser card assembly.

Note: Take precautions to avoid damage from static electricity. Wear an anti-static wrist strap and use a static-protected mat or surface. For more information, see “Handling static-sensitive devices” on page xxiv.

To remove the SAN Volume Controller 2145-8G4 PCI express riser card assembly, follow the instructions in “Removing the SAN Volume Controller 2145-8G4 fibre-channel adapter assembly” on page 193.

Replacing the PCI express riser-card assembly

Use these instructions when you are prompted to replace the SAN Volume Controller PCI express riser card assembly.

Replacing the SAN Volume Controller 2145-8A4 PCI express riser-card assembly

Use these instructions when you are prompted to replace the SAN Volume Controller 2145-8A4 PCI express riser card assembly.

Follow the instructions in “Replacing the SAN Volume Controller 2145-8A4 fibre-channel adapter assembly” on page 199.

Replacing the SAN Volume Controller 2145-8G4 PCI express riser-card assembly

Use these instructions when you are prompted to replace the SAN Volume Controller 2145-8G4 PCI express riser card assembly.

Follow the instructions in “Replacing the SAN Volume Controller 2145-8G4 fibre-channel adapter assembly” on page 200.

Removing the operator-information panel assembly

You might be prompted to remove the SAN Volume Controller operator-information panel.

Take precautions to avoid damage from static electricity. Wear an anti-static wrist strap and use a static-protected mat or surface. For more information, see “Handling static-sensitive devices” on page xxiv.

Related tasks

“Removing the top cover” on page 81

You can remove the top cover of the SAN Volume Controller node if maintenance is necessary.

“Replacing the top cover” on page 86

You must replace the top cover on the SAN Volume Controller node after maintenance is completed.

Related reference

“Handling static-sensitive devices” on page xxiv

Ensure that you understand how to handle devices that are sensitive to static electricity.

Removing the SAN Volume Controller 2145-CF8 operator-information panel assembly

You can remove the operator-information panel assembly on a SAN Volume Controller 2145-CF8.

DANGER

Multiple power cords. The product might be equipped with multiple power cords. To remove all hazardous voltages, disconnect all power cords.

This service action requires you to:

- Turn off the node.
- Disconnect the power cables.

Make careful note of the layout of the cables as you go through this procedure as you must replace them in the same position when you replace the operator-information panel assembly.

Perform the following steps to remove the operator-information panel:

1. Read the safety information to which “Preparing to remove and replace parts” on page 24 refers.
2. Follow the procedure in MAP 5350 in the *IBM System Storage SAN Volume Controller Troubleshooting Guide* to verify that the node data is mirrored and synchronized, and that there are no dependent virtual disks (VDisks) before turning off the node.
3. Slide the node out on its slide rails to the fully extended position.
You can perform most service actions when the node is fully extended from the rack on its slide rails. You can leave the fibre-channel and Ethernet cables connected, if you are using the cable-management arm and if you are not removing the node from the rack. If the location of the node in the rack is too high or too low to work comfortably, you can remove the node from the rack.
4. When the node is completely turned off, remove the cable-retention brackets and disconnect the power cables, as described in “Removing the cable-retention bracket” on page 34.
5. Optional: If you must remove the node from the rack to work on it, perform the following procedure to remove all cables and remove the node from the rack:
 - a. To make sure that you can replace all cables in the same ports from which they were removed, label the port position of each fibre-channel and Ethernet cable; then remove all cables from the back of the node.

- b. Remove the node from the rack and place it on a flat, static-protective surface. See “Removing the SAN Volume Controller from a rack” on page 48.
6. From the rear of the operator-information panel assembly, disconnect the cable.
7. Use an object to push down on the release tab (**2** in Figure 205).
Hold down the release tab and push the blue push point on the rear of the panel toward the front of the node.

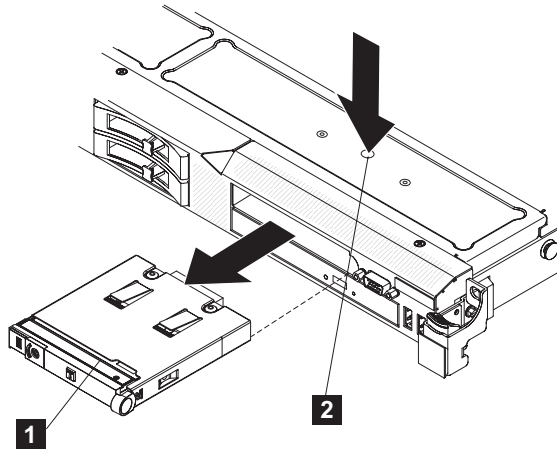

Figure 205. Using the release tab to remove the SAN Volume Controller 2145-CF8 operator-information panel

- 1** Operator-information panel
- 2** Release tab
8. From the front of the node, carefully pull the assembly (**1**) out of the node while you move the assembly slightly from side to side.
9. If you are instructed to return the operator-information panel assembly, follow all packaging instructions, and use any packaging materials for shipping that are supplied to you.

Removing the SAN Volume Controller 2145-8A4 operator-information panel

You might have to remove the operator-information panel on a SAN Volume Controller 2145-8A4 due to required maintenance.

Make careful note of the layout of the cables as you go through this procedure as they will need replacing in the same position when you replace the operator-information panel.

Perform the following steps to remove the operator-information panel:

1. Turn off the node while ensuring that its data is mirrored and synchronized. See MAP 5350 in the *IBM System Storage SAN Volume Controller Troubleshooting Guide* for more information.
2. Remove the cable-retention bracket and disconnect the power cable from the node. See “Removing the cable-retention bracket” on page 34.
3. Remove the node from the rack and place it on a flat, static-protective surface. See “Removing the SAN Volume Controller from a rack” on page 48.
4. Remove the top cover. See “Removing the top cover” on page 81.

5. Remove the screws (**3** in Figure 206) that secure the operator-information panel to the CD/DVD bay housing.

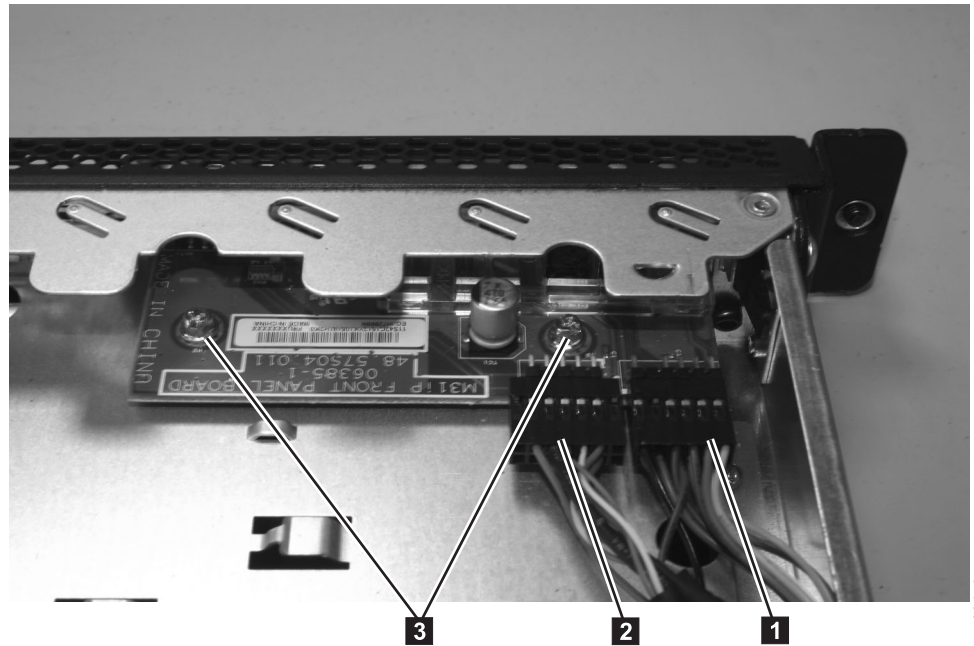

Figure 206. SAN Volume Controller 2145-8A4 operator-information panel

6. Lift the operator-information panel out of the node.
7. Disconnect the light-panel cable **1** and the USB cable **2** from the operator-information panel board, shown in Figure 206.

Removing the SAN Volume Controller 2145-8G4 operator-information panel assembly

You might have to remove the operator-information panel assembly on a SAN Volume Controller 2145-8G4 due to required maintenance.

Make careful note of the layout of the cables as you go through this procedure as they will need replacing in the same position when you replace the operator-information panel assembly.

Perform the following steps to remove the operator-information panel:

1. Turn off the node while ensuring that its data is mirrored and synchronized. See MAP 5350 in the *IBM System Storage SAN Volume Controller Troubleshooting Guide* for more information.
2. Remove the cover and open the fan door. See “Removing the top cover” on page 81.
3. Release the dummy CD/DVD drive **2** by pressing the release button **1** and sliding the drive out approximately 2 cm (1 in), as shown in Figure 207 on page 224. It is possible to push the drive from the back to start it moving. Do not remove the drive from the casing.

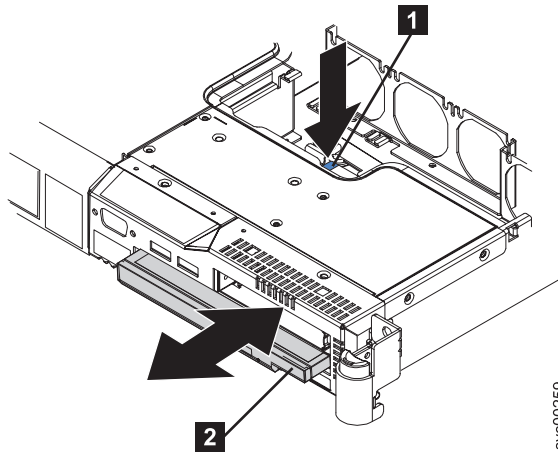

Figure 207. SAN Volume Controller 2145-8G4 dummy CD/DVD drive

- 1** Release button
- 2** Dummy CD/DVD drive

4. Remove the CD interposer card (**2** in Figure 208) by unscrewing it, lifting it slightly and then removing the cable from it.

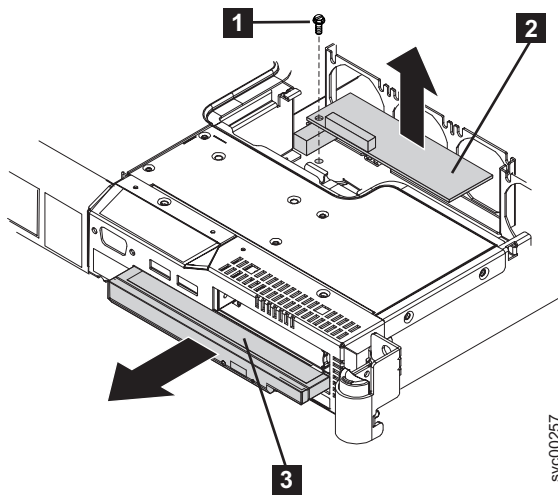

Figure 208. Removing the CD interposer card

- 1** Screw
- 2** Interposer card
- 3** Dummy CD/DVD drive

5. Remove fan 3, as shown in Figure 209 on page 225.

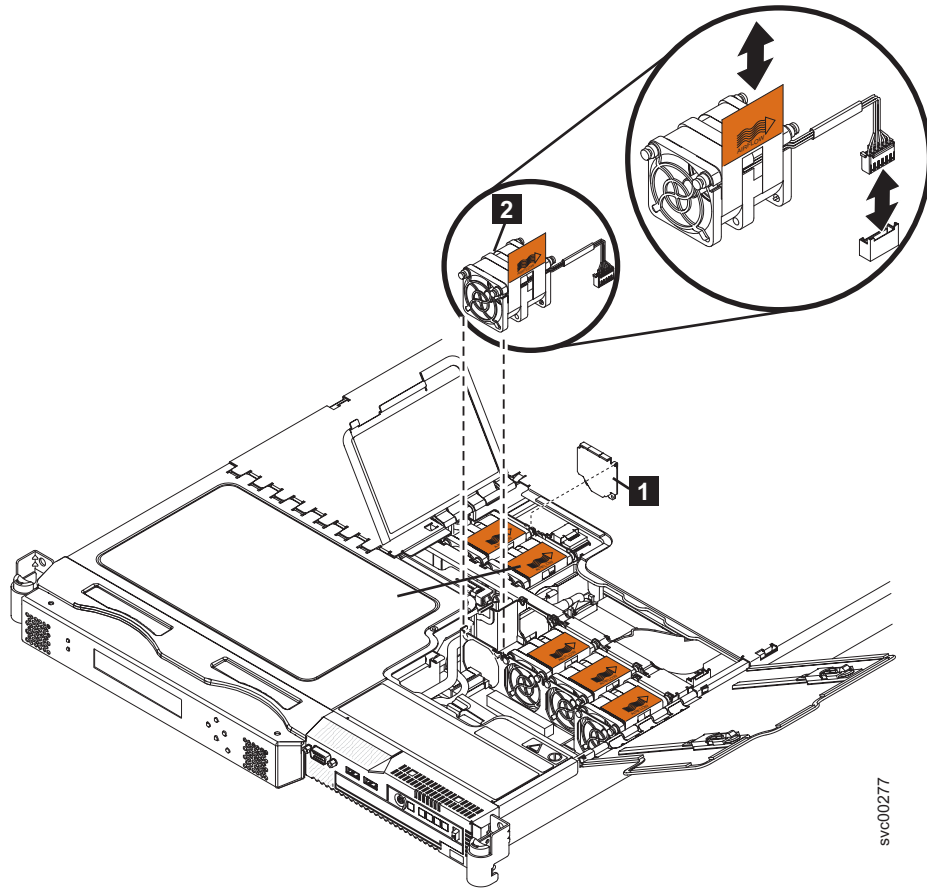

Figure 209. SAN Volume Controller 2145-8G4 fan 3

1 Air baffle

2 Fan 3

6. Remove the air baffle (**2** in Figure 210 on page 226).

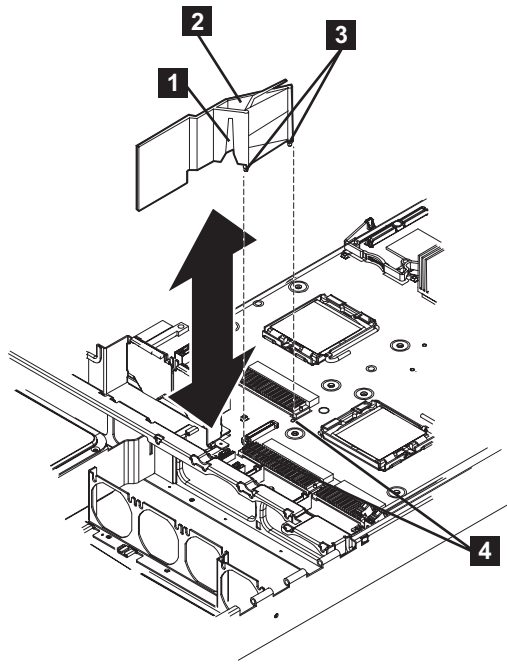

Figure 210. SAN Volume Controller 2145-8G4 air baffle

- 1** Cable routing slot
- 2** Air baffle
- 3** Baffle pins
- 4** Baffle mounting holes

7. Unplug the video cable **8**, the USB cable **7** and the CD/DVD cable **9** from the system board. There is no need to completely remove these cables. Unplugging them makes it easier to maneuver the light path ribbon cable **4**. In Figure 211 on page 227, the front of the node is at the bottom of the illustration.

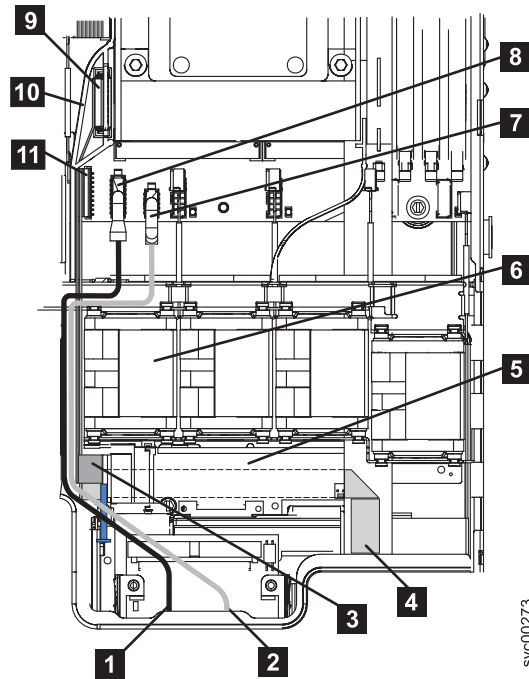

Figure 211. SAN Volume Controller 2145-8G4 video, USB, and the CD/DVD cables

- 1** Video cable
- 2** USB cable
- 3** CD-RW cable
- 4** Light path cable
- 5** Interposer card
- 6** Fan 3
- 7** USB cable connector
- 8** Video cable connector
- 9** CD-RW connector
- 10** Air baffle
- 11** Light path cable connector

8. Unplug the light path ribbon cable **4** from the system board connector **11** and completely unthread the cable removing it from the three retaining brackets. Also release it from any tape holding it in place. The cable should be free to move forward with the operator-information panel.
9. Press the release button (**1** in Figure 212 on page 228) on the front of the operator-information panel **2** and pull forward until it locks in place.

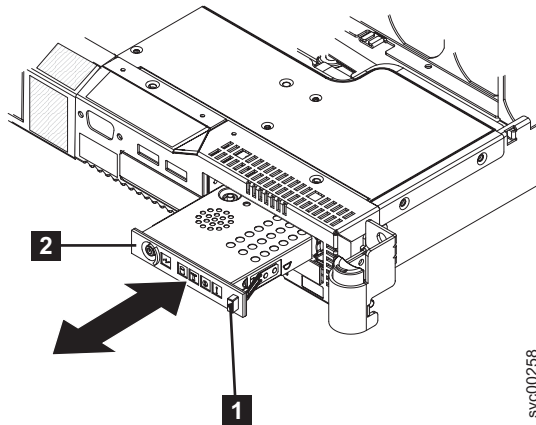

Figure 212. SAN Volume Controller 2145-8G4 operator-information panel

10. Press the two release buttons (2 in Figure 213) that are visible through the top of the node and pull the assembly 3 completely out of the node. Carefully pull the attached light path ribbon cable 1 out of the server.

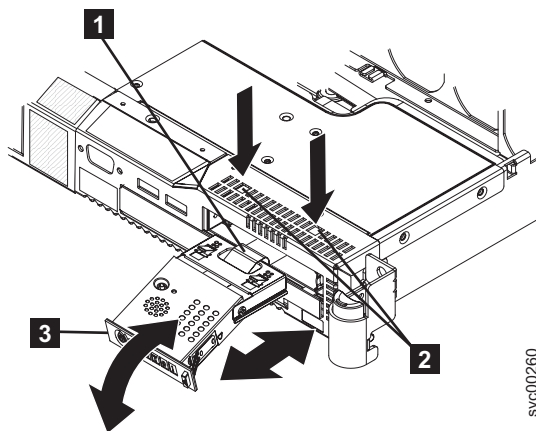

Figure 213. Removing the SAN Volume Controller 2145-8G4 operator-information panel

Removing the SAN Volume Controller 2145-8F4 or SAN Volume Controller 2145-8F2 operator-information panel

You might have to remove the operator-information panel on a SAN Volume Controller 2145-8F2 or SAN Volume Controller 2145-8F4 due to required maintenance.

Perform the following steps to remove the operator-information panel:

1. Turn off the node while ensuring that its data is mirrored and synchronized. See MAP 5350 in the *IBM System Storage SAN Volume Controller Troubleshooting Guide* for more information.
2. Remove the SAN Volume Controller 2145-8F4 cable retention bracket.
3. To make sure that you can replace all cables in the same ports from which they were removed, record the position of all fibre-channel and Ethernet cables; then remove all cables from the back of the node.
4. Remove the top cover. See “Removing the top cover” on page 81. If necessary, you might have to remove the node from the rack.

5. Press the operator-information panel release latch (**2** in Figure 214) and slide the operator-information panel away from the SAN Volume Controller 2145-8F2.

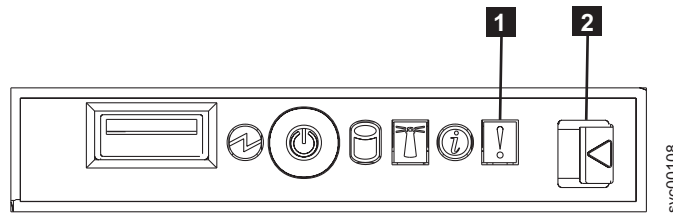

Figure 214. SAN Volume Controller 2145-8F4 operator-information panel

6. Use a small screwdriver to push in the retention springs (**1** in Figure 215) on the sides of the operator-information panel assembly.

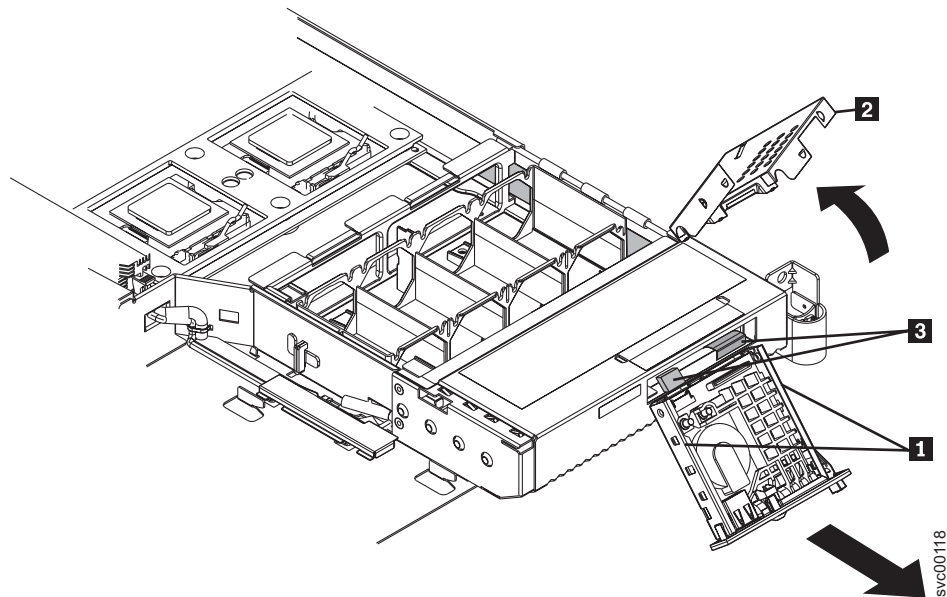

Figure 215. SAN Volume Controller 2145-8F2 with exposed operator-information panel

- 1** Retention springs
- 2** Operator-information panel assembly cover
- 3** Cables

7. Slide the assembly forward and out of the node.
8. Push out on the two sides of the assembly cover to flare it out.
9. Rotate the assembly cover (**2** in Figure 215) up and off of the operator-information panel assembly.
10. Unplug the two cables from the rear of the assembly (**3** in Figure 215).

Replacing the operator-information panel assembly

You might be prompted to replace the SAN Volume Controller operator-information panel assembly.

Take precautions to avoid damage from static electricity. Wear an anti-static wrist strap and use a static-protected mat or surface. For more information, see “Handling static-sensitive devices” on page xxiv.

Related tasks

“Removing the top cover” on page 81

You can remove the top cover of the SAN Volume Controller node if maintenance is necessary.

“Replacing the top cover” on page 86

You must replace the top cover on the SAN Volume Controller node after maintenance is completed.

Related reference

“Handling static-sensitive devices” on page xxiv

Ensure that you understand how to handle devices that are sensitive to static electricity.

Replacing the SAN Volume Controller 2145-CF8 operator-information panel assembly

You can replace the operator-information panel on a SAN Volume Controller 2145-CF8.

DANGER

Multiple power cords. The product might be equipped with multiple power cords. To remove all hazardous voltages, disconnect all power cords.

This service action assumes that:

- The node is turned off. If you must turn off the node, ensure that its data is mirrored and synchronized, and that there are no dependent virtual disks (VDisks), as described in MAP 5350 in the *IBM System Storage SAN Volume Controller Troubleshooting Guide*.
- The power cables are disconnected.
- The top cover is removed.

Perform the following steps to replace the operator-information panel:

1. Read the safety information to which “Preparing to remove and replace parts” on page 24 refers.
2. From the front of the node, slide the operator-information panel into the node until it clicks into place.
3. Inside the node, connect the cable to the rear of the operator information panel assembly.

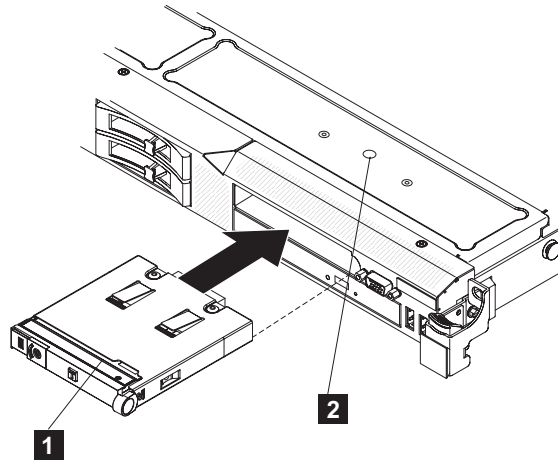

Figure 216. Replacing the SAN Volume Controller 2145-CF8 operator-information panel

- 1** Operator-information panel
- 2** Release tab

The following illustration shows the cable routing for the operator-information panel:

Note: The operation information panel cable should go in above the Video/USB cable in the node.

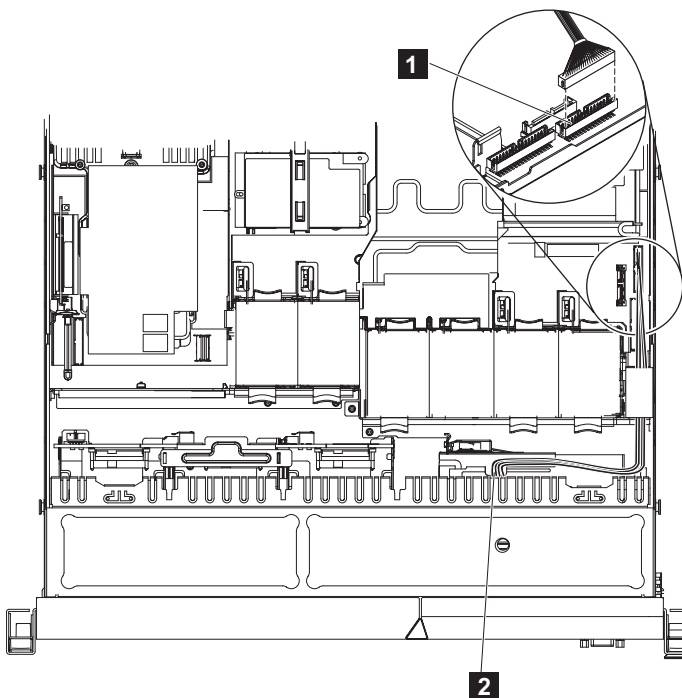

Figure 217. Connecting the SAN Volume Controller 2145-CF8 operator-information panel cable

- 1** Operator-information panel connector
- 2** Operator-information panel cable

4. Replace the top cover. See “Replacing the top cover” on page 86.

5. If you removed the node from the rack, replace the node in the rack, as described in “Replacing the SAN Volume Controller in a rack” on page 59.
6. If you removed any fibre-channel or Ethernet cables, use the labels you placed on each cable to replace all fibre-channel and Ethernet cables in the same ports from which they were removed.
7. If you removed the power cords, replace the power cords and the cable-retention brackets, as described in “Replacing the cable-retention bracket” on page 40.
8. Lift the locking levers (**1** in Figure 218) on the slide rails and push the server **2** all the way into the rack until it clicks into place.

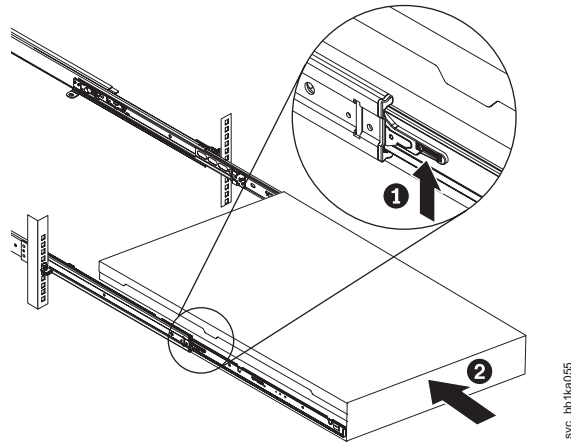

Figure 218. Raising the SAN Volume Controller 2145-CF8 locking levers of the slide rails of the rack

9. Turn on the node.

Replacing the SAN Volume Controller 2145-8A4 operator-information panel

You might have to replace the operator-information panel assembly on a SAN Volume Controller 2145-8A4 due to required maintenance.

Perform the following steps to replace the operator-information panel:

1. Connect the light panel cable **1** and the front USB cable **2**, shown in Figure 219 on page 233, to the operator-information panel board.

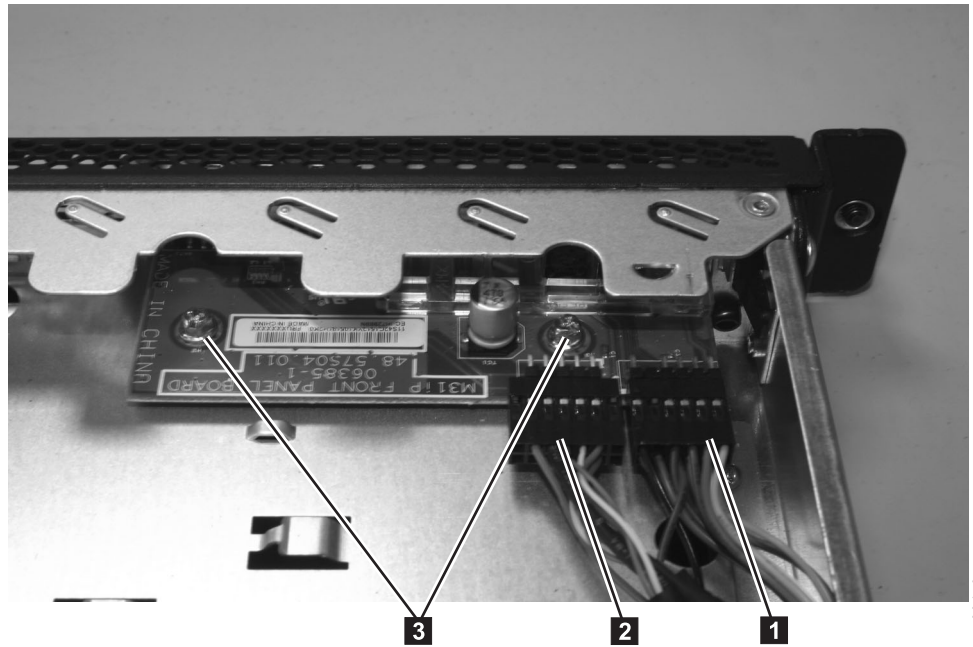

Figure 219. SAN Volume Controller 2145-8A4 operator-information panel

2. Guide the operator-information panel into position on top of the CD/DVD bay housing. Make sure that the LEDs and the USB connectors are aligned with the openings in the bezel and that the holes in the board align with the screw holes in the top of the bay housing.
3. Tighten the screws **3** to secure the operator-information panel onto the top of the CD/DVD bay housing.
4. Replace the top cover. See “Replacing the top cover” on page 86.
5. Place the node in the rack. See “Replacing the SAN Volume Controller in a rack” on page 59.
6. Connect the power cable to the node and replace the cable-retention bracket. See “Replacing the cable-retention bracket” on page 40.
7. Turn on the node.

Replacing the SAN Volume Controller 2145-8G4 operator-information panel assembly

You might have to replace the operator-information panel on a SAN Volume Controller 2145-8G4 due to required maintenance.

Perform the following steps to replace the operator-information panel:

1. From the front of the node, thread the light path ribbon cable through the panel housing in the node.
2. Slide the operator-information panel into its cage, as shown in Figure 220 on page 234, until it locks in place with a click (in the In position); gently pull the cable through at the back as you do this.

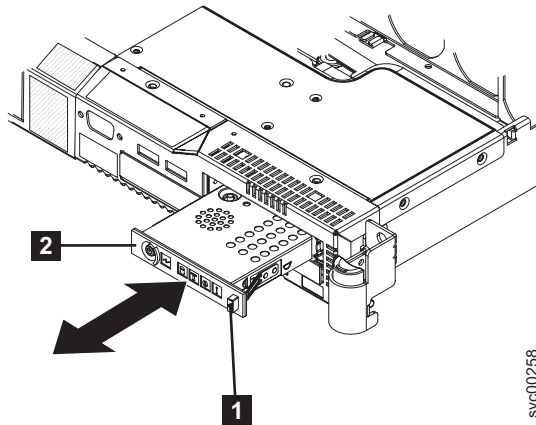

Figure 220. SAN Volume Controller 2145-8G4 operator-information panel

- 1** Release button
 - 2** Operator-information panel
3. Carefully thread the light path assembly ribbon cable **4** back under its retaining brackets and replace the tape securing it in place.
 4. Thread the light path assembly ribbon cable **4** back to the system board. Reconnect the cable to the system board socket **11**. In Figure 221, the front of the node is shown at the bottom of the illustration. The connectors on the cable plug go towards the center of the node and the blue side is towards the outside of the node.

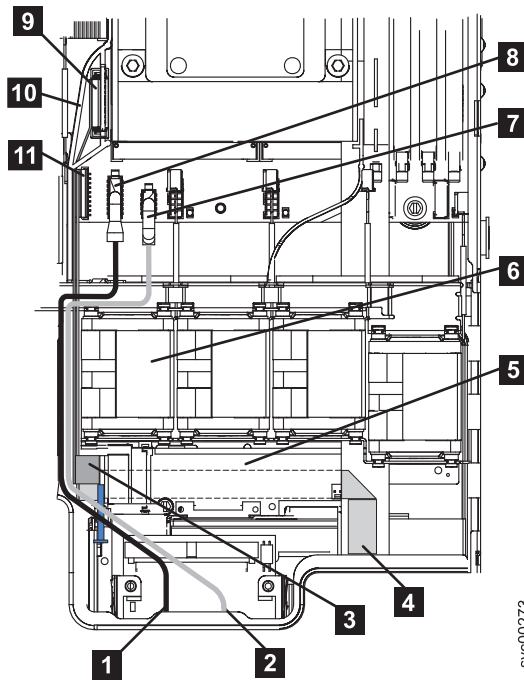

Figure 221. SAN Volume Controller 2145-8G4 video, USB, and the CD/DVD cables

- 1** Video cable
- 2** USB cable

- 3** CD-RW cable
- 4** Light path cable
- 5** Interposer card
- 6** Fan 3
- 7** USB cable connector
- 8** Video cable connector
- 9** CD-RW connector
- 10** Air baffle
- 11** Light path cable connector

5. Reconnect the video cable **8** , the USB cable **7** and the CD/DVD cable **9** to the system board.
6. Replace the air baffle **2** . It is easier to do this if you remove fan 2. Ensure that all the cables are routed correctly, as shown in Figure 222, and not obstructing the fan doors.

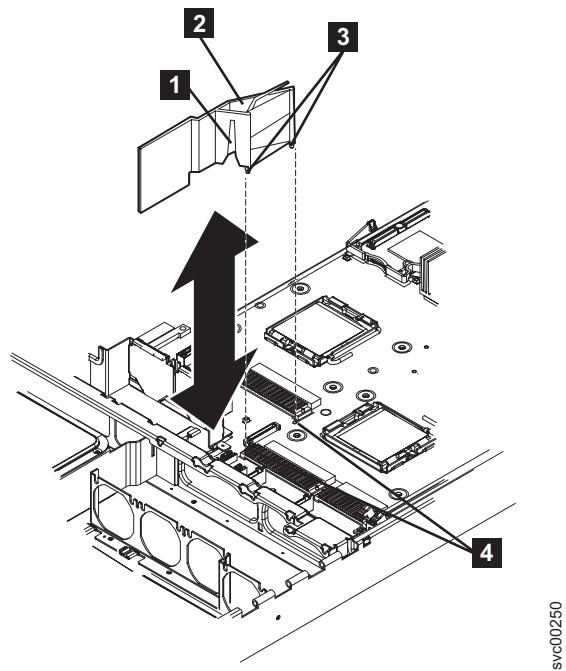
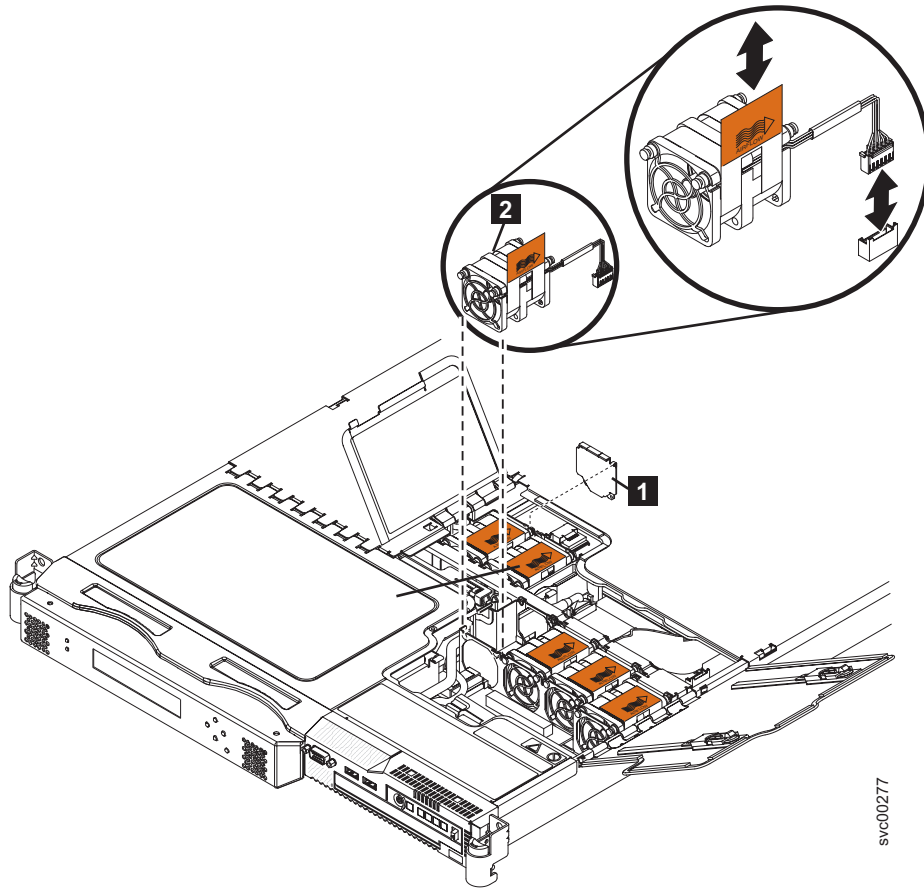

Figure 222. SAN Volume Controller 2145-8G4 air baffle

- 1** Cable routing slot
- 2** Air baffle
- 3** Baffle pins
- 4** Baffle mounting holes

7. Replace fan 3 as shown in Figure 223 on page 236.



svc00277

Figure 223. SAN Volume Controller 2145-8G4 fan 3

1 Air baffle

2 Fan 3

8. Reconnect the CD cable to the interposer card, locating the pins on the right hand side; then, mount the card to the node with the screw that you removed.
9. Slide the dummy CD/DVD drive **2** back into its enclosure.

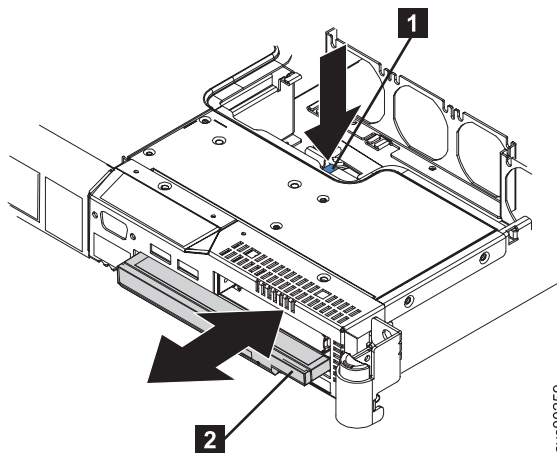

svc00259

Figure 224. SAN Volume Controller 2145-8G4 dummy CD/DVD drive

- 1** Release button
- 2** Dummy CD/DVD drive

10. Ensure that the fan door still closes; realign the cable if it does not.
11. Reopen the fan door and replace the cover; close all doors.
12. Replace the node in the rack, reconnect all cables, and power on the node.

Replacing the SAN Volume Controller 2145-8F2 or SAN Volume Controller 2145-8F4 operator-information panel

You might have to replace the operator-information panel on a SAN Volume Controller 2145-8F2 or SAN Volume Controller 2145-8F4 due to required maintenance.

Perform the following steps to replace the operator-information panel:

1. Plug in the two cables on the rear of the assembly **1**. See Figure 225.

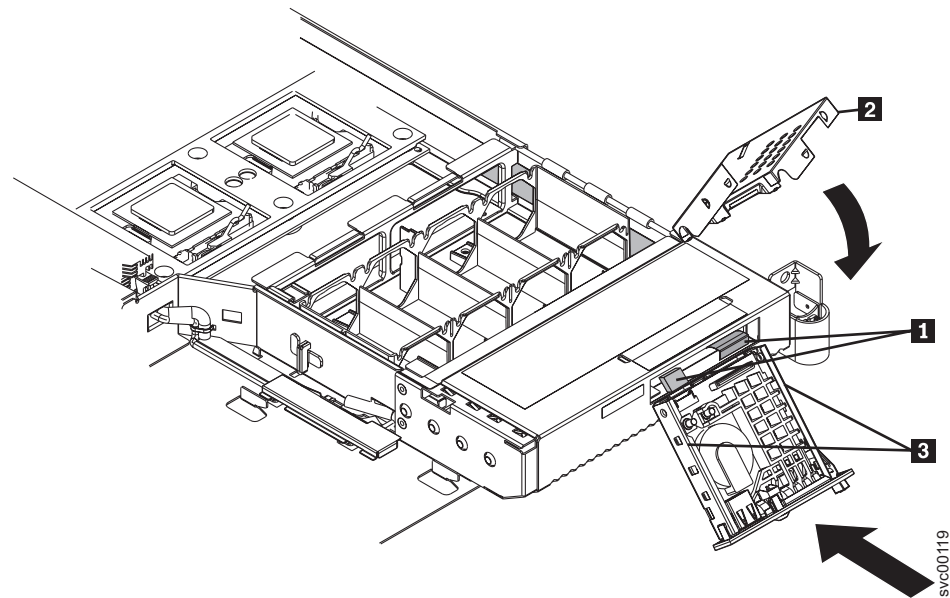

Figure 225. Replacing the operator-information panel

- 1** Cables
- 2** Operator-information panel assembly cover

2. Replace the assembly cover **2** onto the operator-information panel assembly.
3. Slide the assembly into the node until it is firmly anchored.
4. Replace the top cover and replace the node in the rack, if necessary.
5. Connect all power cords and external cables to the back of the server.
6. Turn on the node.

Removing the operator-information panel cable

Use these instructions when you are prompted to remove the operator-information panel cable.

Take precautions to avoid damage from static electricity. Wear an anti-static wrist strap and use a static-protected mat or surface. For more information, see “Handling static-sensitive devices” on page xxiv.

Removing the SAN Volume Controller 2145-CF8 operator-information panel cable

Use these instructions when you are prompted to remove the operator-information panel cable from the SAN Volume Controller 2145-CF8.

DANGER

Multiple power cords. The product might be equipped with multiple power cords. To remove all hazardous voltages, disconnect all power cords.

This service action assumes that:

- The node is turned off. If you must turn off the node, ensure that its data is mirrored and synchronized, and that there are no dependent virtual disks (VDisks), as described in MAP 5350 in the *IBM System Storage SAN Volume Controller Troubleshooting Guide*.
- The power cables are disconnected.
- The top cover is removed.

Perform the following steps to remove the operator-information panel cable:

1. Read the safety information to which “Preparing to remove and replace parts” on page 24 refers.
2. Disconnect the cable from the rear of the operator-information panel.
3. Disconnect the cable from the connector above the Video/USB cable connector on the right side of the node, as shown in Figure 226 on page 239.

The following illustration shows the cable routing for the operator-information panel cable.

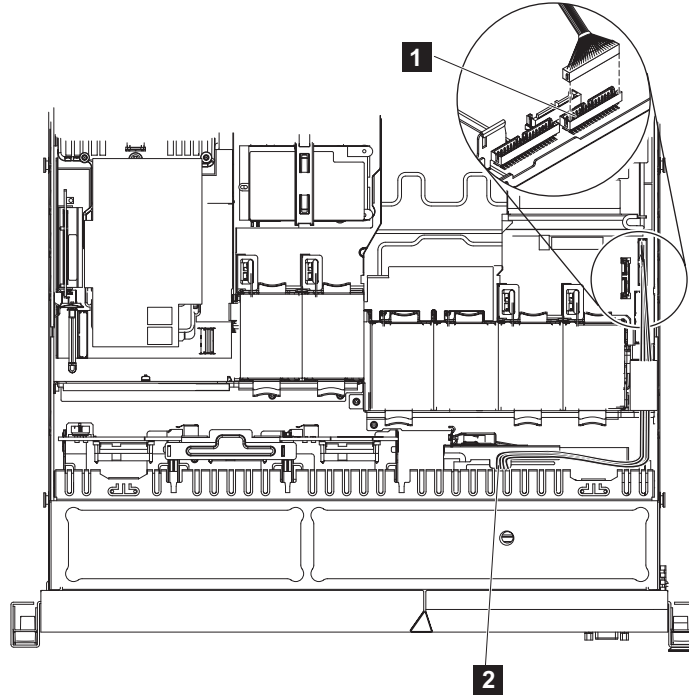

Figure 226. Disconnecting the SAN Volume Controller 2145-CF8 operator-information panel cable

1 Operator-information panel connector

2 Operator-information panel cable

4. Lift the cable from the node.
5. Replace the cable before proceeding.

Removing the SAN Volume Controller 2145-8A4 operator-information panel cable

Use these instructions when you are prompted to remove the operator-information panel cable from the SAN Volume Controller 2145-8A4.

Make careful note of the layout of the cables as you go through this procedure as they will need replacing in the same position when you replace the operator-information panel cable.

Attention: It is easier to remove the operator-information panel cable if you first remove the service controller, disk drive, and the back plate. If you decide to do that, see “Removing the disk drive” on page 118 before using this procedure.

Perform the following steps to remove the operator-information panel cable:

1. Turn off the node while ensuring that its data is mirrored and synchronized. See MAP 5350 in the *IBM System Storage SAN Volume Controller Troubleshooting Guide* for more information.
2. Remove the cable-retention bracket and disconnect the power cable. To make sure that you can replace all cables in the same ports from which they were removed, record the position of all fibre-channel and Ethernet cables; then remove all external cables from the node. See “Removing the cable-retention bracket” on page 34.
3. Remove the node from the rack and place it on a flat, static-protective surface. See “Removing the SAN Volume Controller from a rack” on page 48.

4. Optionally, remove the service controller and pull the disk drive slightly out of the node to disengage it from the back plate. You can then lift the back plate out of the way when you remove the cable.
5. Remove the top cover. See “Removing the top cover” on page 81.
6. Disconnect the light-panel cable **1** and the USB cable **2** from the operator-information panel board shown in Figure 227.

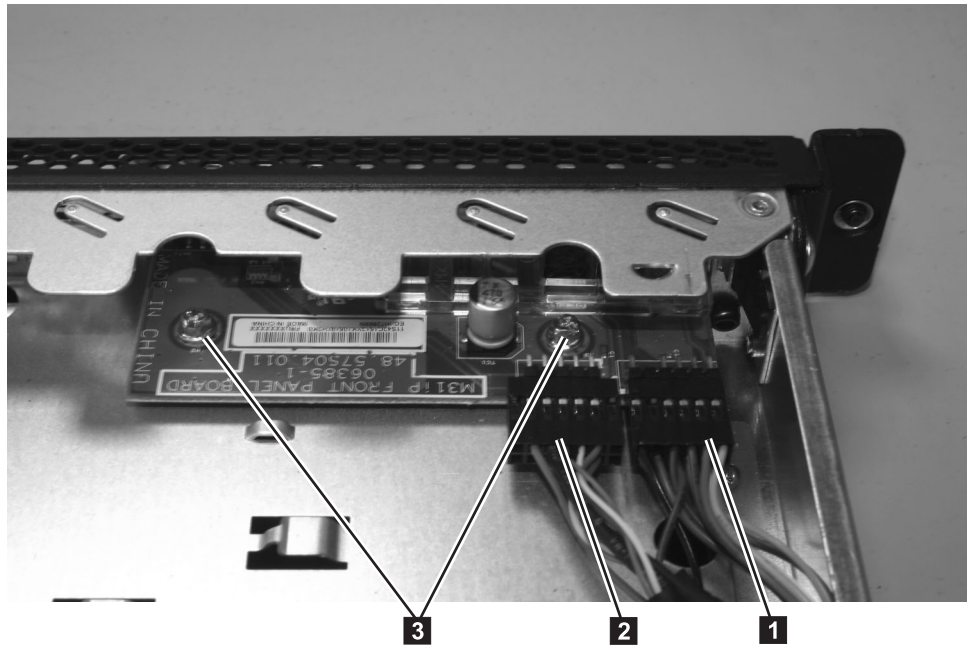

Figure 227. SAN Volume Controller 2145-8A4 operator-information panel

7. The operator-information panel cable consists of two thick cables and a number of thinner cables that are bundled together and routed through the chassis. It provides connectivity for the operator-information panel and the front USB ports. Trace this cable assembly through to the right side of the system board (next to the power supply) and disconnect the Front USB connector **1** and the operator-information panel connector **2** from the system board shown in Figure 228 on page 241.

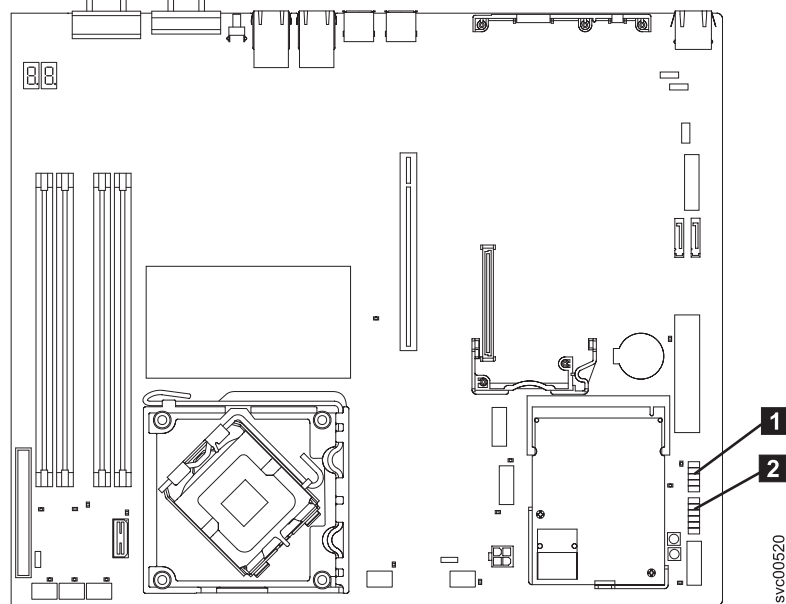

Figure 228. Connectors for the operator-information panel on the SAN Volume Controller 2145-8A4 system board

1 Front USB connector

2 Operator-information panel connector

8. Rotate (lift) the air deflector out of the way. It is easier to access the cable if you lift the back plate out of the way. You do not need to remove either SATA disk cable.
9. Remove the operator-information panel cable assembly from the retention-clip next to the air deflector, but leave the power-supply cable in the retention-clip.
10. A tie-wrap holds the cable assembly to the mounting bracket for the rightmost fan (when viewed from the front of the node and ignoring the fan on the power supply). Cut this tie-wrap to release the cable assembly.
11. Carefully extract the cable assembly from the node. To do this, you must displace other cables; particularly, the optical drive cables, power-supply cables, and the SATA cables. Minimize disruption to these cables as much as possible.

Replacing the operator-information panel cable

Use these instructions when you are prompted to replace the operator-information panel cable.

Take precautions to avoid damage from static electricity. Wear an anti-static wrist strap and use a static-protected mat or surface. For more information, see “Handling static-sensitive devices” on page xxiv.

Replacing the SAN Volume Controller 2145-CF8 operator-information panel cable

Use these instructions when you are prompted to replace the operator-information panel cable for the SAN Volume Controller 2145-CF8.

DANGER

Multiple power cords. The product might be equipped with multiple power cords. To remove all hazardous voltages, disconnect all power cords.

This service action assumes that:

- The node is turned off. If you must turn off the node, ensure that its data is mirrored and synchronized, and that there are no dependent virtual disks (VDisks), as described in MAP 5350 in the *IBM System Storage SAN Volume Controller Troubleshooting Guide*.
- The power cables are disconnected.
- The top cover is removed.

Perform the following steps to replace the operator-information panel cable:

1. Read the safety information to which “Preparing to remove and replace parts” on page 24 refers.
2. Thread the new cable from the operator-information panel to the connector above the Video/USB cable connector on the right side of the node, as shown in Figure 229.

The following illustration shows the cable routing for the operator-information panel cable.

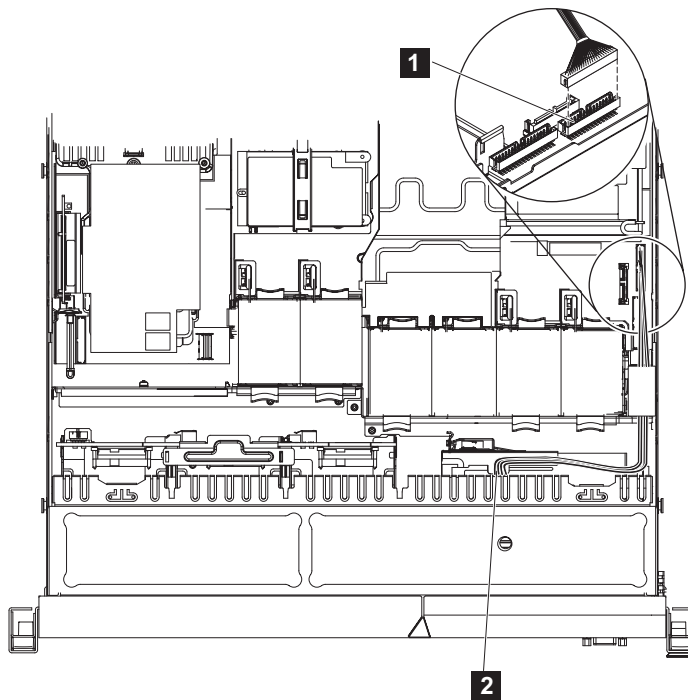

Figure 229. Connecting the SAN Volume Controller 2145-CF8 operator-information panel cable

1 Operator-information panel connector

2 Operator-information panel cable

3. Connect the cable to the connector above the Video/USB cable connector on the right side of the node, as shown in Figure 229.
4. Connect the cable to the rear of the operator-information panel.

5. Replace the top cover. See “Replacing the top cover” on page 86.
6. If you removed the node from the rack, replace the node in the rack, as described in “Replacing the SAN Volume Controller in a rack” on page 59.
7. If you removed any fibre-channel or Ethernet cables, use the labels you placed on each cable to replace all fibre-channel and Ethernet cables in the same ports from which they were removed.
8. If you removed the power cords, replace the power cords and the cable-retention brackets, as described in “Replacing the cable-retention bracket” on page 40.
9. Lift the locking levers (**1** in Figure 230) on the slide rails and push the server **2** all the way into the rack until it clicks into place.

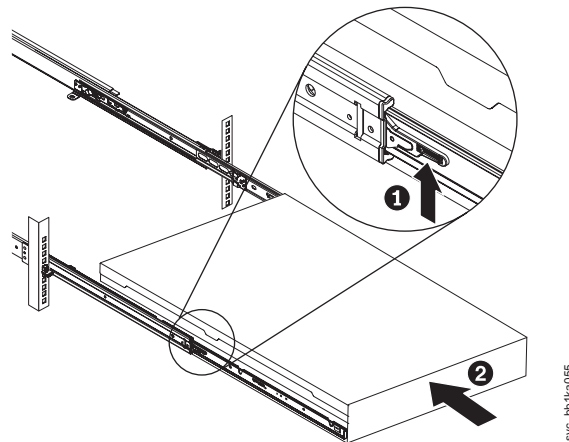

Figure 230. Raising the SAN Volume Controller 2145-CF8 locking levers of the slide rails of the rack

10. Turn on the node.

Replacing the SAN Volume Controller 2145-8A4 operator-information panel cable

Use these instructions when you are prompted to replace the operator-information panel cable for the SAN Volume Controller 2145-8A4.

Perform the following steps to replace the operator-information panel cable:

1. Connect the two connectors at one end of the operator-information panel cable assembly to the Front USB connector **1** and the Operator-information panel connector **2** on the system board. The connectors are keyed and it is important to insert the correct connector on the cable assembly onto the correct connector on the system board.

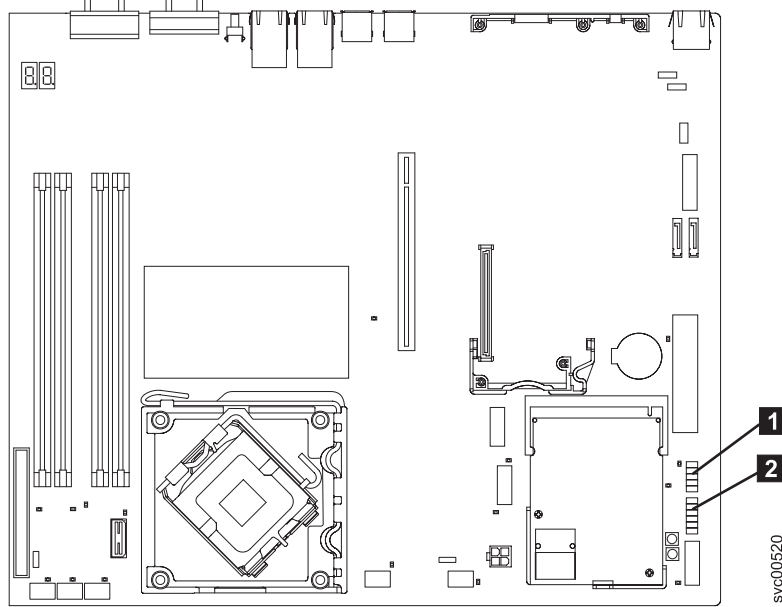

Figure 231. Connectors for the operator-information panel on the SAN Volume Controller 2145-8A4 system board

1 Front USB connector

2 Operator-information panel connector

2. Route the operator-information panel cable into position along the same path that it was removed from:
 - a. Pass to the right of the mounting bracket for the rightmost fan (when viewed from the front of the node and ignoring the fan on the power supply).
 - b. Go between the fans and the disk drive back plate, under the cable retention-clip, and around the processor fans to the left side of the node.
 - c. Bring it forward to the operator-information panel.
3. Use a tie-wrap to hold the cable assembly to the lower right front corner of the mounting bracket for the rightmost fan.
4. Connect the two connectors on the other end of the cable to the connectors on the operator-information panel board. The connectors are keyed and it is important to insert the correct connector on the cable onto the correct connector on the operator-information panel board.
5. If the back plate was removed, replace the back plate, disk drive, and service controller. See “Removing the disk-drive backplane” on page 136.
6. Rotate the air deflector back into place, making sure not to pinch any cables beneath it, and press it down firmly. Ensure that any other cable that was unplugged or moved is returned to its original position and does not obstruct the top cover of the node.
7. Replace the top cover. See “Replacing the top cover” on page 86.
8. Place the node in the rack. See “Replacing the SAN Volume Controller in a rack” on page 59.
9. Connect the power cable to the node and replace the cable-retention bracket. See “Replacing the cable-retention bracket” on page 40.

Removing the fans

The SAN Volume Controller fans might have to be replaced due to failure.

Related tasks

“Replacing the fans” on page 250

You might have to replace one or more SAN Volume Controller fans if they fail.

“Removing the SAN Volume Controller from a rack” on page 48

During some service procedures, you might need to remove the SAN Volume Controller from a rack.

“Replacing the SAN Volume Controller in a rack” on page 59

You must use caution when you replace the SAN Volume Controller in a rack.

“Removing the top cover” on page 81

You can remove the top cover of the SAN Volume Controller node if maintenance is necessary.

“Replacing the top cover” on page 86

You must replace the top cover on the SAN Volume Controller node after maintenance is completed.

“Removing the SAN Volume Controller 2145-8F4 or SAN Volume Controller 2145-8F2 VRM” on page 278

You might remove the voltage regulator module (VRM) to perform maintenance on the SAN Volume Controller 2145-8F2 or SAN Volume Controller 2145-8F4.

“Removing and replacing the SAN Volume Controller power-cable assembly” on page 110

Make sure that power to the SAN Volume Controller is turned off before you remove the power-cable assembly. Turn off the node while ensuring that its data is mirrored and synchronized, as described in MAP 5350 in the *IBM System Storage SAN Volume Controller Troubleshooting Guide*.

Related reference

“Handling static-sensitive devices” on page xxiv

Ensure that you understand how to handle devices that are sensitive to static electricity.

Removing the SAN Volume Controller 2145-CF8 fans

You can remove a SAN Volume Controller 2145-CF8 fan.

Take precautions to avoid damage from static electricity. Wear an anti-static wrist strap and use a static-protected mat or surface. For more information, see “Handling static-sensitive devices” on page xxiv.

Important: You can hot swap a fan. However, using MAP 5350 to power off the node through proven methods avoids risking an abrupt power failure on the node, which avoids the possible corruption of data.

Perform the following steps to remove a failed fan:

1. Read the safety information to which “Preparing to remove and replace parts” on page 24 refers.
2. Optional: Follow the procedure in MAP 5350 in the *IBM System Storage SAN Volume Controller Troubleshooting Guide* to verify that the node data is mirrored and synchronized, and that there are no dependent virtual disks (VDisks) before turning off the node.

Important: If you decide to hot swap the fan, use MAP 5350 to make all of the necessary checks that ensure that the partner node in the I/O group can take over all I/O group operations, if necessary, and that there are no dependent VDisks on the node. With the partner node

available and no dependent VDisks on the node, you do not lose access to data if this node accidentally powers off.

- Slide the node forward to remove the cover and expose the fans, as described in “Removing the SAN Volume Controller 2145-CF8 top cover” on page 82.

Figure 232 shows fan locations within the SAN Volume Controller 2145-CF8 node.

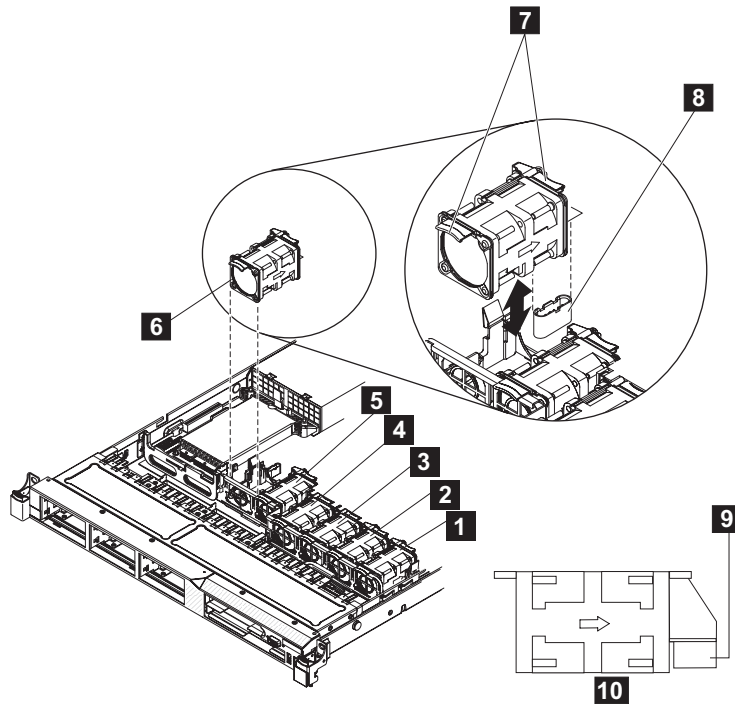

Figure 232. SAN Volume Controller 2145-CF8 fan locations and connectors

- 1** Fan 1
- 2** Fan 2
- 3** Fan 3
- 4** Fan 4
- 5** Fan 5
- 6** Fan 6
- 7** Fan tabs
- 8** Fan connector on the system board
- 9** Fan connector
- 10** Side view of fan showing air-flow indicator

The node has six fan positions that are numbered right to left. The LED near the connector of the failing fan assembly is lit, unless you remove the power cable.

- Grasp the orange fan tabs on both ends of the existing fan and pull it up out of the server. If you are removing fans 3 or 4, lift up the clear tab on the DIMM air baffle first.

Figure 233 on page 247 shows a fan being removed from the node.

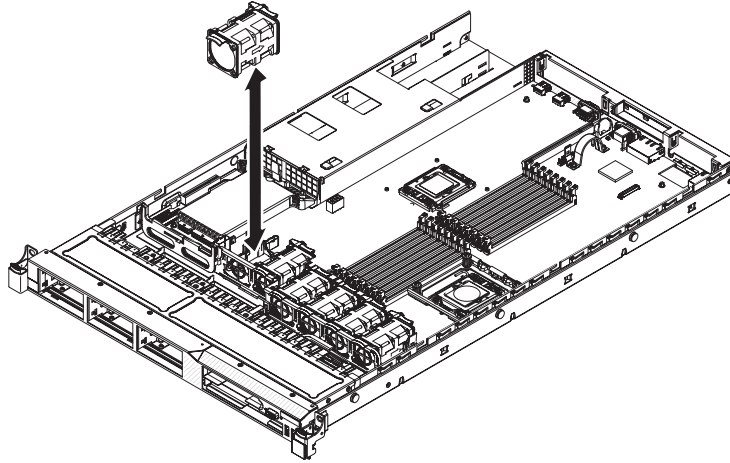

Figure 233. Removing or replacing a fan in the SAN Volume Controller 2145-CF8 node

Attention: To ensure proper operation, replace a failed fan within 30 seconds.

5. If you are instructed to return the fan, follow all of the packaging instructions, and use any packaging materials for shipping that are supplied to you.

Removing the SAN Volume Controller 2145-8A4 fans

Take precautions to avoid damage from static electricity. Wear an anti-static wrist strap and use a static-protected mat or surface. For more information, see “Handling static-sensitive devices” on page xxiv.

Perform the following steps to remove a failed fan:

1. Turn off the node while ensuring that its data is mirrored and synchronized. See MAP 5350 in the *IBM System Storage SAN Volume Controller Troubleshooting Guide* for more information.
2. Remove the cable-retention bracket and disconnect the power cable from the node. See “Removing the cable-retention bracket” on page 34.
3. Remove the node from the rack and place it on a flat, static-protective surface. See “Removing the SAN Volume Controller from a rack” on page 48.
4. Remove the top cover. See “Removing the top cover” on page 81.
5. Reconnect the power cord and then turn on the node.

Attention: Operating the node for extended periods of time (more than 30 minutes) with the cover removed might damage server components.

6. Determine which fan to replace by checking the LEDs on the system board. Each fan has an LED next to it. A lit LED indicates the fan to replace.
7. Turn off the node and then disconnect the power cord again.
8. Remove the failed fan.
 - a. Disconnect the fan cable from the system board.

Note: Make a note of the routing of the fan cable to the connector. You will have to route the fan cable the same way when you install the fan.

- b. Grasp the top of the fan with your index finger and thumb and lift the fan out of the server.

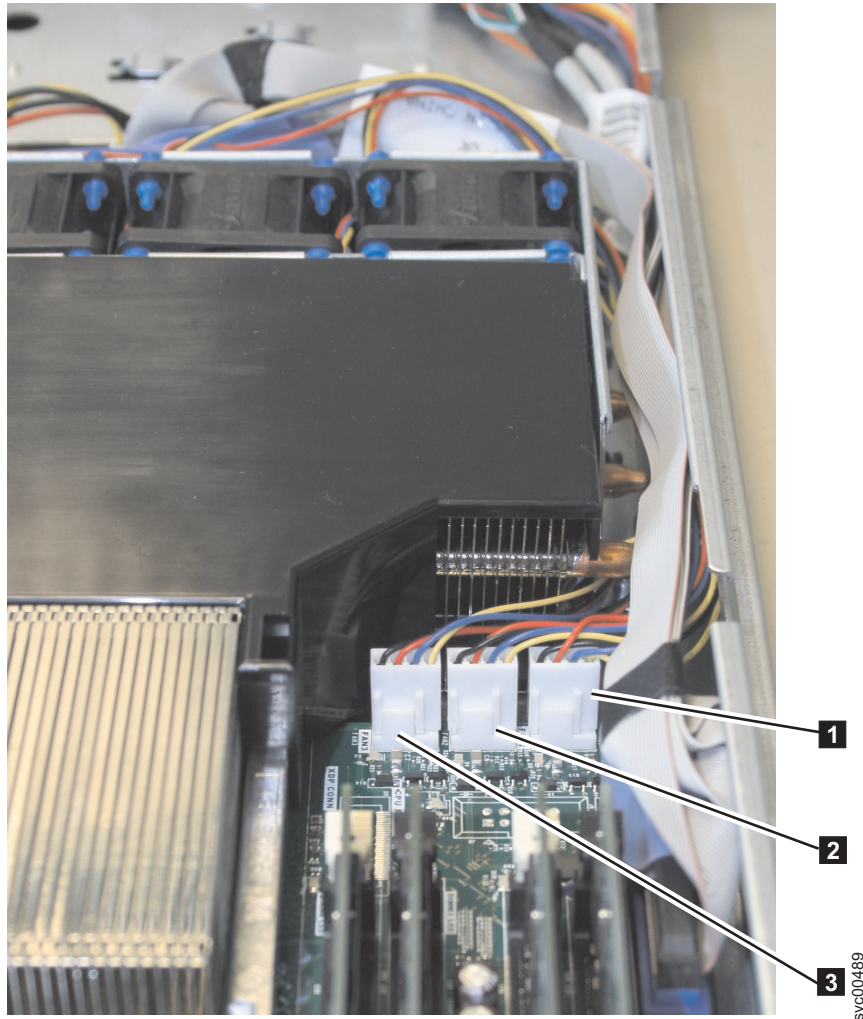

Figure 234. Connectors for the SAN Volume Controller 2145-8A4 heat exchange fans

- 1** Fan 3
- 2** Fan 2
- 3** Fan 1

Removing the SAN Volume Controller 2145-8G4 fans

Take precautions to avoid damage from static electricity. Wear an anti-static wrist strap and use a static-protected mat or surface. For more information, see “Handling static-sensitive devices” on page xxiv.

Perform the following steps to remove a failed fan:

1. Turn off the node while ensuring that its data is mirrored and synchronized. See MAP 5350 in the *IBM System Storage SAN Volume Controller Troubleshooting Guide* for more information.
2. Slide the node forward to gain access to the fan doors (**1** in Figure 235 on page 249).
3. Open the fan door for the failing fan. The LED near the connector of the failing fan assembly is lit, unless you remove the power cable.

Note: The node has six fan positions that are numbered left to right under the two fan doors.

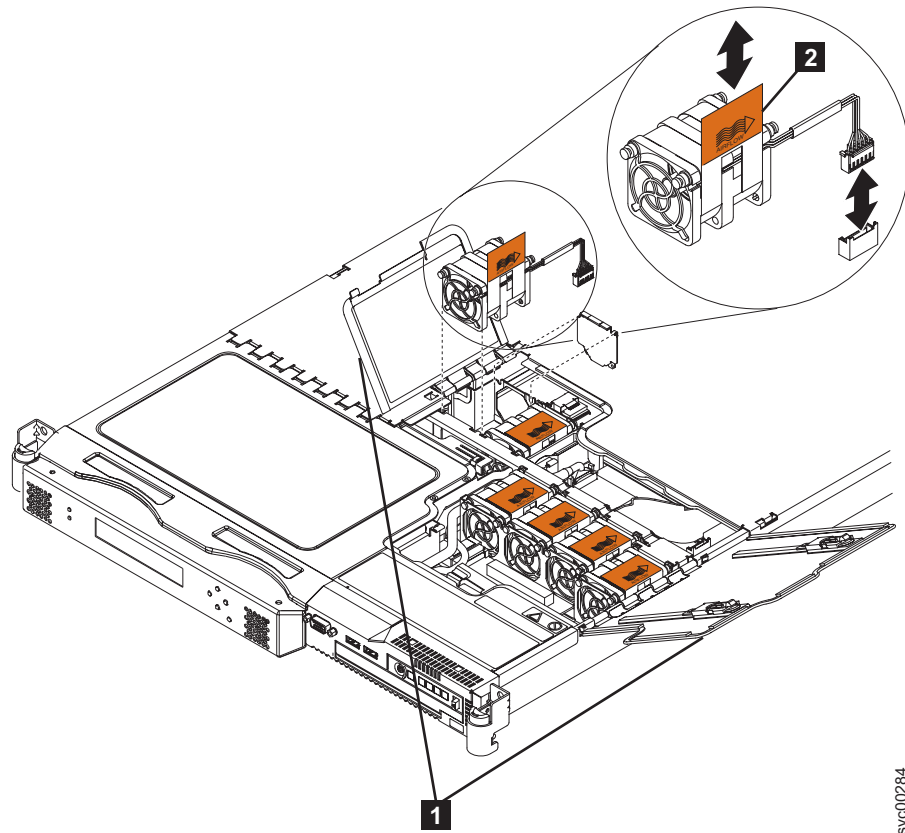

svc00284

Figure 235. SAN Volume Controller 2145-8G4 fan doors, locations, and connectors

4. Disconnect the cable of the failing fan from the connector on the system board by pressing the release latch on the plug at the end of the cable.
5. Pull up on the orange tab (**2** in Figure 235) of the failing fan to lift the fan out of the node.

Removing the SAN Volume Controller 2145-8F4 or SAN Volume Controller 2145-8F2 fans

Ensure that you are aware of the procedures for handling static-sensitive devices before you remove the SAN Volume Controller 2145-8F4 or SAN Volume Controller 2145-8F2 fans.

Perform the following steps to remove a failed fan:

1. Turn off the node while ensuring that its data is mirrored and synchronized. See MAP 5350 in the *IBM System Storage SAN Volume Controller Troubleshooting Guide* for more information.
2. Remove the node from the rack and place it on a flat, static-protective surface. See “Removing the SAN Volume Controller from a rack” on page 48.
3. Open the fan door where the failed fan resides. Fans 1, 2, and 3 are under fan door A **1**. Fans 4 through 7 are under fan door B **2**, as shown in Figure 236 on page 250.

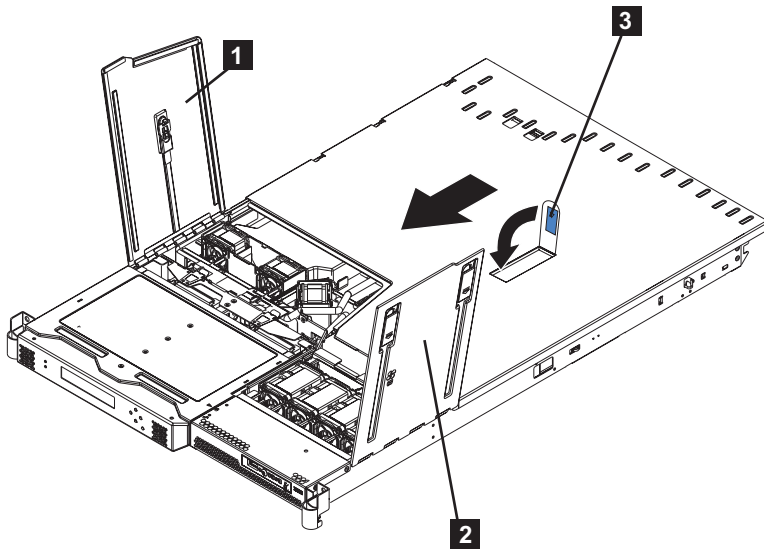

svc00087

Figure 236. SAN Volume Controller 2145-8F2 with the access doors open

- 1** Fan door A
- 2** Fan door B

4. Disconnect the cable of the failing fan from the connector. Figure 237 shows the location of the fans.

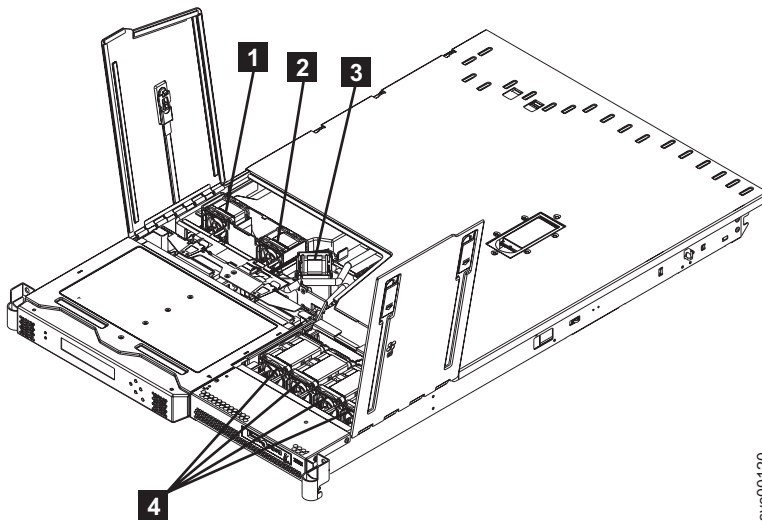

svc00120

Figure 237. SAN Volume Controller 2145-8F2 fan locations

- 1** Fan 1
- 2** Fan 2
- 3** Fan 3
- 4** Fans 4, 5, 6, and 7

5. Pull up on the orange tab on the side of the failing fan.
 6. Lift the fan out of the node.

Replacing the fans

You might have to replace one or more SAN Volume Controller fans if they fail.

Related tasks

“Removing the fans” on page 244

The SAN Volume Controller fans might have to be replaced due to failure.

“Replacing the SAN Volume Controller in a rack” on page 59

You must use caution when you replace the SAN Volume Controller in a rack.

“Replacing the top cover” on page 86

You must replace the top cover on the SAN Volume Controller node after maintenance is completed.

Related reference

“Handling static-sensitive devices” on page xxiv

Ensure that you understand how to handle devices that are sensitive to static electricity.

Replacing the SAN Volume Controller 2145-CF8 fans

Replace any of the six fans in the SAN Volume Controller 2145-CF8 node.

Attention: To ensure proper operation, replace a failed fan within 30 seconds.

Take precautions to avoid damage from static electricity. Wear an anti-static wrist strap and use a static-protected mat or surface. For more information, see “Handling static-sensitive devices” on page xxiv.

Important: You can hot swap a fan. However, using MAP 5350 to power off the node through proven methods avoids risking an abrupt power failure on the node, which avoids the possible corruption of data.

Perform the following steps to replace a fan:

1. Read the safety information to which “Preparing to remove and replace parts” on page 24 refers.
2. Optional: Follow the procedure in MAP 5350 in the *IBM System Storage SAN Volume Controller Troubleshooting Guide* to verify that the node data is mirrored and synchronized, and that there are no dependent virtual disks (VDisks) before turning off the node.

Important: If you decide to hot swap the fan, use MAP 5350 to make all of the necessary checks that ensure that the partner node in the I/O group can take over all I/O group operations, if necessary, and that there are no dependent VDIs on the node. With the partner node available and no dependent VDIs on the node, you do not lose access to data if this node accidentally powers off.

3. Slide the node forward to remove the cover and expose the fans and fan connectors, as described in “Removing the SAN Volume Controller 2145-CF8 top cover” on page 82.

Figure 238 on page 252 shows fan locations within the SAN Volume Controller 2145-CF8 node.

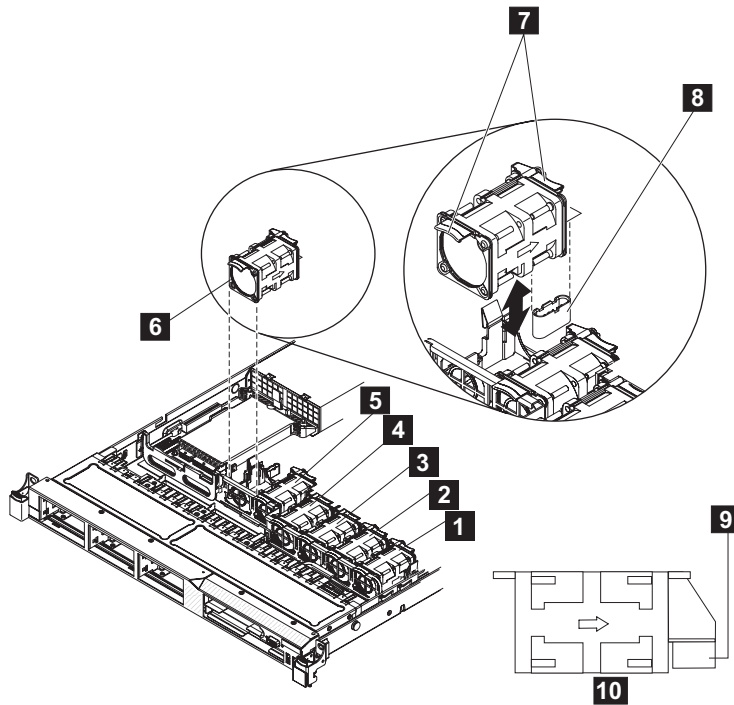

Figure 238. SAN Volume Controller 2145-CF8 fan locations and connectors

- 1** Fan 1
- 2** Fan 2
- 3** Fan 3
- 4** Fan 4
- 5** Fan 5
- 6** Fan 6
- 7** Fan tabs
- 8** Fan connector on the system board
- 9** Fan connector
- 10** Side view of fan showing air-flow indicator

The node has six fan positions that are numbered from right to left.

4. Orient the new fan over the appropriate fan slot in the fan-assembly bracket so that the fan connector aligns with the connector on the system board. This alignment assures that the air-flow indicator arrow on the side of the fan is pointing to the rear of the node. Figure 239 on page 253 shows a fan being replaced.

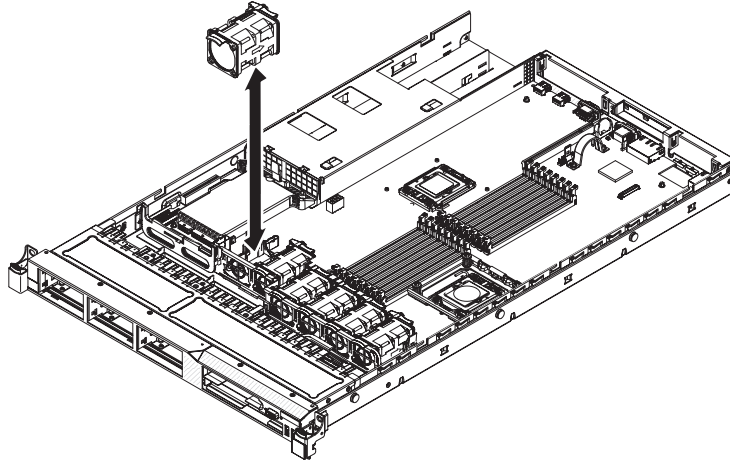

Figure 239. Removing or replacing a fan in the SAN Volume Controller 2145-CF8 node

5. Insert the fan into the fan slot in the fan-assembly bracket and press it down until it is seated correctly in the slot and the fan connector is seated correctly in the connector on the system board.
6. Make sure that all cables, adapters, and other components are installed and seated correctly and that you have not left loose tools or parts inside the node. Make sure that all internal cables are correctly routed. If you disconnected the fibre-channel and Ethernet cables, make sure that each cable is reconnected to the same port from which it was removed.
7. Replace the top cover. See “Replacing the top cover” on page 86.
8. If you removed the node from the rack, replace the node in the rack, as described in “Replacing the SAN Volume Controller in a rack” on page 59.
9. If you removed any fibre-channel or Ethernet cables, use the labels you placed on each cable to replace all fibre-channel and Ethernet cables in the same ports from which they were removed.
10. If you removed the power cords, replace the power cords and the cable-retention brackets, as described in “Replacing the cable-retention bracket” on page 40.
11. Lift the locking levers (**1** in Figure 240 on page 254) on the slide rails and push the server **2** all the way into the rack until it clicks into place.

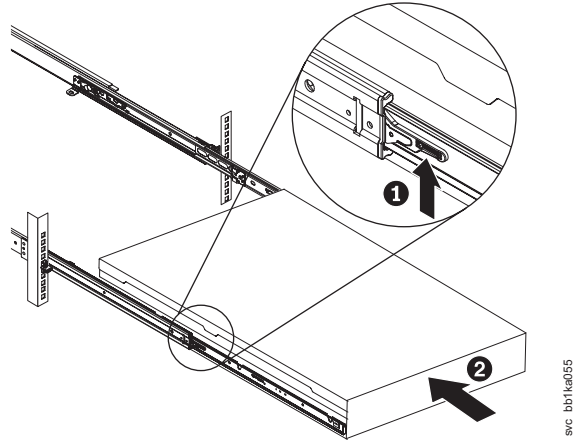

Figure 240. Raising the SAN Volume Controller 2145-CF8 locking levers of the slide rails of the rack

12. Turn on the node.

Replacing the SAN Volume Controller 2145-8A4 fans

This topic describes how to replace the SAN Volume Controller 2145-8A4 fans.

Take precautions to avoid damage from static electricity. Wear an anti-static wrist strap and use a static-protected mat or surface. For more information, see “Handling static-sensitive devices” on page xxiv.

Perform the following steps to replace a failed fan:

1. Position the replacement fan, shown in Figure 241 on page 255, so that the airflow arrow on the side of the fan points toward the rear of the node.

Note: Correct airflow is from the front to the rear of the node.

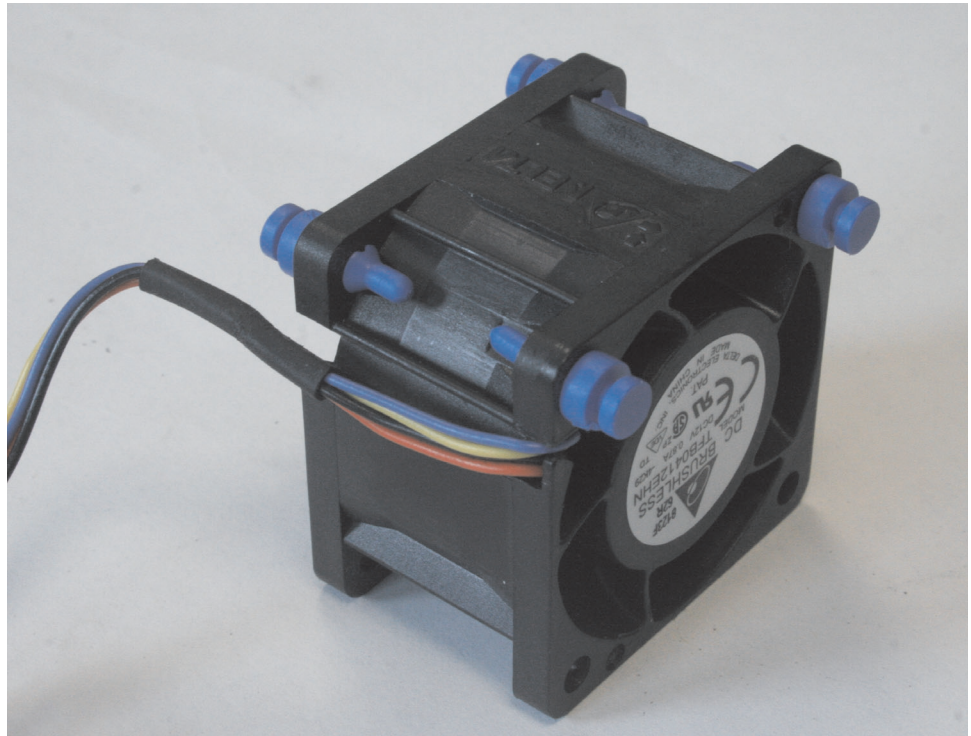

svc00512

Figure 241. A close up of the SAN Volume Controller 2145-8A4 fan

2. Install the replacement fan in the bracket:
 - a. Make sure that the fan cable sits in the channel **1**, as shown in Figure 242, on the side of the fan.
 - b. Route the fan cable into its slot in the fan bracket top and then insert the fan into the bracket.
 - c. Make sure that each of the soft blue tabs on the fan is fully seated in its slot in the fan bracket.

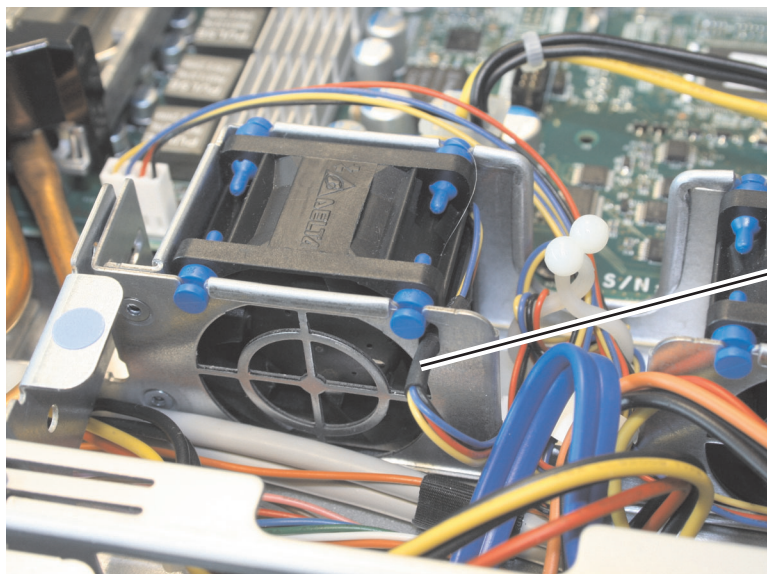

svc00490

Figure 242. Routing the SAN Volume Controller 2145-8A4 fan cable

- d. Reconnect the fan cable to the system board, routing the cable in the same way as it was originally.
3. Connect the cable of the replacement fan into the system-board connector.
4. Replace the top cover. See “Replacing the top cover” on page 86.
5. Place the node in the rack. See “Replacing the SAN Volume Controller in a rack” on page 59.
6. Replace the cable-retention bracket. See “Replacing the cable-retention bracket” on page 40.
7. Turn on the node.

Replacing the SAN Volume Controller 2145-8G4 fans

This topic describes how to replace the SAN Volume Controller 2145-8G4 fans.

Take precautions to avoid damage from static electricity. Wear an anti-static wrist strap and use a static-protected mat or surface. For more information, see “Handling static-sensitive devices” on page xxiv. The replacement procedures in this topic assume that the following are true:

- The failed fan is removed
- The node power is turned off
- The node is removed from the rack

Perform the following steps to replace a failed fan:

1. Orient the new fan in the same position as the fan that you removed. Make sure that the airflow indicator on the orange tab, (**2** in Figure 243 on page 257) is pointing to the rear of the node.

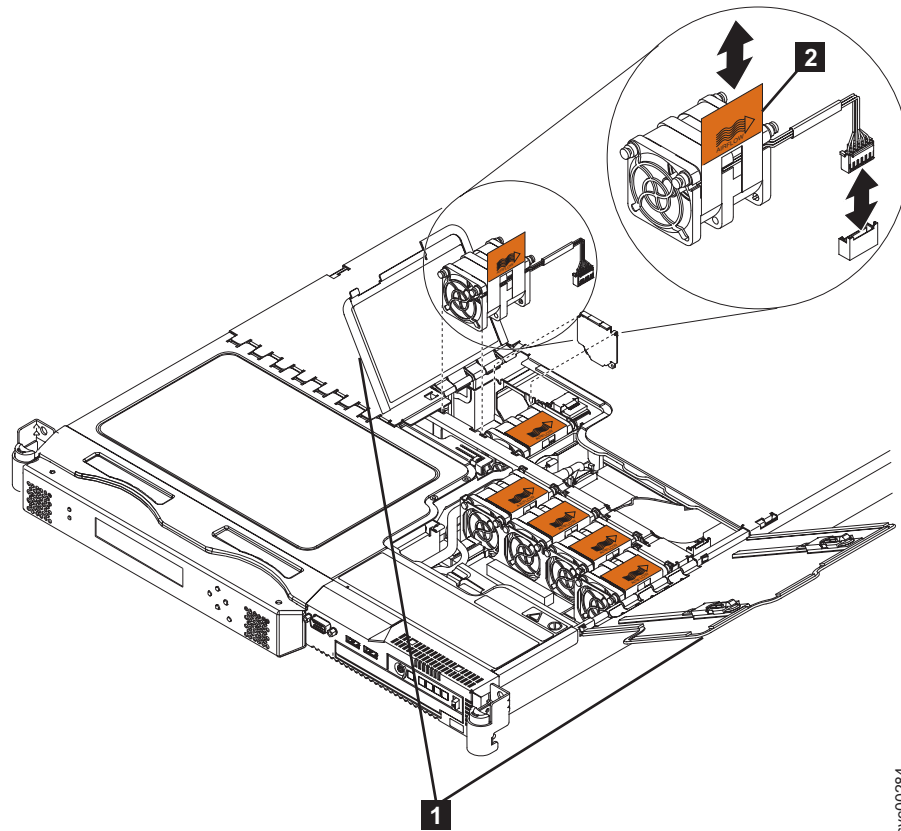

svc00284

Figure 243. SAN Volume Controller 2145-8G4 fan doors, locations, and connectors

2. Push the fan assembly down into the server until the blue mounting grommets are correctly seated.
3. Connect the cable of the replacement fan into the system board connector.
4. Close the fan door **1**.
5. Place the node in the rack. See “Replacing the SAN Volume Controller in a rack” on page 59.
6. Turn on the node.

Replacing the SAN Volume Controller 2145-8F4 or SAN Volume Controller 2145-8F2 fans

Take precautions to avoid damage from static electricity. Wear an anti-static wrist strap and use a static-protected mat or surface. For more information, see “Handling static-sensitive devices” on page xxiv. The replacement procedures in this topic assume that the following are true:

- The failed fan is removed
- The node power is turned off
- The node is removed from the rack

Perform the following steps to replace the SAN Volume Controller 2145-8F4 or SAN Volume Controller 2145-8F2 fans:

1. Orient the new fan in the same position as the fan you removed. Make sure that the airflow indicator, on top of the fan, is pointing to the rear of the server.

2. Push the fan assembly down into the server until the blue grommets are correctly seated.
3. Connect the cable of the replacement fan into the connector.
4. Close the fan door.
5. Replace the top cover. See “Replacing the top cover” on page 86.
6. Place the node in the rack. See “Replacing the SAN Volume Controller in a rack” on page 59.
7. Reconnect the cables and power cords that were removed.
8. Turn on the node.

Removing the SAN Volume Controller 2145-8F2 or SAN Volume Controller 2145-8F4 fan holder and fan backplanes

The fan holder with fan backplanes field-replaceable unit (FRU) is supplied as a kit of parts. Replace only the failed assembly and discard any unused part.

Perform the following steps to remove the fan holder with fan backplane:

1. Turn off the node while ensuring that its data is mirrored and synchronized. See MAP 5350 in the *IBM System Storage SAN Volume Controller Troubleshooting Guide* for more information.
2. To make sure that you can replace all cables in the same ports from which they were removed, record the position of all fibre-channel and Ethernet cables; then remove all cables from the back of the node.
3. Remove the node from the rack and place it on a flat, static-protective surface. See “Removing the SAN Volume Controller from a rack” on page 48.
4. Remove the top cover. See “Removing the top cover” on page 81.
5. Unplug the fans from the fan backplane.
6. Remove the screws and set them in a safe place.
7. Disconnect the fan cable.
8. Pull the fan bracket out of the node.

Replacing the SAN Volume Controller 2145-8F2 or SAN Volume Controller 2145-8F4 fan holder and fan backplanes

The fan holder with fan backplanes field-replaceable unit (FRU) is supplied as a kit of parts. Replace only the failed assembly and discard any unused part.

Perform the following steps to replace the fan holder with fan backplane:

1. Place the fan bracket into the node.
2. Connect the fan cable.
3. Replace the screws that you had set aside.
4. Plug the fans into the fan backplane.
5. Replace the top cover.
6. Replace the node in the rack.
7. Connect all power cords and external cables into the back of the node.
8. Turn on the node.

Tip: When reinstalling the fan brackets on the front right side of the node, remove the cage assembly that holds the disk drive and service controller

and remove the fan cable cover. Pull the cable loose before plugging it into the fan backplane, then install the fan holder and backplane assembly in the node.

Related tasks

“Replacing the top cover” on page 86

You must replace the top cover on the SAN Volume Controller node after maintenance is completed.

“Replacing the SAN Volume Controller in a rack” on page 59

You must use caution when you replace the SAN Volume Controller in a rack.

Related reference

“Handling static-sensitive devices” on page xxiv

Ensure that you understand how to handle devices that are sensitive to static electricity.

Removing the microprocessor

You can remove the microprocessor that is used in the SAN Volume Controller nodes.

Take precautions to avoid damage from static electricity. Wear an anti-static wrist strap and use a static-protected mat or surface. For more information, see “Handling static-sensitive devices” on page xxiv.

Related tasks

“Removing the SAN Volume Controller from a rack” on page 48

During some service procedures, you might need to remove the SAN Volume Controller from a rack.

“Removing the top cover” on page 81

You can remove the top cover of the SAN Volume Controller node if maintenance is necessary.

“Removing the SAN Volume Controller 2145-8F4 or SAN Volume Controller 2145-8F2 VRM” on page 278

You might remove the voltage regulator module (VRM) to perform maintenance on the SAN Volume Controller 2145-8F2 or SAN Volume Controller 2145-8F4.

“Replacing the microprocessor” on page 266

Use this topic when you are required to replace a microprocessor.

Related reference

“Handling static-sensitive devices” on page xxiv

Ensure that you understand how to handle devices that are sensitive to static electricity.

Removing the SAN Volume Controller 2145-CF8 microprocessor

Use this information to remove the SAN Volume Controller 2145-CF8 microprocessor and heat sink.

DANGER

Multiple power cords. The product might be equipped with multiple power cords. To remove all hazardous voltages, disconnect all power cords.

To correctly perform this task, you must have alcohol wipes and thermal grease available. If you do not already have them, order these separately.

This service action requires you to remove the cover and:

- Turn the node off.
- Disconnect the power cables.
- Disconnect the data cables.

Attention:

- Do not permit the thermal grease on the microprocessor and heat sink to come in contact with anything. Contact with any surface can compromise the thermal grease and the microprocessor socket.
- Use great care when handling microprocessors. Dropping the microprocessor during installation or removal can damage the contacts.
- Do not touch the microprocessor contacts; handle the microprocessor by the edges only. Contaminants on the microprocessor contacts, such as oil from your skin, can cause connection failures between the contacts and the socket.

To remove a microprocessor and heat sink, complete the following steps:

1. Read the safety information to which “Preparing to remove and replace parts” on page 24 refers.
2. Follow the procedure in MAP 5350 in the *IBM System Storage SAN Volume Controller Troubleshooting Guide* to verify that the node data is mirrored and synchronized, and that there are no dependent virtual disks (VDisks) before turning off the node.
3. Slide the node out on its slide rails to the fully extended position.
You can perform most service actions when the node is fully extended from the rack on its slide rails. You can leave the fibre-channel and Ethernet cables connected, if you are using the cable-management arm and if you are not removing the node from the rack. If the location of the node in the rack is too high or too low to work comfortably, you can remove the node from the rack.
4. When the node is completely turned off, remove the cable-retention brackets and disconnect the power cables, as described in “Removing the cable-retention bracket” on page 34.
5. To make sure that you can replace all cables in the same ports from which they were removed, label the port position of each fibre-channel and Ethernet cable; then remove all cables from the back of the node.
6. Optional: Remove the node from the rack and place it on a flat, static-protective surface. See “Removing the SAN Volume Controller from a rack” on page 48.
7. Remove the top cover. See “Removing the top cover” on page 81.
8. Disconnect any cables that impede access to the heat sink (**3** in Figure 244 on page 261) and the microprocessor (**1**).

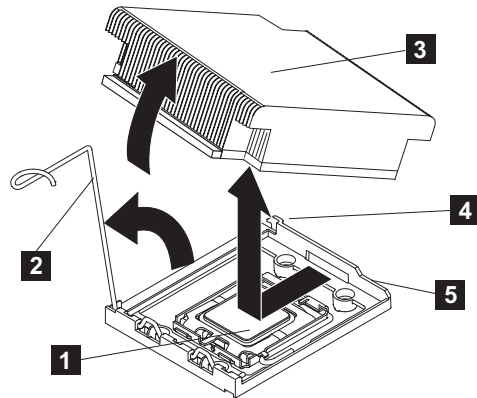

Figure 244. Removing the heat sink from the SAN Volume Controller 2145-CF8 microprocessor

- 1** Microprocessor
- 2** Heat-sink release lever
- 3** Heat sink
- 4** Lock tab
- 5** Retainer bracket

9. Push the heat-sink release lever (**1**) down and away from the processor, then lift the lever until it is perpendicular to the system board.
10. Lift the heat sink from the side nearest the lever, in its upright position and remove. After removal, place the heat sink on its side on a clean, flat surface.
11. Release the microprocessor-release lever (**2** in Figure 245), by pressing down on the curved end of the lever, moving that end away from the middle of the processor, and releasing the lever up to the open position.

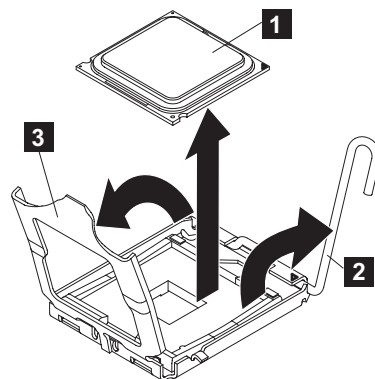

Figure 245. Opening the SAN Volume Controller 2145-CF8 microprocessor-bracket frame

- 1** Microprocessor
- 2** Microprocessor-release lever
- 3** Microprocessor-bracket frame

12. Open the microprocessor-bracket frame by lifting the tab that is on the top edge. Keep the bracket frame in the open position, as shown in Figure 245.
13. Carefully lift the microprocessor straight up and out of the socket, and place it on a static-protective surface. Be careful to touch only the edges of the microprocessor.

14. If you are instructed to return the microprocessor, follow all packaging instructions, and use any packaging materials for shipping that are supplied to you.

Removing the SAN Volume Controller 2145-8A4 microprocessor

Use this information to remove the SAN Volume Controller 2145-8A4 microprocessor.

You must order alcohol wipes and thermal grease separately, if you do not already have them, to correctly perform this task.

To remove the microprocessor, complete the following steps:

1. Turn off the node while ensuring that its data is mirrored and synchronized. See MAP 5350 in the *IBM System Storage SAN Volume Controller Troubleshooting Guide* for more information.
2. Remove the cable-retention bracket and disconnect the power cable from the node. See “Removing the cable-retention bracket” on page 34.
3. Remove the node from the rack and place it on a flat, static-protective surface. See “Removing the SAN Volume Controller from a rack” on page 48.
4. Remove the top cover. See “Removing the top cover” on page 81.
5. Remove the air baffle (1 in Figure 246). Grasp the air baffle by the leftmost and rightmost rear corners and lift it up out of the node.

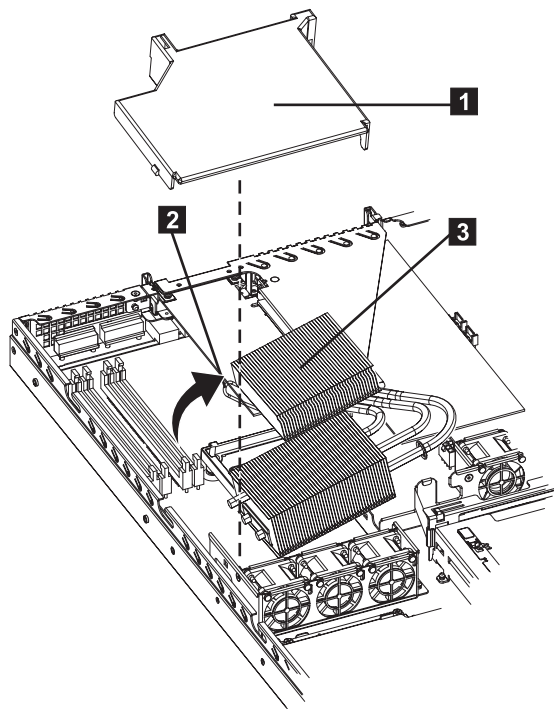

Figure 246. SAN Volume Controller 2145-8A4 air baffle and heat-exchanger assembly

6. Open the heat-exchanger-assembly release latch (2 in Figure 246) to the fully open position.
7. Lift the side of the heat-exchanger assembly (3 in Figure 246) that is closer to the middle of the node, slide it toward the middle of the node slightly, and lift the entire assembly out of the node.

8. Open the microprocessor release latch to the fully open position.

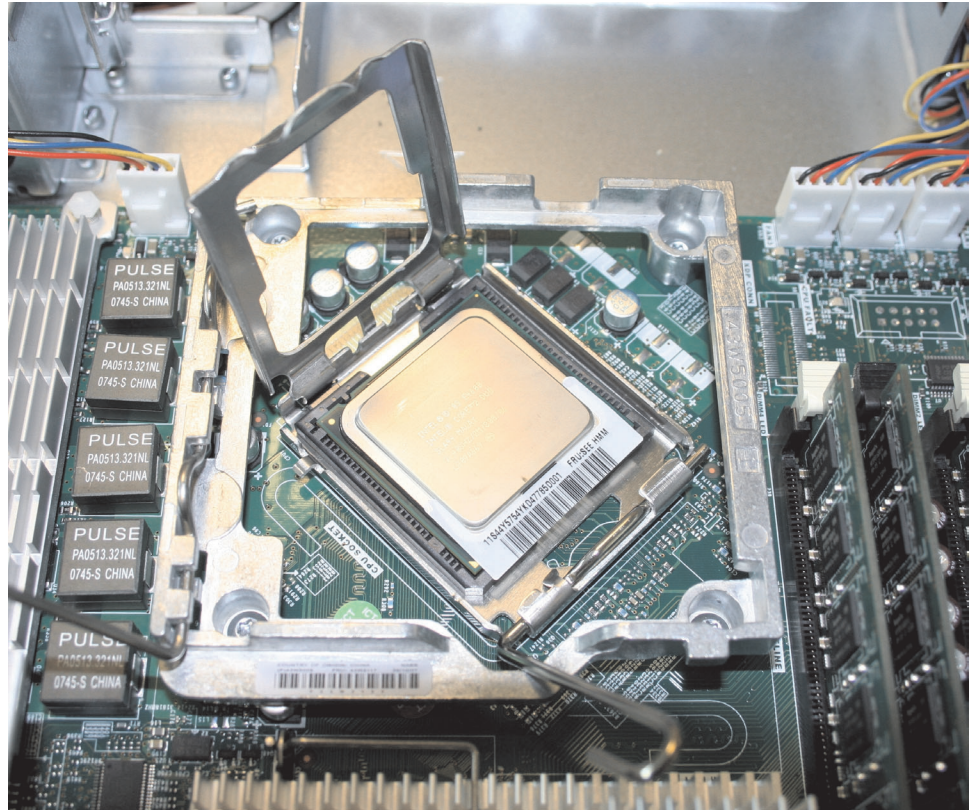

Figure 247. The SAN Volume Controller 2145-8A4 microprocessor bracket frame fully opened

9. Open the microprocessor bracket frame.

Note: Handle the microprocessor carefully. Dropping the microprocessor during removal can damage the contacts. Also, contaminants on the microprocessor contacts, such as oil from your skin, can cause connection failures between the contacts and the socket.

10. Remove the microprocessor:
 - a. Carefully lift the microprocessor straight up and out of the socket, without touching the microprocessor contacts.
 - b. Place the microprocessor on a static-protective surface.

Removing the SAN Volume Controller 2145-8G4 microprocessor

Use this information to remove the SAN Volume Controller 2145-8G4 microprocessor and heat sink.

To correctly perform this task, you must have alcohol wipes and thermal grease available. If you do not already have them, order these separately.

Attention:

- Do not allow the thermal grease on the microprocessor and heat sink to come in contact with anything. Contact with any surface can compromise the thermal grease and the microprocessor socket.
- Use great care when handling microprocessors. Dropping the microprocessor during installation or removal can damage the contacts.
- Do not touch the microprocessor contacts; handle the microprocessor by the edges only. Contaminants on the microprocessor contacts, such as oil from your skin, can cause connection failures between the contacts and the socket.

To remove a microprocessor and heat sink, complete the following steps:

1. Turn off the node while ensuring that its data is mirrored and synchronized. See MAP 5350 in the *IBM System Storage SAN Volume Controller Troubleshooting Guide* for more information.
2. Remove the top cover. See “Removing the top cover” on page 81.
3. Remove the heat sink (**1** in Figure 248). Loosen two captive screws on alternate sides of the heat sink fully before loosening the other two captive screws. (This helps to break the bond between the heat sink and the microprocessor.) After the captive screws are loosened, remove the heat sink.

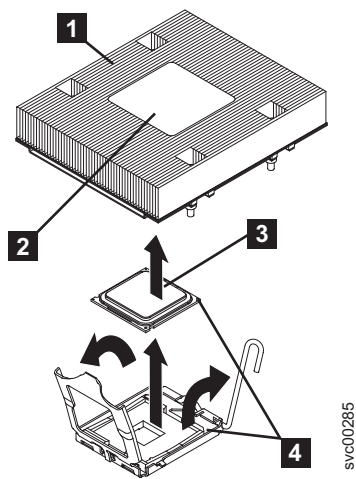
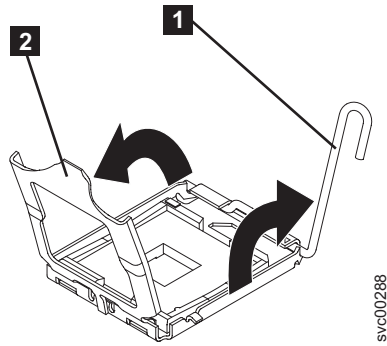

Figure 248. Removing the heat sink from the microprocessor

- 1** Heat sink
- 2** Heat sink installation label
- 3** Microprocessor
- 4** Alignment indicator

4. Open the microprocessor release lever (**1** in Figure 249 on page 265) to the fully open position.



svc00288

Figure 249. The microprocessor release lever and bracket frame fully opened

- 1** Microprocessor release lever
- 2** Microprocessor bracket frame

5. Open the microprocessor bracket frame (**2** in Figure 249).
6. Carefully remove the microprocessor from the socket. Be careful to only touch the edges of the microprocessor.

Removing the SAN Volume Controller 2145-8F4 or SAN Volume Controller 2145-8F2 microprocessor

The SAN Volume Controller 2145-8F4 or SAN Volume Controller 2145-8F2 must always be fitted with both microprocessors to function correctly.

Figure 250 shows the microprocessors and voltage regulator modules (VRMs).

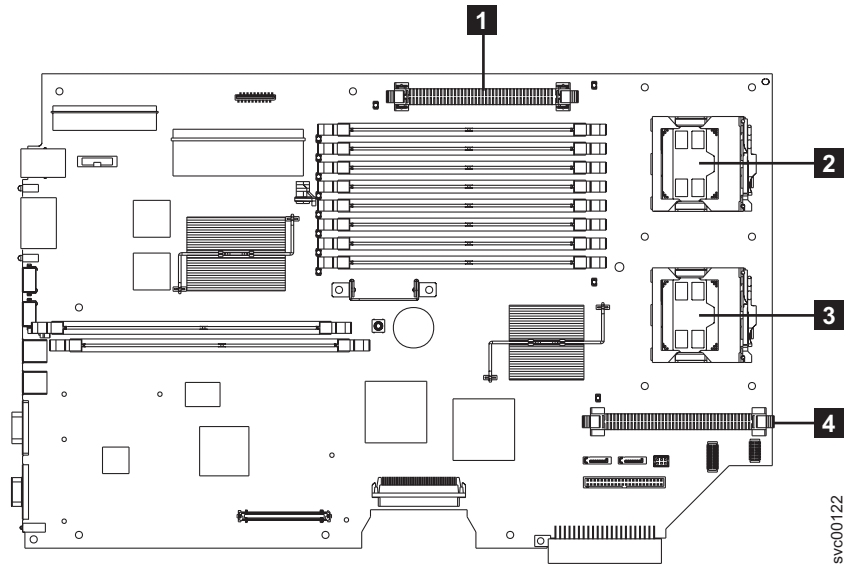

svc00122

Figure 250. Location of the microprocessor and VRM sockets

- 1** VRM 1
- 2** Microprocessor 1
- 3** Microprocessor 2
- 4** VRM 2

Each microprocessor is matched with a VRM and a heat sink. When removing the microprocessor, you must first remove the heat sink.

Perform the following steps to remove a microprocessor:

1. Turn off the node while ensuring that its data is mirrored and synchronized. See MAP 5350 in the *IBM System Storage SAN Volume Controller Troubleshooting Guide* for more information.
2. To make sure that you can replace all cables in the same ports from which they were removed, record the position of all fibre-channel and Ethernet cables; then remove all cables from the back of the node.
3. Remove the node from the rack and place it on a flat, static-protective surface. See “Removing the SAN Volume Controller from a rack” on page 48.
4. Remove the top cover. See “Removing the top cover” on page 81.
5. Fully loosen one captive screw before loosening the other captive screw. This helps to break the bond between the heat sink and the microprocessor.
6. Remove the heat sink.

Important: Be careful when handling the microprocessor and heat sink. If you wish to reuse the thermal grease between the heat sink and the microprocessor, do not contaminate it. If thermal grease is supplied with your replacement microprocessor, remove all traces of the used thermal grease before applying the new grease.

7. Rotate the microprocessor socket lever arm upward to its maximum vertical position.
8. Remove the microprocessor from the socket.

Replacing the microprocessor

Use this topic when you are required to replace a microprocessor.

Take precautions to avoid damage from static electricity. Wear an anti-static wrist strap and use a static-protected mat or surface. For more information, see “Handling static-sensitive devices” on page xxiv.

Related tasks

“Replacing the top cover” on page 86

You must replace the top cover on the SAN Volume Controller node after maintenance is completed.

“Replacing the SAN Volume Controller in a rack” on page 59

You must use caution when you replace the SAN Volume Controller in a rack.

“Replacing the SAN Volume Controller 2145-8F2 or SAN Volume Controller 2145-8F4 VRM” on page 280

Before you replace the microprocessor, you must replace the voltage regulator module (VRM).

“Removing the microprocessor” on page 259

You can remove the microprocessor that is used in the SAN Volume Controller nodes.

Related reference

“Handling static-sensitive devices” on page xxiv

Ensure that you understand how to handle devices that are sensitive to static electricity.

Replacing the SAN Volume Controller 2145-CF8 microprocessor

You need one alcohol wipe and one thermal grease syringe to replace the microprocessor. If you do not already have these, order them before you begin to replace the part.

DANGER

Multiple power cords. The product might be equipped with multiple power cords. To remove all hazardous voltages, disconnect all power cords.

To correctly perform this task, you must have alcohol wipes and thermal grease available. If you do not already have them, order these separately.

This procedure is based on the following assumptions:

- You are a trained IBM service technician.
- You removed all power from the node.
- You removed the node from the rack.
- You removed the top cover of the node.
- You removed the microprocessor that is being replaced.

Furthermore, always replace the microprocessor in microprocessor socket one.

Attention: Removing the heat sink from the microprocessor destroys the even distribution of the thermal grease and requires replacing the thermal grease.

If the thermal-grease protective cover (for example, a plastic cap or tape liner) is removed from the heat sink, do not touch the thermal grease on the bottom of the heat sink or set down the heat sink.

Perform the following steps to replace the microprocessor and heat sink:

1. To open the socket in preparation for inserting the microprocessor, press down and out on the release lever (**2** in Figure 251 on page 268 as you did to remove the microprocessor, and lift up the microprocessor-release lever until it stops in the fully open position.

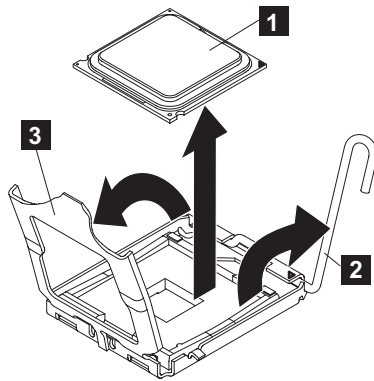

Figure 251. Opening the SAN Volume Controller 2145-CF8 microprocessor-bracket frame

- 1** Microprocessor
- 2** Microprocessor-release lever
- 3** Microprocessor-bracket frame

2. Lift the hinged microprocessor-bracket frame into an open position and remove the microprocessor dust cover, tape, or label from the surface of the microprocessor socket, if one is present. Store the dust cover in a safe place.
3. Touch the static-protective package that contains the new microprocessor to any *unpainted* metal surface on the node; then, remove the microprocessor from the package.
 - Do not touch the microprocessor contacts; handle the microprocessor by the edges only. Contaminants on the microprocessor contacts, such as oil from your skin, can cause connection failures between the contacts and the socket.
 - Handle the microprocessor carefully. Dropping the microprocessor during installation or removal can damage the contacts.
 - Do not use excessive force when you press the microprocessor into the socket.
 - Verify that the microprocessor is oriented, aligned, and positioned in the socket before you try to close the lever.
4. To align the microprocessor with the socket, use the triangular alignment cutout on the microprocessor socket and the triangular alignment mark (**4** in Figure 252 on page 269) on the microprocessor. Also use the position of the notches to align the microprocessor.
5. After alignment, carefully place the microprocessor onto the socket. Close the microprocessor-bracket frame (**3**).

Tip: Do not force the microprocessor. The microprocessor fits only one way on the socket.

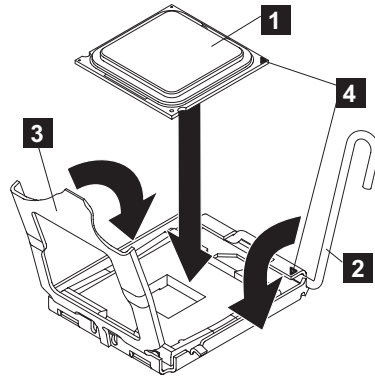

Figure 252. Closing the SAN Volume Controller 2145-CF8 microprocessor-bracket frame

- 1** Microprocessor
- 2** Microprocessor-release lever
- 3** Microprocessor-bracket frame

6. Carefully close the microprocessor-release lever (**2**) to the closed position to secure the microprocessor in the socket.
7. Clean the grease from the heat sink and apply new grease on the microprocessor.

When you are installing the heat sink on the same microprocessor that it was removed from, make sure that the following requirements are met:

- The thermal grease on the heat sink and microprocessor is not contaminated.
- Additional thermal grease is not added to the existing thermal grease on the heat sink and microprocessor.

To replace damaged or contaminated thermal grease on the microprocessor and heat sink, complete the following steps:

- a. Place the heat sink on a clean work surface.
- b. Remove the cleaning pad from its package and unfold it completely.
- c. Use the cleaning pad to wipe the thermal grease from the bottom of the heat sink.

Note: Make sure that all of the thermal grease is removed.

- d. Use a clean area of the cleaning pad to wipe the thermal grease from the microprocessor; then, dispose of the cleaning pad after all of the thermal grease is removed.
- e. Use the thermal-grease syringe to place 9 uniformly spaced dots of 0.02 mL each on the top of the microprocessor, as shown in Figure 253 on page 270. The outermost dots must be within approximately 5 mm of the edge of the microprocessor to ensure uniform distribution of the grease.

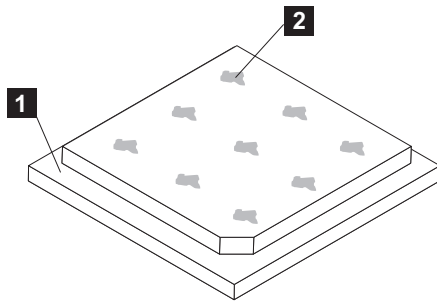

Figure 253. Applying thermal grease to the SAN Volume Controller 2145-CF8 microprocessor

- 1 Microprocessor
- 2 0.02 mL of thermal grease

Note: If properly applied, approximately half of the grease remains in the syringe when you are done.

8. Align the heat sink on top of the microprocessor, as shown in Figure 254.

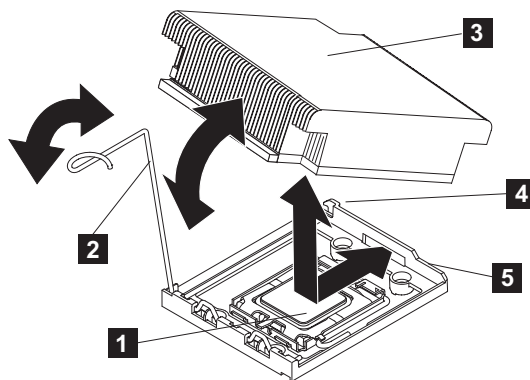

Figure 254. Installing the heat sink on the SAN Volume Controller 2145-CF8 microprocessor

- 1 Microprocessor
- 2 Heat-sink release lever
- 3 Heat sink
- 4 Lock tab
- 5 Retainer bracket

9. Lower the rear flange of the heat sink into the opening in the retainer bracket (5) and press down firmly on the front of the heat sink until it is seated securely.
10. Rotate the heat-sink release lever (2) to the closed position and hook the lever underneath the lock tab (4).
11. If you removed the air baffle for the other microprocessor, install it at this time.
12. Make sure that all cables, adapters, and other components are installed and seated correctly and that you have not left loose tools or parts inside the node. Make sure that all internal cables are correctly routed. If you disconnected the fibre-channel and Ethernet cables, make sure that each cable is reconnected to the same port from which it was removed.
13. Replace the top cover. See “Replacing the top cover” on page 86.

14. If you removed the node from the rack, replace the node in the rack, as described in “Replacing the SAN Volume Controller in a rack” on page 59.
15. If you removed any fibre-channel or Ethernet cables, use the labels you placed on each cable to replace all fibre-channel and Ethernet cables in the same ports from which they were removed.
16. If you removed the power cords, replace the power cords and the cable-retention brackets, as described in “Replacing the cable-retention bracket” on page 40.
17. Lift the locking levers (**1** in Figure 255) on the slide rails and push the server **2** all the way into the rack until it clicks into place.

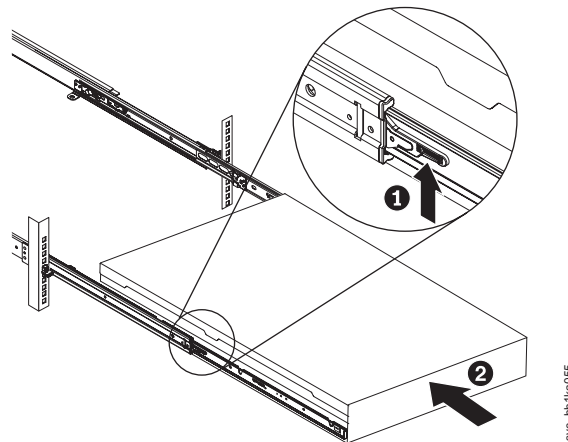

Figure 255. Raising the SAN Volume Controller 2145-CF8 locking levers of the slide rails of the rack

18. Turn on the node.

Replacing the SAN Volume Controller 2145-8A4 microprocessor

This topic describes how to replace the microprocessor.

Perform the following steps to replace the microprocessor:

1. Make sure that the microprocessor bracket frame **1** and release latch **4**, shown in Figure 256 on page 272, are both fully open.

Attention:

- The microprocessor contacts are fragile; handle the microprocessor very carefully. Do not touch the microprocessor contacts with your skin.
- The microprocessor fits only one way on the socket.

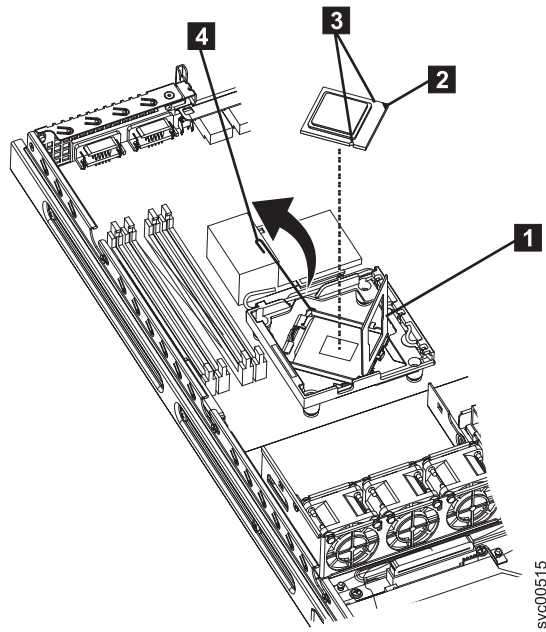

Figure 256. SAN Volume Controller 2145-8A4 microprocessor

2. Align the microprocessor with the socket as shown in Figure 256. (Note the alignment mark **2** and the position of the notches **3**.) Then, carefully place the microprocessor on the socket, close the microprocessor bracket frame **1**, and close the microprocessor release latch **4**.
3. Install the heat-exchanger assembly.
 - If you are installing a new heat-exchanger assembly, peel off the protective backing from the thermal material that is on the underside of the new heat exchanger.
 - If you are reinstalling a heat-exchanger assembly that was previously removed, replace the contaminated or missing thermal grease:
 - a. Place the heat-exchanger assembly on a clean work surface.
 - b. Remove the cleaning pad from its package and unfold it completely.
 - c. Use the cleaning pad to wipe the thermal grease from the bottom of the heat exchanger. Make sure that all of the thermal grease is removed.
 - d. Apply thermal grease to the top of the microprocessor, as shown in Figure 257 on page 273. Apply nine dots of thermal grease in three rows of three dots each with the outer rows approximately 5 mm from the edge of the microprocessor. The diameter of the cap from the thermal grease syringe is 5 mm, so you can use it to judge the required position of the dots of thermal grease

Note: 0.01mL is one tick mark on the syringe. If the grease is properly applied, approximately half (0.22 mL) of the grease will remain in the syringe.

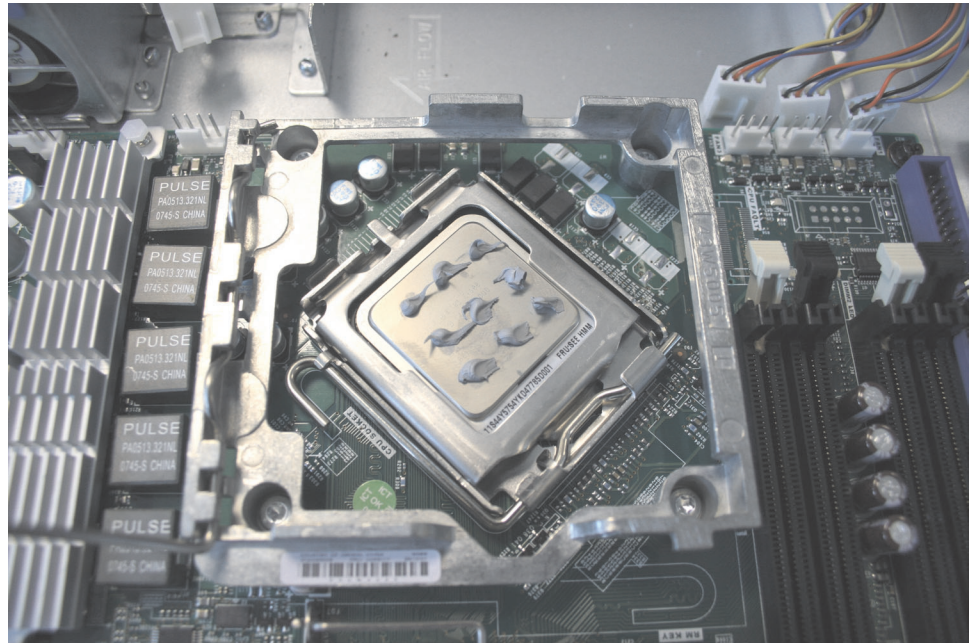

Figure 257. Complete set of nine thermal grease dots on the SAN Volume Controller 2145-8A4 microprocessor

4. Make sure that the heat-exchanger assembly release latch is fully opened.
5. With the heat-exchanger assembly at an angle, carefully align the heat-exchanger assembly with the microprocessor and the heat exchanger retention module (socket) on the system board. Make sure that the alignment pins **1**, shown in Figure 258 on page 274, protrude through the alignment hole (the opening in the side of the heat-exchanger bracket) and that the flange of the heat sink rests under the lip of the heat-exchanger socket.

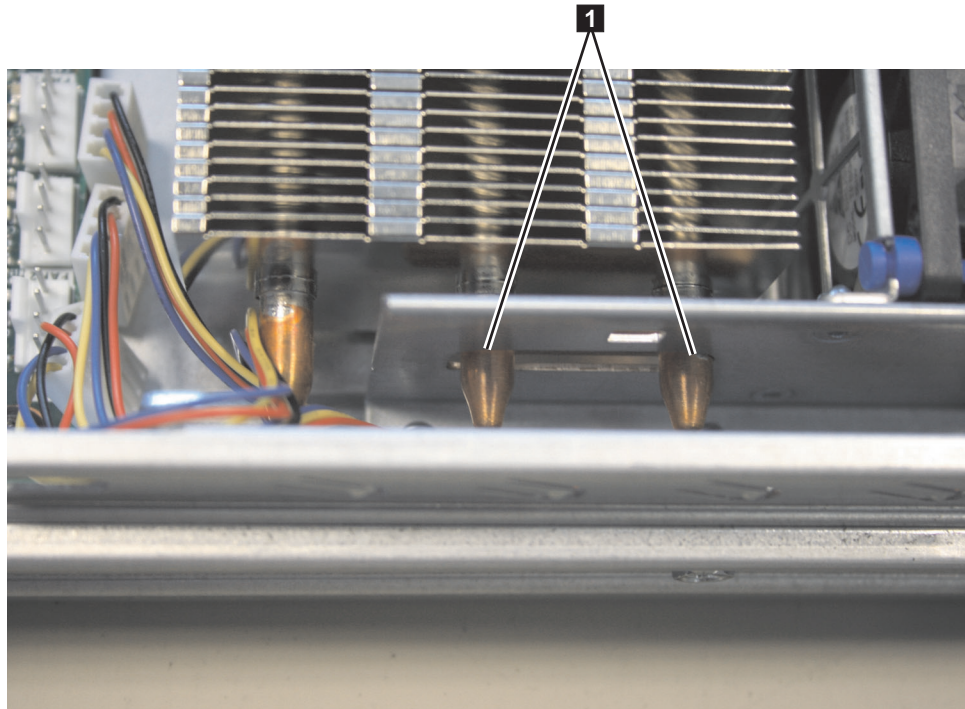

Figure 258. Alignment pins on the SAN Volume Controller 2145-8A4 heat-exchanger assembly

6. Gently press the assembly into place.
7. Close the heat-exchanger-assembly release latch, catching it under the hook on the socket.
8. Replace the air baffle. Align the air baffle and then press the air baffle into position until it clicks into place.
9. Replace the top cover. See “Replacing the top cover” on page 86.
10. Place the node in the rack. See “Replacing the SAN Volume Controller in a rack” on page 59.
11. Reconnect the power cords and any cables that were removed.
12. Turn on the node.

Replacing the SAN Volume Controller 2145-8G4 microprocessor

This topic describes how to replace the microprocessor.

There are two versions of the SAN Volume Controller 2145-8G4 node: Rev 1 and Rev 2. One difference between these two versions is in the processor configuration. The original version (Rev 1) has two microprocessors, while the second version (Rev 2) has one microprocessor. The label on the Rev 1 node does not include a version number. An additional label on the front of the Rev 2 node includes the version number. Ensure that you have the correct microprocessor for the node that you are servicing.

You need 1 alcohol wipe and 1 thermal grease syringe for each microprocessor that you will replace. If you do not already have these, order them before you begin to replace the part.

The documented steps to replace the SAN Volume Controller 2145-8G4 microprocessor assume that you:

- Removed all power from the node
- Removed the node from the rack
- Removed the top cover of the node
- Removed the microprocessor that is being replaced

Perform the following steps to replace the microprocessor:

1. Rotate the release lever from the closed and locked position to the open position.
2. Touch the static-protective package that contains the new microprocessor to any *unpainted* metal surface on the node.
3. Remove the microprocessor from the package.

Attention: Be careful how you handle the microprocessor. Do not touch the microprocessor contacts; handle the microprocessor by the edges only. Dropping the microprocessor during installation or removal can damage the contacts. Also, contaminants on the microprocessor contacts, such as oil from your skin, can cause connection failures between the contacts and the socket.

4. Position the microprocessor **1** over the microprocessor socket, as shown in Figure 259. Use the triangular alignment cutout on the microprocessor socket and the triangular alignment mark **2** on the microprocessor to assist you in aligning the microprocessor to the socket. Then, carefully place the microprocessor onto the socket. Do not force the microprocessor. It only fits one way onto the socket.

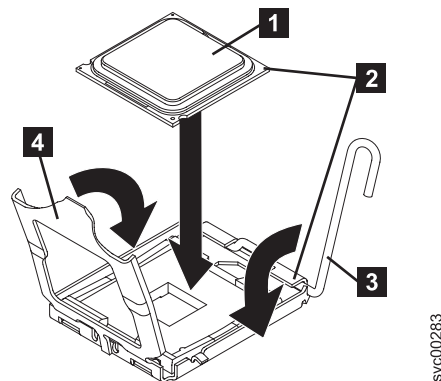

Figure 259. Aligning the microprocessor with the socket

- 1** Microprocessor
- 2** Alignment marks
- 3** Microprocessor release lever
- 4** Microprocessor bracket frame

5. Place the microprocessor bracket frame **4** down over the microprocessor and the microprocessor socket to secure the microprocessor position in the socket.
6. Rotate the microprocessor release lever **3** into a closed position.
7. Place the heat sink **1** on top of the microprocessor **3** with the thermal grease **2** side down, as shown in Figure 260 on page 276. Tighten the captive screws to secure the heat sink to the system board. Alternate among

the screws on either side of the heat sink until they are snug, and then alternate again until they are tight, making sure that you do not overtighten any of them.

Attention: If you are working on a Rev 1 node, do not touch the thermal grease on the bottom of the heat sink after you remove the plastic cover. Touching the thermal grease contaminates it.

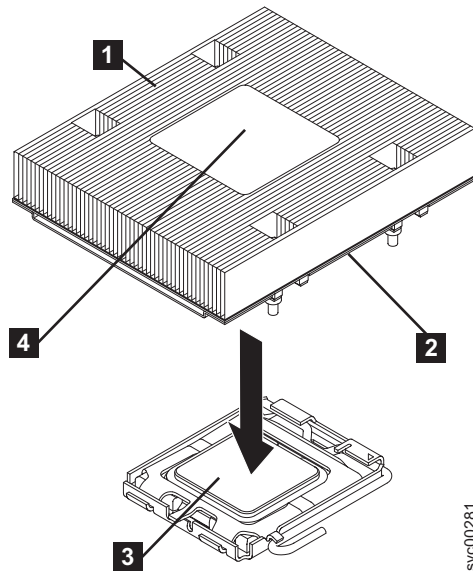

Figure 260. Installing the heat sink

- 1 Heat sink
- 2 Thermal grease
- 3 Microprocessor
- 4 Heat sink installation label

8. Replace the top cover. See “Replacing the top cover” on page 86.
9. Place the node in the rack. See “Replacing the SAN Volume Controller in a rack” on page 59.
10. Reconnect the power cable and any other cables that were removed.
11. Turn on the node.

Replacing the SAN Volume Controller 2145-8F4 or SAN Volume Controller 2145-8F2 microprocessor

The SAN Volume Controller 2145-8F4 or SAN Volume Controller 2145-8F2 must always be fitted with both microprocessors in order to function correctly.

The documented steps to replace the SAN Volume Controller 2145-8F4 or SAN Volume Controller 2145-8F2 microprocessor assume that you:

- Removed all power from the node
- Removed the node from the rack
- Removed the top cover of the node
- Removed the microprocessor that is being replaced

Perform the following steps to replace the SAN Volume Controller 2145-8F4 or SAN Volume Controller 2145-8F2 microprocessor:

1. Touch the static-protective package that contains the new microprocessor to any *unpainted* metal surface on the node.
2. Remove the microprocessor from the package.
3. Rotate the locking lever **3** from the closed position to the open position, as shown in Figure 261.

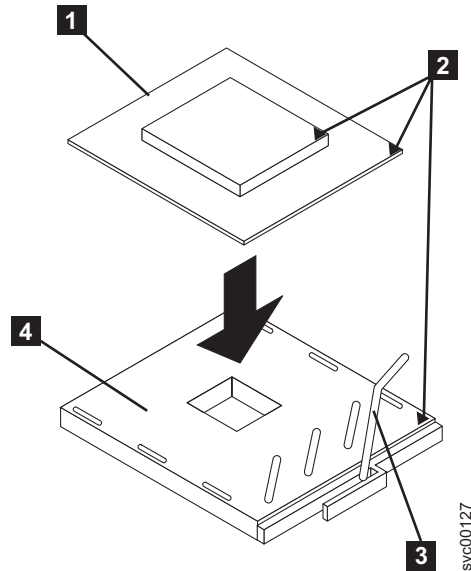

Figure 261. Microprocessor locking lever in open position

- 1** Microprocessor
- 2** Corner marks
- 3** Locking lever
- 4** Microprocessor socket

4. Center the microprocessor **1** over the microprocessor socket **4**.
5. Align the triangle **2** on the corner of the microprocessor with the triangle on the corner of the socket and carefully press the microprocessor into the socket.

Attention: Do not use excessive force when pressing the microprocessor into the socket.

6. Close the lever.

Note: A voltage regulator module (VRM) and a heat sink are included in the microprocessor package.

- Do not set the heat sink down after removing it from the package.
- Do not touch or contaminate the thermal grease on the bottom of the heat sink. Doing so damages its heat-conducting capability and exposes the microprocessor to overheating.
- If you must remove the heat sink after installing it, note that the thermal grease might have formed a strong bond between the heat sink and the microprocessor. Do not force the heat sink and microprocessor apart; doing so causes damage to the microprocessor pins. Loosen one captive screw fully before loosening the other captive screw to help break the bond between the components without damaging them.

7. Install the heat sink **2** on top of the microprocessor **3**, as shown in Figure 262.

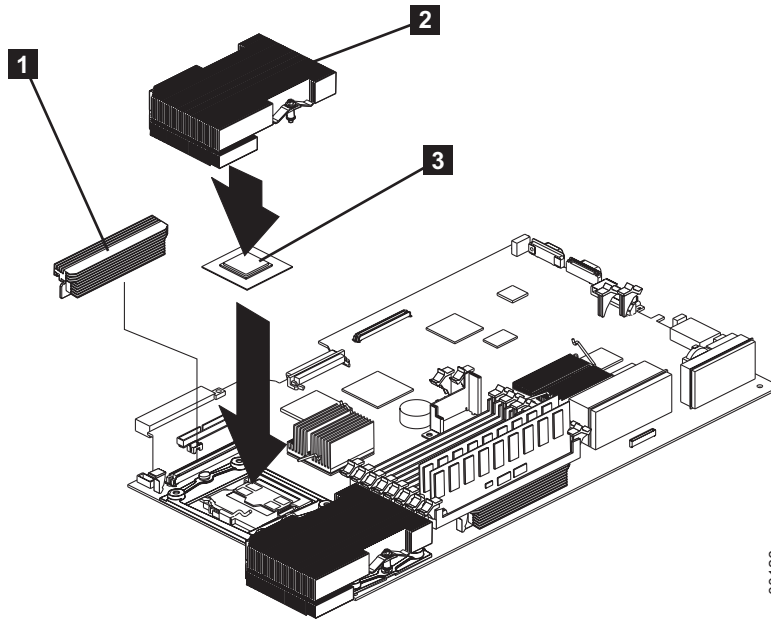

Figure 262. Microprocessor and heat sink locations

- 1** VRM
- 2** Heat sink
- 3** Microprocessor

8. Tighten the captive screws. Alternate between the screws until they are all tightened. Do not overtighten.
9. Replace the top cover. See “Replacing the top cover” on page 86.
10. Place the node in the rack. See “Replacing the SAN Volume Controller in a rack” on page 59.
11. Reconnect the power cords and any cables that were removed.
12. Turn on the node.

Removing the SAN Volume Controller 2145-8F4 or SAN Volume Controller 2145-8F2 VRM

You might remove the voltage regulator module (VRM) to perform maintenance on the SAN Volume Controller 2145-8F2 or SAN Volume Controller 2145-8F4.

Take precautions to avoid damage from static electricity. Wear an anti-static wrist strap and use a static-protected mat or surface. For more information, see “Handling static-sensitive devices” on page xxiv.

Figure 263 on page 279 shows the microprocessors and VRMs.

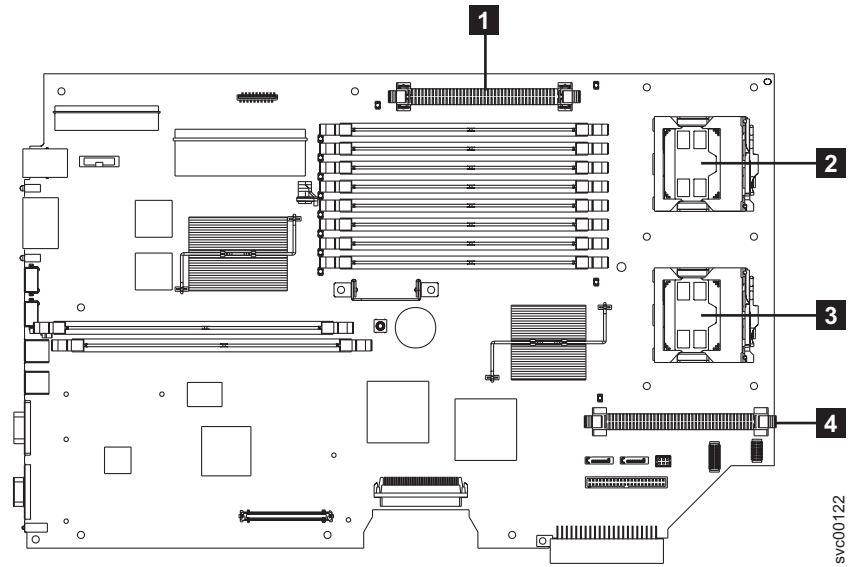

Figure 263. Location of the microprocessor and VRM sockets

- 1** VRM 1
- 2** Microprocessor 1
- 3** Microprocessor 2
- 4** VRM 2

Perform the following steps to remove the VRM:

1. Turn off the node while ensuring that its data is mirrored and synchronized. See MAP 5350 in the *IBM System Storage SAN Volume Controller Troubleshooting Guide* for more information.
2. Remove the SAN Volume Controller 2145-8F4 cable retention bracket.
3. To make sure that you can replace all cables in the same ports from which they were removed, record the position of all fibre-channel and Ethernet cables; then remove all cables from the back of the node.
4. Remove the top cover. See “Removing the top cover” on page 81.
5. Press the latches on both sides of the VRM downward and outward.

The VRM is pulled out of the node and you can now replace the VRM.

Related tasks

“Removing the SAN Volume Controller from a rack” on page 48
During some service procedures, you might need to remove the SAN Volume Controller from a rack.

“Removing the top cover” on page 81

You can remove the top cover of the SAN Volume Controller node if maintenance is necessary.

“Replacing the SAN Volume Controller 2145-8F2 or SAN Volume Controller 2145-8F4 VRM”

Before you replace the microprocessor, you must replace the voltage regulator module (VRM).

Related reference

“Handling static-sensitive devices” on page xxiv

Ensure that you understand how to handle devices that are sensitive to static electricity.

Replacing the SAN Volume Controller 2145-8F2 or SAN Volume Controller 2145-8F4 VRM

Before you replace the microprocessor, you must replace the voltage regulator module (VRM).

Take precautions to avoid damage from static electricity. Wear an anti-static wrist strap and use a static-protected mat or surface. For more information, see “Handling static-sensitive devices” on page xxiv.

Perform the following steps to replace the VRM:

1. Align the VRM in the connector.
2. Press both sides of the VRM downward until the latches click into place.
3. If you are replacing the microprocessor, perform the steps required to do so. If not, replace the SAN Volume Controller 2145-8F2 or SAN Volume Controller 2145-8F4 top cover.
4. Place the node in the rack. See “Replacing the SAN Volume Controller in a rack” on page 59.
5. Reconnect the fibre-channel and Ethernet cables. Ensure that you replace the fibre-channel and Ethernet cables in the same ports from which they were removed.
6. Turn on the node.

Removing the SAN Volume Controller system board

You must remove the system board if you are instructed to replace the SAN Volume Controller system board field-replaceable unit (FRU).

Removing the SAN Volume Controller 2145-CF8 system board

You must remove the system board if you are instructed to replace the SAN Volume Controller 2145-CF8 system board FRU.

DANGER

Multiple power cords. The product might be equipped with multiple power cords. To remove all hazardous voltages, disconnect all power cords.

You must remove and replace the microprocessor when you replace the system board. Ensure that you have alcohol wipes and thermal grease available to correctly perform this task.

Before you proceed with the system board removal, ensure that you do the following:

- Have a static-protected surface available to hold the components that you remove from the old system board.
- Follow all standard safety and handling instructions. The components that you will be handling are electrostatic-discharge sensitive. Take precautions to avoid damage from static electricity. Wear an anti-static wrist strap and use a static-protected mat or surface. For more information, see “Handling static-sensitive devices” on page xxiv.

This service action requires you to remove the cover and:

- Turn the node off.
- Disconnect the power cables.
- Disconnect the data cables.

Notes:

- You must remove a number of components before you can remove and replace the system board. You will reuse all the components with the new system board. Therefore, take care when you remove and store these components.
- Each connector on the system board has its use printed next to it on the board.
- All left or right observations are when you are looking at the front of the unit.

To remove the system board, perform the following steps:

1. Read the safety information to which “Preparing to remove and replace parts” on page 24 refers.
2. Follow the procedure in MAP 5350 in the *IBM System Storage SAN Volume Controller Troubleshooting Guide* to verify that the node data is mirrored and synchronized, and that there are no dependent virtual disks (VDisks) before turning off the node.
3. Slide the node out on its slide rails to the fully extended position.
4. When the node is completely turned off, remove the cable-retention brackets and disconnect the power cables, as described in “Removing the cable-retention bracket” on page 34.
5. To make sure that you can replace all cables in the same ports from which they were removed, label the port position of each fibre-channel and Ethernet cable; then remove all cables from the back of the node.
6. Optional: Remove the node from the rack and place it on a flat, static-protective surface. See “Removing the SAN Volume Controller from a rack” on page 48.

You can perform most service actions when the node is fully extended from the rack on its slide rails. If the location of the node in the rack is too high or too low to work comfortably, you can remove the node from the rack.

7. Remove the top cover. See “Removing the top cover” on page 81.
8. Remove the fibre-channel adapter and riser-card assembly from slot 1. Set the adapter and riser card aside on the static-protected surface. See “Removing the fibre-channel adapter assembly” on page 189.
9. Remove the high-speed SAS adapter and riser card assembly, if it is present, as described in “Removing the SAN Volume Controller 2145-CF8 high-speed SAS adapter assembly” on page 202.
10. Remove the disk-controller and USB riser-card assembly, as described in “Removing the SAN Volume Controller 2145-CF8 disk-controller and USB riser-card assembly” on page 212.
11. Remove the power supplies, as described in “Removing a SAN Volume Controller 2145-CF8 power supply” on page 165.
12. Remove the microprocessor in slot 1, as described in “Removing the SAN Volume Controller 2145-CF8 microprocessor” on page 259; then remove the white plastic air baffles by lifting them straight up.
13. Remove the memory modules and set them aside on a static-protective surface, as described in “Removing the memory modules (DIMM)” on page 112.

Note: Make a note of the location of each DIMM as you remove it, so that you can later reinstall it in the same connector.

14. Disconnect all cables from the system board. Make a list of each cable as you disconnect it; you can then use this as a checklist when you install the new system board.
15. Remove the hot-swap fans, as described in “Removing the SAN Volume Controller 2145-CF8 fans” on page 245.
16. Press the fan bracket release latches (one is to the left of fan 6 and one is to the right of fan 1) inward toward the fans and rotate the fan assembly brackets up toward the front of the node.
17. Grasp the system board handle (**1** in Figure 264 on page 283) and slide the system board away from the back of the node. Lift the side of the system board that is nearer to the power supply units slightly so that it disengages from the locator pin; then, slide the system board slightly toward the left of the node, as shown in Figure 264 on page 283.

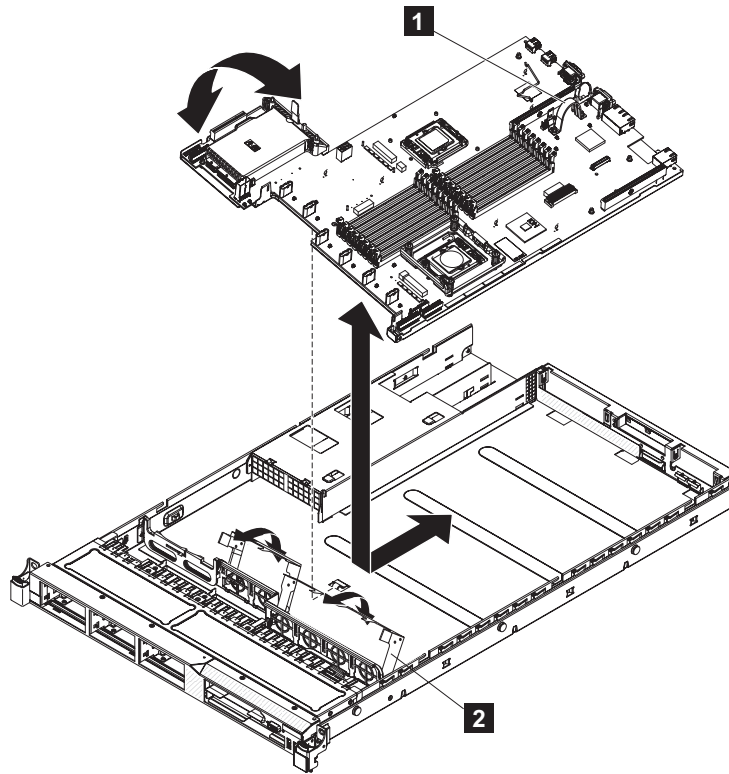

Figure 264. Removing and replacing the SAN Volume Controller 2145-CF8 system board

1 System-board handle

2 Fan-assembly bracket

18. Lift up the system board and carefully remove it from the node, being careful not to damage any surrounding components.
19. If you are instructed to return the system board, follow all packaging instructions, and use any packaging materials for shipping that are supplied to you.

Removing the SAN Volume Controller 2145-8A4 system board

You must remove the system board if you are instructed to replace the SAN Volume Controller 2145-8A4 system board field-replaceable unit (FRU).

You must remove and replace the microprocessor when you replace the system board. Also, ensure that you have alcohol wipes and thermal grease available to correctly perform this task.

Before you proceed with the system board removal, ensure that you do the following:

- Identify and label all the cables that are attached to the SAN Volume Controller 2145-8A4 node so they can be replaced in the same port.
- Have a static-protected surface available to hold the components that you remove from the old system board.
- Follow all standard safety and handling instructions. The components that you will be handling are electrostatic-discharge sensitive. Take precautions to avoid damage from static electricity. Wear an anti-static wrist strap and use a static-protected mat or surface. For more information, see “Handling static-sensitive devices” on page xxiv.

Notes:

- You must remove a number of components before you can remove and replace the system board. You will reuse all the components that are removed with the new system board. Therefore, take care when you remove and store these components.
- Each connector on the system board has its use printed next to it on the board.

To remove the system board, perform the following steps:

1. Read the safety precautions in “Safety and environmental notices” on page xvii.
2. Ensure that the node is turned off. If the node is an active member of a cluster, you must take care not to turn off the only node that services one or more VDisks, because the host applications will lose access to their data. See MAP 5350 in the *IBM System Storage SAN Volume Controller Troubleshooting Guide*.
3. Remove the cable-retention bracket and disconnect the power cable from the node. See “Removing the cable-retention bracket” on page 34.
4. Remove the node from the rack and place it on a flat, static-protective surface. See “Removing the SAN Volume Controller from a rack” on page 48.
5. Remove the top cover. See “Removing the top cover” on page 81.
6. Remove the riser-card and fibre-channel adapter. Place them on a static-protective surface for reinstallation. You do not need to separate the riser-card and fibre-channel adapter assembly. See “Removing the fibre-channel adapter assembly” on page 189.
7. Mark the cables to ensure that you know where each one goes. Figure 265 on page 285 shows the connectors on the SAN Volume Controller 2145-8A4 system board.

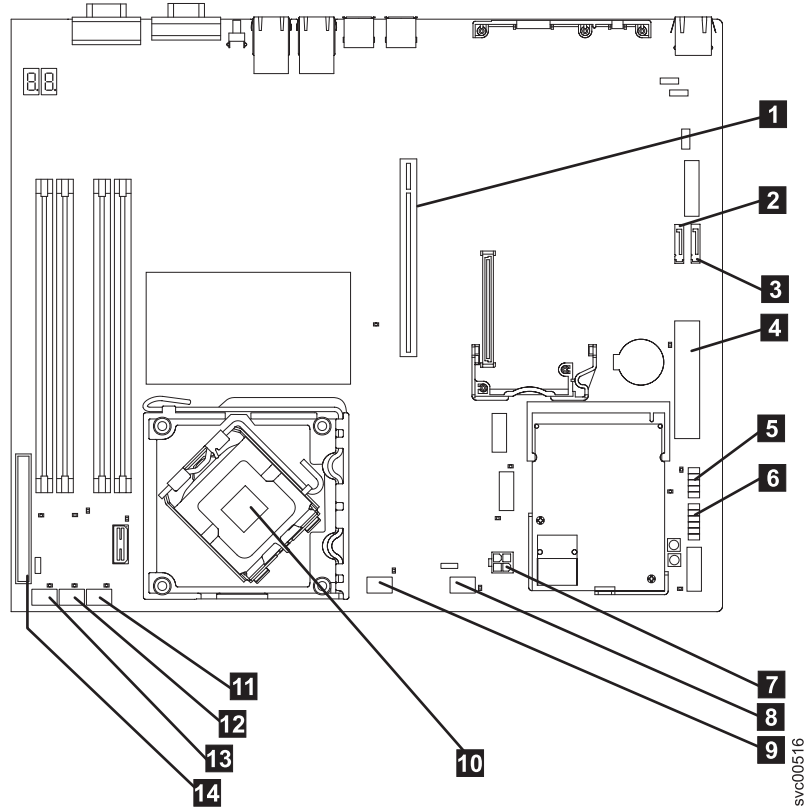

Figure 265. Connectors that are used on the SAN Volume Controller 2145-8A4 system board

- 1** PCI express riser card connector
- 2** SATA 2 connector
- 3** SATA 0 connector
- 4** Power connector P1
- 5** Front USB connector
- 6** Operator-information panel connector
- 7** Power connector P6
- 8** Fan 5 connector
- 9** Fan 4 connector
- 10** Microprocessor connector
- 11** Fan 3 connector
- 12** Fan 2 connector
- 13** Fan 1 connector
- 14** IDE connector

8. Disconnect and remove both SATA disk cables from sockets SATA 0 and SATA 1 from the system board, as shown in Figure 266 on page 286.

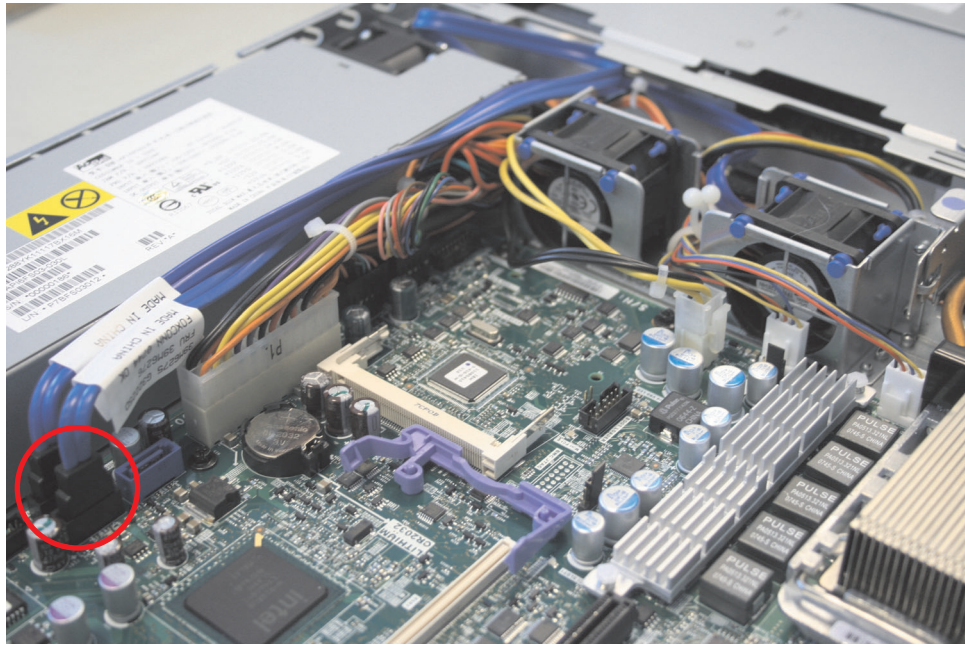

Figure 266. SAN Volume Controller 2145-8A4 SATA cable connectors

9. Remove power connectors P1 **1** and P6 **2**, as shown in Figure 267.

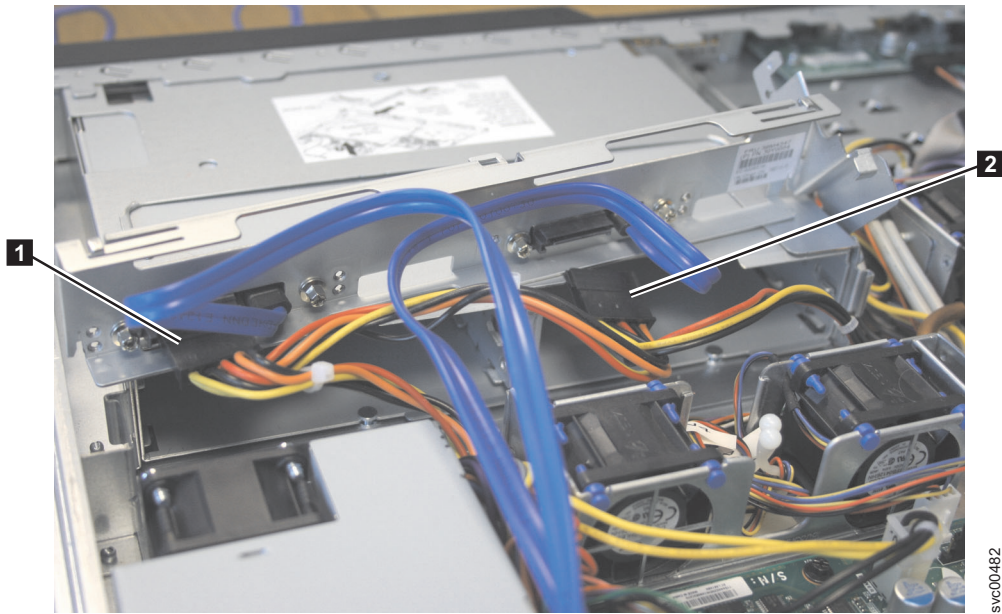

Figure 267. SAN Volume Controller 2145-8A4 power supply connectors

10. Remove the cables from the Front USB and the Front panel sockets.
11. Remove the cable from the IDE connector, which is identified in Figure 268 on page 287.



Figure 268. The IDE connector on the SAN Volume Controller 2145-8A4 system board

12. Remove the five fan connectors along the front edge of the system board. Figure 269 on page 288 shows three of the fan connectors.

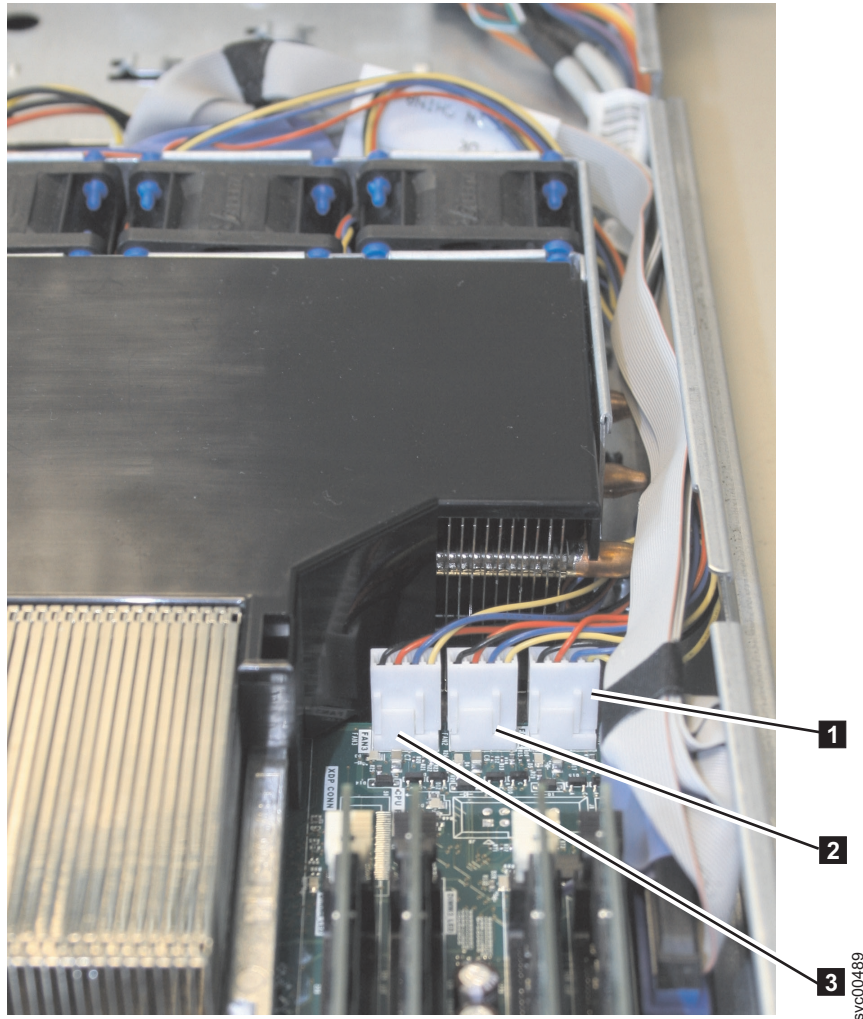

Figure 269. Connectors for the SAN Volume Controller 2145-8A4 heat exchange fans

13. Remove the four memory modules and place them on a static-protective surface for reinstallation. See “Removing the memory modules (DIMM)” on page 112.
14. Remove the heat-sink air baffle and the heat sink. Clean the thermal grease from the microprocessor before you remove it. You can also clean the heat sink now.
15. Remove the microprocessor. See “Removing the microprocessor” on page 259.
16. Notice the orientation of the microprocessor retention module and then remove the four screws (**1** in Figure 270 on page 289) that hold the microprocessor retention module to the system board. Then, lift the retention module out of the server.

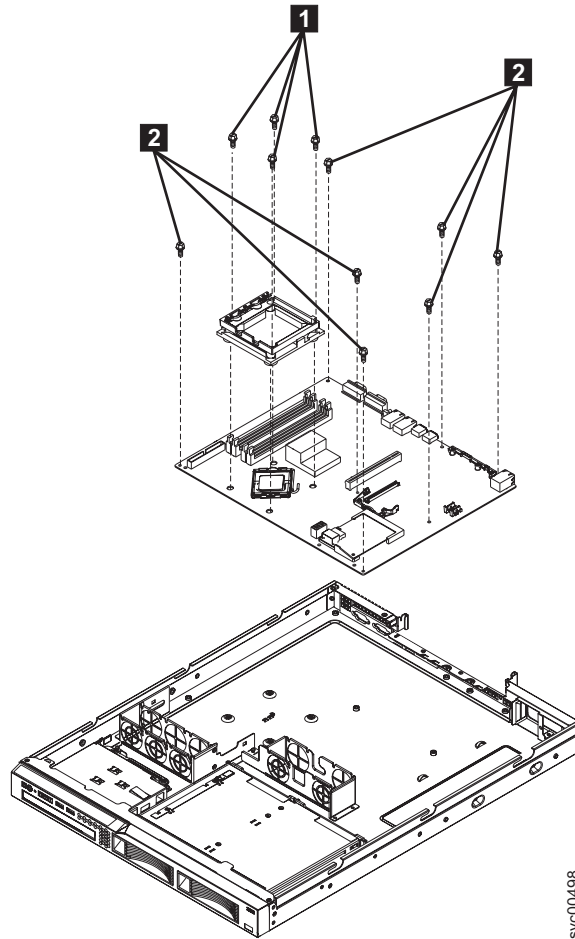

Figure 270. SAN Volume Controller 2145-8A4 system board and microprocessor retention module

17. Remove the remaining eight screws (**2** in Figure 270) that secure the system board to the chassis. Put the screws in a safe place.
18. Lift the system board out of the server.

Removing the SAN Volume Controller 2145-8G4 system board

You must remove the system board if you are instructed to replace the SAN Volume Controller 2145-8G4 system board FRU.

The system board field-replaceable unit (FRU) consists of the planar. You must order alcohol wipes and thermal grease separately. There are two versions of the SAN Volume Controller 2145-8G4. The original version (Rev 1) has two microprocessors and eight 1 GB memory modules. The second version (Rev 2) has one microprocessor and four 2 GB memory modules.

Before you proceed with the system board removal, ensure that you do the following:

- Identify and label all the cables that are attached to the SAN Volume Controller 2145-8G4 node so they can be replaced in the same port.
- Have a static-protected surface available to hold the components that you removed from the old system board.

You must follow all standard safety and handling instructions. The components that you will be handling are electrostatic-discharge sensitive. Take precautions to avoid damage from static electricity. Wear an anti-static wrist strap and use a static-protected mat or surface. For more information, see “Handling static-sensitive devices” on page xxiv.

Notes:

1. All left or right observations are when you are looking at the front of the unit.
2. You must remove a number of components before you can remove and replace the system board. You will reuse all the components that are removed with the new system board. Therefore, take care when you remove and store these components.

Perform the following steps to remove the system board:

1. Ensure that the node is turned off. If the node is an active member of a cluster, you must take care not to turn off the only node servicing one or more VDisks, because the host applications will lose access to their data. See MAP 5350 in the *IBM System Storage SAN Volume Controller Troubleshooting Guide* for more information.
2. Remove the node from the rack and place it on a flat, static-protective surface. See “Removing the SAN Volume Controller from a rack” on page 48.
3. Remove the top cover. See “Removing the top cover” on page 81.
4. Remove the fibre-channel adapter and riser card in slot 1. Set the adapter and riser card aside on the static-protected surface. See “Removing the fibre-channel adapter assembly” on page 189.
5. Remove the riser card in slot 2.
6. Disconnect the first set of cables from the system board, which are shown in Figure 271 on page 291. From the left front side of the system board, remove the following:
 - a. The right disk signal cable connector **1**.
 - b. The left disk signal cable connector **2**.
 - c. The fan 1 connector **3**. To remove the fan connectors, press the release latch in the center and then pull up.
 - d. The fan 2 connector **4**.

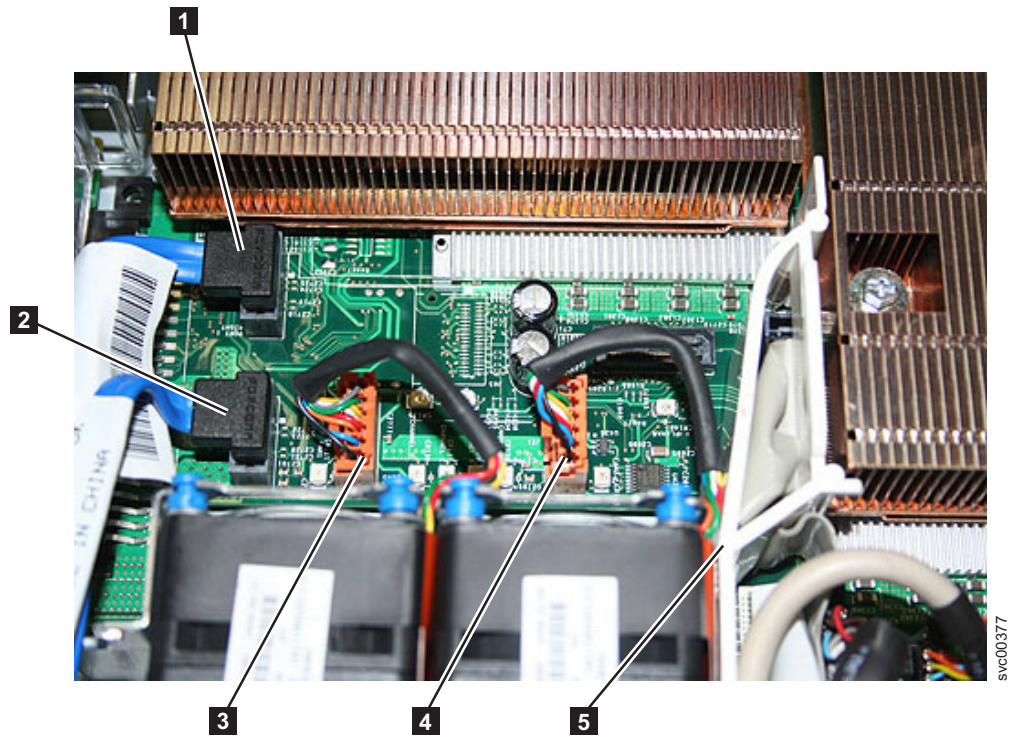

Figure 271. Connectors on the SAN Volume Controller 2145-8G4 system board

7. To ease other tasks, remove fan 2.
8. Notice how the cables are arranged within and beside the left air baffle **5**. Then remove the left air baffle by pulling up gently.

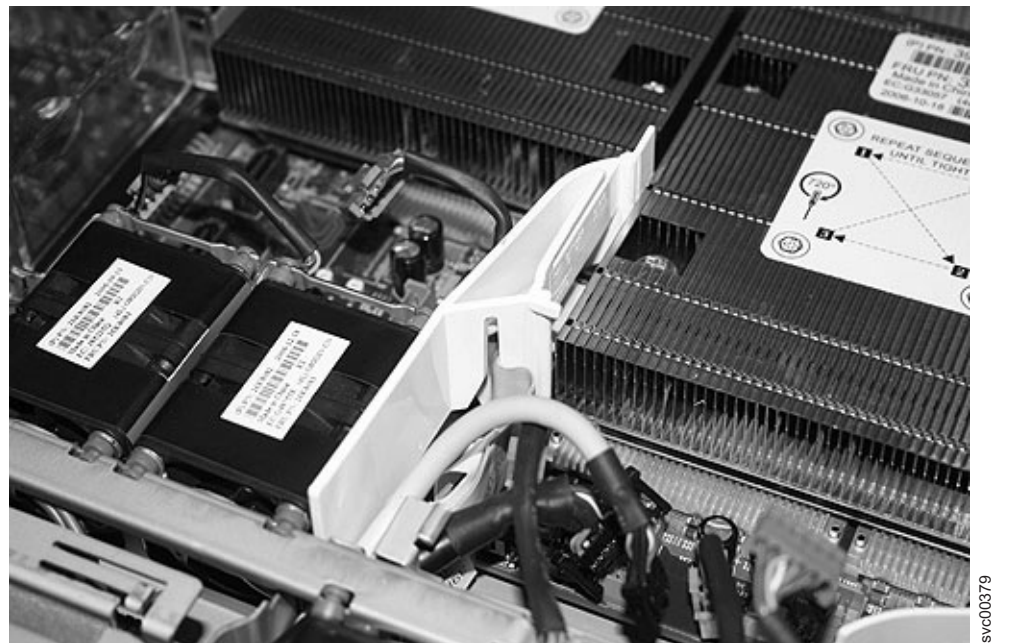

Figure 272. Left air baffle on the SAN Volume Controller 2145-8G4

9. Disconnect the connectors from the system board, which are shown in Figure 273. From the right front side of the system board, remove the following:
 - a. The fan 3 connector **5** by pressing the release latch in the center and then pulling up.
 - b. The fan 4 connector **6** by pressing the release latch in the center and then pulling up.
 - c. The fan 5 connector **7** by pressing the release latch in the center and then pulling up.
 - d. The fan 6 connector **8** by pressing the release latch in the center and then pulling up.
 - e. The uninterruptible power supply cable connector **4**.
 - f. The video cable connector **3**.



Figure 273. Connectors on the right front side of the SAN Volume Controller 2145-8G4 system board

10. Remove the remaining cables from the system board:
 - a. The CD-RW ribbon cable connector **1** by gently pulling the connector upward.
 - b. The light path ribbon cable connector **2** by gently pulling the connector upward.

All cables should now have been removed from the system board. You do not need to disconnect the disk power cable connector **1** on the power backplane **2**, which are shown in Figure 274 on page 293.

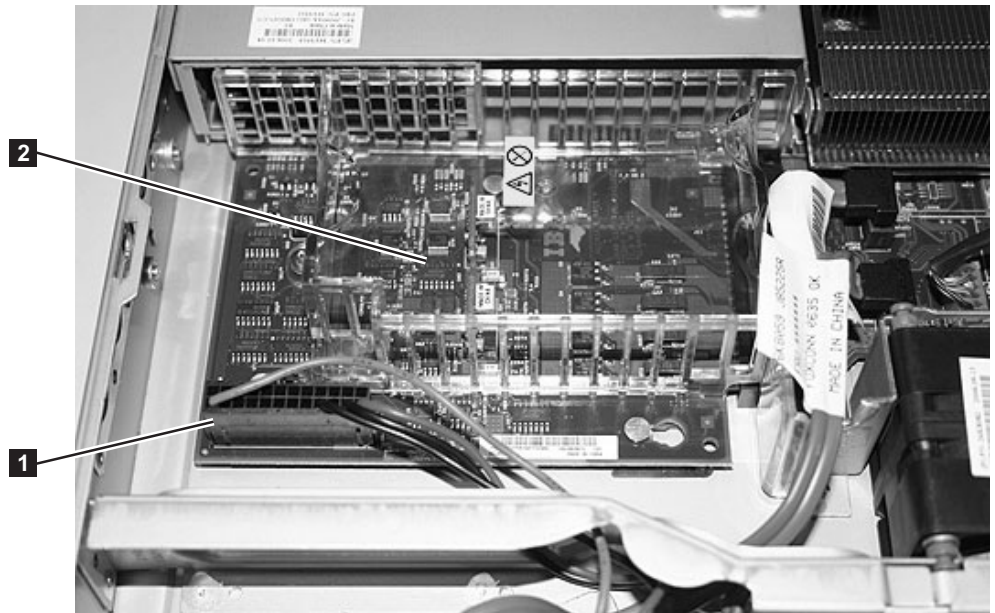

Figure 274. Disk power cable connector and power backplane on the SAN Volume Controller 2145-8G4 system board

11. Remove the right air baffle, which is shown in Figure 275. First, pull the air baffle to the right and then push the connector towards the back of the unit to release it from the support rail. Next, pull the baffle forward and then upward to release the clip from the system board. Finally, lift the baffle free.

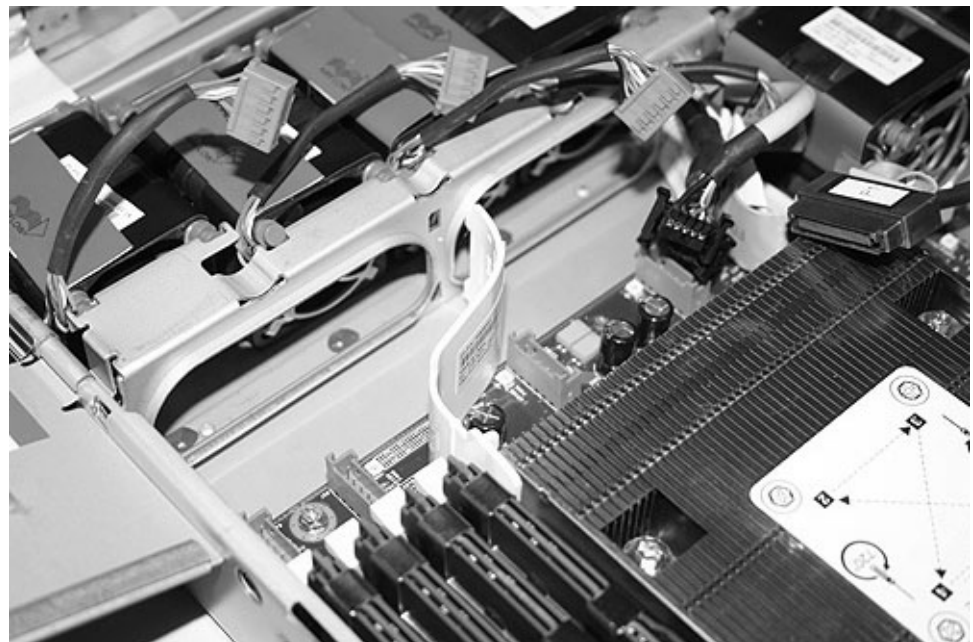

Figure 275. Right air baffle on the SAN Volume Controller 2145-8G4 system board

12. Carefully remove all the memory modules and set them aside on the static-protected surface. See “Removing the memory modules (DIMM)” on page 112.

13. Depending on the version of the SAN Volume Controller 2145-8G4 node, you must remove either one or two heat sinks. Remove the thermal grease from the heat sink, and set it aside on the static-protected surface.

Tip: Fully loosen both screws from one side of the heat sink before you loosen either screw on the other side to help break the thermal grease seal between the microprocessor and the heat sink.

Use an alcohol wipe to remove the thermal grease from the heat sink.

14. Clean the thermal grease from the top of each microprocessor with an alcohol wipe, as shown in Figure 276. Cleaning the microprocessor before it is removed reduces the amount of handling it is subjected to.

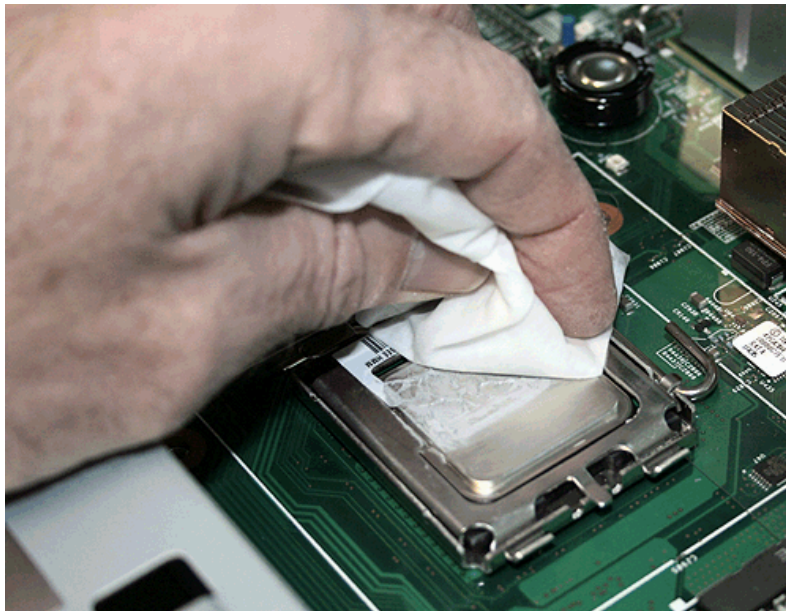

Figure 276. Removing thermal grease from the SAN Volume Controller 2145-8G4 microprocessor

15. Remove the microprocessors.
 - a. Open the microprocessor release lever and then open the bracket frame.
 - b. Carefully remove the microprocessor from the socket. Be careful to touch only the edges of the microprocessor.
 - c. Set the microprocessors aside on a static-protected surface.
16. Push down the orange clip and pull the power supply approximately two inches out of the chassis so it disconnects with the power backplane.
17. Disconnect the power backplane from the system board by sliding it to the left. Move it far enough to the side so it does not obstruct the system board removal. See “Removing the power backplane” on page 181.
18. Remove the four stand-off screws from by the serial and video I/O ports at the rear of the node. Figure 277 on page 295 shows the location of the stand-off screws.

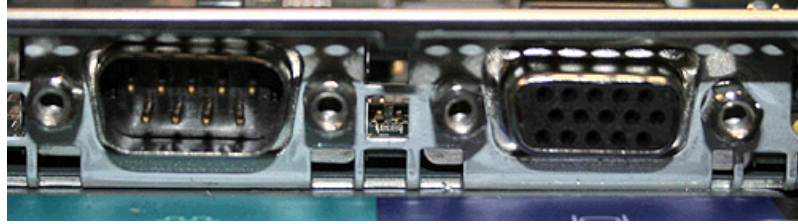

Figure 277. Serial and video ports on the SAN Volume Controller 2145-8G4

19. Remove the six screws on the system board, as shown in Figure 278, that secure the system board to the chassis.

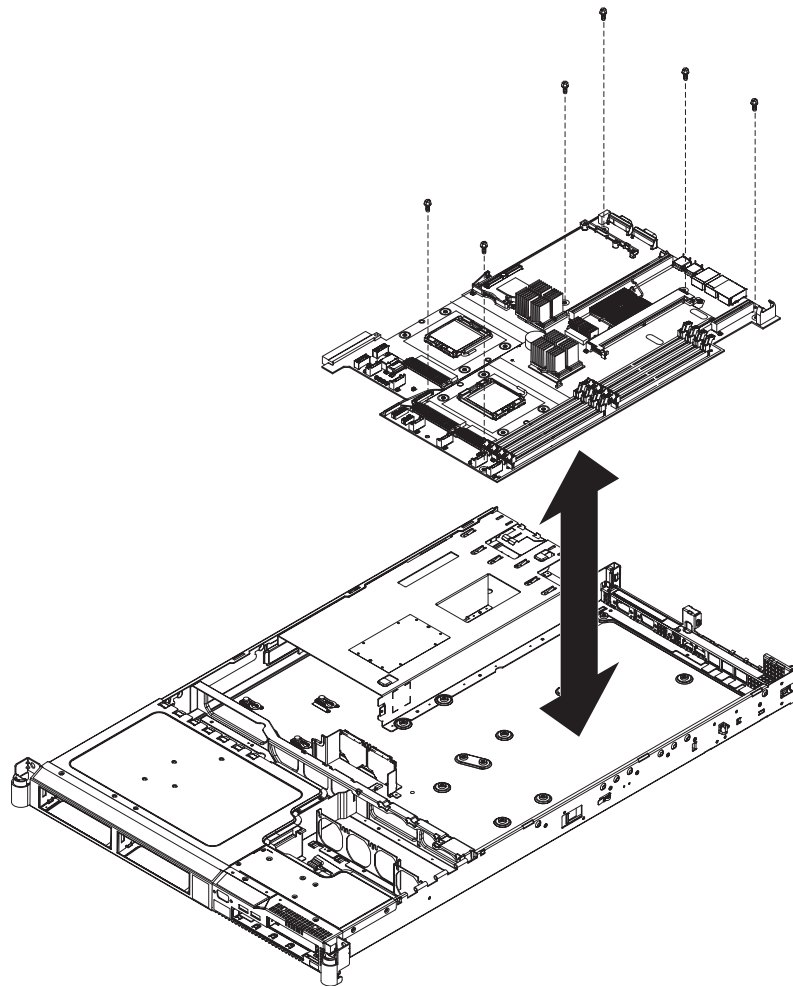

Figure 278. The placement of the screws that secure the SAN Volume Controller 2145-8G4 system board

20. Lift up the front edge of the system board slightly so that it disengages from the locator pin. Slide the system board slightly toward the front of the node so that the I/O ports are free of the chassis.
21. Lift up the left side of the system board.
22. Lift up the rest of the system board and carefully remove it from the node, being careful not to disturb any surrounding components.

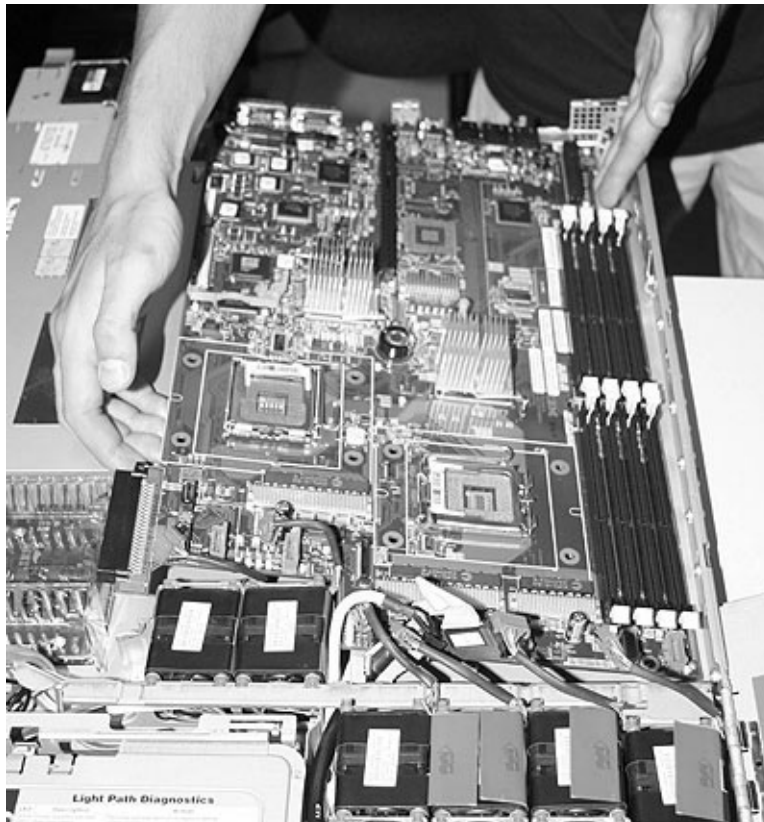

Figure 279. SAN Volume Controller 2145-8G4 system board

Related tasks

“Removing the microprocessor” on page 259

You can remove the microprocessor that is used in the SAN Volume Controller nodes.

“Replacing the SAN Volume Controller 2145-8G4 system board” on page 302

All the components that were removed when you removed the system board are reused during the installation of the new system board.

Replacing the SAN Volume Controller system board

You will reuse all the components from the system board that you are replacing with the new SAN Volume Controller system board field-replaceable unit (FRU).

Replacing the SAN Volume Controller 2145-CF8 system board

All the components that were removed when you removed the system board are reused during the installation of the new system board.

Ensure that you have a monitor and USB keyboard available because they are required during this procedure. You also need a power cable so that you can turn on the node while it is out of the rack, if necessary.

You must remove and replace the microprocessor when you replace the system board. Ensure that you have alcohol wipes and thermal grease available to correctly perform this task.

Note: When you reassemble the components in the node, be sure to route all cables carefully so that they are not exposed to excessive pressure.

DANGER

Multiple power cords. The product might be equipped with multiple power cords. To remove all hazardous voltages, disconnect all power cords.

This service action assumes that:

- The node is turned off.
- The power cables are disconnected.
- The top cover is removed.
- The system board is removed.

Perform the following steps to install the system board:

1. Place the side of the system board assembly that is farther from the power supply units beneath the catches. Lower the opposite side of the system board until it is flat in the chassis. Align the rear connectors with the holes in the rear of the server and slide the system board towards the rear of the node, as shown in Figure 280.

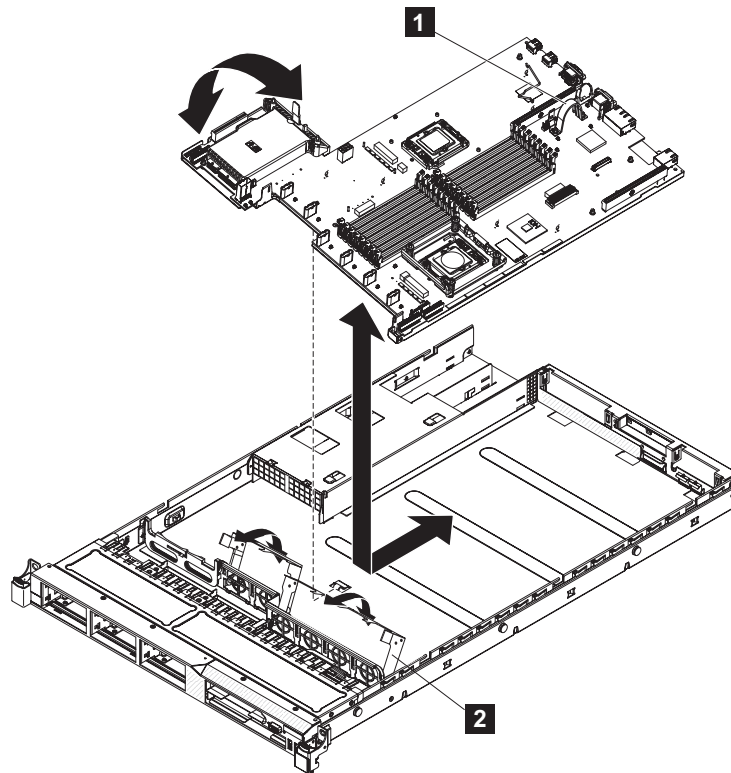

Figure 280. Removing and replacing the SAN Volume Controller 2145-CF8 system board

- 1** System-board handle
- 2** Fan-assembly bracket

2. Grasp the fan assembly brackets and rotate them down toward the chassis.
3. Replace all of the cables that were removed previously.
4. Reinstall the hot-swap fans, as described in “Replacing the SAN Volume Controller 2145-CF8 fans” on page 251.
5. Reinstall the microprocessor and heat sink, as described in “Replacing the SAN Volume Controller 2145-CF8 microprocessor” on page 267.

6. Reinstall the DIMMs, as described in “Replacing the memory modules (DIMM)” on page 116.
7. Reinstall the white plastic air baffles.
8. Reinstall the power supply units, as described in “Replacing a SAN Volume Controller 2145-CF8 power supply” on page 172.
9. Replace the disk-controller and USB riser-card assembly, as described in “Replacing the SAN Volume Controller 2145-CF8 disk-controller and USB riser-card assembly” on page 215.
10. Replace the optional high-speed SAS-adapter and riser-card assembly, as described in “Replacing the SAN Volume Controller 2145-CF8 high-speed SAS adapter assembly” on page 204.
11. Replace the fibre-channel adapter and riser card. See “Replacing the fibre-channel adapter assembly” on page 197.
12. Make sure that all cables, adapters, and other components are installed and seated correctly and that you have not left loose tools or parts inside the node. Make sure that all internal cables are correctly routed. If you disconnected the fibre-channel and Ethernet cables, make sure that each cable is reconnected to the same port from which it was removed.
13. Replace the top cover. See “Replacing the top cover” on page 86.
14. If you removed the node from the rack, replace the node in the rack, as described in “Replacing the SAN Volume Controller in a rack” on page 59.
15. If you removed any fibre-channel or Ethernet cables, use the labels you placed on each cable to replace all fibre-channel and Ethernet cables in the same ports from which they were removed.
16. If you removed the power cords, replace the power cords and the cable-retention brackets, as described in “Replacing the cable-retention bracket” on page 40.
17. Lift the locking levers (**1** in Figure 281) on the slide rails and push the server **2** all the way into the rack until it clicks into place.

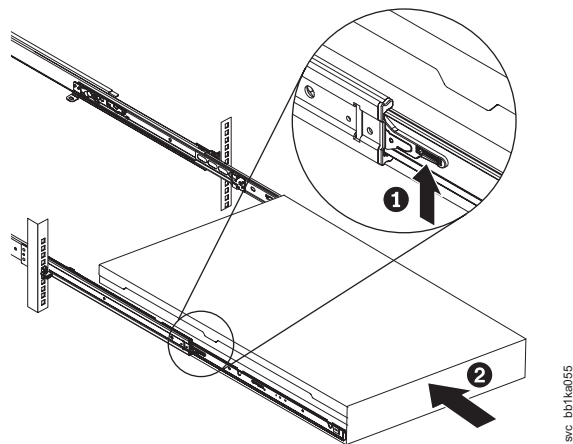

Figure 281. Raising the SAN Volume Controller 2145-CF8 locking levers of the slide rails of the rack

18. Turn on the node. Wait for the front panel display to remain stable for at least five minutes before taking any further action.

- If the repair has been successful and if the node was able to save its state data before shutting down, the node starts and rejoins the cluster. The front panel displays Cluster: and a cluster name if the node has rejoined a cluster.
- If the repair has been successful but the node was not able to save its state data before shutting down, the node displays node error 578. Follow the procedures in "Deleting a node from a cluster" in the *IBM System Storage SAN Volume Controller Troubleshooting Guide* to delete the node from the cluster and then add it back into the cluster. If more than one node has failed, ensure that the node is added back into its original I/O group. See "Adding a node to a cluster" in the *IBM System Storage SAN Volume Controller Troubleshooting Guide* for more information.
- If any other message is shown on the front panel, use MAP 5000 to resolve the problem.

Note: It is essential that you perform all the stages of the next step to ensure that the replacement system is set to the serial number of the original machine. Failure to do this might invalidate the customer's warranty or service agreement.

19. After you make sure that the node is operating as part of the cluster, perform the following steps to restore the original machine serial number to the new system board:
 - a. Start the command-line interface (CLI). See "Accessing the SAN Volume Controller CLI" in the *IBM System Storage SAN Volume Controller Troubleshooting Guide*.
 - b. Write down the 7-character serial number from the serial number label that is on the front of the node. Ignore any hyphens (-) in the serial number.
 - c. On the front-panel display, press and release the down button until the Node panel is displayed. Write down the node name that is shown on the bottom line.
 - d. Issue the following command, substituting the values for *nodeserialnumber* and *nodename* that you wrote in the previous steps:

```
svctask writesernum -sernum nodeserialnumber nodename
```

 where *nodeserialnumber* is the serial number on the front of the node and *nodename* is the name of the node.

For example, to write the machine serial number to the system board when the serial number is "13-FEDCB" and the node name is "ZYXW3," you would issue the following command:

```
svctask writesernum -sernum 13FEDCB ZYXW3
```

Note: The node will restart as soon as the serial number has been written to it.

Replacing the SAN Volume Controller 2145-8A4 system board

All the components that were removed when you removed the system board are reused during the installation of the new system board.

Ensure that you have a monitor and USB keyboard available because they are required during this procedure. You also need a power cable so that you can turn on the node while it is out of the rack.

Note: When you reassemble the components in the server, be sure to route all cables carefully so that they are not exposed to excessive pressure.

Perform the following steps to install the system board:

1. Align the system board with the chassis, and replace the eight screws that you removed
2. Orient the microprocessor retention module as shown in Figure 282.

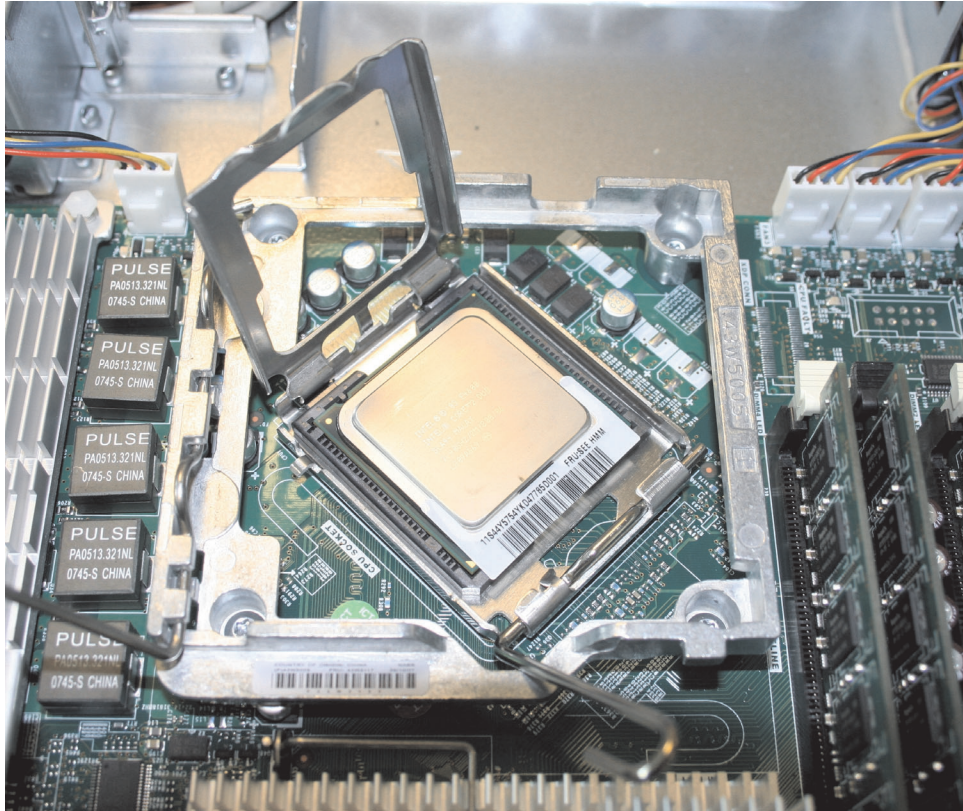

Figure 282. The SAN Volume Controller 2145-8A4 microprocessor bracket frame fully opened

Attention: In the following step, do not overtighten the screws or touch the system board with the screwdriver. Tighten the screws only until they are snug, and then tighten them an additional quarter turn.

3. Replace the microprocessor retention module. Gently secure it with the four screws that you removed.
4. Replace the microprocessor, heat sink, and air baffle. See “Replacing the microprocessor” on page 266.
5. Replace the memory modules. See “Replacing the memory modules (DIMM)” on page 116.
6. Replace the fan connectors. See “Replacing the fans” on page 250.
7. Reconnect the cable to the IDE connector.
8. Reconnect the cables to the front USB and the front panel sockets.
9. Replace power connectors P1 and P6.
10. Replace the riser-card and fibre-channel adapter, and place them on a static-protective surface for reinstallation. See “Replacing the fibre-channel adapter assembly” on page 197.
11. Replace the top cover. See “Replacing the top cover” on page 86.

12. You must change a BIOS configuration setting before SAN Volume Controller can operate. Ensure that you read and understand these next steps before you proceed because some panels time out when there is no input for 30 seconds.
 - a. Connect a display and keyboard to the node.
 - b. Connect a power cable (it does not need to be from the 2145 UPS-1U).
 - c. Turn on the node.
13. A number of messages are displayed and then message 3001 is displayed:

ERROR
3001 SMART Failure Predicted on Hard Drive

This prediction is not correct. It is displayed because the SAN Volume Controller front panel attaches as a disk drive. After a short pause, the Setup Utility main menu is displayed, but the menu exits if you do not perform an action within 30 seconds.

Perform the following steps to change the BIOS configuration setting:

 - a. Press the down arrow key to move to the Start Options menu and press the Enter key to select it. The current start options settings are displayed.
 - b. Press the down arrow to move to the HDD S.M.A.R.T. Capability option and press the right arrow key to change it to **Disabled**.
 - c. Press the Esc key to return to the main menu and then press the down arrow key to move to the Save Settings option.
 - d. Press the Enter key to select it and then press the Enter key again to confirm that you want to save the settings.
14. After you have saved the settings, press the power button on the operator-information panel to turn off the node. Remove the power cable, keyboard, and monitor.
15. Place the node in the rack. See “Replacing the SAN Volume Controller in a rack” on page 59.
16. Reconnect the fibre-channel and Ethernet cables. Ensure that you replace the fibre-channel and Ethernet cables in the same ports from which they were removed.
17. Replace the cable-retention bracket. See “Replacing the cable-retention bracket” on page 40.
18. Turn on the node. Wait for the front-panel display to remain stable for at least five minutes before taking any further action.
 - If the repair has been successful and if the node was able to save its state data before shutting down, the node starts and rejoins the cluster. The front panel displays Cluster: and a cluster name if the node has rejoined a cluster.
 - If the repair has been successful but the node was not able to save its state data before shutting down, the node displays node error 578. Follow the procedures in “Deleting a node from a cluster” in the *IBM System Storage SAN Volume Controller Troubleshooting Guide* to delete the node from the cluster and then add it back into the cluster. If more than one node has failed, ensure that the node is added back into its original I/O group. See “Adding a node to a cluster” in the *IBM System Storage SAN Volume Controller Troubleshooting Guide* for more information.
 - If any other message is shown on the front panel, use MAP 5000 in the *IBM System Storage SAN Volume Controller Troubleshooting Guide* to resolve the problem.

Note: It is essential that you perform all the stages of the next step to ensure that the replacement system is set to the serial number of the original machine. Failure to do this might invalidate the customer's warranty or service agreement.

19. After you make sure that the node is operating as part of the cluster, perform the following steps to restore the original machine serial number to the new system board:
 - a. Start the command-line interface (CLI). See "Accessing the SAN Volume Controller CLI" in the *IBM System Storage SAN Volume Controller Troubleshooting Guide*.
 - b. Write down the 7-character serial number from the serial number label that is on the front of the node. Ignore any hyphens (-) in the serial number.
 - c. On the front-panel display, press and release the down button until the Node panel is displayed. Write down the node name that is shown on the bottom line.
 - d. Issue the following command, substituting the values for *nodeserialnumber* and *nodename* that you wrote in the previous steps:

```
svctask writesernum -sernum nodeserialnumber nodename
```

where *nodeserialnumber* is the serial number on the front of the node and *nodename* is the name of the node.

For example, to write the machine serial number to the system board when the serial number is "13-FEDCB" and the node name is "ZYXW3," you would issue the following command:

```
svctask writesernum -sernum 13FEDCB ZYXW3
```

Note: The node will restart as soon as the serial number has been written to it.

Replacing the SAN Volume Controller 2145-8G4 system board

All the components that were removed when you removed the system board are reused during the installation of the new system board.

There are two versions of the SAN Volume Controller 2145-8G4. The original version (Rev 1) has two microprocessors and eight 1 GB memory modules. The second version (Rev 2) has one microprocessor and four 2 GB memory modules.

Perform the following steps to install the system board:

1. Lower the right side into place with the system board positioned slightly towards the front of the box. Lower the left edge of the system board into place and then push the system board towards the back of the box until it engages in place and the screw holes line up. Take care to ensure that the Ethernet ports on the rear of the system board engage in the frame cutouts.

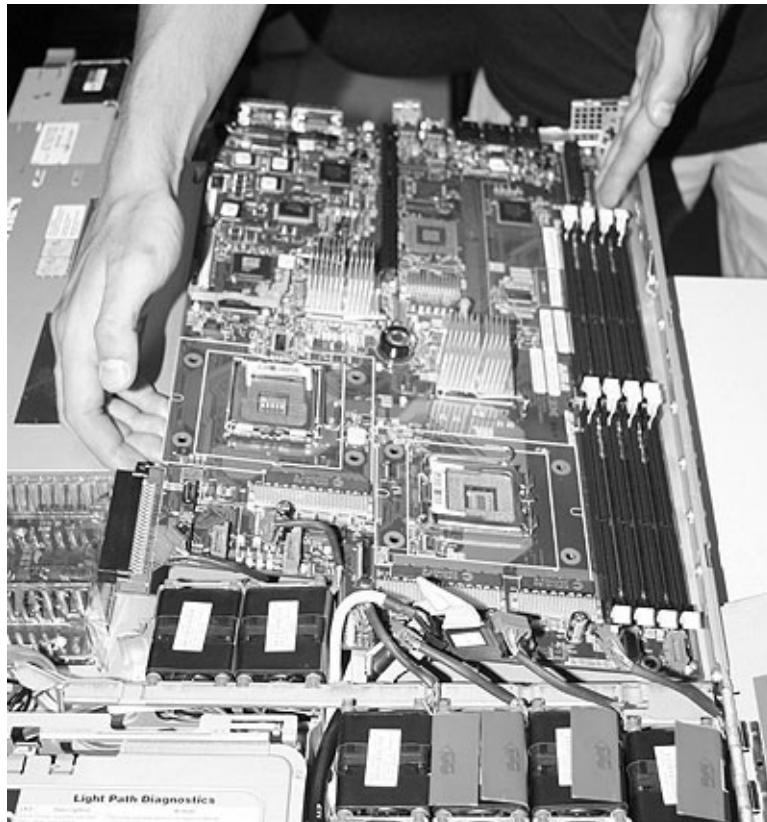

Figure 283. SAN Volume Controller 2145-8G4 system board

2. Replace the six screws on the system board, as shown in Figure 284 on page 304, to secure the system board to the chassis.

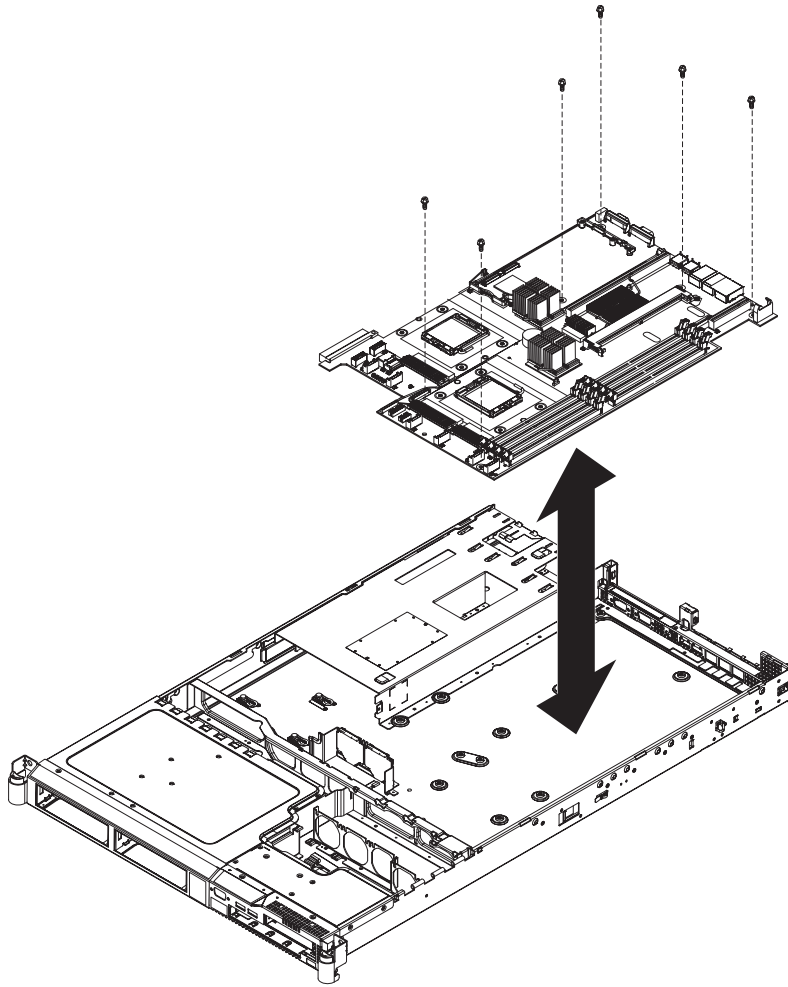

Figure 284. The placement of the screws that secure the SAN Volume Controller 2145-8G4 system board

3. Replace the four stand-off screws from beside the I/O ports at the rear of the server. Figure 285 shows the location of the stand-off screws.

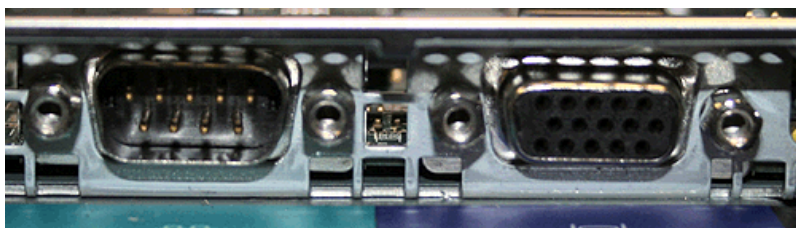
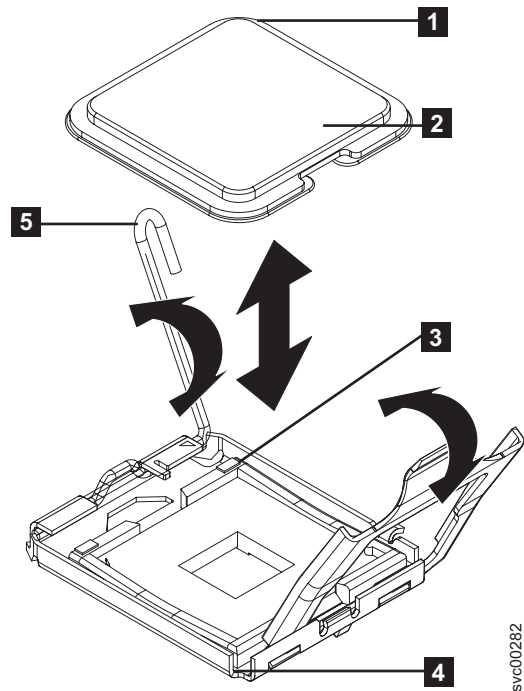

Figure 285. Serial and video ports on the SAN Volume Controller 2145-8G4

4. Replace the power backplane by pushing it right to connect it to the system board and pushing the power supply back in to connect to it. See “Replacing the power backplane” on page 183.
5. Install one of the microprocessors while carefully checking the orientation and remembering to close the release lever, which is shown in Figure 286 on page 305.



svc00282

Figure 286. Installing the microprocessor

- 1** Microprocessor orientation indicator
 - 2** Microprocessor
 - 3** Microprocessor orientation indicator
 - 4** Microprocessor connector
 - 5** Microprocessor release lever
6. Install a heat sink. If this is an original version of the SAN Volume Controller 2145-8G4 node, you will install the other heat sink in step 7 on page 306.
- a. Apply thermal grease to the top of the microprocessor. Apply nine dots of thermal grease in three rows of three dots each with the outer rows approximately 5 mm from the edge of the microprocessor. The diameter of the cap from the thermal grease syringe is 5 mm, so you can use it to judge the required position of the dots of thermal grease, as shown in Figure 287 on page 306.

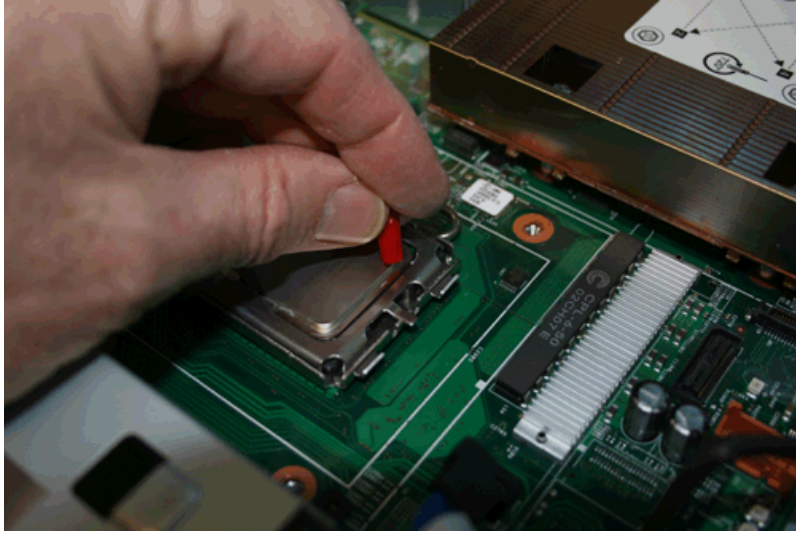

Figure 287. Estimating the position of the thermal grease dots

- b. For each dot of thermal grease, use two divisions on the syringe scale, which is 0.02 ml of grease. You will use about half the syringe contents for the nine dots. Figure 288 shows how the microprocessor appears with the nine dots of grease.



Figure 288. Complete set of nine thermal grease dots on the microprocessor

- c. Install the heat sink by gently squeezing it down onto the thermal grease and then tightening the four retaining screws alternately and evenly.
7. If this is a Rev 1 node, repeat steps 5 on page 304 and 6 on page 305 for the second microprocessor and heat sink. If this is a Rev 2 node, continue with the next step.
8. Replace either eight memory modules for the Rev 1 node or four memory modules for the Rev 2 node. See “Replacing the memory modules (DIMM)” on page 116.
9. Replace the right air baffle, which is shown in Figure 289 on page 307.

- a. Locate the pin on the bottom of the air baffle in the locating hole on the system board.
- b. Push the baffle backwards to locate it in place.
- c. Pull the baffle slightly to the right to locate the two clips in the support rail.

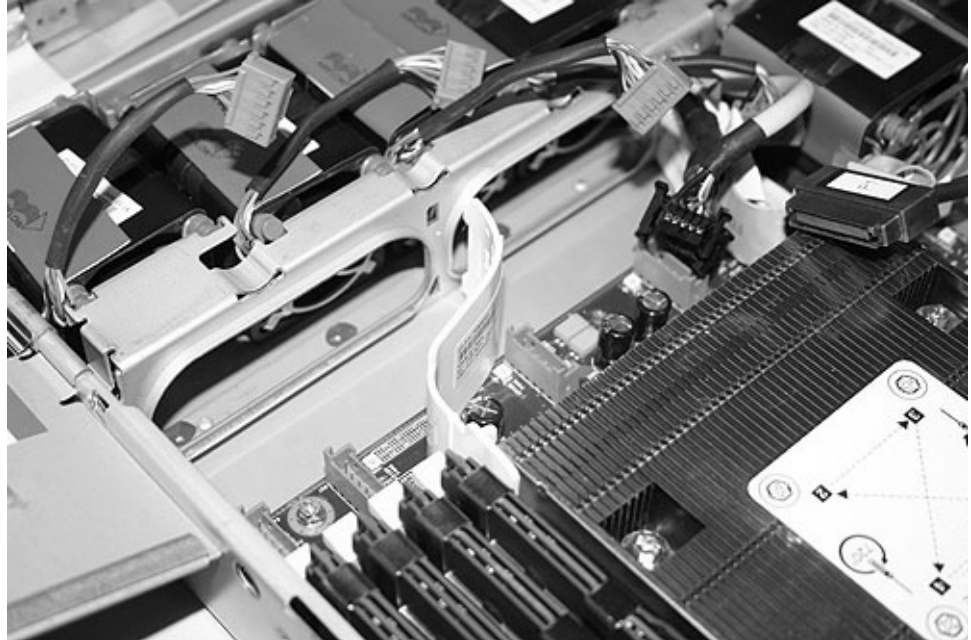

Figure 289. Right air baffle on the SAN Volume Controller 2145-8G4 system board

10. Reconnect the light path ribbon cable connector and the CD-RW ribbon cable connector, as shown in Figure 290 on page 308.
 - a. Replace the video cable connector and the USB cable connector.
 - b. Replace the cable connectors for fans 6, 5, 4 and 3.



Figure 290. Connectors on the right front side of the SAN Volume Controller 2145-8G4 system board

- 1** CD-RW connector
- 2** Light path cable connector
- 3** Video cable connector
- 4** USB cable connector
- 5** Fan 3 connector
- 6** Fan 4 connector
- 7** Fan 5 connector
- 8** Fan 6 connector

11. Replace the left air baffle, which is shown in Figure 291 on page 309. You must position the CD-RW cable within the baffle.

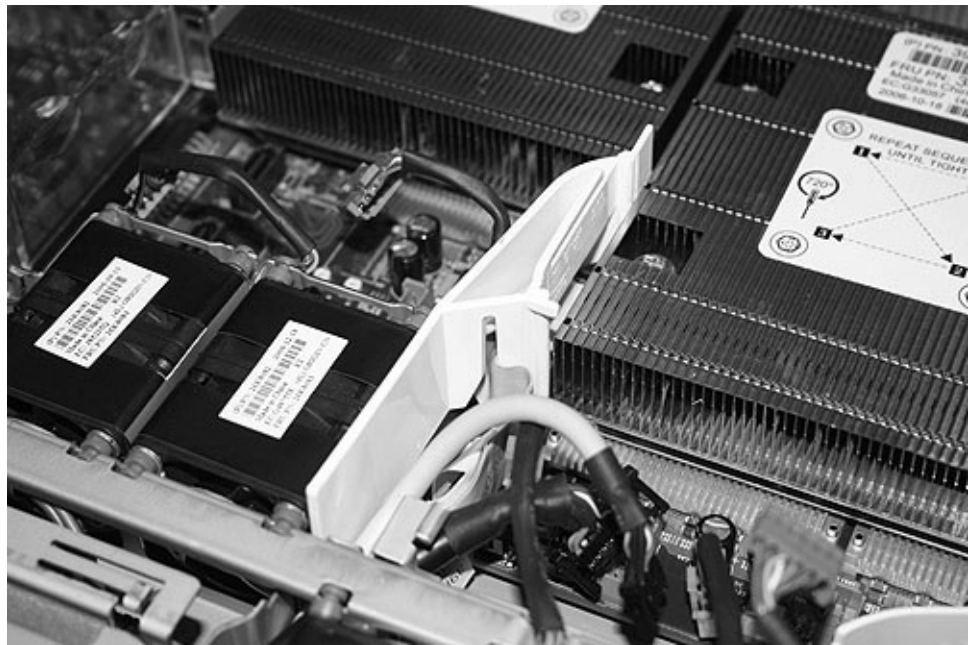

Figure 291. Left air baffle on the SAN Volume Controller 2145-8G4

12. Replace fan 2.
13. Replace the cable connectors for fans 2 and 1, as shown in Figure 292.

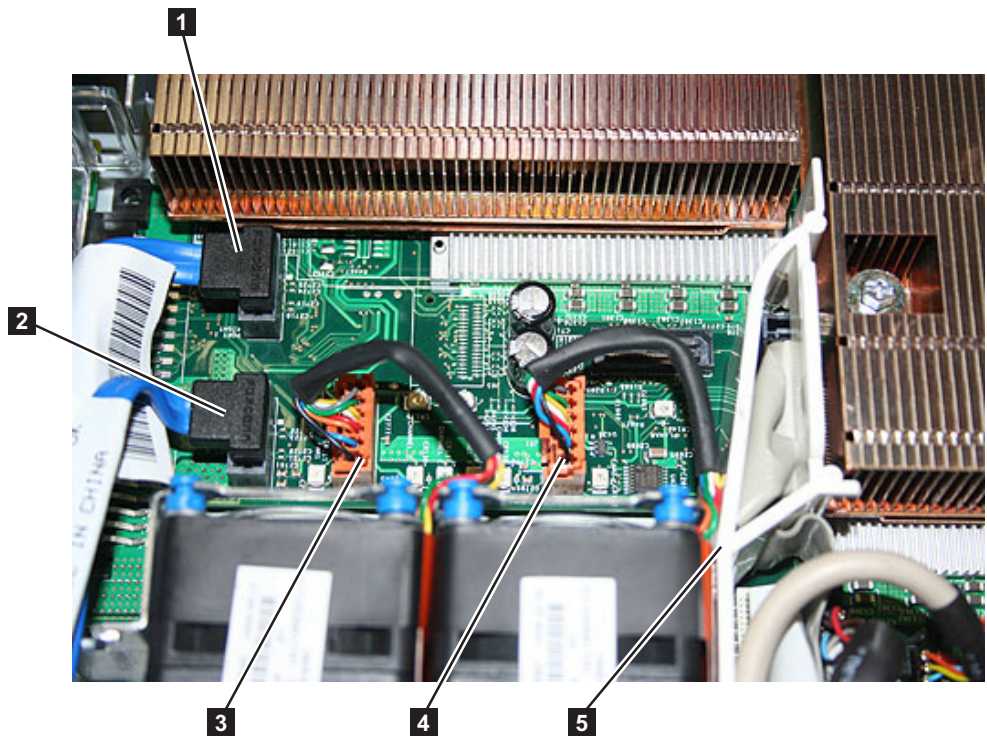

Figure 292. Connectors on the SAN Volume Controller 2145-8G4 system board

- 1** Right disk signal cable connector
- 2** Left disk signal cable connector

3 Fan 1 connector

4 Fan 2 connector

14. Replace the left disk drive cable in the front socket and the right disk drive cable in the rear socket.
15. Replace the riser card that you removed from adapter slot 2. Push it into its connector.
16. Replace the fibre-channel adapter and riser card. See “Replacing the fibre-channel adapter assembly” on page 197.
17. Replace the top cover. See “Replacing the top cover” on page 86.
18. Place the node in the rack. See “Replacing the SAN Volume Controller in a rack” on page 59.
19. Turn on the node. Wait for the front panel display to remain stable for at least five minutes before taking any further action.
 - If the repair has been successful and if the node was able to save its state data before shutting down, the node starts and rejoins the cluster. The front panel displays Cluster: and a cluster name if the node has rejoined a cluster.
 - If the repair has been successful but the node was not able to save its state data before shutting down, the node displays node error 578. Follow the procedures in “Deleting a node from a cluster” in the *IBM System Storage SAN Volume Controller Troubleshooting Guide* to delete the node from the cluster and then add it back into the cluster. If more than one node has failed, ensure that the node is added back into its original I/O group. See “Adding a node to a cluster” in the *IBM System Storage SAN Volume Controller Troubleshooting Guide* for more information.
 - If any other message is shown on the front panel, use MAP 5000 to resolve the problem.

Note: It is essential that you perform all the stages of the next step to ensure that the replacement system is set to the serial number of the original machine. Failure to do this might invalidate the customer’s warranty or service agreement.

20. After you make sure that the node is operating as part of the cluster, perform the following steps to restore the original machine serial number to the new system board:
 - a. Start the command-line interface (CLI). See “Accessing the SAN Volume Controller CLI” in the *IBM System Storage SAN Volume Controller Troubleshooting Guide*.
 - b. Write down the 7-character serial number from the serial number label that is on the front of the node. Ignore any hyphens (-) in the serial number.
 - c. On the front-panel display, press and release the down button until the Node panel is displayed. Write down the node name that is shown on the bottom line.
 - d. Issue the following command, substituting the values for *nodeserialnumber* and *nodename* that you wrote in the previous steps:

```
svctask writesernum -sernum nodeserialnumber nodename
```

where *nodeserialnumber* is the serial number on the front of the node and *nodename* is the name of the node.

For example, to write the machine serial number to the system board when the serial number is “13-FEDCB” and the node name is “ZYXW3,” you would issue the following command:

Note: The node will restart as soon as the serial number has been written to it.

Removing the redundant ac-power switch

Use this topic when you need to remove a redundant ac-power switch.

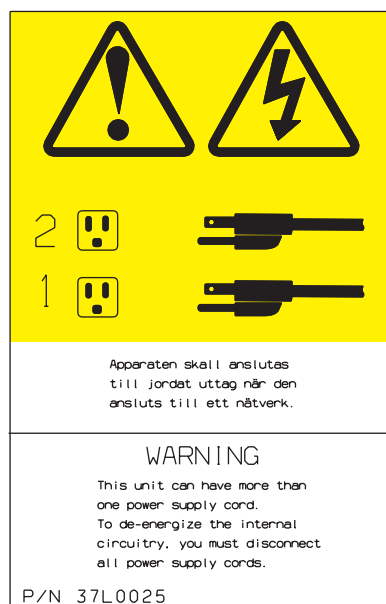

Use the reference numbers in parentheses at the end of each notice, such as (C003) for example, to find the matching translated notice in *IBM Systems Safety Notices*.

To remove a redundant ac-power switch, complete the following steps:

1. Turn off each SAN Volume Controller node that is connected by an uninterruptible power supply to the redundant ac-power switch. See MAP 5350 in the *IBM System Storage SAN Volume Controller Troubleshooting Guide*.
 - a. One or two nodes might be connected to the redundant ac-power switch. If two nodes are connected to the redundant ac-power switch, you must ensure that both nodes are not in the same I/O group before you turn off the nodes. If the nodes are both turned off and they are in the same I/O group, the customer will lose access to the data that is managed by that I/O group.
 - b. If both nodes that are powered by the redundant ac-power switch are in the same I/O group, turn off one node, disconnect it from the redundant ac-power switch, and connect it to a different power source. Then turn the node back on. When it has recovered and rejoined the I/O group, it can maintain the I/O access when the other node is turned off and when the redundant ac-power switch is removed. If you have had to perform this operation, pay particular attention to checking when it is safe to turn off the second node. See MAP 5350 in the *IBM System Storage SAN Volume Controller Troubleshooting Guide*.
2. Remove both the redundant ac-power switch input-power cables from the site power distribution unit and unthread them in the rack, so they will slide out

when the redundant ac-power switch is removed. There might be enough access to disconnect them from the redundant ac-power switch while it is in the rack, but often it is more convenient to leave them attached and remove them with the redundant ac-power switch.

3. Remove the one or two redundant ac-power switches to 2145 UPS-1U power cables from the redundant ac-power switch. There is no need to disconnect them from the 2145 UPS-1U.
4. Remove the four screws that hold the redundant ac-power switch in the rack. Be careful to support the redundant ac-power switch during this procedure because the screws are the only support for the unit.
5. The redundant ac-power switch can be slid out of the rack along with the input-power cables if they are still attached.

Replacing the redundant ac-power switch

Use this topic when you need to replace a redundant ac-power switch.

The redundant ac-power switch FRU assembly includes the redundant ac-power switch and the input power cables. They should all be replaced together.

These instructions assume that a redundant ac-power switch has been removed and the one or two nodes that were connected to it are powered off.

To replace a redundant ac-power switch, complete the following steps:

1. Attach each of the two mounting plates to the redundant ac-power switch using three M3 Torx T8 head screws. Position the mounting face, as shown in Figure 293, on the side of the redundant ac-power switch that contains the output power sockets.



Figure 293. Attaching the mounting plates

2. Using the labels provided, label each end of the two redundant ac-power switch input power cables. Unless the configuration is changing, the labels are the same as those on the cables removed with the old redundant ac-power switch. Label the rack power distribution end “Power source <name>, outlet <id>” to redundant ac-power switch <location> <MAIN | BACKUP> input. For example: “Power source D2, outlet 4 to redundant ac-power switch pos 7 MAIN input”.
3. Label the redundant ac-power switch end “redundant ac-power switch <location> <MAIN | BACKUP> input from Power source <name>, outlet <id>”.

4. Connect the input power cables to the redundant ac-power switch. You want to connect the cables now, because it is difficult to access the input power sockets on the redundant ac-power switch when it is installed in a rack.
5. Connect the main input power cable to the redundant ac-power switch.
6. Connect the backup input power cable to the redundant ac-power switch.
7. Secure both the redundant ac-power switch input cables, as shown in Figure 294, using the clips of the redundant ac-power switch.



Figure 294. Power cable clips

8. Install the redundant ac-power switch in the rack. The four “C” clips for mounting the unit should already be positioned in the rack mounting bar.
9. Position the redundant ac-power switch in the rack, pushing the cables through to the front of the rack. Mount in place using the four M6 screws.
10. Connect the redundant ac-power switch power input cables to the site power.
 - a. Determine a suitable cable route from the redundant ac-power switch to the power distribution units.
 - b. Route the main input power cable of the redundant ac-power switch to the specified power distribution unit, and connect it.
 - c. Route the backup input power cable of the redundant ac-power switch to the specified power distribution unit, and connect it.
 - d. Verify that the redundant ac-power switch power cables are tidy. Ensure that they do not obstruct other equipment and are tied in place where necessary.
11. Test the redundant ac-power switch before connecting it to the 2145 UPS-1U, using MAP 5340 in the *IBM System Storage SAN Volume Controller Troubleshooting Guide*.
12. Connect the one or two 2145 UPS-1U units that are powered by this redundant ac-power switch. The power cables should still be plugged into the 2145 UPS-1U units.
 - a. Connect the other end into the output power sockets on the front of the redundant ac-power switch.
 - b. Check the labels on the cables to see which socket they should be connected to.

- c. If the uninterruptible power supply units do not power on automatically, power them on by pressing the power button for five seconds.
13. Power on the one or two SAN Volume Controller nodes connected to this redundant ac-power switch.

Removing and replacing 2145 UPS-1U parts

The remove and replace procedures for the 2145 UPS-1U field replaceable units are described in the topics which follow.

Removing and replacing the 2145 UPS-1U power cable-retention bracket

The 2145 UPS-1U power cable-retention bracket prevents accidental removal of the power cable that connects the 2145 UPS-1U to the SAN Volume Controller node.

Note: The 2145 UPS-1U power cable-retention bracket (shown in Figure 295) can be attached only to the most recent versions of the 2145 UPS-1U. Older versions do not have the correct mounting holes.

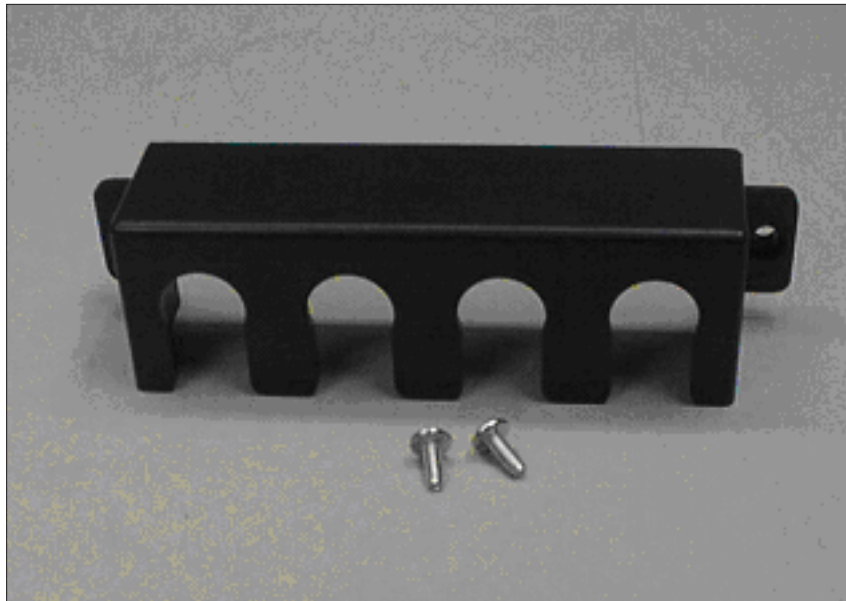

Figure 295. 2145 UPS-1U power cable-retention bracket hardware

Removing the 2145 UPS-1U power cable-retention bracket

Perform the following steps to remove the 2145 UPS-1U power cable-retention bracket:

1. Remove the retaining screw from each side of the bracket.



Figure 296. 2145 UPS-1U power cable-retention bracket

2. Lift the bracket off the cable.

Replacing the 2145 UPS-1U power cable-retention bracket:

Perform the following steps to replace the 2145 UPS-1U power cable-retention bracket:

1. Ensure that the output power cable is securely in place.
2. Place the bracket over the power supply inlets on the right rear of the 2145 UPS-1U, so that the two screw holes line up.
3. Ensure that the power cable runs through the rightmost slot in the bracket.
4. Secure the bracket in place with one screw on each side, as shown in Figure 297.



Figure 297. 2145 UPS-1U power cable-retention bracket

Removing the 2145 UPS-1U

Before you remove the 2145 UPS-1U, read all safety notices.

Use the reference numbers in parentheses at the end of each notice, such as (C003) for example, to find the matching translated notice in *IBM Systems Safety Notices*.

DANGER

Uninterruptible power supply units contain specific hazardous materials. Observe the following precautions if your product contains an uninterruptible power supply:

- The uninterruptible power supply contains lethal voltages. All repairs and service must be performed only by an authorized service support representative. There are no user serviceable parts inside the uninterruptible power supply.
- The uninterruptible power supply contains its own energy source (batteries). The output receptacles might carry live voltage even when the uninterruptible power supply is not connected to an ac supply.
- Do not remove or unplug the input cord when the uninterruptible power supply is turned on. This removes the safety ground from the uninterruptible power supply and the equipment connected to the uninterruptible power supply.
- The uninterruptible power supply is heavy because of the electronics and batteries that are required. To avoid injury, observe the following precautions:
 - Do not attempt to lift the uninterruptible power supply by yourself. Ask another service representative for assistance.
 - Remove the battery, electronics assembly, or both from the uninterruptible power supply before removing the uninterruptible power supply from the shipping carton or installing or removing the uninterruptible power supply in the rack.

(D007)

CAUTION:

This part or unit is heavy but has a weight smaller than 18 kg (39.7 lb). Use care when lifting, removing, or installing this part or unit. (C008)

Perform the following steps to remove the 2145 UPS-1U:

Attention: Check to make sure that the SAN Volume Controller that is powered by this 2145 UPS-1U is shut down and turned off, prior to step 1. See MAP 5350 in the *IBM System Storage SAN Volume Controller Troubleshooting Guide*.

1. At the front of the 2145 UPS-1U, press and hold the on/off button (**1** in Figure 298) until the power light is extinguished (approximately five seconds). On some versions of the 2145 UPS-1U, you need a pointed device, such as a screwdriver, to press the on/off button. The 2145 UPS-1U enters standby mode.

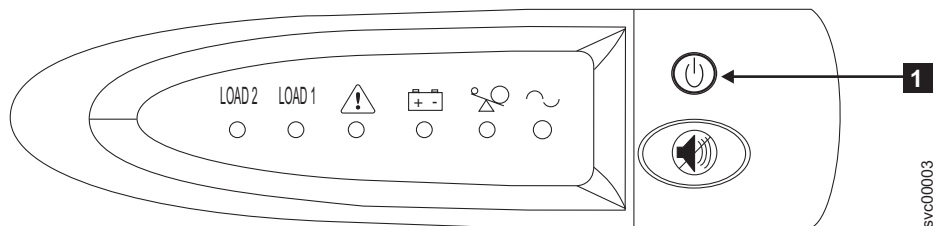

Figure 298. The 2145 UPS-1U front-panel assembly

2. At the back of the 2145 UPS-1U, remove the power cable retainer before disconnecting the SAN Volume Controller power cable from load segment receptacle 2 (**3** in Figure 299).
3. Disconnect the signal cable from the communication port (**2** in Figure 299).
4. Disconnect the main power cable from the main power source (**1** in Figure 299).

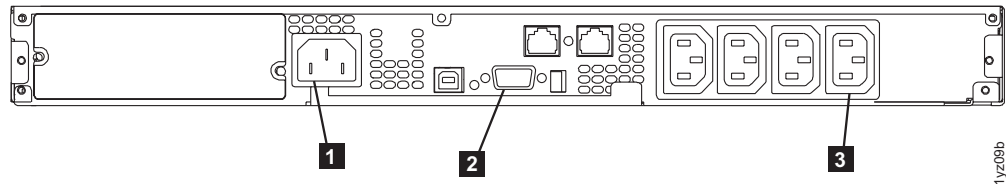

Figure 299. 2145 UPS-1U (rear view)

Some SAN Volume Controller node types have two power supply units. Both power supplies must be connected to the same 2145 UPS-1U. The SAN Volume Controller 2145-CF8 is an example of a node that has two power supplies. The SAN Volume Controller 2145-8A4 is an example of a node that has a single power supply.

5. Remove the 2145 UPS-1U front panel, as shown in Figure 300.

Note: If you are having difficulty pulling the right side of the panel free from the 2145 UPS-1U, insert a flat-blade screwdriver between the right side of the cover and the frame and gently pry it free.

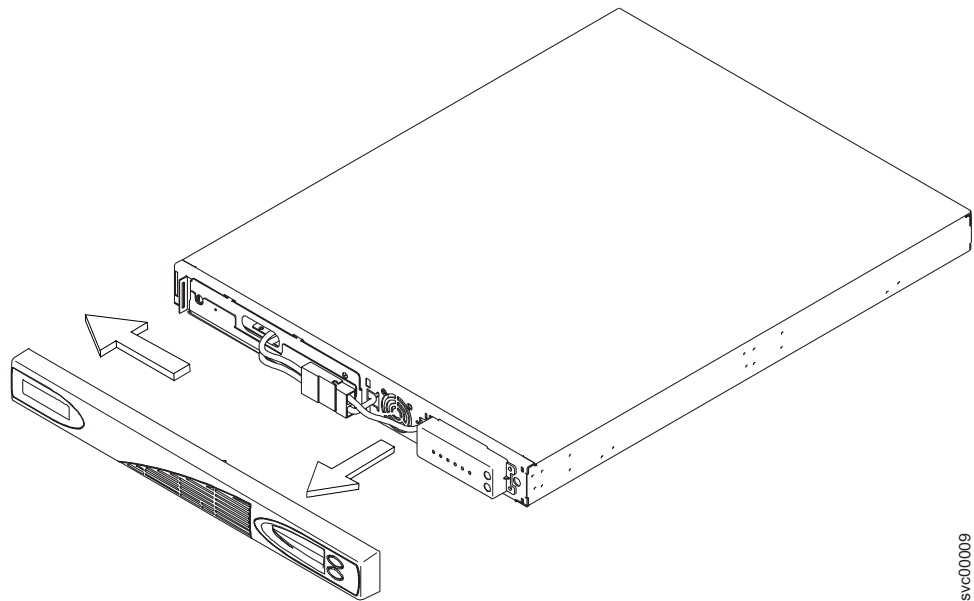
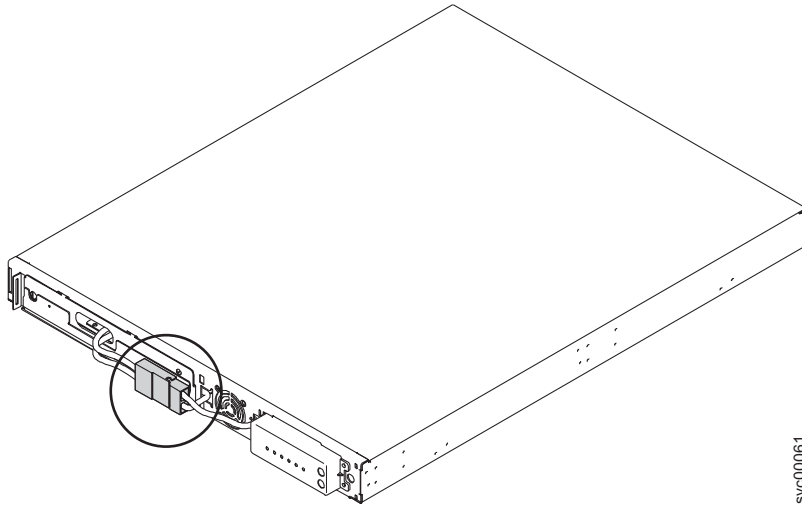

Figure 300. Removing the 2145 UPS-1U front panel

6. Disconnect the internal battery connector, which is circled in Figure 301 on page 318.



svc-00061

Figure 301. The 2145 UPS-1U internal-battery connector

7. After pulling the two connectors apart, cover the exposed battery connector (shown in Figure 302) with adhesive tape.

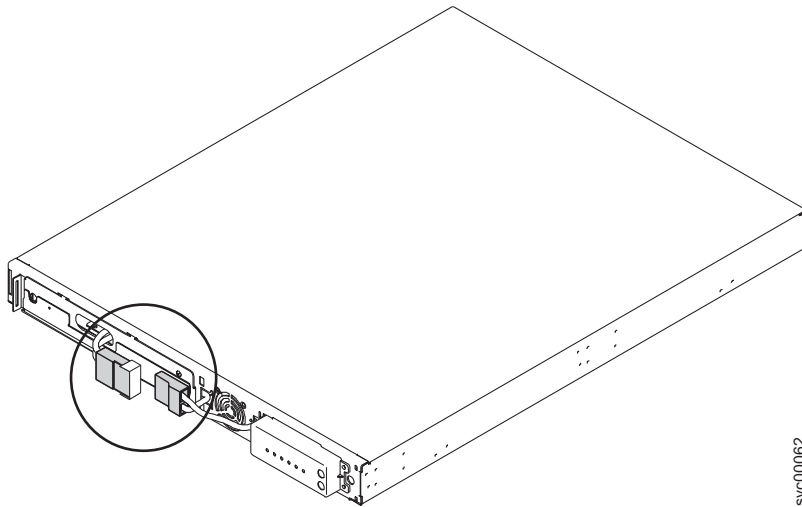

svc-00062

Figure 302. The 2145 UPS-1U internal battery connector with protective tape

8. Reinstall the front panel.
9. At the front of the 2145 UPS-1U, unscrew the two mounting screws **1**, as shown in Figure 303 on page 319.

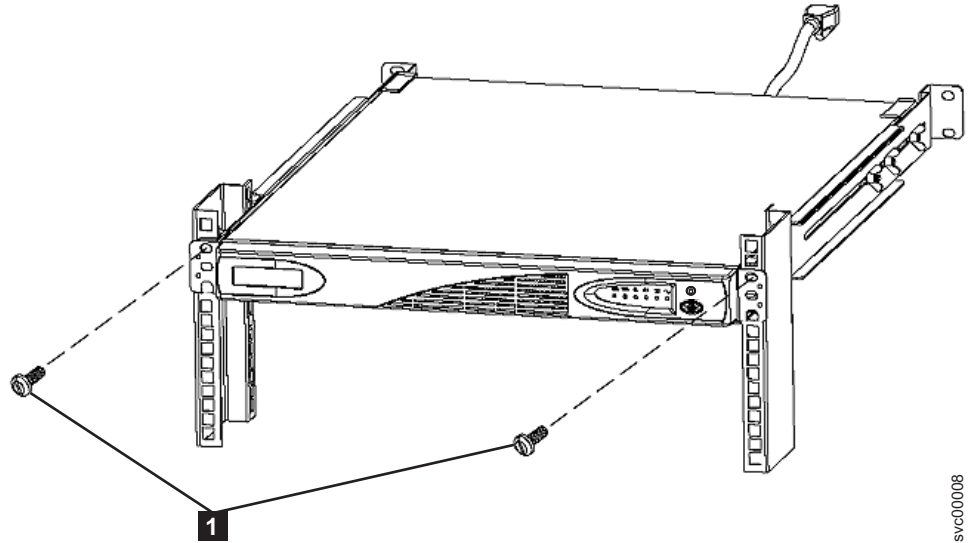

svc00008

Figure 303. Mounting screws for the 2145 UPS-1U

10. From the back of the rack, push the 2145 UPS-1U forward approximately 5 cm (2 in) to enable you to pull it from the rack.
11. Go to the front of the rack.
12. Pull the 2145 UPS-1U forward and remove it from the rack.

Related tasks

“Removing the 2145 UPS-1U battery” on page 329

Follow all safety notices when you are removing the 2145 UPS-1U battery.

“Replacing the 2145 UPS-1U”

You can replace the 2145 UPS-1U only after you remove the previous uninterruptible power supply.

Replacing the 2145 UPS-1U

You can replace the 2145 UPS-1U only after you remove the previous uninterruptible power supply.

Use the reference numbers in parentheses at the end of each notice, such as (C003) for example, to find the matching translated notice in *IBM Systems Safety Notices*.

DANGER

Uninterruptible power supply units contain specific hazardous materials. Observe the following precautions if your product contains an uninterruptible power supply:

- The uninterruptible power supply contains lethal voltages. All repairs and service must be performed only by an authorized service support representative. There are no user serviceable parts inside the uninterruptible power supply.
- The uninterruptible power supply contains its own energy source (batteries). The output receptacles might carry live voltage even when the uninterruptible power supply is not connected to an ac supply.
- Do not remove or unplug the input cord when the uninterruptible power supply is turned on. This removes the safety ground from the uninterruptible power supply and the equipment connected to the uninterruptible power supply.
- The uninterruptible power supply is heavy because of the electronics and batteries that are required. To avoid injury, observe the following precautions:
 - Do not attempt to lift the uninterruptible power supply by yourself. Ask another service representative for assistance.
 - Remove the battery, electronics assembly, or both from the uninterruptible power supply before removing the uninterruptible power supply from the shipping carton or installing or removing the uninterruptible power supply in the rack.

(D007)

CAUTION:

This part or unit is heavy but has a weight smaller than 18 kg (39.7 lb). Use care when lifting, removing, or installing this part or unit. (C008)

Perform the following steps to replace the 2145 UPS-1U:

1. Place the 2145 UPS-1U on a flat, stable surface with the front of the 2145 UPS-1U facing toward you.
2. On each side of the 2145 UPS-1U, attach the long end of a mounting bracket to the 2145 UPS-1U using four of the supplied M3 × 6 screws (**2** in Figure 304).

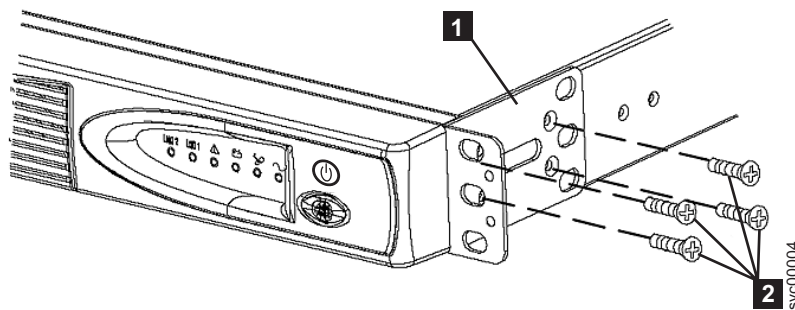

Figure 304. Installing the support rails for a 2145 UPS-1U into the rack

3. Stand at the front of the rack and place the back of the 2145 UPS-1U onto the support rails, and then slide the 2145 UPS-1U into the rack.

4. At the front of the 2145 UPS-1U, install the two mounting screws (**1** in Figure 305).

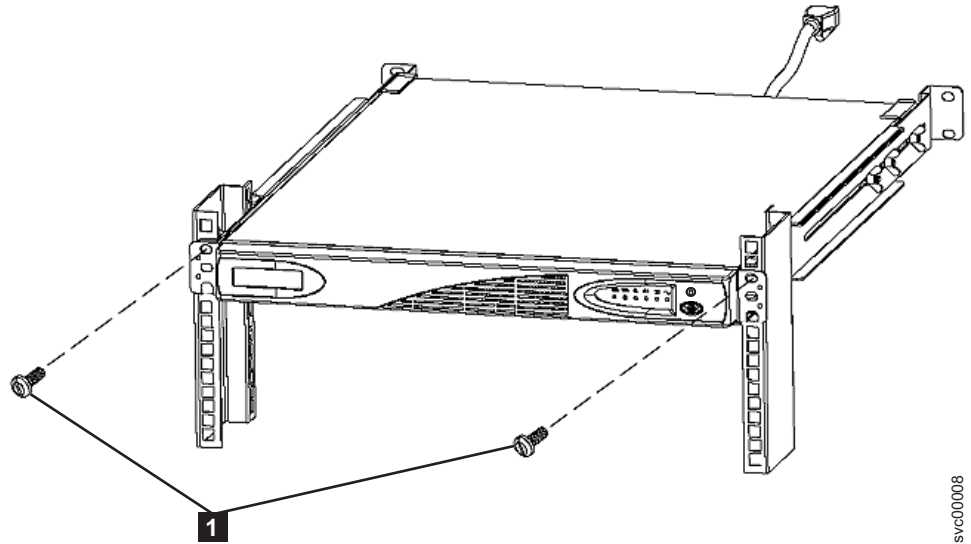

Figure 305. Mounting screws for the 2145 UPS-1U

5. Remove the 2145 UPS-1U front panel by pulling it towards you and to the left, as shown in Figure 306.

Note: If you are having difficulty pulling the right side of the panel free from the 2145 UPS-1U, insert a flat-blade screwdriver between the right side of the cover and the frame and gently pry it free.

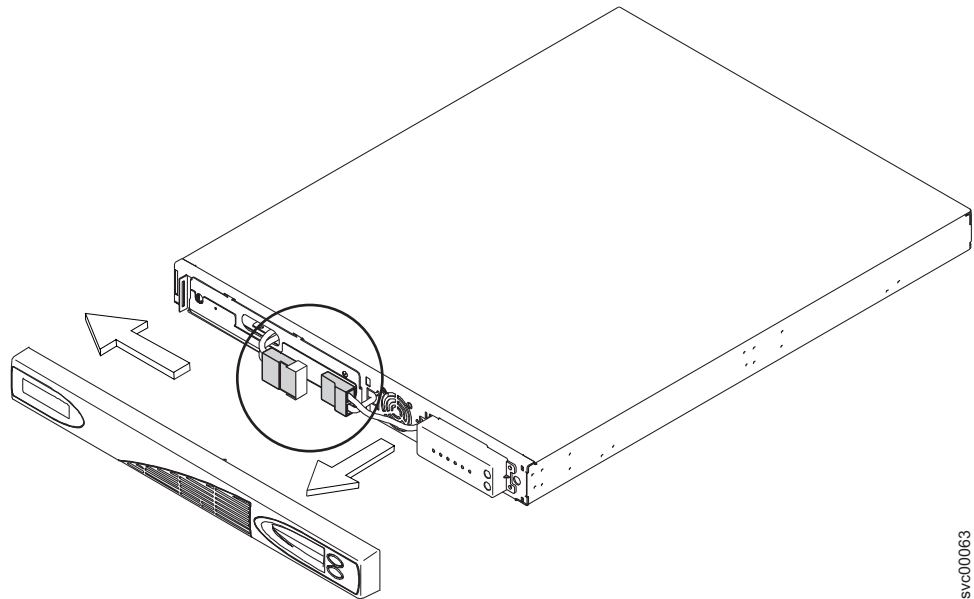
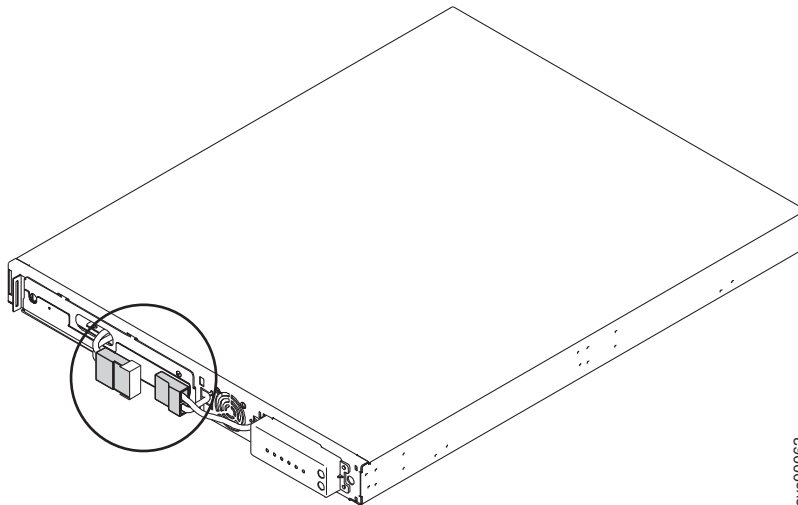

Figure 306. Removing the 2145 UPS-1U front panel

6. Remove the protective tape from the internal battery connector (circled in Figure 307 on page 322).



svc-00062

Figure 307. The 2145 UPS-1U internal battery connector with protective tape

7. Connect the internal battery connector (circled in Figure 308).

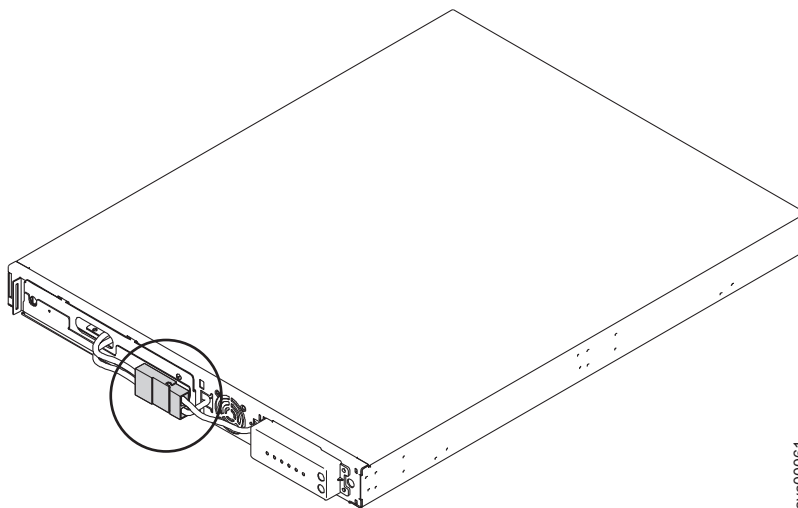

svc-00061

Figure 308. The 2145 UPS-1U with internal battery connectors in place

Note: A small amount of arcing may occur when connecting the batteries. This is normal and does not damage the unit or present any safety concerns.

8. Reinstall the front panel.
9. At the back of the 2145 UPS-1U, connect the SAN Volume Controller power cable to load segment 2 receptacle (**3** in Figure 310 on page 323). If applicable, install the power cable-retention bracket (shown in Figure 309 on page 323).

Note: The 2145 UPS-1U is intended to maintain power on a single SAN Volume Controller node until data can be saved to the local hard disk drive. Only SAN Volume Controller nodes can be plugged in to the 2145 UPS-1U or else the SAN Volume Controller cluster malfunctions. You must attach only one SAN Volume Controller to the 2145 UPS-1U, and nothing else.



Figure 309. The 2145 UPS-1U cable retention bracket connected to the 2145 UPS-1U

10. Reconnect the SAN Volume Controller signal cable to the communication port (**2** in Figure 310).
11. Reconnect the 2145 UPS-1U main power cable, from either the power distribution unit or from the redundant ac-power switch, into the input connector (**1** in Figure 310).

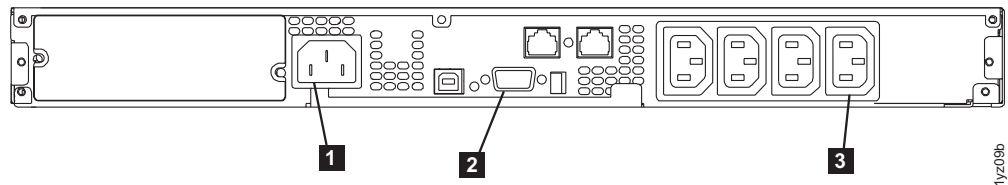

Figure 310. 2145 UPS-1U (rear view)

The 2145 UPS-1U is now in standby mode with the SAN Volume Controller offline. All indicators that are shown in Figure 310 are off.

12. To turn on the 2145 UPS-1U, press and hold the on/off button (**2** in Figure 311). On some versions of the 2145 UPS-1U, you need a pointed device, such as a screwdriver, to press the on/off button. The 2145 UPS-1U undergoes a self-test, taking approximately five seconds, before the power-on indicator **1** and the load indicators (**7** and **8**) light up permanently to indicate that the 2145 UPS-1U is supplying power to the SAN Volume Controller. The 2145 UPS-1U begins to charge its battery while in normal mode.

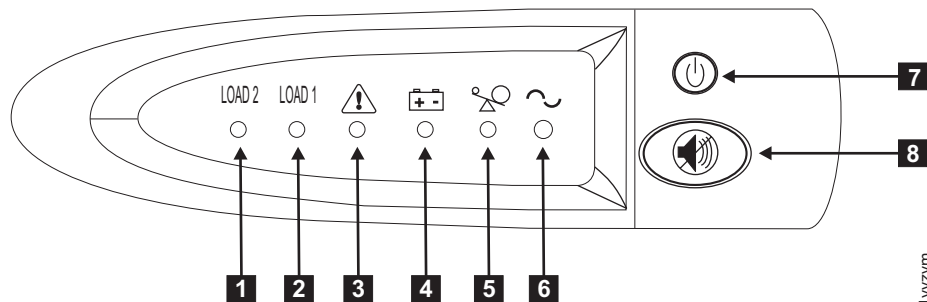

Figure 311. 2145 UPS-1U front-panel assembly

Note: If the 2145 UPS-1U battery is not sufficiently charged, the SAN Volume Controller node will not be able to join the cluster. The node will display Charging on its front panel until the 2145 UPS-1U battery has reached sufficient charge, which could take an hour. When the SAN Volume

Controller node rejoins the cluster, it might display Recovering on its front panel while the 2145 UPS-1U battery finalizes its charge.

Related tasks

“Removing the 2145 UPS-1U battery” on page 329

Follow all safety notices when you are removing the 2145 UPS-1U battery.

Removing the support rails for a 2145 UPS-1U

You can remove the support rails for the 2145 UPS-1U.

Perform the following steps to remove the support rails:

1. Loosen and remove the two M6 × 10 screws from each side of the 2145 UPS-1U. See **1** in Figure 312.

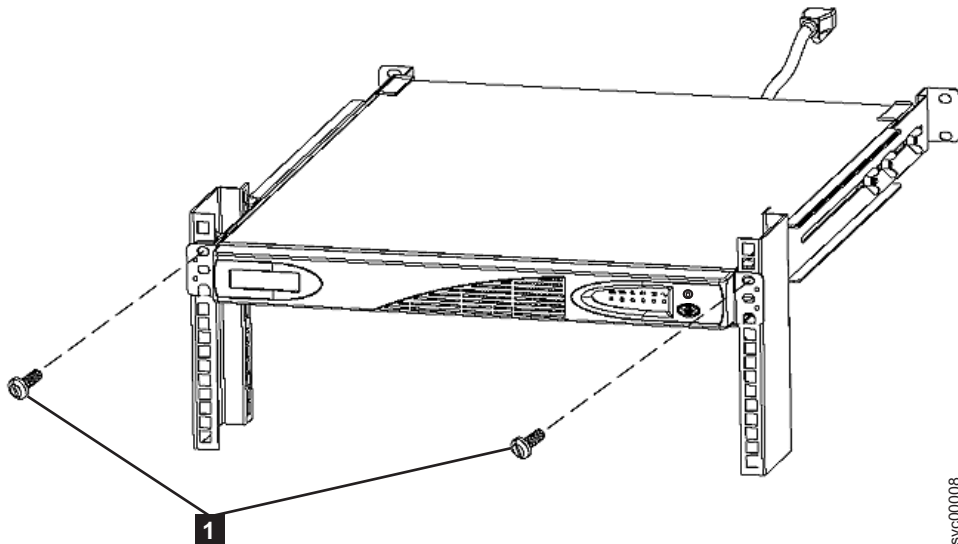

Figure 312. Removing the front screws from the 2145 UPS-1U

2. Remove the 2145 UPS-1U from the rack.
3. Remove the clip nut from the top hole of the rail (**3** in Figure 313 on page 325).

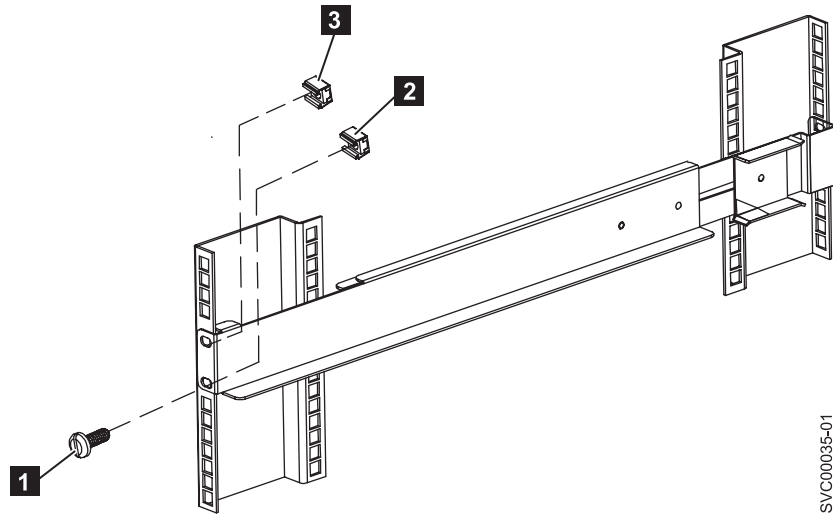

Figure 313. Removing the front rail on the 2145 UPS-1U

4. Detach the M6 × 10 screw **1** from the clip nut **2** in the bottom hole of the rail.
5. Remove the two M6 × 10 screws from the rear side of the rail (**1** in Figure 314) and the two clip nuts (**2**).

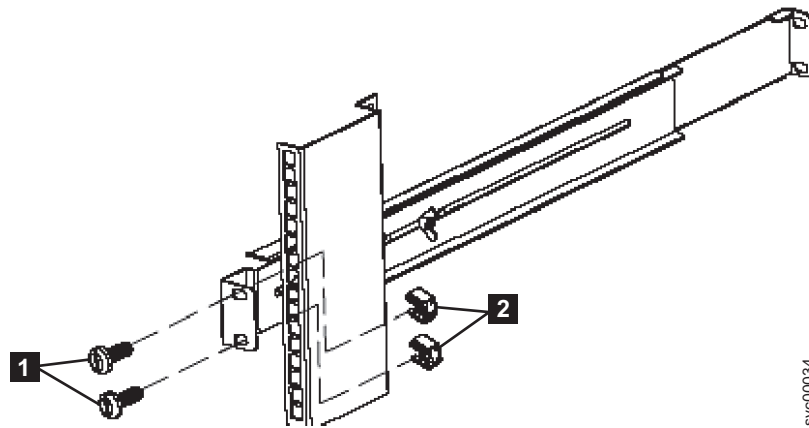

Figure 314. Removing the rear rail on the 2145 UPS-1U

6. Remove the rail from the rack.
7. Repeat steps 3 on page 324 through 6 to remove the other rail from the rack.

Installing the support rails for the 2145 UPS-1U

You must install the support rails in the rack before installing the 2145 UPS-1U.

Complete the following prerequisites before installing the support rails:

1. Use the customer's hardware-location chart to determine where in the rack that the 2145 UPS-1U is to be installed.
2. At the back of the rack, observe the Electronic Industries Alliance (EIA) positions and determine where you are going to install the 2145 UPS-1U. Because of its weight, position the 2145 UPS-1U where it is easy to handle in one of the lower positions in the rack.

Perform the following steps to install the support rails for the 2145 UPS-1U:

1. Open the top of the 2145 UPS-1U shipping carton. Grip the flaps on either side of the 2145 UPS-1U.
2. Lift the 2145 UPS-1U clear of the shipping carton and place it on a flat, stable surface with the front facing you.
3. Attach the long side of a mounting bracket **1** to each side of the 2145 UPS-1U using four M3 × 6 screws **2** for each bracket, as shown in Figure 315.

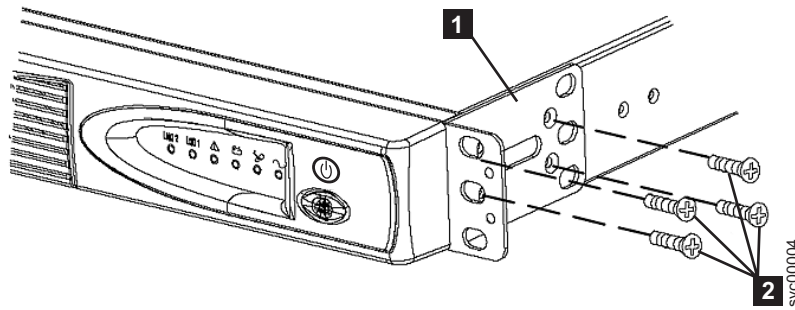

Figure 315. Installing the support rails for a 2145 UPS-1U into the rack

4. Loosen the assembly wing nuts (**1** in Figure 316) on both rail assemblies and adjust the rail size to the depth of your rack. After you adjust the depth, tighten the assembly wing nuts as much as possible while still allowing some movement.

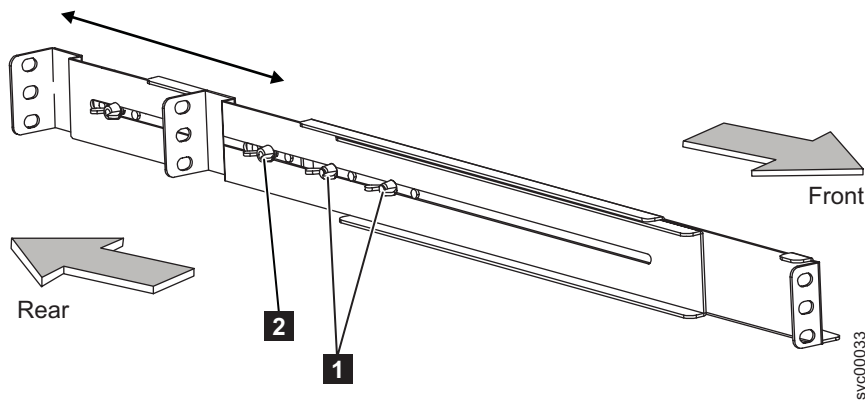

Figure 316. Adjusting the rail depth on the 2145 UPS-1U

1 Assembly wing nuts

2 Wing nut

5. Select the holes in the rail where you want to position the 2145 UPS-1U.

Note: The bottom flange of the support rail must align with the EIA mark on the rack.

6. Using two M6 × 10 screws (**1** in Figure 317 on page 327) and two clip nuts **2**, attach the rail to the rear of the rack. The customer's rack might be different than the one shown here, and if so, might require different clip nuts or fasteners.

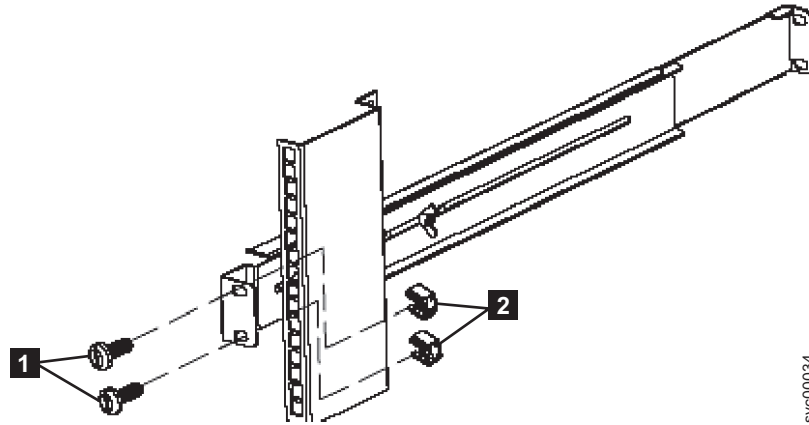

Figure 317. Securing the rear rail on the 2145 UPS-1U

7. Install two clip nuts (**2** and **3** in Figure 318) to the front of the rack, then attach the rail using just one M6 x 10 screw in the bottom mounting hole **1** .

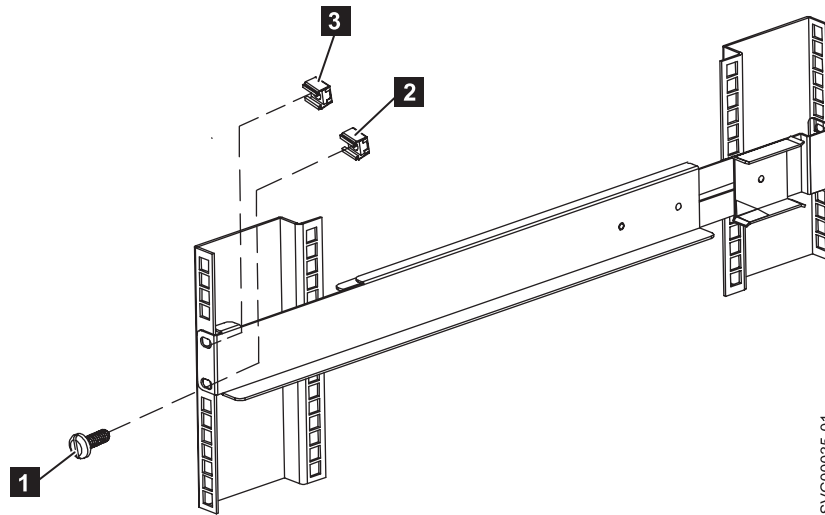

Figure 318. Securing the front rail on the 2145 UPS-1U

8. Repeat steps 6 on page 326 and 7 for the other rail.
9. Tighten the assembly wing nuts on both rail assemblies.

Removing the power cable from the 2145 UPS-1U

You can remove the power cable from the 2145 UPS-1U if you are having problems with the power supply and suspect that the power cable is defective.

Perform the following steps to remove the power cable:

1. Remove the power from each SAN Volume Controller node. See MAP 5350 in the *IBM System Storage SAN Volume Controller Troubleshooting Guide* for information about removing the power cable from the SAN Volume Controller.
2. Press and hold the on/off button **2** until the power light **1** is extinguished (approximately five seconds). On some versions of the 2145 UPS-1U, you need a pointed device, such as a screwdriver, to press the on/off button. The 2145 UPS-1U enters standby mode, with all indicators off. Figure 319 on page 328

illustrates the front and rear views of the 2145 UPS-1U.

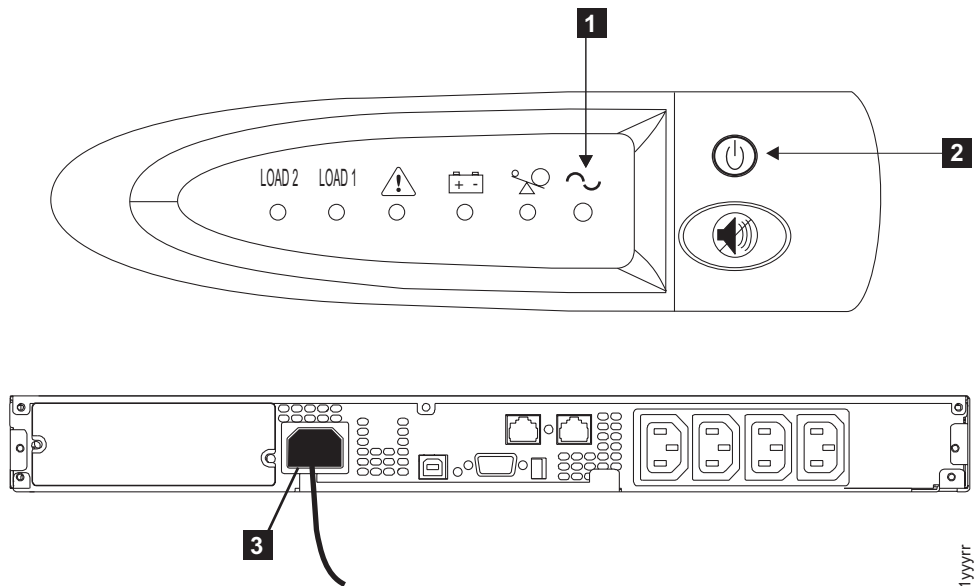

Figure 319. Front and back panels for the 2145 UPS-1U

- 1** Power-on indicator
 - 2** On/off button
 - 3** Power cable
3. Disconnect the power cable from the main power source **3**.
 4. Replace the power cable and make sure it is seated. The 2145 UPS-1U enters standby mode. All indicators are off and power is not available to the SAN Volume Controller. The battery recharges when necessary.
 5. To turn the 2145 UPS-1U on, press and hold the on/off button **2** until the 2145 UPS-1U power button **1** is illuminated (approximately five seconds). On some versions of the 2145 UPS-1U, you need a pointed device, such as a screwdriver, to press the on/off button. The front panel indicators then cycle through a startup sequence while the 2145 UPS-1U conducts a self-test. When the self-test completes, the power-on indicator and the load indicators illuminate to show that the 2145 UPS-1U is supplying power. The 2145 UPS-1U resumes service in normal mode.

Related tasks

“Removing and replacing the SAN Volume Controller power-cable assembly” on page 110

Make sure that power to the SAN Volume Controller is turned off before you remove the power-cable assembly. Turn off the node while ensuring that its data is mirrored and synchronized, as described in MAP 5350 in the *IBM System Storage SAN Volume Controller Troubleshooting Guide*.

Removing the 2145 UPS-1U battery

Follow all safety notices when you are removing the 2145 UPS-1U battery.

CAUTION:

Lead-acid batteries can present a risk of electrical burn from high, short-circuit current. Avoid battery contact with metal materials; remove watches, rings, or other metal objects, and use tools with insulated handles. To avoid possible explosion, do not burn.

Exchange only with the IBM-approved part. Recycle or discard the battery as instructed by local regulations. In the United States, IBM has a process for the collection of this battery. For information, call 1-800-426-4333. Have the IBM part number for the battery unit available when you call. (C004)

Use the reference numbers in parentheses at the end of each notice, such as (C003) for example, to find the matching translated notice in *IBM Systems Safety Notices*.

Perform the following steps to remove the 2145 UPS-1U battery:

1. Ensure the SAN Volume Controller that is connected to the 2145 UPS-1U is turned off. Use the instructions in MAP 5350 in the *IBM System Storage SAN Volume Controller Troubleshooting Guide* to turn off the node if it is not already off.

Note: There is no need to turn off the 2145 UPS-1U or remove it from the rack.

2. Pull the front panel from the right side until the panel is released from the right and middle sections of the 2145 UPS-1U. Push the front panel to the left to release the catch on the left end of the panel, as shown in Figure 320 on page 330.

Note: If you are having difficulty pulling the right side of the panel free from the 2145 UPS-1U, insert a flat-blade screwdriver between the right side of the cover and the frame and gently pry it free.

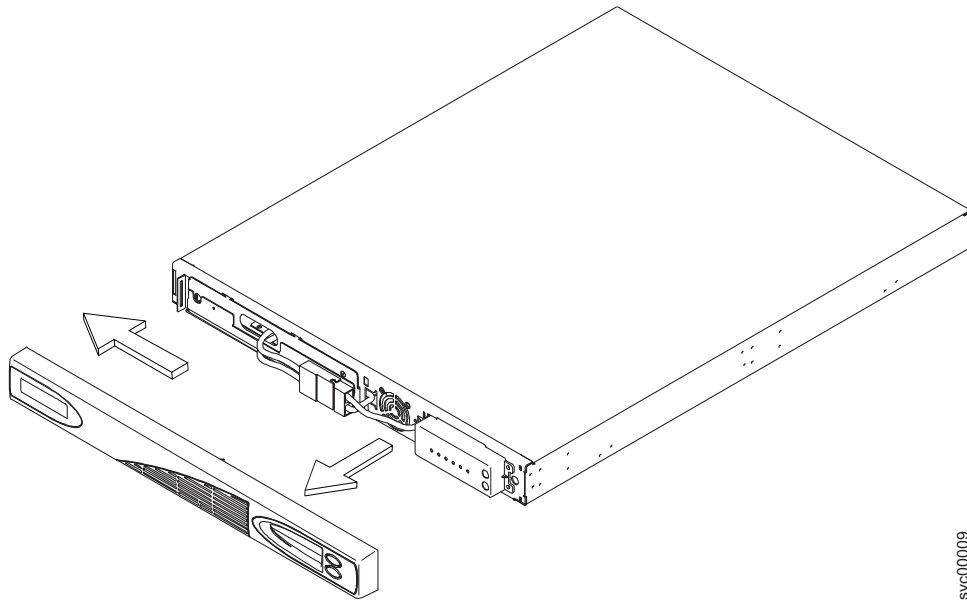

svc00009

Figure 320. Removing the 2145 UPS-1U front panel

3. Disconnect the internal battery connector, circled in Figure 321.

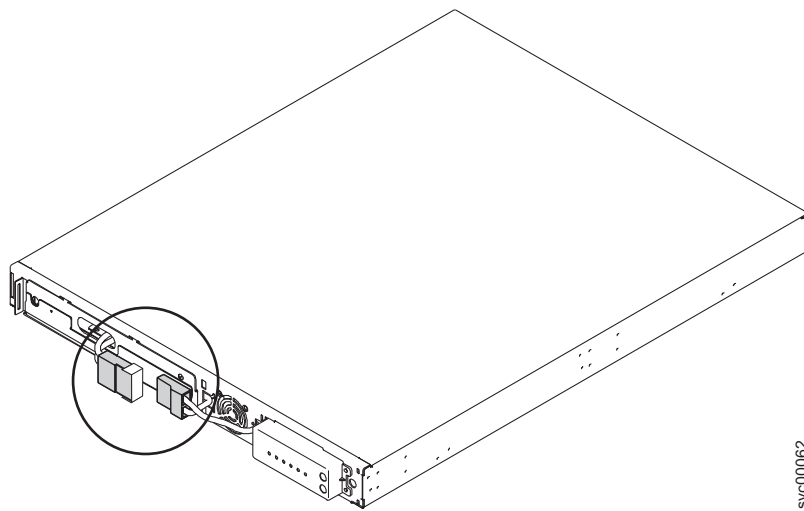

svc00062

Figure 321. The 2145 UPS-1U internal battery connector with protective tape

4. Slide the battery cover to the right and remove it.
5. Slide the battery out of the 2145 UPS-1U, as shown in Figure 322 on page 331, and remove it, laying it on a flat surface.

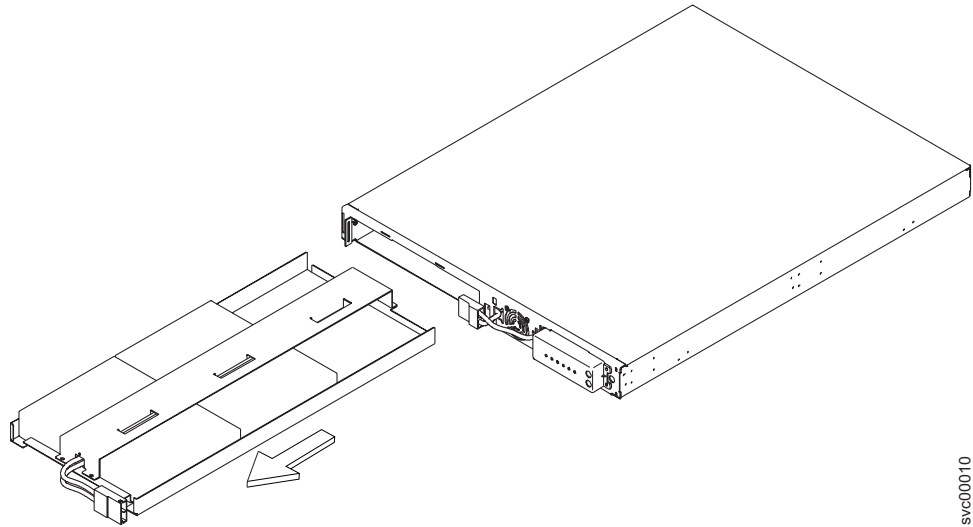

svc00010

Figure 322. Removing the 2145 UPS-1U battery

Related tasks

“Removing the 2145 UPS-1U” on page 315
Before you remove the 2145 UPS-1U, read all safety notices.

“Replacing the 2145 UPS-1U” on page 319
You can replace the 2145 UPS-1U only after you remove the previous uninterruptible power supply.

Replacing the 2145 UPS-1U battery

Follow all safety notices when you are replacing the 2145 UPS-1U battery.

CAUTION:

Lead-acid batteries can present a risk of electrical burn from high, short-circuit current. Avoid battery contact with metal materials; remove watches, rings, or other metal objects, and use tools with insulated handles. To avoid possible explosion, do not burn.

Exchange only with the IBM-approved part. Recycle or discard the battery as instructed by local regulations. In the United States, IBM has a process for the collection of this battery. For information, call 1-800-426-4333. Have the IBM part number for the battery unit available when you call. (C004)

Use the reference numbers in parentheses at the end of each notice, such as (C003) for example, to find the matching translated notice in *IBM Systems Safety Notices*.

This task assumes that you have disconnected the 2145 UPS-1U battery and have turned off the SAN Volume Controller. Perform the following steps to replace the 2145 UPS-1U battery:

1. Slide the battery into the 2145 UPS-1U, as shown in Figure 323 on page 332.

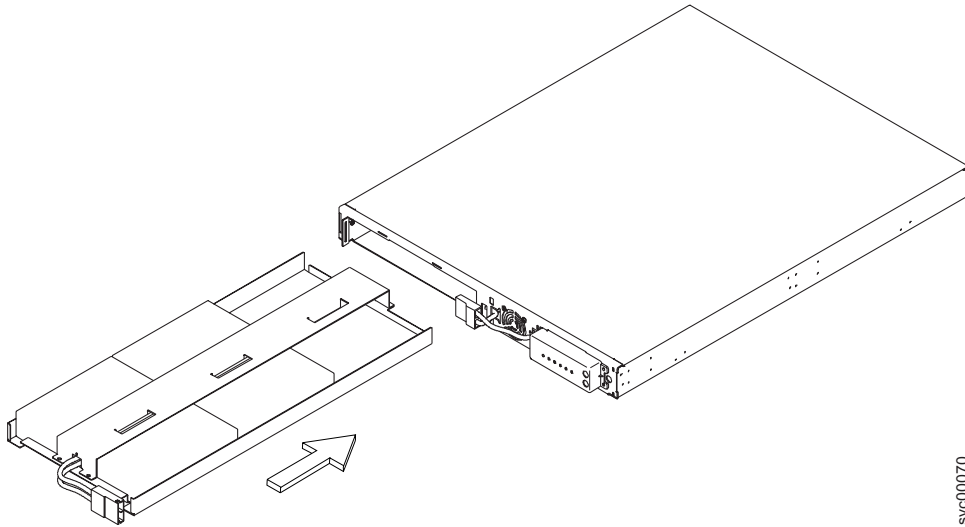

svc00070

Figure 323. Replacing the 2145 UPS-1U battery

2. Thread the battery connector through the battery cover. Position the battery cover in place and slide it to the left to secure it.
3. Connect the internal battery connector, as shown in Figure 325 on page 333. Each end of the keyed connector has two wires: one red (+) and one black (-). Join the black wires and the red wires together.

Note: A small amount of arcing might occur when connecting the batteries. This is normal and does not damage the unit or present any safety concerns.

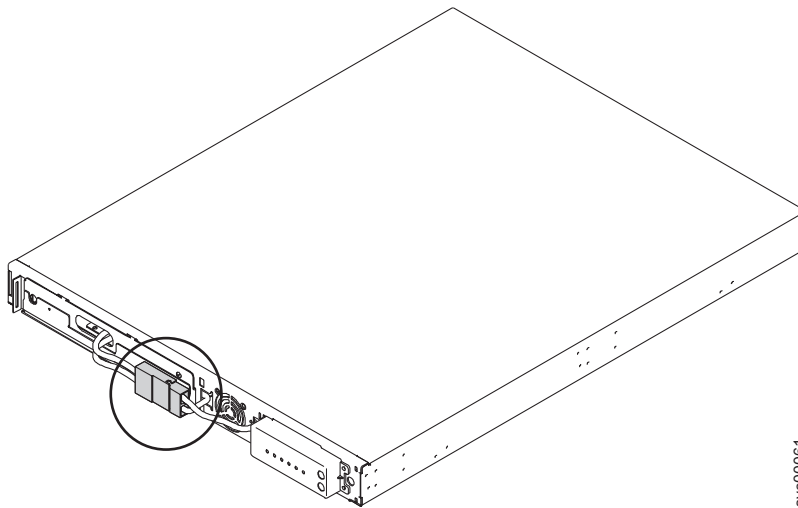

svc00061

Figure 324. The 2145 UPS-1U internal-battery connector

4. Push the front panel to the right to catch on the left end of the panel. Push the front panel forward until the panel snaps into the right and middle sections of the 2145 UPS-1U, as shown in Figure 325 on page 333.

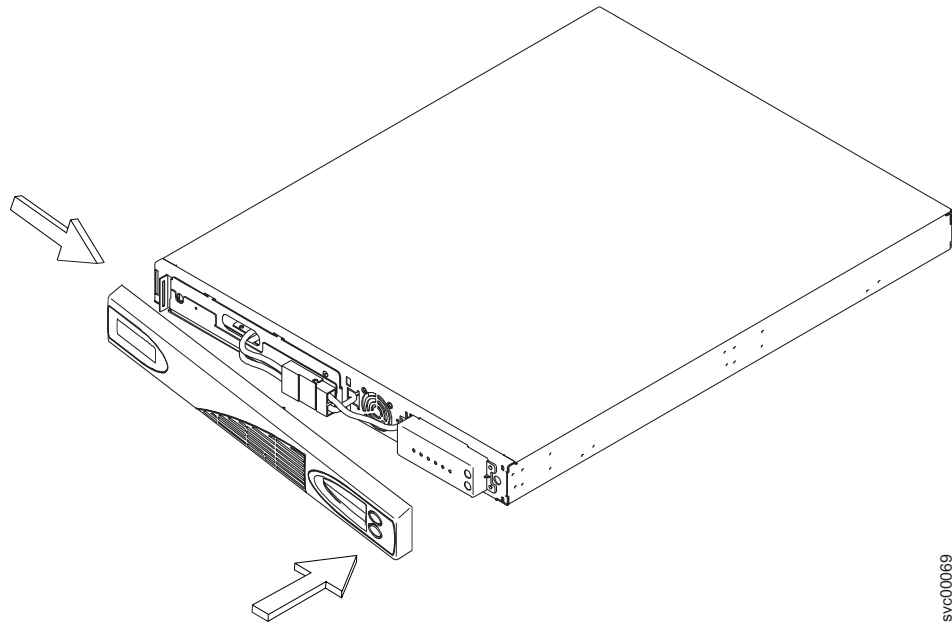

svc00069

Figure 325. Replacing the 2145 UPS-1U front panel

5. Ensure that the 2145 UPS-1U is turned on. Press and hold the 2145 UPS-1U test button for three seconds to start the self-test. If any of the Alarm, Battery, or Overload indicators are on or the buzzer is sounding, go to MAP 5150 in the *IBM System Storage SAN Volume Controller Troubleshooting Guide* to resolve the problem.

Note: Ignore all error indicators until the self-test has been run.

6. Turn on the SAN Volume Controller.

Note: If the new battery does not have enough charge to support the actions that are required during a power failure, the SAN Volume Controller node pauses with Charging displayed on its front panel until a sufficient charge is available. If there is a sufficient charge to support the actions that are required during a single power failure but not sufficient charge to support two power failures, the node starts and joins the cluster but displays Recovering on its front panel.

Appendix. Accessibility

Accessibility features help a user who has a physical disability, such as restricted mobility or limited vision, to use software products successfully.

Features

These are the major accessibility features in the SAN Volume Controller Console:

- You can use screen-reader software and a digital speech synthesizer to hear what is displayed on the screen. The following screen reader has been tested: Window-Eyes v6.1.
- You can operate all features using the keyboard instead of the mouse.
- When setting or changing an IP address on the SAN Volume Controller front panel, you can disable the fast increase and decrease address scrolling speed function of the up and down buttons to two seconds. This feature is documented in the topic that discusses initiating cluster creation from the front panel, which is located in the IBM System Storage SAN Volume Controller Information Center and the *IBM System Storage SAN Volume Controller Software Installation and Configuration Guide*.

Navigating by keyboard

You can use keys or key combinations to perform operations and initiate many menu actions that can also be done through mouse actions. You can navigate the SAN Volume Controller Console and help system from the keyboard by using the following key combinations:

- To traverse to the next link, button, or topic, press Tab inside a frame (page).
- To expand or collapse a tree node, press → or ←, respectively.
- To move to the next topic node, press V or Tab.
- To move to the previous topic node, press ^ or Shift+Tab.
- To scroll all the way up or down, press Home or End, respectively.
- To go back, press Alt+←.
- To go forward, press Alt+→.
- To go to the next frame, press Ctrl+Tab.
- To move to the previous frame, press Shift+Ctrl+Tab.
- To print the current page or active frame, press Ctrl+P.
- To select, press Enter.

Accessing the publications

You can find the HTML version of the IBM System Storage SAN Volume Controller information at the following Web site:

<http://publib.boulder.ibm.com/infocenter/svcic/v3r1m0/index.jsp>

You can access this information using screen-reader software and a digital speech synthesizer to hear what is displayed on the screen. JAWS version 10 has been tested.

Notices

This information was developed for products and services offered in the U.S.A.

IBM may not offer the products, services, or features discussed in this document in other countries. Consult your local IBM representative for information on the products and services currently available in your area. Any reference to an IBM product, program, or service is not intended to state or imply that only that IBM product, program, or service may be used. Any functionally equivalent product, program, or service that does not infringe any IBM intellectual property right may be used instead. However, it is the user's responsibility to evaluate and verify the operation of any non-IBM product, program, or service.

IBM may have patents or pending patent applications covering subject matter described in this document. The furnishing of this document does not give you any license to these patents. You can send license inquiries, in writing, to:

*IBM Director of Licensing
IBM Corporation
North Castle Drive
Armonk, NY 10504-1785
U.S.A.*

For license inquiries regarding double-byte (DBCS) information, contact the IBM Intellectual Property Department in your country or send inquiries, in writing, to:

*Intellectual Property Licensing
Legal and Intellectual Property Law
IBM Japan, Ltd.
3-2-12, Roppongi, Minato-ku, Tokyo 106-8711 Japan*

The following paragraph does not apply to the United Kingdom or any other country where such provisions are inconsistent with local law:

INTERNATIONAL BUSINESS MACHINES CORPORATION PROVIDES THIS PUBLICATIONS "AS IS" WITHOUT WARRANTY OF ANY KIND, EITHER EXPRESS OR IMPLIED, INCLUDING, BUT NOT LIMITED TO, THE IMPLIED WARRANTIES OF NON-INFRINGEMENT, MERCHANTABILITY OR FITNESS FOR A PARTICULAR PURPOSE. Some states do not allow disclaimer of express or implied warranties in certain transactions, therefore, this statement may not apply to you.

This information could include technical inaccuracies or typographical errors. Changes are periodically made to the information herein; these changes will be incorporated in new editions of the publication. IBM may make improvements and/or changes in the product(s) and/or the program(s) described in this publication at any time without notice.

Any references in this information to non-IBM Web sites are provided for convenience only and do not in any manner serve as an endorsement of those Web sites. The materials at those Web sites are not part of the materials for this IBM product and use of those Web sites is at your own risk.

IBM may use or distribute any of the information you supply in any way it believes appropriate without incurring any obligation to you.

Licensees of this program who wish to have information about it for the purpose of enabling: (i) the exchange of information between independently created programs and other programs (including this one) and (ii) the mutual use of the information which has been exchanged, should contact:

*IBM Corporation
Almaden Research
650 Harry Road
Bldg 80, D3-304, Department 277
San Jose, CA 95120-6099
U.S.A.*

Such information may be available, subject to appropriate terms and conditions, including in some cases, payment of a fee.

The licensed program described in this document and all licensed material available for it are provided by IBM under terms of the IBM Customer Agreement, IBM International Program License Agreement or any equivalent agreement between us.

Any performance data contained herein was determined in a controlled environment. Therefore, the results obtained in other operating environments may vary significantly. Some measurements may have been made on development-level systems and there is no guarantee that these measurements will be the same on generally available systems. Furthermore, some measurement may have been estimated through extrapolation. Actual results may vary. Users of this document should verify the applicable data for their specific environment.

Information concerning non-IBM products was obtained from the suppliers of those products, their published announcements or other publicly available sources. IBM has not tested those products and cannot confirm the accuracy of performance, compatibility or any other claims related to non-IBM products. Questions on the capabilities of non-IBM products may be addressed to the suppliers of those products.

All statements regarding IBM's future direction or intent are subject to change or withdrawal without notice, and represent goals and objectives only.

This information is for planning purposes only. The information herein is subject to change before the products described become available.

This information contains examples of data and reports used in daily business operations. To illustrate them as completely as possible, the examples include the names of individuals, companies, brands, and products. All of these names are fictitious and any similarity to the names and addresses used by an actual business enterprise is entirely coincidental.

COPYRIGHT LICENSE:

This information contains sample application programs in source language, which illustrate programming techniques on various operating platforms. You may copy, modify, and distribute these sample programs in any form without payment to IBM, for the purposes of developing, using, marketing or distributing application programs conforming to the application programming interface for the operating platform for which the sample programs are written. These examples have not been thoroughly tested under all conditions. IBM, therefore, cannot guarantee or imply reliability, serviceability, or function of these programs. The sample programs are provided

"AS IS", without warranty of any kind. IBM shall not be liable for any damages arising out of your use of the sample programs.

If you are viewing this information softcopy, the photographs and color illustrations may not appear.

Trademarks

IBM, the IBM logo, and ibm.com are trademarks or registered trademarks of International Business Machines Corp., registered in many jurisdictions worldwide. Other product and service names might be trademarks of IBM or other companies. A current list of IBM trademarks is available on the Web at Copyright and trademark information at www.ibm.com/legal/copytrade.shtml.

Adobe and the Adobe logo are either registered trademarks or trademarks of Adobe Systems Incorporated in the United States, and/or other countries.

Intel, Intel logo, Intel Xeon, and Pentium are trademarks or registered trademarks of Intel Corporation or its subsidiaries in the United States and other countries.

Java and all Java-based trademarks and logos are trademarks of Sun Microsystems, Inc. in the United States, other countries, or both.

Linux is a registered trademark of Linus Torvalds in the United States, other countries, or both.

Microsoft, Windows, Windows NT, and the Windows logo are trademarks of Microsoft Corporation in the United States, other countries, or both.

UNIX is a registered trademark of The Open Group in the United States and other countries.

Other company, product, or service names may be trademarks or service marks of others.

Electronic emission notices

The following electronic emission statements apply to this product. The statements for other products that are intended for use with this product are included in their accompanying documentation.

Federal Communications Commission (FCC) statement

Ensure that you are familiar with the Federal Communications Commission (FCC) statement.

This equipment has been tested and found to comply with the limits for a Class A digital device, pursuant to Part 15 of the FCC Rules. These limits are designed to provide reasonable protection against harmful interference when the equipment is operated in a commercial environment. This equipment generates, uses, and can radiate radio frequency energy and, if not installed and used in accordance with the instruction manual, might cause interference to radio communications. Operation of this equipment in a residential area is likely to cause harmful interference, in which case the user will be required to correct the interference at his own expense.

Properly shielded and grounded cables and connectors must be used in order to meet FCC emission limits. Neither the provider nor the manufacturer is responsible for any radio or television interference caused by using other than recommended cables and connectors or by unauthorized changes or modifications to this equipment. Unauthorized changes or modifications could void the user's authority to operate the equipment.

This device complies with Part 15 of FCC Rules. Operation is subject to the following two conditions: (1) this device might not cause harmful interference, and (2) this device must accept any interference received, including interference that might cause undesired operation.

Industry Canada compliance statement

This Class A digital apparatus complies with IECS-003.

Avis de conformité à la réglementation d'Industrie Canada

Cet appareil numérique de la classe A est conforme à la norme NMB-003 du Canada.

New Zealand compliance statement

Ensure that you are familiar with the New Zealand compliance statement.

This is a Class A product. In a domestic environment this product might cause radio interference, in which event the user might be required to take adequate measures.

European Union EMC Directive conformance statement

Ensure that you are familiar with the European Union (EU) statement.

This product is in conformity with the protection requirements of EU council directive 2004/108/EC on the approximation of the laws of the Member States relating to electromagnetic compatibility. IBM cannot accept responsibility for any failure to satisfy the protection requirements resulting from a nonrecommended modification of the product, including the fitting of non-IBM option cards.

This product has been tested and found to comply with the limits for Class A Information Technology Equipment according to European Standard EN 55022. The limits for Class A equipment were derived for commercial and industrial environments to provide reasonable protection against interference with licensed communication equipment.

Attention: This is a Class A product. In a domestic environment this product may cause radio interference in which case the user may be required to take adequate measures.

Ensure that you use properly shielded and grounded cables and connectors in order to reduce interference to radio and TV communications and to other electrical or electronic equipment. Such cables and connectors are available from IBM authorized dealers. IBM cannot accept responsibility for any interference caused by using other than recommended cables and connectors.

European community contact:

IBM Technical Regulations
Pascalstr. 100, Stuttgart, Germany 70569

Telephone: 0049 (0)711 785 1176
Fax: 0049 (0)711 785 1283
E-mail: tjahn@de.ibm.com

Germany compliance statement

Deutschsprachiger EU Hinweis:

Hinweis für Geräte der Klasse A EU-Richtlinie zur Elektromagnetischen Verträglichkeit

Dieses Produkt entspricht den Schutzanforderungen der EU-Richtlinie 2004/108/EG zur Angleichung der Rechtsvorschriften über die elektromagnetische Verträglichkeit in den EU-Mitgliedsstaaten und hält die Grenzwerte der EN 55022 Klasse A ein.

Um dieses sicherzustellen, sind die Geräte wie in den Handbüchern beschrieben zu installieren und zu betreiben. Des Weiteren dürfen auch nur von der IBM empfohlene Kabel angeschlossen werden. IBM übernimmt keine Verantwortung für die Einhaltung der Schutzanforderungen, wenn das Produkt ohne Zustimmung der IBM verändert bzw. wenn Erweiterungskomponenten von Fremdherstellern ohne Empfehlung der IBM gesteckt/eingebaut werden.

EN 55022 Klasse A Geräte müssen mit folgendem Warnhinweis versehen werden: "Warnung: Dieses ist eine Einrichtung der Klasse A. Diese Einrichtung kann im Wohnbereich Funk-Störungen verursachen; in diesem Fall kann vom Betreiber verlangt werden, angemessene Maßnahmen zu ergreifen und dafür aufzukommen."

Deutschland: Einhaltung des Gesetzes über die elektromagnetische Verträglichkeit von Geräten

Dieses Produkt entspricht dem "Gesetz über die elektromagnetische Verträglichkeit von Geräten (EMVG)". Dies ist die Umsetzung der EU-Richtlinie 2004/108/EG in der Bundesrepublik Deutschland.

Zulassungsbescheinigung laut dem Deutschen Gesetz über die elektromagnetische Verträglichkeit von Geräten (EMVG) (bzw. der EMC EG Richtlinie 2004/108/EG) für Geräte der Klasse A

Dieses Gerät ist berechtigt, in Übereinstimmung mit dem Deutschen EMVG das EG-Konformitätszeichen - CE - zu führen.

Verantwortlich für die Konformitätserklärung des EMVG ist die IBM Deutschland GmbH, 70548 Stuttgart.

Generelle Informationen:

Das Gerät erfüllt die Schutzanforderungen nach EN 55024 und EN 55022 Klasse A.

Japanese Voluntary Control Council for Interference (VCCI) statement

この装置は、情報処理装置等電波障害自主規制協議会（VCCI）の基準に基づくクラスA情報技術装置です。この装置を家庭環境で使用すると電波妨害を引き起こすことがあります。この場合には使用者が適切な対策を講ずるよう要求されることがあります。

vcci

People's Republic of China Class A Electronic Emission Statement

中华人民共和国“A类”警告声明

声明

此为A级产品，在生活环境中，该产品可能会造成无线电干扰。在这种情况下，可能需要用户对其干扰采取切实可行的措施。

International Electrotechnical Commission (IEC) statement

This product has been designed and built to comply with (IEC) Standard 950.

United Kingdom telecommunications requirements

This apparatus is manufactured to the International Safety Standard EN60950 and as such is approved in the U.K. under approval number NS/G/1234/J/100003 for indirect connection to public telecommunications systems in the United Kingdom.

Korean Class A Electronic Emission Statement

이 기기는 업무용으로 전자파 적합등록을 받은 기기 이오니, 판매자 또는 사용자는 이점을 주의하시기 바라며, 만약 잘못 구입하셨을 때에는 구입한 곳에서 비업무용으로 교환하시기 바랍니다.

Taiwan Class A compliance statement

警告使用者:

這是甲類的資訊產品，在居住的環境中使用時，可能會造成射頻干擾，在這種情況下，使用者會被要求採取某些適當的對策。

European Contact Information

This topic contains the product service contact information for Europe.

European Community contact:
IBM Technical Regulations
Pascalstr. 100, Stuttgart, Germany 70569
Tele: 0049 (0)711 785 1176
Fax: 0049 (0)711 785 1283
e-mail: <mailto:tjahn@de.ibm.com>

Taiwan Contact Information

This topic contains the product service contact information for Taiwan.

IBM Taiwan Product Service Contact Information:
IBM Taiwan Corporation
3F, No 7, Song Ren Rd., Taipei Taiwan
Tel: 0800-016-888

台灣IBM 產品服務聯絡方式：
台灣國際商業機器股份有限公司
台北市松仁路7號3樓
電話：0800-016-888

f2c00790

Index

Numerics

- 2145 UPS
 - emergency power-off shutdown xxiv
 - shutdown, emergency power-off xxiv
- 2145 UPS-1U
 - assembly 18
 - battery
 - removing 329
 - replacing 331
 - bracket, retention 314
 - power cables 20
 - removing 315
 - removing power cable 327
 - replacing 319
 - support rails 324, 325
- 2145-8A4 node
 - FRUs 6
- 2145-8F2 node
 - FRUs 15
- 2145-8F4 node
 - FRUs 13
- 2145-8G4 node
 - FRUs 9
- 2145-CF8 node
 - FRUs 1

A

- accessibility
 - keyboard 335
 - repeat rate of up and down buttons 335
 - shortcut keys 335
- adapter assembly
 - removing 189
 - replacing 197
- arm
 - cable-management
 - SAN Volume Controller 2145-CF8 25, 30

B

- bracket
 - 2145 UPS-1U
 - removing 314
 - replacing 314
 - cable retention
 - SAN Volume Controller 2145-8A4 36
 - SAN Volume Controller 2145-8F4 40
 - SAN Volume Controller 2145-8G4 44

C

- cable retention bracket
 - removing
 - SAN Volume Controller 2145-8A4 36
 - SAN Volume Controller 2145-8F4 40

- cable retention bracket (*continued*)
 - replacing
 - SAN Volume Controller 2145-8G4 44
- cable-management arm
 - removing
 - SAN Volume Controller 2145-CF8 25
 - replacing
 - SAN Volume Controller 2145-CF8 30
- cable-retention bracket
 - removing
 - 2145 UPS-1U 314
 - SAN Volume Controller 2145-8G4 37
 - replacing
 - 2145 UPS-1U 314
 - SAN Volume Controller 2145-8A4 42
 - SAN Volume Controller 2145-8F4 47
- cable-retention brackets
 - removing
 - SAN Volume Controller 2145-CF8 35
 - replacing
 - SAN Volume Controller 2145-CF8 41
- cables
 - 2145 UPS-1U
 - power requirements 20
 - removing from 327
- Canadian electronic emission notice 340
- catalog 1
- caution notices
 - heavy weight 315
- CMOS battery
 - SAN Volume Controller 2145-8A4
 - removing 153
 - replacing 160
 - SAN Volume Controller 2145-8F2
 - removing 156
 - replacing 164
 - SAN Volume Controller 2145-8F4
 - removing 156
 - replacing 164
 - SAN Volume Controller 2145-8G4
 - removing 155
 - replacing 162
 - SAN Volume Controller 2145-CF8
 - removing 151
 - replacing 158
- concurrent maintenance 23
- contact information
 - European 343
 - Taiwan 343

D

- danger notices
 - power control switches 49, 51, 54
- Deutschsprachiger EU Hinweis 341
- disk drives
 - removing 120
 - replacing 110, 120

- disk-controller
 - riser-card assembly
 - removing 212
 - replacing 214
- disk-drive backplane
 - removing 136
 - replacing 143
- disposal
 - product xxv

E

- electronic emission notices
 - Avis de conformité à la réglementation d'Industrie Canada 340
 - Deutschsprachiger EU Hinweis 341
 - European Union (EU) 340
 - Federal Communications Commission (FCC) 339
 - French Canadian 340
 - Germany 341
 - Industry Canada 340
 - International Electrotechnical Commission (IEC) 342
 - Japanese Voluntary Control Council for Interference (VCCI) 341
 - Korean 342
 - New Zealand 340
 - People's Republic of China 342
 - Taiwan 342
 - United Kingdom 342
- EMC statement, People's Republic of China 342
- emergency power-off (EPO) event xxiv
- environmental notices xvii, xxiv
- EPO (emergency power-off) event xxiv
- European contact information 343
- European Union (EU), EMC Directive conformance statement 340
- external device safety check xxi

F

- fans
 - removing 245
 - replacing 251
- FCC (Federal Communications Commission) electronic emission notice 339
- Federal Communications Commission (FCC) electronic emission notice 339
- fibre-channel
 - adapter assemblies
 - removing 189
 - replacing 197
 - SFP connector 188
- field replaceable units
 - SAN Volume Controller 2145-8F2 15
 - SAN Volume Controller 2145-8F4 13
- field-replaceable units
 - part numbers 1, 6, 9
 - SAN Volume Controller 2145-8A4 6
 - SAN Volume Controller 2145-8G4 9
 - SAN Volume Controller 2145-CF8 1

- frame assembly
 - removing 185
 - replacing 185
- French Canadian electronic emission notice 340

G

- Germany electronic emission compliance statement 341

H

- hazards xix, xxiii
- hot-swap drive
 - SAS IDs 124

I

- IDs for SAS hot-swap drives 124
- IEC (International Electrotechnical Commission) electronic emission notice 342
- information
 - center xxvii
- inspections, safety
 - external device check xxi
 - internal device check xxi
 - SAN Volume Controller xix
 - uninterruptible power supply xxiii
- installing
 - SAN Volume Controller 2145-8A4
 - support rails 72
 - SAN Volume Controller 2145-8F2
 - support rails 78
 - SAN Volume Controller 2145-8F4
 - support rails 78
 - SAN Volume Controller 2145-8G4
 - support rails 75
 - SAN Volume Controller 2145-CF8
 - support rails 70
 - support rails
 - 2145 UPS-1U 325
 - SAN Volume Controller 70
 - SAN Volume Controller 2145-8A4 72
 - SAN Volume Controller 2145-8F2 78
 - SAN Volume Controller 2145-8F4 78
 - SAN Volume Controller 2145-8G4 75
 - SAN Volume Controller 2145-CF8 70
 - the heat sink 270
- internal device safety check xxi
- International Electrotechnical Commission (IEC) electronic emission notice 342

J

- Japanese electronic emission notice 341

K

- keyboard 335
- Korean electronic emission statement 342

L

legal notices 337

M

memory modules

removing 112

replacing 116

microprocessor

removing 259, 262, 263

replacing 266

N

New Zealand electronic emission statement 340

non-IBM Alteration form xxi

O

operator-information panel cable

removing 238, 239

replacing 241, 242, 243

SAN Volume Controller 2145-8A4

removing 239

replacing 243

SAN Volume Controller 2145-CF8

removing 238

replacing 242

P

part numbers

FRUs 1

redundant ac-power switch 18

SAN Volume Controller 2145-8A4 6

SAN Volume Controller 2145-8G4 9

SAN Volume Controller 2145-CF8 1

parts

catalog 1

listing 1

removing

overview 23

preparing 24

replacing

overview 23

preparing 24

parts listing 3

PCI express riser card assembly

removing 219

replacing 220

SAN Volume Controller 2145-8A4

removing 220

replacing 220

SAN Volume Controller 2145-8G4

removing 220

replacing 220

PDU (power distribution unit) 20

People's Republic of China, electronic emission statement 342

power

cables

2145 UPS-1U 20

country or region 20

distribution unit (PDU) 20

emergency power-off event xxiv
off

SAN Volume Controller 48

on with the node cover off 24

supply

removing 165

replacing 172

power backplane

SAN Volume Controller 2145-8G4

replacing 183

R

redundant ac-power switch

assembly 18

part numbers 18

power cables 20

related information xxvii

removing 188

2145 UPS-1U 315

2145 UPS-1U battery 329

2145 UPS-1U retention bracket 314

2145-8F2

power supply 171

2145-8F4

power supply 171

adapter assembly 189

cable-management arm

SAN Volume Controller 2145-CF8 25

cable-retention bracket

2145 UPS-1U 314

SAN Volume Controller 2145-8A4 36

SAN Volume Controller 2145-8F4 40

disk-drive backplane 136

fibre-channel SFP connector 188

memory modules 112

operator-information panel cable 238

parts

overview 23

preparing 24

PCI express riser card assembly 219

power cable

2145 UPS-1U 327

power-cable assembly 110

redundant ac-power switch

microprocessor 311

redundant ac-power switch 311

removing 311

riser-card assembly 212

SAN Volume Controller 2145-4F2

disk drive 120

SAN Volume Controller 2145-8A4

CMOS battery 153

disk drive 118, 124

disk-drive backplane 139

fans 247

removing (*continued*)

SAN Volume Controller 2145-8A4 (*continued*)

- fibre-channel adapter assembly 192
- heat sink 262
- microprocessor 262
- operator-information panel 222
- operator-information panel cable 239
- PCI express riser card assembly 220
- power supply 167
- service controller 98
- support rails 67
- voltage regulator module 262

SAN Volume Controller 2145-8F2

- adapter assembly 195
- CMOS battery 156
- disk drive 119, 125
- fan backplanes 258
- fan holder 258
- frame assembly 185
- heat sink 265
- microprocessor 265
- operator-information panel 228
- power backplane 182
- service controller 100
- voltage regulator module 265, 278

SAN Volume Controller 2145-8F4

- adapter assembly 195
- CMOS battery 156
- disk drive 119, 125
- fan backplanes 258
- fan holder 258
- fans 249
- frame assembly 185
- heat sink 265
- microprocessor 265
- operator-information panel 228
- power backplane 182
- service controller 100
- voltage regulator module 265, 278

SAN Volume Controller 2145-8G4

- CMOS battery 155
- disk drive 118, 124
- disk-drive backplane 141
- fans 248
- fibre-channel adapter assembly 193
- heat sink 263
- microprocessor 263
- operator-information panel 223
- PCI express riser card assembly 220
- power backplane 181
- power supply 170
- service controller 98
- voltage regulator module 263

SAN Volume Controller 2145-CF8

- boot drive 122
- CMOS battery 151
- disk drive 122
- disk-controller and USB riser-card assembly 212
- disk-drive backplane 136
- fans 245
- fibre-channel adapter assembly 190

removing (*continued*)

SAN Volume Controller 2145-CF8 (*continued*)

- heat sink 259
- high-speed cable 206
- high-speed SAS adapter assembly 202
- microprocessor 259
- operator-information panel 221
- operator-information panel cable 238
- power supply 166
- service controller 91
- solid-state drive (SSD) 131
- voltage regulator module 259

SAN Volume Controller from a rack 48

service controller

- cable from the SAN Volume Controller 2145-CF8 94
- SAN Volume Controller 2145-8A4 98
- SAN Volume Controller 2145-8F2 100
- SAN Volume Controller 2145-8F4 100
- SAN Volume Controller 2145-8G4 98
- SAN Volume Controller 2145-CF8 91

SFP connector 188

signal cable 110

support rails

- 2145 UPS-1U 324
- SAN Volume Controller 2145-8A4 67
- SAN Volume Controller 2145-8F2 69
- SAN Volume Controller 2145-8F4 69
- SAN Volume Controller 2145-8G4 68
- SAN Volume Controller 2145-CF8 66

system board

- SAN Volume Controller 280
- SAN Volume Controller 2145-8A4 283
- SAN Volume Controller 2145-8G4 289
- SAN Volume Controller 2145-CF8 281

top cover

- SAN Volume Controller 2145-8A4 83
- SAN Volume Controller 2145-8F2 85
- SAN Volume Controller 2145-8F4 85
- SAN Volume Controller 2145-8G4 84
- SAN Volume Controller 2145-CF8 82

replacing

- 2145 UPS-1U battery 331
- 2145 UPS-1U retention bracket 314
- adapter assembly 197
- cable-management arm
 - SAN Volume Controller 2145-CF8 30
- cable-retention bracket
 - SAN Volume Controller 2145-8A4 42
 - SAN Volume Controller 2145-8F4 47
 - SAN Volume Controller 2145-8G4 44
- disk-drive backplane 143
- fibre-channel SFP connector 188
- hard disk drive 110
- memory modules 116
- operator-information panel cable 241
- parts
 - overview 23
 - preparing 24
- PCI express riser card assembly 220

- replacing (*continued*)
 - power supplies
 - 2145 UPS-1U 319
 - redundant ac-power switch
 - microprocessor 312
 - redundant ac-power switch 312
 - replacing 312
 - riser-card assembly 214
 - SAN Volume Controller 2145-4F2
 - disk drive 120
 - SAN Volume Controller 2145-8A4
 - CMOS battery 160
 - disk drive 129
 - disk-drive backplane 147
 - fans 254
 - fibre-channel adapter assembly 199
 - heat sink 271
 - microprocessor 271
 - operator-information panel 232
 - operator-information panel cable 243
 - PCI express riser card assembly 220
 - power supply 175
 - top cover 88
 - voltage regulator module 271
 - SAN Volume Controller 2145-8F2
 - adapter assembly 201
 - CMOS battery 164
 - disk drive 130
 - fan backplanes 258
 - fan holder 258
 - frame assembly 185
 - heat sink 276
 - microprocessor 276
 - operator-information panel 237
 - power backplane 184
 - power supply 179
 - service controller 108
 - voltage regulator module 276
 - SAN Volume Controller 2145-8F4
 - adapter assembly 201
 - CMOS battery 164
 - disk drive 130
 - fan backplanes 258
 - fan holder 258
 - fans 257
 - frame assembly 185
 - heat sink 276
 - microprocessor 276
 - operator-information panel 237
 - power backplane 184
 - power supply 179
 - SAN Volume Controller 2145-8F2 89
 - service controller 108
 - top cover 89
 - voltage regulator module 276
 - SAN Volume Controller 2145-8G4
 - CMOS battery 162
 - disk drive 129
 - disk-drive backplane 149
 - fans 256
 - fibre-channel adapter assembly 200

- replacing (*continued*)
 - SAN Volume Controller 2145-8G4 (*continued*)
 - heat sink 274
 - microprocessor 274
 - operator-information panel 233
 - PCI express riser card assembly 220
 - power backplane 183
 - power supply 178
 - top cover 88
 - voltage regulator module 274
 - SAN Volume Controller 2145-CF8
 - CMOS battery 158
 - disk drive 127
 - disk-controller and USB riser-card assembly 215
 - disk-drive backplane 143
 - fans 251
 - fibre-channel adapter assembly 198
 - heat sink 267
 - high speed SAS adapter 204
 - high-speed cable 209
 - microprocessor 267
 - operator-information panel 230
 - operator-information panel cable 242
 - power supply 173
 - solid-state drive (SSD) 134
 - top cover 87
 - voltage regulator module 267
 - SAN Volume Controller in the rack 59
 - service controller 102, 108, 110
 - cable from the SAN Volume Controller 2145-CF8 94
 - SFP connector 188
 - system board
 - SAN Volume Controller 296
 - SAN Volume Controller 2145-8A4 299
 - SAN Volume Controller 2145-8G4 302
 - SAN Volume Controller 2145-CF8 296
 - top cover
 - SAN Volume Controller 2145-8A4 88
 - SAN Volume Controller 2145-8F2 89
 - SAN Volume Controller 2145-8F4 89
 - SAN Volume Controller 2145-8G4 88
 - SAN Volume Controller 2145-CF8 87
 - requirements
 - power cables 20
 - redundant ac-power switch 20
 - uninterruptible power supply xxiii
 - riser-card assembly
 - removing 212
 - replacing 214

S

- safety notices xvii
- SAN Volume Controller
 - checking grounding xxi
 - removing from a rack 48
 - replacing in the rack 59
 - support rails
 - installing 70
 - removing 66

SAN Volume Controller *(continued)*

system board

removing 280

replacing 296

turning off 48

SAN Volume Controller 2145-4F2

emergency power-off shutdown xxiv

shutdown, emergency power-off xxiv

SAN Volume Controller 2145-8A4

adapter assembly

removing 192

replacing 199

assembly 6

cable retention bracket 36

CMOS battery

removing 153

replacing 160

disk-drive backplane

removing 139

replacing 147

fans

removing 247

replacing 254

operator-information panel

removing 222

replacing 232

power supply

removing 167

replacing 175

replacing in the rack 63

service controller 105

removing 98

support rails 67, 72

system board

removing 283

replacing 299

SAN Volume Controller 2145-8F2

adapter assembly

removing 195

replacing 201

assembly 15

CMOS battery

removing 156

replacing 164

fans

removing 249

replacing 257

operator-information panel

removing 228

replacing 237

replacing in the rack 65

support rails 78

removing 69

SAN Volume Controller 2145-8F4

adapter assembly

removing 195

replacing 201

assembly 13

cable retention bracket 40

CMOS battery

removing 156

SAN Volume Controller 2145-8F4 *(continued)*

CMOS battery *(continued)*

replacing 164

operator-information panel

removing 228

replacing 237

replacing in the rack 65

support rails 78

removing 69

SAN Volume Controller 2145-8G4

adapter assembly

removing 193

replacing 200

assembly 9

cable retention bracket 44

CMOS battery

removing 155

replacing 162

disk-drive backplane

removing 141

replacing 149

fans

removing 248

replacing 256

operator-information panel

removing 223

replacing 233

power supply

removing 170

replacing 178

replacing in the rack 64

service controller 106

removing 98

support rails 75

removing 68

system board

removing 289

replacing 302

SAN Volume Controller 2145-CF8

adapter assembly

removing 190

replacing 198

assembly 1

cable-management arm 25, 30

CMOS battery

removing 151

replacing 158

disk drive

replacing 127

disk-controller and USB riser-card assembly

removing 212

replacing 215

disk-drive backplane

removing 136

replacing 143

fans

removing 245

replacing 251

high-speed cable

removing 206

replacing 209

- SAN Volume Controller 2145-CF8 *(continued)*
 - high-speed SAS adapter
 - replacing 204
 - high-speed SAS adapter assembly
 - removing 202
 - operator-information panel
 - removing 221
 - replacing 230
 - power supply
 - removing 166
 - replacing 173
 - replacing in the rack 61
 - service controller 102
 - removing 91
 - solid-state drive (SSD)
 - removing 131
 - replacing 134
 - support rails 70
 - removing 66
 - system board
 - removing 281
 - replacing 296
- SAN Volume Controller library
 - related publications xxvii
- SAS
 - IDs for hot-swap drives 124
- service
 - controller
 - replacing 110
 - replacing from a SAN Volume Controller 2145-CF8 94
- service controller
 - cable
 - removing from a SAN Volume Controller 2145-CF8 94
 - removing
 - SAN Volume Controller 2145-8F2 100
 - SAN Volume Controller 2145-8F4 100
 - removingSAN Volume Controller 2145-8A4 98
 - removingSAN Volume Controller 2145-8G4 98
 - removingSAN Volume Controller 2145-CF8 91
 - replacing
 - SAN Volume Controller 2145-8A4 105
 - SAN Volume Controller 2145-8F2 108
 - SAN Volume Controller 2145-8F4 108
 - SAN Volume Controller 2145-8G4 106
 - SAN Volume Controller 2145-CF8 102
- SFP connector 188
 - replacing 188
- shortcut keys 335
- static-sensitive devices xxiv
- support rails
 - 2145 UPS-1U 325
 - removing 66
 - SAN Volume Controller 2145-8A4 67, 72
 - SAN Volume Controller 2145-8F2 78
 - SAN Volume Controller 2145-8F4 78
 - SAN Volume Controller 2145-8G4 75
 - SAN Volume Controller 2145-CF8 70

- system board
 - removing
 - SAN Volume Controller 280
 - SAN Volume Controller 2145-8A4 283
 - SAN Volume Controller 2145-8G4 289
 - SAN Volume Controller 2145-CF8 281
 - replacing
 - SAN Volume Controller 296
 - SAN Volume Controller 2145-8A4 299
 - SAN Volume Controller 2145-8G4 302
 - SAN Volume Controller 2145-CF8 296

T

- Taiwan
 - contact information 343
 - electronic emission notice 342
- top cover
 - removing
 - SAN Volume Controller 2145-8A4 83
 - SAN Volume Controller 2145-8F2 85
 - SAN Volume Controller 2145-8F4 85
 - SAN Volume Controller 2145-8G4 84
 - SAN Volume Controller 2145-CF8 82
 - replacing
 - SAN Volume Controller 2145-8A4 88
 - SAN Volume Controller 2145-8F2 89
 - SAN Volume Controller 2145-8F4 89
 - SAN Volume Controller 2145-8G4 88
 - SAN Volume Controller 2145-CF8 87
- trademarks 339

U

- uninterruptible power supply
 - 2145 UPS-1U
 - power cables 20
 - checking grounding xxi
 - removing the power 110
 - United Kingdom electronic emission notice 342
- USB
 - riser-card assembly
 - removing 212
 - replacing 214

V

- voltage regulator module
 - removing 278

W

- Web sites xxx
- worldwide node names
 - service controller
 - restoring 102
 - rewriting 102

Readers' Comments — We'd Like to Hear from You

**IBM System Storage SAN Volume Controller
Hardware Maintenance Guide
Version 5.1.0**

Publication No. GC27-2226-02

We appreciate your comments about this publication. Please comment on specific errors or omissions, accuracy, organization, subject matter, or completeness of this book. The comments you send should pertain to only the information in this manual or product and the way in which the information is presented.

For technical questions and information about products and prices, please contact your IBM branch office, your IBM business partner, or your authorized remarketer.

When you send comments to IBM, you grant IBM a nonexclusive right to use or distribute your comments in any way it believes appropriate without incurring any obligation to you. IBM or any other organizations will only use the personal information that you supply to contact you about the issues that you state on this form.

Comments:

Thank you for your support.

Send your comments to the address on the reverse side of this form.

If you would like a response from IBM, please fill in the following information:

Name

Address

Company or Organization

Phone No.

E-mail address



Fold and Tape

Please do not staple

Fold and Tape



NO POSTAGE
NECESSARY
IF MAILED IN THE
UNITED STATES

BUSINESS REPLY MAIL

FIRST-CLASS MAIL PERMIT NO. 40 ARMONK, NEW YORK

POSTAGE WILL BE PAID BY ADDRESSEE

International Business Machines Corporation
Information Development
Department 61C
9032 South Rita Road
Tucson, Arizona
USA 85775-4401



Fold and Tape

Please do not staple

Fold and Tape



Part Number: 31P1173

Printed in USA

GC27-2226-02



(1P) P/N: 31P1173



Spine information:



IBM System Storage SAN Volume
Controller

SAN Volume Controller Hardware Maintenance Guide Version 5.1.0