

IBM System Storage SAN768B



Installation, Service, and User Guide

Service information: 2499-384

Read Before Using

This product contains software that is licensed under written license agreements. Your use of such software is subject to the license agreements under which they are provided.

IBM System Storage SAN768B



Installation, Service, and User Guide

Service information: 2499-384

Note:

Before using this information and the product it supports, read the information in "Notices" on page 163.

Portions Copyright © 2008-2012 Brocade Communications Systems, Inc. All Rights Reserved.

The following paragraph does not apply to any country (or region) where such provisions are inconsistent with local law.

INTERNATIONAL BUSINESS MACHINES CORPORATION PROVIDES THIS PUBLICATION "AS IS" WITHOUT WARRANTY OF ANY KIND, EITHER EXPRESS OR IMPLIED, INCLUDING, BUT NOT LIMITED TO, THE IMPLIED WARRANTIES OF MERCHANTABILITY OR FITNESS FOR A PARTICULAR PURPOSE. Some states (or regions) do not allow disclaimer of express or implied warranties in certain transactions; therefore, this statement may not apply to you.

© Copyright IBM Corporation 2008, 2012.

US Government Users Restricted Rights – Use, duplication or disclosure restricted by GSA ADP Schedule Contract with IBM Corp.

Read this first

Summary of changes

This is the seventh edition of the *IBM System Storage SAN768B Installation, Service, and User Guide*. The content changes since the last edition of this publication are noted by a vertical line placed in the left margin beside each change. Minor edits are not identified by this mark. A summary of the changes for each edition are listed below.

Seventh edition

The following changes were made in this edition:

- Addition of FIPS tamper-proof seals—Feature code 7230
- Information regarding availability of a model conversion to 2499-816 through an MES procedure
- Updated instructions on ordering the lift tool load plate (now included with the lift tool)

Sixth edition

The following changes were made in this edition:

- Addition of an 16-port encryption blade (FS8-18)—Feature code 7895
- Updated Fabric Operating System (FOS) supported version
- Updated safety notices section
- Updated IBM support information and access to firmware and release notes to include the IBM Support Portal

Fifth edition

The following changes were made in this edition:

- Addition of a Fibre Channel 8 Gbps 64-port blade (FC8-64)—Feature code 3864
- New mini-SFP (mSFP) transceivers associated with the FC8-64 blade
- Introduction of 8 Gbps FICON® Accelerator
- Addition of the Server Application Optimization (SAO) optional feature
- A change to the Fabric Operating System (FOS) version required for the FC8-64 blade
- Update of the Notices section

Fourth edition

The following changes were made in the this edition:

- The addition of the CEE 10GbE 24-port blade (FCOE10-24)
- The addition of the 8 Gbps routing blade (FX8-24)
- Inter-chassis linking (ICL), including 3-way ICL connection configurations was added
- An update of how to submit comments on this publication
- Battery removal and disposal instructions were added
- General reorganization of content

Third edition

The following changes were made in the this edition:

- FICON Accelerator functionality was added
- Data Center Fabric Manager was added as an additional management software option
- An additional Web site was added to the environmental notices
- The IBM® trademark information was updated

Second edition

The following changes were made in the second edition:

- The section on power cords was corrected.
- The rack installation instructions were modified to reflect a new rack installation kit.
- The Integrated Routing feature was added.
- Minor changes were made to the environmental, safety, and other notices.
- Minor changes to Fabric OS publication titles.

Getting help

For the latest version of your product documentation, visit the web at www.ibm.com/shop/publications/order. Search by form number or title.

IBM Redbooks® often provide in depth information about product best practices, configurations, and more technical information. For redbooks associated with this product, enter search terms on the following Web site: www.redbooks.ibm.com/.

For more information about IBM SAN products, see the following Web site: www.ibm.com/servers/storage/san/

For support information for this and other IBM products, see the IBM Support Portal, www.ibm.com/supportportal. Search for the product Machine type or product name.

For Fabric OS Release Notes and access to Fabric OS firmware downloads, go to the IBM Support Portal, www.ibm.com/supportportal. Search for the product Machine type or product name, and then follow links for **Downloads**. More detailed instructions are available through the **Accessing firmware updates and OS documentation updates** link on the product documentation CD that is shipped with this product.

You can also contact IBM within the United States at 1-800-IBMSERV (1-800-426-7378). For support outside the United States, you can find the service number at: www.ibm.com/planetwide/.

Visit www.ibm.com/contact for the contact information for your country or region.

For detailed information about the Fibre Channel standards, see the Fibre Channel Industry Association (FCIA) Web site at: www.fibrechannel.org/

For information about storage industry standards, see the Storage Networking Industry Association (SNIA) Web site at: www.snia.org/

Taiwan Contact Information

IBM Taiwan Product Service Contact Info:
IBM Taiwan Corporation
3F, No 7, Song Ren Rd., Taipei Taiwan
Tel: 0800-016-888

台灣IBM 產品服務聯絡方式：
台灣國際商業機器股份有限公司
台北市松仁路7號3樓
電話：0800-016-888

12c00790

How to send your comments

Your feedback is important in helping us provide the most accurate and high-quality information. If you have comments or suggestions for improving this document, send us your comments by e-mail to starpubs@us.ibm.com. Be sure to include the following:

- Exact publication title
- Publication form number (for example, GC26-1234-02)
- Page, table, or illustration numbers
- A detailed description of any information that should be changed

Contents

Read this first iii

Summary of changes	iii
Seventh edition	iii
Sixth edition	iii
Fifth edition	iii
Fourth edition	iii
Third edition	iv
Second edition	iv
Getting help	iv
Taiwan Contact Information	v
How to send your comments	v

Figures xi

Tables xiii

Safety and environmental notices . . . xv

Safety notices and labels	xv
Danger notices	xv
Caution notices	xviii
Safety labels	xx
Attention notices	xxi
Rack safety	xxii
Rack installation	xxii
Rack relocation (19" rack)	xxiii
Safety inspections	xxiv
Removing ac power	xxiv
External machine checks	xxiv
Internal machine checks	xxiv
Product recycling and disposal	xxv

About this document xxvii

Who should read this document	xxvii
Product documents	xxvii
Brocade documents	xxvii
IBM and Brocade product matrix	xxviii
Accessibility features for SAN768B	xxviii

Chapter 1. Introduction 1

Overview of the SAN768B	1
Hardware components	2
SAN768B blades	4
High availability	7
Reliability	7
Serviceability	7
Software features	8
Security	8
Network Manageability	9

Chapter 2. Installing and removing a SAN768B 11

Ordering the lift tool	12
World trade locations	12
United States locations	12

Installation guidelines	13
Installing a SAN768B in a cabinet	14
Time required	14
Tools required	15
Parts list	15
Unpacking the SAN768B	16
Attaching the shelf brackets	17
Removing the chassis door and cable management comb	18
Using the lift tool, the 24-inch load plate, and the bridge tool	19
Port numbering	25
Chassis slots	26
Cable organization	27
Removing a SAN768B from the cabinet	28

Chapter 3. Starting and configuring the SAN768B 31

Providing power to the SAN768B	33
Establishing a serial connection and logging on to the SAN768B	33
Logging in to the serial console port	34
Configuring the IP addresses	34
Logging off the serial console port and disconnecting the serial cable	36
Connecting an Ethernet cable and opening a Telnet session	36
Customize a switch name	36
Customizing a chassis name	36
Setting the Domain ID	37
Setting the date and time	37
Setting the date	37
Setting the time zone	38
Synchronizing local time	38
Verifying the PID mode and connecting to the fabric	39
Enabling software licenses	39
Installing transceivers and attaching cables	39
Managing cables	40
Planning for encryption (optional)	41
Configuring for encryption (optional)	42
Summary of procedure	42
Avoid double encryption	43
Verifying correct operation and backing up the configuration	43
Fabric OS firmware updates	44
Downloading and installing firmware	45
Powering off the SAN768B	45

Chapter 4. Monitoring system components 47

Port, application, or encryption blade status	47
Control processor blade (CP8) status	59
Core switch blade (CR8) status	61
Power supply status	63
Blower assembly status	64

WWN bezel and WWN card status	66
---	----

Chapter 5. Removing and installing components 69

Removing and installing the chassis door	69
Time and items required	69
Removing the chassis door	69
Removing and installing a cable management comb	70
Time and items required	70
Removing a cable management comb.	70
Installing a cable management comb	71
Removing and installing port, application, and encryption blades	71
Time and items required	72
Removing a blade	72
Installing a blade	74
Removing and installing blade filler panels.	75
Removing a filler panel	75
Installing a filler panel.	76
Removing and installing a control processor blade (CP8)	76
Time and items required	77
Verifying the necessity of installation	77
Recording critical SAN768B information.	77
Removing a control processor blade (CP8)	78
Installing a control processor blade (CP8)	79
Verifying operation of the new CP blade.	80
Removing and installing a core switch blade (CR8)	82
Time and items required	82
Verifying the necessity of installation	82
Removing a core switch blade (CR8)	82
Installing a core switch blade (CR8)	83
Removing and installing an FR4-18i router blade	84
Time required	84
Items required	84
Removing a router blade	84
Installing a router blade	86
Configuring FCIP and Fibre Channel routing services and enabling the ports.	87
Cabling the FR4-18i router blade	87
Removing and installing a power supply	88
Time and items required	88
Removing a power supply	88
Installing a power supply	89
Removing and installing a blower assembly	90
Time and items required	90
Removing a blower assembly	90
Installing a blower assembly.	91
Removing and installing a WWN bezel and WWN card	91
Time and items required	91
Verifying necessity of installation	92
Removing the WWN bezel and WWN card.	93
Installing the WWN bezel and WWN card	94
Removing and installing transceivers.	95
Time required	95
Items required	95
Removing and replacing an SFP, SFP+, or XFP optical transceiver	95
Removing and replacing an mSFP optical transceiver.	96

Removing and installing inter-chassis link (ICL) cables	97
Time and items required	98
Removing an ICL cable	98
Installing an ICL cable.	99
Removing the batteries	106
Removing and replacing the chassis	108
Verifying necessity of replacement	109
Preparing for a chassis replacement	109
Disconnecting the SAN768B from the network and fabric	112
Removing components from the chassis	113
Removing and replacing the chassis from the cabinet	113
Installing components into the new chassis	114
Downloading the configuration	115
Verifying the correct operation of the system	115
Reconnecting the system to the network and fabric	116
Verifying the correct configuration of the fabric	117
Cable routing tables	118

Chapter 6. Installing new features 121

FC3017 - Installing a 16-Gbps core blade kit (model conversion)	121
FC3816, FC3832, FC3848 - Installing an 8-Gb port blade (16, 32, or 48 ports)	122
Time required	122
Items required	122
Procedures	122
FC3864 - Installing an 8-Gb 64-port port blade	123
Time required	123
Items required	123
Procedures	124
FC3850 - Installing an FR4-18i routing blade	125
Time required	125
Items required	125
Procedures	125
FC3870 - Installing an FC10-6 10 Gb blade.	126
Time required	126
Items required	126
Procedures	127
FC3880 - Installing an FCOE10-24 blade	127
Time required	127
Items required	128
Procedures	128
FC3890 - Installing an FX8-24 extension blade	129
Time required	129
Items required	129
Procedures	129
FC3895 - Installing an FS8-18 encryption blade	130
Time required	131
Items required	131
Procedures	131
Avoid double encryption	132
FC7230 - Installing FIPS security seals	132
FC7870 - Installing an inter-chassis cable kit	132
Time required	132
Items required	132
Procedures	132

Appendix A. Product specifications 135

General specifications 135
System architecture 135
System size and weight 138
Facility requirements 139
Power specifications 139
Environmental requirements 140
Fibre Channel port specifications 140
Data transmission ranges 141
FR4-18i router Fibre channel port specifications . . 141
FR4-18i router GbE port specifications 142
Power cords 142

Appendix B. Application blades . . . 143

FR4-18i blade 143
FS8-18 blade. 143
FX8-24 blade 144
FCOE10-24 blade 145

Appendix C. Diagnostics and troubleshooting 147

Obtaining chassis and component status 147
Interpreting POST and boot results 148
 POST 148
 Boot 149
Diagnostics 149
Troubleshooting 149

Appendix D. Blade port numbering 153

Notices 163

Trademarks 165
Electronic emission notices 166
 Federal Communications Commission (FCC)
 Class A Statement 166
 Industry Canada Class A Emission Compliance
 Statement 166
 Avis de conformité à la réglementation
 d'Industrie Canada 166
 European Union EMC Directive Conformance
 Statement 166
 Germany Electromagnetic Compatibility
 Directive 167
 People's Republic of China Class A Electronic
 Emission Statement 168
 Japan Voluntary Control Council for Interference
 (VCCI) Class A Statement 168
 Japan Electronics and Information Technology
 Industries Association (JEITA) Statement . . . 168
 Korea Communications Commission (KCC)
 Class A Statement 168
 Russia Electromagnetic Interference (EMI) Class
 A Statement 169
 Australia and New Zealand Class A Statement 169
 Taiwan Class A Electronic Emission Statement 169

Index 171

Figures

1. Port side of the SAN768B (sample configuration)	3	32. Filler panel removal and installation	76
2. Blower (non-port) side of the SAN768B (sample configuration)	4	33. Removing the control processor (CP8) blade	79
3. Parts in the 14U rack mount kit	16	34. Removing the core switch blade.	83
4. Left and right shelf brackets installed on the cabinet rails	17	35. FR4-18i router blade and components.	85
5. Installing clip or retainer nuts on the vertical cabinet rails	18	36. Power supply locations	88
6. Chassis door removal	19	37. Removing and installing a power supply	89
7. Chassis installation from rear (exhaust aisle side) of the cabinet	20	38. Removal and replacement of the blower assembly	91
8. Locking the shelf into position	22	39. WWN bezel and card removal and installation	94
9. Attaching the port side of the chassis to the cabinet rails	23	40. Optical transceiver (SFP, SFP+, and XFP) extraction tool.	95
10. Aligning the chassis door with the ball studs on the chassis	24	41. Replacing an optical transceiver.	96
11. Details of the chassis and door, showing the ball studs on the chassis and the mounting hardware on the door	25	42. Optical mSFP transceiver	97
12. Cable design for the mSFP patch cables for the FC8-64 high density port blade	27	43. ICL cable	98
13. Flow of basic configuration tasks	32	44. ICL cable connections between two SAN768B chassis	100
14. Encryption configuration	43	45. ICL cable connections between two SAN768B chassis	101
15. FC8-16 port blade	48	46. ICL cable connections between two SAN768B chassis	102
16. FC8-32 port blade	49	47. ICL cable connections between two SAN768B chassis	103
17. FC8-48 port blade	50	48. 3-way ICL cable connections between a SAN384B and two SAN768B chassis.. . . .	104
18. FC8-64 port blade	51	49. 3-way ICL cable connections between a SAN768B and two SAN384B chassis.. . . .	105
19. FC10-6 port blade	52	50. 3-way ICL cable connections between three SAN768B chassis	106
20. FR4-18i routing blade	53	51. Battery locations on the CP8 blade	107
21. FS8-18 encryption blade	54	52. Encryption blade battery location	108
22. FX8-24 extension blade.	55	53. FC8-16 port blade	154
23. FCOE10-24 blade.	56	54. FC8-32 port blade	155
24. Control processor blade (CP8) components	60	55. FC8-48 port blade	156
25. Core switch blade (CR8) LEDs	62	56. FC8-64 port blade	157
26. Power supply LEDs.	64	57. FC10-6 port blade, ports 0-5 (bottom to top)	158
27. Blower assembly LEDs.	65	58. FR4-18i routing blade	159
28. LEDs on the WWN card and bezel.	67	59. FS8-18 encryption blade	160
29. Chassis door	70	60. FX8-24 extension blade	161
30. Cable management comb	71	61. FCOE10-24 blade	162
31. Port, application, and encryption blade removal and installation (FC8-48 port blade shown as example)	74		

Tables

1. Brocade and IBM product and model number matrix	xxviii	15. ICL connector port LEDs	98
2. Blades available for the SAN768B	4	16. Critical information checklist example	110
3. Security features	8	17. Sample cable routing table for SAN768B	118
4. Items supplied with the 14U rack mount kit	15	18. Cable routing table for SAN768B (64 ports shown).	119
5. Port blades available on the SAN768B.	25	19. General specifications.	135
6. Port, application, and encryption blade LED descriptions	57	20. System architecture	135
7. CP8 blade LED descriptions	60	21. System sizes and weights	138
8. CR blade LED descriptions	62	22. System FRU weights	138
9. Power supply LED descriptions.	64	23. Power specifications	139
10. Blower assembly LED descriptions.	65	24. Environmental requirements	140
11. Messages that may indicate WWN card failure	66	25. Supported optics, speeds, cables, and distances	141
12. WWN bezel LED descriptions	67	26. Environmental status and maintenance commands	148
13. Commands identifying the WWN card status	92	27. Troubleshooting.	149
14. WWN card related system log messages	92		

Safety and environmental notices

This section contains information about:

- “Safety notices and labels”
- “Rack safety” on page xxii
- “Safety inspections” on page xxiv
- “Product recycling and disposal” on page xxv

Safety notices and labels

When using this product, observe the danger, caution, and attention notices contained in this guide. The notices are accompanied by symbols that represent the severity of the safety condition. The danger and caution notices are listed in numerical order based on their IDs, which are displayed in parentheses, for example (D004), at the end of each notice. Use this ID to locate the translation of these danger and caution notices in the *IBM System Storage SAN b-type Safety Notices* publication, which is shipped with this product.

The following notices and statements are used in IBM documents. They are listed below in order of increasing severity of potential hazards. Follow the links for more detailed descriptions and examples of the danger, caution, and attention notices in the sections that follow.

- **Note:** These notices provide important tips, guidance, or advice.
- **“Attention notices” on page xxi:** These notices indicate potential damage to programs, devices, or data.
- **“Caution notices” on page xviii:** These statements indicate situations that can be potentially hazardous to you.
- **“Danger notices”:** These statements indicate situations that can be potentially lethal or extremely hazardous to you. Safety labels are also attached directly to products to warn of these situations.
- In addition to these notices, “Safety labels” on page xx may be attached to the product to warn of potential hazards.

Danger notices

A danger notice calls attention to a situation that is potentially lethal or extremely hazardous to people. A lightning bolt symbol accompanies a danger notice to represent a dangerous electrical condition. Read and comply with the following danger notices before installing or servicing this device.



DANGER

To prevent a possible shock from touching two surfaces with different protective ground (earth), use one hand, when possible, to connect or disconnect signal cables. (D001)



DANGER

Overloading a branch circuit is potentially a fire hazard and a shock hazard under certain conditions. To avoid these hazards, ensure that your system electrical requirements do not exceed branch circuit protection requirements. Refer to the information that is provided with your device or the power rating label for electrical specifications. (D002)



DANGER

If the receptacle has a metal shell, do not touch the shell until you have completed the voltage and grounding checks. Improper wiring or grounding could place dangerous voltage on the metal shell. If any of the conditions are not as described, STOP. Ensure the improper voltage or impedance conditions are corrected before proceeding. (D003)



DANGER

An electrical outlet that is not correctly wired could place hazardous voltage on metal parts of the system or the devices that attach to the system. It is the responsibility of the customer to ensure that the outlet is correctly wired and grounded to prevent an electrical shock. (D004)

A general electrical danger notice provides instructions on how to avoid shock hazards when servicing equipment. Unless instructed otherwise, follow the procedures in the following danger notice.



DANGER

When working on or around the system, observe the following precautions:

Electrical voltage and current from power, telephone, and communication cables are hazardous. To avoid a shock hazard:

- Connect power to this unit only with the IBM provided power cord. Do not use the IBM provided power cord for any other product.
- Do not open or service any power supply assembly.
- Do not connect or disconnect any cables or perform installation, maintenance, or reconfiguration of this product during an electrical storm.
- The product might be equipped with multiple power cords. To remove all hazardous voltages, disconnect all power cords.
- Connect all power cords to a properly wired and grounded electrical outlet. Ensure that the outlet supplies proper voltage and phase rotation according to the system rating plate.
- Connect any equipment that will be attached to this product to properly wired outlets.
- When possible, use one hand only to connect or disconnect signal cables.
- Never turn on any equipment when there is evidence of fire, water, or structural damage.
- Disconnect the attached power cords, telecommunications systems, networks, and modems before you open the device covers, unless instructed otherwise in the installation and configuration procedures.
- Connect and disconnect cables as described below when installing, moving, or opening covers on this product or attached devices.

To Disconnect:

1. Turn off everything (unless instructed otherwise).
2. Remove the power cords from the outlets.
3. Remove the signal cables from the connectors.
4. Remove all cables from the devices.

To Connect:

1. Turn off everything (unless instructed otherwise).
2. Attach all cables to the devices.
3. Attach the signal cables to the connectors.
4. Attach the power cords to the outlets.
5. Turn on the devices.

(D005)

The weight of the SAN cabinet (2109-C36) with two SAN768Bs is greater than 227 kg (500 lb), and has a fully loaded capacity of 816 kg (1795 lb). Under these conditions, the following statement and notice apply.

Delivery and subsequent transportation of the equipment

The customer should prepare his environment to accept the new product based on the installation planning information provided, with assistance from an IBM Installation Planning Representative (IPR) or IBM authorized service provider. In anticipation of the equipment delivery, the final installation site should be prepared in advance such that professional movers/riggers can transport the equipment to the final installation site within the computer room. If for some reason, this is not possible at the time of delivery, the customer will need to make arrangements to have professional movers/riggers return to finish the transportation at a later date. Only professional movers/riggers should transport the equipment. The IBM authorized service provider will only perform minimal frame repositioning within the computer room, as needed, to perform required service actions. The customer is also responsible for using professional movers/riggers in the case of equipment relocation or disposal.









DANGER

Heavy equipment—personal injury or equipment damage might result if mishandled. (D006)

Caution notices

A caution notice calls attention to a situation that is potentially hazardous to people because of some existing condition. A caution notice can be accompanied by different symbols, as in the examples below:

If the symbol is...	It means....
	A hazardous electrical condition with less severity than electrical danger.
	A generally hazardous condition not represented by other safety symbols.
	A specification of product weight that requires safe lifting practices. The weight range of the product is listed below the graphic, and the wording of the caution varies, depending on the weight of the device.
	A potential hazard of pinching the hand or other body parts between parts.
	A hazardous condition due to moving parts nearby.
	A hazardous condition due to the use of a laser in the product. Laser symbols are always accompanied by the classification of the laser as defined by the U. S. Department of Health and Human Services (for example, Class I, Class II, and so forth).

Read and comply with the following caution notices before installing or servicing this device.



CAUTION:

Energy hazard present. Shorting may result in system outage and possible physical injury. Remove all metallic jewelry before servicing. (C001)



svc00169

CAUTION:

The weight of this part or unit is more than 55 kg (121.2 lb). It takes specially trained persons, a lifting device, or both to safely lift this part or unit. (C011)

>55kg (121.2 lb)



CAUTION:

The system contains circuit cards, assemblies, or both that may contain lead solder. To avoid the release of lead (Pb) into the environment, do not burn. Discard the circuit card as instructed by local regulations. (C014)



CAUTION:

This product is equipped with a 3-wire (two conductors and ground) power cable and plug. Use this power cable with a properly grounded electrical outlet to avoid electrical shock. (C018)



Class I

CAUTION:

This product might contain one or more of the following devices: CD-ROM drive, DVD-ROM drive, DVD-RAM drive, or laser module, which are Class 1 laser products. Note the following information:

- Do not remove the covers. Removing the covers of the laser product could result in exposure to hazardous laser radiation. There are no serviceable parts inside the device.
- Use of the controls or adjustments or performance of procedures other than those specified herein might result in hazardous radiation exposure.

(C026)



CAUTION:

The power-control button on the device does not turn off the electrical current supplied to the device. The device might also have more than one connection to dc power. To remove all electrical current from the device, ensure that all connections to dc power are disconnected at the dc power input terminals. (C031)



CAUTION:

Servicing of this product or unit is to be performed by trained service personnel only. (C032)

CAUTION:

For CA residents only: IBM recommends installing this product in a room size of 62 cubic meters (2190 cubic feet) or larger at 0.4 ACH ventilation rate to reduce the concentrations of any chemicals emitted by the product.

Safety labels

As an added precaution, safety labels are often installed directly on products or product components to warn of potential hazards. These can be either danger or caution notices, depending upon the level of the hazard.

The actual product safety labels may differ from these sample safety labels:



DANGER

Hazardous voltage, current, or energy levels are present inside any component that has this label attached. Do not open any cover or barrier that contains this label. (L001)

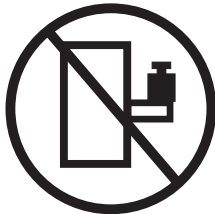

DANGER

Rack-mounted devices are not to be used as a shelf or work space. (L002)

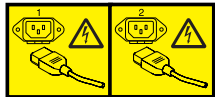

DANGER

Multiple power cords. The product might be equipped with multiple power cords. To remove all hazardous voltages, disconnect all power cords. (L003)



DANGER

Hazardous voltage present. Voltages present constitute a shock hazard, which can cause severe injury or death. (L004)



CAUTION:

Hazardous energy present. Voltages with hazardous energy might cause heating when shorted with metal, which might result in splattered metal, burns, or both. (L005)

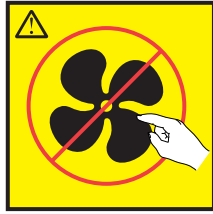

CAUTION:
Hazardous moving parts nearby (L008)



CAUTION:
Pinch hazard. (L012)

SJ000752

Attention notices

An attention notice indicates the possibility of damage to a program, device, or system, or to data. An exclamation point symbol may accompany an attention notice, but is not required. A sample attention notice follows:

Attention: Do not bend a fibre cable to a radius less than 5 cm (2 in.); you can damage the cable. Tie wraps are not recommended for optical cables because they can be easily overtightened, causing damage to the cable.

ESD precautions

Attention: Many of the field replaceable units (FRUs) are sensitive to electrostatic discharge (ESD), and can potentially be damaged by improper handling. Wear a wrist grounding strap connected to chassis ground (if the SAN768B is plugged in) or a bench ground. Store all ESD-sensitive components in antistatic packaging.

Rack safety

Rack installation

DANGER

Observe the following precautions when working on or around your IT rack system:

- Heavy equipment—personal injury or equipment damage might result if mishandled.
- Always lower the leveling pads on the rack cabinet.
- Always install stabilizer brackets on the rack cabinet.
- To avoid hazardous conditions due to uneven mechanical loading, always install the heaviest devices in the bottom of the rack cabinet. Always install servers and optional devices starting from the bottom of the rack cabinet.
- Rack-mounted devices are not to be used as shelves or work spaces. Do not place objects on top of rack-mounted devices.



- Each rack cabinet might have more than one power cord. Be sure to disconnect all power cords in the rack cabinet when directed to disconnect power during servicing.
- Connect all devices installed in a rack cabinet to power devices installed in the same rack cabinet. Do not plug a power cord from a device installed in one rack cabinet into a power device installed in a different rack cabinet.
- An electrical outlet that is not correctly wired could place hazardous voltage on the metal parts of the system or the devices that attach to the system. It is the responsibility of the customer to ensure that the outlet is correctly wired and grounded to prevent an electrical shock.

(R001 part 1 of 2)

CAUTION:

- Do not install a unit in a rack where the internal rack ambient temperatures will exceed the manufacturer's recommended ambient temperature for all your rack-mounted devices.
- Do not install a unit in a rack where the air flow is compromised. Ensure that air flow is not blocked or reduced on any side, front, or back of a unit used for air flow through the unit.
- Consideration should be given to the connection of the equipment to the supply circuit so that overloading of the circuits does not compromise the supply wiring or overcurrent protection. To provide the correct power connection to a rack, refer to the rating labels located on the equipment in the rack to determine the total power requirement of the supply circuit.
- *(For sliding drawers)* Do not pull out or install any drawer or feature if the rack stabilizer brackets are not attached to the rack. Do not pull out more than one drawer at a time. The rack might become unstable if you pull out more than one drawer at a time.
- *(For fixed drawers)* This drawer is a fixed drawer and must not be moved for servicing unless specified by the manufacturer. Attempting to move the drawer partially or completely out of the rack might cause the rack to become unstable or cause the drawer to fall out of the rack.

(R001 part 2 of 2)

Rack relocation (19" rack)

CAUTION:

Removing components from the upper positions in the rack cabinet improves rack stability during relocation. Follow these general guidelines whenever you relocate a populated rack cabinet within a room or building:

- Reduce the weight of the rack cabinet by removing equipment starting at the top of the rack cabinet. When possible, restore the rack cabinet to the configuration of the rack cabinet as you received it. If this configuration is not known, you must do the following:
 - Remove all devices in the 32U position and above.
 - Ensure that the heaviest devices are installed in the bottom of the rack cabinet.
 - Ensure that there are no empty U-levels between devices installed in the rack cabinet below the 32U level.
 - If the rack cabinet you are relocating is part of a suite of rack cabinets, detach the rack cabinet from the suite.
 - Inspect the route that you plan to take when moving the rack to eliminate potential hazards.
 - Verify that the route that you choose can support the weight of the loaded rack cabinet. Refer to the documentation that came with your rack cabinet for the weight of a loaded rack cabinet.
 - Verify that all door openings are at least 760 x 2030 mm (30 x 80 in.).
 - Ensure that all devices, shelves, drawers, doors, and cables are secure.
 - Ensure that the four leveling pads are raised to their highest position.
 - Ensure that there is no stabilizer bracket installed on the rack cabinet during movement.
 - Do not use a ramp inclined at more than 10 degrees.
 - Once the rack cabinet is in the new location, do the following:
 - Lower the four leveling pads.
 - Install stabilizer brackets on the rack cabinet.
 - If you removed any devices from the rack cabinet, repopulate the rack cabinet from the lowest position to the highest position.
 - If a long distance relocation is required, restore the rack cabinet to the configuration of the rack cabinet as you received it. Pack the rack cabinet in the original packaging material, or equivalent. Also, lower the leveling pads to raise the casters off of the pallet and bolt the rack cabinet to the pallet.

(R002)

Safety inspections

Perform the following safety checks to identify unsafe conditions. Be cautious of potential safety hazards that are not covered in the safety checks. If unsafe conditions are present, determine how serious the hazards are and whether you should continue before you correct the problem.

Removing ac power

Perform the following steps to remove the alternating current (ac) power:

1. Perform a controlled system shutdown.
2. Set the power switch on the product to the off position.
3. Disconnect the power cables from the power source.

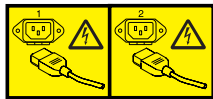

DANGER

Multiple power cords. (L003)

External machine checks

Perform the following external machine checks:

1. Verify that all external covers are present and are not damaged.
2. Ensure that all latches and hinges are in correct operating condition.
3. Check the power cable for damage.
4. Check the external signal cable for damage.
5. Check the cover for sharp edges, damage, or alterations that expose the internal parts of the device.
6. Check that any unused serial ports are covered for dust and ESD protection. The cover should be kept on the serial port whenever it is not being used.
7. Correct any problems that you find.

Internal machine checks

Perform the following internal machine checks:

1. Check for any non-IBM changes that might have been made to the machine. If any are present, obtain the "Non-IBM Alteration Attachment Survey" form, number R009, from the IBM branch office. Complete the form and return it to the branch office.
2. Check the condition of the inside of the machine for:
 - Metal or other contaminants
 - Indications of water or other fluid
 - Fire
 - Smoke damage
3. Check for any obvious mechanical problems, such as loose components.
4. Check any exposed cables and connectors for wear, cracks, or pinching.

Product recycling and disposal

Refer to the *IBM Systems Environmental Notices and User Guide (Z125-5823)* on the product documentation CD for translated environmental statements and information regarding product recycling and disposal. This document may be provided either in printed version or on the product documentation CD. See "Removing the batteries" on page 106 for battery removal instructions, if needed to meet environmental regulations.

About this document

This document describes how to install and service the IBM System Storage[®] SAN768B fabric backbone. Throughout this document, the product is referred to as the *SAN768B*. This document includes information specific to the SAN768B running Fabric OS version 6.4.1. and later. For information about a Fabric OS version other than 6.4.1, refer to the documentation specific to your Fabric OS version.

The sections that follow provide information about:

- “Who should read this document”
- “Product documents”
- “Brocade documents”

Who should read this document

This document is intended for trained service representatives who are responsible for installing and servicing the SAN768B, and for network administrators responsible for maintaining and using the SAN768B.

Product documents

The following documents contain information related to this product. The documentation may be printed material, on the documentation CD that is shipped with the product, or available on the web through the IBM Support Portal or IBM Publications Center.

- *IBM System Storage SAN768B Installation, Service, and User Guide*, GA32-0574 (this document, which is also available in accessible HTML format on the documentation CD).
- *IBM System Storage SAN b-type Safety Notices*
- *IBM Systems Environmental Notices and User Guide*, Z125-5823
- IBM Warranty
- *Implementing an IBM/Brocade SAN with 8 Gbps Directors and Switches*, (an IBM Redbook), SG24-6116
- *IBM System Storage FIPS 140-2 Security Seal Application Procedures* (GA32-2220-00), available online only for this optional feature.

Brocade documents

IBM switches use software licensed from Brocade Communications Systems, Inc. You can find information related to the software that supports the SAN768B in the following documents on the CD-ROM supplied with this product:

Brocade Fabric OS

- *Fabric OS Administrator's Guide*
- *Fabric OS Command Reference Manual*
- *Fabric OS MIB Reference*
- *Fabric OS Message Reference*
- *Fabric OS Troubleshooting and Diagnostics Guide*

- *Fabric OS FCIP Administrator's Guide*
- *FICON Administrator's Guide*
- *Fabric OS Encryption Administrator's Guide Supporting Tivoli Key Lifecycle Manager (TKLM) Environments*

Brocade Fabric OS optional features

- *Fabric Watch Administrator's Guide*
- *Web Tools Administrator's Guide*

Brocade HBA publication

- *Brocade Adapters Administrator's Guide*

IBM and Brocade product matrix

When you use any of the Brocade documents, such as Fabric Operating System (FOS) publications, you will notice that the model numbers reflect the corresponding Brocade products. Table 1 provides a product matrix for you to use to correlate the Brocade products and models to the IBM product names and machine types and model numbers. Products withdrawn from marketing are not listed.

Table 1. Brocade and IBM product and model number matrix

Brocade product name	IBM product name	IBM machine type and model number
Brocade 6505	SAN24B-5	2498 Model F24, 249824G
Brocade 6510	SAN48B-5	2498 Model F48
Brocade DCX 8510-4	SAN384B-2	2499 Model 416
Brocade DCX 8510-8	SAN768B-2	2499 Model 816
Brocade DCX-4S	SAN384B	2499 Model 192
Brocade DCX	SAN768B	2499 Model 384
Brocade Encryption Switch	SAN32B-E4	2498 Model E32
Brocade 8000	IBM Converged Switch B32	3758 Models B32 and L32
Brocade 7800	SAN06B-R	2498 Model R06
Brocade 5300	SAN80B-4	2498 Model B80
Brocade 5100	SAN40B-4	2498 Models B40 and 40E
Brocade 300	SAN24B-4	2498 Models B24 and 24E

Accessibility features for SAN768B

Accessibility features help users who have a disability, such as restricted mobility or limited vision, to use information technology products successfully.

Accessibility features

Use and operation of this device is accomplished primarily through external devices which may provide different accessibility features.

The following list includes the major accessibility features in the SAN768B either directly or through external devices or interfaces:

- Keyboard-only operation
- Interfaces that are commonly used by screen readers

- Keys that are discernible by touch but do not activate just by touching them
- Industry-standard devices for ports and connectors
- The attachment of alternative input and output devices

Keyboard navigation

This product uses standard Microsoft Windows navigation keys.

Vendor software

The SAN768B includes certain vendor software that is not covered under the IBM license agreement. IBM makes no representation about the accessibility features of these products. Contact the vendor for the accessibility information about its products.

Related accessibility information

You can view the publications for the SAN768B in Adobe Portable Document Format (PDF) using the Adobe Acrobat Reader. The PDFs are provided on a CD that is packaged with the product.

IBM and accessibility

See the IBM Human Ability and Accessibility Center for more information about the commitment that IBM has to accessibility: www.ibm.com/able.

Chapter 1. Introduction

This chapter introduces the features and components of the IBM System Storage SAN768B fabric backbone. Throughout the remainder of this document, the product will be referred to as the *SAN768B*, or more generically as *system*, *device*, or *chassis*, where appropriate. This chapter contains the following information:

- “Overview of the SAN768B”
- “Hardware components” on page 2
- “High availability” on page 7
- “Reliability” on page 7
- “Serviceability” on page 7
- “Software features” on page 8

Overview of the SAN768B

The SAN768B represents the next generation of advanced Fibre Channel directors used to intelligently interconnect storage devices, hosts, and servers in a Storage Area Network (SAN). It satisfies the most demanding Reliability, Availability, and Serviceability (RAS), performance, and scalability requirements, while delivering investment protection, interoperability, and fabric-based intelligence advantages found only in the IBM SAN product family.

Key features of the SAN768B include:

- Up to 512 ports operating at a full 8 Gbps speed in a single chassis, providing high port density for a scalable solution to drive high-port-count SAN configurations.
- Support for high-performance port blades running at 1-, 2-, 4-, 8-, or 10-Gbps, enabling flexible system configuration.
- Up to 1024 ports in the same rack can connect with the use of inter-chassis links (ICLs). Up to 1536 ports can be connected via ICLs in adjacent racks.
- Supports 1-, 2-, 4-, and 8-Gbps auto-sensing Fibre Channel ports. Trunking technology groups up to eight ports to create high performance 64-Gbps ISL trunks between switches. (10 Gbps ports (FC10-6) are 10 Gbps only.)
- Dual-redundant control processor blades (CP8) and core switch blades (CR8) provide high availability and enable nondisruptive software upgrades.
- Redundant and hot-swappable CP8 and CR8 blades, power supplies, blower assemblies, and WWN cards enable a high availability platform for mission critical SAN applications.
- Universal ports self-configure as E_ports, F_ports, FL_ports, Ex_ports, and M_ports (mirror ports).
 - 10 Gbps ports (FC10-6) are E-Ports only.
 - Ex_ports are supported only on the FR4-18i application blade.
 - FL_ports are not supported on the FC8-48 port blade.
- Data cryptographic (encryption/decryption) and data compression capabilities through the FS8-18 Encryption Blade.
- Inter-chassis linking (ICL) through CR8 blades.
- Fibre Channel over IP (FCIP) functionality through the FX8-24 blade
- Fibre Channel over Ethernet (FCoE) capability through the FCOE10-24 blade.

Hardware components

The SAN768B features a modular and scalable mechanical construction that allows a wide range of flexibility in installation, fabric design, and maintenance. The chassis may be mounted with the cables facing the front of the equipment rack or to the rear, and consists of the following:

- Up to eight hot-swappable port blade assemblies can be configured in a single chassis, delivering up to 512 Fibre Channel ports.
- Two slots for control processor blades (CP8):
 - A single active CP8 blade can control all 512 ports in the chassis.
 - The standby CP8 blade assumes control of the SAN768B if the active CP fails.
- Two slots for core switch blades (CR8):
 - CR8 blade interconnects all port blades
 - Two inter-chassis link (ICL) connectors per blade to connect to another chassis
 - Both CR8 blades are active
- Modular hot-swappable port blades:
 - 16-port, 8-Gbps blades (FC8-16)
 - 32-port, 8-Gbps blades (FC8-32)
 - 48-port, 8-Gbps blades (FC8-48)
 - 64-port 8-Gbps blades (FC8-64)
 - 6-port, 10-Gbps blades (FC10-6)
- Modular hot-swappable application blades:
 - FR4-18i: 18-port (16 FC + 2 GbE), up to 4 blades per chassis, supporting Fibre Channel Routing Services and FCIP
 - FX8-24: 24-port (12 FC, 10 GbE, 2 10GbE) FCIP extension blade enabling long distance communication over existing IP infrastructure
 - FCOE10-24: 24-port (24 10GbE) CEE-based FCoE blade enabling enhanced connectivity using existing Ethernet infrastructure. This blade cannot be used in the same chassis as the high density port blade FC8-64 or any of the application blades (FX8-24, FR4-18i, or FS8-18).
- Modular hot-swappable encryption blades:
 - FS8-18: 16-port, up to 4 blades per chassis, supporting data cryptographic (encryption/decryption) and data-compression capabilities.
- Modular hot-swappable field replaceable units (FRUs):
 - Three blower assemblies
 - Up to four power supplies
 - Two WWN cards
 - Small Form-factor Pluggable (SFP, SFP+, and mSFP) optical transceivers. SFP transceivers support speeds of 1, 2, and 4 Gbps. SFP+ and mSFP transceivers support speeds of 2, 4, and 8 Gbps.
 - Extended Form-factor Pluggable (XFP) optical transceivers (10-Gbps)
 - 1 GbE copper SFP transceivers for the IP ports on the routing blade

Note: The 8-Gbps SFPs and mSFPs auto-negotiate at 2, 4, and 8 Gbps. The 4-Gbps SFPs auto-negotiate at 1, 2, and 4 Gbps.

- All blades are serviced from the port side of the SAN768B. Blowers, power supplies, and power cables are serviced from the nonport side.
- Improved cable management using a redesigned cable management comb and chassis door

- Constant intake and FRU temperature monitoring
- World Wide Name (WWN) cards on the nonport side, to maintain chassis-specific information such as WWNs, IP addresses, and summary status information of each port blade and power supply through LEDs
- Redundant AC primary power connections to ensure high availability. Each power supply has its own connector

Note: Airflow in the SAN768B is from the non-port (non-cable) side to the port (cable) side and out the exhaust vent.
Figure 1 shows a sample configuration of the port side of the SAN768B, with the chassis door removed.

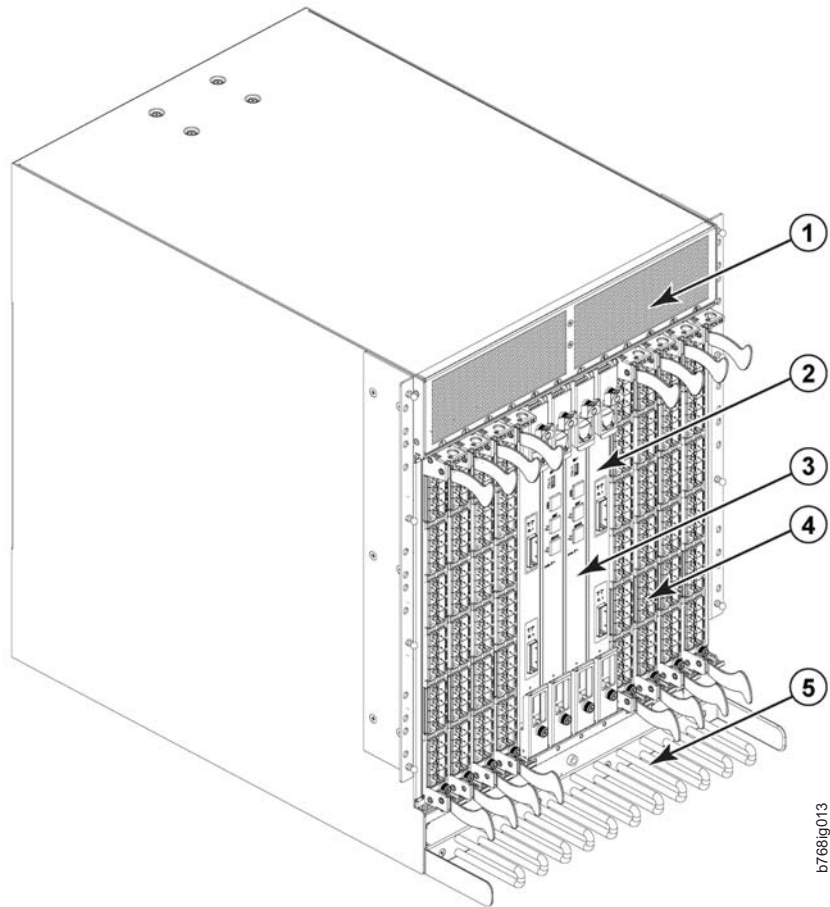

Figure 1. Port side of the SAN768B (sample configuration)

- | | | | |
|----------|-------------------------|----------|-------------------------------|
| 1 | Exhaust vent | 3 | Control processor blade (CP8) |
| 2 | Core switch blade (CR8) | 4 | FC8-48 port blade |
| | | 5 | Cable management comb |

Figure 2 on page 4 shows a sample configuration of the non-port side of the SAN768B.

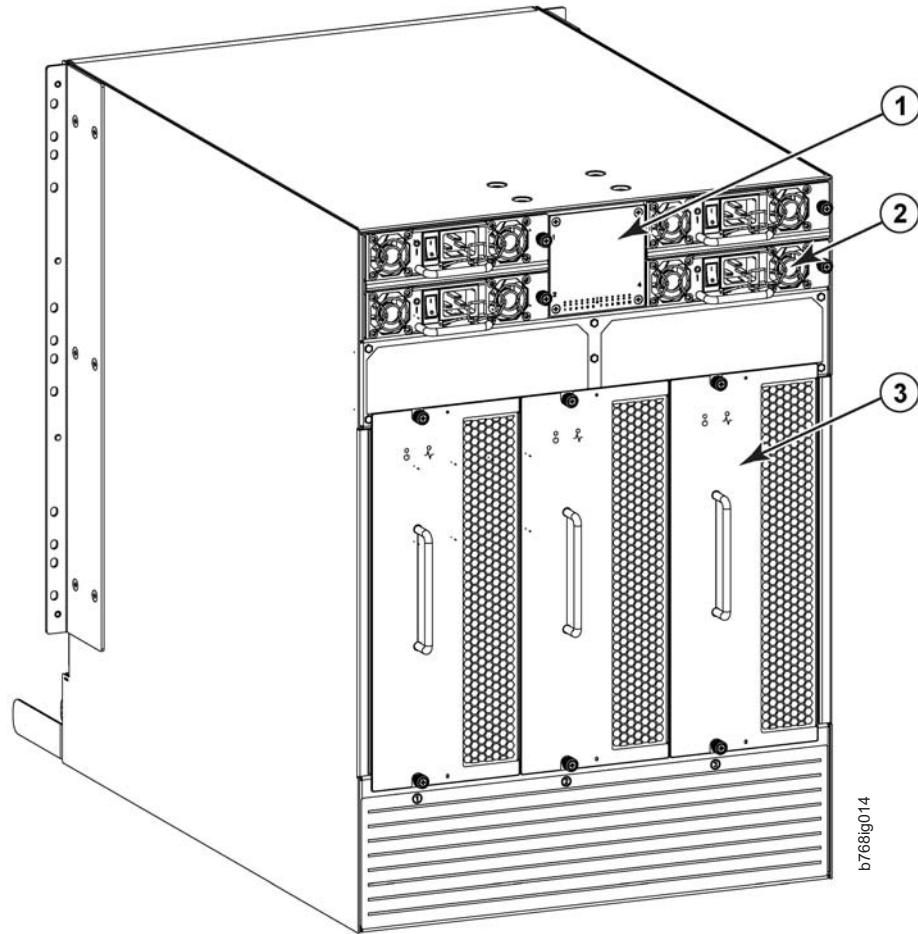

Figure 2. Blower (non-port) side of the SAN768B (sample configuration)

- 1** WWN bezel
- 2** Power supply
- 3** Blower assembly

SAN768B blades

Table 2 summarizes the port, application, control processor, and core switch blades that are available for the SAN768B.

Table 2. Blades available for the SAN768B

Description	Feature Code	Name	Function
Control processor blade	N/A	CP8	The CP8 blade contains the control plane for the chassis. There are two CP8 blades for redundancy.

Table 2. Blades available for the SAN768B (continued)

Description	Feature Code	Name	Function
Core switch blade	N/A	CR8	The CR8 blade contains the ASICs for switching between port blades. Every port blade connects to every core switch blade. There are 384 total ports for port blades. Each core switch blade connects to 192 backplane ports. Core switch blades have additional front port connectivity to connect multiple chassis and backplane connections for the storage server blade.
16-port 8-Gbps port blade	FC3816	FC8-16	A 16-port blade supporting 1-, 2-, 4-, and 8-Gbps port speeds.
32-port 8-Gbps port blade	FC3832	FC8-32	A 32-port blade supporting 1-, 2-, 4-, and 8-Gbps port speeds.
48-port 8-Gbps port blade	FC3848	FC8-48	A 48-port blade supporting 1-, 2-, 4-, and 8-Gbps port speeds.
64-port 8-Gbps port blade	FC3864	FC8-64	A 64-port port blade supporting 2, 4, and 8 Gbps port speeds. This blade cannot be used in the same chassis with an FCOE10-24 blade.
6-port 10-Gbps port blade	FC3870	FC10-6	A 6-port blade supporting 10-Gbps port speed. Blade provides 10-Gbps ISLs.

Table 2. Blades available for the SAN768B (continued)

Description	Feature Code	Name	Function
Fibre Channel router blade	FC3850	FR4-18i	The FR4-18i blade has 16 physical 4-Gbps Fibre Channel SFP ports supporting Fibre Channel Routing Services and two physical Gigabit Ethernet (GbE) SFP ports supporting Fibre Channel Over IP (FCIP). The two physical GbE ports can support up to 16 virtual E_ports.
FCIP extension blade	FC3890	FX8-24	The FX8-24 blade enables FCIP functionality over existing IP infrastructure. It has twelve FC ports, ten 1 GbE ports, and two 10 GbE ports available.
Fibre Channel over Ethernet blade	FC3880	FCOE10-24	The FCOE10-24 blade enables FCoE functionality over existing Ethernet infrastructure utilizing CEE protocols. It has twenty-four 10 GbE ports available. This blade cannot be used in the same chassis with an FC8-64 high density port blade or any of the other application blades (FR4-18i, FX8-24, or FS8-18).
Encryption blade	FC3895	FS8-18	The FS8-18 blade enables data cryptographic (encryption/ decryption) and data-compression capabilities. It has sixteen Fibre Channel optical SFP ports. This blade requires the use of 220 VAC power supplies. This blade cannot be used in the same chassis with an FCOE10-24 blade.

High availability

The following features contribute to the SAN768B's high-availability design:

- Redundant, hot-swappable blades and FRUs
- Enhanced data integrity on all data paths
- Fabric Shortest Path First (FSPF) rerouting around failed links
- Integration with Simple Network Management Protocol (SNMP) managers
- Automatic control processor failover
- Nondisruptive "hot" software code loads and activation
- Easy configuration, save, and restore
- Hot-swappable World Wide Name (WWN) cards

The high-availability software architecture of the SAN768B provides a common framework for all applications that reside on the system, allowing global and local status to be maintained through any component failure. High-availability elements consist of the High Availability Manager, the heartbeat, the fault/health framework, the replicated database, initialization, and software upgrade.

The High Availability Manager controls access to the standby control processor, facilitates software upgrades, prevents extraneous switchover activity, closes and flushes streams as needed, provides flow control and message buffering, and supports a centralized active and standby state.

Reliability

The SAN768B uses the following error detection and correction mechanisms to ensure reliability of data:

- Data is protected by the Error Detection and Correction mechanism, which checks for encoder errors and fault isolation, such as cyclic redundancy checking (CRC), parity checking, checksum, and illegal address checking
- Power-on self test (POST)
- Dual control processors that enable hot, nondisruptive fast firmware upgrades
- Each control processor contains one serial port and two Ethernet ports, for management and for service. Offline control processor diagnostics and remote diagnostics simplify troubleshooting. The standby control processor monitors diagnostics to ensure it is operational, should a failover be necessary
- Bus monitoring and control of blades and other field-replaceable units (FRUs).

Serviceability

The SAN768B provides the following features to enhance and ensure serviceability:

- Modular design with hot-swappable components
- Flash memory that stores two firmware images per control processor
- USB port on control processor blades for all tasks that formerly required an FTP/SCP server, including software and firmware upgrades
- Nonvolatile random-access memory (NVRAM), containing the OEM serial number, IBM serial number, revision information, and part number information
- Background health-check daemon
- Memory scrubber, self test, and bus ping to determine if a bus is not functioning
- RASlog messages

- SMI-S compliant
- Watchdog timers
- Status LEDs
- Predictive diagnostics analysis through Fabric Watch
- SNMP (including version 3) integration with higher-layer managers

Software features

The Fabric OS allows any Fibre Channel-compliant device to attach to the switches as long as it conforms to the device login, name service, and related Fibre Channel standards. Each operating environment requires that a Fibre Channel host bus adapter (HBA) be available with a standards-compliant driver for correct interface to the fabric.

Fabric OS consists of a set of embedded applications running on top of an embedded Linux operating system kernel. These applications include:

- Name server
- Alias server
- Zone server
- Simple Network Management Protocol (SNMP) agent
- SMI-S compliant API
- Syslog auditing
- RCS (Reliable Commit Service)
- NTP
- Tasks to manage address assignment, routing, link initialization, fabric initialization, link shutdown, shutdown, and the user interface.
- Integrated Routing—This feature allows any port in a SAN768B, SAN80B-4, and SAN40B-4 to be configured as an EX_port supporting Fibre Channel (FC) routing. This eliminates the need to add a routing blade or use of the SAN18B-R for FC routing (FCR) purposes, and this also provides double the bandwidth for each FC router connection when connected to another 8 Gbps-capable port.
- 8 Gbps FICON Accelerator, an optional feature (FC 7893), leverages emulation techniques to reduce or eliminate performance degradation for mainframe applications across IP WANs.
- Server Application Optimization (SAO), an optional feature (FC 9010) is designed to bring Quality of Service (QoS) enhancements for server consolidation and virtualization.

For more information about these features, refer to the *Fabric OS Administrator's Guide*. The *Brocade Adapters Administrator's Guide* provides additional information that may be useful when setting up SAO.

Security

Table 3 highlights some of the key security features available for the SAN768B and for other switches running Fabric OS 5.2.0 or newer.

Table 3. Security features

Security Feature	Description
DH-CHAP	Login banner
SSHv2 (using AES, 3DES, RSA)	Monitoring of attempted security breaches (via audit logging)

Table 3. Security features (continued)

Security Feature	Description
HTTPS (using AES)	Monitoring of attempted security breaches (via Fabric Watch Security Class)
SNMPv3	Fibre Channel security policies: DCC and SCC
FC-SP	Trusted Switch (FCS) for central security management
Secure RPC	Management access controls (SNMPv3, Telnet, FTP, serial port, front panel)
Secure file copy (SCP)	Hardware-enforced zoning by WWN and/or domain/port ID
Telnet disable	Default zoning
Telnet timeout	RSCN suppression and aggregation
IP filters (block listeners)	Configurable RSCN suppression by port
Secure passwords (centralized control via RADIUS/CHAP)	NTPv3 (to synchronize timestamps)
Multiple user accounts (MUAs). Up to 255.	Event auditing
Role-based access controls (RBACs)	Change tracking
Administrative domains/Virtual fabrics	Firmware change alerts in Fabric Manager
Boot PROM password reset	Persistent port disable
Password hardening policies	Persistent domain ID
Upfront login in Web Tools	E_port disable

Installation of the optional Federal Information Processing Standards 140-2 (FIPS 140-2) security seals to the SAN384B chassis, blades, and other components is available through Feature Code 7230. The *IBM System Storage FIPS 140-2 Security Seal Application Procedures* (GA32-2220-00) publication provides complete instructions for installing this feature on this and other models. The publication is available through the IBM Support Portal, www.ibm.com/supportportal or the IBM Publications Center www.ibm.com/shop/publications/order. Search by title or publication form number on either site.

Network Manageability

The SAN768B has a single domain and is managed as a single element with the Data Center Fabric Manager, Enterprise Fabric Connectivity Manager (EFCM), or Fabric Manager. The SAN768B responds to its own IP address and appears as a separate entity to the Telnet protocol and SNMP.

All management interfaces, such as Telnet, Web Tools, standards compliant SMI-S, and Management Server, support a “port N within blade M” naming scheme.

The SAN768B supports SNMPv1 and SNMPv3. When SNMP devices send SNMP messages to a management console running SAN management software, the information is stored in a management information base (MIB). Fabric OS v6.1.1 and later supports the latest Fibre Alliance Fibre Channel Management (FCMGMT) and Storage Management Initiative (SMI) MIBs, which allow common information necessary for management software to provide information to a SAN administrator. Fabric OS v6.4.x and later is required for the optional feature, FICON Accelerator.

Note: Refer to the *Fabric OS MIB Reference* for additional MIB information.

Chapter 2. Installing and removing a SAN768B

The SAN768B is only available for installation in the IBM TotalStorage 2109 SAN Switch Cabinet C36. This SAN768B is to be installed and serviced only by qualified IBM service representatives. The SAN768B can be ordered pre-installed in the cabinet, or the SAN768B can be added to an existing C36 cabinet. The cabinet is designed to support a total of two SAN256Bs or SAN768Bs. The SAN384B can also be installed in the C36 cabinet.

Attention: The SAN768B is only available for installation in the IBM TotalStorage 2109 SAN Switch Cabinet C36. The SAN768B can be pre-installed in the cabinet, or it can be added to an existing IBM C36 cabinet. For installation into an existing C36 cabinet, a special bridge tool ships with the SAN768B which is designed to attach to the IBM C36 cabinet. This bridge tool supports the weight of the director as it is moved into the cabinet. This tool may not attach to non-IBM cabinets. There is a risk of personal injury or machine damage during installation into any cabinet other than the approved IBM cabinets .

This chapter describes how to install the SAN768B into a C36 cabinet, and how to remove the SAN768B from the cabinet in the event you need to move or replace the SAN768B. One SAN768B is installed in the cabinet at the factory. If the SAN768B is already installed in the cabinet, continue on to Chapter 3, “Starting and configuring the SAN768B,” on page 31.

Note: Some illustrations in this chapter display different models of IBM SAN directors. Details, such as the cable management comb and blades may differ, but the procedures remain the same for the SAN768B.

Attention: Refer to “Safety and environmental notices” on page xv for general safety instructions, and “Rack safety” on page xxii before performing any installation or service procedures.



CAUTION:

The weight of this part or unit is more than 104 kg (228 lb). It takes specially trained persons with a lifting device to safely lift this part or unit. (C011)

CAUTION:

A fully populated (512 port) SAN768B weighs approximately 159.2 kg (351 lb). Before you install it, verify that the additional weight of the chassis does not exceed the cabinet's weight limit or unbalance the cabinet. When you calculate the additional weight, include the weights of all components that can potentially be added, to avoid overloading in the future.

CAUTION:

For CA residents only: IBM recommends installing this product in a room size of 2190 cubic feet (62 cubic meters) or larger at 0.4 ACH ventilation rate to reduce the concentrations of any chemicals emitted by the product.

Before you install a SAN768B into the cabinet, perform the following tasks:

- To ensure adequate cooling, plan to install the chassis with the port side facing the aisle where exhaust air is released (usually called the service aisle). This prevents the fans from pulling in heated exhaust air.
- Plan for managing the cables before you install the chassis. A fully populated SAN768B will have a large number of cables that must be carefully routed to minimize problems with installation and replacement of components, and in order to maintain the minimum bend radius required for optical cables. Refer to “Managing cables” on page 40 for more specific information. You can manage the cables in a variety of ways, such as:
 - Routing the cables down through the cable management tray
 - Routing the cables out either side of the chassis
 - Routing the cables through the cable channels on the sides of the cabinet
 - Using patch panels
- Ensure that the airflow in the vicinity of the SAN768B is a minimum of 595 cubic meters per hour (350 cubic feet per minute).
- Ensure that the air temperature that is measured at the blower inlet does not exceed 40°C (104°F) during operation.

Ordering the lift tool

Important

The lift tool is required only when you install an additional SAN768B or when you install or remove the SAN768B from the cabinet.

The ordering procedures for the lift tool vary depending on your location. You should direct questions about these procedures to your regional representative.

Note: The bridge tool (PN 18P5855), which is required for installation, is shipped with a new or a replacement SAN768B. The bridge tool, when installed, serves as a temporary ramp between the lift tool and the SAN768B rails that are installed in a C36 cabinet. You do not need to return the bridge tool when you are finished with it.

World trade locations

The following ordering procedures are for world trade locations:

- Order the lift tool by using the parts order system, like any other part.
- Use the following part numbers when you order:
 - Lift tool: PN 09P2481
 - The lift tool will include the required 24–inch load plate: PN 11P4369
- You do not record parts usage.
- Return the lift tool and the 24–inch load plate to the parts center after you complete the installation or removal of the SAN768B.

United States locations

In the United States, call UPS Logistics at 800–528–6070 to order the lift tool and the 24–inch load plate.

Note: For the SSR branch and territory, the United States cannot order the lift tool or 24-inch load plate through the parts order system. UPS Logistics are used to ship and return the lift tool and 24-inch load plate.

Use the following part numbers when you order:

- Lift tool: PN 09P2481 (lift tool includes 24-inch load plate: PN 11P4369)

Note: When you order the lift tool, you will receive an 18-inch load plate and a 24-inch load plate. Do *not* use the 18-inch load plate. You *must* use the 24-inch load plate when you install the SAN768B.

You must provide the following information when you order the lift tool. This information is necessary to ensure that the lift tool is delivered when you need it. Failure to provide this information might delay the completion of the order request and the shipping request. It might also result in a time and date to return the tool that is different from what you need.

- Phone number and customer contact
- Account code: 98577
- Time and date of delivery
- Accurate destination address with zip code
- Time and date of return pickup

You must return the lift tool at the time that was scheduled with UPS Logistics. If you need to change the scheduled return time or date, contact UPS Logistics.

You are responsible for ensuring that all of the paperwork and components are packed and restored in the arbocrate (shipping container) of the lift tool. Ensure that the lift tool is functioning properly before you release the tool to UPS Logistics for return. You are accountable for the lift tool until UPS Logistics picks up the lift tool for return delivery to their parts storage facility.

Contact your branch office tools coordinator or your region specialist if you have any questions or concerns.

Installation guidelines

Follow these general installation guidelines:

1. Provide a space that is 14 rack units (14U) high, 61.29 cm (24.09 in.) deep, and 43.74 cm (17.22 in.). 1U is equal to 4.45 cm (1.75 in.).
2. Plan to install the SAN768B with the non-port side facing the air-intake aisle. The SAN768B can be installed facing either direction, if serviceability and cooling requirements are met.
3. Plan for cable management before installing the chassis. See “Managing cables” on page 40.

Cables can be managed in a variety of ways, such as by routing cables below the chassis, to either side of the chassis, through cable channels on the sides of the cabinet, or by using patch panels.

4. Ensure that dedicated electrical branch circuits with the following characteristics are available:
 - 200 – 240 VAC, 50–60 Hz (two branch circuits)
 - Two cables for 200 - 240 VAC service
 - Protected by a circuit breaker in accordance with local electrical codes

- Supply circuit, line fusing, and wire size adequate to the electrical rating on the chassis nameplate
- Location close to the chassis and easily accessible
- Grounded outlets installed by a licensed electrician, compatible with the power cords

Attention: To maximize fault tolerance, connect each power cord to a separate power source.

5. Ensure that the following are available for configuration of the chassis:
 - Workstation with an installed terminal emulator, such as HyperTerminal
 - Serial cable (provided)
 - Three Ethernet cables (including one spare)
 - Access to an FTP server for backing up the switch configuration or collecting supportsave output data (optional)
 - SFPs (provided) and compatible cables
6. Ensure that the air intake and exhaust vents have a minimum of 2 in. of airspace.
7. Ensure that the air temperature on the air intake side is less than 40 degrees Celsius (104 degrees Fahrenheit) during operation.

CAUTION:

Use safe lifting practices when moving the product. (C015)

Note: A fully populated SAN768B (eight FC8-64 port cards, 512 ports) weighs approximately 159.2 kg (351 lb) and requires the specified lift tool to install it.

Installing a SAN768B in a cabinet

This section describes how to install the SAN768B in the Model C36 cabinet. These procedures use parts that are included in the 14U rack mount kit.

Time required

Allow approximately 3 hours to complete this procedure. This includes unpacking, assembling, and repacking the lift tool. This is for the physical installation of the SAN768B only. It does not include installing Ethernet cables, SFPs, attaching and routing the fiber optic cables, or completing the initial configuration.

The SAN768B and the lift tool should be delivered to a location near to the final installation, with clear aisles for maneuvering the lift tool loaded with the chassis. Since the lift tool can be used to move the chassis the short distance from the delivery location to the installation, it is recommended that you assemble the lift tool before starting the installation steps.

Attention: If optional feature FC 7230, FIPS 140-2 Level 2 Tamper Proof Seals is also ordered, be sure to sequence the installation steps to allow for application of the FIPS seals on the chassis prior to installing the chassis in a rack. These locations may be difficult to access once the chassis is installed. Refer to the *IBM System Storage FIPS 140-2 Security Seal Application Procedures (GA32-2220-00)* publication for complete instructions.

Note: Assembly instructions for the lift tool are in the shipping container.

Tools required

You will require the following items to install the SAN768B in the cabinet:

- Torque wrench with #2 Phillips screwdriver tip
- Flathead screwdriver
- Lift tool

Parts list

The following parts list refers to items illustrated in Figure 3 on page 16

Table 4. Items supplied with the 14U rack mount kit

Item	Description	Quantity
For all types of installations		
A	Left rack mount shelf bracket (rail brackets may differ from the illustration)	1
B	Right rack mount shelf bracket (rail brackets may differ from the illustration)	1
C	10-32 x 5/8 inch (1.58 cm) panhead Phillips screw, washer	6
For cabinets that have vertical rails with round holes		
D	10-32 clip nut	6
E	1/4-20 x 1/2 in. (1.27 cm) panhead Phillips screw, with lock washer	16
For cabinets that have vertical rails with square holes		
F	10-32 retainer nut	6
G	1/4-20 x 1/2 in. (1.27 cm) panhead Phillips screw, with glue	16
H	0.375 in. (0.953 cm) alignment washer	16

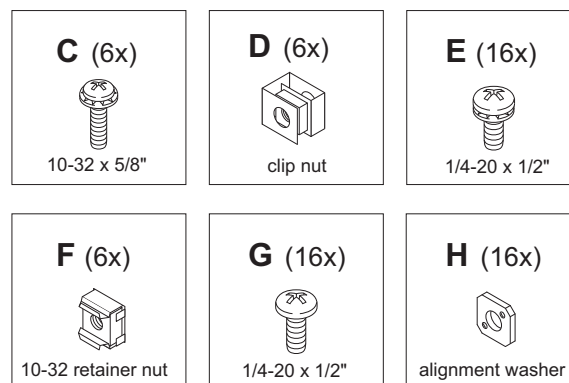
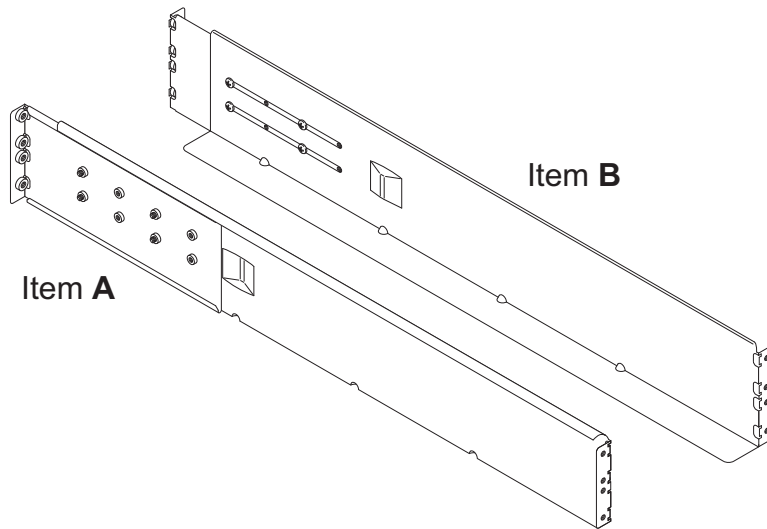

b768ig027

Figure 3. Parts in the 14U rack mount kit

Unpacking the SAN768B

To unpack the SAN768B, follow these steps:

1. Cut the bands that encircle the packaging.
2. Remove the lid, the 14U rack mount kit, the accessory kit, and the packing foam from the top of the chassis. Set the kits aside for later use.
3. Lift the cardboard box off the chassis and remove the plastic bag from around the chassis. Save the packing materials if you are returning an old chassis.
4. Leave the chassis on top of the plastic shipping tray if the chassis must be transported to the installation location.

Note: The standard packaging does not incorporate a wood pallet and pallet brackets. The chassis sits on top of a plastic shipping tray.

5. Use the lift tool to transport the new chassis to the installation area. Doorways must be wider than 91 cm (36 in.) to accommodate the chassis on the shipping tray.

Attaching the shelf brackets

Complete the following steps to install the shelf brackets to the cabinet rails:

1. Find the left and right rack mount shelf brackets (**A** and **B** in Figure 4) in the 14U rack mount kit. These brackets are adjustable to allow for different cabinet depths.
2. Loosen the adjusting screws on both brackets enough to allow the brackets to slide easily to adjust the length.

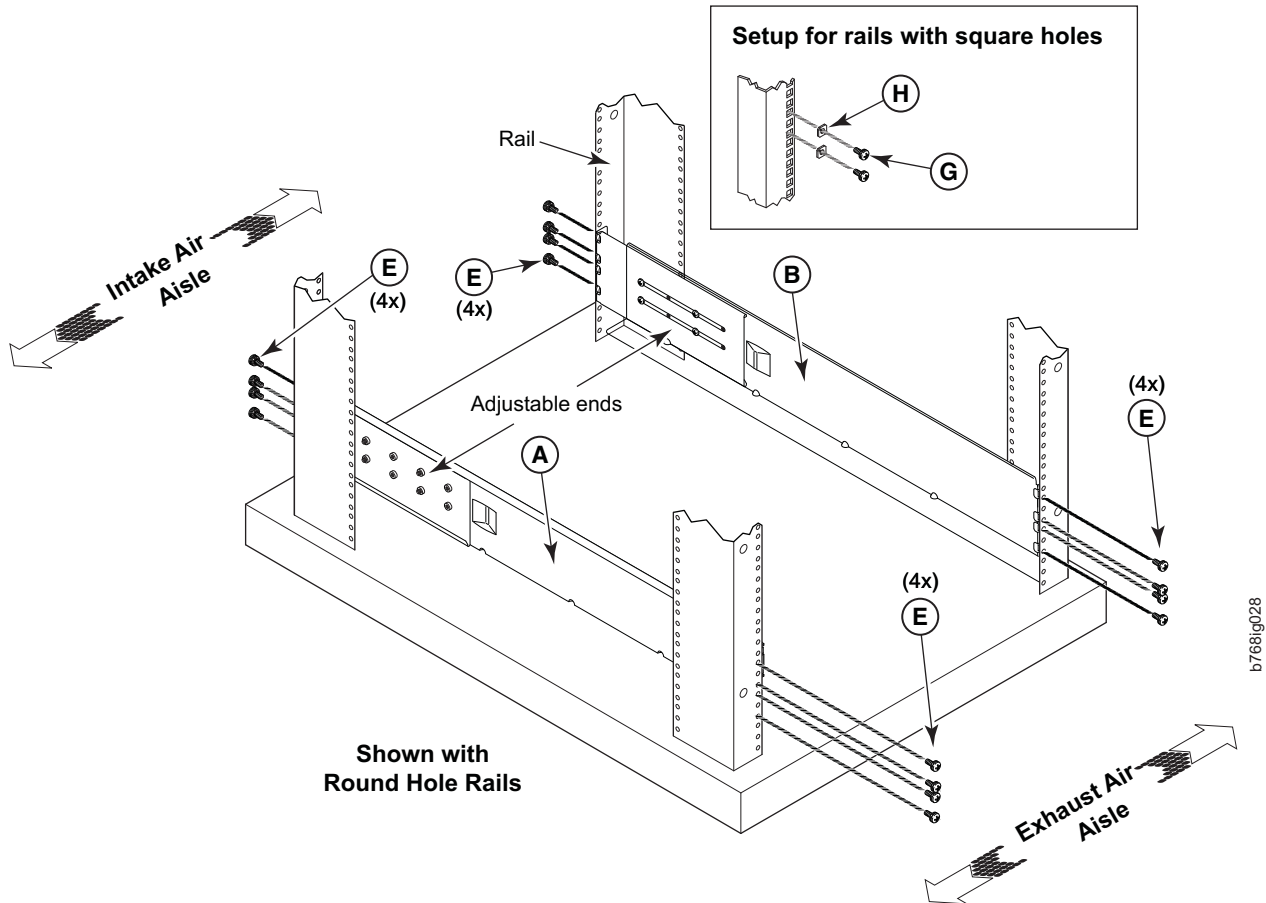

Figure 4. Left and right shelf brackets installed on the cabinet rails

3. Position the shelf brackets (**A** and **B**) with the adjustable ends at the intake aisle side of the cabinet (see Figure 4) and attach them to the cabinet rails.
 - For rails with round holes: Use eight screws with lock washers (**E**) for each bracket, four at each end. Tighten the screws to a torque of 92 cm-kg (80 in.-lb).
 - For rails with square holes: Use eight screws (**G**) eight alignment washers (**H**) for each bracket, four at each end. Tighten the screws to a torque of 92 cm-kg (80 in.-lb).

Note: Standard EIA rails have holes in sets of three; spaces between the holes are 1.58 cm, 1.58 cm, 1.27 cm (5/8 in., 5/8 in., and 1/2 in.). If cables are to be routed down through the cable management comb, allow at least 1U space below the brackets for cable management.

4. Tighten the adjusting screws on the shelf brackets to a torque of 37 cm-kg (32 in.-lb).

- Attach the clip nuts **D** (for rails with round holes) or retainer nuts **F** (for rails with square holes) to the vertical rails on the exhaust aisle side of the cabinet (see Figure 5). These nuts are used for securing the port side of the chassis to the rack rails using 10-32 x 5/8-inch screws. Use three nuts on each rail. Place the nuts in optimum locations for securing the chassis to the rails. See Figure 7 on page 20 for approximate positions.

Note: Do not align the clip or retainer nuts with the top or bottom holes of the SAN768B mounting brackets because the door will interfere with the screw heads.

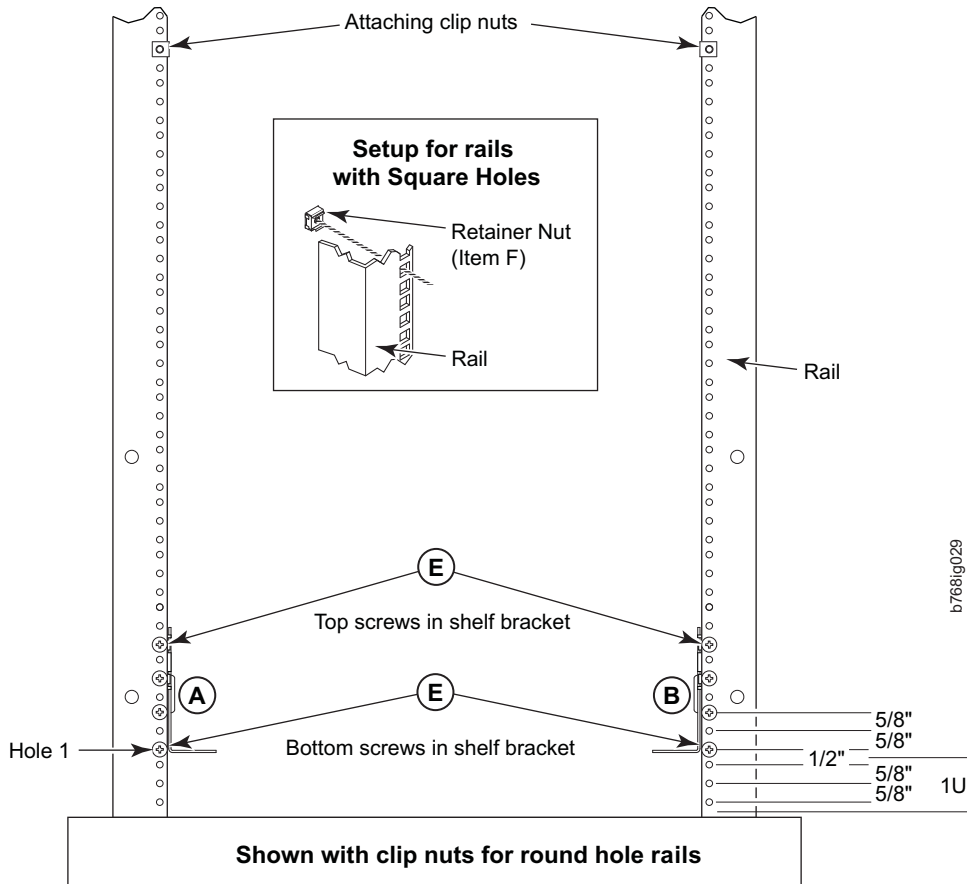

Figure 5. Installing clip or retainer nuts on the vertical cabinet rails

Removing the chassis door and cable management comb

The chassis door must be removed before the chassis can be installed into the cabinet. The door is not hinged. It is held to the chassis by mounting hardware on the door that snaps onto eight ball studs on the chassis. To remove the door, grip both sides of the door, and gently pull the door straight out until it releases from the ball studs on the chassis.

Set the door aside for later reinstallation.

Note: Reinstall the chassis door once the chassis is installed and all cabling and configuration is complete. The chassis door must be installed to ensure the SAN768B meets EMI and other regulatory certifications.

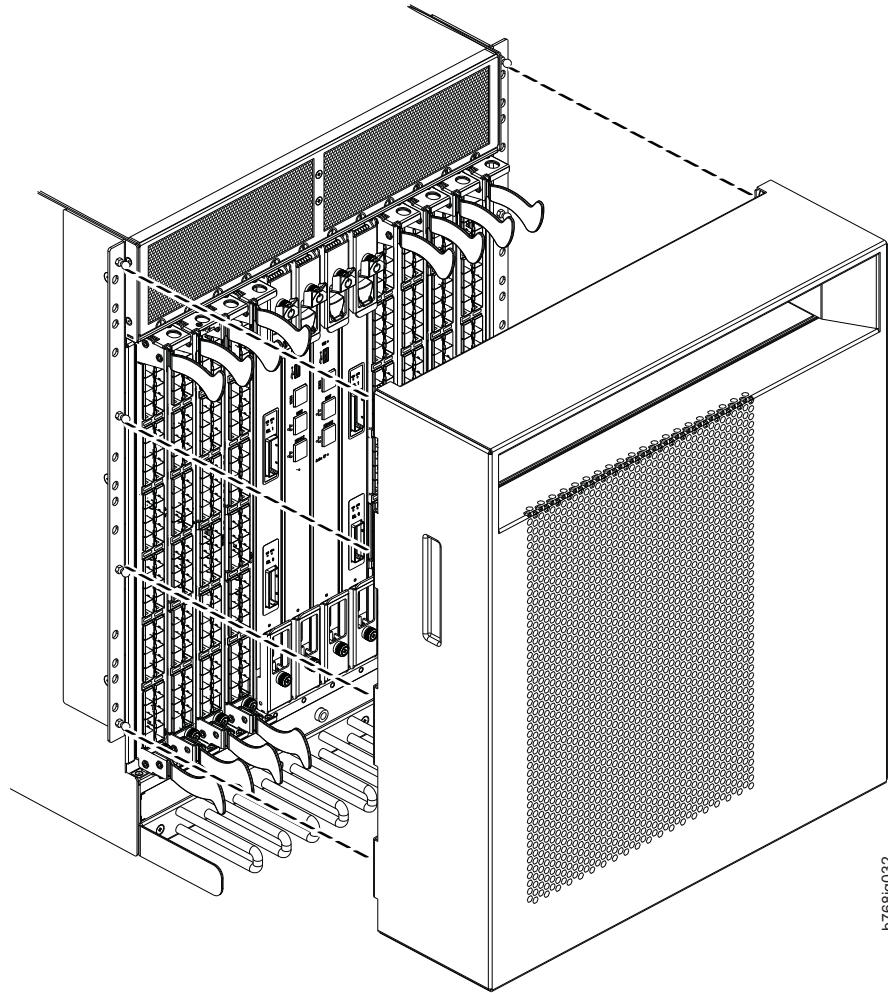

Figure 6. Chassis door removal

Remove the cable management comb (see “Removing and installing a cable management comb” on page 70), and set the parts aside for later reinstallation.

Using the lift tool, the 24-inch load plate, and the bridge tool

Step 1 on page 20 through step 9 on page 21 describe how to use the lift tool (PN 09P2481) and the 24-inch load plate (PN 11P4369) to install a SAN768B in the cabinet. Step 10 on page 21 through step 23 on page 23 describe how to install the bridge tool (PN 18P5855) in the cabinet for the lower SAN768B or the upper SAN768B. This procedure uses parts from the 14U chassis mount kit. See “Items required” on page 109 for a list of these parts.



CAUTION:

A fully populated SAN768B weighs approximately 159.2 kg (351 lb) and requires a minimum of two people and a lift tool to install it. (C011)

Attention: Before you install it, verify that the additional weight of the chassis does not exceed the cabinet's weight limits or unbalance the cabinet. When you calculate the additional weight, include the cards or power supplies that partially extend out of the chassis.



CAUTION:
A pinch point exists between the load plate and the bridge tool.

Perform the following steps to install the SAN768B:

1. Assemble the lift tool if it is not assembled. The assembly and disassembly instructions are included with the lift tool.
2. Attach the 24-inch load plate to the lift tool.
3. Although not required, you can remove the power supplies and blower assemblies from the SAN768B to reduce the weight. This can reduce the weight by up to 27 kg (60 lb).
4. Move the lift tool next to the pallet that contains the SAN768B.
 - a. Adjust the load platform to the same height.
 - b. Slide the SAN768B from the pallet onto the load platform.
 - c. Center the switch on the load platform.
5. Attach the retention straps around the drawer.
6. If the load platform is not at its lowest position, lower the load platform to its lowest position.
7. Move the lift tool to a position near the rear of the cabinet. See Figure 7.

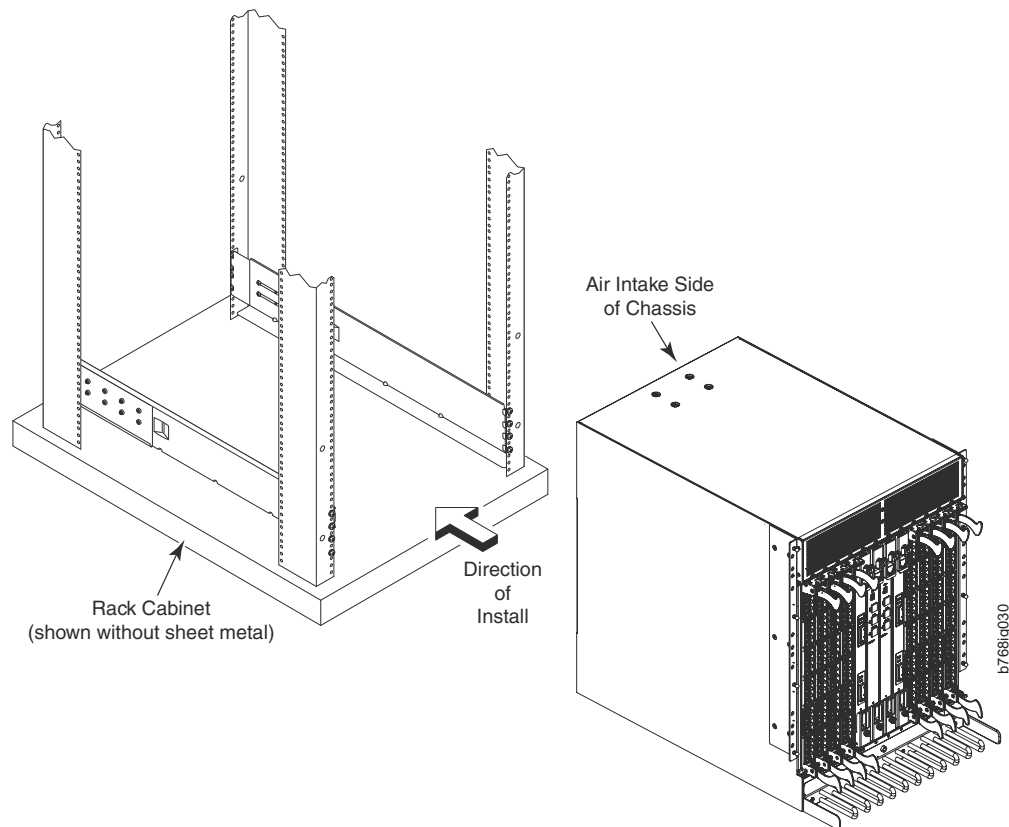

Figure 7. Chassis installation from rear (exhaust aisle side) of the cabinet

Note: If you are passing through a narrow passage or door, it might be necessary to rotate the drawer on the load platform.

8. Set the wheel brake by pressing down on the wheel brake pedal.

9. Locate the anti-tips bars. If they are not attached, attach them to the lift tool by performing step 9a through step 9d. If the anti-tip bars were previously attached, go to step 10.
 - a. Pull up on the leg lock pins and insert the anti-tip bars inside the legs.
 - b. Pull on the legs and anti-tip bars to ensure that they are locked into position.
 - c. Raise the platform to allow enough room to attach the anti-tip bracket.
 - d. Secure the anti-tip bars by using the anti-tip bracket and bolt.
10. If you are installing the lower SAN768B, go to step 11. If you are installing the upper SAN768B, go to step 12 on page 22.
11. For the lower SAN768B, install the bridge tool by completing the following steps:
 - a. Remove the bridge tool from the box and adjust the two supports 45°.
 - b. Hold the bridge tool between the two vertical supports near EIA unit 3, and move the two supports another 45°. Make sure that the following conditions are met:
 - The two-pin section of the support is on the back of the vertical support.
 - The one-pin section of the support is on the front of the vertical support.
 - c. Align the two-pin section of the support on the back of the vertical rail with the bottom and middle holes in EIA unit 3.
 - d. Align the one-pin section of the support on the front of the vertical rail with the middle hole in EIA unit 1.

Note: Tilt the bridge tool towards the back of the cabinet approximately 45° to make it easier to align the two-pin and the one-pin sections with the vertical support.

- e. Lock the shelf into position. See Figure 8 on page 22.

Note: The shelf in the picture below is shown with a different director.

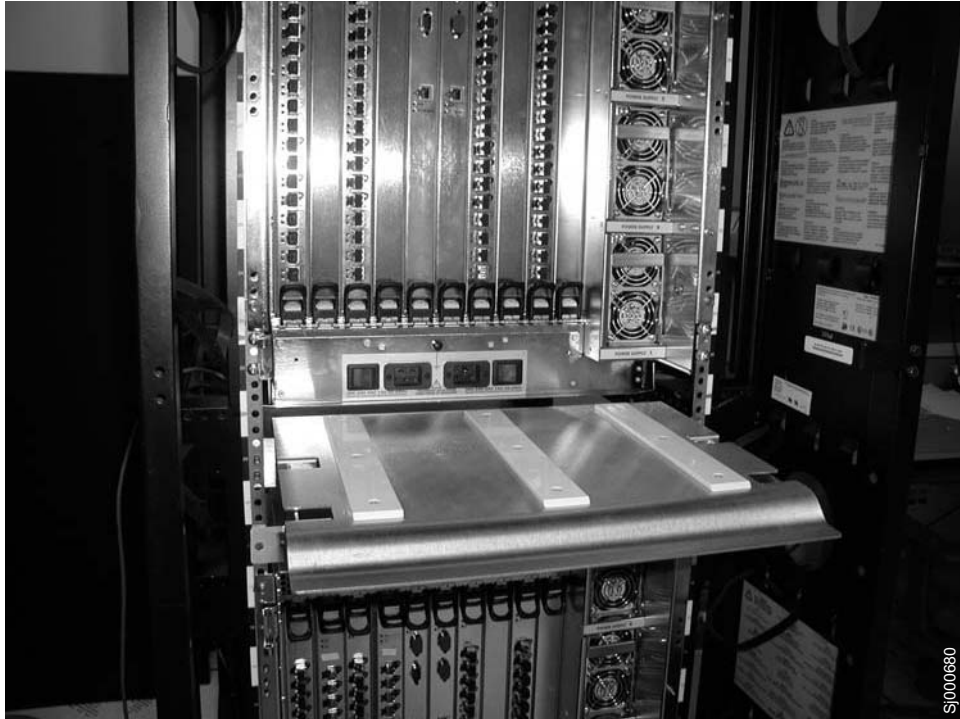
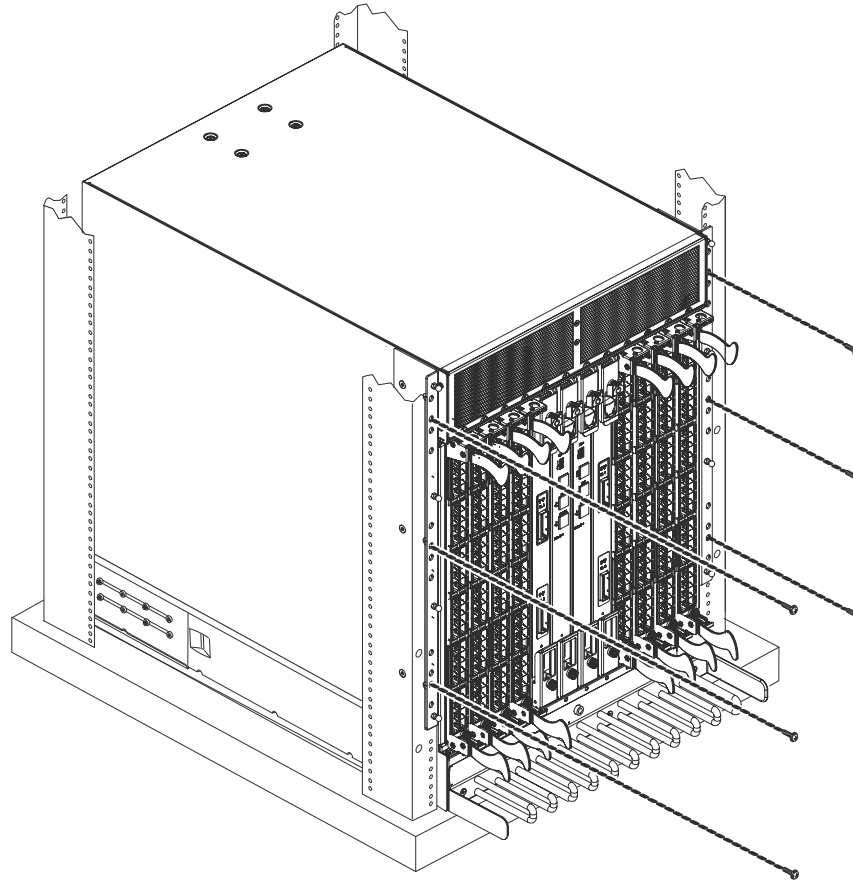

Figure 8. Locking the shelf into position

12. For the upper SAN768B, install the bridge tool by completing the following steps:
 - a. Remove the bridge tool from the box and adjust the two supports 45°.
 - b. Hold the bridge tool between the two vertical supports near EIA unit 20, and move the two supports another 45°. Make sure that the following conditions are met:
 - The two-pin section of the support is on the back of the vertical support.
 - The one-pin section is on the front of the vertical support.
 - Note:** Tilt the bridge tool towards the back of the cabinet approximately 45° to make it easier to align the two-pin and one-pin sections with the vertical support.
 - c. Align the two-pin section of the support on the front of the vertical rail with the bottom hole and the middle hole in EIA unit 20.
 - d. Align the one-pin section of the support on the front of the vertical rail with the middle hole in EIA unit 18.
13. Turn the winch crank counterclockwise, 1/4 turn, to set the winch brake.
14. Set the wheel brake and place the wheel chocks around the wheels.
15. Remove the retention straps.
16. Slide the SAN768B into the cabinet until it rests securely on the shelf brackets.
17. Remove the wheel chocks, release the wheel brake, and move the lift tool away from the cabinet.
18. Uninstall the bridge tool and return it to its original box.
19. Reinstall the power supplies and blower assemblies if any were removed.
20. Fasten the port side of the chassis to the cabinet rails. Use three 10–32 x 5/8-in. Phillips panhead screws with washers **C** on each side to attach to the

clip nuts (**D**) or retainer nuts (**F**) installed on the rails earlier. Tighten the screws to a torque of 37 cm-kG (32 in-lb). See Figure 9 for the approximate location of the screws.

Note: Do not use the top or bottom holes of the SAN768B mounting brackets because the screw heads will interfere with the chassis door.



b768ig031

Figure 9. Attaching the port side of the chassis to the cabinet rails

21. Reinstall the cable management comb, if it was removed (see “Removing and installing a cable management comb” on page 70).
22. If ICL cables will not be used, ensure that the ICL sockets in the core switch blades have EMI plugs inserted.
23. Reinstall the chassis door. Align the door with the chassis and push it into place, as shown in Figure 10 on page 24 and Figure 11 on page 25.

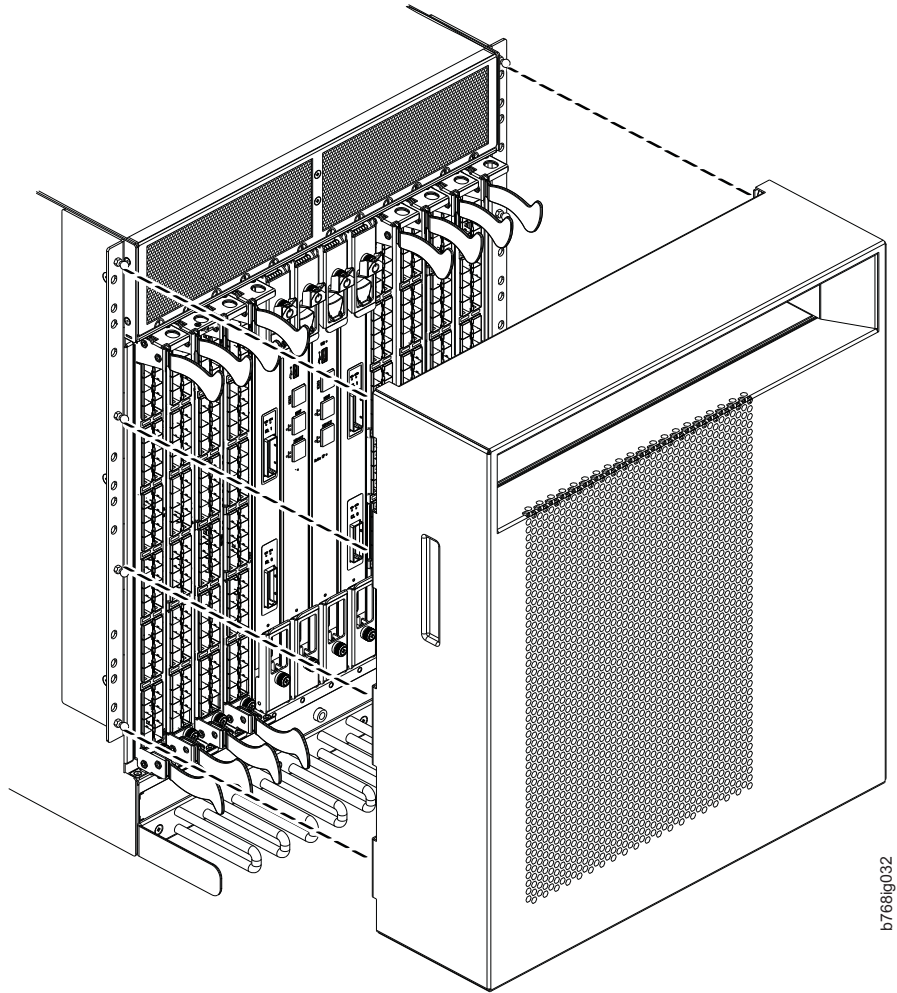

Figure 10. Aligning the chassis door with the ball studs on the chassis

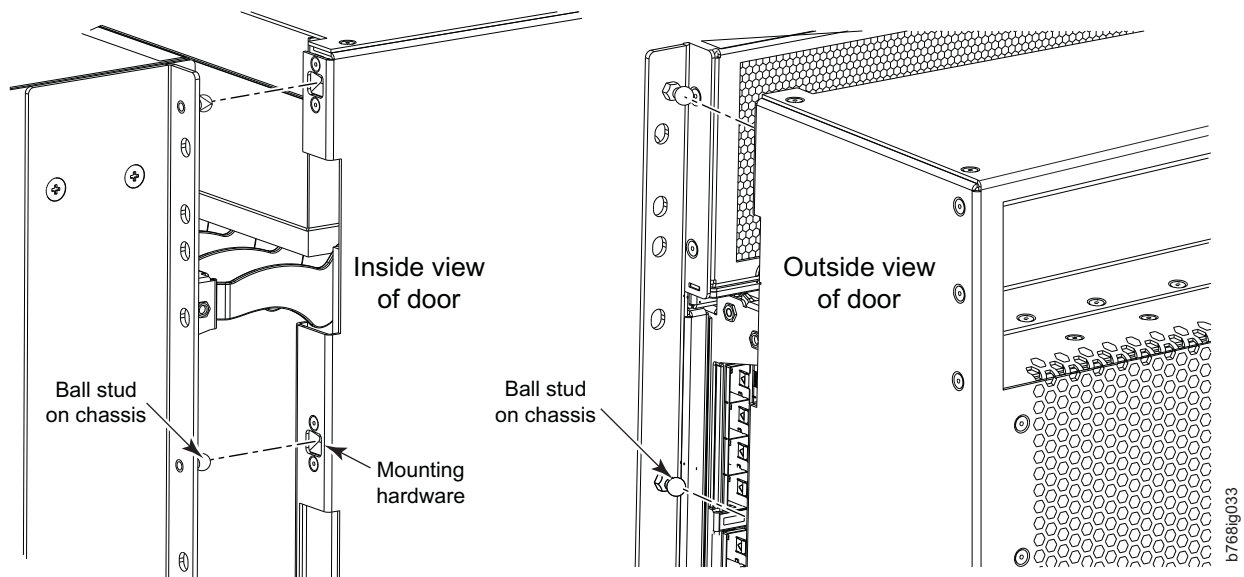

Figure 11. Details of the chassis and door, showing the ball studs on the chassis and the mounting hardware on the door

Note: For turning on the power and for the configuration instructions, see Chapter 3, “Starting and configuring the SAN768B,” on page 31.

Attention: Do not connect the SAN768B to the network until the IP addresses are correctly set.

Port numbering

Table 5 has a list of available port blades for the SAN768B.

Table 5. Port blades available on the SAN768B

Blade label	Blade description	Feature code
FC8-16	16 port 8 Gbps FC blade	3816
FC8-32	32 port 8 Gbps FC blade	3832
FC8-48	48 port 8Gbps FC blade	3848
FC8-64	64 port 8 Gbps FC blade	3864
FC10-6	10Gb Fibre Channel Blade	3870
FR4-18i	FC Routing Blade	3850
FX8-24	FCIP extension blade	3890
FCoE10-24	Fibre Channel over Ethernet blade	3880
FS8-18	16 port encryption blade	3895

The SAN768B uses the following port numbering scheme for each of the supported blades (see also Appendix D, “Blade port numbering,” on page 153 for sample configurations).

- FC8-16 port blade - Ports are numbered from 0 through 15 from bottom to top.
- FC8-32 port blade - Ports are numbered from 0 through 15 from bottom to top on the left set of ports and 16 through 31 from bottom to top on the right set of ports.

- FC8-48 port blade - Ports are numbered from 0 through 23 from bottom to top on the left set of ports and 24 through 47 from bottom to top on the right set of ports.
- FC8-64 port blade - Ports are numbered from 0 through 31 from bottom to top on the left set of ports and 32 through 63 from bottom to top on the right set of ports. See Figure 56 on page 157 for more information. Trunking groups are permitted with up to eight ports per group. trunking groups are as follows: 0-7, 8-15, 16-23, 24-31, 32-39, 40-47, 48-55, and 56-63.
- FC10-6 port blade - Ports are numbered from 0 through 5 from bottom to top.
- FR4-18i router blade - The 16 physical Fibre Channel ports are numbered from 0 through 15 from bottom to top. The two GbE ports, numbered GE0 and GE1, are located below the Fibre Channel ports. These ports, when fully configured, enable 16 VE_ports or VEX_ports and appear in the **switchShow** command as ports 16 through 31.
- FS8-18 blade — The 16 physical Fibre Channel ports on this blade are numbered 0 through 15 from bottom to top. The two 10/100/1000 BaseT ports are numbered from the bottom as GE0 and GE1.
- FX8-24 FCIP extension blade - The port numbering scheme is fairly complex for this blade, but is displayed for reference on the blade itself in a diagram towards the lower end of the blade. (See Figure 60 on page 161 for a description and illustration of the port layout.) There are twenty-four physical ports. Twelve FC ports are located towards the lower end of the blade, with ports 0 through 5 on the left side, and ports 6 through 11 on the right side. Two 10 Gigabit Ethernet (10GbE or XGE) ports are located in the middle of the blade on the left side, and are numbered 0 and 1, from bottom to top. Ten GbE ports are located towards the top of the blade, with eight clustered at the top, and the remaining two located to the right of the two 10GbE ports. The GbE ports 0 through 3, numbered from bottom to top are located on the left side at the top of the blade. Ports 4 and 5 are located above the two 10GbE ports, and ports 6 through 9 (numbered bottom to top) are at the top on the right side, to the right of ports 0 through 3. Up to three FC trunking groups. The three groups are defined as:
 - Trunk group 0: FC ports 0, 1
 - Trunk group 1: FC ports 6, 7
 - Trunk group 2: FC ports 2, 3, 4, 5, 8, 9, 10, 11
- FCoE10-24 FC over Ethernet blade - The 24 physical ports are numbered 0 through 11 from bottom to top on the right side, and 12 through 23 from bottom to top on the left side (see Figure 61 on page 162).

Chassis slots

Slots are numbered 1 through 12, from left to right when facing the port side of the SAN768B. Control processor blades (CP8) can be installed only in slots 6 and 7. Core switch blades (CR8) can be installed only in slots 5 and 8. Port, application, or encryption blades can be installed in slots 1–4 and 9–12. Unused slots must be filled with blade filler panels to maintain adequate cooling.

See Appendix D, “Blade port numbering,” on page 153 for port numbering details of the SAN768B port blades. Also refer to the IBM Redbook, *Implementing an IBM/Brocade SAN with 8 Gbps Directors and Switches*, SG24-6116, for more comprehensive information on port numbering and area port numbering, and other technical information. This publication is available through www.redbooks.ibm.com/. Search by title or publication number.

Cable organization

The cable management comb (**5** in Figure 1 on page 3) is attached to the chassis under the chassis door and allows for simple cable management. The comb can be installed without service disruption.

Route the cables down in front of the blades to keep LEDs visible. Leave at least one meter of slack for each fiber optic cable to provide room to remove and replace blades.

Attention: Do not route the cables in front of the air exhaust vent, which is located at the top of the port side of the chassis.

The FC8-64 high density port blade cannot use the standard LC cables because the pitch between optics in the new mSFP transceiver is smaller than in standard SFPs. Patch cables and panels can be used to attach standard size cabling to the blade if necessary. Figure 12 illustrates the mSFP to SFP patch cable. The mSFP transceivers are used only with the FC8-64 port blade. Narrower OM-3 LC cables are used to connect the FC8-64. These cables are offered by several major manufacturers. Contact your IBM representative for options regarding different cable and patch panel configurations to simplify cable management with higher density FC8-64 port blades.

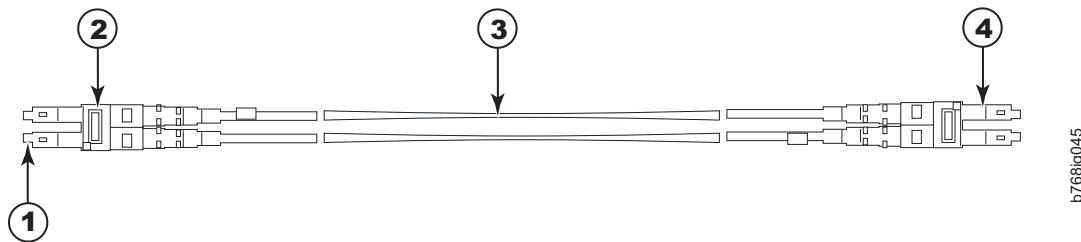

Figure 12. Cable design for the mSFP patch cables for the FC8-64 high density port blade

- | | | | |
|----------|---------------------|----------|---------------|
| 1 | mini-SFP connector | 3 | 1.6 mm cable |
| 2 | Duplex clip (black) | 4 | SFP connector |

Note that the duplex clip on the mSFP end of the cable is black for easier recognition. See Table 25 on page 141 for a listing of the qualified mSFP optical cables for the FC8-64 port blade.

If ISL Trunking is in use, group the cables by trunking group. The ports are color-coded to indicate which ports can be used in the same ISL Trunking group: eight ports marked with solid black ovals alternate with eight ports marked with oval outlines.

Table 25 on page 141 provides a listing of supported cable speeds and distances. Optional inter-chassis link cables (ICL) can also be installed between two or three chassis. See “Removing and installing inter-chassis link (ICL) cables” on page 97 for instructions on installing these cables.

Removing a SAN768B from the cabinet

If you need to remove a SAN768B chassis from a cabinet to move it to a new location, follow the instructions below to remove the chassis, and then follow the installation instructions (“Installing a SAN768B in a cabinet” on page 14) to install the chassis in the new cabinet. If you are replacing the chassis, follow the complete instructions in “Removing and replacing the chassis” on page 108.

Attention: Refer to “Safety notices and labels” on page xv before starting any service procedure. Due to the weight of the product, this procedure requires a lift tool. See “Ordering the lift tool” on page 12 for information on ordering the lift tool.

Step 1 through step 5 describes how to use the lift tool (PN 09P2481) and the 24-inch load plate (PN 11P4369) to remove a SAN768B from the cabinet. Step 6 through step 17 on page 29 describes how to remove the bridge tool (PN 18P5855) from the cabinet.

Perform the following steps to remove a SAN768B:

1. Assemble the lift tool if it is not assembled. The assembly and disassembly instructions are included with the lift tool.
2. Remove both power cords from the SAN768B.
3. Optionally, remove the power supplies and blower assemblies to reduce the weight.
4. Remove the chassis door from the chassis. See “Removing the chassis door and cable management comb” on page 18.
5. Remove the three 10-32 x 5/8 in. Phillips panhead screws with washers on each side. See Figure 9 on page 23 for the location of the screws.
6. If you are replacing the lower SAN768B, go to step 7. If you are replacing the upper SAN768B, go to step 8.
7. Install the bridge tool by completing the following steps:
 - a. Remove the bridge tool from its box and adjust the two supports 45°.
 - b. Hold the bridge tool between the two vertical supports near EIA unit 3.
 - c. Move the two supports another 45°. Make sure that the following conditions are met:
 - The two-pin section of the support is on the back of the vertical support.
 - The one-pin section of the support is on the front of the vertical support.
 - d. Align the two-pin section of the support on the back of the vertical rail with the bottom and middle holes in EIA unit 3.
 - e. Align the one-pin section of the support on the front of the vertical rail with the middle hole in EIA unit 1.

Note: Tilt the bridge tool towards the back of the cabinet approximately 45° to make it easier to align the two-pin and one-pin sections with the vertical support.

- f. Lock the shelf into position.
8. For the upper SAN768B, install the bridge tool by completing the following steps:
 - a. Remove the bridge tool from its box and adjust the two supports 45°.
 - b. Hold the bridge tool between the two vertical supports near EIA unit 20.

- c. Move the two supports another 45°. Make sure that the following conditions are met:
 - The two-pin section of the support is on the back of the vertical support.
 - The one-pin section of the support is on the front of the vertical support.
 - d. Align the two-pin section of the support on the back of the vertical rail with the bottom and middle holes in EIA unit 20.
 - e. Align the one-pin section of the support on the front of the vertical rail with the middle hole in EIA unit 18.
 - f. Lock the shelf into position.
9. Locate the anti-tip bars and if they are not attached, attach them to the lift tool. If anti-tip bars were previously attached, go to step 10.
 - a. Pull up on the leg-lock pins and insert the anti-tip bars inside the legs.
 - b. Pull on the legs and anti-tip bars to ensure that they are locked into position.
 - c. Raise the platform to allow enough room to attach the anti-tip bracket.
 - d. Secure the anti-tip bars with the anti-tip bracket and bolt.
 10. Move the lift tool to a position near the rear of the cabinet.
 11. Turn the winch crank clockwise to raise the switch. Move the lift tool into position in front of the cabinet while you align the 24-inch load plate with the line on the bridge tool.
 12. Turn the winch crank counterclockwise 1/4 turn to set the winch brake.
 13. Set the wheel brake. Place the wheel chocks around the wheels.



CAUTION:

A fully populated SAN768B weighs approximately 159.2 kg (351 lb) and requires a minimum of two people and a lift tool to install it. (C011)



CAUTION:

A pinch point exists between the load plate and the bridge tool.

14. Slide the SAN768B from the cabinet onto the 24-inch load plate. Center the SAN768B on the platform.
15. Install the retention straps.
16. Remove the wheel chocks, release the wheel brake, and move the lift tool away from the cabinet.
17. Lower the load platform to its lowest position.
18. Remove the bridge tool.

Chapter 3. Starting and configuring the SAN768B

Attention: Refer to the latest Fabric OS Release Notes or Interoperability Matrix for information regarding Fabric OS compatibility. This is particularly important for fabrics with 1-Gbps switches using earlier Fabric OS versions. To access the appropriate matrix:

- Go to the IBM SAN web page www.ibm.com/systems/storage/san
- Select the **IBM System Storage SAN768B and SAN384B** product link
- On the displayed product page, click the **Interoperability Matrix** link in the **Learn more** section.

The SAN768B must be configured before it is connected to the fabric, and all of the configuration commands must be entered through the active CP blade. The SAN768B configuration includes the following parameters:

- IP address and subnet mask for the chassis
- IP addresses, host names, subnet masks, and gateway addresses for both CP blades
- Switch name
- Domain ID for the SAN768B (optional)
- WWN for the SAN768B

Note: The SAN768B WWN is initially set by the factory to match the license ID (which is based on the chassis serial number). The WWN can be changed, but the license ID cannot be modified.

The configuration information is mirrored to the standby CP blade, which allows the most current configuration to remain available even if the active CP blade fails. The configuration information for the SAN768B is stored in the WWN cards and the flash memory of the CP blades. The configuration can be backed up to a workstation (uploaded) and then downloaded to the active CP blade if necessary.

Note: If the FS8-18 encryption blade is installed, refer to the *Fabric OS Encryption Administrator's Guide Supporting Tivoli Key Lifecycle Manager (TKLM) Environments* for the procedures to configure the encryption functions.

Figure 13 on page 32 provides an overview of the sequence of tasks to configure the SAN768B.

Configuration Tasks

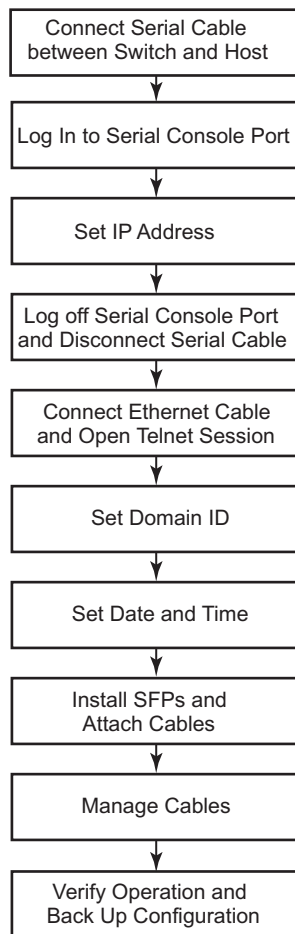

384b004

Figure 13. Flow of basic configuration tasks

The initial physical hardware installation continues with the following steps:

- “Providing power to the SAN768B” on page 33
- “Establishing a serial connection and logging on to the SAN768B” on page 33
- “Configuring the IP addresses” on page 34

The following additional steps are customer responsibilities, generally completed during the initial configuration:

1. Establish an Ethernet connection. See “Connecting an Ethernet cable and opening a Telnet session” on page 36.
2. Specify a switch name. See “Customize a switch name” on page 36.
3. Specify a domain ID for the SAN768B. See “Setting the Domain ID” on page 37.
4. Verify the PID mode and connect the SAN768B to the fabric. See “Verifying the PID mode and connecting to the fabric” on page 39.
5. Enable software licenses. See “Enabling software licenses” on page 39.
6. Configure the optional FS8-18 encryption blade. See “Configuring for encryption (optional)” on page 42
7. Back up the configuration. See “Verifying correct operation and backing up the configuration” on page 43.

Providing power to the SAN768B

DANGER

Use the supplied power cords. Ensure the facility power receptacle is the correct type, supplies the required voltage, and is properly grounded. (D004)

To provide power to the SAN768B:

1. Connect the AC power cords to the power supply assemblies. One to four power cords are required depending on electrical service.
2. Connect the power cords to a power source with voltage of 200 to 240 VAC, 47 to 63 Hz (normally two power cords).
3. Turn the AC power switches on the power supplies to ON (I). The AC power switches light green when switched on and power is supplied.
4. The SAN768B performs a power-on self-test (POST) each time it is powered on. POST takes approximately 10 minutes and is complete when indicator light activity indicates the operational state. For information about LED patterns, see Chapter 4, “Monitoring system components,” on page 47.

You can bypass POST by using the **fastBoot** command. You can also disable POST for successive reboots on the SAN768B using the **diagDisablePost** command.

Attention: To prevent a potential IP address conflict, do not connect the SAN768B to the network until the IP addresses are configured.

Note: To power off the SAN768B, see “Powering off the SAN768B” on page 45.

Establishing a serial connection and logging on to the SAN768B

Note: The preferred method of establishing a connection to the SAN768B is via the serial port. However, if a serial connection is not possible (for example, if a serial cable is not available), then an Ethernet connection can be established using an Ethernet crossover cable. To establish an Ethernet connection, you must know the IP address of the control processor.

To establish a serial connection and log on to the SAN768B:

1. Verify that the SAN768B is powered on and that POST is complete by verifying that all power LED indicators on the port, control processor, and core switch blades display a steady green light.
2. Remove the shipping cap from the CONSOLE port on the active CP. The active CP blade is indicated by an illuminated (blue) LED. Use the serial cable provided with the SAN768B to connect the CONSOLE port on the active CP to a computer workstation.

Attention: The CONSOLE port is intended primarily for the initial setting of the IP address and for service purposes.

3. Access the SAN768B using a terminal emulator application (such as HyperTerminal in a Windows environment or TERM in a UNIX environment).
4. Disable any serial communication programs running on the workstation (such as synchronization programs).
5. Open the terminal emulator application and configure as follows:
 - For most Microsoft Windows systems, use the following configuration parameters.

Bits per second: 9600
Data bits: 8
Parity: None
Stop bits: 1
Flow control: None

- For most UNIX systems, type the string at the prompt:

```
term /dev/ttyb -9600
```

If ttyb is already taken, use ttya instead and enter the following string at the prompt:

```
term /dev/ttya -9600
```

When the terminal emulator application stops reporting information, press Enter. You will receive the following login prompt:

```
CP0 Console Login:
```

Logging in to the serial console port

To log in to the SAN768B through the serial connection, follow these steps.

1. Log in to the SAN768B as **admin**. The default password is "**password**." At the initial login, you are prompted to change the default passwords. Record the new passwords and keep this information in a secure location. The example below shows the login without changing the password.

```
Fabric OS (swDir)
```

```
swDir login: admin
```

```
Password:
```

```
Please change your passwords now.
```

```
Use Control-C to exit or press 'Enter' key to proceed.
```

```
Password was not changed. Will prompt again at next login  
until password is changed.
```

```
swDir:admin>
```

2. (Optional) Modify passwords. To skip modifying the password, press **Ctrl+C**. Passwords can be 8 to 40 characters long. They must begin with an alphabetic character. They can include numeric characters, the dot (.), and the underscore (_). Passwords are case-sensitive, and they are not displayed when you enter them on the command line. For more information on passwords, refer to the *Fabric OS Administrator's Guide*.

Configuring the IP addresses

The SAN768B requires three IP addresses, which are set using the **ipAddrSet** command. IP addresses are required for both CP blades (CP0 and CP1) and for the chassis management IP (shown as SWITCH under the **ipAddrShow** command). These IP addresses are set using the **ipAddrSet** command through the serial or Ethernet connection to the active CP blade.

Note: The default IP addresses and host names for the SAN768B are as follows:

- 10.77.77.75 for CP0 (the CP blade in slot 6 at the time of configuration)
- 10.77.77.74 for CP1 (the CP blade in slot 7 at the time of configuration)

Attention: Resetting an IP address while the SAN768B has active IP traffic such as Fabric Manager, Fabric Watch, SNMP, or other applications can cause traffic to be interrupted or stopped.

Follow these steps to configure the IP addresses for both CP blades (from the active CP blade):

1. Log in to the active CP as **admin** using the serial connection.
2. Set up the SAN768B IP address by entering the **ipaddrset -chassis** command at the prompt.

```
swDir:admin> ipaddrset -chassis
```

Enter the information at the prompts. Specify the **-chassis** IP address. The **-sw 0** IP address is no longer valid on this chassis.

Note: The addresses 10.0.0.0 through 10.0.0.255 are reserved and used internally by the SAN768B. External IPs must not use these addresses.

3. Set up the CP0 blade IP address by entering the **ipaddrset -cp 0** command at the prompt.

```
swDir:admin> ipAddrSet -cp 0
```

Enter the requested information at the prompts.

4. Set up the CP1 blade IP address by entering the **ipaddrset -cp 1** command at the prompt.

```
swDir:admin> ipAddrSet -cp 1
```

Enter the requested information at the prompts.

The following is a sample IP configuration for the SAN768B (chassis) and the two CP blades (cp0 and cp1).

```
swDir:admin>ipaddrset -chassis
Ethernet IP Address [0.0.0.0]: 123.123.123.120
Ethernet Subnetmask [0.0.0.0]: 123.123.123.123
Fibre Channel IP Address [0.0.0.0]:
Fibre Channel Subnetmask [0.0.0.0]:
Issuing gratuitous ARP...Done.
Committing configuration...Done.
```

```
swDir:admin> ipaddrset -cp 0
Host Name [cp0]:
Ethernet IP Address [10.77.77.75]: 123.123.123.121
Ethernet Subnetmask [0.0.0.0]: 123.123.123.123
Gateway IP Address [0.0.0.0]: 123.123.123.124
IP address is being changed...Done.
Committing configuration...Done.
```

```
swDir:admin> ipaddrset -cp 1
Host Name [cp1]:
Ethernet IP Address [10.77.77.74]: 123.123.123.122
Ethernet Subnetmask [0.0.0.0]: 123.123.123.123
Gateway IP Address [0.0.0.0]: 123.123.123.124
IP address of remote CP is being changed...Done.
Committing configuration...Done.
swDir:admin> reboot
```

5. Enter **reboot** at the prompt to reboot the SAN768B

Logging off the serial console port and disconnecting the serial cable

You can use the serial port to monitor error messages through the serial connection. If the serial port is no longer required, use the **logout** command to log out of the serial console, remove the serial cable, and replace the plug in the serial port.

Connecting an Ethernet cable and opening a Telnet session

Note: Connecting the CP blades to a private network/VLAN is recommended.

After using a serial connection to configure the IP addresses for the SAN768B, you can connect the active CP blade to the local area network (LAN) if desired.

By establishing an Ethernet connection, you can complete the SAN768B configuration using a serial session, Telnet, or management applications, such as Web Tools or DCFM.

To establish an Ethernet connection to the SAN768B, follow these steps:

1. Remove the shipping plug from the Ethernet port on the active CP blade.
2. Insert one end of an Ethernet cable into the Ethernet port.
3. Connect the other end to an Ethernet 10/100/1000 Base-T LAN.

The SAN768B can now be accessed by remote connection using any of the available management tools, such as such as Telnet, Web Tools, or DCFM.

4. To complete any additional SAN768B configuration procedures through a Telnet session, log in to the SAN768B by Telnet, using the **admin** login. The default password is **password**.

Customize a switch name

The *switch* name of the SAN768B can be up to 30 characters long as of Fabric OS release 6.3.0; can include letters, numbers, and underscore characters; and must begin with a letter. Fabric OS releases earlier than 6.3.0 require switch names of 15 characters or less.

Note: Changing the name causes a domain address format RSCN to be issued.

To customize the name, follow these steps:

1. Enter the **switchName** command followed by the new name in double quotes..

```
swDir:admin> "swModularSwitch5"  
Committing configuration...  
Done.  
swModularSwitch5:admin>
```

2. Record the new name for future reference.

Customizing a chassis name

For Fabric OS 6.2.0 and later, the chassis name of the SAN768B can be up to 15 characters long; can include letters, numbers, and underscore characters; and must begin with a letter.

1. Enter **chassisName** followed by the new name in double quotes.

```
switch:admin> chassisname "SAN768B_chassis_1"  
Committing configuration...  
Done.
```

2. Display the new chassis name.
switch:admin> **chassisname** SAN768B_chassis_1
3. Record the new name for reference.

Setting the Domain ID

Each switch in the fabric must have a unique Domain ID. The Domain ID can be set using the **configure** command or can be automatically set. The default Domain ID for the SAN768B is "1".

To set the Domain ID, follow these steps:

1. Enter the **fabricShow** command to display the already assigned Domain IDs.
2. Enter the **switchDisable** command to disable the SAN768B.
3. Enter the **configure** command.
4. Enter **y** at the "Fabric parameters" prompt:

```
Fabric parameters (yes, y, no, n): [no] y
```

5. Enter a unique Domain ID:

```
Domain: (1..239) [1] 3
```

6. Complete the remaining prompts or press **Ctrl+D** to accept the settings and to exit.
7. Enter the **switchEnable** command to reenable the SAN768B.

Setting the date and time

The date and time settings are used for logging events. Switch operation does not depend on the date and time; a switch with an incorrect date and time value still functions properly. However, because the date and time are used for logging, error detection, and troubleshooting, they should be set correctly.

Setting the date

To set the date, follow these steps.

1. If necessary, log on to the SAN768B by Telnet, using the **admin** account.
2. Enter the **date** command, using the following syntax:**date "mmddHHMMyy"**
Where:
 - mm is the month; valid values are 01 through 12.
 - dd is the date; valid values are 01 through 31.
 - HH is the hour; valid values are 00 through 23
 - MM is minutes; valid values are 00 through 59.
 - yy is the year; valid values are 00 through 99 (values greater than 69 are interpreted as 1970 through 1999, and values less than 70 are interpreted as 2000-2069).

```
switch:admin> date  
Fri Sep 26 17:01:48 UTC 2008  
switch:admin> date "0926123008"  
Fri Sep 26 12:30:00 UTC 2008  
switch:admin>
```

Setting the time zone

To set the time zone, follow these steps.

1. If necessary, log on to the switch by Telnet, using the **admin** account.
2. Enter the **tsTimeZone** command as follows:

```
switch:admin> ts timezone [--interactive]/ [, timezone_fmt]
```

Use **timezone_fmt** to set the time zone by Country/City or by time zone ID, such as MST.

The following example shows how to change the time zone to US/Mountain.

```
switch:admin> ts timezone  
Time Zone : US/Pacific  
switch:admin> ts timezone US/Mountain  
switch:admin> ts timezone  
Time Zone : US/Mountain
```

The following procedure describes how to set the current time zone using interactive mode.

1. Enter the **tsTimeZone** command as follows:

```
switch:admin> ts timezone --interactive
```

You will be prompted to select a general location.

Please identify a location so that time zone rules can be set correctly.

2. Enter the appropriate number or **Ctrl+D** to quit.
3. At the prompt, select a country location.
4. At the prompt, enter the appropriate number to specify the time zone region or **Ctrl+D** to quit.

Synchronizing local time

To synchronize the local time of the principal or primary switch with that of an external NTP server, follow these steps.

1. If necessary, log on to the switch by Telnet, using the **admin** account.
2. **switch:admin> ts clockserver "<ntp1;ntp2>"**

where ntp1 is the IP address or DNS name of the first NTP server, which the switch must be able to access. The variable ntp2 is the second NTP server and is optional. The operand "<ntp1;ntp2>" is optional; by default, this value is LOCL, which uses the local clock of the principal or primary switch as the clock server.

The **tsClockServer** command accepts multiple server addresses in either IPv4, IPv6, or DNS name formats. When multiple NTP server addresses are passed, **ts clockserver** sets the first obtainable address as the active NTP server. The others will be stored as backup servers that can take over if the active NTP server fails. The principal or primary FCS switch synchronizes its time with the NTP server every 64 seconds.

```
switch:admin> ts clockserver  
LOCL  
switch:admin> ts clockserver "132.163.135.131"  
switch:admin> ts clockserver  
132.163.135.131  
switch:admin>
```

The following example shows how to set up more than one NTP server using a DNS name:

```
switch:admin> tsclockserver "10.32.170.1;10.32.170.2;ntp.localdomain.net"
Updating Clock Server configuration...done.
Updated with the NTP servers
```

Changes to the clock server value on the principal or primary FCS switch are propagated to all switches in the fabric

Verifying the PID mode and connecting to the fabric

To verify PID mode, connect the system to the fabric and verify status, follow these steps:

1. Before connecting the SAN768B to the fabric, verify that the port identifier (PID) mode on the SAN768B matches the other switches in the fabric. This parameter must be set identically on all switches in the fabric. This parameter is set using the **configure** command. For information on PID mode, refer to the *Fabric OS Administrator's Guide*.
2. Verify the SAN768B switch and port status by entering the **switchShow** command. This command provides detailed information about the SAN768B.
3. Verify fabric connectivity by entering the **fabricShow** command. This command provides general information about the fabric.

Enabling software licenses

To determine which licenses are currently enabled, enter the **licenseShow** command.

```
swDir:admin> licenseshow
AAbbccDDeeFFeeGG:
  Web license
  Zoning license
  Extended Fabric license
  Fabric Watch license
  Performance Monitor license
  Trunking license
  Security license
```

In the example above, the license key is AAbbccDDeeFFeeGG. Make sure you keep a copy of your license key in a secure location for reference.

The 64-bit chassis ID is required to obtain and activate licenses for the SAN768B. The chassis ID is available through the **licenseIdShow** command.

Both the **licenseShow** and **licenseIdShow** commands must be entered through the active CP blade.

For information about activating licenses, refer to the *Fabric OS Administrator's Guide*.

Installing transceivers and attaching cables

Follow these steps to install SFPs, SFP+s, mSFPs (FC8-64 port blade only), or XFPs (FC10-6 port blade only) and cables to the SAN768B.

Note: For a listing of transceivers compatible with this product:

- Go to the IBM SAN web page www.ibm.com/systems/storage/san
- Select the **IBM System Storage SAN768B and SAN384B** product link

- On the displayed product page, click the **Interoperability Matrix** link from the **Learn more** section
- In the Interoperability matrix document, click the **Transceivers** link.

Attention: mSFP transceivers are compatible only with the FC8-64 port blade. While they will fit in other blades, this configuration is unsupported and will generate an error.

The ports are color-coded to indicate which can be used in the same port group for trunking (trunking port groups can be up to eight ports). The ports and cables used in trunking groups must meet specific requirements. Refer to the *Fabric OS Administrator's Guide* for more information.

1. Position one of the optical transceivers so that the key is oriented correctly to the port. Insert the transceiver into the port until it is firmly seated and the latching mechanism clicks.

Transceivers are keyed so that they can only be inserted with the correct orientation. If a transceiver does not slide in easily, ensure that it is correctly oriented.

2. Position a cable so that the key (the ridge on one side of the cable connector) is aligned with the slot in the transceiver; then, insert the cable into the transceiver until the latching mechanism clicks.

Cables are keyed so that they can only be inserted with the correct orientation. If a cable does not slide in easily, ensure that it is correctly oriented.

3. Repeat steps 1 and 2 for the remaining ports.
4. Organize the cables as required. For recommendations regarding cable management, refer to “Managing cables.”
5. Verify the SAN768B and port status using the **switchShow** command.
6. Verify fabric connectivity using the **fabricShow** command.

Note: The chassis door must be installed to ensure the SAN768B meets EMI and other regulatory certifications. Once all transceivers and cables are attached and arranged, and configuration is complete, reinstall the chassis door. See “Removing and installing the chassis door” on page 69.

Managing cables

Attention: The minimum bend radius should be no smaller than 10x the cable radius.

Note: Contact your IBM representative for options regarding different cable and patch panel configurations to simplify cable management with higher density FC8-64 port blades.

A horizontal cable management finger assembly (shown in Figure 30 on page 71) is attached to the chassis under the chassis door and allows for simple cable management.

Cable management recommendations:

- Leave at least 1 m (3.28 ft) of slack for each port cable. This provides room to remove and replace blades in the chassis, allows for inadvertent movement of the rack, and helps prevent the cables from being bent to less than the minimum bend radius.

- If ISL Trunking is in use, group the cables by trunking group. The ports are color-coded to indicate which ports can be used in the same ISL Trunking group: eight ports marked with solid black ovals alternate with eight ports marked with oval outlines.
- Use only hook-and-loop fasteners for securing cables. Do not use cable ties. They can be easily overtightened and can break the optical cables.
- For easier maintenance, label the fiber optic cables and record the devices to which they are connected.
- Route the cables to the bottom of the chassis through the cable comb.
- Keep LEDs visible by routing port cables and other cables away from the LEDs.

For the procedure to install the ICL cables see “Removing and installing inter-chassis link (ICL) cables” on page 97.

Planning for encryption (optional)

Encryption is an optional feature available on the SAN768B through the installation and use of the FS8-18 encryption blade. Advance planning is essential to achieve a successful implementation of encryption.

Attention: Setup of the FS8-18 blade for encryption requires the use of this document for the physical installation of the blade. Critical information required for enabling and managing encryption is contained in the *Fabric OS Encryption Administrator's Guide Supporting Tivoli Key Lifecycle Manager (TKLM) Environments*, which is included on the documentation CD-ROM that is shipped with the product. You must use both documents in order to successfully set up the switch for encryption.

Careful attention to details of setup and configuration are essential to enabling a secure encryption functionality. The following guidelines should be followed when planning for encryption with the 16-port encryption blade (FS8-18), which is available for the SAN768B and SAN384B products, or the SAN32B-E4.

- Redundancy of hardware is essential because if the encryption path is disrupted, access to the encrypted data will be lost with a single encryption device. You must have two encryption devices to ensure backup and access in the event that one of the devices goes down. If one of the devices in the encryption pair is not functioning, you will only have read access to the encrypted data on the functioning device until the non-functioning device is restored. Redundancy of hardware for encryption can be accomplished with the following:
 - Two Key Vault locations on different devices
 - Two encryption devices in any combination of encryption switches (SAN32B-E4) and FS8-18 encryption blades (in SAN768B or SAN384B chassis)
- Cable planning for the encryption switch and its back-up and for a primary and secondary key vault manager is critical. These devices can be separated by distance as long as they can maintain constant communication contact. One device must back up the other to ensure access to encrypted data. Refer to the *Fabric OS Encryption Administrator's Guide Supporting Tivoli Key Lifecycle Manager (TKLM) Environments* for more information on Master Keys (MK).
- Begin with a limited application of encryption in a test environment and once an expanded encryption test is successful, move the encryption into production
- Avoid dual encryption (Fabric encryption and device encryption). While this should not cause any encryption errors, it will degrade performance.

- There is no support of Cisco switches at this time by IBM. The section in the *Fabric OS Encryption Administrator's Guide Supporting Tivoli Key Lifecycle Manager (TKLM) Environments* related to Cisco Fabric connectivity does not currently apply.
- The use of Smart Cards provides additional encryption security management, and is highly recommended. Smart cards can be ordered as FRUs through IBM.
- The Top Talker feature is not compatible with redirection zones. The Top Talker feature should not be enabled when an encryption switch or blade is present in the fabric.
- Alias zoning is not supported in encryption environments. You must use the real WWPN.
- Refer to the "Steps for connecting to a TKLM appliance" section of the *Fabric OS Encryption Administrator's Guide Supporting Tivoli Key Lifecycle Manager (TKLM) Environments* for detailed information on initial setup. That section includes the following information:
 - All switches you plan to include in an encryption group must have a secure connection to the Tivoli Key Lifecycle Manager (TKLM). A local LINUX host must be available to transfer certificates.
 - Be sure that the clock time on the TKLM server and on the Brocade encryption nodes are the same. A difference of only a few minutes can cause the TLS connectivity to fail.
 - Repeat the same steps for configuring both the primary and the secondary key vault.
 - Both the primary and secondary key vaults should be registered before exporting MK or encrypting LUNs. If the secondary key vault is registered midway after encryption is done for some of the LUNs, then the key database should be backed up and restored on the secondary TKLM from the already registered primary TKLM before registering the secondary TKLM.
 - The following is a suggested order for the initial steps needed to create a secure connection to TKLM. (Refer to the "Steps for connecting to a TKLM appliance" section of the *Fabric OS Encryption Administrator's Guide Supporting Tivoli Key Lifecycle Manager (TKLM) Environments* for additional steps.)
 1. Initialize all encryption nodes to generate Key authentication center (KAC) certificates and export the signed KAC certificates to a local LINUX host.
 2. Obtain the necessary user credentials and log in to the TKLM server appliance from the TKLM management web console.

Configuring for encryption (optional)

Summary of procedure

The optional FS8-18 encryption blade requires configuration to enable the configuration functions. This section provides a brief overview of those configuration steps. Refer to the *Fabric OS Encryption Administrator's Guide Supporting Tivoli Key Lifecycle Manager (TKLM) Environments* for the detailed procedures to configure the encryption functions.

Note:

If the encryption blade (FS8-18) is being configured for the first time for encryption services, you will need to perform several pre-initialization tasks related to configuring the encryption node (switch), including:

- Generating the Critical Security Parameters (CSPs) and certificates

- Loading and setting up the certificates
- Establishing a trusted link (LKM Appliance)
- Configuring the global parameters and policies of the encryption group
- Generating and backing up the master key in RSA environments
- Handling key-vault high-availability
- Configuring cluster interconnect

After completing the pre-initialization tasks, you may need to perform several tasks related to configuring the encryption group. Figure 14 summarizes the flow of the encryption-configuration tasks.

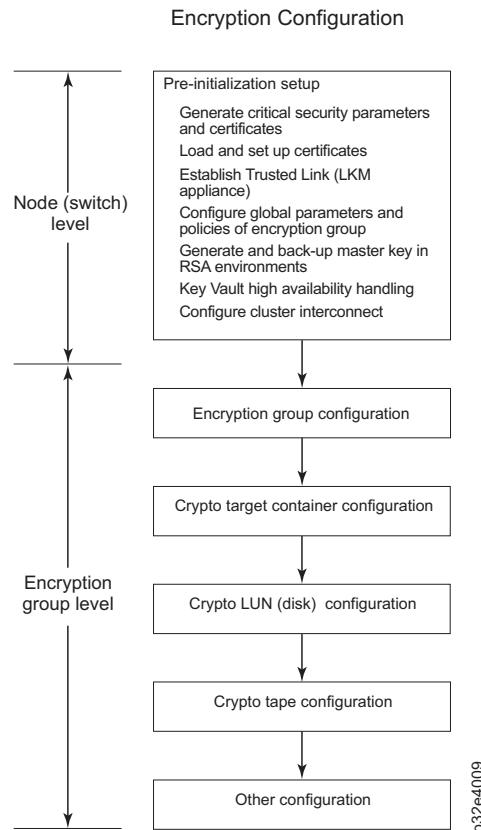

Figure 14. Encryption configuration

Avoid double encryption

Encryption and decryption at the storage device level does not affect the encryption switch or blade capabilities, and does not cause problems with decrypting the data. However, double encryption adds the unnecessary need to manage two sets of encryption keys, increases the risk of losing data, may reduce performance, and does not add security.

Verifying correct operation and backing up the configuration

To verify correct operation and to back up the system, follow these steps.

1. Check the LEDs to verify that all components are functional. For information about LED patterns, see Chapter 4, “Monitoring system components,” on page 47.
2. If necessary, log on to the switch by Telnet, using the **admin** account.

3. Verify the correct operation of the system by entering the **switchShow** command from the workstation. This command provides information about switch and port status.
4. Verify the correct operation of the SAN768B in the fabric by entering the **fabricShow** command from the workstation. This command provides general information about the fabric.
5. To back up the configuration, run the following two steps:
 - a. Enter the **configupload -vf** command. This command uploads the system virtual fabric data.
 - b. Enter the **configupload** command. This command uploads the system configuration.
6. Run the following commands to see additional configuration information that you can then copy to a file to save:
 - **configShow**
 - **ipAddrShow**
 - **licenseShow**
 - **switchShow**

Note: Passwords are not saved in the configuration file, and are not uploaded during a **configUpload**. Password information should be saved in hardcopy in a secure location for emergency reference, subject to your security and password management policy.

Note: It is recommended that the configuration be backed up on a regular basis to ensure that a complete configuration is available for downloading to a replacement device.

Fabric OS firmware updates

To ensure optimum functioning of your system, IBM recommends operating your system with the latest Fabric OS version and firmware updates. Refer to the latest Fabric OS Release Notes and Interoperability Matrix for information regarding Fabric OS compatibility. This is particularly important for fabrics with 1-Gbps switches using earlier Fabric OS versions. Detailed information on downloading and installing firmware are provided in the *Fabric OS Administrator's Guide*.

To access the appropriate matrix:

- Go to the IBM SAN web page www.ibm.com/systems/storage/san
- Select the **SAN768B and SAN384B** product link
- On the displayed product page, click the **Interoperability Matrix** link in the **Learn more** section.

Firmware release notes and download files are available through the IBM Support Portal.

To view release notes and to download firmware:

- Go to the IBM Support Portal www.ibm.com/supportportal.
- Search for the product Machine type, 2499 or the product name.
- On the next page that is displayed, select **Download** under the **Task** section.
- From the displayed page, select the Release notes link. Review the release notes of the appropriate release version before installing the firmware update.

- Click the **Release Firmware** link and follow the online prompts to navigate to the **Brocade Downloads for IBM End Users** page.
- Follow the links and instructions on the Brocade pages. Note that associated FOS documentation can also be downloaded from this site.

Downloading and installing firmware

1. The firmware version on both the active and backup CP blade should match, and should be at the latest level. If High Availability is enabled (**haEnable**), the system will automatically update the firmware level on both CP blades.
Attention: Firmware downloads require Ethernet connections to both CP blades. Procedures for downloading and installing firmware are fully described in the *Fabric OS Administrator's Guide*.
2. When you have navigated to the appropriate download site, follow the online instructions on the displayed Fabric OS download pages, referring to the *Fabric OS Administrator's Guide* as needed.
3. Enter **firmwareDownload -s** on your to download the firmware to one of the CP blades from your server.

Powering off the SAN768B

If you need to power off the system, follow these steps to avoid loss of data.

1. Shut down the system using the **sysShutdown** command.

```
switch::admin> sysshutdown
This command will shutdown the operating systems on your switch.
You are required to power-cycle the switch in order to restore operation.
Are you sure you want to shutdown the switch [y/n]? y
HA is disabled
Stopping blade 1
Shutting down the blade....
Stopping blade 4
Shutting down the blade....
Stopping blade 10
Shutting down the blade....
Broadcast message from root (pts/1) Tue Aug 23 14:23:06 2008...
The system is going down for system halt NOW !!
```

2. Power off the chassis by flipping the AC power switches on the power supplies to "O". The LEDs inside AC power switches should turn off. To maintain the ground connections, leave the power cords connected to the power supplies and to the electrical outlets.

Chapter 4. Monitoring system components

The SAN768B is engineered for reliability and requires no routine operational steps or maintenance. This chapter provides information about determining the status of the following components using LEDs and CLI commands. Refer to the *Web Tools Administrator's Guide* and the *Fabric OS Administrator's Guide* for additional information.

- “Port, application, or encryption blade status”
- “Control processor blade (CP8) status” on page 59
- “Core switch blade (CR8) status” on page 61
- “Power supply status” on page 63
- “Blower assembly status” on page 64
- “WWN bezel and WWN card status” on page 66

Port, application, or encryption blade status

To determine the status of a port or application blade:

1. Check the LEDs on the blade.
 - Figure 15 on page 48 illustrates the FC8-16 port blade.
 - Figure 16 on page 49 illustrates the FC8-32 port blade.
 - Figure 17 on page 50 illustrates the FC8-48 port blade.
 - Figure 18 on page 51 illustrates the FC8-64 port blade.
 - Figure 19 on page 52 illustrates the FC10-6 port blade.
 - Figure 20 on page 53 illustrates the FR4-18i routing blade.
 - Figure 21 on page 54 illustrates the FS8-18 encryption blade
 - Figure 22 on page 55 illustrates the FX8-24 extension blade
 - Figure 23 on page 56 illustrates the FCOE10-24 Fibre Channel over Ethernet blade
2. The LED patterns may temporarily change during POST and other diagnostic tests. For information about how to interpret the LED patterns, see Table 6 on page 57, which describes the port, application, and routing blade LED patterns and the recommended actions for those patterns.
3. Check the blade status by entering **slotShow**.

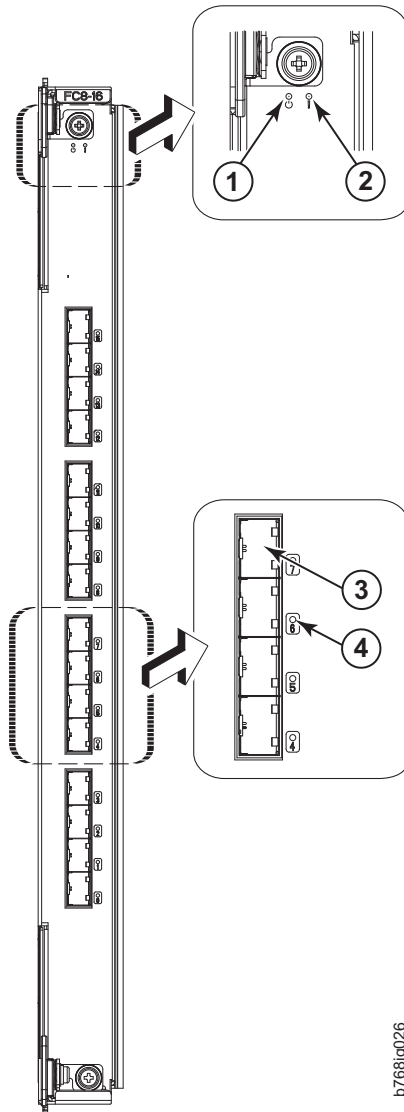

b768ig026

Figure 15. FC8-16 port blade

- 1** Blade power LED
- 2** Blade status LED

- 3** Fibre Channel port
- 4** Port status LED

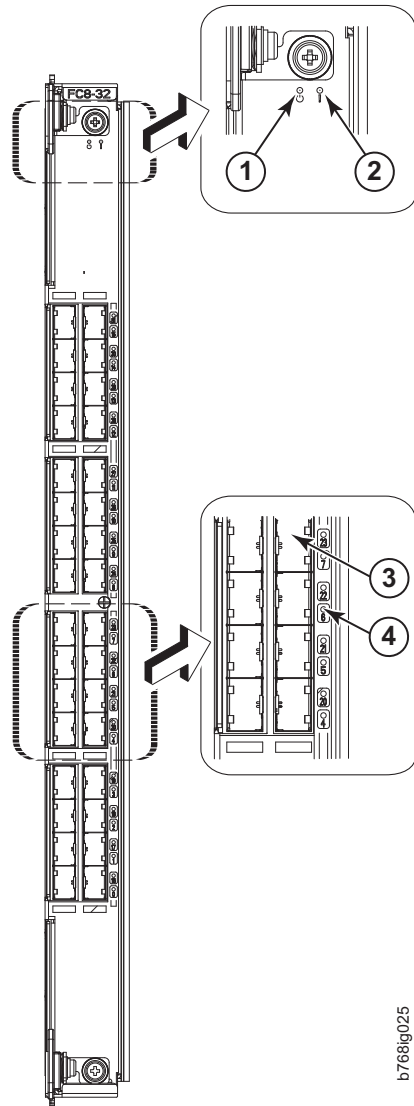

b768ig025

Figure 16. FC8-32 port blade

- 1** Blade power LED
- 2** Blade status LED

- 3** Fibre Channel port
- 4** Port status LED

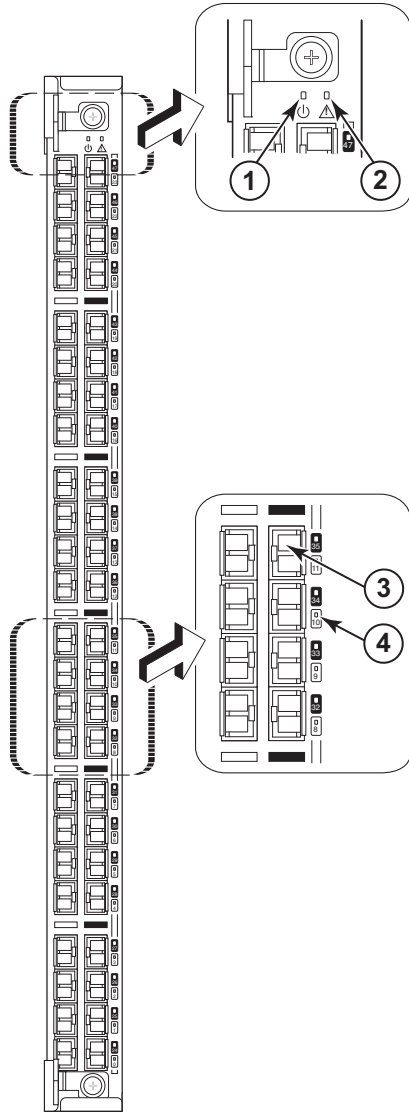

b768ig024

Figure 17. FC8-48 port blade

- 1** Blade power LED
- 2** Blade status LED
- 3** Fibre Channel port
- 4** Port status LED

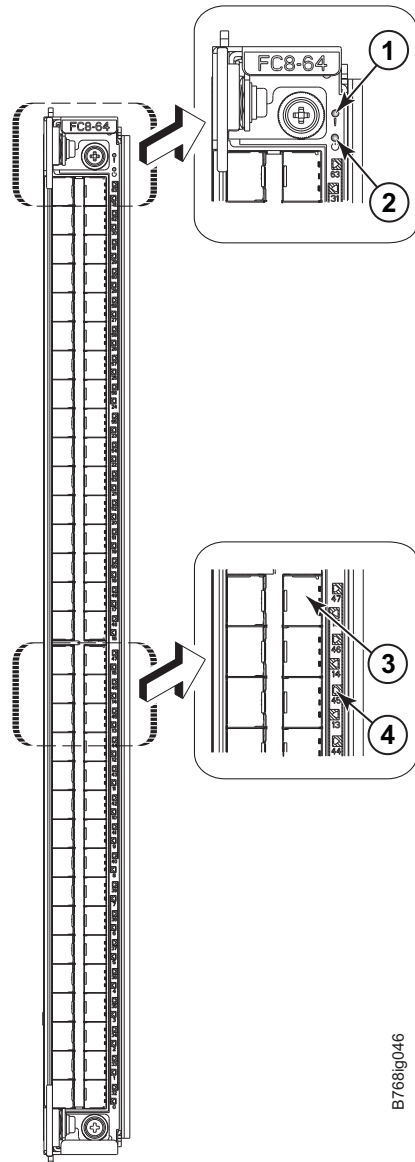

B768g046

Figure 18. FC8-64 port blade

- | | | | |
|----------|------------------|----------|--------------------|
| 1 | Blade status LED | 3 | Fibre Channel port |
| 2 | Blade power LED | 4 | Port status LED |

Note: The FC8-64 port blade requires narrower OM-3 LC cables.

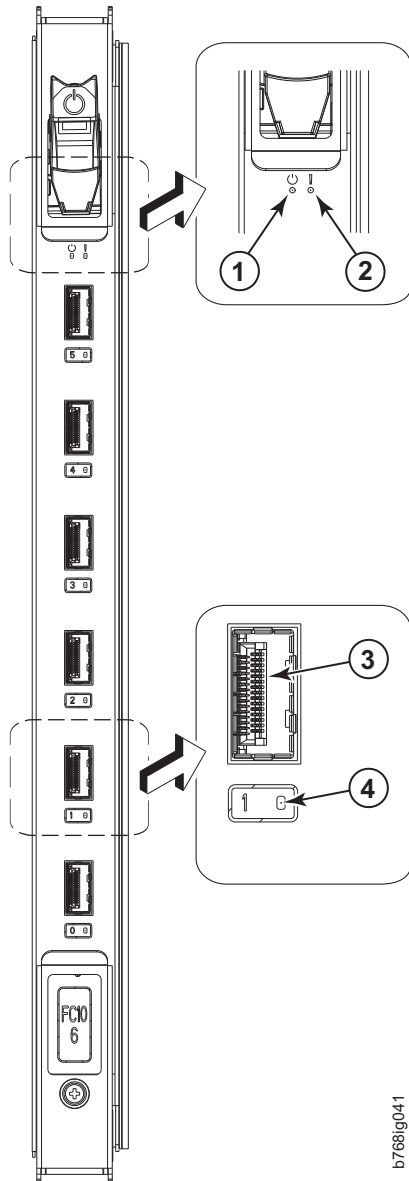

b7688g041

Figure 19. FC10-6 port blade

- | | | | |
|----------|------------------|----------|--------------------|
| 1 | Blade power LED | 3 | Fibre Channel port |
| 2 | Blade status LED | 4 | Port status LED |

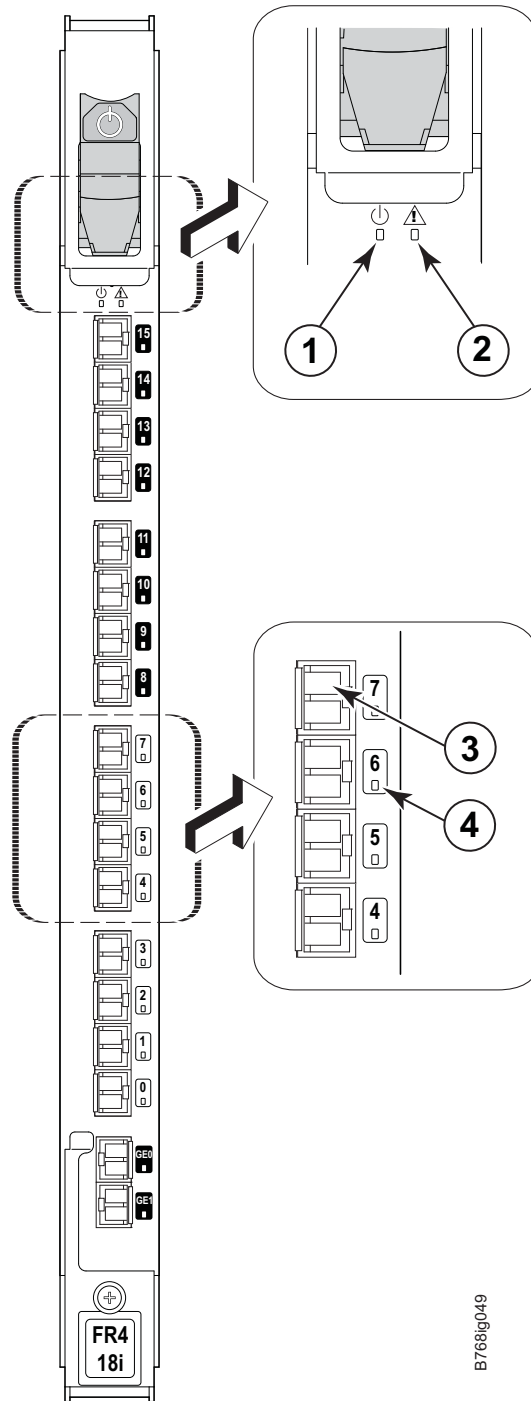

B768ig049

Figure 20. FR4-18i routing blade

- 1** Blade power LED
- 2** Blade status LED
- 3** Fibre Channel port
- 4** Port status LED

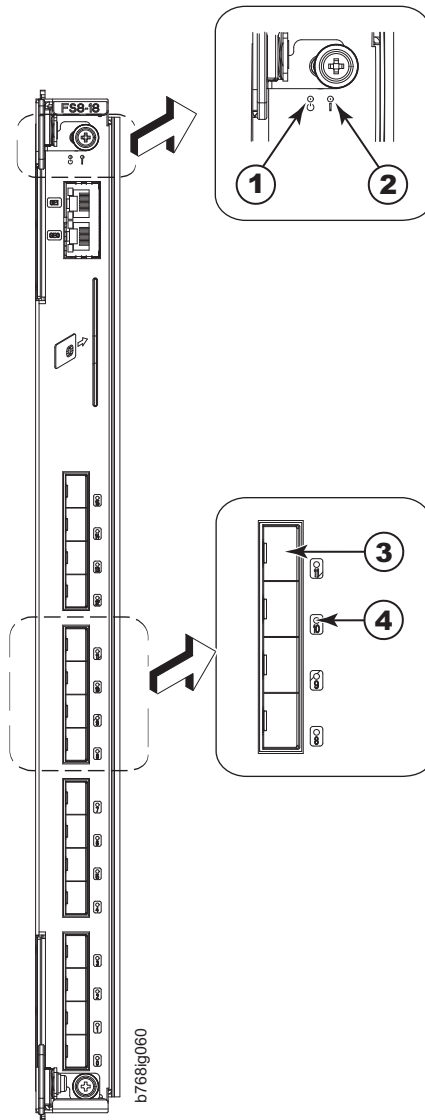
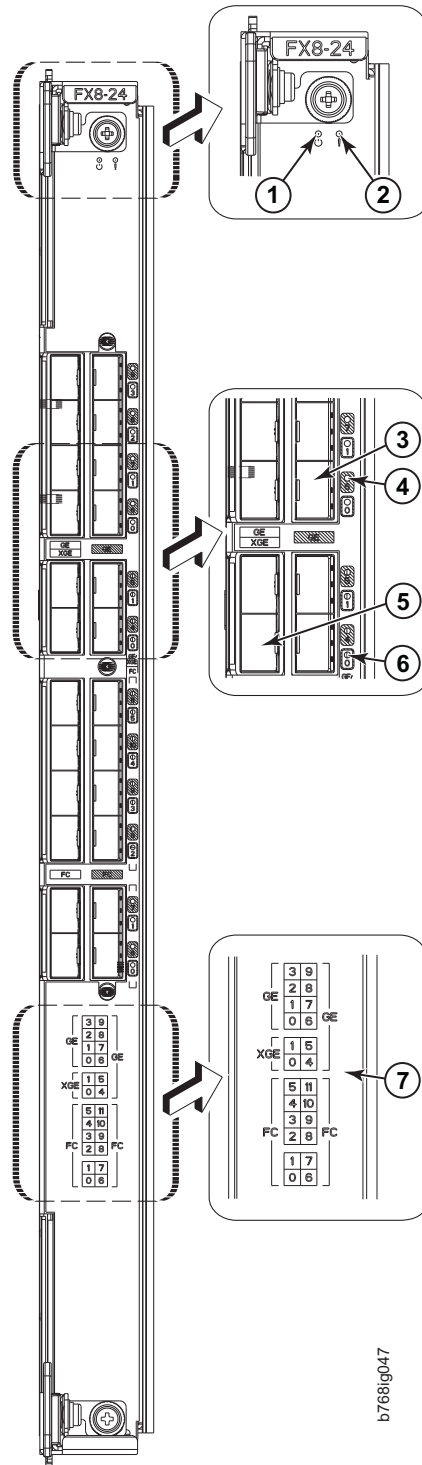

Figure 21. FS8-18 encryption blade

- 1** Blade power LED
- 2** Blade status LED

- 3** Fibre Channel port
- 4** Port status LED



b7688g047

Figure 22. FX8-24 extension blade

- | | | | | | |
|----------|------------------|----------|-------------------|----------|----------|
| 1 | Blade power LED | 4 | GbE port 6 LED | 7 | Port map |
| 2 | Blade status LED | 5 | 10 GbE port 0 | | |
| 3 | GbE port 6 | 6 | 10 GbE port 0 LED | | |

See “FX8-24 blade” on page 144 for information about trunking groups on this blade.

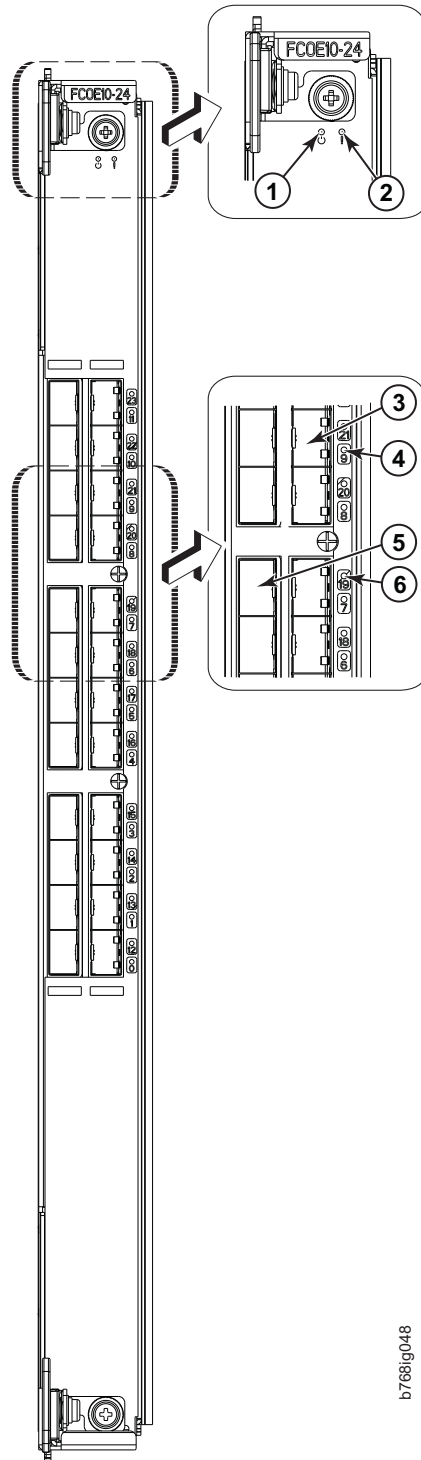

b768ig048

Figure 23. FCOE10-24 blade

- | | | | |
|----------|--------------------|----------|-------------------------|
| 1 | Blade power LED | 4 | 10 GbE FCoE port 9 LED |
| 2 | Blade status LED | 5 | 10 GbE FCoE port 19 |
| 3 | 10 GbE FCoE port 9 | 6 | 10 GbE FCoE port 19 LED |

Table 6 describes the port, application, and encryption blade LED patterns and the recommended actions for those patterns.

Table 6. Port, application, and encryption blade LED descriptions

LED purpose	Color	Status	Recommended action
Blade power LED	Steady green	Blade is enabled.	No action required.
	No light (LED is off)	Blade is not powered on.	Ensure that the blade is firmly seated and either the thumbscrew is fully engaged or the slider is pushed up and the ejectors are fully engaged.
Blade status LED	No light (LED is off)	Blade is either healthy or does not have power.	Verify that the power LED is on.
	Steady amber	Blade is faulty.	Ensure blade is firmly seated and check status by entering the slotShow command. Blade may not be compatible with other blades in the chassis. See “FCOE10-24 blade” on page 145 for limitations. If LED remains amber, contact IBM.
	Slow-flashing amber (on 2 seconds, then off 2 seconds)	Blade is not seated correctly or is faulty.	Pull blade out and reseal it. If the LED continues to flash, replace the blade.
	Fast-flashing amber (on 1/2 second, then off 1/2 second)	Environmental range exceeded.	Check for out-of-bounds environmental condition and correct it.

Table 6. Port, application, and encryption blade LED descriptions (continued)

LED purpose	Color	Status	Recommended action
FC port status	No light (LED is off)	Port has no incoming power, or there is no light or signal carrier detected.	Verify that the power LED is on, check the transceiver and cable.
		Polling is in progress.	Allow 60 seconds for polling to complete.
		Connected device is configured in an offline state.	Verify the status of the connected device.
	Steady green	Port is online (connected to an external device) but has no traffic.	No action required.
	Slow-flashing green (on 1 second, then off 1 second)	Port is online but segmented, indicating a loopback plug or cable or an incompatible switch.	Verify that the correct device is attached to the SAN768B.
	Fast-flashing green (on 1/4 second, then off 1/4 second)	Port is in internal loopback (diagnostic).	No action required.
	Flickering green	Port is online, with traffic flowing through port.	No action required.
	Steady amber	Port is receiving light or signal carrier, but it is not online yet.	Reset the port from the workstation using the portEnable or portCfgPersistentEnable command.
	Slow-flashing amber (on 2 seconds, then off 2 seconds)	Port is disabled due to diagnostic tests or portDisable or portCfgPersistentEnable command.	Reset the port from the workstation using the portEnable or portCfgPersistentEnable command.
	Fast-flashing amber (on 1/2 second, then off 1/2 second)	Transceiver or port is faulty.	Change the transceiver or reset the switch from the workstation.
	Alternating green/amber	Port is bypassed	Reset port from workstation using the portEnable or portCfgPersistentEnable command.
	Green, amber, off (cycle is about 1 second)	Beaconing initiated on the local switch.	No action required. Beaconing used to locate/identify port.
	Amber, amber, pause (cycle is about 1 second)	Beaconing initiated on the HBA and reflected on the port.	No action required. Beaconing used to locate/identify port.
GbE port status (FX8-24) - both 1 GbE and 10 GbE ports	No light (LED is off)	Port has no incoming power, or there is no light or signal carrier detected.	Verify that the power LED is on, check the transceiver and cable.
	Steady green	Port is online but has no traffic.	No action required.
	Slow-flashing green (on 1 second, then off 1 second)	Beacon. Used to identify specific ports.	No action required.
	Flickering green	Port is online, with traffic flowing through port.	No action required.
	Fast-flashing amber (on 1/4 second, then off 1/4 second)	Transceiver or port is faulty.	Change the transceiver or reset the switch from the workstation.

Table 6. Port, application, and encryption blade LED descriptions (continued)

LED purpose	Color	Status	Recommended action
10GbE port status (FCOE10-24)	No light (LED is off)	Port is offline.	Verify that the power LED is on, check the transceiver and cable.
	Steady green	Port is online but has no traffic.	No action required.
	Flickering green	Port is online, with traffic flowing through port.	No action required.
	Steady amber	Port is receiving light but it is not online yet.	Reset the port by doing a shutdown and no shutdown sequence from a cmsh session.
	Slow-flashing amber (on 2 seconds, then off 2 seconds)	Port is disabled.	Enable the port by using the no shutdown command from a cmsh session.
	Fast-flashing amber (on 1/4 second, then off 1/4 second)	Transceiver or port is faulty.	Change the transceiver or reset the port by doing a shutdown and no shutdown sequence from a cmsh session.

For more information on the CEE Management Shell (cmsh), see the *Fabric OS Command Reference Manual* or the *Converged Enhanced Ethernet Command Reference*.

Control processor blade (CP8) status

To determine the status of a CP blade:

1. Check the LED indicators on the CP blade (see Figure 24 on page 60). The LED patterns may temporarily change during POST and other diagnostic tests. For information about how to interpret the LED patterns, see Table 7 on page 60.
2. Check port blade status by typing **slotShow** and **haShow**.

Figure 24 on page 60 identifies the control processor blade (CP8) and its components.

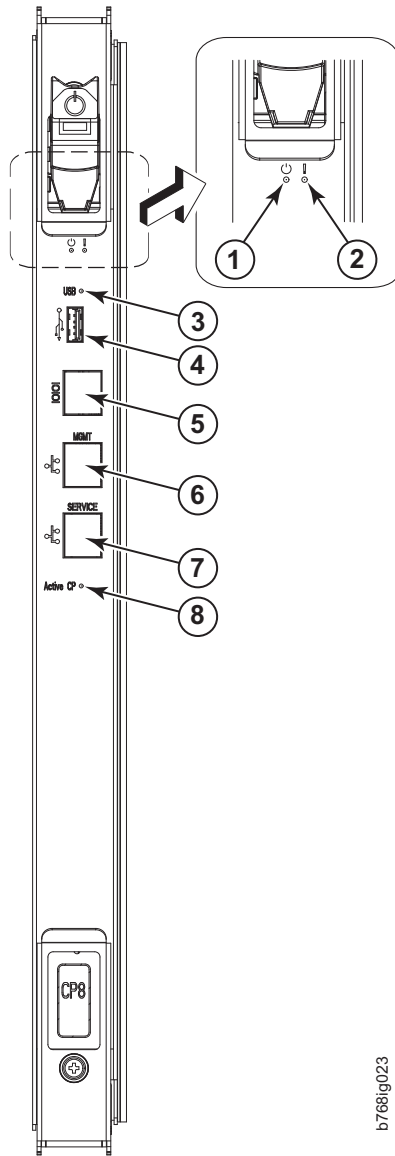

b7681g023

Figure 24. Control processor blade (CP8) components

- | | | | |
|----------|------------------|----------|----------------------------|
| 1 | Blade status LED | 5 | Console port (10101) |
| 2 | Blade power LED | 6 | Ethernet port (MGMT IP) |
| 3 | USB LED | 7 | Ethernet port (SERVICE IP) |
| 4 | USB port | 8 | Active CP LED |

Table 7. CP8 blade LED descriptions

LED purpose	Color	Status	Recommended Action
Blade power	Steady green	CP blade is on.	No action required.
	No light (LED is off)	CP blade is not on.	Ensure blade is firmly seated and has power.

Table 7. CP8 blade LED descriptions (continued)

LED purpose	Color	Status	Recommended Action
Blade status	No light (LED is off)	CP blade is either healthy or does not have power.	Verify that the power LED is on.
	Steady amber	CP blade is faulty or the switch is still booting.	Ensure blade is firmly seated and switch has completed booting. If LED remains amber, contact IBM.
	Slow-flashing amber (on 2 seconds; then off 2 seconds)	CP blade is not seated correctly or is faulty.	Pull blade out and reseat it. If LED continues to flash, replace the blade.
	Fast-flashing amber (on 1/2 second; then off 1/2 second)	Environmental range exceeded.	Check for out-of-bounds environmental condition and correct it.
Ethernet link status	No light (LED is off)	Either an Ethernet link is not detected, or it does not have incoming power.	Ensure the blade has power, Ethernet cable is firmly seated, and connected device is functioning.
	Flickering green/amber	Ethernet link is healthy and traffic is flowing through port.	No action required.
Ethernet link speed	No light (LED is off)	Ethernet link speed is 10 Mbps or CP blade does not have incoming power	Ensure CP has power. Note: To force a persistent Ethernet link speed, type the ifModeSet command.
	Steady green	Ethernet link speed is 100/1000 Mbps	No action required.
Active CP	Steady blue	Active CP blade.	No action required.
	No light (LED is off)	Standby CP blade.	No action required.

Core switch blade (CR8) status

To determine the status of a CR blade:

1. Check the LED indicators on the core switch blade (Figure 25 on page 62). The LED patterns may temporarily change during POST and other diagnostic tests; for information about how to interpret the LED patterns, see Table 8 on page 62.
2. Check core switch blade status by typing **slotShow** and **haShow**.

Figure 25 on page 62 identifies the core switch blade.

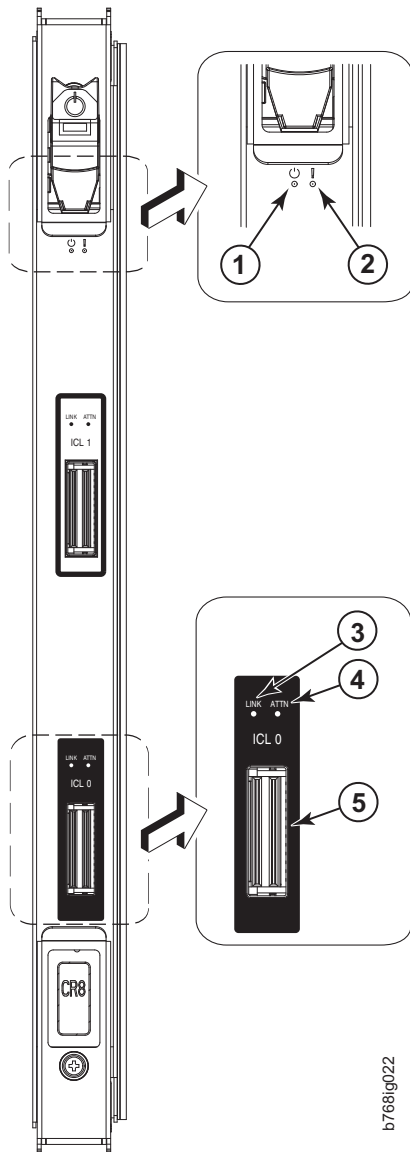

b768ig022

Figure 25. Core switch blade (CR8) LEDs

- | | | | |
|----------|------------------|----------|---------------|
| 1 | Blade power LED | 4 | ATTN LED |
| 2 | Blade status LED | 5 | ICL Connector |
| 3 | LINK LED | | |

Table 8. CR blade LED descriptions

LED purpose	Color	Status	Recommended Action
Blade power	Steady green	CP blade is on	No action required.
	No light (LED is off)	CP blade is not on	Ensure that the blade is firmly seated and has power.

Table 8. CR blade LED descriptions (continued)

LED purpose	Color	Status	Recommended Action
Blade status	No light (LED is off)	CP blade is either healthy or does not have power.	Verify that the power LED is on.
	Steady amber	CP blade is faulty or the switch is still booting.	Ensure blade is firmly seated and switch has completed booting. Blade may not be compatible with other blades in the chassis. See "FCOE10-24 blade" on page 145 for limitations. If LED remains amber, contact IBM.
	Slow-flashing amber (on 2 seconds; then off 2 seconds)	CP blade is not seated correctly or is faulty.	Pull blade out and reset it. If LED continues to flash, replace blade.
	Fast-flashing amber (on 1/2 second; then off 1/2 second)	Environmental range exceeded.	Check for out-of-bounds environmental condition and correct it.
LINK LED	No light (LED is off)	No ICL or ICL is cable present, but no connection.	Ensure that the ICL cable is correctly installed.
	Steady green	ICL connected	No action required.
ATTN LED	No light (LED is off)	No ICL	No action required.
	Blinking amber	Attention required	Ensure that the ICL cable is correctly installed.

Power supply status

To determine the status of a power supply:

1. Check the LED indicator on the power supply (see Figure 26 on page 64). The LED patterns may temporarily change during POST and other diagnostic tests; for information about how to interpret the LED patterns, see Table 9 on page 64.
2. Check the power supply status by entering **psShow**. The power supply status displays OK, Absent, or Faulty. If a power supply is absent or faulty, contact IBM.

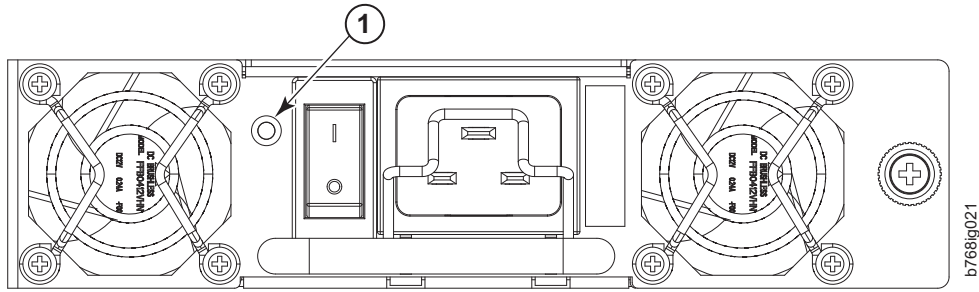

Figure 26. Power supply LEDs

1 Power LED

Table 9. Power supply LED descriptions

LED purpose	Color	Status	Recommended Action
Power	No light (LED is off)	Power supply does not have incoming power and is not providing power to the SAN768B.	Ensure power supply is firmly seated, SAN768B has incoming power, both power cables are connected, and AC power switches are on.
	Steady green	Power supply has incoming power and is providing power to the SAN768B.	No action required.
	Flashing green	Power supply is about to fail.	Replace power supply.

Blower assembly status

To determine the status of a blower assembly:

1. Check the LED indicators on the blower assembly (see Figure 27 on page 65). The LED patterns may temporarily change during POST and other diagnostic tests; for information about how to interpret the LED patterns, see Table 10 on page 65.
2. Check the blower assembly status using the **fanShow** command.
The status for each blower assembly displays OK, Absent, or Faulty. The RPM of each fan in the assembly is also provided. If a blower assembly is absent or faulty, contact IBM.

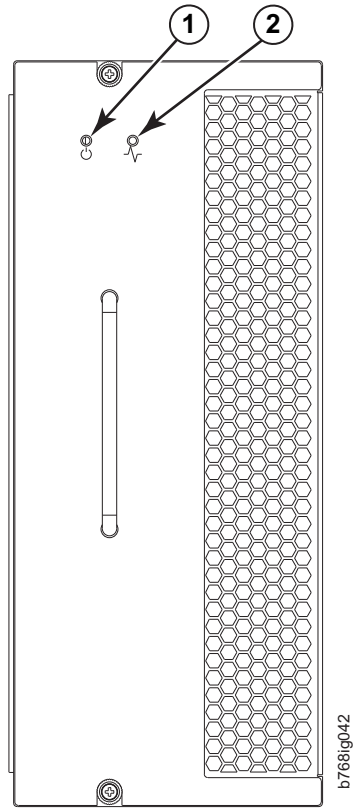

Figure 27. Blower assembly LEDs

Item Description

- 1** Power LED
- 2** Fault LED

Table 10. Blower assembly LED descriptions

LED purpose	Color	Status	Recommended action
Power	No Light (LED is off)	Blower assembly does not have power.	Ensure that the blower assembly is firmly seated and has power.
	Steady green	Blower assembly has power.	No action required.

Table 10. Blower assembly LED descriptions (continued)

LED purpose	Color	Status	Recommended action
Fault	No Light (LED is off)	Blower assembly is either healthy or does not have power.	Ensure that the blower assembly has power.
	Steady amber	Blower assembly has a failure (full or partial).	Replace the blower assembly.
	Slow-flashing amber (on 2 seconds, then off 2 seconds)	Blower assembly is not seated correctly or is faulty.	Pull the unit out and reseal it. If the LED continues to flash, replace the unit.
	Flashing amber (on 1/2 second, then off 3.5 second)	Fan is disabled.	Run the fanEnable command to enable the fan.
	Fast-flashing amber (on 1/2 second, then off 1/2 second)	Environmental range exceeded.	Check for out-of-bounds environmental condition, resolve any problems, and reseal the unit. If the LED continues to flash, replace the unit.

WWN bezel and WWN card status

To determine the status of the WWN card:

Note: The WWN bezel covers the WWN cards. The LEDs on the WWN cards are not visible unless the bezel is removed.

1. Enter the **chassisShow** command to display information about the WWN card. WWN units correspond to information specific to the WWN card (see Figure 39 on page 94). Error messages that may indicate problems with a WWN card are summarized in Table 11.

Table 11. Messages that may indicate WWN card failure

Type of Message	Sample error message
WWN unit fails its FRU (field replaceable unit) header access.	0x24c (fabos): Switch: switchname, error EM-I2C_TIMEOUT, 2, WWN 1 I2C timed out: state 0x4
WWN unit is being faulted.	0x24c (fabos): Switch: switchname, Critical EM-WWN_UNKNOWN, 1, Unknown WWN #2 is being faulted
WWN unit is not present or is not accessible.	0x24c (fabos): Switch: switchname, Error EM-WWN_ABSENT, 2, WWN #1 not present
Writing to the FRU history log (hilSetFruHistory) has failed.	0x24c (fabos): Switch: switchname, Error EM-HIL_FAIL, 2, HIL Error: hilSetFruHistory failed, rc=-3 for SLOT 3

Figure 28 displays the WWN bezel.

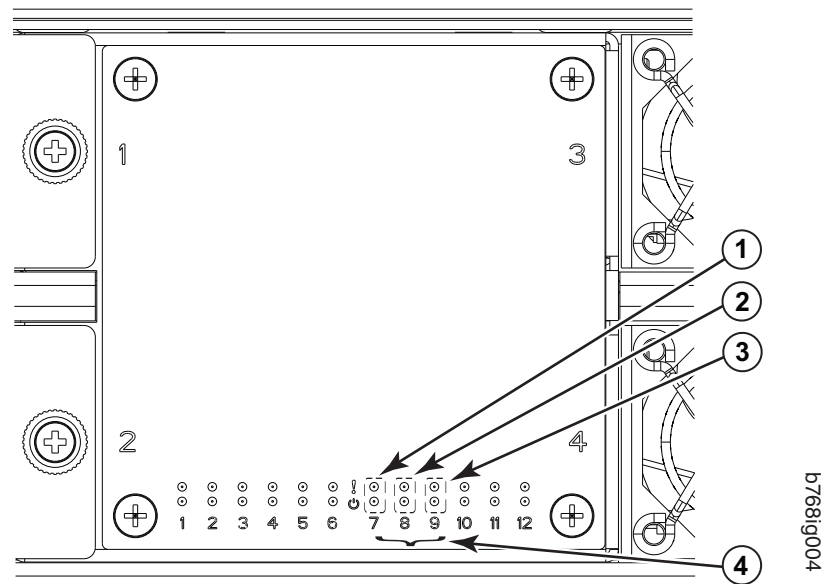

Figure 28. LEDs on the WWN card and bezel

- 1** CP blade Status (above) and Power (below) LEDs
- 2** CR blade Status (above) and Power (below) LEDs
- 3** Port blade Status (above) and Power (below) LEDs
- 4** Slot numbers

The WWN card LED patterns and the recommended actions for those patterns are described in Table 12.

Table 12. WWN bezel LED descriptions

LED purpose	Color	Status	Recommended action
Port blade/CP blade/ CR blade Power	Steady green	Power is OK.	No action required.
Port blade/CP blade/ CR blade Status	Steady amber	Blade is faulty.	Check blade.
	No light (LED is OFF)	Blade is OK.	No action required.
Note: If a blade slot or power supply bay has a filler panel installed, the corresponding LEDs on the WWN blade do not light up.			

Chapter 5. Removing and installing components

Note: Read the safety notices before servicing (see “Safety notices and labels” on page xv).

The field replaceable units (FRUs) in the SAN768B can be removed and installed without special tools. The SAN768B can continue operating during many of the FRU replacements if the conditions specified in the procedure are followed.

This chapter contains the following component removal and installation procedures.

- “Removing and installing the chassis door”
- “Removing and installing a cable management comb” on page 70
- “Removing and installing port, application, and encryption blades” on page 71
- “Removing and installing blade filler panels” on page 75
- “Removing and installing a control processor blade (CP8)” on page 76
- “Removing and installing a core switch blade (CR8)” on page 82
- “Removing and installing an FR4-18i router blade” on page 84
- “Removing and installing a power supply” on page 88
- “Removing and installing a blower assembly” on page 90
- “Removing and installing a WWN bezel and WWN card” on page 91
- “Removing and installing transceivers” on page 95
- “Removing and installing inter-chassis link (ICL) cables” on page 97
- “Removing the batteries” on page 106

Removing and installing the chassis door

Note: The chassis door must be installed to ensure the SAN768B meets EMI and other regulatory certifications. Additionally, if ICL cables are not used, EMI plugs must be inserted in the ICL cable ports to meet certification standards.

Time and items required

The replacement procedure for the chassis door takes less than 5 minutes.

Removing the chassis door

To remove a chassis door:

1. Support the door to prevent it from falling.
2. Pull and remove the door.

To install a chassis door:

1. Align the door and push it into place. See Figure 6 on page 19.

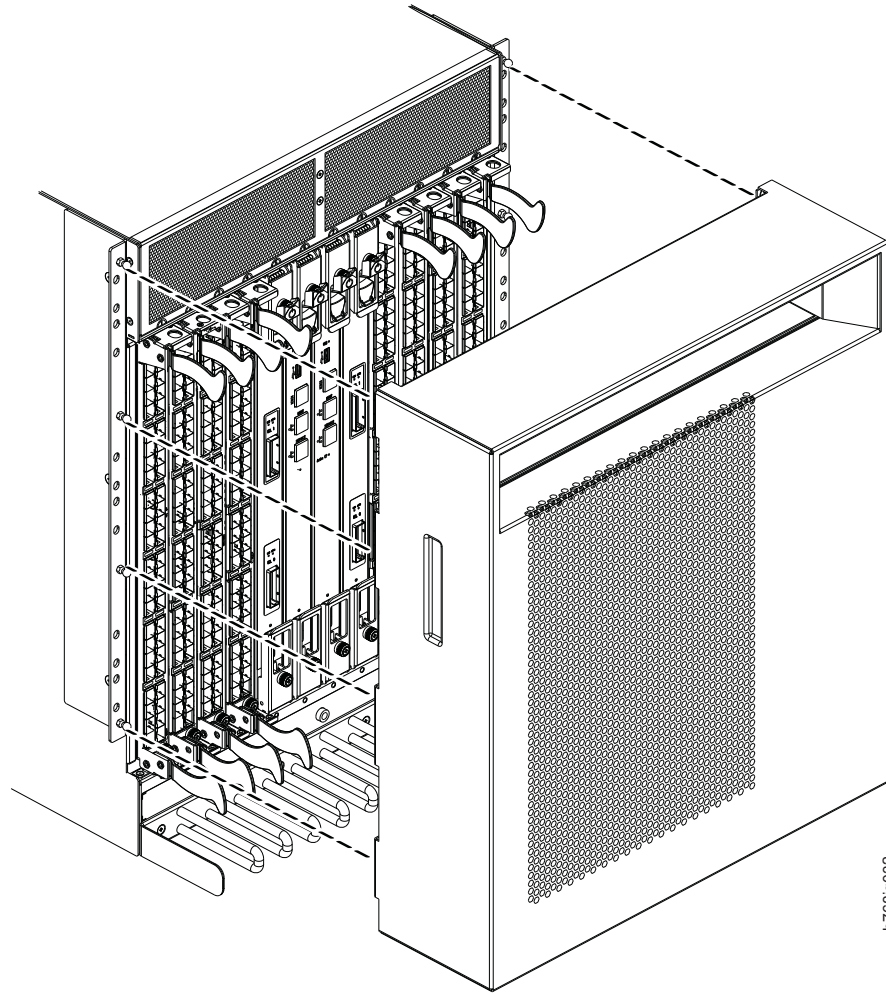

Figure 29. Chassis door

Removing and installing a cable management comb

The SAN768B can continue to operate during the replacement of the cable management comb.

Time and items required

The replacement procedure for the cable management comb takes less than 5 minutes. A #1 Phillips screwdriver is required.

Removing a cable management comb

To remove the cable management comb, do the following:

1. Remove the chassis door (“Removing and installing the chassis door” on page 69).
2. Remove the cables from the cable management comb and rearrange around the comb.
3. Unscrew and save the four screws holding the comb to the chassis (see Figure 30 on page 71). Support the comb to prevent it from falling.
4. Remove the cable management comb.

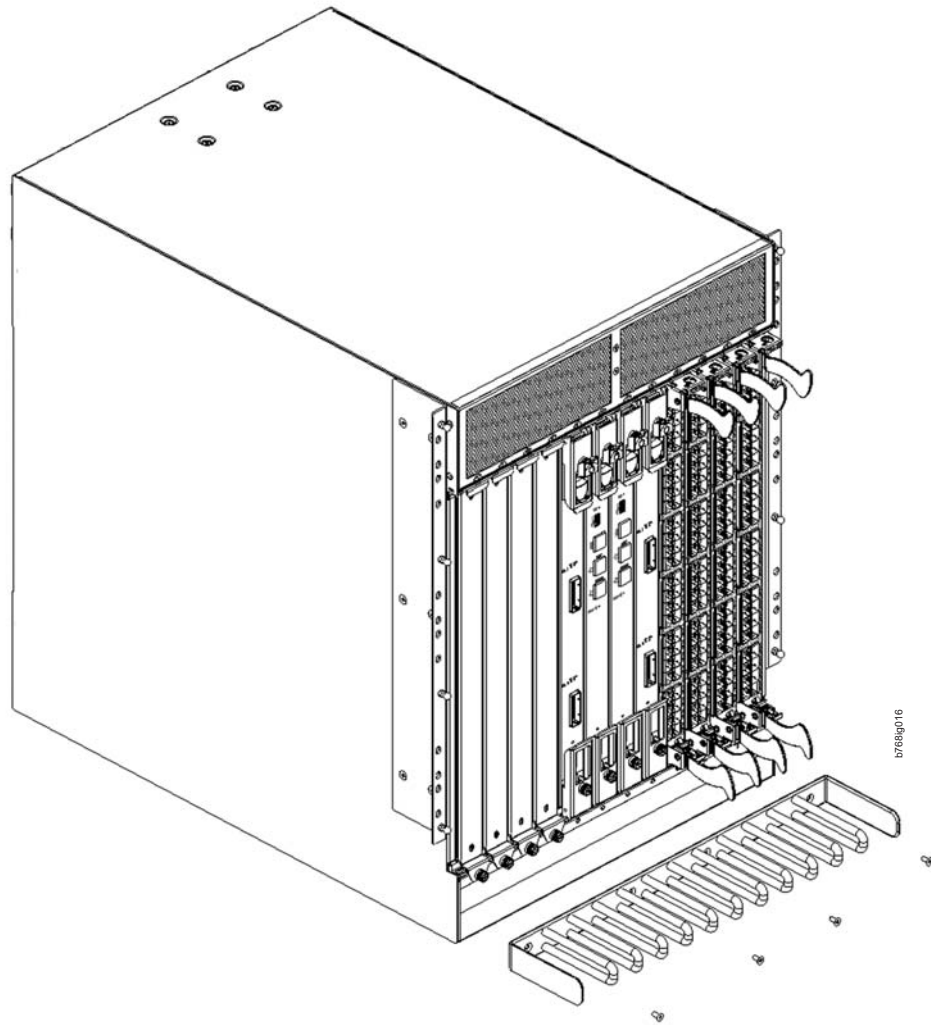

Figure 30. Cable management comb

Installing a cable management comb

To install a cable management comb, do the following:

1. Align the comb with the four screw holes on the chassis.
2. Position and tighten the four screws to secure the cable management comb to the chassis.
3. Arrange the cables along the cable management comb.
4. Replace the chassis door.

Removing and installing port, application, and encryption blades

This section describes how to remove and install port, application, router, and encryption. See “Removing and installing an FR4-18i router blade” on page 84 for instructions specific to that application blade.

Attention: A filler panel should be removed only when being replaced with another blade or a filler panel. Any slot that is not occupied by a blade should be occupied by a filler panel to ensure correct cooling of the chassis and protection from dust.

Slots are numbered from 1 through 12, from left to right when facing the port side of the SAN768B. Port, application, and encryption blades can be installed in slots 1 through 4 and 9 through 12.

Attention: The FCOE10-24 application blade is not compatible with the FC8-64 high-density port blade and the other application blades (FR4-18i and FX8-24, , and FS8-18) in the same chassis.

Time and items required

The installation procedure for each blade takes 5 to 25 minutes, depending on the number of ports, transceivers, and cables involved. The following items are required for the blade and filler panel installation:

- ESD (electrostatic discharge) grounding strap
- Workstation computer
- Installation blade or filler panel
- Phillips screwdriver
- Small form-factor pluggable (SFP, SFP+, or mSFP (FC8-64 only)) or extended form-factor pluggable (XFP) (FC10-6 blade only) transceivers, as needed
- Optical cables (as needed)

Removing a blade

To remove a port blade, do the following:

Attention: Follow ESD precautions (see “ESD precautions” on page xxi) for removal or replacement of any blade.

1. Remove the chassis door (see “Removing and installing the chassis door” on page 69).
2. A failed port or application blade can be identified by inspecting the LEDs on the front panel of each blade. Check the power LED, status LED, and port status LED to identify any possible problems. See Figure 15 on page 48 to Figure 23 on page 56 for LED locations.
3. Establish a Telnet or console session.
Before installing a blade, establish a Telnet or console connection to determine a failure and verify operation after installation. Use the **switchShow** command to view the status of blades.
4. Check for adequate cable slack. Ensure there is plenty of cable slack to remove a blade without cable obstruction.
5. Ensure that the part number on the unit being installed matches the replacement part number. The **chassisShow** command displays information about the blades, including part numbers, serial numbers, and additional status.
6. Ensure that traffic is not flowing through the blade (port status LED should be off) prior to disconnecting cables.

Note: Before removing any cables from a blade, note the cable order (identify each cable by its physical port). If multiple blades are being installed, install one blade at a time. It is a good practice to keep a listing of cable to port mapping. See “Cable routing tables” on page 118 for a blank sample table.

7. Disconnect all cables and the SFP, SFP+, or XFP transceivers from the blade. For mSFP transceivers(FC8-64 only), it is recommended that you use the pull tab to remove the transceiver from the blade before removing the cable from the transceiver.
8. Perform the appropriate following action based on the type of blade:
 - **For FC8-16, FC8-32, FC8-48, FC8-64, and FC10-6 port blades, FX8-24 and FCOE10-24 application blades, and FS8-18 encryption blades:** Unscrew the two thumbscrews from the top and bottom ejectors on the blade (see Figure 31 on page 74) using the Phillips screwdriver. Unscrew the top thumbscrew until it pops out. This initiates a hot-swap request.
 - **For FC10-6 port blade, and the FR4-18i application blades:** Turn the blade off by sliding the slider switch in the top ejector down to the off position. This initiates a hot-swap request.
9. Wait for the power LED to turn off in response to the hot-swap request before removing the blade.
10. Perform the appropriate following action based on the type of blade:
 - **For FC8-16, FC8-32, FC8-48, FC8-64 port blades, FX8-24 and FCOE10-24 application blades, and FS8-18 encryption blades:** Open the ejectors by pulling them toward the center of the blade face. Pull the blade out of the chassis using the ejectors (Figure 31 on page 74).
 - **For the FC10-6 port blade, and the FR4-18i application blade:** Unscrew the two thumbscrews from the top and bottom ejectors on the blade using the Phillips screwdriver. Open both ejectors simultaneously to approximately 45 degrees and pull the blade out of the chassis.
11. If the blade is not being replaced by another blade, install a filler panel. See “Removing and installing blade filler panels” on page 75.

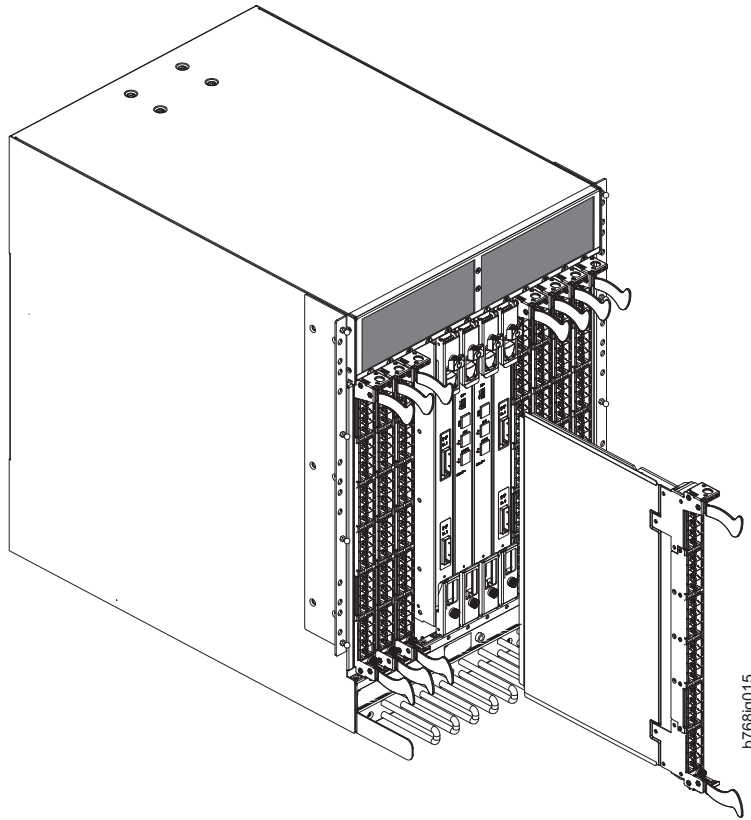

Figure 31. Port, application, and encryption blade removal and installation (FC8-48 port blade shown as example)

Installing a blade

To install a port, application, or encryption blade, complete the following steps. See “Removing and installing an FR4-18i router blade” on page 84 for additional instructions specific to that application blade.

Attention: Follow ESD precautions (see “ESD precautions” on page xxi).

Note: An FA4-18i routing blade and the SAN768B must have the same version of firmware. To upgrade firmware versions, refer to the *Fabric OS Administrator’s Guide*. See also “Fabric OS firmware updates” on page 44.

1. Orient the blade so that the ports are at the front of the chassis and the flat side of the blade is on the left.
2. Perform the appropriate following action based on the type of blade:
 - **For FC8-16, FC8-32, FC8-48, FC8-64 port blades, FX8-24 and FCOE10-24 application blades, and FS8-18 encryption blades:** Adjust the ejectors to the open position, align the flat side of the blade inside the upper and lower rail guides in the slot, and slide the blade into the slot until it is firmly seated.
 - **For FC10-6 port blade, and the FR4-18i application blade:** Open the ejectors to approximately 45 degrees, align the flat side of the port blade inside the upper and lower rail guides in the slot, and slide the blade into the slot, with slight pressure to the left, until it is firmly seated.

Adjust the ejectors to the open position, align the flat side of the blade inside the upper and lower rail guides in the slot, and slide the blade into the slot until it is firmly seated.

3. Perform the appropriate following action based on the type of blade:
 - **For FC8-16, FC8-32, FC8-48, FC8-64 port blades, FX8-24 and FCOE10-24 application blades, and FS8-18 encryption blades:** Adjust the ejectors to the closed position by pulling them away from the center of the blade.
 - **For FC10-6 port blade, and the FR4-18i application blades:** Close the ejectors by pushing the handles toward the center of the blade until the ejectors lock. The levering action of the handles seats the blade in the slot.
4. Perform the appropriate following action based on the type of blade:
 - **For FC8-16, FC8-32, FC8-48, FC8-64 port blades, FX8-24 and FCOE10-24 application blades, and FS8-18 encryption blades:** Tighten the upper and lower thumbscrews using the Phillips screwdriver.
 - **For FC10-6 port blade, and the FR4-18i application blades:** Tighten the thumbscrew inside each handle using the Phillips screwdriver.
5. Perform the appropriate following action based on the type of blade:
 - **For FC8-16, FC8-32, FC8-48, FC8-64 port blades, FX8-24 and FCOE10-24 application blades, and FS8-18 encryption blades:** Skip to step 6.
 - **For FC10-6 port blade, and the FR4-18i application blades:** Turn the blade on by sliding the slider switch in the top ejector up, covering the thumbscrew.
6. Verify that the power LED on the blade displays a steady green light (it might require a few seconds to turn on). If it does not turn on, ensure that the blade is firmly seated.
7. Install the SFP, SFP+, or XFP (FC10-6 only) transceivers and cables in the blade. For mSFP (FC8-64 only) transceivers, it is recommended that you install the cables in the transceivers before installing the transceivers in the blade.
8. Group and route the cables through the cable management comb.
9. Install the chassis door.

Note: The FS8-18 encryption blade requires additional configuration to enable encryption. See “Configuring for encryption (optional)” on page 42.

Removing and installing blade filler panels

This section describes how to remove and install port blade filler panels.

Removing a filler panel

Attention: A filler panel should be removed only when being replaced with a port, application, or encryption blade or new filler panel. Any slot that is not occupied by a blade should be occupied by a filler panel to ensure correct cooling of the chassis and protection from dust.

To remove a filler panel, do the following:

1. Remove the chassis door.
2. Unscrew the thumb screw at the bottom of the panel using a Phillips screwdriver.
3. Pull the filler panel out of the chassis. (See Figure 32 on page 76.)

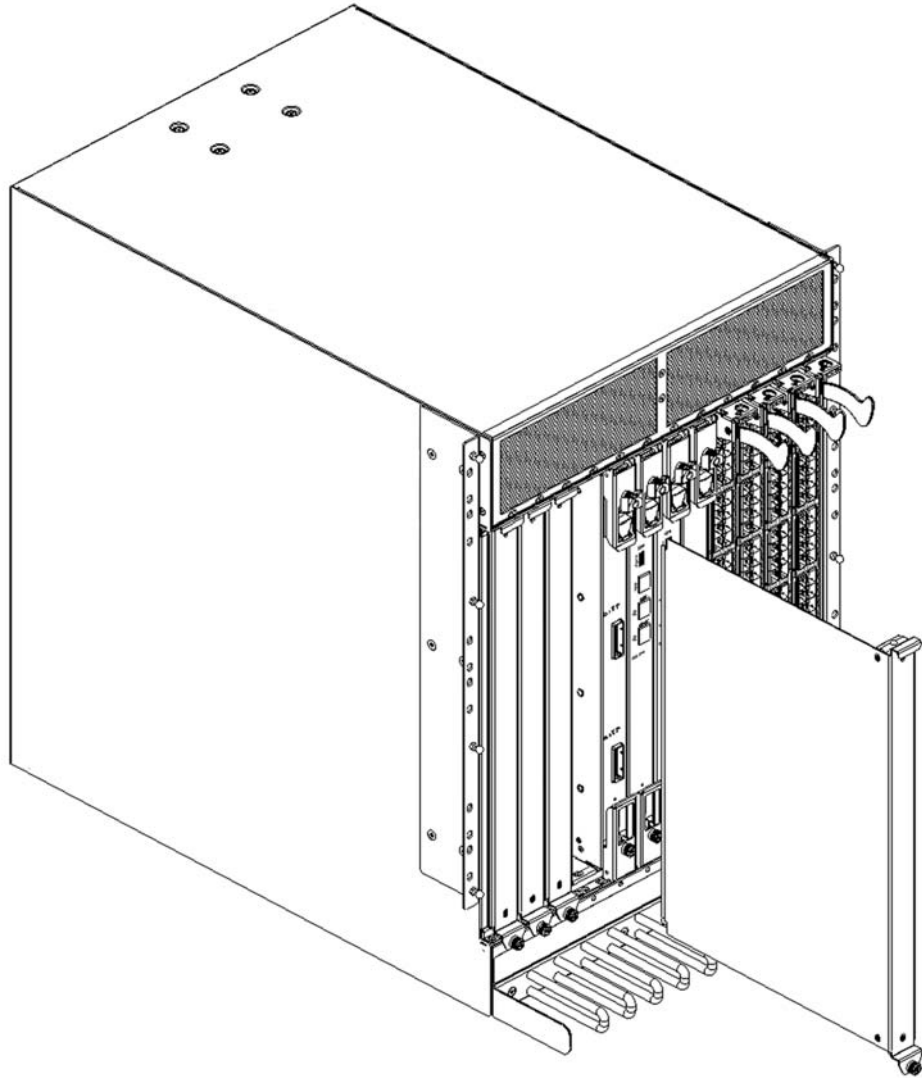

Figure 32. Filler panel removal and installation

Installing a filler panel

To install a filler panel, do the following:

1. Orient the filler panel.
2. Slide the filler panel into the slot until it is firmly seated.
3. Tighten the thumb screw at the bottom of the panel.
4. Install the chassis door.

Removing and installing a control processor blade (CP8)

This section describes how to remove and install a control processor (CP8) blade. Each SAN768B has two CP8 blades located in slot 6 and slot 7.

Note: If the new CP blade does not have the same firmware as the active CP blade, you must upgrade the new blade to the same firmware version.

Firmware downloads require that Ethernet connections be made to both CP blades. Procedures for loading firmware are described in the *Fabric OS Administrator's Guide*.

Time and items required

The installation procedure for the CP blade takes approximately 30 minutes. The following items are required for the CP blade installation:

- ESD grounding strap
- Workstation computer
- Serial cable
- IP address of an FTP server for backing up the SAN768B configuration
- Phillips #2 screwdriver
- Replacement CP blade (CP8).

Verifying the necessity of installation

Confirm that you need to install the CP blade. The following events might indicate that a CP blade is faulty:

- The status LED on the CP blade is lit amber, or the power LED is not lit.
- The CP blade does not respond to Telnet commands, or the serial console is not available.
- The **slotShow** command does not show that the CP blade is enabled.
- The **haShow** command indicates an error.
- The clock is inaccurate, or the CP blade does not boot up or shut down normally.
- Any of the following messages display in the error log:
 - “Slot unknown” message relating to a CP slot
 - CP blade errors or I²C timeouts
 - FRU: FRU_FAULTY messages for a CP blade
 - Configuration loader messages or “Sys PCI config” messages
 - Generic system driver messages (“FABSYS”)
 - Platform system driver messages (“Platform”)
 - EM messages that indicate a problem with a CP blade
 - Function fail messages for the CP master

For more information about error messages, refer to the *Fabric OS Message Reference*.

Recording critical SAN768B information

Back up the SAN768B configuration before you replace a CP blade. Refer to the *Fabric OS Administrator's Guide* for backup information.

To record critical SAN768B information, do the following:

1. Login to the functioning CP blade as admin, using either a Telnet or a serial console connection.
2. Enter **haShow** to determine which CP blade is active:

```
swDir:admin> haShow
Local CP (Slot 7, CP1) : Active
Remote CP (Slot 6, CP0) : Standby, Healthy
HA Enabled, Heartbeat Up, HA State Synchronized
```

3. Enter all remaining commands from the serial console for the active CP blade, unless otherwise indicated. For more information about commands, refer to the *Fabric OS Command Reference*.
4. If one CP blade is faulted, confirm that the other CP blade is now the active CP blade and log in to the active CP blade and skip to step 7.
5. If both CP blades are healthy and you want to replace the standby CP blade, log in to the active CP blade and skip to step 7.
6. If both CP blades are healthy and you want to replace the active CP blade, log in to the active CP blade and run the following steps:
 - a. Run the **haFailover** command to make the standby CP blade the active blade. The currently active CP blade becomes the standby blade. Wait until the status LED on the currently active CP blade is no longer lit.
 - b. Confirm the completion of the failover by running the **hashow** command.
 - c. Log in to the new active CP blade.
 - d. Run the **firmwareShow** command to confirm the firmware version of the active CP blade.
 - e. Run the **haDisable** command to prevent failover or communication between the CP blades during the replacement.
 - f. Continue with step 7.
7. Enter **firmwareShow** to note the firmware version of the active CP blade.
8. Enter **haDisable** from the active CP blade to prevent failover or communication between the CP blades during the replacement.
9. Logged into the active CP, run the following two steps to upload the system configuration to a specified FTP server. Enter information at the prompts.
 - a. Enter the **configupload -vf** command. This command uploads the system virtual fabric data.
 - b. Enter the **configupload** command. This command uploads the system configuration.

Removing a control processor blade (CP8)

The SAN768B continues to operate while a CP blade is being installed if the redundant CP blade is active and a failover does not occur. You can prevent failover by entering the **haDisable** command.

Attention: Follow ESD precautions (“ESD precautions” on page xxi)

To remove a CP blade, complete the following steps:

1. Remove the chassis door. (See “Removing and installing the chassis door” on page 69.)
2. Power off the blade by sliding the slider switch in the top ejector down to the off position (see Figure 33 on page 79).
3. Disconnect all cables from the CP blade you are replacing.
4. Unscrew the thumb screw from both ejectors using a Phillips screwdriver.
5. Open both ejectors simultaneously to approximately 45 degrees and pull the CP blade out of the chassis (see Figure 33 on page 79).

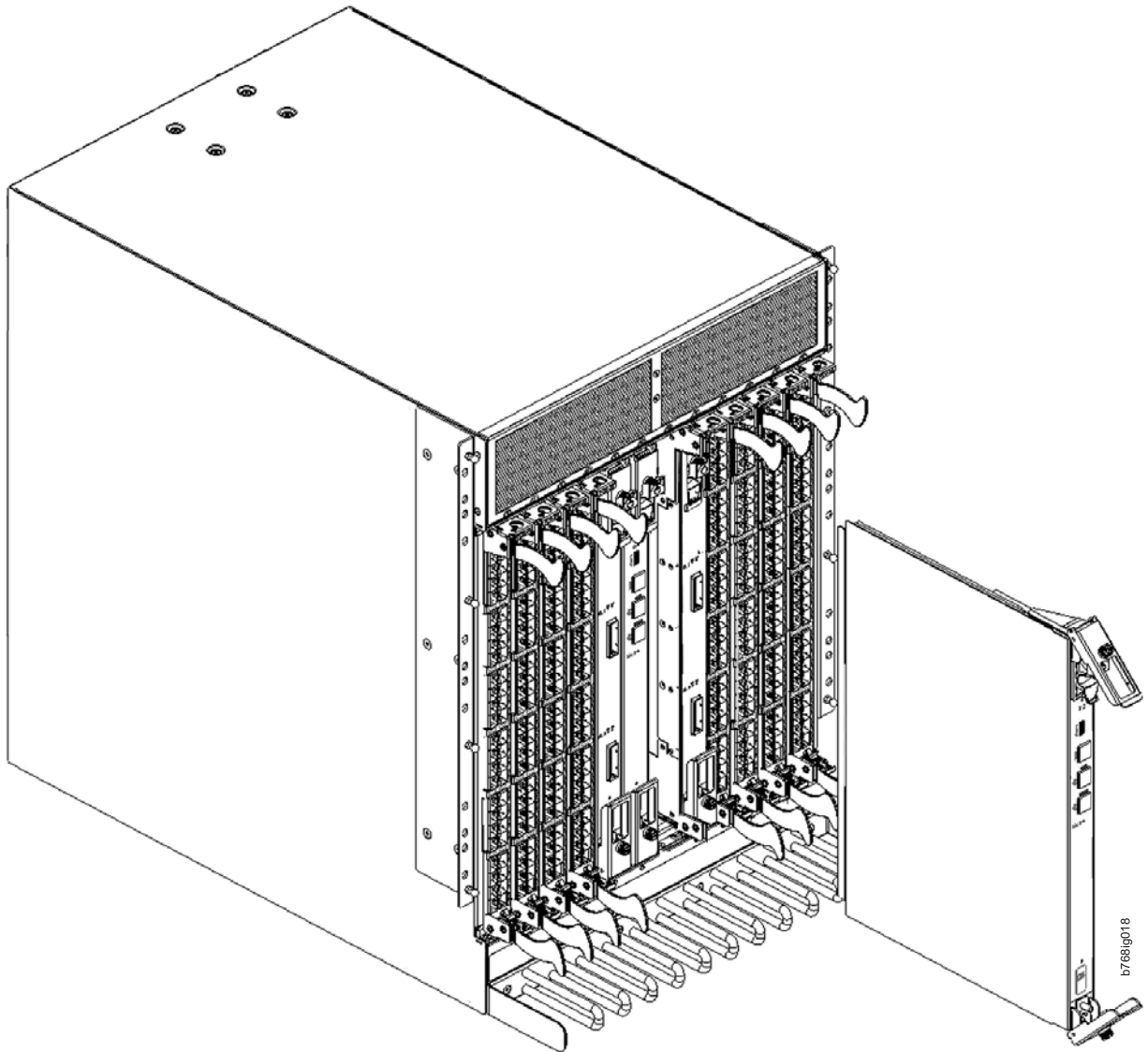

Figure 33. Removing the control processor (CP8) blade

Installing a control processor blade (CP8)

Attention: Follow ESD precautions (“ESD precautions” on page xxi).

To install a CP blade (slot 6 or 7):

1. Open the ejector handles to approximately 45 degrees. Orient the CP blade so that the handles are toward you and the flat metal side is on your left.
2. Align the flat metal side of the CP blade inside the lower and upper blade guides in the slot. Slide the CP blade into the slot until it is firmly seated.
3. Tighten the thumb screw inside each handle using a Phillips screwdriver.
4. Turn the CP blade on by sliding the ON/OFF switch in the top handle up, to cover the thumb screw.
5. Verify that the power LED is green. If not, ensure that the CP blade has power and is firmly seated and that the ejectors are in the locked position.

6. Connect the cables to the new CP blade.
7. Verify the installation. (See “Verifying operation of the new CP blade.”)
8. Once the installation is verified, install the chassis door. (See “Removing and installing the chassis door” on page 69.)

Verifying operation of the new CP blade

To verify that boot and POST are complete on the new CP blade and that the CP blade has achieved failover redundancy:

1. Enter **slotShow**. The command output shows the new CP blade as “enabled.”
2. Determine the version by typing **firmwareShow**.
3. If the firmware versions for both CP blades are the same, skip to step 8 under “Downloading firmware from an FTP server.”
4. If the firmware version on the replacement blade does not match that on the active CP blade, a warning message appears with the results of the **firmwareShow** command. You must bring the replacement blade to the same firmware level as the active blade using the **firmwareDownload -s** command to bring it up to the proper level. If you are using an FTP Server to download the firmware, skip to “Downloading firmware from an FTP server.” If you are using a USB device to download the firmware, skip to “Downloading firmware from a USB drive” on page 81.

Downloading firmware from an FTP server

1. Log out of the active CP blade and log in to the standby CP blade.
2. Enter **firmwareDownload -s** to download the firmware to the standby CP blade. The **-s** option also disables the autoreboot, so you will have to manually issue a reboot after the download finishes to initiate **firmwareCommit**. Enter all requested information (use default values).
3. To download firmware,
 - a. Go to the IBM Support Portal, www.ibm.com/supportportal
 - b. Search for your product machine type (2499) or product name
 - c. On the displayed page click **Download** in the **Task** section
 - d. From the displayed page, select the appropriate release notes link and read the release notes prior to downloading and installing the firmware update
 - e. From the **Release notes** page, click the **Release Firmware** link and follow the online prompts to navigate to the **Brocade Downloads for IBM End Users** page.
 - f. Follow the instructions on the Brocade pages.
4. Enter all requested information (use default values).
5. Enter **firmwareDownloadStatus** to verify that the firmware has been updated.
6. Ensure that you are still logged in to the standby CP blade (the blade for which you just changed the firmware level) and type **reboot**. The reboot of the standby CP will initiate a firmwarecommit to the secondary partition and log you out.
7. Log back in to the standby CP blade and type **firmwareDownloadStatus** on the standby CP blade to validate a successful commit. This may take up to 10 minutes.
8. Log out of the standby CP blade and log in to the active CP blade.
9. Type **haEnable** to re-enable HA on the active CP blade.

Note: For Fabric OS 6.3.0 and later, **haEnable** will cause the standby CP blade to reboot. Wait until the power cycles and the POST completes before moving to the next step.

10. Type **haShow** and verify that the command output includes “HA Enabled Heartbeat Up”. If not, re-enter the command until you have verified that redundancy is achieved.
11. Type **version** or **firmwareShow** to verify that the firmware version has been updated.
12. Pack the faulty CP blade in the packaging provided with the new CP blade for return to IBM, following local procedures.
13. Install the chassis door (See “Removing and installing the chassis door” on page 69.)

Downloading firmware from a USB drive

Firmware can be downloaded from a Brocade USB drive. The folder structure on the USB device must be as follows in order to allow the device to be enabled:

```
brocade>
config
firmware
firmwareKey
support
```

The firmware folder contains the folder for the specific release you are installing.

1. Insert the USB drive into the USB port of the active CP blade.
2. Attach a serial cable from the PC to the active CP blade.
3. Log in to the active CP blade and enter **usbStorage - e** to enable the USB device.
4. Remove the serial cable from the active CP blade and attach it to the standby CP blade.
5. Enter **firmwareDownload -s -U vX.X.X** (where X.X.X is the firmware version you are downloading) to download the firmware to the standby CP blade. The **-s** option also disables the autoreboot, so you must manually issue a reboot after the download finishes to initiate **firmwarecommit**. Enter all requested information (use default values). The **-U** option indicates that the download should come from the USB device. If you do not use this option, you are prompted with *Download from USB [No]*: Enter **Y** to download from the USB device.
6. When the download process finishes, type **firmwareDownloadStatus** to verify that the firmware has been updated.
7. Ensure that you are still logged in to the standby CP blade (the blade for which you just changed the firmware level) and type **reboot**. The reboot of the standby CP will initiate a **firmwarecommit** to the secondary partition and log you out.
8. Log back in to the standby CP blade and type **firmwareDownloadStatus** on the standby CP blade to validate a successful commit. This may take up to 10 minutes.
9. Log out of the standby CP blade and log in to the active CP blade.
10. Type **haEnable** to re-enable HA on the active CP blade.
11. Type **haShow** and verify that the command output includes “HA enabled, Heartbeat Up, HA State synchronized”. If not, re-enter the command until you have verified that redundancy is achieved.
12. Type **firmwareShow** to verify that the firmware version has been updated and that the versions are the same on the two CP blades.

13. Pack the faulty CP blade in the packaging provided with the new CP blade for return to IBM, following local procedures.
14. Install the chassis door (“Removing and installing the chassis door” on page 69).

Removing and installing a core switch blade (CR8)

This section describes how to remove and install a core switch blade. Each SAN768B has two core switch blades: one in slot 5 and one in slot 8. Note that the blade in Figure 34 on page 83 is shown with EMI plugs installed.

Time and items required

The installation procedure for the core switch blade takes approximately 30 minutes. The following items are required for the core switch blade installation:

- ESD grounding strap
- Phillips #2 screwdriver
- Replacement core switch blade (CR8).

Verifying the necessity of installation

Confirm that you need to replace the core switch blade before continuing. The following events might indicate that a core switch blade is faulty:

- The status LED on the core switch blade is lit amber, or the power LED is not lit.
- The **slotShow** command does not show that the core switch blade is enabled.
- The **haShow** command indicates an error.
- Any of the following messages display in the error log:
 - “Slot unknown” message relating to a core switch blade slot
 - core switch blade errors or I²C timeouts
 - FRU: FRU_FAULTY messages for a core switch blade
 - Configuration loader messages or “Sys PCI config” messages
 - Generic system driver messages (“FABSYS”)
 - Platform system driver messages (“Platform”)
 - Error messages that indicate a problem with a core switch blade
 - Function fail messages for the core switch blade master

For more information about error messages, refer to the *Fabric OS Message Reference*.

Removing a core switch blade (CR8)

The SAN768B continues to operate while a core switch blade is being replaced.

Attention: Follow ESD precautions (“ESD precautions” on page xxi).

Note: The CR8 blade is compatible only with the SAN768B

To remove a CR blade, complete these steps:

1. Remove the chassis door (see “Removing and installing the chassis door” on page 69).

2. Power off the blade by sliding the slider switch in the top ejector down to the off position (see Figure 34). Do not eject the blade until the power LED has gone off and you have completed the next two steps.
3. Disconnect cables from the faulty core switch blade.
4. Unscrew the thumb screws from both ejectors using a Phillips screwdriver.
5. Open both ejectors simultaneously to approximately 45 degrees and pull the core switch blade out of the chassis (see Figure 34).

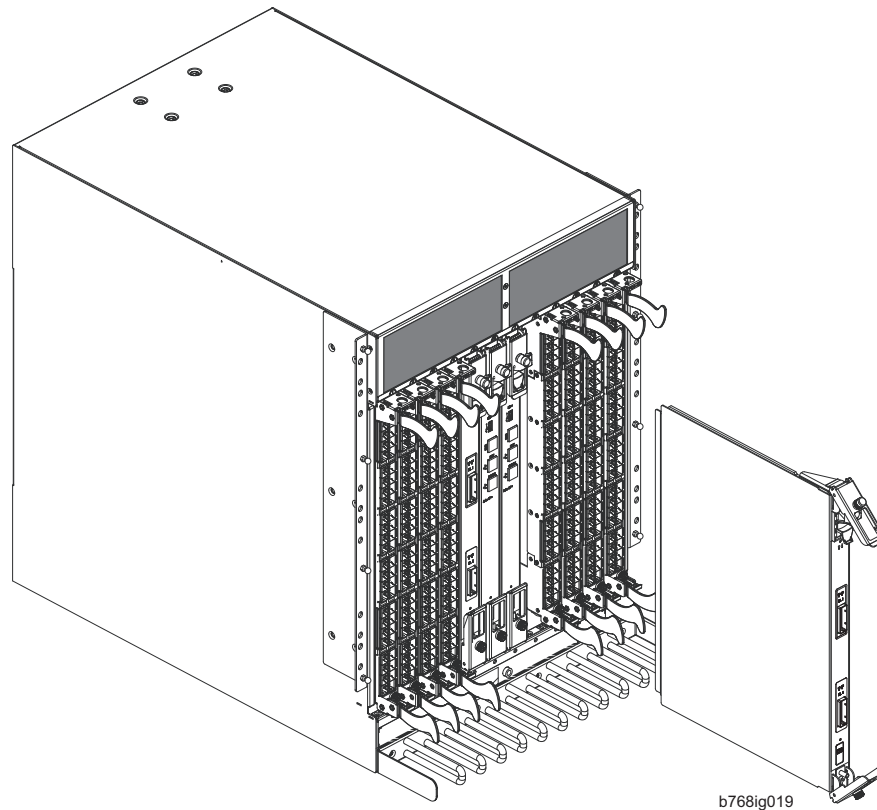

Figure 34. Removing the core switch blade

Installing a core switch blade (CR8)

Attention: Follow ESD precautions (“ESD precautions” on page xxi).

To install a CR blade (slots 5 or 8), do the following:

1. Open the ejector handles to approximately 45 degrees. Orient the CR blade so that the handles are toward you and the flat metal side is on your left.
2. Align the flat metal side of the core switch blade inside the lower and upper blade guides in the slot. Slide the core switch blade into the slot until it is firmly seated.
3. Close the ejector handles and then tighten the thumbscrews inside each handle using the Phillips screwdriver.
4. Turn the core switch blade on by sliding the ON/OFF switch in the top handle up, to cover the thumb screw.
5. Verify that the power LED is green (this might require a few seconds). If not, ensure that the core switch blade has power and is firmly seated and that the ejectors are in the locked position.

6. Connect the cables to the new core switch blade. If ICL cables are not used, insert EMI plugs into the EMI cable sockets.
7. Install the chassis door. (See “Removing and installing the chassis door” on page 69.)
8. Pack the faulty core switch blade in the packaging provided with the new core switch blade for return to IBM, following local procedures.

Removing and installing an FR4-18i router blade

This section describes how to remove and install an FR4-18i router blade in the SAN768B. You can install up to four router blades in any of slots 1-4 and 9-12. To ensure proper cooling, balance the installation of the router blades between the two slot groupings. The physical removal of a router blade is the same as for port blades. See “Removing a blade” on page 72, for blade removal and installation, as an example of how to remove a router blade.

Attention: Follow these precautions for all procedures in this section to avoid damaging the router blades or chassis:

- Wear a grounded ESD strap when handling the router blade.
- To ensure adequate system pressure for cooling purposes, leave the faulty router blade in the slot until you are ready to perform the installation or replacement procedure.
- Do not force the router blade into the chassis. If the blade does not slide in easily, ensure that it is correctly aligned inside the rail guides before continuing. Installing a router blade with incorrect alignment can damage both the chassis and the router blade.
- Hold the router blade by the edges of the metal pan. Do not use the ejectors to hold a router blade.
- Disassembling any part of a router blade voids the part warranty and regulatory certifications. There are no user-serviceable parts inside the router blade.

Time required

Approximately 10 minutes

Items required

- ESD (electrostatic discharge) grounding strap
- Workstation computer
- Replacement router blade
- Phillips screwdriver

Removing a router blade

A failed router blade can be identified by inspecting its LEDs and by using CLI commands to verify status. Refer to Table 6 on page 57 for a description of the blade LEDs, their status, and recommended actions. See the *Fabric OS Administrator's Guide* for information about how to check the status of hardware components using the CLI.

Perform the following steps to remove a router blade:

1. Using Figure 35 on page 85 as a guide, check the power LED, status LED, and port status LEDs to identify any possible problems with the router blade.

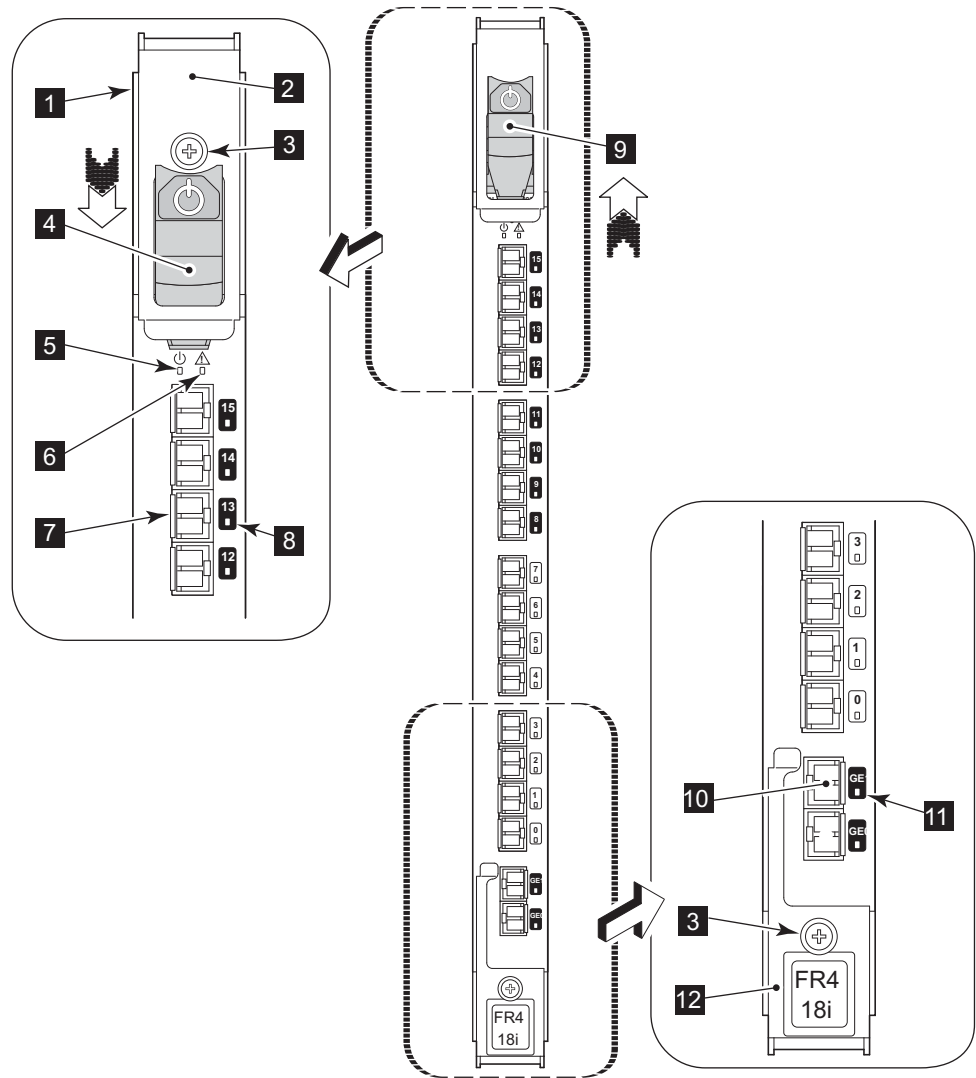

Figure 35. FR4-18i router blade and components

- | | | | |
|----------|---------------------------------|-----------|------------------------------------|
| 1 | FR4-18i router blade | 7 | Fibre Channel port (16) |
| 2 | Upper ejector | 8 | Fiber Channel port status LED (16) |
| 3 | Thumb screw (2) | 9 | On/Off switch (in On position) |
| 4 | On/Off switch (in Off position) | 10 | GbE ports (2) |
| 5 | Blade power LED | 11 | GbE port status (2) |
| 6 | Blade status LED | 12 | Lower ejector |

2. Establish a Telnet or console session before removing a router blade to determine a failure and verify operation before removal. Use the **switchShow** command to view the status of blades on the SAN768B.
3. Check for adequate cable slack.
Make sure there is plenty of cable slack to remove a router blade without optical, power, or Ethernet cable obstruction. Refer to “Managing cables” on page 40 for cabling guidelines.
4. Ensure that you have the proper spare part (filler panel or replacement router blade).

Make sure that the part numbers match the unit being replaced. The **chassisShow** command displays information about the router blades, including part numbers, serial numbers, and additional status.

5. Ensure that traffic is not flowing through the router blade (all port status LEDs **8** and **11** should be off) prior to disconnecting cables.

Note: Before removing any cables from the faulty router blade, label the cables or make a note of the cable order by identifying each cable by the physical port it attaches to. This will reduce confusion when you reattach cables. If two router blades are being replaced, install one blade at a time.

6. Disconnect all cables and remove the SFP transceivers from the Fibre Channel (**7**) and GbE (**10**) ports as required.
7. Turn the router blade off by sliding the on/off switch in the top ejector down, to the off position (**4**). This initiates a hot-swap request.
8. Wait for the power LED (**5**) to turn off in response to the hot-swap request before removing the router blade.
9. Unscrew the captive screws (**3**) from the top (**2**) and bottom (**12**) ejectors on the blade using a Phillips screwdriver.
10. Lever both ejectors open simultaneously to approximately 45 degrees, and pull the router blade out of the chassis.
11. If the blade is not being replaced by another router blade, install a filler panel to ensure correct cooling of the chassis and protection from dust. See “Installing a filler panel” on page 76 for instructions.

Installing a router blade

You can install up to four router blades in any of slots 1-4 and 9-12. To ensure proper cooling, balance the installation of the router blades between the two slot groupings. The control processor (CP) blades occupy slots 6 and 7. The core switch (CR) blades occupy slots 5 and 8. Any slots that are not occupied by a port blade, router blade, or CP blade must have a filler panel installed to ensure proper cooling of the chassis and protection from dust. If you are performing a new installation of a router blade, you must either remove the filler panel or a port blade from the slot where you will install the router blade.

Attention: All ports on the router blades are by default, persistently disabled to avoid unintentional merging of fabrics. Before you can successfully configure FCIP tunnels, you must enable the ports. When the blade is first powered up, all port status LEDs will continue to flash amber. This is normal. Use the **portCfgShow** command to view the status of the ports. Use the **portCfgPersistentEnable** command to enable a port. Refer to the *Fabric OS Administrator’s Guide* and the *Fabric OS Command Reference Manual* for more information on these commands.

To install an FR4-18i router blade, complete these steps (refer to Figure 35 on page 85 for blade component locations):

1. Select an empty slot from slots 1-4 or 9-12 to install the router blade.
2. If you are performing a new installation of a router blade, you must either remove the filler panel or a port blade from the slot where you will install the router blade.
3. Orient the router blade so that the ports are at the front of the chassis and the router blade power switch is at the top.
4. Make sure the ejector latches (**2** and **12**) on the router blade are unscrewed and open.

5. Slide the router blade into the open slot until it is fully seated.
6. Close the latches and tighten the screws (**3**) on the latches.
7. Power on the blade using the power switch at the top of the blade (**9** in Figure 35 on page 85). Keep the blade in an offline (disabled) state until the ports are configured.

Note: The router blade will begin POST as soon as the power is turned on. After POST is complete the firmware version on the blade will autolevel with the firmware version on the active CP.

8. Verify that the blade power **5** and blade status **6** LEDs are green after the blade has completed booting up.
9. Verify the installation (see the appropriate section of Chapter 4, “Monitoring system components,” on page 47). For information about how to check the status of hardware components using the CLI, see the *Fabric OS Administrator’s Guide*, or the *Fabric OS Command Reference Manual* , which are located on the product documentation CD.
10. Log into the SAN768B as the **admin** user.

Configuring FCIP and Fibre Channel routing services and enabling the ports

Refer to the *Fabric OS Administrator’s Guide* or the *Web Tools Administrator’s Guide* for detailed information on configuring the router blade. The following steps provide only a brief overview of the procedure.

1. Verify that the FR4-18i router blade is in an offline (disabled) state until the ports are configured.

Attention: The ports on the FR4-18i router blade are initially set to persistently disabled. They will flash amber until they are enabled. This is normal. If you want to use the FC ports and EX_Ports, you must configure the Fibre Channel Routing Services feature prior to enabling the ports.

2. Use the **portCfgPersistentEnable** command to enable standard E_ports or F_ports.

Note: The GbE ports can only be used once you have configured FCIP and enabled VE_Ports. See the *Fabric OS Administrator’s Guide* for detailed instructions on configuring the Fibre Channel Router ports and GbE ports on the FR4-18i router blade.

Cabling the FR4-18i router blade

Complete the router blade configuration by installing the SFP transceivers in the Fibre Channel and GbE ports.

1. Install the SFP transceivers in the Fibre Channel and GbE ports, as required. Refer to “Removing and installing transceivers” on page 95 for more detailed instructions.
2. Remove the rubber plugs from the ports to be used.
3. Position a transceiver so that it is oriented correctly and insert it into a port until it is firmly seated and the latching mechanism clicks. For instructions specific to the type of transceiver, see the transceiver manufacturer’s documentation.

Note: The transceivers are keyed to ensure correct orientation. If a transceiver does not install easily, ensure that it is correctly oriented.

4. Repeat Steps 2 and 3 for the remaining ports, as required.

5. Connect the cables to the transceivers.
Attention: A 50-micron cable should not be bent to a radius less than 2 inches under full tensile load and 1.2 inches with no tensile load. Tie wraps are not recommended for optical cables because they are easily overtightened.
6. Orient a cable connector so that the key (the ridge on one side of connector) aligns with the slot in the transceiver. Then, insert the cable into the transceiver until the latching mechanism clicks. For instructions specific to cable type, see the cable manufacturer's documentation.
7. Repeat Step 6 for the remaining cables as required.
8. Check the LEDs to verify that all components are functional. For information about LED patterns, see Table 6 on page 57.
9. Log in to the SAN768B as **admin**.
10. Verify the correct operation of the FR4-18i router blade ports by typing the **switchShow** command from the SAN768B command prompt. This command provides information about switch and port status.

Once the FR4-18i router blade is installed and fully configured in a SAN768B, the **switchShow** command displays 32 Fibre Channel ports (port numbers 0 through 31) and 2 GbE ports. The first 16 Fibre Channel ports are physical ports on the FR4-18i router blade, Ports 16-23 are virtual ports associated with the GE0 physical GbE link and ports 24-31 are virtual ports associated with GE1 physical GbE links. The GbE ports are displayed as ge0 and ge1 and are not assigned port numbers or area numbers.

Removing and installing a power supply

Use this procedure to remove and install a power supply. The SAN768B can continue operating during the replacement if at least one power supply continues operating. Figure 36 shows the location and identification of the power supplies.

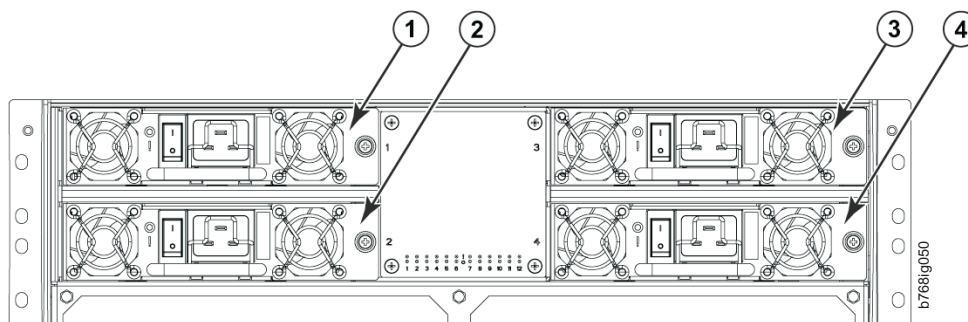

Figure 36. Power supply locations

- | | | | |
|----------|----------------------|----------|----------------------|
| 1 | Power supply 1 (PS1) | 3 | Power supply 3 (PS3) |
| 2 | Power supply 2 (PS2) | 4 | Power supply 4 (PS4) |

Time and items required

The installation procedure for each power supply takes less than 5 minutes. A power supply unit or filler panel is required for the power supply installation.

Removing a power supply

To remove a power supply, do the following:

1. If the SAN768B will not be operating during the replacement procedure, go to step 2.

If the SAN768B will continue operating during the replacement, check the power LEDs to verify that the minimum number of power supplies is functioning. A fully populated SAN768B requires a minimum of one power supply slot at all times to ensure power to the SAN768B.

2. Turn off the power switch.
3. Remove the power cord.
4. Loosen the thumbscrew.
5. Grasp the handle and pull, sliding the power supply from the chassis, supporting the power supply from beneath as you remove it. (see Figure 37).
6. If you are not replacing the power supply, insert a filler panel into the slot.

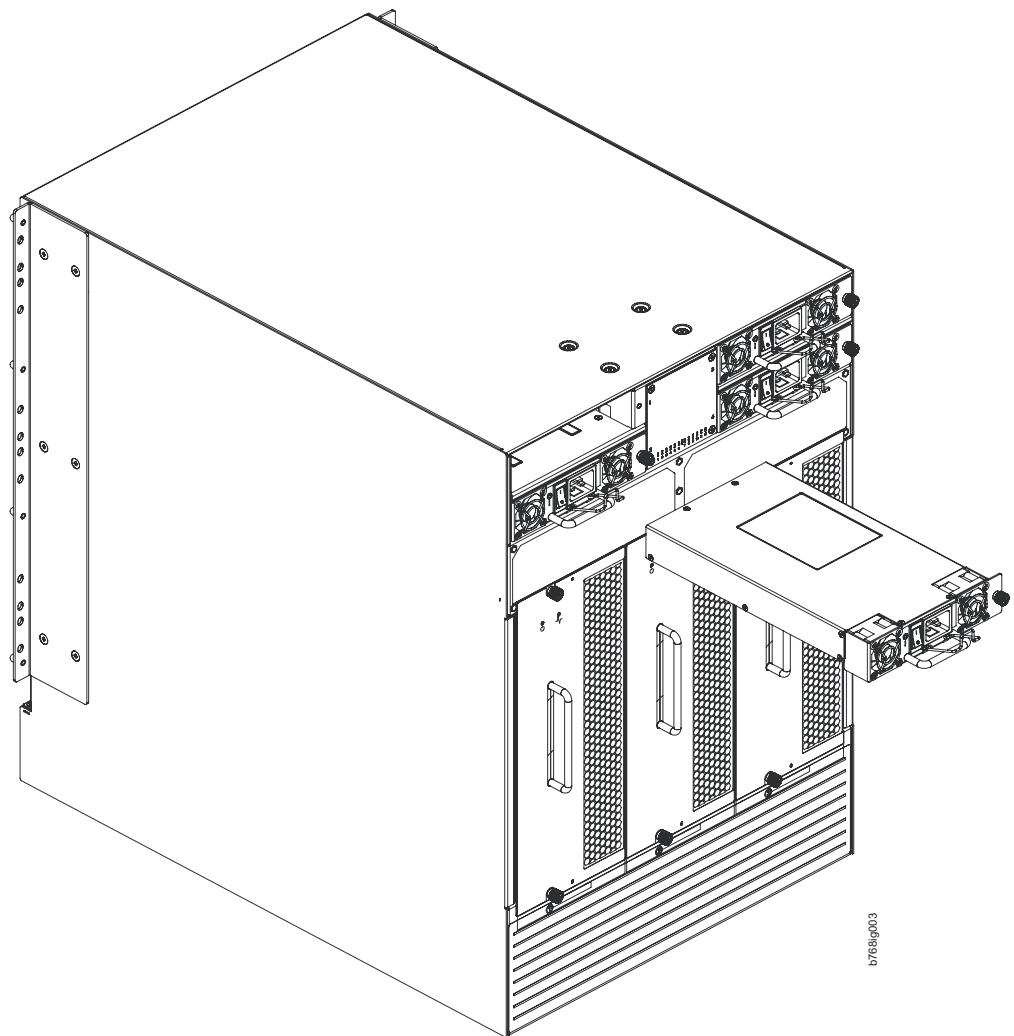

Figure 37. Removing and installing a power supply

Installing a power supply

To install a power supply, do the following:

1. Remove any filler panels.

2. Insert the power supply into the slot and push the handle up. Verify that the power supply is seated by gently pulling on the handle. The power supply should resist movement as you pull.
3. Tighten the thumbscrew.
4. Replace the power cord.
5. Turn on the power switch.
6. Verify that the power LED on the power supply displays a steady green light.

Removing and installing a blower assembly

This procedure provides instructions for removing and installing a blower assembly.

Attention: The BSAN768B can continue operating during the replacement of one blower assembly if the other two blower assemblies are operating. To ensure continuous adequate cooling, maintain three operating blower assemblies at all times except for the brief period when replacing a blower assembly.

Time and items required

The installation procedure for each blower assembly takes less than 5 minutes. The following items are required for the blower assembly installation:

- Replacement blower assembly
- Phillips #2 screwdriver

Removing a blower assembly

To remove a blower assembly, do the following:

1. Before removing a blower assembly, verify that the other blower assemblies are functioning correctly. The power LEDs should be steady green.
2. Use the Phillips screwdriver to loosen the captive screws at the top and bottom of blower assembly (see Figure 38 on page 91).
3. Grasp the handle and pull, sliding the blower assembly from the chassis and supporting the blower assembly from beneath as you remove it.

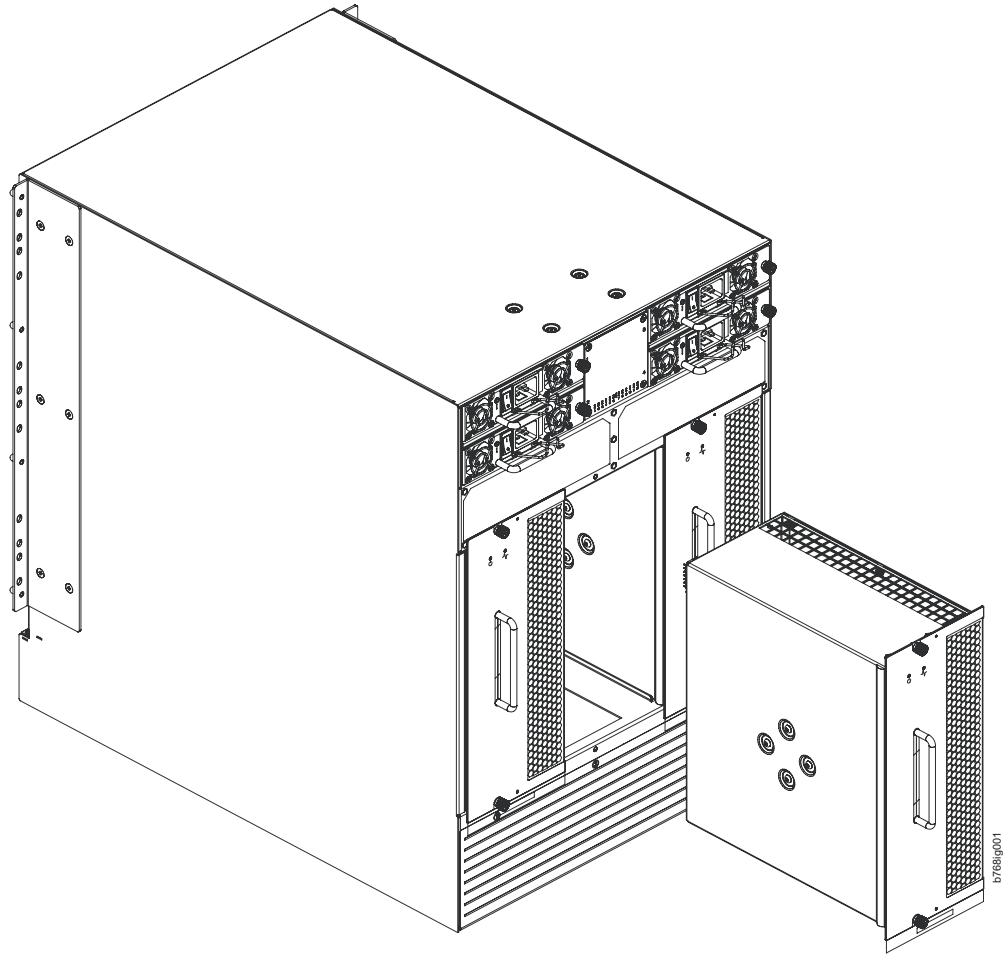

Figure 38. Removal and replacement of the blower assembly

Installing a blower assembly

To install a blower assembly, do the following:

1. Orient the blower assembly and slide it into the chassis, pushing firmly to ensure that it is seated.
2. Verify that the power LED displays a green light.
3. Use the screwdriver or your fingers to tighten the captive screws.

Removing and installing a WWN bezel and WWN card

Note: The World Wide Name (WWN) cards contain fully redundant circuits and normally do not require installation. Two WWN cards are located beneath the WWN bezel.

Time and items required

Allow approximately 20 minutes to replace a WWN card. The following items are needed to install a WWN card:

- ESD grounding strap
- #2 Phillips screwdriver (required only for some versions of the WWN card)

- If a serial console session is used: serial cable and a workstation computer with a terminal emulator application (such as HyperTerminal for Windows systems or TIP for Solaris systems)

Verifying necessity of installation

Before installing a WWN card, verify that the installation is necessary. Any of the following events can indicate that the card requires installation:

- Status LEDs on the WWN bezel do not reflect the actual status of the components
- Power or status LEDs on WWN card indicate a problem.
- Problems viewing or modifying the data stored on the WWN card (see Table 13).
- Error messages regarding WWN units #1 or #2 (see Table 14).

To determine the status of a WWN card, do the following:

1. Check the LED indicators on the WWN bezel (see Figure 28 on page 67) and verify that they reflect the actual status of the components. The WWN bezel covers the WWN cards and allows its LEDs to shine through. The LEDs on the WWN bezel provide a consolidated view of the port, CP, and CR blade status, see Table 12 on page 67.
2. Check the WWN card status using the commands listed in Table 13. Difficulty retrieving or modifying this data could indicate a WWN card failure.

Table 13. Commands identifying the WWN card status

Data	Related commands
WWN values	wwn , chassisShow
Data about the chassis and WWN card	chassisShow
Ethernet and Fibre Channel IP address information for the CP blades	ipAddrShow , ipAddrSet
History log information	historyShow , historyLastShow
Name of switch	switchName

3. An error message is logged that indicates the status of the WWN unit (see Table 14). WWN units correspond to information specific to the WWN card and are displayed by the **chassisShow** command.

Table 14. WWN card related system log messages

Type of message	System message (errshow or errdump)
WWN unit removal was detected	<timestamp>, [EM-1050], <sequence-number>, INFO, <system-name>, FRU WWN # removal detected.
WWN unit insertion was detected	<timestamp>, [EM-1049], <sequence-number>,, INFO, <system-name>, FRU WWN # insertion detected.
WWN unit fails to power on	<timestamp>, [EM-1004], <sequence-number>,, CRITICAL, <system-name>, WWN # failed to power on
WWN unit is being faulted	<timestamp>, [EM-1034], <sequence-number>,, ERROR, <system-name>, WWN # set to faulty, rc=<return code>

Removing the WWN bezel and WWN card

To remove the WWN bezel and WWN card, complete the following steps.

Attention: Follow ESD precautions.

1. Open a Telnet session to the SAN768B and log in to the active CP as **admin**. The default password is **password**.
2. Verify you are logged into the active CP. Run the **haShow** command to determine the active CP.
3. Enter **fruReplace wwn** from the active CP blade and wait for the phrase, "Do you wish to continue [y/n]?" to display; then enter **y**.
4. Wait until the WWN card data is backed up. **Do not** enter continue until the mechanical replacement is complete (see "Installing the WWN bezel and WWN card" on page 94).

```
switch:admin> frureplace wwn
This is the WWN card hot swap interface.
Continuing from this point will require
the whole process to be completed.
If this process is not complete due to a
power cycle, or CP failover, please follow
the recovery procedure in
Core Switch WWN Card Removal and
Replacement document.
Do you wish to continue [y/n]?
```

Backing up WWN card data, please wait about 25 seconds for further instruction.
Please install the new FRU now.

If this session lost for any reason, please re-enter the frureplace command and follow the instructions to complete the operation.

Please enter the word `continue' after the new WWN card has been installed:

5. Wait until all the LEDs on the WWN bezel turn off.
6. Remove the four screws from the WWN bezel (see Figure 39 on page 94). Pull the bezel away from chassis and set it aside. The WWN cards are visible.
7. Remove a WWN card as follows:
 - To remove a WWN card that has handles: Use the handles to remove the card.
 - To remove a WWN card that does not have handles: Use a Phillips screwdriver to unscrew the two screws which secure the WWN card to the chassis. Hold the card by the edges and remove it.
8. Set the WWN card on a static-free surface, such as a grounding pad.

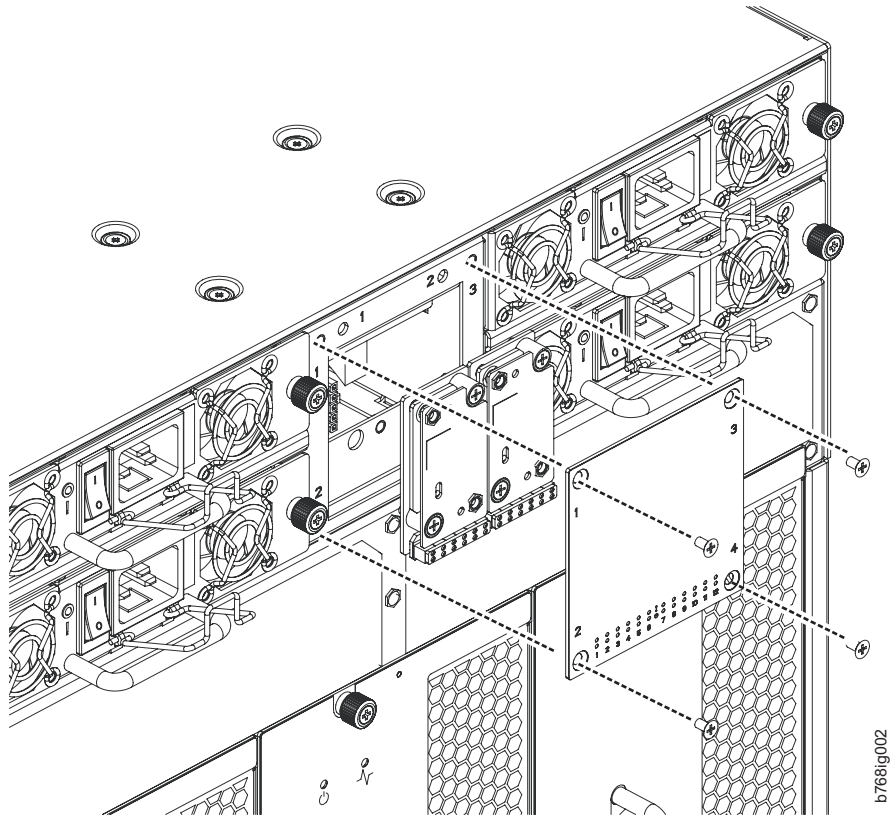

Figure 39. WWN bezel and card removal and installation

Installing the WWN bezel and WWN card

To install the WWN bezel and WWN card, do the following:

Attention: Follow ESD precautions.

1. Unpack the new WWN card and save the packaging.
2. Hold the card by the edges and insert the WWN cable onto the WWN module until it is fully seated. Use the Phillips screwdriver and the two screws to attach the WWN card to the chassis.
3. Install the WWN bezel. Orient the bezel on the chassis (see Figure 39). Insert and tighten the four screws.

Note: If a serial console session is active, several “removal detected” and “insertion detected” messages display on the console because of the installation.

4. In the CLI session, enter **continue** to indicate that the replacement has been completed.

Please enter the word `continue' after the new WWN card has been installed: **continue**

```
Restoring the information to the replacement FRU now, please
wait about 20 seconds to complete
Verifying the replacement FRU now...
WWN card hot swap is now complete.
FRU replacement completed successfully!
```

5. Verify that the WWN card is correctly connected by checking the LEDs on the WWN card.

Note: The LEDs might take up to 2 minutes after WWN card installation to begin functioning.

6. Pack the faulty WWN card in the packaging provided with the new card for return to IBM, following local procedures.

Removing and installing transceivers

Note: For a listing of SFPs, SFP+, mSFPs, and XFPs compatible with this product:

- Go to the IBM SAN web page www.ibm.com/systems/storage/san
- Select the **IBM System Storage SAN768B and SAN384B** product link
- On the displayed product page, click the **Interoperability Matrix** link in the **Learn more** section.
- In the Interoperability matrix, click the **Transceivers** link.

Note: The 8-Gbps-capable mSFPs and SFP+s auto-negotiate at 2, 4, and 8 Gbps. The 4-Gbps SFPs auto-negotiate at 1, 2, and 4 Gbps. The mSFPs are compatible only with the FC8-64 high density port blade.

Note: The XFP transceivers are used only with the FC10-6 port card. They should not be used in any 1 GE port.

Time required

The replacement procedure for a transceiver takes less than five minutes

Items required

- Replacement mSFP, SFP, SFP+, or XFP
- Optical transceiver extraction tool (for SFP, SFP+, and XFP transceivers)

Removing and replacing an SFP, SFP+, or XFP optical transceiver

The SAN768B comes with a transceiver extraction tool (see Figure 40) and holster. The extraction tool is designed to remove transceivers from blades where the space is limited. To use the extraction tool, slide the tool on to the bale of the transceiver and pull it out.

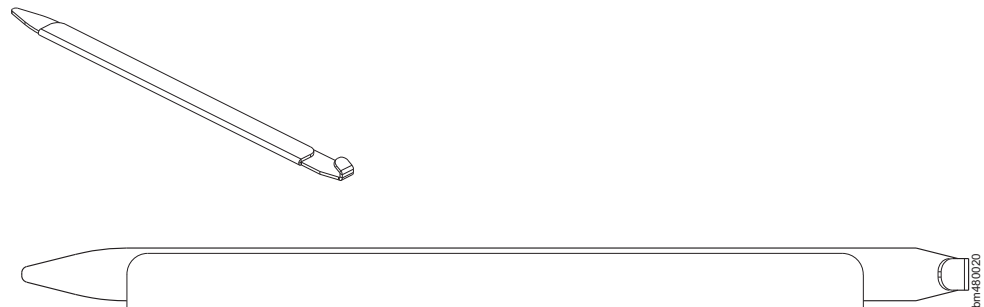

Figure 40. Optical transceiver (SFP, SFP+, and XFP) extraction tool

Note: This tool is part of the SAN768B ship group and should be kept with the SAN768B.

Attention: mSFP optical transceivers should not be inserted into ports intended for SFP or SFP+ transceivers. They will be faulted on power-up for Fabric OS 6.4.0 and later.

Removing an SFP, SFP+, or XFP optical transceiver

To remove an SFP, SFP+, or XFP (FC6-10 blade only) transceiver, complete the following steps.

1. Remove any cables that are inserted into the transceiver. Use the extraction tool to open the cable latching mechanism.
2. Pull the bail (wire handle) **1** away from its pivot point and out, sliding the transceiver out of the port (Figure 41).

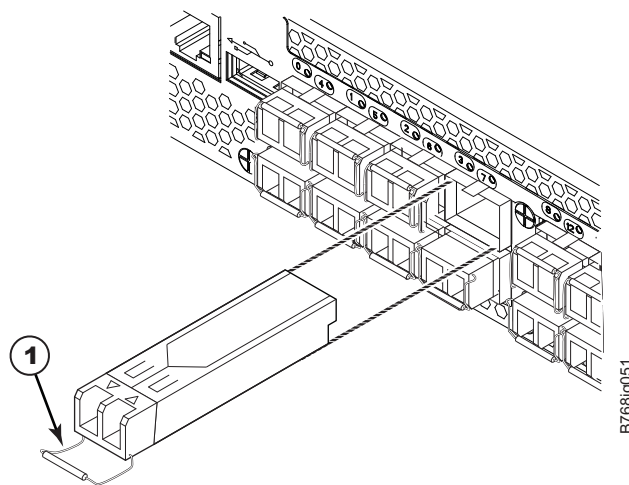

Figure 41. Replacing an optical transceiver

Replacing an SFP, SFP+, or XFP transceiver

1. Position the optical transceiver so that the key is oriented correctly to the port. Insert the transceiver into the port until it is firmly seated and the latching mechanism clicks. Transceivers are keyed so that they can only be inserted with the correct orientation. If a transceiver does not slide in easily, ensure that it is correctly oriented.
2. Position a cable so that the key (the ridge on one side of the cable connector) is aligned with the slot in the transceiver. Insert the cable into the transceiver until the latching mechanism clicks. Cables are keyed so that they can be inserted in only one way. If a cable does not slide in easily, ensure that it is correctly oriented.

Removing and replacing an mSFP optical transceiver

Note: mSFP optical transceivers should not be inserted into ports intended for SFP or SFP+ transceivers. They will be faulted on power-up For Fabric OS 6.4.0 and later.

To replace an mSFP transceiver, complete the following steps. Note that it is recommended that the optical cable should be either removed from or inserted into the mSFP while the transceiver is out of the switch or blade.

Removing an mSFP transceiver

Note: The mSFP transceivers are used only with the FC8-64 port blade. Narrower OM-3 LC cables are used to connect the FC8-64. These cables are offered by several major manufacturers. Contact your IBM representative for options regarding different cable and patch panel configurations to simplify cable management with higher density FC8-64 port blades.

Attention: The pull tabs are not designed to be bent. Doing so may result in damage to the pull tab.

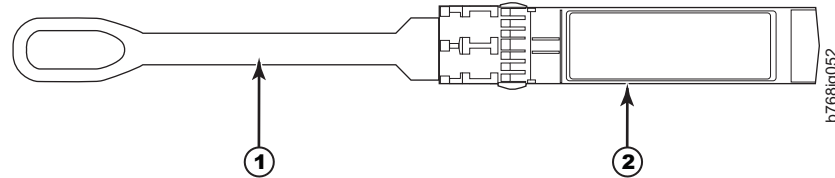

Figure 42. Optical mSFP transceiver

1 Pull tab **2** mSFP transceiver

1. Grasp the pull tab **1** firmly and pull the unit out of the port.
2. Remove the cable from the transceiver.

Replacing an mSFP transceiver

1. Insert the cable into the new transceiver until the latching mechanism clicks.
2. Position the optical transceiver so that the key is oriented correctly to the port. Insert the transceiver into the port until it is firmly seated and the latching mechanism clicks.
Transceivers are keyed so that they can only be inserted with the correct orientation. If a transceiver does not slide in easily, ensure that it is correctly oriented.

Removing and installing inter-chassis link (ICL) cables

Note: ICL ports can be used only with an ICL license. After the addition or removal of a license, the license enforcement is performed on the ICL ports only when the **portDisable** and **portEnable** commands are issued on the ports. An ICL license must be installed on all systems forming the ICL connection. The systems can be any combination of up to three SAN384B and SAN768B chassis.

Note: For FOS 6.4.0 and later, three SAN768 chassis can be supported in a triangular ICL configuration as long as the third chassis is housed in an immediately adjacent rack so that the cables can reach the ICL ports.

Attention: If ICL cables are not in use, the ports must have EMI plugs installed to meet EMI and other regulatory certifications.

Table 15 on page 98 describes the ICL connector port LED patterns and the recommended actions for those patterns.

Table 15. ICL connector port LEDs

LED purpose	Color	Status	Recommended action
LINK LED	No light (LED is off)	No ICL, or ICL cable present but no connection.	Ensure that the ICL cable is correctly installed.
	Steady green	ICL connected.	No action required.
ATTN LED	No light (LED is off)	ICL operational.	No action required.
	Blinking amber	Attention required.	Ensure that the ICL cable is correctly installed.

Follow this procedure to remove and install the ICL cables. Refer to the *Fabric OS Administrator's Guide* for the configuration procedure and requirements.

Figure 43 shows the two ends of an ICL cable. The ICL cables (2 meters long) and the ICL connectors on the CR8 core switch blades are color-coded and labeled for ease of installation. Figure 44 on page 100 through Figure 49 on page 105 show the acceptable cabling configurations for the inter-chassis link (ICL) feature. Connect the ICL cables in one of the configurations shown. The cables can connect ICL connector ports on the SAN768B core switch blades (CR8) or SAN384B core switch blades (CR4S-8). Figure 48 on page 104 and Figure 49 on page 105 show 3-way ICL connections between SAN768B and SAN384B models.

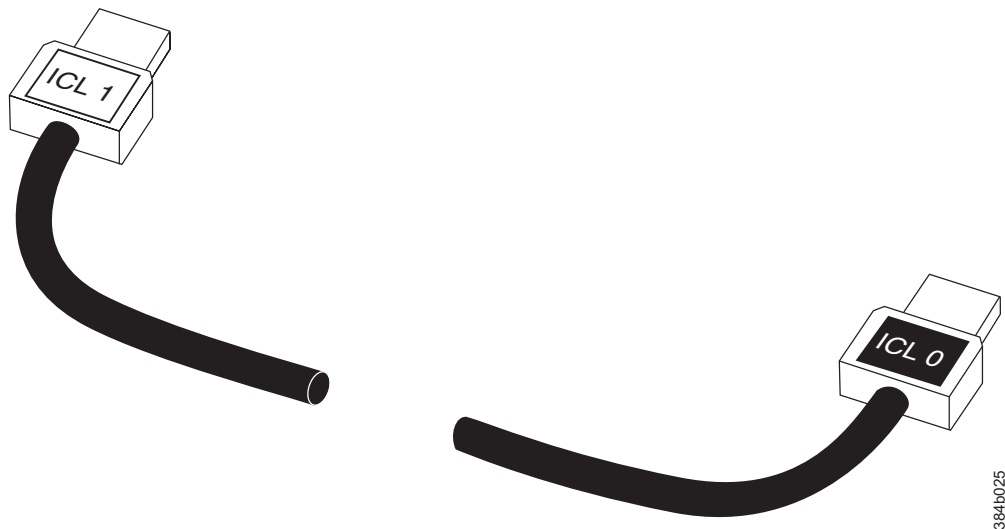

Figure 43. ICL cable

Time and items required

The replacement procedure for an ICL cable takes less than five minutes. A replacement ICL cable is the only item needed.

Removing an ICL cable

Attention: To prevent the latch mechanism from wear, use the color-coded (green) latch-release tab for cable removal. Pull the tab to disengage the retention latch before cable removal.

1. Remove the chassis door (“Removing and installing the chassis door” on page 69).
2. If you are replacing an ICL cable, note the cable routing, paying attention to which cable end plug into which socket. Replace only one ICL cable at a time to minimize errors.
3. Using the latch release tabs, pull each plug on the cable from its respective socket on the SAN768B core switch blades (CR8) or SAN384B core switch blades (CR4S-8).
4. Repeat for each cable that requires replacement.
5. If you are not replacing the ICL cables, insert the EMI plugs into each ICL socket.

Installing an ICL cable

1. Align the color-coded and labeled (ICL 1 and ICL 0) plugs on either end of the ICL cable with their respective connectors on the core switch blades.
2. Push each plug in until the latch mechanism clicks into place.
3. Repeat steps 1 and 2 for each cable that you are installing.
If you are installing ICL cables for the first time, pay particular attention to the configuration in which the cables must be installed.

Note: The cables can cross between the slot 5 CR8 blade and the slot 8 CR8 blade as long as the top-to-bottom rule is followed.

Attention: Connect the cables from the top connectors (ICL 1) of the core blades in one chassis to the bottom connectors (ICL 0) of the core blades in another chassis. Similarly, connect the cables from the bottom connectors (ICL 0) of the core blades in one chassis to the top connectors (ICL 1) of the core blades in another chassis. Pay special attention to this configuration when creating a 3-way connection between three chassis. The ports and cable connectors are color-keyed to help keep the orientation correct. When connecting SAN768B and SAN384B chassis, it is important to note the relationship of the horizontal SAN384B layout to the vertical layout of the SAN768B in each figure.

Note: The same general configuration applies regardless of which chassis are used. The illustrations for 3-way ICL cable connections are used to show the *ICL cable connections* between the different chassis. They are *not* meant to illustrate installation of multiple chassis in a single cabinet. Because of cabinet installation limits, the chassis for some configurations will be installed in adjacent cabinets.

4. Replace the chassis door (“Removing and installing the chassis door” on page 69).
5. Once all the cables are attached, see the *Fabric OS Administrator’s Guide* for the configuration procedure.

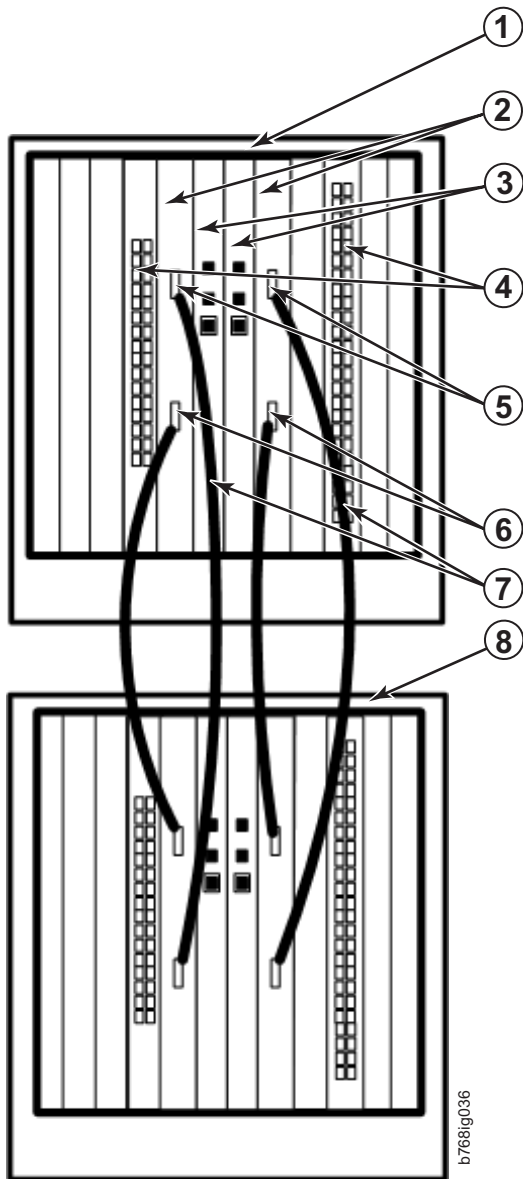

Figure 44. ICL cable connections between two SAN768B chassis

- 1** Chassis 1
- 2** Core switch blades (CR8)
- 3** Control processor blades (CP8)
- 4** Port blades
- 5** ICL connector (ICL 1)
- 6** ICL connector (ICL 0)
- 7** ICL cables
- 8** Chassis 2

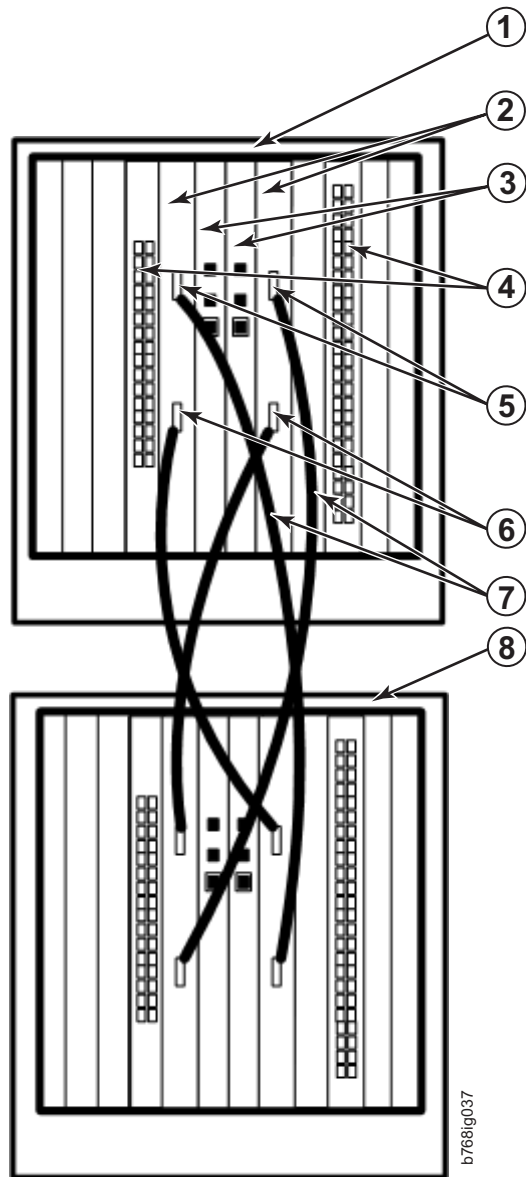

Figure 45. ICL cable connections between two SAN768B chassis

- 1** Chassis 1
- 2** Core switch blades (CR8)
- 3** Control processor blades (CP8)
- 4** Port blades
- 5** ICL connector (ICL 1)
- 6** ICL connector (ICL 0)
- 7** ICL cables
- 8** Chassis 2

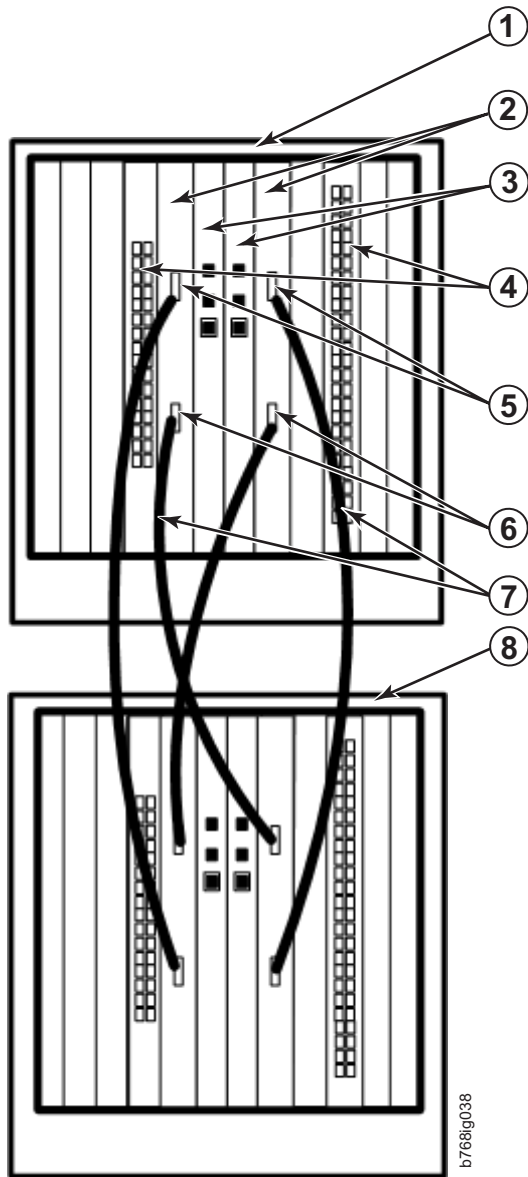

Figure 46. ICL cable connections between two SAN768B chassis

- 1** Chassis 1
- 2** Core switch blades (CR8)
- 3** Control processor blades (CP8)
- 4** Port blades
- 5** ICL connector (ICL 1)
- 6** ICL connector (ICL 0)
- 7** ICL cables
- 8** Chassis 2

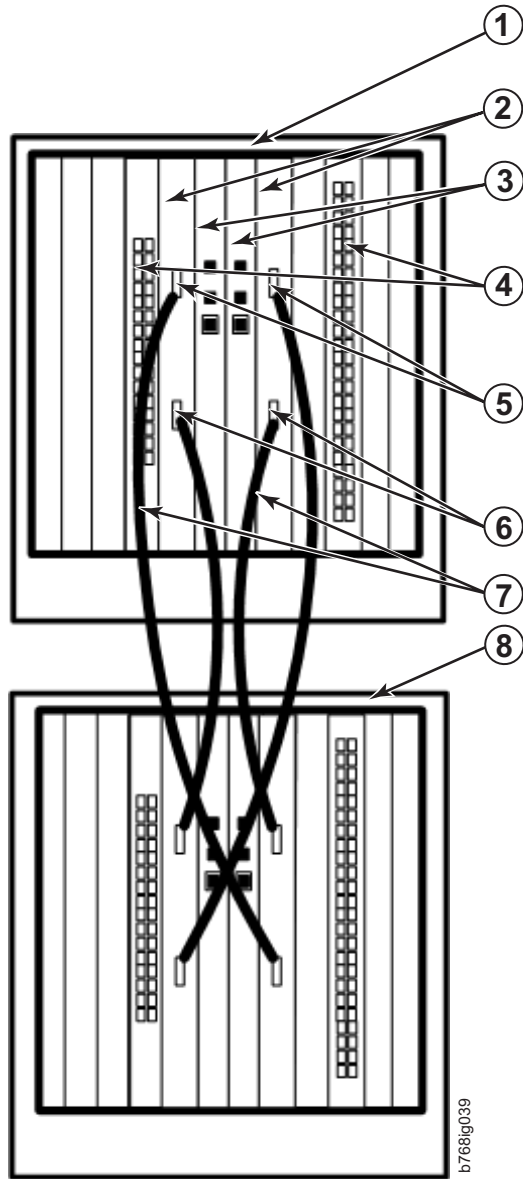

Figure 47. ICL cable connections between two SAN768B chassis

- 1** Chassis 1
- 2** Core switch blades (CR8)
- 3** Control processor blades (CP8)
- 4** Port blades
- 5** ICL connector (ICL 1)
- 6** ICL connector (ICL 0)
- 7** ICL cables
- 8** Chassis 2

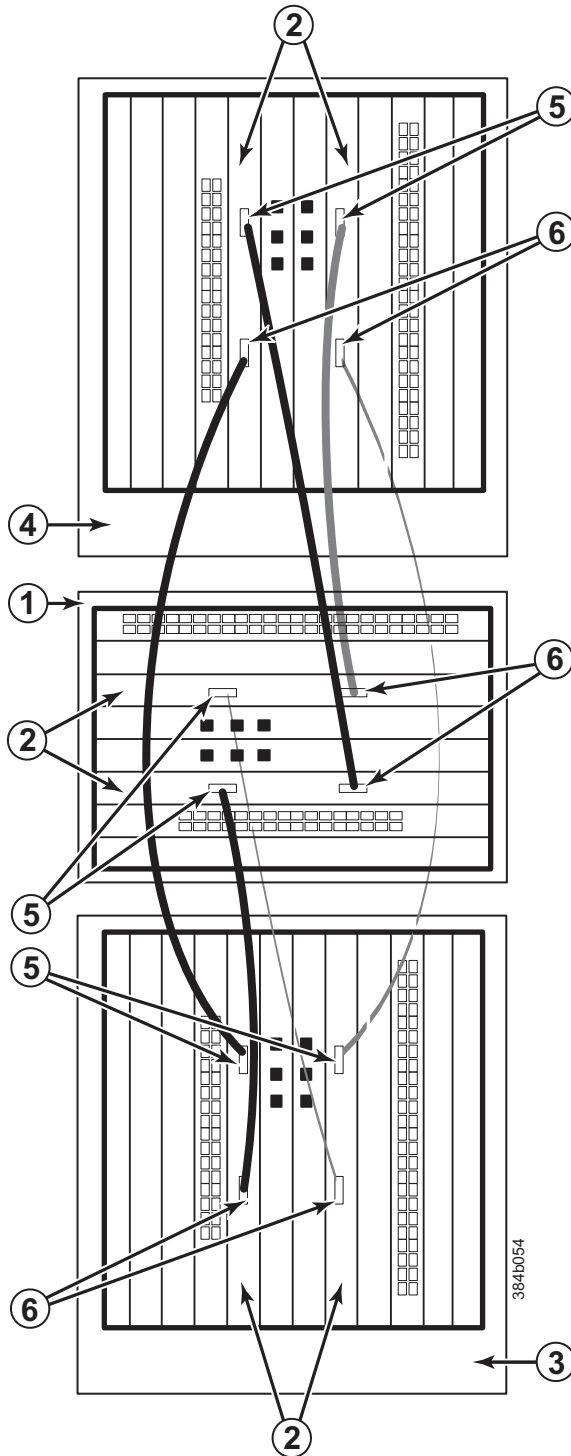

Figure 48. 3-way ICL cable connections between a SAN384B and two SAN768B chassis.

- 1** Chassis 1 (SAN384B)
- 2** Core switch blades (CR4S-8)
- 3** Chassis 2 (SAN768B)
- 4** Chassis 3 (SAN768B)
- 5** ICL connector (ICL 1)
- 6** ICL connector (ICL 0)

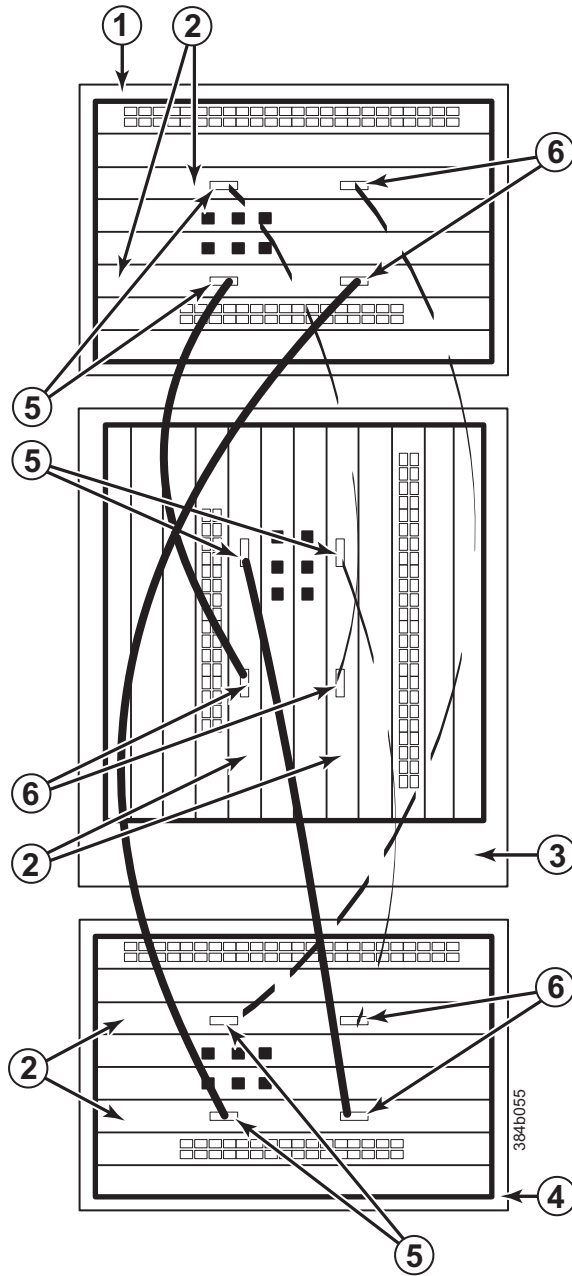

Figure 49. 3-way ICL cable connections between a SAN768B and two SAN384B chassis.

- | | |
|--------------------------------------|--------------------------------|
| 1 Chassis 1 (SAN384B) | 4 Chassis 3 (SAN384B) |
| 2 Core switch blades (CR4S-8) | 5 ICL connector (ICL 1) |
| 3 Chassis 2 (SAN768B) | 6 ICL connector (ICL 0) |

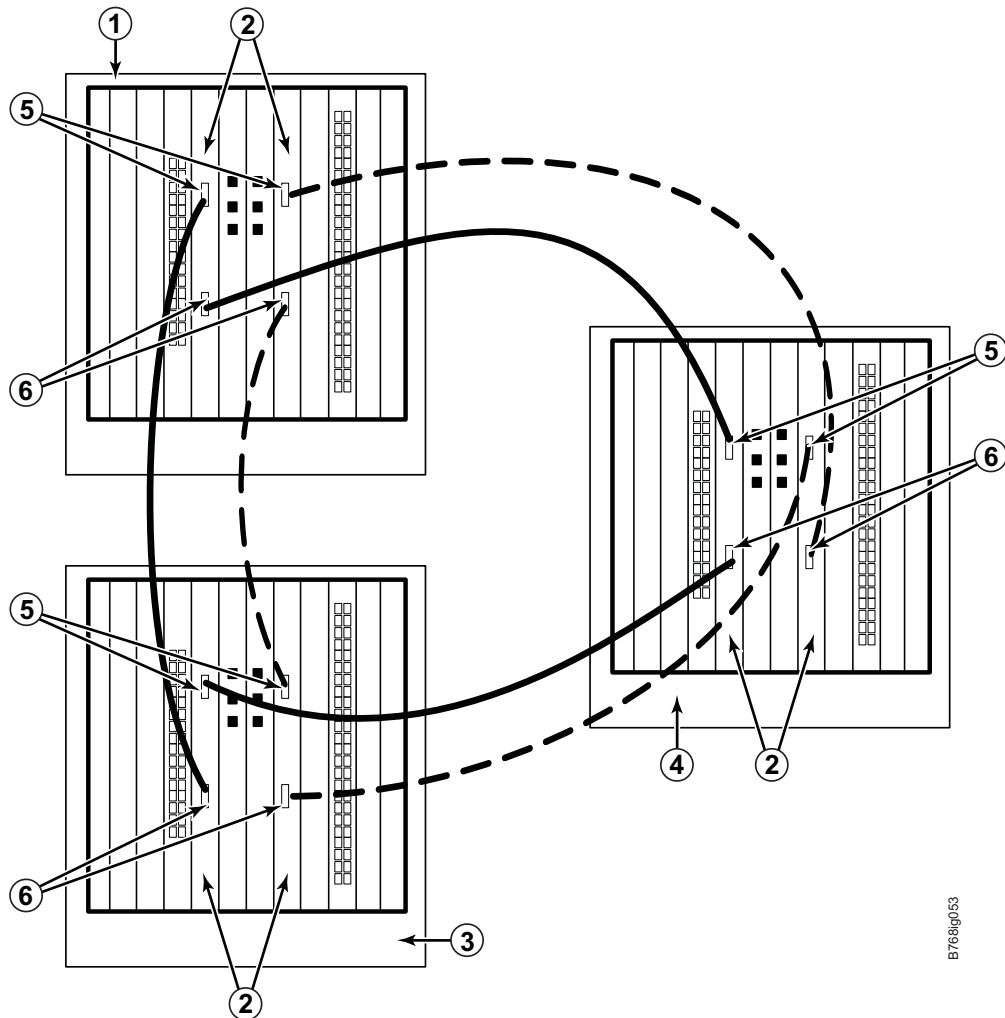

Figure 50. 3-way ICL cable connections between three SAN768B chassis

- | | |
|------------------------------|--------------------------------|
| 1 Chassis 1 (SAN768B) | 4 Chassis 3 (SAN768B) |
| 2 Core switch blades | 5 ICL connector (ICL 1) |
| 3 Chassis 2 (SAN768B) | 6 ICL connector (ICL 0) |

For Fabric OS 6.4.0 and later, you can use three SAN768B chassis as an ICL configuration if the third chassis is in an immediately adjacent rack.

Note: For clarity, the two sets of cables are drawn differently (solid and dashed) in Figure 48 on page 104 through Figure 50. Also note that one set is connected to only the blades in the "low order" slots (slot 3 in the SAN384B and slot 5 in the SAN768B) and the other set is connected to the blades in the "high order" slots (slot 5 in the SAN384B and slot 8 in the SAN768B). Keeping the sets apart in this manner minimizes the cable confusion.

Removing the batteries

Local regulations may require removal of the battery before recycling or disposing of the product. Batteries are located in the control processor blades (CP8) and also in optional Encryption blades (FS8-18). Follow these steps to remove the batteries from the product:

CAUTION:

The battery contains lithium. To avoid possible explosion, do not burn or charge the battery.

DO NOT:

- Throw or immerse into water
- Heat to more than 100°C (212°F)
- Repair or disassemble

Exchange only with the IBM-approved part. Recycle or discard the battery as instructed by local regulations. In the United States, IBM has a process for the collection of this battery. For information, call 1-800-426-4333. Have the IBM part number for the battery unit available when you call. (C003)

1. Remove any installed modules.
2. Remove any installed power supplies.
3. Unscrew fasteners and remove any fan trays or fan assemblies.
4. Unscrew fasteners, unplug all connectors and remove any Printed Circuit Board Assembly (PCBA) from the fan trays or fan assemblies.
5. In the two control processor blade (CP8) assemblies, locate the central processor PCBAs.
6. Go to the following locations and remove the two BR1225 batteries from each of the PCBAs (see **1** in Figure 51):
 - a. XB1
 - b. XB

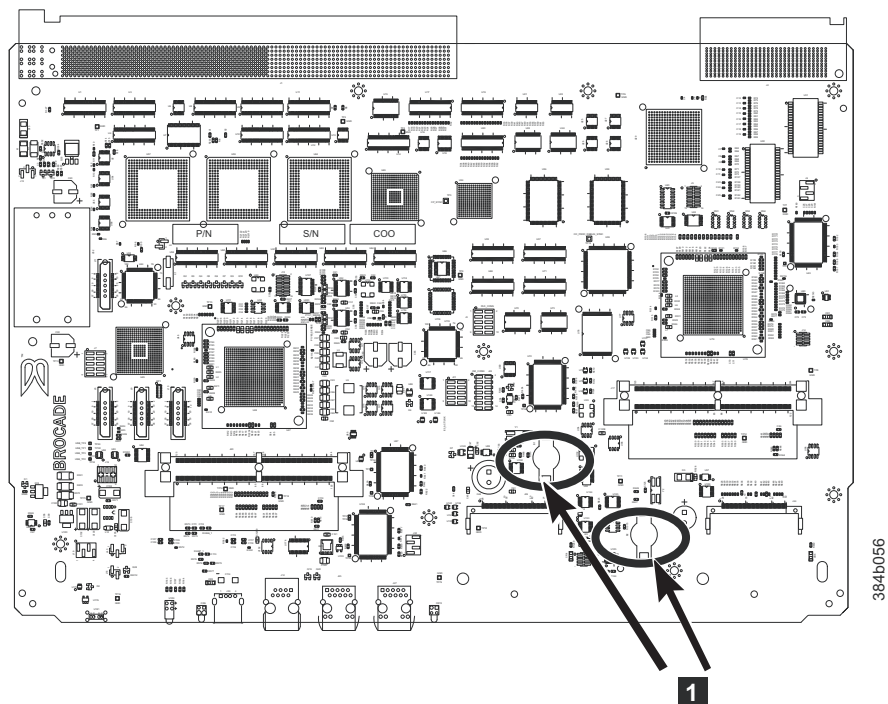

Figure 51. Battery locations on the CP8 blade

7. For the optional FS8-18 encryption blade, go to the BC1 location (see **1** in Figure 52 on page 108) on the main board and remove the BR1225 battery.

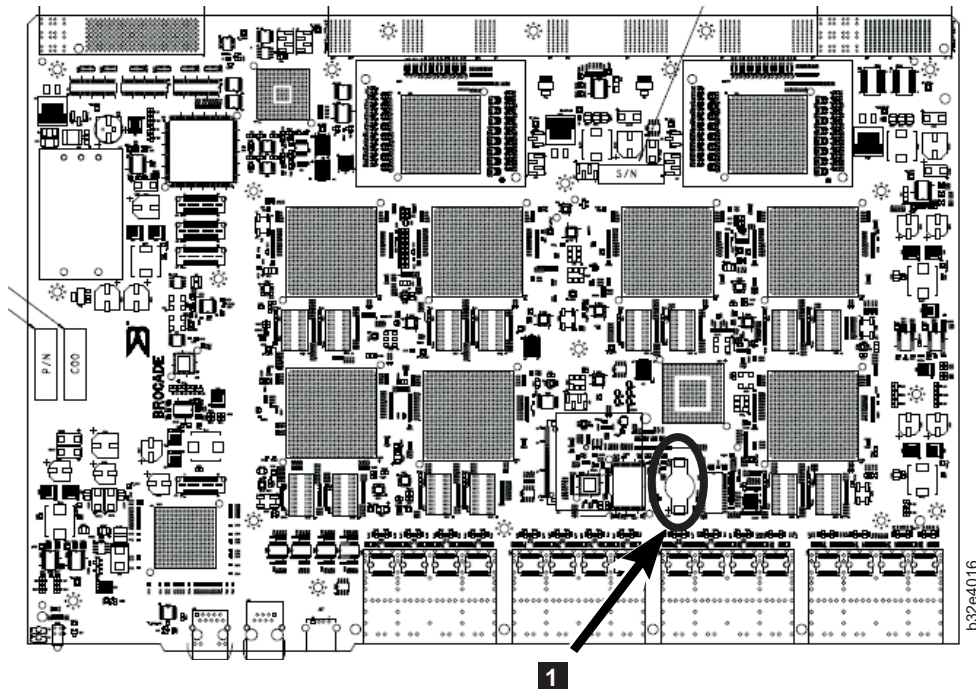

Figure 52. Encryption blade battery location

8. Recycle the batteries as appropriate.

Refer to the *Environmental Notices and User Guide* shipped with the product for more information on battery recycling and disposal.

Removing and replacing the chassis

The SAN768B chassis is highly reliable and unlikely to fail. This chapter describes how to remove and replace a chassis in the unlikely event of a failure. The SAN768B must be removed from the fabric and powered off to perform this procedure. Contact IBM if you have any questions about whether the SAN768B chassis requires replacement. This procedure is to be completed only by a qualified IBM service representative.

Refer to the following sections of this chapter for specific information:

- “Verifying necessity of replacement” on page 109
- “Preparing for a chassis replacement” on page 109
 - “Time required” on page 109
 - “Items required” on page 109
 - “Recording critical SAN768B and SAN information” on page 109
- “Disconnecting the SAN768B from the network and fabric” on page 112
- “Removing components from the chassis” on page 113
- “Removing and replacing the chassis from the cabinet” on page 113
- “Installing components into the new chassis” on page 114
- “Verifying the correct operation of the system” on page 115
- “Reconnecting the system to the network and fabric” on page 116
- “Verifying the correct configuration of the fabric” on page 117

Note: The SAN768B must be removed from the fabric and powered off to perform this procedure. Contact IBM Support if you have any questions about whether the chassis requires replacement.

Verifying necessity of replacement

Before replacing the chassis, verify that the replacement is necessary. Ensure that the components are firmly seated when troubleshooting. Contact IBM if you have any questions about whether the chassis should be replaced.

Any of the following events might indicate that the chassis requires replacement:

- Visible mechanical damage to the chassis, including damage to sheet metal or blade guides that prevents correct installation of a component.
- Bent or damaged connectors on the main backplane (the surface inside the chassis to which the various blades connect)
- One or more SAN768B components (such as a power supply, blower assembly, port blade, CP blade, or WWN card) do not function properly even after the component is replaced.
- The **psShow** or **fanShow** commands continue to show a faulty component even though the component has been replaced.
- The **slotShow** command continues to show a faulty CP blade or port blade even though the blade has been replaced.

Preparing for a chassis replacement

Use the following information to help prepare for a chassis replacement.

Attention: Refer to “Safety notices and labels” on page xv before performing any removal or installation procedures.

Time required

The chassis replacement procedure takes approximately 3 hours to complete.

Items required

The following items are required for the chassis replacement procedure:

- ESD grounding strap.
- ESD grounding pads for protecting all blades and WWN cards
- Serial cable and workstation computer with a terminal emulator application (such as HyperTerminal for Windows systems or TIP for Solaris systems), required only if serial console session used.
- Lifting tool (see “Ordering the lift tool” on page 12).
- A surface to place the old chassis on, such as a second lift or the pallet originally provided with the old chassis.
- Torque wrench with #2 Phillips screwdriver tip (if switch is installed in a cabinet).
- #2 slotted screwdriver.

Recording critical SAN768B and SAN information

All commands must be entered from a CLI session (Telnet or serial) to the active CP blade unless otherwise indicated. For detailed information about Fabric OS commands, refer to the *Fabric OS Command Reference Manual*. Use a checklist to ensure that all required information is recorded (see Table 16 on page 110).

Note: Run **supportShow**, which will provide most of the information in Table 16 and more. The customer should also record the location of the .txt files, which are created by the customer and are not called out in the **supportShow** results.

Table 16. Critical information checklist example

Checked?	Data	Notes
Configuration information		
	Location of "config-switch.txt" file:	
	Location of "config-miscinfo.txt" file:	
	IP address, subnet mask:	
	WWN for SAN768B:	
SAN profile		
	Location of "SANbefor.txt" file:	
	Notes regarding nsShow output:	
	Notes regarding nsAllShow output:	
	Notes regarding switchShow output:	
	Notes regarding fabricShow output:	
Output from supportShow command		
	Location of "spptshow.txt" file:	
	Notes regarding supportShow output:	
Information about the new chassis		
	New factory serial number:	
	New serial number (if available):	

To record critical switch and SAN information:

1. Open a Telnet session and login to the SAN768B as **admin**. The default password is **password**. Refer to your records for current passwords. Enable the logging function on your Telnet or serial console connection.
2. Back up the current configuration.

Note: If you are using the virtual fabric feature, you should run **configupload -vf** before running the **configupload** command in order to save the logical switch configuration.

Enter **configUpload -all**; then enter the requested information at the prompts. This command uploads the chassis configuration to the customer-defined FTP server, making it available for downloading. For more information about this command, refer to the *Fabric OS Command Reference*.

```
switch:admin> configupload -all
Protocol (scp or ftp) [ftp]: ftp
Server Name or IP Address [host]: 123.123.123.123
User Name [user]: Admin24
File Name [config.txt]: config-switch0.txt
Password:
Upload complete
switch:admin>
```

Alternatively, you can save the configuration file to a Brocade USB drive.

3. Record the SAN768B values on a workstation, following steps 4 on page 111 through 9 on page 112 below.

- Record the WWN value: Enter **wwn**, then copy the command output into a file named `configmiscinfo.txt`.

```
switch:admin> wwn  
10:00:00:60:69:00:00:0a
```

- Record the IP address information. Enter **ipAddrShow -sw**, then copy the command output into the `config-miscinfo.txt` file.

```
switch:admin> ipaddrshow -sw  
Ethernet IP Address: 10.32.50.12  
Ethernet Subnetmask: 255.55.0.0  
Fibre Channel IP Address: 1.2.3.4  
Fibre Channel Subnetmask: 255.255.255.0  
CP0  
Ethernet IP Address: 10.32.50.10  
Ethernet Subnetmask: 255.55.0.0  
HostName : cp0  
Gateway Address: 10.32.40.1  
CP1  
Ethernet IP Address: 10.32.50.11  
Ethernet Subnetmask: 255.55.0.0  
HostName : cp1  
Gateway Address: 10.32.40.1  
Backplane IP address of CP0 : 10.0.0.6  
Backplane IP address of CP1 : 10.0.0.7  
switch:admin>switch:admin>
```

- Display and record the manufacturer serial numbers. Enter **chassisShow**, then copy the command output into the `config-miscinfo.txt` file.

"Factory Serial Num" and "Serial Num" are listed under "Chassis/WWN Unit 1." If the current WWN cards are the original cards, the factory serial number listed is the same as the chassis serial number. If a "Serial Num" value displays, contact IBM to determine whether this serial number should be modified after the new WWN card is installed.

```
switch:admin> chassisshow  
Chassis Backplane Revision: 1F  
SW BLADE Slot: 1  
Header Version: 2  
Power Consume Factor: -50  
Factory Part Num: 60-0001532-03  
Factory Serial Num: KP000000195  
Manufacture: Day: 1 Month: 1 Year: 2007  
Update: Day: 14 Month: 3 Year: 2012  
Time Alive: 187 days  
Time Awake: 3 days  
<output truncated>  
CHASSIS/WWN Unit: 1 (in same assembly as WWN Unit: 2)  
Header Version: 2  
Power Consume Factor: -3  
Factory Part Num: 60-0001501-07  
Factory Serial Num: FT02X805BE2  
Manufacture: Day: 26 Month: 3 Year: 2007  
Update: Day: 14 Month: 3 Year: 2010  
Time Alive: 207 days  
Time Awake: 3 days  
<output truncated>  
switch:admin>
```

- Create a SAN profile by entering and recording the information provided by the following commands:

- **nsShow**
- **nsAllShow**
- **switchShow**
- **fabricShow**

Copy the command output into a text file named SANbefor.txt. After the SAN768B is restored to the fabric, this information can be used to verify that no unintentional changes have occurred to the fabric.

```
switch:admin> nsshow
Enter Pid COS PortName NodeName TTL
<output truncated>
switch:admin> nsallshow
12 Nx_Ports in the Fabric
<output truncated>
switch:admin> switchshow
switchName: switch
<output truncated>
switch:admin> fabricshow
Switch ID Worldwide Name Enet IP Addr FC IP Addr Name
<output truncated>
switch:admin>
```

8. Enter **supportShow**, then copy the command output into a text file named spptshow.txt.

Note: The **supportShow** command has very long output and time for completion. It may last 20 minutes or longer depending on the size of the SAN.

This file provides a backup of all the information that might be required by Technical Support. The information can be used after the SAN768B is restored to the fabric, to verify that no unintentional changes have occurred to the fabric

```
switch:admin> supportshow
version: 6.0.0
<output truncated>
```

```
switch:admin>
```

9. Record the cable connections between the SAN768B and the target device and ports. (See "Cable routing tables" on page 118).

Disconnecting the SAN768B from the network and fabric

To disconnect the SAN768B from the network and fabric, complete these steps:

1. Shut down the system by entering the **switchShutdown** command.

```
switch:admin> sysshutdown
This command will shutdown the operating systems on your switch.
You are required to power-cycle the switch in order to restore operation.
Are you sure you want to shutdown the switch [y/n]? y
HA is disabled
Stopping blade 1
Shutting down the blade....
Stopping blade 4
Shutting down the blade....
Stopping blade 10
Shutting down the blade....
Broadcast message from root (pts/1) Tue Jul 18 14:23:06 2006...
The system is going down for system halt NOW !!
```
2. Power off the chassis by flipping all ac power switches to the off position "O" (the LEDs inside the clear plastic ac power switches should turn off).
3. Remove the power cords from the power supplies and the power outlets.
4. Label the cables connected to all blades, if not already labeled, and record the connections in the "Cable routing tables" on page 118, making extra copies as needed.
5. Disconnect all cables from the port blades and set them aside. Remove each mSFP transceiver and cable as a unit. The SFP, SFP+, or XFP transceivers can be left in the blades or removed.

- Attention:** Follow the instructions in “Removing and replacing an SFP, SFP+, or XFP optical transceiver” on page 95, particularly for the mSFPs.
6. Disconnect all cables from the CP8 and CR8 blades.
 7. Disconnect any ICL cables.

Removing components from the chassis

Attention: Before removing any components, refer to “Safety notices and labels” on page xv, and particularly to “Rack safety” on page xxii to ensure that any component removals and installations do not affect the stability of the cabinet.

Attention: Follow ESD precautions (see “ESD precautions” on page xxi)

You must remove the field replaceable units (FRUs) from the SAN768B chassis in the order listed below. Refer to the instructions in Chapter 5, “Removing and installing components,” on page 69 for component-specific removal instructions.

1. Remove the cable management comb as described in “Removing and installing a cable management comb” on page 70.
2. Remove the port blades or filler panels as described in “Removing and installing port, application, and encryption blades” on page 71 and “Removing and installing blade filler panels” on page 75.
3. Remove the FR4-18i router blades (if any), as described in “Removing and installing an FR4-18i router blade” on page 84.
4. Remove the core switch blades (CR8) as described in “Removing and installing a core switch blade (CR8)” on page 82
5. Remove the control processor blades (CP8) as described in “Removing and installing a control processor blade (CP8)” on page 76.
6. Remove the power supply units or filler panels as described in “Removing and installing a power supply” on page 88.
7. Remove the blower assembly as described in “Removing and installing a blower assembly” on page 90.
8. Remove the WWN bezel and card as described in “Installing the WWN bezel and WWN card” on page 94.

Removing and replacing the chassis from the cabinet

Although the empty chassis is lighter than a fully populated chassis, a lifting device is still required to move it. Refer to “Removing a SAN768B from the cabinet” on page 28 for more detailed instructions on removing a SAN768B from a cabinet. The instructions below only provide an outline of the steps required to complete this process.



CAUTION:

The weight of this part or unit is at least 47 kg (104 lb) with all components removed. It takes specially-trained persons and/or a lifting device to safely lift this part or unit. (C011)

Attention: Do not place a SAN768B chassis directly on the floor. It cannot be easily moved from the floor back onto a lift or pallet.

1. Uninstall the chassis from the cabinet (see “Removing a SAN768B from the cabinet” on page 28 for detailed steps) and place it onto an extra lift or on the

shipping pallet originally provided with the chassis. Remove the mounting brackets, and set the hardware aside for use with the new chassis.

2. Unpack the new chassis (see “Unpacking the SAN768B” on page 16)
3. Attach the brackets to the new chassis (see “Attaching the shelf brackets” on page 17)
4. Install the chassis in the cabinet, using a lift tool to raise the chassis to the correct level. See “Using the lift tool, the 24–inch load plate, and the bridge tool” on page 19 for detailed steps.

Installing components into the new chassis

Install the components into the new SAN768B chassis in the order listed below. Refer to Chapter 5, “Removing and installing components,” on page 69 for more specific installation information.

Attention: Do not force the installation of any of the components. If the component does not slide in easily, ensure that it is correctly aligned and positioned before continuing.

Attention: Do not turn on the power until it is time to verify hardware operation

Attention: Follow ESD precautions (“ESD precautions” on page xxi)

1. Install the WWN cards and bezel in the new chassis as described in “Installing the WWN bezel and WWN card” on page 94.
2. Install the blower assemblies in the new chassis as described in “Removing and installing a blower assembly” on page 90.
3. Install the power supplies or filler panels in the new chassis as described in “Removing and installing a power supply” on page 88.
4. Install the control processor (CP8) blades in the new chassis as described in “Removing and installing a control processor blade (CP8)” on page 76.
5. Replace the core switch blades (CR8) as described in “Removing and installing a core switch blade (CR8)” on page 82
6. If ICL cables are not used, insert EMI plugs in the ICL sockets in the core switch blades (CR8).
7. Install the port, application blades or filler panels in the new chassis as described in “Installing a blade” on page 74 or “Installing a filler panel” on page 76.
8. Install the FR4-18i router blades in the new chassis as described in “Removing and installing an FR4-18i router blade” on page 84
9. Replace the cable management comb “Removing and installing a cable management comb” on page 70
10. Connect the power cords to the power supplies and the power outlets.
11. Install the chassis door as described in “Removing and installing the chassis door” on page 69.
12. Power-on the chassis “Providing power to the SAN768B” on page 33
13. The system performs a power-on self-test (POST). The POST takes a minimum of three minutes and is complete when LED activity returns to standard state.
14. Verify that the POST is complete (all power LED indicators on the port, control processor, and core switch blades should be a steady green).
15. Verify that all components are functioning correctly by checking their LEDs. If the LEDs do not indicate correct operation, try reinstalling the corresponding component.

Downloading the configuration

Once the chassis and its various components have been reassembled and powered back on, use the **configDownload** command to restore the original configuration. The **configDownload** command can be entered through a Telnet or serial session, but the chassis must have an Ethernet connection to the server name or IP of the host for the download process to complete. For more information, refer to the **help configdownload** command or the *Fabric OS Command Reference Manual*.

1. Log in to the chassis as **admin**:

```
switch:admin> login
login: admin
password: xxxxxxxx
switch:admin>
```

Note: If you are using the Virtual Fabric feature, you should run **configdownload -vf** before running the **configdownload** command in order to restore the logical switch configuration.

2. Enter **configDownload** command:

```
switch:admin> configdownload -all
Server Name or IP Address [host]: 123.123.123.123
User Name [None]: Admin24
File Name [config.txt]: config-switch.txt
Password: xxxxxxxx
download complete
switch:admin>
```

3. Reboot the system.

Verifying the correct operation of the system

Follow these steps to verify that the hardware is operating correctly.

1. Log in to the SAN768B as **admin**:

```
switch:admin> login
login: admin
password: xxxxxxxx
switch:admin>
```

2. Enter the **slotShow -m** command and verify that all the installed cards are detected and that their status is operational (enabled).

```
switch:admin> slotShow -m
```

Slot	Blade Type	ID	Model Name	Status
1	AP BLADE	75	FX8-24	ENABLED
2	AP BLADE	75	FX8-24	ENABLED
3	SW BLADE	51	FC8-48	ENABLED
4	UNKNOWN		VACANT	
5	CORE BLADE	52	CR8	ENABLED
6	CP BLADE	50	CP8	ENABLED
7	CP BLADE	50	CP8	ENABLED
8	CORE BLADE	52	CR8	ENABLED
9	SW BLADE	51	FC8-48	ENABLED
10	SW BLADE	51	FC8-48	ENABLED
11	SW BLADE	51	FC8-48	ENABLED
12	UNKNOWN		VACANT	

```
switch:admin>
```

3. Verify that the SAN768B is functioning correctly by entering **switchShow** or **switchStatusShow**. The **switchShow** command displays chassis and port status information.

```
switch:admin> switchshow
switchName: switch
switchType: 62.1
```

```

switchState: Online
switchMode: Native
switchRole: Subordinate
switchDomain: 11
switchId: fffc0b
switchWwn: 10:00:00:05:1e:39:59:67
zoning: OFF
switchBeacon: OFF
blade3 Beacon: OFF
blade5 Beacon: OFF
blade8 Beacon: OFF
blade10Beacon: OFF

```

```

Index Slot Port Address Media Speed State Proto
=====
32 3 0 0b2000 id N4 Online L-Port 5 public
33 3 1 0b2100 _ N8 No_Module
34 3 2 0b2200 _ N8 No_Module
35 3 3 0b2300 _ N8 No_Module
36 3 4 0b2400 id N4 Online F-Port
10:00:00:00:c9:51:00:2d
37 3 5 0b2500 _ N8 No_Module
switch:admin>

```

4. Verify that all the IP address information is correct by entering the **ipAddrShow** command and checking the results against the IP information recorded in the config-miscinfo.txt file.

```

switch:admin> ipaddrshow
SWITCH
Ethernet IP Address: 10.32.50.12
Ethernet Subnetmask: 255.55.0.0
Fibre Channel IP Address: 1.2.3.4
Fibre Channel Subnetmask: 255.255.255.0
CP0
Ethernet IP Address: 10.32.50.10
Ethernet Subnetmask: 255.55.0.0
HostName : cp0
Gateway Address: 10.32.40.1
CP1
Ethernet IP Address: 10.32.50.11
Ethernet Subnetmask: 255.55.0.0
HostName : cp1
Gateway Address: 10.32.40.1
Backplane IP address of CP0 : 10.0.0.5
Backplane IP address of CP1 : 10.0.0.6
switch:admin>switch:admin>

```

Reconnecting the system to the network and fabric

Attention: Refer to “Managing cables” on page 40 for information on how to physically manage the arrangement of the cables within the SAN768B chassis, and cautions on handling and routing the cables.

Refer to the cable routing information recorded in “Cable routing tables” on page 118 to ensure the correct cable connections in the steps below.

1. Connect the CP blades to the local area network, one blade at a time.
 - a. Insert the appropriate Ethernet cables into each Ethernet port.
 - b. Connect the other ends to an Ethernet 10/100/1000 Base-T LAN, if not already connected.

Note: The SAN768B can be accessed by remote connection using any of the available management tools, such as Telnet or Web Tools. Ensure that the SAN768B is not modified from other connections during the rest of this procedure.

2. Reconnect the transceivers and cables to the port blades, as required (see "Removing and installing transceivers" on page 95) for details.

Note: The ports and cables used in trunking groups must meet specific requirements. For a list of these requirements, refer to the *Fabric OS Administrator's Guide*.

- a. Install a transceiver into each port, if not already installed (see "Removing and installing transceivers" on page 95).
- b. Select the cable that corresponds to the port and position it so that the key (the ridge on one side of the cable connector) is aligned with the slot in the transceiver. Insert the cable into the transceiver until the latching mechanism clicks.
- c. Repeat step b for each remaining port on the blade.

Attention: Do not route cables in front of the air exhaust vent (located on the upper port side of the chassis.)

The minimum bend radius should be no smaller than 10x the cable radius.

Tie wraps are not recommended for optical cables because they are easily overtightened and can unknowingly break the cable causing connectivity problems.

- d. Repeat steps a through c for each of the remaining port and application blades.
3. Organize the cables as required (see "Managing cables" on page 40).

Verifying the correct configuration of the fabric

Details on configuring the fabric are included in the *Fabric OS Administrator's Guide* and the *Fabric OS Command Reference Manual*, which are included on the product documentation CD shipped with the product.

Copying the command outputs from this section into a file is recommended. Verify the correct configuration of the fabric by following the steps below.

1. Create an "after" SAN profile by entering the following commands and copying the output to a text file named "SANafter.txt".

- **nsShow**
- **nsAllShow**
- **switchShow**
- **fabricShow**
- **lscfg --show** (if using the virtual fabric feature)

```
switch:admin> nsshow
Type Pid COS PortName NodeName TTL(sec)
N 020f00; 3;10:00:00:01:73:00:29:46;10:00:00:01:73:00:29:46; na
Fabric Port Name: 20:0f:00:60:69:90:03:f0
<output truncated>
```

```
switch:admin> nsallshow
{
```

```
020f00 021fda 021fdc 021fe0 021fe1
5 Nx_Ports in the Fabric}
```

```
switch:admin> switchshow
switchName: swDir
<output truncated>
```

```
switch:admin> fabricshow
Switch ID Worldwide Name Enet IP Addr FC IP Addr Name
<output truncated>
switch:admin>
```

```
switch:admin>lscfg --show
Created switches: 128(ds) 1 2(bs)
Port 0 1 2 3 4 5 6 7 8 9
-----
FID 1 | 1 | 1 | 1 | 1 | 128 | 128 | 128 | 128 | 128 |
<output truncated>
```

```
switch:admin>
```

2. Determine any differences between the information in the "SANafter.txt" file and the information in the "SANbefor.txt" file created earlier. In particular, look for differences in the following:
 - Device types
 - Number of devices
 - ISL and port states
 - Number of switches in the fabric
3. Resolve any issues or unintentional changes to the SAN768B or fabric.
 - If there are any mechanical problems, try reseating the associated component.
 - If the configuration information is not correct for the SAN768B, modify as required.
 - If other issues exist, contact technical support.

Cable routing tables

Table 17 provides a sample of cable routing information. Create your own table, or use copies of Table 18 on page 119 to record this information, if it is not already available. Table 18 on page 119 is a 64-port template for a cable routing table. Make copies of the table to cover the total number of ports in the system.

Table 17. Sample cable routing table for SAN768B

Slot/Port	Cable labels		Connected device	Slot/Port of device
	Switch end	Device end		
Slot 1 Port 0	North 24 - 1/0	East 26 - 0	SANB32 East 26	0
Slot 5 Serial	North 24 - 5 / Serial	Work 5 - 2	Workstation 5	Com 2
Slot 8 Port 15	North 24 - 8/15	RAID 16 - 4	RAID 16	4

Table 18. Cable routing table for SAN768B (64 ports shown)

Slot/Port		Cable labels		Connected device	Slot/Port of device
Slot	Port	Switch end	Device end		
	0				
	1				
	2				
	3				
	4				
	5				
	6				
	7				
	8				
	9				
	10				
	11				
	12				
	13				
	14				
	15				
	16				
	17				
	18				
	19				
	20				
	21				
	22				
	23				
	24				
	25				
	26				
	27				
	28				
	29				
	30				
	31				
	32				
	33				
	34				
	35				
	36				
	37				
	38				

Table 18. Cable routing table for SAN768B (64 ports shown) (continued)

Slot/Port		Cable labels		Connected device	Slot/Port of device
Slot	Port	Switch end	Device end		
	39				
	40				
	41				
	42				
	43				
	44				
	45				
	46				
	47				
	48				
	49				
	50				
	51				
	52				
	53				
	54				
	55				
	56				
	57				
	58				
	59				
	60				
	61				
	62				
	63				
	64				

Chapter 6. Installing new features

Attention: Refer to “Safety notices and labels” on page xv before performing any service or installation procedures.

The SAN768B can be upgraded with any of the following hot-pluggable features while the SAN768B is operational. Refer to the individual feature installation instructions for any possible exceptions.

Use this chapter as a starting point when installing new features on an existing SAN768B. Installation instructions link from here to the appropriate sections.

- “FC3017 - Installing a 16-Gbps core blade kit (model conversion)”
- “FC3816, FC3832, FC3848 - Installing an 8-Gb port blade (16, 32, or 48 ports)” on page 122
- “FC3864 - Installing an 8-Gb 64-port port blade” on page 123
- “FC3850 - Installing an FR4-18i routing blade” on page 125
- “FC3870 - Installing an FC10-6 10 Gb blade” on page 126
- “FC3880 - Installing an FCOE10-24 blade” on page 127
- “FC3890 - Installing an FX8-24 extension blade” on page 129
- “FC3895 - Installing an FS8-18 encryption blade” on page 130
- “FC7230 - Installing FIPS security seals” on page 132
- “FC7870 - Installing an inter-chassis cable kit” on page 132

FC3017 - Installing a 16-Gbps core blade kit (model conversion)

Feature Code 3017, installing the 16-Gbps core blade kit, is a model conversion of the 8 Gbps SAN768B (2499-384) fabric backbone to a 16 Gbps SAN768B-2 (2499-816) fabric backbone. This is a miscellaneous equipment specification (MES) procedure completed by an IBM service support representative (SSR). Complete printed instructions, *IBM System Storage 8 Gbps to 16 Gbps Model Conversion Guide*, are shipped with the 16-Gbps core blade kit. Installation of this feature may also require the removal of one or more features from the SAN384B. Contact your IBM representative for full details.

Attention: This feature requires a minimum Fabric OS version 7.0.1. Refer to the *IBM System Storage 8 Gbps to 16 Gbps Model Conversion Guide*, which is shipped with the kit for complete installation instructions, including FOS upgrade procedures.

Once this feature is installed, this manual no longer applies to the converted model. It should be replaced by the *IBM System Storage SAN768B-2 Installation, Service, and User Guide*, which is available through the IBM Support Portal www.ibm.com/supportportal or IBM Publication Center www.ibm.com/shop/publications/order.

FC3816, FC3832, FC3848 - Installing an 8-Gb port blade (16, 32, or 48 ports)

These features can be installed while the SAN768B is operational.

Attention: Follow these precautions for all procedures in this section to avoid damaging the port blades or chassis:

- Wear a grounded ESD strap when handling a port blade.
- Carefully remove the protective strip (if any) covering the blade connectors before installing any blades.
- Do not force the port blade installation. If the port blade does not slide in easily, ensure that it is correctly aligned inside the rail guides before continuing. Installing a port blade with incorrect alignment damages both the chassis and the replacement part.
- Hold the port blade by the edges of the metal pan. Do not use the ejectors to hold a port blade.
- Disassembling any part of a port blade voids the part warranty and regulatory certifications. There are no user-serviceable parts inside the port blade.

These instructions cover installing a new FC3816, FC3832, or FC3848 in the SAN768B chassis.

Time required

10 minutes or less per port blade

Items required

- ESD (electrostatic discharge) grounding strap
- Workstation computer
- Port blade
- Phillips screwdriver
- Small form factor pluggable (SFP) transceivers (as needed)
- Optical cables (as needed)

Procedures

Follow the links in the steps below to complete this installation:

1. Remove the chassis door. See “Removing and installing the chassis door” on page 69.
2. Verify that the port blade is the correct part: 21R9996 for the 16-port blade, and 21R9997 for the 32-port blade, and 21R9998 for the 48-port blade.
3. Verify which slot to install the blade. Slots are numbered from one through ten, from left to right, when facing the port side of the SAN768Bs. Port blades can be installed in any of the slots 1-4 and 9-12.
4. We recommend having the latest firmware version on the CP blade. If the firmware is not at the latest level, obtain new code from the code download website, and install it prior to installing the port blade. See “Removing and installing port, application, and encryption blades” on page 71.

Note: Firmware downloads require that Ethernet connections be made to both CP blades. Procedures for loading firmware are described in the *Fabric OS Administrator's Guide*.

Attention: A filler panel should be removed only when being replaced with a port blade or new filler panel. Any slot that is not occupied by a port blade should be occupied by a filler panel to ensure correct cooling of the chassis and protection from dust.

5. Remove the filler panel or port blade. Refer to “Removing a filler panel” on page 75 or “Removing a blade” on page 72.
6. Follow the instructions for “Installing a blade” on page 74.
7. Follow the instructions for “Removing and installing transceivers” on page 95. Because of port density, it may be easier to remove and install the SFPs while the 32-port or 48-port blade is out of the chassis. However, you must handle the blade carefully while it is out of the chassis to avoid damaging it.
8. Install, group and route the cables as desired. See “Managing cables” on page 40 for additional cabling instructions.

Attention: Do not route cables in front of the exhaust vent, which is located at the top on the port side of the chassis.

9. Verify the installation (see the appropriate section of Chapter 4, “Monitoring system components,” on page 47). For information about how to check the status of hardware components using the CLI, see the *Fabric OS Administrator’s Guide*, which is located on the product documentation CD.
10. Reinstall the chassis door. See “Removing and installing the chassis door” on page 69.

FC3864 - Installing an 8-Gb 64-port port blade

This feature can be installed while the SAN768B is operational.

Attention: Follow these precautions for all procedures in this section to avoid damaging the port blades or chassis:

- Wear a grounded ESD strap when handling a port blade.
- Carefully remove the protective strip (if any) covering the blade connectors before installing any blades.
- Do not force the port blade installation. If the port blade does not slide in easily, ensure that it is correctly aligned inside the rail guides before continuing. Installing a port blade with incorrect alignment damages both the chassis and the replacement part.
- Hold the port blade by the edges of the metal pan. Do not use the ejectors to hold a port blade.
- Disassembling any part of a port blade voids the part warranty and regulatory certifications. There are no user-serviceable parts inside the port blade.

Note: This 8-Gb 64-port blade (FC3864) cannot be installed in the same chassis as a FCOE10-24 blade (FC3880)

These instructions cover installing a new FC3864 in the SAN768B chassis.

Time required

20 minutes or more per port blade due to port and cable density

Items required

- ESD (electrostatic discharge) grounding strap
- Workstation computer

- Port blade
- Phillips screwdriver
- mSFP transceivers (as needed)
- OM-3 LC optical cables (as needed)

Procedures

Follow the links in the steps below to complete this installation:

1. Remove the chassis door. See “Removing and installing the chassis door” on page 69.
2. Verify that the port blade is the correct part (45W7566)
3. Verify which slot to install the blade. Slots are numbered from one through ten, from left to right, when facing the port side of the SAN768Bs. Port blades can be installed in any of the slots 1-4 and 9-12.
4. We recommend having the latest firmware version on the CP blade. If the firmware is not at the latest level, obtain new code from the code download website, and install it prior to installing the port blade. See “Removing and installing port, application, and encryption blades” on page 71.

Note: Firmware downloads require that Ethernet connections be made to both CP blades. Procedures for loading firmware are described in the *Fabric OS Administrator’s Guide*.

Attention: A filler panel should be removed only when being replaced with a port blade or new filler panel. Any slot that is not occupied by a port blade should be occupied by a filler panel to ensure correct cooling of the chassis and protection from dust.

5. Remove the filler panel or port blade. Refer to “Removing a filler panel” on page 75 or “Removing a blade” on page 72.
6. Remove any mSFPs that are pre-installed in the new FC8-64 blade and set them aside for later installation. See “Removing and replacing an mSFP optical transceiver” on page 96, paying particular attention to the notices to avoid damaging the mSFP pull tabs or mSFPs.
7. Follow the instructions for “Installing a blade” on page 74.

Note: The FC8-64 high density port blade cannot use the standard LC cables because the pitch between optics in the new mSFP transceiver is smaller than in standard SFPs. Patch cables and panels can be used to attach standard size cabling to the blade if necessary. Figure 12 on page 27 illustrates the mSFP to SFP patch cable. The mSFP transceivers are used only with the FC8-64 port blade. Narrower OM-3 LC cables are used to connect the FC8-64. These cables are offered by several major manufacturers. Contact your IBM representative for options regarding different cable and patch panel configurations to simplify cable management with higher density FC8-64 port blades.

8. Insert an OM-3 (narrow) cable into an mSFP, and then insert the mSFP/cable unit into a port. See “Removing and replacing an mSFP optical transceiver” on page 96, paying particular attention to the notices to avoid damaging the mSFP pull tabs, mSFPs and cables.
9. Repeat step 8 for each port in the FC8-64 blade, proceeding in a systematic manner to avoid tangling the cables.
10. Group and route the cables as desired. See “Managing cables” on page 40 for additional cabling instructions.

Attention: Do not route cables in front of the exhaust vent, which is located at the top on the port side of the chassis.

11. Verify the installation (see the appropriate section of Chapter 4, “Monitoring system components,” on page 47). For information about how to check the status of hardware components using the CLI, see the *Fabric OS Administrator’s Guide*, which is located on the product documentation CD.
12. Reinstall the chassis door. See “Removing and installing the chassis door” on page 69.

FC3850 - Installing an FR4-18i routing blade

This feature can be installed while the SAN768B is operational.

Attention: Follow these precautions for all procedures in this section to avoid damaging the blades or chassis:

- Wear a grounded ESD strap when handling a blade.
- Carefully remove the protective strip (if any) covering the blade connectors before installing any blades.
- Do not force the blade installation. If the blade does not slide in easily, ensure that it is correctly aligned inside the rail guides before continuing. Installing a blade with incorrect alignment can damage both the chassis and the blade.
- Hold the blade by the edges of the metal pan. Do not use the ejectors to hold a blade.
- Disassembling any part of a blade voids the part warranty and regulatory certifications. There are no user-serviceable parts inside the blade.

These instructions cover installing a new FC3850 in the SAN768B chassis.

Time required

Approximately 20 minutes per blade

Items required

- ESD (electrostatic discharge) grounding strap
- Workstation computer
- Router blade
- Phillips screwdriver
- Small form factor pluggable (SFP) transceivers (as needed)
- Optical cables (as needed)

Procedures

Follow the links in the steps below to complete this installation

1. Remove the chassis door. See “Removing and installing the chassis door” on page 69.
2. Verify that the router blade is the correct part: 23R1646.
3. Verify which slot to install the blade. Slots are numbered from one through ten, from left to right, when facing the port side of the SAN768B. A maximum of two router blades can be installed in a single SAN768B chassis. Router blades can be installed in any slot 1-4 and 9-12. If there are two router blades, to ensure proper cooling install one router blade in one of the slots 1-4, and the other in one of the slots 9-12.

Attention: A filler panel should be removed only when being replaced with a blade or new filler panel. Any slot that is not occupied by a blade should be occupied by a filler panel to ensure correct cooling of the chassis and protection from dust.

4. Remove the filler panel (see “Removing a filler panel” on page 75). Store the filler panel in a location for possible future use.
5. Install the router blade (see “Installing a router blade” on page 86. Remove the protective strip from the blade contacts (if any) before installing the blade.
6. Repeat steps 1-4 for the second router blade, if any.
7. Install transceivers, as needed. Follow the instructions for “Removing and installing transceivers” on page 95.
8. Install, group and route the cables as desired. See “Managing cables” on page 40 for additional cabling instructions.

Attention: Do not route cables in front of the exhaust vent, which is located at the top on the port side of the chassis.

9. Configure the router blade. Configuration instructions are provided in the *Fabric OS Administrator's Guide* in the "Using the FC-FC Routing Service" chapter.
10. Verify the installation (see the appropriate section of Chapter 4, “Monitoring system components,” on page 47). For information about how to check the status of hardware components using the CLI, see the *Fabric OS Administrator's Guide*, which is located on the product documentation CD.
11. Reinstall the chassis door. See “Removing and installing the chassis door” on page 69.

FC3870 - Installing an FC10-6 10 Gb blade

This feature can be installed while the SAN768B is operational.

Attention: Follow these precautions for all procedures in this section to avoid damaging the port blades or chassis:

- Wear a grounded ESD strap when handling a port blade.
- Carefully remove the protective strip (if any) covering the blade connectors before installing any blades.
- Do not force the port blade installation. If the port blade does not slide in easily, ensure that it is correctly aligned inside the rail guides before continuing. Installing a port blade with incorrect alignment damages both the chassis and the replacement part.
- Hold the port blade by the edges of the metal pan. Do not use the ejectors to hold a port blade.
- Disassembling any part of a port blade voids the part warranty and regulatory certifications. There are no user-serviceable parts inside the port blade.

Time required

Less than 20 minutes.

Items required

- ESD (electrostatic discharge) grounding strap
- Workstation computer
- Port blade
- Phillips screwdriver

- Small form factor pluggable (SFP) transceivers (as needed)
- Optical cables (as needed)

Procedures

Follow the links in the steps below to complete this installation.

1. Remove the chassis door. See “Removing and installing the chassis door” on page 69.
2. Verify that the port blade is the correct part: 17P9651.
Attention: A filler panel should be removed only when being replaced with a port blade or new filler panel. Any slot that is not occupied by a port blade should be occupied by a filler panel to ensure correct cooling of the chassis and protection from dust.
3. Remove the filler panel or existing port blade. Refer to “Removing a filler panel” on page 75 or “Removing a blade” on page 72.
4. Follow the instructions for “Installing a blade” on page 74.
5. Follow the instructions for “Removing and installing transceivers” on page 95.
6. Install, group and route the cables as desired. See “Managing cables” on page 40 for additional cabling instructions.
Attention: Do not route cables in front of the exhaust vent, which is located at the top on the port side of the chassis.
7. Verify the installation (see the appropriate section of Chapter 4, “Monitoring system components,” on page 47). For information about how to check the status of hardware components using the CLI, see the *Fabric OS Administrator’s Guide*, which is located on the product documentation CD.
8. Reinstall the chassis door. See “Removing and installing the chassis door” on page 69.

FC3880 - Installing an FCOE10-24 blade

This feature can be installed while the SAN768B is operational.

Attention: This blade cannot be used in the same chassis with an FC8-64 high density port blade or the FR4-18i, FX8-24, or FS8-18 application blades.

Attention: Follow these precautions for all procedures in this section to avoid damaging the port blades or chassis:

- Wear a grounded ESD strap when handling a port blade (see “ESD precautions” on page xxi).
- Carefully remove the protective strip (if any) covering the blade connectors before installing any blades.
- Do not force the port blade installation. If the port blade does not slide in easily, ensure that it is correctly aligned inside the rail guides before continuing. Installing a port blade with incorrect alignment damages both the chassis and the replacement part.
- Hold the port blade by the edges of the metal pan. Do not use the ejectors to hold a port blade.
- Disassembling any part of a port blade voids the part warranty and regulatory certifications. There are no user-serviceable parts inside the port blade.

Time required

Less than 20 minutes.

Items required

- ESD (electrostatic discharge) grounding strap
- Workstation computer
- Port blade
- Phillips screwdriver
- SFP+ transceivers (as needed)
- Optical cables (as needed)

Procedures

Follow the links in the steps below to complete this installation.

1. Remove the chassis door. See “Removing and installing the chassis door” on page 69.
2. Verify that the blade is the correct part.
3. Verify which slot to install the blade. Port and application blades can be installed in any slot 1-4 and 9-12.
4. We recommend having the latest firmware version on the CP blade. The firmware version should match on both the active and the backup CP blades. If the firmware is not at the latest level, obtain new code from the code download website, and install it prior to installing the port blade. See “Fabric OS firmware updates” on page 44 for instructions.

Note: Firmware downloads require that Ethernet connections be made to both CP blades. Procedures for downloading and installing firmware are described in the *Fabric OS Administrator’s Guide*.

5. Remove the filler panel or existing port blade. Refer to “Removing a filler panel” on page 75 or “Removing a blade” on page 72.
Attention: A filler panel should be removed only when being replaced with a port blade or new filler panel. Any slot that is not occupied by a port blade should be occupied by a filler panel to ensure correct cooling of the chassis and protection from dust.
6. Install the blade (“Installing a blade” on page 74). Remove the protective strip from the blade contacts (if any) before installing the blade.
7. Repeat steps 1-5 for additional blades, if any.
8. Install the transceivers (“Removing and installing transceivers” on page 95), and confirm the proper operation of the blade.
9. Install, group, and route the cables as desired. See “Managing cables” on page 40 for additional cabling instructions.
Attention: Do not route cables in front of the exhaust vent, which is located at the top on the port side of the chassis.
10. Verify the installation (see the appropriate section of Chapter 4, “Monitoring system components,” on page 47). For information about how to check the status of hardware components using the CLI, see the *Fabric OS Administrator’s Guide*, or the *Fabric OS Command Reference Manual*, which are located on the product documentation CD.
11. Reinstall the chassis door. See “Removing and installing the chassis door” on page 69.

FC3890 - Installing an FX8-24 extension blade

This feature can be installed while the SAN768B is operational.

Attention: Follow these precautions for all procedures in this section to avoid damaging the port blades or chassis:

- Wear a grounded ESD strap when handling a port blade (see “ESD precautions” on page xxi).
- Carefully remove the protective strip (if any) covering the blade connectors before installing any blades.
- Do not force the port blade installation. If the port blade does not slide in easily, ensure that it is correctly aligned inside the rail guides before continuing. Installing a port blade with incorrect alignment damages both the chassis and the replacement part.
- Hold the port blade by the edges of the metal pan. Do not use the ejectors to hold a port blade.
- Disassembling any part of a port blade voids the part warranty and regulatory certifications. There are no user-serviceable parts inside the port blade.

Time required

Less than 20 minutes.

Items required

- ESD (electrostatic discharge) grounding strap
- Workstation computer
- Port blade
- Phillips screwdriver
- Transceivers (as needed)
- Optical cables (as needed)

Procedures

Follow the links in the steps below to complete this installation.

1. Remove the chassis door. See “Removing and installing the chassis door” on page 69.
2. Verify that the blade is the correct part.
3. Verify which slot to install the blade. Port and application blades can be installed in any slot 1-4 and 9-12.
4. We recommend having the latest firmware version on the CP blade. The firmware version should match on both the active and the backup CP blades. If the firmware is not at the latest level, obtain new code from the code download website, and install it prior to installing the port blade. See “Fabric OS firmware updates” on page 44 for instructions.

Note: Firmware downloads require that Ethernet connections be made to both CP blades. Procedures for downloading and installing firmware are described in the *Fabric OS Administrator’s Guide*.

5. Remove the filler panel or existing port blade. Refer to “Removing a filler panel” on page 75 or “Removing a blade” on page 72.

Attention: A filler panel should be removed only when being replaced with a port blade or new filler panel. Any slot that is not occupied by a port blade should be occupied by a filler panel to ensure correct cooling of the chassis and protection from dust.

6. Install the port blade (“Installing a blade” on page 74). Remove the protective strip from the blade contacts (if any) before installing the blade.
7. Repeat steps 1-5 for additional blades, if any.
8. Install the transceivers (“Removing and installing transceivers” on page 95), and confirm the proper operation of the blade.
9. Install, group, and route the cables as desired. See “Managing cables” on page 40 for additional cabling instructions.

Attention: Do not route cables in front of the exhaust vent, which is located at the top on the port side of the chassis.

10. Verify the installation (see the appropriate section of Chapter 4, “Monitoring system components,” on page 47). For information about how to check the status of hardware components using the CLI, see the *Fabric OS Administrator’s Guide*, or the *Fabric OS Command Reference Manual*, which are located on the product documentation CD.
11. Reinstall the chassis door. See “Removing and installing the chassis door” on page 69.

FC3895 - Installing an FS8-18 encryption blade

Attention: Thoroughly review “Planning for encryption (optional)” on page 41 prior to installing the FS8-18 encryption blade. You must also refer to the *Fabric OS Encryption Administrator’s Guide Supporting Tivoli Key Lifecycle Manager (TKLM) Environments* to successfully complete installation, configuration, and management of the encryption functionality.

This feature can be installed while the SAN768B is operational.

Attention: This blade cannot be used in the same chassis with an FCOE10-24 blade.

Note: If three or more FS8-18 encryption blades are installed, four power supplies are required for redundancy.

Attention: Follow these precautions for all procedures in this section to avoid damaging the port blades or chassis:

- Wear a grounded ESD strap when handling a port blade (see “ESD precautions” on page xxi).
- Carefully remove the protective strip (if any) covering the blade connectors before installing any blades.
- Do not force the port blade installation. If the port blade does not slide in easily, ensure that it is correctly aligned inside the rail guides before continuing. Installing a port blade with incorrect alignment damages both the chassis and the replacement part.
- Hold the port blade by the edges of the metal pan. Do not use the ejectors to hold a port blade.
- Disassembling any part of a port blade voids the part warranty and regulatory certifications. There are no user-serviceable parts inside the port blade.

Time required

Less than 20 minutes.

Items required

- ESD (electrostatic discharge) grounding strap
- Workstation computer
- Encryption blade
- Phillips screwdriver
- Transceivers (as needed)
- Optical cables (as needed)

Procedures

Follow the links in the steps below to complete this installation.

1. Verify that the blade is the correct part.
2. Verify which slot to install the blade. Port, application, and encryption blades can be installed in any slot 1-4 and 9-12. Up to four FS8-18 encryption blades can be installed in a single chassis.
3. We recommend having the latest firmware version on the CP blade. The firmware version should match on both the active and the backup CP blades. If the firmware is not at the latest level, obtain new code from the code download website, and install it prior to installing the port blade. See “Fabric OS firmware updates” on page 44 for instructions.

Note: Firmware downloads require that Ethernet connections be made to both CP blades. Procedures for downloading and installing firmware are described in the *Fabric OS Administrator's Guide*.

4. Remove the filler panel or port blade. Refer to “Removing and installing port, application, and encryption blades” on page 71 and “Removing and installing blade filler panels” on page 75.

Attention: A filler panel should be removed only when being replaced with a blade or new filler panel. Any slot that is not occupied by a blade should be occupied by a filler panel to ensure correct cooling of the chassis and protection from dust.

5. Install the encryption blade (“Installing a blade” on page 74). Remove the protective strip from the blade contacts (if any) before installing the blade.
6. Repeat steps 1-5 for additional blades, if any.
7. Install the transceivers (“Removing and installing transceivers” on page 95), and confirm the proper operation of the blade.
8. Install, group, and route the cables as desired. See “Managing cables” on page 40 for additional cabling instructions.

Attention: Do not route cables in front of the exhaust vent, which is located at the top on the port side of the chassis.

9. Verify the installation. For information about how to check the status of hardware components using the CLI, see the *Fabric OS Administrator's Guide*, which is located on the product documentation CD.
10. The FS8-18 encryption blade requires additional configuration to enable encryption. See “Configuring for encryption (optional)” on page 42 for an overview of those steps. Refer to the *Fabric OS Encryption Administrator's Guide Supporting Tivoli Key Lifecycle Manager (TKLM) Environments* for more detailed information regarding encryption and TKLM key management.

Avoid double encryption

Encryption and decryption at the storage device level does not affect the encryption switch or blade capabilities, and does not cause problems with decrypting the data. However, double encryption adds the unnecessary need to manage two sets of encryption keys, increases the risk of losing data, may reduce performance, and does not add security.

FC7230 - Installing FIPS security seals

The majority of the seals in this feature can be installed while the SAN768B is operational. However, there are several seals that may be difficult to apply to the chassis and port side exhaust kit if the chassis is already installed in a cabinet. Plan the installation of the chassis and other features accordingly. Refer to the separate publication, *IBM System Storage FIPS 140-2 Security Seal Application Procedures (GA32-2220-00)*, for installation instructions of these seals for several different models. This publication is available through the IBM Support Portal www.ibm.com/supportportal and the IBM Publications Center www.ibm.com/shop/publications/order.

FC7870 - Installing an inter-chassis cable kit

This feature can be installed while the SAN768B is operational.

Time required

Less than 10 minutes, not including installation of the ICL license or any needed configuration.

Items required

- Inter-chassis link kit (includes two ICL cables)
- FC 7883 (ICL license) is required for each chassis that you are connecting. Instructions for installation are included with that license feature.

Procedures

Attention: If ICL cables are not in use, the ports must have EMI plugs installed to meet EMI and other regulatory certifications.

Follow the links in the steps below to complete this installation.

1. Remove the chassis door. See “Removing and installing the chassis door” on page 69.
2. Verify that the inter-chassis link kit is the correct part: 21R9976. The cable PN is 21R9959.
3. Verify with the customer that the ICL license is installed on each chassis to be connected. Enter the **licenseIdShow** command for each chassis. If required, install the ICL license, following the instructions included with the license.
4. Determine the cable routing and ICL sockets on the core switch blades that you will be using to connect the two chassis. Refer to “Removing and installing inter-chassis link (ICL) cables” on page 97 for possible valid options.
5. Remove the EMI plugs from the ICL sockets that you will be connecting. Save the EMI plugs for possible future use.
6. Install the two ICL cables (“Installing an ICL cable” on page 99).
7. Install the chassis door (“Removing and installing the chassis door” on page 69).

8. Enable the inter-chassis links. See the **iclCfg** section in the *Fabric OS Command Reference Manual* for CLI command options.
9. Verify the operation of the ICL (see Table 15 on page 98).

Appendix A. Product specifications

This appendix provides product specifications for the SAN768B for the following:

- “System architecture”
- “System size and weight” on page 138
- “Facility requirements” on page 139
- “Power specifications” on page 139
- “Environmental requirements” on page 140
- “Fibre Channel port specifications” on page 140
- “Data transmission ranges” on page 141

General specifications

Table 19 lists the general specifications for the SAN768B.

Table 19. General specifications

Configurable port types	F_Port, FL_Port, E_Port, VEX_Port, VE_Port, EX_Port, and M_Port
System architecture	Nonblocking shared memory
System processor	FreeScale 8548, 1.2 GHz
ANSI fibre channel protocol	FC-PH (Fibre Channel Physical and Signalling Interface standard)
Modes of operation	Fibre Channel Class 2, Class 3, and Class F
Fabric initialization	Complies with FC-SW 5.0
FC-IP (IP over fibre channel)	Complies with FC-IP 2.3 of the FCA profile
Aggregate I/O bandwidth	4.09 Tbps per chassis (fully populated with eight FC8-64 blades)
Port to port latency	Less than 2 microseconds with no contention (destination port is free)
Routing capacity	A minimum aggregate routing capacity of four million frames per second (for Class 2, Class 3, and Class F frames in a 64-port switch)

System architecture

Table 20 lists the system architecture for the SAN768B.

Table 20. System architecture

Fibre Channel Ports	Up to 512 ports, universal (E_Port, F_Port, FL_port, Ex_port, and M_port)
Control Processor	Redundant (active/standby) control processor modules
Scalability	Full fabric architecture: 239 switches maximum

Table 20. System architecture (continued)

Performance	<p>1.063 Gbps line speed, full duplex</p> <p>2.125 Gbps line speed, full duplex</p> <p>4.25 Gbps line speed, full duplex</p> <p>8.50 Gbps line speed, full duplex</p> <p>10.51875 Gbps line speed, full duplex (with FC10-6 blade)</p> <p>Autosensing of 1, 2, 4, and 8 Gbps port speeds optionally programmable to fixed port speed, speed matching between 1, 2, 4, and 8 Gbps port speeds. Range depends on use of 4 Gbps or 8 Gbps SFPs.</p>
ISL Trunking	Can use up to 8 ports in a trunk group to form a 64 Gbps trunk
Aggregate bandwidth	4.09 Tbps per chassis
Switch latency	<p>FC8-16, FC8-32, FC8-48, FC8-64 blades: <2.1 msec any port to any port at 8 Gbps, cut-through routing.</p> <p>For the FR4-18i blade: <3.6 msec any port to any port at 4 Gbps, cut-through routing.</p> <p>For the FX8-24 blade: <2.1 msec any port to any port at 8 Gbps, cut-through routing.</p> <p>For the FCOE10-24 blade: CEE to CEE and FCOE to FC, <5 msec any port to any port at 10 Gbps, cut-through routing</p>
Maximum frame size	2112-byte payload
Frame buffers	2048 per ASIC, dynamically allocated.
Classes of service	Class 2, Class 3, Class F (interswitch frames)

Table 20. System architecture (continued)

<p>Port types</p>	<p>FC8-16 and FC8-32 support these port types: FL_Port, F_Port, E_Port, and M_Port</p> <p>FC8-48 supports these port types: E_Port, F_Port, and M_Port FC8-64 supports these port types: F_Port, FL_Port, E_Port, Ex_Port, and M_Port</p> <p>FC10-6 supports these port types: E_Port and M_Port</p> <p>FR4-18i supports these port types: FL_Port, F_Port, E_Ports, M_Port, VE_Port, EX_Port, and VEX_Port</p> <p>FS8-18 supports these port types: FL_Port, F_Port, E_Ports, EX_Port, and M_Port</p> <p>FX8-24 supports these port types: F_Port, FL_Port, E_Port, and Ex_Port on FC VE_Port on GbE</p> <p>FCOE10-24 supports these port types: VF_Port Note: Self-discovery is based on switch type (U_Port) with an optional port type control.</p>
<p>Data traffic types</p>	<p>Fabric switches supporting unicast, multicast (255 groups), and broadcast</p>
<p>Media types</p>	<p>Note: For a listing of SFPs, SFP+, mSFPs and XFPs compatible with this product:</p> <ul style="list-style-type: none"> • Go to the IBM SAN web page www.ibm.com/systems/storage/san • Select the SAN768B product link • On the SAN768B product page, click the Interoperability Matrix link. • In the Interoperability matrix, click the Transceivers link.
<p>Fabric services</p>	<p>Access Control Lists (ACLs); Advanced Performance Monitoring; Adaptive Networking (Ingress Rate Limiting, Traffic Isolation, QoS); auditing; BB credit recovery; Brocade Advanced Zoning (default zoning, port/WWN zoning, broadcast zoning); Dynamic Path Selection (DPS); End-to-End Performance monitoring; Extended Fabrics; Fabric Watch; FDMI; FICON CUP; Frame Redirection; FSPF; Integrated Routing (FR4-18i SAN Extension blade not required for routing); IPFC; ISL Trunking; Management Server; N_Port Trunking; NPIV; NTP v3; Port Fencing; RASlog; Registered State Change Notification (RSCN); Reliable Commit Service (RCS); Simple Name Server (SNS); syslog; Top Talkers; Virtual Fabrics (Logical Switch, Logical Fabric); Web Tools</p>
<p>Inter-chassis linking (ICL)</p>	<p>Chassis-to-chassis linkage through connectors on the core switch blade (CR8)</p>

System size and weight

The weight of the SAN768B can vary considerably depending on the combination of blades installed. Use Table 21 and Table 22 to determine the weight of the system with your combination of port and application blades.

Table 21. System sizes and weights

System size	Size or weight
Width	43.74 cm (17.22 in.)
Height	61.24 cm (24.11 in./14U)
Depth (without door)	61.29 cm (24.09 in.)
Depth (with door)	73.20 cm (28.82 in.)
SAN768B: 512-port configuration with eight FC8-64 port blades	159.2 kg (351 lb)
Empty chassis: <ul style="list-style-type: none"> • No blades • No CPs • No CRs • No power supplies • No fan assemblies 	39.55 kg (87.2 lb.)

Table 22 lists the weights of the compatible blades and FRUs

Table 22. System FRU weights

FRU	Weight
CP blade (CP8)	3.0 kg (6.6 lb)
CR blade (CR8)	3.27 kg (7.2 lb)
FC8-16 port blade	3.0 kg (6.6 lb) without media
FC8-32 port blade	3.27 kg (7.2 lb) without media
FC8-48 port blade	3.36 kg (7.4 lb) without media
FC8-64 port blade	3.36 kg (7.4 lb) without media
FC10-6 port blade	3.1 kg (6.8 lb) without media
FR4-18i router blade	3.36 kg (7.4 lb) without media
FS8-18 encryption blade	5.5 kg (12.0 lb) without media
FX8-24 extension blade	4.2 kg (9.2 lb) without media
FCOE10-24 FCoE blade	3.72 kg (8.2 lb) without media
Port card filler panel	1.5 kg (3.2 lb)
Power supply	2.45 kg (5.4 lb)
Blower assembly	5.73 kg (12.6 lb)
WWN bezel	0.3 kg (0.6 lb)
Cable management comb	0.45 kg (1.0 lb)
Chassis door	2.09 kg (4.6 lb.)

Facility requirements

The facility where the SAN768B is in use must meet the following requirements to provide for correct operation:

- Adequate supply circuit, line fusing, and wire size, as specified by the electrical rating on the chassis nameplate
- An air flow of at least 595 cubic meters per hour (350 cubic feet per minute), available in the immediate vicinity of the SAN768B
- The power specifications listed in Table 23
- The environmental specifications listed in Table 24 on page 140
- If the SAN768B will be installed in an EIA rack, ensure the following:
 - All equipment installed in the rack has a reliable branch circuit ground connection, and does not rely on a connection to a branch circuit, such as a power strip.
 - The rack is balanced and mechanically secured to provide stability in the event of an earthquake.
 - Additional equipment does not exceed the rack's weight limits.

Power specifications

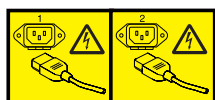

DANGER

Multiple power cords. The product might be equipped with multiple power cords. To remove all hazardous voltages, disconnect all power cords. (L003)

The power subsystem is a redundant +48 V dc power distribution system with a provision for up to four 2000-watt, 48V dc bulk power supplies. Bulk power supplies produce the intermediate distribution voltage in the distributed power system.

The power specifications listed in Table 23 are calculated for fully-loaded systems with four power supplies, eight FC8-48 port blades, two CP8 blades, two CR8 blades, and three blower assemblies. The use of application and/or encryption blades will consume additional power.

Table 23. Power specifications

Specification	Value
Voltage	Range: 85 - 264 VAC Auto-volt, Nominal: 100 to 240 VAC (auto-sensing)
Power supply output (each)	Low line (85- 132 VAC), 1000W; High line (180 - 264 VAC), 2000W
Input frequency	Range: 47-63 Hz; Nominal: 50 - 60 Hz
AC inrush	Maximum 20A peak
System power consumption	AC power consumption is configuration-specific. A system with four FC8-48 port blades (loaded with 1W SFPs), two CP8 blades, two CR8 blades, and two blower assemblies consumes 1514 W.

The base unit SAN768B comes with two power supplies. If three or more FS8-18 encryption blades are installed, four power supplies are required for redundancy.

Environmental requirements

Table 24 lists the environmental operating ranges for the SAN768B. The requirements for non-operating conditions are also provided for acceptable storage and transportation environments.

CAUTION:

For CA residents only: IBM recommends installing this product in a room size of 2190 cubic feet (62 cubic meters) or larger at 0.4 ACH ventilation rate to reduce the concentrations of any chemicals emitted by the product.

Table 24. Environmental requirements

Condition	Acceptable range during operation	Acceptable range during nonoperation
Ambient temperature	10° to 40° C outside switch (50° to 104° F)	-25° to +70° C outside switch (-13° to 158° F)
Humidity	10% to 85% RH noncondensing, at 40° Celsius, with maximum gradient of 10% per hour	10% to 93% RH noncondensing, at 70° Celsius
Altitude	Up to 3 km (10,000 ft.) above sea level	0 to 12 km (40,000 ft.) above sea level
Shock	20G, 11ms duration, half-sine wave	33G, 11ms duration, half-sine wave
Vibration	1G p-p, 5-500 Hz at 1.0 octave/minute	2.4G p-p, 5-500 Hz at 1.0 octave/minute
Air flow	595 cu m/hr (350 cu ft/min)	None required.
Heat dissipation	1337 Watts or 4564 BTU/hr (384-port configuration)	Not applicable.

Note: The 10° to 40° Celsius range applies to the ambient air temperature at the air intake vents on the nonport side of the SAN768B. The temperature inside the system can be up to 75° Celsius during operation. If the internal temperature range exceeds the operating ranges of the components, the LEDs, error messages, and Fabric Watch alerts will indicate a problem. Use the **tempShow** command or Fabric Watch commands to view temperature status.

Fibre Channel port specifications

The Fibre channel ports in the SAN768B support full duplex link speeds at 1, 2, 4, 8, or 10 Gbps inbound and outbound, automatically negotiating to the highest common speed of all devices connected to the port.

The ports are compatible with optical SWL (short wavelength: approximately 850 nm), optical LWL (long wavelength: approximately 1310 nm), and Extended Long Wavelength (ELWL) laser transmitter SFPs, SFP+, mSFP (FC8-64 only), and XFPs (FC10-6 only) (approximately 1550 nm). The strength of the

The ports are universal and self-configuring, capable of becoming F_Ports (fabric ports), FL_Ports (fabric loop-enabled), or E_Ports (expansion ports).

The ports meet all required safety standards.

Data transmission ranges

Table 25 provides the data transmission ranges for different transceivers, cable types, and port speeds.

Note: The full range of 1, 2, 4, 8, and 10 Gbps can only be achieved by a combination of 4 Gbps SFPs (1, 2, and 4 Gbps), 8 Gbps SFP+ (2, 4, and 8 Gbps), and 10 Gbps XFP transceivers.

Note: There is no LWL or ELWL version of the mSFP transceiver

Table 25. Supported optics, speeds, cables, and distances

Transceiver type	Form factor	Speed	Multi-Mode Media Maximum Distance			Single Mode Media Maximum Distance
			62.5 microns (OM1)	50 microns (OM2)	50 microns (OM3)	9 microns
SWL	SFP	1 Gbps	300 m (984 ft.)	500 m (1640 ft.)	860 m (2821 ft.)	N/A
	mSFP/SFP/SFP+	2 Gbps	150 m (492 ft.)	300 m (984 ft.)	500 m (1640 ft.)	N/A
	mSFP/SFP/SFP+	4 Gbps	70 m (229 ft.)	150 m (492 ft.)	380 m (1264 ft.)	N/A
	mSFP/SFP+	8 Gbps	21 m (68 ft.)	50 m (164 ft.)	150 m (492 ft.)	N/A
	XFP	10 Gbps	N/A	N/A	300 m (984 ft.)	N/A
LWL	SFP	2 Gbps	N/A	N/A	N/A	30 km (18.6 mi)
	SFP	4 Gbps	N/A	N/A	N/A	30 km (18.6 mi)
	SFP+	8 Gbps	N/A	N/A	N/A	N/A
	XFP	10 Gbps	N/A	N/A	N/A	10 km (6.2 mi)
ELWL	XFP	10 Gbps	N/A	N/A	N/A	40 km (24.8 mi)

FR4-18i router Fibre channel port specifications

The Fibre Channel ports in the FR4-18i router blade are compatible with SWL, LWL, and ELWL SFP transceivers. The strength of the signal is determined by the type of transceiver in use. The ports meet all required safety standards. For more information about these standards, refer to the Federal Communications Commission (FCC) Class A Statement, “Federal Communications Commission (FCC) Class A Statement” on page 166. The ports are capable of operating at 1-, 2-, or 4-Gbps and are able to auto-negotiate to the maximum link speed.

FR4-18i router GbE port specifications

The GbE ports in the FR4-18i router blade are compatible with SWL, LWL, and ELWL SFP transceivers. A copper SFP is also available. The strength of the signal is determined by the type of transceiver in use. The ports meet all required safety standards. For more information about these standards, refer to the Federal Communications Commission (FCC) Class A “Federal Communications Commission (FCC) Class A Statement” on page 166. The GbE ports are capable of operating at 1-Gbps. The eight virtual FCIP Fibre Channel links over each physical GbE connection share this bandwidth.

Power cords

Two power cords for connecting between the SAN768B and the power distribution units on the 2109 C36 cabinet are shipped with the product. Two additional power cords are provided if the optional upgrade power supply feature is ordered (Feature Code 7880). See the *IBM TotalStorage SAN Cabinet 2109 Model C36 Installation and Service Guide* for information on connecting the cabinet to the facility power source. If the stand-alone feature is ordered for the SAN768B, then you must also order the country-specific power cords. Contact your IBM representative for more information on these power cords.

Appendix B. Application blades

This appendix contains specification information about optional application blades

FR4-18i blade

The FR4-18i blade has 16 physical Fibre Channel SFP ports supporting the Fibre Channel Routing Services, and two physical Gigabit Ethernet (GbE) SFP ports supporting the Fibre Channel Over IP (FCIP) feature. It operates with the Fabric Operating System and can communicate with another FR4-18i or a SAN04B-R for both Fibre Channel Routing services and FCIP.

The FR4-18i blade is intended as a platform for Fibre Channel Routing Services and FCIP. Refer to the *Fabric OS Administrator's Guide* for information on configuring these features.

The FR4-18i blade provides the following features:

- 16 Fibre Channel SFP ports supporting the Fibre Channel Routing Services with link speeds up to 1, 2, or 4 Gbps.
- 2 GbE ports supporting the FCIP and Fibre Channel Routing Services with fixed link speed at 1 Gbps:
 - Each GbE port can support up to eight FCIP tunnels.
 - Each FCIP tunnel is represented and managed as a virtual Fibre Channel E_Port.
 - Fibre Channel Routing Services can be used over the FCIP link.
 - Fabrics connected through FCIP merge if the ports are configured as VE_Ports, and do not merge if they are configured as VEX_Ports. If VE_Ports are used in a Fibre Channel Routing Services backbone fabric configuration, then the backbone fabric merges, but the EX_Port-attached edge fabrics do not merge. For more information refer to the *Fabric OS Administrator's Guide*.

FS8-18 blade

The FS8-18 encryption blade is a high performance 16 port auto-sensing blade with data cryptographic (encryption/decryption) and data compression capabilities designed for enterprises to secure their data against theft or unauthorized use and to compress tape data for maximum utilization of tape media. The encryption blade is a network-based solution that secures data-at-rest for heterogeneous tape drives, disk array LUNs, and virtual tape libraries.

The FS8-18 blade provides the following major features:

- 16 auto-sensing F, FL, E, EX, and M ports at 8 Gbps FC ports
- 16 SFP media interfaces
- Encryption engines
- Key management/generation
- Key management with these hardware interfaces:
 - Two 1000Base copper type media interfaces
 - One smart card interface
- Security supervisor tamper detection and response capability

- CC (Common Criteria) EAL-3 compliance

FX8-24 blade

The FX8-24 blade has 12 external Fibre Channel (FC) SFP ports supporting the Fibre Channel Routing Services and 10 external 1 Gigabit Ethernet (GbE or GE) SFP ports supporting the Fibre Channel Over IP (FCIP) feature. There are also 2 licensable external 10 Gigabit Ethernet (10GbE or 10GE) SFP ports supporting FCIP. It operates with the Fabric Operating System and can communicate with another FX8-24 or a SAN06B-R for both Fibre Channel Routing Services and FCIP. The GbE ports on the FX8-24 are *not* compatible with the GbE ports on the FR4-18i blade or the SAN04B-R switch.

Note: The port diagram on the front panel of the blade uses the abbreviations GE for 1 GbE and 10GE for 10 GbE ports.

The FX8-24 operates in one of three modes: 1) ten 1GbE ports, 2) ten 1GbE ports and one 10 GbE port, or 3) two 10 GbE ports depending on licensing and subsequent configuration of GbE port mode. If operating in 10GbE mode the other end of the circuit must also be an FX8-24 operating in either 10GbE mode or dual mode with the corresponding VE_ports in 10GbE mode.

The FX8-24 blade is intended as a platform for FCIP and Fibre Channel Routing Services. Refer to the *Fabric OS Administrator's Guide* for information on configuring these features. The FX8-24 blade provides the following hardware features:

- 12 autosensing FC ports with link speeds of 1, 2, 4 or 8 Gbps
- Ten GbE ports supporting FCIP with fixed link speed at 1 Gbps
- Two 10GbE ports (licensable) supporting FCIP with fixed link speed at 10 Gbps

The FX8-24 blade also provides the following functionality features:

- FCIP
- Compression (on FC frames before FCIP encapsulation)
- FC Routing (licensable)
- FCIP Trunking (licensable) with network-based failure recovery (failover only) and load balancing
- Multiple circuits per trunk
 - Four per trunk through the GbE ports
 - Ten per trunk through the 10 GbE ports
- SO-TCP with reorder resistance
- FastWrite over FCIP
- Tape pipelining over FCIP
- FICON XRC emulation and tape pipelining over FCIP (licensable)
- FICON CUP (licensable)
- Virtual E_ports
- FCIP QoS
- Support for 200 ms RTT (on a limited number of GbE ports)
- Adaptive Rate Limiting (licensable)
- TCP performance graphing in Web Tools
- FCIP Tunnels
 - A maximum of 10 FCIP Tunnels for all GbE ports

- Four tunnels maximum per GbE port
- Two 10 GbE ports can support up to ten FCIP tunnels each
- Each FCIP tunnel is represented and managed as a virtual Fibre Channel E_Port
- Fibre Channel Routing Services can be used over the FCIP link
- Fabrics connected through FCIP merge if the ports are configured as VE_Ports, and do not merge if they are configured as VEX_Ports. If VE_Ports are used in a Fibre Channel Routing Services backbone fabric configuration, then the backbone fabric merges, but the EX_Port-attached edge fabrics do not merge. For more information refer to the *Fabric OS Administrator's Guide*.
- Up to three FC trunking groups. The three groups are defined as:
 - Trunk group 0: FC ports 0, 1
 - Trunk group 1: FC ports 6, 7
 - Trunk group 2: FC ports 2, 3, 4, 5, 8, 9, 10, 11

FCOE10-24 blade

The FCOE10-24 blade has 24 Fibre Channel over Ethernet (FCoE) ports that enables the transmission of FC frames over an Ethernet network via encapsulation in standard Ethernet packets. This is enabled by adherence to Converged Enhanced Ethernet (CEE) standards, a low latency, lossless Ethernet standard. This does not require dedicated Ethernet lines, but rather can make use of existing Ethernet infrastructure to reduce costs.

Attention: This blade cannot be used in the same chassis with any of the other application blades (FR4-18i, FX8-24, FS8-18).

There are no licensing requirements for functionality on this blade. Refer to the *Fabric OS Administrator's Guide* for information on configuring these features.

The FCOE10-24 blade supports only optical cabling and transceivers (SFP+).

The FCOE10-24 blade provides the following hardware features:

- 24 FCoE ports operating at 10 Gbps
- 32 FC ports operating at 8-Gbps through the backplane
- Hot pluggable
- I²C Management interface through the backplane
- JTAG support
- Blade power and status LEDs
- Link status LEDs per port

The FCOE10-24 blade also provides the following functionality features:

- FCoE switching
- CEE switching
- Layer 2 Ethernet protocols STP/MSTP/RSTP, 802.1q, and Link Aggregation (802.1ad)
- Standard Ethernet encapsulation
- End of row deployment

Refer to the *Fabric OS Administrator's Guide* for information on configuring these features.

Appendix C. Diagnostics and troubleshooting

For information about troubleshooting the entire fabric, refer to the *Fabric OS Administrator's Guide*.

The SAN768B includes a number of diagnostic tools to assist with troubleshooting, including LEDs on the hardware, commands that display current status, diagnostic tests for hardware and software, and error messages. In addition, a number of managing and monitoring features are available, such as Fabric Manager, Web Tools, Fabric Watch, and Advanced Performance Monitoring.

If the SAN768B does not operate as expected, the following steps can be taken to diagnose the problem:

- Check the LEDs and refer to the LED tables (see Chapter 4, “Monitoring system components,” on page 47) for interpretation and recommended actions.
- Review the results of the last POST run by the SAN768B (see “Interpreting POST and boot results” on page 148).
- Review the error logs (refer to the *Fabric OS System Error Messages Reference Manual* and the *Fabric OS Administrator's Guide* for more information).
- Review RASlog entries.
- Enter the **sensorShow** command to determine the status of the hardware components.
- Run diagnostic tests (see “Diagnostics” on page 149).
- Reboot the SAN768B or power the entire chassis off (“Powering off the SAN768B” on page 45) and then back on (“Providing power to the SAN768B” on page 33).

If the problem is still unresolved after these steps, contact technical support.

This appendix provides the following information:

- “Obtaining chassis and component status”
- “Interpreting POST and boot results” on page 148
- “Diagnostics” on page 149
- “Troubleshooting” on page 149

Obtaining chassis and component status

The CLI commands listed in Table 26 on page 148 provide status and environmental information about the chassis and its components. These commands provide information only, and they do not interrupt traffic flow. For more information about these commands, refer to the *Fabric OS Command Reference Manual*.

Table 26. Environmental status and maintenance commands

Command	Information Displayed
sensorShow	<ul style="list-style-type: none"> • Temperature readings for the port blades • Temperature readings for the CP blades • Status and RPM of all operational fans • Status of all operational power supplies
tempShow	<ul style="list-style-type: none"> • Temperature readings for the port blades • Temperature readings for the CP blades
psShow	Status of all operational power supplies
fanShow	Status and RPM of all operational fans
chassisShow	Serial number, time awake, and additional information about each component
slotShow	Slot occupancy
errShow errDump	System error log. Refer to the <i>Fabric OS Message Reference</i> for more information on the messages in this log.

Interpreting POST and boot results

The SAN768B performs power on self test (POST) by default each time the system is powered on, rebooted, or reset. The system can be rebooted using the **reboot** (to reboot each CP individually), or **fastBoot** commands. The **fastBoot** command reboots the system without running POST. If the active CP blade is rebooted, it fails over to the standby CP blade.

POST

The system automatically performs POST each time it is powered on or reset.

To verify that POST has completed without error:

- Verify that all LEDs return to a normal state after POST completes (see Chapter 4, “Monitoring system components,” on page 47).

If one or more LEDs do not return to a normal state, and this is not due to the SAN768B being set to beacon, refer to the relevant LED table to identify and correct the problem. For port blades, CP blades, and core switch blades, the **slotShow** command can be used to check the status of the slots. For information about turning beaconing on/off, refer to the *Fabric OS Administrator's Guide*.

- Verify that the switch prompt displays when POST completes.
If it does not display, POST was not successfully completed. Contact IBM for support.
- Review the system error log using the **errShow** or **errDump** commands.
- Any errors detected during POST are written to the system log, which is accessible through the **errShow** command. For information about error messages, refer to the *Fabric OS Message Reference*.

POST includes the following steps:

1. Preliminary POST diagnostics are run.
2. Operating system is initialized.
3. Hardware is initialized.

4. Diagnostic tests are run on several functions, including circuitry, port functionality, ability to send and receive frames, all aspects of memory, parity, statistics counters, and serialization.

Boot

In addition to POST, boot includes the following steps after POST is complete:

1. Universal port configuration is performed.
2. Links are initialized.
3. Fabric is analyzed. If any ports are connected to other switches, the SAN768B participates in a fabric configuration.
4. The SAN768B obtains a domain ID and assigns port addresses.
5. Unicast routing tables are constructed.
6. Normal port operation is enabled.

Diagnostics

Diagnostic tests are automatically run during POST to check the status of the system. Any error messages generated during POST are sent to the error logs and to the serial console, if connected.

Diagnostic tests can also be run manually to test and troubleshoot the hardware and the firmware, including internal connections and circuitry, transceivers, and port cables. However, diagnostic tests are generally intended for use by support personnel.

Note: Diagnostic error messages do not necessarily indicate that the system requires maintenance.

Each diagnostic test can be implemented by entering the related command through a Telnet or serial session. For a list of diagnostic tests and commands, refer to the *Fabric OS Administrator's Guide*.

All diagnostic tests are run at link speeds of 1, 2, 4, and 8 Gb/sec. They might temporarily lock the transmit and receive speeds to a specific speed. Some diagnostic tests require interconnecting the ports to each other or using loopback plugs. If ports are interconnected, the media (cables and transceivers) at each end of the connection must be of the same type. For example, short wavelength media must be connected to short wavelength media, and likewise with long wavelength media and copper media.

For more information about diagnostic tests and how to run them, refer to the *Fabric OS Administrator's Guide* and the *Fabric OS Command Reference Manual*. For information about diagnostic error messages (**errShow** or **errDump**), refer to the *Fabric OS Troubleshooting and Diagnostics Guide*.

Troubleshooting

Table 27 provides a list of issues, possible causes, and recommended actions.

Table 27. Troubleshooting

Issue	Possible Cause	Recommended Action
Entire chassis powers off automatically.	Power supplies are inadequate to support the installed components.	Add an additional power supply.

Table 27. Troubleshooting (continued)

Several or all components are not operating.	One or more power cables may not be connected to a live source.	Ensure that all power cables are connected to live outlets.
	One or more AC power supplies may be off	Ensure that all switches on the AC power supplies are turned on. (AC switches light up green when on).
Serial connection is faulty or serial port logs have incorrect or missing information.	Serial cable is not connected correctly.	Ensure that the cable is firmly connected to workstation computer and to the SAN768B.
	Terminal emulator application parameters are not set correctly.	Ensure that the terminal emulator application is configured as follows: 9600 bits per second, 8 databits, no parity, 1 stop bit, no flow control.
	Serial port might be incompatible (only RS-232 is supported).	Ensure that the SAN768B is connected to an RS-232 port. RS-423 serial ports might experience difficulties due to corner-case incompatibilities of the standards.
	Pins on the serial cable or serial port might be damaged.	Remove the cable and inspect the pins on the cable and in the serial port. Do not reinstall if the pins on either component have any visible damage, as this could damage the pins on the other component. Replace components as required.
CP Ethernet link speed is different than expected or a link cannot be established.	There might be a conflict with the CP Ethernet link speed negotiation set up by the network.	Specify the CP Ethernet link speed by entering the ifModeSet command.
Configuration data is inaccurate or cannot be accessed.	Chassis was powered off/on while the WWN card was uninstalled or failed.	Install an operational WWN card and power the system off/on again.
	The SAN768B was rebooted while the WWN card was uninstalled or failed.	
Initial set up results in IP address/Domain ID conflict.	The SAN768B was connected to the fabric before being configured.	Refer to Chapter 3, "Starting and configuring the SAN768B," on page 31 and the <i>Fabric OS Administrator's Guide</i> for configuration information.
LEDs on one or more components are changing rapidly or do not indicate a healthy state.	The SAN768B might be booting or running POST.	Verify that boot and POST are complete. The SAN768B requires a minimum of 3 minutes, usually, after power-on to complete POST.
	Beaconing might be on for the entire SAN768B or for individual components.	Determine whether beaconing is on by entering the switchShow command and determine whether switch beaconing or blade beaconing is on.
	Individual components might have failed.	Refer to the LED tables in Chapter 4, "Monitoring system components," on page 47 for interpretation and recommended actions.
	Pins on the components might be damaged.	Remove component from chassis and inspect pins on component and inside chassis. Do not reinstall if pins on either component are visibly damaged, as this could damage pins on other component. Replace parts as required.

Table 27. Troubleshooting (continued)

None of the LEDs on an individual component are on.	Component might not be seated correctly.	Ensure that the SAN768B has power and component is firmly seated. If problem continues, run the sensorShow command to determine component status. If component is a CP blade or port blade, enter the slotShow command to determine status.
	Component might have failed.	Replace component as necessary.
CP blades are failing over frequently.	A third-party application has a memory leak.	Check application for memory leaks.
	There is excessive serial port activity.	Ensure that serial port activity remains below specified amount.
	CP blade is attached to an Ethernet with high traffic loads.	Ensure that Ethernet traffic remains below specified amount.
	Chassis is overheated.	Enter the tempShow and sensorShow commands to check internal temperature. If components are overheating, shut down the port blades as necessary to return the temperature to operating range.
One or more port or application blades have either shut down or failed POST as indicated by the error log.	Blades might be overheated.	Enter the sensorShow command to check the internal temperature readings. If components are overheating, shut down the port blades as necessary to return the temperature readings to the operating ranges.
	Blades might be faulty.	Enter the slotShow command to determine status. For more information, enter the diagDisablePost command; then, the slotPowerOff [slot number] and slotPowerOn [slot number] commands. Resolve the source of the problem or replace the blade as required.
	Pins on the blade or on the backplane (inside the slot) might be damaged.	Remove blade from chassis and inspect pins on blade and on backplane inside slot. Do not reinstall if pins on either component are visibly damaged, as this could damage pins on other component. Replace components as required.
An individual component is not operating as expected.	Component may not have power or may not be firmly seated.	Ensure component is receiving power (power LED should be on) and component is firmly seated.
	Pins on the component or the backplane might be damaged.	Remove component from chassis and inspect pins on blade and inside chassis. Do not reinstall if pins on either component are visibly damaged, as this could damage pins on other component. Replace parts as required.
	The component might have failed.	Enter the tempShow and sensorShow commands to determine component status. If component is a CP blade or port blade, enter the slotShow command to determine the status. Replace the component as necessary.

Appendix D. Blade port numbering

The illustrations in this appendix show the port numbering for the different SAN768B blades. See “Port numbering” on page 25 for details on the port numbering pattern for the different blades.

- Figure 53 on page 154 shows an FC8-16 port blade
- Figure 54 on page 155 shows an FC8-32 port blade
- Figure 55 on page 156 shows an FC8-48 port blade
- Figure 56 on page 157 shows an FC8-64 port blade
- Figure 57 on page 158 shows an FC10-6 port blade
- Figure 58 on page 159 shows an FR4-18i routing blade
- Figure 59 on page 160 show an FS8-18 encryption blade
- Figure 60 on page 161 shows the FX8-24 extension blade
- Figure 61 on page 162 shows the FCOE10-24 Fibre Channel over Ethernet blade

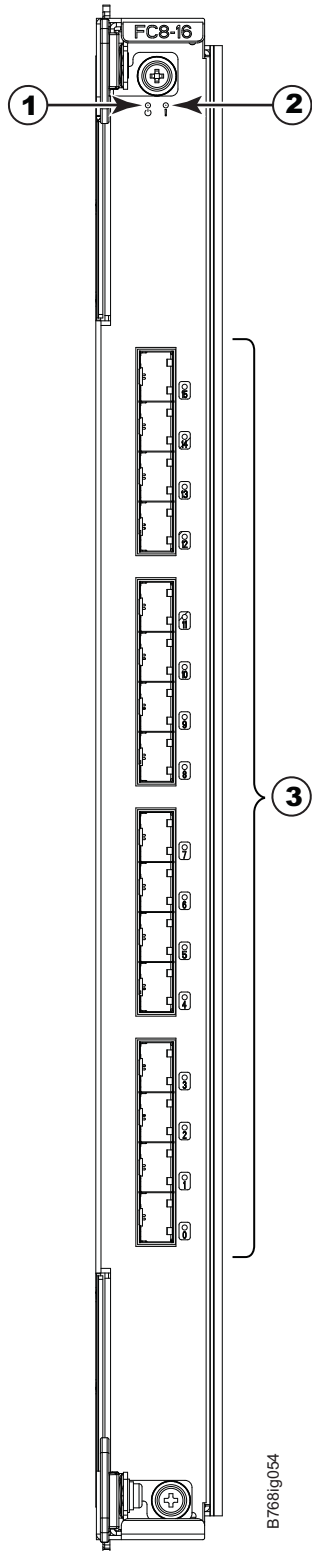

Figure 53. FC8-16 port blade

- 1** Blade power LED
- 2** Blade status LED

- 3** FC ports 0-15 (bottom to top)

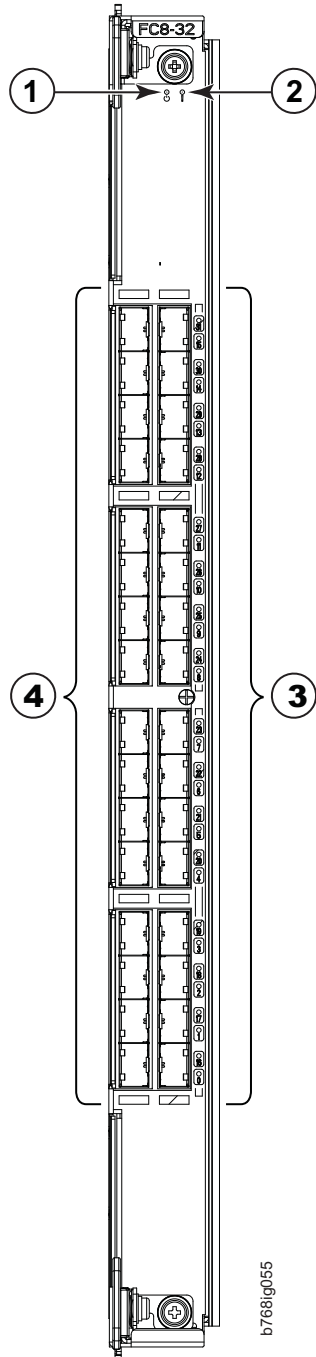

Figure 54. FC8-32 port blade

- | | |
|--|--|
| <p>1 Blade power LED</p> <p>2 Blade status LED</p> | <p>3 FC ports 16-31 (bottom to top)</p> <p>4 FC ports 0-15 (bottom to top)</p> |
|--|--|

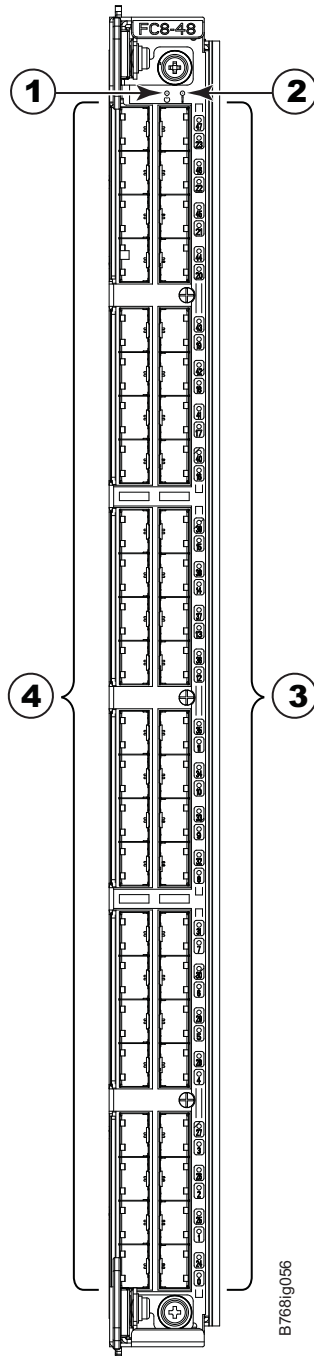

Figure 55. FC8-48 port blade

- 1** Blade power LED
- 2** Blade status LED

- 3** FC ports 24-47 (bottom to top)
- 4** FC ports 0-23 (bottom to top)

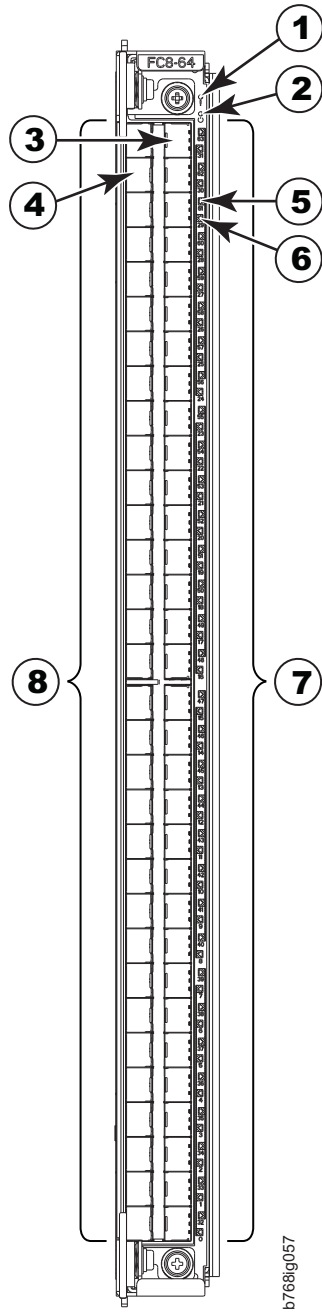

Figure 56. FC8-64 port blade

- | | | | |
|----------|------------------|----------|--------------------------------|
| 1 | Blade power LED | 5 | port 61 LED |
| 2 | Blade status LED | 6 | port 29 LED |
| 3 | Port 63 | 7 | FC ports 32-63 (bottom to top) |
| 4 | Port 30 | 8 | FC ports 0-31 (bottom to top) |

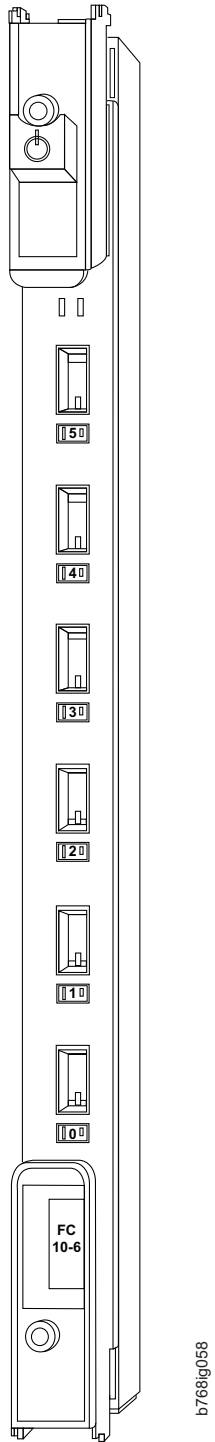

Figure 57. FC10-6 port blade, ports 0-5 (bottom to top)

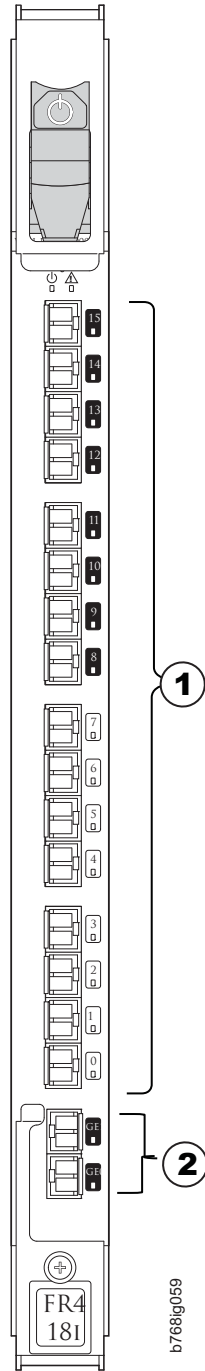

Figure 58. FR4-18i routing blade

1 FC ports 0-15 (bottom to top)

2 GbE ports (GE0 bottom, GE1 top)

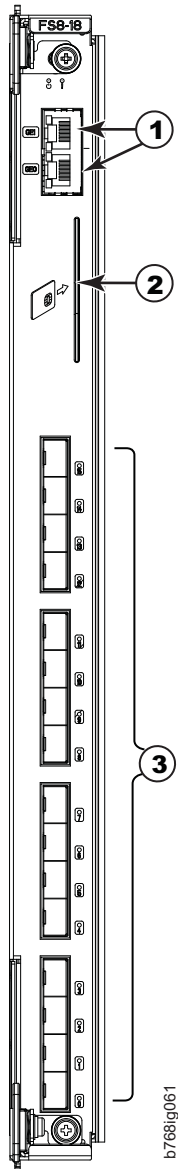

Figure 59. FS8-18 encryption blade

- 1** Key management 1000Base media interfaces
- 2** Key management smart card interface
- 3** FC ports 0-15 (bottom to top)

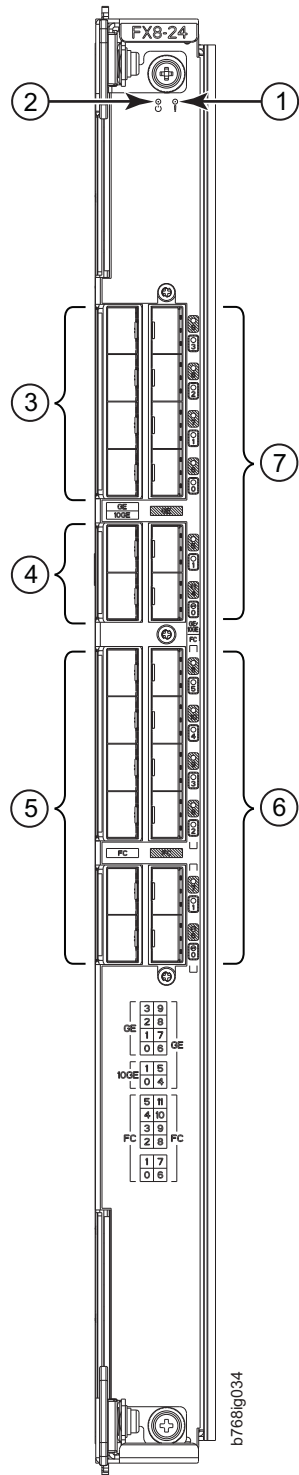

Figure 60. FX8-24 extension blade

- | | | | |
|----------|---|----------|--|
| 1 | Status LED | 5 | FC ports 0-5 (numbered bottom to top) |
| 2 | Power LED | 6 | FC ports 6-11 (numbered bottom to top) |
| 3 | 1 GbE ports 0-3 (numbered bottom to top) | 7 | 1 GbE ports 4-9 (numbered bottom to top) |
| 4 | 10 GbE ports 0-1 (numbered bottom to top) | | |

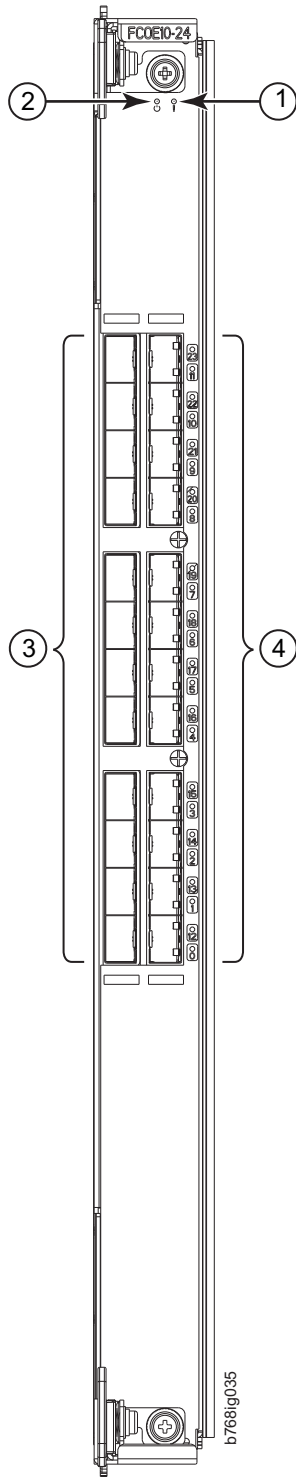

Figure 61. FCOE10-24 blade

- | | |
|--|--|
| <p>1 Status LED</p> <p>2 Power LED</p> | <p>3 10 GbE FCoE ports 0-11 (numbered bottom to top)</p> <p>4 10 GbE FCoE ports 12-23 (numbered bottom to top)</p> |
|--|--|

Notices

This information was developed for products and services offered in the USA.

IBM may not offer the products, services, or features discussed in this document in other countries. Consult your local IBM representative for information on the products and services currently available in your area. Any reference to an IBM product, program, or service is not intended to state or imply that only that IBM product, program, or service may be used. Any functionally equivalent product, program, or service that does not infringe on any IBM intellectual property right may be used instead. However, it is the user's responsibility to evaluate and verify the operation of any non-IBM product, program, or service.

IBM may have patents or pending patent applications covering subject matter described in this document. The furnishing of this document does not give you any license to these patents. You can send license inquiries, in writing to:

*IBM Director of Licensing
IBM Corporation
North Castle Drive
Armonk, N.Y. 10504-1785
U.S.A.*

For additional information, visit the web at:
www.ibm.com/ibm/licensing/contact/

The following paragraph does not apply to the United Kingdom or any other country where such provisions are inconsistent with local law:

INTERNATIONAL BUSINESS MACHINES CORPORATION PROVIDES THIS PUBLICATION "AS IS" WITHOUT WARRANTY OF ANY KIND, EITHER EXPRESS OR IMPLIED, INCLUDING, BUT NOT LIMITED TO, THE IMPLIED WARRANTIES OF NON-INFRINGEMENT, MERCHANTABILITY OR FITNESS FOR A PARTICULAR PURPOSE. Some states do not allow disclaimer of express or implied warranties in certain transactions, therefore, this statement may not apply to you.

This information could include technical inaccuracies or typographical errors. Changes are periodically made to the information herein; these changes will be incorporated in new editions of the publication. IBM may make improvements and/or changes in the product(s) and/or the program(s) described in this publication at any time without notice.

Any references in this information to non-IBM web sites are provided for convenience only and do not in any manner serve as an endorsement of those web sites. The materials at those web sites are not part of the materials for this IBM product and use of those web sites is at your own risk.

IBM may use or distribute any of the information you supply in any way it believes appropriate without incurring any obligation to you.

Any performance data contained herein was determined in a controlled environment. Therefore, the results obtained in other operating environments may vary significantly. Some measurements may have been made on development-level

systems and there is no guarantee that these measurements will be the same on generally available systems. Furthermore, some measurement may have been estimated through extrapolation. Actual results may vary. Users of this document should verify the applicable data for their specific environment.

Information concerning non-IBM products was obtained from the suppliers of those products, their published announcements or other publicly available sources. IBM has not tested those products and cannot confirm the accuracy of performance, compatibility or any other claims related to non-IBM products. Questions on the capabilities of non-IBM products should be addressed to the suppliers of those products.

If you are viewing this information in softcopy, the photographs and color illustrations may not appear.

Trademarks

IBM, the IBM logo, and [ibm.com](http://www.ibm.com)[®] are trademarks or registered trademarks of International Business Machines Corporation in the United States, other countries, or both. A complete and current list of other IBM trademarks is available on the Web at www.ibm.com/legal/copytrade.shtml

Adobe, the Adobe logo, PostScript, and the PostScript logo are either registered trademarks or trademarks of Adobe Systems Incorporated in the United States, and/or other countries.

Java and all Java-based trademarks and logos are trademarks of Sun Microsystems, Inc. in the United States, other countries, or both.

Linux is a registered trademark of Linus Torvalds in the United States, other countries, or both.

Microsoft and Windows are trademarks of Microsoft Corporation in the United States, other countries, or both.

UNIX is a registered trademark of The Open Group in the United States and other countries.

Other product and service names might be trademarks of IBM or other companies.

Electronic emission notices

The following statements apply to this product. The statements for other products intended for use with this product will appear in their accompanying manuals.

Federal Communications Commission (FCC) Class A Statement

This equipment has been tested and complies with the limits for a Class A digital device, pursuant to Part 15 of the FCC Rules. These limits are designed to provide reasonable protection against harmful interference when the equipment is operated in a commercial environment. This equipment generates, uses, and can radiate radio frequency energy and, if not installed and used in accordance with the instruction manual, may cause harmful interference to radio communications. Operation of this equipment in a residential area is likely to cause harmful interference, in which case the user will be required to correct the interference at his own expense.

Properly shielded and grounded cables and connectors must be used in order to meet FCC emission limits. IBM is not responsible for any radio or television interference caused by using other than recommended cables and connectors or by unauthorized changes or modifications to this equipment. Unauthorized changes or modifications could void the user's authority to operate the equipment.

This device complies with Part 15 of the FCC Rules. Operation is subject to the following two conditions: (1) this device may not cause harmful interference, and (2) this device must accept any interference received, including interference that may cause undesired operation.

Industry Canada Class A Emission Compliance Statement

This Class A digital apparatus complies with Canadian ICES-003.

Avis de conformité à la réglementation d'Industrie Canada

Cet appareil numérique de la classe A est conforme à la norme NMB-003 du Canada.

European Union EMC Directive Conformance Statement

This product is in conformity with the protection requirements of EU Council Directive 2004/108/EC on the approximation of the laws of the Member States relating to electromagnetic compatibility. IBM cannot accept responsibility for any failure to satisfy the protection requirements resulting from a non-recommended modification of the product, including the fitting of non-IBM option cards.

Attention: This is an EN55022 Class A product. In a domestic environment this product may cause radio interference in which case the user may be required to take adequate measures.

Responsible manufacturer:
International Business Machines Corp.
New Orchard Road
Armonk, New York 10504
Tel: 919-499-1900

European community contact:
IBM Deutschland GmbH

Technical Regulations, Department M372
IBM-Allee 1, 71139 Ehningen, Germany
Tele: 0049 (0) 7032 15-2941
e-mail: lugi@de.ibm.com

Germany Electromagnetic Compatibility Directive

Deutschsprachiger EU Hinweis:

Hinweis für Geräte der Klasse A EU-Richtlinie zur Elektromagnetischen Verträglichkeit

Dieses Produkt entspricht den Schutzanforderungen der EU-Richtlinie 2004/108/EG zur Angleichung der Rechtsvorschriften über die elektromagnetische Verträglichkeit in den EU-Mitgliedsstaaten und hält die Grenzwerte der EN 55022 Klasse A ein.

Um dieses sicherzustellen, sind die Geräte wie in den Handbüchern beschrieben zu installieren und zu betreiben. Des Weiteren dürfen auch nur von der IBM empfohlene Kabel angeschlossen werden. IBM übernimmt keine Verantwortung für die Einhaltung der Schutzanforderungen, wenn das Produkt ohne Zustimmung der IBM verändert bzw. wenn Erweiterungskomponenten von Fremdherstellern ohne Empfehlung der IBM gesteckt/eingebaut werden.

EN 55022 Klasse A Geräte müssen mit folgendem Warnhinweis versehen werden: "Warnung: Dieses ist eine Einrichtung der Klasse A. Diese Einrichtung kann im Wohnbereich Funk-Störungen verursachen; in diesem Fall kann vom Betreiber verlangt werden, angemessene Maßnahmen zu ergreifen und dafür aufzukommen."

Deutschland: Einhaltung des Gesetzes über die elektromagnetische Verträglichkeit von Geräten

Dieses Produkt entspricht dem "Gesetz über die elektromagnetische Verträglichkeit von Geräten (EMVG)". Dies ist die Umsetzung der EU-Richtlinie 2004/108/EG in der Bundesrepublik Deutschland.

Zulassungsbescheinigung laut dem Deutschen Gesetz über die elektromagnetische Verträglichkeit von Geräten (EMVG) (bzw. der EMC EG Richtlinie 2004/108/EG) für Geräte der Klasse A

Dieses Gerät ist berechtigt, in Übereinstimmung mit dem Deutschen EMVG das EG-Konformitätszeichen - CE - zu führen.

Verantwortlich für die Einhaltung der EMV Vorschriften ist der Hersteller:
International Business Machines Corp.
New Orchard Road
Armonk, New York 10504
Tel: 919-499-1900

Der verantwortliche Ansprechpartner des Herstellers in der EU ist:
IBM Deutschland GmbH
Technical Regulations, Abteilung M372
IBM-Allee 1, 71139 Ehningen, Germany
Tele: 0049 (0) 7032 15-2941
e-mail: lugi@de.ibm.com

Generelle Informationen:

Das Gerät erfüllt die Schutzanforderungen nach EN 55024 und EN 55022 Klasse A.

People's Republic of China Class A Electronic Emission Statement

中华人民共和国“A类”警告声明

声明

此为A级产品，在生活环境中，该产品可能会造成无线电干扰。在这种情况下，可能需要用户对其干扰采取切实可行的措施。

Japan Voluntary Control Council for Interference (VCCI) Class A Statement

この装置は、クラス A 情報技術装置です。この装置を家庭環境で使用する
と電波妨害を引き起こすことがあります。この場合には使用者が適切な対策
を講ずるよう要求されることがあります。 VCCI-A

Translation: This is a Class A product based on the standard of the VCCI Council. If this equipment is used in a domestic environment, radio interference may occur, in which case, the user may be required to take corrective actions.

Japan Electronics and Information Technology Industries Association (JEITA) Statement

Japanese Electronics and Information Technology Industries Association (JEITA)
Confirmed Harmonics Guideline (products greater than 20 A per phase).

高調波ガイドライン準用品

jeita2

Korea Communications Commission (KCC) Class A Statement

Please note that this equipment has obtained EMC registration for commercial use. In the event that it has been mistakenly sold or purchased, please exchange it for equipment certified for home use.

이 기기는 업무용(A급)으로 전자파적합기기로서 판매자 또는 사용자는 이 점을 주의하시기
바라며, 가정외의 지역에서 사용하는 것을 목
적으로 합니다.

Russia Electromagnetic Interference (EMI) Class A Statement

ВНИМАНИЕ! Настоящее изделие относится к классу А.
В жилых помещениях оно может создавать
радиопомехи, для снижения которых необходимы
дополнительные меры

rusemi

Australia and New Zealand Class A Statement

Attention: This is a Class A product. In a domestic environment this product might cause radio interference in which case the user might be required to take adequate measures.

Taiwan Class A Electronic Emission Statement

警告使用者：
這是甲類的資訊產品，在
居住的環境中使用時，可
能會造成射頻干擾，在這
種情況下，使用者會被要
求採取某些適當的對策。

taiemi

Index

Numerics

- 24-inch load plate
 - part number 12
 - using 19
- 3870 port blades 126
- 8 GbpsFICON Accelerator 8

A

- about this document xxvii
 - how to send your comments v
- ac power
 - removing xxiv
- accessibility features for this product xxviii
- application blades
 - FCOE10-24 71
 - FX8-24 71
- attaching
 - Fibre cables 39
- attention notice
 - definition xxi
 - example xxi
- attention notices xxi

B

- backing up the configuration 43
- backup
 - configuration file 44
- blades
 - 3870 126
 - FC8-16 122
 - FC8-32 122
 - FC8-64 123
- blower assembly
 - installing 90
 - removing 90, 91
- brackets, installing 17
- bridge tool 12
 - ordering 12
 - using 19
- Brocade
 - documents xxvii
- Brocade documents xxvii

C

- C36
 - cabinet 11
- C8P blade
 - verifying operation 80
- cabinet
 - C36 11
 - installing a SAN768B 14
- cable management comb
 - high density 70
 - installing 70
 - lower density 70

- cable management comb (*continued*)
 - removing 70
- cable management tray
 - removing 71
- cable routing tables 118
- cables
 - attaching 39
 - installing 39
 - managing 40
- cabling
 - FR4-18i 87
 - router blade 87
- caution notices xviii
 - definition xviii
 - examples xix
- chassis
 - installing components 114
 - removing 113
 - replacing 113
- chassis door 69
 - installing 69
 - removing 69
- chassis replacement, preparation 109
- chassis replacement, verifying need 109
- chassis, installing components 114
- chassis, replacing 108
- comments
 - sending v
- components
 - installing 69
 - removing 69
- configuration
 - backing up 43
 - encryption blade 31
 - parameters 33
- configuration file
 - backup 44
 - uploading 44
- configuration parameters, initial 34
- configuring
 - encryption 42
 - IP addresses 34
 - SAN768B 31
- configuring FCIP
 - FR4-18i 87
 - router blade 87
- configuring Fibre channel routing services
 - FR4-18i 87
 - router blade 87
- connecting to the fabric 39
- connection
 - serial 33
- connection, Ethernet 36
- cords, power 142
- CP blade
 - installing 76
 - removing 76
- CR blade
 - installing 82, 83
 - removing 82

- critical SAN information
 - recording 109
- critical SAN768B information
 - recording 109

D

- danger notices xv
 - definitions xv
 - examples xv
- data transmission
 - distance 141
 - range 141
 - speed 141
- date
 - setting 37
- diagnostics 147
- director of licensing, address 163
- disconnecting
 - SAN768B from network and fabric 112
- documents
 - Brocade xxvii
 - product xxvii
- documents, Brocade xxvii
- documents, product xxvii
- Domain ID 37
- door, chassis 69
- double encryption
 - avoiding 43, 132

E

- edition notice ii
- electronic emission notices 166
- enabling ports
 - FR4-18i 87
- enabling software licenses 39
- encryption
 - configuration tasks 43
 - configuring 42
 - double 43, 132
 - planning 41
 - pre-initialization tasks 42
 - redundancy 41
- encryption blade
 - configuration 31
 - description 143
 - features 143
 - FS8-18 47, 71
 - installing 130
 - monitoring 47
 - removing 71
 - status 47
- environmental notices xv, xxv
- environmental requirements 140
- ESD 122, 123, 125
- ESD strap 122, 123, 125, 126, 127, 129, 130
- Ethernet connection 36

Ethernet connection (*continued*)
 establishing 36
extension blade
 installing 129
external machine checks xxiv

F

fabric
 connecting to 39
fabric configuration 117
fabric configuration, verifying 117
fabric, connecting to 39
fabric, reconnecting 116
facility requirements 139
FC10-6 blade
 installing 74
 LEDs 57
 removing 72
 status 47, 57
FC3816
 installing 16-port blade 122
FC3832
 installing 32-port blade 122
FC3848
 installing 48-port blade 122
FC3850
 installing routing blade 125
FC3864
 installing 64-port blade 123
FC3870
 installing 48-port blade 126
 inter-chassis cable kit 132
FC3880
 FCOE10-24 blade 127
FC3890
 FX8-24 blade 129
FC3895
 FS8-18 encryption blade 130
 installing 130
FC7230
 FIPS seals 132
FC8-16 blade
 installing 74
 LEDs 57
 removing 72
 status 47, 57
FC8-16 port blades 71, 122
FC8-32 blade
 installing 74
 LEDs 57
 removing 72
 status 47, 57
FC8-32 port blades 71, 122
FC8-48 blade
 installing 74
 LEDs 57
 removing 72
 status 47, 57
FC8-48 port blades 71
FC8-64 blade
 installing 74
 LEDs 57
 removing 72
 status 47, 57
FC8-64 port blades 123

FCIP extension blade
 FX8-24 47
FCOE10-24 blade 56, 145
 components 56, 162
 installing 74, 127
 removing 72
 status 47
features
 high availability 7
features and components 1
features, Installing new 121
features, software 8
Fibre cables
 attaching 39
Fibre Channel over Ethernet
 installing 127
Fibre Channel over Ethernet blade
 FCOE10-24 47
FICON Accelerator 8
filler panel 75
FIPS seals
 installing 132
FIPS security seals 9
 installation sequence 14
FR4-18i
 cabling 87
 configuring FCIP 87
 configuring Fibre channel routing
 services 87
 enabling ports 87
 installing 86
 removing 84
FR4-18i blade 143
 installing 74
 removing 72
 status 47
FR4-18i router blade
 installing 84
 removing 84
FR4-18i routing blade 53, 125
 components 53
 LEDs 57
 status 57
FRU
 weights 138
FRUs
 Smart card 42
FRX8-24 blade
 components 55
FS8-18
 description 143
 encryption blade iii, 47, 143
 features 143
FS8-18 blade
 installing 74
 removing 72
 status 47
FS8-18 encryption blade 54
 components 54
 installing 130
 LEDs 57
 status 57
FX8-24 blade 144
 installing 74, 129
 removing 72
 status 47

FX8-24 extension blade
 components 161
 illustration 55

G

getting help iv

H

hardware, verifying 115
help iv
high availability 7
 features 7
how to send your comments v

I

IBM
 notices 163
 trademarks 165
ID, Domain 37
initial configuration parameters 34
inspections, safety xxiv
installation
 planning 11
 preparation 11
installation guidelines 13
installing 97
 blower assembly 90
 brackets 17
 chassis door 69
 components 69, 114
 CP blade 76
 CR blade 82, 83
 FC10-6 71, 74
 FC3880 127
 FC3890 129
 FC3895 130
 FC8-16 71
 FC8-16 blade 74
 FC8-32 71
 FC8-32 blade 74
 FC8-48 71
 FC8-48 blade 74
 FC8-64 71
 FC8-64 blade 74
 FCOE10-24 71
 FCOE10-24 blade 74, 127
 filler panel 75
 FIPS seals 132
 FR4-18i 74, 86
 FR4-18i router blade 84
 FS8-18 71
 FS8-18 encryption blade 74, 130
 FX8-24 71
 FX8-24 blade 74, 129
 inter-chassis cable kit 132
 inter-chassis link (ICL) cable 99
 mSFP 95
 mSFPs 39
 port blade 75, 122, 123, 126
 power supply 88
 router blade 84, 86
 routing blade 125
 SAN768B 11, 14, 19

- installing (*continued*)
 - time required 14
 - tools required 15
- SFP 95
- SFP+ 95
- SFP+s 39
- SFPs 39
- WWN bezel and card 91
- XFP 95
- XFPs 39
- installing components 69
- Installing new features 121
- intellectual property 163
- inter-chassis cable kit
 - installing 132
- inter-chassis link (ICL)
 - status 97
- inter-chassis link (ICL) cable
 - installing 97, 99
 - removing 97, 98
- internal machine checks xxiv
- introduction 1
- IP addresses
 - SAN768B 34
- IP addresses, SAN768B 34

L

- labels, safety xx
- LEDs
 - encryption blades 57
 - port blades 57
 - routing blades 57
- license, for patents 163
- licenses, software 39
- lift tool 12, 14
 - ordering procedure 12
 - part number 12
 - United States ordering procedure 12
 - using 19, 28
 - world trade ordering procedure 12
- local time
 - synchronizing 38
- login
 - serial console port 34

M

- machine checks
 - external xxiv
 - internal xxiv
- master keys 41
- modem 31
- mSFP 39, 137
 - installing 95
 - removing 95
- mSFP transceivers 39, 137
- mSFPs
 - compatible 39
 - installing 39

N

- network manageability 9
- Network Management System 9
- network, reconnecting 116

- new features, Installing 121
- notice, edition ii
- notices
 - attention xxi
 - caution xviii
 - danger xv
 - environmental xv, xxv
 - general 163
 - IBM 163
 - patents 163
 - safety xv
 - safety and environmental xv
 - types xv
- notices ,danger xv
- notices and labels
 - safety xv
- notices, attention xxi
- notices, caution xviii
- NTP server 38

O

- ordering the lift tool and the 24-inch load plate 12
- organizing
 - cables 40
- overview 1

P

- parameters
 - configuration 33
- parameters, initial configuration 34
- part number
 - 24-inch load plate 12
 - lift tool 12
- parts
 - power cords 142
- password 34
 - changing 34
 - saving 44
- patents 163
- PID mode, verifying 39
- port blade
 - FC10-6 47
 - FC8-16 47
 - FC8-32 47
 - FC8-48 47
 - FC8-64 47
 - FCOE10-24 47
 - FX8-24 47
 - installing 71, 74, 122, 123, 126
 - monitoring 47
 - removing 71
 - status 47
- port blades
 - 3870 126
 - FC10-6 71
 - FC8-16 71, 122
 - FC8-32 71, 122
 - FC8-48 71
 - FC8-64 71
- port blades, 3470 126
- port blades, FC10-6 71
- port blades, FC8-16 71, 122
- port blades, FC8-32 71, 122

- port blades, FC8-48 71
- port blades, FC8-64 71, 123
- port groups
 - trunking 40
- port numbering 25
 - fully populated (256 ports) 26
- power
 - cords 142
 - off 45
 - SAN768B 33
- power specifications 139
- power supply
 - filler panel 88
 - installing 88
 - removing 88
- preparing for chassis replacement 109
- product
 - components 2
 - features 2
 - features and components 1
 - hardware components 2
 - introduction 1
 - overview 1
 - reliability 7
 - serviceability 7
 - software features 8
 - specifications 135
- product documents xxvii
- product specifications 135
- providing power to the SAN768B 33

R

- rack
 - safety xxii
- rack relocation safety xxiii
- rack safety xxii
- read this first iii
- reconnecting to the fabric 116
- reconnecting to the network 116
- recording
 - critical SAN information 109
 - critical SAN768B information 109
- reliability 7
- removing
 - ac power xxiv
 - blower assembly 90, 91
 - cable management tray 71
 - chassis 113
 - chassis door 69
 - components 69, 113
 - CP blade 76
 - CR blade 82
 - FC10-6 71, 72
 - FC8-16 71
 - FC8-16 blade 72
 - FC8-32 71
 - FC8-32 blade 72
 - FC8-48 71
 - FC8-48 blade 72
 - FC8-64 71, 72
 - FCOE10-24 71
 - FCOE10-24 blade 72
 - filler panel 75
 - FR4-18i 72, 84
 - FR4-18i router blade 84
 - FS8-18 71

- removing (*continued*)
 - FS8-18 blade 72
 - FX8-24 71
 - FX8-24 blade 72
 - inter-chassis link (ICL) cable 97, 98
 - mSFP 95
 - port blade 75
 - power supply 88
 - router blade 84
 - SAN768B 11, 28
 - SFP 95
 - SFP+ 95
 - WWN bezel and card 91
 - XFP 95
- removing components 69
- replacing
 - chassis 108, 113
 - WWN card 91
- requirements
 - environmental 140
 - facility 139
- router blade
 - installing 84
 - removing 84
- routing blade
 - FR4-18i 47
 - installing 74
 - monitoring 47
 - status 47

S

- safety xv
 - inspections xxiv
 - labels xv, xx
 - examples xx
 - notices xv
 - rack xxii
 - rack installation xxii
 - rack relocation xxiii
- safety inspection
 - external machine checks xxiv
 - internal machine checks xxiv
- safety inspections xxiv
- safety labels xx
- safety notices xv
- safety, rack xxii
- safety, rack installation xxii
- safety, rack relocation xxiii
- SAN Switch Cabinet C36 11
- SAN768B
 - configuring 31
 - installation guidelines 13
 - installing 11
 - IP addresses 34
 - library xxvii
 - physical dimensions 138
 - providing power 33
 - removing 11, 28
 - size 138
 - starting 31
 - switch name 36
 - weight 138
- security 8
- security features 8
- security features table 8
- serial connection 33

- serial connection, establishing 33
- serial console port
 - login 34
- Server Application Optimization (SAO) 8
- serviceability 7
- setting
 - date 37
 - Domain ID 37
 - time 37
 - timezone 38
- SFP 39, 137
 - installing 95
 - removing 95
- SFP transceivers 39, 137
- SFP+ 39, 137
 - installing 95
 - removing 95
- SFP+ transceivers 39, 137
- SFP+s
 - compatible 39
 - installing 39
- SFPs
 - compatible 39
 - installing 39
- Smart card 42
- SNMP 9
- software features 8
- software licenses
 - enabling 39
- specifications
 - power 139
- specifications, product 135
- standard features
 - software
 - Advanced Zoning 8
 - Fabric Watch 8
 - ISL Trunking 8
 - Performance Monitoring 8
 - Web Tools 8
- standard software features 8
- starting
 - SAN768B 31
- status
 - encryption blades 57
 - FC10-6 blade 57
 - FC8-16 blade 57
 - FC8-32 blade 57
 - FC8-48 blade 57
 - FC8-64 blade 57
 - FR4-18i routing blade 57
 - FS8-18 encryption blade 57
 - inter-chassis link (ICL) 97
 - port blades 57
 - routing blades 57
- strap, ESD 122, 123, 125, 126, 127, 129, 130
- switch name 36
- synchronizing
 - time zone 38
- system
 - power off 45
 - shutdown 45
- system architecture 135

T

- tables, cable routing 118
- time
 - setting 37
- time required
 - installing a SAN768B 14
- time server
 - NTP 38
- time zone
 - setting 38
- tools required
 - installing a SAN768B 15
- trademarks 165
- transceivers
 - mSFP 39, 137
 - SFP 39, 137
 - SFP+ 39, 137
 - XFP 39, 137
- transceivers, mSFP 39
- transceivers, SFP 39, 137
- transceivers, SFP+ 39
- transceivers, XFP 39, 137
- transmission range
 - multi-mode media 141
 - OM1 141
 - OM2 141
 - OM3 141
 - SFP types 141
 - single mode media 141
 - transceiver 141
- trunking
 - port groups 40

V

- verifying
 - chassis replacement need 109
 - fabric configuration 117
- verifying hardware 115
- verifying operation
 - CP8 blade 80
- verifying PID mode 39
- VLAN 36

W

- Web sites iv
- weights, FRUs 138
- who should read this document xxvii
- WWN bezel 91
- WWN card 91
- WWN card, replacing 91

X

- XFP 39, 137
 - installing 95
 - removing 95
- XFP transceivers 39, 137
- XFPs
 - compatible 39
 - installing 39



Part Number: 98Y2671

Printed in USA

GA32-0574-06



(1P) P/N: 98Y2671

