



Business Service Management

– Aligning IT operations with business priorities using IBM Tivoli Business Systems Manager

Dan Urdaneta – Automation Sales

Christopher O Lockyer-bratton - WW Sales Enablement

IBM Tivoli Software

IBM® IT Service Management

*A Better Way to Manage
the Business of IT*



Agenda

- **IT Service Management Intro**
- **Business Service Management**
- **Future Direction**



IT Ineffective In Preventing Business Service Disruption



- 85% of problems are caused by IT changing something
- 80% of problems are reported by users
- IT customers have become the IT systems test team

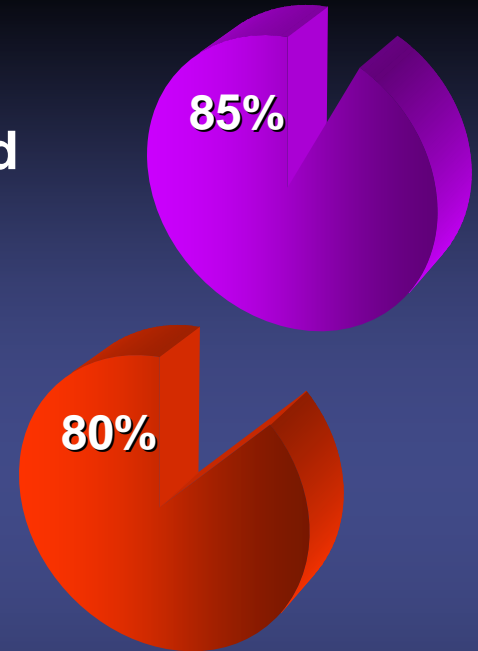

Source: Tivoli Primary Research 2005

IT Dilemma: Managing Cost and Responsiveness Across IT Silos

Many Businesses Struggle to Manage Composite Applications

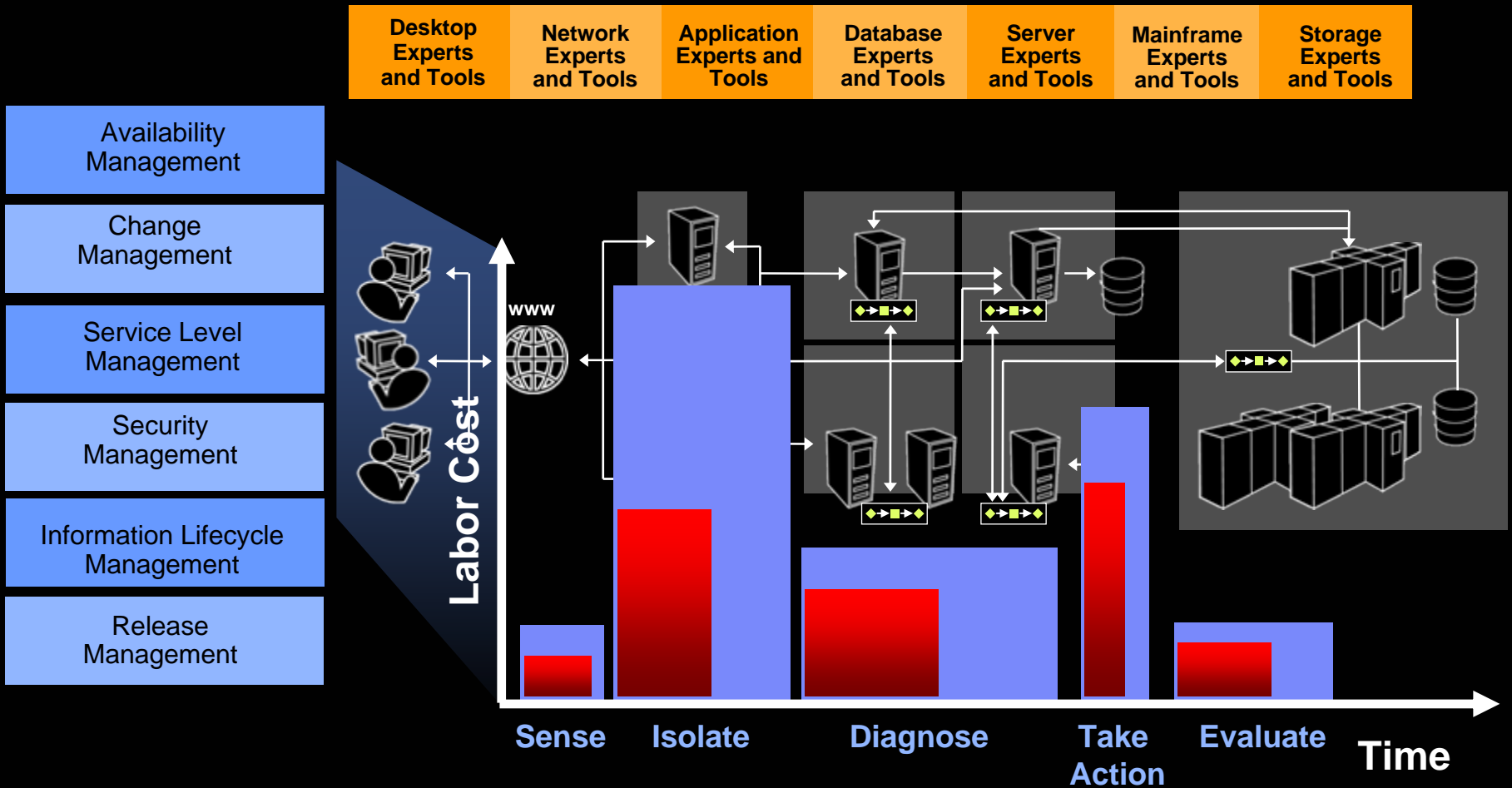

Primary Driver: Architectural Complexity Reduces IT Efficiency & Effectiveness

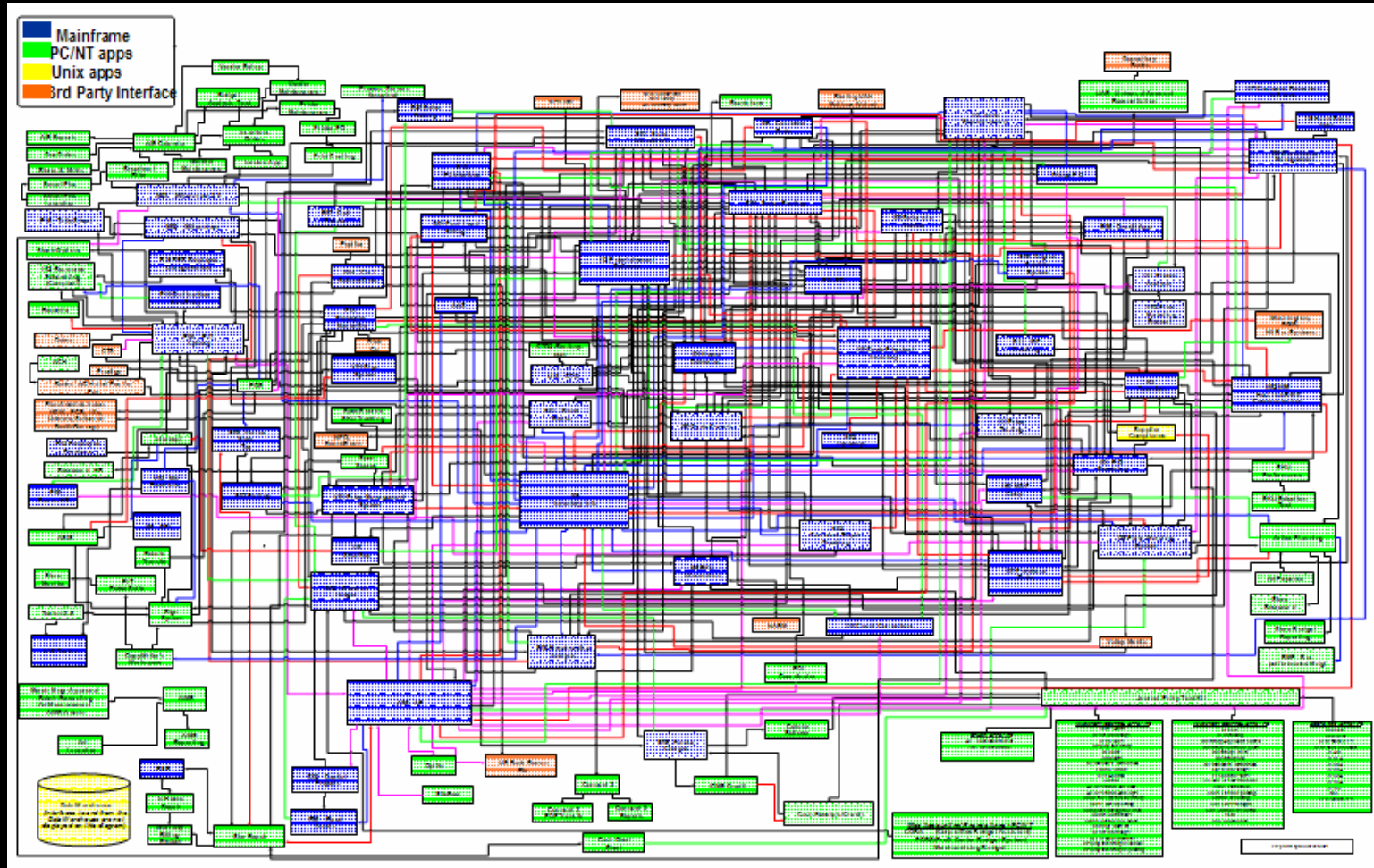

Actual Application Architecture for Consumer Electronics Company

Innovation that Matters – IBM IT Service Management

An innovative vision for the optimal intersection of people, process, information and technology

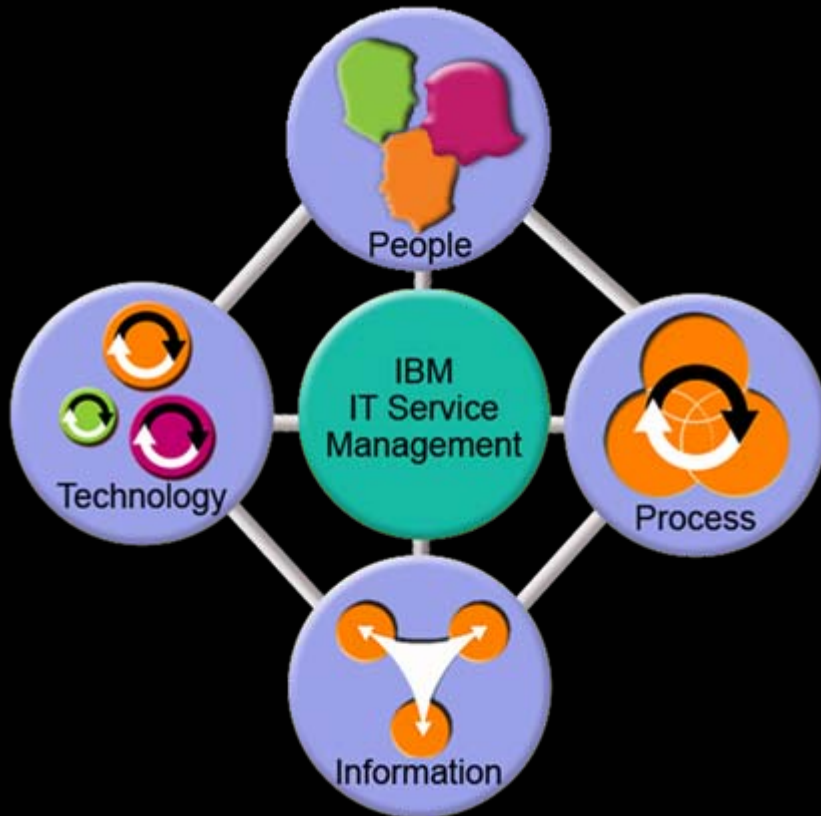

- **Optimize the sharing of information across people, processes and technology**
- **Establish decision-making policies to collaborate across organizations**
- **Automate and integrate IT processes aligned to business**
- **Leverage IBM's modular approach to achieve your business goals**

IBM IT Service Management – A New Approach

IBM IT Service Management



Traditional Approach

- Manual processes
- Inconsistent execution
- Unable to audit processes
- No CMDB or CMDB not integrated
- Inconsistent policy enforcement
- Incomplete tool portfolio
- Point function focus
- Limited data integration
- Guidelines for process execution

IBM Approach

- Automated processes
- Automation enforces consistent execution
- Audit-enabled processes
- CMDB integrated with management tools and process automation
- Policies enforced through ITSM platform
- Comprehensive tool portfolio
- Process enabling integration
- Information shared by management tools
- Tivoli Unified Process from IBM

The Change and Configuration Management Database (CCMDB) Is At the Heart of Innovation

IBM IT Service Management

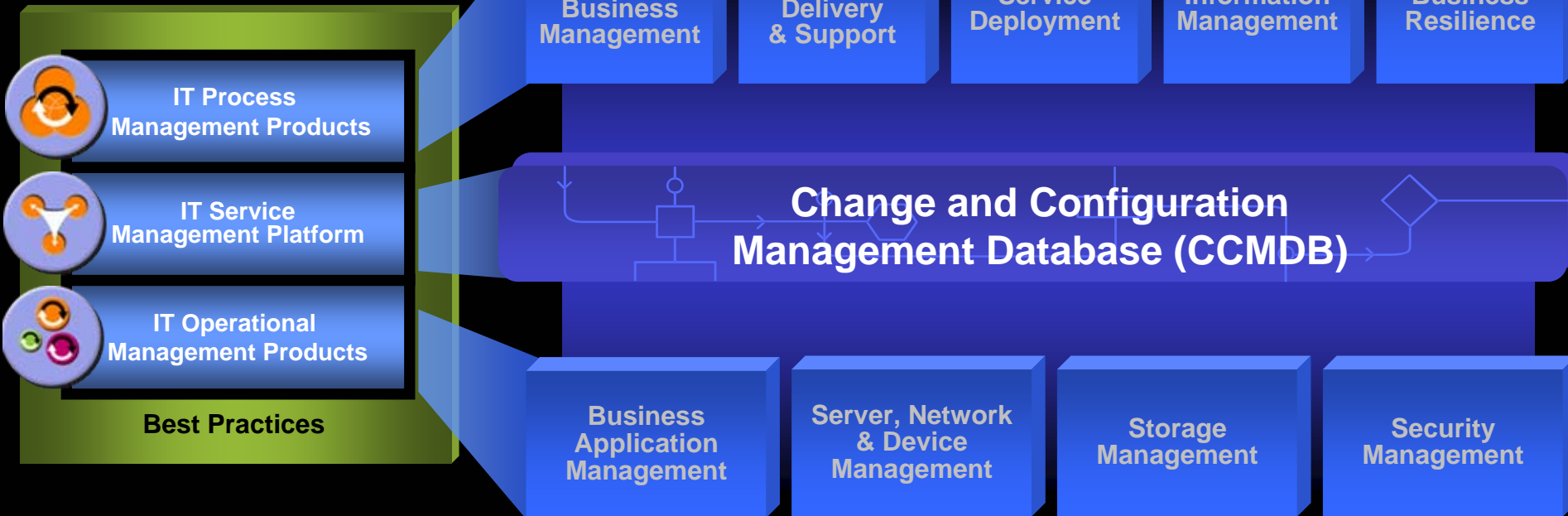

Do You *Really* Have a CMDB Today?

Existing databases and repositories were not designed with a CMDB in mind, and they lack one or more of four management-related critical capabilities needed to provide desired CMDB capability: reconciliation, federation, synchronization, and mapping and visualization

Does your CMDB:

1. **Bring multiple data sources into a coalesced view that represents relationships across components?**
2. **Rationalize the same instance of a CI or component that might come into the CMDB from multiple sources?**
3. **Use approved changes for updates and identify changes that are not approved?**
4. **Illustrate logically or physically the peer-to-peer and hierarchical relationships between CIs?**

Is your CMDB a service desk or inventory management tool in disguise?

Source: Gartner report "CMDB or Configuration Database: Know the Difference" 13 March 2006

What are the Process Managers?

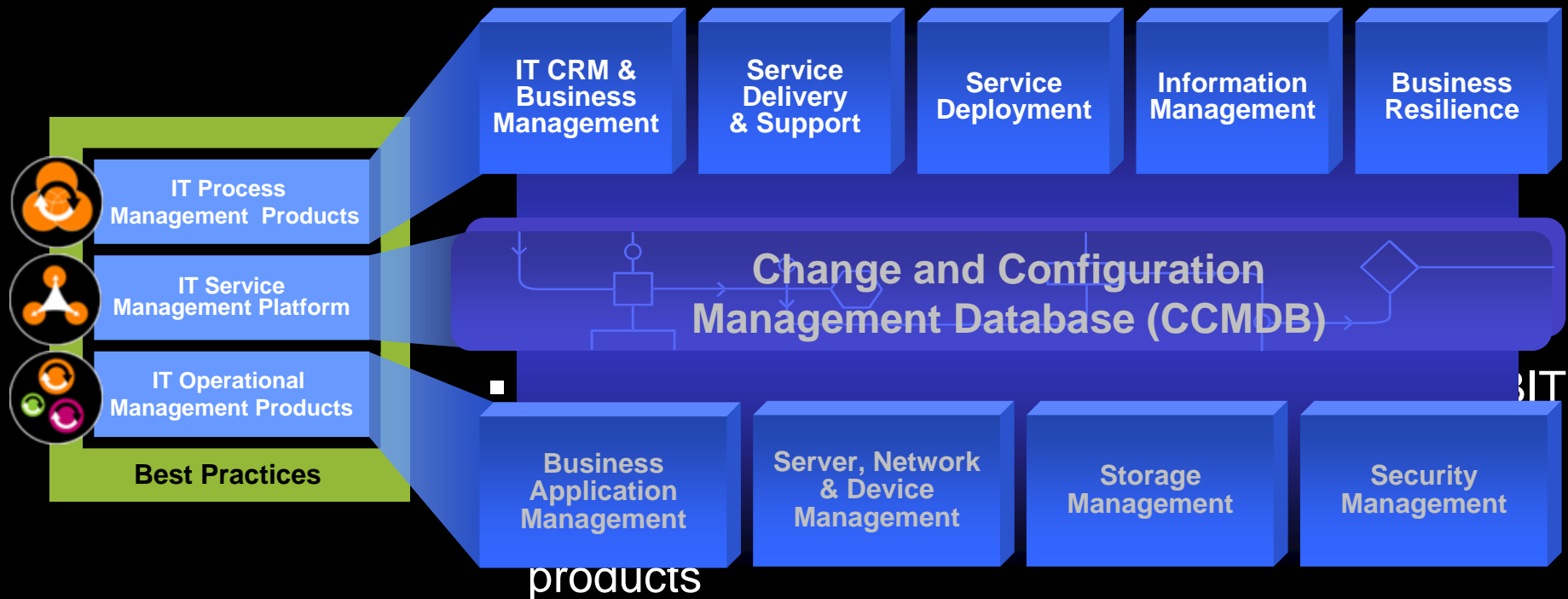

- Customization tools allow you to:
 - Customize the processes
 - Integrate additional products into the processes including in-house and third party applications

IT Process Managers Bridge Organizational Silos

IBM IT Service Management



IT CRM & Business Management	Service Delivery & Support	Service Deployment	Information Management	Business Resilience
Financial Assessment Process Manager	Availability Management Process Manager	Release Management Process Manager	Storage Management Process Manager	Service Continuity Management Process Manager
Service Level Management Process Manager	Change and Configuration Management Process Manager			Security Management Process Manager
Asset Management Process Manager	Capacity Management Process Manager			Compliance Management Process Manager

Change and Configuration Management Database

Available in June 2006!

Available in 2H 2006!

Future Directions

IT Operational Management Products

Integrated across silos through ITSM Platform and to IT Process

Management Products

IBM IT Service Management



Business Application Management	Server, Network & Device Management	Storage Management	Security Management
<p>Products include:</p> <ul style="list-style-type: none"> ▪ Tivoli Composite Application Management • Tivoli Business Systems Manager • Tivoli Intelligent Orchestrator • Tivoli Service Level Advisor • Tivoli License Manager • Tivoli License Compliance Manager • Netcool/Impact 	<p>Products include:</p> <ul style="list-style-type: none"> ▪ Tivoli Enterprise Console • Tivoli Monitoring • Tivoli OMEGAMON • Tivoli NetView • Tivoli Remote Control • Tivoli Systems Automation • Tivoli Workload Scheduler • Tivoli Provisioning Manager • Tivoli Configuration Manager • Tivoli Decision Support for z/OS • Netcool/OMNIBus • Netcool/Proviso • Netcool/Precision • Netcool/Monitors 	<p>Products include:</p> <ul style="list-style-type: none"> • Tivoli Storage Manager • Tivoli Continuous Data Protection for Files • TotalStorage Productivity Center 	<p>Products include:</p> <ul style="list-style-type: none"> • Tivoli Access Manager • Tivoli Identity Manager • Tivoli Federated Identity Manager • Tivoli Directory Server • Tivoli Directory Integrator • Security Compliance Manager • Netcool/NeuSecure

Tivoli Product Portfolio Available TODAY!

Multiple Entry Points to IT Service Management

Starting point depends on your organization's priorities

- Innovation Workshops
- Services Readiness Assessment
- ITIL® Consulting
- IT Service Management Design
- IT Service Management Implementation Services

ENTRY

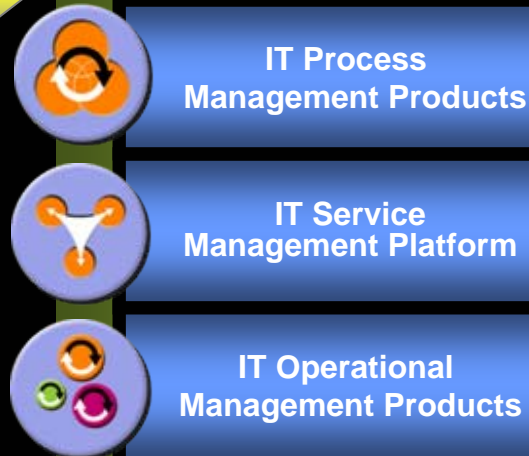

IT Process Management Products

IT Service Management Platform

IT Operational Management Products

Best Practices

- IT Process Managers
- IBM Tivoli Unified Process
- IT Service Management Assessment Tool
- Tivoli and other IBM Products

ENTRY

IBM IT Service Management

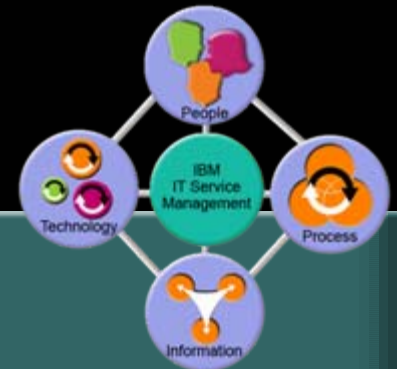

A Better Way to Manage the Business of IT

- **Effectively and Efficiently Deliver IT Services** – Aligned with business priorities
- **Quantifiable process performance** – End-to-end process measurements and quantification
- **Extract Greater Value of Existing Investments** – Tighter Integration across technology, information and people
- **Increase IT Organizational Productivity** – Alignment of IT silos through data and workflow integration

Agenda

- IT Service Management Intro
- **Business Service Management**
- Future Direction





Business Service Management

Christopher O Lockyer-bratton
WW Sales Enablement

IBM Tivoli Software

IBM® IT Service Management

*A Better Way to Manage
the Business of IT*



What is Business Service Management?

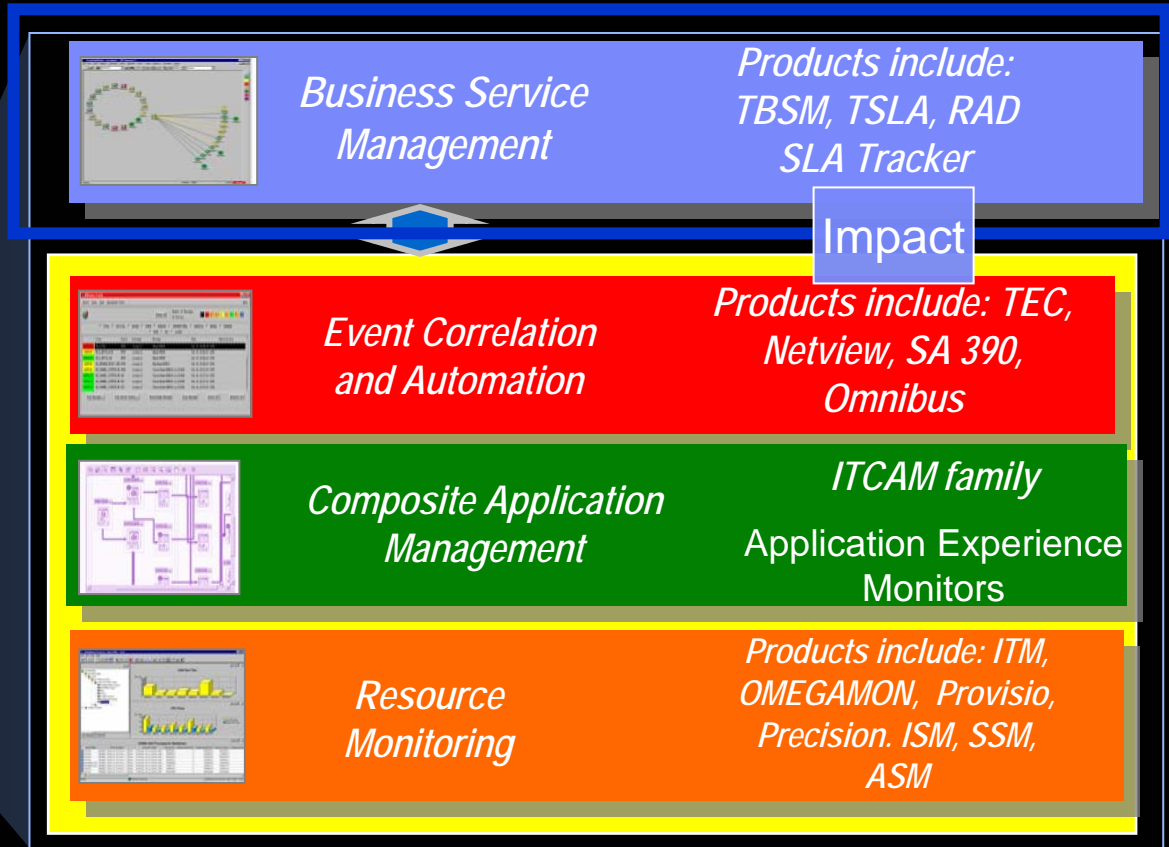

Category of IT operations software products that link the availability and performance status of the underlying IT infrastructure and application components to business oriented IT services that enable business processes - Gartner October 2005

Business service management dynamically links business-focused IT services to the underlying IT infrastructure. A business-focused IT service may be a specific IT service or part of a business process, but it must support a significant, visible business metric for a business owner - Forrester - Feb. 2006

With BSM IT Organizations can:

Visualize

How does this IT component support the application and the service we provide?

Prioritize

How does this problem impact the services we deliver ?



“IBM Tivoli Business Systems Manager allows us to view our IT infrastructure from a business process perspective in real-time , and respond to problems with the correct priority. This helps to ensure that we maintain the service levels that our customers demand.”

IT Operations Management with Tivoli 2006 and Beyond

Transactions
Monitoring &
Management
■ CICS

Resources
Systeming &
Management
■ Middleware
■ Storage
■ Network

Federated IT Properties

Transaction Views

Tivoli Enterprise Portal Views:

Business Service Views

Event View

Service Level Views

Discovery

Topology

Resource Views
Monitor Data

Tivoli Enterprise Portal – Demonstrable Deep Integration

A Dynamic Role-based Workspace for Integrating IT Operations Silos – One portal to manage the overall health of the infrastructure

Business Services Distributed Resources J2EE Transactions Mainframe Resources

The screenshot displays a comprehensive IT monitoring dashboard. On the left, there are sections for 'Service Level Reporting' and an 'Executive Dashboard' with four status indicators. The central area features a tree view for 'AnyCorp' with a selected path: AnyCorp > AnyBank > Regions > West > ABK_Application_Down_West - ATM. Below this is a table titled 'AnyBank Business KPIs'.

Region	Transaction Type	Customer Interactions	Interactions OK	Interactions Failed
North	ATM	16161	16022	139
North	Online	241	229	12
North	Branch	9714	8797	917
North	CheckCard	449	435	14
North	Phone	8596	7961	635
South	ATM	29584	28722	862
South	Online	25753	24896	857
South	Branch	4031	3652	379

Other visualizations include a 'Transaction History by Region' line chart showing trends over time for North, South, West, East, and MidWest. Below it are 'Current Business Volumes' represented by five 3D pie charts for East, MidWest, North, South, and West, with a legend for ATM, Branch, CheckCard, Online, and Phone. The right side of the interface shows a network diagram with 'DB2' databases, 'Web App. Server', and 'MQ Mgr.' components.

Launch in Context

Everything at your Fingertips

IBM Tivoli Business Service Management Solutions

Business Systems Management

- Helps IT operations to visualize the components of an IT business service
- Helps IT operations reduce mean-time-to-repair through quicker isolation of problem area
- Enables the prioritization of IT activities based on business Impact
- Provides a vehicle for IT to communicate to the business
- Service status/health from external sources
- Dynamic visualization of key performance indicators (KPIs)
- Has some discovery capability as well as integration to more robust discovery technology such as ITADDM

Service Level Management

- Historical analysis and reporting of service level data
- Rich graphic reporting helps IT executives visualize service performance
- Provides trend information to assist IT in prioritization
- Enables communication of service performance to executives
- Real-Time tracking of SLA's



Tivoli Business Systems Management

IBM IT Service Management

*A Better Way to Manage
the Business of IT*



Operator Challenges

▪ Too many consoles and events

- Based on skill & comfort level
- Easy to miss critical messages
- Messages are resource oriented
- No awareness of desired resource state
- False alerts
- System overhead

▪ Information overload

- Leads to operational errors

▪ Common Industry response:

- Manager of managers
- Console consolidation

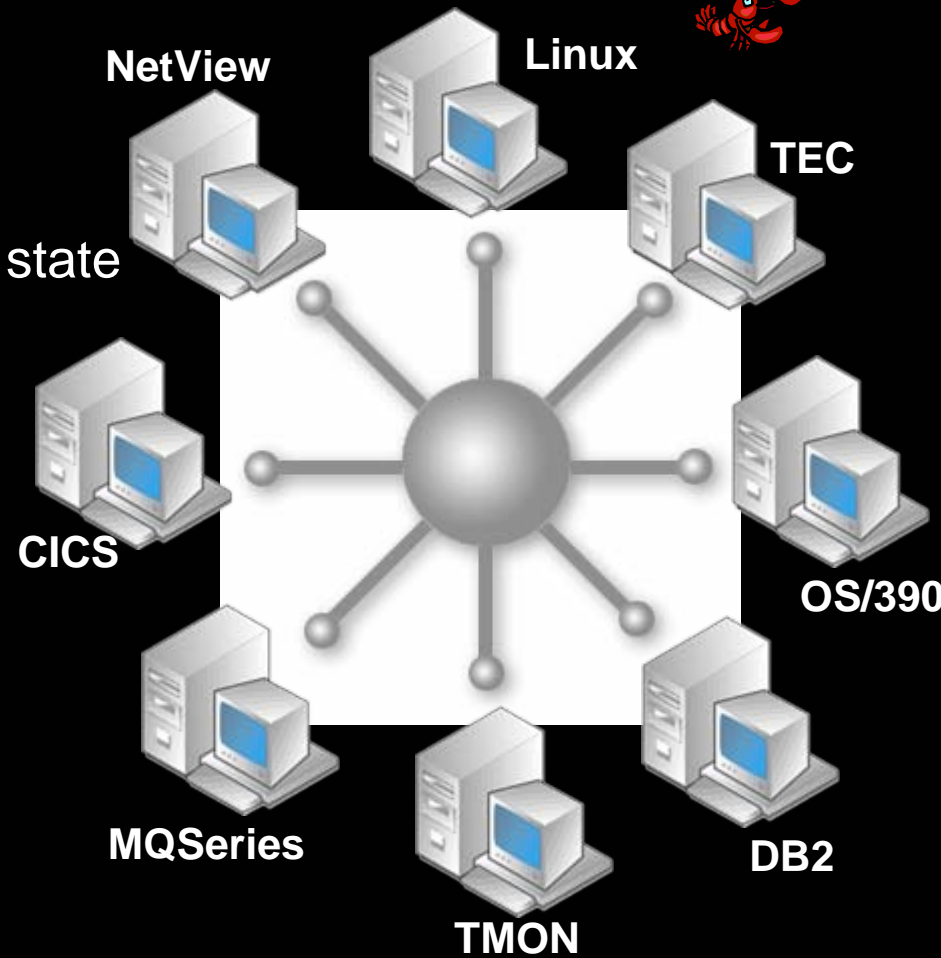

Managing Lines of Business

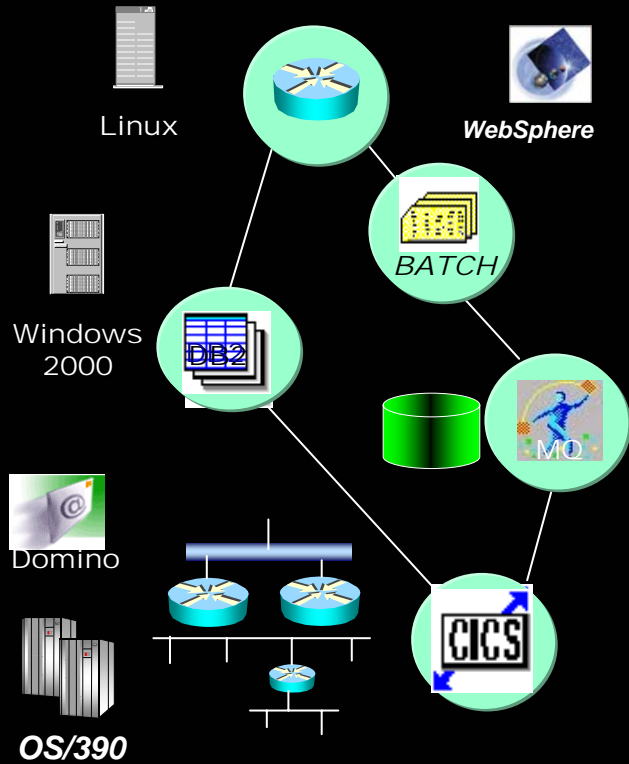

Resources

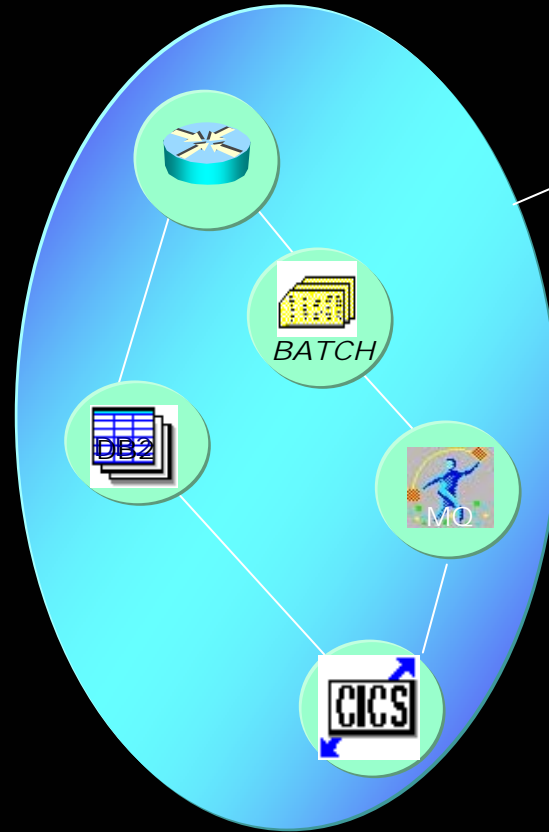

Lines of Business

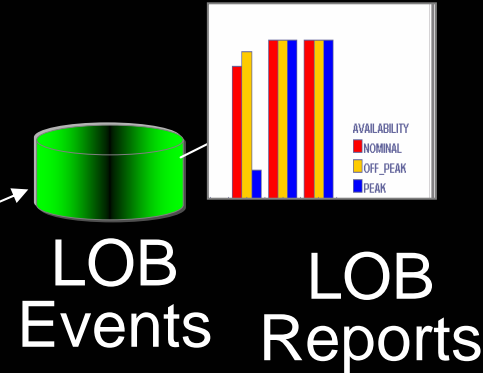

What is the SLA on my LOBs?

Know the State of the Business

- **Manage IT based on business objectives**

- **Line-of-business views**

- Organizational hierarchy
- Geography
- Major applications
- Key resources

- **Logical relationships match business model**

- Created via drag-and-drop

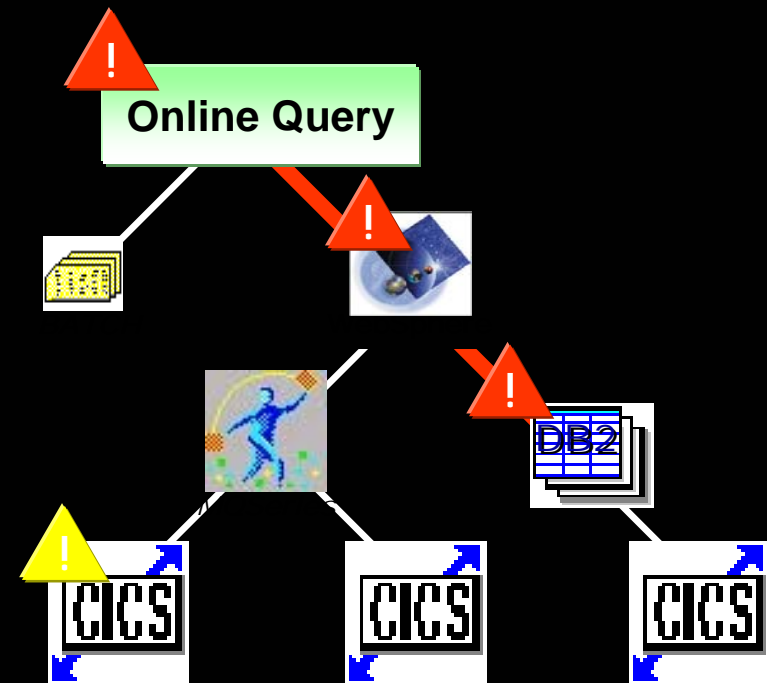

Business-orientation tells you that customers are having trouble with Online Query due to DB2 not CICS!

Business Impact Analysis

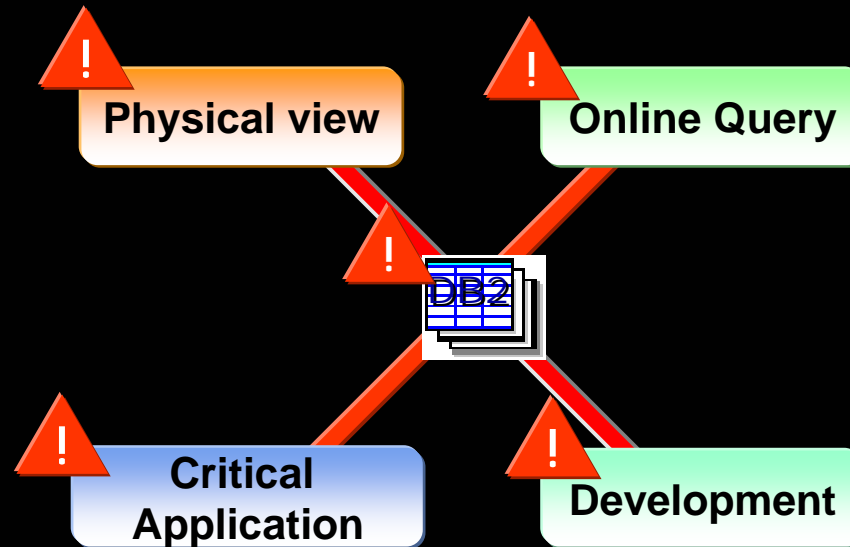

- Unique “drill-out” function from any resource
- Identifies all affected lines-of-business via a single action

Tivoli Business Systems Manager

Discover

- Systems**
Unix, OS400, Windows, OS/2, NetWare, Linux
- OS/390 z/OS**
- CICS**
- DB2**
- IMS**
- MQSeries**
- Batch**
- IDMS**
- Tasks**
- Networks**
- Domino**
- Exchange**
- Oracle**
- Informix**
- Sybase**
- SQL Server**
- WebSphere**
- mySAP.com**
- IIS**
- iPlanet**
- Siebel**
- Apache**

Leverage

- Candle Omegamon**
- Candle AF/Operator**
- IBM SA/390, OPC**
- IBM SMS, RMF**
- NetView for OS/390**
- DB2PM, DFSMS**
- CICSPLex**
- CA OPS/MVS**
- CA/7, CA-TNG**
- ASG Zeke**
- Landmark TMON**
- BMC MainView, Patrol, Control-M**
- BMC Auto Operator**
- netIQ AppManager**
- Tivoli Framework**
- TEC**
- Tivoli Monitoring**
- Tivoli NetView**
- Workload Scheduler**
- Tivoli Storage Mgr**
- Tivoli Monitoring**
- for:
- Applications**
- Databases**
- Infrastructure**
- Messaging**

Online Query

West Coast

WebSphere MQ

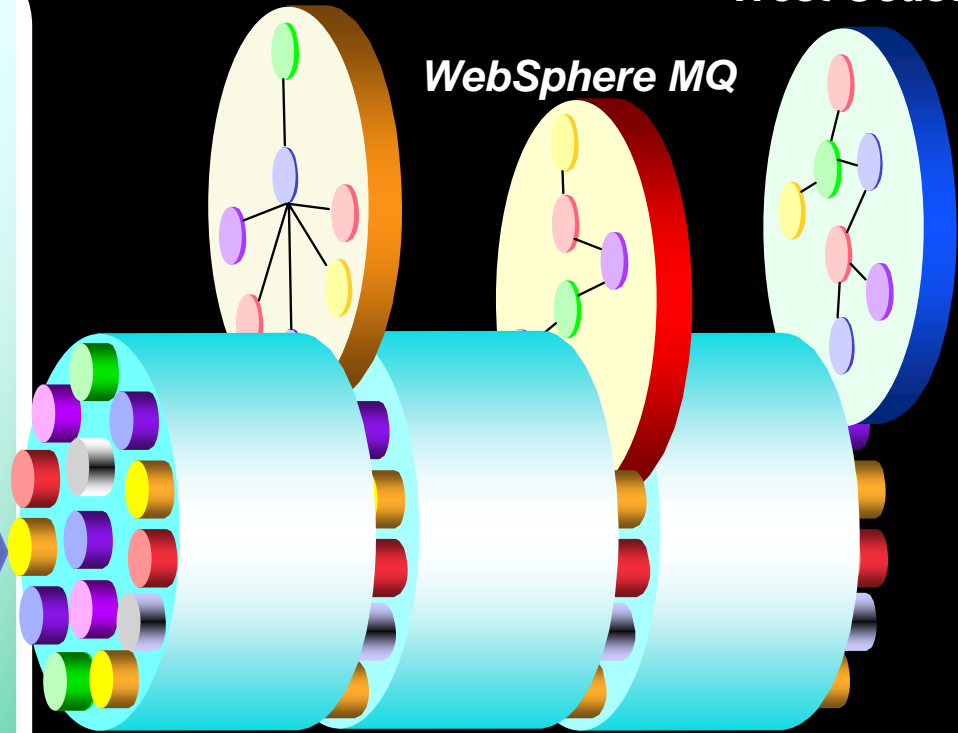

Simplify

The Right View for Everyone

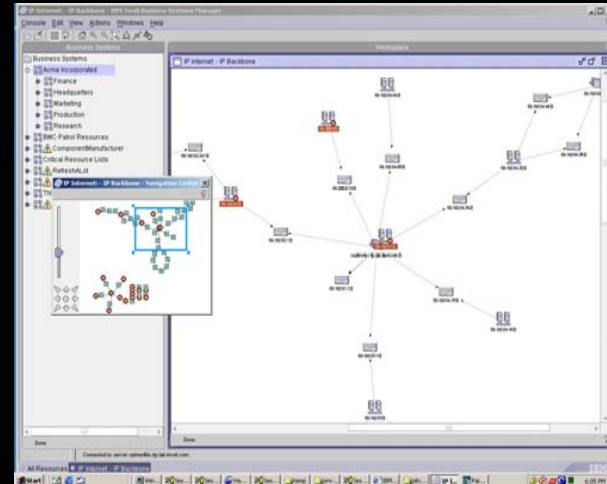
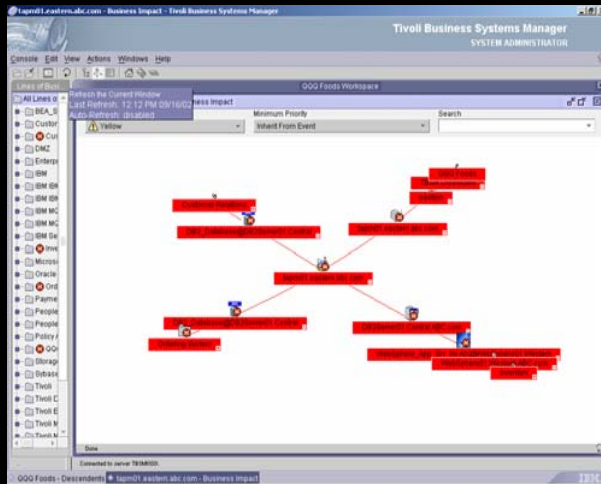

Business Impact

Topology

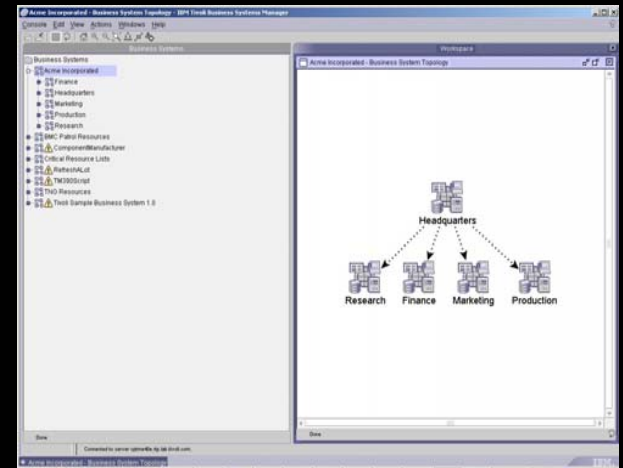
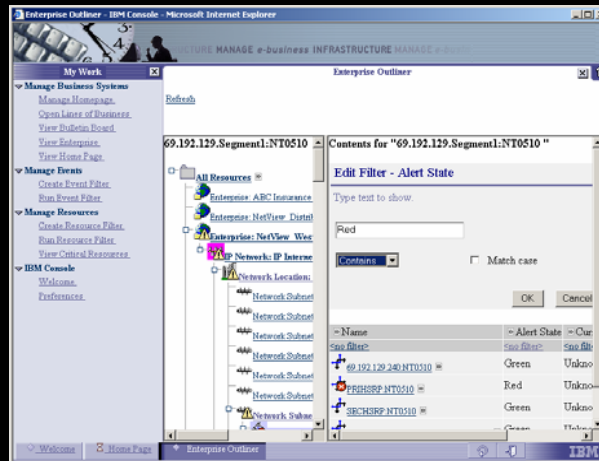

Web Console

Business Process



Challenges Managing the OS/390

- I see multiple errors for a shared resource in a parallel sysplex.
- Who is impacted because of a batch job is running late?
- What files are holding up my CICS Region?
- If a CICS regions fails what are the impacted connecting CICS regions?
- What are the CICS to DB2 connections?
- Shared DB2 datasets problems can impact applications in multiple systems
- How can I monitor critical IMS databases and transactions?
- What is the status of the key WebSphere 390 Servers?
- I have a critical dataset that is key for my Business Systems

TBSM OS/390 – z/OS Management

• Discovery and Event processing

- Hierarchy of CICS, DB2, IMS, WebSphere Resources
- Batch jobs
- OS/390 – z/OS Hierarchy of Resources
- IDMS
- Sysplex
- Tasks
- Storage
- NetView for OS/390 – z/OS (RODM and SNA)

• Proactive monitoring

• In-context commands

• Leverage

- CA-7, ASG-Zeke, BMC CONTROL-M, IBM TWS, OPC
- BMC MAINVIEW for MVS, CICS, IMS, DB2
- ASG-TMON for DB2, CICS, MVS
- OPS/MVS, IBM System Automation for OS/390, BMC AutoOperator
- Candle OMEGAMON II for MVS, CICS, DB2, IMS, AF Operator
- NetView for OS/390 and z/OS, RODM
- IBM RMF, DB2PM, CICSplex System Manager for OS/390
- DFSMS Hierarchical Storage Manager, XRC

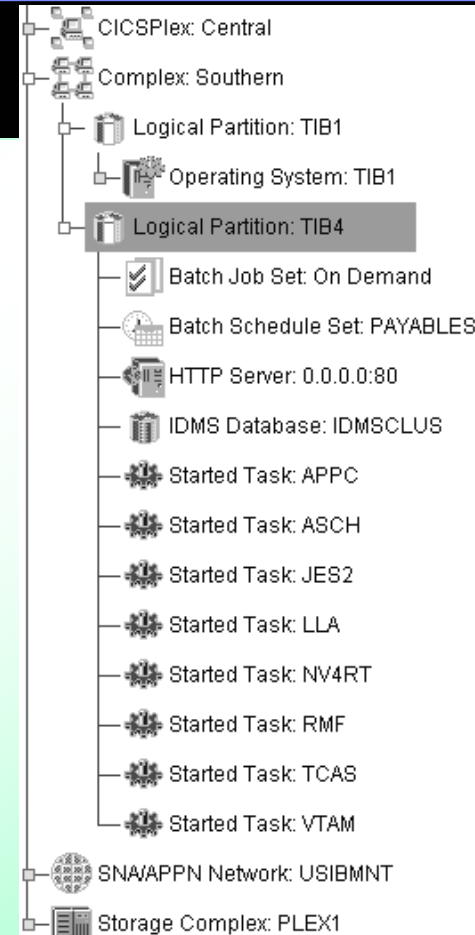

TBSM support for WebSphere/390

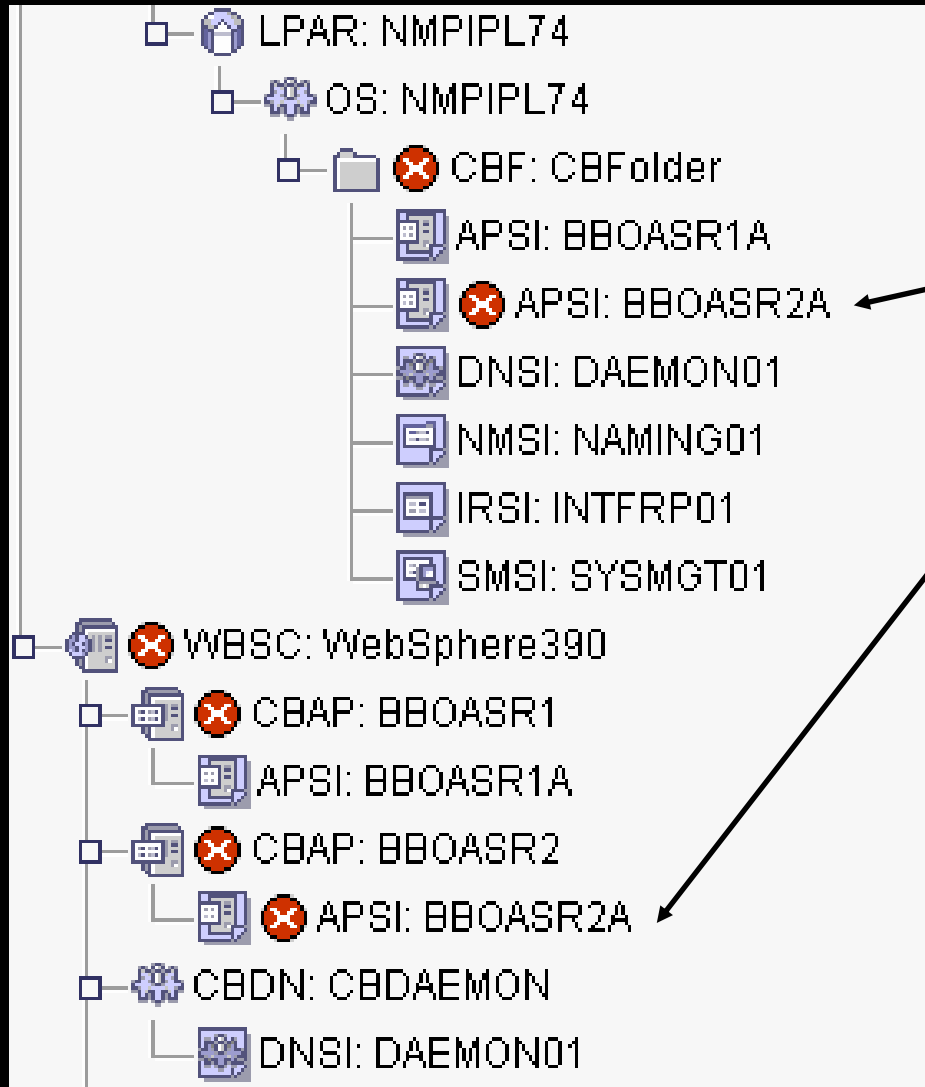

WebSphere/390 Servers

By OS

By Enterprise

WebSphere Objects:

- Daemon
- Interface Repository
- Naming
- System Management
- Application Server

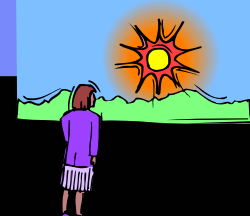

TBSM Management of CICS, IMS, and DB2

• Discovery

- Hierarchy of CICS, DB2 and IMS Resources
- Cross Enterprise Application views
- Topology of CICS to CICS Connections

• In-context commands

• Leverage

- Omegamon, TMON, MAINVIEW, CICSplex, DB2PM

• Proactive monitoring

Alert Stat	Type	Location	Scheduled S	Current State	Unavailable (3154)	Change (0)	Registered (4381)	Unregistered (4246)
Red		Eastern/IBM-1H/H001/CICEH000	Unknown	Abended	0	0	0	0
Green		Western/IBM-3JJ003/CICWJ110	Unknown	Unknown	0	0	0	0
Green		Western/IBM-3JJ003/CICWJ098	Unknown	Unknown	0	0	0	0
Green		Western/IBM-3JJ003/CICWJ124	Unknown	Unknown	0	0	0	0
Green		Western/IBM-1JJ001/CICWJ027	Unknown	Unknown	436	0	444	546
Green		Western/IBM-1JJ001/CICWJ042	Unknown	Unknown	0	0	25	57

Location	Dataset	Status	Last Update	Priority	Reg	Stale
CICWJ027/ADSIF02X	*UNKNOWN*	-----\-----	09:00 AM 1...	Medium	✓	0
CICWJ027/ADSIF03X	*UNKNOWN*	-----\-----	09:00 AM 1...	Medium	✓	0
CICWJ027/ADSIF06X	*UNKNOWN*	-----\-----	09:00 AM 1...	Medium	✓	0

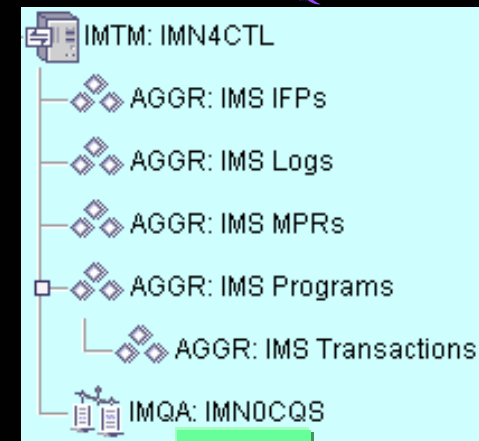

IMS

CICS

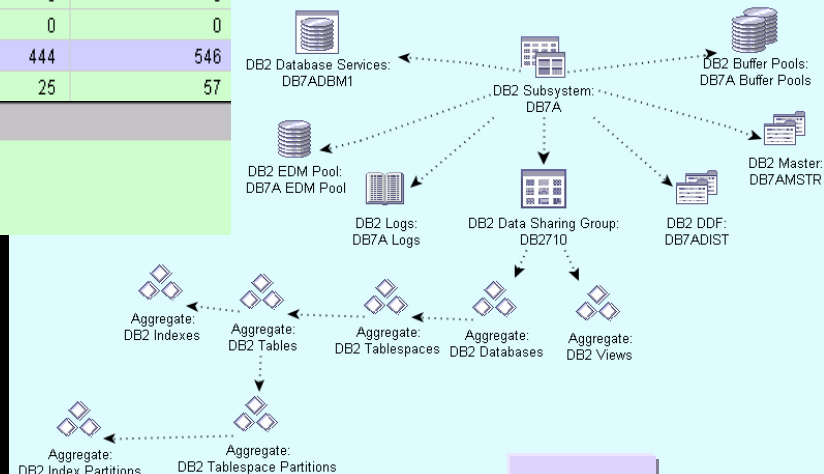
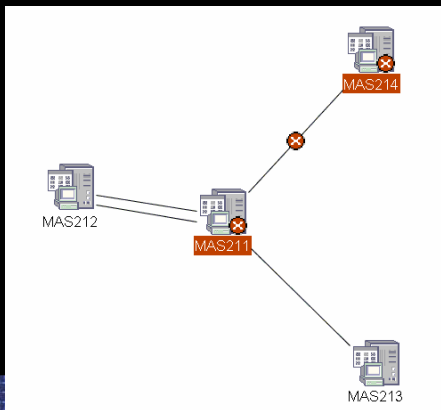

DB2

Challenges in Managing CICS



Challenge	TBSM Vision
If I have a problem with a CICS Region, I need to determine what other Regions might be impacted	With a CICS topology, I could see the connecting regions that might be impacted
How do I know if any CICS region is having problems talking to DB2?	View all CICS to DB2 connection statuses in your enterprise
Sometimes I have problems with CICS Regions waiting for file availability	View of all files that could be impacting CICS Region availability
Certain CICS transactions are critical for the business	Discover and include key CICS transactions into the Business System

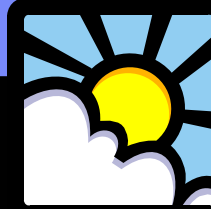

TBSM CICS Views

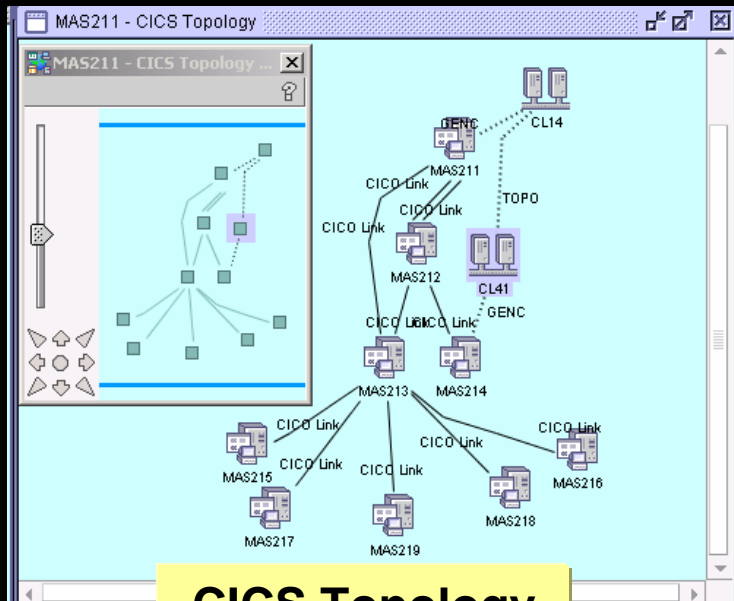

CICS Topology

CICSplex Information	CICSplex WUI Launch...
Notes	Disable CICSplex Monitoring...
Insert	Enable CICSplex Monitoring...
Properties... Alt-Enter	CICSplex Discovery Request...
CICSplex System Group: ALL	CICS Corba Servers...
CICSplex System Group: ALL	CICS Jar Files...
	CICS to CICS Connections...
	CICS to DB2 Connections...

CICS In-Context Commands

Alert Stat	Type	Location	Scheduled S	Current State	Unavailable (3154)	Change (0)	Registered (4381)	Unregistered (4246)
Red	Green	Eastern/IBM-1H/H001/CICEH000	Unknown	Abended	0	0	0	0
Green	Green	Western/IBM-3JJ003/CICWJ110	Unknown	Unknown	0	0	0	0
Green	Green	Western/IBM-3JJ003/CICWJ098	Unknown	Unknown	0	0	0	0
Green	Green	Western/IBM-3JJ003/CICWJ124	Unknown	Unknown	0	0	0	0
Green	Green	Western/IBM-1JJ001/CICWJ027	Unknown	Unknown	436	0	444	546
Green	Green	Western/IBM-1JJ001/CICWJ042	Unknown	Unknown	0	0	25	57

Location	Dataset	Status	Last Update	Priority	Reg	Stale
CICWJ027/ADSIF02X	*UNKNOWN*	---- \----	09:00 AM 1...	Medium	✓	0
CICWJ027/ADSIF03X	*UNKNOWN*	---- \----	09:00 AM 1...	Medium	✓	0
CICWJ027/ADSIF06X	*UNKNOWN*	---- \----	09:00 AM 1...	Medium	✓	0

CICS cross enterprise view

TBSM IMS Views

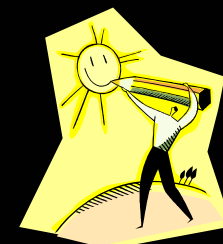

- IMS - IMS
- IMS Address SPACE - IMAS
- IMS Area - IMAR
- IMS Base - IMBA
- IMS BMP - IMBM
- IMS Connect - IMIT
- IMS CQS - IMQA
- IMS Database - IMDA
- IMS DBCTL - IMDB
- IMS DCCTL - IMTM
- IMS Dependent Region - IMDR
- IMS ESAF DB2 - IMD2
- IMS ESAF MQS - IMMQ
- IMS FDBR - IMFD
- IMS IFP - IMFP
- IMS IRLM - IMIR
- IMS Log - IMLG
- IMS MPR - IMMPP
- IMS Partition DB - IMPA
- IMS Program - IMPG
- IMS SubProgram - IMSP
- IMS Subsystem - IMSU
- IMS TM/DB - IMSS
- IMS Transaction - IMTX

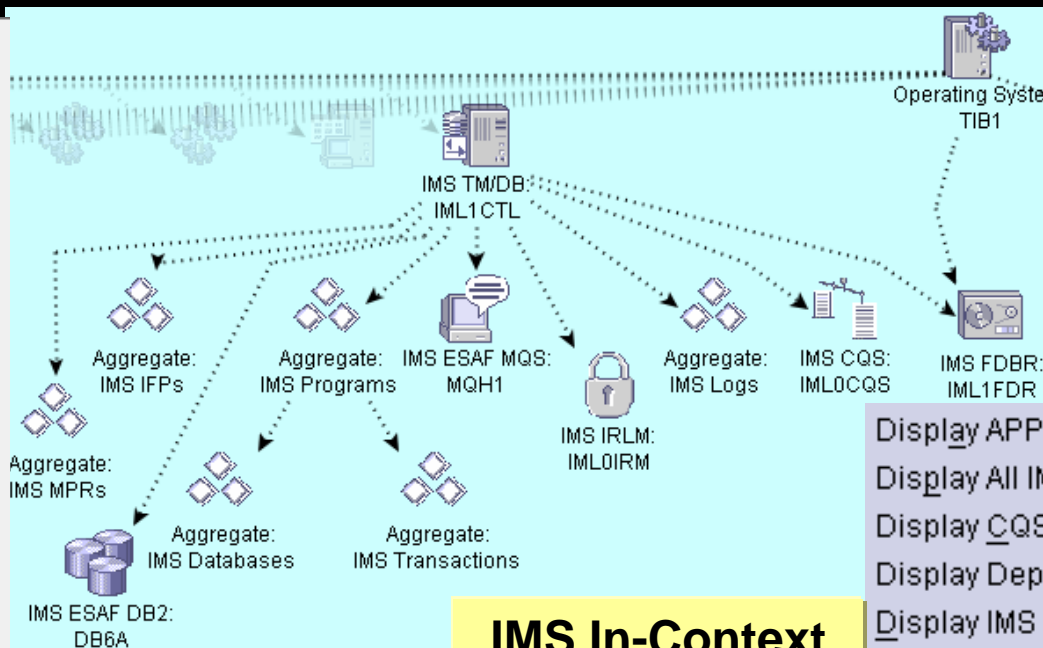

IMS Hierarchy | IMS In-Context Commands

- Display APPC...
- Display All IMS Pools...
- Display CQS...
- Display Dependent Regions...
- Display IMS DC...
- Display IMS Dead Letter Queue...
- Display IMS Online Logs...

Perth Systems/IBM-TIB/TIB1/TIB1/IML1CTL/DFSOLS04	IMS Log	DFSOLS04	Inh...	Unk...	...	DFSOLS04
Perth Systems/IBM-TIB/TIB1/TIB1/IML1CTL/DFSOLS05	IMS Log	DFSOLS05	Inh...	Unk...	...	DFSOLS05
Perth Systems/IBM-TIB/TIB1/TIB1/IML1CTL/DFSSAM02	IMS Program	DFSSAM02	Ign...	Unk...	...	
Perth Systems/IBM-TIB/TIB1/TIB1/IML1CTL/DFSSAM07	IMS Program	DFSSAM07	Ign...	Unk...	...	
Perth Systems/IBM-TIB/TIB1/TIB1/IML1CTL/EVISPP11	IMS Program	EVISPP11	Ign...	Unk...	...	
Perth Systems/IBM-TIB/TIB1/TIB1/IML1CTL/IML1FP1	IMS IFP	IML1FP1	Inh...	Unk...	...	
Perth Systems/IBM-TIB/TIB1/TIB1/IML1CTL/IML1FP2	IMS IFP	IML1FP2	Inh...	Unk...	...	
Perth Systems/IBM-TIB/TIB1/TIB1/IML1FDR	IMS FDBR	IML1FDR	Inh...	Unk...	...	
Perth Systems/IBM-TIB/TIB4/TIB4/IMN4CTL/IMN4MP1	IMS MPR	IMN4MP1	Inh...	Unk...	...	
Southern/Perth 390/TIB1/TIB1/IMH3CTL	IMS DBCTL	IMH3CTL	Inh...	Unk...	...	
Southern/Perth 390/TIB1/TIB1/IMH3CTL/DB6A	IMS ESAF DB2	DB6A	Inh...	Unk...	...	
Southern/Perth 390/TIB1/TIB1/IMH3CTL/DBF#FPU0	IMS Program	DBF#FPU0	Ign...	Unk...	...	



TBSM DB2 Views

- DB2 Subsystem
- DB2 Master Address Space
- IRLM Region
- Stored Procedures Address Space
- Database Services (DBM1)
- Distributed Data Facility (DIST)
- Buffer Pools
- EDM Pool
- DB2 Logs
- DB2PM
- Data Sharing Group
 - Database
 - Tablespace
 - Table
 - Index
 - Tablespace Partition
 - Index Partition
- DB2 View

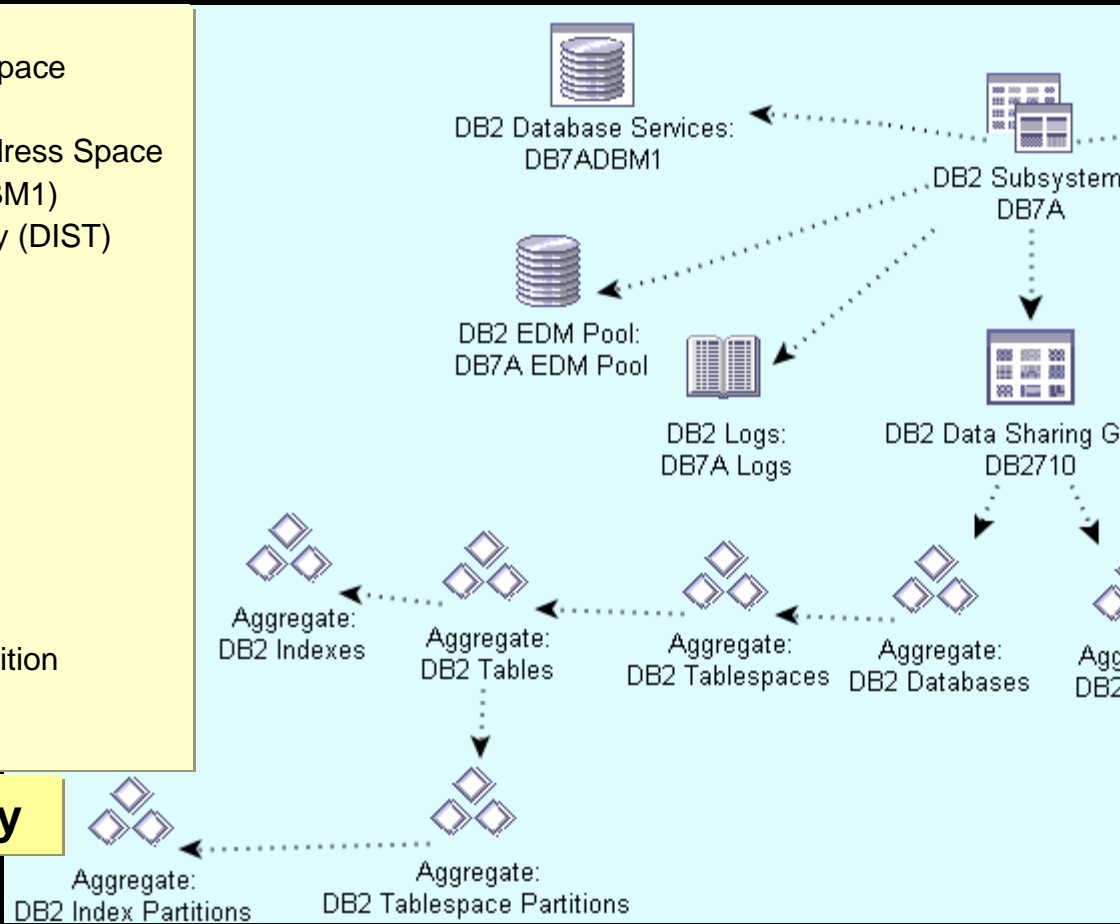

DB2 Hierarchy

DB2 In-Context Commands

- Display Database...
- Display Group...
- Display Location...
- Display RLimit...
- Display Thread...
- Display Trace...
- Display Utility...
- Set Poll Monitor Intervals...
- Free-form Display...
- Rediscover DB2 Resources...
- Send Test Event...



TBSM Storage Management

Storage Complex

- Disk Devices
- Disk Volumes
- Data Sets
- Catalogs
- Catalog Entries

Extended Remote Copy (XRC)

- XRC Sessions

Hierarchical Storage Manager DFSMSHsm

- HSM ABARS
- HSM Backup
- HSM Control Data Set
- HSM Dump
- HSM Migration
- HSM Recall

Storage Hierarchy

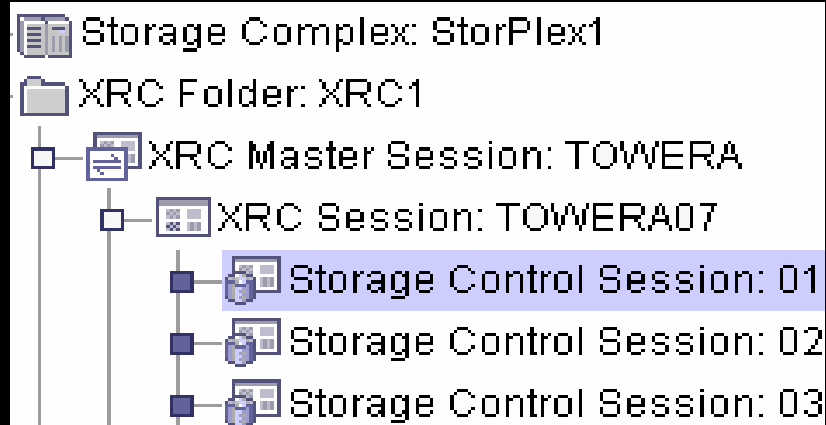
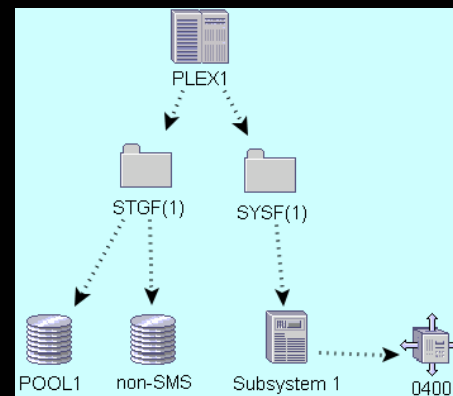

Launch HSM Monitor/Tuner workstation

01:28 PM 0...	Yellow	MON0030	Tape copy function i...
01:28 PM 0...	Yellow	MON0031	Tape replace functi...
01:28 PM 0...	Red	MON0033	Journaling is inhibited
01:28 PM 0...	Yellow	MON0012	ARECOVER function...

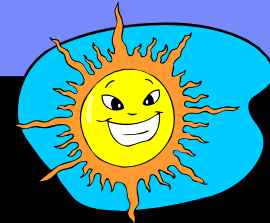

RODM objects loaded into TBSM

NetView for z/OS

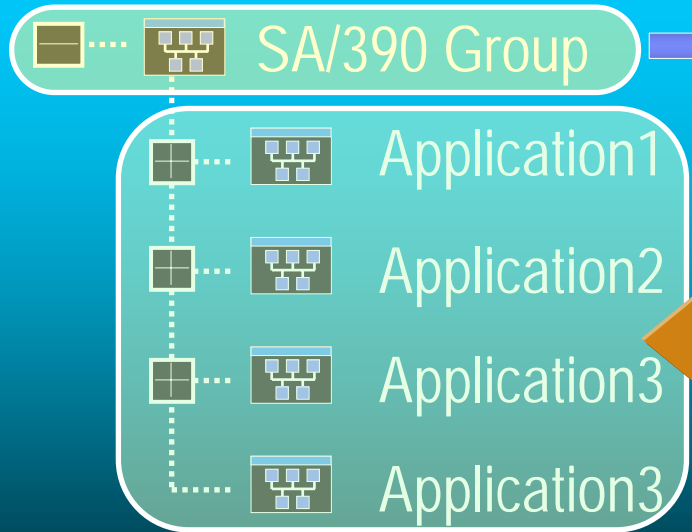
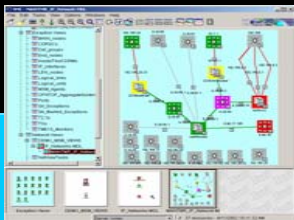

RODM GMFHS_Aggregates

Objects
& Status



TBSM

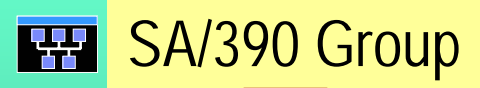
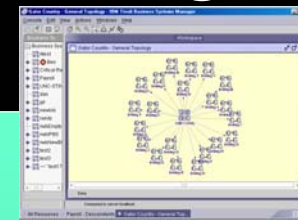

NMC
Launch



Java Console

Command and Control

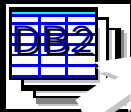

Start

Stop

Query State

Query Thresholds

Set Pulse

View Properties

OS/390

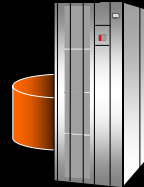

IMS
CICS
DB2

Distributed Systems

DB2
Exchange
MQSeries
WebSphere
Oracle
SAP R/3
Domino
Microsoft SQL Server

- **Discovery**
- **Commands**
 - Out of box
 - Simplified operations
- **Password proliferation**
 - Reduce number of logons
- **Application monitors**

NetView
for z/OS

Tivoli Framework

Automated Business System (ABS) Creation

How can I keep my lines of business up to date?



■ Views created from consistent set of criteria:

- By monitoring for objects that satisfy stated criteria.
 - i.e all operating systems with names that begin with the letter “A” and are in complex “RTP”

■ Dynamic Update of ABS View contents

- Qualifying new objects will automatically be added

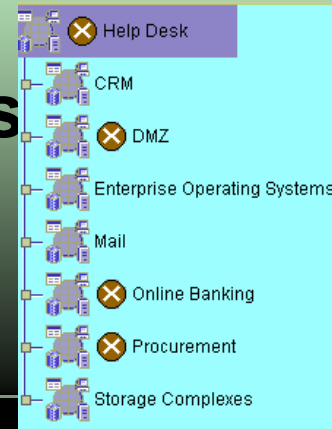

IT Challenges**IBM Tivoli Business Systems Manager****Business impact****Aligns IT with business**

- Line-of-business views
- Business impact analysis

Reactive operations**Understand true cause of problems**

- Focus on root-cause analysis
- Reporting based on LOB

Operator effectiveness**Simplified operations**

- Increased awareness
- Reduced user errors

Islands of Process**Process - enabled repository**

- Integrated service level solution

24x7 Availability**Increases system management ROI**

- Leverages IT Investment

Agenda

- IT Service Management Intro
- Business Service Management Overview
- Future Direction



IT Operations Management with Tivoli 2006 and Beyond

Transactions
Monitoring &
Management
■ CICS

Resources
Systeming &
Management
■ Middleware
■ Storage
■ Network

Federated IT Properties

Transaction Views

Tivoli Enterprise Portal Views:

Business Service Views

Event View

Service Level Views

Discovery

Topology

Resource Views
Monitor Data

Tivoli Enterprise Portal – Demonstrable Deep Integration

A Dynamic Role-based Workspace for Integrating IT Operations Silos – One portal to manage the overall health of the infrastructure

Business Services Distributed Resources J2EE Transactions Mainframe Resources

The screenshot displays a complex dashboard with several key components:

- Service Level Reporting:** A small window in the top left showing a line graph.
- Executive Dashboard:** A window in the bottom left with four circular gauges.
- AnyCorp Tree View:** A hierarchical tree on the left side listing regions (East, MidWest, North, South, West) and various application services like 'AnyBank', 'AnyInsurance', etc.
- Transaction History by Region:** A large line chart in the top right showing transaction counts over time for different regions.
- AnyBank Business KPIs:** A table in the bottom left providing a summary of business metrics.
- Current Business Volumes:** Five 3D pie charts in the bottom right showing the distribution of transactions by type (ATM, Branch, CheckCard, Online, Phone) across different regions.
- Background Infrastructure:** A faint background image shows server racks, databases (DB2), and other IT components.

Launch in Context

Everything at your Fingertips



Micromuse Acquisition What Does it Mean to You

IBM IT Service Management

*A Better Way to Manage
the Business of IT*



Micromuse and IBM Tivoli Have Joined Forces



MICROMUSE™
NETCOOL® SOLUTIONS

- Headquartered in San Francisco, CA; ~650 employees worldwide
- 24 offices worldwide
- Extensive product portfolio under flagship Netcool® brand
- More than 1,800 customers sold worldwide
- Customer base includes 14 of the top 20 companies in the Fortune 500 and **the 20 largest telecommunications carriers worldwide**
- Worldwide direct sales and partner ecosystem with **deep network management experience**



Tivoli

- Headquartered in Austin, Texas; ~3,250 employees worldwide
- Part of IBM's Software Group; ~40,000 employees worldwide
- Focus on systems, storage, and security management software to deliver comprehensive IT Service Management (ITSM)
- Market share leader in Enterprise Systems Management for four years in a row (Gartner, June 2005)
- 22,000 Tivoli software customers worldwide
- Many customers in common with Micromuse (especially in financial services)

The deal brings IBM a highly scalable event management system proven in large service provider and enterprise accounts, an innovative security event management product line, and network discovery capabilities. -- IDC - December, 2005

Dual Stacks to Combine and Integrate

Key Goal is to insure we leave no customer behind !!

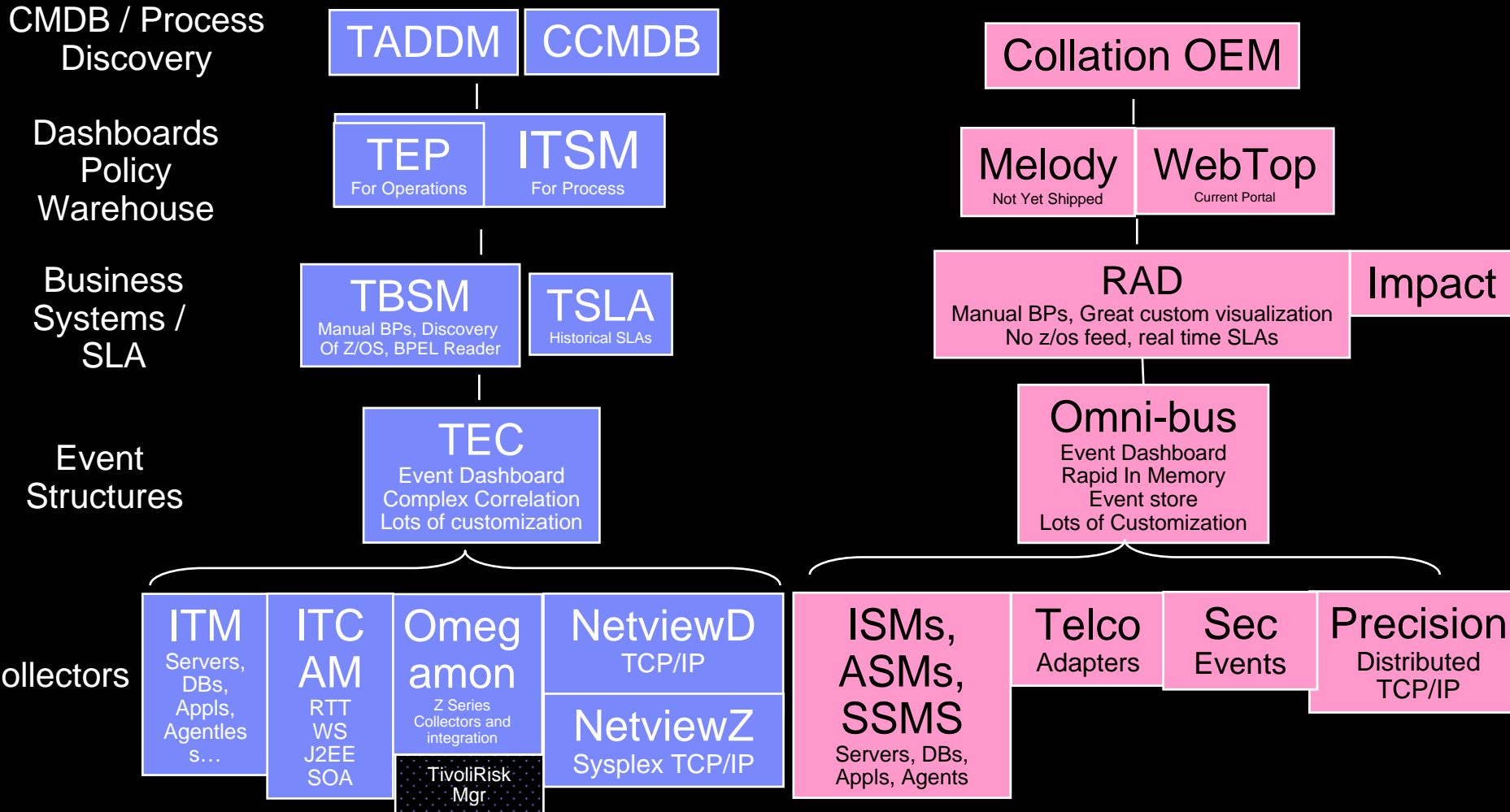

Integration Goals

Combine

Assets for broadest possible solution.

Integrate

- Appropriate Portfolio Integration Starting Immediately
- Planning underway to Integrate and Converge Roadmaps
 - Customers are key to this effort

Converge

- Converged Solutions in Key areas combining Tivoli and Netcool Technology.

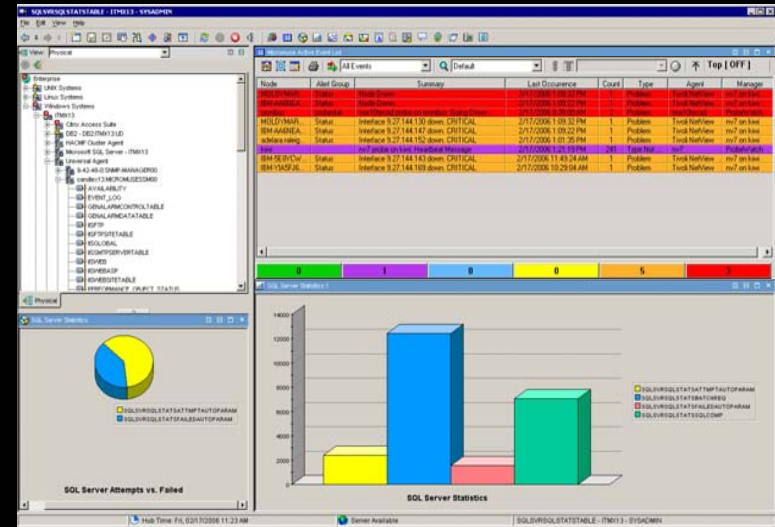

Business Service Management Today

- Tivoli and Micromuse solutions both leverage TADDM for Application Discovery
- Event and Monitoring Strategy allows either BSM product to provide fully integrated solution
- No Customer Left Behind

Tivoli Application Dependency Discover Manager

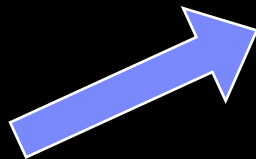
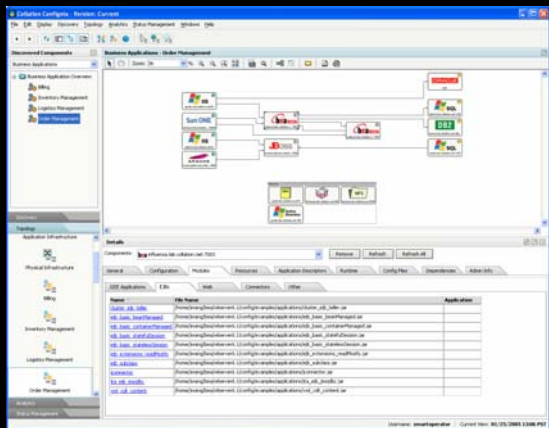

DLA feeds TBSM



Collation OEM feeds RAD

Tivoli BSM

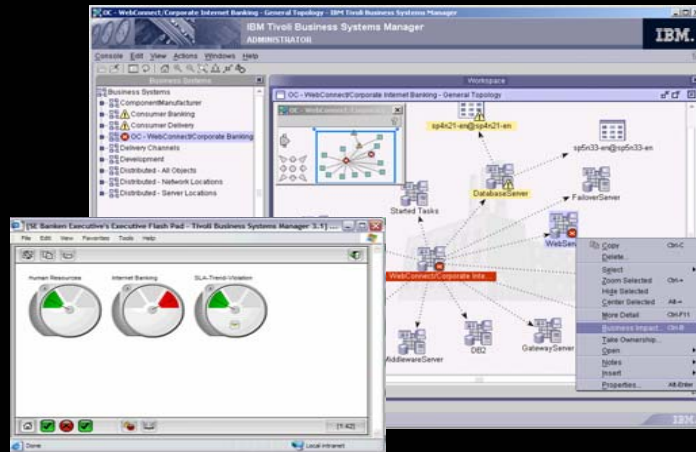

Netcool Realtime Active Dashboard

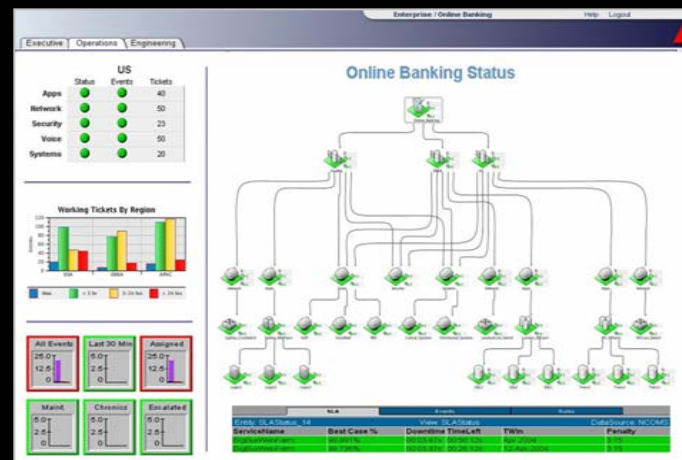

Future Tivoli Business Service Management

Tivoli BSM in TEP

- Tivoli and Micromuse solutions both leverage TADDM for Application Discovery
- Event and Monitoring Strategy allows either BSM product to provide fully integrated solution
- No Customer Left Behind

Tivoli BSM

- Deliver Converged BSM Solution Function

- Leverage Tivoli Discovery

- Integrate Tightly with CMDB solutions

- Provide Coexistence for

- Retail system end to end

- end to end solution

Tivoli Application Dependency Discover Manager

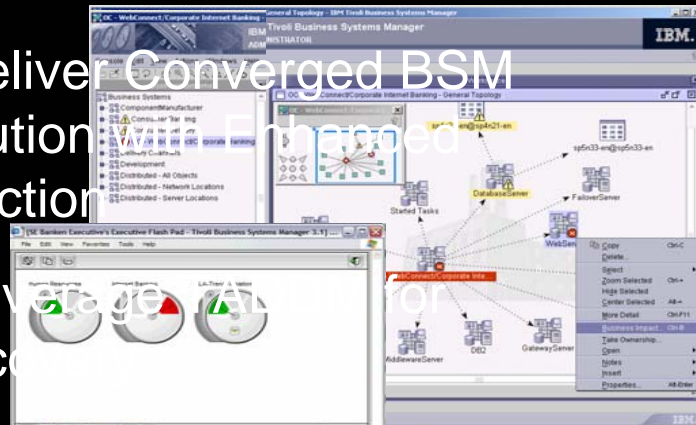
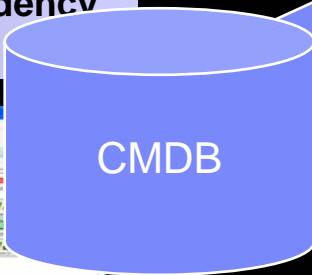
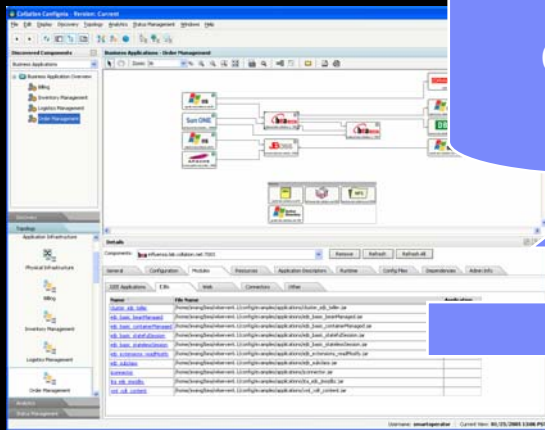

Netcool RAD

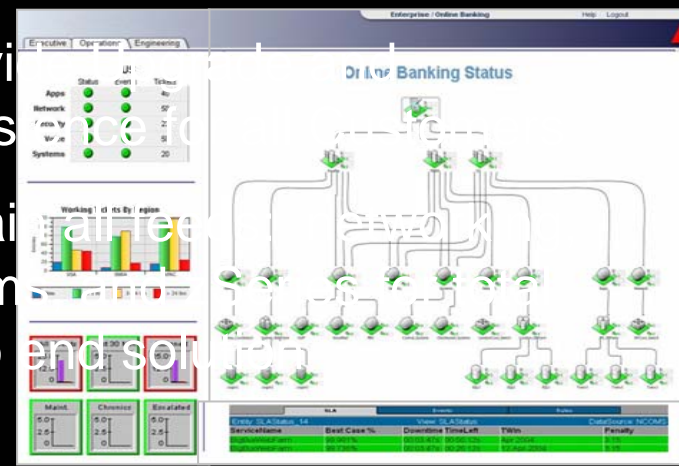

Collation of CMDB feeds RAD

Direction Forward for RAD within IBM

Business
Application
Management

Today

Netcool/Application
Discovery

Netcool/Real-time Active
Dashboards

IBM Tivoli Business
Systems Manager

Netcool/Impact

Netcool/RAD
SLA Tracker

IBM Tivoli Service Level
Advisor

Future

IBM TADDM and CCMDB

Tivoli Business **Service**
Manager

- Integrate TBSM mainframe support w/ RAD numerical, scalability, and multi-platform support

Netcool/Impact

Advanced SLA Offering
(TSLA and TBSM)

- Integrate TSLA historical tracking and reporting with RAD real-time capability

TBSM Roadmap

RAD 3.0: July 2006

- > Numeric formulas
- > CMDB/Inventory for services
- > Advanced scorecards/viz
- > Simplified administration
- > ISM provisioning

Q3 06

Q4 06

Q1 07

Q2 07

Q3 07

TBSM 3.1 Fixpack 2: July 2006

- > Select 3.2 function on TBSM 3.1
- > Discovery Library
- > ITM/TEP Integration
- > Support for key accounts

TBSM 4.1: 1Q2007

- > Automated Discovery via:
 - > TADDM,
 - > z/OS and TMS (ITM) IDML
 - > Service Component Repository
- > Status Event Integration
 - > z/OS and Distributed sources
 - > TEC, ITM, OMNibus support
 - > Mapping rules for ITM/TEC
- > TEP Bi-Directional Launch in Context
- > Initial Bluewash
 - > Licensing, Branding, OSS
- > ISMP-based Installation
- > Self-Management Agent (MOSWOS)
- > TSLA Integration

TBSM 4.2: 4Q2007

- > DB2 for Data Storage
- > Enhanced TEP Integration (Topo, Events, Navigator)
- > Deeper z/OS Support
 - > Discovery and Events
- > TBSM 3.1 Upgrade
- > Enhanced ISMP Installation
 - Embed OMNIBus
- > Enhanced Self-Management (MOSWOS)

TBSM 3.1 Fixpack 3:1Q07

TBSM Future:

- > Complete TEP integration
 - > ITAPM integration
 - > API level integration with TADDM
 - > TEP integration of RT SLA reports
 - > Other TEP level reports
- (By this time working off a single Event Engine)

Summary

- Tivoli BSM solutions offer unparalleled coverage in end-to-end IT management
- BSM is both a realtime, and predictive management paradigm
- BSM touches many IT processes with the 2 predominate being Availability Management and Service Level Management
- BSM portfolio has been enhanced and strengthened by Micromuse acquisition



Disclaimers and Trademarks

No part of this document may be reproduced or transmitted in any form without written permission from IBM Corporation.

Product data has been reviewed for accuracy as of the date of initial publication. Product data is subject to change without notice. Any statements regarding IBM's future direction and intent are subject to change or withdrawal without notice, and represent goals and objectives only.

THE INFORMATION PROVIDED IN THIS DOCUMENT IS DISTRIBUTED "AS IS" WITHOUT ANY WARRANTY, EITHER EXPRESS OR IMPLIED. IBM EXPRESSLY DISCLAIMS ANY WARRANTIES OF MERCHANTABILITY, FITNESS FOR A PARTICULAR PURPOSE OR NON-INFRINGEMENT. IBM products are warranted according to the terms and conditions of the agreements (e.g. IBM Customer Agreement, Statement of Limited Warranty, International Program License Agreement, etc.) under which they are provided.

IBM customers are responsible for ensuring their own compliance with legal requirements. It is the customer's sole responsibility to obtain advice of competent legal counsel as to the identification and interpretation of any relevant laws and regulatory requirements that may affect the customer's business and any actions the customer may need to take to comply with such laws.

The following terms are trademarks or registered trademarks of the IBM Corporation in either the United States, other countries or both: DB2, e-business logo, eServer, IBM, IBM eServer, IBM logo, Lotus, Tivoli, WebSphere, Rational, z/OS, zSeries, System z.

Java and all Java-based trademarks are trademarks of Sun Microsystems, Inc. in the United States and/or other countries.

Microsoft, Windows, Windows NT, and the Windows logo are trademarks of Microsoft Corporation in the United States and/or other countries.

UNIX is a registered trademark of The Open Group in the United States and other countries.

Linux is a trademark of Linus Torvalds in the United States and other countries.

Other company, product, or service names may be trademarks or service marks of others.

ITIL® is a Registered Trade Mark, and a Registered Community Trade Mark of the Office of Government Commerce, and is Registered in the U.S. Patent and Trademark Office.

IT Infrastructure Library® is a Registered Trademark of the Central Computer and Telecommunications Agency which is now part of the Office of Government Commerce.