

IBM WebSphere Business Integration Server
Express Plus



Adapter for WebSphere Commerce User Guide

Version 4.3.1

IBM WebSphere Business Integration Server
Express Plus



Adapter for WebSphere Commerce User Guide

Version 4.3.1

Note!

Before using this information and the product it supports, read the information in "Notices" on page 91.

30July2004

This edition of this document applies to IBM WebSphere Business Integration Server Express, version 4.3, IBM WebSphere Business Integration Server Express Plus, version 4.3, and to all subsequent releases and modifications until otherwise indicated in new editions. This edition of this document applies to IBM WebSphere Business Integration Server Express Plus, version 4.3.1.

To send us your comments about this document, e-mail doc-comments@us.ibm.com. We look forward to hearing from you. To send us your comments about IBM WebSphere Business Integration documentation, e-mail doc-comments@us.ibm.com. We look forward to hearing from you.

When you send information to IBM, you grant IBM a nonexclusive right to use or distribute the information in any way it believes appropriate without incurring any obligation to you.

© Copyright International Business Machines Corporation 2004. All rights reserved.

US Government Users Restricted Rights – Use, duplication or disclosure restricted by GSA ADP Schedule Contract with IBM Corp.

Preface

The product IBM^(R) WebSphere Business Integration Server Express Plus is made up of the following components: InterChange Server Express, the associated Toolset Express, CollaborationFoundation, and a set of software integration adapters. The tools in Toolset Express help you to create, modify, and manage business processes. You can choose from among the prepackaged adapters for your business processes that span applications. The standard processes template--CollaborationFoundation--allows you to quickly create customized processes.

This document describes configuration, troubleshooting, and business object development for the IBM WebSphere Business Integration Server Express Plus Adapter for WebSphere Commerce.

Audience

This document is for consultants, developers, and system administrators who use the connector at customer sites.

Prerequisites for this document

Users of this document should be familiar with the IBM WebSphere InterChange Server Express, with business object and collaboration development, with the WebSphere Commerce application, and with WebSphere MQ.

Related documents

The complete set of documentation available with this product describes the features and components common to all WebSphere Business Integration Server Express installations, and includes reference material on specific components.

You can download, install, and view the documentation at the following site:
<http://www.ibm.com/websphere/wbiserverexpress/infocenter>

Note: Important information about this product may be available in Technical Support Technotes and Flashes issued after this document was published. These can be found on the WebSphere Business Integration Support Web site, <http://www.ibm.com/software/integration/websphere/support/>. Select the component area of interest and browse the Technotes and Flashes sections.

Typographic conventions

This document uses the following conventions:

<code>courier font</code>	Indicates a literal value, such as a command name, filename, information that you type, or information that the system prints on the screen.
bold	Indicates a new term the first time that it appears.
<i>italic</i> ,	Indicates a variable name or a cross-reference.

<i>blue text</i>	Blue text, which is visible only when you view the manual online, indicates a cross-reference hyperlink. Select any blue text to jump to the object of the reference.
{ }	In a syntax line, curly braces surround a set of options from which you must choose one and only one.
[]	In a syntax line, square brackets surround an optional parameter.
...	In a syntax line, ellipses indicate a repetition of the previous parameter. For example, <code>option[,...]</code> means that you can enter multiple, comma-separated options.
< >	In a naming convention, angle brackets surround individual elements of a name to distinguish them from each other, as in <code><server_name><connector_name>tmp.log</code> .
/, \	In this document, backslashes (\) are used as the convention for directory paths. For UNIX, OS/400, and Linux use forward slashes (/) for directory paths. All product pathnames are relative to the directory where the product is installed on your system.
----UNIX/Windows-----	Paragraphs beginning with either of these indicate notes listing operating system differences.
%text% and \$text	Text within percent (%) signs indicates the value of the Windows <i>text</i> system variable or user variable. The equivalent notation in a UNIX environment is \$text, indicating the value of the text UNIX environment variable.
<i>ProductDir</i>	Represents the directory where the product is installed. The defaults for each platform are as follows: Windows: IBM\WebSphereServer OS/400: /QIBM/ProdData/WBIServer43/AdapterCapacityPack

Contents

Preface	iii
Audience	iii
Prerequisites for this document	iii
Related documents	iii
Typographic conventions	iii
New in This Release	vii
New in Release 4.3.1	vii
New in Release 4.3	vii
Chapter 1. Overview of the Adapter	1
Adapter architecture	1
Application-adapter communication	4
Event handling	5
Guaranteed event delivery	6
Business object requests	7
Verb processing	7
Common configuration tasks	10
Chapter 2. Installing and configuring the connector	15
Adapter environment	15
Prerequisite tasks	16
Installing the adapter and related files	30
Installed file structure	30
Configuring the adapter	32
Enabling guaranteed event delivery	36
Queue uniform resource identifiers (URIs)	40
Configuring meta-object attributes	42
Creating multiple connector instances	49
Configuring the startup file	51
Starting the connector	52
Starting the connector	52
Stopping the connector	54
Chapter 3. Working with business objects	57
Business object structure	57
Error handling	58
Tracing	59
Chapter 4. Troubleshooting	61
Start-up problems	61
Event processing	61
Appendix A. Standard configuration properties for connectors	63
Configuring standard connector properties	63
Summary of standard properties	64
Standard configuration properties	67
Appendix B. Connector Configurator Express	77
Overview of Connector Configurator Express	77
Starting Connector Configurator Express	78
Running Configurator Express from System Manager	78
Creating a connector-specific property template	78
Creating a new configuration file	81

Using an existing file	82
Completing a configuration file.	83
Setting the configuration file properties	83
Saving your configuration file	88
Completing the configuration	88
Using Connector Configurator Express in a globalized environment	88
Notices	91
Notices	91

New in This Release

New in Release 4.3.1

This release adds support for the following operating systems:

- IBM OS/400, V5R2, V5R3
- Red Hat Enterprise Linux AS 3.0, Update 1
- SuSE Linux Enterprise Server 8.1
- Microsoft Windows 2003 (for InterChange Server Express and adapters only, in production mode)

New in Release 4.3

This is the first release of this guide.

Chapter 1. Overview of the Adapter

This chapter describes the Adapter for WebSphere Commerce component of the WebSphere Business Integration Server Express Plus.

The adapter enables the IBM WebSphere Business Integration Server Express Plus to exchange messages with WebSphere Commerce, Business Edition, Version 5.4 with Fix Pack 6 or later, or WebSphere Commerce, Business Edition, Version 5.5 with Fix Pack 4 or later. The topics included in this chapter include:

- “Adapter architecture” on page 1
- “Application-adapter communication” on page 4
- “Event handling” on page 5
- “Guaranteed event delivery” on page 6
- “Business object requests” on page 7
- “Verb processing” on page 7
- “Common configuration tasks” on page 10

WebSphere Commerce software is a flexible platform for fulfilling a variety of commerce integration roles. The adapter for WebSphere Commerce can be used in a solution that uses the integration broker to integrate business data exchanges between WebSphere Commerce and other enterprise information system applications for which appropriate adapters have been installed.

Connectors consist of an application-specific component and the connector framework. The application-specific component contains code tailored to a particular application. The adapter framework, whose code is common to all adapters, acts as an intermediary between the integration broker and the application-specific component. The adapter framework provides the following services between the integration broker and the application-specific component:

- Receives and sends business objects
- Manages the exchange of startup and administrative messages

This document contains information about the adapter framework and the connector. It refers to both of these components as the adapter. For more information about the relationship of the integration broker to the adapter, see the *WebSphere Business Integration Server Express System Administration Guide*.

Note: All WebSphere Business Integration Server Express Plus adapters operate with the InterChange Server Express integration broker, which is described in the *System Implementation Guide*.

Adapter architecture

The adapter is meta-data-driven. The adapter uses an MQ implementation of the JavaTM Message Service (JMS), an API for accessing enterprise-messaging systems.

The adapter uses WebSphere MQ queues to enable asynchronous data exchange from WebSphere Commerce to InterChange Server Express and from InterChange Server Express to WebSphere Commerce. Data is sent between the queues for WebSphere Commerce and InterChange Server Express in the form of XML

messages. An XML data handler is used to convert the data into business objects that can be processed by InterChange Server Express collaboration objects.

For information about using the adapter in synchronous exchanges, see “Synchronous request and reply interactions” on page 3.

Asynchronous messages from WebSphere Commerce to InterChange Server Express

When an order is placed in WebSphere Commerce, an OrderCreate message is generated in XML format and is placed in the WebSphere MQ output queue as shown in the following figure. (In this illustration, it is assumed that WebSphere Commerce and InterChange Server Express are installed on different machines using different queue managers, making it necessary to have a remote queue definition for output from WebSphere Commerce, connecting to an input queue that is local to InterChange Server Express. When WebSphere Commerce and InterChange Server Express are installed on the same machine, a single queue can function as both the output queue from WebSphere Commerce and input queue for InterChange Server Express.)

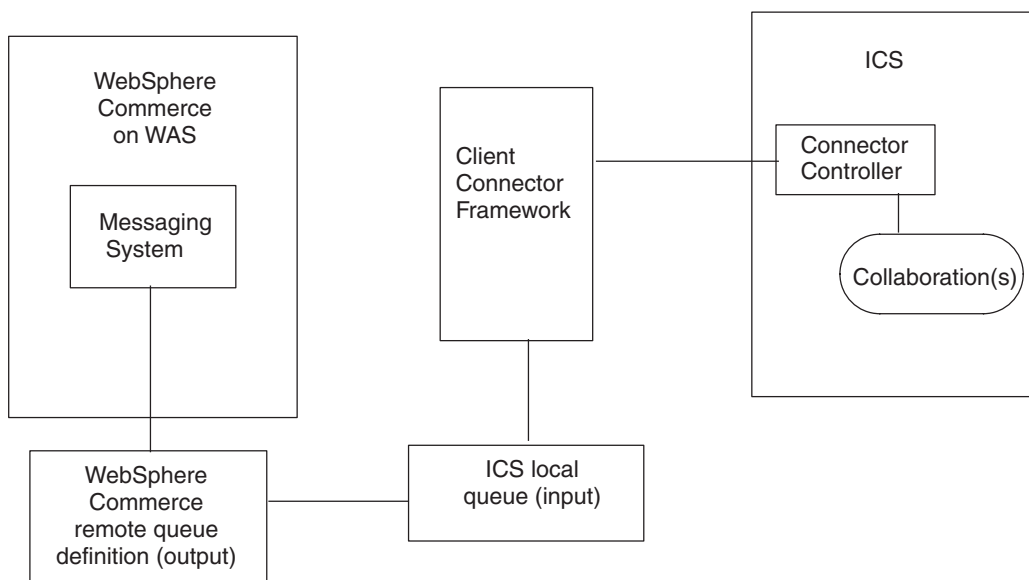

Figure 1. Adapter architecture

To detect data events in WebSphere Commerce, the adapter polls the WebSphere Commerce output queues for new XML messages. When it discovers a new message, the adapter passes it to an input queue, calls a data handler to convert the message to a business object that is specific to the structure of data originating from WebSphere Commerce, and then passes the business object to the connector in InterChange Server Express. The connector invokes maps to generate a generic business object from the WebSphere Commerce-specific business object, and then delivers the generic business object to one or more collaboration objects. After the collaboration objects have processed the business object, the generic business object is mapped to an application-specific business object, which is delivered to an adapter (such as a WebSphere Business Integration Server Express adapter for SAP) that has been configured for a back-end application.

Asynchronous messages to WebSphere Commerce from InterChange Server Express

In the opposite direction, the adapter for WebSphere Commerce receives business objects from collaborations, converts them into XML-format messages using the data handler, and then delivers the messages to the WebSphere Commerce WebSphere MQ queue.

Synchronous request and reply interactions

Synchronous request and reply interactions require additions to or customization of the WebSphere Commerce application, as described in the following topics.

Requests from WebSphere Commerce to InterChange Server Express

With the addition of the WebSphere Commerce Enhancement Pack, available at <http://www-3.ibm.com/software/webservers/commerce/epacks/v54/>, you can use the adapter to set up a synchronous message flow for request and reply interactions from the WebSphere Commerce messaging system to InterChange Server Express or other external systems. For information about this approach, see the integration documentation for WebSphere Commerce 5.4 and the IBM WebSphere Business Integration Server Express system.

Requests from InterChange Server Express to WebSphere Commerce

Note: This approach requires a customization of the commands that are executed in WebSphere Commerce when a business object comes from InterChange Server Express. The commands should retrieve the "ReplyTo" queue from the message, and place a reply on the queue within the ResponseTimeout interval. For information about creating and customizing commands in WebSphere Commerce, refer to the *Programmer's Guide for WebSphere Commerce, V. 5.4*.

Without using WebSphere Commerce Enhancement Pack, you can set up a simulated synchronous exchange between WebSphere Commerce and InterChange Server Express, using Replyto queues.

See "Synchronous delivery" on page 8, later in this guide, for more information related to this approach.

Event notification

Notification of data events that have occurred in the WebSphere Commerce application is accomplished through the polling mechanism of the adapter. The adapter can poll multiple input queues, polling each in a round-robin manner and retrieving a specified number of messages from each queue. For each message retrieved during polling, the adapter adds a dynamic child meta-object (if specified in the business object). The child meta-object values can direct the adapter to populate attributes with the format of the message as well as with the name of the input queue from which the message was retrieved.

When a message is retrieved from the input queue, the adapter looks up the business object name associated with the FORMAT field contained in the message header. The message body, along with a new instance of the appropriate business object, is then passed to the data handler. If a business object name is not found associated with the format, the message body alone is passed to the data handler.

If a business object is successfully populated with message content, the adapter checks to see if it is subscribed, and then delivers it to InterChange Server Express.

Business objects and WebSphere MQ message header

The type of business object and verb used in processing a message is based on the FORMAT field contained in the WebSphere MQ message header. The adapter uses meta-object entries to determine business object name and verb. You construct a meta-object to store the business object name and verb to associate with the WebSphere MQ message header FORMAT field text.

You can optionally construct a dynamic meta-object that is added as a child to the business object passed to the adapter. The child meta-object values override those specified in the static meta-object that is specified for the adapter as a whole. If the child meta-object is not defined or does not define a required conversion property, the adapter, by default, examines the static meta-object for the value. You can specify one or more dynamic child meta-objects instead of, or to supplement, a single static adapter meta-object.

Application-adapter communication

The adapter makes use of IBM's WebSphere MQ implementation of the Java Message Service (JMS). JMS is an open-standard API for accessing enterprise messaging systems. It is designed to allow business applications to asynchronously send and receive business data and events.

Message request

Figure 2 illustrates a message request communication. When the `doVerbFor()` method receives a business object from a collaboration, the adapter passes the business object to the data handler. The data handler converts the business object into XML text and the adapter issues it as a message to a queue. There, the JMS layer makes the appropriate calls to open a queue session and route the message.

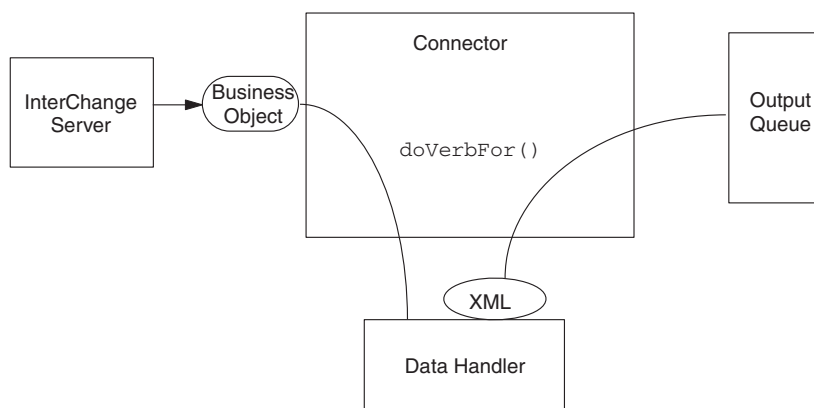

Figure 2. Application-adapter communication method: Message request

Message return

Figure 3 illustrates the message return direction. The `pollForEvents()` method retrieves the next applicable message from the input queue. The message is staged in the in-progress queue where it remains until processing is complete. Using

either the static or dynamic meta-objects, the adapter first determines whether the message type is supported. If so, the adapter passes the message to the configured data handler, which converts the message into a business object. The verb that is set reflects the conversion properties established for the message type. The adapter then determines whether the business object is subscribed to by a collaboration. If so, the `gotAppEvents()` method delivers the business object to InterChange Server Express, and the message is removed from the in-progress queue.

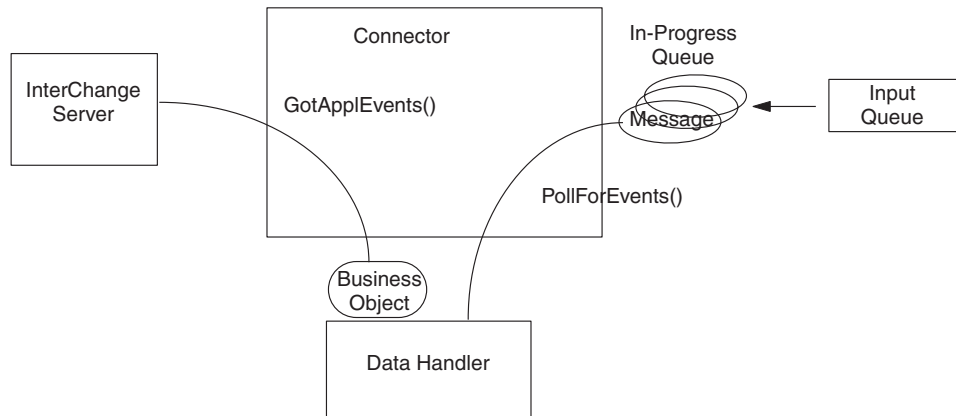

Figure 3. Application-adaptor communication method: Message return

Event handling

For event notification, the adapter detects events written to a queue by WebSphere Commerce.

Retrieval

The adapter uses the `pollForEvents()` method to poll the queue at regular intervals for messages. When the adapter finds a message, it retrieves it from the queue and examines it to determine its format. If the format has been defined in the adapter's static meta-object, the adapter passes both the message body and a new instance of the business object associated with the format to the configured data handler; the data handler is expected to populate the business object and specify a verb. If the format is not defined in the static meta-object, the adapter passes only the message body to the data handler; the data handler is expected to determine, create and populate the correct business object for the message. See "Error handling" on page 58 for event failure scenarios.

The adapter processes messages by first opening a transactional session to the input queue. This transactional approach allows for a small chance that a business object could be delivered to a collaboration twice due to the adapter successfully submitting the business object but failing to commit the transaction in the queue. To avoid this problem, the adapter moves all messages to an in-progress queue. There, the message is held until processing is complete. If the adapter shuts down unexpectedly during processing, the message remains in the in-progress queue instead of being reinstated to the original input queue.

Note: Transactional sessions with WebSphere MQ require that every requested action on a queue be performed and committed before events are removed from the queue. Accordingly, when the adapter retrieves a message from the

queue, it does not commit to the retrieval until three things occur: 1) The message has been converted to a business object; 2) the business object is delivered to InterChange Server Express by the `gotAppEvents()` method, and 3) a return value is received.

Recovery

Upon initialization, the adapter checks the in-progress queue for messages that have not been completely processed, presumably due to a connector shutdown. The connector configuration property `InDoubtEvents` allows you to specify one of four options for handling recovery of such messages: fail on startup, reprocess, ignore, or log error.

Fail on startup

With the fail on startup option, if the adapter finds messages in the in-progress queue during initialization, it logs an error and immediately shuts down. It is the responsibility of the user or system administrator to examine the message and take appropriate action, either to delete these messages entirely or move them to a different queue.

Reprocess

With the reprocessing option, if the adapter finds any messages in the in-progress queue during initialization, it processes these messages first during subsequent polls. When all messages in the in-progress queue have been processed, the adapter begins processing messages from the input queue.

Ignore

With the ignore option, if the adapter finds any messages in the in-progress queue during initialization, the adapter ignores them, but does not shut down.

Log error

With the log error option, if the adapter finds any messages in the in-progress queue during initialization, it logs an error but does not shut down.

Archiving

If the connector property `ArchiveQueue` is specified and identifies a valid queue, the adapter places copies of all successfully processed messages in the archive queue. If `ArchiveQueue` is undefined, messages are discarded after processing. For more information on archiving unsubscribed or erroneous messages, see “Error handling” on page 58.

Note: By JMS conventions, a retrieved message cannot be issued immediately to another queue. To enable archiving and re-delivery of messages, the adapter first produces a second message that duplicates the body and the header (as applicable) of the original. To avoid conflicts with the WebSphere Commerce messaging service, only JMS-required fields are duplicated. Accordingly, the format field is the only additional message property that is copied for messages that are archived or re-delivered.

Guaranteed event delivery

The guaranteed-event-delivery feature enables the connector framework to ensure that events are never lost and never sent twice between the connector’s event store, the JMS event store, and the destination’s JMS queue. To become JMS-enabled, you must configure the connector `DeliveryTransport` standard property to JMS. Thus configured, the connector uses the JMS transport and all

subsequent communication between the connector and InterChange Server Express occurs through this transport. The JMS transport ensures that the messages are eventually delivered to their destination. Its role is to ensure that once a transactional queue session starts, the messages are cached there until a commit is issued; if a failure occurs or a rollback is issued, the messages are discarded.

Note: Without use of the guaranteed-event-delivery feature, a small window of possible failure exists between the time that the connector publishes an event (when the connector calls the `gotAppEvent()` method within its `pollForEvents()` method) and the time it updates the event store by deleting the event record (or perhaps updating it with an “event posted” status). If a failure occurs in this window, the event has been sent but its event record remains in the event store with an “in progress” status. When the connector restarts, it finds this event record still in the event store and sends it, resulting in the event being sent twice.

You can configure the guaranteed-event-delivery feature for a JMS-enabled connector with, or without, a JMS event store. To configure the connector for guaranteed event delivery, see “Enabling guaranteed event delivery” on page 36.

If the connector framework cannot deliver the business object to the InterChange Server Express integration broker, then the object is placed on a `FaultQueue` (instead of `UnsubscribedQueue` and `ErrorQueue`) and generates a status indicator and a description of the problem. `FaultQueue` messages are written in MQRFH2 format.

Business object requests

Business object requests are processed when InterChange Server Express sends a business object to the `doVerbFor()` method. Using the configured data handler, the adapter converts the business object to an WebSphere MQ message and issues it. There are no requirements regarding the type of business objects processed except those of the data handler.

Verb processing

The adapter processes business objects passed to it by a collaboration based on the verb for each business object. The adapter uses business object handlers and the `doForVerb()` method to process the business objects that the adapter supports. The adapter supports the following business object verbs:

- Create
- Update
- Delete
- Retrieve
- Exists
- Retrieve by Content

Note: Business objects with Create, Update, and Delete verbs can be issued either asynchronously or synchronously. The default mode is asynchronous. The adapter does not support asynchronous delivery for business objects with the Retrieve, Exists, or Retrieve by Content verbs. Accordingly, for Retrieve, Exists, or Retrieve by Content verbs, the default mode is synchronous.

Create, update, and delete

Processing of business objects with create, update and delete verbs depends on whether the objects are issued asynchronously or synchronously.

Asynchronous delivery

The default delivery mode for business objects with create, update, and delete verbs is asynchronous. A message is created from the business object using a data handler and then written to the output queue. If the message is delivered, the adapter returns BON_SUCCESS, else BON_FAIL.

Note: The adapter has no way of verifying whether the message is received or if action has been taken.

Synchronous delivery

Note: This approach requires a customization of the commands that are executed in WebSphere Commerce when a business object comes from InterChange Server Express. The commands should retrieve the "ReplyTo" queue from the message, and place a reply on the queue within the ResponseTimeout interval. For information about creating and customizing commands in WebSphere Commerce, refer to the *Programmer's Guide for WebSphere Commerce, V. 5.4*.

If a replyToQueue has been defined in the connector properties and a ResponseTimeout exists in the conversion properties for the business object, the adapter issues a request in synchronous mode. The adapter then waits for a response to verify that appropriate action was taken by WebSphere Commerce.

The adapter initially issues a message with a header as shown in Table 1.

Table 1. Request message descriptor header (MQMD)

Field	Description	Value
Format	Format name	Output format as defined in the conversion properties and truncated to 8 characters to meet IBM requirements (example: MQSTR)
MessageType	Message Type	MQMT_DATAGRAM*
Report	Options for report message requested.	When a response message is expected, this field is populated as follows: MQRO_PAN* to indicate that a positive-action report is required if processing is successful. MQRO_NAN* to indicate that a negative-action report is required if processing fails. MQRO_COPY_MSG_ID_TO_CORREL_ID* to indicate that the correlation ID of the report generated should equal the message ID of the request originally issued.
ReplyToQueue	Name of reply queue	When a response message is expected this field is populated with the value of connector property ReplyToQueue.
Persistence	Message persistence	MQPER_PERSISTENT*
Expiry	Message lifetime	MQEI_UNLIMITED*

* Indicates constant defined by IBM.

The message header described in Table 1 is followed by the message body. The message body is a business object that has been serialized using the data handler.

The Report field is set to indicate that both positive and negative action reports are expected from the WebSphere Commerce. The thread that issued the message waits for a response message that indicates whether WebSphere Commerce was able to process the request.

When WebSphere Commerce receives a synchronous request from the adapter, it processes the data of the business object and issues a report message as described in Table 2, Table 3, and Table 4.

Table 2. Response message descriptor header (MQMD)

Field	Description	Value
Format	Format name	Input format of busObj as defined in the conversion properties.
MessageType	Message Type	MQMT_REPORT*
* Indicates constant defined by IBM.		

Table 3. Population of response message

Verb	Feedback field	Message body
Create, Update, or Delete	SUCCESS VALCHANGE	(Optional) A serialized business object reflecting changes.
	VALDUPES FAIL	(Optional) An error message.

Table 4. WebSphere MQ feedback codes and InterChange Server Express response values

WebSphere MQ feedback code	Equivalent InterChange Server Express response
MQFB_PAN or MQFB_APPL_FIRST	SUCCESS
MQFB_NAN or MQFB_APPL_FIRST + 1	FAIL
MQFB_APPL_FIRST + 2	VALCHANGE
MQFB_APPL_FIRST + 3	VALDUPES
MQFB_APPL_FIRST + 4	MULTIPLE_HITS
MQFB_APPL_FIRST + 5	FAIL_RETRIEVE_BY_CONTENT
MQFB_APPL_FIRST + 6	BO_DOES_NOT_EXIST
MQFB_APPL_FIRST + 7	UNABLE_TO_LOGIN
MQFB_APPL_FIRST + 8	APP_RESPONSE_TIMEOUT (results in immediate termination of connector)
MQFB_NONE	What the connector receives if no feedback code is specified in the response message

If the business object can be processed, the application creates a report message with the feedback field set to MQFB_PAN (or a specific InterChange Server Express value). Optionally the application populates the message body with a serialized business object containing any changes. If the business object cannot be processed, the application creates a report message with the feedback field set to MQFB_NAN (or a specific InterChange Server Express value) and then optionally includes an error message in the message body. In either case, the application sets the correlationID field of the message to the messageID of the adapter message and issues it to the queue specified by the replyTo field.

Upon retrieval of a response message, the adapter matches the correlationID of the response to the messageID of a request message. The adapter then notifies the thread that issued the request. Depending on the feedback field of the response, the adapter either expects a business object or an error message in the message body. If a business object was expected but the message body is not populated, the adapter simply returns the same business object that was originally issued by InterChange Server Express for the Request operation. If an error message was expected but the message body is not populated, a generic error message will be returned to InterChange Server Express along with the response code.

Creating custom feedback codes: You can extend the WebSphere MQ feedback codes to override default interpretations shown in Table 4 by specifying the connector property FeedbackCodeMappingMO. This property allows you to create a meta-object in which all InterChange Server Express-specific return status values are mapped to the WebSphere MQ feedback codes.

The return status assigned to a feedback code is passed to InterChange Server Express. For more information, see “FeedbackCodeMappingMO” on page 34.

Retrieve, exists, and retrieve by content

Business objects with the retrieve, exists, and retrieve by content verbs support synchronous delivery only. The connector processes business objects with these verbs as it does for the synchronous delivery defined for create, update and delete. However, when using retrieve, exists, and retrieve by content verbs, the responseTimeout and replyToQueue are required. Furthermore, for retrieve and retrieve by content verbs, the message body must be populated with a serialized business object to complete the transaction.

Table 5 shows the response messages for these verbs.

Table 5. Population of response message

Verb	Feedback field	Message body
Retrieve or RetrieveByContent	FAIL FAIL_RETRIEVE_BY_CONTENT	(Optional) An error message.
	MULTIPLE_HITS SUCCESS	A serialized business object.
Exist	FAIL	(Optional) An error message.
	SUCCESS	

Common configuration tasks

After installing the adapter, you must configure the connector before starting it. This section provides an overview of some of the configuration and startup tasks that most developers will need to perform.

Installing the adapter

See Chapter 2, “Installing and configuring the connector,” on page 15, for a description of what and where you must install.

Configuring connector properties

Connectors have two types of configuration properties: standard configuration properties and connector-specific configuration properties. Some of these properties have default values that you do not need to change. You may need to set the

values of some of these properties before running the connector. For more information, see Chapter 2, “Installing and configuring the connector,” on page 15.

When you configure connector properties for the adapter for WebSphere Commerce, make sure that:

- The value specified for connector property `HostName` matches that of the host of your WebSphere MQ server.
- The value specified for connector property `Port` matches that of the port for the listener of the queue manager used by the adapter.
- The value specified for connector property `Channel` matches the server connection channel for the queue manager used by the adapter.
- The values specified for queues match the names you used in creating the queues.
- The queue URI's for connector properties `InputQueue`, `InProgressQueue`, `ArchiveQueue`, `ErrorQueue`, and `UnsubscribeQueue` are valid and actually exist. See Table 10.

Sending requests without notification

To configure the adapter to send requests without notification (the default asynchronous mode, also known as “fire and forget”):

- Create a business object that represents the request you want to send and is compatible with the XML data handler.
- Use either a static or a dynamic meta-object to specify the target queue and format. For more on static and dynamic meta-objects, see “Static meta-objects” on page 42 and “Dynamic child meta-objects” on page 46.
- Set the property `ResponseTimeout` in the (static or dynamic) meta-object to `-1`. This forces the connector to issue the business object without checking for a return.

Sending requests and get notifications

Note: This approach requires a customization of the commands that are executed in WebSphere Commerce when a business object comes from InterChange Server Express. The commands should retrieve the “ReplyTo” queue from the message, and place a reply on the queue within the `ResponseTimeout` interval. For information about creating and customizing commands in WebSphere Commerce, refer to the *Programmer's Guide for WebSphere Commerce 5.4*.

If you configure the adapter to send requests and get notifications, specify a positive `ResponseTimeout` value to indicate how long the adapter waits for a reply.

This approach also requires that you define a `ReplyTo` queue in the connector properties. See “Synchronous delivery” on page 8 for more information and details about what the connector expects in a response message. If the requirements listed are not met by the response message, the connector may report errors or fail to recognize the response message. See also sections on “Configuring meta-object attributes” on page 42, and Chapter 3, “Working with business objects,” on page 57.

Configuring a static meta-object

A static meta-object contains application-specific information that you specify about business objects and how the connector processes them. A static meta-object provides the connector with all the information it needs to process a business object when the connector is started.

If you know at implementation time which queues different business objects must be sent to, use a static meta-object. To create and configure this object:

- Follow the steps in “Static meta-objects” on page 42.
- Make sure the connector subscribes to the static meta-object by specifying the name of the static meta-object in the connector-specific property `DataHandlerConfigMO`. For more information, see “Connector-specific properties” on page 32.

Configuring a dynamic meta-object

If the connector is required to process a business object differently depending on the scenario, use a dynamic meta-object. This is a child object that you add to the business object. The dynamic meta-object tells the connector (at run-time) how to process a request. Unlike the static meta-object, which provides the connector with all of the information it needs to process a business object, a dynamic meta-object provides only those additional pieces of logic required to handle the processing for a specific scenario. To create and configure a dynamic meta-object:

- Create the dynamic meta-object and add it as a child to the request business object
- Program your collaboration with additional logic that populates the dynamic meta-object with information such as the target queue, message format, etc., before issuing it to the connector.

The connector will check for the dynamic meta-object and use its information to determine how to process the business object. For more information, see “Dynamic child meta-objects” on page 46.

Configuring MQMD formats

MQMDs are message descriptors. MQMDs contain the control information accompanying application data when a message travels from one application to another. You must specify a value for the MQMD attribute `OutputFormat` in either your static or dynamic meta-object. For more information, see “Create, update, and delete” on page 8.

Configuring queue URIs

To configure queues for use with the connector:

- Specify all queues as Uniform Resource Identifiers (URIs). The syntax is:
`queue://<InterChangeServerName.queue.manager>/<actual queue>`
- Specify the host for the queue manager in connector-specific configuration properties (see Table 10).
- If your target application expects an MQMD header only and cannot process the extended MQRFH2 headers used by JMS clients, append `?targetClient=1` to the queue URI. For more information, see “Queue uniform resource identifiers (URIs)” on page 40 and the WebSphere MQ programming guide.

Configuring the XML data handler

The XML data handler is required for using the adapter with WebSphere Commerce. There are two ways to configure the data handler:

- Specify the data handler class name in the connector-specific property `DataHandlerClassName`. For more information, see “Connector-specific properties” on page 32.
- Specify the mime type and the data handler meta-object that defines the configuration for that mime type in the connector-specific properties `DataHandlerMimeType` and `DataHandlerConfigMO`, respectively. For more information, see Table 10 and the *IBM WebSphere Business Integration Server Express Data Handler Guide*.

Modifying the startup script

See Chapter 2, “Installing and configuring the connector,” on page 15, for a description of how to start the connector. You must configure connector properties before startup. You must also modify the startup file:

- Make sure you modify the `start_connector` script to point to the location of the client libraries. Do not install multiple versions of the client libraries or versions that are not up-to-date with your WebSphere MQ server. For more information, see “Configuring the startup file” on page 51.

Chapter 2. Installing and configuring the connector

This chapter describes how to install and configure the adapter and enable the WebSphere Commerce application to work with the connector. The topics covered in this chapter are:

- “Adapter environment”
- “Prerequisite tasks” on page 16
- “Installing the adapter and related files” on page 30
- “Installed file structure” on page 30
- “Configuring the adapter” on page 32
- “Enabling guaranteed event delivery” on page 36
- “Queue uniform resource identifiers (URIs)” on page 40
- “Configuring meta-object attributes” on page 42
- “Creating multiple connector instances” on page 49
- “Configuring the startup file” on page 51
- “Starting the connector” on page 52
- “Stopping the connector” on page 54

Adapter environment

Before installing, configuring, and using the adapter, you must understand its environment requirements. They are listed in the following sections.

- “Adapter platforms”
- “Adapter dependencies”
- “Locale-dependent data” on page 16

Adapter platforms

This adapter is supported on the following software:

Operating systems:

- Microsoft Windows 2000
- Microsoft Windows 2003
- IBM OS/400 V5R2, V5R3
- Red Hat Enterprise Linux AS 3.0, Update 1
- SuSE Linux Enterprise Server 8.1 with SP3

Databases:

- DB2

Third-party software:

- WebSphere Commerce, Version 5.4 with Fix Pack 6 or later
- WebSphere Commerce, Version 5.5 with Fix Pack 4 or later

Adapter dependencies

The adapter for WebSphere Commerce has the following dependencies.

- Requires WebSphere Application Server (WAS) libraries/API.

Locale-dependent data

The adapter has been internationalized so that it can support double-byte character sets, and deliver message text in the specified language. When the adapter transfers data from a location that uses one character code set to a location that uses a different code set, it performs character conversion to preserve the meaning of the data.

The Java runtime environment within the Java Virtual Machine (JVM) represents data in the Unicode character code set. Unicode contains encodings for characters in most known character code sets (both single-byte and multibyte). Most components in the WebSphere Business Integration Server Express system are written in Java. Therefore, when data is transferred between most WebSphere Business Integration Server Express system components, there is no need for character conversion.

To log error and informational messages in the appropriate language and for the appropriate country or territory, configure the Locale standard configuration property for your environment. For more information on configuration properties, see Appendix A, "Standard configuration properties for connectors," on page 63.

Prerequisite tasks

This section describes the installation and configuration tasks you must perform for WebSphere Commerce and other software before you can install and run the adapter.

These tasks are:

1. Install and configure WebSphere Commerce
2. Install and configure the Commerce Enhancement Pack
3. Publish a WebSphere Commerce store
4. Create and configure WebSphere MQ queues
5. Configure WebSphere Application Server (WAS) JMS settings
6. Configure JMS ConnectionSpec within WebSphere Commerce
7. Update WebSphere Commerce JVM Settings
8. Enable WebSphere Commerce Adapter

Installing and configuring WebSphere Commerce

Install WebSphere Commerce, Version 5.4, with Fix Pack 6 or later, or install WebSphere Commerce, Version 5.5, with Fix Pack 4 or later. Refer to the documentation that comes with the product for the installation steps and the post-install configuration. The WebSphere Commerce messaging system is equipped to handle the messages to interact with back-end systems.

You must update the CMDREG table, which is the command registry table in your WebSphere Commerce database, to use the XML message format.

Installing the Commerce enhancement pack

To install the Commerce Enhancement Pack, download the Commerce Enhancement Pack driver from the following URL and follow the instructions in the readme.txt file:

<http://www.ibm.com/software/commerce/epacks>

Publishing a store

You can use this adapter with an existing WebSphere Commerce published store, or you can create a new store.

Configuring WebSphere MQ queues

The WebSphere MQ queue configuration required for using the adapter depends in part upon the topology of your WebSphere Commerce and IBM WebSphere InterChange Server Express installations. You may be using any of the following topologies:

- Single machine

WebSphere Commerce and IBM WebSphere InterChange Server Express and the adapter are all installed on the same machine

- Two machines with two queue managers

WebSphere Commerce is installed on one machine, and IBM WebSphere InterChange ServerExpress and the connector are installed on another machine. A different queue manager is used on each machine.

- Two machines with a single queue manager

WebSphere Commerce is installed on one machine, and IBM WebSphere InterChange Server Express and the connector are installed on another machine. The same queue manager is used to manage the queues on both machines.

Single-machine topology

In this topology, WebSphere Commerce, InterChange Server Express and the adapter for WebSphere Commerce are all installed on a single machine. A single queue manager handles all the WebSphere MQ queues used in the solution. It is recommended that you use the queue manager that you set up when you installed InterChange Server Express.

Note: The default queue managers are different for Windows, OS/400, and Linux. For example, for OS/400, the default queue manager is `serverName.QUEUE.MANAGER` where `serverName` is the name of the InterChange Server Express instance. The instance created at default is `QWBIDFT`, so its queue manager is `QWBIDFT.QUEUE.MANAGER`. For more information, see the Console help menu (from the console menu, Help -> Help).

This topology requires queues that perform the following roles:

- Inbound Queue

WebSphere Commerce requires that this queue exist. However, the adapter does not make use of it in this solution.

- Parallel Inbound Queue

WebSphere Commerce requires that this queue exist. However, the adapter does not make use of it in this solution.

- Serial Inbound Queue

For receiving messages sent from InterChange Server Express to WebSphere Commerce.

- Outbound Queue

For sending messages from WebSphere Commerce to InterChange Server Express.

- InProgress Queue

The original versions of valid messages sent from WebSphere Commerce to InterChange Server Express are stored here until the adapter completes processing; when processing is completed, the original message is moved to the local Archive queue.

- **Archive_Queue**
When a message has been fully processed by the adapter and sent to InterChange Server Express from WebSphere Commerce, the original version of the message is stored here.
- **Unsubscribed_Queue**
If a message is successfully parsed but does not correspond to any business object supported by the adapter, it is stored here.
- **ICS_Error_Queue**
If a message is not successfully converted to a business object and sent to the InterChange Server Express, it is stored here.
- **WCS_Error_Queue**
Stores messages that cannot be successfully processed by WebSphere Commerce.
- **ReplyTo Queue**
Used only in configurations that are set up for synchronous data exchange.

All of the above queues are local in the single machine topology. If you create the queues manually, you choose the names that you assign for them; if you use the batch file provided with this solution (described below), the batch file will create the queues with pre-assigned names.

Generating queues for a Windows environment: If you are using the adapter in a Windows environment, you can use a batch file to generate queues that are appropriate for a single machine topology. The file is installed with your product package in the \Connector\WebSphereCommerce\Utilities subdirectory within the root directory you used for your IBM InterChange Server Express installation. To create the queues using the batch file, run the file `ConfigureWebSphereCommerceAdapter.bat`, as follows:

From the command prompt, enter:

```
ConfigureWebSphereCommerceAdapter  
<InterChangeServerName>.queue.manager
```

where, <InterChangeServerName> is the name of your WebSphere InterChange Server Express.

This will create a queue manager named `InterChange ServerName.queue.manager` and it will create the required WebSphere MQ queues. The names of the created queues, as created by the batch file, are as follows:

`WC_MQCONN.IN_PROGRESS` In Progress queue for the adapter.

`WC_MQCONN.ERROR` InterChange Server Express Error Queue for the adapter.

`WC_MQCONN.ARCHIVE` Archive Queue for the adapter.

`WC_MQCONN.REPLY` Reply-To_Queue for the adapter.

`WC_MQCONN.UNSUBSCRIBED` UnSubscribed Queue for the adapter.

WCS_Serial_Inbound Serial Inbound Queue for WebSphere Commerce. Must match a JMS queue name defined for WebSphere Commerce, as described in “Configuring WebSphere Application Server JMS settings for WAS 4.x” on page 24

WCS_Outbound Outbound queue for WebSphere Commerce. Must match a JMS queue name defined for WebSphere Commerce, as described in “Configuring WebSphere Application Server JMS settings for WAS 4.x” on page 24

WCS_Parallel_Inbound Parallel inbound queue for WebSphere Commerce. Must match a JMS queue name defined for WebSphere Commerce, as described in “Configuring WebSphere Application Server JMS settings for WAS 4.x” on page 24

WCS_Error Error queue for WebSphere Commerce. Must match a JMS queue name defined for WebSphere Commerce, as described in “Configuring WebSphere Application Server JMS settings for WAS 4.x” on page 24

WCS_Inbound Inbound queue for WebSphere Commerce. Must match a JMS queue name defined for WebSphere Commerce, as described in “Configuring WebSphere Application Server JMS settings for WAS 4.x” on page 24

Generating queues for an OS/400 environment: If you are using the adapter in an OS/400 environment, you must create the queues.

Depending on your installation, there are 2 ways to create queues:

- WebSphere Business Integration Server Express Console (if installed)
- CL commands

Using WebSphere Business Integration Server Express Console to create queues

If you are using WebSphere Business Integration Server Express Console, create the queues as follows:

1. Start the WebSphere Business Integration Server Express Console application.
2. Select Start > Programs > IBM WebSphere Business Integration Console > Console.
3. Enter the OS/400 system name or IP address and enter a user profile and password.

The user profile must have access to the WebSphere MQ queue, QWBIDFT.QUEUE.MANAGER, created during the install of the Server Express component.

4. From the File menu of the console, select File > Configure Queue Manager item.

Notepad opens to the edit file, mq_temp.tst.

5. You must enter the "*" character in column 1 on all the lines that do not have the "*" in column 1.

6. Add the following lines to the top of the file:

```
DEFINE QL (WC_MQCONN.IN_PROGRESS)
DESCR (WBI Adapter In Progress Queue)
DEFINE QL (WC_MQCONN.ERROR)
DESCR (WBI Adapter Error Queue)
DEFINE QL (WC_MQCONN.ARCHIVE)
DESCR (WBI Adapter Archive Queue)
DEFINE QL (WC_MQCONN.REPLY)
```

```

DESCR (WBI Adapter Reply-To Queue)
DEFINE QL (WC_MQCONN.UNSUBSCRIBED)
DESCR (WBI Adapter UnSubscribed Queue)
DEFINE QL (WCS_Serial_Inbound)
DESCR (WebSphere Commerce MQ Adapter JMS Serial Inbound Queue)
DEFINE QL (WCS_Outbound)
DESCR (WebSphere Commerce MQ Adapter JMS Outbound Queue)
DEFINE QL (WCS_Parallel_Inbound)
DESCR (WebSphere Commerce MQ Adapter JMS Parallel Inbound Queue)
DEFINE QL (WCS_Error)
DESCR (WebSphere Commerce MQ Adapter JMS Error Queue)
DEFINE QL (WCS_Inbound)
DESCR (WebSphere Commerce MQ Adapter JMS Inbound Queue)

```

7. Save and close Notepad.

The console creates the queues on OS/400 for you.

Using the command line to create queues

If you are using CL commands to create queues, from the command prompt, enter:

1. STRMQM MQMNAME (serverName.QUEUE.MANAGER)
2. CRTMQMQ QNAME (WC_MQCONN.IN_PROGRESS)
3. QTYPE (*LCL)
4. MQMNAME (serverName.QUEUE.MANAGER)
5. TEXT (WBI Adapter In Progress Queue)
6. CRTMQMQ QNAME (WC_MQCONN.ERROR)
7. QTYPE (*LCL)
8. MQMNAME (serverName.QUEUE.MANAGER)
9. TEXT (WBI Adapter Error Queue)
10. CRTMQMQ QNAME (WC_MQCONN.ARCHIVE)
11. QTYPE (*LCL)
12. MQMNAME (serverName.QUEUE.MANAGER)
13. TEXT (WBI Adapter Archive Queue)
14. CRTMQMQ QNAME (WC_MQCONN.REPLY)
15. QTYPE (*LCL)
16. MQMNAME (serverName.QUEUE.MANAGER)
17. TEXT (WBI Adapter Reply-To Queue)
18. CRTMQMQ QNAME (WC_MQCONN.UNSUBSCRIBED)
19. QTYPE (*LCL)
20. MQMNAME (serverName.QUEUE.MANAGER)
21. TEXT (WBI Adapter UnSubscribed Queue)
22. CRTMQMQ QNAME (WCS_Serial_Inbound)
23. QTYPE (*LCL)
24. MQMNAME (serverName.QUEUE.MANAGER)
25. TEXT (WebSphere Commerce MQ Adapter JMS Serial Inbound Queue)
26. CRTMQMQ QNAME (WCS_Outbound)
27. QTYPE (*LCL)

28. MQMNAME (serverName.QUEUE.MANAGER)
 29. TEXT (WebSphere Commerce MQ Adapter JMS Outbound Queue)
 30. CRTMQMQ QNAME (WCS_Parallel_Inbound)
 31. QTYPE (*LCL)
 32. MQMNAME (serverName.QUEUE.MANAGER)
 33. TEXT (WebSphere Commerce MQ Adapter JMS Parallel Inbound Queue)
 34. CRTMQMQ QNAME (WCS_Error')
 35. QTYPE (*LCL)
 36. MQMNAME (serverName.QUEUE.MANAGER)
 37. TEXT (WebSphere Commerce MQ Adapter JMS Error Queue)
 38. CRTMQMQ QNAME (WCS_Inbound)
 39. QTYPE (*LCL)
 40. MQMNAME (serverName.QUEUE.MANAGER)
 41. TEXT (WebSphere Commerce MQ Adapter JMS Inbound Queue)
- where serverName is the InterChange Server Express instance (the default for OS/400 is QWBIDFT)

Two-machine, two-Queue Manager topology

In this topology, WebSphere Commerce is installed on one machine and IBM WebSphere InterChange Server Express and the adapter for WebSphere Commerce are installed on another machine.

WebSphere MQ must be installed on each machine, and each installation uses a different queue manager. These are the queues you create on each machine.

Note: In this table, the queue names indicate the role of each queue, but you can establish different queue names, as long as you synchronize the queue names with JMS queue names used on your WebSphere Commerce system. In the table, the prefix WCS indicates a queue that is created on the machine on which the WebSphere Commerce system is installed, and that is managed by a queue manager that resides on that machine. The prefix InterChange Server Express indicates a queue that is created on the machine on which InterChange Server Express and the connector are installed, and that is managed by a queue manager that resides on that machine.

Queues on the WebSphere Commerce machine	Queues on the InterChange Server Express machine
<p>WCS_Outbound Queue</p> <p>For sending messages from WebSphere Commerce to InterChange Server Express. This queue is created as a remote queue definition, pointing to ICS_Inbound on the InterChange Server Express machine as the remote queue.</p>	<p>ICS_Inbound queue</p> <p>For receiving messages sent from WebSphere Commerce to InterChange Server Express.</p>
<p>WCS_Serial Inbound queue</p> <p>For receiving messages sent from InterChange Server Express to WebSphere Commerce.</p>	<p>ICS_Outbound queue</p> <p>For sending messages from InterChange Server Express to WebSphere Commerce. This queue is created as a remote queue definition, pointing to WCS_Serial Inbound on the WebSphere Commerce machine as the remote queue</p>

Queues on the WebSphere Commerce machine	Queues on the InterChange Server Express machine
To InterChange Server Express	To WebSphere Commerce
Transmission queue from WebSphere Commerce system to InterChange Server Express.	Transmission queue from InterChange Server Express to WebSphere Commerce system.
WCS_Error_queue	ICS_Error_queue
Stores messages that cannot be successfully processed by WebSphere Commerce.	If a message is not successfully converted to a business object, it is stored here.
WCS_Parallel Inbound	The adapter does not make use of a parallel inbound queue.
	ICS_InProgress_queue
	The original versions of valid messages sent from WebSphere Commerce to InterChange Server Express are stored here until the adapter completes processing; when processing is completed, the original message is moved to the local Archive queue.
	ICS_Archive_queue
	When a message has been fully processed by the adapter and sent to InterChange Server Express from WebSphere Commerce, the original version of the message is stored here.
	ICS_Unsubscribed_queue
	If a message is successfully converted to a business object but does not correspond to any business object supported by the adapter, it is stored here.

To enable communication between the two systems, use channels and transmission queues.

Channels that perform the following roles must be created on each machine for this topology.

Channels On the WebSphere Commerce machine	Channels On the InterChange Server Express machine
Sender_WCS	Sender_ICS
Receiver_ICS	Receiver_WCS

Creating the channels: In the following instructions, specific server and queue manager names are specified so that they correlate the different machines and queues. Channels are used to make sure that the correct queues refer to each other; the “local” versions of the queues are used to hold the actual information.

Perform the following configuration tasks on the WebSphere Commerce machine:

Note: The channel names used here are examples only.

1. Create two channels in the WebSphere Commerce system using WebSphere MQ Explorer. One sender channel named 'WCS' and one receiver channel named 'ICS'.
2. Create a local queue, for example, using the name 'ToICSSystem'.
3. Set the ToICSSystem queue as the transmission queue.
4. Set the following properties for the WCS_Outbound queue.
 - a. Remote queue name ICS_InboundRemote queue manager name ICS_server_name.queue.manager. For example, ICS.queue.manager.
 - b. Set the transmission queue name property to 'ToICSSystem' as created in step 2.
5. To configure the sender channel do the following:
 - a. Specify the connection name with the IP address and the port, for example, 9.182.12.235(1414). Where, 9.182.12.235 is the IP address of the machine where InterChange Server Express is running and 1414 is the default listener port.
 - b. Specify the transmission queue name as 'ToICSSystem'.

This completes the configuration tasks for the WebSphere Commerce machine.

Perform the following configuration tasks on the InterChange Server Express machine:

1. Create two channels using WebSphere MQ Explorer: One sender channel named 'ICS' and one receiver channel named 'WCS'.

Note: The name of the sender channel in the WebSphere Business Integration Server Express system must be identical to the name of the receiver channel in WebSphere Commerce. The name of the receiver channel in the WebSphere Business Integration Server Express system must be identical to the name of the sender channel in WebSphere Commerce.

2. Create a new local queue, for example 'ToWCSSystem'. Set the ToWCSSystem queue as the transmission queue.
3. Create a remote definition queue in the WebSphere Business Integration Server Express system. This remote definition queue must be used in the connector component as the output queue. Set the following properties:
 - a. Remote queue name WCS_SerialInbound
 - b. Remote queue manager name <wcssystem_Q_manager_name>. For example, QM_wcsfvt3.
 - c. Set the transmission queue name property to 'ToWCSSystem'.
4. To configure the sender channel do the following:
 - a. Specify the connection name with the IP address and the port, for example, 9.182.12.18(1414). Where, 9.182.12.18 is the IP address of the machine where WebSphere Commerce is running and 1414 is the default listener port.
 - b. Specify the transmission queue name as 'TOWCSSystem'.

After you finish configuring the WebSphere MQ queues and channels on both the WebSphere Commerce machine and the InterChange Server Express machine, start the receiver channel and then the sender channel.

Two-machine, one-queue manager topology

In this topology, WebSphere Commerce is installed on one machine and InterChange Server Express and the adapter for WebSphere Commerce are

installed on another machine. Only one instance of WebSphere MQ is running, and the queues used by both machines are managed by a single queue manager. This scenario uses only local queues.

This topology requires queues that perform the following roles:

- Inbound Queue
WebSphere Commerce requires that this queue exist. However, the adapter does not make use of it in this solution.
- Serial Inbound Queue
For sending messages from InterChange Server Express to WebSphere Commerce.
- Outbound Queue
For receiving messages sent from WebSphere Commerce to InterChange Server Express.
- InProgress Queue
The original versions of valid messages sent from WebSphere Commerce to InterChange Server Express are stored here until the adapter completes processing; when processing is completed, the original message is moved to the local Archive queue.
- Archive_Queue
When a message has been fully processed by the adapter and sent to InterChange Server Express from WebSphere Commerce, the original version of the message is stored here.
- Unsubscribed_Queue
If a message is successfully parsed but does not correspond to any business object supported by the adapter, it is stored here.
- WebSphere Commerce Error Queue
- ICS_Error_Queue
If a message is not successfully converted to a business object and sent to InterChange Server Express, it is stored here.
- WCS_Error_Queue
Stores messages that cannot be successfully processed by WebSphere Commerce.
- ReplyTo Queue
Used only in configurations that are set up for synchronous data exchange.

Configuring WebSphere Application Server JMS settings for WAS 4.x

You must configure WebSphere Application Server (WAS) to create the Java Messaging Service Connection Factory and JMS queues to work with WebSphere MQ. To do so, perform the following steps.

Note: Before configuring WebSphere Application Server JMS settings, you must install WebSphere Commerce, Version 5.4 with Fix Pack 6 or later. The following instructions apply only to WAS 4.x. You can find installation instructions in the appropriate manuals for the versions of WebSphere Commerce and WAS that you are using.

1. From the command prompt:
 - a. Update your classpath variable by typing the following command on one line:

```

set classpath= %classpath%;
MQ_install_path\java\lib\com.ibm.mqjms.jar;
MQ_install_path\java\lib\com.ibm.mq.jar;
MQ_install_path\java\lib\com.ibm.mq.iopp.jar;
MQ_install_path\java\lib\com.ibm.ibmorb.jar;WAS_install_path\lib\ns.jar

```

MQ_install_path The path in which you installed WebSphere MQ

WAS_install_path The path in which you installed the WebSphere Application Server

- b. Add a new environment variable named MQ_JAVA_INSTALL_PATH by typing the following command:

```
set MQ_JAVA_INSTALL_PATH=MQ_install_path\java
```

MQ_install_path The path in which you installed WebSphere MQ

- c. Update the environment to use the JDK (Java Development Kit) that comes with WebSphere Application Server by typing the following command:

```
set PATH = WAS_Install_Path\Java\bin;%PATH%
```

WAS_install_path The path in which you installed the WebSphere Application Server

2. Ensure that the WebSphere Application Server is running and the correct classpath and environment variables defined in Step 1 above are added. Also check to make sure the JDK being used is the one in WAS by executing `java -version` and checking the version with the one found in `WAS_Install_Path\Java\bin`.
3. In the `MQ_install_path\java\bin` directory, open the `JMSAdmin.config` file and set the following values:

```
INITIAL_CONTEXT_FACTORY=com.ibm.ejs.ns.jndi.CNInitialContextFactory
PROVIDER_URL=iiop://localhost:900
```

The values above assume that WebSphere Commerce and WebSphere MQ are installed on the same machine.

```
SECURITY_AUTHENTICATION=none
```

4. Run the `JMSAdmin` program by providing the `JMSAdmin.config` file as a command line input:

```
CommandPrompt:> JMSAdmin -cfg JMSAdmin.config -t -v
```

Executing this command should enable you to lookup the JNDI (Java Naming and Directory Interface) service provided by WebSphere Application Server. You will see an `InitCtx>` prompt that you can use to run the JMS administration commands.

5. Register the `QueueConnectionFactory` and set the coded character set identifier by typing the following commands:

- `define qcf (JMS_QueueConnectionFactory) qmanager (Your_QueueManager_Name)`
- `alter qcf (JMS_QueueConnectionFactory) ccsid(1208)`

Where `JMS_QueueConnectionFactory` is the name of the `MQQueueConnectionFactory` JMS object.

When you execute the above set of commands, an entry for this queue connection factory is created in the WebSphere Application Server database under the `BINDINGBEANTBL` table. These objects are registered in the WebSphere Application Server database.

- Define the following JMSQueues to map to the names you have established for your WebSphere MQ queues and the WebSphere MQ queue manager you are using. You can customize the JMSqueue names according to your own requirements, but the WebSphere MQ names to which you define them must match exactly, including casing, queue names you have established in WebSphere MQ. If you are using the batch file provided with this adapter for creating the appropriate WebSphere MQ queues for a single-machine topology, be sure to use those generated WebSphere MQ queue names as the values to which you define the JMS queues, as described in the table below.

The following syntax defines the JMS Queues:

Note: If you are using a remote queue definition for the outbound queue, as you would in a two-machine, two-queue manager topology, the JMS_Outbound_Queue should not be defined to a local WebSphere MQ queue. If you are using a remote queue definition, the syntax for the outbound queue would be: define

```
q(JMS_Outbound_Queue)qmanager(Your_Queue_Manager_Name)
define q(JMS_Outbound_Queue)qmanager
  (Your_Queue_Manager_Name)
  queue(Your_Outbound_QueueName)
define q(JMS_Inbound_Queue)qmanager
  (Your_Queue_Manager_Name)
  queue(Your_Inbound_QueueName)
define q(JMS_Parallel_Inbound_Queue)qmanager
  (Your_Queue_Manager_Name)queue
  (Your_Parallel_Inbound_Queue_Name)
define q(JMS_Serial_Inbound_Queue)qmanager
  (Your_Queue_Manager_Name)queue
  (Your_Serial_Inbound_Queue_Name)
define q(JMS_Error_Queue)qmanager
  (Your_Queue_Manager_Name)
  queue (Your_Error_Queue_Name)
```

Table 6. Defining JMS queue names

<i>Your_Outbound_QueueName</i>	The WebSphere MQ queue created for the outbound queue. By default, this is the queue which the adapter polls to pick up messages from WebSphere Commerce to pass to InterChange Server Express. In the default WebSphere MQ queue setup created by the batch file, this value should be WCS_Outbound
<i>Your_Serial_Inbound_Queue</i>	The WebSphere MQ queue created for the serial inbound queue. This is the queue into which WebSphere Commerce MQ Adapter places messages sent from InterChange Server Express to Websphere Commerce. In the default WebSphere MQ queue setup created by the batch file, this value should be WCS_Serial_Inbound
<i>Your_Parallel_Inbound_Queue_Name</i>	This is the WebSphere MQ queue created for the parallel inbound queue
<i>Your_Error_Queue_Name</i>	The WebSphere MQ queue created for the error queue. This is where WebSphere Commerce MQ Adapter sends messages when it encounters an error with the message. In the default WebSphere MQ queue setup created by the batch file, this value should be WCS_Error

Table 6. Defining JMS queue names (continued)

<i>Your_Queue_Manager_Name</i>	The name of the queue manager handling WebSphere MQ queues in your set up for the WebSphere Commerce system. In a typical single machine setup, such as the setup created by the batch file <code>ConfigureAdapterQueues.bat</code> (see "Installing and configuring WebSphere Commerce" on page 16), the queue manager that you established for InterChange Server Express would be used to manage the queues for the WebSphere Commerce system as well. For such a setup, the default would be <code><InterchangeServerName>.queue.manager</code>
--------------------------------	---

After creating the queues, set the following property for the outbound and error queues using the JMSAdmin console. This procedure specifies that JMS is dealing with a native WebSphere MQ application.

- alter q(JMSOutboundQueue) targclient(MQ)
- alter q(JMSErrorQueue) targclient(MQ)

To exit the JMSAdmin tool, enter `end`. This completes your task for configuring the Java Messaging Service with WebSphere Application Server running WebSphere Commerce.

Configuring WebSphere Application Server JMS settings for WAS 5.x

With the introduction of WebSphereCommerce 5.5, Commerce instances are created as a WebSphere Application Server in WAS 5.x. When configuring JMS for 5.x versions of WebSphere Application Server, the JMS settings must be configured through the WAS administrator user interface, and not using the JMSAdministrator tool as described for WAS 4.x versions. Once you are logged into the WAS administrator interface (see your WAS documentation for connecting to the admin interface), use the following general steps to configure JMS.

To configure JMS for WebSphere Application Server in WAS 5.x:

1. Select Resources > WebSphere MQ JMS Provider.
2. Set the scope to be that of your WebSphere Commerce server (named `WC_<YourCommerceInstance>`) and select Apply.
3. Select WebSphere MQ Queue Connection Factories.
4. Add a new connection factory by selecting New on the connection factory screen.
5. Fill out the following settings for the factory:
 - a. Connection Name (this can be any name)
 - b. JNDI Name (the name you will refer to this connection as using JNDI)
 - c. Queue Manager (the queue manager which contains the queues defined in the previous steps. For example, `<ICSName>.QUEUE.MANAGER`)
 - d. Host (the host name which contains the queue manager)
 - e. Port (the MQ Listener port for the queue manager. For example, 1416)
 - f. Channel (the MQ channel defined in the queue manager for communication. For example, CHANNEL1)
 - g. Deselect the Enable XA check box for the factory
 - h. Set the Transport Type to Client

6. Under Additional Properties > Connection Pools, enter a Max Connection value of 50 (Note: this number is a suggested value, not a required value).
7. Select OK.
8. Select MQ Queue Destinations and add a destination for each queue defined in the previous steps.
9. Complete the following values for each Queue Destination:
 - a. Name (the queue name For example, JMS_Outbound_Queue)
 - b. JNDI Name (the name to refer to the queue by in JNDI. For example, JMS_Outbound_Queue)
 - c. Base Queue Name (the actual queue name in the queue manager. For example, WCS_Outbound)
 - d. Base Queue Manager (the queue manager name that contains the queues defined in the previous section. For example, <ICSName>.QUEUE.MANAGER)
 - e. Target Client (set to MQ)
10. Save the changes to the main configuration in WAS.

Note: If the queue manager is on OS/400, run the following command line command:

```
GRTMQMAUT OBJ(*ALL) OBJTYPE(*ALL)
USER(<WAS_SubSystem_Name>) AUT(*ALL)
MQMNAME(<ICSName>.QUEUE.MANAGER)
```

For example: GRTMQMAUT OBJ(*ALL) OBJTYPE(*ALL) USER(QEJBSVR) AUT(*ALL) MQMNAME(QWBIDFT.QUEUE.MANAGER)

Configuring JMS ConnectionSpec within WebSphere Commerce

Note: The JMSQueue names and JMS connection factory must be the same as the values entered in the connectionSpec section of Commerce Configuration Manager, in the instance XML file. You can find the details under the Transports section in the WebSphere Commerce Configuration Manager. Also see the instructions below.

Start the WebSphere Commerce Administration Console. Log in as a Site Administrator, go to the Configuration section and choose the Transport option. Select WebSphere MQ as your transport and change the status to active. Log out from the Administration Console.

The WebSphere Commerce solution requires the creation and use of a “store,” as described in the *WebSphere Commerce Installation Guide*. When you have completed publishing the store as described in “Publishing a Sample Store” section of that guide, log into the Administration Console, this time as a Store Administrator, and select the store you are using. In the Configuration section, add MQ Transport to the store. An entry for this is made in the STORETRANS table.

To enable the messaging system transport adapter, launch the WebSphere Commerce Configuration Manager and do the following:

1. Select Host name > Instance.
2. Open the Components folder.

3. Select TransportAdapter.
4. Select the Enable Component checkbox and select Apply.

Configure JMSQueue names and JMS Connection Factory with the values that you are using for the connectionSpec in this instance, as follows:

1. Select the Host Name > Instance
2. Select Transports, then expand Outbound > JMS
3. Select the ConnectionSpec
4. Input the ConnectionFactory name created when configuring the JMS settings for WAS. Enter the Inbound, Error and Outbound queue names created above.
5. Select Apply.
6. Expand Inbound > JMSInbound CCF Connector-Serial
7. Select the ConnectionSpec
8. Input the ConnectionFactory Name, SerialInbound, Error and Output JMS queues.
9. Select Apply.
10. Expand Inbound-JMSInbound CCF Connector-Parallel
11. Select the ConnectionSpec
12. Input the ConnectionFactory, ParallelInbound, Error and Output JMS queues.
13. Select Apply.

When you are finished, exit the Configuration Manager.

Updating WebSphere Commerce JVM settings

You must update the WebSphere Application Server class path for the instance, adding the additional jar file entries. To do so, open the WebSphere Application Server Advanced Administrative Console and complete the following:

1. Select the host on which you are running your WebSphere Commerce instance.
2. Select the WebSphere Administrative Domain.
3. Select Nodes.
4. Select your host name.
5. Select Application Servers.
6. Select the WebSphere Commerce Server instance_name, where instance_name is the name of your WebSphere Commerce instance.
7. Go to the JVM settings of the instance.
8. Select Add a new system property.
9. Enter the following system property:
name= ws.ext.dirs value=MQ_INSTALL_PATH/java/lib
Where MQ_INSTALL_PATH is the path where you installed WebSphere WebSphere MQ.
10. Restart the WebSphere Application Server service for all the changes to take affect.

Enabling WebSphere MQ for the adapter

In WebSphere Commerce, use the configuration option under the Administration console to configure WebSphere Commerce to communicate with the WebSphere MQ queues for outbound and inbound messaging that you are using in your

implementation of WebSphere Commerce and IBM WebSphere InterChange Server Express. See the *WebSphere Commerce Online Help* guide for additional instructions if needed.

Installing the adapter and related files

For information on installing the adapter, see the discussion of installing from the Adapter Capacity Pack for WebSphere Business Integration Server Express Plus, in the *Installation Guide for WebSphere Business Integration Server Express*. For located in the WebSphere Business Integration Server Express Infocenter at the following site:

<http://www.ibm.com/websphere/wbiserverexpress/infocenter>

For information on installing the adapter, refer to the WebSphere Business Integration Server Express installation guide for Windows, for OS/400, or for Linux located in the WebSphere Business Integration Server Express Infocenter at the following site:

<http://www.ibm.com/websphere/wbiserverexpress/infocenter>

Installed file structure

The following subsections describe the installed file structure of the adapter on Windows, OS/400, and Linux platforms.

Table 7 describes the Windows file structures, Table 8 on page 31 describes the OS/400 file structures, and Table 9 on page 31 describes the Linux file structures used by the connector.

For more information on installing the connector component, refer to the installation guide, *Installation Guide for IBM WebSphere Business Integration Serve Express Plus*.

Installed file structure for Windows

Table 7. Installed Windows file structure for the connector

Subdirectory of %ProductDir%	Description
connectors\WebSphereCommerce	Contains the start up scripts, start_WebSphereCommerce.bat and start_WebSphereCommerce_service.bat. It also contains the CWWebSphereCommerce.jar file.
connectors\WebSphereCommerce\utilities	Contains the script for creating queue or alter ccid for the queue manager.
connectors\messages	Contains the WebSphereCommerceConnector.txt file as well as the WebSphereCommerceConnector_IL_TT.txt files (message files specific to a language (IL) and a country or territory (TT)).
repository	Contains the CN_WebSphereCommerce.txt file.
lib	Contains the WBIA.jar file.
bin	Contains the CWConnEnv.bat file.

For Windows, the installer adds an icon for the connector file that you can view by selecting Programs > IBM WebSphere Business Integration Express > Adapters > Connectors. For a fast way to start the connector, create a shortcut to this file on the desktop.

Installed file structure for OS/400

Table 8. Installed OS/400 file structure for the connector

Subdirectory of %ProductDir%	Description
connectors/WebSphereCommerce	Contains the connector CWWebSphereCommerce.jar and the start_WebSphereCommerce.sh files.
connectors/messages	Contains the WebSphereCommerceConnector.txt file as well as the WebSphereCommerceConnector_II_TT.txt files (message files specific to a language (II) and a country or territory (TT)).
repository	Contains the CN_WebSphereCommerce.txt file.
lib	Contains the WBIA. jar file.
bin	Contains the CWConnEnv.sh file.

For OS/400, a fast way to start the connector is to use the Console function. For information about the Console, refer to the online help provided with the Console.

Installed file structure for Linux

Table 9. Installed Linux file structure for the connector

Subdirectory of %ProductDir%	Description
connectors/WebSphereCommerce	Contains the connector CWWebSphereCommerce.jar and the start_WebSphereCommerce.sh.files.
connectors/WebSphereCommerce/utilities	Contains the script for creating queue or alter ccid for the queue manager.
connectors/messages	Contains the WebSphereCommerceConnector.txt file as well as the WebSphereCommerceConnector_II_TT.txt files (message files specific to a language (II) and a country or territory (TT)).
repository	Contains the CN_WebSphereCommerce.txt file.
lib	Contains the WBIA. jar file.
bin	Contains the CWConnEnv.sh file.

For Linux, you must start the connector using the "connector_manager" command.

Configuring the adapter

Connectors have two types of configuration properties: standard configuration properties and connector-specific configuration properties. You must set the values of these properties before you can run the adapter. To configure connector properties with InterChange Server Express as your integration broker, use Connector Configurator Express. For more information, refer to Appendix B, “Connector Configurator Express,” on page 77.

A connector obtains its configuration values at startup. During a runtime session, you may want to change the values of one or more connector properties. Changes to some connector configuration properties, such as `AgentTraceLevel`, take effect immediately. Changes to other connector properties require component restart or system restart after a change. To determine whether a property is dynamic (taking effect immediately) or static (requiring either connector component restart or system restart), refer to the Update Method column in Connector Configurator Express.

Standard connector properties

Standard configuration properties provide information that all connectors use. See Appendix A, “Standard configuration properties for connectors,” on page 63, for documentation of these properties.

Because this adapter supports only InterChange Server Express as the integration broker, the only configuration properties relevant to it are for InterChange Server Express.

Connector-specific properties

Connector-specific configuration properties provide information needed by the connector at runtime. They also provide a way of changing static information or logic within the adapter without having to recode and rebuild the agent.

The following table lists the connector-specific configuration properties for the adapter. See the sections that follow for explanations of the properties.

Note: These properties include default queue name values. You will need to change these values to match the queue names you are actually using in your set up.

Table 10. Connector-specific configuration properties

Name	Possible values	Default value	Required
<code>ApplicationPassword</code>	<i>Login password</i>		No
<code>ApplicationUserName</code>	<i>Login user ID</i>		No
<code>ArchiveQueue</code>	<i>Queue to which copies of successfully processed messages are sent</i>	<code>queue://<queue_manager_name>/WC_MQCONN.ARCHIVE</code>	No
<code>Channel</code>	<i>MQ server connector channel</i>		Yes
<code>ConfigurationMetaObject</code>	<i>Name of configuration meta-object</i>		Yes
<code>DataHandlerClassName</code>	<i>Data handler class name</i>	<code>com.crossworlds.DataHandlers.text.xml</code>	No
<code>DataHandlerConfigMO</code>	<i>Data handler meta-object</i>	<code>MO_DataHandler_Default</code>	Yes
<code>DataHandlerMimeType</code>	<i>MIME type of file</i>	<code>text/xml</code>	No
<code>ErrorQueue</code>	<i>Queue for unprocessed messages</i>	<code>queue://<queue_manager_name>/WC_MQCONN.ERROR</code>	No

Table 10. Connector-specific configuration properties (continued)

Name	Possible values	Default value	Required
FeedbackCodeMappingMO	Feedback code meta-object		No
HostName	WebSphere MQ server		Yes
InDoubtEvents	FailOnStartup Reprocess Ignore LogError	Reprocess	No
InputQueue	Poll queues	queue://<queue_manager_name>/ WC_MQCONN.IN	No
InProgressQueue	In-progress event queue	queue://<queue_manager_name>/ WC_MQCONN.IN_PROGRESS	Yes
PollQuantity	Number of messages to retrieve from each queue specified in the InputQueue property	1	No
Port	Port established for the WebSphere MQ listener		Yes
ReplyToQueue	Queue to which response messages are delivered when the adapter issues requests	queue://<queue_manager_name>/ WC_MQCONN.REPLYTO	No
UnsubscribedQueue	Queue to which unsubscribed messages are sent	queue://<queue_manager_name>/ WC_MQCONN.UNSUBSCRIBE	No
UseDefaults	true or false	false	

ApplicationPassword

Password used with UserID to log in to WebSphere MQ.

Default = None.

If the ApplicationPassword is left blank or removed, the adapter uses the default password provided by WebSphere MQ.

ApplicationUserName

User ID used with Password to log in to WebSphere MQ.

Default=None.

If the ApplicationUserName is left blank or removed, the adapter uses the default user ID provided by WebSphere MQ.

ArchiveQueue

Queue to which copies of successfully processed messages are sent.

Default = queue://<queue_manager_name>/WC_MQCONN.ARCHIVE

Channel

MQ server adapter channel through which the adapter communicates with WebSphere MQ.

Default=none.

If the Channel is left blank or removed, the adapter uses the default server channel provided by WebSphere MQ.

ConfigurationMetaObject

Name of static meta-object containing configuration information for the connector.

Default = none.

DataHandlerClassName

Data handler class to use when converting messages to and from business objects.

Default = `com.crossworlds.DataHandlers.text.xml`

DataHandlerConfigMO

Meta-object passed to data handler to provide configuration information.

Default = `MO_DataHandler_Default`

DataHandlerMimeType

Allows you to request a data handler based on a particular MIME type. The XML data handler is required for use with WebSphere Commerce.

Default = `text/xml`

ErrorQueue

Queue to which messages that could not be processed are sent.

Default = `queue://<queue_manager_name>/WC_MQCONN.ERROR`

FeedbackCodeMappingMO

Allows you to override and reassign the default feedback codes used to synchronously acknowledge receipt of messages to InterChange Server Express. This property enables you to specify a meta-object in which each attribute name is understood to represent a feedback code. The corresponding value of the feedback code is the return status that is passed to InterChange Server Express. For a listing of the default feedback codes, see "Synchronous delivery" on page 8. The adapter accepts the following attribute values representing WebSphere MQ-specific feedback codes:

- `MQFB_APPL_FIRST`
- `MQFB_APPL_FIRST_OFFSET_N` where *N* is an integer (interpreted as the value of `MQFB_APPL_FIRST + N`)

The adapter accepts the following InterChange Server Express-specific status codes as attribute values in the meta-object:

- `SUCCESS`
- `FAIL`
- `APP_RESPONSE_TIMEOUT`
- `MULTIPLE_HITS`
- `UNABLE_TO_LOGIN`
- `VALCHANGE`
- `VALDUPES`

The following table shows a sample meta-object.

Table 11. Sample feedback code meta-object attributes

Attribute name	Default value
MQFB_APPL_FIRST	SUCCESS
MQFB_APPL_FIRST + 1	FAIL
MQFB_APPL_FIRST + 2	UNABLE_TO_LOGIN

Default = none.

HostName

The name of the server hosting WebSphere MQ.

Default=none.

InDoubtEvents

Specifies how to handle in-progress events that are not fully processed due to unexpected adapter shutdown. Choose one of four actions to take if events are found in the in-progress queue during initialization:

- **FailOnStartup**. Log an error and immediately shut down.
- **Reprocess**. Process the remaining events first, then process messages in the input queue.
- **Ignore**. Disregard any messages in the in-progress queue.
- **LogError**. Log an error but do not shut down

Default = Reprocess.

InputQueue

Message queues that will be polled by the adapter for new messages. The adapter accepts multiple semi-colon delimited queue names. For example, to poll the following three queues: MyQueueA, MyQueueB, and MyQueueC, the value for connector configuration property *InputQueue* would equal: MyQueueA;MyQueueB;MyQueueC.

If the InputQueue property is not supplied, the connector starts up properly but prints a warning message, and performs request processing only. It will not perform any event processing.

The adapter polls the queues in a round-robin manner and retrieves up to *pollQuantity* number of messages from each queue. For example, if *pollQuantity* equals 2, and MyQueueA contains 2 messages, MyQueueB contains 1 message and MyQueueC contains 5 messages, the adapter retrieves messages in the following manner:

Since we have a *pollQuantity* of 2, the adapter will retrieve at most two messages from each queue per call to *pollForEvents*. For the first cycle (1 of 2), the adapter retrieves the first message from each of MyQueueA, MyQueueB, and MyQueueC. That completes the first round of polling and if we had a *pollQuantity* of 1, the adapter would stop.

Since we have a *pollQuantity* of 2, the adapter starts a second round of polling (2 of 2) and retrieves one message each from MyQueueA and MyQueueC--it skips MyQueueB since it is now empty. After polling all queues 2x each, the call to the method *pollForEvents* is complete. Here's the sequence of message retrieval:

1. 1 message from MyQueueA
2. 1 message from MyQueueB
3. 1 message from MyQueueC
4. 1 message from MyQueueA
5. Skip MyQueueB since it's now empty
6. 1 message from MyQueueC

Default = queue://<queue_manager_name>/WC_MQCONN.IN

InProgressQueue

Message queue where messages are held during processing.

Default= queue://<queue_manager_name>/WC_MQCONN.IN_PROGRESS

PollQuantity

Number of messages to retrieve from each queue specified in the InputQueue property during a pollForEvents scan.

Default =1

Port

Port established for the WebSphere MQ listener.

Default=None.

ReplyToQueue

Queue to which response messages are delivered when the adapter issues requests.

Default = queue://<queue_manager_name>/WC_MQCONN.REPLY

UnsubscribedQueue

Queue to which messages that are not subscribed are sent.

Default = queue://<queue_manager_name>/WC_MQCONN.UNSUBSCRIBED

Note: *Always check the values WebSphere MQ provides since they may be incorrect or unknown. If so, please implicitly specify values.

UseDefaults

On a Create operation, if UseDefaults is set to true, the connector checks whether a valid value or a default value is provided for each isRequired business object attribute. If a value is provided, the Create operation succeeds. If the parameter is set to false, the connector checks only for a valid value and causes the Create operation to fail if it is not provided. The default is false.

Enabling guaranteed event delivery

You can configure the guaranteed-event-delivery feature for a JMS-enabled connector in one of the following ways:

- If the connector uses a JMS event store (implemented as a JMS source queue), the connector framework can manage the JMS event store. For more information, see "Guaranteed event delivery for connectors with JMS event stores" on page 37.
- If the connector uses a non-JMS event store (for example, implemented as a JDBC table, Email mailbox, or flat files), the connector framework can use a JMS

monitor queue to ensure that no duplicate events occur. For more information, see “Guaranteed event delivery for connectors with non-JMS event stores” on page 39.

Guaranteed event delivery for connectors with JMS event stores

If the JMS-enabled connector uses JMS queues to implement its event store, the connector framework can act as a “container” and manage the JMS event store (the JMS source queue). In a single JMS transaction, the connector can remove a message from a source queue and place it on the destination queue. This section provides the following information about use of the guaranteed-event-delivery feature for a JMS-enabled connector that has a JMS event store:

- “Enabling the feature for connectors with JMS event stores”
- “Effect on event polling” on page 38

Enabling the feature for connectors with JMS event stores

To enable the guaranteed-event-delivery feature for a JMS-enabled connector that has a JMS event store, set the connector configuration properties to values shown in Table 12.

Table 12. Guaranteed-event-delivery connector properties for a connector with a JMS event store

Connector property	Value
DeliveryTransport	JMS
ContainerManagedEvents	JMS
PollQuantity	The number of events to processing in a single poll of the event store
SourceQueue	Name of the JMS source queue (event store) which the connector framework polls and from which it retrieves events for processing Note: The source queue and other JMS queues should be part of the same queue manager. If the connector’s application generates events that are stored in a different queue manager, you must define a remote queue definition on the remote queue manager. WebSphere MQ can then transfer the events from the remote queue to the queue manager that the JMS-enabled connector uses for transmission to the integration broker. For information on how to configure a remote queue definition, see your IBM WebSphere MQ documentation.

In addition to configuring the connector, you must also configure the data handler that converts between the event in the JMS store and a business object. This data-handler information consists of the connector configuration properties that Table 13 summarizes.

Table 13. Data-handler properties for guaranteed event delivery

Data-handler property	Value	Required?
MimeType	The MIME type that the data handler handles. This MIME type identifies which data handler to call.	Yes
DHClass	The full name of the Java class that implements the data handler	Yes
DataHandlerConfigMOName	The name of the top-level meta-object that associates MIME types and their data handlers	Optional

Note: The data-handler configuration properties reside in the connector configuration file with the other connector configuration properties.

If you configure a connector that has a JMS event store to use guaranteed event delivery, you must set the connector properties as described in Table 12 and Table 13. To set these connector configuration properties, use the Connector Configurator Express tool. Connector Configurator Express displays the connector properties in Table 12 on its Standard Properties tab. It displays the connector properties in Table 13 on its Data Handler tab.

Note: Connector Configurator Express activates the fields on its Data Handler tab only when the DeliveryTransport connector configuration property is set to JMS and ContainerManagedEvents is set to JMS.

For information on Connector Configurator Express, see Appendix B, “Connector Configurator Express,” on page 77.

Effect on event polling

If a connector uses guaranteed event delivery by setting ContainedManagedEvents to JMS, it behaves slightly differently from a connector that does not use this feature. To provide container-managed events, the connector framework takes the following steps to poll the event store:

1. Start a JMS transaction.
2. Read a JMS message from the event store.
The event store is implemented as a JMS source queue. The JMS message contains an event record. The name of the JMS source queue is obtained from the SourceQueue connector configuration property.
3. Call the data handler to convert the event to a business object.
The connector framework calls the data handler that has been configured with the properties in Table 13 on page 38.
4. Send the resulting message to the JMS destination queue.
The message sent to the JMS destination queue is the business object.
5. Commit the JMS transaction.
When the JMS transaction commits, the message is written to the JMS destination queue and removed from the JMS source queue in the same transaction.
6. Repeat step 1 through 5 in a loop. The PollQuantity connector property determines the number of repetitions in this loop.

Important: A connector that sets the `ContainerManagedEvents` property is set to JMS does *not* call the `pollForEvents()` method to perform event polling. If the connector's base class includes a `pollForEvents()` method, this method is *not* invoked.

Guaranteed event delivery for connectors with non-JMS event stores

If the JMS-enabled connector uses a non-JMS solution to implement its event store (such as a JDBC event table, Email mailbox, or flat files), the connector framework can use duplicate event elimination to ensure that duplicate events do not occur. This section provides the following information about use of the guaranteed-event-delivery feature with a JMS-enabled connector that has a non-JMS event store:

- “Enabling the feature for connectors with non-JMS event stores”
- “Effect on event polling” on page 38

Enabling the feature for connectors with non-JMS event stores: To enable the guaranteed-event-delivery feature for a JMS-enabled connector that has a non-JMS event store, you must set the connector configuration properties to values shown in Table 14.

Table 14. Guaranteed-event-delivery connector properties for a connector with a non-JMS event store

Connector property	Value
<code>DeliveryTransport</code>	JMS
<code>DuplicateEventElimination</code>	true
<code>MonitorQueue</code>	Name of the JMS monitor queue, in which the connector framework stores the <code>ObjectEventId</code> of processed business objects

If you configure a connector to use guaranteed event delivery, you must set the connector properties as described in Table 14. To set these connector configuration properties, use the Connector Configurator Express tool. It displays these connector properties on its Standard Properties tab. For information on Connector Configurator Express, see Appendix B, “Connector Configurator Express,” on page 77.

Effect on event polling: If a connector uses guaranteed event delivery by setting `DuplicateEventElimination` to true, it behaves slightly differently from a connector that does not use this feature. To provide the duplicate event elimination, the connector framework uses a JMS monitor queue to track a business object. The name of the JMS monitor queue is obtained from the `MonitorQueue` connector configuration property.

After the connector framework receives the business object from the application-specific component (through a call to `getAppEvent()` in the `pollForEvents()` method), it must determine if the current business object (received from `getAppEvents()`) represents a duplicate event. To make this determination, the connector framework retrieves the business object from the JMS monitor queue and compares its `ObjectEventId` with the `ObjectEventId` of the current business object:

- If these ObjectEventIds are the same, the current business object represents a duplicate event. In this case, the connector framework ignores the event that the current business object represents; it does *not* send this event to InterChange Server Express.
- If these ObjectEventIds are *not* the same, the business object does *not* represent a duplicate event. In this case, the connector framework copies the current business object to the JMS monitor queue and then delivers it to the JMS delivery queue, all as part of the same JMS transaction. The name of the JMS delivery queue is obtained from the DeliveryQueue connector configuration property. Control returns to the connector's pollForEvents() method, after the call to the gotAppEvent() method.

For a JMS-enabled connector to support duplicate event elimination, you must make sure that the connector's pollForEvents() method includes the following steps:

- When you create a business object from an event record retrieved from the non-JMS event store, save the event record's unique event identifier as the business object's ObjectEventId attribute.
The application generates this event identifier to uniquely identify the event record in the event store. If the connector goes down after the event has been sent to InterChange Server Express but before this event record's status can be changed, this event record remains in the event store with an In-Progress status. When the connector comes back up, it should recover any In-Progress events. When the connector resumes polling, it generates a business object for the event record that still remains in the event store. However, because both the business object that was already sent and the new one have the same event record as their ObjectEventIds, the connector framework can recognize the new business object as a duplicate and not send it to InterChange Server Express.
- During connector recovery, make sure that you process In-Progress events *before* the connector begins polling for new events.
Unless the connector changes any In-Progress events to Ready-for-Poll status when it starts up, the polling method does not pick up the event record for reprocessing.

Queue uniform resource identifiers (URIs)

The URI for a queue begins with the sequence queue:// followed by:

- The name of the queue manager on which the queue resides
- Another /
- The name of the queue
- Optionally, a list of name-value pairs to set the remaining queue properties.

For example, the following URI connects to queue IN on queue manager <queue.manager.name> and causes all messages to be sent as WebSphere MQ messages with priority 5.

```
queue://<queue.manager.name>/WC_MQCONN.IN?targetClient=1&priority=5
```

The following table shows property names for queue URIs.

Table 15. WebSphere MQ-specific connector property names for queue URIs

Property name	Description	Values
expiry	Lifetime of the message in milliseconds.	0 = unlimited. positive integers = timeout (in ms).
priority	Priority of the message.	0-9, where 1 is the highest priority. A value of -1 means that the property should be determined by the configuration of the queue. A value of -2 specifies that the connector can use its own default value.
persistence	Whether the message should be 'hardened' to disk.	1 = non-persistent 2 = persistent A value of -1 means that the property should be determined by the configuration of the queue. A value of -2 specifies that the connector can use its own default value.
CCSID	Character set of the destination.	Integers - valid values listed in base WebSphere MQ documentation.
targetClient	Whether the receiving application is JMS compliant or not.	0 = JMS (MQRFH2 header) 1 = MQ (MQMD header only)
encoding	How to represent numeric fields.	An integer value as described in the base WebSphere MQ documentation.

The adapter has no control of the character set (CCSID) or encoding attributes of data in MQMessages. Because data conversion is applied as the data is retrieved from or delivered to the message buffer, the adapter relies upon the IBM WebSphere MQ implementation of JMS to convert data (see the IBM WebSphere MQ Java client library documentation). Accordingly, these conversions should be bi-directionally equivalent to those performed by the native WebSphere MQ API using option MQGMO_CONVERT.

The adapter has no control over differences or failures in the conversion process. The adapter can retrieve message data of any CCSID or encoding supported by WebSphere MQ without additional modifications. To deliver a message of a specific CCSID or encoding, the output queue must be a fully-qualified URI and specify values for CCSID and encoding. The adapter passes this information to WebSphere MQ, which (via the JMS API) uses the information when encoding data for MQMessage delivery.

Often, lack of support for CCSID and encoding can be resolved by downloading the most recent version of the IBM WebSphere MQ Java client library from IBM's

web site. If problems specific to CCSID and encoding persist, contact Technical Support to discuss the possibility of using an alternate Java Virtual Machine to run the adapter.

Configuring meta-object attributes

The adapter for WebSphere Commerce can recognize and read two kinds of meta-objects:

- a static connector meta-object
- a dynamic child meta-object

The attribute values of the dynamic child meta-object duplicate and override those of the static meta-object.

Static meta-objects

A WebSphere Commerce static meta-object consists of a list of conversion properties defined for different business objects. To define the conversion properties for a business object, first create a string attribute and name it using the syntax `busObj_verb`. For example, to define the conversion properties for a Customer object with the verb Create, create an attribute named `Customer_Create`. In the application-specific text of the attribute, you specify the actual conversion properties.

Additionally, a reserved attribute named `Default` can be defined in the meta-object. When this attribute is present, its properties act as default values for all business object conversion properties.

Note: If a static meta object is not specified, the connector is unable to map a given message format to a specific business object type during polling. When this is the case, the connector passes the message text to the configured data handler without specifying a business object. If the data handler cannot create a business object based on the text alone, the adapter reports an error indicating that this message format is unrecognized.

Table 16 describes the meta-object properties.

Table 16. WebSphere Commerce static meta-object properties

Property name	Description
<code>CollaborationName</code>	Note: This property is only for synchronous event handling, which is not supported in this version of the adapter.
<code>DataEncoding</code>	<code>DataEncoding</code> is the encoding to be used to read and write messages. If this property is not specified in the static meta-object, the connector tries to read the messages without using any specific encoding. <code>DataEncoding</code> defined in a dynamic child meta-object overrides the value defined in the static meta-object. The default value is <code>Text</code> . The format for the value of this attribute is <code>messageType[:enc]</code> . I.e., <code>Text:ISO8859_1</code> , <code>Text:UnicodeLittle</code> , <code>Text</code> , or <code>Binary</code> .
<code>DataHandlerConfigMO</code>	Meta-object passed to data handler to provide configuration information. If specified in the static meta-object, this will override the value specified in the <code>DataHandlerConfigMO</code> connector property. If defined in a dynamic child meta-object, this property will override the connector property and the static meta-object property. The specified business object must be supported by the adapter.

Table 16. WebSphere Commerce static meta-object properties (continued)

Property name	Description
DataHandlerMimeType	<p>Specifies the data handler based on a particular MIME type. You must use the text/xml MIME type in order for the adapter to interact with WebSphere Commerce.</p> <p>If specified in the static meta-object, this property will override the value specified in the DataHandlerMimeType connector property. If defined in a dynamic child meta-object, this property will override the connector property and the static meta-object property. The business object specified in DataHandlerConfigM0 should have an attribute that corresponds to the value of this property.</p>
DoNotReportBusObj	<p>Optionally, the user can include the DoNotReportBusObj property. By setting this property to true, all PAN report messages issued will have a blank message body. This is recommended when a requestor wants to confirm that a request has been successfully processed and does not need notification of changes to the business object. This does not effect NAN reports.</p> <p>If this property is not found in the static meta-object, the adapter will default it to false and populate the message report with the business object.</p> <p>Note: This property is only for synchronous event handling, which is not supported in this version of the adapter.</p>
InputFormat	<p>The InputFormat is the message format to associate with the given business object. When a message is retrieved and is in this format, it is converted to the given business object if possible.</p>
OutputFormat	<p>The OutputFormat is set on messages created from the given business object. If the OutputFormat is not specified, the input format is used, if available. An OutputFormat defined in a dynamic child meta-object overrides the value defined in the static meta-object.</p>
InputQueue	<p>The input queue that the connector polls to detect new messages. You can use connector-specific properties to configure multiple InputQueues and optionally map different data handlers to each queue.</p>
OutputQueue	<p>The OutputQueue is the output queue to which messages derived from the given business object are delivered. An OutputQueue defined in a dynamic child meta-object overrides the value defined in the static meta-object.</p>
ResponseTimeout	<p>Indicates the length of time in milliseconds to wait before timing out when waiting for a response. The adapter returns SUCCESS immediately without waiting for a response if this is left undefined or with a value less than zero. A ResponseTimeout defined in a dynamic child meta-object overrides the value defined in the static meta-object.</p>
TimeoutFatal	<p>If this property is defined and has a value of True, the adapter returns APP_RESPONSE_TIMEOUT when a response is not received within the time specified by ResponseTimeout. All other threads waiting for response messages immediately return APP_RESPONSE_TIMEOUT to InterChange Server Express. This causes InterChange Server Express to terminate the adapter. A TimeoutFatal defined in a dynamic child meta-object overrides the value defined in the static meta-object.</p>

Table 17. JMS static meta-object structure for Customer_Create

Attribute name	Application-specific text
Customer_Create	DataEncoding=Text:UnicodeLittle; InputFormat=CUST_IN; OutputFormat=CUST_OUT; OutputQueue=QueueA; ResponseTimeout=10000; TimeoutFatal=False

Application-specific text

The application-specific text is structured in name-value pair format, separated by semicolons. For example:

```
InputFormat=CUST_IN;OutputFormat=CUST_OUT
```

Mapping data handlers to InputQueues

You can use the `InputQueue` property in the application-specific information of the static meta-object to associate a data handler with an input queue. This feature is useful when dealing with multiple trading partners who have different formats and conversion requirements. To do so you must:

1. Use connector-specific properties (see “`InputQueue`” on page 35) to configure one or more input queues.
2. For each input queue, specify the queue manager and input queue name as well as data handler class name and mime type in the application-specific information.

For example, the following attribute in a static meta-object associates a data handler with an `InputQueue` named `CompReceipts`:

```
[Attribute]
Name = Cust_Create
Type = String
Cardinality = 1
MaxLength = 1
IsKey = false
IsForeignKey = false
IsRequired = false
AppSpecificInfo = InputQueue=//queue.manager/CompReceipts;
  DataHandlerClassName=com.crossworlds.
  DataHandlers.MQ.disposition_notification;DataHandlerMimeType=message/
  disposition_notification
IsRequiredServerBound = false
[End]
```

Overloading input formats

When retrieving a message, the connector normally matches the input format to one specific business object and verb combination. The adapter then passes the business object name and the contents of the message to the data handler. This allows the data handler to verify that the message contents correspond to the business object that the user expects.

If, however, the same input format is defined for more than one business object, the connector will be unable to determine which business object the data represents before passing it to the data handler. In such cases, the adapter passes the message contents only to the data handler and then looks up conversion properties based on the business object that is generated. Accordingly, the data handler must determine the business object based on the message content alone.

If the verb on the generated business object is not set, the connector searches for conversion properties defined for this business object with any verb. If only one set

of conversion properties is found, the connector assigns the specified verb. If more properties are found, the connector fails the message because it is unable to distinguish among the verbs.

A sample meta-object

The meta-object shown below configures the connector to convert Customer business objects using the verb Create.

```
[BusinessObjectDefinition]
Name = MO_WebSphereCommerceConfig
Version = 3.0.0

  [Attribute]
  Name = Default
  Type = String
  MaxLength = 1
  IsKey = true
  IsForeignKey = false
  IsRequired = false
  AppSpecificInfo = OutputQueue=queue://<Queue Manager
    Name>/WCS_Serial_Inbound?targetClient=1;
    OutputFormat=MQSTR
  IsRequiredServerBound = false
  [End]
  [Attribute]
  Name = WCS_Create_WCS_Customer_Create
  Type = String
  MaxLength = 255
  IsKey = false
  IsForeignKey = false
  IsRequired = false
  AppSpecificInfo = OutputQueue=queue://<Queue Manager
    Name>/WCS_Serial_Inbound?targetClient=1;
    OutputFormat=MQSTR
  IsRequiredServerBound = false
  [End]
  [Attribute]
  Name = WCS_Report_NC_PurchaseOrder_Create
  Type = String
  MaxLength = 255
  IsKey = false
  IsForeignKey = false
  IsRequired = false
  AppSpecificInfo = InputFormat=MQSTR
  IsRequiredServerBound = false
  [End]
  [Attribute]
  Name = ObjectEventId
  Type = String
  MaxLength = 255
  IsKey = false
  IsForeignKey = false
  IsRequired = false
  IsRequiredServerBound = false
  [End]

  [Verb]
  Name = Create
  [End]

  [Verb]
  Name = Delete
  [End]

  [Verb]
  Name = Retrieve
  [End]
```

```

[Verb]
Name = Update
[End]
[End]

```

Dynamic child meta-objects

If it is difficult to specify the meta-data through a static meta-object, the connector can accept meta-data specified at run time for each business object instance.

The connector recognizes and reads conversion properties from a dynamic meta-object added as a child to the top-level business object passed to the connector. The attribute values of the dynamic child meta-object duplicate the conversion properties that you can specify via the static meta-object that is used to configure the connector.

Since dynamic child meta object properties override those found in static meta-objects, if you specify a dynamic child meta-object, you need not include a connector property that specifies the static meta-object. Accordingly, you can use a dynamic child meta-object independently of the static meta-object and vice-versa.

Table 17 and Table 18 show sample static and dynamic child meta-objects, respectively, for business object `Customer_Create`. Note that the application-specific text consists of semi-colon delimited name-value pairs.

Table 18. WebSphere Commerce Dynamic Child Meta-Object Structure for Customer_Create

Attribute name	Value
DataEncoding	Text:UnicodeLittle
DataHandlerMimeType ^a	text/delimited
OutputFormat	CUST_OUT
OutputQueue	QueueA
ResponseTimeout	10000
TimeoutFatal	False

a. Assumes that `DataHandlerConfigMO` has been specified in either the connector configuration properties or the static meta-object.

The connector checks the application-specific text of top-level business objects to determine whether tag `cw_mo_conn` specifies a child meta-object. If so, the dynamic child meta-object values override those specified in the static meta-object.

Activity during polling

In order to provide collaborations with more information regarding messages retrieved during polling, the connector populates specific attributes of the dynamic meta-object, if already defined for the business object created.

Table 19 shows how a dynamic child meta-object might be structured for polling.

Table 19. JMS dynamic child meta-object structure for polling

Attribute name	Sample value
InputFormat	CUST_IN
InputQueue	MYInputQueue
OutputFormat	CxIgnore
OutputQueue	CxIgnore
ResponseTimeout	CxIgnore
TimeoutFatal	CxIgnore

As shown in Table 19, you can define an additional attribute, `InputQueue`, in a dynamic child meta-object. This attribute contains the name of the queue from which a given message has been retrieved. If this property is not defined in the child meta-object, it will not be populated.

Example scenario:

- The connector retrieves a message with the format `CUST_IN` from the queue `MyInputQueue`.
- The connector converts this message to a `Customer` business object and checks the application-specific text to determine if a meta-object is defined.
- If so, the connector creates an instance of this meta-object and populates the `InputQueue` and `InputFormat` attributes accordingly, then publishes the business object to available collaborations.

Sample dynamic child meta-object

```
[BusinessObjectDefinition]
Name = MO_Sample_Config
Version = 1.0.0

  [Attribute]
  Name = OutputFormat
  Type = String
  MaxLength = 1
  IsKey = true
  IsForeignKey = false
  IsRequired = false
  DefaultValue = CUST
  IsRequiredServerBound = false
  [End]
  [Attribute]
  Name = OutputQueue
  Type = String
  MaxLength = 1
  IsKey = false
  IsForeignKey = false
  IsRequired = false
  DefaultValue = OUT
  IsRequiredServerBound = false
  [End]
  [Attribute]
  Name = ResponseTimeout
  Type = String
  MaxLength = 1
  IsKey = false
  IsForeignKey = false
  IsRequired = false
  DefaultValue = -1
  IsRequiredServerBound = false
  [End]
  [Attribute]
  Name = TimeoutFatal
  Type = String
  MaxLength = 1
  IsKey = false
  IsForeignKey = false
  IsRequired = false
  DefaultValue = false
  IsRequiredServerBound = false
  [End]
  [Attribute]
  Name = InputFormat
```

```

Type = String
MaxLength = 1
IsKey = true
IsForeignKey = false
IsRequired = false
IsRequiredServerBound = false
[End]
[Attribute]
Name = InputQueue
Type = String
MaxLength = 1
IsKey = false
IsForeignKey = false
IsRequired = false
IsRequiredServerBound = false
[End]
[Attribute]
Name = ObjectEventId
Type = String
MaxLength = 255
IsKey = false
IsForeignKey = false
IsRequired = false
IsRequiredServerBound = false
[End]

[Verb]
Name = Create
[End]

[Verb]
Name = Delete
[End]

[Verb]
Name = Retrieve
[End]

[Verb]
Name = Update
[End]
[End]
[BusinessObjectDefinition]
Name = Customer
Version = 1.0.0
AppSpecificInfo = cw_mo_conn=MyConfig

[Attribute]
Name = FirstName
Type = String
MaxLength = 1
IsKey = true
IsForeignKey = false
IsRequired = false
IsRequiredServerBound = false
[End]
[Attribute]
Name = LastName
Type = String
MaxLength = 1
IsKey = true
IsForeignKey = false
IsRequired = false
IsRequiredServerBound = false
[End]
[Attribute]
Name = Telephone

```

```

Type = String
MaxLength = 1
IsKey = false
IsForeignKey = false
IsRequired = false
IsRequiredServerBound = false
[End]
[Attribute]
Name = MyConfig
Type = MO_Sample_Config
ContainedObjectVersion = 1.0.0
Relationship = Containment
Cardinality = 1
MaxLength = 1
IsKey = false
IsForeignKey = false
IsRequired = false
IsRequiredServerBound = false
[End]
[Attribute]
Name = ObjectEventId
Type = String
MaxLength = 255
IsKey = false
IsForeignKey = false
IsRequired = false
IsRequiredServerBound = false
[End]

[Verb]
Name = Create
[End]

[Verb]
Name = Delete
[End]

[Verb]
Name = Retrieve
[End]

[Verb]
Name = Update
[End]
[End]

```

Creating multiple connector instances

Note: When you create an additional instance of this adapter (or any adapter that is supplied with WebSphere Business Integration Server Express or Express Plus), that instance of the adapter will be counted as a separate adapter by the licensing function that limits the total number of adapters that can be deployed.

You can set your system up to create and run multiple instances of a connector by following the steps below. You must:

- Create a new directory for the connector instance
- Make sure you have the requisite business object definitions
- Create a new connector definition file
- Create a new start-up script

Create a new directory

You must create a connector directory for each connector instance. Name the connector directory:

- For Windows platforms,

ProductDir\connectors\connectorInstance

If the connector has any connector-specific meta-objects, you must create a meta-object for the connector instance. If you save the meta-object as a file, create this directory and store the file here:

ProductDir\Repository\connectorInstance

Specify the ICS servername as a parameter of startup.bat; an example is start_WebSphereCommerce.bat connName serverName.

- For OS/400 platforms,

/QIBM/UserData/WBIServer43/WebSphereICSName/connectors/connectorInstance

where connectorInstance uniquely identifies the connector instance and where WebSphereICSName is the name of the InterChange Server Express instance with which the connector runs

If the connector has any connector-specific meta-objects, you must create a meta-object for the connector instance. If you save the meta-object as a file, create this directory and store the file here:

/QIBM/UserData/WBIServer43/WebSphereICSName/repository/connectorInstance

where WebSphereICSName is the name of the InterChange Server Express instance with which the connector runs

Specify the ICS servername as a parameter of start_WebSphereCommerce.sh; an example is start_WebSphereCommerce.sh connName serverName [-cConfigFile].

- For Linux platforms,

ProductDir/connectors/connectorInstance

where connectorInstance uniquely identifies the connector instance. If the connector has any connector-specific meta-objects, you must create a meta-object for the connector instance. If you save the meta-object as a file, create this directory and store the file here: *ProductDir/repository/connectorInstance*

Specify the ICS servername as a parameter of connector_manager; an example is connector_manager -start connName [-cConfigFile].

Create business object definitions

If the business object definitions for each connector instance do not already exist within the project, you must create them.

1. If you need to modify business object definitions that are associated with the initial connector, copy the appropriate files and use Business Object Designer Express to import them. You can copy any of the files for the initial connector. Just rename them if you make changes to them.
2. Files for the initial connector should reside in the appropriate directory:
 - Windows:
\ProductDir\Repository\initialConnectorInstance
Any additional files you create should be in the appropriate connector instance subdirectory of *\ProductDir\Repository*
 - OS/400: *QIBM/UserData/WBIServer43/WebSphereICSName/repository/initialConnectorInstance* where WebSphereICSName is the name of the InterChange Server Express server instance with which the connector runs

Any additional files you create should be in the appropriate connectorInstance subdirectory of:
/QIBM/UserData/WBIServer43/WebSphereICSName/repository

- Linux:

/ProductDir/repository/initialConnectorInstance

Any additional files you create should be in the appropriate connectorInstance subdirectory of /ProductDir/repository

Create a connector definition

You create a configuration file (connector definition) for the connector instance in Connector Configurator Express. To do so:

1. Copy the initial connector's configuration file (connector definition) and rename it.
2. Make sure each connector instance correctly lists its supported business objects (and any associated meta-objects).
3. Customize any connector properties as appropriate.

Create a start-up script

To create a startup script:

1. Copy the initial connector's startup script and name it to include the name of the connector directory:
dirname
(For Linux only.) You must change the start-up script CONJAR from
CONJAR=\${CONDIR}/CW\${CONNNAME}.jar to
"CONJAR=\${CONDIR}/CWWebSphereCommerce.jar"
2. Put this startup script in the connector directory you created in "Create a new directory" on page 50
3. (For Windows only.) Create a startup script shortcut.
4. (For Windows only.) Copy the initial connector's shortcut text and change the name of the initial connector (in the command line) to match the name of the new connector instance.
5. (For OS/400 only.) Create a job description for the connector using the information below: CRTDUPOBJ OBJ(QWBWEBCSC) FROMLIB(QWBISVR43) OBJTYPE(*JOB) TOLIB(QWBISVR43) NEWOBJ(newcommercename)
where *newcommercename* is a 10-character name that you use for the job description for your new WebSphere Commerce connector.
6. (For OS/400 only.) Add the new connector to the Console. For information about the Console, refer to the online help provided with the Console.

You can now run both instances of the connector on your integration server at the same time.

Configuring the startup file

Before you start the adapter for WebSphere Commerce, you must configure the startup file.

Windows

To complete the configuration of the adapter for Windows platforms, you must modify the startup file (either start_WebSphereCommerceAdapter.bat or start_WebSphereCommerce.bat, whichever is provided with your adapter):

1. Open the start_WebSphereCommerceAdapter.bat file.

- Specify the directory containing your WebSphere MQ Java client libraries.

OS/400

On the OS/400 it is not necessary to configure the startup file. The `start_WebSphereCommerce.sh` script can be used as installed to start the adapter.

Linux

To complete the configuration of the adapter for Linux platforms, you must modify the startup file (either `start_WebSphereCommerceAdapter.sh` or `start_WebSphereCommerce.sh`, whichever is provided with your adapter):

- Open the `start_WebSphereCommerceAdapter.sh` file.
- Scroll to the section beginning with “Set the directory containing your WebSphere MQ Java client libraries,” and specify the location of your WebSphere MQ Java client libraries.

Starting the connector

A connector must be explicitly started using its connector start-up script. The startup script should reside in the connector’s runtime directory. For example, for Windows use:

```
ProductDir\connectors\connName
```

where *connName* identifies the connector. The name of the startup script depends on the operating-system platform, as seen in Table 20.

Table 20. Startup scripts for a connector

Operating system	Startup script
Windows	<code>start_connName.bat</code>
OS/400	<code>start_connName.sh</code>
Linux	<code>connector_manager -start connName [-cConfigFile]</code> sets environmental variables and starts the <code>start_connName.sh</code> start-up script automatically. You do not have to run the start-up script manually.

For more information on how to start a connector, including the command line start-up options, refer to the *System Administration Guide*.

Starting the connector

Invoking the start-up script on Windows

On Windows platforms, you can invoke the connector start-up script in the following ways:

- From system Monitor
 - You can load, activate, deactivate, pause, shutdown or delete a connector using this tool.
- From the **Start** menu
 - Select Program > IBM WebSphere Business Integration Express > Adapters > Connectors > `your_connector_name`.

By default, the program name is "IBM WebSphere Business Integration Express." However, it can be customized. Alternatively, you can create a desktop shortcut to your connector.

On Windows systems, you can configure the connector to start as a Windows service. In this case, the connector starts when the Windows system boots (for an Auto service) or when you start the service through the Windows Services window (for a Manual service).

- From the command line

```
start_connName connName WebSphereICSName [-cconfigFile ]
```

where *connName* is the name of the connector and *WebSphereICSName* is the name of the InterChange Server Express instance. By default, the name of the InterChange Server Express instance is *WebSphereICS*.

Invoking the start-up script on OS/400

On OS/400 platforms, you can invoke the connector start-up script in the following ways:

- From Windows (where the WBI SE Console is installed)
 1. Select Programs > IBM WebSphere Business Integration Console > Console.
 2. Specify the OS/400 system name or IP address and a user profile and password that has *JOBCTL special authority.
 3. Select the *connName* adapter from the list of adapters and select the Start Adapter button.
- From the OS/400 command line
- From System Monitor

You can load, activate, deactivate, pause, shutdown or delete a connector using this tool.

In Batch mode: Run the command line command QSH and from the QSHELL environment, run `/QIBM/ProdData/WBIServer43/bin/submit_adapter.sh connName WebSphereICSName pathToConnNameStartScript jobDescriptionName`

where *connName* is the connector name, *WebSphereICSName* is the InterChange Server Express server name (default is *QWBIDFT*), *pathToConnNameStartScript* is the full path to the connector start script, *jobDescriptionName* is the name of the job description to use in the *QWBISVR43* library (default job description name, *QWBIWEBCSC*).

In interactive mode: Run the command line command QSH and from the QSHELL environment, run

```
/QIBM/UserData/WBIServer43/WebSphereICSName/connectors  
/connName/start_connName.sh connName WebSphereICSName  
[-cConfigFile]
```

where *connName* is the name of your connector and *WebSphereICSName* is the name of the Interchange Server Express instance.

Note: To start with the TCP/IP autostart servers on OS/400, run the command line command QSH and from QShell, run the following script:

```
/QIBM/ProdData/WBIServer43/bin/add_autostart_adapter.sh connName  
WebSphereICSName pathToConnNameStartScript jobDescriptionName
```

where `connName` is the connector name, `WebSphereICSName` is the InterChange Server Express server name (default is `QWBIDFT`), `pathToConnNameStartScript` is the full path to the connector start script, and `jobDescriptionName` is the name of the job description to use in the `QWBISVR43` library (default job description name is `QWBIWEBCSC`).

Invoking the start-up script on Linux

On Linux platforms, you can invoke the connector start-up script in the following way:

```
connector_manager -start connName WebSphereICSName |[-cConfigFile]
```

where `connName` is the name of the connector.

Stopping the connector

The way to stop a connector depends on the way that the connector was started.

Stopping the connector from Windows

On Windows platforms, you can stop the connector in the following ways:

- From System Monitor
You can load, activate, deactivate, pause, shutdown or delete a connector using this tool.
- Activate the connector window.
- Enter "q" and press Enter.
- If the connector started as a Windows service, you can stop it by using the Control Panel (Control panel > Administrative Tools > Services > CWConnectorWBIWebSphereCommerceAdapter).

Stopping the connector from OS/400

On OS/400 platforms, you can stop the connector in the following ways:

- From the Console or command line (in batch mode)
If you started the connector using the Console or using the "submit_adapter.sh" script in QSHELL:
 1. From the OS/400 command entry, display the jobs for the Server Express product by using the CL command, `WRKACTJOB SBS(QWBISVR43)`.
 2. Scroll the list and find the job with a jobname that matches the job description for the connector. For example, for the WebSphere Commerce connector the jobname is `QWBIWEBCSC`.
 3. To get the prompt for the ENDJOB command, select option 4 on this job, and press F4.
 4. Specify *IMMED for the Option parameter and press enter.
- If you used the `start_connName.sh` script to start the adapter from QSHELL, press F3 to end the connector.
- From System Monitor
You can load, activate, deactivate, pause, shutdown, or delete a connector using this tool.

Stopping the connector from Linux

On Linux systems, connectors run in the background so they have no separate window. Instead, run the following command to stop the connector:

```
connector_manager -stop connName WebSphereICSName [-cConfigFile]
```

where connName is the name of the connector.

Chapter 3. Working with business objects

This chapter describes how the adapter processes business objects and describes the assumptions the connector makes. You can use this information as a guide to implementing new business objects.

This chapter also describes how the adapter processes business objects and describes the assumptions the connector makes. You can use this information as a guide to implementing new business objects. Topics in this chapter include:

- “Business object structure”
- “Error handling” on page 58
- “Tracing” on page 59

The adapter comes with sample business objects only. The systems integrator, consultant, or customer must build your specific business objects.

The sample business objects are contained under the /samples directory in your delivered adapter package.

The adapter is metadata-driven. In this context, metadata is data about the application, which is stored in a business object definition and which helps the adapter interact with an application. A metadata-driven connector handles each business object that it supports based on metadata encoded in the business object definition rather than on instructions hard-coded in the connector.

Business object metadata includes the structure of a business object, the settings of its attribute properties, and the content of its application-specific text. Because the connector is metadata-driven, it can handle new or modified business objects without requiring modifications to the adapter code. However, the adapter’s configured data handler makes assumptions about the structure of its business objects, object cardinality, the format of the application-specific text, and the database representation of the business object. Therefore, when you create or modify a business object for the adapter, your modifications must conform to the rules the adapter is designed to follow, or it cannot process new or modified business objects correctly.

Business object structure

After installing the adapter, you must create business objects.

The adapter for WebSphere Commerce retrieves WebSphere MQ messages from a queue and attempts to populate business objects (defined by the meta-object) with the business data contained in the message.

The business data in the MQ Series messages exchanged by the adapter is contained within XML documents. The adapter uses an XML data handler to convert the data from the XML documents into business objects, and from business objects into XML documents.

The structure of the business object definitions must conform to the requirements of the XML data handler. For information about these requirements, and for instructions on how to use XML DTDs and the Edifecs SpecBuilder utility to

translate a DTD into a business object definition, refer to the *WebSphere Business Integration Server Express Data Handler Guide*.

To see the properties and structure used in a typical Customer_Create business object definition for WebSphere Commerce, open the file `/connector/WebSphereCommerce/samples/WC_BODefinition.in`.

Error handling

All error messages generated by the adapter are stored in a message file named `WebSphereCommerce.txt`. (The name of the file is determined by the `LogFile` standard connector configuration property.) Each error has an error number followed by the error message:

Message number
Message text

The adapter handles specific errors as described in the following sections.

Application timeout

The error message `BON_APPRESPONSETIMEOUT` is returned when:

- The adapter cannot establish a connection to WebSphere MQ during message retrieval.
- The connector successfully converts a business object to a message but cannot deliver it the outgoing queue due to connection loss.
- The adapter issues a message but times out waiting for a response for a business object with conversion property `TimeoutFatal` equal to `True`.
- The adapter receives a response message with a return code equal to `APP_RESPONSE_TIMEOUT` or `UNABLE_TO_LOGIN`.

Unsubscribed business object

If the adapter retrieves a message that is associated with an unsubscribed business object, the adapter delivers a message to the queue specified by the `UnsubscribedQueue` property.

Note: If the `UnsubscribedQueue` is not defined, unsubscribed messages will be discarded.

Data handler conversion

If the data handler fails to convert a message to a business object, or if a processing error occurs that is specific to the business object (as opposed to WebSphere MQ), the message is delivered to the queue specified by `ErrorQueue`. If the `ErrorQueue` is not defined, messages that cannot be processed due to errors will be discarded.

If the data handler fails to convert a business object to a message, `BON_FAIL` is returned.

Tracing

Tracing is an optional debugging feature you can turn on to closely follow adapter behavior. Trace messages, by default, are written to STDOUT. See the connector configuration properties for more on configuring trace messages. For more information on tracing, including how to enable and set it, see the *System Implementation Guide*.

What follows is recommended content for trace messages.

- | | |
|---------|---|
| Level 0 | This level is used for trace messages that identify the adapter version. |
| Level 1 | Use this level for trace messages that provide key information on each business object processed or record each time a polling thread detects a new message in an input queue. |
| Level 2 | Use this level for trace messages that log each time a business object is posted to InterChange Server Express, either from <code>gotAppEvent()</code> or <code>executeCollaboration()</code> . |
| Level 3 | Use this level for trace messages that provide information regarding message-to-business-object and business-object-to-message conversions or provide information about the delivery of the message to the output queue. |
| Level 4 | Use this level for trace messages that identify when the adapter enters or exits a function. |
| Level 5 | Use this level for trace messages that indicate adapter initialization, represent statements executed in the application, indicate whenever a message is taken off of or put onto a queue, or record business object dumps. |

Chapter 4. Troubleshooting

This chapter describes problems that you may encounter when starting up or running the adapter.

Start-up problems

Problem

The adapter shuts down unexpectedly during initialization and the following message is reported:
Exception in thread "main"
java.lang.NoClassDefFoundError:
javax.jms/JMSException...

The adapter shuts down unexpectedly during initialization and the following message is reported:
Exception in thread "main"
java.lang.NoClassDefFoundError:
com.ibm/mq/jms/MQConnectionFactory...

The adapter shuts down unexpectedly during initialization and the following message is reported:
Exception in thread "main"
java.lang.NoClassDefFoundError:
javax.naming.Referenceable...

The adapter shuts down unexpectedly during initialization and the following exception is reported:
java.lang.UnsatisfiedLinkError: no mqjbd01 in shared library path

The adapter reports MQJMS2005: failed to create MQQueueManager for ':'

The adapter reports that classes could not be found.

The adapter hangs on startup

Potential solution / explanation

Adapter cannot find file `jms.jar` from the IBM WebSphere MQ Java client libraries. Ensure that variable `MQSERIES_JAVA_LIB` in `start_connector.bat` points to the IBM WebSphere MQ Java client library folder.

Adapter cannot find file `com.ibm.mqjms.jar` from the IBM WebSphere MQ Java client libraries. Ensure that variable `MQSERIES_JAVA_LIB` in `start_connector.bat` points to the IBM WebSphere MQ Java client library folder.

Adapter cannot find file `jndi.jar` from the IBM WebSphere MQ Java client libraries. Ensure that variable `MQSERIES_JAVA_LIB` in `start_connector.bat` points to the IBM WebSphere MQ Java client library folder.

Adapter cannot find a required run-time library from the IBM WebSphere MQ Java client libraries. Ensure that your path includes the IBM WebSphere MQ Java client library folder.

Explicitly set values for the following properties: `HostName`, `Channel`, and `Port`.

Verify that the following directories are included in the paths for the classes:

```
<MQSeries Install>\java\lib
```

```
<install_path>\bin
```

Verify that the WebSphere MQ listener is running.

Event processing

Problem

The adapter delivers all messages with an `MQRFH2` header.

The adapter truncates all message formats to 8-characters upon delivery regardless of how the format has been defined in the adapter meta-object.

Potential solution / explanation

To deliver messages with only the `MQMD` WebSphere MQ header, append `?targetClient=1` to the name of output queue URI. For example, if you output messages to queue `queue://my.queue.manager/OUT`, change the URI to `queue://my.queue.manager/OUT?targetClient=1`. See Chapter 2, "Installing and configuring the connector," on page 15, for more information.

This is a limitation of the WebSphere MQ `MQMD` message header and not the adapter.

Appendix A. Standard configuration properties for connectors

This appendix describes the standard configuration properties for the connector component of the adapters in WebSphere Business Integration Server Express, running on WebSphere InterChange Server Express.

Not every connector makes use of all these standard properties. When you select an integration broker from Connector Configurator Express, you will see a list of the standard properties that you need to configure for your adapter.

For information about properties specific to the connector, see the relevant adapter user guide.

Configuring standard connector properties

Adapter connectors have two types of configuration properties:

- Standard configuration properties
- Connector-specific configuration properties

This section describes the standard configuration properties. For information on configuration properties specific to a connector, see its adapter user guide.

Using Connector Configurator Express

You configure connector properties from Connector Configurator Express, which you access from System Manager. For more information on using Connector Configurator Express, refer to the Connector Configurator Express appendix.

Setting and updating property values

The default length of a property field is 255 characters.

The connector uses the following order to determine a property's value (where the highest number overrides other values):

1. Default
2. Repository
3. Local configuration file
4. Command line

A connector obtains its configuration values at startup. If you change the value of one or more connector properties during a run-time session, the property's **Update Method** determines how the change takes effect. There are four different update methods for standard connector properties:

- **Dynamic**
The change takes effect immediately after it is saved in System Manager.
- **Component restart**
The change takes effect only after the connector is stopped and then restarted in System Manager. You do not need to stop and restart the application-specific component or the integration broker.

- **Server restart**
The change takes effect only after you stop and restart the application-specific component and the integration broker.
- **Agent restart**
The change takes effect only after you stop and restart the application-specific component.

To determine how a specific property is updated, refer to the **Update Method** column in the Connector Configurator Express window, or see the Update Method column in the Property Summary table below.

Summary of standard properties

Table 21 provides a quick reference to the standard connector configuration properties. Not all the connectors make use of all these properties, and property settings may differ from integration broker to integration broker, as standard property dependencies are based on RepositoryDirectory.

You must set the values of some of these properties before running the connector. See the following section for an explanation of each property.

Table 21. Summary of standard configuration properties

Property name	Possible values	Default value	Update method	Notes
AdminInQueue	Valid JMS queue name	CONNECTORNAME /ADMININQUEUE	Component restart	Delivery Transport is JMS
AdminOutQueue	Valid JMS queue name	CONNECTORNAME/ADMINOUTQUEUE	Component restart	Delivery Transport is JMS
AgentConnections	1-4	1	Component restart	Delivery Transport is IDL
AgentTraceLevel	0-5	0	Dynamic	
ApplicationName	Application name	Value specified for the connector application name	Component restart	
BrokerType	ICS	ICS		
CharacterEncoding	ascii7, ascii8, SJIS, Cp949, GBK, Big5, Cp297, Cp273, Cp280, Cp284, Cp037, Cp437 Note: This is a subset of supported values.	ascii7	Component restart	
ConcurrentEventTriggeredFlows	1 to 32,767	1	Component restart	Repository directory is <REMOTE>
ContainerManagedEvents	No value or JMS	No value	Component restart	Delivery Transport is JMS
ControllerStoreAndForwardMode	true or false	truetrue	Dynamic	Repository directory is <REMOTE>

Table 21. Summary of standard configuration properties (continued)

Property name	Possible values	Default value	Update method	Notes
ControllerTraceLevel	0-5	0	Dynamic	Repository directory is <REMOTE>
DeliveryQueue		CONNECTORNAME/DELIVERYQUEUE	Component restart	JMS transport only
DeliveryTransport	IDL or JMS	IDL	Component restart	
DuplicateEventElimination	true or false	false	Component restart	JMS transport only: Container Managed Events must be <NONE>
EnableOidForFlowMonitoring	true or false	false	Component restart	
FaultQueue		CONNECTORNAME/FAULTQUEUE	Component restart	JMS transport only
jms.FactoryClassName	CxCommon.Messaging.jms.IBMMQSeriesFactory or any Java class name	CxCommon.Messaging.jms.IBMMQSeriesFactory	Component restart	JMS transport only
jms.MessageBrokerName	crossworlds.queue.manager	crossworlds.queue.manager	Component restart	JMS transport only
jms.NumConcurrentRequests	Positive integer	10	Component restart	JMS transport only
jms.Password	Any valid password		Component restart	JMS transport only
jms.UserName	Any valid name		Component restart	JMS transport only
JvmMaxHeapSize	Heap size in megabytes	128m	Component restart	Repository directory is <REMOTE>
JvmMaxNativeStackSize	Size of stack in kilobytes	128k	Component restart	Repository directory is <REMOTE>
JvmMinHeapSize	Heap size in megabytes	1m	Component restart	Repository directory is <REMOTE>
Locale	en_US, ja_JP, ko_KR, zh_CN, zh_TW, fr_FR, de_DE, it_IT, es_ES, pt_BR Note: This is a subset of the supported locales.	en_US	Component restart	
LogAtInterchangeEnd	true or false	false	Component restart	
MaxEventCapacity	1-2147483647	2147483647	Dynamic	Repository Directory is <REMOTE>
MessageFileName	Path or filename	InterchangeSystem.txt	Component restart	

Table 21. Summary of standard configuration properties (continued)

Property name	Possible values	Default value	Update method	Notes
MonitorQueue	Any valid queue name	CONNECTORNAME/MONITORQUEUE	Component restart	JMS transport only: DuplicateEvent Elimination must be true
OADAutoRestartAgent	true or false	false	Dynamic	Repository Directory is <REMOTE>
OADMaxNumRetry	A positive number	1000	Dynamic	Repository Directory is <REMOTE>
OADRetryTimeInterval	A positive number in minutes	10	Dynamic	Repository Directory is <REMOTE>
PollEndTime	HH:MM (HH is 0-23, MM is 0-59)	HH:MM	Component restart	
PollFrequency	A positive integer in milliseconds no (to disable polling) key (to poll only when the letter p is entered in the connector's Command Prompt window)	10000	Dynamic	
PollQuantity	1-500	1	Agent restart	JMS transport only: Container Managed Events is specified
PollStartTime	HH:MM(HH is 0-23, MM is 0-59)	HH:MM	Component restart	
RequestQueue	Location of metadata repository		Agent restart	Set to <REMOTE>
RequestQueue	Valid JMS queue name	CONNECTORNAME/REQUESTQUEUE	Component restart	Delivery Transport is JMS
ResponseQueue	Valid JMS queue name	CONNECTORNAME/RESPONSEQUEUE	Component restart	Delivery Transport is JMS:
RestartRetryCount	0-99	3	Dynamic	
RestartRetryCount	A sensible positive value in minutes: 1 - 2147483547	1	Dynamic	
SourceQueue	Valid JMS queue name	CONNECTORNAME/SOURCEQUEUE	Agent restart	Only if Delivery Transport is JMS and Container Managed Events is specified
SynchronousRequestQueue	Valid JMS queue name	CONNECTORNAME/ SYNCHRONOUSREQUESTQUEUE	Component restart	Delivery Transport is JMS

Table 21. Summary of standard configuration properties (continued)

Property name	Possible values	Default value	Update method	Notes
SynchronousRequestTimeout	0 - any number (milliseconds)	0	Component restart	Delivery Transport is JMS
SynchronousResponseQueue	Valid JMS queue name	CONNECTORNAME/ SYNCHRONOUSRESPONSEQUEUE	Component restart	Delivery Transport is JMS
WireFormat	CwBO	CwBO	Agent restart	

Standard configuration properties

This section lists and defines each of the standard connector configuration properties.

AdminInQueue

The queue that is used by the integration broker to send administrative messages to the connector.

The default value is CONNECTORNAME/ADMININQUEUE.

AdminOutQueue

The queue that is used by the connector to send administrative messages to the integration broker.

The default value is CONNECTORNAME/ADMINOUTQUEUE.

AgentConnections

The AgentConnections property controls the number of ORB connections opened by `orb.init[]`.

By default, the value of this property is set to 1. There is no need to change this default.

AgentTraceLevel

Level of trace messages for the application-specific component. The default is 0. The connector delivers all trace messages applicable at the tracing level set or lower.

ApplicationName

Name that uniquely identifies the connector's application. This name is used by the system administrator to monitor the WebSphere business integration system environment. This property must have a value before you can run the connector.

BrokerType

Identifies the integration broker that you are using, which is ICS.

CharacterEncoding

Specifies the character code set used to map from a character (such as a letter of the alphabet, a numeric representation, or a punctuation mark) to a numeric value.

Note: Java-based connectors do not use this property. A C++ connector currently uses the value `ascii7` for this property.

By default, a subset of supported character encodings only is displayed in the drop list. To add other supported values to the drop list, you must manually modify the `\Data\Std\stdConnProps.xml` file in the product directory. For more information, see the appendix on using Connector Configurator Express in this guide.

ConcurrentEventTriggeredFlows

Determines how many business objects can be concurrently processed by the connector for event delivery. Set the value of this attribute to the number of business objects you want concurrently mapped and delivered. For example, set the value of this property to 5 to cause five business objects to be concurrently processed. The default value is 1.

Setting this property to a value greater than 1 allows a connector for a source application to map multiple event business objects at the same time and deliver them to multiple collaboration instances simultaneously. This speeds delivery of business objects to the integration broker, particularly if the business objects use complex maps. Increasing the arrival rate of business objects to collaborations can improve overall performance in the system.

To implement concurrent processing for an entire flow (from a source application to a destination application), you must:

- Configure the collaboration to use multiple threads by setting its `Maximum number of concurrent events` property high enough to use multiple threads.
- Ensure that the destination application's application-specific component can process requests concurrently. That is, it must be multi-threaded, or be able to use connector agent parallelism and be configured for multiple processes. Set the `Parallel Process Degree` configuration property to a value greater than 1.

The `ConcurrentEventTriggeredFlows` property has no effect on connector polling, which is single-threaded and performed serially.

ContainerManagedEvents

This property allows a JMS-enabled connector with a JMS event store to provide guaranteed event delivery, in which an event is removed from the source queue and placed on the destination queue as a single JMS transaction.

This property only appears if the `DeliveryTransport` property is set to the value `JMS`.

The default value is `No value`.

When `ContainerManagedEvents` is set to `JMS`, you must configure the following properties to enable guaranteed event delivery:

- `PollQuantity` = 1 to 500
- `SourceQueue` = `CONNECTORNAME/SOURCEQUEUE`

You must also configure a data handler with the `MimeType`, `DHClass`, and `DataHandlerConfigMOName` (optional) properties. To set those values, use the **Data Handler** tab in Connector Configurator Express. The fields for the values under the Data Handler tab will be displayed only if you have set `ContainerManagedEvents` to `JMS`.

Note: When `ContainerManagedEvents` is set to `JMS`, the connector does *not* call its `pollForEvents()` method, thereby disabling that method's functionality.

ControllerStoreAndForwardMode

Sets the behavior of the connector controller after it detects that the destination application-specific component is unavailable.

If this property is set to `true` and the destination application-specific component is unavailable when an event reaches ICS, the connector controller blocks the request to the application-specific component. When the application-specific component becomes operational, the controller forwards the request to it.

However, if the destination application's application-specific component becomes unavailable **after** the connector controller forwards a service call request to it, the connector controller fails the request.

If this property is set to `false`, the connector controller begins failing all service call requests as soon as it detects that the destination application-specific component is unavailable.

The default is `true`.

ControllerTraceLevel

Level of trace messages for the connector controller. The default is `0`.

DeliveryQueue

Applicable only if `DeliveryTransport` is `JMS`.

The queue that is used by the connector to send business objects to the WebSphere InterChange Server Express.

The default value is `CONNECTORNAME/DELIVERYQUEUE`.

DeliveryTransport

Specifies the transport mechanism for the delivery of events. Possible values are `IDL` for CORBA IIOP or `JMS` for Java Messaging Service. The default is `IDL`.

The connector sends service call requests and administrative messages over CORBA IIOP if the value configured for the `DeliveryTransport` property is `IDL`.

JMS

Enables communication between the connector and client connector framework using Java Messaging Service (JMS).

If you select `JMS` as the delivery transport, additional JMS properties such as `jms.MessageBrokerName`, `jms.FactoryClassName`, `jms.Password`, and `jms.UserName`, appear in Connector Configurator Express. The first two of these properties are required for this transport.

Important: There may be a memory limitation if you use the `JMS` transport mechanism for a connector running on WebSphere InterChange Server Express.

In this environment, you may experience difficulty starting both the connector controller (on the server side) and the connector (on the client side) due to memory use within the WebSphere MQ client.

DuplicateEventElimination

When you set this property to true, a JMS-enabled connector can ensure that duplicate events are not delivered to the delivery queue. To use this feature, the connector must have a unique event identifier set as the business object's **ObjectEventId** attribute in the application-specific code. This is done during connector development.

This property can also be set to false.

Note: When DuplicateEventElimination is set to true, you must also configure the MonitorQueue property to enable guaranteed event delivery.

EnableOidForFlowMonitoring

When you set this property to true, the adapter framework will mark the incoming **ObjectEventId** as a foreign key for the purpose of flow monitoring.

The default is false.

FaultQueue

If the connector experiences an error while processing a message then the connector moves the message to the queue specified in this property, along with a status indicator and a description of the problem.

The default value is CONNECTORNAME/FAULTQUEUE.

JvmMaxHeapSize

The maximum heap size for the agent (in megabytes).

The default value is 128m.

JvmMaxNativeStackSize

The maximum native stack size for the agent (in kilobytes).

The default value is 128k.

JvmMinHeapSize

The minimum heap size for the agent (in megabytes).

The default value is 1m.

jms.FactoryClassName

Specifies the class name to instantiate for a JMS provider. You *must* set this connector property when you choose JMS as your delivery transport mechanism (DeliveryTransport).

The default is CxCommon.Messaging.jms.IBMMQSeriesFactory.

jms.MessageBrokerName

Specifies the broker name to use for the JMS provider. You *must* set this connector property when you choose JMS as your delivery transport mechanism (see DeliveryTransport).

The default is `crossworlds.queue.manager`.

jms.NumConcurrentRequests

Specifies the maximum number of concurrent service call requests that can be sent to a connector at the same time. Once that maximum is reached, new service calls block and wait for another request to complete before proceeding.

The default value is 10.

jms.Password

Specifies the password for the JMS provider. A value for this property is optional.

There is no default.

jms.UserName

Specifies the user name for the JMS provider. A value for this property is optional.

There is no default.

Locale

Specifies the language code, country or territory, and, optionally, the associated character code set. The value of this property determines such cultural conventions as collation and sort order of data, date and time formats, and the symbols used in monetary specifications.

A locale name has the following format:

ll_TT.codeset

where:

<i>ll</i>	a two-character language code (usually in lower case)
<i>TT</i>	a two-letter country or territory code (usually in upper case)
<i>codeset</i>	the name of the associated character code set; this portion of the name is often optional.

By default, only a subset of supported locales appears in the drop list. To add other supported values to the drop list, you must manually modify the `\Data\Std\stdConnProps.xml` file in the product directory. For more information, see the appendix on using Connector Configurator Express in this guide.

The default value is `en_US`. If the connector has not been globalized, the only valid value for this property is `en_US`. To determine whether a specific connector has been globalized, see the connector version list on these websites:

<http://www.ibm.com/software/websphere/wbiadapters/infocenter>, or
<http://www.ibm.com/websphere/integration/wicserver/infocenter>

LogAtInterchangeEnd

Specifies whether to log errors to the integration broker's log destination. Logging to the broker's log destination also turns on e-mail notification, which generates e-mail messages for the MESSAGE_RECIPIENT specified in the InterchangeSystem.cfg file when errors or fatal errors occur.

For example, when a connector loses its connection to its application, if LogAtInterChangeEnd is set to true, an e-mail message is sent to the specified message recipient. The default is false.

MaxEventCapacity

The maximum number of events in the controller buffer. This property is used by flow control.

The value can be a positive integer between 1 and 2147483647. The default value is 2147483647.

MessageFileName

The name of the connector message file. The standard location for the message file is \connectors\messages. Specify the message filename in an absolute path if the message file is not located in the standard location.

If a connector message file does not exist, the connector uses InterchangeSystem.txt as the message file. This file is located in the product directory.

Note: To determine whether a specific connector has its own message file, see the individual adapter user guide.

MonitorQueue

The logical queue that the connector uses to monitor duplicate events. It is used only if the DeliveryTransport property value is JMS and DuplicateEventElimination is set to TRUE.

The default value is CONNECTORNAME/MONITORQUEUE

OADAutoRestartAgent

Specifies whether the connector uses the automatic and remote restart feature. This feature uses the MQ-triggered Object Activation Daemon (OAD) to restart the connector after an abnormal shutdown, or to start a remote connector from System Monitor.

This property must be set to true to enable the automatic and remote restart feature. For information on how to configure the MQ-triggered OAD feature, see the *Installation Guide for Windows*.

The default value is false.

OADMaxNumRetry

Specifies the maximum number of times that the MQ-triggered OAD automatically attempts to restart the connector after an abnormal shutdown. The OADAutoRestartAgent property must be set to true for this property to take effect.

The default value is 1000.

OADRetryTimeInterval

Specifies the number of minutes in the retry-time interval for the MQ-triggered OAD. If the connector agent does not restart within this retry-time interval, the connector controller asks the OAD to restart the connector agent again. The OAD repeats this retry process as many times as specified by the OADMaxNumRetry property. The OADAutoRestartAgent property must be set to true for this property to take effect.

The default is 10.

PollEndTime

Time to stop polling the event queue. The format is *HH:MM*, where *HH* represents 0-23 hours, and *MM* represents 0-59 seconds.

You must provide a valid value for this property. The default value is *HH:MM*, but must be changed.

PollFrequency

The amount of time between polling actions. Set *PollFrequency* to one of the following values:

- The number of milliseconds between polling actions.
- The word *key*, which causes the connector to poll only when you type the letter *p* in the connector's Command Prompt window. Enter the word in lowercase.
- The word *no*, which causes the connector not to poll. Enter the word in lowercase.

The default is 10000.

Important: Some connectors have restrictions on the use of this property. To determine whether a specific connector does, see the installing and configuring chapter of its adapter guide.

PollQuantity

Designates the number of items from the application that the connector should poll for. If the adapter has a connector-specific property for setting the poll quantity, the value set in the connector-specific property will override the standard property value.

PollStartTime

The time to start polling the event queue. The format is *HH:MM*, where *HH* represents 0-23 hours, and *MM* represents 0-59 seconds.

You must provide a valid value for this property. The default value is *HH:MM*, but must be changed.

RequestQueue

The queue that is used by WebSphere InterChange Server Express to send business objects to the connector.

The default value is *CONNECTOR/REQUESTQUEUE*.

RepositoryDirectory

The location of the repository from which the connector reads the XML schema documents that store the meta-data for business object definitions.

This value must be set to <REMOTE> because the connector obtains this information from the InterChange Server Express repository.

ResponseQueue

Applicable only if DeliveryTransport is JMS.

Designates the JMS response queue, which delivers a response message from the connector framework to the integration broker. WebSphere InterChange Server Express sends the request and waits for a response message in the JMS response queue.

RestartRetryCount

Specifies the number of times the connector attempts to restart itself. When used for a parallel connector, specifies the number of times the master connector application-specific component attempts to restart the slave connector application-specific component.

The default is 3.

RestartRetryInterval

Specifies the interval in minutes at which the connector attempts to restart itself. When used for a parallel connector, specifies the interval at which the master connector application-specific component attempts to restart the slave connector application-specific component. Possible values ranges from 1 to 2147483647.

The default is 1.

SourceQueue

Applicable only if DeliveryTransport is JMS and ContainerManagedEvents is specified.

Designates the JMS source queue for the connector framework in support of guaranteed event delivery for JMS-enabled connectors that use a JMS event store. For further information, see “ContainerManagedEvents” on page 68

The default value is CONNECTOR/SOURCEQUEUE.

SynchronousRequestQueue

Applicable only if DeliveryTransport is JMS.

Delivers request messages that require a synchronous response from the connector framework to the broker. This queue is necessary only if the connector uses synchronous execution. With synchronous execution, the connector framework sends a message to the SynchronousRequestQueue and waits for a response back from the broker on the SynchronousResponseQueue. The response message sent to the connector bears a correlation ID that matches the ID of the original message.

The default is CONNECTORNAME/SYNCHRONOUSREQUESTQUEUE

SynchronousResponseQueue

Applicable only if DeliveryTransport is JMS.

Delivers response messages sent in reply to a synchronous request from the broker to the connector framework. This queue is necessary only if the connector uses synchronous execution.

The default is CONNECTORNAME/SYNCHRONOUSRESPONSEQUEUE

SynchronousRequestTimeout

Applicable only if DeliveryTransport is JMS.

Specifies the time in minutes that the connector waits for a response to a synchronous request. If the response is not received within the specified time, then the connector moves the original synchronous request message into the fault queue along with an error message.

The default value is 0.

WireFormat

This is the message format on the transport. The setting is CwB0.

Appendix B. Connector Configurator Express

This appendix describes how to use Connector Configurator Express to set configuration property values for your adapter.

The topics covered in this appendix are:

- “Overview of Connector Configurator Express” on page 77
- “Starting Connector Configurator Express” on page 78
- “Creating a connector-specific property template” on page 78
- “Creating a new configuration file” on page 81
- “Setting the configuration file properties” on page 83
- “Using Connector Configurator Express in a globalized environment” on page 88

Overview of Connector Configurator Express

Connector Configurator Express allows you to configure the connector component of your adapter for use with WebSphere InterChange Server Express.

You use Connector Configurator Express to:

- Create a **connector-specific property template** for configuring your connector.
- Create a **connector configuration file**; you must create one configuration file for each connector you install.
- Set properties in a configuration file.
You may need to modify the default values that are set for properties in the connector templates. You must also designate supported business object definitions and maps for use with collaborations as well as specify messaging, logging and tracing, and data handler parameters, as required.

Connector configuration properties include both standard configuration properties (the properties that all connectors have) and connector-specific properties (properties that are needed by the connector for a specific application or technology).

Because **standard properties** are used by all connectors, you do not need to define those properties from scratch; Connector Configurator Express incorporates them into your configuration file as soon as you create the file. However, you do need to set the value of each standard property in Connector Configurator Express.

The range of standard properties may not be the same for all brokers and all configurations. Some properties are available only if other properties are given a specific value. The Standard Properties window in Connector Configurator Express will show the properties available for your particular configuration.

For **connector-specific properties**, however, you need first to define the properties and then set their values. You do this by creating a connector-specific property template for your particular adapter. There may already be a template set up in your system, in which case, you simply use that. If not, follow the steps in “Creating a new template” on page 79 to set up a new one.

Note: Connector Configurator Express runs only in a Windows environment. If you are running the connector in another environment, use Connector Configurator Express in Windows to modify the configuration file and then copy the file to the other environment.

Starting Connector Configurator Express

You can start and run Connector Configurator Express in either of two modes:

- Independently, in stand-alone mode
- From System Manager

Running Configurator Express in stand-alone mode

You can run Connector Configurator Express independently and work with connector configuration files, irrespective of your broker.

To do so:

- From **Start>Programs**, click **IBM WebSphere Business Integration Server Express>Toolset Express>Development>Connector Configurator Express**.
- Select **File>New>Configuration File**.

You may choose to run Connector Configurator Express independently to generate the file, and then connect to System Manager to save it in a System Manager project (see “Completing a configuration file” on page 83.)

Running Configurator Express from System Manager

You can run Connector Configurator Express from System Manager.

To run Connector Configurator Express:

1. Open the System Manager.
2. In the System Manager window, expand the **Integration Component Libraries** icon and highlight **Connectors**.
3. From the System Manager menu bar, click **Tools>Connector Configurator Express**. The Connector Configurator Express window opens and displays a **New Connector** dialog box.

To edit an existing configuration file:

1. In the System Manager window, select any of the configuration files listed in the Connector folder and right-click on it.
2. Click the Standard Properties tab to see which properties are included in this configuration file.

Creating a connector-specific property template

To create a configuration file for your connector, you need a connector-specific property template as well as the system-supplied standard properties.

You can create a brand-new template for the connector-specific properties of your connector, or you can use an existing file as the template.

- To create a new template, see “Creating a new template” on page 79.
- To use an existing file, simply modify an existing template and save it under the new name.

Creating a new template

This section describes how you create properties in the template, define general characteristics and values for those properties, and specify any dependencies between the properties. Then you save the template and use it as the base for creating a new connector configuration file.

To create a template:

1. Click **File>New>Connector-Specific Property Template**.
2. The **Connector-Specific Property Template** dialog box appears, with the following fields:
 - **Template**, and **Name**
Enter a unique name that identifies the connector, or type of connector, for which this template will be used. You will see this name again when you open the dialog box for creating a new configuration file from a template.
 - **Old Template**, and **Select the Existing Template to Modify**
The names of all currently available templates are displayed in the **Template Name** display.
 - To see the connector-specific property definitions in any template, select that template's name in the **Template Name** display. A list of the property definitions contained in that template will appear in the **Template Preview** display. You can use an existing template whose property definitions are similar to those required by your connector as a starting point for your template.
3. Select a template from the **Template Name** display, enter that template name in the **Find Name** field (or highlight your selection in **Template Name**), and click **Next**.

If you do not see any template that displays the connector-specific properties used by your connector, you will need to create one.

Specifying general characteristics

When you click **Next** to select a template, the **Properties - Connector-Specific Property Template** dialog box appears. The dialog box has tabs for General characteristics of the defined properties and for Value restrictions. The General display has the following fields:

- **General:**
 - Property Type
 - Updated Method
 - Description
- **Flags**
 - Standard flags
- **Custom Flag**
 - Flag

After you have made selections for the general characteristics of the property, click the **Value** tab.

Specifying values

The **Value** tab enables you to set the maximum length, the maximum multiple values, a default value, or a value range for the property. It also allows editable values. To do so:

1. Click the **Value** tab. The display panel for Value replaces the display panel for General.

2. Select the name of the property in the **Edit properties** display.
3. In the fields for **Max Length** and **Max Multiple Values**, make any changes. The changes will not be accepted unless you also open the **Property Value** dialog box for the property, described in the next step.
4. Right-click the box in the top left-hand corner of the value table and click **Add**. A **Property Value** dialog box appears. Depending on the property type, the dialog box allows you to enter either a value, or both a value and range. Enter the appropriate value or range, and click **OK**.
5. The **Value** panel refreshes to display any changes you made in **Max Length** and **Max Multiple Values**. It displays a table with three columns:

The **Value** column shows the value that you entered in the **Property Value** dialog box, and any previous values that you created.

The **Default Value** column allows you to designate any of the values as the default.

The **Value Range** shows the range that you entered in the **Property Value** dialog box.

After a value has been created and appears in the grid, it can be edited from within the table display. To make a change in an existing value in the table, select an entire row by clicking on the row number. Then right-click in the **Value** field and click **Edit Value**.

Setting dependencies

When you have made your changes to the **General** and **Value** tabs, click **Next**. The **Dependencies - Connector-Specific Property Template** dialog box appears.

A dependent property is a property that is included in the template and used in the configuration file *only if* the value of another property meets a specific condition. For example, `PollQuantity` appears in the template only if `JMS` is the transport mechanism and `DuplicateEventElimination` is set to `True`.

To designate a property as dependent and to set the condition upon which it depends, do this:

1. In the **Available Properties** display, select the property that will be made dependent.
2. In the **Select Property** field, use the drop-down menu to select the property that will hold the conditional value.
3. In the **Condition Operator** field, select one of the following:
 - == (equal to)
 - != (not equal to)
 - > (greater than)
 - < (less than)
 - >= (greater than or equal to)
 - <=(less than or equal to)
4. In the **Conditional Value** field, enter the value that is required in order for the dependent property to be included in the template.
5. With the dependent property highlighted in the **Available Properties** display, click an arrow to move it to the **Dependent Property** display.
6. Click **Finish**. Connector Configurator Express stores the information you have entered as an XML document, under `\data\app` in the `\bin` directory where you have installed Connector Configurator Express.

Creating a new configuration file

You create a connector configuration file from a connector-specific template or by modifying an existing configuration file.

Creating a configuration file from a connector-specific template

Once a connector-specific template has been created, you can use it to create a configuration file:

1. Click **File>New>Connector Configuration**.

2. The **New Connector** dialog box appears, with the following fields:

- **Name**

Enter the name of the connector. Names are case-sensitive. The name you enter must be unique, and must be consistent with the file name for a connector that is installed on the system.

Important: Connector Configurator Express does not check the spelling of the name that you enter. You must ensure that the name is correct.

- **System Connectivity**

The default broker is ICS. You cannot change this value.

- **Select Connector-Specific Property Template**

Type the name of the template that has been designed for your connector. The available templates are shown in the **Template Name** display. When you select a name in the Template Name display, the **Property Template Preview** display shows the connector-specific properties that have been defined in that template.

Select the template you want to use and click **OK**.

3. A configuration screen appears for the connector that you are configuring. The title bar shows the integration broker and connector names. You can fill in all the field values to complete the definition now, or you can save the file and complete the fields later.

4. To save the file, click **File>Save>To File** or **File>Save>To Project**. To save to a project, System Manager must be running.

If you save as a file, the **Save File Connector** dialog box appears. Choose *.cfg as the file type, verify in the File Name field that the name is spelled correctly and has the correct case, navigate to the directory where you want to locate the file, and click **Save**. The status display in the message panel of Connector Configurator Express indicates that the configuration file was successfully created.

Important: The directory path and name that you establish here must match the connector configuration file path and name that you supply in the startup file for the connector.

5. To complete the connector definition, enter values in the fields for each of the tabs of the Connector Configurator Express window, as described later in this chapter.

Using an existing file

To use an existing file to configure a connector, you must open the file in Connector Configurator Express, revise the configuration, and then save the file as a configuration file (*.cfg).

You may have an existing file available in one or more of the following formats:

- A connector definition file.
This is a text file that lists properties and applicable default values for a specific connector. Some connectors include such a file in a \repository directory in their delivery package (the file typically has the extension .txt; for example, CN_XML.txt for the XML connector).
- An InterChange Server Express repository file.
Definitions used in a previous InterChange Server Express implementation of the connector may be available to you in a repository file that was used in the configuration of that connector. Such a file typically has the extension .in or .out.
- A previous configuration file for the connector.
Such a file typically has the extension *.cfg.

Although any of these file sources may contain most or all of the connector-specific properties for your connector, the connector configuration file will not be complete until you have opened the file and set properties, as described later in this chapter.

To use an existing file to configure a connector, you must open the file in Connector Configurator Express, revise the configuration, and then resave the file.

Follow these steps to open a *.txt, *.cfg or *.in file from a directory:

1. In Connector Configurator Express, click **File>Open>From File**.
2. In the **Open File Connector** dialog box, select one of the following file types to see the available files:
 - Configuration (*.cfg)
 - InterChange Server Express Repository (*.in, *.out)
Choose this option if a repository file was used to configure the connector. A repository file may include multiple connector definitions, all of which will appear when you open the file.
 - All files (*.*)
Choose this option if a *.txt file was delivered in the adapter package for the connector, or if a definition file is available under another extension.
3. In the directory display, navigate to the appropriate connector definition file, select it, and click **Open**.

Follow these steps to open a connector configuration from a System Manager project:

1. Start System Manager. A configuration can be opened from or saved to System Manager only if System Manager has been started.
2. Start Connector Configurator Express.
3. Click **File>Open>From Project**.

Completing a configuration file

When you open a configuration file or a connector from a project, the Connector Configurator Express window displays the configuration screen, with the current attributes and values.

Connector Configurator Express requires values for properties described in the following sections:

- “Setting standard connector properties”
- “Setting application-specific configuration properties” on page 84
- “Specifying supported business object definitions” on page 85
- “Associated maps” on page 86
- “Setting trace/log file values” on page 87

Note: For connectors that use JMS messaging, an additional category may display, for special configuration of data handlers that convert the data to business objects. For further information, see “Data handlers” on page 88.

Setting the configuration file properties

When you create and name a new connector configuration file, or when you open an existing connector configuration file, Connector Configurator Express displays a configuration screen with tabs for the categories of required configuration values.

Standard properties differ from connector-specific properties as follows:

- Standard properties of a connector are shared by both the application-specific component of a connector and its broker component. All connectors have the same set of standard properties. These properties are described in Appendix A of each adapter guide. You can change some but not all of these values.
- Application-specific properties apply only to the application-specific component of a connector, that is, the component that interacts directly with the application. Each connector has application-specific properties that are unique to its application. Some of these properties provide default values and some do not; you can modify some of the default values. The installation and configuration chapters of each adapter guide describe the application-specific properties and the recommended values.

The fields for **Standard Properties** and **Connector-Specific Properties** are color-coded to show which are configurable:

- A field with a grey background indicates a standard property. You can change the value but cannot change the name or remove the property.
- A field with a white background indicates an application-specific property. These properties vary according to the specific needs of the application or connector. You can change the value and delete these properties.
- You can configure Value fields.
- The **Update Method** displayed for each property indicates whether a component or agent restart is necessary to activate changed values.

Setting standard connector properties

To change the value of a standard property:

1. Click in the field whose value you want to set.
2. Either enter a value, or select one from the drop-down menu if it appears.

3. After entering all the values for the standard properties, you can do one of the following:
 - To discard the changes, preserve the original values, and exit Connector Configurator Express, click **File>Exit** (or close the window), and click **No** when prompted to save changes.
 - To enter values for other categories in Connector Configurator Express, select the tab for the category. The values you enter for **Standard Properties** (or any other category) are retained when you move to the next category. When you close the window, you are prompted to either save or discard the values that you entered in all the categories as a whole.
 - To save the revised values, click **File>Exit** (or close the window) and click **Yes** when prompted to save changes. Alternatively, click **Save>To File** from either the File menu or the toolbar.

Setting application-specific configuration properties

For application-specific configuration properties, you can add or change property names, configure values, delete a property, and encrypt a property. The default property length is 255 characters.

1. Right-click in the top left portion of the grid. A pop-up menu bar will appear. Click **Add** to add a property. To add a child property, right-click on the parent row number and click **Add child**.
2. Enter a value for the property or child property.
3. To encrypt a property, select the **Encrypt** box.
4. Choose to save or discard changes, as described for “Setting standard connector properties” on page 83.

The Update Method displayed for each property indicates whether a component or agent restart is necessary to activate changed values.

Important: Changing a preset application-specific connector property name may cause a connector to fail. Certain property names may be needed by the connector to connect to an application or to run properly.

Encryption for connector properties

Application-specific properties can be encrypted by selecting the **Encrypt** check box in the **Edit Property** window. To decrypt a value, click to clear the **Encrypt** check box, enter the correct value in the **Verification** dialog box, and click **OK**. If the entered value is correct, the value is decrypted and displays.

The adapter user guide for each connector contains a list and description of each property and its default value.

If a property has multiple values, the **Encrypt** check box will appear for the first value of the property. When you select **Encrypt**, all values of the property will be encrypted. To decrypt multiple values of a property, click to clear the **Encrypt** check box for the first value of the property, and then enter the new value in the **Verification** dialog box. If the input value is a match, all multiple values will decrypt.

Update method

Refer to the descriptions of update methods found in the *Standard configuration properties for connectors* appendix, under “Setting and updating property values” on page 63.

Connector properties are almost all static and the **Update Method** is Component restart. For changes to take effect, you must restart the connector after saving the revised connector configuration file.

Specifying supported business object definitions

Use the **Supported Business Objects** tab in Connector Configurator Express to specify the business objects that the connector will use. You must specify both generic business objects and application-specific business objects, and you must specify associations for the maps between the business objects.

For you to specify a supported business object, the business objects and their maps must exist in the system. Business object definitions, including those for data handler meta-objects, and map definitions should be saved into Integration Component Library (ICL) projects. For more information on ICL projects, see the *User Guide for WebSphere Business Integration Server Express*.

Note: Some connectors require that certain business objects be specified as supported in order to perform event notification or additional configuration (using meta-objects) with their applications. For more information, see the chapter on business objects in this guide as well as the *Business Object Development Guide*.

To specify that a business object definition is supported by the connector, or to change the support settings for an existing business object definition, click the **Supported Business Objects** tab and use the following fields.

Business object name

To designate that a business object definition is supported by the connector, with System Manager running:

1. Click an empty field in the **Business Object Name** list. A drop-down list displays, showing all the business object definitions that exist in the System Manager project.
2. Click on a business object to add it.
3. Set the **Agent Support** (described below) for the business object.
4. In the File menu of the Connector Configurator Express window, click **Save to Project**. The revised connector definition, including designated support for the added business object definition, is saved to the project in System Manager.

To delete a business object from the supported list:

1. To select a business object field, click the number to the left of the business object.
2. From the **Edit** menu of the Connector Configurator Express window, click **Delete Row**. The business object is removed from the list display.
3. From the **File** menu, click **Save to Project**.

Deleting a business object from the supported list changes the connector definition and makes the deleted business object unavailable for use in this implementation of this connector. It does not affect the connector code, nor does it remove the business object definition itself from System Manager.

Agent support

If a business object has Agent Support, the system will attempt to use that business object for delivering data to an application via the connector agent.

Typically, application-specific business objects for a connector are supported by that connector's agent, but generic business objects are not.

To indicate that the business object is supported by the connector agent, check the **Agent Support** box. The Connector Configurator Express window does not validate your Agent Support selections.

Maximum transaction level

The maximum transaction level for a connector is the highest transaction level that the connector supports.

For most connectors, Best Effort is the only possible choice.

You must restart the server for changes in transaction level to take effect.

Associated maps

Each connector supports a list of business object definitions and their associated maps that are currently active in InterChange Server Express. This list appears when you select the **Associated Maps** tab.

The list of business objects contains the application-specific business object which the agent supports and the corresponding generic object that the controller sends to the subscribing collaboration. The association of a map determines which map will be used to transform the application-specific business object to the generic business object or the generic business object to the application-specific business object.

If you are using maps that are uniquely defined for specific source and destination business objects, the maps will already be associated with their appropriate business objects when you open the display, and you will not need (or be able) to change them.

If more than one map is available for use by a supported business object, you will need to explicitly bind the business object with the map that it should use.

The **Associated Maps** tab displays the following fields:

- **Business Object Name**

These are the business objects supported by this connector, as designated in the **Supported Business Objects** tab. If you designate additional business objects under the Supported Business Objects tab, they will be reflected in this list after you save the changes by choosing **Save to Project** from the **File** menu of the Connector Configurator Express window.

- **Associated Maps**

The display shows all the maps that have been installed to the system for use with the supported business objects of the connector. The source business object for each map is shown to the left of the map name, in the **Business Object Name** display.

- **Explicit**

In some cases, you may need to explicitly bind an associated map.

Explicit binding is required only when more than one map exists for a particular supported business object. When InterChange Server Express boots, it tries to automatically bind a map to each supported business object for each connector.

If more than one map takes as its input the same business object, the server attempts to locate and bind one map that is the superset of the others.

If there is no map that is the superset of the others, the server will not be able to bind the business object to a single map, and you will need to set the binding explicitly.

To explicitly bind a map:

1. In the **Explicit** column, place a check in the check box for the map you want to bind.
2. Select the map that you intend to associate with the business object.
3. In the **File** menu of the Connector Configurator Express window, click **Save to Project**.
4. Deploy the project to InterChange Server Express.
5. Reboot the server for the changes to take effect.

Resources

The **Resource** tab allows you to set a value that determines whether and to what extent the connector agent will handle multiple processes concurrently, using connector agent parallelism.

Not all connectors support this feature. If you are running a connector agent that was designed in Java to be multi-threaded, you are advised not to use this feature, since it is usually more efficient to use multiple threads than multiple processes.

Setting trace/log file values

When you open a connector configuration file or a connector definition file, Connector Configurator Express uses the logging and tracing values of that file as default values. You can change those values in Connector Configurator Express.

To change the logging and tracing values:

1. Click the **Trace/Log Files** tab.
2. For either logging or tracing, you can choose to write messages to one or both of the following:

- To console (STDOUT):
Writes logging or tracing messages to the STDOUT display.

Note: You can only use the STDOUT option from the **Trace/Log Files** tab for connectors running on the Windows platform.

- To File:
Writes logging or tracing messages to a file that you specify. To specify the file, click the directory button (ellipsis), navigate to the preferred location, provide a file name, and click **Save**. (If your connector is not running on the Windows platform on which you have installed Connector Configurator Express, you must first map a drive to a location on the system where you want the file.) Logging or tracing message are written to the file and location that you specify.

Note: Both logging and tracing files are simple text files. You can use the file extension that you prefer when you set their file names. For tracing files, however, it is advisable to use the extension `.trace` rather than `.trc`, to avoid confusion with other files that might reside on the system. For logging files, `.log` and `.txt` are typical file extensions.

Data handlers

The data handlers section is available for configuration only if you have designated a value of JMS for DeliveryTransport and a value of JMS for ContainerManagedEvents. Adapters that make use of the guaranteed event delivery enable this tab.

See the descriptions under ContainerManagedEvents in the Standard Properties appendix for values to use for these properties.

Saving your configuration file

After you have created the configuration file and set its properties, you need to deploy it to the correct location for your connector. Save the configuration in an ICL project, and use System Manager to load the file into InterChange Server Express.

The file is saved as an XML document. You can save the XML document in three ways:

- From System Manager, as a file with a *.con extension in an Integration Component Library, or
- In a directory that you specify.
- In stand-alone mode, as a file with a *.cfg extension in a directory folder.

For details about using projects in System Manager, and for further information about deployment, see the *User Guide for IBM WebSphere Business Integration Server Express*.

Completing the configuration

After you have created a configuration file for a connector and modified it, make sure that the connector can locate the configuration file when the connector starts up.

To do so, open the startup file used for the connector, and verify that the location and file name used for the connector configuration file match exactly the name you have given the file and the directory or path where you have placed it.

Using Connector Configurator Express in a globalized environment

Connector Configurator Express is globalized and can handle character conversion between the configuration file and the integration broker. Connector Configurator Express uses native encoding. When it writes to the configuration file, it uses UTF-8 encoding.

Connector Configurator Express supports non-English characters in:

- All value fields
- Log file and trace file path (specified in the **Trace/Log files** tab)

The drop list for the CharacterEncoding and Locale standard configuration properties displays only a subset of supported values. To add other values to the drop list, you must manually modify the \Data\Std\stdConnProps.xml file in the product directory.

For example, to add the locale en_GB to the list of values for the Locale property, open the stdConnProps.xml file and add the line in boldface type below:

```
<Property name="Locale"
isRequired="true"
updateMethod="component restart">
  <ValidType>String</ValidType>
  <ValidValues>
    <Value>ja_JP</Value>
    <Value>ko_KR</Value>
    <Value>zh_CN</Value>
    <Value>zh_TW</Value>
    <Value>fr_FR</Value>
    <Value>de_DE</Value>
    <Value>it_IT</Value>
    <Value>es_ES</Value>
    <Value>pt_BR</Value>
    <Value>en_US</Value>
    <Value>en_GB</Value>
  <DefaultValue>en_US</DefaultValue>
</ValidValues>
</Property>
```

Notices

Notices

IBM may not offer the products, services, or features discussed in this document in all countries. Consult your local IBM representative for information on the products and services currently available in your area. Any reference to an IBM product, program, or service is not intended to state or imply that only that IBM product, program, or service may be used. Any functionally equivalent product, program, or service that does not infringe any IBM intellectual property right may be used instead. However, it is the user's responsibility to evaluate and verify the operation of any non-IBM product, program, or service.

IBM may have patents or pending patent applications covering subject matter described in this document. The furnishing of this document does not give you any license to these patents. You can send license inquiries, in writing, to:

IBM Director of Licensing IBM Corporation North Castle Drive Armonk, NY 10504-1785 U.S.A.

The following paragraph does not apply to the United Kingdom or any other country where such provisions are inconsistent with local law:

INTERNATIONAL BUSINESS MACHINES CORPORATION PROVIDES THIS PUBLICATION "AS IS" WITHOUT WARRANTY OF ANY KIND, EITHER EXPRESS OR IMPLIED, INCLUDING, BUT NOT LIMITED TO, THE IMPLIED WARRANTIES OF NON-INFRINGEMENT, MERCHANTABILITY OR FITNESS FOR A PARTICULAR PURPOSE. Some states do not allow disclaimer of express or implied warranties in certain transactions, therefore, this statement may not apply to you.

This information could include technical inaccuracies or typographical errors. Changes are periodically made to the information herein; these changes will be incorporated in new editions of the publication. IBM may make improvements and/or changes in the product(s) and/or program(s) described in this publication at any time without notice.

Any references in this information to non-IBM Web sites are provided for convenience only and do not in any manner serve as an endorsement of those Web sites. The materials at those Web sites are not part of the materials for this IBM product and use of those Web sites is at your own risk.

IBM may use or distribute any of the information you supply in any way it believes appropriate without incurring any obligation to you.

Licensees of this program who wish to have information about it for the purpose of enabling: (i) the exchange of information between independently created programs and other programs (including this one) and (ii) the mutual use of the information which has been exchanged, should contact:

IBM Burlingame Laboratory Director IBM Burlingame Laboratory 577 Airport Blvd., Suite 800 Burlingame, CA 94010 U.S.A

Such information may be available, subject to appropriate terms and conditions, including in some cases, payment of a fee.

The licensed program described in this document and all licensed material available for it are provided by IBM under terms of the IBM Customer Agreement, IBM International Program License Agreement, or any equivalent agreement between us.

Any performance data contained herein was determined in a controlled environment. Therefore, the results obtained in other operating environments may vary significantly. Some measurements may have been made on development-level systems and there is no guarantee that these measurements will be the same on generally available systems. Furthermore, some measurement may have been estimated through extrapolation. Actual results may vary. Users of this document should verify the applicable data for their specific environment.

Information concerning non-IBM products was obtained from the suppliers of those products, their published announcements or other publicly available sources. IBM has not necessarily tested those products and cannot confirm the accuracy of performance, compatibility or any other claims related to non-IBM products. Questions on the capabilities of non-IBM products should be addressed to the suppliers of those products.

This information may contain examples of data and reports used in daily business operations. To illustrate them as completely as possible, the examples may include the names of individuals, companies, brands, and products. All of these names are fictitious and any similarity to the names and addresses used by an actual business enterprise is entirely coincidental.

All statements regarding IBM's future direction or intent are subject to change or withdrawal without notice, and represent goals and objectives only.

COPYRIGHT LICENSE

This information may contain sample application programs in source language, which illustrates programming techniques on various operating platforms. You may copy, modify, and distribute these sample programs in any form without payment to IBM, for the purposes of developing, using, marketing or distributing application programs conforming to the application programming interface for the operating platform for which the sample programs are written. These examples have not been thoroughly tested under all conditions. IBM, therefore, cannot guarantee or imply reliability, serviceability, or function of these programs.

Programming interface information

Programming interface information, if provided, is intended to help you create application software using this program

General-use programming interfaces allow you to write application software that obtain the services of this program's tools.

However, this information may also contain diagnosis, modification, and tuning information. Diagnosis, modification and tuning information is provided to help you debug your application software.

Note: Do not use this diagnosis, modification, and tuning information as a programming interface because it is subject to change.

Trademarks and service marks

The following terms are trademarks or registered trademarks of International Business Machines Corporation in the United States or other countries, or both:

IBM
the IBM logo
AIX
CrossWorlds
DB2
DB2 Universal Database
Domino
Lotus
Lotus Notes
MQIntegrator
MQSeries
Tivoli
WebSphere

Microsoft, Windows, Windows NT, and the Windows logo are trademarks of Microsoft Corporation in the United States, other countries, or both.

MMX, Pentium, and ProShare are trademarks or registered trademarks of Intel Corporation in the United States, other countries, or both.

Java and all Java-based trademarks are trademarks of Sun Microsystems, Inc. in the United States, other countries, or both.

UNIX is a registered trademark of The Open Group in the United States and other countries.

Linux is a trademark of Linus Torvalds in the United States, other countries, or both.

Other company, product or service names may be trademarks or service marks of others.

System Manager includes software developed by the Eclipse Project (<http://www.eclipse.org/>)



IBM WebSphere Business Integration Server Express Plus V4.3.1



Printed in USA