

IBM WebSphere Business Integration



Installation Guide for WebSphere Business Integration Adapters

IBM WebSphere Business Integration



Installation Guide for WebSphere Business Integration Adapters

Note!

Before using this information and the product it supports, read the information in "Notices" on page 47.

25June2004

This edition of this document applies to IBM WebSphere InterChange Server, version 4.2.2, IBM WebSphere Business Integration Adapter Framework, version 2.4.0, and to all subsequent releases and modifications until otherwise indicated in new editions.

To send us your comments about this document, email doc-comments@us.ibm.com. We look forward to hearing from you.

When you send information to IBM, you grant IBM a nonexclusive right to use or distribute the information in any way it believes appropriate without incurring any obligation to you.

© **Copyright International Business Machines Corporation 2003, 2004. All rights reserved.**

US Government Users Restricted Rights – Use, duplication or disclosure restricted by GSA ADP Schedule Contract with IBM Corp.

Contents

About this document	v
Audience	v
Related documents	v
Typographic conventions	vi

New in this release	vii
New with WebSphere Business Integration Adapter Framework v2.4 (25Jun2004)	vii
New in release 2.4	vii
New in release 2.3.1	vii

Chapter 1. Installation process overview	1
Local adapter environments	1
Distributed adapter environments	2
Remote adapter environments	4
Adapter development environments	5

Chapter 2. Installation requirements	7
Hardware requirements.	7
Software requirements	8
Installing and configuring other software.	9
Data handler requirements	11

Chapter 3. Installing WebSphere Business Integration Adapters products	13
Preparing the installation media	13
General procedures for using installation media	14
Installing the Adapter Framework	16

Installing data handlers	19
Installing adapters	21
Installing the Adapter Development Kit	24
WBIA directories, files, and environment variables	26

Chapter 4. Uninstalling WebSphere Business Integration Adapters products	31
Uninstalling WebSphere Business Integration Adapters using the graphical uninstaller.	31
Performing a silent uninstallation	33

Chapter 5. Distributing connector agents across networks	35
Which components to install.	35
Installation tasks.	36
Security	41

Chapter 6. Upgrading WebSphere Business Integration Adapters	43
Upgrading an adapter development environment.	43
Upgrading a WebSphere Business Information adapter.	43
Upgrading a custom adapter	44

Notices	47
Programming interface information	48
Trademarks and service marks	49

About this document

The IBM^(R) WebSphere^(R) Business Integration Adapter portfolio supplies integration connectivity for leading e-business technologies and enterprise applications. The system includes the IBM WebSphere Business Integration Toolset and templates for customizing, creating, and managing components for business process integration.

This document describes how to install the IBM WebSphere Business Integration Adapters in Windows, Solaris, AIX, and HP-UX environments.

Note: This document explains installation for adapters and adapter components released with the June 2004 release of WebSphere Business Integration Adapters. If you are using an adapter released prior to June, 2004, it uses a different installation procedure than what is documented in this manual. **Make sure to refer to the version of the WebSphere Business Integration Adapters Installation Guide that corresponds to the adapter you are installing.** The following adapters, in particular, use a prior installation program (released December 2003) not documented in this manual and you should refer to the December 2003 Installation Guide:

- Adapter for Acord
- Adapter for Ariba
- Adapter for FIX
- Adapter for Healthcare Data Protocols
- Adapter for mySAP.com
- Adapter for QAD MFG/PRO

The Adapter Development Kit and Adapter Framework also use this prior installation program; however, the instructions in this Installation Guide (June 2004) are the correct version for these components.

Note: Although you may be installing the adapters on a UNIX computer, you must have one Windows computer to run the tools.

Audience

This document is for consultants, developers, and system administrators who plan, install, deploy, and administer WebSphere Business Integration Adapters.

Related documents

You can install the documentation or read it directly only at the following sites:

- For general adapter information; for using adapters with WebSphere message brokers (WebSphere MQ Integrator, WebSphere MQ Integrator Broker, WebSphere Business Integration Message Broker); and for using adapters with WebSphere Application Server:

<http://www.ibm.com/websphere/integration/wbiadapters/infocenter>

- For using adapters with WebSphere InterChange Server:

<http://www.ibm.com/websphere/integration/wicsserver/infocenter>

These sites contain simple directions for downloading, installing, and viewing the documentation.

Note: Important information about the products described in this guide may be available in Technical Support Technotes and Flashes issued after this document was published. These can be found on the WebSphere Business Integration Support Web site, <http://www.ibm.com/software/integration/websphere/support/>. Select the component area of interest and browse the Technotes and Flashes section.

Typographic conventions

This document uses the following conventions:

Note: In this document backslashes (\) are used as the convention for directory paths. For UNIX installations, substitute slashes (/) for backslashes. All file pathnames are relative to the directory where the product is installed on your system.

<code>courier font</code>	Indicates a literal value, such as a command name, file name, information that you type, or information that the system prints on the screen.
<i>italic, italic</i>	Indicates a new term the first time that it appears, a variable name, or a cross-reference.
<i>blue text</i>	A blue outline, which is visible only when you view the manual online, indicates a cross-reference hyperlink. Click inside the outline to jump to the object of the reference.
{ }	In a syntax line, curly braces surround a set of options from which you must choose one and only one.
	In a syntax line, a pipe separates a set of options from which you must choose one and only one.
[]	In a syntax line, square brackets surround an optional parameter.
...	In a syntax line, ellipses indicate a repetition of the previous parameter. For example, <code>option[...]</code> means that you can enter multiple, comma-separated options.
< >	Angle brackets surround individual elements of a name to distinguish them from each other, as in <code><server_name><connector_name>tmp.log</code> .
/, \	In this document, backslashes (\) are used as the convention for directory paths. For UNIX installations, substitute slashes (/) for backslashes. All product pathnames are relative to the directory where the connector for Ariba Buyer is installed on your system.
<code>%text%</code> and <code>\$text</code>	Text within percent (%) signs indicates the value of the Windows text system variable or user variable. The equivalent notation in a UNIX environment is <code>\$text</code> , indicating the value of the <code>text</code> UNIX environment variable.
<i>ProductDir</i>	Represents the directory where the product is installed.

New in this release

New with WebSphere Business Integration Adapter Framework v2.4 (25Jun2004)

The following changes have been made for this release:

- New installed file structures
- Each adapter installer now provides the option to register the adapter as a Windows service, if supported by the adapter and if running Interchange Server as the broker
- Document installation for new adapters
- New installation batch file (Windows) and shell script file (UNIX)

New in release 2.4

The following changes have been made for this release:

- Each WebSphere Business Integration Adapters product now has its own installer. For information on using each installer, see Chapter 3, “Installing WebSphere Business Integration Adapters products,” on page 13.
- This guide now features Chapter 1, “Installation process overview,” on page 1, which provides procedural direction for preparing different types of WebSphere Business Integration Adapters environments.
- This guide now features Chapter 2, “Installation requirements,” on page 7, which describes hardware and software prerequisites.
- This guide now features Chapter 5, “Distributing connector agents across networks,” on page 35, which provides information on how to enable adapters for remote communication by using WebSphere MQ Internet pass-thru.
- This guide now features Chapter 6, “Upgrading WebSphere Business Integration Adapters,” on page 43, which provides information on how to upgrade environments in which you develop adapters, run custom-developed adapters, and run adapters that are part of the WebSphere Business Integration Adapters product.
- The uninstallation process for WebSphere Business Integration Adapters has changed. For information on how to uninstall WebSphere Business Integration Adapters, see Chapter 4, “Uninstalling WebSphere Business Integration Adapters products,” on page 31.
- The IBM Java Development Kit is now delivered with the Adapter Framework for the Windows platform. For information on how to install the IBM JDK, see “Installing the IBM Java Development Kit on Windows” on page 10.
- The VisiBroker Object Request Broker has been replaced by the IBM Java Object Request Broker.
- The adapter scripts have been modified for this release. For information on changes you might have to make to existing scripts, see the release notes.

New in release 2.3.1

This book is new as of WBIA version 2.3.1.

Chapter 1. Installation process overview

This chapter presents a description of the different kinds of WebSphere Business Integration Adapters environments you might have to prepare and the workflow you have to follow in order to do so.

Figure 1 illustrates the types of WebSphere Business Integration Adapters environments.

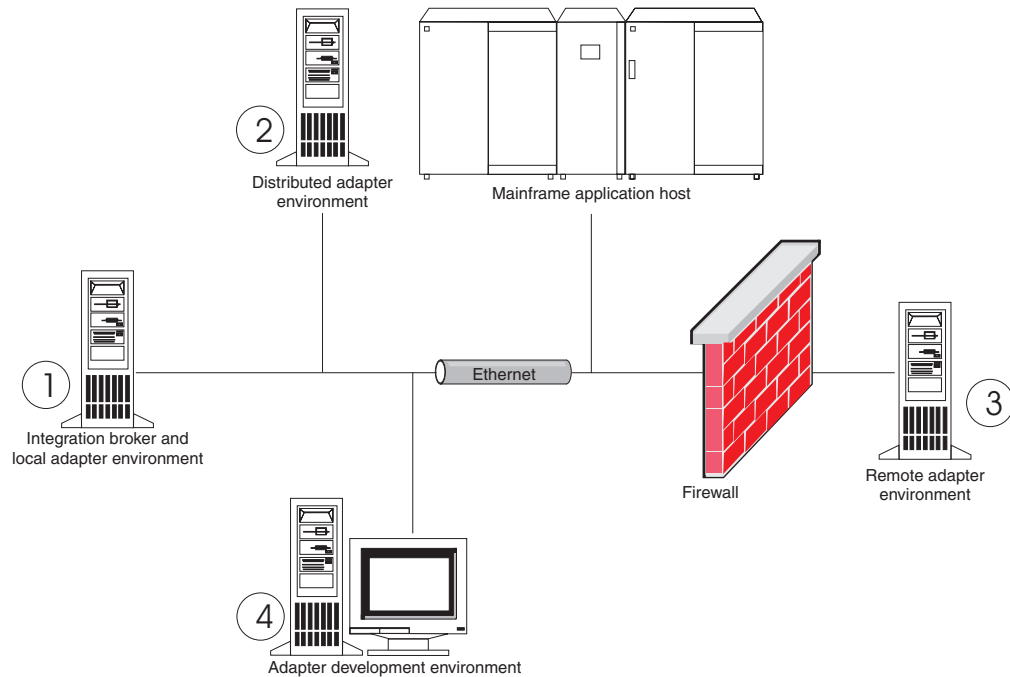

Figure 1. WebSphere Business Integration Adapter environments

Local adapter environments

Typically you install an adapter on the same computer where the integration broker is installed and runs. This type of environment is easiest to maintain and manage, particularly when you are developing and testing interfaces, because all the components in the business integration system are installed on a single computer. Environment 1 in Figure 1 illustrates this type of environment.

Do the following to prepare a local adapter environment:

1. Obtain computers that satisfy the hardware requirements for each of the required environments.
For more information about hardware requirements, see “Hardware requirements” on page 7.
2. If your integration broker is WebSphere Business Integration Message Broker or WebSphere Application Server, install the WebSphere MQ client as described in the WebSphere MQ documentation. The supported version of the WebSphere MQ client is listed in Table 5 on page 8.
3. Do one of the following depending on which integration broker you are implementing:

- If your integration broker is WebSphere InterChange Server, then install WebSphere InterChange Server and all its prerequisite software as described in the *System Installation Guide for Windows* or *System Installation Guide for UNIX*.
- If your integration broker is one of the supported message brokers or WebSphere Application Server, install the Adapter Framework as described in “Installing the Adapter Framework” on page 16.

Note: If your integration broker is WebSphere InterChange Server and you are installing WebSphere Business Integration Adapters on the same computer on which InterChange Server is installed, then do not install the Adapter Framework. The Adapter Framework is installed with WebSphere InterChange Server.

4. Read the chapter named “Installing and configuring the connector” in the guide for each adapter you plan to install in the environment and determine any data handler requirements for the environment.
5. Install each data handler required for the environment as described in “Installing data handlers” on page 19.
6. Install each adapter required for the environment as described in “Installing adapters” on page 21.
7. Perform any adapter-specific installation steps, such as installing the application client on the adapter host computer, as described in the guide for each adapter required in the environment.

Distributed adapter environments

Although it is frequently possible to install adapters on the same computer that hosts the integration broker, it is sometimes necessary to distribute the adapters. This means installing the adapters on a different computer than the computer on which the broker is installed.

There are several reasons you might want to distribute connectors agents, including the following:

- You might improve the performance of the business integration system by relieving the computer that hosts the broker of the load imposed by adapters.
- You might improve the performance of an adapter by installing it on a computer close in proximity on the network to the computer that hosts the application.
- You might not be able to obtain a version of the adapter on the operating system of the computer that hosts the broker.

Environment 2 in Figure 1 on page 1 illustrates this type of environment, where the adapter is distributed to communicate with a mainframe application.

Do the following to prepare a distributed adapter environment within the enterprise network:

1. Obtain computers that satisfy the hardware requirements for each of the required environments.
For more information about hardware requirements, see “Hardware requirements” on page 7.
2. Install the WebSphere MQ client as described in the WebSphere MQ documentation. Be sure to install the Java Messaging feature. The supported version of the WebSphere MQ client is listed in Table 5 on page 8.
3. Do the following depending on your integration broker:

- If your integration broker is WebSphere Application Server or one of the supported messaging brokers, do the following:
 - a. Install the Adapter Framework as described in “Installing the Adapter Framework” on page 16.
 - b. Read the chapter named “Installing and configuring the connector” in the guide for each adapter you plan to install in the environment and determine any data handler requirements for the environment.
 - c. Install each data handler required for the environment as described in “Installing data handlers” on page 19.
 - d. Install each adapter required for the environment as described in “Installing adapters” on page 21.
- If your integration broker is WebSphere InterChange Server, do the following:
 - a. Run the installer for WebSphere InterChange Server on the distributed computer to install the proper version of the Adapter Framework on it. When the InterChange Server Configuration Wizard is presented, specify the same configuration values as those specified when installing InterChange Server on the broker host computer. For more information on installing WebSphere InterChange Server, see the *System Installation Guide for Windows* or *System Installation Guide for UNIX*.

Note: You should not start this instance of InterChange Server. You are only installing it to install a compatible version of the Adapter Framework on the adapter host computer.
 - b. Apply any patches that have been applied to the InterChange Server host computer to the distributed computer so that the broker and adapter environments are running at the same patch level.
 - c. Install the adapter as described in “Installing adapters” on page 21 on the distributed computer.

At the IBM WebSphere InterChange Server screen, specify the name of the InterChange Server instance on the broker host computer, rather than the name of the InterChange Server instance you installed on the adapter host computer (which you had to install to install the Adapter Framework on the computer).
 - d. Import the connector definition created in the repository directory into your development environment as described in the *Implementation Guide for WebSphere Interchange Server*.
 - e. Configure the connector as described in the guide for the adapter.
 - f. Deploy the connector to the InterChange Server repository as described in the *Implementation Guide for WebSphere Interchange Server*.
- 4. Do the following to configure the environment to communicate with the broker:
 - a. Open the shared environment file located in the *ProductDir\bin* directory in a text editor.

On Windows computers, the shared environment file is named `CWSharedEnv.bat`.

On UNIX computers, the shared environment file is named `adapterEnv.sh` or `CWSharedEnv.sh`, depending on the broker you are using and the version of its release.

- b. Set the value of the ORB_PORT property to the port over which the Object Request Broker installed on the broker computer is configured to communicate.
 - c. Set the value of the ORB_HOST property to the IP address of the computer on which the broker is installed.
5. Perform any adapter-specific installation steps, such as installing the application client on the adapter host computer, as described in the guide for each adapter required in the environment.

Remote adapter environments

You must prepare a remote adapter environment to enable an adapter to exchange data with the integration broker across the boundaries of the network. This is common when a company must exchange business data with trading partners.

Environment 3 in Figure 1 on page 1 illustrates this type of environment, where the adapter is enabled to communicate with the broker over the internet.

Do the following to prepare a remote adapter environment:

1. Obtain computers that satisfy the hardware requirements for each of the required environments.
For more information about hardware requirements, see “Hardware requirements” on page 7.
2. Install the WebSphere MQ client as described in the WebSphere MQ documentation. Be sure to install the Java Messaging feature. The supported version of the WebSphere MQ client is listed in Table 5 on page 8.
3. Install and configure WebSphere MQ Internet pass-thru as described in Chapter 5, “Distributing connector agents across networks,” on page 35.
4. Do the following depending on your integration broker:
 - If your integration broker is WebSphere Application Server or one of the supported messaging brokers, do the following:
 - a. Install the Adapter Framework as described in “Installing the Adapter Framework” on page 16.
 - b. Read the chapter named “Installing and configuring the connector” in the guide for each adapter you plan to install in the environment and determine any data handler requirements for the environment.
 - c. Install each data handler required for the environment as described in “Installing data handlers” on page 19.
 - d. Install each adapter required for the environment as described in “Installing adapters” on page 21.
 - If your integration broker is WebSphere InterChange Server, do the following:
 - a. Run the installer for WebSphere InterChange Server on the distributed computer to install the proper version of the Adapter Framework on it. When the InterChange Server Configuration Wizard is presented, specify the same configuration values as those specified when installing InterChange Server on the broker host computer.
For more information on installing WebSphere InterChange Server, see the *System Implementation Guide for Windows* or the *System Implementation Guide for UNIX*.

Note: You should not start this instance of InterChange Server. You are only installing it to install a compatible version of the Adapter Framework on the adapter host computer.

- b. Apply any patches that have been applied to the InterChange Server host computer to the distributed computer so that the broker and adapter environments are running at the same patch level.
 - c. Install the adapter as described in “Installing adapters” on page 21 on the distributed computer.

At the IBM WebSphere InterChange Server screen, specify the name of the InterChange Server instance on the broker host computer, rather than the name of the InterChange Server instance you installed on the adapter host computer (which you had to install to install the Adapter Framework on the computer).
 - d. Import the connector definition created in the repository directory into your development environment as described in the *Implementation Guide for WebSphere Interchange Server*.
 - e. Configure the connector as described in the guide for the adapter.
 - f. Deploy the connector to the InterChange Server repository as described in the *Implementation Guide for WebSphere Interchange Server*.
5. Perform any adapter-specific installation steps, such as installing the application client on the adapter host computer, as described in the guide for each adapter required in the environment.

Adapter development environments

You must prepare an adapter development environment in order to create custom adapters. Although you can develop adapters in an environment in which the broker is installed and adapters are running, you can also use an environment that is dedicated exclusively to adapter development.

Environment 4 in Figure 1 on page 1 illustrates this type of environment.

Do the following to prepare an adapter development environment:

1. Obtain computers that satisfy the hardware requirements for each of the required environments.

For more information about hardware requirements, see “Hardware requirements” on page 7.
2. Install the Adapter Framework as described in “Installing the Adapter Framework” on page 16.
3. Install each data handler that will be required for the adapters you are developing as described in “Installing data handlers” on page 19.
4. Install the Adapter Development Kit as described in “Installing the Adapter Development Kit” on page 24.
5. Install a compiler appropriate for the language in which you will be developing the adapter:
 - If you will be developing the adapter in C or C++, install a C or C++ compiler.
 - If you will be developing the adapter in Java, install the IBM Java Development Kit:
 - It is assumed that if your operating system is AIX then you already have the supported version of the IBM JDK installed.

- For information on installing the IBM Java Development Kit on Windows, see “Installing the IBM Java Development Kit on Windows” on page 10.
- For information on installing the Sun Java Development Kit, see the Sun JDK documentation.
- For information on installing the HP Java Development Kit, see the HP JDK documentation.

Chapter 2. Installation requirements

This chapter contains the following sections:

- “Hardware requirements”
- “Software requirements” on page 8

Before you install the IBM WebSphere Business Integration Adapters software, ensure that you have all the necessary prerequisites. The topics in this chapter give you a brief overview of the system hardware and software requirements, the prerequisite software, and the user accounts required to run WebSphere Business Integration Adapters.

Hardware requirements

Table 1 lists the minimum hardware requirements. The actual requirements for your system may be greater, however, depending on the particular WebSphere Business Integration Adapter products you install and your integration requirements. Also, the following information is for the WebSphere Business Integration Adapter products only. If you run other products, such as the integration brokers or application clients on the same computer as the WebSphere Business Integration Adapter products, then you must adjust the requirements accordingly.

Table 1. Windows hardware requirements

Component	Minimum Required
Processor	IBM eServer xSeries and Intel-based system (or equivalent) running at a minimum processor speed of 1 GHz
Memory	512 MB
Disk space	435 MB

Table 2. AIX hardware requirements

Component	Minimum Required
Processor	IBM eServer pSeries or RS/6000 system with either a uniprocessor or symmetric multiprocessor running at a minimum processor speed of 375 MHz
Memory	512 MB
Disk space	435 MB

Table 3. Solaris hardware requirements

Component	Minimum Required
Processor	Sun Microsystems UltraSPARC processor system running at a minimum processor speed of 450 MHz
Memory	512 MB
Disk space	435 MB

Table 4. HP-UX hardware requirements

Component	Minimum Required
Processor	Hewlett-Packard HP-9000 PA-RISC processor system running at a minimum processor speed of 440 MHz
Memory	512 MB
Disk space	435 MB

Software requirements

The WebSphere Business Integration Adapters product set consists of IBM components and third-party components. Other third-party software, such as Java Development Kits for Sun Solaris and HP-UX, are not provided by IBM.

Table 5 lists the software requirements for the WebSphere Business Integration Adapters products. Also refer to the individual user guide for the particular adapter you are installing for information about prerequisite software for that adapter.

Table 5. Software requirements for Windows

Software	Version and patch	Comments
Operating system (one of the following)		
One of the following: <ul style="list-style-type: none"> • Windows 2000, Professional, Server, and Advanced Server • Windows XP • AIX 5.1 • AIX 5.2 • Sun Solaris 7 • Sun Solaris 8 • HP-UX 11.11 (11i) 	<ul style="list-style-type: none"> • Service Pack 4 • Service Pack 1A • Maintenance level 4 • Maintenance level 1 • Solaris 7 recommended patch cluster date 23 July 2003 • Solaris 8 recommended patch cluster date 23 July 2003 • GOLDAPPS 11i, r=B.11.11.0306.4 and GOLDBASE 11i, r=B.11.11.03.06.4 	<ul style="list-style-type: none"> • Supported only for WebSphere Business Integration Adapters toolset. Not supported for the running of adapters.
Integration broker		
One of the following: <ul style="list-style-type: none"> • WebSphere Application Server, Enterprise Edition • IBM WebSphere MQ Integrator Broker • WebSphere Business Integration Message Broker 	<ul style="list-style-type: none"> • 5.0.2 • 2.1 CSD05 • 5.0 CSD02 	

Table 5. Software requirements for Windows (continued)

Software	Version and patch	Comments
<ul style="list-style-type: none"> WebSphere InterChange Server 	<ul style="list-style-type: none"> 4.1.1, 4.2.0, 4.2.1, 4.2.2 <p>Note: Some adapters are not compatible with all listed versions of InterChange Server. For more information, see your adapter guide.</p>	
Other required software (based on needed function)		
IBM WebSphere MQ Server and Client	Version 5.3.0.2 with CSD05 Important: If you do not apply CSD 05, the connectors will not be able to initialize.	Required for event persistence during communication between connectors and broker.
IBM WebSphere MQ Internet pass-thru (MQIPT)	Version 1.3, Support Pac MS81	Option for use with Remote Agent (refer to Chapter 5, "Distributing connector agents across networks," on page 35)
Sun JRE	Version 1.4	For use with Remote Agent
Java Development Kit		
One of the following, depending on operating system:		
<ul style="list-style-type: none"> IBM JDK (for Windows and AIX computers) Sun JDK (for Solaris computers) HP JDK (for HP-UX computers) 	<ul style="list-style-type: none"> 1.3.1 SR5 1.3.1_07 1.3.1_06 	
One of the following browsers:		Required to view documents.
<ul style="list-style-type: none"> Microsoft Internet Explorer Netscape Navigator 	<ul style="list-style-type: none"> N/A Version 4.x 	
Adobe Acrobat Reader 4.0 or later. IBM recommends using version 4.0.5 or later of Acrobat Reader, with Search option, so that you can take advantage of the PDF Search feature. Go to http://www.adobe.com for the latest version of Adobe Acrobat Reader for your platform.		
Tool framework		
One of the following:		
<ul style="list-style-type: none"> WebSphere Studio Workbench WebSphere Studio Application Developer Integration Edition 	<ul style="list-style-type: none"> 2.0.3 5.0.1 	

Installing and configuring other software

This section contains information about installing and configuring software that is not delivered with WebSphere Business Integration Adapters and does not necessarily have its own documentation. You will be directed to perform these tasks by other sections of this guide when necessary.

Configuring your environment for X emulation

If you are installing on a UNIX computer, but are using a Windows computer to connect to the UNIX computer then do the following to configure the environment for X emulation:

1. Determine the IP address of the Windows computer that you are using to connect to the UNIX computer.

You can execute the `ipconfig` command at the Windows command line interface to display the IP address of the Windows computer.

2. Set the `DISPLAY` environment variable on the UNIX computer to the IP address determined in step 1.

You must be sure to follow the IP address with a colon and the identifier for the monitor or display on the Windows client computer. If the Windows client computer only has a single monitor then the display value is `0.0`.

The following example shows the `DISPLAY` environment variable being set to the single monitor on a Windows computer whose IP address is `9.26.244.30`:

```
DISPLAY=9.26.244.30:0.0
```

3. Export the `DISPLAY` environment variable on the UNIX computer by executing the following command:

```
export DISPLAY
```

4. Start the X emulation client on the Windows computer and connect to the UNIX computer.

Installing the IBM Java Development Kit on Windows

Do the following to install the IBM Java Development Kit on Windows:

1. Copy the files named `ibm-sdk-in131.exe` and `ibm-sdk-tn131.exe` from the `IBM_JDK_WIN32` directory of the Adapter Framework installation media to a temporary directory on your system.
2. Double-click the files named `ibm-sdk-in131.exe` and `ibm-sdk-tn131.exe` in the temporary directory to extract their contents.
3. Double-click the file named `install.exe`, which was created when the contents of the compressed files were extracted in step 2.
4. At the language selection prompt, choose the desired language from the drop-down menu and click **OK**.
5. At the Welcome screen click **Next**.
6. At the Software License Acceptance screen click **Yes**.
7. At the Choose Destination Location screen, either accept the default path or perform one of the following tasks, then click **Next** when done:
 - Click **Browse** and select a directory to install the JDK to, then click **OK**
 - Click **Browse**, type the directory into which you want to install the JDK to in the **Path** field, then click **OK**
8. At the Select Components screen, leave all the checkboxes for the components enabled and click **Next**.
9. When prompted to install the Java Runtime Environment as the System JVM click **No**.
10. At the Start Copying Files screen click **Next**.
11. At the Setup Complete screen click **Finish**.

Data handler requirements

Table 6 lists the data handler requirements for each adapter if it has any.

Table 6. Data handler requirements for adapters

IBM WebSphere Business Integration Adapter for...	Data handlers required
ACORD XML	XML
Complex Data Handler	XML
SAP Exchange Infrastructure	XML
HTTP	XML
i2	XML
NightFire Applications	XML
Siebel eBusiness Applications	XML
Telcordia	XML
WebSphere Commerce	XML
WebSphere Business Integration Message Broker	XML
WebSphere MQ Workflow	XML
XML	XML
QAD MFG/PRO	XML

Chapter 3. Installing WebSphere Business Integration Adapters products

This chapter describes how to install WebSphere Business Integration Adapters.

If you are upgrading an adapter from a previous version, be sure to back up your integration broker system first, as described in the installation or implementation guides for your broker.

This chapter includes the following sections:

- “Preparing the installation media”
- “General procedures for using installation media” on page 14
- “Installing the Adapter Framework” on page 16
- “Installing data handlers” on page 19
- “Installing adapters” on page 21
- “Installing the Adapter Development Kit” on page 24
- “WBIA directories, files, and environment variables” on page 26

Preparing the installation media

Perform the steps in one of the following sections depending on your installation media:

- “Preparing a product CD”
- “Using Passport Advantage” on page 14

Preparing a product CD

If your WebSphere Business Integration Adapters product is on a CD, do the following to prepare the computer for installation depending on your operating system:

- On AIX:

Insert the product CD into the CD drive of the AIX computer and execute the following command to mount the CD:

```
mount -V cdrfs -o ro /dev/cd0 /cdrom
```

- On Windows:

Insert your product CD into the CD drive of the Windows computer.

- On Solaris:

Insert the product CD into the CD drive of the Solaris computer and execute the following command to mount the CD:

```
mount -r -F hsfs /dev/sr0 /cdrom
```

- On HP-UX:

Insert the product CD into the CD drive of the HP-UX computer and execute the following command to mount the CD:

1. Execute the following commands to start the PFS mounting daemon:

```
/usr/sbin/pfs_mountd &  
/usr/sbin/pfsd &
```

2. Add a line such as the following to the `etc/pfs_fstab` file:

```
/dev/dsk/cdrom_device /mount_point pfs-iso9660
xlat=unix 0 0
```

where *cdrom_device* is the identifier for the CD-ROM disk device (such as *c3t2d0*) and */mount_point* is the desired mount point through which you want to access the CD (such as */cdrom*).

3. Execute the following command to mount the CD:

```
mount /mount_point
```

where */mount_point* is the mount point you specified in step 2 on page 13.

Using Passport Advantage

If you obtain your WebSphere Business Integration Adapters product from Passport Advantage, do the following to prepare the installation media:

- On Windows, download the self-extracting executable from Passport Advantage and then double-click it to extract the installation files.
- On UNIX, download the compressed .tar file from Passport Advantage and then inflate it to extract the installation files.

General procedures for using installation media

This section describes general procedures for using the installation media. Other sections in this guide refer to the content in this section.

Invoking the graphical WBI installer

The graphical WebSphere Business Integration Adapters Installer presents you with a wizard that allows you to make choices about the installation of WebSphere Business Integration Adapters. You invoke Installer by running platform-specific executables for the different product installers. The product installers are identical whether you obtain them from a CD or from Passport Advantage. This section describes how to invoke Installer for any of the WebSphere Business Integration Adapters products on both Windows and UNIX computers.

Invoking Installer in a Windows environment

Make sure you are logged in with administrative privileges before you install WebSphere Business Integration Adapters in a Windows environment. To invoke Installer in a Windows environment, navigate to the Windows directory of the installation media and execute `setupwin32.exe`.

Invoking Installer in a UNIX environment

The WBI installer in a UNIX environment is invoked through a .bin file specific to the platform, located in the UNIX directory of the installation media.

When you install on a UNIX-based computer, the permissions of the folders and files that are created are set based on the permissions of the user account that performs the installation. Make sure that you do not install WebSphere Business Integration Adapters as root on an AIX computer. The entry that is added to the Object Data Manager (ODM) when installing as root prevents you from using SMIT to uninstall other applications, so you should not install WBI as root.

Follow the steps in one of the following sections to invoke the installer depending on how you are working with the UNIX computer:

- “If you are running CDE on the UNIX computer” on page 15
- “If you are connecting to the UNIX computer through X emulation software” on page 15

If you are running CDE on the UNIX computer: Navigate to the UNIX directory of the installation media and double-click the `.bin` file specific to the operating system.

You can also navigate to the UNIX directory of the installation media and execute the `.bin` file at the command line. The following example shows how to do so on an AIX computer:

```
# ./setupAIX.bin
```

If you are connecting to the UNIX computer through X emulation software: Do the following to invoke the installer:

1. Follow the steps in “Configuring your environment for X emulation” on page 10.
2. Execute the `.bin` file specific to the operating system. The following example shows how to do so on an AIX computer:

```
# ./setupAIX.bin
```

The graphical installer starts on the Windows computer that you are using to connect to the UNIX computer.

Note: Accessibility hotkeys do not function when you are working on a UNIX computer through emulation software. To use accessibility hotkeys, you must work directly on the UNIX computer.

Performing a silent installation

You can perform a silent installation of WebSphere Business Integration Adapters, where you provide your installation choices in a file rather than at the screens of the installation wizard. This is particularly helpful when you have to perform multiple installations that are identical.

To perform a silent installation, you create a file with your installation choices as described in “Preparing the installation response file” and then perform the installation using the file as described in “Executing the silent installation” on page 16. The following sections about installing the different types of WebSphere Business Integration Adapters products address the installation options that are specific to each product type:

- “Installing the Adapter Framework silently” on page 17
- “Installing data handlers silently” on page 20
- “Installing adapters silently” on page 22
- “Installing the Adapter Development Kit silently” on page 25

Preparing the installation response file

When performing a silent installation, you prepare a response file (or options file) that contains your installation choices. IBM provides response file templates that contain the options for each WebSphere Business Integration Adapters product. The response file templates are named `settings.txt` and are provided with the other installation files.

If you are performing identical installations on multiple machines, you can easily record an image of the first installation to a file and use that file as the installation response file for subsequent installations. Refer to “Recording installation selections” on page 24 for more information.

The following tables list the options that are available for each type of WebSphere Business Integration Adapters products:

- Table 8 on page 18
- Table 9 on page 20
- Table 10 on page 23
- Table 11 on page 25

Be sure to read all the information in the **Option values** column, as it specifies when particular options should be commented out and what the broker and platform compatibilities are.

You can modify one of the response file templates and use it for the silent installation. In this case you should be sure that any options that are incompatible with others you require are commented out by placing a hash symbol # in front of them. Alternatively, you can create a new response file with the options you require. This approach has the benefit that no unnecessary options or commented description blocks are present to clutter the response file, making it easier to read and edit. If you take this latter approach, it is recommended that you copy a template file and remove the sections and options that are not necessary, rather than typing the necessary options into a new file.

Note: There should not be any spaces in front of any of the options in the response file.

Executing the silent installation

To execute the silent installation, you run the platform-specific installer executable at the command line with several options, including the name of the response file you prepared.

The following example shows how to do so on a Windows computer where the response file exists in the C:\data directory:

```
D:\WebSphereBI>setupwin32.exe -silent -options C:\data\settings.txt
```

The following example shows how to do so on an AIX computer where a custom response file named install.txt has been created in the /home/wbia directory:

```
# ./setupAIX.bin -silent -options /home/wbia/install.txt
```

Installing the Adapter Framework

Follow the instructions in one of the following sections to install the Adapter Framework if indicated by the procedural overview in Chapter 1, “Installation process overview,” on page 1:

- “Installing the Adapter Framework using the graphical installer”
- “Installing the Adapter Framework silently” on page 17

Installing the Adapter Framework using the graphical installer

Do the following to install the Adapter Framework:

Note: If you are installing WebSphere Business Integration Adapters on the same computer on which InterChange Server is installed, you must not install the Adapter Framework.

1. Invoke Installer as described in “Invoking the graphical WBIA installer” on page 14 for the Adapter Framework.
2. At the language selection prompt, choose the desired language from the drop-down menu and click **OK**.
3. At the Welcome screen click **Next**.

4. At the IBM license acceptance screen, click **I accept the terms in the license agreement** and then click **OK**.
5. At the product directory screen, perform one of the following tasks:
 - Type the full path of the directory into which you want to install the Adapter Framework in the **Directory Name** field and click **Next**
 - Click **Browse** to select a directory and click **Next**
 - Accept the default path and click **Next**

Table 7 lists the default product directories for WebSphere Business Integration Adapters on the supported operating systems:

Table 7. Default product directories for WebSphere Business Integration Adapters

Operating system	Default product directory
Windows	C:\IBM\WebSphereAdapters
UNIX (AIX, Solaris, HP-UX)	/opt/IBM/WebSphereAdapters

Important: You must specify a product directory path and name that does not contain spaces.

6. The summary screen lists the features that will be installed, the specified product directory, and the amount of disk space required. Read the information to verify it and then click **Next**.
7. At the WebSphere MQ Java library screen, either type the directory path to the `java\lib` directory of the WebSphere MQ installation or click **Browse** to select the directory, then click **Next**.
8. If you are installing on Windows and installer detects that you have a supported version of WebSphere Studio Application Developer Integration Edition installed then it presents a screen where you must do one of the following:
 - Leave the **Add plug-ins to an existing workbench installation** radio button enabled if you want to install the tools plug-ins into the detected installation of WebSphere Studio Application Developer Integration Edition, then click **Next**.
 - Enable the **Install WebSphere Studio Workbench and plug-ins** radio button to install WebSphere Studio Workbench and install the tools plug-ins, then click **Next**.
9. If you enabled the **Add plug-ins to an existing workbench installation** radio button at step 8 then you are presented with a screen displaying the path of the default WSADIE directory. This is the path where the tools plug-ins will be installed.

To change the default to the location of a different WSADIE directory, either type the path to the installation directory of WSADIE in the text field labeled **IBM WebSphere Studio Workbench directory** or click **Browse** to navigate to the directory, then click **Next**.
10. If you are installing on a Windows computer then Installer next presents the program folder selection screen. In the **Program Group** field, type the name of the program group in which shortcuts for the adapters should be created or accept the default program group and then click **Next**.
11. After Installer finishes successfully, click **Finish**.

Installing the Adapter Framework silently

Do the following to perform a silent installation of the Adapter Framework:

1. Prepare a response file to install the Adapter Framework as described in “Preparing the installation response file” on page 15, using the desired options listed in Table 8.

Table 8. Silent installation options for the Adapter Framework

Option name	Option values
-P installLocation	<p>Set this option to the path and name of the directory into which you want the product installed.</p> <p>If you leave this option commented, the product installs to the default directory listed in Table 7 on page 17.</p> <p>This value must not contain any spaces.</p>
-W mqDirectoryUserInput.mqLibraryLocation	<p>Set this option to the path of the java\lib directory within the WebSphere MQ installation on the computer when the operating system is Windows.</p> <p>Comment out this option if your broker is WebSphere InterChange Server and you are installing the Adapter Framework on the same computer where the broker is installed or if the operating system is not Windows.</p> <p>Comment out this option if you want to use the default values. On the Windows platform, installer searches the Windows registry by default and uses the value it finds there.</p>
-W mqUserInputAIX.mqLibraryLocation	<p>Set this option to the path of the java/lib directory within the WebSphere MQ installation on the computer when the operating system is AIX.</p> <p>Comment out this option if your broker is WebSphere InterChange Server and you are installing the Adapter Framework on the same computer where the broker is installed, or if the platform is not AIX.</p> <p>Comment out this option if you want to use the default values. On the AIX platform, installer uses the default value /usr/mqm/java/lib.</p>
-W mqUserInputSOL.mqLibraryLocation	<p>Set this option to the path of the java/lib directory within the WebSphere MQ installation on the computer when the operating system is Solaris or HP-UX.</p> <p>Comment out this option if your broker is WebSphere InterChange Server and you are installing the Adapter Framework on the same computer where the broker is installed, or if the platform is not Solaris or HP-UX.</p> <p>Comment out this option if you want to use the default values. On the Solaris and HP-UX platforms, installer uses the default value /opt/mqm/java/lib.</p>
-W workbenchChoice.workbenchList	<p>Set this option to 1 to add the tools plug-ins to an existing installation of WebSphere Studio Workbench or WebSphere Studio Application Developer Integration Edition.</p> <p>Set this option to 2 to install WebSphere Studio Workbench.</p> <p>This option is only relevant on the Windows platform. Comment out this option when installing on UNIX.</p>

Table 8. Silent installation options for the Adapter Framework (continued)

Option name	Option values
-W workbenchLocation.workbenchLocDirectory	<p>If you specified that WebSphere Studio Workbench be installed by setting the value of the workbenchChoice.workbenchList option to 2, then set this option to the directory in which the workbench should be installed, for example C:\WebSphereAdapters\Tools.</p> <p>This option is only relevant on the Windows platform. Comment out this option when installing on UNIX.</p>
-W inputShortcuts.folder	<p>Set this option to the name of the program group created for the WBIA product, for example IBM WebSphere Business Integration Adapters.</p> <p>This option is only relevant on the Windows platform. Comment out this option when installing on UNIX.</p>
-G replaceExistingResponse	<p>Set this option to yesToAll or yes to replace all files found on the system that have the same name as those being copied by the installer.</p> <p>Set this option to noToAll or no to not replace any files found on the system that have the same name as those being copied by the installer.</p>
-G replaceNewerResponses	<p>Set this option to yesToAll or yes to replace all files found on the system that are newer than those being copied by the installer.</p> <p>Set this option to noToAll or no to not replace any files found on the system that are newer than those being copied by the installer.</p>
-G createDirectoryResponse	<p>Set this option to yes to create the product directory specified by the option if it does not already exist.</p> <p>Set this option to no to not have the product directory created if it does not exist.</p> <p>You must set this option to yes if the specified directory does not exist for the installation to succeed.</p>
-G removeExistingResponse	<p>This option is not relevant for any broker on any platform. Comment out this option.</p>
-G removeModifiedResponse	<p>This option is not relevant for any broker on any platform. Comment out this option.</p>

2. Perform the silent installation as described in “Executing the silent installation” on page 16, using the response file prepared in step 1 on page 18.

Installing data handlers

Follow the instructions in one of the following sections to install a data handler if indicated by the procedural overview in Chapter 1, “Installation process overview,” on page 1:

- “Installing data handlers using the graphical installer”
- “Installing data handlers silently” on page 20

Installing data handlers using the graphical installer

Do the following to install a data handler using the graphical installer:

1. Invoke Installer as described in “Invoking the graphical WBIA installer” on page 14 for your data handler.
2. At the language selection prompt, choose the desired language from the drop-down menu and click **OK**.
3. At the Welcome screen click **Next**.
4. At the IBM license acceptance screen, click **I accept the terms in the license agreement** and then click **OK**.
5. The product directory screen allows you to specify where to install the data handlers. The adapter installer will try to locate the installation location of the Adapter Framework; if it finds it, this path will be displayed by default. If it does not find it, then the following defaults are displayed: For Windows: C:\IBM\WebSphereAdapters and for UNIX, /opt/IBM/WebSphereAdapters.
You may specify another directory, but it must contain an installation of a compatible version of the Adapter Framework. For information on installing the Adapter Framework, see “Installing the Adapter Framework” on page 16. For more information on installing WebSphere InterChange Server, see the *System Implementation Guide for Windows* or *System Implementation Guide for UNIX*. At the product directory screen, perform one of the following tasks:
 - Type the full path of the directory into which you want to install the Adapter Framework in the **Directory Name** field and click **Next**
 - Click **Browse** to select a directory and click **Next**
 - Accept the default path and click **Next**
6. The summary screen lists the features that will be installed, the specified product directory, and the amount of disk space required. Read the information to verify it and then click **Next**.
7. If you are installing on a Windows computer then Installer presents the program folder selection screen for some data handlers. In the **Program Group** field, type the name of the program group in which you want to create shortcuts for the adapters or accept the default program group and then click **Next**.
8. After Installer finishes successfully, click **Finish**.

Installing data handlers silently

Do the following to perform a silent installation of a data handler:

1. Prepare a response file to install the data handler as described in “Preparing the installation response file” on page 15, using the desired options listed in Table 9.

Table 9. Silent installation options for data handlers

Option name	Option values
-W destination.path	Set this option to the directory path in which the WebSphere Business Integration Adapters product is installed.
-G replaceExistingResponse	Set this option to yesToAll or yes to replace all files found on the system that have the same name as those being copied by the installer. Set this option to noToAll or no to not replace any files found on the system that have the same name as those being copied by the installer.

Table 9. Silent installation options for data handlers (continued)

Option name	Option values
-G replaceNewerResponses	<p>Set this option to <code>yesToAll</code> or <code>yes</code> to replace all files found on the system that are newer than those being copied by the installer.</p> <p>Set this option to <code>noToAll</code> or <code>no</code> to not replace any files found on the system that are newer than those being copied by the installer.</p>
-G createDirectoryResponse	<p>Set this option to <code>yes</code> to create the product directory specified by the option if it does not already exist.</p> <p>Set this option to <code>no</code> to not have the product directory created if it does not exist.</p> <p>You must set this option to <code>yes</code> if the specified directory does not exist for the installation to succeed.</p>
-G removeExistingResponse	<p>This option specifies whether to remove a response file that exists on the system. Note that this option is for uninstall only. Set this option to <code>yesToAll</code> or <code>yes</code> to remove existing response files. Set it to <code>noToAll</code> or <code>no</code> to leave existing files on the system.</p>
-G removeModifiedResponse	<p>This option specifies whether to remove a response file that has been modified since it was last installed. Note that this option is for uninstall only. Set this option to <code>yesToAll</code> or <code>yes</code> to remove response files that have been modified. Set it to <code>noToAll</code> or <code>no</code> to leave modified files on the system.</p>

2. Perform the silent installation as described in “Executing the silent installation” on page 16, using the response file prepared in step 1 on page 20.

Installing adapters

Follow the instructions in one of the following sections to install an adapter if indicated by the procedural overview in Chapter 1, “Installation process overview,” on page 1:

- “Installing adapters using the graphical installer”
- “Installing adapters silently” on page 22
- “Recording installation selections” on page 24

Note that on UNIX platforms, filenames are case-sensitive. If you change the case of any filename, the adapter will fail during start-up and log an error. If you receive an error when you attempt to start the adapter, check the filenames of the XSD files in the Connector Configurator repository. The XSD files must have a lower-case `.xsd` extension. For example, a filename of `Customer.XSD` will cause the adapter to fail. In this case, you must change the name of the file to `Customer.xsd`.

Installing adapters using the graphical installer

Do the following to install an adapter using the graphical installer:

1. Invoke Installer for your adapter as described in “Invoking the graphical WBI A installer” on page 14.
2. At the language selection prompt, choose the desired language from the drop-down menu and click **OK**.
3. At the Welcome screen click **Next**.

4. At the IBM license acceptance screen, click **I accept the terms in the license agreement** and then click **OK**.

Note: The Installer checks your system for certain software prerequisites at this point. If a prerequisite is not found, the Installer displays a screen informing you of this, and stating that the item must be installed before adapter installation can continue. Install the required software and restart the WebSphere Business Integration Adapters Installer.

5. The product directory screen allows you to specify where to install the adapters. The adapter installer will try to locate the installation location of the Adapter Framework; if it finds it, this path will be displayed by default. If it does not find it, then the following defaults are displayed: For Windows: C:\IBM\WebSphereAdapters and for UNIX, /opt/IBM/WebSphereAdapters.

You may specify another directory, but it must contain an installation of a compatible version of the Adapter Framework.

For information on installing the Adapter Framework, see “Installing the Adapter Framework” on page 16. For more information on installing WebSphere InterChange Server, see the .

At the product directory screen, perform one of the following tasks:

- Type the full path of the directory into which you want to install the Adapter Framework in the **Directory Name** field and click **Next**
 - Click **Browse** to select a directory and click **Next**
 - Accept the default path and click **Next**
6. The summary screen lists the features that will be installed, the specified product directory, and the amount of disk space required. Read the information to verify it and then click **Next**.
 7. At the IBM WebSphere InterChange Server screen, do one of the following tasks depending on your integration broker:
 - If your integration broker is WebSphere InterChange Server, type the name of the InterChange Server instance with which the adapters will communicate in the **IBM WebSphere InterChange Server Name** field. If you want the adapter to be registered as a Microsoft Windows service, click the Windows service checkbox. Then click **Next**.

Note: Registration as a Windows service is supported only if the broker being used is WebSphere Interchange Server.

- If you are using an integration broker other than WebSphere InterChange Server, click **Next**.
8. If you are installing on a Windows computer then Installer presents the program folder selection screen. In the **Program Group** field, type the name of the program group in which you want to create shortcuts for the adapters or accept the default program group and then click **Next**.
 9. After Installer finishes successfully, click **Finish**.

Installing adapters silently

Do the following to perform a silent installation of an adapter:

1. Prepare a response file to install the adapter as described in “Preparing the installation response file” on page 15, using the desired options listed in Table 10 on page 23.

Table 10. Silent installation options for adapters

Option name	Option values
-W destination.path	<p>Set this option to the directory path in which the WebSphere Business Integration Adapters product is to be installed. For example,</p> <pre>-W destination.path="C:\IBM\WebSphereAdapters"</pre> <p>The install path cannot contain any spaces. The install location must contain a compatible version of the adapter framework.</p>
-W inputServer.name	<p>Set this option to the name of the InterChange Server instance with which the installed adapters will communicate, if you are using WebSphere Interchange Server as the broker. If you are not using WebSphere Interchange Server as the broker, comment out this option. The name is case-sensitive and must be specified accurately or the adapters will not be able to communicate with the server.</p> <p>You must make sure this option is not commented and is set to the proper value when installing adapters to communicate with WebSphere InterChange Server.</p>
-W inputShortcuts.folder	<p>Set this option to the name of the program group created for the WBIA product, for example IBM WebSphere Business Integration Adapters.</p> <p>This option is only relevant on the Windows platform. Comment out this option when installing on UNIX.</p>
-W inputServer.adapterService	<p>Set this option to yes if you want the adapter to be registered as a Windows service. Set this option to no if you do not want the adapter to be registered as a Windows service.</p> <p>This option is only relevant on the Windows platform. Comment out this option when installing on UNIX.</p>
-G replaceExistingResponse	<p>Set this option to yesToAll or yes to replace all files found on the system that have the same name as those being copied by the installer.</p> <p>Set this option to noToAll or no to not replace any files found on the system that have the same name as those being copied by the installer.</p>
-G replaceNewerResponses	<p>Set this option to yesToAll or yes to replace all files found on the system that are newer than those being copied by the installer.</p> <p>Set this option to noToAll or no to not replace any files found on the system that are newer than those being copied by the installer.</p>
-G removeExistingResponse	<p>This option specifies whether to remove a response file that exists on the system. Note that this option is for uninstall only. Set this option to yestoall or yes to remove existing response files. Set it to notoall or no to leave existing files on the system.</p>
-G removeModifiedResponse	<p>This option specifies whether to remove a response file that has been modified since it was last installed. Note that this option is for uninstall only. Set this option to yestoall or yes to remove response files that have been modified. Set it to notoall or no to leave modified files on the system.</p>

2. Perform the silent installation as described in “Executing the silent installation” on page 16, using the response file prepared in step 1 on page 22.

Recording installation selections

You can record your installation selections to a file by using a special option when invoking the installation program from the command line. At the completion of the install, your installation selections are recorded to the file you specified on the command line. You can use the recorded installation information in this file as a record of your installation settings and as a response file for silent installations on other machines.

To create this file, type the following command from the command line:

```
<installation launcher executable> -options-record <filename>
```

For example, type the following command in a command window to record the installation selections of your adapter installation on a Windows computer:

```
setupwin32.exe -options-record C:\data\settings.txt
```

Installing the Adapter Development Kit

Follow the instructions in one of the following sections to install the Adapter Development Kit if indicated by the procedural overview in Chapter 1, “Installation process overview,” on page 1:

- “Installing the Adapter Development Kit using the graphical installer”
- “Installing the Adapter Development Kit silently” on page 25

Installing the Adapter Development Kit using the graphical installer

Do the following to install the Adapter Development Kit using the graphical installer:

1. Invoke Installer as described in Invoke Installer as described in “Invoking the graphical WBIA installer” on page 14.
2. At the language selection prompt, choose the desired language from the drop-down menu and click **OK**.
3. At the Welcome screen click **Next**.
4. At the IBM license acceptance screen, click **I accept the terms in the license agreement** and then click **OK**.
5. The product directory screen allows you to specify where to install the Adapter Development Kit. The adapter installer will try to locate the installation location of the Adapter Framework; if it finds it, this path will be displayed by default. If it does not find it, then the following defaults are displayed: For Windows: C:\IBM\WebSphereAdapters and for UNIX, /opt/IBM/WebSphereAdapters.

You may specify another directory, but it must contain an installation of a compatible version of the Adapter Framework.

For information on installing the Adapter Framework, see “Installing the Adapter Framework” on page 16. For more information on installing WebSphere InterChange Server, see the .

At the product directory screen, perform one of the following tasks:

- Type the full path of the directory into which you want to install the Adapter Framework in the **Directory Name** field and click **Next**
 - Click **Browse** to select a directory and click **Next**
 - Accept the default path and click **Next**
6. The summary screen lists the features that will be installed, the specified product directory, and the amount of disk space required. Read the information to verify it and then click **Next**.
 7. After Installer finishes successfully, click **Finish**.

Installing the Adapter Development Kit silently

Do the following to perform a silent installation of the Adapter Development Kit:

1. Prepare a response file to install the Adapter Development Kit as described in “Preparing the installation response file” on page 15, using the desired options listed in Table 11.

Table 11. Silent installation options for the Adapter Development Kit

Option name	Option values
-W installLocation.active	<p>You must set this option to the value true to be able to specify the installation location through the use of the installLocation.value option.</p> <p>If you comment out this option or set it to false, the silent installation is affected as follows:</p> <ul style="list-style-type: none"> • If you are installing on Windows and installer detects the presence of the CROSSWORLDS environment variable, then the product installs to the location specified by the environment variable. • If you are installing on UNIX and installer finds an entry for the product in the vpd.properties file, then the product installs to the location specified in the file. • If you are installing on Windows and installer does not detect the presence of the CROSSWORLDS environment variable, but there is a lib directory in the default installation location specified in Table 7 on page 17 that contains a valid version of CROSSWORLDS.JAR, then the product installs to the default location specified in Table 7 on page 17. • If you are installing on UNIX and installer does not find an entry for the product in the vpd.properties file, but there is a lib directory in the default installation location specified in Table 7 on page 17 that contains a valid version of CROSSWORLDS.JAR, then the product installs to the default location specified in Table 7 on page 17.
-W installLocation.value	Set this option to the directory path in which the WebSphere Business Integration Adapters product is installed.
-G replaceExistingResponse	<p>Set this option to yesToAll or yes to replace all files found on the system that have the same name as those being copied by the installer.</p> <p>Set this option to noToAll or no to not replace any files found on the system that have the same name as those being copied by the installer.</p>

Table 11. Silent installation options for the Adapter Development Kit (continued)

Option name	Option values
-G replaceNewerResponses	Set this option to <code>yesToAll</code> or <code>yes</code> to replace all files found on the system that are newer than those being copied by the installer. Set this option to <code>noToAll</code> or <code>no</code> to not replace any files found on the system that are newer than those being copied by the installer.
-G createDirectoryResponse	Set this option to <code>yes</code> to create the product directory specified by the option if it does not already exist. Set this option to <code>no</code> to not have the product directory created if it does not exist. You must set this option to <code>yes</code> if the specified directory does not exist for the installation to succeed.
-G removeExistingResponse	This option is not relevant for any broker on any platform. Comment out this option.
-G removeModifiedResponse	This option is not relevant for any broker on any platform. Comment out this option.

2. Perform the silent installation as described in “Executing the silent installation” on page 16, using the response file prepared in step 1 on page 25.

WBIA directories, files, and environment variables

Installer creates a number of directories, files, and environment variables depending on the selections you made while running Installer.

WBIA directories and files

After the installation is complete, you can view the file system and its contents. Table 12 lists some of the directories you might need to know about. The folders and files created vary depending on the choices made during the installation and on the operating system.

Table 12. WebSphere Business Integration Adapter directories

Directory name	Contents
<code>_jvm</code>	This directory contains the Java Runtime files. Note: If you are upgrading from a previous version of WBIA, the existing directory name is retained from that release.
<code>_uninst_AdapterDevKit</code>	This directory contains files that are required to uninstall the Adapter Development Kit. For more information on uninstalling WebSphere Business Integration Adapters products, see Chapter 4, “Uninstalling WebSphere Business Integration Adapters products,” on page 31. Note: If you are upgrading from a previous version of WBIA, the existing directory name is retained from that release.

Table 12. WebSphere Business Integration Adapter directories (continued)

Directory name	Contents
<code>_uninst_AdapterFramework</code>	<p>This directory contains files that are required to uninstall the Adapter Framework.</p> <p>For more information on uninstalling WebSphere Business Integration Adapters products, see Chapter 4, “Uninstalling WebSphere Business Integration Adapters products,” on page 31.</p> <p>Note: If you are upgrading from a previous version of WBIA, the existing directory name is retained from that release.</p>
<code>_uninst_adapter</code>	<p>This directory contains files that are required to uninstall an adapter. For example, the directory named <code>_uninst_JDBC</code> contains files that are required to uninstall the WebSphere Business Integration Adapter for JDBC.</p> <p>For more information on uninstalling WebSphere Business Integration Adapters products, see Chapter 4, “Uninstalling WebSphere Business Integration Adapters products,” on page 31.</p> <p>Note: If you are upgrading from a previous version of WBIA, the existing directory name is retained from that release.</p>
<code>_uninst_datahandler</code>	<p>This directory contains files that are required to uninstall a data handler. For example, the directory named <code>_uninst_xml dh</code> contains files that are required to uninstall the XML data handler.</p> <p>For more information on uninstalling WebSphere Business Integration Adapters products, see Chapter 4, “Uninstalling WebSphere Business Integration Adapters products,” on page 31.</p> <p>Note: If you are upgrading from a previous version of WBIA, the existing directory name is retained from that release.</p>
<code>_uninst_Zip</code>	<p>This directory contains log files about tool plug-ins installed.</p>
<code>bin</code>	<p>This directory contains the executable files and shell scripts that the business integration adapters use.</p>
<code>connectors</code>	<p>This directory contains files specific to each adapter in the system. It also contains adapter-specific files that you may need to install in the application that the adapter supports.</p>
<code>DataHandlers</code>	<p>This directory contains the <code>.jar</code> files for the data handlers.</p>
<code>DevelopmentKits</code>	<p>This directory contains the files needed to develop connectors.</p>
<code>docs</code>	<p>This directory contains the license file for the Java Runtime Environment.</p>
<code>installLogs</code>	<p>This directory contains log files about the installation of WebSphere Business Integration Adapters products.</p>
<code>jre</code>	<p>This directory contains the Java Runtime Environment.</p>
<code>lib</code>	<p>This directory contains shared libraries and <code>.jar</code> files for the system.</p>
<code>license_AdapterDevKit</code>	<p>This directory contains the license files for the Adapter Development Kit.</p>

Table 12. WebSphere Business Integration Adapter directories (continued)

Directory name	Contents
license_AdapterFramework	This directory contains the license files for the Adapter Framework.
license_datahandler	This directory contains the license files for a data handler. For example, the directory named _license_xml dh contains the license files for the XML data handler.
license_adapter	This directory contains the license files for an adapter. For example, the directory named _license_JDBC contains the license files for the WebSphere Business Integration Adapter for JDBC.
logs	This directory is provided to contain log and trace files.
messages	This directory contains message text files used by the connectors to generate log and trace messages.
ODA	This directory contains the .jar and .bat files for each Object Discovery Agent.
repository	This directory contains the connector definition files.
templates	This directory contains sample script files for creating and clearing WebSphere MQ queues. If your integration broker is one of the supported message brokers or WebSphere Application Server, see your broker implementation guide for more information on using these scripts. If your integration broker is WebSphere InterChange Server, see the installation guide for InterChange Server on the appropriate platform.
Tools	This directory contains the WSWB203 directory, which in turn contains the installation of WebSphere Studio Workbench if you chose to install it.

Environment variables

If you chose one of the supported message brokers or WebSphere Application Server as your broker, Installer takes the actions described in Table 13 to create and update environment variables on the computer. These actions are not taken if you chose WebSphere InterChange Server as your integration broker, because the environment variables required for that broker are created during installation of the broker itself.

Table 13. Actions taken by Installer for environment variables

Environment variable name	Installer action
CROSSWORLDS	Creates this environment variable to reference the WebSphere Business Integration Adapters product directory, as specified when using Installer.
MQ_LIB	Creates this environment variable to contain the path to the Java\lib directory within the WebSphere MQ installation, as specified when using Installer.

Table 13. Actions taken by Installer for environment variables (continued)

Environment variable name	Installer action
PATH	Adds the following entries: <i>ProductDir\jre\bin\classic;</i> <i>ProductDir\bin;</i> <i>ProductDir\bin\connectors;</i>
SM_PATH	Creates this environment variable to contain the path to the installation of WebSphere Studio Application Developer Integration Edition or WebSphere Studio Workbench into which the tools plug-ins are installed.

Chapter 4. Uninstalling WebSphere Business Integration Adapters products

This chapter describes how to install WebSphere Business Integration Adapters products.

This chapter includes the following sections:

- “Uninstalling WebSphere Business Integration Adapters using the graphical uninstaller”
- “Performing a silent uninstallation” on page 33

Note: If you have to uninstall the Adapter Framework as well as other components such as adapters, data handlers, or the Adapter Development Kit, you should uninstall the Adapter Framework last, because uninstalling it also removes the Java Runtime Environment that is required to uninstall the other products.

Uninstalling WebSphere Business Integration Adapters using the graphical uninstaller

Do the following to uninstall WebSphere Business Integration Adapters using the graphical uninstaller:

1. Start the graphical uninstaller as described in “Invoking the graphical uninstaller.”
2. Proceed through the uninstallation wizard to make your selections as described in “Using the graphical uninstaller” on page 33.

Invoking the graphical uninstaller

To uninstall any WebSphere Business Integration Adapters components, you can either use the command line as described in “Invoking the graphical uninstaller at the command line” on page 32 or, if you are in a Microsoft Windows environment, you can invoke the uninstaller from the Windows Add/Remove Programs control panel as described in “Invoking the graphical uninstaller from the Windows Add/Remove Programs control panel” on page 33.

Note: Using the Add/Remove Programs control panel to launch the uninstall program is available only for those adapter components and adapters newly released during or after June 2004. This includes the Adapter Framework, all data handlers, and most adapters. However, it does not include the Adapter Development Kit. Refer to “About this document” on page v for a complete list of those components and adapters that cannot use this feature.

To uninstall the Adapter Framework, follow the instructions in “Invoking the graphical uninstaller for the Adapter Framework” on page 32.

Note: Uninstall all your WebSphere Business Integration Adapters components before you uninstall the Adapter Framework.

Invoking the graphical uninstaller at the command line

Note: Using the .bat or .sh file method described below to launch the uninstaller is available only for those adapter components and adapters newly released during or after June 2004. This includes the Adapter Framework, all data handlers, and most adapters. However, it does not include the Adapter Development Kit. Refer to “About this document” on page v for a complete list of those components and adapters that cannot use this feature. For these adapters, use the `java -jar` file command line described at the end of this section.

To execute the graphical uninstaller for any WebSphere Business Integration Adapters component, execute the following command at the command line:

In a Windows environment:

```
ProductDir\UninstallDirectory\uninstaller.bat
```

In a UNIX environment:

```
ProductDir/UninstallDirectory/uninstaller.sh
```

where the following are true:

- *ProductDir* is the product directory
- *UninstallDirectory* is the directory that contains the uninstallation files for the component you want to uninstall. For example, the directory `_uninst_JDBC` contains the uninstallation files for the WebSphere Business Integration Adapter for JDBC.

For more information on the directory structure of WebSphere Business Integration Adapters, see “WBIA directories and files” on page 26.

You can also execute the following at the command line:

```
ProductDir\_jvm\jre\bin\java -jar  
ProductDir\UninstallDirectory\uninstall.jar
```

Note: You must use the `java -jar` method above to uninstall adapter components and adapters last released prior to the WebSphere Business Integration Adapters release in June, 2004.

Invoking the graphical uninstaller for the Adapter Framework

Follow the instructions in one of the following sections to invoke the graphical installer for the Adapter Framework, depending on your operating system:

- “To invoke the uninstaller in a Windows environment”
- “To invoke the uninstaller in a UNIX environment” on page 33

On a Windows-based system, you can also use the Windows Add/Remove control panel as described in “Invoking the graphical uninstaller from the Windows Add/Remove Programs control panel” on page 33.

Note: Uninstall all your WebSphere Business Integration Adapters components before you uninstall the Adapter Framework.

To invoke the uninstaller in a Windows environment: Navigate to the *ProductDir/_uninst_AdapterFramework* directory and execute `uninstaller.exe`.

To invoke the uninstaller in a UNIX environment: Navigate to the *ProductDir/_uninst_AdapterFramework* directory and execute the WBI Uninstaller, *uninstaller.bin*.

If you are running the Common Desktop Environment and are working directly on the UNIX computer then you can double-click the *uninstaller.bin* file.

If you are using X emulation software to connect to the UNIX computer from a Windows computer then you must execute the *uninstaller.bin* file from the command line, as in the following example:

```
# ./uninstaller.bin
```

Invoking the graphical uninstaller from the Windows Add/Remove Programs control panel

Do the following to uninstall WebSphere Business Integration Adapters from a Microsoft Windows-based system by using the Add/Remove Programs control panel:

1. Select Start -> Settings -> Control Panel.
2. Select Add/Remove Programs to open the Add/Remove Programs control panel.
3. Select the adapter you want to uninstall or the Adapter Framework from the Currently installed programs list.
4. Click Remove.
5. Follow the instructions in the uninstaller to uninstall the adapter.

Using the graphical uninstaller

Do the following to uninstall a WebSphere Business Integration Adapters component:

1. At the language selection prompt, choose the desired language from the drop-down menu and click **OK**.
2. At the "Welcome" screen click **Next**.
3. The "summary" screen lists the components that will be uninstalled and the product directory from which they will be removed. Read the information to verify it and then click **Next**.
4. After the uninstaller finishes successfully, click **Finish**.

Performing a silent uninstallation

Note: Using the .bat file or .sh method described below is available only for those adapter components and adapters newly released during or after June 2004. This includes the Adapter Framework, all data handlers, and most adapters. However, it does not include the Adapter Development Kit. Refer to "About this document" on page vfor a complete list of those components and adapters that cannot use this feature. For these adapters, use the `java -jar` command line described at the end of this section.

To perform a silent uninstallation for any WebSphere Business Integration Adapters component, execute the following command at the command line:

In a Windows environment:

```
ProductDir\UninstallDirectory\uninstaller.bat-silent
```

In a UNIX environment:

```
ProductDir/UninstallDirectory/uninstaller.sh -silent
```

where the following are true:

- *ProductDir* is the product directory
- *UninstallDirectory* is the directory that contains the uninstallation files for the component you want to uninstall. For example, the directory *_uninst_JDBC* contains the uninstallation files for the WebSphere Business Integration Adapter for JDBC.

For more information on the directory structure of WebSphere Business Integration Adapters, see “WBIA directories and files” on page 26.

You can also invoke the following on the command line:

```
ProductDir\_jvm\jre\bin\java -jar  
ProductDir\UninstallDirectory\uninstall.jar  
-silent
```

Note: You must use the `java -jar` method above to uninstall adapter components and adapters last released prior to the WebSphere Business Integration Adapters release in June, 2004.

Chapter 5. Distributing connector agents across networks

This chapter contains the following sections:

- “Which components to install”
- “Installation tasks” on page 36
- “Security” on page 41

The chapter describes how to install adapters to exchange business data through MQ intercommunication across the Internet.

Note: This capability is supported only when IBM WebSphere InterChange Server is used as the integration broker.

In this environment, implement a hub-and-spoke feature called Remote Agent technology—in which a hub site has a complete broker system, but the spoke sites need install only a connector agent.

You would typically use this feature where data exchanges need to go across the Internet and traverse a firewall. However, you can also use it in situations where there is no firewall.

Which components to install

This section describes the operating system and software requirements for the Remote Agent.

Operating system requirements

Remote Agent technology is supported on AIX 5.1, Windows 2000, Windows XP, and Sun Solaris 2.8/8.0. The hub and spoke sites can run different operating systems. JRE v. 1.4 is also required.

Some adapters can run only on specific operating systems. Refer to the guide for your adapter to determine if it has any operating system restrictions.

This guide assumes that your site is the hub site and that IBM WebSphere InterChange Server is installed on Windows 2000.

Required software for hub sites

You must install the following components at the hub site:

- WebSphere InterChange Server (the only supported integration broker)
- Supported version of WebSphere MQ server
- WebSphere MQ Internet pass-thru (required if HTTP/HTTPS is the configured transport)
- JRE (Java Run-Time Environment)

For information on supported software versions, see “Software requirements” on page 8

Required software for spoke sites

You must install the following components at the spoke site:

- The adapters that will participate in the data exchange and their prerequisite WebSphere Business Integration Adapters products
- Supported version of WebSphere MQ server
- WebSphere MQ Internet pass-thru (required if HTTP/HTTPS is the configured transport)

For information on supported software versions, see “Software requirements” on page 8

Installation tasks

The following installation tasks must be performed to implement MQ intercommunication:

- “Planning the installation”
- “Configuring the Remote Agent”
- “Enabling the application to interact with the connector” on page 40
- “Starting the Remote Agent components” on page 40

Planning the installation

Before you install and configure the Remote Agent, you should address a number of planning considerations, including the following:

- Who will be responsible for establishing the configurations at the spoke sites?

Because the implementer at the hub site typically has primary responsibility for planning the overall process, this chapter describes the necessary installation tasks for both the hub and spoke sites.

- What are the security needs of the hub site? The spoke site?

Your security requirements may differ from those of your trading partners, and there may be different requirements among your trading partners. See “Security” on page 41 for some of the choices that you can make in setting the configuration properties that define your levels of security.

- What configuration properties need to be coordinated between the hub and spoke sites?

Certain configuration properties, port numbers, and some security settings, need to be coordinated between the hub and spoke sites.

Configuring the Remote Agent

The Remote Agent can be configured for use with either Native WebSphere MQ or HTTP/HTTPS protocols for communication over the internet. The Native WebSphere MQ option is configured using only the software delivered with the product. The HTTP option requires WebSphere MQ Internet pass-thru, which is not delivered and must be acquired separately. This section describes both configurations.

Note: JMS is the only supported transport for both configurations.

Native WebSphere MQ

This configuration option uses the WebSphere MQ protocol, along with Secure Sockets Layer (SSL) to ensure secure communication over the internet. This configuration provides better performance; however, it requires that a port be

opened on the firewall to allow WebSphere MQ across through the firewall. Figure 2 on page 38. illustrates this configuration.

You must configure the WebSphere MQ channels for bidirectional communication between the broker and the adapter. Two channels are required—one for each direction.

Note: The following steps assume that MQ1 and MQ2 are listening on port 1414.

To configure channels for Native WebSphere MQ:

1. Channel 1 (MQ1 is the sender and MQ2 is the receiver):
 - a. Create the CHANNEL1 sender channel on MQ1.
 - b. Create the CHANNEL1 receiver channel on MQ2.
2. Channel 2 (MQ2 is the sender and MQ1 is the receiver):
 - a. Create the CHANNEL2 sender channel on MQ2.
 - b. Create the CHANNEL2 receiver channel on MQ1.
3. Configure firewall 1 to forward traffic on port 1414 to MQ1 and configure firewall 2 to forward traffic on port 1414 to MQ2.

Note: Assume that MQ1 and MQ2 are listening on port 1414 and that the firewall allows network traffic based on port forwarding. The actual configuration may change, depending on the type of firewall being used.

4. Set the IpAddress of sender Channel 1 to the connection name of firewall 2.
5. Set the IpAddress of sender Channel 2 to the connection name of firewall 1.

To configure queues for Native WebSphere MQ:

1. MQ1 (Q1 is used for communication from the hub site to the spoke site):
 - a. Set Q1 as the remote queue and Q2 as the local queue.
 - b. Set MQ2 as the remote queue manager for Q1.
2. MQ2 (Q2 is used for communication from the spoke site to the hub site):
 - a. Set Q2 as the remote queue and Q1 as the local queue.
 - b. Set MQ1 as the remote queue manager for Q2.
3. Set up a transmission queue on each queue manager.
4. Set up a dead letter queue on each queue manager.
5. Confirm that the fault queue is local to each queue manager.

Refer the RemoteAgentSample.mqsc and RemoteServerSample.mqsc sample scripts, located in *ProductDir*\mqseries to configure the queue managers.

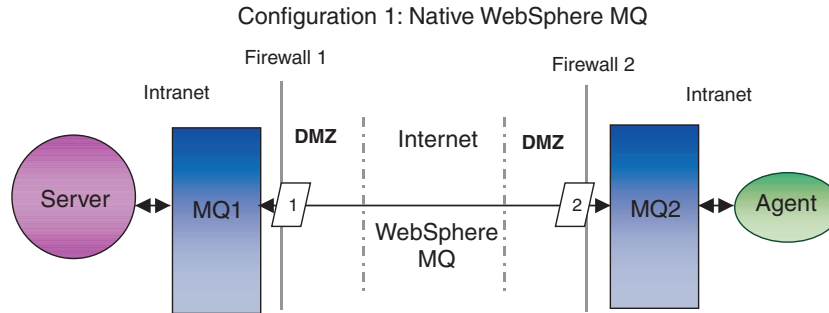

Figure 2. Native WebSphere MQ Configuration

HTTP/HTTPS

This configuration option uses WebSphere MQ Internet pass-thru to pass information over the internet using HTTP. Figure 3 on page 40 illustrates this configuration.

You must define routes to specify the port, IP address, and SSL details. Two routes must be configured for bidirectional communication between the hub and the spoke site. Two routes at each site are required—one for each direction.

Channels must be configured for bidirectional communication between the hub site and the spoke site. Two channels are required—one for each direction.

Note: The following steps assume that MQ1 and MQ2 are listening on port 1414.

To configure channels for HTTP/HTTPS:

1. Channel 1 (MQ1 is the sender and MQ2 is the receiver):
 - a. Create the CHANNEL1 sender channel on MQ1.
 - b. Create the CHANNEL1 receiver channel on MQ2.
2. Channel 2 (MQ2 is the sender and MQ1 is the receiver):
 - a. Create the CHANNEL2 sender channel on MQ2.
 - b. Create the CHANNEL2 receiver channel on MQ1.
3. Set the ConnectionName of CHANNEL1 to the IpAddress and ListenerPort of MQIPT1.
4. Set the ConnectionName of CHANNEL2 to the IpAddress and ListenerPort of MQIPT2.
5. Set firewall 1 to forward all traffic on the ListenerPort to MQIPT1.
6. Set firewall 2 to forward all traffic on the ListenerPort to MQIPT2.

To configure queues for HTTP/HTTPS:

1. MQ1 (Q1 is used for communication from the hub site to the spoke site):
 - a. Set Q1 as the remote queue and Q2 as the local queue.
 - b. Set MQ2 as the remote queue manager for Q1.
2. MQ2 (Q2 is used for communication from the spoke site to the hub site):
 - a. Set Q2 as the remote queue and Q1 as the local queue.
 - b. Set MQ1 as the remote queue manager for Q2.
3. Set up a transmission queue on each queue manager.

4. Set up a dead letter queue on each queue manager.
5. Confirm that the fault queue is local to each queue manager.

Refer the `RemoteAgentSample.mqsc` and `RemoteServerSample.mqsc` sample scripts, located in `ProductDir\mqseries` to configure the queue managers.

To configure routes for MQIPT1:

- Route1 — Set the following parameters:
 - ListenerPort = Port on which MQIPT1 is listening for messages from queue manager MQ1
 - Destination = Domain name or IP address of MQIPT2
 - DestinationPort = Port on which MQIPT2 is listening
 - HTTP = true
 - HTTPS = true
 - HTTPProxy = IpAddress of firewall2 (or a proxy server if there is one in the DMZ)
 - SSLClient = true
 - SSLClientKeyRing = Path to the file that contains the MQIPT1 certificate
 - SSLClientKeyRingPW = Path to the file that contains the password for the ClientKeyRing file
 - SSLClientCAKeyRing = Path to the file that contains the trusted CA certificates
 - SSLClientCAKeyRingPW = path to the file that contains the password for the CAKeyRing file
- Route2 — Set the following parameters:
 - ListenerPort = Port on which MQIPT1 is listening for messages from MQIPT2
 - Destination = Domain name or IPaddress for queue manager MQ1
 - DestinationPort = Port on which MQ1 is listening
 - SSLServer = true
 - SSLServerKeyRing = Path to the file that contains the MQIPT1 certificate
 - SSLServerKeyRingPW = Path to the file that contains the password for the ServerKeyRing file
 - SSLServerCAKeyRing = Path to the file that contains the trusted CA certificates
 - SSLServerCAKeyRingPW = Path to the file that contains the password for the CAKeyRing file

To configure routes for MQIPT2:

- Route1 - Set the following parameters:
 - ListenerPort = Port on which MQIPT2 is listening for MQIPT1
 - Destination = Domain name of IPaddress of queue manager MQ2
 - DestinationPort = Port on which MQ2 is listening
 - SSLServer = true
 - SSLServerKeyRing = Path to the file that has MQIPT2s certificate
 - SSLServerKeyRingPW = Path to the file that has the password for the ServerKeyRing file
 - SSLServerCAKeyRing = Path to the file that contains the trusted CA certificates

- SSLServerCAKeyRingPW = Path to the file that contains the password for the CAKeyRing file
- Route2 - Set the following parameters:
 - ListenerPort = Port on which MQIPT2 is listening for messages from MQ2
 - Destination = Domain name or IP address of MQIPT1
 - DestinationPort = Port on which MQIPT1 is listening
 - HTTP = true
 - HTTPS = true
 - HTTPProxy= IpAddress of firewall1 (or a proxy server if there is one in the DMZ)
 - SSLClient = true
 - SSLClientKeyRing = Path to the file that contains the MQIPT2 certificate
 - SSLClientKeyRingPW = Path to the file that contains the password for the ClientKeyRing file
 - SSLClientCAKeyRing = Path to the file that has trusted CA certificates
 - SSLClientCAKeyRingPW = Path to the file that contains the password for the CAKeyRing file

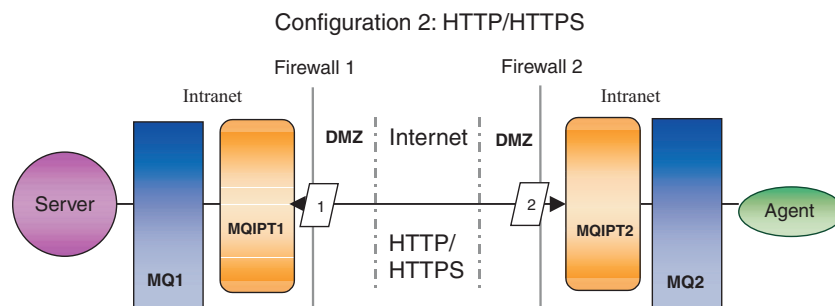

Figure 3. HTTP/HTTPS Configuration

Enabling the application to interact with the connector

You may have to perform configuration tasks in some applications for the connectors to be able to perform the necessary operations with this particular communication model. Refer to the guide for your adapter to determine if any such configuration tasks are necessary.

Starting the Remote Agent components

Remote Agent requires that the following be running:

- The integration broker
 - For information on how to start the WebSphere InterChange Server broker, see the *System Installation Guide for Windows* or the *System Installation Guide for UNIX*. See the WebSphere Application Server documentation for information on how to start that broker.
 - See the documentation on a supported message broker for information on how to start that broker.
- Connector agent
 - For information on how to start connectors if your broker is WebSphere InterChange Server, see the *System Administration Guide*.

For information on how to start connectors if your broker is WebSphere Application Server, see Implementing Adapters with WebSphere Application Server.

For information on how to start connectors if your broker is one of the supported message brokers, see Implementing Adapters with WebSphere MQ Integrator Broker.

- Queue managers at both the hub and spoke sites

For information on how to start WebSphere MQ services, see the WebSphere MQ documentation.

- WebSphere MQ internet pass-thru (if HTTP/HTTPS is the configured transport)

For information on how to start WebSphere MQ Internet pass-thru, see the WebSphere MQ Internet pass-thru documentation.

Security

The Remote Agent uses the Secure Sockets Layer (SSL) protocol to provide security. Both WebSphere MQ and WebSphere MQ Internet pass-thru support SSL at the link level. SSL provides a secure connection between two queue managers in the Native WebSphere MQ option and between two WebSphere MQ Internet pass-thru installations in the HTTP/HTTPS option.

Refer to the WebSphere MQ product documentation for details on configuring SSL.

Chapter 6. Upgrading WebSphere Business Integration Adapters

This chapter describes how to upgrade environments in which you develop adapters, run custom-developed adapters, and run adapters that are part of the WebSphere Business Integration Adapters product.

Upgrading an adapter development environment

Do the following to upgrade an adapter development environment when your integration broker is one of the supported message brokers or WebSphere Application Server:

1. Upgrade the hardware of the computer on which you are upgrading the adapter development environment as necessary to meet the WebSphere Business Integration Adapters 2.4 requirements.
For more information about hardware requirements, see “Hardware requirements” on page 7.
2. Uninstall the VisiBroker Object Request Broker.
The IBM Java Object Request Broker has replaced the VisiBroker Object Request Broker in WebSphere Business Integration Adapters 2.4.
3. Install the Adapter Framework as described in “Installing the Adapter Framework” on page 16 into a directory other than the one where the adapter framework is currently installed.
4. Install each data handler that will be required for the adapters you are developing as described in “Installing data handlers” on page 19.
5. Install the Adapter Development Kit as described in “Installing the Adapter Development Kit” on page 24.

Upgrading a WebSphere Business Information adapter

This section describes how to upgrade an adapter that is released as part of the WebSphere Business Integration Adapters product set.

1. Do the following in a development environment:
 - a. Back up the integration broker system to preserve it.
 - b. Open the definition for the version of the adapter that is currently in use in Connector Configurator.
Record all configuration information about the adapter.
 - c. Upgrade the hardware of the computer on which you are upgrading the adapter as necessary to meet the WebSphere Business Integration Adapters 2.4 requirements.
For more information about hardware requirements, see “Hardware requirements” on page 7.
 - d. Uninstall the VisiBroker Object Request Broker.
The IBM Java Object Request Broker has replaced the VisiBroker Object Request Broker in WebSphere Business Integration Adapters 2.4.
 - e. Upgrade any prerequisite software to the required version.
For more information on software requirements, see “Software requirements” on page 8.

- f. If your integration broker is one of the supported message brokers or WebSphere Application Server, install the Adapter Framework as described in “Installing the Adapter Framework” on page 16 into a directory other than the one where the adapter framework is currently installed.

Note: If your integration broker is WebSphere InterChange Server and you are installing WebSphere Business Integration Adapters on the same computer on which InterChange Server is installed, then do not install the Adapter Framework. The Adapter Framework is installed with WebSphere InterChange Server.

- g. If your integration broker is InterChange Server, rename the directory of the currently-installed adapter to preserve it.
 - h. Install the new version of the adapter as described in “Installing adapters” on page 21.
 - i. Import the definition for the WebSphere Business Integration Adapters 2.4 version of the adapter into the integration broker environment.
 - j. Read the chapter named “Installing and configuring the connector” in the guide for the adapter you are upgrading and determine any new properties that must be configured.
 - k. Configure the adapter definition imported in step 1i with the information recorded in step 1b on page 43 and any new properties discovered in step 1j.
 - l. Install each data handler required for the environment as described in “Installing data handlers” on page 19.
 - m. Perform any adapter-specific installation steps, such as installing the application client on the adapter host computer, as described in the guide for each adapter required in the environment.
 - n. Perform regression testing to ensure that the upgraded adapter still meets the business requirements of the implementation.
2. Perform step 1 on page 43 to upgrade the adapter in a stress-testing environment and then perform regression testing to ensure that the upgraded adapter still meets the performance requirements of the implementation.
 3. Perform step 1 on page 43 to upgrade the adapter in the production environment.

Upgrading a custom adapter

Do the following to upgrade an adapter that you have developed to use the WebSphere Business Integration Adapters 2.4 adapter framework when your integration broker is one of the supported message brokers or WebSphere Application Server:

1. Do the following in a development environment:
 - a. Back up the integration broker system to preserve it.
 - b. Save the definition for the adapter to a file.
 - c. Upgrade the hardware of the computer on which you are upgrading the adapter as necessary to meet the WebSphere Business Integration Adapters 2.4 requirements.

For more information about hardware requirements, see “Hardware requirements” on page 7.

- d. Uninstall the VisiBroker Object Request Broker.

The IBM Java Object Request Broker has replaced the VisiBroker Object Request Broker in WebSphere Business Integration Adapters 2.4.

- e. Upgrade any prerequisite software to the required version.
For more information on software requirements, see “Software requirements” on page 8.
 - f. Install the Adapter Framework as described in “Installing the Adapter Framework” on page 16 into a directory other than the one where the adapter framework is currently installed.
 - g. Prepare an upgraded adapter development environment as described in “Upgrading an adapter development environment” on page 43 and re-compile the adapter using the WebSphere Business Integration Adapters 2.4 Adapter Framework.
 - h. Follow the direction of the adapter developer to install the re-compiled adapter into the framework environment prepared in step 1f. Be sure to modify any path references or other environment-specific information in any scripts used by the adapter.
 - i. Modify the adapter scripts in the following ways:
 - Remove any references to vbjapp.jar and vbjorb.jar.
 - Add references to ibmorb.jar in %CROSSWORLDS%\jre\lib\ext.These modifications update the adapter script to use the IBM Java Object Request Broker, which replaces the VisiBroker Object Request Broker in WebSphere Business Integration Adapters 2.4.
 - j. Import the definition for the adapter into the integration broker environment.
 - k. Perform regression testing to ensure that the upgraded adapter still meets the business requirements of the implementation.
2. Perform step 1 on page 43 to upgrade the adapter in a stress-testing environment and then perform regression testing to ensure that the upgraded adapter still meets the performance requirements of the implementation.
 3. Perform step 1 on page 43 to upgrade the adapter in the production environment.

Notices

IBM may not offer the products, services, or features discussed in this document in all countries. Consult your local IBM representative for information on the products and services currently available in your area. Any reference to an IBM product, program, or service is not intended to state or imply that only that IBM product, program, or service may be used. Any functionally equivalent product, program, or service that does not infringe any IBM intellectual property right may be used instead. However, it is the user's responsibility to evaluate and verify the operation of any non-IBM product, program, or service.

IBM may have patents or pending patent applications covering subject matter described in this document. The furnishing of this document does not give you any license to these patents. You can send license inquiries, in writing, to:

IBM Director of Licensing
IBM Corporation
North Castle Drive
Armonk, NY 10504-1785
U.S.A.

The following paragraph does not apply to the United Kingdom or any other country where such provisions are inconsistent with local law:

INTERNATIONAL BUSINESS MACHINES CORPORATION PROVIDES THIS PUBLICATION "AS IS" WITHOUT WARRANTY OF ANY KIND, EITHER EXPRESS OR IMPLIED, INCLUDING, BUT NOT LIMITED TO, THE IMPLIED WARRANTIES OF NON-INFRINGEMENT, MERCHANTABILITY OR FITNESS FOR A PARTICULAR PURPOSE. Some states do not allow disclaimer of express or implied warranties in certain transactions, therefore, this statement may not apply to you.

This information could include technical inaccuracies or typographical errors. Changes are periodically made to the information herein; these changes will be incorporated in new editions of the publication. IBM may make improvements and/or changes in the product(s) and/or program(s) described in this publication at any time without notice.

Any references in this information to non-IBM Web sites are provided for convenience only and do not in any manner serve as an endorsement of those Web sites. The materials at those Web sites are not part of the materials for this IBM product and use of those Web sites is at your own risk.

IBM may use or distribute any of the information you supply in any way it believes appropriate without incurring any obligation to you.

Licensees of this program who wish to have information about it for the purpose of enabling: (i) the exchange of information between independently created programs and other programs (including this one) and (ii) the mutual use of the information which has been exchanged, should contact:

IBM Burlingame Laboratory Director
IBM Burlingame Laboratory
577 Airport Blvd., Suite 800

Burlingame, CA 94010
U.S.A

Such information may be available, subject to appropriate terms and conditions, including in some cases, payment of a fee.

The licensed program described in this document and all licensed material available for it are provided by IBM under terms of the IBM Customer Agreement, IBM International Program License Agreement, or any equivalent agreement between us.

Any performance data contained herein was determined in a controlled environment. Therefore, the results obtained in other operating environments may vary significantly. Some measurements may have been made on development-level systems and there is no guarantee that these measurements will be the same on generally available systems. Furthermore, some measurement may have been estimated through extrapolation. Actual results may vary. Users of this document should verify the applicable data for their specific environment.

Information concerning non-IBM products was obtained from the suppliers of those products, their published announcements or other publicly available sources. IBM has not necessarily tested those products and cannot confirm the accuracy of performance, compatibility or any other claims related to non-IBM products. Questions on the capabilities of non-IBM products should be addressed to the suppliers of those products.

This information may contain examples of data and reports used in daily business operations. To illustrate them as completely as possible, the examples may include the names of individuals, companies, brands, and products. All of these names are fictitious and any similarity to the names and addresses used by an actual business enterprise is entirely coincidental.

All statements regarding IBM's future direction or intent are subject to change or withdrawal without notice, and represent goals and objectives only.

COPYRIGHT LICENSE

This information may contain sample application programs in source language, which illustrates programming techniques on various operating platforms. You may copy, modify, and distribute these sample programs in any form without payment to IBM, for the purposes of developing, using, marketing or distributing application programs conforming to the application programming interface for the operating platform for which the sample programs are written. These examples have not been thoroughly tested under all conditions. IBM, therefore, cannot guarantee or imply reliability, serviceability, or function of these programs.

Programming interface information

Programming interface information, if provided, is intended to help you create application software using this program.

General-use programming interfaces allow you to write application software that obtain the services of this program's tools.

However, this information may also contain diagnosis, modification, and tuning information. Diagnosis, modification and tuning information is provided to help you debug your application software.

Warning: Do not use this diagnosis, modification, and tuning information as a programming interface because it is subject to change.

Trademarks and service marks

The following terms are trademarks or registered trademarks of International Business Machines Corporation in the United States or other countries, or both:

IBM
the IBM logo
AIX
CrossWorlds
DB2
DB2 Universal Database
Domino
Lotus
Lotus Notes
MQIntegrator
MQSeries
Tivoli
WebSphere

Microsoft, Windows, Windows NT, and the Windows logo are trademarks of Microsoft Corporation in the United States, other countries, or both.

MMX, Pentium, and ProShare are trademarks or registered trademarks of Intel Corporation in the United States, other countries, or both.

Java and all Java-based trademarks are trademarks of Sun Microsystems, Inc. in the United States, other countries, or both.

Other company, product or service names may be trademarks or service marks of others.



WebSphere Business Integration Adapter Framework V2.4.0

IBM WebSphere InterChange Server V4.2.1, IBM WebSphere Business Integration Toolset V4.2.1, IBM WebSphere Business Integration Adapters, V2.3.1.



Printed in USA