



**Program Directory for
VisualAge Generator Server for MVS**

Version 1, Release 2, Modification Level 0

Program Number 5648-B02

for Use with
MVS
OS/390

Document Date: July 1, 1998

GI10-0812-01

Note!

Before using this information and the product it supports, be sure to read the general information under "Notices" on page viii.

A form for reader's comments appears at the back of this publication. When you send information to IBM, you grant IBM a nonexclusive right to use or distribute the information in any way it believes appropriate without incurring any obligation to you.

© **Copyright International Business Machines Corporation 1994, 1998. All rights reserved.**

Note to U.S. Government Users — Documentation related to restricted rights — Use, duplication or disclosure is subject to restrictions set forth in GSA ADP Schedule Contract with IBM Corp.

Contents

Notices	viii
Trademarks	ix
1.0 Introduction	1
1.1 VA Gen Server Description	2
1.2 VA Gen Server FMIDs	2
2.0 Program Materials	3
2.1 Basic Machine-Readable Material	3
2.2 Optional Machine-Readable Material	9
2.3 Program Publications	9
2.3.1 Basic Program Publications	9
2.3.2 Optional Program Publications	9
2.4 Program Source Materials	9
2.5 Publications Useful During Installation	9
3.0 Program Support	11
3.1 Program Services	11
3.2 Preventive Service Planning	11
3.3 Statement of Support Procedures	11
4.0 Program and Service Level Information	13
4.1 Program Level Information	13
4.2 Service Level Information	14
4.3 Cumulative Service Tape	14
5.0 Installation Requirements and Considerations	15
5.1 Driving System Requirements	15
5.1.1 Machine Requirements	15
5.1.2 Programming Requirements	15
5.2 Target System Requirements	15
5.2.1 Machine Requirements	16
5.2.2 Programming Requisites	16
5.2.2.1 Minimum Requisites	16
5.2.2.2 Functional Requisites	17
5.2.2.3 Toleration/Coexistence Requisites	18
5.2.2.4 Incompatibility (Negative) Requisites	18
5.2.3 DASD Storage Requirements	18
5.3 FMIDs Deleted	22
5.4 Special Considerations	24
6.0 Installation Instructions	25

6.1	Installing VA Gen Server	25
6.1.1	SMP/E Considerations for Installing VA Gen Server	25
6.1.2	SMP/E Environment	25
6.1.3	SMP/E Options Subentry Values	26
6.1.4	Unload the Sample JCL from the Product Tape	26
6.1.5	Perform SMP/E RECEIVE	27
6.1.6	RECEIVE the Cumulative Service Tape	27
6.1.7	Allocate SMP/E Target and Distribution Libraries	27
6.1.8	Create DDDEF Entries	27
6.1.8.1	Create DDDEF Entries for Optional Feature	27
6.1.8.2	Create CALLLIB DDDEF Entries	28
6.1.9	Create HFS Directories (Optional)	28
6.1.10	Perform SMP/E APPLY CHECK	28
6.1.11	Perform SMP/E APPLY	29
6.1.12	Perform SMP/E ACCEPT CHECK	29
6.1.13	Perform SMP/E ACCEPT	29
6.2	Activating VA Gen Server	30
6.2.1.1	Customization Tasks	30
6.2.1.2	ALL ENVIRONMENTS	32
6.2.1.2.1	Create Variable Blocked CLIST Data Set (Optional)	32
6.2.1.2.2	Installation Customization	32
6.2.1.2.2.1	Run-Time Default Options	42
6.2.1.2.2.2	Language-dependent Options	43
6.2.1.2.2.3	Default Code Page Conversion Tables	45
6.2.1.2.2.4	Saving Modified Values	45
6.2.1.2.3	Change Default Installation Options	46
6.2.1.2.4	Change Language-dependent Options	46
6.2.1.2.5	Modify LE Options and Exits	48
6.2.1.2.5.1	Working Storage Initialization Option	48
6.2.1.2.5.2	LE Assembler User Exit Processing	48
6.2.1.2.6	Links Required for LE Exits	49
6.2.1.2.7	Link Pack Area (LPA) Considerations	50
6.2.1.2.8	Prepare ANSI SQL Program	50
6.2.1.2.9	Modify and Copy Compile and Link Procedures	51
6.2.1.2.10	Run the Customization Verification Program (CVP)	53
6.2.1.3	MVS/TSO ENVIRONMENT	54
6.2.1.3.1	Update MVS/TSO Concatenation Lists	54
6.2.1.3.2	Run the CVP for MVS/TSO	54
6.2.1.4	IMS/VS ENVIRONMENT	55
6.2.1.4.1	Install a Work Database	55
6.2.1.4.1.1	DL/I Work Database	55
6.2.1.4.1.2	DB2 Work Database	58
6.2.1.4.1.3	Perform a DB2 Bind	59
6.2.1.4.2	Install VA Gen Server PSBs	61
6.2.1.4.2.1	For DL/I Work Database	61
6.2.1.4.2.2	For All Work Databases	61

6.2.1.4.3	Modify IMS System Definition	62
6.2.1.4.4	Modify IMS Control and Message Region JCL	63
6.2.1.4.4.1	IMS Control Region JCL	63
6.2.1.4.4.2	IMS Message Region JCL	64
6.2.1.4.5	Assemble and Link the VA Gen Server Maps	65
6.2.1.4.5.1	Tailor the Trace Facility Maps	65
6.2.1.4.5.2	Tailor the Customization Verification Maps	65
6.2.1.4.5.3	Tailor the Critical Error Maps	65
6.2.1.4.6	Run the IMS Online Change Utility	66
6.2.1.4.7	Link and Run the Customization Verification Program for IMS	67
6.2.1.4.7.1	Verify IMS/VS with a DL/I Work Database	67
6.2.1.4.7.2	Verify IMS/VS with a DB2 Work Database	68
6.2.1.5	CICS ENVIRONMENT	69
6.2.1.5.1	Add CICS Diagnostic Controller Utility Support	69
6.2.1.5.1.1	Intrapartition Transient Data Queue	70
6.2.1.5.1.2	Extrapartition Transient Data Queue	70
6.2.1.5.1.3	Journals	71
6.2.1.5.2	Modify CICS Tables and Definitions	73
6.2.1.5.3	Modify CICS Region JCL	77
6.2.1.5.4	Run the CVP for CICS	77
6.2.1.6	Tailor VA Gen Server Messages	78
6.2.1.7	Java Gateway Support for OS/390	79
6.2.1.7.1	Environment Variables	79
6.2.1.7.2	HTML Page Server	80
Appendix A. Post-installation Customization Procedures		81
Appendix B. VA Gen Server Data Set Descriptions		90
B.1.1	Product Data Sets	90
B.1.2	Non-VSAM Customization Data Sets	90
B.1.3	VSAM Customization Data Sets	90
Appendix C. VA Gen Server Install Logic		92
C.1	SMP/E Modification Control Statements	92
C.2	SMP/E JCLIN	92
Reader's Comments		93

Figures

1.	Basic Material: Program Tape	3
2.	Program Tape: File Content	6
3.	Basic Material: Unlicensed Publications	9
4.	Publications Useful During Installation	9
5.	PSP Upgrade and Subset ID	11
6.	Component IDs	11
7.	Driving System Software Requirements	15
8.	Minimum Requisites	16
9.	Functional Requisites	17
10.	Total DASD Space Required by VA Gen Server	19
11.	Storage Requirements for SMP/E Work Data Sets	19
12.	Storage Requirements for SMP/E Data Sets	20
13.	Storage Requirements for VA Gen Server Target Libraries	21
14.	Storage Requirements for VA Gen Server Distribution Libraries	21
15.	Storage Requirements for VA Gen Server HFS Directories	22
16.	Storage Requirements for VA Gen Server Non-SMP/E Data Sets	22
17.	Storage Requirements for VA Gen Server Non-SMP/E VSAM Data Sets	22
18.	FMIDs Deleted	22
19.	SMP/E Options Subentry Values	26
20.	Total DASD Space Required by VA Gen Server	28
21.	Customization Tasks for the Host Environment	31
22.	Overview of Customization Dialogs for ELACCUST	34
23.	VA Gen Server Installation Customization Panel (ELACCUST)	36
24.	VA Gen Server System Variables Panel (ELACCUST)	37
25.	VA Gen Server Variables Panel (ELACCUST)	38
26.	Specify Application Preparation User Data Set Panel (ELACCUST)	38
27.	IMS Variables Panel (ELACCUST)	39
28.	CICS Variables Panel (ELACCUST)	39
29.	DB2 Variables Panel (ELACCUST)	40
30.	COBOL and LE Variables Panel (ELACCUST)	40
31.	JCL Variables Panel (ELACCUST)	41
32.	Run-time Default Options Panel (ELACCUST)	42
33.	Run-time Default Options	42
34.	Language-dependent Options Customization Panels (ELACCUST)	43
35.	Language-dependent Options	44
36.	Default Code Page Conversion for SBCS Languages	45
37.	Default Code Page Conversion for DBCS Languages	45
38.	Saving Customized Values (ELACCUST)	46
39.	Language Code Conversion Table	47
40.	LE sample user exits	48
41.	VA Gen Server JCL Procedures	51
42.	Sample ELACJCPY Job	52

43.	Customization Verification Panel	53
44.	Customization Verification Panel	54
45.	Customization Verification Panel	55
46.	DL/I Work Database DBD	56
47.	PSB to Load DL/I Work Database	57
48.	PSB to Delete Root Segment and Clean Up DL/I Work Database	57
49.	DB2 Work Database DDL	59
50.	Sample ELACJPT2 Job	60
51.	PSB Generation	61
52.	Sample ELACJPSB job	62
53.	IMS Control Region JCL Statement(s)	63
54.	IMS Load Library JCL	64
55.	Trace Transaction Selection Panel	66
56.	Panel ELAM02	67
57.	CICS Intrapartition Data Queue Example	70
58.	CICS Extrapartition Data Queue Example	71
59.	CICS Journal Entry Example	72
60.	Sample ELACJDCF Job	72
61.	CICS Table Entries for VA Gen Server.	74
62.	IBM Copyright Panel	77
63.	Diagnostic Controller Menu Panel	78
64.	VA Gen Server Post-installation Customization Procedures	82
65.	Product Data Set Descriptions	90
66.	Non-VSAM Customization Data Sets	90
67.	VSAM Customization Data Sets	91

Notices

References in this document to IBM products, programs, or services do not imply that IBM intends to make these available in all countries in which IBM operates. Any reference to an IBM product, program, or service is not intended to state or imply that only IBM's product, program, or service may be used. Any functionally equivalent product, program, or service that does not infringe on any of IBM's intellectual property rights may be used instead of the IBM product, program, or service. Evaluation and verification of operation in conjunction with other products, except those expressly designated by IBM, is the user's responsibility.

APAR numbers are provided in this document to assist in locating PTFs that may be required. Ongoing problem reporting may result in additional APARs being created. Therefore, the APAR lists in this document may not be complete. To obtain current service recommendations and to identify current product service requirements, always contact the IBM Customer Support Center.

IBM may have patents or pending patent applications covering subject matter in this document. The furnishing of this document does not give you any license to these patents. You can send license inquiries, in writing, to the

International Business Machines Corporation
IBM Director of Licensing
500 Columbus Avenue
Thornwood, New York 10594
USA

For online versions of this book, we authorize you to:

- Copy, modify, and print the documentation contained on the media, for use within your enterprise, provided you reproduce the copyright notice, all warning statements, and other required statements on each copy or partial copy.
- Transfer the original unaltered copy of the documentation when you transfer the related IBM product (which may be either machines you own, or programs, if the program's license terms permit a transfer). You must, at the same time, destroy all other copies of the documentation.

You are responsible for payment of any taxes, including personal property taxes, resulting from this authorization.

THERE ARE NO WARRANTIES, EXPRESS OR IMPLIED, INCLUDING THE WARRANTIES OF MERCHANTABILITY AND FITNESS FOR A PARTICULAR PURPOSE.

Some jurisdictions do not allow the exclusion of implied warranties, so the above exclusion may not apply to you.

Your failure to comply with the terms above terminates this authorization. Upon termination, you must destroy your machine readable documentation.

Trademarks

The following terms are trademarks or registered trademarks of the IBM Corporation in the United States or other countries or both:

AD/Cycle	GDDM	OS/390
AIX	IBM	ProductPac
BookManager	IBMLink	RACF
CBPDO	IMS	RETAIN
CBIPO	IMS/ESA	SAA
CICS	Language Environment	SystemPac
CICS/ESA	MVS	System/370
CICS/MVS	MVS/SP	System/390
C/370	MVS/XA	S/390
DATABASE 2	MVS/ESA	VisualAge
DB2	OpenEdition	VisualGen
DRDA	OS/2	

Domino is a trademark or registered trademark of Lotus Development Corporation.

Microsoft, Windows, Windows NT, and the Windows 95 logo are trademarks or registered trademarks of Microsoft Corporation.

Java is a trademark or registered of Sun Microsystems, Inc..

1.0 Introduction

This program directory is intended for the system programmer responsible for program installation and maintenance. It contains information concerning the material and procedures associated with the installation of VisualAge Generator Server for MVS Version 1, Release 2, Modification 0. This publication refers to VisualAge Generator Server for MVS as VA Gen Server. You should read all of this program directory before installing the program and then keep it for future reference.

The program directory contains the following sections:

- 2.0, "Program Materials" on page 3 identifies the basic and optional program materials and documentation for VA Gen Server.
- 3.0, "Program Support" on page 11 describes the IBM support available for VA Gen Server.
- 4.0, "Program and Service Level Information" on page 13 lists the APARs (program level) and PTFs (service level) incorporated into VA Gen Server.
- 5.0, "Installation Requirements and Considerations" on page 15 identifies the resources and considerations for installing and using VA Gen Server.
- 6.0, "Installation Instructions" on page 25 provides detailed installation instructions for VA Gen Server. It also describes the procedures for activating the functions of VA Gen Server, or refers to appropriate publications.
- Appendix C, "VA Gen Server Install Logic" on page 92 provides the install logic for VA Gen Server.

Before installing VA Gen Server, read 3.2, "Preventive Service Planning" on page 11. This section tells you how to find any updates to the information and procedures in this program directory.

Do not use this program directory if you are installing VA Gen Server with an MVS Custom-Built Installation Process Offering (CBIPO), SystemPac, or ServerPac. When using these offerings, use the jobs and documentation supplied with the offering. This documentation may point you to specific sections of the program directory as required.

If you are installing VA Gen Server using the MVS Custom-Built Product Delivery Offering (CBPDO) (5751-CS3), use the softcopy program directory provided on the CBPDO tape. Your CBPDO contains a softcopy preventive service planning (PSP) upgrade for this product. All service and HOLDDATA for VA Gen Server are included on the CBPDO tape.

1.1 VA Gen Server Description

The VisualAge Generator products are a set of program development tools in the IBM Application Productivity Family that provide definition, test, generation and runtime support for both standalone and client/server programs. With VA Gen Server, you can prepare, install, and run generated COBOL programs on MVS in a batch mode or interactive mode. These programs can be standalone host programs or server programs that communicate with client programs through the provided communications support.

1.2 VA Gen Server FMIDs

VA Gen Server consists of the following FMIDs:

- H09912J
- J099100
- J099101
- J09912A
- J09912B
- J09912C
- J09912D
- J09912E
- J09912F
- J09912H
- J09912I

2.0 Program Materials

An IBM program is identified by a program number and a feature number. The program number for VA Gen Server is 5648-B02.

Basic Machine-Readable Materials are materials that are supplied under the base license and feature code, and are required for the use of the product. Optional Machine-Readable Materials are orderable under separate feature codes, and are not required for the product to function.

The program announcement material describes the features supported by VA Gen Server. Ask your IBM representative for this information if you have not already received a copy.

2.1 Basic Machine-Readable Material

The distribution medium for this program is 9-track magnetic tape (written at 6250 BPI), 3480 cartridge, or 4mm cartridge. The tape or cartridge contains all the programs and data needed for installation. It is installed using SMP/E, and is in SMP/E RELFILE format. See 6.0, "Installation Instructions" on page 25 for more information about how to install the program.

Figure 1 describes the tape or cartridge. Figure 2 on page 6 describes the file content of the program tape or cartridge.

Note: If you are installing VA Gen Server using the MVS Custom-Built Product Delivery Offering (CBPDO) (5751-CS3), some of the information in these figures may not be valid. Consult the CBPDO documentation for actual values.

Medium	Feature Number	Physical Volume	External Label Identification	VOLSER
6250	5891	1	VAGEN SVR MVS CHS	09912D
		1	VAGEN SVR MVS BASE	09912J
		1	VAGEN JAVA SVR MVS	099101
3480	5892	1	VAGEN SVR MVS CHS	09912D
		1	VAGEN SVR MVS BASE	09912J
		1	VAGEN JAVA SVR MVS	099101
4mm	6478	1	VAGEN SVR MVS CHS	09912D
		1	VAGEN SVR MVS BASE	09912J
		1	VAGEN JAVA SVR MVS	099101
6250	5040	1	VAGEN SVR MVS DES	09912A
		1	VAGEN SVR MVS BASE	09912J

Figure 1 (Page 2 of 4). Basic Material: Program Tape

Medium	Feature Number	Physical Volume	External Label Identification	VOLSER
		1	VAGEN JAVA SVR MVS	099101
3480	6608	1	VAGEN SVR MVS DES	09912A
		1	VAGEN SVR MVS BASE	09912J
		1	VAGEN JAVA SVR MVS	099101
4mm	6609	1	VAGEN SVR MVS DES	09912A
		1	VAGEN SVR MVS BASE	09912J
		1	VAGEN JAVA SVR MVS	099101
6250	5050	1	VAGEN SVR MVS DEU	09912C
		1	VAGEN SVR MVS BASE	09912J
		1	VAGEN JAVA SVR MVS	099101
3480	6612	1	VAGEN SVR MVS DEU	09912C
		1	VAGEN SVR MVS BASE	09912J
		1	VAGEN JAVA SVR MVS	099101
4mm	6613	1	VAGEN SVR MVS DEU	09912C
		1	VAGEN SVR MVS BASE	09912J
		1	VAGEN JAVA SVR MVS	099101
6250	5080	1	VAGEN SVR MVS ENP	099100
		1	VAGEN SVR MVS BASE	09912J
		1	VAGEN JAVA SVR MVS	099101
3480	5963	1	VAGEN SVR MVS ENP	099100
		1	VAGEN SVR MVS BASE	09912J
		1	VAGEN JAVA SVR MVS	099101
4mm	6479	1	VAGEN SVR MVS ENP	099100
		1	VAGEN SVR MVS BASE	09912J
		1	VAGEN JAVA SVR MVS	099101
6250	5020	1	VAGEN SVR MVS ENU	09912F
		1	VAGEN SVR MVS BASE	09912J
		1	VAGEN JAVA SVR MVS	099101
3480	5976	1	VAGEN SVR MVS ENU	09912F
		1	VAGEN SVR MVS BASE	09912J
		1	VAGEN JAVA SVR MVS	099101

Figure 1 (Page 3 of 4). Basic Material: Program Tape

Medium	Feature Number	Physical Volume	External Label Identification	VOLSER
4mm	6485	1	VAGEN SVR MVS ENU	09912F
		1	VAGEN SVR MVS BASE	09912J
		1	VAGEN JAVA SVR MVS	099101
6250	5030	1	VAGEN SVR MVS ESP	09912B
		1	VAGEN SVR MVS BASE	09912J
		1	VAGEN JAVA SVR MVS	099101
3480	5989	1	VAGEN SVR MVS ESP	09912B
		1	VAGEN SVR MVS BASE	09912J
		1	VAGEN JAVA SVR MVS	099101
4mm	6486	1	VAGEN SVR MVS ESP	09912B
		1	VAGEN SVR MVS BASE	09912J
		1	VAGEN JAVA SVR MVS	099101
6250	5881	1	VAGEN SVR MVS JPN	09912I
		1	VAGEN SVR MVS BASE	09912J
		1	VAGEN JAVA SVR MVS	099101
3480	6618	1	VAGEN SVR MVS JPN	09912I
		1	VAGEN SVR MVS BASE	09912J
		1	VAGEN JAVA SVR MVS	099101
4mm	6619	1	VAGEN SVR MVS JPN	09912I
		1	VAGEN SVR MVS BASE	09912J
		1	VAGEN JAVA SVR MVS	099101
6250	5060	1	VAGEN SVR MVS KOR	09912E
		1	VAGEN SVR MVS BASE	09912J
		1	VAGEN JAVA SVR MVS	099101
3480	6615	1	VAGEN SVR MVS KOR	09912E
		1	VAGEN SVR MVS BASE	09912J
		1	VAGEN JAVA SVR MVS	099101
4mm	6616	1	VAGEN SVR MVS KOR	09912E
		1	VAGEN SVR MVS BASE	09912J
		1	VAGEN JAVA SVR MVS	099101
6250	5070	1	VAGEN SVR MVS PTB	09912H

Figure 1 (Page 4 of 4). Basic Material: Program Tape

Medium	Feature Number	Physical Volume	External Label Identification	VOLSER
		1	VAGEN SVR MVS BASE	09912J
		1	VAGEN JAVA SVR MVS	099101
3480	5882	1	VAGEN SVR MVS PTB	09912H
		1	VAGEN SVR MVS BASE	09912J
		1	VAGEN JAVA SVR MVS	099101
4mm	6620	1	VAGEN SVR MVS PTB	09912H
		1	VAGEN SVR MVS BASE	09912J
		1	VAGEN JAVA SVR MVS	099101

Figure 2 (Page 1 of 3). Program Tape: File Content

VOLSER	File	Name	Dist Library	RECFM	LRECL	BLK SIZE
09912J	1	SMPMCS	n/a	FB	80	27920
	2	IBM.H09912J.F1	JCLIN	FB	80	27920
	3	IBM.H09912J.F2	AELAMOD	U	0	32760
	4	IBM.H09912J.F3	AELACLST	FB	80	27920
	5	IBM.H09912J.F4	AELAJCL	FB	80	27920
	6	IBM.H09912J.F5	AELAPNL	FB	80	27920
	7	IBM.H09912J.F6	AELASAMP	FB	80	27920
	8	IBM.H09912J.F7	AELACOPY	FB	80	27920
	9	IBM.H09912J.F8	AELADBRM	FB	80	27920
	10	IBM.H09912J.F9	AELAMFS	FB	80	27920
	11	IBM.H09912J.F10	AELAMOD2	U	0	32760
	12	IBM.H09912J.F11	AELAMOD1	U	0	32760
	13	IBM.H09912J.F12	AELAESF	FB	80	27920
099100	1	SMPMCS	n/a	FB	80	27920
	2	IBM.J099100.F1	JCLIN	FB	80	27920
	3	IBM.J099100.F2	AELAMOD	U	0	32760
	4	IBM.J099100.F3	AELAMFS	FB	80	27920
	5	IBM.J099100.F4	AELAJCL	FB	80	27920
	6	IBM.J099100.F5	AELAESF	FB	80	27920
	7	IBM.J099100.F6	AELASAMP	FB	80	27920

Figure 2 (Page 2 of 3). Program Tape: File Content

VOLSER	File	Name	Dist Library	RECFM	LRECL	BLK SIZE
099101	1	SMPMCS	n/a	FB	80	27920
	2	IBM.J099101.F1	JCLIN	FB	80	27920
	3	IBM.J099101.F2	AELAMOD	U	0	32760
	4	IBM.J099101.F3	AELAHFS	VB	151	27998
09912A	1	SMPMCS	n/a	FB	80	27920
	2	IBM.J09912A.F1	JCLIN	FB	80	27920
	3	IBM.J09912A.F2	AELAMOD	U	0	32760
	4	IBM.J09912A.F3	AELAMFS	FB	80	27920
	5	IBM.J09912A.F4	AELAJCL	FB	80	27920
	6	IBM.J09912A.F5	AELAESF	FB	80	27920
	7	IBM.J09912A.F6	AELASAMP	FB	80	27920
09912B	1	SMPMCS	n/a	FB	80	27920
	2	IBM.J09912B.F1	JCLIN	FB	80	27920
	3	IBM.J09912B.F2	AELAMOD	U	0	32760
	4	IBM.J09912B.F3	AELAMFS	FB	80	27920
	5	IBM.J09912B.F4	AELAJCL	FB	80	27920
	6	IBM.J09912B.F5	AELAESF	FB	80	27920
	7	IBM.J09912B.F6	AELASAMP	FB	80	27920
09912C	1	SMPMCS	n/a	FB	80	27920
	2	IBM.J09912C.F1	JCLIN	FB	80	27920
	3	IBM.J09912C.F2	AELAMOD	U	0	32760
	4	IBM.J09912C.F3	AELAMFS	FB	80	27920
	5	IBM.J09912C.F4	AELAJCL	FB	80	27920
	6	IBM.J09912C.F5	AELAESF	FB	80	27920
	7	IBM.J09912C.F6	AELASAMP	FB	80	27920
09912D	1	SMPMCS	n/a	FB	80	27920
	2	IBM.J09912D.F1	JCLIN	FB	80	27920
	3	IBM.J09912D.F2	AELAMOD	U	0	32760
	4	IBM.J09912D.F3	AELAMFS	FB	80	27920
	5	IBM.J09912D.F4	AELAJCL	FB	80	27920
	6	IBM.J09912D.F5	AELAESF	FB	80	27920

Figure 2 (Page 3 of 3). Program Tape: File Content

VOLSER	File	Name	Dist Library	RECFM	LRECL	BLK SIZE
	7	IBM.J09912D.F6	AELASAMP	FB	80	27920
09912E	1	SMPMCS	n/a	FB	80	27920
	2	IBM.J09912E.F1	JCLIN	FB	80	27920
	3	IBM.J09912E.F2	AELAMOD	U	0	32760
	4	IBM.J09912E.F3	AELAMFS	FB	80	27920
	5	IBM.J09912E.F4	AELAJCL	FB	80	27920
	6	IBM.J09912E.F5	AELAESF	FB	80	27920
	7	IBM.J09912E.F6	AELASAMP	FB	80	27920
09912F	1	SMPMCS	n/a	FB	80	27920
	2	IBM.J09912F.F1	JCLIN	FB	80	27920
	3	IBM.J09912F.F2	AELAMOD	U	0	32760
	4	IBM.J09912F.F3	AELAMFS	FB	80	27920
	5	IBM.J09912F.F4	AELAJCL	FB	80	27920
	6	IBM.J09912F.F5	AELAESF	FB	80	27920
	7	IBM.J09912F.F6	AELASAMP	FB	80	27920
09912H	1	SMPMCS	n/a	FB	80	27920
	2	IBM.J09912H.F1	JCLIN	FB	80	27920
	3	IBM.J09912H.F2	AELAMOD	U	0	32760
	4	IBM.J09912H.F3	AELAMFS	FB	80	27920
	5	IBM.J09912H.F4	AELAJCL	FB	80	27920
	6	IBM.J09912H.F5	AELAESF	FB	80	27920
	7	IBM.J09912H.F6	AELASAMP	FB	80	27920
09912I	1	SMPMCS	n/a	FB	80	27920
	2	IBM.J09912I.F1	JCLIN	FB	80	27920
	3	IBM.J09912I.F2	AELAMOD	U	0	32760
	4	IBM.J09912I.F3	AELAMFS	FB	80	27920
	5	IBM.J09912I.F4	AELAJCL	FB	80	27920
	6	IBM.J09912I.F5	AELAESF	FB	80	27920
	7	IBM.J09912I.F6	AELASAMP	FB	80	27920

2.2 Optional Machine-Readable Material

No optional machine-readable materials are provided for VA Gen Server.

2.3 Program Publications

The following sections identify the basic and optional publications for VA Gen Server.

2.3.1 Basic Program Publications

Figure 3 identifies the basic unlicensed program publications for VA Gen Server. One copy of each of these publications is included when you order the basic materials for VA Gen Server. For additional copies, contact your IBM representative.

<i>Figure 3. Basic Material: Unlicensed Publications</i>	
Publication Title	Form Number
VisualAge Generator Server for MVS, VSE, and VM: LPS	GH23-0255-00
VisualAge Generator Server Guide for MVS, VSE, and VM	SH23-0256-00

There are no basic licensed program publications for VA Gen Server.

2.3.2 Optional Program Publications

No optional publications are provided for VA Gen Server.

2.4 Program Source Materials

No program source materials or viewable program listings are provided for VA Gen Server.

2.5 Publications Useful During Installation

The publications listed in Figure 4 may be useful during the installation of VA Gen Server. To order copies, contact your IBM representative.

<i>Figure 4 (Page 1 of 2). Publications Useful During Installation</i>	
Publication Title	Form Number
<i>System Modification Program Extended: User's Guide, Release 8.1</i>	SC28-1302

Figure 4 (Page 2 of 2). Publications Useful During Installation

Publication Title	Form Number
<i>System Modification Program Extended: Reference, Release 8.1</i>	SC28-1107
<i>System Modification Program Extended: Messages and Codes, Release 8.1</i>	SC28-1108
<i>TSO/E User's Guide</i>	SC28-1307
<i>TSO/E Command Reference</i>	SC28-1333
<i>ISPF/PDF V2 MVS Guide</i>	SC34-4118
<i>ISPF/PDF V3 MVS Guide</i>	SC34-4135

3.0 Program Support

This section describes the IBM support available for VA Gen Server.

3.1 Program Services

Contact your IBM representative for specific information about available program services.

3.2 Preventive Service Planning

Before installing VA Gen Server, you should review the current Preventive Service Planning (PSP) information. If you obtained VA Gen Server as part of a CBPDO, there is HOLDDATA and PSP information included on the CBPDO tape.

If you obtained VA Gen Server on a product tape, or if the CBPDO is more than two weeks old when you install it, you should contact the IBM Support Center or use S/390 SoftwareXcel to obtain the current "PSP Bucket".

PSP Buckets are identified by UPGRADEs, which specify product levels, and SUBSETs, which specify the FMIDs for a product level. The UPGRADE and SUBSET values for VA Gen Server are:

UPGRADE	SUBSET	Description
VGHS120	H09912J	VisualAge GEN Server 120

3.3 Statement of Support Procedures

Report any difficulties you have using this program to your IBM Support Center. If an APAR is required, the Support Center will provide the address to which any needed documentation can be sent.

Figure 6 identifies the component IDs (COMPID) for VA Gen Server.

FMID	COMPID	Component Name	RETAIN Release
H09912J	5648B0201	VisualAge Generator Server for MVS (Base)	12J
J099100	5648B0201	VisualAge Generator Server for MVS (ENP)	100
J099101	5648B0201	VisualAge Generator JAVA Server MVS (Base OPT)	101

Figure 6 (Page 2 of 2). Component IDs

FMID	COMPID	Component Name	RETAIN Release
J09912A	5648B0201	VisualAge Generator Server for MVS (DES)	12A
J09912B	5648B0201	VisualAge Generator Server for MVS (ESP)	12B
J09912C	5648B0201	VisualAge Generator Server for MVS (DEU)	12C
J09912D	5648B0201	VisualAge Generator Server for MVS (CHS)	12D
J09912E	5648B0201	VisualAge Generator Server for MVS (KOR)	12E
J09912F	5648B0201	VisualAge Generator Server for MVS (ENU)	12F
J09912H	5648B0201	VisualAge Generator Server for MVS (PTB)	12H
J09912I	5648B0201	VisualAge Generator Server for MVS (JPN)	12I

4.0 Program and Service Level Information

This section identifies the program and any relevant service levels of VA Gen Server. The program level refers to the APAR fixes incorporated into the program. The service level refers to the PTFs integrated. Information about the cumulative service tape is also provided.

4.1 Program Level Information

The following APAR fixes against previous releases of VA Gen Server have been incorporated into this release. They are listed by FMID.

- FMID H09912J

PN60839	PN71752	PN83387
PN60840	PN71891	PN84536
PN61759	PN72181	PN84772
PN61760	PN72704	PN85007
PN61761	PN74851	PN85021
PN61762	PN75410	PN86611
PN61763	PN75452	PN86848
PN61764	PN77474	PN87636
PN61769	PN77673	PN88551
PN61774	PN78482	PN90784
PN61775	PN79378	PN90797
PN61777	PN79579	PN90873
PN61779	PN79631	PN91101
PN62441	PN80474	PN92482
PN65028	PN80837	PQ00667
PN65956	PN81235	PQ02387
PN66551	PN81484	PQ03266
PN68066	PN81588	PQ04188
PN69731	PN82268	PQ06999
PN69850	PN82880	PQ09365
PN70807	PN82970	PQ09698
PN71227	PN83324	PQ09848

4.2 Service Level Information

PTFs containing APAR fixes against this release of VA Gen Server have been incorporated into this product tape. For a list of included PTFs, please refer to Appendix C, "VA Gen Server Install Logic" on page 92.

4.3 Cumulative Service Tape

A cumulative service tape, containing PTFs not incorporated into this release, might be included with this program. Installation instructions for cumulative service tapes can be found in the SMP/E publications.

If you received this product as part of a CBPDO or a ProductPac, PTFs not incorporated into this release are provided on the tape, and a separate cumulative service tape will not be provided.

5.0 Installation Requirements and Considerations

The following sections identify the system requirements for installing and activating VA Gen Server. The following terminology is used:

- *Driving system*: the system used to install the program.
- *Target system*: the system on which the program is installed.

In many cases, the same system can be used as both a driving system and a target system. However, you may want to set up a clone of your system to use as a target system by making a separate IPL-able copy of the running system. The clone should include copies of all system libraries that SMP/E updates, copies of the SMP/E CSI data sets that describe the system libraries, and your PARMLIB and PROCLIB.

Some cases where two systems should be used include the following:

- When installing a new level of a product that is already installed, the new product will delete the old one. By installing onto a separate target system, you can test the new product while still keeping the old one in production.
- When installing a product that shares libraries or load modules with other products, the installation can disrupt the other products. Installing onto a test system or clone will allow you to assess these impacts without disrupting your production system.

5.1 Driving System Requirements

This section describes the environment of the driving system required to install VA Gen Server.

5.1.1 Machine Requirements

The driving system can run in any hardware environment that supports the required software.

5.1.2 Programming Requirements

Figure 7. Driving System Software Requirements

Program Number	Product Name and Minimum VRM/Service Level
5668-949	System Modification Program/Extended (SMP/E) Release 8.1 or later

5.2 Target System Requirements

This section describes the environment of the target system required to install and use VA Gen Server.

5.2.1 Machine Requirements

The target system can run in any hardware environment that supports the required software.

5.2.2 Programming Requisites

5.2.2.1 Minimum Requisites

A minimum requisite is defined as one of the following:

1. *Installation Requisite:* A product that is required at installation time. i.e. this product **will not install** successfully unless this requisite is met. This includes products that are specified as REQs, PREs, or CALLLIBs.
2. *Run Time Requisite:* A product that is **not** required for the successful installation of this product, but **is** needed at run time in order for this product to work.

Figure 8. Minimum Requisites

Program Number	Product Name and Minimum VRM/Service Level	Install Req?
Any one of the following:		
5695-047 or 5695-048	MVS/ESA Version 4.2 or later (See notes a. & b.)	Yes
5645-001	OS/390 Version 1.1 or later (See note b.)	Yes
The following are required for all installations.		
5668-949	SMP/E Version 8.1 or later	Yes
5688-198	IBM Language Environment for MVS & VM Version 1.5 or later	Yes
The following are required for Java support:		
5645-001	OS/390 Version 1.3 or later with MVS OpenEdition active and TCP/IP enabled. (See note c.)	Yes
5655-018	CICS/ESA Version 4.1 or later (See note d.)	Yes

Notes:

- a. MVS/ESA Version 5.1 or later is required for using DCE communications.
- b. OS/390 Version 1.3 or later is required for OpenEdition web server support.
- c. IF Domino Go Webserver is used, OS/390 Version 2.4 (Product number 5647-A01) is required.
- d. For OS/390 Open Edition web server support, CICS/ESA version 4.1 or later (Program number 5655-018) is required.

5.2.2.2 Functional Requisites

A functional requisite is defined as a product that is *not* required for the successful installation of this product or for the base function of the product, but *is* needed at run time for a specific function of this product to work. This includes products that are specified as IF REQs.

<i>Figure 9 (Page 1 of 2). Functional Requisites</i>			
Program Number	Product Name and Minimum VRM/Service Level	Function	Install Req?
5655-042	Interactive System Productivity Facility (ISPF) Version 4.1	ISPF products	No
5696-234	IBM High Level Assembler Version 1.2 or later	Assembler products	No
Any one of the following:			
5688-197	IBM COBOL for MVS and VM Version 1.2	Compile products	No
5648-A25	IBM COBOL for OS/390 and VM Version 2.1 or later	Compile products	No
Any one of the following:			
5665-HAL	TCP/IP Version 3.1 or later	File transfer	No
5665-311	IBM 3270/PC File Transfer Program/MVS Release 1	File transfer	No
Any or all of the following:			
5685-083	CICS/ESA Version 3.3 or later (See note 1.)	MVS CICS software	No
5685-012	IMS/ESA Database Manager Version 4.1 or later (See note 2.)	IMS products	No
5685-DB2	IBM DATABASE 2 (DB2) Version 3.1 or alter (See note 3.)	Relational Databases	No
5655-064	For DCE client/server communications, IBM OpenEdition DCE Application Support for MVS/ESA Version 1.2	Communications support	No
The following are required for Java support:			
5655-A46	Java Development Kit 1.1.4 for OS/390 or later	OS/390 OpenEdition web server support	No

Figure 9 (Page 2 of 2). Functional Requisites

Program Number	Product Name and Minimum VRM/Service Level	Function	Install Req?
	One of the following: <ul style="list-style-type: none"> • IBM Internet Connection Secure Server (ICSS) for OS/390 Version 2.1 or later (Product number 5697-B14) • Domino Go Webserver for OS/390 Version 4.6.1 (Product number 5697-C58) (See note 4.) 	Compile products	No
5695-167	To access the Interactive Chart Utility from a VisualAge Generator program, Graphical Data Display Manager/MVS (GDDM/MVS) Version 3.1.1 or later.	Interactive Chart Utility access	No

Notes:

1. The IMS/ESA Transaction Manager Version 4.1 or later (Program number 5685-013 is required in addition to the IMS/ESA Database Manager Version 4.1 or later for MPPs, Fast Path regions, or Fast Path main-storage databases.
2. IBM DB2 for MVS/ESA Version 4 or later is required for participation of a DB2 database in a DRDA distributed unit of work.

5.2.2.3 Toleration/Coexistence Requisites

A toleration/coexistence requisite is defined as a product which must be present on a sharing system. These systems can be other systems in a multisystem environment (not necessarily sysplex), a shared DASD environment (such as test and production), or systems that reuse the same DASD at different time intervals.

There are no toleration/coexistence requisites for VA Gen Server.

5.2.2.4 Incompatibility (Negative) Requisites

A negative requisite identifies products which must *not* be installed on the same system as this product.

HCSP100 - CSP Runtime Service R1.0 (Program number 5688-150).

5.2.3 DASD Storage Requirements

VA Gen Server libraries can reside on a 3880, 3390, or equivalent DASD.

Figure 10 lists the total space required for each type of library.

Figure 10. Total DASD Space Required by VA Gen Server

Library Type	Total Space Required
Target	165-3390 tracks, plus 20 tracks for each additional language
Distribution	190-3390 tracks, plus 20 tracks for each additional language
HFS	30-3390 tracks (optional FMID)

Notes:

1. The data set sizes specified contain 15% extra space. You may wish to revise these numbers based on your plans for adding additional function or service.
2. IBM recommends use of system determined block sizes for efficient DASD utilization for all non-RECFM U data sets. For RECFM U data sets, IBM recommends a block size of 32760, which is the most efficient from a performance and DASD utilization perspective.

If you choose not to use system determined block sizes, use the block sizes and numbers of blocks specified to allocate the data sets. Data sets can be reblocked to a larger size. Please note that the maximum allowable block size will depend on the type of DASD on which the dataset will reside; for example, the block size of datasets on a 3350 DASD cannot exceed 19,069.

3. Abbreviations used for the data set type are:

- U** Unique data set used by only the FMIDs listed. In order to determine the correct storage needed for this data set, this table provides all required information; no other tables (or program directories) need to be referenced for the data set size.
- S** Shared data set used by more than the FMIDs listed. In order to determine the correct storage needed for this data set, the storage size given in this table needs to be added to other tables (perhaps in other program directories). If the data set already exists, it must have enough free space to accommodate the storage size given in this table.

If you currently have a previous release of this product installed in these libraries, the installation of this release will delete the old one and reclaim the space used by the old release and any service that had been installed. You can determine whether or not these libraries have enough space by deleting the old release with a dummy function, compressing the libraries, and comparing the space requirements with the free space in the libraries.

For more information on the names and sizes of the required data sets, please refer to 6.1.7, "Allocate SMP/E Target and Distribution Libraries" on page 27.

Figure 11 (Page 1 of 2). Storage Requirements for SMP/E Work Data Sets

Library DDNAME	T	D S	R E C F M	L R E C L L	No. of Blks	BLK SIZE	No. of 3380/ 9345 Trks	No. of 3390 Trks	No. of DIR Blks
SMPWRK1	S	PO	FB	80	36	3120	15	10	50

Figure 11 (Page 2 of 2). Storage Requirements for SMP/E Work Data Sets

Library DDNAME	T Y P E	D S R O G	R E C F M	L R E C L	No. of Blks	BLK SIZE	No. of 3380/ Trks	No. of 3390 Trks	No. of DIR Blks
SMPWRK2	S	PO	FB	80	36	3120	15	10	50
SMPWRK3	S	PO	FB	80	36	3120	15	10	50
SMPWRK4	S	PO	FB	80	36	3120	15	10	50
SMPWRK6	S	PO	FB	80	36	3120	15	10	50
SYSUT1	U	PS	--	--	230	6160	30	25	0
SYSUT2	U	PS	--	--	230	6160	30	25	0
SYSUT3	U	PS	--	--	230	6160	30	25	0
SYSUT4	U	PS	--	--	230	6160	30	25	0

The following table provides an estimate of the storage needed in the SMP/E data sets for VA Gen Server. The estimates must be added to those of any other programs and service being installed to determine the total additional storage requirements.

Figure 12. Storage Requirements for SMP/E Data Sets

Library DDNAME	T Y P E	D S R O G	R E C F M	L R E C L	No. of Blks	BLK SIZE	No. of 3380/ Trks	No. of 3390 Trks	No. of DIR Blks
SMPLTS	S	PO	U	0	500	6144	70	65	15
SMPMTS	S	PO	FB	80	10	27920	7	5	5
SMPPTS	S	PO	FB	80	1	27920	1	1	1
SMPSCDS	S	PO	FB	80	1	27920	1	1	1
SMPSTS	S	PO	FB	80	10	27920	7	5	5

The following figures list the target and distribution libraries (data sets) and their attributes required to install VA Gen Server. The storage requirements of VA Gen Server must be added to the storage required by other programs having data in the same data set (library). Data set sizings are based upon the installation of the base and 1 language. For each additional VA Gen Server language to be installed, increase the SELAESF, SELALMD, and SELAMFS data set allocations by six 3390 tracks and increase the AELAESF, AELAMFS, and AELAMOD data set allocations by four 3390 tracks.

Figure 13. Storage Requirements for VA Gen Server Target Libraries

Library DDNAME	T Y P E	D S R G	R E C F M	L R E C L	No. of Blks	BLK SIZE	No. of 3380/ 9345 Trks	No. of 3390 Trks	No. of DIR Blks
SELACLST	U	PO	FB	80	18	8800	12	9	5
SELACOPY	U	PO	FB	80	10	8800	7	5	5
SELADBRM	U	PO	FB	80	4	8800	3	2	5
SELAESF	U	PO	FB	80	8	8800	5	4	5
SELAJCL	U	PO	FB	80	14	8800	9	7	6
SELALMD	U	PO	U	0	66	6144	80	66	50
SELAMFS	U	PO	FB	80	14	8800	9	7	6
SELAMOD1	U	PO	U	0	2	6144	3	2	4
SELAMOD2	U	PO	U	0	3	6144	4	3	4
SELAPNL	U	PO	FB	80	8	8800	5	4	5
SELASAMP	U	PO	FB	80	112	8800	71	60	8

Figure 14. Storage Requirements for VA Gen Server Distribution Libraries

Library DDNAME	T Y P E	D S R G	R E C F M	L R E C L	No. of Blks	BLK SIZE	No. of 3380/ 9345 Trks	No. of 3390 Trks	No. of DIR Blks
AELACLST	U	PO	FB	80	18	8800	12	9	5
AELACOPY	U	PO	FB	80	10	8800	7	5	5
AELADBRM	U	PO	FB	80	9	8800	3	2	5
AELAESF	U	PO	FB	80	8	8800	5	4	5
AELAHFS	U	PO	VB	151	46	8800	30	23	5
AELAJCL	U	PO	FB	80	14	8800	9	7	6
AELAMFS	U	PO	FB	80	14	8800	9	7	6
AELAMOD	U	PO	U	0	68	6144	80	68	50
AELAMOD1	U	PO	U	0	2	6144	2	2	4
AELAMOD2	U	PO	U	0	3	6144	3	3	4
AELAPNL	U	PO	FB	80	8	8800	5	4	5
AELASAMP	U	PO	FB	80	112	8800	71	60	8

Figure 15. Storage Requirements for VA Gen Server HFS Directories

Library DDNAME	Path	Space Required
SELAHFS	/usr/lpp/vgwgs31/IBM	30 tracks

The following figures list data sets that are not used by SMP/E, but are required for VA Gen Server to execute.

Figure 16. Storage Requirements for VA Gen Server Non-SMP/E Data Sets

Data Set Name	T Y P E	D S R G	R E C O R D S	L R E C O R D S	No. of Blks	BLK SIZE	No. of 3380/ 9345 Trks	No. of 3390 Trks	No. of DIR Blks
ELA.V1R2M0.ELACLST	U	PO	FB	80	30	6160	6	4	5
ELA.V1R2M0.ELAJCL	U	PO	FB	80	150	6160	26	20	10
ELA.V1R2M0.ELASAMP	U	PO	FB	80	88	6160	17	14	15
ELA.V1R2M0.ELAWORK	U	PS	FBS	8192	75	8192	15	12	0

Figure 17. Storage Requirements for VA Gen Server Non-SMP/E VSAM Data Sets

Data Set Name	Avg. Record Size	Max. Record Size	Records
ELA.V1R2M0.ELACFIL	40	40	(50)
ELA.V1R2M0.DSNDBC.ELADBCTL.ELAWRKTS.I0001.A01	(Linear)		(50 50)
ELA.V1R2M0.DSNDBC.ELADBCTL.TEMPKEY.I0001.A01	(Linear)		(50 50)

5.3 FMIDs Deleted

Installing VA Gen Server will result in the deletion of the following FMIDs:

Figure 18 (Page 1 of 3). FMIDs Deleted

Deleted FMID	Deleting FMID	Description
H0G2110	H09912J	VisualGen Host Services Base
J0G2111	H09912J	VisualGen Host Services ENU
J0G2112	H09912J	VisualGen Host Services DES
J0G2113	H09912J	VisualGen Host Services DEU

Figure 18 (Page 2 of 3). FMIDs Deleted

Deleted FMID	Deleting FMID	Description
J0G2114	H09912J	VisualGen Host Services ESP
J0G2115	H09912J	VisualGen Host Services JPN
J0G2116	H09912J	VisualGen Host Services KOR
J0G2117	H09912J	VisualGen Host Services PTB
J0G2118	H09912J	VisualGen Host Services ENP
J0G2119	H09912J	VisualGen Host Services CHS
H0G2160	H09912J	VisualGen Communication Services Base
J0G2161	H09912J	VisualGen Communication Services ENU
J0G2162	H09912J	VisualGen Communication Services DES
J0G2163	H09912J	VisualGen Communication Services DEU
J0G2164	H09912J	VisualGen Communication Services ESP
J0G2115	H09912J	VisualGen Communication Services JPN
J0G2166	H09912J	VisualGen Communication Services KOR
J0G2167	H09912J	VisualGen Communication Services PTB
J0G2168	H09912J	VisualGen Communication Services CHS
HBDH100	H09912J	CSP/370 Runtime Services Base
JBDH110	H09912J	CSP/370 Runtime Services ENU
JBDH111	H09912J	CSP/370 Runtime Services ENP
JBDH113	H09912J	CSP/370 Runtime Services DES
JBDH114	H09912J	CSP/370 Runtime Services DEU
JBDH115	H09912J	CSP/370 Runtime Services ESP
JBDH117	H09912J	CSP/370 Runtime Services JPN
JBDH118	H09912J	CSP/370 Runtime Services KOR
JBDH119	H09912J	CSP/370 Runtime Services PTB
JBDH120	H09912J	CSP/370 Runtime Services CHS
HVM2100	H09912J	CSP/370 Application Development Base
JVM2110	H09912J	CSP/370 Application Development ENU
JVM2111	H09912J	CSP/370 Application Development ENP
JVM2112	H09912J	CSP/370 Application Development DES
JVM2113	H09912J	CSP/370 Application Development DEU
JVM2114	H09912J	CSP/370 Application Development ESP

Figure 18 (Page 3 of 3). FMIDs Deleted

Deleted FMID	Deleting FMID	Description
JVM2115	H09912J	CSP/370 Application Development JPN
JVM2116	H09912J	CSP/370 Application Development KOR
JVM2117	H09912J	CSP/370 Application Development PTB
JVM2119	H09912J	CSP/370 Application Development CHS

5.4 Special Considerations

VA Gen Server has no special considerations for the target system.

6.0 Installation Instructions

This chapter describes the installation method and the step-by-step procedures to install and to activate the functions of VA Gen Server.

Please note the following:

- If you want to install VA Gen Server into its own SMP/E environment, consult the SMP/E manuals for instructions on creating and initializing the SMP/CSI and the SMP/E control data sets.
- Sample jobs have been provided to help perform some or all of the installation tasks. The SMP/E jobs assume that all DDDEF entries required for SMP/E execution have been defined in the appropriate zones.
- The SMP/E dialogs may be used instead of the sample jobs to accomplish the SMP/E installation steps.

6.1 Installing VA Gen Server

6.1.1 SMP/E Considerations for Installing VA Gen Server

This release of VA Gen Server is installed using the SMP/E RECEIVE, APPLY, and ACCEPT commands. The SMP/E dialogs may be used to accomplish the SMP/E installation steps.

6.1.2 SMP/E Environment

All SMP/E installation jobs provided assume that all necessary DD statements for the execution of SMP/E are defined using DDDEFs.

Sample jobs are provided to assist you in installing VA Gen Server. After the RECEIVE step has been completed, the sample jobs can be found in SMPTLIB: **IBM.H09912J.F1**. Make a copy of these jobs in your own library and modify them to use during the installation of VA Gen Server. The sample jobs are:

ELAIJREC	Sample RECEIVE job
ELAIJADS	Sample job to allocate target and distribution libraries
ELAISMKD	Sample job to create HFS directories for VisualAge Generator Java Server
ELAIJDEF	Sample job to define SMP/E DDDEFs
ELAIJDE1	Sample job to define SMP/E DDDEFs for VisualAge Generator Java Server
ELAIJAPP	Sample APPLY/APPLY CHECK job
ELAIJACC	Sample ACCEPT/ACCEPT CHECK job

In the sample SMP/E jobs provided, the name of the SMP/E CSI is #GLOBALCSI. The global zone name in the SMP/E CSI is GLOBAL. The distribution zone name is #DZONE. The target zone name is #TZONE. The sample jobs should be updated to reflect the CSI and zone names used at your installation.

6.1.3 SMP/E Options Subentry Values

The recommended values for some SMP/E CSI subentries are shown in Figure 19. Use of values lower than these may result in failures in the installation process. DSSPACE is a subentry in the GLOBAL options entry. PEMAX is a subentry of the GENERAL entry in the GLOBAL options entry. Refer to the SMP/E manuals for instructions on updating the global zone.

<i>Figure 19. SMP/E Options Subentry Values</i>		
SUB-ENTRY	Value	Comment
DSSPACE	(600, 200, 100)	The space allocation for SMPTLIB data sets
PEMAX	9999	The SMP/E default is larger than what can be specified here

6.1.4 Unload the Sample JCL from the Product Tape

Sample installation jobs are provided on the distribution tape to help you install VA Gen Server. You can access the sample installation jobs by performing an SMP/E RECEIVE for FMID H09912J, and then copying the jobs from dataset **IBM.H09912J.F4** to a work dataset for editing and submission.

If you prefer, you can use the following sample JCL to copy the VA Gen Server jobs from the tape. Add a job card and modify the parameters in boldface to uppercase values to meet your site's requirements before submitting.

```
//STEP1 EXEC PGM=IEBCOPY
//SYSPRINT DD SYSOUT=A
//IN DD DSN=IBM.H09912J.F4,UNIT=tunit,VOL=SER=09912J,
// LABEL=(5,SL),DISP=(OLD,KEEP)
//OUT DD DSNAME=jcl-library-name,
// DISP=(NEW,CATLG,DELETE),
// VOL=SER=dasdvol,UNIT=dunit,
// DCB=*.STEP1.IN,SPACE=(6160,(65,5,5))
//SYSUT3 DD UNIT=SYSDA,SPACE=(CYL,(1,1))
//SYSIN DD *
COPY INDD=IN,OUTDD=OUT
/*
```

where **tunit** is the unit value matching the product tape or cartridge, **jcl-library-name** is the name of the data set where the sample jobs will reside, **dasdvol** is the volume serial of the DASD device where the data set will reside, and **dunit** is the DASD unit type of the volume.

6.1.5 Perform SMP/E RECEIVE

Edit and submit sample job ELAIJREC to perform the SMP/E RECEIVE for VA Gen Server. Consult the instructions in the sample job for more information.

NOTE: if you obtained VA Gen Server as part of a CBPDO, you can use the RCVPDO job found in the CBPDO RIMLIB data set to RECEIVE the VA Gen Server FMIDs as well as any service, HOLDDATA, or preventive service planning (PSP) information included on the CBPDO tape. For more information, refer to the documentation included with the CBPDO.

Expected Return Codes and Messages: RC=0

6.1.6 RECEIVE the Cumulative Service Tape

NOTE: This step is bypassed if receiving the product from a CBPDO.

6.1.7 Allocate SMP/E Target and Distribution Libraries

Edit and submit sample job ELAIJADS to allocate the SMP/E target and distribution libraries for VA Gen Server. Consult the instructions in the sample job for more information.

Expected Return Codes and Messages: RC=0

6.1.8 Create DDDEF Entries

Edit and submit sample job ELAIJDEF to create DDDEF entries for the SMP/E target and distribution libraries for VA Gen Server. Consult the instructions in the sample job for more information.

Expected Return Codes and Messages: RC=0

6.1.8.1 Create DDDEF Entries for Optional Feature

If you plan to install optional FMID J099101 (VisualAge Generator Java Server MVS (Base OPT)), edit and submit sample JOB ELAIJDE1 to create DDDEF entries for the SMP/E target and distribution libraries for VisualAge Generator Java Server. Consult the instructions in the sample job for more information.

Expected Return Codes and Messages: RC=0

6.1.8.2 Create CALLLIB DDDEF Entries

To satisfy the CALLLIBs needed for IBM Language Environment for MVS & VM, a DDDEF for SCEELKED must be defined.

The following DDDEF for functional requisite products must be defined to satisfy the CALLLIBs for VA Gen Server. If the products are not installed, then allocate an empty data set and define the DDDEF to point to the empty data set.

Figure 20. Total DASD Space Required by VA Gen Server

Product	DDDEFs Required
CICS	SDFHLOAD SDFHEXCI
DB2	SDSNLOAD
IMS	RESLIB

6.1.9 Create HFS Directories (Optional)

If you are installing J099101 VisualAge Generator Java Server MVS (Base OPT), edit and submit sample JOB ELAISMKD to create HFS directories required for the installation of VisualAge Generator Java Server MVS (Base OPT).

Expected Return Codes and Messages: RC=0 or RC=4

Consult the job comments for an explanation of the return code.

6.1.10 Perform SMP/E APPLY CHECK

Edit and submit sample job ELAIJAPP to perform an SMP/E APPLY CHECK for VA Gen Server. Consult the instructions in the sample job for more information.

To receive the full benefit of the SMP/E Causer SYSMOD Summary Report, do *not* bypass the following on the APPLY CHECK: PRE, ID, REQ, and IFREQ. This is because the SMP/E root cause analysis identifies the cause only of **ERRORS** and not of **WARNINGS** (SYSMODs that are bypassed are treated as warnings, not errors, by SMP/E).

The GROUPEXTEND operand indicates that SMP/E will apply all requisite SYSMODs. The requisite SYSMODS might be applicable to other functions.

Expected Return Codes and Messages: RC=0

6.1.11 Perform SMP/E APPLY

The base FMID H09912J must be applied concurrently with the language or accepted before applying language FMID(s).

Edit and submit sample job ELAIJAPP to perform an SMP/E APPLY for VA Gen Server. Consult the instructions in the sample job for more information.

Expected Return Codes and Messages: RC=0 or RC=4

A RC=4 issues the following messages:

```
IEW2454W 9203 SYMBOL xxxxxxxx UNRESOLVED. NO AUTOCALL (NCAL)
          SPECIFIED.
IEW2646W 4B07 ESD RMODE(24) CONFLICTS WITH USER-SPECIFIED
          RMODE(ANY)
IEW2651W 511C ESD AMODE 24 CONFLICTS WITH USER-SPECIFIED AMODE 31
IEW2480W A711 EXTERNAL SYMBOL xxxxxxxx OF TYPE LD WAS ALREADY
          DEFINED AS A SYMBOL OF TYPE LD IN SECTION xxxxxxxx.
GIM23903W LINK-EDIT PROCESSING FOR SYSMOD J099100 WAS SUCCESSFUL FOR
          MODULE ..... IN LMOD ..... IN THE ..... LIBRARY.
          THE RETURN CODE WAS 04.
```

6.1.12 Perform SMP/E ACCEPT CHECK

Edit and submit sample job ELAIJACC to perform an SMP/E ACCEPT CHECK for VA Gen Server. Consult the instructions in the sample job for more information.

To receive the full benefit of the SMP/E Causer SYSMOD Summary Report, do *not* bypass the following on the ACCEPT CHECK: PRE, ID, REQ, and IFREQ. This is because the SMP/E root cause analysis identifies the cause only of **ERRORS** and not of **WARNINGS** (SYSMODs that are bypassed are treated as warnings, not errors, by SMP/E).

The GROUPEXTEND operand indicates that SMP/E accept all requisite SYSMODs. The requisite SYSMODS might be applicable to other functions.

Expected Return Codes and Messages: RC=0

6.1.13 Perform SMP/E ACCEPT

Edit and submit sample job ELAIJACC to perform an SMP/E ACCEPT for VA Gen Server. Consult the instructions in the sample job for more information.

Before using SMP/E to load new distribution libraries, it is recommended that you set the ACCJCLIN indicator in the distribution zone. This will cause entries produced from JCLIN to be saved in the distribution zone whenever a SYSMOD containing inline JCLIN is ACCEPTed. For more information on the ACCJCLIN indicator, see the description of inline JCLIN in the SMP/E manuals.

Expected Return Codes and Messages: RC=0

If PTFs containing replacement modules are being ACCEPTed, SMP/E ACCEPT processing will linkedit/bind the modules into the distribution libraries. During this processing, the Linkage Editor or Binder may issue messages documenting unresolved external references, resulting in a return code of 4 from the ACCEPT step. These messages can be ignored, because the distribution libraries are not executable and the unresolved external references will not affect the executable system libraries.

6.2 Activating VA Gen Server

Although the product has been installed on your MVS system, some customization is required before additional verification procedures can be run and before VA Gen Server can be used.

Customization of VA Gen Server means tailoring the product for use in site-specific environments. This might include adding support for another product or changing values that are currently in effect.

This chapter contains the information you need to customize your installation of VA Gen Server.

- Figure 21 lists all the possible customization tasks in the MVS host environment.
- The rest of the chapter consists of detailed descriptions of the customization procedures, including the panel dialog that results from running the interactive customization program in the ELACCUST CLIST.

In addition to the procedures described in this chapter, Appendix A contains a table that outlines the steps you follow if you need to customize VA Gen Server after it is installed.

6.2.1.1 Customization Tasks

The table in Figure 21 is divided up by environment. The tasks described under the **ALL** environment should be completed first. Other environments can be customized as desired. Tasks listed for environments in which the product will not be used can be ignored.

Figure 21. Customization Tasks for the Host Environment

Step #	Environment	Task Description	Job(s)
1	ALL	6.2.1.2.1, "Create Variable Blocked CLIST Data Set (Optional)" on page 32	ELACCNVT
2		6.2.1.2.2, "Installation Customization" on page 32	ELACCUST
3		6.2.1.2.3, "Change Default Installation Options" on page 46	ELACPIOP
4		6.2.1.2.4, "Change Language-dependent Options" on page 46	ELANJLLL
5		6.2.1.2.5, "Modify LE Options and Exits" on page 48	None
6		6.2.1.2.6, "Links Required for LE Exits" on page 49 <ul style="list-style-type: none"> • LE exits used • LE exits used with CICS 	<ul style="list-style-type: none"> • ELACJCEM • ELACJCEC
7		6.2.1.2.7, "Link Pack Area (LPA) Considerations" on page 50	None
8		6.2.1.2.8, "Prepare ANSI SQL Program" on page 50	None
9		6.2.1.2.9, "Modify and Copy Compile and Link Procedures" on page 51	ELACJCPY
10		6.2.1.2.10, "Run the Customization Verification Program (CVP)" on page 53	ELACJVP1
11	MVS/TSO	6.2.1.3.1, "Update MVS/TSO Concatenation Lists" on page 54	None
12		6.2.1.3.2, "Run the CVP for MVS/TSO" on page 54	<ul style="list-style-type: none"> • ELACVP2C
13	IMS/VS	6.2.1.4.1, "Install a Work Database" on page 55	<ul style="list-style-type: none"> • ELACJWKD • ELACJWK2 • ELACJPT2
14		6.2.1.4.2, "Install VA Gen Server PSBs" on page 61	ELACJPSB
15		6.2.1.4.3, "Modify IMS System Definition" on page 62	None
16		6.2.1.4.4, "Modify IMS Control and Message Region JCL" on page 63	ELACJDAT
17		6.2.1.4.5, "Assemble and Link the VA Gen Server Maps" on page 65	<ul style="list-style-type: none"> • ELACILLL • ELACJCVM • ELACJRSM
18		6.2.1.4.6, "Run the IMS Online Change Utility" on page 66	OLCUTL
19		6.2.1.4.7, "Link and Run the Customization Verification Program for IMS" on page 67 <ul style="list-style-type: none"> • with DL/I work database • with DB2 work database 	<ul style="list-style-type: none"> • Transaction ELACVP3 • ELACJVP4 – Transaction ELACVP4
20	CICS	6.2.1.5.1, "Add CICS Diagnostic Controller Utility Support" on page 69	ELACJDCF
21		6.2.1.5.2, "Modify CICS Tables and Definitions" on page 73	None
22		6.2.1.5.3, "Modify CICS Region JCL" on page 77	None
23		6.2.1.5.4, "Run the CVP for CICS" on page 77	Transaction ELAC

6.2.1.2 ALL ENVIRONMENTS

All tasks described in this section are necessary for customization of VA Gen Server regardless of the program target environment(s) used with VA Gen Server. If you have changed the high-level qualifier from the default (ELA.V1R2M0), then use your value throughout the customization steps.

6.2.1.2.1 Create Variable Blocked CLIST Data Set (Optional): Modify member **ELACCNVT** in ELA.V1R2M0.SELAJCL per the comments in the JCL, then submit it to create a variable blocked CLIST data set. This data set is necessary if the data sets concatenated to your SYSPROC list are variable blocked.

6.2.1.2.2 Installation Customization: Member **ELACCUST** in data set ELA.V1R2M0.SELACLST contains a CLIST that will customize CLISTs, jobs, and samples. This CLIST will allocate data sets ELACLST, ELAJCL, and ELASAMP, edit selected members of the SELACLST, SELAJCL, and SELASAMP system libraries, and store these customized members in these new libraries.

Notes:

1. The CLISTs, jobs, and procedures in the ELACLST, ELAJCL, and ELASAMP libraries are replaced when you run the ELACCUST CLIST. If you have made extensive manual modifications to these members during system installation, you might want to manually tailor the jobs, procedures, and templates with the new values instead of running ELACCUST. If you decide to use ELACCUST, make back-up copies of these libraries, run ELACCUST, compare the newly generated libraries to the back-up copies, and manually enter any changes that might be required.
2. You can use job **ELACJCST** in ELA.V1R2M0.SELAJCL to pre-allocate the ELACLST, ELAJCL, AND ELASAMP data sets.

To run ELACCUST, enter the following TSO command from the ISPF environment:

```
EXEC 'ELA.V1R2M0.SELACLST(ELACCUST)' 'ELAHLQ(ELA.V1R2M0)'
```

Notes:

1. If you created a variable blocked CLIST data set in 6.2.1.2.1, "Create Variable Blocked CLIST Data Set (Optional)," then you would issue the following command instead:

```
EXEC 'ELA.V1R2M0.VB.SELACLST(ELACCUST)' 'ELAHLQ(ELA.V1R2M0)'
```
2. The ELAHLQ parameter specifies the high-level qualifier for the VA Gen Server data sets. The default is ELA.V1R2M0.

Once a customized set of values has been saved, the values can be re-accessed by adding the keyword ELAPARM to the invocation of the ELACCUST CLIST. For example:

```
EXEC 'ELA.V1R2M0.SELACLST(ELACCUST)' 'ELAHLQ(ELA.V1R2M0)  
ELAPARM(xxxx)'
```

where **ELAPARM** specifies the identifier for the set of customized values, and **xxxx** are the four characters entered on the Modified Values Description panel on the first invocation of ELACCUST. See page 45.

Running this CLIST will display the panels that are mapped in Figure 22 and detailed starting with Figure 23 on page 36.

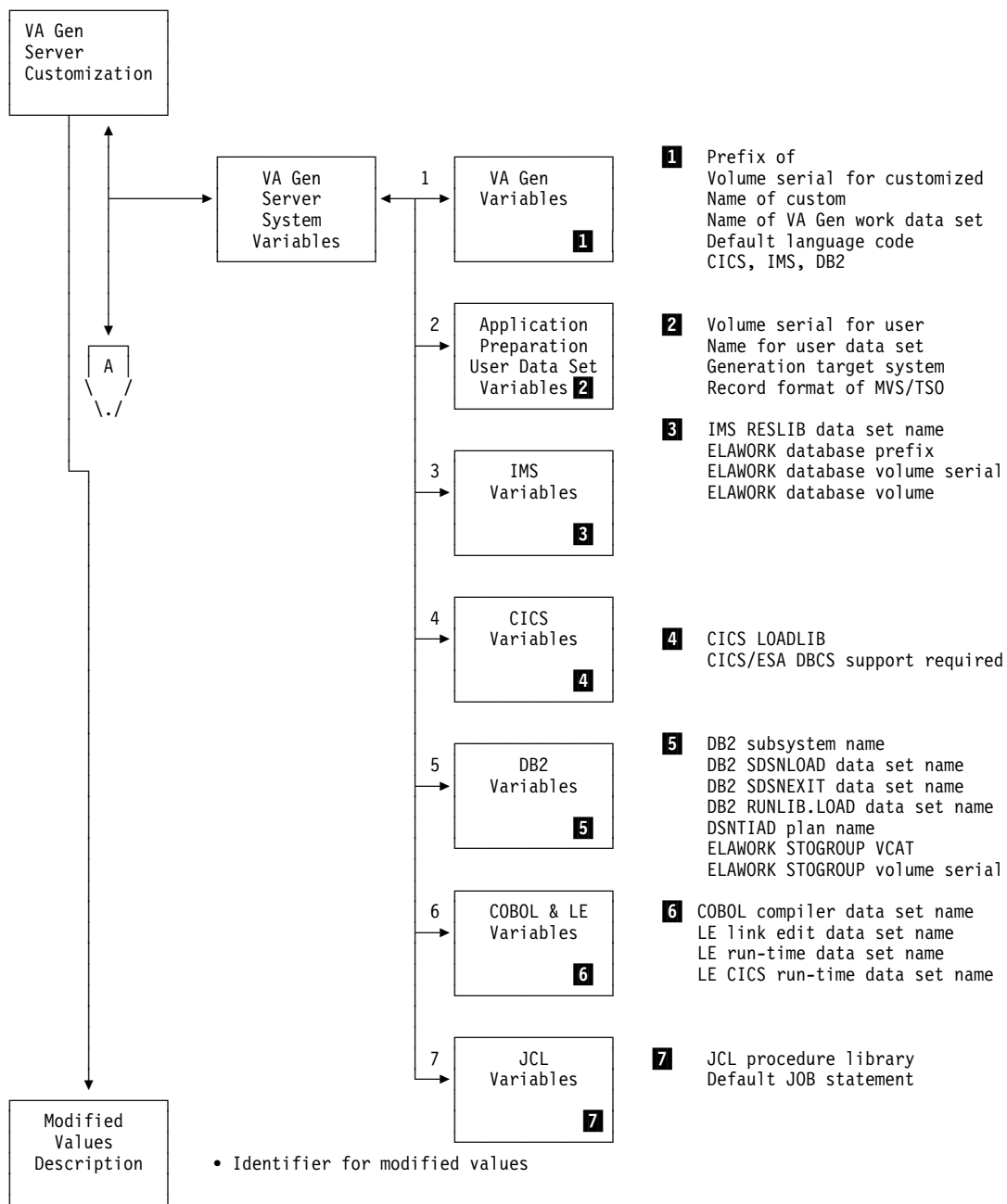

Figure 22 (Part 1 of 2). Overview of Customization Dialogs for ELACCUST

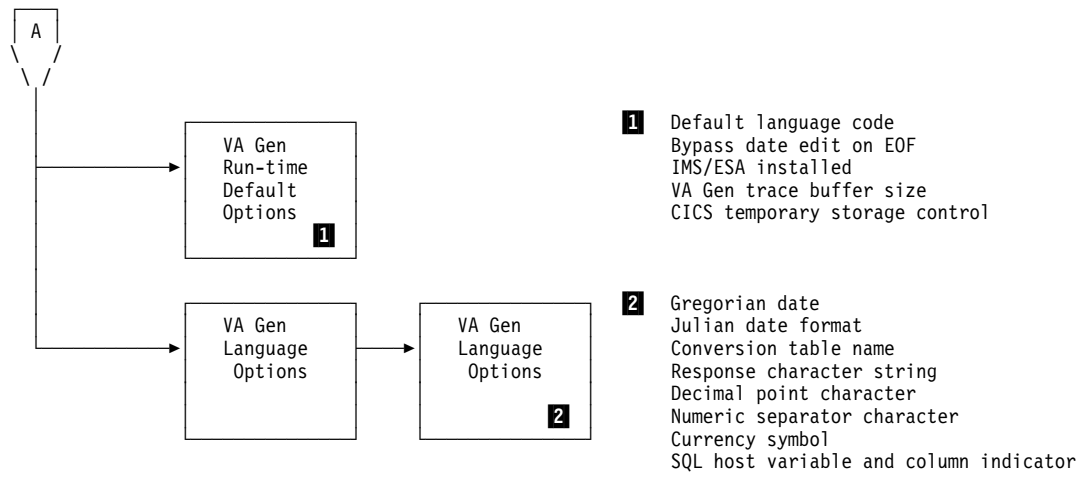

Figure 22 (Part 2 of 2). Overview of Customization Dialogs for ELACCUST

```
VisualAge Generator Server Customization
Option ==>

Select the desired service and press ENTER

1 - Specify VisualAge Generator Server system variables
2 - Specify VisualAge Generator Server run-time default
  options
3 - Specify VisualAge Generator Server language dependent
  options

LICENSED MATERIAL - PROGRAM PROPERTY OF IBM

5648-B02 (C) COPYRIGHT IBM CORP. 1994, 1998. ALL RIGHTS
RESERVE US Government Users Restricted Rights - Use,
duplication or disclosure restricted by GSA ADP Schedule
Contract with IBM Corp.

PRESS: END or PF3 to EXIT  HELP or PF1 for more information
```

Figure 23. VA Gen Server Installation Customization Panel (ELACCUST)

From this panel, select a service and press enter. Selecting option 1 will display the panel in Figure 24 on page 37. This service allows you to specify information which will be used to customize installation JCL, CLISTS, samples, etc. Selecting option 2 will display the panel in Figure 32 on page 42. This service will customize job **ELACPIOP** in ELA.V1R2M0.SELAJCL, which is used to produce the default run-time option module. Selecting option 3 will display the panel in Figure 34 on page 43. This service will customize job **ELANJLLL**—where **LLL** is a language code—in ELA.V1R2M0.SELAJCL, which is used to produce the language-dependent options module. See Figure 39 on page 47 for a list of three-character codes. This service should be repeated for each language installed.

When you exit from any service, a message will be displayed asking if the customization process should proceed. If you press EXIT again, no customization or changes will be processed. If you press ENTER, the ELACCUST CLIST will use the TSO editor and ISPF edit macros to produce customized members. The help for each panel will provide information for each option or input field.

```
VisualAge Generator Server System Variables
Option ==>

Select the desired service and press ENTER

1 - Specify VisualAge Generator variables
2 - Specify program preparation user data set variables
3 - Specify IMS variables
4 - Specify CICS variables
5 - Specify DB2 variables
6 - Specify COBOL variables
7 - Specify installation JCL variables

PRESS: END or PF3 to EXIT  HELP or PF1 for more information
```

Figure 24. VA Gen Server System Variables Panel (ELACCUST)

On the following panels, pressing ENTER saves any changes and END cancels any changes before returning to the Customization or VA Gen Server System Variables panel.

```

          VisualAge Generator Server Variables
====>

Enter data below:

  Prefix of VisualAge Generator customized data sets.. ELA.V1R2M0
  Prefix of VisualAge Generator VSAM data sets..... ELA.V1R2M0
  Volume serial for VisualAge Generator data sets..... ELAVOL
  Unit name of VisualAge Generator data set volume.... SYSDA
  Unit name of VisualAge Generator work data sets..... VIO
  Default language code..... ENU

Which of the following are installed?
  CICS..... YES      Yes or No
  IMS..... YES      Yes or No
  DB2..... YES      Yes or No

PRESS: ENTER to save  END or PF3 to EXIT  HELP or PF1 for more information

```

Figure 25. VA Gen Server Variables Panel (ELACCUST)

```

          Specify Application Preparation User Data Set Variables
====>

Enter data below:

  Volume serial for user data sets..... USRVOL
  Unit name for user data set volume..... SYSDA

Which of the following target systems will you be generating for?
  MVS CICS..... NO      Yes or No
  MVS/TSO..... NO      Yes or No
  IMS/VS..... NO      Yes or No
  IMSBMP..... NO      Yes or No
  MVS Batch..... NO      Yes or No

RECFM of TSO CLIST library..... FB      VB or FB

PRESS: ENTER to save  END or PF3 to EXIT  HELP or PF1 for more information

```

Figure 26. Specify Application Preparation User Data Set Panel (ELACCUST)

```

                                     IMS Variables
====>
Enter data below:
  IMS RESLIB data set name..... SYS1.RESLIB
  ELAWORK database prefix..... DBSHLQ
  ELAWORK database volume serial..... DBSVOL
  ELAWORK database volume unit name.. DBSUNIT

PRESS: ENTER to save  END or PF3 to EXIT  HELP or PF1 for more information

```

Figure 27. IMS Variables Panel (ELACCUST)

```

                                     CICS Variables
====>
Enter data below:
  CICS LOADLIB data set name..... DFH.SDFHLOAD
  CICS/ESA DBCS support required..... NO    Yes or No

PRESS: ENTER to save  END or PF3 to EXIT  HELP or PF1 for more information

```

Figure 28. CICS Variables Panel (ELACCUST)

```

                                     DB2 Variables
====>
Enter data below:
  DB2 subsystem name..... DSN
  DB2 DSNLOAD data set name..... DSN.SDSNLOAD
  DB2 DSNEXIT data set name..... DSN.SDSNEXIT
  DB2 RUNLIB.LOAD data set name..... DSN.RUNLIB.LOAD
  DSNTIAD plan name..... DSNTIA??
  ELAWORK STOGROUP VCAT..... ELADB2
  ELAWORK STOGROUP volume serial number.... DB2VOL

PRESS: ENTER to save  END or PF3 to EXIT  HELP or PF1 for more information

```

Figure 29. DB2 Variables Panel (ELACCUST)

```

                                     IBM COBOL and LE Variables
====>
Enter data below:
  COBOL compiler data set name..... IGY.SIGYCOMP
  LE link edit data set name..... CEE.SCEELKED
  LE run-time data set name..... CEE.SCEERUN
  LE CICS run-time data set name... CEE.SCEECICS

PRESS: ENTER to save  END or PF3 to cancel  HELP or PF1 for more information

```

Figure 30. COBOL and LE Variables Panel (ELACCUST)

```

                                     JCL Variables
====>
Enter data below:
    JCL procedure library..... USER.PROCLIB
Enter JOB statement:
//JOBNAME JOB (ACCOUNT),NAME,
// CLASS=A,MSGCLASS=A,MSGLEVEL=(1,1),REGION=4M
//*
//*
//*
//*
//*
//*
PRESS: ENTER to save  END or PF3 to cancel  HELP or PF1 for more information

```

Figure 31. JCL Variables Panel (ELACCUST)

6.2.1.2.2.1 *Run-Time Default Options*: The panel in Figure 32 is used for customizing the run-time default options. The table in Figure 33 explains the IBM-supplied default options.

```

VisualAge Generator Run-Time Default Options
====>
Enter data below:
  Default language code..... ENU
  Bypass date edit on EOF..... NO   Yes or No
  IMS/ESA installed..... NO   Yes or No
  VisualAge Generator trace buffer size..... 64
  CICS temporary storage control interval size... 32

PRESS: ENTER to save  END or PF3 to cancel  HELP or PF1 for more information

```

Figure 32. Run-time Default Options Panel (ELACCUST)

Figure 33. Run-time Default Options

OPTION	Value(s)	Default	Description
Default language code	LLL	ENU	Specifies the language code representing the language currently being customized. See Figure 39 on page 47 for a list of three-character codes.
Bypass date edit on EOF	N,Y	N	If N, specifies that a valid date must be entered before allowing a user to exit map. If Y, specifies that the user can bypass the edit checking of a date field by using the Erase EOF key on that field.
IMS/ESA installed	N,Y	N	Specifies whether IMS/ESA is installed. For CICS users, if you are using local DL/I, IMS/ESA should be 'N' even if you have IMS/ESA installed.
VA Gen Server trace buffer size	size in K	64	Specifies the buffer size in K for the VA Gen Server trace facility
CICS temporary storage control interval size	size in K	32	Specifies, in 1K increments, the CICS control interval size for the VSAM data sets allocated for CICS auxiliary temporary storage queues. The larger the size, the better the performance for pseudo-conversational programs.

6.2.1.2.2.2 *Language-dependent Options*: The panels in Figure 34 are used for customizing the language-dependent options. Initially, the first panel shows only the Language Code field; when a valid language code is entered, the default options for that language are displayed.

```

                VisualAge Generator Server Language Options
====>

Enter language code and press ENTER

  Language code.....

PRESS: ENTER to save  END or PF3 to cancel  HELP or PF1 for more information

```

```

                VisualAge Generator Server Language Options
====>

Enter data below:

  Language code..... ENU

  Long Gregorian date format..... MM/DD/YYYY
  Short Gregorian date format..... MM/DD/YY
  Long Julian date format..... YYYY-DDD
  Short Julian date format..... YY-DDD
  Conversion table name..... ELACNENU
  Positive response character string..... YES
  Negative response character string..... NO
  Decimal point character..... .
  Numeric separator character..... ,
  Currency symbol..... $
  SQL host variable indicator..... :
  SQL host column indicator..... !

PRESS: ENTER to save  END or PF3 to cancel  HELP or PF1 for more information

```

Figure 34. *Language-dependent Options Customization Panels (ELACCUST)*

The following table lists the language-dependent options for language code ENU (U.S. English) that are used by the panels in Figure 34. See Figure 39 on page 47 for a mapping of one- and three-character codes to their languages. Also refer to the *Planning* manual for defaults for other languages.

Figure 35. Language-dependent Options

OPTION	Value(s)	Default	Description
Language code	LLL	ENU	Specifies the language code representing the language currently being customized. (This is used in generation of the CSECT name.)
Long Gregorian date format	mask	MM/DD/YYYY	Specifies the default long Gregorian date edit mask. The long Gregorian date edit mask consists of 'DD', 'MM', and 'YYYY', in any order, separated by any valid separator character. Any non-numeric single-byte character, except 'D', 'M', and 'Y', is valid as a separator character.
Short Gregorian date format	mask	MM/DD/YY	Specifies the default short Gregorian date edit mask. The short Gregorian date edit mask consists of 'DD', 'MM', and 'YY', in any order, separated by any valid separator character. Any non-numeric single-byte character, except 'D', 'M', and 'Y', is valid as a separator character.
Long Julian date format	mask	YYYY-DDD	Specifies the default long Julian date. The long Julian date edit mask consists of 'DDD' and 'YYYY', in any order, separated by any valid separator character. Any non-numeric single-byte character, except 'D', 'M', and 'Y', is valid as a separator character.
Short Julian date format	mask	YY-DDD	Specifies the default short Julian date. The short Julian date edit mask consists of 'DDD' and 'YY', in any order, separated by any valid separator character. Any non-numeric single-byte character, except 'D', 'M', and 'Y', is valid as a separator character.
Conversion table name	xxxxxxx	ELACN LLL	Specifies the default 1- to 8-character conversion table name, where LLL is what was specified for the language code on Figure 34 on page 43.
Positive response character string	yyy	YES	Specifies the 1- to 3-character string used by VA Gen Server to denote a positive response.
Negative response character string	nnn	NO	Specifies the 1- to 3-character string used by VA Gen Server to denote a negative response.
Decimal point character	x	.	Specifies the character used by VA Gen Server to denote a decimal point. The character specified must be a '.' or a ',' and must be distinct from the characters assigned for numeric separator and currency symbol.
Numeric separator character	x	,	Specifies the character used by VA Gen Server to denote a numeric separator. The character specified must be a ',' or a '.' and must be distinct from the characters assigned for decimal point and currency symbol.
Currency symbol	x	\$	Specifies the character used by VA Gen Server to denote a currency symbol. The character specified must be distinct from the characters assigned for decimal point and numeric separator. The character specified must also be a valid COBOL currency symbol.
SQL host variable indicator	x	:	Specifies the character used by VA Gen Server as the SQL host variable indicator. The character assigned must be distinct from the character assigned for the SQL host column indicator.
SQL host column indicator	x	!	Specifies the character used by VA Gen Server as the SQL host column indicator. The character assigned must be distinct from the character assigned for the SQL host variable indicator.

6.2.1.2.2.3 Default Code Page Conversion Tables: A default code page conversion table is provided for each language. The conversion table name specified on the Language Dependent Options panel for the language being used at run-time is used if the program requests a default conversion table for cooperative processing support. The language conversion tables support the following code pages:

Figure 36. Default Code Page Conversion for SBCS Languages

Language	Conversion Table	ASCII Code Page	EBCDIC Code Page
English	ELACNENU	437	037
Upper Case English	ELACNENP	437	037
German	ELACNDEU	850	500
Swiss German	ELACNDES	850	500
Spanish	ELACNESP	850	284
Brazilian Portuguese	ELACNPTB	850	037

Figure 37. Default Code Page Conversion for DBCS Languages

Language	Conversion Table	ASCII SBCS Code Page	ASCII DBCS Code Page	EBCDIC SBCS Code Page	EBCDIC DBCS Code Page
Simplified Chinese	ELACNCHS	1042	928	836	837
Japanese	ELACNJPN	1041	301	290	300
Japanese (Latin)	ELACNJPL	1041	301	1027	300
Korean	ELACNKOR	1040	926	833	834

Note: Two Japanese tables are provided. ELACNJPN is the default table associated with the JPN language code. You can change the default table to ELACNJPL. ELACNJPN and ELACNJPL are shipped with the Japanese language for VA Gen Server.

6.2.1.2.2.4 Saving Modified Values: Upon exit from the Customization options panel in Figure 23 on page 36, you will be asked if the values should be saved. If you respond positively, then the panel in Figure 38 on page 46 is displayed and the information you enter is used to save the values that represent your customization of this VA Gen Server installation.

The Identifier for modified values field lets you specify a four-character identifier for the customization values you want to save. You should specify this value so you can change VA Gen Server customization values later.

```

====>          Modified Values Description

Enter data below:

  Identifier for modified values..... CUST

  Enter a description of this set of modified values:

  _____
  _____
  _____

PRESS: ENTER to save  END or PF3 to cancel  HELP or PF1 for more information

```

Figure 38. Saving Customized Values (ELACCUST)

6.2.1.2.3 Change Default Installation Options: VA Gen Server provides default installation options. Job **ELACPIOP** in ELA.V1R2M0.ELAJCL will produce the installation options module. If you changed any values on the VisualAge Generator Run-time Default Options panel (Figure 32 on page 42) you need to run this job. If you accepted the default values on that panel, you can skip this step.

Submit job **ELACPIOP** to assemble and link-edit the installation options load module.

6.2.1.2.4 Change Language-dependent Options: VA Gen Server provides language-dependent options that can be customized for each language being installed. Job **ELANJLLL** in ELA.V1R2M0.ELAJCL will produce the language-dependent option module. If you changed any values on the VisualAge Generator Server Language Options panel (Figure 34 on page 43), you need to run this job for that language. If you accepted the default values for a language, you can skip this step for that language. See Figure 39 on page 47 for a mapping of one- and three-character codes to their languages.

Figure 39 shows the one- and three-character codes for all the VA Gen Server languages.

Figure 39. Language Code Conversion Table

Language	1-Character Code	3-Character Code
English	E	ENU
Swiss German	W	DES
German	G	DEU
Spanish	S	ESP
Japanese	J	JPN
Korean	K	KOR
Brazilian (Portuguese)	P	PTB
Uppercase English	U	ENP
Chinese (Simplified)	C	CHS

Note: You can run the ELACCUST CLIST to customize ELANJLLL; see 6.2.1.2.2, “Installation Customization” on page 32 for details.

6.2.1.2.5 Modify LE Options and Exits

6.2.1.2.5.1 Working Storage Initialization Option: Generated VisualAge Generator programs for non-CICS environments rely on the LE working storage being initialized to binary zeroes to determine whether VA Gen Server has been initialized.

You have the following options:

1. Assemble the global default module, CEEDOPT, specifying STORAGE=00 for the first subparameter (heap-allocation-value) of the STORAGE parameter.
This technique affects all COBOL modules running in each non-CICS environment.
2. Assemble a program defaults module, CEEUOPT, specifying STORAGE=(00), and link CEEUOPT with each generated program.
This technique allows you to link the CEEUOPT module with generated programs without affecting non-VisualAge Generator programs.

If you use this technique, modify the VisualAge Generator preparation templates to include CEEUOPT in each link-edit step for non-CICS environments. Refer to the *VisualAge Generator Generation Guide* manual for details about tailoring the preparation templates.

Refer to the installation and customization manual for your version of LE for more information on how to initialize working storage.

6.2.1.2.5.2 LE Assembler User Exit Processing: When LE detects an error that is not handled by the subsystem, high-level language, or program condition handlers, LE writes error messages and calls entry point CEEBXITA for a user exit. The user exit indicates whether LE is to ABEND or return to the system with an error return code. The default action is to return with an error code. No automatic rollback is performed, and if database or recoverable-resources updates are pending, they are committed.

CEEBXITA is the entry point name for the user exit in any environment. The following samples are shipped in the LE sample library:

Figure 40. LE sample user exits

Member's CSECT name	Environment
CEEBX05A	non-CICS
CEECXITA	CICS

For generated programs, modify the default user exit in all environments to always request ABEND (set CEEAUE_ABND to 1) on any abnormal termination (CEEAUE_ABTERM=1). This will ensure that rollback for database and recoverable-resources updates is performed on any abnormal termination.

When you modify CEEBX05A or CEECXITA, you have the following options:

1. Assemble CEEBX05A or CEECXITA and link it with LE so it is available to all programs in their respective environments.
2. Assemble CEEBX05A or CEECXITA and link it with each generated program. This technique allows you to link the user exit with generated programs without affecting non-VisualAge Generator programs.

If you use this technique, modify the VisualAge Generator preparation templates to include CEEBX05A or CEECXITA in each link-edit step for all environments. Refer to the *VisualAge Generator Generation Guide* manual for details about tailoring the preparation templates.

Refer to the *Language Environment Programming Guide*, for more information about LE condition handling and the assembler user exit.

6.2.1.2.6 Links Required for LE Exits: Edit and run **ELACJCEM** in ELA.V1R2M0.ELAJCL according to the instructions in the job.

If you use CICS and you are not using a global version of the assembler user exit CEEBXITA, edit and run **ELACJCEC** in ELA.V1R2M0.ELAJCL according to the instructions in the job. See 6.2.1.2.5, “Modify LE Options and Exits” on page 48 for information about the CEEUOPT and assembler user exit modules. CEEBXITA is the entry point for the assembler user exit. The LE sample for CICS is CEECXITA.

6.2.1.2.7 Link Pack Area (LPA) Considerations: The following load modules are not eligible for the LPA:

ELANCENU	ELARK24A	ELARK24B	ELARK240
ELARMAIN	ELARPRTR	ELARSDCB	ELARSINC
ELARSINT	ELASTB07	ELAZCHRT	ELAZSTI
ELA2SSQL	ELA2SSQX	ELA2SSQY	

Note: Any modules placed into the LPA should not be in any library in any STEPLIB, JOBLIB, or ISPLLIB concatenation list.

Migration consideration:

Many of the VA Gen Server load modules have the same names as CSP/370RS load modules. If you have installed CSP/370RS and intend to run it in parallel during the migration to VA Gen Server, you will have to move any CSP/370RS load modules back into the CSP/370RS load library before you replace them in the LPA with the new VA Gen Server load modules of the same names.

6.2.1.2.8 Prepare ANSI SQL Program: If a non-IBM ANSI SQL data-base manager is to be used with this product instead of DB2, take the following steps:

1. Prepare COBOL source module ELARPANS in library ELA.V1R2M0.SELASAMP for execution as directed in the module prologue.
2. Customize the preparation procedures that invoke SQL preprocessing/bind to use the non-IBM data-base manager instead of DB2. The procedures were customized and placed in data set ELA.V1R2M0.ELASAMP during step 1 of the customization. The preparation procedures that might require customization are: ELAPCLB, ELACLB, ELAPC, ELAPTC, ELALB and ELAPTCLB. The preparation and execution JCL templates and execution CLISTS templates might need to be tailored when installing VisualAge Generator.
3. Specify ANSISQL(YES) as a COBOL option for generation of all SQL programs.

6.2.1.2.9 Modify and Copy Compile and Link Procedures: Figure 41 shows the catalogued JCL procedures shipped with VA Gen Server. These procedures are placed in ELA.V1R2M0.ELASAMP during step 2 of the customization process. All the procedures are used to prepare generated VisualAge Generator programs. The templates shipped with VisualAge Generator are the skeletons that the generation function uses to build the preparation JCL for generated programs. These templates invoke the preparation procedures shipped with VA Gen Server. Changes you make to the templates when you install VisualAge Generator might require corresponding changes to the preparation procedures. Therefore, it is easier to do the tailoring for both the procedures and the templates at the same time.

Figure 41. VA Gen Server JCL Procedures

Procedure	Purpose
ELACL	COBOL compile and link
ELAPCLB	DB2 preprocessor, COBOL compile, link, and DB2 BIND
ELACLB	COBOL compile, link, and DB2 BIND. Used for programs that do not have any SQL statements, but that have specified a DB2 work database
ELAC	COBOL compile only
ELAPC	DB2 preprocessor and COBOL compile
ELAPTC	DB2 preprocessor, CICS translate and COBOL compile
ELAL	Link only
ELALB	Link and DB2 BIND
ELAPTCLB	DB2 preprocessor, CICS translator, COBOL compile, link, and DB2 bind
ELATC	CICS translator and COBOL compile
ELATCL	CICS translator, COBOL compile and link
ELARLINK	Link edit only for the re-link JCL

Submit member **ELACJCPY** in ELA.V1R2M0.ELAJCL to copy the VA Gen Server procedures into your procedure library.

Figure 42 on page 52 is an example of job ELACJCPY.

```

//*****
//*
//* DOC: ELACJCPY - COPY VISUALAGE GENERATOR SERVER PROCEDURES
//*          TO A PROCEDURE LIBRARY
//*
//* LICENSED MATERIALS - PROPERTY OF IBM
//* 5648-B02 (C) COPYRIGHT IBM CORP. 1994, 1998
//* SEE COPYRIGHT INSTRUCTIONS
//*
//* STATUS = VERSION 1, RELEASE 2, LEVEL 0
//*
//* TAILORING:
//*
//*     1. TAILORING IS DONE BY CUSTOMIZATION CLIST (ELACCUST)
//*
//*****
//*
//ELACJCPY EXEC PGM=IEBCOPY
//INDD    DD DISP=SHR,DSN=ELA.V1R2M0.ELASAMP
//OUTDD1  DD DISP=SHR,DSN=USER.PROCLIB
//SYSPRINT DD SYSOUT=*
//SYSIN   DD *
COPY INDD=((INDD,R)),OUTDD=OUTDD1
SELECT MEMBER=(ELACL,ELAPCLB,ELACLB,ELAC,ELAPC,ELAL,ELARLINK,
               ELALB,ELAPTCLB,ELATC,ELAPTC,ELATCL,ELAB)

```

Figure 42. Sample ELACJCPY Job

Migration consideration:

- The preparation procedures shipped with VA Gen Server have the same names as the preparation procedures for IBM SAA Cross System Product/370 Runtime Services. If you plan to continue generating programs using IBM SAA Cross System Product/370 Runtime Services at the same time that you are generating programs using VA Gen Server, you will need to include either a JES2 JOBPARM, a JES3 `//*MAIN` statement, or a JCLLIB statement after the preparation JOB statement to point to the correct procedure library. Alternatively, you can rename the preparation procedures for one product and change the preparation templates for that product to point to the new names. The following preparation procedures are affected by this:

- ELACL
- ELAPCLB
- ELACLB
- ELAC
- ELAPC
- ELAL
- ELALB

6.2.1.2.10 Run the Customization Verification Program (CVP): If you are using a system default module to clear working storage, it must be made available in the link pack area, the link list, or in the STEPLIB of each batch job executing VA Gen Server.

The batch customization verification program, ELACVP1, is a VisualAge Generator program that was generated as a COBOL program and shipped as an object module. It allows you to verify that VA Gen Server has been properly installed. To run this verification, submit member **ELACJVP1** in data set ELA.V1R2M0.ELAJCL. This job contains a step to run the program. The output from EZEPRINT should appear similar to the panel shown in Figure 43. The date appears in the upper-left corner and the time in the upper-right corner. The date is in the format MM/DD/YY.

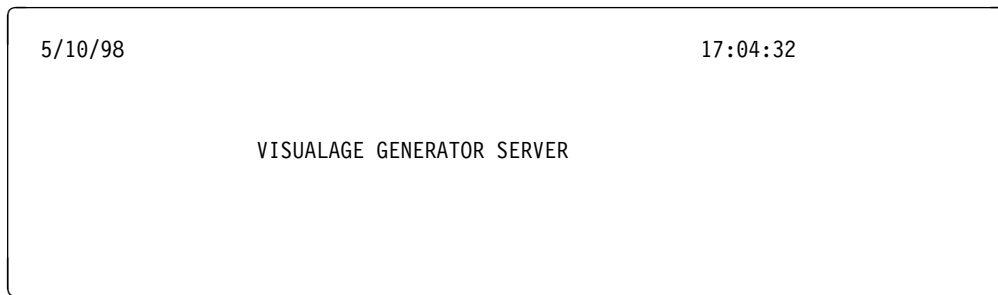

Figure 43. Customization Verification Panel

6.2.1.3 MVS/TSO ENVIRONMENT

The tasks described in this section are necessary for customization of VA Gen Server only if the MVS/TSO environment is a target environment for this product. If VisualAge Generator generated programs will not be run in the MVS/TSO environment, this section can be skipped.

6.2.1.3.1 Update MVS/TSO Concatenation Lists: Data set ELA.V1R2M0.SELALMD must be added to the STEPLIB concatenation list of your TSO logon procedure or its contents must be moved to a data set in the LNKLST concatenation list. In addition, the LE run-time data sets must be made available. If you are using a system default module to clear working storage, it must also be made available.

If the load libraries in your STEPLIB concatenation list are authorized data sets, then ELA.V1R2M0.SELALMD must also be made an authorized data set. (VA Gen Server has no special requirements for running authorized.)

6.2.1.3.2 Run the CVP for MVS/TSO: CLIST **ELACVP2C** in ELA.V1R2M0.ELACLST runs program ELACVP2, which is the customization verification program for MVS/TSO. ELACVP2 is a VisualAge Generator program that was generated as a COBOL program and shipped as an object module. It allows you to verify that VA Gen Server is properly installed. To run the program:

- Log on to TSO using the logon procedure customized in the previous step and enter:

```
EXEC 'ELA.V1R2M0.ELACLST(ELACVP2C)'
```

The resulting map should look similar to the panel shown in Figure 44.

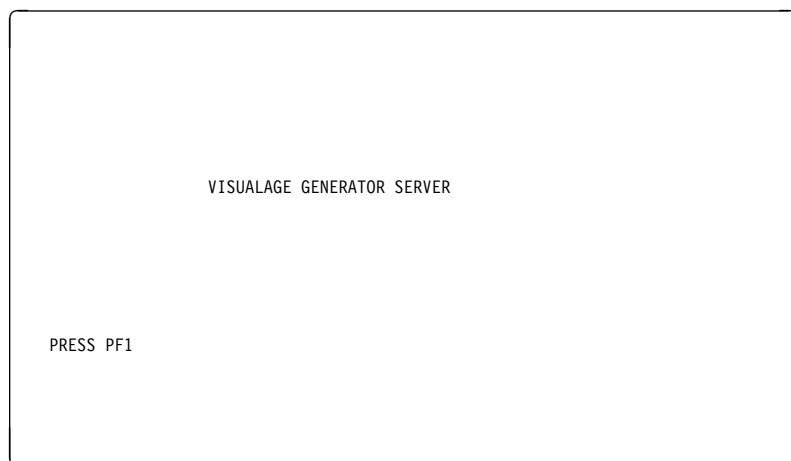

Figure 44. Customization Verification Panel

- Press the PF1 key.

The map should look similar to the panel shown in Figure 45 on page 55, displaying a message indicating the successful installation of the product. The date appears in the upper-left corner, the time in the upper-right corner. The date is in the format MM/DD/YY.

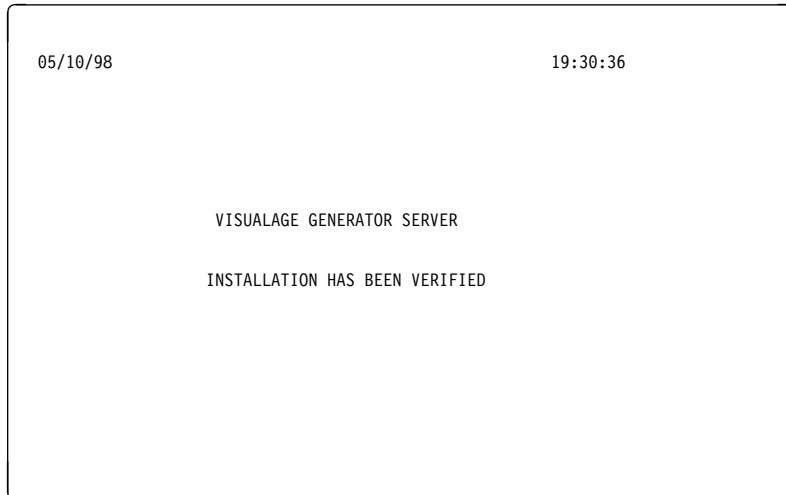

Figure 45. Customization Verification Panel

- Press the PF3 key to exit the customization verification program.

6.2.1.4 IMS/VS ENVIRONMENT

The tasks described in this section are necessary for customization of VA Gen Server only if IMS/VS is a target environment for this product. If VisualAge Generator generated programs will not be run in the IMS/VS environment, this section can be skipped.

6.2.1.4.1 Install a Work Database: *Migration consideration:*

- If you previously installed a work database for IBM SAA Cross System Product/370 Runtime Services or VGen Host Services 1.1, you can skip this step.

6.2.1.4.1.1 DL/I Work Database: If you plan to use a DL/I implementation for the work database, you might need to tailor the data-base description (DBD) before you run the job that creates and initializes the DL/I work database. Figure 46 shows the DBD for the work database. The source for the DBD is supplied as ELAWORK in ELA.V1R2M0.ELASAMP.

```

*****
**      DBD FOR VISUALAGE GENERATOR SERVER ELAWORK DATABASE
*****
      DBD  NAME=ELAWORK,                X
            ACCESS=(HDAM,OSAM),        X
            RMNAME=(DFSHDC40,3,wblks)
      DATASET DD1=ELAWORK,DEVICE=3380,SIZE=8192
      SEGM  NAME=ELAWCNTL,              X
            BYTES=(160),                X
            PARENT=0
      FIELD NAME=(WORKKEY,SEQ,U),      X
            BYTES=8,                    X
            START=1,                    X
            TYPE=C
      SEGM  NAME=WORKLV01,              X
            PARENT=ELAWCNTL,            X
            BYTES=(4060,4),             X
            RULES=(,LAST)
      SEGM  NAME=WORKLV02,              X
            PARENT=WORKLV01,            X
            BYTES=(4060,4),             X
            RULES=(,LAST)
      :
      SEGM  NAME=WORKLV14,              X
            PARENT=WORKLV13,            X
            BYTES=(4060,4),             X
            RULES=(,LAST)
      SEGM  NAME=MSGVL01,               X
            PARENT=ELAWCNTL,            X
            BYTES=(4060,4),             X
            RULES=(,LAST)
      SEGM  NAME=MSGVL02,               X
            PARENT=MSGVL01,              X
            BYTES=(4060,4),             X
            RULES=(,LAST)
      :
      SEGM  NAME=MSGVL14,               X
            PARENT=MSGVL13,              X
            BYTES=(4060,4),             X
            RULES=(,LAST)
      PRINT NOGEN
      DBDGEN
      FINISH
      END

```

Figure 46. DL/I Work Database DBD

You can modify the DBD name, number of root anchor points, block size, number of blocks, randomizing routine, and device type. However, the segment names, segment size, and FIELD information must not be changed. The DL/I work database key is the terminal ID (LTERM name).

The **wblks** parameter defines the number of blocks to be used in the randomizing algorithm for the database. You can estimate this number by using the following formula:

$$\text{wblks} = (\#_of_terminals * 114000) / 8192$$

Where *#_of_terminals* is the number of users of VisualAge Generator programs.

The default value for **wblks** is 100. The SIZE value is set to 8192; you can increase this value. This is desirable if the programs tend to be large and complex with many storage areas.

Figure 47 shows the PSB that initializes the work database by loading a single root segment into it. Figure 48 shows the PSB that is used to remove obsolete records from the work database. The two PSBs are supplied as members ELAWKLD and ELAWKPB1, respectively, in ELA.V1R2M0.ELASAMP. If you change the NAME parameter in the DBD, you must also change the DBDNAME field in both PSBs.

```
*****
**  LOAD PSB FOR VISUALAGE GENERATOR SERVER ELAWORK DATABASE
*****
      PCB      TYPE=DB,DBDNAME=ELAWORK,PROCOPT=LS,POS=S,KEYLEN=8
      SENSEG   NAME=ELAWCNTL,PARENT=0
      PRINT    NOGEN
      PSBGEN   PSBNAME=ELAWKLD,LANG=COBOL,CMPAT=NO
      END
```

Figure 47. PSB to Load DL/I Work Database

```
*****
**  DRAIN PSB FOR VISUALAGE GENERATOR SERVER ELAWORK DATABASE
*****
      PCB      TYPE=TP,MODIFY=YES
      PCB      TYPE=TP,MODIFY=YES,EXPRESS=YES
      PCB      TYPE=DB,DBDNAME=ELAWORK,PROCOPT=AP,KEYLEN=8
      SENSEG   NAME=ELAWCNTL,PARENT=0
      PRINT    NOGEN
      PSBGEN   PSBNAME=ELAWKPB1,LANG=COBOL,CMPAT=YES
      END
```

Figure 48. PSB to Delete Root Segment and Clean Up DL/I Work Database

Submit member **ELACJWKD** in ELA.V1R2M0.ELAJCL to generate the database description (DBD), generate the PSBs and ACBs, allocate the space for the database data, and initialize the database with the DL/I test program, DFSDDLTO. A return code of 4 is normal for the CRTACBS step (the ACB generation step).

It is recommended that you make the DL/I work database a non-recoverable database. This reduces the amount of logging for this database. You can make the DL/I work database non-recoverable by doing the following:

- Register the DL/I work database with database recovery control (DBRC).

- Define the database to DBRC as a non-recoverable resource by using the NONRECOV option on the INIT.DB command.
- Use DBRC when the program is run.

Refer to the IMS/ESA manuals for additional information.

6.2.1.4.1.2 DB2 Work Database: The DB2 work database uses a 32K-byte page size; therefore, if you are using a DB2 work database, you might need to increase the allocation of the 32K-byte buffers. To increase the allocation of buffers, you need to modify and assemble the DB2 parameter module (default is DSNZPARM). Refer to the DB2 manuals for your system for additional information.

If you plan to use a DB2 implementation for the work database, review the database definition before you run the job that initializes the DB2 work database. Figure 49 on page 59 shows the DB2 definition for the work database. The source for the work database description (DDL) is supplied as member ELAWORK2 in ELA.V1R2M0.ELASAMP.

The table name and field names cannot be changed.

```

CREATE DATABASE ELADBCTL ;

CREATE TABLESPACE ELAWRKTS
  IN ELADBCTL
  USING VCAT ELADB2
  BUFFERPOOL BP32K
  LOCKSIZE PAGE
  CLOSE NO;

CREATE TABLE ELA.ELAWORK
  (ELA_TERMID      CHAR(8)  NOT NULL,
   ELA_SEQUENCE    CHAR(3)  NOT NULL,
   ELA_DATE        CHAR(6),
   ELA_TIME        CHAR(6),
   ELA_APPL_NAME   CHAR(8),
   ELA_VSN_PGM     CHAR(16),
   ELA_TGT_TRAN    CHAR(8),
   ELA_SRC_TRAN    CHAR(8),
   ELA_WS_BYTES    INTEGER,
   ELA_MS_BYTES    INTEGER,
   ELA_CONTROL_INFO CHAR(80),
   ELA_WS_DATA     LONG VARCHAR,
   ELA_MS_DATA     LONG VARCHAR)
  IN ELADBCTL.ELAWRKTS;

CREATE UNIQUE INDEX TEMPKEY ON ELA.ELAWORK
  (ELA_TERMID ASC,
   ELA_SEQUENCE ASC)
  USING VCAT ELADB2
  CLUSTER
  SUBPAGES 16
  CLOSE NO;

GRANT DELETE,INSERT,SELECT,UPDATE ON ELA.ELAWORK TO PUBLIC;

```

Figure 49. DB2 Work Database DDL

The JCL to create the DB2 table for the work database is in member **ELACJWK2** in ELA.V1R2M0.ELAJCL.

Ensure that you have DB2 system administrator authority and then submit ELACJWK2 to create the DB2 table for the work database. The first time you run this job, the return code is 08 on the WRKDROP step because there is no database to drop.

6.2.1.4.1.3 Perform a DB2 Bind: Submit member ELACJPT2 in ELA.V1R2M0.ELAJCL to perform a DB2 bind for the plan used by the IMS/VS trace facility using a DB2 work database. Figure 50 is an example of job ELACJPT2.

Each developer or system administrator should create a SYNONYM in order to access the ELAWORK DB2 table. The CREATE SYNONYM has the following format:

CREATE SYNONYM ELAWORK FOR ELA.ELAWORK

Each developer should create the SYNONYM before binding any program plans that access the work database.

```

/*****
/*
/* DOC: ELACJPT2 - BIND THE VISUALAGE GENERATOR SERVER IMS/VIS
/*          TRACE PROGRAM USING A DB2 DATABASE.
/*
/* LICENSED MATERIALS - PROPERTY OF IBM
/* 5648-B02 (C) COPYRIGHT IBM CORP. 1994, 1998
/* SEE COPYRIGHT INSTRUCTIONS
/*
/* STATUS = VERSION 1, RELEASE 2, LEVEL 0
/*
/* TAILORING:
/*
/*     1. TAILORING IS DONE BY CUSTOMIZATION CLIST (ELACCUST)
/*
*****/
/*
//CPT2B PROC ELA='ELA.V1R2M0',
//      DSNLOAD='DSN.DSNLOAD',
//      RGN=4096K,
//      SOUT='*'
//B      EXEC PGM=IKJEFT01,DYNAMNBR=20,COND=(5,LT),REGION=&RGN
//STEPLIB DD DISP=SHR,DSN=&DSNLOAD
//DBRMLIB DD DISP=SHR,DSN=&ELA..SELADBRM
//SYSTSPRT DD SYSOUT=&SOUT,DCB=BLKSIZE=13300
//SYSPRINT DD SYSOUT=&SOUT,DCB=BLKSIZE=13300
//SYSUDUMP DD SYSOUT=&SOUT,DCB=BLKSIZE=13300
//SYSOUT DD SYSOUT=&SOUT,DCB=BLKSIZE=13300
//REPORT DD SYSOUT=&SOUT,DCB=BLKSIZE=13300
// PEND
//DBRMPT2 EXEC CPT2B
//SYSTSIN DD *
DSN SYSTEM(DSN)
BIND PLAN(ELAIP2) -
      MEMBER(ELADBRM3) -
      ACT(REP) -
      RETAIN -
      ISOLATION(CS)
/*

```

Figure 50. Sample ELACJPT2 Job

6.2.1.4.2 Install VA Gen Server PSBs

- If you previously defined the PSBs for VGen Host Services 1.1, you can skip this step.

The VA Gen Server utility that prints the error diagnostic information requires a program specification block (PSB). Because it runs as a BMP, it also requires an application control block (ACB) generation. The four online customization verification programs and the VA Gen Server Trace Facility have PSBs that require PSB and ACB generations.

Figure 51 shows the five PSBs that are needed for the IMS environment.

Figure 51. PSB Generation

PSB Source	PSB Name	Purpose
ELAMPUTL	ELAMPUTL	Error diagnostic utility
ELACVP3P	ELACVP3	Online customization verification (DL/I implementation of the work database)
ELACVP4P	ELACVP4	Online customization verification (DB2 implementation of the work database)
ELAIPZG	ELAIPZ	Online trace facility - DL/I work database
ELAIPZG	ELAIPZ2	Online trace facility - DB2 work database

Migration consideration:

- If you currently use a DL/I message database, you should continue to use the ELAPCB macro from IBM SAA Cross System Product/370 Runtime Services 1.1 because it includes the PCB for the DL/I message database. Existing programs generated with IBM SAA Cross System Product/370 Runtime Services 1.1 can continue to use the message database. Programs generated with VisualAge Generator must use message tables.

6.2.1.4.2.1 For DL/I Work Database: If you plan to use DL/I for the work database, modify your PSB-generation procedure by copying member **ELAPCB** from ELA.V1R2M0.SELASAMP into a library within your SYSLIB concatenation. This makes the ELAPCB macro available. The ELAPCB macro is used to provide the PCB definitions needed for the work database.

6.2.1.4.2.2 For All Work Databases: If you did not install a DL/I work database, then delete step ELA3PSB and statement BUILD PSB=ELACVP3 from member **ELACJPSB** in ELA.V1R2M0.ELAJCL.

If you did not install a DB2 work database, then delete step ELA4PSB and statement BUILD PSB=ELACVP4 from member **ELACJPSB** in ELA.V1R2M0.ELAJCL.

Submit member **ELACJPSB** to generate the PSBs and ACBs. Figure 52 is an example of job ELACJPSB.

```

//*****
//*
//* DOC: ELACJPSB - GENERATE PSBS AND ACBS FOR THE
//*                VISUALAGE GENERATOR SERVER ERROR
//*                DIAGNOSTIC PRINT UTILITY AND THE CVPS
//*
//* LICENSED MATERIALS - PROPERTY OF IBM
//* 5648-B02 (C) COPYRIGHT IBM CORP. 1994, 1998
//* SEE COPYRIGHT INSTRUCTIONS
//*
//* STATUS = VERSION 1, RELEASE 2, LEVEL 0
//*
//* TAILORING:
//*
//*     1. TAILORING IS DONE BY CUSTOMIZATION CLIST (ELACCUST)
//*
//*****
//*
//PRNTPSB EXEC PSBGEN,MBR=ELAMPUTL
//C.SYSIN DD DISP=SHR,DSN=ELA.V1R2M0.SELASAMP(ELAMPUTL)
//*
//ELA3PSB EXEC PSBGEN,MBR=ELACVP3
//C.SYSLIB DD
//          DD DISP=SHR,DSN=ELA.V1R2M0.SELASAMP
//C.SYSIN DD DISP=SHR,DSN=ELA.V1R2M0.SELASAMP(ELACVP3P)
//*
//ELA4PSB EXEC PSBGEN,MBR=ELACVP4
//C.SYSIN DD DISP=SHR,DSN=ELA.V1R2M0.SELASAMP(ELACVP4P)
//*
//ELAIPTZ EXEC PSBGEN,MBR=ELAIPZ
//C.SYSIN DD DISP=SHR,DSN=ELA.V1R2M0.SELASAMP(ELAIPZG)
//*
//ELAIPT2 EXEC PSBGEN,MBR=ELAIP2
//C.SYSIN DD DISP=SHR,DSN=ELA.V1R2M0.SELASAMP(ELAIP2G)
//*
//CRTACBS EXEC ACBGEN
//SYSIN   DD *
           BUILD PSB=ELAMPUTL
           BUILD PSB=ELACVP3
           BUILD PSB=ELACVP4
           BUILD PSB=ELAIPZ
           BUILD PSB=ELAIP2

```

Figure 52. Sample ELACJPSB job

6.2.1.4.3 Modify IMS System Definition

- If you previously added the IMS definitions for VGen Host Services 1.1, you can skip this step.

Member ELASTG1 in ELA.V1R2M0.ELASAMP contains the system definition entries you need to include in your stage 1 IMS definition. Refer to the IMS manuals for your system for additional information. If you

are installing several destinations for diagnostic messages (ERRDESTs), you can include additional TRANSACT macros after the APPLCTN macro for ELAMPUTL.

Run an IMS stage 1 generation. Use the MODBLKS option on the SYSTEM parameter in the IMSCTRL macro when you do the stage 1 generation.

Migration considerations:

- If you previously installed IBM SAA Cross System Product/370 Runtime Services 1.1, the following were added to your IMS system definition for that release. If you have programs that use a message database, you will need to keep the first two entries until you have converted to message tables.

Note: Existing programs generated with IBM SAA Cross System Product/370 Runtime Services 1.1 can continue to use the message database. Programs being generated with VisualAge Generator must use message tables.

- You no longer need:
 1. DATABASE DBD=ELAMSG
 2. APPLCTN PGMTYPE=BATCH, PSB=ELAMSUDL
 3. APPLCTN PGMTYPE=TP, PSB=ELACVP1, (4) TRANSACT
 4. TRANSACT CODE=ELACVP1
 5. TRANSACT CODE=ELACVP2

6.2.1.4.4 Modify IMS Control and Message Region JCL

6.2.1.4.4.1 IMS Control Region JCL: If you previously installed IBM SAA Cross System Product/370 Runtime Services 1.1 or VGen Host Services 1.1, you can skip this step.

Modify the IMS control region JCL to include the work database if it is implemented using DL/I.

Figure 53 shows the sample DD statement to add.

```
//ELAWORK DD DISP=SHR,DSN=ELA.V1R2M0.ELAWORK
```

Figure 53. IMS Control Region JCL Statement(s)

Alternatively, you can use member **ELACJDAT** in ELA.V1R2M0.ELAJCL to add the database to the IMS dynamic allocation table.

If you have a large IMS online system, you might not need to override the values for the PSB work area pool, the FORMAT pool, the MFS test area, or the communications input/output area in the JCL that is used to start the IMS control region. However, you should review the following parameters:

- The PSBW parameter should be at least 90.
- The FBP parameter should be at least 125.
- The MFS parameter should be at least 100.

- The TPDP parameter should be at least 5 greater than the MFS parameter.

The specific values might vary for your installation. Monitor the values as you start to use VA Gen Server to determine the proper values for your installation. Refer to the IMS manuals for your release of IMS for additional information.

6.2.1.4.4.2 IMS Message Region JCL: Modify the STEPLIB concatenation for each IMS message region or fast-path region to include the VA Gen Server load library. Figure 54 shows the additional DD statement.

```
//          DD DISP=SHR,DSN=ELA.V1R2M0.SELALMD
```

Figure 54. IMS Load Library JCL

Ensure that the LE run-time library is either in the STEPLIB concatenation for your message region or in the link list. In addition, if you are using a system default module to clear working storage, it must also be made available.

Migration consideration:

If you previously installed IBM SAA Cross System Product/370 Runtime Services or VGen Host Services 1.1, you can change the DSN to reflect the VA Gen Server name and skip the rest of this step.

Before making the following modifications for the ELASNAP and ELAPRINT DD statements, refer to VA Gen Server error reporting information in the *VisualGen: Running Applications on MVS* manual for information about when these data sets are used and the information that is contained in each data set. The error information written to ELAPRINT is identical to that written to the IMS message queue specified by the ERRDEST generation option. Therefore, you might decide to omit the ELAPRINT DD statement and use only ERRDEST. However, the ELASNAP DD statement is recommended so that you can obtain as much information as possible when an error occurs.

To obtain a SNAP dump when a VA Gen Server error occurs, include the following DD statement:

```
//ELASNAP DD SYSOUT=*
```

If you use a data set for the SNAP dump, allocate the data set with RECFM=VBA, LRECL=125, and BLKSIZE=882. If you do not use these attributes when you allocate the data set, VA Gen Server changes the data set attributes to these values. You need to use DISP=MOD on the ELASNAP DD statement if you use a data set.

To obtain a listing or a data set that contains error information, include the following DD statement:

```
//ELAPRINT DD SYSOUT=*
```

If you use a data set for the error information, allocate the data set with RECFM=FA, LRECL=133, BLKSIZE=133. If you do not use these attributes when you allocate the data set, VA Gen Server changes the data set attributes to these values. You need to use DISP=MOD on the ELAPRINT DD statement if you use a data set.

6.2.1.4.5 Assemble and Link the VA Gen Server Maps: The MFS source shipped with VA Gen Server might need to be tailored before being assembled and linked. The MFS source members are in library ELA.V1R2M0.SELAMFS. If you need to tailor the MFS source, you should copy the MFS source to another library before making changes. Prior to submitting the jobs included in this step, ensure that the SOR parameters on the MID and MOD, and the FEAT parameter on the DEV statements, match your IMS system generation. Check existing MFS source for other application systems as an aid in determining the SOR and FEAT parameters that match your IMS system.

MFS source is shipped for the trace facility, for the CVPs for IMS, and for the critical error maps. If you need to make changes to the MFS source, you should copy it to another library and then change the JCL that assembles the MFS to point to the library.

6.2.1.4.5.1 Tailor the Trace Facility Maps: The MFS source for the trace facility must be tailored, assembled and linked for each language installed. Repeat the following steps for each language, including English, that you are installing:

Note: See Figure 39 on page 47 for a mapping of one- and three-character codes to their languages.

1. Tailor the MFS source in **ELAYTLXM** in ELA.V1R2M0.SELAMFS, where **L** is a one-character language code.
2. Submit member **ELACILLL**, (where **LLL** is a three-character language code) in ELA.V1R2M0.ELAJCL to assemble and link the MFS source.

6.2.1.4.5.2 Tailor the Customization Verification Maps: The MFS source for either IMS/VS CVP that will be run must be tailored, assembled and linked. This is done by the following steps:

1. Tailor the MFS source in ELAYT3XM in ELA.V1R2M0.SELAMFS if you are using a DL/I work database with IMS, or ELAYT4XM in ELA.V1R2M0.SELAMFS if you are using a DB2 work database with IMS.
2. Submit member **ELACJCVL** in ELA.V1R2M0.ELAJCL to assemble and link the customization verification maps. Because the CVP maps will only be used for checking customization, job ELACJCVL uses the MFSTEST procedure to assemble them.

6.2.1.4.5.3 Tailor the Critical Error Maps: The critical error maps are used to display error messages if a problem occurs when an end user runs a program. You can tailor these maps for your installation (for example, to provide a help desk phone number).

Perform the following steps for each language, including English, that you are installing.

1. Tailor the MFS source in **ELALLLXM** in ELA.V1R2M0.SELAMFS, where **LLL** is the three-character language code.
2. Change the language parameter in ELACJRSM to specify the code for the language you are installing.
3. Submit member **ELACJRSM** in ELA.V1R2M0.ELAJCL to assemble and link the MFS source.

6.2.1.4.6 Run the IMS Online Change Utility: Take the following steps to make the IMSGEN, ACBs and critical error maps available to IMS:

1. Run IMS utility OLCUTL to copy the new VA Gen Server definitions from the staging libraries into the inactive IMS control region libraries.
2. Enter the following IMS commands:

```
/MODIFY PREPARE FMTLIB ACBLIB MODBLKS  
/MODIFY COMMIT
```

You should now verify the VA Gen Server trace facility maps by doing the following:

- After installing the trace facility maps, you should use the IMS /FORMAT command for at least one of the maps in the map group for each type of terminal that program developers or end users will be using. This helps to verify that the MFS source was tailored properly. The format of the command is:

```
/FORMAT ELAYTLO ELAZ01
```

Where **L** is the language code.

Figure 55 shows an example of ELAZ01.

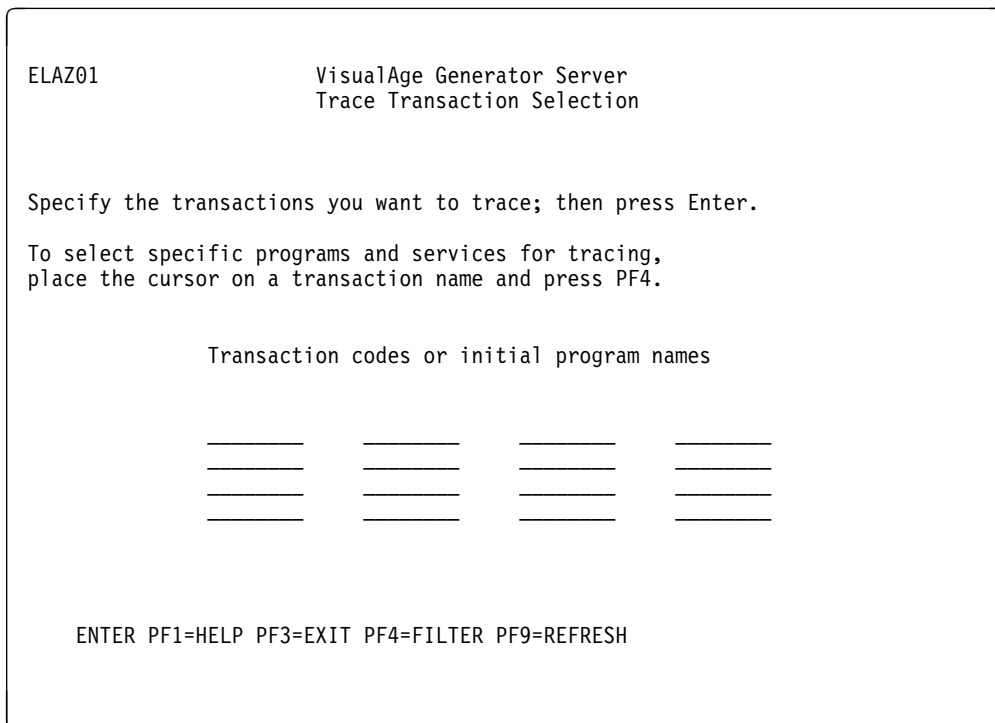

Figure 55. Trace Transaction Selection Panel

- If you installed the critical error maps, you should use the IMS /FORMAT command for at least one of the maps in the map group for each type of terminal that application developers or end users will be using. This helps to verify that the MFS source was tailored properly. The format of the command is:

/FORMAT ELALLLO ELAM02

Where **LLL** is the language code.

Figure 56 shows an example of ELAM02 before the text is modified.

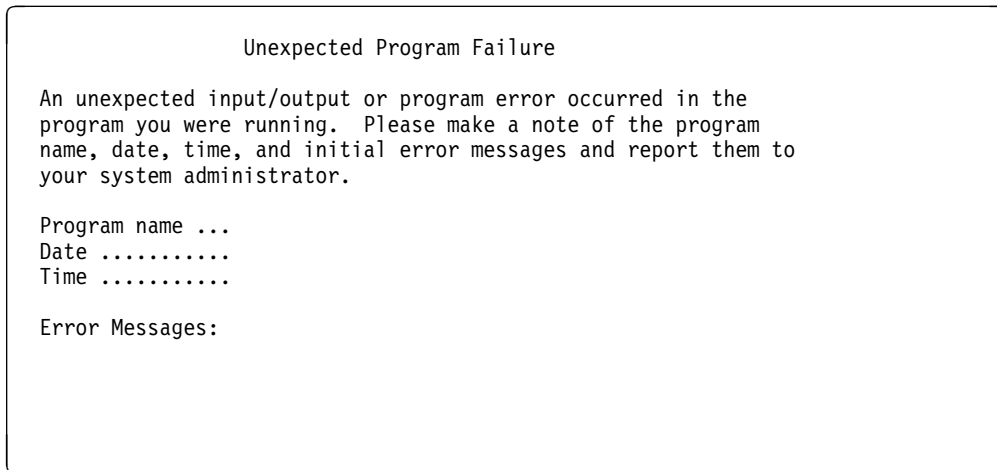

Figure 56. Panel ELAM02

6.2.1.4.7 Link and Run the Customization Verification Program for IMS: The customization verification programs for IMS/VS, **ELACVP3** and **ELACVP4**, are VisualAge Generator programs that were generated as COBOL programs and shipped as object modules. They allow you to verify that VA Gen Server is properly installed.

6.2.1.4.7.1 Verify IMS/VS with a DL/I Work Database: If your IMS/VS target environment was installed with a DL/I work database, perform the following steps to verify that your system has been installed properly:

- Sign on to the customized IMS region using your normal sign-on procedure and enter the following commands:
 - /TEST MFS
 - ELACVP3

Type one blank after the transaction name, ELACVP3, before pressing the Enter key.

The resulting map should look similar to that in Figure 44 on page 54.

- Press the PF1 key.

The map should look similar to the panel shown in Figure 45 on page 55, with a message indicating the successful installation of the product. The date appears in the upper-left corner and the time in the upper-right corner. The date is in the format MM/DD/YY.

- Press the PF3 key to exit the customization verification program.
- Enter /END
- Enter /RCL

6.2.1.4.7.2 Verify IMS/VS with a DB2 Work Database: If your IMS/VS target environment was installed with a DB2 work database, perform the following steps to verify that your system has been installed properly.

- You must do a BIND for ELACVP4. Submit member **ELACJVP4** in ELA.V1R2M0.ELAJCL to bind the application.
- /TEST MFS
- ELACVP4

Type one blank after the transaction name, ELACVP4, before pressing the Enter key.

The map should appear similar to that in Figure 44 on page 54.

- Press the PF1 key.

The map should look similar to the panel shown in Figure 45 on page 55, with a message indicating the successful installation of the product. The date appears in the upper-left corner and the time in the upper-right corner. The date is in the format MM/DD/YY.

- Press the PF3 key to exit the customization verification program.
- Enter /END
- Enter /RCL

6.2.1.5 CICS ENVIRONMENT

- If you previously installed VGen Host Services 1.1 and completed the CICS setup, you can skip to 6.2.1.5.2, “Modify CICS Tables and Definitions” on page 73.

The tasks described in this section are necessary for customization of VA Gen Server only if the CICS environment is a target environment for this product. If VisualAge Generator generated programs will not be run in the CICS environment, this section can be skipped.

6.2.1.5.1 Add CICS Diagnostic Controller Utility Support: VA Gen Server includes CICS menus that allow you to specify diagnostic options for CICS transactions. These options are maintained in a VSAM diagnostic controller file. You need a unique controller file for each active CICS region. To define and initialize controller file ELA.V1R2M0.ELACFIL, submit job **ELACJDCF** in ELA.V1R2M0.ELAJCL. Following the definition and initialization of the file, the options should only be changed by entering CICS diagnostic controller transaction **ELAC**, which displays the diagnostic controller menu Change/View Diagnostic Options for a Transaction.

The file is initialized with the following values:

- Transaction ID = blanks
- Transaction ABENDS = 3 (Task dump)
- Runtime Error dump option = 3 (Task dump)
- Error Destination Queue Name = ELAD
- Journal number = spaces
- Journal Record Identification = EZ
- Disable on Run Unit Failure = N

The diagnostic controller utility lets you direct error messages to a transient data queue, a journal, or both. The default transient data file queue name is ELAD. The transient data files used by the diagnostic controller utility can be INTRAPARTITION, EXTRAPARTITION, INDIRECT or REMOTE. ELADCT2 in ELA.V1R2M0.ELASAMP contains a DCT entry for an intrapartition transient data queue using the default destination identification of ELAD. Include the entry for ELAD in your DCT CICS table if you want to use an intrapartition transient data queue. An extrapartition transient data queue can also be used. This type of queue might be useful for viewing the data set outside of the CICS region.

6.2.1.5.1.1 *Intrapartition Transient Data Queue*: Figure 57 is an example of the intrapartition transient data queue using the default queue name of ELAD from the ELADCT2.

DFHDCT TYPE=INTRA,	1	X
DESTID=ELAD,	2	X
DESTFAC=FILE,	3	X
DESTRCV=NO,	4	X
REUSE=NO	5	

1	Intrapartition destination
2	Destination identification
3	Transient destination queue type file
4	Not recoverable
5	Non-reusable intrapartition control intervals without a transient data purge request (Note: this option is obsolete with CICS 3.2.1 and is ignored.)

Figure 57. CICS Intrapartition Data Queue Example

6.2.1.5.1.2 *Extrapartition Transient Data Queue*: If an extrapartition transient data file will be used, add the appropriate JCL to the CICS execution JCL to assign the file name. The JCL used in the extrapartition destination data queue sample requires the following JCL:

```
//ELAXPRNT DD SYSOUT=*,DCB=(RECFM=VBA,LRECL=654,BLKSIZE=658)
```

Figure 58 on page 71 is an example of an extrapartition transient data queue using the default queue name of ELAD. If you decide to use an extrapartition transient data queue, you must remove the intrapartition transient data queue definition from your DCT. You cannot have an extrapartition transient data queue and an intrapartition data queue with the same name. This can be included when generating a destination control table:

DFHDCT TYPE=SDSCI,	1	X
DSCNAME=ELAXPRNT,	2	X
RECFORM=VARBLKA,	3	X
RECSIZE=654,	4	X
BLKSIZE=658,	5	X
TYPEFLE=OUTPUT	6	
DFHDCT TYPE=EXTRA,	7	X
DESTID=ELAD,	8	X
DSCNAME=ELAXPRNT,	9	X
OPEN=INITIAL	10	

- 1** Entry contains data set control information
- 2** Data set control name
- 3** Record format of the data set
- 4** Record length of the data set
- 5** Block size of the data set
- 6** Output data set
- 7** Extrapartition destination
- 8** Destination identification
- 9** Data set control name
- 10** Open data set at system initialization

Figure 58. CICS Extrapartition Data Queue Example

6.2.1.5.1.3 Journals: The Diagnostic Controller Utility can write to journal(s) indicated by the diagnostic controller file. Journal identifications of 01 through 99 are acceptable for use by the utility. Spaces indicate that there should be no journaling for the transaction. If new journal control table entries are defined for use by the diagnostic controller utility, the journals should be allocated and initialized.

For information about defining and initializing journals, refer to the CICS operations manual for your release of CICS.

Figure 59 on page 72 is an example of an entry for a journal, using a journal identification of 02. This can be included when generating a journal control table if journaling is desired:

```

DFHJCT TYPE=ENTRY,           X
      JFILEID=02,           1 X
      BUFSIZE=4096,        2 X
      Jouropt=INPUT,       3 X
      JTYPE=DISK1         4

```

- 1** Journal identification
- 2** Buffer size for journal I/O operations
- 3** Journal option to accept input operations
- 4** Journal type of disk

Figure 59. CICS Journal Entry Example

For information about defining DCT and JCT entries, refer to the CICS resource definition manual for your release of CICS.

Figure 60 is an example of job ELACJDCF.

```

/*****
/**
/** DOC:  ELACJDCF - DEFINE AND INITIALIZE THE CICS DIAGNOSTIC
/**          CONTROLLER FILE FOR VISUALAGE GENERATOR
/**          SERVER
/**
/** LICENSED MATERIALS - PROPERTY OF IBM
/** 5648-B02 (C) COPYRIGHT IBM CORP. 1994, 1998
/** SEE COPYRIGHT INSTRUCTIONS
/**
/** STATUS = VERSION 1, RELEASE 2, LEVEL 0
/**
/** TAILORING:
/**
/**          1. FOR JES3, SPLIT THE JOB AFTER STEP 'DEFINE'
/**
/*****
/**
//DEFINE    EXEC PGM=IDCAMS
//SYSPRINT DD SYSOUT=*
//SYSIN     DD *
          DELETE ELA.V1R2M0.ELACFIL PURGE CLUSTER
          IF LASTCC = 8 -
              THEN SET MAXCC = 0          /*CLUSTER NOT FOUND IS OK.*/

```

Figure 60 (Part 1 of 2). Sample ELACJDCF Job

```

DEFINE CLUSTER (NAME(ELA.V1R2M0.ELACFIL)      -
                VOLUME(ELAVOL)                -
                RECORDS(50 1)                 -
                KEYS(04 0)                    -
                RECORDSIZE(40 40)             -
                IMBED                          -
                REPLICATE                     -
                SPEED                          -
                REUSE                          -
                INDEXED )                     -
DATA (NAME(ELA.V1R2M0.ELACFIL.DATA)         -
      CONTROLINTERVALSIZE(4096))           -
INDEX (NAME(ELA.V1R2M0.ELACFIL.INDEX))
//*****
//*
//*      FOR JES3, SPLIT THE JOB HERE
//*
//*****
//INITIAL EXEC PGM=IEBGENER
//SYSPRINT DD SYSOUT=*
//SYSUT1 DD *

//SYSUT2 DD DISP=(MOD,PASS),DSN=&&TEMP1,UNIT=SYSDA,
//      DCB=(RECFM=FB,LRECL=40,BLKSIZE=40),SPACE=(TRK,(1,1))
//SYSIN DD *
      GENERATE MAXFLDS=1,MAXLITS=19
      RECORD FIELD=(19,' 33ELAD 00EZN',,1)
//STEP03 EXEC PGM=IDCAMS
//SYSPRINT DD SYSOUT=*
//IN1 DD DSN=&&TEMP1,DISP=(MOD,DELETE)
//OUT1 DD DISP=OLD,DSN=ELA.V1R2M0.ELACFIL
//SYSIN DD *
      REPRO
                INFILE(IN1)
                OUTFILE(OUT1) REUSE

```

Figure 60 (Part 2 of 2). Sample ELACJDCF Job

6.2.1.5.2 Modify CICS Tables and Definitions: Include the VA Gen Server table entries from members ELADCT1 and ELADCT2 in ELA.V1R2M0.ELASAMP into your present CICS tables.

Run the CICS system definition utility program (DFHCSDUP) and load into your CSD the definitions in members ELAGRP and ELAGLLL (where LLL is a three-character language code). See Figure 39 on page 47 for a mapping of one- and three-character codes to their languages. Then add group ELAGRP to the list of groups loaded during CICS initialization. The FCT and DEFINE FILE entries provided with VA Gen Server use CICS dynamic allocation for the VSAM data set. The files can be defined via macros or RDO using members ELAFCT or ELAGRP in ELA.V1R2M0.ELASAMP respectively.

Migration considerations:

If you previously installed CSP/AE and plan to run CSP/AE and VA Gen Server in the same CICS region, you need to make modifications to your CICS tables and JCL.

- Remove from your CSP/AE DCT source the definitions for the extrapartition queue with DESTID=ETLP, the indirect queues with DESTID=EZEP, and DESTID=EZET, and the SDSCI entry with DSCNAME=ASAPR.
- Change the TRANSID parameters for any DCT INTRA queues with TRANSID=XSPZ to TRANSID=EZEP and TRANSID=XSPZ to TRANSID=EZEZ. The VA Gen Server transactions EZEP and EZEZ are compatible with the CSP/AE XSPZ and XSPZ transactions and they should be used instead.
- Remove from your CICS start-up JCL the ASAPR DD statement.

Be sure the appropriate CICS tables have been updated to add support for LE.

Figure 61 (Page 1 of 3). CICS Table Entries for VA Gen Server.

Member	Entry Types	Name/ID	Description
ELADCT1	DCT	EZEPRINT	DSCNAME for printer output
ELADCT2	DCT	ETLP	Extra-partition DESTID for printer output
	DCT	EZEP	Indirect DESTID for printer output
	DCT	EZET	Indirect DESTID for trace output
	DCT	ELAD	Diagnostic controller output
ELAFCT	FCT	ELACFIL	Diagnostic controller VSAM file
ELAGRP	PCT	ELAN	New copy transaction
		ELAC	Diagnostic controller transaction
		ELAU	Diagnostic print transaction
		ELAM	Utility menu transaction
		EZEP	Terminal print for non-DBCS printers
		EZEZ	Terminal print for DBCS printers
		ELAZ	Trace facility
	PPT	CSOCLOCK	Math function
		CSOTICKS	Math function
		ELABNEW	Batch new copy program
		ELACLU2	Common Services LU2 catcher program
		ELALU2FM	Common Services LU2 catcher map
		EZESBLKT	String function
		EZESCCWS	String function
		EZESCMPR	String function

Figure 61 (Page 2 of 3). CICS Table Entries for VA Gen Server.

Member	Entry Types	Name/ID	Description
		EZESCNCT	String function
		EZESCOPY	String function
		EZESFIND	String function
		EZESNULT	String function
		EZESSET	String function
		EZESTLEN	String function
		EZESTOKN	String function
		EZEFLSET	Math function
		EZEFLADD	Math function
		EZEFLSUB	Math function
		EZEFLMUL	Math function
		EZEFLDIV	Math function
		EZEFLMOD	Math function
		EZEPRCSN	Math function
		EZENCMPR	Math function
		EZEMIN	Math function
		EZEMAX	Math function
		EZEROUND	Math function
		EZESIN	Math function
		EZECOS	Math function
		EZETAN	Math function
		EZEASIN	Math function
		EZEACOS	Math function
		EZEATAN	Math function
		EZEATAN2	Math function
		EZESINH	Math function
		EZECOSH	Math function
		EZETANH	Math function
		EZEEXP	Math function
		EZELOG	Math function
		EZELOG10	Math function

Figure 61 (Page 3 of 3). CICS Table Entries for VA Gen Server.

Member	Entry Types	Name/ID	Description
		EZEPOW	Math function
		EZESQRT	Math function
		EZECEIL	Math function
		EZEFLOOR	Math function
		EZEABS	Math function
		EZELDEXP	Math function
		EZEFREXP	Math function
		EZEMODF	Math function
		EZEBYTES	Math function
ELAGLLL		ELACLLL	Language-dependent conversion tables (one for each language installed, where LLL is the language code)
		ELANLLL	Language-dependent constants tables (one for each language installed, where LLL is the language code)
		ELARLLL	Language-dependent installation options module (one for each language installed, where LLL is the language code)
		ELALLLFM	Critical error maps - map group format module (one for each language installed, where LLL is the language code)
		ELACLLL	Error messages (one for each language installed, where LLL is the language code)
		ELACUL	Utility maps (one for each language installed, where L is the language code)
		ELACULFM	Utility maps - map group format module (one for each language installed, where L is the language code)
		ELACTL	Trace facility maps (one for each language installed, where L is the language code)
		ELAYYNL	Yes/No table for utilities and trace (one for each language installed, where L is the language code)
		ELAYTLFM	Map group format module for trace (one for each language installed, where L is the language code)

Note:

1. The transaction codes described above can be changed if they cause conflicts within your CICS system.
2. The FCT entries are set up to use the dynamic allocation facility. This avoids having to modify the CICS system JCL.
3. See Figure 39 on page 47 for a mapping of one- and three-character codes to their languages.

Terminals must have their alternate screen size either specified correctly or omitted so the default of the primary screen size will be used. An alternate screen size specification of (0,0) is not valid.

Any terminal used in an application that is the target of an XFER must have a terminal status of TRANSCEIVE specified.

Any terminal defined as UCTRAN and used for running pseudo-conversational processing might give different results from a terminal that is not defined as UCTRAN.

Make INQUIRESET available.

The SIT requires SPOOL=YES if your programs access the JES spool.

6.2.1.5.3 Modify CICS Region JCL: Include ELA.V1R2M0.SELALMD in the DFHRPL concatenation of the CICS region JCL. The LE run-time libraries also need to be included in the DFHRPL concatenation of the CICS region JCL and, if their contents are not available from either the link pack area of the link list, the LE run-time libraries should be authorized and included in the STEPLIB concatenation of the CICS region JCL.

Add the JCL in member ELACICS of ELA.V1R2M0.ELASAMP to your CICS start-up JCL for the DCT entries.

Recycle CICS to activate the table and JCL changes.

6.2.1.5.4 Run the CVP for CICS: The VA Gen Server Diagnostic Controller utility was written as a VisualAge Generator program, generated as a COBOL program, and shipped as an object module. By running the utility, you can verify that VA Gen Server was properly installed. To run the utility, do the following:

- Log on to the modified CICS region.
- Run transaction ELAC by entering: ELAC
- The IBM copyright notice as shown in Figure 62 should appear.

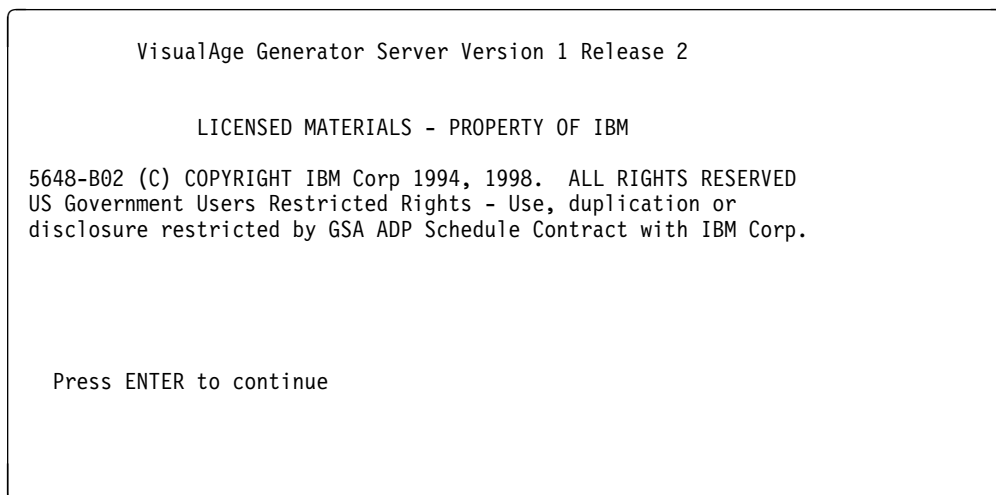

Figure 62. IBM Copyright Panel

- Press enter

- The Diagnostic Controller Menu as shown in Figure 63 should appear.

```

ELAC01                               VisualAge Generator Server
                                       Diagnostic Control Options

Select one of the following actions; then press Enter.

Action..... 1
  1. Change or View the Diagnostic Control Options for a Transaction
  2. Change or View the Default Diagnostic Control Options

ENTER  F1=HELP  F3=EXIT

```

Figure 63. Diagnostic Controller Menu Panel

- Press PF3 to exit
- Clear the screen and enter CESF LOGOFF to log off CICS.

6.2.1.6 Tailor VA Gen Server Messages

If you want to use your own text for VA Gen Server messages, and you have VisualAge Generator installed, you can customize the run-time messages issued by VA Gen Server by using the VisualAge Generator editor and generation facilities to create a new message table.

Take the following steps:

1. To make the message information available in a program, import the external source format file containing the messages you want to customize. The external source format file is in member ELACLLL (where LLL is the language code; see Figure 39) member of ELA.V1R2M0.SELAESF.
2. Edit the messages using the table editor in VisualAge Generator. You can change the TYPE of the MSGTEXT field, but the BYTES for the MSGTEXT field must be 140. For the MSGNUMBER field, TYPE must be NUM and BYTES must be 4.

The inserts are indicated by “%nntll,” where **nn** is the insert number, **t** is the insert type, and **ll** is the insert length. You can change the order in which the inserts appear in the message, but must not change the number of inserts or their type or length.

Refer to the online help facility provided with VisualAge Generator for information about modifying tables.

3. Generate the message table using VisualAge Generator. You should generate the table as shared. If enough storage is available, you might want to generate the table as resident. Refer to the *VisualAge Generator Generation Guide* manual for information about table generation.

Note: You only need to generate the table for one target environment: the same table program can be used for all target environments.

4. Compile and link edit the table into your load library.

Make sure your load library precedes ELA.V1R2M0.SELALMD in the concatenation sequence for the environments that have tailored messages.

5. For the IMS environment, recycle the message region to access the customized version of the messages.

6. For the CICS environment, use the VA Gen Server new copy utility to cause a fresh copy of the messages to be used the next time a load request is issued for the table. Refer to the *VisualGen: Running Applications on MVS* manual for more information on the VA Gen Server utilities.

6.2.1.7 Java Gateway Support for OS/390

6.2.1.7.1 Environment Variables: Once the Java Support for OS/390 has been installed, users need to set the following environment variables in their .profile datasets in order to access the installed code. If you have changed the install directory name to something other than /usr/lpp/vgwgs31, then change any references to directory /usr/lpp/vgwgs31 to the directory used for installation.

PATH Must be set to include the directory containing Java Development Kit 1.1.x or Java Runtime Environment 1.1.x classes.

LIBPATH Must include /usr/lpp/vgwgs31. Ensure that the permission bits for files cso31api.dll, csoexci.dll, and libcsojava.so are set to make these files executable.

DPATH Must include /usr/lpp/vgwgs31.

CLASSPATH Must include /usr/lpp/vgwgs31/csojava.jar, or you must explode /usr/lpp/vgwgs31/csojava.jar relative to a base directory that is placed in CLASSPATH. To explode /usr/lpp/vgwgs31/csojava.jar into subdirectories of /usr/base, for example, change to directory /usr/base and enter the Java command:

```
jar xvf /usr/lpp/vgwgs31/csojava.jar
```

Executing this command adds subdirectory ibm/cso to /usr/base and class files are placed in directory /usr/base/ibm/cso. Directory /usr/base should then be added to the CLASSPATH environment variable.

STEPLIB If the CICS External CICS Interface (EXCI) load modules (shipped with CICS qualifier SDFHEXCI) are not included in the system library, the STEPLIB environment variable can be specified to include the SDFHEXCI dataset.

CSOLINKTBL If server programs to be started from Java classes are generated with runtime binding specified in their linkage table, either the linkage table must be in a file specified in the DPATH environment variable, or the CSOLINKTBL environment variable must specify where the runtime linkage table resides.

6.2.1.7.2 HTML Page Server: To access applets referenced by html pages, you need to configure an html page server for security and for translating an http address to the directory containing the associated html file. IBM Internet Connection Secure Server for OS/390 is a product that provides such services for OS/390 Version 1 Release 3, and Lotus Domino GO Web Server provides services for OS/390 Version 2 Release 4 and later. You need to add Pass directives to convert http addresses to directories. The directives required for security vary depending on the level of security required.

Additional information for setting up the CICS EXCI is provided in the *VisualAge Generator Client/Server Communications Guide* (SH23-6602). The current documentation is also available in html format that you can view from a browser, if you run a self-extracting executable shipped with VisualAge Generator Common Services V3.1 for OS/2 or Windows NT, or by expanding a tar file shipped with VisualAge Generator Common Services V3.1 for AIX. To expand the html files, do the following:

- For Windows NT:

Change to the directory in which you want the html files expanded, and run javawin.exe (found in the hptcsow directory) after the installation for Windows NT.

- For OS/2:

Change to the directory in which you want the html files expanded, and run javaos2.exe (found in the hptcsow directory) after the installing for OS/2.

- For AIX:

Change to the directory in which you want the html files expanded, and run command "tar -xvf /usr/lpp/vgwgs31/csojavadoc.tar" after the installation for AIX.

Appendix A. Post-installation Customization Procedures

The table in this appendix outlines the steps you follow to customize VA Gen Server after it has been installed—to add a new language feature or upgrade a related product, for example, or to do some further tailoring of VA Gen Server defaults.

Note that the “Explanation” column includes references to specific panels in the interactive customization dialog invoked by ELACCUST.¹ A roadmap to these panels is in Figure 22 on page 34. Pictures of the individual panels are included in the detailed descriptions of the procedures in 6.2.1.1, “Customization Tasks.”

¹ The CLISTs, jobs, and procedures in the ELACLST, ELAJCL, and ELASAMP libraries are replaced when you run the ELACCUST CLIST. If you have made extensive manual modifications to these members during system installation, you might want to manually tailor the jobs, procedures, and templates with the new values instead of running ELACCUST. If you decide to use ELACCUST, make back-up copies of these libraries, run ELACCUST, compare the newly generated libraries to the back-up copies, and manually enter any changes that might be required.

Figure 64 (Page 1 of 8). VA Gen Server Post-installation Customization Procedures

Procedure	Explanation
<p>VA Gen Server Default Installation Options</p> <p>You can change one or more of the following installation options:</p> <ul style="list-style-type: none"> • Default language code • Bypass date edit on EOF • IMS/ESA installed • VA Gen Server trace buffer size • CICS temporary storage control interval size. 	To customize installed default values.
1. See 6.2.1.2.2, "Installation Customization" on page 32. ¹	To use the customization panels to change the option. Make the changes on the VA Gen Server Run-time Default Options panel. If you are changing the default language code, also specify the new default on the VA Gen Server Variables panel.
2. See 6.2.1.2.3, "Change Default Installation Options" on page 46.	To create a new version of the installation options module.
3. If you put the module ELARPIOP into the LPA, move the new version into the LPA.	To make the new module available.
4. If the environment is IMS, stop and start the message region.	To make the new module available.
5. If the environment is CICS, use the CICS NEWCOPY command for module ELARPIOP.	To make the new module available.
6. See 6.2.1.2.10, "Run the Customization Verification Program (CVP)" on page 53.	To verify that the changes were made correctly.

Figure 64 (Page 2 of 8). VA Gen Server Post-installation Customization Procedures

Procedure	Explanation
<p>VA Gen Server Default Language-dependent Options</p> <p>To customize the language-dependent options.</p> <p>You can change one or more of the following language-dependent options:</p> <ul style="list-style-type: none"> • Gregorian or Julian date formats • Conversion table name • Character strings for positive and negative responses • Decimal point character • Numeric separator character • Currency symbol • SQL host variable indicator • SQL host column indicator. 	
1. See 6.2.1.2.2, "Installation Customization" on page 32. ¹	To use the customization panels to change the option. Make the changes on the VA Gen Server Language Dependent Options panel.
2. See 6.2.1.2.4, "Change Language-dependent Options" on page 46.	To create a new version of the language-dependent options module.
3. If you put the module ELARILLL (where LLL is the language code) into the LPA, move the new version of the module into the LPA.	To make the new module available.
4. If the environment is IMS, stop and start the message region.	To make the new module available.
5. If the environment is CICS, use the CICS NEWCOPY command for module ELARILLL (where LLL is the language code).	To make the new module available.
6. See 6.2.1.2.10, "Run the Customization Verification Program (CVP)" on page 53.	To verify that the changes were made correctly.
<hr/>	
MVS Batch Support	To add support for the MVS Batch target environment.
1. See 6.2.1.2.2, "Installation Customization" on page 32. ¹	To add MVS Batch as a target environment. Use the Specify Application Preparation User Data Set Variables panel.
2. See 6.2.1.2.5, "Modify LE Options and Exits" on page 48.	To establish a modified LE run-time options module to initialize working storage. Also to set up the LE termination user exit.
3. See 6.2.1.2.10, "Run the Customization Verification Program (CVP)" on page 53	To verify that the changes were made correctly.

Figure 64 (Page 3 of 8). VA Gen Server Post-installation Customization Procedures

Procedure	Explanation
MVS/TSO Support	To add support for MVS/TSO.
1. See 6.2.1.2.2, "Installation Customization" on page 32. ¹	To add MVS/TSO as a target environment. Use the Specify Application Preparation User Data Set Variables panel.
2. See 6.2.1.2.5, "Modify LE Options and Exits" on page 48.	To establish a modified LE run-time options module to initialize working storage. Also to set up the LE termination user exit.
3. See 6.2.1.3.1, "Update MVS/TSO Concatenation Lists" on page 54.	To make the VA Gen Server modules available to application users.
4. See 6.2.1.3.2, "Run the CVP for MVS/TSO" on page 54	To verify that the changes were made correctly.
CICS Support	To add support for CICS.
1. See 6.2.1.2.2, "Installation Customization" on page 32. ¹	To add CICS as a target environment. Use the VA Gen Server Variables panel to indicate that CICS is installed. Use the Specify Application Preparation User Data Set Variables panel. Also use the CICS Variables panel to specify CICS library names.
2. See 6.2.1.2.5, "Modify LE Options and Exits" on page 48.	To set up the LE termination user exit.
3. See 6.2.1.2.9, "Modify and Copy Compile and Link Procedures" on page 51.	To modify procedures that include the CICS translation and to copy them to your procedure library.
4. See 6.2.1.5.1, "Add CICS Diagnostic Controller Utility Support" on page 69.	To provide control over error handling on a transaction basis.
5. See 6.2.1.5.2, "Modify CICS Tables and Definitions" on page 73.	To provide the CICS table definitions required by VA Gen Server.
6. See 6.2.1.5.3, "Modify CICS Region JCL" on page 77.	To make the VA Gen Server libraries, as well as the LE libraries, available to CICS.
7. See 6.2.1.5.4, "Run the CVP for CICS" on page 77.	To verify that the changes were made correctly.

Figure 64 (Page 4 of 8). VA Gen Server Post-installation Customization Procedures

Procedure	Explanation
IMS Support	To add support for IMS.
1. See 6.2.1.2.2, "Installation Customization" on page 32. ¹	To add the IMS environment as a target environment. Use the VA Gen Server Variables panel to indicate that IMS is installed. Use the Specify Application Preparation User Data Set Variables panel. Also use the IMS Variables panel to specify IMS library name.
2. If you are installing IMS/ESA:	
a. See 6.2.1.2.2, "Installation Customization" on page 32.	To change the installation options module. Use the VA Gen Server Run-time Default Options panel.
b. See 6.2.1.2.3, "Change Default Installation Options" on page 46.	To create a new version of the installation options module.
3. See 6.2.1.2.5, "Modify LE Options and Exits" on page 48.	To establish a modified LE run-time options module to initialize working storage. Also to set up the LE termination user exit.
4. See 6.2.1.2.9, "Modify and Copy Compile and Link Procedures" on page 51.	To modify procedures that include the IMS RESLIB and to copy them to your procedure library.
5. See 6.2.1.4.1, "Install a Work Database" on page 55.	To define a work database where information can be stored during a CONVERSE or XFER with map.
6. See 6.2.1.4.2, "Install VA Gen Server PSBs" on page 61.	To define the PSBs and ACBs used by VA Gen Server.
7. See 6.2.1.4.3, "Modify IMS System Definition" on page 62.	To define to IMS the PSBs, transactions, and databases used by VA Gen Server.
8. See 6.2.1.4.4, "Modify IMS Control and Message Region JCL" on page 63.	To make the VA Gen Server libraries, as well as the LE libraries, available to IMS. If you are using a DL/I work database, this also makes it available to IMS.
9. See 6.2.1.4.5, "Assemble and Link the VA Gen Server Maps" on page 65.	To generate the MFS control blocks for VA Gen Server error, trace facility, and CVP maps.
10. See 6.2.1.4.6, "Run the IMS Online Change Utility" on page 66.	To put the new IMS system definition, ACBs, and MFS control blocks into effect.
11. See 6.2.1.4.7, "Link and Run the Customization Verification Program for IMS" on page 67.	To verify that the changes were made correctly.

Figure 64 (Page 5 of 8). VA Gen Server Post-installation Customization Procedures

Procedure	Explanation
Terminal or Printer Devices (IMS environments only)	To add or change a device definition in your IMS system definition.
1. See 6.2.1.4.5, "Assemble and Link the VA Gen Server Maps" on page 65.	To generate the MFS control blocks that VA Gen Server uses to display errors and for the trace facility. This step is required for the trace-facility maps.
2. Use the IMS command /MODIFY PREPARE FMTLIB followed by /MODIFY COMMIT .	To put the new maps into effect.
DL/I Database Support	To add support for DL/I databases without adding IMS environment support.
1. See 6.2.1.2.2, "Installation Customization" on page 32. ¹	To specify that IMS is installed. Use the VA Gen Server System Variables panel. Also use the Specify Application Preparation User Data Set panel if you need to add IMS BMP as a target environment and are installing IMS/ESA DM. Use the IMS Variables panel to specify the IMS libraries and batch procedures.
2. If you are installing IMS/ESA with DL/I database access:	
a. See 6.2.1.2.2, "Installation Customization" on page 32.	To change the installation options module. Use the VA Gen Server Run-time Default Options panel.
b. See 6.2.1.2.3, "Change Default Installation Options" on page 46.	To create the new version of the installation options module.
3. See 6.2.1.2.5, "Modify LE Options and Exits" on page 48.	To set up the LE termination user exit.
4. See 6.2.1.2.9, "Modify and Copy Compile and Link Procedures" on page 51.	To modify procedures that include the IMS RESLIB and to copy them to your procedure library.
5. See 6.2.1.2.10, "Run the Customization Verification Program (CVP)" on page 53.	To verify that the changes were made correctly.

Figure 64 (Page 6 of 8). VA Gen Server Post-installation Customization Procedures

Procedure	Explanation
DB2 Support	To add support for DB2.
1. See 6.2.1.2.2, "Installation Customization" on page 32. ¹	To specify information about the DB2 subsystem and libraries. Use the DB2 Variables panel. Also use the VA Gen Server Language Dependent Options panel to change the default values for the SQL host variable indicator or the SQL host column indicator.
2. See 6.2.1.2.5, "Modify LE Options and Exits" on page 48.	To set up the LE termination user exit.
3. See 6.2.1.2.9, "Modify and Copy Compile and Link Procedures" on page 51.	To modify the procedures that have steps related to DB2 and to copy them to your procedure library.
DL/I Work Database	To add a DL/I work database to the IMS environment.
1. See 6.2.1.4.1, "Install a Work Database" on page 55.	To define a work database where information can be stored during a CONVERSE or XFER with map.
2. See 6.2.1.4.2, "Install VA Gen Server PSBs" on page 61.	To define the PSBs and ACBs used by VA Gen Server.
3. See 6.2.1.4.3, "Modify IMS System Definition" on page 62.	To define to IMS the PSBs, transactions, and databases used by VA Gen Server.
4. See 6.2.1.4.4, "Modify IMS Control and Message Region JCL" on page 63.	To make the DL/I work database available to IMS.
5. See 6.2.1.4.5, "Assemble and Link the VA Gen Server Maps" on page 65.	To tailor the MFS control blocks for the CVP that uses a DL/I work database (MFS source ELAYT3XM).
6. See 6.2.1.4.6, "Run the IMS Online Change Utility" on page 66, specifying MODBLKS, ACBLIB, and FMTLIB.	To put the new IMS system definition, ACBs, and MFS control blocks into effect.
7. See 6.2.1.4.7, "Link and Run the Customization Verification Program for IMS" on page 67.	To verify that the changes were made correctly.

Figure 64 (Page 7 of 8). VA Gen Server Post-installation Customization Procedures

Procedure	Explanation
DB2 Work database	To add a DB2 work database to the IMS environment.
1. See 6.2.1.4.1, "Install a Work Database" on page 55.	To define a work database where information can be stored during a CONVERSE or XFER with map.
2. See 6.2.1.4.1.3, "Perform a DB2 Bind" on page 59.	To bind the plan for the trace utility program.
3. See 6.2.1.4.2, "Install VA Gen Server PSBs" on page 61.	To define the PSBs and ACBs used by VA Gen Server.
4. See 6.2.1.4.3, "Modify IMS System Definition" on page 62.	To define to IMS the PSBs, transactions, and databases used by VA Gen Server.
5. See 6.2.1.4.5, "Assemble and Link the VA Gen Server Maps" on page 65.	To tailor the MFS control blocks for the CVP that uses a DB2 work database (MFS source ELAYT4XM).
6. See 6.2.1.4.6, "Run the IMS Online Change Utility" on page 66, specifying MODBLKS, ACBLIB, and FMTLIB.	To put the new IMS system definition, ACBs, and MFS control blocks into effect.
7. See 6.2.1.4.7, "Link and Run the Customization Verification Program for IMS" on page 67.	To verify that the changes were made correctly.
ANSI SQL database Support	To add support for an ANSI SQL database.
See 6.2.1.2.8, "Prepare ANSI SQL Program" on page 50.	To prepare the VA Gen Server ANSI SQL commit and rollback program for use with the ANSI database manager, and to tailor preparation procedures for use with the ANSI database manager.
VA Gen Server Messages	To customize the messages issued by VA Gen Server.
1. See 6.2.1.6, "Tailor VA Gen Server Messages" on page 78	To use your own text for VA Gen Server messages, if you have VisualAge Generator installed.

Figure 64 (Page 8 of 8). VA Gen Server Post-installation Customization Procedures

Procedure	Explanation
COBOL and LE Customization	To customize COBOL and LE
1. See 6.2.1.2.2, "Installation Customization" on page 32. ¹	To select the COBOL and LE libraries. Use the COBOL and LE Variables panel.
2. Ensure that the MVS TSO, IMS, and CICS environments are set up to use LE run-time libraries. Refer to the LE customization manual.	To make LE run-time routines available to COBOL programs generated for these environments.
3. See 6.2.1.2.5, "Modify LE Options and Exits" on page 48.	To establish an LE defaults module to initialize working storage and to set a default LE user exit for abnormal termination.
4. See 6.2.1.2.8, "Prepare ANSI SQL Program" on page 50.	To prepare the ANSI SQL program using COBOL and LE.
5. See 6.2.1.2.9, "Modify and Copy Compile and Link Procedures" on page 51.	To modify procedures that use the COBOL and LE libraries and to copy them to your procedure library.
6. Important: if you are linking CEEUOPT and/or the CEEBXITA user exit (sample CEEBX05A for non-CICS and sample CEECXITA for CICS) with each program, see 6.2.1.2.5, "Modify LE Options and Exits" on page 48.	To put the LE options and exits into effect for existing programs. For examples of LE exit modules to include, use ELACJCEM for the non-CICS environment or ELACJCEC for CICS.

Appendix B. VA Gen Server Data Set Descriptions

B.1.1 Product Data Sets

Figure 65 lists the target data sets for VA Gen Server and their contents. The descriptions of the distribution data sets (ELA.V1R2M0.AELAxxxx) are the same. Figure 66 and Figure 67 list the contents of the customization data sets.

Figure 65. Product Data Set Descriptions

Data Set Name	Description
ELA.V1R2M0.SELACLST	Installation/customization CLISTS
ELA.V1R2M0.SELACOPY	COBOL copybook source
ELA.V1R2M0.SELADBRM	Database request modules for DB2
ELA.V1R2M0.SELAESF	ESF source for VA Gen Server error messages and critical error maps
ELA.V1R2M0.SELAJCL	Installation and customization jobs
ELA.V1R2M0.SELALMD	Load modules
ELA.V1R2M0.SELAMOD1	Load modules used during installation
ELA.V1R2M0.SELAMOD2	Load modules used during installation
ELA.V1R2M0.SELAMFS	MFS source library
ELA.V1R2M0.SELAPNL	Installation/customization ISPF panels and messages
ELA.V1R2M0.SELASAMP	Sample jobs and procedures, DBD source, PSB source, SQL source, CICS table definition entries, IMS stage-1 system definition entries, PCB macros, default options macros.

B.1.2 Non-VSAM Customization Data Sets

Figure 66. Non-VSAM Customization Data Sets

Data Set Name	Description
ELA.V1R2M0.ELACLST	Customized CLISTS
ELA.V1R2M0.ELAJCL	Customized jobs
ELA.V1R2M0.ELASAMP	Customized sample jobs, procedures, DBD source, PSB source, SQL source, CICS table definition entries, IMS stage-1 system definition entries.
ELA.V1R2M0.ELAWORK	DL/I work database

B.1.3 VSAM Customization Data Sets

Figure 67. VSAM Customization Data Sets

Data Set Name	Description
ELA.V1R2M0.ELACFIL	Diagnostic controller file
ELA.V1R2M0.DSNDBC.ELADBCTL. ELAWRKTS.10001.A001	DB2 work database
ELA.V1R2M0.DSNDBC.ELADBCTL. TEMPKEY.10001.A001	DB2 work database

Appendix C. VA Gen Server Install Logic

C.1 SMP/E Modification Control Statements

The SMP/E Modification Control Statements (SMPMCS) for VA Gen Server are contained in the SMPMCS file on the installation tape. The SMPMCS for each FMID in the product will be loaded to the SMPPTS dataset, with a member name matching the FMID, when the FMID is SMP/E RECEIVED. You may browse or print these members using TSO/E, ISPF, or IEBGENER (or IEBTPCH).

C.2 SMP/E JCLIN

The JCLIN for VA Gen Server is contained in the RELFILEs on the installation tape. These files will be loaded to disk by SMP/E when the product is SMP/E RECEIVED. You may browse or print these files using TSO/E, ISPF, or IEBGENER (or IEBTPCH).

The files containing JCLIN are:

- FMID H09912J: 'IBM.H09912J.F1(H09912J)
- FMID J099100: 'IBM.J099100.F1(J099100)
- FMID J099101: 'IBM.J099101.F1(J099101)
- FMID J09912A: 'IBM.J09912A.F1(J09912A)
- FMID J09912B: 'IBM.J09912B.F1(J09912B)
- FMID J09912C: 'IBM.J09912C.F1(J09912C)
- FMID J09912D: 'IBM.J09912D.F1(J09912D)
- FMID J09912E: 'IBM.J09912E.F1(J09912E)
- FMID J09912F: 'IBM.J09912F.F1(J09912F)
- FMID J09912H: 'IBM.J09912H.F1(J09912H)
- FMID J09912I: 'IBM.J09912I.F1(J09912I)

Note: The high-level qualifier is the qualifier specified as the DSPREFIX in the SMP/E OPTIONS.

Reader's Comments

Program Directory for VisualAge Generator Server for MVS Version 1, Release 2, Modification Level 0

You may use this form to comment about this document, its organization, or subject matter with the understanding that IBM may use or distribute whatever information you supply in any way it believes appropriate without incurring any obligation to you.

For each of the topics below please indicate your satisfaction level by circling your choice from the rating scale. If a statement does not apply, please circle N.

RATING SCALE					
very satisfied	<----->	very dissatisfied	not applicable		
1	2 3 4	5	N		

	Satisfaction					
Ease of product installation	1	2	3	4	5	N
Contents of program directory	1	2	3	4	5	N
Installation Verification Programs	1	2	3	4	5	N
Time to install the product	1	2	3	4	5	N
Readability and organization of program directory tasks	1	2	3	4	5	N
Necessity of all installation tasks	1	2	3	4	5	N
Accuracy of the definition of the installation tasks	1	2	3	4	5	N
Technical level of the installation tasks	1	2	3	4	5	N
Ease of getting the system into production after installation	1	2	3	4	5	N

How did you order this product?

- CBIPO
- CBPDO
- CustomPac
- ServerPac
- Independent
- Other

Is this the first time your organization has installed this product?

- Yes
- No

Were the people who did the installation experienced with the installation of MVS products?

___ Yes
___ No

If yes, how many years? ___

If you have any comments to make about your ratings above, or any other aspect of the product installation, please list them below:

Please provide the following contact information:

Name and Job Title

Organization

Address

Telephone

Thank you for your participation.

Please send the completed form to (or give to your IBM representative who will forward it to the VisualAge Generator Server for MVS Development group):

International Business Machines Corporation
Attn: Information Development
Department G71A, Building 062
P.O. Box 12195
Research Triangle Park, NC 27709-2195

FAX Number: (919) 254-0206

E-Mail: kfrye@us.ibm.com



Program Number: 5648-B02 5892
6478
5891
5963
6479
5080
5976
6485
5020

Printed in U.S.A.

GI10-0812-01

