zEnterprise Value for Business Workloads and Applications: Becoming Responsive, Flexible and Competitive



Trademarks

The following are trademarks of the International Business Machines Corporation in the United States and/or other countries.

AIX*	Geographically Dispersed Parallel Sysplex	OS/390*	Virtualization Engine
APPN*	HiperSockets	Parallel Sysplex*	VSE/ESA
CICS*	HyperSwap	PR/SM	VTAM*
DB2*	IBM*	Processor Resource/Systems Manager	WebSphere*
DB2 Connect	eServer	RACF*	z/Architecture
DirMaint	IBM logo*	Resource Link	z/OS*
DRDA*	IMS	RMF	z/VM*
Distributed Relational Database Architecture	InfoPrint*	S/390*	z/VSE
e-business logo*	Language Environment*	Sysplex Timer*	zSeries*
ECKD	MQSeries*	System z	
Enterprise Storage Server*	Multiprise*	System z9	
ESCON*	NetView*	System z10	
FICON*	On demand business logo	TotalStorage*	
GDPS*			

* Registered trademarks of IBM Corporation

The following are trademarks or registered trademarks of other companies.

Intel is a trademark of Intel Corporation in the United States, other countries, or both.

Java and all Java-related trademarks and logos are trademarks of Sun Microsystems, Inc., in the United States and other countries

Linux is a registered trademark of Linus Torvalds in the United States, other countries, or both.

UNIX is a registered trademark of The Open Group in the United States and other countries.

Microsoft, Windows and Windows NT are registered trademarks of Microsoft Corporation.

Red Hat, the Red Hat "Shadow Man" logo, and all Red Hat-based trademarks and logos are trademarks or registered trademarks of Red Hat, Inc., in the United States and other countries.

SET and Secure Electronic Transaction are trademarks owned by SET Secure Electronic Transaction LLC.

* All other products may be trademarks or registered trademarks of their respective companies.

Notes:

Performance is in Internal Throughput Rate (ITR) ratio based on measurements and projections using standard IBM benchmarks in a controlled environment. The actual throughput that any user will experience will vary depending upon considerations such as the amount of multiprogramming in the user's job stream, the I/O configuration, the storage configuration, and the workload processed. Therefore, no assurance can be given that an individual user will achieve throughput improvements equivalent to the performance ratios stated here.

IBM hardware products are manufactured from new parts, or new and serviceable used parts. Regardless, our warranty terms apply.

All customer examples cited or described in this presentation are presented as illustrations of the manner in which some customers have used IBM products and the results they may have achieved. Actual environmental costs and performance characteristics will vary depending on individual customer configurations and conditions.

This publication was produced in the United States. IBM may not offer the products, services or features discussed in this document in other countries, and the information may be subject to change without notice. Consult your local IBM business contact for information on the product or services available in your area.

All statements regarding IBM's future direction and intent are subject to change or withdrawal without notice, and represent goals and objectives only.

Information about non-IBM products is obtained from the manufacturers of those products or their published announcements. IBM has not tested those products and cannot confirm the performance, compatibility, or any other claims related to non-IBM products. Questions on the capabilities of non-IBM products should be addressed to the suppliers of those products.

Prices subject to change without notice. Contact your IBM representative or Business Partner for the most current pricing in your geography.

Agenda

- **Recognizing the Workloads**
- **The Value of zEnterprise**
- **Real Customers - Real Value**
- **Assessing the Value**

Agenda

➤ **Recognizing the Workloads**

➤ The Value of zEnterprise

➤ Real Customers - Real Value

➤ Assessing the Value

Industries are re-shaping business models to meet the demands of a sophisticated consumer and fiercely competitive economy

Smart Work for a Smarter Planet

	<p>Smarter Money: Using advanced analytics to turn a numerical ocean into actionable insight and intelligence.</p>	<p>Mobile Banking Having the ability to check balances, move money across accounts and initiate payment to a vendor, all from your cellular phone.</p>
	<p>Smarter Shopping: Information exchange and collaboration, offer a tremendous opportunity to strengthen customer loyalty.</p>	<p>Upromise: Providing the ability to shop online at over 100 websites, stores, restaurants while earning and accumulating savings for college education.</p>
	<p>Smart Thinking: Taking advantage of a new wealth of information to be able to make more intelligent decisions and rise to the top.</p>	<p>'Single Moments of Truth': Insurance, Banking, Retail, Travel & transportation are all industries that want a single view of all information for Customer Care & Insight.</p>
	<p>Smarter Healthcare: Smarter healthcare starts with the individual. Changing the way patient information is used to treat the "whole" person, not parts at a time.</p>	<p>Medical Home: Primary care physicians act as "coaches," leading a team that manages a patient's wellness, preventive and chronic care needs.</p>
	<p>Smarter Cloud: Conserve energy. Consolidate resources. With mandates like these, we have to be smarter about accessing, processing and storing data.</p>	<p>Online Universities: Providing millions the ability to remotely take courses from several colleges and universities simultaneously, consolidating resources and skills.</p>

These new business models are driving requirements for changes to the components of a traditional workload or application

What is a workload?

The relationship between a **group** applications and/or systems related across several business functions to satisfy one or more business processes. e.g. Retail Merchandising, On-line Banking

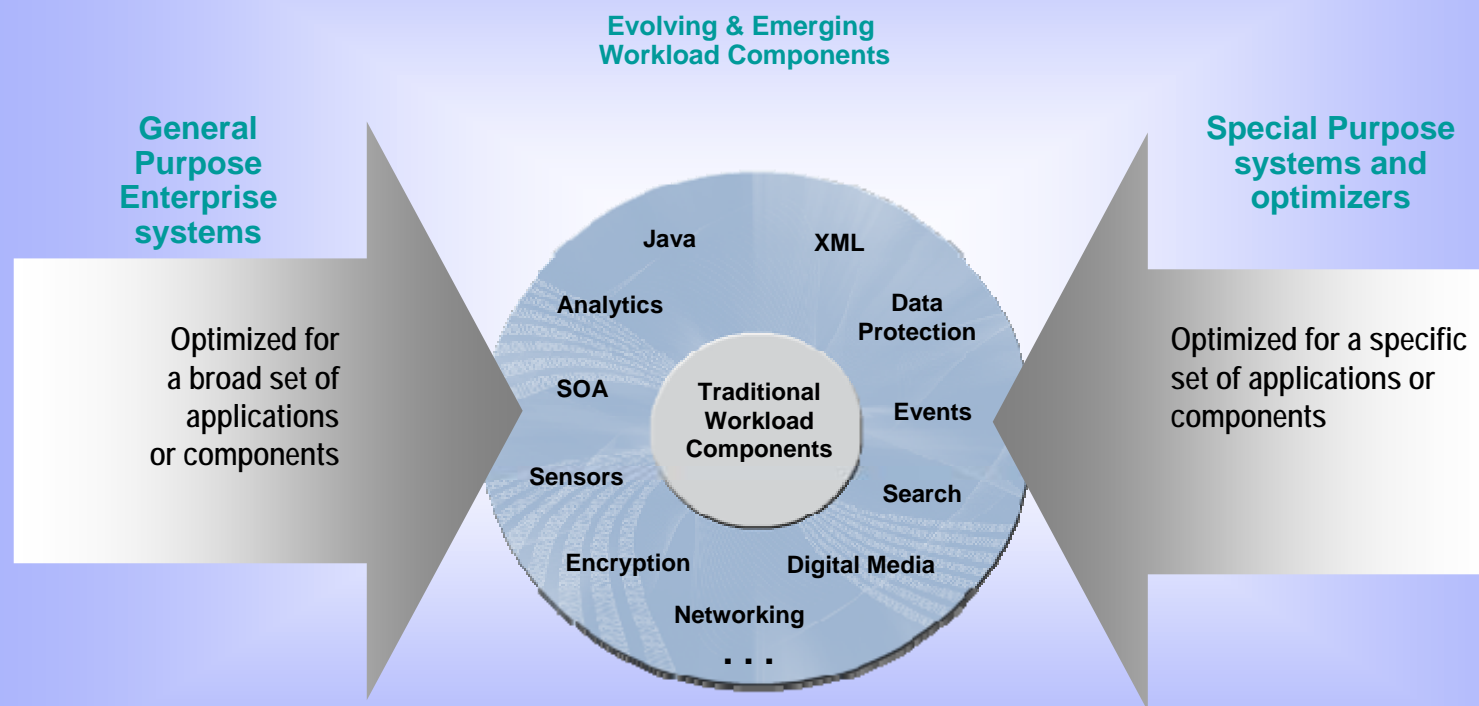

Future requirements include complete application integration in an optimal fashion

While the Panacea of “one size fits all” is attractive in reality it is unachievable.

While in theory, all workloads could run on a single platform...

... truthfully all platforms have a role to play

- You need the **data serving strengths** of the mainframe, the security, the resiliency, the scalability
- You need the **computational strength** of power systems, for HPC and large scale application serving
- You need the **breadth** of System x, for front end applications, special function servers and a myriad of niche applications

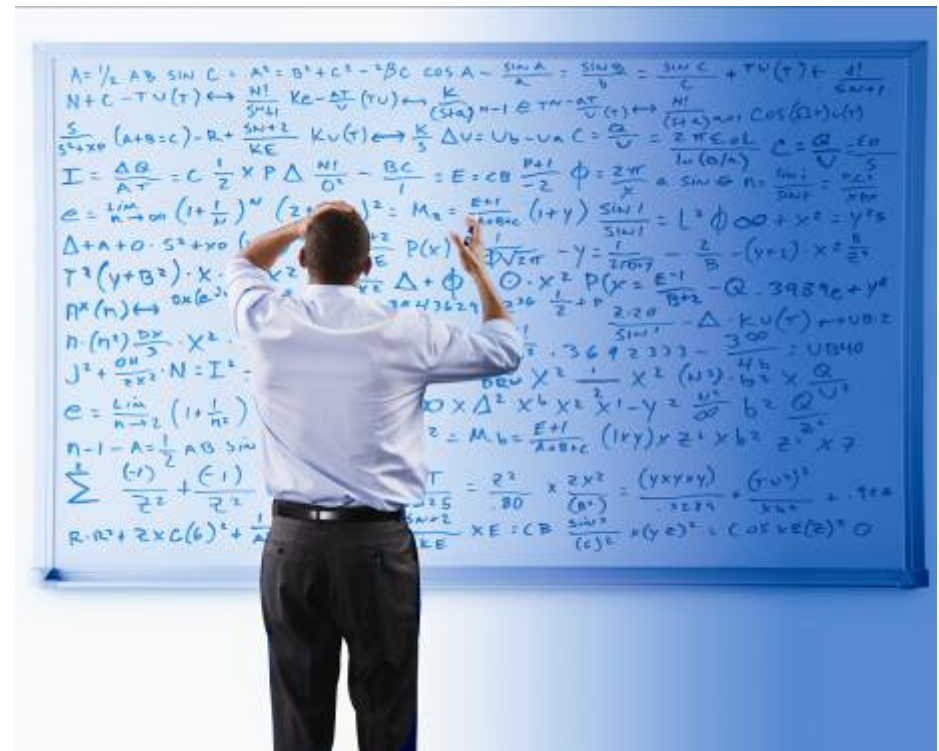

Creating a single platform infrastructure would be highly inefficient and ineffective and unsustainable in the long term

zEnterprise provides the foundation for the ‘smart’ infrastructure on which we can build the workloads of today and tomorrow

They are workloads that.....

- ...rely on data serving in System z
e.g. DB2 or ORACLE
- ...are solutions that need to leverage classic strengths of System z:
 - High availability
 - High i/o bandwidth capabilities
 - Superior disaster recovery
 - Industry leading security
 - Consolidation effects
- ...have application components on Power or Intel servers but require a higher level of integration capability and efficiency



....and / or.....

- ...currently reside in low utilization / development environments
- ...can be made more efficient through consolidation of servers, storage, applications and/or databases
- ...integrate using SOA and Middleware
- can be optimized by using the newest virtualization technology

....but also may.....

- ...reside in complex IT environments involving multiple server architectures, ISVs or operating systems
- ...require flexible development and test infrastructure
- ...require simplified, integrated policy and management
- ...need shorter end to end path length between co-existing apps
- ...realize improved performance through reductions in network traffic

Workloads we see every day that match these characteristics

Banking	Insurance	Retail	Healthcare	Public Sector
<i>Core Banking</i>	<i>Internet Rate Quotes</i>	<i>On-line Catalog</i>	<i>Patient Care Systems</i>	<i>Electronic IRS</i>
<i>Wholesale Banking – Payments</i>	<i>Policy Sales & Management (e.g. Life, Annuity, Auto)</i>	<i>Supply Chain Management</i>	<i>On– line Claims Submission & Payments</i>	<i>Web based Social Security</i>
<i>Customer Care & Insight</i>	<i>Claims Processing</i>	<i>Customer Analysis</i>		



These workloads have recognizable patterns

Core Applications	
Database (z) ✓ DB2 for z/OS Application (z) ✓ CICS ✓ COBOL ✓ WebSphere	Database (z) ✓ DB2 for z/OS ✓ Oracle on Linux for z Application (z) ✓ WebSphere

SAP Patterns	
Database (z) ✓ DB2 for z/OS Application (z) ✓ Linux for z 	Database (z) ✓ DB2 for z/OS Application (Intel) ✓ Linux for x86
Database (z) ✓ DB2 for z/OS Application (Power) ✓ AIX 	

Multi-Tier Web Serving Patterns	
Database (z) •DB2 for z/OS Application (z) •WebSphere Application (Intel) •WebSphere •Apache •Tomcat 	Database (z) •DB2 for z/OS Application (Power / Unix) •WebSphere •JBoss
Database (z) •DB2 for z/OS or IMS Transaction Processing (z) •CICS, MQ Application (Power /UNIX) •WebSphere •JBoss Presentation (Intel) •WebSphere •Windows 	Database (z) •DB2 for z/OS or IMS Application (Power /UNIX) •WebSphere •JBoss Presentation (Intel) •WebSphere •Apache / Tomcat

Data Warehouse & Analytics
Master Data Management Database (z) ▪ DB2 for z/OS Application (z) ▪ WebSphere MDM (AIX, Linux on z)
Analytics ▪ System z/OS ▪ DB2 ▪ Cognos (Soon!) ▪ SAS ▪ Linux for System z ▪ Cognos ▪ SPSS ▪ InfoSphere Warehouse

Agenda

- Recognizing the Workloads

- **The Value of zEnterprise**

- Real Customers - Real Value

- Assessing the Value

The Value begins at the heart of zEnterprise.....

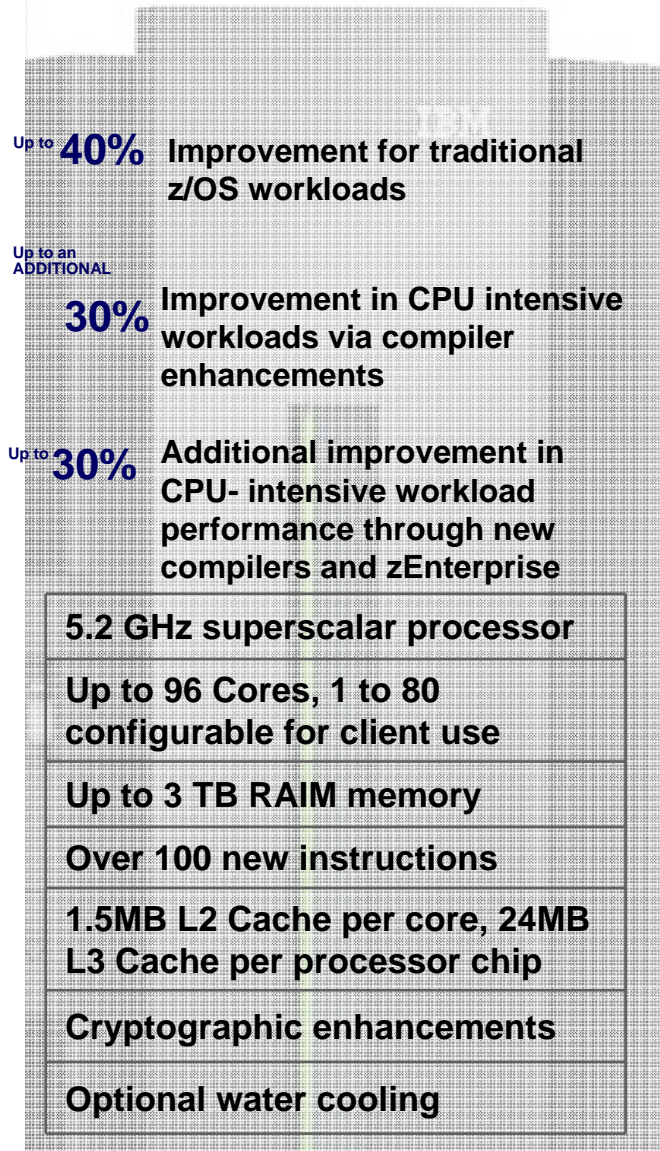

SAP

- Speed, Scalability and Memory/Cache enhancements allow large SAP systems to continue grow effectively at a competitive cost.
- Security on System z increasingly provides the safest data serving capability in the industry from which to build a flexible SAP infrastructure
- *Key to Banking, Retail, Manufacturing*

Multi-Tier Web Serving

- New instructions, combined with new compilers ensures a place for System z as a scalable and available platform for web growth and flexibility
- *Key to Banking, Insurance, Government, Healthcare*

Business Intelligence / Data Warehousing

- Increased Speed, Memory architecture and processor capacity open up avenues to extend the value of DB2 in the analytics arena
- *Key Cross Industry*



..... reaching across the levels of architecture.....

Optimize System z Business Workloads and Applications

- Extending System z as a hosting environment for a **broader set of workloads**
- **Increasing the application inventory** on the platform
- Increasing System z relevancy to existing clients by **extending the value** proposition across the application portfolio
- Providing **competitive price-performance** for new workloads
- Extending **superior manageability** and **QoSs** for solutions that have **distributed applications accessing data hosted on System z**, facilitating lower overall cost of operations, while improving user experience

IBM Blades –Power 7 and System x (SOD)

- Provide **Choice** for application hosting
 - Choose the IT platform that best fits the needs of a workload at the lowest cost
- Provide **Speed** for deployment
 - Liberate the lines of business enabling them to focus on Functional Requirements for expanding and growing their contribution to the bottom line – typically, get function out faster to generate revenue

IBM Smart Analytics Optimizer

*Add a new dimension to traditional workloads, extending most DB2 application to become a source of **information and analytics**.*



..... and made possible by the Unified Resource Manager

Integrated Resource Discovery and Inventory

- Saves time, cost and simplifies asset management, no need to configure adapters, no need to reconcile discovery of resources in the environment with different names.
- Fixes existing process that tend to be manually intensive, error-prone and incomplete leading to inaccurate discovery/inventory.

Integrated Hardware Management

- Simplifies problem determination and resolution , cross complex power on/off, call home – pre-emptive actions for failures (before customer notices), guided repair
- Increases availability and decreases time consuming cost of coordination / collaboration across disparate platforms

Workload Representation

- Provides deep insight to how IT resources are being used within the context of their implications to a business workload

Platform Performance Management

- Allow critical workloads to receive resource and priority based on goal-oriented policies established by business requirements
- A single consolidated and consistent view of resources facilitating smart business adjustments

Virtual Server Lifecycle Management

- Gain Flexibility, Consistency and Uniformity of Virtualization across platforms
- Provide the business the fastest time to market with the best choices, deploying multiple Virtual images within minutes to create a cross platform infrastructure.

Blade Hypervisors as Firmware

- Shipped and serviced as firmware, simplifying installation and increasing speed to deploy servers, cut test cycle time gaining significant time to market.

Intra-Ensemble Data Network (IEDN)

- Integrated network, dedicated to workloads running within zEnterprise System, providing, higher security, lower latency and simplified management for applications.

Internal Platform Management Network (INMN)

- Single private, secure and physically isolated network facilitates management of complex without impact from or to business function running on data networks



Agenda

- Recognizing the Workloads
- The Value of zEnterprise
- **Real Customers - Real Value**
- Assessing the Value

Retail Client using SAP Financials (today)



Today's Environment

SAP Financial modules are run with data serving on DB2 for z/OS and the application servers are spread across several Power based systems; also currently using SAP Business Warehouse Accelerator.

Challenges/Issues

- Coordination of application across platforms is resource intensive and vulnerable to several points of impact.
- Too many network hops from one platform to another to get data
- Hardware microcode updates cannot be applied without an outage
- Different monitoring software tools per server type with different software process for site failovers

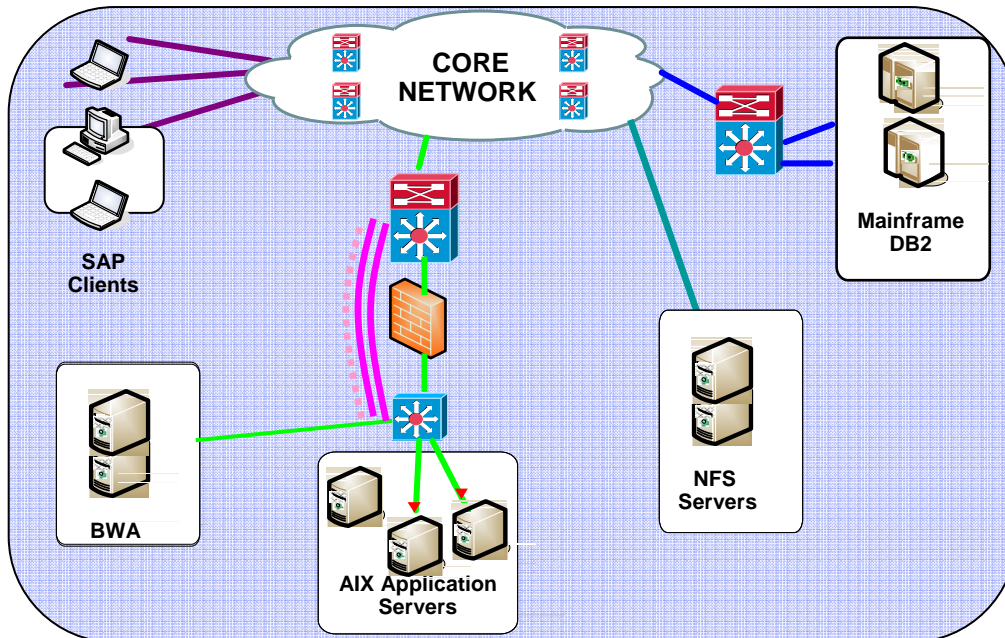

Retail Client using SAP Financials (tomorrow)

The Environment with zEnterprise

SAP data server on DB2 z/OS with application serving on Power 7 Blades in zBX integrated in a zEnterprise system.

"We think we can anticipate a reduction of 12 hops across the network down to 1, saving network cost and improving our application performance!"
Client IT Management

Business Advantage

- Ensuring business controls, such as security and compliance, are achieved on a consistent basis across the applications and platforms

Operational Advantage

- Ability to monitor and manage a critical application end to end from a workload view
- Ability to make adjustments in available resources, apply maintenance, manage server availability and handle business peaks with true application insulation
- Potential of up to 60% savings identified for the SAP workload across power, cooling and floor space

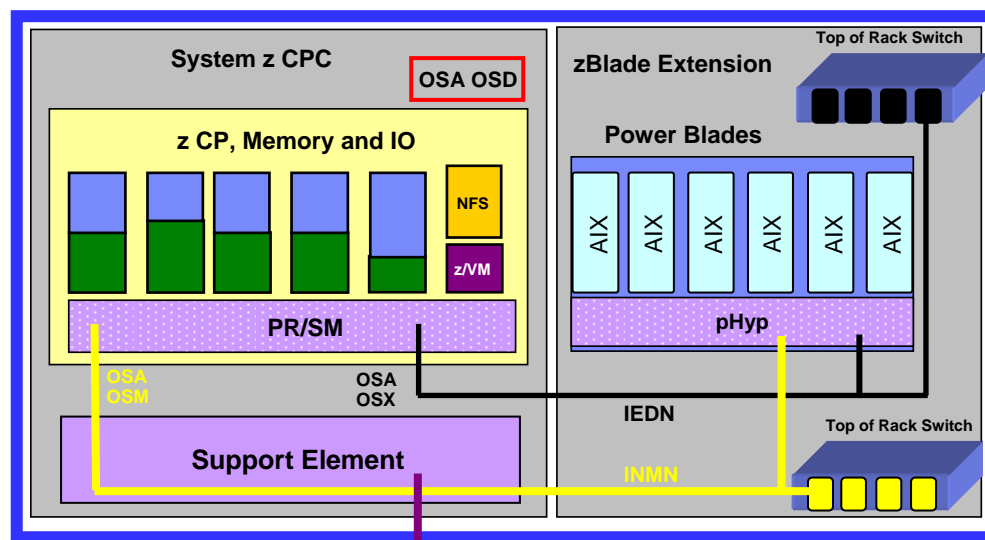

Organizational Advantage

- Insulate application development teams from Infrastructure technology
- Consolidation of skills thru consistent tools

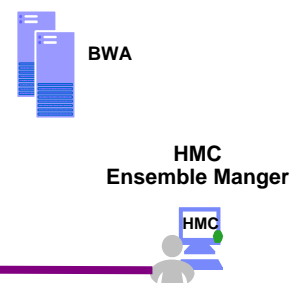

German Public Sector Client: Internet Tax Application (today)

Today's Environment

Database on DB2 z/OS and WebSphere application servers on Power and web servers on x86 running Linux and Windows

Challenges/Issues

- Not able to respond quickly for need of new function.
- High cost of staff required to maintain multi-tier application

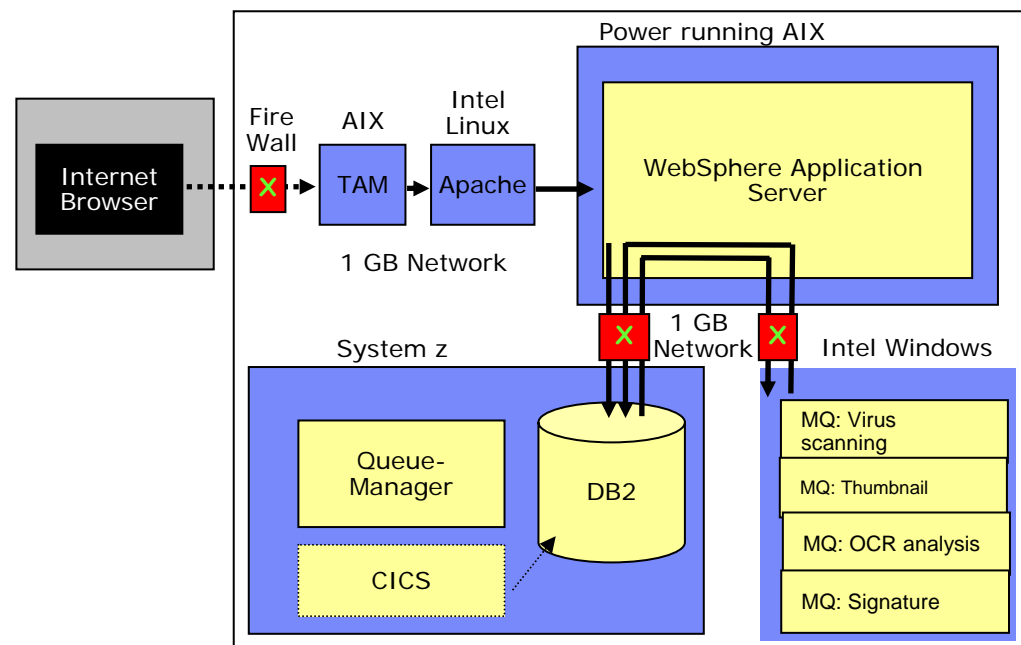

German Public Sector Client: Internet Tax Application (tomorrow)

The Environment with zEnterprise

Database on DB2 z/OS with application serving on Power 7 Blades in zBX, utilizing IBM WebSphere DataPower for web service enablement.

Operational Advantage

- Improved Network speed (10 GB Network in zNext vs. 1 GB network in datacenter - that means 10x increase)
- Horizontal workload management view for one specific application across many platforms (Linux on Intel, AIX, z/OS)

Organizational Advantage

- Everything is pre tested, pre configured, etc. for their mission critical application this is a large benefit

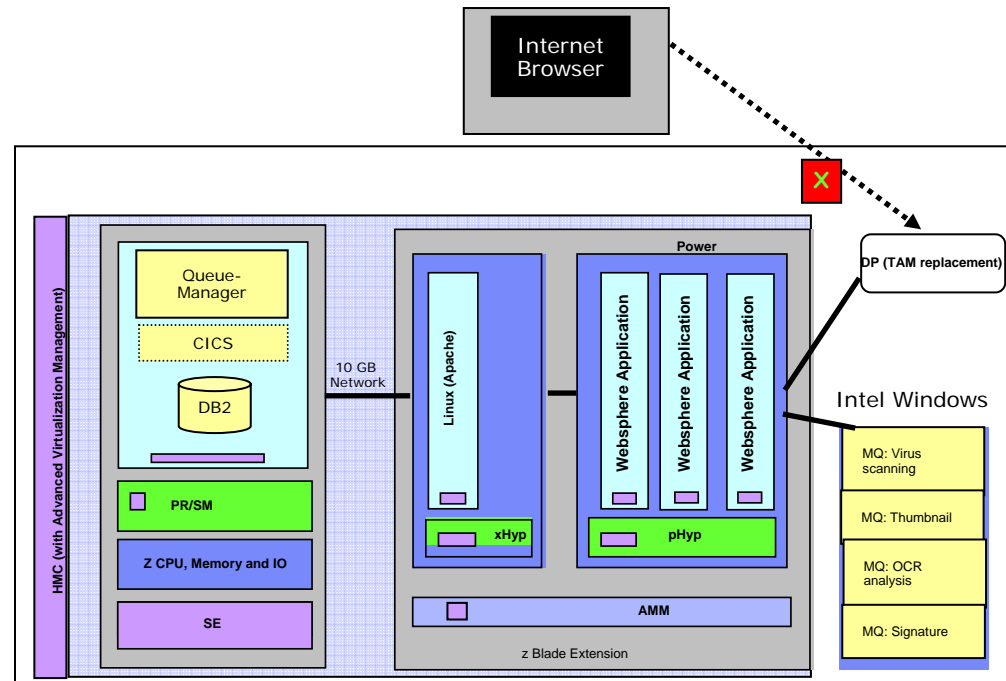

Large European Bank – Internet Banking (today)

Today's Environment

System z with CICS, IMS and DB2 for data serving and core business logic, using WebSphere on Power for additional business logic and presentation capability; web servers on System x Blades running Linux

Challenges/Issues

- Extremely complex environment
- Majority of maintenance applied to systems manually
- Several single points of failure
- Bank presence in multiple countries across Europe and are maintaining different infrastructures based on acquisitions

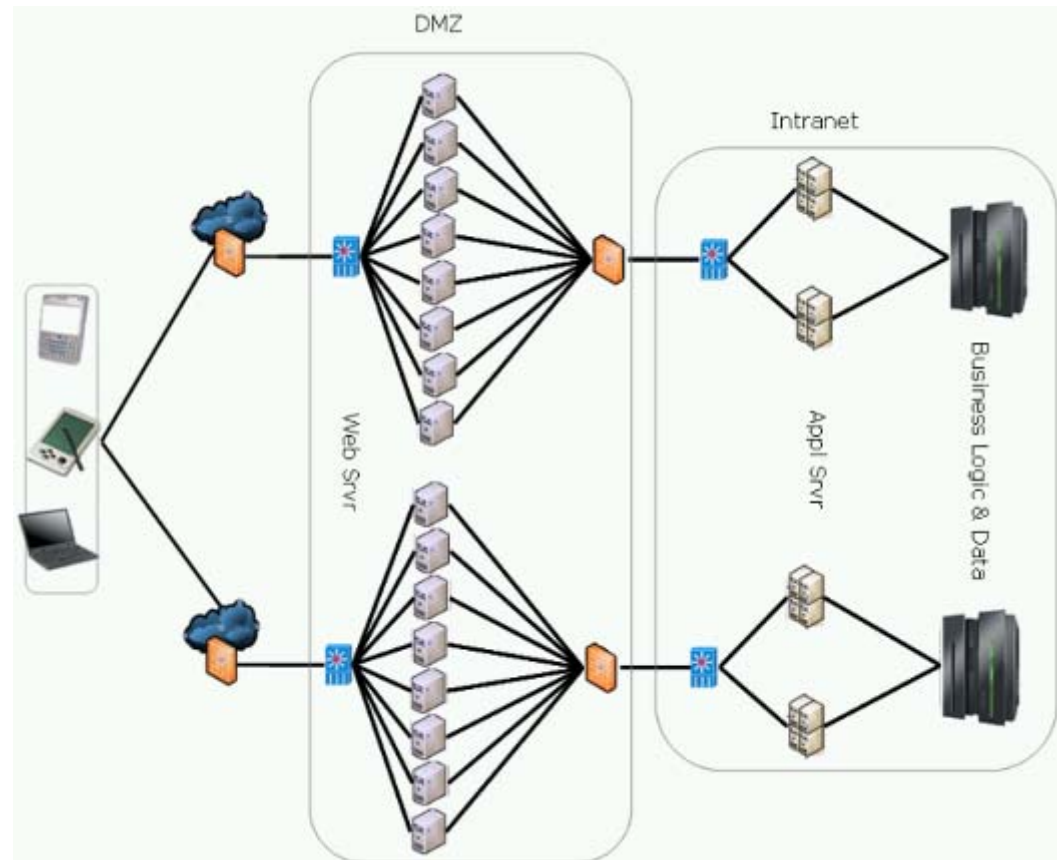

Large European Bank – Internet Banking (tomorrow)

The Environment with zEnterprise

Integrate core business logic and data serving on System z (IMS/CICS/DB2) with IBM Blades; Power 7 Blades running WebSphere and System x Blades as virtualized Linux based Web Servers, all managed in a zBX.

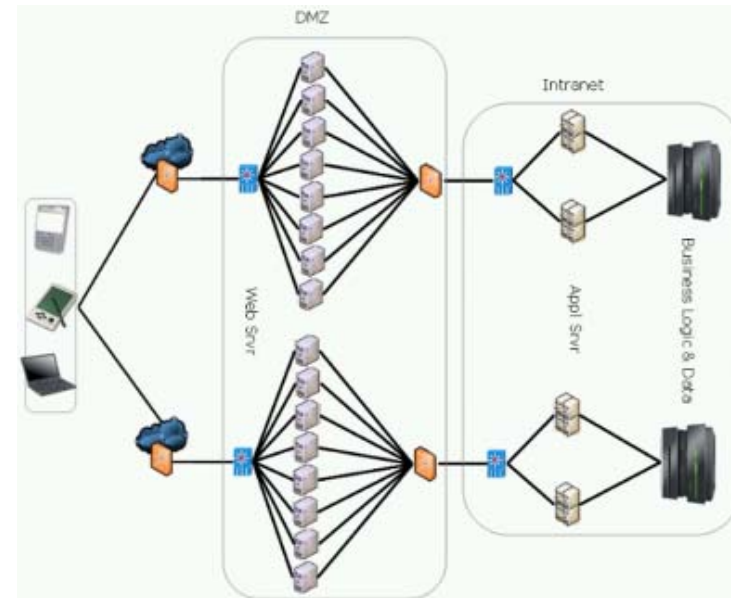

Business Advantage

Simplification and standardization of the environment will allow bank to be more flexible responsive to local country banks adding functionality and growing banking revenue.

Operational Advantage

- A single management and policy framework across web serving, transactions and database to lower the cost of enterprise computing
- Mainframe Quality of Service characteristics will be extended to application servers to manage risks
- The dynamic resource management of the mainframe is extended to all devices within a multi-tier architecture to improve quality of services

Organizational Advantage

Reduce level of manual coordination, freeing up staff to train and focus on backlog of business application function development

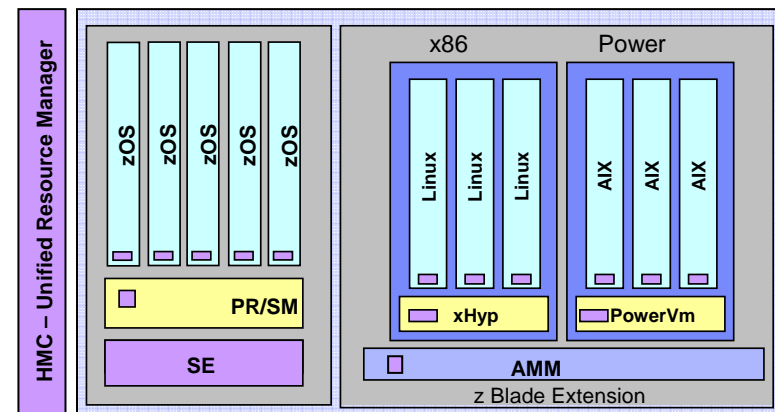

European Financial Service Provider – SAP ERP and Human Resources

Today's Environment

SAP Approximately 100 SAP systems with Data Serving and Application Servers deployed on UNIX. These SAP systems that run internal bank workload, namely the “legacy SAP” systems supporting ERP/FICO and HR. Approx 100 SAP systems (including production, QA and test)

Challenges/Issues

- SAP systems are manually spread across POWER systems, this is resource intensive.
- High “white space” due to inefficient utilization, causing increased environmental costs
- Don't have end to end monitoring capability
- Long decision cycles for changes, new acquisitions

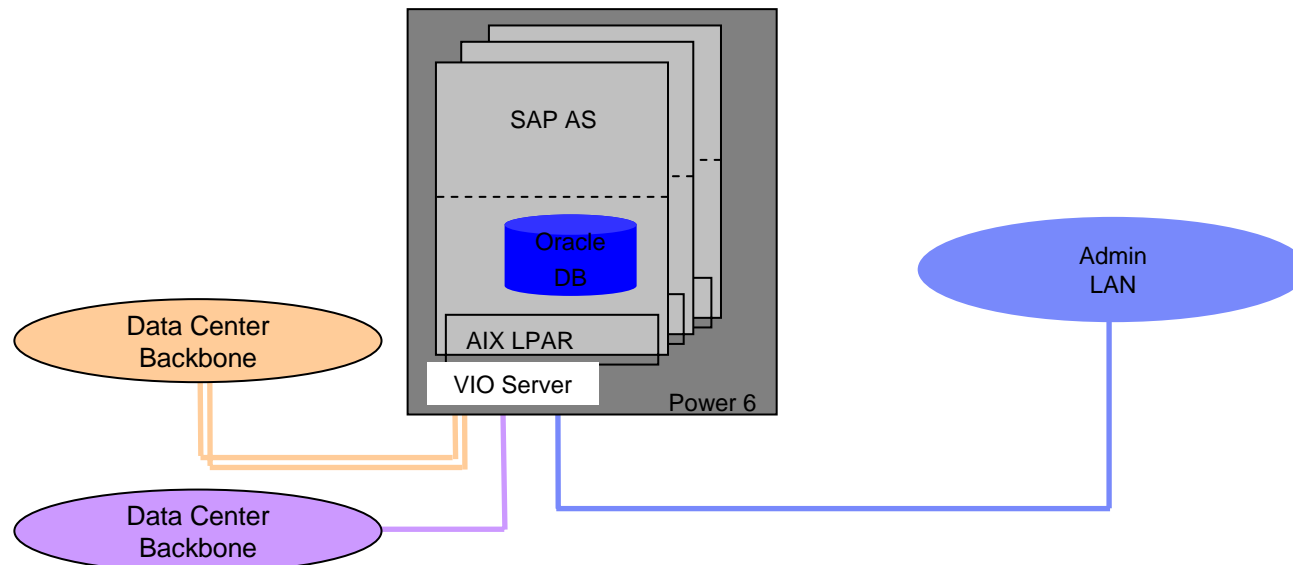

European Financial Service Provider – SAP ERP and Human Resources

The Future with zEnterprise

SAP Data Server on DB2 z/OS; Application Serving can be hosted on Linux for System z or Application Server Blades (p7 or System x) in zBX integrated in a zEnterprise system. Possible integration of a current BI component to use ISAO.

Business Advantage

- Future business advantage will be to provide SAP systems to bank clients in an “assembly line” fashion, rapidly, with little manual intervention, at a cost that accords with overall profit targets.
- Reduces TCO to support SAP Systems

Operational Advantage

- Enhanced end to end monitoring capabilities in the overall application infrastructure spanning architectures
- Allows different axis of scalability (scale-up AND scale-out), allowing more degrees of choice for platform decisions
- Reduces “white space”, improving energy, cooling and floor space utilization

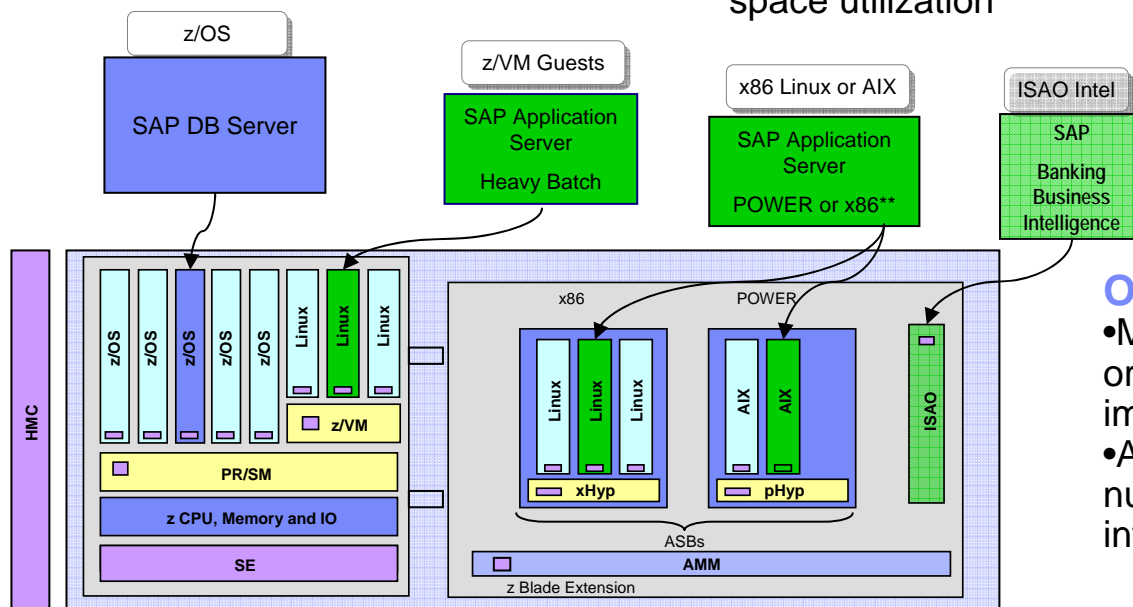

Organizational Advantage

- Minimizes the communication within client organization for required changes / new implementation, shorten time to market
- A single point of control will reduce number of people required to maintain infrastructure

US Healthcare Provider – Information Hubs (today)

Today's Environment

Master Data Management Server is running on AIX today on Power servers front ending multiple data stores on DB2 on z/OS and IMS

Challenges/Issues

- Client grew through acquisitions and has multiple systems – looking to consolidate data and systems to reduce complexity and the number of systems to update
- Challenged to support new industry mandates
- Need to standardize on platforms to reduce complexity for dev/test/prod
- Need to reduce the time required to configure a new dev/test environment
- Need ability to monitor the end-to-end transaction flow to determine bottlenecks
- *New Application – Some architectural choices still being investigated*

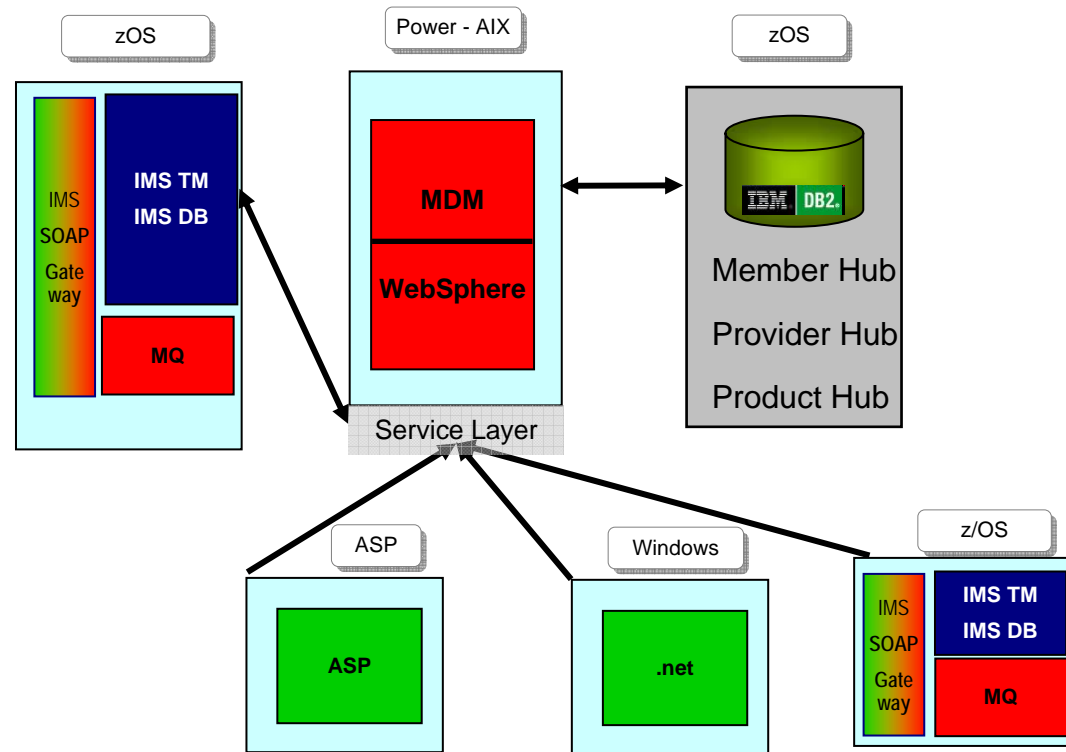

US Healthcare Provider-Information Hubs (tomorrow)

The Environment with zEnterprise

Consolidate information into 'information hubs' that will be used by all aspects of the business. Two options being considered for Master Data Management using DB2 on z/OS for consolidated data store, with WebSphere on either AIX or Linux for System z.

Business Advantage

- Consolidation and Simplification will provide client agility to better compete in the highly volatile and competitive healthcare industry.

Operational Advantage

- Application and Data Proximity
- Flexibility of architectural choices as designs are selected for performance and cost
- Network –high speed, private, possible opportunity for reduced requirements for firewalls and encryption
- Allows for virtualization across multiple tier workloads
- Consistency /Standardization of OS/middleware/application reduces variations in test
- Consolidate floor space, reduced energy costs

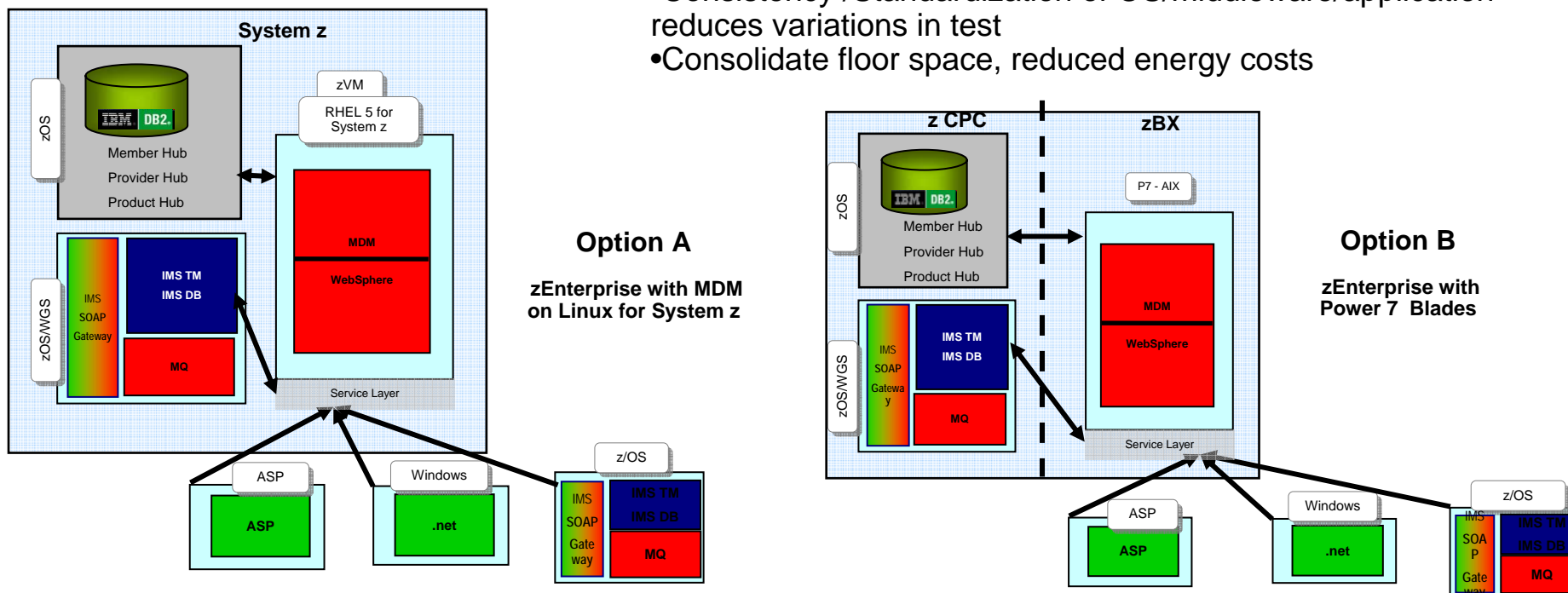

Agenda

- Recognizing the Workloads
- The Value of zEnterprise
- Real Customers - Real Value
- **Assessing the Value**

The 'Advantages' of zEnterprise are derived from the incredible wealth of Business and IT Value being delivered

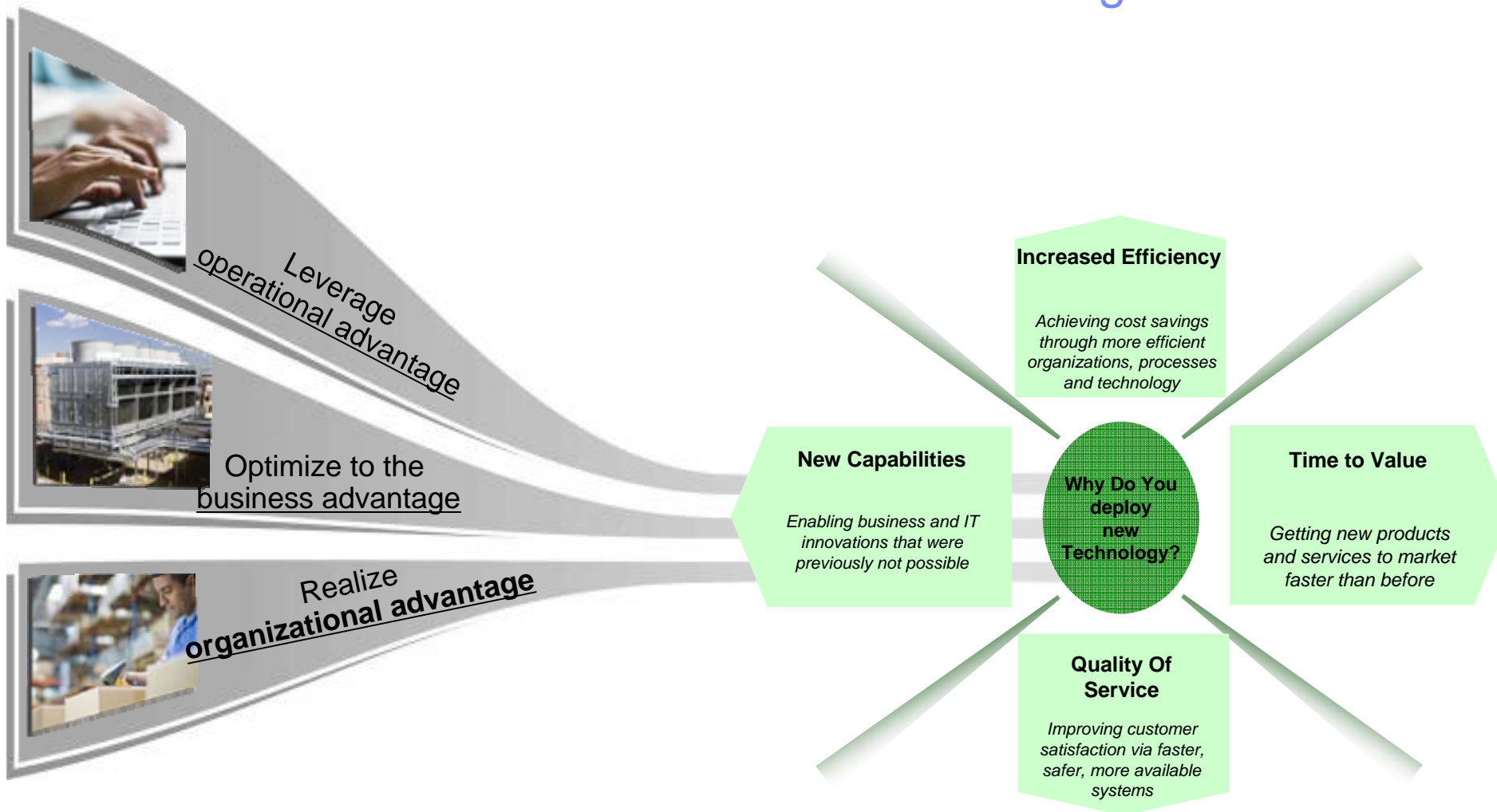

The Application Workload Workshop – mapping technology to value

- Structured follow up to the identification of workloads that might fit zEnterprise
- Validation of selected workloads as being high potential for zEnterprise
- Identification of agreed business benefits that make migration to zEnterprise worthwhile
- Agreement of next steps which might include; benefits quantification; detailed migration planning; proposal; etc

WORKSHOP AGENDA

- Introductions and welcome
- Objectives and agenda
- zEnterprise level setting
- Customer description of the application to be evaluated
 - Current architecture
 - Current issues
 - Possible benefits with zEnterprise
- Evaluation quadrant
 - Benefits of zEnterprise to the workload
 - Grouping of benefits
- Prioritisation of the benefits
- High level quantification of the benefits to determine business value
- Conclusions and output
- Next steps

Questions?

