



# New Workloads on System z

Colin Page  
System z Enterprise Architect  
IBM Software Group  
cjpage2@uk.ibm.com  
+44 (0)1962 815071



**The Future Runs on System z**

# Trademarks

The following are trademarks of the International Business Machines Corporation in the United States and/or other countries.

IBM*	IBM eServer	IBM logo*	BladeCenter*
CICS*	DB2*	Enterprise Storage Server*	Lotus*
Lotus Notes*	OMEGAMON*	Parallel Sysplex*	RACF*
System p	System Storage	System z	System z9*
System z10	Tivoli*	WebSphere*	z/OS*
z/VM*	zSeries*		

\* Registered trademarks of IBM Corporation

## The following are trademarks or registered trademarks of other companies.

Intel, Intel logo, Intel Inside, Intel Inside logo, Intel Centrino, Intel Centrino logo, Celeron, Intel Xeon, Intel SpeedStep, Itanium, and Pentium are trademarks or registered trademarks of Intel Corporation in the United States, other countries, or both.

Java and all Java-based trademarks and logos are trademarks of Sun Microsystems, Inc., in the United States, other countries or both.

Linux is a registered trademark of Linus Torvalds in the United States, other countries, or both.

UNIX is a registered trademark of The Open Group in the United States and other countries.

Microsoft, Windows, Windows NT and the Windows logo are trademarks of Microsoft Corporation in the United States, other countries, or both.

Red Hat, the Red Hat "Shadow Man" logo, and all Red Hat-based trademarks and logos are trademarks or registered trademarks of Red Hat, Inc., in the United States and other countries.

SET and Secure Electronic Transaction are trademarks owned by SET Secure Electronic Transaction LLC.

\* All other products may be trademarks or registered trademarks of their respective companies.

### Notes:

Performance is in Internal Throughput Rate (ITR) ratio based on measurements and projections using standard IBM benchmarks in a controlled environment. The actual throughput that any user will experience will vary depending upon considerations such as the amount of multiprogramming in the user's job stream, the I/O configuration, the storage configuration, and the workload processed. Therefore, no assurance can be given that an individual user will achieve throughput improvements equivalent to the performance ratios stated here.

IBM hardware products are manufactured from new parts, or new and serviceable used parts. Regardless, our warranty terms apply.

All customer examples cited or described in this presentation are presented as illustrations of the manner in which some customers have used IBM products and the results they may have achieved. Actual environmental costs and performance characteristics will vary depending on individual customer configurations and conditions.

This publication was produced in the United States. IBM may not offer the products, services or features discussed in this document in other countries, and the information may be subject to change without notice. Consult your local IBM business contact for information on the product or services available in your area.

All statements regarding IBM's future direction and intent are subject to change or withdrawal without notice, and represent goals and objectives only.

Information about non-IBM products is obtained from the manufacturers of those products or their published announcements. IBM has not tested those products and cannot confirm the performance, compatibility, or any other claims related to non-IBM products. Questions on the capabilities of non-IBM products should be addressed to the suppliers of those products.

Prices subject to change without notice. Contact your IBM representative or Business Partner for the most current pricing in your geography.

# What's new in 'New Workloads' ?

*work-load (wûrk l d )*

*n.*

- 1. The amount of work assigned to or expected from a worker in a specified time period.*
- 2. The amount of work that a machine produces or can produce in a specified time period.*

System z10 EC and BC machines bring together key Qualities of Service to drive the best out of the hardware and software capabilities. Exploiting those Qualities in new and innovative ways is ***New Workload***.

Today's presentation describes how innovation and exploitation can be applied to both new and existing solutions to derive value add to your business.

This can be achieved in 4 easy steps..

Lesson 1: Why choose the mainframe for *New Workload*

Lesson 2: Leveraging *new features & functions* of the hardware

Lesson 3: *Exploiting applications* designed for high availability, scalability and usability

Lesson 4: *Consolidating* and *Virtualising* workloads from other platforms



*Lesson 1:  
Why choose the mainframe  
for New Workload ?*



# Do the Maths add up?

**Total K\$ / year = A + B \* MSUs**

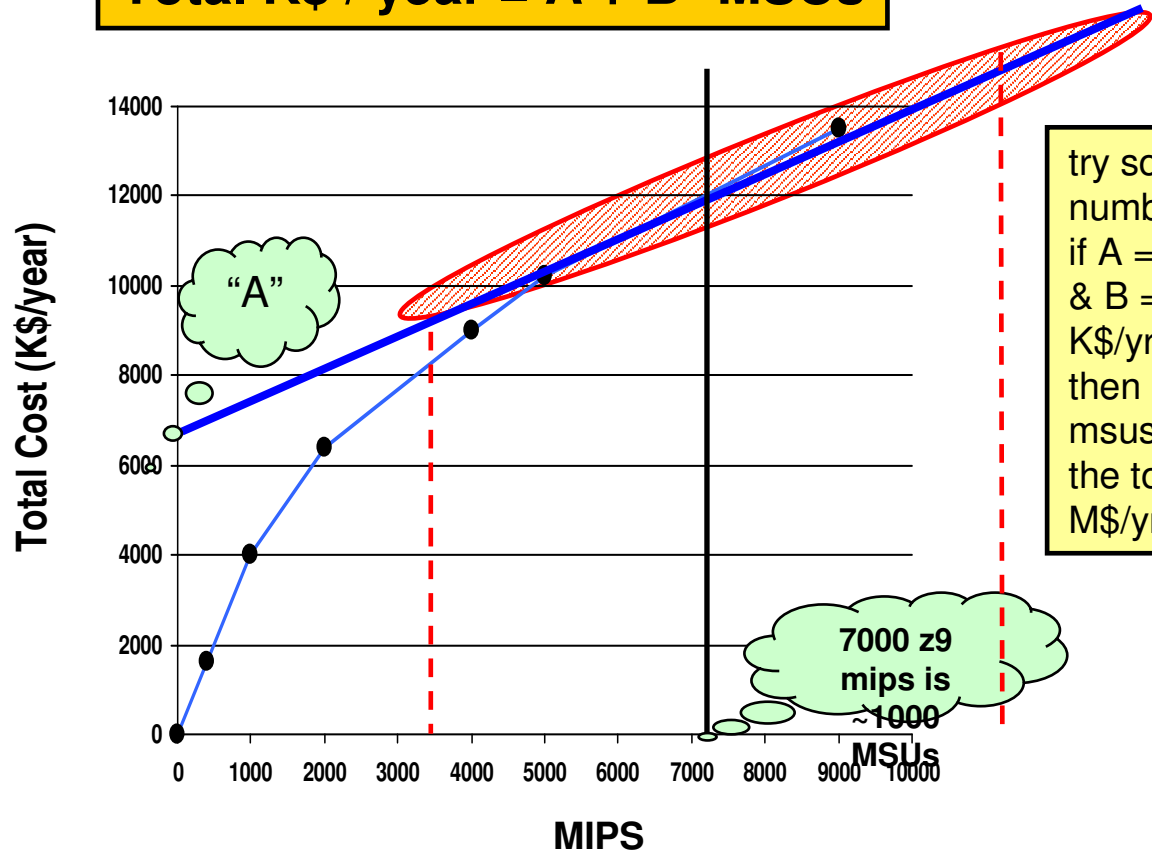

try some numbers:  
 if A = 6 M\$/yr.  
 & B = 6  
 K\$/yr./msu  
 then at 1000  
 msus  
 the total is 12  
 M\$/yr.

7000 MIPS is  
 ~1000 MSUs

Incremental  
 Cost of  
 Ownership?

# Non-functional requirements ?

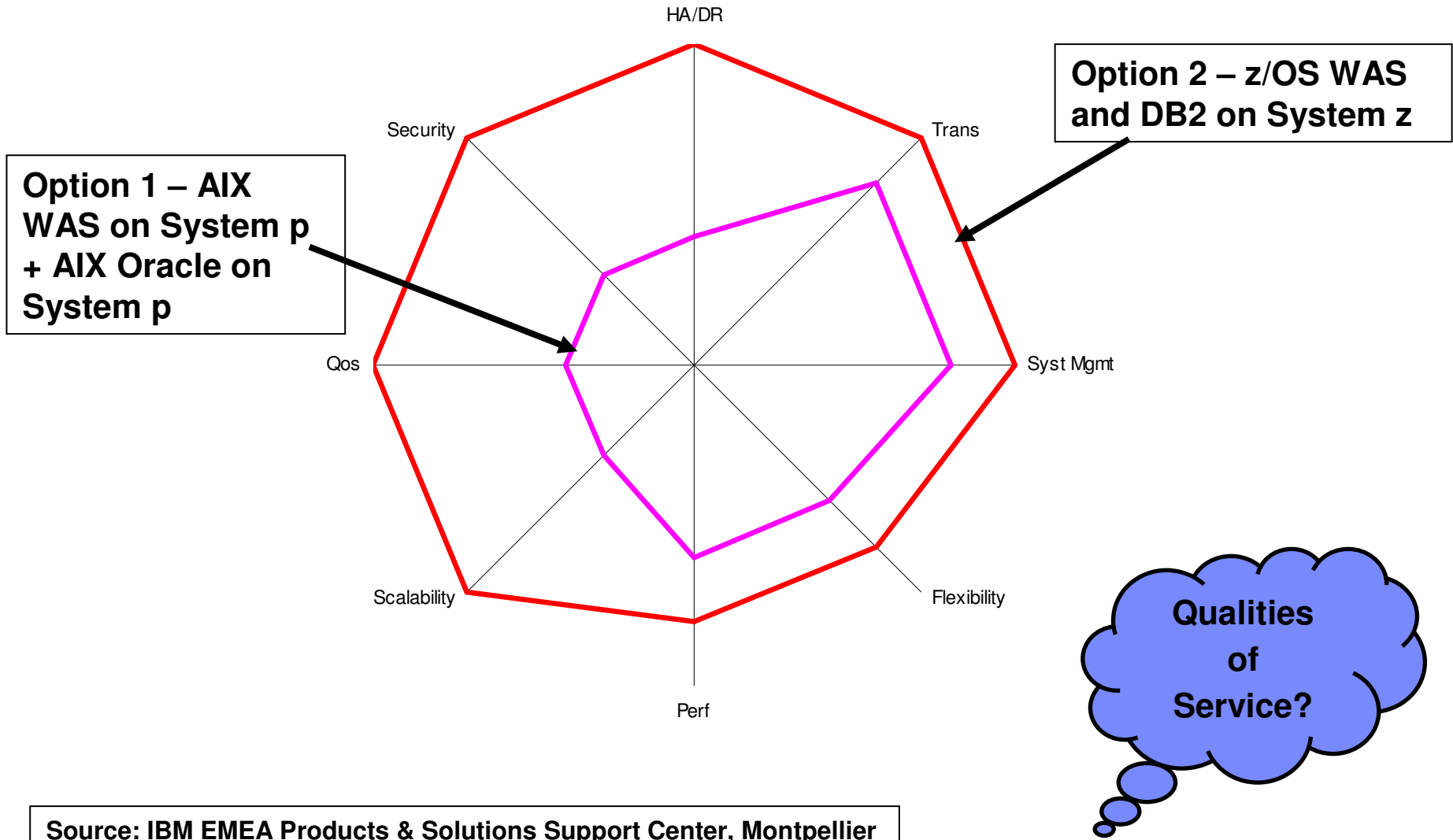

Source: IBM EMEA Products & Solutions Support Center, Montpellier

# Database Selection ?

## High Availability and Disaster Recovery (HA/DR)

- Parallel Sysplex DB2 Data Sharing availability much better than on DB2 UDB on AIX (see radar chart)
- Very fast and automated recoveries to any point in time
- DB2 online utilities
- WMQ highly available on z/OS through the shared queuing capabilities in a Sysplex environment
- GDPS / Hyperswap & GDPS (0 data lost for Disaster Recovery)

## Transactionality

- DB2 and z/OS integration supports (Two phase commit on z/OS using RRS)

## System Management

- Superior, policy based disk and tape management (virtualization over the external storage resources)
- Dynamic Workload management: z/OS WLM exploitation by DB2 enables consolidating workloads with different Service Level Agreements (SLA)
- Hardware Data compression (less storage, faster Backups and Batch Performance)

## Flexibility

- Virtual Networks / Hipersockets
- Less Routers and Switches needed

## Performance & Scalability

- Excellent scalability of DB2 data sharing
- Virtual Networks / Hipersockets performance
- Hardware Data compression (for batch and backup activities)

## Quality of service (QoS)

- DB2 and z/OS integration supports (Two phase commit on z/OS using RRS)
- Automated DB2 recoveries to any point in time

## Security

- z/OS Security Server (RACF) and DB2 internal authorization and security mechanisms (Multi-Level Security)
- Data Encryption using cryptographic features

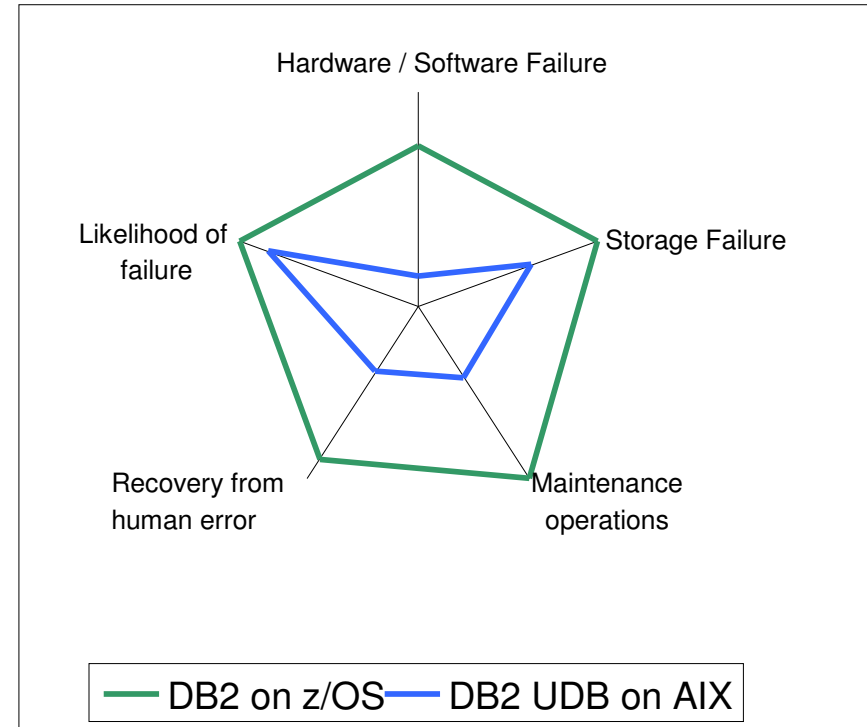

A Mainframe is a small, low-cost server...

Too big for  
your needs?



... that delivers cost-effective service



# Or are you worried about your ISVs..?

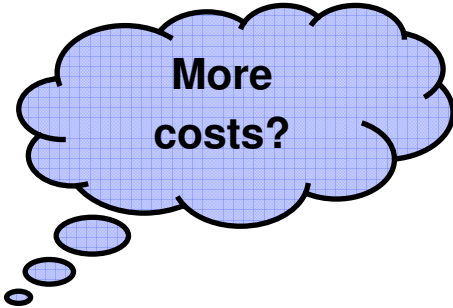

## What the customers are saying..?

**“that the per transaction cost is really very modest”**

*Kevin Campbell, Chief Application Architect, Univar USA*

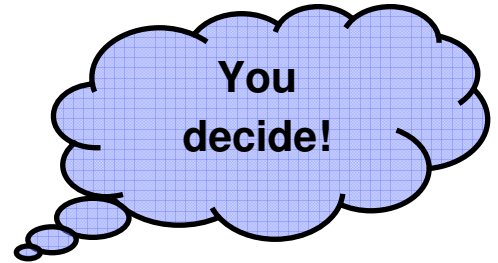

### Mainframe Costs

The cost of running incremental workload on the mainframe goes down as the total workload grows

**Labour costs hold steady as workload grows**

**Mainframe design & pricing favor the addition of more workload**

**Highly Efficient Power and Cooling – Small Footprint**

**Lower software costs per transaction as workload grows – and PRA can lower ISV tool costs**

**High Availability and Security Translate into low cost**

Customers have learned that mainframes deliver economies of scale, especially as the workload grows

### Distributed Costs

The cost of running additional workload on distributed servers goes up more linearly

**Labour is now the highest cost element in distributed environments  
Administrative staff costs increase in proportion to the number of servers**

**New workload requires additional servers and licenses**

**Energy and Space cost is more linear**

**Cost of software licenses is more linear**

**Fractionally less Availability and Security can drive Significant downstream costs**

Result – scale out strategies do not deliver equivalent economies of scale as the workload grows

*Lesson 2:  
Leveraging new features &  
functions of the hardware*



# IBM System z10 Enterprise Class

*Innovative Enterprise Systems Solutions, Now and in the Future*

IBM System z10™ Enterprise Class enables clients to **consolidate and virtualize** their server environment...

to **reduce costs and simplify** their IT infrastructure...

with high performance, **energy efficient green technologies**,...

providing the most **resilient and secure** system to support business innovation and growth.



**The Future Runs on System z**

# Technology Evolution with Mainframe Specialty Engines

Building on a strong track record of technology innovation with specialty engines, IBM introduced the System z9 Integrated Information Processor



**IBM System z9 Integrated Information Processor (IBM zIIP) 2006**

Centralized data sharing across mainframes

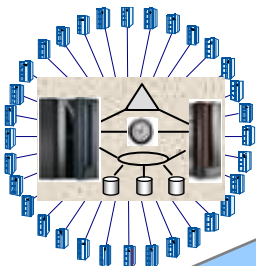

**Internal Coupling Facility (ICF) 1997**



**Integrated Facility for Linux (IFL) 2001**

- Support for new workloads and open standards



**System z9 Application Assist Processor (zAAP) 2004**

- Incorporation of JAVA into existing mainframe solutions

- Designed to help improve resource optimization for eligible data workloads within the enterprise

# zAAPs and zIIPs

## *More application technology exploiters, more benefits*

- **zAAPs and zIIPs are designed to help implement new application technologies on System z and to integrate them with core applications and data.**
  - Java eligible for zAAP – lowering the cost of computing for WebSphere Application Server and other Java technology-based applications
  - Centralized data serving eligible for zIIP - workloads such as BI, ERP, and CRM applications running on distributed servers with remote connectivity to DB2 V8
  - Network encryption on zIIP - zIIP becomes an IPsec encryption engine helpful in creating highly secure connections in an enterprise (with z/OS V1.8)
  - z/OS XML System Services eligible for zAAP and zIIP - helps make hosting XML data and transactions on System z more attractive. DB2 9, Enterprise Cobol V4.1, and XML Toolkit for z/OS V1.9 are first IBM exploiters (introduced with z/OS V1.9 and rolled back to V1.8 and V1.7)
  - Remote mirror on zIIP – zIIP assisted z/OS Global Mirror function (zGM, formerly XRC) Most of the System Data Mover (SDM) processing eligible for zIIP offload. Helps reduce server utilization at recovery site (with z/OS V1.9)
  - ISV exploitation of zIIPs

Available  
6/07

Available  
starting  
9/07

new!

**IBM System z10 Integrated Information Processor and  
IBM System z9 Integrated Information Processor**

**IBM System z10 Application Assist Processor and  
IBM System z9 Application Assist Processor**

# DB2 for z/OS exploitation of IBM zIIP value add

## ■ Portions of the following DB2 for z/OS v8 & v9 workloads may benefit from zIIP\*:

1 - ERP, CRM, Business Intelligence or other enterprise applications

- Via DRDA over a TCP/IP connection (enclave SRBs, not stored procedures or UDFs)



+ Specialty Engine

2 - Data warehousing applications\*

- Requests that utilize parallel queries

3 - DB2 for z/OS v8 & v9 utilities LOAD, REORG & REBUILD\*

- DB2 utility functions used to maintain index maintenance structures

\* The zIIP is designed so that a program can work with z/OS to have all or a portion of its enclave Service Request Block (SRB) work directed to the zIIP. The above types of DB2 V8/9 work are those executing in enclave SRBs, of which portions can be sent to the zIIP.

# Hardware-assisted data compression

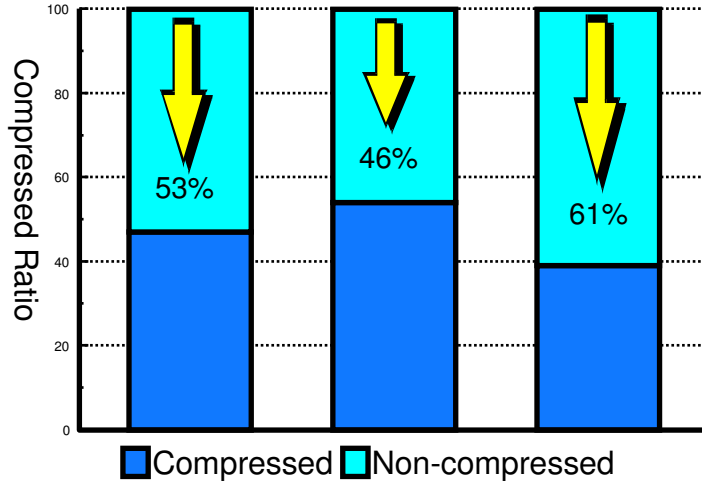

← Compression Ratios Achieved

In V9 Indexes Can also be compressed

→ Effects of Compression on Elapsed Time

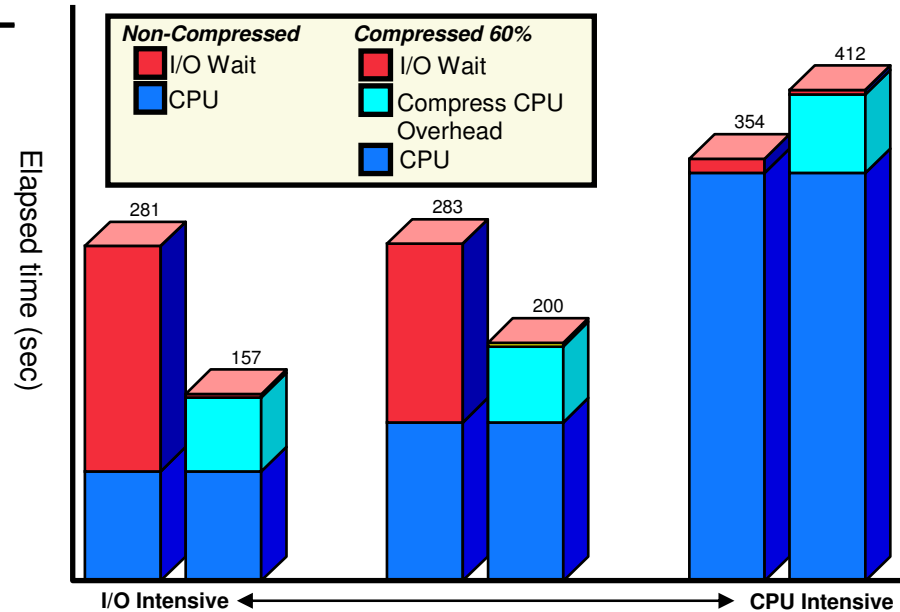



# Consolidation & Virtualization Server Optimization and Integration Services for System z10

## *Customer Needs*

- Stop server sprawl
- Reduce energy and related facility costs
- Improve security and reliability
- Increase flexibility for changing business needs
- Get control of workload/systems management

## *System z Value Proposition*

- Allows customers to rely on GTS consolidation experts skilled on System z10 platform technologies to assess current IT deployment, design and implement changes
- Measure and document improvements and related cost savings
- Gives customers the assistance needed for consolidation projects

... The Power of many



... The Simplicity of ONE

## *GTS Services on System z10*

- Based on internally developed assessment tools combined with GTS subject matter expertise and System z skills offered to clients on a custom basis tailored to their specific enterprise needs

## *Solution Components*

- System z10 with z/VM®, Linux
- Services that include:
  - assessment,
  - planning,
  - design,
  - implementation

# Software Leveraging the Strengths of the z10

## Compiler Optimization and Performance

- Decimal Floating-Point (DFP)
- Exploit Additional Floating-Point Registers (AFP)
- Exploit 64-bit instruction set and registers even in 32-bit code
- Support IEEE Binary Floating-Point which eases platform portability

## DB2 for z/OS

- More, faster CPUs, more memory, network bandwidth means significantly improved SQL performance
- Improved connectivity for remote apps, especially batch inserts for large queries
- More efficient disk usage minimizes disk constraints
- More efficient XML parsing
- Hash DSAB Searches brings faster startup/restart
- Improved decimal float data type performance efficiency
- Reduced allocation and catalog overhead

## Systems Management

- OMEGAMON XE for z/OS 4.1.0 XE workspaces and Classic commands view of HiperDispatch

## Transaction Management

- HiperSockets™ Multi Write Facility
- More, faster CPUs, More memory, More network bandwidth
- Potential for significant performance
- z Specific Java and WAS enhancements

## z/OS

- 64-way support for a single z/OS image
- HiperDispatcher
- Up to 4 TB Real Memory
- Hardware Decimal Floating Point
- Capacity Provisioning
- Large (1 MB) Page support improves performance
- HiperSockets Multi Write Facility
- Crypto Exploitation
- Parallel Sysplex support for InfiniBand Coupling links
- SDM offload to zIIP
- OSA-Express3 10 Gbps – CHPID OSD

## Development Tools

- Rational Developer for System z performance improvements of C, C++, COBOL, PL/I, Java language applications

**Rational**®

**WebSphere**®

**Information Management**

**Lotus**®

**Tivoli**®

# Project 'Big Green'



*Double compute capacity with no increase in consumption or impact by 2010*

## IBM to reallocate \$1 billion each year

- To accelerate “green” technologies and services
- To offer a roadmap for clients to address the IT energy crisis while leveraging IBM hardware, software, services, research, and financing teams
- To create a global “green” team of almost 1,000 energy efficiency specialists from across IBM

## Re-affirming a long standing IBM commitment

- Energy conservation efforts from 1990 – 2005 have resulted in a 40% reduction in CO2 emissions and a quarter billion dollars of energy savings
- Annually invest \$100M in infrastructure to support remanufacturing and recycling best practices

## Major proof point for Project Big Green

**IBM'S PROJECT BIG GREEN SPURS GLOBAL SHIFT TO LINUX ON MAINFRAME**

ARMONK, NY, August 1, 2007

- *IBM will consolidate and virtualize thousands of servers onto approximately 30 IBM System z™ mainframes*
- *Substantial savings expected in multiple dimensions: energy, software and system support costs*
- *The consolidated environment will use 80% less energy and 85% less floor space*
- *This transformation is enabled by the System z sophisticated virtualization capability*



***Think what we could do for you***

# Enterprise Business Value – Expectations

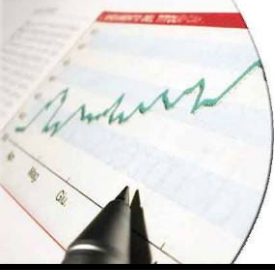

## Business case

- Early modeling identified **significant potential for savings** through zLinux virtualization
- Performed **TCO virtualization assessment** on IBM portfolio as cross-IBM effort
  - System z, SW Migration Services, STG Lab Services, IBM Academy, ITO Migration Factory
- **Identified substantial savings opportunity**
  - Energy
  - Labor
  - Floor space
  - Software



## Energy savings

- **Annual energy usage to be reduced by 80%**
- **Total floor space to be reduced by 85%**
  - 11,045 square feet for distributed solution
  - 1,643 square feet for System z solution



## Quality service

- Leverages maturity of System z stack products - **high availability, resiliency**
- Reduces complexity and increases stability, centralizes **service mgmt**
- Potential for faster provisioning speed (months → days)
- **Dynamic allocation** of compute power
- Provides world-class **security**

## Comparison of Annual Energy Usage for Workloads

	Distributed Solution		System z Solution	
	Kilowatt hours (K)	Cost* (\$K)	Kilowatt hours (K)	Cost* (\$K)
Power	24,000	\$2,400	4,796	\$479
Cooling**	14,400	\$1,440	2,877	\$287
<b>Total Energy</b>	38,400	<b>\$3,840</b>	7,673	<b>\$767</b>

# IBM is Using a 'Work in Process' Approach to Manage the Migration

## Management Approach and Reporting

- Process approach borrowed from factory line management
- Metrics for each process and sub-process
- Quality measured with process fallout – tracked by cause
- Daily status calls for issue resolution
- Weekly status reporting for CIO and management team

**Weekly Pipeline Summary - Server Metrics**

**IBM ECM End to End Process**

Project Phase	Server Inventory Verification	Server / Application Qualification	Migration Planning	Server / Application Migration	Post Production	Total Servers In Pipeline
Ph 1: US						
Ph 2: US						
Ph 3: Americas						
Ph 4: Europe						
Ph 5: AP/Japan						
Total						

Pipeline Management	Finance	Comms	Process	Technical Solution
---------------------	---------	-------	---------	--------------------

# Decommission Process Overview



**Server available  
as a result of  
virtualization  
efforts**

**Server  
Ready**



**Check for technical viability and asset  
value to determine if h/w is a  
redeployment candidate**

*If redeployed*

**Request completed to  
coordinate shipping  
and update property  
control**

*If not redeployed*

**Complete Machine  
List Database and  
ship to GARS\***

**Apply to Neuwing for  
energy efficiency  
certificates**

**Tracking tool is updated to reflect  
disposition of the assets in the project**

**Capture savings in business plan and  
business case**

*\*IBM Global Asset Recovery Services*

# Enterprise Approach to Workload Migration

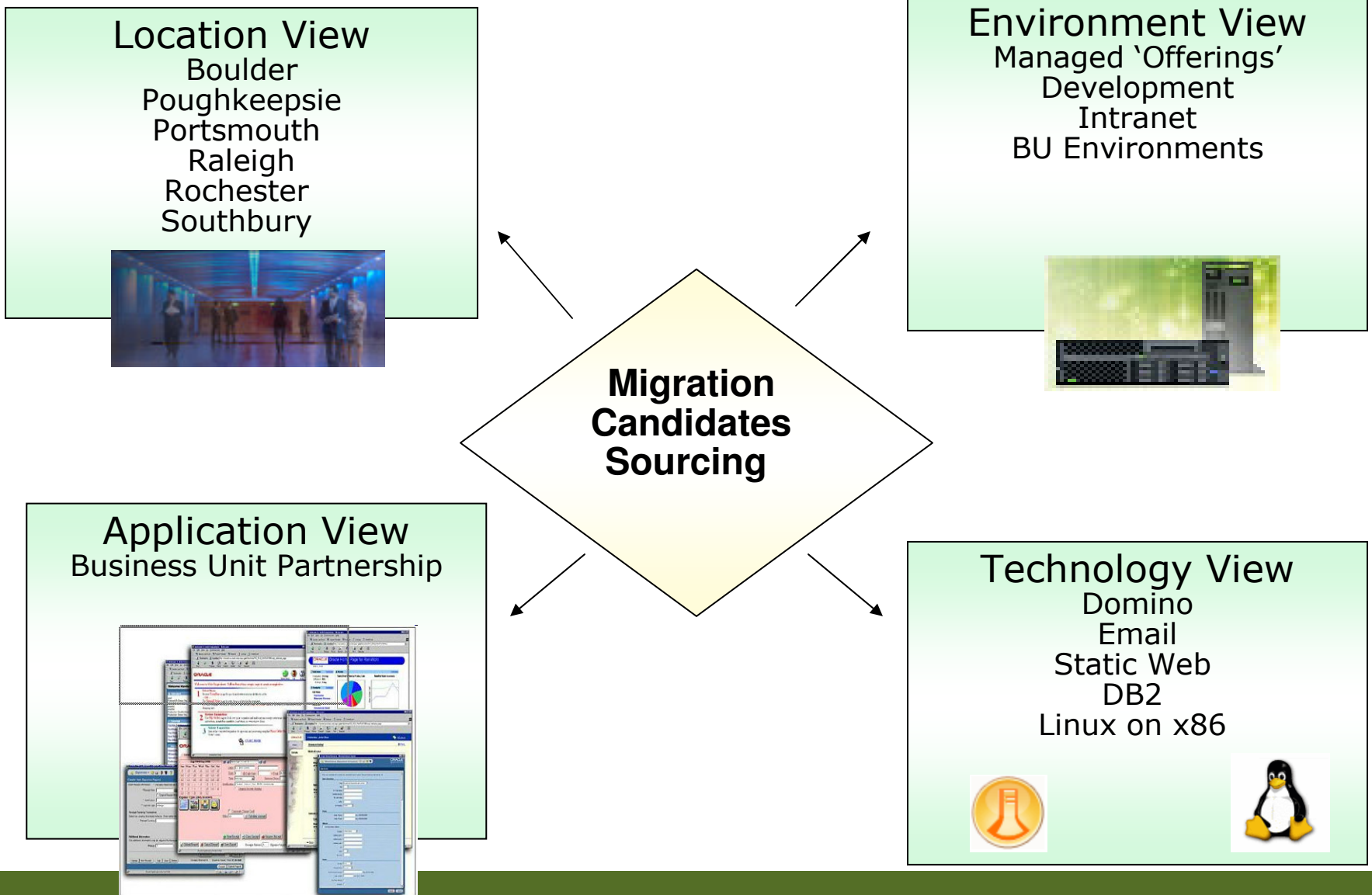

# Each Workload is Evaluated for Suitability Based on Technical Attributes

## Priority Workloads for Consolidation:

- WebSphere® applications
- Domino® Applications
- Selected tools: Tivoli®, WebSphere® and internally developed
- WebSphere MQ
- DB2® Universal Database™

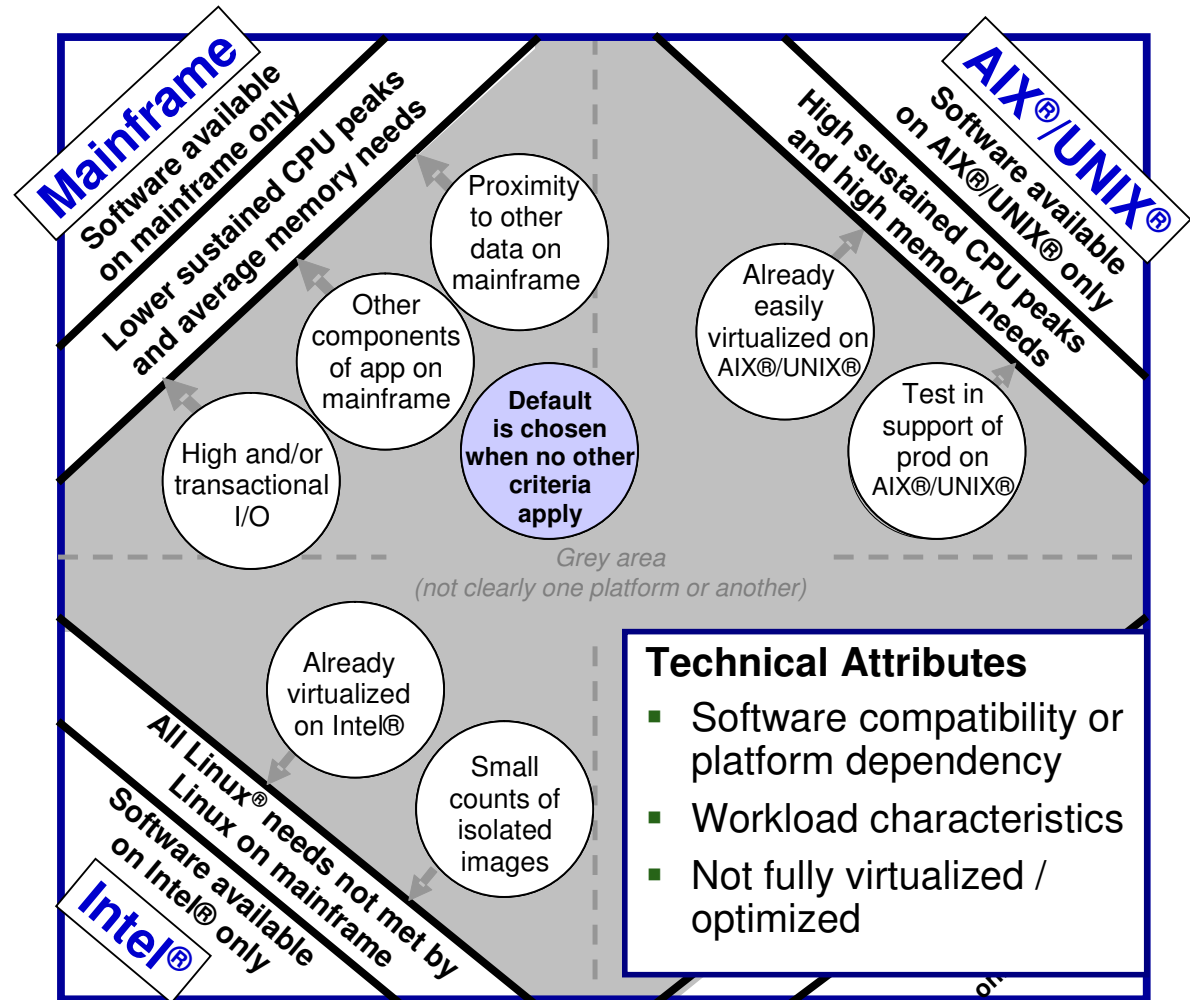



# Operationally, the goal is to minimize change while leveraging the capability of System z

The distributed and mainframe support teams collaborated with IBM's Design Center to develop the reference architecture and the basis for the operational approach

## ■ Approach:

- Adapt existing UNIX® team processes
- Engage z team to operate System z and z/OS®
- Broaden the VM/mainframe knowledge of the mid-range team through training, to assist in support of VM Hypervisor (z/VM®) and Linux
- Use existing monitoring and operational tools, i.e.
  - Tivoli Monitoring and Enterprise Portal
  - VM Resource Manager
  - Monitor and Performance Toolkit
  - Administer Capacity, OS Provisioning and Software Distribution Tools

Lesson 3:  
*Exploiting applications*  
designed for high  
availability, scalability and  
usability



# System z10 Designed for New Customer Workloads

New System z10 based solutions for workloads and Industry processes that leverage the full power of System z10

- ACI BASE24-eps and ACI Proactive Risk Manager on System z10
- Data Warehousing on System z10
- Real-time Enterprise Business Intelligence on System z10
- Encryption Authentication - Digital Certificate Authority on System z10
- SAP Solution Edition on System z10



# ACI BASE24-eps on System z has capabilities to improve the product development process by 50% to realise revenue quicker

## ACI's Improvements to Products

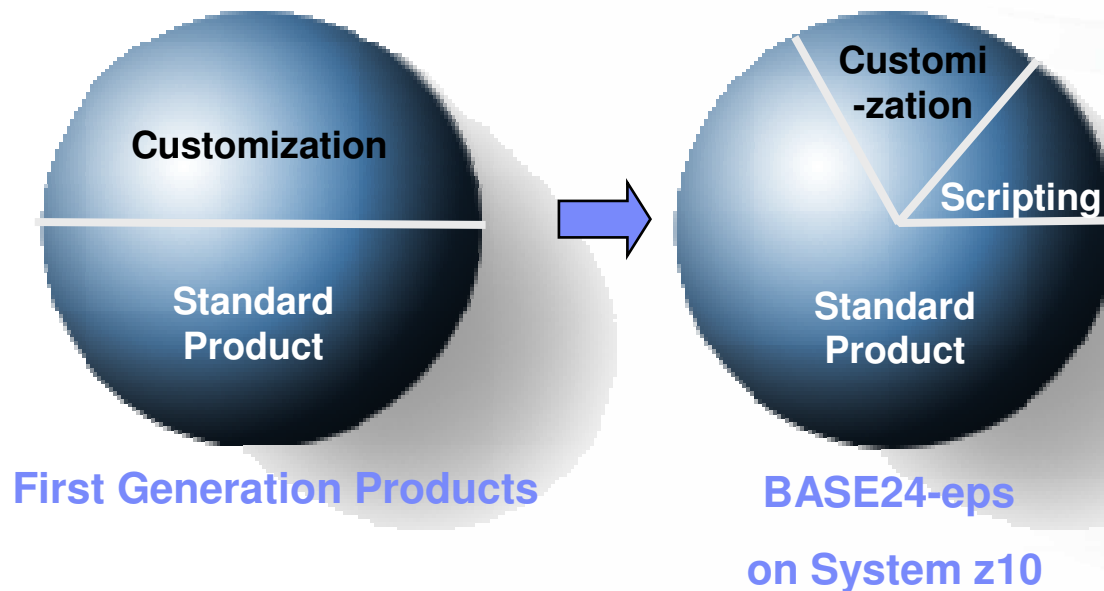

BASE24-eps can

- Improve speed to market for new product functions and features
- Eliminate existing barriers to new product development



# BASE24—eps' advanced transaction location capabilities enable mobile proximity payments using NFC mobile devices

- **E-Wallet:** Customers can use their mobile devices as electronic wallets by downloading credit and debit card applications
- **Targeted Marketing:** Coupons and promotions can be delivered to users by tapping on a smart poster for targeted marketing
- **Loyalty Programs:** Loyalty programs can be accessed via mobile devices
- **Ticketing:** Chips on mobile devices can be used for transit or other ticketing
- **Enhance Security:** NFC devices have inherent security and can be remotely disabled in realtime. At the same time, handset manufacturers are building in security features such as biometrics (e.g. Kyocera Wallet)

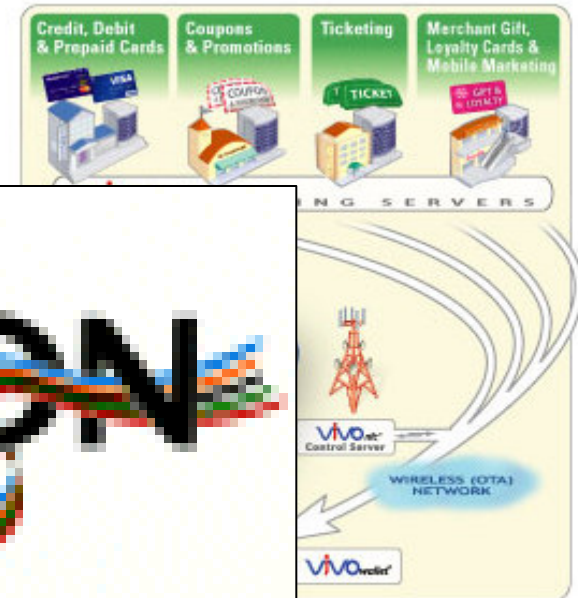

Mobile User taps smart posters for promotions



Mobile User uses phone as wallet

# However... improving payments services increases fraudulent activity

## Fraud fears rise as Faster Payments takes off

Author: Karl Flinders  
Posted: 17:19 08 Jul 2008

BOOKMARK

More than £2bn has already been sent through the [Faster Payments](#) clearing system since its introduction at the end of May.

By 27 June, exactly one month after the launch of Faster Payments, banks had completed over four million banking transactions, worth a total of £2.26bn

Faster Payments allows banks to clear payments in hours rather than the three days needed for [Bacs payments](#).

But the system has also attracted the attention of fraudsters who see an opportunity to steal and get away with money before they are detected. The banks have recognised the [need to upgrade their anti-fraud systems](#) in response.

"Security technology has always been a high priority," said a Barclays spokesperson. "For the Faster Payments project it is a particularly relevant concern because the high volumes of payments and the speed at which the funds are transferred could potentially allow fraudsters to take advantage of this system and transfer [money] away quickly."



# ACI Proactive Risk Manager (PRM) provides holistic financial crime protection – fraud detection for credit, check, debit products across multiple channels including wire transfer, the branches, point of sale and ATMs

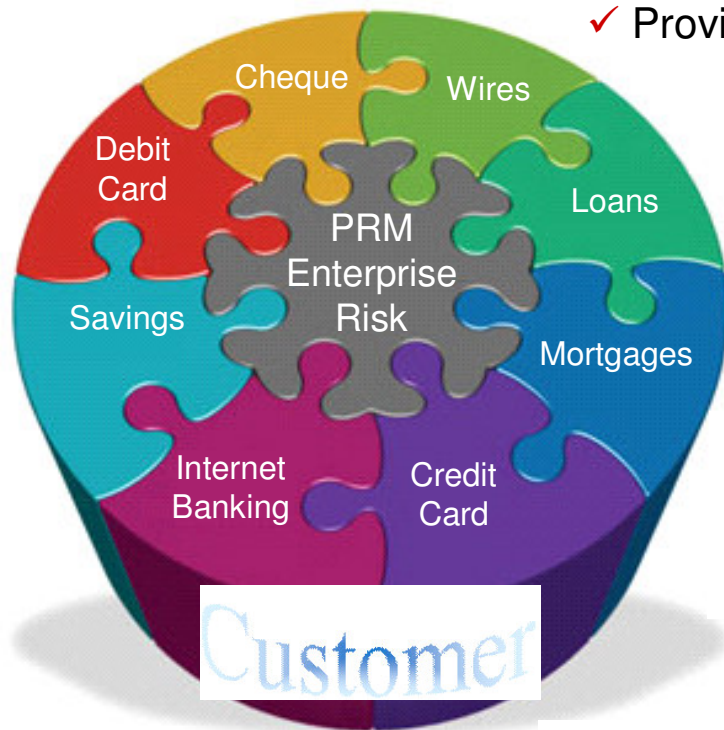

- ✓ Provides a holistic approach to fraud management
- ✓ Scalable to protect fraud on all products
- ✓ Monitors at a customer level
- ✓ Allows rapid detection of all fraud types, financial crime and compliance
- ✓ Simultaneous cross payment and product monitoring

# IBM System z: The Reference Platform for BASE24-eps – IBM and ACI products are tightly integrated to achieve scalability, flexibility and efficiencies

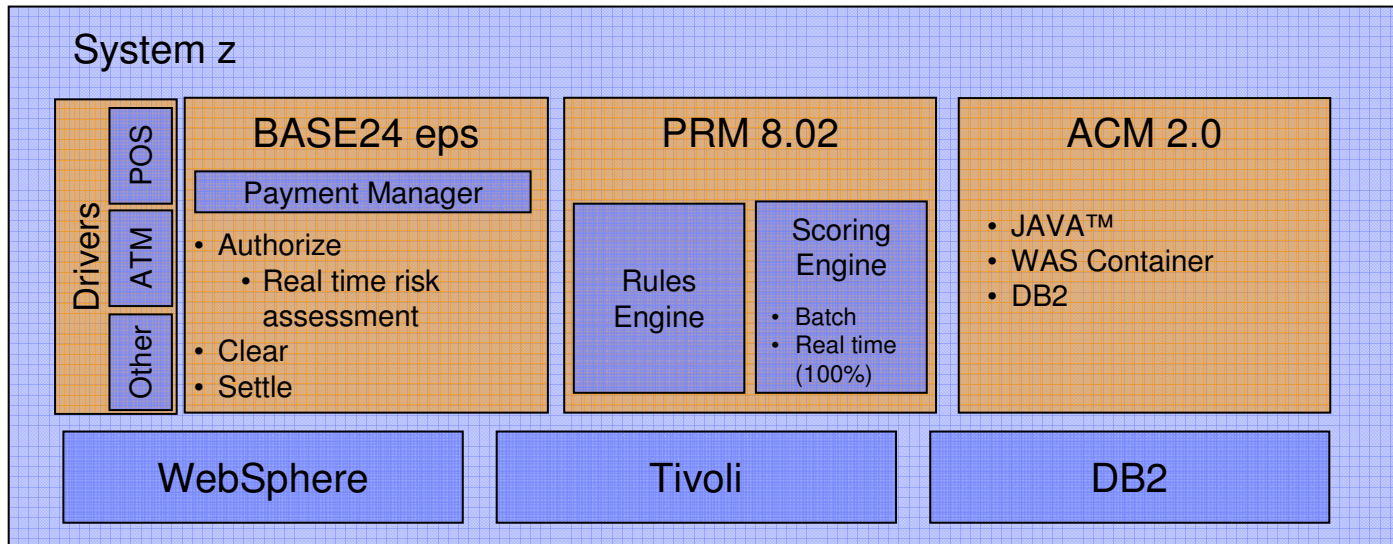

**PRM=Proactive Risk Manager**

**ACM=Automated Case Management**

## Key Advantages of z platform

- Shared hardware, software, support personnel, and processes
- PRM/CRM shares common database results in benefits in
  - Data integration
  - Operational efficiency
  - Long-term cost of ownership based on total transaction volume

➤ ***Integration on System z offers reduced overall complexity and therefore improved business flexibility and time to market***



# System z10 Designed for New Customer Workloads

New System z10 based solutions for workloads and Industry processes that leverage the full power of System z10

- ACI BASE24-eps and ACI Proactive Risk Manager on System z10
- Data Warehousing on System z10
- Real-time Enterprise Business Intelligence on System z10
- Encryption Authentication - Digital Certificate Authority on System z10
- SAP Solution Edition on System z10



# Dynamic Warehousing with System z

## *Mission-critical analysis of operational data*

Rapid and secure user-access to data analysis

- ***Interactive executive dashboards and information portals***

Improved query and reporting optimizations

- ***SQL Procedures may be run on zIIP***

Up to 50% reduction of storage for indexes

- ***Improved index compression***

Up to 50% reduction of CPU utilization

- ***Across most utilities***

Agility

Performance



**Over 1 Billion per Hour**  
UPS runs DB2 for z/OS to support the  
world's largest known peak database workload  
- 1.1 Billion SQL statements per hour! <sup>(1)</sup>

# Best Practice: Solution Architecture on System z

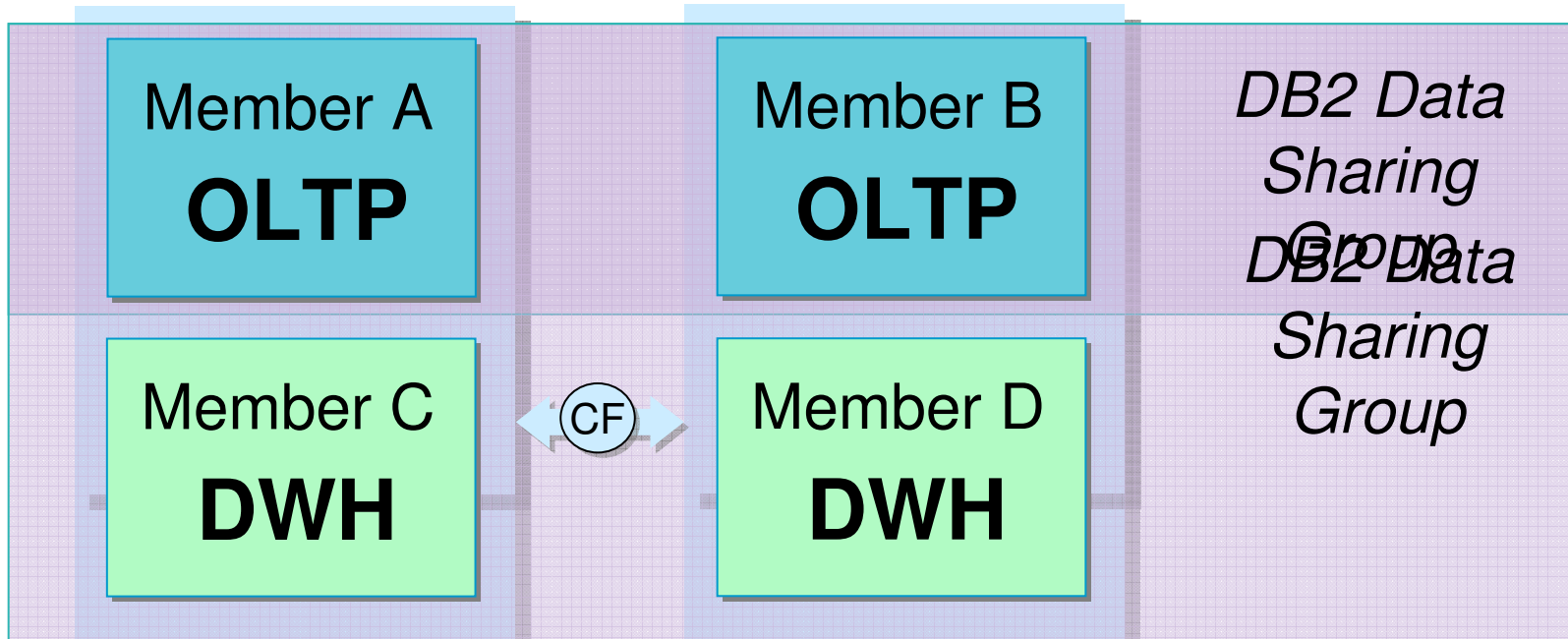

Within a data sharing environment, the data warehouse resides in the same group as the transactional data.

# Best Practice: Initial load of the Data Warehouse

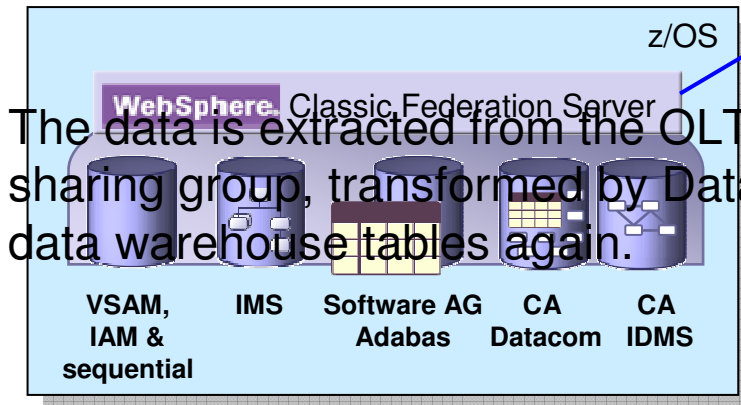
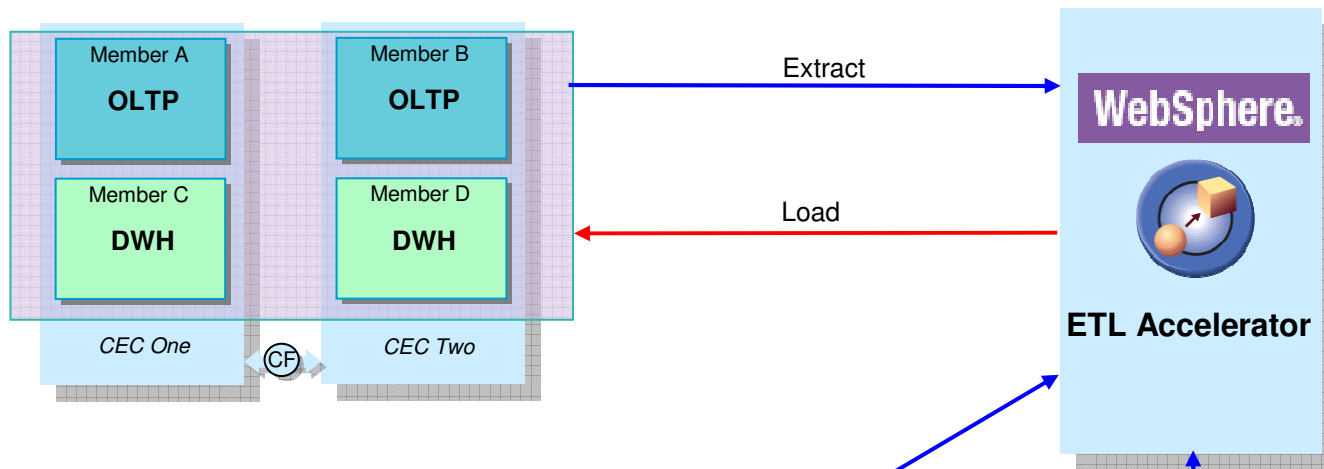

The data is extracted from the OLTP information and the data sharing group, transformed by DataStage and then loaded into the data warehouse tables again.

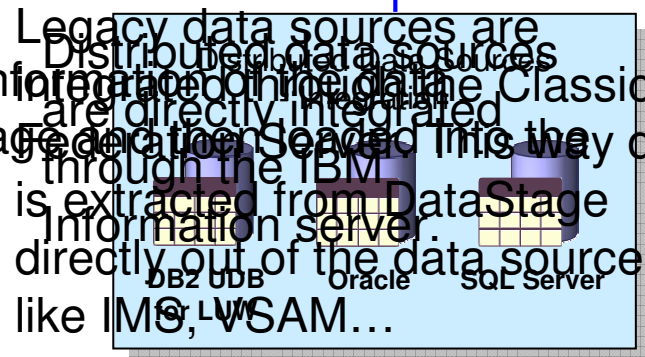

Legacy data sources are distributed data sources are directly integrated through the IBM Information server. This way data is extracted from DataStage directly out of the data sources like IMS, VSAM...

# Best Practice: At runtime, DWH is updated incrementally

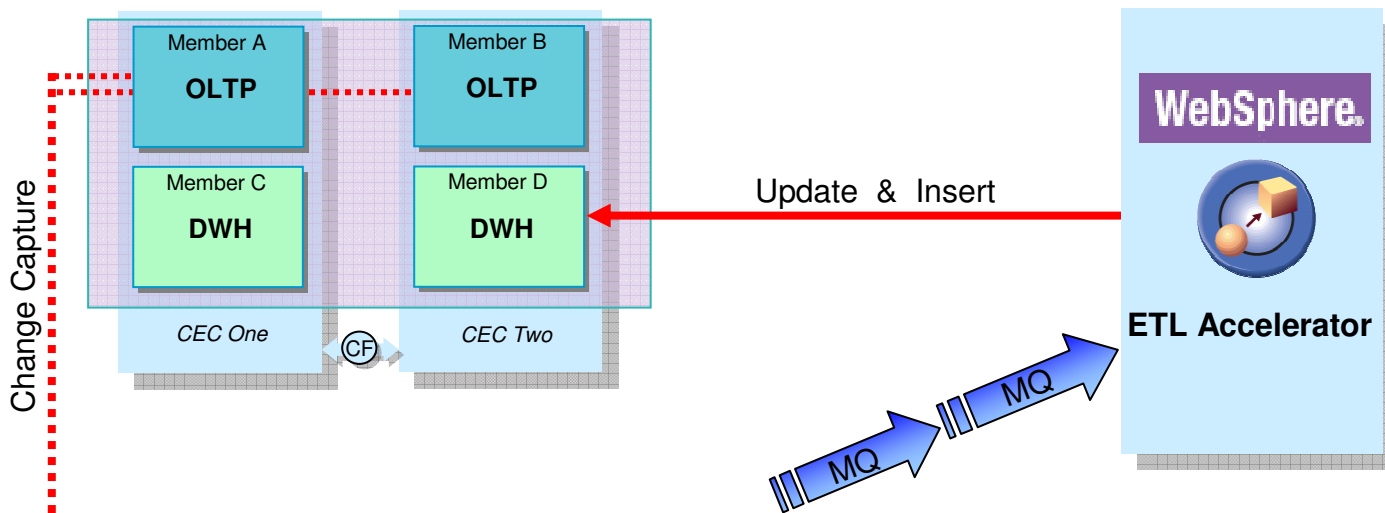

Once, the data warehouse is loaded, only incremental updates are performed. The changes from the original data sources (z/OS and distributed) are captured by WebSphere Data Event Publisher and sent through MQ to the ETL Accelerator. Special DataStage stages take the change information from MQ and updates or inserts are performed on the data warehouse data. This might of course be delayed to batch windows by just receiving the changes and only updating the warehouse at a later point in time.

# Best Practice: DB ELT is triggered by DataStage

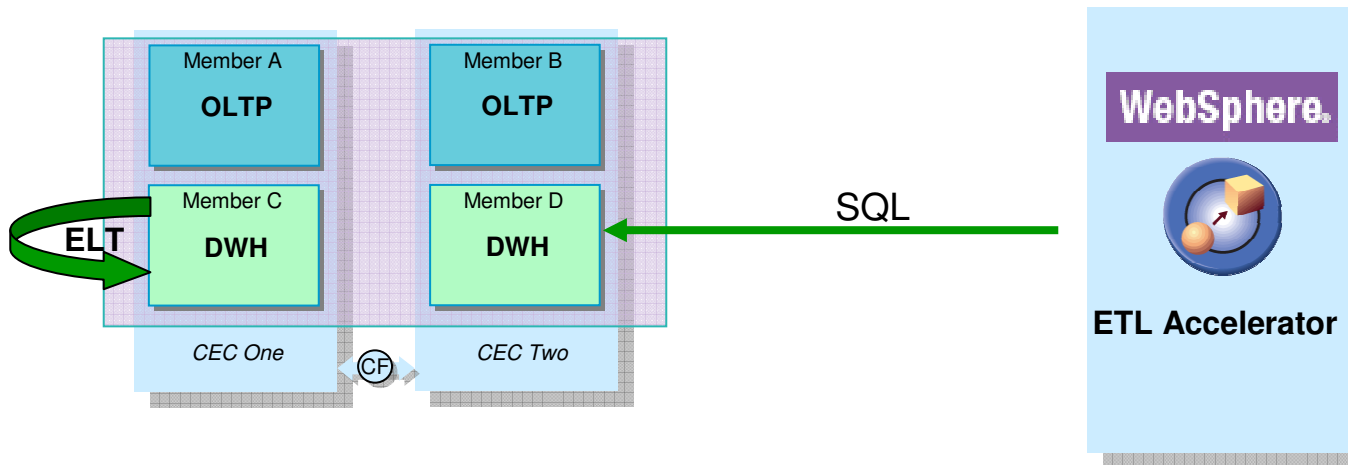

## Simple example:

Whenever possible, “In Database” transformations (ELT) are used to spare the transport of the data to the accelerator. But the used SQL is still sent from the ETL Accelerator to the database to have one place of documentation for all ETL steps.

This can also be used to shift the data up the hierarchy within the Layered Data Architecture.

```
-- Aggregate by salary by department into AGGRSALARY
INSERT INTO AGGRSALARY ( DEPTCODE, AVGBAND, AVGSALARY )
SELECT DEPTCODE, AVG( BAND ) AS AVGBAND, AVG( SALARY ) AS AVGSALARY
FROM STAFF
GROUP BY DEPTCODE
```

# DataQuant – Visualisation of Data

- Adds compelling new Warehouse/Business Intelligence component to DWH on z
- Visual Dashboards, Enhanced Graphical Reporting, Security and Personalization, SOA Layer, Enhanced Analytics, access to most relational databases
- Offers a “thick” client with DataQuant for Workstation, or a pure HTML, browser based client with DataQuant for WebSphere

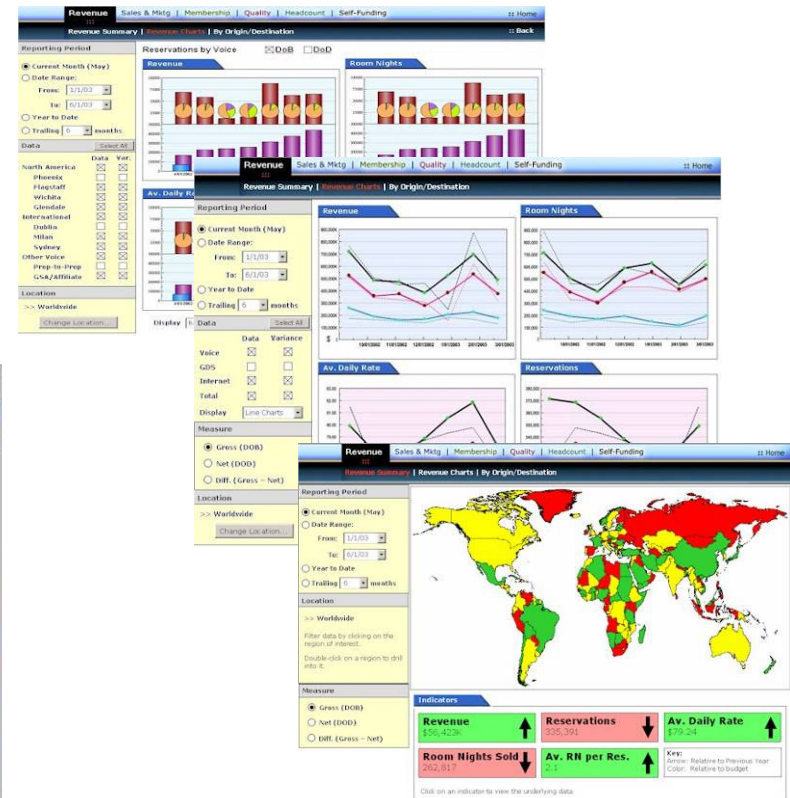

# IBM DB2 Alphablox – data analytics directly via zLinux

- Provide reporting and dashboard capabilities on key indicators
- Leverage operations such as ranking, ordering, filtering, trending, and other sophisticated statistical functions and calculations
- Drive data analysis from multiple data sources, both relational and multidimensional

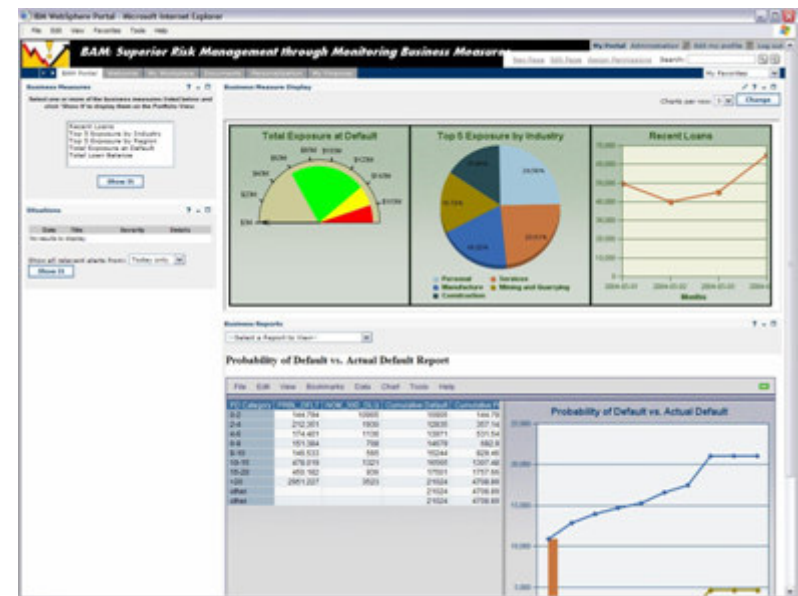
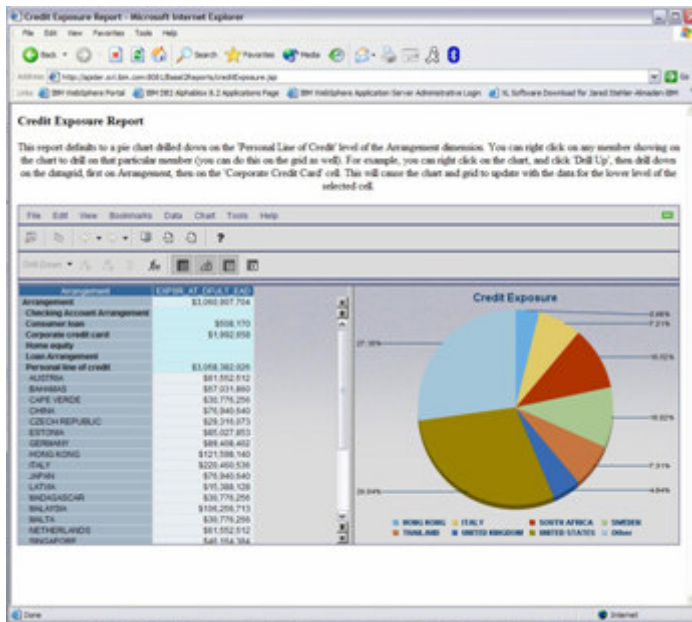



# System z10 Designed for New Customer Workloads

New System z10 based solutions for workloads and Industry processes that leverage the full power of System z10

- ACI BASE24-eps and ACI Proactive Risk Manager on System z10
- Data Warehousing on System z10
- Real-time Enterprise Business Intelligence on System z10
- Encryption Authentication - Digital Certificate Authority on System z10
- SAP Solution Edition on System z10



# Companies Buy BI Technology in Multiple Ways

## IBM Addresses them All...With Cognos

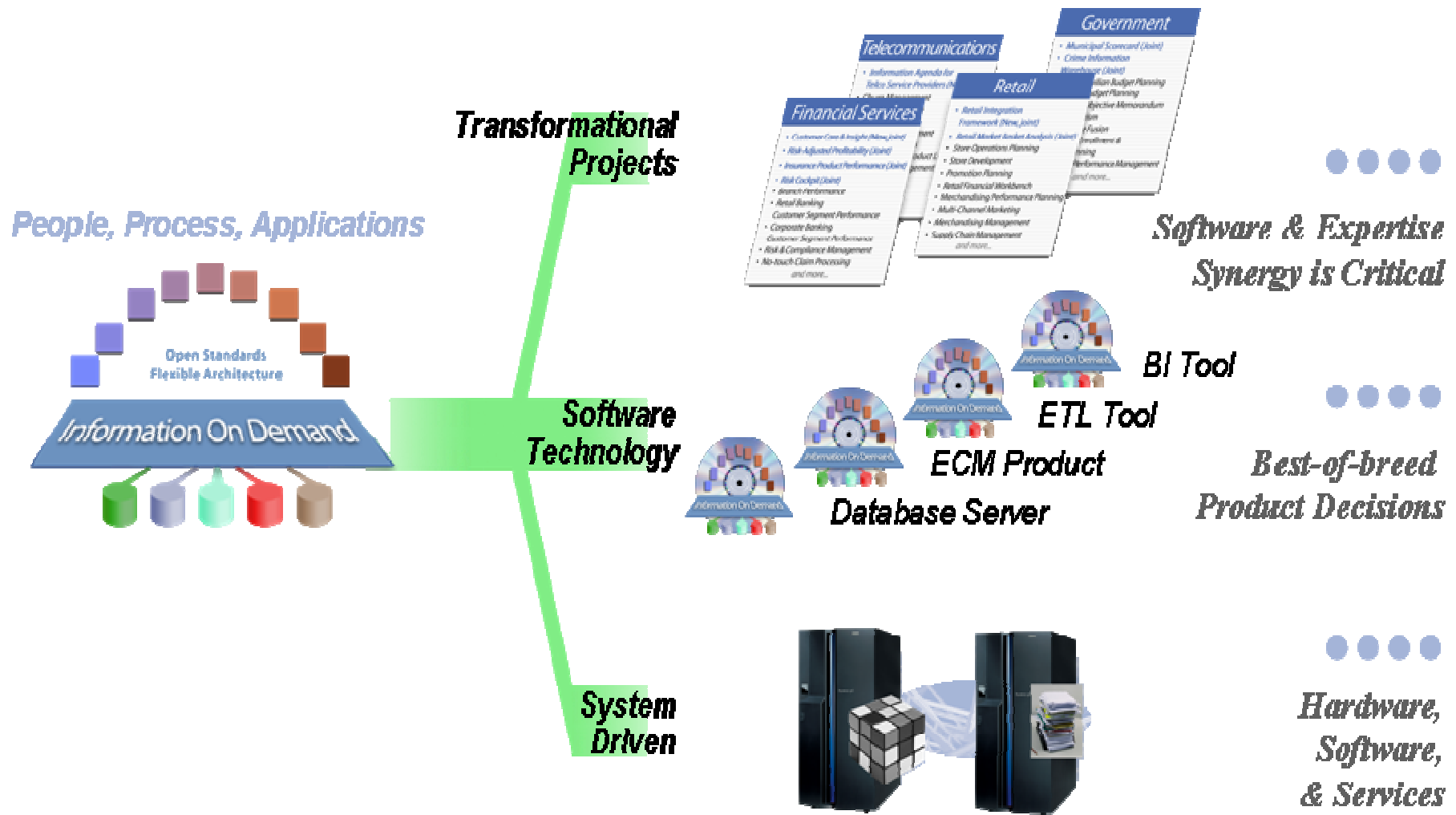

# One Platform, One Architecture

## USER

Zero Footprint  
Task-Based Interfaces

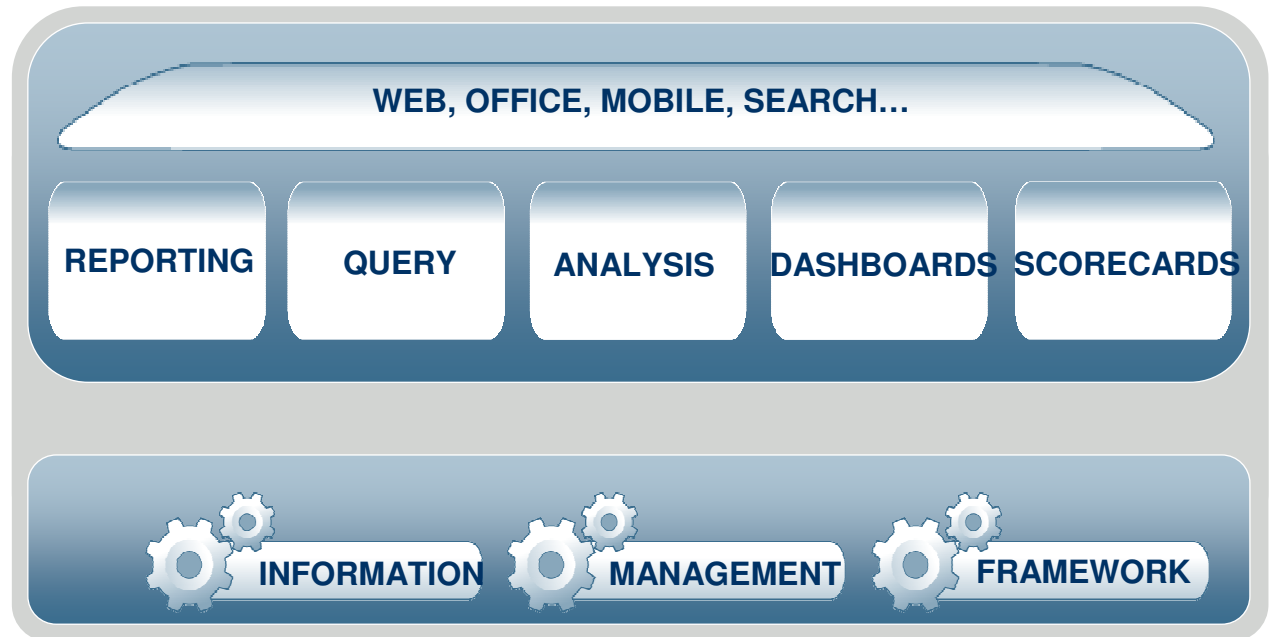

## SERVICES

Purpose-Built Web  
Services Architecture

## DATA

Open Data Access



# Cognos 8 BI from IBM

## Cognos 8 Performance Management Platform

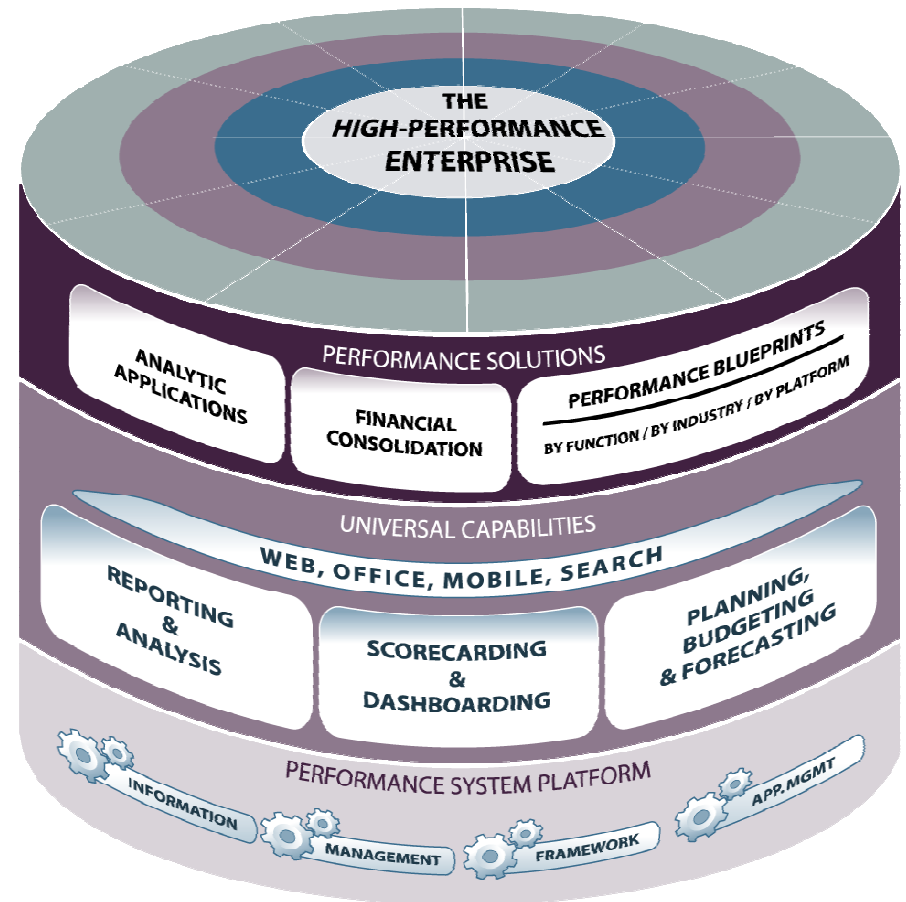
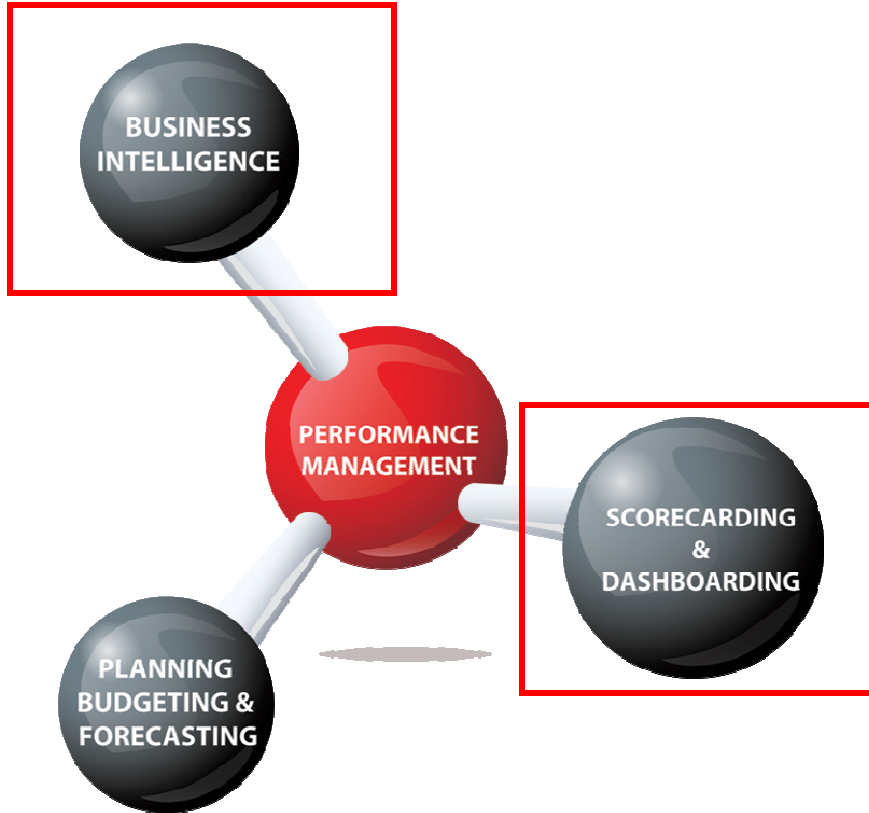

### Cognos 8 BI for System z Linux

# Cognos 8 BI Portfolio

- Report Studio
- Query Studio
- Analysis Studio
- PowerPlay Studio
- Event Studio
- Metrics Studio
- Go! Search
- Go! Mobile
- Cognos Now!

**Top 10 Product Contributions to Revenue - Detail Data**

Material Number	Material Description	Invoice Amount (Previous Year)	Invoice Amount	% of Total Invoice Amount	Cumulative % of Total Invoice Amount	Invoice Profit Margin	Invoice Profit Margin %	Invoice Quantity	UOM
100000	WaveStation 4200 FP		1,411,586,267.11	79.30%	79.30%	1,254,386,267.11	88.86%	147,375.25	Each
881000	One Year Maintenance - revenue recognition	522,293,452.28	79,937,261.95	4.49%	83.79%	79,937,261.95	100.00%	7,088	Each

# Cognos 8 – Enterprise Architecture

- **Minimize risk on mission-critical deployments**
  - **Peer-to-peer services provide infinitely flexible distribution with zero duplication and zero inter-dependency for full fault tolerance**
  
- **Gain high performance AND IT agility**
  - **Intelligent load balancing for optimized performance. Configurable rules eliminate manual tuning and easily adapt to change**
  
- **Best leverage existing infrastructure**
  - **Location transparency across heterogeneous operating environments – now and in the future**
  
- **Confidently rollout to thousands of users**
  - **Linearly scalability ensures predictability as user volumes and demands grow**

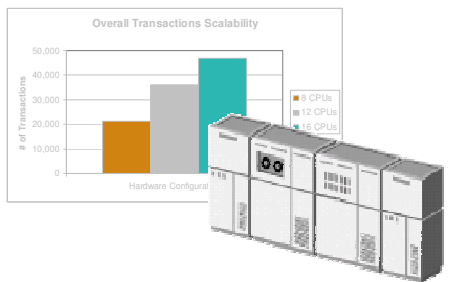
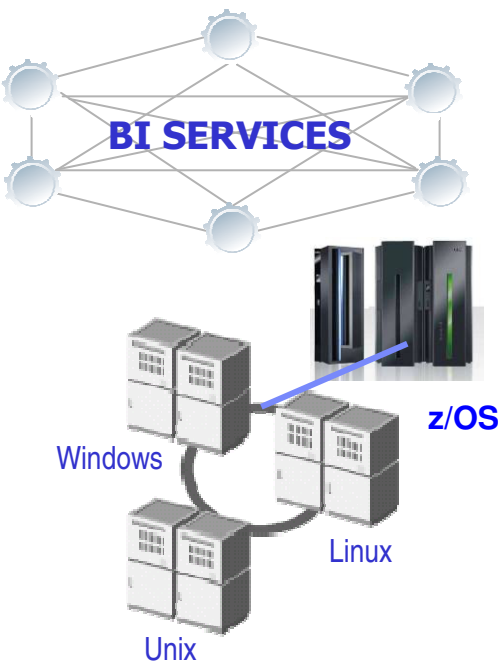

# System z10 Designed for New Customer Workloads

New System z10 based solutions for workloads and Industry processes that leverage the full power of System z10

- ACI BASE24-eps and ACI Proactive Risk Manager on System z10
- Data Warehousing on System z10
- Real-time Enterprise Business Intelligence on System z10
- Encryption Authentication - Digital Certificate Authority on System z10
- SAP Solution Edition on System z10



# Encryption Authentication – Digital Certificate Authority on System z10

## *Customer Needs*

- Deploy secure transactions and network connections
- Securely exchange encryption keys
- Manage the lifecycle of digital certificates

## *System z Value Proposition*

- Save thousands to millions of dollars by replacing third party hosting of digital certificates
- Full certificate life cycle management
- Highly available and highly secure



## *Saving costs*

- Relatively low MIPS to drive thousands of certificates using no-cost feature of z/OS

## *Industry certification*

- Certified by Identrust, a global leader in trusted identity solutions recognized by global financial institutions, government agencies and businesses

## *System z robustness*

- Leverages resiliency and disaster recovery features
- Highly secure using mainframe access and audit controls and encryption features
- Services available to accelerate

## *New ISV support*

- Venafi™ solutions for centralized digital certificate management now support z/OS Certificate Authority



# System z10 Designed for New Customer Workloads

New System z10 based solutions for workloads and Industry processes that leverage the full power of System z10

- ACI BASE24-eps and ACI Proactive Risk Manager on System z10
  - Data Warehousing on System z10
  - Real-time Enterprise Business Intelligence on System z10
  - Encryption Authentication - Digital Certificate Authority on System z10
- SAP Solution Edition on System z10



# Today, a dynamic global economy poses significant challenges for delivering information across a business:

## Pain Points

### Delivering current information, in a 24x7 economy

- Globally dispersed organizations
- Data fragmented into geographies, time zones, and applications
- Outages impact overall business

### Secure business data from intrusions

- Data breaches continue
- Identity information is the data at risk

### Balance data center efficiency, against growing business needs

- Power cost and consumption are a real concern
- Redundant servers and components escalate costs

In the 21<sup>st</sup> Century, data availability is everything

# What's new for SAP?

## Introducing SAP Solution Edition for System z

**Delivering mission critical availability at a price that will surprise you**

### Offering a new pricing model:

- Bottom-line pricing
- Competitively priced
- Low cost of entry, with low cost growth

### Leveraging the latest technology enhancements:

- Enhanced processor speeds
- Improved technology costs
- DB2 database enhancements

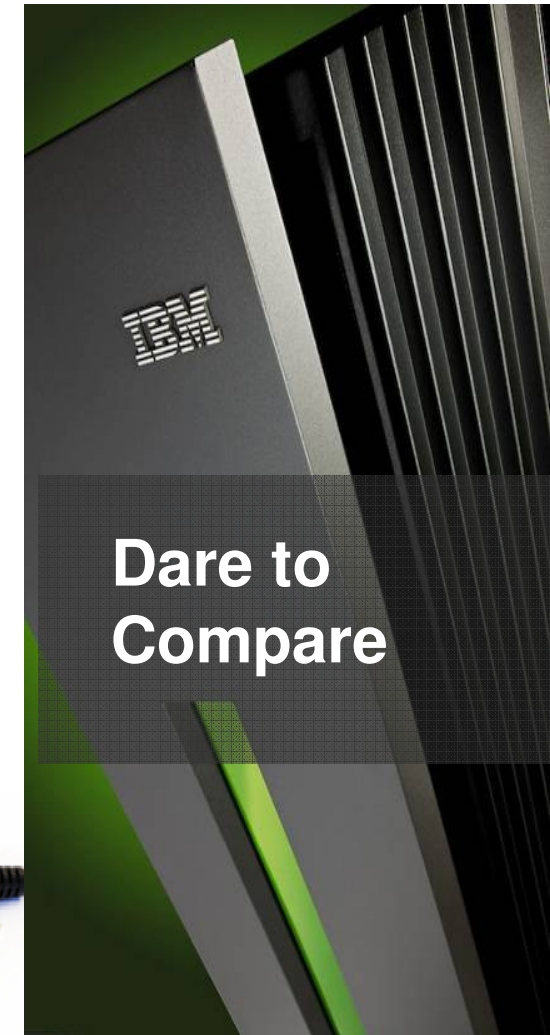

# IBM SAP Solution Edition for System z10

## *New Pricing Model*

- Bottom-line pricing
- Competitively priced
- Low cost of entry, with low cost growth

## *System z Value Proposition*

Bringing new levels of Value for SAP on System z

- Continuous Availability
- Unlimited Scalability
- Security
- Manageability
- Workload Consolidation
- Total Cost of Ownership



## *Provides*

**Current information, in a 24x7 economy**

- Globally dispersed organizations
- Data fragmented into geographies, time zones, and applications
- Outages impact overall business

## *Resolves*

**Secure business data from intrusions**

- Data breaches continue
- Identity information is the data at risk

## *Delivers*

**Balance data center efficiency, against growing business needs**

- Power cost and consumption are a real concern
- Redundant servers and components escalate costs

Lesson 4:  
*Consolidating* and  
*Virtualising* workloads from  
other platforms



# Service Oriented Architecture and Industry Specific Solutions

*Powered on System z10*

## Banking and Payments

- ACI Worldwide's BASE24-eps for Banking Payments
- EFD Data Navigator for Banking Payments
- Core Banking Renovation with SmartBank SOA Solutions
- Enterprise Payments Platform powered by System z
- SAS Fraud Management

## Insurance Industry

- Life Insurance SOA on System z

## Public Sector

- *Inform's* Student Information System (SIS<sup>J2K</sup>)
- Integrated Case Management with Cúram Software

## Automotive Industry

- Supplier Parts Quality on System z



# Payments Solutions leveraging the strengths of System z

## *Customer Needs*

- Reduce fraud exposure
- Comply with new standards and regulations
- Enhance customer service
- Achieve a single view of the customer relationship
- Improve operational effectiveness

## *System z Value Proposition*

- Robust and flexible platform for enterprise payments processing
- Performance, scalability and reliability supporting high-volume and highly available transaction processing



## *ACI Worldwide's BASE24-eps*

- Supports payment transaction flexibility
- A major UK bank is implementing on mainframe to meet requirements for real-time funds transfer between retail bank accounts

## *EFD DataNavigator®*

- Enables a real-time enterprise-wide view of all consumer transactions.
- DataNavigator forms the transaction management layer of EFD's Enterprise Payments Framework.

## *SAS® Fraud Management*

- Enables real-time protection against credit and debit card fraud using sophisticated analytic intelligence
- HSBC leverages mainframe to manage card portfolio and reduce fraud

# Core Banking and Insurance Solutions Leveraging the SOA Strengths of System z

## *Customer Needs*

- Address consumer demands for more personalized service and product flexibility
- Respond to regulatory pressures
- Extend the functionality of existing core systems
- Improve operational effectiveness

## *System z Value Proposition*

- The solutions, which address key business processes, showcase the mainframe's strengths as the SOA and data integration hub for insurance and banking core systems



## *Life Insurance SOA Solutions*

- System z based IBM middleware and ISV solution components include DB2, WebSphere Process Server, WebSphere Customer Center, Workplace Forms and Tivoli Enterprise Monitoring; LIDP, Allfinanz, Mapinfo, and Informatica.

## *Core Banking SOA Solutions*

- System z based IBM middleware and ISV solution components include WebSphere Process Server, MQ, CICS® Transaction Server, DB2 and Tivoli; Fidelity Information Systems, and ACI

## *Enterprise Payments Platform (EPP) powered By System z*

- System z based IBM middleware and ISV solution components include WebSphere Process Server, Message Broker, MQ, DB2 and WebSphere Transformation Extender; ACI and Intercope.



# Public Sector Solutions leveraging the value of System z10

## *Customer Needs*

- Cut costs and increase operational efficiency
- Allow students access to their own data over the Internet
- Respond quickly to clients needs and changes in government policies

## *System z Value Proposition*

- Flexible and resilient platform for student information systems and integrated case management across the enterprise
- Advanced security features for controlling system access and ensuring confidentiality



## *Informs Student Information System (SIS<sup>J2K</sup>)*

- Web-based Student Information System developed by Information Management Specialist, Inc. (*Informs*)
- System z solution components include WebSphere Application Server and DB2. SIS<sup>J2K</sup> can run on either the z/OS or Linux<sup>®</sup> operating Systems.

## *Integrated Case Management with Cúram Software*

- Cúram Business Application Suite<sup>™</sup>, designed for social enterprises enables an integrated service delivery model
- System z solution components include z/OS, DB2, DB2 Content manager for z/OS, and MQ.
- Utah Department of Human Services implemented on mainframe to integrate service delivery and improve eligibility determination.

# Automotive's Supplier Parts Quality Solution on System z10

## *Customer Needs*

- Today, manufacturers from a variety of industries, especially automotive, face a number of major supplier quality issues, including maintaining the quality of the overall product while outsourcing (direct and indirect) many of the materials and parts used in the manufacturing process.

## *System z Value Proposition*

- Provides business insights into parts quality to avoid excessive warranty costs and issues related to manufacturing.



## *Solution Composition*

- DB2
- Alphablox
- Data Warehouse Edition
- WebSphere
- GBS Customized assets

## *System z Helping to Meet Automotive Needs*

- The automotive industry has experienced significant increases in warranty claims that have been tied to an increase in supplier (sub-tier) components – where 67% of warranty costs are parts related, and 33% are labor related.



# The Future Runs on System z



# System z and z/OS Security

- ISS
- Global Services: Security & Privacy Consulting
- IBM Services: Ethical Hacking

- z/OS CommServer (IDS)
- System zAlerts
- SMF & Tivoli zSecure
- z/OS Healthchecker
- DB2 Audit Tool

- Robust Encryption Infrastructure
- Tape encryption
- DB2 & IMS Encryption & Test Tools
- z/OS Encryption Facility V1.2 (Jan 2007)
- Network encryption: SSL/TLS, IPsec, AT-TLS, OpenSSH, NSS
- ISO Format 3 Pin Block (1.9)

- System Integrity
- RACF MLS
- z/OS PKI Services
- Tivoli Identity Manager (TIM)
- Tivoli Federated Identity Manager (TAM)
- Tivoli zSecure

- EAL 5 for z9 LPAR
- EAL(1.8) & FIPS Certifications
- Linux on System z as DMZ
- z/OS CommServer Security

- **With z/OS V1.10, designed to support industry security standards!\***
- **ICSF**
  - 4096-bit RSA key support (with z10 EC, z9 EC and z9 BC)
  - IBM: SHA-224, SHA-384\*\*, and SHA-512\*\*
  - AES-192 and AES-256 algorithms \*\*
  - ISO Format-3 PIN Block support (meets ISO 9564-1 Banking standard) (with z10 EC, z9 EC and z9 BC)
  - ALSO in ICSF - Random number callable service
- **System SSL**
  - Utilize hardware support for RSA digital signature \*\*
  - SHA-224, SHA-256, SHA-384, and SHA-512 algorithms \*\*
- **z/OS Communications Server**
  - IPV6 standards RFCs 4301-4305, 4308



# A z/OS Management Facility \*

*A Web-browser based management console for z/OS*

- Designed to provide the infrastructure, services, and interfaces to support a browser based graphical user interface needed to support a management console for z/OS.
- This initial release of the z/OS Management Facility plans to provide job and process management and Parallel Sysplex management support.

Navigator is tailored to each user's role and responsibilities.

Log of system events. Clicking on an event brings up details.

Select	Event Type	Description	Severity	Date and Time	Sysplex	System	Component	z/OS Release	Category
<input type="checkbox"/>	Abend	Description	Critical	01/09/2007 8:34 PM	PETPLEX	System2	Component	Release	z/OS
<input type="checkbox"/>	Message	Description	Critical	01/09/2007 8:00 PM	PETPLEX	System1	Component	Release	DB2
<input type="checkbox"/>	Dump	Description	Critical	01/09/2007 9:30 PM	PETPLEX	System 3	Component	Release	WebSphere
<input type="checkbox"/>	Abend	Description	Warning	01/09/2007 7:46 AM	PETPLEX	System 1	Component	Release	z/OS
<input type="checkbox"/>	Abend	Description	Warning	01/08/2007 9:12 PM	PETPLEX	System 2	Component	Release	z/OS

Health check metrics

Count Category	Count
Normal Count	40
High Count	10
Medium Count	5
Low Count	10

# z/OS optimization and management\*

## *Announced/Previewed with z/OS with z/OS V1.10*

- **Policy based Capacity Provisioning for System z10**
  - A new Capacity Provisioning Manager planned for z/OS V1.10 (and z/OS V1.9 with PTF) plans to monitor System z10 servers and manage z/OS 1.9 and 1.10 systems and add /remove temporary capacity automatically.
  - In the future, z/OS will allow authorized applications to query, change, and perform basic operational procedures against the installed System z hardware base - efficiently deploying server resources when needed\*
- **z/OS Workload Manager:**
  - Improved Contention Management
    - Longer promotion, will now promote resource holders to the priority of the highest-priority waiter
  - WLM to manage more address spaces in service class SYSTEM:
    - XCFAS, GRS, SMSPDSE, SMSPDSE1, CONSOLE, IEFSCHAS, IXGLOGR, SMF, and CATALOG (in addition to \*MASTER\* and WLM)
  - More Performance Block (PB) delays
    - Up to 15 from 5
    - Applications can specify names to replace the default names
  - zIIP CPU management = Manage zIIPs like CPs and zAAPs



# Taking z/OS storage volumes to the extreme

- **An Extended Address Volume (EAV) is a volume with over 65,280 cylinders**
  - 223 GB volumes initially supported on z/OS V1.10\* and IBM System Storage DS8000\*
  - Larger volumes are planned to be rolled out over time \*
  - First exploiter is VSAM – applications that uses VSAM data sets (including DB2 and CICS®) can benefit from EAV
  - IBM intends to enable other access methods in the future \*
- **EAV helps address storage constraints for very large storage**
- **In the future, EAV can help simplify storage management.**
  - Manage fewer, large volumes as opposed to many small volumes
- **DS8000 HyperPAV function complements EAV by allowing the scaling of the I/O rates against a single, larger volume**
- **DS8000 Dynamic Volume Expansion can allow non-disruptive migration to larger volume sizes**

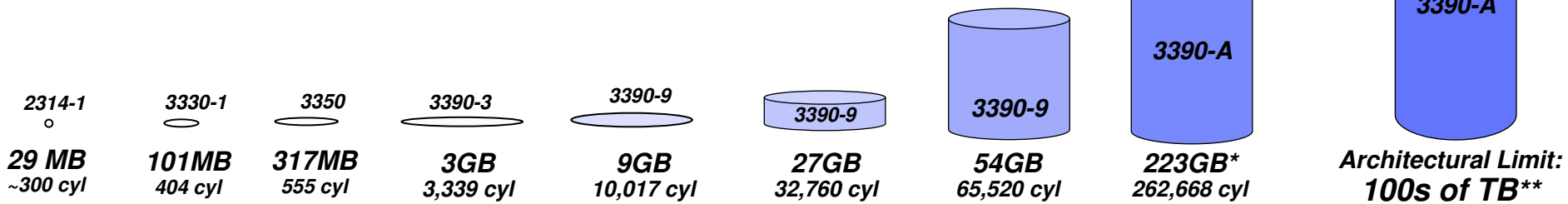

# zIIP Assisted z/OS Global Mirror: a cost effective mirroring solution

- **z/OS Global Mirror (formerly Extended Remote Copy, XRC) is enabled for the zIIP**
  - z/OS DFSMS™ allows a part of System Data Mover (SDM) processing to be eligible for the zIIPs
  - Most SDM processing associated with zGM/XRC is made eligible to run on the zIIP.
  
- **zIIP assisted z/OS Global Mirror function, can help provide better price performance and improved utilization of resources at the mirrored site.**
  - A part of DFSMS SDM processing is redirected to a zIIP processor which can lower system utilization at the mirrored site.

- **Available with:**
  - z/OS V1.10 (when available), or z/OS V1.9 and V1.8 with PTF for APAR OA23174
  - IBM System Storage DS8000, or any storage controller supporting z/OS Global Mirror
  - IBM System z9 or z10 server

\* For illustrative purposes only, your results will vary.

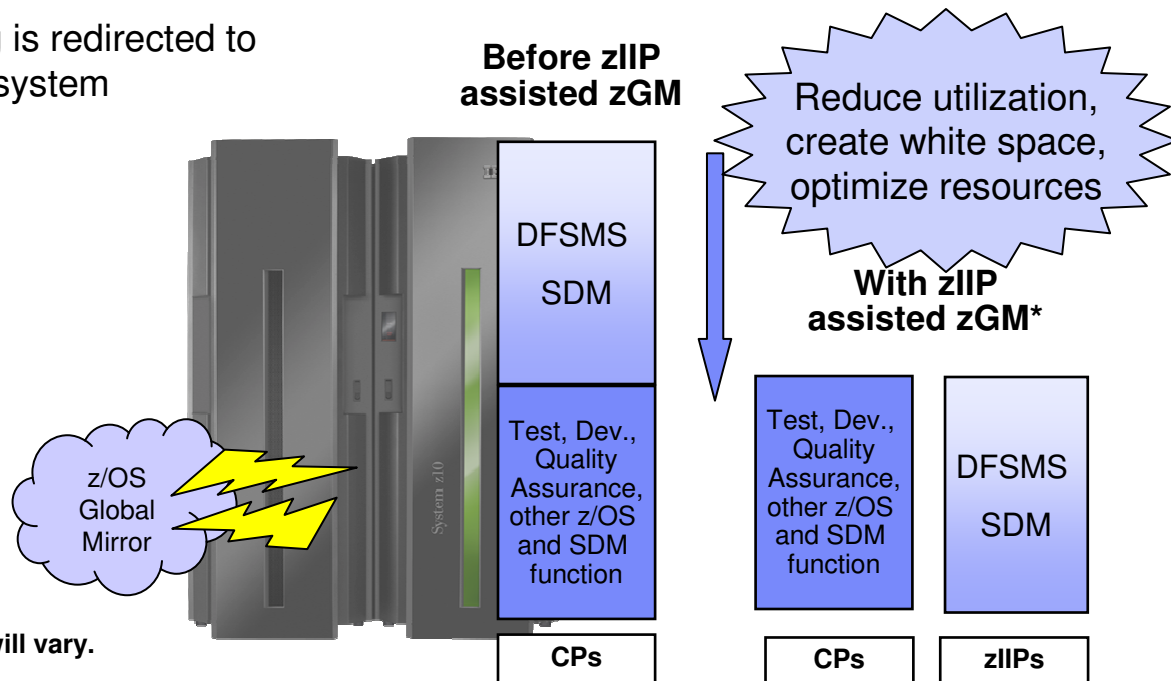







*What our ISV's are doing..?*







# What our ISVs are saying about System z

	<p><i>"Offering Cúram for deployment on Linux for IBM System z underscores our commitment to providing customers with the widest possible range of implementation choices," said Ronan Rooney, chief technology officer, Cúram Software. "The mainframe's mature and powerful industry leading virtualization technology has allowed IBM to continue to improve energy efficiency, add capacity dynamically and provide platform flexibility. Cúram applications deployed on Linux on System z will help our customers to further simplify their IT infrastructure and ultimately lower costs without sacrificing reliability - this is critical to the success of any software implementation."</i></p>
	<p><i>"BM's mainframe systems are important to the SAS Enterprise Intelligence Platform. IBM's new System z10 Business Class mainframe enables SAS customers to execute business intelligence and advanced analytic functions at an enterprise level on state-of-the-art hardware. By working together to ensure critical BI and analytic applications can operate effectively on the mainframe – which helps significantly reduce energy, space and cooling costs – SAS and IBM are actively enabling their mutual customers to support their own corporate sustainability efforts. – Craig Rubendall, Director, Research and Development</i></p>
	<p><i>"The demands being placed on core transactional systems, such as trading platforms, continue to grow to unprecedented levels. What hasn't grown are the budgets required to support these mission-critical systems," said Joe Gentry, Software AG's Chief Technology Officer for the Enterprise Transaction Systems division. "By moving aggressively to support new and emerging platforms such as [zMR], Software AG is helping customers take advantage of faster and more efficient systems to meet these requirements</i></p>
	<p><i>"As critical as product and service differentiation is in the global Property &amp; Casualty Insurance Industry, business interruption is inexcusable. Innovation Group clients deploying our enterprise software solutions on System z leverage the mainframe's unparalleled performance and bullet-proof reliability to gain competitive advantage in this highly competitive industry."</i></p> <p><b>Andrew Labrot, Jr., CTO, Innovation Group</b></p>





# What our ISVs are saying about System z

	<p><i>"BMC Software and IBM are committed to ensuring that the mainframe remains the most scalable, reliable and secure platform for commercial applications", said Bill Miller, senior vice president and general manager of BMC's Mainframe Service Management business unit. With our 'day one' support of IBM's zOS V1 Release 10, BMC Software is further demonstrating its ability to provide service optimization and efficiency improvements across the mainframe whenever our customers are ready to deploy the latest technologies. BMC's recent mainframe industry survey indicated that the platform will continue to grow and attract new workloads and BMC's support of zOS Release 10 is just one more way we can demonstrate our leadership in technology innovation and give our customers superior support for their demanding and critical environments." - Bill Miller, Senior Vice President and General Manager, Mainframe Service Management</i></p>
	<p><b>"CA's comprehensive solutions for System z enable IT organizations to maximize the scalability, security, and reliability that continue to make the mainframe both the greenest and most cost-effective choice for hosting business-critical IT services." - Chris O'Malley, Executive Vice President and General Manager, Mainframe Business Unit</b></p> <p><i>Customer quote from CA:</i></p> <p><i>"As the volume and complexity of our IBM System z mainframe workloads keep growing, we need management tools that ensure our ability to keep pace—despite the resource constraints we face in IT," said Rich Resnick, Manager of Systems and Operations, University Community Hospital, a not-for profit community hospital network strategically represented throughout the Tampa, Fla. Metropolitan area. "By continuing to add high-value features and functionality to its already-rich management solutions portfolio, CA has demonstrated its ongoing commitment to fulfilling this need."</i></p>
	<p><b>"The IBM mainframe has always been the platform of choice for the large scale enterprises that choose Model 204 as their strategic database platform. The ever increasing capacity, flexibility and reliability of the System z mainframes ensures that this platform will support the growth of their businesses. The new, entry-level machines will enable smaller enterprises to plan for growth with confidence." - Chris Ramsdale, Director of Strategic Product Planning</b></p>
	<p><b>"Designed to meet the evolving integration needs of System z mainframe customers, DataDirect Shadow provides a single, industry standard architecture to streamline legacy data access and mainframe SOA enablement, allowing organizations to more rapidly develop and deploy new business services with reduced complexity and cost. Shadow's patent-pending technology can exploit the zIIP and zAAP specialty engines across a wide range of workloads and target systems for lower mainframe TCO and improved performance." - Gregg Willhoit, Chief Software Architect, DataDirect Technologies.</b></p>





# What our ISVs are saying about System z

	<p>"Our customers tell us they need 24 x 7x 365 availability, the capability to sustain application growth, meet privileged information protection responsibilities and contain cost. And that is exactly the features we see IBM providing in the new IBM z10 processors and z/OS 1.10 operating system". -Thomas J Meehan, Vice President</p>
	<p>"T-REX ensures the health of your ICF catalogs and TMC which are critical to data availability, integrity, recoverability. Xtinct ensures security standards are met by permanently and irrevocably deleting the original data. " - Murray Kruger, CEO</p>
	<p>"DTS Software is committed to enhancing the mainframe platform by providing the most up to date software to meet the needs of our customers with support for z/OS 1.10 and EAV on GA of z/OS 1.10." - Don Thimsen, President</p>
	<p>"Our flagship mainframe SOA product, Ivory Service Architect, is designed for the System z, exploiting many of its key architectural strengths. GT Software is a leading mainframe SOA solution provider, with our products optimized for System z. In my opinion, the System z will continue to grow and emerge as the dominant server for mainframe Web services." - Steve Able, Vice President of R&amp;D</p>

# What our ISVs are saying about System z

	<p>"Our clients are able to achieve significant cost reductions and compliance improvements when using eventACTION and ussACTION to assist them in managing their mainframe environments."</p> <p>Gord Tomlin, Action Software International (a division of Mazda Computer Corporation)</p>
	<p>"RealTime Defrag (RTD) installations optimize use of their mainframe DASD space in real-time while ensuring SLAs are met and energy costs are reduced."</p> <p>Howard Kirby, Director International Operations</p>
	<p>"I/S Management Strategies, Ltd.'s LPAR Capacity and Software Usage Analysis (LCS) is ready on Day 1 to assist sites in auditing and managing their IBM software charges on all levels of z/OS and any System z hardware."</p> <p>Al Sherkow, I/S Management Strategies, Ltd</p>
	<p>"Clients use our mainframe printing, debugging, and productivity software tools to deliver robust, reliable and secure mainframe applications to their end users and business units."</p> <p>Mike Marler, President, MacKinney Systems, Inc.</p>



# What our ISVs are saying about System z

	<p>"NEON Enterprise Software, Inc. is committed to providing value-add solutions which utilize and exploit the power of IBM's System Z technology. We are partners in helping our combined customers understand that with its reliability, security, scalability, and overall lower TCO, there is no better source for business application computing than System Z."</p>
	<p>"(E)JES customers agree that robust spool and system management is one of the qualities of service that help make z/OS and System z their first choice for deployment of new business applications." – Amy Gilbert, Marketing Manager</p>
	<p>"OpenTech Systems Inc. is a leading provider of Comprehensive Solutions for Disaster Recovery, Data and Storage Management, Encryption and Tape Data Migration for IBM z/OS centric data centers. From infrastructure backup and critical application data identification to virtual tape backup and migration, OpenTech Systems provides a suite of products for Disaster Recovery Assurance and compliance. OpenTech products are used worldwide to automate DR processes, lower tape media and hardware expenses while reducing backup windows and administrative requirements." - Terry Siegrist, Vice President.</p>
	<p>"Complex <u>threads of application processing</u> invoke hundreds of programs in typical mainframe legacy applications. For the analyst who is changing or enhancing one of these applications, success is dependent upon understanding these complex threads. Ironically, traditional approaches to analysis (tools or manual) are program-oriented not application-oriented.</p> <p>PathPoint materializes these complex threads of application processing by tracing and capturing user-entered business transactions of interest - without any change to source code. Understand how legacy applications "really" work on System z – with PathPoint." - Tom Cushing</p>

# What our ISVs are saying about System z

	<p><u>CFI</u>: "By deploying CyberFusion Integration Suite™ (CFI) for managed file transfer, on the IBM mainframe, our clients can integrate all major computing platforms in their organization while securely automating the movement of key data across enterprise systems, platforms, and applications."</p> <p><u>SecurAccess</u>: "SecurAccess™, from Proginet, is a single sign-on solution for the IBM mainframe that enables users to access corporate resources and applications using a single, secure password. SecurAccess™ can be combined with hardware tokens to provide two-factor authentication."</p> <p><u>SecurForce</u>: "By deploying SecurForce™ for Sync and Reset, on the mainframe, clients have reported up to 90 percent reduction in password-related help desk costs – resulting in rapid ROI, and significant productivity and efficiency gains." – Kevin Bohin, CIO</p>
	<p>"Our enterprise clients view System z as the best platform for their high volume batch processing. As they progress towards continuous operation in a global, shared data environment, our System z customers must endow their batch applications with restart capability so they can better tolerate abends and downtime. Smart/RESTART from RAI enables z/OS batch applications to restart from near the point of failure after abends, recompiles, even system IPLs -- with all resources in a consistent state. Often without changes to application source code. RAI's active support of System z ensures Smart/RESTART customers can exploit the latest z/OS enhancements (such as Extended Address Volumes - EAV), contemporaneous with their IBM General Availability dates." - Carl Feinberg, CEO</p>
	<p>"Select Business Solution, with its many years of experience and support of the mainframe (System z) environment, provides efficient, real-time, reporting access to critical business data enabling our clients to improve service, productivity and overall decision making." - Roger Cox, Sr. Product Marketing Manager</p>
	<p>"SyncSort for z/OS goes beyond mere compatibility with System z technology, exploiting zIIP, MIDAW and PAV functionality to deliver significant performance benefits." - Ken Cooper, Manager, Product Engineering</p>

# What our ISVs are saying about System z

 <p><b>SINE NOMINE</b> ASSOCIATES</p>	<p>“Providing Linux and OpenSolaris for System z technology on the same System z processor allows customers to put their amassed skills from both the open systems and traditional mainframe world together for the optimum match in software and hardware technology.” - David Boyes, President/CTO</p>
 <p><b>Voltage</b> security</p>	<p>“Voltage SecureData allows z/OS customers to easily encrypt Personally Identifiable Information, both “at rest” (in the databases where it resides) and “in motion” (as it traverses the network), thus protecting against identity theft and improving compliance with PCI DSS, Sarbanes-Oxley, FACTA “Red Flag”, HIPAA, SB 1386, European and Japanese privacy regulations, et al. With Voltage’s transparent stateless key server that links data to identities, groups, and roles, traditional key management headaches are avoided; and with Format Preserving Encryption, the data can remain encrypted throughout the lifecycle of a transaction, with complete or partial decryption only at the final destination as appropriate—all without changes to database schema or middleware. The same technology can also be applied to mask data for QA/testing, thus avoiding data leaks while providing realistic test environments.” - Phil Smith III</p>



# SAS

**“IBM's new System z server provides a robust, flexible environment for delivering our enterprise intelligence solutions such as SAS Fraud Management for Card Portfolios, SAS Enterprise Business Intelligence, SAS Enterprise Miner and SAS IT Resource Management. The substantial enhancements in processing and memory capacity support the demanding workloads for business intelligence and analytics applications to quickly deliver business insights across the enterprise. We are encouraged by IBM's continued commitment to the System z platform as we continue to develop new workloads to support our System z customers. Our enterprise intelligence solutions on System z deliver the performance and energy efficiencies that customers demand, enabling significant reductions in data center carbon footprint. IBM is clearly taking lead to establish its System z servers as excellent choice for green IT computing.”**

- Craig Rubendall, Director, Research and Development, SAS  
[www.sas.com](http://www.sas.com), <http://www.sas.com/partners/directory/ibm/index.html>

**NOTE:** *In addition to approval to use quote, Craig agrees to serve as a media reference for IBM*

# The Future runs on System z...

## ...The Future begins today

# The System z10 Enterprise class



**“Our customers are rapidly adopting server virtualization and grid computing as a way to save space, energy and other costs. Oracle sees a growing number who are incorporating Oracle software on System z Linux virtual servers as part of that strategy,” says Robert Shimp, Oracle vice president, Global Technology Business Unit. “With this announcement the IBM System z10 becomes an even more attractive platform for deploying Oracle Database, Oracle Fusion Middleware and the Oracle E-Business Suite.”**

**ORACLE**

# Thank you!

- **IBM's commitment to the mainframe helps deliver:**
  - Extreme scalability, and availability
  - Reduced costs and simplified IT infrastructure
  - High performance and energy efficient technologies
  - a resilient and security rich system

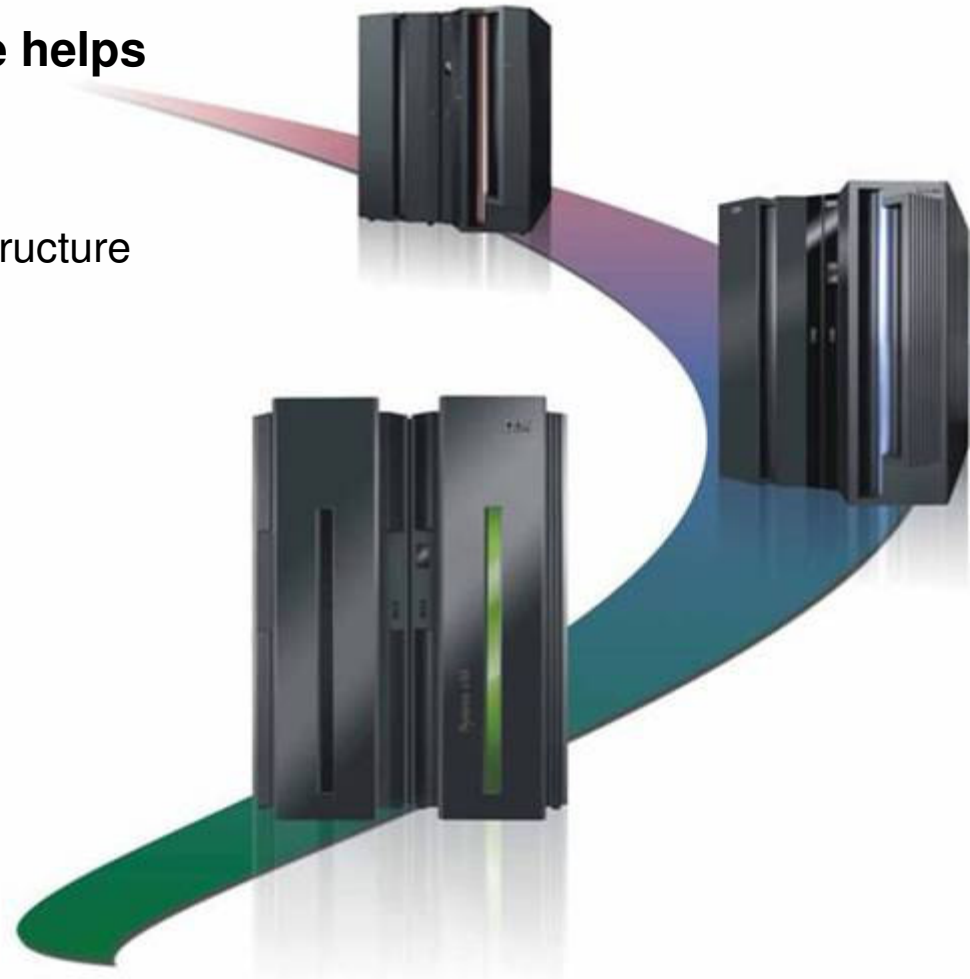



# Backup

