

IBM® Tivoli® Workload Scheduler for Applications



Readme File for Fix Pack 2 - PTF U498712

Version 8.2

IBM® Tivoli® Workload Scheduler for Applications



Readme File for Fix Pack 2 - PTF U498712

Version 8.2

Note

Before using this information and the product it supports, read the information in Chapter 4, "Notices," on page 37.

Second Edition (July 2004)

This edition applies to fix pack 2 (PTF U498712) for version 8, release 2, modification level 0 of IBM Tivoli Workload Scheduler for Applications (program number 5698-WSE).

© **Copyright International Business Machines Corporation 2003, 2004. All rights reserved.**

US Government Users Restricted Rights - Use, duplication or disclosure restricted by GSA ADP Schedule Contract with IBM Corp.

Contents

Chapter 1. IBM Tivoli Workload Scheduler for Applications, Version 8.2 Readme File for Fix Pack 2 (PTF U498712)	1
About this release	1
Fix pack structure	2
New features	3
Features introduced with fix pack 1.	3
Product fix history	3
APARs and defects fixed in IBM Tivoli Workload Scheduler for Applications, Version 8.2 fix pack 2	3
Common APARs and defects	3
APARs and defects fixed for Oracle E-business Suite	4
APARs and defects fixed for PeopleSoft	4
APARs and defects fixed for R/3	4
APARs and defects fixed for z/OS	4
APARs and defects fixed in IBM Tivoli Workload Scheduler for Applications, Version 8.2 fix pack 1	4
Common APARs and defects	5
APARs and defects fixed for Oracle E-business Suite	5
APARs and defects fixed for PeopleSoft	5
APARs and defects fixed for R/3	5
APARs and defects fixed for z/OS	5
Limitations	5
Common limitations.	6
Limitations for Oracle E-business Suite	6
Limitations for PeopleSoft	6
Limitation for R/3	6
Limitation for z/OS	6
Installation	7
Hardware and software requirements	7
Supported platforms.	7
System requirements.	7
Fix pack installation methods.	7
Tier 1 installation methods.	8
Tier 2 installation method	10
z/OS installation method.	11
Documentation notes	11
New information contained in this fix pack.	11
Documentation problems and corrections contained in this fix pack	15
Chapter 2. End-to-end Dynamic R3 Job Definition Feature	23
Job Creation Parameters	23
Summary of Supported Parameters	25
Supported Attributes for Step Definition	28
New Parameters Used in the Job Definition	30
Executing from a Tivoli Workload Scheduler End-to-end Environment	32
Specifying Job Parameters Using Variable Substitution	33
Defining and Updating R3 Jobs Using the End-to-end Dynamic Allocation Feature	33
Chapter 3. Contacting IBM Software Support	35
Chapter 4. Notices.	37
Trademarks	38

Chapter 1. IBM Tivoli Workload Scheduler for Applications, Version 8.2 Readme File for Fix Pack 2 (PTF U498712)

Date 02 July 2004

Fix Pack
8.2.0-WSE-FP02

PTF Number
U498712

Product
IBM Tivoli Workload Scheduler for Applications, Version 8.2

General Description
IBM Tivoli Workload Scheduler for Applications, Version 8.2 Fix Pack 2

This readme file provides important information about Fix Pack 2 (PTF U498712) for IBM Tivoli Workload Scheduler for Applications, Version 8.2. This readme file is the most current information for the fix pack and takes precedence over all other documentation for IBM Tivoli Workload Scheduler for Applications, Version 8.2. This fix pack fixes a variety of defects on the following access methods:

- Oracle E-business Suite
- PeopleSoft
- R/3
- z/OS

Please review this section thoroughly before installing or using this fix pack.

About this release

This section includes the following topics:

- “Fix pack structure” on page 2
- “New features” on page 3
- “Features introduced with fix pack 1” on page 3
- “Product fix history” on page 3
- “Limitations” on page 5
- “Installation” on page 7
- “Documentation notes” on page 11

Fix pack structure

IBM Tivoli Workload Scheduler for Applications, Version 8.2 Fix Pack 2 has the following structure:

```
+---8.2.0-WSE-FP02.README (This File)
|---8.2.0-WSE-FP02.VSR
+---AIX
|   |   setup.bin
|   |   \---SPB
|   |       TWS4APPS_MCMAGENT_AIX_FP02.SPB
|   |       TWS4APPS_R3BATCH_AIX_FP02.SPB
|   |       TWS4APPS_ZOSAGENT_AIX_FP02.SPB
|   |       TWS4APPS_OPTED_FP02.SPB
+---DYNIX
|   |   TWS4APPS_ZOSAGENT_DYNIX.TAR
+---HP
|   |   setup.bin
|   |   \---SPB
|   |       TWS4APPS_MCMAGENT_HP_FP02.SPB
|   |       TWS4APPS_R3BATCH_HP_FP02.SPB
|   |       TWS4APPS_ZOSAGENT_HP_FP02.SPB
|   |       TWS4APPS_OPTED_FP02.SPB
+---I386NT
|   |   setup.exe
|   |   \---SPB
|   |       TWS4APPS_PSAGENT_I386NT_FP02.SPB
|   |       TWS4APPS_R3BATCH_I386NT_FP02.SPB
|   |       TWS4APPS_ZOSAGENT_I386NT_FP02.SPB
|   |       TWS4APPS_OPTED_FP02.SPB
+---I386NT_GA
|   |   setup.exe
+---IRIX
|   |   TWS4APPS_ZOSAGENT_IRIX.TAR
+---LINUX
|   |   setup.bin
|   |   \---SPB
|   |       TWS4APPS_R3BATCH_LINUX_FP02.SPB
|   |       TWS4APPS_OPTED_FP02.SPB
+---LINUX390
|   |   setup.bin
|   |   \---SPB
|   |       TWS4APPS_R3BATCH_LINUX390_FP02.SPB
|   |       TWS4APPS_ZOSAGENT_LINUX390_FP02.SPB
|   |       TWS4APPS_OPTED_FP02.SPB
+---OSF
|   |   TWS4APPS_R3BATCH_OSF.TAR
|   |   TWS4APPS_ZOSAGENT_OSF.TAR
+---RESPONSE_FILE
|   |   silentfp.txt
+---SOLARIS
|   |   setup.bin
```



```

\---SPB
    TWS4APPS_MCMAGENT_SOLARIS_FP02.SPB
    TWS4APPS_R3BATCH_SOLARIS_FP02.SPB
    TWS4APPS_ZOSAGENT_SOLARIS_FP02.SPB
    TWS4APPS_OPTED_FP02.SPB
\---ZOS
    LOADLIB_820WSEFP02
    SAMPLES_820WSEFP02

```

New features

The following new feature has been introduced in this fix pack:

- APAR IY57872: A new set of parameters has been introduced to dynamically define a SAP job at submission time from an end-to-end z/OS® environment. Refer to Chapter 2, “End-to-end Dynamic R3 Job Definition Feature,” on page 23 for a detailed description of this feature.

Features introduced with fix pack 1

The following features have introduced with fix pack 1:

- APAR IY51812, APAR IY51890: For the IBM Tivoli Workload Scheduler for Applications, Version 8.2 R/3 access method (r3batch) new options have been introduced to control the retrieval of the SAP joblog, the spoolists, and Business Warehouse (BW) process chain logs.
- Internal feature 11451: To enables PeopleSoft access method to schedule jobs containing in-line bind variable parameters in their job definitions.

Product fix history

IBM Tivoli Workload Scheduler for Applications, Version 8.2 Fix Pack 2 supersedes all the fixes released previously for the product. The following section include all the APARs and defects shipped since IBM Tivoli Workload Scheduler for Applications Version 8.2. It contains the following sub-sections:

- “APARs and defects fixed in IBM Tivoli Workload Scheduler for Applications, Version 8.2 fix pack 2”
- “APARs and defects fixed in IBM Tivoli Workload Scheduler for Applications, Version 8.2 fix pack 1” on page 4

APARs and defects fixed in IBM Tivoli Workload Scheduler for Applications, Version 8.2 fix pack 2

This section lists the APARs and defects fixed in IBM Tivoli Workload Scheduler for Applications, Version 8.2 Fix Pack 2 by access methods. It is divided into the following sub-sections:

- “Common APARs and defects”
- “APARs and defects fixed for Oracle E-business Suite” on page 4
- “APARs and defects fixed for PeopleSoft” on page 4
- “APARs and defects fixed for R/3” on page 4
- “APARs and defects fixed for z/OS” on page 4

Common APARs and defects: The following APARs and defects were fixed for parts that are common to all the access methods:

- APAR PQ89884: In some cases the access method abends while recording trace information.
- Defect 11878: In the Options Editor the description of some options is missing.
- Defect 12295: The trace-*access method*.log file can be accessed in read and write mode only by the user that creates it.

- Defect 12358: Fix pack installation checks the size of the file system used for the previous installation instead of the size of the file system that is used to run the current installation.
- Defect 12575: The *.jar files of the Options Editor are not replaced if they are newer than the ones installed by applying the fix pack.

APARs and defects fixed for Oracle E-business Suite: The following APARs and defects were fixed for Oracle E-business Suite:

- APAR IY56633: The MCMAGENT access method abends in some Solaris operating environment.
- Defect 12301: The Enigma utility generates shell control characters in encrypted passwords.
- Defect 12454: On an AIX® operating system, the mcminstall script erroneously logs warning messages while changing the ownership of a file.

APARs and defects fixed for PeopleSoft: The following APARs and defects were fixed for PeopleSoft:

- Defect 11881: The stdlist does not explain the failure due to a missing ITWS_PROCESSREQUEST component interface.
- Defect 11975: The nVisionReport process is submitted again, if the PeopleSoft application Server is stopped and restarted.
- Defect 12025: The TVPUPSFT.exe hangs, if the PeopleSoft application Server is stopped and restarted.

APARs and defects fixed for R/3: The following APARs and defects were fixed for R/3:

- APAR IY54566: The r3batch access method retention field default value is incorrect.
- Defect 12134: If the name of the workstation is wrong the following misleading message appears:
Could not find the r3options file.
- Defect 12150: The r3batch access method has connection problems in an environment where the Master is an AIX workstation and the r3batch access method is hosted on a Solaris operating environment fault-tolerant agent.

APARs and defects fixed for z/OS: The following APARs and defects were fixed for z/OS:

- APAR PQ85489: JES interface does not report exit code status correctly for failed jobs when using the CA7INTERFACE(NO) value.
- APAR PQ85648: z/OS extended agent does not work correctly when JES migration exits are turned off. The \$D 'jobname' is no longer supported. The command has been replaced by the \$D J'jobname' command.
- APAR PQ88345: The EEWI27I message has been modified and the following messages have been added:
 - EEWI33W
 - EEWI34W

APARs and defects fixed in IBM Tivoli Workload Scheduler for Applications, Version 8.2 fix pack 1

This section lists the APARs and defects fixed in IBM Tivoli Workload Scheduler for Applications, Version 8.2 fix pack 1 by access methods. It contains the following sub-sections:

- “Common APARs and defects” on page 5

- “APARs and defects fixed for Oracle E-business Suite”
- “APARs and defects fixed for PeopleSoft”
- “APARs and defects fixed for R/3”
- “APARs and defects fixed for z/OS”

Common APARs and defects: The following APAR was fixed for parts that are common to all the access methods:

- APAR IY50679: The installation of IBM Tivoli Workload Scheduler for Applications on Windows® XP does not work.

APARs and defects fixed for Oracle E-business Suite: The following APARs and defects were fixed for Oracle E-business Suite:

- Defect 11879: In a three tier configuration the MCMAGENT access method fails to authenticate in the Oracle applications system.
- Defect 12012: Installing the fix pack 1, the ownership of the MCMAGENT access method is not correctly assigned.
- Defect 12013: The files in the OracleTMP folder are not replaced if they are newer than the ones installed applying the fix pack 1.

APARs and defects fixed for PeopleSoft: The following APARs and defects were fixed for PeopleSoft:

- APAR IY52805: A job cancelled using the PeopleSoft GUI assumes a status that is not recognized by IBM Tivoli Workload Scheduler .
- Defect 11962: On Windows 2000, if the CLASSPATH environment variable is set, the psagent.exe access method abends.

APARs and defects fixed for R/3: The following APARs and defects were fixed for R/3:

- APAR IY53104: If an R/3 job step does not run, in the Tivoli Workload Scheduler environment, the R/3 job assumes the abend status.
- APAR IY51812: Cannot disable the spool data entries in the job stdlist.
- APAR IY51890: With IBM Tivoli Workload Scheduler for Applications, the SAP spoolist is always sent to the job stdlist.
- Defect 11414: Process chains were not interrupted by the kill task.

APARs and defects fixed for z/OS: The following APARs and defects were fixed for z/OS:

- APAR PQ85524: Cumulative APAR to align the IBM Tivoli Workload Scheduler for Applications, Version 8.2.0 to the level of fixes included in Version 8.1.1.
- Defect 11124: The events 2003, 2007, and 2008 have been mapped in ABEND status for a job.
- Defect 11700: The TWSoslayer.dll is not installed in the **methods** directory.
- Defect 11973: The event 2004 sent in response to a QJ event is incorrectly mapped in WAIT status for a job.
- Defect 12037: Garbage in the transaction buffer sent to the Gateway.

Limitations

This section describes all limitations applying to IBM Tivoli Workload Scheduler for Applications, Version 8.2 Fix Pack 2. It contains the following sub-sections:

- “Common limitations” on page 6
- “Limitations for Oracle E-business Suite” on page 6
- “Limitations for PeopleSoft” on page 6

- “Limitation for R/3”
- “Limitation for z/OS”

Common limitations

The following limitations apply to all the access methods:

- Defect 12944: If you perform a rollback action of the fix pack when an access method is running, the rollback fails but a successful completion message appears.
- No defect number: Before running the setup in silent mode, you have to set the environment variable DISPLAY to a valid value, Even if no graphical interface will be shown.

Limitations for Oracle E-business Suite

The following limitations apply to Oracle E-business Suite:

- Defect 13128: Even if erroneously the MCMSTAT is not replaced, a successful completion message is displayed by the **mcminstall** script.
- Defect 13171: In a three-tier connectivity configuration a coredump occurs killing a job when DBserver Oracle is stopped.

Limitations for PeopleSoft

The following limitations apply to PeopleSoft:

- Defect 11875: If you uninstall the IBM Tivoli Workload Scheduler for Applications, Version 8.2 product after applying a fix pack, the TVPUPSFT.exe file is not removed automatically.
WORKAROUND: Remove the TVPUPSFT.exe file manually.
- During the upload of the project, a basic set of Process Types whose name starts with "ITWS_" is loaded. The project load operation loads approximately 145 process types for PeopleTools Version 8.4x, and approximately 96 for PeopleTools Version 8.1x. If you submit a process with in-line bind variables belonging to a Process Type *ProcessType* that does not have any corresponding *ITWS_ProcessType*, then you must create it manually by using the PeopleSoft GUI.
- Defect 12742: Due to a PeopleSoft, Version 8.44 problem (Case ID 3338196), when the application server is on a UNIX platform, the PeopleSoft access method submits a process successfully but it fails to get the PeopleSoft job status. For this reason, the Tivoli Workload Scheduler job status is always ABEND. PeopleSoft has fixed this problem in the fix pack 11 for PeopleTools, Version 8.44.

Limitation for R/3

The following limitation applies to R/3:

- Defect 12945: It is not possible to create a job with new variant without vpar.

Limitation for z/OS

The following limitation applies to z/OS:

- On the IRIX platform under certain condition the mvs access methods hang and do not perform any submission.
WORKAROUND: Add in the *mvs_access_method.properties* file the following line:
`mvs_access_method.multiproc=0`

where *mvs_access_method* can assume one of the following values:

- mvsjs
- mvsopc

- mvsc7

t is not possible to create a job with new variant without vpar.

Installation

This section describes how to install IBM Tivoli Workload Scheduler for Applications, Version 8.2 fix pack 2. Fix pack 2 upgrades all the extended agents associated to the selected Tivoli® Workload Scheduler for Application, Version 8.2 instances. Fix packs are cumulative: so you can apply them directly to the general availability version of the product without having to install previous fix packs. Remember, however, that no fix pack will install unless you have the general availability version of the product installed on your computer. Before you install the fix pack, ensure that the following prerequisites are met:

- Tivoli Workload Scheduler processes are stopped.
- No extended agent method is running.

It is divided into the following sections:

- “Hardware and software requirements”
- “Fix pack installation methods”

Hardware and software requirements

This section includes the following topics:

- “Supported platforms”
- “System requirements”

Supported platforms:

Supported platforms at the time of the release are detailed in the *IBM Tivoli Workload Scheduler for Applications: Release Notes*. For the most recent information, consult the supported platforms matrix on the IBM® software support Web site: <http://www.ibm.com/software/support>

1. From the Web site, select **Tivoli support** from the **Other support sites** list.
2. When the page displays, select **IBM Tivoli Workload Scheduler for Applications** from the **Choose a product** pull-down list.
3. Click the **Supported Platforms** in the Related Links section.
4. Click the **Tivoli Platform and Database Support Matrix** link
5. Enter your IBM registration ID and password.

System requirements:

Hardware and software prerequisites are detailed in the *IBM Tivoli Workload Scheduler for Applications: Release Notes*. There are currently no changes to the information included in the *Release Notes*.

Fix pack installation methods

The type of installation method you can use to install the fix pack for IBM Tivoli Workload Scheduler for Applications, Version 8.2 depends on the platform you are working on.

For Tier 1 platforms, use one of the following installation methods:

- “The InstallShield MultiPlatform (ISMP) wizard” on page 8
- “Silent Installation” on page 8
- “Software Distribution command line” on page 10

For Tier 2 platforms, use the installation method described in:

“Tier 2 installation method” on page 10

For the z/OS component of the z/OS access method, use the installation method described in:

“z/OS installation method” on page 11

Tier 1 installation methods:

This section describes the installation methods you can use to install on the Tier1 platforms. It is divided into the following sub-sections:

- “The InstallShield MultiPlatform (ISMP) wizard”
- “Silent Installation”
- “Software Distribution command line” on page 10

The InstallShield MultiPlatform (ISMP) wizard:

To install the fix pack using the InstallShield MultiPlatform (ISMP) wizards perform the following steps:

1. Run the setup installation command appropriate for the platform on which you are installing the fix pack. The setup installation commands are located in platform specific directories. The installation program is launched.
2. The Welcome window is displayed. Click **Next** to continue. The installation programs detects and lists all the instances installed on your workstation.
3. From the list, select the instance on which you want to apply the fix pack, and click **Next** to continue.
4. Choose one of the following actions and click **Next** to continue:
 - Apply
 - Rollback
 - Commit
 - Repair
5. You are prompted to specify a new LUser for each extended agent if you want to override the original one, otherwise leave it blank, click **Next** to continue.
6. You are shown the location where the files are installed with the features you selected, click **Next** to continue.
7. The installation starts.
8. Click **Finish** to complete the installation.

Silent Installation:

This section describes how to install the fix pack using the **setup** installation command in silent mode. You can either specify the installation options directly on the command line or in a response file.

Note: Use the Installation option strings the exact way they are given below

To install the fix pack specifying the installation options directly on the command line, run one of the following commands:

In a Windows environment:

setup.exe -silent installation_options

In a UNIX® environment:

setup.bin -silentinstallation_options

where the *installation_options* are:

-W CHANGE_INSTANCE_NAME_BEAN.value="INSTANCE_NAME"

Required

-W DISPLAY_ACTION.selectedAction="ACTION"

Required

-W LJUSER_method_INPUT_BEAN.LJUSER="LJUSER"

Optional

where:

INSTANCE_NAME

Any TWS for Applications instance is identified by an instance name. This is usually the TWS user that owns the TWS home directory where the method was installed, but there are installation procedures that let the user choose the name for the instance (e.g. when performing a GA silent installation). You have to specify the instance name assigning its value to this option.

LJUSER

Is the name of the operating system user ID used to launch the access method.

ACTION

Is the type of action you can perform. It can be one of the following values:

- APPLY
- UNDO
- COMMIT

method

Is the access method you want to upgrade. It can be one of the following values:

- R3BATCH
- ZOSAGENT
- MCMAGENT
- PSAGENT

This is an example that performs the APPLY action to a fix pack on a UNIX workstation:

```
setup.bin -silent  
-W CHANGE_INSTANCE_NAME_BEAN.value="twuser"  
-W DISPLAY_ACTION.selectedAction="APPLY"
```

To install the fix pack using a response file, create your response file, or customize the silentfp.txt template response file contained in the RESPONSE_FILE directory of the fix pack. See the "Fix pack structure" on page 2 for a detailed description of the fix pack structure CD-ROM. The response file must be accessible from the workstation where you want to perform the installation. Entries in the response file use the following format: option=value. Each entry must be written on a separate line.

To install the fix pack using a response file, run one of the following commands depending on the operating system in which you are applying the fix pack:

In a Windows environment

```
setup.exe -silent -options responsefile
```

where *responsefile* is the name of the response file you created.

In a UNIX environment

```
setup.bin -silent -options responsefile
```

where *responsefile* is the name of the response file you created.

This is an example of a response file that performs the APPLY action on the fix pack:

```
-W CHANGE_INSTANCE_NAME_BEAN.value="maestro"  
-W DISPLAY_ACTION.selectedAction="APPLY"  
-W LJUSER_R3BATCH_INPUT_BEAN.LJUSER="maestro"  
-W LJUSER_ZOSAGENT_INPUT_BEAN.LJUSER="maestro"  
-W LJUSER_MCMAGENT_INPUT_BEAN.LJUSER="maestro"
```

Software Distribution command line:

To install the fix pack using the Software Distribution command line perform the following steps:

1. Import the TWS4APPS_method_platform.SPB into the Profile Manager, using the **wimpspo** command as follows:

```
wimpspo -c @ProfileManager -f SOURCE_PATH\TWS4APPS_method_platform_FP02.SPB  
-t build -p DEST_PATH\TWS4APPS_method_platform_FP02B.SPB  
[SoftwarePackageName.8.2.0.02]
```

If you specify the *SoftwarePackageName*, this must be the same name you specified to install the IBM Tivoli Workload Scheduler for Applications, Version 8.2 software package. As default, if you do not specify the *SoftwarePackageName*, the software package profile TWS4APPS_method.8.2.0.02 is created in the profile manager. For a complete listing of the options required, see Chapter 2, "Using Tivoli Configuration manager" in the *User's Guide*.

This section describes an example to install the fix pack 2 of the r3batch access method to a Windows endpoint, where the *SoftwarePackageName* of the IBM Tivoli Workload Scheduler for Applications, Version 8.2 software package was TWS4APPS_R3BATCH_I386NT.8.2. To install the fix pack 2 of the r3batch access method launch the following command:

```
wimpspo -c @myprofilemanager -f e:\I386NT\SPB\TWS4APPS_R3BATCH_I386NT_FP02.SPB  
-t build -p c:\fixpack\TWS4APPS_R3BATCH_I386NT_FP02.SPB  
TWS4APPS_R3BATCH_I386NT.8.2.0.02
```

Refer to the *IBM Tivoli Configuration Manager Reference Manual for Software Distribution* for a detailed explanation of the **wimpspo** command.

2. To install the fix pack in undoable mode, run the following command:

```
winstsp -uy -D INSTALL_DIR=TWSHOME -D LJUSER=twuser  
@SoftwarePackageName.8.2.0.02 @Endpoint:endpointname
```

3. To roll back to the previous code level, run the following command:

```
wundosp @SoftwarePackageName.8.2.0.02 @Endpoint:endpointname
```

4. To commit the fix pack, run the following command:

```
wacctsp @SoftwarePackageName.8.2.0.02 @Endpoint:endpointname
```

5. After the commit action, if you want to remove the software package, run the following command:

```
wremovsp @SoftwarePackageName.8.2.0.02 @Endpoint:endpointname
```

6. To repair a fix pack installation, run the following command:

```
winstsp -mr @SoftwarePackageName.8.2.0.02 @Endpoint:endpointname
```

Tier 2 installation method:

Note: Before applying the fix pack, back up the **methods** directory.

To install the fix pack follow the installation process described in the *User's Guide*, Chapter 14. "Installing on the Tier 2 Platforms".

z/OS installation method:

To install the fix pack 2, download the LOADLIB_820WSEFP02 and the SAMPLES_820WSEFP02 files contained in the Z05 directory of the fix pack to the z/OS system by following the instructions described in the *User's Guide*, Chapter 24 "Installing on z/OS", Section "Unloading the Files from the CD-ROM".

These files replace the files stored in the IBM Tivoli Workload Scheduler for Applications, Version 8.2 CD-ROM. See the "Fix pack structure" on page 2 for a detailed description of the fix pack CD-ROM structure.

Documentation notes

This section contains new information and documentation corrections contained in this fix pack.

New information contained in this fix pack

This section contains new information for the *User's Guide*.

- APAR IY51812: In Part 4: "R/3 access method". The following sections have been added:

Retrieval of joblogs of SAP jobs

Once a SAP job has been run successfully, its joblog is retrieved by r3batch and appended to the Tivoli Workload Scheduler joblog.

For jobs with large joblogs, this can take a significant amount of time. To control the retrieval of the joblog, a new option has been introduced with the IBM Tivoli Workload Scheduler for Applications, Version 8.2 fix pack as follows:

- At a global level in the r3batch.opts global options file.
- At a local level in the *workstation_r3batch.opts* local options file.
- At a job level.

Note: The SAP panels of Job Scheduling Console, Version 1.3 fix pack 2 or earlier do not contain this new option. To enable the joblog, edit the r3batch.opts global options file and disable the **jobdef=r3batch** option. In this way the Job Scheduling Console will treat all the r3batch jobs as standard Tivoli Workload Scheduler jobs

If this option is not specified, the joblog is added to the stdlist.

This section describes how to enable or disable the retrieval of the joblog at any level:

- Global level:

To retrieve the SAP joblogs in the stdlist, specify the following option in the r3batch.opts global options file:

RETRIEVE_JOBLOG

Specify whether to enable or disable the retrieval of the joblog. Possible values are ON or OFF. The default value is ON.

- Local level:

To retrieve the SAP joblogs in the stdlist, specify the following option in the *workstation_r3batch.opts* local options file:

RETRIEVE_JOBLOG

Specify whether to enable or disable the retrieval of the joblog. Possible values are ON or OFF. The default value is ON.

- Job level:

At job level, use either the Job Scheduling Console, Version 1.3 fix pack 3 or the COMPOSER command line as follows:

On the COMPOSER command line specify the following options in the Tivoli Workload Scheduler job definition:

-flag **ENABLE_JOBLOG**

To enable the retrieval of SAP joblogs

-flag **DISABLE_JOBLOG**

To disable the retrieval of SAP joblogs

Using the Job Scheduling Console, Version 1.3 fix pack 3 perform the following steps:

1. In the Actions list of the Job Scheduling Console main window, select the job for which you want to enable or disable the retrieval of SAP joblogs
2. Select a Tivoli Workload Scheduler engine and from the engine list click SAP. The Properties - Job Definition window is displayed.
3. Select **Task**. The Task page is displayed.
4. In the Job Options section, from the Job Log list, select **Enabled** to enable the retrieval of SAP joblog. Select **Disabled** to disable the retrieve of the SAP joblogs.

Note: If you disable the retrieval of SAP joblogs you also disable the return code mapping for the joblog entries.

- APAR IY51812: In Part 4: "R/3 access method". The following sections have been added:

Retrieval of the spoolists of SAP jobs

Once a SAP job has been run successfully, the spoolists of all the ABAP steps of the job are retrieved by the r3batch access method and appended to the Tivoli Workload Scheduler joblog.

For jobs with large spoolists, this can take a significant amount of time and a lot of disk space. To control the retrieval of the spoolists, new options have been introduced with the IBM Tivoli Workload Scheduler for Applications, Version 8.2 fix pack 1 as follows:

- At a global level in the *r3batch.opts* global options file.
- At a local level in the *workstation_r3batch.opts* local options file.
- At a job level.

Note: The SAP panels of Job Scheduling Console, Version 1.3 fix pack 2 or earlier do not contain these new options. To enable the spoollists, edit the `r3batch.opts` global options file and disable the `jobdef=r3batch` option. In this way all the `r3batch` jobs are treated as standard Tivoli Workload Scheduler jobs.

If these options are not specified, the spoollists, are added to the `stdlist`.

This section describes how to enable or disable the retrieval of the spoollists at any level:

– **Global level:**

To retrieve the spoollists in the `stdlist`, specify the following option in the `r3batch.opts` global options file:

RETRIEVE_SPOOLLIST

Specify whether to enable or disable the retrieval of the spoollists. Possible values are ON or OFF. The default value is ON.

– **Local level:**

To retrieve the spoollists in the `stdlist`, specify the following option in the `workstation_r3batch.opts` local options file:

RETRIEVE_SPOOLLIST

Specify whether to enable or disable the retrieval of the spoollists. Possible values are ON or OFF. The default value is ON.

– **Job level:**

At job level, use either the Job Scheduling Console, Version 1.3 fix pack 3 or the COMPOSER command line as follows:

On the COMPOSER command line, specify the following options in the Tivoli Workload Scheduler job definition:

-flag ENABLE_SPOOLLIST

To enable the retrieval of spoollists.

-flag DISABLE_SPOOLLIST

To disable the retrieval of spoollists.

Using the Job Scheduling Console, Version 1.3 fix pack 3 perform the following steps:

1. In the Actions list of the Job Scheduling Console main window, select the job for which you want to enable or disable the retrieval of a spoollists.
2. Select a Tivoli Workload Scheduler engine and from the engine list click SAP. The Properties - Job Definition window is displayed.
3. Select **Task**. The Task page is displayed.
4. In the Job Options section, from the Job Spoollist list, select **Enabled** to enable the retrieval of spoollists. Select **Disabled** to disable the retrieval of spoollists.

Note: If you disable the retrieval of spoollists you also disable the return code mapping for the spoollists entries.

Retrieval of the SAP BW Process Chain log

Once a SAP BW Process Chain has been run successfully, its log is retrieved by r3batch and appended to the Tivoli Workload Scheduler joblog.

For SAP BW Process Chain jobs with a large log, this can take a significant amount of time. To manage the retrieval of logs, a new option has been introduced with the IBM Tivoli Workload Scheduler for Applications, Version 8.2 fix pack 1 as follows:

- At a global level in the `r3batch.opts` global options file.
- At a local level in the `workstation_r3batch.opts` local options file.
- At a job level.

Note: The SAP panels of Job Scheduling Console, Version 1.3 fix pack 2 or earlier do not contain this new option. To enable the logs, edit the `r3batch.opts` global options file and disable the **jobdef=r3batch** option. In this way all the r3batch jobs are treated as standard Tivoli Workload Scheduler jobs.

If this option is not specified, the Process Chain logs, are added to the stdlist.

This section describes how to enable or disable the retrieval of logs at any level:

- **Global level:**

To retrieve the logs in the stdlist, specify the following option in the `r3batch.opts` global options file:

RETRIEVE_PCHAINLOG

Specify whether to enable or disable the retrieval of logs.
Possible values are ON or OFF. The default value is ON.

- **Local level:**

To retrieve the logs in the stdlist, specify the following option in the `workstation_r3batch.opts` local options file:

RETRIEVE_PCHAINLOG

Specify whether to enable or disable the retrieval of logs.
Possible values are ON or OFF. The default value is ON.

- **Job level:**

At job level, use either the Job Scheduling Console, Version 1.3 fix pack 3 or the COMPOSER command line as follows:

On the COMPOSER command line, specify the following options in the Tivoli Workload Scheduler job definition:

-flag ENABLE_PCHAINLOG

To enable the retrieval of logs.

-flag DISABLE_PCHAINLOG

To disable the retrieval of logs.

Using the Job Scheduling Console, Version 1.3 fix pack 3 perform the following steps:

1. In the Actions list of the Job Scheduling Console main window, select the job for which you want to enable or disable the retrieval of a log.
2. Select a Tivoli Workload Scheduler engine and from the engine list click SAP. The Properties - Job Definition window is displayed.

3. Select **Task**. The Task page is displayed.
4. In the Job Options section, from the PChain Log list, select **Enabled** to enable the retrieval of logs. Select **Disabled** to disable the retrieval of logs.

Note: If you disable the retrieval of the BW Process Chain log you also disable the return code mapping for the log entries.

- APAR IY57872: In Part 4: "R/3 access method". Section *End-to-end Dynamic R3 Job Definition Feature* has been added. Refer to Chapter 2, "End-to-end Dynamic R3 Job Definition Feature," on page 23 for a detailed description of the feature.

Documentation problems and corrections contained in this fix pack

This section contains problems and corrections for the IBM Tivoli Workload Scheduler for Applications, Version 8.2 User's Guide:

The following information changes apply to the *User's Guide*.

- Feature 11451: To enable the PeopleSoft access method to schedule jobs containing in-line bind variable parameters in their job definitions.

The aim of this fix pack is to supply an enhancement to base PeopleSoft APIs to enable current IBM Tivoli Workload Scheduler for Applications for PeopleSoft to schedule jobs containing in-line bind variable parameters in their job definitions.

Due to limitations in the PeopleSoft APIs when invoked from a batch environment, it is not possible to schedule such jobs. With current PeopleSoft APIs, data that is stored in the PeopleSoft Database and referred to by a "runcontrolid parameter" that is used to retrieve a "runcontrol data record", needs to be loaded into the "Component Buffer" before scheduling the API invocation. This cannot be done from a batch environment. Therefore, when invoking the PeopleSoft scheduling APIs from a batch interface, the data related to the runcontrol ID is not available for the submission of a job, even though it is available in the database. When unresolved data is present in the submitted job, the PeopleSoft system refuses submission and ends with an error.

The fix pack provides the ability to use the data already present in the database to resolve in-line variable values by taking data from the database and substituting it with variable definitions. It then allows job submission regardless of the use of in-line variable definitions in the jobs.

The submission activity from the Tivoli Workload Scheduler perspective does not depend on the types of jobs that are being submitted. There are limitations, when the data used for PeopleSoft jobs is volatile (never stored in the database). In these cases the data ends its life when a PeopleSoft GUI transaction is complete.

When these types of process are used, the "runcontrol data record" is referred to as the "Work record". The resolution of the work record data used in in-line bind variables is not possible, as it is for other kinds of control records, and requires special management. This case is currently out of the scope of this feature.

When you submit Tivoli Workload Scheduler using a process that has in line bind variables, the process type in the PeopleSoft GUI will be called *ITWS_process type*. For example, "ITWS_SQR Process" instead of "SQR Process".

The following section explains how to load and configure the ITWS_PSOXA PeopleSoft project to the PeopleSoft software environment.

This fix pack installs the PeopleSoft project directories related to PeopleTools Versions 8.1x and 8.4x, as shown in the following structure:

```
TWS_HOME\methods\
\---PeopleSoft
  \---PT81x
    \---ITWS_PSYA
      BCM.DAT
      BCM.KEY
      CLM.DAT
      CLM.KEY
      ITWS_PSYA.ini
      MSG.DAT
      MSG.KEY
      PCM.DAT
      PCM.KEY
      PJM.DAT
      PJM.KEY
      SMDL.DAT
      SMDL.KEY
  \---PT84x
    \---ITWS_PSYA
      ITWS_PSYA.ini
      ITWS_PSYA.XML
```

The backend shipped with the new package by default invokes the new Component Interface (CI) ITWS_PROCESSREQUEST. It is possible to force the invocation of the original CI (or any compatible CI) by defining the following new configuration options. A new configuration option can be used to invoke the original component interface (PROCESSREQUEST). The new options are as follows:

```
TWSXA_INLINE_CI=<CI name>
TWSXA_SCHED_METH=<methname>
TWSXA_SKEDM_TYPE= [ i | f | b ]
```

where:

<CI name>=Component Interface Name.

If this is not set the default value will be set as: ITWS_PROCESSREQUEST

<methname>=Name of the PeopleSoft method invoked by the Component Interface.

Ensure that the TWSXA_SCHED_METH method is used by the TWSXA_INLINE_CI Component Interface (for example:

ITWS_PROCESSREQUEST uses Schedule).

If you want to use the PeopleSoft component interface PROCESSREQUEST to submit processes without in-line bind variables, you must set

TWSXA_INLINE_CI=PROCESSREQUEST.

TWSXA_SKEDM_TYPE is the return value type of the method:

where (i= [integer], f= [float], and b=[boolean]).

The last option is used only for PeopleTools version 8.1x.

After installing the patch you must follow the steps as shown below:

1. A new PeopleSoft project called ITWS must be manually uploaded into the PeopleSoft Database. Start the Application Designer and from the signon window select to start the Application Designer in tier two mode as follows:
 - Connection Type: <Database used> for example : Oracle
 - Database Name: <Database Name>
 - User ID: <Operator PS> for example: PS

- Password of User ID
 - The Application Designer starts
2. Using the Application Designer:
- Copy Project from the file
 - Using the browser, edit the full path to specify the folder where the project that you want to load is located
 - The project is contained in the <TWSHOME>/methods/PeopleSoft/project-version subdirectories under the specific PeopleTools version directories, where: project-version = PT84x | PT81x
 - After you have chosen the folder PT84X (or PT81X) of project, a list of projects appears in the Project Name Field of the "Copy Project From File" window. Choose ITWS_P SXA and click on the copy Button
 - A Copy "window" appears showing a list of Object Types
 - To set the new settings, click the "Options" button
 - Click on "Report Filter" tab
 - Click on "Select All" button
 - Click on the "OK" button
 - Click on "select All"
 - Click on "Copy", a copy progress bar appears

After loading the project, the PeopleSoft Database contains the following objects:

- ITWS ProcessType Definition
 - ITWS Permission List
 - ITWS Cls
3. To create the new Security Role ITWS_ROLE, you can use the PeopleSoft Web GUI or the Application Designer. Follow the steps below:
- From the menu of the PeopleSoft Web GUI:
- a. People tools -> Security -> Permission and Roles -> Roles
 - b. From the Tabs select "Add a new value"
 - c. Edit ITWS_ROLE in the Role Name Field
 - d. Select the permission lists tab, select ITWS from the list, and Save.
- From the Application Designer GUI:
- a. Using Maintain Security, edit the ITWS_ROLE window
 - b. Select the Permissions list tab, select ITWS from the list, and save.
- To grant the ITWS_ROLE to all users who need to schedule jobs from Tivoli Workload Scheduler, you can use the PeopleSoft Web GUI or the Application Designer, following the steps below:
- From the Application Designer GUI:
- a. Using Maintain Security, edit the user name
 - b. Select the Roles tab
 - c. Add the ITWS_ROLE and Save.
- From the PeopleSoft WEB GUI:
- a. People Tools -> Security -> User Profiles ->
 - b. Edit the User Name
 - c. Select the Roles Tab
 - d. Add the ITWS_ROLE and Save

4. To add the ITWS process Types Definitions to the required Process Scheduler you can use the PeopleSoft Web GUI or the Application Designer. Follow the steps below:

From the Application Designer GUI:

- a. Using Process Scheduler Manager
- b. Select the Server and add the ITWS_* Type definitions
- c. Process Type definitions
- d. Type definition

From the PeopleSoft WEB GUI:

- PeopleTools -> Process Scheduler -> Servers -> Search your server -> Add the ITWS_*Process Types -> Save.

Note: From the SQL interactive command line, the same task can be performed by the following sample statement, customized for your database environment:

```
INSERT INTO PS_SERVERCLASS SELECT o.SERVERNAME,
o.OPSYS, 'ITWS_'||o.PRCSTYPE,o.PRCSPRIORITY,
o.MAXCONCURRENT FROM PS_SERVERCLASS
o WHERE ( SELECT count(*) FROM PS_SERVERCLASS i WHERE
i.SERVERNAME=o.SERVERNAME AND i.OPSYS=o.OPSYS AND
i.PRCSTYPE='ITWS_'||o.PRCSTYPE ) = 0
AND ( select count(*) from PS_PRCSTYPEDEFN
a where a.PRCSTYPE='ITWS_'||o.PRCSTYPE AND a.OPSYS=o.OPSYS ) > 0
```

5. Restart the process servers.

You do not need to make any changes to the existing Tivoli Workload Scheduler job definitions, except for the scheduling nVision process, where the runcontrol ID must be specified using the <BUSINESS_UNIT>.<REPORT_ID>convention.

An example related to Job Definition for the scheduling nVision process is shown below:

```
-process <process-name>-type nVision-Report -runcontrol
<BUSINESS_UNIT>.<REPORT_ID>
-process 'NVSRUN' -type nVision-Report -runcontrol AUS01.VARIABLE
```

- APAR IY50679:

To install the IBM Tivoli Workload Scheduler for Applications, Version 8.2 product on Windows XP, use the setup.exe contained in the I386NT_GA directory of the fix pack.

In Chapter 2. Installing IBM Tivoli Workload Scheduler for Applications, section "How to install", add the subsection "Installing on Windows XP":

Installing on Windows XP and Windows 2003

To install the IBM Tivoli Workload Scheduler for Applications, Version 8.2 product on Windows XP and Windows 2003 perform the following steps:

- From the Tivoli Workload Scheduler for Applications 8.2 CD-ROM, copy all the content of the I386NT directory locally maintaining the original directory structure.
- Substitute the setup.exe with the one provided in the fix pack CD - ROM that is located in the I386NT_GA folder.
- Launch the setup.exe. The installation proceeds as described in the "Using the Installation Wizard".

- APAR PQ85524:

In Chapter 26. "Reference Information", section "Technical Overview", Sub-section "Operation with JES", add the following information at the bottom of subsection *Checking JES Jobs*.

The IEFU84 exit cannot handle every job without impacting the performance of the entire system because it is invoked for each job running on the z/OS system.

- If the job is not present in the gateway dataspace, the IEFU84 exit does not perform any action.
- If the job is submitted by Tivoli Workload Scheduler, the gateway inserts the job in the dataspace. In this case the IEFU84 exit monitors the status of the job and of each step contained in the job.
- If the job is not submitted by Tivoli Workload Scheduler the gateway inserts the job into the dataspace only if the gateway receives the request from Tivoli Workload Scheduler to check its status because the job represents an internetwork dependency.

To have the internetwork dependencies of a z/OS job correctly handled by Tivoli Workload Scheduler on the z/OS system, ensure that there are no occurrences of the z/OS job in any job queue including the output queue. If any occurrences of the z/OS job are present then purge them. The internetwork dependencies of a z/OS job are handled by Tivoli Workload Scheduler in the following ways:

- If there are no occurrences of z/OS jobs in the job queues, the gateway inserts the job into the dataspace the first time it receives the request from Tivoli Workload Scheduler to check the job status. The gateway inserts the job into the dataspace with an unknown jobid ready to be monitored.
- When the z/OS job is submitted, the IEFU84 exit finds the job in the dataspace and updates the corresponding entry with the JES jobid. From now on the z/OS job is monitored using the associated JES jobID. If the job is completed successfully, the gateway returns the information to Tivoli Workload Scheduler, and the internetwork dependency is correctly resolved.

In Chapter 26. Reference Information, section "Gateway Messages", add the following message:

```
"EEWI31E TASK task MODULE module LAUNCH OF JOB 'jobname' FAILED"
```

- APAR PQ85489:

In Chapter 24. Introduction, Section "Installation Overview", sub-section "Additional Notes[®] SYSTSIN Variables" add the **JESINTERFACE** variable and modify the description of the **MAXWAIT** and **MCSSTORAGE** variables in Table 21. SYSTSIN variables as shown below:

Variables	Description
JESINTERFACE(CONSOLE)	CONSOLE is the only supported interface for JES and it is the default value for this variable. Set to NO if you do not use this interface
MAXWAIT(500)	The maximum amount of time, in hundredths of a second, to wait for a response to commands. This variable is ignored if you set both CA7INTERFACE and JESINTERFACE to NO.
MCSSTORAGE(3)	The amount of storage, in megabytes, used by each extended console used by the gateway. This variable is ignored if you set both CA7INTERFACE and JESINTERFACE to NO.

In Chapter 26. Reference Information, section "Gateway Messages", add the following message:

```
EEWI32S yymdd hhmss module AT LEAST ONE INTERFACE MUST BE DIFFERENT FROM NO
```

- APAR PQ88345

In Chapter 26. Reference Information, section "Gateway Messages", change the text of the EEWI27I message and add the EEWI33W and EEWI34W messages as shown below:

- EEWI27I APPLICATION *application* WAS INSERTED IN CP WITH INPUT ARRIVAL DATE AND TIME *yymmddhhss*
- EEWI33W *yymmdd hhmmss* TASK *task* APPLICATION *application* NOT FOUND
- EEWI34W APPLICATION *application* NOT FOUND

Note: All the above messages are written in the EEWSPACE or in the EEWSERVE log. These are the files indicated in the SYSTSPRT DD card of the respective procedure. In the files the messages are written starting from column 1, except for the messages that do not contain the date and time after the message identifier, for example EEWI27I. These messages appear with different characteristics in the z/OS system and on the Tivoli Workload Scheduler. In the z/OS system log the messages appear in the text of another message and in some cases they might appear truncated. This is because the maximum length of each text record is limited to 251 characters. In Tivoli Workload Scheduler they are always displayed in their complete form.

- Defect 11879

In the three tier connection the user can use two Oracle Server UNIX computers, the MCMAGENT will reside on a computer where no APPS DB is present, (or is not used in the configuration file). The DB is located in the second UNIX computer where it can be reached using Oracle Network connectivity.

To work in a 3 tier connectivity environment the new option THREE_TIER_DB has been introduced. Its value is the TNS service name defined in an Oracle environment pointing to a remote DB server. The Oracle DB instance value is not mandatory, it is mandatory only for a 3 tier connectivity.

The following is an example: of a *WORKSTATION_MCMAGENT.opts* containing the new option:

<WS>_MCMAGENT.opts contents

```
MIN_TIME=10
ORACLE_HOME=/oracle/db/TST
ORACLE_SID=TST
ORA_APP_TOPDIR=/oracle/Apps11
FND_TOPDIR=$APPL_TOP/fnd/11.0.28
PATH=$PATH:$FND_TOP/bin:$MCM_TOP/bin
ENV=$APPL_TOP/APPTST.env
USERID=apps
PASSWORD=##3Y-UGcZ-3Kap-6m
PRINTER_NAME=prt4b2
MAX_TIME=150
THREE_TIER_DB=TST
```

where TST is the name of the oracle DB instance where the APPS DB is located. All other parameters are related to the local DB and APPS installation.

For the three tier configuration to work, you must define the **TWO_TASK** environment variables inside the Oracle environment setup scripts.

Note: When running the **mcminstall** script, the environment variable **TWO_TASK** must not be set externally or in the scripts given to **mcminstall** as an input parameter, otherwise you cannot perform the re-link steps successfully.

- Part 6. Common Serviceability, Chapter 29. Configuring the Trace Utility, add the following message:

The trace utility cannot be completely disabled. A minimum set of traces is always printed in the trace file. If you want to disable the trace utility completely, add the following line in the *accessmethod.properties* file:

```
access_method.trace.traces.logging=false
```

In this case if any problems occur no traces are printed in the *trace-accessmethod.log* file.

Chapter 2. End-to-end Dynamic R3 Job Definition Feature

Currently IBM Tivoli Workload Scheduler 8.2 is only capable of running SAP Pre-Defined jobs. These Pre-Defined jobs are created either using the SAPGUI or using the Tivoli Workload Scheduler Job Scheduling Console (in a distributed environment only). When Tivoli Workload Scheduler is about to start a SAP job, it makes a copy of the Pre-Defined job (known as a template job) and launches the copy.

If the same job is to be run on several SAP systems, currently you need to manually create the template job in each SAP system.

This new feature allows users in a Tivoli Workload Scheduler End-to-end environment to create a SAP job instantly and launch it without having to create or reference a Pre-Defined job template.

Therefore the same job can be launched in any number of SAP systems. If the Tivoli Workload Scheduler job definition contains the SAP job ID, Tivoli Workload Scheduler first retrieves the definition of the SAP job that corresponds to the given job name and the job ID, then it creates a new SAP job using the settings of the SAP job as template, and replaces them with the corresponding values from the Tivoli Workload Scheduler job definition.

Although it is possible to use the new functionality on all R/3 releases supported by Tivoli Workload Scheduler 8.2, it is strongly suggested to install XBP 2.0, because the older versions of XBP do not support the full set of print and archive parameters, or provide a way to set the job class, or the spool list recipient.

Note: The End-to-end centralized script feature is not supported when working with the R/3 x-agent. This limitation has not currently been resolved.

Job Creation Parameters

In order to dynamically define and submit a SAP job using the new feature, use the JOBCMD in JOBREC statement with the following syntax:

The syntax below defines the attributes of steps:

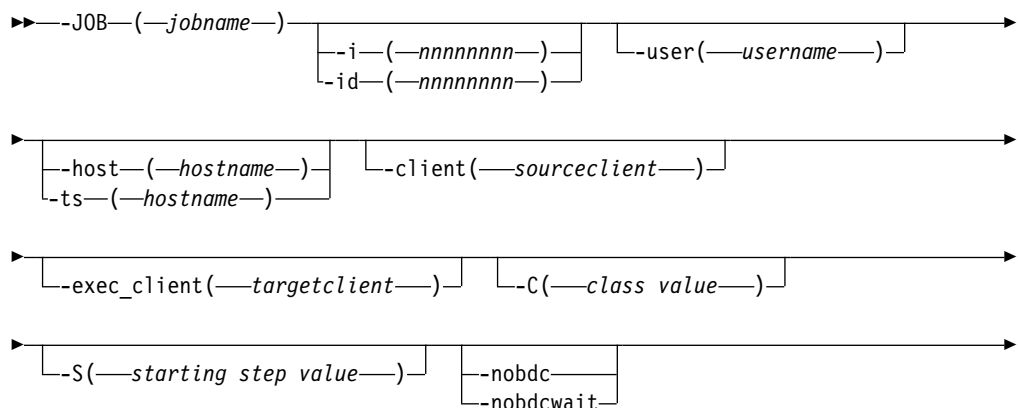

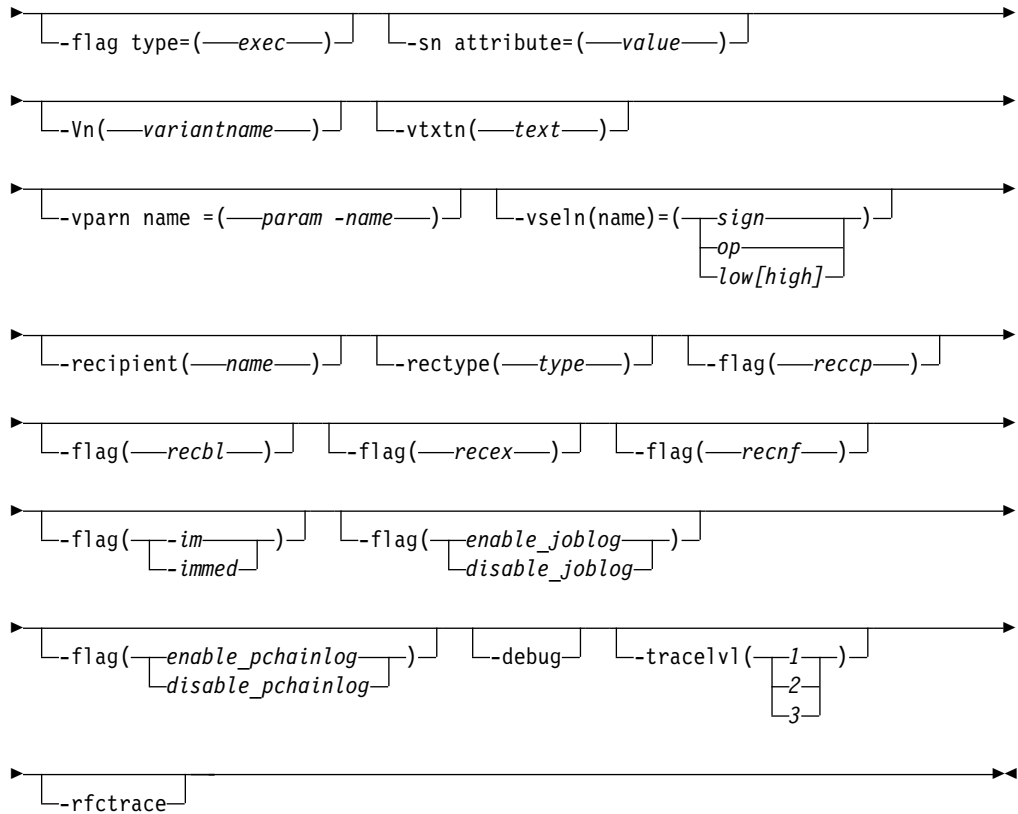

The syntax below defines the attributes of the steps:

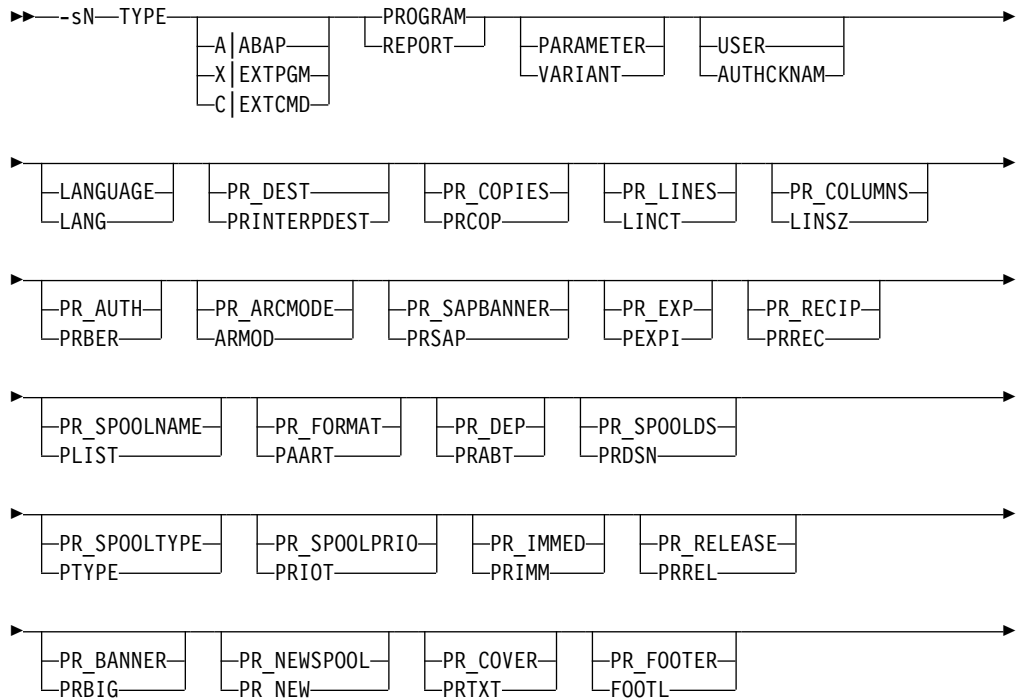

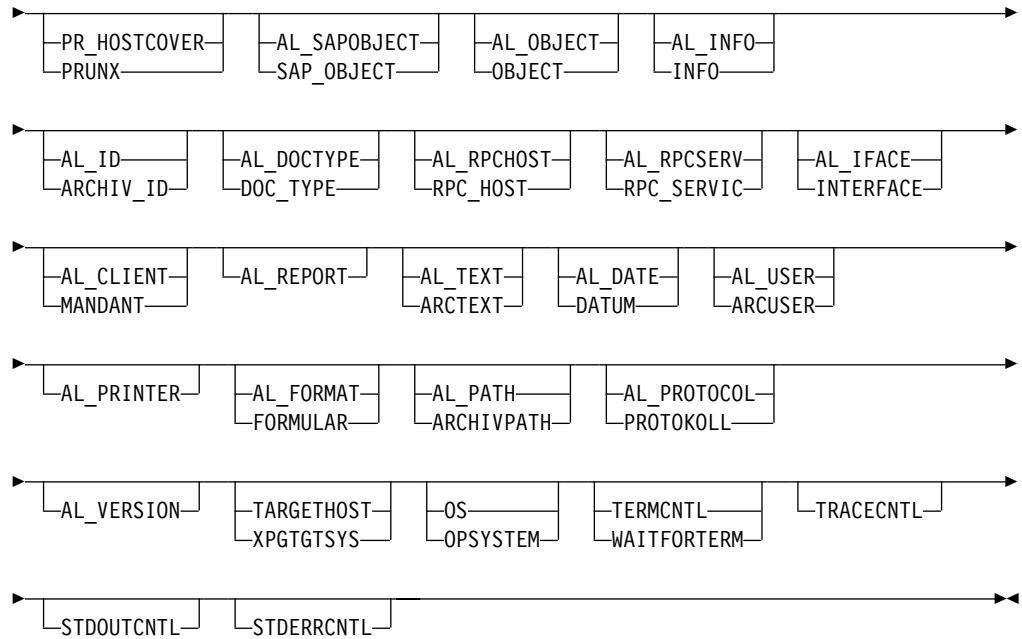

The following is an example of a JOBREC statement in the SCRPTLIB member referenced by the Tivoli Workload Scheduler job definition:

```
JOBREC
  JOBCMD('/ -job SAPTEST -C A -user MAESTRO -s2 variant=BVT -s1 program=BTCTEST
-s2 report=BTCTEST -s1 type=A -s2 type=A -flag type=exec -s1 pr_release
-vpar2 TESTNAME=test -vtxt2 Test ') JOBUSR(TWSuser)
```

Summary of Supported Parameters

A complete new job definition may be built by using 6 major sections related to the attributes of a SAP job, as summarized in the following table, the sections are related to:

- Job
- Steps (associated with the job)
- Variants (associated with steps)
- Spool List recipients (associated with the job)
- Flags (associated with the job)
- Tracing (associated with the job)

Section	Parameters	Description
JOB	-job <i>jobname</i>	Job name (this is a mandatory parameter)
	-i value -id value	Job ID (this is a mandatory parameter in all cases except in job creation)
	-user <i>username</i>	Owner of the job
	-host value -ts value	Target server
	-client value	Source client
	-exec_client value	Target client for job execution
	-C value	Job class
	-S value	Starting step
	-nobdc -nobdcwait	Disable BDC Wait feature (enabled by default)
	-flag type=exec	Type of job definition. In order to trigger the creation/redefinition of an SAP job this parameter is mandatory.
	STEP Note: Refer to the "Supported Attributes for step definition" shown on page 8	-sN attribute[=value]
VARIANT	-vtxtN text	Variant description for step N
	-vN name	Variant name for step N
	-vparN name=value	Value for a variant parameter for step N (this parameter is mandatory when creating a new variant)
	-vselN name=sign#op#low[#high]	Value for a variant selection option for step N

SPOOL	-recipient <i>name</i>	Login name of an R/3 user
	-flag reccp	The spool list is sent as a copy to the recipient
	-flag recbl	The spool list is sent as a blind copy to the recipient
	-flag recex	The spool list is sent as an express message to the recipient
	-flag recnf	The recipient is not allowed to forward the spool list
	-rectype type	<ul style="list-style-type: none"> • ' ' - SAP user (default value) • 'B' - SAP user • 'C' - shared distribution list • 'D' - X.500 address • 'G' - organization object/ID • 'H' - organization unit • 'T' - SAP object • 'L' - telex number • 'O' - SAPOffice user • 'P' - private distribution list • 'R' - SAP user in another SAP system • 'U' - internet address • 'I' - other recipient type
FLAGS	-flag im -flag immed	Launch job immediately, meaning that if there are no spare work processes, the job will fail
	-flag ENABLE_JOBLOG -flag DISABLE_JOBLOG	Enable or disable retrieval of the joblog
	-flag ENABLE_SPOOLLIST -flag DISABLE_SPOOLLIST	Enable or disable retrieval of the spool lists of the job
	-flag ENABLE_PCHAINLOG -flag DISABLE_PCHAINLOG	Enable or disable retrieval of the process chain log
TRACING	-debug	Enable maximum trace level
	-tracelvl 1 2 3	Enable specified trace level
	-rfctrace	Enable RFC trace

Supported Attributes for Step Definition

The following table shows all supported attributes for step definition:

Primary attribute name	Synonym	Description
TYPE	TYP	<p>Step type:</p> <ul style="list-style-type: none"> • A: ABAP step • X: external program step • C: external command step <p>Alternatively, this attribute accepts the following values:</p> <ul style="list-style-type: none"> • ABAP: ABAP step • EXTPGM: external program step • EXTCMD: external command step <p>A check for correct attribute values is performed prior to launching the job.</p>
PROGRAM	REPORT	ABAP program name or name of the external program or command
PARAMETER	VARIANT	ABAP variant name or parameters for the external program or command
USER	AUTHCKNAM	User of the step
LANGUAGE	LANG	<p>Step language</p> <p>This attribute accepts language names in either the ISO format (two characters, for example DE, EN) or the SAP format (one character, for example D, E)</p> <p>If this attribute is not specified, the login language of the access method is used (customizes via the option XAMETH_LANG in the r3batch option files)</p> <p>Check for a valid language is performed prior to launching the job.</p>
PR_DEST	PRINTERPDEST	Print Parameter: Printer for the output
PR_COPIES	PRCOP	<p>Print Parameter: Number of copies</p> <p>The value of this attribute has to be numeric. A corresponding check is performed prior to launching the job.</p>
PR_LINES	LINCT	<p>Print Parameter: Page length</p> <p>The value of this attribute has to be numeric. A corresponding check is performed prior to launching the job.</p>
PR_COLUMNS	LINSZ	<p>Print Parameter: Page width</p> <p>The value of this attribute has to be numeric. A corresponding check is performed prior to launching the job.</p>
PR_AUTH	PRBER	Print Parameter: Authorization
PR_ARCMODE	ARMOD	Print Parameter: Archiving mode

PR_SAPBANNER	PRSAP	Print Parameter: SAP cover page
PR_EXP	PEXPI	Print Parameter: Spool retention period The value of this attribute has to be a single digit. A corresponding check is performed prior to launching the job.
PR_RECIP	PRREC	Print Parameter: Recipient
PR_SPOOLNAME	PLIST	Print Parameter: Name of spool request *)
PR_FORMAT	PAART	Print Parameter: Print formatting *)
PR_DEP	PRABT	Print Parameter: Department on cover page *)
PR_SPOOLDS	PRDSN	Print Parameter: Name of spool dataset *)
PR_SPOOLTYPE	PTYPE	Print Parameter: Type of spool request *)
PR_SPOOLPRIO	PRIOT	Print Parameter: Spool request priority *)
PR_IMMED	PRIMM	Print Parameter: Print immediately **)
PR_RELEASE	PRREL	Print Parameter: Delete after printing **)
PR_BANNER	PRBIG	Print Parameter: Selection cover page **)
PR_NEWSPPOOL	PRNEW	Print Parameter: New spool request *) **)
PR_COVER	PRTXT	Print Parameter: Text for cover page *) **)
PR_FOOTER	FOOTL	Print Parameter: Output footer *) **)
PR_HOSTCOVER	PRUNX	Print Parameter: Host spool cover page *) **)
AL_SAPOBJECT	SAP_OBJECT	SAP ArchiveLink: Object type of business object
AL_OBJECT	OBJECT	SAP ArchiveLink: Document type
AL_INFO	INFO	SAP ArchiveLink: Info field
AL_ID	ARCHIV_ID	SAP ArchiveLink: Target storage system *)
AL_DOCTYPE	DOC_TYPE	SAP ArchiveLink: Document class *)
AL_RPCHOST	RPC_HOST	SAP ArchiveLink: PRC host *)
AL_RPCSERV	RPC_SERVIC	SAP ArchiveLink: RPC service / RFC destination *)
AL_IFACE	INTERFACE	SAP ArchiveLink: Name of communication connection component *)
AL_CLIENT	MANDANT	SAP ArchiveLink: Client *)
AL_REPORT		SAP ArchiveLink: Report name *)
AL_TEXT	ARCTEXT	SAP ArchiveLink: Text information field *)
AL_DATE	DATUM	SAP ArchiveLink: Archiving date *)
AL_USER	ARCUSER	SAP ArchiveLink: Data element for user *)
AL_PRINTER		SAP ArchiveLink: Target printer *)
AL_FORMAT	FORMULAR	SAP ArchiveLink: Output format *)
AL_PATH	ARCHIVPATH	SAP ArchiveLink: Standard archive path *)
AL_PROTOCOL	PROTOKOLL	SAP ArchiveLink: Storage connection protocol *)
AL_VERSION		SAP ArchiveLink: Version number *)
TARGETHOST	XPGTGTSYS	Target host for external program or command
OS	OPSYSTEM	Operating system for external command

TERMCNTL	WAITFORTERM	Control flag: whether an external command or program is to be run synchronously **)
TRACECNTL		Control flag: whether SAP tracing level 3 is activated for tracing SAPXPG, the program that starts an external command or program *) **)
STDOUTCNTL		Control flag: indicates whether standard output from an external command or program is to be written to the job log *) **)
STDERRCNTL		Control flag: indicates whether standard error from an external command or program is to be written to the job log *) **)

*) this attribute is available since XBP 2.0 (XBP 6.10)

**) this attribute is a flag, i.e. it does not have a value, e.g. -s2#pr_release

New Parameters Used in the Job Definition

To allow the definition and scheduling of jobs in R/3 environment without defining template jobs, a set of new command line parameters has been introduced. Shown below is the description of these new parameters together with an example of how they are used.

Job

-flag type=exec

Besides the attributes for the step definition, r3batch needs this additional flag to be specified on the command line to be able to recognize the new job definition.

This flag is mandatory to define or update jobs using this feature. If you want to reference an existing SAP template, you can omit this keyword providing you supply the correct job id of the template.

Steps (associated with the job)

Step definition is done using the following command line parameters:

-sN attribute[=value]: as in -s8 REPORT=MYPGM

where:

N: Step number

attribute: Name of the attribute

value: value of the attribute, this is optional for some attributes

Only valid attribute names are accepted. The validation on the attributes is performed before the job is created in the SAP system. If the validation fails, the Tivoli Workload Scheduler job will go into the ABEND state.

Variants (associated with steps)

For example: -v3 ACCT01 -vtxt3 My variant -vsel3 ACCTNUM=I#BT#001#999

The variant management is done using following command line parameters for the Nth step:

-vN variant: name of the variant

-vtxtN: text variant description, in the Tivoli Workload Scheduler logon language (customizes by the r3batch option TWSXA_LANG); max. 30 characters

-vparN name=value: for ABAP program parameters, max. 45 characters.

-vselN name=sign#op#low[#high]: for ABAP program selections

Where:

sign: sign of the operation

op: operation

low: value of the selection; max. 45 characters

high: high value of the selection; max. 45 characters; optional

- The valid values for the sign of the operation are 'I' (include) and 'E' (exclude), while the valid operations are described in the following table:

Operation	Description
EQ	Equals
NE	Not equal to
BT	Between
NB	Not between
LT	Less than
LE	Less than or equal to
GT	Greater than
GE	Greater than or equal to
CP	Contains pattern
NP	Does not contain pattern

When using this feature to create or update SAP jobs, remember the following facts about variants:

To create or reference a variant within an ABAP step you can use one of the following equivalent syntaxes:

- -s1 Variant=Var1
- -s1 Parameter=Var1
- -v1 Var1

If a variant does not exist, it is created with the parameters specified in the job definition statement. In this case, all mandatory attributes of the variant should be given a value. The creation of empty variants is not supported.

If the variant is already present in the R/3 system, its values are modified according to the command line parameters. If the existing variant is an extended one, a new instance of it is created with resolved placeholders and updated counters. This new variant instance is then updated using the values from the command line. Finally, the job step is executed using this variant instance.

Note: All changes to the variant values are permanent, that is, Tivoli Workload Scheduler neither restores the old values of the variants nor deletes the variants created after the job is run. Tivoli Workload Scheduler does not change the case of the variant values.

- Flags (associated with the job)
- Tracing (associated with the job)

Refer to the summary of supported parameters table for details on Flags and Tracing.

Executing from a Tivoli Workload Scheduler End-to-end Environment

To use IBM Tivoli Workload Scheduler for Applications for R/3, Tivoli Workload Scheduler for z/OS must be enabled with the end-to-end feature. To schedule an R/3 extended agent job, follow these steps:

1. Define an extended agent for R/3 workstation in the IBM Tivoli Workload Scheduler for z/OS environment.
2. Define a job in IBM Tivoli Workload Scheduler for z/OS (SCRPTLIB member) contains the job definition statement for this feature.
3. Create a job stream (or application) that Tivoli Workload Scheduler for Applications for R/3 jobs.

The definitions above must implement a Tivoli Workload Scheduler configuration where the x-agent for SAP is installed on a distributed Tivoli Workload Scheduler FTA in a Tivoli Workload Scheduler network mastered by a Tivoli Workload Scheduler for z/OS agent. Refer to the *IBM Tivoli Workload Scheduler for Applications 8.2 Users Guide* Chapters 4 and 5, The enhancement described in this document affects the way that the JOBREC statement is built for the r3batch jobs.

Tivoli Workload Scheduler performs the following syntax validation on job attributes:

- Only valid attributes are allowed
- Checks if a particular attribute requires a value
- The values of following attributes are checked: TYPE, LANGUAGE, PR_COPIES, PR_LINES, PR_COLUMNS

The validation is performed before the job is created in the SAP system. If the validation fails, the Tivoli Workload Scheduler job goes into the ABEND state.

Specifying Job Parameters Using Variable Substitution

It is also possible to provide parameters at execution time by using the Variable substitution feature of the Tivoli Workload Scheduler for z/OS. In this case the value will appear as:

- -s1 report=&VARNAME

The variable substitution will occur at symphony file creation time by Tivoli Workload Scheduler.

See the *Tivoli Workload Scheduler Reference Guide* for more information about Tivoli Workload Scheduler parameters.

Defining and Updating R3 Jobs Using the End-to-end Dynamic Allocation Feature

This section describes some usage examples of this feature:

- **Job definition and run scenario (using the new -flag type exec option)**

The following example creates and runs a 3 step job assigned to the user MAESTRO. The first step runs the ABAP MYPROG1 using variant VAR01 and associated variant parameter. Step 2 has a step user defined. Step 3 uses the same ABAP as step 1 with no associated variant.

The only requirement is that the elements referred are known in the SAP system (user, program). If the variant does not exist there should be a set of values to define the content of the variant for its creation (pairs of -vpar<N> -vsel<N> parameters for the parameters and selections of the ABAP program)

```
JOBCMD( -job TESTJOB01 -user MAESTRO -c A -s1 type=A -s1 program=MYPROG1
-v1 VAR01 -vpar1 TESTNAME=TST -s2 report=SPOOLX1 -s2 user=PRTUSER
-s3 type=A -s3 program=MYPROG1 -flag type=exec)
```

The job returns job ID 12345678

- **Job copy/overwrite of the job created in previous step**

The following job statement references the job created in the previous example. A new copy of the job is made and the parameters specified in the invocation are used to update the definition. In this case the variant for step 1 is modified and a new external program step (step 4) is added.

```
JOBCMD( -job TESTJOB01 -i 12345678 -s1 variant=VAR01A -vpar1 TESTNAME=TST2
-s4 type=X -s4 report=niping -s4 parameter=-t -flag type=exec)
```

- **Copy overwrite of a job referencing an existing job template**

The following example shows a job creation referencing a job template (previously created without using this feature). A template job called `TEMPLAJOB` already exists on SAP system with ID of 56780123. It is a single ABAP step job to which we now add some print parameters.

```
JOBCMD(-job TEMPLAJOB -I 56780123 -s1 pr_immed -flag type=exec)
```

Chapter 3. Contacting IBM Software Support

Before contacting IBM Software Support with a problem, refer to the IBM Software Support site by accessing the following Web address:

<http://www.ibm.com/software/support>

To access Tivoli support, click the Tivoli support link at the bottom right of the page.

If you want to contact IBM Software Support, see the *IBM Software Support Guide* at the following Web site:

<http://techsupport.services.ibm.com/guides/handbook.html>

The guide provides information about how to contact IBM Software Support, depending on the severity of your problem, and the following information:

- Registration and eligibility.
- Telephone numbers, depending on the country in which you are located.
- Information you must have before contacting IBM Software Support.

Chapter 4. Notices

This information was developed for products and services offered in the U.S.A. IBM may not offer the products, services, or features discussed in this document in other countries. Consult your local IBM representative for information on the products and services currently available in your area. Any reference to an IBM product, program, or service is not intended to state or imply that only that IBM product, program, or service may be used. Any functionally equivalent product, program, or service that does not infringe any IBM intellectual property right may be used instead. However, it is the user's responsibility to evaluate and verify the operation of any non-IBM product, program, or service.

IBM may have patents or pending patent applications covering subject matter described in this document. The furnishing of this document does not give you any license to these patents. You can send license inquiries, in writing, to:

IBM Director of Licensing
IBM Corporation
North Castle Drive
Armonk, NY 10504-1785 U.S.A.

For license inquiries regarding double-byte (DBCS) information, contact the IBM Intellectual Property Department in your country or send inquiries, in writing, to:

IBM World Trade Asia Corporation
Licensing
2-31 Roppongi 3-chome, Minato-ku
Tokyo 106, Japan

The following paragraph does not apply to the United Kingdom or any other country where such provisions are inconsistent with local law:

INTERNATIONAL BUSINESS MACHINES CORPORATION PROVIDES THIS PUBLICATION "AS IS" WITHOUT WARRANTY OF ANY KIND, EITHER EXPRESS OR IMPLIED, INCLUDING, BUT NOT LIMITED TO, THE IMPLIED WARRANTIES OF NON-INFRINGEMENT, MERCHANTABILITY OR FITNESS FOR A PARTICULAR PURPOSE.

Some states do not allow disclaimer of express or implied warranties in certain transactions, therefore, this statement might not apply to you.

This information could include technical inaccuracies or typographical errors. Changes are periodically made to the information herein; these changes will be incorporated in new editions of the publication. IBM may make improvements and/or changes in the product(s) and/or the program(s) described in this publication at any time without notice.

Any references in this information to non-IBM Web sites are provided for convenience only and do not in any manner serve as an endorsement of those Web sites. The materials at those Web sites are not part of the materials for this IBM product and use of those Web sites is at your own risk.

IBM may use or distribute any of the information you supply in any way it believes appropriate without incurring any obligation to you.

Licensees of this program who wish to have information about it for the purpose of enabling: (i) the exchange of information between independently created programs and other programs (including this one) and (ii) the mutual use of the information which has been exchanged, should contact:

IBM Corporation
2Z4A/101
11400 Burnet Road
Austin, TX 78758 U.S.A.

Such information may be available, subject to appropriate terms and conditions, including in some cases payment of a fee.

The licensed program described in this document and all licensed material available for it are provided by IBM under terms of the IBM Customer Agreement, IBM International Program License Agreement or any equivalent agreement between us.

Any performance data contained herein was determined in a controlled environment. Therefore, the results obtained in other operating environments may vary significantly. Some measurements may have been made on development-level systems and there is no guarantee that these measurements will be the same on generally available systems. Furthermore, some measurement may have been estimated through extrapolation. Actual results may vary. Users of this document should verify the applicable data for their specific environment.

Information concerning non-IBM products was obtained from the suppliers of those products, their published announcements or other publicly available sources. IBM has not tested those products and cannot confirm the accuracy of performance, compatibility or any other claims related to non-IBM products. Questions on the capabilities of non-IBM products should be addressed to the suppliers of those products.

This information contains examples of data and reports used in daily business operations. To illustrate them as completely as possible, the examples include the names of individuals, companies, brands, and products. All of these names are fictitious and any similarity to the names and addresses used by an actual business enterprise is entirely coincidental.

If you are viewing this information in softcopy form, the photographs and color illustrations might not display.

Trademarks

IBM, the IBM logo, AIX, Tivoli, the Tivoli logo, and z/OS are trademarks or registered trademarks of International Business Machines Corporation in the United States, other countries, or both.

Microsoft, Windows, and Windows NT are registered trademarks of Microsoft Corporation in the United States, other countries, or both.

UNIX is a registered trademark of The Open Group in the United States and other countries



Java™ and all Java-based trademarks and logos are trademarks or registered trademarks of Sun Microsystems, Inc. in the United States, other countries, or both.

Linux™ is a trademark of Linus Torvalds in the United States, other countries, or both.

Other company, product, and service names may be trademarks or service marks of others.



Program Number: 5698-WSE