

IBM® Tivoli® Workload Scheduler for Applications



Readme File for Fix Pack 7 - PTF (U805771)

Version 8.2

Note

Before using this information and the product it supports, read the information in Chapter 4, "Notices," on page 53.

Second Edition (December 2005)

This edition applies to fix pack 7 (PTF U805771) for version 8, release 2, modification level 0 of IBM Tivoli Workload Scheduler for Applications.

© Copyright International Business Machines Corporation 2004, 2005. All rights reserved.

US Government Users Restricted Rights – Use, duplication or disclosure restricted by GSA ADP Schedule Contract with IBM Corp.

Contents

Chapter 1. IBM Tivoli Workload Scheduler for Applications Fix Pack 7 for Version 8.2 . . . 1

About this release	1
Fix pack structure	1
Features Introduced with Fix Pack 3	2
Features introduced with fix pack 2.	3
Features introduced with fix pack 1.	3
Product fix history	3
APARs and Defects fixed in IBM Tivoli Workload Scheduler for Applications, Version 8.2 fix pack 7	3
APARs and Defects fixed for R/3	3
APARs and Defects fixed for z/OS	4
APARs and Defects fixed for Oracle	4
APARs and Defects fixed for PeopleSoft	4
APARs and Defects fixed in IBM Tivoli Workload Scheduler for Applications, Version 8.2 fix pack 6	4
Common APARs and Defects	4
APARs and Defects fixed for R/3	5
APARs and Defects fixed for z/OS	5
APARs and Defects fixed for Oracle	5
APARs and Defects fixed for PeopleSoft	5
APARs and Defects fixed in IBM Tivoli Workload Scheduler for Applications, Version 8.2 fix pack 5	5
APARs and Defects fixed for R/3	6
APARs and Defects fixed for z/OS	6
APARs and Defects fixed for Oracle	6
APARs and Defects fixed in IBM Tivoli Workload Scheduler for Applications, Version 8.2 fix pack 4	6
Common APARs and Defects	6
APARs and Defects fixed for R/3	6
APARs and Defects fixed for z/OS	7
APARs and Defects fixed for Oracle	7
APARs and Defects fixed in IBM Tivoli Workload Scheduler for Applications, Version 8.2 fix pack 3	7
Common APARs and Defects	7
APARs and Defects fixed for PeopleSoft	7
APARs and Defects fixed for R/3	7
APARs and Defects fixed for z/OS	8
APARs and Defects fixed in IBM Tivoli Workload Scheduler for Applications, Version 8.2 fix pack 2	8
Common APARs and Defects	8
APARs and Defects fixed for Oracle E-business Suite	9
APARs and Defects fixed for PeopleSoft	9
APARs and Defects fixed for R/3	9
APARs and Defects fixed for z/OS	9
APARs and Defects fixed in IBM Tivoli Workload Scheduler for Applications, Version 8.2 fix pack 1	9
Common APARs and Defects	9
APARs and Defects fixed for Oracle E-business Suite	9
APARs and Defects fixed for PeopleSoft	10
APARs and Defects fixed for R/3	10
APARs and Defects fixed for z/OS	10
Limitations	10
Common limitations	10
Limitations for Oracle E-business Suite	11
Limitations for PeopleSoft	11
Limitation for R/3	14
Limitation for z/OS	14
Installation	15
Hardware and software requirements.	15
Supported platforms	15
Fix pack installation methods	15
Tier 1 installation methods	16
Tier 2 installation method	19

z/OS installation method.	19
Documentation notes	19
New information	19
Alternate install script instructions.	23
Documentation problems and corrections	27
Common	27
PeopleSoft	29
R/3	32
Oracle	33
z/OS	34
Chapter 2. End-to-end Dynamic R3 Job Definition Feature	39
Job Creation Parameters	39
Summary of Supported Parameters	41
Supported Attributes for Step Definition	44
New Parameters Used in the Job Definition	46
Executing from a Tivoli Workload Scheduler End-to-end Environment	48
Specifying Job Parameters Using Variable Substitution	49
Defining and Updating R3 Jobs Using the End-to-end Dynamic Allocation Feature	49
Chapter 3. Contacting IBM Software Support	51
Chapter 4. Notices	53
Trademarks	54

Chapter 1. IBM Tivoli Workload Scheduler for Applications Fix Pack 7 for Version 8.2

Date December 16, 2005

Fix Pack
8.2.0-TIV-TWSWSE-FP0007

PTF Number
U805771

Product
IBM Tivoli Workload Scheduler for Applications, Version 8.2

General Description
IBM Tivoli Workload Scheduler for Applications, Version 8.2 Fix Pack 7

Review this section thoroughly before installing or using this fix pack.

About this release

This section includes the following topics:

- “Fix pack structure”
- “Features Introduced with Fix Pack 3” on page 2
- “Features introduced with fix pack 2” on page 3
- “Features introduced with fix pack 1” on page 3
- “Product fix history” on page 3
- “Limitations” on page 10
- “Installation” on page 15
- “Documentation notes” on page 19

Fix pack structure

IBM Tivoli Workload Scheduler for Applications, Version 8.2 Fix Pack 7 has the following structure:

```
+---8.2.0-TIV-TWSWSE-FP0007.README (This File)
|---8.2.0-TIV-TWSWSE-FP0007.VSR
+---AIX
|   |   setup.bin
|   |   \---SPB
|   |       TWS4APPS_MCMAGENT_AIX_FP07.SPB
|   |       TWS4APPS_R3BATCH_AIX_FP07.SPB
|   |       TWS4APPS_ZOSAGENT_AIX_FP07.SPB
|   |       TWS4APPS_OPTED_FP07.SPB
+---DYNIX
|   |   TWS4APPS_ZOSAGENT_DYNIX.TAR
+---HP
|   |   setup.bin
|   |   \---SPB
|   |       TWS4APPS_MCMAGENT_HP_FP07.SPB
|   |       TWS4APPS_R3BATCH_HP_FP07.SPB
|   |       TWS4APPS_ZOSAGENT_HP_FP07.SPB
|   |       TWS4APPS_OPTED_FP07.SPB
```

```

|
+---I386NT
|   setup.exe
|   \---SPB
|         TWS4APPS_PSAGENT_I386NT_FP07.SPB
|         TWS4APPS_R3BATCH_I386NT_FP07.SPB
|         TWS4APPS_ZOSAGENT_I386NT_FP07.SPB
|         TWS4APPS_OPTED_FP07.SPB
|
+---I386NT_GA
|   setup.exe
|
+---IRIX
|   TWS4APPS_ZOSAGENT_IRIX.TAR
|
+---IY63385
|   libaixppk.so
|
+---LINUX
|   setup.bin
|   \---SPB
|         TWS4APPS_R3BATCH_LINUX_FP07.SPB
|         TWS4APPS_OPTED_FP07.SPB
|
+---LINUX390
|   setup.bin
|   \---SPB
|         TWS4APPS_R3BATCH_LINUX390_FP07.SPB
|         TWS4APPS_ZOSAGENT_LINUX390_FP07.SPB
|         TWS4APPS_OPTED_FP07.SPB
|
+---OSF
|   TWS4APPS_R3BATCH_OSF.TAR
|   TWS4APPS_ZOSAGENT_OSF.TAR
|
+---RESPONSE_FILE
|   silentfp.txt
|
+---SOLARIS
|   setup.bin
|   \---SPB
|         TWS4APPS_MCMAGENT_SOLARIS_FP07.SPB
|         TWS4APPS_R3BATCH_SOLARIS_FP07.SPB
|         TWS4APPS_ZOSAGENT_SOLARIS_FP07.SPB
|         TWS4APPS_OPTED_FP07.SPB
|
\---ZOS
      LOADLIB_820WSEFP07
      SAMPLES_820WSEFP07

```

Features Introduced with Fix Pack 3

The following features have been introduced in fix pack 3:

- APAR IY58262: The fix pack installation downloads PeopleTools projects specific to the different supported PeopleTools versions. The PeopleTools project has to be uploaded on the PeopleTools Application server after applying this fix pack.

This fix pack introduces a new project located in the following directory:

<TWS_HOME>\methods\PT844. This project must be uploaded on PeopleTools 8.44 server, following the usual procedure as specified in this readme, section "Documentation Notes", subsection "Documentation problems and corrections" on page 27".

Features introduced with fix pack 2

The following feature has been introduced with fix pack 2:

- APAR IY57872: A new set of parameters has been introduced to dynamically define a SAP job at submission time from an end-to-end z/OS® environment.

Features introduced with fix pack 1

The following features have introduced with fix pack 1:

- APAR IY51812, APAR IY51890: For the IBM Tivoli Workload Scheduler for Applications, Version 8.2 R/3 access method (r3batch) new options have been introduced to control the retrieval of the SAP joblog, the spoolists, and Business Warehouse (BW) process chain logs.
- Internal feature 11451: To enable PeopleSoft access method to schedule jobs containing in-line bind variable parameters in their job definitions.

Product fix history

IBM Tivoli Workload Scheduler for Applications, Version 8.2 Fix Pack 7 supersedes all the fixes released previously for the product. The following section includes all the APARs and Defects shipped since IBM Tivoli Workload Scheduler for Applications Version 8.2. It contains the following sub-sections:

- “APARs and Defects fixed in IBM Tivoli Workload Scheduler for Applications, Version 8.2 fix pack 7”
- “APARs and Defects fixed in IBM Tivoli Workload Scheduler for Applications, Version 8.2 fix pack 6” on page 4
- “APARs and Defects fixed in IBM Tivoli Workload Scheduler for Applications, Version 8.2 fix pack 5” on page 5
- “APARs and Defects fixed in IBM Tivoli Workload Scheduler for Applications, Version 8.2 fix pack 4” on page 6
- “APARs and Defects fixed in IBM Tivoli Workload Scheduler for Applications, Version 8.2 fix pack 3” on page 7
- “APARs and Defects fixed in IBM Tivoli Workload Scheduler for Applications, Version 8.2 fix pack 2” on page 8
- “APARs and Defects fixed in IBM Tivoli Workload Scheduler for Applications, Version 8.2 fix pack 1” on page 9

APARs and Defects fixed in IBM Tivoli Workload Scheduler for Applications, Version 8.2 fix pack 7

This section lists the APARs and Defects fixed in IBM Tivoli Workload Scheduler for Applications, Version 8.2 Fix Pack 7 by access methods. It is divided into the following sub-sections:

- “APARs and Defects fixed for R/3”
- “APARs and Defects fixed for z/OS” on page 4
- “APARs and Defects fixed for Oracle” on page 4
- “APARs and Defects fixed for PeopleSoft” on page 4

APARs and Defects fixed for R/3: The following APARs and defects were fixed for R/3:

- APAR IY72498
Symptoms: SAP job class not being honoured. Still runs as class C even though defined to run as B.
- APAR IY77257
Symptoms: TWS sometimes reports as abended successful R3 jobs that spawn child jobs.
- Defect 17218

Symptoms: Step (print) parameter PRTXT is incorrectly used as a flag.

- Defect 16164

Symptoms: SIGSEGV error occurs during job submission from r/3 batch running on Linux to SAP r/3 Version 4.0B

- Defect 16018

Symptoms: Workaround for SAP note 581152 (ported from 10101)

APARs and Defects fixed for z/OS: The following APARs and Defects were fixed for z/OS:

- APAR PK06244

Symptoms: Message EEWI38I issued with status of unknown for a job submitted with TYPRUN=HOLD (so \$DJ is issued to check status)

- APAR PK07114

Symptoms: JES job reported as ended in U5320 while successfully completed

- APAR PK08337

Symptoms: Incomplete message in EEWSERVE log if "AWAITING EXECUTION" status detected by the JES2 interface (MVSJES2)

- APAR PK09703

Symptoms: Change format of JES2 inquiry command issued to \$DJ

- APAR PK10484

Symptoms: CA-7 Ignores command if TSSERVER is sending them to close together in time.

- APAR PK11512

Symptoms: Internetwork dependency check sometime does not work.

APARs and Defects fixed for Oracle: The following APARs and Defects were fixed for Oracle:

- APAR IY74916

Symptoms: Problem with default END_DATE with Oracle XA 8.2

APARs and Defects fixed for PeopleSoft: The following APARs and Defects were fixed for PeopleSoft:

- APAR IY75124

Symptoms: Distribution Status not taken into account to determine tws job status

- APAR IY77581

Symptoms: New Psoft job state needs to be managed

APARs and Defects fixed in IBM Tivoli Workload Scheduler for Applications, Version 8.2 fix pack 6

This section lists the APARs and Defects fixed in IBM Tivoli Workload Scheduler for Applications, Version 8.2 Fix Pack 6 by access methods. It is divided into the following sub-sections:

- "Common APARs and Defects"
- "APARs and Defects fixed for R/3" on page 5
- "APARs and Defects fixed for z/OS" on page 5
- "APARs and Defects fixed for Oracle" on page 5
- "APARs and Defects fixed for PeopleSoft" on page 5

Common APARs and Defects: The following APARs and Defects were fixed for parts that are common to all the access methods:

- APAR IY69757: Cannot install TWS for Apps 8.2 on RHEL 3.0 - *twsinst* script.
- APAR IY71434: Unable to install TWS for Apps patches on individual method basis.

APARs and Defects fixed for R/3: The following APARs were fixed for R/3:

- APAR IY70236
Symptoms: TWS for Apps, R3BATCH, aliases object does not work.
- APAR IY70361
Symptoms: RFC_OPEN_RETRY does not work for unlimited RETRY -1.
- APAR IY71395
Symptoms: Child job abends on TWS although successfully completed on SAP.

APARs and Defects fixed for z/OS: The following APARs and Defects were fixed for z/OS:

- APAR PK01968
Symptoms: IKJ56286I and IKJ56284I issued after U800142 (FP04)
- APAR PK03371
Symptoms: "EEWI38I STSDBKP3(JOB09220) 122 0 EXEC S322" messages in job stdlist on z/OS xagent
- APAR PK03988
Symptoms: EEWSERVE ABEND138 ABEND0C2 when z/OS method "FOLLOWS" incorrectly defined.
- APAR PK03873
Symptoms: If jestyle=JES3 and JES3 jobno has a maximum value of 99999 or less, the format of the inquiry command generated is incorrect.
- APAR PK04954
Symptoms: TWS z/OS x-agent 8.2.0 reports a runtime of 42864166 seconds when a job starts, executes, and completes within 30 seconds from midnight.

APARs and Defects fixed for Oracle: The following APARs and Defects were fixed for Oracle:

- APAR IY71063
Symptoms: Oracle extended agent postinstall fails with re-link of module

APARs and Defects fixed for PeopleSoft: The following APARs and Defects were fixed for PeopleSoft:

- APAR IY69686
Symptoms: Application server cycling when 2 consecutive PeopleSoft jobs fail in TWS.
- Internal CMVC Defect 14192
Symptoms: Failure of xagent PeopleSoft 8.44 jobs run concurrently.

APARs and Defects fixed in IBM Tivoli Workload Scheduler for Applications, Version 8.2 fix pack 5

This section lists the APARs and Defects fixed in IBM Tivoli Workload Scheduler for Applications, Version 8.2 Fix Pack 5 by access methods. It is divided into the following sub-sections:

- "APARs and Defects fixed for R/3" on page 6
- "APARs and Defects fixed for z/OS" on page 6
- "APARs and Defects fixed for Oracle" on page 6

APARs and Defects fixed for R/3: The following APARs were fixed for R/3:

- APAR IY63049
Symptoms: R3BATCH is not saving variant settings like \$(TODAY +3 DAYS)
- APAR IY64340
Symptoms: No error message is displayed when the variant data is too long to fit into the SAP variant structure.
- APAR IY64493
Symptoms: DATECALC PIC option is ignored when evaluating extended variants
- APAR IY65314
Symptoms: R/3 jobs with blank space in jobname when submitted after SAP job interception.
- APAR IY65371
Symptoms: SAP varient created without creation data and time being set.
- APAR IY66567
Symptoms: Short interval, long interval ignored for INFOPACKAGES

APARs and Defects fixed for z/OS: The following APARs and Defects were fixed for z/OS:

- APAR PQ99689
Symptoms: This APAR has been created to track fixes on 8.2.0. Details on each fix will be given at APAR closure. (OPC internetwork dependency with wrong IA)
- APAR PQ99690
Symptoms: Align last step handling with TWS for z/OS

APARs and Defects fixed for Oracle: The following APARs and Defects were fixed for Oracle:

- APAR IY64444
Symptoms: Oracle access method does not correctly handle process parameters with blanks in job definitions.

APARs and Defects fixed in IBM Tivoli Workload Scheduler for Applications, Version 8.2 fix pack 4

This section lists the APARs and Defects fixed in IBM Tivoli Workload Scheduler for Applications, Version 8.2 Fix Pack 4 by access methods. It is divided into the following sub-sections:

- “Common APARs and Defects”
- “APARs and Defects fixed for R/3”
- “APARs and Defects fixed for z/OS” on page 7
- “APARs and Defects fixed for Oracle” on page 7

Common APARs and Defects: The following APARs and Defects were fixed for parts that are common to all the access methods:

- APAR IY63385: GA Installer fails to install on AIX 4.3.3 upgraded from a version prior to 4.3.2.0
- Internal CMVC Defect 13305: When you apply the fix pack in silent mode twice, the latter action results in a commit of the fix pack.

APARs and Defects fixed for R/3: The following APARs were fixed for R/3:

- APAR IY53854: BW jobs with Japanese name do not displayed on picklist.

- APAR IY57872: A new set of parameters has been introduced to dynamically define a SAP job at submission time from an end-to-end z/OS environment.
- APAR IY56719: Update TWS 8.2 for Apps users guide - R3 - that options files are required before creating jobs.
- Internal CMVC Defect 13371: Workaround for the SAP QOS problem
- Internal CMVC Defect 13345: On OSF, group 150 assigned to the user owner of r3batch files
- Internal CMVC Defect 13349: R/3 batch -v does not show the fix pack level.

APARs and Defects fixed for z/OS: The following APARs and Defects were fixed for z/OS:

- APAR PQ92628: Usability improvements of the OPC and JES interfaces.
- APAR PQ89268: CheckInterval Parameter not taken into account when receiving '9' as QJR.
- Internal CMVC Defect 13342: mvscs7 - INVALID TRANS SYNT when '9' is returned after a LJ.
- Internal IDSS PTR 51: A CA-7 LATE job is reported as ABENDED to TWS.

APARs and Defects fixed for Oracle: The following APARs and Defects were fixed for Oracle:

- Defect 13128: Even if erroneously the MCMSTAT is not replaced, a successful completion message is displayed by the **mcminstall** script.
- Defect 13438: ps command shows pwd decrypted of OracleApps user

APARs and Defects fixed in IBM Tivoli Workload Scheduler for Applications, Version 8.2 fix pack 3

This section lists the APARs and Defects fixed in IBM Tivoli Workload Scheduler for Applications, Version 8.2 Fix Pack 3 by access methods. It is divided into the following sub-sections:

- "Common APARs and Defects"
- "APARs and Defects fixed for PeopleSoft"
- "APARs and Defects fixed for R/3"
- "APARs and Defects fixed for z/OS" on page 8

Common APARs and Defects: The following APARs and Defects were fixed for parts that are common to all the access methods:

- Internal CMVC Defect 13239: Option Editor code must be aligned to the Option Editor code of IBM Tivoli Workload Scheduler for Virtualized Data Centers.
- Internal CMVC Defect 13240: The new CCLOG level code has been built in TWS4APPS 82 Fixpack 3

APARs and Defects fixed for PeopleSoft:

- APAR IY58262: PeopleTools version 8.44 is not supported.

APARs and Defects fixed for R/3: The following APARs and Defects were fixed for R/3:

- APAR IY56894: r3 process chain jobs started by ITWS in turn run child subchain jobs which spawn ABAPs. ABAP results cannot be seen in jobstdlist.
- Internal CMVC Defect 12496: Business Warehouse jobs which the server was defined as Language Japanese are not displayed.
- Internal CMVC Defect 13214: Update ABAP code to allow job execution in arbitrary SAP client.

- Internal CMVC Defect 13255: On OSF platform, during the installation the r3batch.properties file cannot be copied, and also the installation is corrupted.
- Internal CMVC Defect 13262: The interception_collector job finished with exit code 0, although it discovered the error: "AWSBHU025E Schedule not found." It should fail.

APARs and Defects fixed for z/OS: The following APARs and Defects were fixed for z/OS:

- APAR PQ89040: Maestro Identifiers longer than 64 characters are not correctly managed by the host Gateway.
- APAR PQ88600: TWS external dependencies on OPC jobs does not work if no OPNO (operation number) is specified.
- APAR PQ90636: When TWS submits a non existing JES JCL, the messages EEWI09E and EEWI01E are incorrectly formatted in the EEWSEERVE log.
- Internal CMVC Defect 13052: When the method mvsjes receives the '9' return code (= "Expected response not found") in response to a QJ, then the next QJ is issued without waiting the amount of time as specified in the CheckInterval option.
- Internal CMVC Defect 13200: Using an internetwork dependency, with a TWS Job dependent by a Job JES . If this jes job ends in error, the mvsjes method doesn't send the FJ event to MVS.
- Internal CMVC Defect 13238: When checking an external dependency against an MVS OPC Application, the method mvsopc first sends a CA transaction and then starts to send QJ transactions. This is incorrect, only CA transactions must be issued in this case. (this Defect is a fix together with APAR PQ88600)
- Internal CMVC Defect 13273: mvsjes method handles incorrectly maestro IDs longer than 64 characters (this Defect is a fix together with APAR PQ89040)

APARs and Defects fixed in IBM Tivoli Workload Scheduler for Applications, Version 8.2 fix pack 2

This section lists the APARs and Defects fixed in IBM Tivoli Workload Scheduler for Applications, Version 8.2 Fix Pack 2 by access methods. It is divided into the following sub-sections:

- "Common APARs and Defects"
- "APARs and Defects fixed for Oracle E-business Suite" on page 9
- "APARs and Defects fixed for PeopleSoft" on page 9
- "APARs and Defects fixed for R/3" on page 9
- "APARs and Defects fixed for z/OS" on page 9

Common APARs and Defects: The following APARs and Defects were fixed for parts that are common to all the access methods:

- APAR PQ89884: In some cases the access method abends while recording trace information.
- Internal CMVC Defect 11878: In the Options Editor the description of some options is missing.
- Internal CMVC Defect 12295: The trace-access_method.log file can be accessed in read and write mode only by the user that creates it.
- Internal CMVC Defect 12358: Fix pack installation checks the size of the file system used for the previous installation instead of the size of the file system that is used to run the current installation.
- Internal CMVC Defect 12575: The *.jar files of the Options Editor are not replaced if they are newer than the ones installed by applying the fix pack.

APARs and Defects fixed for Oracle E-business Suite: The following APARs and Defects were fixed for Oracle E-business Suite:

- APAR IY56633: The MCMAGENT access method abends in some Solaris operating environment.
- Internal CMVC Defect 12301: The Enigma utility generates shell control characters in encrypted passwords.
- Internal CMVC Defect 12454: On an AIX® operating system, the mcminstall script erroneously logs warning messages while changing the ownership of a file.

APARs and Defects fixed for PeopleSoft: The following APARs and Defects were fixed for PeopleSoft:

- Internal CMVC Defect 11881: The stdlist does not explain the failure due to a missing ITWS_PROCESSREQUEST component interface.
- Internal CMVC Defect 11975: The nVisionReport process is submitted again, if the PeopleSoft application Server is stopped and restarted.
- Internal CMVC Defect 12025: The TVPUPSFT.exe hangs, if the PeopleSoft application Server is stopped and restarted.

APARs and Defects fixed for R/3: The following APAR was fixed for R/3:

- APAR IY54566: The r3batch access method retention field default value is incorrect.

APARs and Defects fixed for z/OS: The following APARs and Defects were fixed for z/OS:

- APAR PQ85489: JES interface does not report exit code status correctly for failed jobs when using the CA7INTERFACE(NO) value.
- APAR PQ85648: z/OS extended agent does not work correctly when JES migration exits are turned off. The \$D 'jobname' is no longer supported. The command has been replaced by the \$D J'jobname' command.
- APAR PQ88345: The EEWI271 message has been modified and the following messages have been added:
 - EEWI33W
 - EEWI34W

APARs and Defects fixed in IBM Tivoli Workload Scheduler for Applications, Version 8.2 fix pack 1

This section lists the APARs and Defects fixed in IBM Tivoli Workload Scheduler for Applications, Version 8.2 fix pack 1 by access methods. It contains the following sub-sections:

- "Common APARs and Defects"
- "APARs and Defects fixed for Oracle E-business Suite"
- "APARs and Defects fixed for PeopleSoft" on page 10
- "APARs and Defects fixed for R/3" on page 10
- "APARs and Defects fixed for z/OS" on page 10

Common APARs and Defects: The following APAR was fixed for parts that are common to all the access methods:

- APAR IY50679: The installation of IBM Tivoli Workload Scheduler for Applications on Windows® XP does not work.

APARs and Defects fixed for Oracle E-business Suite: The following APARs and Defects were fixed for Oracle E-business Suite:

- Internal CMVC Defect 11879: In a three tier configuration the MCMAGENT access method fails to authenticate in the Oracle applications system.
- Internal CMVC Defect 12012: Installing the fix pack 1, the ownership of the MCMAGENT access method is not correctly assigned.
- Internal CMVC Defect 12013: The files in the OracleTMP folder are not replaced if they are newer than the ones installed applying the fix pack 1.

APARs and Defects fixed for PeopleSoft: The following APARs and Defects were fixed for PeopleSoft:

- APAR IY52805: A job cancelled using the PeopleSoft GUI assumes a status that is not recognized by IBM Tivoli Workload Scheduler .
- Internal CMVC Defect 11962: On Windows 2000, if the CLASSPATH environment variable is set, the psagent.exe access method abends.

APARs and Defects fixed for R/3: The following APARs and Defects were fixed for R/3:

- APAR IY53104: If an R/3 job step does not run, in the Tivoli Workload Scheduler environment, the R/3 job assumes the abend status.
- APAR IY51812: Cannot disable the spool data entries in the job stdlist.
- APAR IY51890: With IBM Tivoli Workload Scheduler for Applications, the SAP spoolist is always sent to the job stdlist.
- Internal CMVC Defect 11414: Process chains were not interrupted by the kill task.

APARs and Defects fixed for z/OS: The following APARs and Defects were fixed for z/OS:

- APAR PQ85524: Cumulative APAR to align the IBM Tivoli Workload Scheduler for Applications, Version 8.2.0 to the level of fixes included in Version 8.1.1.
- Internal CMVC Defect 11124: The events 2003, 2007, and 2008 have been mapped in ABEND status for a job.
- Internal CMVC Defect 11700: The TWSoslayer.dll is not installed in the **methods** directory.
- Internal CMVC Defect 11973: The event 2004 sent in response to a QJ event is incorrectly mapped in WAIT status for a job.
- Internal CMVC Defect 12037: Garbage in the transaction buffer sent to the Gateway.

Limitations

This section describes all limitations applying to IBM Tivoli Workload Scheduler for Applications, Version 8.2. It contains the following sub-sections:

- “Common limitations”
- “Limitations for Oracle E-business Suite” on page 11
- “Limitations for PeopleSoft” on page 11
- “Limitation for R/3” on page 14
- “Limitation for z/OS” on page 14

Common limitations

The following limitations apply to all the access methods:

- Defect 12944: If you perform a rollback action of the fix pack when an access method is running, the rollback fails but a successful completion message appears.

- Defect 15933: **twappsinst** command works even if `-install`, `-uninst`, and `-patch` options are omitted. If you run `./twappsinst -twuser <username>` without any options, the command works normally, but it ends with the following message:

```
EEWAI035I: twappsinst successfully terminated
```

Actually, no action is performed and the SPB catalog (listed by **wdlssp**) shows that the status has not changed. The command syntax requires one of the three options as mandatory.

- Defect 15934: Using the **twappsinst** command to install, upgrade to Fix Pack 6, and then uninstall a GA version of an access method, some files in the `$HOME_MAESTRO\methods` directory are not uninstalled. If you do not apply the fix pack, the uninstall is clean. This behavior is probably caused by the Fix Pack 6 SPB, which does not build those files.
- Defect 15936: When you uninstall or apply the fix pack through the `./twappsinst -uninst -twuser <username>`, or `./twappsinst -patch -twuser <username>` command, the procedures perform also a check for MCMAGENT and ZOSAGENT SPBs, which are irrelevant because those extended agents are not supported for Linux.
- Defect 15976: Tivoli Workload Scheduler for Applications 8.2 with Fix Pack 6 setup lists Tivoli Workload Scheduler for Applications 8.2.1 GA as Fix Pack 1.
- No Defect number: Before running the setup in silent mode, you have to set the environment variable `DISPLAY` to a valid value, even if no graphical interface is shown. Use before running the setup in silent mode. This is valid for UNIX platforms only.

Limitations for Oracle E-business Suite

The following limitations apply to Oracle E-business Suite:

- Internal CMVC Defect 13171: In a three-tier connectivity configuration a coredump occurs killing a job when DBserver Oracle is stopped.

Limitations for PeopleSoft

The following limitations apply to PeopleSoft:

- Internal CMVC Defect 11875: If you uninstall the IBM Tivoli Workload Scheduler for Applications, Version 8.2 product after applying a fix pack, the `TVPUPSFT.exe` file is not removed automatically.
WORKAROUND: Remove the `TVPUPSFT.exe` file manually.
- During the upload of the project, a basic set of Process Types whose name starts with "ITWS_" is loaded. The project load operation loads approximately 145 process types for PeopleTools Version 8.4x, and approximately 96 for PeopleTools Version 8.1x. If you submit a process with in-line bind variables belonging to a Process Type *ProcessType* that does not have any corresponding *ITWS_ProcessType*, then you must create it manually by using the PeopleSoft GUI.
- Internal CMVC Defect 12742: Due to a PeopleSoft Version 8.44 problem (Case ID 3338196), when the application server is on a UNIX platform, the PeopleSoft access method submits a process successfully but it fails to get the PeopleSoft job status. For this reason, the Tivoli Workload Scheduler job status is always ABEND. PeopleSoft has fixed this problem in the fix pack 11 for PeopleTools, Version 8.44.
- Internal CMVC Defect 14822: Inconsistencies in the Process Monitor page when using filters on Process Types. This is a PeopleSoft external defect and Case ID 3877368 has been opened against it. Processes using inline bind variables

scheduled with Tivoli Workload Scheduler should be listed in the Process Monitor page with a process type different from the original one (ITWS_<Original Process Type>). With PeopleTools 8.45 the process type displayed is the same as the original.

- Internal CMVC Defect 15058: This is a PeopleSoft external defect scheduling jobs to Peoplesoft 8.21 using Tivoli Workload Scheduler remotely. You can schedule jobs to PeopleSoft 8.21 only if the CLASSPATH environment variable contains the *extapi.jar* file and the environment variable path contains the full path of JVM.DLL. If the *extapi.jar* file is not referred to in the CLASSPATH environment variable, a java exception occurs, because the file `/psft/pt8/joltmw/Session.class` is not found.

WORKAROUND: The following workaround has been provided with the Solution ID 200779704 in the PeopleSoft support site, and is reported here for your convenience. Refer to www.peoplesoft.com for detailed information.

For Enterprise PeopleTools 8.21, you must have Sun's Java Virtual Machine installed and set up to create the C++ and COM APIs to connect to the BEA JOLT layer. To set up the COM and C++ APIs for component interfaces follow these steps:

1. Install the Java Runtime Environment on the client workstation.
2. From the Control Panel, select **System Properties, Advanced Tab, Environment Variables** to set the system environment variables.
3. Add the full path of JVM.DLL (preferably hotspot or classic) to the system user variable path.
4. Edit the system environment variable CLASSPATH to contain the full path of *extapi.jar* as follows: `C:\WINNT\JAVA\Classes\extapi.jar`.

Note: These actions must be applied on the FTA system where PeopleSoft Xagent and External API PeopleSoft 8.21 are installed.

- Internal CMVC Defect 15066: This error is caused by a defect in the PeopleTools 8.21 (Case ID 3869562 - Component Interface: PROCESSREQUEST is failing in CI Tester in PT 8.21). If a PeopleSoft job is submitted successfully, Tivoli Workload Scheduler documents it as ABEND and the Tivoli Workload Scheduler job log contains the following lines:
 - PeopleSoftMessage:'Built-in function DatePart parameter 1 is invalid. (2,195)
 - At PRCSRQSTBC_WRK.REQUESTTYPE.FieldFormula GetPrCsRqst PCPC:6975 Statement:111'
 - PeopleSoftMessage:'Error changing value. {PROCESSREQUEST.PROCESSINSTANCE} (91,34)'

WORKAROUND: The following workaround has been provided in the Solution ID 200731827 in the PeopleSoft support site. Refer to www.peoplesoft.com for detailed information

The GetPrCsRqst function in the PRCSRQSTBC_WRK.REQUESTTYPE.FieldFormula PeopleCode has to be modified with these changes for the 8.1X codeline:

1. From your PeopleSoft Development Workstation open the Application Designer application.
2. Select **Insert, Objects into Project** (or press the shortcut **Control-F7**). The **Insert into Project** panel is displayed.
3. Open an object type of **Component Interfaces**.
4. In the Selection Criteria control group, in the **Name** field, type *PROCESSREQUEST* and press the **Enter** key to select the records.

5. Click **Select All** and then **Insert**.
6. Close the **Insert into Project** panel before continuing.
7. The PROCESSREQUEST Component Interface is shown in the tree view of the Application Designer window. You may need to expand the Component Interface folder to see it.
8. Double click the PROCESSREQUEST (or right click and select **View Definition**). You are shown the definition on the right panel. Expand the **Scroll - Level 0** item.
9. Right click the **PRCSRQSTBC_WRK** record and select **View Definition**.
10. On the new panel you see the record format of PRCSRQSTBC_WRK. Go to the field named **REQUESTTYPE** (it should be in bold typeface). Right-click it and select **View PeopleCode**.
11. The **PRCSRQSTBC_WRK.REQUESTTYPE.FieldFormula (Record PeopleCode)** panel is the active one on the right side of your screen.
12. Select **Edit->Find** (or press **Control-F**) to search on the PeopleCode for the string *GetPrcsRqst*.
13. In the first lines of the PeopleCode Function *GetPrcsRqst* there is an SQLExec statement:

```
SQLExec("SELECT A.RUNCNTLID, A.PRCSTYPE, A.PRCNAME, A.PRCJOBNAME,
        A.RUNLOCATION,A.SERVERNAMERQST, A.SERVERNAMERUN, A.RECURNAME,
        A.RUNDTM, A.OUTDESTTYPE, A.OUTDESTFORMAT, B.OUTDEST, A.RUNSTATUS,
        C.XLATSHORTNAME FROM PSPRCRQST A, PSPRCSPARMS B, XLATTABLE C,
        WHERE A.PRCINSTANCE = B.PRCINSTANCE AND A.PRCINSTANCE = :1 AND
        C.FIELDNAME = 'RUNSTATUS' AND C.FIELDVALUE = A.RUNSTATUS AND
        C.EFF_STATUS = 'A",&ProcessInstance, RUNCONTROLID, PRCSTYPE,
        PROCESSNAME, JOBNAME, &RunLocation, &SERVERNAMERQST, &SERVERNAMERUN,
        RUNRECURRANCE, &RUNDTM, &OutDestType, &OutDestFormat, OUTDEST,
        RUNSTATUS, RUNSTATUSDESCR);
```

14. You need to update it as follows:

```
SQLExec("SELECT A.RUNCNTLID, A.PRCSTYPE, A.PRCNAME, A.PRCJOBNAME,
        A.RUNLOCATION, A.SERVERNAMERQST, A.SERVERNAMERUN, A.RECURNAME,
        %DateTimeOut(A.RUNDTM), A.OUTDESTTYPE, A.OUTDESTFORMAT, B.OUTDEST,
        A.RUNSTATUS, C.XLATSHORTNAME FROM PSPRCRQST A, PSPRCSPARMS B,
        XLATTABLE C, PSOPTIONS D WHERE A.PRCINSTANCE = B.PRCINSTANCE AND
        A.PRCINSTANCE = :1 AND C.FIELDNAME = 'RUNSTATUS' AND C.FIELDVALUE =
        A.RUNSTATUS AND C.EFF_STATUS = 'A' AND C.LANGUAGE_CD = D.LANGUAGE_CD",
        &ProcessInstance, RUNCONTROLID, PRCSTYPE, PROCESSNAME, JOBNAME,
        &RunLocation, &SERVERNAMERQST, &SERVERNAMERUN, RUNRECURRANCE, &RUNDTM,
        &OutDestType, &OutDestFormat, OUTDEST, RUNSTATUS, RUNSTATUSDESCR);
```

Note: Duplicate the line before making the correction, and then comment out the original statement by using the block comment characters (`"/** <lines to comment> */`).

15. Select **File->Save** (or **Control-S**) to save your changes.
 16. Select **File->Exit** (or **Control-Q**) to close the Application Designer. If you are prompted to save your project, select **No**.
- Defect 15971: After loading the PeopleSoft 844 project, which is located in `$TWS_HOME\methods\PeopleSoft\P844`, a component interface in the ITWS permission list appears: PROCESSDEFINITION2. This component interface is accidentally loaded. If you open the correct component interface, PROCESSDEFINITION, an empty method name with "No access" permission appears in the methods list.
 - Defect 15972: After loading the PeopleSoft 844 project, which is located in `$TWS_HOME\methods\PeopleSoft\P844`, the ITWS_P SXA project opens.

Double-clicking on ITWS_PROCESSDEFINITION under Component Interface, the following error is displayed in the "Validate" tab of Application Designer:

```
Begin validating component Interface integrity
*** Found error ***
Please review Component Interface structure
End Component Interface validation
```

The job submission of job with inline bind var runs successfully, anyway.

- Defect 16198: TWSXA_PT84_JVMPATH cannot be used for PeopleSoft 821. The WS_psagent.opts file referring to a PeopleSoft 821 target System should not contain any reference by var TWSXA_PT84_JVMPATH to jvm path provided with Fixpack Installation \$TWS_HOME\methods_tools_jvm\jre\bin\classic because it causes a trap for TVPUPST. The var TWSXA_PT84_JVMPATH is valid only for configuration with PeopleSoft 84x System.
- Sometimes the submission of PeopleSoft processes fails sporadically with no specific pattern. The process may be submitted, but not monitored or not submitted at all. If the TWS job is rerun, everything may be fine. If these errors are accompanied by messages like the following in the Tuxedo log in the target PeopleSoft Application server:
 - 002901.nch8k04b!JSH.21752.1.-2: JOLT_CAT:1185: "INFO: Userid: [MAESTRO], Clientid: [hdqncvmtwsbar1] timed out due to inactivity"
 - 002901.nch8k04b!JSH.21752.1.-2: JOLT_CAT:1198: "WARN: Forced shutdown of client; user name 'MAESTRO'; client name 'hdqncvmtwsbar1'"

(being MAESTRO the PeopleSoft operator that the TWS method uses to establish the connection), this error is likely to be due to a Tuxedo timeout that drops the connection with the Application Server before the PeopleSoft process is finished. To solve this, follow the suggestions reported in the PeopleSoft Solution ID 200724711. It consists in copying the pstools.properties file from the Application Server to the TWS methods directory. In this file appropriate values for the timeout parameters can be set. A sample follows:

- tuxedo_network_disconnet_timeout=0
- tuxedo_send_timeout=50
- tuxedo_receive_timeout=600

Limitation for R/3

The following limitation applies to R/3:

- Internal CMVC Defect 12945: It is not possible to create a job with new variant without vpar.
- Internal CMVC Defect 13497: On OSF platform in r3batch.properties files if trace level is set to the DEBUG_MAX the pick list from Job Scheduling Console does not work.

Limitation for z/OS

The following limitation applies to z/OS:

- On the IRIX platform under certain condition the mvs access methods hang and do not perform any submission.
WORKAROUND: Add in the *mvs_access_method*.properties file the following line:
mvs_access_method.multiproc=0

where *mvs_access_method* can assume one of the following values:

- mvsjes
- mvsopc
- mvscs7

Installation

This section describes how to install IBM Tivoli Workload Scheduler for Applications, Version 8.2 fix pack 6. Fix pack 6 upgrades all the extended agents associated to the selected Tivoli® Workload Scheduler for Application, Version 8.2 instances. Fix packs are cumulative: so you can apply them directly to the general availability version of the product without having to install previous fix packs. Remember, however, that no fix pack will install unless you have the general availability version of the product installed on your computer. Before you install the fix pack, ensure that the following prerequisites are met:

- Tivoli Workload Scheduler processes are stopped.
- No extended agent method is running.

It is divided into the following sections:

- “Hardware and software requirements”
- “Fix pack installation methods”

Hardware and software requirements

This section includes the following topics:

- “Supported platforms”

Supported platforms:

Supported platforms at the time of the release are detailed in the *User's Guide*. For the most recent information, consult the supported platforms matrix on the IBM® software support Web site: <http://www.ibm.com/software/support>

1. From the Web site, select **Tivoli support** from the **Other support sites** list.
2. When the page displays, select **IBM Tivoli Workload Scheduler for Applications** from the **Choose a product** pull-down list.
3. Click the **Supported Platforms** in the Related Links section.
4. Click the **Tivoli Platform and Database Support Matrix** link
5. Enter your IBM registration ID and password.

System requirements:

Hardware and software prerequisites are detailed in the Tivoli Workload Scheduler for Applications: Release Notes. There are currently no changes to the information included in the Release Notes.

Fix pack installation methods

The type of installation method you can use to install the fix pack for IBM Tivoli Workload Scheduler for Applications, Version 8.2 depends on the platform you are working on.

For Tier 1 platforms, use one of the following installation methods:

- “The InstallShield MultiPlatform (ISMP) wizard” on page 16
- “Silent Installation” on page 16
- “Software Distribution command line” on page 18

For Tier 2 platforms, use the installation method described in:

“Tier 2 installation method” on page 19

For the z/OS component of the z/OS access method, use the installation method described in:

“z/OS installation method” on page 19

Tier 1 installation methods:

This section describes the installation methods you can use to install on the Tier1 platforms. It is divided into the following sub-sections:

- “The InstallShield MultiPlatform (ISMP) wizard”
- “Silent Installation”
- “Software Distribution command line” on page 18

The InstallShield MultiPlatform (ISMP) wizard:

To install the fix pack using the InstallShield MultiPlatform (ISMP) wizards perform the following steps:

1. Run the setup installation command appropriate for the platform on which you are installing the fix pack. The setup installation commands are located in platform specific directories. The installation program is launched.
2. The Welcome window is displayed. Click **Next** to continue. The installation program detects and lists all the instances installed on your workstation.
3. From the list, select the instance on which you want to apply the fix pack, and click **Next** to continue.
4. Choose one of the following actions and click **Next** to continue:
 - Apply
 - Rollback
 - Commit
 - Repair
5. You are prompted to specify a new LJuser for each extended agent if you want to override the original one, otherwise leave it blank, click **Next** to continue.
6. You are shown the location where the files are installed with the features you selected, click **Next** to continue.
7. The installation starts.
8. Click **Finish** to complete the installation.

Silent Installation:

This section describes how to install the fix pack using the **setup** installation command in silent mode. You can either specify the installation options directly on the command line or in a response file.

Note: Use the Installation option strings the exact way they are given below

To install the fix pack specifying the installation options directly on the command line, run one of the following commands:

In a Windows environment:

```
setup.exe -silent installation_options
```

In a UNIX® environment:

```
setup.bin -silent installation_options
```

where the *installation_options* are:

```
-W CHANGE_INSTANCE_NAME_BEAN.value="INSTANCE_NAME"  
Required
```

```
-W DISPLAY_ACTION.selectedAction="ACTION"  
Required
```

-W LJUSER_method_INPUT_BEAN.LJUSER="LJUSER"
Optional

where:

INSTANCE_NAME

Any TWS for Applications instance is identified by an instance name. This is usually the TWS user that owns the TWS home directory where the method was installed, but there are installation procedures that let the user choose the name for the instance (e.g. when performing a GA silent installation). You have to specify the instance name assigning its value to this option.

ACTION

Is the type of action you can perform. It can be one of the following values:

- APPLY

Apply the fix pack. If the fix pack is already applied it will be interpreted as a repair action

- UNDO

Rollback the fix pack.

- COMMIT

Commit the fix pack.

method

Is the access method you want to upgrade. It can be one of the following values:

- R3BATCH
- ZOSAGENT
- MCMAGENT
- PSAGENT

LJUSER

Is the name of the operating system user ID used to launch the access method.

This is an example that performs the APPLY action to a fix pack on a UNIX workstation:

```
setup.bin -silent  
-W CHANGE_INSTANCE_NAME_BEAN.value="twuser"  
-W DISPLAY_ACTION.selectedAction="APPLY"
```

To install the fix pack using a response file, create your response file, or customize the silentfp.txt template response file contained in the RESPONSE_FILE directory of the fix pack. See the "Fix pack structure" on page 1 for a detailed description of the fix pack structure CD-ROM. The response file must be accessible from the workstation where you want to perform the installation. Entries in the response file use the following format: option=value. Each entry must be written on a separate line.

To install the fix pack using a response file, run one of the following commands depending on the operating system in which you are applying the fix pack:

In a Windows environment

```
setup.exe -silent -options responsefile
```

where *responsefile* is the name of the response file you created.

In a UNIX environment

```
setup.bin -silent -options responsefile
```

where *responsefile* is the name of the response file you created.

This is an example of a response file that performs the APPLY action on the fix pack:

```
-W CHANGE_INSTANCE_NAME_BEAN.value="maestro"  
-W DISPLAY_ACTION.selectedAction="APPLY"  
-W LJUSER_R3BATCH_INPUT_BEAN.LJUSER="maestro"  
-W LJUSER_ZOSAGENT_INPUT_BEAN.LJUSER="maestro"  
-W LJUSER_MCMAGENT_INPUT_BEAN.LJUSER="maestro"
```

Software Distribution command line:

To install the fix pack using the Software Distribution command line perform the following steps:

1. Import the TWS4APPS_method_platform.SPB into the Profile Manager, using the **wimpspo** command as follows:

```
wimpspo -c @ProfileManager -f SOURCE_PATH\TWS4APPS_method_platform_FP07.SPB  
-t build -p DEST_PATH\TWS4APPS_method_platform_FP06.SPB  
[SoftwarePackageName.8.2.0.07]
```

If you specify the *SoftwarePackageName*, this must be the same name you specified to install the IBM Tivoli Workload Scheduler for Applications, Version 8.2 software package. As default, if you do not specify the *SoftwarePackageName*, the software package profile TWS4APPS_method.8.2.0.07 is created in the profile manager. For a complete listing of the options required, see Chapter 2, "Using Tivoli Configuration manager" in the *User's Guide*.

This section describes an example to install the fix pack 7 of the r3batch access method to a Windows endpoint, where the *SoftwarePackageName* of the IBM Tivoli Workload Scheduler for Applications, Version 8.2 software package was TWS4APPS_R3BATCH_I386NT.8.2. To install the fix pack 7 of the r3batch access method launch the following command:

```
wimpspo -c @myprofilemanager -f e:\I386NT\SPB\TWS4APPS_R3BATCH_I386NT_FP07.SPB  
-t build -p c:\fixpack\TWS4APPS_R3BATCH_I386NT_FP07.SPB  
TWS4APPS_R3BATCH_I386NT.8.2.0.07
```

Refer to the IBM Tivoli Configuration Manager Reference Manual for Software Distribution for a detailed explanation of the **wimpspo** command.

For a complete list of options required to install by Software Distribution refer to the tables in Chapter 2 of "IBM Tivoli Workload Scheduler for Applications: *User's Guide*" Version 8.2.

2. To install the fix pack in undoable mode, run the following command:

```
winstsp -uy -D INSTALL_DIR=TWSHOME -D LJUSER=twuser  
@SoftwarePackageName.8.2.0.04@Endpoint:endpointname
```

Note: This is not valid for PeopleSoft.

3. To roll back to the previous code level, run the following command:

```
wundosp @SoftwarePackageName.8.2.0.07 @Endpoint:endpointname
```

4. To commit the fix pack, run the following command:

```
waccptsp @SoftwarePackageName.8.2.0.07 @Endpoint:endpointname
```

5. After the commit action, if you want to remove the software package, run the following command:

```
wremovsp @SoftwarePackageName.8.2.0.07 @Endpoint:endpointname
```

6. To repair a fix pack installation, run the following command:

```
winstsp -mr @SoftwarePackageName.8.2.0.07 @Endpoint:endpointname
```

Tier 2 installation method:

Note: Before applying the fix pack, back up the **methods** directory.

To install the fix pack follow the installation process described in the *User's Guide*, Chapter 14. "Installing on the Tier 2 Platforms".

z/OS installation method: To install the fix pack 4, download the LOADLIB_820WSEFP03 and the SAMPLES_820WSEFP03 files contained in the ZOS directory of the fix pack to the z/OS system by following the instructions described in the *User's Guide*, Chapter 24 "Installing on z/OS", Section "Unloading the Files from the CD-ROM".

These files replace the files stored in the IBM Tivoli Workload Scheduler for Applications, Version 8.2 CD-ROM. See the "Fix pack structure" on page 1 for a detailed description of the fix pack CD-ROM structure.

Documentation notes

This section contains new information and documentation corrections.

New information

This section contains new information for the *User's Guide*.

- APAR IY51812: In Part 4: "R/3 access method". The following sections have been added:

Retrieval of joblogs of SAP jobs

Once a SAP job has been run successfully, its joblog is retrieved by r3batch and appended to the Tivoli Workload Scheduler joblog.

For jobs with large joblogs, this can take a significant amount of time. To control the retrieval of the joblog, a new option has been introduced with the IBM Tivoli Workload Scheduler for Applications, Version 8.2 fix pack 1 as follows:

- At a global level in the r3batch.opts global options file.
- At a local level in the *workstation_r3batch.opts* local options file.
- At a job level.

If this option is not specified, the joblog is added to the stdlist.

This section describes how to enable or disable the retrieval of the joblog at any level:

– Global level:

To retrieve the SAP joblogs in the stdlist, specify the following option in the r3batch.opts global options file:

RETRIEVE_JOBLOG

Specify whether to enable or disable the retrieval of the joblog. Possible values are ON or OFF. The default value is ON.

– Local level:

To retrieve the SAP joblogs in the stdlist, specify the following option in the *workstation_r3batch.opts* local options file:

RETRIEVE_JOBLOG

Specify whether to enable or disable the retrieval of the joblog. Possible values are ON or OFF. The default value is ON.

– Job level:

At job level, use either the Job Scheduling Console, Version 1.3 fix pack 3 or the COMPOSER command line as follows:

On the COMPOSER command line specify the following options in the Tivoli Workload Scheduler job definition:

-flag ENABLE_JOBLOG

To enable the retrieval of SAP joblogs

-flag DISABLE_JOBLOG

To disable the retrieval of SAP joblogs

Using the Job Scheduling Console, Version 1.3 fix pack 3 perform the following steps:

1. In the Actions list of the Job Scheduling Console main window, select the job for which you want to enable or disable the retrieval of SAP joblogs
2. Select a Tivoli Workload Scheduler engine and from the engine list click SAP. The Properties - Job Definition window is displayed.
3. Select **Task**. The Task page is displayed.
4. In the Job Options section, from the Job Log list, select **Enabled** to enable the retrieval of SAP joblog. Select **Disabled** to disable the retrieve of the SAP joblogs.

Note: If you disable the retrieval of SAP joblogs you also disable the return code mapping for the joblog entries.

Retrieval of the spoollists of SAP jobs

Once a SAP job has been run successfully, the spoollists of all the ABAP steps of the job are retrieved by the r3batch access method and appended to the Tivoli Workload Scheduler joblog.

For jobs with large spoollists, this can take a significant amount of time and a lot of disk space. To control the retrieval of the spoollists, new options have been introduced with the IBM Tivoli Workload Scheduler for Applications, Version 8.2 fix pack 1 as follows:

- At a global level in the r3batch.opts global options file.
- At a local level in the *workstation_r3batch.opts* local options file.
- At a job level.

If these options are not specified, the spoollists, are added to the stdlist.

This section describes how to enable or disable the retrieval of the spoollists at any level:

– Global level:

To retrieve the spoollists in the stdlist, specify the following option in the r3batch.opts global options file:

RETRIEVE_SPOOLLIST

Specify whether to enable or disable the retrieval of the spoollists. Possible values are ON or OFF. The default value is ON.

– **Local level:**

To retrieve the spoollists in the stdlist, specify the following option in the *workstation_r3batch.opts* local options file:

RETRIEVE_SPOOLLIST

Specify whether to enable or disable the retrieval of the spoollists. Possible values are ON or OFF. The default value is ON.

– **Job level:**

At job level, use either the Job Scheduling Console, Version 1.3 fix pack 3 or the COMPOSER command line as follows:

On the COMPOSER command line, specify the following options in the Tivoli Workload Scheduler job definition:

-flag ENABLE_SPOOLLIST

To enable the retrieval of spoollists.

-flag DISABLE_SPOOLLIST

To disable the retrieval of spoollists.

Using the Job Scheduling Console, Version 1.3 fix pack 3 perform the following steps:

1. In the Actions list of the Job Scheduling Console main window, select the job for which you want to enable or disable the retrieval of a spoollist.
2. Select a Tivoli Workload Scheduler engine and from the engine list click SAP. The Properties - Job Definition window is displayed.
3. Select **Task**. The Task page is displayed.
4. In the Job Options section, from the Job Spoollist list, select **Enabled** to enable the retrieval of spoollists. Select **Disabled** to disable the retrieval of spoollists.

Note: If you disable the retrieval of spoollists you also disable the return code mapping for the spoollists entries.

Retrieval of the SAP BW Process Chain log

Once a SAP BW Process Chain has been run successfully, its log is retrieved by r3batch and appended to the Tivoli Workload Scheduler joblog.

For SAP BW Process Chain jobs with a large log, this can take a significant amount of time. To manage the retrieval of logs, a new option has been introduced with the IBM Tivoli Workload Scheduler for Applications, Version 8.2 fix pack 1 as follows:

- At a global level in the *r3batch.opts* global options file.
- At a local level in the *workstation_r3batch.opts* local options file.
- At a job level.

If this option is not specified, the Process Chain logs, are added to the stdlist.

This section describes how to enable or disable the retrieval of logs at any level:

– **Global level:**

To retrieve the logs in the stdlist, specify the following option in the `r3batch.opts` global options file:

RETRIEVE_PCHAINLOG

Specify whether to enable or disable the retrieval of logs.
Possible values are ON or OFF. The default value is ON.

– **Local level:**

To retrieve the logs in the stdlist, specify the following option in the `workstation_r3batch.opts` local options file:

RETRIEVE_PCHAINLOG

Specify whether to enable or disable the retrieval of logs.
Possible values are ON or OFF. The default value is ON.

– **Job level:**

At job level, use either the Job Scheduling Console, Version 1.3 fix pack 3 or the COMPOSER command line as follows:

On the COMPOSER command line, specify the following options in the Tivoli Workload Scheduler job definition:

-flag ENABLE_PCHAINLOG

To enable the retrieval of logs.

-flag DISABLE_PCHAINLOG

To disable the retrieval of logs.

Using the Job Scheduling Console, Version 1.3 fix pack 3 perform the following steps:

1. In the Actions list of the Job Scheduling Console main window, select the job for which you want to enable or disable the retrieval of a log.
2. Select a Tivoli Workload Scheduler engine and from the engine list click SAP. The Properties - Job Definition window is displayed.
3. Select **Task**. The Task page is displayed.
4. In the Job Options section, from the PChain Log list, select **Enabled** to enable the retrieval of logs. Select **Disabled** to disable the retrieval of logs.

Note: If you disable the retrieval of the BW Process Chain log you also disable the return code mapping for the log entries.

- APAR IY57872: In Part 4: "R/3 access method". Section *End-to-end Dynamic R3 Job Definition Feature* has been added.
- APAR IY69757: Cannot install TWS for Apps 8.2 on RHEL 3.0 - *twsinst* script.
- APAR IY71434: Unable to install TWS for Apps patches on individual method basis.
- APAR IY75124 Starting from the PeopleTools versions 8.44, the possible status values a process can have, have been split up into two tables.

The status is now the combination of the "Run Status" and "Distribution Status". After introducing this new status type, PeopleSoft has not updated the component interface PROCESSREQUEST therefore the fix to this APAR will be effective only when the corresponding fix to the PeopleTools is applied. The Distribution Status will determine the final TWS job state.

A new option has been introduced to give the ability to switch off this feature, that is, to ignore the Distribution Status information: PS_DISTSTATUS If this option is set to 0 (zero) the Distribution Status will be ignored. In all the other

cases (set to a value other than zero, or not set at all) the Distribution Status will be taken into account (if PeopleTools makes it available) to determine the final TWS job status.

LOGIC OF THE DETERMINATION OF THE TWS JOB STATUS: After the submission of a PeopleSoft Process, its RunStatus is monitored until it is at final state. If the final state is not successful, then we do not read the distribution status and set the TWS job status to ABEND. If the Run Status is successful, then the Distribution Status is read and the TWS job status will be:

- SUCC if Distribution Status is: Posted (5), None (0)
 - ABEND if Distribution Status is: Not Post (4), Delete (6)
 - EXEC if Distribution Status is: N/A, Processing, Generated, Posting.
- APAR PK09691

Symptoms: Users guide manual incorrectly states that flushed steps are never taken into consideration for the job completion.

Alternate install script instructions: Starting from IBM Tivoli Workload Scheduler for Applications 8.2 Fix pack 6, an installation mechanism is provided for AIX 5.x and LINUX RHEL 3.0: an installation script (*twsappsinst*) similar to the one provided with IBM Tivoli Workload Scheduler 8.2. This script can be used to install/uninstall the base product and apply a fix pack. Whether you want to use *twsappsinst* to install the base product, please see the instructions stated in the "How to install the base product" section below. This mechanism has been implemented to fix the APARs IY69757 and IY71434.

FEATURES

The following are the *twsappsinst* script features:

- Tivoli Workload Scheduler for Applications 8.2 installation
- Tivoli Workload Scheduler for Applications 8.2 uninstall of all the access method or the selected ones
- Tivoli Workload Scheduler for Applications 8.2 fix pack installation in commit only mode (no rollback) for all the access methods or the selected ones
- Tivoli Workload Scheduler Engine version independence: the script is independent from the Tivoli Workload Scheduler Engine, version 8.1 or 8.2
- Self-consistency: it leverages on the Software Distribution CLI provided with the script itself
- Working directory independence: you can put this script and the CLI wherever you want, provided that you specify where the Software Package Block files are located

RESTRICTIONS AND REQUIREMENTS

The following are the *twsappsinst* script restrictions and requirements:

- Fix packs are installed in commit state, so it is not possible to rollback the installation of a fix pack: in this case it would be needed to uninstall the access method (say r3batch) and install it from scratch (product + fix pack installation)
- This installation script does not install the Option Editor
- The installation script is not localized: all the messages are shown in English
- Only one installation/patching mechanism must be used to install and patch a Tivoli Workload Scheduler for Application 8.2 instance: it is possible to install the product with the ISMP installer but, once

twappsinst has been used to install a fix pack, this script must be used for further fix pack installations and product uninstall

- It is not possible to install a fix pack with the ISMP installer on a Tivoli Workload Scheduler for Applications 8.2 installed with *twappsinst*
- Different access methods belonging to different Tivoli Workload Scheduler for Applications, version 8.2 or 8.1.1 can coexist: for instance r3batch 8.1.1 and mcmagent 8.2

HOW TO INSTALL THE BASE PRODUCT

Since this installation script is included in the fix pack package, you can use it directly from the fix pack CD while applying a fix pack. Instead, to install the base product with it, you have two possibilities:

- Copy the script and the Software Distribution Command Line, provided along with the script itself, into a temporary directory (say /tmp), then run the script from that directory by providing the absolute path to the directory containing the base product software package blocks (SPBs):

```
[/tmp]# ./twappsinst -install -twsuser tws82 -r3_ljuser twsr3 -spbdir /mnt/cdrom/AIX/SPB
```

- Copy the base product software package blocks (SPBs) into a temporary directory (say /tmp/GASPB) and run *twappsinst* from the fix pack CD by providing the absolute path to that directory:

```
[/mnt/cdrom/AIX]# ./twappsinst -install -twsuser tws82 -r3_ljuser twsr3 -spbdir /tmp/GASPB
```

USAGE

Use the *twappsinst* script as follows:

```
twappsinst -u | -v
```

```
twappsinst -install -twsuser <user_name> [-<access_method>_ljuser <user_name> [-spbdir <SPB_Directory> -<access_method>_ljuser <user_name>]... [-twsdir <TWSinstallation_directory>]
```

```
twappsinst -uninst -twsuser <user_name> [-<access_method> -twsdir <TWSinstallation_directory>]
```

```
twappsinst -patch -twsuser <user_name> [-<access_method> -<access_method>_ljuser <user_name> -spbdir <SPB_Directory> -twsdir <TWSinstallation_directory>]
```

where:

- *twsuser <user_name>*: The user under which Tivoli Workload Scheduler is installed
- *<access_method>*: The access method to patch or uninstall. *access_method* can assume one of the following values:
 - r3
 - mcm
 - zos
- *<access_method>_ljuser <user_name>*: The Ljuser to launch the access method. *access_method* can assume one of the following values:
 - r3
 - mcm
 - zos
- *twsdir <TWSinstallation_directory>*: The absolute path to the directory where you installed the Tivoli Workload Scheduler. Default value is the home directory of the user specified using the *-twsuser* option

- `spbdir <SPB_Directory>`: The absolute path to the directory containing the SPB files. If not specified, it is the "SPB" directory in the working directory
- `clidir <SWDCLI_Directory>`: The absolute path to the directory containing the Software Distribution command line. If not specified, it is "CLI" directory in the working directory

You can copy the script and the CLI wherever you want in the file system and then provide the installation parameters. At the end of the installation you will find a copy of `twappsinst` and the CLI in `methods/_xauninst` and `methods/_tools/_swdcli` directories respectively. Please note that the **twmdir** parameter is required when Tivoli Workload Scheduler is not installed on the home directory of the `twuser`, for instance when it is installed on the `/home/twuser/maestro` directory.

The script automatically detects the fix pack version of the SPBs contained in the SPB directory, so it manages the versions without any customization. All the SPBs are installed in commit state, so it is not possible to rollback a fix pack installation: you need to uninstall and install again (at least the access method you want to downgrade). By default both uninstalling and patching do involve all the access methods at once, unless you have specified the access method you want to patch or uninstall. When applying a fix pack, it is possible to specify a `ljuser` to override the one provided at install or last patching time.

EXAMPLES

Here follow some usage examples.

INSTALL

The `-inst` option allows you to install the GA version of Tivoli Workload Scheduler for Applications 8.2. You need to provide the LJuser for each access method you want to install.

- Install `r3batch` in the home directory of the `tw82` user, by using `tw82` as the LJUSER and get the SPB files in `/mnt/cdrom/LINUX/SPB`:

```
[tmp]# ./twappsinst -install -twuser tw82 -r3_ljuser tw82 -spbdir /mnt/cdrom/LINUX/SPB
```

- Install `r3batch` in Tivoli Workload Scheduler installation in `/opt/maestro`, belonging to the `tw82` user, by using `tw82` as LJUSER and getting the SPB files in `/tmp/LINUX/SPB`:

```
[tmp]# ./twappsinst -install -twuser tw82 -r3_ljuser tw82 -spbdir /mnt/cdrom/LINUX/SPB -twmdir /opt/tw82
```

- Install `r3batch` and `zosagent` in the `tw82` home directory, by using `tw82` and `tw82` as LJUSERS:

```
[tmp]# ./twappsinst -install -twuser tw82 -zos_ljuser tw82 -r3_ljuser tw82 -spbdir /mnt/cdrom/AIX/SPB
```

PATCH

The `-patch` option allows you to install the fix pack to all the installed access method or to the selected ones. In all these examples, the script is supposed to be in the `/mnt/cdrom/AIX` directory with the SPB directory as well and Tivoli Workload Scheduler is supposed to be installed in the `tw82` home directory (`/home/tw82`).

- Install the patch to all the access methods belonging to the `tw82` installation:

```
[/mnt/cdrom/AIX]# ./twappsinst -patch -twuser tw82
```

- The following example is equivalent to the previous (it just explicitly lists all the access methods):

```
[/mnt/cdrom/AIX]# ./twsappsinst -patch -twsuser tws82 -r3 -zos -mcm
```
- Install the patch to all the access methods belonging to the tws82 installation, and for r3batch only, it overrides the ljuser:

```
[/mnt/cdrom/AIX]# ./twsappsinst -patch -twsuser tws82 -r3_ljuser r3user
```
- Install the patch to r3batch and zosagent only, and for r3batch only, it overrides the ljuser:

```
[/mnt/cdrom/AIX]# ./twsappsinst -patch -twsuser tws82 -r3 -zos -r3_ljuser r3user
```
- Install the patch to zosagent and r3batch and ignores the ljuser option for the mcmagent (a warning message is generated):

```
[/mnt/cdrom/AIX]# ./twsappsinst -patch -twsuser tws82 -r3 -zos -mcm_ljuser twsmcm
```
- Install the patch to zosagent and r3batch by providing the ljuser for both:

```
[/mnt/cdrom/AIX]# ./twsappsinst -patch -twsuser tws82 -r3 -zos -r3_ljuser twsr3 -zos_ljuser twszos
```

UNINSTALL

The **-uninst** option allows you to uninstall all the access methods or the selected ones belonging to a Tivoli Workload Scheduler for Application, version 8.2 installation. Whether a list of selected access method to uninstall is provided, the utility directories (methods/_tools and methods/_xauninst) are not removed.

- Uninstall the whole product (so all the access methods) installed in the tws82 home directory; this will remove _tools and _xauninst too:

```
[/home/tws82/methods]# ./_xauninst/twsappsinst -uninstall -twsuser tws82
```
- Uninstall the whole product (so all the access methods) installed in the Tivoli Workload Scheduler instance in /opt/TWS82; this will remove _tools and _xauninst too:

```
[/home/tws82/methods]# ./_xauninst/twsappsinst -uninstall -twsuser tws82 -twsdir /opt/TWS82
```
- Uninstall r3batch and zosagent only (mcmagent is supposed to be installed too), both installed in the tws82 home directory; this will not remove _tools and _xauninst:

```
[/home/tws82/methods]# ./_xauninst/twsappsinst -uninstall -twsuser tws82 -r3 -zosagent
```
- Internal CMVC defect 14192: Failure of xagent PeopleSoft 8.44 jobs run concurrently

This fix pack 6 contains the fix to the problem of concurrent submissions of PeopleSoft processes that contain inline bind variables. If a submission fails due to a clash with another submission of the same PeopleSoft process, then the submission is retried up to a maximum number of time. A retry operation is performed after a random amount of time between a minimum and a maximum.

The following options have been introduced to configure the maximum number of retries and the delay between two consecutive retries. These options are not mandatory, so include them in the options file only if you need a customization different than the default.

Table 1.

OPTION	DESCRIPTION	DEFAULT
TWS_RETRY_SAVE	Maximum number of times the submission is retried before giving up and setting the TWS job to ABEND. If it is set to 0 (zero) it will retry indefinitely (use with caution!)	10
TWS_MIN_WAIT_TIME	The random delay between to consecutive retries will not be shorter than the seconds specified in this option	5
TWS_MAX_WAIT_TIME	The random delay between two consecutive retries will not be longer than the seconds specified in this option	10

Of course TWS_MIN_WAIT_TIME should not be greater than TWS_MAX_WAIT_TIME. If this condition is not satisfied, then the default values will be used.

Documentation problems and corrections

This section contains problems and corrections for the IBM Tivoli Workload Scheduler for Applications, Version 8.2 User's Guide by access methods. It contains the following sub-sections:

- "Common"
- "PeopleSoft" on page 29
- "R/3" on page 32
- "Oracle" on page 33
- "z/OS" on page 34

Common:

- APAR IY50679:

To install the IBM Tivoli Workload Scheduler for Applications, Version 8.2 product on Windows XP, use the setup.exe contained in the I386NT_GA directory of the fix pack.

In Chapter 2. Installing IBM Tivoli Workload Scheduler for Applications, section "How to install", add the subsection "Installing on Windows XP":

Installing on Windows XP and Windows 2003

To install the IBM Tivoli Workload Scheduler for Applications, Version 8.2 product on Windows XP and Windows 2003 perform the following steps:

- From the Tivoli Workload Scheduler for Applications 8.2 CD-ROM, copy all the content of the I386NT directory locally maintaining the original directory structure.

Substitute the setup.exe with the one provided in the fix pack CD - ROM that is located in the I386NT_GA folder.

Launch the setup.exe. The installation proceeds as described in the "Using the Installation Wizard".

- APAR IY53993:

Update for the troubleshooting and error messages section for TWS for Applications

Description: PROBLEM SUMMARY: TWS instances up to version 8.1 are not discovered if the components file is different from the default (/usr/unison/components) as indicated by the environment variable UNISON_COMPONENTS_FILE.

PROBLEM CONCLUSION: In the ITWS for Apps 8.2 in the Section "Troubleshooting" (page 181)add an item: Area: Installation: Discovering Tivoli Workload Scheduler instances problem: TWS instances up to version 8.1 are not discovered if the components file is different from the default (usr/unison/components) as indicated by the environment variable UNISON_COMPONENTS_FILE.

Solution: Before performing the interactive ISMP installation in the file /usr/unison/components (create it if it does not exist), add an entry that points to the TWS instance to be discovered. You can copy this entry from the actual components file (referenced to by the environment variable UNISON_COMPONENTS_FILE). Make sure that at least root can read the /usr/unison/components file.

- APAR IY55042:

TWS 8.2 for Applications User Guide - add information about error logs
Description: PROBLEM SUMMARY: In the InstallShield log file the error: "File /usr/unison/components does not exist or is not readable" might appear even if the installation is successful.

PROBLEM CONCLUSION: In the ITWS for Apps 8.2 in the Section "Troubleshooting" (page 181)add an item: Area: Installation: Discovering Tivoli Workload Scheduler instances

Problem: In the InstallShield log file the error: "File /usr/unison/components does not exist or is not readable", even if the installation was successful
Solution: If TWS 8.2 instances only are present, then no components file will be present in the machine. Nonetheless the TWS 8.2 instances will be discovered and installation will proceed as expected. So this message doesn't point to any real problem during installation.

- APAR IY63385:

The installation of the TWS for Applications 8.2 GA through InstallShield (both interactive and silent) fails on some specific AIX platforms. The root cause for the failure of the TWS for Applications 8.2 installation through ISMP is due to an error in the detection of the operating system in an InstallShield library. It was an ISMP problem related to an upgraded AIX 4.3.3 This problem can be bypassed applying the workaround described below:

When you need to apply the workaround: The installation generally works correctly on AIX. You need to apply the described workaround when the command "lspp -l bos.rte" returns more than one entry and one of those entries has a bos.rte level prior to 4.3.2.0. For example, you need to apply the work around if the "lspp -l bos.rte" command yields:

```
Fileset Level State Description Path: /usr/lib/objrepos bos.rte 4.3.3.76
COMMITTED Base Operating System Runtime Path: /etc/objrepos bos.rte
4.3.1.0 COMMITTED Base Operating System Runtime because the second item is
prior to 4.3.2.0.
```

Workaround:

1. Copy the library libaixppk.so locally to the AIX machine where the TWS for Applications has to be installed : (this is extracted from the hotfix T for the ISMP 4.53). In the fix pack distribution it is located in the directory: /IY63385 For example, you can copy it to the /tmp directory.
2. In the shell where you will run the ISMP installer, export the environment variable AIX_LIB_LOC assigning to it the full absolute path name of the library as follows: export AIX_LIB_LOC=/tmp/libaixppk.so (of course the specific value depends on the actual location of the library).
3. Then launch the GA ISMP setup.bin of the TWS for Applications 8.2.

4. Then apply the fix pack using ISMP in the same shell. If you want to apply the fix pack later on, you just need to set the environment variable AIX_LIB_LOC as in point 2) before launching the fix pack installer. The library setting of the AIX_LIB_LOC environment variable to the above library must be made prior to using the ISMP installer.

PeopleSoft: The following information changes apply to the *User's Guide*,

- Feature 11451: To enable the PeopleSoft access method to schedule jobs containing in-line bind variable parameters in their job definitions.

The aim of this fix pack is to supply an enhancement to base PeopleSoft APIs to enable current IBM Tivoli Workload Scheduler for Applications for PeopleSoft to schedule jobs containing in-line bind variable parameters in their job definitions.

Due to limitations in the PeopleSoft APIs when invoked from a batch environment, it is not possible to schedule such jobs. With current PeopleSoft APIs, data that is stored in the PeopleSoft Database and referred to by a "runcontrolid parameter" that is used to retrieve a "runcontrol data record", needs to be loaded into the "Component Buffer" before scheduling the API invocation. This cannot be done from a batch environment. Therefore, when invoking the PeopleSoft scheduling APIs from a batch interface, the data related to the runcontrol ID is not available for the submission of a job, even though it is available in the database. When unresolved data is present in the submitted job, the PeopleSoft system refuses submission and ends with an error.

The fix pack provides the ability to use the data already present in the database to resolve in-line variable values by taking data from the database and substituting it with variable definitions. It then allows job submission regardless of the use of in-line variable definitions in the jobs.

The submission activity from the Tivoli Workload Scheduler perspective does not depend on the types of jobs that are being submitted. There are limitations, when the data used for PeopleSoft jobs is volatile (never stored in the database). In these cases the data ends its life when a PeopleSoft GUI transaction is complete.

When these types of process are used, the "runcontrol data record" is referred to as the "Work record". The resolution of the work record data used in in-line bind variables is not possible, as it is for other kinds of control records, and requires special management. This case is currently out of the scope of this feature.

When you submit Tivoli Workload Scheduler using a process that has in line bind variables, the process type in the PeopleSoft GUI will be called *ITWS_process type*. For example, "ITWS_SQR Process" instead of "SQR Process".

The following section explains how to load and configure the ITWS_PSOXA PeopleSoft project to the PeopleSoft software environment.

This fix pack installs the PeopleSoft project directories related to PeopleTools Versions 8.1x and 8.4x, as shown in the following structure:

```
TWS_HOME\methods\
\---PeopleSoft
  \---PT81x
    \---ITWS_P SXA
      BCM.DAT
      BCM.KEY
      CLM.DAT
      CLM.KEY
      ITWS_P SXA.ini
      MSG.DAT
      MSG.KEY
      PCM.DAT
      PCM.KEY
      PJM.DAT
      PJM.KEY
      SMDL.DAT
      SMDL.KEY
  \---PT84x
    \---ITWS_P SXA
      ITWS_P SXA.ini
      ITWS_P SXA.XML
  \---PT844
    \---ITWS_P SXA
      ITWS_P SXA.ini
      ITWS_P SXA.XML
```

The PeopleSoft project in PT81x directory applies to PeopleSoft Version 8.1x, the project in PT84x directory applies to PeopleSoft Version 8.4x with x up to 3 and the project in PT844 directory applies to PeopleSoft Version 8.44.

The backend shipped with the new package by default invokes the new Component Interface (CI) ITWS_PROCESSREQUEST. It is possible to force the invocation of the original CI (or any compatible CI) by defining the following new configuration options. A new configuration option can be used to invoke the original component interface (PROCESSREQUEST). The new options are as follows:

```
TWSXA_INLINE_CI=<CI name>
TWSXA_SCHED_METH=<methname>
TWSXA_SKEDM_TYPE= [ i | f | b ]
```

where:

<CI name>=Component Interface Name.

If this is not set the default value will be set as: ITWS_PROCESSREQUEST

<methname>=Name of the PeopleSoft method invoked by the Component Interface.

Ensure that the TWSXA_SCHED_METH method is used by the TWSXA_INLINE_CI Component Interface (for example:

ITWS_PROCESSREQUEST uses Schedule).

If you want to use the PeopleSoft component interface PROCESSREQUEST to submit processes without in-line bind variables, you must set TWSXA_INLINE_CI=PROCESSREQUEST.

TWSXA_SKEDM_TYPE is the return value type of the method:

where (i= [integer], f= [float], and b=[boolean]).

The last option is used only for PeopleTools version 8.1x.

After installing the patch you must follow the steps as shown below:

1. A new PeopleSoft project called ITWS must be manually uploaded into the PeopleSoft Database. Start the Application Designer and from the signon window select to start the Application Designer in tier two mode as follows:
 - Connection Type: <Database used> for example : Oracle
 - Database Name: <Database Name>
 - User ID: <Operator PS> for example: PS
 - Password of User ID
 - The Application Designer starts
2. Using the Application Designer:
 - Copy Project from the file
 - Using the browser, edit the full path to specify the folder where the project that you want to load is located
 - The project is contained in the <TWSHOME>/methods/PeopleSoft/project-version subdirectories under the specific PeopleTools version directories, where: project-version = PT84x | PT81x
 - After you have chosen the folder PT84X (or PT81X) of project, a list of projects appears in the Project Name Field of the "Copy Project From File" window. Choose ITWS_P SXA and click on the copy Button
 - A Copy "window" appears showing a list of Object Types
 - To set the new settings, click the "Options" button
 - Click on "Report Filter" tab
 - Click on "Select All" button
 - Click on the "OK" button
 - Click on "select All"
 - Click on "Copy", a copy progress bar appears

After loading the project, the PeopleSoft Database contains the following objects:

 - ITWS ProcessType Definition
 - ITWS Permission List
 - ITWS Cls
3. To create the new Security Role ITWS_ROLE, you can use the PeopleSoft Web GUI or the Application Designer. Follow the steps below:

From the menu of the PeopleSoft Web GUI:

 - a. People tools -> Security -> Permission and Roles -> Roles
 - b. From the Tabs select "Add a new value"
 - c. Edit ITWS_ROLE in the Role Name Field
 - d. Select the permission lists tab, select ITWS from the list, and Save.

From the Application Designer GUI:

 - a. Using Maintain Security, edit the ITWS_ROLE window
 - b. Select the Permissions list tab, select ITWS from the list, and save.

To grant the ITWS_ROLE to all users who need to schedule jobs from Tivoli Workload Scheduler, you can use the PeopleSoft Web GUI or the Application Designer, following the steps below:

From the Application Designer GUI:

 - a. Using Maintain Security, edit the user name
 - b. Select the Roles tab
 - c. Add the ITWS_ROLE and Save.

From the PeopleSoft WEB GUI:

- a. People Tools -> Security -> User Profiles ->
 - b. Edit the User Name
 - c. Select the Roles Tab
 - d. Add the ITWS_ROLE and Save
4. To add the ITWS process Types Definitions to the required Process Scheduler you can use the PeopleSoft Web GUI or the Application Designer. Follow the steps below:

From the Application Designer GUI:

- a. Using Process Scheduler Manager
- b. Select the Server and add the ITWS_* Type definitions
- c. Process Type definitions
- d. Type definition

From the PeopleSoft WEB GUI:

- PeopleTools -> Process Scheduler -> Servers -> Search your server -> Add the ITWS_*Process Types -> Save.

Note: From the SQL interactive command line, the same task can be performed by the following sample statement, customized for your database environment:

```
INSERT INTO PS_SERVERCLASS SELECT o.SERVERNAME,
o.OPSYS, 'ITWS_'||o.PRCSTYPE,o.PRCSPRIORITY,
o.MAXCONCURRENT FROM PS_SERVERCLASS
o WHERE ( SELECT count(*) FROM PS_SERVERCLASS i WHERE
i.SERVERNAME=o.SERVERNAME AND i.OPSYS=o.OPSYS AND
i.PRCSTYPE='ITWS_'||o.PRCSTYPE ) = 0
AND ( select count(*) from PS_PRCSTYPEDEFN
a where a.PRCSTYPE='ITWS_'||o.PRCSTYPE AND a.OPSYS=o.OPSYS ) > 0
```

5. Restart the process servers.

You do not need to make any changes to the existing Tivoli Workload Scheduler job definitions, except for the scheduling nVision process, where the runcontrol ID must be specified using the <BUSINESS_UNIT>.<REPORT_ID>convention.

An example related to Job Definition for the scheduling nVision process is shown below:

```
-process <process-name>-type nVision-Report -runcontrol
<BUSINESS_UNIT>.<REPORT_ID>
-process 'NVSRUN' -type nVision-Report -runcontrol AUS01.VARIABLE
```

R/3:

- APAR IY53891:

Abstract: Correction in job definition for SAP interception collector job.

Description: PROBLEM SUMMARY: The Users Guide of TWS for Applications 8.2 must be corrected in Chapter 22 "Implementing Job Interception" "Collecting Intercepted Jobs Periodically". The job definition: "TWShome/methods/r3batch -HIJ -c CPUNAME" is wrong. It must be as follows: "TWShome/methods/r3batch -t HIJ -c CPUNAME"

PROBLEM CONCLUSION: The User's Guide of Tivoli Workload Scheduler for Applications 8.2 must be corrected in Chapter 22 "Implementing Job Interception" "Collecting Intercepted Jobs Periodically". The job definition: "TWShome/methods/r3batch -HIJ -c CPUNAME" is wrong. It must be as follows: "TWShome/methods/r3batch -t HIJ -c CPUNAME":

1. The option -t XXX is a standard XA option, which denotes the task, while HIJ is a task type specific to r3batch. It stands for "Handle Intercepted Jobs".
 2. The directory TWShome/methods/r3batch_icp and all the files located in this directory have to be created manually.
- IY62615
THE CORRECT SAP NOTE IS SAPKW31009 INSTEAD OF SAPK31009 IN "TWS FOR APPS USER'S GUIDE" PAGE 87. In the TWS for Apps 8.2 User's Guide the SAP Note SAPKW1009 will be replaced with SAPKW31009 everywhere it's mentioned (on pages 87 and 115).
 - Internal CMVC Defect 13371
Due to the poor implementation of the Windows QOS Service, on Microsoft Windows platform the SAP RFC library is not able to use the QOS feature and the r3batch method fails to establish a connection to the R/3 system. This service is supposed to be automatically launched by the operating system, when an application requests network connections with the QOS feature enabled. To bypass this limitation, you can specify the following option in the options file: qos_disable=on This setting disables the use of the QOS feature in the SAP RFC library.
 - If you want to use the option -exec in the r3batch job definition, you need to upload the transport and control files named R000538.TV1 and K000538.TV1, respectively, which were distributed since fix pack 3. If you do not want to use the -exec option, you can still use the transport and control files distributed with the GA version: R000443.TV1 and K000443.TV1.

Oracle:

- Internal CMVC Defect 11879
In the three tier connection the user can use two Oracle Server UNIX computers, the MCMAGENT will reside on a computer where no APPS DB is present, (or is not used in the configuration file). The DB is located in the second UNIX computer where it can be reached using Oracle Network connectivity.
To work in a 3 tier connectivity environment the new option THREE_TIER_DB has been introduced. Its value is the TNS service name defined in an Oracle environment pointing to a remote DB server. The Oracle DB instance value is not mandatory, it is mandatory only for a 3 tier connectivity.

The following is an example: of a *WORKSTATION_MCMAGENT.opts* containing the new option:

```
<WS>_MCMAGENT.opts contents

MIN_TIME=10
ORACLE_HOME=/oracle/db/TST
ORACLE_SID=TST
ORA_APP_TOPDIR=/oracle/Apps11
FND_TOPDIR=$APPL_TOP/fnd/11.0.28
PATH=$PATH:$FND_TOP/bin:$MCM_TOP/bin
ENV=$APPL_TOP/APPTST.env
USERID=apps
PASSWORD=##3Y-UGcZ-3Kap-6m
PRINTER_NAME=prt4b2
MAX_TIME=150
THREE_TIER_DB=TST
```

where TST is the name of the oracle DB instance where the APPS DB is located. All other parameters are related to the local DB and APPS installation.

For the three tier configuration to work, you must define the **TWO_TASK** environment variables inside the Oracle environment setup scripts.

Note: When running the **mcminstall** script, the environment variable **TWO_TASK** must not be set externally or in the scripts given to **mcminstall** as an input parameter, otherwise you cannot perform the re-link steps successfully.

- Part 6. Common Serviceability, Chapter 29. Configuring the Trace Utility, add the following message:

The trace utility cannot be completely disabled. A minimum set of traces is always printed in the trace file. If you want to disable the trace utility completely, add the following line in the *accessmethod.properties* file:

```
access_method.trace.traces.logging=false
```

In this case if any problems occur no traces are printed in the *trace-accessmethod.log* file.

- The SAP panels of Job Scheduling Console, Version 1.3 fix pack 2 or earlier do not allow you to edit the TWS job task like for the other extended agent jobs. To make JSC use the common extended agent panels for the job definition, instead of the SAP specific ones, edit the **r3batch.opts** global options file on the TWS master and disable the **jobdef=r3batch** option. In this way the Job Scheduling Console will treat all the r3batch jobs as any other extended agent access method.

z/OS:

- APAR PQ83371:

The following changes refer to the SC32-1278-01 "IBM Tivoli Workload Scheduler for Applications User's Guide" Version 8.2. (Maintenance Release April 2004).

On page 147, delete the last sentence in the description of the COMPLETIONCODE parameter, the one starting with "This variable sets the default for jobs that do not have ...", and replace it with the following: "Any condition code different from 0 in the last step (if LASTSTEP has been selected) or in any step (if MAXSTEP selected) will cause the job to be considered unsuccessfully completed, unless differently specified through the condcode option at level of the job definition in TWS. Note that if a step is flushed, it will not be taken into consideration, unless the flushed step is the last one, in which case the job will always be considered unsuccessfully completed".

- APAR PQ85524:

In Chapter 26. "Reference Information", section "Technical Overview", Sub-section "Operation with JES", add the following information at the bottom of subsection *Checking JES Jobs*.

The IEFU84 exit cannot handle every job without impacting the performance of the entire system because it is invoked for each job running on the z/OS system.

- If the job is not present in the gateway dataspace, the IEFU84 exit does not perform any action.
- If the job is submitted by Tivoli Workload Scheduler, the gateway inserts the job in the dataspace. In this case the IEFU84 exit monitors the status of the job and of each step contained in the job.
- If the job is not submitted by Tivoli Workload Scheduler the gateway inserts the job into the dataspace only if the gateway receives the request from Tivoli Workload Scheduler to check its status because the job represents an internetwork dependency.

To have the internetwork dependencies of a z/OS job correctly handled by Tivoli Workload Scheduler on the z/OS system, ensure that there are no occurrences of the z/OS job in any job queue including the output queue. If any occurrences of

the z/OS job are present then purge them. The internetwork dependencies of a z/OS job are handled by Tivoli Workload Scheduler in the following ways:

- If there are no occurrences of z/OS jobs in the job queues, the gateway inserts the job into the dataspace the first time it receives the request from Tivoli Workload Scheduler to check the job status. The gateway inserts the job into the dataspace with an unknown jobid ready to be monitored.
- When the z/OS job is submitted, the IEFU84 exit finds the job in the dataspace and updates the corresponding entry with the JES jobid. From now on the z/OS job is monitored using the associated JES jobID. If the job is completed successfully, the gateway returns the information to Tivoli Workload Scheduler, and the internetwork dependency is correctly resolved.

In Chapter 26. Reference Information, section "Gateway Messages", add the following message:

```
"EEWI31E TASK task MODULE module LAUNCH OF JOB 'jobname' FAILED"
```

- APAR PQ85489:

In Chapter 24. Introduction, Section "Installation Overview", sub-section "Additional Notes[®] SYSTSIN Variables" add the **JESINTERFACE** variable and modify the description of the **MAXWAIT** and **MCSSTORAGE** variables in Table 21. SYSTSIN variables as shown below:

Variables	Description
JESINTERFACE(CONSOLE)	CONSOLE is the only supported interface for JES and it is the default value for this variable. Set to NO if you do not use this interface
MAXWAIT(500)	The maximum amount of time, in hundredths of a second, to wait for a response to commands. This variable is ignored if you set both CA7INTERFACE and JESINTERFACE to NO.
MCSSTORAGE(3)	The amount of storage, in megabytes, used by each extended console used by the gateway. This variable is ignored if you set both CA7INTERFACE and JESINTERFACE to NO.

In Chapter 26. Reference Information, section "Gateway Messages", add the following message:

```
EEWI32S yymmdd hhmmss module AT LEAST ONE INTERFACE MUST BE DIFFERENT FROM NO
```

- APAR PQ88345

In Chapter 26. Reference Information, section "Gateway Messages", change the text of the EEWI27I message and add the EEWI33W and EEWI34W messages as shown below:

- EEWI27I APPLICATION *application* WAS INSERTED IN CP WITH INPUT ARRIVAL DATE AND TIME yymmddhhss
- EEWI33W yymmdd hhmmss TASK *task* APPLICATION *application* NOT FOUND
- EEWI34W APPLICATION *application* NOT FOUND

Note: All the above messages are written in the EEWSpace or in the EEWSERVE log. These are the files indicated in the SYSTSPRT DD card of the respective procedure. In the files the messages are written starting from column 1, except for the messages that do not contain the date and time after the message identifier, for example EEWI27I. These messages appear with different characteristics in the z/OS system and on the Tivoli Workload Scheduler. In the z/OS system log the messages appear in the text of another message and in some cases they might appear truncated.

This is because the maximum length of each text record is limited to 251 characters. In Tivoli Workload Scheduler they are always displayed in their complete form.

- APAR PQ90636
Abstract: EEWI35W JCL dataset(member) NOT FOUND
- APAR PQ90157:
TWS FOR APPS DOES NOT RETURN MULTIPLE CPOPCOM ENTRIES ERROR FROM TWS FOR Z/OS TO TWS ON DISTRIBUTED PLATFORM
The following paragraph will be added in the IBM Tivoli Workload Scheduler for Applications 8.2 User's Guide (SC32-1278-01) at the bottom of section "Task Definition Syntax for Other z/OS Jobs" in page 155: "The details of the outcome of such jobs must be demanded to the subsystem where these jobs were launched. From Tivoli Workload Scheduler you should only expect to find out whether these jobs completed successfully or not. To find the reason for the failed submission or completion of one of these jobs, or to check for dependency failures, the Tivoli Workload Scheduler operator should work with the host subsystem operator who can obtain this information from the EEWSERVE log."
- APAR PQ90636:
The following changes refer to the IBM Tivoli Workload Scheduler for Applications 8.2 User's Guide (SC32-1278-00). At page 159 add, at the bottom of the messages and before the note added with APAR PQ88345, the following line: "EEWI35W JCL dataset (member) NOT FOUND"
- APAR PQ92628:
The following paragraph will be added in the IBM Tivoli Workload Scheduler for Applications 8.2 User's Guide (SC32-1278-00) at the bottom of the messages and before the note in page 159 add the following lines: "EEWI36W yymmdd hhmss IA and IATIME cannot be specified together EEWI37W yymmdd hhmss DEADLINE and DEADLINETIME cannot be specified together EEWI38I jobname (jobid) nl n2 result (restype), where:
 - nl contains the number of seconds passed from the request
 - n2 contains the number of seconds of CPU time consumed
 - result can have one of the following values:
 - ABEND - If the job is abended, in which case restype will contain: Sxyz in case of System Abend or Unnnn in case of User Abend.
 - CONDCOD - If the job does not end successfully due to the condition code of one step that does not match the definition, in which case restype will contain: RC=nnnnn value of the return code of the last executed step (if LASTSTEP specified) or of the worst step not matching the definition of the job on the distributed side.
 - EXEC - When the job is in execution or in the input queue.
 - JCLERRO - In case the job failed for JCL error.
 - SUCCES. - If the job ends successfully.
 - UNKNOWN - If the jobid is unknown.
 - blank - In case of an internetwork dependency when the manual submission has not yet happened"
- APAR PK10484:
Symptoms: CA7WAIT has been introduced.

The following changes refer to the manual SC32-1278-01 "User's Guide for z/OS Access Method" Version 8.2.0 Maintenance Release April 2004 At page 146 include, after CA7USER, a new variable CA7WAIT(0) with the following description:

"The amount of time, in hundredths of a second, that each Gateway task has to wait, after that CA-7 has sent to the console the answer which confirms that the Gateway request to LOGON to it has been successfully processed, before issuing the next command to CA-7 itself. The default is 0, which means that no wait will happen. The maximum value must be in any case lower than half of the value specified by MAXWAIT.

At page 163 add, at the bottom of the messages the following: "EEWI39E CA7WAIT MUST BE LOWER THAN HALF OF MAXWAIT"

- APAR PK09691:

The following changes refer to the manual SC32-1278-01 IBM Tivoli Workload Scheduler for Applications User's Guide Version 8.2 .

At page 147 the description of the COMPLETIONCODE parameter, must be modified. The sentence: Note that if a step is flushed, it will not be taken into consideration, included the case in which the flushed step is the last one, must be substituted with the old one:

"Note that if a step is flushed, it will not be taken into consideration, unless the flushed step is the last one. If that is the case, the job will always be considered unsuccessfully completed"

Chapter 2. End-to-end Dynamic R3 Job Definition Feature

Currently IBM Tivoli Workload Scheduler 8.2 is only capable of running SAP Pre-Defined jobs. These Pre-Defined jobs are created either using the SAPGUI or using the Tivoli Workload Scheduler Job Scheduling Console (in a distributed environment only). When Tivoli Workload Scheduler is about to start a SAP job, it makes a copy of the Pre-Defined job (known as a template job) and launches the copy.

If the same job is to be run on several SAP systems, currently you need to manually create the template job in each SAP system.

This feature allows users in a Tivoli Workload Scheduler End-to-end environment to create a SAP job instantly and launch it without having to create or reference a Pre-Defined job template.

Therefore the same job can be launched in any number of SAP systems. If the Tivoli Workload Scheduler job definition contains the SAP job ID, Tivoli Workload Scheduler first retrieves the definition of the SAP job that corresponds to the given job name and the job ID, then it creates a new SAP job using the settings of the SAP job as template, and replaces them with the corresponding values from the Tivoli Workload Scheduler job definition.

Although it is possible to use the new functionality on all R/3 releases supported by Tivoli Workload Scheduler 8.2, it is strongly suggested to install XBP 2.0, because the older versions of XBP do not support the full set of print and archive parameters, or provide a way to set the job class, or the spool list recipient.

Note: The End-to-end centralized script feature is not supported when working with the R/3 x-agent. This limitation has not currently been resolved.

Job Creation Parameters

In order to dynamically define and submit a SAP job using the new feature, use the JOBCMD in JOBREC statement with the following syntax:

The syntax below defines the attributes of steps:

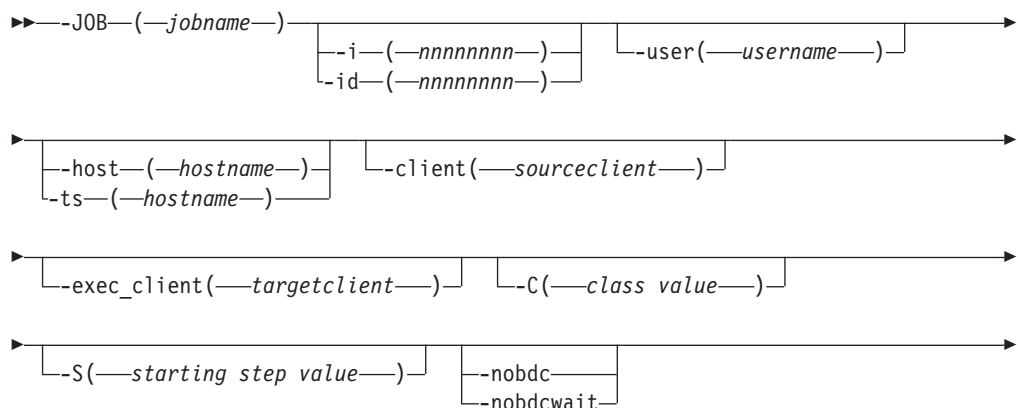



The syntax below defines the attributes of the steps:

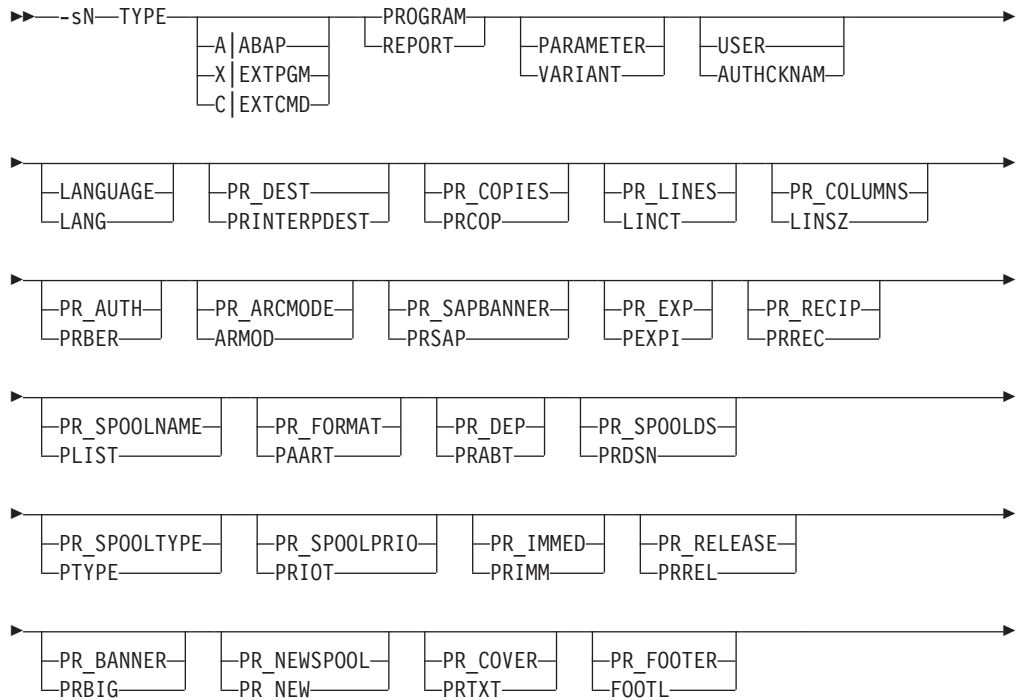

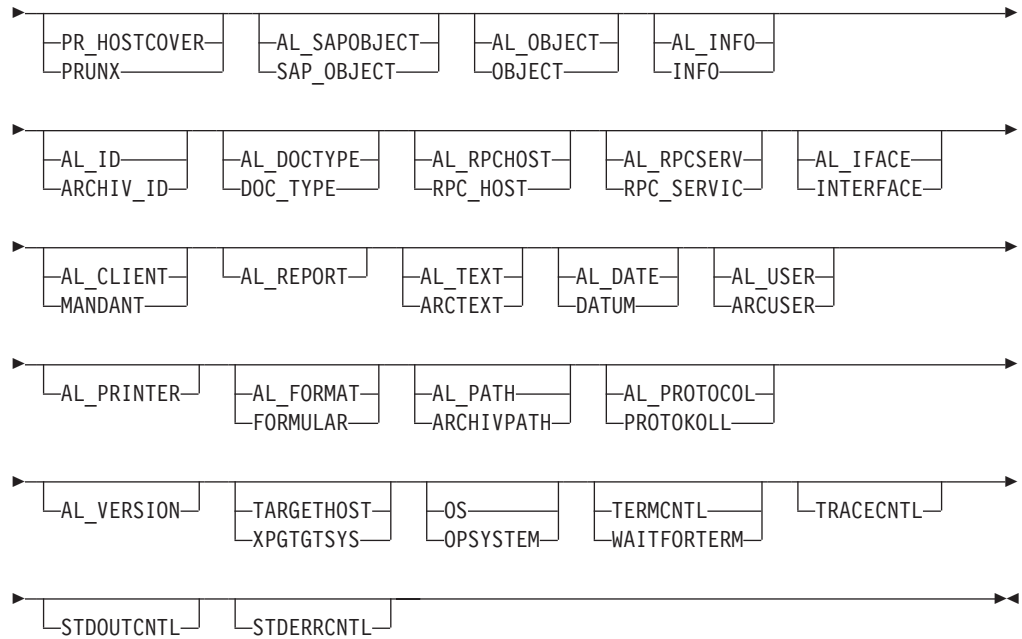

The following is an example of a JOBREC statement in the SCRPTLIB member referenced by the Tivoli Workload Scheduler job definition:

```
JOBREC
  JOBCMD('/ -job SAPTEST -C A -user MAESTRO -s2 variant=BVT -s1 program=BTCTEST
-s2 report=BTCTEST -s1 type=A -s2 type=A -flag type=exec -s1 pr_release
-vpar2 TESTNAME=test -vtxt2 Test ') JOBUSR(TWSuser)
```

Summary of Supported Parameters

A complete new job definition may be built by using 6 major sections related to the attributes of a SAP job, as summarized in the following table, the sections are related to:

- Job
- Steps (associated with the job)
- Variants (associated with steps)
- Spool List recipients (associated with the job)
- Flags (associated with the job)
- Tracing (associated with the job)

Section	Parameters	Description
JOB	-job <i>jobname</i>	Job name (this is a mandatory parameter)
	-i value -id value	Job ID (this is a mandatory parameter in all cases except in job creation)
	-user <i>username</i>	Owner of the job
	-host value -ts value	Target server
	-client value	Source client
	-exec_client value	Target client for job execution
	-C value	Job class
	-S value	Starting step
	-nobdc -nobdcwait	Disable BDC Wait feature (enabled by default)
	-flag type=exec	Type of job definition. In order to trigger the creation/redefinition of an SAP job this parameter is mandatory.
	STEP	-sN attribute[=value]
VARIANT	-vtxtN text	Variant description for step N
	-vN name	Variant name for step N
	-vparN name=value	Value for a variant parameter for step N (this parameter is mandatory when creating a new variant)
	-vselN name=sign#op#low[#high]	Value for a variant selection option for step N

SPOOL	-recipient <i>name</i>	Login name of an R/3 user
	-flag reccp	The spool list is sent as a copy to the recipient
	-flag recbl	The spool list is sent as a blind copy to the recipient
	-flag recex	The spool list is sent as an express message to the recipient
	-flag recnf	The recipient is not allowed to forward the spool list
	-rectype <i>type</i>	<ul style="list-style-type: none"> • ' ' - SAP user (default value) • 'B' - SAP user • 'C' - shared distribution list • 'D' - X.500 address • 'G' - organization object/ID • 'H' - organization unit • 'I' - SAP object • 'L' - telex number • 'O' - SAPOffice user • 'P' - private distribution list • 'R' - SAP user in another SAP system • 'U' - internet address • '1' - other recipient type
FLAGS	-flag im -flag immed	Launch job immediately, meaning that if there are no spare work processes, the job will fail
	-flag ENABLE_JOBLOG -flag DISABLE_JOBLOG	Enable or disable retrieval of the joblog
	-flag ENABLE_SPOOLLIST -flag DISABLE_SPOOLLIST	Enable or disable retrieval of the spool lists of the job
	-flag ENABLE_PCHAINLOG -flag DISABLE_PCHAINLOG	Enable or disable retrieval of the process chain log
TRACING	-debug	Enable maximum trace level
	-tracelvl 1 2 3	Enable specified trace level
	-rfctrace	Enable RFC trace

Supported Attributes for Step Definition

The following table shows all supported attributes for step definition:

Primary attribute name	Synonym	Description
TYPE	TYP	<p>Step type:</p> <ul style="list-style-type: none"> • A: ABAP step • X: external program step • C: external command step <p>Alternatively, this attribute accepts the following values:</p> <ul style="list-style-type: none"> • ABAP: ABAP step • EXTPGM: external program step • EXTCMD: external command step <p>A check for correct attribute values is performed prior to launching the job.</p>
PROGRAM	REPORT	ABAP program name or name of the external program or command
PARAMETER	VARIANT	ABAP variant name or parameters for the external program or command
USER	AUTHCKNAM	User of the step
LANGUAGE	LANG	<p>Step language</p> <p>This attribute accepts language names in either the ISO format (two characters, for example DE, EN) or the SAP format (one character, for example D, E)</p> <p>If this attribute is not specified, the login language of the access method is used (customizes via the option XAMETH_LANG in the r3batch option files)</p> <p>Check for a valid language is performed prior to launching the job.</p>
PR_DEST	PRINTERPDEST	Print Parameter: Printer for the output
PR_COPIES	PRCOP	<p>Print Parameter: Number of copies</p> <p>The value of this attribute has to be numeric. A corresponding check is performed prior to launching the job.</p>
PR_LINES	LINCT	<p>Print Parameter: Page length</p> <p>The value of this attribute has to be numeric. A corresponding check is performed prior to launching the job.</p>
PR_COLUMNS	LINSZ	<p>Print Parameter: Page width</p> <p>The value of this attribute has to be numeric. A corresponding check is performed prior to launching the job.</p>
PR_AUTH	PRBER	Print Parameter: Authorization
PR_ARCMODE	ARMOD	Print Parameter: Archiving mode

PR_SAPBANNER	PRSAP	Print Parameter: SAP cover page
PR_EXP	PEXPI	Print Parameter: Spool retention period The value of this attribute has to be a single digit. A corresponding check is performed prior to launching the job.
PR_RECIP	PRREC	Print Parameter: Recipient
PR_SPOOLNAME	PLIST	Print Parameter: Name of spool request *)
PR_FORMAT	PAART	Print Parameter: Print formatting *)
PR_DEP	PRABT	Print Parameter: Department on cover page *)
PR_SPOOLDS	PRDSN	Print Parameter: Name of spool dataset *)
PR_SPOOLTYPE	PTYPE	Print Parameter: Type of spool request *)
PR_SPOOLPRIO	PRIOT	Print Parameter: Spool request priority *)
PR_IMMED	PRIMM	Print Parameter: Print immediately **)
PR_RELEASE	PRREL	Print Parameter: Delete after printing **)
PR_BANNER	PRBIG	Print Parameter: Selection cover page **)
PR_NEWSPPOOL	PRNEW	Print Parameter: New spool request *) **)
PR_COVER	PRTXT	Print Parameter: Text for cover page *) **)
PR_FOOTER	FOOTL	Print Parameter: Output footer *) **)
PR_HOSTCOVER	PRUNX	Print Parameter: Host spool cover page *) **)
AL_SAPOBJECT	SAP_OBJECT	SAP ArchiveLink: Object type of business object
AL_OBJECT	OBJECT	SAP ArchiveLink: Document type
AL_INFO	INFO	SAP ArchiveLink: Info field
AL_ID	ARCHIV_ID	SAP ArchiveLink: Target storage system *)
AL_DOCTYPE	DOC_TYPE	SAP ArchiveLink: Document class *)
AL_RPCHOST	RPC_HOST	SAP ArchiveLink: PRC host *)
AL_RPCSERV	RPC_SERVIC	SAP ArchiveLink: RPC service / RFC destination *)
AL_IFACE	INTERFACE	SAP ArchiveLink: Name of communication connection component *)
AL_CLIENT	MANDANT	SAP ArchiveLink: Client *)
AL_REPORT		SAP ArchiveLink: Report name *)
AL_TEXT	ARCTEXT	SAP ArchiveLink: Text information field *)
AL_DATE	DATUM	SAP ArchiveLink: Archiving date *)
AL_USER	ARCUSER	SAP ArchiveLink: Data element for user *)
AL_PRINTER		SAP ArchiveLink: Target printer *)
AL_FORMAT	FORMULAR	SAP ArchiveLink: Output format *)
AL_PATH	ARCHIVPATH	SAP ArchiveLink: Standard archive path *)
AL_PROTOCOL	PROTOKOLL	SAP ArchiveLink: Storage connection protocol *)
AL_VERSION		SAP ArchiveLink: Version number *)
TARGETHOST	XPGTGTSYS	Target host for external program or command
OS	OPSYSTEM	Operating system for external command

TERMCNTL	WAITFORTERM	Control flag: whether an external command or program is to be run synchronously **)
TRACECNTL		Control flag: whether SAP tracing level 3 is activated for tracing SAPXPG, the program that starts an external command or program *) **)
STDOUTCNTL		Control flag: indicates whether standard output from an external command or program is to be written to the job log *) **)
STDERRCNTL		Control flag: indicates whether standard error from an external command or program is to be written to the job log *) **)

*) this attribute is available since XBP 2.0 (XBP 6.10)

**) this attribute is a flag, i.e. it does not have a value, e.g. -s2#pr_release

New Parameters Used in the Job Definition

To allow the definition and scheduling of jobs in R/3 environment without defining template jobs, a set of new command line parameters has been introduced. Shown below is the description of these new parameters together with an example of how they are used.

Job

-flag type=exec

Besides the attributes for the step definition, r3batch needs this additional flag to be specified on the command line to be able to recognize the new job definition.

This flag is mandatory to define or update jobs using this feature. If you want to reference an existing SAP template, you can omit this keyword providing you supply the correct job id of the template.

Steps (associated with the job)

Step definition is done using the following command line parameters:

-sN attribute[=value]: as in -s8 REPORT=MYPGM

where:

N: Step number

attribute: Name of the attribute

value: value of the attribute, this is optional for some attributes

Only valid attribute names are accepted. The validation on the attributes is performed before the job is created in the SAP system. If the validation fails, the Tivoli Workload Scheduler job will go into the ABEND state.

Variants (associated with steps)

For example: -v3 ACCT01-vtxt3 My_variant -vsel3 ACCTNUM=I#BT#001#999

The variant management is done using following command line parameters for the Nth step:

-vN variant: name of the variant

-vtxtN: text variant description, in the Tivoli Workload Scheduler logon language (customizes by the r3batch option TWSXA_LANG); max. 30 characters

-vparN name=value: for ABAP program parameters, max. 45 characters.

-vselN name=sign#op#low[#high]: for ABAP program selections

Where:

sign: sign of the operation

op: operation

low: value of the selection; max. 45 characters

high: high value of the selection; max. 45 characters; optional

- The valid values for the sign of the operation are 'I' (include) and 'E' (exclude), while the valid operations are described in the following table:

Operation	Description
EQ	Equals
NE	Not equal to
BT	Between
NB	Not between
LT	Less than
LE	Less than or equal to
GT	Greater than
GE	Greater than or equal to
CP	Contains pattern
NP	Does not contain pattern

When using this feature to create or update SAP jobs, remember the following facts about variants:

To create or reference a variant within an ABAP step you can use one of the following equivalent syntaxes:

- -s1 Variant=Var1
- -s1 Parameter=Var1
- -v1 Var1

If a variant does not exist, it is created with the parameters specified in the job definition statement. In this case, all mandatory attributes of the variant should be given a value. The creation of empty variants is not supported.

If the variant is already present in the R/3 system, its values are modified according to the command line parameters. If the existing variant is an extended one, a new instance of it is created with resolved placeholders and updated counters. This new variant instance is then updated using the values from the command line. Finally, the job step is executed using this variant instance.

Note: All changes to the variant values are permanent, that is, Tivoli Workload Scheduler neither restores the old values of the variants nor deletes the variants created after the job is run. Tivoli Workload Scheduler does not change the case of the variant values.

- Flags (associated with the job)
- Tracing (associated with the job)

Refer to the summary of supported parameters table for details on Flags and Tracing.

Executing from a Tivoli Workload Scheduler End-to-end Environment

To use IBM Tivoli Workload Scheduler for Applications for R/3, Tivoli Workload Scheduler for z/OS must be enabled with the end-to-end feature. To schedule an R/3 extended agent job, follow these steps:

1. Define an extended agent for R/3 workstation in the IBM Tivoli Workload Scheduler for z/OS environment.
2. Define a job in IBM Tivoli Workload Scheduler for z/OS (SCRPTLIB member) contains the job definition statement for this feature.
3. Create a job stream (or application) that Tivoli Workload Scheduler for Applications for R/3 jobs.

The definitions above must implement a Tivoli Workload Scheduler configuration where the x-agent for SAP is installed on a distributed Tivoli Workload Scheduler FTA in a Tivoli Workload Scheduler network mastered by a Tivoli Workload Scheduler for z/OS agent. Refer to the *IBM Tivoli Workload Scheduler for Applications 8.2 Users Guide* Chapters 4 and 5, The enhancement described in this document affects the way that the JOBREC statement is built for the r3batch jobs.

Tivoli Workload Scheduler performs the following syntax validation on job attributes:

- Only valid attributes are allowed
- Checks if a particular attribute requires a value
- The values of following attributes are checked: TYPE, LANGUAGE, PR_COPIES, PR_LINES, PR_COLUMNS

The validation is performed before the job is created in the SAP system. If the validation fails, the Tivoli Workload Scheduler job goes into the ABEND state.

Specifying Job Parameters Using Variable Substitution

It is also possible to provide parameters at execution time by using the Variable substitution feature of the Tivoli Workload Scheduler for z/OS. In this case the value will appear as:

- -s1 report=&VARNAME

The variable substitution will occur at symphony file creation time by Tivoli Workload Scheduler.

See the *Tivoli Workload Scheduler Reference Guide* for more information about Tivoli Workload Scheduler parameters.

Defining and Updating R3 Jobs Using the End-to-end Dynamic Allocation Feature

This section describes some usage examples of this feature:

- **Job definition and run scenario (using the new -flag type exec option)**

The following example creates and runs a 3 step job assigned to the user MAESTRO. The first step runs the ABAP MYPROG1 using variant VAR01 and associated variant parameter. Step 2 has a step user defined. Step 3 uses the same ABAP as step 1 with no associated variant.

The only requirement is that the elements referred are known in the SAP system (user, program). If the variant does not exist there should be a set of values to define the content of the variant for its creation (pairs of -vpar<N> -vsel<N> parameters for the parameters and selections of the ABAP program)

```
JOBCMD( -job TESTJOB01 -user MAESTRO -c A -s1 type=A -s1 program=MYPROG1
-v1 VAR01 -vpar1 TESTNAME=TST -s2 report=SPOOLX1 -s2 user=PRTUSER
-s3 type=A -s3 program=MYPROG1 -flag type=exec)
```

The job returns job ID 12345678

- **Job copy/overwrite of the job created in previous step**

The following job statement references the job created in the previous example. A new copy of the job is made and the parameters specified in the invocation are used to update the definition. In this case the variant for step 1 is modified and a new external program step (step 4) is added.

```
JOBCMD( -job TESTJOB01 -i 12345678 -s1 variant=VAR01A -vpar1 TESTNAME=TST2
-s4 type=X -s4 report=niping -s4 parameter=-t -flag type=exec)
```

- **Copy overwrite of a job referencing an existing job template**

The following example shows a job creation referencing a job template (previously created without using this feature). A template job called `TEMPLAJOB` already exists on SAP system with ID of 56780123. It is a single ABAP step job to which we now add some print parameters.

```
JOB CMD(-job TEMPLAJOB -I 56780123 -s1 pr_immed -flag type=exec)
```

Chapter 3. Contacting IBM Software Support

Before contacting IBM Software Support with a problem, refer to the IBM Software Support site by accessing the following Web address:

<http://www.ibm.com/software/support>

To access Tivoli support, click the Tivoli support link at the bottom right of the page.

If you want to contact IBM Software Support, see the *IBM Software Support Guide* at the following Web site:

<http://techsupport.services.ibm.com/guides/handbook.html>

The guide provides information about how to contact IBM Software Support, depending on the severity of your problem, and the following information:

- Registration and eligibility.
- Telephone numbers, depending on the country in which you are located.
- Information you must have before contacting IBM Software Support.

Chapter 4. Notices

This information was developed for products and services offered in the U.S.A. IBM may not offer the products, services, or features discussed in this document in other countries. Consult your local IBM representative for information on the products and services currently available in your area. Any reference to an IBM product, program, or service is not intended to state or imply that only that IBM product, program, or service may be used. Any functionally equivalent product, program, or service that does not infringe any IBM intellectual property right may be used instead. However, it is the user's responsibility to evaluate and verify the operation of any non-IBM product, program, or service.

IBM may have patents or pending patent applications covering subject matter described in this document. The furnishing of this document does not give you any license to these patents. You can send license inquiries, in writing, to:

IBM Director of Licensing
IBM Corporation
North Castle Drive
Armonk, NY 10504-1785 U.S.A.

For license inquiries regarding double-byte (DBCS) information, contact the IBM Intellectual Property Department in your country or send inquiries, in writing, to:

IBM World Trade Asia Corporation
Licensing
2-31 Roppongi 3-chome, Minato-ku
Tokyo 106, Japan

The following paragraph does not apply to the United Kingdom or any other country where such provisions are inconsistent with local law:

INTERNATIONAL BUSINESS MACHINES CORPORATION PROVIDES THIS PUBLICATION "AS IS" WITHOUT WARRANTY OF ANY KIND, EITHER EXPRESS OR IMPLIED, INCLUDING, BUT NOT LIMITED TO, THE IMPLIED WARRANTIES OF NON-INFRINGEMENT, MERCHANTABILITY OR FITNESS FOR A PARTICULAR PURPOSE.

Some states do not allow disclaimer of express or implied warranties in certain transactions, therefore, this statement might not apply to you.

This information could include technical inaccuracies or typographical errors. Changes are periodically made to the information herein; these changes will be incorporated in new editions of the publication. IBM may make improvements and/or changes in the product(s) and/or the program(s) described in this publication at any time without notice.

Any references in this information to non-IBM Web sites are provided for convenience only and do not in any manner serve as an endorsement of those Web sites. The materials at those Web sites are not part of the materials for this IBM product and use of those Web sites is at your own risk.

IBM may use or distribute any of the information you supply in any way it believes appropriate without incurring any obligation to you.

Licensees of this program who wish to have information about it for the purpose of enabling: (i) the exchange of information between independently created programs and other programs (including this one) and (ii) the mutual use of the information which has been exchanged, should contact:

IBM Corporation
2Z4A/101
11400 Burnet Road
Austin, TX 78758 U.S.A.

Such information may be available, subject to appropriate terms and conditions, including in some cases payment of a fee.

The licensed program described in this document and all licensed material available for it are provided by IBM under terms of the IBM Customer Agreement, IBM International Program License Agreement or any equivalent agreement between us.

Any performance data contained herein was determined in a controlled environment. Therefore, the results obtained in other operating environments may vary significantly. Some measurements may have been made on development-level systems and there is no guarantee that these measurements will be the same on generally available systems. Furthermore, some measurement may have been estimated through extrapolation. Actual results may vary. Users of this document should verify the applicable data for their specific environment.

Information concerning non-IBM products was obtained from the suppliers of those products, their published announcements or other publicly available sources. IBM has not tested those products and cannot confirm the accuracy of performance, compatibility or any other claims related to non-IBM products. Questions on the capabilities of non-IBM products should be addressed to the suppliers of those products.

This information contains examples of data and reports used in daily business operations. To illustrate them as completely as possible, the examples include the names of individuals, companies, brands, and products. All of these names are fictitious and any similarity to the names and addresses used by an actual business enterprise is entirely coincidental.

If you are viewing this information in softcopy form, the photographs and color illustrations might not display.

Trademarks

IBM, the IBM logo, AIX, Tivoli, the Tivoli logo, and z/OS are trademarks or registered trademarks of International Business Machines Corporation in the United States, other countries, or both.

Microsoft, Windows, and Windows NT are registered trademarks of Microsoft Corporation in the United States, other countries, or both.

UNIX is a registered trademark of The Open Group in the United States and other countries



Java™ and all Java-based trademarks and logos are trademarks or registered trademarks of Sun Microsystems, Inc. in the United States, other countries, or both.

Linux™ is a trademark of Linus Torvalds in the United States, other countries, or both.

Other company, product, and service names may be trademarks or service marks of others.