



Extending Your Mainframe For More Business Value

The Truth About Offloading

Typical Scenarios

- Most data centers are not green field projects
- Cost concerns drive typical scenarios:
- Large transactional workloads and database
 - ▶ Scale may compel platform choice
- Adding new workload to an existing System z
 - ▶ The rule of three
- Server consolidation to Linux on IFLs
 - ▶ Consolidation Math
- Offloading projects
 - ▶ Proliferation of cores defeats distributed price advantages

Who Are The Offloading Competitors?

1. Oracle Modernization Alliance
 - ▶ <http://www.oracle.com/technology/tech/modernization/index.html>
2. Application Modernization Initiative (HP, Oracle, Intel)
 - ▶ <http://www.hp.com/go/ami>
3. Mainframe Migration Alliance (Microsoft-initiated)
 - ▶ <http://mainframemigration.org/>
4. Mainframe Re-hosting Partnership (Sun, BEA-Tuxedo, CSC, MetaWare)
 - ▶ <http://www.sun.com/third-party/global/bea/initiatives/mfr.html>
5. Migration and Transformation Consortium (Micro Focus-led)
 - ▶ <http://www.microfocus.com/partners/mtc.asp>

Typical Promises Made By Mainframe Competitors



CIO

We can help you save a lot of money by offloading to our servers . . .

The quality of service is just as good

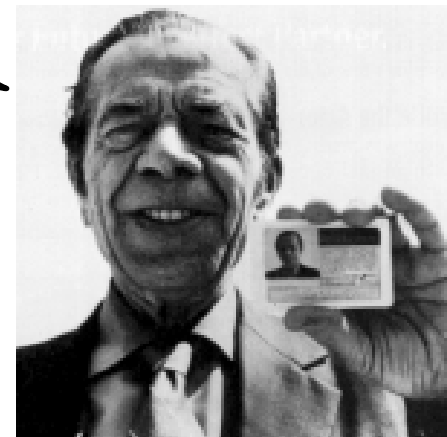

Mainframe Competitor

Consolidation Saves Money

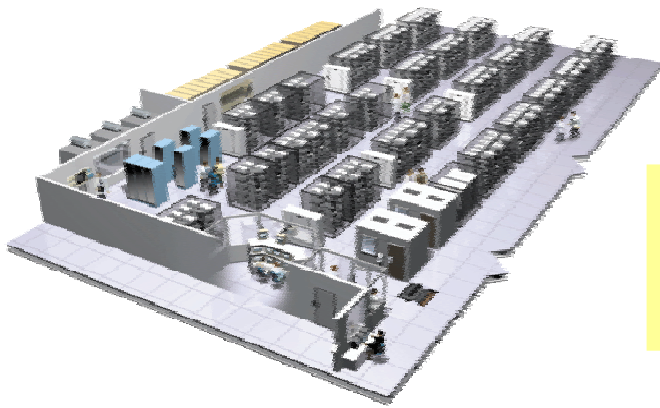

Consolidation



High Cost
Core Proliferation
Slow Provisioning
Power Consumption
Lower Availability

Lower Cost
High Core Utilization
Easy Growth
Power Efficiency
Business Resiliency

Offloading Is The Reverse Of Consolidation

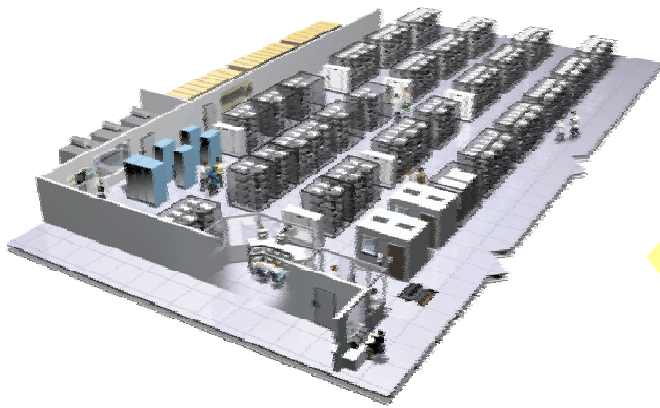

High Cost
Core Proliferation
Slow Provisioning
Power Consumption
Lower Availability



Lower Cost
High Core Utilization
Easy Growth
Power Efficiency
Business Resiliency

Common Cost Issues In Offload Comparisons

- Core proliferation not fully taken into account
 - ▶ Utilization, functional separation, and growth drive proliferation
 - ▶ Path length expansion – COBOL to Java
 - ▶ Database expansion – Hierarchical to Relational
- High cost of ISV software best addressed by switching to IBM
- Useful lifecycle of distributed servers
 - ▶ Cost of server refresh for end of life distributed servers
 - ▶ Running dual environments during migration
- Zero or less than 100% disaster recovery
- Failure to take advantage of mainframe pricing concessions – sub capacity, capacity on demand, backup capacity on demand, consolidation opportunities

Database Is A Key Consideration In Any Large Offload Proposal

- The only distributed replacement option for DB2 is Oracle RAC
- Let's take a brief look at Oracle RAC
 - ▶ Scalability
 - ▶ Core Proliferation
 - ▶ Availability
 - ▶ Security

Oracle RAC Is Designed For Commodity Hardware

DB2 for z/OS

Centralized Sysplex Design

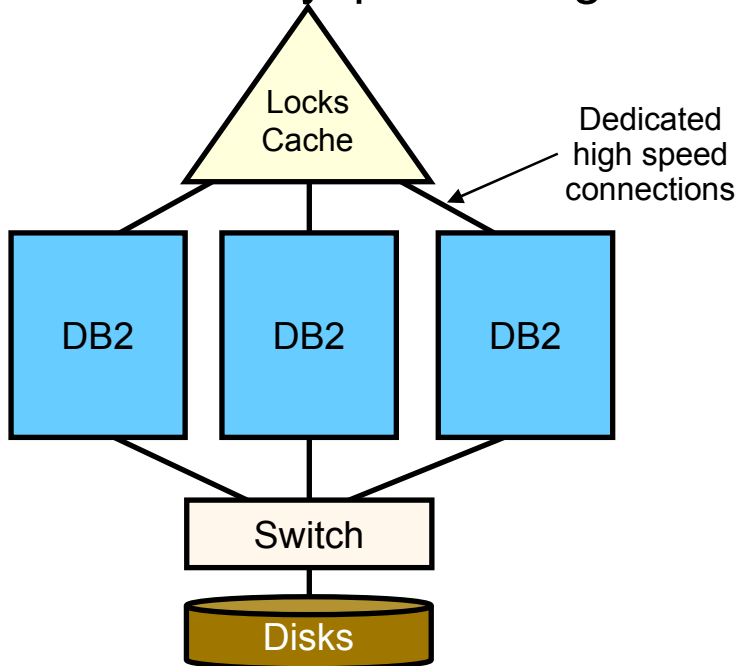

High speed centralized
lock manager in
coupling facility

Oracle RAC

Distributed Lock and Data Design

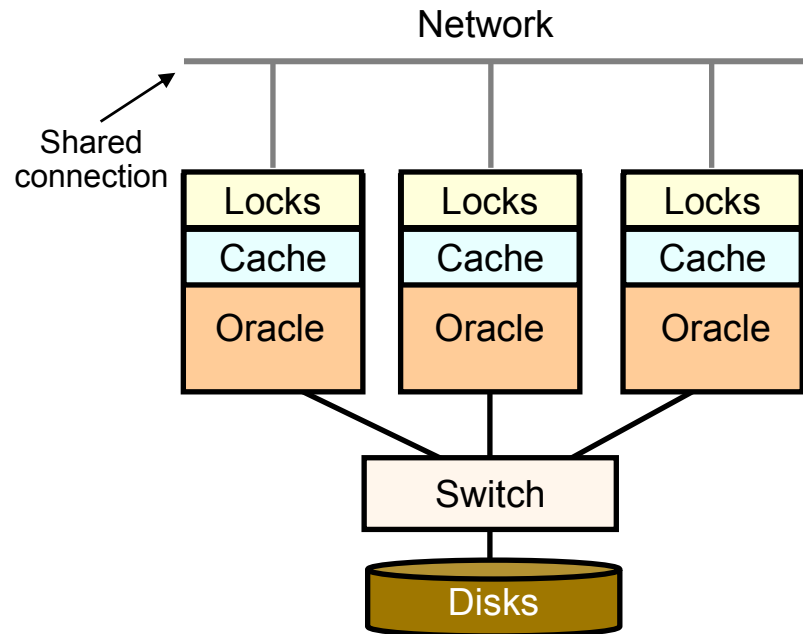

Distributed lock
management with
high messaging **overhead**

Oracle RAC: Lock Management Overhead

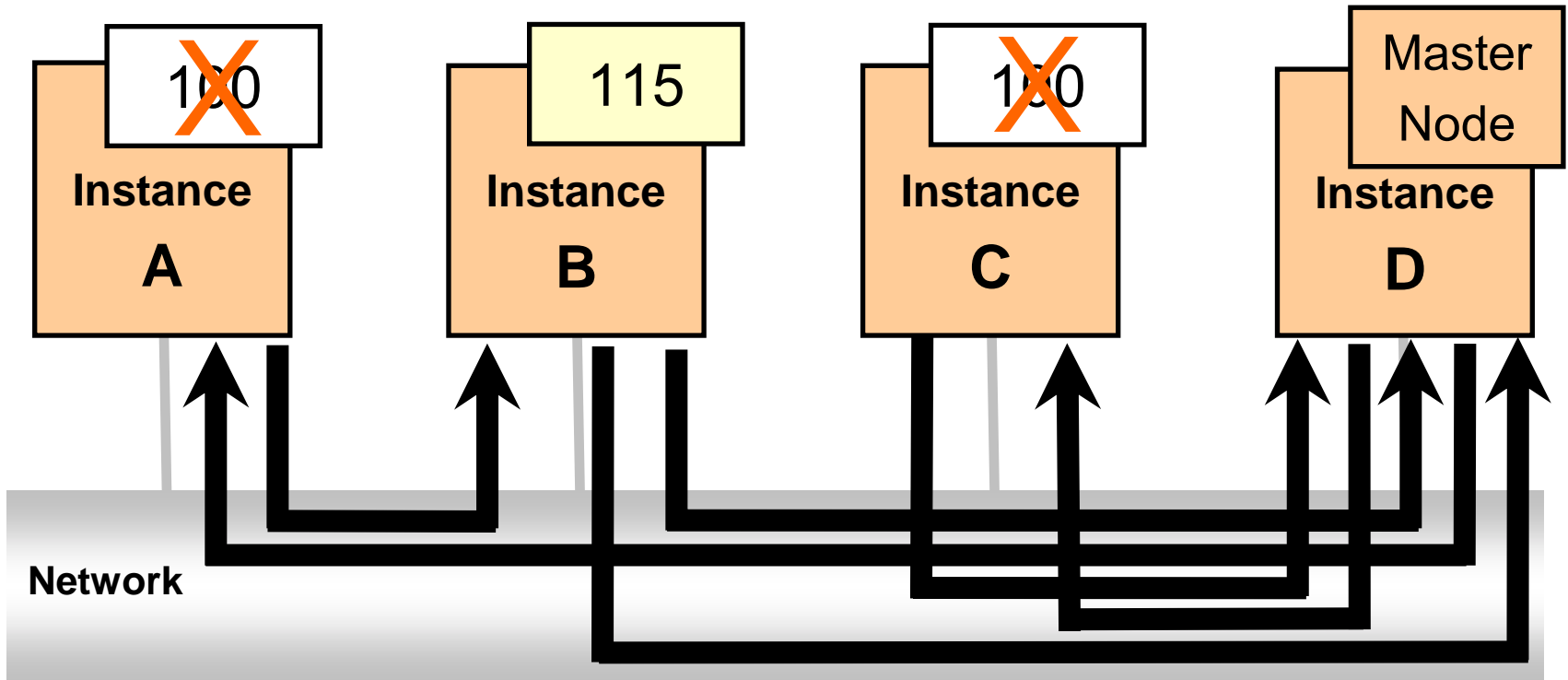

Lock Assume

7. B Updates local copy

Inter-node connections: 6

In a cluster with 4 nodes, an update operation may need 6 network connections and two in-memory calls (not shown).

Example based on Oracle's US Patent 7,107,319 B2.

Oracle RAC Inter-Node Network Traffic Increases With The Number Of Nodes...

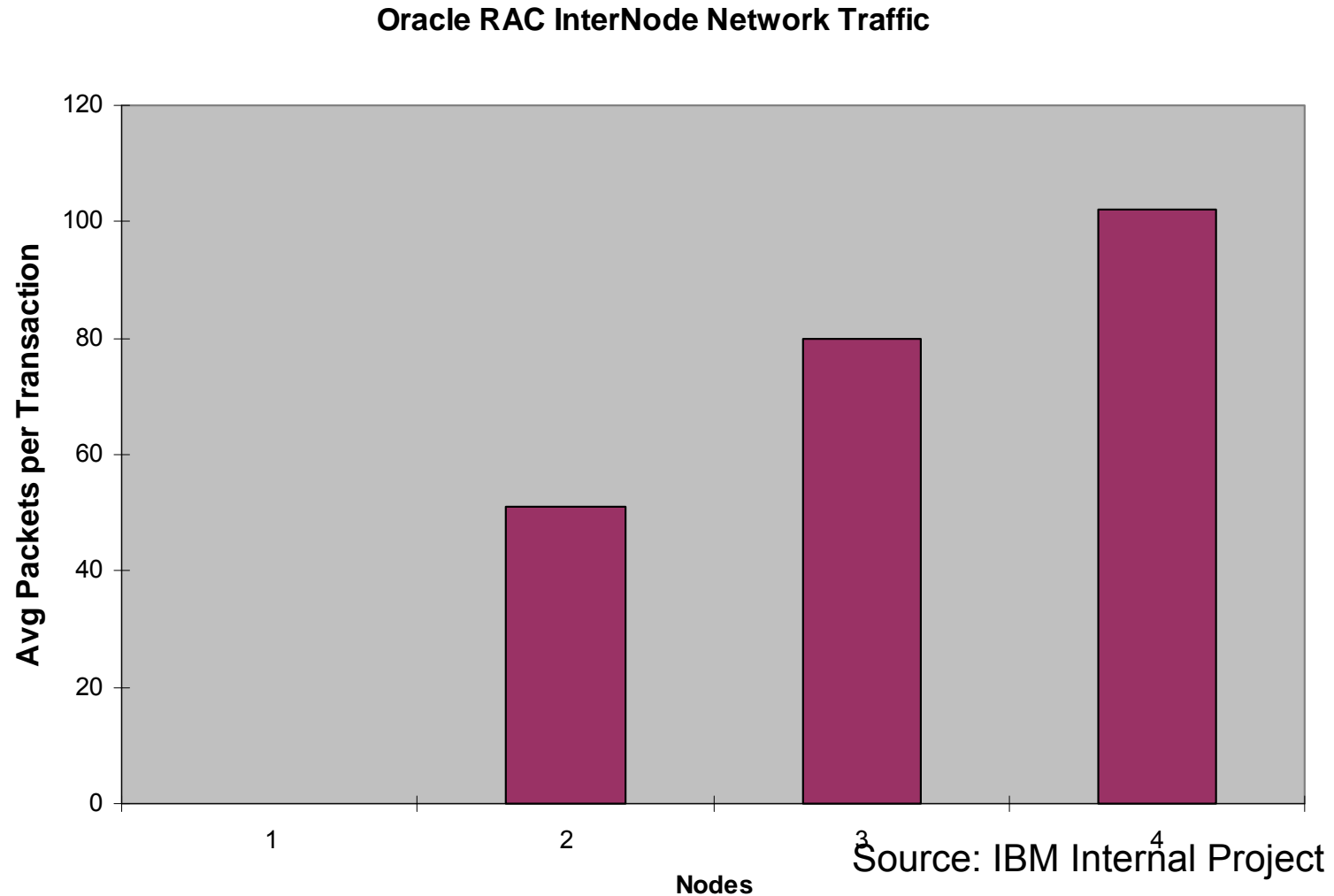

...So There Are Less Transactions Per Node ...

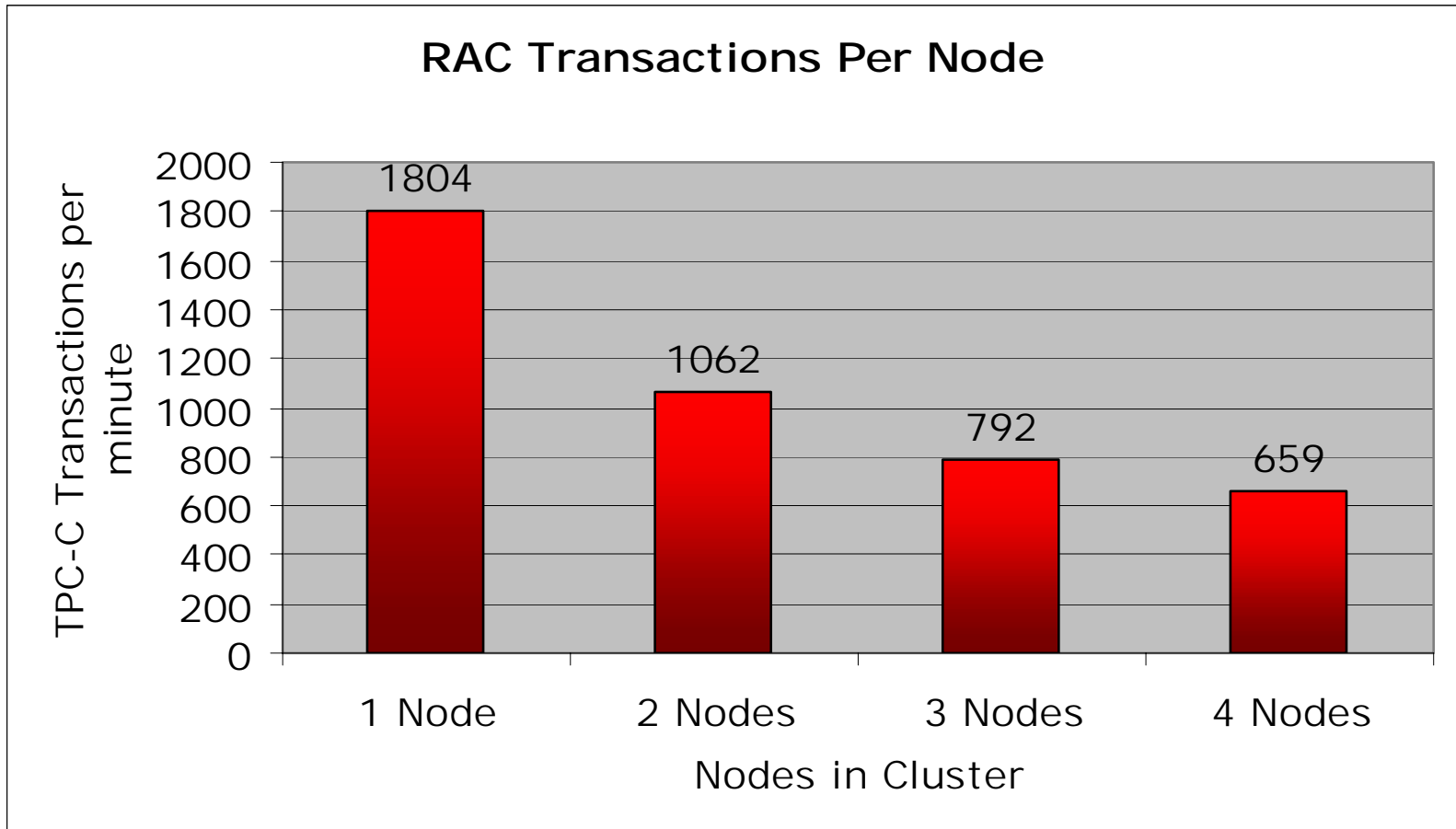

... And Oracle RAC Cluster Throughput Does Not Scale Linearly

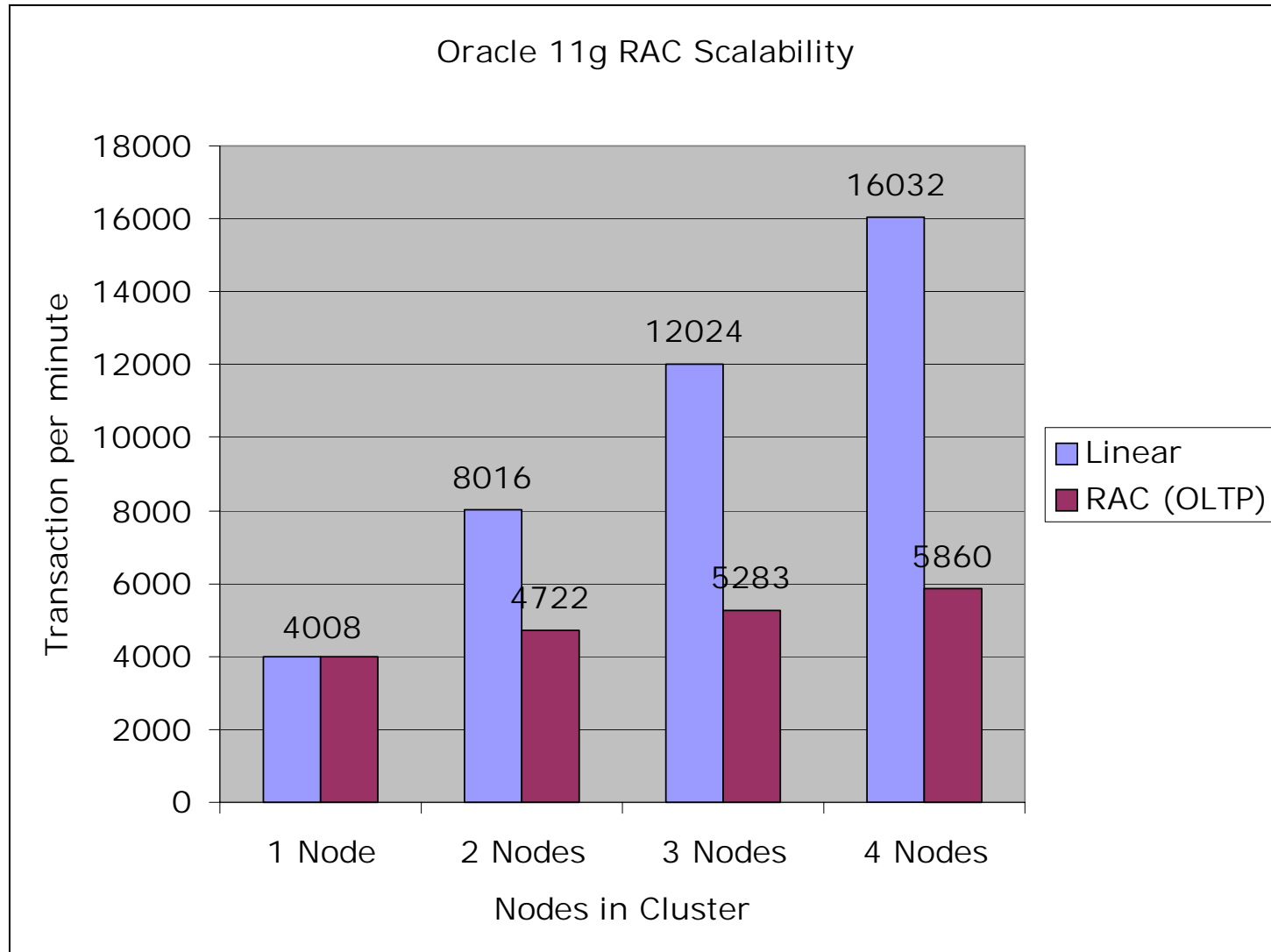

Source: IBM Internal Project

HP Agrees! Oracle RAC Scale Out Is Limited

- DB2 for z/OS provides near-linear scalability with relatively little overhead as nodes are added
- With Oracle RAC, overhead increases rapidly as additional nodes are added and performance degrades after only 4 to 6 nodes

Sources: "Scale-up versus scale-out using Oracle 10g with HP StorageWorks", Hewlett-Packard, 2005

"Enterprise Data Base Clustering Solutions" ITG, October 2003

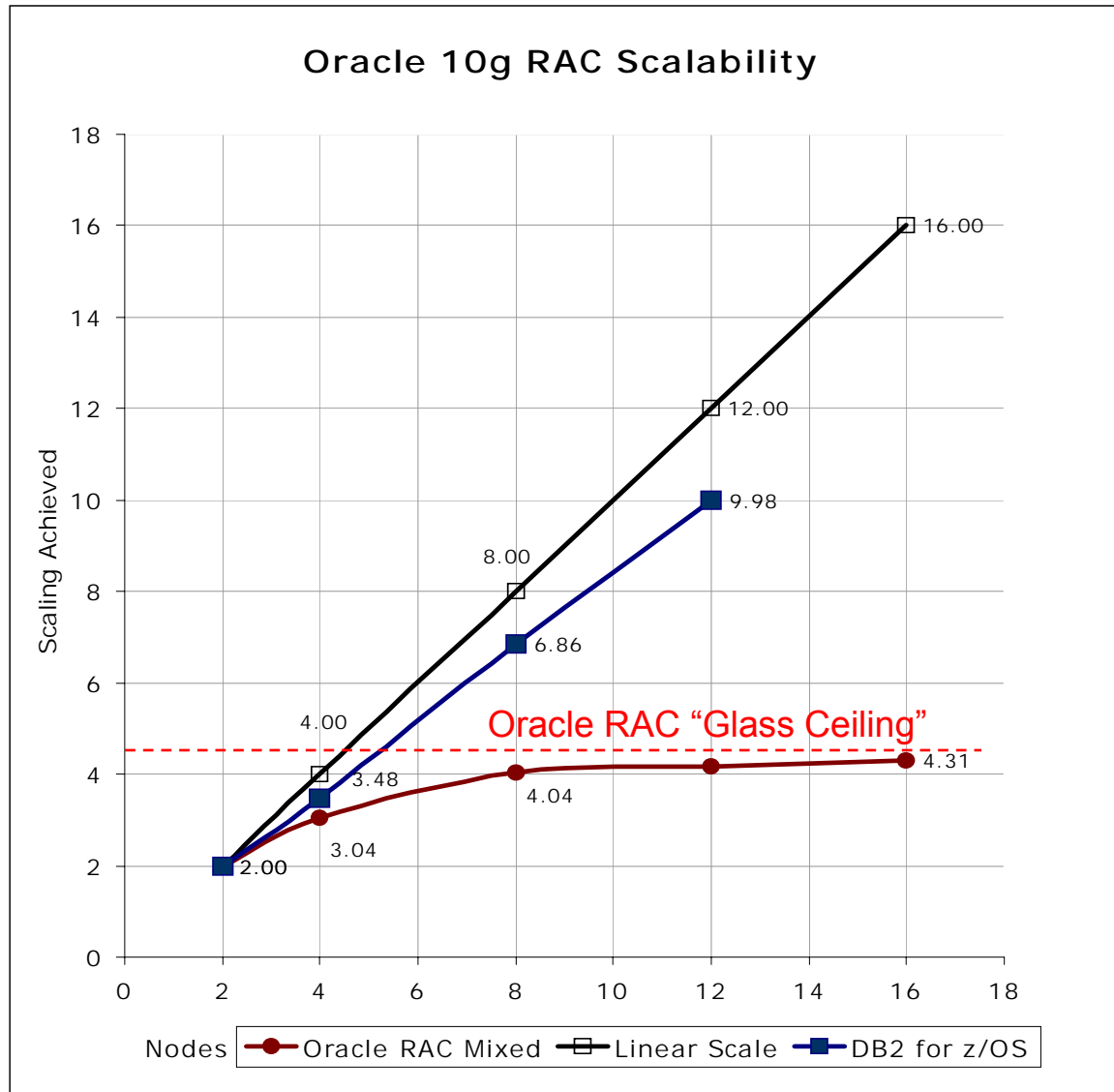

Centralized Coupling Facility Enables Near Linear Scalability With DB2 For z/OS

- IBM benchmarked the workloads of Bank of China and another large Asian bank to demonstrate workload capacity
- Near linear scaling was achieved through a range of MIPS

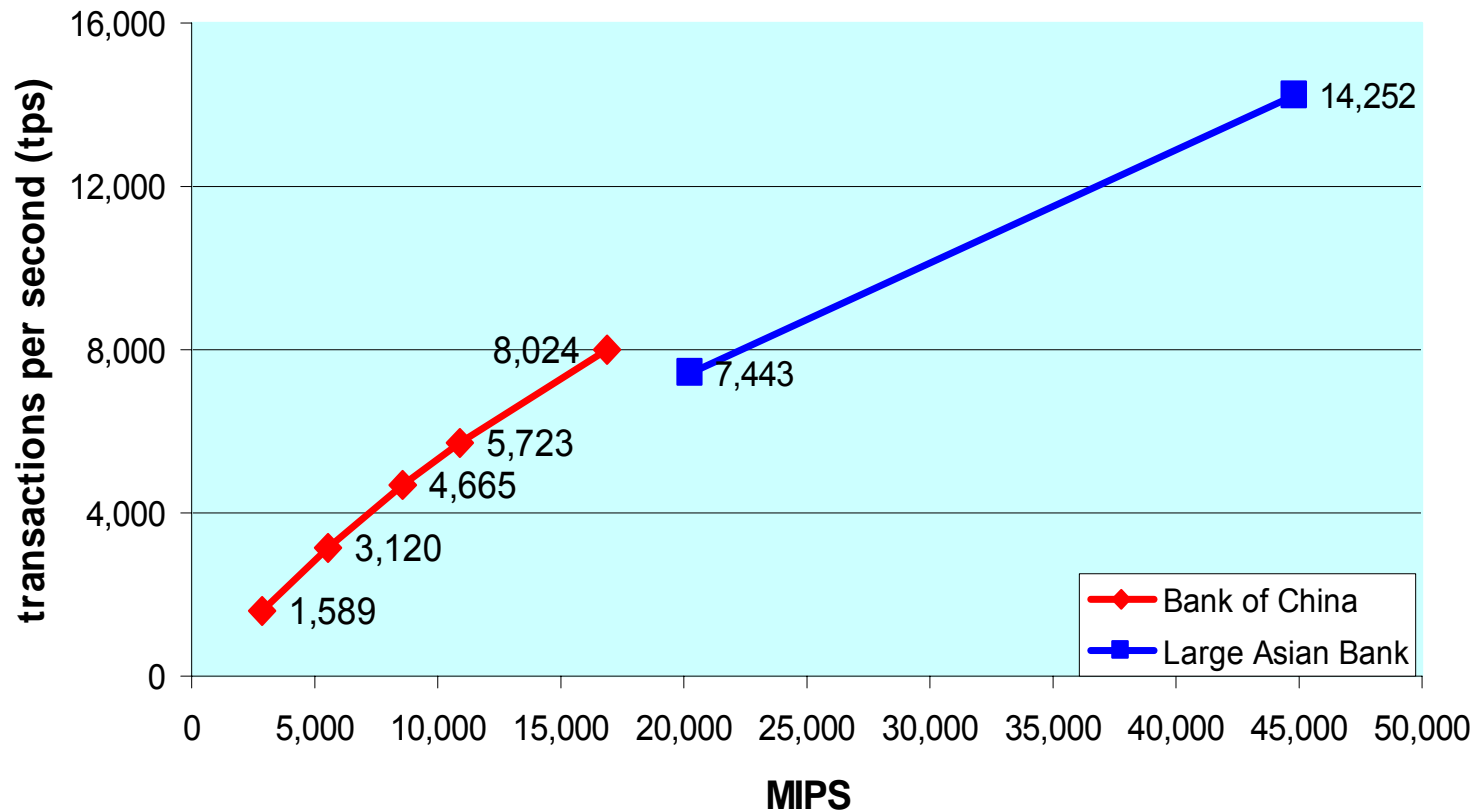

DB2 For z/OS Delivers Better Availability

- Fractional Improvements Result in Millions in Savings
- Financial Impact of Downtime Per Hour for financial industry is \$1.145M
- Financial Services Company Example:
 - ▶ \$300B assets, 2500+ branches, 15M customers
 - ▶ Retail banking, loans, mortgages, wealth management, credit cards
 - ▶ CRM System – branches, financial advisors, call centers, internet
 - ▶ Number of users – 20,000+

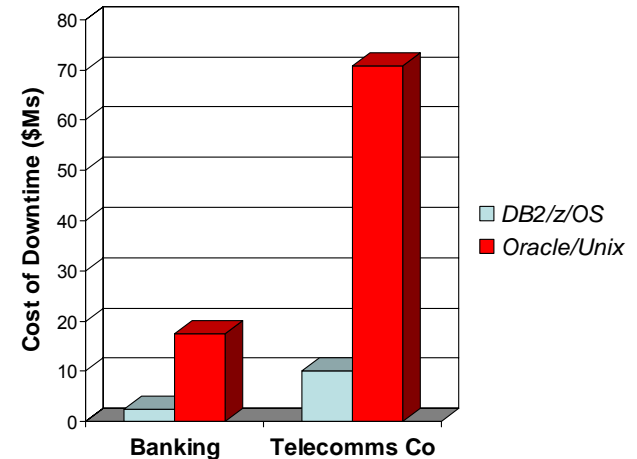

	<i>Unix/Oracle</i>	<i>zSeries/DB2</i>
Availability %	99.825%	99.975%
Annual outage	15h 20m	2h 11m
Cost of Downtime	\$17.6M	\$2.5M

\$15.1 Million dollar difference!

Sources: Picking up the value of PKI: Leveraging z/OS for Improving Manageability, Reliability, and Total Cost of Ownership of PKI and Digital Certificates by Jerald Murphy: 2007

DB2 For z/OS Has A Proven Security Track Record

DB2 for z/OS Security

- 10 security related patches in the last 10 years
- Proven RACF and Multi Level Security
- End-to-end encryption via hardware assist
- Optim Test Data Management
 - ▶ Ensures anonymous access to data necessary for testing
- Optim Archiving Expert
 - ▶ Allows customers to easily archive and access data
- DB2 Audit Management Expert
 - ▶ Supports compliance requirements
 - ▶ Consul for enterprise wide audit

Oracle's Security Exposures

- **Oracle.com – July 2008**
45 security patches, including **14** for database
- **Oracle.com – April 2008**
41 security patches, including **17** for database
- **eWeek.com – January 2008**
26 security patches, including **9** for database
- **eWeek.com – October 2007**
51 security patches, including **27** for database

In the last year Oracle has issued 163 security patches, **67** for the database

TCO Case Studies Consistently Demonstrate Distributed Core Proliferation

Scenarios	Cost of Distributed vs. z	Distributed Cost Ratio	Cores vs. z Processors	Core Ratio	Performance Units per MIP
Offloading cases					
- Banking Benchmark	\$43.3M vs \$18.2M	2.4x	560 vs 7	80 : 1	187:1
- NA financial company	\$84.7M vs \$24.2M	3.5x	264 vs 6	44 : 1	482:1
- European financial	\$17.9M vs \$4.9M	3.7x	52 vs 2	26 : 1	670:1
- Asian financial company	\$119 M vs \$53 M	2.2x	408 vs 17	24 : 1	122:1
Offloading studies					
- European agency	€386M vs €204 M	1.9x	568 vs 30	19 : 1	185:1
- Restaurant chain	\$56.3M vs \$23.3M	2.4x	32 vs 4	8 : 1	116:1
Offloading studies pending					
- US Utility	\$13.4M vs \$6.2M	2.2x	112 vs 3	37 : 1	
- US Manufacturer	\$64.0M vs \$43.3M	1.5x	96 vs 6	16 : 1	

2.5x

32 : 1

294:1

Core proliferation drives higher costs

In addition to costing more, offload projects result in lower qualities of service...

Let's compare the technologies



IBM

TD Bank Achieves 99.999% Availability

■ Background

- ▶ TD Bank has been running Parallel Sysplex
 - no Sysplex-wide outage for **12 years**
- ▶ System z is used for Customer Account Data for applications supporting Tellers, Internet Banking and ATMs

■ TD Bank Recommendations

- ▶ Keep sysplex up – do not bring it down
- ▶ Practice Rolling IPLs
- ▶ Exploit concurrent hardware upgrades
- ▶ Use automation
- ▶ Configure your sysplex for availability
 - IMS/DB2 Data-sharing
 - Transaction routing
 - Sysplex Distributor for TCP/IP
 - Online database reorganizations
 - Clone each image
 - Ensure applications exploit parallel sysplex

➤ Client Environment

- **System z**
- **z/OS**
- **DB2**
- **IMS**
- **WMQ**
- **GDPS**

Parallel Sysplex Deployment consists of five System z across two sites running 42 M business transactions a day



HP “Non-Stop” Stopped For Over 9 Hours At Bursa Malaysia

Sequence of events	
5.30am	One hard disk fails
5.35am	Faulty disk replaced
6.00am	Replacement disk faces problems; triggers failure of other disk and the CPU
6.30am	System restarts; several brokers unable to connect to central trading system
8.00am	Over 50% of brokers fail to connect
8.30am	Suspends trading; activates back-up site
1.00pm	Back-up site start-up process takes longer than expected
1.20pm	Decides to start afternoon session from primary site
3.15pm	Pre-opening orders keyed-in; connectivity problem crops up
3.30pm	Unable to resolve connectivity with brokers in time; extends trading suspension



**Estimated
opportunity
loss of about
RM450,000**

“After spending millions of Ringgit, their information technology (IT) people still haven't got their act together. The IT system should be fail-safe but (in this case) the back-up system also failed.”

Jimmy Vong
EquitiesTracker Founder

<http://biz.thestar.com.my/news/story.asp?file=/2008/7/4/business/21738638&sec=business>
<http://biz.thestar.com.my/news/story.asp?file=/2008/7/5/business/21748124&sec=business>

300-Year-Old London Stock Exchange Suffers .NET Crash On Fannie and Freddie Bailout Day

Sequence of events

- 9:00am Traders unable to route orders to LSE
- 9:21am LSE notified clients and FTSE-100 largely froze
- 3:50pm LSE notified clients trading would resume soon
- 4:00pm After 6 hours 45 minutes downtime trading platform finally back up



**Leaving
Billions of
Dollars in
Business
undone!**

“Microsoft .NET Framework is simply incapable of performing this kind of work, and SQL Server 2000, or any version of SQL Server really, can’t possibly handle the world’s number three stock exchange’s transaction load on a consistent basis”

Steven J. Vaughan-Nichols
Computerworld Blogger

http://blogs.computerworld.com/london_stock_exchange_suffers_net_crash

http://online.wsj.com/article_email/SB122088611707510173-IMyQjAxMDI4MjAwOTgwODk2Wj.html

Average Customer Cost Per MIP

Average Annual IBM Software Cost Per MIP
(Total Payments/Total MIPS)

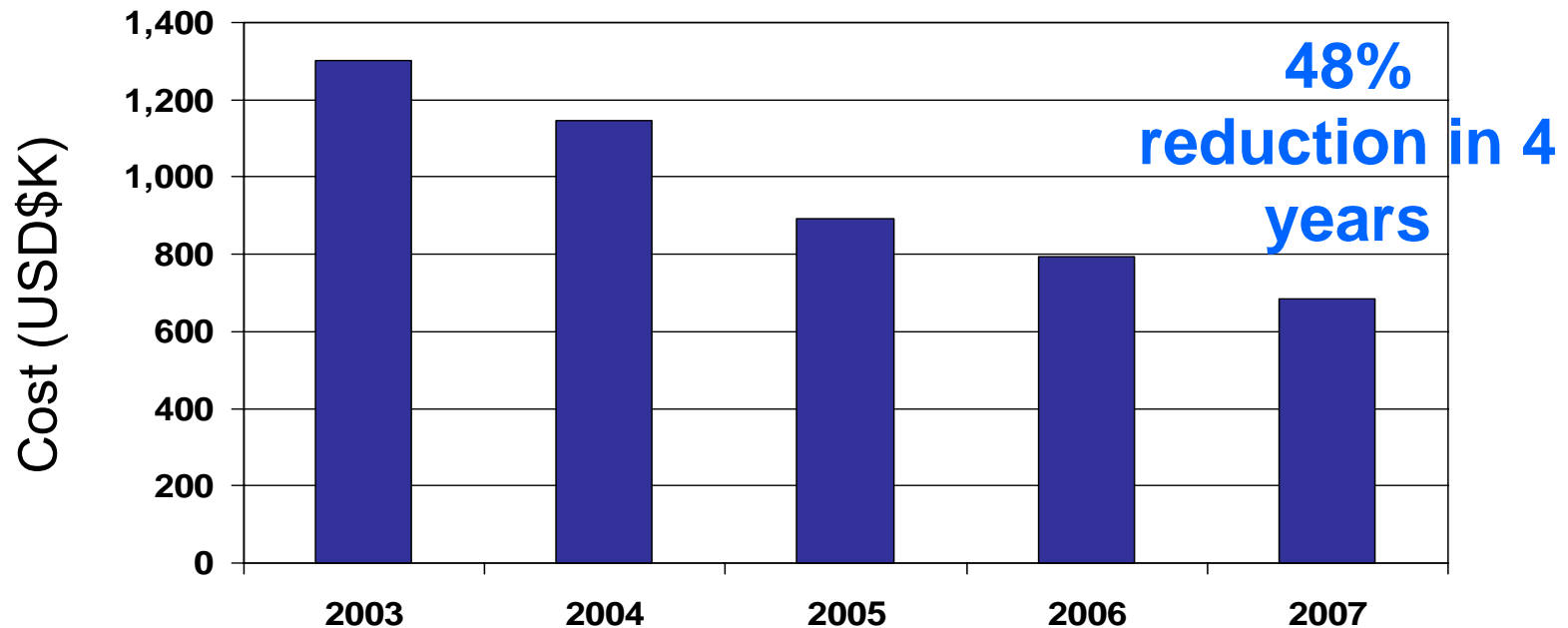

Source: IBM, total payments includes MLC and OTC

Typical Promises Made By Mainframe Competitors

I think I need some help to get the true story



CIO

Lower cost...
just as good...

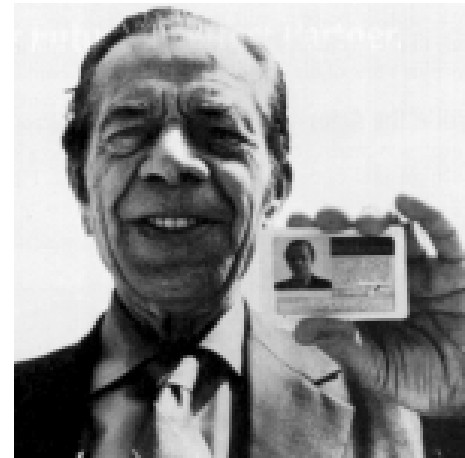

Mainframe Competitor

Need Help With TCO Issues?

<p>Craig Bender Manager IBM Mainframe Total Cost of Ownership Services</p>	<p>518-929-2290 csbender@us.ibm.com</p>
<p>Stephanie Schmader Program Manager IBM Software Group Competitive Project Office</p>	<p>724-293-4098 schmader@us.ibm.com</p>

