

**IBM 4610 SureMark Fiscal Printer  
Hungary – Models  
KR3/KR5 (Duna RS-485) - Version 1F  
and  
KD3/KD5 (Jacare RS-232) - Version 20  
Programming Guide Supplement**



# Summary of Changes

Changes resulting in document revisions will be summarized in this table in chronological sequence. Revision numbers and letters will highlight the text changed in new document versions.

	Version	Date	Change Description	Protocol
	V01 01 ALPHA	Jan. 31.2001	<ul style="list-style-type: none"> <li>This version of Technical Specification corresponds to microcode EC level 01. Internal microcode version 01.</li> </ul>	
<a href="#">H1</a>			<ul style="list-style-type: none"> <li>Change of typefaces</li> </ul>	
<a href="#">H2</a>			<ul style="list-style-type: none"> <li>Delete of Print typeface</li> </ul>	
			<ul style="list-style-type: none"> <li>Delete 19 – Modify Decimal Indication</li> </ul>	
<a href="#">H3</a>			<ul style="list-style-type: none"> <li>Modification the length of Trailer Message lines</li> </ul>	
<a href="#">H4</a>			<ul style="list-style-type: none"> <li>Modification of Command format D2 – Item Sale</li> </ul>	
<a href="#">H5</a>			<ul style="list-style-type: none"> <li>Modification of Command format D3 – Negative Item Sale</li> </ul>	
<a href="#">H6</a>			<ul style="list-style-type: none"> <li>Modification of Command format D4 – Total / Subtotal Printing</li> </ul>	
<a href="#">H7</a>			<ul style="list-style-type: none"> <li>Modification of Command format D5 – Payment</li> </ul>	
			<ul style="list-style-type: none"> <li>Delete D8 – Not Paid</li> </ul>	
<a href="#">H8</a>			<ul style="list-style-type: none"> <li>Modification of Command format EA – Normal Printing Lines on CR Station</li> </ul>	
<a href="#">H9</a>			<ul style="list-style-type: none"> <li>Modification of Command format 20 – Set TAX Table</li> </ul>	
<a href="#">H10</a>			<ul style="list-style-type: none"> <li>Modification of Command format 21 – Verify TAX Table</li> </ul>	
<a href="#">H11</a>			<ul style="list-style-type: none"> <li>Change of typefaces in EB – Application Originated Printing on DI Station</li> </ul>	
<a href="#">H12</a>			<ul style="list-style-type: none"> <li>Modification of Command format 14 – Summary Fiscal Report</li> </ul>	
<a href="#">H13</a>			<ul style="list-style-type: none"> <li>Modification of Command format 01 – Print Header</li> </ul>	
<a href="#">H14</a>			<ul style="list-style-type: none"> <li>Change of Date Format in Electronic Fiscal Report Response Format</li> </ul>	
<a href="#">H15</a>			<ul style="list-style-type: none"> <li>Modification at Response to the Option 0: Read Accumulators and Counters Command</li> </ul>	
<a href="#">H16</a>			<ul style="list-style-type: none"> <li>Modification of Command format 15 - Print Multi-Day Fiscal Report (Fiscal Memory Dump)</li> </ul>	
			<ul style="list-style-type: none"> <li>Delete EE – Cut Paper</li> </ul>	
<a href="#">H17</a>			<ul style="list-style-type: none"> <li>Modification of Command format DD - Start Application-Originated Report</li> </ul>	
<a href="#">H18</a>			<ul style="list-style-type: none"> <li>Modification at Acceptable State Restrictions for Barcode Size Set and Print Barcode command</li> </ul>	
<a href="#">H19</a>			<ul style="list-style-type: none"> <li>Description of the supported IBM 4610 SureMark Fiscal Printer KR3/KR5 (RS-485) Printer typefaces</li> </ul>	
<a href="#">H20</a>			<ul style="list-style-type: none"> <li>Modification of Default Decimal Printing Status for Hungary</li> </ul>	
<a href="#">H21</a>			<ul style="list-style-type: none"> <li>Modification of Fiscal Memory Information</li> </ul>	
<a href="#">H22</a>			<ul style="list-style-type: none"> <li>New data to the Fiscal Memory Variables</li> </ul>	
<a href="#">H23</a>			<ul style="list-style-type: none"> <li>Modifications on Fiscal Memory Daily Table</li> </ul>	
<a href="#">H24</a>			<ul style="list-style-type: none"> <li>Modification in Fiscal Memory Repair Action Table Format</li> </ul>	
			<ul style="list-style-type: none"> <li>Delete Fiscal memory Decimal Point Table Format</li> </ul>	
<a href="#">H25</a>			<ul style="list-style-type: none"> <li>Modification of subtotal discount and uplift computations</li> </ul>	
<a href="#">H26</a>			<ul style="list-style-type: none"> <li>Modification of Format of Fiscal Voucher Single Retailer Version                             <ul style="list-style-type: none"> <li>- Layout width</li> <li>- VAT code</li> <li>- Type of transaction</li> <li>- Date</li> </ul> </li> </ul>	
<a href="#">H27</a>			<ul style="list-style-type: none"> <li>Modification of Format of Fiscal Voucher Gasoline Station Version                             <ul style="list-style-type: none"> <li>- Layout width</li> <li>- Change of data of enterprises A and B</li> <li>- VAT code</li> <li>- type of transaction</li> <li>- date</li> </ul> </li> </ul>	
<a href="#">H28</a>			<ul style="list-style-type: none"> <li>Modification of Format of Cancelled Fiscal Voucher for Single Retailer Version – Items Sold                             <ul style="list-style-type: none"> <li>- layout width</li> <li>- VAT code</li> <li>- type of transaction</li> <li>- date</li> </ul> </li> </ul>	

	Version	Date	Change Description	Protocol
<a href="#">H29</a>			<ul style="list-style-type: none"> <li>• Modification of Format of Cancelled Fiscal Voucher for Single Retailer Version – Payment in Progress <ul style="list-style-type: none"> <li>- layout width</li> <li>- VAT code</li> <li>- type of transaction</li> <li>- date</li> </ul> </li> </ul>	
<a href="#">H30</a>			<ul style="list-style-type: none"> <li>• Modification of Format of Cancelled Fiscal Voucher for Single Retailer Version – Only Header Printed <ul style="list-style-type: none"> <li>- layout width</li> <li>- denomination of Hungarian currency: Ft</li> <li>- date</li> </ul> </li> </ul>	
<a href="#">H31</a>			<ul style="list-style-type: none"> <li>• Modification of Format of Cancelled Fiscal Voucher for Gasoline Station Version – Only Header Printed <ul style="list-style-type: none"> <li>- layout width</li> <li>- change of data of enterprises A and B</li> <li>- denomination of Hungarian currency: Ft</li> <li>- date</li> </ul> </li> </ul>	
<a href="#">H32</a>			<ul style="list-style-type: none"> <li>• New: Format of Simplified Invoice Printed on CR</li> </ul>	
<a href="#">H33</a>			<ul style="list-style-type: none"> <li>• New: Format of Cancelled Simplified Invoice Printed on CR</li> </ul>	
<a href="#">H34</a>			<ul style="list-style-type: none"> <li>• Modification of Format Closure Printout <ul style="list-style-type: none"> <li>- layout width</li> <li>- daily turnover splitted by VAT rates</li> <li>- number of simplified invoices</li> <li>- checksum after RAM reset</li> <li>- date</li> </ul> </li> </ul>	
			<ul style="list-style-type: none"> <li>• Delete: Format of Closure Printout for Gasoline Station Version</li> </ul>	
<a href="#">H35</a>			<ul style="list-style-type: none"> <li>• Modification of Format of X-Report Printout <ul style="list-style-type: none"> <li>- layout width</li> <li>- daily turnover splitted by VAT rates</li> <li>- number of simplified invoices</li> <li>- checksum after RAM reset</li> <li>- date</li> </ul> </li> </ul>	
			<ul style="list-style-type: none"> <li>• Delete: Format of X-Report Printout for Gasoline Station Version</li> </ul>	
<a href="#">H36</a>			<ul style="list-style-type: none"> <li>• Modification of Format of Fiscal Memory Dump Slip <ul style="list-style-type: none"> <li>- layout width</li> <li>- fiscal memory serial number</li> <li>- date of serialization</li> <li>- firmware checksum</li> <li>- VAT rates</li> <li>- daily turnover splitted by VAT rates</li> <li>- number of simplified invoices</li> <li>- checksum after RAM reset</li> <li>- subtotal at change VAT rates</li> <li>- date</li> </ul> </li> </ul>	
			<ul style="list-style-type: none"> <li>• Delete: Format of Fiscal Memory Dump Slip for Gasoline Station Version</li> </ul>	
<a href="#">H37</a>			<ul style="list-style-type: none"> <li>• Modification of Format of X-Report Voided Slip (Recovery after Error or PLD) <ul style="list-style-type: none"> <li>- Message</li> <li>- layout width</li> <li>- date</li> </ul> </li> </ul>	
<a href="#">H38</a>			<ul style="list-style-type: none"> <li>• Modification of Format of Fiscal Memory Dump Voided Slip (Recovery after Error or PLD) <ul style="list-style-type: none"> <li>- Message</li> <li>- layout width</li> <li>- date</li> </ul> </li> </ul>	

	Version	Date	Change Description	Protocol
<a href="#">H39</a>			<ul style="list-style-type: none"> <li>Modification of Format of Serialized, In Fiscal Mode, Working in Non-Fiscal or Idle Status <ul style="list-style-type: none"> <li>Message</li> <li>layout width</li> <li>date</li> </ul> </li> </ul>	
<a href="#">H40</a>			<ul style="list-style-type: none"> <li>Modification of Format of Serialized, In Fiscal Mode, Jumper Active <ul style="list-style-type: none"> <li>Message</li> <li>layout width</li> <li>date</li> </ul> </li> </ul>	
<a href="#">H41</a>			<ul style="list-style-type: none"> <li>Modification of Format of Serialized, In Fiscal Mode, Not Working <ul style="list-style-type: none"> <li>Message</li> </ul> </li> </ul>	
<a href="#">H42</a>			<ul style="list-style-type: none"> <li>Modification of Format of Not Serialized, Not in Fiscal Mode, Working <ul style="list-style-type: none"> <li>Date</li> </ul> </li> </ul>	
<a href="#">H43</a>			<ul style="list-style-type: none"> <li>Modification of Format of Serialized, Not In Fiscal Mode, Working <ul style="list-style-type: none"> <li>date</li> </ul> </li> </ul>	
<a href="#">H44</a>			<ul style="list-style-type: none"> <li>Modification of Format of Closure Printout Voided Slip (Recovery after Error or PLD) <ul style="list-style-type: none"> <li>Message</li> <li>layout width</li> <li>date</li> </ul> </li> </ul>	
	V02 01 BETA	Apr. 20.2001	<ul style="list-style-type: none"> <li>This version of Technical Specification corresponds to microcode EC level 02. Internal microcode version 01.</li> </ul>	
<a href="#">H45</a>			<ul style="list-style-type: none"> <li>Detailed Description of Printer Status Bytes</li> </ul>	
<a href="#">H46</a>			<ul style="list-style-type: none"> <li>New Command Extension in Fiscal Parameter Configuration Command (Code page Selecting)</li> </ul>	
<a href="#">H47</a>			<ul style="list-style-type: none"> <li>Character Set PC 852</li> </ul>	
<a href="#">H48</a>			<ul style="list-style-type: none"> <li>Character Set Windows Latin 2</li> </ul>	
<a href="#">H49</a>			<ul style="list-style-type: none"> <li>Hungarian Fiscal Logo</li> </ul>	
<a href="#">H50</a>			<ul style="list-style-type: none"> <li>Change of command F8 - Report Printer EC for F8 – Device Information Command</li> </ul>	
			<ul style="list-style-type: none"> <li>Delete Command: E8 - Set Number of Dot Rows per Linefeed</li> </ul>	
<a href="#">H51</a>			<ul style="list-style-type: none"> <li>Modification of return codes 071, 073, 074 and 075.</li> </ul>	
<a href="#">H52</a>			<ul style="list-style-type: none"> <li>Modification of command: 68 - Set/Get Max Wasted Space</li> </ul>	
<a href="#">H53</a>			<ul style="list-style-type: none"> <li>Error Handling during CF Full</li> </ul>	
<a href="#">H54</a>			<ul style="list-style-type: none"> <li>Modification of Transaction Counters</li> </ul>	
<a href="#">H55</a>			<ul style="list-style-type: none"> <li>Modification of Daily Accumulators</li> </ul>	
<a href="#">H56</a>			<ul style="list-style-type: none"> <li>Modification of Daily Counters</li> </ul>	
<a href="#">H57</a>			<ul style="list-style-type: none"> <li>Modification of Command 20 - Set TAX Table States Changed by Successful Execution of the Command</li> </ul>	
<a href="#">H58</a>			<ul style="list-style-type: none"> <li>Modification of Command 21 – Verify TAX Table States Changed by Successful Execution of this Command</li> </ul>	
			<ul style="list-style-type: none"> <li>Delete of the Command 64 - Close Journal Period</li> </ul>	
<a href="#">H59</a>			<ul style="list-style-type: none"> <li>New Format: Format of Start Sale Period Printout</li> </ul>	
<a href="#">H60</a>			<ul style="list-style-type: none"> <li>New Format: Format of Fiscal Memory Dump Voided Slip (after CF Full)</li> </ul>	
	V03 01 SUBMISSION	July. 12. .2001	<ul style="list-style-type: none"> <li>This version of Technical Specification corresponds to microcode EC level 03. Internal microcode version 01.</li> </ul>	
<a href="#">H61</a>			<ul style="list-style-type: none"> <li>Command syntax change in 1B - Serialize Fiscal Printer</li> </ul>	
<a href="#">H62</a>			<ul style="list-style-type: none"> <li>Command syntax change in 06 - End of Transaction</li> </ul>	
<a href="#">H63</a>			<ul style="list-style-type: none"> <li>Command syntax change in D4 - Total/Subtotal Printing</li> </ul>	
<a href="#">H64</a>			<ul style="list-style-type: none"> <li>New Return Code: 006</li> </ul>	
<a href="#">H65</a>			<ul style="list-style-type: none"> <li>New Return Code: 014</li> </ul>	
<a href="#">H66</a>			<ul style="list-style-type: none"> <li>New Return Code: 070</li> </ul>	
<a href="#">H67</a>			<ul style="list-style-type: none"> <li>New Return Code: 077</li> </ul>	
<a href="#">H68</a>			<ul style="list-style-type: none"> <li>Error handling description modifications in Error Conditions</li> </ul>	
<a href="#">H69</a>			<ul style="list-style-type: none"> <li>Error handling description modifications in PLD - Power Line Disturbance</li> </ul>	
<a href="#">H70</a>			<ul style="list-style-type: none"> <li>New Power-On Printout Format</li> </ul>	
			<ul style="list-style-type: none"> <li>Return Code 30 deleted</li> </ul>	
<a href="#">H71</a>			<ul style="list-style-type: none"> <li>Explanation change in Return Code 122</li> </ul>	
<a href="#">H72</a>			<ul style="list-style-type: none"> <li>Change of Max Amount in D2 - Item Sale</li> </ul>	

	Version	Date	Change Description	Protocol
<a href="#">H73</a>			<ul style="list-style-type: none"> <li>Change of Max Amount in D3 - Negative Item Sale</li> </ul>	
<a href="#">H74</a>			<ul style="list-style-type: none"> <li>Command format change in 20 - Set TAX Table</li> </ul>	
<a href="#">H75</a>			<ul style="list-style-type: none"> <li>Command format change in 21 - Verify TAX Table</li> </ul>	
<a href="#">H76</a>			<ul style="list-style-type: none"> <li>Void Discount type is admitted for enterprise B in D3 - Negative Item Sale</li> </ul>	
<a href="#">H77</a>			<ul style="list-style-type: none"> <li>Insert Uplift totaliser and counter in Response to the Option 0: Read Accumulators and Counters Command</li> </ul>	
<a href="#">H78</a>			<ul style="list-style-type: none"> <li>Insert Day_N_Slip counter in DE - End Application-Originated Report</li> </ul>	
<a href="#">H79</a>			<ul style="list-style-type: none"> <li>Explanation change in Return Code 15</li> </ul>	
			<ul style="list-style-type: none"> <li>Return Code 19 deleted</li> </ul>	
			<ul style="list-style-type: none"> <li>Return Code 45 deleted</li> </ul>	
<a href="#">H80</a>			<ul style="list-style-type: none"> <li>Change of Fiscal Memory Layout - EPROM 512KB</li> </ul>	
<a href="#">H81</a>			<ul style="list-style-type: none"> <li>Change of structure in Fiscal Memory Serial Number + Fiscal Logo Table</li> </ul>	
<a href="#">H82</a>			<ul style="list-style-type: none"> <li>Change in Compact Flash Management</li> </ul>	
	V04 01 SUBMISSION	Oct. 04. .2001	<ul style="list-style-type: none"> <li>This version of Technical Specification corresponds to microcode EC level 04. Internal microcode version 01.</li> </ul>	
<a href="#">H83</a>			<ul style="list-style-type: none"> <li>Change in Initialisation sequence Change / Format Compact Flash</li> </ul>	
			<ul style="list-style-type: none"> <li>Delete of the Command 6B - Delete All Compact Flash Files</li> </ul>	
<a href="#">H84</a>			<ul style="list-style-type: none"> <li>Acceptable State Restrictions change in Set Header</li> </ul>	
<a href="#">H85</a>			<ul style="list-style-type: none"> <li>Acceptable State Restrictions change in Set Tax Identification Information</li> </ul>	
<a href="#">H86</a>			<ul style="list-style-type: none"> <li>Acceptable State Restrictions change in Set Tax Table</li> </ul>	
<a href="#">H87</a>			<ul style="list-style-type: none"> <li>Acceptable State Restrictions change in Verify Tax Tabable</li> </ul>	
<a href="#">H88</a>			<ul style="list-style-type: none"> <li>Acceptable State Restrictions change in Fiscal Parameter Configuration</li> </ul>	
<a href="#">H89</a>			<ul style="list-style-type: none"> <li>Acceptable State Restrictions change in End of Transaction</li> </ul>	
<a href="#">H90</a>			<ul style="list-style-type: none"> <li>Acceptable State Restrictions change in Cancel Transaction</li> </ul>	
<a href="#">H91</a>			<ul style="list-style-type: none"> <li>Acceptable State Restrictions change in Item Sale</li> </ul>	
<a href="#">H92</a>			<ul style="list-style-type: none"> <li>Max Amount change in D3 - Negative Item Sale</li> </ul>	
<a href="#">H93</a>			<ul style="list-style-type: none"> <li>Arithmetic Pre-Checking change in D3 - Negative Item Sale</li> </ul>	
<a href="#">H94</a>			<ul style="list-style-type: none"> <li>Acceptable State Restrictions change in Negative Item Sale</li> </ul>	
<a href="#">H95</a>			<ul style="list-style-type: none"> <li>Rules change in Total/Subtotal Printing</li> </ul>	
<a href="#">H96</a>			<ul style="list-style-type: none"> <li>Acceptable State Restrictions change in Electronic Fiscal Report</li> </ul>	
<a href="#">H97</a>			<ul style="list-style-type: none"> <li>Acceptable State Restrictions change in Start Application-Originated Report</li> </ul>	
<a href="#">H98</a>			<ul style="list-style-type: none"> <li>Acceptable State Restrictions change in End Application-Originated Report</li> </ul>	
<a href="#">H99</a>			<ul style="list-style-type: none"> <li>Acceptable State Restrictions change in Normal Printing Lines on CR Station</li> </ul>	
<a href="#">H100</a>			<ul style="list-style-type: none"> <li>Acceptable State Restrictions change in Normal Printing Lines on DI Station</li> </ul>	
<a href="#">H101</a>			<ul style="list-style-type: none"> <li>Acceptable State Restrictions change in MICR Read</li> </ul>	
<a href="#">H102</a>			<ul style="list-style-type: none"> <li>New return code:149</li> </ul>	
<a href="#">H103</a>			<ul style="list-style-type: none"> <li>New return code:189</li> </ul>	
<a href="#">H104</a>			<ul style="list-style-type: none"> <li>RAM Reset message change in Format of Closure Printout</li> </ul>	
<a href="#">H105</a>			<ul style="list-style-type: none"> <li>RAM Reset message change in Format of X-Report Printout</li> </ul>	
<a href="#">H106</a>			<ul style="list-style-type: none"> <li>RAM Reset message change in Format of Fiscal Memory Dump Slip</li> </ul>	
	V05 01 SUBMISSION	Nov. 07. .2001	<ul style="list-style-type: none"> <li>This version of Technical Specification corresponds to microcode EC level 05. Internal microcode version 01.</li> </ul>	
<a href="#">H107</a>			<ul style="list-style-type: none"> <li>Modification of Format of Serialized, In Fiscal Mode, Working in Non-Fiscal or Idle Status</li> </ul>	
<a href="#">H108</a>			<ul style="list-style-type: none"> <li>Modification of Format of Serialized, In Fiscal Mode, Jumper Active</li> </ul>	
<a href="#">H109</a>			<ul style="list-style-type: none"> <li>Modification of Format of Serialized, In Fiscal Mode, CF in error</li> </ul>	
<a href="#">H110</a>			<ul style="list-style-type: none"> <li>Modification of Format of Serialized, In Fiscal Mode, Working with Open Transaction Status</li> </ul>	
<a href="#">H111</a>			<ul style="list-style-type: none"> <li>Modification of Format of Serialized, In Fiscal Mode, EJ error with Open Transaction Status</li> </ul>	
<a href="#">H112</a>			<ul style="list-style-type: none"> <li>New Software restart codes</li> </ul>	
<a href="#">H113</a>			<ul style="list-style-type: none"> <li>New FENDNON Status Flag</li> </ul>	
<a href="#">H114</a>			<ul style="list-style-type: none"> <li>New FCANNON Status Flag</li> </ul>	
<a href="#">H115</a>			<ul style="list-style-type: none"> <li>New Cancel bit in DE - End Application-Originated Report Command Extension</li> </ul>	
<a href="#">H116</a>			<ul style="list-style-type: none"> <li>New Cancelled NonFiscal Slip</li> </ul>	
<a href="#">H117</a>			<ul style="list-style-type: none"> <li>New RC 187,188</li> </ul>	
<a href="#">H118</a>			<ul style="list-style-type: none"> <li>New Fiscal unit procedure in progress values</li> </ul>	

	Version	Date	Change Description	Protocol
	V06 01 SUBMISSION	Nov. 29. .2001	<ul style="list-style-type: none"> <li>This version of Technical Specification corresponds to microcode EC level 06. Internal microcode version 01.</li> </ul>	
<a href="#">H119</a>			<ul style="list-style-type: none"> <li>New command extension (Key Freezing) Set Private and Public Key command</li> </ul>	
<a href="#">H120</a>			<ul style="list-style-type: none"> <li>New EJ error 44 (EJ_KEY_FREEZED)</li> </ul>	
<a href="#">H121</a>			<ul style="list-style-type: none"> <li>Command syntax change in D2 - Item Sale</li> </ul>	
<a href="#">H122</a>			<ul style="list-style-type: none"> <li>Command syntax change in D3 - Negative Item Sale</li> </ul>	
<a href="#">H123</a>			<ul style="list-style-type: none"> <li>Simplified Invoice Printout changes (Invoice Info)</li> </ul>	
<a href="#">H124</a>			<ul style="list-style-type: none"> <li>Simplified Invoice Printout changes (Invoice Info)</li> </ul>	
<a href="#">H125</a>			<ul style="list-style-type: none"> <li>Electronic Engineering Dump Acceptable State Restrictions changes</li> </ul>	
<a href="#">H126</a>			<ul style="list-style-type: none"> <li>Return code 99 deleted</li> </ul>	
<a href="#">H127</a>			<ul style="list-style-type: none"> <li>X-Report Printout Printout changes</li> </ul>	
<a href="#">H128</a>			<ul style="list-style-type: none"> <li>Electronic Fiscal Report Response new fields(Tra_VAT_g, Day_VAT_g)</li> </ul>	
	V07 01 SUBMISSION	Mar. 21. .2002	<ul style="list-style-type: none"> <li>This version of Technical Specification corresponds to microcode EC level 07. Internal microcode version 01.</li> </ul>	
	V09 BETA	Jun 13.2002	<ul style="list-style-type: none"> <li>This version of Technical Specification corresponds to microcode IBM 4610 SureMark Fiscal Printer KR3/KR5 (RS-485) EC level 07 and IBM 4610 SureMark Fiscal Printer <b>KD3/KD5 (RS-232) EC level 09.</b></li> </ul>	
<a href="#">A001</a>			<ul style="list-style-type: none"> <li>Display(s) Connected – (FDISPLAY): Only RS-485 message was added</li> </ul>	RS-485
<a href="#">A002</a>			<ul style="list-style-type: none"> <li>Calculations while the jumper is active was modified</li> </ul>	RS-485 / RS-232
<a href="#">A003</a>			<ul style="list-style-type: none"> <li>Calculations when the jumper is moved to the store position was modified</li> </ul>	RS-485 / RS-232
<a href="#">A004</a>			<ul style="list-style-type: none"> <li>Display Checking: Only RS-485 message was added</li> </ul>	RS-485
<a href="#">A005</a>			<ul style="list-style-type: none"> <li>Initialization Sequence – Set Display Address: Only RS-485 message was added</li> </ul>	RS-485
<a href="#">A006</a>			<ul style="list-style-type: none"> <li>Initialization Commands – Set Display Address: Only RS-485 message was added</li> </ul>	RS-485
<a href="#">A007</a>			<ul style="list-style-type: none"> <li>1A – Set Display Address: Only RS-485 message was added</li> </ul>	RS-485
<a href="#">A008</a>			<ul style="list-style-type: none"> <li>Command Set Summary List – Initialization – Set Display Address: Only RS-485 message was added</li> </ul>	RS-485
<a href="#">A009</a>			<ul style="list-style-type: none"> <li>4610 RS-232 Printer and Fiscal Unit Status was added</li> </ul>	RS-232
<a href="#">A010</a>			<ul style="list-style-type: none"> <li>4610 RS-232 Country Code and Version Number was added</li> </ul>	RS-232
<a href="#">A011</a>			<ul style="list-style-type: none"> <li>Return Codes (RC 131): Only RS-485 message was added</li> </ul>	RS-485
<a href="#">A012</a>			<ul style="list-style-type: none"> <li>Communication with the RS-232 Fiscal Printer was added</li> </ul>	RS-232
<a href="#">A013</a>			<ul style="list-style-type: none"> <li>Electronic Journal Return Codes: RC 45 (x2D) was added</li> </ul>	RS-485 / RS-232
<a href="#">A014</a>			<ul style="list-style-type: none"> <li>Electronic Journal Return Codes: RC 46 (x2E) was added</li> </ul>	RS-485 / RS-232
	VOA BETA	Jun 21.2002	<ul style="list-style-type: none"> <li>This version of Technical Specification corresponds to IBM 4610 SureMark Fiscal Printer KR3/KR5 (RS-485) EC level 07 and IBM 4610 SureMark Fiscal Printer <b>KD3/KD5 (RS-232) EC level 0A.</b></li> </ul>	
<a href="#">A015</a>			<ul style="list-style-type: none"> <li>CD - Cash Drawer Management Command was added</li> </ul>	RS-232
<a href="#">A016</a>			<ul style="list-style-type: none"> <li>Command Set Summary List – Cash Drawer Support – Cash Drawer Management Command was added</li> </ul>	RS-232
<a href="#">A017</a>			<ul style="list-style-type: none"> <li>Command xDB – Response was changed</li> </ul>	RS-485 / RS-232
<a href="#">A018</a>			<ul style="list-style-type: none"> <li>Command xDC – Response was changed</li> </ul>	RS-485 / RS-232
<a href="#">A019</a>			<ul style="list-style-type: none"> <li>Command x62 – Response was changed</li> </ul>	RS-485 / RS-232
<a href="#">A020</a>			<ul style="list-style-type: none"> <li>Command x63 – Response was changed</li> </ul>	RS-485 / RS-232
<a href="#">A021</a>			<ul style="list-style-type: none"> <li>Command x65 – Response was changed</li> </ul>	RS-485 / RS-232
<a href="#">A022</a>			<ul style="list-style-type: none"> <li>Command x67 – Response was changed</li> </ul>	RS-485 / RS-232
<a href="#">A023</a>			<ul style="list-style-type: none"> <li>Command x68 – Response was changed</li> </ul>	RS-485 / RS-232

	Version	Date	Change Description	Protocol
<a href="#">A024</a>			<ul style="list-style-type: none"> <li>Command x69 – Response was changed</li> </ul>	RS-485 / RS-232
<a href="#">A025</a>			<ul style="list-style-type: none"> <li>Command x6A – Response was changed</li> </ul>	RS-485 / RS-232
<a href="#">A026</a>			<ul style="list-style-type: none"> <li>Command xE7 – Response was changed</li> </ul>	RS-485 / RS-232
<a href="#">A027</a>			<ul style="list-style-type: none"> <li>Command xF8 – Response was changed</li> </ul>	RS-485 / RS-232
<a href="#">A028</a>			<ul style="list-style-type: none"> <li>Command xFC – Response was changed</li> </ul>	RS-485 / RS-232
	V08 01 SUBMISSION	Sept. 10. .2002	<ul style="list-style-type: none"> <li>This version of Technical Specification corresponds to IBM 4610 SureMark Fiscal Printer <b>KR3/KR5 (RS-485) EC level 08</b> and IBM 4610 SureMark Fiscal Printer KD3/KD5 (RS-232) EC level 0A.</li> </ul>	
<a href="#">H129</a>			<ul style="list-style-type: none"> <li>Electronic Fiscal Report Response change field 43-48 (RS-485) to Reserved</li> </ul>	RS-485
<a href="#">H130</a>			<ul style="list-style-type: none"> <li>Set/Get Max Wasted Space command rules changes</li> </ul>	RS-485
<a href="#">H131</a>			<ul style="list-style-type: none"> <li>Ordinary printing threshold max value changed from 4 to 10</li> </ul>	RS-485
	V0C 01 SUBMISSION	Sept. 23. .2002	<ul style="list-style-type: none"> <li>This version of Technical Specification corresponds to microcode IBM 4610 SureMark Fiscal Printer <b>KR3/KR5 (RS-485) EC level 0C</b> and IBM 4610 SureMark Fiscal Printer KD3/KD5 (RS-232) EC level 0A.</li> </ul>	
	V0B BETA	Nov.07.2002	<ul style="list-style-type: none"> <li>This version of Technical Specification corresponds to microcode IBM 4610 SureMark Fiscal Printer KR3/KR5 (RS-485) EC level 0C and IBM 4610 SureMark Fiscal Printer <b>KD3/KD5 (RS-232) EC level 0B.</b></li> </ul>	
<a href="#">A029</a>			<ul style="list-style-type: none"> <li>Communication with the RS-232 Fiscal Printer: was updated</li> </ul>	RS-232
<a href="#">A030</a>			<ul style="list-style-type: none"> <li>CE – Attached Display Management Command was added</li> </ul>	RS-232
<a href="#">A031</a>			<ul style="list-style-type: none"> <li>Command Set Summary List – Attached Devices – Attached Display Management Command was added</li> </ul>	RS-232
	V0D SUBMISSION	Apr.21.2003	<ul style="list-style-type: none"> <li>This version of Technical Specification corresponds to IBM 4610 SureMark Fiscal Printer <b>KR3/KR5 (RS-485) EC level 0D</b> and IBM 4610 SureMark Fiscal Printer KD3/KD5 (RS-232) EC level 0B.</li> </ul>	
<a href="#">A032</a>			<ul style="list-style-type: none"> <li>Definition of Daily Counters: Add the Simplified invoice order number by enterprise (Day_N_Inv_g(gg))</li> </ul>	RS-485 / RS-232
<a href="#">A033</a>			<ul style="list-style-type: none"> <li>Command xDB - Electronic Fiscal Report Response: Add the Simplified invoice order number (Day_N_Inv and Day_N_Inv_g(gg)) in fields 174-175 and 176-177 (RS-485)</li> </ul>	RS-485
<a href="#">A034</a>			<ul style="list-style-type: none"> <li>Simplified invoice order number (Day_N_Inv and Day_N_Inv_g(gg)) - Update printouts: <ul style="list-style-type: none"> <li>Simplified Invoice</li> <li>Cancelled Simplified Invoice</li> <li>Closure</li> <li>X-Report</li> </ul> </li> </ul>	RS-485 / RS-232
<a href="#">A035</a>			<ul style="list-style-type: none"> <li>Simplified invoice order number (Day_N_Inv and Day_N_Inv_g(gg)) - Update calculations: <ul style="list-style-type: none"> <li>Command x06 – End of Transaction</li> <li>Command x07 – Cancel Transaction</li> <li>Command x13 – Daily Closure (Z-Report)</li> </ul> </li> </ul>	RS-485 / RS-232
<a href="#">A036</a>			<ul style="list-style-type: none"> <li>Command xEA - Normal Printing Lines on CR Station (Fiscal Printer Format): Update notes (value changed from 4 to 10)</li> </ul>	RS-485
<a href="#">A037</a>			<ul style="list-style-type: none"> <li>Fiscal Memory Dump Slip: Fiscal Memory recovery printout (Engineering Dump format for the fiscal memory error area ) was added</li> </ul>	RS-485 / RS-232
<a href="#">A038</a>			<ul style="list-style-type: none"> <li>Engineering Dump Fiscal RAM and Fiscal Memory printout: was added</li> </ul>	RS-485 / RS-232
<a href="#">A039</a>			<ul style="list-style-type: none"> <li>Full J4 (CE) jumper description was changed</li> </ul>	RS-485 / RS-232
<a href="#">A040</a>			<ul style="list-style-type: none"> <li>Fiscal Memory Daily Table has been updated: The <i>FM_Voucher_Nbr = Lif_N_Vouc</i> was changed by <i>FM_Voucher_Nbr = Day_N_Vouc</i></li> </ul>	RS-485 / RS-232
<a href="#">A041</a>			<ul style="list-style-type: none"> <li>The Transaction and Daily Item Uplift Accumulator and Counter - Update calculations: <ul style="list-style-type: none"> <li>Command xD3 – Negative Item Sale</li> <li>Command x06 – End of Transaction</li> <li>Command x07 – Cancel Transaction</li> <li>Command x13 – Daily Closure (Z-Report)</li> </ul> </li> </ul>	RS-485 / RS-232
<a href="#">A042</a>			<ul style="list-style-type: none"> <li>The Set Date Rules (Command x16) was updated: <ul style="list-style-type: none"> <li>The following rule was erased: The date cannot be set previous to the time stamp of the last closure in the fiscal memory (FlagFJUMPER = NO).</li> </ul> </li> </ul>	RS-485 / RS-232
<a href="#">A043</a>			<ul style="list-style-type: none"> <li>Initialization Sequence: Ram Clear (Full J4 (CE) Jumper) was updated</li> </ul>	RS-485 / RS-232



	Version	Date	Change Description	Protocol
<a href="#">A044</a>			<ul style="list-style-type: none"> <li>The Voucher Sales Transaction in Progress condition was added in the xD9 (Uplift/Discount on Subtotal) and the xD5 (Payment) commands</li> </ul>	RS-485 / RS-232
<a href="#">A045</a>			<ul style="list-style-type: none"> <li>Printer Features and Printer Models was added</li> </ul>	RS-485 / RS-232
			<ul style="list-style-type: none"> <li>The description Duna was changed by IBM 4610 SureMark Fiscal Printer KR3/KR5 (RS-485) and Jacare was changed by IBM 4610 SureMark Fiscal Printer KD3/KD5 (RS-232)</li> </ul>	RS-485 / RS-232
	VOE	May.9.2003	<ul style="list-style-type: none"> <li>This version of Technical Specification corresponds to IBM 4610 SureMark Fiscal Printer <b>KR3/KR5 (RS-485) EC level 0E</b> and IBM 4610 SureMark Fiscal Printer KD3/KD5 (RS-232) EC level 0B.</li> </ul>	
	VOF	May.15. 2003	<ul style="list-style-type: none"> <li>This version of Technical Specification corresponds to IBM 4610 SureMark Fiscal Printer KR3/KR5 (RS-485) EC level 0E and IBM 4610 SureMark Fiscal Printer <b>KD3/KD5 (RS-232) EC level 0F</b>.</li> </ul>	
<a href="#">A046</a>			<ul style="list-style-type: none"> <li>Set/Get Max Wasted Space command rules changes</li> </ul>	RS-232
<a href="#">A047</a>			<ul style="list-style-type: none"> <li>Electronic Fiscal Report Response change field 49-54 (RS-232) to Reserved</li> </ul>	RS-232
<a href="#">A048</a>			<ul style="list-style-type: none"> <li>Ordinary printing threshold max value changed from 4 to 10</li> </ul>	RS-232
<a href="#">A049</a>			<ul style="list-style-type: none"> <li>Command xEA - Normal Printing Lines on CR Station (Fiscal Printer Format): Update notes (value changed from 4 to 10)</li> </ul>	RS-232
<a href="#">A050</a>			<ul style="list-style-type: none"> <li>M16 and M17 messages were added</li> </ul>	RS-232
<a href="#">A051</a>			<ul style="list-style-type: none"> <li>Power ON Reports: The Serialized, In Fiscal Mode and Jumper Active printout has been updated.</li> </ul>	RS-232
<a href="#">A052</a>			<ul style="list-style-type: none"> <li>Fiscal Memory Layout: has been changed</li> </ul>	RS-232
<a href="#">A053</a>			<ul style="list-style-type: none"> <li>Fiscal Memory Full CE Jumper Table: has been added</li> </ul>	RS-232
<a href="#">A054</a>			<ul style="list-style-type: none"> <li>F7- Command Buffer Management Command was added</li> </ul>	RS-232
<a href="#">A055</a>			<ul style="list-style-type: none"> <li>Command Set Summary List – Utilities – Command Buffer Management Command was added</li> </ul>	RS-232
<a href="#">A056</a>			<ul style="list-style-type: none"> <li>Command xDB - Electronic Fiscal Report Response: Add the Simplified invoice order number (Day_N_Inv and Day_N_Inv_g(gg)) in fields 180-181 and 182-183 (RS-232)</li> </ul>	RS-232
<a href="#">A057</a>			<ul style="list-style-type: none"> <li>The Compact Flash list was added</li> </ul>	RS-485 / RS-232
<a href="#">A058</a>			<ul style="list-style-type: none"> <li>Return Code 116 was added</li> </ul>	RS-232
<a href="#">A059</a>			<ul style="list-style-type: none"> <li>The Negative Items Accumulators by VAT (<i>Tra_Void_vg, Tra_Disc_vg, Tra_Uplf_vg and Day_Void_vg, Day_Disc_vg, Day_Uplf_vg</i>) was deleted on: <ul style="list-style-type: none"> <li>Command xD3 – Negative Item Sale</li> <li>Command x06 – End of Transaction</li> <li>Command x07 – Cancel Transaction</li> <li>Command x13 – Daily Closure (Z-Report)</li> </ul> </li> </ul>	RS-485 / RS-232
<a href="#">A060</a>			<ul style="list-style-type: none"> <li>The IBM 4610 SureMark Fiscal Printer KD3/KD5 (RS-232) - Printer and Fiscal Unit Status was changed to zero based.</li> </ul>	RS-232
<a href="#">A061</a>			<ul style="list-style-type: none"> <li>Command 15 - Print Multi-Day Fiscal Report (Fiscal Memory Dump): The Return Code 135 was added.</li> </ul>	RS-485 / RS-232
<a href="#">A062</a>			<ul style="list-style-type: none"> <li>Display(s) Connected – (FDISPLAY): The RS-232 message was added</li> </ul>	RS-232
<a href="#">A063</a>			<ul style="list-style-type: none"> <li>Display Checking: The RS-232 Display Checking procedure was added</li> </ul>	RS-232
<a href="#">A064</a>			<ul style="list-style-type: none"> <li>Initialization Sequence – Display Sensing Definition: Add xC4 command for the IBM 4610 SureMark Fiscal Printer KD3/KD5 (RS-232) was added</li> </ul>	RS-232
<a href="#">A065</a>			<ul style="list-style-type: none"> <li>Initialization Sequence – Set Display Address: Add x1A command for the IBM 4610 SureMark Fiscal Printer KD3/KD5 (RS-232) was added</li> </ul>	RS-232
<a href="#">A066</a>			<ul style="list-style-type: none"> <li>Initialization Commands – Set Display Address: Only RS-485 message was removed</li> </ul>	RS-485 / RS-232
<a href="#">A067</a>			<ul style="list-style-type: none"> <li>1A – Set Display Address: Only RS-485 message was removed and the RS-232 rules was added</li> </ul>	RS-485 / RS-232
<a href="#">A068</a>			<ul style="list-style-type: none"> <li>Command Set Summary List – Initialization – Set Display Address: Only RS-485 message was removed</li> </ul>	RS-485 / RS-232
<a href="#">A069</a>			<ul style="list-style-type: none"> <li>Return Codes (RC 131): The RS-232 explanation and user response was added</li> </ul>	RS-232
<a href="#">A070</a>			<ul style="list-style-type: none"> <li>C4 - Fiscal Parameter Configuration: Add the cmd.extension 02 (Fiscal Parameter Configuration)</li> </ul>	RS-232
<a href="#">A071</a>			<ul style="list-style-type: none"> <li>Command xDB – Electronic Fiscal Report Response: Add the field (byte 34) to show the Display Number to be sensed</li> </ul>	RS-232
<a href="#">A072</a>			<ul style="list-style-type: none"> <li>CE – Attached Display Management Command: Command Extension 00 (Disable polling to attached displays), 01 (Enable polling to attached display 1) and 02 (Enable polling to attached display 2) restrictions were added</li> </ul>	RS-232
<a href="#">A073</a>			<ul style="list-style-type: none"> <li>69 - Get Compact Flash Information : The cmd.extension 01 (Get Compact Flash Serial Number and Size) was added.</li> </ul>	RS-232

	Version	Date	Change Description	Protocol
<a href="#">A074</a>			<ul style="list-style-type: none"> <li>The Lifetime Closure number (Lif_N_Clos) maximum range was changed from 3840 to 4000.</li> </ul>	RS-485 / RS-232
<a href="#">A075</a>			<ul style="list-style-type: none"> <li>The Lifetime Number of repair actions (Lif_N_Ract) maximum range was changed from 200 to 199.</li> </ul>	RS-485 / RS-232
<a href="#">A076</a>			<ul style="list-style-type: none"> <li>Fiscal Voucher Single Retailer and Gasoline Station Version, and Simplified Invoice Printed on CR: The Normal Printing Lines was changed from 4 to 10</li> </ul>	RS-485 / RS-232
<a href="#">A077</a>			<ul style="list-style-type: none"> <li>Command xC4 (Fiscal Parameter Configuration): Fiscal Printer Set in Fiscal Mode (FISCFLG) State Required was added.</li> </ul>	RS-485 / RS-232
<a href="#">A078</a>			<ul style="list-style-type: none"> <li>Command x01 (Print Header): Displays Operational State Required (FDISPLAY): Only RS-485 message was deleted.</li> </ul>	RS-485 / RS-232
	V10	Sep.23. 2003	<ul style="list-style-type: none"> <li>This version of Technical Specification corresponds to IBM 4610 SureMark Fiscal Printer KR3/KR5 (RS-485) EC level 0E and IBM 4610 SureMark Fiscal Printer <b>KD3/KD5 (RS-232) EC level 10.</b></li> </ul>	
<a href="#">A079</a>			<ul style="list-style-type: none"> <li>C9 - Print Barcode: Rule was added</li> </ul>	RS-485 / RS-232
<a href="#">A080</a>			<ul style="list-style-type: none"> <li>15 – Print Multi-Day Fiscal Report (Fiscal Memory Dump): The field ‘Reserved for Password’ (20-23) was changed by ‘Reserved’</li> </ul>	RS-485 / RS-232
<a href="#">A081</a>			<ul style="list-style-type: none"> <li>15 – Print Multi-Day Fiscal Report (Fiscal Memory Dump): The return code 129 was changed by 122 for the Acceptable State Restrictions (FISCFLG)</li> </ul>	RS-485 / RS-232
<a href="#">A082</a>			<ul style="list-style-type: none"> <li>Operational Modes section was added</li> </ul>	RS-485 / RS-232
<a href="#">A083</a>			<ul style="list-style-type: none"> <li>The Pos Id Table was splitted in two tables for Enterprise A and Enterprise B.</li> </ul>	RS-485 / RS-232
<a href="#">A084</a>			<ul style="list-style-type: none"> <li>Fiscal Memory Serial Number + Fiscal Logo Table: The SN_Checksum field was changed by SN_CRC</li> </ul>	RS-485 / RS-232
	V11	Oct.30. 2003	<ul style="list-style-type: none"> <li>This version of Technical Specification corresponds to IBM 4610 SureMark Fiscal Printer <b>KR3/KR5 (RS-485) EC level 11</b> and IBM 4610 SureMark Fiscal Printer <b>KD3/KD5 (RS-232) EC level 10.</b></li> </ul>	
	V12	Feb.20.2004	<ul style="list-style-type: none"> <li>This version of Technical Specification corresponds to IBM 4610 SureMark Fiscal Printer KR3/KR5 (RS-485) EC level 11 and IBM 4610 SureMark Fiscal Printer <b>KD3/KD5 (RS-232) EC level 12.</b></li> </ul>	
<a href="#">A085</a>			<ul style="list-style-type: none"> <li>Ordinary printing threshold max value changed from 10 to 99</li> </ul>	RS-232
<a href="#">A086</a>			<ul style="list-style-type: none"> <li>Command xEA - Normal Printing Lines on CR Station (Fiscal Printer Format): Update notes (value changed from 10 to 99)</li> </ul>	RS-232
<a href="#">A087</a>			<ul style="list-style-type: none"> <li>Fiscal Voucher Single Retailer and Gasoline Station Version, and Simplified Invoice Printed on CR: The Normal Printing Lines was changed (show as multiple lines)</li> </ul>	RS-485 / RS-232
<a href="#">A088</a>			<ul style="list-style-type: none"> <li>Simplified Invoice printout: Note to explain Vat Total printing was added</li> </ul>	RS-485 / RS-232
	V13	Feb.25.2004	<ul style="list-style-type: none"> <li>This version of Technical Specification corresponds to IBM 4610 SureMark Fiscal Printer KR3/KR5 (RS-485) EC level 11 and IBM 4610 SureMark Fiscal Printer <b>KD3/KD5 (RS-232) EC level 13.</b></li> </ul>	
<a href="#">A089</a>			<ul style="list-style-type: none"> <li>Command xC4 (Fiscal Parameter Configuration): Blank Amount Item Lines max value was changed from 4 to 99</li> </ul>	RS-232
<a href="#">A090</a>			<ul style="list-style-type: none"> <li>Command xD2 (Item Sale): The transaction rule about Blank Amount Item Lines max value was changed from 4 to 99</li> </ul>	RS-232
	V14	Mar.01.2004	<ul style="list-style-type: none"> <li>This version of Technical Specification corresponds to IBM 4610 SureMark Fiscal Printer KR3/KR5 (RS-485) EC level 11 and IBM 4610 SureMark Fiscal Printer <b>KD3/KD5 (RS-232) EC level 14.</b></li> </ul>	
<a href="#">A091</a>			<ul style="list-style-type: none"> <li>Command xD2 (Item Sale - blank amount lines): Add new command extension to allow 32 characters in the blank amount item lines.</li> </ul>	RS-232
	V15	Mar.04.2004	<ul style="list-style-type: none"> <li>This version of Technical Specification corresponds to IBM 4610 SureMark Fiscal Printer <b>KR3/KR5 (RS-485) EC level 15</b> and IBM 4610 SureMark Fiscal Printer <b>KD3/KD5 (RS-232) EC level 14.</b></li> </ul>	
<a href="#">A092</a>			<ul style="list-style-type: none"> <li>Ordinary printing threshold max value changed from 10 to 99 – Messages RS-232/RS-485 were removed.</li> </ul>	RS-485
<a href="#">A093</a>			<ul style="list-style-type: none"> <li>Command xEA - Normal Printing Lines on CR Station (Fiscal Printer Format): Update notes (value changed from 10 to 99) – Messages RS-232/RS-485 were removed.</li> </ul>	RS-485
<a href="#">A094</a> <a href="#">A089</a>			<ul style="list-style-type: none"> <li>Command xC4 (Fiscal Parameter Configuration): Blank Amount Item Lines max value was changed from 4 to 99 – Messages RS-232/RS-485 were removed.</li> </ul>	RS-485
<a href="#">A095</a>			<ul style="list-style-type: none"> <li>Command xD2 (Item Sale): The transaction rule about Blank Amount Item Lines max value was changed from 4 to 99 – Messages RS-232/RS-485 were removed.</li> </ul>	RS-485
<a href="#">A096</a>			<ul style="list-style-type: none"> <li>Command xD2 (Item Sale - blank amount lines): Add new command extension to allow 32 characters in the blank amount item lines. – Messages RS-232/RS-485 were removed.</li> </ul>	RS-485

	Version	Date	Change Description	Protocol
<a href="#">A097</a>			<ul style="list-style-type: none"> <li>Command xD7 (Set Header): Increase number of header lines from 4 to 8.</li> </ul>	RS-485
<a href="#">A098</a>			<ul style="list-style-type: none"> <li>Printouts: Increase number of header lines from 4 to 8.</li> </ul>	RS-485
<a href="#">A099</a>			<ul style="list-style-type: none"> <li>Initialization Sequence: Update set header section.</li> </ul>	RS-485
<a href="#">A100</a>			<ul style="list-style-type: none"> <li>Command x01 (Print Header): Update command to add two additional lines in Simplified Invoice Print Header.</li> </ul>	RS-485
<a href="#">A101</a>			<ul style="list-style-type: none"> <li>Printouts: Add two additional lines in Simplified Invoice Header.</li> </ul>	RS-485
<a href="#">A102</a>			<ul style="list-style-type: none"> <li>Simplified Invoice printout: Note to explain Total by Vat printing was updated</li> </ul>	RS-485
<a href="#">A103</a>			<ul style="list-style-type: none"> <li>Printouts: Blank amount item lines with 32 characters were added in the Fiscal Vouchers and Simplified Invoice.</li> </ul>	RS-485 / RS-232
	V16	Mar.26.2004	<ul style="list-style-type: none"> <li>This version of Technical Specification corresponds to IBM 4610 SureMark Fiscal Printer <b>KR3/KR5 (RS-485) EC level 16</b> and IBM 4610 SureMark Fiscal Printer KD3/KD5 (RS-232) EC level 14.</li> </ul>	
<a href="#">A104</a>			<ul style="list-style-type: none"> <li>Command x01 (Print Header): Update command to add seven (7) additional lines in Simplified Invoice Print Header.</li> </ul>	RS-485
<a href="#">A105</a>			<ul style="list-style-type: none"> <li>Command xD2 (Item Sale - blank amount lines): Increase the 32 characters in the blank amount item lines to allow 34 characters.</li> </ul>	RS-485
<a href="#">A106</a>			<ul style="list-style-type: none"> <li>Command xD5 (Payment): Add new command extension to allow 17 characters in the payment description.</li> </ul>	RS-485
<a href="#">A107</a>			<ul style="list-style-type: none"> <li>Simplified Invoice printout: Additional header lines were added.</li> </ul>	RS-485
	V17	Apr.02.2004	<ul style="list-style-type: none"> <li>This version of Technical Specification corresponds to IBM 4610 SureMark Fiscal Printer KR3/KR5 (RS-485) EC level 16 and IBM 4610 SureMark Fiscal Printer <b>KD3/KD5 (RS-232) EC level 17</b>.</li> </ul>	
<a href="#">A108</a>			<ul style="list-style-type: none"> <li>Return Codes: The return code 39 was added.</li> </ul>	RS-485 / RS-232
<a href="#">A109</a>			<ul style="list-style-type: none"> <li>Command xD7 (Set Header): Increase number of header lines from 4 to 8 – Messages RS-232/RS-485 were removed.</li> </ul>	RS-232
<a href="#">A110</a>			<ul style="list-style-type: none"> <li>Printouts: Increase number of header lines from 4 to 8 – Messages RS-232/RS-485 were removed.</li> </ul>	RS-232
<a href="#">A111</a>			<ul style="list-style-type: none"> <li>Initialization Sequence: Update set header section – Messages RS-232/RS-485 were removed.</li> </ul>	RS-232
<a href="#">A112</a>			<ul style="list-style-type: none"> <li>Command x01 (Print Header): Update command to add additional lines in Simplified Invoice Print Header.</li> </ul>	RS-232
<a href="#">A113</a>			<ul style="list-style-type: none"> <li>Simplified Invoice printout: Additional header lines were added.</li> </ul>	RS-232
<a href="#">A114</a>			<ul style="list-style-type: none"> <li>Printouts: Blank amount item lines with 34 characters were added in the Fiscal Vouchers and Simplified Invoice.</li> </ul>	RS-485 / RS-232
<a href="#">A115</a>			<ul style="list-style-type: none"> <li>Command xD2 (Item Sale - blank amount lines): Increase the 32 characters in the blank amount item lines to allow 34 characters.</li> </ul>	RS-232
<a href="#">A116</a>			<ul style="list-style-type: none"> <li>Command xD5 (Payment): Add new command extension to allow 17 characters in the payment description.</li> </ul>	RS-232
<a href="#">A117</a>			<ul style="list-style-type: none"> <li>Printouts: Payment description lines with 17 characters were added in the Fiscal Vouchers and Simplified Invoice.</li> </ul>	RS-485 / RS-232
<a href="#">A118</a>			<ul style="list-style-type: none"> <li>Simplified Invoice printout: Note to explain Total by Vat printing was updated</li> </ul>	RS-232
<a href="#">A119</a>			<ul style="list-style-type: none"> <li>Open Sale Period printout for Gasoline Station version was added.</li> </ul>	RS-485 / RS-232
<a href="#">A120</a>			<ul style="list-style-type: none"> <li>Command x60 (Open Compact Flash File): The file name description was added.</li> </ul>	RS-485 / RS-232
<a href="#">A121</a>			<ul style="list-style-type: none"> <li>Application-Originated Report on CR and DI station printouts were added</li> </ul>	RS-485 / RS-232
	V18	Apr.12.2004	<ul style="list-style-type: none"> <li>This version of Technical Specification corresponds to IBM 4610 SureMark Fiscal Printer <b>KR3/KR5 (RS-485) EC level 18</b> and IBM 4610 SureMark Fiscal Printer KD3/KD5 (RS-232) EC level 17.</li> </ul>	
<a href="#">A122</a>			<ul style="list-style-type: none"> <li>Command xD2 (Item Sale) / xD3 (Negative tem Sale): The Total Requested (FTOTALR) = NO was added in the States Changed.</li> </ul>	RS-485 / RS-232
	V19	Apr.22.2004	<ul style="list-style-type: none"> <li>This version of Technical Specification corresponds to IBM 4610 SureMark Fiscal Printer KR3/KR5 (RS-485) EC level 18 and IBM 4610 SureMark Fiscal Printer <b>KD3/KD5 (RS-232) EC level 19</b>.</li> </ul>	
<a href="#">A123</a>			<ul style="list-style-type: none"> <li>Command xD5 (Payment): New command extension to allow 44 characters in the payment additional description line was added.</li> </ul>	RS-232
<a href="#">A124</a>			<ul style="list-style-type: none"> <li>Printouts: Payment description lines with 44 characters were added in the Fiscal Vouchers and Simplified Invoice.</li> </ul>	RS-232
<a href="#">A125</a>			<ul style="list-style-type: none"> <li>Printouts: Note with Taxpayer Id Number printing mode explanation (the same that the last header line set) was added.</li> </ul>	RS-232
<a href="#">A126</a>			<ul style="list-style-type: none"> <li>Command xD7 (Set Header):Note with Taxpayer Id Number printing mode explanation (the same that the last header line set) was added.</li> </ul>	RS-232
<a href="#">A127</a>			<ul style="list-style-type: none"> <li>Communication with the RS-232 Fiscal Printer: The different baud rates</li> </ul>	RS-232

	Version	Date	Change Description	Protocol
			support was added.	
	V1A	May.17.2004	<ul style="list-style-type: none"> <li>This version of Technical Specification corresponds to IBM 4610 SureMark Fiscal Printer <b>KR3/KR5 (RS-485) EC level 1A</b> and IBM 4610 SureMark Fiscal Printer KD3/KD5 (RS-232) EC level 19.</li> </ul>	
<a href="#">A128</a>			<ul style="list-style-type: none"> <li>Daily Closure (Z-Report) command: The command response was added.</li> </ul>	RS-485 / RS-232
	V1B	May.19.2004	<ul style="list-style-type: none"> <li>This version of Technical Specification corresponds to IBM 4610 SureMark Fiscal Printer <b>KR3/KR5 (RS-485) EC level 1B</b> and IBM 4610 SureMark Fiscal Printer KD3/KD5 (RS-232) EC level 19.</li> </ul>	
	V1C	May.24.2004	<ul style="list-style-type: none"> <li>This version of Technical Specification corresponds to IBM 4610 SureMark Fiscal Printer <b>KR3/KR5 (RS-485) EC level 1C</b> and IBM 4610 SureMark Fiscal Printer KD3/KD5 (RS-232) EC level 19.</li> </ul>	
<a href="#">A129</a>			<ul style="list-style-type: none"> <li>Command xD5 (Payment): New command extension to allow 44 characters in the payment additional description line was added.</li> </ul>	RS-485
<a href="#">A130</a>			<ul style="list-style-type: none"> <li>Printouts: Payment description lines with 44 characters were added in the Fiscal Vouchers and Simplified Invoice.</li> </ul>	RS-485
<a href="#">A131</a>			<ul style="list-style-type: none"> <li>Printouts: Note with Taxpayer Id Number printing mode explanation (the same that the last header line set) was added.</li> </ul>	RS-485
<a href="#">A132</a>			<ul style="list-style-type: none"> <li>Command xD7 (Set Header): Note with Taxpayer Id Number printing mode explanation (the same that the last header line set) was added.</li> </ul>	RS-485
	V1D	Jun.11.2004	<ul style="list-style-type: none"> <li>This version of Technical Specification corresponds to IBM 4610 SureMark Fiscal Printer <b>KR3/KR5 (RS-485) EC level 1C</b> and IBM 4610 SureMark Fiscal Printer <b>KD3/KD5 (RS-232) EC level 1D</b>.</li> </ul>	
<a href="#">A133</a>			<ul style="list-style-type: none"> <li>Command xCC (User NVRAM Management) Command was added</li> </ul>	RS-232
<a href="#">A134</a>			<ul style="list-style-type: none"> <li>Command Set Summary List – Attached Devices – User NVRAM Management Command was added</li> </ul>	RS-232
<a href="#">A135</a>			<ul style="list-style-type: none"> <li>Return Codes: The return code 116 was updated.</li> </ul>	RS-232
	V1E	Ago.17.2004	<ul style="list-style-type: none"> <li>This version of Technical Specification corresponds to IBM 4610 SureMark Fiscal Printer <b>KR3/KR5 (RS-485) EC level 1E</b> and IBM 4610 SureMark Fiscal Printer KD3/KD5 (RS-232) EC level 1D.</li> </ul>	
	V1F	Ago.25.2004	<ul style="list-style-type: none"> <li>This version of Technical Specification corresponds to IBM 4610 SureMark Fiscal Printer <b>KR3/KR5 (RS-485) EC level 1F</b> and IBM 4610 SureMark Fiscal Printer KD3/KD5 (RS-232) EC level 1D.</li> </ul>	
	V20	Oct.13.2004	<ul style="list-style-type: none"> <li>This version of Technical Specification corresponds to IBM 4610 SureMark Fiscal Printer <b>KR3/KR5 (RS-485) EC level 1F</b> and IBM 4610 SureMark Fiscal Printer <b>KD3/KD5 (RS-232) EC level 20</b>.</li> </ul>	
<a href="#">A136</a>			<ul style="list-style-type: none"> <li>Command xC4 (Fiscal Parameter Configuration): The jumper restriction were removed for the command extension 06 (Blank amount item lines) (for KD3/KD5 (RS-232) models).</li> </ul>	RS-232
<a href="#">A137</a>			<ul style="list-style-type: none"> <li>Definition of Fiscal Printer States: 200 Repair Actions Already Performed - (FEPROMR) were removed. (When this condition is reached the fiscal printer state is the Fiscal Memory Full (FEPROMF)).</li> </ul>	RS-485 / RS-232
<a href="#">A138</a>			<ul style="list-style-type: none"> <li>Command xCC (User NVRAM Management): The Full J4 (CE) Jumper procedure doesn't delete the writing NVRAM area note was added.</li> </ul>	RS-232
<a href="#">A139</a>			<ul style="list-style-type: none"> <li>Command x18 (Set Fiscal Mode): The parameter indication Reserved was changed by Password.</li> </ul>	RS-485 / RS-232
<a href="#">A140</a>			<ul style="list-style-type: none"> <li>Command xFC (Report Microcode EC): The command extension descriptions were updated.</li> </ul>	RS-485 / RS-232

# Contents

<b>1</b>	<b>Fiscal Accounting Technical Description .....</b>	<b>21</b>
<b>1.1</b>	<b>Fiscal Printer Operation.....</b>	<b>21</b>
<b>1.2</b>	<b>Definition of Terminology .....</b>	<b>21</b>
<b>1.3</b>	<b>Definition of Fiscal Printer States.....</b>	<b>22</b>
1.3.1	Initialization States.....	22
1.3.1.1	Fiscal Printer Serialized - (FMEMNIT) .....	22
1.3.1.2	Fiscal Printer Set in Fiscal Mode - (FISCFLG).....	22
1.3.1.3	Date/Time Set - (FSETDAT).....	22
1.3.1.4	POS Headers Set - (FHEADER).....	22
1.3.1.5	Identification Information Loaded - (FPOSIDS).....	22
1.3.1.6	Items/Negative Items with Blank Amount Set - (FBLKAMT).....	22
1.3.2	POS Fiscal States .....	22
1.3.2.1	Sales Period in Progress - (FSALEON) .....	22
1.3.2.2	Fiscal Voucher Sales Transaction .....	22
1.3.2.2.1	Header Printed - (FHDRPRT):.....	22
1.3.2.2.2	Item Processed - (FTRANON):.....	22
1.3.2.2.3	Total Requested - (FTOTALR):.....	22
1.3.2.2.4	Discount or Uplift on Subtotal Requested (FDISCTL):.....	22
1.3.2.2.5	Payment in Progress - (FPAYMNT):.....	22
1.3.2.2.6	End of Transaction Attempted - (FENDTRA):.....	22
1.3.2.2.7	Cancel Transaction Attempted - (FCANCEL):.....	22
1.3.2.3	Customer Receipt Station Non-Fiscal Report in Progress - (FOPENCR).....	22
1.3.2.4	DI Station Portrait Application-Originated Report in Progress - (FOPNDIF) .....	22
1.3.2.5	DI Station Landscape Application-Originated Report in Progress (FOPNDIN).....	23
1.3.2.6	End of NonFiscal Attempted - (FENDNON):.....	23
1.3.2.7	Cancel NonFiscal Attempted - (FCANNON): .....	23
1.3.2.8	Power on in Progress - (FIPLINP) .....	23
1.3.2.9	Fiscal Printer Ready - (FISCRDY) .....	23
1.3.2.10	End of Transaction Status - (FENTRAN) .....	23
1.3.2.11	Cancel Voucher Executed - (FCNLVOU) .....	23
1.3.2.12	CE Jumper Finished - (FJMPFIN) .....	23
1.3.3	POS Fiscal Hardware States.....	23
1.3.3.1	CE Jumper Active - (FJUMPER).....	23
1.3.3.2	Fiscal Memory Connected - (FEPROMC).....	23
1.3.3.3	Fiscal Memory Full - (FEPROMF) .....	23
1.3.3.4	Fiscal RAM Pattern Good - (FRAMPOK).....	23
1.3.3.5	Display(s) Connected - (FDISPLAY) .....	23
1.3.3.6	Check Procedure in Progress - (FCHECK) .....	23
<b>1.4</b>	<b>POS Fiscal General Information and Rules.....</b>	<b>24</b>
1.4.1	Fiscal Memory Connection .....	24
<b>1.5</b>	<b>Electronic Journaling.....</b>	<b>25</b>
1.5.1	Electronic Journaling Operation.....	25
1.5.1.1	Compact Flash.....	25
<b>1.6</b>	<b>Check Printing.....</b>	<b>26</b>
1.6.1	Load Check Data.....	26
1.6.2	Cancel Check .....	26
<b>1.7</b>	<b>Operational Modes.....</b>	<b>26</b>
<b>2</b>	<b>Fiscal Accounting Variables and Command Reference.....</b>	<b>27</b>

<b>2.1</b>	<b>Definition of Accounting Variables.....</b>	<b>27</b>
2.1.1	Definition of Transaction Accumulators .....	27
2.1.1.1	Transaction Accumulators – Totals and Taxes .....	27
2.1.1.2	Transaction Accumulators – Negative Items, Payment, and Subtotal Operations .....	28
2.1.2	Definition of Transaction Counters.....	29
2.1.3	Definition of Daily Accumulators.....	30
2.1.3.1	Daily Accumulators – Totals and Taxes .....	30
2.1.3.2	Daily Accumulators – Negative Items, Payment, and Subtotal Operations .....	31
2.1.4	Definition of Daily Counters.....	32
2.1.4.1	Daily Counters. ....	32
2.1.5	Definition of Lifetime Accumulators .....	33
2.1.5.1	Lifetime Accumulators.....	33
2.1.6	Definition of Lifetime Counters .....	33
2.1.6.1	Lifetime Counters.....	33
<b>2.2</b>	<b>Fiscal Hardware Functions .....</b>	<b>34</b>
2.2.1	Power On / J4 (CE) Jumper Functions .....	34
2.2.1.1	Calculations while the jumper is active:.....	34
2.2.1.2	Calculations when the jumper is moved to the stored position .....	34
2.2.2	Full J4 (CE) Jumper .....	34
2.2.3	Display Checking .....	34
2.2.3.1	RS-232 Display Checking - Flow.....	35
<b>2.3</b>	<b>Initialization Sequence.....</b>	<b>36</b>
<b>2.4</b>	<b>Initialization Commands .....</b>	<b>38</b>
2.4.1	1B - Serialize Fiscal Printer .....	39
2.4.1.1	Rules.....	39
2.4.2	18 - Set Fiscal Mode .....	40
2.4.2.1	Rules.....	40
2.4.3	16 - Set Date.....	41
2.4.3.1	Rules.....	41
2.4.4	D7 - Set Header.....	42
2.4.4.1	Rules.....	42
2.4.5	1A - Set Display Address .....	43
2.4.5.1	Calculations.....	43
2.4.5.2	Rules.....	43
2.4.5.2.1	Rules for IBM 4610 SureMark Fiscal Printer KR3/KR5 (RS-485) .....	43
2.4.5.2.2	Rules for IBM 4610 SureMark Fiscal Printer KD3/KD5 (RS-232) .....	43
2.4.6	F1 - Communicate Power On Status .....	44
2.4.6.1	Calculations.....	44
2.4.6.2	Rules.....	44
2.4.7	F9 - Read Current Status .....	45
2.4.7.1	Calculations.....	45
2.4.7.2	Rules.....	45
2.4.8	1E - Set TAX Identification Information .....	46
2.4.8.1	Calculations.....	46
2.4.8.2	Rules.....	46
2.4.9	20 - Set TAX Table.....	47
2.4.9.1	Command format.....	47
2.4.9.2	Rules.....	47
2.4.10	21 – Verify TAX Table.....	48
2.4.10.1	Command format.....	48
2.4.10.2	Rules.....	48
2.4.11	C4 - Fiscal Parameter Configuration.....	49
2.4.11.1	Calculations.....	49
2.4.11.2	Rules.....	50
2.4.11.2.1	Rules for command extension 02 (Display Sensing Definition): .....	50



<b>2.5</b>	<b>Sales Period in Progress Commands .....</b>	<b>51</b>
2.5.1	General Fiscal Voucher Rules .....	51
2.5.2	01 - Print Header .....	52
2.5.2.1	Example.....	53
2.5.2.2	Calculations.....	53
2.5.2.3	Rules.....	53
2.5.3	06 - End of Transaction.....	54
2.5.3.1	Calculations.....	54
2.5.3.1.1	Clearing Transaction Accumulators:.....	54
2.5.3.2	Rules.....	55
2.5.4	07 - Cancel Transaction.....	56
2.5.4.1	Calculations.....	56
2.5.4.2	Rules.....	56
2.5.5	D2 - Item Sale .....	57
2.5.5.1	Calculations.....	57
2.5.5.2	Item Sale Rules .....	57
2.5.5.2.1	Transaction rules: .....	57
2.5.6	D3 - Negative Item Sale.....	59
2.5.6.1	Negative Item Sale Calculations .....	59
2.5.6.2	Rules.....	60
2.5.6.2.1	Arithmetic Pre-Checking.....	60
2.5.7	D4 - Total/Subtotal Printing.....	61
2.5.7.1	Calculations.....	61
2.5.7.2	Rules.....	61
2.5.8	D5 – Payment.....	62
2.5.8.1	Calculations.....	62
2.5.8.1.1	Rectify = NO:.....	62
2.5.8.1.2	Rectify = YES: .....	62
2.5.8.2	Rules.....	62
2.5.9	D9 - Uplift/Discount on Subtotal .....	63
2.5.9.1	Calculations.....	63
2.5.9.1.1	Discount: (rectify = no):.....	63
2.5.9.1.2	Discount: (rectify = yes):.....	63
2.5.9.1.3	Uplift: (rectify = no):.....	63
2.5.9.1.4	Uplift: (rectify = yes): .....	64
2.5.9.2	Rules.....	64
<b>2.6</b>	<b>Report Printing Commands .....</b>	<b>65</b>
2.6.1	General Application-Originated Printing Rules .....	65
2.6.1.1	Inserted 'NOT FISCAL' Message Rules During a Application-Originated Report.....	65
2.6.2	13 - Daily Closure (Z-Report).....	66
2.6.2.1	Daily Closure (Z-Report) command Response Format .....	66
2.6.2.2	Calculations.....	67
2.6.2.3	Rules.....	68
2.6.3	14 - Summary Fiscal Report (X-Report).....	69
2.6.3.1	Calculations.....	69
2.6.4	DB - Electronic Fiscal Report .....	70
2.6.4.1	Electronic Fiscal Report Response Format (DB) .....	71
2.6.4.2	Response to the Option 0: Read Accumulators and Counters Command .....	73
2.6.4.3	Calculations.....	75
2.6.4.4	Rules.....	75
2.6.5	15 - Print Multi-Day Fiscal Report (Fiscal Memory Dump).....	76
2.6.5.1	Calculations.....	76
2.6.5.1.1	Successful completion of command:.....	76
2.6.5.2	Rules.....	76
2.6.6	DD - Start Application-Originated Report .....	77
2.6.6.1	Calculations.....	77
2.6.6.2	Rules.....	77
2.6.7	DE - End Application-Originated Report.....	78

2.6.7.1	Calculations.....	78
2.6.7.1.1	Customer Receipt Application-Originated Report Calculations .....	78
2.6.7.1.2	Document Insert Application-Originated Report Calculations .....	78
<b>2.7</b>	<b>Printer commands.....</b>	<b>79</b>
2.7.1	EA - Normal Printing Lines on CR Station (Fiscal Printer Format) .....	79
2.7.1.1	Command Format.....	79
2.7.1.2	Rules.....	79
2.7.2	EB – Application – Originated Printing on DI Station (Fiscal Printer Format) .....	80
2.7.2.1	Command Format.....	80
2.7.2.2	Rules.....	80
2.7.3	EC - Line Feed .....	81
2.7.3.1	Command Format.....	81
2.7.4	ED - Ready Document .....	82
2.7.4.1	Command Format.....	82
2.7.5	EF - Document Eject.....	83
2.7.5.1	Command Format.....	83
2.7.6	F4 - Home Position & Open/Close 4610 Throat.....	84
2.7.6.1	Command Format.....	84
<b>2.8</b>	<b>Check printing commands.....</b>	<b>85</b>
2.8.1	DC - MICR Read .....	85
2.8.1.1	Command Format.....	85
2.8.1.2	MICR Read command Response Format .....	85
2.8.2	C0 - Load Check Data.....	86
2.8.2.1	Command Format.....	86
2.8.2.2	Rules.....	87
2.8.3	C1 - Print Loaded Check.....	88
2.8.3.1	Command Format.....	88
2.8.3.2	Rules.....	88
2.8.4	C2 - Cancel Loaded Check.....	89
2.8.4.1	Command Format.....	89
2.8.4.2	Rules.....	89
2.8.5	C3 - Flip Check.....	90
2.8.5.1	Command Format.....	90
2.8.5.2	Rules.....	90
<b>2.9</b>	<b>Barcode printing commands .....</b>	<b>91</b>
2.9.1	C8 - Set Barcode Size .....	91
2.9.1.1	Command Format.....	91
2.9.1.2	Rules.....	91
2.9.2	C9 - Print Barcode.....	92
2.9.2.1	Command Format.....	92
2.9.2.2	Rules.....	92
<b>2.10</b>	<b>Attached Devices commands (ONLY VALID FOR IBM 4610 SureMark Fiscal Printer KD3/KD5 (RS-232)).....</b>	<b>93</b>
2.10.1	CC – User NVRAM Management .....	93
2.10.1.1	Command Format.....	93
2.10.2	CD – Cash Drawer Management.....	94
2.10.2.1	Command Format.....	94
2.10.3	CE - Attached Display Management.....	95
2.10.3.1	Command Format.....	95
<b>2.11</b>	<b>Electronic Journaling Commands .....</b>	<b>97</b>
2.11.1	60 - Open Compact Flash File.....	97
2.11.1.1	Command Format.....	97
2.11.1.2	Rules.....	97
2.11.2	61 - Close Compact Flash File .....	98



2.11.2.1	Command Format.....	98
2.11.2.2	Rules.....	98
2.11.3	62 - Read Compact Flash File .....	99
2.11.3.1	Command Format.....	99
2.11.3.2	Read Compact Flash File command Response Format .....	99
2.11.3.3	Rules.....	100
2.11.4	63 - Get Extended EJ Error .....	101
2.11.4.1	Command Format.....	101
2.11.4.2	Get Extended EJ Error command Response Format .....	101
2.11.4.3	Rules.....	101
2.11.5	65 - Get Compact Flash Directory .....	102
2.11.5.1	Command Format.....	102
2.11.5.2	Get compact flash directory command Response Format .....	102
2.11.5.3	Rules.....	103
2.11.6	66 - Set Public and Private Key.....	104
2.11.6.1	Command Format.....	104
2.11.6.2	Rules.....	104
2.11.7	67 - Get Public Key.....	105
2.11.7.1	Command Format.....	105
2.11.7.2	Get Public Key command (for FIRST) Response Format .....	105
2.11.7.3	Get Public Key command (for NEXT) Response Format .....	105
2.11.7.4	Rules.....	106
2.11.8	68 - Set/Get Max Wasted Space.....	107
2.11.8.1	Command Format.....	107
2.11.8.2	Set/Get Max Wasted Space command (for GET) Response Format.....	107
2.11.8.3	Rules.....	107
2.11.9	69 - Get Compact Flash Information.....	109
2.11.9.1	Command Format.....	109
2.11.9.2	Get Compact Flash Free Space command Response Format .....	109
2.11.9.3	Rules.....	110
2.11.10	6A - Read Current Compact Flash File .....	111
2.11.10.1	Command Format.....	111
2.11.10.2	Read Current Compact Flash File command Response Format .....	111
2.11.10.3	Rules.....	112
<b>2.12</b>	<b>Additional Information for OEM Interface.....</b>	<b>113</b>
2.12.1	00 - System Commands.....	113
2.12.1.1	Command Format.....	113
2.12.2	E7 - Diagnostic and Alignment Utilities .....	114
2.12.2.1	Command Format.....	114
2.12.2.2	Diagnostic and Alignment Utilities Command for Read MCT Value Response Format ...	116
2.12.3	F7- Command Buffer Management (ONLY VALID FOR IBM 4610 SureMark Fiscal Printer KD3/KD5 (RS-232)).....	117
2.12.3.1	Command Format.....	117
2.12.3.2	Example.....	118
2.12.3.2.1	'Command Buffer Management' Response - Additional Information: .....	118
2.12.3.3	Rules.....	118
2.12.4	F8 – Device Information Command.....	119
2.12.4.1	Command Format.....	119
2.12.4.2	Device Information Command Response Format .....	119
2.12.4.2.1	Fiscal Response - IBM 4610 SureMark Fiscal Printer KR3/KR5 (RS-485):.....	119
2.12.4.2.2	Fiscal Response - IBM 4610 SureMark Fiscal Printer KD3/KD5 (RS-232):.....	120
2.12.4.2.3	Printer Response - IBM 4610 SureMark Fiscal Printer KR3/KR5 (RS-485):.....	121
2.12.4.2.4	Printer Response - IBM 4610 SureMark Fiscal Printer KD3/KD5 (RS-232): .....	122
2.12.5	FA - Perform POR .....	123
2.12.5.1	Command Format.....	123
2.12.6	FB - Run Online Diagnostics .....	124
2.12.6.1	Command Format.....	124
2.12.7	FC - Report Microcode EC .....	125

2.12.7.1	Command Format.....	125
2.12.7.2	Report Microcode EC command for Device Information Response Format .....	125
2.12.8	FF - Engineering Dump Fiscal RAM and Fiscal EPROM .....	127
2.12.8.1	Command Format.....	127
<b>2.13</b>	<b>Command Set Summary List.....</b>	<b>128</b>
2.13.1	Initialization .....	128
2.13.2	Sales Transaction .....	128
2.13.3	Check printing.....	128
2.13.4	Barcode support .....	129
2.13.5	Attached Devices .....	129
2.13.6	Close Sales Period.....	129
2.13.7	Dump.....	129
2.13.8	Reports .....	129
2.13.9	Printer.....	129
2.13.10	Utilities.....	130
2.13.11	Electronic journaling.....	130
<b>3</b>	<b>Fiscal Status Byte and Return Code Definition .....</b>	<b>131</b>
3.1.1	Status Byte Definition .....	131
3.1.2	IBM 4610 SureMark Fiscal Printer KR3/KR5 (RS-485) .....	132
3.1.2.1	Printer and Fiscal Unit Status.....	132
3.1.2.1.1	Byte 0 - 5 (1 – 6): Printer status .....	133
3.1.2.2	Country Code and Version Number Definition.....	134
3.1.3	IBM 4610 SureMark Fiscal Printer KD3/KD5 (RS-232).....	135
3.1.3.1	Printer and Fiscal Unit Status.....	135
3.1.3.2	Country Code and Version Number Definition.....	138
3.1.4	Return Codes.....	139
3.1.5	Electronic Journal Return Codes.....	151
3.1.5.1	EJ Return Code Descriptions .....	151
3.1.6	Return Code Conversion Table (4694 OS to DOS/WINDOWS).....	154
<b>4</b>	<b>Fiscal Software and Hardware Interface Information.....</b>	<b>157</b>
<b>4.1</b>	<b>Printer Features .....</b>	<b>157</b>
<b>4.2</b>	<b>Printer Models.....</b>	<b>157</b>
<b>4.3</b>	<b>Supported Printer Typefaces .....</b>	<b>157</b>
4.3.1	Print typefaces on CR (Thermal Printer Station).....	157
4.3.2	Print typefaces on DI (Document Insert Station) .....	157
<b>4.4</b>	<b>Error Conditions.....</b>	<b>158</b>
<b>4.5</b>	<b>PLD - Power Line Disturbance .....</b>	<b>159</b>
<b>4.6</b>	<b>Communication with the RS232 Fiscal Printer .....</b>	<b>160</b>
4.6.1	Protocol.....	160
4.6.2	Packet Format.....	160
4.6.3	Header Format.....	160
4.6.4	Communication parameters.....	161
4.6.5	State machine for Host.....	161
4.6.6	State machine for Slave.....	161
4.6.7	Initialization .....	161
4.6.8	Initialization flow .....	162
4.6.8.1	Normal case.....	162
4.6.8.2	Slave reset when Host has an ongoing communication.....	162
4.6.8.3	Host reset and Slave not with Host recognizing.....	162
4.6.8.4	Slave reset when Host has an ongoing communication.....	162
4.6.9	Normal communication.....	162

4.6.10	Normal communication flow.....	162
4.6.10.1	Normal case.....	162
4.6.10.2	Bad CRC Packet received by Host.....	162
4.6.10.3	No Packet received by Host .....	163
4.6.10.4	Bad CRC Packet received by Slave.....	163
4.6.10.5	No Packet received by Slave .....	163
4.6.11	Timing .....	163
4.6.12	Polling .....	163
4.6.13	Retries .....	164
<b>5</b>	<b>Hungary - Specific Information .....</b>	<b>165</b>
5.1.1	Power-On or Reset Printout Format.....	165
5.1.1.1	Serialized, In Fiscal Mode, Working in Non-Fiscal or Idle Status.....	165
5.1.1.2	Serialized, In Fiscal Mode, Jumper Active.....	165
5.1.1.3	Serialized, In Fiscal Mode, CF in error .....	166
5.1.1.4	Serialized, In Fiscal Mode, Working with Open Transaction Status.....	167
5.1.1.5	Serialized, In Fiscal Mode, EJ error with Open Transaction Status .....	167
5.1.1.6	Software restart codes. ....	168
5.1.1.7	Serialized, In Fiscal Mode, Not Working.....	169
5.1.1.8	Not Serialized, Not in Fiscal Mode, Working .....	169
5.1.1.9	Serialized, Not In Fiscal Mode, Working.....	169
5.1.1.10	Not Serialized, Not In Fiscal Mode, Not Working.....	170
5.1.1.11	Serialized, Not In Fiscal Mode, Not Working.....	170
5.1.2	Error Handling during Paper Fail.....	171
5.1.3	Error Handling after Power Line Disturbance.....	172
5.1.4	Error Handling during CF Full.....	173



# 1 Fiscal Accounting Technical Description

This section discusses the fiscal printer operation, defines the terminology used in the operation of the printer, and describes the fiscal commands, in terms of the function they provide.

## 1.1 Fiscal Printer Operation

The fiscal printer operates under control of an application program communicating with it through a serial link (Device Channel). It is designed to execute a predefined set of commands, logically sequenced according to the type of operations to be performed. The application program has no direct control of the resources residing in the fiscal unit, but it can retrieve data related to accumulators, counters, fiscal unit state, and fiscal memory.

The fiscal printer performs the following operations, assuring that they are executed according to the fiscal law in Hungary:

- Record serialization parameters
- Record fiscal configuration options
- Record store configuration options
- Record sales amount and generate customer fiscal voucher
- Print X-Report
- Record daily sales in the fiscal memory and generate closure report
- Generate fiscal memory content reports
- Print reports generated by the application program
- Report selected data to the application program

## 1.2 Definition of Terminology

Some of the terminology was originally translated from Italian to English and documented at that time. The English terminology may be different than you would expect. Please study these definitions:

<b>Cancel</b>	is used when cancelling or voiding an entire sales transaction.
<b>Discount</b>	is the reduction of the item price (negative item), or the reduction of a part of a sales transaction (discount on subtotal), or the reduction of an entire sales transaction (discount on total).
<b>Document Insert (DI)</b>	is the print station that has the capability to insert forms from the top or the bottom of the printer and print either in a forward or reverse direction, where allowed.
<b>Fiscal Voucher</b>	This is where the terminology gets complicated! The fiscal voucher is the slip of paper that verifies that a sales transaction occurred and is commonly called the “customer receipt” in US English. The fiscal voucher is printed on the customer receipt station of the printer.
<b>Electronic Journal (EJ)</b>	The principle of this method is the saving in the compact flash (CF) all data printed in the customer receipt station (CR)
<b>J4 (CE) Jumper</b>	is a procedure performed by service representatives that clears the battery-backed RAM.
<b>Ordinary Printing</b>	also known as application-originated (or normal) printing, these are print lines that do not have a specific fiscal law function monitored or controlled by the printer.
<b>Rectify</b>	is an option on certain sales transaction commands used to modify, cancel, or undo a previous operation.
<b>Sales Period</b>	is a group of sales transactions over a given amount of time, usually measured daily.
<b>Sales Transaction</b>	is a process of recording item sales and arriving at the amount to be paid by or to a customer. The receiving of payment for merchandise or services is also included in a transaction.
<b>Tendering</b>	is the process of concluding a sales transaction and accounting for the methods of payment.
<b>Void</b>	is used when cancelling or voiding items.

## **1.3 Definition of Fiscal Printer States**

### **1.3.1 Initialization States**

#### **1.3.1.1 Fiscal Printer Serialized - (FMEMNIT)**

The fiscal printer has been serialized; fiscal commands can be executed. However, fiscal memory is not used until the fiscal printer is placed in the Fiscal Mode of operation.

#### **1.3.1.2 Fiscal Printer Set in Fiscal Mode - (FISCFLG)**

This is the normal mode of fiscal operation. Totals are stored into the fiscal memory at the time of the daily closure.

#### **1.3.1.3 Date/Time Set - (FSETDAT)**

This indicates that the time and date has been set.

#### **1.3.1.4 POS Headers Set - (FHEADER)**

This indicates that the POS headers have been loaded into the fiscal printer.

#### **1.3.1.5 Identification Information Loaded - (FPOSIDS)**

#### **1.3.1.6 Items/Negative Items with Blank Amount Set - (FBLKAMT)**

This state indicates that the quantity of the blank amount item sale lines between two normal item/negitem lines is loaded and operational.

### **1.3.2 POS Fiscal States**

#### **1.3.2.1 Sales Period in Progress - (FSALEON)**

This indicates that a daily sales period has been started. Typically, many of the fiscal configuration commands cannot be allowed during a day. To end this state a daily closure must be performed.

#### **1.3.2.2 Fiscal Voucher Sales Transaction**

Steps in a fiscal voucher transaction are listed below:

##### **1.3.2.2.1 Header Printed - (FHDRPRT):**

This indicates that the POS header has been printed. This event can happen at the beginning of Print Header, Daily Closure, Summary Fiscal Report, Print Multi-Day Fiscal Report, Start Application-Originated Report on CR commands.

##### **1.3.2.2.2 Item Processed - (FTRANON):**

This indicates that the Print Header command has been processed. So a fiscal voucher or simplified invoice is officially started.

##### **1.3.2.2.3 Total Requested - (FTOTALR):**

This indicates that the total has been requested.

##### **1.3.2.2.4 Discount or Uplift on Subtotal Requested (FDISCTL):**

This indicates that an operation on subtotal has been requested.

##### **1.3.2.2.5 Payment in Progress - (FPAYMNT):**

This indicates that the payment phase is in progress due to either a payment or a not paid command.

##### **1.3.2.2.6 End of Transaction Attempted - (FENDTRA):**

This indicates that an end of transaction command was attempted but an error or power down occurred before all the printing associated with this command could complete.

##### **1.3.2.2.7 Cancel Transaction Attempted - (FCANCEL):**

This indicates that a cancel transaction command was attempted but an error or power down occurred before all the printing associated with this command could complete.

#### **1.3.2.3 Customer Receipt Station Non-Fiscal Report in Progress - (FOPENCR)**

This indicates that an application-originated report is open on the customer receipt station.

#### **1.3.2.4 DI Station Portrait Application-Originated Report in Progress - (FOPNDIF)**

This indicates that a portrait application-originated report is open on the document insert station.

### **1.3.2.5 DI Station Landscape Application-Originated Report in Progress (FOPNDIN)**

This indicates that a landscape application-originated report is open on the document insert station

### **1.3.2.6 End of NonFiscal Attempted - (FENDNON):**

H113

This indicates that an end of non-fiscal document command was attempted but an irrecoverable error occurred before all the printing associated with this command could complete.

### **1.3.2.7 Cancel NonFiscal Attempted - (FCANNON):**

H114

This indicates that a cancel non-fiscal command was attempted but an irrecoverable error occurred before all the printing associated with this command could complete or an irrecoverable error occurred before all the printing associated with the non-fiscal document could complete.

### **1.3.2.8 Power on in Progress - (FIPLINP)**

This indicates that a power on sequence is in progress.

### **1.3.2.9 Fiscal Printer Ready - (FISCRDY)**

This indicates that the fiscal printer is ready for new commands.

### **1.3.2.10 End of Transaction Status - (FENTRAN)**

This indicates that a sales transaction has been completed successfully.

### **1.3.2.11 Cancel Voucher Executed - (FCNLVOU)**

This indicates that in countries where this operation is allowed, the previous sales transaction has already been cancelled.

### **1.3.2.12 CE Jumper Finished - (FJMPFIN)**

The CE jumper activation procedure was performed. Certain initialization procedures are allowed before normal fiscal commands are executed.

## **1.3.3 POS Fiscal Hardware States**

### **1.3.3.1 CE Jumper Active - (FJUMPER)**

The CE jumper is in the active position.

### **1.3.3.2 Fiscal Memory Connected - (FEPROMC)**

The fiscal memory is connected to the fiscal processor card. Each time that this flag is tested in the specification, the microcode is reading a test pattern from the fiscal memory to ensure that it is connected. If the test pattern is bad, the FEPROMC state is cleared. This state can only be set when the CE jumper is active.

### **1.3.3.3 Fiscal Memory Full - (FEPROMF)**

The fiscal memory is full.

[A137]

### **1.3.3.4 Fiscal RAM Pattern Good - (FRAMPOK)**

The fiscal RAM pattern is correct.

### **1.3.3.5 Display(s) Connected - (FDISPLAY)**

[A001] **ONLY VALID FOR IBM 4610 SureMark Fiscal Printer KR3/KR5 (RS-485)**

This indicates that the displays that have been configured by the 1A command are connected and working. Note that there is no 'Displays Set' state. Therefore, until they are set correctly, this state will not be set.

[A062] **ONLY VALID FOR IBM 4610 SureMark Fiscal Printer KD3/KD5 (RS-232)**

This indicates that the SIO display(s) attached to the fiscal printer that have been required are connected and working. Note that there is no 'Displays Set' state. Therefore, until they are set correctly, this state will not be set.

### **1.3.3.6 Check Procedure in Progress - (FCHECK)**

Check Printing Procedure in Progress.

## 1.4 POS Fiscal General Information and Rules

### 1.4.1 Fiscal Memory Connection

Fiscal memory may not be disconnected. The microcode checks for a good connection at power up and before execution of the following commands:

- (01) Print Header
- (06) End Transaction
- (15) Fiscal Memory Report
- (13) Daily Closure

If the fiscal memory is not connected, an error is reported to the application when the application attempts to execute the commands above.

Once the memory is detected as being disconnected, an error is sent to the application if any of the following commands are sent to the printer:

- (1B) Serialize Fiscal Printer
- (18) Set Fiscal Mode
- (C4) Fiscal Parameter Configuration
- (07) Cancel Transaction
- (D2) Item Sale
- (D3) Negative or Uplift Item Sale
- (D4) Total/Subtotal without Tax Printing
- (D5) Payment
- (D9) Uplift/Discount on Subtotal
- (14) X-Report
- (1F) Print POS ID Info Report
- (DD) Start Application-Originated Report
- (DE) End Application-Originated Report
- All Printer Commands

If Fiscal memory is not connected, an error is reported to the application. Recovery from this error requires that the RAM has to be cleared using the hardware J4 (CE) jumper.



## 1.5 Electronic Journaling

### 1.5.1 Electronic Journaling Operation

The IBM 4610 SureMark Fiscal Printer KR3/KR5/KD3/KD5 includes the hardware and related microcode in order to implement an electronic journaling method. Briefly, this method consists in saving all data printed in the customer receipt station (CR) in the compact flash (CF) inserted in the respective slot.

To be considered valid for fiscal and audit purposes, this data is signed safely at the end of the journal period (JP) using a private/public key signature method.

#### 1.5.1.1 Compact Flash

[A057]

The fiscal microcode EC level was tested with the following CF brands:

<b>Compact Flash Manufacturer</b>	<b>64 Mb</b>	<b>128 Mb</b>	<b>256 Mb</b>
Apacer		X	X
Hi Speed	X	X	
IBM	X		
Kingston	X	X	X
SanDisk	X	X	
Simpletech	X	X	
TDK		X	
Viking		X	



## 2 Fiscal Accounting Variables and Command Reference

A detailed description of the rules governing the execution of fiscal commands and the effect on fiscal memory, accumulators, and counters is described in this section.

**Note:** In all of the commands, bit 7 is the most significant bit and bit 0 is the least significant bit.

### 2.1 Definition of Accounting Variables

The following variables are defined in this section:

- Transaction accumulators.
- Transaction counters.
- Daily accumulators.
- Daily counters.
- Lifetime accumulators.
- Lifetime counters.

#### 2.1.1 Definition of Transaction Accumulators

##### 2.1.1.1 Transaction Accumulators – Totals and Taxes

Accumulator Name	Description	Minimum Range	Maximum Range
<b>Note:</b> These accumulators are used before the Total command:			
Tra_Tot_vg(vv,gg)	Individual totals by VAT category and enterprise(gg)	0	549755813887
<b>Note:</b> Immediately after the Total command but not after subsequent items, negative items, or operations on subtotal are done, the following accumulators are used:			
Tra_Tot	Shopper transaction total	0	549755813887
Tra_Tot_g(gg)	Transaction total by enterprise(gg)	0	549755813887

**Where:**

gg = Dual enterprise, range from 01 to 02.

### 2.1.1.2 Transaction Accumulators – Negative Items, Payment, and Subtotal Operations

Accumulator Name	Description	Minimum Range	Maximum Range
Tra_Void_g(gg)	Transaction voids total by enterprise(gg)	0	549755813887
Tra_Disc_g(gg)	Transaction discounts total by enterprise(gg)	0	549755813887
Tra_Uplf_g(gg)	Transaction uplifts total by enterprise(gg)	0	549755813887
Tra_Notp	Transaction not paid total	0	549755813887
Tra_Amt_Due	Amount due/Change	-549755813888	549755813887
Tra_Tdsc_g(gg)	Transaction discount on subtotal by enterprise(gg)	0	549755813887
Tra_Tupl_g(gg)	Transaction uplift on subtotal by enterprise(gg)	0	549755813887

**Where:**

gg = Dual enterprise, range from 01 to 02.

## 2.1.2 Definition of Transaction Counters

Table 4 lists the counters used during a Sales Transaction.

Table 4. Transaction Counters

Counter Name	Description	Minimum Range	Maximum Range
Tra_N_Void	Number of voided items	0	65535
Tra_N_Disc	Number of discounted items	0	65535
H54 Tra_N_Uplf	Number of uplifted items	0	65535
Tra_N_Tdsc	Number of discounts on subtotal	0	65535
Tra_N_Tupl	Number of uplifts on subtotal	0	65535

## 2.1.3 Definition of Daily Accumulators

### 2.1.3.1 Daily Accumulators – Totals and Taxes

Accumulator Name	Description	Minimum Range	Maximum Range
Day_Tot_g(gg)	Daily total	0	140737488355327

**Where:**

gg = Dual enterprise, range from 01 to 02.

### 2.1.3.2 Daily Accumulators – Negative Items, Payment, and Subtotal Operations

H55

Accumulator Name	Description	Minimum Range	Maximum Range
Day_Void_g(gg)	Daily voids total by enterprise(gg)	0	140737488355327
Day_Disc_g(gg)	Daily discounts total by enterprise(gg)	0	140737488355327
Day_Uplf_g(gg)	Daily uplifts total by enterprise(gg)	0	140737488355327
Day_Tdsc_g(gg)	Daily discount on subtotal by enterprise(gg)	0	140737488355327
Day_Tupl_g(gg)	Daily uplift on subtotal by enterprise(gg)	0	140737488355327
Day_Canc_g(gg)	Daily cancelled transaction total by enterprise(gg)	0	140737488355327

**Where:**

gg = Dual enterprise, range from 01 to 02.

## 2.1.4 Definition of Daily Counters

### 2.1.4.1 Daily Counters.

H56, [A032]

Counter Name	Description	Minimum Range	Maximum Range
Day_N_Vouc	Number of fiscal vouchers	0	9999
Day_N_Fisc	Number of fiscal slips printed	0	9999
Day_N_Inv	Number of simplified invoices printed	0	9999
Day_N_Inv_g(gg)	Number of simplified invoices printed by enterprise(gg)	0	9999
Day_N_Slip	Number of all fiscal and application-originated slips printed	0	9999
Day_N_NFR	Number of application-originated reports – all stations	0	9999
Day_N_NFCR	Number of CR station NFR	0	9999
Day_N_NFDI	Number of DI station NFR	0	9999
Day_N_Void	Number of voided items	0	65535
Day_N_Uplf	Number of uplifted items	0	65535
Day_N_Disc	Number of discounted items	0	65535
Day_N_Tdsc	Number of discounts on subtotal	0	65535
Day_N_Tupl	Number of uplifts on subtotal	0	65535
Day_N_Canc	Number of cancelled transactions	0	9999
Day_N_Ract	Number of repair actions	0	200
Day_N_Dump	Number of fiscal memory reports	0	9999
Day_N_X	Number of X-Reports	0	9999

**Where:**

gg = Dual enterprise, range from 01 to 02.



## 2.1.5 Definition of Lifetime Accumulators

### 2.1.5.1 Lifetime Accumulators

Accumulator Name	Description	Minimum Range	Maximum Range
Gran_Tot_g(gg)	Grand total by enterprise(gg)	0	1080863910568915200

**Where:**

gg = Dual enterprise, range from 01 to 02.

## 2.1.6 Definition of Lifetime Counters

### 2.1.6.1 Lifetime Counters

Counter Name	Description	Minimum Range	Maximum Range	See Notes
Lif_N_Clos [A074]	Closure number	1	4000	3
Lif_N_Ract [A075]	Number of repair actions	0	199	3
Lif_N_Vouc	Number of fiscal vouchers	1	999999	1, 2
Lif_N_Dump	Lifetime number of fiscal memory reports (dumps)	1	999999	1, 2
Lif_N_FM_Dump	Lifetime number of fiscal memory reports (dumps) (kept in fiscal memory)	1	200	3, 4,
Lif_N_Slip	Lifetime number of all fiscal and application-originated slips printed	1	999999	1, 2

**Notes:**

1. After reaching 999999, the lifetime number rolls over to 000001.
2. This value is reset to 000001 by use of the J4 (CE) jumper procedure.
3. This counter must be recovered from the fiscal memory in the case of the J4 (CE) jumper activation procedure being performed.
4. After reaching 200 entries, a fiscal memory report command (x'15') will result in RC 159.

## 2.2 Fiscal Hardware Functions

### 2.2.1 Power On / J4 (CE) Jumper Functions

The RAM is cleared and all totals are reset when the J4 (CE) jumper is activated. Available information, such as the serial number, is loaded from the fiscal memory to the RAM.

The activate jumper procedure consists in:

- Turn off the Fiscal Printer
- Put the J4 (CE) jumper in ON position
- Turn on the Fiscal Printer

The deactivate jumper procedure consists in:

- Turn off the Fiscal Printer
- Put the J4 (CE) jumper in OFF position
- Turn on the Fiscal Printer

**Note:** Only authorized service personnel can move the J4 jumper. Flags are set or cleared as shown below. The RAM pattern is initialized after all the other initialization has been completed.

#### 2.2.1.1 Calculations while the jumper is active:

[A002]

There are no calculations.

#### 2.2.1.2 Calculations when the jumper is moved to the stored position

[A003]

Recover the following counters from the fiscal memory tables and operate on them as shown below:

*Lif\_N\_Clos*

*Lif\_N\_Ract*

*Lif\_N\_Ract* = *Lif\_N\_Ract* + 1

*Day\_N\_Ract* = *Day\_N\_Ract* + 1

### 2.2.2 Full J4 (CE) Jumper

[A039]

Full J4 (CE) Jumper consists in 5 consecutive IPL's (Power OFF/ON or x0040) with jumper. Only in this case all internal variables related with Compact Flash management are cleared. EJ information is not lost after a normal (only one) jumper operation to allow keeping data from previous operations (as the SJ roll of paper isn't lost due to an intervention).

It's possible also that due to a microcode/hardware failure or just if the current Compact Flash is removed and lost in the middle of a Journal Period, the EJ information needs to be completely cleared. In that case the Full J4 (CE) Jumper procedure must be performed. Note that only the file for the current period at the time of the Full J4 (CE) Jumper procedure will be lost.

### 2.2.3 Display Checking

[A004] **ONLY VALID FOR IBM 4610 SureMark Fiscal Printer KR3/KR5 (RS-485)**

The microcode continually checks for connection of the POS displays by monitoring the Serial I/O (Device Channel) connection for display polls and then checking for appropriate responses.

If the microcode detects a required display missing, the FDISPLY flag is set to NO. If the correct number of displays is connected and operational, the microcode sets the FDISPLY state to YES.

[A063] **ONLY VALID FOR IBM 4610 SureMark Fiscal Printer KD3/KD5 (RS-232)**

- By default, the number of displays (attached to the fiscal printer) to be sensed is two (2).
- The number of displays (attached to the fiscal printer) can be set to zero (0), one (1) or two (2)
- The number of displays to be set return to their default value when RAM is cleared by installation of the J4 (CE) jumper.

- The command to set the minimum number of displays (attached to the fiscal printer) to be sensed is the xC402 (Display Sensing Definition) command.
- Microcode default addresses are x'21', x'22'.
- Display addresses are set to their default values when RAM is cleared by installation of the J4 (CE) jumper.
- The command to set the addresses of the one (1) or two (2) display(s) that have to be monitored for connection by the fiscal printer is the x1A (Set Display Address) command.
- The command to show information to the display(s) (attached to the fiscal printer) is the xCE (Attached Display Management) command.
- The display(s) to be sensed by the RS-232 fiscal microcode are only the SIO display(s) attached to the fiscal printer.
- If the microcode detects a required display missing, the FDISPLY flag is set to NO. If the correct number of displays is connected and operational, the microcode sets the FDISPLY state to YES (DISPLAY OPERATIONAL)

### 2.2.3.1 RS-232 Display Checking - Flow

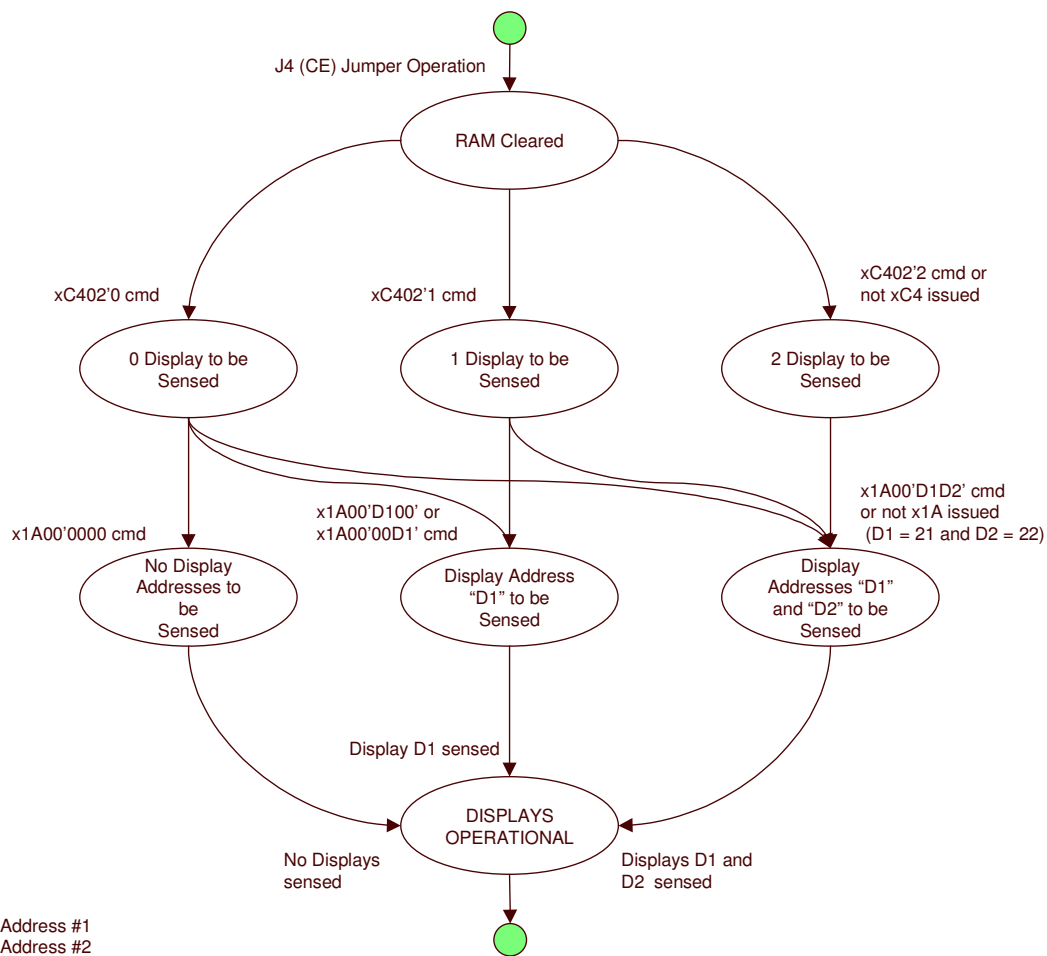

## 2.3 Initialization Sequence

The initialization sequence for Hungary is:

### 1. Step: Fiscal Memory and Compact Flash Initialization

[A043]

#### 1.1. RAM CLEAR (FULL J4 (CE) JUMPER)

- Turn on the fiscal printer **with Jumper OFF**
- **Put Jumper ON**
- Execute --> Reset = 1B66 0040 or Power OFF/ON (5 times)
- Execute --> Set Date = 1B66 1600
- **Put Jumper OFF**
- Execute --> Reset = 1B66 0040 or Power OFF/ON

#### 1.2. SET PUBLIC AND PRIVATE KEY

- Execute --> Set Public and Private Key = 1B66 6600 (1 time)
- Execute --> Set Public and Private Key = 1B66 6601 (0 or 1 or more times)
- Execute --> Set Public and Private Key = 1B66 6602 (1 time) OR
- Execute --> Set Public and Private Key = 1B66 6603 (1 time)

#### 1.3. SERIALIZATION

- Execute --> Set Primary Serial Number = 1B66 1B00

#### 1.4. FISCALIZATION

- Execute --> Set Fiscal Mode (Dual Enterprise) = 1B66 1803
- OR**
- Execute --> Set Fiscal Mode (Single Enterprise) = 1B66 1804

#### 1.5. SET IDENTIFICATION INFORMATION

- Execute --> Set Store/POS (Single Enterprise) = 1B66 1E42
- OR**
- Execute --> Set Store/POS (Dual Enterprise) = 1B66 1E46

#### 1.6. SET TAX RATES

- Execute --> Set TAX rates = 1B66 2001
- Execute --> Verify TAX rates = 1B66 2101

#### 1.7. CHECK / FORMAT COMPACT FLASH

H83

- Execute --> Reset = 1B66 0040 or Power OFF/ON

## 2. Step: RAM Initialization

The points 2.1 – 2.6 should be repeated after every RAM CLEAR  
[A099] [A111]

### 2.1. SET HEADERS

(Minimum = 1, Maximum = 8)

- Execute --> Set Header 1 (Single Enterprise) = 1B66 D701
- Execute --> Set Header 2 (Single Enterprise) = 1B66 D702
- Execute --> Set Header 3 (Single Enterprise) = 1B66 D703
- Execute --> Set Header 4 (Single Enterprise) = 1B66 D704
- Execute --> Set Header 5 (Single Enterprise) = 1B66 D705
- Execute --> Set Header 6 (Single Enterprise) = 1B66 D706
- Execute --> Set Header 7 (Single Enterprise) = 1B66 D707
- Execute --> Set Header Extra Line (Single Enterprise)  
= 1B66 D700

#### OR

(Minimum = 1, Maximum = 8)

- Execute --> Set Header 1 (Dual Enterprise) = 1B66 D741
- Execute --> Set Header 2 (Dual Enterprise) = 1B66 D742
- Execute --> Set Header 3 (Dual Enterprise) = 1B66 D743
- Execute --> Set Header 4 (Dual Enterprise) = 1B66 D744
- Execute --> Set Header 5 (Dual Enterprise) = 1B66 D745
- Execute --> Set Header 6 (Dual Enterprise) = 1B66 D746
- Execute --> Set Header 7 (Dual Enterprise) = 1B66 D747
- Execute --> Set Header Extra Line (Dual Enterprise)  
= 1B66 D740

### 2.2. VERIFY TAX RATES

- Execute --> Verify TAX rates = 1B66 2101

### 2.3. SET FISCAL PARAMETER CONFIGURATION

- Execute --> Set Ordinary Printing Threshold = 1B66 C400 (OPTIONAL)

### 2.4. SET FISCAL PARAMETER CONFIGURATION

[A064] ONLY VALID FOR IBM 4610 SureMark Fiscal Printer KD3/KD5 (RS-232)

- Execute --> Display Sensing Definition = 1B66 C402 (OPTIONAL)

### 2.5. SET FISCAL PARAMETER CONFIGURATION

- Execute --> Set Blank Amount = 1B66 C406

### 2.6. SET FISCAL PARAMETER CONFIGURATION

- Execute --> Character Set = 1B66 C407 (OPTIONAL)

### 2.7. SET DISPLAY ADDRESS

[A005] (ONLY VALID FOR IBM 4610 SureMark Fiscal Printer KR3/KR5 (RS-485))

- Execute --> Set Display = 1B66 1A00

[A065] (ONLY VALID FOR IBM 4610 SureMark Fiscal Printer KD3/KD5 (RS-232))

- Execute --> Set Display = 1B66 1A00 (OPTIONAL)

### 2.8. SET MAX WASTED SPACE

- Execute --> Set Max Wasted Space = 1B66 6800
- Execute --> Set Date = 1B66 1600

## 2.4 Initialization Commands

These are the initialization commands:

- (16) Set Date
- (66) Set Public and Private Key
- (1B) Serialize Fiscal Printer
- (18) Set Fiscal Mode
- (1E) Set TAX Identification Information
- (20) Set TAX Table
- (21) Verify TAX Table
- (D7) Set Header
- (C4) Fiscal Parameter Configuration  
[A006] [A066]
- (1A) Set Display Address
- (68) Set/Get Max Wasted Space

There are no calculations performed for any of the initialization commands.

## 2.4.1 1B - Serialize Fiscal Printer

	BYTE	BIT	CONTENT	TYPE	LENGTH
	0-1		1B66 - cmd prefix	hex	2
	2		1B - Serialize Fiscal Printer	hex	1
	3		00 - Primary Serial Number	hex	1
	4 -12		Serial number	ASCII	9 (Note 1)
H61	13 – 14		Reserved	ASCII	2 (Note 2)

**Note1 :** Numeric field

**Note2.:** Compulsory field, filled with blanks

### 2.4.1.1 Rules

- This procedure is used at the end of manufacturing process to serialize the fixed area of fiscal memory.
- This procedure can be executed only once.

## 2.4.2 18 - Set Fiscal Mode

BYTE	BIT	CONTENT	TYPE	LENGTH
0-1		1B66 - cmd prefix	Hex	2
2		18 - Set Fiscal Mode	Hex	1
3		3 Set Enterprise Mode 03 = Dual 04 = Single	hex	1
4-7		[A139] Password	ASCII	4

### 2.4.2.1 Rules

- This procedure is used to set the fiscal mode in fiscal memory. Once this procedure has been executed, the fiscal printer operates according to the configured country fiscal law.
- This procedure can be executed only once.
- The Set Enterprise Mode is kept into fiscal memory.
- The CE jumper must be used immediately before execution of this command to clear all RAM.



### 2.4.3 16 - Set Date

BYTE	BIT	CONTENT	TYPE	LENGTH
0-1		1B66 - cmd prefix	hex	2
2		16 - Set Date	hex	1
3		00	hex	1
4-5		Day	ASCII	2
6-7		Month	ASCII	2
8-11		Year	ASCII	4
12-13		Hours	ASCII	2
14-15		Minutes	ASCII	2
16-17		Seconds	ASCII	2

#### 2.4.3.1 Rules

This procedure is used to update the fiscal printer time of day clock.

Sets the fiscal unit time-of-day clock. The following rules apply to setting the date and time in the fiscal unit:  
[A042]

- The Set Date and Time command is rejected if a sale period is in progress (Flag FJUMPER = NO).
- The Set Date command can be issued only once after each closure.
- The time can be set back until last midnight (Flag FJUMPER = NO) but the next closure could be issued if the date and time is after the last closure date in the fiscal memory.
- The Set Time and Date command is rejected if the new date is more than one day after the current date (Flag FJUMPER = NO).
- The Set Time and Date command is accepted if the new date is after the last closure date in the fiscal memory (Flag FJUMPER = YES). Only authorized service personnel can execute this.

## 2.4.4 D7 - Set Header

	BYTE	BIT	CONTENT	TYPE	LENGTH
	0-1		1B66 - cmd prefix	hex	2
	2		D7 - Set Header	hex	1
	3		Cmd extension		1
		7	Reserved	binary	
		6	0 = Enterprise A 1 = Enterprise B	binary	
H1 H1 H1 H1 H1 H1 H1 H1 H1		5-3	Print typeface 000 = 44 char / line 001 = 38 char / line 010 = 48 char / line 011 = 44 char / line double-high 100 = 44 char / line emphasized 101 = 38 char / line emphasized 110 = 48 char / line emphasized 111 = 44 char / line double-high, emph.	binary	
A097 A109		2-0	Header Line Number 000 (00) = Extra Line of Store Header 001 (01) = First Line of Store Header 010 (02) = Second Line of Store Header 011 (03) = Third Line of Store Header 100 (04) = Fourth Line of Store Header 101 (05) = Fifth Line of Store Header 110 (06) = Sixth Line of Store Header 111 (07) = Seventh Line of Store Header	Binary	(Note 1)
H1	4-51		Data	ASCII	48

### Notes:

- If an all-blank character string is specified then the corresponding header line is not printed.
- If a header line is not set, it is not printed.
- Double high characters are allowed only in the first line of Store Header

[A126] [A132]

- The printing mode of the last header line set applies also to the Taxpayer Id Number line (included in the printouts header).

### Note 1:

- The extra line (cmd.ext.bit 2-0 = 000) is printed after the Seventh Store Header Line (like a Eighth Store Header).

### 2.4.4.1 Rules

- Loads the store header into fiscal printer battery backed up RAM.
- The store header is erased when RAM is cleared by activation of the CE jumper.
- This command cannot be executed when Sales Period is in progress.

## 2.4.5 1A - Set Display Address

[A007] [A067]

BYTE	BIT	CONTENT	TYPE	LENGTH
0-1		1B66 - cmd prefix	hex	2
2		1A - Set Display Address	hex	1
3		00 – Command Extension	hex	1
4-7		Password	ASCII	4
8-9		First Display Address	ASCII	2 (Note 1)
10-11		Second Display Address	ASCII	2 (Note 1)

### Notes:

- Specify the ASCII representation of the hexadecimal address.  
Example: for hexadecimal address x'2A' specify ASCII characters '2', 'A'.  
Valid display addresses are: x'20'-x'27' and x'2A'-x'2F'.

### 2.4.5.1 Calculations

There are no calculations for this command.

### 2.4.5.2 Rules

#### 2.4.5.2.1 Rules for IBM 4610 SureMark Fiscal Printer KR3/KR5 (RS-485)

This procedure is used to set the addresses of the 2 display(s) that have to be monitored for connection by the fiscal unit. Display addresses are erased when RAM is cleared by activation of the CE jumper.

When the customer display breaks down then the following takes place:

- The printer continues working normally but no fiscal receipts or simplified invoices can be issued again
- After the fiscal logo is printed, the message CUSTOMER DISPLAY NOT READY is printed.

#### 2.4.5.2.2 Rules for IBM 4610 SureMark Fiscal Printer KD3/KD5 (RS-232)

This procedure is used to set the addresses of the one (1) or two (2) display(s) that have to be monitored for connection by the fiscal printer.

The number of different addresses set must be more or equal than the minimum number of displays to be sensed (C402 cmd).

Display addresses are set to their default values when RAM is cleared by installation of the J4/CE jumper.

When the customer display breaks down then the following takes place:

- The printer continues working normally but no fiscal receipts or simplified invoices can be issued again.
- After the fiscal logo is printed, the message CUSTOMER DISPLAY NOT READY is printed.

Address Range:

- Microcode default addresses are x'21', x'22'.
- If two displays must be sensed specify the first address different than the second address.
- If only one display must be sensed, specify the first or second address as x'00' for single display sensing.
- If only no displays must be sensed, specify the first and the second address as x'0000'. (To do this the minimum of displays to be sensed set the xC402 command must be 0).
- After the execution of this command, the number of displays to be sensed is determined by the displays addresses set.

## 2.4.6 F1 - Communicate Power On Status

BYTE	BIT	CONTENT	TYPE	LENGTH
0-1		1B66 – command prefix	hex	2
2		F1 – Communicate IPL Completion Status	hex	1
3		00	hex	1

### 2.4.6.1 Calculations

There are no calculations for this command.

### 2.4.6.2 Rules

This command requests the fiscal unit to communicate the power-on completion status.

This command determines if the printer power was turned off in the middle of a command as shown by status byte 6, bit 4.

## 2.4.7 F9 - Read Current Status

BYTE	BIT	CONTENT	TYPE	LENGTH
0-1		1B66 – command prefix	hex	2
2		F9 – Report Current Status	hex	1
3		00	hex	1

### 2.4.7.1 Calculations

There are no calculations for this command.

### 2.4.7.2 Rules

This command requests the fiscal unit to report its current status.

## 2.4.8 1E - Set TAX Identification Information

	BYTE	BIT	CONTENT	TYPE	LENGTH
	0-1		1B66 – command prefix	hex	2
	2		1E - POS TAX Identification	hex	1
	3		Command Extension	hex	1
		7	Reserved	binary	
		6	Final Entry 1 = YES	binary	
H2		5-3	Reserved	binary	
		2	Item Group 0 = Primary group Enterprise A goods 1 = Secondary group Enterprise B goods	binary	
		1	Line Number 1 = First line	binary	
		0	Reserved	binary	
	4-7		Reserved	ASCII	4
	8-11		Reserved	ASCII	4
	12-27		Taxpayer ID Number	ASCII	16
	28-49		Reserved	ASCII	22
	50-55		Reserved	ASCII	6

### Note:

For Item Group = 0, the Taxpayer ID Number will be for Enterprise A.

For Item Group = 1, the Taxpayer ID Number will be for Enterprise B.

The Taxpayer ID Number is stored in the fiscal EPROM and may be changed up to 10 times. The Taxpayer ID Number is not changed by the microcode if it is equal to the last loaded or if it is blank or missing with the exception of the date field. The Taxpayer ID Number is represented in the printouts by ffffffff... for enterprise A and gggggggg... for enterprise B.

### 2.4.8.1 Calculations

There are not calculations for this command.

### 2.4.8.2 Rules

- Loads specific store information into the RAM.
- Loads specific store information into the fiscal memory.
- New Taxpayer ID Number information can be loaded into the fiscal memory 10 time(s) during the life of the fiscal printer.
- The Taxpayer ID Number is compared to the last entry in the table.  
If the data is the same, the new entry will not be added to the table.

## 2.4.9 20 - Set TAX Table

This command is used to load the TAX rates in RAM memory.

### 2.4.9.1 Command format

	BYTE	BIT	CONTENT	TYPE	LENGTH
	0-1		1B66 – command prefix	Hex	2
	2		20 – Set TAX Table	Hex	1
H9	3		01 – Command extension		1
H74	4 – 7		Reserved	ASCII	4
H9	8 – 14		VAT Rate for Category 01	ASCII	7 (Note 1, 2)
H9	15 – 21		VAT Rate for Category 02	ASCII	7 (Note 1, 2)
H9	22 – 28		VAT Rate for Category 03	ASCII	7 (Note 1, 2)
H9	29 – 35		VAT Rate for Category 04	ASCII	7 (Note 1, 2)
H9	36 – 42		VAT Rate for Category 05	ASCII	7 (Note 1, 2)
H9	43 - 49		VAT Rate for Category 06	ASCII	7 (Note 1, 2)

Note 1: VAT rate field consists of seven characters zzzrrrr.

The first three (zzz) represent the tributary identifier and the last four (rrrr) represent the VAT rate.

The values of the VAT rates are the following:

If the value of the last character of the identifier is "%", then the value of the VAT rate is a real value

If the value of the last character of the identifier is "alpha", then the value of the VAT rate is zero

If the value of the last character of the identifier is "space", then the value of the VAT rate is "9999"

Current values of the VAT Categories:

Category 01: V1% 0000

Category 02: V2% 1200

Category 03: V3% 2500

Category 04: AJT 0000

Category 05: TAM 0000

Category 06: " " 9999

Note 2: VAT rate is a fixed-point number with 2 decimal digits.

Separator characters must not be included in the VAT rate string.

For example, for VAT rate 8%, specify ~0800~.

Note 3: VAT rate field can range from ~0000~ to ~9999~.

Values from ~0000~ to ~9998~ are used to specify the VAT rate, while value ~9999~ is used to inhibit the corresponding category.

Note 4: The print format for VAT rates depends on their specification:

a) If all rates are specified as ~xx00~ the print format will be rr %

b) If at least one rate is not specified as ~xx00~ the print format will be rr,rr %

### 2.4.9.2 Rules

- This command is allowed without EC jumper operation (OFF) to set new TAX categories after Closure Report (13 command) and before start sale period.
- The Tax Rates can be changed 20 times.

## 2.4.10 21 – Verify TAX Table

This command is used to compare the VAT rates loaded with 20 command.

### 2.4.10.1 Command format

	BYTE	BIT	CONTENT	TYPE	LENGTH
	0-1		1B66 – command prefix	Hex	2
	2		21 – Set TAX Table	Hex	1
H10	3		01 – Command extension		1
H75	4 - 7		Reserved	ASCII	4
H10	8 - 14		VAT Rate for Category 01	ASCII	7 (Note 1, 2)
H10	15 - 21		VAT Rate for Category 02	ASCII	7 (Note 1, 2)
H10	22 – 28		VAT Rate for Category 03	ASCII	7 (Note 1, 2)
H10	29 – 35		VAT Rate for Category 04	ASCII	7 (Note 1, 2)
H10	36 – 42		VAT Rate for Category 05	ASCII	7 (Note 1, 2)
H10	43 - 49		VAT Rate for Category 06	ASCII	7 (Note 1, 2)

Note 1: VAT rate field consists of seven characters zzzrrrr.

The first three (zzz) represent the tributary identifier and the last four (rrrr) represent the VAT rate.

The values of the VAT rates are the following:

If the value of the last character of the identifier is "%", then the value of the VAT rate is a real value

If the value of the last character of the identifier is "alpha", then the value of the VAT rate is zero

If the value of the last character of the identifier is "space", then the value of the VAT rate is "9999"

Current values of the VAT Categories:

Category 01:	V1%	0000
Category 02:	V2%	1200
Category 03:	V3%	2500
Category 04:	AJT	0000
Category 05:	TAM	0000
Category 06:	" "	9999

Note 2: VAT rate is a fixed-point number with 2 decimal digits.

Separator characters must not be included in the TAX rate string.

For example, for TAX rate 8%, specify ~0800~.

Note 3: VAT rate field can range from ~0000~ to ~9999~.

Values from ~0000~ to ~9998~ are used to specify the VAT rate, while value ~9999~ is used to inhibit the corresponding category.

Note 4: The print format for VAT rates depends on their specification:

a) If all rates are specified as ~xx00~ the print format will be rr %

b) If at least one rate is not specified as ~xx00~ the print format will be rr,.rr %

### 2.4.10.2 Rules

- This command is allowed without EC jumper operation (OFF) to set new VAT categories after Closure Report (13 command) and before start sale period.
- The Tax Rates can be changed 20 times.



## 2.4.11 C4 - Fiscal Parameter Configuration

	BYTE	BIT	CONTENT	TYPE	LENGTH
	0-1		1B66 – cmd prefix	hex	2
	2		C4 – Fiscal Parameter Configuration	hex	1
H46	3		Command Extension 00 - Set Ordinary Printing Threshold 02 – Display Sensing Definition 06 – Set Blank Amount allowed item lines 07 – Set Code page	hex	1
	4-7		Password	ASCII	4
			If Cmd Extension = 00, specify:		
H131 A048 A085 A092	8-9		Ordinary printing threshold	ASCII	2 (Note 1)
A070			<b>ONLY VALID FOR IBM 4610 SureMark Fiscal Printer KD3/KD5 (RS-232)</b> If Cmd Extension = 02, specify:		
	8		Display Sensing Definition: 0 = None Display 1 = Single Display 2 = Dual Display	ASCII	1 (Note 2)
			If Cmd Extension = 06, specify:		
A089 A094	8-9		Blank amount item lines	ASCII	2 (Note 3)
			If Cmd Extension = 07, specify:		
H46	8		Character Set '0' – PC 852 '1' – Windows Latin2	ASCII	1 (Note 4)

### Notes:

- 1. This field is for command extension 00.  
This command can be executed only once for each extension after CE jumper.  
The default value is '00'.  
Ordinary printing threshold ranges from '00' to '99'.
- 2. This field is for command extension 02.  
**ONLY VALID FOR IBM 4610 SureMark Fiscal Printer KD3/KD5 (RS-232)**  
It must be executed before the set display (1A cmd.), otherwise the code will sense two displays.
- 3. This field is for command extension 06.  
The maximum allowed value is '99', the minimum value is '01'.  
[A136]  
**ONLY VALID FOR IBM 4610 SureMark Fiscal Printer KR3/KR5 (RS-485)**  
This command can be executed only once for each extension after CE jumper.
- 4. This field is for command extension 07.  
This command can be executed only once for each extension after CE jumper.  
The default value is '0'.

### 2.4.11.1 Calculations

There are no calculations for this command.

[A070]

## 2.4.11.2 Rules

### 2.4.11.2.1 Rules for command extension 02 (Display Sensing Definition):

#### **ONLY VALID FOR IBM 4610 SureMark Fiscal Printer KD3/KD5 (RS-232)**

This procedure is used to set the minimum number of displays (attached to the fiscal printer) to be sensed.

- It must be executed before the set display (1A cmd.), otherwise the code senses two displays.
- This command can be issued only once after J4/CE jumper operation (otherwise the return code 102 is returned).
- When RC 102 is returned for command extension 02:
  - Trying to execute C4 cmd. with cmd. extension 02 successfully more than once.  
Explanation: If two displays were sensed, can't change to a single or none display sensing until a J4/CE jumper is performed.
  - If set display address (1A cmd.) is issued, the use of C402 is not allowed, not even once.  
Explanation: Issuing 1A cmd. without previous C4 cmd. with cmd. extension 02 only allows two display addresses. So, this way it is assumed that two displays will be used. So, the only meaning to issue a C4 cmd. with cmd. extension 02 after a 1A cmd. is to try to sense only one or none display. But, because this could be performed by an application or a user with bad intentions this is not allowed.

## 2.5 Sales Period in Progress Commands

These commands are executed to start a Sale Transaction (Print Header) or when a Sales Transaction is in progress.

- (01) Print Header
- (06) End of Transaction
- (07) Cancel Transaction
- (D2) Item Sale
- (D3) Negative Item Sale
- (D4) Total/Subtotal without Tax Printing
- (D5) Payment
- (D9) Uplift/Discount on Subtotal

The calculations listed in this section are performed after the successful execution of the command.

### 2.5.1 General Fiscal Voucher Rules

1. Payment phase is required.
2. During a fiscal voucher, including before any items have been sold, only a total of 0 normal customer receipt print lines can be printed.

## 2.5.2 01 - Print Header

	BYTE	BIT	CONTENT	TYPE	LENGTH
	0-1		1B66 – cmd prefix	hex	2
	2		01 - Print Store Header	hex	1
H13	3		Command Extension		1
		7 – 5	Reserved	bin	
A100 A112		4	Simplified Invoice Additional Header lines 1 - Set Additional Header Lines	bin	(Note 1)
A104 A112		3	Customer Data 0 - Print Normal Customer Data 1 - Print Extended Customer Data	bin	(Note 5)
H13		2	0 – Enterprise A 1 – Enterprise B	bin	
H13		1 - 0	00 – Voucher 01 – Simplified Invoice	bin	
			<b>If cmd.ext. Bit 4 = 0</b>		
H13	4 – 33		Customer Name	ASCII	30 (Note 2)
H13	34 – 63		Customer Address Line 1	ASCII	30 (Note 2)
H13	64 – 93		Customer Address Line 2	ASCII	30 (Note 2)
			<b>If cmd.ext. Bit 4 = 1</b>		
	4 – 5		Additional Header Line Number	ASCII	2 (Note 3)
	4 – 49		Additional Header Line Description	ASCII	44 (Note 4)

[A104] [A112]

- **Note 1:**

- The additional header lines are buffered in RAM. When a Simplified Invoice Header is printed, these lines are also printed.
- This additional header lines (cmd.ext.bit 4 = 1) must be issued before the print header (cmd.ext.bit 4 = 0).
- There are nine (9) additional header lines to set.
- If a additional header line is not set, it is not printed.
- The additional header lines can be sent in any order.
- The additional header lines are not available for the voucher.
- If the additional header lines is set (cmd.ext.bit 4 = 1), the another cmd.ext.bits must be zero, otherwise the RC = 66 (invalid command extension) is returned.

- **Note 2:**

- For Voucher these fields are not printed.
- If the cmd.ext. Bit 3 = 0, then these fields are compulsory for Simplified Invoice.
- If the cmd.ext. Bit 3 = 1, then these fields are ignored for Simplified Invoice.

- **Note 3:**

- Additional Line Range = 01..09

- \* **EXTRA HEADER LINES:**

- The Additional Line number 01 will be printed 'before' the Store Header Lines (set by xD7 command)
- The Additional Header Line number 02 will be printed 'after' the Store Header Lines (set by xD7 command)

- \* **CUSTOMER HEADER LINES:**

- The Additional Header Line numbers from 03 to 05 will be printed as Extended Customer Data.

- \* **COLUMNS HEADER LINES:**

- The Additional Header Line numbers from 06 to 09 will be printed as Header Column Lines.
- If the Additional Header Line numbers from 06 to 09 are set (at least one), then these lines will be printed instead the predefined messages (S52-S53-S54).
- If the no Additional Header Line numbers from 06 to 09 are set, then the predefined messages (S52-S53-S54) will be printed as Header Column Lines.

- **Note 4:**

- If an all-blank character string is specified then the corresponding additional header line is not printed.

- **Note 5:**

- To print the Extended Customer Data the Additional Header Line numbers from 03 to 05 must be set before, otherwise no data are printed.

### 2.5.2.1 Example

[A100] [A112]

The following is the commands sequence to set and print the Simplified Invoice Additional Header Lines:

```
* The following commands buffer the Additional Header Lines in RAM:
'0110'01<----- Additional Header Line #1 ----->
'0110'02<----- Additional Header Line #2 ----->

* The following command prints the Simplified Invoice Header with the Additional Header Lines
Set:
'0101'<---- Customer Name Field ----><-- Customer Address Line 1 --><-- Customer Address Line 2
->'

* The printout will be the following:
MSG 0      1      2      3      4
NUM 12345678901234567890123456789012345678901234
-----
|<----- Additional Header Line #1 ----->|
|<----- header - line A1 ----->|
|<----- header - line A2 ----->|
|<----- header - line A3 ----->|
|<----- header - line A4 ----->|
|<----- header - line A5 ----->|
|<----- header - line A6 ----->|
|<----- header - line A7 ----->|
|<----- header - Extra line ----->|
|<----- Additional Header Line #2 ----->|
S48|      ADÓIGAZGATÁSI SZÁM: ffffffff          | 'TAXPAYER ID NUMBER'
:
:
```

### 2.5.2.2 Calculations

There are no calculations for this command.

### 2.5.2.3 Rules

H13 This procedure is used to print the Store Header on Voucher or Simplified Invoice. After print header only is allowed Cancel Transaction or Item Sale commands.

### 2.5.3 06 - End of Transaction

	BYTE	BIT	CONTENT	TYPE	LENGTH
	0-1		1B66 - cmd prefix	hex	2
	2		06 - End Transaction	hex	1
	3		Command Extension	hex	1
		7	Retry 0 – NO 1 – YES	binary	
		6-0	Reserved	binary	
	4-15		Operator/Terminal/Store number	ASCII	12
H62	16-59		Trailer Message line 1	ASCII	44 (Note)
H62	60-103		Trailer Message line 2	ASCII	44 (Note)

**Note:** If Trailer lines are not necessary, the corresponding fields must be filled with spaces.

#### 2.5.3.1 Calculations

[A059]

$Day\_N\_Vouc = Day\_N\_Vouc + 1$

$Lif\_N\_Vouc = Lif\_N\_Vouc + 1$

$Day\_N\_Fisc = Day\_N\_Fisc + 1$

$Day\_N\_Slip = Day\_N\_Slip + 1$

[A035]

- If Simplified Invoice is in progress, then  
 $Day\_N\_Inv = Day\_N\_Inv + 1$   
 $Day\_N\_Inv\_g(gg) = Day\_N\_Inv\_g(gg) + 1$   
*for value of gg ranging from 1 to the maximum values*

$Day\_Tot\_vg(vv,gg) = Day\_Tot\_vg(vv,gg) + Tra\_Tot\_vg(vv,gg)$   
*for values of vv and gg ranging from 1 to the maximum values*  
 $Day\_Tot\_g(gg) = \text{Sum of } Day\_Tot\_vg(vv,gg)$   
*for values of vv and gg ranging from 1 to the maximum values*

#### According to the negative item type:

$Day\_N\_Void = Day\_N\_Void + Tra\_N\_Void$

$Day\_N\_Disc = Day\_N\_Disc + Tra\_N\_Disc$

[A041]

$Day\_N\_Uplf = Day\_N\_Uplf + Tra\_N\_Uplf$

$Day\_N\_Tdsc = Day\_N\_Tdsc + Tra\_N\_Tdsc$

$Day\_N\_Tupl = Day\_N\_Tupl + Tra\_N\_Tupl$

$Day\_Void\_g(gg) = Day\_Void\_g(gg) + Tra\_Void\_g(gg)$   
*for values of gg ranging from 1 to the maximum values*

$Day\_Disc\_g(gg) = Day\_Disc\_g(gg) + Tra\_Disc\_g(gg)$   
*for values of gg ranging from 1 to the maximum values*

$Day\_Uplf\_g(gg) = Day\_Uplf\_g(gg) + Tra\_Uplf\_g(gg)$   
*for values of gg ranging from 1 to the maximum values*

$Day\_Tdsc\_g(gg) = Day\_Tdsc\_g(gg) + Tra\_Tdsc\_g(gg)$   
*for values of gg ranging from 1 to the maximum values*

$Day\_Tupl\_g(gg) = Day\_Tupl\_g(gg) + Tra\_Tupl\_g(gg)$   
*for values of gg ranging from 1 to the maximum values*

#### 2.5.3.1.1 Clearing Transaction Accumulators:

$Tra\_Tot\_vg(vv,gg) = 0$   
*for values of vv, and gg ranging from 1 to the maximum values*

*Tra\_Tot\_g*(gg) = 0  
for values of gg ranging from 1 to the maximum values  
*Tra\_Void\_g*(gg) = 0  
for values of gg ranging from 1 to the maximum values  
*Tra\_Disc\_g*(gg) = 0  
for values of gg ranging from 1 to the maximum values  
*Tra\_Uplf\_g*(gg) = 0  
for values of gg ranging from 1 to the maximum values  
*Tra\_Notp* = 0  
*Tra\_Tdsc\_g*(gg) = 0  
for values of gg ranging from 1 to the maximum values  
*Tra\_Tupl\_g*(gg) = 0  
for values of gg ranging from 1 to the maximum values  
*Tra\_N\_Void* = 0  
*Tra\_N\_Disc* = 0  
[A040]  
*Tra\_N\_Uplf* = 0  
*Tra\_N\_Tdsc* = 0  
*Tra\_N\_Tupl* = 0

### 2.5.3.2 Rules

This procedure is used to end the sales transaction.

- End Transaction command is executed only if the total paid amount is not less than the Transaction Total amount if the payment phase is selected. *Tra\_Amt\_Due* must be less than or equal to 0.
- The string ÖSSZESEN in upper, lower or mixed case is not allowed in the description field of this command.
- If PLD occurs during an end of transaction, after the next IPL completion, this command will be executed again automatically.

## 2.5.4 07 - Cancel Transaction

BYTE	BIT	CONTENT	TYPE	LENGTH
0-1		1B66 - cmd prefix	hex	2
2		07 – Cancel Transaction	hex	1
3		Command Extension	hex	1
	7	Retry 0 – NO 1 - YES	binary	
	6-0	Reserved	binary	
4-15		Store/Operator/Terminal number	ASCII	12

### 2.5.4.1 Calculations

[A059]

$Day\_N\_Vouc = Day\_N\_Vouc + 1$

$Day\_N\_Fisc = Day\_N\_Fisc + 1$

$Day\_N\_Slip = Day\_N\_Slip + 1$

$Lif\_N\_Vouc = Lif\_N\_Vouc + 1$

$Day\_N\_Canc = Day\_N\_Canc + 1$

[A035]

- If Simplified Invoice is in progress, then

$Day\_N\_Inv = Day\_N\_Inv + 1$

$Day\_N\_Inv\_g(gg) = Day\_N\_Inv\_g(gg) + 1$

for value of gg ranging from 1 to the maximum values

$Tra\_Tot\_g(gg) = Sum\ of\ Tra\_Tot\_vg(vv,gg)$

for values of vv and gg ranging from 1 to the maximum values

$Day\_Canc\_g(gg) = Day\_Canc\_g(gg) + Tra\_Tot\_g(gg)$

for values of gg ranging from 1 to the maximum value

$Tra\_Tot\_vg(vv,gg) = 0$

for values of vv and gg ranging from 1 to the maximum values

$Tra\_Void\_g(gg) = 0$

for values of gg ranging from 1 to the maximum values

$Tra\_Disc\_g(gg) = 0$

for values of gg ranging from 1 to the maximum values

$Tra\_Uplf\_g(gg) = 0$

for values of gg ranging from 1 to the maximum values

$Tra\_Notp = 0$

$Tra\_Tdsc\_g(gg) = 0$

for values of gg ranging from 1 to the maximum values

$Tra\_Tupl\_g(gg) = 0$

for values of gg ranging from 1 to the maximum values

$Tra\_N\_Void = 0$

$Tra\_N\_Disc = 0$

[A040]

$Tra\_N\_Uplf = 0$

$Tra\_N\_Tdsc = 0$

$Tra\_N\_Tupl = 0$

### 2.5.4.2 Rules

The Cancel Transaction command cancels the sales transaction at any point in the sales transaction.

- The string ÖSSZESEN in upper, lower or mixed case is not allowed in the description field of this command.



## 2.5.5 D2 - Item Sale

	BYTE	BIT	CONTENT	TYPE	LENGTH
	0-1		1B66 - cmd prefix	hex	2
	2		D2 - Item Sale	hex	1
	3		Cmd Extension		1
H4		7 - 6	Reserved	binary	
A091 A096		5	Extended Blank Amount Item Line 1 = Print Blank Amount Item Description	binary	(Note 4)
		4	Item Group 0 = Primary group Enterprise A goods 1 = Secondary group Enterprise B goods	binary	
H4		3-0	Reserved	binary	
		<b>If cmd.ext. Bit 5 = 0</b>			
H4	4-27		Description	ASCII	24
	28-37		Amount	ASCII	10 (Note 1, 2)
H4	38-39		VAT Category	ASCII	2
H121	40-79		Invoice Info	ASCII	40 (Note 3)
		<b>If cmd.ext. Bit 5 = 1</b>			
A091 A105 A115	4-37		Blank Amount Item Description	ASCII	34

### Notes:

H72

- 1. Amount string can be blank for printing comment lines between items (See “(C4) – Fiscal Parameter Configuration” )  
Max amount = 2 147 483 647 .
- 2. If amount string is blank then the transaction counters are not affected.
- 3. The field Invoice Info should be completed if the command is used in Simplified invoice. The content of this field is printed before the Item Sale line. The information in this field is unstructured, but should contain the statistical code, the unit price, the quantity and the quantity unit of the sold item, taking into consideration the format defined in the Simplified invoice header lines.
- 4. This command extension can be issued for printing comment lines between items (See “(C4) – Fiscal Parameter Configuration”) with a maximum of 34 characters.

### 2.5.5.1 Calculations

$$Tra\_Tot\_vg(vv,gg) = Tra\_Tot\_vg(vv,gg) + Item\_Amt$$

Where: specific values of vv, gg are determined from the item sale command.

vv = VAT category

gg = Dual enterprise, range = 01 to 02

### 2.5.5.2 Item Sale Rules

This procedure is used to record the amount of an item and to print a line containing item description and item amount.

[A090] [A095]

#### 2.5.5.2.1 Transaction rules:

- There are two ways to print comment lines between items:
  - 1) Cmd.Ext.bit 5 = 0 - Cmd.Description from 01 to 24 characters:  
Amount field in command string of Item must be blank.
  - 2) Cmd.Ext.bit 5 = 1 - Cmd.Description from 01 to 34 characters:  
There are not amount field.

- This allows the processing of items with description longer than the number of characters allowed in one line.
- The number of items with blank amount, which can be sent between non-blank item/negative item lines is 99. (See “(C4) – Fiscal Parameter Configuration”)
- The string ÖSSZESEN in upper, lower or mixed case is not allowed in the description field of this command.

### 2.5.6 D3 - Negative Item Sale

	BYTE	BIT	CONTENT	TYPE	LENGTH
	0-1		1B66 - cmd prefix	hex	2
	2		D3 – Negative or Uplift Item Sale	hex	1
	3		Cmd Extension		1
		7	Reserved		
		6	Rectify 0 = NO 1 = YES	binary	
H5		5	Reserved		
		4	Item Group 0 = Primary group Enterprise A goods 1 = Secondary group Enterprise B goods		
H5		3	Reserved		
H76		2-0	Negative item type binary 1 = VOID 3 = DISCOUNT 6 = UPLIFT		(Note 4)
	4-27		Description	ASCII	24 (Note 1)
	28-37		Amount	ASCII	10 (Note 2)
H5	38-39		VAT Category	ASCII	2
H5	40-79		Invoice Info	ASCII	40 (Note 3)

**Notes:**

- 1. Depending on the print options specified the Item description may be cut off shorter than 24 characters.
- 2. Amount string cannot be blank.  
Max amount = 2 147 483 647
- 3. The field Invoice Info should be completed if the Negative item type =Void and the command is used in Simplified invoice. The content of this field is printed before the Item Void line. The information in this field is unstructured, but should contain the statistical code, the unit price, the quantity and the quantity unit of the sold item, taking into consideration the format defined in the Simplified invoice header lines.
- 4. VOID cannot be rectified.

#### 2.5.6.1 Negative Item Sale Calculations

[A059]

**For rectify option = NO and all Negitems except uplift:**

$$Tra\_Tot\_vg(vv,gg) = Tra\_Tot\_vg(vv,gg) - Neg\_Item\_Amt$$

for values of vv and gg ranging from 1 to the maximum values

**According to the negative item type:**

$$Tra\_Void\_g(gg) = Tra\_Void\_g(gg) + Neg\_Item\_Amt$$

for values of gg ranging from 1 to the maximum values

$$Tra\_N\_Void = Tra\_N\_Void + 1$$

$$Tra\_Disc\_g(gg) = Tra\_Disc\_g(gg) + Neg\_Item\_Amt$$

for values of gg ranging from 1 to the maximum values

$$Tra\_N\_Disc = Tra\_N\_Disc + 1$$

[A041]

**For rectify option = NO and Negitems uplift:**

$$Tra\_Tot\_vg(vv,gg) = Tra\_Tot\_vg(vv,gg) + Neg\_Item\_Amt$$

for values of vv and gg ranging from 1 to the maximum values

$$Tra\_Uplf\_g(gg) = Tra\_Uplf\_g(gg) + Neg\_Item\_Amt$$

for values of gg ranging from 1 to the maximum values  
 $Tra\_N\_Uplf = Tra\_N\_Uplf + 1$

**For rectify option = YES and all Negitems except uplift:**

$Tra\_Tot\_vg(vv,gg) = Tra\_Tot\_vg(vv,gg) + Neg\_Item\_Amt$   
for values of vv and gg ranging from 1 to the maximum values

**According to the negative item type:**

$Tra\_Void\_g(gg) = Tra\_Void\_g(gg) - Neg\_Item\_Amt$   
for values of gg ranging from 1 to the maximum values

$Tra\_Disc\_g(gg) = Tra\_Disc\_g(gg) - Neg\_Item\_Amt$   
for values of gg ranging from 1 to the maximum values

[A041]

**For rectify option = YES and Negitems uplift:**

$Tra\_Tot\_vg(vv,gg) = Tra\_Tot\_vg(vv,gg) - Neg\_Item\_Amt$   
for values of gg ranging from 1 to the maximum values

$Tra\_Uplf\_g(gg) = Tra\_Uplf\_g(gg) - Neg\_Item\_Amt$   
for values of gg ranging from 1 to the maximum values

## 2.5.6.2 Rules

Records the amount of a negative item and prints a line containing the item description and item amount.

- A minus sign is printed for negative items with the Rectify option equal to NO.
- The Rectify option equal to YES allows modification or cancellation of a previous negative item operation.

The rectified value is added to the appropriate negative item category.

### 2.5.6.2.1 Arithmetic Pre-Checking

H93

- Negative Item Void for Enterprise A and B will be (sale - negitem void) greater than or equal to 0
- Negative Item Discount for Enterprise A and B will be (sale - negitem discount) greater than 0
- None of the negative or uplift item accumulators may be allowed to become negative as a result of the command or the command cannot be accepted.
- The string ÖSSZESEN in upper, lower or mixed case is not allowed in the description field of this command.

## 2.5.7 D4 - Total/Subtotal Printing

	BYTE	BIT	CONTENT	TYPE	LENGTH
	0-1		1B66 - cmd prefix	hex	2
	2		D4 – Total/Subtotal Printing	hex	1
H63	3		00	hex	1
	4-15		Amount	ASCII	12

### Notes:

#### 2.5.7.1 Calculations

$Tra\_Tot\_g(gg) = \text{Sum of } Tra\_Tot\_vg(vv,gg) \text{ by } vv$

for values of vv and gg ranging from 1 to the maximum values

$Tra\_Tot = \text{Sum of } Tra\_Tot\_g(gg) \text{ by } gg$

for values of gg ranging from 1 to the maximum values

$Tra\_Amt\_Due = Tra\_Tot$

#### 2.5.7.2 Rules

H95

- Verifies that the total amount accumulated by the fiscal unit matches the amount accumulated by the application program. If the total amount accumulated by the application program is different from the total amount accumulated by the fiscal unit the return code 24 is generated. After this error the application should cancel the transaction.
- Calculates transaction total and amount due.

## 2.5.8 D5 – Payment

	BYTE	BIT	CONTENT	TYPE	LENGTH
	0-1		1B66 - cmd prefix	hex	2
	2		D5 – Payment	hex	1
	3		Cmd Extension	hex	1
		7	Reserved	binary	
		6	Rectify 0 = NO 1 = YES	binary	
H7		5-2	Reserved	binary	
A123 A129		1	Payment Additional Description Line	binary	
A106 A116		0	Payment description 0 = Normal description 1 = Extended description	binary	
			If cmd.ext. Bit 0 = 0 and Bit 1 = 0		
	4-13		Description	ASCII	10
	14-25		Amount	ASCII	12
			If cmd.ext. Bit 0 = 1 and Bit 1 = 0		
	4-20		Description	ASCII	17
	21-32		Amount	ASCII	12
			If cmd.ext. Bit 1 = 1		
	4-47		Payment Additional Description Line	ASCII	44

### 2.5.8.1 Calculations

#### 2.5.8.1.1 Rectify = NO:

$Tra\_Amt\_Due = Tra\_Amt\_Due - Payment\_Amt$

#### 2.5.8.1.2 Rectify = YES:

$Tra\_Amt\_Due = Tra\_Amt\_Due + Payment\_Amt$

### 2.5.8.2 Rules

- Payment command (D5) starts the payment phase.
- When the command extension bit 1 is set, the 'payment additional description line' is printed (without payment amount)
- The 'payment additional description line' also starts the payment phase.
- The 'payment additional description line' can be printed during the payment phase.
- There are no limit to print 'payment additional description line'.

Once the payment phase has begun:

- The End Transaction / Normal Printing lines commands can be executed only if the total paid amount is greater than or equal to the transaction total.
- After 'CHANGE DUE' line is allowed to print 99 Normal Printing lines.
- When the End Transaction or Normal Printing lines command is issued no more 'payment additional description line' can be printed.
- The string ÖSSZESEN in upper, lower or mixed case is not allowed in the description field of this command.

## 2.5.9 D9 - Uplift/Discount on Subtotal

BYTE	BIT	CONTENT	TYPE	LENGTH
0-1		1B66 - cmd prefix	hex	2
2		D9 - Discount/Uplift Subtotal	hex	1
3		Cmd extension		1
	7	Reserved	binary	
	6	Rectify 0 = NO 1 = YES	binary	
	5	Item Group binary 0 = Primary group Enterprise A goods 1 = Secondary group Enterprise B goods		
	4-1	Reserved		
	0	Operation Type 0 = DISCOUNT ON SUBTOTAL 1 = UPLIFT ON SUBTOTAL	binary	
4-23		Description	ASCII	20
24-25		Reserved	ASCII	2
26-37		Amount	ASCII	12

### 2.5.9.1 Calculations

#### 2.5.9.1.1 Discount: (rectify = no):

H25  $Tra\_dsc\_amt\_vg(vv,gg) = TRUNC [(Amount \times Tra\_Tot\_vg(vv,gg))/Tra\_Tot\_g(gg)] + 0.5]$   
for values of vv ranging from 0 to 5  
The computation follows the highest remaining rule

$$Tra\_Tot\_vg(vv,gg) = Tra\_Tot\_vg(vv,gg) - Tra\_dsc\_amt\_vg(vv,gg)$$

for values of vv ranging from 0 to 5

$$Tra\_Tdsc\_g(gg) = Tra\_Tdsc\_g(gg) + Amount$$

$$Tra\_Tot\_g(gg) = Tra\_Tot\_g(gg) - Amount$$

#### 2.5.9.1.2 Discount: (rectify = yes):

H25  $Tra\_Tot\_vg(vv,gg) = Tra\_Tot\_vg(vv,gg) + Tra\_dsc\_amt\_vg(vv,gg)$   
for values of vv ranging from 0 to 5  
 $Tra\_Tdsc\_g(gg) = Tra\_Tdsc\_g(gg) - Amount$   
 $Tra\_Tot\_g(gg) = Tra\_Tot\_g(gg) + Amount$

Note: the Amount value should be the same with last DISCONT ON SUBTOTAL Amount value

#### 2.5.9.1.3 Uplift: (rectify = no):

H25  $Tra\_upl\_amt\_vg(vv,gg) = TRUNC [(Amount \times Tra\_Tot\_vg(vv,gg))/Tra\_Tot\_g(gg)] + 0.5]$   
for values of vv ranging from 0 to 5  
The computation follows the highest remaining rule

$$Tra\_Tot\_vg(vv,gg) = Tra\_Tot\_vg(vv,gg) + Tra\_upl\_amt\_vg(vv,gg)$$

for values of vv ranging from 0 to 5

$$Tra\_Tupl\_g(gg) = Tra\_Tupl\_g(gg) + Amount$$

$$Tra\_Tot\_g(gg) = Tra\_Tot\_g(gg) + Amount$$

#### 2.5.9.1.4 Uplift: (rectify = yes):

H25  $Tra\_Tot\_vg(vv,gg) = Tra\_Tot\_vg(vv,gg) - Tra\_upl\_amt\_vg(vv,gg)$   
for values of vv ranging from 0 to 5  
 $Tra\_Tupl\_g(gg) = Tra\_Tupl\_g(gg) - Amount$   
 $Tra\_Tot\_g(gg) = Tra\_Tot\_g(gg) - Amount$

Note: the Amount value should be the same with last UPLIFT ON SUBTOTAL Amount value

#### 2.5.9.2 Rules

This procedure is used to apply discount or uplift on subtotal.

- The string ÖSSZESEN in upper, lower or mixed case is not allowed in the description field of this command.
- The amount field must be greater than 0, otherwise return code 052 is issued.
- Discount on Subtotal for Enterprise A will be (sale - discount on subtotal) greater than or equal to 0
- Discount on Subtotal for Enterprise B will be (sale - discount on subtotal) greater than 0



## 2.6 Report Printing Commands

These are the report printing commands:

- (13) Daily closure (Z-Report)
- (DB) Electronic fiscal report
- (14) Summary fiscal report printing (X-Report)

There is one multi-day report printing command:

- (15) Print multi-day fiscal report (fiscal dump)

There are two commands that control application-originated reports:

- (DD) Start application-originated report
- (DE) End application-originated report

### 2.6.1 General Application-Originated Printing Rules

If a special printout format is available for an application-originated report, it will be defined in the section 'Format of Printouts for Hungary'.

#### 2.6.1.1 Inserted 'NOT FISCAL' Message Rules During a Application-Originated Report

- An application-originated report to the customer receipt station is preceded by an inserted 'NOT FISCAL' message.
- An application-originated report to the customer receipt station is ended by an inserted 'NOT FISCAL' message.
- In Hungary no count is kept of empty lines due to linefeed commands on the document insert for the purpose of inserting 'NOT FISCAL' messages.

## 2.6.2 13 - Daily Closure (Z-Report)

BYTE	BIT	CONTENT	TYPE	LENGTH
0-1		1B66 - cmd prefix	hex	2
2		13 – Close Sales Period	hex	1
3		Command Extension	hex	1
	7	Retry 0 – NO 1 – YES	binary	
	6-0	Reserved	binary	

### 2.6.2.1 Daily Closure (Z-Report) command Response Format

[A128]

#### Daily Closure (Z-Report) command Response Format for IBM 4610 SureMark Fiscal Printer KR3/KR5 (RS-485):

BYTE	BIT	CONTENT	TYPE	LENGTH	VARIABLE NAME
0-8		Fiscal Unit status	Hex	9	
9-30		Additional Information			(Note 1)

Note 1: See below the Additional Information Response.

#### Daily Closure (Z-Report) command Response Format for IBM 4610 SureMark Fiscal Printer KD3/KD5 (RS-232):

BYTE	BIT	CONTENT	TYPE	LENGTH	VARIABLE NAME
0-14		Fiscal Unit status	hex	15	
15-36		Additional Information			(Note 1)

Note 1: See below the Additional Information Response.

#### Additional Information Response:

BYTE RS-485	BYTE RS-232	BIT	CONTENT	TYPE	LENGTH
9	15		EJ Error	hex	1
10-21	16-27		Filename	ASCII	12 (Note 2)
22	28		File Attributes	hex	1 (Note 3)
23-24	29-30		File Last Modification Time	hex	2 (Note 4, 6)
25-26	31-32		File Last Modification Date	hex	2 (Note 5, 6)
27-30	33-36		File Length	hex	4 (Note 6)

Note 1: This field will be:

0 = file info returned

0x1B = no more files available

Note 2: Specified in normal DOS format (filename.ext) padded with spaces if necessary.

The file name format is “ssssc.ccc.EJ” where

ssss = the last four characters of the serial number

cccc = closure number

.EJ = extension

Note 3: Specified in normal DOS format.

Note 4: Specified in normal DOS format (hhhhmmmmmmsssss).

hhhhh = hours (0 to 23)

mmmmm = minutes (0 to 59)

sssss = seconds divided by 2 (0 to 29)

Note 5: Specified in normal DOS format (yyyyyyymmmddddd).

yyyyyy = year (1980 based)

mmmm = month (1 to 12)

dddd = day (1 to 31)

Note 6: Specified in INTEL format (LSB First) for DOS compatibility.

### 2.6.2.2 Calculations

[A059]

The following calculations are performed before printing the report and writing the fiscal memory:

$Lif\_N\_Clos = Lif\_N\_Clos + 1$

$Day\_N\_Slip = Day\_N\_Slip + 1$

$Lif\_N\_Slip = Lif\_N\_Slip + Day\_N\_Slip$

$Day\_N\_Fisc = Day\_N\_Fisc + 1$

$Day\_Tot\_g(gg) = \text{Sum of } Day\_Tot\_vg(vv,gg) \text{ by } vv$

for values of vv and gg ranging from 1 to the maximum values

$Gran\_Tot\_g(gg) = Gran\_Tot\_g(gg) + Day\_Tot\_g(gg)$

for values of gg ranging from 1 to the maximum value

**The following operations are performed after writing the fiscal memory:**

$Day\_Tot\_vg(vv,gg) = 0$

for values of vv and gg ranging from 1 to the maximum values

$Day\_Tot\_g(gg) = 0$

for values of gg ranging from 1 to the maximum value

$Day\_Void\_g(gg) = 0$

for values of gg ranging from 1 to the maximum value

$Day\_Disc\_g(gg) = 0$

for values of gg ranging from 1 to the maximum value

[A041]

$Day\_Up!f\_g(gg) = 0$

for values of gg ranging from 1 to the maximum value

$Day\_Notp = 0$

$Day\_Tdsc\_g(gg) = 0$

for values of gg ranging from 1 to the maximum value

$Day\_Tupl\_g(gg) = 0$

for values of gg ranging from 1 to the maximum value

$Day\_Canc\_g(gg) = 0$

for values of gg ranging from 1 to the maximum value

$Day\_RetV\_g(gg) = 0$

for values of gg ranging from 1 to the maximum value

**Clearing Daily Counters:**

*Day\_N\_Ract = 0*

*Day\_N\_Vouc = 0*

*Day\_N\_Fisc = 0*

*Day\_N\_Slip = 0*

*Day\_N\_Dump = 0*

*Day\_N\_Doc = 0*

*Day\_N\_CRFR = 0*

*Day\_N\_SJFR = 0*

*Day\_N\_DIFR = 0*

*Day\_N\_Chek = 0*

*Day\_N\_Void = 0*

*Day\_N\_Disc = 0*

[A041]

*Day\_N\_Uplf = 0*

*Day\_N\_Tdsc = 0*

*Day\_N\_Tupl = 0*

*Day\_N\_RetV = 0*

*Day\_N\_X = 0*

[A035]

*Day\_N\_Inv = 0*

*Day\_N\_Inv\_g(gg) = 0*

**2.6.2.3 Rules**

- Close Sales Period updates the fiscal memory if the fiscal printer has been placed in the fiscal mode of operation and generates the closure report.
- The data stored in the fiscal memory is defined in the individual country sections of this document under the heading 'Fiscal Memory Format'.
- If PLD occurs during a Closure Report, after IPL completion, the incomplete report will be cancelled and the report will be completely reprinted.

### 2.6.3 14 - Summary Fiscal Report (X-Report)

	BYTE	BIT	CONTENT	TYPE	LENGTH
	0-1		1B66 - cmd prefix	hex	2
	2		14 - Print X-Report/Daily Acc.	hex	1
H12	3		Command extension	hex	1
		7	Retry 0 – NO 1 – YES	binary	
H12		6 - 1	Reserved	binary	
H12		0	0 – Enterprise A 1 – Enterprise B	binary	

#### 2.6.3.1 Calculations

The calculations done during the Summary Fiscal Report (X-Report) are the same as those done during the Daily Closure command before the fiscal memory is written.

PLUS THE FOLLOWING IS ALSO DONE:

$$Day\_N\_X = Day\_N\_X + 1$$

AND THE FOLLOWING ARE **NOT** DONE:

$$Lif\_N\_Clos = Lif\_N\_Clos + 1$$

$$Lif\_N\_Slip = Lif\_N\_Slip + Day\_N\_Slip$$

The calculations done during the Daily Closure command (after the fiscal memory is written) are NOT done in the X-Report command.

## 2.6.4 DB - Electronic Fiscal Report

BYTE	BIT	CONTENT	TYPE	LENGTH
0-1		1B66 – command prefix	hex	2
2		DB – Electronic Fiscal Report	hex	1
3		Command Extension	hex	1
	7-1	Reserved		
	0	Read Accumulators and Counters		
4		Auxiliary Command Extension	hex	1
	7-1	Reserved		
	0	Read Accumulators and Counters 0 = Transaction 1 = Daily		
5		Enterprise (1 or 2)	ASCII	1

### 2.6.4.1 Electronic Fiscal Report Response Format (DB)

[A017]

#### Electronic Fiscal Rep. Response Format (DB) for IBM 4610 SureMark Fiscal Printer KR3/KR5 (RS-485):

BYTE	BIT	CONTENT	TYPE	LENGTH	VARIABLE NAME
0-8		Fiscal Unit status	hex	9	
9-255		Additional Information			(Note 1)

Note 1: See below the Additional Information Response.

#### Electronic Fiscal Rep. Response Format (DB) for IBM 4610 SureMark Fiscal Printer KD3/KD5 (RS-232):

BYTE	BIT	CONTENT	TYPE	LENGTH	VARIABLE NAME
0-14		Fiscal Unit status	hex	15	
15-261		Additional Information			(Note 1)

Note 1: See below the Additional Information Response.

#### Additional Information Response:

	BYTE RS-485	BYTE RS-232	BIT	CONTENT	TYPE	LENGTH	VARIABLE NAME
	9	15		DB – Record identification	hex	1	
H14	10-23	16-29		Request date and time (ddmmyyyy hh:mm)	ASCII	14	
	24	30		Return code 43 = Good completion	hex	1	
H118	25	31		Fiscal unit procedure in progress 00 = No procedure in progress 01 = Sales transaction in progress 02 = Reserved 03 = Reserved 04 = Reserved 05 = Application-originated report on CR in progress 07 = Application-originated report on DI for portrait document in progress 08 = Application-originated report on DI for landscape document in progress 09 = End NonFiscal in progress 0A = Cancel NonFiscal in progress	hex	1	

(DB Response continued on next page)

**Additional Information Response (continuation):**

	BYTE RS-485	BYTE RS-232	BIT	CONTENT	TYPE	LENGTH	VARIABLE NAME
	26	32		Sales transaction step		1	
			7	1 = Header printed	binary		
			6	1 = Fiscal voucher or simplified invoice started	binary		
			5	1 = Total requested	binary		
			4	1 = Payment in progress	binary		
			3	1 = End transaction in progress	binary		
			2	1 = Cancel transaction in progress	binary		
			1-0	Reserved = 0	binary		
	27	33		Fiscal unit mode		1	
			7	1 = Fiscal mode set	binary		
			6	Reserved			
			5	1 = Sales period in progress	binary		
			4-0	Reserved (set to 0)	binary		
	28			Reserved (set to 0)		1	
A071		34		Initialization State		1	
			7-6	Display Number to be sensed: 00 = No Display 01 = One Display 10 = Two Display (default) 11 = Reserved	binary	2	(Note 1)
			5-0	Reserved (set to 0)	binary	6	
	29-30	35-36		Reserved (set to 0)	hex	2	

Note 1:

**ONLY VALID FOR IBM 4610 SureMark Fiscal Printer KD3/KD5 (RS-232)**

The Display Number to sense by default is two (2). This value can be set with the xC4 (Fiscal Parameter Configuration) and can be changed x1A (Set Display Address) commands.

(DB Response continued on next page)



### 2.6.4.2 Response to the Option 0: Read Accumulators and Counters Command

Response to the Option 0: Read Accumulators and Counters command is formatted as follows:

IF AUX COMMAND EXTENSION BIT 0 = 0 ==> BYTES 31 TO XXX ARE SHOWN BELOW:  
TRANSACTION ACCUMULATORS AND COUNTERS

	BYTE RS-485	BYTE RS-232	BIT	CONTENT	TYPE	LENGTH	VARIABLENAME
<b>ACCUMULATORS</b>							
	31-36	37-42		Total	hex	6	Tra_Tot_g(gg) (Note 2)
	37-42	43-48		Reserved	hex	6	
H129 A047	43-48	49-54		Reserved	hex	6	
	49-66	55-72		Reserved	hex	18	
	67-72	73-78		VOIDS	hex	6	Tra_Void_g(gg)
	73-78	79-84		Reserved	hex	6	
	79-84	85-90		Discounts	hex	6	Tra_Disc_g(gg)
	85-96	91-102		Reserved	hex	12	
H77	97-102	103-108		Uplift	hex	6	Tra_Uplf_g(gg)
H15	103-108	109-114		Reserved	hex	6	
	109-114	115-120		Transaction Discounts on Subtotal	hex	6	Tra_Tdsc_g(gg)
	115-120	121-126		Transaction Uplifts on Subtotal	hex	6	Tra_Tupl_g(gg)
	121-125	127-131		Amount Due (signed)	hex	5	Tra_Amt_Due
H15	126-161	132-167		Total / VAT Category	hex	36	Tra_Tot_vg[vv][gg]
<b>COUNTERS</b>							
	162-179	168-185		Reserved	hex	18	
	180-181	186-187		VOIDED ITEMS	hex	2	Tra_N_Void
	182-183	188-189		Discounted Items	hex	2	Tra_N_Disc
	184-189	190-195		Reserved	hex	6	
H77	190-191	196-197		Uplifts	hex	2	Tra_N_Uplf
	192-193	198-199		Discounts on Subtotal	hex	2	Tra_N_Tdsc
	194-195	200-201		Uplifts on Subtotal	hex	2	Tra_N_Tupl
	196-207	202-213		Reserved	hex	12	
	208	214		Repair actions since last closure	hex	1	
	209-227	215-233		Reserved for additional counters	hex	19	

(DB Response continued on next page)

IF AUX COMMAND EXTENSION BIT 0 = 1 ==> BYTES 31 TO XXX ARE SHOWN BELOW:  
DAILY ACCUMULATORS AND COUNTERS

	BYTE RS-485	BYTE RS-232	BIT	CONTENT	TYPE	LENGTH	VARIABLENAME
<b>ACCUMULATORS</b>							
	31-36	37-42		Total	hex	6	Day_Tot_g(gg) (Note 3)
	37-42	43-48		Reserved	hex	6	
H129 A047	43-48	49-54		Reserved	hex	6	
	49-66	55-72		Reserved	hex	18	
	67-72	73-78		Voids	hex	6	Day_Void_g(gg)
	73-78	79-84		Reserved	hex	6	
	79-84	85-90		Discounts	hex	6	Day_Disc_g(gg)
	85-96	91-102		Reserved	hex	12	
H77	97-102	103-108		Uplift	hex	6	Day_Uplf_g(gg)
H15	103-108	109-114		Reserved	hex	6	
	109-114	115-120		Transaction Discounts on Subtotal	hex	6	Day_Tdsc_g(gg)
	115-120	121-126		Transaction Uplifts on Subtotal	hex	6	Day_Tupl_g(gg)
	121-125	127-131		Reserved	hex	5	
H15	126-161	132-167		Total / VAT Category	hex	36	Day_Tot_vg [vv][gg]
<b>COUNTERS</b>							
	162-163	168-169		Fiscal Voucher Counter	hex	2	Day_N_Vouc
	164-165	170-171		Total Slips Counter	hex	2	Day_N_Slip
	166-167	172-173		Total Application-Originated Reports	hex	2	Day_N_NFR
	168-169	174-175		Customer Receipt Application- Originated Reports	hex	2	Day_N_NFCR
	170-171	176-177		Reserved	hex	2	
	172-173	178-179		Document Insert Application- Originated Reports	hex	2	Day_N_NFDI
A033 A056	174-175	180-181		Number of simplified invoices printed	hex	2	Day_N_Inv
A033 A056	176-177	182-183		Number of simplified invoices printed by enterprise	hex	2	Day_N_Inv_g (gg)
A033 A056	178-179	184-185		Reserved	hex	2	
	180-181	186-187		Voided Items	hex	2	Day_N_Void
	182-183	188-189		Discounted Items	hex	2	Day_N_Disc
	184-189	190-195		Reserved	hex	6	
H77	190-191	196-197		Uplifts	hex	2	Day_N_Uplf
	192-193	198-199		Discounts on Subtotal	hex	2	Day_N_Tdsc
	194-195	200-201		Uplifts on Subtotal	hex	2	Day_N_Tupl
	196-197	202-203		Cancelled Transactions	hex	2	Day_N_Canc
	198-207	204-213		Reserved	hex	10	
	208	214		Repair actions since last closure	hex	1	
	209-227	215-233		Reserved for additional counters	hex	19	

(DB Response continued on next page)

LIFETIME ACCUMULATORS AND COUNTERS

---

	BYTE RS-485	BYTE RS-232	BIT	CONTENT	TYPE	LENGTH	VARIABLENAME
	228	234		Reserved	hex	1	
	229-236	235-242		Grand Total	hex	8	
	237-238	243-244		Last Closure Number	hex	2	
	239-240	245-246		Repair Actions	hex	2	
	241-244	247-250		Lifetime Voucher Counter	hex	4	

FIXED FIELDS

---

	BYTE RS-485	BYTE RS-232	BIT	CONTENT	TYPE	LENGTH	VARIABLENAME
	245	251		Reserved	Hex	1	
	246-255	252-261		Fiscal Printer Serial Number	ASCII	10	

**Notes:**

1. For all Type hex, hex data is in normal format, not byte switch format.
2. This value is calculated at the time the command is executed.  
 $Tra\_Tot\_g(gg) = \text{Sum of } Tra\_Tot\_vg(vv,gg) \text{ by } vv$
3. This value is calculated at the time the command is executed.  
 $Day\_Tot\_g(gg) = \text{Sum of } Day\_Tot\_vg(vv,gg) \text{ by } vv$

**2.6.4.3 Calculations**

There are no calculations for this command.

**2.6.4.4 Rules**

This command requests the fiscal unit to report the content of accumulators and counters.

## 2.6.5 15 - Print Multi-Day Fiscal Report (Fiscal Memory Dump)

	BYTE	BIT	CONTENT	TYPE	LENGTH
	0-1		1B66 - cmd prefix	hex	2
	2		15 - Dump Fiscal Memory	hex	1
	3		Cmd extension	hex	1
		7	Retry 0 – NO 1 – YES	binary	
H16		6-4	Reserved	binary	
H16		3	0 – Enterprise A 1 – Enterprise B	binary	
		2-0	Range 4 - Between Closure Numbers 2 - Between Closure Dates 1 - All Fiscal Memory	binary	
		If range = 1 specify:			
	4-19		Reserved	ASCII	16
	20-23		Reserved	ASCII	4
	24-31		Reserved	ASCII	8
		If range = 2 specify:			
	4-11		First Closure Date	ASCII	8 (Note 1)
	12-19		Last Closure Date	ASCII	8 (Note 1)
[A080]	20-23		Reserved	ASCII	4
	24-31		Reserved	ASCII	8
		If range = 4 specify:			
	4-7		First Closure Number	ASCII	4
	8-11		Last Closure Number	ASCII	4
	12-19		Reserved	ASCII	8
	20-23		Reserved	ASCII	4
	24-31		Reserved	ASCII	8

### Notes:

1. Date strings must be formatted as: ddmmyyyy where: dd = day, mm = month, yyyy = year.

### 2.6.5.1 Calculations

#### 2.6.5.1.1 Successful completion of command:

$Day\_N\_Dump = Day\_N\_Dump + 1$

$Day\_N\_Fisc = Day\_N\_Fisc + 1$

$Day\_N\_Slip = Day\_N\_Slip + 1$

$Lif\_N\_Dump = Lif\_N\_Dump + 1$

### 2.6.5.2 Rules

- Fiscal memory content can be printed on customer receipt station using Dump Fiscal Memory command.
- There was at least one daily closure.

## 2.6.6 DD - Start Application-Originated Report

	BYTE	BIT	CONTENT	TYPE	LENGTH
	0-1		1B66 – command prefix	hex	2
	2		DD - Start Application-Originated Report	hex	1
	3		Command extension		1
		7-2	Reserved	binary	
H17		1-0	Station selection 00 = Start Application-Originated Report on CR 10 = Start Application-Originated Report on DI – Portrait 11 = Start Application-Originated Report on DI – Landscape	binary	

### 2.6.6.1 Calculations

There are no calculations for this command.

### 2.6.6.2 Rules

The execution of the Start Application-Originated Report command sets the fiscal unit into the Application-Originated Report in Progress

## 2.6.7 DE - End Application-Originated Report

H115

BYTE	BIT	CONTENT	TYPE	LENGTH
0-1		1B66 – command prefix	hex	2
2		DE - End Application-Originated Report	hex	1
3		Command extension	hex	1
	7	Retry 0 – NO 1 – YES		
	6-1	Reserved		
	0	Cancel 0- End Application Originated Report 1- Cancel Application Originated Report		Note

**Note:**

If Cancel = 0 and FCANNON is ON RC = 188 is returned.

If Cancel = 1 and FENDNON is ON RC = 187 is returned.

### 2.6.7.1 Calculations

#### 2.6.7.1.1 Customer Receipt Application-Originated Report Calculations

$H78 \text{ Day}_N \text{ Slip} = \text{Day}_N \text{ Slip} + 1$

#### 2.6.7.1.2 Document Insert Application-Originated Report Calculations

There are no calculations for this command.

## 2.7 Printer commands

### 2.7.1 EA - Normal Printing Lines on CR Station (Fiscal Printer Format)

This command is used to print free lines on CR station.

#### 2.7.1.1 Command Format

	BYTE	BIT	CONTENT	TYPE	LENGTH
	0-1		1B66 – Cmd Prefix	hex	2
	2		EA - Normal Printing Lines on CR Station	hex	1
	3		Cmd Extension	hex	1
		7-6	Reserved		
H8		5-3	Print typeface 000 = 44 char / line 001 = 38 char / line 010 = 48 char / line 011 = 44 char / line double-high 100 = 44 char / line emphasized 101 = 38 char / line emphasized 110 = 48 char / line emphasized 111 = 44 char / line double-high, emph.	binary	
		2-0	Number of Line Feed (min 1, max 7)		
H8	4-51		Print Data	ASCII	48

#### 2.7.1.2 Rules

[A036] [A049] [A086] [A093]

- The string ÖSSZESEN in upper, lower or mixed case is not allowed in the description field of this command.
- During a fiscal voucher, only 99 normal print lines during payment phase are allowed.

## 2.7.2 EB – Application – Originated Printing on DI Station (Fiscal Printer Format)

### 2.7.2.1 Command Format

	BYTE	BIT	CONTENT	TYPE	LENGTH
	0-1		1B66 – Cmd Prefix	hex	2
	2		EB – Norm. Print on DI – Extended	hex	1
	3		Cmd Extension	hex	1
		7-6	Reserved	bin	
		5-3	Print typeface	bin	
			000 Print @ 15 CPI		
			001 Print @ 12 CPI		
H11			010 Print @ 17 CPI		
			011 Print @ 15 CPI double high		
			100 Print @ 15 CPI emphasized		
			101 Print @ 12 CPI emphasized		
H11			110 Print @ 17 CPI emphasized		
			111 Print @ 15 CPI double high, emphasized		
		2 - 0	Reserved	bin	
	4-89		Description	ASCII	86

### 2.7.2.2 Rules

- The string ÖSSZESEN in upper, lower or mixed case is not allowed in the description field of this command.



### 2.7.3 EC - Line Feed

This command is used to feed the paper a specified number of lines on CR or DI station.

#### 2.7.3.1 Command Format

BYTE	BIT	CONTENT	TYPE	LENGTH
0-1		1B66 – Cmd Prefix	hex	2
2		EC - Line Feed	hex	1
3		Cmd Extension	hex	1
	7-6	Reserved		
	5-4			
		00	CR	
		10	DI – Forward	
	3-0	Number of Line Feed (min 0, max 15)		

## 2.7.4 ED - Ready Document

This command is used to request the printer to advance the inserted document to the first print position no matter how the paper was inserted.

### 2.7.4.1 Command Format

BYTE	BIT	CONTENT	TYPE	LENGTH
0-1		1B66 – Cmd Prefix	hex	2
2		ED - Ready Document	hex	1
3		Cmd Extension 00 = Ready Document		

## 2.7.5 EF - Document Eject

This command is used to request the printer to line feed a document (on DI station) until it is completely ejected.

### 2.7.5.1 Command Format

BYTE	BIT	CONTENT	TYPE	LENGTH
0-1		1B66 – Cmd Prefix	hex	2
2		EF - Document Eject	hex	1
3		Cmd Extension 00 = Forward 01 = Reverse	hex	1

## 2.7.6 F4 - Home Position & Open/Close 4610 Throat

This command is used to requests the printer to return the print head to center or left home position and to open or close the 4610 throat.

### 2.7.6.1 Command Format

BYTE	BIT	CONTENT	TYPE	LENGTH
1		1B66 – Cmd Prefix	hex	2
2		F4 - Home Position & Open/Close 4610 Throat	hex	1
3		Cmd Extension	hex	1
	7-2	Reserved		
	1-0	Home Position & Open/Close 4610 Throat 00 = Home Position – Center 01 = Home Position – Left 02 = Open 4610 Throat 03 = Close 4610 Throat (Note 2)		(Note 1) (Note 2)

Note 1: Open 4610 throat to insert a document in DI station by the side.

Note 2: Close 4610 throat to print a document in DI station inserted by the side.

## 2.8 Check printing commands

### 2.8.1 DC - MICR Read

This command reads the checks magnetic ink data and returns it as part of the command response.

#### 2.8.1.1 Command Format

BYTE	BIT	CONTENT	TYPE	LENGTH
0-1		1B66 - Cmd Prefix	hex	2
2		DC – MICR Read	hex	1
3		00 – Cmd Extension	hex	1

Response to the MICR Read command will be formatted as follows :

#### 2.8.1.2 MICR Read command Response Format

[A018]

**MICR Read command Response Format for IBM 4610 SureMark Fiscal Printer KR3/KR5 (RS-485):**

BYTE	BIT	CONTENT	TYPE	LENGTH	VARIABLE NAME
0-8		Fiscal Unit status	hex	9	
9-89		Additional Information			(Note 1)

Note 1: See below the Additional Information Response.

**MICR Read command Response Format for for IBM 4610 SureMark Fiscal Printer KD3/KD5 (RS-232):**

BYTE	BIT	CONTENT	TYPE	LENGTH	VARIABLE NAME
0-14		Fiscal Unit status	hex	15	
15-95		Additional Information			(Note 1)

Note 1: See below the Additional Information Response.

#### Additional Information Response:

BYTE RS-485	BYTE RS-232	BIT	CONTENT	TYPE	LENGTH
9	15		DC – MICR Read	hex	1
10-23	16-29		Request Date and Time (ddmmyyyy hh:mm)	ASCII	14 (Note 1)
24	30		Return code 43 = Good Completion	hex	1
25-89	31-95		MICR Read	ASCII	65 (Note 2)

Note 1: When DST (Daylight Savings Time) is active, the time format will be hhmmV.

Note 2: This is the maximum data length that could be returned by the fiscal printer. Always the data is padded to right with 0 hex.

## 2.8.2 C0 - Load Check Data

The load check data is used to load check information.

### 2.8.2.1 Command Format

BYTE	BIT	CONTENT	TYPE	LENGTH
0-1		1B66 - Cmd Prefix	hex	2
2		C0 – Load Check Data	hex	1
3		Cmd Extension	hex	1
		00 = Check Layout - Load Field Co-ordinates (Mandatory) 01 = Load Amount (Mandatory) 02 = Load Receiver Name (Mandatory) 03 = Load Place and Date (Mandatory) 04 = Load Additional Information Line 1 (Optional) 05 = Load Additional Information Line 2 (Optional)		
		If Cmd Extension = 00, specify:		
4-10		Amount (in numbers) Co-ordinates	ASCII	7 (Note 1)
11-17		Amount (in letters) Co-ordinates – 1 <sup>st</sup> . Line	ASCII	7 (Note 1)
18-24		Amount (in letters) Co-ordinates – 2 <sup>nd</sup> . Line	ASCII	7 (Note 1)
25-31		Receiver Name Co-ordinates	ASCII	7 (Note 1)
32-38		Place and Day Co-ordinates	ASCII	7 (Note 1)
39-45		Month Co-ordinates	ASCII	7 (Note 1)
46-52		Year Co-ordinates	ASCII	7 (Note 1, 7)
53-59		Additional Information Line 1 Co-ordinates (Optional)	ASCII	7 (Note 1, 2)
60		Check Side Additional Information Line 1 (Optional) 0 = Front 1 = Reverse	ASCII	1
61-67		Additional Information Line 2 Co-ordinates (Optional)	ASCII	7 (Note 1, 2)
68		Check Side Additional Information Line 2 (Optional) 0 = Front 1 = Reverse	ASCII	1
		If Cmd Extension = 01, specify:		
4-13		Amount	ASCII	10 (Note 3)
		If Cmd Extension = 02, specify:		
4-89		Receiver Name	ASCII	86 (Note 4, 6)
		If Cmd Extension = 03, specify:		
4-33		Place	ASCII	30 (Note 4)
34-41		Date (ddmmyyyy)	ASCII	8 (Note 5)
		If Cmd Extension = 04, specify:		
4-63		Additional Information Text - Line 1	ASCII	60 (Note 6)
		If Cmd Extension = 05, specify:		
4-63		Additional Information Text - Line 2	ASCII	60 (Note 6)

Note : If the string sent is longer than the field length specified, an error will be returned.

Note 1: Co-ordinates are specified relative to the printing area (see below) in the following way:

Bytes:

0-1 X-co-ordinate (positive) from left edge (LE) of the printing area in characters  
(1 character = approx. 1/15 inch, up to 86).

2-4 Y-co-ordinate (positive) from bottom edge (BE) of the printing area in motor steps  
(1 step = 1/127 inch or 1/5 mm, up to 999).

5-6 Field length (FL) in characters from X-co-ordinate.

The printing area includes all the area inside the following margins (considering the check in the normal orientation for read):

Left Margin: approx. 35 mm

Right Margin: approx. 10 mm

Bottom Margin: approx. 17 mm.

Top Margin: there is no margin.

Warning: If a line runs out of this printing area over the right margin, the rest of the line will be printed beginning from the left in the same line.

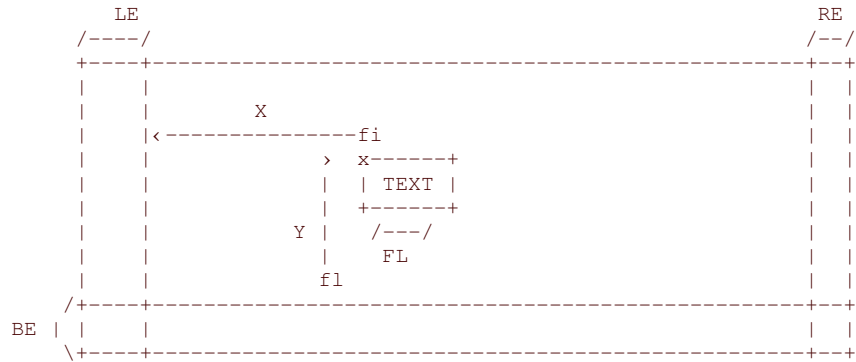

Note 2: If a line longer than 60 characters is desired, the second can be specified adjacent to the line 1 field.

Note 3: This field can not be blank or have the value zero.

Note 4: This field can not be blank.

Note 5: Date will be validated by the command.

Note 6: The maximum length depends on the value loaded as field length in their respective co-ordinates (loaded with cmd extension 00).

Note 7: The field length values can be 02 or 04 only.

Note 8: If additional information is directed to the reverse side of the check, an eject will take place after the printing of the front side.

### 2.8.2.2 Rules

- The Check Layout - Load Field Co-ordinates (cmd extension 00) has to be loaded first.
- The cmd extensions 00, 01, 02 and 03 with valid data have to be executed in order to print the check via command C1 (Print Loaded Check). This condition will be discarded after printing or cancelling the check.

## 2.8.3 C1 - Print Loaded Check

This command prints the already loaded check information with C0 command and restores the conditions previous to the C0 command issuing.

### 2.8.3.1 Command Format

BYTE	BIT	CONTENT	TYPE	LENGTH
0-1		1B66 - Cmd Prefix	hex	2
2		C1 - Print Loaded Check	hex	1
3		Check Side 00 = Front 01 = Reverse	hex	1

### 2.8.3.2 Rules

- All printing will be done at approx. 15 CPI, single height, single wide.
- After the literal amount is printed, the rest of the line will be filled with the characters 'x' (ASCII 20).
- After printing all the information, an eject will take place.



## 2.8.4 C2 - Cancel Loaded Check

This command discards the already loaded check information with C0 command and restores the conditions previous to the C0 command issuing.

### 2.8.4.1 Command Format

BYTE	BIT	CONTENT	TYPE	LENGTH
0-1		1B66 - Cmd Prefix	hex	2
2		C2 - Cancel Loaded Check	hex	1
3		Cmd Extension	hex	1

### 2.8.4.2 Rules

There are not rules for this command.

## 2.8.5 C3 - Flip Check

This command is used to flip automatically the check to print the reverse side.

### 2.8.5.1 Command Format

BYTE	BIT	CONTENT	TYPE	LENGTH
0-1		1B66 - Cmd Prefix	hex	2
2		C3 - Flip Check	hex	1
3		Cmd Extension	hex	1

### 2.8.5.2 Rules

- Specifications for documents that can be flipped (refer to 4610 User's Guide)
  - Minimum form length: 80 mm (3.14 in.)
  - Maximum form length: 223 mm (8.78 in.)
  - Maximum form width: 102 mm (4 in.)
  - Paper weight : 75-95 g/m<sup>2</sup>

## 2.9 Barcode printing commands

### 2.9.1 C8 - Set Barcode Size

#### 2.9.1.1 Command Format

BYTE	BIT	CONTENT	TYPE	LENGTH
0-1		1B66 - Cmd Prefix	hex	2
2		C8 - Barcode Size Set	hex	1
3		00 - Cmd Extension	hex	1
4		Barcode Width	ASCII	1 (Note 1)
5-7		5-7 Barcode Height	ASCII	3 (Note 2)

Note 1: Horizontal magnification of the line width in the barcode.

Minimum = 2

Maximum = 4

Note 2: The dot height of the barcode.

Minimum = 001

Maximum = 255

#### 2.9.1.2 Rules

- Horizontal default magnification of the line width is 3.
- The dot height default is 162.

## 2.9.2 C9 - Print Barcode

### 2.9.2.1 Command Format

BYTE	BIT	CONTENT	TYPE	LENGTH
0-1		1B66 - Cmd Prefix	hex	2
2		C9 - Print Barcode	hex	1
3		Cmd Extension	hex	1
	7	Reserved		
	6	HRI font 1 = 12 CPI 0 = 15 CPI		(Note 1)
	5-4	HRI location 11 = both above and below the barcode 10 = below the barcode 01 = above the barcode 00 = not printed		(Note 2)
	3-0	Barcode Type 1111 = Reserved 1110 = Reserved 1101 = Reserved 1100 = Reserved 1011 = Reserved 1010 = Reserved 1001 = Reserved 1000 = CODE93 0111 = CODE128 0110 = CODABAR 0101 = ITF 0100 = CODE39 0011 = JAN8 0010 = JAN13 0001 = UPC_E 0000 = UPC_A		
4-n		Barcode Data	ASCII	n (Note 3)

Note 1: The Human Readable Characters font, if it must be printed

Note 2: Printing Position of the Human Readable Characters

Note 3: Data to be encoded in the barcode. The data must be null terminated and each barcode type has it's own rules.

#### 2.9.2.2 Rules

There are not rules for this command.

## 2.10 Attached Devices commands

(ONLY VALID FOR IBM 4610 SureMark Fiscal Printer KD3/KD5 (RS-232))

[A133]

### 2.10.1 CC – User NVRAM Management

#### 2.10.1.1 Command Format

BYTE	BIT	CONTENT	TYPE	LENGTH
0-1		1B66 - Cmd Prefix	hex	2
2		CC – User NVRAM Management	hex	1
3		Command Extension 00 = Read NVRAM 01 = Write NVRAM	hex	1
4-8		Offset	ASCII	1 (Note 1)
9-11		Length	ASCII	1 (Note 1)
		For Command Extension = 00		
12- (n+11)		Data to write		1 (Note 2)

Note 1: The Offset and the Length are represented as decimal values, and the valid ranges are the following:

- $0 < \text{Length} \leq 128$
- $0 \leq \text{Offset} \leq 4095$
- $\text{Offset} + \text{Length} \leq 4096$

Note 2:

- $1 \leq n \leq 128$
- If the length of the data to write sent (n) is less than the number specified in the length parameter then, the RC = 55 is returned

[A138]

- This writing NVRAM area is not deleted by the Full J4 (CE) Jumper procedure.

**Response to the ‘Read NVRAM’ (cmd.ext. = 00) will be formatted as follows:**

BYTE	BIT	CONTENT	TYPE	LENGTH
0-14		Fiscal Unit Status	hex	15
15- (n+14)		Data read	hex	n (Note 1)

[A015]

## 2.10.2 CD – Cash Drawer Management

### 2.10.2.1 Command Format

BYTE	BIT	CONTENT	TYPE	LENGTH
0-1		1B66 - Cmd Prefix	hex	2
2		CD - Cash Drawer Management	hex	1
3		Cmd Extension 00 = Open Cash Drawer 01 = Get Cash Drawer Status	hex	1
		For Command Extension = 00		
4		Cash Drawer Number	hex	1 (Note 1)
5		Pulse width on time	hex	1 (Note 2)
6		Pulse width off time	hex	1 (Note 2)

Note 1: Valid numbers are: 0 or 1.

Note 2: The number given in this field should be multiplied by 2 in order to get the pulse width on/off time in milliseconds.

Valid range: from x0 to xFF.

**Response to the Cash Drawer Management command for Get Cash Drawer Status (cmd.ext. = 01) will be formatted as follows:**

BYTE	BIT	CONTENT	TYPE	LENGTH
0-14		Fiscal Unit Status	hex	15
15		Cash Drawer Status 00 = Open 01 = Close	hex	1

## 2.10.3 CE - Attached Display Management

[A030]

### 2.10.3.1 Command Format

BYTE	BIT	CONTENT	TYPE	LENGTH
0-1		1B66 – Cmd Prefix	hex	2
2		CE Cmd – Attached Display Management	hex	1
3		Cmd Extension 00 = Disable polling to attached displays 01 = Enable polling to attached display 1 02 = Enable polling to attached display 2 03 = Get communication state with attached displays 04 = Scan for Attached Displays 06 = Write to Attached Display 1 07 = Write to Attached Display 2 08 = Read from Attached Display 1 09 = Read from Attached Display 2	hex	1 (Note 1)
		If Cmd. Extension = 01 or 02 specify		
4		SIO address of attached display	hex	1
		If Cmd. Extension = 06 or 07 specify	hex	1
4		Length to write	hex	1
5-(n+4)		Data to write	hex	n (Note 2)

[A072]

Note 1:

#### **ONLY VALID FOR IBM 4610 SureMark Fiscal Printer KD3/KD5 (RS-232)**

- If cmd.extension = 00 (Disable polling to attached displays) and the Displays Number to Sense (xC4 and x1A commands) is two (2) then,  
the Disable polling is not allowed and return RC = 131
- If cmd.extension = 01 (Enable polling to attached display 1) and the Displays Number to Sense (xC4 and x1A commands) is two (2) or one (1) then,  
the Enable polling to display 1 is not allowed and return RC = 131
- If cmd.extension = 02 (Enable polling to attached display 2) and the Displays Number to Sense (xC4 and x1A commands) is two (2) then,  
the Enable polling to display 2 is not allowed and return RC = 131

Note 2: 1 =< n =< 255

**Response to the 'Get communication state with attached displays' (cmd.ext. = 03) will be formatted as follows:**

BYTE	BIT	CONTENT	TYPE	LENGTH
0-14		Fiscal Unit Status	hex	15
15		Attached Display 1 SIO Address	hex	1
16-17		Attached Display 1 Serial Port Flags	hex	2 (Note 1)
18		Attached Display 2 SIO Address	hex	1
19-20		Attached Display 2 Serial Port Flags	hex	2 (Note 1)

Note 1: Attached Display n Serial Port Flags:

Where,

If byte 16 or 17 then n = 1

If byte 19 or 20 then n = 2

BYTE BIT CONTENT

16/19

```

7 Attached Display n Serial Request (Msg.Received)
6 Attached Display n Message to be Transmitted
5 Timeout Expired- ReXmit Message to Attached Display n
4 Major Communication Error to Attached Display n
3 Indicates Attached Display n wasn't reset
2 Send I-Frame to Attached Display n (For DWAIT Setting)
1 Reserved
0 Reserved

```

17/20

```

7 Attached Display n Serial Link Active
6 Attached Display n SNRM Response pending
5 Attached Display n Message ACK pending
4 Attached Display n Message from XMPRT1 to be transmitted
3 Attached Display n Address has been received
2 Reserved
1 Attached Display n Message received
0 Reserved

```

**Response to the 'Scan for Attached Displays' (cmd.ext. = 04) will be formatted as follows:**

BYTE	BIT	CONTENT	TYPE	LENGTH
0-14		Fiscal Unit Status	hex	15
15		Attached Display 1 SIO Address	hex	1
16		Attached Display 2 SIO Address	hex	1

**Response to the 'Read from Attached Display 1/2' (cmd.ext. = 08/09) will be formatted as follows:**

BYTE	BIT	CONTENT	TYPE	LENGTH
0-14		Fiscal Unit Status	hex	15
15		Length of data received	hex	1
16-(n+15)		Data read	hex	n (Note 1)

Note 1: 0 =< n =< 255



## 2.11 Electronic Journaling Commands

### 2.11.1 60 - Open Compact Flash File

This command is used to specify the CF file that is necessary to begin to read.

#### 2.11.1.1 Command Format

BYTE	BIT	CONTENT	TYPE	LENGTH
0-1		1B66 – Cmd Prefix	hex	2
2		60 – Open Compact Flash File	hex	1
3		00 - Cmd Extension	hex	1
4-15		Filename	ASCII	12

#### 2.11.1.2 Rules

[A120]

- The filename specified must be in normal DOS format (filename.ext). The period (.) must be included if an extension is used.
- The file name format is “sssscxxx.EJ” where  
ssss = the last four characters of the serial number  
cccc = closure number  
.EJ = extension
- The filename field must be right padded with spaces. e.g. "sssscxxx.EJ "

## 2.11.2 61 - Close Compact Flash File

This command is used to close the CF file that is currently been read.

### 2.11.2.1 Command Format

BYTE	BIT	CONTENT	TYPE	LENGTH
0-1		1B66 – Cmd Prefix	hex	2
2		61 - Close Compact Flash File	hex	1
3		00 - Cmd Extension	hex	1

### 2.11.2.2 Rules

There are not rules for this command.

### 2.11.3 62 - Read Compact Flash File

This command is used to read the CF file opened with Open Compact Flash File (60 cmd.)

#### 2.11.3.1 Command Format

BYTE	BIT	CONTENT	TYPE	LENGTH
0-1		1B66 – Cmd Prefix	hex	2
2		62 – Read Compact Flash File	hex	1
3		00 – Cmd Extension	hex	1
4-7		Sequence	hex	4 (Note 1)

Response to the Read Compact Flash File command will be formatted as follows:

#### 2.11.3.2 Read Compact Flash File command Response Format

[A019]

**Read Compact Flash File command Response Format for IBM 4610 SureMark Fiscal Printer KR3/KR5 (RS-485):**

BYTE	BIT	CONTENT	TYPE	LENGTH	VARIABLE NAME
0-8		Fiscal Unit status	hex	9	
9-138		Additional Information			(Note 1)

Note 1: See below the Additional Information Response.

**Read Compact Flash File command Response Format for IBM 4610 SureMark Fiscal Printer KD3/KD5 (RS-232):**

BYTE	BIT	CONTENT	TYPE	LENGTH	VARIABLE NAME
0-14		Fiscal Unit status	hex	15	
15-144		Additional Information			(Note 1)

Note 1: See below the Additional Information Response.

#### Additional Information Response:

BYTE RS-485	BYTE RS-232	BIT	CONTENT	TYPE	LENGTH
9-10	15-16		Length Read	hex	2 (Note 1)
11-138	17-144		Bytes read from the file	hex	128 (Note 2)

Note 1: Specified in Motorola format (MSB first).

Note 2: If length read < 128, the end of file was reached and bytes beyond length read are not meaningful.

### 2.11.3.3 Rules

- This command reads always in 128 byte blocks.
- The first time after an Open CF File (60 cmd.), sequence must be 0.
- Later, the sequence can be:
  - 0 = reads the first block
  - n = read again the last block read
  - n + 1 = read the block following the last block read
- Length read will be between 0 and 128.
- If length read is less than 128, the end of file was reached.

## 2.11.4 63 - Get Extended EJ Error

This command is used to get the extended EJ error.

Due to the limited number of return codes available, all commands that fails due to a problem related with EJ, just fail returning a general EJ error "84".

If the application needs to know the reason for failure, it must send this command. To know the meaning of a particular EJ error, refer to 3.1.5 Electronic Journal Return Codes, on page 151.

### 2.11.4.1 Command Format

BYTE	BIT	CONTENT	TYPE	LENGTH
0-1		1B66 – Cmd Prefix	hex	2
2		63 – Get Extended EJ Error	hex	1
3		00 – Cmd Extension	hex	1

Response to the Get Extended EJ Error command will be formatted as follows:

### 2.11.4.2 Get Extended EJ Error command Response Format

[A020]

**Get Extended EJ Error command Response Format for IBM 4610 SureMark Fiscal Printer KR3/KR5 (RS-485):**

BYTE	BIT	CONTENT	TYPE	LENGTH	VARIABLE NAME
0-8		Fiscal Unit status	Hex	9	
9-10		Additional Information			(Note 1)

Note 1: See below the Additional Information Response.

**Get Extended EJ Error command Response Format for IBM 4610 SureMark Fiscal Printer KD3/KD5 (RS-232):**

BYTE	BIT	CONTENT	TYPE	LENGTH	VARIABLE NAME
0-14		Fiscal Unit status	hex	15	
15-16		Additional Information			(Note 1)

Note 1: See below the Additional Information Response.

### Additional Information Response:

BYTE RS-485	BYTE RS-232	BIT	CONTENT	TYPE	LENGTH
9	15		Extended EJ Error	hex	1
10	16		Extended EJ Error Subcode	hex	1 (Note 1)

Note 1: This subcode is used to identify the different situations when the same extended EJ error is returned.

### 2.11.4.3 Rules

There are not rules for this command.

## 2.11.5 65 - Get Compact Flash Directory

This command is used to retrieve the CF directory.

### 2.11.5.1 Command Format

BYTE	BIT	CONTENT	TYPE	LENGTH
0-1		1B66 – Cmd Prefix	Hex	2
2		65 – Get Compact Flash Directory	Hex	1
3		Cmd Extension 00 = Find First 01 = Find Next	Hex	1
		If Cmd Extension = 00 specify:		
4-15		Filename	ASCII	12
16		Arch Attribute State 0 = Clear 1 = Set 2 = Both	Hex	1

Response to the get compact flash directory command will be formatted as follows:

### 2.11.5.2 Get compact flash directory command Response Format

[A021]

**Get compact flash directory command Response Format for IBM 4610 SureMark Fiscal Printer KR3/KR5 (RS-485):**

BYTE	BIT	CONTENT	TYPE	LENGTH	VARIABLE NAME
0-8		Fiscal Unit status	Hex	9	
9-30		Additional Information			(Note 1)

Note 1: See below the Additional Information Response.

**Get compact flash directory command Response Format for IBM 4610 SureMark Fiscal Printer KD3/KD5 (RS-232):**

BYTE	BIT	CONTENT	TYPE	LENGTH	VARIABLE NAME
0-14		Fiscal Unit status	hex	15	
15-36		Additional Information			(Note 1)

Note 1: See below the Additional Information Response.

### Additional Information Response:

BYTE RS-485	BYTE RS-232	BIT	CONTENT	TYPE	LENGTH
9	15		EJ Error	hex	1
10-21	16-27		Filename	ASCII	12 (Note 2)
22	28		File Attributes	hex	1 (Note 3)
23-24	29-30		File Last Modification Time	hex	2 (Note 4, 6)
25-26	31-32		File Last Modification Date	hex	2 (Note 5, 6)
27-30	33-36		File Length	hex	4 (Note 6)

Note 1: This field will be:

0 = file info returned

0x1B = no more files available

Note 2: Specified in normal DOS format (filename.ext) padded with spaces if necessary.

The file name format is “sssscccc.EJ” where

ssss = the last four characters of the serial number

cccc = closure number  
.EJ = extension

Note 3: Specified in normal DOS format.

Note 4: Specified in normal DOS format (hhhhmmmmsssss).  
hhhhh = hours (0 to 23)  
mmmmmm = minutes (0 to 59)  
sssss = seconds divided by 2 (0 to 29)

Note 5: Specified in normal DOS format (yyyyymmddddd).  
yyyyyy = year (1980 based)  
mmmm = month (1 to 12)  
dddd = day (1 to 31)

Note 6: Specified in INTEL format (LSB First) for DOS compatibility.

### 2.11.5.3 Rules

- The normal use will be to send a find first option followed by successive calls to find next until it returns EJ Error 27 (hex 1B).  
In this case, the RC will be 67, because this is not really an error, just a message to signal that no more files are available.
- There is only a root directory in the CF. No support for subdirectories is available.
- The filename specified must be in normal DOS format (filename.ext). The period (.) must be included if an extension is used.
- If less than 12 chars are used in Filename field, it must be right padded with spaces. e.g. "EJDATA.TXT "
- Wildcards (\*) and (?) can be used as usual in DOS. e.g. "EJ\*.T?? "
- The arch attribute state can be used to restrict the search only to the files with the arch attribute in the specified condition.
- Find first will retrieve data related with the first file in the directory that matches the filename and attribute requested.
- Find next will retrieve successive files matching the filename and attribute specified in find first.

## 2.11.6 66 - Set Public and Private Key

This command is used to set the public and private key used to sign EJ files.

### 2.11.6.1 Command Format

BYTE	BIT	CONTENT	TYPE	LENGTH
0-1		1B66 – Cmd Prefix	hex	2
2		66 - Set Public and Private Key	hex	1
3		Cmd Extension 00 = First 01 = Next 02 = Last 03 = Unique 04 = Key Freezing (H119)	Hex	1
		For Cmd Extension = 00		(Note 2)
4-5		Length	hex	2
6-69		Data	hex	64
		For Cmd Extension = 01		
4-67		Data	hex	64
		For Cmd Extension = 02		
4-67		Data	hex	64 (Note 1)
		For Cmd Extension = 03		
4-5		Length	hex	2
6-69		Data	hex	64 (Note 1)

Note 1: The remainder data bytes are sent. This is up to 64 bytes.

Note 2. After Key Freezing command execution the following Set Key commands are refused by an EJ\_KEY\_FREEZED EJ error.

### 2.11.6.2 Rules

- This command must be issued before the fiscal printer serialization (1B command).
- Key Length vs. Cmd. Extension
  - 64 bytes < Key length <= 128 bytes ---> first and last (00 and 02 cmd. ext.) are used.
  - Key length > to 128 bytes ---> first, next ... next and last (00, 01..01 and 02 cmd.ext.) are used.
  - Key length <= to 64 bytes ---> unique (03 cmd.ext.) is used.
- Currently only the DSA 512 bits (Digital Signature Algorithm) is supported (defined in the document FIPS PUB 186-1). In this case, the key must be specified in the following way:
  - Length = 00E9h (constant)
  - Data
    - Key Type (1 byte) = 01h (DSA 512 bits)
    - Subprime (20 bytes)
    - Prime (64 bytes)
    - Base (64 bytes)
    - Public Key (64 bytes)
    - Private Key (20 bytes)
- If a PLD occurs before the complete sequence is sent, the command must be reissued beginning from first.



## 2.11.7 67 - Get Public Key

This command is used to get the public key.

### 2.11.7.1 Command Format

BYTE	BIT	CONTENT	TYPE	LENGTH
0-1		1B66 – Cmd Prefix	hex	2
2		67 - Get Public Key	hex	1
3		Cmd Extension 00 = First 01 = Next	hex	1
		For Cmd Extension = 00		
4-5		Key Number	ASCII	2

**Response to the Get Public Key command (for FIRST) will be formatted as follows:**

### 2.11.7.2 Get Public Key command (for FIRST) Response Format

[A022]

**Get Public Key command (for FIRST) Response Format for IBM 4610 SureMark Fiscal Printer KR3/KR5 (RS-485):**

BYTE	BIT	CONTENT	TYPE	LENGTH	VARIABLE NAME
0-8		Fiscal Unit status	Hex	9	
9-90		Additional Information			(Note 1)

Note 1: See below the Additional Information Response.

**Get Public Key command (for FIRST) Response Format for IBM 4610 SureMark Fiscal Printer KD3/KD5 (RS-232):**

BYTE	BIT	CONTENT	TYPE	LENGTH	VARIABLE NAME
0-14		Fiscal Unit status	Hex	15	
15-96		Additional Information			(Note 1)

Note 1: See below the Additional Information Response.

### Additional Information Response:

BYTE RS-485	BYTE RS-232	BIT	CONTENT	TYPE	LENGTH
9-10	15-16		Key Number	ASCII	2
11-18	17-24		Creation Date (ddmmyyyy)	ASCII	8
19-23	25-29		Creation Time (hh:mm)	ASCII	5
24	30		Record Type 0 = Next 1 = Last	ASCII	1
25-26	31-32		Key Length	hex	2
27-90	33-96		Key	hex	64

**Response to the Get Public Key command (for NEXT) will be formatted as follows:**

### 2.11.7.3 Get Public Key command (for NEXT) Response Format

**Get Public Key command (for NEXT) Response Format for IBM 4610 SureMark Fiscal Printer KR3/KR5 (RS-485):**

BYTE	BIT	CONTENT	TYPE	LENGTH	VARIABLE NAME
0-8		Fiscal Unit status	Hex	9	
9-73		Additional Information			(Note 1)

Note 1: See below the Additional Information Response.

**Get Public Key command (for NEXT) Response Format for IBM 4610 SureMark Fiscal Printer KD3/KD5 (RS-232):**

BYTE	BIT	CONTENT	TYPE	LENGTH	VARIABLE NAME
0-14		Fiscal Unit status	Hex	15	
15-79		Additional Information			(Note 1)

Note 1: See below the Additional Information Response.

**Additional Information Response:**

BYTE RS-485	BYTE RS-232	BIT	CONTENT	TYPE	LENGTH
9	15		Record Type 0 = Next 1 = Last	ASCII	1
10-73	16-79		Key	hex	64

**2.11.7.4 Rules**

- To begin getting key, the cmd. extension 00 (FIRST) must be used. If the length returned is  $\leq 64$  bytes, all data is returned in the response. Else, subsequent calls with cmd extension 01 (NEXT) will bring the following data in 64 bytes chunks until the length is exhausted.

## 2.11.8 68 - Set/Get Max Wasted Space

This command is used to set or get the value to be compared against the remaining space in CF before any command.

### 2.11.8.1 Command Format

	BYTE	BIT	CONTENT	TYPE	LENGTH
	0-1		1B66 – Cmd Prefix	hex	2
	2		68 - Set/Get Max Wasted Space	hex	1
	3		Cmd Extension 00 = Set 01 = Get	hex	1
			For Cmd Extension = 00		
	4-7		Value1	hex	4 (Note 1)
H52	8-11		Value2	hex	4 (Note 2)

Response to the Set/Get Max Wasted Space command (for GET) will be formatted as follows:

### 2.11.8.2 Set/Get Max Wasted Space command (for GET) Response Format

[A023]

**Set/Get Max Wasted Space command (for GET) Response Format for IBM 4610 SureMark Fiscal Printer KR3/KR5 (RS-485):**

BYTE	BIT	CONTENT	TYPE	LENGTH	VARIABLE NAME
0-8		Fiscal Unit status	hex	9	
9-16		Additional Information			(Note 1)

Note 1: See below the Additional Information Response.

**Set/Get Max Wasted Space command (for GET) Response Format for IBM 4610 SureMark Fiscal Printer KD3/KD5 (RS-232):**

BYTE	BIT	CONTENT	TYPE	LENGTH	VARIABLE NAME
0-14		Fiscal Unit status	hex	15	
15-22		Additional Information			(Note 1)

Note 1: See below the Additional Information Response.

### Additional Information Response:

	BYTE RS-485	BYTE RS-232	BIT	CONTENT	TYPE	LENGTH
	9-12	15-18		Value1	hex	4 (Note 1)
H52	13-16	19-22		Value2	hex	4 (Note 2)

Note 1: Specified in Motorola format (MSB First) the value of MaxWasted1. (See 5.1.4) The minimum value of Value1 is 100K (100\*1024) If the value of Value1 is less than 100K, the Return Code 103 is generated.

Note 2: Specified in Motorola format (MSB First) the value of MaxWasted2. (See 5.1.4) The minimum value of Value2 is 15K (15\*1024) If the value of Value2 is less than 15K, the Return Code 103 is generated.

### 2.11.8.3 Rules

H52 – H130 – [A046]

The check of the CF free space is performed in the bellow described forms:

1. If the free space is less than MaxWasted1 + MaxWasted2 then the Return Code is 71

The above-described check is performed before starting the following command:

- 01 - Print Header (Sales period is not started)

- 14 - Summary Fiscal Report (X-Report) (Sales period is not started)
  - DD - Start Application-Originated Report (Sales period is not started)
2. If the free space is less than MaxWasted2 +10 K, then the Return Code is 73  
The above-described check is performed before starting the following commands:
- 01 - Print Header (Sales period is already started)
  - 14 - Summary Fiscal Report (X-Report) ) (Sales period is already started)
  - DD - Start Application-Originated Report ) (Sales period is already started)
3. If the free space is less than MaxWasted2 + 5 K, then the Return Code is 74  
The above-described check is performed before starting the following commands:
- D2 - Item Sale
  - D3 - Negative Item Sale
  - D4 - Total/Subtotal Printing
  - D5 – Payment
  - D9 – Uplift/Discount on Subtotal
  - EA – Normal Printing Lines on CR Station (Fiscal Printer Format)
  - EC – Line Feed
4. If the free space is less than MaxWasted2 + 10 K, then the Return Code is 75  
The above-described check is performed before starting the following command:
- 15 – Print Multi-Day Fiscal Report (Fiscal Memory Dump)
- Note:** If during the execution of the print the free space gets under MaxWasted2 + 10 K, the print is cancelled and Return code 75 is generated.

## 2.11.9 69 - Get Compact Flash Information

[A073]

This command is used to get the compact flash serial number, the compact flash size (ONLY VALID FOR IBM 4610 SureMark Fiscal Printer KD3/KD5 (RS-232)) and the remaining free space in the inserted CF.

### 2.11.9.1 Command Format

BYTE	BIT	CONTENT	TYPE	LENGTH
0-1		1B66 – Cmd Prefix	hex	2
2		69 – Get Compact Flash Information	hex	1
3		Cmd Extension 00 = Get Compact Flash Free Space 01 = Get Compact Flash Serial Number and Size	hex	1  (Note 1)

Note 1: The cmd.extension is 01 (Get Compact Flash Serial Number and Size) is ONLY VALID FOR IBM 4610 SureMark Fiscal Printer KD3/KD5 (RS-232)

Response to the Get Compact Flash Free Space command will be formatted as follows:

### 2.11.9.2 Get Compact Flash Free Space command Response Format

[A024]

Get Compact Flash Free Space command Response Format for IBM 4610 SureMark Fiscal Printer KR3/KR5 (RS-485):

BYTE	BIT	CONTENT	TYPE	LENGTH	VARIABLE NAME
0-8		Fiscal Unit status	Hex	9	
9-12		Additional Information			(Note 1)

Note 1: See below the Additional Information Response.

Get Compact Flash Free Space command Response Format for IBM 4610 SureMark Fiscal Printer KD3/KD5 (RS-232):

BYTE	BIT	CONTENT	TYPE	LENGTH	VARIABLE NAME
0-14		Fiscal Unit status	Hex	15	
15-18		Additional Information			(Note 1)

Note 1: See below the Additional Information Response.

Additional Information Response to Get Compact Flash Free Space (command extension = 00) will be formatted as follows:

BYTE RS-485	BYTE RS-232	BIT	CONTENT	TYPE	LENGTH
9-12	15-18		Compact Flash Free Space (in bytes)	Hex	4 (Note 1)

Note 1: Specified in Motorola format (MSB First).

**Additional Information Response to Get Compact Flash Serial Number and Size (command extension = 01) will be formatted as follows:**

**ONLY VALID FOR IBM 4610 SureMark Fiscal Printer KD3/KD5 (RS-232)**

	BYTE RS-232	BIT	CONTENT	TYPE	LENGTH
	15-34		Compact Flash Serial Number	ASCII	20
	35-38		Compact Flash Size (in bytes)	hex	4 (Note 1)

Note 1: Specified in Motorola format (MSB First).

### **2.11.9.3 Rules**

There are not rules for this command.

## 2.11.10 6A - Read Current Compact Flash File

This command is used to read the CF file that is being generated.

### 2.11.10.1 Command Format

BYTE	BIT	CONTENT	TYPE	LENGTH
0-1		1B66 – Cmd Prefix	Hex	2
2		6A - Read Current Compact Flash File	Hex	1
3		00 – Cmd Extension	Hex	1
4-7		Sequence	Hex	4 (Note 1)

Response to the Read Current Compact Flash File command will be formatted as follows:

### 2.11.10.2 Read Current Compact Flash File command Response Format

[A025]

**Read Current Compact Flash File command Response Format for IBM 4610 SureMark Fiscal Printer KR3/KR5 (RS-485):**

BYTE	BIT	CONTENT	TYPE	LENGTH	VARIABLE NAME
0-8		Fiscal Unit status	Hex	9	
9-138		Additional Information			(Note 1)

Note 1: See below the Additional Information Response.

**Read Current Compact Flash File command Response Format for IBM 4610 SureMark Fiscal Printer KD3/KD5 (RS-232):**

BYTE	BIT	CONTENT	TYPE	LENGTH	VARIABLE NAME
0-14		Fiscal Unit status	Hex	15	
15-144		Additional Information			(Note 1)

Note 1: See below the Additional Information Response.

#### Additional Information Response:

BYTE RS-485	BYTE RS-232	BIT	CONTENT	TYPE	LENGTH
9-10	15-16		Length Read	hex	2 (Note 1)
11-138	17-144		Bytes read from the file	hex	128 (Note 2)

Note 1: Specified in Motorola format (MSB first).

Note 2: If length read < 128, the end of file was reached and bytes beyond length read are not meaningful.

### 2.11.10.3 Rules

- To read the current CF file, there is no open or close commands. So, this command can be used anytime. This is different from closed EJ files that must be previously open with command 60 in order to be read with command 62.
- This command reads always in 128 byte blocks.
- When this command is issued by first time in a Journal Period, sequence must be zero.
  - Later, the sequence can be:
    - 0 = reads the first block
    - n = read again the last block read
    - n + 1 = read the block following the last block read
- Length read will be between 0 and 128.
- If length read is less than 128, the end of file was reached.



## 2.12 Additional Information for OEM Interface

### 2.12.1 00 - System Commands

#### 2.12.1.1 Command Format

BYTE	BIT	CONTENT	TYPE	LENGTH
0		00 – System Commands	hex	1
1		Command 00 = Device Information 10 = Test 20 = Status 40 = POR 80 = EC LEVEL	hex	1
		For Command = 00		
2		01 = Device Information	hex	1 (Note 1)

Note 1: This command response is identical to command FC cmd.ext. 10.  
(See 2.11.6 “FC - Report Microcode EC”).

If command byte 1 is different than those defined here, no processing is performed and no response is given.

**System commands are processed as follows:**

**Test** - First a fiscal unit test is performed and then the fiscal unit status is sent over the communication link.

**Status** - The fiscal unit status is sent over the communication link.

**POR** - The microcode performs a software fiscal unit POR.

**EC level** - Bytes 6 and 7 of the fiscal unit status followed by the 1-microcode EC level byte are sent over the communication link.

## 2.12.2 E7 - Diagnostic and Alignment Utilities

This command is used to do all diagnostic and alignment utilities.

### 2.12.2.1 Command Format

BYTE	BIT	CONTENT	TYPE	LENGTH
0-1		1B66 – Cmd Prefix	hex	2
2		E7 - Diagnostic and Alignment Utilities	hex	1
3		Cmd Extension 00 = Set MCT Value 01 = DI Print Document Top Registration Pattern 02 = Reserved 03 = DI Print Backlash Adjustment Pattern 04 = Reserved 05 = CR Read MCT Value 06 = Reserved 07 = Reserved 08 = CR Print Test Command 09 = CR Print „HIHI...HIHI” Pattern 0A = DI Print „HIHI...HIHI” Pattern 0B = DI Character Alignment 0C = DI MICR Read, Print Front Check, Print Back Check & CR Print MICR data 0D = CR Cut Paper 0E = DI Home Head Left 0F = DI Home Head Right	hex	1
		If cmd extension = 00 or 01		
4		MCT Number	hex	1
5		MCT Value – High Order Byte	hex	1
6		MCT Value – Low Order Byte	hex	1

(Continued in the next page)

Diagnostic and Alignment Utilities Command continued ....

BYTE	BIT	CONTENT	TYPE	LENGTH
		If cmd extension = 03 or 0B		
4		MCT Number 1	hex	1
5		MCT Value 1 – High Order Byte	hex	1
6		MCT Value 1– Low Order Byte	hex	1
7		MCT Number 2	hex	1
8		MCT Value 2 – High Order Byte	hex	1
9		MCT Value 2 – Low Order Byte	hex	1
10		MCT Number 3	hex	1
11		MCT Value 3 – High Order Byte	hex	1
12		MCT Value 3 – Low Order Byte	hex	1
13		MCT Number 4	hex	1
14		MCT Value 4 – High Order Byte	hex	1
15		MCT Value 4 – Low Order Byte	hex	1
16		MCT Number 5	hex	1
17		MCT Value 5 – High Order Byte	hex	1
18		MCT Value 5 – Low Order Byte	hex	1
19		MCT Number 6	hex	1
20		MCT Value 6 – High Order Byte	hex	1
21		MCT Value 6 – Low Order Byte	hex	1
22		MCT Number 7	hex	1
23		MCT Value 7 – High Order Byte	hex	1
24		MCT Value 7 – Low Order Byte	hex	1
25		MCT Number 8	hex	1
26		MCT Value 8 – High Order Byte	hex	1
27		MCT Value 8 – Low Order Byte	hex	1
28		MCT Number 9	hex	1
29		MCT Value 9 – High Order Byte	hex	1
30		MCT Value 9 – Low Order Byte	hex	1
		If cmd extension = 05		
	4-4	MCT Number	hex	1

**Response to the Diagnostic and Alignment Utilities Command for Read MCT Value (cmd extension 05):**

### 2.12.2.2 Diagnostic and Alignment Utilities Command for Read MCT Value Response Format

[A026]

#### Diagnostic and Alignment Utilities Command for Read MCT Value Response Format for IBM 4610 SureMark Fiscal Printer KR3/KR5 (RS-485):

BYTE	BIT	CONTENT	TYPE	LENGTH	VARIABLE NAME
0-8		Fiscal Unit status	Hex	9	
9-10		Additional Information			(Note 1)

Note 1: See below the Additional Information Response.

#### Diagnostic and Alignment Utilities Command for Read MCT Value (cmd extension 05) for IBM 4610 SureMark Fiscal Printer KD3/KD5 (RS-232):

BYTE	BIT	CONTENT	TYPE	LENGTH	VARIABLE NAME
0-14		Fiscal Unit status	Hex	15	
15-16		Additional Information			(Note 1)

Note 1: See below the Additional Information Response.

#### Additional Information Response:

BYTE RS-485	BYTE RS-232	BIT	CONTENT	TYPE	LENGTH
9	15		MCT Value - High Order Byte	hex	1
10	16		MCT Value - Low Order Byte	hex	1

## 2.12.3 F7- Command Buffer Management (ONLY VALID FOR IBM 4610 SureMark Fiscal Printer KD3/KD5 (RS-232))

[A054]

This command is used to retrieve the last commands issued of the command buffer.

### 2.12.3.1 Command Format

BYTE	BIT	CONTENT	TYPE	LENGTH
0-1		1B66 – Cmd Prefix	hex	2
2		F7 - Command Buffer Management	hex	1
3		Cmd Extension 00 = Retrieve Last Command 01 = Retrieve Previous Command 02 = Clear Command Buffer	hex	1

**Response to the Command Buffer Management will be formatted as follows:**

#### Command Buffer Management Response Format for Jacare RS-232:

BYTE	BIT	CONTENT	TYPE	LENGTH	VARIABLE NAME
0-14		Fiscal Unit status	Hex	15	
15-16		Additional Information			(Note 1)

Note 1: See below the Additional Information Response.

#### Additional Information Response:

BYTE RS-232	BIT	CONTENT	TYPE	LENGTH
15		Type	hex	1 (Note 1)
16		Command Data Length	hex	1 (Note 2)
17		Additional Data Length	hex	1 (Note 3)
18		Command	hex	1
		Command Extension	hex	n0
		Command Data	hex	n1
		Additional Data	hex	n2 (Note 4)
		Fiscal Unit Status Executed Command	hex	n3 (Note 5)

Note: The 'Command Buffer Management' Response length without Fiscal Unit Status (Additional Information) is:

- RS-232: 114 bytes

Note 1: Type:

- 0xFF command retrieved
- 0xFE there was a new command between F700 and F701
- 0x00 no commands found

Note 2: Command Data Length is 1 + n0 + n1 bytes, where

- Command = 1 byte
- Command Ext. = n0 bytes
- Command Data = n1 bytes

Note 3: Additional Data Length is n2 bytes, where

- Command Response = n2 bytes
- $n2 = 129 - (\text{Type} + \text{Command} + \text{Command Ext.} + \text{Command Data} + \text{Fiscal Unit Status})$

Note 4: The Additional Data of the Executed Command is shown in the remaining bytes (n2) of the Additional Information Response. If the Additional Data of the Executed Command length is greater than the remaining bytes (n2) of the Additional Information Response the Additional is truncated.

Note 5: Fiscal Unit Status Executed Command (buffering command) length is n3, where:  
 - RS-232: 15 bytes

### 2.12.3.2 Example

#### 2.12.3.2.1 'Command Buffer Management' Response - Additional Information:

```

+---+---+---+---+---+---+---+---+---+---+---+---+---+---+---+
| 0| 1| 2| 3| 4| 5| 6| 7| 8| 9| A| B| C| D| E| F|
+---+---+---+---+---+---+---+---+---+---+---+---+---+---+---+
|FF|10|5F|FF|11|30|35|30|30|43|30|35|30|39|30|34|
|39|31|36|FF|FF|FF|FF|FF|FF|FF|FF|FF|FF|FF|FF|FF|
|FF|FF|FF|FF|FF|FF|FF|FF|FF|FF|FF|FF|FF|FF|FF|FF|
|FF|FF|FF|FF|FF|FF|FF|FF|FF|FF|FF|FF|FF|FF|FF|FF|
|FF|FF|FF|FF|FF|FF|FF|FF|FF|FF|FF|FF|FF|FF|FF|FF|
|FF|FF|FF|FF|FF|FF|FF|FF|FF|FF|FF|FF|FF|FF|FF|FF|
|FF|FF|FF|FF|FF|FF|FF|FF|FF|FF|FF|FF|FF|FF|FF|FF|
|FF|FF|FF|FF|FF|FF|FF|FF|FF|FF|FF|FF|FF|FF|FF|FF|
|FF|FF|08|4F|00|0A|20|07|28|00|00|80|02|01|0B|43|
|00| | | | | | | | | | | | | | | |
+---+---+---+---+---+---+---+---+---+---+---+---+---+---+---+
  
```

#### 2.12.3.3 Rules

- The Command Buffer size is 2 Kb (2048 bytes).
- When a command is executed, this command is stored in the Command Buffer (except the xF7 command).
- If the Command Buffer is full the oldest command is removed of the Command Buffer.
- If a PLD occurs during the command execution, the interrupted command is stored in the Command Buffer and the Fiscal Unit Status of the executed command is equal to zero.

## 2.12.4 F8 – Device Information Command

H50

### 2.12.4.1 Command Format

	BYTE	BIT	CONTENT	TYPE	LENGTH
	0-1		1B66 – Cmd Prefix	Hex	2
	2		F8 - Report Printer EC	Hex	1
H50	3		Cmd Extension 01 = Fiscal 02 = Printer	Hex	1

Response to the Device Information Command will be formatted as follows:

[A027]

### 2.12.4.2 Device Information Command Response Format

#### 2.12.4.2.1 Fiscal Response - IBM 4610 SureMark Fiscal Printer KR3/KR5 (RS-485):

	BYTE	BIT	CONTENT	TYPE	LENGTH
	0-5		Printer status	hex	6
	6			hex	1
		7-1	Fiscal status		
		0	Fiscal / Printer device info: 0 = fiscal device info is NOT contained in this message 1 = fiscal device info IS contained in this message		
	7			hex	1
		7	Additional data status bit (set to "1" for device information response)		
		6-0	Version and country codes		
	8		Fiscal return code	hex	1
	9		Device type 0x31 = Fiscal Printer	hex	1
	10		Device ID 0x00 = IBM 4610 SureMark Fiscal Printer Kxy (Duna / Jacare) 0x01 = IBM 4610 SureMark Fiscal Printer Gxy (Macarena) 0x02 – 0xFF = (reserved)	hex	1
	11		Feature byte #1	hex	1
		7	(reserved)		
		6	(reserved)		
		5	(reserved)		
		4	(reserved)		
		3	Reference database: 0 = Reference database NOT present 1 = Reference database present		
		2	Microcode flash update 0 = Microcode can NOT be "flashed" 1 = Microcode CAN be "flashed"		
		1	Compact flash present 0 = Compact flash NOT present 1 = Compact flash present		
		0	Fiscal memory size 0 = 512 KB 1 = 256 KB		
	12		Feature byte #2 (reserved)	hex	1
	13		Fiscal EC level	hex	1

### 2.12.4.2.2 Fiscal Response - IBM 4610 SureMark Fiscal Printer KD3/KD5 (RS-232):

BYTE	BIT	CONTENT	TYPE	LENGTH
0-7		Printer status	hex	8
8		Reserved	Hex	1
9			Hex	1
	7	Additional data status bit (set to "1" for device information response)		
	6-0	Reserved		
10		Country Code	hex	1
11		Country Version	hex	1
12		Country EC Level	hex	1
13		Fiscal return code	hex	1
14		Fiscal return code	hex	1
15		Device type 0x31 = Fiscal Printer	hex	1
16		Device ID 0x00 = IBM 4610 SureMark Fiscal Printer Kxy (Duna / Jacare) 0x01 = IBM 4610 SureMark Fiscal Printer Gxy (Macarena) 0x02 – 0xFF = (reserved)	hex	1
17		Feature byte #1	hex	1
	7	(reserved)		
	6	(reserved)		
	5	(reserved)		
	4	(reserved)		
	3	Reference database: 0 = Reference database NOT present 1 = Reference database present		
	2	Microcode flash update 0 = Microcode can NOT be "flashed" 1 = Microcode CAN be "flashed"		
	1	Compact flash present 0 = Compact flash NOT present 1 = Compact flash present		
	0	Fiscal memory size 0 = 512 KB 1 = 256 KB		
18		(reserved)	hex	1
19		Fiscal EC level	hex	1



### 2.12.4.2.3 Printer Response - IBM 4610 SureMark Fiscal Printer KR3/KR5 (RS-485):

H50

BYTE	BIT	CONTENT	TYPE	LENGTH
0-5		Printer status	hex	6
6			hex	1
	7-1	Fiscal status		
	0	Fiscal / Printer device info: 0 = printer device info is NOT contained in this message 1 = printer device info IS contained in this message		
7			hex	1
	7	Additional data status bit (set to "1" for device information response)		
	6-0	Version and country codes		
8		Fiscal return code	hex	1
9		Device type = d	hex	1
10		Device ID 00 = Models TI1 and TI2 (impact DI / thermal CR) 01 = Models TI3 and TI4 (high speed; impact DI/ thermal CR) 02 = Models TI3 and TI4 with the 2 MB option 03 = Models TF6 and TM6 (512 K; thermal CR) 04 = Models TI3 and TI4 with the 8 MB option 05 = Models TF6 and TM6 with the 8 MB option 06 = Reserved 07 = Models TF6 and TM6 with the 2 MB option	hex	1
11		First byte of features	hex	1
	7	Set to 1 when the printer is in Model 4 emulation mode		
	6	Set to 1 when the printer has capability of printing two colours		
	5	Set to 1 when the 2 MB option is used for user flash memory		
	4	Reserved		
	3	Set to 1 when the printer is in XON/XOFF mode		
	2	Set to 1 when the printer has the 2 MB option		
	1	Set to 1 when Check Flipper is present		
	0	Set to 1 when MICR is present		
12		Second byte of the features (Reserved)	hex	1
13		EC level = EC level of loaded code	hex	1

#### 2.12.4.2.4 Printer Response - IBM 4610 SureMark Fiscal Printer KD3/KD5 (RS-232):

BYTE	BIT	CONTENT	TYPE	LENGTH
0-7		Printer status	hex	8
8		Reserved	hex	1
9			hex	1
	7	Additional data status bit (set to "1" for device information response)		
	6-0	Reserved		
10		Country Code	hex	1
11		Country Version	hex	1
12		Country EC level	hex	1
13		Fiscal return code	hex	1
14		Fiscal return code	hex	1
15		Device type = d	hex	1
16		Device ID 00 = Models TI1 and TI2 (impact DI / thermal CR) 01 = Models TI3 and TI4 (high speed; impact DI/ thermal CR) 02 = Models TI3 and TI4 with the 2 MB option 03 = Models TF6 and TM6 (512 K; thermal CR) 04 = Models TI3 and TI4 with the 8 MB option 05 = Models TF6 and TM6 with the 8 MB option 06 = Reserved 07 = Models TF6 and TM6 with the 2 MB option	hex	1
17		First byte of features	hex	1
	7	Set to 1 when the printer is in Model 4 emulation mode		
	6	Set to 1 when the printer has capability of printing two colours		
	5	Set to 1 when the 2 MB option is used for user flash memory		
	4	Reserved		
	3	Set to 1 when the printer is in XON/XOFF mode		
	2	Set to 1 when the printer has the 2 MB option		
	1	Set to 1 when Check Flipper is present		
	0	Set to 1 when MICR is present		
18		Second byte of the features (Reserved)	hex	1
19		EC level = EC level of loaded code	hex	1

## 2.12.5 FA - Perform POR

### 2.12.5.1 Command Format

BYTE	BIT	CONTENT	TYPE	LENGTH
0-1		1B66 – Cmd Prefix	hex	2
2		FA - Perform POR	hex	1
3		Cmd Extension	hex	1
	7-1	Reserved		
	0	Unit 0 = Fiscal Unit 1 = Printer		

## 2.12.6 FB - Run Online Diagnostics

### 2.12.6.1 Command Format

BYTE	BIT	CONTENT	TYPE	LENGTH
0-1		1B66 – Cmd Prefix	hex	2
2		FB - Run Online Diagnostics	hex	1
3		Cmd Extension	hex	1
	7-2	Reserved		
	1-0	Unit 01 = Fiscal Unit 10 = Printer 11 = Both		

## 2.12.7 FC - Report Microcode EC

### 2.12.7.1 Command Format

BYTE	BIT	CONTENT	TYPE	LENGTH
0-1		1B66 – Cmd Prefix	hex	2
2		FC – Report Microcode EC	hex	1
3	[A140]	Cmd Extension 00 = Fiscal Microcode EC Level 01 = Fiscal Microcode Internal EC Level 02 = Country Code 03 = Country Version (Hardware Model) 10 = Device Information	hex	1

**Response to the Report Microcode EC command for Device Information (cmd.ext. 10) will be formatted as follows:**

### 2.12.7.2 Report Microcode EC command for Device Information Response Format

[A028]

**Report Microcode EC command for Device Information Response Format for IBM 4610 SureMark Fiscal Printer KR3/KR5 (RS-485):**

BYTE	BIT	CONTENT	TYPE	LENGTH	VARIABLE NAME
0-8		Fiscal Unit status	Hex	9	
9-13		Additional Information			(Note 1)

Note 1: See below the Additional Information Response.

**Report Microcode EC command for Device Information Response for IBM 4610 SureMark Fiscal Printer KD3/KD5 (RS-232):**

BYTE	BIT	CONTENT	TYPE	LENGTH	VARIABLE NAME
0-14		Fiscal Unit status	Hex	15	
15-19		Additional Information			(Note 1)

Note 1: See below the Additional Information Response.

**Additional Information Response:**

BYTE RS-485	BYTE RS-232	BIT	CONTENT	TYPE	LENGTH
9	15		DEVICE TYPE 0x31 = Fiscal Printers	hex	1
10	16		DEVICE ID 00 = 3F 01 = IBM 4610 SureMark Fiscal Printer Kxy (Duna / Jacare) 02 = IBM 4610 SureMark Fiscal Printer Gxy (Macarena) 03 = Single Station Thermal	hex	1
11	17		FEATURES BYTE #1	hex	1
			Diagnostic Command Set 0 = Old Set 1 = New Set		
			Reserved		
			Check Flipper 0 = No Flipper 1 = Flipper		
			MICR 0 = No MICR 1 = MICR		
12	18		FEATURES BYTE #2	hex	1
			Reserved		
			ADDITIONAL DATA 0 = No Additional Data Byte after byte #13 1 = Additional Data Byte after #13		
			Reserved		
13	19		FISCAL PROCESSOR EC LEVEL	hex	1

## 2.12.8 FF - Engineering Dump Fiscal RAM and Fiscal EPROM

### 2.12.8.1 Command Format

BYTE	BIT	CONTENT	TYPE	LENGTH
0-1		1B66 – Cmd Prefix	hex	2
2		FF - Engineering Dump Fiscal RAM and EPROM	hex	1
3		Cmd Extension	hex	1
	7-5	Reserved		
	4	Dump – Type 0 = Printer 1 = Electronic		
	3-1	Reserved		
	0	Dump - Type Memory 0 = Fiscal RAM 1 = Fiscal EPROM		(Note 1)
4-8		Start Address	ASCII	5 (Note 2)
9-13		End Address	ASCII	5 (Note 2)
14-17		Password	ASCII	4

Note 1: Is printed on CR station.

Note 2: Specify the ASCII representation of the hexadecimal address.

Fiscal RAM address range (64 Kbytes): '00000' - '0FFFF'.

Fiscal EPROM address range (512 Kbytes): '00000' - '7FFFF'

**Response to the Engineering Dump Fiscal RAM and EPROM Read for Electronic Dump will be formatted as follows:**

BYTE	BIT	CONTENT	TYPE	LENGTH
0-8		Fiscal Unit Status	hex	9
9-218		Electronic Data	hex	hex 210 (Note 3)
10		MCT Value - Low Order Byte	hex	1

Note 3: The data are shown in a block of 210 bytes where valid are only those specified in the command, the rest is padded with zeroes.

## 2.13 Command Set Summary List

This section contains a cross-reference between the fiscal unit command code and command name. The command code preceding the command name represents the hexadecimal value of command byte 0.

### 2.13.1 Initialization

<b>16</b>	Set Date
<b>66</b>	Set Public and Private Key
<b>1B</b>	Serialize Fiscal Printer
<b>18</b>	Set Fiscal Mode
<b>1E</b>	Set TAX Identification Information
<b>20</b>	Set TAX Table
<b>21</b>	Verify TAX Table
<b>D7</b>	Set Header
<b>C4</b>	Fiscal Parameter Configuration
[A008] – [A068]	
<b>1A</b>	Set Display Address
<b>68</b>	Set/Get Max Wasted Space

### 2.13.2 Sales Transaction

<b>01</b>	Print Store Header
<b>D2</b>	Item Sale
<b>D3</b>	Negative or Uplift Item Sale
	Voids
	Discounts
	Uplifts
<b>D4</b>	Transaction Total
<b>D5</b>	Payment
<b>06</b>	End of Transaction
<b>07</b>	Cancel Sales Transaction
<b>D9</b>	Discount/Uplift on Subtotal

### 2.13.3 Check printing

<b>CO</b>	Load check data
<b>C1</b>	Print load check
<b>C2</b>	Cancel load check
<b>C3</b>	Flip check



### 2.13.4 Barcode support

- C8** Set Barcode Size
- C9** Print Barcode

### 2.13.5 Attached Devices

**ONLY VALID FOR IBM 4610 SureMark Fiscal Printer KD3/KD5 (RS-232)**

- [A134]
- CC** User NVRAM Management
- [A016]
- CD** Cash Drawer Management
- [A031]
- CE** Attached Display Management

### 2.13.6 Close Sales Period

- 13** Closure

### 2.13.7 Dump

- 15** Dump Fiscal Memory
- FF** Engineering Dump Fiscal RAM and Fiscal Memory

### 2.13.8 Reports

- 14** Print X-Report
- DD** Start Application-Originated Report
- DE** End Application-Originated Report

### 2.13.9 Printer

- EA** Ordinary Print on Customer Receipt
- EB** Ordinary Printing on Document Insert Station + Line Feed
- EC** Line Feed
- ED** Ready Document (Top/Bottom Registration)
- EF** Eject document
- F4** Return Print Head to Center/Left Home Position
- 00** System Commands

## 2.13.10 Utilities

<b>DB</b>	Read Accumulators and Counters
<b>DC</b>	MICR read
<b>F1</b>	Report IPL Completion Status
<b>FC</b>	Communicate Fiscal Printer EC
[A055]	
<b>F7</b>	Command Buffer Management - <b>ONLY VALID FOR IBM 4610 SureMark Fiscal Printer KD3/KD5 (RS-232)</b>
<b>F8</b>	Communicate Printer EC
<b>F9</b>	Report Current Status
<b>FA</b>	Reset Fiscal Printer
<b>FB</b>	Run Diagnostics
<b>FF</b>	Engineering dump

## 2.13.11 Electronic journaling

<b>60</b>	Open compact flash file
<b>61</b>	Close compact flash file
<b>62</b>	Read compact flash file
<b>63</b>	Get Extended EJ Error
<b>65</b>	Get Compact Flash Directory
<b>66</b>	Set Public and Private Key
<b>67</b>	Get Public Key
<b>68</b>	Set / Get Max Wasted Space
<b>69</b>	Get Compact Flash Free Space
<b>6A</b>	Read Current Compact Flash File

## 3 Fiscal Status Byte and Return Code Definition

The fiscal unit return codes are defined in 3.1.4 Return Codes on page 139

### 3.1.1 Status Byte Definition

The fiscal unit status is sent to the terminal when any of the following conditions occur:

- When the printer status is received from the printer and no command is in execution (for example: printer cover open, printer key pressed).
- When the printer status is received from the printer and the printer command complete status bit is off (byte 6 is 00).
- When the printer status is received from the printer and the printer cover open status bit is on.
- During command execution, whenever 2.5 seconds have elapsed since the fiscal unit command execution was started or since the last fiscal unit status was sent.
- When command execution is ended.
- When the fiscal unit IPL sequence is completed.

Use the F9 command to read the current status of the fiscal unit.

### 3.1.2 IBM 4610 SureMark Fiscal Printer KR3/KR5 (RS-485)

#### 3.1.2.1 Printer and Fiscal Unit Status

The fiscal unit response to the application program is contained in the Fiscal Unit Status, which is 9 bytes long (6 bytes for the printer status and 3 bytes for fiscal unit status).

Byte	Bit	Content
0 – 5		Printer Status*
6		Fiscal Unit Status Note: When fiscal unit status byte 6 is 00 then command is complete.
	7	Fiscal Unit Busy. Set to 1 when a command is received while a previous command is still in execution.
	6	Intermediate Status. When set it indicates that execution of a command is still in progress.
	5	Asynchronous Status. When set it indicates that the fiscal unit is executing an internal command (e.g. POR sequence) or it received an asynchronous status from the printer.
	4	PLD. This bit is set at IPL time to indicate that a command was in execution during PLD and that all modifications caused by the suspended command have been deleted.
	3	Microcode EC. When set it indicates that status byte 8 contains the microcode EC.
	2	IPL in Progress. Set to indicate that the fiscal unit is performing the IPL sequence.
	1	IPL Status. When set, it indicates that status byte 8 contains the IPL completion status; and bit 4 of byte 6 is set as it was at IPL time.
	0	Reserved. Always set to 0.
7		Additional Data and Country Code
	7	Set to 1. Where additional data follows the 9 fiscal status bytes.
	6-5	Version Number
	4-0	Country Code
8		Fiscal Unit Return Code <b>Note:</b> When Fiscal Unit Return Code is X'43' (67 decimal), it means that no error is indicated on this status message. The fiscal unit return codes are defined in 4.1.3, "Return Codes" on page 110.
9 – n		Additional data, if byte 7 bit 7 is on.

**Note:** Fiscal Unit Status. Bit 7 is the most significant bit and bit 0 is the least significant bit.

\* Detailed see above

### 3.1.2.1.1 Byte 0 - 5 (1 – 6): Printer status

Status Byte: Bit	4610 Fiscal (2 & 3 Station) status bytes	4610 Non fiscal status byte:bit mapped	Model 3	BPF Device Driver
1:0	Don't use, meaningless. Always 1	NA	Cmd Complete	Not to be used
1:1	Document right home position. Set to 1 if print head in right home position	1:3 as noted in 4610 fiscal	Center home position.	as noted in Model 3. Set to 1 if print head in center home position
1:2	Always 0	NA	Set to 1 for Model 4A. Zero otherwise.	Reserved. Always 0
1:3	MICR present. Set to 1 if MICR present	NA	Set to 1 if MICR Present	Reserved. Always 0 (This may be wrong in BPF documentation)
1:4	Always 0	NA	Home Error before printing	Reserved. Always 0
1:5	Home error	3:1 as noted in 4610 fiscal	Home position error	as noted to Model 3. Set to 1 when the print head arrives or leaves a home position too soon or too late
1:6	Document Error	3:2 as noted in 4610 fiscal	Front document insert error	as noted in Model 3. Set to 1 when a front document insert operation is specified and a document has not been inserted
1:7	Not to be used. Set to 1 when printer command is rejected, 0 otherwise.	1:7 Cmd reject	Command reject	Not to be used. Printer card command reject.
2:0	Reserved. Always 0	NA	Reserved. Always 0	Reserved. Always 0
2:1	Always 0	NA	Journal Movement Error	Set to 1 when paper path error is detected in journal
2:2	Printer Key Pressed. Set to 1 when key was pressed	7:4 as noted in 4610 fiscal	Printer Key pressed	Set to 1 when printer key was pressed
2:3	EC Level Response. Set to 1 when responding an EC level request	5:1 as noted in 4610 fiscal	Ec Level	Set to 1 when printer EC level follows
2:4	Cover Open/Out of paper error. Set to 1 when DI or CR cover is open or CR out of paper	1:5 or 1:6	Cover Open	Set to 1 when top cover is open
2:5	Document Ready. Set to 0 when document is ready for printing	2:0 as noted in 4610 fiscal	Document Ready	Set to 0 when inserted document is ready for printing.
2:6	Document present under front sensor. Set to 0 when document is under bottom sensor	2:1 as noted in 4610 fiscal	Document present under front sensor	Set to 0 when document is under bottom document sensor
2:7	CR Cover Open/Out of paper. Set to 1 when CR is out of paper or the CR cover is open.	1:6 as noted in 4610 fiscal	CR out of paper (have to update spec)	Reserved

Status Byte: Bit	4610 Fiscal (2 & 3 Station) status bytes	4610 Non fiscal status byte:bit mapped	Model 3	BPF Device Driver
3:0	Left Home Position. Set to 1 when print head is in left home position	1:2 as noted in 4610 fiscal	Left Home Position	Set to 1 when print head is in the left home position
3:1	Always 0	NA	Top load DI error	Set to 1 when a top load error
3:2	Document present under top sensor. Set to 0 when document is under top sensor	2:2 as noted in 4610 fiscal	Document present under top sensor	Set to 0 when a document is under the top document sensor
3:3	Don't use, meaningless Always 0	NA	JNL print error	Not to be used
3:4	Flash EPROM load error or MCT load error. Set to 1 when loading error	3:3 as noted in 4610 fiscal	EEPROM load error	Set to 1 when error occurs loading the EPROM
3:5	Reserved	NA	Reserved	Reserved
3:6	Always 0	NA	Paper load direction for DI station	Set to 0 when document inserted from the front, 1 when inserted from the top. This bit is only valid when status byte #2 bit #5 is zero.
3:7	Reserved	NA	Reserved	Reserved
Byte 4	Microcode EC	4:x as noted in 4610 fiscal	Microcode EC	Status byte 6 form fiscal unit or EC level data. See byte 2:3
Byte 5	CRC High byte for EC req MCT High byte for MCT info FONT 2 CRC High for CRC chk	NA	CRC/MCT/FON T2 HIGH	NA
Byte 6	CRC High byte for EC req MCT High byte for MCT info FONT 2 CRC High for CRC chk	NA	CRC/MCT/FON T2 LOW	NA

### 3.1.2.2 Country Code and Version Number Definition

Country Name	Country Code	Model N.
Hungary	100	IBM 4610 SureMark Fiscal Printer KR3/KR5 (RS-485)

### 3.1.3 IBM 4610 SureMark Fiscal Printer KD3/KD5 (RS-232)

#### 3.1.3.1 Printer and Fiscal Unit Status

[A009] [A060]

The printer and fiscal unit response to the application program is contained in the fiscal unit status, which is 15 bytes long (8 bytes for the fiscal printer status and 7 bytes for fiscal unit status).

The following figure shows the content of the fiscal status.

Byte	Bit	Content
<b>0</b>		<b>PRINTER UNIT STATUS</b>
	0 (LSB)	COMMAND LOADED For RS-232 buffered commands. Set to 1 when the command is received into the print buffer. Note: this is not when the line is actually printed. COMMAND COMPLETE For RS-232 immediate command and flash storage commands. Set to 1 when the command is complete.
	1	CASH RECEIPT RIGHT HOME POSITION Set to 1 when the print head is in the cash receipt right home position.
	2	LEFT HOME POSITION Set to 1 when the print head is in the left home position.
	3	DOCUMENT RIGHT HOME POSITION Set to 1 when the print head is in the document right home position.
	4	RESERVED (Always = '0')
	5	RIBBON COVER OPEN Set to 1 when the ribbon cover is open.
	6	CASH RECEIPT PRINT ERROR Paper cover is open or the CR station is out of paper.
	7 (MSB)	COMMAND REJECT
<b>1</b>		<b>PRINTER UNIT STATUS</b>
	0 (LSB)	DOCUMENT READY Set to 0 when the DI station is ready for printing. This occurs when both document sensors are made and the document has been fed to the first print position.
	1	DOCUMENT PRESENT UNDER THE FRONT SENSOR Set to 0 when a document is under the front document sensor.
	2	DOCUMENT PRESENT UNDER THE TOP SENSOR Set to 0 when a document is under the top document sensor.
	3	RESERVED (Always = '1').
	4	PRINT BUFFER HELD Set to a 1 when the print buffer is being held. Cleared when buffer released. The printer may be held due to a hold buffer command or one of the following printer errors: - Ribbon cover open with commands to be printed on the DI station. - CR print error with commands to the CR station.
	5	OPEN THROAT POSITION Set to 1 when the print head is in the open throat position.
	6	BUFFER EMPTY Set when there is no longer any print data or commands in the buffer.
	7 (MSB)	BUFFER FULL Set when only 512 bytes remain in the buffer. Cleared when 3k bytes are free (RS485 only).
<b>2</b>		<b>PRINTER UNIT STATUS</b>
	0 (LSB)	MEMORY SECTOR IS FULL
	1	HOME ERROR
	2	DOCUMENT ERROR

Byte	Bit	Content
		The document not inserted after document station was selected and the wait timed out.
	3	FLASH EPROM LOAD ERROR OR MCT LOAD ERROR
	4	RESERVED (Always = '0')
	5	USER FLASH STORAGE SECTOR IS FULL
	6	FIRMWARE ERROR CRC on the firmware failed. The printer is running out of the boot sector. ONLY system commands and firmware commands will be accepted.
	7 (MSB)	FISCAL BIT Set to show a line completed printing.
<b>3</b>		<b>PRINTER UNIT STATUS</b> <b>Contains the printer EC level with all status messages.</b>
<b>4</b>		<b>PRINTER UNIT STATUS</b>
	0 (LSB)	PRINTER ID REQUEST/EXTENDED ADDRESS CMD Set to 1 when responding to a printer ID request.
	1	EC LEVEL Set to 1 when responding to an EC level request.
	2	MICR READ Set to 1 when responding to a MICR read command.
	3	MCT READ Set to 1 when responding to a MCT read command.
	4	USER FLASH READ Set to 1 when responding to a user flash read command.
	5	Reserved (Always = '1').
	6	ONLY VALID FOR MACARENA MODELS SJ COVER OPEN Set to 1 when the cover on the SJ station is open.
	7	ONLY VALID FOR MACARENA MODELS SJ STATION PAPER FAULT Set to 1 when the paper is not present.
<b>5</b>		<b>PRINTER UNIT STATUS</b> <b>Contains the current line count the printer is on.</b>
<b>6</b>		<b>PRINTER UNIT STATUS</b>
	0 (LSB)	JOURNAL STATUS SELECTION (Note 1) 1 = Selected 0 = Not Selected
	1	+24 Volt Power Supply Status: 1 = Voltage Below Spec 0 = Voltage in Spec
	2	RESERVED
	3	CASH DRAWER STATUS Set to 1 when cash draw is opened.
	4	PRINTER KEY PRESSED Set to 1 when a printer key operation is in progress.
	5	RESERVED (Always = '1')
	6	STATION SELECTED Set when the DI station is selected. Clear when the CR station is selected.
	7 (MSB)	DOCUMENT FEED ERROR Set when there is an error after a MICR command is executed.
<b>7</b>		<b>PRINTER UNIT STATUS</b> (RESERVED for future use)
<b>8</b>		<b>FISCAL UNIT STATUS</b>
	0	RESERVED (Always = '0')



Byte	Bit	Content
	1	IPL STATUS When set, it indicates that status byte 14 contains the IPL completion status and bit 4 of byte 5 is set as it was at IPL time.
	2	IPL IN PROGRESS Set to indicate that the fiscal unit is performing the IPL sequence.
	3	MICROCODE EC When set it indicates that status byte 13 contains the microcode EC.
	4	PLD This bit is set at IPL time to indicate that a command was in execution during PLD and that all modifications caused by the suspended command have been deleted.
	5	ASYNCHRONOUS STATUS When set it indicates that the fiscal unit is executing an internal command (e.g. POR sequence) or it received an asynchronous status from the printer).
	6	INTERMEDIATE STATUS When set it indicates that execution of a command is still in progress.
	7	FISCAL UNIT BUSY Set to 1 when a command is received while a previous command is still in execution.
<b>9</b>		<b>FISCAL UNIT STATUS</b>
	0-6	RESERVED (Always = '0')
	7	ADDITIONAL DATA (= 1 when any data is available; otherwise = 0) (Note 2)
<b>10</b>		<b>COUNTRY CODE</b> 04 = Hungary
<b>11</b>		<b>COUNTRY VERSION (hardware model)</b> 05 = IBM 4610 SureMark Fiscal Printer KD3/KD5 (RS-232)
<b>12</b>		FISCAL MICROCODE EC LEVEL
<b>13</b>		FISCAL UNIT RETURN CODE (Note 3)
<b>14</b>		FISCAL UNIT RETURN CODE (reserved for future use)
<b>15-n</b>		ADDITIONAL DATA (if byte 9 bit 7 is ON)

Note : Bit 7 is the most significant bit and bit 0 is the least significant bit.

Note 1: In order to remain compatible with existing 4610 printer status definitions, when reading the status bytes to determine which station is selected, the journal station selected status bit and the CR/DI station selected status bit must be checked in the following sequence:

1 - Check byte 6, bit 0 first

- If it is '1' then the journal station is selected
- If it is '0' then the journal station is not selected and status byte 6, bit 6 must be checked to determine which station is selected.  
If status byte 6, bit 6 is a '0' then the CR is selected.  
If status byte 6, bit 6 is a '1' then the DI is selected.

Note 2: Where additional data follows the fifteen fiscal status bytes.

Note 3: When fiscal unit return code is 43 hex. (67<sub>10</sub>), it means that no error is indicated on this status message.

**3.1.3.2 Country Code and Version Number Definition**

[A010]

Country Name	Country Code	Country Version (hardware model)
Hungary	04	05

### 3.1.4 Return Codes

---

**000 => DOS 80900100 => 4690 OS**

**Explanation:** An overflow occurred. The Transaction Total or one of the 14 TAX Transaction Gross Sales total exceeds the maximum allowed value (2147483647) on an ITEM fiscal request. The request is not processed.

**User Response:** Issue a Total and End Transaction request to close the voucher or Cancel it.

---

**002 => DOS 80900102 => 4690 OS**

**Explanation:** An overflow occurred. The Void transaction total exceeds the maximum allowed value. The request is not processed.

**User Response:** Issue the Total and End Transaction commands to end the sales transaction or a Cancel Transaction command to cancel the sales transaction.

---

**004 => DOS 80900104 => 4690 OS**

**Explanation:** An overflow occurred. The Discount transaction total exceeds the maximum allowed value. The request is not processed.

**User Response:** Issue the Total and End Transaction commands to end the sales transaction or a Cancel Transaction command to cancel the sales transaction.

---

H64

**006 => DOS 80900106 => 4690 OS**

**Explanation:** An overflow occurred. The Uplift transaction total exceeds the maximum allowed value. The request is not processed.

**User Response:** Issue the Total and End Transaction commands to end the sales transaction or a Cancel Transaction command to cancel the sales transaction.

---

**007 => DOS 80900107 => 4690 OS**

**Explanation:** An overflow occurred. The Notpaid transaction total exceeds the transaction total value. The request is not processed.

**User Response:** Make the Notpaid amount less than or equal to the transaction total.

---

**008 => DOS 80900108 => 4690 OS**

**Explanation:** An underflow occurred. The current transaction total or one of the VAT Category (or Department) transaction sales totals is less than the minimum allowed value. The request is not processed.

**User Response:** Cancel the transaction or make the total greater than the minimum allowed value.

---

**010 => DOS 80900110 => 4690 OS**

**Explanation:** An underflow occurred. The Void transaction total is less than the minimum allowed value. The request is not processed.

**User Response:** Issue the Total and End Transaction commands to end the sales transaction or a Cancel Transaction command to cancel the sales transaction.

---

**012 => DOS 80900112 => 4690 OS**

**Explanation:** An underflow occurred. The Discount transaction total is less than the minimum allowed value. The request is not processed.

**User Response:** Issue the Total and End Transaction commands to end the sales transaction or a Cancel Transaction command to cancel the sales transaction.

---

H65

**014 => DOS 80900114 => 4690 OS**

**Explanation:** An underflow occurred. The Uplift transaction total is less than the minimum allowed value. The request is not processed.

**User Response:** Issue the Total and End Transaction commands to end the sales transaction or a Cancel Transaction command to cancel the sales transaction.

---

H79

**015 => DOS 80900115 => 4690 OS**

**Explanation:** The payment transaction total is negative. The request is not processed.

**User Response:** Make the payment total greater than or equal to zero

---

---

**016 => DOS 80900116 => 4690 OS**

**Explanation:** An overflow occurred. The daily total or one of the VAT Category (or Department) daily sales totals exceeds the maximum allowed value at Total request time. The request is not processed.

**User Response:** Make the total less than or equal to the maximum allowed value, issue an End Transaction or Cancel Transaction command, and then issue a Daily Closure command.

---

**018 => DOS 80900118 => 4690 OS**

**Explanation:** An overflow occurred. The Void daily total exceeds the maximum allowed value at end transaction time. The request is not processed.

**User Response:** Make the total less than or equal to the maximum allowed value, issue an End Transaction or Cancel Transaction command, and then issue a Daily Closure command.

---

**020 => DOS 80900120 => 4690 OS**

**Explanation:** An overflow occurred. The Discount daily total exceeds the maximum allowed value at end transaction time. The request is not processed.

**User Response:** Make the total less than or equal to the maximum allowed value, issue an End Transaction or Cancel Transaction command, and then issue a Daily Closure command.

---

**024 => DOS 80900124 => 4690 OS**

**Explanation:** The user total amount is not equal to the fiscal total amount. The values associated with the total request do not match the totals stored in the fiscal memory. The request is not processed.

**User Response:** Correct the computation procedure of the total, then issue an End Transaction or Cancel Transaction command.

---

**025 => DOS 80900125 => 4690 OS**

**Explanation:** A fiscal rules violation has occurred. The word 'total' (or equivalent) occurs in a message when not allowed, or a reserved character is used in the message, or a number string matched the fiscal unit serial number. Note that not all rules violations apply to all countries. The request is not processed.

**User Response:** Correct the fiscal rules violation and try the command again.

---

**026 => DOS 80900126 => 4690 OS**

**Explanation:** An underflow occurred. A transaction amount was negative at Total request time. This return code applies (where applicable) to:

- Transaction total
- VAT total
- VAT category (or department) total accumulator
- VAT category (or department) tax accumulator

The request is not processed.

**User Response:** Make the amount greater than or equal to zero, then issue an End Transaction or Cancel Transaction command.

---

**027 => DOS 8090061B => 4690 OS**

**Explanation:** An overflow occurred. The Discount on Subtotal exceeds the maximum allowed value. The request is not processed.

**User Response:** Make the amount less than the maximum allowed value, then issue an End Transaction or Cancel Transaction command.

---

**028 => DOS 8090061C => 4690 OS**

**Explanation:** An overflow occurred. The Uplift on Subtotal exceeds the maximum allowed value. The request is not processed.

**User Response:** Make the amount less than the maximum allowed value, then issue an End Transaction or Cancel Transaction command.

---

**029 => DOS 80900129 => 4690 OS**

**Explanation:** Tender is not completed. The Payment total was less than the transaction total. The request is not processed.

**User Response:** Use the Rectify option on the Payment command or issue an additional Payment command to complete processing.

---

---

**031 => DOS 8090061F => 4690 OS**

**Explanation:** An underflow occurred. The sum of the Discount on Subtotal operations in this sales transaction is less than the minimum allowed value. The request is not processed.

**User Response:** Make the amount greater than or equal to the minimum allowed value, then issue an End Transaction or Cancel Transaction command.

---

**032 => DOS 80900620 => 4690 OS**

**Explanation:** An underflow occurred. The sum of the Uplift on Subtotal operations in this sales transaction is less than the minimum allowed value. The request is not processed.

**User Response:** Make the total greater than or equal to zero, then issue an End Transaction or Cancel Transaction command.

---

**033 => DOS 80900141 => 4690 OS**

**Explanation:** An underflow occurred. The Return daily total is less than the minimum allowed value. The request is not processed.

**User Response:** Make the total greater than or equal to the minimum allowed value, issue an End Transaction or Cancel Transaction command, and then issue a Daily Closure command.

---

**034 => DOS 80900142 => 4690 OS**

**Explanation:** An underflow occurred. The Void daily total is less than the minimum allowed value. The request is not processed.

**User Response:** Make the total greater than or equal to the minimum allowed value, issue an End Transaction or Cancel Transaction command, and then issue a Daily Closure command.

---

**036 => DOS 80900144 => 4690 OS**

**Explanation:** An underflow occurred. The Discount daily total is less than the minimum allowed value. The request is not processed.

**User Response:** Make the total greater than or equal to the minimum allowed value, issue an End Transaction or Cancel Transaction command, and then issue a Daily Closure command.

---

[A108]

**039 => DOS 80900627 => 4690 OS**

**Explanation:** A command was issued that is not allowed before the Total command is successfully executed once a discount or uplift on subtotal operation was performed. The request is not processed.

**User Response:** Correct the application program sequence.

---

**040 => DOS 80900628 => 4690 OS**

**Explanation:** The tax category field is not blank and the amount field is blank in an Item Sales transaction. The request is not processed.

**User Response:** Correct the application program.

---

**041 => DOS 80900629 => 4690 OS**

**Explanation:** TAX table not verified. The request is not processed.

**User Response:** Check application program. Program must issue a Compare TAX Table command before further operations can be processed.

---

**042 => DOS 8090062A => 4690 OS**

**Explanation:** TAX table mismatch. The request is not processed.

**User Response:** Correct the application TAX table and reissue the command.

---

**043 => DOS 8090062B => 4690 OS**

**Explanation:** Fiscal memory tax table is full. The request is not processed.

**User Response:** Change the fiscal memory if the modification of the VAT table is required.

---

**044 => DOS 8090062C => 4690 OS**

**Explanation:** The tax category specified in Item Sale or Negative Item Sale command is not valid. For example, entering a non-zero rate for a category that must be equal to a rate of zero. The request is not processed.

**User Response:** Correct the application program.

---

**048 => DOS 80900630 => 4690 OS**

**Explanation:** An overflow occurred. The sum of the daily operations for Discount on Subtotal exceeds the maximum allowed value at end transaction time. The request is not processed.

---

**User Response:** Make the total less than or equal to the maximum allowed value, issue an End Transaction or Cancel Transaction command, and then issue a Daily Closure command.

---

**049 => DOS 80900631 => 4690 OS**

**Explanation:** An overflow occurred. The sum of the daily operations for Uplift on Subtotal exceeds the maximum allowed value. The request is not processed.

**User Response:** Make the total less than or equal to the maximum allowed value, issue an End Transaction or Cancel Transaction command, and then issue a Daily Closure command.

---

**050 => DOS 80900632 => 4690 OS**

**Explanation:** An underflow occurred. The sum of the daily operations for Discount on Subtotal is less than the minimum allowed value. The request is not processed.

**User Response:** Make the total greater than the minimum allowed value, issue an End Transaction or Cancel Transaction command, and then issue a Daily Closure command.

---

**051 => DOS 80900633 => 4690 OS**

**Explanation:** An overflow occurred. The sum of the daily operations for the uplift on subtotal daily transaction total is less than the minimum allowed value. The request is not processed.

**User Response:** Make the total greater than the minimum allowed value, issue an End Transaction or Cancel Transaction command, and then issue a Daily Closure command.

---

**052 => DOS 80900634 => 4690 OS**

**Explanation:** The Uplift and Discount on Subtotal commands are not allowed when the transaction total is equal to zero.

**User Response:** Adjust the transaction total or issue a Cancel Transaction command.

---

**053 => DOS 80900635 => 4690 OS**

**Explanation:** The requested time used on the Set Date command is not within the allowed range of the current fiscal printer time or the requested time is previous to the date of the last closure stored in the fiscal memory.

**User Response:** Either correct the time sent to the fiscal printer or, if the fiscal printer time differs from the actual time by more than the allowed range, call for service.

---

**055 => DOS 80900203 => 4690 OS**

**Explanation:** The fiscal request message length is less than the minimum required value. The request is not processed.

**User Response:** Check the application program.

---

**056 => DOS 80900150 => 4690 OS**

**Explanation:** An overflow occurred. The cancel transaction daily total exceeds the maximum allowed value at cancel transaction time. The request is not processed.

**User Response:** Make the total less than or equal to the maximum allowed value, issue a Cancel Transaction command, and then issue a Daily Closure command.

---

**058 => DOS 8090063A => 4690 OS**

**Explanation:** An overflow occurred. The Amount Due accumulator exceeds the maximum allowed value. The request is not processed.

**User Response:** Correct the payment amount and issue the command again.

---

**059 => DOS 8090063B => 4690 OS**

**Explanation:** An underflow occurred. The Amount Due accumulator is less than the minimum allowed value. The request is not processed.

**User Response:** Correct the payment amount and issue the command again.

---

**061 => DOS 8090063D => 4690 OS**

**Explanation:** An overflow occurred. The transaction total or one of the VAT category (or department) transaction sales totals exceeds the maximum allowed value on an Item command. The request is not processed.

**User Response:** Issue an End Transaction or Cancel Transaction command.

---

**063 => DOS 8090063F => 4690 OS**

**Explanation:** The Set Identification Information is not loaded. The request is not processed.

**User Response:** Use the Set Identification Information (1E) command to load the information. Depending on the country laws, this command may require IBM service personnel.

**064 => DOS 80900127 => 4690 OS**

**Explanation:** An overflow occurred. The specified value received amount from the application program exceeds the maximum allowed amount. The request is not processed.

**User Response:** Correct the value and try the operation again or Cancel the voucher.

---

**065 => DOS 80900201 => 4690 OS**

**Explanation:** A request was sent to the fiscal unit and the fiscal command byte is not recognized. The request is not processed.

**User Response:** Check the application program.

---

**066 => DOS 80900202 => 4690 OS**

**Explanation:** A request was sent to the fiscal unit and the fiscal command byte extension is not recognized. The request is not processed.

**User Response:** Check the application program.

---

**067 => DOS 80900643 => 4690 OS**

**Explanation:** The command was processed successfully. No error occurred.

**User Response:** No action is required.

---

**069 => DOS 80900205 => 4690 OS**

**Explanation:** An attempt was made to print a line on the customer receipt station that exceeds the maximum number of ordinary print lines allowed during a fiscal voucher. The request is not processed.

**User Response:** issue either an End Transaction or Cancel Transaction command before printing the ordinary print lines. If this error occurred during the online printer diagnostic test, it indicates that the test cannot be completed because a sales transaction is in progress. Either have the salesperson end the transaction or diagnose the printer problem using the offline printer test that is invoked by pressing the keys on the printer in the correct sequence.

---

H66

**070 => DOS 80900206 => 4690 OS**

**Explanation:** Max Wasted Space not set.

**User Response:** Issue Set Max Wasted Space Command.

---

H51

**071 => DOS 80900207 => 4690 OS**

**Explanation:** Not enough space on CF at start of Journal Period. Available space is less than MaxWasted1+ MaxWasted2.

**User Response:** Change current CF to a formatted empty one.

---

**072 => DOS 80900302 => 4690 OS**

**Explanation:** CF not ready.

**User Response:** Check the correct insertion of CF

---

H51

**073 => DOS 80900303 => 4690 OS**

**Explanation:** Not enough space on CF at Print Header Lines / Start of X-Report / Start of Application- Originated Report. Available space is less than MaxWasted2 +10 K.

**User Response:** Execute a Daily Closure and change current CF to a formatted empty one.

---

H51

**074 => DOS 80900208 => 4690 OS**

**Explanation:** Not enough space on CF during the execution of print lines inside a Fiscal or Non-Fiscal document on CR, or during the execution of Set Date command. Available space is less than MaxWasted2 + 5 K.

**User Response:** Cancel the current document, execute a Daily Closure and change current CF to a formatted empty one. If the error happens at Set Date, only change current CF to a formatted empty one.

---

H51



---

**075 => DOS 80900209 => 4690 OS**

**Explanation:** Not enough space on CF before, or during the print of Fiscal Memory Dump. Available space is less than MaxWasted2 + 10 K. The command is refused, or the report is cancelled by the printer.

**User Response:** Execute a Daily Closure and change current CF to a formatted empty one.

---

**076 => DOS 80900210 => 4690 OS**

**Explanation:** An attempt was made to print on invalid print station. The request is not processed.

**User Response:** Check the application program.

---

H67

**077 => DOS 80900211 => 4690 OS**

**Explanation:** The Daily Closure procedure tries to create on CF an existing file.

**User Response:** Service the printer.

---

**079 => DOS 80900212 => 4690 OS**

**Explanation:** A line feed on the customer receipt station is not allowed during printing of inserted fiscal documents. The request is not processed.

**User Response:** Check the application program.

---

**080 => DOS 80900213 => 4690 OS**

**Explanation:** A line feed on an inserted document is not allowed at this point during a sales transaction. The request is not processed.

**User Response:** Check the application program.

---

**081 => DOS 80900651 => 4690 OS**

**Explanation:** The print typeface specified is not valid. The request is not processed.

**User Response:** Specify a valid print typeface.

---

**082 => DOS 80900306 => 4690 OS**

**Explanation:** A request to print on the customer receipt or document insert station was made without the correct application-originated report mode selected. The request is not processed.

**User Response:** Check the application program sequence.

---

**083 => DOS 80900307 => 4690 OS**

**Explanation:** An unrecoverable error occurred reading the fiscal memory identification/status/setup area.

**User Response:** Service the printer.

---

**084 => DOS 80900308 => 4690 OS**

**Explanation:** General EJ error

**User Response:** Due to the limited number of return codes available, all commands that fails due to a problem related with EJ, just fail returning this general EJ error "84".

To know the exact reason for failure, the application must send a Get Extended EJ Error (63 command) to get the specific EJ return code. Refer to 3.1.5 Electronic Journal Return Codes on page 151.

---

**085 => DOS 80900309 => 4690 OS**

**Explanation:** The tax rate for this tax category is not valid. The request is not processed.

**User Response:** Check the application program.

---

**086 => DOS 80900401 => 4690 OS**

**Explanation:** The password entered is not valid or the maximum number of attempts to enter the correct password was exceeded. The request is not processed.

**User Response:** Reenter the correct password or, if the maximum number of attempts was exceeded, use the J4 (CE) jumper to restore normal operation. Note: Only authorized service personnel can perform functions that require a password.

---

**087 => DOS 80900657 => 4690 OS**

**Explanation:** The printer command received by the fiscal printer is not valid. The request is not processed.

**User Response:** Issue a valid printer command.

---

**089 => DOS 80900312 => 4690 OS**

**Explanation:** The fiscal memory is full. All fiscal commands are rejected except the Fiscal Memory Dump commands.

---



**User Response:** Service the printer.

---

**090 => DOS 8090065A => 4690 OS**

**Explanation:** The requested Daily Closure was not found in the fiscal memory. The request is not processed.

**User Response:** Specify a valid closure number or valid dates for the Fiscal Memory Dump command.

---

**091 => DOS 80900314 => 4690 OS**

**Explanation:** An error occurred while printing the start-up message.

**User Response:** Turn the power OFF and ON again. If the error continues, service the printer.

---

**092 => DOS 80900315 => 4690 OS**

**Explanation:** The requested internal table register was not found in the fiscal memory. The request is not processed.

**User Response:** Specify a valid table entry.

---

**094 => DOS 80900317 => 4690 OS**

**Explanation:** NFR Accumulator not defined or it does not match the Start Non-Fiscal. The request is not processed.

**User Response:** Correct the input data.

---

**095 => DOS 80900425 => 4690 OS**

**Explanation:** The address or length data is not valid. The requested address range is not valid or is wrong in the engineering dump command. The request is not processed.

**User Response:** Correct the input data.

---

**096 => DOS 80900140 => 4690 OS**

**Explanation:** A numeric field contains characters that are not valid or more lines tried to print between two items lines than allowed within the Fiscal Parameter Configuration command. The request is not processed.

**User Response:** Correct the value and issue the command again.

---

**097 => DOS 80900410 => 4690 OS**

**Explanation:** Fiscal RAM is in error or does not match the fiscal memory.

**User Response:** Service the printer. The J4 (CE) jumper procedure is required. Note: Only authorized service personnel can move the J4 jumper.

---

**098 => DOS 80900411 => 4690 OS**

**Explanation:** Fiscal RAM is restored.

**User Response:** Remove the J4 (CE) jumper to restore normal operation. Note: Only authorized service personnel can move the J4 jumper.

---

**100 => DOS 80900329 => 4690 OS**

**Explanation:** An error occurred while reading from the fiscal memory. The request is not processed.

**User Response:** Service the printer.

---

**101 => DOS 80900326 => 4690 OS**

**Explanation:** An unrecoverable error occurred when writing to fiscal memory. The request is not processed.

**User Response:** Service the printer.

---

**102 => DOS 80900327 => 4690 OS**

**Explanation:** The Fiscal Parameter Configuration (C4) command was attempted more than once with the same extension since the last J4 (CE) jumper reset. The request is not processed.

**User Response:** Reset the printer using the J4 (CE) jumper procedure and initialize the printer again. Note: Only authorized service personnel can move the J4 jumper.

---

**103 => DOS 80900421 => 4690 OS**

**Explanation:** The data is not valid. The requested data or number is out-of-range. The request is not processed.

**User Response:** Correct the input data.

---

**106 => DOS 80900362 => 4690 OS**

**Explanation:** An unexpected command error occurred. The request is not processed.

**User Response:** If the error continues, service the fiscal printer.

---

**107 => DOS 8090066B => 4690 OS**

**Explanation:** There is a print header application password matching error. The request is not processed.

**User Response:** Issue the command again using the correct password.

---

**108 => DOS 80900328 => 4690 OS**

**Explanation:** The store/POS identification information table is full. The request is not processed.

**User Response:** If the table must be updated, exchange the fiscal memory.

---

**109 => DOS 80900324 => 4690 OS**

**Explanation:** The fiscal memory is not connected. The fiscal unit cannot restart processing.

**User Response:** Service the printer. When servicing, first check to ensure the cable connections on the fiscal processor card are correct. The J4 (CE) jumper procedure is required when the fiscal memory is reconnected.

Note: Only authorized service personnel can move the J4 jumper.

---

**112 => DOS 80900670 => 4690 OS**

**Explanation:** The fiscal printer was reset.

**User Response:** No action is required.

---

**113 => DOS 80900341 => 4690 OS**

**Explanation:** An unrecoverable printer error occurred after two power-on resets.

**User Response:** Turn the power off and then on again. If the problem persists, service the printer.

---

**114 => DOS 80900363 => 4690 OS**

**Explanation:** A printer communication error occurred.

**User Response:** Service the printer.

---

[A058] [A135]

**116 => DOS 80900702 => 4690 OS**

**Explanation:** The selected display (1 or 2) is not initialized (Enable polling to attached display) or it is disconnected when the "Attached Display Management" command (xCE) with the "Write to Attached Display 1/2" or "Read from Attached Display 1/2" command extension is sent. The request is not processed.

**User Response:** Send the "Attached Display Management" command (xCE) with the "Enable polling to attached display 1 or 2" command extension before send the "Read or Write to the Attached Display 1 or 2" command extension or be sure that the display is correctly connected.

---

**119 => DOS 80900677 => 4690 OS**

**Explanation:** Alphabetic field with invalid data. The request is not processed.

**User Response:** Correct the data and then issue the command again.

---

**120 => DOS 80900678 => 4690 OS**

**Explanation:** A printer card time-out occurred while executing a command.

**User Response:** Turn the power OFF and then ON again. If the problem persists, service the printer.

---

**121 => DOS 80900679 => 4690 OS**

**Explanation:** A printer card time-out occurred while executing a command.

**User Response:** Turn the power OFF and then ON again. If the problem persists, service the printer.

---

H71

**122 => DOS 8090067A => 4690 OS**

**Explanation:** Invalid command not allowed before set fiscal.

**User Response:** Issue set fiscal mode (18 cmd)

---

**123 => DOS 8090067B => 4690 OS**

**Explanation:** Operation not valid. Possible reasons are:

- error reading MICR data
- error doing flipper function
- flip check function not present in the printer
- MICR function not present in the printer

**User Response:** Test again with another check. If the error persist, service the printer.

---

**124 => DOS 8090067C9 => 4690 OS**

**Explanation:** Attempt to Print Check with incomplete or missing information.

**User Response:** Load the information with C0 command and issue C1 command again.

---

**125 => DOS 8090067D => 4690 OS**

**Explanation:** The requested closure date/time is previous to the date of the last closure stored in the fiscal memory.

**User Response:** Issue the closure report when date/time is greater than the last closure date/time stored in the fiscal memory.

---

**128 => DOS 80900320 => 4690 OS**

**Explanation:** Fiscal memory is not serialized. The request is not processed.

**User Response:** Service the printer.

---

[A011] – [A069]

**131 => DOS 80900323 => 4690 OS**

**ONLY VALID FOR IBM 4610 SureMark Fiscal Printer KR3/KR5 (RS-485)**

**Explanation:** A problem was detected in a display or in the configuration for the point-of-sale displays. No fiscal commands can be executed. The minimum number of POS displays that must be configured is 2.

**User Response:** Follow the technical specification procedures to set the configuration correctly. If problem persists, service the POS terminal.

**ONLY VALID FOR IBM 4610 SureMark Fiscal Printer KD3/KD5 (RS-232)**

**Explanation:** The request is not processed. Possible causes are:

- At least one of the displays that have to be monitored for connection by the fiscal printer is not connected.
- The command x1A has been issued with invalid display addresses.
- The command xCE has been issued to enable / disable polling to a display that has to be monitored for connection by the fiscal printer. Polling to such displays is always enabled.

**User Response:** Follow the technical specification procedures to set the configuration correctly. If problem persists, service the printer.

---

**134 => DOS 80900325 => 4690 OS**

**Explanation:** The fiscal unit detected an internal hardware error. The request is not processed.

**User Response:** Run the printer test to determine the cause of the problem. Service the printer.

---

**135 => DOS 80900220 => 4690 OS**

**Explanation:** The command is not valid outside of a sales period. The request is not processed.

**User Response:** Open the day by issuing a fiscal or non-fiscal document.

---

**136 => DOS 80900221 => 4690 OS**

**Explanation:** A voucher-related sales transaction command was issued while a sales transaction was not in progress. The request is not processed.

**User Response:** Correct the application program sequence.

---

**140 => DOS 80900225 => 4690 OS**

**Explanation:** A fiscal voucher-related command was issued before printing the store header. The request is not processed.

**User Response:** Correct the application program sequence.

---

**141 => DOS 80900226 => 4690 OS**

**Explanation:** A command was issued that is not allowed before the Total command is successfully executed. The request is not processed.

**User Response:** Correct the application program sequence.

---

**142 => DOS 80900227 => 4690 OS**

**Explanation:** The transaction payment procedure is not in progress. The request is not processed.

**User Response:** Correct the application program sequence.

---

**144 => DOS 80900229 => 4690 OS**

**Explanation:** The command was issued before the store header was set. The request is not processed.

**User Response:** Correct the application program sequence to set the store headers before issuing this command.

---

**145 => DOS 80900691 => 4690 OS**

**Explanation:** The command is not accepted when the J4 (CE) jumper is not active. The request is not processed.

**User Response:** Activate the CE jumper and try issuing the command again.

---

**146 => DOS 80900692 => 4690 OS**

**Explanation:** Barcode information not null terminated. The request is not processed.

**User Response:** Correct the application program.

---

**147 => DOS 80900693 => 4690 OS**

**Explanation:** Barcode size is invalid. The request is not processed.

**User Response:** Correct the application program

---

H102

**149 => DOS 80900695 => 4690 OS**

**Explanation:** Blank Amount lines not set. The request is not processed.

**User Response:** Execute the blank amount lines number set command (C406)

---

**158 => DOS 8090069E => 4690 OS**

**Explanation:** The date is not set by application program. The request is not processed.

**User Response:** Correct the application program sequence.

---

**160 => DOS 80900330 => 4690 OS**

**Explanation:** Fiscal memory is serialized. The request is not processed.

**User Response:** No action is required.

---

**161 => DOS 80900331 => 4690 OS**

**Explanation:** The fiscal unit is in fiscal mode. The request is not processed.

**User Response:** No action is required.

---

**164 => DOS 80900350 => 4690 OS**

**Explanation:** The power-on sequence is in progress.

**User Response:** No action is required.

---

**167 => DOS 80900230 => 4690 OS**

**Explanation:** The requested command cannot be issued while a sales period is in progress. The request is not processed.

**User Response:** Perform a Daily Closure command and then issue the command again.

---

**168 => DOS 80900231 => 4690 OS**

**Explanation:** A command not related to a sales transaction voucher was issued while a sales transaction is in progress. The request is not processed.

**User Response:** Issue the command again after the fiscal voucher is completed. If this error was encountered during the online printer diagnostic test, it indicates that the test cannot be completed because a sales transaction is in progress. Either have the salesperson end the transaction or diagnose the printer problem using the offline printer test that is invoked by pressing the keys on the printer in the correct sequence.

---

**172 => DOS 80900235 => 4690 OS**

**Explanation:** Only a fiscal voucher-related sales transaction command is accepted after the store header is printed. The request is not processed.

**User Response:** Check the application program.

---

**173 => DOS 80900236 => 4690 OS**

**Explanation:** After the Total command was issued, the command sequence is not valid. The request is not processed.

**User Response:** Check the application program.

---

**174 => DOS 80900237 => 4690 OS**

**Explanation:** A Payment is in progress. The request is not processed.

**User Response:** After the Payment processing is complete, issue the request again.

---

**176 => DOS 80900239 => 4690 OS**

**Explanation:** The fiscal unit detected an internal hardware error. The request is not processed.

**User Response:** Service the printer.

---

**177 => DOS 809006B1 => 4690 OS**

**Explanation:** Fiscal EPROM is in error. Serialization mismatch between RAM and EPROM.

---

**User Response:** Service the printer.

---

**178 => DOS 80900241 => 4690 OS**

**Explanation:** The enterprise specified is different than the set one. The request is not processed.

**User Response:** Specify the correct enterprise.

---

**179 => DOS 809006B3 => 4690 OS**

**Explanation:** Fiscal RAM is in error. Return to the FB command.

**User Response:** Service the printer.

---

**180 => DOS 809006B4 = 4690 OS**

**Explanation:** Fiscal EPROM is in error. EPROM serialized but pattern not found.

**User Response:** Service the printer.

---

**181 = DOS 809006B5 = 4690 OS**

**Explanation:** Fiscal RAM is in error. Return to the FB command.

**User Response:** Service the printer.

---

**182 => DOS 809006B6 => 4690 OS**

**Explanation:** An error occurred on an End Transaction command. The request is not processed.

**User Response:** Issue the End Transaction command again. If this error was encountered during the online printer diagnostic test, it indicates that the test cannot be completed because a sales transaction is in progress. Either have the salesperson end the transaction or diagnose the printer problem using the offline printer test that is invoked by pressing the keys on the printer in the correct sequence.

---

**183 => DOS 809006B7 => 4690 OS**

**Explanation:** An error occurred on a Cancel Transaction command, or the firmware is waiting for a Cancel Transaction command. The request is not processed.

**User Response:** Issue the Cancel Transaction command. If this error was encountered during the online printer diagnostic test, it indicates that the test cannot be completed because a sales transaction is in progress. Either have the salesperson end the transaction or diagnose the printer problem using the offline printer test that is invoked by pressing the keys on the printer in the correct sequence.

---

**184 => DOS 809006B8 => 4690 OS**

**Explanation:** The command sequence is not valid. A command was requested that is not allowed during an Application-Originated Report. The request is not processed.

**User Response:** Check the application program sequence.

---

**185 => DOS 809006B9 => 4690 OS**

**Explanation:** An EEPROM load error occurred on the printer logic card. The request is not processed.

**User Response:** Service the printer.

---

**186 = 4684 809006BA = 4690**

**Explanation:** Mismatch between RAM Fiscalization Flag and EPROM Mark. The request is not processed.

**User Response:** Insert the jumper and reinitialize the printer. If the problem persists, service the printer.

---

H117

**187 => DOS 809006BB => 4690 OS**

**Explanation:** An unrecoverable error occurred in the 'DE00' – End Application-Originated Report command execution. The request is not processed.

**User Response:** Reexecute the 'DE00' – End Application-Originated Report command.

---

**188 => DOS 809006BC => 4690 OS**

**Explanation:** An unrecoverable error occurred in the 'DE01' – Cancel Application-Originated Report command execution or during the generation of the Application-Originated Report. The request is not processed.

**User Response:** Execute the 'DE01' – Cancel Application-Originated Report command.

---

H103

**189 => DOS 809006BD => 4690 OS**

**Explanation:** Invalid command related to Check procedure. An attempt to execute a command not related to check while a check procedure is in progress or to execute a check command when a check procedure is not in progress. The request is not processed.

**User Response:** Check the application program sequence.

---

**191 => DOS 80900523 => 4690 OS**

**Explanation:** Fiscal unit locked. The request is not processed.

**User Response:** Service the printer.

---

**192 => DOS 80900524 => 4690 OS**

**Explanation:** The command is rejected from the printer logic card. The request is not processed.

**User Response:** Check for a device driver programming error.

---

**194 => DOS 80900521 => 4690 OS**

**Explanation:** A print head home error occurred. The request is not processed. (On 4690 Operating System, this error could be reported for other types of printer problems besides home errors.)

**User Response:** If the problem persists, service the printer.

---

**200 => DOS 80900527 => 4690 OS**

**Explanation:** The printer cover is open, or a paper error occurred in CR station. The request is not processed.

**User Response:** Close the printer cover or add paper. If the cover is already closed, service the printer.

---

**202 => DOS 80900527 => 4690 OS**

**Explanation:** The inserted document is not ready. The request is not processed.

**User Response:** Try removing the document and reinserting it. If the problem persists, service the printer.

---

**203 => DOS 80900522 => 4690 OS**

**Explanation:** The printer cover is open. The request is not processed.

**User Response:** Close the printer cover. If the cover is already closed, service the printer.

---

**205 => DOS 80900526 => 4690 OS**

**Explanation:** A printer keybutton is pressed. The request is not processed.

**User Response:** Release the pressed keybutton. If a keybutton is not pressed, service the printer.

---

**207 => DOS 80900714 => 4690 OS**

**Explanation:** PDF barcode generation problem. The request is not processed.

**User Response:** Service the printer.

---

**208 => DOS 809006D0 => 4690 OS**

**Explanation:** Printer error. The request is not processed.

**User Response:** Service the printer.

---

**210 => DOS 809006d2 => 4690 OS**

**Explanation:** Printer DI throat is opened. The request is not processed.

**User Response:** Close the throat and issue the command print again.

---

**214 => DOS 80900527 => 4690 OS**

**Explanation:** A top-insert document error occurred. The request is not processed.

**User Response:** Ensure that the document is inserted correctly.

---



### 3.1.5 Electronic Journal Return Codes

Due to the limited number of return codes available, all commands that fails due to a problem related with EJ, just fail returning a general EJ error "84".

To know the reason for failure, the application must send the Get Extended EJ Error (63 command) to get the following EJ return codes.

#### 3.1.5.1 EJ Return Code Descriptions

**000 (hex 0)**

**Explanation:** No error occurred.

**User Response:** No action is required.

---

**001 (hex 1)**

**Explanation:** Compact Flash not present. The request is not processed.

**User Response:** Insert the compact flash and issue the command again.

---

**002 (hex 2)**

**Explanation:** Not enough free space in Compact Flash (CF). The request is not processed.

**User Response:** Close the current Journal Period, then replace the CF with a new one and then issue the command again.

---

**003 (hex 3)**

**Explanation:** Flash Transfer Error. The request is not processed.

**User Response:** Retry the command. If the error persists, replace the CF, insert the jumper, and reinitialize the printer.

---

**004 (hex 4)**

**Explanation:** The Compact Flash was changed inside a journal period.

**User Response:** Put again the old one.

---

**005 (hex 5)**

**Explanation:** Internal Error. The request is not processed.

**User Response:** Service the printer.

---

**006 (hex 6)**

**Explanation:** Internal Error. The request is not processed.

**User Response:** Service the printer.

---

**007 (hex 7)**

**Explanation:** Internal Error. The request is not processed.

**User Response:** Service the printer.

---

**008 (hex 8)**

**Explanation:** The Compact Flash has a wrong format.

**User Response:** The Compact Flash will be formatted during IPL.

---

**009 (hex 9)**

**Explanation:** Internal Error. The request is not processed.

**User Response:** Service the printer.

---

**010 (hex A)**

**Explanation:** Internal Error. The request is not processed.

**User Response:** Service the printer.

---

**011 (hex B)**

**Explanation:** EJ Filename exists. The request is not processed.

**User Response:** Change the EJ filename and issue the command again.

---

**012 (hex C)**

**Explanation:** Invalid EJ Filename. The first five chars of an EJ filename specified cannot be equal to the five chars used for automatic generated EJ filenames. These chars are usually equal to the first five chars of the serial number. The request is not processed.

**User Response:** Change the EJ filename and issue the command again.

---

**013 (hex D)**

**Explanation:** Invalid Char in EJ Filename. The EJ filenames can only consist of the following chars: A to Z, a to z, 0 to 9, '-', and '\_'. The request is not processed.

**User Response:** Change the EJ filename and issue the command again.

---

**014 (hex E)**

**Explanation:** Key length or command length invalid. The request is not processed.

**User Response:** Check the application program sequence.

---

**015 (hex F)**

**Explanation:** The algorithm specified is not known. The request is not processed.

**User Response:** Correct the input data and issue the 66 command again.

---

**016 (hex 10)**

**Explanation:** The key specified is too long to be handle by the microcode. The request is not processed.

**User Response:** Correct the input data and issue the 66 command again.

---

**017 (hex 11)**

**Explanation:** The length specified is invalid. The request is not processed.

**User Response:** Correct the input data and issue the 66 command again.

---

**018 (hex 12)**

**Explanation:** Invalid sequence during set public and private key command. The request is not processed.

**User Response:** Correct the sequence and issue the 66 command again.

---

**019 (hex 13)**

**Explanation:** The key prime or subprime is invalid. The request is not processed.

**User Response:** Correct the input data and issue the 66 command again.

---

**020 (hex 14)**

**Explanation:** The key base is invalid. The request is not processed.

**User Response:** Correct the input data and issue the 66 command again.

---

**021 (hex 15)**

**Explanation:** The public and private key does not form a valid pair. The request is not processed.

**User Response:** Correct the input data and issue the 66 command again.

---

**022 (hex 16)**

**Explanation:** The key prime and subprime do not form a valid pair. The request is not processed.

**User Response:** Correct the input data and issue the 66 command again.

---

**023 (hex 17)**

**Explanation:** Key Table full. The request is not processed.

**User Response:** Change fiscal memory.

---

**024 (hex 18)**

**Explanation:** Key not set. The request is not processed.

**User Response:** Issue the 66 command (Set Public and Private Key).

---

**025 (hex 19)**

**Explanation:** Key corrupt. The request is not processed.

**User Response:** Change the fiscal memory.

---

**026 (hex 1A)**

**Explanation:** Internal Error. The request is not processed.

**User Response:** Service the printer.

---

**027 (hex 1B)**

**Explanation:** File not found. The CF does not have any (open CF file or get directory first file) or more (get directory next file) file matching the filename specified. The request is not processed.

**User Response:** (none).

---

**028 (hex 1C)**

**Explanation:** Invalid filename characters. The filename specified includes invalid characters. The request is not processed.

**User Response:** Correct the application program.

---

**029 (hex 1D)**

**Explanation:** CF File already open. There is one CF file currently open. The request is not processed.

**User Response:** Correct the application program.

---

**030 (hex 1E)**

**Explanation:** CF File not open. There is no one CF file open. The request is not processed.

**User Response:** Correct the application program.

---

**031 (hex 1F)**

**Explanation:** Internal Error. The request is not processed.

**User Response:** Service the printer.

---

**032 (hex 20)**



**Explanation:** Invalid CF File attributes. The CF file attribute requested is invalid. The request is not processed.

**User Response:** Correct the application program.

---

**034 (hex 22)**

**Explanation:** Internal Error. The request is not processed.

**User Response:** Service the printer.

---

**035 (hex 23)**

**Explanation:** The current Journal Period must be closed. The request is not processed.

**User Response:** Close the Journal Period.

---

**036 (hex 24)**

**Explanation:** Internal error.

**User Response:** Service the printer.

---

**037 (hex 25)**

**Explanation:** Invalid sequence reading CF file.

**User Response:** The sequence must be "0" (first block), "n" (again the last read block) or "n + 1" (read the next block).

---

**038 (hex 26)**

**Explanation:** Compact flash hardware error. It did not pass the diagnostic test.

**User Response:** Insert a new compact flash.

---

**040 (hex 28)**

**Explanation:** Compact flash hardware error.

**User Response:** Issue the command again. If the problem persists, remove and insert the CF and reissue the command.

---

**041 (hex 29)**

**Explanation:** The arch attribute state specified is invalid.

**User Response:** Select the correct arch attribute state and issue the command again.

---

**043 (hex 2B)**

**Explanation:** Compact flash not ready.

**User Response:** Issue the command again.

---

H120

**044 (hex 2C)**

**Explanation:** The Private and Public keys are frozen. The request is not processed.

**User Response:** (none)

---

[A013]

**045 (hex 2D)**

**Explanation:** The compression type is unknown. The request is not processed.

**User Response:** (none)

---

[A014]

**046 (hex 2E)**

**Explanation:** The compressed file is corrupted. The request is not processed.

**User Response:** (none)

---

### **3.1.6 Return Code Conversion Table (4694 OS to DOS/WINDOWS)**

The following table is for converting 4690 OS return codes into DOS/WINDOWS return codes. Find the DOS/WINDOWS return codes under 3.1.4 Return Codes on page 139.

<b>4690 OS Return Code</b>	<b>Equivalent DOS/WINDOWS Return Code</b>
80900100	000
80900102	002
80900104	004
80900106	006
80900107	007
80900108	008
80900110	010
80900112	012
80900114	014
80900115	015
80900116	016
80900118	018
80900120	020
80900124	024
80900125	025
80900126	026
80900127	064
80900129	029
80900140	096
80900141	033
80900142	034
80900144	036
80900150	056
80900201	065
80900202	066
80900203	055
80900205	069
80900206	070
80900207	071
80900208	074
80900209	075
80900210	076
80900211	077
80900212	079
80900213	080
80900220	135
80900221	136
80900225	140
80900226	141
80900227	142
80900229	144
80900230	167
80900231	168
80900235	172
80900236	173
80900237	174
80900239	176
80900241	178
80900302	072
80900303	073
80900306	082
80900307	083
80900308	084
80900309	085

<b>4690 OS Return Code</b>	<b>Equivalent DOS/WINDOWS Return Code</b>
80900312	089
80900314	091
80900315	092
80900317	094
80900320	128
80900323	131
80900324	109
80900325	134
80900326	101
80900327	102
80900328	108
80900329	100
80900330	160
80900331	161
80900341	113
80900350	164
80900362	106
80900363	114
80900401	086
80900410	097
80900411	098
80900421	103
80900425	095
80900521	194
80900522	203
80900523	191
80900524	192
80900526	205
80900527	200
80900527	202
80900527	214
8090061B	027
8090061C	028
8090061F	031
80900620	032
80900628	040
80900629	041
8090062A	042
8090062B	043
8090062C	044
80900630	048
80900631	049
80900632	050
80900633	051
80900634	052
80900635	053
8090063A	058
8090063B	059
8090063D	061
8090063F	063
80900643	067
80900651	081
80900657	087
8090065A	090

<b>4690 OS Return Code</b>	<b>Equivalent DOS/WINDOWS Return Code</b>
8090066B	107
80900670	112
80900677	119
80900678	120
80900679	121
8090067A	122
8090067B	123
8090067C9	124
8090067D	125
80900691	145
80900692	146
80900693	147
80900695	149
8090069E	158
809006B1	177
809006B3	179
809006B4	180
809006B5	181
809006B6	182
809006B7	183
809006B8	184
809006B9	185
809006BA	186
809006BB	187
809006BC	188
809006BD	189
809006D0	208
809006D2	210
80900702	116
80900714	207

## 4 Fiscal Software and Hardware Interface Information

[A045]

### 4.1 Printer Features

The printer features are:

- Customer Receipt Station (CR) - thermal printing
- Document Insert Station (DI) - impact printing (Only KR3 / KD3 models)
- Electronic Journaling
- RS-485 communication interface (Only KR3 / KR5 models)
- RS-232 communication interface (Only KD3 / KD5 models)
- Barcode generation (CR station only)
- Barcode printing capability (CR station only)
- MICR character reading (DI station only) (Only KR3 / KD3 models)
- Paper Cutter (CR station only)
- Document Flipping (DI station only) (Only KR3 / KD3 models)

### 4.2 Printer Models

Model	Printer	Type	Interface	Power	Stations	
					SJ	DI
KR3	4610 SureMark Fiscal Printer	Fiscal	RS-485	Terminal	NO	YES
KR5	4610 SureMark Fiscal Printer	Fiscal	RS-485	Terminal	NO	NO
KD3	4610 SureMark Fiscal Printer	Fiscal	RS-232	Brick	NO	YES
KD5	4610 SureMark Fiscal Printer	Fiscal	RS-232	Brick	NO	NO

### 4.3 Supported Printer Typefaces

H19 The IBM 4610 SureMark Fiscal Printer KR3/KR5/KD3/KR5 typefaces supported are:

#### 4.3.1 Print typefaces on CR (Thermal Printer Station)

- 44 char / line
- 38 char / line
- 48 char / line
- 44 char / line double-high
- 44 char / line emphasized
- 38 char / line emphasized
- 48 char / line emphasized
- 44 char / line double-high, emph.

#### 4.3.2 Print typefaces on DI (Document Insert Station)

- 15 characters per inch (CPI) (47 char. / line, portrait )
- 12 characters per inch (CPI) (37 char. / line, portrait )
- 17 characters per inch (CPI) (52 char. / line, portrait )
- 15 characters per inch (CPI) double high (47 char. / line, portrait )
- 15 characters per inch (CPI) emphasized (47 char. / line, portrait )
- 12 characters per inch (CPI) emphasized (37 char. / line, portrait )
- 17 characters per inch (CPI) emphasized (52 char. / line, portrait )
- 15 characters per inch (CPI) double high, emphasized (47 char. / line, portrait )

The application program controls the print typeface by setting the required bits in the command extension. The selected print typeface applies to all characters of the same line.

## 4.4 Error Conditions

H68

Errors encountered during command execution are processed as follows:

- Command processing is suspended.
- Internal accumulators and counters are restored to their original value (the value they had before the command in error was received).
- An error is included in the final status sent over the communication link. The error type indicates the cause of the abnormal termination.
- As answer to a asynchronous or intermediate error the driver retransmits the last command with Retry bit (Command Extension bit 7) on. This Retry bit has effect only on the following commands, but it may be used on all other fiscal commands with no adverse effect
  - 06 End Transaction
  - 07 Cancel Transaction
  - 13 Daily Closure (Z-Report)
  - 14 Summary Fiscal Report (X-Report)
  - 15 Print Multi-Day Fiscal Report(Fiscal Memory Dump)
  - DE End Application-Originated Report
- The application program can send the same command again (retry) or send any other command that is valid for the procedure in progress.

The error can happen in the following situations:

- After **Print Header** command and before **End Transaction** or **Cancel Transaction** commands FCANCEL flag is set, that means no more Item sale, Negative Item Sale, Total/Subtotal Printing, Discount/Uplift on Subtotal, Payment, End Transaction commands are accepted. In this situation only the Cancel Transaction is accepted. In this situation the Electronic Fiscal Report response byte 26 bit 2 is set. (See 2.6.4.1). This bit will be cleared by the Cancel Transaction command.
- **Daily Closure** Command - On receipt of the first command after error, the closure is completed in one of the following two ways:
  - Fiscal Memory Already Updated** - The Daily Closure command is terminated as if the error did not occur.
  - Fiscal Memory Not Yet Updated** - The daily data is restored as it was before the Daily Closure command and the closure report printout is voided.
- **Print Multi-day Fiscal Report command** - On receipt of first command after an error, the memory report function is terminated and the report is voided.
- **End Transaction** - Only the End Transaction or Cancel Transaction commands are accepted.
- **Cancel Transaction** - Only the Cancel Transaction command is accepted.

## 4.5 PLD - Power Line Disturbance

H69

When a PLD occurs the fiscal unit goes into a power off state. When power is restored the microcode checks if command execution was in progress when PLD occurred. If no command was in progress a normal IPL is performed. If command was in progress then internal Accumulators and Counters are restored to their original value (the value they had at PLD time). A bit (PLD bit) is included in the IPL status sent over the communication link. The PLD bit indicates to the Application that the last command sent was not executed because of PLD.

The IPL routines restore the accumulators and counters to their original values, but no actions can be performed on totally or partially printed lines.

When PLD occurs:

- After **Print Header** command and before **End Transaction** or **Cancel Transaction** commands. On IPL completion, FCANCEL flag is set, that means no more Item sale, Negative Item Sale, Total/Subtotal Printing, Discount/Uplift on Subtotal, Payment, End Transaction commands are accepted. In this situation only the Cancel Transaction is accepted. In this situation the Electronic Fiscal Report response byte 26 bit 2 is set. (See 2.6.4.1). This bit will be cleared by the Cancel Transaction command.
- In **Daily Closure command** - On IPL completion, after a PLD, the closure is completed in one of the following two ways:
  - **Fiscal memory already updated** - The Daily Closure command is terminated as if the PLD did not occur.
  - **Fiscal memory not yet updated** - The daily data is restored as it was before the Daily Closure command and the closure report printout is voided. The Daily Closure command is terminated as if the PLD did not occur.
- In **Print Multi-day Fiscal Report command** - On IPL completion, after a PLD, this dump function is terminated and the memory report printout is voided.

## 4.6 Communication with the RS232 Fiscal Printer

[A012] [A029] ONLY VALID FOR IBM 4610 SureMark Fiscal Printer KD3/KD5 (RS-232)

### 4.6.1 Protocol

The protocol implemented for communication with the Fiscal Printer has two main characteristics:

- The Host begins all communications.
- The Fiscal Printer will never send an unsolicited message.

So, the protocol could be defined as one of type Host (PC) / Slave (Fiscal Printer)

The protocol is a one-bit sliding window protocol<sup>1</sup>. In this kind of protocol, the partners speak successively one each time. The first to speak will be always the host. Every part keeps internally a packet counter. After initialization, this counter is used to distinguish between new packets and retransmissions changing from 0 to 1 continuously. (see normal communication below).

All packets have the same format. There are no special packets for ACKs, NAKs, etc.

### 4.6.2 Packet Format

Header	Length	Data	CRC-16
1 byte	2 bytes	Length bytes	2 bytes

- Header: Source / Packet Type (see below Header Format)
- Length: A binary 2 bytes unsigned value representing a number from 0 to 0xFFFF = 65535. This is the maximum theoretical length of the data to be transmitted. The real maximum will be a lot shorter due to buffer limits. Length can be > 0 only for packet types IF0 and IF1.
- Data: This is the meaningful data to be transmitted. If length = 0, then no Data must be present. This is mandatory for packet types SNRM, ROL and NSA. It's optional for packet types IF0 and IF1. In this last case, such a packet can be used from the Host side to give 'the right to speak' to the device (polling), or, from the Slave side, to recognize successful reception of a previous packet from Host when the Slave has no data to send.
- CRC-16: This is the CRC-16 of all the preceding data ( Header + Length + Data ). The polynomial used is  $x^{16}+x^{12}+x^5+1$  (the one recommended by CCITT).

Note that Length and CRC are transmitted in Big Endian Format (most significant byte first). That's the format used internally by the device C microcode. While most of the Hosts will have to swap the bytes because they use Little Endian Format, we choose to favor the slowest device.

### 4.6.3 Header Format

Bits 7-4	Bit 3	Bits 2 - 0
Reserved (specify 0)	Source	Packet Type

- Source: The source of the packet ( 0 = Host / 1 = Slave )
- Packet Type: One of these values

Name	Value	Direction	Length field
SNRM (Set Normal Response Mode)	0x04	From Host	Must be 0 (no data)
ROL (Request On Line)	0x05	From Slave	Must be 0 (no data)
NSA (Non Sequence Acknowledge)	0x06	From Slave	Must be 0 (no data)
RESET	0x07	From Host	Must be 0 (no data)
Information Frame #0	0x00	Both	0 to 0xFFFF
Information Frame #1	0x01	Both	0 to 0xFFFF

<sup>1</sup>See Computer Networks by Andrew Tanenbaum



## 4.6.4 Communication parameters

[A127]

28800/19200/9600 bits per second / No Parity / 8 bits / 1 Stop bit

- The RS-232 Fiscal Printer is able to communicate at different baud rates.
- The microcode will detect automatically at which baud rate the host communicates among these: 28800, 19200 and 9600.
- At IPL the microcode will start at 28800, and after a bad reception, it will cycle to the next baud rate through this sequence 28800 -> 19200 -> 9600 -> 28800.

## 4.6.5 State machine for Host

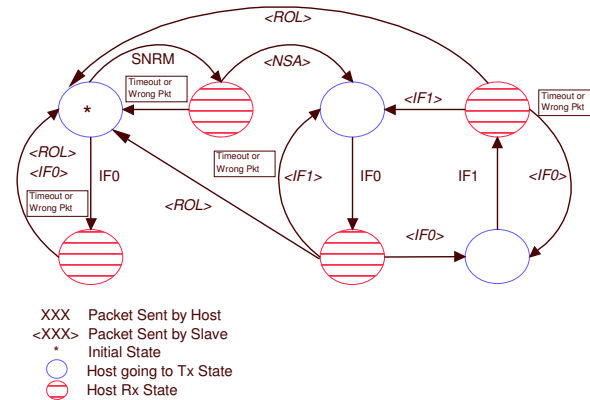

## 4.6.6 State machine for Slave

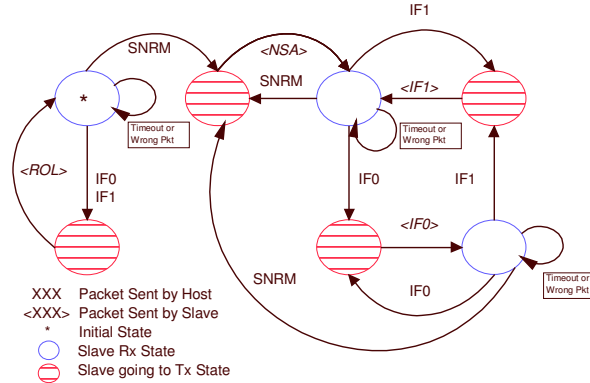

## 4.6.7 Initialization

The very first packet that the Host transmits must be a SNRM (Set Normal Response Packet) or an IF0 without data. (See State Machine below) If an IF0 is sent, the Slave can respond in two different ways: with a ROL (Request On Line) if the Slave is just initiating communication also, or with an IF0 if the Slave has a previous communication ongoing. If this info result useful to recognize between these two cases, the IF0 must be sent first and then SNRM. If it's not necessary, the SNRM can be sent directly.

When a SNRM is sent, after successful reception, the Slave will reset its internal packet counter to 0 and send a NSA (Non Sequence Acknowledge). If the Host receives it successfully, it will continue with the normal communication. If it's not, the host must resend the SNRM packet.

Initially, the slave will wait for a packet from host (it always speaks **after** the host). If the first packet received is a SNRM, the slave must respond with NSA. If something different is correctly received, the slave must send a ROL (Request On Line) packet, asking the host to resynchronize communication. After reception the host must send a SNRM and set its internal packet counter to 0. The Slave will respond with NSA, and normal communication will continue.

## 4.6.8 Initialization flow

### 4.6.8.1 Normal case

Host		Slave
	-----SNRM----->	Received OK
Received OK	<----- NSA -----	

### 4.6.8.2 Slave reset when Host has an ongoing communication

Host		Slave
	-----IF0 or IF1----->	Received OK
Received OK	<----- ROL -----	
	-----SNRM----->	Received OK
Received OK	<----- NSA -----	

### 4.6.8.3 Host reset and Slave not with Host recognizing

Host		Slave
	-----IF0 ----->	Received OK
Received OK	<----- IF0 -----	
	-----SNRM----->	Received OK
Received OK	<----- NSA -----	

### 4.6.8.4 Slave reset when Host has an ongoing communication

Host		Slave
	-----IF0 or IF1----->	Received OK
Received OK	<----- ROL -----	
	-----SNRM----->	Received OK
Received OK	<----- NSA -----	

## 4.6.9 Normal communication

Information Frame (IF) packets are interchanged between host and slave. These IF packets have two different types 0 and 1 corresponding to the internal counter kept by each part. The first packet to be sent will be IF0, then IF1, then IF0 and so on. This way, the partner can recognize a new packet from a retransmission. A packet is automatically acknowledged when the partner sends the following packet with the expected numbering. If the host receives a packet with wrong CRC, the preceding host packet will be retransmitted forcing the slave to retransmit its packet. If the slave receives a packet with wrong CRC it will just ignore it and the host must retransmit it when the time waiting for a response has expired. If the host doesn't receive a response for its packet, it must resend the packet after a time-out period.

## 4.6.10 Normal communication flow

### 4.6.10.1 Normal case

Host		Slave
	----- IF0 ----->	Received OK
Received OK	<----- IF0 -----	
	----- IF1 ----->	Received OK
Received OK	<----- IF1 -----	

### 4.6.10.2 Bad CRC Packet received by Host

Host		Slave
	-----IF0 ----->	Received OK
Bad received	<----- IF0 -----	
	----- IF0 ----->	Received OK
Received OK	<----- IF0 -----	
	----- IF1 ----->	Received OK

Received OK	<----- IF1 ----->	
-------------	-------------------	--

#### 4.6.10.3 No Packet received by Host

Host		Slave
	----- IF0 ----->	Received OK
No received	X <--- IF0 ----->	
Retransmitted After time-out	----- IF0 ----->	Received OK
Received OK	<----- IF0 ----->	
	----- IF1 ----->	Received OK
Received OK	<----- IF1 ----->	

#### 4.6.10.4 Bad CRC Packet received by Slave

Host		Slave
	----- IF0 ----->	Received OK
Received OK	<----- IF0 ----->	
	----- IF1 ----->	Bad received, discarded
Retransmitted after time-out	----- IF1 ----->	Received OK
Received OK	<----- IF1 ----->	

#### 4.6.10.5 No Packet received by Slave

Host		Slave
	----- IF0 ----->	Received OK
Received OK	<----- IF0 ----->	
	----- IF1 -----> X	No received
Retransmitted after time-out	----- IF1 ----->	Received OK
Received OK	<----- IF1 ----->	Received OK

### 4.6.11 Timing

The maximum delay between consecutive bytes sent by any device is 50ms. Also, after the host ends sending a packet, the device has a maximum of 250ms for sending the first byte of the response. The host has no restriction about how often it must send packets to the slave, the slave must wait forever to receive something from it, but, if the host doesn't give a 'chance to speak' to the device, it will be unable to inform the host of any asynchronous event detected i.e. cover open/close.

### 4.6.12 Polling

Even if this is not strictly related to the protocol, it's important to note that the Fiscal Printer responses are always status. These status can be one of three different types:

- Intermediate: Status sent during execution of a command while not complete.
- Final: Status sent at command execution ending.
- Asynchronous: Status sent outside command execution.

After sending a command, it is very important to keep 'polling' the printer (sending IFs without data) until the slave returns a final status. This way the host gives the Fiscal Printer a chance to send its status back. If command execution is not quick, the Fiscal Printer will send intermediate status periodically until the command is ended and a final status is sent.

The Fiscal Printer can generate also asynchronous status, that is status generated outside the execution of any command. These status are mainly originated due to changes in the status of the printer (covers open/close, buttons pressed, etc.). If the host needs to take care of these status, it must keep polling the printer even when no command is executed. The polling inside command execution must be more frequent to avoid slowing the device throughput (around once every 0.05 sec). The polling outside command execution can be usually slower (maybe

once every 0.50 sec). These times doesn't need to be exact and some tuning could be necessary to achieve optimum performance.

#### **4.6.13 Retries**

The number of retries is infinite for the slave. This means that, by example, it will keep sending IF0s all the time if, while it's waiting an IF1, it continuously receives IF0s from the host. For the host, the number of retries must be decided according to the perceived quality of the communication link. Anyway, at least 5 retries before considering the communication as broken are strongly suggested.

## 5 Hungary - Specific Information

---

### 5.1.1 Power-On or Reset Printout Format

H70

The message is printed on customer receipt to inform operator of fiscal unit status.

#### 5.1.1.1 Serialized, In Fiscal Mode, Working in Non-Fiscal or Idle Status

The format of the power-on message for the case where the fiscal printer is serialized, set in fiscal mode and working correctly is shown in the above figure:

---

H39,H107

```
MSG 0      1      2      3      4
      12345678901234567890123456789012345678901234
-----|-----|-----|-----|
M05|-----| NEM ADÓÜGYI BIZONYLAT |-----| 'NOT FISCAL'
    |jFSS0001| sssssssss | vv | s.s = Serial Number, vv = version number
C58| SOFTWARE RESTART: rrr | 'SOFTWARE RESTART:'
C59| ÁRAMKIMARADÁS | 'POWER LINE DISTURBANCE'
C60| HARDWARE RESET | 'HARDWARE RESET'
M01|r ADÓÜGYI TÁROLÓ ÜZEMKÉSZ | 'FISCAL REGISTER OPERATIONAL'
    |yyyy.mm.dd hh:mm | Date and Time
M05|-----| NEM ADÓÜGYI BIZONYLAT |-----| 'NOT FISCAL'
-----|-----|-----|-----|
```

j: blank, if EJ is closed, \*, if EJ is opened

r: blank, if in IPL procedure the status is not restored, R, if in IPL procedure the status is restored

Only one of the lines: C58, C59, C60 is printed. rrr: restart code (see).

---

#### 5.1.1.2 Serialized, In Fiscal Mode, Jumper Active

The format of the power-on message for the case where the fiscal printer is serialized, set in fiscal mode and jumper active is shown in the above figure:

---

H40, H108

```
MSG 0      1      2      3      4
      12345678901234567890123456789012345678901234
-----|-----|-----|-----|
M05|-----| NEM ADÓÜGYI BIZONYLAT |-----| 'NOT FISCAL'
    |jFSS0001| sssssssss | vv | s.s = Serial Number, vv = version number
C58| SOFTWARE RESTART: rrr | 'SOFTWARE RESTART:'
C59| ÁRAMKIMARADÁS | 'POWER LINE DISTURBANCE'
C60| HARDWARE RESET | 'HARDWARE RESET'
M15| RESET JUMPER AKTÍV | 'RESET JUMPER ACTIVE'
M16| RAM TÖRLÉS - E.N. VÁLTOZATLAN | RAM CLEARED - EJ KEPT (Note 1)
M17| RAM TÖRLÉS - E.N. TÖRÖLVE | RAM CLEARED - EJ CLEARED (Note 2)
    |yyyy.mm.dd hh:mm | Date and Time
M05|-----| NEM ADÓÜGYI BIZONYLAT |-----| 'NOT FISCAL'
-----|-----|-----|-----|
```

j: blank, if EJ is closed, \*, if EJ is opened

Only one of the lines: C58, C59, C60 is printed. rrr: restart code (see 5.1.1.6).

[A051]

\* Note 1:

**ONLY VALID FOR IBM 4610 SureMark Fiscal Printer KD3/KD5 (JACARE RS-232)**

Printed only when the CE jumper is active and the Full CE Jumper procedure is not finished.

\* Note 2:

**ONLY VALID FOR IBM 4610 SureMark Fiscal Printer KD3/KD5 (JACARE RS-232)**

Printed only when the CE jumper is active and when the Full CE Jumper procedure has been performed.

---

### 5.1.1.3 Serialized, In Fiscal Mode, CF in error

The format of the power-on message for the case where the fiscal printer is serialized, set in fiscal mode and CF in error is shown in the above figure:

---

H40, H109

```
MSG 0      1      2      3      4
      12345678901234567890123456789012345678901234
-----|-----|-----|-----|-----|
M05|-----| NEM ADÓÜGYI BIZONYLAT |-----| 'NOT FISCAL'
    |jFSS0001      sssssssss      vv      | s..s = Serial Number, vv = version number
C58| SOFTWARE RESTART: rrr      | 'SOFTWARE RESTART:'
C59| ÁRAMKIMARADÁS      | 'POWER LINE DISTURBANCE'
C60| HARDWARE RESET      | 'HARDWARE RESET'
D47|r CF ADATHORDOZÓ HIBA: eee-sss      | 'COMPACT FLASH ERROR:'
    |YYYY.mm.dd hh:mm      | Date and Time
M05|-----| NEM ADÓÜGYI BIZONYLAT |-----| 'NOT FISCAL'
-----|-----|-----|-----|-----|
```

j: blank, if EJ is closed, \*, if EJ is opened

r: blank, if in IPL procedure the status is not restored, R, if in IPL procedure the status is restored

eee: Extended EJ Error

sss: Extended EJ Error Subcode

Only one of the lines: C58, C59, C60 is printed. rrr: restart code (see 5.1.1.6).

---

#### 5.1.1.4 Serialized, In Fiscal Mode, Working with Open Transaction Status

The format of the power-on message for the case where the fiscal printer is serialized, set in fiscal mode and working correctly during an open transaction (Voucher, Closure, X-Report or Dump) is shown in the above figure:

---

```
H110
MSG 0      1      2      3      4
      12345678901234567890123456789012345678901234
-----
C58|  SOFTWARE RESTART: rrr          | 'SOFTWARE RESTART:'
C59|  ÁRAMKIMARADÁS                 | 'POWER LINE DISTURBANCE'
C60|  HARDWARE RESET                 | 'HARDWARE RESET'
M01|r  ADÓÜGYI TÁROLÓ ÜZEMKÉSZ      | 'FISCAL REGISTER OPERATIONAL'
-----
```

r: blank, if in IPL procedure the status is not restored, R, if in IPL procedure the status is restored  
Only one of the lines: C58, C59, C60 is printed. rrr: restart code (see 5.1.1.6).

---

#### 5.1.1.5 Serialized, In Fiscal Mode, EJ error with Open Transaction Status

The format of the power-on message for the case where the fiscal printer is serialized, set in fiscal mode and EJ error during an open transaction (Voucher, Closure, X-Report or Dump) is shown in the above figure:

---

```
H111
MSG 0      1      2      3      4
      12345678901234567890123456789012345678901234
-----
C58|  SOFTWARE RESTART: rrr          | 'SOFTWARE RESTART:'
C59|  ÁRAMKIMARADÁS                 | 'POWER LINE DISTURBANCE'
C60|  HARDWARE RESET                 | 'HARDWARE RESET'
D47|r  CF ADATHORDOZÓ HIBA: eee-sss | 'COMPACT FLASH ERROR:'
-----
```

r: blank, if in IPL procedure the status is not restored, R, if in IPL procedure the status is restored  
eee: Extended EJ Error  
sss: Extended EJ Error Subcode  
Only one of the lines: C58, C59, C60 is printed. rrr: restart code (see 5.1.1.6).

---

### 5.1.1.6 Software restart codes.

H112

---

**001**

**Explanation:** The restart is generated by the 'FA00' (Perform Fiscal Unit POR) or '0040' (System Command POR)

---

**002**

**Explanation:** The restart is generated in EJ routines if a Compact Flash Not Present status is detected.

---

**003**

**Explanation:** The restart is generated in IPL sequence after the Compact Flash has been formatted.

---

**004**

**Explanation:** The restart is generated in IPL sequence if an EJ error is detected.

---

**005**

**Explanation:** The restart is generated if a printer ROL message is received.

---

**006**

**Explanation:** Internal error. Unexpected status detected in printer driver.

---

**007**

**Explanation:** Internal error. Unexpected hardware interrupt occurred.

---

**008**

**Explanation:** Internal error. Unexpected status detected in SUPERIN.

---

**009**

**Explanation:** Internal error. Unexpected status detected in SUPERVS.

---

**010**

**Explanation:** Internal error. Unexpected return form MAIN.

---



### 5.1.1.7 Serialized, In Fiscal Mode, Not Working

The format of the power-on message for the case where the fiscal printer is serialized, set in fiscal mode but not working correctly is shown in the above figure:

---

H41

```
MSG 0      1      2      3      4
12345678901234567890123456789012345678901234
-----
M05|-----      NEM ADÓÜGYI BIZONYLAT      -----| 'NOT FISCAL'
|jFSS0002-nnn      sssssssss      vv      | s..s = Serial Number, vv = version number
M02|      ADÓÜGYI TÁROLÓ NEM ÜZEMKÉSZ      | 'FISCAL REGISTER NOT OPERATIONAL'
M05|-----      NEM ADÓÜGYI BIZONYLAT      -----| 'NOT FISCAL'
-----
nnn = error code
j: blank, if EJ is closed, *, if EJ is opened
```

### 5.1.1.8 Not Serialized, Not in Fiscal Mode, Working

The format of the power-on message for the case where the fiscal printer is not serialized and not set in fiscal mode and working correctly is shown in the above figure:

---

H42

```
MSG 0      1      2      3      4
12345678901234567890123456789012345678901234
-----
|jFSS0003      vv      | Fiscal memory not initialized, vv = version code number
M03|      KASSZA ÜZEMKÉSZ      | 'CASH REGISTER OPERATIONAL'
|yyyy.mm.dd hh:mm      | Date and Time
-----
```

j: blank, if EJ is closed, \*, if EJ is opened

---

### 5.1.1.9 Serialized, Not In Fiscal Mode, Working

The format of the power-on message for the case where the fiscal printer is serialized, not set in fiscal mode and working correctly is shown in the above figure:

---

H43

```
MSG 0      1      2      3      4
12345678901234567890123456789012345678901234
-----
|jFSS0004      sssssssss      vv      | s..s = Serial Number, vv = version number
M03|      KASSZA ÜZEMKÉSZ      | 'CASH REGISTER OPERATIONAL'
|yyyy.mm.dd hh:mm      | Date and Time
-----
```

j: blank, if EJ is closed, \*, if EJ is opened

---

### 5.1.1.10 Not Serialized, Not In Fiscal Mode, Not Working

The format of the power-on message for the case where the fiscal printer is not serialized, not in fiscal mode and not working correctly is shown in the above figure:

---

```
MSG 0      1      2      3      4
      12345678901234567890123456789012345678901234
-----
| jFSS0005-nnn          vv | nnn = error code  vv = version code
M04 |  KASSZA NEM ÜZEMKÉSZ          | 'CASH REGISTER NOT OPERATIONAL'
```

---

j: blank, if EJ is closed, \*, if EJ is opened

### 5.1.1.11 Serialized, Not In Fiscal Mode, Not Working

The format of the power-on message for the case where the fiscal printer is serialized, not in fiscal mode and not working correctly is shown in the above figure:

---

```
MSG 0      1      2      3      4
      12345678901234567890123456789012345678901234
-----
| jFSS0006-nnn      ssssssss          vv | s..s = serial number, vv = version number
M04 |  KASSZA NEM ÜZEMKÉSZ          | 'CASH REGISTER NOT OPERATIONAL'
```

---

nnn: error code

j: blank, if EJ is closed, \*, if EJ is opened

---

## 5.1.2 Error Handling during Paper Fail

### Paper Fail during a Fiscal Voucher or Simplified Invoice is Printed – no Transaction Lines are Printed

Event	Error code	User reaction
a./ Paper out	200	Add new paper
b./ New paper added; The printer prints automatically on the new paper the Header Lines and the Denomination of the document.	-	The document can be continued.

### Paper Fail during a Fiscal Voucher or Simplified Invoice is Printed – Transaction Lines are Printed

Event	Error code	User reaction
a./ Paper out	200	Add new paper
b./ New paper added; The printer waits for a Cancel Transaction Command.	183	Cancel Transaction Command must be issued by the Application
c./ The printer cancels the Document	-	-

### Paper Fail during a Fiscal Voucher or Simplified Invoice is Printed – one Part of End Voucher Command is Printed

Event	Error code	User reaction
a./ Paper out	200	Add new paper
b./ New paper added; The printer completes the document on the new paper.	-	-

### 5.1.3 Error Handling after Power Line Disturbance

**Power Line Disturbance during a Fiscal Voucher or Simplified Invoice is Printed – no Transaction Lines are printed**

<b>Event</b>	<b>Error code</b>	<b>User reaction</b>
a./ Power Line Disturbance	-	Solve the PLD problem
b./ The system is switched on again; The Application tries to proceed the document.	183	Cancel Transaction Command must be issued by the Application
c./ The printer cancels the document.		

**Power Line Disturbance during a Fiscal Voucher or Simplified Invoice is Printed – Transaction Lines are printed**

<b>Event</b>	<b>Error code</b>	<b>User reaction</b>
a./ Power Line Disturbance	-	Solve the PLD problem
b./ The system is switched on again; The Application tries to proceed the document.	183	Cancel Transaction Command must be issued by the Application
c./ The printer cancels the document.		

**Power Line Disturbance during a Fiscal Voucher or Simplified Invoice is Printed – one Part of End Voucher Command is printed**

<b>Event</b>	<b>Error code</b>	<b>User reaction</b>
a./ Power Line Disturbance	-	Solve the PLD problem
b./ The system is switched on again; The printer completes the document.	-	-

### 5.1.4 Error Handling during CF Full

#### CF Full before JP is started

Event	Error code	Service / User reaction
a./ CF full. The command is refused by the printer	071	The Service has to change the current CF to an empty one.
b./ CF is changed; The printer allows to start the JP	-	The Application can start the JP

#### CF Full at Print Header Lines / Start of X-Report / Start of Application-Originated Report

Event	Error code	Service / User reaction
a./ CF full. The command is refused by the printer	073	The Application must issue a Daily Closure command. The Service has to change the current CF to an empty one.
b./ CF is changed; The printer allows to proceed operation	-	The Application can reissue the command refused before CF full. The printed data will be recorded into a new EJ file.

#### CF Full during Print on CR

Event	Error code	Service / User reaction
a./ CF full. The command is refused by the printer	074	The Application must cancel the printed document (except if Set Data is refused) and must issue a Daily Closure command. The Service has to change the current CF to an empty one.
b./ CF is changed; The printer allows to proceed operation	-	The Application can restart to print the cancelled document, or it can reissue the Set Date command. The printed data will be recorded into a new EJ file.

#### CF Full before or during the Print of Fiscal Memory Dump

Event	Error code	Service / User reaction
a./ CF full. The command is refused or the report is cancelled by the printer	075	The Application must issue a Daily Closure command. The Service has to change the current CF to an empty one.
b./ CF is changed; The printer allows to proceed operation	-	The Application can reissue the command. The printed data will be recorded into a new EJ file.