

Rational Software Corporation®

# RATIONAL® CLEARCASE®

MANAGING SOFTWARE PROJECTS

UNIX

VERSION: 2002.05.00 AND LATER

PART NUMBER: 800-025059-000

**Rational**  
the software development company

**Managing Software Projects**  
**Document Number 800-025059-000 October 2001**  
**Rational Software Corporation 20 Maguire Road Lexington, Massachusetts 02421**

**IMPORTANT NOTICE**

**Copyright**

Copyright © 1992, 2001 Rational Software Corporation. All rights reserved.  
Copyright 1989, 1991 The Regents of the University of California  
Copyright 1984–1991 by Raima Corporation

**Permitted Usage**

THIS DOCUMENT IS PROTECTED BY COPYRIGHT AND CONTAINS INFORMATION PROPRIETARY TO RATIONAL. ANY COPYING, ADAPTATION, DISTRIBUTION, OR PUBLIC DISPLAY OF THIS DOCUMENT WITHOUT THE EXPRESS WRITTEN CONSENT OF RATIONAL IS STRICTLY PROHIBITED. THE RECEIPT OR POSSESSION OF THIS DOCUMENT DOES NOT CONVEY ANY RIGHTS TO REPRODUCE OR DISTRIBUTE ITS CONTENTS, OR TO MANUFACTURE, USE, OR SELL ANYTHING THAT IT MAY DESCRIBE, IN WHOLE OR IN PART, WITHOUT THE SPECIFIC WRITTEN CONSENT OF RATIONAL.

**Trademarks**

Rational, Rational Software Corporation, the Rational logo, Rational the e-development company, Rational Suite ContentStudio, ClearCase, ClearCase MultiSite ClearQuest, Object Testing, Object-Oriented Recording, Objexy, PerformanceStudio, PureCoverage, PureDDTS, PureLink, Purify, Purify'd, Quantify, Rational Apex, Rational CRC, Rational PerformanceArchitect, Rational Rose, Rational Suite, Rational Summit, Rational Unified Process, Rational Visual Test, Requisite, RequisitePro, RUP, SiteCheck, SoDA, TestFactory, TestMate, TestStudio, The Rational Watch, among others are trademarks or registered trademarks of Rational Software Corporation in the United States and in other countries. All other names are used for identification purposes only, and are trademarks or registered trademarks of their respective companies.

Sun, Solaris, and Java are trademarks or registered trademarks of Sun Microsystems, Inc.

Microsoft, the Microsoft logo, the Microsoft Internet Explorer logo, Windows, the Windows logo, Windows NT, the Windows Start logo are trademarks or registered trademarks of Microsoft Corporation in the United States and other countries.

**Patent**

U.S. Patent Nos. 5,574,898 and 5,649,200 and 5,675,802. Additional patents pending.

**Government Rights Legend**

Use, duplication, or disclosure by the U.S. Government is subject to restrictions set forth in the applicable Rational License Agreement and in DFARS 227.7202-1(a) and 227.7202-3(a) (1995), DFARS 252.227-7013(c)(1)(ii) (Oct 1988), FAR 12.212(a) 1995, FAR 52.227-19, or FAR 52.227-14, as applicable.

**Warranty Disclaimer**

This document and its associated software may be used as stated in the underlying license agreement. Rational Software Corporation expressly disclaims all other warranties, express or implied, with respect to the media and software product and its documentation, including without limitation, the warranties of merchantability or fitness for a particular purpose or arising from a course of dealing, usage, or trade practice.

**Technical Acknowledgments**

This software and documentation is based in part on BSD Networking Software Release 2, licensed from the Regents of the University of California. We acknowledge the role of the Computer Systems Research Group and the Electrical Engineering and Computer Sciences Department of the University of California at Berkeley and the Other Contributors in its development.

This product includes software developed by Greg Stein <gstein@lyra.org> for use in the mod\_dav module for Apache ([http://www.webdav.org/mod\\_dav/](http://www.webdav.org/mod_dav/)).

# Contents

<b>Preface</b> .....	xix
About This Manual .....	xix
Product-Specific Features .....	xix
Organization .....	xix
ClearCase Documentation Roadmap .....	xx
ClearCase LT Documentation Roadmap .....	xxi
Typographical Conventions .....	xxii
Online Documentation .....	xxiii
Technical Support .....	xxiii
<b>1. Choosing Between UCM and Base ClearCase</b> .....	1
1.1 Differences Between UCM and Base ClearCase .....	1
Branching and Creating Views .....	2
Using Components to Organize Files .....	3
Creating and Using Baselines.....	3
Managing Activities.....	4
Enforcing Development Policies.....	4
<b>Part 1: Working in UCM</b>	
<b>2. Understanding UCM</b> .....	9
2.1 Overview of the UCM Process .....	9
2.2 Creating the Project.....	12
Creating a PVOB .....	12
Organizing Directories and Files into Components.....	13
Shared and Private Work Areas.....	14
Starting from a Baseline .....	14
Setting Up the UCM-ClearQuest Integration.....	16
2.3 Setting Policies .....	17

2.4	Assigning Work .....	18
2.5	Creating a Testing Stream .....	18
2.6	Building Components .....	19
	MultiSite Consideration.....	19
2.7	Making a New Baseline .....	20
2.8	Recommending the Baseline .....	21
2.9	Monitoring Project Status .....	23
2.10	Overview of the UCM-ClearQuest Integration.....	23
	Associating UCM and ClearQuest Objects.....	23
	UCM-Enabled Schema .....	25
	State Types.....	25
	Queries in a UCM-Enabled ClearQuest Schema.....	26
<b>3.</b>	<b>Planning the Project .....</b>	<b>27</b>
3.1	Using the System Architecture as the Starting Point .....	27
	Mapping System Architecture to Components.....	28
	Deciding What to Place Under Version Control.....	28
	Mapping Components to Projects.....	29
	Amount of Integration.....	29
	Need for Parallel Releases.....	29
	Example .....	30
3.2	Organizing Components .....	30
	Deciding How Many VOBs to Use .....	31
	Identifying Additional Components .....	32
	Defining the Directory Structure.....	32
	Identifying Read-Only Components .....	34
3.3	Choosing a Stream Strategy .....	35
3.4	Specifying a Baseline Strategy .....	36
	Identifying a Project Baseline.....	37
	When to Create Baselines .....	39
	Identifying the Initial Baseline .....	39
	Ongoing Baselines .....	39
	Defining a Naming Convention .....	40
	Identifying Promotion Levels to Reflect State of Development .....	40

	Planning How to Test Baselines.....	40
3.5	Planning PVOBs .....	41
	Deciding How Many PVOBs to Use.....	41
	Understanding the Role of the Administrative VOB.....	42
3.6	Identifying Special Element Types .....	43
	Nonmerging Elements.....	43
	Nonautomerging Elements.....	44
	Defining the Scope of Element Types .....	44
3.7	Planning How to Use the UCM-ClearQuest Integration .....	44
	Mapping PVOBs to ClearQuest User Databases .....	44
	MultiSite Requirement .....	45
	Projects Linked to Same Database Must Have Unique Names.....	45
	Use One Schema Repository for Linked Databases.....	45
	Deciding Which Schema to Use .....	46
	Overview of the UnifiedChangeManagement Schema.....	47
	Enabling a Schema for UCM .....	48
<b>4.</b>	<b>Setting Policies.....</b>	<b>49</b>
4.1	Components and Baselines.....	49
	Modifiable Components.....	49
	Default Promotion Level for Recommending Baselines .....	49
4.2	Default View Types .....	50
4.3	Deliver Operations.....	50
	Allow Deliveries from Stream with Pending Checkouts .....	51
	Rebase Before Deliver.....	51
	Deliver Operations to Nondefault Targets.....	51
	Allow Deliveries from Streams in Other Projects .....	53
	Allow Deliveries That Contain Changes in Foundation Baselines....	53
	Allow Deliveries That Contain Changes Made to Components Not in Target Stream .....	54
	Allow Deliveries That Contain Changes to Nonmodifiable Components.....	55
4.4	UCM-ClearQuest Integration.....	55
	Check Before Work On.....	55

Check Before ClearCase Delivery .....	55
Do ClearQuest Action After Delivery .....	56
Check Mastership Before Delivery .....	56
<b>5. Setting Up a ClearQuest User Database .....</b>	<b>59</b>
5.1 Using the Predefined UCM-Enabled Schemas.....	59
5.2 Enabling a Schema to Work with UCM .....	60
Requirements for Enabling Custom Record Types .....	62
Setting State Types .....	63
State Transition Default Action Requirements for Record Types .....	64
5.3 Upgrading Your Schema to the Latest UCM Package .....	65
5.4 Customizing ClearQuest Project Policies.....	65
5.5 Associating Child Activity Records with a Parent Activity Record .....	66
Using Parent/Child Controls .....	67
5.6 Creating Users.....	67
5.7 Setting the Environment.....	67
<b>6. Setting Up the Project .....</b>	<b>69</b>
6.1 Creating a Project from Scratch .....	70
Creating the Project VOB.....	70
Creating a Component for Storing the Project Baseline .....	71
Creating Components for Storing Elements.....	72
Creating One Component Per VOB.....	72
Creating a VOB That Stores Multiple Components .....	73
Creating the Project .....	75
Defining Promotion Levels .....	76
Creating an Integration View .....	76
Creating the Composite Baseline That Represents the Project .....	78
Creating and Setting an Activity .....	79
Creating the Directory Structure .....	80
Importing Directories and Files from Outside ClearCase .....	81
Making and Recommending a Baseline .....	82
6.2 Creating a Project Based on an Existing ClearCase Configuration .....	82
Creating the PVOB .....	82

	Making a VOB into a Component.....	82
	Making a Baseline from a Label.....	83
	Creating the Project.....	84
	Creating an Integration View .....	84
6.3	Creating a Project Based on an Existing Project .....	84
	Using a Composite Baseline to Capture Final Baselines .....	84
	Reusing Existing PVOB and Components.....	85
	Creating the Project.....	85
	Creating an Integration View .....	86
6.4	Enabling a Project to Use the UCM-ClearQuest Integration .....	86
	Migrating Activities .....	87
	Setting Project Policies.....	88
	Assigning Activities.....	89
	Disabling the Link Between a Project and a ClearQuest User Database .	89
	Fixing Projects That Contain Linked and Unlinked Activities.....	90
	Detecting the Problem .....	90
	Correcting the Problem .....	90
	How MultiSite Affects the UCM-ClearQuest Integration.....	91
	Replica and Naming Requirements .....	91
	Transferring Mastership of the PVOB's Root Folder .....	91
	Transferring Mastership of the Project .....	92
	Linking Activities to ClearQuest Records .....	92
	Changing Project Policy Settings .....	92
	Changing the Project Name.....	92
6.5	Creating a Development Stream for Testing Baselines .....	93
6.6	Creating a Feature-Specific Development Stream.....	94
<b>7.</b>	<b>Managing the Project.....</b>	<b>97</b>
7.1	Adding Components .....	97
	Making the Component Modifiable .....	99
	Synchronizing the View .....	99
	Updating Snapshot View Load Rules .....	99
7.2	Building Components.....	100

	Locking the Integration Stream .....	100
	Finding Work That Is Ready to Be Delivered.....	101
	Completing Remote Deliver Operations.....	101
	Undoing a Deliver Operation .....	102
	Building and Testing the Components.....	102
7.3	Creating a New Baseline.....	103
	Making the New Baseline.....	103
	Making a Baseline for a Set of Activities.....	105
	Making a Baseline of One Component.....	105
	Unlocking the Stream.....	105
7.4	Testing the Baseline .....	105
	Fixing Problems .....	106
7.5	Recommending the Baseline.....	107
7.6	Resolving Baseline Conflicts .....	108
	Conflicts Between a Composite Baseline and a Noncomposite Baseline .....	108
	Conflicts Between Two Composite Baselines.....	109
7.7	Monitoring Project Status.....	109
	Comparing Baselines.....	109
	Querying ClearQuest User Databases.....	111
7.8	Cleaning Up the Project.....	112
	Removing Unused Objects.....	113
	Projects .....	113
	Streams.....	113
	Components .....	113
	Baselines.....	114
	Activities .....	114
	Locking and Making Obsolete the Project and Streams .....	114
<b>8.</b>	<b>Using Triggers to Enforce Development Policies .....</b>	<b>115</b>
8.1	Overview of Triggers.....	115
	Preoperation and Postoperation Triggers.....	116
	Scope of Triggers .....	117
	Using Attributes with Triggers.....	118



	When to Use ClearQuest Scripts Instead of UCM Triggers.....	118
8.2	Sharing Triggers Between UNIX and Windows.....	118
	Using Different Pathnames or Different Scripts.....	119
	Using the Same Script.....	119
	Tips.....	120
8.3	Enforce Serial Deliver Operations.....	120
	Setup Script.....	120
	Preoperation Trigger Script.....	122
	Postoperation Trigger Script.....	123
8.4	Send Mail to Developers on Deliver Operations.....	123
	Setup Script.....	124
	Postoperation Trigger Script.....	124
8.5	Do Not Allow Activities to Be Created on the Integration Stream.....	126
8.6	Implementing a Role-Based Access Control System.....	127
	Preoperation Trigger Script.....	128
8.7	Additional Uses for UCM Triggers.....	129
<b>9.</b>	<b>Managing Parallel Releases of Multiple Projects.....</b>	<b>131</b>
9.1	Managing a Current Project and a Follow-On Project Simultaneously	131
	Example.....	132
	Performing Interproject Rebase Operations.....	133
9.2	Incorporating a Patch Release into a New Version of the Project.....	134
	Example.....	134
	Delivering Work to Another Project.....	136
9.3	Using a Mainline Project.....	136
9.4	Merging from a Project to a Non-UCM Branch.....	137

## Part 2: Working in Base ClearCase

<b>10.</b>	<b>Managing Projects in Base ClearCase.....</b>	<b>141</b>
10.1	Setting Up the Project.....	142
	Creating and Populating VOBs.....	142
	Planning a Branching Strategy.....	142

Branch Names .....	143
Branches and ClearCase MultiSite .....	143
Creating Shared Views and Standard Config Specs .....	144
Recommendations for View Names .....	144
10.2 Implementing Development Policies .....	144
Using Labels .....	145
Using Attributes, Hyperlinks, Triggers, and Locks .....	145
Global Types .....	146
Generating Reports .....	146
10.3 Integrating Changes .....	147
<b>11. Defining Project Views .....</b>	<b>149</b>
11.1 How Config Specs Work .....	149
11.2 Default Config Spec .....	150
The Standard Configuration Rules .....	150
Omitting the Standard Configuration Rules .....	151
11.3 Config Spec Include Files .....	151
11.4 Project Environment for Sample Config Specs .....	152
11.5 Views for Project Development .....	153
View for New Development on a Branch .....	153
Variation That Uses a Time Rule .....	154
View to Modify an Old Configuration .....	154
Omitting the /main/LATEST Rule .....	155
Variation That Uses a Time Rule .....	156
View to Implement Multiple-Level Branching .....	156
View to Restrict Changes to a Single Directory .....	157
11.6 Views to Monitor Project Status .....	158
View That Uses Attributes to Select Versions .....	158
Pitfalls of Using This Configuration for Development .....	160
View That Shows Changes of One Developer .....	161
Historical View Defined by a Version Label .....	161
Historical View Defined by a Time Rule .....	162
11.7 Views for Project Builds .....	162
View That Uses Results of a Nightly Build .....	163

Variations That Select Versions of Project Libraries .....	164
View That Selects Versions of Application Subsystems.....	164
View That Selects Versions That Built a Particular Program.....	165
Configuring the Makefile.....	165
Fixing Bugs in the Program .....	166
Selecting Versions That Built a Set of Programs.....	166
11.8 Sharing Config Specs Between UNIX and Windows .....	167
Pathname Separators .....	167
Pathnames in Config Spec Element Rules .....	167
Config Spec Compilation .....	168
Example .....	168
<b>12. Implementing Project Development Policies .....</b>	<b>169</b>
12.1 Good Documentation of Changes Is Required .....	169
12.2 All Source Files Require a Progress Indicator .....	170
12.3 Label All Versions Used in Key Configurations.....	171
12.4 Isolate Work on Release Bugs to a Branch.....	172
12.5 Avoid Disrupting the Work of Other Developers.....	173
12.6 Deny Access to Project Data When Necessary .....	174
12.7 Notify Team Members of Relevant Changes .....	174
12.8 All Source Files Must Meet Project Standards .....	175
12.9 Associate Changes with Change Orders .....	176
12.10 Associate Project Requirements with Source Files.....	177
12.11 Prevent Use of Certain Commands .....	179
12.12 Certain Branches Are Shared Among MultiSite Sites.....	180
12.13 Sharing Triggers Between UNIX and Windows.....	181
Using Different Pathnames or Different Scripts.....	181
Using the Same Script.....	182
Notes .....	182
<b>13. Setting Up the Base ClearCase-ClearQuest Integration .....</b>	<b>183</b>
13.1 Overview of the Integration .....	183
13.2 Configuring ClearQuest and ClearCase .....	184
Adding ClearCase Definitions to a ClearQuest Schema .....	185

Installing Triggers in ClearCase VOBs .....	186
Quick Start for Evaluations .....	187
Setting Environment Variables for the ClearQuest Web Interface ..	187
Setting the Environment for the ClearQuest Perl API .....	187
Editing the Configuration File .....	188
Testing the Integration.....	188
Checking Performance.....	188
13.3 Using the Integration Query Wizard .....	189
<b>14. Integrating Changes .....</b>	<b>191</b>
14.1 How Merging Works .....	191
Using the GUI to Merge Elements .....	193
Using the Command Line to Merge Elements .....	194
14.2 Common Merge Scenarios .....	194
Scenario: Selective Merge from a Subbranch.....	195
Scenario: Removing the Contributions of Some Versions.....	196
Scenario: Merging All Project Work .....	197
All Project Work Is Isolated on a Branch .....	197
All Project Work Isolated in a View.....	197
Scenario: Merging a New Release of an Entire Source Tree.....	198
Scenario: Merging Directory Versions.....	201
14.3 Using Your Own Merge Tools .....	202
<b>15. Using Element Types to Customize Processing of File Elements .....</b>	<b>205</b>
15.1 File Types in a Typical Project .....	205
15.2 How ClearCase Assigns Element Types .....	206
15.3 Element Types and Type Managers.....	207
Other Applications of Element Types .....	209
Using Element Types to Configure a View .....	209
Processing Files by Element Type.....	210
15.4 Predefined and User-Defined Element Types.....	210
15.5 Predefined and User-Defined Type Managers.....	211
UNIX—Creating a New Type Manager .....	211

	UNIX—Writing a Type Manager Program .....	212
	Exit Status of a Method .....	212
15.6	Type Manager for Manual Page Source Files .....	212
	Creating the Type Manager Directory .....	213
	Inheriting Methods from Another Type Manager .....	213
	The create_version Method .....	213
	The construct_version Method .....	215
	Implementing a New compare Method.....	217
	Testing the Type Manager .....	218
	Installing and Using the Type Manager .....	219
15.7	Icon Use by GUI Browsers .....	220
<b>16.</b>	<b>Using ClearCase Throughout the Development Cycle.....</b>	<b>223</b>
16.1	Project Overview .....	223
16.2	Development Strategy .....	225
	Project Manager and ClearCase Administrator.....	225
	Use of Branches .....	225
	Creating Project Views .....	228
16.3	Creating Branch Types .....	228
16.4	Creating Standard Config Specs .....	229
16.5	Creating, Configuring, and Registering Views.....	229
16.6	Development Begins .....	230
	Techniques for Isolating Your Work .....	230
16.7	Creating Baseline 1.....	231
	Merging Two Branches .....	231
	Integration and Test.....	232
	Labeling Sources.....	232
	Removing the Integration View .....	233
16.8	Merging Ongoing Development Work.....	233
	Preparing to Merge .....	234
	Merging Work .....	236
16.9	Creating Baseline 2.....	238
	Merging from the r1_fix Branch.....	239
	Preparing to Merge from the major Branch .....	239

Merging from the major Branch .....	240
Decommissioning the major Branch .....	241
Integration and Test .....	242
16.10 Final Validation: Creating Release 2.0 .....	242
Labeling Sources .....	243
Restricting Use of the main Branch .....	243
Setting Up the Test View .....	243
Setting Up the Trigger to Monitor Bug-fixing .....	244
Fixing a Final Bug .....	244
Rebuilding from Labels .....	245
Wrapping Up .....	245
<b>A. ClearCase-ClearQuest Integrations .....</b>	<b>247</b>
A.1 Understanding the ClearCase-ClearQuest Integrations .....	247
Managing Coexisting Integrations .....	248
Schema .....	248
Presentation .....	248
<b>Index .....</b>	<b>251</b>

# Figures

<b>Figure 1</b>	Branching Hierarchy in Base ClearCase.....	2
<b>Figure 2</b>	Project Manager, Developer, and Integrator Work Flows.....	11
<b>Figure 3</b>	VOB Containing Multiple Components.....	13
<b>Figure 4</b>	Baselines of Two Components.....	15
<b>Figure 5</b>	Composite Baseline .....	16
<b>Figure 6</b>	Rebase Operation.....	21
<b>Figure 7</b>	Promoting Baselines .....	22
<b>Figure 8</b>	Association of UCM and ClearQuest Objects in Integration.....	24
<b>Figure 9</b>	Components Used by Transaction Builder Project.....	30
<b>Figure 10</b>	Storing Multiple Components in a VOB .....	31
<b>Figure 11</b>	Using a Read-Only Component.....	34
<b>Figure 12</b>	Using a Feature-Specific Development Stream .....	36
<b>Figure 13</b>	Using a System-Level Composite Baseline .....	38
<b>Figure 14</b>	Related Projects Sharing One PVOB.....	42
<b>Figure 15</b>	Projects in Multiple PVOBs Linked to the Same ClearQuest Database.....	45
<b>Figure 16</b>	Using the Same Schema Repository for Multiple ClearQuest Databases ...	46
<b>Figure 17</b>	UCM Tab of Record Form for a UCM-Enabled Record Type .....	47
<b>Figure 18</b>	Main Tab of Record Form for the BaseCMActivity Record Type.....	48
<b>Figure 19</b>	Default and Nondefault Deliver Targets in a Stream Hierarchy.....	52
<b>Figure 20</b>	Delivering Changes Made to a Foundation Baseline .....	54
<b>Figure 21</b>	Associating a User Database with a UCM-Enabled Schema.....	60
<b>Figure 22</b>	Assigning State Types to a Record Type's States.....	61
<b>Figure 23</b>	Navigating to Record Type's State Transition Matrix.....	62
<b>Figure 24</b>	State Transitions of UCM-enabled BaseCMActivity Record Type.....	64
<b>Figure 25</b>	Navigating to Integration Stream in Project Explorer.....	77
<b>Figure 26</b>	Using the Edit Baseline Dependencies GUI.....	79
<b>Figure 27</b>	Step 2 of New Project Wizard .....	85
<b>Figure 28</b>	Enabling a Project to Work with a ClearQuest User Database .....	87
<b>Figure 29</b>	Navigating to the UCMProjects Query .....	88
<b>Figure 30</b>	Add Baseline Dialog Box .....	98

<b>Figure 31</b>	Make Baseline Dialog Box.....	104
<b>Figure 32</b>	Comparing Baselines .....	110
<b>Figure 33</b>	Comparing Baselines by Activity .....	111
<b>Figure 34</b>	Preoperation and Postoperation Triggers .....	117
<b>Figure 35</b>	Managing a Follow-on Release .....	132
<b>Figure 36</b>	Incorporating a Patch Release .....	135
<b>Figure 37</b>	Making a Change to an Old Version .....	155
<b>Figure 38</b>	Multiple-Level Auto-Make-Branch .....	157
<b>Figure 39</b>	Development Config Spec vs. QA Config Spec .....	159
<b>Figure 40</b>	Checking Out a Branch of an Element .....	160
<b>Figure 41</b>	Requirements Tracing.....	179
<b>Figure 42</b>	Versions Involved in a Typical Merge .....	192
<b>Figure 43</b>	ClearCase Merge Algorithm.....	193
<b>Figure 44</b>	Selective Merge from a Subbranch .....	195
<b>Figure 45</b>	Removing the Contributions of Some Versions .....	196
<b>Figure 46</b>	Merging a New Release of an Entire Source Tree .....	199
<b>Figure 47</b>	Data Handling: File Type, Element Type, Type Manager .....	208
<b>Figure 48</b>	User-Defined Icon Display .....	222
<b>Figure 49</b>	Project Plan for Release 2.0 Development .....	224
<b>Figure 50</b>	Development Milestones: Evolution of a Typical Element.....	227
<b>Figure 51</b>	Creating Baseline 1.....	231
<b>Figure 52</b>	Updating Major Enhancements Development .....	234
<b>Figure 53</b>	Merging Baseline 1 Changes into the major Branch .....	237
<b>Figure 54</b>	Baseline 2 .....	238
<b>Figure 55</b>	Element Structure After the Pre-Baseline-2 Merge .....	241
<b>Figure 56</b>	Final Test and Release .....	242
<b>Figure 57</b>	Change Sets in ClearQuest GUI .....	249



# Tables

<b>Table 1</b>	Recommended Directory Structure for Components.....	33
<b>Table 2</b>	State Types in UCM-Enabled Schema .....	63
<b>Table 3</b>	Environment Variables Required for Integration .....	68
<b>Table 4</b>	Queries in UCM-Enabled Schema.....	112
<b>Table 5</b>	Files Used in a Typical Project .....	206



# Preface

Rational ClearCase, a *configuration management* system, is designed to help software development teams track the objects used in software builds. You can use base ClearCase to create a customized configuration management environment, or you can adopt the Unified Change Management (UCM) process.

---

## About This Manual

This manual shows project managers how to set up and manage a configuration management environment for their development team using either UCM or the customizable features of base ClearCase.

## Product-Specific Features

This manual describes Rational ClearCase and Rational ClearCase LT. ClearCase LT does not include all features available in ClearCase. In addition, some user interfaces are different in the two products. This manual uses the following label to call out differences: **PRODUCT NOTE**. When used outside of a **PRODUCT NOTE** section, ClearCase refers to both products.

## Organization

The manual is divided into two parts:

- *Part 1: Working in UCM.* Read this part if you plan to use UCM to implement your team's development process.
- *Part 2: Working in Base ClearCase.* Read this part if you plan to use the base ClearCase features to implement a customized development process for your team.

---

# ClearCase Documentation Roadmap

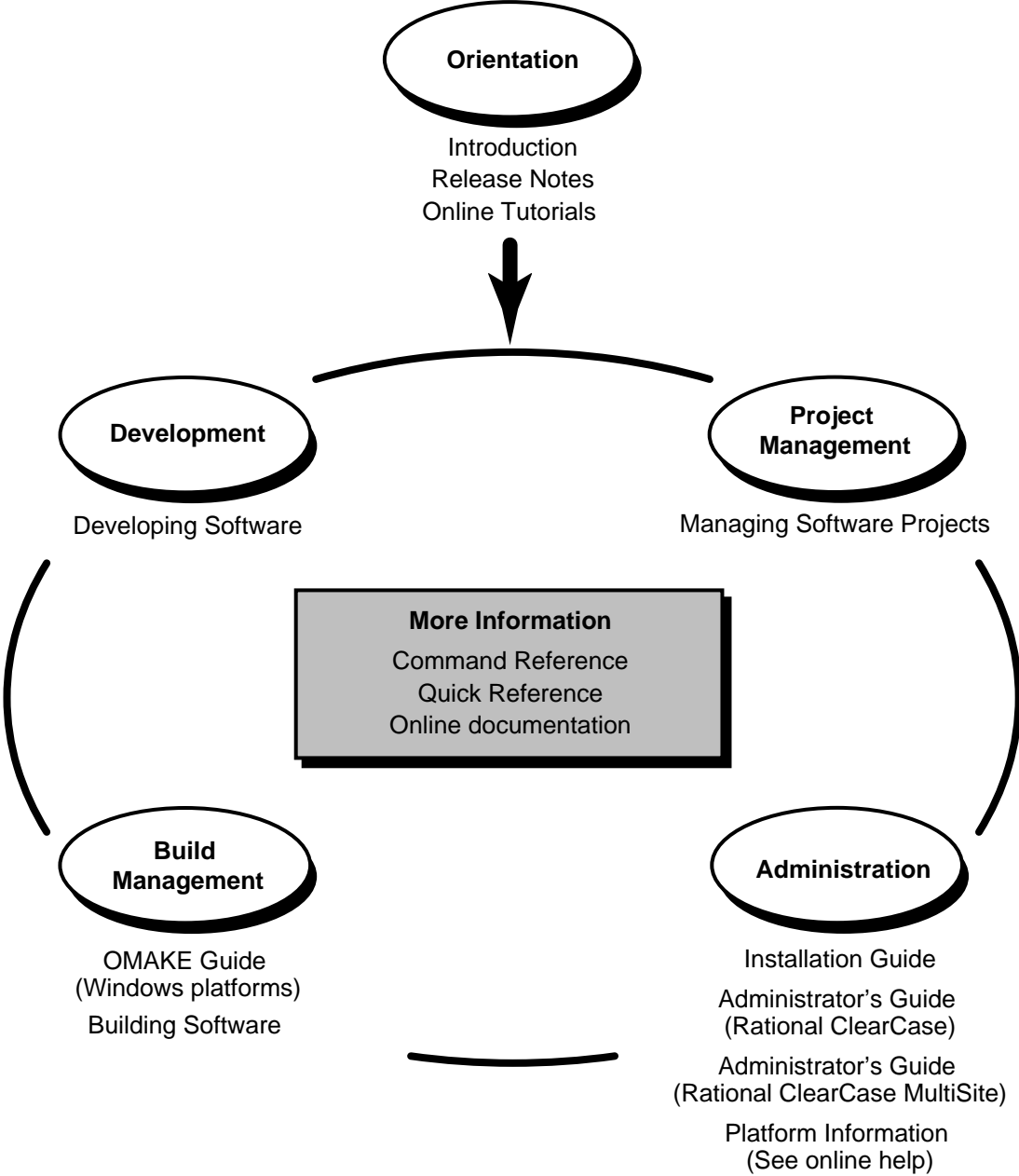

---

## ClearCase LT Documentation Roadmap

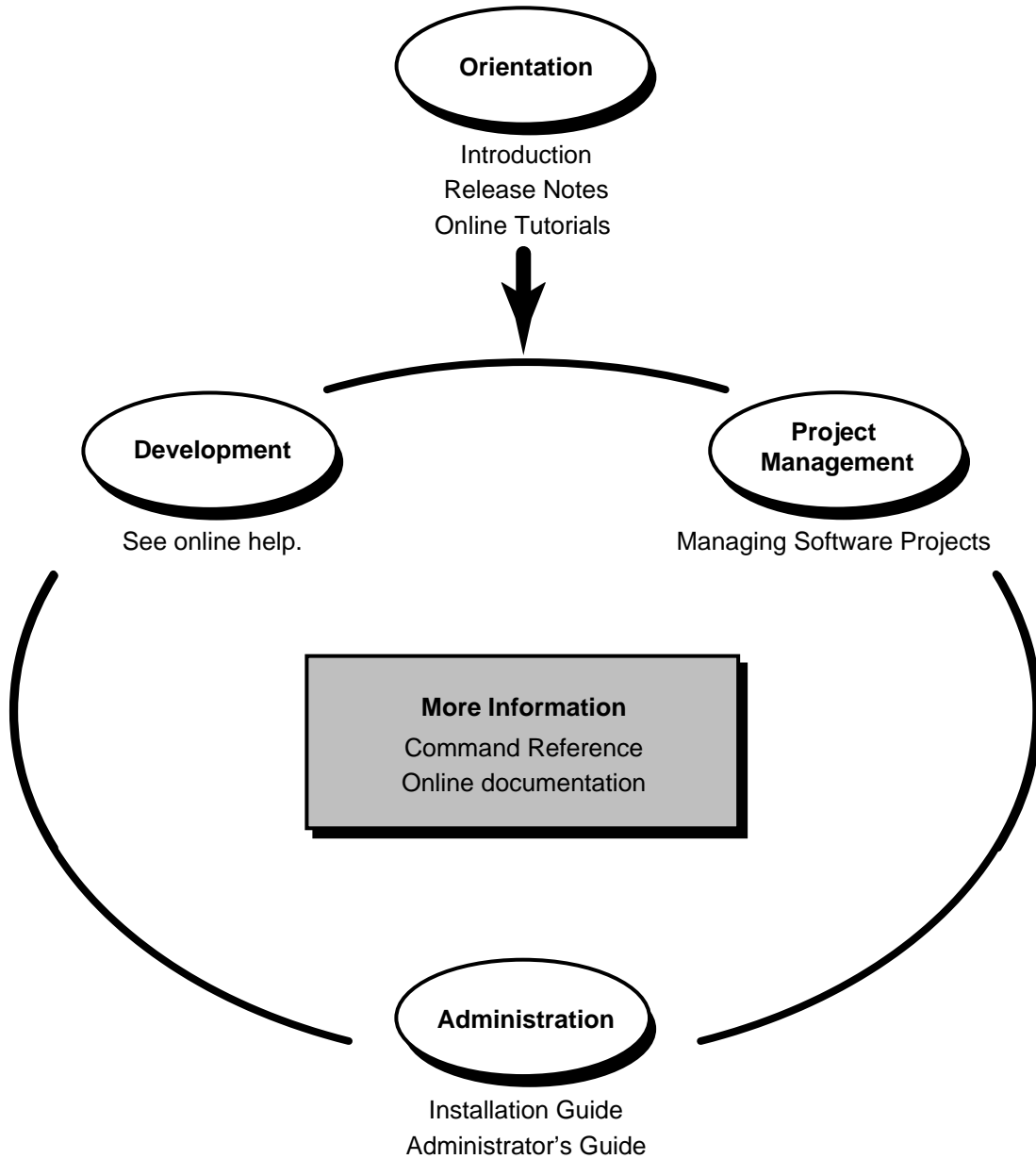

---

## Typographical Conventions

This manual uses the following typographical conventions:

- *ccase-home-dir* represents the directory into which the ClearCase Product Family has been installed. By default, this directory is `/usr/atria` on UNIX and `C:\Program Files\Rational\ClearCase` on Windows.
- *attache-home-dir* represents the directory into which ClearCase Attache has been installed. By default, this directory is `C:\Program Files\Rational\Attache`, except on Windows 3.x, where it is `C:\RATIONAL\ATTACHE`.
- **Bold** is used for names the user can enter; for example, all command names, file names, and branch names.
- *Italic* is used for variables, document titles, glossary terms, and emphasis.
- A monospaced font is used for examples. Where user input needs to be distinguished from program output, **bold** is used for user input.
- Nonprinting characters are in small caps and appear as follows: `<EOF>`, `<NL>`.
- Key names and key combinations are capitalized and appear as follows: `SHIFT`, `CTRL+G`.
- [ ] Brackets enclose optional items in format and syntax descriptions.
- { } Braces enclose a list from which you must choose an item in format and syntax descriptions.
- | A vertical bar separates items in a list of choices.
- ... In a syntax description, an ellipsis indicates you can repeat the preceding item or line one or more times. Otherwise, it can indicate omitted information.

**NOTE:** In certain contexts, ClearCase recognizes “...” within a pathname as a wildcard, similar to “\*” or “?”. See the **wildcards\_ccase** reference page for more information.

- If a command or option name has a short form, a “medial dot” ( · ) character indicates the shortest legal abbreviation. For example:

### **lsc·heckout**

This means that you can truncate the command name to **lsc** or any of its intermediate spellings (**lsch**, **lsche**, **lschec**, and so on).

---

## Online Documentation

The ClearCase graphical interface includes a Microsoft Windows-like help system.

There are three basic ways to access the online help system: the **Help** menu, the **Help** button, or the F1 key. **Help > Contents** provides access to the complete set of ClearCase online documentation. For help on a particular context, press F1. Use the **Help** button on various dialog boxes to get information specific to that dialog box.

ClearCase also provides access to full “reference pages” (detailed descriptions of ClearCase commands, utilities, and data structures) with the **cleartool man** subcommand. Without any argument, **cleartool man** displays the **cleartool** overview reference page. Specifying a command name as an argument gives information about using the specified command. For example:

% **cleartool man** *(display the cleartool overview page)*

% **cleartool man man** *(display the cleartool man reference page)*

% **cleartool man checkout** *(display the cleartool checkout reference page)*

ClearCase’s **-help** command option or **help** command displays individual subcommand syntax. Without any argument, **cleartool help** displays the syntax for all **cleartool** commands. **help checkout** and **checkout -help** are equivalent.

% **cleartool uncheckout -help**

Usage: uncheckout | unco [-keep | -rm] [-cact | -cwork ] pname ...

Additionally, the online *ClearCase Tutorial* provides important information on setting up a user’s environment, along with a step-by-step tour through ClearCase’s most important features. To start the *ClearCase Tutorial* from the command line, type **hyperhelp cc\_tut.hlp**.

---

## Technical Support

If you have any problems with the software or documentation, please contact Rational Technical Support via telephone, fax, or electronic mail as described below. For information regarding support hours, languages spoken, or other support information, click the **Technical Support** link on the Rational Web site at [www.rational.com](http://www.rational.com).

Your Location	Telephone	Facsimile	Electronic Mail
---------------	-----------	-----------	-----------------

North America	800-433-5444 toll free or 408-863-4000 Cupertino, CA	408-863-4194 Cupertino, CA 781-676-2460 Lexington, MA	<b>support@rational.com</b>
Europe, Middle East, and Africa	+31-(0)20-4546-200 Netherlands	+31-(0)20-4546-201 Netherlands	<b>support@europe.rational.com</b>
Asia Pacific	61-2-9419-0111 Australia	61-2-9419-0123 Australia	<b>support@apac.rational.com</b>



# Choosing Between UCM and Base ClearCase

# 1

Before you can start to use Rational ClearCase to manage the version control and configuration needs of your development project, you need to decide whether to use the out-of-the-box Unified Change Management (UCM) process or base ClearCase. This chapter describes the main differences between the two methods from the project management perspective.

The rest of this manual is organized into two parts. Part 1 describes how to manage a project using UCM. Part 2 describes how to manage a project using the various tools in base ClearCase.

---

## 1.1 Differences Between UCM and Base ClearCase

Base ClearCase consists of a set of powerful tools to establish an environment in which developers can work in parallel on a shared set of files, and project managers can define policies that govern how developers work together.

UCM is one prescribed method of using ClearCase for version control and configuration management. UCM is layered on base ClearCase. Therefore, it is possible to work efficiently in UCM without having to master the details of base ClearCase.

UCM offers the convenience of an out-of-the-box solution; base ClearCase offers the flexibility to implement virtually any configuration management solution that you deem appropriate for your environment.

---

## Branching and Creating Views

Base ClearCase uses branches to enable parallel development. A *branch* is an object that specifies a linear sequence of versions of an element. Every element has one **main branch**, which represents the principal line of development, and may have multiple subbranches, each of which represents a separate line of development. For example, a project team may use the **main** branch for new development work while using a subbranch simultaneously for fixing a bug.

Subbranches can have subbranches. For example, a project team may designate a subbranch for porting a product to a different platform. The team may then decide to create a bug-fixing subbranch off that porting subbranch. Base ClearCase allows you to create complex branch hierarchies. Figure 1 illustrates a multilevel branch hierarchy. As a project manager in such an environment, you need to ensure that developers are working on the correct branches. Developers work in views. A *view* is a work area for developers to create versions of elements. Each view includes a *config spec*, which is a set of rules that determines which versions of elements the view selects.

Figure 1 Branching Hierarchy in Base ClearCase

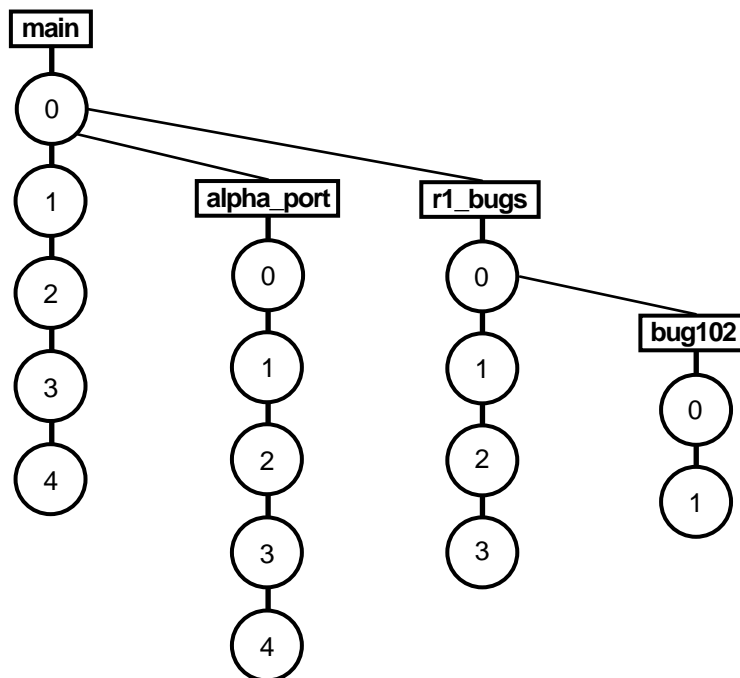

As project manager, you tell developers which rules to include in their *config specs* so that their views access the appropriate set of versions.

UCM uses branches also, but you do not have to manipulate them directly because it layers streams over the branches. A *stream* is a ClearCase object that maintains a list of activities and baselines and determines which versions of elements appear in a developer's view. In UCM, a project contains one *integration stream*, which records the project's shared set of elements, and multiple *development streams*, in which developers work on their parts of the project in isolation from the team. The project's integration stream uses one branch. Each development stream uses its own branch. You can create a hierarchy of development streams, and UCM creates the branching hierarchy to support those streams.

As project manager of a UCM project, you need not write rules for config specs. Streams configure developers' views to access the appropriate versions on the appropriate branches.

---

## Using Components to Organize Files

As the number of files and directories in your system grows, you need a way to reduce the complexity of managing them. In UCM you use components to simplify the organization of your files and directories. The elements that you group into a component typically implement a reusable piece of your system architecture. By organizing related files and directories into components, you can view your system as a small number of identifiable components, rather than one large set of directories and files.

---

## Creating and Using Baselines

Both base ClearCase and UCM allow you to create baselines. UCM automates the creation process and provides additional support for performing operations on baselines. A *baseline* identifies the set of versions of files that represent a project at a particular milestone. For example, you may create a baseline called **beta1** to identify an early snapshot of a project's source files.

Baselines provide two main benefits:

- The ability to reproduce an earlier release of a software project
- The ability to tie together the complete set of files related to a project, such as source files, a product requirements document, a documentation plan, functional and design specifications, and test plans

In base ClearCase, you can create a baseline by creating a version label and applying that label to a set of versions.

In UCM, baseline support appears throughout the user interface because UCM requires that you use baselines. When developers join a project, they must first populate their work areas with the contents of the project's recommended baseline. This method ensures that all team members start with the same set of shared files. In addition, UCM lets you set a property on the baseline to indicate the quality level of the versions that the baseline represents. Examples of quality levels include "project builds without errors," "passes initial testing," and "passes regression testing." By changing the quality-level property of a baseline to reflect a higher degree of stability, you can, in effect, promote the baseline.

---

## Managing Activities

In base ClearCase, you work at the version and file level. UCM provides a higher level of abstraction: activities. An *activity* is a ClearCase object that you use to record the work required to complete a development task. For example, an activity may be to change a graphical user interface (GUI). You may need to edit several files to make the changes. UCM records the set of versions that you create to complete the activity in a *change set*. Because activities appear throughout the UCM user interface, you can perform operations on sets of related versions by identifying activities rather than having to identify numerous versions.

Because activities correspond to significant project tasks, you can track the progress of a project more easily. For example, you can determine which activities were completed in which baselines. If you use the UCM-ClearQuest integration, you gain additional project management control, such as the ability to assign states and state transitions to activities. You can then generate reports by issuing queries such as "show me all activities assigned to Pat that are in the Ready state."

---

## Enforcing Development Policies

A key part of managing the configuration management aspect of a software project is establishing and enforcing development policies. In a parallel development environment, it is crucial to establish rules that govern how team members access and update shared sets of files. Such policies are helpful in two ways:

- They minimize project build problems by identifying conflicting changes made by multiple developers as early as possible.
- They establish greater communication among team members.

These are examples of common development policies:

- Developers must synchronize their private work areas with the project's recommended baseline before delivering their work to the project's shared work area.
- Developers must notify other team members by e-mail when they deliver work to the project's shared work area.

In base ClearCase, you can use tools such as triggers and attributes to create mechanisms to enforce development policies. UCM includes a set of common development policies, which you can set through the GUI or command-line interface (CLI). You can set these policies at the project and stream levels. In addition, you can use triggers and attributes to create new UCM policies.



## **Part 1: Working in UCM**





## Understanding UCM

# 2

This chapter provides an overview of Unified Change Management (UCM), which is available with Rational ClearCase. Specifically, it introduces the main UCM objects and describes the tasks involved in managing a UCM project. Subsequent chapters describe in detail the steps required to perform these tasks.

---

### 2.1 Overview of the UCM Process

In UCM, your work follows a cycle that complements an iterative software development process. Members of a project team work in a UCM *project*. A project is the object that contains the configuration information needed to manage a significant development effort, such as a product release. A project contains one main shared work area and typically multiple private work areas. Private work areas allow developers to work on activities in isolation. The project manager and integrator are responsible for maintaining the project's shared work area. Work within a project progresses as follows:

1. You create a project and identify an initial set of baselines of one or more components. A *component* is a group of related directory and file elements, which you develop, integrate, and release together. A *baseline* is a version of one or more components.
2. Developers join the project by creating their private work areas and populating them with the contents of the project's baselines.
3. Developers create activities and work on one activity at a time. An *activity* records the set of files that a developer creates or modifies to complete a development task, such as fixing a bug. This set of files associated with an activity is known as a *change set*.

4. When developers complete activities, and build and test their work in their private work areas, they share their work with the project team by performing *deliver* operations. A deliver operation merges work from the developer's private work area to the project's shared work area.
5. Periodically, the integrator builds the project's executable files in the shared work area, using the delivered work.
6. If the project builds successfully, the integrator creates new baselines. In a separate work area, a team of software quality engineers performs more extensive testing of the new baselines.
7. Periodically, as the quality and stability of baselines improve, the integrator adjusts the promotion level attribute of baselines to reflect appropriate milestones, such as Built, Tested, or Released. When the new baselines pass a sufficient level of testing, the integrator designates them as the *recommended* set of baselines.
8. Developers perform *rebase* operations to update their private work areas to include the set of versions represented by the new recommended baselines.
9. Developers continue the cycle of working on activities, delivering completed activities, updating their private work areas with new baselines.

Figure 2 illustrates the connection between the project management, development, and integration cycles. This manual describes the steps performed by project managers and integrators. See *Developing Software* for information about the steps performed by developers.

Figure 2 Project Manager, Developer, and Integrator Work Flows

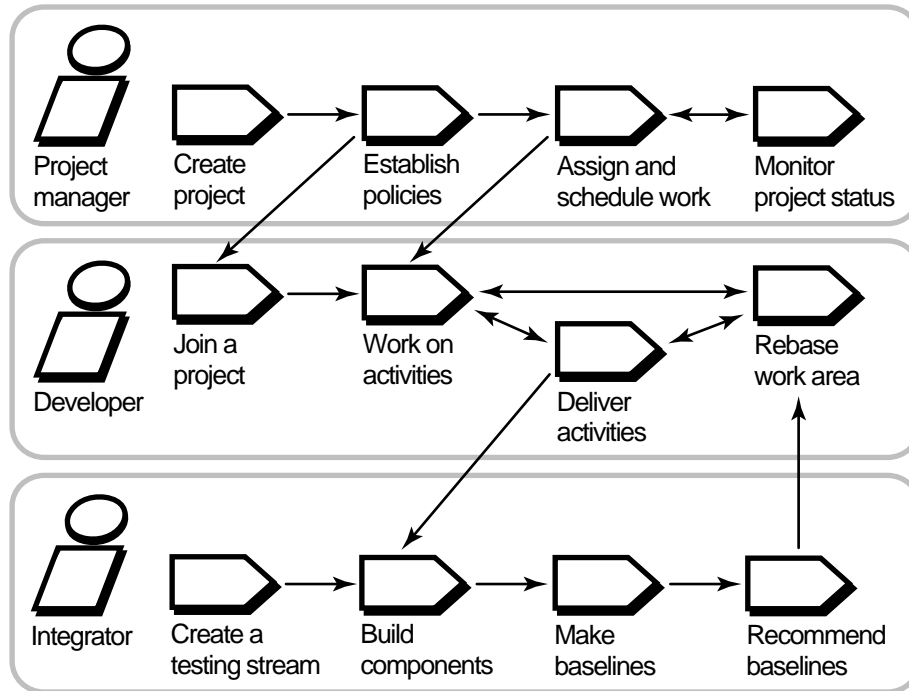

---

## 2.2 Creating the Project

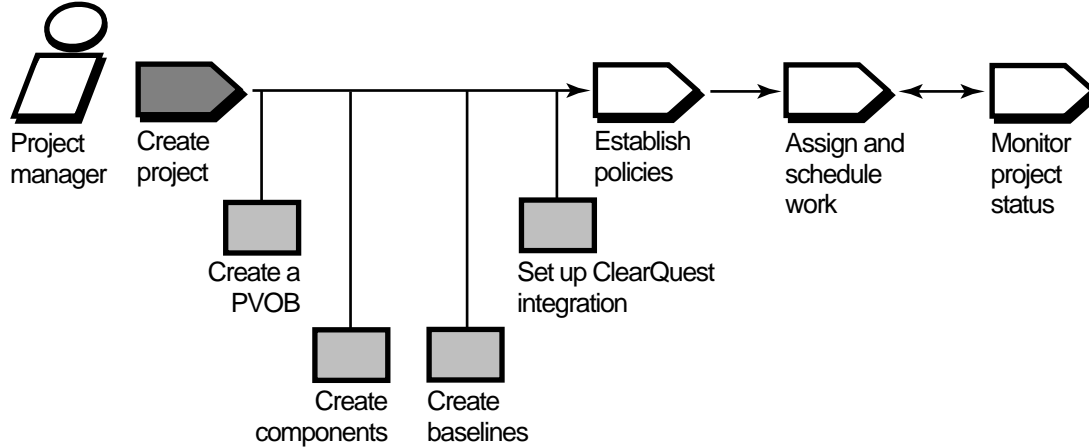

To create and set up a project, you must perform the following tasks:

- Create a repository for storing project information
- Create components that contain the set of files the developers work on
- Create baselines that identify the versions of files with which the developers start their work

To use UCM with Rational ClearQuest, you must perform additional setup steps.

---

### Creating a PVOB

ClearCase stores file elements, directory elements, derived objects, and metadata in a repository called a versioned object base (VOB). In UCM, each project must have a project VOB (PVOB). A PVOB is a special kind of VOB that stores UCM objects, such as projects, activities, and change sets. A PVOB must exist before you can create a project. Check with your site's ClearCase administrator to see whether a PVOB has already been created. For details on creating a PVOB, see *Creating the Project VOB* on page 70.

---

## Organizing Directories and Files into Components

As the number of files and directories in your system grows, you need a way to reduce the complexity of managing them. Components are the UCM mechanism for simplifying the organization of your files and directories. The elements that you group into a component typically implement a reusable piece of your system architecture. By organizing related files and directories into components, you can view your system as a small number of identifiable components, rather than as one large set of directories and files.

The directory and file elements of a component reside physically in a VOB. The component object resides in a PVOB. Within a component, you organize directory and file elements into a directory tree. In Figure 3, the directory trees for the **GUI**, **Admin**, and **Reports** components appear directly under the VOB's root directory. You can convert existing VOBs or directory trees within VOBs into components, or you can create a component from scratch. For details on creating a component from scratch, see *Creating Components for Storing Elements* on page 72. For details on converting a VOB into a component, see *Making a VOB into a Component* on page 82.

Figure 3 VOB Containing Multiple Components

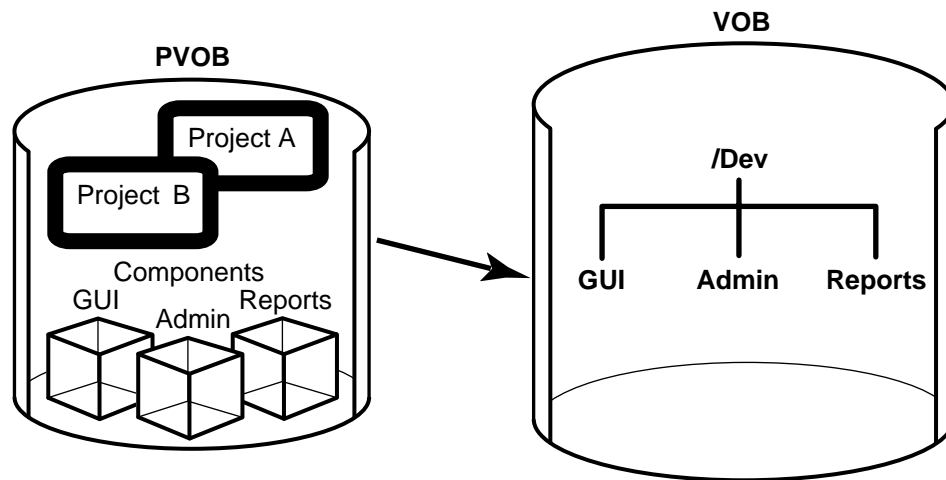

---

## Shared and Private Work Areas

A work area consists of a view and a stream. A *view* is a directory tree that shows a single version of each file in your project. A *stream* is a ClearCase object that maintains a list of activities and baselines and determines which versions of elements appear in your view.

A project contains one *integration stream*, which records the project's baselines and enables access to shared versions of the project's elements. The integration stream and a corresponding integration view represent the project's shared work area.

Each developer on the project has a private work area, which consists of a development stream and a corresponding development view. The *development stream* maintains a list of the developer's activities and determines which versions of elements appear in the developer's view.

In the basic UCM process, the integration stream is the project's only shared work area. You may want to create additional shared work areas for developers who are working together on specific parts of the project. You can accomplish this by creating a hierarchy of development streams. For example, you can create a development stream and designate it as the shared work area for developers working on a particular feature. Developers then create their own development streams and views under the development stream for this feature. The developers deliver work to and rebase their streams to recommended baselines in the feature's development stream. See *Choosing a Stream Strategy* on page 35 for details on development stream hierarchies.

When you create a project from the UCM GUI, ClearCase creates the integration stream for you. If you create a project from the command-line interface, you need to create the integration stream explicitly. Developers create their development streams and development views when they join the project. See *Developing Software* for information on joining a project.

---

## Starting from a Baseline

After you create project components or select existing components, you must identify and recommend the baseline or baselines that serve as the starting point for the team's developers. A baseline identifies one version of every element visible in a component. Figure 4 shows baselines named BL1 and BL2 that identify versions in component A and component B, respectively.

When developers join the project, they populate their work areas with the versions of directory and file elements represented by the project's recommended baselines. Alternatively, developers can join the project at a feature-specific development stream level, in which case they populate

their work areas with the development stream's recommended baselines. This practice ensures that all members of the project team start with the same set of files.

If your project team works on multiple components, you may want to use a composite baseline. A *composite baseline* selects baselines in other components. In Figure 5, the **ProjBL1** composite baseline selects baselines **BL1** and **BL2** of components **A** and **B**, respectively. The **Proj** component does not contain any elements of its own. It contains only the composite baseline that selects the recommended baselines of the project's components. By using a composite baseline in this manner, you can identify one baseline to represent the entire project.

Figure 4 Baselines of Two Components

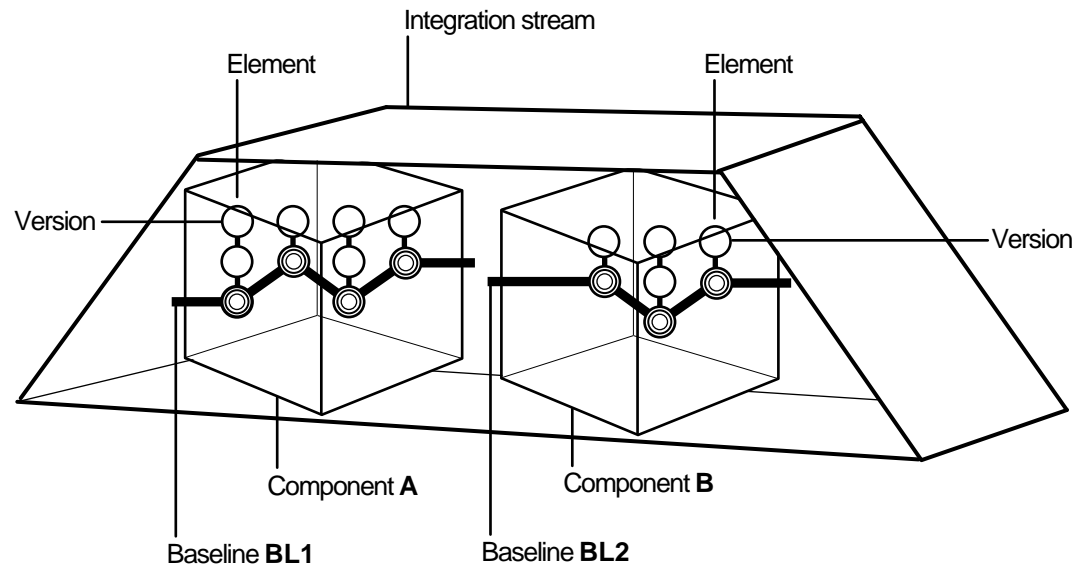
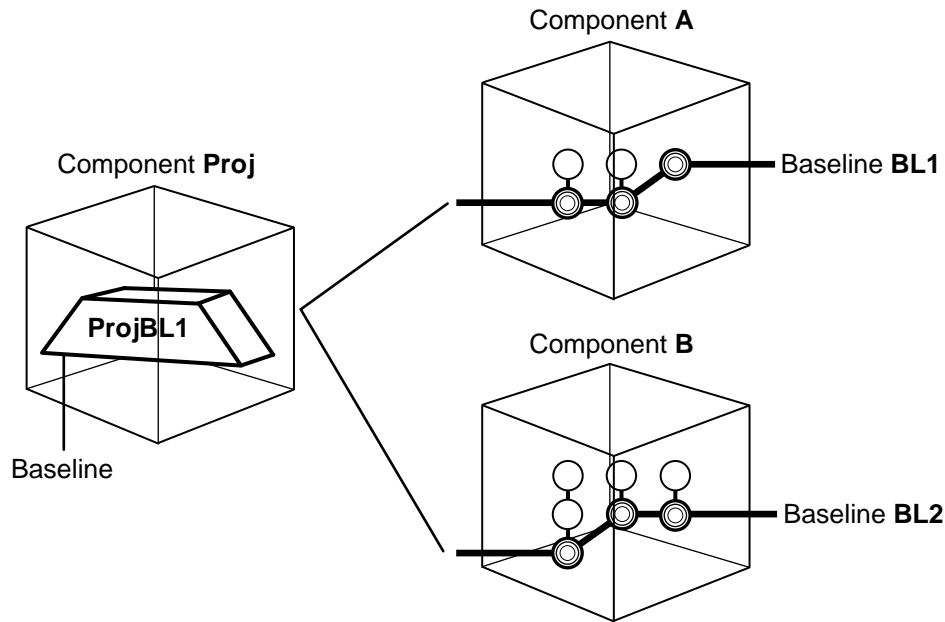

Figure 5 Composite Baseline



---

## Setting Up the UCM-ClearQuest Integration

You can use UCM without Rational ClearQuest, the change request management tool, but the integration with ClearQuest adds significant project management and activity management capabilities. When you set up a UCM project to work with ClearQuest, the integration links all project activities to ClearQuest records. You can then take advantage of UCM-ClearQuest's state transition model and ClearQuest's query, reporting, and charting features. These features allow you to do the following:

- Assign activities to developers
- Use states and state transition rules to manage activities
- Generate reports based on database queries
- Select additional development policies to be enforced

To set up the UCM-ClearQuest integration:

1. Enable a ClearQuest schema to work with UCM or use a predefined UCM-enabled schema.



2. Create or upgrade a ClearQuest user database to use the schema.
3. Enable your UCM project to work with ClearQuest.

See *Overview of the UCM-ClearQuest Integration* on page 23 for additional information about the integration.

---

## 2.3 Setting Policies

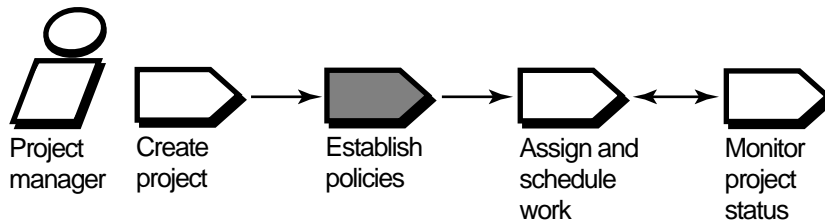

UCM includes a set of policies that you can set to enforce development practices among members of the project team. By setting policies, you can improve communication among project team members and minimize the problems you may encounter when integrating their work. For example, you can set a policy that requires developers to update their work areas with the project's latest recommended baseline before they deliver work. This practice reduces the likelihood that developers will need to work through complex merges when they deliver their work. For a description of all policies you can set in UCM, see Chapter 4, *Setting Policies*. You can set policies on projects and streams.

In addition to the set of policies that UCM provides, you can create triggers on UCM operations to enforce customized development policies. See Chapter 8, *Using Triggers to Enforce Development Policies* for details about creating triggers.

---

## 2.4 Assigning Work

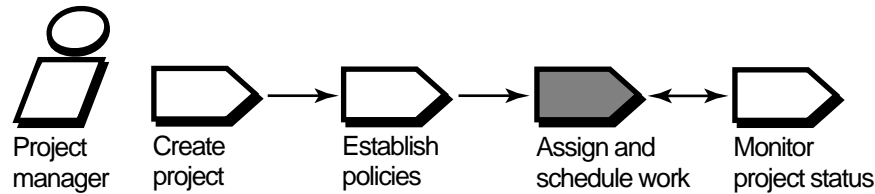

This task is optional and is possible only if you use the UCM-ClearQuest integration. As project manager, you are responsible for identifying and scheduling the high-level tasks for your project team. In some organizations, the project manager creates activities and assigns them to developers. In other organizations, the developers create their own activities. See *Assigning Activities* on page 89 for details on creating and assigning activities in ClearQuest.

---

## 2.5 Creating a Testing Stream

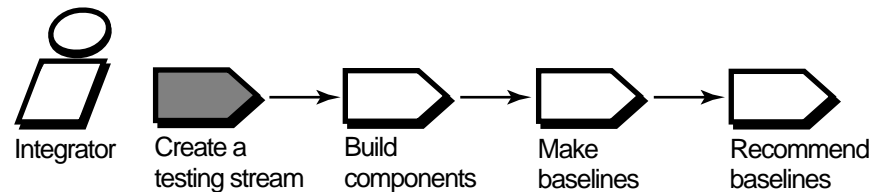

In your role as integrator, you are responsible for building the work delivered by developers, creating baselines, and testing those baselines. When you make baselines in the integration stream, you lock the stream to prevent developers from delivering work. This practice ensures that you work with a static set of files. It is acceptable to perform quick validation tests of the new baselines in the integration stream. However, we recommend that you do not lock the integration stream for a long time because you will create a backlog of deliveries. To perform more rigorous testing, such as regression testing, you should create a development stream to be used solely for testing baselines. See *Creating a Development Stream for Testing Baselines* on page 93 for details on creating a testing stream.

---

## 2.6 Building Components

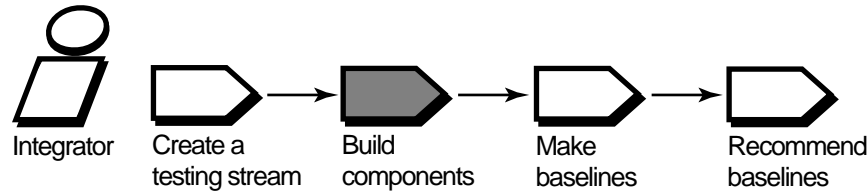

Before you make new baselines, build the components in the integration stream by using the current baselines plus any work that developers have delivered to the stream since you created the current baselines. Lock the integration stream before you build the components to ensure that you work with a static set of files. If the build succeeds, you can make baselines that select the latest delivered work. If your project uses feature-specific development streams, perform this task on those streams as well as on the integration stream.

---

### MultiSite Consideration

**PRODUCT NOTE:** Rational ClearCase LT does not currently support Rational ClearCase MultiSite.

In most cases, developers complete the deliver operations that they start. If your project uses ClearCase MultiSite, you may need to complete some deliver operations before you can build the components. Many ClearCase customers use MultiSite, a product layered on ClearCase, to support parallel software development across geographically distributed project teams. MultiSite lets developers work on the same VOB concurrently at different locations. Each location works on its own copy of the VOB, known as a *replica*.

To avoid conflicts, MultiSite uses an exclusive-right-to-modify scheme, called *mastership*. VOB objects, such as streams and branches, are assigned a *master replica*. The master replica has the exclusive right to modify or delete these objects.

In a MultiSite configuration, a team of developers may work at a remote site, and the project's integration stream may be mastered at a different replica than the developers' development streams. In this situation, the developers cannot complete deliver operations to the integration stream. As integrator, you must complete these deliver operations. UCM provides a variation of the deliver operation called a *remote deliver*. When UCM determines that the integration stream is mastered at a remote site, it makes the deliver operation a remote deliver, which starts the deliver operation but does not merge any versions. You then complete the deliver operation at the remote site.

For details on completing remote deliver operations, see *Finding Work That Is Ready to Be Delivered* on page 101.

---

## 2.7 Making a New Baseline

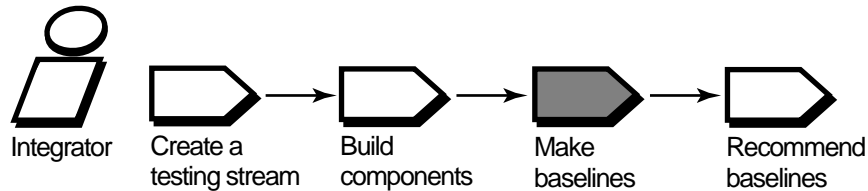

To ensure that developers stay in sync with each other's work, make new baselines regularly. A new baseline includes the work developers have delivered to the integration stream since the last baseline. If your project uses feature-specific development streams, perform this task on those streams as well as on the integration stream. In some environments, the lead developer working on a feature may assume the role of integrator for a feature-specific development stream. To make a new baseline:

1. Make sure that the integration stream is locked to prevent developers from delivering work while you create the baseline. Developers can continue to work on activities in their development streams.
2. Verify the stability of the project by testing its components.
3. Make the baseline.
4. Unlock the integration stream so that developers can deliver work.

After your team of software quality engineers tests the new baseline more extensively and determines that it is stable, make the baseline the *recommended* baseline. Developers then update their work areas with the new baseline by performing a rebase operation, which merges files and directories from the integration stream or feature-specific development stream to their development streams.

Figure 6 illustrates a rebase operation from baseline **BL1** to **BL2**. For details on making baselines, see *Creating a New Baseline* on page 103.

Figure 6 Rebase Operation

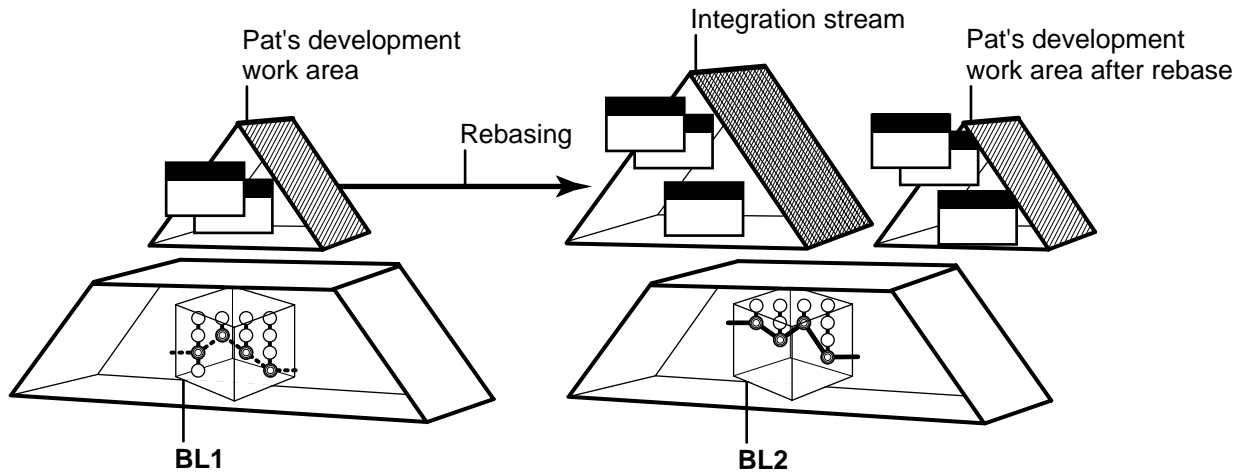

## 2.8 Recommending the Baseline

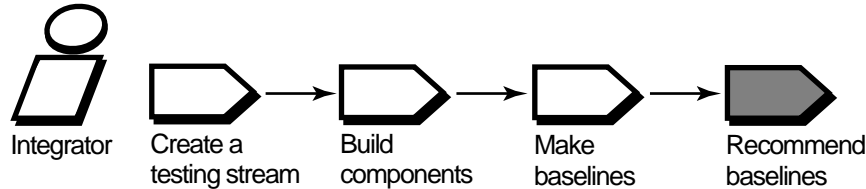

As work on your project progresses and the quality and stability of the components improve, change the baseline's promotion level attribute to reflect important milestones. The promotion level attribute typically indicates a level of testing. For example, Figure 7 shows the evolution of baselines through three levels of testing; the **BL8** baseline is ready for production.

When baselines pass the level of testing required to be considered stable, make them the recommended set of baselines. Developers then rebase their development streams to the recommended baselines. You can set a policy that requires developers to rebase their development streams to the set of recommended baselines before they deliver work. This policy helps to ensure that developers update their work areas whenever a baseline passes an acceptable level of testing.

For details on recommending baselines, see *Recommending the Baseline* on page 107.

Figure 7 Promoting Baselines

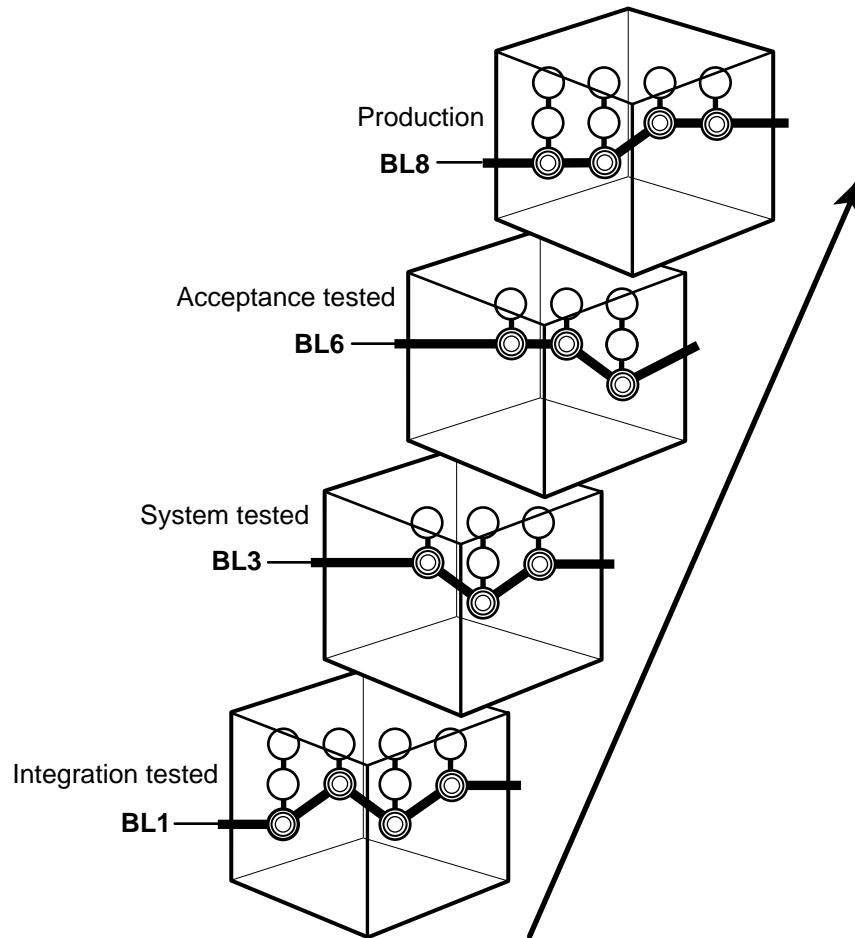

---

## 2.9 Monitoring Project Status

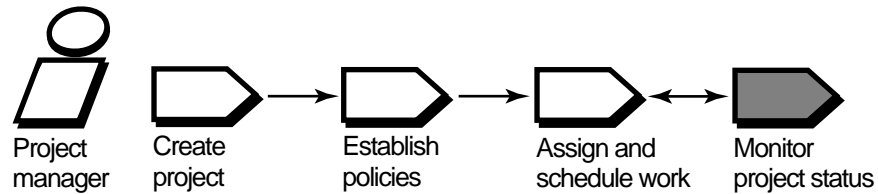

ClearCase provides several tools to help you track the progress of your project:

- The UCM-ClearQuest integration includes six ClearQuest queries, which you can use to retrieve information about activities in your project. For example, you can see all activities that are in an active state or all active activities assigned to a particular developer. In addition, you can create customized ClearQuest queries.
- The Compare Baselines GUI compares any two baselines of a component and displays the differences in activities and versions associated with each baseline. You can use this feature to determine when a particular feature was included in a baseline.

See *Monitoring Project Status* on page 109 for details on using these tools.

---

## 2.10 Overview of the UCM-ClearQuest Integration

This section describes the following UCM-ClearQuest integration concepts:

- Association of UCM and ClearQuest objects
- UCM-enabled schema
- Queries
- State types

---

### Associating UCM and ClearQuest Objects

Setting up the integration links UCM and ClearQuest objects. Figure 8 shows the bidirectional linking of these objects.

Figure 8 Association of UCM and ClearQuest Objects in Integration

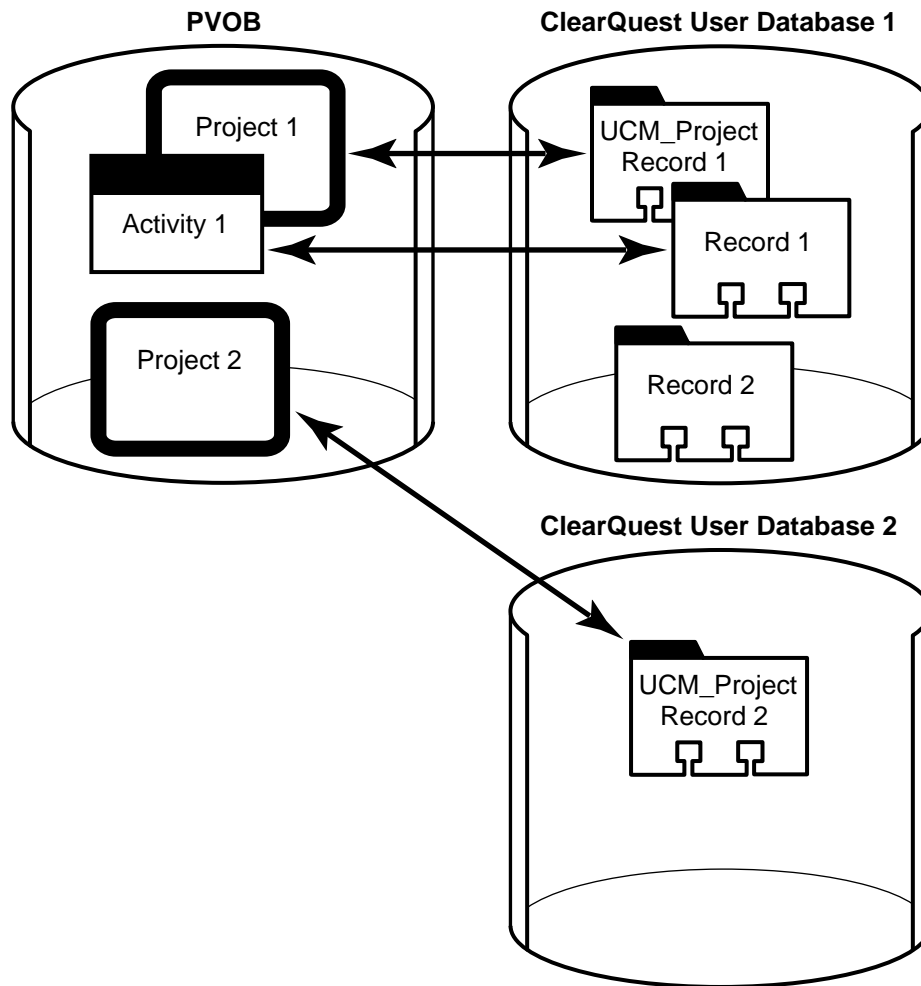

When you enable a project to link to a ClearQuest user database, the integration stores a reference to that database in the project's PVOB.

Every project enabled for ClearQuest is linked to a project record of record type **UCM\_Project** in the ClearQuest user database.



Every activity in a project enabled for ClearQuest is linked to a record in the database. An activity's headline is linked to the headline field in its corresponding ClearQuest record. If you change an activity's headline in ClearCase, the integration changes the headline in ClearQuest to match the new headline, and the reverse is also true. Similarly, an activity's ID is linked to the ID field in its ClearQuest record.

It is possible for a ClearQuest user database to contain some records that are linked to activities and some records that are not linked. Record 2 in Figure 8 is not linked to an activity. You may encounter this situation if you have a ClearQuest user database in place before you adopt UCM. As you create activities, the integration creates corresponding ClearQuest records. However, any records that existed in that user database before you enabled it to work with UCM remain unlinked. In addition, UCM does not link a record to an activity until a developer sets work to that record.

---

## UCM-Enabled Schema

In ClearQuest, a schema is the definition of a database. To use the integration, you must create or upgrade a ClearQuest user database that is based on a UCM-enabled schema. A UCM-enabled schema contains certain fields, scripts, actions, and state types. ClearQuest includes two predefined UCM-enabled schemas, which you can use. You can also enable a custom schema or another predefined schema to work with UCM. For details on UCM-enabled schemas, see *Deciding Which Schema to Use* on page 46.

---

## State Types

ClearQuest uses states to track the progress of change requests from submission to completion. A state represents a particular stage in this progression. Each movement from one state to another is a state transition. The integration uses a particular state transition model. To implement this model, the integration uses state types. A state type is a category of states that UCM uses to define state transition sequences. You can define as many states as you want, but all states in a UCM-enabled record type must be based on one of the following state types:

- Waiting
- Ready
- Active
- Complete

Multiple states can belong to the same state type. However, you must define at least one path of transitions between states of state types as follows: Waiting to Ready to Active to Complete. For details on state types, see *Setting State Types* on page 63.

---

## Queries in a UCM-Enabled ClearQuest Schema

A UCM-enabled schema includes six queries. When you create or upgrade a ClearQuest user database to use a UCM-enabled schema, the integration installs these queries in two subfolders of the Public Queries folder in the user database's workspace. These queries make it easy for developers to see which activities are assigned to them and for project managers to see which activities are active in a particular project. For details on these queries, see *Querying ClearQuest User Databases* on page 111

## Planning the Project

# 3

This chapter describes the issues you need to consider in planning to use one or more UCM projects as your configuration management environment in Rational ClearCase. We strongly recommend that you write a configuration management plan before you begin creating projects and other UCM objects. After you create your plan, see Chapter 6, *Setting Up the Project* for information on how to implement it.

---

### 3.1 Using the System Architecture as the Starting Point

Essential to developing and maintaining high-quality software is the definition of the system's architecture. The Rational Unified Process states that defining and using a system architecture is one of the six best practices to follow in developing software. A system architecture is the highest level concept of a system in its environment. The Rational Unified Process states that a system architecture encompasses the following:

- The significant decisions about the organization of a software system
- The selection of the structural elements and their interfaces of which the system is composed, together with their behavior as specified in the collaboration among those elements
- The composition of the structural and behavioral elements into progressively larger subsystems
- The architectural style that guides this organization, these elements, and their interfaces, their collaborations, and their composition

A well-documented system architecture improves the software development process. It is also the ideal starting point for defining the structure of your configuration management environment.

---

## Mapping System Architecture to Components

Just as different types of blueprints represent different aspects of a building's architecture (floor plans, electrical wiring, plumbing, and so on), a good software system architecture contains different views to represent its different aspects. The Rational Unified Process defines an architectural view as a simplified description (an abstraction) of a system from a particular perspective or vantage point, covering particular concerns and omitting entities that are not relevant to this perspective.

The Rational Unified Process suggests using five architectural views. Of these, the implementation view is most important for configuration management. The implementation view identifies the physical files and directories that implement the system's logical packages, objects, or modules. For example, your system architecture may include a licensing module. The implementation view identifies the directories and files that make up the licensing module.

From the implementation view, you should be able to identify the set of UCM components you need for your system. Components are groups of related directory and file elements, which you develop, integrate, and release together. Large systems typically contain many components. A small system may contain one component.

---

## Deciding What to Place Under Version Control

In deciding what to place under version control, do not limit yourself to source code files and directories. The power of configuration management is that you can record a history of your project as it evolves so that you can re-create the project quickly and easily at any point in time. To record a full picture of the project, include all files and directories connected with it. These include, but are not limited to the following:

- Source code files and directories
- Model files, such as Rational Rose files
- Libraries
- Executable files
- Interfaces
- Test scripts
- Project plans

- Compilers, other developer tools, and system header files
- System and user documentation
- Requirements documents

---

## Mapping Components to Projects

After mapping your system architecture to a set of components and identifying the full set of files and directories to place under version control, you need to determine whether to use one project or multiple projects. In general, think of a project as the configuration management environment for a project team working on a specific release. Team members work together to develop, integrate, test, and release a set of related components. For many systems, all work can be done in one project. For some systems, work must be separated into multiple projects. In deciding how many projects to use, consider the following factors:

- Amount of integration required
- Whether you need to develop and release multiple versions of the product concurrently

### Amount of Integration

Determine the relationships between the various components. Related components that require a high degree of integration belong to the same project. By including related components in the same project, you can build and test them together frequently, thus avoiding the problems that can arise when you integrate components late in the development cycle.

### Need for Parallel Releases

If you need to develop multiple versions of your system in parallel, consider using separate projects, one for each version. For example, your organization may need to work on a patch release and a new release at the same time. In this situation, both projects use mostly the same set of components. (Note that multiple projects can modify the same set of components.) When work on the patch release project is complete, you integrate it with the new release project.

If you anticipate that your team will develop and release numerous versions of your system over time, you may want to create a mainline project. A mainline project serves as a single point of integration for related projects over a period of time. See Chapter 9, *Managing Parallel Releases of Multiple Projects* for additional information about using a mainline project.

## Example

Figure 9 shows the initial set of components planned for the Transaction Builder system. A team of 30 developers work on the system. Because a high degree of integration between components is required, and most developers work on several components, the project manager included all components in one project.

Figure 9 Components Used by Transaction Builder Project

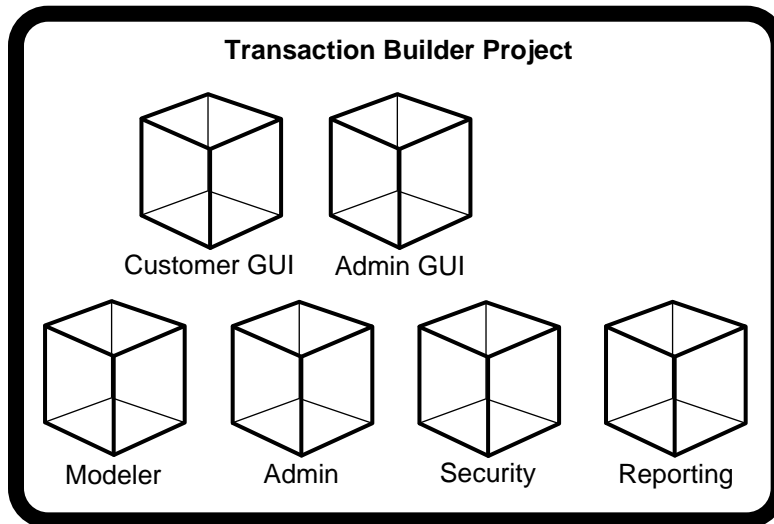

---

## 3.2 Organizing Components

After you map your system architecture to an initial set of components and determine which projects will access those components, refine your plan by performing the following tasks:

- Decide how many VOBS to use
- Identify any additional components
- Define the component directory structures
- Identify read-only components

---

## Deciding How Many VOBs to Use

ClearCase lets you store multiple components in a VOB. If your project uses a small number of components, you may want to use one VOB per component. However, if your project uses many components, you may want to store multiple components in several VOBs. A VOB can store many versions of many elements. It is inefficient to use a VOB to store one small component.

Keep in mind the following restrictions:

- A component's root directory must be the VOB's root directory or one level beneath it. A component includes all directory and file elements under its root directory. For example, in Figure 10, **Libs** cannot be a component.
- You cannot nest components. For example, in Figure 10, **GUI**, **Admin**, and **Reports** can be components only if **Dev** is not a component.
- If you make a component at the VOB's root directory, that VOB can never contain more than that one component.

Figure 10 Storing Multiple Components in a VOB

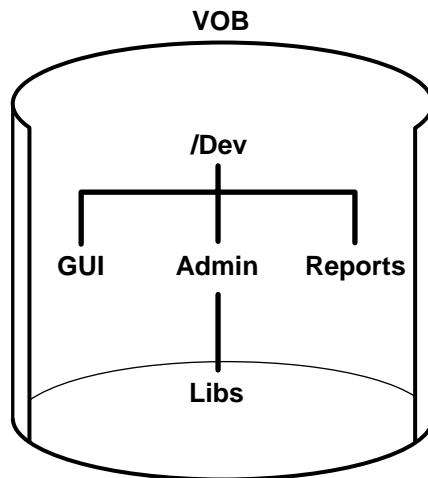

---

## Identifying Additional Components

Although you should be able to identify nearly all necessary components by examining your system architecture, you may overlook a few. For example:

System component	It is a good idea to designate one component for storing system-level files. These items include project plans, requirements documents, and system model files and other architecture documents.
Project baseline component	If you plan to use a composite baseline that selects baselines from all of the project's components, we recommend that you store the composite baseline in its own component. See <i>Identifying a Project Baseline</i> on page 37 for details.
Testing component	Consider using a separate component for storing files related to testing the system. This component includes files such as test scripts, test results and logs, and test documentation.
Deployment component	At the end of a development cycle, you need a separate component to store the generated files that you plan to ship with the system or deploy inhouse. These files include executable files, libraries, interfaces, and user documentation.
Tools component	In addition to placing source files under version control, it is a good idea to place your team's developer tools, such as compilers, and system header files under version control.

---

## Defining the Directory Structure

After you complete your list of components, you need to define the directory structures within those components. We recommend that you start with a directory structure similar to the one shown in Table 1; then modify the structure to suit your system's needs.

In Table 1, Component\_1 through Component\_n refers to the components that map to the set of logical packages in your system architecture.



Table 1 Recommended Directory Structure for Components

Component	Directories	Typical contents
System	plans	Project plans, mission statement, and so on
	requirements	Requirements documents
	models	Rose files, other architecture documents
	documentation	System documentation
Component_1 through Component_n	requirements	Component requirements
	models	Component model files
	source	Source files for this component
	interfaces	Component public interfaces
	binaries	Executable and other binary files for this component
	libraries	Libraries used by this component
	tests	Test scripts and related documents for this component
Test	scripts	Test scripts
	results	Test results and logs
	documentation	Test documentation
Deployment	binaries	Deployed executable files
	libraries	Deployed libraries
	interfaces	Deployed interfaces
	documentation	User documentation

Table 1 Recommended Directory Structure for Components

Component	Directories	Typical contents
Tools	compilers	Developer tools such as Visual InterDev and Rational Rose
	headers	System header files
Project baseline	none	Composite baseline that selects baselines from all components in the project

## Identifying Read-Only Components

When you create a project, you must indicate whether each component is modifiable in the context of that project. In most cases, you make them modifiable. However, in some cases you want to make a component read-only, which prevents project team members from changing its elements. Components can be used in multiple projects. Therefore, one project team may be responsible for maintaining a component, and another project team may use that component to build other components.

For example, in Figure 11, **Project A** team members maintain a set of library files. **Project B** team members reference some of those libraries when they build their components. In **Project A**, the **cm\_libs** component is modifiable. In **Project B**, the same component is read-only. With respect to the **cm\_libs** component, **Project A** and **Project B** have a producer-consumer relationship.

Figure 11 Using a Read-Only Component

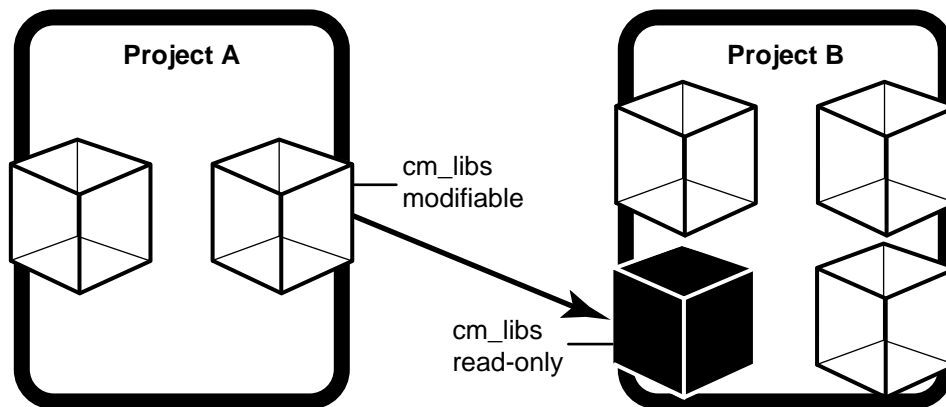

---

### 3.3 Choosing a Stream Strategy

The basic UCM process uses the integration stream as the project's sole shared work area. Developers join the project by using the integration stream's recommended baselines to populate their development streams; deliver completed work to the integration stream where the integrator incorporates the work into new baselines; and rebase their development streams to the new recommended baselines. Depending on the size of your project and the number of developers working on it, this process may be a good choice for your team.

Alternatively, you can use UCM's development stream hierarchy feature to create multiple shared work areas within a project. This approach supports a project organization that consists of small teams of developers where each team develops a specific feature.

For example, in Figure 12, the project manager created a development stream called **Permissions\_dev** for two developers who are working on a permissions feature. The developers, Pat and Pedro, joined the project at the **Permissions\_dev** level rather than at the integration stream level. They deliver completed work to the **Permissions\_dev** stream. Periodically, the integrator or lead developer responsible for managing the **Permissions\_dev** stream incorporates the delivered work into new baselines, and the developers rebase their development streams to those new baselines.

When the two developers finish working on the permissions feature, they deliver their last work to the **Permissions\_dev** stream. The integrator incorporates their delivered work into a final set of baselines and delivers those baselines to the integration stream.

Figure 12 Using a Feature-Specific Development Stream

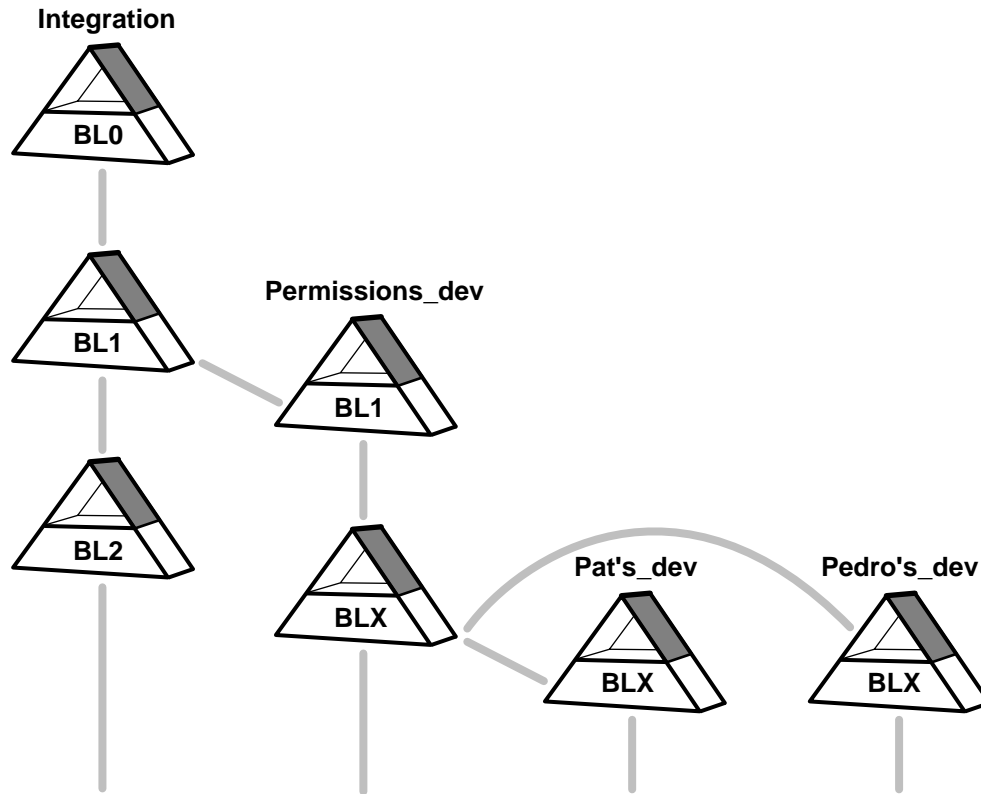

---

### 3.4 Specifying a Baseline Strategy

After you organize the project's components, determine your strategy for creating baselines of those components. The baseline strategy must define the following:

- A project baseline
- When to create baselines

- How to name baselines
- The set of promotion levels
- How to test baselines

---

## Identifying a Project Baseline

In your role as integrator, you are responsible for telling developers which baselines to use when they join the project and when they rebase their development streams. You could keep track of a list of baselines, one for each component. However, a more efficient practice is to use a composite baseline to represent the project baseline. A *composite baseline* selects baselines from other components.

For example, in Figure 13, **Project A** uses a composite baseline, **PABL**, to select baselines in the **GUI** and **Admin** components. **Project B** also uses a composite baseline, **PBBL**. Baselines that are selected by a composite baseline are referred to as *members*.

After you create a composite baseline to represent the project baseline, the next time you invoke the make baseline operation on the component that contains the project baseline, UCM performs the operation recursively. If a component that contributes to the composite baseline has changed since its latest baseline, UCM creates a new baseline in that component. For example, assume that developers made changes to files in the **GUI** component after the integrator created the **BL1** baseline. The next time the integrator makes a new project baseline, UCM creates a new baseline in the GUI component that incorporates the changed files, and the new project baseline selects the new GUI baseline.

A composite baseline can select other composite baselines. For example, if your system is so large that it consists of multiple projects, you may want to use a composite baseline to represent the system baseline. In Figure 13, **SystemBL** is a composite baseline that selects the **PABL** and **PBBL** baselines of **Project A** and **Project B**, respectively.

In addition to using a composite baseline to represent the project, you can use multiple composite baselines within the same project. When working with multiple composite baselines, you can encounter situations where two composite baselines select different baselines of the same component. When this happens, you need to resolve the conflict by choosing one of the member baselines. To avoid these conflicts, we recommend that you choose a simple baseline design, rather than one that uses a complex hierarchy of composite baselines. See *Resolving Baseline Conflicts* on page 108 for details about baseline conflicts.

Like all baselines, a composite baseline must belong to a component. However, that component does not need to contain any of its own elements. For example, in Figure 13, the **System\_Comp**,

**ProjA\_Comp**, and **ProjB\_Comp** components consist only of their composite baselines. When you create a component to be used solely for housing a composite baseline, you can specify an option that directs UCM to make the component without creating a root directory in a VOB. Such a component can never contain its own elements.

Figure 13 Using a System-Level Composite Baseline

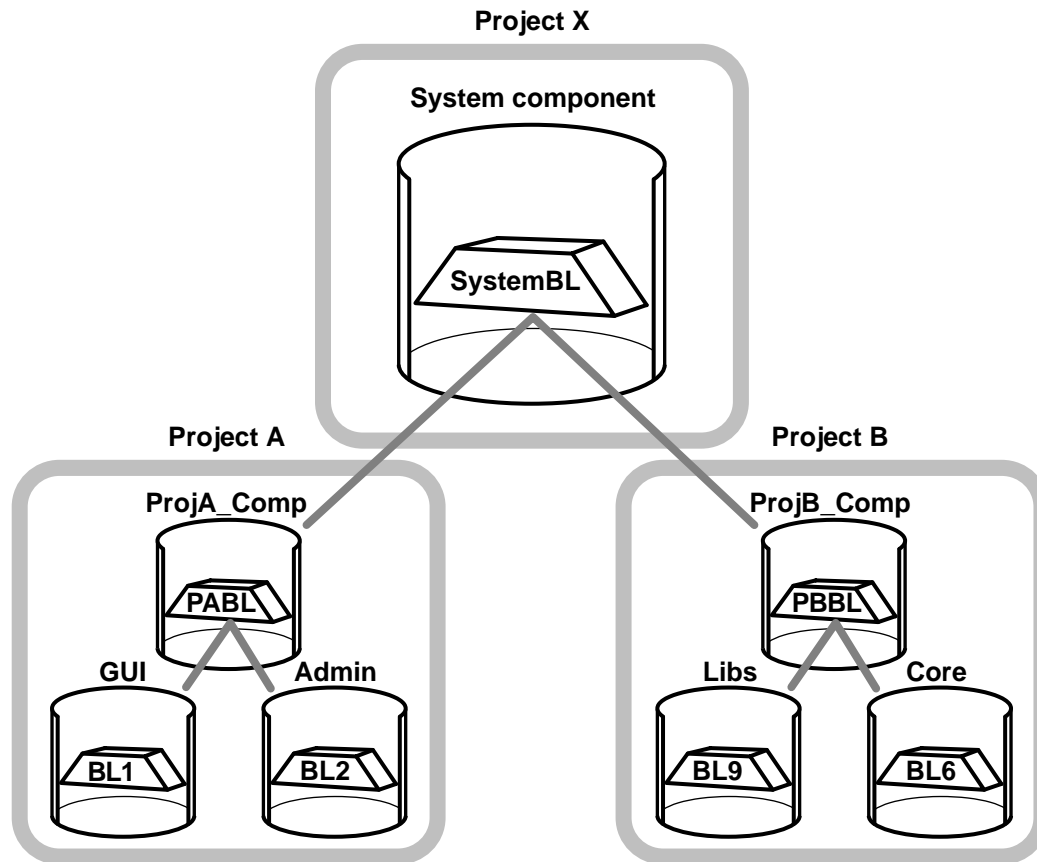

---

## When to Create Baselines

At the beginning of a project, you must identify the baseline or baselines that represent the starting point for new development. As work on the project progresses, you need to create new baselines periodically.

### Identifying the Initial Baseline

If your project represents a new version of an existing project, you probably want to start work from the latest recommended baselines of the existing project's components. For example, if you are starting work on version 3.2 of the Transaction Builder project, identify the baselines that represent the released, or production, versions of its version 3.1 components.

If you are converting a base ClearCase configuration to a project, you can make baselines from existing labeled versions. Check whether the latest stable versions are labeled. If they are not, you need to create a label type and apply it to the versions that you plan to include in your project.

### Ongoing Baselines

After developers start working on the new project and making changes, create baselines on the integration stream and on any feature-specific development streams on a frequent (nightly or weekly) basis. This practice has several benefits:

- Developers stay in sync with each other's work.

It is critical to good configuration management that developers have private work areas where they can work on a set of files in isolation. Yet extended periods of isolation cause problems. Developers are unaware of each other's work until you incorporate delivered changes into a new baseline, and they rebase their development streams.

- The amount of time required to merge versions is minimized.

When developers rebase their development streams, they may need to resolve merge conflicts between files that the new baseline selects and the work in their private work areas. When you create baselines frequently, they contain fewer changes, and developers spend less time merging versions.

- Integration problems are identified early.

When you create a baseline, you first build and test the project by incorporating the work delivered since the last baseline. By creating baselines frequently, you have more opportunities to discover any serious problems that a developer may introduce to the project

inadvertently. By identifying a serious problem early, you can localize it and minimize the amount of work required to fix the problem.

---

## Defining a Naming Convention

Because baselines are an important tool for managing a project, define a meaningful convention for naming them. You may want to include some or all of the following information in a baseline name:

- Project name
- Milestone or phase of development schedule
- Date created

For example: `V4.0TRANS_BL2_June12`

---

## Identifying Promotion Levels to Reflect State of Development

A promotion level is an attribute of a baseline that you can use to indicate the quality or stability of the baseline. ClearCase provides the following default promotion levels:

- Rejected
- Initial
- Built
- Tested
- Released

You can use some or all of the default promotion levels, and you can define your own. The levels are ordered to reflect a progression from lowest to highest quality. You can use promotion levels to help you recommend baselines to developers. The Recommended Baselines dialog box displays baselines that have a promotion level equal to or higher than the one you specify. You can use this feature to filter the list of baselines displayed in the dialog box. Determine the set of promotion levels for your project and the criteria for setting each level.

---

## Planning How to Test Baselines

Typically, software development teams perform several levels of testing. An initial test, known as a validation test, checks to see that the software builds without errors and appears to work as



it should. A more comprehensive type of testing, such as regression testing, takes much longer and is usually performed by a team of software quality engineers.

When you make a new baseline, you need to lock the integration stream to prevent developers from delivering additional changes. This allows you to build and test a static set of files. Because validation tests are not exhaustive, you probably do not need to lock the integration stream for a long time. However, more extensive testing requires substantially more time.

Keeping the integration stream locked for a long time is not a good practice because it prevents developers from delivering completed work. One solution to this problem is to create a development stream to be used solely for extensive testing. After you create a new baseline that passes a validation test, your testing team can rebase the designated testing development stream to the new baseline. When the baseline passes the next level of testing, promote it. When you are confident that the baseline is stable, make it the recommended baseline so that developers can rebase their development streams to it.

For information on creating a testing development stream, see *Creating a Development Stream for Testing Baselines* on page 93. For information on testing baselines, see *Testing the Baseline* on page 105.

---

## 3.5 Planning PVOBs

ClearCase stores UCM objects such as projects, streams, activities, and change sets in project VOBs (PVOBs). PVOBs can also function as administrative VOBs. You need to decide how many PVOBs to use for your system and whether to take advantage of the administrative capabilities of the PVOB.

---

### Deciding How Many PVOBs to Use

**PRODUCT NOTE:** This section does not apply to Rational ClearCase LT because that product allows for only one PVOB per server.

Projects that use the same PVOB have access to the same set of components. If developers on different projects need to work on some of the same components, use one PVOB for those projects. For example, Figure 14 shows concurrent development of two versions of the **Webotrans** product. While most members of the team work on the 4.0 release in one project, a small group works on the 4.0.1 release in a separate project. Both projects use the same components, so they use one PVOB.

Figure 14 Related Projects Sharing One PVOB

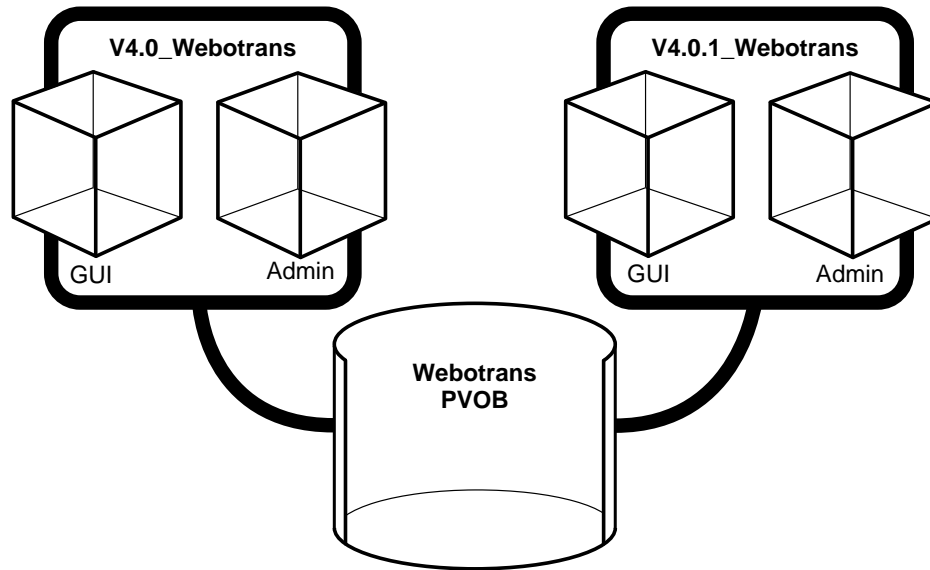

Consider using multiple PVOBs only when one or both of the following conditions applies:

- The projects do not share components, and you anticipate that they will never need to share components.
- The projects are so large that PVOB capacity becomes an issue.

---

## Understanding the Role of the Administrative VOB

An *administrative VOB* stores global type definitions. VOBs that are joined to the administrative VOB with **AdminVOB** hyperlinks share the same type definitions without having to define them in each VOB. For example, you can define element types, attribute types, hyperlink types, and so on in an administrative VOB. Any VOB linked to that administrative VOB can then use those type definitions to make elements, attributes, and hyperlinks.

If you currently use an administrative VOB, you can associate it with your PVOB when you create the PVOB. ClearCase then creates an **AdminVOB** hyperlink between the PVOB and the administrative VOB. Thereafter, when you create components, ClearCase creates **AdminVOB** hyperlinks between the components and the administrative VOB so that the components can use the administrative VOB's global type definitions.

If you do not currently use an administrative VOB, do not create one. When you create components, ClearCase makes **AdminVOB** hyperlinks between the components and the PVOB, and the PVOB assumes the role of administrative VOB.

For details on administrative VOBs and global types, see the *Administrator's Guide* for Rational ClearCase or the *Administrator's Guide* for Rational ClearCase LT.

---

## 3.6 Identifying Special Element Types

The concept of element types allows ClearCase to handle each class of elements differently. An *element type* is a class of file elements. ClearCase includes predefined element types, such as **file** and **text\_file**, and lets you define your own. When you create an element type for use in UCM projects, you can specify a **mergetype** attribute, which determines how deliver and rebase operations handle merging of files of that element type.

When ClearCase encounters a merge situation during a deliver or rebase operation, it attempts to merge versions of the element. ClearCase requires user interaction only if it cannot reconcile differences between the versions. For certain types of files, you may want to impose different merging behavior.

---

### Nonmerging Elements

Some types of files never need to be merged. For these files, you may want to ensure that no one attempts to merge them accidentally. For example, the deployment, or staging, component contains the executable files that you ship to customers or install in-house. These files are not under development; they are the product of the development phase of the project cycle. For these types of files, you can create an element type and specify **never** merge behavior.

**NOTE:** If you fail to specify **never** merge behavior for these elements, developers may encounter problems when they attempt to deliver work to the project's integration stream. Developers create executable files when they build and test their work prior to delivering it. If these files are under version control as *derived objects*, they are included in the current activity's change set. During a deliver operation, ClearCase attempts to merge these executable files to the integration stream unless the files are of an element type for which **never** merge behavior is specified.

---

## Nonautomerging Elements

For some types of files, you may want to merge versions manually rather than let ClearCase merge them. One example is a Visual Basic form file, which is a generated text file. Visual Basic generates the form file based on the form that a developer creates in the Visual Basic GUI. Rather than let ClearCase change the form file during a merge operation, you want to regenerate the form file from the Visual Basic GUI.

For these types of files, you can create an element type and specify **user** merge behavior. For information on creating element types, see Chapter 15, *Using Element Types to Customize Processing of File Elements*, and the **mkeltype** reference page in the *Command Reference*.

---

## Defining the Scope of Element Types

When you define an element type, its scope can be ordinary or global. By default, the element type is ordinary; it is available only to the VOB in which you create it. If you create the element type in an administrative VOB and define its scope as global, other VOBs that have **AdminVOB** hyperlinks to that administrative VOB can use the element type. If you want to define an element type globally, and you do not currently use a separate administrative VOB, define the element type in the PVOB.

---

## 3.7 Planning How to Use the UCM-ClearQuest Integration

Before you can set up the UCM-ClearQuest integration, you need to make some decisions, which fall into two general categories:

- How to map PVOBs to ClearQuest user databases
- Which schema to use for the ClearQuest user databases

---

### Mapping PVOBs to ClearQuest User Databases

This section describes three issues that you need to consider in deciding how many PVOBs to use for projects that link to ClearQuest user databases.

## MultiSite Requirement

If you use ClearCase MultiSite, all PVOB replicas must have access to the ClearQuest user database.

## Projects Linked to Same Database Must Have Unique Names

Although UCM allows you to create projects with the same name in different PVOBs, you cannot link those projects to the same ClearQuest user database. Figure 15 illustrates this naming requirement.

Figure 15 Projects in Multiple PVOBs Linked to the Same ClearQuest Database

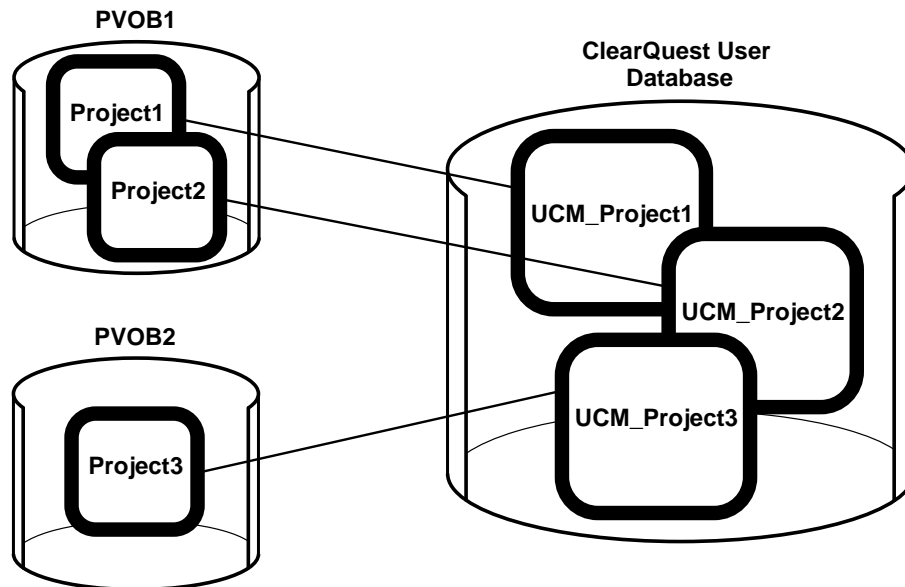

## Use One Schema Repository for Linked Databases

If some developers on your team work on multiple projects, we recommend that you store the schemas for the ClearQuest user databases that are linked to those projects in one schema repository, as shown in Figure 16. This allows developers to switch between projects easily. If you store the schemas in different schema repositories, developers must use the ClearQuest Maintenance Tool to connect to a different schema repository whenever they switch projects.

Figure 16 Using the Same Schema Repository for Multiple ClearQuest Databases

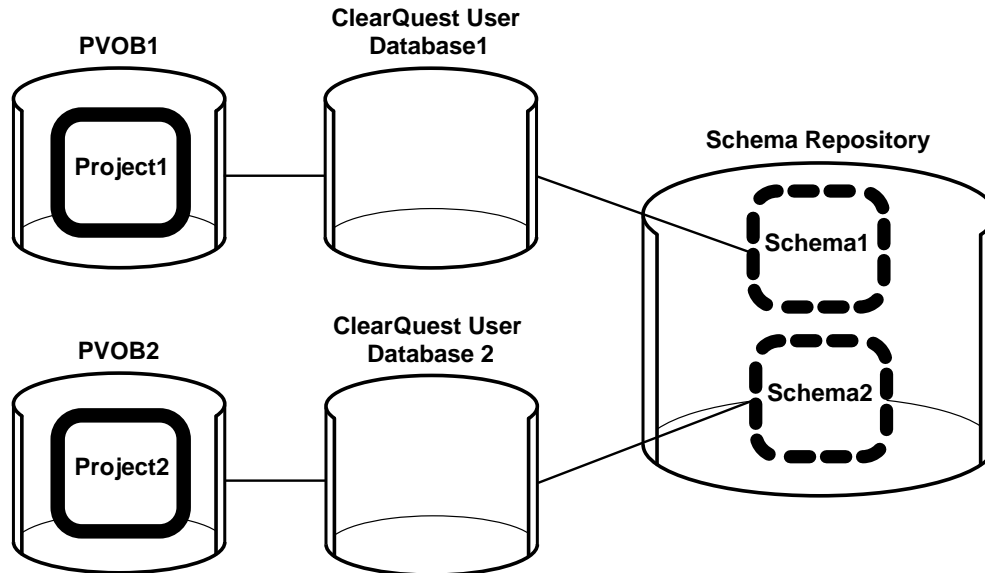

---

## Deciding Which Schema to Use

To use the integration, you must create or upgrade a ClearQuest user database that is based on a UCM-enabled schema. A UCM-enabled schema meets the following requirements:

- ▶ The **UnifiedChangeManagement** package has been applied to the schema. A package contains metadata, such as records, fields, and states, that define specific functionality. Applying a package to a schema provides a way to add functionality quickly so that you do not have to build the functionality from scratch.
- ▶ The **UnifiedChangeManagement** package has been applied to at least one record type. This package adds fields and scripts to the record type, and adds the **Unified Change Management** tab to the record type's forms. Figure 17 shows the **Unified Change Management** tab.
- ▶ The **UCMPolicyScripts** package has been applied to the schema. This package contains the scripts for three ClearQuest development policies that you can enforce.

ClearQuest includes two predefined UCM-enabled schemas: **UnifiedChangeManagement** and **Enterprise**. You can start using the integration right away by using one of these schemas, or you can use the ClearQuest Designer and the ClearQuest Package Wizard to enable a custom schema or another predefined schema to work with UCM. You can also use one of the predefined UCM-enabled schemas as a starting point and then modify it to suit your needs.

Figure 17 UCM Tab of Record Form for a UCM-Enabled Record Type

The screenshot shows a software interface with a tabbed window. The active tab is labeled 'Unified Change Management'. Below the tab, there is a 'Main' sub-tab. The form contains several input fields: 'UCM Project' is a dropdown menu; 'Stream' is a text input field; 'View' is a text input field; and 'Change Set' is a large text area. The text 'Change Set' is also visible inside the text area.

### Overview of the UnifiedChangeManagement Schema

The UnifiedChangeManagement schema includes the following record types:

- **BaseCMActivity**  
This is a lightweight record type that you can use to store information about activities that do not require additional fields. Figure 18 shows the **Main** tab of the BaseCMActivity record form. You may want to use this record type as a starting point and then modify it to include additional fields and states.
- **Defect**  
This record type is identical to the record type of the same name that is included in ClearQuest's other predefined schemas, with one exception: it is enabled to work with UCM. The Defect record type contains more fields and form tabs than the BaseCMActivity record type to allow you to record detailed information.
- **UCMUtilityActivity**  
This record type is not intended for general use. The integration uses this record type when it needs to create records for itself, such as when you link a project that contains activities to a ClearQuest user database. You cannot modify this record type.

Figure 18 Main Tab of Record Form for the BaseCMAActivity Record Type

The screenshot shows a web form titled "Unified Change Management" with a "Main" tab. The form contains the following fields:

- ID:** A text input field.
- Owner:** A dropdown menu.
- State:** A text input field.
- Headline:** A text input field.
- Description:** A large text area.

### Enabling a Schema for UCM

If you decide not to use one of the predefined UCM-enabled schemas, you need to do some additional work to enable your schema to work with UCM. Before you can do this, you need to answer the following questions:

- Which record types are you enabling for UCM? You do not need to enable all record types in your schema, but you can link only records of UCM-enabled record types to activities.
- For each UCM-enabled record type:
  - Which state type does each state map to? You must map each state to one of the four UCM state types: Waiting, Ready, Active, Complete. See *Setting State Types* on page 63.
  - Which default actions are you using to transition records from one state to another? See *State Transition Default Action Requirements for Record Types* on page 64.
  - Which policies do you want to enforce? The integration includes policies that you can set to enforce certain development practices. You can also edit the policy scripts to change the policies. See Chapter 4, *Setting Policies* for details.



## Setting Policies

# 4

UCM includes policies that you can set to enforce certain development practices within a project. Some policies are available only if you enable the project to work with Rational ClearQuest. In addition to the policies that UCM supplies, you can create your own policies by using triggers on UCM operations. For information on using triggers, see Chapter 8, *Using Triggers to Enforce Development Policies*.

---

### 4.1 Components and Baselines

This section describes the policies related to components and baselines.

---

#### Modifiable Components

In most cases, you want components to be modifiable. For information on when to use read-only components, see *Identifying Read-Only Components* on page 34.

---

#### Default Promotion Level for Recommending Baselines

*Recommended baselines* are the set of baselines that project team members use to rebase their development streams. In addition, when developers join the project, their development work areas are initialized with the recommended baselines. When you recommend baselines, the

**Recommend Baselines** dialog box lists the latest baselines that have promotion levels equal to or higher than the promotion level that you specify as the default promotion level for recommending baselines.

---

## 4.2 Default View Types

When developers join a project, they use the Join Project Wizard to create their development views, integration views, and development streams. They use a development view and a development stream to work in isolation from the project team. They use an integration view to build and test their work against the latest work delivered to the integration stream or feature-specific development stream by other developers.

Rational ClearCase provides two kinds of views: dynamic and snapshot. Specify which type of view to use as the default for development and integration views. When developers join the project, they may choose to accept or reject the default view types. The Join Project Wizard uses the default values the first time that a developer creates views for a project. Thereafter, the wizard uses the developer's most recent selections as the default view types.

**PRODUCT NOTE:** Rational ClearCase LT supports only snapshot views.

*Dynamic views* use the ClearCase multiversion file system (MVFS) to provide immediate, transparent access to files and directories stored in VOBs. *Snapshot views* copy files and directories from VOBs to a directory on your computer.

We recommend that you use dynamic views as the default view type for integration views. Dynamic views ensure that when developers deliver work to the integration stream or feature-specific development stream, they build and test their work against the latest work that other developers have delivered since the last baseline was created. Snapshot views require developers to copy the latest delivered files and directories to their computer (a *snapshot view update* operation), which they may forget to do.

---

## 4.3 Deliver Operations

This section describes the policies that affect deliver operations. You can set these policies to apply to all streams within the project or you can set the policies on a per-stream basis. When a developer starts a deliver operation, UCM checks the policy settings on the target stream and the

project. If the target stream's policy setting is different than its project's policy setting, the project's setting takes precedence.

---

## **Allow Deliveries from Stream with Pending Checkouts**

This policy allows developers to deliver work to the target stream even if some files remain checked out in the source stream. If you do not set this policy, developers must check in all files in their source streams before delivering work. You may want to require developers to check in files to avoid the following situation:

1. A developer completes work on an activity, but forgets to check in the files associated with that activity.
2. The developer works on other activities.
3. Having completed several activities, the developer delivers them to the target stream. Because the files associated with the first activity are still checked out, they are not included in the deliver operation. Even though the developer may build and test the changes successfully in the development work area, the changes delivered to the target may fail because they do not include the checked-out files.

---

## **Rebase Before Deliver**

This policy requires developers to rebase their source streams to the target stream's current *recommended baselines* before they deliver work to the target stream. The goal of this policy is to have developers build and test their work in their development work areas against the work included in the most recent stable baselines before they deliver to the target stream. This practice minimizes the amount of merging that developers must do when they perform deliver operations.

---

## **Deliver Operations to Nondefault Targets**

As shown in Figure 19, you can create a hierarchy of development streams. Such a hierarchy allows you to designate a development stream as a shared area for developers working on a particular feature. Developers who work on that feature deliver work to the feature-specific development stream.

Figure 19 Default and Nondefault Deliver Targets in a Stream Hierarchy

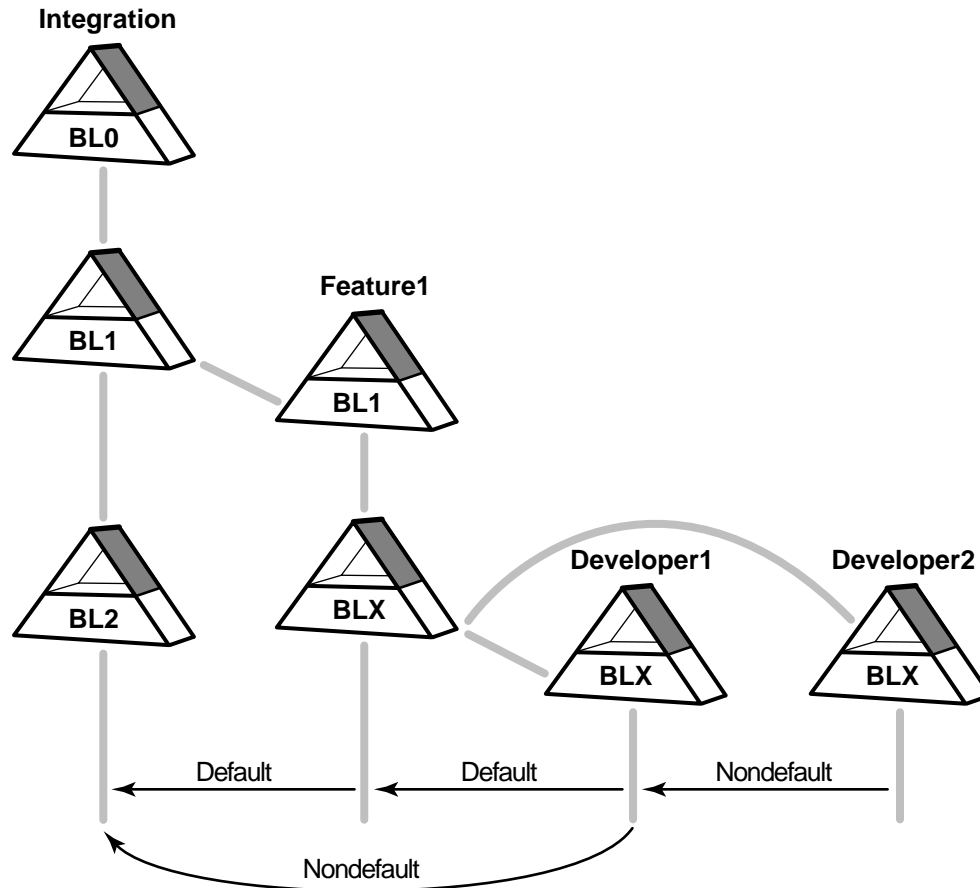

Within a stream hierarchy, streams have an ancestor-descendant relationship. In Figure 19, the integration stream and the **Feature1** development stream are ancestors of the **Developer1** and **Developer2** development streams. **Feature1**, **Developer1**, and **Developer2** are descendants of the integration stream. A stream's immediate ancestor is its parent stream. A stream's immediate descendant is its child stream.

Because a project can contain a set of complex development stream hierarchies, a development stream may deliver to numerous target streams within the project. In addition, streams may deliver to streams in other projects. The default target for a deliver operation from a development stream is that stream's parent stream. Developers may also deliver to nondefault target streams.

The arrows in Figure 19 illustrate default and nondefault deliver targets. The following policies apply only to nondefault target streams.

### **Allow Deliveries from Streams in Other Projects**

Set this policy to control whether streams accept deliveries from streams in other projects. See Chapter 9, *Managing Parallel Releases of Multiple Projects*, for examples of when you may want to deliver work from one project to another.

### **Allow Deliveries That Contain Changes in Foundation Baselines**

UCM uses *foundation baselines* to configure a stream's view. A view attached to a stream selects the versions of elements identified by the stream's foundation baselines plus the versions of elements associated with any activities created in the stream. For example, in Figure 20, **BL1** is the foundation baseline for the **Feature1** development stream. The **BLX** baseline is the foundation baseline for the **Developer1** development stream.

If the developer working in the **Developer1** stream delivers work to the integration stream, the deliver operation includes the activities created in the **Developer1** stream plus the files represented by the **BLX** foundation baseline. The integrator responsible for the integration stream may want to receive work that the developer working in the **Developer1** stream has completed; however, the integrator may be unaware that the deliver operation also contains changes made in the **BLX** baseline. You may want to set this policy to **Disabled** so that target streams do not accept deliver operations that contain changes in the source stream's foundation baselines.

UCM contains two versions of this policy: one for interproject deliver operations, and one for intraproject deliver operations.

Figure 20 Delivering Changes Made to a Foundation Baseline

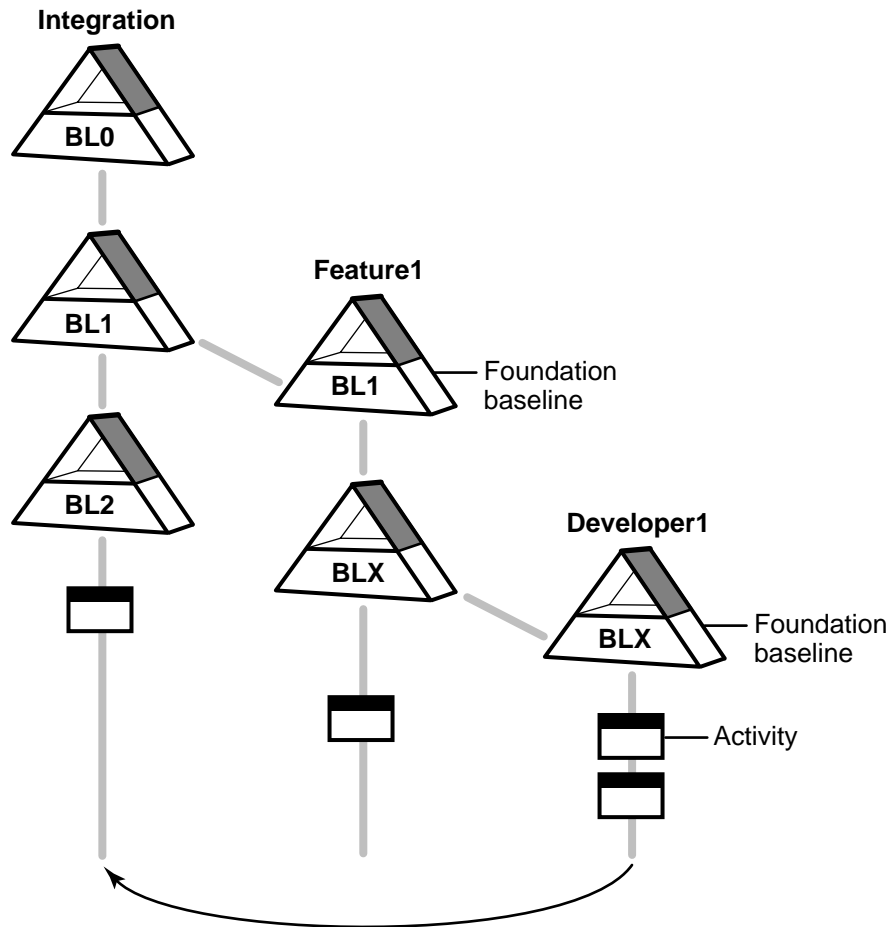

### Allow Deliveries That Contain Changes Made to Components Not in Target Stream

Set this policy to control whether streams accept deliveries that contain changes to components that are not in the target streams' configurations. If you set this policy to **Enabled**, UCM allows the deliver operation, but the changes to any missing components are not included. UCM contains two versions of this policy: one for interproject deliver operations, and one for intraproject deliver operations.

## Allow Deliveries That Contain Changes to Nonmodifiable Components

Set this policy to control whether streams accept interproject deliveries that contain changes to components that are not modifiable in the target stream's project. If you set this policy to **Enabled**, UCM allows the deliver operation, but the changes to any nonmodifiable components are not included.

---

### 4.4 UCM-ClearQuest Integration

This section describes the policies that are available only when you enable the project to work with ClearQuest. ClearQuest uses scripts to implement these policies. You can modify a policy's behavior by editing its script. See *Customizing ClearQuest Project Policies* on page 65.

---

#### Check Before Work On

ClearQuest invokes this policy when a developer attempts to work on an activity. The default policy script checks to see whether the developer's user name matches the name in the ClearQuest record's Owner field. If the names match, the developer can work on the activity. If the names do not match, the Work On action fails.

The intent of this policy is to ensure that all criteria are met before a developer can start working on an activity. You may want to modify the policy to check for additional criteria.

---

#### Check Before ClearCase Delivery

This default policy script is a placeholder: it does nothing. ClearCase invokes this policy when a developer attempts to deliver an activity in a UCM-enabled project. We recommend that you edit the script to implement an approval process to control deliver operations. For example, you may want to add an **Approved** check box to the activity's record type and require that the project manager select it before allowing developers to deliver activities.

---

## Do ClearQuest Action After Delivery

ClearCase calls this policy at the end of a deliver operation for each activity included in the deliver operation. The default policy script uses the activity's default action to transition the activity to a Complete type state. If the default action requires entries in certain fields of the activity's record, and one of those fields is empty, the script returns an error and leaves the deliver operation in an uncompleted state. This state prevents the developer from performing another deliver operation, but it does not affect the current one. It does not roll back changes made during the merging of versions.

To recover from an error, the developer needs to fill in the required fields in the activity's record and resume the deliver operation.

The integration runs this script for each activity in the deliver operation. The script may return success for any number of activities before returning an error on an activity. For the successful activities, the script may change their state when it invokes the default action. When you recover from an error and rerun the deliver operation, the script looks at all activities again. For those that succeeded previously, the script does not attempt to change state. If you modify the script, be sure that it adheres to this behavior. ClearQuest returns an error if you attempt to change the state of a record to its current state.

---

## Check Mastership Before Delivery

The Do ClearQuest Action After Delivery project policy transitions activities to a Complete type state when a deliver operation completes successfully. For that policy to work correctly in a MultiSite environment, the activities being delivered must be mastered by the same replica that masters the target stream. To ensure that this is the case, you can set the Check Mastership Before Delivery policy.

The behavior of the Check Mastership Before Delivery policy depends on whether the deliver operation is local or remote. If the deliver operation is local, meaning that the target stream is mastered by the local PVOB replica, this policy causes the deliver operation to fail unless all activities being delivered are mastered locally.

A *remote deliver* operation is one for which the target stream is mastered by a remote PVOB replica. The developer starts the deliver operation, but ClearCase leaves the operation in a *posted* state. The integrator at the remote site completes the deliver operation.



For a remote deliver operation, the Check Mastership Before Delivery policy causes the following behavior:

- If all activities in the deliver operation are mastered by the remote replica, ClearCase allows the deliver operation to proceed.
- If the deliver operation contains activities that are mastered by the local replica, MultiSite transfers mastership of those activities to the remote replica. After the integrator at the remote site performs any required merges and completes the deliver operation, MultiSite transfers mastership of the activities back to the local replica.
- If the deliver operation contains activities that are mastered by a third replica, the deliver operation fails.



## Setting Up a ClearQuest User Database

# 5

This chapter describes how to set up a ClearQuest user database so that you can use the UCM-ClearQuest integration for your project. The steps in this chapter are typically completed by the ClearQuest database administrator. Rational ClearQuest includes predefined schemas that are ready for use with UCM. You can also enable a custom schema, or another predefined schema, to work with UCM. For information about the decisions you need to make before setting up the integration, see *Planning How to Use the UCM-ClearQuest Integration* on page 44.

---

### 5.1 Using the Predefined UCM-Enabled Schemas

The predefined UCM schemas, named **UnifiedChangeManagement** and **Enterprise**, include the record type, field, form, state, and other definitions necessary to work with a UCM project. To set up a ClearQuest user database to work with UCM:

1. Create a user database that is associated with one of the predefined UCM-enabled schemas. In the ClearQuest Designer, click **Database > New Database** to start the New Database Wizard.
2. Complete the steps in the wizard. Step 4 prompts you to select a schema to associate with the new database. Scroll the list of schema names and select the new schema, as shown in Figure 21.
3. Click **Finish**.

Figure 21 Associating a User Database with a UCM-Enabled Schema

	Schema Name	Schema Version	Checked Out	Check Out
4	AnalystStudio	1	No	
5	DevelopmentStudio	1	No	
6	TestStudio	1	No	
7	Enterprise	1	No	
8	UnifiedChangeManagement	1	No	

---

## 5.2 Enabling a Schema to Work with UCM

The predefined UCM schemas let you use the UCM-ClearQuest integration right away, but you may prefer to design a custom schema to track your project's activities and change requests, or you may prefer to use a different predefined schema. To enable a schema to work with UCM:

1. Ensure that the schema does not contain a record type named **UCM\_Project**, which is a reserved name used by the UCM-ClearQuest integration.
2. In the ClearQuest Designer, click **Package > Package Wizard** to start the Package Wizard.
3. Although it is not necessary, you may want to use the Package Wizard to apply the **BaseCMAActivity** package to your schema. The **BaseCMAActivity** package adds the BaseCMAActivity record type to your schema. The BaseCMAActivity record type is a lightweight activity record type. You may want to use the BaseCMAActivity record type as a starting point and then modify it to include additional fields, states, and so on. If you want to rename the BaseCMAActivity record type, be sure to do so before you create any records of that type.
4. Apply the **UnifiedChangeManagement** package to the schema. Select **UnifiedChangeManagement**, and click **Next**.
5. In the second page of the wizard, select your schema. Click **Next**.
6. The third page of the wizard prompts you to specify the schema's record types. Select the check boxes of the record types that you want to enable. Click **Next**. All selected record types must meet the requirements listed in *Requirements for Enabling Custom Record Types* on page 62.

- In the fourth page of the wizard, you must assign state types to the states for each record type that you choose to enable. For each state, click in the adjacent state type cell to display the list of available state types, as shown in Figure 22, and select one. To enable another record type, click the arrow in the Record Type list to see the available record types. See *Setting State Types* on page 63 for a description of the four state types, and the rules for setting them.

When you are finished, click **Finish** to check out the schema.

**NOTE:** In some cases, the **Setup State Types** page of the wizard does not appear. If that happens, assign state types to the states by clicking **Package > Setup State Types**.

Figure 22 Assigning State Types to a Record Type's States

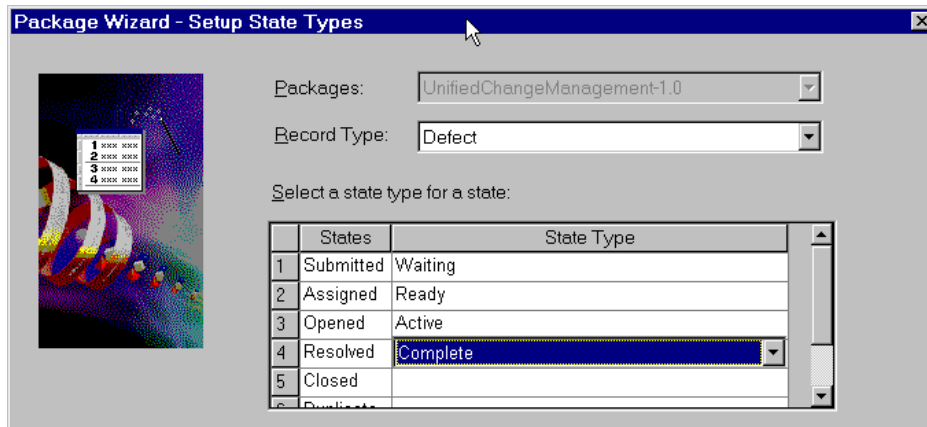

- Before you can check in your schema, you must set default actions for the states of each enabled record type. Default actions are state transition actions that ClearQuest takes when a developer begins to work on an activity or delivers an activity. In the ClearQuest Designer workspace, navigate to the record type's state transition matrix, as shown in Figure 23.

Figure 23 Navigating to Record Type's State Transition Matrix

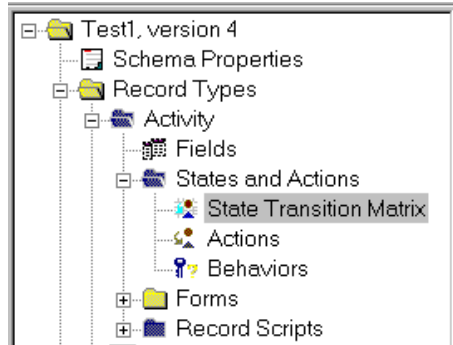

Double-click **State Transition Matrix** to display the matrix. Right-click the state column heading, and select **Properties** from its shortcut menu. Click the **Default Action** tab. Select the default action. See *State Transition Default Action Requirements for Record Types* on page 64 for default action requirements. Before you can set default actions, you may need to add some actions to the record type. To do so, double-click **Actions** to display the Actions grid, and then click **Edit > Add Action**.

9. Validate the schema changes by clicking **File > Validate**. Fix any errors that ClearQuest displays, and then check in the schema by clicking **File > Check In**.
10. In the ClearQuest Designer workspace, navigate to the record type's **Behaviors**. Double-click **Behaviors** to display the Behaviors grid. Verify that the **Headline** field is set to **Mandatory** for all states. Verify that the **Owner** field is set to Mandatory for all Active state types.
11. Validate the schema changes by clicking **File > Validate**. Fix any errors that ClearQuest displays, and then check in the schema by clicking **File > Check In**.
12. Upgrade the user database so that it is associated with the UCM-enabled version of the schema by clicking **Database > Upgrade Database**. Alternatively, create a new user database that is based on the UCM-enabled version of the schema.

---

## Requirements for Enabling Custom Record Types

Before you can apply the **UnifiedChangeManagement** package to a custom record type, the record type must meet the following requirements:

- It contains a field named **Headline** defined as a SHORT\_STRING, and a field named **Owner** defined as a REFERENCE to the ClearQuest-supplied **users** record type. The **Headline** field must be at least 120 characters long.
- It does not contain fields with these names:
  - **ucm\_vob\_object**
  - **ucm\_stream**
  - **ucm\_stream\_object**
  - **ucm\_view**
- It contains an action named **Modify** of type Modify.

---

## Setting State Types

The integration uses a state transition model to help you monitor the progress of activities. To implement this model, the integration adds state types to UCM-enabled schemas. Table 2 lists and describes the four state types. You must assign each state to a state type. You must have at least one state definition of state type *Waiting*, one of state type *Ready*, one of state type *Active*, and one of state type *Complete*.

Table 2 State Types in UCM-Enabled Schema

State type	Description
Waiting	The activity is not ready to be worked on, either because it has not been assigned or it has not satisfied a dependency.
Ready	The activity is ready to be worked on. It has been assigned, and all dependencies have been satisfied.
Active	The developer has started work on the activity but has not completed it.
Complete	The developer has either worked on and completed the activity, or not worked on and abandoned the activity.

---

## State Transition Default Action Requirements for Record Types

Record types can include numerous state definitions. However, UCM-enabled record types must have at least one path of transitions among state types as follows: Waiting to Ready to Active to Complete. The transition from one state to the next must be made by a default action.

For example, Figure 24 shows the actions and default actions between the states defined in the UCM-enabled BaseCMActivity record type included in the predefined UCM schema. The default actions are identified with an asterisk (\*). The state types are in uppercase letters enclosed in brackets. The states appear immediately above their state types.

Figure 24 State Transitions of UCM-enabled BaseCMActivity Record Type

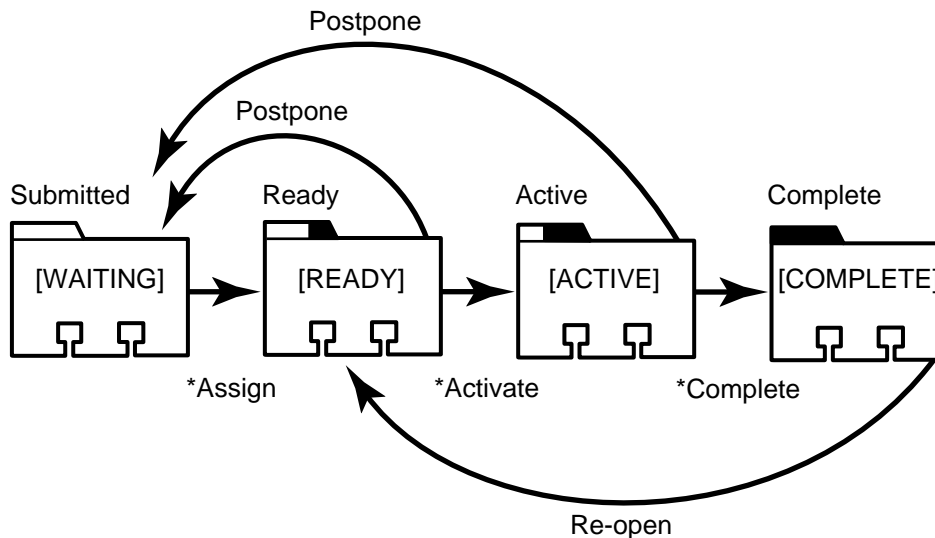

In addition to this single path requirement, states must adhere to the following rules:

- ▶ All Waiting type states must have a default action that transitions to another Waiting type state or to either a Ready or Active type state.
- ▶ If a Ready type state has an action that transitions directly to a Waiting type state, that Waiting type state must have a default action that transitions directly to that Ready type state.



- All Ready type states must have a default action that transitions to another Ready type state or to an Active type state.
- All Ready type states must have at least one action that transitions directly to a Waiting type state.
- For the BaseCMActivity record type, its initial state must be a Waiting type.

---

## 5.3 Upgrading Your Schema to the Latest UCM Package

If you have a UCM-enabled ClearQuest schema from a previous release of ClearQuest, you may want to upgrade that schema with the latest revision of the **UnifiedChangeManagement** package so that you can use new functionality. To upgrade the schema, perform the following steps:

1. In the ClearQuest Designer, click **Package > Upgrade Installed Packages** to start the Upgrade Installed Packages Wizard.
2. The first page of the wizard lists all schemas that have at least one package that needs to be upgraded. Select the schema that you want to upgrade, and click **Next**.
3. The second page of the wizard lists the packages that will be upgraded. Click **Upgrade** to accept the changes.
4. If the **UnifiedChangeManagement** package that you are upgrading from is earlier than revision 3.0, you need to assign states to state types for each UCM-enabled record type.
5. Validate the schema changes by clicking **File > Validate**. Fix any errors that ClearQuest displays, and then check in the schema by clicking **File > Check In**.
6. Upgrade the user database to associate it with the new version of the schema by clicking **Database > Upgrade Database**.

---

## 5.4 Customizing ClearQuest Project Policies

To implement the project policies, the integration adds the following pairs of scripts to a UCM-enabled schema:

- **UCM\_ChkBeforeDeliver** and **UCM\_ChkBeforeDeliver\_Def**
- **UCM\_ChkBeforeWorkOn** and **UCM\_ChkBeforeWorkOn\_Def**
- **UCM\_CQActAfterDeliver** and **UCM\_CQActAfterDeliver\_Def**

Each policy has two scripts: a base script and a default script. The default scripts have **\_Def** appended to their names and are installed by the **UnifiedChangeManagement** package. The integration invokes the base scripts, which are installed by the **UCMPolicyScripts** package. The base script calls the corresponding default script, which contains the logic for the default behavior. To modify the behavior of a policy, remove the call to the default script from the base script. Then add logic for the new behavior to the base script. Adhere to the rules stated in the base script.

Each script has a Visual Basic version and a Perl version. The Visual Basic scripts have a **UCM** prefix. The Perl scripts have a **UCU** prefix. For ClearQuest clients on Windows NT, the integration uses the Visual Basic scripts. For ClearQuest clients on UNIX, the integration uses the Perl scripts. If you modify a policy's behavior and your environment includes ClearQuest clients on both platforms, be sure to make the same changes in both the Visual Basic and Perl versions of the policy's script. Otherwise, the policy will behave differently for ClearQuest clients on UNIX and Windows NT.

For descriptions of these policies, see *UCM-ClearQuest Integration* on page 55.

---

## 5.5 Associating Child Activity Records with a Parent Activity Record

As project manager, you may assign activities for large tasks to developers. When the developers research their activities, they may determine that they need to perform several separate activities to complete one large activity.

For example, an “Add customer verification functionality” activity may require significant work in the product's GUI, the command-line interface, and a library. To more accurately track the progress of the activity, you can decompose it into three separate activities.

By using the parent/child controls in ClearQuest, you can accomplish this decomposition and tie the child activities back to the parent activity.

---

## Using Parent/Child Controls

In ClearQuest, you use controls to display fields in record forms. A parent/child control, when used with a reference or reference list field, lets you link related records. By adding a parent/child control to the record form of a UCM-enabled record type, you can provide the developers on your team with the ability to decompose a parent activity into several child activities.

To have ClearQuest change the state of the parent activity to Complete when all child activities have been completed, you need to write a hook. See *Administering Rational ClearQuest* for an example of such a hook.

---

## 5.6 Creating Users

Before you can assign activities to the developers on your project team, you must create user account profiles for each developer in ClearQuest. To do so:

1. In ClearQuest Designer, click **Tools > User Administration**.
2. Click **Add**.
3. Complete the **User Information** dialog box.

See *Administrator's Guide* for Rational ClearQuest and the ClearQuest Designer online help for details on creating user profiles.

---

## 5.7 Setting the Environment

Before you can enable a UCM project to work with a ClearQuest user database, you must define two environment variables as shown in Table 3. Developers who want to use the integration must also define these variables on their machines.

The ClearQuest installation directory includes a C shell script, `cq_setup.csh`, which you can execute to set the environment variables for you. For example:

```
% source ClearQuest-install-directory/cq_setup.csh
```

Table 3 Environment Variables Required for Integration

Variable	Setting
\$CQ_HOME	<i>ClearQuest-install-directory/releases/ClearquestClient</i>
\$LD_LIBRARY_PATH (\$SHLIB_PATH on HP-UX)	Must include: <i>ClearCase-install-directory/shlib</i> and <i>ClearQuest-install-directory/releases/ClearquestClient/architecture/shlib</i>

In addition, if you have multiple ClearQuest schema repositories, you must set the `$$SQUID_DBSET` environment variable to the name of the schema repository you want to use.

## Setting Up the Project

# 6

This chapter describes how to set up a project so that a team of developers can work in the Unified Change Management (UCM) environment. Before you set up a project, be sure to plan the project. See Chapter 3, *Planning the Project*, for information on what to include in a configuration management plan.

The chapter presents the following scenarios:

- Creating a project from scratch
- Creating a project based on an existing base ClearCase configuration
- Creating a project based on an existing project
- Enabling a project to use the UCM-ClearQuest integration
- Creating a development stream reserved for testing new baselines
- Creating a feature-specific development stream

---

## 6.1 Creating a Project from Scratch

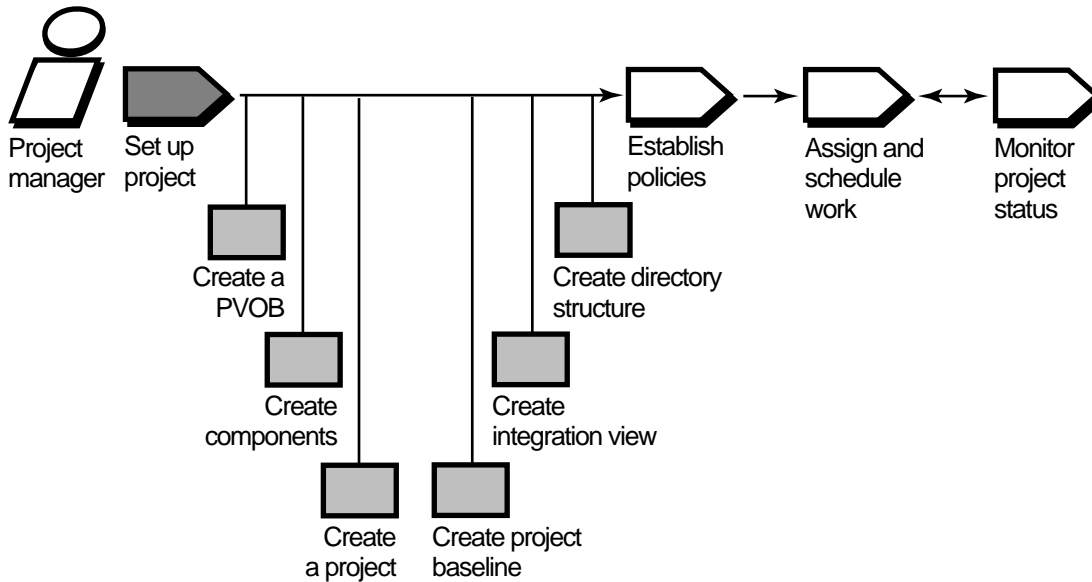

This section describes how to create and set up a new project that is not based on an existing project or on an existing set of ClearCase VOBs.

---

### Creating the Project VOB

**PRODUCT NOTE:** This task does not apply to ClearCase LT users. The ClearCase administrator creates the PVOB during the installation.

To create a PVOB:

1. Issue the `cleartool mkvob` command. For example:

```
cleartool mkvob -tag /vobs/myproj2_pvob -nc -ucmproject \  
/usr/vobstore/myproj2_pvob.vbs
```

The `-ucmproject` option indicates that you are creating a PVOB instead of a VOB. The `/usr/vobstore/myproj2_pvob.vbs` path specifies the location of the PVOB's storage directory. A PVOB storage directory is a directory tree that serves as the repository for the PVOB's

contents. A PVOB's storage directory contains the same subdirectories as a VOB's storage directory. For details about VOB storage directory structure, see the *Administrator's Guide* for Rational ClearCase or the *Administrator's Guide* for Rational ClearCase LT.

If you are in an MVFS environment and developers use dynamic views, perform the following two steps.

2. Create the PVOB mount point to match the PVOB-tag. For example:

```
mkdir /vobs/myproj2_pvob
```

3. Mount the PVOB. For example:

```
cleartool mount /vobs/myproj2_pvob
```

The PVOB assumes the role of administrative VOB. When you create components, ClearCase automatically makes **AdminVOB** hyperlinks between the components and the PVOB.

---

## Creating a Component for Storing the Project Baseline

This task is optional but we strongly recommend it. Using a *composite baseline* to represent the project is easier than keeping track of a set of baselines, one for each component. Although you can store a composite baseline and elements in the same component, it is cleaner to dedicate one component for storing the project baseline. To ensure that nobody creates elements in this component, create the component without a VOB root directory. A component that has no VOB root directory cannot store its own elements. To create a component without a VOB root directory:

1. Enter the command **clearprojexp** to start the Project Explorer. The Project Explorer is the graphical user interface (GUI) through which you create, manage, and view information about projects.
2. The left pane of the Project Explorer lists folders for all PVOBs in the local ClearCase domain. Each PVOB has its own root folder. ClearCase creates the root folder using the name of the PVOB. Navigate to the PVOB that you created.
3. ClearCase also creates a folder called **Components**, which contains entries for each component in the PVOB. Right-click the **Components** folder and select **Create Component Without a VOB** from its shortcut menu.
4. In the **Create Component Without a VOB** dialog box, enter a name and description for the component. Click **OK**.

You may decide to use multiple composite baselines in your project. If you do, we recommend that you still use one top-level composite baseline that selects the baselines of all components in the project, either directly or indirectly through other composite baselines.

---

## Creating Components for Storing Elements

This section describes how to create components for storing the files that your team develops.

**PRODUCT NOTE:** The process for creating components that store elements is slightly different for Rational ClearCase and Rational ClearCase LT.

When you create a component, you must specify the VOB that stores the component's directory tree. You can store multiple components in a VOB, or you can create a VOB that stores one component. See *Deciding How Many VOBs to Use* on page 31 for details about using one VOB to store multiple components.

### Creating One Component Per VOB

To create a VOB and its one component in ClearCase:

1. Make a view by using the **cleartool mkview** command. For a dynamic view, also issue the **cleartool setview** command. For example:

```
cleartool mkview -tag myview /net/host2/view_store/myview.vws
```

```
cleartool setview myview
```

2. Create a VOB by using the **cleartool mkvob** command. For example:

```
cleartool mkvob -nc -tag /vobs/testvob1 /usr/vobstore/testvob1.vbs
```

If you are in an MVFS environment and developers use dynamic views, perform the following two steps.

3. Create the VOB mount point to match the VOB-tag. For example:

```
mkdir /vobs/testvob1
```

4. Mount the VOB. For example:

```
cleartool mount /vobs/testvob1
```



5. Issue the **cleartool mkcomp** command. For example:

```
cleartool mkcomp -nc -root /vobs/testvob1 testcomp1@/vobs/myproj2_pvob
```

In this example, the **mkcomp** command creates a component named **testcomp1** based on the VOB named **testvob1**. Although this example uses different names for the VOB and component, you can use the same name for both. The VOB and PVOB must be mounted before you issue the command. All projects that use the **myproj2\_pvob** PVOB can access the **testcomp1** component.

To create a component in ClearCase LT:

1. Make a view and change to it. For example:

```
cleartool mkview -stgloc dev_views ~/chris_snap_view  
cd ~/chris_snap_view
```

2. Create a VOB by using the **cleartool mkvob** command. For example:

```
cleartool mkvob -nc -tag /testvob1 -stgloc vobstore
```

3. Issue the **cleartool mkcomp** command. For example:

```
cleartool mkcomp -nc -root testvob1 testcomp1@/myproj2_pvob
```

As an alternative to using the **cleartool mkcomp** command, you can convert an existing VOB into a component by using the ClearCase Project Explorer. See *Making a VOB into a Component* on page 82 for details.

### **Creating a VOB That Stores Multiple Components**

To create a VOB that can store multiple components in ClearCase:

1. Use the **cleartool mkvob** command. For example:

```
cleartool mkvob -nc -tag /vobs/testvob13 /usr/vobstore/testvob13.vbs
```

If you are in an MVFS environment and developers use dynamic views, perform the following two steps.

2. Create the VOB mount point to match the VOB-tag. For example:

```
mkdir /vobs/testvob13
```

3. Mount the VOB. For example:

```
cleartool mount /vobs/testvob13
```

To create a VOB that can store multiple components in ClearCase LT, use the **cleartool mkvob** command. For example:

```
cleartool mkvob -nc -tag /testvob13 -stgloc vobstore
```

To create a component and store it in the VOB in ClearCase:

1. Make a view by using the **cleartool mkview** command. For a dynamic view, also issue the **cleartool setview** command. For example:

```
cleartool mkview -tag myview /net/host2/view_store/myview.vws
```

```
cleartool setview myview
```

2. Issue the **cleartool mkcomp** command. For example:

```
cleartool mkcomp -nc -root /vobs/testvob13/libs libs@/vobs/myproj2_pvob
```

In this example, the **mkcomp** command creates a component named **libs** in the VOB named **testvob13**. The component's root directory in the VOB is **libs**. The component's root directory must be at or directly below the VOB root directory. If the component's root directory is at the VOB root directory, that VOB cannot store multiple components. The VOB and PVOB must be mounted before you issue the command. All projects that use the **myproj2\_pvob** PVOB can access the **libs** component.

To create a component and store it in the VOB in ClearCase LT:

1. Make a view by using the **cleartool mkview** command and change to it. For example:

```
cleartool mkview -stgloc dev_views ~/chris_snap_view
```

```
cd ~/chris_snap_view
```

2. Issue the **cleartool mkcomp** command. For example:

```
cleartool mkcomp -nc -root testvob13/libs libs@/myproj2_pvob
```

In this example, the **mkcomp** command creates a component named **libs** in the VOB named **testvob13**. The component's root directory in the VOB is **libs**. The component's root directory must be at or directly below the VOB root directory. If the component's root directory is at the VOB root directory, that VOB cannot store multiple components. The VOB

and PVOB must be mounted before you issue the command. All projects that use the **myproj2\_pvob** PVOB can access the **libs** component.

---

## Creating the Project

This section shows how to create a project by using the Project Explorer and the New Project Wizard. For information on creating a project from the command-line interface (CLI), see the **cleartool mkproject**, **mkstream**, and **mkfolder** reference pages. To create a project:

1. On the command line, type **clearprojexp**.
2. The left pane of the Project Explorer lists root folders for all PVOBs in the local ClearCase domain. Each PVOB has its own root folder. ClearCase creates the root folder using the name of the PVOB.  
  
ClearCase also creates a folder called **Components**, which contains entries for each component in the PVOB. Folders can contain projects and other folders. Select the root folder for the PVOB that you want to use for storing project information.
3. Click **File > New > Folder** to create a project folder. You do not need to create a project folder, but it is a good idea. As the number of projects grows, project folders are helpful in organizing related projects.
4. In the left pane, select the project folder or root folder. Click **File > New > Project**. The New Project Wizard appears.
5. In Step 1 of the New Project Wizard, enter a descriptive name for the project in the **Project Title** box. Enter a comment in the **Description** box to describe the purpose of this project.
6. Step 2 asks whether you want to create the project based on an existing project. Because you are creating a project from scratch, click **No**.
7. Step 3 asks you to choose the baselines that the project will use.

Click **Add** to open the **Add Baseline** dialog box. In the **Component** list, select one of the components that you previously created. The component's initial baseline appears in the **Baselines** list. Select the baseline. Click **OK**. The baseline now appears in the list in Step 3. Continue to use the **Add Baseline** dialog box until the project contains its full set of foundation baselines.

8. Step 4 prompts you to specify the development policies to enforce for this project. Select the check boxes for the policies you want to enforce. See Chapter 4, *Setting Policies* for information about each policy.
9. Step 5 asks whether to configure the project to work with the ClearQuest integration. To enable the project to work with Rational ClearQuest, click **Yes** and select a ClearQuest user database from the list. See *Enabling a Project to Use the UCM-ClearQuest Integration* on page 86 for details about the integration.

## Defining Promotion Levels

ClearCase provides five baseline promotion levels. You can keep some or all of them, and you can define your own promotion levels. To define the promotion levels that your project uses:

1. In the Project Explorer, select the PVOB root folder that contains your project, and then click **Tools > Define Promotion Level**. All projects that use that PVOB have access to the same set of promotion levels.
2. The **Define Promotion Levels** dialog box opens. To remove an existing promotion level, select it and click **Remove**. To change the order of promotion levels, select a promotion level and use the **Move Up** or **Move Down** buttons.
3. To add a new promotion level, click **Add**. The **Add Promotion Level** dialog box opens. Enter the name of the new promotion level and click **OK**. The new promotion level appears in the list of promotion levels in the **Define Promotion Levels** dialog box. Move it to the desired place in the order.
4. When you finalize the set and order of promotion levels, select one to be the initial promotion level for new baselines. The initial promotion level is the level assigned by default when you create a baseline.

For information on defining promotion levels from the CLI, see the **cleartool setplevel** reference page.

---

## Creating an Integration View

When you create a project, ClearCase creates the project's integration stream for you. To see and make changes to the project's shared elements, you need an *integration view*. To create an integration view:

1. In the Project Explorer, navigate to the integration stream by moving down the object hierarchy:
  - a. Root folder
  - b. Project folder
  - c. Project
  - d. Stream

Figure 25 illustrates this hierarchy.

Figure 25 Navigating to Integration Stream in Project Explorer

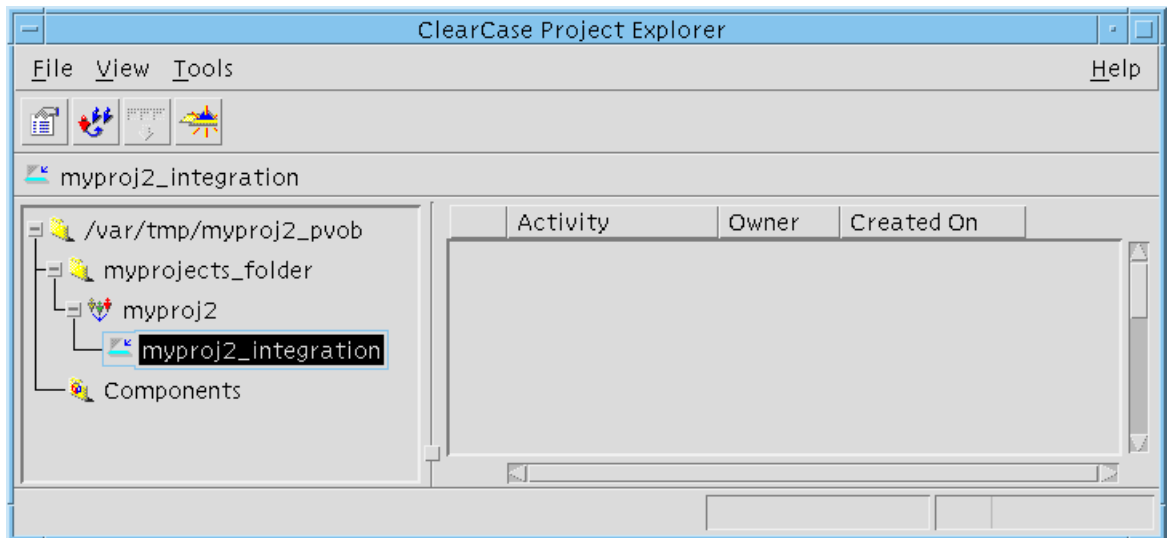

2. Select the integration stream and click **File > New > View**.
3. The **Create View** dialog box opens. Accept the default values to create an integration view attached to the integration stream. By default, the **Create View** dialog box uses this convention for the integration view name: *username\_Integration*.

ClearCase supports two kinds of views:

- > Dynamic views, which use the ClearCase multiversion file system (MVFS) to provide immediate, transparent access to files and directories stored in VOBs.

- > Snapshot views, which copy files and directories from VOBs to a directory on your computer.

**PRODUCT NOTE:** Rational ClearCase LT supports only snapshot views.

We recommend that you make the integration view a dynamic view to ensure that you always see the correct version of files and directories that developers deliver to the integration stream. With a snapshot view, you have to perform an *update* operation to copy the latest delivered files and directories to your computer. For more information about dynamic and snapshot views, see *Developing Software*.

---

## Creating the Composite Baseline That Represents the Project

To create a composite baseline that represents the project by selecting a baseline from each component that the project uses, perform the following steps:

1. In the Project Explorer, right-click the project's integration stream to display its shortcut menu. Click **Edit Baseline Dependencies**.
2. The **Edit Baseline Dependencies** dialog box displays a list of all components that the project uses. Identify the component that will contain the composite baseline. Drag the other components onto the component that will contain the composite baseline. For example, in Figure 26, the **myproj2\_comp** component contains the composite baseline. The composite baseline selects baselines from the **libs** and **api** components.
3. Click **OK**. The **Create Baseline Dependencies** dialog box opens.
4. Enter the name that you want to use for the baselines that UCM creates for these components.
5. Click **OK**.

Figure 26 Using the Edit Baseline Dependencies GUI

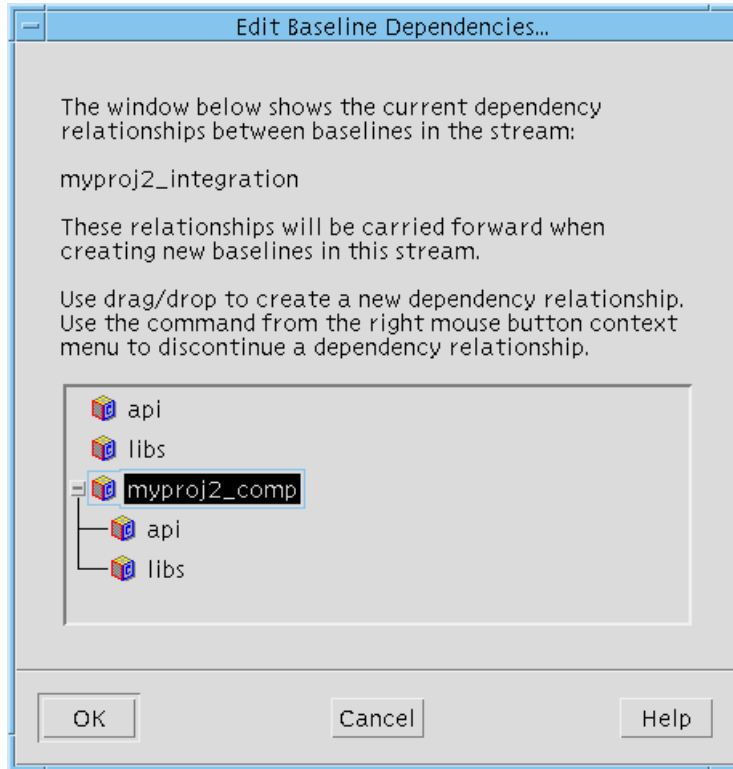

---

## Creating and Setting an Activity

Before you can add elements to the integration stream, you need to create and set an activity.

1. Set your integration view if it is a dynamic view. For example:

```
cleartool setview kmt_Integration
```

If your integration view is a snapshot view, change to it.

2. Issue the `cleartool mkactivity` command. For example:

```
cleartool mkactivity -headline "Create Directories" create_directories
```

The ClearCase GUI tools use the name specified with **-headline** to identify the activity. The last argument, **create\_directories**, is the activity-selector. Use the activity-selector when you issue **cleartool** commands.

3. By default, when you make an activity with the **cleartool mkactivity** command, ClearCase sets your view to that activity. ClearCase does not set your view to an activity if you create multiple activities in the same command line or if you specify a stream with the **-in** option. If you need to set your integration view to the activity, use the **cleartool setactivity** command. For example:

```
cleartool setactivity create_directories
```

---

## Creating the Directory Structure

Because you are creating the project from scratch, you need to create the directory elements within the project's components to implement the directory structure that you define during the planning phase. See *Defining the Directory Structure* on page 32. To add a directory element to a component:

1. With your integration view set to an activity, navigate to the component. If the component is in a VOB that you created to store multiple components, the component appears as a directory under the VOB. For example:

```
cd /vobs/testvob13/libs
```

2. Check out the component's root directory. For example:

```
cleartool co -nc .
```

3. Issue the **cleartool mkelem** command. For example:

```
cleartool mkelem -nc -eltype directory design
```

This example creates a directory element called **design**. By default, the **mkelem** command leaves the element checked out. To add elements, such as subdirectories, to the directory element, you must leave the directory element checked out.

4. When you finish adding elements to the new directory, check it in. For example:

```
cleartool ci -nc design
```



5. When you finish creating directory elements, check in the component's root directory. For example:

```
cleartool ci -nc .
```

For more information about creating directory and file elements, see *Developing Software* and the **mkelem** reference page.

---

## Importing Directories and Files from Outside ClearCase

If you have a large number of files and directories that you want to place under ClearCase version control, you can speed the process by using the **clearexport** and **clearimport** command-line utilities. These two utilities allow you to migrate an existing set of directories and files from another version control software system, such as RCS or PVCS, to ClearCase.

To migrate source files into a component:

1. Create and set a non-UCM view by using the **cleartool mkview** and **setview** commands.
2. From within the view, run **clearexport** to generate a data file from your source files.
3. From within the view, run **clearimport** to populate the component with the files and directories from the data file.
4. In the component, create a baseline from a labeled set of versions. If the versions that you want to include in the baseline are not labeled, create a label type and apply it to the versions. See *Making a Baseline from a Label* on page 83 for details.

As an alternative, you can use **clearexport** and **clearimport** on VOBs, and then convert the VOBs to components. See *Creating a Project Based on an Existing ClearCase Configuration* on page 82 for details on converting VOBs into components.

To migrate directories and flat files that are not currently under any version control, use the **clearfsimport** command-line utility. See the **clearfsimport** reference page for details.

For details on using **clearexport** and **clearimport**, see the *Administrator's Guide* for Rational ClearCase or the *Administrator's Guide* for Rational ClearCase LT and the **clearexport** and **clearimport** reference pages.

---

## Making and Recommending a Baseline

After you create the directory structure and import files, create and recommend a new baseline that selects those directory and file elements. Developers who join the project populate their development streams with the versions identified by the recommended baseline. For details on making baselines, see *Creating a New Baseline* on page 103. For details on recommending baselines, see *Recommending the Baseline* on page 107.

---

## 6.2 Creating a Project Based on an Existing ClearCase Configuration

If you have existing VOBs, you may want to convert them into components so that you can include them in projects. This section describes how to set up a project based on existing VOBs.

---

### Creating the PVOB

Use the **cleartool mkvob** command as described in *Creating the Project VOB* on page 70. If you currently use an administrative VOB, use the **cleartool mkhlink** command to create an **Admin** hyperlink between the PVOB and the administrative VOB. When you create components, they then use the existing administrative VOB.

---

### Making a VOB into a Component

To make a VOB into a component:

1. In the Project Explorer, select the PVOB. Click **Tools > Import VOB**. The **Import VOB** dialog box opens.
2. In the **Available VOBs** list, select the VOB that you want to make into a component. Click **Add** to move the VOB to the **VOBs to Import** list. You can add more VOBs to the **VOBs to Import** list. If you change your mind, you can select a VOB in the **VOBs to Import** list and click **Remove** to move it back to the **Available VOBs** list. When you are finished, click **Import**.

You may want to organize the contents of a VOB into multiple components. To make a directory tree within a VOB into a component, use the **cleartool mkcomp** command. For example:

```
cleartool mkcomp -root /myvob/admin_comp admin_comp@/my_pvob
```

This command creates the **admin\_comp** component in **myvob**. The **admin\_comp** component contains the **admin\_comp** directory and all its subdirectories and files. The component's root directory must be at or directly below the VOB root directory. If the component's root directory is at the VOB root directory, that VOB cannot store multiple components.

---

## Making a Baseline from a Label

After you convert an existing VOB into a component, to access the directories and files in that component, you must create a baseline from the set of versions identified by a label type. To create the baseline:

1. If the set of versions that you want to use are not already labeled, use the **cleartool mklbtype** and **mklable** commands to create and apply a label type. For example:

```
% cleartool mklbtype -c "label for release 2" REL2
Created label type "REL2".

% cleartool mklable -recurse REL2 .
Created label "REL2" on "." version "/main/5".
Created label "REL2" on "./src" version "/main/6".
Created label "REL2" on "./src/Makefile" version "/main/2".
```

The **-recurse** option directs ClearCase to apply the label to all versions at or below the current working directory.

2. In the Project Explorer, select the PVOB. Click **Tools > Import Label**. Step 1 of the Import Label Wizard appears.
3. In the **Available Components** list, select the component that contains the label from which you want to create a baseline. Click **Add** to move that component to the **Selected Components** list. If you change your mind, select a component in the **Selected Components** list and click **Remove** to move the component back to the **Available Components** list.
4. In Step #2, select the label type that you want to import, and enter the name of the baseline that you want to create for the versions identified by that label type. Then select the baseline's promotion level. **NOTE:** You cannot import a label type from a global label type definition.

---

## Creating the Project

Use the New Project Wizard to create the project as described in *Creating the Project* on page 75.

---

## Creating an Integration View

Create an integration view as described in *Creating an Integration View* on page 76.

---

### 6.3 Creating a Project Based on an Existing Project

As you create new projects, you may need to create new versions of existing projects. For example, suppose you have released version 3.0 of the Webotrans project and are planning for version 3.1. You anticipate that version 3.1 will use the same components as version 3.0. Therefore, you want to use the latest baselines in the version 3.0 components as the foundation baselines for version 3.1 development.

---

#### Using a Composite Baseline to Capture Final Baselines

If the existing project contains numerous components, you may want to create a composite baseline that selects the final baselines of those components before you create the new project. This composite baseline serves as a single starting point for teams that want to start their work from the final approved baselines of the existing project. To create such a composite baseline, perform the following steps:

1. Create a component that does not have a root directory in a VOB. See *Creating a Component for Storing the Project Baseline* on page 71.
2. Add the initial baseline of the component to the integration stream. See *Adding Components* on page 97.
3. In the component, create a composite baseline that selects baselines of all other components in the project. See *Creating the Composite Baseline That Represents the Project* on page 78.
4. Recommend the composite baseline. See *Recommending the Baseline* on page 107.

---

## Reusing Existing PVOB and Components

Because your project is a new version of an existing project and uses the same components as the existing project, do not create a new PVOB for this project. Continue to use the existing PVOB.

---

## Creating the Project

Start the New Project Wizard, as described in *Creating the Project* on page 75, to create the project.

In Step 2 of the wizard, select **Yes** to indicate that the project begins from the baselines in an existing project. Then navigate to the project that contains those baselines. Figure 27 shows that the new project is based on the baselines in **myproj2**.

Figure 27 Step 2 of New Project Wizard

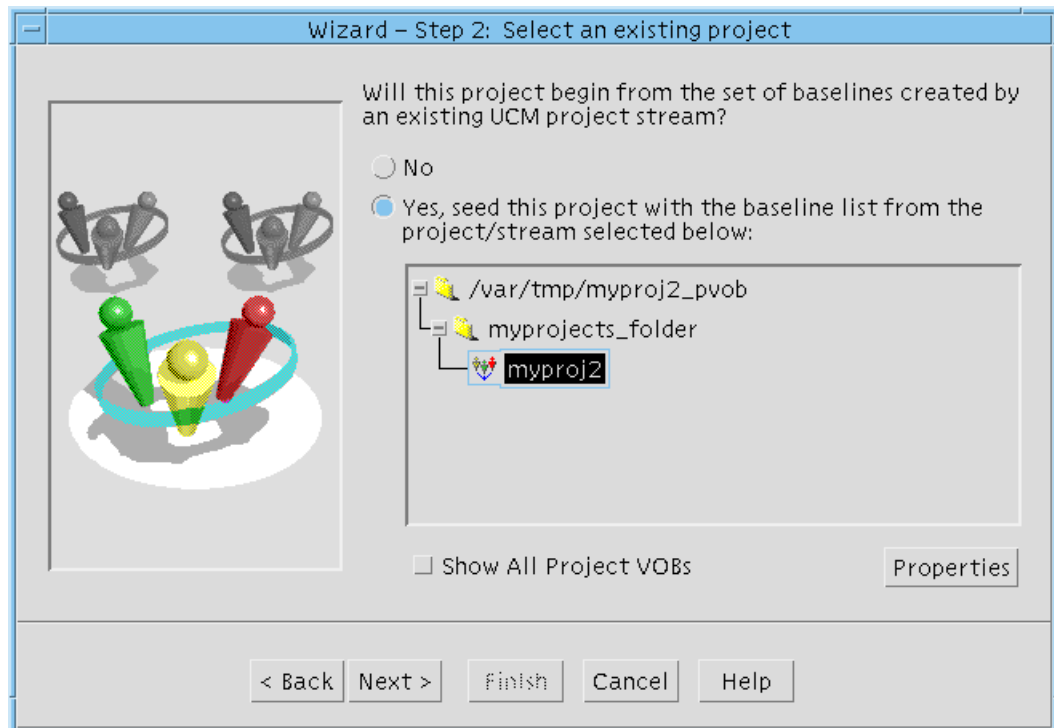

Step 3 lists the latest baselines in the project that you select in Step 2. If you created a composite baseline to capture the final approved baselines in the existing project, select it. You can add baselines from components that are not part of the existing project by clicking **Add** to open the **Add Baseline** dialog box. Similarly, you can remove a baseline by selecting it and clicking **Remove**.

Finish the remaining steps in the wizard as described in *Creating the Project* on page 75.

---

## Creating an Integration View

When you create a new project, ClearCase creates a new integration stream for you. Therefore, you need to create a new integration view to access elements in the integration stream. Create an integration view as described in *Creating an Integration View* on page 76.

---

## 6.4 Enabling a Project to Use the UCM-ClearQuest Integration

Before you can connect a project to a ClearQuest user database, you must set up the database to use a UCM-enabled schema. See Chapter 5, *Setting Up a ClearQuest User Database*.

To enable a project to work with a ClearQuest user database:

1. In the left pane of the Project Explorer, right-click the project to display its shortcut menu. Click **Properties** to display its property sheet.
2. Click the **ClearQuest** tab and then select the **Project is ClearQuest-enabled** check box. Select the user database that you want to link to the project. The first time that you enable a project, ClearQuest opens its **Login** dialog box. Enter your user name, password, and the name of the database to which you are linking the project.
3. Select the development policies that you want to enforce. See *UCM-ClearQuest Integration* on page 55 for a description of these policies. Click **OK** when you are finished.

If you are creating a new project, you can enable the project to work with ClearQuest by selecting **Yes, use the ClearQuest database selected below** and selecting the user database in Step 5 of the New Project Wizard, as shown in Figure 28.

After you enable a UCM project to work with a ClearQuest user database, you may decide to link the project to a different user database. You can switch databases by selecting a different one on the **ClearQuest** tab of the project's property sheet if no activities have been created.

## Migrating Activities

If your project contains activities when you enable it to work with a ClearQuest database, the integration creates records for each of those activities by using the **UCMUtilityActivity** record type. If you want to store all of your project's activities in records of some other record type, enable the project when you create it, before team members create any activities. After the migration is complete, any new activities that you create can link to records of any UCM-enabled record type.

Figure 28 Enabling a Project to Work with a ClearQuest User Database

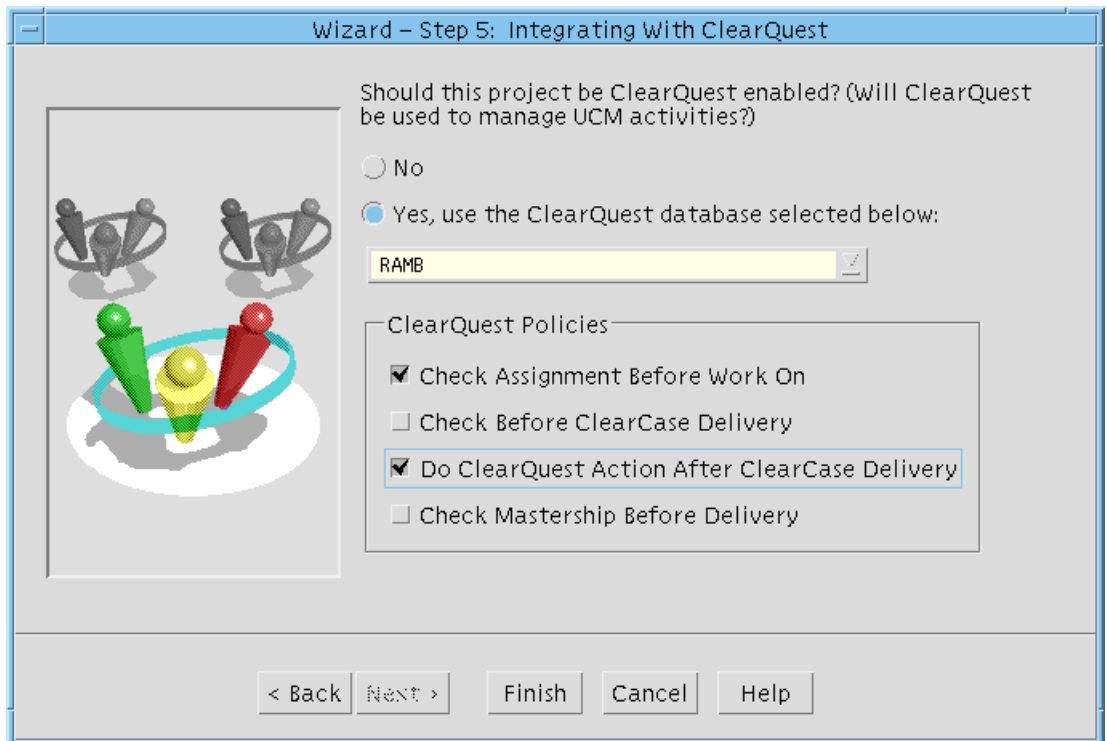

---

## Setting Project Policies

A UCM-enabled schema includes four policies that you can set from either ClearCase or ClearQuest.

In ClearCase, set the policies by selecting check boxes on the **ClearQuest** tab of the project's property sheet, as shown in Figure 28.

To set policies from ClearQuest:

1. Start the ClearQuest client by entering **clearquest** at the shell prompt. In the ClearQuest client workspace, navigate to the **UCMProjects** query, as shown in Figure 29.
2. Double-click the query to display all UCM-enabled projects.
3. Select a project from the **Results** set. The project's form appears.
4. On the form, click **Actions** and select **Modify**. Select the check boxes for the policies you want to set.

For descriptions of the policies, see *UCM-ClearQuest Integration* on page 55.

Figure 29 Navigating to the UCMProjects Query

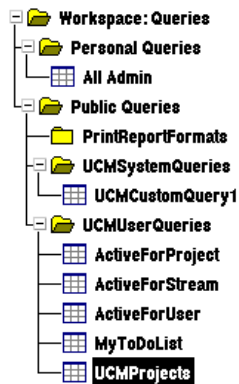



---

## Assigning Activities

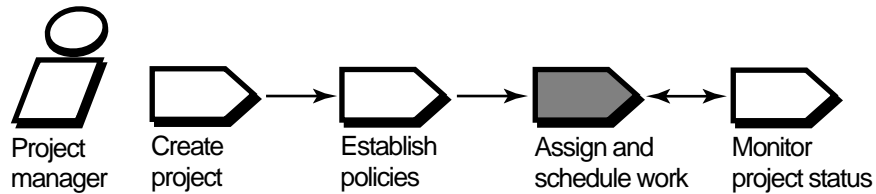

To create and assign activities in ClearQuest:

1. Start the ClearQuest client, and log on to the user database connected to the project.
2. Click **Actions > New**. The **Choose a record type** dialog box opens. Select a UCM-enabled record type, and click **OK**.
3. The **Submit** form appears. Fill in the boxes on each tab. On the **Main** tab, you must fill in at least the **Headline** and **Owner** boxes. On the **Unified Change Management** tab, select the project. When you finish filling in the boxes, click **OK**. ClearQuest creates the record.

User account profiles must exist in ClearQuest for the developers to whom you assign activities. See *Creating Users* on page 67 for details on creating user account profiles.

---

## Disabling the Link Between a Project and a ClearQuest User Database

There may be times when you want to disable the link between a project and a ClearQuest user database. To disable the links:

1. On the **ClearQuest** tab of the project's property sheet, clear the **Project is ClearQuest-enabled** check box.
2. Click **OK** on the **ClearQuest** tab. The integration disables the link between the project and the ClearQuest database. The integration also removes any existing links between activities and their corresponding ClearQuest records.
3. Display the project's property sheet again, select the **Project is ClearQuest-enabled** check box, and select another user database if you want to link the project to a different user database.

**NOTE:** If you select the same user database that you just unlinked, the integration creates new ClearQuest records for the project's activities; it does not link the activities to the ClearQuest records with which they were previously linked.

---

## Fixing Projects That Contain Linked and Unlinked Activities

It is possible that after you enable a project to work with ClearQuest, some of the project's activities remain unlinked to ClearQuest records. Similarly, when you disable the link between a project and ClearQuest, some activities may remain linked. Two scenarios can cause your project to be in this inconsistent state:

- A network failure or a general system crash occurs during the enabling or disabling operation and interrupts the activity migration.
- The project's PVOB is in a ClearCase MultiSite configuration, and unlinked activities were added by a MultiSite synchronization operation to the local PVOB's project, which is enabled to work with ClearQuest.

### Detecting the Problem

If a developer attempts to take an action, such as modifying an unlinked activity in an enabled project, the integration displays an error and disallows the action.

### Correcting the Problem

To restore the project to a consistent state:

1. In the Project Explorer, display the project's property sheet, and click the **ClearQuest** tab. If you are using MultiSite, perform these steps at the remote site.
2. Click **Ensure all Activities are Linked**. The integration checks all the project's activities. If the project is enabled, the integration links any unlinked activities. The integration then displays the following summary information:
  - Number of activities that had to be linked.
  - Number of activities that were previously linked.
  - Number of activities that could not be linked because they are not mastered in the current PVOB replica. In this case, the integration also displays a list of replicas on which

you must run the **Ensure all Activities are Linked** operation again to correct the problem.

3. At each replica on the list described in Step #2, repeat Step #1 and Step #2.

---

## How MultiSite Affects the UCM-ClearQuest Integration

If you use ClearCase MultiSite to replicate the PVOB or ClearQuest user database and schema repository involved in the UCM-ClearQuest integration, you need to be aware of several requirements. This section describes those requirements.

### Replica and Naming Requirements

When you set up the UCM-ClearQuest integration, you establish a link between a project and a ClearQuest user database. If you use MultiSite, the following requirements apply:

- Each site that has a PVOB replica that contains a linked project must have a replica of the ClearQuest user database to which the project is linked and the user database's schema repository. Similarly, each site that contains a linked ClearQuest user database replica must contain a replica of the PVOB that contains the project to which the user database is linked.
- The name of the ClearQuest replica must match the name of the PVOB replica at the same site.

### Transferring Mastership of the PVOB's Root Folder

The first time you enable a project within a PVOB to work with ClearQuest, your current PVOB replica must master the PVOB's root folder. If your current replica does not have mastership, transfer mastership of the root folder by using the **multitool chmaster** command at the replica that masters the root folder. The following example transfers mastership of the root folder from the current replica to the **lowell** replica.

```
multitool chmaster lowell folder:RootFolder
```

See the *Administrator's Guide* for Rational ClearCase MultiSite for details on transferring mastership.

## Transferring Mastership of the Project

Before you enable a project to work with ClearQuest, your current PVOB replica must master the project. If your replica does not master the project, transfer mastership of the project by using the **multitool chmaster** command at the replica that masters the project.

When you enable the project to work with ClearQuest, the integration creates a corresponding project record in the ClearQuest user database and assigns mastership of that record to the current replica of the ClearQuest user database. If a project record with the same name as the project exists in the ClearQuest user database when you enable the project, and that project record is not mastered by your current replica, you must transfer mastership of the project record to your current replica.

## Linking Activities to ClearQuest Records

If a project contains activities, when you enable that project to work with ClearQuest, the integration creates corresponding ClearQuest records for the activities and links the records to the activities. The integration cannot link activities that are mastered by remote replicas. See *Fixing Projects That Contain Linked and Unlinked Activities* on page 90 for the procedure to link activities that are mastered by a remote replica.

## Changing Project Policy Settings

Before you can change a project's policy settings from within ClearQuest, the ClearQuest project record must be mastered. Similarly, before you can change a project's policy settings from within ClearCase, the project object must be mastered. After you change a project's policy settings in the current replica, the new settings do not take effect in streams in sibling replicas until you synchronize the current replica with those replicas. See the *Administrator's Guide for Rational ClearCase MultiSite* for details on synchronizing replicas.

## Changing the Project Name

The integration links a project name to the title field in the corresponding ClearQuest project record. If you change the project name in ClearCase, the integration makes the same change to the title field in the corresponding ClearQuest project record. Similarly, if you change the title in ClearQuest, the integration makes the same change to the project name in ClearCase. Before you can change the project name and title in a MultiSite environment, the project record and the project object must both be mastered.

---

## 6.5 Creating a Development Stream for Testing Baselines

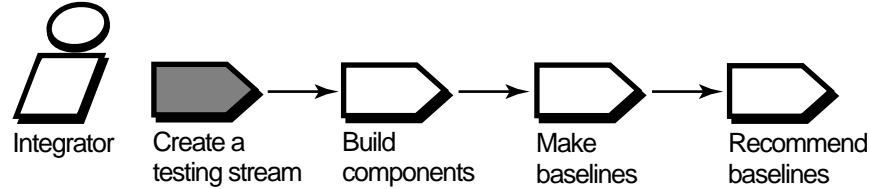

When you make a new baseline, we recommend that you lock the integration stream so that you can build and test a static set of files. Otherwise, developers can inadvertently cause confusion by delivering changes while you are building and testing. Locking the integration stream for a short period of time is acceptable; locking the integration stream for several days can result in a backlog of completed but undelivered activities. To avoid locking out developers for a long period of time, you may want to create a development stream and use it for extensive testing of baselines. If your project uses feature-specific development streams, you may want to create a testing stream for each feature-specific development stream so that you can test the baselines created in those streams.

To create a development stream:

1. In ClearCase Project Explorer, select the integration stream, and click **File > New > Child Stream**.

The **Create a Development Stream** dialog box appears.

2. Enter a name and description for the new stream. Be sure that the **Prompt me to create a View for this stream** check box is selected. Click **OK**.

The **Create View** dialog box appears.

3. Fill in the fields of the **Create View** dialog box to create a development view for the stream.

By default, ClearCase uses the set of *recommended baselines* when creating a development stream. Because the new baseline has not been tested extensively, you probably have not yet promoted it to the level associated with recommended baselines. Therefore, you need to change the development stream's foundation baseline to be the one that you want to test:

1. In ClearCase Project Explorer, select the new development stream, and click **File > Properties** to display the stream's property sheet.

2. Click the **Configuration** tab. Select the component whose foundation baseline you want to change. Click **Change**.

The **Change Baseline** dialog box appears.

3. Select the baseline that you want to test. Click **OK**.
4. If you want to change the foundation baseline of another component, select it from the **Configuration** tab, and repeat the process. When you are finished, click **OK** to dismiss the property sheet.

Now the development stream is configured so that you can build and test the new baselines, and developers can deliver changes to the integration stream without being concerned about interfering with the building and testing process. For information on testing baselines, see *Testing the Baseline* on page 105.

---

## 6.6 Creating a Feature-Specific Development Stream

The basic UCM process uses the integration stream as the project's sole shared work area. You may choose to organize your project into small teams of developers where each team develops a specific feature. To support this type of organization, create a development stream to serve as the shared work area for each team of developers. The developers who work on that feature create their own development streams based on the recommended baselines in the feature-specific development stream. See *Choosing a Stream Strategy* on page 35 for additional information about feature-specific development streams.

To create a feature-specific development stream:

1. In ClearCase Project Explorer, select the integration stream, and click **File > New > Child Stream**.

The **Create a Development Stream** dialog box appears.

2. Enter a name and description for the new stream. Be sure that the **Prompt me to create a View for this stream** check box is selected. Click **OK**.

The **Create View** dialog box appears.

3. Fill in the fields of the **Create View** dialog box to create a development view for the stream.

4. In ClearCase Project Explorer, right-click the feature-specific development stream, and select **Recommend Baselines**.
5. In the Recommended Baselines dialog, click **Add** to display the Add Baseline dialog box. Select the baselines that you want to recommend to developers who will work on this feature. When developers create their own development streams, those streams will be based on the recommended baselines. When you finish selecting the baselines, click **OK** in the Recommended Baselines dialog.





## Managing the Project

# 7

After you create and set up a project, developers join the project, work on activities, and deliver completed activities to the integration stream or feature-specific development stream. In your role as integrator, you need to maintain the project so that developers do not get out of sync with each other's work. This chapter describes the following maintenance tasks:

- Adding components
- Building components
- Making new baselines
- Testing baselines
- Recommending baselines
- Monitoring project status
- Cleaning up the project

---

### 7.1 Adding Components

Over time, the scope of your project typically broadens, and you may need to add components. To add a component to a stream:

1. Enter **clearprojexp** to start ClearCase Project Explorer.
2. In the left pane, select the project.
3. In the right pane, select the stream. Click **File > Properties** to open the stream's **Properties** dialog box.

4. Click the **Configuration** tab, and then click **Add**. The **Add Baseline** dialog box opens.
5. In the **Component** list, select the component that you want to add. The component's baselines appear in the Baselines list. To add a baseline from another stream, click the arrow at the end of the **From Stream** field and navigate to the stream. Figure 30 shows the baselines available in the **myproj2\_comp** component.

Figure 30 Add Baseline Dialog Box

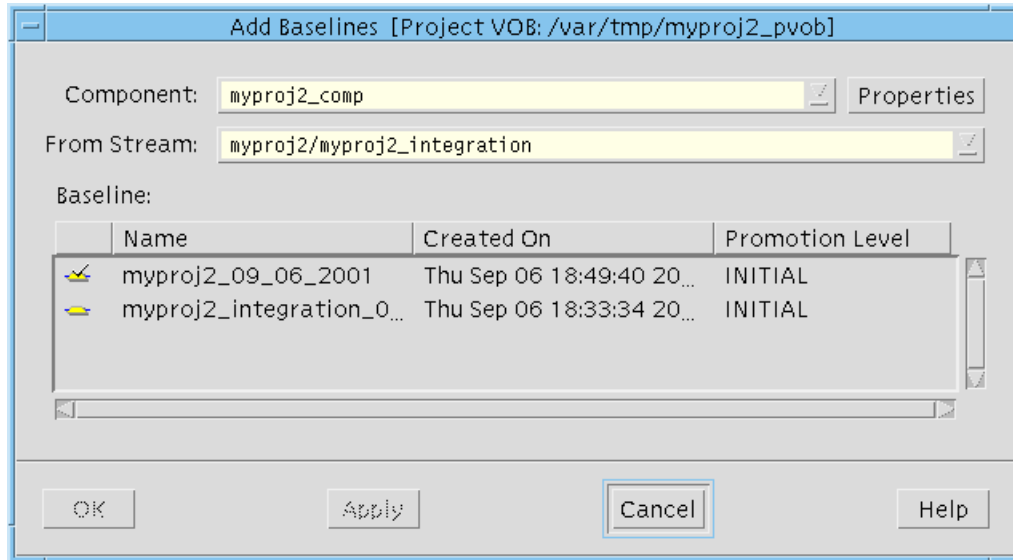

6. In the **Baselines** list, select the baseline that you want to add to the project.
7. Click **OK**. The **Add Baseline** dialog box closes, and the baseline that you chose appears on the **Configuration** tab.
8. Click **OK** to close the stream's **Properties** dialog box.

The **Rebase Stream Preview** dialog box opens. To modify the stream's configuration to include the new foundation baseline, UCM needs to rebase the stream.
9. Click **OK** in the **Rebase Stream Preview** dialog box.
10. Click **Complete** to finish the rebase operation.

---

## Making the Component Modifiable

By default, Rational ClearCase adds the component to the project as read-only. To make the component modifiable within the project, perform the following steps:

1. In the Project Explorer, select the project, and click **File > Policies**.
2. In the **Components** tab, click the check box next to the component.
3. Click **OK**.

---

## Synchronizing the View

Before you can access the component that you added, you must synchronize your view with the stream's new configuration by performing the following steps:

1. In the Project Explorer, select the stream that contains the component you added, and click **File > Properties**.
2. Click the **Views** tab. Select the view and click **Properties**.
3. On the **General** tab, click **Synchronize with stream**.

---

## Updating Snapshot View Load Rules

If your view is a snapshot view, you need to edit the view's load rules to include the components that you add to the stream. A snapshot view's load rules specify which components ClearCase loads into the view. To edit the view's load rules:

1. In the Project Explorer, select the stream, and click **File > Properties** to display the stream's property sheet.
2. In the property sheet, click the **Load Rules** tab.
3. Select the component or components that you added to the stream.
4. Click **Add**. Click **OK** to close the property sheet.

In addition, you need to know whether any developers working on the project use snapshot views for their development views. When a developer who uses a snapshot view rebases to a baseline that contains a new component, ClearCase updates the snapshot view's config spec, but it does not update the view's load rules. When you add a component, notify developers who use snapshot views that they need to update the load rules for their development views after they rebase their development streams to the new baseline.

---

## 7.2 Building Components

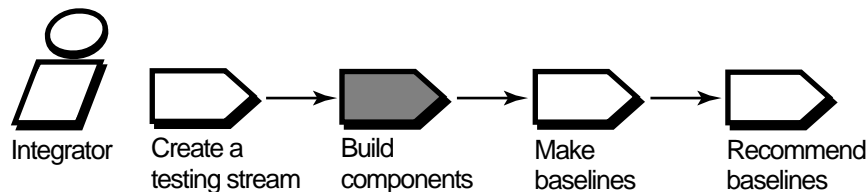

Before you make new baselines in a stream, build the components by using the current baselines plus any work that developers have delivered to the stream since you created the current baselines. If the build succeeds, you can make baselines that select the latest delivered work. Building components involves the following tasks:

- Locking the stream
- Finding remote deliver operations
- Completing remote deliver operations
- Undoing bad deliver operations
- Building and testing the components

---

### Locking the Integration Stream

Before you build components in the integration stream or feature-specific development stream, lock the stream to prevent developers from delivering work. This ensures that you are dealing with a static set of files.

1. In the Project Explorer, select the stream.
2. Click **File > Properties** to display the stream's property sheet.
3. Click the **Lock** tab.

4. Click **Locked** and then click **OK**.

---

## Finding Work That Is Ready to Be Delivered

Before you build components, you may need to complete some deliver operations. In most cases, developers complete their deliver operations. However, in a MultiSite configuration in which the target stream is mastered at a different replica than the developer's source stream, the developer cannot complete deliver operations. When ClearCase detects such a stream mastership situation, it makes the deliver operation a *remote deliver* operation.

In a remote deliver operation, ClearCase starts the deliver operation but leaves it in the posted state. It is up to you, as integrator, to find and complete deliver operations in the posted state. Developers who have deliver operations in the posted state cannot deliver from or rebase their source development streams until you complete or cancel their deliver operations.

**PRODUCT NOTE:** Rational ClearCase LT does not support ClearCase MultiSite.

To find all deliver operations that are in the posted state:

1. In the Project Explorer, select the project.
2. Click **Tools > Find Posted Deliveries**. If the project contains posted deliveries, the **Find Posted Deliveries** dialog box appears and lists all streams within the project that contain deliver operations in the posted state. For each posted deliver operation, the dialog box shows the source stream and the target stream.

---

## Completing Remote Deliver Operations

To complete remote deliver operations for a development stream:

1. Select the development stream from the list in the **Find Posted Deliveries** dialog box.
2. Click **Deliver**. The **Deliver** dialog box opens. Click **Resume** to resume the deliver operation. Click **Cancel** to cancel the deliver operation. See *Developing Software* for details on completing the deliver operation.

---

## Undoing a Deliver Operation

At any time before developers complete the deliver operation, they can back out of it and undo any changes made; but if they check in their versions to the integration view, they cannot undo the changes easily. When this happens, you may need to remove the checked-in versions by using the **cleartool rmver -xhlink** command.

**NOTE:** The **rmver** command erases part of your organization's development history, and it may have unintended consequences. Therefore, be very conservative in using this command, especially with the **-xhlink** option. See the **rmver** reference page in the *Command Reference* for details.

Note that removing a version does not guarantee that the change is really gone. If a successor version was created or if the version was merged before you removed the version, the change still exists. You may need to check out the file, edit it to remove the change, and check the file back in.

---

## Building and Testing the Components

After you lock the stream and complete any outstanding deliver operations, you are ready to build and test the project's executable files to make sure that the changes delivered by developers since the last baseline do not contain any bugs. For information on performing builds, see *Building Software*. Because you lock the stream when you build and test in it, we recommend that you use a separate development stream for extensive testing of new baselines. Perform only quick validation tests in the current stream so that it is not locked for an extended period of time. See *Testing the Baseline* on page 105 for information about using a development stream for testing new baselines.

---

## 7.3 Creating a New Baseline

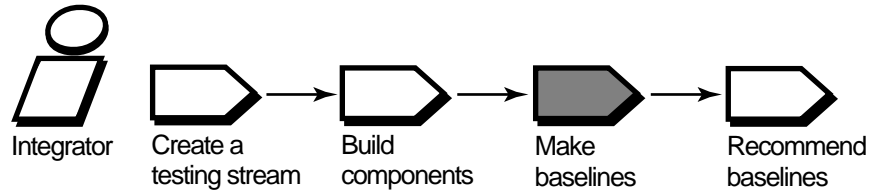

As developers deliver work to the integration stream or feature-specific development stream, it is important that you make new baselines frequently to record the changes. Developers can then rebase to the new baselines and stay current with each other's changes. Before you make the baseline, make sure that the stream is still locked so that developers cannot deliver work to the stream.

---

### Making the New Baseline

To make new baselines for all components in the stream:

1. In the Project Explorer, select the integration stream or feature-specific development stream where you want to make the baseline.
2. Click **Tools > Make Baseline**. The **Make Baseline** dialog box opens, (Figure 31).

Figure 31 Make Baseline Dialog Box

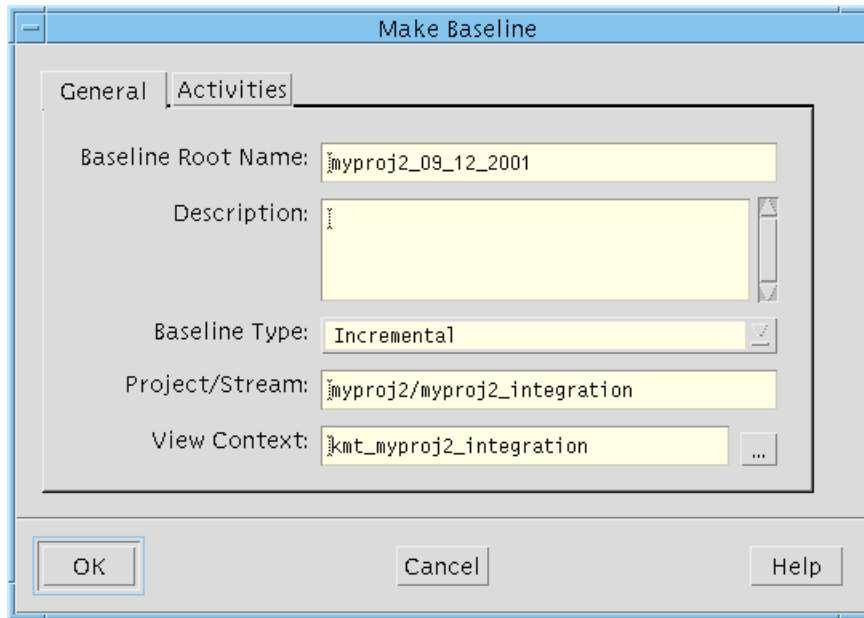

3. Enter a name in the **Baseline Root Name** box. By default, ClearCase names the baseline by appending the date to the project's name. If the baseline is a composite baseline, ClearCase uses the root name plus a unique suffix for each of the member baselines that contribute to the composite baseline.

4. Choose the type of baseline to create.

An *incremental baseline* is a baseline that ClearCase creates by recording the last full baseline and those versions that have changed since the last full baseline was created.

A *full baseline* is a baseline that ClearCase creates by recording all versions below the component's root directory.

Generally, incremental baselines are faster to create than full baselines; however, ClearCase can look up the contents of a full baseline faster than it can look up the contents of an incremental baseline.

5. Specify a view in which to perform the operation. Choose a view that is attached to the stream where you want to make the baseline.



## Making a Baseline for a Set of Activities

By default, all activities modified since the last baseline was made are included in the new baseline. There might be times when you want to create a baseline that includes only certain activities. To do so, click the **Activities** tab in the **Make Baseline** dialog box, and select the activities that you want to go into the baseline.

## Making a Baseline of One Component

To make a baseline for one specific component rather than all components in the stream, perform the following steps:

1. In the Project Explorer, select the stream in which you want to create a new baseline. Click **File > Properties** to display the stream's property sheet.
2. Click the **Baselines** tab. Select a component, and click **Make Baseline**.
3. Fill in the fields of the **Make Baseline** dialog box, then click **OK**.

---

## Unlocking the Stream

After you create a new baseline, unlock the integration or feature-specific development stream so that developers can resume delivering work to the stream. To unlock the stream:

1. In the Project Explorer, select the stream.
2. Click **File > Properties** to display the stream's property sheet.
3. Click the **Lock** tab.
4. Click **Unlocked** and then click **OK**.

---

## 7.4 Testing the Baseline

To avoid locking the integration stream or feature-specific development stream for an extended period of time, we recommend that you use a separate development stream for performing extensive testing, such as system, regression, and acceptance tests, on new baselines. See *Creating*

a *Development Stream for Testing Baselines* on page 93 for information on creating a development stream.

After you create a new baseline and verify that it builds and passes an initial validation test in the integration stream, rebase the development stream:

1. In the Project Explorer, select the development stream and click **Tools > Rebase Stream**.

The **Rebase Stream Preview** dialog box opens.

2. By default, ClearCase rebases your development stream to the *recommended baselines*. Because the new baseline has not been tested extensively, you probably have not yet promoted it to the level associated with recommended baselines. To rebase to the baseline, or baselines, you want to test, click **Change**.

The **Change Rebase Configuration** dialog box opens.

3. Select a component that contains a baseline you want to test. Click **Advanced**.

The **Change Rebase Configuration** dialog box opens, listing all baselines for the component.

4. Select the baseline that you want to test, and click **OK**.
5. Select another component in the **Change Rebase Configuration** dialog box and repeat the process. When you finish selecting baselines, click **OK** to close the **Change Rebase Configuration** dialog box.
6. Click **OK** in the **Rebase Stream Preview** dialog box to continue the rebase operation. See online help or *Developing Software* for details on rebasing a development stream. When you finish rebasing the development stream, you are ready to begin testing the new baselines.

---

## Fixing Problems

If you discover a problem with a baseline while testing it, fix the affected files and deliver the changes to the integration stream as follows:

1. From the development view attached to the development stream, check out the files you need to fix. When you check out a file, you need to specify an activity.
2. Make the necessary changes to the files and check them in.
3. Build and test the changes in the development view.

4. When you are confident that the changes work, make a new baseline that incorporates the changes in the development stream.
5. Deliver the new baseline to the integration or feature-specific development stream. When you deliver the new baseline to the integration or feature-specific development stream, you merge changes with work that developers have delivered since the last baseline was created. For information about delivering baselines, see Chapter 9, *Managing Parallel Releases of Multiple Projects*.
6. Change the set of recommended baselines for the integration stream or feature-specific development stream to include the new baseline that you made in the testing stream. For details about recommending a baseline in another stream, see *Recommending the Baseline* on page 107.

---

## 7.5 Recommending the Baseline

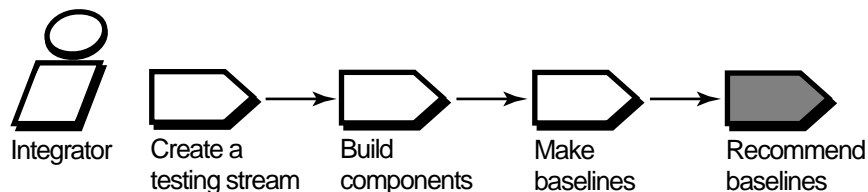

As work on your project progresses and the quality and stability of the components improve, change the baseline's promotion level attribute to reflect a level of testing that the baseline has passed, and recommend baselines that have passed extensive testing.

To change a baseline's promotion level:

1. In the Project Explorer, select the stream. Click **File > Properties** to open the stream's **Properties** dialog box.
2. Click the **Baselines** tab.
3. In the **Components** list, select the component that contains the baseline you want to promote. In the **Baselines** list, select the baseline. Click **Properties**. The baseline's **Properties** dialog box opens.
4. Click the arrow in the **Promotion Level** list to display all available promotion levels. Select the new promotion level.

To recommend a baseline or set of baselines:

1. In the Project Explorer, select the stream. Click **Tools > Recommend Baselines**.
2. In the **Recommended Baselines** dialog box, you can filter the list of baselines displayed by selecting a promotion level and clicking **Set List**. The dialog box then displays only baselines at or above the selected promotion level.
3. To remove a baseline from the list, select it and click **Remove**. To add a baseline, click **Add** and select the baseline in the **Add Baseline** dialog box.
4. To recommend a different baseline of a component, select the baseline and click **Change**. In the **Change Baseline** dialog box, select the baseline that you want to recommend. To select a baseline in another stream, such as a testing stream, click **Change** and navigate to the stream in the **Change Baseline** dialog box.
5. When you finalize your list of recommended baselines, click **OK** in the **Recommended Baselines** dialog box.

---

## 7.6 Resolving Baseline Conflicts

If your project uses composite baselines, you may encounter a situation where you must resolve a conflict in a stream's configuration between two different baselines of the same component. Conflicts can occur during operations that involve baselines, such as the following:

- Making a baseline
- Adding a baseline to a stream's configuration
- Recommending a baseline
- Rebasing a stream

---

### Conflicts Between a Composite Baseline and a Noncomposite Baseline

The simpler of the two conflict cases is when a composite baseline conflicts with a noncomposite baseline. For example, assume that a stream's configuration includes a composite baseline that selects baseline **BL4** of component **A**, and that the composite baseline is the recommended baseline. After testing a new baseline, **BL5**, of component **A**, you decide to recommend it. By doing so, you override the member baseline, **BL4**, selected by the composite baseline. The **Recommended Baselines** dialog box identifies **BL5** as an override and **BL4** as overridden. UCM uses the same override and overridden identifiers in other GUIs.

---

## Conflicts Between Two Composite Baselines

The more complex conflict case can occur when a stream's configuration includes multiple composite baselines where each composite baseline selects a baseline of the same component. A stream cannot select two different baselines of the same component. If you attempt to perform an operation that would cause this situation, UCM recognizes the conflict and forces you to resolve it before completing the operation.

---

## 7.7 Monitoring Project Status

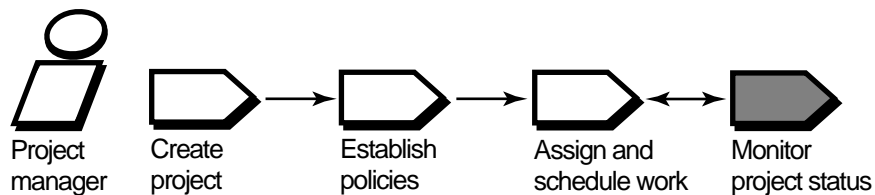

ClearCase provides several tools to help you track the progress of your project. This section describes how to use those tools.

---

## Comparing Baselines

ClearCase allows you to display the differences between two baselines graphically. To compare two baselines, use the `cleardiffbl` command. For example:

```
% cleardiffbl OM_proj2.0_Integration_08_12_01 OM_proj2.0_09_06_01
```

This command opens the **Compare Baselines** dialog box, as shown in Figure 32. You can also open the **Compare Baselines** dialog box from within the baseline's property sheet:

1. In ClearCase Project Explorer, select the integration stream, and click **File > Properties** to display the integration stream's property sheet.
2. Click the **Baselines** tab and then select the component that contains the baseline you want to compare.

3. Select the baseline; then right-click it and select **Compare with Previous Baseline** or **Compare with Another Baseline**.

Figure 32 Comparing Baselines

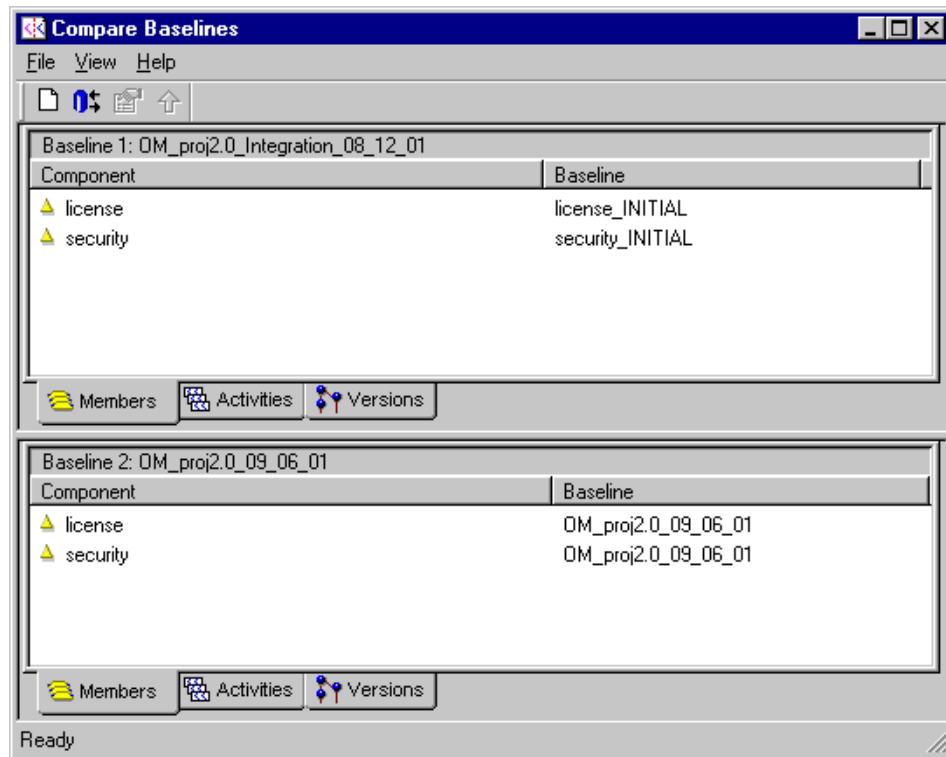

The Compare Baselines window in Figure 32 shows the results of a comparison of two composite baselines named **OM\_proj2.0\_Integration\_08\_12\_01** and **OM\_proj2.0\_09\_06\_01**. The **Members** tab shows the baselines that contribute to each composite baseline.

To see the activities included in each baseline, click **Activities**. In Figure 33, the first baseline contains no activities because its member baselines are the initial baselines of the **license** and **security** components.

To see the change sets associated with the activities, click **Versions**.

Figure 33 Comparing Baselines by Activity

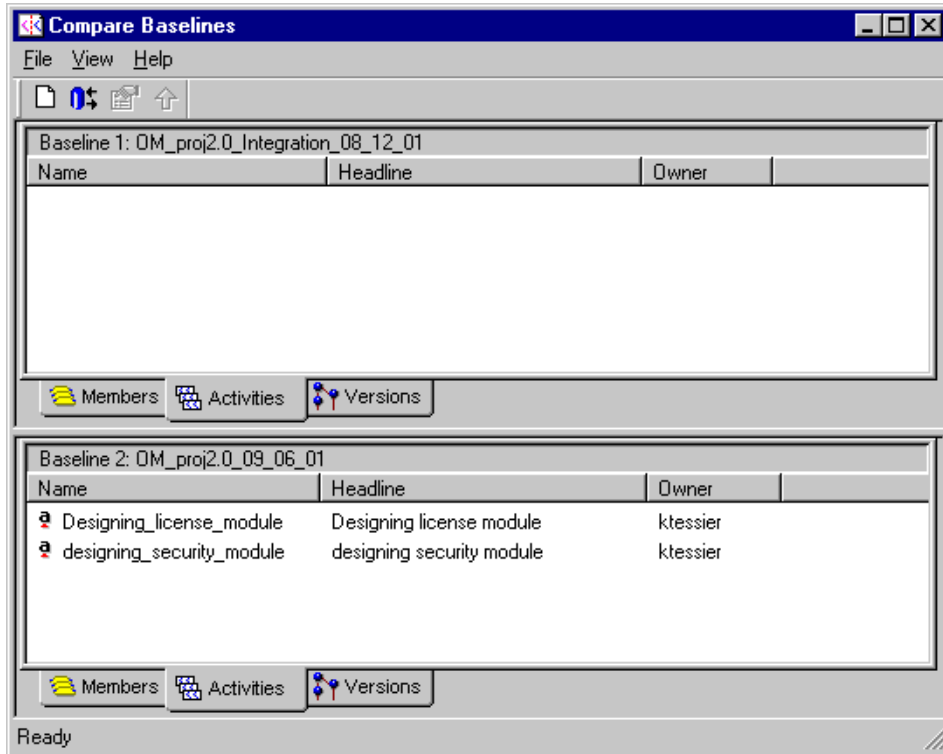

---

## Querying ClearQuest User Databases

If you use the UCM-ClearQuest integration, you can use ClearQuest queries to retrieve information about the state of your project. When you create or upgrade a ClearQuest user database to use a UCM-enabled schema, the integration installs six queries in two subfolders of the Public Queries folder in the user database's workspace. These queries make it easy for developers to see which activities are assigned to them and for project managers to see which activities are active in a particular project. Table 4 lists and describes the queries.

Table 4 Queries in UCM-Enabled Schema

Query	Description
ActiveForProject	For one or more specified projects, selects all activities in an active state type.
ActiveForStream	For one or more specified streams, selects all activities in an active state type.
ActiveForUser	For one or more specified developers, selects all assigned activities in an active state type.
MyToDoList	Selects all activities in an active or ready state type assigned to the developer running the query.
UCMProjects	Selects all projects linked to the ClearQuest user database.
UCMCustomQuery1	This query is not intended to be used directly by users; the integration uses it. When a developer checks out or checks in a file, or adds a file to source control and is prompted to select an activity, the integration calls this query to display the list of activities available in the stream associated with the developer's view.  You can customize this query on a per-developer basis by copying the query from the <b>Public Queries</b> folder to the developer's <b>Personal Queries</b> folder and using the Query editor.

You can also create your own queries by clicking **Query > New Query** within the ClearQuest client. In the **Choose a record type** dialog box that opens, select **All UCM Activities** if you want the query to search all UCM-enabled record types.

---

## 7.8 Cleaning Up the Project

When your team finishes work on a project and releases or deploys the new software, you should clean up the project environment before creating the next version of the project. Cleaning up involves removing any unused objects, and locking and hiding the project and its streams. This process reduces clutter and makes it easier to navigate in the Project Explorer.



---

## Removing Unused Objects

During the life of the project, you or a developer might create an object and then decide not to use it. Perhaps you decide to use a different naming convention, and you create a new object instead of renaming the existing one. To avoid confusion and reduce clutter, remove these unused objects.

To delete a project, stream, component, or activity, select the object in the Project Explorer, and click **File > Delete**. To delete a baseline, use the **cleartool rmbl** command.

### Projects

You can delete a project only if it does not contain any streams. When you create a project with the Project Creation Wizard, the wizard also creates an integration stream. Therefore, you can delete a project only if you created it with the **cleartool mkproject** command, or if you first delete the integration stream. For more information on removing projects, see the **rmproject** reference page in the *Command Reference*.

### Streams

You can delete a development stream or an integration stream only if all of the following conditions are true:

- The stream contains no activities.
- No baselines have been created in the stream.
- No views are attached to the stream.

In addition, you cannot delete an integration stream if the project contains any development streams. For more information on removing streams, see the **rmstream** reference page in the *Command Reference*.

### Components

You can delete a component only if all of the following conditions are true:

- No baselines of the component other than its initial baseline exist.
- The component's initial baseline does not serve as a *foundation baseline* for another stream.

For more information about removing components, see the **rmcomp** reference page in the *Command Reference*.

## Baselines

You can delete a baseline only if all of the following conditions are true:

- The baseline does not serve as a foundation baseline.
- The baseline is not a component's initial baseline.
- A stream has not made changes to the baseline.
- The baseline is not used as the basis for an incremental baseline.

For more information about removing baselines, see the **rmbl** reference page in the *Command Reference*.

## Activities

You can delete an activity only if both of the following conditions are true:

- The activity has no versions in its change set.
- No view is currently set to the activity.

For more information about removing activities, see the **rmactivity** reference page in the *Command Reference*.

---

## Locking and Making Obsolete the Project and Streams

To prevent a project or a stream from appearing in the Project Explorer, lock the object and use the obsolete option. The obsolete option hides the object.

1. In the Project Explorer, select the stream or project that you want to hide, and click **File > Properties** to display its property sheet.
2. Click the **Lock** tab, and select **Obsolete**. Click **OK**.

To see objects that you have made obsolete, click **View > Show Obsolete Items** in the Project Explorer.

## Using Triggers to Enforce Development Policies

# 8

UCM provides a group of development policies that you can easily set in a project by using the GUI or CLI. In addition, you can use triggers on certain UCM operations to enforce customized development policies for your project team. This chapter describes how to create triggers and shows how to use triggers to implement various development policies in UCM projects. For additional information, see the **cleartool mktrigger** and **mktrtype** reference pages.

---

### 8.1 Overview of Triggers

A *trigger* is a monitor that causes one or more procedures or actions to be executed whenever a certain ClearCase operation is performed. Typically, the trigger executes a Perl, batch, or shell script. You can use triggers to restrict operations to specific users and to specify the conditions under which they can perform those operations. You can use triggers with the following UCM operations:

- **chbl**
- **chfolder**
- **chproject**
- **chstream**
- **deliver**
- **mkactivity**
- **mkbl**
- **mkcomp**
- **mkfolder**
- **mkproject**

- **mkstream**
- **rebase**
- **rmb1**
- **rmcomp**
- **rmfolder**
- **rmproject**
- **rmstream**
- **setactivity**
- **setplevel**

---

## **Preoperation and Postoperation Triggers**

Triggers fall into one of two categories. Preoperation triggers *fire*, or execute their corresponding procedures, before an operation takes place. Postoperation triggers fire after an operation occurs. Use preoperation triggers to prevent users from performing operations unless certain conditions apply. Use postoperation triggers to perform actions after an operation completes. For example, you may want to place a postoperation trigger on the deliver operation to notify team members whenever a developer delivers work to the project's integration stream. Figure 34 illustrates the timing of preoperation and postoperation triggers.

Figure 34 Preoperation and Postoperation Triggers

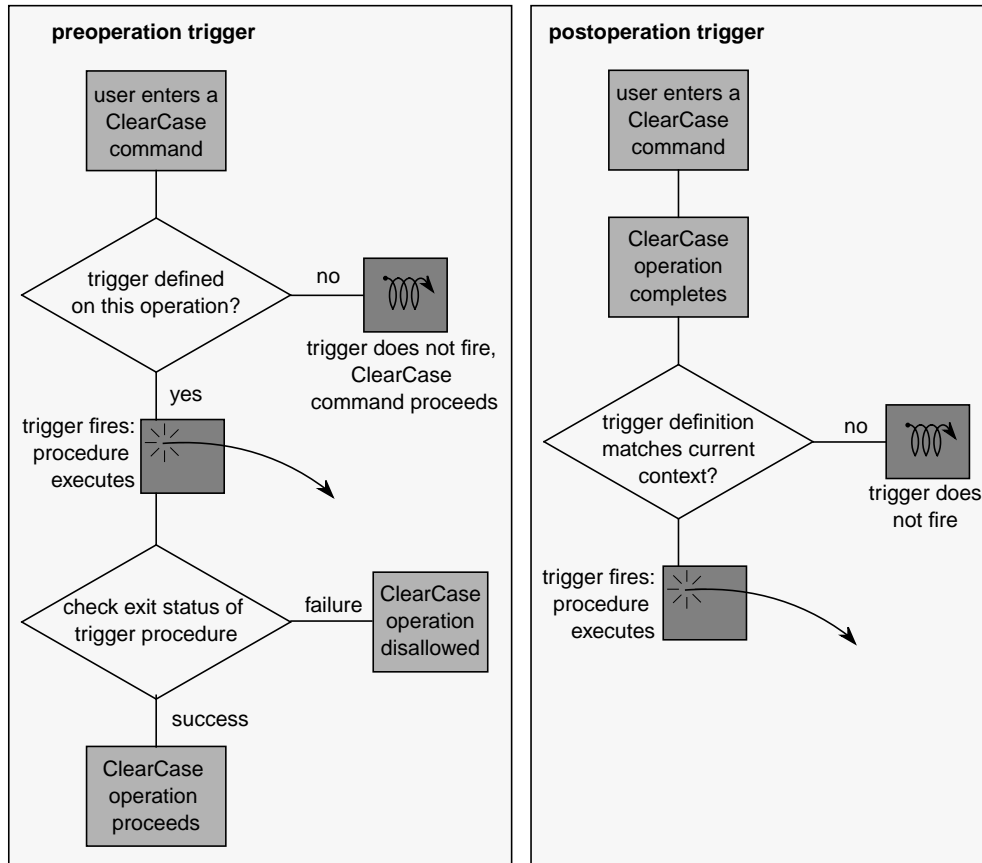

## Scope of Triggers

A *trigger type* defines a trigger for use within a VOB or PVOB. When you create a trigger type, with the **cleartool mktrtype** command, you specify the scope to be one of the following:

- An *element trigger type* applies to one or more elements. You attach an instance of the trigger type to one or more elements by using the **cleartool mktrigger** command.
- An *all-element trigger type* applies to all elements in a VOB.
- A *type trigger type* applies to type objects, such as attributes types, in a VOB.

- A *UCM trigger type* applies to a UCM object, such as a stream or a project, in a PVOB.
- An *all-UCM-object trigger type* applies to all UCM objects in a PVOB.

---

## Using Attributes with Triggers

As you design triggers to enforce development policies, you may find it useful to use attributes. An *attribute* is a name/value pair. An *attribute type* defines an attribute. You can apply an attribute to an object, such as a stream or an activity, or to a version of an element. In your trigger scripts, you can test the value of an attribute to determine whether to fire the trigger. For example, you could define an attribute type called **TESTED** and attach a **TESTED** attribute to elements to indicate whether they had been tested. Acceptable values would be **Yes** and **No**.

---

## When to Use ClearQuest Scripts Instead of UCM Triggers

This chapter presents several use cases for UCM triggers. If your UCM project is enabled to work with Rational ClearQuest, you can set the following policies, which are described in *UCM-ClearQuest Integration* on page 55:

- Check Before Work On
- Check Before ClearCase Delivery
- Do ClearQuest Action After Delivery
- Check Mastership Before Delivery

Each of these policies has a ClearQuest global hook script associated with it, which you can edit or replace in ClearQuest Designer to customize the policy for your environment. You can also write your own ClearQuest hooks to enforce development policies. In general, if the policy you want to enforce involves a ClearQuest action, use one of the ClearQuest policies listed above or use ClearQuest hooks. If the policy you want to enforce involves a ClearCase action, use UCM triggers.

---

## 8.2 Sharing Triggers Between UNIX and Windows

You can define triggers that fire correctly on both UNIX and Windows computers. The following sections describe two techniques. With one, you use different pathnames or different scripts; with the other, you use the same script for both platforms.

---

## Using Different Pathnames or Different Scripts

To define a trigger that fires on UNIX, Windows, or both, and that uses different pathnames to point to the trigger scripts, use the `-execunix` and `-execwin` options with the `mktrtype` command. These options behave the same as `-exec` when fired on the appropriate platform (UNIX or Windows, respectively). On the other platform, they do nothing. This technique allows a single trigger type to use different paths for the same script or to use completely different scripts on UNIX and Windows computers. For example:

```
cleartool mktrtype -element -all -nc -preop checkin \
-execunix /public/scripts/precheckin.sh -execwin \\neon\scripts\precheckin.bat
pre_ci_trig
```

NOTE: The command line example is broken across lines to make it easier to read. You must enter it all on one line.

On UNIX, only the script `precheckin.sh` runs. On Windows, only `precheckin.bat` runs.

To prevent users on a new platform from bypassing the trigger process, triggers that specify only `-execunix` always fail on Windows. Likewise, triggers that specify only `-execwin` fail on UNIX.

---

## Using the Same Script

To use the same trigger script on Windows and UNIX platforms, you must use a batch command interpreter that runs on both operating systems. For this purpose, Rational ClearCase includes the `ccperl` program, a version of Perl that you can use on Windows and UNIX.

The following `mktrtype` command creates sample trigger type `pre_ci_trig` and names `precheckin.pl` as the executable trigger script.

```
cleartool mktrtype -element -all -nc -preop checkin \
-execunix 'Perl /public/scripts/precheckin.pl' \
-execwin 'ccperl \\neon\scripts\precheckin.pl' \
pre_ci_trig
```

---

## Tips

- To tailor script execution for each operating system, use environment variables in Perl scripts.
- To collect or display information interactively, you can use the **clearprompt** command.

---

## 8.3 Enforce Serial Deliver Operations

Because UCM allows multiple developers to deliver work to the same integration stream concurrently, conflicts can occur if two or more developers attempt to deliver changes to the same element. If one developer's deliver operation has an element checked out, the second developer cannot deliver changes to that element until the first deliver operation is completed or canceled. The second deliver operation attempts to check out all elements other than the checked-out one, but it does not proceed to the merge phase of the operation. The second developer must either wait for the first deliver operation to finish or undo the second deliver operation.

You may want to implement a development policy that eliminates the confusion that concurrent deliveries can cause developers. This section shows three Perl scripts that prevent multiple developers from delivering work to the same integration stream concurrently:

- Script 1 creates the trigger types and an attribute type.
- Script 2 is the preoperation trigger action that fires at the start of a deliver operation.
- Script 3 is the postoperation trigger action that fires at the end of a deliver operation.

---

## Setup Script

This setup script creates a preoperation trigger type, a postoperation trigger type, and an attribute type. The preoperation trigger action fires when a deliver operation starts, as represented by the **deliver\_start** operation kind (*opkind*). The postoperation trigger action fires when a deliver operation is canceled or completed, as represented by the **deliver\_cancel** and **deliver\_complete** opkinds, respectively.

The script runs on both UNIX and Windows platforms. Because the command-line syntax to run the preoperation and postoperation scripts on Windows differs slightly depending on whether



the PVOB resides on Windows or UNIX, the setup script uses an **IF ELSE** Boolean expression to set the appropriate **execwin** command.

The **mktrtype** command uses the **-ucmobject** and **-all** options to specify that the trigger type applies to all UCM objects in the PVOB, but the **-stream** option restricts the scope to one integration stream.

The **mkatype** command creates an attribute type called **deliver\_in\_progress**, which the preoperation and postoperation scripts use to indicate whether a developer is delivering work to the integration stream.

```
# perl script to set up triggers for enforcing serial delivery.
use Config;

# define platform-dependent arguments.
my $PVOBTAG;
my $PREOPCMDW;
my $POSTOPCMDW;
if ($Config{'osname'} eq 'MSWin32') {
    $PVOBTAG = '\cyclone_pvob';
    $PREOPCMDW = '-execwin "ccperl
\\\\pluto\disk1\ucmtrig_examples\ex1\ex1_preop.pl"';
    $POSTOPCMDW = '-execwin "ccperl
\\\\pluto\disk1\ucmtrig_examples\ex1\ex1_postop.pl"';
}
else {
    $PVOBTAG = '/pvobs/cyclone_pvob';
    $PREOPCMDW = '-execwin "ccperl
\\\\\\\\pluto\disk1\ucmtrig_examples\ex1\ex1_preop.pl"';
    $POSTOPCMDW = '-execwin "ccperl
\\\\\\\\pluto\disk1\ucmtrig_examples\ex1\ex1_postop.pl"';
}

my $PREOPCMDU = '-execunix "Perl
/net/pluto/disk1\ucmtrig_examples/ex1/ex1_preop.pl"';
my $POSTOPCMDU = '-execunix "Perl
/net/pluto/disk1\ucmtrig_examples/ex1/ex1_postop.pl"';
my $STREAM = "stream:Pl_int\@$PVOBTAG";
my $PREOPTRTYPE = "trtype:ex1_preop\@$PVOBTAG";
my $POSTOPTRTYPE = "trtype:ex1_postop\@$PVOBTAG";
my $ATYPE = "atype:deliver_in_progress\@$PVOBTAG";
```

```

# set up the trigger types and attribute type.
print `cleartool mktrtype -ucmobject -all -preop deliver_start $PREOPCMDU
$PREOPCMDW -stream $STREAM -nc $PREOPTRTYPE`;
print `cleartool mktrtype -ucmobject -all -postop deliver_complete,
deliver_cancel $POSTOPCMDU $POSTOPCMDW -stream $STREAM -nc $POSTOPTRTYPE`;
print `cleartool mkatttype -vtype integer -default 1 -nc $ATTTYPE`;

```

---

## Preoperation Trigger Script

This preoperation trigger action fires when a developer begins to deliver work to the specified integration stream. The script attempts to attach an attribute of type **deliver\_in\_progress** to the integration stream. If another developer is in the process of delivering work to the same stream, the **mkattr** command fails and the script displays a message suggesting that the developer try again later. Otherwise, the **mkattr** command succeeds and prevents other developers from delivering to the integration stream until the current deliver operation finishes.

```

# perl script that fires on deliver_start preop trigger.
use Config;

# define platform-dependent arguments.
my $PVOBTAG;
if ($Config{'osname'} eq 'MSWin32') {
    $PVOBTAG = '\cyclone_pvob';
}
else{
    $PVOBTAG = '/pvobs/cyclone_pvob';
}
my $STREAM = $ENV{"CLEARCASE_STREAM"};
my $ATTTYPE = "atttype:deliver_in_progress@$PVOBTAG";

# try to create the attribute, capture the output.
$msg = `cleartool mkattr -default $ATTTYPE $STREAM 2>&1`;

# if the attribute already existed, a deliver is in progress, disallow this
delivery.
if (index($msg, "Error: Object already has an attribute") >= 0) {
    print "****\n";
    print "**** A deliver operation is already in progress. Please try again
later.\n";
    print "****\n";
    exit 1;
}

```

```
# the attribute was created, deliveries will be disallowed until postop fires.
exit 0
```

---

## Postoperation Trigger Script

This postoperation trigger action fires when a developer cancels or completes a deliver operation to the specified integration stream. This script removes the **deliver\_in\_progress** attribute that the preoperation script attaches to the integration stream at the start of the deliver operation. After the attribute is removed, another developer can deliver work to the integration stream.

```
# perl script that fires on deliver_complete or deliver_cancel postop trigger.
use Config;

# define platform-dependent arguments.
my $PVOBTAG;
if ($Config{'osname'} eq 'MSWin32') {
    $PVOBTAG = '\cyclone_pvob';
}
else{
    $PVOBTAG = '/pvobs/cyclone_pvob';
}
my $STREAM = $ENV{"CLEARCASE_STREAM"};
my $ATYPE = "atype:deliver_in_progress\@$PVOBTAG";

# remove the attribute to allow deliveries.
print `cleartool rmattr -nc $ATYPE $STREAM`;
exit 0;
```

---

## 8.4 Send Mail to Developers on Deliver Operations

To improve communication among developers on your project team, you may want to create a trigger type that sends an e-mail message to team members whenever a developer completes a deliver operation. This section includes two scripts:

- Script 1 creates a trigger type that fires at the end of a successful deliver operation.
- Script 2 is the postoperation trigger action that sends e-mail messages to developers.

---

## Setup Script

This script creates a postoperation trigger type that fires when a developer finishes a deliver operation, as represented by the **deliver\_complete** opkind. The **mktrtype** command uses the **-stream** option to indicate that the trigger type applies only to deliver operations that target the specified integration stream.

```
# This is a Perl script to set up the triggertype
# for e-mail notification on deliver.
use Config;

# define platform-dependent arguments.
my $PVOBTAG;
if ($Config{'osname'} eq 'MSWin32') {
    $PVOBTAG = '\cyclone_pvob';
    $WCMD    = '-execwin "ccperl
\\\\pluto\disk1\ucmtrig_examples\ex2\ex2_postop.pl"';
}
else {
    $PVOBTAG = '/pvobs/cyclone_pvob';
    $WCMD    = '-execwin "ccperl
\\\\\\\\pluto\disk1\ucmtrig_examples\ex2\ex2_postop.pl"';
}
my $STREAM = "stream:P1_int\@$PVOBTAG";
my $TRTYPE = "trtype:ex2_postop\@$PVOBTAG";
my $UCMD   = '-execunix "Perl
/net/pluto/disk1\ucmtrig_examples/ex2/ex2_postop.pl"';

print 'cleartool mktrtype -ucmobject -all -postop deliver_complete $WCMD $UCMD
-stream $STREAM -nc $TRTYPE`';
```

---

## Postoperation Trigger Script

This postoperation trigger action fires when a developer finishes delivering work to the integration stream. The script composes and sends an e-mail message to other developers on the project team telling them that a deliver operation has just finished. The script uses ClearCase environment variables to provide the following details about the deliver operation in the body of the message:

- Project name
- Development stream that delivered work
- Integration stream that received delivered work

- Integration activity created by the deliver operation
- Activities delivered
- Integration view used by deliver operation

```
# Perl script to send mail on deliver complete.

#####
# Simple package to override the "open" method of Mail::Send so we
# can control the mailing mechanism.

package SendMail;

use Config;
use Mail::Send;

@ISA = qw(Mail::Send);

sub open {
    my $me = shift;
    my $show; # How to send mail
    my $notused;
    my $mailhost;

    # On Windows use SMTP

    if ($Config{'osname'} eq 'MSWin32') {
        $show = 'smtp';
        $mailhost = "localmail0.company.com";
    }

    # else use defaults supplied by Mail::Mailer

    Mail::Mailer->new($show, $notused, $mailhost)->open($me);
}

#
#####
# Main program

my @to = "developers\@company.com";
my $subject = "Delivery complete";
```

```

my $body = join '', ("\n",
    "UCM Project: ", $ENV{CLEARCASE_PROJECT}, "\n",
    "UCM source stream: ", $ENV{CLEARCASE_SRC_STREAM}, "\n",
    "UCM destination stream: ", $ENV{CLEARCASE_STREAM}, "\n",
    "UCM integration activity: ", $ENV{CLEARCASE_ACTIVITY}, "\n",
    "UCM activities delivered: ", $ENV{CLEARCASE_DLVR_ACTS}, "\n",
    "UCM view: ", $ENV{CLEARCASE_VIEW_TAG}, "\n"
);

my $msg = new SendMail(Subject=>$subject);

$msg->to(@to);
my $fh = $msg->open($me);
$fh->print($body);
$fh->close();
1; # return success
#
#####

```

---

## 8.5 Do Not Allow Activities to Be Created on the Integration Stream

Anyone who has an integration view attached to the integration stream can create activities on that stream, but the UCM process calls for developers to create activities in their development streams. You may want to implement a policy that prevents developers from creating activities on the integration stream inadvertently. This section shows a Perl script that enforces that policy.

The following **mktrtype** command creates a preoperation trigger type called **block\_integration\_mkact**. The trigger type fires when a developer attempts to make an activity.

```

cleartool mktrtype -ucmobject -all -preop mkactivity -execwin "ccperl ^
\\pluto\disk1\triggers\block_integ_mkact.pl" -execunix "Perl ^
/net/jupiter/triggers/block_integ_mkact.pl" block_integration_mkact@\my_pvob

```

The following preoperation trigger script runs when the **block\_integration\_mkact** trigger fires. The script uses the **cleartool lsproject** command and the **CLEARCASE\_PROJECT** environment variable to determine the name of the project's integration stream. ClearCase creates an integration activity to keep track of changes that occur during a deliver operation. The script uses the **CLEARCASE\_POP\_KIND** environment variable to determine whether the activity being created is an integration activity. If the **mkactivity** operation is the result of a deliver operation, the value of **CLEARCASE\_POP\_KIND**, which identifies the parent operation, is **deliver\_start**.

If the value of `CLEARCASE_POP_KIND` is not `deliver_start`, the activity is not an integration activity, and the script disallows the `mkactivity` operation.

```
# Get the integration stream name for this project
my $istream = `cleartool lsproject -fmt "%[istream]p"
$ENV{"CLEARCASE_PROJECT"}`;

# Get the current stream and strip off VOB tag
$_ = $ENV{"CLEARCASE_STREAM"};
s/\@.*//;
my $curstream = $_;

# If it's the same as our stream, then it is the integration stream
if ($istream eq $curstream) {
    # Only allow this mkact if it is a result of a deliver
    # Determine this by checking the parent op kind
    if ($ENV{"CLEARCASE_POP_KIND"} ne "deliver_start") {
        print "Activity creation is only permitted in integration streams for
        delivery.\n";
        exit 1
    }
}

exit 0
```

---

## 8.6 Implementing a Role-Based Access Control System

In a ClearCase environment, where users perform different roles, you may want to restrict access to certain ClearCase operations based on role. This section shows a trigger definition and script that implement a role-based access control system.

The following `mktrtype` command creates a preoperation trigger type called `role_restrictions`. The trigger type fires when a user attempts to make a baseline, stream, or activity.

```
cleartool mktrtype -nc -ucmobject -all -preop mkstream,mkbl,mkactivity \
-execunix "perl /net/jupiter/triggers/role_restrictions.pl" \
-execwin "ccperl \\pluto\disk1\triggers\role_restrictions.pl" \
role_restrictions@\my_pvob
```

---

## Preoperation Trigger Script

The following preoperation trigger script maps users to the following roles:

- Project manager
- Integrator
- Developer

The script maps the **mkactivity**, **mkbl**, and **mkstream** operations to the roles that are permitted to perform them. For example, only users designated as project managers or integrators can make a baseline.

The script uses the `CLEARCASE_USER` environment variable to retrieve the user's name, the `CLEARCASE_OP_KIND` environment variable to identify the operation the user attempts to perform, and the `CLEARCASE_POP_KIND` environment variable to identify the parent operation. If the parent operation is **deliver** or **rebase**, the script does not check permissions.

```
use strict;

sub has_permission
{
    my ($user,$op,$pop,$proj) = @_;

    #When performing a composite operation like 'deliver' or 'rebase',
    #we don't need to check permissions on the individual sub-operations
    #that make up the composite.

    return 1 if($pop eq 'deliver_start' || $pop eq 'rebase_start' ||
        ($pop eq 'deliver_complete' || $pop eq 'rebase_complete' ||
        ($pop eq 'deliver_cancel' || $pop eq 'rebase_cancel'));

    # Which roles can perform what operations?
    # Note that these maps could be stored in a ClearCase attribute
    # on each project instead of hard-coded here in the trigger script
    # to give true per-project control.

    my %map_op_to_roles = (
        mkactivity => [ "projectmgr", "integrator", "developer" ],
        mkbl       => [ "projectmgr", "integrator" ],
        mkstream   => [ "projectmgr", "integrator", "developer" ],
    );

    # Which users belong to what roles?
```



```

my %map_role_to_users = (
    projectmgr => [ "kate" ],
    integrator => [ "kate", "mike" ],
    developer  => [ "kate", "mike", "jones" ],
);

# Does user belong to any of the roles that can perform this operation?

my ($role,$tmp_user);

for $role (@{ $map_op_to_roles{$op} }) {
    for $tmp_user (@{ $map_role_to_users{$role} }) {
        if ($tmp_user eq $user) {
            return 1;
        }
    }
}

return 0;
}

sub Main
{
    my $user = $ENV{CLEARCASE_USER};
    my $proj = $ENV{CLEARCASE_PROJECT};
    my $op   = $ENV{CLEARCASE_OP_KIND};
    my $pop  = $ENV{CLEARCASE_POP_KIND};

    my $perm = has_permission($user, $op, $proj);

    printf("$user %s permission to perform '$op' in project $proj\n",
        $perm ? "has" : "does NOT have");

    exit($perm ? 0 : 1);
}

Main();

```

---

## 8.7 Additional Uses for UCM Triggers

The examples shown in the previous sections represent just a few ways that you may use UCM triggers to enforce development policies. Other uses for UCM triggers include the following:

- ▶ Creating an integration between UCM and a change request management (CRM) system. Although we expect that most customers will use the out-of-the-box integration with ClearQuest, you may want to integrate with another CRM system. To accomplish this, you could do the following:
  - Create a trigger type on **mkactivity** that creates a corresponding record in the CRM database when a developer makes a new activity.
  - Create a trigger type on **setactivity** that transitions the record in the CRM database to a scheduled state when a developer starts working on an activity.
  - Create a trigger type on **deliver** that transitions the record in the CRM database to a completed state when a developer finishes delivering the activity to the integration stream.
- ▶ Creating a trigger type on **rebase** that prevents developers from rebasing certain development streams. You may want to enforce this policy on a development stream that is being used to fix one particular bug.
- ▶ Creating a trigger type on **setactivity** that allows specific developers to work on specific activities.

## Managing Parallel Releases of Multiple Projects

# 9

The previous chapters describe how to manage a single project. However, you may need to manage multiple releases of a project simultaneously. To do so, you need to merge changes from one project to another. This chapter describes how to accomplish that merging in two common scenarios:

- Managing a current project and a follow-on project simultaneously
- Incorporating a patch release into a new release of the project

This chapter also describes how to use base ClearCase tools to merge work from a UCM project to a base ClearCase project.

---

### 9.1 Managing a Current Project and a Follow-On Project Simultaneously

Given the tight software development schedules that most organizations operate within, it is common practice to begin development of the next release of a project before work on the current release is completed. The next release may add new features, or it may involve porting the current release to a different platform.

## Example

Figure 35 illustrates the flow of a current project, Webotrans 4.0, and a follow-on project, Webotrans 4.1.

Figure 35 Managing a Follow-on Release

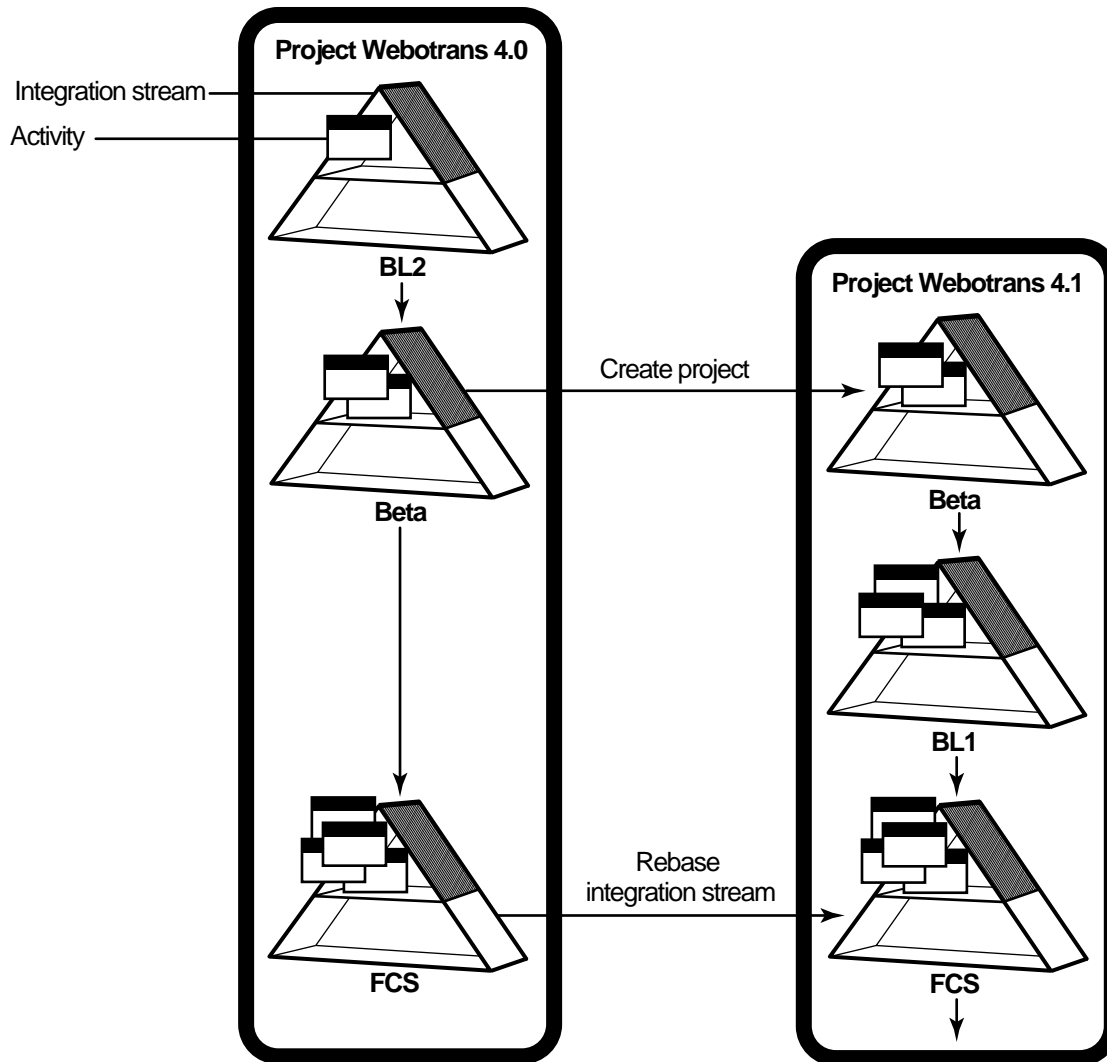

In this example:

- The project manager for the follow-on project created the Webotrans 4.1 project based on the Beta baselines of the components used in the Webotrans 4.0 project. Developers on both project teams then continued to make changes, and the 4.0 and 4.1 integrators continued to create new baselines that incorporate those changes.
- When the 4.0 team completed its work, the integrator created the final baselines, named FCS. The 4.1 project manager then rebased the 4.1 integration stream to the FCS baselines.

---

## Performing Interproject Rebase Operations

To rebase an integration stream to a set of baselines in another project's integration stream, perform the following steps:

1. In ClearCase Project Explorer, select the integration stream that you want to rebase.
2. Click **Tools > Rebase Stream**.
3. In the **Rebase Stream Preview** dialog box, click **Advanced**.
4. In the **Change Rebase Configuration** dialog box, select a component that contains the baseline you want to use to rebase your stream. Click **Change**.
5. In the **Change Baseline** dialog box, click the arrow at the end of the **From Stream** field.
6. Select the integration stream of the other project. This updates the **Change Baseline** dialog box with the set of baselines available in the other project's integration stream.
7. In the **Change Baseline** dialog box, select the component. The **Baselines** list displays all baselines available for the selected component in the other project's integration stream. Select the baseline to which you want to rebase your integration stream. Click **OK**. The baseline that you selected now appears in the **Change Rebase Configuration** dialog box.
8. Repeat steps Step #4 through Step #7 until you finish selecting the set of baselines to which you want to rebase your integration stream.
9. Click **OK** to close the **Change Rebase Configuration** dialog box. Click **OK** in the **Rebase Stream Preview** dialog box.
10. ClearCase merges all nonconflicting changes automatically. If ClearCase encounters conflicting changes, it prompts you to start Diff Merge, a tool with which you resolve

conflicting changes. For details on using Diff Merge, see the Diff Merge online help and *Developing Software*.

Note that you can rebase your project's integration stream only if the baseline to which you are rebasing is a successor of your integration stream's current *foundation baseline*. In the above example, the FCS baseline is a successor to the Beta baseline, which is the current foundation baseline for the Webotrans 4.1 integration stream.

---

## 9.2 Incorporating a Patch Release into a New Version of the Project

Another common parallel development scenario involves working on a patch release and a new release of a project at the same time. This section describes this scenario.

---

### Example

Figure 36 illustrates the flow of a patch release and a new release. In this example:

- Both the Webotrans 3.0 Patch and Webotrans 4.0 projects use the FCS baselines of the components in the Webotrans 3.0 project as their *foundation baselines*. The purpose of the patch release is to fix a problem detected after Webotrans 3.0 was released. Webotrans 4.0 represents the next major release of the Webotrans product.
- Development continues in both the 3.0 Patch and 4.0 projects, with the integrators creating baselines periodically.
- The developers working on the 3.0 Patch project finish their work, and the integrator incorporates the final changes in the BL2 baseline. The integrator then needs to deliver those changes from the 3.0 Patch integration stream to the 4.0 integration stream so that the 4.0 project contains the fix.

Figure 36 Incorporating a Patch Release

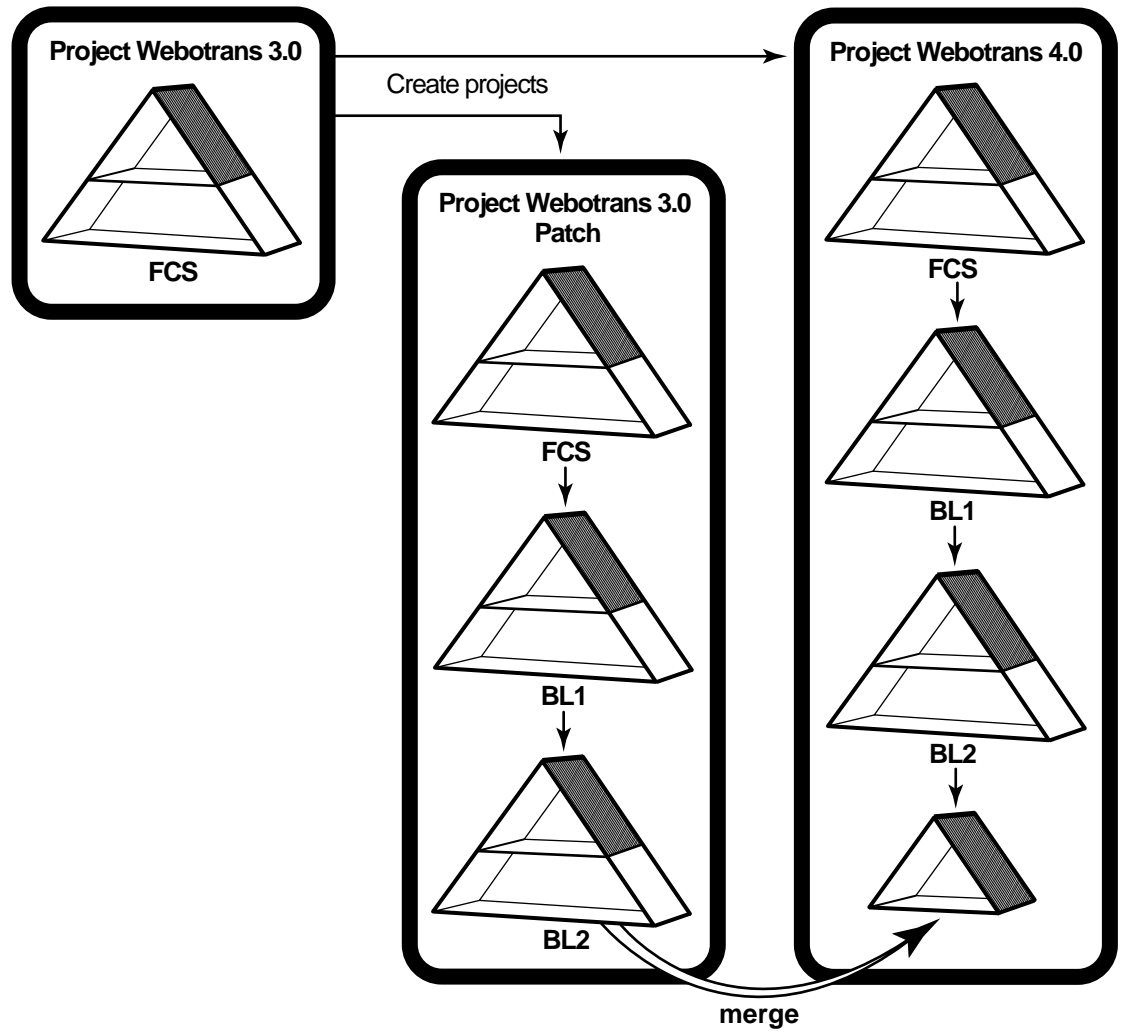

---

## Delivering Work to Another Project

To deliver work from an integration stream in one project to an integration stream in another project, perform the following steps:

1. In the source stream, make one or more baselines that incorporate the changes you want to deliver. When you deliver work from an integration stream, you must deliver baselines.
2. Check the deliver policy settings for the target integration stream to confirm that it allows deliveries from other projects. In the Project Explorer, select the target integration stream, and click **File > Policies**. If the **Allow interproject deliver to project or stream** policy is not enabled, ask the project manager to change the setting to **enabled**.
3. In the Project Explorer, select the source integration stream, and click **Tools > Deliver Baselines To Default** or **Deliver To Alternate Target**. To determine the default deliver target for the integration stream, select the stream and click **File > Properties**. The **Deliver to** box on the **General** tab identifies the default deliver target. You can change the default deliver target by clicking **Change**. The **Deliver To Alternate Target** option opens the **Deliver from Stream (alternate target)** dialog box, which lets you select the target stream.
4. In the **Deliver from Stream Preview** dialog box, use **Add**, **Change**, and **Remove** to select the baselines that you want to deliver. Make sure that the **View** box identifies a view that is attached to the target integration stream. If necessary, click **Change** to select a different view. Click **OK** to start the merge part of the deliver operation.
5. Rational ClearCase merges all nonconflicting changes automatically. If it encounters conflicting changes, it prompts you to start Diff Merge, a tool with which you resolve conflicting changes. For details on using Diff Merge, see the Diff Merge online help and *Developing Software*.
6. When you finish merging files, click **Complete** to check in the changes.

---

### 9.3 Using a Mainline Project

If you anticipate that your team will develop and release numerous versions of your system, you may want to create a mainline project. A mainline project serves as a single point of integration for related projects over a period of time. It is not specific to any single release.

For example, assume the Webotrans team plans to develop and release new versions of their product every six months. For each new version, the project manager could create a project



whose foundation baselines are the final recommended baselines in the prior project's integration stream. For example, the foundation baselines of Webotrans 2.0 are the final recommended baselines in Webotrans 1.0's integration stream; the foundation baselines for Webotrans 3.0 are the final recommended baselines in Webotrans 2.0's integration stream, and so on. This approach is referred to as a cascading projects design. The disadvantage to this approach is that you must look at all integration streams to see the entire history of the Webotrans projects.

In the mainline project approach, the Webotrans project manager creates a mainline project with an initial set of baselines, and then creates Webotrans 1.0 based on those initial baselines. When developers finish working on Webotrans 1.0, the project manager delivers the final recommended baselines to the mainline project's integration stream. These baselines in the mainline project's integration stream serve as the foundation baselines for the Webotrans 2.0 project. When the Webotrans 2.0 team finishes its work, the project manager delivers the final recommended baselines to the mainline project's integration stream, and so on. The advantage to this approach is that each project's final recommended baselines are available in the mainline project's integration stream.

---

## 9.4 Merging from a Project to a Non-UCM Branch

You may be in a situation in which part of the development team works in a project, and the rest of the team works in base ClearCase. If you are a longtime ClearCase user, you may decide to use UCM initially on a small part of your system. This approach would allow you to migrate from base ClearCase to UCM gradually, rather than all at once.

In this case, you need to merge work periodically from the project's integration stream to the branch that serves as the integration branch for the system. To do so, use a script similar to the one shown here, which uses base ClearCase functionality to merge changes.

```
# Sample Perl script for delivering contents of one UCM project to
# a nonUCM project. Run this script while set to a view that sees the
# destination branch.
#
# Usage: Perl <this-script> <project-name> <project-vob>

use strict;

my $mergeopts = '-print';
my $project = shift @ARGV;
my $pvob = shift @ARGV;
my $bl;
```

```

chdir ($pvob) or die("can't cd to project VOB '$pvob'");

print("##### Getting recommended baselines for project '$project'\n");

my @recbls = split(' ', `cleartool lsproject -fmt "[%rec_bls]p" $project`);

foreach $bl (@recbls) {

    my $comp = `cleartool lsbl -fmt "[%component]p" $bl`;
    my $vob = `cleartool lscomp -fmt "[%root_dir]p" $comp`;

    print("##### Merging changes from baseline '$bl' of $vob\n");

    my $st = system("cleartool findmerge $vob -fver $bl $mergeopts");
    $st == 0 or die("findmerge error");
}

exit 0;

```

The script finds the recommended baselines for the integration stream from which you are merging. It then uses the **cleartool findmerge** command to find differences between the versions represented by those recommended baselines and the latest versions in the target branch. For details, see the **findmerge** reference page.

We recommend that you add error handling and other logic appropriate for your site to this script before using it.

## **Part 2: Working in Base ClearCase**



## Managing Projects in Base ClearCase

# 10

As a project manager, you are responsible for planning, staffing, and managing the technical aspects of a software development project. You decide what will be worked on, assign work to the project's team members, establish the work schedule, and perhaps the policies and procedures for doing the work.

When development is underway, you monitor progress and generate project status reports. You may also approve the specific work items included in a build and subsequently a baseline.

You may also be the project integrator, responsible for incorporating work that each developer completes into a deliverable and buildable system. You create the project's baselines and establish the quality level of those baselines.

Base ClearCase offers many features to make this work easier. Before development begins, you need to complete several planning and setup tasks:

- Setting up the project environment
- Implementing development policies
- Defining and implementing an integration policy

This chapter introduces these topics. The remaining chapters cover the implementation details. Chapter 16, *Using ClearCase Throughout the Development Cycle*, follows a project throughout the development cycle to show how you can use Rational ClearCase.

Before reading this part of the manual, read *Developing Software* to become familiar with the concepts of VOBs, views, and config specs.

---

## 10.1 Setting Up the Project

This section describes the planning and setup work you need to do before development begins.

---

### Creating and Populating VOBs

If your project is migrating to ClearCase from another version control product or is adopting a configuration and change management plan for the first time, you must populate the VOBs for your project with an initial collection of data (file and directory elements). If your site has a dedicated ClearCase administrator, he or she may be responsible for creating and maintaining VOBs, but not for importing data into them.

The *Administrator's Guide* for Rational ClearCase and the *Administrator's Guide* for Rational ClearCase LT include detailed information on these topics.

---

### Planning a Branching Strategy

ClearCase uses branches to enable parallel development. A *branch* is an object that specifies a linear sequence of versions of an element. Every element has one *main branch*, which represents the principal line of development, and may have multiple subbranches, each of which represents a separate line of development. For example, a project team can use two branches concurrently: the **main** branch for new development work and a subbranch to fix a bug. The aggregated **main** branches of all elements constitutes the **main** branch of a code base.

Subbranches can have subbranches. For example, a project team designates a subbranch for porting a product to a different platform; the team then decides to create a bug-fixing subbranch off that porting subbranch. ClearCase allows you to create complex branch hierarchies. Figure 1 on page 2 illustrates a multilevel branching hierarchy. As a project manager in such an environment, you need to ensure that developers are working on the correct branches. To do that, you must tell them which rules to include in their *config specs* so that their views access the appropriate set of versions.

Chapter 11, *Defining Project Views*, describes config specs and branches in detail. Before you read it, a little background on branching strategies may be helpful.

Branching policy is influenced by the development objectives of the project and provides a mechanism to control the evolution of the code base. There are as many variations of branching

policy as organizations that use ClearCase. But there are also similarities that reflect common adherence to best practices. Some of the more common branch types and uses are presented here.

Task branches are short-lived, typically involve a small percentage of files, and are merged into their parent branch after the task is completed. Task branches promote accountability by leaving a permanent audit trail that associates a set of changes with a particular task; they also make it easy to identify the task artifacts, such as views and derived objects, that can be removed when they are no longer needed. If individual tasks don't require changes to the same files, it is easy to merge a task branch to its parent.

Private development branches are useful when a group of developers need to make a more comprehensive set of changes on a common code base. By branching as much of the **main** branch as needed, developers can work in isolation as long as necessary. Merging back to the **main** branch can be simplified if, before merging, each developer merges the **main** branch to the private branch to resolve any differences there before checking in the changed files.

Integration branches provide a buffer between private development branches and the **main** branch and can be useful if you delegate the integration task to one person, rather than making developers responsible for integrating their own work.

### **Branch Names**

It's a good idea to establish naming conventions that indicate the work the branch contains. For example, **rel2.1\_main** is the branch on which all code for Release 2.1 ultimately resides, **rel2.1\_feature\_abc** contains changes specific to the ABC feature, and **rel2.1\_b12** is the second stable baseline of Release 2.1 code. (If necessary, branch names can be much longer and more descriptive, but long branch names can crowd a version tree display.)

**NOTE:** Make sure that you do not create a branch type with the same name as a label type. This can cause problems when config specs use labels in version selectors. For example, make all branch names lowercase, and make all label names uppercase.

### **Branches and ClearCase MultiSite**

**PRODUCT NOTE:** Rational ClearCase LT does not support ClearCase MultiSite.

Branches are particularly important when your team works in VOBs that have been replicated to other sites with the ClearCase MultiSite product. Developers at different sites work on different branches of an element. This scheme prevents collisions—for example, developers at two sites creating version **/main/17** of the same element. In some cases, versions of files cannot or should not be merged, and developers at different sites must share branches. For more information, see *Certain Branches Are Shared Among MultiSite Sites* on page 180.

---

## Creating Shared Views and Standard Config Specs

As a project manager, you want to control the config specs that determine how branches are created when developers check out files. There are several ways to handle this task:

- Create a config spec template that each developer must use. Developers can either paste the template into their individual config specs or use the ClearCase include file facility to get the config spec from a common source.
- Create a view that developers will share. This is usually a good way to provide an integration view for developers to use when they check in work that has evolved in isolation on a private branch.

**NOTE:** Working in a single shared view is not recommended because doing so can degrade system performance.

- To ensure that all team members configure their views the same way, you can create files that contain standard config specs. For example:
  - > `/public/config_specs/ABC` contains the ABC team's config spec
  - > `/public/config_specs/XYZ` contains the XYZ team's config spec

Store these config spec files in a standard directory outside a VOB, to ensure that all developers get the same version.

---

## Recommendations for View Names

You may want to establish naming conventions for views for the same reason that you do for branches: it is easier to associate a view with the task it is used for. For example, you can require all view names (called view-tags) to include the owner's name and the task (`bill_V4.0_bugfix`) or the name of the computer hosting the view (`platinum_V4.0_int`).

---

## 10.2 Implementing Development Policies

To enforce development policies, you can create ClearCase *metadata* to preserve information about the status of versions. To monitor the progress of the project, you can generate a variety of reports from this data and from the information captured in event records.



---

## Using Labels

A label is a user-defined name that can be attached to a version. Labels are a powerful tool for project managers and system integrators. By applying labels to groups of elements, you can define and preserve the relationship of a set of file and directory versions to each other at a given point in the development lifecycle. For example, you can apply labels to these versions:

- All versions considered stable after integration and testing. Use this baseline label as the foundation for new work.
- All versions that are partially stable or contain some usable subset of functionality. Use this checkpoint label for intermediate testing or as a point to which development can be rolled back in the event that subsequent changes result in regressions or instability.
- All versions that contain changes to implement a particular feature or that are part of a patch release.

---

## Using Attributes, Hyperlinks, Triggers, and Locks

Attributes are name/value pairs that allow you to capture information about the state of a version from various perspectives. For example, you can attach an attribute named **CommentDensity** to each version of a source file, to indicate how well the code is commented. Each such attribute can have the value **unacceptable**, **low**, **medium**, or **high**.

Hyperlinks allow you identify and preserve relationships between elements in one or more VOBs. This capability can be used to address process-control needs, such as requirements tracing, by allowing you to link a source file to a requirements document.

Triggers allow you to control the behavior of **cleartool** commands and ClearCase operations by arranging for a specific program or executable script to run before or after the command executes. Virtually any operation that modifies an element can fire a trigger. Special environment variables make the relevant information available to the script or program that implements the procedure.

Preoperation triggers fire before the designated ClearCase command is executed. A preoperation trigger on **checkin** can prompt the developer to add an appropriate comment. Postoperation triggers fire after a command has exited and can take advantage of the command's exit status. For example, a postoperation trigger on the **checkin** command can send an e-mail message to the QA department, indicating that a particular developer modified a particular element.

Triggers can also automate a variety of process management functions. For example:

- Applying attributes or attaching labels to objects when they are modified
- Logging information that is not included in the ClearCase event records
- Initiating a build and/or source code analysis whenever particular objects are modified

For more information on these mechanisms, see Chapter 12, *Implementing Project Development Policies*.

A lock on an element or directory prevents all developers (except those included on an exception list) from modifying it. Locks are useful for implementing temporary restrictions. For example, during an integration period, a lock on a single object—the **main** branch type—prevents all users who are not on the integration team from making any changes.

The effect of a lock can be small or large. A lock can prevent any new development on a particular branch of a particular element; another lock can apply to the entire VOB, preventing developers from creating any new element of type **compressed\_file** or using the version label **RLS\_1.3**.

Locks can also be used to retire names, views, and VOBs that are no longer used. For this purpose, the locked objects can be tagged as *obsolete*, effectively making them invisible to most commands.

---

## Global Types

The ClearCase global type facility makes it easy for you to ensure that the branch, label, attribute, hyperlink, and element types they need are present in all VOBs your project uses. The *Administrator's Guide for Rational ClearCase* and the *Administrator's Guide for Rational ClearCase LT* have more information about creating and using global types.

---

## Generating Reports

ClearCase creates and stores an event record each time an element is modified or merged. Many ClearCase commands include selection and filtering options that you can use to create reports based on these records. The scope of such reports can cover a single element, for a set of objects, or for entire VOBs.

Chapter 12, *Implementing Project Development Policies*, provides more detail on using event records and metadata to implement project policies. Event records and other metadata can also be useful if you need to generate reports on activities managed by ClearCase (for example, the complete history of changes to an element). ClearCase provides a variety of report-generation tools. For more information on this topic, see the `fmt_ccase` reference page in the *Command Reference*.

---

## 10.3 Integrating Changes

During the lifetime of a project, the contents of individual elements diverge as they are branched and usually converge in a merge operation. Typically, the project manager periodically merges most branches back to the **main** branch to ensure that the code base maintains a high degree of integrity and to have a single latest version of each element from which new versions can safely branch. Without regular merges, the code base quickly develops a number of dangling branches, each with slightly different contents. In such situations, a change made to one version must be propagated by hand to other versions, a tedious process that is prone to error.

As a project manager, you must establish merge policies for your project. Typical policies include the following:

- Developers merge their changes to the **main** branch. This can work well when the number of developers and/or the number of changed files is small and the developers are familiar with the mechanics of merging. Developers must also understand the nature of other changes they may encounter when the merge target is not the immediate predecessor of the version being merged, which happens when several developers are working on the same file in parallel.
- Developers merge their changes to an integration branch. This provides a buffer between individual developers' merges and the **main** branch. The project manager or system integrator then merges the integration branch to the **main** branch.
- Developers must merge from the **main** branch to their development branch before merging to the **main** branch or integration branch. This type of merge promotes greater stability by forcing merge-related instability to the developers' private branches, where problems can be resolved before they affect the rest of the team.
- The project manager designates slots for developer merges to the **main** branch. This is a variation on several of the mechanisms already described. It provides an additional level of control in situations where parallel development is going on.

There are other scenarios as well. Chapter 14, *Integrating Changes*, describes merging in detail.

## Defining Project Views

# 11

This chapter explains how config specs work and provides sample config specs useful for project development work, for nondevelopment tasks such as monitoring progress and doing research, and for running project builds. It also explains how to share config specs between Windows and UNIX systems.

---

### 11.1 How Config Specs Work

When you create views for your project, you must prepare one or more *config specs* (configuration specifications). Config specs allow you to achieve the degree of control that you need to have over project work by controlling which versions developers see and what operations they can perform in specific views. You can narrow a view to a specific branch or open it to an entire VOB. You can also disallow checkouts of all selected versions or restrict checkouts to specific branches.

A config spec contains a series of rules that Rational ClearCase uses to select the versions that appear in the view. When team members use a view, they see the versions that match at least one of the rules in the config spec. ClearCase searches the version tree of each element for the first version that matches the first rule in the config spec. If no versions match the first rule, ClearCase searches for a version that matches the second rule. If no versions of an element match any rule in the config spec, no versions of the element appear in the view.

The order in which rules appear in the config spec determine which version of a given element is selected. The various examples in this chapter examine this behavior in different contexts. For details about preparing config specs, see the `config_spec` reference page.

---

## 11.2 Default Config Spec

This config spec defines a dynamic configuration, which selects changes made on the **main** branch of every element throughout the entire source tree, by any developer:

- (1) `element * CHECKEDOUT`
- (2) `element * /main/LATEST`

This is the *default config spec*, to which each newly created view is initialized. When you create a view with the **mkview** command, the contents of file **default\_config\_spec** (located in *ccase-home-dir*) become the new view's config spec.

A view with this config spec provides a private work area that selects your checked-out versions (Rule 1). By default, when you check out a file, you check out from the latest version on the **main** branch (Rule 2). While an element is checked out to you, you can change it without affecting anyone else's work. As soon as you check in the new version, the changes are available to developers whose views select **/main/LATEST** versions.

The view also selects all other elements (that is, all elements that you have not checked out) on a read-only basis. If another user checks in a new version on the **main** branch of such an element, the new **LATEST** version appears in this *dynamic view* immediately.

By default, *snapshot views* also include the two *version selection rules* shown above. In addition, snapshot view config specs include *load rules*, which specify which elements or subtrees to load into the snapshot view. For details on creating snapshot views see *Developing Software* or online help.

**PRODUCT NOTE:** Rational ClearCase LT supports only snapshot views.

---

### The Standard Configuration Rules

The two configuration rules in the default config spec appear in many of this chapter's examples. The **CHECKEDOUT** rule allows you to modify existing elements. If you try to check out elements in a view that omits this rule, you can do so, but **cleartool** generates this warning:

```
% cleartool checkout -nc cmd.c
cleartool: Warning: Unable to rename "cmd.c" to "cmd.c.keep": Read-only
filesystem.
cleartool: Error: Checked out version, but could not copy to "cmd.c": File
exists.
Correct the condition, then uncheckout and re-checkout the element.
cleartool: Warning: Copied checked out version to "cmd.c.checkedout".
cleartool: Warning: Checked-out version is not selected by view.
Checked out "cmd.c" from version "/main/7".
```

In this example, the config spec continues to select version 7 of element **cmd.c**, which is read-only. A read-write copy of this version, **cmd.c.checkedout**, is created in view-private storage. (This is not a recommended way of working.)

The **/main/LATEST** rule selects the most recent version on the **main** branch to appear in the view.

In addition, a **/main/LATEST** rule is required to create new elements in a view. If you create a new element when this rule is omitted, your view cannot “see” that element. (Creating an element involves creating a **main** branch and an empty version, **/main/0**.)

### Omitting the Standard Configuration Rules

It makes sense to omit one or both of the standard configuration rules only if a view is not going to be used to modify data. For example, you can configure a historical view, to be used only for browsing old data. Similarly, you can configure a view in which to compile and test only or to verify that sources have been labeled properly.

---

## 11.3 Config Spec Include Files

ClearCase supports an include file facility, which makes it easy to ensure that all team members are using the same config spec. For example, the configuration rules in this config spec can be placed in file **/public/c\_specs/major.csp**. Each developer then needs a one-line config spec:

(1) `include /public/c_specs/major.csp`

**NOTE:** If you are sharing config specs between UNIX and Windows NT computers where the VOB-tags are different, you must have two sources, or you must store the config spec in a UNIX directory that is accessible from both platforms.

If you want to modify this config spec (for example, to adopt the no-directory-branching policy), only the contents of **major.csp** need to change. You can use this command to reconfigure your view with the modified config spec:

```
% cleartool setcs -current
```

---

## 11.4 Project Environment for Sample Config Specs

You can use different config specs for different kinds of development and management tasks. The three sections that follow present sample config specs useful for various aspects of project development, project management and research, and project builds. This section presents the development environment that these config specs are based on.

**PRODUCT NOTE:** In the examples that follow, arguments that show multicomponent VOB-tags, such as **/vobs/monet**, are not applicable to ClearCase LT, which recognizes only single-component VOB-tags, such as **/monet**.

Developers use a VOB whose VOB-tag is **/vobs/monet**, which has this structure:

<b>/vobs/monet</b>	<i>(VOB-tag, VOB mount point)</i>
<b>src/</b>	<i>(C language source files)</i>
<b>include/</b>	<i>(C language header files)</i>
<b>lib/</b>	<i>(project's libraries)</i>

For the purposes of this chapter, suppose that the **lib** directory has this substructure:

<b>lib/</b>	
<b>libcalc.a</b>	<i>(checked-in staged version of library)</i>
<b>libcmd.a</b>	<i>(checked-in staged version of library)</i>
<b>libparse.a</b>	<i>(checked-in staged version of library)</i>
<b>libpub.a</b>	<i>(checked-in staged version of library)</i>
<b>libaux1.a</b>	<i>(checked-in staged version of library)</i>
<b>libaux2.a</b>	<i>(checked-in staged version of library)</i>
<b>libcalc/</b>	<i>(sources for calc library)</i>
<b>libcmd/</b>	<i>(sources for cmd library)</i>
<b>libparse/</b>	<i>(sources for parse library)</i>
<b>libpub/</b>	<i>(sources for pub library)</i>
<b>libaux1/</b>	<i>(sources for aux1 library)</i>
<b>libaux2/</b>	<i>(sources for aux2 library)</i>



Sources for libraries are located in subdirectories of **lib**. After a library is built in its source directory, it can be staged to **/vobs/monet/lib**. The build scripts for the project's executable programs can instruct the link editor, **ld(1)**, to use the libraries in this directory (the library staging area) instead of a more standard location (for example, **/usr/local/lib**).

The following labels are assigned to versions of **monet** elements.

Version Labels	Description
<b>R1.0</b>	First customer release
<b>R2_BL1</b>	Baseline 1 prior to second customer release
<b>R2_BL2</b>	Baseline 2 prior to second customer release
<b>R2.0</b>	Second customer release

These version labels have been assigned to versions on the **main** branch of each element. Most project development work takes place on the **main** branch. For some special tasks, development takes places on a subbranch.

Subbranches	Description
<b>major</b>	Used for work on the application's graphical user interface, certain computational algorithms, and other major enhancements
<b>r1_fix</b>	Used for fixing bugs in Release 1.0

---

## 11.5 Views for Project Development

The config specs in this section are useful for project development because they enforce various branching policies.

---

### View for New Development on a Branch

You can use this config spec for work to be isolated on branches named **major**:

- (1) `element * CHECKEDOUT`
- (2) `element * ../major/LATEST`
- (3) `element * BASELINE_X -mkbranch major`
- (4) `element * /main/LATEST -mkbranch major`

In this scheme, all checkouts occur on branches named **major** (Rule 2).

**major** branches are created at versions that constitute a consistent baseline: a major release, a minor release, or a set of versions that produces a working version of the application. In this config spec, the baseline is defined by the version label **BASELINE\_X**.

### Variation That Uses a Time Rule

Sometimes, other developers check in versions that become visible in your view, but are incompatible with your own work. In such cases, you can continue to work on sources as they existed before those changes were made. For example, Rule 2 in this config spec selects the latest version on the main branch as of 4:00 P.M. on November 12:

```
(1) element * CHECKEDOUT
(2) element * /major/LATEST -time 12-Nov.16:00
(3) element * BASELINE_X -mkbranch major
(4) element * /main/LATEST -mkbranch major
```

Note that this rule has no effect on your own checkouts.

---

### View to Modify an Old Configuration

This config spec allows developers to modify a configuration defined with version labels:

```
(1) element * CHECKEDOUT
(2) element * ../r1_fix/LATEST
(3) element * R1.0 -mkbranch r1_fix
```

Note the following:

- Elements can be checked out (Rule 1).
- The **checkout** command creates a branch named **r1\_fix** at the initially selected version (the *auto-make-branch* clause in Rule 3).

A key aspect of this scheme is that the same branch name, **r1\_fix**, is used in every modified element. The only administrative overhead is the creation of a single branch type, **r1\_fix**, with the **mkbrtype** command.

This config spec is efficient: two rules (Rules 2 and 3) configure the appropriate versions of all elements:

- For elements that have been modified, this version is the most recent on the **r1\_fix** subbranch (Rule 2).
- For elements that have not been modified, this version is the one labeled **R1.0** (Rule 3).

Figure 37 illustrates these elements. The **r1\_fix** branch is a subbranch of the **main** branch. But Rule 2 handles the more general case, too: the ... wildcard allows the **r1\_fix** branch to occur anywhere in any element's version tree, and at different locations in the version trees of different elements.

Figure 37 Making a Change to an Old Version

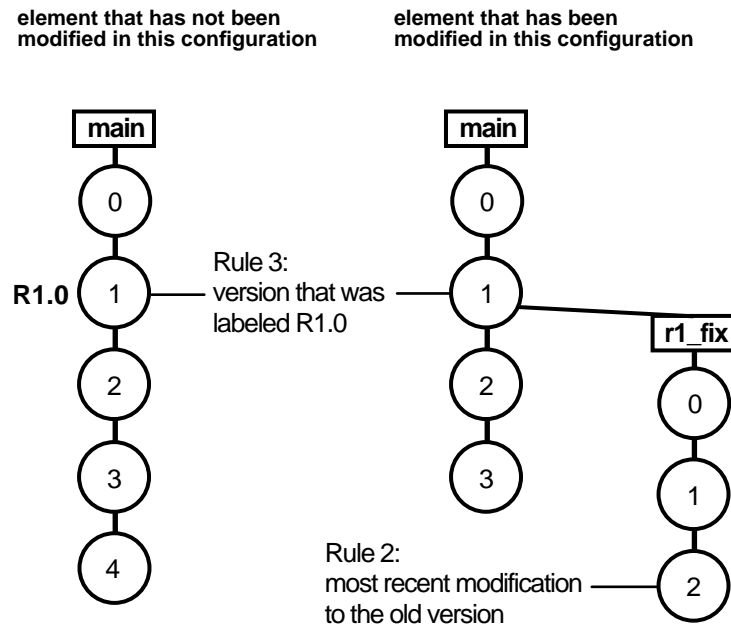

### Omitting the /main/LATEST Rule

The config spec in *View to Modify an Old Configuration* on page 154 omits the standard **/main/LATEST** rule. This rule is not useful for work with VOBs in which the version label **R1.0** does not exist. In addition, it is not useful in situations where new elements are created. If your development policy is to not create new elements during maintenance of an old configuration, the absence of a **/main/LATEST** rule is appropriate.

To allow creation of new elements during the modification process, add a fourth configuration rule:

```
(1) element * CHECKEDOUT
(2) element * /main/r1_fix/LATEST
(3) element * R1.0 -mkbranch r1_fix
(4) element * /main/LATEST -mkbranch r1_fix
```

When a new element is created with **mkelem**, the **-mkbranch** clause in Rule 4 causes the new element to be checked out on the **r1\_fix** branch (which is created automatically). This rule conforms to the scheme of localizing all changes to **r1\_fix** branches.

### Variation That Uses a Time Rule

This baseline configuration is defined with a time rule.

```
(1) element * CHECKEDOUT
(2) element * /main/r1_fix/LATEST
(3) element * /main/LATEST -time 4-Sep:02:00 -mkbranch r1_fix
```

---

## View to Implement Multiple-Level Branching

This config spec implements and enforces consistent multiple-level branching.

```
(1) element * CHECKEDOUT
(2) element * ../major/autumn/LATEST
(3) element * ../major/LATEST -mkbranch autumn
(4) element * BASELINE_X -mkbranch major
(5) element * /main/LATEST -mkbranch major
```

A view configured with this config spec is appropriate in the following situation:

- All changes from the baseline designated by the **BASELINE\_X** version label must be made on a branch named **major**.
- Moreover, you are working on a special project, whose changes are to be made on a subbranch of **major**, named **autumn**.

Figure 38 shows what happens in such a view when you check out an element that has not been modified since the baseline.

Figure 38 Multiple-Level Auto-Make-Branch

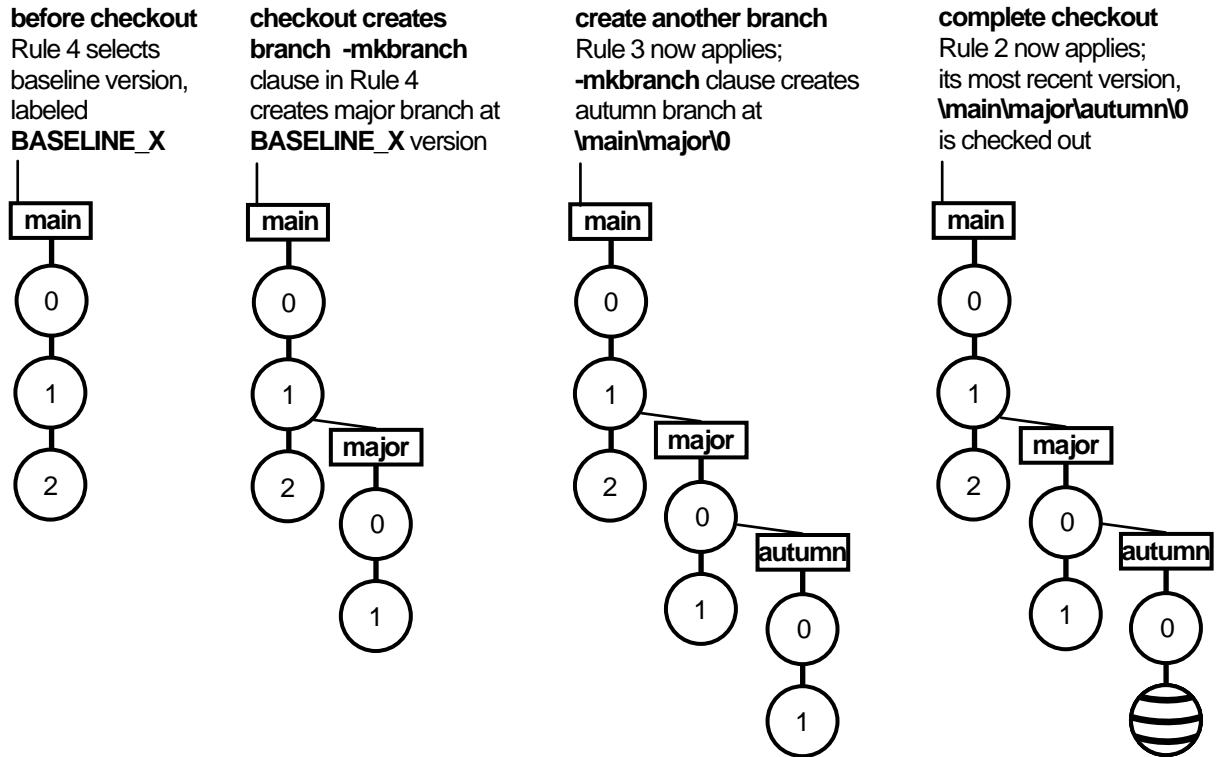

For more on multiple-level branching, see the `config_spec` and `checkout` reference pages.

---

## View to Restrict Changes to a Single Directory

This config spec is appropriate for a developer who can make changes in one directory only, `/vobs/monet/src`:

- (1) `element * CHECKEDOUT`
- (2) `element src/* /main/LATEST`
- (3) `element * /main/LATEST -nocheckout`

The most recent version of each element is selected (Rules 2 and 3), but Rule 3 prevents checkouts to all elements except those in the directory specified.

Note that Rule 2 matches elements in any directory named **src**, in any VOB. The pattern **/vobs/monet/src/\*** restricts matching to only one VOB.

This config spec can be extended easily with additional rules that allow additional areas of the source tree to be modified.

---

## 11.6 Views to Monitor Project Status

The config specs presented here are useful for views used for research and monitoring project status.

---

### View That Uses Attributes to Select Versions

Suppose that the QA team also works on the **major** branch. Individual developers are responsible for making sure that their modules pass a QA check. The QA team builds and tests the application, using the most recent versions that have passed the check.

The QA team can work in a view that uses this config spec:

```
(1) element -file src/* /main/major/{QAOK=="Yes" }
(2) element * /main/LATEST
```

To make this scheme work, you must create an attribute type, **QAOK**. Whenever a new version that passes the QA check is checked in on the **major** branch, an instance of **QAOK** with the value **Yes** is attached to that version. (This can be done manually or with a ClearCase trigger.)

If an element in the **/src** directory has been edited on the **major** branch, this view selects the branch's most recent version that has been marked as passing the QA check (Rule 1). If no version has been so marked or if no **major** branch has been created, the most recent version on the **main** branch is used (Rule 2).

**NOTE:** Rule 1 on this config spec does not provide a match if an element has a **major** branch, but no version on the branch has a **QAOK** attribute. This command can locate the branches that do not have this attribute:

```
% cleartool find . -branch '{brtype(major) && \! attype_sub(QAOK)}' -print
```

The backslash ( \ ) is required in the C shell only, to keep the exclamation point ( ! ) from indicating a history substitution.

The **atype\_sub** primitive searches for attributes on an element's versions and branches, as well as on the element itself.

This scheme allows the QA team to monitor the progress of the rest of the group. The development config spec always selects the most recent version on the **major** branch, but the QA config spec may select an intermediate version (Figure 39).

Figure 39 Development Config Spec vs. QA Config Spec

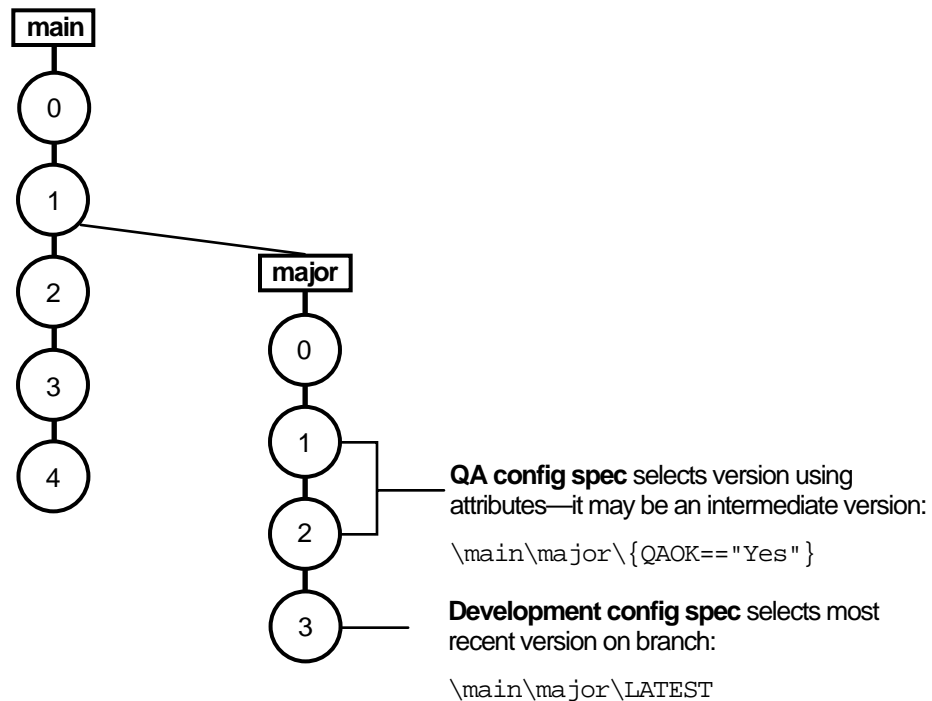

## Pitfalls of Using This Configuration for Development

You may be tempted to add a **CHECKEDOUT** rule to the above config spec, turning the QA configuration into a development configuration:

```
(0) element * CHECKEDOUT
(1) element -file src/* /main/major/{QAOK=="Yes"}
(2) element * /main/LATEST
```

It may seem desirable to use attributes, or other kinds of metadata, in addition to (or instead of) branches to control version selection in a development view. But such schemes introduce complications. Suppose that the config spec above selects version **/main/major/2** of element **.../src/cmd.c** (Figure 40).

Figure 40 Checking Out a Branch of an Element

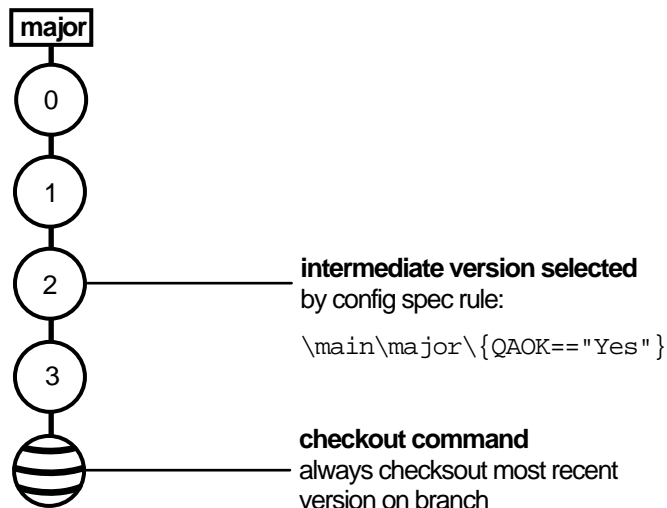

Performing a checkout in this view checks out version **/main/major/3**, not version **/main/major/2**:

```
cleartool: Warning: Version checked out is different from version previously
selected by view.
Checked out "cmd.c" from version "/main/major/3".
```

This behavior reflects the ClearCase restriction that new versions can be created only at the end of a branch. Although such operations are possible, they are potentially confusing to other team members. And in this situation, it is almost certainly not what the developer who checks out the element wants to happen.



You can avoid this problem by modifying the config spec and creating another branching level at the version that the attribute selects. This is the new config spec:

```
(0) element * CHECKEDOUT
(0a) element * /main/major/temp/LATEST
(1) element -file src/* /main/major/{QAOK=="Yes"} -mkbranch temp
(2) element * /main/LATEST
```

---

## View That Shows Changes of One Developer

This config spec makes it easy to examine all changes a developer has made since a certain milestone:

```
(1) element * '/main/{created_by(jackson) && created_since(25-Apr)}'
(2) element * /main/LATEST -time 25-Apr
```

NOTE: Rule 1 must be contained on a single physical text line.

A particular date, April 25, is used as the milestone. The configuration is a snapshot of the main line of development at that date (Rule 2), overlaid with all changes that user **jackson** has made on the **main** branch since then (Rule 1).

The output of the **cleartool ls** command distinguishes **jackson**'s files from the others: each entry includes an annotation as to which configuration rule applies to the selected version.

This is a research view, not a development view. The selected set of files may not be consistent: some of **jackson**'s changes may rely on changes made by others, and those other changes are excluded from this view. Thus, this config spec omits the standard **CHECKEDOUT** and **/main/LATEST** rules.

---

## Historical View Defined by a Version Label

This config spec defines a historical configuration:

```
(1) element * R1.0 -nocheckout
```

This view always selects the set of versions labeled **R1.0**. In this scenario, all these versions are on the **main** branch of their elements. If the **R1.0** label type is *one-per-element*, not *one-per-branch*,

this config spec selects the **R1.0** version on a subbranch. (For more information, see the **mklbtype** reference page.)

The **-nocheckout** qualifier prevents any element from being checked out in this view. (It also prevents creation of new elements, because the parent directory element must be checked out.) Thus, there is no need for the **CHECKEDOUT** configuration rule.

**NOTE:** The set of versions selected by this view can change, because version labels can be moved and deleted. For example, using the command **mklbtype -replace** to move **R1.0** from version 5 of an element to version 7 changes which version appears in the view. Similarly, using **rmlbtype** suppresses the specified elements from the view. (The **clear tool ls** command lists them with a `[no version selected]` annotation.) If the label type is locked with the **lock** command, the configuration cannot change.

You can use this configuration to rebuild Release 1.0, verifying that all source elements have been labeled properly. You can also use it to browse the old release.

---

## Historical View Defined by a Time Rule

This config spec defines a frozen configuration in a slightly different way than the previous one:

(1)

```
element * /main/LATEST -time 4-Sep.02:00 -nocheckout
```

This configuration selects the version that was the most recent on the **main** branch on September 4 at 2 A.M. Subsequent checkouts and checkins cannot change which versions satisfy this criterion; only deletion commands such as **rmver** or **rmelem** can change the configuration. The **-nocheckout** qualifier prevents anyone from checking out or creating elements.

This configuration can be used to view a set of versions that existed at a particular point in time. If modifications must be made to this source base, you must modify the config spec to “unfreeze” the configuration.

---

## 11.7 Views for Project Builds

The config specs in this section are useful for running the various types of builds required for a project.

---

## View That Uses Results of a Nightly Build

Many projects use scripts to run unattended software builds every night. The success or failure of these builds determine the impact of any checked-in changes on the application. In layered build environments, they can also provide up-to-date versions of lower-level software (libraries, utility programs, and so on).

Suppose that every night, a script does the following:

- Builds libraries in various subdirectories of **/vobs/monet/lib**
- Checks them in as DO versions in the library staging area, **/vobs/monet/lib**
- Labels the versions **LAST\_NIGHT**

You can use this config spec if you want to use the libraries produced by the nightly builds:

```
(1) element * CHECKEDOUT
(2) element lib/*.a LAST_NIGHT
(3) element lib/*.a R2_BL2
(4) element * /main/LATEST
```

The **LAST\_NIGHT** version of a library is selected whenever such a version exists (Rule 2). If a nightly build fails, the previous night's build still has the **LAST\_NIGHT** label and is selected. If no **LAST\_NIGHT** version exists (the library is not currently under development), the stable version labeled **R2\_BL2** is used instead (Rule 3).

For each library, selecting versions with the **LAST\_NIGHT** label rather than the most recent version in the staging area allows developers to stage new versions the next day, without affecting developers who use this config spec.

---

## Variations That Select Versions of Project Libraries

The scheme described above uses version labels to select particular versions of libraries. For more flexibility, the **LAST\_NIGHT** version of some libraries may be selected, the **R2\_BL2** version of others, and the most recent version of still others:

```
(1) element * CHECKEDOUT
(2a) element lib/libcmd.a LAST_NIGHT
(2b) element lib/libparse.a LAST_NIGHT
(3a) element lib/libcalc.a R2_BL2
(3b) element lib/*.a /main/LATEST
(4) element * /main/LATEST
```

(Rule 3b is not required here, because Rule 4 handles all other libraries. It is included for clarity only.)

Other kinds of metadata can also be used to select library versions. For example, **lib\_selector** attributes can take values such as **experimental**, **stable**, and **released**. A config spec can mix and match library versions like this:

```
(1) element * CHECKEDOUT
(2) element lib/libcmd.a {lib_selector=="experimental"}
(3) element lib/libcalc.a {lib_selector=="experimental"}
(4) element lib/libparse.a {lib_selector=="stable"}
(5) element lib/*.a {lib_selector=="released"}
(6) element * /main/LATEST
```

---

## View That Selects Versions of Application Subsystems

This config spec selects specific versions of the application's subsystems:

```
(1) element * CHECKEDOUT
(2) element /vobs/monet/lib/... R2_BL1
(3) element /vobs/monet/include/... R2_BL2
(4) element /vobs/monet/src/... /main/LATEST
(5) element * /main/LATEST
```

In this situation, a developer is making changes to the application's source files on the **main** branch (Rule 4). Builds of the application use the libraries in directory **/lib** that were used to build Baseline 1, and the header files in directory **/include** that were used to build Baseline 2.

---

## View That Selects Versions That Built a Particular Program

This config spec defines a view that selects only enough files required to rebuild a particular program or examine its sources:

(1) `element * -config /vobs/monet/src/monet`

All elements that were not involved in the build of **monet** appear in the output of ClearCase **ls** with a `[no version selected]` annotation.

This config spec selects the versions listed in the config record (CR) of a particular derived object (and in the config records of all its build dependencies). It can be a derived object that was built in the current view, or another view, or it can be a *DO version*.

In this config spec, **monet** is a derived object in the current view. You can reference a derived object in another view with an extended pathname that includes a *DO-ID*:

(1) `element * -config /vobs/monet/src/monet@@09-Feb.13:56.812`

But typically, this kind of config spec is used to configure a view from a derived object that has been checked in as a DO version.

### Configuring the Makefile

By default, a derived object's config record does not list the version of the makefile that was used to build it. Instead, the CR includes a copy of the build script itself. (Why? When a new version of the makefile is created with a revision to one target's build script, the configuration records of all other derived objects built with that makefile are not rendered out of date.)

But if the **monet** program is to be rebuilt in this view using **clearmake** (or even standard **make**), a version of the makefile must be selected somehow. You can have **clearmake** record the makefile version in the config record by including the special **clearmake** macro invocation `$(MAKEFILE)` in the target's dependency list:

```
monet: $(MAKEFILE) monet.o ...
      cc -o monet ...
```

**clearmake** always records the versions of explicit dependencies in the CR.

Alternatively, you can configure the makefile at the source level: attach a version label to the makefile at build time, and then use a config spec like the one in *Historical View Defined by a*

*Version Label* on page 161 or *View to Modify an Old Configuration* on page 154 to configure a view for building. You can also use the special target `.DEPENDENCY_IGNORED_FOR_REUSE`; for more information, see *Building Software*.

## Fixing Bugs in the Program

If a bug is discovered in the `monet` program, as rebuilt in a view that selects only enough files required to rebuild a particular program, it is easy to convert the view from a build configuration to a development configuration. As usual, when making changes in old sources, follow this strategy:

- ▶ Create a branch at each version to be modified
- ▶ Use the same branch name (that is, create an instance of the same branch type) in every element

If the fix branch type is `r1_fix`, this modified config spec reconfigures the view for performing the fix:

```
(1) element * CHECKEDOUT
(2) element * ../r1_fix/LATEST
(3) element * -config /vobs/monet/src/monet -mkbranch r1_fix
(4) element * /main/LATEST -mkbranch r1_fix
```

## Selecting Versions That Built a Set of Programs

It is easy to expand the config spec that selects only enough files required to rebuild a particular program to configure a view with the sources used to build a set of programs, rather than a single program:

```
(1) element * -config /proj/monet/src/monet
(2) element * -config /proj/monet/src/xmonet
(3) element * -config /proj/monet/src/monet_conf
```

There can be version conflicts in such configurations, however. For example, different versions of file `params.h` may have been used in the builds of `monet` and `xmonet`. In this situation, the version used in `monet` is configured, because its configuration rule came first. Similarly, there can be conflicts when using a single `-config` rule: if the specified derived object was created by actually building some targets and using DO versions of other targets, multiple versions of some source files may be involved.

You can modify this config spec as described in *Fixing Bugs in the Program* on page 166, to change the build configuration to a development configuration.

---

## 11.8 Sharing Config Specs Between UNIX and Windows

You can, in principle, share config specs between UNIX and Windows systems. That is, users on both systems, using views whose storage directories reside on either platform, can set and edit the same set of config specs.

We recommend that you avoid sharing config specs across platforms. If possible, maintain separate config specs for each platform. However, if you must share config specs, adhere to the following requirements:

- Use slashes (/), not backslashes (\) in pathnames.
- Use relative, not full, pathnames whenever possible, and do not use VOB-tags in pathnames. You can ignore this restriction if your UNIX and Windows VOB-tags both use single, identical pathname components that differ only in their leading slash characters—\src and /src, for example.
- Always edit and set config specs on UNIX.

The following sections describe these requirements in detail.

---

### Pathname Separators

When writing config specs to be shared by Windows and UNIX computers, you must use slash (/), not backslash (\), as the pathname separator. ClearCase on UNIX recognizes slashes only. (Note that **cleartool** recognizes both slashes and backslashes in pathnames; **clearmake** is less flexible. See *Building Software* for more information.)

---

### Pathnames in Config Spec Element Rules

Windows and UNIX network regions often use different VOB-tags to register the same VOBs. Only single-component VOB-tag names, such as \proj1, are permitted on Windows computers; multiple-component VOB-tags, such as /vobs/src, are common on UNIX.

When VOB-tags differ between regions, any config spec element rules that use full pathnames (which include VOB-tags) can be resolved when the config spec is compiled (**cleartool edcs** and **setcs** commands) but only by computers in the applicable network region. This implies a general restriction regarding shared config specs: a given config spec must be compiled only on the

operating system for which full pathnames in element rules make sense. That is, a config spec with full pathnames is shareable across network regions, even when VOB-tags disagree, but it must be compiled in the right place.

The restrictions do not apply if either of the following is true (see *Example* on page 168):

- The config spec's element rules use only relative pathnames, which do not include VOB-tags.
- Shared VOBs are registered with identical, single-component VOB-tags in both Windows and UNIX network regions. (The VOB-tags `\r3vob` and `/r3vob` are treated as if they were identical because they differ only in the leading slashes.)

---

## Config Spec Compilation

A config spec that is in use exists in both text file and compiled formats. A config spec's compiled form is portable. The restriction is that full VOB pathnames in element rules must be resolvable at compile time. A config spec is compiled when you edit or set it (with the `cleartool edcs` or `cleartool setcs` command or a ClearCase GUI). If a user on the other operating system recompiles a config spec (by issuing the `edcs` or `setcs` command or causing the GUI to execute one of these commands) the config spec becomes unusable by *any* computer using that view. If this happens, recompile the config spec on the original operating system.

---

## Example

This config spec element rule may cause problems:

```
element \vob_p2\abc_proj_src\*          \main\rel2\LATEST
```

If the VOB is registered with VOB-tag `\vob_p2` on a Windows network region, but with VOB-tag `/vobs/vob_p2` on a UNIX network region, only Windows computers can compile the config spec.

To address the problem, do one of the following:

- Use relative pathnames that do not include VOB-tags, for example:

```
element ...\abc_proj_src\*          \main\rel2\LATEST
```

- On UNIX, change the VOB-tag so that it has a single component, `/vob_p2`.



## Implementing Project Development Policies

# 12

This chapter presents brief scenarios that show how you can implement and enforce common development policies with Rational ClearCase. The scenarios use various combinations of these functions and metadata:

- Attributes
- Labels
- Branches
- Triggers
- Config specs
- Locks
- Hyperlinks

*Sharing Triggers Between UNIX and Windows* on page 181 describes how to define triggers for use on UNIX and Windows computers.

---

### 12.1 Good Documentation of Changes Is Required

Each ClearCase command that modifies a VOB creates one or more *event records*. Many such commands (for example, **checkin**) prompt for a comment. The event record includes the user name, date, comment, host, and description of what was changed.

To prevent developers from subverting the system by providing empty comments, you can create a preoperation trigger to monitor the **checkin** command. The trigger action script analyzes

the user's comment (passed in an environment variable), disallowing unacceptable ones (for example, those shorter than 10 words).

Trigger Definition:

```
% cleartool mkrtrtype -element -all -preop checkin -c "must enter descriptive comment" \  
-exec /public/scripts/comment_policy.sh CommentPolicy
```

Trigger Action Script:

```
#!/bin/sh  
#  
#   comment_policy  
#  
ACCEPT=0  
REJECT=1  
WORDCOUNT=`echo $CLEARCASE_COMMENT | wc -w`  
  
if [ $WORDCOUNT -ge 10 ] ; then  
    exit $ACCEPT  
else  
    exit $REJECT  
fi
```

---

## 12.2 All Source Files Require a Progress Indicator

You may want to monitor the progress of individual files or determine which or how many files are in a particular state. You can use attributes to preserve this information and triggers to collect it.

In this case, you can create a string-valued attribute type, **Status**, which accepts a specified set of values.

Attribute Definition:

```
% cleartool mkattrtype -c "standard file levels" \  
-enum ' "inactive","under_devt","QA_approved" ' Status  
Created attribute type "Status".
```

Developers apply the **Status** attribute to many different versions of an element. Its value in early versions on a branch is likely to be **inactive** and **under\_devt**; on later versions, its value is

**QA\_approved.** The same value can be used for several versions, or moved from an earlier version to a later version.

To enforce conscientious application of this attribute to versions of all source files, you can create a **CheckStatus** trigger whose action script prevents developers from checking in versions that do not have a **Status** attribute.

Trigger Definition:

```
% cleartool mktrtype -element -all -preop checkin \  
-c "all versions must have Status attribute" \  
-exec 'Perl /public/scripts/check_status.pl' CheckStatus
```

Trigger Action Script:

```
$pname = $ENV{'CLEARCASE_PN'};  
$val = "";  
$val = `cleartool describe -short -aattr Status $pname`;  
  
if ($val eq "") {  
  exit (1);  
} else {  
  exit (0);  
}
```

---

## 12.3 Label All Versions Used in Key Configurations

To identify which versions of which elements contributed to a particular baseline or release, you can attach labels to these versions. For example, after Release 2 is built and tested, you can create label type **REL2**, using the **mklbtype** command. You can then attach **REL2** as a version label to the appropriate source versions, using the **mklablel** command.

Which are the appropriate versions? If Release 2 was built from the bottom up in a particular view, you can label the versions selected by that view:

```
% cleartool mklbtype -c "Release 2.0 sources" REL2  
  
% cleartool mklablel -recurse REL2 top-level-directory
```

Alternatively, you can use the configuration records of the release's derived objects to control the labeling process:

% **clearmake vega**

*... sometime later, after QA approves the build:*

% **cleartool mklabel -config vega@@17-Jun.18:05 REL2**

Using configuration records to attach version labels ensures accurate and complete labeling, even if developers have created new versions since the release build. Development work can continue while quality assurance and release procedures are performed.

To prevent version label **REL2** from being used again, you must lock the label type:

% **cleartool lock -nusers vobadm lbtype:REL2**

The object is locked to all users except those specified with the **-nusers** option, in this case, **vobadm**.

---

## 12.4 Isolate Work on Release Bugs to a Branch

You may want to fix bugs found in the released system on a named bug-fix branch, and to begin this work with the exact configuration of versions from that release.

This policy reflects the ClearCase baseline-plus-changes model. First, a label (**REL2**, for example) must be attached to the release configuration. Then, you or any team member can create a view with the following config spec to implement the policy:

```
element * CHECKEDOUT
element * ../rel2_bugfix/LATEST
element * REL2 -mbranch rel2_bugfix
```

If all fixes are made in one or more views with this configuration, the changes are isolated on branches of type **rel2\_bugfix**. The **-mkbranch** option causes such branches to be created, as needed, when elements are checked out.

This config spec selects versions from **rel2\_bugfix** branches, where branches of this type exist; it creates such a branch whenever a **REL2** version is checked out.

---

## 12.5 Avoid Disrupting the Work of Other Developers

To work productively, developers need to control when they see changes and which changes they see. The appropriate mechanism for this purpose is a view. Developers can modify an existing config spec or create a new one to specify exactly which changes to see and which to exclude.

To implement this policy, you can also require developers to write and distribute the config spec rule that filters out their checked-in changes. Some sample config specs:

- To select your own work, plus all the versions that went into the building of Release 2:

```
element * CHECKEDOUT
element * REL2
```

- To select your own work, plus the latest versions as of Sunday evening:

```
element * CHECKEDOUT
element * /main/LATEST -time Sunday.18:00
```

- To select your own work, new versions created in the **graphics** directory, and the versions that went into last night's build:

```
element * CHECKEDOUT
element graphics/* /main/LATEST
element * -config myprog@12-Jul.00:30
```

- To select your own work, the versions either you (**jones**) or Mary has checked in today, and the most recent quality-assurance versions:

```
element * CHECKEDOUT
element * '/main/{ created_since(06:00) && ( created_by(jones) ||
created_by(mary) ) }'
element * /main/{QAed=="TRUE"}
```

- You can also use the config spec include facility to set up standard sets of configuration rules for developers to add to their own config specs:

```
element * CHECKEDOUT
element msg.c /main/18
include /usr/csspecs/rules_for_rel2_maintenance
```

---

## 12.6 Deny Access to Project Data When Necessary

Occasionally, you may need to deny access to all or most project team members. For example, you may want to prevent changes to public header files until further notice. The **lock** command is designed to enforce such temporary policies:

- Lock all header files in a certain directory:  
    % **cleartool lock src/pub/\*.h**
- Lock the header files for all users except Mary and Fred:  
    % **cleartool lock -nusers mary,fred src/pub/\*.h**
- Lock all header files in the VOB:  
    % **cleartool lock eltype:c\_header**
- Lock an entire VOB:  
    % **cleartool lock vob:/vobs/myproj**

---

## 12.7 Notify Team Members of Relevant Changes

To help team members keep track of changes that affect their own work, you can use postoperation triggers to send notifications of various events. For example, when developers change the GUI, an e-mail message to the doc group ensures that these changes are documented.

To enforce this policy, create a trigger type that sends mail, and then attach it to the relevant elements.

Trigger Definition:

```
% cleartool mktrtype -nc -element -postop checkin \  
    -exec /public/scripts/informwriters.sh InformWriters  
Created trigger type "InformWriters".
```

Trigger Action Script:

```

#!/bin/sh
#
#Init
tmp=/tmp/checkin_mail

# construct mail message describing checkin

cat > $tmp <<EOF
Subject: Checkin $CLEARCASE_PNAME by $CLEARCASE_USER
$CLEARCASE_XPNAME
Checked in by $CLEARCASE_USER.

Comments:
$CLEARCASE_COMMENT
EOF

# send the message

mail docgrp <$tmp

# clean up

#rm -f $tmp

```

To attach triggers to existing elements:

1. Place the trigger on the *inheritance list* of all existing directory elements within the GUI source tree:

```

% cleartool find /vobs/gui_src -type d \
-exec 'cleartool mktrigger -nattach InformWriters $CLEARCASE_PN'

```

2. Place the trigger on the *attached list* of all existing file elements within the GUI source tree:

```

% cleartool find /vobs/gui_src -type f \
-exec 'cleartool mktrigger InformWriters $CLEARCASE_PN'

```

---

## 12.8 All Source Files Must Meet Project Standards

To ensure that developers are following coding guidelines or other standards, you can evaluate their source files. You can create preoperation triggers to run user-defined programs, and cancel the commands that trigger them.

For example, you may want to disallow checkin of C-language files that do not satisfy quality metrics. You may have your own metrics program, or you can run **lint(1)**. Suppose that you have defined an element type, **c\_source**, for C language files (\*.c).

Trigger Definition:

```
% cleartool mktrtype -element -all -eltype c_source \  
-preop checkin -exec '/public/scripts/apply_metrics.sh $CLEARCASE_PN' ApplyMetrics
```

This trigger type **ApplyMetrics** applies to all elements; it fires when any element of type **c\_source** is checked in. (When a new **c\_source** element is created, it is monitored.) If a developer attempts to check in a **c\_source** file that fails the **apply\_metrics.sh** test, the checkin fails.

**NOTE:** The **apply\_metrics.sh** script can read the value of **CLEARCASE\_PN** from its environment. Having it accept a file-name argument provides flexibility because the script can be invoked as a trigger action, and developers can also use it manually.

---

## 12.9 Associate Changes with Change Orders

To keep track of work done in response to an engineering change order (ECO), you can use attributes and triggers. For example, to associate a version with an ECO, define **ECO** as an integer-valued attribute type:

```
cleartool mkatttype -c "bug number associated with change" -vtype integer ECO  
Created attribute type "ECO".
```

Then, define an all-element trigger type, **EcoTrigger**, which fires whenever a new version is created and runs a script to attach the **ECO** attribute:

Trigger Definition:

```
cleartool mktrtype -element -all -postop checkin -c "associate change with bug number" \  
-execunix 'Perl /public/scripts/eco.pl' -execwin 'ccperl \\neon\scripts\eco.pl' EcoTrigger  
Created trigger type "EcoTrigger".
```

Trigger Action Script:



```

$name = $ENV{'CLEARCASE_XPN'};

print "Enter the bug number associated with this checkin: ";
$bugnum = <STDIN>;
chomp ($bugnum);
$command = "cleartool mkattr ECO $bugnum $pname";

@returnvalue = ` $command `;
$rval = join " ",@returnvalue;
print "$rval";

exit(0);

```

When a new version is created, the attribute is attached to the version. For example:

#### **cleartool checkin -c "fixes for 4.0" src.c**

```

Enter the bug number associated with this checkin: 2347
Created attribute "ECO" on "/vobs/dev/src.c@@/main/2".
Checked in "src.c" version "/main/2".

```

#### **cleartool describe src.c@@/main/2**

```

version "src.c@@/main/2"
...
  Attributes:
    ECO = 2347

```

---

## 12.10 Associate Project Requirements with Source Files

You can implement requirements tracing with *hyperlinks*, which associate pairs of VOB objects. The association should be at the version level (rather than the branch or element level): each version of a source code module must be associated with a particular version of a related design document.

For example, the project manager creates a hyperlink type named **DesignDoc**, which is used to associate source code with design documents:

```

cleartool mkhltype -c "associate code with design docs" \
DesignDoc@/vobs/dev DesignDoc@/vobs/design
Created hyperlink type "DesignDoc".
Created hyperlink type "DesignDoc".

```

The *hyperlink inheritance* feature makes the implementation of requirements tracing easy:

- When the source module, **hello.c**, and the design document, **hello\_dsn.doc**, are updated, the project manager creates a new hyperlink connecting the two updated versions:

```
cleartool mkhlink -c "source doc" DesignDoc hello.c /vobs/design/hello_dsn.doc
Created hyperlink "DesignDoc@90@/vobs/dev".
```

- When either the source module or the design document incorporates a minor update, no hyperlink-level change is required: the new version *inherits* the hyperlink connection of its predecessor.

```
cleartool checkin -c "fix bug" hello.c
Checked in "hello.c" version "/main/2".
```

To list the inherited hyperlink, use the **-ihlink** option to the **describe** command:

```
version that           % cleartool describe -ihlink DesignDoc hello.c@@/main/2
inherits hyperlink-> hello.c@@/main/2
                        Inherited hyperlinks: DesignDoc@90@/vobs/dev
version to which -> /vobs/dev/hello.c@@/main/1 ->
hyperlink is explicitly /vobs/doc/hello_dsn.doc@@/main/1
attached
```

- When either the source module or the design document incorporates a significant update, which renders the connection invalid, the project manager creates a null-ended hyperlink to sever the connection:

```
cleartool mkhlink -c "sever connection to design doc" DesignDoc hello.c
Created hyperlink "DesignDoc@94@/vobs/dev".
```

Figure 41 illustrates the hyperlinks that connect the source file to the design doc.

Figure 41 Requirements Tracing

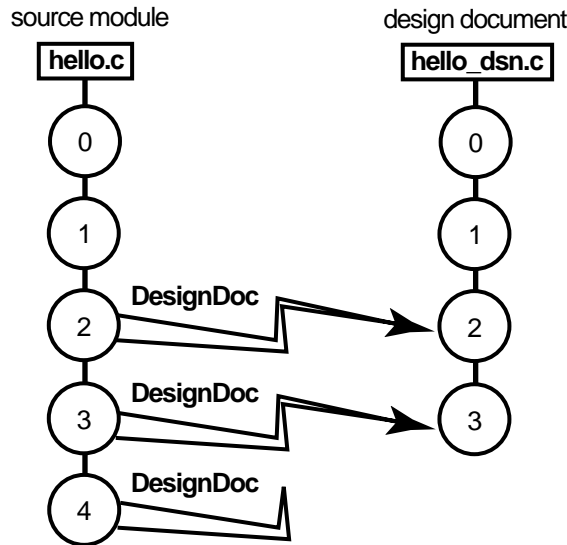

---

## 12.11 Prevent Use of Certain Commands

To control which users can execute certain commands on ClearCase objects, you can create a pair of trigger types—one to control the use of the command on element-related objects, and one to control the use of the command on type objects. Both trigger types use the **-nuser** flag to specify the users who are allowed to use the command.

**NOTE:** You cannot use triggers to prevent a command from being used on an object that is not element related or a type object. For example, you cannot create a trigger type to prevent operations on VOB objects or replica objects.

For a list of commands that can be triggered, see the **events\_ccase** and **mktrtype** reference pages.

For example, the following commands create two trigger types that prevent all users except **stephen**, **hugh**, and **emma** from running the **chmaster** command on element-related objects and type objects in the current VOB:

```
cleartool mkrtrtype -element -all -preop chmaster -nusers stephen,hugh,emma \  
-execunix 'Perl -e "exit -1;"' -execwin 'ccperl -e "exit (-1);" \  
-c "ACL for chmaster" elem_chmaster_ACL
```

```
cleartool mkrtrtype -type -preop chmaster -nusers stephen,hugh,emma \  
-execunix 'Perl -e "exit -1;"' -execwin 'ccperl -e "exit (-1);" \  
-attype -all -brtype -all -eltype -all -lbtype -all -hltype -all \  
-c "ACL for chmaster" type_chmaster_ACL
```

When user **tony** tries to run the **chmaster** command on a restricted object, the command fails. For example:

```
cleartool chmaster -c "give mastership to london" london@/vobs/dev \  
/vobs/dev/acc.c@@/main/lex_dev  
cleartool: Warning: Trigger "elem_chmaster_ACL" has refused to let chmaster  
proceed.  
cleartool: Error: Unable to perform operation "change master" in replica "lex"  
of VOB "/vobs/dev".
```

---

## 12.12 Certain Branches Are Shared Among MultiSite Sites

PRODUCT NOTE: Rational ClearCase LT does not support ClearCase MultiSite.

If your company uses ClearCase MultiSite to support development at different sites, you must tailor your branching strategy to the needs of these sites. The standard MultiSite development model is to have a replica of the VOB at each site. Each replica controls (masters) a site-specific branch type, and developers at one site cannot work on branches mastered at another site. (For more information on MultiSite mastership, see the *Administrator's Guide* for Rational ClearCase MultiSite.)

However, sometimes you cannot, or may not want to, branch and merge an element. For example, some file types cannot be merged, so development must occur on a single branch. In this scenario, all developers must work on a single branch (usually, the main branch). MultiSite allows only one replica to master a branch at any given time. Therefore, if a developer at another site needs to work on the element, mastership of the branch must be transferred to that site.

MultiSite provides two models for transferring mastership of a branch:

- The push model, in which the administrator at the replica that masters the branch uses the **chmaster** command to give mastership to another replica.

This model is not efficient in a branch-sharing situation, because it requires communication with an administrator at a remote site. For more information about this model, see the *Administrator's Guide* for Rational ClearCase MultiSite.

- The pull model, in which the developer who needs to work on the branch uses the **reqmaster** command to request mastership of it.

**NOTE:** The developer can also request mastership of branch types. For more information, see the *Administrator's Guide* for Rational ClearCase MultiSite.

This model requires the MultiSite administrators to enable requests for mastership in each replica and to authorize individual developers to request mastership. If you decide to implement this model, you must provide the following information to your MultiSite administrator:

- > Replicated VOBs that should be enabled to handle mastership requests
- > Identities (domain names and user names) of developers who should be authorized to request mastership
- > Branch types and branches for which mastership requests should be denied (for example, branch types that are site specific, or branches that must remain under the control of a single site)

The *Administrator's Guide* for Rational ClearCase MultiSite describes the process of enabling the pull model and a scenario in which developers use the pull model. The *Developing Software* manual describes the procedure developers use to request mastership.

---

## 12.13 Sharing Triggers Between UNIX and Windows

You can define triggers that fire correctly on both UNIX and Windows computers. The following sections describe two techniques. With one, you use different pathnames or different scripts; with the other, you use the same script for both platforms.

---

### Using Different Pathnames or Different Scripts

To define a trigger that fires on UNIX, Windows, or both, and that uses different pathnames to point to the trigger scripts, use the **-execunix** and **-execwin** options with the **mktrtype** command. These options behave the same as **-exec** when fired on the appropriate platform

(UNIX or Windows, respectively). On the other platform, they do nothing. This technique allows a single trigger type to use different paths for the same script or to use completely different scripts on UNIX and Windows computers. For example:

```
cleartool mkrtype -element -all -nc -preop checkin \  
-execunix /public/scripts/precheckin.sh -execwin \\neon\scripts\precheckin.bat \  
pre_ci_trig
```

On UNIX, only the script **precheckin.sh** runs. On Windows, only **precheckin.bat** runs.

To prevent users on a new platform from bypassing the trigger process, triggers that specify only **-execunix** always fail on Windows. Likewise, triggers that specify only **-execwin** fail on UNIX.

---

## Using the Same Script

To use the same trigger script on both Windows and UNIX platforms, you must use a batch command interpreter that runs on both operating systems. For this purpose, ClearCase includes the **ccperl** program. On Windows, **ccperl** is a version of the Perl program available on UNIX.

The following **mkrtype** command creates sample trigger type **pre\_ci\_trig** and names **precheckin.pl** as the executable trigger script.

```
% cleartool mkrtype -element -all -nc -preop checkin \  
-execunix 'Perl /public/scripts/precheckin.pl' \  
-execwin 'ccperl \\neon\scripts\precheckin.pl' \  
pre_ci_trig
```

---

## Notes

- To conditionalize script execution based on operating system, use environment variables in Perl scripts.
- To collect or display information interactively, you can use the **clearprompt** command.
- For more information on using the **-execunix** and **-execwin** options, see the **mkrtype** reference page.

## Setting Up the Base ClearCase-ClearQuest Integration

# 13

This chapter provides an overview of the base ClearCase-ClearQuest integration and describes how to set up the integration. For information on working in the integration, see *Developing Software*.

---

### 13.1 Overview of the Integration

Rational ClearQuest manages change requests, which report defects or request modifications for a project or product. Rational ClearCase manages versions of the elements that represent a project or product. Each version embodies one or more changes to an element.

The integration of ClearQuest and ClearCase associates one or more ClearQuest change requests with one or more ClearCase versions.

A single change request may be associated with more than one version. The set of versions that implement the requested change is called the change set for that request.

A single version may be associated with more than one change request. These change requests are called the request set for that version.

The integration has the following interfaces:

- As a ClearCase project manager, you specify the conditions under which users are prompted to associate versions with change requests. You can specify VOBs, branches, and element types for which users can or must associate change requests.
- As a ClearQuest administrator, you add ClearCase definitions to a ClearQuest schema. These definitions enable change requests in databases that use the schema to contain and display associated change sets.
- As a ClearCase developer, you can:
  - Associate a version with one or more change requests at the time you check in or check out the version.
  - View the change set for a request.
  - Submit queries to identify the change requests that are associated with a project over a period of time.

---

## 13.2 Configuring ClearQuest and ClearCase

Before developers can associate ClearCase versions with ClearQuest change requests, you need to configure ClearQuest and ClearCase as follows:

1. Add ClearCase definitions to a ClearQuest schema. If you have ClearQuest 2.0 (or a more recent release) installed, use the ClearQuest Designer's Package Wizard to add these definitions. If you have an earlier release of ClearQuest installed, use the ClearQuest Integration Configuration application on Windows to add the definitions. You associate the ClearCase definitions with one or more record types and with one or more forms for each associated record type. Each form then contains a **ClearCase** tab that displays the change set for a change request.
2. Use the ClearQuest Designer to upgrade the database with the new version of the schema. See the *Upgrading an existing database* topic in the ClearQuest Designer help. If you move the integration to a different database, be sure to repeat this step for that database. For example, you can try out the integration on a sample database before deciding to use it on a production database.
3. Using the ClearQuest Integration Configuration application, set a policy for each VOB that determines the conditions under which users are prompted to associate versions with change requests. You can specify that users are prompted on checking out a version, checking in a version, or both. You can also specify that prompting occurs only for some



branch types or element types. Associations of checked-in versions with change requests can be either optional or required.

---

## Adding ClearCase Definitions to a ClearQuest Schema

A ClearQuest schema contains the attributes associated with a set of ClearQuest user databases, including definitions of record types, fields, and forms. Before developers can associate ClearCase versions with ClearQuest change requests in a user database, you must add some ClearCase definitions to the schema that the database uses. To do so, use the Package Wizard within ClearQuest Designer, as follows:

1. Click **Start > Programs > Rational ClearQuest > Rational ClearQuest Designer**.
2. In ClearQuest Designer, click **Package > Package Wizard**.
3. In the Package Wizard, look for the ClearCase 1.0 and ClearCase Upgrade 1.0 packages. If these packages are not listed, click **More Packages**, and add them to the list from the Install Packages dialog box.
4. If you are upgrading a schema that currently uses the ClearCase-ClearQuest integration from ClearQuest release 1.1 to release 2.0, select ClearCase Upgrade 1.0, and click **Next**. If you are enabling a schema to use the ClearCase-ClearQuest integration for the first time, select ClearCase 1.0, and click **Next**.
5. Select the schema for the ClearQuest user database that you want to use in the integration with ClearCase. Click **Next**.
6. Select the record type of ClearQuest records to be associated with ClearCase versions. This record type must match the record type that you specify on the **ClearCase** tab of the ClearQuest Integration Configuration application. Click **Finish**.
7. Click **File > Check In** to save the new version of the schema.
8. Click **Database > Upgrade Database** to upgrade the ClearQuest user database with the new version of the schema.

If you are using a pre-2.0 release of ClearQuest, use the ClearQuest Integration Configuration application to add ClearCase definitions to a ClearQuest schema. To start the application, click **Start > Programs > Rational ClearCase Administration > Integrations > ClearQuest Integration Configuration**. Alternatively, you can start the application by entering `cqconfig` at the command prompt. Click the **ClearQuest** tab. Click **Help** for instructions on completing the fields on the tab.

---

## Installing Triggers in ClearCase VOBs

The integration uses ClearCase triggers on **cleartool checkin**, **checkout**, and **uncheckout** commands to allow developers to associate versions with ClearQuest change requests. To install these triggers in a VOB, use the ClearQuest Integration Configuration application.

**PRODUCT NOTE:** To start the ClearQuest Integration Configuration:

- ▶ In ClearCase, click **Start > Programs > Rational ClearCase Administration > Integrations > ClearQuest Integration Configuration**.
- ▶ In ClearCase LT, click **Start > Programs > Rational ClearCase LT Server > ClearQuest Integration Configuration**.

Alternatively, you can start the Configuration application by entering **cqconfig** at the command prompt.

In previous releases, the integration used a Visual Basic trigger on Windows and a Perl trigger on UNIX. This release adds a new Perl trigger that runs on Windows and UNIX. Specify which trigger you want to use by clicking **V1** or **V2** in the **Windows Trigger Selection** and **UNIX Trigger Selection** fields of the application. V1 refers to the Visual Basic and Perl triggers used in previous releases. V2 refers to the new Perl trigger.

The V2 trigger provides a text-based user interface for developers who use the **cleartool** command-line interface and a **clearprompt** pop-up window user interface for developers who use one of the ClearCase GUIs such as ClearCase Explorer (on Windows) or **xclearcase** (on UNIX). The V2 trigger does not provide a GUI for developers. For Windows client machines that have ClearQuest installed, you may want to use the V1 Visual Basic trigger, which provides a GUI for developers.

The V2 trigger uses a configuration file, which specifies your local configuration parameters. When you select V2, the Configuration application fills in the Path field with **CQCC/config.pl**, the path to the configuration file. In this path, CQCC resolves to *ccase-home-dir/lib/perl5/CQCCTrigger/CQCC* on each local client. You can change the path to a UNC path name so that the integration uses one central configuration file.

For information on completing the other fields in the application, click **Help** within the application.

---

## Quick Start for Evaluations

The default configuration file is set to use the SAMPL user database that ClearQuest provides for evaluations. You can test the integration with the SAMPL ClearQuest user database. If ClearQuest is installed on the client machine, the integration uses the ClearQuest Perl API to communicate with the ClearQuest user database. If ClearQuest is not installed on the client machine, the integration uses the ClearQuest Web Interface to communicate with the ClearQuest user database.

### Setting Environment Variables for the ClearQuest Web Interface

To enable a client to use the ClearQuest Web Interface, set the following environment variables:

- ▶ **CQCC\_SERVER**: name of the host where the ClearQuest Web server resides
- ▶ **CQCC\_SERVERROOT**: root directory where the ClearQuest Web Interface files are installed

### Setting the Environment for the ClearQuest Perl API

To enable a client to use the ClearQuest Perl API, perform the following tasks:

On Windows:

- ▶ Use the ClearQuest Maintenance Tool to connect to the schema repository that stores the schema used by the ClearQuest user database. From the Windows Start menu, click **Start > Programs > Rational ClearQuest Administration > Rational ClearQuest Maintenance Tool**.

For Windows and UNIX:

- ▶ If the ClearQuest database set is something other than the default, set the **CQCC\_DATABASE\_SET** environment variable.

On Windows, the ClearQuest Perl API attempts to connect to the schema repository that the ClearQuest Maintenance Tool has most recently connected to. On UNIX, the API uses the default schema repository specified for your ClearQuest installation.

Database sets allow users to select from multiple schema repositories when they start ClearQuest, or the base ClearCase-ClearQuest integration, without having to use the ClearQuest Maintenance Tool.

---

## Editing the Configuration File

The configuration file contains parameters that define local policy choices and how to access ClearQuest. The configuration file is set to access the ClearQuest SAMPL user database. To use the integration with a different ClearQuest user database, you need to change parameters. The configuration file contains comments that describe how to set the parameters. Before you can edit the configuration file, change its permissions to make it modifiable.

---

## Testing the Integration

After you install the triggers on one or more VOBs and edit the configuration file, you can test the connection between ClearCase and ClearQuest by entering the following command:

On Windows:

```
cqcc_launch CQCC\config.pl -test
```

On UNIX:

```
cqcc_launch CQCC/config.pl -test
```

**NOTE:** The commands shown above use the default path for the configuration file. If you specified a different path when you installed the triggers, use that path when invoking the `cqcc_launch` command.

The command displays output indicating whether it is able to connect to the target ClearQuest user database. For more detailed output messages, set the `CQCC_DEBUG` environment variable to 2.

---

## Checking Performance

The performance of the integration triggers can vary depending on how they access ClearCase and ClearQuest. You can set the `CQCC_TIMER` environment variable to 1 to record timing information about the trigger session. The integration writes the information to standard output and `cqcc_output.log` in the directory defined by the `TMPDIR` environment variable.

---

## 13.3 Using the Integration Query Wizard

After you establish associations between ClearCase versions and ClearQuest change requests, you can use the ClearQuest Integration Query wizard on Windows to identify the change requests that are associated with a project over a period of time. For example, you might use the wizard to answer the question, “Which change requests were associated with Release 3.1 of Project X?”

To start the wizard from the Windows Start menu, click **Start > Programs > Rational ClearCase Administration > ClearQuest Integration Query**. Alternatively, you can start the wizard by entering **cqquery** at the command prompt. Click **Help** for instructions on completing each page of the wizard.



In a parallel development environment, the opposite of branching is merging. In the simplest scenario, merging incorporates changes on a subbranch into the **main** branch. However, you can merge work from any branch into any other branch. This chapter describes techniques and scenarios for merging versions of elements and branches. ClearCase includes automated merge facilities for handling almost any scenario.

---

### 14.1 How Merging Works

A merge combines the contents of two or more files or directories into a single new file/directory. The ClearCase merge algorithm uses the following files during a merge (see Figure 42):

- ▶ Contributors, which are typically one version from each branch you are merging. (You can merge up to 15 contributors.) You specify which versions are contributors.
- ▶ The base contributor, which is typically the closest common ancestor of the contributors. (For selective merges, subtractive merges, and merges in an environment with complex branch structures, the base contributor may not be the closest common ancestor.) ClearCase determines which contributor is the base contributor.
- ▶ The target contributor, which is typically the latest version on the branch that will contain the results of the merge. You determine which contributor is the target contributor.
- ▶ The merge output file, which contains the results of the merge and is usually checked in as a successor to the target contributor. By default, the merge output file is the checked-out version of the target contributor, but you can choose a different file to contain the merge output.

Figure 42 Versions Involved in a Typical Merge

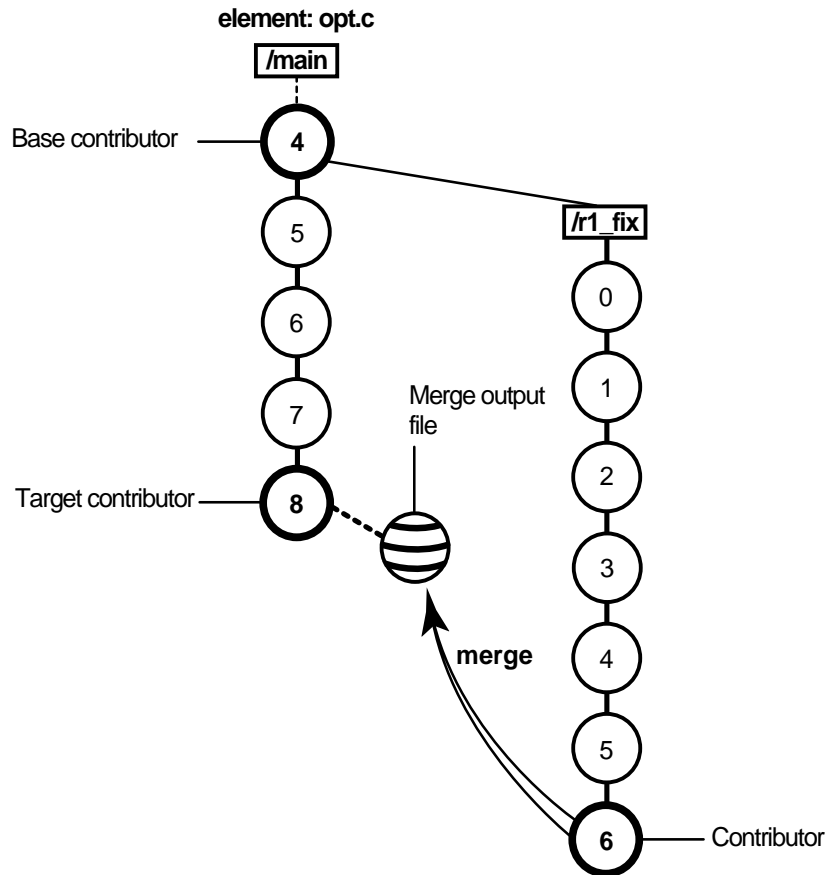

To merge files and directories, ClearCase takes the following steps:

1. It identifies the base contributor.
2. It compares each contributor against the base contributor. (See Figure 43.)
3. For any line that is unchanged between the base contributor and any other contributor, it copies the line to the merge output file.
4. For any line that has changed between the base contributor and one other contributor, it accepts the change in the contributor; depending on how you started the merge operation, ClearCase may copy the change to the merge output file. However, you can disable the



automated merge capability for any given merge operation. If you disable this capability, you must approve each change to the merge output file.

5. For any line that has changed between the base contributor and more than one other contributor, ClearCase requires that you resolve the conflicting difference.

Figure 43 ClearCase Merge Algorithm

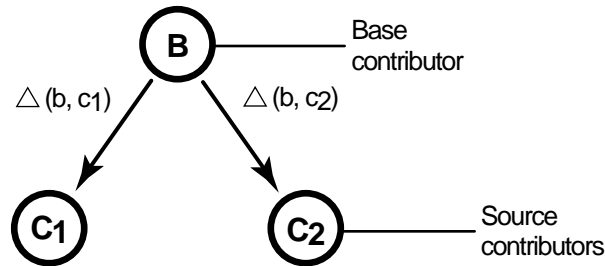

$$\text{Destination version} = B + \Delta(b, c1) + \Delta(b, c2)$$

To merge versions, you can use the GUI tools, described briefly in the next section, or the command-line interface, described in *Using the Command Line to Merge Elements* on page 194.

---

## Using the GUI to Merge Elements

ClearCase provides three graphical tools to help you merge elements:

- Merge Manager
- Diff Merge
- Version Tree Browser

The Merge Manager manages the process of merging one or more ClearCase elements. It automates the processes of gathering information for a merge, starting a merge, and tracking a merge. It can also save and retrieve the state of a merge for a set of elements.

You can use the Merge Manager to merge from many directions:

- From a branch to the **main** branch
- From the **main** branch to another branch
- From one branch to another branch

To start the Merge Manager, type **clearmrgman** at a command prompt.

The Diff Merge utility shows the differences between two or more versions of file or directory elements. Use this tool to compare up to 16 versions at a time, navigate through versions, merge versions, and resolve differences between versions.

To start the Diff Merge utility, type **xcleardiff** or use the **cleartool merge –graphical** command at a command prompt.

The Version Tree Browser displays the version tree for an element. The version tree is useful when merging to do the following:

- Locate versions or branches that have contributed to or resulted from a merge
- Start a merge by clicking on the appropriate symbol

The merge can be recorded with a merge arrow, which is implemented as a hyperlink of type **Merge**.

To start the Version Tree Browser, use one of these methods:

- At a command prompt, type **cleartool lsvtree –graphical**
- In the ClearCase File Browser, click an element and click **Versions > Show version tree**

---

## Using the Command Line to Merge Elements

Use the following commands to perform merges from the command line:

- **cleartool merge**
- **cleartool findmerge**
- **cleardiff**

For more information on these commands, see the *Command Reference*.

---

## 14.2 Common Merge Scenarios

The following sections present a series of merge scenarios that require work on one branch of an element to be incorporated into another branch. Each scenario shows the version tree of an element that requires a merge and indicates the appropriate command to perform the merge.

## Scenario: Selective Merge from a Subbranch

In this scenario, you want to incorporate the changes in version `/main/r1_fix/4` into new development. To perform the merge, you specify which versions on the `r1_fix` branch to include. See Figure 44.

Figure 44 Selective Merge from a Subbranch

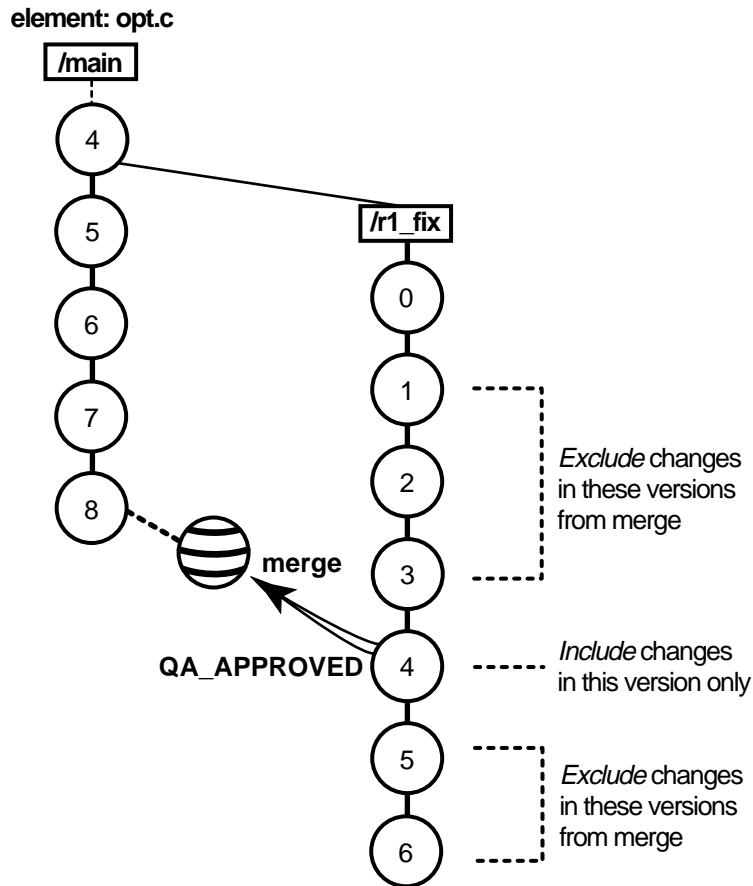

In a view configured with the default config spec, enter these commands to perform the selective merge:

```
% cleartool checkout opt.c
% cleartool merge -to opt.c -insert -version /main/r1_fix/4
```

You can also specify a range of consecutive versions to be merged. For example, this command merges only the changes in versions `/main/r1_fix/2` through `/main/r1_fix/4`:

```
% cleartool merge -to opt.c -insert -version /main/r1_fix/2 /main/r1_fix/4
```

No merge arrow is created for a selective merge.

---

## Scenario: Removing the Contributions of Some Versions

A new feature, implemented in versions 14 through 16 on the `main` branch, will not be included in the product. You must remove the changes made in those versions. See Figure 45.

Figure 45 Removing the Contributions of Some Versions

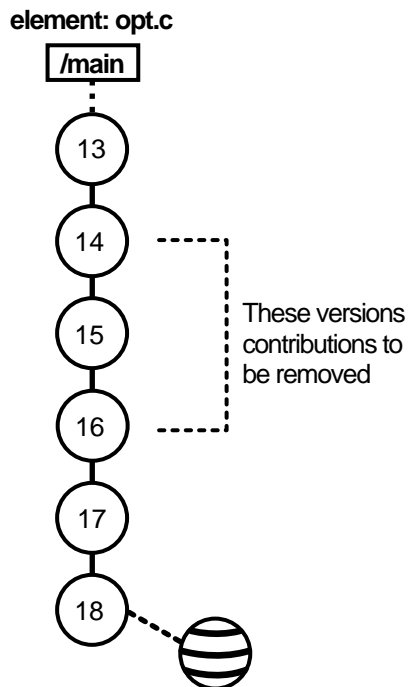

Enter these commands to perform this subtractive merge:

```
% cleartool checkout opt.c
% cleartool merge -to opt.c -delete -version /main/14 /main/16
```

No merge arrow is created for a subtractive merge.

---

## Scenario: Merging All Project Work

Your team has been working on a branch. Now, your job is to merge all the changes into the **main** branch.

The **findmerge** command can handle most common cases easily. It can accommodate the following schemes for isolating the project's work.

### All Project Work Is Isolated on a Branch

The standard approach to parallel development isolates all project work on the same branch. More precisely, all new versions of source files are created on like-named branches of their respective elements (that is, on branches that are instances of the same *branch type*). This makes it possible for a single **findmerge** command to locate and incorporate all the changes. Suppose the common branch is named **gopher**. You can enter these commands in a view configured with the default config spec:

```
% cd root-of-source-tree
% cleartool findmerge . -fversion .../gopher/LATEST -merge -graphical
```

The **-merge -graphical** syntax causes the merge to take place automatically whenever possible, and to start the graphical merge utility if an element's merge requires user interaction. If the project has made changes in several VOBs, you can perform all the merges at once by specifying several pathnames, or by using the **-avobs** option to **findmerge**.

### All Project Work Isolated in a View

Some projects are organized so that all changes are made in a single view (typically, a shared view). For such projects, use the **-ftag** option to **findmerge**. Suppose the project's work has been done in a view whose view-tag is **goph\_vu**. These commands perform the merge:

```
% cd root-of-source-tree
% cleartool findmerge . -ftag goph_vu -merge -graphical
```

**NOTE:** Working in a single shared view is not recommended because doing so can degrade system performance.

---

## Scenario: Merging a New Release of an Entire Source Tree

Your team has been using an externally supplied source-code product, maintaining the sources in a VOB. The successive versions supplied by the vendor are checked in to the **main** branch and labeled **VEND\_R1**, **VEND\_R2**, and **VEND\_R3**. Your team's fixes and enhancements are created on subbranch **enhance**. The views that your team works in are configured to branch from the **VEND\_R3** baseline:

```
element * CHECKEDOUT
element * ../enhance/LATEST
element * VEND_R3 -mkbranch enhance
element * /main/LATEST -mkbranch enhance
```

The version trees in Figure 46 show various likely cases:

- An element that your team started changing at Release 1 (**enhance** branch created at the version labeled **VEND\_R1**)
- An element that your team started changing at Release 3
- An element that your team has never changed

Figure 46 Merging a New Release of an Entire Source Tree

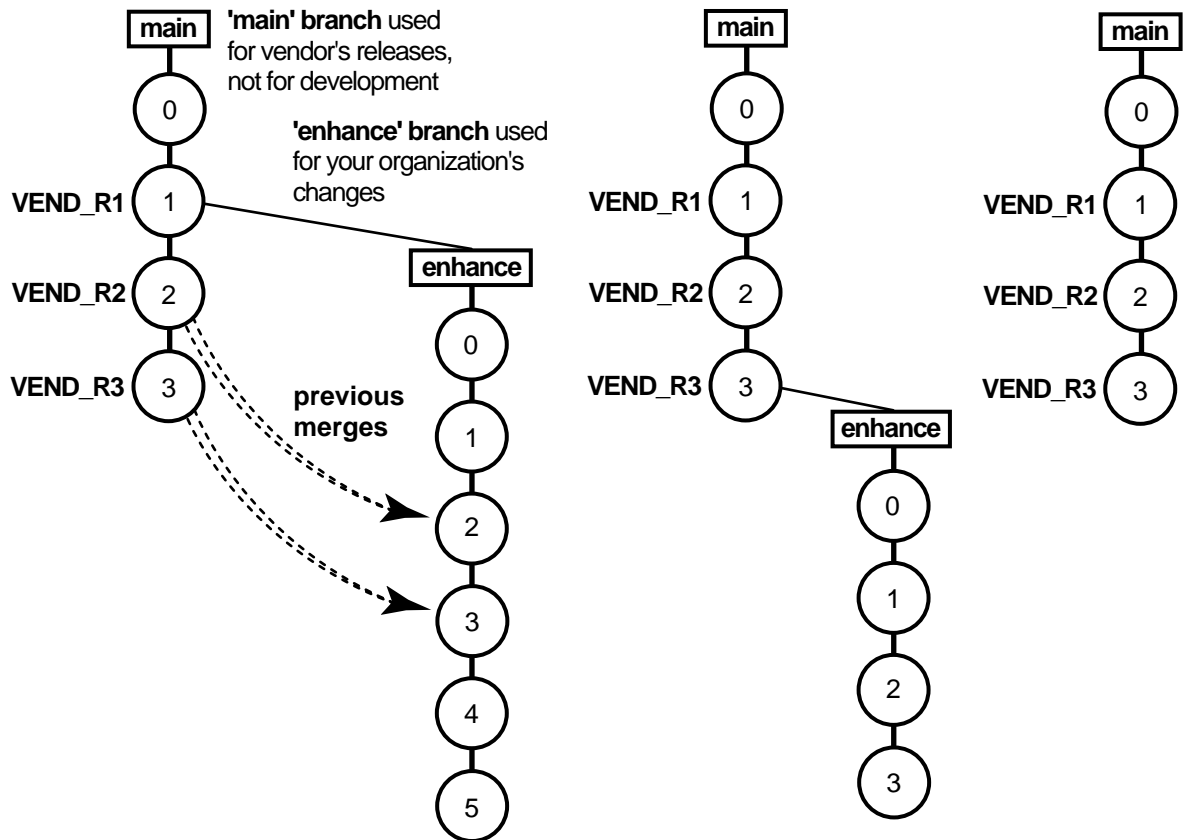

Release 4 has arrived, and you need to integrate this release with your team's changes.

To prepare for the merge, add the new release to the **main** branch and label the versions **VEND\_R4**. Merging the source trees involves merging from the version labeled **VEND\_R4** to the most recent version on the **enhance** branch; if an element has no **enhance** branch, nothing is merged.

This procedure accomplishes the integration:

1. Load the vendor's Release 4 media into a standard directory tree:

```
%cd /usr/tmp
% tar -xv
```

The directory tree created is **mathlib\_4.0**.

2. As the VOB owner, run **clearexport\_ffile**, to create a datafile containing descriptions of the new versions.

```
% cd ./mathlib_4.0
% clearexport_ffile
. (lots of output)
.
```

3. In a view configured with the default config spec, start **clearimport** on the file **clearexport\_ffile** created. This creates Release 4 versions on the **main** branches of elements (and creates new elements as needed).

```
% cleartool setview mainline

% cd /vobs/proj/mathlib
% clearimport /usr/tmp/mathlib_4.0/cvt_data
```

4. Label the new versions:

```
% cleartool mklbtype -c "Release 4 of MathLib sources" VEND_R4
Created label type "VEND_R4".
% cleartool mklabel -recurse VEND_R4 /vobs/proj/mathlib
. (lots of output)
.
```

5. Set to a view that is configured with your team's config spec and selects the versions on the **enhance** branch:

```
% cleartool setview enh_vu
```

6. Merge from the **VEND\_R4** configuration to your view:

```
% cleartool findmerge -nback /vobs/proj/mathlib -fver VEND_R4 -merge -graphical
```

The **-merge -graphical** syntax instructs **findmerge** to merge automatically if possible, but if not, start the graphical merge tool.

7. Verify the merges, and check in the modified elements.



You have now established Release 4 as the new baseline. Developers on your team can update their view configurations as follows:

```
element * CHECKEDOUT
element * .../enhance/LATEST
element * VEND_R4 -mkbranch enhance           (change from VEND_R3 to VEND_R4)
element * /main/LATEST -mkbranch enhance
```

Elements that have been active continue to evolve on their **enhance** branches. When elements are revised for the first time, their **enhance** branches are created at the **VEND\_R4** version.

---

## Scenario: Merging Directory Versions

One of the most powerful features of ClearCase is versioning of directories. Each version of a directory element catalogs a set of file elements, directory elements, and VOB symbolic links. In a development project, directories change as often as files do. Merging the changes to another branch is as easy as merging files.

Take a closer look at the source tree scenario from the previous section. Suppose you find that the vendor has made several changes in directory **/vobs/proj/mathlib/src**:

- File elements **Makefile**, **getcwd.c**, and **fork3.c** have been revised.
- File elements **readln.c** and **get.c** have been deleted.
- A new file element, **newpaths.c**, has been created.

When you use **findmerge** to merge the changes made in the **VEND\_R4** sources to the **enhance** branch, the changes to both the files and the directory are handled automatically. The following **findmerge** excerpt shows the directory merge activity:

```
*****
<<< directory 1: /vobs/proj/mathlib/src@@/main/3
>>> directory 2: .@@/main/enhance/1
>>> directory 3: .
*****
-----[ removed directory 1 ]-----|-----[ directory 2]-----
get.c 19-Dec-1991 drp                  |-
*** Automatic: Applying REMOVE from directory 2
-----[ directory 1 ]-----|-----[ added directory 2]-----
                                -| newpaths.c 08-Mar.21:49 drp
*** Automatic: Applying ADDITION from directory 2
-----[ removed directory 1 ]-----|-----[ directory 2]-----
readln.c 19-Dec-1991 drp                |-
*** Automatic: Applying REMOVE from directory 2
Recorded merge of ".".
```

If you have changes to merge from both files and directories, it may be a good idea to run **findmerge** twice: first to merge directories, and again to merge files. Using the **-print** option to a **findmerge** command does not report everything that is merged, because **findmerge** does not see new files or subdirectories in the merge-from version of a directory until after the directories are merged. To report every merge that takes place, use **findmerge** to merge the directories only, and then use **findmerge -print** to get information about the file merges needed. Afterward, you can cancel the directory merges by using the **uncheckout** command on the directories.

---

## 14.3 Using Your Own Merge Tools

You can create a merged version of an element manually or with any available analysis and editing tools. Check out the target version, revise it, and check it in. Immediately before (or after) the checkin, record your activity by using the **merge** command with the **-ndata** (no data) option:

```
% cleartool checkout nextwhat.c
Checkout comments for "nextwhat.c":
merge enhance branch
.
Checked out "nextwhat.c" from version "/main/1".

% <invoke your own tools to merge data into checked-out version>

% cleartool merge -to nextwhat.c -ndata -version ../enhance/LATEST
Recorded merge of "nextwhat.c".
```

This form of the **merge** command does not change any file system data; it merely attaches a merge arrow (a hyperlink of type **Merge**) to the specified versions. After you've made this annotation, your merge is indistinguishable from one performed with ClearCase tools.



## Using Element Types to Customize Processing of File Elements

# 15

Most projects involve many different file types. For example, in a typical software release, developers may work on C-language source files, C-language header files, document files in binary format, and library files.

Every file that is stored in a ClearCase VOB is associated with an element type. Rational ClearCase provides predefined element types for various kinds of file types, and every element type has an associated type manager, which handles the operations performed on versions of the element.

For some file types in your project, you may want to create your own element types so that you can customize the handling of the files. You can also create your own type managers.

This chapter describes how ClearCase uses element types and type managers to classify and manage files. It also describes how you can customize file classification and management.

---

### 15.1 File Types in a Typical Project

Table 5 lists the files used in a typical development project.

Table 5 Files Used in a Typical Project

Type of File	Identifying Characteristic
<b>Source Files</b>	
C-language source file	.c file-name extension
C-language header file	.h file-name extension
FrameMaker binary file	.doc or .mif file-name extension, first line of file begins with <Maker
manual page source file	.1 – .9 file-name extension
<b>Derived Files</b>	
ar(1) archive (library)	.a file-name extension
compiled executable	<varies with system architecture>file-name extension

## 15.2 How ClearCase Assigns Element Types

In various contexts, ClearCase determines one or more *file types* for an existing file system object, or for a name to be used for a new object. When you create a new element and do not specify an element type, ClearCase determines the file type for the element.

The file-typing routines use predefined and user-defined *magic files*, as described in the **cc.magic** reference page. A magic file can use many different techniques to determine a file type, including file-name pattern-matching, **stat(2)** data, and standard UNIX magic numbers.

For example, the following magic file specifies several file types for each kind of file listed in Table 5.

#### Sample Magic File

```
(1) c_src src_file text_file file:      -name "*.c" ;
(2) hdr_file text_file file:          -name "*.h" ;
(3) frm_doc binary_delta_file doc file: -magic 0, "<MakerFile" ;
(4) manpage src_file text_file file:   -name "*.[1-9]" ;
(5) archive derived_file file:         -magic 32, "archive" ;
(6) sunexec derived_file file:         -magic 40, "SunBin" ;
```

---

## 15.3 Element Types and Type Managers

ClearCase can handle different classes of files differently because it uses *element types* to categorize elements. Each file element in a VOB must have an element type. An element gets its type when it is created; you can change an element's type subsequently, with the **chtype** command. (An element is an *instance* of its element type, in the same way that an attribute is an instance of an attribute type and a version label is an instance of a label type.)

Each element type has an associated *type manager*, a suite of programs that handle the storage and retrieval of versions from storage pools. (See the **type\_manager** reference page for information on how type managers work.) Thus, the way in which a file element's data is handled depends on its element type.

**NOTE:** Each directory element also has an element type. But directory elements do not use type managers; the contents of a directory version are stored in the VOB database itself, not in storage pools.

Figure 47 shows how an element type is assigned to a newly created element.

Figure 47 Data Handling: File Type, Element Type, Type Manager

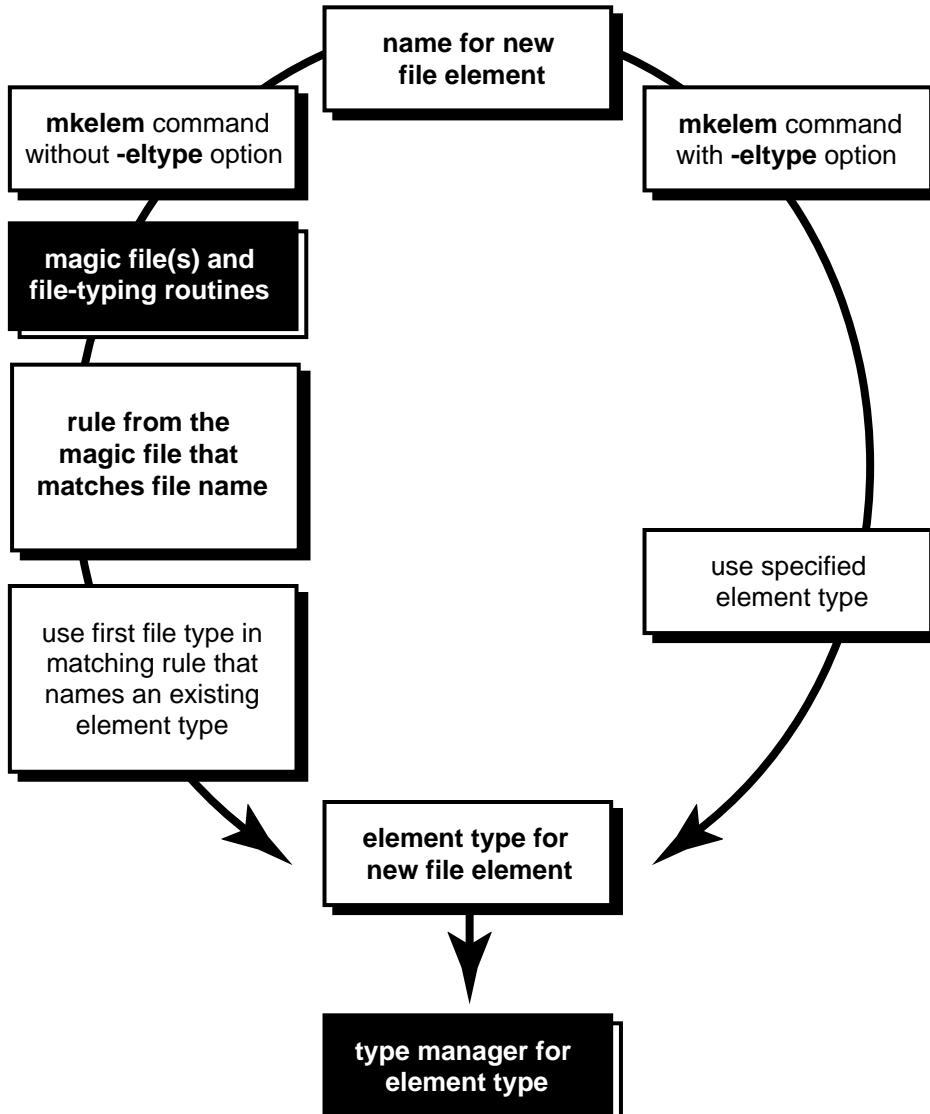

For example, a new element named `monet_adm.1` is assigned an element type as follows:

1. A developer creates an element:

```
% cleartool mkelem monet_adm.1
```



2. Because the developer did not specify an element type (`-eltype` option), **mkelem** uses one or more magic files to determine the file types of the specified name.

NOTE: ClearCase supports a search path facility, using the environment variable `MAGIC_PATH`. See the **cc.magic** reference page for details.

Suppose that the magic file shown in *Sample Magic File* on page 207 is the first (or only) one to be used. In this case, rule (4) is the first to match the name **monet\_adm.1**, yielding this list of file types:

```
manpage src_file text_file file
```

3. This list is compared with the set of element types defined for the new element's VOB. Suppose that **text\_file** is the first file type that names an existing element type; in this case, **monet\_adm.1** is created as an element of type **text\_file**.
4. Data storage and retrieval for versions of element **monet\_adm.1** are handled by the type manager associated with the **text\_file** element type; its name is **text\_file\_delta**:

```
% cleartool describe eltype:text_file
element type "text_file"
...
  type manager: text_file_delta
  supertype: file
  meta-type of element: file element
```

File-typing mechanisms are defined on a per-user or per-site basis; element types are defined on a per-VOB basis. (To ensure that element types are consistent across VOBs, the ClearCase administrator can use global types.) In this case, a new element, **monet\_adm.1**, is created as a **text\_file** element; in a VOB with a different set of element types, the same magic file may have created it as a **src\_file** element.

---

## Other Applications of Element Types

Element types allow differential and customized handling of files beyond the selection of type managers. Following are some examples.

### Using Element Types to Configure a View

Creating all C-language header files as elements of type **hdr\_file** allows flexibility in configuring views. Suppose that one developer has reorganized the project header files, working on a branch

named **header\_reorg** to avoid disrupting the team's work. To compile with the new header files, another developer can use a view reconfigured with one additional rule:

```
element * CHECKEDOUT
element -eltype hdr_file * /main/header_reorg/LATEST
element * /main/LATEST
```

### Processing Files by Element Type

Suppose that a coding-standards program named **check\_var\_names** is to be executed on each C-language source file. If all such files have element type **c\_src**, a single **cleartool** command runs the program:

```
% cleartool find -avobs -visible -element 'eltype(c_src)' \
    -exec 'check_var_names $CLEARCASE_PN'
```

---

## 15.4 Predefined and User-Defined Element Types

Some of the element types described in this chapter (for example, **text\_file**) are predefined. Others (for example, **c\_src** and **hdr\_file**) are not; the previous examples work only if user-defined element types with these names are created with the **mkeltype** command.

When a new VOB is created, it contains a full set of the predefined element types. Each is associated with one of the type managers provided with ClearCase. The **mkeltype** reference page describes the predefined element types and their type managers.

When you create a new element type with **mkeltype**, you must specify an existing element type as its *supertype*. By default, the new element type uses the same type manager as its supertype; in this case, the only distinction between the new and old types is for the purposes described in *Other Applications of Element Types* on page 209. For differential data handling, use the **-manager** option to create an element type that uses a different type manager from its supertype.

Directory *ccase-home-dir/examples/clearcase/mkeltype* contains shell scripts that create a hierarchy of element types.

---

## 15.5 Predefined and User-Defined Type Managers

ClearCase provides predefined type managers. The type managers are described in the **type\_manager** reference page. Each type manager is implemented as a suite of programs in a subdirectory of *ccase-home-dir/lib/mgrs*; the name of the subdirectory is the name of the type manager.

The **mkeltype -manager** command creates an element type that uses an existing type manager. You can further customize ClearCase by creating new type managers and creating new element types that use them. Architecturally, type managers are mutually independent, but new type managers can use symbolic links to inherit some of the functions of existing ones.

---

### UNIX—Creating a New Type Manager

You can create any number of new type managers for use throughout the local network. Use these guidelines:

1. Choose a name for the new type manager—ideally one that shows its relationship to the data format (for example, **bitmap\_mgr**). Create a subdirectory of *ccase-home-dir/lib/mgrs* with this name.

**NOTE:** Names of user-defined type managers must not begin with underscore.

2. Create symbolic links to make the new type manager inherit some of its methods (file-manipulation operations) from an existing type manager.
3. Create your own program for the methods that you want to customize. See *UNIX—Writing a Type Manager Program*.
4. On each other ClearCase or ClearCase LT client host in the network, either make a copy of the new type manager directory, or create a symbolic link to it. The standard storage, performance, and reliability trade-offs apply.
5. If your company uses ClearCase MultiSite, repeat Step #4 at every site.

**NOTE:** An element type belongs to a VOB, and thus is available on every host that mounts its VOB. But a type manager is host-specific; it is some host's *ccase-home-dir/lib/mgrs/manager-name* directory.

See the **type\_manager** reference page and the file *ccase-home-dir/lib/mgrs/mgr\_info.h* for additional information on type managers.

---

## UNIX—Writing a Type Manager Program

When invoking a type manager method, **cleartool** passes to it all the arguments needed to perform the operation, in ASCII format. For example, many methods accept a *new\_container\_name* argument, specifying the pathname of a data container to which data is to be written.

In many cases, one or more of the parameters can be ignored. For example, the **create\_version** method is passed **pred\_container\_name**, the pathname of the predecessor version's data container. If the type manager implements incremental differences, this is required information; otherwise, the predecessor's data container is of no interest.

Arguments are often object identifiers (OIDs). You need not know anything about how OIDs are generated; consider each OID to be a unique name for an element, branch, or version. In general, only type managers that store multiple versions in the same data container need be concerned with OIDs.

For more information on argument processing, see files *ccase-home-dir/lib/mgrs/mgr\_info.h* (for C language programs) and *ccase-home-dir/lib/mgrs/mgr\_info.sh* (for Bourne shell scripts).

### Exit Status of a Method

A user-defined type manager method must return an exit status to **cleartool**, indicating how the command is to be completed. The symbolic constants in *ccase-home-dir/lib/mgrs/mgr\_info.h* specify all valid exit statuses. For example, an invocation of **create\_version** may create a new data container, and return the exit status **MGR\_STORE\_KEEP\_JUST\_NEW**; if creation of the new data container fails, it returns the exit status **MGR\_STORE\_KEEP\_JUST\_OLD**.

---

## 15.6 Type Manager for Manual Page Source Files

One kind of file listed in Table 5 is a manual page source file, a file coded in **nroff(1)** format. A type manager for this kind of file may have these characteristics:

- ▶ It stores all versions in compressed form in separate data containers, like the **z\_whole\_copy** type manager.
- ▶ It implements version-comparison (compare method) by running **diff** on formatted manual pages instead of the source versions.

The basic strategy is to use most of the **z\_whole\_copy** type manager's methods. The compare method uses **nroff(1)** to format the versions before displaying their differences.

---

## Creating the Type Manager Directory

The name **mp\_mgr** (manual page manager) is appropriate for this type manager. The first step is to create a subdirectory with this name in the *ccase-home-dir/lib/mgrs* directory. For example:

```
# mkdir /usr/atria/lib/mgrs/mp_mgr
```

---

## Inheriting Methods from Another Type Manager

Most of the **mp\_mgr** methods are inherited from the **z\_whole\_copy** type manager, through symbolic links. You can enter the following commands as the *root* user in a Bourne shell:

```
# MP=${ATRIAHOME}/lib/mgrs/mp_mgr
# for FILE in create_element create_version construct_version \
    create_branch delete_branches_versions \
    merge xmerge xcompare get_cont_info
> do
> ln -s ../z_whole_copy/$FILE $MP/$FILE
> done
#
```

Any methods that the new type manager does not support can be omitted from this list. The lack of a symbolic link causes ClearCase to generate an `Unknown Manager Request` error.

The following sections describe two of these inherited methods, **create\_version** and **construct\_version**, which can serve as models for user-defined methods. Both are actually implemented as scripts in the same file, *ccase-home-dir/lib/mgrs/z\_whole\_copy/Zmgr*.

### The **create\_version** Method

The **create\_version** method is invoked when a **checkin** command is entered. The **create\_version** method of the **z\_whole\_copy** type manager does the following:

1. Compresses the data in the checked-out version
2. Stores the compressed data in a data container located in a source storage pool

3. Returns an exit status to the calling process, indicating what to do with the new data container

The file *ccase-home-dir/lib/mgrs/mgr\_info.h* lists the arguments passed to the method from the calling program (usually **cleartool** or **xcclearcase**):

```
/*
 * create_version
 * Store the data for a new version.
 * Store the version's data in the supplied new container, combining it
 * with the predecessor's data if desired (e.g for incremental deltas).
 *
 * Command line:
 * create_version create_time new_branch_oid new_ver_oid new_ver_num
 *                 new_container_pname pred_branch_oid pred_ver_oid
 *                 pred_ver_num pred_container_pname data_pname
 */
```

The only arguments that require special attention are *new\_container\_pname* (fifth argument), which specifies the pathname of the new data container, and *data\_pname* (tenth argument), which specifies the pathname of the checked-out file.

The file *ccase-home-dir/lib/mgrs/mgr\_info.sh* lists the appropriate exit statuses and provides a symbolic name for the *create\_version* method:

```
# Any unexpected value is treated as failure
MGR_FAILED=1

# Return Values for store operations
MGR_STORE_KEEP_NEITHER=101
MGR_STORE_KEEP_JUST_OLD=102
MGR_STORE_KEEP_JUST_NEW=103
MGR_STORE_KEEP_BOTH=104
.
.
MGR_OP_CREATE_VERSION="create_version"
```

The example here is the code that implements the **create\_version** method.

```

(1)      shift 1
(2)      if [ -s $4 ] ; then
(3)          echo '$0: error: new file is not of length 0!'
(4)          exit $MGR_FAILED
(5)      fi
(6)      if $gzip < $9 > $4 ; ret=$? ; then : ; fi
(7)      if [ "$ret" = "2" -o "$ret" = "0" ] ; then
(8)          exit $MGR_STORE_KEEP_BOTH
(9)      else
(10)         exit $MGR_FAILED
(11)     fi

```

The Bourne shell allows only nine command-line arguments. The `shift 1` in Line 1 discards the first argument (*create\_time*), which is unneeded. Thus, the pathname of the checked-out version (*data\_pname*), originally the tenth argument, becomes \$9.

In Line 6, the contents of *data\_pname* are compressed, then appended to the new, empty data container: *new\_container\_pname*, originally the fifth argument, but shifted to become \$4. (Lines 2 through 5 verify that the new data container is, indeed, empty.)

Finally, the exit status of the **gzip** command is checked, and the appropriate value is returned (Lines 7 through 11). The exit status of the `create_version` method indicates that both the old data container (which contains the predecessor version) and the new data container (which contains the new version) are to be kept.

### The `construct_version` Method

An element's `construct_version` method is invoked when standard UNIX software reads a particular version of the element (unless the contents are already cached in a *cleartext* storage pool). For example, the `construct_version` method of element **monet\_admin.1** is invoked by the **view\_server** when a user enters these commands:

```

% cp monet_admin.1 /usr/tmp           (read version selected by view)
% cat monet_admin.1@@/main/4         (read a specified version)

```

It is also invoked during a **checkout** command, which makes a view-private copy of the most recent version on a branch.

The `construct_version` method of the **z\_whole\_copy** type manager does the following:

1. Uncompresses the contents of the data container
2. Returns an exit status to the calling process, indicating what to do with the new data container

The file *ccase-home-dir/lib/mgrs/mgr\_info.h* lists the arguments passed to the method.

```

/*****
 * construct_version
 * Fetch the data for a version.
 * Extract the data for the requested version into the supplied pathname, or
 * return a value indicating that the source container can be used as the
 * cleartext data for the version.
 *
 * Command line:
 *   construct_version source_container_pname data_pname version_oid

```

The file *ccase-home-dir/lib/mgrs/mgr\_info.sh* lists the appropriate exit statuses and provides a symbolic name for the `construct_version` method:

```

# Any unexpected value is treated as failure
MGR_FAILED=1

# Return Values for construct operations
MGR_CONSTRUCT_USE_SRC_CONTAINER=101
MGR_CONSTRUCT_USE_NEW_FILE=102
.
.
MGR_OP_CONSTRUCT_VERSION="construct_version"

```

This example is the code that implements the `construct_version` method.

#### **construct\_version Method**

```

(1) if $gzip -d < $1 > $2 ; then
(2)     exit $MGR_CONSTRUCT_USE_NEW_FILE
(3) else
(4)     exit $MGR_FAILED
(5) fi

```

In Line 1, the contents of *source\_container\_pname* are uncompressed and stored in the cleartext container, *data\_pname*. The remaining lines return the appropriate value to the calling process, depending on the success or failure of the `gzip` command.



---

## Implementing a New compare Method

The **compare** method is invoked by a **cleartool diff** command. This method does the following:

1. Formats each version using **nroff(1)**, producing an ASCII text file
2. Compares the formatted versions, using **cleardiff** or **xcleardiff**

The file *ccase-home-dir/lib/mgrs/mgr\_info.h* lists the arguments passed to the method from **cleartool** or **xclearcase**.

```
/******  
* compare  
* Compare the data for two or more versions.  
* For more information, see man page for cleartool diff.  
*  
* Command line:  
* compare [-tiny | -window] [-serial | -diff | -parallel] [-columns n]  
*         [pass-through-options] pname pname ...
```

This listing shows that a user-supplied implementation of the **compare** method must accept all the command-line options that the ClearCase **diff** command supports. The strategy here is to pass the options to **cleardiff**, without attempting to interpret them. After all options are processed, the remaining arguments specify the files to be compared.

The file *ccase-home-dir/lib/mgrs/mgr\_info.sh* lists the appropriate exit statuses and provides a symbolic name for the **compare** method.

```
# Return Values for COMPARE/MERGE Operations  
MGR_COMPARE_NODIFFS=0  
MGR_COMPARE_DIFF_OR_ERROR=1  
.  
.  
MGR_OP_COMPARE="compare"
```

The Bourne shell script listed in *Script for compare Method* implements the compare method. (You can modify this script to implement the **xcompare** method as a slight variant of compare.)

## Script for compare Method

```
#!/bin/sh -e
MGRDIR=${ATRIAHOME:-/usr/atria}/lib/mgrs

#### read file that defines methods and exit statuses
. $MGR_DIR/mgr_info.sh

#### process all options: pass them through to cleardiff
OPTS=""
while (expr $1 : '\-' > /dev/null) ; do
    OPTS="$OPTS $1"
    if [ "$1" = "$MGR_FLAG_COLUMNS" ] ; then
        shift 1
        OPTS="$OPTS $1"
    fi
    shift 1
done
#### all remaining arguments ($) are files to be compared
#### first, format each file with NROFF
COUNT=1
TMP=/usr/tmp/compare.$$
for X in $* ; do
    nroff -man $X | col | ul -Tcrt > $TMP.$COUNT
    COUNT=`expr $COUNT + 1`
done

#### then, compare the files with cleardiff
cleardiff -quiet $OPTS $TMP.*

#### cleanup and return appropriate exit status
if [ $? -eq MGR_COMPARE_NODIFFS ] ; then
    rm -f $TMP.*
    exit MGR_COMPARE_NODIFFS
else
    rm -f $TMP.*
    exit MGR_COMPARE_DIFF_OR_ERROR
fi
```

## Testing the Type Manager

You can test a new type manager only by using it on some ClearCase host. This process need not be obtrusive. Because the type manager has a new name, no existing element type—and therefore, no existing element—uses it automatically. To place the type manager in service, create a new element type, create some test elements of that type, and run some tests.

The following testing sequence continues the **mp\_mgr** example.

**Creating a Test Element Type.** To make sure that an untested type manager is not used accidentally, associate it with a new element type, **manpage\_test**, of which you are the only user.

```
% cleartool mkeltype -nc -supertype compressed_file \  
    -manager mp_mgr manpage_test  
% cleartool lock -nusers $USER eltype:manpage_test
```

**Creating and Using a Test Element.** These commands create a test element that uses the new type manager, and tests the various data-manipulation methods:

```
% cd directory-in-test-VOB  
% cleartool checkout -nc . (tests create_element method)  
% cleartool mkelem -eltype manpage_test -nc -nco test.1  
% cleartool checkout -nc test.1 (tests construct_version method)  
% vi test.1 (edit checked-out version)  
% cleartool checkin -c "first" test.1 (tests create_version method)  
% cleartool checkout -nc test.1 (tests construct_version method)  
% vi test.1 (edit checked-out version)  
% cleartool checkin -c "second" test.1 (tests create_version method)  
% cleartool diff test.1@@/main/1 test.1@@/main/2 (tests compare method)
```

## Installing and Using the Type Manager

After a type manager has been fully tested, you can make it available to all users with the following procedure.

### 1. Install the type manager.

A VOB is a networkwide resource; it can be mounted on any ClearCase host. But a type manager is a host resource: a separate copy must be installed on each host where ClearCase client programs run. If the copy is not installed, elements of the new type cannot be used. (It need not be installed on hosts that serve only as repositories for VOBs and/or views.)

If the VOB is replicated, you must install the type manager at all sites. Custom type managers are not replicated.

To install the type manager on a particular host, create a subdirectory in *ccase-home-dir/lib/mgrs*, and populate it with the programs that implement the methods. You can create symbolic links across the network to a master copy on a server host.

### 2. Create element types.

Create one or more element types that use the type manager, just as you did in *Testing the Type Manager* (do not include “test” in the name of the element type). For example, you can name the element type **manpage** or **nroff\_src**.

### 3. Convert existing elements.

You’ll probably want to have at least a few existing elements use the new type manager. The **chtype** command changes an element’s type:

```
% cleartool chtype -force manpage pathname ...
```

Permission to change an element’s type is restricted to the element’s owner, the VOB owner, and the *root* user.

### 4. Revise magic files.

If you want the new element types to be used automatically for certain newly created elements, create (or update) a **local.magic** file in each host’s *ccase-home-dir/config/magic* directory:

```
manpage src_file text_file file: -name ".*[1-9]" ;
```

### 5. Inform the project team (and other teams, if appropriate).

Advertise the new element types to all team members, describing the features and benefits of the new type manager. Be sure to provide directions on how to gain access to the new functionality automatically (through file names that match magic-file rules) and explicitly (with **mkelem -eltype**).

---

## 15.7 Icon Use by GUI Browsers

An **xclearcase** browser can display file system objects either by name or graphically. In the latter case, **xclearcase** selects an icon for each file system object as follows:

1. The object’s name or its contents determines a list of file types, as described in *How ClearCase Assigns Element Types* on page 206.
2. One by one, the file types are compared to the rules in predefined and user-defined icon files, as described in the **cc.icon** reference page. For example, the file type **c\_source** matches this icon file rule:

```
c_source : -icon c ;
```

When a match is found, the search ends. The token that follows **-icon** names the file that contains the icon to be displayed.

3. **xclearcase** searches for the file, which must be in **bitmap(1)** format, in directory **\$HOME/.bitmaps**, or *ccase-home-dir/config/ui/bitmaps*, or the directories specified by the environment variable **BITMAP\_PATH**.
4. If a valid bitmap file is found, **xclearcase** displays it; otherwise, the search for an icon continues with the next file type.

The name of an icon file must include a numeric extension, which need not be specified in the icon file rule. The extension specifies how much screen space **xclearcase** must allocate for the icon. Each bitmap supplied with ClearCase is stored in a file with a **.40** suffix (for example, **lib.40**), indicating a 40x40 icon.

This procedure causes **xclearcase** to display manual page source files with a customized icon. All manual pages have file type **manpage**.

1. Add a rule to your personal magic file (in directory **\$HOME/.magic**) that includes **manpage** among the file types assigned to all manual page source files:

```
manpage src_file text_file file: -name "*. [1-9]" ;
```

2. Add a rule to your personal icon file (in directory **\$HOME/.icon**) that maps **manpage** to a user-defined bitmap file:

```
manpage : -icon manual_page_icon ;
```

3. Create a **manpage** icon in your personal bitmaps directory (**\$HOME/.bitmaps**) by revising one of the standard icon bitmaps with the standard X **bitmap** utility:

```
% mkdir $HOME/.bitmaps
% cd $HOME/.bitmaps
% cp $ATRIAHOME/config/ui/bitmaps/c.40 manual_page_icon.40
% bitmap manual_page_icon.40
```

4. Test your work by having an **xclearcase** browser display a manual page source file (Figure 48).

Figure 48 User-Defined Icon Display

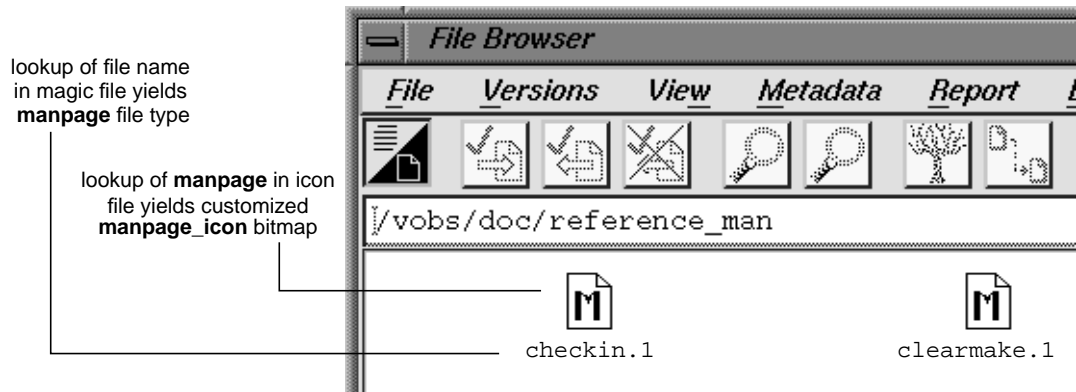

## Using ClearCase Throughout the Development Cycle

# 16

The previous chapters describe various aspects of managing a project with Rational ClearCase. This chapter presents one way in which you can use ClearCase to organize the work throughout a development project. During this cycle, developers create a new release and maintain the previous release.

This chapter describes concepts and methods to address typical organizational needs. There are many other approaches that ClearCase supports.

---

### 16.1 Project Overview

Release 2.0 development of the **monet** project includes the following kinds of work:

- ▶ Patches. Several high-priority bug fixes to Release 1.0 are needed.
- ▶ Minor enhancements. Some commands need new options; some option names need to be shortened (**-recursive** becomes **-r**); some algorithms need performance work.
- ▶ Major new features. A graphical user interface is required, as are many new commands and internationalization support.

These three development efforts can proceed largely in parallel (Figure 49), but critical dependencies and milestones must be considered:

- ▶ Several Release 1.0 patch releases will ship before Release 2.0 is complete.
- ▶ New features take longer to complete than minor enhancements.

- Some new features depend on the minor enhancements.

Figure 49 Project Plan for Release 2.0 Development

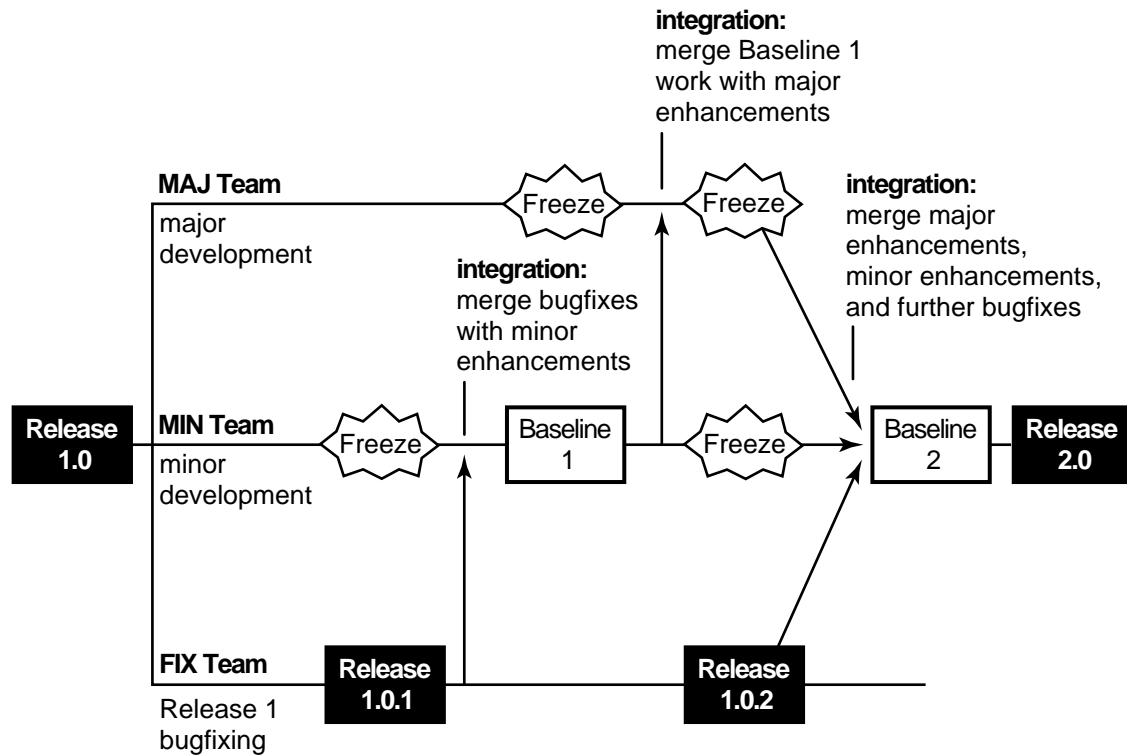

The plan uses a baseline-plus-changes approach. Periodically, developers stop writing new code, and spend some time integrating their work, building, and testing. The result is a *baseline*: a stable, working version of the application. ClearCase makes it easy to integrate product enhancements incrementally and frequently. The more frequent the baselines, the easier the tasks of merging work and testing the results.

After a baseline is produced, active development resumes; any new efforts begin with the set of source versions that went into the baseline build.

You define a baseline by assigning the same version label (for example, **R2\_BL1** for Release 2.0, Baseline 1) to all the versions that go into, or are produced by, the baseline build.



The project team is divided into three smaller teams, each working on a different development effort: the MAJ team (new features), the MIN team (minor enhancements), and the FIX team (Release 1.0 bug fixes and patches).

**NOTE:** Some developers may belong to multiple teams. These developers work in multiple views, each configured for the respective team's tasks.

**PRODUCT NOTE:** In the examples that follow, arguments that show multicomponent VOB-tags, such as **/vobs/monet**, do not apply to Rational ClearCase LT, which recognizes only single-component VOB-tags, such as **/monet**.

The development area for the **monet** project is shown here. At the beginning of Release 2.0 development, the most recent versions on the **main** branch are labeled **R1.0**.

<code>/vobs/monet</code>	<i>(project top-level directory)</i>
<code>src/</code>	<i>(sources)</i>
<code>include/</code>	<i>(include files)</i>
<code>lib/</code>	<i>(shared libraries)</i>

---

## 16.2 Development Strategy

This section describes the ClearCase issues to be resolved before development begins.

---

### Project Manager and ClearCase Administrator

In most development efforts, the project manager and the system administrator are different people. The user name of the project manager is **meister**. The administrator is the **vobadm** user, who creates and owns the **monet** and **libpub** VOBs.

---

### Use of Branches

In general, different kinds of work is done on different branches. The Release 1.0 bug fixes, for example, are made on a separate branch to isolate this work from new development. The FIX team can then create patch releases that do not include any of the Release 2.0 enhancements or incompatibilities.

Because the MIN team will produce the first baseline release on its own, the project manager gives the **main** branch to this team. The MAJ team will develop new features on a subbranch, and will not be ready to integrate for a while; the FIX team will fix Release 1.0 bugs on another subbranch and can integrate its changes at any time.

Each new feature can be developed on its own subbranch, to better manage integration and testing work. For simplicity, this chapter assumes that work for new features is done on a single branch.

The project manager has created the first baseline from versions on the **main** branches of their elements. But this is not a requirement; you can create a release that uses versions on any branch, or combination of branches.

Figure 50 shows the evolution of a typical element during Release 2.0 development, and indicates correspondences to the overall project plan (Figure 49).

Figure 50 Development Milestones: Evolution of a Typical Element

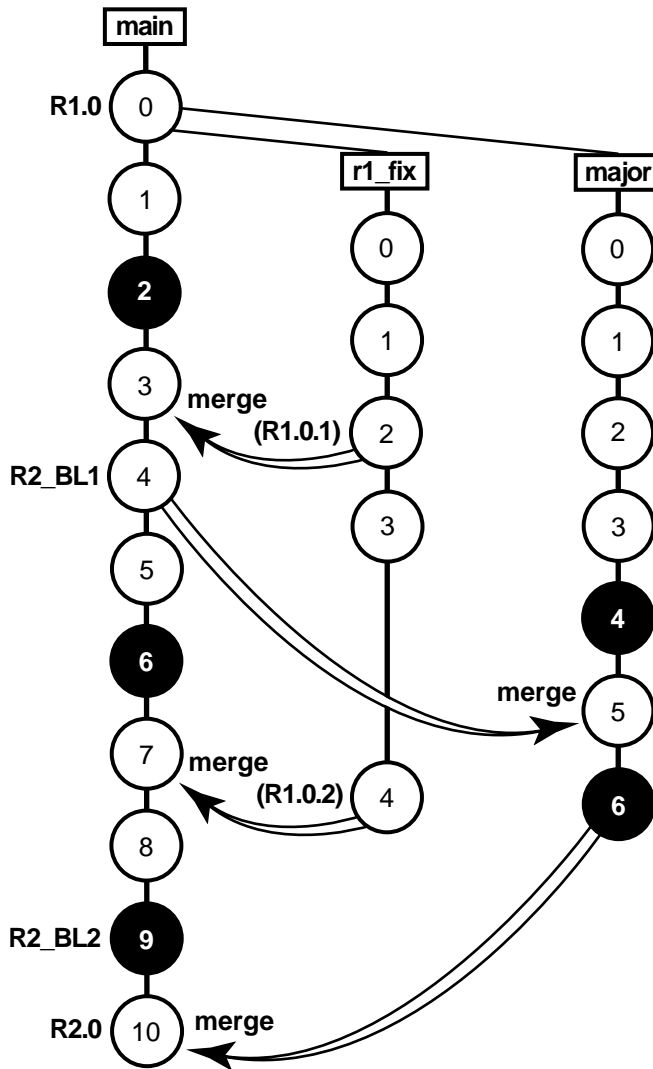

1. (All branches) Start minor and major enhancements, along with R1.0 bug fixing
2. (main) Freeze minor enhancements work
3. (main) Merge bug fixes from Release 1.0.1 into minor enhancements
4. (main) Baseline 1 release
5. (major) Freeze major enhancements work
6. (major) Merge Baseline 1 changes into major enhancements
7. (main) Freeze minor enhancements work
8. (main) Merge additional bugfixes into minor enhancements
9. (major) Freeze major enhancements work
10. (main) Merge major enhancements work with minor enhancements work
11. (main) Baseline 2 release
12. (main) Final testing period
13. (main) Release 2.0

---

## Creating Project Views

The MAJ team works on a branch named **major** and uses this config spec:

- (1) `element * CHECKEDOUT`
- (2) `element * ../major/LATEST`
- (3) `element * R1.0 -mkbranch major`
- (4) `element * /main/LATEST -mkbranch major`

The MIN team works on the **main** branch and uses the default config spec:

- (1) `element * CHECKEDOUT`
- (2) `element * ../main/LATEST`

The FIX team works on a branch named **r1\_fix** and uses this config spec:

- (1) `element * CHECKEDOUT`
- (2) `element * ../r1_fix/LATEST`
- (3) `element * R1.0 -mkbranch r1_fix`
- (4) `element * /main/LATEST -mkbranch r1_fix`

For the MAJ and FIX teams, use of the *auto-make-branch* facility in Rule (3) and Rule (4) enforces consistent use of subbranches. It also relieves developers of the task of creating branches explicitly and ensures that all branches are created at the version labeled **R1.0**.

---

## 16.3 Creating Branch Types

The project manager creates the **major** and **r1\_fix** branch types required for the config specs in *Creating Project Views* on page 228:

```
cleartool mkbtype -c "monet R2 major enhancements" \  
major@/vobs/libpub major@/vobs/monet  
Created branch type "major".  
Created branch type "major".
```

```
cleartool mkbtype -c "monet R1 bugfixes" r1_fix@/vobs/libpub r1_fix@/vobs/monet  
Created branch type "r1_fix".  
Created branch type "r1_fix".
```

**NOTE:** Because each VOB has its own set of branch types, the branch types must be created separately in the **monet** VOB and the **libpub** VOB.

---

## 16.4 Creating Standard Config Specs

To ensure that all developers in a team configure their views the same way, the project manager creates files containing standard config specs:

- `/public/config_specs/MAJ` contains the MAJ team's config spec.
- `/public/config_specs/FIX` contains the FIX team's config spec.

These config spec files are stored in a standard directory outside a VOB, to ensure that all developers get the same version.

---

## 16.5 Creating, Configuring, and Registering Views

Each developer creates a view under his or her home directory. For example, developer **arb** enters these commands:

```
% mkdir $HOME/view_store
% cleartool mkview -tag arb_major $HOME/view_store/arb_major.vws
Created view.
Host-local path: phobos:export/home/arb/view_store/arb_major.vws
Global path:      /net/phobos/export/home/arb/view_store/arb_major.vws
It has the following rights:
User : arb       : rwx
Group: user     : rwx
Other:          : r-x
```

A new view has the default config spec. Thus, developers on the MAJ and FIX teams must reconfigure their views, using the standard file for their team. **arb** edits her config spec with the **cleartool edcs** command, deletes the existing lines, and adds the following line:

```
/public/config_specs/MAJ
```

If the project manager changes the standard file, **arb** must enter the command **cleartool setcs -current** to pick up the changes.

---

## 16.6 Development Begins

To begin the project, a developer sets a properly configured view, checks out one or more elements, and starts work. For example, developer **david** on the MAJ team enters these commands:

```
% cleartool setview david_major
% cd /vobs/monet/src
% cleartool checkout -nc opt.c prs.c
Created branch "major" from "opt.c" version "/main/6".
Checked out "opt.c" from version "/main/major/0".
Created branch "major" from "prs.c" version "/main/7".
Checked out "prs.c" from version "/main/major/0".
```

The auto-make-branch facility causes each element to be checked out on the **major** branch (see Rule 4 in the MAJ team's config spec in *Creating Project Views* on page 228). If a developer on the MIN team enters this command, the elements are checked out on the **main** branch, with no conflict.

ClearCase is fully compatible with standard development tools and practices. Thus, developers use the editing, compilation, and debugging tools they prefer (including personal scripts and aliases) while working in their views.

Developers check in work periodically to make their work available to other team members (that is, those whose views select the most recent version on the team's branch). This allows intrateam integration and testing to proceed throughout the development period.

---

### Techniques for Isolating Your Work

Individual developers may need or prefer to isolate their work from the changes made by other team members. To do so, they can use these techniques to configure their views:

- ▶ Time rules. When someone checks in an incompatible change, a developer can reconfigure the view to select the versions at a point before those changes were made.
- ▶ Private subbranches. A developer can create a private subbranch in one or more elements (for example, **/main/major/anne\_wk**). The config spec must be changed to select versions on the **/main/major/anne\_wk** branch instead of versions on the **/main/major** branch.
- ▶ Viewing only their own revisions. Developers can use a ClearCase query to configure a view that selects only their own revisions to the source tree.

---

## 16.7 Creating Baseline 1

The MIN team has implemented and tested the first group of minor enhancements, and the FIX team has produced a patch release, whose versions are labeled **R1.0.1**. It is time to combine these efforts, to produce Baseline 1 of Release 2.0 (Figure 51).

Figure 51 Creating Baseline 1

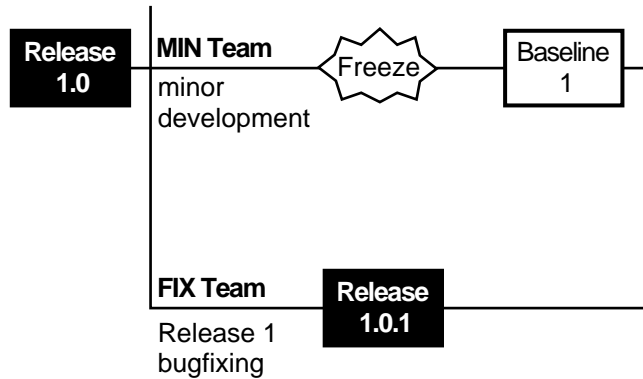

---

### Merging Two Branches

The project manager asks the MIN developers to merge the **R1.0.1** changes from the **r1\_fix** branch to their own branch (**main**). All the changes can be merged by using the **findmerge** command once. For example:

```
% cleartool findmerge /vobs/libpub /vobs/monet/src \  
-fversion ../r1_fix/LATEST -merge -graphical  
.  
. <lots of output>  
.
```

---

## Integration and Test

After the merges are complete, the **/main/LATEST** versions of certain elements represent the efforts of the MIN and FIX teams. Members of the MIN team now compile and test the **monet** application to find and fix incompatibilities in the work of both teams.

The developers on the MIN team integrate their changes in a single, shared view. The project manager creates the view storage area in a location that is accessible from all developer hosts:

```
% umask 2
% mkdir /netwide/public
% cleartool mkview -tag base1_vu /netwide/public/base1_vu.vws
Created view.
Host-local path: infinity:/netwide/public/base1_vu.vws
Global path:      /net/infinity/netwide/public/base1_vu.vws.
It has the following rights:
User : meister   : rwx
Group: mon       : rwx
Other:           : r-x
```

Because all integration work takes place on the **main** branch, there is no need to change the configuration of the new view from the ClearCase default. MIN developers set this view (**cleartool setview base1\_vu**) and coordinate builds and tests of the **monet** application. Because they are sharing a single view, the developers are careful not to overwrite each other's view-private files. Any new versions created to fix inconsistencies (and other bugs) go onto the **main** branch.

---

## Labeling Sources

The **monet** application's minor enhancements and bug fixes are now integrated, and a clean build has been performed in view **base1\_vu**. To create the baseline, the project manager assigns the same version label, **R2\_BL1**, to the **/main/LATEST** versions of all source elements. He begins by creating an appropriate label type:

```
% cleartool mklbtype -c "Release, Baseline 1" R2_BL1@/vobs/monet R2_BL1@/vobs/libpub
Created label type "R2_BL1".
Created label type "R2_BL1".
```

He then locks the label type, preventing all developers (except himself) from using it:



```
% cleartool lock -nusers meister ldtype:R2_BL1@/vobs/monet ldtype:R2_BL1@/vobs/libpub
Locked label type "R2_BL1".
Locked label type "R2_BL1".
```

Before applying labels, he verifies that all elements are checked in on the **main** branch (checkouts on other branches are still permitted):

```
% cleartool lscheckout -all /vobs/monet /vobs/libpub
```

No output from this command indicates that all elements for the **monet** project are checked in. Now, the project manager attaches the **R2\_BL1** label to the currently selected version (**/main/LATEST**) of every element in the two VOBs:

```
% cleartool mklablel -recurse R2_BL1 /vobs/monet /vobs/libpub
Created label "R2_BL1" on "/vobs/monet" version "/main/1".
Created label "R2_BL1" on "/vobs/monet/src" version "/main/3".
<many more label messages>
```

---

## Removing the Integration View

The view registered as **base1\_vu** is no longer needed, so the project manager removes it:

```
% cleartool rmview -force -tag base1_vu
```

---

## 16.8 Merging Ongoing Development Work

After Baseline 1 is created, the MAJ team merges the Baseline 1 changes into its work (Figure 52). The team now has access to the minor enhancements it needs for further development. Team members also have an early opportunity to determine whether any of their changes are incompatible.

Figure 52 Updating Major Enhancements Development

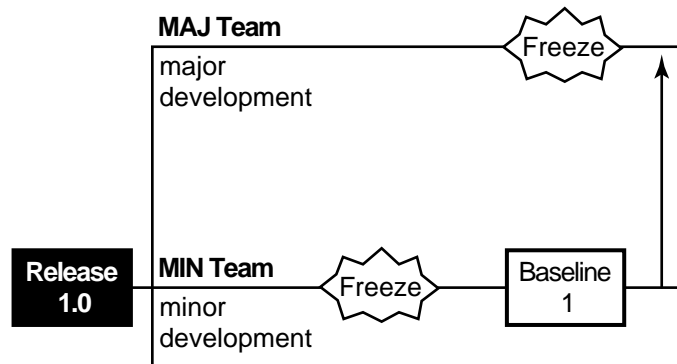

Accordingly, the project manager declares a freeze of major enhancements development. MAJ team members check in all elements and verify that the **monet** application builds and runs, making small source changes as necessary. When all such changes have been checked in, the team has a consistent set of **/main/major/LATEST** versions.

**NOTE:** Developers working on other major enhancements branches can merge at other times, using the same merge procedures described here.

---

## Preparing to Merge

1. The project manager makes sure that no element is checked out on the **major** branch:

‡ **cleartool lscheckout -all /vobs/monet /vobs/libpub**

**NOTE:** Any MAJ team members who want to continue with nonmerge work can create a subbranch at the “frozen” version (or work with a version that is checked out as unreserved).

2. The project manager performs any required directory merges:

```
% cleartool setview major_vu                                (use any MAJ team view)

% cleartool findmerge /vobs/monet /vobs/libpub -type d \
-fversion /main/LATEST -merge
Needs merge /vobs/monet/src [automatic to /main/major/3 from /main/LATEST]
.
. <lots of output>
.
Log has been written to "findmerge.log.04-Feb-99.09:58:25".
```

3. After checking in the files, the project manager determines which elements need to be merged:

```
% cleartool findmerge /vobs/monet /vobs/libpub -fversion /main/LATEST -print
.
. <lots of output>
.
A 'findmerge' log has been written to
"findmerge.log.04-Feb-99.10:01:23"
```

This last **findmerge** log file is in the form of a shell script: it contains a series of **cleartool findmerge** commands, each of which performs the required merge for one element:

```
% cat findmerge.log.04-Feb-99.10:01:23
cleartool findmerge /vobs/monet/src/opt.c@@/main/major/1 -fver /main/LATEST -merge
cleartool findmerge /vobs/monet/src/prs.c@@/main/major/3 -fver /main/LATEST -merge
.
.
cleartool findmerge /vobs/libpub/src/dcanon.c@@/main/major/3 -fver /main/LATEST -merge
cleartool findmerge /vobs/libpub/src/getcwd.c@@/main/major/2 -fver /main/LATEST -merge
cleartool findmerge /vobs/libpub/src/lineseq.c@@/main/major/10 -fver /main/LATEST -merge
```

4. The project manager locks the **major** branch, allowing it to be used only by the developers who are performing the merges:

```
cleartool lock -nusers meister,arb,david,sakai brtype:major@/vobs/monet \
brtype:major@/vobs/libpub
Locked branch type "major".
Locked branch type "major".
```

---

## Merging Work

Because the MAJ team is not contributing to a baseline soon, it is not necessary to merge work (and test the results) in a shared view. MAJ developers can continue working in their own views.

Periodically, the project manager sends an excerpt from the **findmerge** log to an individual developer, who executes the commands and monitors the results. (The developer can send the resulting log files back to the project manager, as confirmation of the merge activity.)

A merged version of an element includes changes from three development efforts: Release 1.0 bug fixing, minor enhancements, and new features (Figure 53).

Figure 53 Merging Baseline 1 Changes into the major Branch

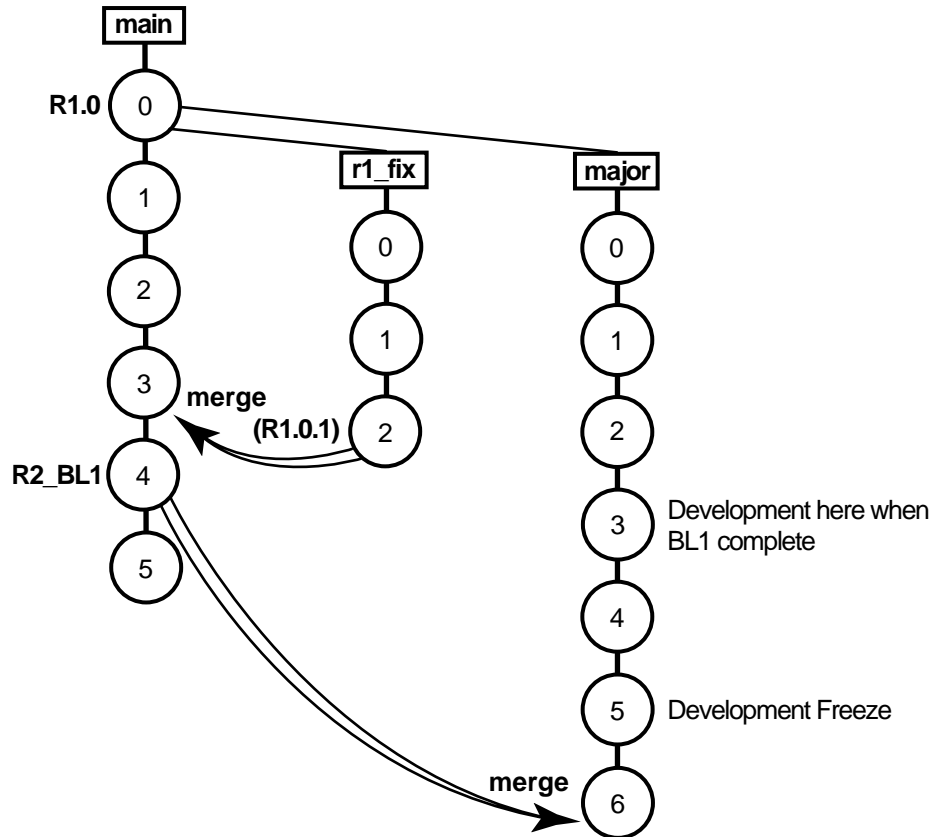

The project manager verifies that no more merges are needed, by entering a **findmerge** command with the **-whynot** option:

```
% cleartool findmerge /vobs/monet/vobs/libpub -fversion /main/LATEST -whynot -print
.
.
No merge "/vobs/monet/src" [/main/major/4 already merged from /main/3]
No merge "/vobs/monet/src/opt.c" [/main/major/2 already merged from /main/12]
.
.
```

The merge period ends when the project manager removes the lock on the **major** branch:

```
% cleartool unlock brtype:major@/vobs/monet brtype:major@/vobs/libpub
Unlocked branch type "major".
Unlocked branch type "major".
```

---

## 16.9 Creating Baseline 2

The MIN team is ready to freeze for Baseline 2, and the MAJ team will be soon (Figure 54). Baseline 2 will integrate all three development efforts, thus requiring two sets of merges:

- Bug fix changes from the most recent patch release (versions labeled **R1.0.2**) must be merged to the **main** branch.
- New features must be merged from the **major** branch to the **main** branch. (This is the opposite direction from the merges described in *Merging Ongoing Development Work* on page 233.)

Figure 54 Baseline 2

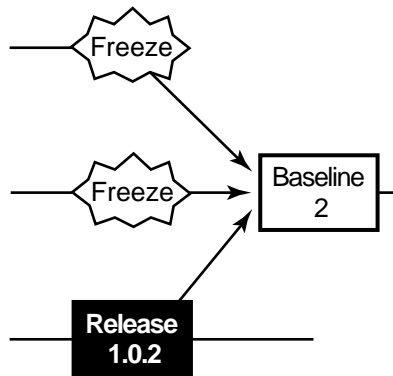

ClearCase supports merges from more than two directions, so both the bug fixes and the new features can be merged to the **main** branch at the same time. In general, though, it is easier to verify the results of two-way merges.

---

## Merging from the r1\_fix Branch

The first set of merges is almost identical to those described in *Merging Two Branches* on page 231.

---

## Preparing to Merge from the major Branch

After the integration of the **r1\_fix** branch is completed, the project manager prepares to manage the merges from the **major** branch. These merges are performed in a tightly controlled environment, because the Baseline 2 milestone is approaching and the **major** branch is to be abandoned.

**NOTE:** It is probably more realistic to build and verify the application, and then apply version labels before proceeding to the next merge.

The project manager verifies that everything is checked in on both the **main** branch and **major** branches:

```
% cleartool lscheckout -brtype main -recurse /vobs/monet /vobs/libpub
% cleartool lscheckout -brtype major -recurse /vobs/monet /vobs/libpub
%
```

No output from these commands indicates that no element is checked out on either its **main** branch or its **major** branch.

Next, the project manager determines which elements require merges:

```
% cleartool setview minor_vu (use any MIN team view)
```

```
% cleartool findmerge /vobs/monet /vobs/libpub -fversion ../major/LATEST -print
```

```
. <lots of output>
```

```
A 'findmerge' log has been written to
"findmerge.log.26-Feb-99.19:18:14"
```

All development on the **major** branch will stop after this baseline. Thus, the project manager locks the **major** branch to all users, except those who are performing the merges. Locking allows ClearCase to record the merges with a hyperlink of type **Merge**:

```
% cleartool lock -nusers arb,david brtype:major@/vobs/monet brtype:major@/vobs/libpub
Locked branch type "major".
Locked branch type "major".
```

Because the **main** branch will be used for Baseline 2 integration by a small group of developers, the project manager asked **vobadm** to lock the **main** branch to everyone else:

```
% cleartool lock -nusers meister,arb,david,sakai \
brtype:main@/vobs/monet brtype:main@/vobs/libpub
Locked branch type "main".
Locked branch type "main".
```

(To lock the branch, you must be the branch creator, element owner, VOB owner, or *root* user. See the **lock** reference page.)

---

## Merging from the major Branch

Because the **main** branch is the destination of the merges, developers work in a view with the default config spec. The situation is similar to the one described in *Preparing to Merge* on page 234. This time, the merges take place in the opposite direction, from the **major** branch to the **main** branch. Accordingly, the **findmerge** command is very similar:

```
% cleartool findmerge /vobs/monet /vobs/libpub -fversion /main/major/LATEST \
-merge -graphical
.
. <lots of output>
.
A 'findmerge' log has been written to
"findmerge.log.23-Mar-99.14:11:53"
```

After checkin, the version tree of a typical merged element appears as in Figure 55.



Figure 55 Element Structure After the Pre-Baseline-2 Merge

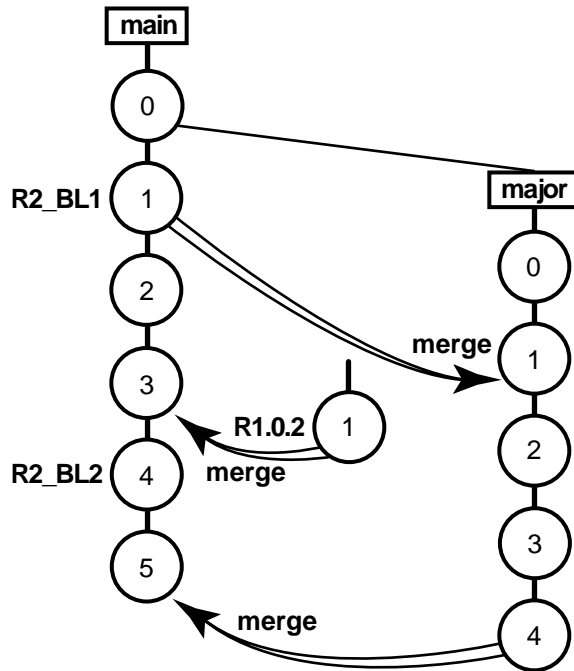

---

## Decommissioning the major Branch

After all data has been merged to the **main** branch, development on the **major** branch will stop. The project manager enforces this policy by making the **major** branch obsolete:

```
% cleartool lock -replace -obsolete brtype:major@/vobs/monet brtype:major@/vobs/libpub  
Locked branch type "major".  
Locked branch type "major".
```

---

## Integration and Test

Structurally, the Baseline 2 integration-and-test phase is identical to the one for Baseline 1 (see *Integration and Test* on page 232). At the end of the integration period, the project manager attaches version label **R2\_BL2** to the **/main/LATEST** version of each element in the **monet** and **libpub** VOBs. (The Baseline 1 version label was **R2\_BL1**.)

---

### 16.10 Final Validation: Creating Release 2.0

Baseline 2 has been released internally, and further testing has found only minor bugs. These bugs have been fixed by creating new versions on the **main** branch (Figure 56).

Figure 56 Final Test and Release



Before it is shipped to customers, the **monet** application goes through a validation phase:

- ▶ All editing, building, and testing is restricted to a single, shared view.
- ▶ All builds are performed from sources with a particular version label (**R2.0**).
- ▶ Only the project manager has permission to make changes involving that label.
- ▶ All labels must be moved by hand.
- ▶ Only high-priority bugs are fixed, using this procedure:
  - a. The project manager authorizes a particular developer to fix the bug, by granting her permission to create new versions (on the **main** branch).
  - b. The developer's checkin activity is tracked by a ClearCase trigger.
  - c. After the bug is fixed, the project manager moves the **R2.0** version label to the fixed version and revokes the developer's permission to create new versions.

---

## Labeling Sources

In a view with the default config spec, the project manager creates the **R2.0** label type and locks it:

```
cleartool mklbtype -c "Release 2.0" R2.0@/vobs/monet R2.0@/vobs/libpub
```

```
Created label type "R2.0".
```

```
Created label type "R2.0".
```

```
cleartool lock -nusers meister lbtype:R2.0@/vobs/monet lbtype:R2.0@/vobs/libpub
```

```
Locked label type "R2.0".
```

```
Locked label type "R2.0".
```

The project manager labels the **/main/LATEST** versions throughout the entire **monet** and **libpub** development trees:

```
cleartool mklablel -recurse R2.0 /vobs/monet /vobs/libpub
```

```
<many label messages>
```

During the final test phase, the project manager moves the label forward, using **mklablel -replace**, if any new versions are created.

---

## Restricting Use of the main Branch

At this point, use of the **main** branch is restricted to a few users: those who performed the merges and integration leading up to Baseline 2 (see *Merging from the major Branch* on page 240). Now, the project manager asks **vobadm** to close down the **main** branch to everyone except himself, **meister**:

```
% cleartool lock -replace -nusers meister brtype:main
```

```
Locked branch type "main".
```

The **main** branch is opened only for last-minute bug fixes (see *Fixing a Final Bug* on page 244.)

---

## Setting Up the Test View

The project manager creates a new shared view, **r2\_vu**, that is configured with a one-rule config spec:

```
% umask 2
% cleartool mkview -tag r2_vu /public/integrate_r2.vws
% cleartool edcs -tag r2_vu
```

This is the config spec:

```
element * R2.0
```

This config spec guarantees that only properly labeled versions are included in final validation builds.

---

## Setting Up the Trigger to Monitor Bug-fixing

The project manager places a trigger on all elements in the **monet** and **libpub** VOBs; the trigger fires whenever a new version of any element is checked in. First, he creates a script that sends mail (for an example script, see *Notify Team Members of Relevant Changes* on page 174).

Then, he asks **vobadm** to create an all-element trigger type in the **monet** and **libpub** VOBs, specifying the script as the trigger action:

```
% cleartool mktrtype -nc -element -all -postop checkin -brtype main \
-exec /public/scripts/notify_manager.sh \
r2_checkin@/vobs/monet r2_checkin@/vobs/libpub
Created trigger type "r2_checkin".
Created trigger type "r2_checkin".
```

Only the VOB owner or **root** user can create trigger types.

---

## Fixing a Final Bug

This section demonstrates the final validation environment in action. Developer **arb** discovers a serious bug and requests permission to fix it. The project manager grants her permission to create new versions on the **main** branch, by having **vobadm** enter this command.

```
% cleartool lock -replace -nusers arb,meister brtype:main
Locked branch type "main".
```

**arb** fixes the bug in a view with the default config spec and tests the fix there. This involves creating two new versions of element **prs.c** and one new version of element **opt.c**. Each time **arb**

uses the **checkin** command, the **r2\_checkin** trigger sends mail to the project manager. For example:

```
Subject: Checkin /vobs/monet/src/opt.c by arb
/vobs/monet/src/opt.c@@/main/9
Checked in by arb.
```

```
Comments:
fixed bug #459: made buffer larger
```

When regression tests verify that the bug has been fixed, the project manager revokes **arb**'s permission to create new versions. Once again, the command is executed by **vobadm**:

```
% cleartool lock -replace -nusers meister brtype:main
Locked branch type "main".
```

The project manager then moves the version labels to the new versions of **prs.c** and **opt.c**, as indicated in the mail messages. For example:

```
% cleartool mklabel -replace R2.0 /vobs/monet/src/opt.c@@/main/9
Moved label "R2.0" on "prs.c" from version "/main/8" to "/main/9".
```

---

## Rebuilding from Labels

After the labels have been moved, developers rebuild the **monet** application again, to verify that a good build can be performed using only those versions labeled **R2.0**.

---

## Wrapping Up

When the final build in the **r2\_vu** passes the final test, Release 2.0 of **monet** is ready to ship. After the distribution medium has been created from derived objects in the **r2\_vu**, the project manager asks the ClearCase administrator to clean up and prepare for the next release:

- The ClearCase administrator removes the checkin triggers from all elements by deleting the all-element trigger type:

```
cleartool rmtree trtype:r2_checkin@/vobs/monet trtype:r2_checkin@/vobs/libpub
Removed trigger type "r2_checkin".
Removed trigger type "r2_checkin".
```

- The ClearCase administrator reopens the **main** branch:

```
cleartool unlock brtype:main  
Unlocked branch type "main".
```

## ClearCase-ClearQuest Integrations

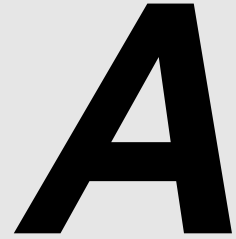

Rational ClearCase supports two integrations with Rational ClearQuest. This appendix provides information that you need to manage both integrations in the same development environment.

---

### A.1 Understanding the ClearCase-ClearQuest Integrations

The integration of ClearQuest and ClearCase associates one or more ClearQuest records with one or more ClearCase versions, allowing you to use features of each product. ClearCase supports two separate integrations with ClearQuest:

- The base ClearCase-ClearQuest integration
- The UCM-ClearQuest integration

For information on setting up the base ClearCase-ClearQuest integration, see Chapter 13, *Setting Up the Base ClearCase-ClearQuest Integration*. Note that this integration cannot be used with UCM projects.

For further information on the UCM-ClearQuest integration, see Part 1 of this book.

In general, we recommend that you use the base ClearCase and UCM integrations separately, and avoid using a common ClearQuest user database. However, it is possible for both integrations to use the same ClearQuest user database. This can be useful if you are moving a project to UCM and have a substantial amount of information in a ClearQuest user database that was created with the base ClearCase-ClearQuest integration. You may want the new work in UCM to be reflected in new ClearQuest records in the same ClearQuest user database.

The remainder of this appendix discusses considerations in managing the coexistence of the base ClearCase-ClearQuest integration and the UCM-ClearQuest integration.

---

## Managing Coexisting Integrations

When a ClearQuest user database that had been integrated with ClearCase previously is configured for integration with UCM, the existing change sets are preserved intact in the ClearQuest user database, but cannot be migrated to the UCM integration.

Change sets of existing records in the ClearQuest user database are preserved, and you can access them from ClearQuest. To continue work on a task in a project that has been migrated to UCM, create a new, corresponding, UCM activity and continue work there.

See *Planning How to Use the UCM-ClearQuest Integration* on page 44 for related information.

---

## Schema

A ClearQuest schema can contain modifications from both the base ClearCase-ClearQuest integration and the UCM-ClearQuest integration. A record type in such a schema would include both the ClearCase package and the Unified Change Management package.

An individual record of that record type can store either ClearCase or UCM change set information, but not both.

---

## Presentation

The form for a record type that uses both integrations includes two tabs to show the change set information associated with each integration, as shown in Figure 57. The **Unified Change Management** tab lists the change set for a UCM activity. The **ClearCase** tab shows the change set associated with a ClearQuest record.



Figure 57 Change Sets in ClearQuest GUI

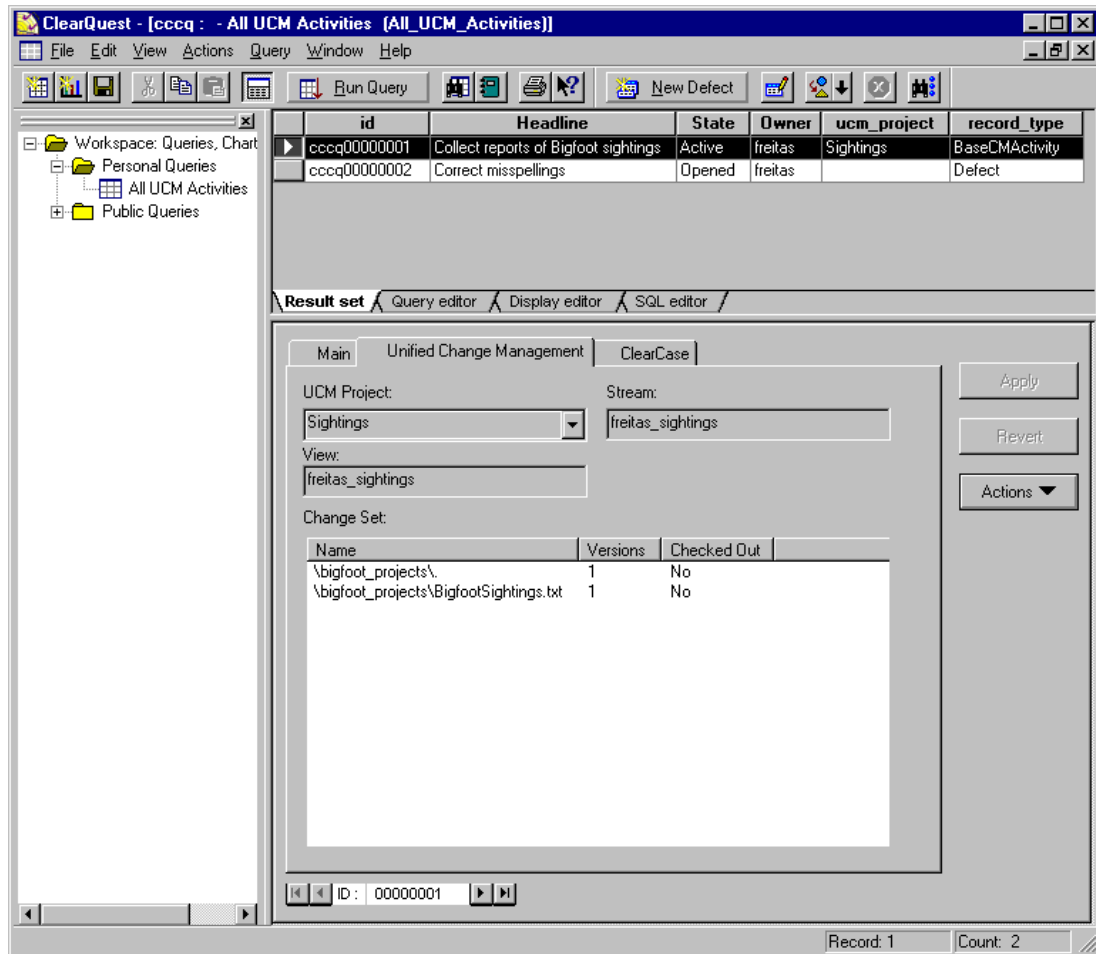



# Index

## A

### activities

- about 9
- creating and assigning in ClearQuest (procedure) 89
- creating and setting in new project (procedure) 79
- decomposing in ClearQuest 66
- fixing ClearQuest links 90
- migrating to ClearQuest integration 87
- state transition after delivery 56
- verifying owner of 55

### administrative VOBs and PVOBs 42

### assignments, verifying 26

### *attache-home-dir* directory xxii

### attributes

- about 145
- change request policy 176
- use in config specs 158
- use in monitoring project status 170

## B

### base ClearCase and UCM, compared 1

### baselines in base ClearCase

- creating, extended example 231, 238
- labeling policy 171

### baselines in UCM

- about 14
- benefits of frequent 39
- comparing (procedure) 109
- creating 20
- creating for imported files (procedure) 83
- creating new (procedures) 103
- creating streams for testing (procedure) 93
- fixing problems (procedure) 106
- foundation 75
- naming convention 40
- promoting and demoting (procedure) 107
- promotion levels 21
- recommended, promotion policy 49
- strategy for 36
- test planning 40
- when to delete 114

### branch types, example 228

### branches

- about 142
- bug-fix policy 172
- config spec rules for 153–154, 156
- controlling creation of 144
- example of project strategy 225
- in MultiSite 143
- mastership transfer models 180
- merge policies 147
- merging elements from UCM projects 137
- merging to main 197
- multiple levels, config specs for 156
- naming conventions 143
- stopping development on 241

### building software, view configurations 162

## C

### *ccase-home-dir* directory xxii

### change requests

- tracking in base ClearCase 176
- tracking states 25

### change sets 9

### ClearQuest integration

- about 16, 23
- customizing policies 65
- database, setting up 59
- decomposing activities 66
- disabling links to project 89
- enabling custom schema (procedure) 60
- enabling projects to use (procedure) 86
- environment variables 67
- planning issues 44
- policies available 55
- querying database 111
- recommended use of 247
- setting up 16
- setting up UCM schemas (procedure) 59

### components

- about 13
- adding to integration stream (procedure) 97
- ancillary 32

- candidates for read-only 34
- conversion of VOBs (procedure) 82
- design considerations 28
- importing files for (procedure) 81
- mapping to projects 29
- organizing for project 30
- recommended directory structure 32
- when to delete 113

**config specs**

- about 144, 149
- default, standard rules in 150
- examples for builds 162
- examples for development tasks 153
- examples for one project 228
- examples of time rules 154, 156, 161–162
- examples to monitor project 158
- include file facility 151
- project environment for samples 152
- restricting changes to one directory 157
- selecting library versions 164
- sharing across platforms 167
- use of element types in 209

**conventions, typographical** xxii

**D**

**deliver operations**

- element types and merging 43
- finding posted work (procedure) 101
- MultiSite and 19, 101
- pending checkouts policy 51
- rebase policy 51
- remote deliver 101
- remote, completing (procedure) 101
- state transition policy 56

**development policies**

- See* policies in base ClearCase; policies in UCM

**development streams** 14

- creating for testing (procedure) 93
- rebasing (procedure) 106
- when to delete 113

**directories, merging** 201

**directory structure**

- creating new (procedure) 80
- recommended, for UCM components 32

**documentation**

- online help description xxiii

**E**

**element types**

- customizing 205
- how assigned 206

- predefined and user-defined 210

**element types in UCM** 43

**environment variables for ClearQuest** 67

**event records** 146

## F

**foundation baselines** 75

## G

**global types** 42, 146

## H

### hyperlinks

- about 145
- requirements tracking mechanism 177

## I

**importing files and directories** 81

**include file facility** 151

### integration streams

- about 14
- adding components (procedure) 97
- locking 93
- locking considerations 41
- merging to base ClearCase branch 137
- rebasing between projects (procedure) 133
- unlocking (procedure) 105
- updating development view load rules 99
- when to delete 113

### integration views

- creating for UCM project (procedure) 76
- recommended view type 50

## J

**Join Project Wizard** 50

## L

### labels

- about 145
- baselines in base ClearCase 171
- use in config specs 161, 163

**load rules, updating for integration stream** 99

**locks**

about 146  
examples 174

**M**

**main branch** 142

**makefiles and config specs** 165

**mastership**

about 19  
models of transfer 180

**merging files**

how it works 191

**merging in base ClearCase**

about 147  
commands for 194  
directory versions 201  
entire source tree 198  
extended example 233, 239  
GUI tools for 193  
how it works 191  
non-ClearCase tools 202  
removing merged changes 196  
selective merge 195  
to main branch 197

**merging in UCM**

*See* deliver operations; rebase operations

**MultiSite**

branches and 143  
ClearQuest links in PVOBs 90  
mastership transfer models 180  
remote deliver 101  
use in UCM 19

**N**

**naming conventions**

branches 143  
ClearQuest schema 45  
UCM baselines 40  
views in base ClearCase 144

**O**

**online help, accessing** xxiii

**P**

**parallel development**

base ClearCase mechanisms 142

extended example in base ClearCase 223  
UCM scenarios 131

**parent/child controls in ClearQuest** 66

**patch release in UCM project** 134

**policies in base ClearCase**

access to project files 174  
bug-fixing on branches 172  
change requests 176  
coding standards 175  
documenting changes 169  
enforcement mechanisms 144, 169  
labeling baselines 171  
monitoring state of sources 170  
notification of new work 174  
on merging 147  
requirements tracking 177  
restricting changes visible 173  
restricting use of commands 179  
transfer of branch mastership 180

**policies in UCM**

about 17  
approval before delivery 55  
customizing ClearQuest 65  
default view types 50  
delivery transition state 56  
delivery with pending checkouts 51  
modifiable components 49  
promotion levels 21  
rebase before deliver 51  
recommended baselines 49  
setting ClearQuest (procedure) 88  
verify activity owner before checkout 55

**Project Explorer** 75

**projects in base ClearCase**

branching strategy 142  
config specs 144  
development policies 144  
extended example of lifecycle 223  
generating reports 146  
merging policies 147  
planning and setup 142  
views to monitor progress 158

**projects in UCM**

about 9  
cleanup tasks 112  
concurrent, managing 131  
creating 12  
creating from existing configuration 82  
creating from existing projects 84  
creating new (procedure) 75  
disabling links to ClearQuest database 89  
factors in gauging scope 29  
fixing ClearQuest activity links 90  
importing components 81  
incorporating patch release 134

- maintenance tasks 97
- mapping components to 29
- merging to base ClearCase branches 137
- planning issues 27
- setting up new 70
- tools to monitor progress 109

#### **promotion levels**

- about 21
- changing (procedure) 107
- default 40
- defining in new project (procedure) 76
- policy for recommended baselines 49

#### **PVOBs**

- about 12
- as administrative VOBs 42
- ClearQuest links and MultiSite 90
- creating from existing configuration 82
- creating new (procedure) 70
- mapping to ClearQuest database 44
- number needed 41

## **Q**

- querying ClearQuest database 26, 111

## **R**

- Rational Unified Process** 27–28

#### **rebase operations**

- between projects (procedure) 133
- element types and merging 43
- policy for deliver operations 51
- updating development view load rules 100

- recommended baselines** 49

- record types for schemas, custom** 62

- remote deliver operations** 101

#### **reports**

- ClearQuest queries 111
- for base ClearCase projects 146

## **S**

#### **schemas (ClearQuest)**

- about 25
- enabling custom for UCM 48
- enabling custom for UCM (procedure) 60
- predefined, using 59
- queries 26
- requirements for UCM 46
- storage issues 45

- selective merge** 195

- smoke tests** 40

#### **state types**

- about 25
- default transition requirements 64
- setting for custom schemas 63

- streams** 14

- subtractive merge** 196

- system architecture** 27

## **T**

- technical support** xxiii

- time rules in config specs** 154, 156, 161–162

#### **triggers**

- about 145
- checkin command example 169
- example script for 174
- sharing in mixed environments 118, 181
- to disallow checkins 175
- to notify team of new work 174
- to restrict use of commands 179

#### **type managers**

- about 207
- creating directory for 213
- how they work 212
- implementing compare method 217
- inheriting methods 213
- predefined 211
- testing 218
- user defined 211

- typographical conventions** xxii

## **U**

- UCM and base ClearCase, compared** 1

- UCMPolicyScripts package** 46

- UnifiedChangeManagement package** 46–47

#### **user accounts**

- creating ClearQuest profiles (procedure) 67

## **V**

- version control, candidates for** 28

#### **views**

- config specs 149
- configuring for builds 162
- configuring for development tasks 153
- configuring historical 161–162
- configuring to monitor project 158
- naming conventions in base ClearCase 144

policy for default types in UCM 50  
restricting changes visible in 173  
sharing for merges 197

#### **VOBs**

converting to UCM components (procedure) 82  
creating and populating in base ClearCase 142

#### **W**

work areas 14

