



System z – A Smart System For A Smarter Planet

Modern Data Serving

Data Plays A Key Role In Smarter Planet Solutions

1 Trillion connected intelligent devices

4 Billion mobile phone subscribers worldwide

2 Billion people on the web



Smart retail



Smart supply chains



Smart healthcare



Smart food systems



Smart countries

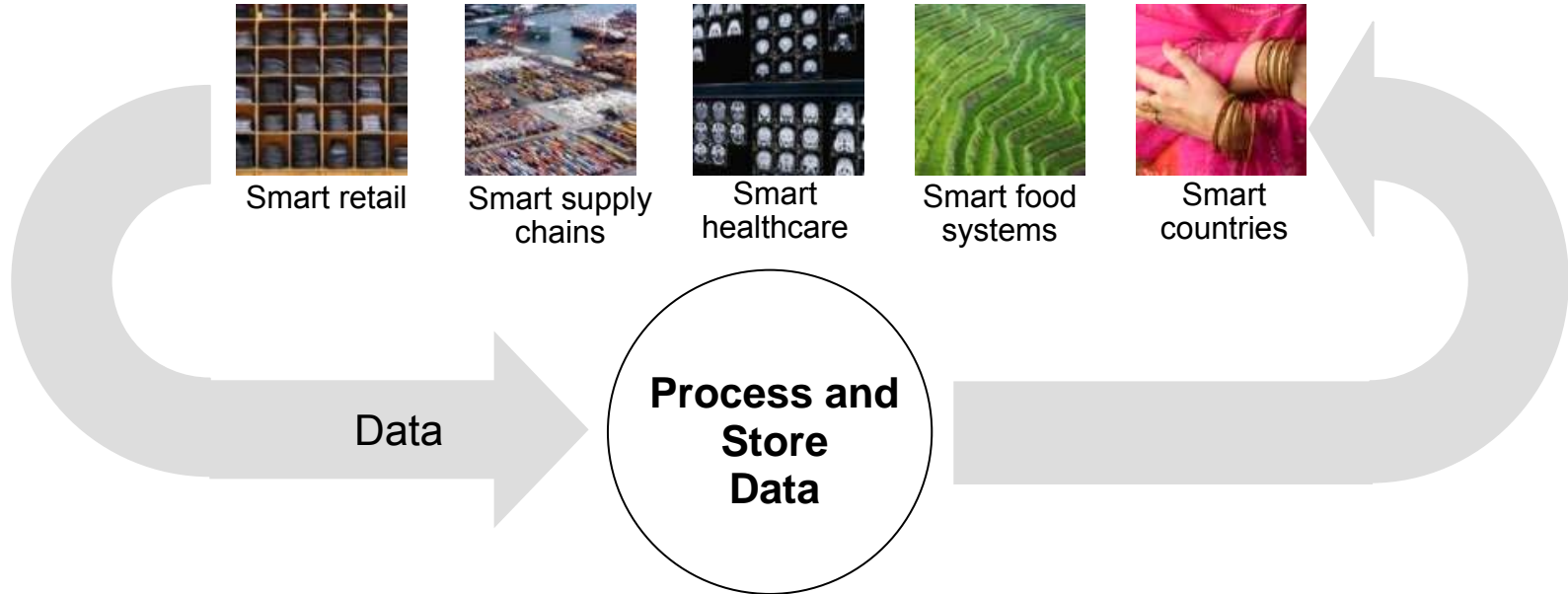

15 petabytes of new information generated daily
64 billion credit card transactions per year (up 35% YTY)
30 billion embedded RFID tags by 2010

Having A Reliable And Scalable Database Is Vital

- Databases help you store, organize, and access information in an efficient manner
- A good database should:
 - ▶ Scale as your data processing needs grow
 - ▶ Be highly available to ensure access to information
 - ▶ Protect the integrity of the data stored
 - ▶ Support new data types and access methods
 - ▶ Protect the security of the data
 - ▶ Compression data to save disk space
 - ▶ Be cost competitive

Database Performance Depends On Two Resources

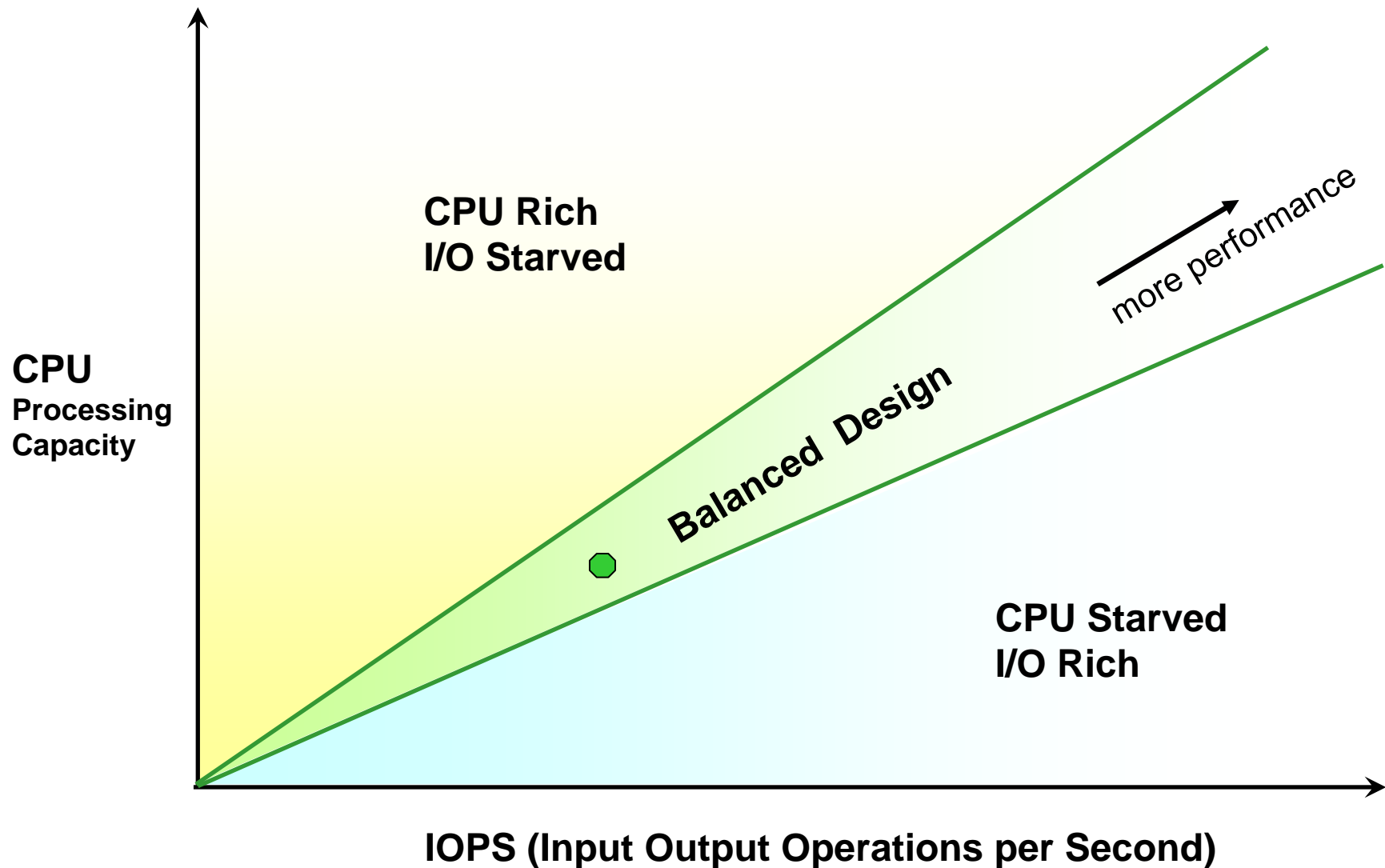

A History Of Database Workload Optimization

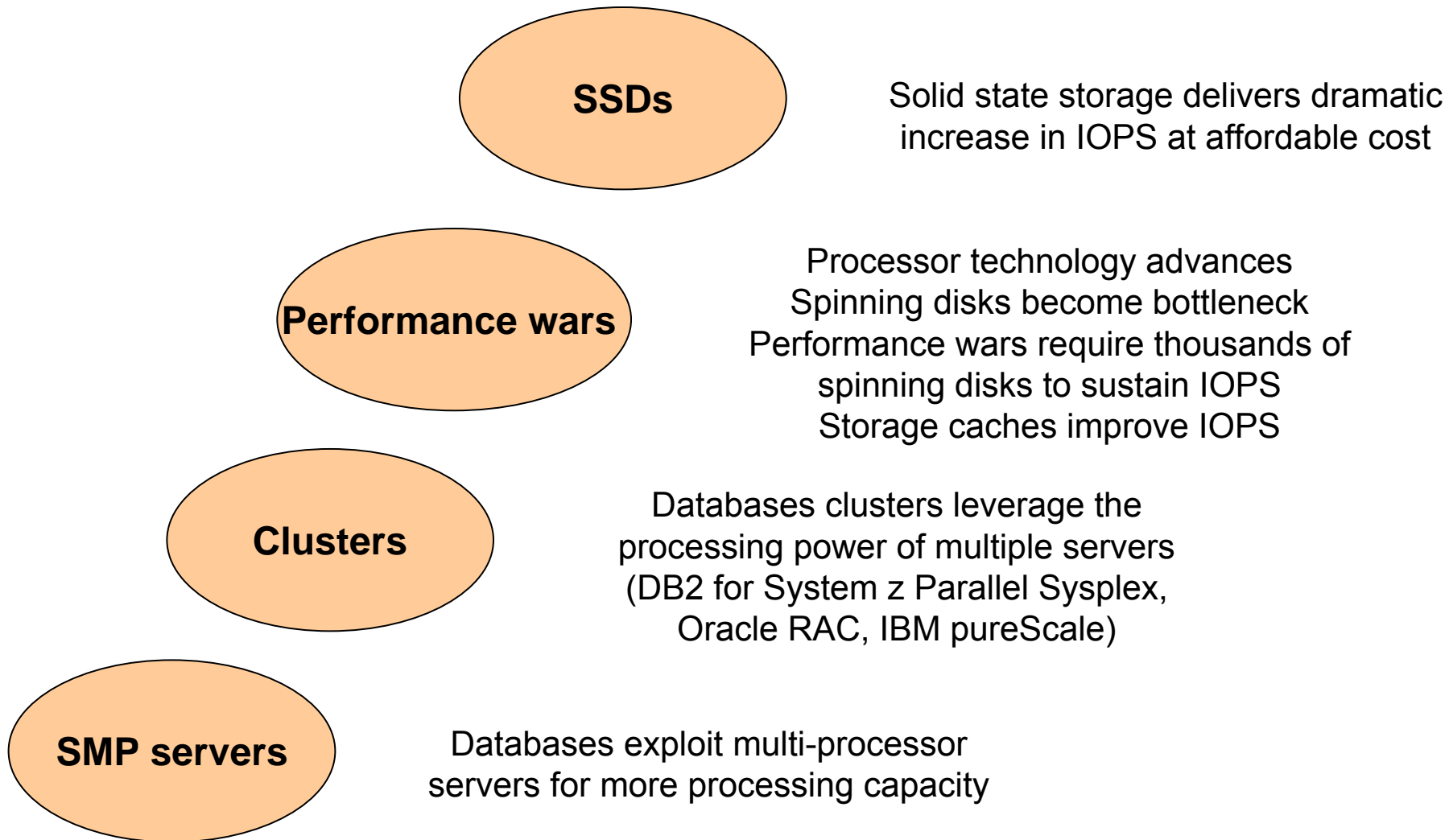

Dramatic Increase In Database Performance Requires Two Tricks

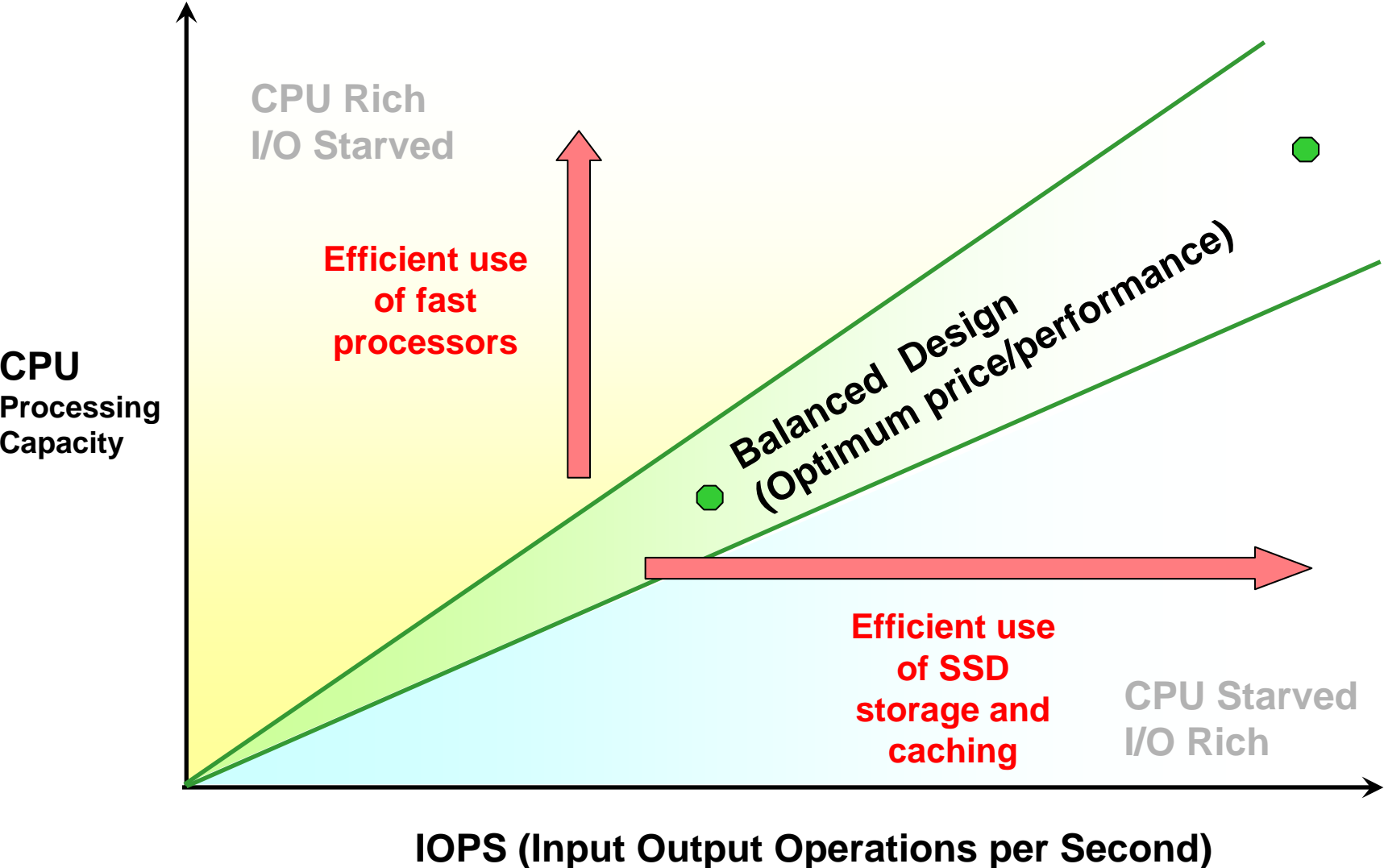

Clusters Leverage More Processing Power For Database Workloads

DB2 for z/OS

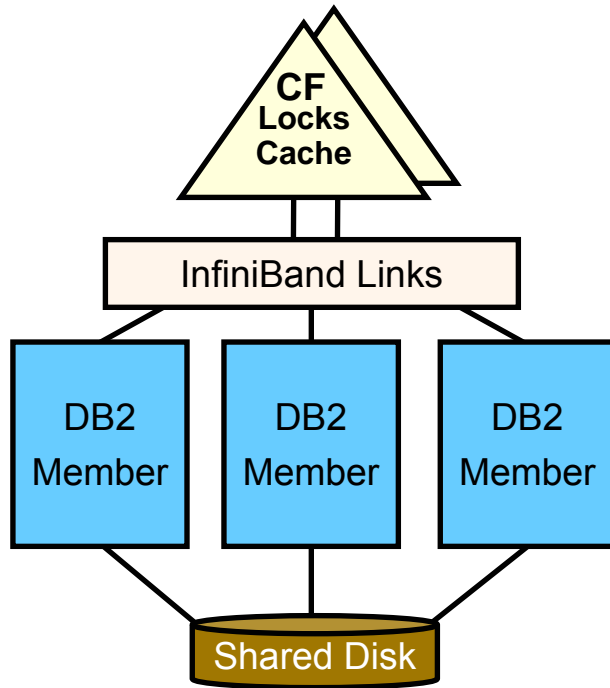

Efficient lock and buffer management achieve near linear scalability

Oracle RAC Distributed Design

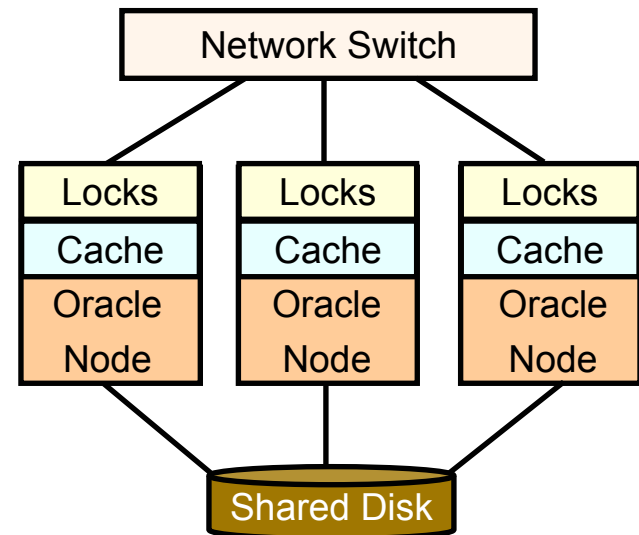

Inefficient distributed locking and buffer management limits scaling

System z Has Dedicated I/O Subsystem Designed For High I/O Bandwidth

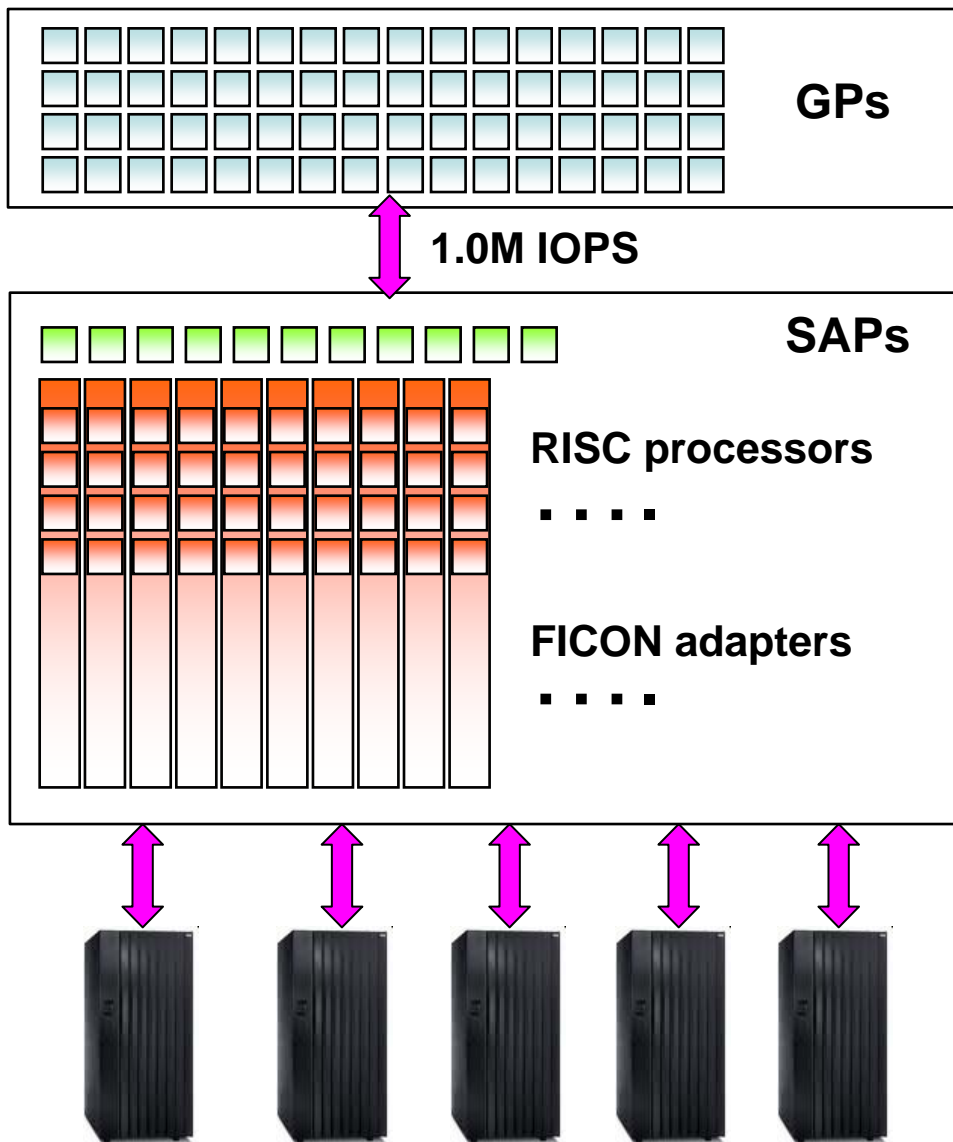

- Up to 64 General Purpose (GP) or Specialty Engine processors
 - ▶ Execute business logic
- Up to 11 System Assist Processors (SAP) to manage I/O requests
 - ▶ Can sustain up to **1.0M IOPS** operations per second
- Logical Channel Subsystem virtualizes I/O
 - ▶ Up to 1024 logical channels
- Up to 84 physical FICON adapters for I/O transfers
 - ▶ Up to **336 RISC channel I/O processors**
 - ▶ High performance FICON (zHPF) connections – z/OS only
- IBM DS8700 Storage System
 - ▶ Up to **420K IOPS capability**
 - ▶ Up to 1024 drives
 - ▶ Up to 32 host adapters with 4 ports, each supporting 4 Gb/sec

Compare Techniques To Provide Sufficient I/O Bandwidth

- DB2 on System z
 - ▶ I/O subsystem hardware is dedicated for I/O processing
 - Up to 11 SAP processors
 - Up to 336 channel processors
 - ▶ Typically attached to a DS8000 class storage subsystem with disk caches and large I/O bandwidth
- Oracle RAC on distributed server
 - ▶ No dedicated I/O subsystem
 - I/O operations executed by general purpose processors
 - ▶ Typically attached to mid tier storage

Compare Techniques To Increase Processing Resources

- DB2 for z/OS supports Parallel Sysplex shared data clustering
- Shared data across nodes
- Hardware-based centralized lock and cache management
 - ▶ Provided by Coupling Facility
 - ▶ Supports near linear scalability
- Recovery from a node failure without a freeze
- Supports rolling upgrades with up to two different releases in a data sharing group

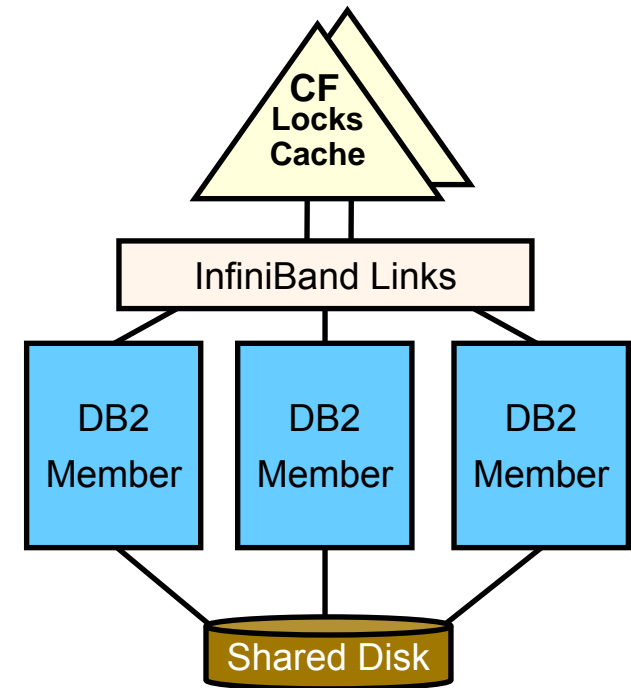

Coming soon – DB2 10 for z/OS:

Up to 20% faster performance

Hash access for faster OLTP

Automatic snapshots of changing data

Improvements in DB2 QMF and Tools suite

10x more concurrent users

More online administration

SQL and pureXML enhancements

DB2 For z/OS Grows Database Capabilities Beyond SMP Solutions

- Lets you **Add Capacity** as you need it
 - ▶ New members automatically process new transactions
 - ▶ Load balancing is automatic
- Provides **Continuous Availability**
 - ▶ Available during unplanned outages
 - Redistribute workload to surviving members automatically
 - In-flight transactions automatically rolled back in as little as 15 seconds
 - ▶ Available during planned outages
 - Remaining members handle workload as a member goes offline
 - Cluster operates continuously during rolling software updates

Compare Techniques To Increase Processing Resources

- Oracle Real Application Cluster (RAC) supports a distributed network clustering architecture
- Shared disk across nodes
- Software-based distributed lock and cache management
- Poor scalability due to increasing interconnect traffic as cluster grows
- Upon node failure clusters can freeze during lock remastering process
- Database software has to be of same release on all nodes

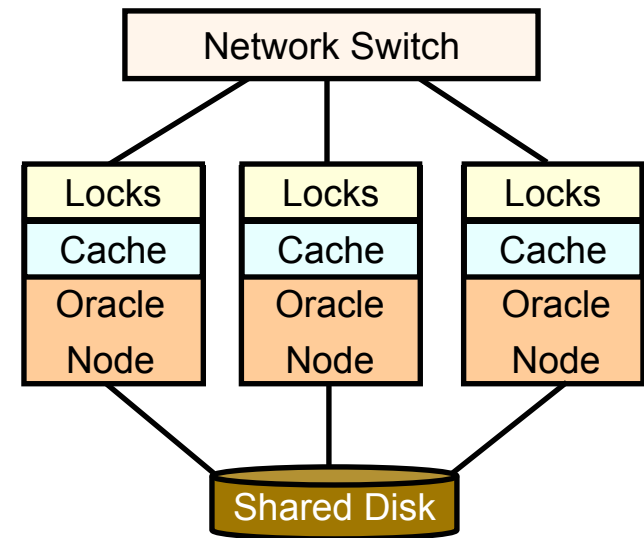

There Are Expensive Consequences For Oracle RAC's Distributed Design

- Cluster members constantly share lock and cache data
 - ▶ In a 4-member cluster, obtaining a write lock could require 6 separate network communications
 - ▶ This is referred to as interconnect traffic
 - ▶ Interconnect traffic grows as the cluster grows and queries disperse across the cluster

Per-member performance declines as the cluster grows.

- During an unplanned outage Oracle RAC “freezes” I/O and lock requests
 - ▶ While re-mastering data blocks to surviving members
 - ▶ While locking pages that require recovery

Oracle RAC does not offer continuous availability.

Bank Of China Benchmark Demonstrates Linear Scalability With System z Across Both Resources

Complex banking transactions (BaNCS – CICS/DB2 z/OS workload)

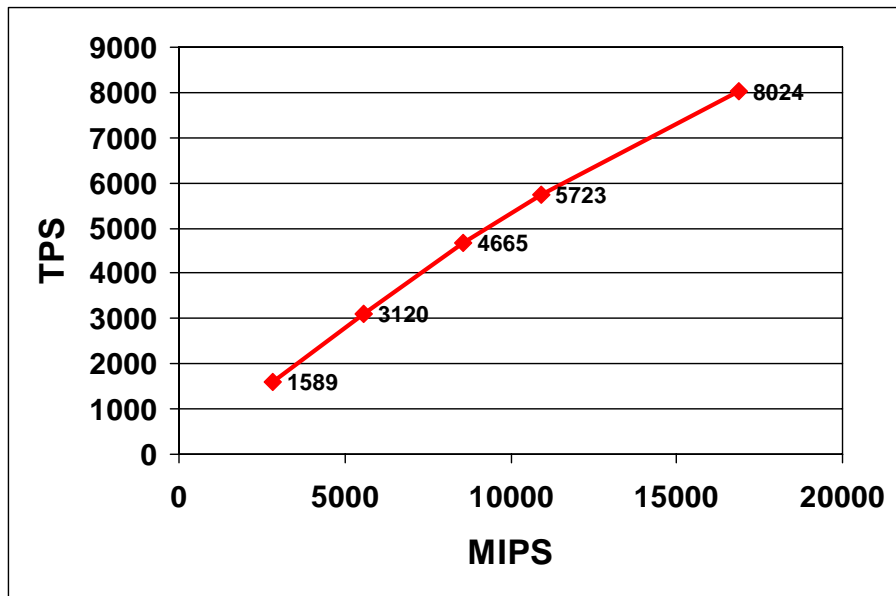

Add MIPS as needed to increase transaction rate

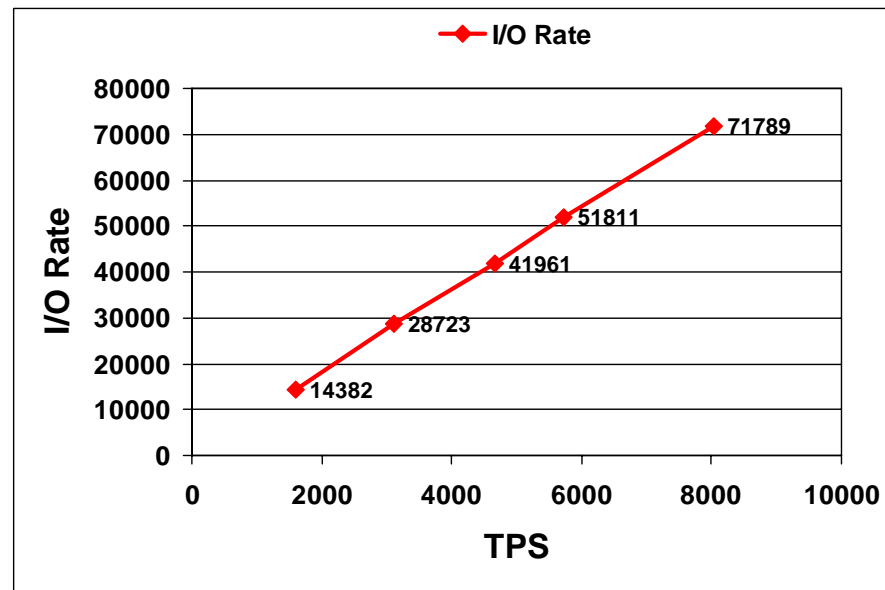

I/O rate scales to sustain transaction rate

Result: Deploy SAP Database On DB2 For z/OS At 28% Of The Distributed Cost

Existing Mainframe



Existing Disaster Recovery Site



Add 2 LPARs for SAP Database (DB2) and SAP Application (z/Linux)

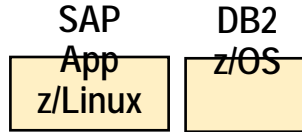

13,541 MIPS additional workload

Existing DR Mainframe



3 year TCA \$1.1M

Incremental:

1 zIIP 645 MIPS DB2
 4 GP 1,931 MIPS DB2 & Tools
 17 IFL 10,965 MIPS SAP App
 131 GB memory, 3.4TB DASD

Existing Backup z10:

1 zIIP, 4 GP, 17 IFL (CBU)
 131 GB memory, 3.4TB DASD

Or add HP Integrity Superdome s2k 9150 N Server for Production

Active RAC node

And add 1 server for Disaster Recovery, Dev & QA

Failover RAC node



207,324 Performance Units



207,324 Performance Units

3 year TCA \$3.96M

■ “Medium”

- ▶ Solution Edition for SAP promotional pricing

Solid State Disk Drives Are Here To Revolutionize Storage

- Response times is around 0.8 milliseconds in contrast to 6 milliseconds for a typical hard disk drive
 - ▶ 5-10x improvement in throughput and queries
 - ▶ SSD drives can sustain I/O rates from 6,000 to 20,000 compared to spinning disk rates of 250 - 300
 - ▶ Cost per TB is 10x cost of spinning disks
 - ▶ Reduce the “batch window”
- Semiconductor storage available in DS8700 storage subsystems
 - ▶ Random access solid state storage – no moving parts
- Benefits
 - ▶ 75% reduction in space
 - ▶ 80+% reduction in power and cooling
 - ▶ Reduce RAM requirements



DS8700 Easy Tier Capability Automatically Migrates Frequently Accessed Data To SSD

- **Automated hotspot detection and migration of data between SSD and HDD**
 - ▶ Transparent to the application, no code changes required
- **Easy Tier maximizes SSD performance gains while minimizing costs**
 - ▶ Increase performance by up to 300%
 - ▶ Relocating just 5% of data to SSDs can reduce response time by 78%
- **Microcode update to DS8700, no charge feature**

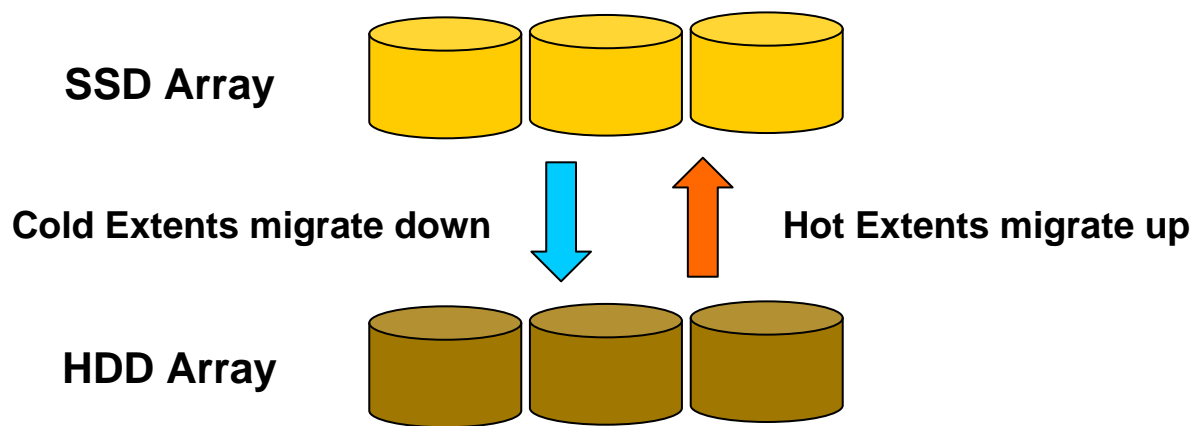

SSD – Solid State Drive
HDD – Hard Disk Drive

Oracle Database Downtime Can Be Significant With 44 Security Patches Issued Last Year

Oracle's Security Exposures

- Oracle.com – April 2010
47 security patches, including **7** for the database
- Oracle.com – January 2010
24 security patches, including **9** for the database
- Oracle.com – October 2009
38 security patches, including **16** for the database
- Oracle.com – July 2009
32 security patches, including **12** for the database
- In the last year, Oracle has issued 141 security patches, **44** for the database
 - ▶ 44 patches x 8 nodes = 352 possible System Freezes for 8-node Oracle RAC

DB2 For z/OS Provides Rock Solid Security

- Proven granular Multi Level Security leveraging RACF
 - ▶ Secures access of tables, views, rows, columns
- End-to-end encryption via hardware assist
 - ▶ CP Assist for Cryptographic Function (CPACF) and Crypto Express3
- Optim Test Data Management
 - ▶ Ensures anonymous access to data necessary for testing
- DB2 Data Archive Expert
 - ▶ Allows customers to easily archive and access data
- DB2 Audit Management Expert
 - ▶ Supports compliance requirements
 - ▶ Tivoli zSecure Audit for enterprise wide audit

DB2 For System z Provides A Balanced Database For All Smarter Planet Solutions

- Exploits System z Parallel Sysplex for availability and scale
 - ▶ RAC's distributed design difficult to scale, freezes during outages
- Dedicated I/O Hardware and Solid State Storage drives I/O throughput
 - ▶ Oracle running on distributed servers use precious general purpose processor cycles for I/O
- Superior Qualities of Service
- Competitive Price