

IMS 11 Migration Stories



Agenda

- The IMS Roadmap and Positioning
- Where We are
 - Trends and Focus areas
- Customer Migrations

IMS Roadmap

- New major version every 2-3 years
 - IMS 10 GA Oct 2007
 - IMS 11 GA Oct, 2009
 - IMS Enterprise Suite 1.1 GA Nov 6, 2009
 - IMS 12 - coming soon
- Support
 - Two current supported field releases
 - N-2 release out of service 1 year after current release GA
- Strategy
 - Simplification
 - Integration
 - Usability
 - Performance

IMS Roadmap ...

- IMS 7 – went out of support in September 2005
 - High Availability Large Database – The IMS partitioning solution
 - IMS Java – 1st Step
- IMS 8 – GA in October 2002 – End of Support September 2008
 - IMS Java – 2nd Step
 - New architecture for better Parallel Sysplex operation management – CSL 1st Step
- IMS 9 – GA in October 2004 – Withdrawn from Marketing September 2009 – End of Support November 2010
 - Online Reorganisation without restrictions for HALDB – 1st Step
 - Storing XML in IMS Databases
 - IMS Java – 3rd Step
 - Distributed JDBC access to IMS Databases

- IMS 10 – GA in October 2007
 - Dynamic resource definition
 - Operation management enhancements
 - SOA Connectivity enhancements including IMS async and sync callout capability
 - Extensive use of the Common Service Layer – CSL 2nd Step
- IMS 11 – GA in October 2009
 - IMS Open Database for IMS database access in z/OS IMSplex or from distributed environments
 - Quiesce function to reduce the complexity in establishing a recovery point for a database
 - Online Reorganisation without restrictions for HALDB – 2nd Step
 - IMS Connect, OTMA enhancements
- IMS 12 – QPP Announced in October 2010
 - FP Secondary indices
 - IMS repository

IMS 12



*Supported
Versions
of IMS*

IMS Positioning

- Do more with less!
 - Reduce CPU utilization
 - Work in memory (above the bar)
 - Remove expired workload
- Infrastructure improvements for the Future!
 - Performance is NOT an option!
 - Capacity - Supporting workload consolidation
 - And also availability, serviceability, security
- Simplifying IMS utilization (management of IMS systems as well as IMS application development)
 - More intuitive UIs and interfaces to talk to IMS
 - Address the changing skills profiles in customers
 - More autonomic IMS Tools
- Enhance and simplify integration of IMS assets with SOA and other Web solutions
 - Support of SOA standards
 - Support of Web 2.0 for lightweight integration and rapid web application assembly

Cost savings

Quality of Services

Simplification

Integration

Openness

Positioning Within the IBM Smarter Planet Strategy



“Data is exploding and it’s in silos”

IMS & Information Integration

IMS & Operational BI



“New business and process demands”

IMS & Business Process Mgmt



“My infrastructure is inflexible and costly”

IMS & Parallel Sysplex



“Our resources are limited”

IMS & Autonomics

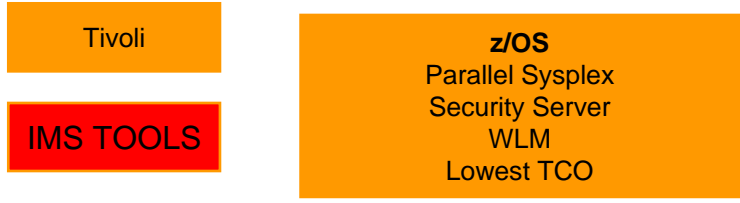
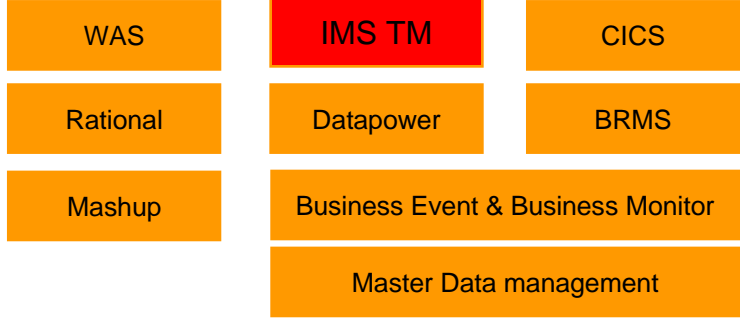
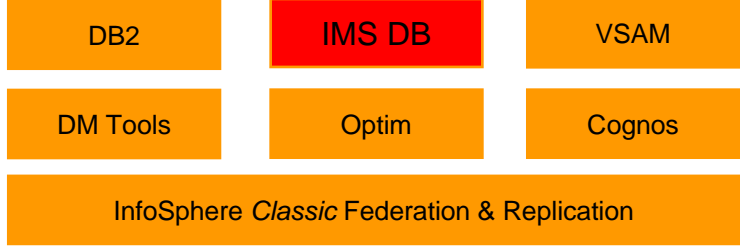

Positioning Within the IBM Smarter Planet Strategy ...

- Event driven business models
- High message processing rates
- Business on a global scale
- Huge transaction rates and high database activity
- Business on the Web
- Java front ends
- ERP, CRM, Financials, etc.
- Custom or Packaged applications
- Periodic business cycles
- Limited batch windows

Message Driven

TM – generation of Business Events
 TM – Inbound and outbound integration with WMQ

Transaction Processing

Leading On-line **Transaction** & **Database** Management System
 TM - Easy integration with BRMS, Events, MDM

Web Facing

TM – Numerous callin & callout capabilities
 DB – JDBC access to hierarchical data from every platforms (distributed or z/OS)
 Web 2.0 support or how to quickly transform IMS assets into RESTful Services

Data Processing

DB – Smarter data management
 DB – Smarter data governance
 DB – Smarter operational BI

Batch Processing

Efficient Batch management thanks to z/OS capabilities
 Highly parallel processing

And More ...

Where We Are

Trends and Focus Areas

Cost Savings – “do more with less”

- IMS – lowest cost per transaction DBMS
- IMS DB – less disk space and CPU
- 25% CPU Reduction IMS Connect – V10
- FP 64 bit buffers – V11
- Transaction Expiration – V11
- Up to 25% CPU Reduction for OLR – V11
- zAAP offload for IMS Java, SOAP Gateway, XML converter, IMS TM Resource Adapter
- zAAP on zIIP with z/OS 1.11
- Bucket for each new release with MIPS reduction items



Application Modernization

- The challenge: outdated “green screen” applications written in 1970-1980’s

- Unwieldy to maintain
- Need to be invoked from the web
 - Connectivity
 - Coexistence with modern programming languages
- Need to be accessed from distributed systems

- **Solution: renovation versus “rip and replace”**

- Therefore: tremendous investment in the **IMS SOAP Gateway**
 - Target web services implementations
 - Top down, bottom up, meet in the middle



From Computer Desktop Encyclopedia
Reproduced with permission.
© 1999 Computer Associates Int'l., Inc.

```
DISPLAY CUSTOMER INFORMATION          Rect = 810093

Credit Limit:$ 0   Finance Charge? Y   Area:      Sort Codes: 8

          BILLING                               SHIPPING
Name: A CLEAN WELL LIGHTED PLACE FOR   Name: A CLEAN WELL LIGHTED PLACE FOR
Address: 601 VAN NESS AVENUE           Address: 601 VAN NESS AVENUE
:                                       :
City: SAN FRANCISCO                     City: SAN FRANCISCO
State: CA                               State: CA
Zip: 94102                               Zip: 94102
Country: U.S.A                          Country:
Phone:                                   Phone:
```

Enter ↑ to skip back, ↓ to skip forward, or <ESC> to exit

IMS Callout

- The Challenge:
 - Interoperate with business logic outside the IMS environment
 - Callout to Java EE apps and Web Services using WebSphere Application Server and IMS TM Resource Adapter
 - Callout to Web services providers (e.g. Microsoft .NET) using IMS SOAP Gateway
- **Solution: enable IMS applications as clients or Web Service requesters**
 - Asynchronous Callout
 - IMS application invokes external applications *without waiting for response*
 - Response can be received by another IMS application
 - Synchronous Callout
 - IMS application invokes external application and *synchronously waits for the response* – new DL/I call ICAL
 - » Eg. Sales tax, stock price, interest rate....

Enhanced Environment for IMS Java Applications

- IMS java programs JMPs and JBPs traditionally run in IMS Java Dependent Regions
 - Supports Java and Cobol interoperability
 - Can issue JMS (ICAL) API and HTTP calls
- IMS APAR PM00360 / PTF UK58285 (V11), PK82214/UK58284 (V10)
 - Provides the ability for Cobol to call Java in an IMS MPR
 - Supports a persistent JVM in MPP/BMP/IFP regions
 - Supports DB2 JDBC calls using IMS ESAF instead of RRS support
 - Corresponding pre-requisites
 - LE (Language Environment) APAR PK99010 is required
 - LE (Language Environment) APAR PM00482 if running z/OS 1.11 or later
 - DB2 for z/OS APAR PK93123 if issuing DB2 calls from the Java application in this environment
 - IBM Enterprise Cobol for zOS (OO Cobol)

Distributed Access to IMS Data – IMS Open DB

- Challenge: direct and simple access to IMS database resources
- Solution: an industry standard mechanism (Distributed Relational Database Architecture -DRDA) that can access IMS databases anywhere in the IMSplex from z/OS and distributed environments
 - IMS Universal DB Resource Adapter - to take advantage of Java Platform, Enterprise Edition (J2EE) platform services, JCA 1.5
 - IMS Universal JDBC driver - to make SQL calls that directly access your IMS data
 - IMS Universal DL/I driver - to issue calls that are similar to DL/I directly to IMS from Java
 - RYO - Use a programming language of your choice to issue DRDA commands directly to IMS Connect



IMS Connect becomes the gateway to IMS Transactions and IMS Data

IMS Simplification

- Challenge: help address the IMS skills availability issues
 - Use industry available Systems Admin and AD skills
- **Solution: more intuitive UIs and interfaces to talk to IMS**
 - Eclipse based tooling for Application Development
 - SQL support from Java with Open Database – IMS 11
 - More consistency with z/OS, CICS, DB2, Omegamon for IMS etc for Operational Interfaces
- **Solution: reduction of planned outages and manual tuning**
 - Online Reorganization – IMS 9
 - Dynamic Resource Definition – IMS 10
 - Database Quiesce – IMS 11
 - Dynamic allocation of ACBLIB data sets – IMS 11
 - Dynamic Database Buffer Pools – IMS 12



IMS Simplification ...

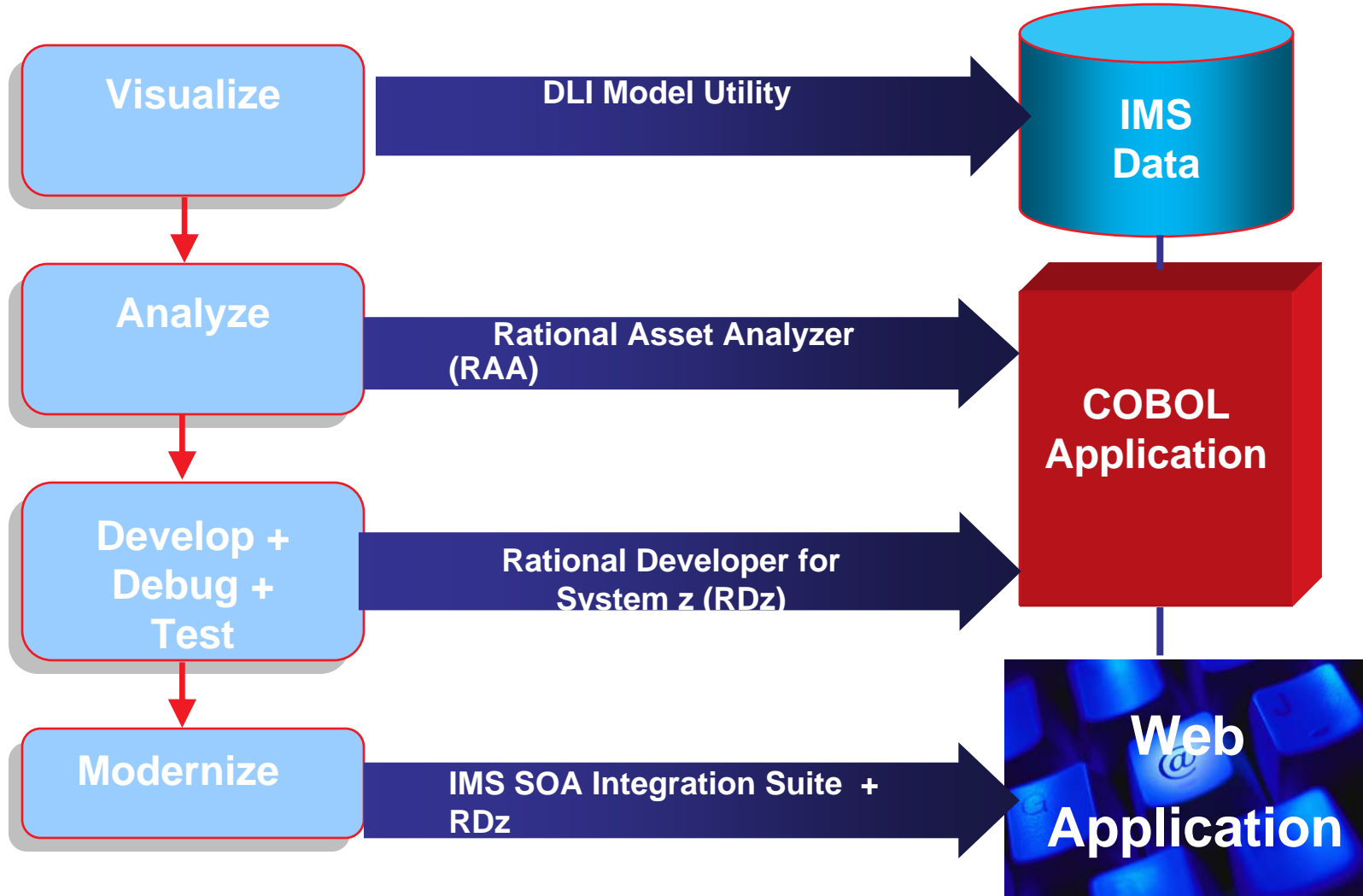

IMS Simplification Strategy

New IMS interfaces and models

IMS interfaces

IMS

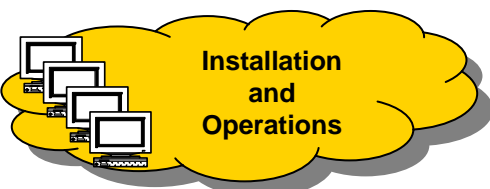

- SQL / JDBC
- IMS Tools
- Rational
- Optim
- Cognos
- InfoSphere
- J2EE
- pureQuery

- JCL
- ISPF
- SDSF
- JES
- User Mods
- User Exits
- DBDGEN
- PSBGEN
- ACBGEN
- OLC
- DRD
- DLI

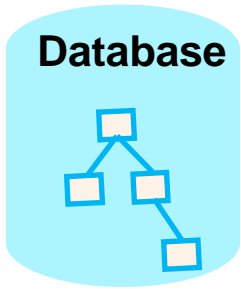

Reduce the need for special, in-depth IMS skills

IMS Explorer...Simplifying IMS application development !

Graphically-driven editors to display and update IMS program and database definitions

Graphical interface to easily access and manipulate IMS data using standard SQL

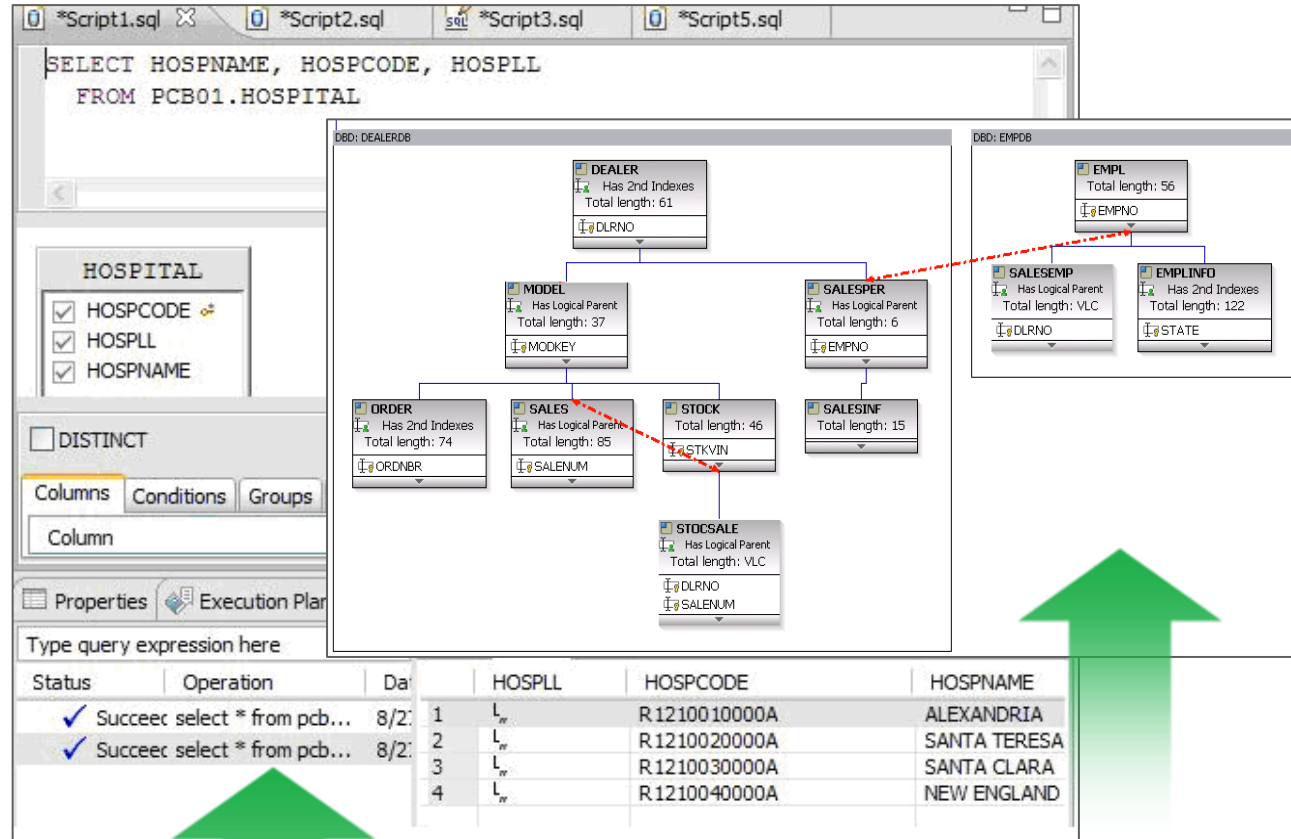

The screenshot shows the IMS Explorer interface. At the top, there are tabs for SQL scripts (*Script1.sql, *Script2.sql, *Script3.sql, *Script5.sql). A query editor contains the following SQL statement:

```
SELECT HOSPNAME, HOSPCODE, HOSPLL
FROM PCB01.HOSPITAL
```

Below the query editor is a graphical database schema. It shows two databases: DBD: DEALERDB and DBD: EMP08. The DEALERDB schema includes tables: DEALER (Total length: 61, Has 2nd Indexes, DLRNO), MODEL (Total length: 37, Has Logical Parent, MCKEY), SALES (Total length: 85, Has Logical Parent, SALENUM), STOCK (Total length: 46, STKVIN), SALESINF (Total length: 15), and STCSALE (Total length: VLC, Has Logical Parent, DLRNO, SALENUM). The EMP08 schema includes tables: EMPL (Total length: 56, EMPNO), SALESEMP (Total length: VLC, Has Logical Parent, DLRNO), and EMPLINFO (Total length: 122, Has 2nd Indexes, STATE). Red dashed lines indicate relationships between tables across the two databases.

At the bottom, a table displays the results of the SQL query:

Status	Operation	Date	HOSPLL	HOSPCODE	HOSPNAME
✓	Succes select * from pcb...	8/2	1	R 1210010000A	ALEXANDRIA
✓	Succes select * from pcb...	8/2	2	R 1210020000A	SANTA TERESA
			3	R 1210030000A	SANTA CLARA
			4	R 1210040000A	NEW ENGLAND



Generate SQL to access IMS data



See database relationships
 Change DBD and PSB definitions

Rapid IMS Application Development

- Extending IMS Application Development to Business Analysts
 - Make decisions based on up-to-the-minute data
- Business Rules
 - ILOG BRMS support – code generation
- Mashups
 - IMS Web 2.0 Solutions for Mashup Center
 - Available in V10 for IMS TM feeds, IMS 11 for IMS Data feeds
 - Ability to easily integrate multiple RESTful services, widgets, data
- COGNOS
 - Real time query of IMS data
 - Business analyst with no IMS skill can make decisions based on data supplied by IMS



Infrastructure Investment for the Future

- Parallel RECON access – IMS 10
- VSCR – items in each version
 - 24 bit to 31 bit CSA/private
 - CSA to private
 - 31 bit ECSA to 64 bit
- Repository – IMS 12
- WADS/logger re-write – IMS 12
 - More efficient, better performance
- MSC over TCP/IP – IMS 12
 - New kind of MSC link
- Connect to Connect – IMS 12
 - Next extension of connectivity between IMS systems



Customer Migrations

IMS - State of the Business

- IMS usage continues to increase across all customers 20%/year
 - Smaller IMS customers: 150% growth over last 5 years
 - Medium IMS customers: 80% growth
 - Large IMS customers: 40% growth
- We see an acceleration in projects around mainframe modernization and server consolidation
 - IMS connectivity – integration & service enablement
 - IMS application modernization
- IBM investment in IMS remains strong (almost 30% growth in past 4 years)
 - Looking to expand in China, Russia and India
- Overall IMS Customers
 - 65% IMS TM/DB
 - 32% IMS DB only
 - 3% IMS TM only
- Top 50 IMS Customers
 - 43 run IMS TM/DB
 - 3 are IMS TM only
 - 3 are DBCTL
 - Over 50% run with SMQ
 - 27 are Fastpath

IMS 11

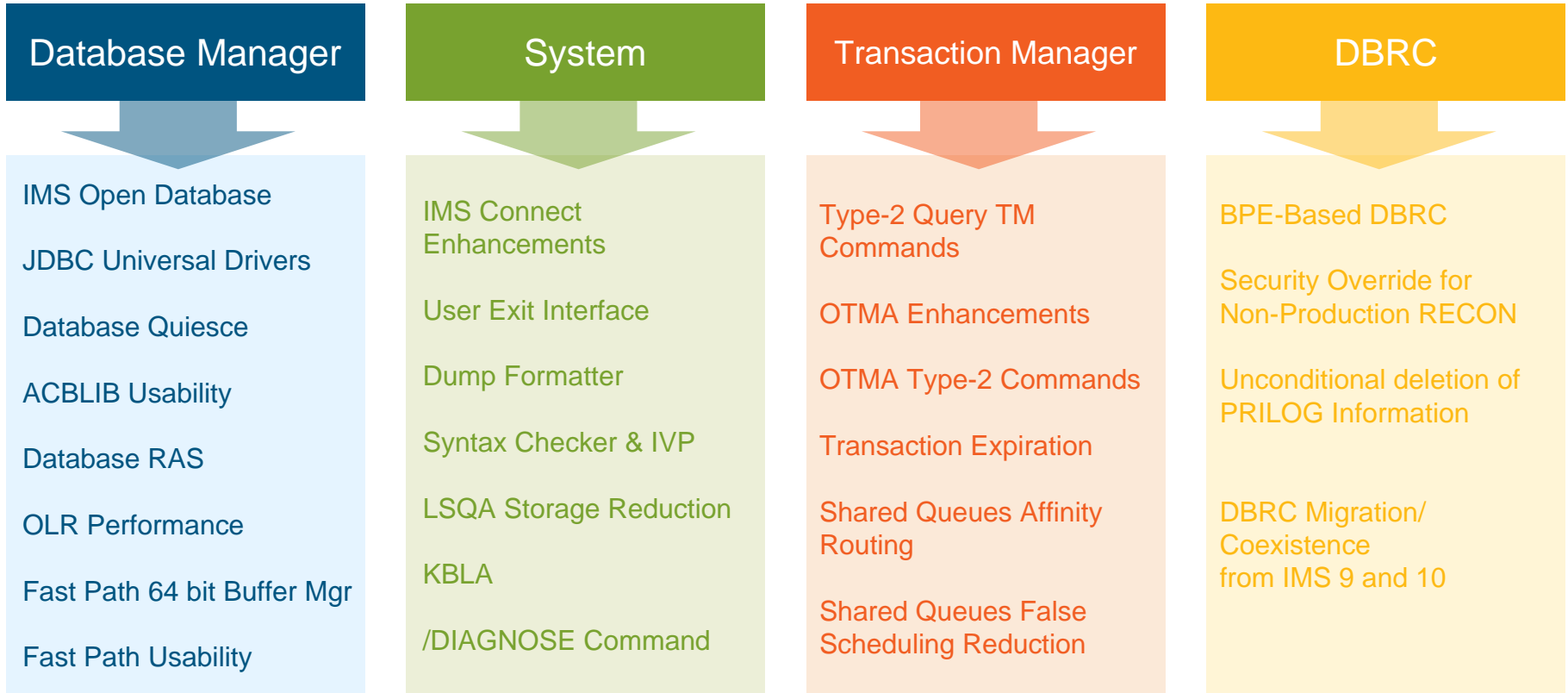

IMS Enterprise Suite

- IMS ES Soap Gateway
- IMS ES Connect APIs for Java and C
- IMS ES DLIModel Utility Plug-In
- IMS Explorer
- IMS ES Java Message Service (JMS) API

IMS 11 – Great Acceptance

- IMS 11 QPP
 - 12 Customers, 2 IBM internal sites, 30 vendors
 - 6 customers in mission critical production prior to GA (range 10M – 98M trans/day)
 - 4 had entire enterprise in production on V11 prior to GA
 - 2 used Shared Queues to migrate to V11 without disruption
 - Customer satisfaction scores higher than V10, especially documentation
- IMS 11 – Record number of first day orders

“This was our first experience as part of IBM's IMS Quality Partnership Program. It has been very valuable for my team ... we expect to be able to achieve the benefits of IMS V11 very quickly.”

“ Thus far we have been very pleased with IMS V11”

QPP Experiences and Comments

- Functionality
 - “IMS 11 opened up our IMS databases to easier access from distributed environments, with the Open DB support, BUT:
 - Implementation needs to be coordinated with Application teams and design
 - Be aware of the impacts of remote data access on your system if updates are to occur”
- VSCR
 - “We were able to get some much needed relief in virtual storage though the 64 bit Fast Path and 64 bit ACBLIB enhancements
 - VSCR allowed us to reduce the amount of ECSA required for IMS, thereby allowing us to increase the amount of extended private available.”

QPP Experiences and comments

- Migration
 - ““The migration from IMS 9 to IMS 11 was straightforward”
 - “No issues with the IMS 10 to IMS 11 migration”
- Ancillary Tools and Products
 - “Contact other vendors to make sure you have the right levels of maintenance”
- Overall Value
 - “The Overall Value of IMS 11 to our company’s business was its stability and its support of continuous availability”
 - “IMS is open to everything ... goes out to our heterogeneous system platforms while managing our heavy workload”



"We need to make IMS applications truly 7x24, ease application development, and ease integration of IMS services with partner platforms."
Wang Chen
Database Technical Services, TD Bank



IMS usage

- Make IMS actively participate in SOA
- **Strongly recommend IMS 11**

IMS Solutions

- IMS and IMS application 7x24 availability
- DRD for development environment
- Expanding IMS Connect application integration options

Benefit

- Top notch availability to business, reduce IMS environment setup time for application development, continuous improvement of IMS connectivity options

FIDUCIA



- **IMS Usage**

- Dynamic ACB allocation and 64 bit pooling for ACBs
- **Strongly recommend IMS 11**

- **Environment**

- Service provider for corporate banks hosting over 800 banks with 10,000 branches and over 22,000 ATMs and 63 million accounts
- over 70 million transactions a day
 - Banking system uses IMS, DB2 and WebSphere MQSeries systems
 - Connected with IMS Connect to over 6,500 servers
 - Three-Tier Architecture with over 100,000 workstations

Migration to IMS 11 was very easy with great system stability...

FIDUCIA depends on IMS and IMS keeps FIDUCIA in business

Caterpillar Challenge and an IMS 11 Solution



- Large manufacturing corporation
 - The Challenge: coordinate the tracking of manufacturing materials between applications based in IMS and applications on Distributed Platforms, using:
 - A full function, 40 year old, legacy IMS application, tracking materials in many factories and warehouses around the world
 - Many distributed applications, both purchased and in-house developed, tracking materials in a single or small group of factories.
 - Legacy FTP of files to communicate between the systems
 - Manual data entry to update systems and process exceptions

Business Challenge

❖ ***Connect IMS applications with distributed applications tracking manufacturing materials across the enterprise, to maintain the currency of data in both systems.***



Old Configuration

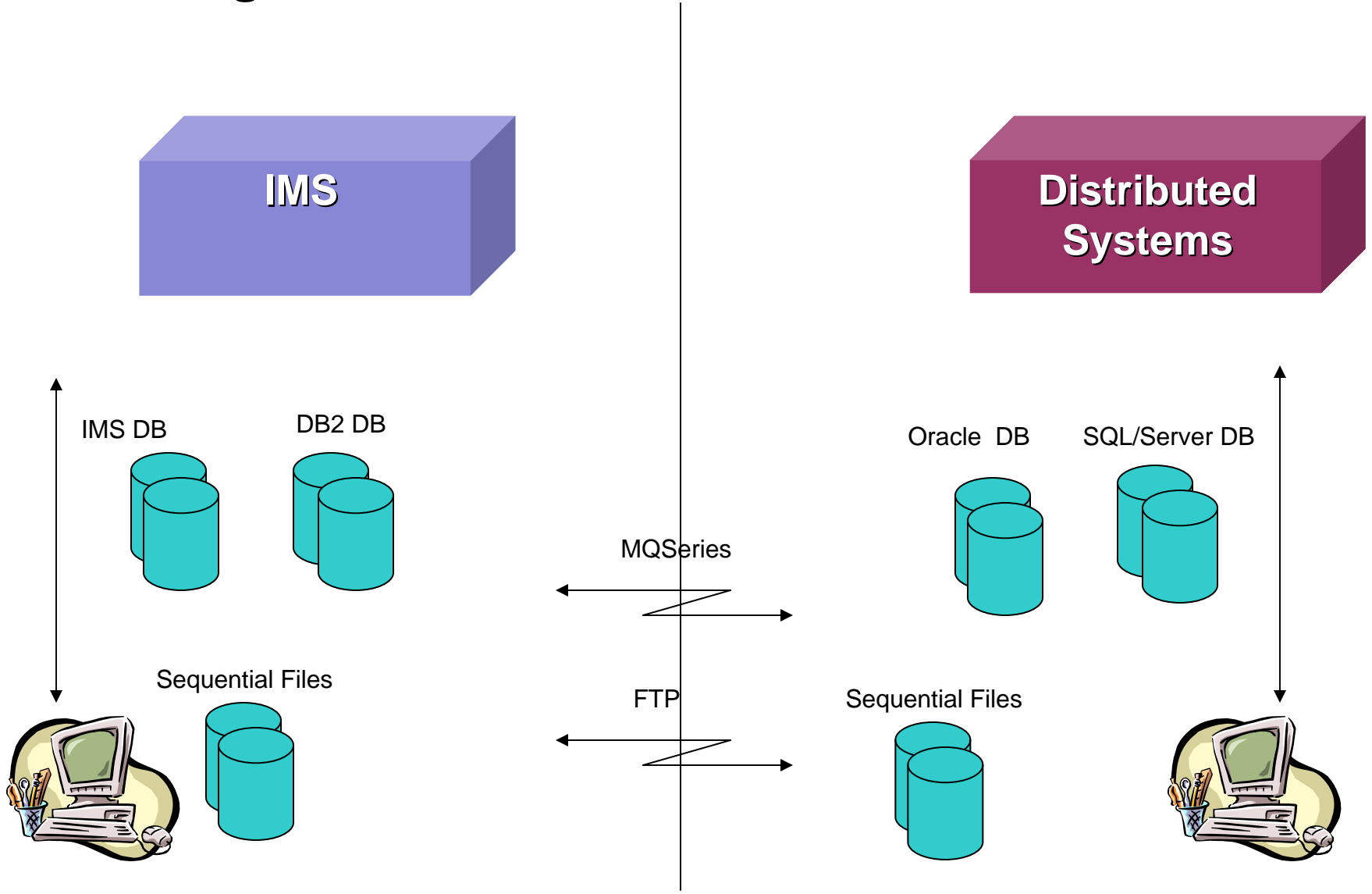

The Solution

- Focus: an Service Oriented Architecture (SOA) solution
 - Implement the IMS SOAP Gateway on z/OS with Web Security
 - Expose IMS Transactions as Web Services
 - Implement both asynchronous and synchronous Callout from IMS programs.
 - Implement IMS V11 With ODBM
 - Use RDz and the DLIMODEL utility as the tooling to implement the solutions

▪ *“IMS “Callout”, ODBM, and the SOAP Gateway has allowed us to keep data in distributed systems in “sync” with that in the legacy IMS systems, helping maintain inventory control.”*

The Solution ...

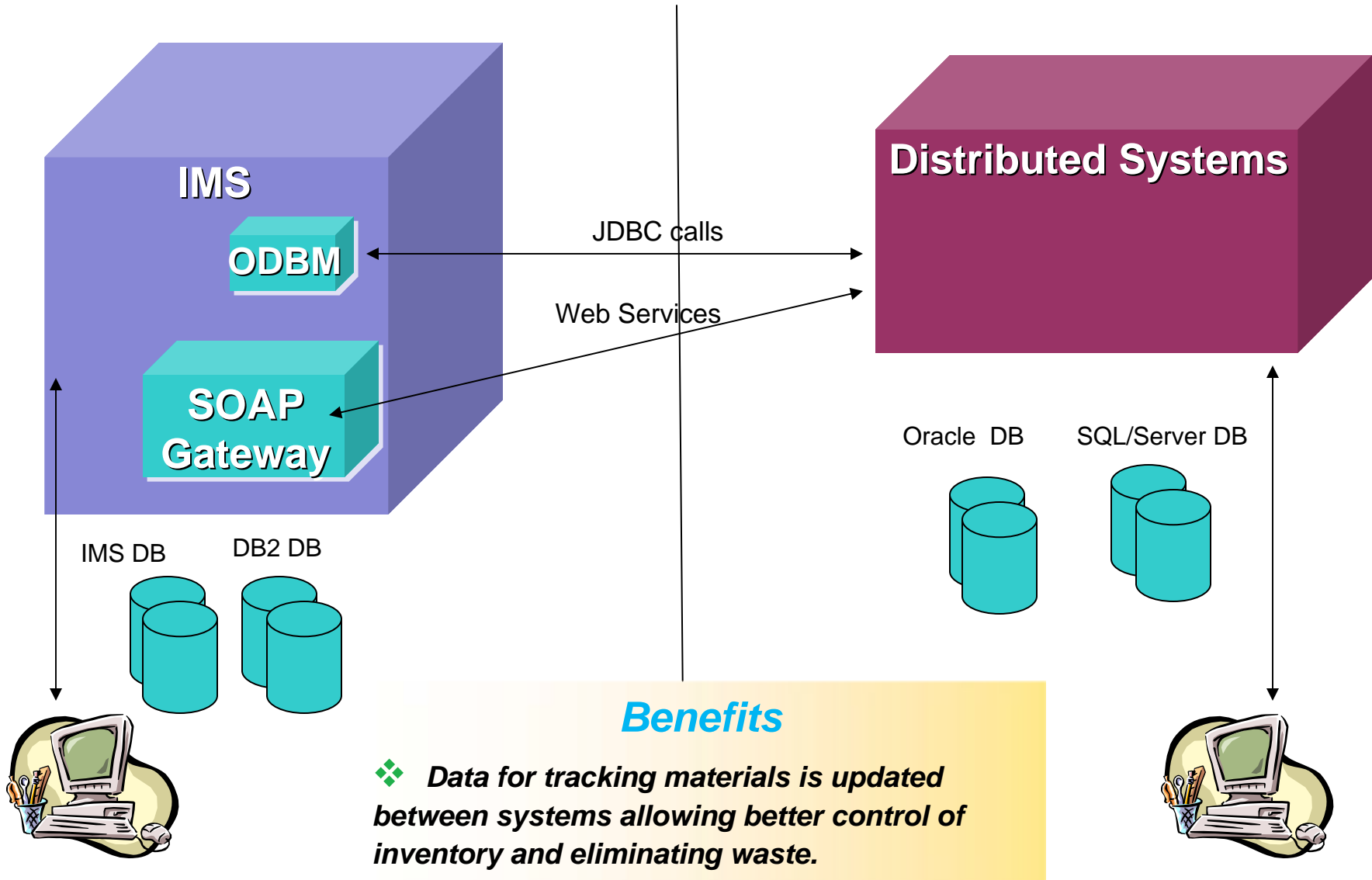

Doing SOA since 1998

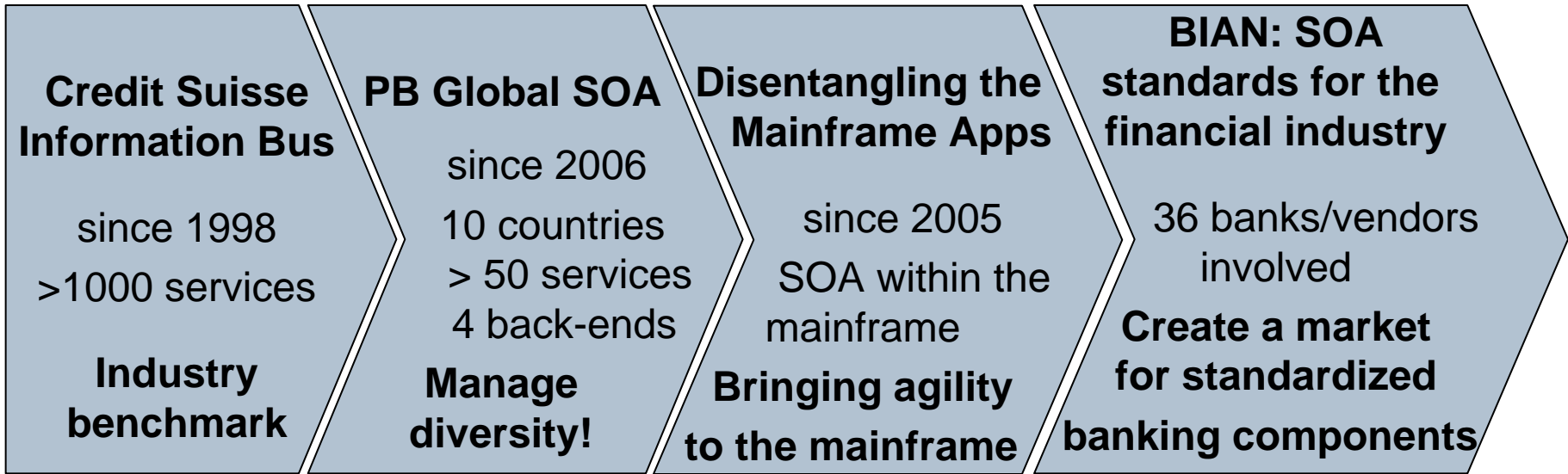

"Credit Suisse succeeded in building a highly business-critical integration infrastructure. The company is fully experiencing the benefits of SOA and the componentization of core business applications. However, to reach that desired state, Credit Suisse went through a lengthy and expensive endeavor that only leading-edge, technically sophisticated enterprises will be able to tackle."

Gartner Group

Credit Suisse...

- The Challenge
 - Credit Suisse's business needs an agile and cost effective IT
 - Tightly coupled legacy systems are no longer sufficient
- SOA is key to achieve agility
 - It requires a business driven & top-down – technology independent **web service solution**
 - A re-architecture of over 2,000 CORBA service mainframe operations
 - Currently, the number of CORBA calls reaches 20 million, or about 500 transactions per second, on busy days.

Business Challenge

❖ *Credit Suisse needs to flexibly and cost efficiently implement new and changed business requirements to isolate the effects of changes and prevent ripple effects of changes. They need services with a business semantic that is unrelated to the current implementation or database schema.*

The Goal

❖ *Integrate IMS systems into overall enterprise SOA infrastructure and maintain high availability and throughput in the new IMS profile*

Credit Suisse...

- The Solution: Evolving top-down web service solution

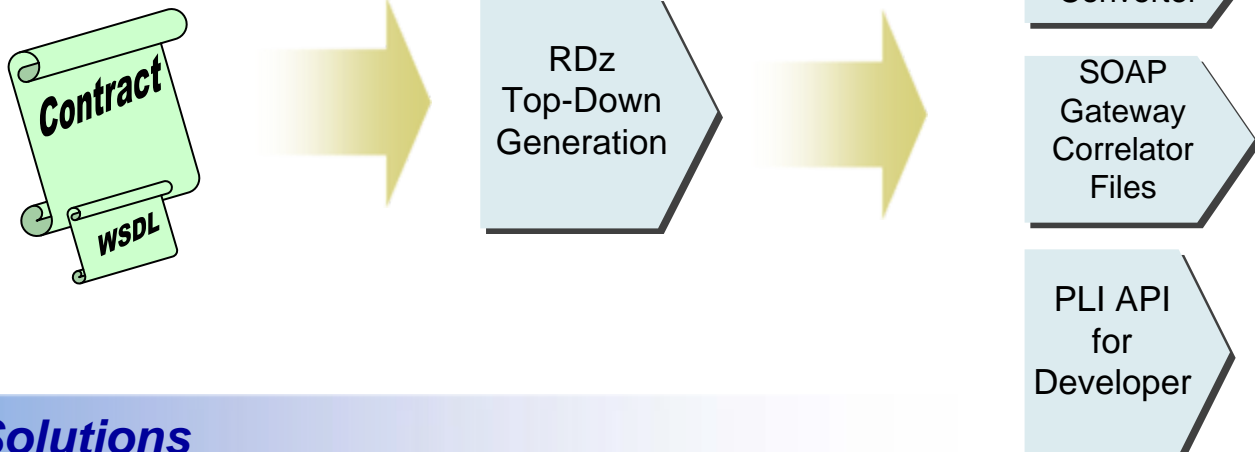

Solutions

- ❖ Credit Suisse's Strategic core banking applications are built and evolved with PL/I as the preferred language on IMS
- ❖ Start with Web services description files (WSDL) that represent the interface contract to develop new and evolve existing IMS applications
- ❖ A top-down approach is required to map complex XML data structures, including unbounded arrays and strings to PL/I
- ❖ Using IMS SOAP Gateway for both inbound and outbound requests, with RDz as the development tooling.

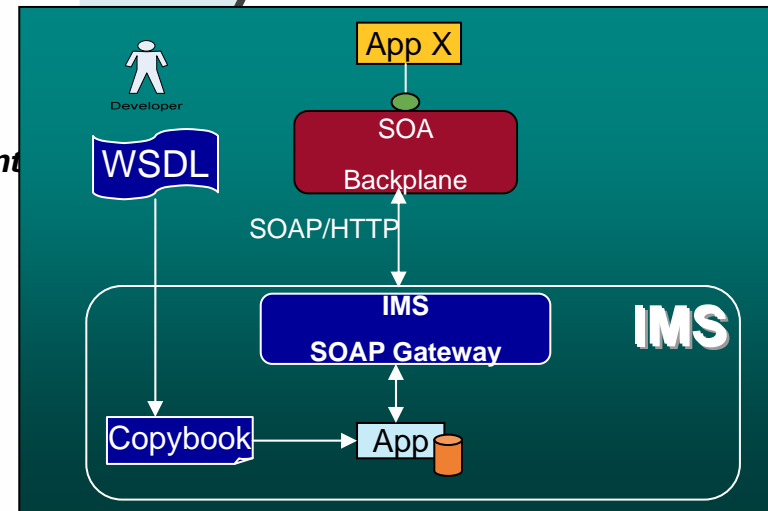

Credit Suisse...

Project Roadmap:

2009: IBM® and Credit Suisse began working together to complete a successful proof-of-concept of the WSDL-first solution for IMS and PL/I.

2010: Was spent creating a workable solution for inbound web service communication with IMS and PL/I.

2011: Planning to have a first pilot in production

IBM: IMS Connect PoC



- Share Orlando (August, 2011) Session Number 9405

What: IMS Connect PoC (Proof of Concept) sandbox environment to learn and discover IMS SOA capabilities

How: Onsite System z Infrastructure Architecture Workshop (zIAW) with customer and IBM SMEs

Subject Applications:

- Online Inquiry System portal integration with mainframe application
- Online Update System portal integration with mainframe application

Hardware:

- 1 LPAR
 - > 1 IFL
 - > 10 GB Memory

Software:

- z/OS LPAR
- z/VM LPAR
- IMS 11 Control Region and IMS Connect
- IMS SOA Integration Suite
- Rational Application Developer Version 7.5.5
- Rational Application Developer for System z Version 7.6
- Websphere Application Server – ND V 7
- Redhat Enterprise Linux for z/OS V5



Migrated application portals :

- Replace Mid-tier AIX platform with Linux on System z
- Replace WMQ calls with IMS TM Resource Adapter / IMS Connect API

Inbound Transaction Use Case Evaluation:

- IMS TM Resource Adapter (J2C 1.5 Architecture)
- IMS Connect API

IBM: IMS Connect PoC ...

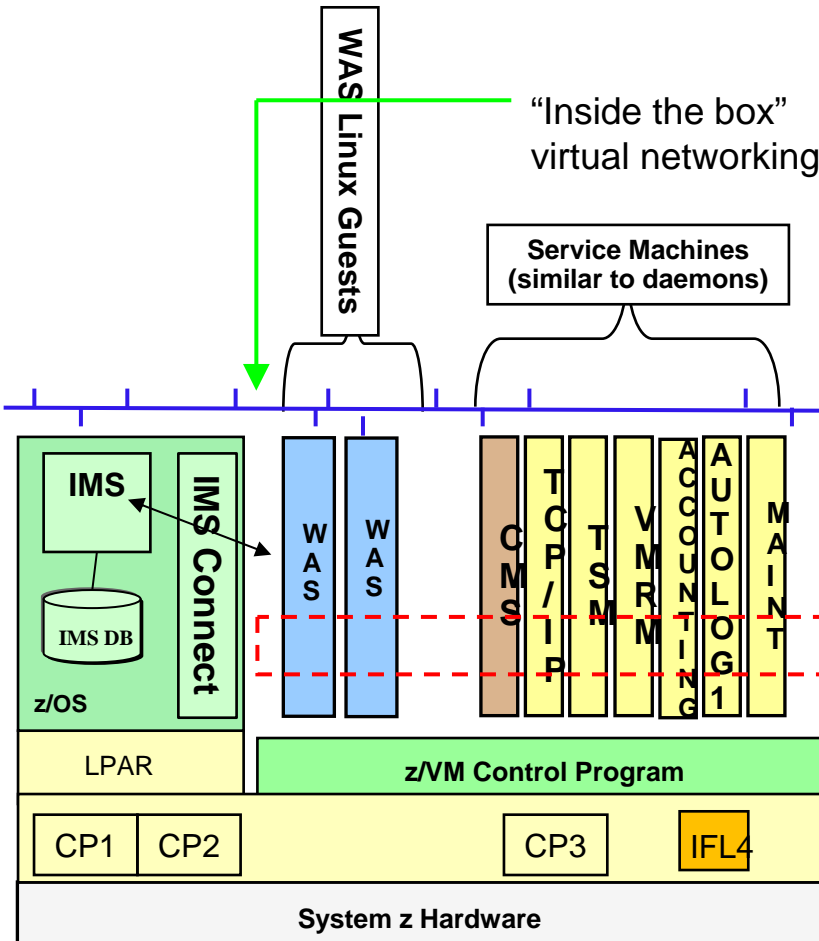

- Steps:**
- (1) User issues request from web browser via HTTP(S)
 - (2) Business service EJB receives request and invokes the IMS JCA adapter
 - (3) IMS JCA adapter sends request to IMS Connect
 - (4) IMS Connect invokes the IMS transaction in IMS and the response is returned to the EJB business service

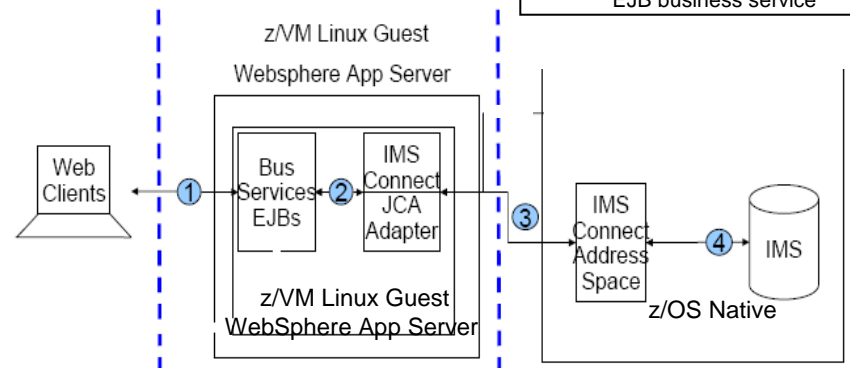

IMS Connect PoC...

- Snap shot of stress test results for use cases

WMQ, IMS Connect and IMS TMRA

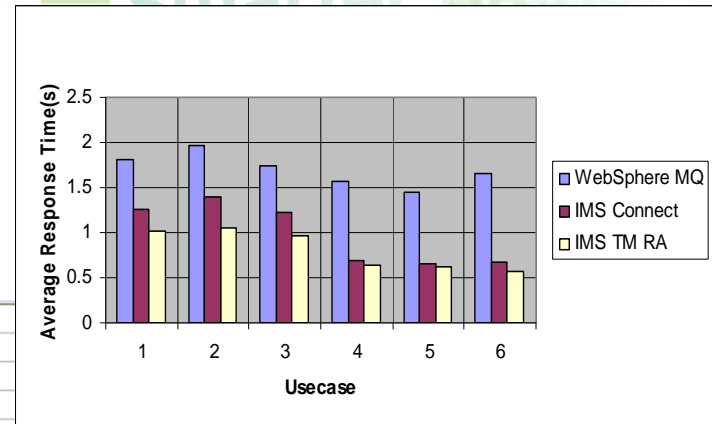

Comparison of usecases								
WebSphere MQ								
Name	MeasureType	Unit	Count	Total	Min	Avg	Max	StdDev
1A_Subscriber_Search	Response time[s]	Seconds	720	1,297.95	0.578	1.803	10.672	1.306
1C_Select_Category_and_click_lookup	Response time[s]	Seconds	360	708.334	0.625	1.968	9.844	1.468
1F_Benefit_Keyword_Search	Response time[s]	Seconds	180	314.88	0.578	1.749	10.437	1.32
2A_Group_SubGrp_Search	Response time[s]	Seconds	720	1,132.43	0.235	1.573	21.97	1.881
2C_Select_Categoery_Lookup_for_Group	Response time[s]	Seconds	360	522.939	0.407	1.453	7.187	1.318
2F_Benefit_Keyword_Search_for_Group	Response time[s]	Seconds	180	299.365	0.344	1.663	19.453	1.941
IMS Connect API								
Average E9 transaction time: 793 ms (12/18/2009)								
1A_Subscriber_Search	Response time[s]	Seconds	720	909.542	0.329	1.263	14.204	0.871
1C_Select_Category_and_click_lookup	Response time[s]	Seconds	360	504.113	0.484	1.4	8.563	0.925
1F_Benefit_Keyword_Search	Response time[s]	Seconds	180	219.625	0.422	1.22	5.969	0.779
2A_Group_SubGrp_Search	Response time[s]	Seconds	720	494.817	0.078	0.687	8.766	0.546
2C_Select_Categoery_Lookup_for_Group	Response time[s]	Seconds	360	236.378	0.156	0.657	3.235	0.339
2F_Benefit_Keyword_Search_for_Group	Response time[s]	Seconds	180	120.54	0.141	0.67	2.906	0.337
IMS TM RA								
Average E9 transaction time: 681 ms (12/21/2009)								
1A_Subscriber_Search	Response time[s]	Seconds	720	728.017	0.281	1.011	7.75	0.686
1C_Select_Category_and_click_lookup	Response time[s]	Seconds	360	378.439	0.484	1.051	4.61	0.614
1F_Benefit_Keyword_Search	Response time[s]	Seconds	180	172.319	0.468	0.957	4.75	0.574
2A_Group_SubGrp_Search	Response time[s]	Seconds	720	456.587	0.11	0.634	8.547	0.506
2C_Select_Categoery_Lookup_for_Group	Response time[s]	Seconds	360	222.155	0.187	0.617	2.328	0.313
2F_Benefit_Keyword_Search_for_Group	Response time[s]	Seconds	180	102.066	0.109	0.567	1.937	0.247

IMS Connect PoC...

Findings:

- > Improved performance of inbound IMS transaction
 - Application response time reduced by 25%
- > Improved performance of Portals under Linux on System z
 - Average 30% improvement in the overall performance
- > Standard and flexible IMS interfaces vs. propriety WMQ calls
 - JDBC, J2EE, TMRA, JCA 1.5 and direct API calls
- > Standard, supported IMS SOA vs. proprietary black box solutions of EIS and BSI application frameworks
- > Flexibility of switching backend IMS subsystems via WAS Admin Console
 - No coding changes required when using WAS and IMS TMRA
- > Paradigm shift to a two-tier architecture model
 - Resulted in code that is cleaner and easier to maintain
- > Narrowed the knowledge gap between mainframe and distributed personnel

Considerations:

- > Little Endian and Big Endian conversion between platforms
 - When the application was migrated to a Linux on System z, the order in which bytes were stored in memory were different
 - > Required specific parsing of the IMS message returned
- > Need to properly handle mainframe transaction ABENDs

Potential Benefits:

- ❖ **IMS Connect and IMS SOA Integration Suite**
 - > Performance and scalability improvements
 - > Reduced configuration and maintenance vs. WMQ setup and maintenance
 - > Assuming MIPs reduction
 - It was determined that an average Claim took 60 - 100 ms of overhead when going through the WMQ calls
 - > Eliminates the multiple points of failure inherent in WMQ hops
 - > Allows a point to point connection to all web

Production Implementation

- ❖ **IMS 11 and IMS Connect , IMS SOA Integration Suite and z/Linux**
- ❖ **Application Portal z/Linux Migration**
 - Software license and administration cost saving
 - Consolidate 11 physical boxes

Wellpoint

- The Challenge: modernization
 - Enabling mainframe assets for SOA using:
 - IMS Connect and
 - DataPower

“ A proof-of-concept project to modernize a proprietary solution that provides online access to mainframe data that resides in IMS™. Access is enabled using IMS programs that we call **RPCs**. RPCs are essentially services that are exposed by our strategic Group Health Insurance processing system (WGS) and our strategic Individual Health Insurance processing system (STAR). The RPC programs are accessed as stored procedure calls from Java and .NET adapters that support the JDBC and ODBC interfaces “

Four key objectives:

- ❖ *Cost savings through reduced mainframe utilization*
- ❖ *Technical support to transition from existing connectivity to WebSphere® DataPower® ESB*
- ❖ *Increased reliability for RPC consumer applications*
- ❖ *Support to evolve to a web services consumption style*

<http://www-148.ibm.com/bin/newsletter/tool/landingPage.cgi?preview=1&lpId=4239>

Wellpoint ...

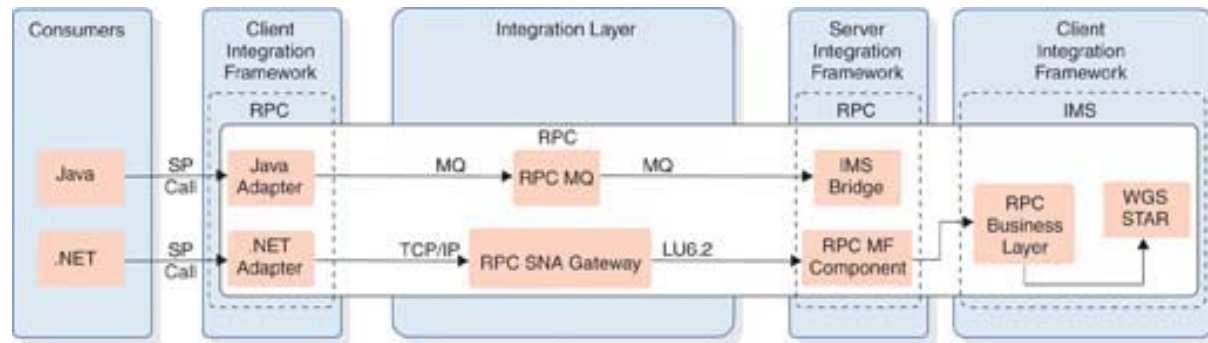

Initial Environment

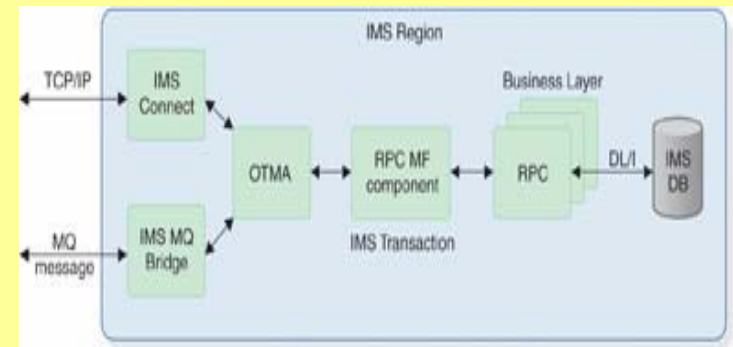
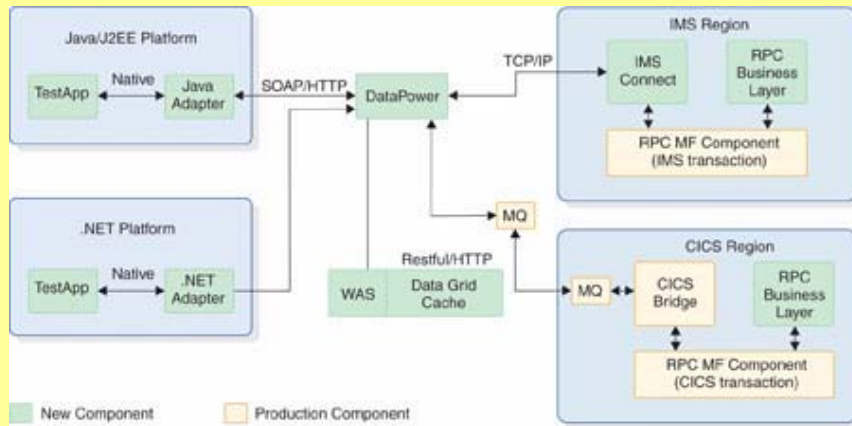

Proof of Concept

Opportunities:

- Modernize the architecture to use the new technologies
- Remove 32K payload limitation
- Streamline the infrastructure by removing a dependency on WebSphere MQ
- Leverage DataGrid cache to boost performance and lower mainframe resource demand, with a goal of lowering costs.

Wellpoint

- Proof of Concept Results

Technology Compatibility:

- ❖ Both Java and .NET adapters communicate with DataPower by using SOAP/HTTP(S) with no issues.
- ❖ Initially, the IMS Connect protocol handler was not interpreting the data correctly when LLZZ was split between two TCP/IP packets, but this problem was quickly fixed with APAR IC70653.
- ❖ The IMS Connect protocol handler was tested and is compatible with both IMS 9 and IMS 11. It was not tested with IMS 10, although we believe that it will be compatible.
- ❖ DataPower exchanges fixed-field messages with the IMS Connect protocol handler and transforms those messages to and from SOAP messages with no issues.

Overall Findings

We found that our new architecture is faster, uses less mainframe CPU, and enables mainframe transaction avoidance through configuration-based side caching.

Specific Findings

- ❖ Java median performance was 17% faster than existing infrastructure, per round trip.
- ❖ .NET median performance was 60% faster than existing infrastructure, per round trip.
- ❖ Mainframe connectivity related to CPU was reduced 20-59% when using IMS Connect instead of IMS MQ Bridge for RPC traffic inbound to WGS.
- ❖ Calling a single 96K payload RPC is more than 200% faster than calling a 24K RPC four times.

BNP PARIBAS

<http://bank.bnpparibas.com/en/pid496/in-brief.html>



BNP PARIBAS

BNP Paribas is a European leader in global banking and financial services and one of the six strongest banks in the world according to Standard & Poor's. Present across Europe through all its business lines, the Group has four domestic retail banking markets in France, Italy, Belgium and Luxembourg. It has one of the largest international networks with operations in 84 countries and 200,900 employees, including 158,700 in Europe, 15,000 in North America and 10,400 in Asia. (03/31/2010) BNP Paribas has key positions in its three core businesses:

- ▲ Retail banking
- ▲ Corporate & Investment Banking
- ▲ Investment Solutions

Ranks 11th of the world leading companies, 1st among French enterprises, 1st worldwide in terms of assets, 7th in the global banking sector and 2nd bank in the euro zone
(*'Global 2000 Forbes' 2009*)

6th most valuable international banking brand, 3rd in Europe
(Brand Finance February 2010)

Ranks 8th among the world's safest banks
(Global Finance - February 2009)

BNPP: IMS Soap Gateway Test – Main Flow

- The messages exchanged between IMS SOAP Gateway and IMS Connect are secured through SSL (Secure Sockets Layer) and those between the Gateway and SOAP Web service use encapsulation of messages issued through HTTPS.

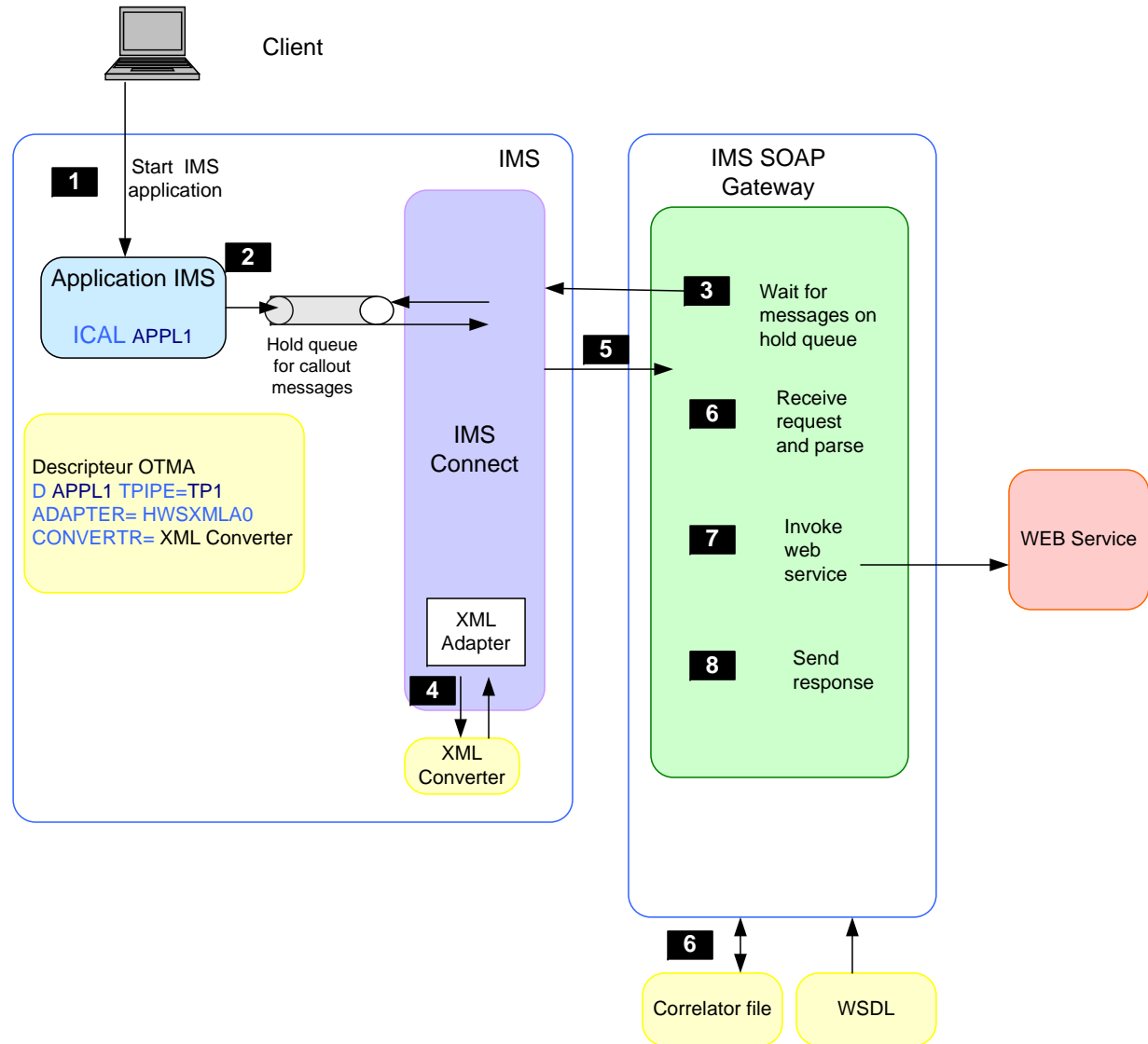

**Scenario 1:
2 IMS SG,
2 IMS Connects,
2 IMS**

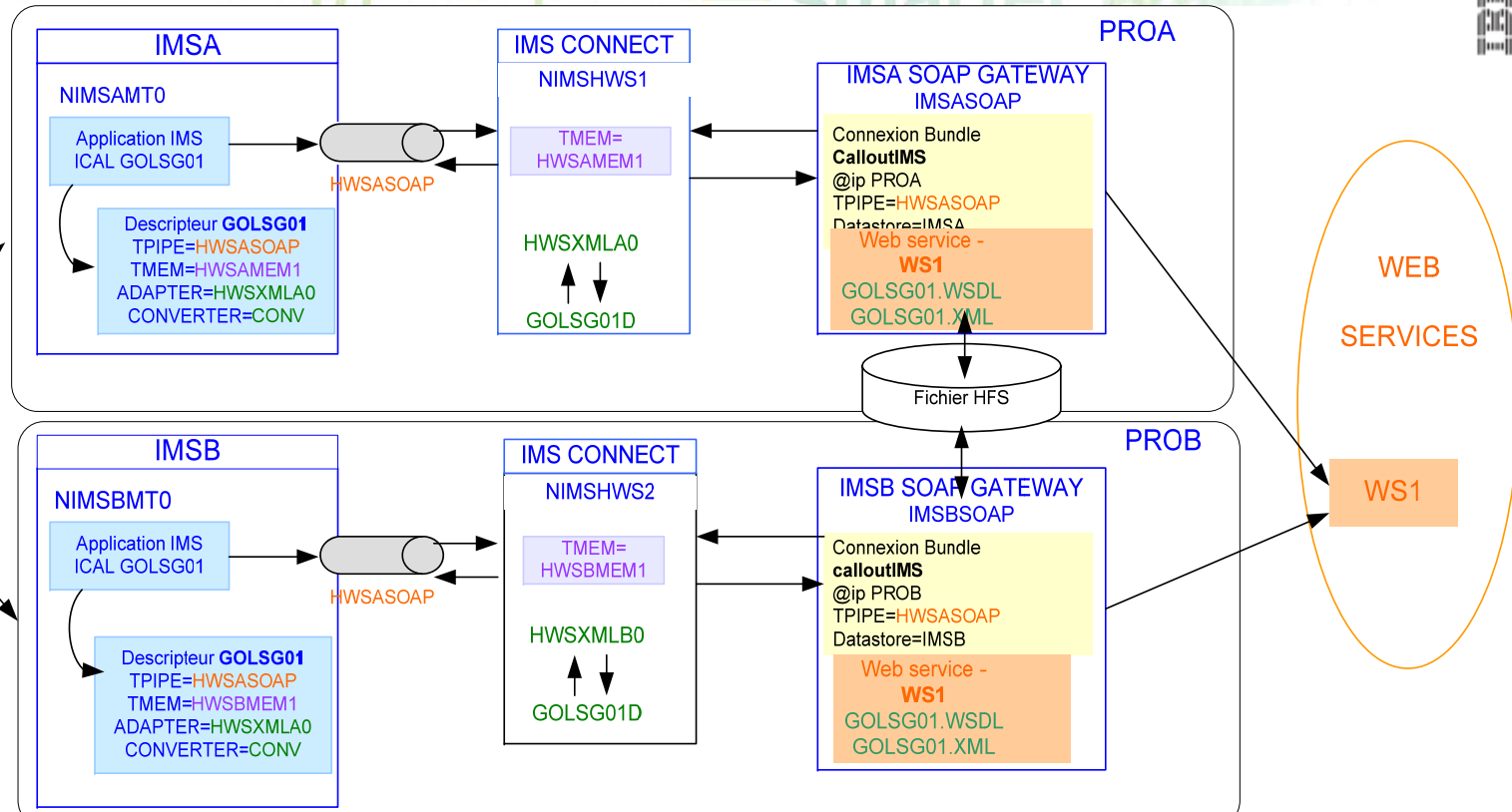

ENVIRONMENT:

Two LPARs: PROA and PROB

Two IMS Soap Gateway instances, each with:

- > A single connection bundle (CalloutIMS) with different contents depending on the partition in which it is running
- > A descriptor file called GOLSG01.WSDL
- > A correlator file called GOLSG01.XML
- > A single web service

Two IMS systems each with:

- > An application GOLSG01 with a descriptor with the same name but different contents depending on the target

Two IMS Connect instances, each with:

- > A converter called GOLSG01D

Test results:

- ❖ ICAL on GOLSG01 PROA: successful
- ❖ ICAL on GOLSG01 PROB: successful

Conclusion:

Scenario 1 works but does not guarantee continuity in case of the loss of a component (IMS connect or Soap Gateway)

Scenario
2 IMS SG,
2 IMS Connects
with Supermember support
2 IMS

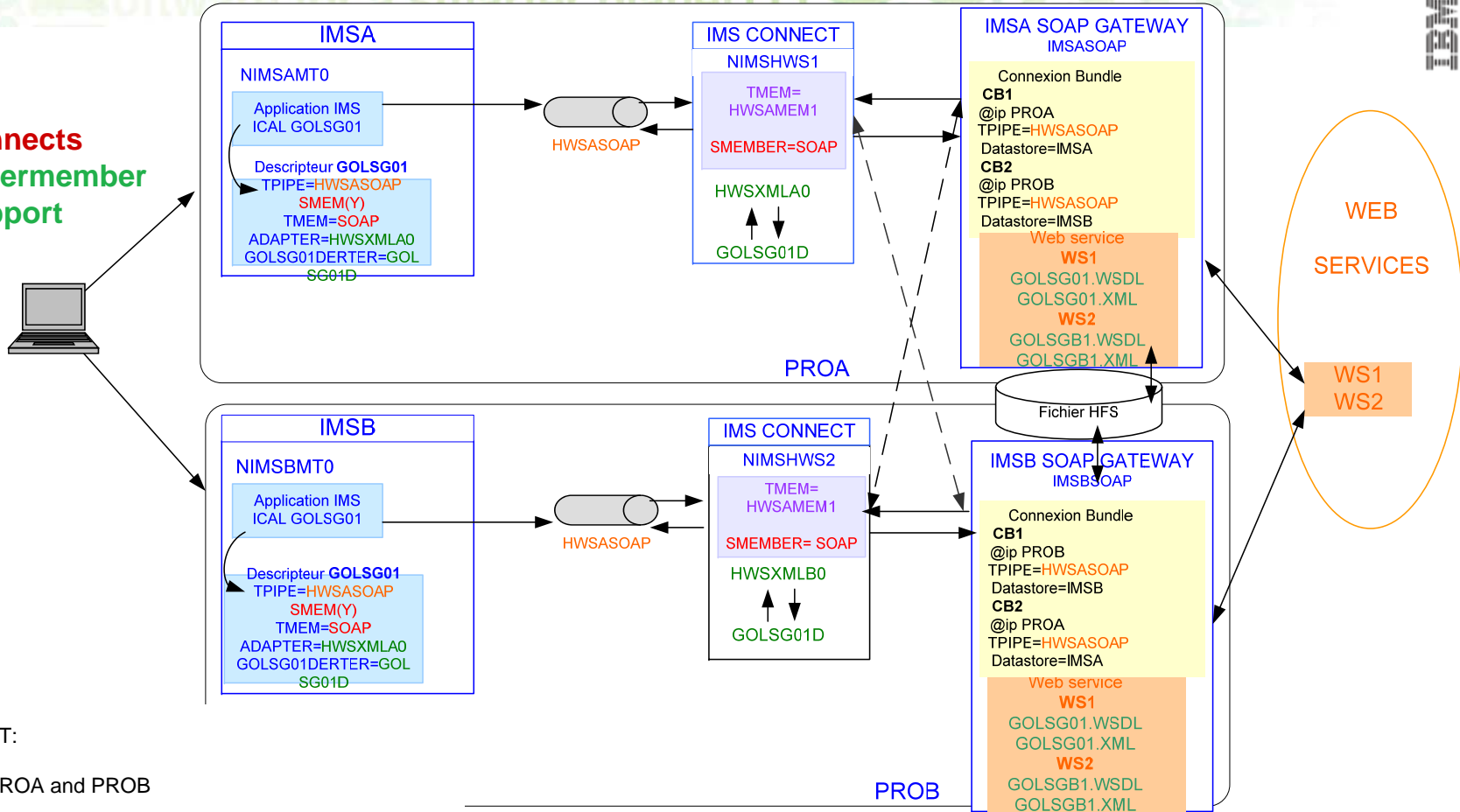

ENVIRONMENT:

Two LPARs: PROA and PROB

Two IMS Soap Gateway instances, each with:

- > Two instances of the same web service
- 2 WSDL files and 2 XML correlator files
- > two Connection Bundles – one for each IMS datastore

Two IMS systems each with:

- > An application GOLSG01 with a descriptor specifying SMEM=Y for Supermember support and TMEM=SOAP

Two IMS Connect instances, each with:

- > A converter called GOLSG01D and SMEMBER=SOAP

Future testing

The goal is to allow redundancy to address single points of failure

Customers Continue to Depend on IMS



20 TB of IMS data and 50 Million IMS transactions per day supporting bank tellers, online banking and ATMs



“Our customers bet their business on the services we provide. And we bet our service performance and availability on IMS.”

Paul Gandolfo, Senior Technical Specialist, Telcordia



Use IMS Sysplex for 24x7 availability via non-disruptive software and hardware maintenance, non-disruptive online database reorgs, workload balancing during peaks and enhanced failover and recovery

Analysts Agree!



“As IMS continues to evolve, it should be able to maintain a strong claim on the highly complex data management and high throughput workloads that it has historically served so well.”

Carl Olofson, IDC

More Information: IMS Regional User Groups World-wide

Free technical education; network with other IMS customers

Americas

- Boston, MA
- Chicago, IL
- Cincinnati, OH
- Columbus, OH
- Costa Mesa, CA
- Dallas, TX
- Detroit, MI
- Glendale, CA
- Hartford, CT
- Jacksonville, FL
- Minneapolis, MN
- NY, NY
- Omaha, NE
- Philadelphia, PA
- Phoenix, AZ
- San Ramon, CA
- Sao Paulo, Brazil
- Seattle, WA
- Springfield, IL
- Tampa, FL
- Toronto, Canada
- Washington, DC
- Vancouver, Canada
- Victoria, BC



EMEA & AP

- Amsterdam
- Brussels
- Copenhagen
- Chennai
- Dusseldorf
- Helsinki
- Johannesburg
- Madrid
- Melbourne
- Munich
- Oslo
- Stockholm
- Stuttgart
- Sydney
- Taipei

Additional Documentation

- IMS V11 Installation and Migration Tips
 - <http://www-03.ibm.com/support/techdocs/atmastr.nsf/WebIndex/WP101605>
- IMS 11 Easier than Ever – A Presentation
 - <http://www-03.ibm.com/support/techdocs/atmastr.nsf/WebIndex/PRS3871>

OR

WWW. IBM.COM / SUPPORT / TECHDOCS
and enter “IMS” in the Search field