



IMS 13

IMS 13 Transaction Manager Enhancements

Information Management software

© 2014 IBM Corporation

TM Topics

- Non-Discardable Message Exit (DFSNDMX0) Enhancements
- MSC enhancement
- OTMA Enhancements
- ISC Over TCP/IP

Enhancements for the Non-Discardable Messages Exit Routine

O2_ IMS 13 TM: 17

This topic summarizes some new enhancements for the non-discardable messages exit routine, DFSNDMX0.

Enhancements for the Non-Discardable Messages Exit Routine

- Customer requirement for a new function to PSTOP an abending transaction
 - Stops scheduling but allows queueing to continue

- New functions provided by for the DFSNDMX0, the Non-Discardable Messages exit routine
 - IMS 11 APAR PM67950 / PTF UK81040
 - IMS 12 APAR PM45943 / PTF UK71989
 - Included in IMS 13

This enhancement provides new function for the DFSNDMX0, the non-discardable messages exit routine.

These enhancements are included in IMS 13 . They are also available for IMS 12 and IMS 11 via PTF.

Enhancements for the Non-Discardable Messages Exit Routine

- Enhancement provides four new transaction status flag options that enable the DFSNDMX0 exit routine to perform one of the following actions
 - Stop the scheduling of messages containing a specific transaction code
 - Like /PSTOP TRAN command
 - Stop input messages for a particular transaction code
 - Like /PURGE TRAN command
 - Stop a particular transaction
 - Like /STOP TRAN command
 - Start a particular transaction
 - Like /START TRAN command
- Documentation is in the [IMS Exit Routines book](#) and the [Information Center](#)

Four new enhancements for the transaction status flag are provided.

Additional documentation in the the IMS Exit Routines book and the Information Center.

Benefits for Enhancements for the Non-Discardable Messages Exit Routine

- Provides additional flexibility in the DFSNDMX0 Non-Discardable Messages exit routine to better handle abending transactions in a high availability environment

MSC Enhancement

- Increase in the maximum number of MSC logical links (MSLINK) and physical links (MSPLINK) to 999
 - V11 - PM90979, prereq PM30837
 - V12 - PM90982, prereq PM30915
 - V13 - PM90983

OTMA Topics (1 of 2)

- Early Termination Notification
 - Enhancement to allow OTMA to leave XCF group earlier in termination process
- Enhancement to Global Flood Control to enforce global flood limit
- Ability to display HOLDq versus PRIMARY queue OUTPUT counts
- WTO messages for Automation
- OTMA Callable Interface (OTMA C/I) Asynchronous Enhancement
- OTMA Client Type
- Reduced TCO Enhancements
- Enhancements to OTMA Destination Descriptors for asynchronous callout
 - Support for WebSphere MQ
 - Simpler override for Exit Routines

OTMA Topics (2 of 2)

- ICAL Enhancements
- SPEs
 - IMS 12 Synchronous Callout SendOnly ACK SPE
 - OTMA MAXTP SPE
 - OTMA Transaction Expiration and Shared Queues Enhancements SPE

OTMA Early Termination Notification

- Enhancement that allows OTMA to leave the XCF group ***earlier*** in termination processing
 - Allows OTMA clients (IMS Connect, WebSphere MQ, OTMA C/I) to be notified of the termination via their XCF Group Exit
 - Can route requests to other systems
 - Addresses issues associated with transactions messages being accepted but not processed
 - Function being added to IMS 12: APAR PM73869
- Benefits
 - Autonomic enhancement for higher availability that allows OTMA clients to be informed of an IMS shutdown in order to choose more timely alternatives
 - Potentially reduces unsuccessful attempts to send in new requests
 - Can expedite shutdown processing

IMS 13 introduces an enhancement that allows OTMA clients (e.g., IMS Connect, WebSphere MQ, OTMA C/I) to be notified of IMS termination earlier in the termination process. This will be done for both scheduled and unscheduled terminations. The IMS OTMA clients can then route new requests to other IMS systems to be processed. This enhancement addresses environments that process high rates of transactions via IMS OTMA and experience some transactions being accepted but not processed by IMS during either scheduled or unscheduled IMS terminations.

OTMA Early Termination – Leaving XCF Group

- Ability to leave the XCF group earlier in termination processing
 - Does not impact IMS termination performance

- Planned outages (e.g., /CHE FREEZE | DUMPQ | PURGE)
 - x'3C' resource monitor protocol message during Phase 1 of IMS shutdown
 - Status of '1' indicates IMS cannot process new requests
 - X'14' protocol message to inform clients to suspend processing for all TPIPEs

- Unplanned outages (e.g. abend)
 - OTMA issues XCF IXCLEAVE immediately after the log buffers are purged
 - XCF group exits informs other members that IMS OTMA is no longer active

OTMA Early Termination Notification is part of the base IMS processing and is autonomic meaning that there are no definition or configuration changes to take advantage of the enhancement.

When IMS has a planned shutdown (/CHE {FREEZE | DUMPQ | PURGE}) then OTMA adds notification to OTMA clients during Phase 1 of shutdown. OTMA sends a TMAMMNTR (x'3C') resource monitor protocol message with TMAMRSIM_S1SHTDN indicating IMS shutdown with TMAMRSIM_STATUS set to '1' indicating IMS cannot process new requests. OTMA also sends a TMAMCSPA (x'14') protocol message informing clients to suspend processing for all TPIPEs. These protocol messages, sent at the start of shutdown, inform OTMA clients that IMS is no longer available and they should route new requests to another system. (note: the resource monitoring protocol was introduced in IMS 11 as a way for OTMA to inform its member clients of potential issues).

When IMS has an unplanned shutdown (abend) then OTMA will issue IXCLEAVE to leave the XCF group immediately after the log buffers are purged. This will inform the OTMA clients via their XCF group exits that IMS OTMA is no longer active in the XCF group. The OMTA clients can then route new requests to another system.

OTMA Global Flood Control Enhancement

- A new global flood control option that ***enforces*** the global flood limit
 - Rejects new transaction input and protects IMS from storage exhaustion
 - Versus just a warning message

- Benefit
 - Ability to address the global flood condition rather than just be warned

IMS OTMA also provides a new option to enforce the global flood limit to reject new requests and protect IMS from storage exhaustion. Previous releases protected flood conditions for individual OTMA clients (TMEMBERS) but only provided warning messages when the global flood limit was reached.

OTMA Global Flood Control Enhancement (Cont'd)

▪ Background

- OTMA message flood detection and control support from previous releases
 - Individual OTMA TMEMBER support
 - Monitors growth of active INPUT messages per member (default of 5000)
 - At 100% of threshold, new input messages from that member are rejected
 - Warning at 80% of flood value and in 5% increments until relieved
 - Global Flood Control
 - /STA TMEMBER **ALL** INPUT ##### (default 8000)
 - Monitors the total number of active input messages for **all** OTMA members
 - DFS4388W to the IMS MTO and system console along with OTMA protocol messages with a warning status to all of the OTMA clients
 - At 100% of the global flood value

In previous releases, OTMA's Message Flood Detection and Control capability provided a mechanism to automatically monitor the growth of active OTMA input messages and the control blocks associated with these input requests. Specifically, when an OTMA member or client sends a transaction to IMS, OTMA internally creates a control block called the TIB (Transaction Instance Block) to track each active input message. If several thousand OTMA input transactions are received from an OTMA member and waiting to be processed, thousands of control blocks representing the requests would take lots of IMS storage which could affect the overall IMS operations in the system. To prevent this type of OTMA message flood condition from an OTMA member, OTMA stops receiving the input transactions from this member based on a maximum value for the number of TIBs allowed for the OTMA member in the system. However, suppressing the input OTMA transactions only targets individual OTMA members that have the maximum value or threshold of TIBs defined. This type of OTMA flood control does not protect the IMS system when it has multiple OTMA members. In this case, each one of them may not reach the flood limit for the member. However, the total TIBs from all the OTMA members could exceed the global flood limit of the IMS system. When this happens, the IMS system (pre-IMS13) issues a warning signal with the Global Flood Control capability introduced in IMS 11 to the system console, the MTO and all the OTMA members without suppressing the input OTMA transactions. New transactions, however, can still come into IMS and flood the system. This could cause the IMS system to fail with a S878 abend.

OTMA Global Flood Control Enhancement (Cont'd)

- Global flood control enhancements
 - New defaults:
 - OTMA global flood limit: 8,000 → 10,000
 - Relief value: 6,400 → 5,000
 - New DFS3428W warning message at 80% and 5% increments until relief
 - Enhanced DFS4388W is issued when the limit is reached and the new support to reject input is not active
 - Actions when global flood control has *not* been requested/activated
 - Warning messages
 - Enhancements to request global flood control (0-99999 new max)
 - **New meaning:** /STA TMEMBER ALL INPUT #####
 - New “global” OTMA Client descriptor: M DFSOTMA INPT=

O2_ IMS 13 TM: 28

The default OTMA global flood limit of the system has been changed from 8,000 to 10,000 along with a default relief level change from 6400 to 5000. New DFS3428W warning message has been introduced when the 80% of global flood limit has reached. This message will be issued every 5% increment thereafter until the global flood limit is reached. Once the global flood limit is reached, the enhanced warning message DFS4388W will be sent to the system console and MTO along with OTMA protocol messages reflecting a warning status to all the OTMA members *when the global flood control has not been activated*. This global flood status can be relieved when the input messages in the system have been processed and the number of TIBS has been reduced to 50% or less of the global limit. The enhanced relief message DFS0793I will then be sent to the IMS MTO and system console along with OTMA protocol messages reflecting a good status to all the OTMA member clients.

The default actions (above) will take place if IMS is activated without limits to request input rejection with global flood control (below). This means that an IMS system without any specification or changes will come with the default OTMA global flood monitoring and a default global limit of 10,000. IMS will send out warning messages DFS3428W and DFS4388W to the system console and MTO along with protocol warning messages to all the OTMA members. No input OTMA transactions will be suppressed. This default mode of OTMA global flood monitoring can be changed to suppress input transactions from all the OTMA members once a global flood control and limits are specified

IMS 13 allows the activation of “global flood control” with two methods: (a) issuing the /STA TMEMBER ALL INPUT ##### command where ##### is the global flood limit as in previous releases but will now cause a rejection of new input when the value is reached in IMS 13, or (b) specifying a global limit value in a new OTMA client descriptor (DFSOTMA).

The valid global flood limit has a new max value and can be specified between 0 and 99999. (The valid range for the member flood limit continues to be between 0 and 9999.) As in previous releases, a non-zero value activates the global flood control for OTMA for the system. A value of 0 deactivates the global flood support and a value between 1 and 200, is treated as though 200 had been specified.

OTMA Global Flood Control Enhancement (Cont'd)

- **/STA TMEMBER ALL INPUT #####**
 - Command enhancement for global message flood control
 - IMS version 10 introduced the INPUT value
 - Overrides the default of 5000 messages for an OTMA member instance
 - The IMS 13 **ALL** parameter provides a global value for all members
 - Default was changed from 8000 to 10000
 - When the global value is reached
 - WTO and MTO messages are issued
 - Action message is sent to all OTMA members
 - **All of the new OTMA input transactions are rejected with NAK X'30' reason X'02'**
- **/DISPLAY OTMA enhancement**
 - New global message flood warning level display under the INPT column of the OTMA Server name
 - New **"SERVER+FLOOD"** status under the user-status column

O2_ IMS 13 TM: 29

In IMS 13 the meaning and actions associated with the `/STA TMEMBER ALL INPUT #####` command have changed. In IMS 11, when this command was issued, OTMA used the specified limit instead of the system default of 8000 to monitor the total active input message count for send-then-commit (CM1) transactions from all of the OTMA members. If the total number reached this specified limit, OTMA issued a DFS4388W to the IMS MTO and system console along with OTMA protocol messages with the warning status to all of the OTMA clients. In IMS 13, the limit is used to for more than a warning and allows OTMA to prevent any new message from being accepted until the flood situation is relieved.

The `/DISPLAY OTMA` command of a degraded system shows "SERVER+FLOOD" in the user status of the OTMA server member when the global flood control has been activated and the global flood limit is reached.

OTMA Global Flood Control Enhancement (Cont'd)

- A special new client descriptor (optional)
 - Using existing 'M' descriptor type in DFSYDTx member of IMS.PROCLIB.

```

M client-name keywords
Where:
  client-name is DFSOTMA
  keywords are:
    INPT= <VALID>
    DRU=  <Ignored>
    T/O=  <Ignored>
    MAXTP= <Described in the OTMA MAXTP SPE section >

```

For example: **M DFSOTMA INPT=22222**

- New system client name for all the OTMA members, DFSOTMA, is introduced to set the global flood limit via INPT parameter.

The option also exists to use a descriptor to define the global flood control limit using a client descriptor. Note that a special system client name, DFSOTMA, has been introduced for this purpose. Activation of this DFSOTMA client descriptor enables the global flood control and requests suppression of any new OTMA transactions when the limit is reached. The parameter that applies to this function in the DFSOTMA client descriptor is INPT=. Specification of other parameters, such as DRU=, T/O= are ignored. The MAXTP parameter capability is described in the OTMA MAXTP SPE later in this presentation.

OTMA Global Flood Control Enhancement (Cont'd)

- **Global** flood control enhancements ...
 - What happens when the global flood control is activated
 - Warning at **80%** of limit – DFS3428W
 - At **100%** of limit: OTMA rejects all new input from any OTMA member
 - Sense code x'0030', reason code x'0002'
 - Sends protocol message with command type set to X'3C'
 - With “unavailable for work” status instead of previous “warning” status
 - New DFS3429E error message is sent to the system console and MTO
 - /DISPLAY OTMA shows “SERVER+FLOOD” in user status
 - Global flood relief occurs when unprocessed input drops to **50%** of limit
 - Enhanced message DFS0793I is sent to IMS MTO and system console
 - OTMA member clients receive protocol messages reflecting a good status
- **Member** flood control limit continues to be 9999
 - OTMA rejects all new input from any OTMA member
 - Sense code x'0030', reason code x'0001'

Global flood control has action points at 80% (warning), 100% (rejection of new messages), and 50% (relief) of the global flood limit. When “global flood control” has been activated and the global flood limit is reached, OTMA rejects all the **new** input transactions from all the members with OTMA sense code x'0030' and reason code x'0002'. Any synchronous program switch requests from the internal OTMA member DFSYICAL are also rejected. The new DFS3429E error message is then sent to the system console and MTO and a protocol message with the command type set to X'3C' is sent to all the OTMA members with an “unavailable for work” status unlike previous releases which only sent a “warning” status. When OTMA members receive this status, they can choose to take corrective action. One example would be the rerouting of all the **new** transaction requests from one IMS system to another. Once IMS reaches the 50% value of the global limit for unprocessed messages, the global flood status is considered to be relieved and IMS begins accepting new input messages. The enhanced relief message DFS0793I is then sent to the IMS MTO and system console along with OTMA protocol messages reflecting a good status to all the OTMA member clients.

Note that the MEMBER flood limit (versus GLOBAL for all members combined) remains at 9999 as in previous releases. When a member reaches the member flood limit, new transactions from this member will be rejected with OTMA sense code x'0030' and the new reason code x'0001'.

OTMA Global Flood Control - Migration

- Migration considerations
 - Messages
 - Enhancements to DFS4388W and DFS0793I messages
 - Possible changes to automation programs that deal with DFS4388W and DFS0793I messages
 - New messages DFS3428W and DFS3429E
 - Changes to the default values
 - OTMA global flood limit: 8,000 → 10,000
 - Relief value: 6,400 → 5,000
 - /STA TMEMBER ALL INPUT ####
 - In previous releases resulted in warning messages
 - **Now** turns on global control and will reject new input
 - IMPACT if you change the value to be below what is currently queued
 - Use of DFSOTMA descriptor reduces the total entries for OTMA clients or members to 254 (instead of 255)

Older releases of IMS provided the following messages for the input message flood condition: DFS1988W, DFS1989E, and DFS0767I.

IMS 11 introduced four new messages: DFS4380W, DFS4381I, DFS4388W, and DFS0793I.

In IMS 13, the existing DFS4388W (when limit is reached and the new global support is not active) and DFS0793I (when flood is relieved) messages have been enhanced to make them clearer and to be consistent with the new messages:

- DFS3428W THE TOTAL OTMA INPUT MESSAGES(TIB) HAVE REACHED XX% OF THE GLOBAL LIMIT ZZZZ
- DFS3429E THE TOTAL OTMA INPUT MESSAGES(TIB) HAVE REACHED THE GLOBAL LIMIT ZZZZ

Prior to IMS 13, issuing the /STA TMEMBER ALL INPUT command turned on global flood notification. The same command in IMS 13 enforces the global limit and will cause any new input to be rejected.

If DFSOTMA is used, IMS considers it to be one entry toward the 255 max member entries. This means the total entries allowed for the OTMA clients or members become 254.

OTMA Global Flood Control – Migration (Cont'd)

▪ Migration considerations

– Pre-IMS 13:

- Changing the value with: /START TMEMBER ALL INPUT 200 command
 - Does not trigger the flood status update in the /DIS OTMA output even if there are more messages than the limit until a new OTMA transaction is entered
 - New input continues to be accepted warning messages are issued

– IMS 13:

- Changing the value with: /START TMEMBER ALL INPUT 200 command
- Immediately takes effect
 - If there are more messages waiting to be processed than the value
 - DFS3429E THE TOTAL OTMA INPUT MESSAGES(TIB) HAVE REACHED THE GLOBAL LIMIT ZZZZ
 - /DIS OTMA shows a status of SERVER+FLOOD
 - New input is rejected

OTMA Global Flood Control – Migration (Cont'd)

- ACTION points (pre-IMS 13)

Member	Default Threshold	80%		(at 5% incr) 85%-95%		100%		Relief	
		WTO MTO	3C	WTO MTO	3C	WTO MTO	3C	WTO MTO	3C
Individual Member Level	5000	X	X	X		X	X	at 50%	
Global Level - All Members	8000					X	X	at 80%	

- Member level

- At 100% of the member threshold, messages are rejected until level is relieved at 50%
- /DIS TMEMBER shows a FLOOD condition at 100%

- Global level

- At 100% of the global threshold, a warning is sent but messages continue to be accepted

The table in this visual shows the action points of the global flood support prior to IMS 13 and the percentages at which WTO and X'3C' protocol action messages are issued. The threshold values shown are the defaults of 5000 for an individual member and 8000 for all members globally.

At the Member Level, both the WTO message and the X'3C' message are sent at 80% as a warning as well as at 100% to indicate a severe condition. At increments of 5% from 85%-95%, only the WTO message is sent. At 50% after the threshold was previously reached, the WTO and X'3C' messages are issued to indicate a relief of the situation.

At the Global Level, the WTO and X'3C' messages are sent both at the 100% mark and subsequently at 80% to indicate a relief of the situation.

OTMA Global Flood Control – Migration (Cont'd)

▪ ACTION points (IMS 13)

Member	Default Threshold	80%		(at 5% incr) 85%-95%		100%		Relief	
		WTO MTO	3C	WTO MTO	3C	WTO MTO	3C	WTO MTO	3C
Individual Member Level	5000	X	X	X		X	X	at 50%	
Global level -All Members	10000	X	X	X		X	X	at 50%	

▪ Member level

- At 100% of the member threshold, messages are rejected until level is relieved at 50%
- /DIS TMEMBER shows a FLOOD condition at 100%

▪ Global level

- At 100% of the global threshold, a warning is sent but messages continue to be accepted
 - this is the default
- **BUT:** if a global flood limit has been specified in client descriptor or /START TMEMBER ALL INPUT command, an error will be sent instead and new trans messages will be rejected.

In IMS 13, the default for global flood controls continues to be a warning message but the default threshold is now at 10000 and the relief at 50%. However, if the global flood limits have been activated by either specification of the DFSOTMA client member descriptor or the /STA TMEMBER ALL INPUT command, reaching the 100% mark results in rejection of new transaction messages until the flood has been relieved at 50%. Additionally, warning messages will be issued at the 80% level.

OTMA Global Flood Control – Migration (Cont'd)

- The length of TIB and INPUT columns of IMS /DISPLAY OTMA command has increased by one
 - These fields can now display up to 5 digits of OTMA message numbers
 - The T27 DSECT and T28 DSECT of IMS DISPLAY MACRO were also updated for these length changes

Ability to Display HOLDq Counts

- Enhancement to /DISPLAY TMEMBER TPIPE command and output
 - Provides separate counts for the two output queues
 - PRIMARY
 - HOLDq
 - Applicable only to HOLDq-capable clients
 - e.g. IMS Connect
 - Output messages retrieved using Resume TPIPE protocol
 - Only affects non-shared queue systems
 - New OUTPUT display parameter is mutually exclusive with SYNC and QCNT parameters
- Benefit
 - Provides a mechanism to differentiate between CM0 versus CM1 output message counts for HOLDq-capable clients
 - Can help analyze potential bottlenecks

HOLDq is a TPIPE secondary queue used for three types of messages:

- ALTPCB messages chained to the first control block used for IOPCB output
- Send-only messages
- Rejected IOPCB output

O2_ IMS 13 TM: 37

IMS OTMA provides two queues for asynchronous output destinations that support “HOLDq”-capable clients (e.g., IMS Connect). Send/Receive responses for Commit Mode 1 (Commit-then-Send) transactions are queued to the PRIMARY queue. Asynchronous messages (from SendOnly transactions or Alternate IOPCB inserts) are queued to the HOLDq queue and are retrieved using Resume TPIPE protocol. Prior to IMS 13, the existing /DISPLAY command output reports the total messages queued to both queues. There is no external method to determine whether the messages are on the PRIMARY or HOLDq or both.

IMS 13 adds a new OUTPUT parameter to the /DISPLAY TMEMBER TPIPE command to report the PRIMARY and HOLDq counts separately. Note that this enhancement is valid only for HOLDq-capable OTMA clients and does not apply to non-HOLDq clients such as WebSphere MQ. This option is also only available for non-shared queues IMS systems and will be ignored when IMS has shared queues enabled. The OUTPUT parameter is mutually exclusive with the SYNC and QCNT parameters.

Ability to Display HOLDq Counts (Cont'd)

- /DISPLAY TMEMBER TPIPE syntax

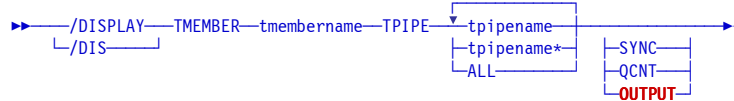

- /DISPLAY TMEMBER TPIPE output example:

– New Status

- PMRY – queue counts for the PRIMARY queue
- HLDQ – queue counts for the HOLDq queue

DFS000I	MEMBER/TPIPE	ENQCT	DEQCT	QCT	INPCT	STATUS	SMEM
DFS000I	HWS1						
DFS000I	-CLIENT03	1	1	0	1	PMRY	
DFS000I	-CLIENT03	1	0	1	0	HLDQ	
DFS000I	-9999	0	0	0	1	PMRY	
DFS000I	-CLIENT02	1	1	0	1	PMRY	
DFS000I	-CLIENT04	1	1	0	1	PMRY	
DFS000I	-CLIENT04	1	0	1	0	HLDQ	

NOTE: May double the command output for holdq clients

This visual gives an example of the new syntax of the /DIS TMEMBER TPIPE command with the new OUTPUT parameter along with an example of the OUTPUT display. Note that for HOLDq client output, the ability to report on both the PRIMARY and HOLDq queues could result in an increase of the display output. Specifying the OUTPUT parameter will double the number of lines for the display. There may be some impact when using the ALL or masked TPIPE names for TMEMBERS with a large number of TPIPEs.

WTO Messages for Automation

- Enhancement to send some MTO-only messages also to the WTO

- No changes to the message content

```

DFS0062W  LOAD FAILED FOR DRU exit
DFS1281E  (N)ACK ON NON-EXISTING TPIPE= tpipe FROM MEMBER= member
DFS1283E  (N)ACK ON NON-EXISTING BLOCK IN TPIPE= tpipe MEMBER= member TOKEN= token
DFS1284E  (N)ACK ON NON-WAITING BLOCK IN TPIPE= tpipe MEMBER= member TOKEN= token
DFS1297E  OTMA TRANCOMPLETED. NO OUTPUT DUE TO MSG SIZE EXCEEDED 32K (32767)
DFS1964E  DESTINATION TMEMBER ... TPIPE or DESTINATION NAME= nn NOT ACCESSIBLE,
DFS2374W  OTMA GROUP NAME HAS CHANGED FROM oldname TO newname
DFS2375W  IMS HAS CHANGED ITS OTMA MEMBER NAME FROM oldname TO newname
DFS2376W  IMS OTMA MEMBER NAME name IS THE SAME AS A PREVIOUSLY ACTIVE CLIENT
DFS2386I  OTMA IS CONNECTING TO THE MEMBER xxxxxxxx
DFS2391I  MESSAGE DEQUEUE FAILED DURING RESYNCH FOR TMEMBER =x TPIPE = x
DFS2393I  SRVRESYNCH REJECTED BY TMEMBER= xxxxxxxxxxxxxxxxx
DFS2396I  RESET SEQUENCE NUMBER FAILED DURING RESYNCH FOR TMEMBER = TPIPE =

```

- Benefit

- Enhances automation with additional console WTO messages

O2_ IMS 13 TM: 39

There are many important IMS OTMA messages that have only been sent to the Master Terminal Operator (MTO) LTERM. Many environments that use automation for console Write To Operator (WTO) messages and could also benefit from these OTMA messages. They are now being sent to both the MTO and WTO to the console. There are no changes to the message content.

The auditlog function for the Operations Manager (OM) has not changed and continues to be controlled by the UOM parameter in the DFSDFxxx member of proclib for unsolicited messages.

OTMA Callable Interface (C/I) Enhancement

- **OTMA C/I has been enhanced to be a HOLDq-capable client**
 - Informs OTMA during the client-bid process
 - For asynchronous flows (CM0)
 - The `otma_send_async_API` call has been changed
 - Uses `SendOnly` with `ACK` protocol
 - Asynchronous output is stored on the `HOLDq` in `IMS`
 - Previously used `otma_send_async`
 - Asynchronous output sent immediately and stored in `XCF` until the client retrieved the response
 - Similarly, the `otma_receive_async_API` has been changed
 - Issues a `Resume TPIPE` request against the `HOLDq`
- **Benefit**
 - Addresses previous timing issues between OTMA C/I and client for asynchronous messages

O2_IMS 13 TM: 40

OTMA Callable Interface (OTMA C/I) provides a high level interface for host infrastructure applications to send and retrieve messages with IMS OTMA using XCF services. Prior to this enhancement, OTMA C/I **asynchronous** (CM0 – Commit-then-Send) messages that are sent using `otma_send_async_API` have the responses sent immediately by OTMA since there is no `HOLDQ`. OTMA C/I must “store” these messages in `XCF` until the client issues `otma_receive_async_API`. This has led to many timing issues between OTMA C/I and the client.

This enhancement changes OTMA C/I to use the OTMA `HOLDQ` support for asynchronous (CM0) messages. OTMA C/I specifies it is `HOLDQ` capable on the client-bid. The `otma_send_async_API` has been changed to use `SendOnly` with `ACK` protocol. The asynchronous output will be placed on the `HOLDQ`. The `otma_receive_async_API` will now use `Resume TPIPE Single` to retrieve the output.

These changes to OTMA C/I are internal with the minor impact to customers outlined in the migration section.

This enhancement does not change the synchronous `Send-then-Commit` (CM1) flows.

OTMA Callable Interface (C/I) – Migration

- Existing OTMA C/I clients will see a change during error conditions:
 - When OTMA NAK's the input for asynchronous messages
 - No longer receive IMS DFS messages
 - Instead, they receive a return and reason code indicating the specific error

 - Example:
 - Prior: OTMA C/I client can receive
 - DFS064 Invalid transaction code
 - New: OTMA C/I client receives
 - RC=00000014, RSN=0000001A,0000001D,00000000,00000002

The OTMA C/I client using asynchronous messaging will no longer receive IMS DFS messages when the input is NAK'd by OTMA. OTMA C/I will be provided return and reason codes to indicate the specific error.

Example: rather than DFS064 for an invalid transaction code, the OTMA C/I client will now receive RC=00000014, RSN=0000001A,0000001D,00000000,00000002.

RC=x'14' indicates OTMA NAK codes, RSN=x'1A' indicates message cancelled, x'1D' indicates SMB not found (invalid transaction code),

OTMA Client Type

- **Each client type has different processing considerations for OTMA**
 - IMS Connect is holdq-capable and supports Resume TPIPE requests
 - MQ supports synchronous TPIPEs for CM1 (Commit-then-Send) messages
 - OTMA C/I has just been enhanced to be holdq-capable
- **Enhancement to the client initialization process (client-bid) allows identification of type**
 - IMS Connect, OTMA CI, Synchronous program switch
- **OTMA clients created by a destination routing descriptor for asynchronous output**
 - Are set to the descriptor's TYPE=IMSCON or TYPE=MQSERIES

IMS OTMA clients (eg. IMS Connect, MQ, OTMA C/I) each have unique processing considerations. IMS Connect is holdq-capable and supports the Resume TPIPE protocol. MQ supports synchronous TPIPEs for Commit Mode 1 (Commit-then-Send) messages. In many cases the differences in client type impact how OTMA processes client requests and messages. The client initialization process (client-bid) has been enhanced to allow clients to declare their “type” to OTMA. Knowing this will allow OTMA to optimize certain functions for greater efficiency.

IMS Connect in IMS 13, OTMA C/I, and the internal DFSYICAL for Synchronous Program Switch identify their client type to OTMA.

IMS OTMA Destination Routing Descriptors can be used to create OTMA clients (TMEMBER) for asynchronous output. If the TMEMBER did not previously exist, the client type is set for TYPE=IMSCON or TYPE=MQSERIES.

Reduced TCO Enhancements

- **Effort to reduce MIPS in IMS 13 includes OTMA**
 - More efficient hashing technique for control blocks
 - IMPACT to an environment depends on volume of activity
 - Example:
 - Every CM1 (Send-then-commit) transaction request has a control block associated with the port TPIPE during processing
 - If a slowdown in IMS or zOS occurs or if the system is actively processing large numbers of requests then an increasing number of these blocks remain active
 - The improved hashing technique results in a more timely and efficient search for a specific block during application GU or checkpoint
 - Usage of the CPOOL and DFSBCB in XCF Message Exit instead of the STORAGE OBTAIN macro
 - Increases EPVT by 167 MB
 - Removal of unnecessary MVCL hot spot

IMS 13 introduces a more efficient hashing mechanism for OTMA control blocks associated with transaction messages. The impact to a specific IMS environment depends on its use of OTMA.

The cell pool macro (CPOOL) provides programs with another way of obtaining virtual storage other than the STORAGE OBTAIN macro. CPOOL provides centralized, high-performance cell management services and DFSBCB is an IMS storage manager service which manages storage in specific storage pools.

OTMA Destination Descriptors

OTMA Descriptors

- **OTMA destination descriptor enhancements**
 - TYPE={MQSERIES}
 - Provides asynchronous callout and messaging support (ISRT ALTPCB)
 - EXIT={YES | NO}
 - Specifies whether or not the OTMA exits are to be called
- **Corresponding enhancement to IMS Type-2 OTMADESC commands**
 - [CREATE | UPDATE | DELETE | QUERY] OTMADESC
 - Recovered across warm and emergency restarts
- **Benefits**
 - Simplifies asynchronous messaging to WMQ
 - Removes the need to code the OTMA exits, DFSYPRX0 and DFSYDRU0
 - Provides dynamic change capability with the Type-2 commands

O2_ IMS 13 TM: 45

The destination descriptor for IMS asynchronous callout has been expanded to introduce a new type, MQSERIES, to allow customers to define message switch destinations (from ALT IOPCB) as WebSphere MQ. This new type of descriptor for WebSphere MQ externalizes the definitions in the DFSYDTx member of IMS.PROCLIB rather than forcing customers to code OTMA routing exits (DFSYPRX0 & DFSYDRU0). Thirteen new parameters for this new descriptor are introduced to prepare the MQMD structure in the OTMA user data prefix.

Dynamic addition, update, or deletion of the destination descriptors for WMQ can be performed using the type-2 commands:

```
CREATE OTMADESC  
UPDATE OTMADESC  
DELETE OTMADESC
```

OTMA Descriptors (Cont'd)

- **Enhancement addresses**
 - Need to support MQ destinations in the OTMA descriptor definitions

- **Restriction**
 - IMS 13 only supports asynchronous callout for MQ
 - ISRT ALTPCB
 - No support for synchronous callout
 - ICAL

The new destination descriptor support for WebSphere MQ destinations cannot be used for synchronous callout ICAL calls.

OTMA Descriptors (Cont'd)

- IMS 13 OTMA Descriptors for MQ

- DFSYDTx PROCLIB member
 - IMS Cold start or /ERE COLDCOMM

```
D MQ*      TYPE=MQSERIES TMEMBER=VC7 TPIPE=MQTPIPE
D MQ*      USERID=USRT001 EXIT=NO SYNCTP=YES
D MQ*      MQRTQMGR=VC7 MQRTQ=OTMA.FROM.IMS
D MQ*      MQREPORT=NONE MQFORMAT=MQIMS MQPERST=YES
D MQ*      MQMSGID=MSG456789012345678901234
D MQ*      MQCORREL=COR456789012345678901234
D MQ*      MQAPPLID=APP45678901234567890123456789012
D MQ*      MQRTF=MQIMSVS MQCOPYMD=NO
```

- Required:
 - TMEMBER, MQRTQMGR, MQRTQ

OTMA Descriptors (Cont'd)

IMS 13 OTMA Descriptors

- EXIT={YES|NO}
 - Specifies whether (Y) or not (N) the OTMA routing exits (DFSYPRX0 and DFSYDRU0) will be called
 - Exits will be passed the descriptor information
 - Exits can accept descriptors routing information or provide override information
 - **Applicable to all destination descriptors (not just TYPE=MQSERIES)**
 - Simpler than using OTMAMD=YES|NO
 - Specification available in previous releases that allowed/disallowed an override of a member client name through DFSYPRX0
 - E.g., When the original input message came from an OTMA client and the destination descriptor for the ALTPCB message included target member name

O2_ IMS 13 TM: 48

A new parameter EXIT= is added to the destination descriptor. When EXIT=YES is specified and OTMA routing exits (DFSYPRX0 and DFSYDRU0) are found in the IMS, the exits are allowed to override the routing information specified in the descriptor. Other IMS exits such as DFSYIOE0 are not affected by this new parameter. The default setting of EXIT is NO which means the OTMA routing exits, if found, cannot be called to override the routing information in the descriptor.

The EXIT= mechanism for providing overrides is simpler than the previous OTMAMD specification which was a way to define whether or not the member override function in the DFSYPRX0 user exit would be invoked when a transaction invoked from an OTMA client for ALTPCB messages. OTMAMD (N) meant that for transactions invoked from a non-OTMA LTERM, the 16-byte member override field of the DFSYPRX0 parameter list could be used to specify an OTMA client member name, but not for transactions originally invoked from an OTMA client. OTMAMD (Y) meant that the member override field of the user exit parameter list could be used for both OTMA and non-OTMA invoked transactions.

Operational Considerations – Commands

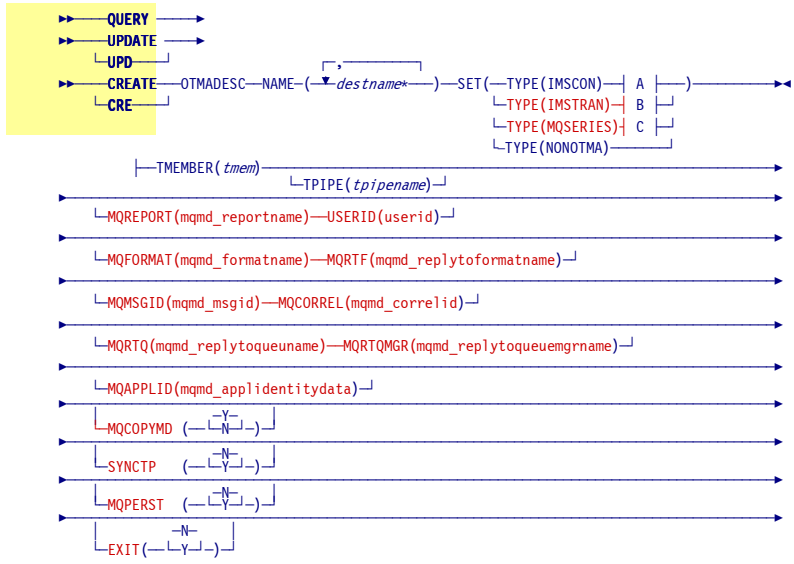

Operational Considerations – Commands (Cont'd)

- Note that QUERY OTMADESC can specify new TYPE and SHOW parameters that include:
 - IMSCON | NONOTMA | **MQSERIES** | **IMSTRAN**
 - Provides the ability to look at information that is targeted at specific capabilities

Example

- WebSphere MQ OTMA Descriptors Example

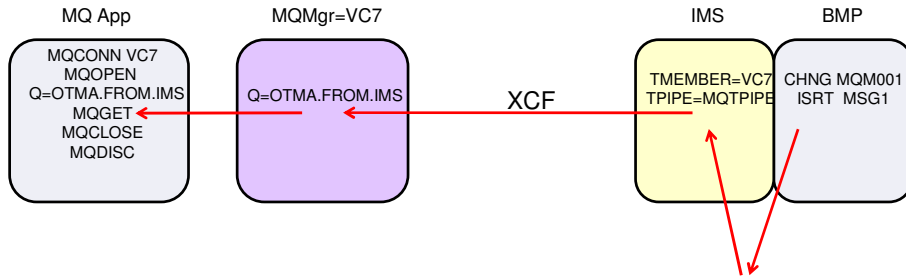

OTMA Descriptor (DFSYDTx)
 =====
 D MQ* TYPE=MQSERIES TMEMBER=VC7
 D MQ* TPIPE=MQTPIPE . . .

Exit Routines

▪ DFSYPRX0 – OTMA Pre-Routing Exit Routine

CONTENTS OF OTMA PRE-ROUTING USER EXIT PARMLIST

+24 = 1-BYTE FLAG

X'08' – If set, indicates that the destination name matches an entry in the OTMA destination descriptor for IMS Connect

X'04' – If set, indicates that the destination name matches an entry in the OTMA destination descriptor for MQ

X'02' – If set, indicates that the destination name matches an entry in the OTMA destination descriptor for Non-OTMA

+27 = 1-BYTE Version

X'80' – If set, indicates that the user exit parmlist is expanded to include the address of OTMA destination descriptor

+88 = ADDR(routing information defined in the descriptor)

CONTENTS OF REGISTERS AT EXIT:

R15 = RETURN CODE

100 : Keep the destination descriptor settings with no changes. This return code will be accepted when the EXIT=Y is specified in the destination descriptor. All of the routing information specified in the descriptor will be used. If the destination is IMS Connect or MQ, DFSYDRU0 user exit will be located and called for more destination determination.

▪ DFSYDRU0 – OTMA Destination Resolution Exit Routine

CONTENTS OF OTMA PRE-ROUTING USER EXIT PARMLIST :

+24 = 1-BYTE FLAG

X'08' – If set, indicates that the destination name matches an entry in the OTMA destination descriptor for IMS Connect

X'04' – If set, indicates that the destination name matches an entry in the OTMA destination descriptor for MQ

+27 = 1-BYTE Version

X'80' – If set, indicates that the user exit parmlist is expanded to include the address of OTMA destination descriptor

+100 = ADDR(routing information defined in the descriptor)

CONTENTS OF REGISTERS AT EXIT:

R15 = RETURN CODE

100 : Keep the destination descriptor settings with no changes. The return code will be accepted when the EXIT=Y is specified in the destination descriptor. All of the routing information specified in the descriptor will be used.

O2_ IMS 13 TM: 52

A new flag, new input field, new return code have been added into the user exit parameter list in the DFSYPRX0 exit routine. The address at +88 points to a location which stores the routing information defined in the descriptor for WebSphere MQ and IMS Connect. If the destination name matches a non-OTMA destination in the descriptor or it does not match any entry in the OTMA destination descriptor, this new field will be zero. For the destination as IMS Connect, please see the TMAMICON_DESCRIPTOR DSECT mapping for the detailed routing information. For the destination as MQ, please see the TMAMMQS_DESCRIPTOR DSECT mapping for the detailed routing information.

Similarly, DFSYDRU0 has added a new flag, new input field and a new return code into the user exit parameter list. The address at +100 points to a location which stores the routing information defined in the descriptor for WebSphere MQ and IMS Connect. If the destination name matches a non-OTMA destination in the descriptor or it does not match any entry in the OTMA destination descriptor, this new field will be zero.

Migration Considerations

- Type-2 Commands support new OTMADESC parameters

ICAL Enhancements

- Enhanced ICAL support for Truncated Messages
- New AIB field - AIBUTKN

Support for Truncated Messages

- **New “RECEIVE” subfunction code**
 - With an expanded response area
 - Retrieves the response message after an ICAL “SENDRECV” is issued with an inadequate response area specification and gets partial data (AIB RC X'100', AIB RS X'00C')
 - IMS 13 keeps a copy of the entire response message in the control region private storage
 - Until a subsequent ICAL “SENDRECV”, syncpoint, or application termination
- **Addresses**
 - Partial response message due to inadequate application specification
- **Benefit**
 - Provides the ability to complete the retrieval of a reply message
 - Without having to re-issue a complete ICAL “SENDRECV” and associated network transmission costs

O2_ IMS 13 TM: 55

IMS 13 introduces a new subfunction of “RECEIVE” for the ICAL. This enhancement supports the retrieval of an entire response message if the original ICAL received partial data and an AIB return code of x'100' and reason code of x'00C'. By taking advantage of the new subfunction and expanding the response area in the call, the IMS application is able to retrieve the copy of the message that is temporarily kept in the IMS control region's private storage.

This enhancement relieves the burden of having to re-issue a full ICAL “SENDRECV” along with any associated network delays.

ICAL subfunction RECEIVE

Format:

- >>-ICAL--aib--response area-----><

AIB

- **AIBSFUNC** value “RECEIVE”
- **AIBOAUSE** is used as an input and output parameter based on AIBSFUNC
 - For the “RECEIVE” call
 - Contains the length of the response area
- **AIBOALEN** = request area length
 - Used as an *output parameter for “RECEIVE”*
 - When complete response is returned in *response area*, this field is 0
 - If partial data is returned (AIB RC X'100', RS X'00C'), this field contains the actual length of the response message

The format of the ICAL with a subfunction of “RECEIVE includes specification of the **aib** and a **response area** that can contain the entire message. Not all the **aib** fields are used for this call. The following apply:

- AIBID = DFSAIB
- AIBLEN = AIB length
- AIBOALEN - request area length. This parameter is an input and output parameter for the SENDRECV subfunction. When this parameter is used for the RECEIVE subfunction, it is used as an output parameter. When the complete response data is returned in the response data area, this output field will be set to 0. When partial data is returned (AIB return code X'100', AIB reason code X'00C'), this field contains the actual length of the response message.
- AIBOAUSE - Response area length. This parameter is an input and output parameter. As an input parameter, this 4-byte field contains the length of the output response area that is specified in the call list. As an output parameter, this field is updated by IMS with the length of the response message that is returned in the response area. When partial data is returned because the response area is not large enough, AIBOAUSE contains the length of the data that is returned in the response area, and AIBOALEN contains the actual length of the response message.
- AIBRETRN = AIB Return code
- AIBREASN = AIB Reason code.

ICAL sub-function RECEIVE ...

Usage example:

❖ ICAL --aib—request area, response area

- ⇒ AIBSFUNC (SENDRECV)
- ⇒ AIBOAUSE – Response area length
- CALL is issued → AIBRETRN=x'100', AIBREASN='00C'
 - ✗ Specified length of the output response area is too small
 - ✗ AIBOAUSE= length of the data that was returned in the response area
 - ✗ AIBOALEN = the actual length of the entire response message
- Using the value in the previous AIBOALEN and leveraging the new support which keeps the message in IMS CTL region private, retrieve the entire response:

❖ ICAL --aib— response area

- ⇒ Where *response area* has been expanded to contain the entire message
- ⇒ AIBSFUNC (RECEIVE)
- ⇒ AIBOAUSE – new response area length
- CALL is issued successfully
 - ✓ AIBOAUSE – length of the response in the response area
 - ✓ AIBOALEN – set to 0 because the call successfully returned the entire response

If an ICAL call with sub-function code SENDRECV is issued with an insufficient response buffer defined, the ICAL will be returned with AIB return code X'100' and AIB reason code X'00C'. A subsequent ICAL call with sub-function code RECEIVE can still be issued to retrieve the entire response message as long as it is defined with the expanded response buffer.

ICAL sub-function RECEIVE ...

- ICAL “RECEIVE” is only valid if previous ICAL “SENDRECV” failed

- Response data is available for retrieval until:
 - A new ICAL call with sub-function code SENDRECV is issued
 - When the IMS application reaches a syncpoint
 - Checkpoint for an BMP application
 - Abnormal termination

In order to issue an ICAL call with the sub-function code RECEIVE to retrieve the entire response message, the ICAL call with sub-function code SENDRECV must have previously been issued and returned with AIB return code X'100' and AIB reason code X'00C'.

IMS keeps a copy of the entire response message in the control region private for any potential subsequent ICAL “RECEIVE” calls. Note that if this copy of the response message in IMS is not subsequently retrieved by the ICAL RECEIVE call, it will be discarded and the storage will be released. The response message is kept until:

- A new ICAL call with sub-function code SENDRECV is issued
- The IMS application issues ROLB call or CHECKPOINT
- The IMS application reaches syncpoint or terminates abnormally

AIBUTKN

- **New AIB field - AIBUTKN**
 - Provides optional specification of a 1-8 byte map name
 - Included in the OTMA state data prefix to be sent to the callout destination
 - IMS 12: PM73135/UK82636

- **Benefit**
 - Ability to send a name to a remote ICAL destination that can be used for message formatting or service identification purposes

The DL/I ICAL call for synchronous callout can optionally use the first 8 bytes of a new AIBUTKN parameter to specify a map name in the application interface block (AIB). This value is passed in the OTMA state data prefix and can be used by the remote destination for message formatting or service identification purposes.

SPEs

IMS 12 Synchronous Callout SendOnly Ack SPE

- **New call for remote servers to use when sending a reply to an IMS synchronous callout (ICAL) interaction**
 - OTMA support for SendOnly ACK
 - Function requires that both the following APAR/PTFs are applied
 - IMS Connect 12: APAR PM39569 (PTF UK74666)
 - IMS OTMA 12: APAR PM39562 (PTF UK74653)

- **Benefit**
 - Synchronous Callout servers are able to request and receive an indication of response delivery to the IMS ICAL application so they can commit or abort their updated resources

The Synchronous Callout SendOnly ACK SPE has been delivered to address IMS 12 environments and is part of base IMS 13. To enable the function both APARs must be applied – one to IMS OTMA and the other to IMS Connect.

This support allows a synchronous callout server, i.e., the target of IMS's outbound ICAL, to process the request and when sending the response to request that IMS acknowledge receipt of the response.

IMS 12 Synchronous Callout SendOnly Ack SPE ...

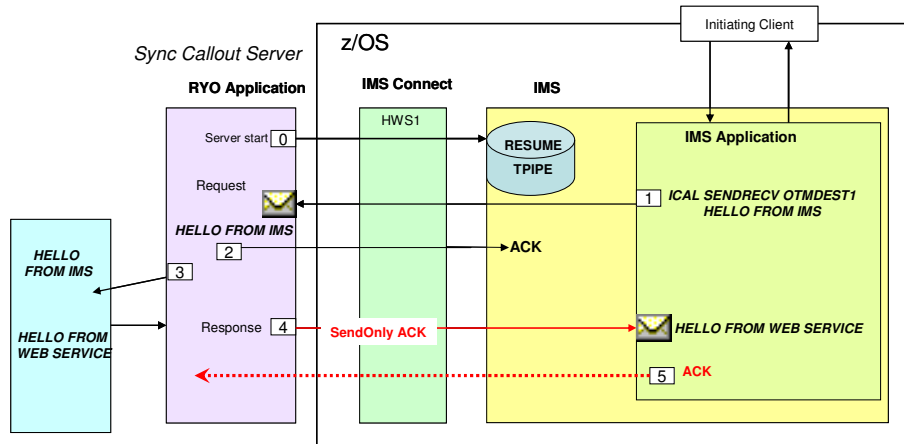

The client sends response (step 4) using Sync Callout Response with SendOnly with ACK. IMS returns ACK/NAK (step 5) indicating delivery of response to IMS ICAL application.

This visual gives an example of the callout process including a request for SendOnly ACK.

IMS 12 Synchronous Callout SendOnly Ack SPE

- There is no requirement to use the new function

- Implementation considerations
 - To take advantage of the support
 - Sync Callout server is required to perform an additional receive for the ACK/NAK
 - Note that there is no impact to the IMS ICAL Application

 - To minimize the impact of the additional receive for the ACK/NAK
 - Callout server can separate the Sync Callout request retrieval (Resume TPIPE) threads from the processing and response threads which can use different sockets

For a synchronous callout server application to take advantage of this new function, an additional receive for the ACK (acknowledgement) or NAK (negative acknowledgement or rejection) must be coded. This implementation does not impact or require any changes to the IMS application that issues the ICAL. The ACK/NAK is sent by OTMA.

To minimize the possible performance impact of coding an additional receive, the server has the option of designing the interaction to separate the request retrieval threads from the processing and response threads. Different threads can use different sockets.

IMS 13 APAR PM90777/UK95578 IMS Connect users

- Socket enhancement for ResumeTPIPE Wait-For-Ever session (listening socket)
 - Immediate detection of a client session termination
 - When the IMS Connect session is in CONN state (waiting on reply from datastore) with execution timeout value of 'wait-for-ever' as a result of a ResumeTpipe auto or single wait

(Also mentioned in the IMS Connect section of the System Topics Part I)

With this service the IMS Connect session that is in CONN state (waiting on reply from datastore) with execution timeout value of 'wait-for-ever' as a result of a ResumeTpipe 'auto' or 'single wait' will immediately detect a session termination of the client application.

OTMA MAXTP Enhancements

▪ OTMA MAXTP SPE

- Base MAXTP support
 - IMS 11: APAR PM14510 (PTFs UK65904/UK65905)
 - IMS 12: APAR PM33681 (PTFs UK75918/UK75919)
 - IMS 13 APAR PM97670 (PTF UK98251)

▪ IMS 11 OTMA MAXTP SPE

- Enhanced support
 - IMS 11: APAR PM71035
 - IMS 12: APAR PM74457

A TPIPE is a logical connection between IMS and the OTMA client, through which all input and output for a given client or client ID is routed and queued. OTMA creates TPIPEs dynamically at the request of the OTMA client. Each TPIPE has extended CSA storage and extended private storage associated with it. When there are too many TPIPEs in the IMS system, it can be a storage concern. In order to limit the growth of OTMA TPIPE creation in the system, the optional parameter, MAXTP, in the OTMA client descriptor was introduced to set a TPIPE limit for an OTMA member. Once this parameter is defined for an OTMA member, OTMA begins monitoring requests for TPIPE creation.

The base support for OTMA MAXTP was previously introduced with APARs to IMS 11, and IMS 12.

Enhancements to this base support are provided with the IMS 11 OTMA MAXTP SPE which includes IMS 11 and IMS 12 environments.

All of these capability are part of the IMS 13 base.

OTMA MAXTP SPE – Base Support

Background

- MAXTP parameter in the OTMA client descriptor in DFYSDTx
 - Defines the maximum number of OTMA TPIPEs that can be created for an OTMA member in an IMS system
 - Enables monitoring of TPIPE creation requests for the specified member
 - Limits the growth of TPIPEs
 - Prevents S40D and other storage abends

M client-name keywords Where:
 client-name is the OTMA client XCF member name
 keywords are:
 DRU=name
 INPT=0-99999
 T/O=0-255
MAXTP=200-99999
indicates the maximum number of TPIPEs for this member that can be created. If the value is between 1 and 200, it is treated as 200. A value of 0 is ignored.

Examples:

M HWS1 MAXTP=3000
 M HWS2 MAXTP=1000

MAXTP is a parameter in the OTMA client descriptor that defines the maximum number of OTMA TPIPEs that can be created for that member. Once the parameter is defined, OTMA begins monitoring of the TPIPE creation requests. This capability is beneficial for limiting the unrestrained growth of TPIPEs which could result in a S40D or other storage abend.

The example on this visual describes the parameters and shows some examples.

OTMA MAXTP SPE – Base Support ...

Monitoring for a single member

Descriptor	
M HWS2	MAXTP=1000

- Occurs when MAXTP is specified in the descriptor
 - **At 80%**, DFS4382w message is sent to the system console and MTO
 - THE TOTAL OTMA TPIPE COUNT 800 HAS REACHED 80% OF 1000 for HWS2
 - **At 100%**, DFS4383E is sent to the system console and MTO
 - THE TOTAL OTMA TPIPE COUNT 1000 HAS REACHED 100% OF 1000 for HWS2
 - Any input transaction requesting a new TPIPE is rejected with NACK code '29'X
 - If the input transaction requests an existing TPIPE it will be accepted
 - Any asynchronous output reroute with a new TPIPE name is ignored
 - Message is sent back to the original queue to be re-processed (for IMS Connect)
 - Any OTMA ALTPCB output message specifying a new TPIPE name is ignored
 - Region receives an A1 or AX status code
 - **At 50%**, relief message DFS4384I is issued
 - THE TOTAL OTMA TPIPE COUNT 500 HAS DECREASED BELOW 50% OF 1000 for HWS2
- Automatic removal of TPIPEs occurs after they have been idle for three consecutive system checkpoints
 - Alternatively, /CHE command can be issued 3 times to force TPIPE cleanup

O2_ IMS 13 TM: 67

Once the MAXTP parameter is defined for an OTMA member, the request for the TPIPE creation for the OTMA member will be monitored.

When the total number of the TPIPEs reaches 80% of the maximum, IMS generates a warning message DFS4382W to system console and MTO. Note that the DFS4382W message is displayed only once (in the situation, for example, where the percentage bounces from 80% to 75% to 84%, etc.). Only after the number drops down to 50% are the internal flags reset. After this reset, if the TPIPE number once again gets to 80%, then the DFS4382W message will be issued.

When the total number of TPIPEs gets to 100%, an error message DFS4383E is sent to the system console and MTO. Any input transaction requesting a new TPIPE will be rejected with a new NACK code '29'X when the maximum TPIPE limit has been reached. On the other hand, if the input transaction requests an exiting TPIPE, it will be accepted. Any asynchronous output reroute with a new TPIPE name is ignored and the message will be washed back to the original queue to be re-processed. (This is mainly for IMS Connect customers). Additionally, OTMA ALTPCB output messages specifying a new TPIPE name will not be processed. The region will receive an A1 or AX status.

When the number of TPIPEs for the member drops back down to 50% of the value then relief message DFS4384I is issued.

IMS automatically attempts to remove transaction pipes after they have been idle for three consecutive system checkpoints. Or, you can issue /CHE commands 3 times to force the tpipe cleanup.

OTMA MAXTP SPE – Base Support ...

- Monitoring for all members that have MAXTP
 - Highest number defined by any member becomes the global TPIPE limit
 - When the total number of TPIPEs in an IMS reaches the global limit
 - Warning message DFS4385W is sent to the system console and MTO

```
DFS4385W THE GLOBAL OTMA TPIPE COUNT 3000 HAS REACHED 100% OF 3000
```
 - Once the total number of the total TPIPEs in an IMS drops down to 80%
 - Relief message DFS4386I is sent

```
DFS4386I THE GLOBAL OTMA TPIPE COUNT 2400 HAS DECREASED BELOW 80% OF 3000
```

Descriptors:

→ M HWS1	MAXTP=3000
M HWS2	MAXTP=1000

When multiple OTMA member clients specify the MAXTP value in their client descriptors, the highest number defined among the members will be treated as the global TPIPE limit for the members. When the total number of TPIPEs in an IMS reaches the global limit, a warning message DFS4385W will be sent to the system console and MTO. Once the total number of the total TPIPEs in an IMS drops down to 80% of the global limit, a relief message DFS4386I will be sent out.

OTMA MAXTP SPE – Base Support ...

- /DISPLAY OTMA and /DISPLAY TMEMBER command output
 - Shows the **current number** of TPIPEs for members using the function
 - Once the limit has been reached, **MAX TPIPE** will be displayed as the USER_STATUS for the member
 - Global TPIPE limit is displayed under the new output field **TPCNT** for the IMS server

/DISPLAY OTMA		/DISPLAY TMEMBER	
GROUP/MEMBER	USER-STATUS	GROUP/MEMBER	USER-STATUS
DFS0001 -IMS1	ACTIVE	DFS0001 -IMS1	ACTIVE
DFS0001 -IMS1	N/A	DFS0001 -IMS1	N/A
DFS0001 -HWS1	ACTIVE	DFS0001 -HWS1	ACTIVE
DFS0001 -HWS1	200	DFS0001 -HWS1	200
DFS0001 -HWS2	ACTIVE	DFS0001 -HWS2	ACTIVE
DFS0001 -HWS2	200	DFS0001 -HWS2	200
		DFS0001 -HWS2	MAX TPIPE

The /DISPLAY OTMA and /DISPLAY TMEMBER commands have been enhanced to allow the display output to show the current number of TPIPEs for those OTMA members that have enabled the MAXTP support. Additionally, the 'MAX TPIPE' status is displayed when the limit has been reached.

OTMA MAXTP SPE – Base Support ...

- OTMA resource monitor function is activated
 - Sends out the protocol command '3C'x to the OTMA members for the various TPIPE warning and relief status
 - No severe status is given
 - Either warning status or degraded status
 - Client applications can reroute subsequent transactions to a different IMS

Example of IMS Connect's command output that shows the status:

```

VIEWDS IMS1
HWSC0001I  DATASTORE=IMS1      STATUS=ACTIVE
HWSC0001I  GROUP=XCFGRP1  MEMBER=HWS1
HWSC0001I  TARGET MEMBER=IMS1      STATE=WARN
HWSC0001I  DEFAULT REROUTE NAME=HWS$DEF
HWSC0001I  RACF APPL NAME=APPLID1
HWSC0001I  OTMA ACEE AGING VALUE=2147483647
HWSC0001I  OTMA ACK TIMEOUT VALUE=120
HWSC0001I  OTMA MAX INPUT MESSAGE=5000
HWSC0001I  SUPER MEMBER NAME=      CM0 ACK TOQ=
  
```

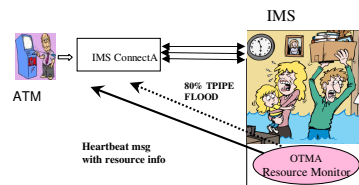

O2_IMS 13 TM: 70

The OTMA resource monitor function is also activated with this support and sends out the protocol command '3C'x to the OTMA members for the various TPIPE warning and relief status (no severe status will be given, the most is the warning status or degraded status.) Client applications can then reroute the subsequent transactions to a different IMS if needed.

OTMA MAXTP SPE – Base Support ...

- OTMA Client handling of the NACK '29'x when MAXTP reaches 100%
 - WebSphere MQ
 - WMQ message is sent to the system console

```
CSQ2003E MQM5 CSQ2QCP0 OTMA REJECTED MESSAGE – SYSTEM ERROR, SENSE
CODE=00290000, XCFGNAME=HARRY XCFMNAME=IMS1 TPIPE=CSQ00013
```
 - /START TMEMBER TPIPE ALL can restart transaction flow
 - OTMA C/I
 - Input message is rejected with RC 20, NACK code is included in reason code 1
 - IMS Connect
 - HWSSMPL0/HWSSMPL1 message exits send NACK code in the RSM

```
LL ZZ *REQSTS* RC = '10'X Reason code ='29'X
```

This visual describes OTMA client handling of the NACK '29'x when MAXTP reaches 100%.

When IMS rejects a transaction request with '29'x, WebSphere MQ sends CSQ2003E error message to the system console. The /START TMEMBER TPIPE ALL can be used to allow WMQ to start submitting transactions to IMS

OTMA C/I clients get a rejection of the input message with a RC 20 along with the NACK code in Reason Code 1.

IMS Connect users that take advantage of the HWSSMPL0 or HWSSMPL1 exit routine receive the '29'x NACK code in the RSM.g

BUT

- There remained a few issues:
 - Shared Queues Environment:
 - Back-end systems experience U0367 abends when the MAXTP is reached
 - Transactions that experience the abend are stopped
 - No messages can be processed for these transactions until they are manually restarted
 - Global MAXTP value for all members
 - Currently calculated from the highest value specified by any of the members
 - Does not offer the flexibility of specifying a value other than the highest of all member client descriptors

After application of the enhancements previously discussed there still remained a few issues. In a Shared Queues environment, U0367 abends occurred in back-end systems when the MAXTP condition was reached. Transactions that receive the abend are stopped and must be manually restarted.

Additionally, calculation for a global MAXTP value is simply based on picking the highest MAXTP value from the OTMA TMEMBERS that specify the value. The method precludes setting a value that accommodates even a partial accumulation of the individual specifications.

So V11 OTMA MAXTP SPE

- Enhancements to OTMA TPIPE flood monitoring
 1. For shared queues:
 - DFS3323I message in a back-end system when MAXTP is reached
 - Optional MAXTPBE in the OTMA client descriptor
 2. A new way to specify global (all members) MAXTP flood control support
 3. MAXTPRL parameter to set TPIPE flood limit relief
 4. Enhanced MAXTP information in /DIS OTMA and /DIS TMEMBER output
 5. NACK rejection of a input instead of DFS1289I when IMS is short on message space

The V11 OTMA MAXTP SPE answers the issues discussed in the previous visual with 4 enhancements.

V11 OTMA MAXTP SPE

1. Enhancement for shared queues environments:

- For non-fastpath transactions
 - Instead of a U0367 abend when MAXTP is reached for non-fastpath trans
 - Input message is discarded during application GU
 - Transaction is not stopped
 - DFS3323I message is sent to the front-end IMS
- For fastpath transactions
 - No change from base support for MAXTP occurrences
 - Transaction is rejected
 - Transaction is not stopped
 - DFS2193I message is sent to the front-end IMS

The first enhancement address the shared queues back-end system abends. After application of the SPE, when an IMS shared queues back-end system attempts to process a front-end initiated OTMA non-fastpath input transaction at application GU time and MAXTP is reached, abend U0367 does no longer occurs. Rather, the input message is discarded, the transaction is not stopped, and a DFS3323I message is sent to the front-end IMS to inform the OTMA client.

Not there has been to change to fastpath transaction processing in this SPE. When a fathpath transaction is processed at the shared queues back-end IMS and experiences a MAXTP condition, the transaction will be rejected and a DFS2193I message is sent back to the front-end IMS. The transaction in the shared queues back-end is NOT stopped.

V11 OTMA MAXTP SPE

1. Enhancement for shared queues environments ...

- Optional MAXTPBE= [YES | NO] in the OTMA client descriptor in the back-end
 - Requests that the MAXTP check be honored [YES] or bypassed [NO]
 - Only checked in individual member client descriptors if MAXTP is also defined
 - Always honored in the global DFSOTMA client descriptor even without MAXTP specification

Optionally, a new parameter MAXTPBE in the OTMA client descriptor of the shared queues back-end can be specified to tell IMS to honor [YES] or ignore [NO] the MAXTP checking at application GU time. Setting this parameter in the back-end IMS allows OTMA front-end initiated transactions to be scheduled without worrying about the number of TPIPE limit defined. This parameter can be specified in the OTMA client descriptor for a member when MAXTP is specified. It will be ignored if the member does not have MAXTP specified. This parameter can also be specified in the special DFSOTMA client member descriptor (discussed earlier in the Global Flood Control Enhancement topic) with or without MAXTP for all the members. It is an optional parameter and defaults to YES.

V11 OTMA MAXTP SPE ...

2. Enhanced Global MAXTP support

- Leverages the **DFSOTMA** client member descriptor which allows specification of global limits
 - **MAXTP** specifies a global limit and a new way of monitoring
 - **80%**: DFS4515W warning message is sent to the system console and MTO
 - OTMA protocol message '3C' sends a warning status to all OTMA members
 - **100%**: DFS4516E error message is sent to the system console and MTO
 - New TPIPE requests are rejected with sense code '29'x
 - Requests for existing TPIPEs continue to be accepted
 - OTMA protocol message '3C' is sent to member clients
 - “Warning” status instead of “unavailable” because requests for existing TPIPEs are still accepted
 - **50%**: DFS4517I relief message is sent to the system console and MTO
 - OTMA protocol message '3C' with a good status is sent to all member clients
- **NOTE**: if MAXTP is not specified in DFSOTMA then the previous monitoring support applies

O2_ IMS 13 TM: 76

The enhancement for global MAXTP support leverages the DFSOTMA client descriptor and provides a MAXTP global limit for all the members. Once this is specified, IMS no longer uses the highest limit defined by any of the members. The MAXTP limit in DFSOTMA activates a new way of monitoring the TPIPE for all the members:

- When 80% of this global limit is reached, a DFS4515W message is sent to the system console and MTO, and an OTMA protocol message reflecting a warning status is sent to all the OTMA members.
- At 100%, when the global flood limit is reached, OTMA rejects all **new** TPIPE creation requests for all the OTMA members in the IMS. For an OTMA input transaction requesting a new TPIPE, a NAK rejection with OTMA sense code '29'x is sent. Additionally, a DFS4516E error message will be sent to the system console and MTO along with the OTMA protocol message reflecting a **warning** status to all the OTMA members. The reason why the protocol message shows the “warning” status instead of the “unavailable” status is that IMS can still accept transaction requests using existing TPIPEs in the system. A /DISPLAY OTMA command of this degraded system will also show “MAX TPIPE” in the user status of the OTMA server member.
- When the number of TPIPEs for all the members is reduced to 50% of the user specified global limit, a relief message DFS4517I is sent to IMS system console and MTO along. Additionally, an OTMA protocol message reflecting a good status is sent to all the OTMA members.

Note that if MAXTP in the special DFSOTMA client member descriptor is not used, IMS continues to use the highest limit defined among the members for the global MAXTP limit. As defined earlier, new TPIPE creation requests can still be accepted even when the global limit is reached. No rejections occur.

V11 OTMA MAXTP SPE ...

3. New MAXTPRL parameter

- Sets the relief level of the TPIPE flood limit
 - Valid values: 50–70

4. Enhancements to the/DIS OTMA and /DIS TMEMBER

- Shows MAXTP limit for the member and server in a new column
 - Previously, MAXTP was not displayed
- Existing TPCNT column shows existing TPIPE counts for member and servers even when MAXTP is not specified in the descriptor
 - Previously TPIPE counts were displayed only when MAXTP was specified in the client descriptor

The new MAXTPRL parameter for the member descriptor sets the relief level of the TPIPE flood limit. The value can be specified between 50 and 70. If not specified, the default level will be 50, which means 50% of the flood limit.

The /DISPLAY OTMA and DISPLAY TMEMBER commands now show the MAXTP limits for the member and server in a new column. Previously, MAXTP for the member was not displayed. Additionally, the TPCNT column has been enhanced to show existing TPIPE counts for members and server, even when MAXTP parameter is not specified in the OTMA client descriptor. (Previously TPCNT displayed TPIPE counts only when MAXTP was specified in the OTMA client descriptor.)

V11 OTMA MAXTP SPE ...

5. When IMS runs short on message space

- For input messages in the message queue buffers
 - Rejection of input transaction message with NACK x'1A', Reason Code x'25
 - Instead of DFS1289I message
 - 67D0 log record is created

```

DFSERA30 - FORMATTED LOG PRINT                                PAGE 000
67 RECORD - 2012-10-02 02:09:07.413957 UTC
00000000 000000 00640000 67D00800 407ED6E3 D4C17E40 C4C6E2E8 E3C9C2F0 CA41A4A8 D67BF526 *..... =OTMA= DFSYTIB0.UYO#5.*
00000020 000020 D5D640D8 40E2D7C1 C3C5C9D4 E2F0F0F0 F0F14040 40404040 4040E3D7 C9D7C5C2 *NO Q SPACEIMS00001 TPIPEB*
00000040 000040 40400000 40404040 40404040 00000001 00000001 CA41A4A8 D67C5F26 00000000 * .. .....UYO@^.....*
00000060 000060 000001BC
DFS707I END OF FILE ON INPUT
DFS708I OPTION COMPLETE

```

- For CM0 output
 - Reduced usage of LUMP storage for CM0 output

O2_ IMS 13 TM: 78

When IMS runs short on message queue space, input transactions are rejected with a NACK x'1A' reason x'25' instead of issuing a DFS1289I message. Additionally, a 67D0 log record will be produced.

OTMA Transaction Expiration and Shared Queues SPE

- **SPE: APAR/PTFs**
 - IMS 10: PM05985 (UK75413/UK75414)
 - IMS 11: PM05984 (UK74312/UK74313)
 - IMS 12: PM46829 (UK75415/UK75416)

- **Enhancements**
 - Options when transaction expiration occurs at application GU time
 - Option to suppress or display symptom dumps and DFS554A messages
 - Option to return input message instead of DFS3688I
 - Improved routing capability of Shared Queues back-end ALTPCB output
 - Improved usability of /DIS TMEMBER TPIPE command

OTMA Transaction Expiration and Shared Queues SPE ...

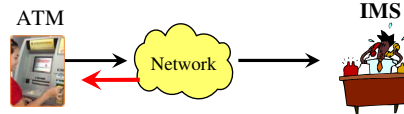

- Enhancements when transaction expiration occurs at application GU
 - Suppression of symptom dumps and DFS554A messages (default)
 - Can be overridden by either:
 - Specifying TODUMP= YES in the client descriptor in DFSYDTx member of PROCLIB
 - Setting the OTMA flag, TMAMDUMP, in the state data prefix of the input transaction
 - Support for original message rather than DFS3688I to be returned
 - Requested by setting TMAMINPT flag in the OTMA input
 - Leveraged by WebSphere MQ 7.1.0 APAR PM47795 (PTF UK75270)
 - Allows the MQMD_REPORT option to return the original input to be honored

O2_ IMS 13 TM: 80

OTMA transaction expiration at GU time has been updated to provide two enhancements:

- By default, the symptom dump of U243 abend and its DFS554A message for an expired transaction are no longer generated to save the CPU cycles. OTMA, however, can be configured to generate the symptom dump and DFS554A message by specifying TODUMP=YES in the DFSYDTx PROCLIB member or by setting the TMAMDUMP flag in the OTMA state data prefix of the input message.

- Also by default, a DFS3688I message instead of DFS555I/DFS2224 is sent to the OTMA client at application GU transaction expiration. OTMA, however, now honors a request to return the original input message instead of the DFS3688I if the TMAMINPT flag is set in the OTMA prefix of the input message. WMQ 7.1.0 with APAR PM47795 supports this capability and sets the flag for requests where the MQMD_REPORT option is to return the original input message.

OTMA Transaction Expiration and Shared Queues SPE ...

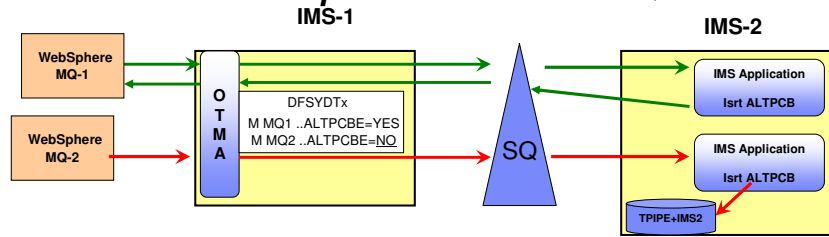

- Ability to override a SQ back-end affinity for ALTPCB messages
 - Allows ALTPCB output generated in a back-end to be routed back to a front-end for delivery
 - Options:
 - Specifying ALTPCBE= YES in the OTMA client descriptor in the DFSYDTx PROCLIB member of the front-end IMS system
 - Setting the TMAMALTB flag (X'01') in the state data prefix of the input message
 - Of value when supermember support (e.g., IMS Connect) is not used or not available (e.g., WMQ)

O2_ IMS 13 TM: 81

Shared queues environments can sometimes pose problems for ALTPCB output that is generated at a back-end IMS. By default, the back-end ALTPCB output is queued to the shared queues with an affinity to that system and must be retrieved from there. IMS Connect has resolved this issue with its supermember support. Other OTMA member clients, however, like WebSphere MQ that are connected to the front-end IMS will not easily be able to retrieve the message. Note that IMS Connect will also have this problem if supermember support is not enabled.

With the enhancements introduced in this SPE, routing of transaction ALTPCB responses in an IMS shared queues environment has been improved. Response output issued to an IMS ALTPCB destination by a back-end IMS system can be more easily returned to non-supermember clients attached to the front-end. This optional IMS function is enabled by specifying ALTPCBE= YES in the OTMA DFSYDTx PROCLIB member or by setting the TMAMALTB flag in the state data prefix of the input transaction.

OTMA Transaction Expiration and Shared Queues SPE ...

```
/DIS TMEMBER M1 TPIPE tpipe1 tpipe2 tpipe3 ...  
/DIS TMEMBER M1 TPIPE tpipe1 tpipe2 tpipe3 QCNT  
/DIS TMEMBER M1 TPIPE tpipe1 tpipe2 tpipe3 SYNC  
/DIS TMEMBER M1 TPIPE tpipe*  
/DIS TMEMBER M1 TPIPE tpipe* QCNT  
/DIS TMEMBER M1 TPIPE tpipe* SYNC
```

- **Generic character or wildcard support in /DIS TMEMBER TPIPE**
 - Allows easier search for specific resources

IMS improves OTMA usability by adding support for a generic character or wildcard at the end of the TPIPE name in the IMS command /DISPLAY TMEMBER TPIPE. By using the wildcard character, a series of TPIPE queues that are similarly named can be easily displayed. The generic form of the TPIPE name can also be used with the QCNT or SYNC keywords. Note that the TPIPE name with a generic character cannot be mixed with other TPIPE names.

IMS 13 PM78056 enhanced user exit services for OTMA exit types

- Adds support for 3 OTMA exits to be queried and dynamically refreshed via the type-2 commands.
 - Enhanced exit services also allows for multiple exit routines for an exit type.
- *Enhanced Exit Type / Existing Exit Name*
 - OTMARTUX / DFSYRTUX
 - OTMAIOED / DFSYIOE0
 - OTMAYPRX / DFSYPRX0

Enable 3 OTMA exit types for the enhanced user exit services. If an installation wishes to not use the enhanced services, all of the existing exits will continue to work as they currently do.

Summary

OTMA Enhancements - Benefits

- **Early Termination Notification**
 - Autonomic enhancement for higher availability that allows OTMA clients to be informed of an IMS shutdown in order to choose more timely alternatives
 - Potentially reduces unsuccessful attempts to send in new requests
 - Can expedite shutdown processing
- **Enhancement to Global Flood Control to enforce global flood limit**
 - Ability to address the global flood condition rather than just be warned
- **Ability to display HOLDq versus PRIMARY queue OUTPUT counts**
 - Provides a mechanism to differentiate between CM0 versus CM1 output message counts for HOLDq-capable clients
 - Can help analyze potential bottlenecks
- **WTO messages for Automation**
 - Enhances automation with additional console WTO messages

OTMA Enhancements - Benefits

- **OTMA Callable Interface (OTMA C/I) Asynchronous Enhancement**
 - Addresses previous timing issues between OTMA C/I and client for asynchronous messages
- **MIPS reductions**
 - Greater efficiency
- **Enhancements to OTMA Destination Descriptors for asynchronous callout**
 - Simplifies asynchronous messaging to WMQ
 - Simplifies override request for Exit Routines
- **Enhanced ICAL support for truncated messages**
 - Provides the ability to complete the retrieval of a reply message
 - Without having to re-issue a complete ICAL “SENDRECV” and associated network transmission costs

ISC Over TCP/IP

ISC Over TCP/IP Topics

- Highlights
- ISC Topologies
- Functionality
- ISC Parallel Sessions
- Definitions
- Message Flows
- Operational Considerations
- Migration/Fallback
- Configuration Consideration
- Appendix

ISC Over TCP/IP

- New option that supports TCP/IP network connectivity for Intersystem Communication (ISC) connections
 - IMS – CICS

- Benefits
 - Provides a strategic protocol alternative to SNA/VTAM
 - Allows an all inclusive TCP/IP solution for networks

IMS 13 enhances Intersystem Communication (ISC) connectivity to include the TCP/IP protocol. This capability applies to connections between IMS and Customer Information Control System (CICS) systems. This new support provides a solution for environments that want to implement an all inclusive TCP/IP network environment.

Highlights

- **ISC communication over TCP/IP networks**
 - Supports both static and dynamic terminals
 - Static terminal definitions
 - SYSGEN stage 1 TYPE, TERMINAL, SUBPOOL macros
 - DFSDCxxx PROCLIB member
 - Dynamic terminal specification
 - Logon descriptors in the DFSDSCMx or DFSDSCTy PROCLIB member
 - Leverages IMS Connect
 - Enhancements to the HWSCFGxx configuration member
 - No IMS Connect user message exit changes
 - Uses CSL to communicate between IMS and IMS Connect
 - Requires Structured Call Interface (SCI) and Operation Manager (OM)
- **IVP and Syntax Checker enhancements**

At a high level, the ISC support using TCP/IP protocols can be defined in IMS environments both statically and dynamically (ETO). It uses the SCI (structure call interface) of the CSL (common service layer) between IMS and IMS Connect in order to leverage the existing IMS Connect TCP/IP support.

ISC Topologies

- **Current ISC VTAM connection between IMS and CICS continues to be supported**
 - Uses SNA protocols (LU6.1)

- **New ISC TCP/IP connection between IMS and CICS**
 - Requires CICS 5.1
 - IMS Connect provides the TCP/IP communication to CICS from IMS
 - Uses new protocols

- **Both VTAM and TCP/IP topologies can co-exist**

ISC VTAM (SNA LU 6.1) connections continue to be supported in IMS 13 alongside the new ISC TCP/IP capability. Connectivity to CICS using TCP/IP requires CICS 5.1. Both VTAM and TCP/IP connections can co-exist in both environments.

ISC Topologies - ISC TCP/IP and ISC VTAM

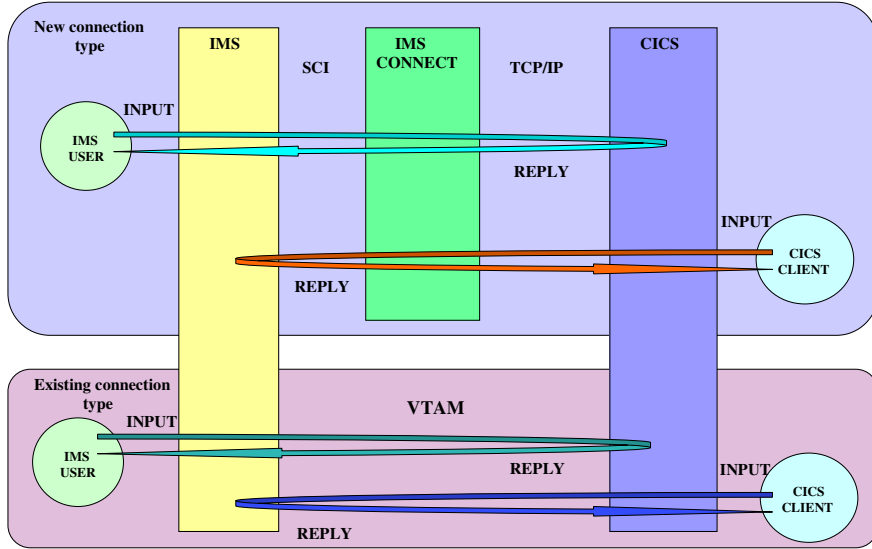

This visual depicts an IMS and CICS system supporting both VTAM and TCP/IP connection. For ISC TCP/IP, IMS communicates with IMS Connect via the Structured Call Interface (SCI). IMS Connect communicates with CICS via TCP/IP network.

Functionality

- CICS IPIC (IP Interconnectivity) provides **START / RETRIEVE** (asynchronous processing) support
 - When CICS is a front-end system:
 - IMS response mode transactions are not supported
 - IMS conversational transactions are not supported
 - CICS application program **cannot use** SEND/RECEIVE
 - When IMS is a front-end system:
 - Transaction support is the same for both ISC VTAM and ISC TCP/IP
 - Transaction flow is always asynchronous
 - **No change to existing programs on either side of the connection**

Connectivity between CICS and IMS only supports the START/RETRIEVE or asynchronous support in IMS 13. This means that when CICS is the front-end system, neither IMS response mode or conversational transactions can be invoked. Additionally, CICS application programs are not able to issue a SEND/RECEIVE (synchronous) type of request.

When IMS is the front-end system, transaction flow is always asynchronous. This interaction has always been true for the ISC VTAM support and is now the same for ISC TCP/IP.

For IMS programs and CICS START/RETRIEVE programs, no changes on either side of the connection is required.

Functionality – Support and Restrictions

Functions And Transactions	Existing in LU6.1	Supported in TCP/IP
CICS transaction – START/RETRIEVE	Yes	Yes
CICS transaction – SEND(INVITE)/RECV	Yes	No
CICS transaction – SEND(LAST)/RECV	Yes	No
IMS non-response mode transaction	Yes	Yes
IMS response mode transaction (including FP)	Yes	No
IMS conversational mode transaction	Yes	No
IMS recoverable transaction	Yes	Yes
IMS non-recoverable transaction	Yes	Yes
IMS message switch	Yes	Yes
IMS operator command	Yes	Yes
Dynamic terminal	Yes	Yes
Static terminal	Yes	Yes
Front-End Switch (FES)	Yes	No
Message Format Service (MFS)	Yes	No
IMSplex Terminal Management (STM)	Yes	No
VTAM Generic Resources (VGR)	Yes	No
Extended Recovery Facility (XRF)	Yes	No

O2_ IMS 13 TM: 94

This visual documents the supported/restricted functionality of the ISC TCP/IP support.

Functionality ...

- Either side can initiate the request

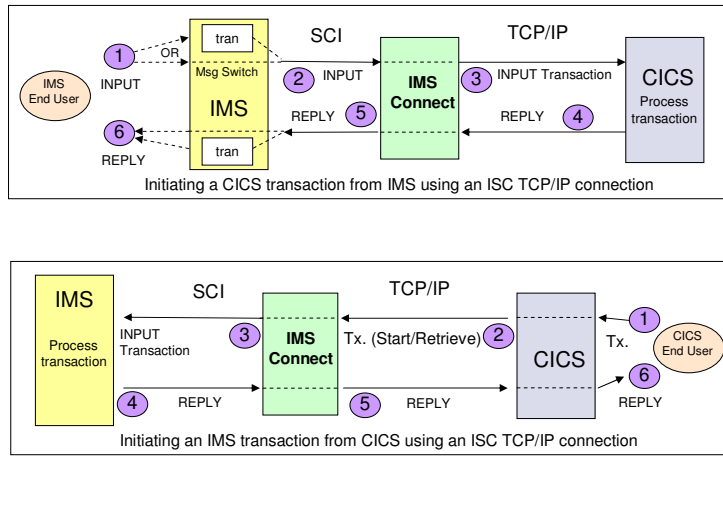

O2_ IMS 13 TM: 95

Initiating a CICS transaction from IMS using an ISC TCP/IP connection:

1. An IMS end user sends in a message-switch that is to be sent to CICS or an input message to an IMS transaction that issues and ISRT, ALTPCB for CICS.
2. IMS uses an active ISC TCP/IP connection to pass the message to IMS Connect using SCI.
3. IMS Connect uses an active socket connection to send the message to CICS.
4. CICS receives the message as a transaction from TCP/IP network, processes it and uses an active ISC TCP/IP connection to send the transaction reply back to IMS.
5. IMS Connect receives the transaction reply from TCP/IP network, passes it to IMS over an active ISC TCP/IP connection using SCI.
6. The reply can invoke an IMS transaction or be a reply that is targeted for an IMS end-user.

Initiating an IMS transaction from CICS using an ISC TCP/IP connection:

1. CICS client enters a transaction request.
2. CICS uses an active ISC TCP/IP connection to send the transaction to IMS.
3. IMS Connect receives the transaction from TCP/IP network and uses an active ISC TCP/IP connection to pass the message to IMS using SCI.
4. IMS processes the transaction, uses an active ISC TCP/IP connection using SCI to pass the transaction reply to IMS Connect.
5. IMS Connect uses an active socket connection to send transaction reply to CICS.
6. CICS sends the reply back to the client.

ISC Parallel Sessions

- **IMS application supports**
 - Session (subpool) level in both ISC VTAM and ISC TCP/IP

- **CICS application supports**
 - Session level in both ISC VTAM and ISC TCP/IP

Parallel sessions are supported in ISC TCP/IP connections as they are in VTAM.

ISC Parallel Sessions – IMS-CICS VTAM Communications

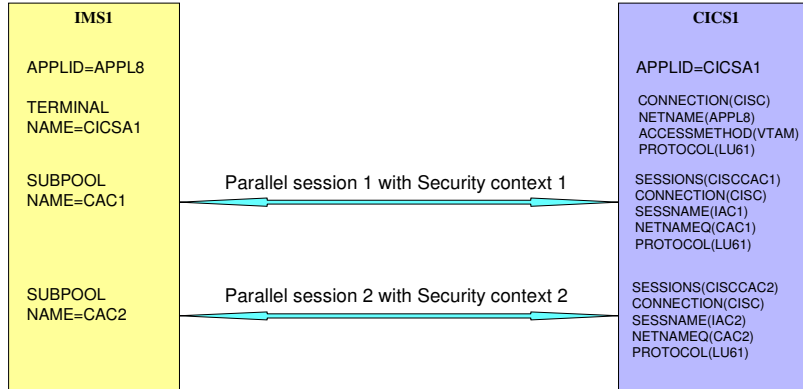

This visual gives an example of an existing set of ISC VTAM sessions between IMS and CICS.

ISC Parallel Sessions – IMS-CICS TCP/IP

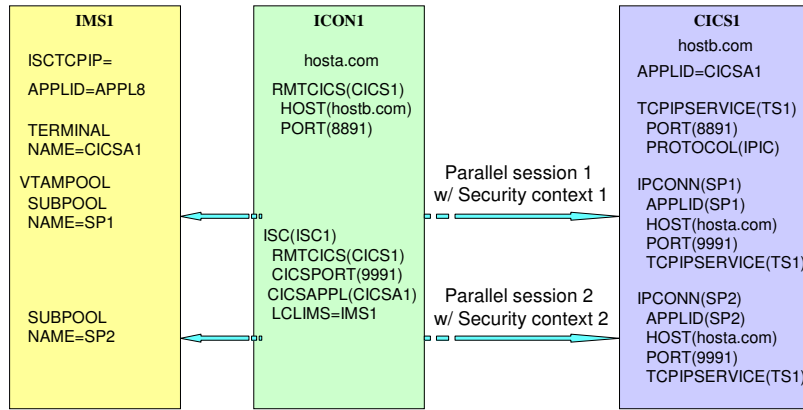

O2_ IMS 13 TM: 98

This visual gives an example of an existing set of ISC TCP/IP sessions between IMS and CICS. The next step is look at the definition requirements in IMS, IMS Connect and CICS.

ISC TCP/IP Support: IMS Definitions

- **IMS terminal definitions**
 - Static terminals:
 - TYPE, TERMINAL, VTAMPOOL and SUBPOOL macros in Stage 1 gen
 - Continue to be required for static ISC terminals (VTAM or TCP/IP)
 - **New** keyword: ISCTCPIP in DFSDCxxx
 - Specifies that an ISC terminal is to use the TCP/IP support
 - Addition, modification, deletion of the ISCTCPIP parameter requires a cold start
 - If ISCTCPIP is changed and IMS crashes, ERE ignores the change
 - Dynamic terminals (ETO):
 - New Logon descriptor information in the DFSDSCMx or DFSDSCTy PROCLIB member
 - DFSDSCTy overrides DFSDSCMx if the same descriptor is defined in both
 - User descriptors are optional
 - Default user descriptor of DFSUSER will be used if there is no user descriptor being defined.

In IMS 13, both dynamic (ETO) and static ISC terminals can use the new TCP/IP support. Static terminal support requires a new parameter, ISCTCPIP, that is specified in the DFSDCxxx member of the IMS PROCLIB dataset. Dynamic/ETO (Extended Terminal Option) ISC terminals use logon descriptors that can be specified in either the DFSDSCMx or the DFSDSCTy members of the IMS.PROCLIB data set. The use of static versus dynamic ISC TCP/IP terminals provides equivalency in many respects, e.g., connections as well as status can be initiated or terminated via IMS commands and both input and output messages can be transported using either terminal type. Where they differ is that dynamic terminals do not require a system definition or a cold start of IMS thereby providing much greater flexibility than static ISC terminals.

For dynamic/ETO terminals new logon descriptor can be added to either the IMS DFSDSCMx or DFSDSCTy PROCLIB member. At least one logon descriptor must exist for the dynamic ISC TCP/IP support and a unique logon descriptor is required for each ISC TCP/IP connection. A default logon descriptor name is DFSLU6T. As a reminder, IMS optionally produces ETO descriptors during system definition placing them in DFSDCMx by specifying the ETOFEAT keyword in the IMSCTRL macro. Subsequent system definitions of the same stage 1 input deck override the DFSDSCMx members. If TSO or a z/OS utility is used to create descriptors, these are placed in member DFSDSCTy which avoids loss when member DFSDSCMx is replaced. TSO or a z/OS utility can also update descriptors in DFSDSCMx that were created during system definition.

ISC TCP/IP Support: IMS Definitions...

- Static terminals: DFSDCxxx

- New keyword ISCTCPIP=(nodename, imconnect_name)

- Only used for static ISC TCP/IP terminal definitions

- Nodename is a static LU6.1 parallel terminal defined in the stage1 sysgen
- Imconnect_name is the name of the local IMS Connect in the IMSplex

- Example:

```
DFSDCxxx:
```

```
ISCTCPIP=(CICSA1,ICON1)
```

```
Where CICSA1 is defined in the stage1 definition as a UNITYPE=LUTYPE6:
```

```
Stage 1 sysgen:
```

```
TYPE UNITYPE=LUTYPE6
```

```
    TERMINAL NAME=CICSA1,SESSION=3...
```

```
VTAMPOOL
```

```
    SUBPOOL NAME=SSN1,MSGDEL=SYSINFO
```

```
        NAME SSNA1,COMPT=2,ICOMPT=1
```

O2_ IMS 13 TM: 100

IMS enhances the DFSDCxxx PROCLIB member to provide static ISC TCP/IP terminal support for parallel sessions. Static ISC TCP/IP terminals do not support single ISC sessions. Because ISC terminals use VTAM support by default, the ISCTCPIP parameter in the DFSDCxxx PROCLIB member must be defined to enable TCP/IP for static LU 6.1 ISC terminals.

ISCTCPIP Sets a static LU 6.1 ISC terminal to use TCP/IP communication protocols. The *nodename* value is the name of an LU 6.1 ISC terminal, as specified on the NAME parameter of the TERMINAL macro that is part of the terminal system definition. The *imconnect_name* value is the IMSplex name of a local IMS Connect instance that manages TCP/IP communications for this IMS. The value must match the name specified on the MEMBER parameter of either the ISC statement or the IMSplex statement in the IMS Connect configuration PROCLIB member (HWSCFGxx).

ISC TCP/IP Support: IMS Definitions...

Static terminals ...

- System definition macros have not been changed
 - TYPE UNITYPE=LUTYPE6
 - Existing keywords applicable to ISC TCP/IP: EDIT and OPTIONS parameters
 - TERMINAL NAME=
 - Existing: COMPTn, EDIT=, FPBUF=, MSGDEL, OUTBUF, SEGSIZE, SESSION, OPTIONS: [AUTOSIGN|NOAUTOSIGN, FORCRESP|NORESP|TRANRESP, NOMTOMSG|MTOMSG, NOPNDST|OPNDST]
 - VTAMPOOL statement for parallel session support
 - One or more SUBPOOL macros
 - Optionally, one or more NAME macros

```

TYPE UNITYPE=LUTYPE6
TERMINAL NAME=CICSA1,MSGDEL=SYSINFO,EDIT=(NO,NO), X
        SESSION=3,OPTIONS=NOMTOMSG,COMPT1=(SINGLE1,VLVB), X
        COMPT2=(SINGLE2,VLVB), COMPT3=MULT1 X
VTAMPOOL
        SUBPOOL NAME=SSN1,MSGDEL=SYSINFO
        NAME SSNA1,COMPT=2,ICOMPT=1
        SUBPOOL NAME=SSN2
        NAME SSNA2
        SUBPOOL NAME=SSN3
        NAME SSNA3

```

O2_ IMS 13 TM: 101

When switching an existing terminal from VTAM to TCP/IP, ensure that UNITYPE=LUTYPE6 is specified on the TYPE macro that defines the ISC TCP/IP terminal. If UNITYPE=LUTYPE6 is not specified, an error message will be issued when the ISCTCPIP parameter (discussed in the previous visual) is processed in the DFSDCxxx member and TCP/IP will not be enabled for the terminal. Other existing parameters in the TYPE macros continue to apply to the new support. The EDIT parameter can continue to be used to define any user-provided physical terminal output edit routine and/or physical terminal input edit routine. For OPTIONS: AUTOSIGN indicates that IMS automatically signs on to static terminals. For ISC terminals the SUBPOOL name is the user ID. NOAUTSGN indicates that IMS does not automatically sign on to static terminals.. This is the default. The AUTOSIGN and NOAUTSGN definitions on the TERMINAL macro override those on the TYPE.

For the TERMINAL macro, existing keywords that apply to the new TCP/IP capability include: COMPTn, EDIT=, FPBUF=, MSGDEL=, OUTBUF=, SEGSIZE=, SESSION= and OPTIONS. The following OPTIONS are applicable to this support: AUTOSIGN|NOAUTOSIGN, FORCRESP|NORESP|TRANRESP, NOMTOMSG|MTOMSG, NOPNDST|OPNDST.

Although the ISC TCP/IP support does not use VTAMPOOL there must be at least 1 VTAMPOOL statement defined for parallel session support and one or more subsequent SUBPOOL macros, each of which can optionally be followed by one or more NAME macros (if at least one SUBPOOL statement has an associated NAME statement).

ISC TCP/IP Support: IMS Definitions...

- **Dynamic (ETO) Terminals: DFSDSCTx**
 - **LOGON** descriptor specifications
 - Define ISCTCPIP value for UNITYPE= keyword
 - Add keyword LCLICON= imsmconnect_name in the IMSplex
 - Example:

```
L LUTYPE61 UNITYPE=ISCTCPIP LCLICON=ICON1
```
 - Other existing descriptor parameters that continue to apply:
 - COMPTn, EDIT, OUTBUF, SEGSIZE,
 - OPTIONS: [FORCRESP|NORESP|TRANRESP, NOMTOMSG|MTOMSG, NOPNDST|OPNDST]
 - **USER** descriptors
 - Optional – defaults to DFSUSER

As mentioned earlier, with the ETOFEAT enabled, stage 1 system definitions for ISC terminals can generate logon descriptors which are placed in the DFSDSCMx member of PROCLIB. On the other hand, you can code logon descriptors directly in the DFSDSCTx member. The descriptors that you can specify in the DFSDSCTy member, as well as the syntax and parameters of those descriptors, are exactly the same as the descriptors that can exist in DFSDSCMx. If a descriptor is specified on both members, however, the specifications coded in the DFSDSCTy member for the descriptor override the specifications coded in the DFSDSCMx member.

The logon descriptor for ISC TCP/IP terminal support includes:

- Specification of UNITYPE=ISCTCPIP
- The LCLICON keyword which is only applicable when UNITYPE=ISCTCPIP is specified. For ISC TCP/IP, this keyword identifies the local IMS Connect (IMSCON) member within an IMSplex that this LUTYPE6T terminal connects to via SCI. *Lcl_imsconnect_name* is a 1 to 8 alphanumeric character name.

As with static definitions, other existing parameters for ISC logon descriptors apply. These include: COMPTn, EDIT=, OUTBUF=, SEGSIZE=, SESSION= and OPTIONS. The following OPTIONS are applicable to this support: FORCRESP|NORESP|TRANRESP, NOMTOMSG|MTOMSG, NOPNDST|OPNDST.

As in previous releases, USER descriptors are not required and default to the use of DFSUSER. If specified, the following keywords are applicable to the ISC TCP/IP support: LTERM, OPTIONS [see logon descriptor], RCVYCONV, RCVYFP, RCVYRESP, RCVYSTSN, and SRMDEF.

ISC TCP/IP Support: CSL for IMS – IMS Connect

- The Common Service Layer (CSL) provides the Structured Call Interface (SCI) for communications
 - Each IMS and its local ISC-routing IMS Connect system must be part of the same IMSplex
 - **IMSPLEX= plexname** parameter in the Common Layer Section of the DFSDFxxx of IMS PROCLIB
 - Must match the IMSPLEX parameter in IMS Connect

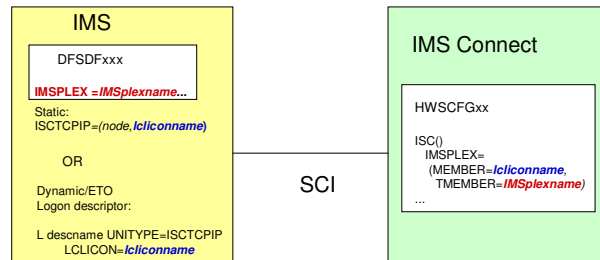

- The Operations Manager (OM) provides type-2 command support

O2_ IMS 13 TM: 103

A basic Common Service Layer (CSL) configuration is required to support ISC TCP/IP. This minimum configuration includes the Structure Call Interface (SCI) and SCI address space for communication between IMS components such as IMS to IMS Connect. The Operations Manager (OM) provides type-2 command support for the environment. The new ISC TCP/IP support does not impose any change on the existing CSL definition structure in the DFSDFxxx member of IMS PROCLIB. The IMSPLEX parameter value in DFSDFxxx is the same value that is referenced in the IMS Connect setup definitions for ISC.

ISC TCP/IP Support: IMS Connect Definitions

- IMS Connect's HWSCFGxx configuration member
 - New CICSPORT parameter in TCPIP statement
 - New ISC statement
 - New RMTCICS statement

TCP/IP support for ISC is provided by IMS Connect and is defined by coding the appropriate configuration statements in the IMS Connect PROCLIB member. These include a new CICSPORT parameter in the existing TCPIP configuration statement, and new ISC as well as RMTCICS statements.

ISC TCP/IP Support: IMS Connect Definitions ...

- HWSCFGxx configuration member
 - New **CICSPORT** parameter in the TCPIP statement

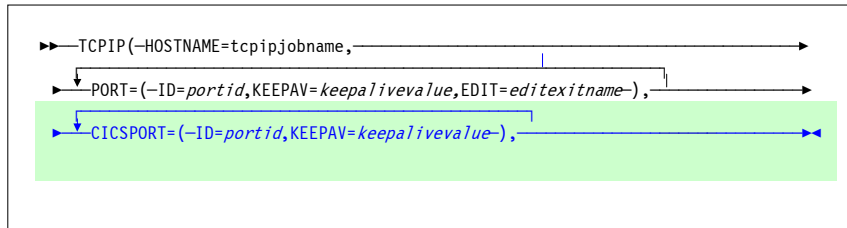

O2_ IMS 13 TM: 105

The HWSCFGxx TCPIP statement has been enhanced to add the CICSPORT parameter. This new parameter identifies specific CICS port(s) to use for the connection. Remember that you can define up to 50 TCP/IP ports for an instance of IMS connect. The combined total for the CICS port(s) plus all others that may be defined in this IMS Connect instance cannot exceed 50.

- ID= defines the port(s) to use and must be unique for a specific instance of IMS Connect without conflicting with other ports already selected.
- KEEPAV= specifies the number of seconds for the TCP/IP KeepAlive interval for sockets on this port. TCP/IP accepts a range from 1- 2147460 seconds. If you specify zero, the KeepAlive interval value is bypassed and the setting for the TCP/IP stack is used (this is the default). TCP/IP KeepAlive enables you to detect error situations on inactive sockets.

ISC TCP/IP Support: IMS Connect Definitions ...

▪ HWSCFGxx ...

– New **ISC** statement

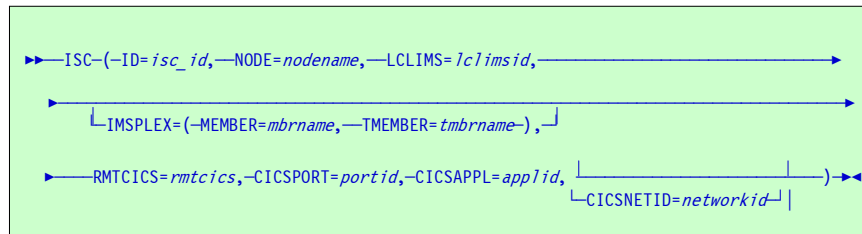

- IMSPLEX
 - Defines the SCI information for communicating with the local IMS
- RMTCICS
 - Defines the CICS information

O2_ IMS 13 TM: 106

The ISC statement defines the send path for an ISC link from the local IMS system to a remote CICS system. This ISC statement in conjunction with a RMTCICS statement establishes a one way send socket path. On the other side of the link, CICS definitions establish the corresponding receive socket for the connection. Additionally the CICS's IPCONN definition establishes a send socket on the CICS side which is matched with a receive socket in IMS. Each ISC parallel session, therefore, establishes two socket connections in IMS Connect. Note that the value specified in the LCLIMS parameter and the value specified in the NODE parameter must be unique for each ISC statement.

The RMTCICS value specifies the remote CICS connection and is the same as the ID= parameter of one of the RMTCICS statements (described in the next visual). ISC links that use separately-defined TCP/IP connections to the same CICS subsystem must specify different IDs on the RMTCICS parameter; however, the different RMTCICS statements that each ISC statement references must specify the same host name or IP address and port number.

- CICSAPPL= equates to the specified APPLID value of the DFHSIT macro definition in the remote CICS. This parameter must be specified if RMTCICS parameter is also specified, otherwise, IMS Connect will issue an error message and an abend on startup.
- CICSNETID= is either the VTAM NETID or the UOWNETQL= parameter of the DFHSIT macro definition in the remote CICS subsystem.
- CICSPORT= specifies a CICSPORT *portid* as defined in the TCPIP statement. Multiple ISC statements can specify the same CICSPORT *portid* if and only if they specify the same LCLIMS. However, if these ISC statements specify the same CICSAPPL value, they must have unique CICSPORT values. Otherwise, IMS Connect will issue an error message and an abend on startup.

ISC TCP/IP Support: IMS Connect Definitions ...

- HWSCFGxx ...
 - New **RMTCICS** statement (CICS partner)

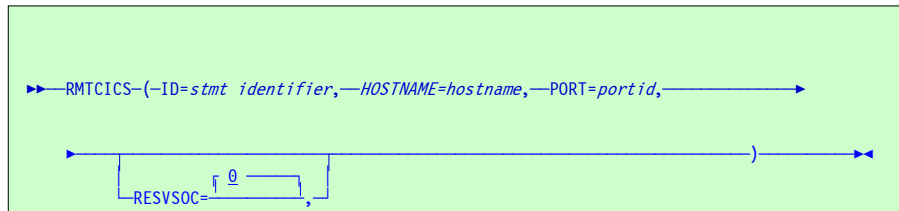

O2_IMS 13 TM: 107

The RMTCICS() statement defines each remote CICS connection that can communicate with this instance of IMS Connect.

- ID= identifies this statement. It matches one or more RMTCICS specification(s) on the ISC() statement (previous visual).
- HOSTNAME= is the hostname of the remote CICS, e.g., CICSA.ibm.com. This parameter can accept up to 60 alphanumeric characters.
- PORT= is the remote CICS port number and must match a definition in the remote CICS.
- RESVSOC= defines the number of sockets to reserve for use by this connection. This value should be equivalent to the number of parallel sessions. IMS Connect reserves this number of sockets from the maximum number of sockets allowed for this instance of IMS Connect, as specified in the MAXSOC= parameter in the TCPIP statement. If additional connections are required for ISC above this RESVSOC count, IMS Connect will get them, if possible, will count the additional sockets towards the max sockets count. The sum of all the RESVSOC= values specified in all the RMTCICS statements must not exceed the value specified in the TCPIP MAXSOC= parameter. If the sum exceeds the MAXSOC value, then IMS Connect will issue an error message and abend on startup.

ISC TCP/IP Support: IMS Connect Definitions ...

- HWSCFGXX Configuration sample

```
TCPIP=(HOSTNAME=TCPIP,PORTID(9996,9997,9998,9999),  
RACFID=GOFISHIN,MAXSOC=5000,  
CICSPORT=(ID=9991),CICSPORT=(ID=9992),CICSPORT=(ID=9993),  
CICSPORT=(ID=9994),CICSPORT=(ID=9995),...)
```

```
RMTCICS(ID=CICS1,PORT=8891,  
HOSTNAME=HOSTB.COM,RESVSOC=10)
```

```
ISC(ID=ISC1,NODE=CICSA1,LCLIMS=IMS1,CICSPORT=9991,  
RMTCICS=CICS1,CICSAPPL=CICSA1,CICSNETID=CICSNET,  
IMSPLEX=(MEMBER=ICON1,TMEMBER=PLEX1))
```

O2_ IMS 13 TM: 108

In this configuration example, note the RMTCICS definition. This shows that the local IMS Connect instance has been defined to use port 8891 for outbound communications with CICS. This is for establishing the SEND sockets from IMS Connect.

The ISC statement shows that IMS Connect has specified that CICSPORT 9991 is for inbound communication from CICS. This is for establishing the RECV sockets for messages from CICS. Also note that the CICSPORT number matches one that has been defined in the CICSPORT parameter of the TCP/IP statement.

ISC TCP/IP Support: CICS

- CICS: leverages existing IPIC definitions

- TCPIP SERVICE statement

```
TCPIP SERVICE (name of service, e.g TS1)
  PORT (port number to listen on)
  PROTOCOL (IPIC)
```

Example:

```
TCPIP SERVICE (TS1)
  PORT (8891)
  PROTOCOL (IPIC)
```

- IPCONN statements for session levels (IMS subpool)

```
IPCONN(name of this definition
  e.g. for IMS: IMSsubpoolName)
  APPLID(= IPCONNname e.g., IMSsubpoolName )
  HOST(targetTCPIP)
  PORT(target port)
  TCPIP SERVICE(associated service)
  SENDCOUNT ()
  RECEIVECOUNT ()
  AUTOCONNECT()
```

```
IPCONN(SSN1)
  APPLID(SSN1)
  HOST(HOSTA.COM)
  PORT(9991)
  TCPIP SERVICE(TS1)
  SENDCOUNT (1)
  RECEIVECOUNT (1)
  AUTOCONNECT (Y)
```

NOTE: For a complete set of parameters, review the CICS documentation

O2_ IMS 13 TM: 109

IPIC or IP interconnectivity requires resources to be defined using the IPCONN and TCPIP SERVICE statements. A TCPIP SERVICE is the CICS resource that listens for TCP/IP communications from a partner region.

TCPIP SERVICE () is the name of the local TCPIP SERVICE resource where inbound requests are received:

- PORT is the port number that CICS will listen on for this service
- PROTOCOL for this type of connection is always IPIC

IPCONN () name of the definition – this matches the IMS subpool name:

- APPLID for the IMS environment this must match the IPCONN name, e.g., IMS subpool name. Since the APPLID value is equal to the IMS subpool name then the connection can be established either by IMS or CICS.
- AUTOCONNECT specifies whether Y | N sessions are to be established when the IPCONN definition is installed .
- HOST is the name of the TCP/IP Stack on the target system MVS image
- PORT is the port named on the TCPIP SERVICE resource of the remote system
- RECEIVECOUNT(1-999) specifies the number of sessions that receive incoming requests. The actual number of receive sessions that are used depends also on the number of send sessions defined in the remote system, e.g., IMS. When the connection is established, these values are exchanged and the lower value is used.
- SENDCOUNT(0-999) specifies the number of sessions that send outgoing requests. The actual number of send sessions that are used depends also on the number of receive sessions defined in the remote system, e.g. IMS. When the connection is established, these values are exchanged and the lower value is used. If 0 is specified, then this IPCONN can only process incoming work, cannot send requests to the connected system, and cannot be acquired. A SENDCOUNT value greater than zero requires PORT to have a numeric value.

ISC TCP/IP Support CICS...

- Takes advantage of existing CICS IPIC message formats and support
 - 2 socket connections per parallel session
 - 1 for send and 1 for receive on each side
 - From IMS to CICS:
 - IMS Connect uses its SEND socket to send a message to CICS
 - CICS uses its RECEIVE socket to receive the message and uses its definitions to route the message to the CICS destination
 - From CICS to IMS:
 - CICS uses its SEND socket to send a message to IMS Connect
 - IMS Connect uses its RECEIVE socket to receive the message and uses its definition to route the message to the IMS destination

The CICS support leverages the IPIC connectivity capability that exists in CICS.

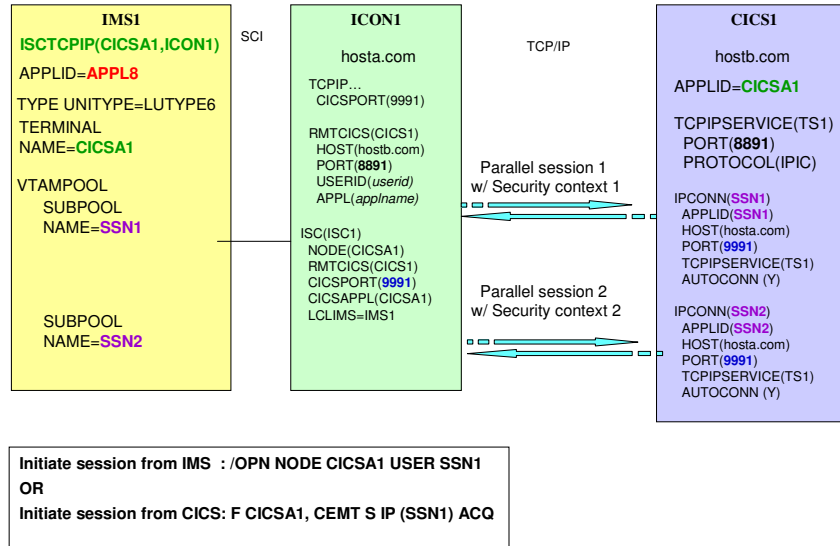
IMS-CICS ISC TCP/IP Communications

O2_ IMS 13 TM: 111

Now that the definitions have been described, this same visual that was shown earlier should make more sense. On the IMS side, this configuration example shows two statically defined parallel sessions and subpools SSN1 and SSN2. Corresponding definitions are provided in CICS with IPCONN statements matching the subpools.

IMS initiates the session using the /OPNDST command:

- Example: /OPN NODE CICSA1 USER SSN1

Or, alternatively, CICS can initiate the session using the CEMT transaction:

- Example: F CICSA1,CEMT S IP(SSN1) ACQ

Message Flow Example: 1 IMS and 1 CICS

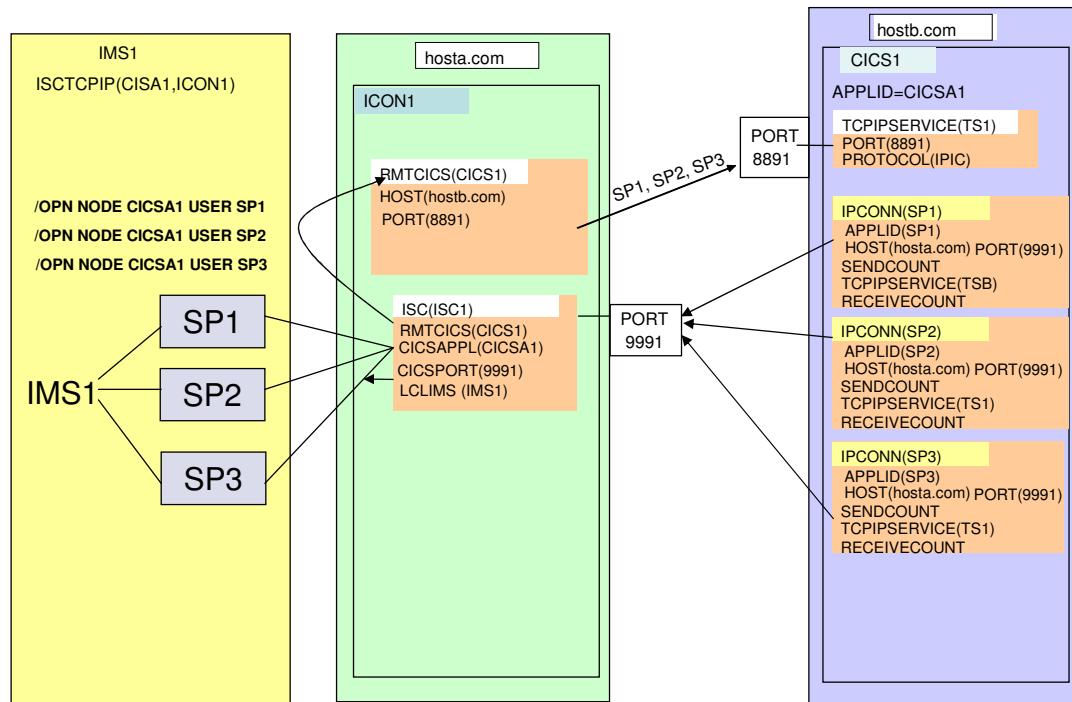

O2_ IMS 13 TM: 112

When an `/OPN NODE CICSA1 USER SP1` command is entered from IMS1, the session connection request is sent to IMS Connect ICON1. ICON1 uses the ISC1 specification to determine that it will use CICS1 RMTCICS specification to communicate with CICS. ICON1 then uses the hostname of hostb.com and port 8891 specified in the RMTCICS statement to send the session connection request to CICS1.

At the other end of the link, CICS1 uses the TCPIP SERVICE specification listening in on Port 8891 to receive the session connection request. CICS1 selects the IPCONN statement whose name is SSN1 to send the reply back to IMS, using the hostname defined in the statement which in this case is hosta.com and port 9991.

ICON1 receives the reply message from CICS1 coming into port 9991. ICON1 then uses the ISC1 definition to forward the reply message back to the LCLIMS which is IMS1.

Note the following:

1. There are no duplicate IPCONN statements with the same NETID and APPLID.
2. The IPCONN name that equates to IMS subpools, e.g. SP1, are defined in IMS.

Message Flow Example: Multiple IMS's and 1 CICS

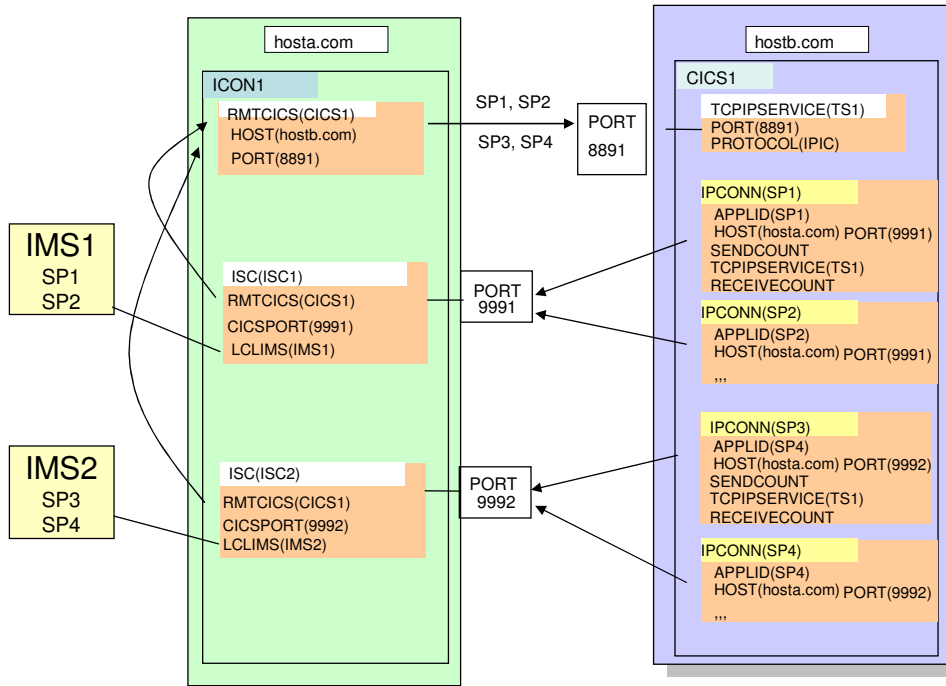

O2_ IMS 13 TM: 113

Multiple IMS systems can use one IMS Connect to route traffic to a single CICS partner.

Message Flow Example: 1 IMS and multiple CICS's

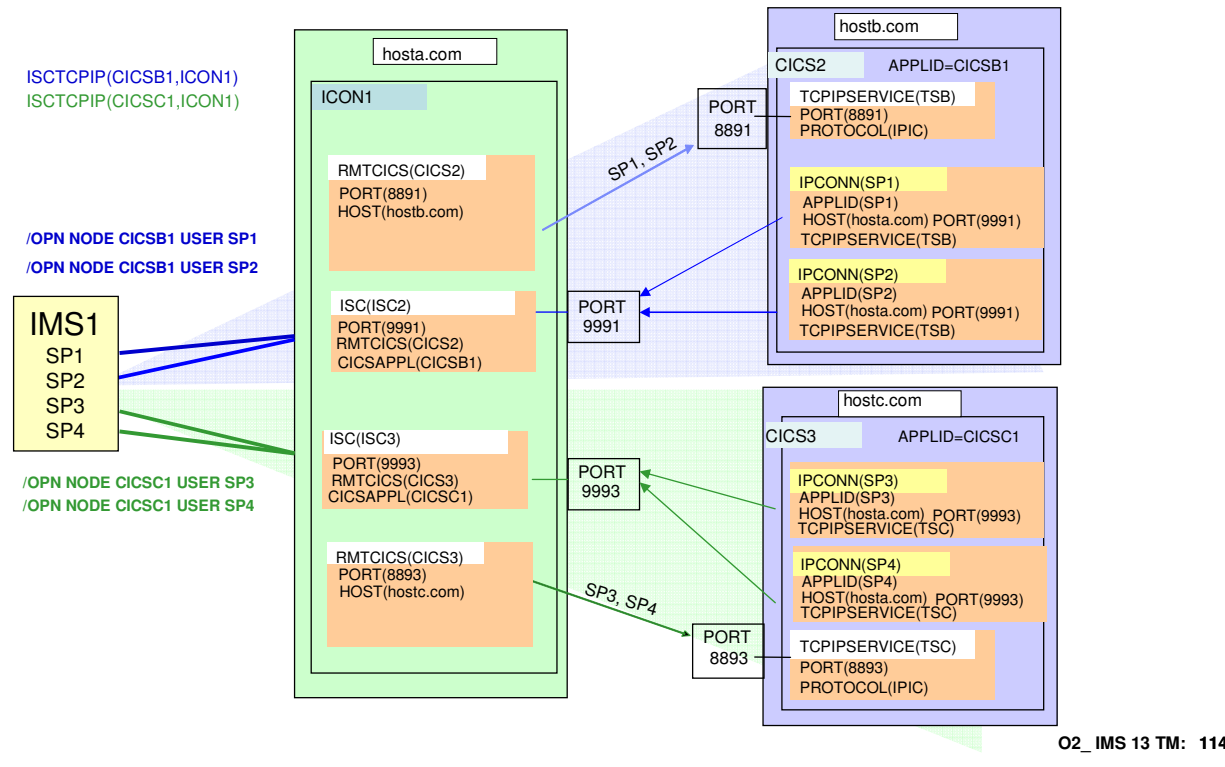

One IMS system can communicate with multiple CICS's using one IMS Connect.

Message Flow Example: Multiple IMS and Multiple CICS

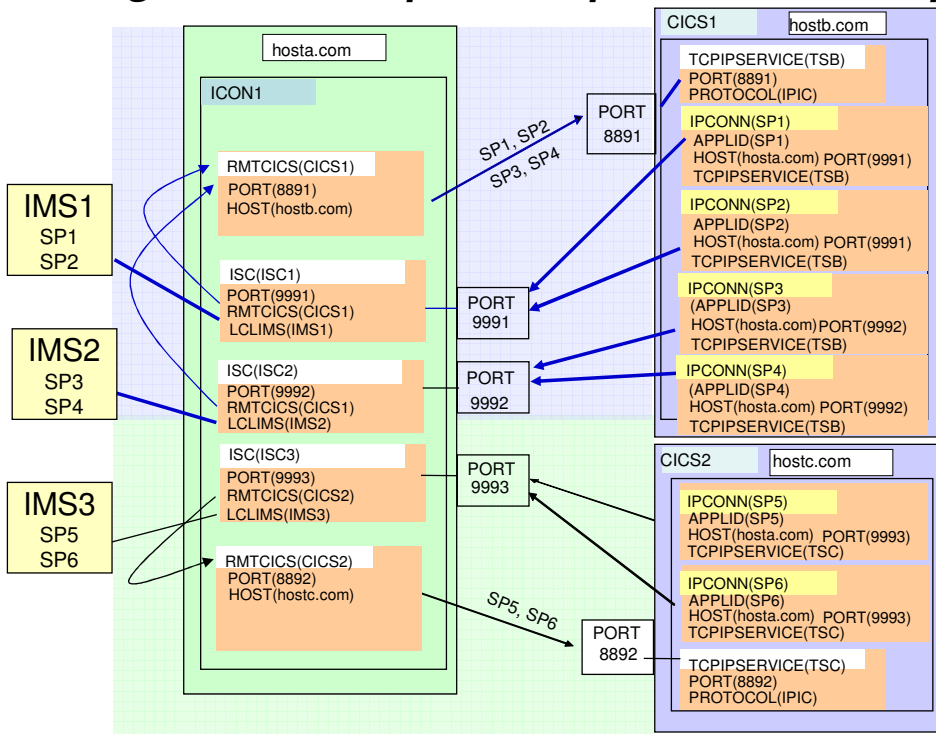

O2_ IMS 13 TM: 115

Configurations can even support complex scenarios.

Operational Considerations

Session Initiation – CICS

```

▶▶ CEMT—SET—IPCONN—name—...▶▶
      | ALL |
      | ACQUIRED |
      | RELEASED |
  
```

- Example: F CICS A1, CEMT S IP (SP1) ACQ

Session Initiation – IMS

Dynamic terminals

```

▶▶ /OPNDST—NODE—nodename—USER—username—...▶▶
      | /OPN |
      | ID—idname | LOGOND—logondname |
  
```

- ID is optional and ignored
- LOGOND optionally overrides a logon descriptor equal to *nodename*
 - Parameter is applicable to dynamic non-ISC and ISC TCPIP terminals

Static terminals

```

▶▶ /OPNDST—NODE—nodename—USER—username—...▶▶
      | /OPN |
      | ID—idname |
  
```

- ID is optional and ignored

The existing /OPNDST command in IMS can be used to initiate a session from the IMS side. If specified, ID *idname* which is optional is ignored (originally for the VTAM half-session qualifier). The LOGOND *logndname* parameter for dynamic terminals is also optional but if specified must reference an ISC TCP/IP logon descriptor in the DFSDSCTX / DFSDSCTx PROCLIB member. The logon descriptor specified as the LOGOND value for ISC must be one that was defined with UNITYPE=ISCTCPIP. Note that the LOGOND parameter which is not available for dynamic ISC VTAM terminals is supported for ISC TCPIP.

From the CICS side, sessions are initiated using the master terminal CEMT transaction. CEMT SET IPCONN (CEMT S IP) followed by one or more connection identifiers or ALL, followed in turn by one or more attribute settings that you want to change. For example, CEMT S IP ALL resets the values for all connections to make them available for use (inservice).

Operational Considerations...

- IMS examples:

IMS to CICS (*Dynamic / ETO*):

```
/OPN NODE CICS1 USER CAC1 LOGOND LU6TCP1
```

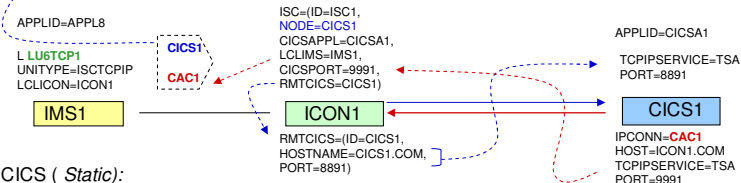

IMS to CICS (*Static*):

```
/OPN NODE CICS2 USER CAC2
```

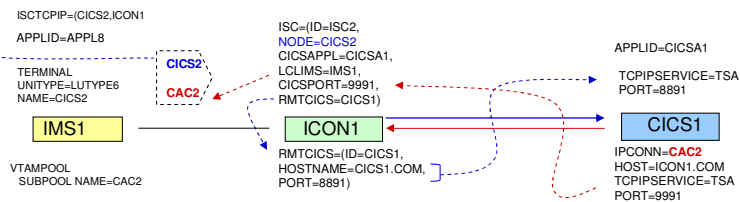

These are examples of what happens when the /OPN command is issued in IMS.

Operational Considerations ...

▪ RESVSOC and MAXSOC

- RMTICIS()
 - RESVSOC value specifies number of sockets to reserve for a connection
 - This should be account for the total number of parallel sessions that can be established by the connection
 - If more are needed, IMS Connect will attempt to get them up to the MAXSOC value
- TCPIP () MAXSOC value
 - Should be greater than or equal to all the possible sockets that can be requested through all the IMS Connect statements
 - If the sum of the defined RESVSOC values exceeds MAXSOC, IMS Connect issues an error message and abends on startup.

O2_ IMS 13 TM: 118

The RESVSOC value which is defined in the RMTICIS() statement is used to specify the number of sockets to reserve for use by a connection. For ISC TCP/IP, this value should be equivalent to the number of parallel sessions that can be established. IMS Connect will reserve this number of sockets from the maximum number of sockets allowed for this instance of IMS Connect, as specified in the MAXSOC= parameter in the TCPIP statement. If additional connections are required for ISC above the RESVSOC count, IMS Connect will get them if possible and they will count towards the max sockets count.

The sum of all the RESVSOC= values in the RMTICIS and RMTIMSCON statements must not exceed the value specified in the TCPIP MAXSOC= parameter. If the sum exceeds the MAXSOC value, then IMS Connect will issue an error message and abend on startup.

This is an optional parameter. The default value is 0.

Configuration Considerations

- Static ISC TCPIP terminals are defined via SYSGEN
 - Additionally, the ISCTCPIP keyword in DFSDCxxx must be coded
- Dynamic/ETO logon descriptors continue to be defined in the DFSDSCMx or DFSDSCTx PROCLIB member
 - Require specification of UNITYPE=ISCTCPIP
 - USER descriptors are optional and default to the use of DFUSER
- CSL environment in IMS must be enabled
- IMS Connect ISC resources definitions need to be added to the HWSCFGxx configuration member
- CICS IPIC resources must match the IMS definitions
 - Specify AUTOCONNECT=YES in the IPCONN statement

Configuration Considerations ...

- **When maintaining both VTAM and TCP/IP connections**
 - Consider creating/using a new set of subpools for TCP/IP support in IMS
 - CICS definitions are different for VTAM versus TCP/IP

IMS: Migration/Fallback Considerations

- **To migrate statically-defined ISC terminals to TCP/IP:**
 - Make sure the IMS definitions are correct
 - If switching an existing terminal from VTAM to TCP/IP
 - Ensure the terminal is defined with UNITTYPE=LUTYPE6 in the TYPE macro
 - If defining a new terminal
 - Code the appropriate system definition macros (TYPE/TERMINAL/SUBPOOL)
 - The TYPE macro must specify UNITYPE=LUTYPE6
 - Specify ISCTCPIP=(nodename,iconname) in the DFSDCxxx PROCLIB member
 - For each node that is to use the TCP/IP support
 - NOTE: Existing definitions in CICS using VTAM will need to be changed to use IP if the same names are being used
 - Cold start IMS

- **To fallback from TCP/IP to VTAM**
 - Delete the ISCTCPIP parameter that specifies the nodename of the terminal from the DFSDCxxx PROCLIB member
 - Cold start IMS(Warm or ERE keeps the ISCTCPIP specification active)
 - Review the CICS requirements

IMS: Migration/Fallback Considerations ...

- **To migrate dynamic/ETO ISC terminals to TCP/IP**
 - Define and Activate Logon descriptors
 - Specify UNITYPE=ISCTCPIP, LCLICON=
 - E.g., Create a generic descriptor that can be used by several nodes
 - Make associated definition changes in CICS
 - Issue command: e.g., /OPNDST NODE *node1* USER *user1* LOGOND *logondescriptor*

- **To fallback**
 - Stop the TCP/IP ISC connections by issuing /STOP or /QUIESCE
 - Put the USER(subpool) associated with TCP/IP connection into cold state so it can be used for the logon of ISC VTAM connections
 - Issue command, e.g., /ASSSIGN USER *user1* TO VTAMPOOL
 - Deallocates the USER *user1* from the TCP/IP connection
 - Note that the USER must not have a status of signed on, in conversation mode, response mode, or preset mode
 - Restart the ISC VTAM connection
 - Issue command, e.g., /OPNDST NODE *node1* USER *user1*

IMS User Exits

- Logon/Signon exits possibly impacted

- DFSLGNXP macro

LGNXPARM	DS	0A	MAP OF USER LOGON EXIT PARM
...			
LGNXPRM1	DS	A	ADDR OF 15-WORD PARMLIST
...			
LGFLAG1	DS	X	FLAG BYTE 1
LG1RM	EQU	X'80'	RM USED TO SHARE RESOURCES
LG1SQ	EQU	X'40'	SHARED QUEUES IS ACTIVE
LG1ASGN	EQU	X'20'	AUTOSIGN HAS BEEN SPECIFIED @PK92195
LGTCPIP	EQU	X'10'	ISC TCPIP TERMINAL LOGON
...			
LGPARMSL	EQU	~LGPARMS	LENGTH OF PARM LIST
LGICONNM	DS	CL8	IMS CONNECT NAME
LGPRMSL1	EQU	~LGPARMS	LENGTH OF PARM LIST WITH ICON NAME

- DFSSGNXP

DFSSGNXP	DSECT	BYTES	DESCRIPTION
SGNFLG1	DS	X 01-01	FLAG BYTE 1
SGN1RM	EQU	X'80'	USING RM TO MANAGE SHR RESOURCES
SGN1SQ	EQU	X'40'	SHARED QUEUE ACTIVE
SGN1ESTN	EQU	X'20'	PROCESSING ETO STSN SIGNON
SGN1STAC	EQU	X'10'	PROCESSING STATIC SIGNON
SGN1TCPI	EQU	X'08'	ISC TCPIP

IVP

- 4 new variables will be defined in the repository server configuration
 - IXUDNAME (Descriptor name) specifies the name of the logon descriptor
 - IXUCONNM (IMS Connect name) specifies the local IMS connect instance
 - IXUOUTSZ (output buffer size) specifies the size of the output buffer to be used. This keyword is the same as the OUTBUF= keyword on the TERMINAL macro
 - IXUSEGSZ (Segment size) specifies the segment size. The acceptable values are from 256 to 32000 bytes. The default is 256 bytes. Refer to the description of the SEGSIZE= keyword in TERMINAL macro for more information about calculating segment size

IVP ...

- Job IVPE302J has been updated to add the configuration member DFSDSCTy into the IVP PROCLIB member
- **New jobs:**
 - IVPV101J Allocate Data Sets
 - IVPV102J Initialize RECON
 - IVPV103J Register Databases
 - IVPV104J Database Initial Load
 - IVPV105J Batch Image Copy
 - IVPV201J Start IRLM
 - IVPV202T Start TCP/IP
 - IVPV203J Start DB/DC Region
 - IVPV205T Cold Start IMS - IVP1
 - IVPV207J Start IMS Connect Region
 - IVPV208T Set up CICS and run
 - IVPV301T Stop IMS Connect region
 - IVPV302T Stop IMS
 - IVPV304T Stop IRLM
 - IVPV401J Scratch Data Sets

Appendix

Appendix Topics

- Log Record Changes
- Automated Operations - Messages
- Commands

IMS Log Record Changes

- X'4021' checkpoint record (DFSCHKPT)

- Recoverable data for TCP/IP terminal

CHKVTNET	DS CL8	CLBNETID, NODE'S NETID OR CLBICON, IMS CONNECT NAME IF CHKVTTCP IS SET
...		
CHKVTFL7	DS X	MISCELLANEOUS FLAGS
CHKVTTCP	EQU X'80'	ISC TCP/IP TERMINAL
	DS XL5	RESERVED
...		
	DS H	TCP/IP INFO
CHKVTLGD DS	CL8	RESERVED
CHKVTICN DS	F	CLBLGND
CHKVTIMS DS	F	CTBICNT
CHKVTICS DS	F	CTBIMSQN
CHKVTPIC DS	XL8	CTBICSDN
CHKVTPIC DS	XL8	CTBPICID
CHKVTCIC DS	XL8	CTBCICID
CHKVTIUW DS	XL8	CTBIUOW
CHKVTOMS DS	F	CTBOMSQN
CHKVTOCS DS	F	CTBOCSQN
CHKVTPOC DS	XL8	CTBPOCID
CHKVTCOC DS	XL8	CTBCOCID
CHKVTOUW DS	XL8	CTBOUOW
CHKVTOCN DS	F	CTBOCNT
CHKVTSZ1 EQU	*-CHKVTNM	SIZE OF NON-DYN VTCB RECORD WITH TCP/IP

- X'16' signon/signoff record (DFSLOG16)

SGNFUNC	DS C	/SIGN FUNCTION
SGNTCP/IP	EQU X'40'	TERMINAL IS TCP/IP

IMS Log Record Changes ...

- X'63' logon/logoff record

- DFSLOG63 (aka LOGCS)

```

S3FLG3      DS  C      FLAG BYTE 3
S33STCP     EQU  X'80'  STATIC ISC TCPIP TERMINAL
S33DTCP     EQU  X'40'  DYNAMIC ISC TCPIP TERMINAL
...
S3LENG1A EQU  S3LENG1+S3LENG3A  LENGTH OF BLOCK WITH TCPIP @U13GKN1
...
* RECOVERABLE TCPIP INFO WITHIN VTCSB
*
S3VTICON    DS  CL8      CLBICON
S3VTLGND    DS  CL8      CLBLGND
S3VTICNT    DS  F        CTBICNT
S3VTIMSQ    DS  F        CTBIMSQN
S3VTICSQ    DS  F        CTBICSQN
S3VTPIC     DS  XL8      CTBPICID
S3VTCIC     DS  XL8      CTBCICID
S3VTIUOW    DS  XL8      CTBIUOW
S3VTOMSQ    DS  F        CTBOMSQN
S3VTOCSQ    DS  F        CTBOCSQN
S3VTPOC     DS  XL8      CTBPOCID
S3VTCOC     DS  XL8      CTBCOCID
S3VTOUOW    DS  XL8      CTBOUOW
S3VTOCNT    DS  F        CTBOCNT
S3LENG3     EQU  *-S3REC63      LENGTH OF EXT. RECORD WITH TCPIP
S3LENG3A    EQU  *-S3VTICON     LENGTH OF TCPIP SECTION

```

Automated Operation – IMS Messages

■ New messages

- **DFS3553E** hh:mm:ss ISC TCPIP SESSION INIT IS REJECTED - NODE = nodename USER = username
RSNCD = 021

- **DFS3594E** hh:mm:ss AN ISC CSLSCMSG REQUEST FAILED, command,
RETCODE = rtncode, RSNCODE = rsncode, LOSTSESS = NONE,
MODULE = modname, NODE = nodename , USER = username

- **DFS3595E** hh:mm:ss IMS CONNECT ERROR MESSAGE RECEIVED, command,
RETCODE = rtncode, RSNCODE = rsncode, LOSTSESS = NONE,
MODULE = modname, NODE = nodename , USER = username

- **DFS3596E** hh:mm:ss ISC TCPIP DETECTED AN ERROR, command,
RETCODE = rtncode, RSNCODE = rsncode, LOSTSESS = NONE,
MODULE = modname, NODE = nodename , USER = username

- **DFS3597E** hh:mm:ss ISC TCPIP DETECTED AN INTERNAL LOGIC ERROR, command, RETCODE = rtncode,
RSNCODE = rsncode, LOSTSESS = NONE, MODULE = modname, NODE = nodename , USER = username

Automated Operation - IMS Connect Messages

HWSG4000I COMMUNICATIONS ON ISC LINK *iscid* STARTED; M=*mc*
HWSG4005I COMMUNICATIONS ON ISC LINK *iscid* STOPPED; M=*mc*
HWSG4015E COMMUNICATIONS WITH ISC FAILED TO OPEN BECAUSE IMS CONNECT IS NOT CONNECTED TO AN IMSPLEX; M=*mc*
HWSG4020W FWE FUNCTION=*func*, FAILED FOR ISC=*iscid*, COMMAND=*hwscmd* IN PROGRESS; M=*mc*
HWSG4025W COMMAND=*hwscmd* FAILED FOR ISC=*iscid*, COMMAND=*prev_hwscmd* ALREADY IN PROGRESS; M=*mc*
HWSG4030W THE ISC COMMUNICATIONS COMPONENT FAILED TO OBTAIN STORAGE; R=*rc*, S=*sc*, B=*bn*, M=*mc*
HWSG4040W SEND FAILED FROM ISC=*iscid* TO NODE=*nodename* ON RMTICIS=*rmtcicsname*; R=*rc*, S=*sc*, M=*mc*
HWSG4045W UNABLE TO NOTIFY ISC=*iscid* SCHEDULER OF COMMUNICATION ERROR; R=*rc*, S=*sc*, M=*mc*
HWSG4060I THE *threatype* THREAD TERMINATED FOR ISC LINK *iscid*; M=*mc*
HWSG4100E FUNCTION WORK ELEMENT PROCESSING FAILED, FUNC=*fn*; R=*rc*, S=*sc*, M=*mc*
HWSG4105W PROCESS OF STOPPING ISCUSER OR LINK FAILED, ISC=*iscid* IS IN DISCONNECT STATE; M=*mc*
HWSG4230W THE ISC DRIVER FAILED TO OBTAIN STORAGE; R=*rc*, S=*sc*, B=*bn*, M=*mc*
HWSG4235W THE ISC DRIVER FAILED TO RELEASE STORAGE; R=*rc*, S=*sc*, B=*bn*, A=*a*, M=*mc*
HWSG4255W ISC IS NOT AVAILABLE: MEMBER *mbrname*; STATE=*s*, M=*mc*
HWSV4400I COMMUNICATIONS SUPPORT FOR REMOTE CICS *rmtcicsname* STARTED; M=*mc*
HWSV4405I COMMUNICATIONS SUPPORT FOR REMOTE CICS *rmtcicsname* STOPPED; M=*mc*
HWSV4410E COMMUNICATIONS SUPPORT FOR REMOTE CICS *rmtcicsname* FAILED TO START; R=*rc*, S=*sc*, M=*mc*

Automated Operation - IMS Connect Messages ...

HWSV4415W IMS CONNECT CANNOT START THE SCHEDULER CONTROLLER FOR REMOTE CICS=*rmtcicsname*;
R=*rc*, S=*sc*, M=*mc*

HWSV4430W THE RMTCICS COMMUNICATIONS COMPONENT FAILED TO OBTAIN STORAGE; R=*rc*, S=*sc*, B=*bn*, M=*mc*

HWSV4435W THE RMTCICS COMM. COMPONENT FAILED TO RELEASE STORAGE; R=*rc*, S=*sc*, B=*bn*, A=*a*, M=*mc*

HWSV4440E UNABLE TO START TCP/IP SEND CLIENT TO REMOTE CICS *rmtcicsname*; R=*rc*, S=*sc*, M=*mc*

HWSV4500E FUNCTION WORK ELEMENT PROCESSING FAILED, FUNC=*fn*; R=*rc*, S=*sc*, M=*mc*

HWSV4600E TCP/IP SOCKET FUNCTION CALL FAILED; F=*fn*, R=*rc*, E=*e*, N=*n*, RIC=*ric*, M=*mc*

HWSV4630W THE RMTCICS DRIVER FAILED TO OBTAIN STORAGE; R=*rc*, S=*sc*, B=*bn*, M=*mc*

HWSV4635W THE RMTCICS DRIVER FAILED TO RELEASE STORAGE; R=*rc*, S=*sc*, B=*bn*, A=*a*, M=*mc*

HWSV4830W THE CICSPOINT COMMUNICATIONS COMPONENT FAILED TO OBTAIN STORAGE; R=*rc*, S=*sc*, B=*bn*, M=*mc*

HWSV4835W THE CICSPOINT COMM. COMPONENT FAILED TO RELEASE STORAGE; R=*rc*, S=*sc*, B=*bn*, A=*a*, M=*mc*

HWSV5000E TCP/IP SOCKET FUNCTION CALL FAILED; F=*fn*, R=*rc*, E=*e*, N=*n*, PORT=*portid*, M=*mc*

HWSV5030W THE CICSPOINT DRIVER FAILED TO OBTAIN STORAGE; R=*rc*, S=*sc*, B=*bn*, M=*mc*

HWSV5035W THE CICSPOINT DRIVER FAILED TO RELEASE STORAGE; R=*rc*, S=*sc*, B=*bn*, A=*a*, M=*mc*

IMS Commands

- **Enhanced IMS commands**
 - /BROADCAST
 - /COMPT
 - /DISPLAY ASMT LTERM|USER|NODE
 - /DISPLAY NODE
 - /DISPLAY STATUS NODE
 - /DISPLAY TIMEOVER
 - /DISPLAY TRACE NODE
 - /OPNDST NODE
 - /SIGN
 - /TEST
 - /TRACE SET ON NODE USER
 - /QUERY NODE

IMS Connect Commands

- **Enhanced**
 - VIEWHWS
 - QUERY MEMBER
 - QUERY IMSCON TYPE(PORT)

- **New IMS Connect type-2 commands**
 - QUERY IMSCON TYPE(ISC)
 - QUERY IMSCON TYPE(ISCUSER)
 - QUERY IMSCON TYPE(RMTCICS)
 - UPDATE IMSCON TYPE(ISC) START|STOP(COMM)
 - UPDATE IMSCON TYPE(RMTCICS) START|STOP(COMM)
 - UPDATE IMSCON TYPE(ISCUSER) START|STOP(COMM)

The following are still to be enhanced:

- STOPCLNT
- STOPCLN
- QUERY IMSCON TYPE(SENDCLNT)
- UPDATE IMSCON TYPE(SENDCLNT) STOP(COMM)
- UPDATE IMSCON TYPE(ISCUSER) START|STOP(COMM)

Commands

- DISPLAY ASMT command examples:

R 49,/DIS ASMT NODE CICS

```
IEE600I REPLY TO 49 IS;/DIS ASMT NODE CICS
DFS000I  NODE      USER      LTERM  IMS1
DFS000I  CICS     IMSUS01    I/O-  IMSUS01      IMS1
DFS000I  *12062/122917*  IMS1
```

R 50,/DIS ASMT USER IMSUS01

```
IEE600I REPLY TO 50 IS;/DIS ASMT USER IMSUS01
DFS000I  USER      USERID  ID      NODE  IMS1
DFS000I  IMSUS01   N/A     IMSUS0  CICS  I/O-  IMSUS01      IMS1
DFS000I  *12062/122949*  IMS1
```

R 51,/DIS ASMT LTERM IMSUS01

```
IEE600I REPLY TO 51 IS;/DIS ASMT LTERM IMSUS01
DFS000I  LTERM    IN-TERMINAL  OUT-TERMINAL  USER  IMS1
DFS000I  IMSUS01  CICS      -1    CICS      -1    IMSUS01      IMS1
DFS000I  *12062/123336*
```

Commands...

- DISPLAY NODE command example:

R 51,/DIS NODE CICS

```
DFS000I  NODE-USR TYPE  CID      RECD ENQCT DEQCT  QCT  SENT IMS1
DFS000I  CICS    TCP   *****  0    0    0    0    0  IDLE CON
          IMS1
```

- DISPLAY TIMEOVER command example:

R 43,/DIS TIMEOVER 10

```
IEE600I REPLY TO 43 IS;/DIS TIMEOVER 10
DFS000I  NODE      USER      LINK#  TYPE  LAST OUTPUT START TIME  IMS1
DFS000I  CICS      IMSUS01   N/A    TCP   12088/171914      IMS1
DFS000I  *12088/101948*      IMS1
```

Commands...

- DISPLAY TRACE NODE command example:

```
IEE600I REPLY TO 46 IS;/DIS TRACE NODE
DFS000I   IMS ACTIVE TRACES   IMS1
DFS000I           IMS1
DFS000I   NODE           TYPE   USERS     IMS1
DFS000I   CICS           TCP    IMSUS01   IMS1
DFS000I   LU6NDPA       TCP    LU6SPA    IMS1
DFS000I           IMS1
DFS000I   LEVEL: 4     MODULE: ALL   IMS1
DFS000I   *12062/122024*   IMS1
```

Commands...

- **QUERY NODE** command syntax:
 - Addition of IMSCON and LOGOND parameters to the SHOW() keyword to show IMS Connect name and the logon descriptor name used for dynamic terminal

```
ALL →  
|AFFIN|  
|CID|  
|CONV|  
|COUNT|  
|EMHQ|  
|ID|  
|IMSCON|  
|LOGOND|  
|LTERM|  
|MODETBL|  
|OWNER|  
|PRESET|  
|QCNT|  
|RECOVERY|  
|STATUS|  
|TYPE|  
|USER|  
|USERID|  
|VERSION|
```

Commands...

- **QUERY NODE** command example:

QUERY NODE NAME(CICS) SHOW(ALL)

TSO SPOC output:

(Screen 1)

Node	ISCUser	MbrName	CC	LQCnt	LType	LclImsCon	LclLogonD
CICS	IMSUS01	IMS1	0	0	TCP	HWS1	LU6TCP1

(Screen 2)

Node	ISCUser	MbrName	RecdCnt	SentCnt	LSRM	LRcvy
CICS	IMSUS01	IMS1	0	0	LCL	STSN

(Screen 3)

Node	ISCUser	MbrName	LUser	LID	LclStat
CICS	IMSUS01	IMS1	IMSUS01	IMSUS01	SIGN, IDLE, CON

Commands...

- QUERY IMSCON TYPE(ISC) command syntax:

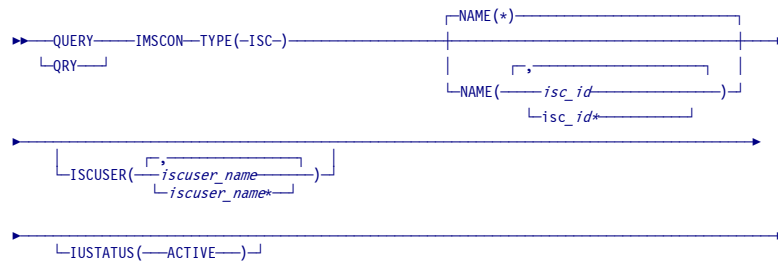

Commands...

- QUERY IMSCON TYPE(ISC) command syntax (continued)

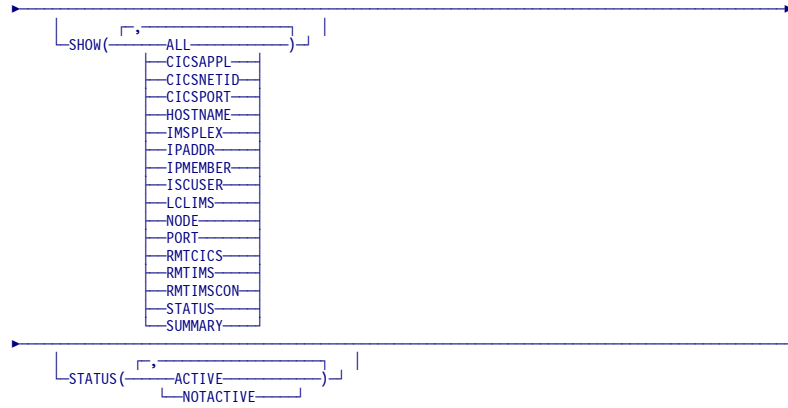

Commands...

- QUERY IMSCON TYPE(ISC) example:

QUERY IMSCON TYPE(ISC) NAME(CICS) SHOW(ALL)
TSO SPOC output:

(Screen 1)

ISCName	MbrName	CC	Node	LclIMS	RmtIMS	IpMember	IMSpIex	RmtCICS
CICS	HWS1	0	CICSTRM1	IMS1		ICON1	PLEX1	ICOMNT1
CICS	HWS1	0						
CICS	HWS1	0						
CICS	HWS1	0						

(Screen 2)

ISCName	MbrName	IpAddress	HostName	Port
CICS	HWS1	009.030.090.091	IMSEC48.SVL.IBM.COM	9999
CICS	HWS1			
CICS	HWS1			
CICS	HWS1			

(Screen 3)

ISCName	MbrName	CICSAppIid	CICSPort	CICSNetid	Status	TotUsers	Totactiv
CICS	HWS1	CICSA1	9991	CICSNET	ACTIVE	2	2
CICS	HWS1						
CICS	HWS1						

(Screen 4)

ISCName	MbrName	TotOther	ISCUser	SendClnt	RecvClnt	IUStatus
CICS	HWS1	0				
CICS	HWS1		IMSUS01	ISC11111	ISC33333	ACTIVE
CICS	HWS1		IMSUS02	ISC22222	ISC44444	ACTIVE

Commands...

- QUERY IMSCON TYPE(ISCUSER) command syntax

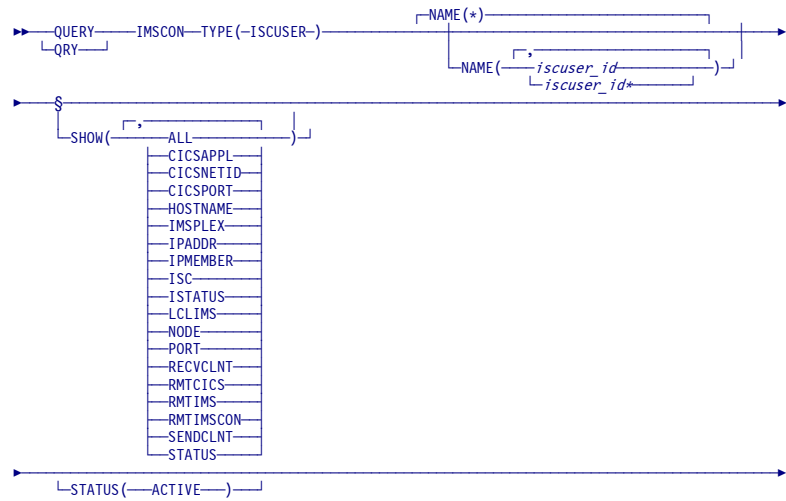

Commands...

- QUERY IMSCON TYPE(ISCUSER) command example:

QUERY IMSCON TYPE(ISCUSER) NAME(IMSUS*) SHOW(ALL)
TSO SPOC output:

(Screen 1)

ISCUser	MbrName	CC	SendClnt	RecvClnt	Status	ISCName	ISCStatus
IMSUS01	HWS1	0	ISC11111	ISC33333	ACTIVE	CICS	ACTIVE
IMSUS02	HWS1	0	ISC22222	ISC44444	ACTIVE	CICS	ACTIVE

(Screen 2)

ISCUser	MbrName	Node	LclIMS	RmtIMS	IpMember	IMSplex	RmtCICS
IMSUS01	HWS1	CICSTRM1	IMS1		ICON1	PLEX1	ICONNT1
IMSUS02	HWS1	CICSTRM1	IMS1		ICON1	PLEX1	ICONNT1

(Screen 3)

ISCUser	MbrName	IpAddress	HostName	Port
IMSUS01	HWS1	9.30.90.91	IMSEC48.SVL.IBM.COM	9998
IMSUS02	HWS1	9.30.90.91	IMSEC48.SVL.IBM.COM	9998

(Screen 4)

ISCUser	MbrName	CICSAppId	CICSPort	CICSNetid
IMSUS01	HWS1	CICSA1	7777	CICSNET
IMSUS02	HWS1	CICSA1	7777	CICSNET

Commands...

- No command syntax change for VIEWPORT, QUERY PORT and QUERY IMSCON TYPE(PORT)

VIEWPORT 9991 and F ICON1,QUERY PORT NAME(9991) SHOW(ALL)

```
HWSC0001I  PORT=9991C  STATUS=ACTIVE  KEEPAV=0  NUMSOC=3
EDIT=      TIMEOUT=0
HWSC0001I  CLIENTID  ISCNAME  STATUS  SECOND  CLNTPORT
IP-ADDRESS
HWSC0001I  ISC33333  LU6TCP2  CONN    14     3579
0:0:0:0:0:FFFF:A64:C803
HWSC0001I  ISC44444  LU6TCP2  CONN    9     2468
0:0:0:0:0:FFFF:A64:C804
HWSC0001I  TOTAL CLIENTS=3  RECV=1  CONN=2  XMIT=0  OTHER=0
```

VIEWPORT, QUERY PORT, and QUERY IMSCON TYPE(PORT) do not have syntax change

Commands...

QUERY IMSCON TYPE(PORT) NAME(9991) SHOW(ALL)

TSO SPOC output:

(Screen 1)

Port	MbrName	CC	KeepAv	NumSoc	EditRtn	TimeOut	Status
9991C	HWS1	0	0	5		0	ACTIVE
9991C	HWS1	0					
9991C	HWS1	0					

(Screen 2)

Port	MbrName	TotClnts	TotRecv	TotRead	TotConn	TotXmit	TotOther
9991C	HWS1	4	2	0	2	0	0
9991C	HWS1						
9991C	HWS1						

(Screen 3)

Port	MbrName	ClientID	UserID	LclPlkID	ISCName	Trancode	DataStore	CStatus
9991C	HWS1							
9991C	HWS1	ISC33333			LU6TCP2			CONN
9991C	HWS1	ISC44444			LU6TCP2			CONN

(Screen 4)

Port	MbrName	Second	ClntPort	IpAddress	ApsbToken
9991C	HWS1				
9991C	HWS1	14	1739	0:0:0:0:FFFF:A64:C802	
9991C	HWS1	9	2684	0:0:0:0:FFFF:A64:C802	

Commands...

- QUERY IMSCON TYPE(RMTCICS) command syntax

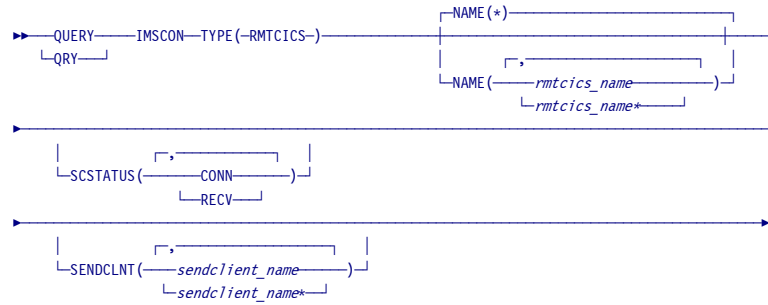

Commands...

- QUERY IMSCON TYPE(RMTCICS) command syntax (continued)

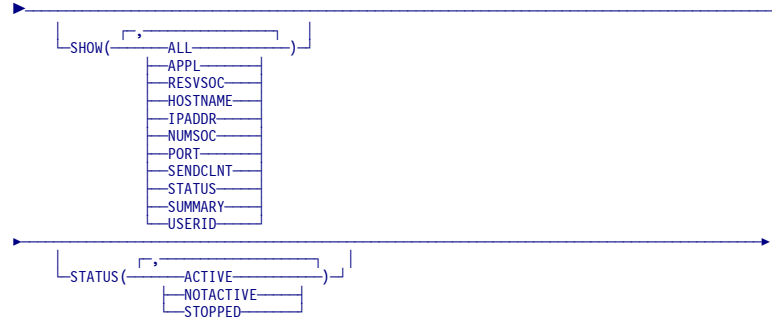

Commands...

- QUERY IMSCON TYPE(RMTCICS) command example:

QUERY IMSCON TYPE(RMTCICS) NAME(ICONNT1) SHOW(ALL)

(Screen 1)

RmtCICS	MbrName	CC	IpAddress	HostName
ICONNT1	HWS1	0	009.030.090.091	IMSEC48.SVL.IBM.COM
ICONNT1	HWS1	0		
ICONNT1	HWS1	0		

(Screen 2)

RmtCICS	MbrName	Port	ResvSoc	NumSoc	Appl	UserID	Status
ICONNT1	HWS1	8891	10	2	APPL02	USER01	ACTIVE
ICONNT1	HWS1						
ICONNT1	HWS1						

(Screen 3)

RmtCICS	MbrName	TotSClnts	TotRecv	TotConn	TotXmit	TotOther
ICONNT1	HWS1	2	0	2	0	0
ICONNT1	HWS1					
ICONNT1	HWS1					

(Screen 4)

RmtCICS	MbrName	SendClnt	ISCName	Second	SendPort
ICONNT1	HWS1				
ICONNT1	HWS1	ISC11111	CICS	100	1234
ICONNT1	HWS1	ISC22222	CICS	89	5678

(Screen 5)

RmtCICS	MbrName	SendStatus
ICONNT1	HWS1	
ICONNT1	HWS1	CONN
ICONNT1	HWS1	CONN

(this page intentionally left blank)