



IBM zEnterprise Technology Summit

The New zEnterprise –
A Cost-Busting Platform
Best Fit Workloads
For System z Private Cloud



Two Cost Reducing Strategies = Private Cloud On System z

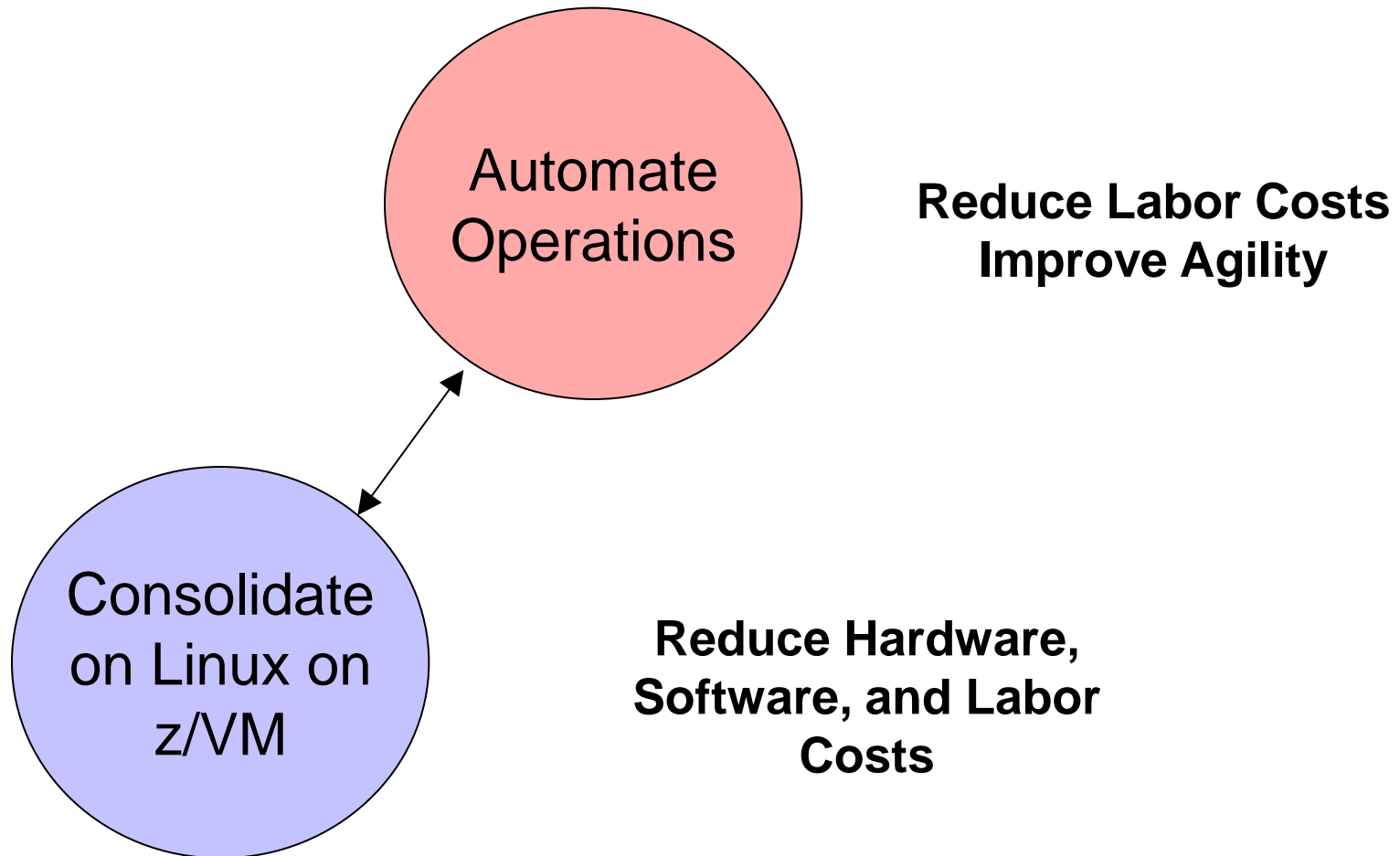

What Workloads Are Best Suited To Consolidate On Linux On z/VM On z?

- High I/O bandwidth
 - ▶ Example: Smaller scale transaction processing workloads
 - ▶ I/O operations offloaded to SAPs to improve performance
- Co-location
 - ▶ Example: Systems of engagement workloads (front ends)
 - ▶ Less latency to improve performance
- High reliability
 - ▶ Example: Applications critical to business revenue
 - ▶ Industry best platform for high availability and disaster recovery
- High number of light workloads
 - ▶ Example: Applications with low utilization
 - ▶ z/VM can define thousands of virtual machines

A Closer Look At Linux On z/VM

Logical Partitions Share Processors, Common Cache Structures, and I/O

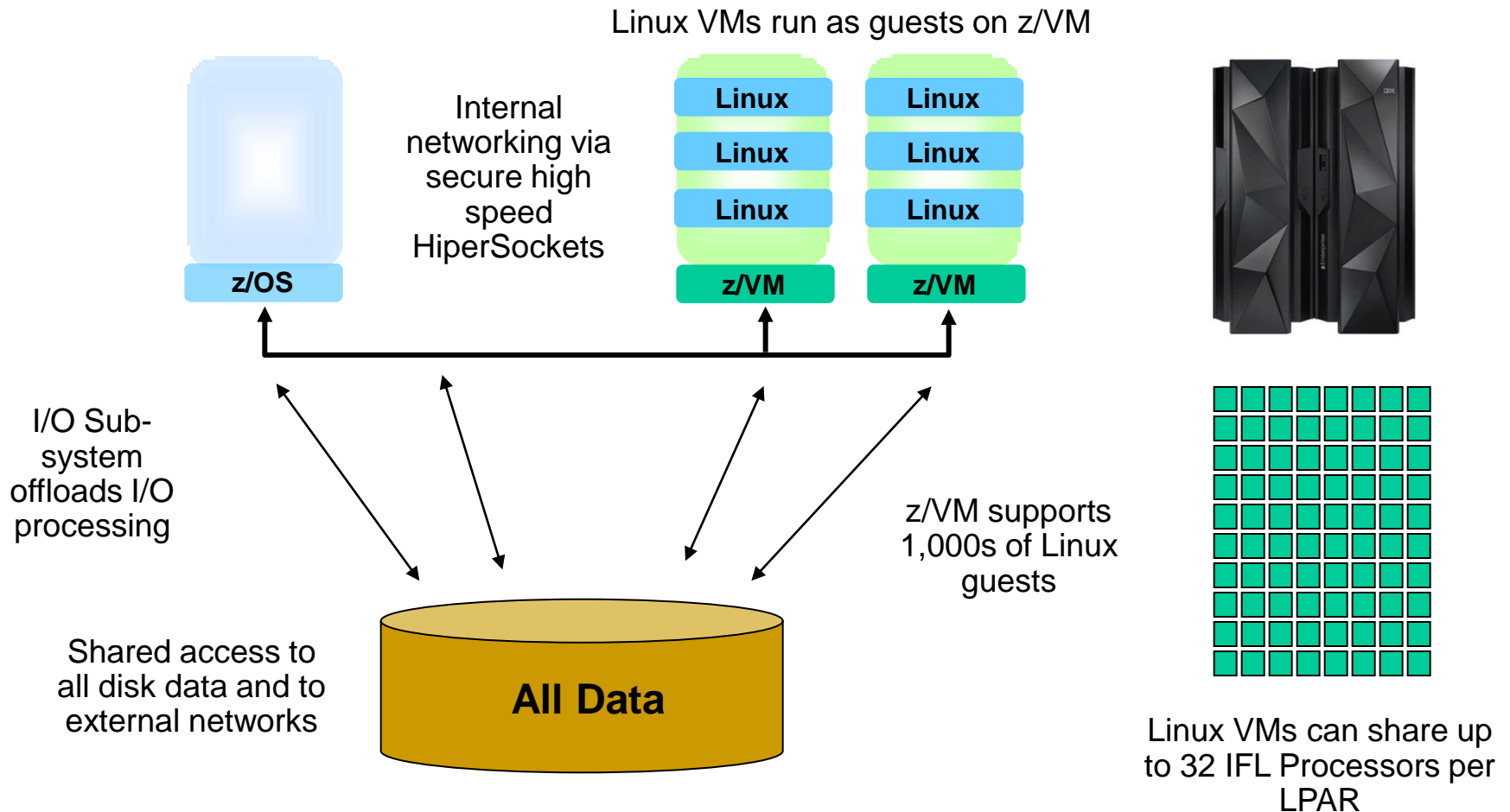

Economics Of Linux On z/VM

- Linux workloads can run entirely on IFL specialty processors
 - ▶ Benefit from discounted hardware pricing per processor
 - \$55K per IFL
 - ▶ Benefit from software license pricing (zEC12 = 120 PVUs)
- No limit on the number of IFLs in a zEC12
- IFL processors have the same performance characteristics as general purpose processors
- Solution Edition pricing can be even more attractive

IFL Processors In zEC12 Deliver Unmatched Processing Capacity

■ World's fastest processor

- ▶ 5.5 GHz clock rate
- ▶ 120 total processors (101 configurable as IFL's)
- ▶ 6 cores per chip

■ More memory

- ▶ 48MB on-chip L3 shared cache
 - 8MB on-chip cache/core
- ▶ 1.5GB total shared L4 cache
 - 384MB per book
- ▶ Up to 3TB Main Memory

■ Large server design

- ▶ Up to 78,000 IFL MIPS capacity

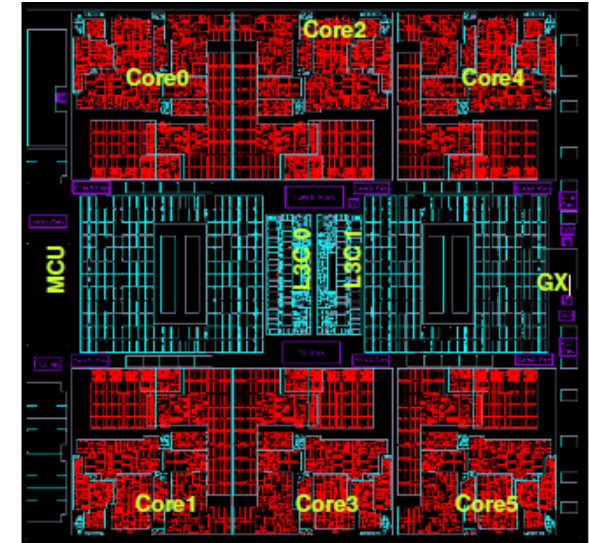

6
cores
per
chip



Multi
Chip
Module

Linux On z/VM Workloads Get The Benefit Of zEC12 Dedicated I/O Subsystem

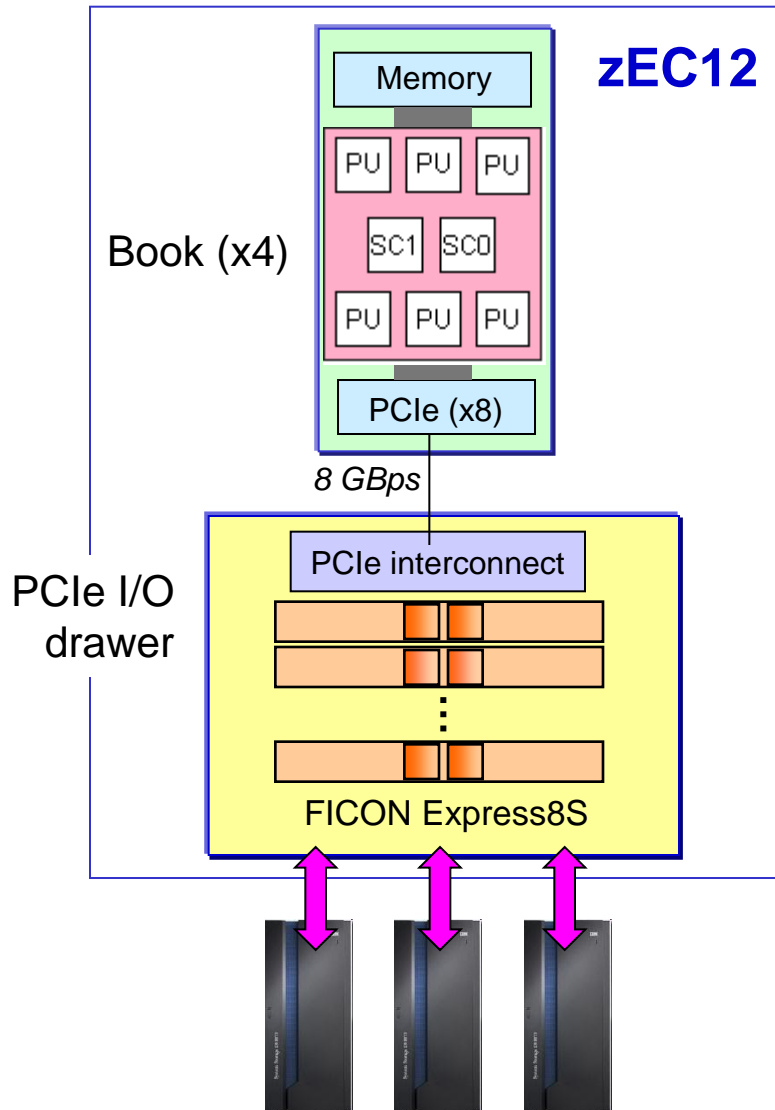

- **Up to 16 dedicated System Assist Processors (SAPs)**
 - ▶ All I/O requests are offloaded to SAPs
 - ▶ Each SAP can sustain up to **2.4M IOPS***
 - ▶ I/O subsystem bus speed of 8 GBps
 - ▶ Number of SAPs increases from 2 to 16 according to system size
- **Up to 160 physical FICON cards for I/O transfers**
 - ▶ Up to 320 RISC processors (2 per card)
 - ▶ Up to 320 FICON channels (2 per card)
 - ▶ 8 Gbps per link, 288 GB/Sec I/O aggregate per zEC12
- **IBM DS8800 Storage System**
 - ▶ Up to 440K IOPS capability
- **Delivers I/O efficiency at scale**

* Recommend 70% max utilization – 1.7M IOPS
Numbers represent High Performance FICON traffic

Workloads With Higher I/O Bandwidth Requirements Benefit From System z Architecture

Which platform provides the lowest TCA over 3 years?

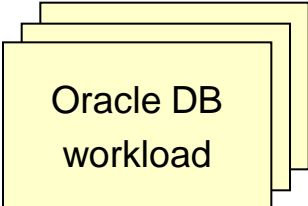

3 Database Workloads
Oracle Enterprise Edition
Oracle Real Application Cluster



3 Oracle RAC clusters
4 server nodes per cluster
12 total Oracle T3-4 servers
(768 cores)

\$28.7M (3 yr. TCA)



3 Oracle RAC clusters
4 nodes per cluster
Each node is a Linux on z guest
zEC12 with 27 IFLs

\$5.7M (3 yr. TCA)

80% less cost!

TCA includes hardware, software, maintenance, support and subscription. Workload Equivalence derived from a proof-of-concept study conducted at a large Cooperative Bank and projecting to T3-4 servers using published TPC-C Results normalizing them to Relative Performance Units as available from Ideas International

City And County Of Honolulu Benefit From System z Architecture

Business challenge:

The City and County of Honolulu wanted to increase government transparency and provide more information, such as the city's financial data, to its citizens.

Solution:

Honolulu deployed an Integrated Facility for Linux (IFL) engine running Linux on IBM System z. This provided the necessary platform to provide the city's data to citizens, and it enabled the city to create a custom cloud environment to deploy applications.

Benefits:

- *Reduced database licensing costs by **68** percent*
- Reduced time to deploy applications from 1 week to only hours
- Increased property tax revenue by \$1.4M

“Working with IBM enabled us to take an innovative approach... we were able to get things up and running quickly.”

—Gordon J. Bruce, director and CIO of the Department of Information Technology, City and County of Honolulu

Solution components

Optimized systems:

- IBM System z with IFL engine running Linux
- IBM XIV Storage System
- IBM Tivoli software

Hybrid Workloads

Mobile and Endpoint devices



Systems of engagement



System of record



Where should we run these workloads?

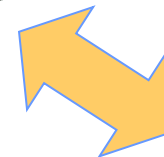
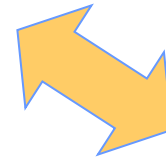

Critical data and core transaction workloads

Co-location Benefit From System z Architecture

Separate Machines

Separate LPARs

Same LPAR

270 tps $\xrightarrow{33\%}$ 360 tps $\xrightarrow{4\%}$ 375 tps

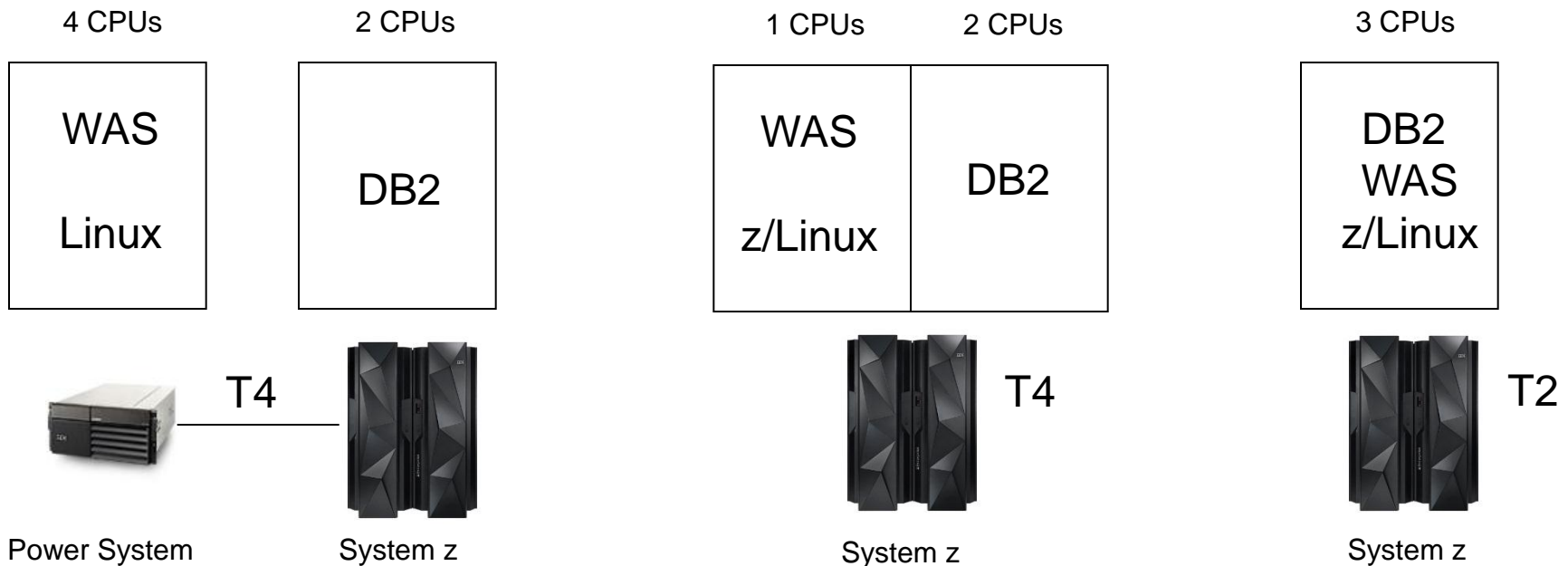

SAP Applications Benefit From Co-location



Business challenge:

Baldor needed to **cut costs** while simultaneously enhancing customer service with very **rapid** order processing, responsive manufacturing and swift delivery.

Solution:

Migrated its mission-critical SAP and DB2-based applications to an IBM System z running Linux, z/OS and z/VM operating systems, eliminating several large Sun servers in the process.

Benefits:

- Reduced IT costs as proportion of sales by **50%**
- Consolidation cuts power by **40%** and reduces data center floor space from 6,000 to 1,000 sq ft
- Cut system administration and maintenance costs

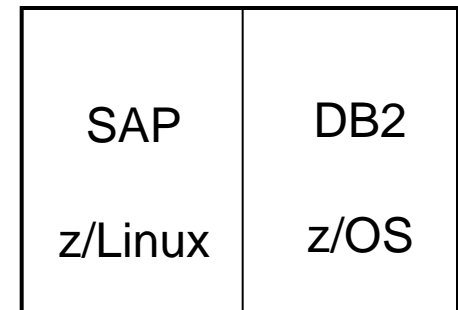

SAP Applications
Co-located on System z

Linux On z/VM Workloads Inherit System z Qualities Of Service

- Reliability, availability, serviceability characteristics of System z
- Capacity on demand upgrades
- Add physical processors to Linux environment without disruption
- Site failover for disaster recovery

System z Capacity On Demand Provides Elasticity To Handle Unexpected Peaks

- Capacity on Demand
 - ▶ “Books” are shipped fully populated
 - ▶ Activate dormant processors as needed
 - ▶ Use for temporary or permanent capacity
 - ▶ Self-managed on/off
- New capacity is immediately available for work without service disruption

One Book with 36 Processors

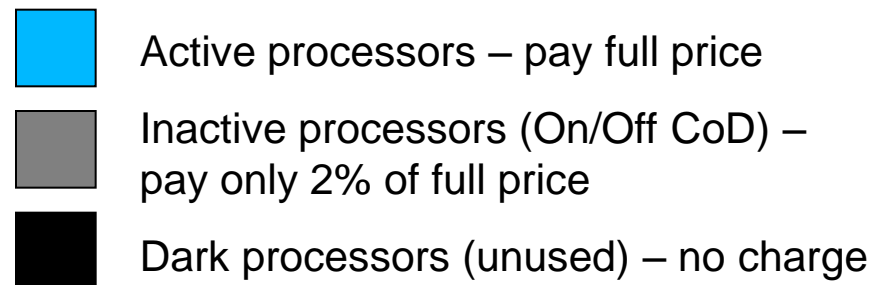
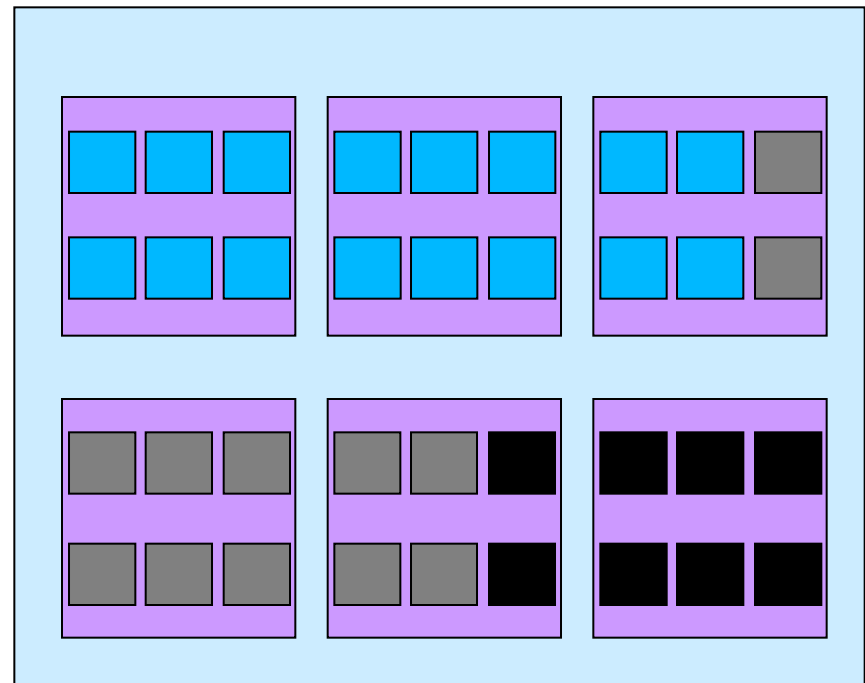

DEMO: Dynamically Add New Processor To z/VM LPAR To Handle Increased Workload Without Disruption

1. A customer has in-house Risk Analysis program running on Linux on System z
2. Increased workload to all 4 Linux guests is causing z/VM LPAR utilization of 90%+
3. Customer determines this is a long term trend - additional physical capacity needed
4. New capacity made available to LPAR as new Logical CPU, available for work
 - ▶ Without disruption in service

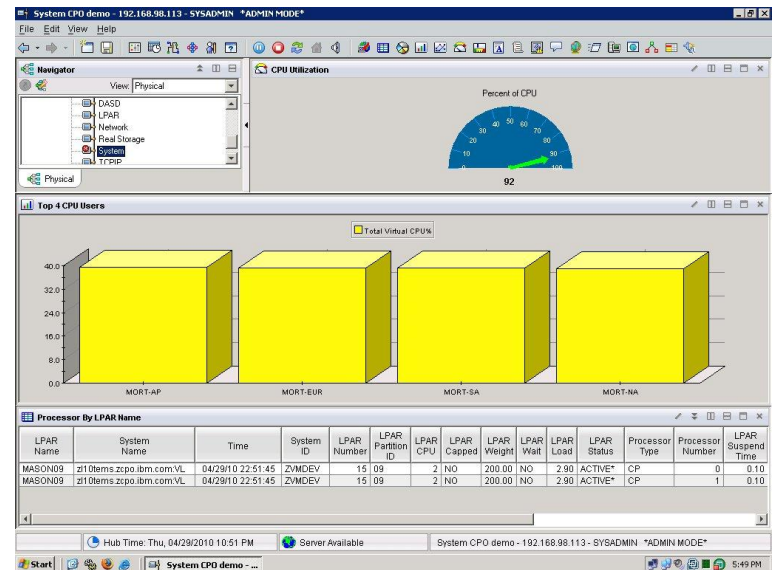

Note: Assumes available processors on installed books

Cognos BI Workloads Benefit From High Reliability

Which platform provides the lowest TCA over 3 years?

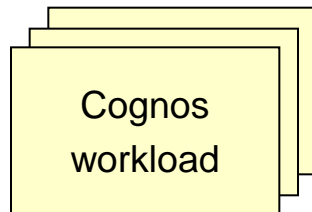

21 Cognos Report Workloads

Cognos 10 BI



21 HP DL580 Wintel servers
(Xeon 2.13 GHz, 1ch/8co)
168 cores total

\$3.32M (3 yr. TCA)



(Cognos runs as a zVM
Linux on System z guest)

zEC12 with 2 IFLs

\$0.40M (3 yr. TCA)



zEC12

88% lower cost!

TCA includes hardware, software, maintenance, support and subscription. Software includes WebSphere and OS. Cognos 10 BI software cost is same for both environments since it is priced per authorized user and hence not included. Case study derived from a customer scenario in government industry.

Transzap Benefits From High Reliability

Business challenge:

As a small business with tens of billions of dollars in client transactions flowing through their systems each year, Transzap needed an economical, reliable platform to provide clients with **high availability** while enabling the capacity to accommodate triple digit **growth** within their software as a service business model.

Solution:

Transzap migrated to System z and virtualized its critical applications on Linux on System z, a platform that supports Transzap's dynamic Java™ and Oracle environments.

Benefits:

- Helps Transzap to serve more than 69,000 users across 6,800 companies
- Provides higher levels of **uptime** for their customers
- Offers peace of mind through 24x7 world-class hardware support

*“We intend to deliver a **99.9% application uptime guarantee** to our customer base, thanks to the availability characteristics of System z.”*

— Peter Flanagan, CEO of Transzap, Inc.

Solution components:

- IBM System z
- Linux on System z
- IBM z/VM



ZSP03141-USEN-00

Two Cost Reducing Strategies = Private Cloud On System z

Now let's focus on labor costs and agility!



Automate Operations

**Reduce Labor Costs
Improve Agility**

Consolidate
on Linux on
z/VM

**Reduce Hardware,
Software, and Labor
Costs**

Automation With IBM SmartCloud Provisioning For Virtual Cloud Environments

- Self-service automated provisioning of virtual systems and applications into pools of external virtualized hardware
 - ▶ “Bring your own cloud”
 - ▶ Supports various hypervisors, including, zVM, PowerVM, VMware ESX
- Standardized IBM middleware virtual images and patterns

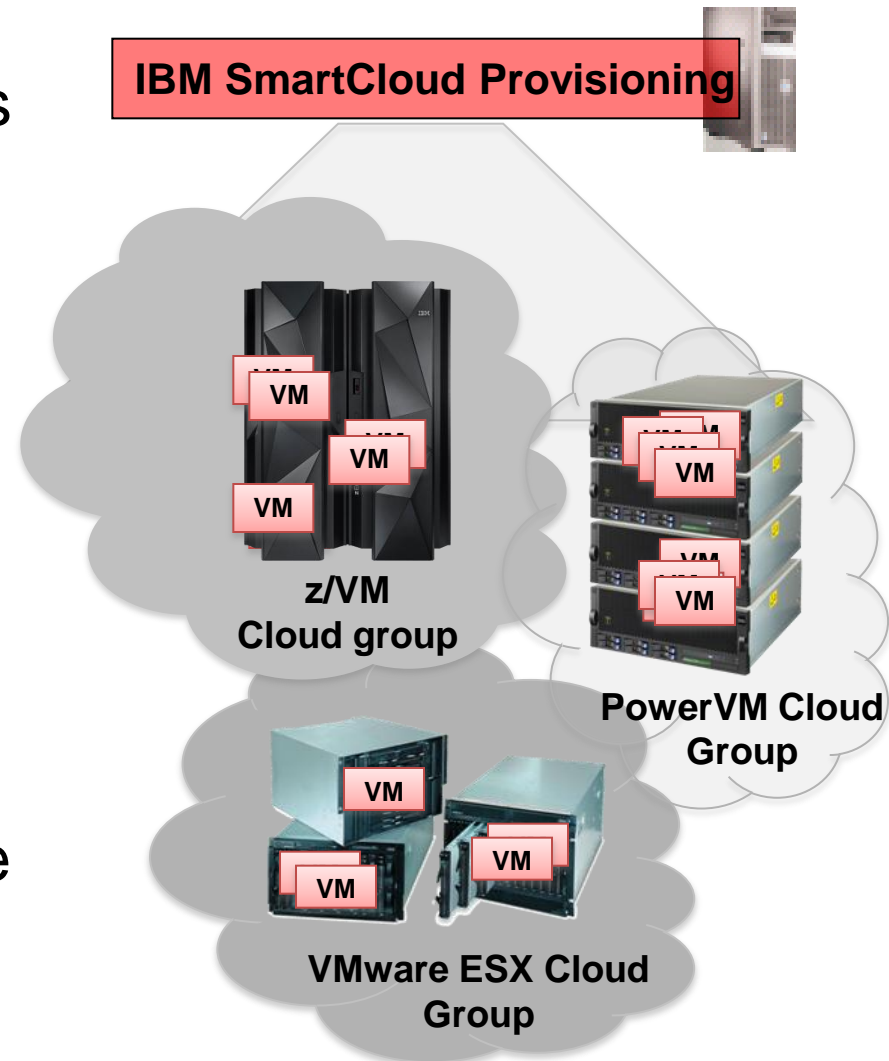

Automation With IBM SmartCloud Provisioning Can Further Reduce Costs



User creates and deploys a pattern

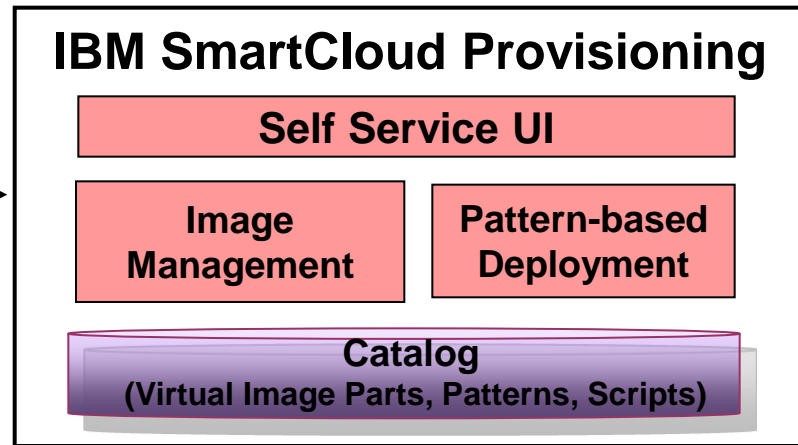

- Self-service console for users
- Catalog stores virtual image parts, patterns, scripts for quick-starts
- Drag and drop tooling for creating and deploying virtual applications using catalog
- Intelligent placement algorithm optimize resource utilization based on cloud activity

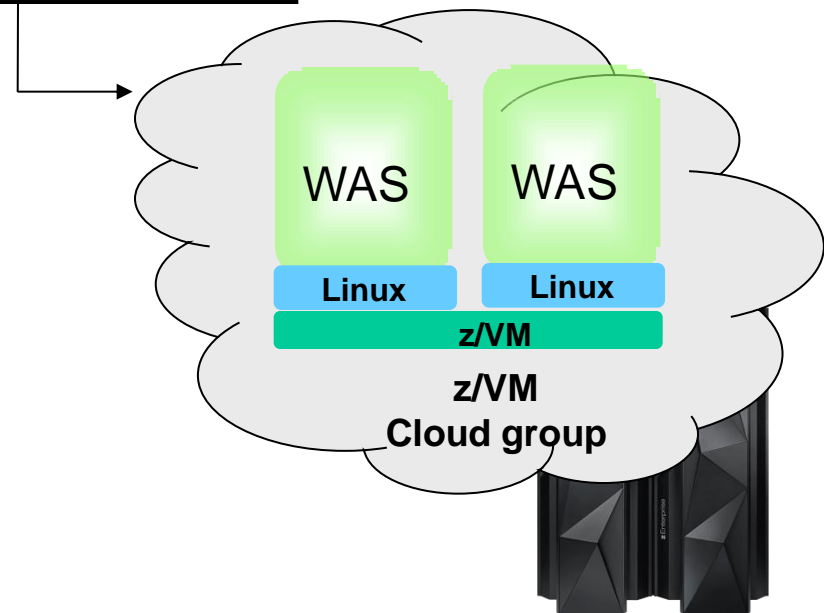

IBM SmartCloud Provisioning Makes It Easier To Get Started With Virtualized Images

- IBM Middleware packaged as Hypervisor Editions (.OVF virtual images), ready to run on a hypervisor
 - ▶ Includes pre-installed and pre-configured image, image-specific tuning/configuration and fast deploy-time activation capabilities
- Hypervisor Editions (HV) offered for z/VM include:
 - ▶ WebSphere Application Server
 - ▶ WebSphere Process Server
 - ▶ WebSphere Portal Server
- Hypervisor Editions imported into SmartCloud Provisioning catalog as virtual image parts that represent topology components
 - ▶ Example: deployment manager, custom node, etc.
- Virtual image parts can be used to create virtual system patterns

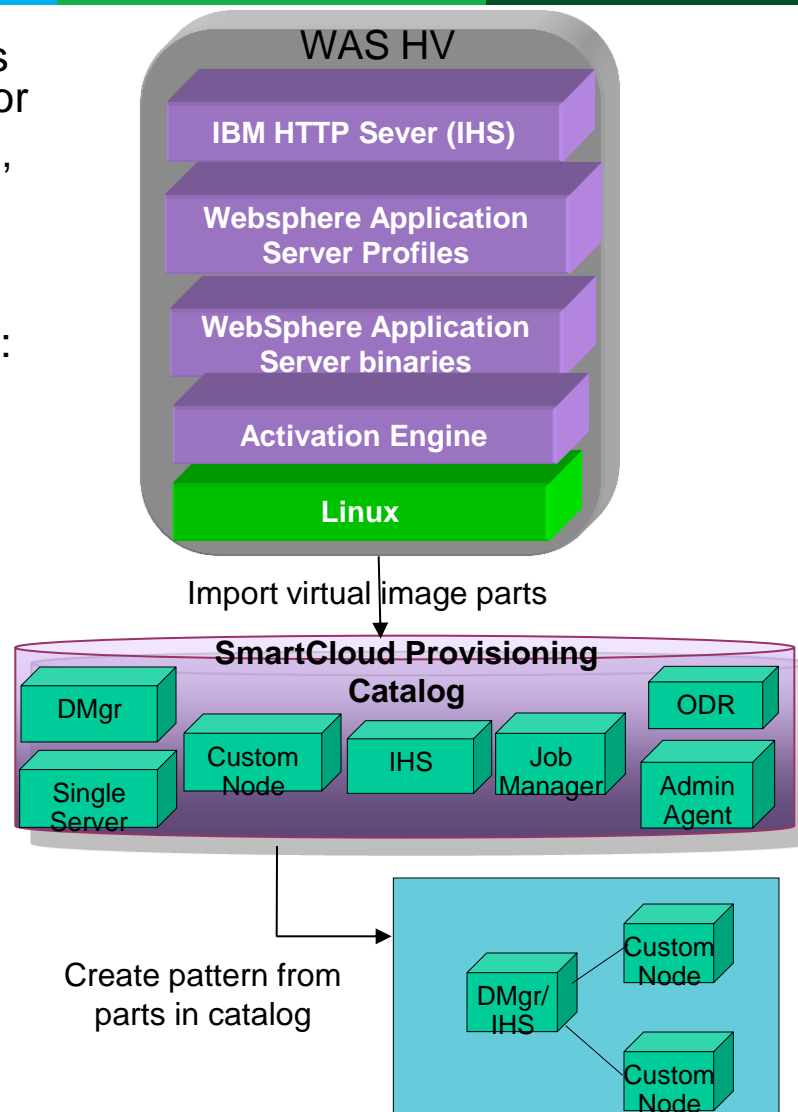

IBM SmartCloud Provisioning Deploys Patterns Of Images

A Virtual System Pattern is one or more virtual images and script packages to satisfy a certain deployment topology

Single Server

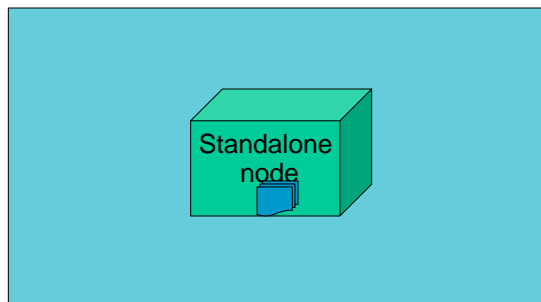

WebSphere cluster

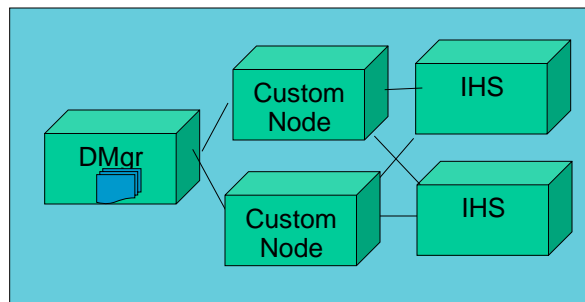

WebSphere Advanced Cluster

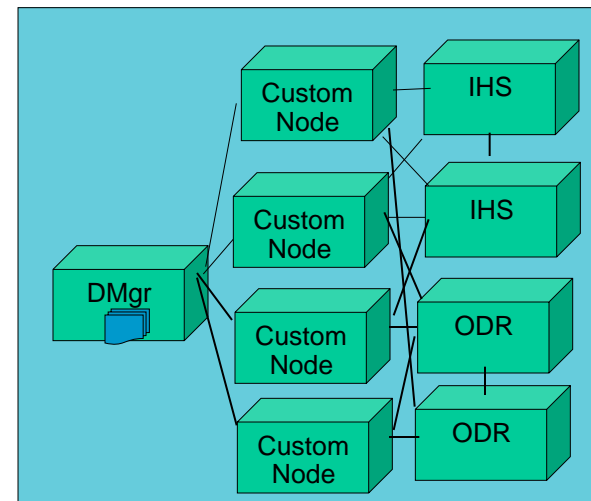

WebSphere cluster (dev)

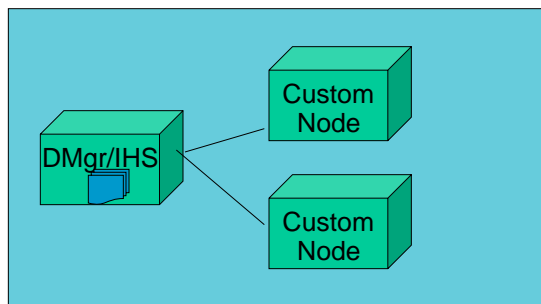

WebSphere Process Server (Scalable)

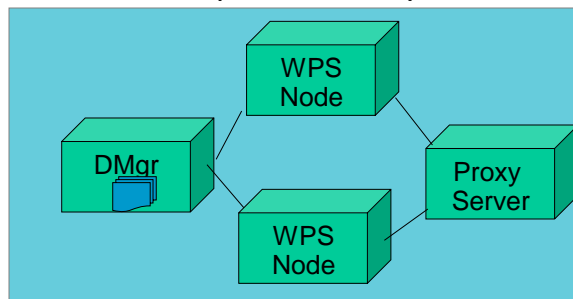

DMgr = Deployment Manager

IHS = IBM http Server

Example Of How It Works - Use Pattern For Automated Deployment Of Single WAS Server



Create and Deploy Pattern

IBM SmartCloud Provisioning

SmartCloud Provisioning

Ready

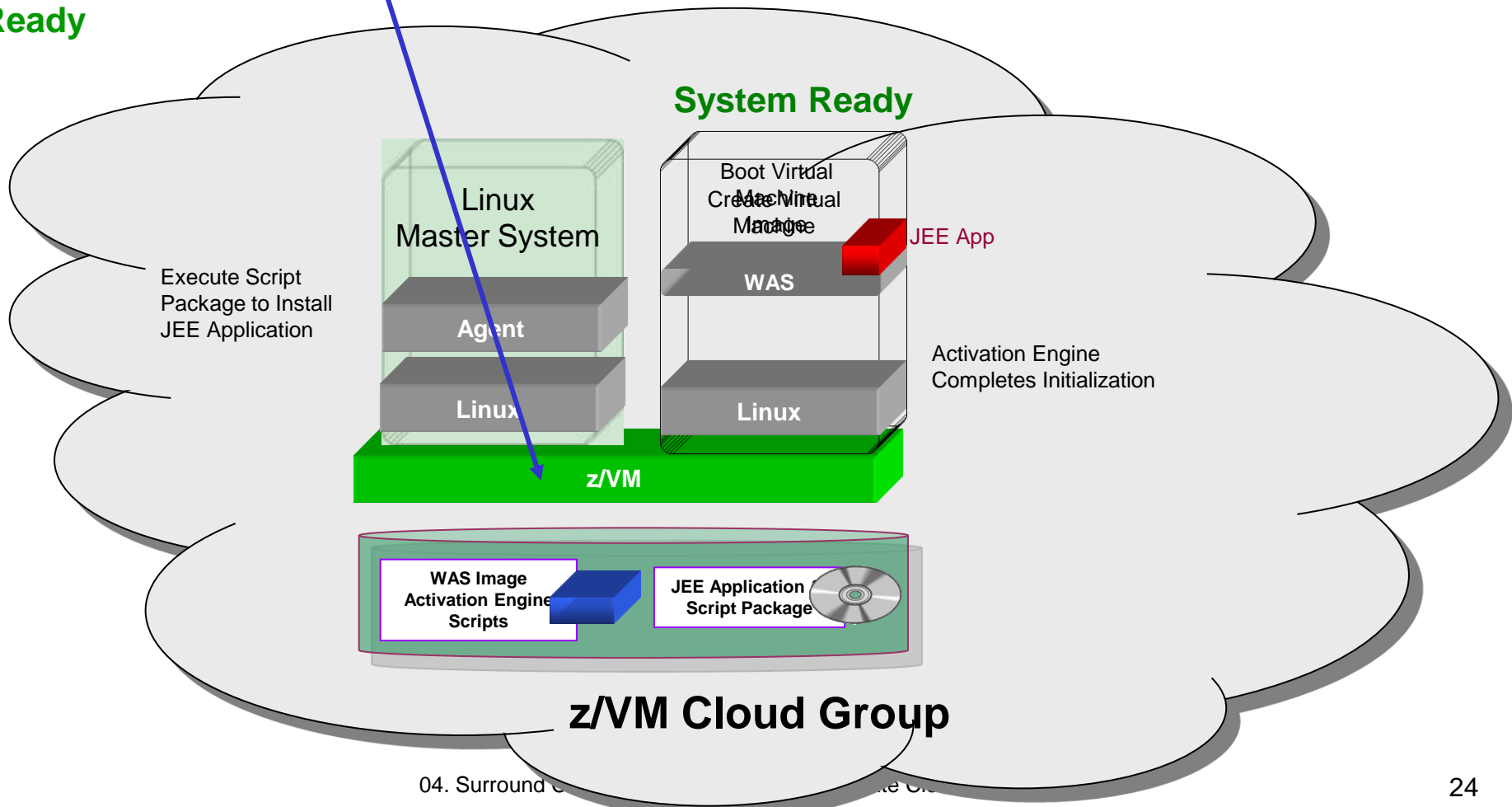

IBM SmartCloud Automated Provisioning Is Fast

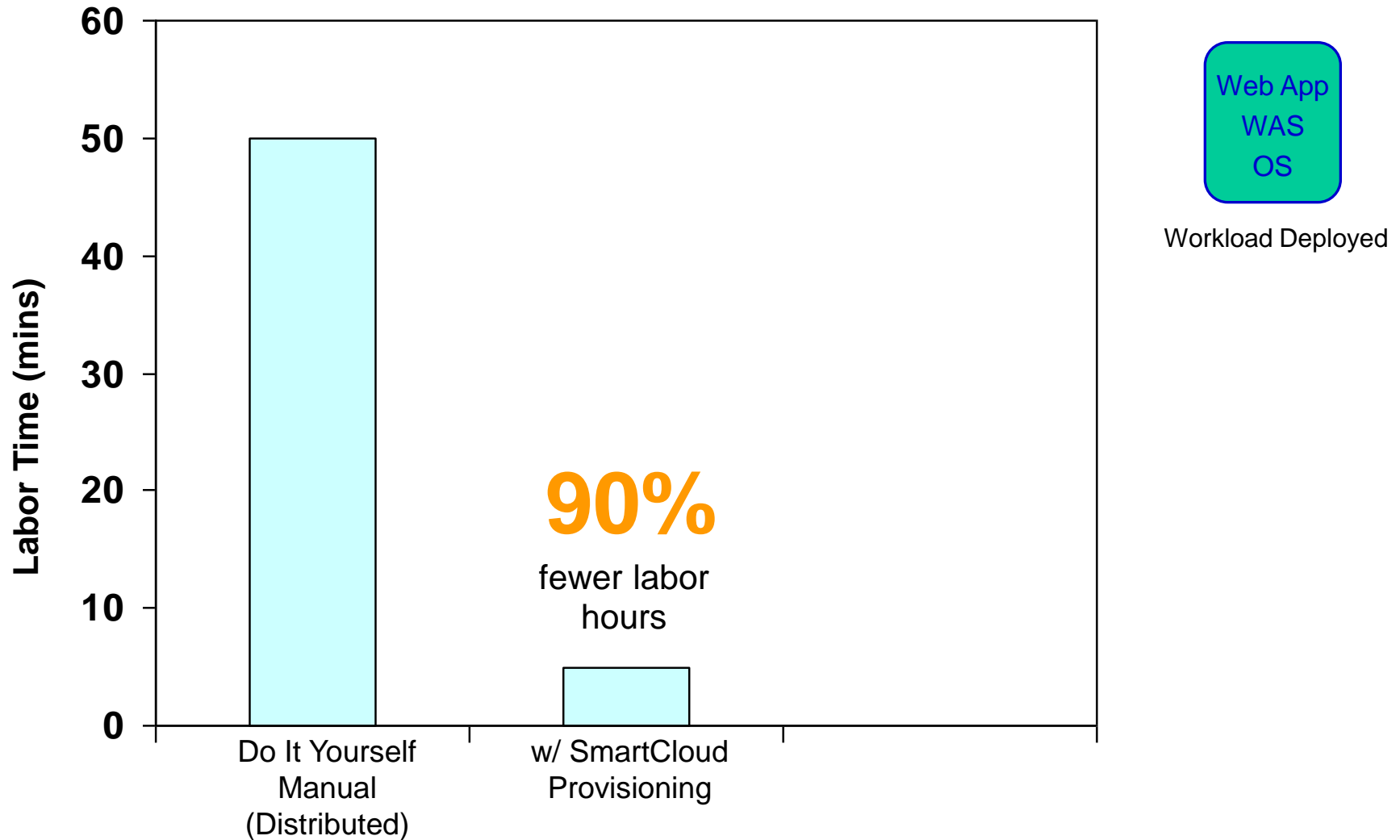

Example: Normal Deployment Steps For WAS High Available Clustered Environment

1. Involves creating 4 virtual servers
 - ▶ 1 WebSphere deployment manager
 - ▶ 2 WebSphere Node
 - ▶ 1 IBM HTTP Server
2. Install the WAS Update Installer and install the required iFixs
3. Create WebSphere Cluster with 2 members
4. Configure the HTTP Server
5. Configure Session replication on servers to support Failover
6. Deploy the Application to the WebSphere Cluster

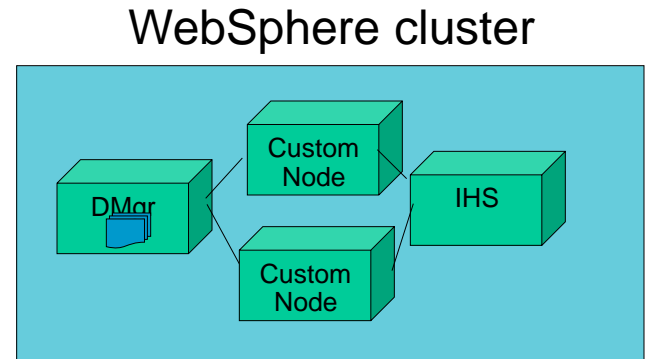

All of these steps are done automatically with IBM SmartCloud Provisioning

DEMO: Fast Deployment Of WAS Cluster With IBM SmartCloud Provisioning

- Self-service console for user
- Drag and drop pattern editor to create a WAS cluster pattern
- Automated provisioning of the cluster

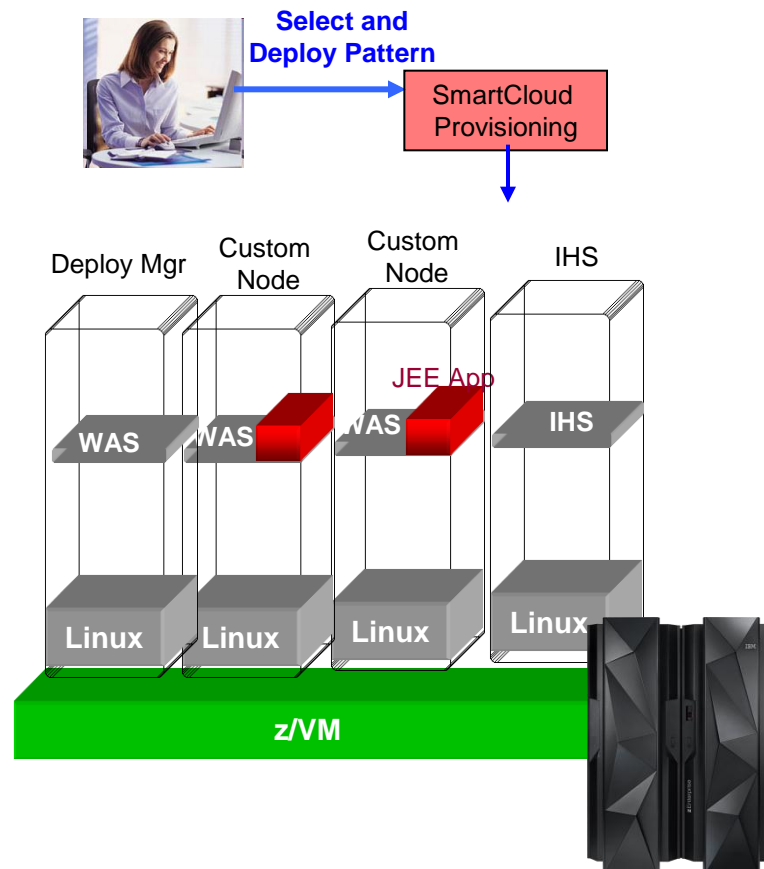

Which Option Requires The Least Amount Of Labor?

Which platform provides the lowest labor costs over 3 years?

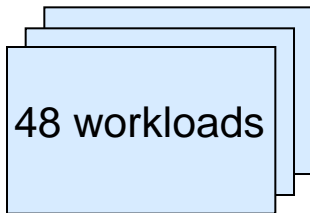

Online banking workloads, each driving **22** transactions per second, with **1 MB I/O per transaction**

48 Sun Fire X4170
M2



1
z/VM on zEC12
32 IFLs



A High-Level View Of The Labor Model

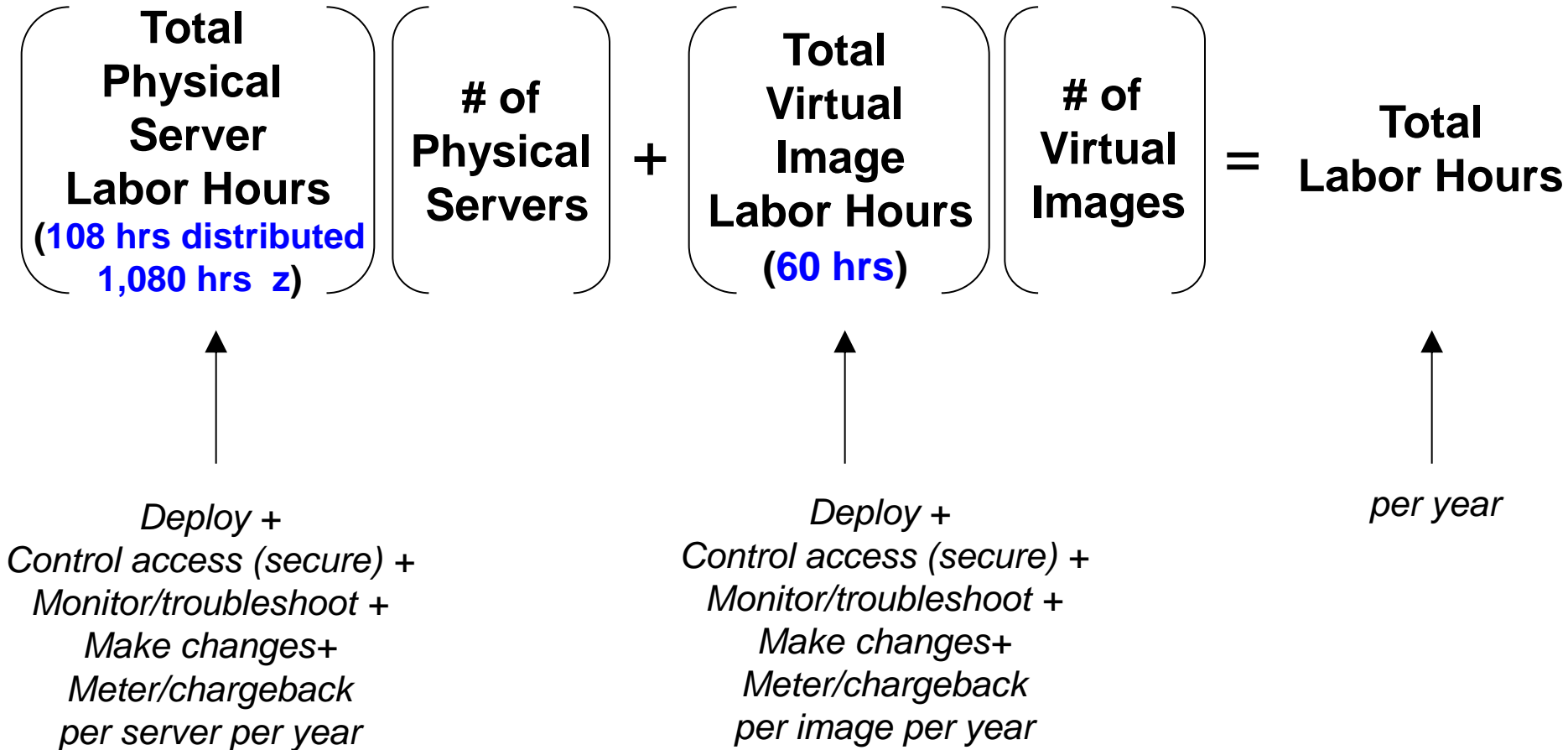

Note: labor model best fitted to field data

A High-Level View Of The Labor Model

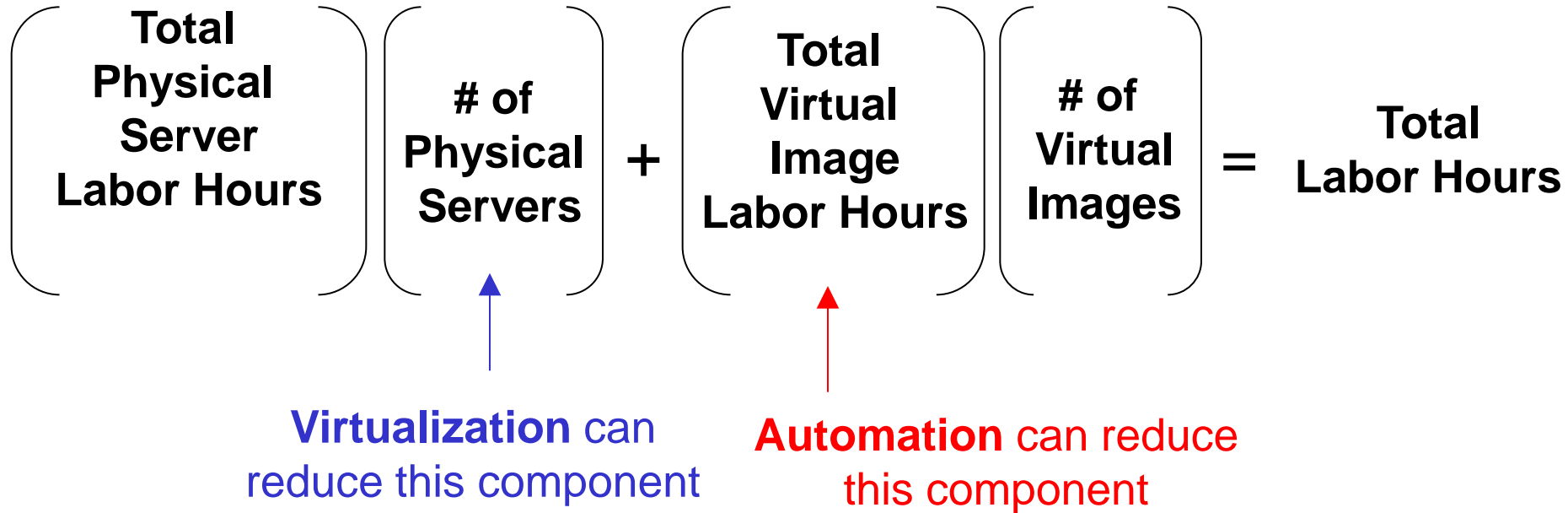

IBM SmartCloud Provisioning Can Lower Labor Costs Further

Labor Estimates Based on 48 Workloads

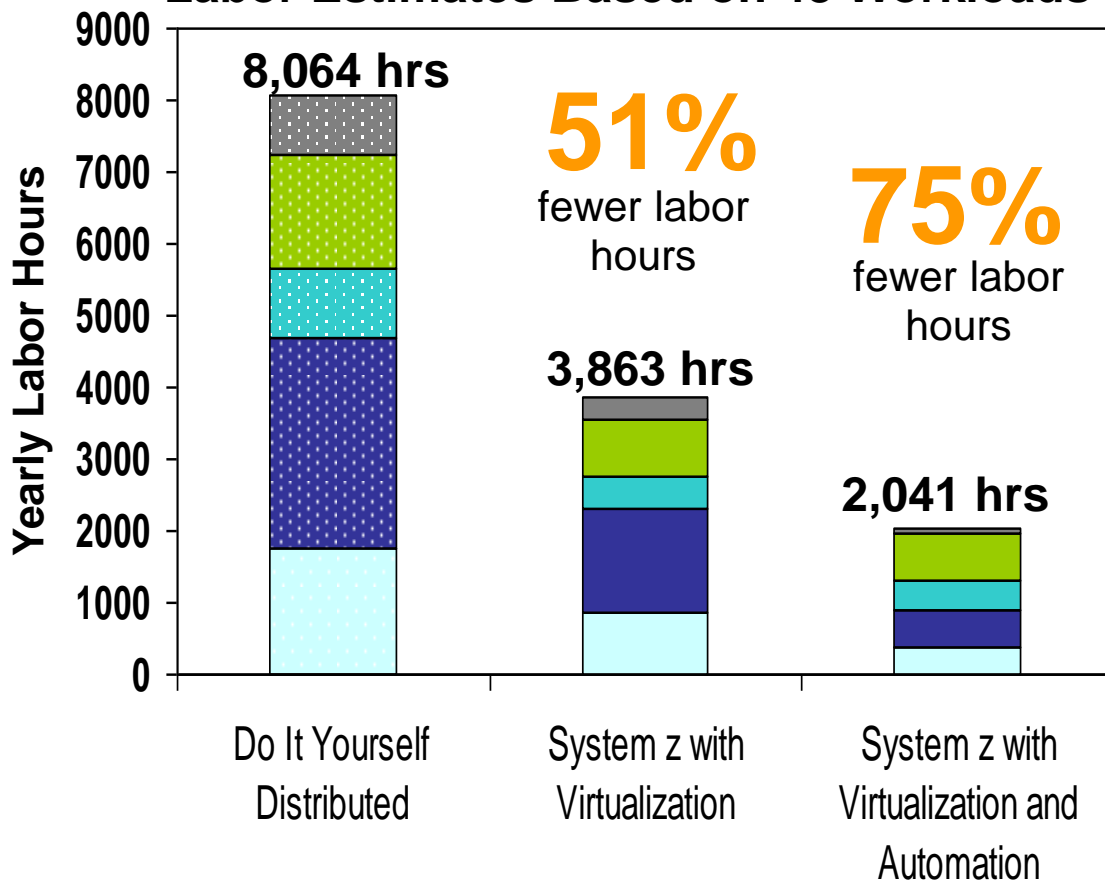

SmartCloud Provisioning Contributors to Labor Savings

- **Deployment**
 - ▶ *Fast pattern-based deployment*
- **Incident/capacity**
 - ▶ *Centrally monitor and resolve issues*
- **Asset**
 - ▶ *Track license usage of products*
- **Security**
 - ▶ *Centralized access control*
- **Change**
 - ▶ *Visibility into relationships of virtual images in a workload*
 - ▶ *Automatically apply changes to desired virtual servers*

Deployment Mgmt Incident/Capacity Mgmt Asset Mgmt Security Mgmt Change Mgmt

Note: The labor savings and assumptions herein are estimates based on a labor model that uses data obtained on the percentage of time customers spend on certain IT lifecycle tasks. It is not a benchmark. As such, actual customer results will vary based on customer applications, differences in stack deployed and other systems variations as well as actual configuration, applications, specific queries and other variables in a production environment.

Summary: System z Can Lower Total Acquisition and Labor Costs

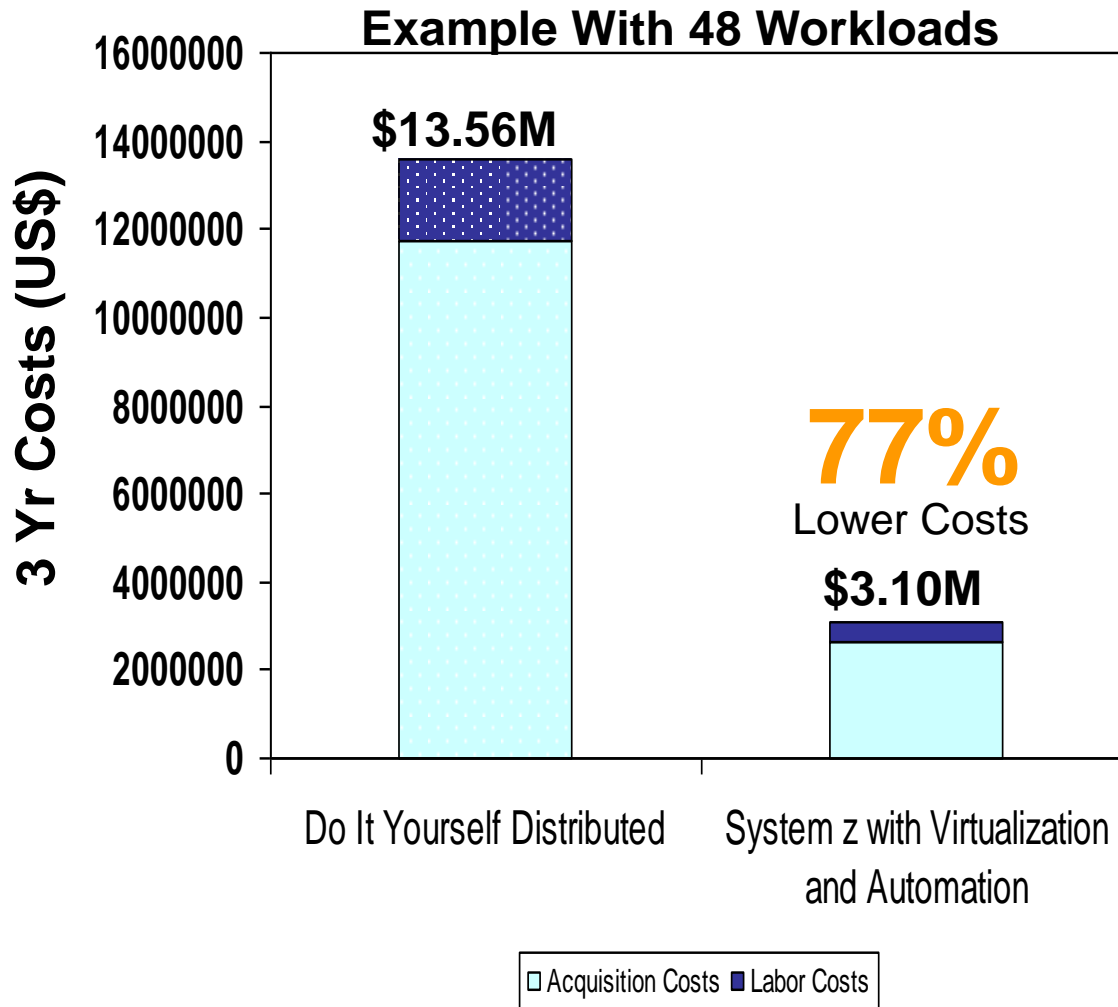

Note: 3yr TCO includes costs for hardware acquisition, maintenance, software acquisition, S&S, and labor. US pricing used which will vary by country.

Summary

Take out costs and be more agile
with cloud technologies on System z!



IBM



THANK YOU

Notice Regarding Specialty Engines (e.g., zIIPs, zAAPs and IFLs):

Any information contained in this document regarding Specialty Engines ("SEs") and SE eligible workloads provides only general descriptions of the types and portions of workloads that are eligible for execution on Specialty Engines (e.g., zIIPs, zAAPs, and IFLs). IBM authorizes customers to use IBM SE only to execute the processing of Eligible Workloads of specific Programs expressly authorized by IBM as specified in the "Authorized Use Table for IBM Machines" provided at

www.ibm.com/systems/support/machine_warranties/machine_code/aut.html ("AUT").

No other workload processing is authorized for execution on an SE.

IBM offers SEs at a lower price than General Processors/Central Processors because customers are authorized to use SEs only to process certain types and/or amounts of workloads as specified by IBM in the AUT.