

IBM Communications Server for Data Center
Deployment on AIX
Version 7.1

Quick Beginnings



Note

Before using this information and the product it supports, be sure to read the general information under [Appendix B, “Notices,” on page 95.](#)

Seventh Edition (January 2021)

This edition applies to IBM Communications Server for Data Center Deployment on AIX 7.1, program number 5725-H32, and to all subsequent releases and modifications until otherwise indicated in new editions or technical newsletters.

Order publications through your IBM representative or the IBM branch office serving your locality. Publications are not stocked at the address below.

IBM welcomes your comments. A form for readers' comments is provided at the back of this publication. If the form has been removed, you may send your comments to the following address:

- International Business Machines Corporation
- Department CGMD
- P.O. Box 12195
- Research Triangle Park, North Carolina
- 27709-2195
- U.S.A.

If you prefer to send comments electronically, use one of the following methods:

- IBMLink: CIBMORCF at RALVM17
- IBM Mail: USIB2HPD at IBMMAIL
- Internet: USIB2HPD@vnet.ibm.com
- Fax: 1-800-227-5088

When you send information to IBM, you grant IBM a nonexclusive right to use or distribute the information in any way it believes appropriate without incurring any obligation to you.

© **Copyright International Business Machines Corporation 1998, 2021.**

US Government Users Restricted Rights – Use, duplication or disclosure restricted by GSA ADP Schedule Contract with IBM Corp.

Contents

Tables.....	vii
Figures.....	ix
Welcome to IBM Communications Server for Data Center Deployment on AIX.....	xi
How to use this book.....	xi
Road map.....	xi
Typographic conventions.....	xii
Abbreviations used in this book.....	xii
What's new.....	xiv
New functions.....	xiv
Functions that have been retired.....	xv
Where to find more information.....	xv
Chapter 1. About IBM Communications Server for Data Center Deployment on AIX.....	1
IBM Communications Server for Data Center Deployment on AIX features and packaging.....	1
IBM Communications Server for Data Center Deployment on AIX.....	1
Advanced networking features.....	5
Features and benefits.....	10
Versatile building blocks.....	10
Client/server operation.....	10
Easy configuration.....	11
Additional user interface choices for administration.....	11
Better performance.....	12
Security options.....	12
Network management flexibility.....	12
Reliability, availability, and serviceability.....	13
Network integration, growth, and change.....	14
Chapter 2. Planning for your network and IBM Communications Server for Data Center Deployment on AIX.....	15
Stages of network planning.....	15
Identifying functional requirements for the network.....	15
Determining how to configure CS/AIX.....	16
Identifying resource requirements for installation and operation.....	16
IPv4 and IPv6 addressing.....	20
Ensuring compatibility among cross-platform configurations.....	21
Naming conventions.....	22
Chapter 3. Installing CS/AIX on AIX servers.....	23
CS/AIX licensing and packaging.....	23
CS/AIX licensing mechanisms.....	23
How the CS/AIX licensed program is packaged.....	24
Preparing for CS/AIX installation.....	26
Installing data link control filesets.....	26
Displaying product installation details.....	26
Changing the language environment variable.....	26
Migrating from previous levels of CS/AIX.....	27

Considerations.....	27
Installing the CS/AIX licensed program.....	27
Installation methods.....	28
Configuring WebSphere Application Server.....	30
Setting up the WebSphere Application Server's secure certificate.....	30
Configuring WebSphere Application Server.....	31
Installing the server configuration file.....	31
Post-installation procedures.....	32
Client/Server operation.....	32
Viewing PDF books.....	32
Reviewing current release information.....	32
Configuring SSL for use with TN Server or TN Redirector.....	32
Configuring a Web Server for the Web Administration Program.....	33
Backing up CS/AIX configuration files.....	33
Restoring a backup copy of CS/AIX configuration files.....	34
Reinitializing configuration files.....	34
Chapter 4. Installing IBM Remote API Clients on Linux.....	37
Hardware and software requirements.....	37
Hardware requirements.....	37
Linux operating system version.....	37
Java.....	38
GSKIT.....	38
Displaying product installation details.....	38
Setting environment variables for use by CS/AIX.....	38
Setting the language environment variable.....	38
Installing the Remote API Client on Linux.....	39
Setting up HTTPS security certificates using GSKIT.....	40
Uninstalling the Remote API Client on Linux.....	40
Chapter 5. Installing IBM Remote API Clients on Linux for System z.....	43
Hardware and software requirements.....	43
Hardware requirements.....	43
Linux operating system version.....	43
Java.....	43
GSKIT.....	43
Displaying product installation details.....	43
Setting environment variables for use by CS/AIX.....	44
Setting the language environment variable.....	44
Installing the Remote API Client on Linux for System z.....	44
Setting up HTTPS security certificates using GSKIT.....	45
Uninstalling the Remote API Client on Linux for System z.....	46
Chapter 6. Installing IBM Remote API Clients on AIX Systems.....	47
Hardware and software requirements.....	47
Hardware requirements.....	47
Operating system version.....	47
Java.....	47
GSKIT.....	47
Setting environment variables for use by CS/AIX.....	47
Changing the language environment variable.....	48
Installing the Remote API Client on AIX.....	48
Installing the Remote API Client by copying files to your AIX workstation.....	48
Installing the Remote API Client from the CD.....	48
Setting up HTTPS security certificates using GSKIT.....	49
Uninstalling the remote API Client on AIX.....	50

Chapter 7. Planning for and installing the Remote API Client on Windows.....	51
Hardware and software requirements.....	51
Accessing the Setup program.....	51
Installing Remote API Client on Windows using the Setup program.....	52
Advanced Options for Remote API Client configuration.....	54
Installing Remote API Client Software from the command line.....	55
Setting up HTTPS security certificates using GSKIT.....	57
Customizing the Remote API Client software after installation.....	58
Reinstalling the Remote API Client software.....	59
Uninstalling the Remote API Client software.....	59
Uninstalling the Remote API Client software from the command line.....	59
Help.....	60
Chapter 8. Configuring and using CS/AIX.....	61
Planning for CS/AIX configuration.....	61
Planning worksheets.....	62
Task sheets.....	62
Setting environment variables for use by CS/AIX.....	62
Using the Motif administration program.....	63
Specifying the path to CS/AIX programs.....	63
Enabling CS/AIX.....	63
Managing CS/AIX with the Motif administration program.....	63
Configuring Client/Server functions.....	67
Configuring the node.....	68
Configuring connectivity.....	69
Configuring an SDLC link for dependent traffic.....	70
Configuring an Ethernet link to support dependent and independent traffic	71
Configuring an Enterprise Extender link.....	72
Configuring type 0-3 LUs.....	72
Defining Type 0-3 LUs.....	73
Defining an LU pool.....	73
Configuring APPC communication.....	74
Configuring a simple APPN network.....	75
Configuring dependent APPC.....	78
Configuring for CPI communications.....	79
Configuring LUA.....	79
Configuring SNA gateway.....	80
Supporting implicit downstream LUs.....	81
Defining downstream LUs.....	81
Configuring DLUR.....	82
Configuring DLUR support on the local node.....	83
Configuring passthrough DLUR support for downstream nodes.....	83
Configuring TN server.....	84
Defining 3270 LUs.....	86
Defining an LU pool.....	86
Configuring TN3270 Server.....	87
Configuring TN Redirector.....	88
Configuring TN Redirector.....	88
Disabling CS/AIX.....	88
Chapter 9. Information resources for CS/AIX and SNA.....	91
SNA library.....	91
Network-accessible information.....	91
Suggested reading.....	92
Appendix A. How to send your comments to IBM.....	93

Email feedback template.....	93
If you have a technical problem.....	93
Appendix B. Notices.....	95
Trademarks.....	96
Bibliography.....	99
CS/AIX publications.....	99
IBM Redbooks.....	100
AIX operating system publications.....	100
Systems Network Architecture (SNA) publications.....	100
Host configuration publications.....	101
z/OS Communications Server publications.....	101
TCP/IP publications.....	101
X.25 publications.....	101
APPC publications.....	101
Programming publications.....	102
Other IBM networking publications.....	102
Index.....	103

Tables

1. Getting started road map.....	xi
2. Typographic Conventions.....	xii

Figures

- 1. SNA Gateway Linking Multiple Downstream AIX Computers to a Host Computer..... 6
- 2. Branch Extender..... 7
- 3. TN Server..... 9
- 4. Node Window..... 65
- 5. CS/AIX Tool Bar..... 67
- 6. CS/AIX Node That Communicates Directly with a Host..... 68
- 7. CS/AIX Nodes in an APPN Network..... 69
- 8. SNA Gateway..... 80
- 9. CS/AIX Node Providing DLUR..... 82
- 10. CS/AIX Node Configured for TN Server..... 84
- 11. TN Server..... 85

Welcome to IBM Communications Server for Data Center Deployment on AIX

This book introduces IBM Communications Server for Data Center Deployment on AIX (CS/AIX), program product number 5725-H32, an IBM® software product that enables a server running IBM's Advanced Interactive Executive (AIX®) operating system to exchange information with other nodes in a Systems Network Architecture (SNA) network. It is the most comprehensive SNA networking product currently available for workstations running the AIX operating system.

IBM Communications Server for Data Center Deployment on AIX is designed to run on an AIX workstation connected to one or more networks. CS/AIX Version 7.1 will run on any IBM Power system that is supported by AIX Version 7.2 or later. In this book, the term AIX workstation is used to indicate any of these systems with the AIX operating system installed.

CS/AIX provides building blocks for a wide variety of networking needs and solutions. They can be used to exchange information with nodes in SNA networks, or to provide host access for Telnet programs communicating over Transmission Control Protocol/Internet Protocol (TCP/IP).

How to use this book

This section explains how information is organized and presented in this book.

Road map

This book is for management and technical personnel involved in network planning, and for anyone interested in Communications Server for the AIX operating system.

To find the information you need to get started with CS/AIX, use [Table 1](#) on [page xi](#).

Table 1. Getting started road map

If you want to...	Refer to...
Read about CS/AIX	Chapter 1, “About IBM Communications Server for Data Center Deployment on AIX,” on page 1
Plan how to use CS/AIX in your network	Chapter 2, “Planning for your network and IBM Communications Server for Data Center Deployment on AIX,” on page 15
Install CS/AIX on AIX servers	Chapter 3, “Installing CS/AIX on AIX servers,” on page 23
Install Remote API Clients on Linux (32-bit Intel, 64-bit Intel/AMD, or pSeries)	Chapter 4, “Installing IBM Remote API Clients on Linux,” on page 37
Install Remote API Clients on Linux for System z	Chapter 5, “Installing IBM Remote API Clients on Linux for System z,” on page 43
Install Remote API Clients on AIX	Chapter 6, “Installing IBM Remote API Clients on AIX Systems,” on page 47

Table 1. Getting started road map (continued)

If you want to...	Refer to...
Install Remote API Clients on Windows	Chapter 7, “Planning for and installing the Remote API Client on Windows,” on page 51
Configure CS/AIX	Chapter 8, “Configuring and using CS/AIX,” on page 61
Find information about the CS/AIX documentation and other publications, including online information	Chapter 9, “Information resources for CS/AIX and SNA,” on page 91
Read notices and trademark information	Appendix B, “Notices,” on page 95

Typographic conventions

The typographic styles used in this document are shown in [Table 2 on page xii](#).

Table 2. Typographic Conventions

Special Element	Sample of Typography
Emphasized words	back up files before deleting
Document title	<i>IBM Communications Server for Data Center Deployment on AIX Administration Guide</i>
File or path name	<code>/usr/spool/uucp/myfile.bkp</code>
Program or application	<code>snaadmin</code>
User input	<code>0p1</code>
Computer output	<code>CLOSE</code>

Abbreviations used in this book

This book uses the following abbreviations:

AIW	APPN Implementers Workshop
AIX	Advanced Interactive Executive
ANR	Automatic network routing
API	Application Programming Interface
APPC	advanced program-to-program communication
APPN	Advanced Peer-to-Peer Networking
ATM	Asynchronous Transfer Mode
BOS	Base operating system
BrNN	Branch Network Node
CICS	Customer Information Control System
COS	Class of Service
CPI-C	Common Programming Interface for Communications
CSV	Common Service Verb
DB2	DATABASE 2

DDDLU	Dynamic Definition of Dependent LUs
DES	data encryption standard
DLC	Data link control
DLUR	Dependent LU Requester
DLUS	Dependent LU Server
FDDI	Fiber Distributed Data Interface
FTP	File Transfer Protocol
HPR	High-Performance Routing
IEEE	Institute of Electrical and Electronics Engineers
IETF	Internet Engineering Task Force
ISO	International Organization for Standards
ISR	Intermediate session routing
LAN	Local area network
LDAP	Lightweight Directory Access Protocol
LEN	Low-entry networking
LLC2	Logical Link Control 2
LU	Logical unit
LUA	Conventional LU Application Programming Interface
MDS-NMVT	Multiple Domain Support - Network Management Vector Transport
MPQP	Multiprotocol Quad Port
MS	Management Services
NMVT	Network Management Vector Transport
NOF	Node Operator Facility
OS/2	Operating System/2®
OSI	Open Systems Interconnection
PU	Physical unit
RFC	Request For Comments
RISC	Reduced Instruction Set Computer
RLE	Run-Length Encoding
RTP	Rapid Transport Protocol
SAA	Systems Application Architecture
SAP	Service access point
SDLC	Synchronous Data Link Control
SLP	Service Location Protocol
SMIT	Systems Management Interface Tool
SMP	Symmetric multiprocessing
SNA	Systems Network Architecture
SNMP-MIB	Simple Network Management Protocol - Management Information Base

What's new

SSL	Secure Sockets Layer
TCP/IP	Transmission Control Protocol/Internet Protocol
TN	Telnet
TP	Transaction program
VT	Virtual Terminal
VTAM	Virtual Telecommunications Access Method
WAN	Wide area network

What's new

CS/AIX Version 7.1 is a follow-on product to CS/AIX Version 7.0, which continues to be supported.

New functions

The following functions have been added to CS/AIX in this release:

- Display of the count of applications used in the Windows Client.
The Windows client monitor program `sxc1app1.exe` has been enhanced to display the count of applications (APC, LUA, PCOMM etc.) using this Windows client.
- Enhancements to the mapping of hard-coded LU aliases on client applications to LU aliases in a domain of servers.

Some applications are hard-coded to use specific LU aliases. If you are running such an application on two or more Remote API Clients, this function maps these LU aliases to specific LUs on the server (with a different LU for each copy of the application). This allows applications migrating from full-SNA stack implementations to configured for specific LU aliases on the server, and to take advantage of some of the redundant capabilities of the server domain implementation, using all of the resources of the servers in that domain. This release adds further configuration options to that function.

- Addition of a poll timer between domain servers.
This function allows faster failover and recovery in a multi-server client-server configuration.
- Ability to define LU 0-3 ranges with two decimal digits in the name.
This function allows more flexibility in naming pools of LUs.
- Support for tn3270 Intrusion Detection Service.
This function permits interworking with the enhancement to VTAM to detect certain violations of the 3270 data stream.
- Docker container support.
This function allows the Linux or AIX Remote API client to run within Docker containers.
- Support for latest encryption ciphers.
The tn3270 server and tn redirector in the product support the TLS 1.0, 1.1, 1.2 and 1.3 encryption standards and their associated algorithms and cipher suites. See the README file for the latest encryption support.
- Allow IPv6 connection network links to use hex address.
When defining a Connection Network on an IPv6 network for HPR/IP, an additional parameter can be specified to indicate if the IP addressing for the Connection Network will use IPv6 DNS names only or IPv6 addresses only. The default is to use IPv6 DNS names only.

Functions that have been retired

No functions have been retired in this release.

Where to find more information

The Bibliography identifies other books in the CS/AIX library, as well as books that contain additional information about SNA, the AIX operating system, and other related products.

Where to find more information

Chapter 1. About IBM Communications Server for Data Center Deployment on AIX

This chapter explains how CS/AIX is packaged and describes its functions, features, and benefits.

IBM Communications Server for Data Center Deployment on AIX features and packaging

CS/AIX Version 7.1 is communication software that runs on the AIX operating system. It consists of the features described in “IBM Communications Server for Data Center Deployment on AIX” on page 1 and “Advanced networking features” on page 5.

IBM Communications Server for Data Center Deployment on AIX

IBM Communications Server for Data Center Deployment on AIX connects applications across SNA and TCP/IP networks. It converts a workstation running AIX into an SNA node by equipping it with SNA resources and protocols; this enables the workstation to communicate with other computers in an SNA network, including host computers. It also provides TCP/IP functions to allow IBM Communications Server for Data Center Deployment on AIX to be used within your TCP/IP network or at the boundary between TCP/IP and SNA networks.

CS/AIX provides the following services:

Network Support

CS/AIX supports subarea and peer-to-peer networks:

SNA Subarea Networks

These networks (also known as host-mediated networks) are hierarchically organized, with one or more host computers controlling communication between computers, managing the network, and providing processing services and high-capacity data storage. All other nodes in the network are dependent on the control of a host.

AIX computers can participate in a subarea network by being configured as host-dependent nodes.

Peer-to-Peer Networks

For distributed processing environments, CS/AIX Version 7.1 supports APPN networks. In these peer-to-peer networks, AIX computers retain processing functions and communicate directly with each other as peers. Peer-to-peer networks fully use the capability of the AIX computer, which today rivals that of expensive host computers.

An APPN network consists of peer nodes of the following types:

- APPN network node (which provides traffic control, dynamic route computation and selection services, and network management services)
- APPN end node (which uses APPN network node services to communicate with peer nodes)
- LEN node (which communicates directly with adjacent nodes or nodes configured to appear adjacent)

Note: Host computers can function as peer nodes in an APPN network by using independent LU 6.2 to communicate with AIX computers and other hosts in the network.

Providing Subarea Functions in an APPN Network

The dependent LU requester (DLUR) function enables traffic between hosts and host-dependent nodes to be carried in an APPN network.

Data Link Control Options

At the link level, CS/AIX offers many connectivity options to help you meet your network's size, speed, security, and cost considerations. (For a detailed list of the link types supported, see [“Installation requirements”](#) on page 17.) It supports data links for different network types, as follows:

Local Area Networks

For LAN connectivity, you can install the appropriate links to communicate using token ring, standard Ethernet, and 802.3 Ethernet protocols. (ATM support can be provided using an emulated LAN interface on a token ring or Ethernet network.)

Wide Area Networks

For WAN connectivity, you can select from the following synchronous links to communicate over established telephone lines:

- EIA-232D
- Smart modem
- X.21
- EIA-422A
- V.25 bis
- V.35

CS/AIX also supports X.25 packet-switched data link control. (These link types require additional separately orderable products.)

IP Integration

If your corporate backbone network is based on IP, you can use the Enterprise Extender (HPR/IP) feature of CS/AIX to integrate this with SNA, allowing your SNA applications to communicate over the IP network. The client/server support also provides SNA over TCP/IP connectivity for support of cloud, mobile and high availability across data centers.

LU Support

Logical units (LUs) are application-specific network resources that reside on each node in an SNA network. Each LU acts as an interface that applications use to access links in order to communicate over the network with partner applications on other nodes.

CS/AIX supports different types of LUs for different classes of applications.

- In a subarea network, CS/AIX supports dependent LUs, which can be any of the following types:
 - LU 0
 - LU 1
 - LU 2
 - LU 3
 - LU 6.2

LU 0 supports primitive program-to-program communication, typically used at point-of-sale transactions in retail and banking. LU 2 supports terminal emulation applications that enable the AIX computer to emulate an IBM 3270-family terminal. The other LU types enable applications to participate in distributed processing or to communicate with various printers or interactive display terminals.

CS/AIX supports host systems that use dynamic definition of dependent LUs (DDDLU), a host feature that enables dependent LUs on the SNA system to be added to the host configuration when the communication link from the SNA system to the host is established. With DDDLU, LUs do not have to be configured statically at the host. (You must still define dependent LUs on the CS/AIX node.) This reduces the initial configuration required at the host, and makes later expansion easier.

CS/AIX can communicate with both DDDLU-capable and non-DDDLU-capable hosts, with no difference in the configuration required. When the communications link from the CS/AIX node to the host is established, a DDDLU-capable host informs the node that it supports DDDLU; the node then sends the required information to define the dependent LUs that use the link. If the host is not

DDDLU-capable, CS/AIX does not send this information; it assumes that the LUs have already been defined statically at the host.

- Independent LU 6.2 supports independent traffic in APPN networks. Independent LU 6.2 supports autonomous communication and network management, as well as distributed processing.

In addition, the DLUR function of CS/AIX enables traffic from dependent LUs to travel over an APPN network.

- Primary RUI support provides the ability for a CS/AIX application to manage downstream LAN/WAN attached dependent LU devices as though it were a mainframe. This function has some restrictions for connectivity, but allows applications to pass data between dependent LU devices without the need for a full mainframe application.

Session Support

A session is a temporary logical channel between partner LUs. Ordinarily, partner applications associated with each LU communicate over the session. CS/AIX can support thousands of sessions. CS/AIX can also support U-shaped sessions (also known as "local/remote transparency"), in which both primary and secondary LUs reside in the same AIX computer. This enables you to develop and test a pair of source and target transaction programs in one computer without requiring a link connection.

The data flowing on a session between two partner LUs may be compressed, to reduce the bandwidth required.

- For LU type 6.2, CS/AIX allows you to specify the use of compression in the configuration of the mode that the session uses. You can specify different compression algorithms to be used, each of which provides a different level of compression (RLE, LZ9, or LZ10). You can also specify different compression levels for data flowing in different directions on the session, or specify compression in one direction but not the other.
- For LU types 0-3, CS/AIX allows you to specify the use of compression in the configuration of the link station or PU that the session uses. RLE compression is used for the inbound direction, and LZ9 for the outbound direction.

API Support

CS/AIX includes application programming interfaces (APIs) for developing applications for certain types of LUs, for distributed processing, for network management, and for administration of CS/AIX itself. In this release, CS/AIX provides a range of APIs that are compatible with the APIs provided by members of the Communications Server family running on other operating systems.

An API is an interface that enables a transaction program (TP) to communicate with its supporting LU. It consists of a library of verbs (also called functions, calls, and subroutines) from which the TP selects those it needs to pass to its LU to request an action, such as SEND_DATA. The LU, in turn, processes the verbs and builds a data stream according to the appropriate protocol, appends a header indicating the destination address, and sends the data over the link to partner LUs.

Common Programming Interface for Communications (CPI-C) is one of the most powerful of the APIs because of its portability. Introduced to support dependent and independent LU 6.2, CPI-C complies with Systems Application Architecture (SAA) mandates to unify different platforms and operating systems. CPI-C uses a set of syntax rules that is common to all systems. It has thus become a standard.

As well as the standard C-language CPI-C API, CS/AIX also includes a CPI-C API for use by Java applications. For more information, refer to *IBM Communications Server for Data Center Deployment on AIX or Linux CPI-C Programmer's Guide*. In the CS/AIX books, all references to CPI-C include Java CPI-C unless stated otherwise.

Other CS/AIX APIs include:

- APPC API for peer-to-peer communications between application programs using LU 6.2. The API has the option of being nonblocking. When a TP uses nonblocking verbs, the API can return control

to the TP before the requested action has completed. Later, the TP is informed when the action has completed.

- LUA API for communications with host applications.
- CSV (Common Service Verb) API for utility functions such as character translation and application trace control.

In addition, CS/AIX includes the following proprietary programming interfaces:

- MS (Management Services) API for network messaging functions.
- NOF (Node Operator Facility) API for applications that configure and manage CS/AIX resources.

Applications using the CS/AIX APIs can be compiled and linked to run in either 32-bit mode or 64-bit mode.

For more detailed information about an API, refer to the programming guide for the API (see the Bibliography).

Client/Server Support

Computers running CS/AIX can be configured to communicate using client/server protocols. When client/server protocols are used in a network, all the computers using client/server protocols to communicate in that network are referred to as a "domain."

The computers running CS/AIX in a client/server configuration can take the following roles:

- A server contains an SNA node and its associated connectivity components. The server provides SNA connectivity to applications on the local system or on other computers in the CS/AIX domain. Servers must be AIX systems.
- A Remote API client does not contain SNA node components, but accesses them through a server. A client can access one or more servers at the same time, and can run concurrent applications as needed. Clients can be running AIX, Linux, or Windows. Clients can run in Linux or AIX containers or AIX WPAR partitions. (An AIX computer can be either a server or a client, but not both; you cannot install both the server and the client on the same computer.)

Servers and clients communicate across the CS/AIX domain using TCP/IP. Alternatively, they can communicate using HTTPS via a WebSphere server, which uses security certificates to authenticate the client connections. You will normally want to use HTTPS if the clients connect across a public network.

In a domain with multiple CS/AIX servers, one server holds the controlling copy of the CS/AIX domain configuration file. This server is known as the controller server. You can define other servers in the domain to be backup servers, or leave them as peer servers. The domain configuration file is copied to backup servers - either when they are started, or when the controller copy is changed - so that all backup servers hold a copy of the latest information. A peer server obtains domain configuration information from the controller server as required, but cannot act as a backup server.

If the controller server fails, the first backup server on the list of servers defined for the domain takes over as the controller. The domain configuration file on this server is used as the controlling copy, and is copied to other servers as necessary. When the controller server is restarted, it receives a copy of the domain configuration from the backup server currently acting as controller, and then takes over as the controller.

Support for Distributed Applications

In a Client/Server CS/AIX system, applications running on Remote API Clients cooperate with connectivity resources on servers to execute a single task. Applications running on other (non-CS/AIX) computers can also cooperate with applications on CS/AIX computers to perform distributed processing.

CS/AIX supports the following types of distributed applications:

- APPC applications (APPC is also known as LU 6.2)
- Support of two popular distributed processing applications:
 - Customer Information Control System (CICS)

- DATABASE 2 (DB2®), developed for LU 6.2 (dependent and independent).

CICS and DB2 (a relational database management system) are SAA-compliant applications that can be readily customized for any environment. CICS and DB2 applications are used together by 90% of the Fortune 500 companies. They are powerful transaction programs that can service thousands of nodes simultaneously. Typically, CICS and DB2 are used to access data from multiple locations, update it, and store it in a central repository.

Advanced networking features

Included in the CS/AIX Version 7.1 base product is a set of features that add advanced networking capabilities to it. These features include the following:

- SNA gateway connects LANs to subarea SNA networks.
- Primary LU support provides support for controlling downstream dependent LU devices in the same way as a host mainframe application.
- Branch Extender simplifies large APPN networks by separating out resources in different locations (for example in separate branches of a large organization). This reduces the amount of topology information that must be stored, while still allowing efficient resource location.
- APPC Application Suite provides selected applications for use in APPN networks.
- Enterprise Extender (EE, also known as HPR/IP) allows SNA traffic to be transported natively over IP networks.
- TN Server provides host access over SNA to TN3270 and TN3270E clients, referred to collectively as TN3270 clients.
- TN Redirector provides passthrough TCP/IP host access to TN3270, TN3270E, TN5250 and VT clients, referred to collectively as Telnet clients.
- Remote API Client server provides redundant and high availability access via cloud-like support for remotely distributed Windows, AIX and Linux clients. Clients can run in Linux or AIX containers or AIX WPARs.

Note: Advancements in highly available network adapters and operating system platforms concentrate on IP networking features. CS/AIX provides SNA over IP connectivity with Enterprise Extender, TN3270 Server, TN redirector and Remote API Client server. To take full advantage of these advancements, consider using these features when modernizing SNA networking. Legacy network connectivity using SNA over LAN or WAN connections can only take advantage of some of the new advancements in highly available networking devices.

SNA Gateway

A gateway is a user-transparent device that connects dissimilar networks or computer systems, supporting both of the environments that it connects. End users perceive each other as residing in the same network.

SNA gateway enables a CS/AIX computer to act as a gateway that links multiple downstream computers in an SNA network to one or more host physical units (PUs), as illustrated in Figure 1 on page 6. To simplify host connectivity, and to eliminate excess links, SNA gateway acts as a PU concentrator - it treats the multiple computers as a single PU (that appears to reside on the SNA gateway node) and communicates with the host over a single physical connection.

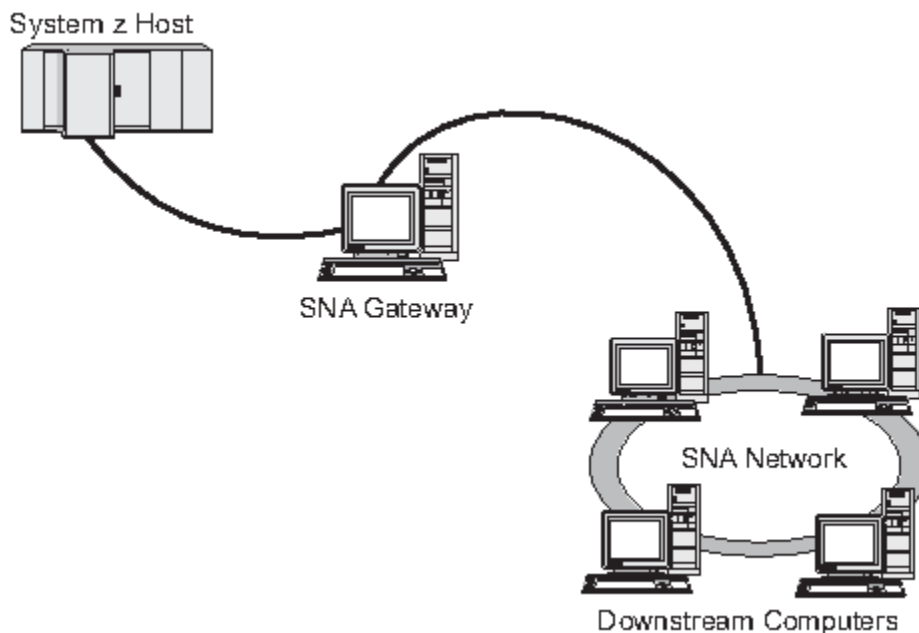

Figure 1. SNA Gateway Linking Multiple Downstream AIX Computers to a Host Computer

Primary LU support

Primary LU support allows a AIX application to control downstream dependent LU devices as though it were a host mainframe application.

LUA applications usually connect to host mainframes as secondary LUs, so that the host application controls the definition for the sessions and is responsible for sending the BIND to start a session. CS/AIX also includes the ability to act as a primary LU to downstream dependent SNA devices over a LAN, using the Primary RUI interface. Using this interface, an application can connect downstream dependent LU sessions without the need for a host mainframe.

To use Primary LU applications, the node must be configured with downstream LUs (or a Downstream PU template) using a host LU name of #PRIRUI#. This indicates to the server that the applications using Primary RUI will control these PUs and the LU resources assigned to them. The PUs can be used on both LAN and WAN ports. Refer to *IBM Communications Server for Data Center Deployment on AIX or Linux LUA Programmer's Guide* for information about programming applications to use Primary RUI.

Branch Extender

Network nodes in an APPN network need to maintain topology information (about the location of other nodes in the network and the communications links between them), and to forward this information around the network when the topology changes. As the network grows in size, the amount of stored information and topology-related network traffic can become large and difficult to manage.

It is possible to avoid these problems by separating the network into subnetworks, so that each node only needs to maintain topology information about the nodes in its own subnetwork. However, this results in increased network traffic when trying to locate resources in other subnetworks.

The Branch Extender feature of APPN, illustrated in [Figure 2 on page 7](#), provides a solution to these problems.

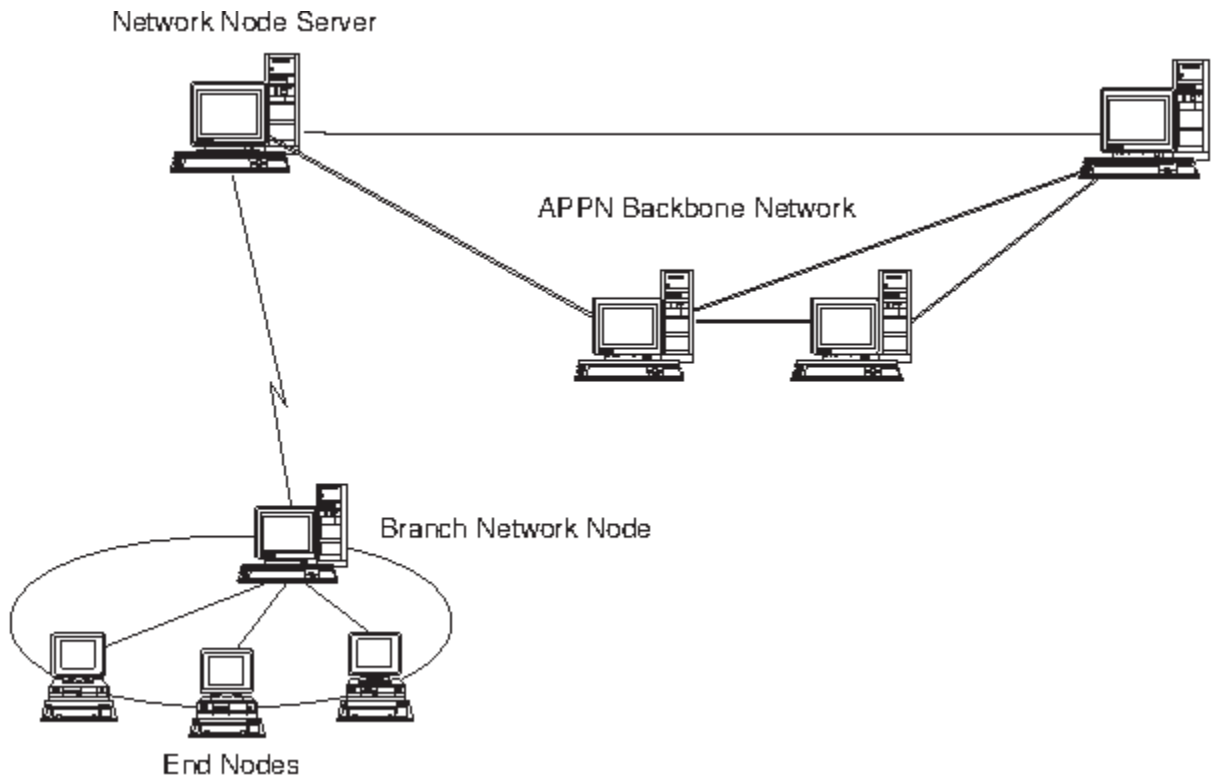

Figure 2. Branch Extender

As the name implies, Branch Extender is designed for networks that can be divided into distinct areas such as separate branches of a large organization. It works by separating out branches from the main backbone APPN network (for example, the network in the organization's headquarters).

Each branch contains a node of a new type called Branch Network Node (BrNN), which is connected to a Network Node in the main APPN backbone network. The BrNN combines the functions of an APPN network node and an APPN end node.

- To the backbone network, the BrNN appears as an End Node, connected to its Network Node Server (NNS) in the backbone network:
 - The nodes in the backbone network are not aware of the nodes within the branch, reducing the amount of topology information that must be stored.
 - Because the BrNN appears as an End Node, it does not receive topology information from the backbone network (topology information is transmitted only between Network Nodes).
 - The BrNN registers all resources in the branch with its NNS as though they were located on the BrNN itself. This means that the nodes in the backbone network can locate resources in the branch without having to be aware of the separate nodes in the branch.
- To the branch network, the BrNN appears as a Network Node, acting as the NNS for End Nodes in the branch. Each node in the branch sees the rest of the network as being connected through its NNS, in the same way as for a standard NNS.

APPC Application Suite

APPC Application Suite is a set of applications that demonstrates the distributed processing capabilities of APPN networks, and can be helpful in configuration verification and problem determination. APPC Application Suite can be used to provide support for operations such as file transfers, which are frequently performed across a network.

APPC Application Suite contains the following applications:

- ACPY (APPC COPY)

- AFTP (APPC File Transfer Protocol)
- ANAME (APPC Name Server)
- APING (APPC Ping)
- AREXEC (APPC Remote EXECution)
- ATELL (APPC TELL)

These applications can be accessed from a server or from a AIX or Windows client.

Enterprise Extender

Enterprise Extender (also known as HPR/IP) provides a mechanism for integrating SNA applications with an IP network.

SNA applications are designed to use SNA protocols to communicate over SNA networks with other SNA applications. When installed in a TCP/IP network using Enterprise Extender, SNA applications can still communicate; the Enterprise Extender function provides a mechanism for transporting SNA protocols over the IP network. In particular, it provides APPN High-Performance Routing (HPR) functionality, giving the applications the benefits of both APPN and IP connectivity.

Enterprise Extender in CS/AIX is implemented simply as a communications link. To connect two SNA applications over IP, you define an Enterprise Extender link, in the same way as for any other link type such as SDLC or Ethernet.

TN Server

3270 emulation programs that communicate over TCP/IP (rather than over an SNA network) are referred to as "TN3270 programs" (Telnet 3270 emulation programs).

TN3270 programs can also include support for TN3270E (Telnet 3270 standard extensions). TN3270E supports 3270 device emulation (including both terminals and printers) using Telnet. It enables a Telnet client to select a particular device (by specifying the LU name or the name of an LU pool), and provides enhanced support for various functions, including the ATTN and SYSREQ keys and SNA response handling.

Note: This guide uses the term TN3270 for information that applies equally to the TN3270, TN3287, and TN3270E protocols.

CS/AIX TN server provides access to 3270 host computers for TN3270 users on other computers. TN server enables TN3270 users to share a host connection with CS/AIX or with other TN3270 users, instead of requiring a direct link. TN server also enables TN3270 users to access hosts that are not running TCP/IP.

The CS/AIX TN server function is illustrated in [Figure 3 on page 9](#).

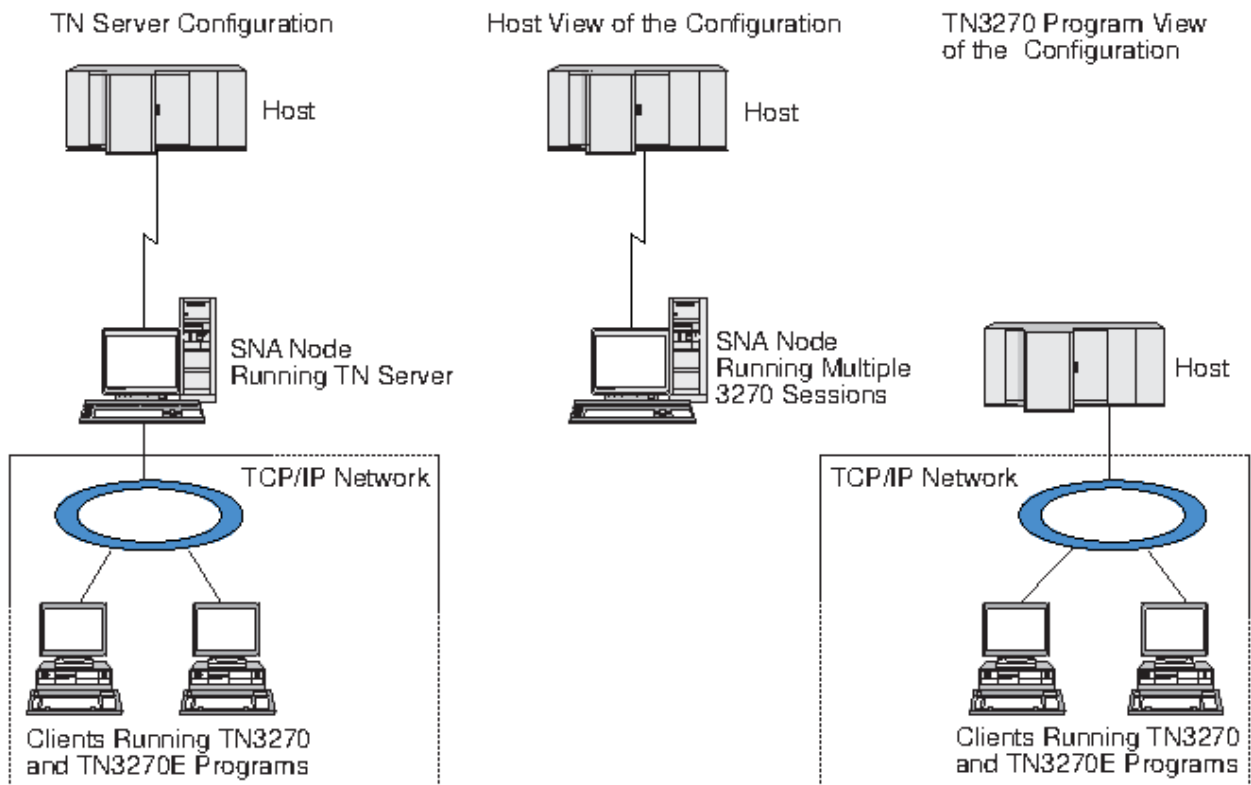

Figure 3. TN Server

The CS/AIX TN server feature provides an association between a TN3270 user and CS/AIX 3270 LU. All data from the TN3270 user is routed to the LU. This means that the configuration for both the host and the TN3270 user is as though they were connected directly; neither needs to be aware that data is being routed through TN server.

CS/AIX TN server supports all TN3270 client emulation programs that correctly implement the protocols defined in IETF RFCs 1123, 1576, 1646, 1647, and 2355.

Security features

CS/AIX TN Server supports data encryption, server authentication, client authentication, and Express Logon, using Secure Sockets Layer (SSL) software:

- Data encryption means that the data flowing between the TN Server and the TN3270 emulator is in encrypted form.
- Server authentication allows a TN3270 client to verify that the TN Server it is connected to is the one it expects.
- Client authentication allows a TN Server to verify that the TN3270 client connecting to it is the one it expects. The TN Server can also check a revocation list on an external directory server to ensure that the client's authorization has not been revoked.
- Express Logon operates in conjunction with client authentication to remove the requirement for TN3270 clients to provide a user ID and password when connecting to the host. Instead, the client's security certificate is used to retrieve the necessary user ID and password information.

Service Location Protocol (SLP)

CS/AIX TN Server also supports Service Location Protocol (SLP), providing service location and load balancing functions. If you use SLP, each TN Server advertises:

- the functions it supports (in this case TN3270)

Features and benefits

- its current load; this is based on the percentage of its available host LUs that are currently in use, but can be factored to allow for other differences between TN Servers.

An SLP-capable TN3270 client can then select the "best" server to connect to (the least loaded server that provides the functions it requires). It does this either by querying TN Servers directly, or by querying a Directory Agent that in turn collects information advertised by TN Servers.

A large SLP network can be divided into "scopes" (typically based on departments or geographical areas), so that information about a TN Server is advertised only to TN3270 clients and Directory Agents that have the same scope as the TN Server. This allows you to control the range of TN3270 clients that can use the services of each TN Server.

Note: The server on which the TN Server runs must support IPv4 addressing: that is, it must have an IPv4 address (although it may also have an IPv6 address). This is because SLP uses UDP broadcasts, which are not available in an installation that supports only IPv6.

TN Redirector

The CS/AIX TN Redirector feature provides passthrough services for 3270, 5250 or VT sessions over TCP/IP. The Telnet user communicates with CS/AIX over a TCP/IP connection; CS/AIX then communicates with the host over another TCP/IP connection.

CS/AIX TN Redirector supports data encryption, server authentication, and client authentication, using Secure Sockets Layer (SSL) software, in the same way as for TN Server for 3270. This allows you to use Secure Sockets Layer (SSL) security checking where necessary, and not on the complete user-to-host connection. For example:

- If clients are connecting to CS/AIX over a TCP/IP LAN where checking is not required, but are connecting to a remote host that requires SSL, you can use SSL over the TCP/IP connection between CS/AIX and the host. This means that security is checked once for all clients, and individual clients do not have to provide security information.
- If CS/AIX is installed on the same site as the host, but clients are connecting in from external sites, you can use SSL over the client connections to CS/AIX without having to install SSL software on the host.

Features and benefits

CS/AIX has features and benefits that range from simplifying configuration to improving problem diagnosis to enhancing network performance.

Versatile building blocks

CS/AIX supports most environments and node functions. In any type of network, subarea or APPN, it enables the AIX computer to function as any one of, or a combination of, the following:

- Host-dependent node
- Peer node (for a description of APPN peer nodes, see the discussion of peer-to-peer networks in [“IBM Communications Server for Data Center Deployment on AIX” on page 1](#))
- Partner (either source or destination) in distributed applications
- Gateway node that interconnects SNA networks

Through network management APIs, the AIX computer can also be configured to function as a Management Services (MS) entry point to provide support for distributed network management. At the link level, the AIX computer can be connected to various LANs and WANs by using any of the supported link types (described in [“IBM Communications Server for Data Center Deployment on AIX” on page 1](#) and [“Installation requirements” on page 17](#)).

Client/server operation

Client/server configuration provides the following benefits:

- Concentrating SNA resources on servers reduces the load on clients, improving client performance and minimizing the storage needed to provide SNA services to clients.
- A single data link can be shared by multiple users on different machines, eliminating the need for each machine to have a physical SNA network connection.
- Multiple servers can provide redundant connectivity (for example, by having multiple servers providing access to the same host). Having multiple paths to an SNA resource enables load balancing across the different servers and provides immediate backup in the event that a particular server or link fails.
- By using LU pools across multiple servers, the administrator can easily configure and add servers and users.
- Having fewer links and PUs for host connectivity reduces the size of the host VTAM definition.
- Administration utilities can be used to configure and manage both node resources (for any computer in the domain) and shared resources. The client/server support provided by CS/AIX administration tools enables transparent administration of all domain resources from any computer in the domain.
- SNA applications can be connected over Internet Protocols using TCP/IP and HTTPS for traversing firewalls and for authentication and security.
- Client applications can be mobile, and the Communications Server can track the user so the host can contact the application wherever the application moves.
- Remote users that run application on a 'farm' of Windows Terminal Servers (WTS), Citrix servers or UNIX X-servers can connect from any server in the farm. The host application will be able to connect back to the remote user, even as the user switches between using different servers.
- Client applications can run in containers that connect to a server for the SNA resources needed to connect sessions to remote SNA nodes.

Easy configuration

CS/AIX is designed with configuration options and capabilities that reduce configuration time and network complexity. For example:

Motif Administration Program

The easiest way to define and modify the CS/AIX configuration is to use the Motif administration program (`xsnaadmin`). This program provides a graphical user interface from which you can view and manage CS/AIX resources. This program also simplifies configuration by exposing only the fields whose values typically vary from one installation to another, using default values for other fields.

The Motif administration program includes help screens that provide overview information for SNA and CS/AIX, reference information for CS/AIX dialogs, and guidance for performing specific tasks.

Web Administration Program

CS/AIX also includes a Web Administration program, providing similar functions to the Motif administration program. This allows you to administer CS/AIX from your browser without the need to start an X session or telnet session to the CS/AIX server, and is particularly useful when connecting over slow or unreliable links.

Dynamic Configuration in APPN Networks

Configuring a node or network is also made easier through the APPN network's dynamic configuration. For example, APPN end nodes and applications dynamically register configuration data to support LU 6.2 sessions, thus making session configuration optional. Further, by having the node control point act as the default local LU, you can avoid LU 6.2 configuration altogether.

APPN also supports dynamic link station configuration in the absence of configured link stations.

Additional user interface choices for administration

The Motif administration program is the recommended interface for configuring and managing CS/AIX. However, you have a choice of interfaces for CS/AIX, which enables you to work with the one that suits your equipment, needs, and preferences.

Features and benefits

Command-Line Administration Program

The command-line administration program (snaadmin) can be used to issue commands to manage individual CS/AIX resources. You can use snaadmin either directly from the AIX command prompt or from within a shell script.

System Management Interface Tool (SMIT)

The SMIT interface is available in the graphic Motif version for AIXwindows environments and the character version for ASCII terminals. In both versions, SMIT displays dialogs for easy entry of configuration and operational data.

NOF API

The CS/AIX NOF API provides the same management functions as the command-line administration program, providing an interface suitable for use within a program (rather than a command script). You can use the NOF API to write your own application programs to administer CS/AIX.

Better performance

CS/AIX enhances the inherently high performance of SNA networks and uses class of service operation. CS/AIX also optimizes network speed through SNA data compression for LU 0-3 session data, and through different traffic-management methods that balance traffic flow according to network size:

- In APPN networks, CS/AIX supports both High-Performance Routing (HPR) and intermediate session routing (ISR), and provides connection network options. While ISR works efficiently for small networks, it degrades the performance of larger ones.
- For larger networks using LAN connectivity options (such as Token Ring or ethernet) or using Enterprise Extender, you can also use the connection network option to improve communication efficiency. The connection network option creates a communications path directly between nodes. This enables traffic to bypass intermediate network nodes.
- Another traffic control mechanism, adaptive session-level pacing, automatically adjusts congestion by regulating the rate at which LUs send message units to partner LUs.

Security options

With networks becoming more complex and moving to an open architecture, security emerges as a major issue. In SNA networks running CS/AIX, you can protect your assets by defining various levels of security through configuration and by implementing certain types of links. For example:

- In a client/server system, you can set up a WebSphere server to provide HTTPS access from Remote API Clients to the servers. This means that the client connections are authenticated using security certificates. (This feature requires some additional software in addition to the standard CS/AIX product. See [“Installation requirements” on page 17](#) for more information.)
- LU 6.2 users can define up to three levels of security - session, resource, and conversation. Respectively, one ensures that the proper LUs are engaged in a session, one restricts access to all applications associated with a particular LU, and one restricts access to a particular application. Additional security is possible through data encryption routines.
- At the link level, fiber optic links provide extra security as a medium that (unlike electrical cabling) does not leak signals and therefore cannot be easily tapped.
- CS/AIX TN Server and TN Redirector can provide data encryption, server authentication, and client authentication between the CS/AIX server and TN3270 or Telnet clients, using Secure Sockets Layer (SSL) software. (This feature requires some additional software in addition to the standard CS/AIX product. See [“Installation requirements” on page 17](#) for more information.)

Network management flexibility

CS/AIX uses two types of network management schemes:

- Multiple Domain Support-Network Management Vector Transport (MDS-NMVT) can work as a centralized, distributed, or hierarchical management scheme. It is based on a focal point/entry point architecture that gives you a high degree of flexibility.

Focal points are control nodes that manage the network according to the data they collect from entry points (management applications that reside on all other nodes in the network).

- In centralized management, a single focal point acts as a control point for the entire network.
- In distributed management, several focal points share in managing the network.
- In hierarchical management, focal points are nested according to function.

MDS-NMVT can thus be adapted to manage subarea, standard APPN, and very large APPN networks.

- Simple Network Management Protocol-Management Information Base (SNMP-MIB), which is adapted for APPN networks from TCP/IP, is a distributed management service based on an agent-manager architecture. This management scheme consists of several components: one or more SNMP agents, a manager, and a MIB database, all of which typically reside on different nodes.
 - An SNMP agent is a process that runs on and monitors the status of the system being managed. The agent maintains a MIB database for that system.
 - The manager (an application) queries the agent for MIB information and processes the response. The manager can also receive unsolicited data (SNMP traps) from the agent. The manager and agent communicate with each other by using the SNMP protocol.

APPN network managers can use APPN SNMP-MIB to gather information to analyze the network and correct problems.

CS/AIX uses agent software that supports the APPN MIB. For more information about the APPN MIB, see *IBM Communications Server for Data Center Deployment on AIX Administration Guide* and the AIW IBM home page at <http://www.networking.ibm.com/app/aiwhome.htm>.

Reliability, availability, and serviceability

To help you maintain reliable system operation, CS/AIX provides a range of display functions and problem-diagnosis tools.

- The Motif administration program provides enhanced configuration and management tools, including the following:
 - Immediate updates of configuration information
 - Status information for links, sessions, and node resources
- Query and status commands provide you with information about:
 - LU-LU sessions
 - APPN intermediate sessions
 - Active links
 - APPN topology databases, which store link information
- Problem-diagnosis tools are available to help you during the different stages of configuration and operation. They include the following:
 - Diagnostics information collection tool (snagetpd) to enable you to collect service information easily
 - Status and error messages to help resolve problems with configuration routines and system operation
 - Logs for collecting network error, failure, and audit information
 - Trace facilities for gathering and formatting detailed problem information

Other utilities help you test for link connectivity and communication between applications.

CS/AIX also includes the Management Services API, which is used to develop tools for sending and receiving network alerts and problem data.

All of these management and problem-diagnosis tools are fully integrated into the CS/AIX Client/Server model, so you can manage the entire CS/AIX domain or collect diagnostics information from a single point in the network.

Network integration, growth, and change

To support network integration, growth, and change, the CS/AIX APIs can be used to develop applications for a particular LU, platform, or operating system as your business needs dictate. CPI-C is an especially important API because it is consistent across different platforms and operating systems. It is used to develop applications that can run on any system.

Enterprise Extender and Remote API Client also provides a mechanism for integrating SNA and TCP/IP networks. The Remote API Client also supports containers for cloud based application implementations.

Chapter 2. Planning for your network and IBM Communications Server for Data Center Deployment on AIX

This chapter provides an overview of the stages of planning a network that runs CS/AIX. It also summarizes the functions that you can configure for the AIX computer and presents guidelines for estimating the resources required to support the functions.

Stages of network planning

This section presents some general guidelines for planning, configuring, and managing networks through the use of various CS/AIX and AIX utilities.

Planning a network involves balancing function, performance, resources, and cost. Although there is no single best plan for a network, some general guidelines and techniques can help ensure that your plan meets your needs. To plan a network, perform the following tasks:

- Determine the functions the network should provide (such as file transfer or 3270 emulation) and your performance requirements.
- Determine how CS/AIX can be configured to provide the functions you need.
- Estimate the resources needed to install CS/AIX, to support your performance and capacity requirements, and to support CS/AIX functions, and identify the associated costs.

Identifying functional requirements for the network

To determine the functions your network should provide, you need to consider the following questions:

- Is the network to be APPN?
- Do the SNA applications need to run in containers? If so a client/server system will be needed to be used since the server cannot be in a container.
- Will CS/AIX run as a client/server system? If so, will all computers operate in a single CS/AIX domain, or do I need to define two or more separate domains?
- Do I need more than one server in the CS/AIX domain to provide load balancing for connectivity resources? If so, which server will be the controller configuration server? Do I need to provide one or more backup configuration servers?
- Do I need to support Remote API Clients connecting to CS/AIX servers using HTTPS?
- Will user applications run on the server or on AIX client computers?
- Will the server provide connectivity resources for Windows applications (such as API transaction programs) running on Windows clients?
- Is each server to be an end-point for sessions or is it to be one of the following types of gateways?
 - APPN
 - LU 0
 - LU 2
 - TN Server or TN Redirector
- What types of physical links will the network use?
- Will CS/AIX need to support IPv4, IPv6 or both types of connections?

The answers to these kinds of questions help you determine which CS/AIX functions the network requires.

Determining how to configure CS/AIX

To determine how CS/AIX is to function, you should first decide how work is to flow through the network. The following questions should be considered:

- What resources (such as applications) should be available through the network?
- How many users need access to remote resources?
- How frequently is each resource accessed?
- How can users get access to the network?
- How will user requests be routed through the network?

You can configure CS/AIX to support many functions, including, for example, the following:

- APPN network node for intermediate session routing (ISR)
- APPN end node (which communicates autonomously with adjacent nodes but uses APPN network node services to communicate with nonadjacent peer nodes)
- Low-entry network (LEN) node (which communicates directly with adjacent nodes or nodes configured to appear adjacent)
- Host terminal emulation using LU 2
- Use of LU 0, LU 1, LU 2, LU 3, and LU 6.2 (dependent and independent)
- SNA gateway connection to a host

One or more functions can be configured for a given node, depending on your needs. For example, you can configure CS/AIX as an APPN network node to provide routing services and ISR, and use the same node for SNA gateway to route dependent LU sessions, such as LU 0 and LU 2. Similarly, you can configure CS/AIX to run TN Server and support a shared database, as well as an independent LU 6.2 connection to MQSeries on the host.

Identifying resource requirements for installation and operation

To estimate support for the functions of CS/AIX, the following questions must be answered:

- What personnel skills do I need?
- What model of AIX workstation do I need?
- What transport media do I anticipate using?
- What are the installation requirements for the configuration I select?
- How much memory and paging space do I need for operation?
- What response time can I expect with the anticipated traffic level?

Answering these questions helps you identify the types of resources that CS/AIX uses when it is configured to support any one or more of the many functions described in [“Identifying functional requirements for the network”](#) on page 15. Answering the questions also helps you to understand the relationship between CS/AIX functions, AIX resources, and network resources.

How you allocate resources to nodes determines how the network will perform.

Personnel requirements

Installing, operating, and tuning CS/AIX requires the following personnel:

- Network administrators, who plan the network, add new devices, and maintain or enhance overall network performance
- System administrators, who install and maintain CS/AIX and the hardware on which it operates, and who configure systems for network connection
- Programmers, who develop customized applications such as transaction programs or network management routines

Network and system administrators should be thoroughly familiar with the hardware on which CS/AIX operates and with the AIX operating system. They must know the networks to which various systems are connected and understand SNA concepts in general. They should also be familiar with the following:

- The Motif interface or the System Management Interface Tool (SMIT) for AIX
- TCP/IP, if they plan to use Client/Server functions, TN server or Enterprise Extender
- Windows, Red Hat Enterprise Linux, SuSE Linux Enterprise Server, Ubuntu Linux and AIX. The Remote API Client runs on all of these.
- WebSphere Application Server, if the CS/AIX system includes Remote API Clients that connect to servers using HTTPS

Programmers who develop customized applications for SNA should be experienced with the C language (or Java if they are using Java CPI-C), and should be familiar with the APIs that are available in CS/AIX.

IBM Power models

IBM Communications Server for Data Center Deployment on AIX is designed to run on an AIX workstation connected to one or more networks. CS/AIX Version 7.1 will run on any IBM Power 8 or Power 9 system that is supported by AIX Version 7.2 or later. (The server must run in the Global Environment, not in a system or application WPAR.)

For information about the relative CPU speeds of the different IBM Power systems, refer to <http://www.ibm.com/it-infrastructure/power>.

Transport media

CS/AIX might need to share the underlying transport medium (such as SDLC, Ethernet) with other communication protocols. Therefore, physical layer bandwidth requirements must accommodate all the protocols and applications sharing the transport medium.

Note: CS/AIX can share the token ring, Ethernet, and X.25 adapters with other protocols such as TCP/IP. You might need to specify unique service access point (SAP) addresses for each protocol to use. CS/AIX can also share a Multiprotocol Quad Port (MPQP) adapter, but not an MPQP port.

Installation requirements

The functions that you assign to CS/AIX (from [“Identifying functional requirements for the network” on page 15](#)) also determine the installation requirements. This section provides an overview of the computer resources required for installing CS/AIX. For more information, see the documentation supplied with each product (see the Bibliography for a list of the books).

Link hardware

Link hardware is required only on a server, and not on a client.

Installing an AIX Power system workstation in one or more networks requires links that conform to the selected network's communication protocol. Link hardware consists of a communication adapter that is installed into the computer and a matching cable for attachment to the network (you also need device driver software).

Note:

1. Communication adapters must be installed with matching cables. For example, an Ethernet adapter requires an Ethernet cable in order for the link to function.
2. If you are using Enterprise Extender as your only link type, the adapters listed in this section are not required; but you must have one of the adapters required by AIX TCP/IP.

CS/AIX supports communication adapters for the following link protocols:

- Token Ring
- Ethernet (standard or IEEE 802.3)
- SDLC

Stages of network planning

- IBM 2 port PCI
- IBM 4 port MPQP

The following link protocols require additional products or features that are not included with CS/AIX:

- X.25 (requires the AIXLink/X.25 product)
- ATM using an emulated LAN (token ring or Ethernet) interface over an IBM AIX ATM adapter
- Frame Relay using an emulated token ring interface

For information about adapters that have been tested with CS/AIX, see http://www.ibm.com/software/network/commsserver/about/comp_products/adapter_csaix.html.

If you have any questions about the appropriate adapter or hardware for your needs, call your IBM Sales Representative.

Software: AIX server

Before you can install and use CS/AIX on your AIX workstation, the workstation must have the following software:

- AIX Base Operating System (BOS), one of the following versions:
 - AIX 7.2 or later
- Appropriate DLC support (not necessary for installation, but required to use CS/AIX). For more information about DLCs, see [“Installing data link control filesets”](#) on page 26.
- Motif level 1.2 support (part of the AIX base operating system; required if you want to use the Secure Sockets Layer functions of CS/AIX TN Server and/or TN Redirector, or if you want to use the Motif administration program).
- Java software (required if you want to use Java CPI-C). The latest Java SDK available from <http://www.ibm.com/developerworks/java/jdk> satisfies all the requirements.

Install the Java SDK package with the `installp` command.

- The AIX option `bos . 64bit` is a prerequisite if you intend to run applications using the CS/AIX APIs in 64-bit mode. As well as installing this option, you need to configure it using the command `smit load64bit`, to ensure that it is loaded before you try to run 64-bit applications. If you intend to compile and link 64-bit applications on this computer but run them on a different computer (for example if you use separate computers for developing and testing applications), the option `bos . 64bit` is not required.
- AIX Certificate and SSL Base Runtime software. This is required on a server if you intend to use TN Server or TN Redirector with the SSL feature. The software is included on the installation media and is installed automatically when you install CS/AIX.
- GSKIT. This is required on a client if it will connect to CS/AIX servers using HTTPS. See the README file on the client installation media for more information about obtaining and installing the GSKIT software.
- A Web server that supports Java servlets (required for the Web administration program). The IBM HTTP Server (IHS) v6.0.1 has been tested with CS/AIX.

If you intend to use another Web server, or if you are installing one of these Web servers after installing CS/AIX, you will need to set up links between CS/AIX directories and the Web server's directories; see [“Configuring a Web Server for the Web Administration Program”](#) on page 33 for details. (If one or more of the above Web servers is already installed, the CS/AIX installation process sets up the required links automatically.)

- A Web browser that supports Java (required for the Web administration program). The following Web browsers have been tested with CS/AIX:
 - Microsoft Internet Explorer v4 SP1 or later
 - Netscape Navigator v4.06 or later

WebSphere Application Server (for HTTPS access)

If you will be running a client/server system in which Remote API Clients connect to CS/AIX servers using HTTPS, you will need to run WebSphere Application Server to provide HTTPS access from these clients to the servers.

CS/AIX operates with WebSphere Application Server Version 8, which can be installed on a computer running any operating system supported by WebSphere. (If necessary it can be installed on the same AIX computer as a CS/AIX server.) Refer to the WebSphere Application Server documentation for more information about installing it. You will also need to install an additional CS/AIX plug-in on this computer to use WebSphere with CS/AIX, as described in [“Configuring WebSphere Application Server”](#) on page 30.

Memory and Storage

To support a full range of configurations and services, a workstation running CS/AIX needs the minimum memory required by the AIX operating system plus 64MB, and 200 MB of disk space. In addition, 250 MB of temporary storage is required during installation.

Messages and help text are supplied in several different national language versions. You must install the filesets for at least one national language; you can install more than one if required. You need 2.5 to 4.0 MB of disk space per language (the amount varies with different languages).

If you decide to install the documentation for CS/AIX in softcopy (PDF) form, you need additional fixed-disk storage. Again, different national language versions are available. You need 28 MB of disk space to install the US English manuals, and up to 17 MB for each additional language version.

Note: Memory and fixed-disk requirements for other licensed programs, user applications, and data are not included in these requirements; carefully review all system, memory, and fixed-disk requirements with your IBM representative or authorized industry remarketer.

Advanced configurations

If you expect to run applications that require more than a basic configuration, you need to plan for extra computer resources.

In general, memory and storage requirements for running CS/AIX depend on many different factors that vary with the function of the AIX workstation and its environment. Nevertheless, by using the rule of thumb that LUs, active links, and ongoing sessions are the dominant consumers of computer resources, you can estimate the amount of additional memory and disk space that is required to support the most demanding applications.

For further information about resource usage, allocation, and optimization with respect to node function, refer to <https://www.ibm.com/products/communications-server-for-data-center>.

Memory and storage requirements for operation

This section describes the memory and storage requirements of a workstation running CS/AIX.

Memory Buffers (Mbufs)

AIX uses memory buffers (mbufs) to enable communication between the communication subsystems and the AIX DLCs. The mbuf pool is a shared resource that must be managed at the system level. CS/AIX uses mbufs to send and receive data across the network, but it is just one of the subsystems that uses mbufs. CS/AIX's mbuf resource utilization can affect the performance of other subsystems, such as TCP/IP, NFS, or DCE. Coordinate with your network administrator in determining mbuf requirements.

Memory, Disk, and Paging Storage

CS/AIX uses primary storage - also known as main memory and random access memory (RAM) - permanent disk storage, and paging disk storage (also known as paging space):

- Control blocks for SNA resources - such as LUs, links, and sessions - consume primary storage.
- Memory buffers consume only primary storage.
- CS/AIX executables, configuration files, and softcopy publications consume permanent disk storage.

IPv4 and IPv6 addressing

- Application programs, sessions, and related processes have paging space requirements that consume permanent disk storage.

Memory and disk storage requirements depend on various factors that widely differ from one environment to another. Transaction programs (TPs) and SNA sessions are the dominant consumers of memory and disk storage.

A TP is a program that uses the SNA application programming interface (API) to access the network. A session is a temporary logical channel between two LUs on partner nodes. TPs use this channel to communicate with each other.

The consumption of memory and disk storage is largely affected by the overall number of sessions, the number of allocated sessions (conversations), the traffic intensity of the conversations, and the number of active user TPs. Memory requirements are mostly affected by the data-traffic intensity and the resulting usage of mbufs. Disk storage requirements stem from the paging space requirements of the TPs, sessions, and related processes.

For all LU types, a distinction is made between an idle session and an allocated session. An idle session is an active session that is not being used by TPs. An allocated session is one that supports an ongoing conversation. To estimate the total memory requirement, you need to estimate the traffic intensity and the portion of the overall number of sessions that will be allocated, on average, at any one time. You can also choose to configure the system to handle peak demand. These estimates vary among environments.

If you increase the session load beyond system memory capacity, you incur the cost of paging.

Processes

CS/AIX requires a minimum of 20 AIX processes.

Response time

Estimating response time for anticipated traffic levels is an impossible task because of the large number of networking conditions that exist. Because response time also cannot be expressed in a concise formula, it is best obtained from experimental data, which you can extrapolate to your network.

To help you in your estimates, the IBM Communications Server web pages at <https://www.ibm.com/products/communications-server-for-data-center> present different network configurations, and show how the response time of each network is affected by such factors as the model of the AIX workstation and the number of ongoing sessions.

IPv4 and IPv6 addressing

Computers running CS/AIX Version 7.1 can use either IPv4 or IPv6 addresses, with the following constraints.

- All servers in a Client/Server domain must use the same addressing format (IPv4 or IPv6).
 - If the servers use IPv4, clients must also use IPv4.
 - If the servers use IPv6, clients can use either IPv6 or IPv4.
- For TN Server, if CS/AIX uses IPv4, TN clients connecting to the TN Server must also use IPv4. If CS/AIX uses IPv6, TN Clients can use either IPv6 or IPv4. By default the TN Server accepts connections from both types of clients, but you can configure it to listen on a particular IP address (using the *listen_local_address* parameter in the command-line administration program or a NOF application) in order to restrict it to one type of client connection.
- For TN Redirector, if CS/AIX uses IPv4, both TCP/IP connections (from the client to CS/AIX and from CS/AIX to the host) must also use IPv4.

If CS/AIX uses IPv6, the TCP/IP connection from the client to CS/AIX follows the same rules as for TN Server. The connection from CS/AIX to the host can use either IPv6 or IPv4. There is no requirement for the two connections to use the same addressing format.

- If you are using SLP, the TN Server must support IPv4 addressing: that is, the server must have an IPv4 address (although it may also have an IPv6 address). This is because SLP uses UDP broadcasts, which are not available in an installation that supports only IPv6.
- For Enterprise Extender (HPR/IP), the ports at both ends of a link must use the same addressing format (IPv4 or IPv6).
 - If CS/AIX uses IPv4, it can connect only to remote systems that are configured to support IPv4.
 - If CS/AIX uses IPv6, you can configure it to use either IPv4 or IPv6 on an Enterprise Extender link. The option you choose must match the configuration at the remote system.

In addition, all links on the same Enterprise Extender port must use the same addressing format (IPv4 or IPv6). If you need to support links with different addressing formats, you must use separate ports. Similarly, all Enterprise Extender ports on the same connection network must use the same addressing format.

To check whether a CS/AIX server is running IPv4 or IPv6, use the command `ifconfig -a` and look at the IP address or addresses in the output. These will be IPv4 dotted-decimal addresses, IPv6 hexadecimal addresses, or both. For a Remote API Client on Windows, the equivalent command is `ipconfig` (with no command-line options). If you need to change the computer's IP addressing format, refer to your operating system documentation.

If you are upgrading an existing CS/AIX system as described in [“Migrating from previous levels of CS/AIX” on page 27](#), and you also want to change to IPv6 addressing, you can do the two processes in either order. However, you cannot use the new IPv6 addressing capabilities until both processes are complete.

- For a Client/Server system, you must change all the servers in the domain from IPv4 to IPv6 at the same time; do not attempt to run a mixed domain of IPv4 and IPv6 servers.
- Because the upgrade to CS/AIX also recommends that you to upgrade all the servers at the same time, you may choose to make the change to IPv6 addressing at the same time as upgrading each server. Alternatively, you can change all the servers to IPv6 either before or after the upgrade, whichever is more convenient.
- After all the servers have been changed to use IPv6 addressing, you can change Remote API Clients to use IPv6 addressing as required. IPv4 clients can continue to operate with IPv6 servers, so there is no need to change all the clients at the same time.

If you are installing a new CS/AIX system, you can install it with only IPv6 addressing on all servers and clients if appropriate, or you can use IPv4 addressing initially and then move to IPv6 later (subject to the restrictions above for Client/Server domains).

Ensuring compatibility among cross-platform configurations

SNA products running on different platforms - such as IBM Personal Communications or IBM Host-On-Demand, or VTAM on a host - can function with CS/AIX if certain requirements are met.

In general, the current release of an SNA networking product can function with CS/AIX as long as it supports PU 2.1 nodes and at least one of the link types supported by CS/AIX. However, some very old releases (such as VTAM V2) might not function reliably. The capabilities of each networking product are documented in its corresponding user's guide.

Other factors to consider include the following:

- If you are using independent LU 6.2 and your network is not APPN, you need to make sure that partner LUs are defined to the local system.
- When working in a heterogeneous environment (TCP/IP and SNA protocols on the same LAN) with multiple LAN segments, make sure that your LAN interconnect devices can "route" TCP/IP and "bridge" SNA frames at the same time.

Naming conventions

You can use network IDs to logically segment your physical network. Also, if you plan to connect to other networks, it is highly recommended that you register your network IDs to avoid network name conflicts.

You can define network and LU names as follows:

Network names

You can define different network names (network IDs) to provide segmentation of APPN networks. Segmentation limits the size of network topology databases and the frequency of broadcast LOCATE requests through each network.

To ensure the uniqueness of a network ID, a network administrator can register the network's ID with the IBM worldwide registry. The IBM registry ensures that each network ID is unique among those registered with it. Registry standards are consistent with Open Systems Interconnection (OSI) standards, including OSI country codes, as established by the International Organization for Standards (ISO). For more information about registration, see *User's Guide for SNA Network Registry*.

LU names

You can use wildcards for LU names to minimize system definition and network searches.

Chapter 3. Installing CS/AIX on AIX servers

This chapter describes how to install CS/AIX on AIX computers. This chapter also provides instructions for maintaining your CS/AIX configuration information.

Note:

1. You must have root privileges in order to install CS/AIX.
2. You must add a data link control (DLC) before you can use CS/AIX. The DLC manages the communication adapter. For more information, refer to the description of the `mkdev` command in *AIX Commands Reference*, or use the Communications option on the Devices menu in System Management Interface Tool (SMIT). (For more information, refer to *AIX Communications Programming Concepts*.)
3. For AIX systems that support WPAR environments, the CS/AIX server must run in the Global Environment, not in a system or application WPAR nor a container. (The Remote API clients can run in application WPARs or containers).

CS/AIX licensing and packaging

This section explains how the CS/AIX product is licensed and packaged.

CS/AIX licensing mechanisms

This section is intended to provide the reader with a high-level understanding of the licensing mechanisms. The *CS/AIX License Information* document provides the complete terms and conditions for the product. In addition, sample scenarios are available for further clarification of licensing for many of the different types of connectivity and functionality provided by CS/AIX. Refer to <https://www.ibm.com/products/communications-server-for-data-center> for this information.

CS/AIX includes several components, described below.

A separate Program license for CS/AIX is required for each machine or SP node on which any or all of the included components are installed.

Licensing for CS/AIX includes the Program (server) license and user licenses.

- A User is defined as a person. You must purchase a User authorization for every concurrent User that will access and use CS/AIX, either directly or indirectly. As an example of indirect usage, if a multiplexing program or application server (for example, CICS, DB2, WebSphere®, or your own business application) connects to CS/AIX providing access on behalf of multiple concurrent Users, then a User license is required for each of the concurrent users.
- In addition, for application programs that are not associated with actual users, a User authorization is required for each active upstream or downstream connection established to the CS/AIX node. In an APPN environment, a connection is an active link to an adjacent node.

Enabling CS/AIX using a nodelock license

CS/AIX uses nodelock licenses to enable or disable the product. (Nodelock licenses are licenses managed at a specific node instead of by a network license server.)

A nodelock license can be either a permanent license or a temporary key that grants the operator use of CS/AIX for a limited time (for example, for an introductory offer or for demonstration purposes). Purchase of the CS/AIX product includes the permanent nodelock license, which is installed automatically into the system's `nodeLock` license file during product installation.

If CS/AIX is installed from demonstration media, such as CD Showcase media, it is installed with a temporary key. To fully enable the product, you must purchase a CS/AIX license using your traditional IBM

marketing channels. To upgrade from a temporary key, you can simply install the permanent key from the CS/AIX installation media. You do not need to reinstall the product.

To extract the key from the CS/AIX installation CD, use the following procedure:

1. Issue the command `smit bffcreate`, and use the resulting SMIT dialog to extract the LPP image from the installation media. Note the name of the file that is created; this should be `sna.7.1.0.0.I` or similar.
2. Use the following commands to extract the key from the LPP image:

```
cd /tmp
restore -f /usr/sys/inst.images/installp/ppc/filename ./usr/lib/sna/install/
license.sna
```

Replace *filename* with the filename that you noted in step 1.

3. Use the following command to copy the key to the `/var/ifor/nodelock` file. Be sure to use the "append" operator `>>` to concatenate the key into the file (do **not** use the `>` operator, which overwrites all old keys).

```
cat /tmp/usr/lib/sna/install/license.sna >> /var/ifor/nodelock
```

Monitoring usage of CS/AIX resources

There are two ways to license the Communications Server for Data Center Deployment which includes CS/AIX. Processor Value Unit (PVU) or Concurrent User licenses. Only one license method is used. If licensed by PVU, the license depends on the number of cores allocated to run CS/AIX servers. Using virtual machines, 2 or more cores can run 1 or more CS/AIX server images. Therefore, monitoring is dependent on the IBM Tivoli License Manager (ITLM) to monitor the PVU usage. If licensed by Concurrent User, the CS/AIX server will log the number of concurrent data sessions used by TN3270 client, TN Redirector ports, APPC and LU0-3 applications. The total value is logged every 30 minutes in the `/var/sna/ad8a7aebefee4d8e9554c14f5f734b7b.s1mtag` file.

How the CS/AIX licensed program is packaged

The CS/AIX Licensed Program Product (LPP) consists of several packages (installable images), which each contain one or more filesets. A fileset is the smallest installable unit of the product. AIX maintains release and level information for each fileset (see the `AIX ls1pp` command in [“Displaying product installation details”](#) on page 26). The licensed program can also contain update files.

Note: For storage requirements, see [“Installation requirements”](#) on page 17.

The following filesets are required when you install CS/AIX, these two packages should be installed together:

sna package

sna.rte

CS/AIX base program.

`sna.rte64` is a prerequisite for `sna.rte`.

sna.rte64

Filesets for 64-bit API support.

`sna.rte` is a prerequisite for `sna.rte64`.

Filesets for SSL support

The following filesets are included for Secure Sockets Layer (SSL) support with TN Server or TN Redirector:

gskta.rte

AIX Certificate and SSL Base Runtime.

sna.gsk_jre

Java JRE for the certificate key manager.

GSKIT8.gskssl32

GSKIT SSL package.

GSKIT8.gskcrypt32

GSKIT cryptography package.

Features included with CS/AIX

The following features are included as part of CS/AIX. You can choose to install them or not.

sna.xsna

Motif administration program.

sna.rte, X11.base.rte, and X11.Dt.helpun are prerequisites for sna.xsna.

sna.wa

Web administration program.

sna.rte is a prerequisite for sna.wa.

sna.docs.Language.data

Online documentation. *Language* indicates the language in which the documents are to be displayed (for example, fr_FR for French).

sna.man.en_US.rte.data, sna.man.en_US.xsna.data

AIX manual pages for CS/AIX commands.

sna.msg.Language package

CS/AIX message catalog, containing messages and dialog help files in the specified language for the run-time environment. The following fileset is required:

sna.msg.Language.rte

Messages and dialog help files for the base CS/AIX features. *Language* indicates the language in which the messages are to be displayed. Choose one of the following language identifiers:

Identifier	Language
en_US	English (United States)
Ja_JP	Japanese (PC)
de_DE	German
es_ES	Spanish
fr_FR	French
ko_KR	Korean
pt_BR	Portuguese
zh_CN	Chinese (Simplified EUC)
zh_TW	Chinese (Traditional)

If you install multiple languages for a product, be sure that you install the preferred (or primary) language first. For example, to install U.S. English as the primary language, specify:

```
sna.msg.en_US.rte
```

sna.rte is a prerequisite for sna.msg.Language.rte.

Communications.Bnd

Bundle definition for use with Easy-Install (as described in [“Installation methods”](#) on page 28).

Preparing for CS/AIX installation

Before installing CS/AIX, you must be running AIX Version 7.2 or later. (The server must run in the Global Environment, not in a system or application WPAR or container.) Perform the following tasks:

- Install and configure any DLCs needed for communication over the network as described in [“Installing data link control filesets”](#) on page 26. (DLCs must be installed and configured before you can use CS/AIX; but you can also install DLCs after installing CS/AIX.)
- If you intend to use the Web administration program and have not yet installed a suitable Web server, install it now. The Web servers supported by CS/AIX are listed in [“Installation requirements”](#) on page 17. Follow the installation instructions provided with the Web server software.
- To ensure that product dialogs and messages are handled correctly, make sure that the LANG environment variable is set properly, as described in [“Changing the language environment variable”](#) on page 26.

Installing data link control filesets

CS/AIX requires at least one AIX data link control (DLC) fileset in order to communicate over the network. The following is a list of these DLC filesets:

- `bos.dlc.token` for token ring link stations
- `bos.dlc.ethernet` for standard Ethernet link stations
- `bos.dlc.8023` for 802.3 Ethernet link stations
- `bos.dlc.qllc` for X.25 link stations
- `bos.dlc.sd1c` for SDLC link stations

All `bos.dlc` filesets are provided as part of the `bos.dlc.usr` package in the AIX base operating system. DLCs must be installed separately.

Note: For more information about AIX data link controls, refer to *AIX Communications Programming Concepts*.

Displaying product installation details

You can display the installation history for CS/AIX (and for some related products) by entering one of the following commands:

Enter:	For Product:
<code>ls1pp -h sna.rte</code>	IBM Communications Server for Data Center Deployment on AIX

To display the program temporary fixes (PTFs) that have been applied to the products since they were installed, enter the command with the `-ha` flag instead of the `-h` flag.

Changing the language environment variable

When you use CS/AIX, make sure that the LANG variable is not set to C.

Use the following procedure to show which LANG variable is in use or to change the LANG variable:

1. From the main SMIT menu, select `System Environments`.
2. From the next SMIT menu, select `Manage Language Environment`.
3. From the next SMIT menu, select `Change/Show Primary Language Environment`.
4. From the next SMIT menu, select `Change/Show Cultural Convention, Language, or Keyboard`.
5. Select the language you want to use. For example, if you are using U.S. English messages, select `en_US`.

Migrating from previous levels of CS/AIX

Considerations

If you are upgrading to CS/AIX Version 7.1 from an earlier version of CS/AIX, you need to consider the following.

1. If you are running CS/AIX in a Client/Server configuration with two or more servers, you are advised to upgrade all the servers to Version 7.1 at the same time, before upgrading the Remote API Clients.
 - While you are in the process of migrating the servers, you will not be able to use the Motif administration program or command-line administration program on a back-level server to view and manage resources on a server running Version 7.1.
 - Version 6.3.1.0 and later versions of the Remote API Client will work with an existing server, but only if the operating system on the client is not configured to use IPv6.
 - Earlier versions of the Remote API Client will work with CS/AIX Version 7.1.
 - In particular older clients on operating systems for which clients are not distributed with CS/AIX Version 7.1 such as 32-bit Windows O/Ss will continue to work with CS/AIX Version 7.1.
2. Several data structures in the NOF API were modified in Version 6.2.3.0 to accept the longer address formats required for IPv6 addresses. This means that, if you use any of the following verbs and/or indications in an existing NOF application that was created before Version 6.2.3.0 (even if you are not using the new IPv6 addressing capabilities), you will need to recompile the application to use it with CS/AIX Version 7.1.
 - DEFINE_LS, DEFINE_PORT, QUERY_LS, QUERY_PORT when used with an Enterprise Extender (HPR/IP) LS or port
 - DEFINE_TN3270_ACCESS, DELETE_TN3270_ACCESS, QUERY_TN3270_ACCESS
 - DEFINE_TN3270_EXPRESS_LOGON, QUERY_TN3270_EXPRESS_LOGON
 - DEFINE_TN3270_SSL_LDAP, QUERY_TN3270_SSL_LDAP
 - DEFINE_TN_REDIRECT, QUERY_TN_REDIRECT_DEF
 - QUERY_LU_0_TO_3 (for any LU type)
 - TN_REDIRECTION_INDICATION
3. If you want to use the new IPv6 addressing capabilities of Version 7.1, you need to ensure that the CS/AIX servers are configured to use IPv6 addressing. See [“IPv4 and IPv6 addressing” on page 20](#) for more details.

Installing the CS/AIX licensed program

After you have installed the prerequisite software, you are ready to install CS/AIX. Use the following procedure:

1. Log in with root privileges.
2. Install and configure the associated AIX DLC for the selected communication adapter. To configure the DLC, use the `mkdev` command (described in *AIX Commands Reference*) or the Communications option on the SMIT Devices menu (described in *AIX Communications Programming Concepts*).
3. Install CS/AIX as described in “Installation methods” on [page 28](#). Select the features you wish to install (including any applicable message filesets), or select `all` to install CS/AIX with all of its included features.

If you select a feature and choose `yes` for the *Install requisite software* field, the system also installs `sna.rte` (the CS/AIX base program).

4. If you installed the AIX Certificate and SSL Base Runtime software in order to use TN Server or TN Redirector with the SSL feature, you need to configure the SSL software after you have installed CS/AIX. See [“Configuring SSL for use with TN Server or TN Redirector” on page 32](#) for more information.

Installing the CS/AIX licensed program

5. Customize CS/AIX configuration information as needed (see [Chapter 8, “Configuring and using CS/AIX,”](#) on page 61, or refer to *IBM Communications Server for Data Center Deployment on AIX Administration Guide*).
6. Start CS/AIX. Note that after installation this will happen automatically when the machine is rebooted.

```
cd /  
sna start
```

Note:

1. Installing CS/AIX automatically reconfigures the SNA device drivers on the local node.
2. You can install adapters after CS/AIX is installed. You do not need to reinstall CS/AIX after adding an adapter; but you cannot use the adapter until the appropriate DLC is installed.

Installation methods

You can install the CS/AIX licensed program using one of the following methods:

- Easy-install
- On the local system
- Over the network (if the local node is a network server)

Installing CS/AIX using Easy-Install

You can install software more easily by using software bundles. A software bundle contains a list of software products that are suited for a particular use. The following sections shows how to install CS/AIX using this feature. Easy-Install can be run either at the system console or remotely, and run either under X-Windows or from an ASCII terminal.

Install CS/AIX on the local node as described in [“Easy-Install using SMIT”](#) on page 28 or [“Easy-Install using Common Desktop Environment”](#) on page 28.

Easy-Install using SMIT

1. Log in with root privileges.
2. Enter the following command:
 - `smit install_bundle`
3. Press PF4, or click on the List button in Motif, to display a list of installation devices and directories for the installation media.
4. Select Media-defined, and press Enter.
5. Select your input device, and press Enter.

Easy-Install using Common Desktop Environment

1. From the desktop launch pad, open the Tools Application Manager.
2. Open the System_Admin folder.
3. Open Easy Install.
4. Select your input device.
5. Select the Media-defined bundle.
6. Click the Install/Update button.

Installing manually on the local node

Install CS/AIX on the local system as described in [“Installing manually using SMIT”](#) on page 29 or [“Installing manually using Common Desktop Environment”](#) on page 29.

Installing manually using SMIT

1. Put the installation medium into the appropriate drive on the AIX workstation.
2. Log in with root privileges.
3. Make sure that the LANG environment variable on your system is not set to C. If you are selecting U.S. English messages, set the LANG variable to en_US. For more information about how to show or change the LANG environment variable, see [“Changing the language environment variable” on page 26](#).
4. Enter the following command on the AIX command line:

```
smit install
```

This command invokes SMIT, which provides a menu-driven environment for the installation.

5. Select the following options on SMIT installation menus to perform a standard installation of selectable software with updates:
 - a. Install and Update Software
 - b. Install/Update Selectable Software (Custom Install)
 - c. Install/Update From All Available Software

This sequence of menu selections is comparable to the following fastpath command:

```
smit install_selectable_all
```

6. On the resulting dialog, select the appropriate device name for the installation medium as the source device for the installation procedure. (To list the device names, use PF4 in the character interface for SMIT or the List button in Motif.)
7. Select sna.rte, the CS/AIX base program, sna.msg.Language.rte (the CS/AIX message catalog), and any additional features and updates for the licensed program (including any other applicable message filesets). To install all of the features on the installation medium, select the all option.

The installation utility displays status messages as each part successfully completes installing.
8. To install the AIX Certificate and SSL Base Runtime software in order to use TN Server or TN Redirector with the SSL feature, also select the AIX Certificate and SSL Base Runtime fileset.

The installation utility displays status messages as each part successfully completes installing.

If you installed this software, you need to configure the SSL software after you have installed CS/AIX. See [“Configuring SSL for use with TN Server or TN Redirector” on page 32](#) for more information.
9. Customize CS/AIX configuration information (see Chapter 8, [“Configuring and using CS/AIX,” on page 61](#), or refer to *IBM Communications Server for Data Center Deployment on AIX Administration Guide*).

Note:

1. Installing CS/AIX automatically reconfigures the SNA device drivers on the local node.
2. For information about user licensing for CS/AIX, see [“CS/AIX licensing mechanisms” on page 23](#).

Installing manually using Common Desktop Environment

1. Put the installation medium into the appropriate drive on the AIX workstation.
2. Log in with root privileges.
3. Make sure that the LANG environment variable on your system is not set to C. If you are selecting U.S. English messages, set the LANG variable to en_US. For more information about how to show or change the LANG environment variable, see [“Changing the language environment variable” on page 26](#).
4. From the desktop launch pad, open the Tools Application Manager.
5. Open the System_Admin folder.
6. Open the Install_Manager folder.
7. Select your input device.

Configuring WebSphere Application Server

8. Select every object shown to install everything on the medium, or expand and select individual objects to customize the Communications Server for AIX options to install.
9. Click on the Install icon to begin installation.
10. Customize CS/AIX configuration information (see Chapter 8, “Configuring and using CS/AIX,” on page 61, or refer to *IBM Communications Server for Data Center Deployment on AIX Administration Guide*).

Note:

1. Installing CS/AIX automatically reconfigures the SNA device drivers on the local node.
2. For information about user licensing for CS/AIX, see “CS/AIX licensing mechanisms” on page 23.

Installing over a network using Network Installation Management

Use this procedure to install CS/AIX over a network:

1. Refer to *AIX Version 7.2 Installation Guide and Reference* for information about setting up the Network Installation server and downloading files to the client.
2. Make sure that the LANG environment variable on your system is not set to C. If you are selecting U.S. English messages, set the LANG variable to en_US. For more information about how to show or change the LANG environment variable, see “Changing the language environment variable” on page 26.
3. Enter the following command on the AIX command line:

```
smit nim
```

This command invokes SMIT, which provides a menu-driven environment for the installation.

4. Follow the directions and answer the prompts on the SMIT installation menus for performing a network installation. Select the files that contain sna.rte and any additional features and updates for the licensed program. The installation utility displays status messages as each part successfully completes installing.

Note:

1. The CS/AIX message catalog, `sna.msg.Language.rte`, automatically installs with CS/AIX when the *Include corresponding LANGUAGE filesets?* option is set to yes (the default).
2. Installing CS/AIX automatically reconfigures the SNA device drivers on the local node.
3. For information about user licensing for CS/AIX, see “CS/AIX licensing mechanisms” on page 23.

Configuring WebSphere Application Server

If you will be running a client/server system in which Remote API Clients connect to CS/AIX servers using HTTPS, you will need a computer running WebSphere Application Server to provide HTTPS access from these clients to the servers, as described in “Installation requirements” on page 17.

This section describes how to set up WebSphere for use with CS/AIX:

- Setting up a secure certificate on the WebSphere server that will be presented to clients
- Configuring WebSphere Application Server to work with CS/AIX
- Installing the server configuration file on the WebSphere server

You will also need to set up the client security certificate and the client network data file on each Remote API Client to access the WebSphere Application Server. For more information, see the chapter on installing the appropriate client type.

Setting up the WebSphere Application Server's secure certificate

Refer to the WebSphere Application Server documentation for instructions on setting up a secure certificate on the server. This is the server's certificate that will be presented to a Remote API Client during the authentication process when it tries to connect using HTTPS.

You are recommended to configure WebSphere so that it enforces client authentication; see the WebSphere Application Server documentation for more information. This means that WebSphere will request security certificates from Remote API Clients during the authentication process, and will accept an incoming connection from a Remote API Client only if it can verify the authenticity of the client's certificate.

Configuring WebSphere Application Server

To configure WebSphere Application Server to operate with CS/AIX, take the following steps. Refer to the WebSphere Application Server documentation for more information.

1. Copy or FTP the two files `snahttpsrv.ear` and `snahttpsrv.cfg` from the `ibm-commserver-https` directory on the Remote API Client installation CD to a directory on the computer where the WebSphere administration console runs, or to a network directory that can be accessed from this computer.

If the administration console is running on Windows, copying the files is not necessary because you can access the files direct from the CD. You just need to insert the Remote API Client installation CD into the Windows computer's CD drive.

2. Start the WebSphere administration console.
3. Follow the WebSphere documentation to create a virtual host that is accessible only via an SSL secured connection. This virtual host will be used for the Java plug-in that manages SNA HTTPS connections.
4. From the menu bar, choose Applications, Install New Application.
5. Specify the location of the `snahttpsrv.ear` file. Choose the Next button.
6. When prompted to specify a virtual host name in the first two screens, enter the name of the virtual host that you have set up for HTTPS. For all other parameters you can accept the default options unless you need to use any specific WebSphere configuration; choose the Next button on the following dialogs until it is replaced by a Finish button, and then choose the Finish button. The screen should then show Application installed successfully.
7. Click on Save to Controller Configuration, and then click on the Save button.
8. From the menu bar, choose Applications, Enterprise Applications.
9. Find `SnaHttpTransport` in the list of applications, click on the checkbox next to it, and click on the Start button to start the application. (After this, the application will be started automatically when WebSphere Application Server is started.)
10. From the menu bar, choose Environment, Update Web Server Plugin, and click the OK button. This updates the WebSphere configuration.

Installing the server configuration file

To operate with CS/AIX, the WebSphere Application Server requires a list of the CS/AIX servers that will be accessed using HTTPS. Create and install this list using the following steps.

1. In the WebSphere administration console menu bar, choose Environment, Manage WebSphere Variables.
2. Look for the `USER_INSTALL_ROOT` variable in this list, and note its value (which is the path of a directory on the WebSphere server). The list of environment variables may span two or more pages, so you may need to use the Next button to scroll through the list.
3. Copy the `snahttpsrv.cfg` file from the location where you saved it in “[Configuring WebSphere Application Server](#)” on page 31 (or from the installation CD) into the directory specified by the `USER_INSTALL_ROOT` variable, and then edit this file using a text editor to include a list of CS/AIX servers that can be accessed by Remote API Clients using HTTPS. Each server must be specified on a separate line of the file, in the following format:

```
server=servername.domainname.com
```

Post-installation procedures

This section explains how to perform maintenance tasks that may be required after installing CS/AIX.

Client/Server operation

After installation, CS/AIX initially operates as a standalone server (with all components on a single AIX system). If you want to run it as a server in a client/server domain, refer to the chapter on Managing CS/AIX Client/Server Systems in *IBM Communications Server for Data Center Deployment on AIX Administration Guide* for instructions.

Viewing PDF books

The manuals included on the installation media for this product are in Portable Document Format (PDF). Softcopy format enables you to search, browse, or print the information easily, using hypertext links for related information. It also makes it easier to share the library across your site, because PDF viewers are available for many different platforms.

If you choose to install the PDF manuals when installing the product, they are installed in the directory `/usr/share/man/info/Language/sna`. The HTML file `SNABOOKS.HTM` in this directory provides a hypertext link to each manual. The manuals are also included in the directory `/DOCS` on the CS/AIX installation media.

You can read the PDF manuals using any PDF viewer, such as Adobe Acrobat on Windows or `xpdf` on Intel Linux.

Reviewing current release information

The latest update of the README file for the product, contained in the `/usr/lpp/sna` directory, contains information about any product changes following the publication of the CS/AIX library. Review the README file whenever you receive product updates.

The README file can be accessed through SMIT, using the following procedure:

1. After installing CS/AIX Version 7.1, access the main SMIT menu for CS/AIX by entering the following command on the command line:

```
smit sna
```

The main SMIT menu for CS/AIX is displayed.

2. Select **Product Information** from the main SMIT menu for CS/AIX. SMIT displays the **Product Information** dialog.
3. Select one of the options on that menu to view the associated README file.

Configuring SSL for use with TN Server or TN Redirector

If you installed the AIX Certificate and SSL Base Runtime software in order to use TN Server or TN Redirector with the SSL feature, you need to configure the SSL software after you have installed CS/AIX.

The SSL software requires two components:

- A key pair is required to allow data encryption and decryption to be carried out.
- A certificate is required to allow server authentication.

The certificate and key pair make up a single record in a keyring database, which is stored on the CS/AIX server running TN Server or TN Redirector. CS/AIX uses the database to implement SSL.

To manage the keyring database, type the following command at the AIX command prompt:

```
snakeyman
```

The snakeyman command launches a Java program. See the help provided with this program for further instructions.

Each record in the database is identified by a unique name known as a label. If you have two or more records to use on different TN Server or TN Redirector sessions, you need to make a note of the labels you assign when setting up the database; these labels are used to identify which record is to be used on each session. You can also identify one of the records as the default, so that sessions will use this record unless you explicitly specify the label of a different record.

After using snakeyman to update the server certificates, you need to exit the snakeyman program and then stop and restart the CS/AIX node in order to use the updated certificates. Use the following commands to stop and restart the node:

```
snaadmin term_node
snaadmin init_node
```

Configuring a Web Server for the Web Administration Program

If you are using the Web administration program with a Web server that is not listed in “Installation requirements” on page 17, or if you install the Web server after installing CS/AIX, you need to set up links between CS/AIX directories and the Web server's directories, so that the Web server can find the required files. Use the ln command to create these links.

- The Web server's "servlets" directory must be linked to /usr/lib/sna/WebAdmin/Server.
- The subdirectory SnaAdmin in the Web server's "public HTML" directory must be linked to /usr/lib/sna/WebAdmin/Client.

For more details of how to set up the Web server, refer to the text file /usr/lpp/sna.wa/README, which is installed when you install the CS/AIX Web Admin package.

Backing up CS/AIX configuration files

CS/AIX automatically backs up the node, domain, TN3270 device data (tn3270dev.dat), and TP configuration files whenever you make changes that affect those files (using any of the CS/AIX administration tools). For example, when you make a change that affects the node configuration file (sna_node.cfg), CS/AIX creates a backup file named sna_node.bkn, where *n* is either 1 or 2:

- The first time you change the file, the existing configuration is saved to sna_node.bk1.
- The second time you change the file, the existing configuration is saved to sna_node.bk2, leaving sna_node.bk1 unchanged.
- The third time you change the file, and any subsequent times, sna_node.bk1 is discarded, sna_node.bk2 is renamed to sna_node.bk1, and the existing configuration is saved to sna_node.bk2.

This process means that there is a maximum of two backup files for the node configuration file at any time. The same process is used to generate filename extensions for other backup files.

In addition to automatic backups, you should back up configuration files to protect against loss of data under any of the following conditions:

- Before installing a new level of the AIX operating system
- Before installing a new release of CS/AIX
- After you create a new configuration

You can back up configuration files using the following commands:

```
cd /etc/sna
/bin/ls -1 sna*cfg sna.net sna_tps ibmcs.* | backup -i -v -q -f Devicename
```

In these commands, *Devicename* is the path and file name of a device to receive data from the files being backed up. Ideally, back up files to external media such as diskette or tape.

Restoring a backup copy of CS/AIX configuration files

To restore CS/AIX configuration files that were backed up as described in [“Backing up CS/AIX configuration files”](#) on page 33, do the following:

1. Ensure that CS/AIX is not active. To determine whether it is, enter the following command:

```
snaadmin status_node
```

If CS/AIX is active, the command displays information about the local node's status; otherwise it displays a message indicating that CS/AIX is inactive.

If CS/AIX is active, enter the following command to deactivate it:

```
sna stop
```

2. Enter the following commands:

```
cd /etc/sna  
restore -x -f Devicename
```

In this command, *Devicename* is the path and file name of the device you used when backing up the files.

This command overwrites any existing configuration files with the same names in the `/etc/sna` directory.

Reinitializing configuration files

If CS/AIX configuration files are inadvertently modified so that the information in them can no longer be used, you may need to reinitialize the files so that you can reconfigure CS/AIX as though it were newly installed. This should be done only if you are sure the configuration information cannot be salvaged.

Note: If you have backup configuration files that are valid, you can copy those files to the `/etc/sna` directory and use them to initialize the node using the `sna start` command.

You can reinitialize the following configuration files:

- Node configuration file `sna_node.cfg`
- Domain configuration file `sna_domn.cfg`
- TP configuration file `sna_tps`
- SSL keyring database file and password stash file

Perform the following steps to reinitialize configuration files:

1. Exit the administration program if it is active, and disable CS/AIX by issuing the following command:

```
sna stop
```

2. Back up the existing configuration files by copying any files you are reinitializing to a different location.
3. Delete the files you are reinitializing.
4. If you deleted the domain configuration file, issue the following command to recreate it (by copying from the empty domain configuration file delivered with CS/AIX):

```
cp -p /usr/lib/sna/samples/empty.cfg /etc/sna/sna_domn.cfg
```

This command creates a new domain configuration file, which is required to start CS/AIX.

5. If you deleted the SSL keyring database file, issue the following command to recreate it (by copying from the sample file delivered with CS/AIX):

```
cp -p /usr/lib/sna/samples/ibmcs.* /etc/sna
```

6. Issue the following command to restart CS/AIX:

```
sna start
```

7. Start the Motif administration program:

```
xснаadmin &
```

If the `sna_node.cfg` file does not exist, the administration program prompts you to configure the node. You can continue by configuring the node and the other resources as described in [Chapter 8, "Configuring and using CS/AIX," on page 61](#) or *IBM Communications Server for Data Center Deployment on AIX Administration Guide*.

If you used a valid `sna_node.cfg` file, the new configuration file is used to initialize the node.

Chapter 4. Installing IBM Remote API Clients on Linux

This chapter describes how to install the IBM Remote API Client on Linux, which enables a Linux workstation to run SNA applications without having a complete SNA stack installation. A Remote API Client on Linux can connect to one or more CS/AIX servers (or CS Linux servers, but not both at the same time) using a TCP/IP network. (CS Linux servers cannot operate in the same domain as CS/AIX servers.)

This chapter applies to IBM Remote API Clients running on 64-bit AMD64/Intel EM64T (x86_64) and Power Systems (ppc64le) computers. If you are installing the IBM Remote API Client on a System z computer (s390x), refer to [Chapter 5, “Installing IBM Remote API Clients on Linux for System z,”](#) on page 43.

The installation program and associated files, including the IBM Remote API Client README file, are located on the installation CD, in the appropriate directory for your client type:

Client Type	Directory On CD
64-bit AMD64/Intel EM64T (x86_64)	/ibm-commserver-clients/linux-x86_64
Power (ppc64le)	/ibm-commserver-clients/linux-ppc64le

You are recommended to read the IBM Remote API Client README file before installing the software.

If you are upgrading from an earlier version of CS/AIX and the Remote API Clients, you are recommended to upgrade all the servers before upgrading the Remote API Clients. See [“Migrating from previous levels of CS/AIX”](#) on page 27 for more details.

Hardware and software requirements

Hardware requirements

The IBM Remote API Client requires a computer supported by one of the Linux distributions below.

Use the command `uname -m` to verify the CPU class of your target computer. The following table shows the appropriate hardware for each client type and the response from the `uname -m` for this hardware.

Client Type	Hardware	uname response
64-bit AMD64/Intel EM64T	x86_64 (AMD64 or Intel EM64T) system	x86_64
pSeries	Power system	ppc64le

Linux operating system version

The current version of the IBM Remote API Client has been tested with the following Linux operating system versions. It may also run satisfactorily on other Linux distributions.

- RedHat Enterprise Linux 7 and 8
- SUSE Linux Enterprise Server 12 and 15
- Ubuntu Linux LTS 18.04 and 20.04

Refer to the README file on the installation CD for details of which optional packages may be required.

Java

If you use the Java CPI-C API, you will require Java software. Refer to the README file on the installation CD for details.

GSKIT

If the client will connect to CS/AIX servers using HTTPS, you will require GSKIT software to enable HTTPS access to the servers through a WebSphere server. See the README file on the installation media for more information about obtaining and installing the GSKIT software.

Displaying product installation details

You can display information about the Remote API Client and related software packages that are already installed. To list all the installed packages, use the following command on RHEL or SLES systems:

```
rpm -q -a
```

To view more details of a specific package, use the following command:

```
rpm -q -i packagename
```

packagename is the base name of the installed package, for example `ibm-commserver-client`.

The corresponding commands on Ubuntu are `dpkg -l` and `dpkg -l packagename` respectively.

Setting environment variables for use by CS/AIX

CS/AIX uses a number of environment variables to control its operation, which must be set before you enable the CS/AIX software on the client. The simplest way to manage these is to set them in a text file that CS/AIX reads on startup.

In the CS/AIX configuration directory, `/etc/opt/ibm/sna`, create a text file named `environment`, and set each environment variable in a separate line. For example:

```
export LANG=en_US
export PATH='$PATH:/usr/bin'
export LD_LIBRARY_PATH=/usr/lib:/usr/lib/sna
export LD_RUN_PATH=/usr/lib:/usr/lib/sna
```

Setting the language environment variable

Use the following command to change the LANG variable to indicate the language you want to use:

```
export LANG=language
```

Replace *language* with the identifier for the language you want to use, which can be one of the following:

Identifier	Language
en_US	English (United States)
ja_JP	Japanese (PC)
de_DE	German
es_ES	Spanish
fr_FR	French
ko_KR	Korean
pt_BR	Portuguese
zh_CN	Chinese (Simplified EUC)

Identifier	Language
zh_TW	Chinese (Traditional)

Installing the Remote API Client on Linux

After you have installed the prerequisite software, you are ready to install the IBM Remote API Client.

If you have a previous level of IBM Remote API Client already installed, follow the steps in section [“Uninstalling the Remote API Client on Linux”](#) on page 40 to remove it before installing this new level. Any configuration information will be left in place for use by the new installation.

1. Log in with root privileges.
2. Mount the CD and make it the current directory.

```
mount /dev/cdrom
cd /media/cdrom
```

The directory name `/media/cdrom` may be different if you have a DVD drive. Use the command `df` to see where Linux mounted the CD.

3. Change to the appropriate subdirectory on the CD, and run the shell script to install the client. The example below shows the `/linux-x86_64` subdirectory for a 64-bit Intel (x86_64) client; replace this with `/linux-ppc64le` if required.

```
cd ibm-commserver-clients/linux-x86_64
./installibmcscli
```

The shell script will test for certain prerequisites and issue warning messages if they are not met. You will be prompted to read and accept the license agreement, then the script will install the rpm/deb packages.

4. Create the client network data file to specify the CS/AIX servers to which the client can connect. You may also want to set up additional configuration to enable the advanced support for tracking LUs and mapping Local LU aliases; this allows you to integrate the clients more dynamically and manage the LU resources in a domain of servers. See the section on managing Remote API Clients in *IBM Communications Server for Data Center Deployment on AIX Administration Guide* for more details.
5. Add the IBM Remote API Client binary directories to your PATH. You may want to change your profile to do this automatically:

```
export PATH='$PATH:/opt/ibm/sna/bin'
export LD_LIBRARY_PATH=/usr/lib:/opt/ibm/sna/lib
export LD_RUN_PATH=/usr/lib:/opt/ibm/sna/lib
```

For Java CPI-C applications you should also set the following environment variable:

```
export CLASSPATH=$CLASSPATH:/opt/ibm/sna/java/cpic.jar
```

For some applications you may also need to set the `LD_PRELOAD` environment variable, but you should not make this a global change in your profile:

```
export LD_PRELOAD=/usr/lib/libpLIS.so
```

6. Start the IBM Remote API Client. After installation this will happen automatically when the machine is rebooted. Make sure you are not still in the CD's directories when you do this.

```
cd /
sna start
```

Note: Before the IBM Remote API Client can connect to servers using HTTPS, you need to use the GSKIT key manager program to set up the security certificate configuration on the client. See [“Setting up HTTPS security certificates using GSKIT”](#) on page 40 for more information.

Setting up HTTPS security certificates using GSKIT

You will also need to update the client network data file to specify the name of the WebSphere server that provides HTTPS support. See the section on managing Remote API Clients in *IBM Communications Server for Data Center Deployment on AIX Administration Guide* for more details.

Setting up HTTPS security certificates using GSKIT

If the client will connect to CS/AIX servers using HTTPS, it must have the GSKIT key manager software installed. See the README file on the installation media for more information about obtaining and installing the GSKIT software.

Before the IBM Remote API Client can connect to servers using HTTPS, you need to use the GSKIT key manager program to set up the security certificate configuration on the client. Take the following steps.

1. Run the GSKIT key manager using the following command:

```
/opt/ibm/sna/bin/snakeyman
```

From within the key manager user interface, open the key database file `/etc/opt/ibm/sna/ibmcs.kdb`, which is in CMS format.

2. The initial password for the key database is `ibmcs`. Before setting up the security certificates, you **must** change this password to keep your configuration secure. In the dialog for changing the password, you will need to mark the checkbox 'Stash the password to a file?' to ensure that the new password is saved so that the client can open the key database.
3. Obtain a copy of the Certificate Authority (CA) certificate that was used to sign the Web Server's security certificate, and install it in the key database. To do this, select Signer Certificates from the key manager user interface and click on Add.
4. If the WebSphere server is configured to require client security certificates, the client must have a certificate issued by a CA whose own certificate is in the Web Server's security certificate database. To request a new certificate:
 - a. Select Create, New Certificate Request from the key manager user interface, and fill in the requested details.
 - b. Save the certificate, extract it to a file and send it to the CA.
 - c. When the certificate is issued, store it in the Web Server's database. To do this, select Personal Certificates from the key manager user interface and click on Receive.

As a temporary measure for your own internal testing, you can create a self-signed client certificate rather than obtaining a certificate from the CA. However, this does not provide the required level of security and must not be used in a live system. To create a self-signed certificate:

- a. Select Create, New Self-Signed Certificate from the key manager user interface, and fill in the requested details.
 - b. Save the certificate and extract it to a file.
 - c. Store the certificate file in the Web Server's database. To do this, select Personal Certificates from the key manager user interface and click on Receive.
5. Exit the GSKIT key manager when you have finished configuring certificates.

Uninstalling the Remote API Client on Linux

You can uninstall the Remote API Client on Linux by using the following commands (use `dpkg -r` on Ubuntu Linux).

```
/usr/bin/sna stop  
rpm -e ibm-commserver-cli  
/sbin/shutdown -r now
```

Not all of the packages listed in these commands will be installed on every system.

Uninstalling IBM Remote API Client on Linux will leave any customized configuration information behind for use by a later installation.

Chapter 5. Installing IBM Remote API Clients on Linux for System z

This chapter describes how to install the IBM Remote API Client on Linux for System z, which enables an System z mainframe to run SNA applications without having a complete SNA stack installation. A Remote API Client on Linux for System z can connect to one or more CS/AIX servers (or CS Linux servers) using a TCP/IP network.

You are recommended to read the IBM Remote API Client README file before installing the software. This file is located in the `/ibm-commserver-clients/linux-systemz` directory on the installation CD.

If you are upgrading from an earlier version of CS/AIX and the Remote API Clients, you are recommended to upgrade all the servers before upgrading the Remote API Clients. See [“Migrating from previous levels of CS/AIX” on page 27](#) for more details.

Hardware and software requirements

Hardware requirements

The IBM Remote API Client requires a 64-bit System z system supported by one of the Linux distributions listed in [“Linux operating system version” on page 43](#).

Use the command `uname -m` to verify the CPU class. It must report `s390x` to indicate a 64-bit environment.

Linux operating system version

The current version of the IBM Remote API Client has been tested with the following Linux operating system versions. It may also run satisfactorily on other Linux distributions.

- RedHat Enterprise Linux 7 and 8
- SUSE Linux Enterprise Server 12 and 15
- Ubuntu Linux LTS 18.04 and 20.04

Refer to the README file on the installation CD for details of which optional packages may be required.

Java

If you use the Java CPI-C API, you will require Java software. Refer to the README file on the installation CD for details.

GSKIT

If the client will connect to CS/AIX servers using HTTPS, you will require GSKIT software to enable HTTPS access to the servers through a WebSphere server. See the README file on the installation media for more information about obtaining and installing the GSKIT software.

Displaying product installation details

You can display information about the Remote API Client and related software packages that are already installed. To list all the installed packages on RHEL or SLES, use the following command:

```
rpm -q -a
```

To view more details of a specific package, use the following command:

Installing the Remote API Client on Linux for System z

```
rpm -q -i packagename
```

packagename is the base name of the installed package, for example `ibm-commserver-client`.

The corresponding commands on Ubuntu are `dpkg -l` and `dpkg -l packagename` respectively.

Setting environment variables for use by CS/AIX

CS/AIX uses a number of environment variables to control its operation, which must be set before you enable the CS/AIX software on the client. The simplest way to manage these is to set them in a text file that CS/AIX reads on startup.

In the CS/AIX configuration directory, `/etc/opt/ibm/sna`, create a text file named `environment`, and set each environment variable in a separate line. For example:

```
export LANG=en_US
export PATH='$PATH:/usr/bin'
export LD_LIBRARY_PATH=/usr/lib:/usr/lib/sna
export LD_RUN_PATH=/usr/lib:/usr/lib/sna
```

Setting the language environment variable

Use the following command to change the `LANG` variable to indicate the language you want to use:

```
export LANG=language
```

Replace *language* with the identifier for the language you want to use, which can be one of the following:

Identifier	Language
en_US	English (United States)
ja_JP	Japanese (PC)
de_DE	German
es_ES	Spanish
fr_FR	French
ko_KR	Korean
pt_BR	Portuguese
zh_CN	Chinese (Simplified EUC)
zh_TW	Chinese (Traditional)

Installing the Remote API Client on Linux for System z

After you have installed the prerequisite software, you are ready to install the IBM Remote API Client.

If you have a previous level of IBM Remote API Client already installed, follow the steps in section [“Uninstalling the Remote API Client on Linux for System z”](#) on page 46 to remove it before installing this new level. Any configuration information will be left in place for use by the new installation.

1. Copy or FTP the `ibm-commserver-client-7.1.0.0-s390x.tgz` file from the `/ibm-commserver-clients/linux-systemz` directory on the CD-ROM to the Linux System z system. Ensure that you use binary mode to copy or FTP the file.
2. Log into the Linux System z system as root.
3. Uncompress and unpack the tar file into an empty temporary directory:

```
mkdir /tmp/ibmcs
cd /tmp/ibmcs
```

```
tar - xzf ibm-commserver-client-7.1.0.0-s390x.tgz
```

4. Run the `installibmccli` shell script:

```
./installibmccli
```

This shell script tests for certain prerequisites and issues warning messages if they are not met. It also prompts you to confirm that you have read and accepted the CS/AIX license terms. You can override this prompt by specifying additional parameters on the `installibmccli` command as described below. When you have responded to the prompt, the shell script installs the rpm/deb package

5. Create the client network data file to specify the CS/AIX servers to which the client can connect. You may also want to set up additional configuration to enable the advanced support for tracking LUs and mapping Local LU aliases; this allows you to integrate the clients more dynamically and manage the LU resources in a domain of servers. See the section on managing Remote API Clients in *IBM Communications Server for Data Center Deployment on AIX Administration Guide* for more details.
6. Add the IBM Remote API Client binary directories to your PATH. You may want to change your profile to do this automatically:

```
export PATH='$PATH:/opt/ibm/sna/bin'
```

```
export LD_LIBRARY_PATH=/usr/lib:/opt/ibm/sna/lib
```

```
export LD_RUN_PATH=/usr/lib:/opt/ibm/sna/lib
```

If you will be running 64-bit applications, use the following:

```
export LD_LIBRARY_PATH=/usr/lib64:/opt/ibm/sna/lib64
```

```
export LD_RUN_PATH=/usr/lib64:/opt/ibm/sna/lib64
```

For Java CPI-C applications you should also set the following environment variable:

```
export CLASSPATH=$CLASSPATH:/opt/ibm/sna/java/cpic.jar
```

For some applications you may also need to set the `LD_PRELOAD` environment variable, but you should not make this a global change in your profile:

```
export LD_PRELOAD=/usr/lib/libpLIS.so
```

7. Start the IBM Remote API Client. After installation this will happen automatically when the machine is rebooted. Make sure you are not still in the CD's directories when you do this.

```
cd /
sna start
```

8. When you are done with the installation, you can erase the `tgz` file and temporary directory that were created during the installation process.

Note: Before the IBM Remote API Client can connect to servers using HTTPS, you need to use the GSKIT key manager program to set up the security certificate configuration on the client. See [“Setting up HTTPS security certificates using GSKIT” on page 45](#) for more information.

You will also need to update the client network data file to specify the name of the WebSphere server that provides HTTPS support. See the section on managing Remote API Clients in *IBM Communications Server for Data Center Deployment on AIX Administration Guide* for more details.

Setting up HTTPS security certificates using GSKIT

If the client will connect to CS/AIX servers using HTTPS, it must have the GSKIT key manager software installed. See the README file on the installation media for more information about obtaining and installing the GSKIT software.

Before the IBM Remote API Client can connect to servers using HTTPS, you need to use the GSKIT key manager program to set up the security certificate configuration on the client. Take the following steps.

1. Run the GSKIT key manager using the following command:

Uninstalling the Remote API Client on Linux for System z

```
/opt/ibm/sna/bin/snakeyman
```

From within the key manager user interface, open the key database file `/etc/opt/ibm/sna/ibmcs.kdb`, which is in CMS format.

2. The initial password for the key database is `ibmcs`. Before setting up the security certificates, you **must** change this password to keep your configuration secure. In the dialog for changing the password, you will need to mark the checkbox 'Stash the password to a file?' to ensure that the new password is saved so that the client can open the key database.
3. Obtain a copy of the Certificate Authority (CA) certificate that was used to sign the Web Server's security certificate, and install it in the key database. To do this, select Signer Certificates from the key manager user interface and click on Add.
4. If the WebSphere server is configured to require client security certificates, the client must have a certificate issued by a CA whose own certificate is in the Web Server's security certificate database. To request a new certificate:
 - a. Select Create, New Certificate Request from the key manager user interface, and fill in the requested details.
 - b. Save the certificate, extract it to a file and send it to the CA.
 - c. When the certificate is issued, store it in the Web Server's database. To do this, select Personal Certificates from the key manager user interface and click on Receive.

As a temporary measure for your own internal testing, you can create a self-signed client certificate rather than obtaining a certificate from the CA. However, this does not provide the required level of security and must not be used in a live system. To create a self-signed certificate:

- a. Select Create, New Self-Signed Certificate from the key manager user interface, and fill in the requested details.
 - b. Save the certificate and extract it to a file.
 - c. Store the certificate file in the Web Server's database. To do this, select Personal Certificates from the key manager user interface and click on Receive.
5. Exit the GSKIT key manager when you have finished configuring certificates.

Uninstalling the Remote API Client on Linux for System z

You can uninstall the Remote API Client on Linux for System z by using the following commands (use `dpkg -r` on Ubuntu Linux).

```
/opt/ibm/sna/bin/sna stop  
rpm -e ibm-commserver-cli  
/sbin/shutdown -r now
```

Uninstalling IBM Remote API Client on Linux for System z will leave any customized configuration information behind for use by a later installation.

Chapter 6. Installing IBM Remote API Clients on AIX Systems

This chapter describes how to install the IBM Remote API Client on AIX, which enables an AIX workstation to run SNA applications without having a complete SNA stack installation. A Remote API Client on AIX can connect to one or more CS/AIX servers (or CS Linux servers) using a TCP/IP network.

You are recommended to read the IBM Remote API Client README file before installing the software. This file is located in the `/ibm-commserver-clients/aix` directory on the installation CD. If you are upgrading from an earlier version of CS/AIX and the Remote API Clients, you are recommended to upgrade all the servers before upgrading the Remote API Clients. See [“Migrating from previous levels of CS/AIX”](#) on page 27 for more details.

Hardware and software requirements

Hardware requirements

The IBM Remote API Client requires a Power system supported by one of the AIX operating systems listed in [“Operating system version”](#) on page 47.

Operating system version

The current version of the IBM Remote API Client has been tested with the following operating system versions.

- AIX 7.2 or later

The client can run in the Global Environment, or in a system or application WPAR. You must ensure that any WPAR in which the client runs has a unique hostname that DNS can resolve.

Java

If you use the Java CPI-C API, you will require Java software. The latest Java SDK available from <http://www.ibm.com/developerworks/java/jdk> satisfies all the requirements.

Install the Java SDK package with the `installp` command.

GSKIT

If the client will connect to CS/AIX servers using HTTPS, you will require GSKIT software to enable HTTPS access to the servers through a WebSphere server. See the README file on the installation media for more information about obtaining and installing the GSKIT software.

Setting environment variables for use by CS/AIX

CS/AIX uses a number of environment variables to control its operation, which must be set before you enable the CS/AIX software on the client. The simplest way to manage these is to set them in a text file that CS/AIX reads on startup.

In the CS/AIX configuration directory, `/etc/sna`, create a text file named `environment`, and set each environment variable in a separate line. For example:

```
export LANG=en_US
export PATH=' $PATH:/usr/bin'
export LD_LIBRARY_PATH=/usr/lib:/usr/lib/sna
export LD_RUN_PATH=/usr/lib:/usr/lib/sna
```

Changing the language environment variable

When you use the Remote API Client, make sure that the LANG variable is not set to C.

Use the following procedure to show which LANG variable is in use or to change the LANG variable:

1. From the main SMIT menu, select System Environments.
2. From the next SMIT menu, select Manage Language Environment.
3. From the next SMIT menu, select Change/Show Primary Language Environment.
4. From the next SMIT menu, select Change/Show Cultural Convention, Language, or Keyboard.
5. Select the language you want to use. For example, if you are using U.S. English messages, select en_US.

Installing the Remote API Client on AIX

After you have installed the prerequisite software, you are ready to install the IBM Remote API Client.

If you have a previous level of IBM Remote API Client already installed, follow the steps in section [“Uninstalling the remote API Client on AIX” on page 50](#) to remove it before installing this new level. Any configuration information will be left in place for use by the new installation.

Installing the Remote API Client by copying files to your AIX workstation

To install the Remote API Client, take the following steps.

1. Copy or FTP the `sna.client.7.1.0.0.I` file from the `/ibm-commserver-clients/aix` directory on the CD-ROM to the AIX workstation. Ensure that you use binary mode to copy or FTP the file.
2. Log into the AIX workstation as root.
3. Install the AIX Client using either `smit` or `installp`. For instructions on how to do this, see the README file in the `/ibm-commserver-clients/aix` directory on the installation CD.
4. When the installation process has completed, you can delete the `sna.client.7.1.0.0.I` file from the working directory.
5. Create the client network data file to specify the CS/AIX servers to which the client can connect. You may also want to set up additional configuration to enable the advanced support for tracking LUs and mapping Local LU aliases; this allows you to integrate the clients more dynamically and manage the LU resources in a domain of servers. See the section on managing Remote API Clients in *IBM Communications Server for Data Center Deployment on AIX Administration Guide* for more details.
6. Start the IBM Remote API Client. After installation this will happen automatically when the machine is rebooted.

```
cd /  
sna start
```

Note: Before the IBM Remote API Client can connect to servers using HTTPS, you need to use the GSKIT key manager program to set up the security certificate configuration on the client. See [“Setting up HTTPS security certificates using GSKIT” on page 49](#) for more information.

You will also need to update the client network data file to specify the CS/AIX servers to which the client can connect and the name of the WebSphere server that provides HTTPS support. See the section on managing Remote API Clients in *IBM Communications Server for Data Center Deployment on AIX Administration Guide* for more details.

Installing the Remote API Client from the CD

To install the Remote API Client, take the following steps.

1. Log into the AIX workstation as root.

2. Mount the CD on the AIX workstation, using the following command.

```
mount -o ro /dev/cd0 /mnt
```

3. Install the AIX Client using either `smit` or `installp`. For instructions on how to do this, see the README file in the `/ibm-commserver-clients/aix` directory on the installation CD.
4. When the installation process has completed, unmount the CD using the following command.

```
umount /mnt
```

5. Create the client network data file to specify the CS/AIX servers to which the client can connect. See the section on managing Remote API Clients in *IBM Communications Server for Data Center Deployment on AIX Administration Guide* for more details.
6. Start the IBM Remote API Client. After installation this will happen automatically when the machine is rebooted. Make sure you are not still in the CD's directories when you do this.

```
cd /
sna start
```

Note: Before the IBM Remote API Client can connect to servers using HTTPS, you need to use the GSKIT key manager program to set up the security certificate configuration on the client. See [“Setting up HTTPS security certificates using GSKIT”](#) on page 49 for more information.

You will also need to update the client network data file to specify the CS/AIX servers to which the client can connect and the name of the WebSphere server that provides HTTPS support. See the section on managing Remote API Clients in *IBM Communications Server for Data Center Deployment on AIX Administration Guide* for more details.

Setting up HTTPS security certificates using GSKIT

Before the IBM Remote API Client can connect to servers using HTTPS, you need to use the GSKIT key manager program to set up the security certificate configuration on the client. Take the following steps.

1. Run the GSKIT key manager using the following command:

```
/usr/bin/snakeyman
```

From within the key manager user interface, open the key database file `/etc/sna/ibmcs.kdb`, which is in CMS format.

2. The initial password for the key database is `ibmcs`. Before setting up the security certificates, you **must** change this password to keep your configuration secure. In the dialog for changing the password, you will need to mark the checkbox 'Stash the password to a file?' to ensure that the new password is saved so that the client can open the key database.
3. Obtain a copy of the Certificate Authority (CA) certificate that was used to sign the Web Server's security certificate, and install it in the key database. To do this, select Signer Certificates from the key manager user interface and click on Add.
4. If the WebSphere server is configured to require client security certificates, the client must have a certificate issued by a CA whose own certificate is in the Web Server's security certificate database. To request a new certificate:
 - a. Select Create, New Certificate Request from the key manager user interface, and fill in the requested details.
 - b. Save the certificate, extract it to a file and send it to the CA.
 - c. When the certificate is issued, store it in the Web Server's database. To do this, select Personal Certificates from the key manager user interface and click on Receive.

As a temporary measure for your own internal testing, you can create a self-signed client certificate rather than obtaining a certificate from the CA. However, this does not provide the required level of security and must not be used in a live system. To create a self-signed certificate:

Uninstalling the Remote API Client on AIX

- a. Select Create, New Self-Signed Certificate from the key manager user interface, and fill in the requested details.
 - b. Save the certificate and extract it to a file.
 - c. Store the certificate file in the Web Server's database. To do this, select Personal Certificates from the key manager user interface and click on Receive.
5. Exit the GSKIT key manager when you have finished configuring certificates.

Uninstalling the remote API Client on AIX

You can uninstall the Remote API Client by using the following commands.

1. Stop the client software if it is running, using the following command.
2. Log in with root privileges.
3. Remove the Remote API Client package and associated software packages by using one of the following commands.

To remove the package using `installp`:

```
installp -u sna.client
```

To remove the package using `smit`:

```
smit remove
```

Chapter 7. Planning for and installing the Remote API Client on Windows

This chapter describes how to install the IBM Remote API Client on Windows, which enables a PC to run SNA applications without having a complete SNA stack installation on the PC. A Remote API Client on Windows can connect to one or more CS/AIX servers (or CS Linux servers) using a TCP/IP network.

If you are upgrading from an earlier version of CS/AIX and the Remote API Clients, you are recommended to upgrade all the servers before upgrading the Remote API Clients. See [“Migrating from previous levels of CS/AIX” on page 27](#) for more details.

Only 64-bit Windows operating systems are supported with the client distributed with CS/AIX Version 7.1. Older CS/AIX clients can continue to be used on 32-bit Windows operating systems with the CS/AIX Version 7.1 server.

The interfaces provided by the IBM Remote API Client on Windows are broadly compatible with those provided by the IBM Personal Communications and Microsoft Host Integration Server products (the Windows Open Server Architecture or WOSA).

The IBM Remote API Client on Windows Software Development Kit (SDK) is an optional package that allows you to use the Remote API Client to develop application programs using the APPC, CPI-C, LUA, and CSV APIs. Refer to the appropriate programmer's reference guide for more information about these APIs. You do not need to install this package if the Remote API Client will be used only to run existing applications (not to develop new ones).

Hardware and software requirements

To run the Setup program and the Remote API Client on Windows, the computer must meet the following requirements:

- It must be running one of the following operating systems. For up-to-date information about specific version numbers that are supported for each operating system version, and any additional requirements for specific versions, please refer to the Windows client information in the README file on the installation CD for more details.
 - Microsoft Windows 10 (64-bit)
 - Microsoft Windows Server 2012
 - Microsoft Windows Server 2016
 - Microsoft Windows Server 2019

It must have access to one or more CS/AIX servers using one of the following mechanisms:

- Access to the server over a TCP/IP network
- Access to a WebSphere server that provides HTTPS access to CS/AIX servers.

Note: Depending on the Windows version that you are using, or the specific Remote API Client features that you want to use, there may be some additional configuration that you need to perform before you can install and use the Remote API Client on Windows. Refer to the Windows client information in the README file on the installation CD for more details. In particular, if the client accesses its servers using HTTPS, you need to install the GSKIT software.

Accessing the Setup program

The Remote API Client and SDK software and the Setup program are included on the installation CD in Windows format, so that you can install them from the CD on the Windows computer. You must install the Remote API Client software on each Windows client PC. The SDK is required only if you will be using the

Installing Remote API Client on Windows using the Setup program

client to develop new applications using the Windows Remote APIs, and is not required if you will be using it only to run existing applications.

The Remote API Client on Windows installation image is a self-extracting ZIP executable file, delivered on the installation CD.

- It is `i_w64cli.exe` in the directory `/ibm-commserver-clients/win-x64` on the CD.

You can copy this file to other Windows PCs across the network, so that you can install them without direct access to the CS/AIX delivery CD. When you run this executable, it unzips the installation image and automatically runs the Setup program. If you simply want to unzip the installation image to a temporary directory, for example to run the Setup program from the command line, you can do so by loading the self-extracting ZIP executable into your unzip program.

The first time you run the Setup program on a particular computer, the program runs from the selected source. The program handles the complete installation process, sets up a basic configuration, and also installs and creates an icon for itself. After installation is complete, you can use the Setup program (either by selecting it from the File Manager or by selecting its icon) if you need to reinstall the software.

After you have extracted the Remote API Client installation image into a temporary directory, you can install the software in either of two ways:

- Run the Setup program through Windows, as explained in [“Installing Remote API Client on Windows using the Setup program”](#) on page 52. You must use this method if you want to install the SDK.
- Enter the setup command from the command line, as explained in [“Installing Remote API Client Software from the command line”](#) on page 55. This method does not allow you to install the SDK.

Note: Before the IBM Remote API Client can connect to servers using HTTPS, you need to update the client network data file to specify the CS/AIX servers to which the client can connect and the name of the WebSphere server that provides HTTPS support. See the section on managing Remote API Clients in *IBM Communications Server for Data Center Deployment on AIX Administration Guide* for more details.

Installing Remote API Client on Windows using the Setup program

Run the setup program, either automatically as part of executing the self-extracting ZIP executable `i_w64cli.exe`, or manually from the command line. The program first displays a Choose Setup Language screen.

1. Select the language that you want to use for installing and configuring the Remote API Client, and choose OK.

The program displays a Welcome screen that introduces you to the Setup program.

2. Choose Next to continue with the installation.

The program displays the Software Licensing Agreement, which you should read and understand.

3. If you are happy to accept the licensing terms, choose Accept to continue.

The program prompts you to specify a destination directory into which the files are to be installed.

4. Enter the destination directory.

The program asks you to choose the type of installation you want:

Standard

Choose this option if you do not need to install the SDK. The SDK is required only if you will be using the client to develop new applications using the Windows Remote APIs, and is not required if you will be using it only to run existing applications.

Developer

Choose this option if you need to install the SDK: that is, if you will be using the client to develop new applications using the Windows Remote APIs.

Note: If you want to install the SDK, you must choose Developer.

5. Choose the installation type.

The program then asks you to enter the name of the program folder in which you wish icons for the Remote API Client on Windows to appear.

6. Enter the folder name.
7. If the System directory already contains .DLL files with names that are the same as files used by this Setup program but are not Remote API Client files (for example, files from some other SNA software), the program prompts you to do one of the following:

- Copy the Remote API Client .DLL files over the existing .DLL files
- Copy the existing .DLL files to a subdirectory named OTHERSNA within the installation directory, and then install the Remote API Client .DLL files. This option enables you to restore the original setup from before the Remote API Client installation if you uninstall the files at a later time (see [“Uninstalling the Remote API Client software”](#) on page 59).
- Cancel the client software installation.

If the Remote API Client .DLL files are already present, the Setup program displays a message indicating this. New .DLL files will overwrite the existing .DLL files only if the existing files have lower version numbers than the Setup program .DLL files.

8. At this point, the Setup program copies files from the specified source, and installs them in the appropriate places. During this process, an information bar displays what portion of the installation is complete. The .DLL files are copied into the System or equivalent directory, and the other files are copied into the destination directory you specified in Step 2. During each file transfer operation, a record is written to the setup.log file, which is created in the directory you specified. If any of the files to be written over is "read only", or any file cannot be copied for any other reason, the new files are removed and you receive a message advising you to look at the setup.log file.
9. If the source from which you are running the Setup program does not contain all the required files, the program prompts you for a directory name. Enter the name of a directory in which the required files are located.

If the information you specified is not sufficient to locate copies of the Remote API Client files, the program displays this screen again.

10. When the required files have been copied, the Setup program displays the Configuration window.

Default configuration values are taken from the domain configuration file. For more information, see the *IBM Communications Server for Data Center Deployment on AIX Administration Guide*. If you do not want to use these default values, you can configure them as shown below:

Domain

Specify the CS/AIX client/server domain name.

If the client uses IPv6 addressing, you must configure the following settings. They are optional if the client uses IPv4 addressing.

Server Name

The screen shows a list of up to nine servers to which this client can connect. The order in which servers appear in this list is the order in which the client selects these servers. If the client cannot connect to the first server on the list, the next server is tried.

Specify each server name in one of the following formats:

- If the client uses HTTPS to access its servers, specify the name of the WebSphere server that provides HTTPS support and the name of the CS/AIX server, in the following format:

webservename : *servername1*

This assumes that WebSphere is set up to use the default port 443 for HTTPS connections. If your network administrator has configured WebSphere to use a different port number, include the port number in the following format:

webservename : *portnumber* : *servername1*

For more details about configuring WebSphere to support HTTPS connections, refer to [“Configuring WebSphere Application Server” on page 30](#).

- If the client does not use HTTPS to access its servers, specify the name of the first server it should try to contact. The *webservname* and *portnumber* parameters are not used and should not be specified.
- If the client is on the same private network as its servers, you can specify that it should find a server running CS/AIX by using a UDP broadcast message to all computers on its TCP/IP subnet (or on all subnets that it can access, if the client computer contains more than one LAN adapter card). To do this, specify * (an asterisk character) instead of the first server name.

This option is available only if the client uses IPv4 addressing. UDP broadcasts are not supported for IPv6.

The client retries the broadcast every 10 seconds, up to the number of attempts specified by the *broadcast_attempt_count* parameter, until it contacts a server. If the limit specified by *broadcast_attempt_count* is reached before a server has been contacted, the client then tries using directed messages to one or more named servers (specified by the following lines of the file).

Note: If you are not using UDP broadcasts, you must specify the names of all servers that this client needs to access. The client can use resources on the servers that are specified in this file, but cannot use resources on other servers.

The following settings are optional:

Advanced

To supply additional values in place of the defaults supplied by the Setup program, click on the Advanced button at the bottom of the window. The Setup program displays the Advanced Options window, which contains advanced settings for Windows client configuration. Most users can use the default settings for these parameters, so you probably do not need to alter the settings in that dialog.

For more information about these parameters, see [“Advanced Options for Remote API Client configuration” on page 54](#).

For more information about any of the configuration parameters or settings, click on Help.

11. When you have completed the Configuration window, click on OK. The Setup program displays a message if you have not completed this screen properly.
12. When the installation has successfully completed, the Finish window is displayed. You can select either or both of the following actions to be taken after you exit the installation program:

View README file

View the README file.

Start client

Begin running this CS/AIX client.

Choose Finish to exit the installation program.

Advanced Options for Remote API Client configuration

The Advanced Options window enables you to configure some advanced parameters for the Remote API Client. Most users do not need to alter these parameters, but you can adjust the default settings if necessary.

LAN access time-out

Specify the time in seconds that the client's connection to a server can remain idle before it is closed. When this check box is empty, no LAN access time-out has been specified (and so an infinite time-out will be used). If you check this box, you can enter a time-out value in seconds in the adjacent field. The minimum value is 60 (for 60 seconds); if you leave the box blank or specify a value lower than 60, the Remote API Client uses the minimum value 60.

Max. broadcast attempts

Specify the maximum number of times the client attempts to connect to a server by broadcast. When the Advanced Options window is opened, the default value of 5 is displayed. The value in this box is used only if the client uses UDP broadcasts: this is indicated by * (an asterisk character) instead of the first server name.

Reconnect time-out

Specify the time in seconds that the client waits before attempting to reconnect to a server after the server has gone down. When the Advanced Options window is opened, the default value of 200 is displayed.

For more information about these parameters, press Help.

When you have completed the Advanced Options window, click on OK. If you have completed the screen properly, the Setup program returns to the Configuration window. If you are installing a new Remote API Client, return to Step “11” on page 54. Otherwise, click on the OK button in the Configuration dialog to complete the configuration.

Installing Remote API Client Software from the command line

Note: If you want to install the SDK, you must use the Setup program, as explained in [“Installing Remote API Client on Windows using the Setup program”](#) on page 52. You cannot install the SDK from the command line.

After you have extracted the Remote API Client installation image into a temporary directory, you can install the Remote API Client software from the command line instead of using the Setup program through Windows. At the command line, enter the `setup` command with one or more options. You can enter these options in uppercase or lowercase, and can precede them with a / (slash) or - (hyphen). If a parameter, such as *folder*, is a string that contains a space, you must enclose the string inside double quotes.

After you enter the `setup` command, the Setup program prompts you for any information you have not included on the command line, and displays confirmation messages at various stages of the setup. If you do not want the Setup program to prompt you, use the `-accept -s` option to run the program in silent mode, accepting the terms of the Software License Agreement.

Following are the setup command options:

-accept -s

Run the installation in silent mode, accepting the terms of the Software License Agreement. This agreement can be found in the `license` subdirectory of the Windows installation image.

The `-s` option must be the last one in the command line, and you must be sure you have specified the domain name (using the `-i` option) and any other parameters that you want to specify. When the installation runs in silent mode, it does not prompt you for any parameters or display confirmation messages. Any command-line arguments after `-s` are ignored.

-f2

Specify the full pathname of the installation log file that is created during silent mode installation (using the `-s` option).

If you do not specify this option, the file is created as `setup.log` in the directory from which you run the installation program. If you are installing in silent mode from the CD drive, you must specify this option to ensure that the file is created on your computer (because it cannot be created on the CD drive).

-kfolder

Specify the Program folder.

-llanguagecode

Specify the language variant of the client that you want to use. If you do not specify this option, the default is to install the English variant.

Installing Remote API Client Software from the command line

Use one of the following codes (including the leading 0x) to indicate the language you want. For example, use -10x000c to install the French variant of the client.

- English (default): 0x0009
- Chinese: 0x0804
- French: 0x000c
- German: 0x0007
- Japanese: 0x0011
- Korean: 0x0012
- Portuguese: 0x0016
- Spanish: 0x000a
- Taiwanese: 0x0404

-pdirectory

Specify the install directory.

-idomain

Specify a domain name for this client. This parameter is required; there is no default.

-wdirectory

Specify the source directory containing CS/AIX client software files if the source is located on a disk or CD. Otherwise, use the -v option.

-vserver

Specify the server from which the client software files are to be downloaded. You can specify either the server name or TCP/IP address. If you are copying the source files from a disk or CD, use the -w option instead of the -v option.

-userver

Specify the name of a server to be included in the list of servers this client can access, in one of the following formats:

- If the client uses HTTPS to access its servers, specify the name of the WebSphere server that provides HTTPS support and the name of the CS/AIX server, in the following format:

webservername : *servername1*

This assumes that WebSphere is set up to use the default port 443 for HTTPS connections. If your network administrator has configured WebSphere to use a different port number, include the port number in the following format:

webservername : *portnumber* : *servername1*

For more details about configuring WebSphere to support HTTPS connections, refer to [“Configuring WebSphere Application Server”](#) on page 30.

- If the client does not use HTTPS to access its servers, specify the name of the server it should try to contact.
- If the client is on the same private network as its servers, you can specify that it should find a server running CS/AIX by using a UDP broadcast message to all computers on its TCP/IP subnet (or on all subnets that it can access, if the client computer contains more than one LAN adapter card). To do this, specify * (an asterisk character) instead of the first server name.

This option is available only if the client uses IPv4 addressing. UDP broadcasts are not supported for IPv6.

The client retries the broadcast every 10 seconds, up to the number of attempts specified by the *broadcast_attempt_count* parameter, until it contacts a server. If the limit specified by *broadcast_attempt_count* is reached before a server has been contacted, the client then tries using directed messages to one or more named servers (specified by the following lines of the file).

Note: If you are not using UDP broadcasts, you must specify the names of all servers that this client needs to access. The client can use resources on the servers that are specified in this file, but cannot use resources on other servers.

- o**
Overwrite existing .DLL files. If the Remote API Client .DLL files are already present, the Setup program overwrites these files even if they have a higher version number than the Setup program .DLL files.
- y**
Save existing .DLL files. If the Remote API Client .DLL files already exist in the required directories, the Setup program copies the existing .DLL files to a subdirectory of the install directory, and then installs the Remote API Client .DLL files. The copies in the subdirectory ensure that if you uninstall the Remote API Client software, the uninstall process will be complete.
- n**
Cancel the installation if existing Remote API Client .DLL files are found.
- atimeout**
Specify the LAN access time-out in seconds. This is the length of time the client's connection to a server can remain idle before being closed. The value 0 indicates no time-out.
- bmax-broadcast**
This option is used only if the client uses UDP broadcasts: this is indicated by * (an asterisk character) instead of the first server name.

Specify the maximum number of UDP broadcast attempts. A UDP broadcast is a client's attempt to connect to any server in the domain rather than to a specific server. The value 0 indicates no broadcast attempts are made.
- jreconnect-timeout**
Specify the time in seconds that the client waits before attempting to reconnect to a server after the server has gone down.

To view summary help information about these options on the screen, use the command `setup -h -l languagecode`, where *languagecode* is the code (as described above) for the language in which you want to view the information. For example, use the command `setup -h -l 10x0009` to view the help information in English. You can also replace `-h` with `-?`, for example `setup -? -l 10x000a` to view the help information in Spanish.

The following is an example command line to install the Remote API Client:

```
setup -imy_domain -userver1.company.com -userver2.company.com -b0 -j30 -accept
-s -f2C:\instrapi.log -y
```

In this example:

- The client is installed in the domain `my_domain`.
- The client has access to two servers in the same private network as the client, and does not use UDP broadcasts to contact any other servers. It waits for 30 seconds before reconnecting if it loses contact with a server.
- The installation runs in silent mode, writing its installation log information to the file `C:\instrapi.log` on the client.
- Existing copies of Remote API Client .DLL files are saved to a subdirectory before the new files are installed.
- No language option is specified, so the default (English) is used.

Setting up HTTPS security certificates using GSKIT

Before the IBM Remote API Client can connect to servers using HTTPS, you need to use the GSKIT key manager program to set up the security certificate configuration on the client. Take the following steps.

1. Run the GSKIT key manager program, which is *installdir*\snakeyman.exe. *installdir* represents the directory in which you installed the client software, which is C:\IBMCS\w32cli (32-bit client) or C:\IBMCS\w64cli (64-bit client) unless you specified a different location during the client installation.

From within the key manager user interface, open the key database file *installdir*\ibmcs.kdb, which is in CMS format.

2. The initial password for the key database is *ibmcs*. Before setting up the security certificates, you **must** change this password to keep your configuration secure. In the dialog for changing the password, you will need to mark the checkbox 'Stash the password to a file?' to ensure that the new password is saved so that the client can open the key database.
3. Obtain a copy of the Certificate Authority (CA) certificate that was used to sign the Web Server's security certificate, and install it in the key database. To do this, select Signer Certificates from the key manager user interface and click on Add.
4. If the WebSphere server is configured to require client security certificates, the client must have a certificate issued by a CA whose own certificate is in the Web Server's security certificate database. To request a new certificate:
 - a. Select Create, New Certificate Request from the key manager user interface, and fill in the requested details.
 - b. Save the certificate, extract it to a file and send it to the CA.
 - c. When the certificate is issued, store it in the Web Server's database. To do this, select Personal Certificates from the key manager user interface and click on Receive.

As a temporary measure for your own internal testing, you can create a self-signed client certificate rather than obtaining a certificate from the CA. However, this does not provide the required level of security and must not be used in a live system. To create a self-signed certificate:

- a. Select Create, New Self-Signed Certificate from the key manager user interface, and fill in the requested details.
 - b. Save the certificate and extract it to a file.
 - c. Store the certificate file in the Web Server's database. To do this, select Personal Certificates from the key manager user interface and click on Receive.
5. Exit the GSKIT key manager when you have finished configuring certificates.

Customizing the Remote API Client software after installation

You can change any of the customized settings any time after the initial installation by running the Configuration Utility program, located in the IBM Remote API program group. The program displays the same Configuration window that was displayed in the initial install process. You can change the information in any field by following the procedure in [“Installing Remote API Client on Windows using the Setup program”](#) on page 52.

If you did not install the SDK files during the initial installation and you now want to add them, you can do this by running the Setup program again and choosing Developer for the installation type.

There are further options for the client that are configured using Windows registry variables. These are described in the *IBM Communications Server for Data Center Deployment on AIX Administration Guide*, one such parameter is a poll_timer that permits the client to issue regular polls to the server to prevent firewalls breaking the TCP/IP connection between the client and the server.

You may also want to set up additional configuration to enable the advanced support for tracking LUs and mapping Local LU aliases; this allows you to integrate the clients more dynamically and manage the LU resources in a domain of servers. See the section on managing Remote API Clients in *IBM Communications Server for Data Center Deployment on AIX Administration Guide* for more details.

Reinstalling the Remote API Client software

You can reinstall the Remote API Client software at any time, for example when you wish to upgrade the software.

To do this, run the Setup program as before, using the instructions in “Installing Remote API Client on Windows using the Setup program” on page 52 or “Installing Remote API Client Software from the command line” on page 55. The Setup program displays the location from which the client software files were copied during the initial installation. Click on OK to get new copies of the files from this same location. When you click on OK, the Setup program copies the files and returns to the Options screen.

Note: If you are reinstalling the Remote API Client software in silent mode (as described in “Installing Remote API Client Software from the command line” on page 55), you may need to restart the computer to complete the installation. This is because some of the program files may be in use during the installation process (for example if the Remote API Client is running), and so cannot be replaced by the new files. In this case, the new files are copied to a temporary directory, and will be moved into place automatically when the computer is next restarted.

To check whether you need to restart the computer, use a text editor such as Notepad to view the contents of the installation log file when the installation process has completed. The installation log file is called `setup.log` and is created in the directory from which you run the Setup program, unless you use the `-f2` command-line option to specify a different path and filename.

At the end of the file, under the heading `Response Result`, the text `Result Code` should be followed by one of the two values 0 (zero) or -12. If the value is 0, there is no need to restart the computer; if the value is -12, restart the computer before attempting to use the Windows Client.

Uninstalling the Remote API Client software

You can uninstall the Remote API Client software at any time, by using the Add/Remove Programs option from the Windows Control Panel. Once the uninstall process is confirmed, Windows does the following:

- Deletes all installed files.
- If any .DLL files were saved to a subdirectory during the initial installation, restores files to their original location.
- Deletes the subdirectory in which the saved .DLL files were stored, as long as the subdirectory is empty.
- Removes the Program folder and created directory if they are empty.
- If the uninstallation is successful, deletes the `setup.log` file, which contains all file transfers and deletions.
- Displays a message saying either that the uninstallation was successful, or that the user should check the `setup.log` file because some part of the installation failed.

The Exit button returns you to Windows.

Uninstalling the Remote API Client software from the command line

Instead of using the Add/Remove Programs option from the Windows Control Panel, you can uninstall the Remote API Client software from the command line. Use the following command:

```
installdir\sxcluninst -y instdir installdir
```

- *installdir* represents the directory in which you installed the client software, which is `C:\IBMCS\w64cli` unless you specified a different location during the client installation.
- The `-y` option is used for confirmation, to prevent accidental use of this command.
- The *instdir* option should be specified if the program was not installed in `C:\IBMCS\w64cli`.

Help

The uninstall program completes without prompts and does not require any further input.

Help

You can access Help at any time by pressing the F1 key. The Configuration and Advanced Options windows each have Help buttons as well.

Chapter 8. Configuring and using CS/AIX

The easiest way to define and modify the CS/AIX configuration is to use the Motif administration program (`xsnaadmin`). This program provides a graphical user interface from which you can view and manage SNA resources on the local node. You can also use other administration tools such as the Web administration program or command-line administration, but the Motif program is recommended.

The Motif administration program includes help screens that provide overview information for SNA and CS/AIX, reference information for CS/AIX dialogs, and guidance for performing specific tasks. For each task (such as configuring the node) or type of communications (such as TN3270 or APPC), the program guides you in setting up the configuration of the required resources.

The Motif administration program enables you to set up all required parameters for standard CS/AIX configurations. For advanced parameters, the Motif administration program supplies default values. You need to supply only the essential configuration information, which enables you to set up SNA communications quickly and easily.

You can also use the Motif administration program to manage the running CS/AIX system. The administration program enables you to make and apply changes to the configuration while CS/AIX is active, and provides easy access to status information for node resources.

The Motif administration program automatically displays status information for CS/AIX resources. Most of this information is shown on the Node window (see [“Managing CS/AIX with the Motif administration program”](#) on page 63). In addition, you can control certain resources - such as nodes and link stations - using the Start and Stop buttons on the Node window. Other resources are always started and stopped automatically, so there is no need to control them manually.

Note:

1. You must be a member of the login group system to define or modify resources for CS/AIX.
2. To use the Motif administration program, you must have a low-function terminal (LFT) or an X-terminal. Otherwise, you can use the System Management Interface Tool (SMIT) or the Web administration program, which provide facilities similar to those in the Motif program. For more information, see *IBM Communications Server for Data Center Deployment on AIX Administration Guide*.
3. For more information about the Motif administration program's user interface, including the buttons and icons that appear in its windows, refer to the program's help screens or to *IBM Communications Server for Data Center Deployment on AIX Administration Guide*.
4. The windows and dialogs in the Motif administration program may differ from those shown in this guide, depending on the choices you make on a particular dialog.

For information about other CS/AIX administration tools, including Web administration, command-line administration and NOF application programs, refer to *IBM Communications Server for Data Center Deployment on AIX Administration Guide*, *IBM Communications Server for Data Center Deployment on AIX Administration Command Reference*, or *IBM Communications Server for Data Center Deployment on AIX NOF Programmer's Guide*.

Planning for CS/AIX configuration

Before you make any configuration changes it is very important to plan thoroughly. Changes that you make can cause disruption, not only to the users of your local node but possibly to users all around the network.

You may find it useful to draw a diagram of any changes that you are making to the topology of the network. If you are adding or removing connections to other nodes, draw a picture showing your node and the other nodes. You can use the Motif administration program to gather configuration information about all of the existing connections and add that information to your diagram.

When you add new resources to your diagram, it is easy to see whether they duplicate existing ones, or whether any names clash. Similarly, your diagram can help you decide which resources you need to remove and help you avoid deleting essential ones.

If you are configuring a Client/Server CS/AIX system with more than one node, ensure that you include all the CS/AIX nodes and their connectivity resources in your diagram. You can then configure each node in turn as described in this chapter, in the same way as you would configure a standalone node.

Once you determine the changes you need to make, collect the configuration information that you need. To guide you in collecting configuration information for specific CS/AIX functions, you can use the task sheets provided in the online help for the Motif administration program, or the planning worksheets provided in *IBM Communications Server for Data Center Deployment on AIX Administration Guide*.

This chapter provides instructions for configuring the most frequently used functions available in CS/AIX. For each configuration task, this guide also notes the information you need to gather before configuring the resource.

Note: This guide does not provide detailed descriptions of the configuration information you need to enter on CS/AIX dialogs. For more information about the fields on a particular dialog, consult the online help for that dialog in the Motif administration program or SMIT.

Planning worksheets

Before you begin to configure resources for CS/AIX, gather all of the configuration data for the new resources. To record all of the information for a particular function or application that you need to support, use the planning worksheets provided in *IBM Communications Server for Data Center Deployment on AIX Administration Guide*.

You will probably need to gather configuration information from several sources, such as network administrators, host administrators, application programmers, and end users.

If you are trying to connect to another node, the administrator at that node is a key contact. The administrator for a node can tell you names, addresses and characteristics of all the resources on that node. Often, you will need to ensure that matching configuration parameters are entered at the local node and the remote node.

Task sheets

The online help screens in the Motif administration program contain task sheets that provide guidance for specific configuration tasks. The task sheets contain pointers to all of the help screens for the dialogs that you will use to enter the configuration information. You can use these to browse the help and see exactly what data you must collect.

The task sheets also refer to more detailed help for each of the individual windows and dialogs that you must use to enter configuration information. Those help screens explain each field that you must fill in or select.

Setting environment variables for use by CS/AIX

CS/AIX uses a number of environment variables to control its operation, which must be set before you enable the CS/AIX software on the server. The simplest way to manage these is to set them in a text file that CS/AIX reads on startup.

In the CS/AIX configuration directory, `/etc/sna`, create a text file named `environment`, and set each environment variable in a separate line. For example:

```
export LANG=en_US
export PATH='/usr/bin'
export LD_LIBRARY_PATH=/usr/lib:/usr/lib/sna
export LD_RUN_PATH=/usr/lib:/usr/lib/sna
```

Using the Motif administration program

Before you use the Motif administration program, you may want to add path information to your `.login` or `.profile` file to enable the system to find executable programs (see [“Specifying the path to CS/AIX programs”](#) on page 63). In addition, you must enable the CS/AIX software before you can use the administration program (see [“Enabling CS/AIX”](#) on page 63).

For information about invoking the Motif administration program and an overview of using the program, see [“Managing CS/AIX with the Motif administration program”](#) on page 63.

Specifying the path to CS/AIX programs

To run CS/AIX programs, you must specify the path to the directory that contains the CS/AIX executable programs. You can specify the path either by adding the directory to your PATH environment variable before you run the programs for the first time, or by including the directory name each time you run the programs.

The Motif administration program is stored in the directory `/usr/bin/X11`, and the other programs are stored in the directory `/usr/bin`. If you add these directories to the definition of the PATH environment variable in your `.login` or `.profile` file, CS/AIX locates the programs automatically. Alternatively, you can specify the directory name when you run the program, as in the following examples:

```
/usr/bin/sna start
/usr/bin/X11/xsnaadmin
```

The sample command lines shown in this manual assume that you have added the directories to your PATH environment variable, and do not include the directory names.

Enabling CS/AIX

CS/AIX must be enabled on the local system before you can configure or manage the local node. As with any X/Motif application, you may also need to set up the DISPLAY environment variable to indicate a suitable X server.

Normally, CS/AIX is enabled automatically after you install the software. If CS/AIX has been disabled, you can re-enable it by entering the following command at the AIX command prompt:

```
sna start
```

Note: When you use the `sna start` command, the CS/AIX software uses the directory from which you issued the command as its current working directory, and maintains one or more open file descriptors in that directory. This means that you will not be able to unmount the file system containing that directory while the CS/AIX software is running. To avoid problems, you should start the CS/AIX software from a directory on a filesystem that does not need to be unmounted; for example, you could use `cd /` to change to the root directory before using the `sna start` command.

When you install CS/AIX, the installation utility automatically updates the startup file `/etc/inittab` to add an entry for `/etc/rc.sna`, which includes the `sna start` command. This ensures that CS/AIX is started automatically at system startup. If you do not want CS/AIX to be started automatically, you can remove or comment out this line, and then follow the instructions in this section to enable the CS/AIX software manually.

CS/AIX writes messages to standard error (normally your terminal's screen) to indicate that it is initializing, and to indicate whether initialization completes successfully.

Managing CS/AIX with the Motif administration program

To use the Motif administration program for CS/AIX, first make sure that CS/AIX is initialized as described in [“Enabling CS/AIX”](#) on page 63. (You may also need to set up the DISPLAY environment variable to indicate a suitable X server.)

To start the Motif administration program in the background, issue the following command:

```
xsnaadmin &
```

CS/AIX displays the Domain window. This window shows all defined nodes, and enables you to start and stop nodes. Double-clicking on any node brings up the Node window for that node, as shown in [Figure 4 on page 65](#).

The Node window shows information about the node and its resources. If you have not yet configured the node, the administration program prompts you to configure it as described in [“Configuring the node” on page 68](#).

Note: This guide uses the term window to describe Motif windows that display information about CS/AIX resources. A window can contain one or more sections, or panes. A dialog is a Motif window on which you can enter information.

The Node window shows most of the information you need, and gives easy access to everything else. It shows all the key resources on the local node.

If you are configuring a Client/Server CS/AIX system with more than one node, follow the instructions in this chapter to configure each node in turn (returning to the Domain window to select the next node).

Other windows can be reached from the Windows menu in the Node window. These windows include the following:

- LU Pools window
- CPI-C Destination Names window

The Services menu in the Node window provides a quick way to add resources and provides help for configuration and management tasks. The Diagnostics menu takes you to the Logging dialog and Tracing dialog.

Node window

A sample Node window is shown in [Figure 4 on page 65](#). The title bar shows the name of the AIX system.

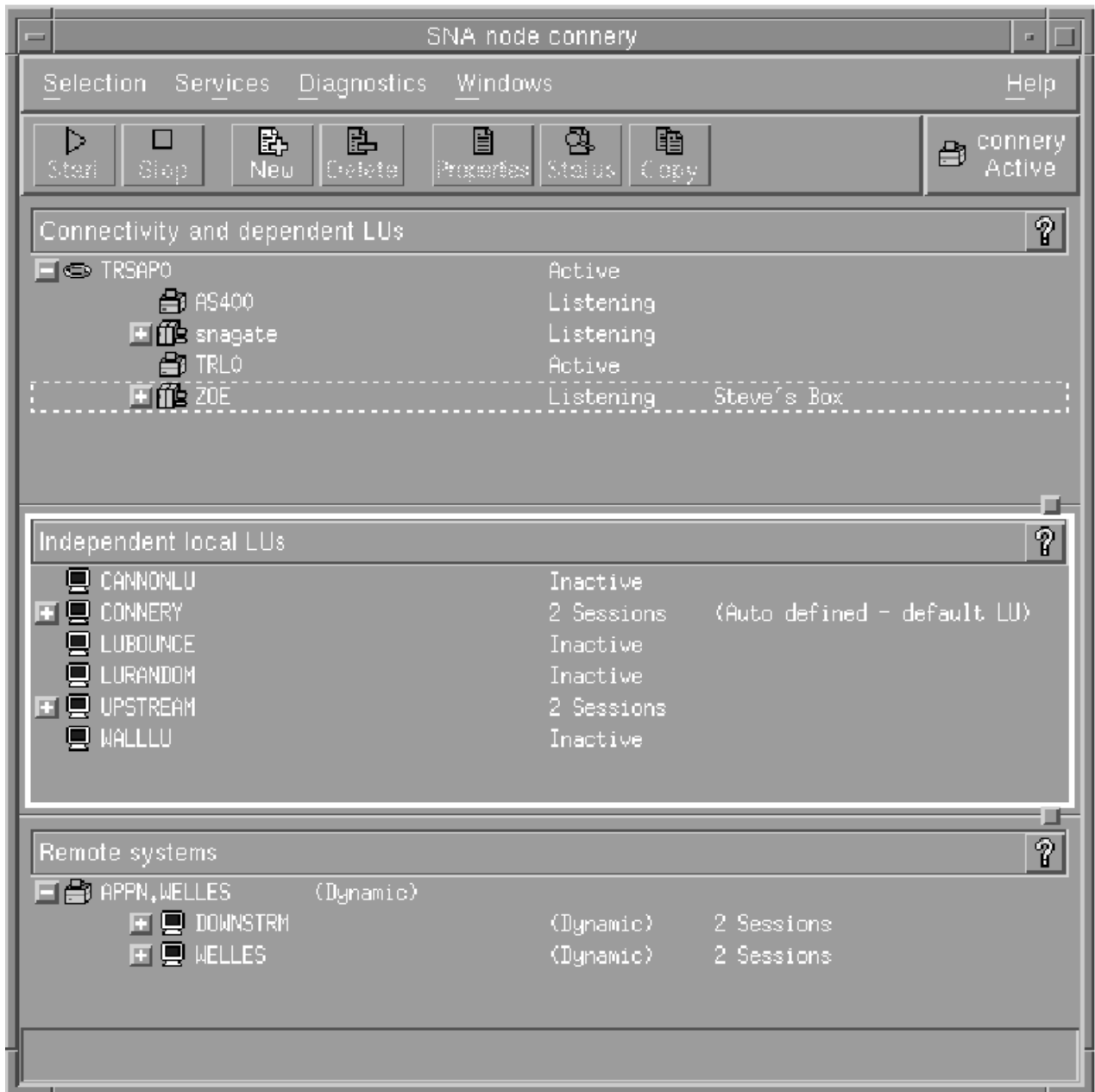

Figure 4. Node Window

From the Node window, you can configure and manage all of the resources and components for the CS/AIX node.

- Ports
- Link stations
- LUs of type 0-3 and dependent LUs of type 6.2
- DLUR internal PUs
- Independent local LUs
- Remote nodes
- Partner LUs

You can add, delete, modify and manage all of these resources from the Node window. The layout of the resources in the window shows the relationships among resources and enables you to control which resources are displayed.

Ports, local LUs, and remote nodes are always displayed. The Node window shows each link station below its parent port, and each dependent LU below its parent link station. It also shows partner LUs below local LUs and below remote nodes.

The Node window contains separate sections for the different types of resources for the node:

- The Node box in the top-right corner of the Node window indicates whether the node is **Active** or **Inactive**.
- The top pane of the Node window (the **Connectivity** pane) lists connectivity resources for the node, including ports, link stations or PUs on each port, and dependent LUs on a specific link station or PU. For each resource, this window shows current status information.
- The middle pane (the **Independent Local LUs** pane) shows independent LUs defined on the local node. This window also displays information about sessions using a particular LU, and any records that define a partner LU's location by the link station that is used to access it.
- The lower pane (the **Remote Systems** pane) shows information about remote nodes and partner LUs. It also shows session information for each remote node or partner LU.

You can select any of these panes by clicking on the pane. You can also select specific resources within a pane by clicking on the line for the resource. To view or modify the configuration for an item, you can double-click on the item. (You can use the buttons and menus on this window to access configuration information for specific resources.)

For each item listed, resources that belong to that item are nested within the information for that item. For example, link stations are grouped under the port to which they belong. You can click on the **Expand** button (+) next to an item to show the resources for that item if they are not currently displayed, or click on the **Contract** button (-) to hide the resources for an item.

You can perform the following administration tasks from the Node window:

Start or stop a resource

Select the resource and click on the **Start** or **Stop** button. (Alternatively, you can select **Start item** or **Stop item** from the **Selection** menu.)

Add a resource for an item

Select the item and click on the **New** button (or select **New** from the **Selection** menu). For example, to add a link station for a port, select the port and click on the **New** button.

Delete a resource

Select the resource and click on the **Delete** button (or select **Delete** from the **Selection** menu).

View or modify the configuration for any resource

Select the resource and click on the **Properties** button (or select **Properties** from the **Selection** menu).

Get status information for any resource

Select the resource and click on the **Status** button (or select **Status** from the **Selection** menu).

Copy the configuration for any resource

Select the resource and click on the **Copy** button (or select **Copy** from the **Selection** menu).

In addition, you can choose specific configuration tasks for the node from the **Services** menu, control logging (for the domain) and tracing (for the node) from the **Diagnostics** menu, and view or modify domain resources by selecting one of the items on the **Windows** menu.

Resource items

The layout of the resources in a window shows the relationships among them.

If an item has one or more child items associated with it, an **Expand** symbol (+) or **Contract** symbol (-) appears next to it:

- An **Expand** symbol indicates that the associated child items are hidden. You can click on the **Expand** symbol, or press the + key on the numeric keypad, to show them.

- A Contract symbol indicates that the child items are shown. You can click on the Contract symbol, or press the - key on the numeric keypad, to hide them.
- If an item has neither symbol next to it, the item has no associated child resources.

For example, a link station is associated with a particular port. In the Connectivity pane of the Node window, the link station is displayed below its parent port, along with all other link stations associated with that port. The port is always displayed, but you can choose whether the list of associated link stations is shown or hidden. Similarly, link stations with a list of associated LUs can be expanded to show the LUs, or contracted to hide them.

A parent resource must always be configured before its child resources, and deleting the parent resource causes all its child resources to be deleted too.

Tool bar buttons

Resource windows include tool bar buttons to make it easy to perform common functions. A tool bar for CS/AIX is shown in [Figure 5](#) on page 67.



Figure 5. CS/AIX Tool Bar

Not all buttons appear in the tool bars of each resource window. If a button's operation is not valid for the currently selected item (or an operation requires an item to be selected, but none is), the outline of the button is displayed in gray, and the function cannot be selected (clicking on the button has no effect). The following buttons can appear on resource windows:

Start

Starts the selected item.

Stop

Stops the selected item.

New

Adds a new resource item.

Delete

Deletes the selected resources.

Properties

Opens the dialog for the selected item to view or modify the item's configuration.

Status

Displays the current status of the selected item.

Copy

Copies the selected item. Clicking on this button opens a dialog whose fields duplicate the configuration of the selected item. Complete the dialog's fields (filling in the new item's name) to add the new resource.

Many resources, such as ports and link stations, cannot be modified while they are active. You can, however, view an active resource's parameters by selecting the resource and clicking on the Properties button to open its dialog. Click on the Close button when you are finished.

Configuring Client/Server functions

This section is relevant only if you installed CS/AIX to run in a client/server environment (with multiple CS/AIX nodes in the same network).

In a client/server environment, a server can be marked as a configuration server; CS/AIX maintains a list of these configuration servers. The first server listed is the controller server, and any other servers listed are backup servers. The servers are listed in order, so that the second server listed (the first backup

Configuring the Node

server) takes over if the controller server is unavailable, the third server listed (the second backup server) takes over if neither the controller nor the first backup server is available, and so on.

When any of the nodes in the domain are active, the first available configuration server in the domain (the first server that can be contacted and has CS/AIX software running) becomes the controller server. If the current controller becomes unavailable (because it cannot be contacted, perhaps due to a network failure, or because the SNA software running on it is stopped), the next available configuration server in the list becomes the new controller.

CS/AIX can run without a controller. This happens if none of the servers in the configuration server list can be contacted. If this happens, you can view and configure node resources only on the servers that can be contacted.

Note: You cannot directly indicate which node acts as the controller server; the controller server is selected based on the order in which nodes are added to the configuration server list. If you wish to move a server to the top of the list, remove all other nodes from the list and then add them again.

In the Motif administration program Domain window, you can add a configuration server by selecting `Make configuration server` from the Selection menu. The server is added to the end of the list; it becomes the controller server only if all other configuration servers are unavailable. To remove a server, select `Remove configuration server` from the Selection menu.

Note: You cannot delete a server if it is the only server listed on which the CS/AIX software is running, because in this case there is no other server that can take over as the controller server. At least one enabled controller server is required in a client/server configuration.

For more information about configuring and managing a Client/Server CS/AIX system, refer to *IBM Communications Server for Data Center Deployment on AIX Administration Guide*. This manual also provides information about advanced Client/Server configuration, including how to move clients and servers into different CS/AIX domains and how to configure the details of client operation.

Configuring the node

The first step in configuring CS/AIX on a system is to configure the local node. Node configuration provides the basic information that the node needs in order to communicate in an SNA network. You must configure the node before you can define connectivity or other resources for the node.

If the node has already been configured, you can use the procedures described in this section to modify the node configuration; but you must stop the node before making configuration changes.

Before configuring the node, decide whether to configure the node as an APPN node or as a non-APPN node. This decision depends on the capabilities of the other SNA nodes with which you are communicating.

A CS/AIX node that communicates directly with a host computer is shown in [Figure 6 on page 68](#).

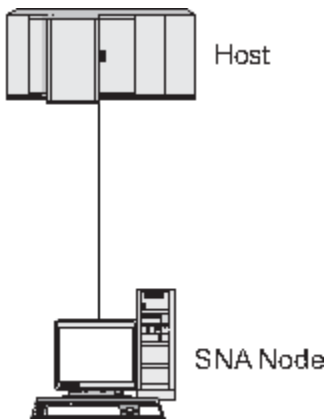

Figure 6. CS/AIX Node That Communicates Directly with a Host

If the host does not support APPN, configure the CS/AIX node as a LEN node. If the host supports APPN, you can configure the CS/AIX node as either an APPN network node or an APPN end node (if CS/AIX uses SNA only for communication with the host, you probably want to configure the CS/AIX node as an end node or branch network node).

Several CS/AIX nodes in an APPN network are shown in [Figure 7 on page 69](#).

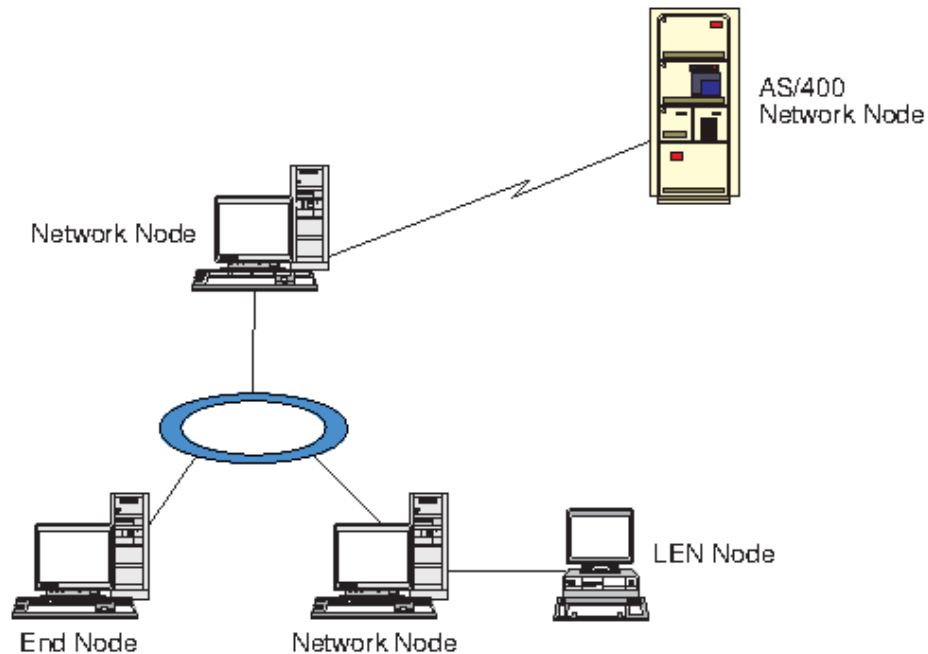

Figure 7. CS/AIX Nodes in an APPN Network

When the local node is part of an APPN network, configure it as an APPN network node if the node is to provide APPN routing services for other nodes. If other nodes provide routing services, configure the local node as an APPN end node. If the local node only communicates with one directly connected node (which can be of any type), configure the node as a LEN node.

Before you begin the node configuration, gather the following information:

- Type of APPN support (network node, branch network node, end node, or LEN node).
- Control point name (and alias, if different). Consult with your network planner to determine this name.
- Default Node ID. (You can override this default when configuring an individual communications link.)

To configure the node, perform the following steps from the Node window:

1. Select **Configure node parameters** from the **Services** menu, or double-click on the Node box in the top-right corner of the Node window. CS/AIX displays the Node Parameters dialog.
2. Specify the level of APPN support, the control point name, and (if necessary) the default node ID.
3. Click on the **OK** button to define the node. When you define the node, CS/AIX automatically defines a default LU with the same name as the control point.

To exit without saving the values you have entered, click on the **Cancel** button.

Configuring connectivity

For a CS/AIX node to communicate with other nodes, you must configure connectivity with at least one adjacent node. A connecting link can be configured to carry dependent traffic, independent traffic, or both.

You can have adapter cards for one or more link protocols installed in your computer. Much of the information you need to enter to configure connectivity depends on the link protocol you are using. For a list of the link protocols supported by CS/AIX, see [“Installation requirements” on page 17](#).

Configuring connectivity

To configure a link, you need to define a port and (in most cases) a link station. When using the Motif administration program, a DLC (data link control) is automatically configured as part of the configuration for the port. In addition, you have the option of defining the port as part of a connection network.

The links that you need to configure depend on what you are trying to achieve, and on whether your network is an APPN network. The information required depends on the link protocol, and on whether the link is for dependent traffic, independent traffic, or both.

As examples, this section explains how to configure the following types of links:

- Link supporting dependent traffic with a host system using an SDLC line.
- Link supporting both dependent and independent traffic into an APPN network using the Ethernet link protocol. This example also defines a connection network on the Ethernet port.
- Enterprise Extender link into an APPN network (note that Enterprise Extender links support only independent traffic).

For other link protocols, refer to *IBM Communications Server for Data Center Deployment on AIX Administration Guide* or the online help for the Motif administration program.

Configuring an SDLC link for dependent traffic

For an SDLC (synchronous data link control) port, you need the following information:

- SNA port name (you can generally use the default). You also need to supply the SDLC device number.
- Whether the port should activate automatically when the node is started.
- Line type (switched outgoing, switched incoming, or leased line).
- Link role (primary, secondary, negotiable, primary multi-drop, or secondary multi-PU).
- Poll address (only for a switched incoming line on a nonprimary port). For other types of ports, you configure the poll address on the link station.

For switched incoming and leased lines, you also need the encoding (NRZ or NRZI) and the duplex setting (half or full). For other types of ports, you configure the encoding and duplex setting on the link station.

- Physical link type (to identify the type of modem).
- Dial string (only needed for a switched incoming line). For a switched outgoing line, configure the dial string on the link station.

For an SDLC link station, you need the following additional information:

- Activation method (by administrator, on node startup, or on demand).
- Type of traffic supported (for this example, dependent only).
- Remote node role (for this example, host).

To configure the SDLC link, perform the following steps from the Node window:

1. Configure the port:
 - a. Select the Connectivity pane of the window.
 - b. Select **New port** from the Connectivity submenu on the Services menu (or click on the **New** button in the button bar).
 - c. On the resulting dialog, select the protocol type from the option menu, then choose to define a port.
When you click on the OK button, CS/AIX displays the SDLC Port dialog.
 - d. Enter appropriate values in the fields on the dialog.
 - e. Click on the OK button to define the port.

The port appears in the Connectivity pane of the Node window.

2. Define a link station on the port:

- a. Make sure you have selected the port to which the link station is being added in the Connectivity pane of the Node window.
- b. Select **New link station** from the Connectivity submenu on the Services menu (or click on the New button in the button bar).
- c. Click on the OK button.

CS/AIX displays the SDLC Link Station dialog.

- d. Enter appropriate values in the fields on the dialog.
- e. Click on the OK button to define the link station.

The link station appears beneath the port to which it belongs in the Connectivity pane of the Node window.

Configuring an Ethernet link to support dependent and independent traffic

This example shows how to configure an Ethernet link supporting both dependent and independent traffic into an APPN network. In addition, it defines a connection network on the Ethernet port.

For an Ethernet port, you need the following information:

- SNA port name (you can generally use the default). If you have multiple Ethernet network adapter cards, you also need to supply the Ethernet card number. You also need to specify the local SAP (service access point) number (normally 04).
- Whether the port should activate automatically when the node is started.
- Connection network name (must be the same on all ports in the same connection network).

For an Ethernet link station, you need the following additional information:

- Activation method (by administrator, on node startup, or on demand).
- Type of traffic supported (for this example, both dependent and independent).
- Remote node control point name (only needed for a LEN node).
- Remote node type (network node, end node, or discover).
- Remote node role (for this example, downstream SNA gateway or passthrough DLUR).
- To configure a selective link station, you need the MAC (medium access control) address and the SAP number (normally 04) for the remote station. If you do not supply address information and you specify **By administrator** for the *Activation* field, the link station is a nonselective listening link station.

To configure the Ethernet link, perform the following steps from the Node window:

1. Configure the port:

- a. Select the Connectivity pane of the window.
- b. Select **New port** from the Connectivity submenu on the Services menu (or click on the New button in the button bar).
- c. On the resulting dialog, select the protocol type from the option menu, then choose to define a port.

When you click on the OK button, CS/AIX displays the Ethernet SAP dialog.

- d. Enter appropriate values in the fields on the dialog.
- e. Click on the OK button to define the port.

The port appears in the Connectivity pane of the Node window.

2. Define a link station on the port:

- a. Make sure you have selected the port to which the link station is being added in the Connectivity pane of the Node window.
- b. Select **New link station** from the Connectivity submenu on the Services menu (or click on the New button in the button bar).
- c. Click on the OK button.

Configuring Type 0-3 LUs

CS/AIX displays the Ethernet Link Station dialog.

- d. Enter appropriate values in the fields on the dialog.
- e. Click on the OK button to define the link station.

The link station appears beneath the port to which it belongs in the Connectivity pane of the Node window.

Configuring an Enterprise Extender link

This example shows how to configure an Enterprise Extender link into an APPN network. Note that Enterprise Extender links support only Independent LU traffic.

For an Enterprise Extender port, you need the following information:

- SNA port name (you can generally use the default). If you have multiple network adapter cards running IP, you also need to supply the IP interface name you want to use (such as `eth0`).
- Whether the port should activate automatically when the node is started.

For an Enterprise Extender link station, you need the following additional information:

- Activation method (by administrator, on node startup, or on demand).
- Remote node type (network node, end node, or discover).
- To configure a selective link station, you need the IP hostname or IP address for the remote station. If you do not supply this information and you specify `By administrator` for the *Activation* field, the link station is a nonselective listening link station.

To configure the Enterprise Extender link, perform the following steps from the Node window:

1. Configure the port:

- a. Select the Connectivity pane of the window.
- b. Select `New port` from the Connectivity submenu on the Services menu (or click on the `New` button in the button bar).
- c. On the resulting dialog, select the protocol type from the option menu, then choose to define a port.
When you click on the OK button, CS/AIX displays the IP Port dialog.
- d. Enter appropriate values in the fields on the dialog.
- e. Click on the OK button to define the port.

The port appears in the Connectivity pane of the Node window.

2. Define a link station on the port:

- a. Make sure you have selected the port to which the link station is being added in the Connectivity pane of the Node window.
- b. Select `New link station` from the Connectivity submenu on the Services menu (or click on the `New` button in the button bar).
- c. Click on the OK button.
CS/AIX displays the IP Link Station dialog.
- d. Enter appropriate values in the fields on the dialog.
- e. Click on the OK button to define the link station.

The link station appears beneath the port to which it belongs in the Connectivity pane of the Node window.

Configuring type 0-3 LUs

To support user applications that use type 0-3 LUs, you must configure dependent LUs. Before doing so, you must perform the following configuration:

- Configure the node as described in [“Configuring the node”](#) on page 68.
- Configure a link to support dependent LU traffic as described in [“Configuring connectivity”](#) on page 69.

You do not need to configure a direct link to the host if you have an upstream link to another node using SNA gateway, or if you are using DLUR. For more information, see [“Configuring SNA gateway”](#) on page 80 and [“Configuring DLUR”](#) on page 82.

You must configure dependent LUs of types 0-3 to support communication with a host system. You can use the information in this section to define an LU to support LUA, DLUR, or PU Concentration. You can also define a range of LUs, to configure multiple LUs of the same type in a single operation.

In addition, you can define a pool of LUs to be used as required, either by assigning an LU to a pool when you define the LU or by assigning previously defined LUs to a pool.

Defining Type 0-3 LUs

Before configuring the 3270 LU, gather the following information:

- LU name. (This is a local identifier, and does not have to match the host configuration.)
- LU number (or numbers for a range of LUs).
- LU type (3270 display model or 3270 printer).
- Pool name (if you are adding the LU to a pool).

To configure an LU of types 0-3 for a previously defined link station, perform the following steps from the Node window:

1. Select the link station to the host in the Connectivity pane of the window.
2. Click on the New button.
3. Select the LU type (New 3270 display LU or New 3270 printer LU) on the resulting dialog.
When you select this item and click on OK, CS/AIX displays the LU Type 0-3 dialog.
4. Enter appropriate values in the fields on the dialog.
5. Click on OK to define the LU.

The LU appears in the Connectivity pane of the Node window, below the link station to the host.

Defining an LU pool

For LU type 0-3, you can define LU pools to simplify user configuration and provide greater flexibility in establishing host sessions. For example, you can define several LUs in a single LU pool, then configure multiple users using this LU pool. This makes configuring the users' sessions easier and enables any session to use any LU in the pool.

Note: You can assign a user's session either to a specific LU or to an LU pool.

- If you assign the user's session to a specific LU that is in a pool, the session uses this LU if it is available; otherwise it uses any free LU from the pool, as though you had assigned it to the LU pool instead of the specific LU.
- If you want the user to use only a specified LU, so that the user's session cannot be established if the LU is already in use, ensure that the LU is not in a pool.

You can view the LU pools for the local CS/AIX node using the LU Pools window. This window lists the LU pools configured on the local system, and enables you to select LUs to add to an LU pool.

You can add the following LU types to a pool (do not mix LUs of different types in the same pool):

- 3270 display LU
- Unrestricted LU

Before you can add LUs to a pool, the LUs must be defined on the local node.

To configure an LU pool, perform the following steps from the Node window:

Configuring APPC communication

1. Select LU Pools from the Windows menu.

CS/AIX displays the LU Pools window.

2. Click on the New button.

CS/AIX displays the LU Pool Configuration dialog.

The box on the right lists LUs that are not yet allocated to any pool. Any of these LUs can be included in the new pool.

3. Select the LU or LUs you wish to add to the pool, and click on the New button to move the selected LUs to the box on the left.

To remove an LU from the box on the left, select it and click on the Remove button.

4. Click on OK to define the LU pool.

All of the LUs in the box on the left are added to the LU pool.

The pool appears in the LU Pools window.

Configuring APPC communication

APPC applications and CPI-C applications require that you configure APPC first. An APPC application uses the node's LU type 6.2 resources to communicate with another APPC or CPI-C application on a host or peer computer, using a specified mode.

Before you can configure APPC communication, you must perform the following configuration:

1. Configure the node as described in [“Configuring the node”](#) on page 68.
2. Configure connectivity as described in [“Configuring connectivity”](#) on page 69.

The remaining configuration steps depend on whether the configuration supports dependent traffic, independent traffic, or both:

Independent APPC

Independent APPC uses independent LUs. Each LU-LU session involves a local LU and a partner LU.

For the local LU, you can use the predefined default LU associated with the node control point, or you can configure new local LUs.

The partner LU need not be configured at all if the CS/AIX node is an end node or network node in an APPN network, because APPN can locate partner LUs dynamically. However, you do have to configure the partner LU if your network is not an APPN network or if the node is a LEN node. In this case, you must configure the remote node where the partner LU resides, then define the partner LU on the remote node.

Dependent APPC

If the remote node is a host that does not support independent LU 6.2, configure for dependent traffic. For dependent APPC, you must configure a local LU.

If the applications use CPI-C, you may need to do additional CPI-C configuration after configuring APPC (see [“Configuring for CPI communications”](#) on page 79). A CPI-C application uses the node's LU type 6.2 and mode resources to communicate with another APPC or CPI-C application on a host or peer computer. You define the same resources for a CPI-C application as for an APPC application. In addition, if the TP on the CS/AIX computer is the invoking TP, also known as the source TP (the TP that starts the conversation), you may need to define one or more side information entries for it, as described in [“Configuring for CPI communications”](#) on page 79. Each of these entries provides information on a partner TP, the LU and mode resources used to access it, and any security information required.

This section explains how to configure a simple APPN network (using independent LU 6.2) that consists of a network node, an end node, and a LEN node, as described in [“Configuring a simple APPN network”](#) on page 75. (This scenario also shows how you can get status information for CP-CP sessions between two nodes.)

This section also explains how to configure dependent APPC communication, as described in [“Configuring dependent APPC”](#) on page 78.

Both of these scenarios assume that APPC sessions use a standard mode and class-of-service (COS).

For information about configuring additional APPC information, such as modes, security, and invocable (target) TPs, refer to *IBM Communications Server for Data Center Deployment on AIX Administration Guide*.

Configuring a simple APPN network

The simplest APPN network you can configure includes only two nodes: an APPN network node and an APPN end node. The network node handles session routing for the end node.

Configuring a network node

This scenario assumes that you are using the control point LU and a standard mode, and that you are using a LAN link type (Token Ring, Ethernet). In this case, you can configure the network node simply by performing the following configuration tasks:

1. Configure the node as described in [“Configuring the node”](#) on page 68. For the *APPN support* field, select the value `Network node`. Make a note of the control point name.
2. Configure connectivity as described in [“Configuring connectivity”](#) on page 69. Configure the link to support independent traffic.

To contact this network node from an adjacent end node, you'll need to know the MAC address and SAP number of the port on the network node. You can use the following procedure to get the MAC address on a CS/AIX node:

1. Select the port on the Node window.
2. Click on the **Start** button to start the port.
3. Click on the **Status** button to get status information for the port. The Port Status dialog shows the MAC address and SAP number.
4. Make a note of the MAC address and SAP number so you can enter those values on the link station configuration dialog for the end node.

Configuring an end node

This scenario assumes that you are using the control point LU and a standard mode, and that you are using a LAN link type (Token Ring, Ethernet). In this case, you can configure the network node simply by performing the following configuration tasks:

1. Configure the node as described in [“Configuring the node”](#) on page 68. For the *APPN support* field, select the value `End node`.
2. Configure connectivity as described in [“Configuring connectivity”](#) on page 69. Configure the link to support independent traffic, and supply the following information for the link station:
 - Enter the name of the network node (see [“Configuring a network node”](#) on page 75) as the value for the *Remote node* field.
 - Enter the MAC address and SAP number for the port on the network node in the Contact Information pane on the link station configuration dialog.

In an APPN network, a single link station to an adjacent network node can be used to communicate with any remote node in the network, so you do not need to configure a separate link station to each remote node.

Verifying connectivity between two nodes

This scenario assumes that you have configured a network node as described in [“Configuring a network node”](#) on page 75, and an end node as described in [“Configuring an end node”](#) on page 75. You can perform the following procedure from the end node:

1. On the Node window, select the link station that connects to the adjacent network node.
2. Click on the Start button to start the link station.

When the link station is started, the CP-CP sessions between the two nodes are established automatically. Those sessions are displayed in the Independent Local LUs pane of the Node window.

3. To get status information for a session, select the session on the Node window and click on the Status button.

Configuring an independent APPC LU

In many cases, applications can use the local node's control point LU, which is automatically defined when you configure the node. This is the default LU - if your application does not specify a particular LU, it can use this one. If the application uses the default LU, you do not need to define a local LU. Check the documentation for your APPC application, or contact the application programmer.

To configure an independent LU 6.2, you need the following information:

- Local LU name.
- Local LU alias (if an alias is used in a TP that this LU supports).

To configure an independent local LU, perform the following steps from the Node window:

1. Select the Independent Local LUs pane of the window.
2. Select New independent local LU from the APPC submenu on the Services menu (or click on the New button).

CS/AIX displays the Local LU dialog.

3. Enter appropriate values in the fields on the dialog.
4. Click on the OK button to define the local LU. The independent LU appears in the Independent Local LUs pane of the Node window.

Configuring partner LUs for a LEN node

You must define a remote node (and the partner LUs on the node) in the following situations:

- If the local node is a LEN node, you must define all of the remote nodes and any partner LUs on the remote node with which it communicates using APPC. A LEN node is not able to dynamically locate partner LUs; the remote node definition enables it to do so.
- If the local node is not part of an APPN network (for example, if you have two end nodes directly connected, with no network node server), LUs cannot be located dynamically. In this case, you must configure each partner LU.
- If the remote node is a LEN node and the local node is a network node that acts as the LEN node's network node server, you must define the LEN node (and its partner LUs) as a remote node on the network node server. This definition enables nodes in the rest of the APPN network to locate LUs on the LEN node.
- If the remote node is in a different APPN network, you must define the remote node because it cannot be dynamically located.

Do not define partner LUs if both the local and remote nodes are part of the same APPN network.

When you add a remote node definition, a partner LU with the same name as the remote node is automatically added; this is the control point LU for the remote node. If your application uses this partner LU, you do not need to add another partner LU, although you may want to add an LU alias for the partner LU. To add an alias, double click on the partner LU and enter the alias in the Partner LU Configuration dialog.

If your application uses an LU alias to refer to its partner LU, you should add a partner LU alias definition.

If either the local node or the remote node is a LEN node, you must define the partner LU as a child of the remote node, because a LEN node cannot take part in dynamic location of LUs. If your application uses

the control point LU of the remote node as its partner LU, the control point LU was defined automatically when you defined the remote node.

You can use the Motif administration program to add a partner LU alias (see [“Defining a partner LU alias”](#) on page 77), add a definition of a partner LU on a specific remote node (see [“Defining a partner LU on a remote node”](#) on page 77), or define multiple partner LUs using wildcards (see [“Defining multiple partner LUs using wildcards”](#) on page 78).

Defining a remote node

Before configuring a remote node, you need the following information:

- Fully qualified SNA network name of the node.

To configure a remote node, perform the following steps from the Node window:

1. Select the Remote Systems pane of the window.
 2. Select `New remote node` from the APPC submenu on the Services menu (or click on the `New` button in the button bar, then select `Define remote node`).
- CS/AIX displays the Remote Node Configuration dialog.
3. Enter appropriate values in the fields on the dialog.
 4. Click on the OK button to define the remote node. The remote node appears in the Remote Systems pane of the Node window.

When you define a remote system, CS/AIX automatically defines the control point LU on the remote node as a partner LU on the local node.

Defining a partner LU alias

To define a partner LU alias, you need the following information:

- Fully qualified partner LU name (SNA network name and LU name)
- Partner LU alias used by a local TP

To add a partner LU alias, perform the following steps from the Node window:

1. Select the Remote Systems pane of the window.
 2. Select `APPC, New partner LUs, and Partner LU alias` from the Services menu (or click on the `New` button in the button bar, and select `Define partner LU alias`).
- CS/AIX displays the Partner LU Alias Configuration dialog.
3. Enter the partner LU name and alias on the dialog.
 4. Click on the OK button to define the partner LU alias. The partner LU alias appears in the Remote Systems pane of the Node window (as part of the Network definition).

Defining a partner LU on a remote node

To define a partner LU on a specific remote node, you need the following information:

- Fully qualified partner LU name.
- Partner LU alias (if an alias is used by a local TP).
- Fully qualified name of the node that contains directory information for the partner LU.

To add a partner LU definition for a specific remote node, perform the following steps from the Node window:

1. Select the remote node.
2. Select `APPC, New partner LUs, and Partner LU on remote node` from the Services menu (or click on the `New` button in the button bar, and select `Define partner LU on remote node`).

CS/AIX displays the Partner LU Configuration dialog.

3. Enter the appropriate values in the fields on the dialog.
4. Click on the OK button to define the partner LU. The partner LU alias appears in the Remote Systems pane of the Node window, under the remote system to which it belongs.

Defining multiple partner LUs using wildcards

You can use wildcards to configure the location for a set of partner LUs that are all located on the same remote node and whose names start with the same characters. Using wildcards means that you do not need to configure each partner LU individually.

When you define partner LUs using wildcards, you must supply the following information:

- Wildcard partner LU name. The wildcard partner LU name consists of two type A EBCDIC strings, each of 1-8 characters, that match the fully qualified LU names of multiple partner LUs.

The first string can be a complete SNA network name that matches the network name for the partner LUs exactly, or a wildcard prefix that matches the beginning of the network name. If you enter a wildcard prefix for the network name, leave the second string blank.

If you supply a complete SNA network name for the first string, you can also enter a value for the second string. (You cannot enter the second string unless you supplied a valid SNA network name for the first string.) The second string is treated as a wildcard prefix, which must match the start of the second part of the fully qualified partner LU names.

- Name of the node where the partner LUs are located.

To add multiple partner LUs, perform the following steps from the Node window:

1. Select the remote node for which you are defining the partner LUs.
2. Select APPC, New partner LUs, and Wildcard partner LUs on remote node from the Services menu (or click on the New button in the button bar, and select Define wildcard partner LUs on remote node).

CS/AIX displays the Wildcard Partner LU Configuration dialog.

3. Enter the appropriate information in the fields on the dialog.
4. Click on the OK button to define the partner LUs. The partner LUs appear in the Remote Systems pane of the Node window, under the remote node to which they belong.

Configuring dependent APPC

To configure a dependent LU 6.2, you need the following information:

- Local LU name.
- Local LU alias (if an alias is used in a TP that this LU supports).
- Name of the link station that provides the connection to the host.
- LU number.
- Whether the LU should be assigned to the default pool for dependent LU 6.2.

If you are configuring dependent LUs of type 6.2 for use with APPC or CPI-C applications, you may wish to define them as members of the default pool. An application that does not specify a particular local LU is assigned an unused LU from the pool of LUs defined as default LUs.

To configure a dependent local LU, perform the following steps from the Node window:

1. Select a link station in the Connectivity pane of the window.
2. Select New dependent local LU from the APPC submenu on the Services menu (or click on the New button in the button bar, and select New dependent local LU).

CS/AIX displays the Local LU dialog.

3. Enter appropriate values in the fields on the dialog.

- Click on the OK button to define the local LU. The dependent LU appears in the Connectivity pane, below the link station to which it belongs.

Configuring for CPI communications

If you are supporting a CPI-C application that uses CPI-C symbolic destination names, you need to define the CPI-C side information. The side information associates the symbolic destination name with information about the partner TP, partner LU, mode, and security for the conversation.

To determine the symbolic destination name for CPI-C, consult the application developer (or for a third-party application, consult the product documentation).

Before configuring CPI-C side information, you need the following information:

- Symbolic destination name used by the TP
- Partner TP name
- Partner LU name or alias
- Mode name

To configure CPI-C side information, perform the following steps from the Node window:

- Select CPI-C from the APPC sub-menu in the Services menu.
CS/AIX displays the CPI-C Destination Names window.
- Click on the New button.
CS/AIX displays the CPI-C Destination Configuration dialog.
- Enter appropriate values in the fields on the dialog.
- Click on the OK button to define the CPI-C side information.

Configuring LUA

The LUA API can be used for applications that use LU types 0-3 to communicate with a host computer. (For detailed information about the LUA API, refer to *IBM Communications Server for Data Center Deployment on AIX or Linux LUA Programmer's Guide*.)

Before configuring LUA, perform the following configuration:

- Configure the node as described in [“Configuring the node”](#) on page 68.
- Configure connectivity for dependent traffic as described in [“Configuring connectivity”](#) on page 69. (If you are using upstream SNA gateway or DLUR, configure the link to the upstream node instead of a direct link to the host.)

To configure LUA, you need the following information:

- LU name or LU pool name.
- LU number for each LU. The LU number must match the LU number configured on the host.

To configure LUA, define the LU using the following procedure:

- Select the link station to the host in the Connectivity pane of the Node window.
- Click on the New button.
- On the resulting dialog, select **New LU for LUA**.
- Enter appropriate values in the fields on the dialog. Specify an LU type of Unrestricted.
- Click on the OK button. The LU appears in the Connectivity pane of the Node window, beneath the link station to the host.
- If you are going to use any LU pools, define them as described in [“Defining an LU pool”](#) on page 73.

Configuring SNA gateway

In addition to providing direct access to a host computer, CS/AIX can provide SNA gateway facilities. This feature enables other computers to access a host computer through a CS/AIX node, instead of requiring a separate connection to the host from each computer.

The SNA gateway feature is shown in [Figure 8 on page 80](#).

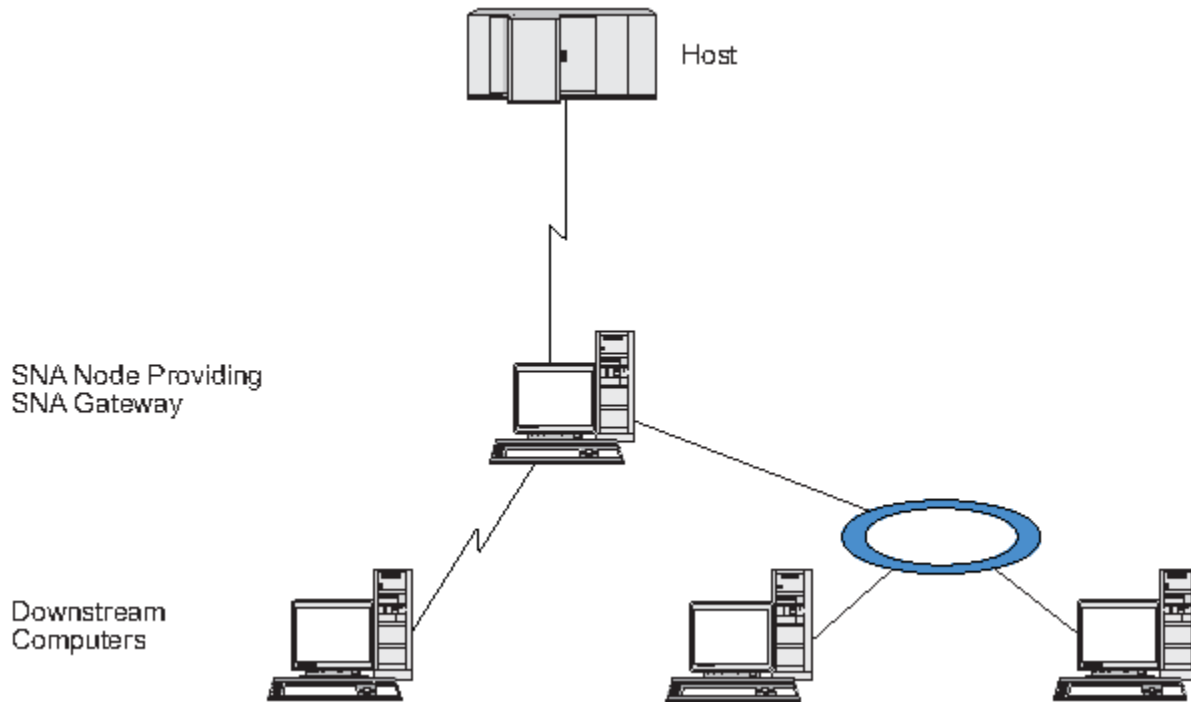

Figure 8. SNA Gateway

The downstream computer must contain an SNA PU type 2.0 or 2.1 to support dependent LUs. For example, the downstream computer could be another CS/AIX computer or a PC running Communications Server for Windows.

When the local CS/AIX node uses the SNA gateway feature, all the data transferred between the host and the downstream computer is routed through the local node. This enables a downstream computer to share a host connection with CS/AIX or with other downstream computers, instead of requiring a direct link. For example, you could set up several downstream computers connected to CS/AIX over a local token ring network, so that they could all access the same long-distance leased line from CS/AIX to the host.

Using SNA gateway also simplifies the configuration at the host, because you do not need to define the downstream computers and the communication links to them. The host configuration needs to include only the CS/AIX computer and its host communication link; the LUs at the downstream computers are configured as part of the resources of the CS/AIX computer. The host computer is not aware that SNA gateway is being used.

Before configuring SNA gateway, you must perform the following configuration tasks:

- Define the local node as described in [“Configuring the node” on page 68](#).
- Configure a port and link station for dependent traffic between the local node and the host, as described in [“Configuring connectivity” on page 69](#). Also, configure ports and link stations for dependent traffic between the local node and the downstream nodes. If you need to support downstream LUs that are not defined in advance, you can define a template on the port to support implicit PUs and downstream LUs (see [“Supporting implicit downstream LUs” on page 81](#)).

- Define the LUs on the local node that are used for communication with the host (upstream LUs). Define the upstream LUs as LU type 0-3 with an LU type of Unrestricted (unknown). (The LUs on downstream nodes can be any LU type.)
- If you are going to use any LU pools, define them as described in [“Defining an LU pool”](#) on page 73.

Supporting implicit downstream LUs

To support downstream LUs that are not predefined to CS/AIX, you can define a template on the port for implicit downstream PUs and LUs (for basic port configuration, see [“Configuring connectivity”](#) on page 69). These templates provide support for downstream LUs without requiring that you configure an LU on the local node to support every LU on a downstream node.

Before configuring a downstream LU for SNA gateway, you need the following information:

- Range of LU numbers to support downstream LUs.
- Host LU name.

To define a template for implicit downstream LUs, perform the following steps:

1. If you have already configured the port, double-click on the port definition in the Connectivity pane of the Node window. CS/AIX displays the port configuration dialog.

If you have not already configured the port, do so now:

- a. Select the Connectivity pane on the Node window.
- b. Click on the New button.
- c. On the resulting dialog, choose to define a port and select the link protocol type.

CS/AIX displays the port configuration dialog.

- d. Enter the basic port parameters as described in [“Configuring connectivity”](#) on page 69.
2. Click on the Advanced button at the bottom of the dialog.
CS/AIX displays the Port Parameters dialog. The lower pane shows settings that affect downstream LU templates.
 3. Select the *Configure downstream LUs for implicit PU access* option.
 4. Click on OK.
CS/AIX displays the Downstream LU Template Configuration dialog.
 5. Enter appropriate values in the fields on the dialog.
 6. Click on OK to define the implicit downstream LU template.

Defining downstream LUs

Before configuring a downstream LU for SNA gateway, you need the following information:

- LU name for each downstream LU. (This is a local identifier, and does not have to match the configuration of the downstream system.)
- LU number for each downstream LU.
- Link station to the downstream node.
- Upstream LU name (for the host LU).

To configure a downstream LU for SNA gateway, perform the following steps:

1. Select the link station to the downstream node in the Connectivity pane of the Node window.
2. Click on the New button.
3. Select New downstream LU and click on OK.

CS/AIX displays the Downstream LU dialog.

4. Enter appropriate values in the fields on the dialog.

Configuring DLUR

5. Click on OK to define the downstream LU.

The LU definition appears in the Connectivity pane of the Node window, below the link station to the downstream node.

Configuring DLUR

In addition to providing direct access to a host computer, CS/AIX can provide dependent LU requester (DLUR) facilities. This feature enables sessions for dependent LUs to span multiple nodes in an APPN network, instead of requiring a direct connection to the host.

Normally, a dependent LU session requires a direct communications link to the host computer. If many nodes (including a host node) are connected together in an APPN network, some of them may not have a direct connection to the host, but only an indirect connection through another node. It is not possible to establish dependent LU sessions to the host from LUs in these indirectly connected nodes.

Dependent LU requester (DLUR) is an APPN feature designed to overcome this limitation.

DLUR on an APPN node (such as a CS/AIX node) works in conjunction with dependent LU server (DLUS) at the host, to route sessions from dependent LUs on the DLUR node across the APPN network to the DLUS host. The route to the host can span multiple nodes and can take advantage of APPN's network management, dynamic resource location, and route calculation facilities. DLUR must be available on the node where the LUs are located, and DLUS must be available on the host node, but DLUR is not required on any intermediate nodes in the session route.

If the CS/AIX DLUR node is a network node or a Branch Network Node, it can also provide passthrough DLUR facilities for dependent LUs on downstream computers connected to the CS/AIX node. These LUs can use DLUR on the CS/AIX node to access the host across the network, in the same way as for LUs internal to the node. The downstream computers do not run DLUR, and indeed do not need to be aware that DLUR is being used.

Figure 9 on page 82 shows a CS/AIX server configured as an APPN network node, implementing passthrough DLUR to support sessions between LUs on the host (the upstream node) and LUs on the nodes in the APPN network (downstream nodes).

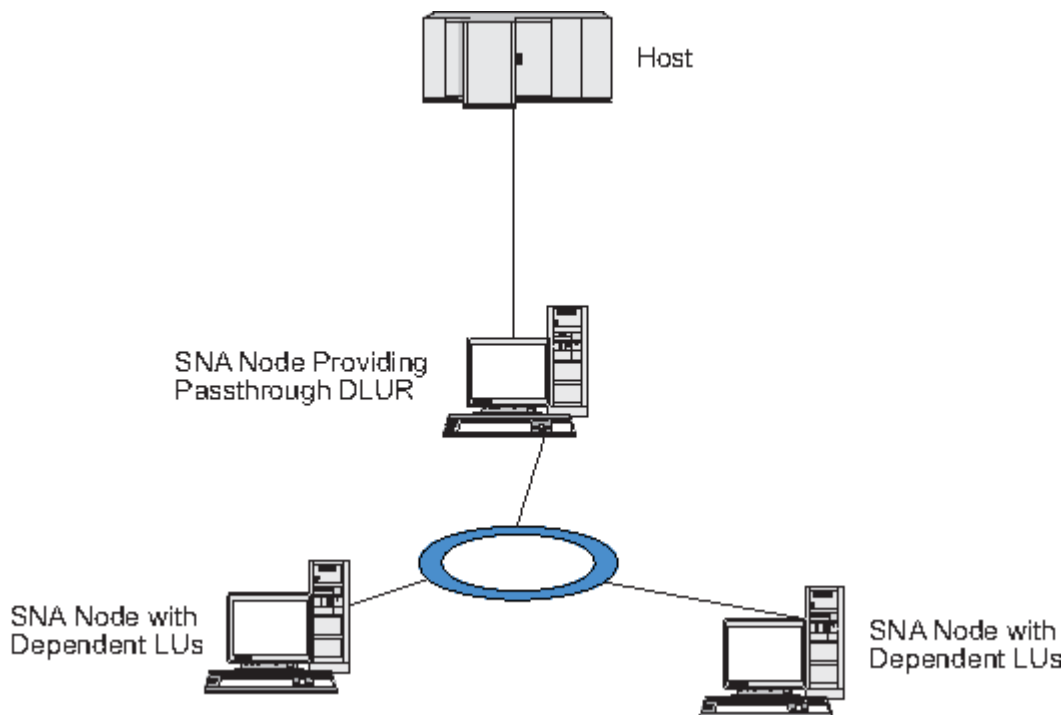

Figure 9. CS/AIX Node Providing DLUR

Note:

1. You cannot configure DLUR on a LEN node.
2. You can configure passthrough DLUR only on a network node or a Branch Network Node.
3. If you are using Branch Extender, you cannot configure DLUR on an end node in the branch (with a Branch Network Node as its network node server). However, you can support dependent LU applications from this node by configuring passthrough DLUR on the Branch Network Node (so that the end node in the branch does not run DLUR, but uses passthrough DLUR on the Branch Network Node).

The tasks you need to perform to configure DLUR depend on whether the dependent LUs are on the local node or on downstream nodes.

Configuring DLUR support on the local node

You need the following information for this task:

- PU ID for the PU on the local node.
- PU name. (This is a local identifier, and does not have to match the host configuration.)
- Name of the DLUS on the host (and the name of the backup DLUS if there is one).
- LU name, LU number, and LU type for each downstream LU. The LU number must match the number configured on the host.

To configure DLUR support on the local node, you must perform the following configuration tasks:

1. Define the local node as described in [“Configuring the node” on page 68](#). If you are providing passthrough DLUR support for downstream nodes, define the node as an APPN network node or branch network node.
2. Configure connectivity to the APPN network. APPN connectivity requires at least a port and link station for independent traffic between the local node and the adjacent APPN network node, as described in [“Configuring connectivity” on page 69](#).
3. Define a DLUR PU on the local node (the DLUR PU supports connectivity to the host).

To configure the DLUR PU, perform the following steps from the Node window:

- a. Select the **Services** menu, then the **Connectivity** submenu, then **New DLUR PU** (or click on the **New** button in the button bar, then select **DLUR PU**).

When you click on the **OK** button, CS/AIX displays the DLUR PU Configuration dialog.

- b. Enter appropriate values in the fields on the dialog.
- c. Click on the **OK** button to define the DLUR PU.

The DLUR PU appears in the **Connectivity** pane below the DLUR item.

4. To configure DLUR to support LUs on the local node, you must add the LUs on the local node. The LUs must be configured to support LUA, as described in [“Configuring LUA” on page 79](#). Depending on the requirements of the user applications supported by the LUs, you may also need to perform further configuration.

Configuring passthrough DLUR support for downstream nodes

You need the following information for this task:

- Downstream PU name for each downstream node, or for each PU on the downstream node. (This is a local identifier, and does not have to match the host configuration.)
- Name of the DLUS on the host.

To configure passthrough DLUR support for downstream nodes, you must perform the following configuration tasks:

1. Define the local node as an APPN network node (see [“Configuring the node” on page 68](#)).

Configuring TN server

2. Configure connectivity to the downstream nodes. Configure ports and link stations for dependent traffic between the local node and each downstream node, as described in [“Configuring connectivity” on page 69](#). (You do not need to define a DLUR PU to support passthrough DLUR for downstream nodes.)
3. A downstream node can support multiple PUs. In this case, each downstream PU is associated with a different link, so you need to configure multiple links between the CS/AIX DLUR node and the downstream node, and you need to know the downstream PU name for each link.

Configuring TN server

3270 emulation programs that communicate over TCP/IP (rather than over an SNA network) are referred to as TN3270 programs (Telnet 3270 emulation programs).

TN3270 programs can also include support for TN3270E (Telnet 3270 standard extensions). TN3270E is an open protocol that supports 3270 device emulation (including both terminals and printers) using Telnet. It enables a Telnet client to select a particular device (by specifying the LU name), and provides enhanced support for various functions, including the ATTN and SYSREQ keys and SNA response handling.

Note: This guide uses the term TN3270 for information that applies equally to the TN3270, TN3287, and TN3270E protocols.

CS/AIX TN server provides access to 3270 host computers for TN3270 users on other computers. TN server enables TN3270 users to share a host connection with CS/AIX or with other TN3270 users, instead of requiring a direct link. TN server also enables TN3270 users to access hosts that are not running TCP/IP.

A CS/AIX node that provides TN server support for TN3270 clients is shown in [Figure 10 on page 84](#). The TN server node and the clients communicate through the TCP/IP network.

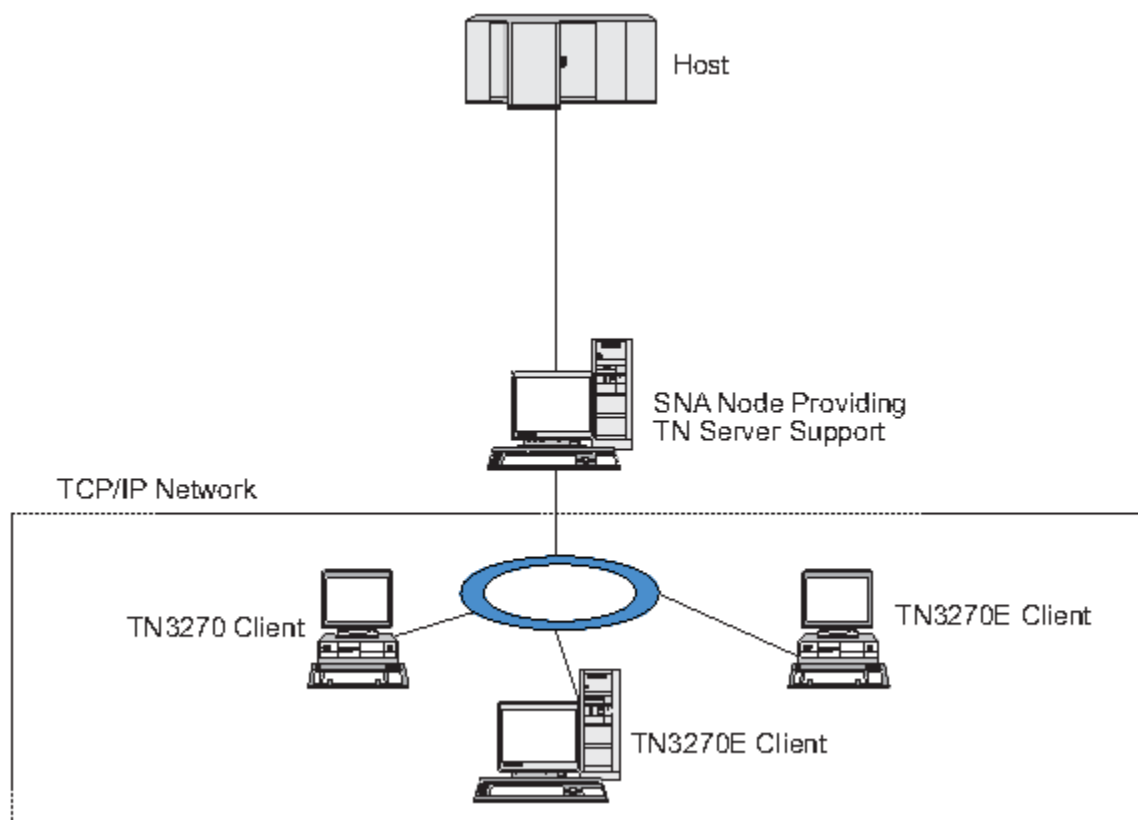

Figure 10. CS/AIX Node Configured for TN Server

The CS/AIX TN server feature provides an association between a TN3270 user and CS/AIX 3270 LU. All data from the TN3270 user is routed to the LU. This means that the configuration for both the host and the TN3270 user is as though they were connected directly; neither needs to be aware that data is being routed through TN server.

CS/AIX TN server supports all TN3270 client emulation programs that correctly implement the protocols defined in IETF RFCs 1123, 1576, 1646, 1647, and 2355.

When a TN3270 program communicates with TN server, CS/AIX identifies the program by the TCP/IP address of the computer where the TN3270 program is running. CS/AIX cannot distinguish between two different TN3270 programs being used by different users on the same computer. In the CS/AIX manuals, the term TN server user refers to the computer where a TN3270 program is running, not to an individual user of that program.

As shown in [Figure 11 on page 85](#), the host and the TN server user view the TN server configuration differently.

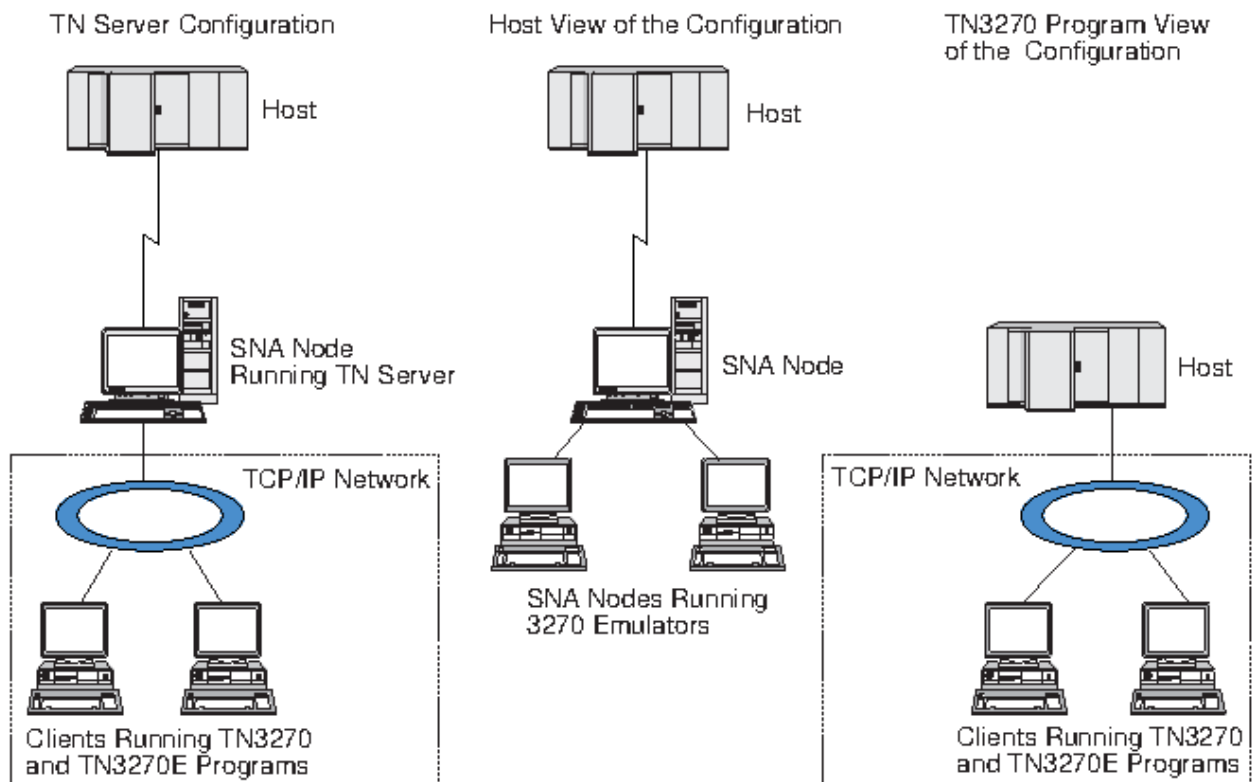

Figure 11. TN Server

Each TN server user connecting to CS/AIX using the TN3270 Server feature is normally configured to access a single 3270 LU, and so is restricted to one host session at a time. However, you can also configure a TN server user to access a pool of 3270 LUs, instead of having a single dedicated 3270 LU for each user. This enables users to access as many sessions as there are available LUs in the pool.

Before you can configure TN server access, you must perform the following configuration tasks:

- Define the local node as described in [“Configuring the node”](#) on page 68.
- Configure a port and link station for dependent traffic between the local node and the host, as described in [“Configuring connectivity”](#) on page 69.

To configure TN server access, you must perform the following configuration tasks:

- Define the 3270 LUs on the local node that are used for communication with the host. To add the LUs, see [“Defining 3270 LUs”](#) on page 86.
- If you are going to use any LU pools, define them as described in [“Defining an LU pool”](#) on page 86.

Defining 3270 LUs

Before configuring the 3270 LU, gather the following information:

- LU name. (This is a local identifier, and does not have to match the host configuration.)
- LU number (or numbers for a range of LUs).
- LU type (3270 display model or 3270 printer).
- Pool name (if you are adding the LU to a pool).

To configure an LU of types 0-3 for a previously defined link station, perform the following steps from the Node window:

1. Select the link station to the host in the Connectivity pane of the window.
2. Click on the New button.
3. Select the LU type (New 3270 display LU or New 3270 printer LU) on the resulting dialog.

When you select this item and click on OK, CS/AIX displays the LU Type 0-3 dialog.

4. Enter appropriate values in the fields on the dialog.
5. Click on OK to define the LU.

The LU appears in the Connectivity pane of the Node window, below the link station to the host.

Defining an LU pool

For 3270, you can define LU pools to simplify user configuration and provide greater flexibility in establishing host sessions. For example, you can define several 3270 LUs in a single LU pool, then configure multiple TN3270 clients using this LU pool. This makes configuring the 3270 sessions easier and enables any client to use any LU in the pool.

Note: You can assign a TN3270 client either to a specific LU or to an LU pool.

- If you assign the client to a specific LU that is in a pool, the client uses this LU if it is available; otherwise it uses any free LU from the pool, as though you had assigned it to the LU pool instead of the specific LU.
- If you want the client to use only a specified LU, so that the client's session cannot be established if the LU is already in use, ensure that the LU is not in a pool.

You can view the LU pools for the local CS/AIX node using the LU Pools window. This window lists the LU pools configured on the local system, and enables you to select LUs to add to an LU pool.

You can add the following LU types to a pool for use by 3270 (do not mix LUs of different types in the same pool):

- 3270 display LU
- Unrestricted LU

Before you can add LUs to a pool, the LUs must be defined on the local node.

To configure an LU pool, perform the following steps from the Node window:

1. Select LU Pools from the Windows menu.

CS/AIX displays the LU Pools window.

2. Click on the New button.

CS/AIX displays the LU Pool Configuration dialog.

The box on the right lists LUs that are not yet allocated to any pool. Any of these LUs can be included in the new pool.

3. Select the LU or LUs you wish to add to the pool, and click on the New button to move the selected LUs to the box on the left.

To remove an LU from the box on the left, select it and click on the Remove button.

4. Click on OK to define the LU pool.

All of the LUs in the box on the left are added to the LU pool.

The pool appears in the LU Pools window.

Configuring TN3270 Server

Before configuring TN3270 Server, you need the following information:

- Whether the server supports only TN3270, or also TN3270E (which includes TN3270 support).
- Whether a TN3270E client can request a specific LU.
- Display and printer LU names (or LU pool names) for each client. (Printer LU names are needed only if you are supporting TN3270E.)
- If only certain clients are permitted, or if you want to restrict certain clients to specific LUs, you need the TCP/IP name or address of the client.
- TCP/IP port number on the TN server node.
- Whether SSL data encryption, client authentication, and server authentication are required (this option is available only if you have installed the additional software required to support it).
- Whether the TN3270 Server is operating in an SLP network.

To associate a display LU and printer LU, you also need the names of those LUs. A TN server association record defines an association between a printer LU and display LU, so that the TN3270E protocol can connect the two. You do not need to define an association record if you are not supporting TN3270E or if you are not supporting printer LUs.

The TN server defaults record defines parameters that are used on all TN3270 client sessions. You can define a single defaults record for each server.

To configure TN3270 server, perform the following steps from the Node window:

1. Define a TN server access record:
 - a. Select TN Server from the Services menu.
CS/AIX displays the TN Server window, which lists all the configured TN server access records in the upper pane and TN server association records in the lower pane.
 - b. Select the pane that contains TN3270 Server access records and click on the New button.
CS/AIX displays the TN Server Access dialog.
 - c. Enter appropriate values in the fields on the dialog.
 - d. Click on OK to define the TN server access record. The record appears in the TN Server window.
2. Define a TN server association record:
 - a. Select the pane that contains association records in the TN Server window and click on the New button.
CS/AIX displays the TN Server Association Record dialog.
 - b. Enter appropriate values in the fields on the dialog.
 - c. Click on OK to define the TN server association record. The record appears in the TN Server window.
3. If you need to force printer responses, specify a keep-alive method for all TN3270 sessions, specify how to access the external LDAP server that holds a revocation list used to check authorization for TN3270 clients, or use TN3270 SLP (Service Location Protocol), use the TN Server Advanced Parameters dialog to do this.

For more information about configuring SSL support for TN Server, refer to the IBM Communications Server Support web pages at <https://www.ibm.com/mysupport/s/topic/0TO0z0000006v30GAQ/communication-server>.

Configuring TN Redirector

The CS/AIX TN Redirector feature provides passthrough TCP/IP host access to TN3270, TN3270E, TN5250 and VT clients, referred to collectively as Telnet clients. The Telnet user communicates with CS/AIX over a TCP/IP connection; CS/AIX then communicates with the host over another TCP/IP connection. This allows you to use Secure Sockets Layer (SSL) security checking where necessary, and not on the complete user-to-host connection. For example:

- If clients are connecting to CS/AIX over a TCP/IP LAN where checking is not required, but are connecting to a remote host that requires SSL, you can use SSL over the TCP/IP connection between CS/AIX and the host. This means that security is checked once for all clients, and individual clients do not have to provide security information.
- If CS/AIX is installed on the same site as the host, but clients are connecting in from external sites, you can use SSL over the client connections to CS/AIX without having to install SSL software on the host.

Configuring TN Redirector

Before you can configure TN Redirector access, you must define the local node as described in [“Configuring the node” on page 68](#). You also need the following information:

- If only certain clients are permitted, you need the TCP/IP name or address of the client.
- TCP/IP port number used by the client to connect to the TN Redirector node.
- TCP/IP name or address of the host.
- TCP/IP port number used by the TN Redirector node to connect to the host.
- Whether SSL data encryption, client authentication, and server authentication are required between the client and the TN Redirector node (this option is available only if you have installed the additional software required to support it).
- Whether SSL data encryption is required between the TN Redirector node and the host.

The TN redirector defaults record defines parameters that are used on all TN redirector client sessions. You can define a single defaults record for each client TCP/IP port number.

To configure TN redirector, perform the following steps from the Node window to define a TN redirector access record:

1. Select `TN Server` from the `Services` menu.
CS/AIX displays the TN Server window, which lists all the configured TN3270 server access records, TN3270 server association records, and TN Redirector access records.
2. Select the pane that contains TN Redirector access records and click on the `New` button.
CS/AIX displays the TN Redirector Access dialog.
3. Enter appropriate values in the fields on the dialog.
4. Click on `OK` to define the TN Redirector access record. The record appears in the TN Redirector pane of the TN Server window.

Note: The SNA node must be active in order to use TN Redirector, although it does not use any of the node's SNA resources.

Disabling CS/AIX

Disabling the CS/AIX software automatically stops the CS/AIX node and its associated connectivity components. Disabling CS/AIX also stops any other processes (such as a 3270 emulation program) from using CS/AIX resources on this server.

In general, you should stop individual services as users finish using them, and only disable the system when there is no CS/AIX activity.

If you need to disable CS/AIX while users are active, warn users that CS/AIX is stopping, and give them time to finish their activities before you disable the software.

If a 3270 emulation program is using LUs on the node when you disable the CS/AIX software, all 3270 emulation sessions using these LUs end. The program continues to run, but the user cannot use the sessions until the software is re-enabled. Applications using the APPC, CSV, LUA, NOF, or MS APIs are notified by a COMM_SUBSYSTEM_ABENDED return code and CPI-C applications by a CM_PRODUCT_SPECIFIC_ERROR return code.

To disable the CS/AIX software, enter the following command at the AIX command prompt:

```
sna stop
```

If CS/AIX is disabled successfully, `sna stop` returns an exit code of 0. Any other exit code indicates that an error occurred and that the CS/AIX software was not disabled. Refer to *IBM Communications Server for Data Center Deployment on AIX Diagnostics Guide* for more information about exit code values.

Chapter 9. Information resources for CS/AIX and SNA

This chapter describes the resources in the SNA library that provide information about SNA technology and the many networking products and services that IBM offers. It also describes information that is available in network forums.

SNA library

The SNA library includes marketing brochures, books, user guides, and tutorials that provide both introductory and in-depth information about the following topics:

- SNA theory
- SNA products
- Product implementation
- Configuration of systems and networks
- SNA application programs and APIs
- Overall planning, performance, and tuning
- Problem diagnosis
- Network management
- Network security

All IBM publications can be ordered through your IBM representative, the IBM branch serving your locality, or by calling IBM directly at 1-800-879-2755.

For a list of publications most relevant to CS/AIX, see the Bibliography at the end of this book.

For information about additional publications, contact your IBM representative.

Network-accessible information

To promote information exchange, IBM sponsors electronic forums and bulletin boards. It posts home pages on the Internet and provides online documentation that is also accessible on CompuServe and the World Wide Web.

Product Support over IBMLink

The IBMLink forum is held over IBM-owned networks. It is designed to help customers with licensed IBM products solve technical problems and other issues related to their system and network. IBM personnel answer questions and mediate online discussions among IBM customers.

For more information about IBMLink, use <http://www.ibm.com/ibmlink>.

Information in IBM Home Pages

On the Internet, various IBM home pages provide access to forums. For comprehensive help, the IBM main home page can be used to navigate to information centers on the Internet and the World Wide Web. The main home page can be accessed by using <http://www.ibm.com>.

You can access information about IBM networking software, including CS/AIX, by using <http://www.ibm.com/software/network>. Information about CS/AIX is at <https://www.ibm.com/products/communications-server-for-data-center>.

For more detailed information about support for CS/AIX, use <https://www.ibm.com/mysupport/s/topic/0TO0z0000006v30GAQ/communication-server>.

Information for Downloading

On the World Wide Web, users can download Redbook publications by using <http://www.redbooks.ibm.com>.

Suggested Reading

Broad access to other helpful information (such as program code) is available through APPC Online on the CompuServe network (use GO APPC).

Information on IBM software can be accessed at <http://www.ibm.com/software>, where you can link to pages about CS/AIX and all of the IBM Software Servers.

Trial Software

In some countries, IBM offers trial SNA software free of charge for 90 days, including the latest version of CS/AIX. For details on how to obtain trial copies, contact your local IBM representative or see the CS/AIX page on the World Wide Web, at <https://www.ibm.com/products/communications-server-for-data-center>.

Suggested reading

For those who want to strengthen their understanding of SNA, the following books cover SNA theory and the use of CS/AIX in practice. The books are helpful to both novices and experts who might need either a starting point for getting acquainted with SNA or an in-depth treatment of the subject.

- *Systems Network Architecture: Technical Overview* (GC30-3073)
- *IBM Communications Server for Data Center Deployment on AIX Administration Guide* (SC31-8586)
- *IBM Communications Server for AIX Version 6* (SG24-5947)
- *IBM CS/AIX Understanding and Migrating to Version 5: Part 1 - Configuration and New Features* (SG24-5215)
- *IBM CS/AIX Understanding and Migrating to Version 5: Part 2 - Performance* (SG24-2136)
- Educational Material for Communications Server for Data Center Deployment at <https://www.ibm.com/support/pages/node/594013>

If you have more specific interests, see the Bibliography for other references, or contact your local IBM representative.

Appendix A. How to send your comments to IBM

We appreciate your input on our publications. Feel free to comment on the clarity, accuracy, and completeness of the information or provide any other feedback that you have.

Use one of the following methods to send your comments:

1. Use the feedback link at the bottom of Knowledge Center.
2. Use the feedback template below and send us an email at "mhvrcfs@us.ibm.com"
3. Mail the comments to the following address:

IBM Corporation
Attention: MHVRCFS Reader's Comments
Department H6MA, Building 707
2455 South Road
Poughkeepsie, NY 12601-5400
US

Email feedback template

Please cut and paste the template below into your email. Then fill in the required information.

- My name:
- My Company, University or Institution:
- The URL of the topic or web page you are commenting on:
- The text of your comment

If you are willing to talk to us about your comment, please feel free to include a phone number and the best time to reach you.

When you send comments to IBM, you grant IBM a nonexclusive right to use or distribute the comments in any way appropriate without incurring any obligation to you.

IBM or any other organizations use the personal information that you supply to contact you only about the issues that you submit.

If you have a technical problem

Do not use the feedback methods that are listed for sending reader's comments. Instead, take one of the following actions:

- Contact your IBM service representative
- Call IBM technical support
- Visit the IBM support portal at <https://www.ibm.com/support/home/>.

Appendix B. Notices

This information was developed for products and services offered in the U.S.A. IBM may not offer the products, services, or features discussed in this document in other countries. Consult your local IBM representative for information on the products and services currently available in your area. Any reference to an IBM product, program, or service is not intended to state or imply that only that IBM product, program, or service may be used. Any functionally equivalent product, program, or service that does not infringe any IBM intellectual property right may be used instead. However, it is the user's responsibility to evaluate and verify the operation of any non-IBM product, program, or service.

IBM may have patents or pending patent applications covering subject matter described in this document. The furnishing of this document does not give you any license to these patents. You can send license inquiries, in writing, to:

- IBM Director of Licensing
- IBM Corporation
- North Castle Drive
- Armonk, NY 10504-1785
- U.S.A.

For license inquiries regarding double-byte (DBCS) information, contact the IBM Intellectual Property Department in your country or send inquiries, in writing, to:

- IBM World Trade Asia Corporation
- Licensing
- 2-31 Roppongi 3-chome, Minato-ku
- Tokyo 106, Japan

The following paragraph does not apply to the United Kingdom or any other country where such provisions are inconsistent with local law: INTERNATIONAL BUSINESS MACHINES CORPORATION PROVIDES THIS PUBLICATION "AS IS" WITHOUT WARRANTY OF ANY KIND, EITHER EXPRESS OR IMPLIED, INCLUDING, BUT NOT LIMITED TO, THE IMPLIED WARRANTIES OF NON-INFRINGEMENT, MERCHANTABILITY OR FITNESS FOR A PARTICULAR PURPOSE. Some states do not allow disclaimer of express or implied warranties in certain transactions, therefore, this statement may not apply to you.

This information could include technical inaccuracies or typographical errors. Changes are periodically made to the information herein; these changes will be incorporated in new editions of the publication. IBM may make improvements and/or changes in the product(s) and/or the program(s) described in this publication at any time without notice.

Any references in this information to non-IBM Web sites are provided for convenience only and do not in any manner serve as an endorsement of those Web sites. The materials at those Web sites are not part of the materials for this IBM product and use of those Web sites is at your own risk.

IBM may use or distribute any of the information you supply in any way it believes appropriate without incurring any obligation to you.

Licensees of this program who wish to have information about it for the purpose of enabling: (i) the exchange of information between independently created programs and other programs (including this one) and (ii) the mutual use of the information which has been exchanged, should contact:

- IBM Corporation
- P.O. Box 12195
- 3039 Cornwallis Road
- Research Triangle Park, NC 27709-2195
- U.S.A.

Such information may be available, subject to appropriate terms and conditions, including in some cases, payment of a fee.

The licensed program described in this information and all licensed material available for it are provided by IBM under terms of the IBM Customer Agreement, IBM International Program License Agreement, or any equivalent agreement between us.

Any performance data contained herein was determined in a controlled environment. Therefore, the results obtained in other operating environments may vary significantly. Some measurements may have been made on development-level systems and there is no guarantee that these measurements will be the same on generally available systems. Furthermore, some measurements may have been estimated through extrapolation. Actual results may vary. Users of this document should verify the applicable data for their specific environment.

Information concerning non-IBM products was obtained from the suppliers of those products, their published announcements or other publicly available sources. IBM has not tested those products and cannot confirm the accuracy of performance, compatibility or any other claims related to non-IBM products. Questions on the capabilities of non-IBM products should be addressed to the suppliers of those products.

This information contains examples of data and reports used in daily business operations. To illustrate them as completely as possible, the examples include the names of individuals, companies, brands, and products. All of these names are fictitious and any similarity to the names and addresses used by an actual business enterprise is entirely coincidental.

COPYRIGHT LICENSE: This information contains sample application programs in source language, which illustrates programming techniques on various operating platforms. You may copy, modify, and distribute these sample programs in any form without payment to IBM, for the purposes of developing, using, marketing or distributing application programs conforming to the application programming interface for the operating platform for which the sample programs are written. These examples have not been thoroughly tested under all conditions. IBM, therefore, cannot guarantee or imply reliability, serviceability, or function of these programs. You may copy, modify, and distribute these sample programs in any form without payment to IBM, for the purposes of developing, using, marketing or distributing application programs conforming to IBM's application programming interfaces.

Each copy or any portion of these sample programs or any derivative work must include a copyright notice as follows: © (your company name) (year). Portions of this code are derived from IBM Corp. Sample Programs. © Copyright IBM Corp. 2000, 2005, 2006, 2007, 2008, 2021. All rights reserved.

Trademarks

The following terms are trademarks of the IBM Corporation in the United States or other countries or both:

- ACF/VTAM
- Advanced Peer-to-Peer Networking
- AIX
- Application System/400
- APPN
- AS/400
- CICS
- DATABASE 2
- DB2
- Enterprise System/3090
- Enterprise System/4381
- Enterprise System/9000
- ES/3090
- ES/9000
- eServer
- IBM
- IBMLink
- IMS
- MVS
- MVS/ESA
- Operating System/2
- Operating System/400
- OS/2
- OS/400
- PowerPC
- PowerPC Architecture
- S/390
- System/390
- System p5
- System z
- System z9
- VSE/ESA
- VTAM
- WebSphere

The following terms are trademarks or registered trademarks of other companies:

Java and all Java-based trademarks are trademarks of Sun Microsystems, Inc., in the United States, other countries, or both.

UNIX is a registered trademark in the United States and other countries licensed exclusively through The Open Group.

Intel and EM64T are trademarks of Intel Corporation.

AMD64 is a trademark of Advanced Micro Devices, Inc.

Linux is a trademark of Linus Torvalds.

RedHat and RPM are trademarks of Red Hat, Inc.

SuSE Linux is a trademark of Novell.

Ubuntu is a trademark of Canonical Limited.

Microsoft, Windows, Windows 10, Windows Server 2012, Windows Server 2016, Windows Server 2019 and the Windows logo are trademarks of Microsoft Corporation in the United States, other countries, or both.

Other company, product, and service names may be trademarks or service marks of others.

Bibliography

The following IBM publications provide information about the topics discussed in this library. The publications are divided into the following broad topic areas:

- CS/AIX, Version 7.1
- Redbooks
- AIX operating system
- Systems Network Architecture (SNA)
- Host configuration
- z/OS Communications Server
- Transmission Control Protocol/Internet Protocol (TCP/IP)
- X.25
- Advanced Program-to-Program Communication (APPC)
- Programming
- Other IBM networking topics

For books in the CS/AIX library, brief descriptions are provided. For other books, only the titles and order numbers are shown here.

CS/AIX publications

The CS/AIX library comprises the following books. In addition, softcopy versions of these documents are provided on the CD-ROM. See *IBM Communications Server for Data Center Deployment on AIX Quick Beginnings* for information about accessing the softcopy files on the CD-ROM. To install these softcopy books on your system, you require 9-15 MB of hard disk space (depending on which national language versions you install).

- *IBM Communications Server for Data Center Deployment on AIX Migration Guide* (SC31-8585)

This book explains how to migrate from Communications Server for AIX Version 4 Release 2 or earlier to CS/AIX Version 6.

- *IBM Communications Server for Data Center Deployment on AIX Quick Beginnings* (GC31-8583)

This book is a general introduction to CS/AIX, including information about supported network characteristics, installation, configuration, and operation.

- *IBM Communications Server for Data Center Deployment on AIX Administration Guide* (SC31-8586)

This book provides an SNA and CS/AIX overview and information about CS/AIX configuration and operation.

- *IBM Communications Server for Data Center Deployment on AIX Administration Command Reference* (SC31-8587)

This book provides information about SNA and CS/AIX commands.

- *IBM Communications Server for Data Center Deployment on AIX or Linux CPI-C Programmer's Guide* (SC23-8591)

This book provides information for experienced 'C' or Java™ programmers about writing SNA transaction programs using the CS/AIX CPI Communications API.

- *IBM Communications Server for Data Center Deployment on AIX or Linux APPC Programmer's Guide* (SC23-8592)

This book contains the information you need to write application programs using Advanced Program-to-Program Communication (APPC).

- *IBM Communications Server for Data Center Deployment on AIX or Linux LUA Programmer's Guide* (SC23-8590)

This book contains the information you need to write applications using the Conventional LU Application Programming Interface (LUA).

- *IBM Communications Server for Data Center Deployment on AIX or Linux CSV Programmer's Guide* (SC23-8589)

This book contains the information you need to write application programs using the Common Service Verbs (CSV) application program interface (API).

- *IBM Communications Server for Data Center Deployment on AIX or Linux MS Programmer's Guide* (SC23-8596)

This book contains the information you need to write applications using the Management Services (MS) API.

- *IBM Communications Server for Data Center Deployment on AIX NOF Programmer's Guide* (SC31-8595)

This book contains the information you need to write applications using the Node Operator Facility (NOF) API.

- *IBM Communications Server for Data Center Deployment on AIX Diagnostics Guide* (SC31-8588)

This book provides information about SNA network problem resolution.

- *IBM Communications Server for Data Center Deployment on AIX or Linux APPC Application Suite User's Guide*(SC23-8595)

This book provides information about APPC applications used with CS/AIX.

- *IBM Communications Server for Data Center Deployment on AIX Glossary* (GC31-8589)

This book provides a comprehensive list of terms and definitions used throughout the CS/AIX library.

IBM Redbooks

IBM maintains an International Technical Support Center that produces publications known as Redbooks. Similar to product documentation, Redbooks cover theoretical and practical aspects of SNA technology. However, they do not include the information that is supplied with purchased networking products.

The following books contain information that may be useful for CS/AIX:

- *IBM Communications Server for AIX Version 6*(SG24-5947)
- *IBM CS/AIX Understanding and Migrating to Version 5: Part 2 - Performance* (SG24-2136)
- *Load Balancing for Communications Servers*(SG24-5305)

On the World Wide Web, users can download Redbook publications by using <http://www.redbooks.ibm.com>.

AIX operating system publications

For all the latest documentation for AIX, refer to the [AIX Knowledge Center \(https://www.ibm.com/support/knowledgecenter/ssw_aix\)](https://www.ibm.com/support/knowledgecenter/ssw_aix).

Systems Network Architecture (SNA) publications

The following books contain information about SNA networks:

- *Systems Network Architecture: Format and Protocol Reference Manual - Architecture Logic for LU Type 6.2* (SC30-3269)
- *Systems Network Architecture: Formats* (GA27-3136)
- *Systems Network Architecture: Guide to SNA Publications* (GC30-3438)
- *Systems Network Architecture: Network Product Formats* (LY43-0081)

- *Systems Network Architecture: Technical Overview* (GC30-3073)
- *Systems Network Architecture: APPN Architecture Reference* (SC30-3422)
- *Systems Network Architecture: Sessions between Logical Units* (GC20-1868)
- *Systems Network Architecture: LU 6.2 Reference - Peer Protocols* (SC31-6808)
- *Systems Network Architecture: Transaction Programmer's Reference Manual for LU Type 6.2* (GC30-3084)
- *Systems Network Architecture: 3270 Datastream Programmer's Reference* (GA23-0059)
- *Networking Blueprint Executive Overview* (GC31-7057)
- *Systems Network Architecture: Management Services Reference* (SC30-3346)

Host configuration publications

The following books contain information about host configuration:

- *ES-9000, ES-3090 IOCP User's Guide Volume A04* (GC38-0097)
- *3174 Establishment Controller Installation Guide* (GG24-3061)
- *3270 Information Display System 3174 Establishment Controller: Planning Guide* (GA27-3918)
- *OS/390 Hardware Configuration Definition (HCD) User's Guide* (SC28-1848)
- *ESCON Director Planning*(GA23-0364)

z/OS Communications Server publications

The following books contain information about z/OS Communications Server:

- *z/OS V1R7 Communications Server: SNA Network Implementation Guide* (SC31-8777)
- *z/OS V1R7 Communications Server: SNA Diagnostics* (Vol 1: GC31-6850, Vol 2: GC31-6851)
- *z/OS V1R6 Communications Server: Resource Definition Reference* (SC31-8778)

TCP/IP publications

The following books contain information about the Transmission Control Protocol/Internet Protocol (TCP/IP) network protocol:

- *z/OS V1R7 Communications Server: IP Configuration Guide* (SC31-8775)
- *z/OS V1R7 Communications Server: IP Configuration Reference* (SC31-8776)
- *z/VM V5R1 TCP/IP Planning and Customization* (SC24-6125)

X.25 publications

The following books contain information about the X.25 network protocol:

- *AIXLink/X.25 for AIX: Guide and Reference* (SC23-2520)
- *RS/6000 AIXLink/X.25 Cookbook*(SG24-4475)
- *Communications Server for OS/2 Version 4 X.25 Programming* (SC31-8150)

APPC publications

The following books contain information about Advanced Program-to-Program Communication (APPC):

- *APPC Application Suite V1 User's Guide* (SC31-6532)
- *APPC Application Suite V1 Administration* (SC31-6533)
- *APPC Application Suite V1 Programming* (SC31-6534)

- *APPC Application Suite V1 Online Product Library* (SK2T-2680)
- *APPC Application Suite Licensed Program Specifications* (GC31-6535)
- *z/OS V1R2.0 Communications Server: APPC Application Suite User's Guide* (SC31-8809)

Programming publications

The following books contain information about programming:

- *Common Programming Interface Communications CPI-C Reference* (SC26-4399)
- *Communications Server for OS/2 Version 4 Application Programming Guide* (SC31-8152)

Other IBM networking publications

The following books contain information about other topics related to CS/AIX:

- *SDLC Concepts*(GA27-3093)
- *Local Area Network Concepts and Products: LAN Architecture* (SG24-4753)
- *Local Area Network Concepts and Products: LAN Adapters, Hubs and ATM* (SG24-4754)
- *Local Area Network Concepts and Products: Routers and Gateways* (SG24-4755)
- *Local Area Network Concepts and Products: LAN Operating Systems and Management* (SG24-4756)
- *IBM Network Control Program Resource Definition Guide* (SC30-3349)

Index

Numerics

3270 LU
defining [86](#)
for TN Server [9](#), [85](#)

A

adaptive session-level pacing [12](#)
adding a resource [66](#)
administration program
command-line [12](#)
Motif [11](#), [13](#)
NOF API [12](#)
SMIT [12](#)
Web [11](#)
advanced configurations, memory and storage requirements [19](#)
Advanced Interactive Executive (AIX) [1](#)
advanced program-to-program communication (APPC) [4](#)
AIX
hardware requirements for CS/AIX [17](#)
manual pages [25](#)
running CS/AIX on [1](#)
alerts [13](#)
alias, defining for partner LU [77](#)
API
CS/AIX types [3](#)
for CS/AIX administration [12](#)
support [3](#)
APPC
application suite [5](#), [7](#)
configuration [74](#)
dependent LU 6.2 [78](#)
distributed application support [4](#)
independent LU 6.2 [76](#)
online [91](#)
APPC Application Suite [7](#)
application programming interface (API) [3](#)
APPN
applications for [5](#), [7](#)
configuration [75](#)
connection network [12](#)
distributed management service [13](#)
DLUR support [1](#)
dynamic configuration [11](#)
end node [1](#)
host support for [1](#)
independent LU support [3](#)
network node [1](#)
node types [1](#)
routing [12](#)
segmentation of networks [22](#)
subarea functions [1](#)

B

backup
configuration files [33](#)
restoring [34](#)
backup server [4](#), [67](#)
base operating system (BOS) [18](#)
BOS (base operating system) [18](#)
Branch Extender [6](#)
Branch Network Node [6](#)
buttons in resource windows [67](#)

C

calls [3](#)
CDE [28](#)
CICS (Customer Information Control System) [4](#)
client [4](#)
client software
customizing [58](#)
reinstalling [59](#)
uninstalling [59](#)
upgrading [59](#)
client/server
configuration [67](#)
client/server installation [32](#)
client/server support [4](#)
command-line administration program [12](#)
comments on publication
sending feedback [93](#)
Common Desktop Environment (CDE) [28](#)
Common Programming Interface for Communications (CPI-C) [3](#)
communication adapters [17](#)
compatibility planning [21](#)
component management [64](#)
compression, on LU session data [3](#)
configuration
APPC communication [74](#)
backup [33](#)
connectivity [69](#)
CPI-C side information [79](#)
DLUR [82](#)
downstream LUs for SNA gateway [80](#)
examples [68](#), [82](#), [84](#)
files [33](#), [34](#)
implicit downstream LU [81](#)
LU 6.2 [76](#), [78](#)
LU type 0-3 [72](#)
modifying [66](#)
node [68](#)
partner LUs for a LEN node [76](#)
planning [61](#)
port [70](#)
remote node [77](#)
TN redirector defaults [88](#)
TN server association records [87](#)

- configuration (*continued*)
 - TN server defaults [87](#)
 - viewing [66](#)
- configuration server
 - adding [68](#)
 - removing [68](#)
- Configuration window, Remote API Client on Windows
 - advanced parameters [54](#)
 - parameters [53](#)
- connection network [12](#)
- connection network, configuration [71](#)
- connectivity
 - configuration [69](#)
 - options [2](#)
- controller server [4](#)
- CPI Communications (CPI-C) [3](#)
- CPI-C
 - API [3](#)
 - configuration [79](#)
 - interoperability [14](#)
- Customer Information Control System (CICS) [4](#)

D

- data link control (DLC) [23](#)
- data link control options [2](#)
- data stream [3](#)
- DATABASE 2 (DB2) [5](#)
- DB2 (DATABASE 2) [5](#)
- DDDLU (Dynamic definition of dependent LUs) [2](#)
- deleting a resource [66](#)
- dependent logical unit server (DLUS) [82](#)
- dependent LU 6.2 [78](#)
- dependent LU requester (DLUR) [1](#)
- dialog [64](#)
- directory for CS/AIX executable programs [63](#)
- disabling CS/AIX [88](#)
- discussion groups, online [91](#)
- disk storage [19](#)
- distributed processing
 - application support [4](#)
 - environment [1](#)
- DLC
 - configuration [71](#), [72](#)
 - in port configuration [70](#)
 - installation [26](#)
 - purpose [23](#)
- DLUR
 - configuration [82](#)
 - description [1](#)
 - on the local node [83](#)
 - PU configuration [83](#)
 - support for downstream nodes [83](#)
- DLUS [82](#)
- documentation, online [91](#)
- domain [4](#)
- Domain parameter [53](#)
- downstream computer [80](#)
- downstream LU
 - configuration [81](#)
 - for SNA gateway [80](#)
 - hardware examples [80](#)
- downstream node [82](#)
- dynamic configuration [11](#)

- Dynamic definition of dependent LUs (DDDLU) [2](#)

E

- Easy-Install
 - using CDE [28](#)
 - using SMIT [28](#)
- enabling CS/AIX
 - on the local system [63](#)
- Enterprise Extender
 - link configuration [72](#)
 - overview [8](#)
 - port dialog [72](#)
- entry point [13](#)
- Ethernet
 - link configuration [71](#)
 - SAP dialog [71](#)

F

- features [25](#)
- feedback
 - email template [93](#)
 - sending reader comments [93](#)
- fixed disk storage [19](#)
- focal point [13](#)
- forums, online [91](#)
- functional requirements [15](#)
- functions [3](#)

G

- gateway
 - definition [5](#)
 - SNA gateway [5](#)
- GSKIT
 - Remote API Client on AIX [47](#), [49](#)
 - Remote API Client on Linux [38](#), [40](#)
 - Remote API Client on Linux for System z [43](#), [45](#)
 - Remote API Client on Windows [57](#)

H

- hardware
 - link [17](#)
 - requirements [17](#)
- hardware requirements
 - Remote API Client on AIX [47](#)
 - Remote API Client on Linux [37](#)
 - Remote API Client on Linux for System z [43](#)
 - Remote API Client on Windows [51](#)
- help
 - Motif administration program [11](#)
 - Web administration program [11](#)
- host
 - in APPN network [1](#)
 - in subarea network [1](#)
 - LU support [2](#)
- HPR
 - compared to ISR [12](#)
- HPR/IP [8](#)
- HTTPS
 - configuring [30](#)

HTTPS (*continued*)

- Remote API Client on AIX [49](#)
- Remote API Client on Linux [40](#)
- Remote API Client on Linux for System z [45](#)
- Remote API Client on Windows [57](#)
- requirements [19](#)

I

- implicit downstream LU configuration [81](#)
- independent LU 6.2 configuration [76](#)
- information resources [91](#)
- installation
 - details of existing packages [26](#)
 - maintenance tasks after [32](#)
 - manual [28–30](#)
 - preparation for [26](#)
 - Remote API Client on AIX [48](#)
 - Remote API Client on Linux [39](#)
 - Remote API Client on Linux for System z [44](#)
 - using Easy-Install [28](#)
- installation requirements [17](#)
- installing a Remote API Client on AIX [48](#)
- installing a Remote API Client on Linux [39](#)
- installing a Remote API Client on Linux for System z [44](#)
- interface choices [11](#)
- intermediate session routing (ISR) [12](#)
- International Organization for Standards (ISO) [22](#)
- IP address formats [20](#)
- IP port dialog [72](#)
- IPv4 address [20](#)
- IPv6 address [20](#)
- ISO (International Organization for Standards) [22](#)
- ISR (intermediate session routing) [12](#)

J

- Java
 - Remote API Client on AIX [47](#)
 - Remote API Client on Linux [38](#)
 - Remote API Client on Linux for System z [43](#)

L

- LAN (local area network) [2](#)
- LAN access time-out parameter [54](#)
- language environment variable
 - Remote API Client on Linux [38](#)
 - Remote API Client on Linux for System z [44](#)
- LEN node
 - description [1](#)
 - partner LU configuration [76](#)
 - remote node identification [71](#)
- licensed program
 - Remote API Client on AIX [48](#)
 - Remote API Client on Linux [39](#)
 - Remote API Client on Linux for System z [44](#)
- licensed program product (LPP) [24](#)
- licensing mechanisms [23](#)
- link hardware [17](#)
- link station
 - defining on port [70](#)
- local area network (LAN) [2](#)

- local LU, defining [76](#)
- local/remote transparency [3](#)
- logical unit (LU) [2](#), [81](#)
- low-entry networking (LEN) node [71](#)
- LPP (licensed program product) [24](#)
- LU
 - configuration [76](#), [78](#), [86](#)
 - downstream [80](#), [81](#)
 - naming conventions [22](#)
 - partner, defining [76](#)
 - pool [85](#), [86](#)
 - support [2](#)
- LU pool
 - configuration [73](#)
 - defining [73](#)
 - viewing [73](#)
- LU type 0-3 [72](#), [73](#)

M

- MAC (medium access control) [71](#)
- main memory [19](#)
- manager application [13](#)
- manual installation [28](#)
- manual pages [25](#)
- Max. broadcast attempts parameter [55](#)
- mbufs (memory buffers) [19](#)
- MDS-NMVT (Multiple Domain Support-Network Management Vector Transport) [12](#)
- medium access control (MAC) [71](#)
- memory buffers (mbufs) [19](#)
- memory requirements
 - advanced configurations [19](#)
 - types of storage [19](#)
- migrating from previous levels of CS/AIX [27](#)
- modifying the configuration [66](#)
- Motif administration program
 - description [11](#)
 - help [11](#)
 - management capabilities [13](#)
 - using [61](#)
- MPQP (Multiprotocol Quad Port) [17](#)
- Multiple Domain Support-Network Management Vector Transport (MDS-NMVT) [12](#)
- multiple servers in a domain [4](#)
- Multiprotocol Quad Port (MPQP) [17](#)

N

- naming conventions [22](#)
- network
 - alerts [13](#)
 - information available through [91](#)
 - management [12](#)
 - naming conventions [22](#)
 - peer-to-peer [1](#)
 - planning [15](#), [16](#), [21](#), [22](#)
 - subarea [1](#)
 - support [1](#)
- Network Installation Management [30](#)
- NIM (Network Installation Management) [30](#)
- node
 - configuration [68](#)

node (*continued*)
 downstream [83](#)
 host communication [68](#)
 in APPN configuration [69](#)
 local [83](#)
 remote [76, 77](#)
 upstream [82](#)
Node window [64](#)
nodelock licenses [23](#)
NOF API [12](#)

O

online
 APPC [91](#)
 discussion groups [91](#)
 documentation [91](#)
 forums [91](#)
 help [11](#)
Open Systems Interconnection (OSI) [22](#)
OSI (Open Systems Interconnection) [22](#)

P

 pacing, session-level [12](#)
 paging storage [19](#)
 partner applications [4](#)
 partner LU
 alias [77](#)
 configuration [76](#)
 defining with wildcards [78](#)
 on remote node [77](#)
 path for CS/AIX executable programs [63](#)
 PDF, viewing books [32](#)
 peer
 network [1](#)
 peer server [4](#)
 personnel requirements [16](#)
 physical unit (PU) [5](#)
 planning worksheets [62](#)
 port configuration [70–72](#)
 post-installation procedures [32](#)
 preinstallation tasks [26](#)
 Primary RUI [3](#)
 primary storage [19](#)
 problem
 data [13](#)
 diagnosis tools [13](#)
 procedures
 installing Remote API Client on Windows [52, 55](#)
 program temporary fixes (PTFs) [26](#)
 PTFs (program temporary fixes) [26](#)
 PU (physical unit) [5](#)
 PU concentration [80](#)
 PU concentrator [5](#)

Q

query commands [13](#)

R

RAM (random access memory) [19](#)

random access memory (RAM) [19](#)
rc.sna file [63](#)
reader comments
 methods of sending feedback [93](#)
Reconnect time-out parameter [55](#)
release information [32](#)
Remote API Client
 AIX hardware requirements [47](#)
 AIX software requirements [47](#)
 Linux for System z hardware requirements [43](#)
 Linux for System z software requirements [43](#)
 Linux hardware requirements [37](#)
 Linux software requirements [37](#)
Remote API Client on Linux
 details of existing packages [38](#)
Remote API Client on Linux for System z
 details of existing packages [43](#)
Remote API Client on Windows
 installing [51](#)
 installing from the command line [55](#)
 installing with the setup program [52](#)
remote node
 configuration [76, 77](#)
 partner LU configuration [77](#)
requirements
 hardware [17](#)
 HTTPS [19](#)
 installation [17](#)
 memory and storage [19](#)
 personnel and skill [16](#)
 software [18](#)
 WebSphere Application Server [19](#)
resource
 defining [66](#)
 deleting [66](#)
 information [91](#)
 items [66](#)
 management [64](#)
 requirements [16](#)
 starting [66](#)
 stopping [66](#)
response time [20](#)
RISC System/6000 workstations [17](#)

S

SAA (Systems Application Architecture) [3](#)
SAP (service access point) [17, 71](#)
SDK software
 Remote API Client on Windows [51](#)
SDLC
 configuration [70](#)
 for dependent traffic [70](#)
Secure Sockets Layer (SSL)
 client authentication [87, 88](#)
 data encryption [32, 87, 88](#)
 server authentication [32, 87, 88](#)
security options [12](#)
server
 adding [68](#)
 removing [68](#)
Server Name [53](#)
server, Telnet [8](#)
service access point (SAP) [17, 71](#)

- session
 - pacing [12](#)
 - routing [12](#)
 - support [3](#)
 - U-shaped [3](#)
- Simple Network Management Protocol-Management Information Base (SNMP-MIB) [13](#)
- skill requirements [16](#)
- SMIT
 - DLC configuration [23](#)
 - Easy-Install [28](#)
 - manual installation [29](#)
- SMIT (System Management Interface Tool) [12](#), [17](#)
- SNA
 - library [91](#)
- SNA gateway
 - configuration [80](#)
 - overview [5](#)
- snaadmin program [12](#)
- SNMP agent [13](#)
- SNMP-MIB (Simple Network Management Protocol-Management Information Base) [13](#)
- software features [5](#)
- software requirements
 - Remote API Client on AIX [47](#)
 - Remote API Client on Linux [37](#)
 - Remote API Client on Linux for System z [43](#)
 - Remote API Client on Windows [51](#)
- start command [63](#)
- starting a resource [66](#)
- starting CS/AIX
 - automatically at system startup [63](#)
- status commands [13](#)
- stop command [88](#)
- stopping a resource [66](#)
- storage requirements [19](#)
- subroutines [3](#)
- suggested reading [92](#)
- synchronous data link control (SDLC) [70](#)
- System Management Interface Tool (SMIT) [12](#), [17](#), [23](#)
- Systems Application Architecture (SAA) [3](#)

T

- task sheets [62](#)
- technical problems
 - methods of resolving [93](#)
- TN Redirector
 - access record configuration [88](#)
 - configuration [88](#)
 - defaults configuration [88](#)
 - overview [10](#)
- TN server
 - access record configuration [87](#)
 - association record configuration [87](#)
 - configuration [84](#)
 - defaults configuration [87](#)
 - multiple session support [85](#)
 - user [85](#)
- TN Server
 - overview [8](#)
- TN3270
 - programs [8](#)
 - server [8](#)

- TN3270 programs [84](#)
- TN3270 user [9](#), [85](#)
- tool bar buttons [67](#)
- TP (transaction program) [3](#)
- transaction program (TP) [3](#)
- transparency, local/remote [3](#)
- transport media [17](#)
- troubleshooting tools [13](#)

U

- U-shaped sessions [3](#)
- uninstalling a Remote API Client on AIX [50](#)
- uninstalling a Remote API Client on Linux [40](#)
- uninstalling a Remote API Client on Linux for System z [46](#)
- upstream node [82](#)

V

- verbs [3](#)
- version, IP address [20](#)
- viewing the configuration [66](#)

W

- WAN (wide area network) [2](#)
- Web administration program
 - description [11](#)
 - help [11](#)
- WebSphere Application Server
 - configuring [30](#)
 - requirements [19](#)
- wide area network (WAN) [2](#)
- wildcards [78](#)
- window [64](#)
- worksheets, planning [62](#)
- workstation
 - requirements [17](#)

X

- xsnaadmin program [11](#), [61](#)



GC31-8583-06

