

Systems Center Hardware Update (Part 1)

SHARE 99, Session 2402, August 20, 2002

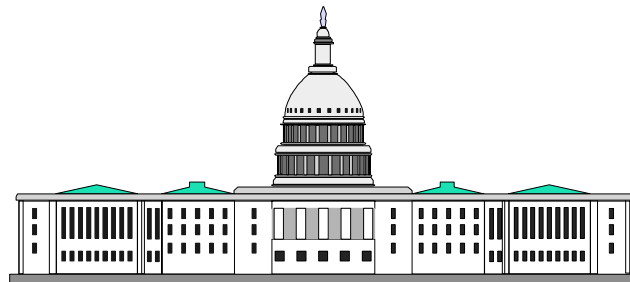

Harv Emery
emeryh@us.ibm.com
Washington Systems Center

Permission to Reprint

Permission is granted to SHARE to publish this presentation in the SHARE Proceedings. IBM retains its right to distribute copies of this presentation to whomever it chooses.

IBM @server. For the next generation of e-business.

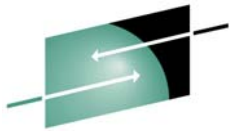

S H A R E

Trademarks

The following are trademarks of the International Business Machines Corporation in the United States and/or other countries.

APPN*	IBM logo*	Virtual Image Facility
DB2*	IMS	VM/ESA*
e-business logo*	Magstar*	VSE/ESA
Enterprise Storage Systems	MVS	VTAM*
ESCON*	Netfinity*	WebSphere
FICON	OS/390*	z/Architecture
GDPS	Parallel Sysplex*	z/OS
Geographically Dispersed Parallel Sysplex	PR/SM	z/OS.e
HiperSockets	S/390*	z/VM
IBM*	S/390 Parallel Enterprise Server	zSeries

* Registered trademarks of IBM Corporation

The following are trademarks or registered trademarks of other companies.

Lotus, Notes, and Domino are trademarks or registered trademarks of Lotus Development Corporation

LINUX is a registered trademark of Linus Torvalds

Penguin (Tux) complements of Larry Ewing

Tivoli is a trademark of Tivoli Systems Inc.

Java and all Java-related trademarks and logos are trademarks or registered trademarks of Sun Microsystems, Inc., in the United States and other countries

UNIX is a registered trademark of The Open Group in the United States and other countries.

Microsoft, Windows and Windows NT are registered trademarks of Microsoft Corporation.

SET and Secure Electronic Transaction are trademarks owned by SET Secure Electronic Transaction LLC.

* All other products may be trademarks or registered trademarks of their respective companies.

Notes:

Performance is in Internal Throughput Rate (ITR) ratio based on measurements and projections using standard IBM benchmarks in a controlled environment. The actual throughput that any user will experience will vary depending upon considerations such as the amount of multiprogramming in the user's job stream, the I/O configuration, the storage configuration, and the workload processed. Therefore, no assurance can be given that an individual user will achieve throughput improvements equivalent to the performance ratios stated here.

IBM hardware products are manufactured from new parts, or new and serviceable used parts. Regardless, our warranty terms apply.

All customer examples cited or described in this presentation are presented as illustrations of the manner in which some customers have used IBM products and the results they may have achieved. Actual environmental costs and performance characteristics will vary depending on individual customer configurations and conditions.

This publication was produced in the United States. IBM may not offer the products, services or features discussed in this document in other countries, and the information may be subject to change without notice. Consult your local IBM business contact for information on the product or services available in your area.

IBM considers a product "Year 2000 ready" if the product, when used in accordance with its associated documentation, is capable of correctly processing, providing and/or receiving date data within and between the 20th and 21st centuries, provided that all products (for example, hardware, software and firmware) used with the product properly exchange accurate date data with it. Any statements concerning the Year 2000 readiness of any IBM products contained in this presentation are Year 2000 Readiness Disclosures, subject to the Year 2000 Information and Readiness Disclosure Act of 1998.

All statements regarding IBM's future direction and intent are subject to change or withdrawal without notice, and represent goals and objectives only.

Information about non-IBM products is obtained from the manufacturers of those products or their published announcements. IBM has not tested those products and cannot confirm the performance, compatibility, or any other claims related to non-IBM products. Questions on the capabilities of non-IBM products should be addressed to the suppliers of those products.

IBM @server. For the next generation of e-business.



Topics

- **IBM Resource Link - Request an ID today!**
 - ▶ <http://www.ibm.com/servers/resourcelink>

- **So, what EC level is that?**

- **z900 EC levels and functions - 3Cg and 3Gf**
 - ▶ **Review for Driver 3Cg - GA2 (October, 2001)**
 - ▶ **Detail for Driver 3Gf - GA3 (May, 2002)**
 - ▶ **Parallel Sysplex and CFCC Levels**

- **New Function APARs for hardware planners**

- **S/390 9672 EC levels for zSeries Compatibility**



IBM Resource Link

The Site for Hardware Information

- **Planning**
 - ▶ **Get ready for system installation**
 - ▶ **P&D and Exception Letters for new Driver (LIC levels)**
- **Education**
 - ▶ **Online courses, task-oriented videos, how-to's, pointers to IBM-sponsored education**
- **Hardware and Operating System Publications Library**
 - ▶ **Documentation including the latest updates**
 - PDF format
 - Viewable online or downloadable
- **Technical Support**
 - ▶ **Research/Subscribe to APAR status, Customer Assets, Hardware Alerts, Cross Platform Support**
- **Group Discussions and ESP Forums**
 - ▶ **Early communication between customers and IBM**

IBM @server. For the next generation of e-business.



Driver Level HMC/SE Application Version

Supported Driver	Version
z800, z900 Dr 3Gf	1.7.3
z900 Dr 3Cg	1.7.2
z900 Dr 38g	1.7.1
z900 Dr 36j	1.7.0
G5/6 Dr 26w	1.6.2
MP3K Dr 24q	1.6.1
G3/4 Dr A2i	1.4.4

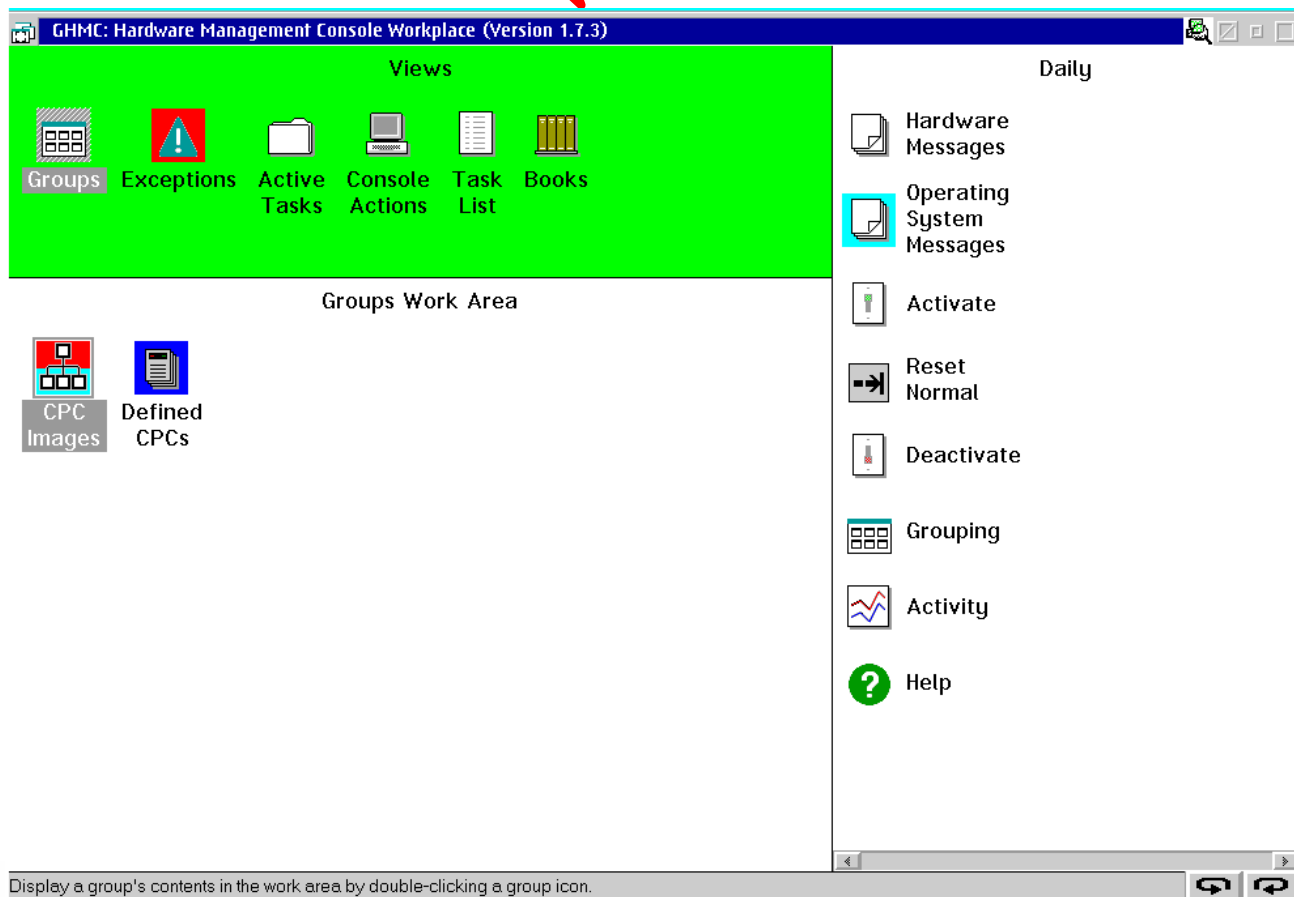

IBM @server. For the next generation of e-business.

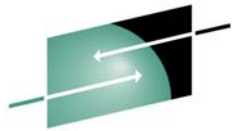

SHARE

Driver Level from CEC SI Panel

SE EC J11213 = Dr 3Gf
 ▲ MCL level 053
 ▲ MCL = Machine Change Level (Patch number)

System Information

Object list:
KSYS

Machine Information

Type: 2064
 Model number: 216
 Serial number: 000020010B2E

Internal Code Change Information

EC Number	Retrieved Level	Installable Concurrent	Installed Level	Activated Level	Accepted Level	Removable Concurrent	Removed Level
J11213	053	053	053	053	038	039	
J11215	003	003	003	003	002	003	
J11202	001	001	001	001	001		
J11203							
J11204	010	010	010	010	008	009	
J11205	002	002	002	002	002		
J11206	005	005	005	005	004	005	
J11207	008	008	008	008	006	007	
J11208	003	003	003	003	002	003	
J11209	001	001	001	001	001		

Details

OK Help



zSeries EC Levels

Machine	GA	Dr	HMC LIC EC	SE LIC EC
z900 Server	12/00	36j	H25122	H25177
z900 Server/CF	5/01	38g	J10012	J10005
z900 Server/CF	10/01	3Cg	J10645	J10638
z900 Server/CF	5/02	3Gf	J11219	J11213

- New Driver Planning - Consider Driver 3Gf NOW!
 - ▶ No charge, ordered as an ECA by service
 - ▶ HMC part is applicable to older machines and required on any HMC that will control a CEC at the new level
 - ▶ Old driver MCL support - at least 6 months
(Dr 36 is out of support, Dr 38 nearing end of support)
- Service Recommendations - Stay current!
 - ▶ Plan nondisruptive MCL apply at least every 3 months
 - ▶ Plan two 4 hour outages for disruptive driver/MCL apply each year

IBM @server. For the next generation of e-business.



z900 Driver 3Cg GA 10/01

- **zSeries 900 Servers (GA 2 Level)**
 - ▶ Concurrent Memory Upgrade
 - ▶ Concurrent CBU model (CP) downgrade
 - ▶ IRD LPAR Weight Management for z/VM and Linux
 - ▶ HiperSockets (IQD Channels)
 - Driver 3C + MCL Bundle 13 (01/16/2002, Concurrent)
 - ▶ FICON CTC
 - Driver 3C + MCL Bundle 14 (02/08/2002, Concurrent)
 - ▶ FICON Express and OSA Express High Speed Token Ring
 - ▶ PCI Cryptographic Accelerator
 - ▶ Dynamic I/O Change for Peer and Receiver Links (+ MCL)

- **zSeries 900 Model 100 CFs (GA 2 Level)**
 - ▶ Up to 64 external coupling links

- **zSeries 900 Servers and CFs**
 - ▶ CFCC Level 10
 - ▶ Sender Links in CF partition
 - ▶ Up to 64 total links

IBM @server. For the next generation of e-business.



zSeries Driver 3Gf

GA - z800 03/02, z900 5/02

- **zSeries 900 Servers (GA 3 Level)**
 - ▶ **New 2xx "Turbo" models**
 - ▶ **Customer Initiated Upgrade (CIU)**
 - ▶ **OSA Express QDIO Mode Enhancements**
 - Multiple secondary router settings
 - IPv6 on Gbit Ethernet and Fast Ethernet for Linux and z/OS V1.4
 - Full VLAN support for Linux
 - SNMP agent onboard for Linux and z/OS V1.4
 - ARP cache management for Linux and z/OS V1.4
 - Broadcast support for Linux, z/OS V1.4 and z/VM
 - ▶ **Linux Support for PCI Cryptographic Accelerator**
 - ▶ **Open FCP Support for Linux (LA, + Concurrent MCL)**
 - ▶ **FICON Express 2 Gbit Link Support**
 - ▶ **FICON Cascade Support (+ Concurrent MCL)**

- **zSeries 800 Servers and CFs (GA Level)**

- **zSeries 900 and 800 Servers and CFs**
 - ▶ **CFCC Level 12**



z900 MSUs per Hour (for pricing)

2002 Models 20 PU

2000 Models 20 PU

2000 Models 12 PU

Model	MSUs	Model	MSUs	Model	MSUs
2C1	52	1C1	43	101	41
2C2	100	1C2	83	102	78
2C3	144	1C3	119	103	112
2C4	184	1C4	153	104	143
2C5	224	1C5	187	105	173
2C6	260	1C6	217	106	199
2C7	296	1C7	247	107	225
2C8	330	1C8	276	108	245
2C9	362	1C9	302	109	265
210	392	110	327		
211	420	111	350		
212	445	112	372		
213	475	113	392		
214	497	114	410		
215	517	115	426		
216	535	116	441		

Caution: Don't use MSUs or MIPs for capacity planning.

IBM @server. For the next generation of e-business.

FICON Express - 2 Gbit Links

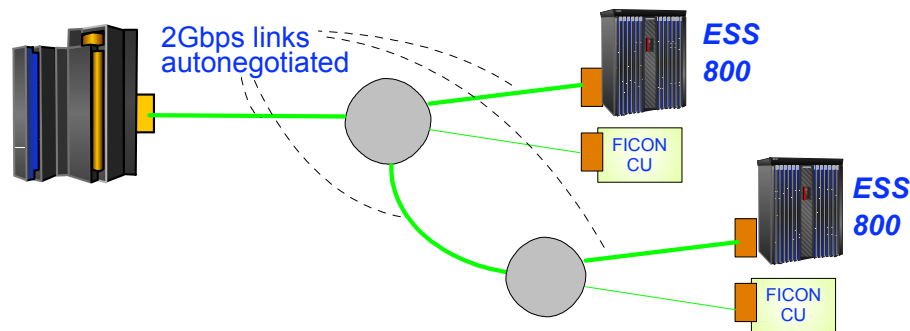
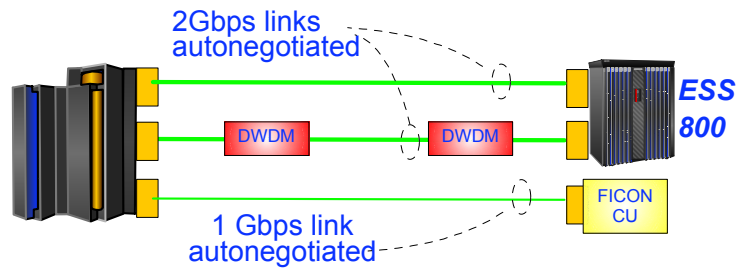

- **Direct Attachment**
 - ▶ IBM Enterprise Storage Server 800
 - **Switched and Cascaded Connectivity**
 - ▶ McDATA ED-6064 (2032-064)
 - ▶ INRANGE FC/9000 (2042)
 - **DWDM and Optical Amplifiers**
 - ▶ Cisco ONS 15540 ESP (LX, SX) and optical amplifier (LX, SX)
 - ▶ Nortel Optera Metro 5200* and 5300E* and optical amplifier
 - ▶ IBM 2029 Fiber Saver*
- *2 Gbit support expected: LX - 4Q02, SX - 2H03

- **Transparent auto-negotiation between ports establishes link speed**
- **Compared to 1 Gbit, 2 Gbit links -**
 - ▶ Improve performance and/or effective bandwidth
 - ▶ Allow channel consolidation
 - ▶ With cascade, reduce fiber required between sites including GDPS



FICON Express - Breaking the Barrier

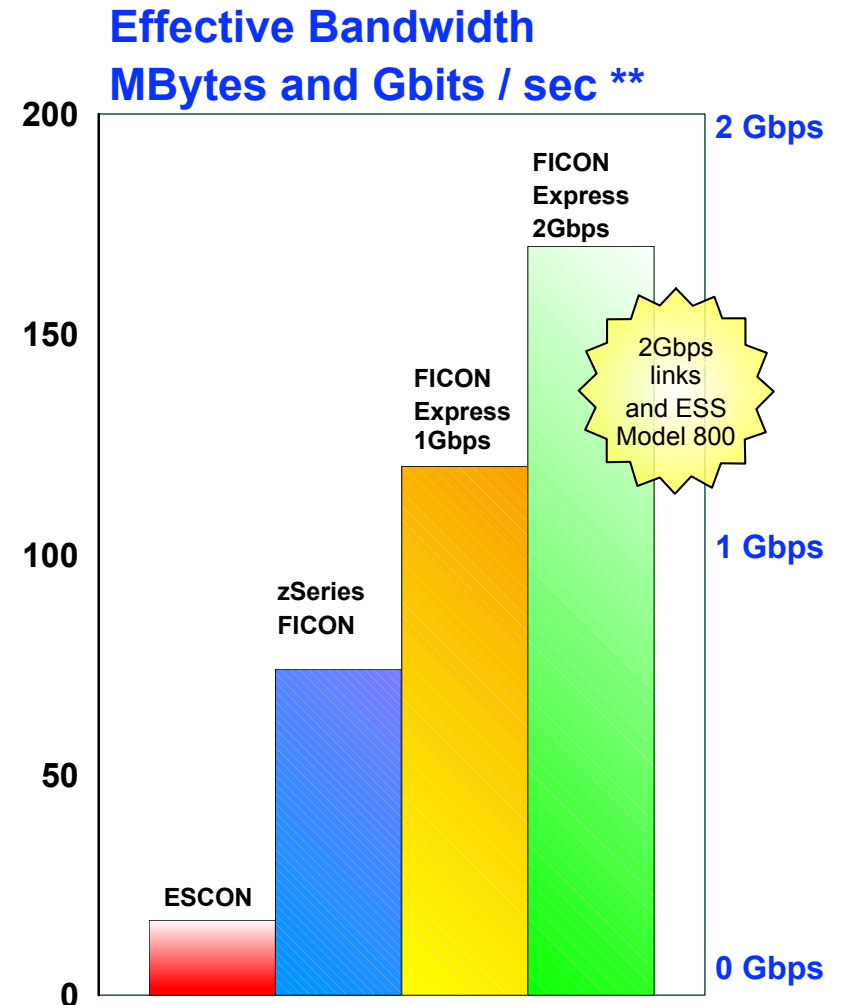
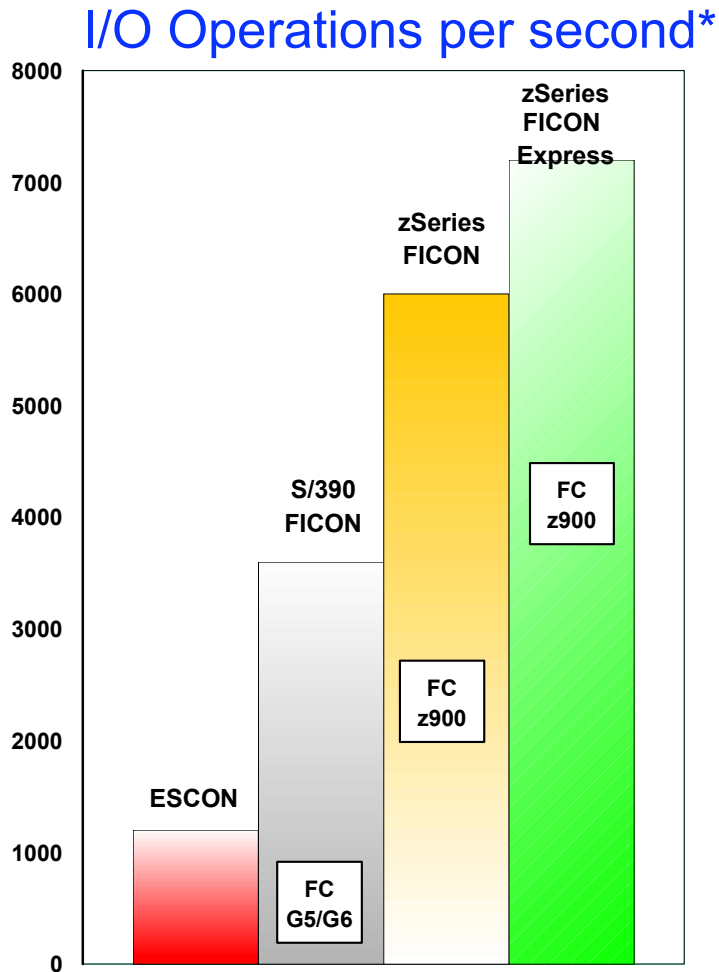

FICON Express Channel Card = Feature Code 2319 LX, and 2320 SX

* Channel 100% utilized, 4K block sizes, FC = Native, 1 or 2 GBit

** Using highly sequential 6x 27k block size, mixed reads and writes

IBM @server. For the next generation of e-business.

FICON Cascaded Directors

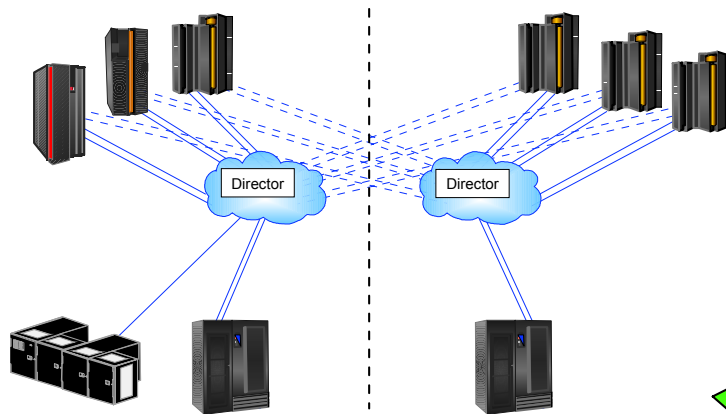

Two site non-cascaded director topology

- Two director fabric, dynamic switching support in both
- Improved cross site connectivity
 - ▶ Less fiber cabling required
 - ▶ More configuration flexibility

■ Requirements

- ▶ zSeries - Driver 3G + MCLs
- ▶ Single vendor, high integrity fabric
- ▶ z/OS V1.4, V1.3 + PTFs

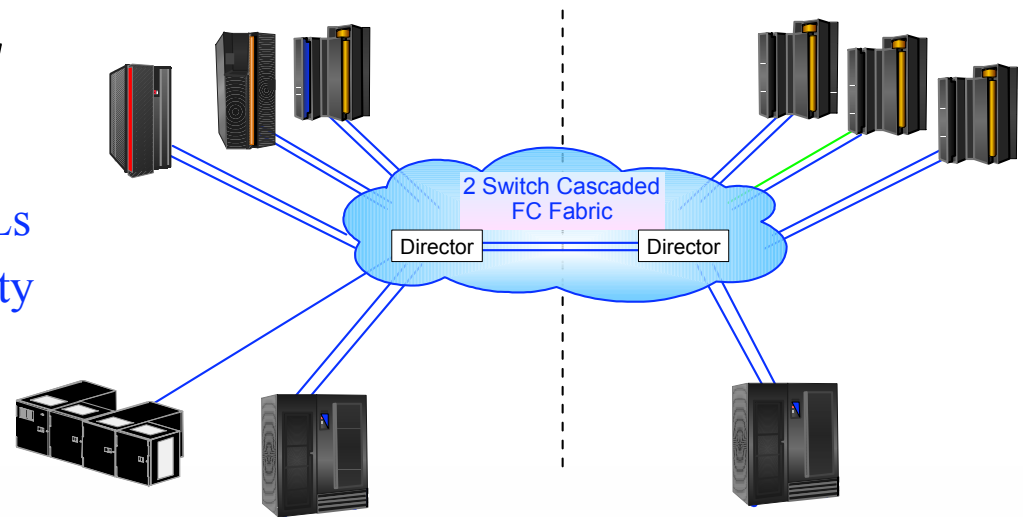

Two Site cascaded director topology

zSeries FCP Attachment Options for Linux Currently Under Test

Initially, FCP support with limited availability

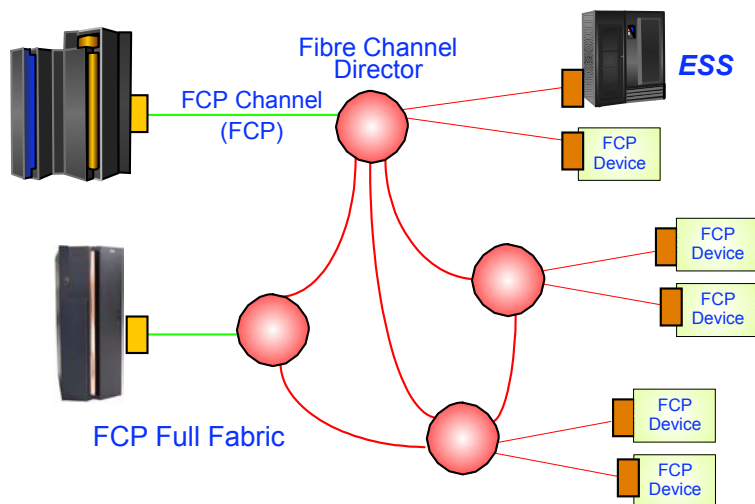

- **FCP Full Fabric Connectivity**
 - ▶ Homogeneous, single vendor fabric
 - ▶ Fibre channel directors
 - INRANGE FC/9000 (IBM 2042)
 - McDATA ED-6064/ 5000 (IBM 2032-064/ 2032-001)
 - IBM 2109-F16/F08/S16/S08 (Brocade 3800/3200/2800/2400)
 - ▶ Devices
 - Enterprise Storage Server

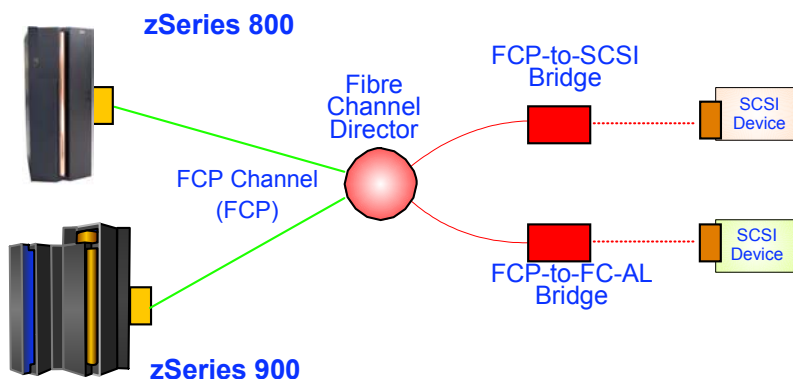

- **FCP to SCSI Bridge**
 - ▶ FCP-to-SCSI Bridges (via switch)
 - IBM 2108-G07 SAN Data Gateway
 - ▶ FCP-to-FC-AL bridge (via switch)
 - McDATA ES-1000 Loop Switch (IBM ES-2031-L00)

Initially, no direct attachment to device or bridge

Message Time Ordering - Fast CF Connection to Sysplex Timer

z900 New 2xx Model with ICF and non-Parallel Sysplex LPARs

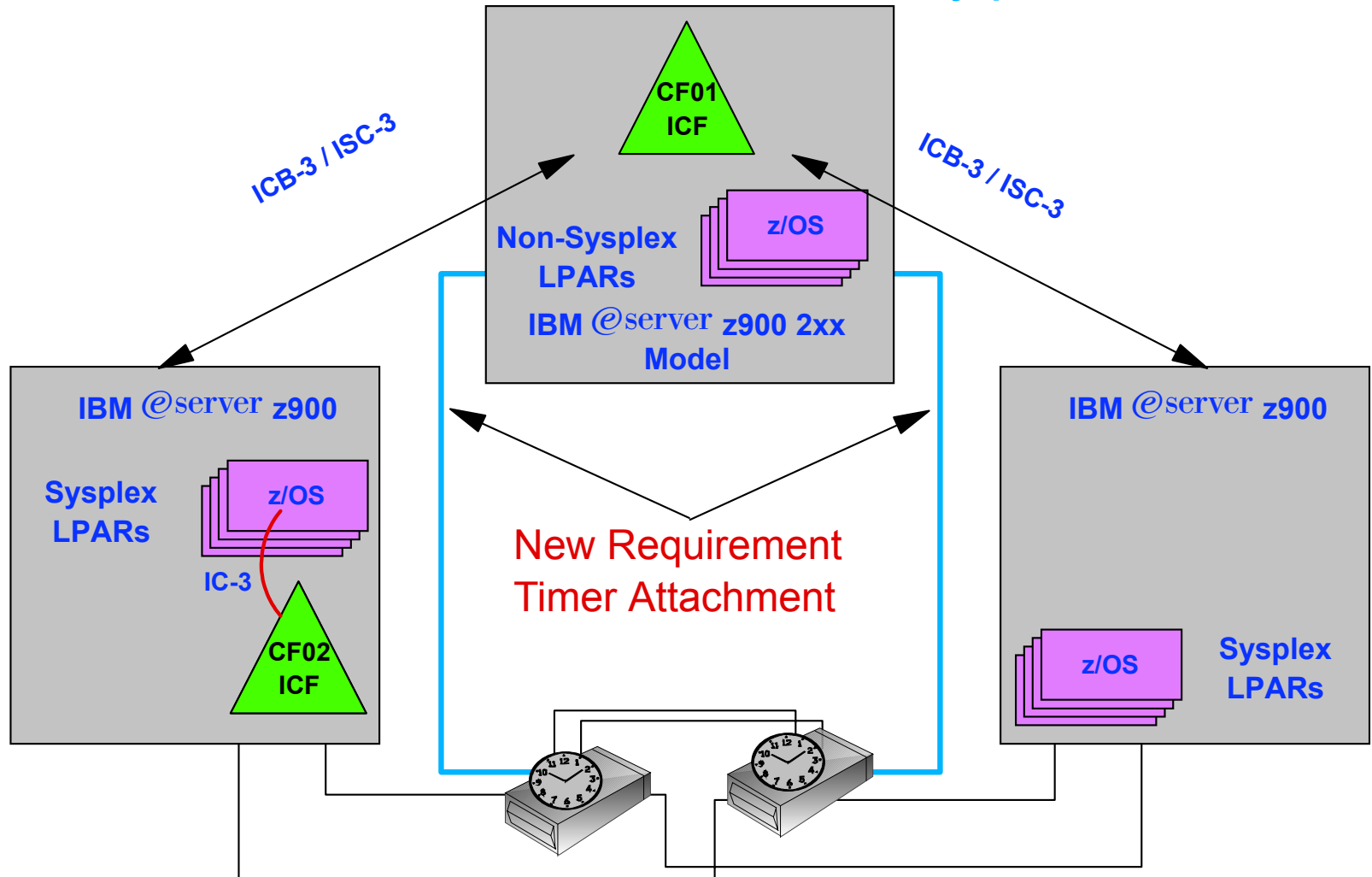

- Required z/OS and OS/390 New Function APAR - OW53831

IBM @server. For the next generation of e-business.

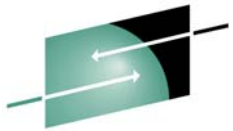

SHARE

IBM Coupling Facility Control Code

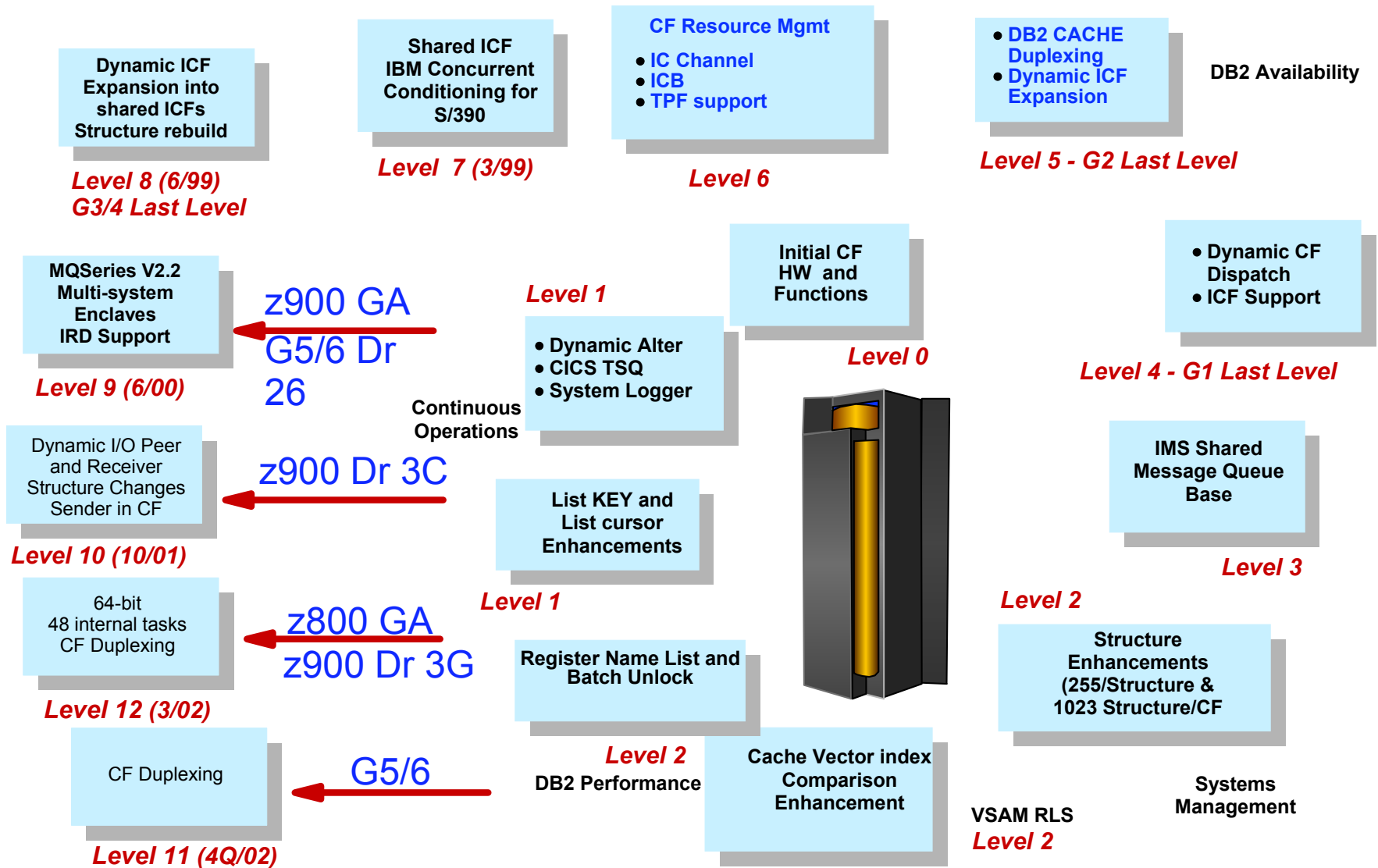

World's Leading and Unrivaled Coupling Technology

IBM @server. For the next generation of e-business.

System Managed CF Structure Duplexing

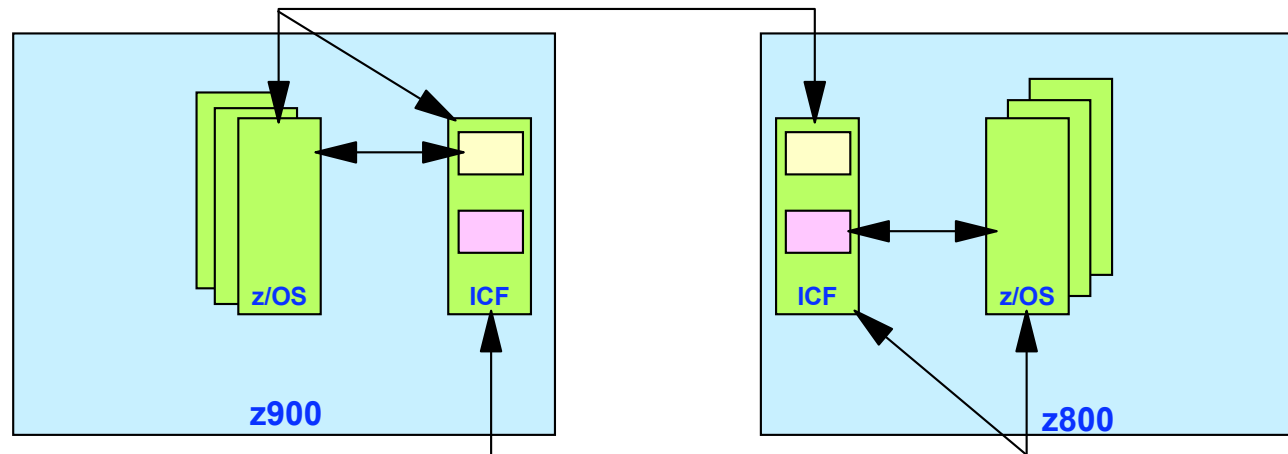

Robust, standard recovery capability

- Ease of use for middleware and ISVs
- Eliminates rebuild delay
- Reduces need for standalone CF

Considerations

- Not all structures supported
- Overhead to duplex
- Storage required to duplex
- See Announcement 102-181 (06/02)

Requirements:

- Sysplex Images -
 - z/OS v1.2 & up
 - APAR OW41617
- Coupling Facilities -
 - ICF or standalone
 - zSeries with CFCC Level 12
 - S/390 G5/6 with CFCC Level 11
 - CF - CF link connectivity



APARs for Hardware Planners

- **IYPIOCP - OS/390 and z/OS (See II02369)**
 - ▶ **zSeries Driver 3G - Level 1.2.0 - OW52993**

- **HCD Support for FCP and z900 2xx Models**
 - ▶ **OW48246**

- **HCD and HCM support for FICON Cascade**
 - ▶ **HCD - OW54246, HCM - IR46549 (Not available - 7/26/02)**

- **IOS Support for FICON Cascade - z/OS V1.3 & up**
 - ▶ **OW55513, OW55514, OW55515 (Not available - 7/26/02)**

- **RMF support for FICON Cascade - z/OS V1.3 & up**
 - ▶ **OW52396 (Not available - 7/26/02)**

- **DCM toleration of FICON Cascade - OS/390 V2.10 & up**
 - ▶ **OW49661**

- **System Automation for OS/390 V2.2 toleration of FICON Cascade**
 - ▶ **OW54640 (Not available - 7/26/02)**



APARs for Hardware Planners (Sysplex)

- **Dynamic I/O for Peer and Receiver - OS/390 V2.8 & up**
 - ▶ **IOS - OW48534 + OW54538 (Not available - 7/26/02)**

- **System Managed Structure Duplexing - z/OS V1.2 & up**
 - ▶ **XCF - OW41617 (Not available - 7/26/02)**

- **Message Time Ordering - OS/390 V2.8 & up**
 - ▶ **SYSPLXDS - OW53831**

- **And finally always check PSP buckets**
 - ▶ **2064DEVICE for z900**
 - ▶ **2066DEVICE for z800**

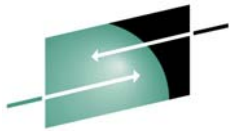

S H A R E

S/390 9672 EC Levels

Machine	GA	Dr	HMC LIC EC	SE LIC EC
S/390 G4 Server/CF S/390 G3 Server/CF S/390 Multiprise S/390 StarterPak	4/98	A2i	F10972	F10980
S/390 G6 Server S/390 G5 Server/CF	6/00	26w	F99933	F99918

Note: Only these Drivers are supported for S/390 9672 sysplex coupling to zSeries or for MCL fixes.

Note: Full HMC compatibility with zSeries requires an HMC #0061, #0073, or #0074 with DVD-RAM and Driver 3Gf. That level HMC fully supports G3 - G6.

IBM @server. For the next generation of e-business.