



# C12

## Revealed! TXSeries V6 - The Next Generation of Distributed CICS

Kevin Sager

**IBM**  
**TRANSACTION & MESSAGING**  
**TECHNICAL CONFERENCE**

Atlanta, GA

June 12-16, 2006

# Agenda

- **Introducing TXSeries**
- **Architecture – how does TXSeries work?**
- **Functionality – what does TXSeries provide?**
- **Strategy – what is the roadmap for TXSeries?**
- **Enhancements – what is new in TXSeries v6?**
- **Choices – where does TXSeries offer choice?**

# What is TXSeries for Multiplatforms?

- IBM's premier **distributed** transaction processing product
- Part of IBM's **CICS family** of products
- Provides business critical **transaction** and **integration** capabilities
- Proven for **more than a decade** to deliver modern, reusable, business critical applications
- Widely used in **support** of IBM mainframe and IBM WebSphere application deployments

# What can TXSeries do?

- Use TXSeries to ...
  - ▶ **Build** new CICS applications using COBOL, PL/I, C, C++, and Java
  - ▶ **Reuse** existing CICS applications and application programming skill sets in your organisation
  - ▶ **Extend** CICS applications to the web and web services via the CICS Transaction Gateway and WebSphere Application Server
  - ▶ **Access** data and applications in various distributed and enterprise systems including
    - CICS and IMS
    - DB2 and Oracle
    - WebSphere MQ

# TXSeries as a component of your SOA

- Enabling end to end distributed mixed language solutions through integration with WebSphere and CICS Transaction Server for z/OS
- The JCA interface provided in the CICS TG connects TXSeries to the following WebSphere SOA server products:
  - ▶ WebSphere ESB
  - ▶ WebSphere Application Server
  - ▶ WebSphere Process Server
- TXSeries with WebSphere MQ can connect to:
  - ▶ WebSphere Message Broker
  - ▶ Any other product that supports native MQSeries transport

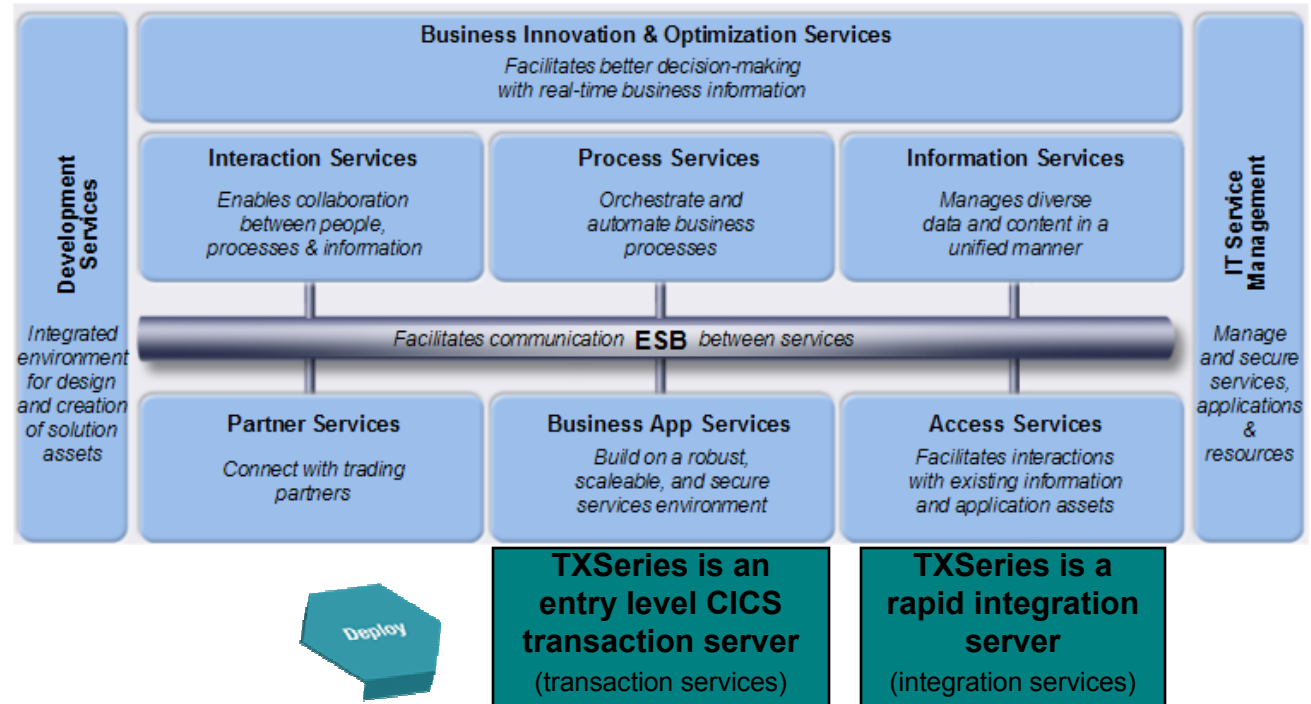

# TXSeries Positioning

- Complementary to J2EE and mainframe environments
  - ▶ Stand-alone: distributed CICS server for business critical workloads
  - ▶ Integration : with WebSphere and CICS TS
- Supports JCA based connectivity to WebSphere, via CICS Transaction Gateway
- Enables end to end distributed mixed language solutions

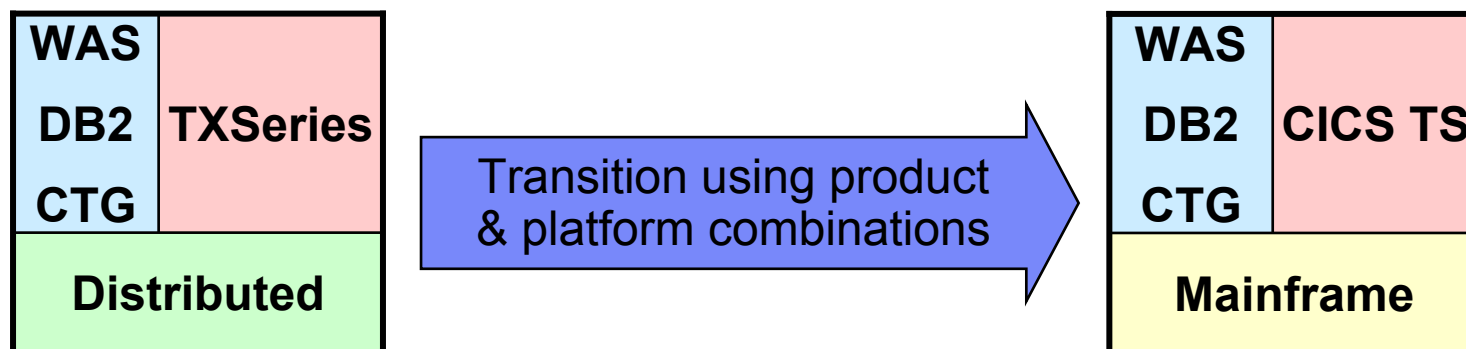

# Scale to CICS Transaction Server as your Business Grows

This is where TXSeries is positioned in the cost/QoS continuum

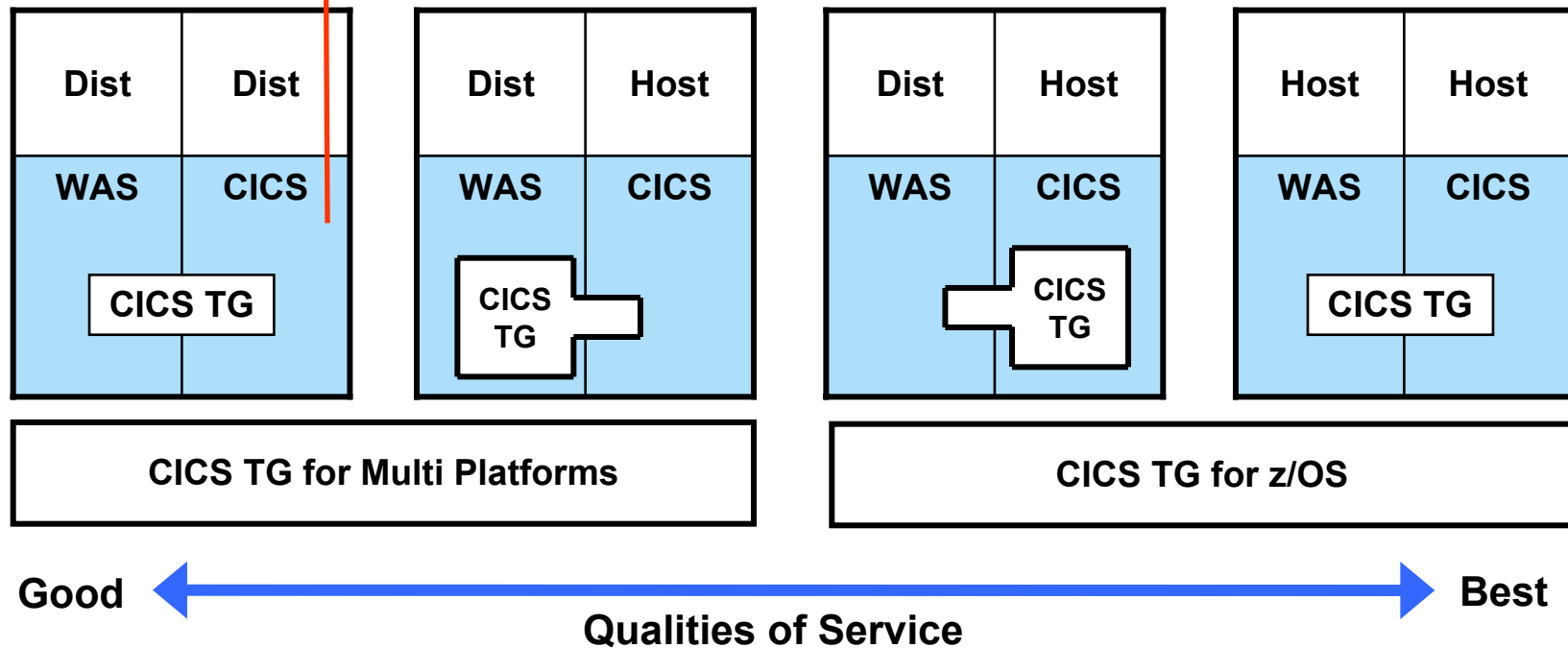

# Common Deployment Scenarios

## Rapid deployment integration server

- A consolidating mid-tier terminal server
- An intelligent mid-tier gateway
- A comprehensive mid-tier integration server

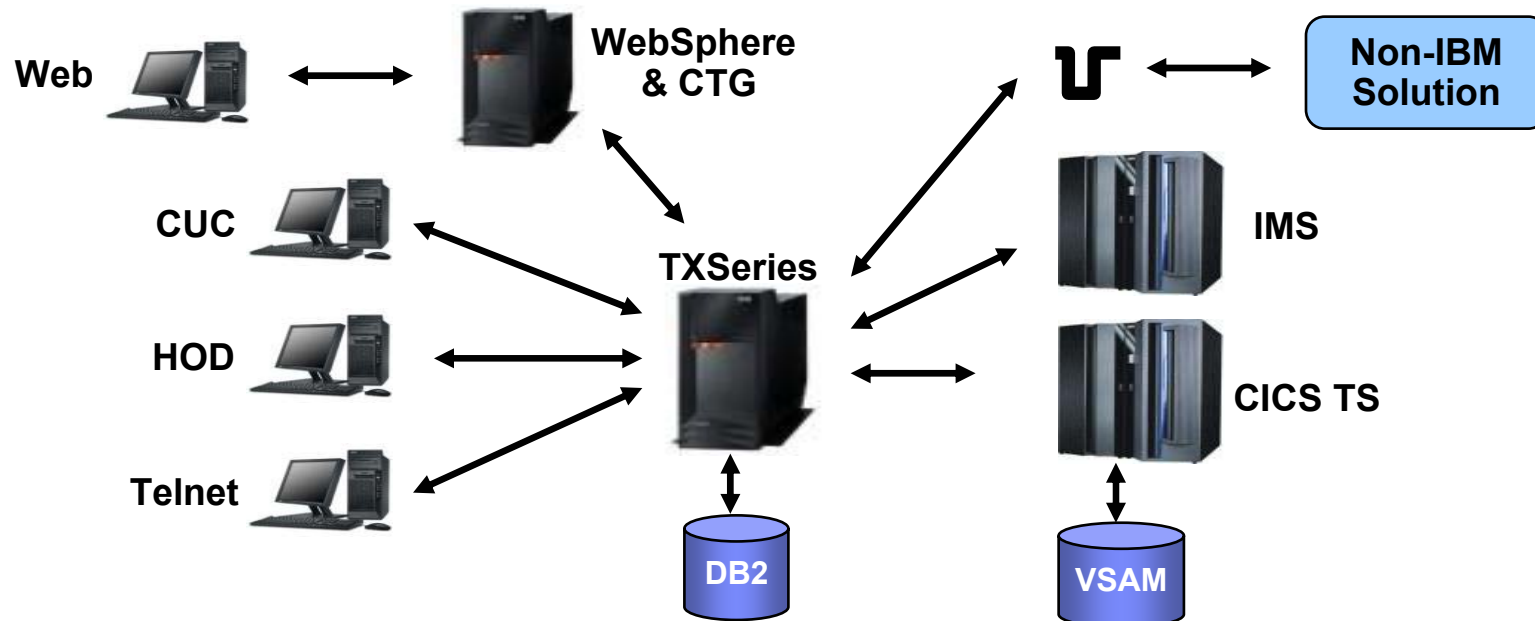



# Common Deployment Scenarios

## Entry level transaction server

- As a transactional run time for custom application services
- As a composite transaction server connected to WebSphere Application Server
- As a distributed CICS server for local branch-level processing

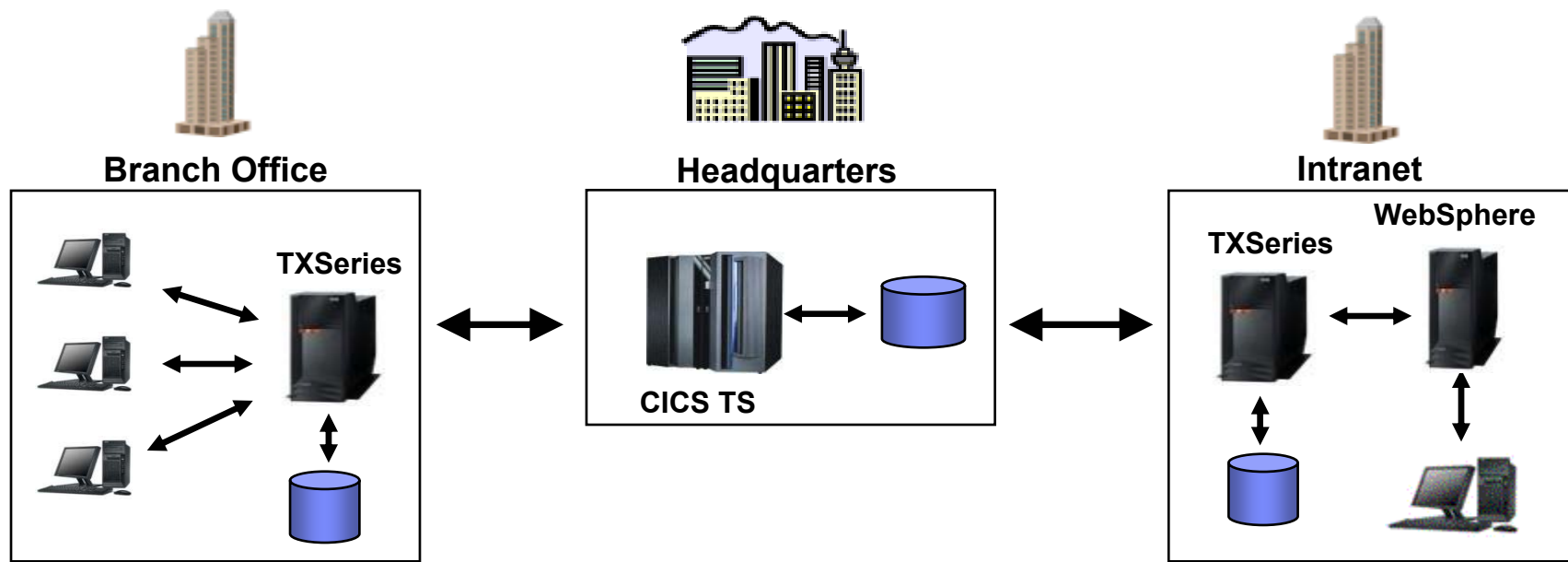

# Maximise Data Integrity

- All data sources can be included in a single unit of work.
- Two-phase commit for data integrity across the network.

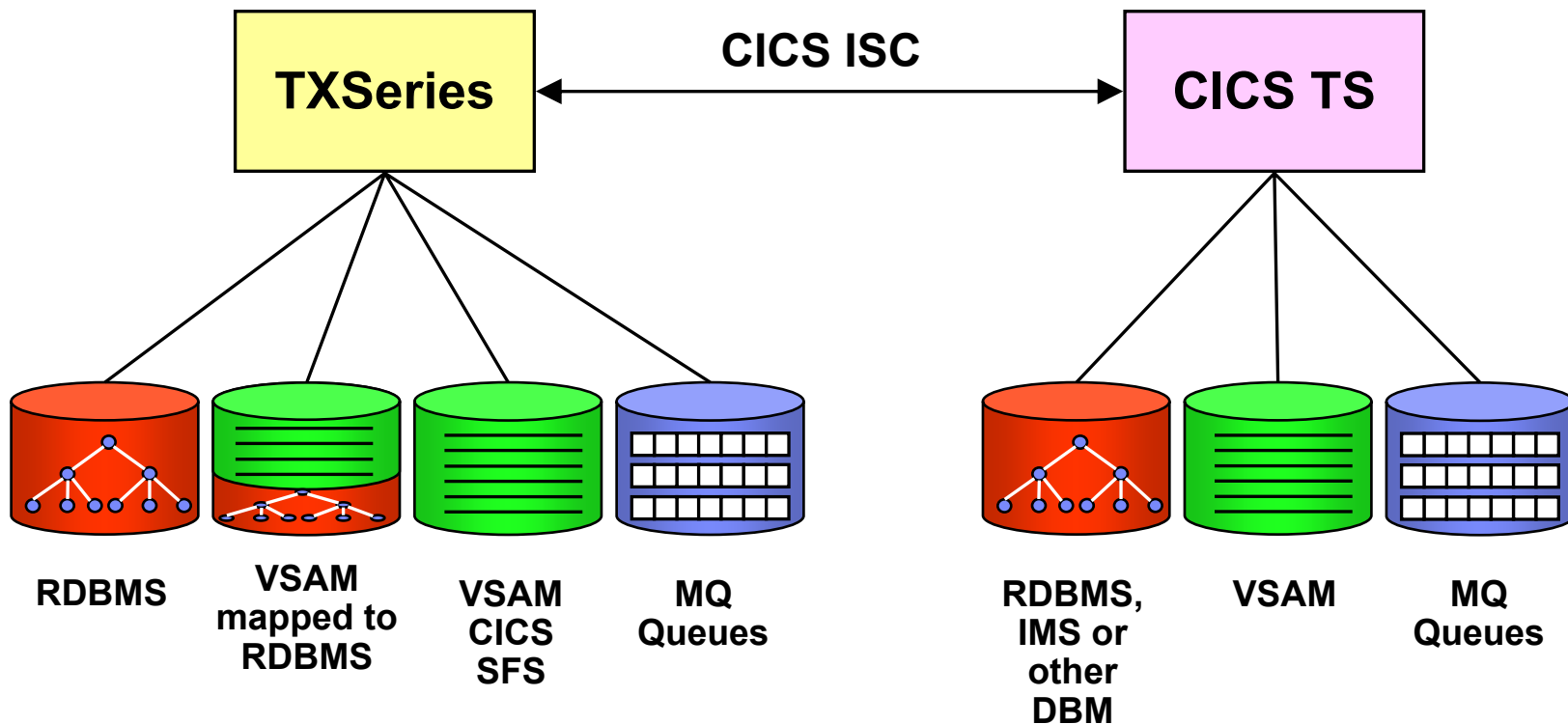

# Agenda

- **Introducing TXSeries**
- **Architecture – how does TXSeries work?**
- **Functionality – what does TXSeries provide?**
- **Strategy – what is the roadmap for TXSeries?**
- **Enhancements – what is new in TXSeries v6?**
- **Choices – where does TXSeries offer choice?**

# Clients

## Clients

- CUC Client Terminal
- Telnet 3270
- Host on Demand
- WebSphere IIOp
- IP Socket



TXSeries CICS



Other CICS Systems



WebSphere & CICS Transaction Gateway

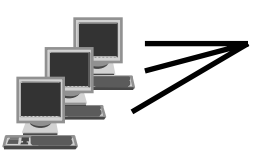

Web Browsers

# TXSeries CICS

## TXSeries CICS Region

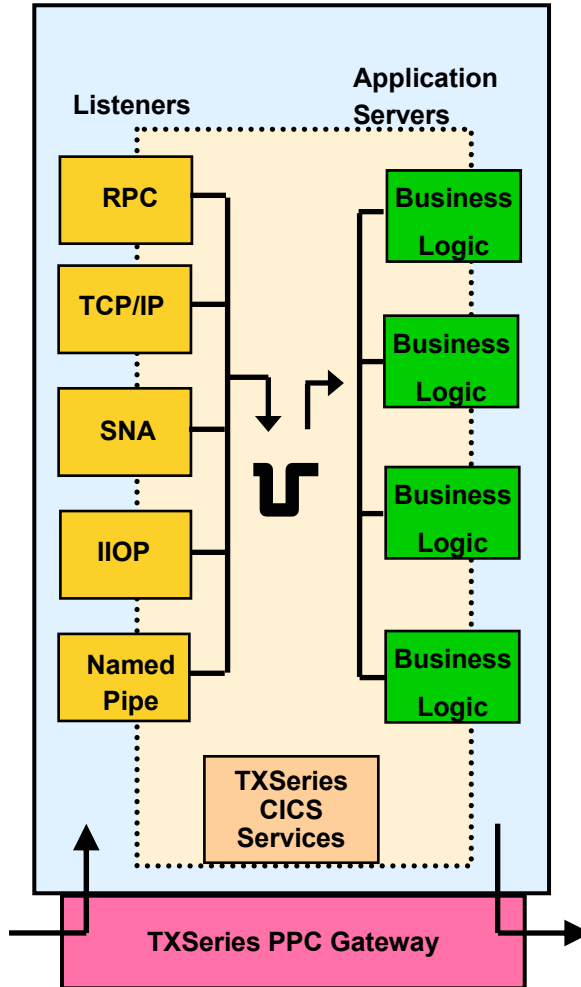

# Resources

Batch Programs

Resource Managers (XA and non-XA)

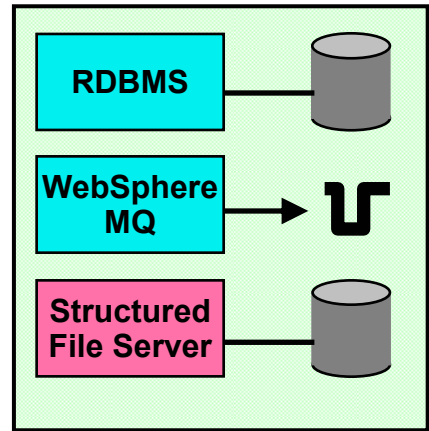

TCP/IP & SNA

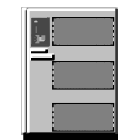

TXSeries CICS & Other CICS & IMS Systems

# Architecture

- Applications isolated and independent of work origin
  - ▶ Execute in own Application Server process
  
- Pool of Application Server processes actively managed
  - ▶ Control over Minimum and Maximum number of servers
  - ▶ Servers constantly monitored
  
- Transaction scheduling
  - ▶ Balances workload over application servers

# Agenda

- **Introducing TXSeries**
- **Architecture – how does TXSeries work?**
- **Functionality – what does TXSeries provide?**
- **Strategy – what is the roadmap for TXSeries?**
- **Enhancements – what is new in TXSeries v6?**
- **Choices – where does TXSeries offer choice?**

# CICS Programming Interface

- Approximately same level as CICS for MVS/ESA 4.1 & CICS TS for VSE/ESA
- Java API support (JCICS) as for CICS TS 1.3
- Includes a limited subset of CICS System programming Interface (SPI)
- Programming Languages
  - ▶ COBOL (IBM, Acucobol, Micro Focus)
  - ▶ C, C++ (IBM, Microsoft, HP, Sun)
  - ▶ PL/I, Java
  - ▶ Assembler not supported

# Data Access

- CICS files and queues supported
- CICS Structured File Server (SFS) used by default for VSAM support
- DB2 or Oracle may be used instead of SFS
- SQL database access via leading RDBM products
- Messaging via WebSphere MQ
  
- ... all via 2 phase commit XA protocols



# Communications

- Full CICS Intersystem Communication support
  - ▶ Function Shipping
  - ▶ Distributed Program Link
  - ▶ Transaction Routing
  - ▶ Distributed Transaction Processing
  - ▶ Asynchronous Transaction Start
  - ▶ Synch Level 2 support over SNA
  - ▶ Synch Level 1 and 2 support over TCP/IP (TXSeries CICS to TXSeries CICS only)

# Security

- CICS provided
  - ▶ Authentication - Password sign-on
  - ▶ Authorization - Transaction and resource access
  
- External Security
  - ▶ User Replaceable Module for Authentication and Authorization
  - ▶ RACF integration via Lightweight Directory Access Protocol (LDAP)

# Resource Management

- Command line interface on all platforms
- User Interface on AIX and Windows
  - ▶ Windows - TXSeries Administration Tool
  - ▶ AIX - System Management Interface Tool (SMIT)
- RDO is supported, but no CEDA transaction
- Resource definition database
  - ▶ Composed of stanza (text) files
  - ▶ One stanza per resource type
  - ▶ Stanza names are different from CICS TS
- Three databases
  - ▶ Permanent, Runtime and Auto

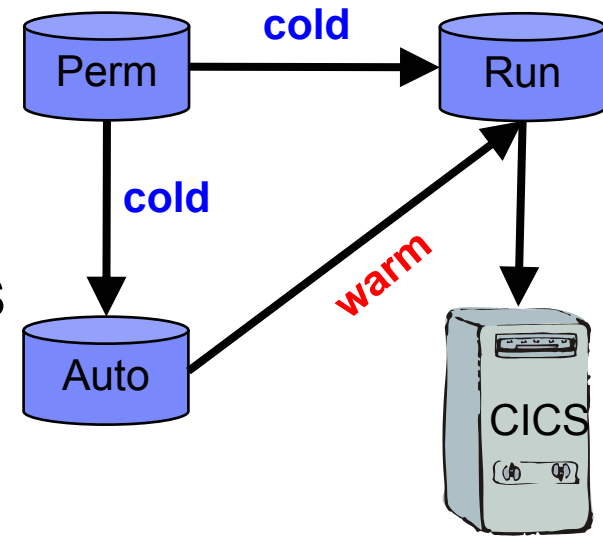

# Resource Definition Tables

TXSeries Tables (stanzas)		Equivalent CICS TS Table	
CD	Communications Definitions	TCT	Terminal Control Table (part)
FD	File Definitions	FCT	File Control Table
GD	Gateway Definitions		
GSD	Gateway Server Definitions		
JD	Journal Definitions	JCT	Journal Control Table
LD	Listener Definitions		
MD	Monitoring Definitions	MCT	Monitoring Control Table
OD	Object Definitions		
PD	Program Definitions	PPT	Processing Program Table
RD	Region Definitions	PLT SIT	Program List Table System Initialization Table
SCD	Schema File Definitions		
SSD	Structured File Server Definitions		
TD	Transaction Definitions	PCT XLT	Program Control table Transaction List Table
TDD	Transient Data Definitions	DCT	Destination Control Table
TSD	Temporary Storage Definitions	TST	Temporary Storage Table
UD	User Definitions	SNT	Signon Table
WD	Terminal Definitions	TCT	Terminal Control Table (part)
XAD	XA Product Definitions		

# CICS Administration Commands

- CICS Control Program (cicscp) - the simple way
  - ▶ Many default values and options
  - ▶ Does most things with CICS, SFS, PPCG & telnet servers
  - ▶ Can be used interactively or in batch
  - ▶ Acts as a wrapper program to underlying commands
  - ▶ Has parameters of `-i` (ignore errors), `-v` (verbose) `-l` (create logfile)
- Plenty of other commands - if you need control
  - ▶ `cicsexport` – copy resource definitions from a region
  - ▶ `cicssdt` – SFS diagnostic tool
  - ▶ `cicsstart` – start a CICS region
  - ▶ `cicssfscree` – create an SFS server



# CICS Supplied Transactions

- A number of supplied transactions including
  - ▶ CEMT – Master terminal
  - ▶ CECI / CECS – Command interpreter
  - ▶ CESN / CESF – Signon / Signoff
  - ▶ CEBR – TS and TD queue browsing
  - ▶ CEDF – CICS debugger
  
- Plus some TXSeries unique transactions
  - ▶ CJDB / CADB / CDCN – Application debuggers
  - ▶ CMLV - Message log viewer
  - ▶ CALF – VSAM data conversion

Note the absence of CEDA.  
RDO is still supported via administration commands

# Problem Determination

- Several diagnostic files
  - ▶ Two console message files
  - ▶ Symptoms Record file for significant errors
  - ▶ CSMT.out for CICS messages
- Dumps
  - ▶ Transaction, System and Core dumps
- Trace
  - ▶ Transaction and System trace
- Monitoring
  - ▶ User and System
- Statistics
  - ▶ 4 types available (Interval, End of Day, Requested, Unsolicited)

# Non Functional Comparison

Feature	CICS TS	TXSeries
<b>Security</b>	Enterprise wide	Application or department wide
<b>Scalability</b>	Unlimited (horizontal and vertical)	Some limitations
<b>Work Load Management</b>	Complex and high volume	Requires machine coupling
<b>Systems Management</b>	CICS Plex wide	Individual Region
<b>High Availability</b>	0 downtime is a reality	4x9's (99.99%) is expensive
<b>Tooling</b>	Choice and flexibility	Less choice
<b>Cost / Quality of Service</b>	Higher / Best	Lower / Good



# Agenda

- **Introducing TXSeries**
- **Architecture – how does TXSeries work?**
- **Functionality – what does TXSeries provide?**
- **Strategy – what is the roadmap for TXSeries?**
- **Enhancements – what is new in TXSeries v6?**
- **Choices – where does TXSeries offer choice?**

# Non-mainframe CICS Strategy

- The future of CICS on distributed platforms is focused around the common CICS for AIX code base
- TXSeries v6.0 for AIX became available on 6th December 2005
- Following customers will be encouraged to migrate to TXSeries v6
  - ▶ TXSeries CICS v4 and v5
  - ▶ CICS TS for Windows
  - ▶ CICS TS for OS/2
- IBM will continue to enhance this common code base for the foreseeable future
- We are taking requirements now – so it is a good time to make requests!

The Encina portion of TXSeries for Multiplatforms will not be significantly enhanced – but will continue to be supported

# TXSeries Strategy: Phase 1

## Separate then Remove DCE and Encina

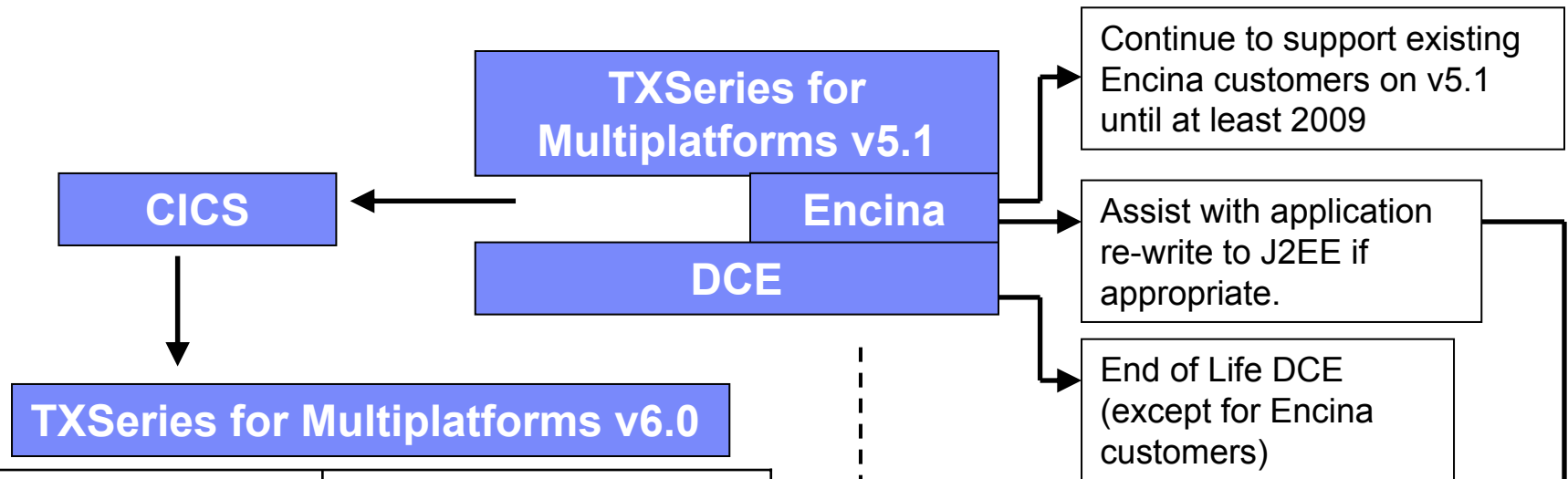

Continue to support existing Encina customers on v5.1 until at least 2009

Assist with application re-write to J2EE if appropriate.

End of Life DCE (except for Encina customers)

- WebSphere Application Server ←
- WebSphere Application Server Network Deployment ←
- WebSphere Extended Deployment ←
- CICS (TS or TXSeries) ←

Action	Customer Benefit
Remove DCE & Encina Develop alternatives Repackage TXSeries	Removes complexity Simplify installation Reduce administration
Continue to enhance mainframe CICS value add proposition	Enhanced integration with mainframe CICS
Continue to enhance WebSphere value add proposition	Integrate with WebSphere and J2EE using CICS TG

# TXSeries Strategy: Phase 2

## Increase TXSeries and overall IBM Value Proposition

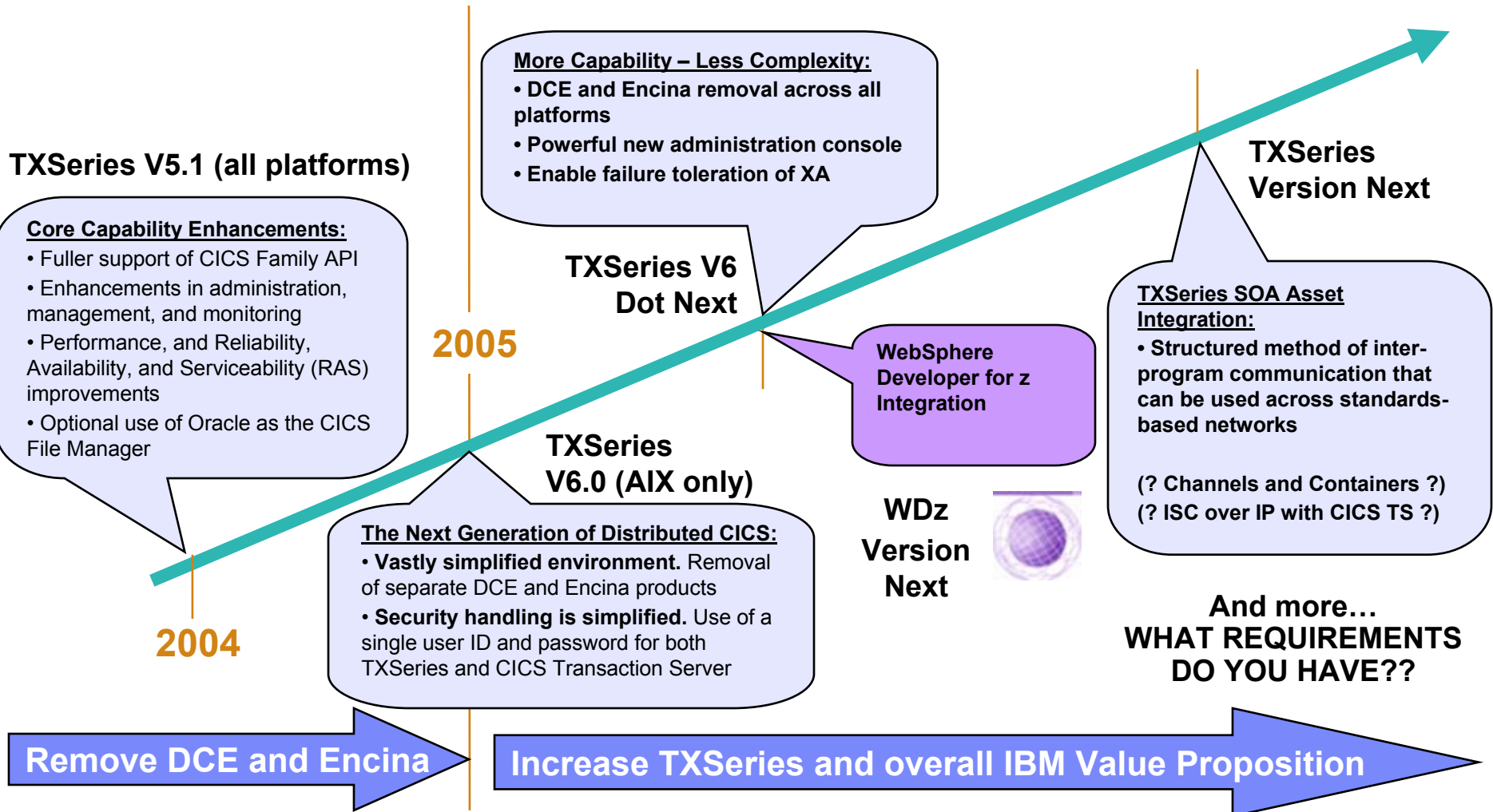

**FUTURE RELEASES/VERSIONS ARE NOT NECESSARILY COMMITTED IBM PLANS**

# Statement of Direction: Planned enhancements to the CICS family of products

## Objectives:

- IBM recently announced a program of major planned enhancements to a number of products in the IBM CICS product portfolio
- The following statement points towards the future areas of enhancements for TXSeries

- TXSeries for Multiplatforms is an entry-level CICS server that for more than a decade has delivered high-performance, CICS-managed transactional services, across a range of distributed platforms.
- To facilitate the ease of integration of existing assets into a modern SOA, IBM has recently removed all dependencies on the separate Distributed Computing Environment (DCE) and Encina products from TXSeries on the AIX platform. **It is planned that this capability will be extended to the remaining platforms later this year.**
- Following that, IBM intends to focus on the integration of TXSeries assets in modern SOAs by delivering a structured method of inter-program communication that can be used across standards-based networks. This will be delivered in line with established CICS design principles to maintain upward compatibility with CICS Transaction Server for z/OS.
- **All statements regarding IBM's plans, directions, and intent are subject to change or withdrawal without notice.**

See IBM Software Announcement 206-096, dated 2<sup>nd</sup> May 2006

# Agenda

- **Introducing TXSeries**
- **Architecture – how does TXSeries work?**
- **Functionality – what does TXSeries provide?**
- **Strategy – what is the roadmap for TXSeries?**
- **Enhancements – what is new in TXSeries v6?**
- **Choices – where does TXSeries offer choice?**

# Key Enhancements in TXSeries v6

- **Vastly simplified environment**
  - ▶ Separate DCE and Encina products completely removed
  - ▶ Equivalent DCE and Encina function now fully integrated
  - ▶ CICS processes now communicate using secure shared memory, called CICSIPC
- **Improved security** handling when using TXSeries in conjunction with RACF
  - ▶ Via supplied External Authentication Manager sample
- **Simplified installation** through industry-standard Install Shield Multiplatform (ISMP)
  - ▶ Via 3 modes: GUI, console or Silent
  - ▶ Removed SMIT (AIX) install option

# Key Enhancements in TXSeries v6

- **Major revision** to the documentation library
  - ▶ To reflect removal of Encina and DCE
- **Improved support**, including IBM Business Partner, Acucorp's open systems COBOL, ACUCOBOL-GT
- **Improved client access**
  - ▶ TXSeries client replaced by CICS Universal Client
  - ▶ One license supplied on TXSeries CD
  - ▶ Local CICS terminal now called cicslterm
- **Updated supported hardware and software levels**
  - ▶ See [www.ibm.com/software/txseries/support](http://www.ibm.com/software/txseries/support)



# Agenda

- **Introducing TXSeries**
- **Architecture – how does TXSeries work?**
- **Functionality – what does TXSeries provide?**
- **Strategy – what is the roadmap for TXSeries?**
- **Enhancements – what is new in TXSeries v6?**
- **Choices – where does TXSeries offer choice?**

# Deployment: Placing VSAM Data

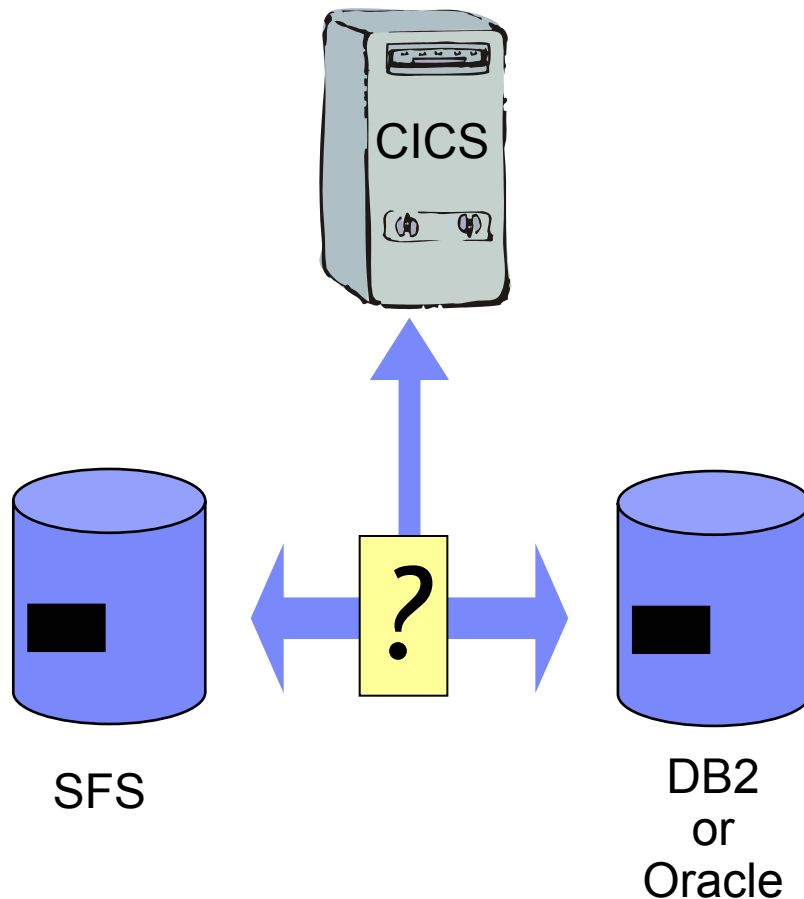

- For VSAM data and queues, CICS can use
  - ▶ SFS (part of TXSeries)
  - ▶ RDBMS (DB2 or Oracle)
- Use RDBMS if
  - ▶ Licenses available
  - ▶ Skills exist to Manage, Configure, Tune and Operate
- Use SFS if
  - ▶ RDBMS not an option
  - ▶ Unrecoverable data widely used

# Deployment: Security

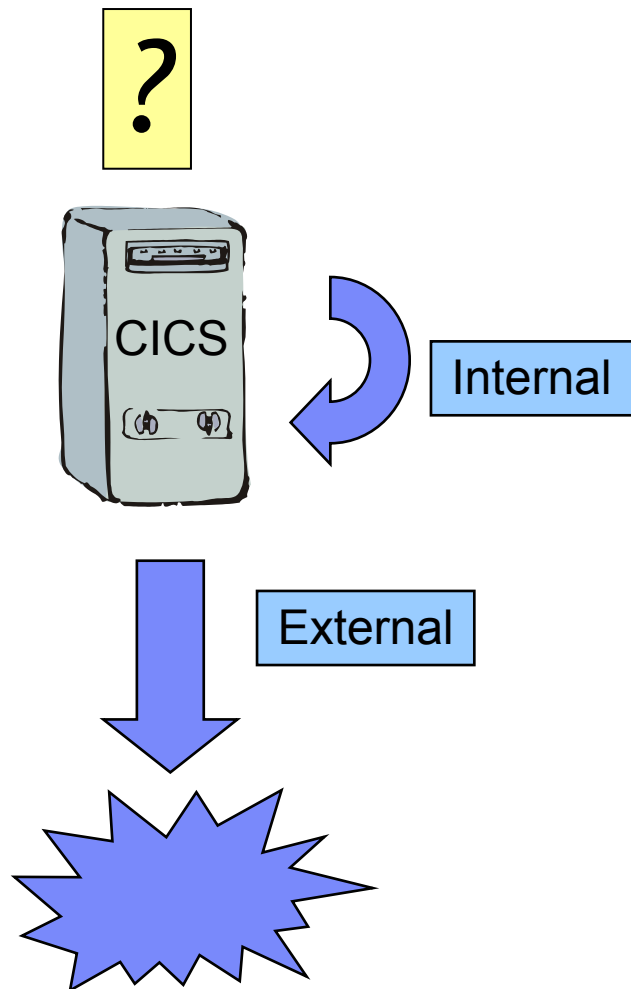

- Internal: using CICS supplied Authentication and Authorization
  - ▶ Simple to setup and use
  - ▶ Secure
- External: using EAM and ESM modules
  - ▶ Integrates with RACF
  - ▶ Flexible
  - ▶ Requires setup and customization

# Deployment: Hardware

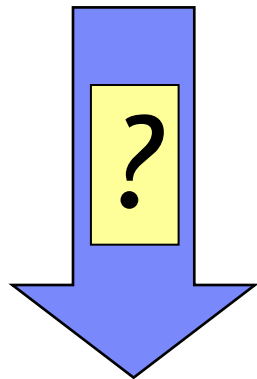
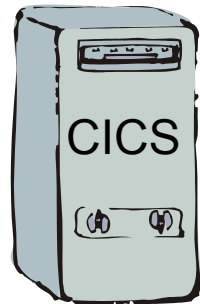

- Target platform depends on
  - ▶ Number of machines required
  - ▶ Location of machines
  - ▶ OS Features such as security, backup
  - ▶ Existing hardware & software
  - ▶ Cost

# Development: The Same Rules Apply

- Application development with TXSeries is no different from CICS TS
  - ▶ Separate logic into presentation, business, error handling etc.
  - ▶ Use common data structures
  - ▶ Keep LUWs **short** and **small**, update close to the syncpoint
  - ▶ Null fill commareas before using
  - ▶ Avoid conversational programs
  - ▶ Minimize terminal traffic
  - ▶ Minimize ENQ and DEQ times

... All of this should be familiar to a CICS programmer

# Administration: Problem Determination

- TXSeries provides a number of problem determination tools
  - ▶ Monitoring
  - ▶ Statistics
  - ▶ Trace
  - ▶ Dump
  
- Use the appropriate tools for the problem

# Administration: Use TClass

**TRN1:**  
**ProgName = PROG1**  
**TClass = 2**

**TRN2:**  
**ProgName = PROG2**  
**TClass = 7**

TClass	1	2	3	4	5	6	7	8	9	10
Class Max Tasks	5	1	5	5	5	5	5	5	5	5

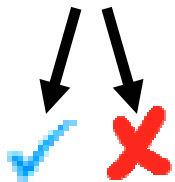

- 11 classes defined to CICS
  - ▶ 1 to 10 plus "NONE" (the default)
- Limit of concurrent transactions per class for classes 1 to 10
- TClass defined in TD stanza

## Recommend

- User transactions have a TClass
- CICS transactions use NONE
- MaxServers = sum(ClassMaxTasks)

## Example

- 1 instance of TRN2. Limit = 5
  - ▶ Allowed to run
- 2 instances of TRN1. Limit = 1
  - ▶ 1 allowed to run, 1 queued

# Administration: Min & Max Servers

RD MinServers = 1  
MaxServers = 5

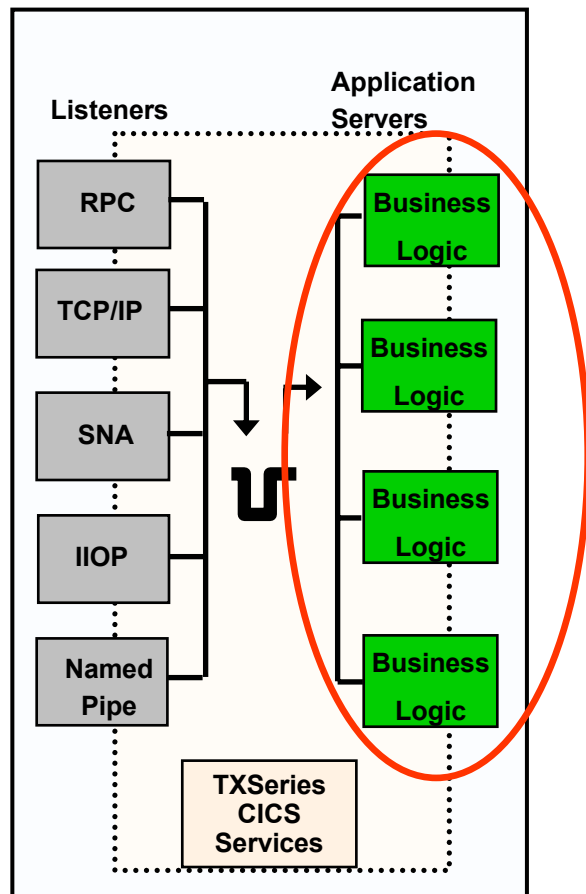

- Defined in RD stanza
- Determines maximum number of tasks in system
- Too small?
  - ▶ Requests queue for dispatch
- Too large?
  - ▶ Idle processes and wasted resources
- Identify correct values through testing, tuning and observations
- To modify
  - ▶ Change RD stanza
  - ▶ Use CEMT INQ SYS



# Summary

- TXSeries is a distributed version of CICS TS
- Supports a number of common deployment and integration scenarios with CICS TS
- Provides some, but not all of the facilities offered by CICS TS
- Version 6 available and further enhancements planned
  - ▶ Removes dependencies on Encina and DCE
  - ▶ Adds additional new functionality
- Provides a range of choices and options

# Trademarks

- The following terms are trademarks of the International Business Machines Corporation in the United States, other countries, or both:
  - ▶ Eserver®, developerWorks®, iSeries™, z/OS®, zSeries®, Candle®, CICS®, CICSplex®, DB2®, IBM®, IMS™, MQSeries®, MVS™, OS/390®, Parallel Sysplex®, Rational®, Redbooks™, RACF®, Tivoli®, VTAM®, WebSphere®
- The following terms are trademarks of other companies:
  - ▶ Enterprise JavaBeans, EJB, Java, Java Naming and Directory Interface, JavaBeans, JavaServer, JDBC, JDK, JSP, JVM, J2EE, Sun, Sun Microsystems, and all Java-based trademarks are trademarks of Sun Microsystems, Inc. in the United States, other countries, or both.
  - ▶ Microsoft, Windows, and the Windows logo are trademarks of Microsoft Corporation in the United States, other countries, or both.
  - ▶ Intel, Pentium, Intel logo, Intel Inside logo, and Intel Centrino logo are trademarks or registered trademarks of Intel Corporation or its subsidiaries in the United States, other countries, or both.
  - ▶ UNIX is a registered trademark of The Open Group in the United States and other countries.
  - ▶ Linux is a trademark of Linus Torvalds in the United States, other countries, or both.
- Other company, product, or service names may be trademarks or service marks of others.