

CICS/ESA



Front End Programming Interface User's Guide

Version 4 Release 1

CICS/ESA



Front End Programming Interface User's Guide

Version 4 Release 1

Note!

Before using this information and the product it supports, be sure to read the general information under “Notices” on page vii.

First edition (October 1994)

This edition applies to Version 4 Release 1 of the IBM licensed program Customer Information Control System/Enterprise Systems Architecture (CICS/ESA), program number 5655-018, and to all subsequent versions, releases, and modifications until otherwise indicated in new editions. Consult the latest edition of the applicable IBM system bibliography for current information on this product.

This book is based on the Front End Programming Interface User's Guide for CICS/ESA 3.3, SC33-0804-00. Changes from that edition are marked by vertical lines to the left of the changes.

The CICS/ESA 3.3 edition remains applicable and current for users of CICS/ESA 3.3.

Order publications through your IBM representative or the IBM branch office serving your locality. Publications are not stocked at the address given below.

At the back of this publication is a page entitled “Sending your comments to IBM”. If you want to make comments, but the methods described are not available to you, please address them to:

IBM United Kingdom Laboratories Limited, Information Development,
Mail Point 095, Hursley Park, Winchester, Hampshire, England, SO21 2JN.

When you send information to IBM, you grant IBM a nonexclusive right to use or distribute the information in any way it believes appropriate without incurring any obligation to you.

© Copyright International Business Machines Corporation 1992, 1994. All rights reserved.

US Government Users Restricted Rights – Use, duplication or disclosure restricted by GSA ADP Schedule Contract with IBM Corp.

Contents

Notices	vii
Programming interface information	vii
Trademarks and service marks	viii
About this book	ix
Who this book is for	ix
What you need to know to understand this book	ix
How to use this book	ix
Notes on terminology	ix
CICS syntax notation used in this book	xi
Determining if a publication is current	xi
Bibliography	xiii
CICS/ESA 4.1 library	xiii
Other CICS books	xiv
Books from related libraries	xiv
Summary of changes	xv
Changes for this edition	xv

Part 1. Concepts and facilities 1

Chapter 1. Introducing FEPI	3
Problems FEPI can solve	3
How FEPI fits into your system	4
Planning for FEPI	5
Chapter 2. Functions and services	7
Programming commands	7
Setup and resources	9
CICS FEPI application programs	10
Terminals supported	11
Security	11
Problem determination, customization, and performance	12

Part 2. Installation and administration 13

Chapter 3. Planning for FEPI	15
Analysis and planning	15
Organizing your pools and property sets	17
Workload balancing in a sysplex	19
Planning FEPI storage	19
Chapter 4. Getting started	21
The installation process	21
Chapter 5. Configuring FEPI	23
CICS configuration	23
VTAM configuration	24
Back-end system configuration	26
FEPI configuration	27
Chapter 6. FEPI operation	39
Controlling FEPI resources	39
Performance	41
Shutdown	42

Using FEPI with XRF	43
Using FEPI with VTAM persistent sessions	46
Chapter 7. Operator control	49
CEMT—master terminal transaction	49
CEMT DISCARD	50
CEMT INQUIRE FECONNECTION	51
CEMT INQUIRE FENODE	53
CEMT INQUIRE FEPOOL	54
CEMT INQUIRE FEPROPSET	55
CEMT INQUIRE FETARGET	56
CEMT SET FECONNECTION	57
CEMT SET FENODE	58
CEMT SET FEPOOL	59
CEMT SET FETARGET	60
CETR—trace control transaction	61
VTAM commands	61
Chapter 8. Customizing FEPI	63
Global user exits	63
Journaling	67
Chapter 9. System programming reference	69
FEPI ADD POOL	71
FEPI DELETE POOL	72
FEPI DISCARD NODELIST	72
FEPI DISCARD POOL	73
FEPI DISCARD PROPERTYSET	73
FEPI DISCARD TARGETLIST	73
FEPI INQUIRE CONNECTION	74
FEPI INQUIRE NODE	76
FEPI INQUIRE POOL	77
FEPI INQUIRE PROPERTYSET	79
FEPI INQUIRE TARGET	81
FEPI INSTALL NODELIST	82
FEPI INSTALL POOL	83
FEPI INSTALL PROPERTYSET	84
FEPI INSTALL TARGETLIST	86
FEPI SET CONNECTION	87
FEPI SET NODE	89
FEPI SET POOL	90
FEPI SET TARGET	91
FEPI SP NOOP	92
Transient data queue records	92
Chapter 10. Problem determination	95
Debugging FEPI applications	95
FEPI dump	95
FEPI trace	98
FEPI messages	98
FEPI abends	99
Reporting a FEPI problem to IBM	100

Part 3. Application programming	101
Chapter 11. Basics	103
Communication and conversations	103
Structure and design	104
Chapter 12. Key stroke and screen-image applications	107
General sequence of commands	107
Sending key stroke data	108
Receiving field-by-field	109
Multiple attentions	110
Sending screen-image data	111
Receiving screen-image data	112
Extracting field data	113
CONVERSE	114
Chapter 13. Data stream applications	115
General sequence of commands	116
Receiving	116
Sending	118
CONVERSE	119
SLU2 mode considerations	119
SLU P mode considerations	120
Chapter 14. Application design	121
Programs	121
Application organization	123
Signon security	127
Error handling	128
System considerations	130
Chapter 15. Specialized functions	135
Set and test sequence number (STSN)	135
DRx responses	135
SNA commands	136
Chapter 16. Application programming reference	137
FEPI ALLOCATE PASSCONVID	138
FEPI ALLOCATE POOL	139
FEPI AP NOOP	140
FEPI CONVERSE DATASTREAM	140
FEPI CONVERSE FORMATTED	143
FEPI EXTRACT CONV	147
FEPI EXTRACT FIELD	148
FEPI EXTRACT STSN	149
FEPI FREE	150
FEPI ISSUE	151
FEPI RECEIVE DATASTREAM	152
FEPI RECEIVE FORMATTED	153
FEPI REQUEST PASSTICKET	155
FEPI SEND DATASTREAM	156
FEPI SEND FORMATTED	157
FEPI START	158
Start data	159
Data formats	160
Ending status	161

Part 4. Appendixes	163
Appendix A. Sample programs	165
COBOL II Sample Restrictions	167
Installing the samples	167
Using the samples	167
Description of the samples	170
Appendix B. CVDA and RESP2 values	185
CVDAs and numeric values in alphabetic sequence	185
CVDAs and numeric values in numeric sequence	186
RESP2 values	187
Glossary	189
Index	195

Notices

The following paragraph does not apply in any country where such provisions are inconsistent with local law:

INTERNATIONAL BUSINESS MACHINES CORPORATION PROVIDES THIS PUBLICATION "AS IS" WITHOUT WARRANTY OF ANY KIND, EITHER EXPRESS OR IMPLIED, INCLUDING, BUT NOT LIMITED TO, THE IMPLIED WARRANTIES OF MERCHANTABILITY OR FITNESS FOR A PARTICULAR PURPOSE. Some states do not allow disclaimer of express or implied warranties in certain transactions, therefore this statement may not apply to you.

References in this publication to IBM products, programs, or services do not imply that IBM intends to make these available in all countries in which IBM operates. Any reference to an IBM product, program, or service is not intended to state or imply that only that IBM product, program, or service may be used. Any functionally equivalent product, program, or service that does not infringe any of the intellectual property rights of IBM may be used instead of the IBM product, program, or service. The evaluation and verification of operation in conjunction with other products, except those expressly designated by IBM, are the responsibility of the user.

IBM may have patents or pending patent applications covering subject matter in this document. The furnishing of this document does not give you any license to these patents. You can send license inquiries, in writing, to the IBM Director of Licensing, IBM Corporation, 500 Columbus Avenue, Thornwood, New York 10594, U.S.A..

Programming interface information

This book is intended to help you use the CICS/ESA Front End Programming Interface. This book primarily documents General-use Programming Interface and Associated Guidance Information provided by CICS.

General-use programming interfaces allow the customer to write programs that obtain the services of CICS.

However, this book also documents Product-sensitive Programming Interface and Associated Guidance Information and Diagnosis, Modification or Tuning Information provided by CICS.

Product-sensitive programming interfaces allow the customer installation to perform tasks such as diagnosing, modifying, monitoring, repairing, tailoring, or tuning of CICS. Use of such interfaces creates dependencies on the detailed design or implementation of the IBM software product. Product-sensitive programming interfaces should be used only for these specialized purposes. Because of their dependencies on detailed design and implementation, it is to be expected that programs written to such interfaces may need to be changed in order to run with new product releases or versions, or as a result of service.

Product-sensitive Programming Interface and Associated Guidance Information is identified where it occurs, by an introductory statement to a chapter or section.

Diagnosis, Modification or Tuning Information is provided to help you diagnose problems with CICS.

Warning: Do not use this Diagnosis, Modification or Tuning Information as a programming interface.

Diagnosis, Modification or Tuning Information is identified where it occurs, by an introductory statement to a chapter or section.

Trademarks and service marks

The following terms, used in this publication, are trademarks or service marks of IBM Corporation in the United States or other countries:

ACF/VTAM, CICS, CICS/ESA, CICS/MVS, C/370, IBM, IBMLink,
IMS/ESA, MVS/ESA, RACF, VTAM

About this book

This book describes the Front End Programming Interface (FEPI) of CICS/ESA Version 4 Release 1. It contains:

- Part 1, “Concepts and facilities” on page 1: An introduction to FEPI.
- Part 2, “Installation and administration” on page 13: Overview, guidance, and reference information for the system programmer and administrator.
- Part 3, “Application programming” on page 101: Overview, guidance, and reference information for the application programmer.
- Part 4, “Appendixes” on page 163: Descriptions of the supplied sample programs, and lists of CVDA and RESP2 values returned by FEPI commands.

Who this book is for

This book is intended primarily for CICS system programmers and administrators responsible for installing and configuring FEPI, and for application programmers responsible for writing FEPI “front-end” application programs.

What you need to know to understand this book

To install FEPI, you need to be familiar with the tasks involved in installing CICS itself; in particular, you should have experience of the MVS/ESA operating system, and the System Modification Program/Extended (SMP/E) licensed program used to install CICS.

To configure FEPI, you need to be familiar with all aspects of CICS administration (such as system definition, resource definition, customization, and operations) and the programming interface to CICS. Information about CICS system definition is in the *CICS/ESA System Definition Guide*. Information about defining resources to CICS is in the *CICS/ESA Resource Definition Guide*. Programming information about customizing CICS is in the *CICS/ESA Customization Guide*. Programming information about EXEC CICS commands is in the *CICS/ESA Application Programming Reference* and the *CICS/ESA System Programming Reference*. You should also be familiar with the ACF/VTAM telecommunication access method and, if you are accessing IMS back-end systems, with IMS/VS or IMS/ESA administration.

To write FEPI “front-end” applications, you need to know how to write programs in at least one of the programming languages that CICS supports. More importantly, you also need knowledge of data communication and protocols. And, if you will be accessing IMS back-end systems, you must also be familiar with using IMS and writing IMS applications.

How to use this book

Read “Part 1, Concepts and facilities”, as an introduction to FEPI. Other parts and chapters are self-contained. Use an individual part or chapter when performing the task described in it.

Notes on terminology

In this book, VTAM refers to ACF/VTAM and IMS refers to IMS/VS and IMS/ESA. CICS/ESA is an abbreviation for Customer Information Control System/Enterprise Systems Architecture. ‘CICS’ refers to CICS/MVS and CICS/ESA.

CICS/ESA supports CICS applications written in:

- Assembler language
- C/370
- OS/VS COBOL
- VS COBOL II
- PL/I.

In this book, the phrase “the languages supported by CICS” refers to the above languages.

KB equals 1024 bytes; MB equals 1024KB.

The following terms have different meanings for FEPI, CICS, IMS, and VTAM:

application	FEPI uses application in the normal sense of a program or suite of programs that do work. VTAM uses application for programs that communicate directly using VTAM; in a FEPI environment, this means the back-end systems on one hand, and FEPI on the other.
conversation	A FEPI conversation is not the same as an IMS conversation, although they would normally coincide, and it is not related to CICS conversational mode. It is analogous to a CICS APPC conversation.
inbound, input	In FEPI and CICS usage, these describe data received by a program from elsewhere. From the point-of-view of the back-end system, this data is outbound or output to a terminal.
message	VTAM and IMS use message to refer to any data transmission, and not just to data displayed for a user’s attention.
node	In VTAM and IMS, a node is a named point in a network. In FEPI, nodes are those points (VTAM nodes) that are the secondary LU terminals simulated by FEPI.
outbound, output	In FEPI and CICS usage, these describe data sent by a program to somewhere else. From the point-of-view of the back-end system, this data is inbound or input from a terminal.
secondary	In VTAM, secondary describes one of the partners of an LU-LU pair; the terminals simulated by FEPI are secondary LUs. This is not the same as the CICS usage of secondary.

CICS syntax notation used in this book

Throughout this book, the syntax of CICS commands is presented in a standard way.

The “EXEC CICS” that always precedes each command’s keyword is not included; nor is the “END_EXEC” statement used in COBOL or the semicolon (;) used in PL/I and C/370 that you must code at the end of each CICS command. In the C/370 language, a null character can be used as an end-of-string marker, but CICS does not recognize this; you must never, therefore, have a comma or period followed by a space (X'40') in the middle of a coding line.

You interpret the syntax by following the arrows from left to right. The conventions are:

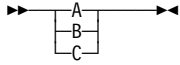
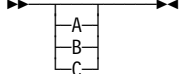
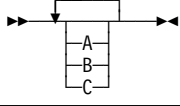
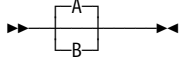
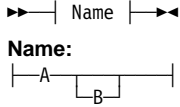
Symbol	Action
	A set of alternatives—one of which you must code.
	A set of alternatives—one of which you may code.
	A set of alternatives—any of which you may code.
	Alternatives where A is the default.
	Use with the named section in place of its name.
Punctuation and uppercase characters	Code exactly as shown.
Lowercase characters	Code your own text, as appropriate (for example, name).

Determining if a publication is current

IBM regularly updates its publications with new and changed information. When first published, both hardcopy and BookManager softcopy versions of a publication are in step, but subsequent updates will probably be available in softcopy before they are available in hardcopy.

For CICS books, these softcopy updates appear regularly on the *Transaction Processing and Data Collection Kit* CD-ROM, SK2T-0730-xx. Each reissue of the collection kit is indicated by an updated order number suffix (the -xx part). For example, collection kit SK2T-0730-06 is more up-to-date than SK2T-0730-05. The collection kit is also clearly dated on the cover.

Here’s how to determine if you are looking at the most current copy of a publication:

- A publication with a higher suffix number is more recent than one with a lower suffix number. For example, the publication with order number SC33-0667-02 is more recent than the publication with order number SC33-0667-01. (Note that suffix numbers are updated as a product moves from release to release, as well as for hardcopy updates within a given release.)
- When the softcopy version of a publication is updated for a new collection kit the order number it shares with the hardcopy version does not change. Also, the date in the edition notice remains that of the original publication. To compare softcopy with

hardcopy, and softcopy with softcopy (on two editions of the collection kit, for example), check the last two characters of the publication's filename. The higher the number, the more recent the publication. For example, DFHPF104 is more recent than DFHPF103. Next to the publication titles in the CD-ROM booklet and the readme files, asterisks indicate publications that are new or changed.

- Updates to the softcopy are clearly marked by revision codes (usually a “#” character) to the left of the changes.

Bibliography

CICS/ESA 4.1 library

Evaluation and planning		
<i>Release Guide</i>	GC33-1161	April 1997
<i>Migration Guide</i>	GC33-1162	April 1997
General		
<i>CICS Family: Library Guide</i>	GC33-1226	April 1995
<i>Master Index</i>	SC33-1187	October 1994
<i>User's Handbook</i>	SX33-1188	April 1997
<i>Glossary (softcopy only)</i>	GC33-1189	n/a
Administration		
<i>Installation Guide</i>	GC33-1163	April 1997
<i>System Definition Guide</i>	SC33-1164	April 1997
<i>Customization Guide</i>	SC33-1165	April 1997
<i>Resource Definition Guide</i>	SC33-1166	April 1997
<i>Operations and Utilities Guide</i>	SC33-1167	April 1997
<i>CICS-Supplied Transactions</i>	SC33-1168	April 1997
Programming		
<i>Application Programming Guide</i>	SC33-1169	October 1994
<i>Application Programming Reference</i>	SC33-1170	April 1997
<i>System Programming Reference</i>	SC33-1171	April 1997
<i>Sample Applications Guide</i>	SC33-1173	October 1994
<i>Distributed Transaction Programming Guide</i>	SC33-1174	October 1994
<i>Front End Programming Interface User's Guide</i>	SC33-1175	October 1994
Diagnosis		
<i>Problem Determination Guide</i>	SC33-1176	October 1994
<i>Messages and Codes</i>	GC33-1177	April 1997
<i>Diagnosis Handbook</i>	LX33-6093	October 1994
<i>Diagnosis Reference</i>	LY33-6082	April 1997
<i>Data Areas</i>	LY33-6083	April 1997
<i>Supplementary Data Areas</i>	LY33-6081	October 1994
<i>Closely-Connected Program Interface</i>	LY33-6084	November 1996
Communication		
<i>Intercommunication Guide</i>	SC33-1181	April 1997
<i>Server Support for CICS Clients</i>	SC33-1591	February 1996
<i>CICS Family: Inter-product Communication</i>	SC33-0824	October 1996
<i>CICS Family: Communicating from CICS on System/390</i>	SC33-1697	October 1996
Special topics		
<i>Recovery and Restart Guide</i>	SC33-1182	October 1994
<i>Performance Guide</i>	SC33-1183	October 1994
<i>CICS-IMS Database Control Guide</i>	SC33-1184	October 1994
<i>CICS-RACF Security Guide</i>	SC33-1185	October 1994
<i>Shared Data Tables Guide</i>	SC33-1186	October 1994
<i>External CICS Interface</i>	SC33-1390	April 1997
<i>CICS ONC RPC Feature for MVS/ESA Guide</i>	SC33-1119	February 1996
<i>CICS Web Interface Guide</i>	SC33-1892	November 1996

The book that you are reading was published in hardcopy format on the date shown in the right-hand column in the above table. Some of the CICS/ESA 4.1 books were republished in new hardcopy editions in April 1997 to incorporate updated information previously available only in softcopy. Note that it is possible that other books in the library will be updated after April 1997.

When a new order is placed for the CICS/ESA 4.1 product, the books shipped with that order will be the latest hardcopy editions.

The style of IBM covers changes periodically. Books in this library have more than one style of cover.

For information about the softcopy books, see "Determining if a publication is current" on page xi. The softcopy books are regularly updated to include the latest information.

Other CICS books

- *CICS Application Migration Aid Guide*, SC33-0768
- *CICS Application Programming Primer (VS COBOL II)*, SC33-0674
- *CICS/ESA Facilities and Planning Guide for CICS/ESA Version 3 Release 3*, SC33-0654
- *CICS/ESA XRF Guide for CICS/ESA Version 3 Release 3*, SC33-0661
- *CICS Family: API Structure*, SC33-1007
- *CICS Family: General Information*, GC33-0155
- *IBM CICS Transaction Affinities Utility MVS/ESA*, SC33-1159

CICS Clients

- *CICS Clients: Administration*, SC33-1436
- *CICS Family: Client/Server Programming*, SC33-1435

Books from related libraries

This section lists the non-CICS books referred to in this manual.

IMS Version 3 and Version 2

- *IMS/ESA Version 3 Customization Guide: Data Communication*, SC26-4625
- *IMS/ESA Version 3 Data Communication Administration Guide*, SC26-4286
- *IMS/VS Version 2 Programming Guide for Remote SNA Systems*, SC26-4186

RACF Version 1 Release 9

- *Security Administrator's Guide*, SC28-1340
- *System Administrator's Guide*, SC28-3726
- *System Programmer's Guide*, SC28-3725

SNA

- *Concepts and Products*, GC30-3072
- *Formats*, GA27-3136
- *Technical Overview*, GC30-3073

VTAM Version 4 Release 2

- *Messages and Codes*, SC31-6493
- *Network Implementation Guide*, SC31-6494
- *Operation*, SC31-6495
- *Programming*, SC31-6496
- *Resource Definition Reference*, SC31-6498

3270 Information Display System

- *Character Set Reference*, GA27-2837
- *Data Stream Programmer's Reference*, GA23-0059
- *3274 Control Unit Description and Programmer's Guide*, GA23-0061
- *3274 Control Unit Reference Summary*, GX20-1878

Summary of changes

This edition of the *CICS/ESA Front End Programming Interface User's Guide* is based on the *Front End Programming Interface User's Guide* for CICS/ESA Version 3.3, SC33-0804-00.

Changes for this edition

The major changes for this edition are:

- Information about signon security has been added to Chapter 2, "Functions and services" and Chapter 14, "Application design."
- Information about using FEPI with VTAM persistent sessions has been added to Chapter 6, "FEPI operation."
- "Using CICS monitoring and statistics" on page 41 describes how to use the new FEPI-related fields in CICS monitoring and statistics records for performance-tuning purposes.
- Chapter 4, "Getting started" has been modified to reflect the fact that, in CICS/ESA 4.1, FEPI is part of the base CICS product.
- Chapter 7, "Operator control" has been reorganized; the CEMT INQUIRE commands are now described separately from their CEMT SET counterparts, and the distinction between input and output fields has been made clearer.
- Chapter 10, "Problem determination" contains information that was previously in the *CICS/ESA Diagnosis Reference* manual.
- Throughout the book, the syntax of programming and operator commands has been translated into "railroad diagrams". The chapters mainly affected are Chapter 7, "Operator control," Chapter 9, "System programming reference," and Chapter 16, "Application programming reference."
- Descriptions of the FEPI messages and codes (Appendix B in the CICS/ESA 3.3 book) have been transferred to the *CICS/ESA Messages and Codes* manual.
- Descriptions of the FEPI trace entries (Appendix C in the CICS/ESA 3.3 book) have been transferred to the *CICS/ESA Diagnosis Reference*.

The differences between this book and the *CICS/ESA 3.3 Front End Programming Interface User's Guide*, SC33-0804-00, are indicated by a vertical bar to the left of the text.

Part 1. Concepts and facilities

This part of the book gives an overview of FEPI, and some general information about functions, services, and implementing applications.

- Chapter 1, "Introducing FEPI" on page 3 explains what FEPI is and what problems it solves; it also describes some planning considerations.
- Chapter 2, "Functions and services" on page 7 describes the various types of FEPI commands and introduces the concepts and functions used by FEPI applications.

Chapter 1. Introducing FEPI

This chapter explains what the CICS/ESA Front End Programming Interface (FEPI) is, what problems it solves, what it does, and how it can help you; it also describes some planning considerations.

The Front End Programming Interface is an integral part of CICS/ESA Version 4.1. The function is called a front-end programming interface because it enables you to write CICS application programs that access other CICS or IMS programs. In other words, it provides a front end to those programs. The interface simulates the terminals that the other programs use.

Problems FEPI can solve

Many users have CICS and IMS applications that they want to use differently; for example, to extend their use by incorporating them into other applications. But they cannot change the way the applications are used because they cannot change the application programs.

FEPI allows existing CICS and IMS application programs to be used in different ways, in different combinations, in different environments, and on different systems, *without changing* them, because it provides a simple integrated interface to these programs.

FEPI also lets you write new programs that add function to old programs.

There are many reasons why existing application programs can't be changed. Perhaps the application was bought in a package, so that you don't have the source. Perhaps someone else owns the application; perhaps it runs on someone else's system. Perhaps the source has been lost, and there's no one around who knows the program well enough. Perhaps the program logic is so complex that any changes are considered too dangerous.

Or perhaps it is an application that was written for one specific environment, such as IBM 3270 information display systems, and you want to use it for another, or you want to extend its function. You don't want to change the application, because it must still work with the 3270s.

To get around this, you can run the existing application unchanged and provide a front-end program to interface to it. Using FEPI, a front-end program can simulate a terminal. This means the program can gain access to applications written to support that terminal. That program can then use the existing applications, and the existing application is unaware that anything has changed.

Therefore, the existing application can be used differently without being changed in any way. The changes are in the simulating program. For example, newly written applications can collect data from several existing applications. The existing applications can be on the same system as the simulating program, or on a different system.

Advantages over alternative solutions

There are other ways of accessing existing programs differently, but they all have their drawbacks.

Can CICS multiregion operation (MRO) or intersystem communication (ISC) be used to access remote applications?

Yes, but using MRO or ISC often requires some changes to the existing application—for example, to change the type of terminal supported or to provide an interface that uses a communication area.

Can VTAM program-to-program support be used?

Yes, if your programmers can write an access program to issue the appropriate VTAM calls. But these VTAM calls cannot be part of a CICS application program.

How FEPI fits into your system

Figure 1 shows the relationship between FEPI and other components of your system. Note, particularly, the unchanged applications in the lower part of the figure, and the new CICS FEPI application near the top. To an existing application, the front-end application looks like a terminal.

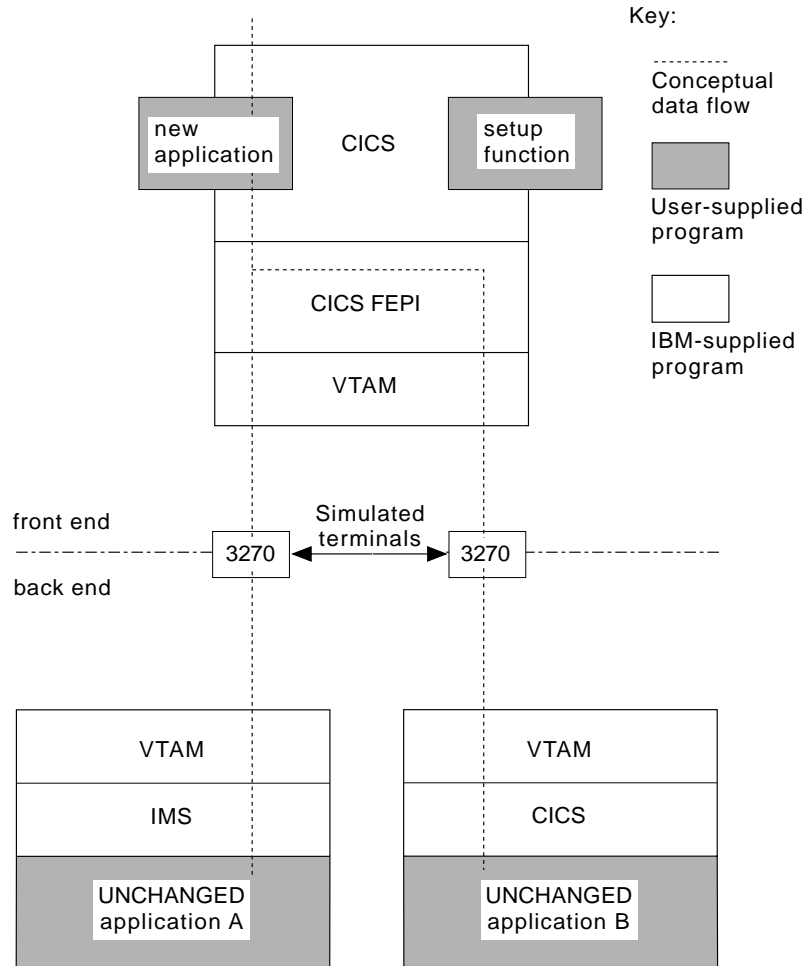

Figure 1. Structure of FEPI and application programs

Now some definitions: the *front end* is the system on which the CICS FEPI application runs, and the *back end* is the system on which the existing application runs. (They may be the same system.)

FEPI allows CICS front-end application programs to communicate with *unchanged* back-end applications running on CICS or IMS systems that are local or remote. The back-end applications continue to work just as if they are being accessed from the type of terminal they were originally written for.

A *CICS FEPI application* is a CICS application that is designed to use FEPI to communicate with existing back-end applications. It is also known as a terminal front-end program.

Planning for FEPI

This section explains what hardware and software you need to use the CICS/ESA Front End Programming Interface (FEPI), what MVS system integrity is involved, what resources you need, and what to consider when installing FEPI and customizing your system.

Hardware and software requirements

There are different requirements for the front-end and the back-end.

Front-end

For front-end systems, FEPI is a part of CICS/ESA Version 3 Release 3 (and of later CICS releases).

Other hardware and software requirements are the same as for CICS/ESA.

Extra 37x5 controllers and network control programs (NCPs) may be needed to provide the necessary intersystem connections.

Back-end

Applications running on the following, and subsequent compatible releases, are supported:

- CICS/MVS Version 2 Release 1 Modification 2
- CICS/ESA Version 3 Release 1
- CICS/ESA Version 3 Release 3
- CICS/ESA Version 4 Release 1
- IMS/VS Version 2 Release 2
- IMS/ESA Version 3 Release 1.

FEPI provides simulation for two very common classes of terminals on these systems:

- 3270-types for CICS and IMS applications (using LU 2 protocol)
- A family of programmable terminals, including the 4700, accessed through an LU 0 protocol (called SLU P), for IMS applications.

System integrity

All application programs that use FEPI run in problem-program mode in user-key storage. No part of FEPI needs to be authorized to run.

IBM accepts authorized program analysis reports (APARs) where the installation of the FEPI function introduces an exposure to the system integrity of MVS. Refer to the *MVS Integrity Programming Announcement* dated 21 October 1981.

Storage

Some storage below the 16MB line is required, but the bulk resides above the 16MB line in storage managed by CICS. For details, see “Planning FEPI storage” on page 19.

There are no inherent resource limits in FEPI. It is limited only by what is configured and the available system storage.

Installation

FEPI is distributed through normal IBM Program Library channels. It is a part of CICS/ESA and cannot be ordered separately. CICS FEPI is supplied in System Modification Program/Extended (SMP/E) format on:

- 9/6250 magnetic tape
- 3480 data cartridge.

All necessary instructions and guidance for installation are included in the *Program Directory*. The function modification identifier (FMID) is JCI3329. See Chapter 4, “Getting started” on page 21 for more information.

Configuration

You need to configure your system specifically for CICS FEPI, for new application programs, and possibly for existing applications. See Chapter 3, "Planning for FEPI" on page 15 and Chapter 5, "Configuring FEPI" on page 23 for more information.

For the CICS FEPI function itself

You may need to adapt your VTAM setup, your CICS system, and CICS FEPI to use the interface effectively.

The CICS system initialization parameter and override, FEPI=YES|NO (default NO), controls whether FEPI is available or not. If it is, it runs as a system transaction that is started automatically when CICS starts; it does not need to be started (or stopped) independently.

FEPI itself is configured with the resources that it can use, by issuing commands from a front-end application program; FEPI does not use a configuration file or CICS RDO. The system programmer should provide a setup program to configure FEPI using these requests; the program can get the configuration data from a file or from whatever source it identifies.

For CICS FEPI applications

CICS FEPI applications must be defined to CICS in the normal way.

For back-end systems

It may be necessary to define simulated terminals for FEPI to use.

Chapter 2. Functions and services

The CICS/ESA Front End Programming Interface (FEPI) function provides access, by means of simulated terminals, to CICS and IMS applications available through a communication network. An application program using FEPI can provide a front end to other CICS or IMS applications. Because this is done by simulating a terminal in session with the non-FEPI application, that application does not have to be changed in any way.

Thus you can write FEPI applications that provide a single integrated interface to previously disparate applications. The scope and usability of your CICS and IMS applications can be extended by using them in combination, in different environments, or on different systems.

Because a FEPI application communicates with other applications that may run in different systems, it is necessary to distinguish between systems and identify the direction of data flows. The convention is:

Front-end The front-end system is the one in which the FEPI application runs.

Back-end Back-end identifies the system in which the other CICS or IMS applications run. (This is equivalent to “partner” system, used elsewhere by CICS.)

Outbound Identifies data *sent* by the FEPI application *to* the back-end application.

Inbound Identifies data *received* by the FEPI application *from* the back-end application.

FEPI provides a programming interface. Its functions can be invoked only through that interface, which is an extension to the EXEC CICS programming interface. All FEPI requests are made by issuing EXEC CICS FEPI commands; all the commands have the qualifier FEPI. The languages supported by the EXEC CICS programming interface (Assembler, VS COBOL II, C/370, PL/I) can be used. For educational and initial development purposes, you could simply use CECL, rather than formally writing a program.

All functions are available in the normal way to all applications, except that some functions are intended for system programmers, and their use can be restricted. All the other facilities that you can use with CICS applications, such as the execution diagnostic facility (EDF) and the command interpreter transaction, CECL, are available.

Samples

To help you develop your own CICS FEPI applications, and to show you what FEPI can do, FEPI includes detailed samples. They form an integrated set, and include a program that sets up the FEPI configuration needed to run the other samples. The samples are supplied in source format. Their names have the form *DFH0xZyy*. *Z* shows that the sample is a FEPI sample and *x* identifies the source language of the sample (*A* for Assembler language, *C* for C, *P* for PL/I, and *V* for VS COBOL II), and *yy* identifies the specific program. See Appendix A, “Sample programs” on page 165.

Programming commands

EXEC CICS FEPI commands provide several ways of developing CICS FEPI applications. The commands are at three logical levels:

High-level: a straightforward interface for normal 3270 applications

Data stream-level: for use with IMS SLU P applications and more complicated 3270 applications

Specialized-level: for access to complex VTAM communication functions and events, designed for use by vendors and experienced CICS FEPI application developers.

High-level FEPI commands

The high-level front-end programming interface consists of two interfaces for everyday use: *key stroke* and *screen-image*, collectively known as *formatted* data. They allow programmers to build their own CICS FEPI applications in a straightforward manner. However, the programmer must understand data communication and protocols.

See Chapter 12, “Key stroke and screen-image applications” on page 107 for details.

The key stroke interface

The key stroke interface allows programmers writing in any of the CICS-supported languages, to specify the keys that an operator might press while using an existing application. The key strokes are specified using easily coded mnemonics; no hexadecimal values are required.

The screen-image interface

The screen-image interface allows programmers writing in any language supported by CICS, to define the contents of a 3270 screen, using a data structure appropriate to the programming language. It uses a buffer with one byte for each screen position (for example, 1920 bytes for a 24 × 80 character screen). This buffer can be defined in any way that suits the application program and the programming language. It is passed as a complete screen buffer to the back-end application.

In both cases, key stroke and screen-image, the data received from the back-end application is presented as a screen image.

Data-stream-level commands

For many applications, the key stroke and screen-image interfaces should be quite adequate. However, where they are not, FEPI data-stream-level commands give an application complete control of the 3270 data stream. These commands are also needed for SLU P applications, which can use only this interface. FEPI does not buffer or interpret the data stream; it is presented as it arrives from the back-end application, and the front-end application must be prepared to handle whatever is presented. Similarly, data sent by the front-end application is transmitted without verification.

A detailed knowledge of data communication and protocols and of data stream format is required.

See Chapter 13, “Data stream applications” on page 115 for details.

Specialized-level commands

These are some of the specialized functions that can be accessed through FEPI:

STSN for SLU P applications: Set and test sequence number (STSN) is a communication protocol used to check and control transmissions. FEPI normally handles all necessary STSN processing automatically. However, FEPI also provides access to STSN information for those applications that need to control sequence number data.

Application access to definite responses: When a flow is received, the receiving LU can choose what response to return to the sending LU. FEPI normally handles this automatically, but also provides facilities for applications to determine this flow.

Other VTAM facilities: Some applications use a VTAM facility known as CLSDST(PASS); this can be used in more sophisticated CICS FEPI application programming.

See Chapter 15, “Specialized functions” on page 135 for details.

List of commands

	All the logical levels use more or less the same set of commands, though the options used
	may vary. The EXEC CICS FEPI application programming commands are:
ALLOCATE	Establishes communication with a back-end application
FREE	Frees communication with a back-end application
SEND	Sends data from a CICS FEPI application to a back-end application
RECEIVE	Receives data into a CICS FEPI application from a back-end application
CONVERSE	Sends data to and receives data from a back-end application
ISSUE	Sends control data to a back-end application
EXTRACT	Gets field data and attributes, set-and-test-sequence-number (STSN) data, or conversation status
START	Schedules a CICS transaction to handle inbound data.

Setup and resources

Besides the application programming functions that communicate with back-end applications, FEPI also provides system programming functions that define and inquire about *FEPI resources* and perform control functions. Defining and configuring FEPI resources is called *setup program*. The EXEC CICS FEPI commands that provide these functions are:

INSTALL, ADD	Sets up communication resources
DISCARD, DELETE	Discards communication resources
INQUIRE	Queries FEPI resource status
SET	Controls FEPI resources.

The setup functions are usually performed by a customer-written transaction that is started from a second-phase program list table post initialization (PLTPI) program. See “FEPI configuration” on page 27.

FEPI resources can be controlled, like other CICS resources, using the CEMT SET and INQUIRE functions. CECI can also be used. See Chapter 7, “Operator control” on page 49.

FEPI resources

There are four types of FEPI resource—*pool*, *property set*, *target*, and *node*. The relationship between them is illustrated below. The resources are further explained in Chapter 5, “Configuring FEPI” on page 23 and the more complex relationships possible between them are illustrated in “Sample FEPI configuration” on page 30.

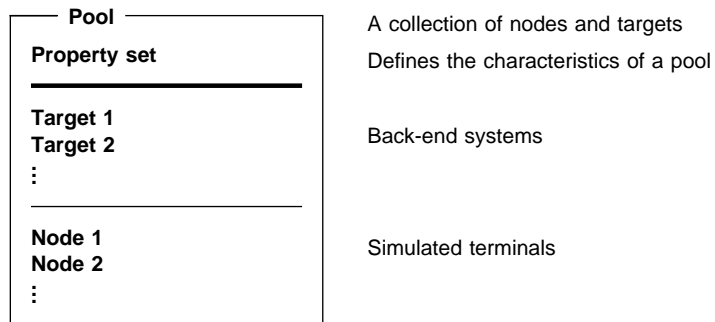

A FEPI pool can have one or more nodes and one or more targets. The same nodes and targets can be in any number of pools, except that the same node-target pair (a *connection*) cannot occur in more than one pool.

A CICS FEPI application can reach a target only by specifying a pool, which defines the set of nodes that can be used to make the connection, and the characteristics of the communication.

A target and an open node in the same pool are 'connected'; when bound, they are 'in session'. To *bind* means to establish a *session* on a *connection*, to make it ready to allow communication.

The process of communicating with a back-end system is called a *conversation*; it is the fundamental entity that a FEPI application deals with. Only one conversation can use a connection at one time, although any number can do so consecutively. For efficiency, the session on the connection is kept bound between conversations, unless you choose otherwise. Furthermore, a conversation is owned by the task that establishes it; no other task can use it.

Note: The use of the term conversation does not mean that the back-end or front-end application has to be conversational, in the CICS meaning of the term.

CICS FEPI application programs

A CICS FEPI application comprises several distinct logical functions:

Access programs:

Communicate with the back-end applications

Begin-session handler:

Handles begin-session processing

End-session handler:

Handles end-session processing

STSN handler:

Assists message synchronization

Unsolicited-data handler:

Handles unsolicited inbound data

Monitor:

Handles unexpected events such as the loss of a session or errors in setup.

These functions can be in separate programs, or contained in one program. The need for each function depends on the requirements of the application; in many cases default processing is all that you need. You might need several styles of each function, again depending on the requirements of your application.

The application programmer always writes the access programs. The system programmer usually writes the monitors to handle the unexpected events that FEPI reports to transient data queues such as CSZX. As for the other functions, sometimes the system programmer writes them providing, perhaps, just one instance of each, so that they are common to everyone. (This approach has the advantage that adherence to standard procedures—for such things as signon and signoff—is enforced.) In other installations, the application programmers provide them.

In many cases, writing a CICS FEPI application is straightforward. However, some applications need more sophisticated programming. The programmer not only has to understand all the displays and protocols of the back-end application and system (CICS or IMS), but must also understand the detailed data-stream protocols. For further information, see Chapter 14, "Application design" on page 121.

Terminals supported

To access back-end applications, FEPI has VTAM secondary logical unit (SLU) support, so that CICS FEPI applications can simulate certain logical unit (LU) types. FEPI uses VTAM program-to-program support to provide this function, and to communicate between front-end and back-end applications.

Note: FEPI cannot send VTAM logon data.

FEPI provides simulation support for two families of terminals. The names **SLU2** and **SLU P** are used to identify the two types of support:

SLU2 for the 3270 family of terminals, used in many CICS and IMS applications. See the *3270 Data Stream Programmer's Reference*.

SLU P for a family of programmable terminals, including the 4700, accessed through an LU 0 protocol, for IMS applications. This protocol is defined in *IMS/VS Programming Guide for Remote SNA Systems* (for IMS/VS Version 2) or *IMS/ESA Customization Guide: Data Communication* (for IMS/ESA Version 3).

Data-stream-level and specialized-level commands can be used with both families of terminals, but the high-level commands, which use formatted data, are only for SLU2.

The mode of a conversation must be either SLU2 or SLU P; it cannot be mixed. For SLU2 conversations, formatted data or data stream data can be used, but cannot be mixed in the same conversation. The mode and data type are controlled by the pool used, which is set up by the system programmer.

These terminals are supported only when they are used to communicate with CICS or IMS systems.

Security

This section introduces FEPI security.

Signon security

Because FEPI is a terminal emulator, the back-end system “sees” the front-end as a terminal rather than a system; it cannot differentiate between FEPI emulation and a real device. Thus, CICS bind, link, and attach-time security are not applicable to FEPI connections. If security is enabled in the back-end system, in order for your FEPI application to access protected resources the emulated terminal must be signed on to the back-end. The alternative is that you do not use CICS security with FEPI—that is, you make all the back-end transactions accessed by FEPI available to the CICS default user. This option is clearly unacceptable; it means that you must either run a security risk or deprive your FEPI applications of access to sensitive data.

When signing on to a back-end system, FEPI applications can ask the external security manager (ESM) to supply a password substitute, or *PassTicket*. Using PassTickets to sign on means that FEPI applications do not need to store user passwords (which is risky), or ask users to reenter them (which is irritating). For information about implementing signon security, see page 127.

Command security

You can restrict access to the FEPI system programming commands by defining operator profiles to your ESM. For details of how to do this, see “Command-level security” on page 22. All application programming commands are generally available.

| **Problem determination, customization, and performance**

Problem determination

Determining the source of an error involves the use of debugging tools, trace, dump routines, and messages. These topics are described in Chapter 10, “Problem determination” on page 95.

Customization

Two CICS global user exits are available. They are described in “Global user exits” on page 63.

Data that flows to and from CICS FEPI applications can be journaled for audit trails. For details, see “Journaling” on page 67.

| **Performance**

| You can use CICS monitoring and statistics data to help you tune FEPI applications, and to
| control the resources that they use. For details, see “Using CICS monitoring and statistics”
| on page 41.

Part 2. Installation and administration

This part of the book is intended for system programmers and administrators responsible for installing and configuring FEPI. It contains the following topics:

- Chapter 3, "Planning for FEPI" on page 15 lists the things you need to consider when organizing your FEPI nodes, pools, and property sets.
- Chapter 4, "Getting started" on page 21 describes how to install FEPI.
- Chapter 5, "Configuring FEPI" on page 23 describes the tasks required to implement your planned FEPI system.
- Chapter 6, "FEPI operation" on page 39 describes how FEPI operates.
- Chapter 7, "Operator control" on page 49 describes the CICS-supplied transactions and VTAM commands that operators can use to control FEPI resources.
- Chapter 8, "Customizing FEPI" on page 63 describes how to use the FEPI global user exits and journaling function.
- Chapter 9, "System programming reference" on page 69 describes the FEPI system programming commands that are used to control FEPI resources.
- Chapter 10, "Problem determination" on page 95 describes how to identify the source of errors that affect your FEPI applications.

|
|

Chapter 3. Planning for FEPI

This chapter is about planning your system and FEPI configuration. To understand it, you need to be familiar with the basic FEPI concepts and terminology described in Part 1, Concepts and facilities. You must also be familiar with all aspects of CICS administration and operations; if you plan to use IMS, you also need to be familiar with IMS administration and operations.

Analysis and planning

First, you need to consider the following:

- Details of the back-end applications and systems
- Names of nodes and targets
- Operator control requirements
- Journaling requirements
- Signon and signoff procedures
- Special event handling
- Pools required for control reasons
- Pools required for functional reasons
- Number of nodes
- Setup program organization.

Then you can decide how to organize your pools, their properties, and the connections.

These are now discussed in turn.

Back-end applications and systems

You need to know whether the back-end systems are CICS or IMS, the terminal types they use, and the timing and volume of transactions expected. Also, are there any restrictions on the use of the terminals? For example:

- Is a specific terminal required, or can any terminal be used?
- Is a specific LU or terminal type defined in the target application—for example, a 3278 model 3?

Names of nodes and targets

Nodes

Decide which VTAM node names are available for use by FEPI as simulated terminals. (Remember that FEPI nodes are VTAM APPL definitions, not logical units (LUs).) Do not use names starting with “DFH”.

Targets

The back-end system already has defined VTAM primary PLU names (applids) which you must use. However, you can define your own local target names to associate with these applids. This means that FEPI applications are not affected if an applid is changed; you simply associate the local name with the new back-end target name. Do not use names starting with “DFH”.

Operator control requirements

The CEMT INQUIRE and SET master terminal transactions can be used to view and amend the state of FEPI resources. CEMT DISCARD can be used to remove resources from FEPI. This is described in Chapter 7, “Operator control” on page 49. If you decide you need extra functions for operators, you will need to write appropriate programs.

Journaling requirements

Journaling is available if you need it. Among the reasons for using FEPI journaling are:

- To create audit trails
- To monitor performance
- To control message security.

For further information, see “Journaling” on page 67.

Signon and signoff procedures

You need to know if there are any specific requirements for signon and signoff to back-end systems. Central control may be required, or applications may perform signon and signoff individually.

Special event handling

In addition to signon and signoff, you need to consider what should be done in the following circumstances, and whether they are to be handled by central functions or by applications individually:

- The receipt of unsolicited data
- Unexpected events
- Beginning a session
- Ending a conversation or session
- Shutdown of the front-end CICS system.

If some sort of enforcement is required, or you want central provision for convenience, commonality, or the upholding of conventions and standards, you must supply a set of standard handlers. Otherwise, the application programs must handle each event. If you need special back-end processing when CICS shuts down, you need an end-session handler.

Unexpected events (including errors in setup) are reported to a transient data (TD) queue, so that a monitoring transaction can be triggered to handle them; they also send a message to the FEPI message log CSZL. You must decide how to handle these events, and which queues to use.

For more detailed information about the design and structure of applications, including information about using the various event handlers, see Chapter 14, “Application design” on page 121.

If you want central control over the range of FEPI commands that applications are permitted to issue, you can use the XSZBRQ global user exit, which is described in “Global user exits” on page 63.

Using pools for control reasons

You can use pools for a number of control purposes. For example, you could define them so as to:

- Restrict users and applications to particular targets or nodes, or restrict access to some targets to particular times of day.
- Force specific begin-session and end-session effects.
- Split resources among different types of back-end requests, according to (for example) priority, or to the department issuing the request. By doing this, you can ensure that there is always a set of connections to a target for time-sensitive requests, while other connections handle long-running requests that are not time-sensitive.
- Ration the use of connections, especially for long-running requests, so that each set of users has access to only a limited number of connections.
- Ease signon considerations.

Using pools for functional reasons

Pools determine the data format and special event handlers used by your FEPI applications. These attributes may be specified by the application programmer, or they may be imposed by the system programmer for central control, especially of signon and signoff.

If you need several types of special event handling, you might need to define your own pool-specific transient data queues, as well as the default queues.

Number of nodes

The number of nodes required depends on:

- How the pools are structured
- How much storage is available
- How many concurrent sessions are required to a particular target.

The number of concurrent sessions to a particular target may depend on the volumes of data to be transmitted and the speed of the network.

Although a node can have only one session with a particular target at a time, it can communicate with several different targets concurrently, and several nodes can communicate with the same target concurrently.

Setup program organization

You must decide:

- How many programs you need—for example, should your setup program consist of a single module, or a set of related modules?
- Whether your programs should take replaceable parameters, or fixed values. (You might use mainly fixed programs, with a flexible program for one-off changes.)
- When programs are to be run—started from a second-phase PLTPI program, under operator control, or at set times of the day.
- Where the definitions required by the setup program are to be obtained—from panel entry, from a file, or by other means.

Organizing your pools and property sets

When you have done the analysis work described in the previous section, you can decide how to organize your pools, their properties, and the connections between nodes and targets.

Organizing pools

There are several ways of organizing your pools:

- If possible, restrict each pool to a single target, but specify as many nodes as you believe you need to satisfy *concurrent* access to the target. The reasons for taking this approach are:
 - It avoids the need for the front-end application to specify a target.
 - It makes it easier to avoid duplicate connection definitions.
 - Because a connection is created for every node-target combination within a pool, having large numbers of both nodes and targets within the same pool may generate more resources than are actually required.
 - The overhead associated with a pool is very small. Therefore there is no reason not to define many pools.

Planning

- The expected concurrent usage of each target may be different. If you have more than one target in the pool, it becomes difficult to estimate the number of nodes required.
- You can define a pool containing only one node and one target. This lets a FEPI application allocate a specific session, which is necessary if the target system associates any special qualities with a particular terminal ID. You can use the XSZBRQ global user exit to control access to the pool.
- You can define pools that use different nodes to reference the same target. By making each pool available to a different group of users, you can eliminate competition for resources. Alternatively, you could use each pool to support a different set of properties, according to application requirements.
- If you plan to use the VTAM CLSDST(PASS) command, other considerations might apply. See “Handling CLSDST(PASS)” on page 36.

Do not use names starting with “DFH” for pools.

Organizing property sets

Property sets allow you to define the properties of pools (such as the data format and special functions they use) separately from the definition of the pool itself. You can use a single property set to define any number of pools. You must define as many property sets as you need to satisfy every unique pool requirement. Because the overhead associated with a property set is very small, there is no reason why you should not define a large number of them.

The properties are:

Device attributes

This specifies which family the simulated terminal belongs to, SLU2 or SLU P. For SLU2, it also determines the presentation size of the display (24 x 80, 32 x 80, and so on), and whether it supports extended attributes such as color.

Many back-end applications can be run with any terminal type, so you can use the default device type (SLU2, 3278 model 2). But if you have applications that demand particular terminal types, you need to define pools with the appropriate device types.

Data handling

This specifies which command level to use (high-level with formatted data, or data stream), how much data can be handled, and how contention is to be handled.

High-level is simpler to use and suits many front-end applications; applications that require sophisticated functions or use SLU P, and those performing a simple pass-through, need the more complex data-stream-level. In most cases the default data size of 4096 is adequate; increase it only if you know there are large amounts of data to send and receive in a single command. Set contention handling so that the front end wins—as for a real terminal—unless you have some particular reason for not doing so.

Session management

This specifies whether begin-session and end-session are to be handled by special transactions, and whether initial inbound data is expected. For SLU P, it also includes whether message resynchronization (“set and test sequence number” (STSN)) is to be handled.

The use of event handlers was introduced on page 16; it is generally preferable to use specially-written transactions for session management, rather than to leave it to be handled individually by applications.

If a back-end system sends initial data (a “good morning” message) you must specify this as a property of the pool, so that FEPI waits for the data to arrive and ensures that the front-end application receives it; otherwise the results will be unpredictable. For SLU2, IMS always sends initial data; CICS might or might not do so, depending on your system definition.

FEPI does all the necessary STSN handling automatically, but you can specify a transaction to handle it yourself.

Unexpected events

This specifies how unsolicited data and other unexpected events (including setup errors) are to be handled.

General considerations of the need for transactions and queues have been discussed earlier in this chapter. If you choose not to handle unsolicited data in your own transaction, you can tell FEPI how to handle it for you—positively or negatively; if the back-end system is IMS, you must specify that FEPI should respond positively. All unexpected events are logged in the FEPI message log (CSZL), even if you specify no unexpected event queue.

Journaling

This specifies what sort of data journaling is required, and which journal to use.

Do not use names starting with “DFH” for property sets.

Workload balancing in a sysplex

In an MVS/ESA 5.1 sysplex, you can create a CICSplex consisting of sets of functionally-equivalent CICS terminal-owning regions (TORs) and application-owning regions (AORs). If the FEPI back-end system is a TOR in such a CICSplex, you can use the VTAM generic resource function to perform workload balancing across the available TORs.

A VTAM application program such as CICS can be known to VTAM by a generic resource name, as well as by the specific network name defined on its VTAM APPL definition statement. A number of CICS regions can use the same generic resource name.

A FEPI application, wishing to start a session with a CICSplex that has several terminal-owning regions, names a target that you have defined as the generic resource name of the TORs. Using the generic resource name, VTAM is able to select one of the CICS TORs to be the target for that session. For this mechanism to operate, the TORs must all register to VTAM under the same generic resource name. VTAM is able to perform dynamic workload balancing of the terminal sessions across the available terminal-owning regions.

For information about defining FEPI targets as VTAM generic resource names, see the APPLLIST option of the FEPI INSTALL TARGETLIST system programming command. For further information about VTAM generic resources, see the *CICS/ESA Intercommunication Guide* and the *VTAM Version 4 Release 2 Release Guide*.

Planning FEPI storage

FEPI does not require any additional MVS storage beyond that recommended for basic CICS/ESA. As for dynamic storage, the storage used by FEPI is allocated exclusively from CDSA and ECDSA; CDSA usage is only that required to support VTAM processing. The following information allows you to estimate the storage requirements of a particular FEPI configuration.

Item	ECDSA	CDSA
Basic	80K	
For each node	288	180
For each node that is currently available for communication	192	
For each target	236	
For each pool	272 + 64 x (number of nodes in pool) + 64 x (number of targets in pool)	
For each property set	176	
For each connection (note 1)	432 if using data stream data 688 if using formatted data	
For each connection that is currently available for communication	384 + additional value from Table 2 on page 20 if using formatted data	
For each current conversation	128	
For each command in progress	2.5K + size of user data (Note 2)	
Notes:		
<ol style="list-style-type: none"> 1. The number of connections is (number of nodes in pool) x (number of targets in pool) for each pool. 2. This is the data that is to be sent and received, or used for defining resources. If global user exits are used, twice the data size is needed; similarly if journaling is used. 		

For each connection that is currently available for communication and that uses formatted data, additional ECDSA storage is required; the amount depends on the device-type and capabilities defined, as shown in Table 2.

Device type	Basic	Additional for color support	Additional for extended data stream support	Maximum
327x model 2	3840	1920	5760	11520
327x model 3	5120	2560	7680	15360
327x model 4	6880	3440	10320	20640
327x model 5	7128	3564	10692	21384

You should add some contingency (say 10%) to your final estimate.

Chapter 4. Getting started

FEPI is installed automatically when you install CICS. However, to make it operative you need to install some additional resources.

The installation process

The process comprises the following tasks:

- Updating CICS resource definitions
- Installing FEPI resource definitions
- Starting CICS.

A note about loading FEPI modules into the LPA

Any of the FEPI modules can be loaded in the MVS Link Pack Area (LPA). However, as with CICS modules in general, it is not recommended that you do so. (For information about installing modules in the LPA, see the *CICS/ESA Installation Guide*.)

Updating CICS definitions

The RDO group DFHFPEPI, which is on the product tape, contains definitions of the following resources:

- The FEPI programs (identified by the prefix DFHSZ)
- The FEPI transaction CSZI.

DFHFPEPI is included in the default startup group list, DFHLIST. No additional RDO definitions are required (other than those for your FEPI application programs). However, if you have installed FEPI modules in the LPA, you must use the CEDA transaction to modify the definitions of the modules in the CICS system definition file (the CSD), so that they specify USELPACOPY(YES).

Transient data queues

Define the following transient data (TD) queues in the destination control table (DCT):

CSZL

The FEPI message log. You can define CSZL as an intrapartition, extrapartition, or indirect destination. Note that CSZL must be defined as non-recoverable (DESTRCV=NO).

It is recommended that you define CSZL as an indirect destination, pointing to CSSL.

CSZX

The destination for information about unexpected events (including setup errors) that do not relate to specific pools. You can define CSZX as an intrapartition, extrapartition, or indirect destination. Note, however, that it must be defined as non-recoverable (DESTRCV=NO).

It is recommended that you define CSZX as an intrapartition destination, with a trigger level of 1, so that each event is processed immediately it is reported. (You must also, of course, write and install the event-handling transaction that is to be triggered.)

Any pool-specific TD queues that you require

Such queues receive information about events that affect specific pools. They can be defined as intrapartition, extrapartition, or indirect destinations. Note, however, that they must be defined as non-recoverable (DESTRCV=NO).

It is recommended that you define pool-specific queues as intrapartition destinations, with trigger levels of 1, so that each event is processed immediately it is reported.

For information about defining transient data queues, see the *CICS/ESA Resource Definition Guide*. Sample definitions for the FEPI TD queues are given in DFH0IZRQ in the samples library.

Getting started

System initialization parameter, FEPI=YES|NO

Code FEPI=YES, to specify that FEPI is available. (The default is FEPI=NO.) For information about setting system initialization parameters, see the *CICS/ESA System Definition Guide*.

Command-level security

If your installation uses CICS command-level security, you can restrict access to the EXEC CICS FEPI system programming commands (and to the equivalent commands that you can issue with the CEMT master terminal transaction) by defining access authorizations to your external security manager (ESM). The commands you can protect in this way are those listed in Chapter 9, “System programming reference” on page 69 and in the CEMT section of Chapter 7, “Operator control” on page 49. You cannot restrict access to the FEPI application programming commands (as listed in Chapter 16, “Application programming reference” on page 137).

To protect the FEPI system programming commands, use the resource identifier 'FEPIRESOURCE' when defining resource profiles to the ESM. Note that, if you use command security, you must ensure that authorized users of CEMT are also authorized to use the FEPI commands.

For RACF users, details of how to define resource profiles to the ESM are in the *Resource Access Control Facility Security Administrator's Guide*. For information about using RACF with CICS, see the *CICS/ESA CICS-RACF Security Guide*. Users of other security managers must refer to the documentation for their own product.

Installing FEPI resource definitions

Ensure that the RDO group DFHFEPI is in your startup group list. (DFHFEPI is in the DFHLIST startup group list, so this should have been done automatically when you installed CICS/ESA 4.1.)

Starting CICS

Start your CICS/ESA 4.1 region. This is described in the *CICS/ESA System Definition Guide*.

Chapter 5. Configuring FEPI

Having done the planning work described in Chapter 3, “Planning for FEPI” on page 15, you can now carry out the configuration tasks. These are:

- Defining your FEPI applications to CICS
- Defining nodes to VTAM
- Defining simulated terminals to back-end systems
- Writing the following for FEPI itself:
 - A setup program, to install your FEPI resources
 - A monitoring program, to handle unexpected events
 - If required:
 - Global user exit programs
 - Common functions
 - Transactions for operator control and administration.

To configure FEPI, you need to be familiar with all aspects of CICS administration (such as system definition, customization, resource definition, and operations) and the programming interface to CICS. Programming information is in the *CICS/ESA Application Programming Reference* and the *CICS/ESA System Programming Reference*. You should also be familiar with VTAM and, if you are accessing IMS back-end systems, with IMS administration.

CICS configuration

Chapter 4, “Getting started” on page 21 covers everything that FEPI itself requires: the RDO group DFHFEPI in the startup group list; definitions of the transient data queues CSZL and CSZX; and any required security access controls.

Now you have to define your FEPI applications to CICS in the usual way. This includes the setup programs, any common functions, and any additional transient data queues that you need for handling pool-specific events.

Define transactions that are to be started by FEPI (the event handlers and pseudoconversational access programs) as CICS started tasks, with SPURGE=NO and TPURGE=NO to prevent them from being accidentally canceled by CICS. See page 21 for details about the queues. Before starting, you should ensure that your CICS system has enough storage available to support your FEPI configuration: for details see “Planning FEPI storage” on page 19.

Note that, in an intercommunication environment, FEPI itself must be run in the application-owning region (AOR) and all transactions that FEPI may start must run locally. This is because FEPI commands cannot be function shipped.

Setup-initialization program in PLT

The setup transaction that installs your FEPI nodes, targets, and pools is typically started by a program list table (PLT) program. This process is described in “Running setup programs” on page 29. If you use this method, you need to include your PLT program in the second part of the program list table post initialization (PLTPI) list.

For information about coding entries in the PLTPI list, see the *CICS/ESA Resource Definition Guide*.

VTAM configuration

For FEPI to communicate with the network, some information must be defined to VTAM. This is described here. For information about configuring VTAM, see the *VTAM Network Implementation Guide* and the *VTAM Resource Definition Reference*.

Defining FEPI nodes to VTAM

Each FEPI node (simulated secondary LU terminal) must have a VTAM application minor node definition. The name of this minor node must be the same as the node name specified on the FEPI INSTALL NODELIST command.

For example, the FEPI node called 'FEPI0001' would require the following application minor node definition in VTAM:

```
DG4FEPI1  APPL ACBNAME=FEPI0001
```

The important points to note are:

- If your network uses a naming convention to manage network resources, you can allow a network-independent name to be used by specifying it on the ACBNAME keyword of the VTAM APPL statement. If this is not the case, you can simplify the definition of the VTAM application minor node by omitting the ACBNAME keyword (which means that the margin-name—DG4FEPI1 in the example—must be the same as the FEPI node name).
- FEPI does not impose any additional restrictions on the naming of nodes, other than that the names should not begin with "DFH"; apart from this, any values acceptable to VTAM are acceptable to FEPI.

If you require password protection of the minor nodes, you can use the PRTCT keyword of the VTAM APPL statement to specify a password of 1–8 characters. The password must then be specified on the corresponding FEPI INSTALL NODELIST command.

VTAM application minor node definition statements are stored collectively as one or more members of an MVS partitioned data set (usually SYS1.VTAMLST), accessed by VTAM via the VTAMLST data-definition statement in the VTAM startup JCL. If you are defining multiple FEPI nodes, you may choose to place them all in a single member (also known as a VTAM application major node) or in several members. They may also be added to an existing VTAM application major node. How you choose to organize the VTAM definitions may depend on how your installation manages its network resources, or how you plan to manage the FEPI configuration.

Availability of network resources

For FEPI to communicate with the network using a node, both the application minor node and the defining major node must be active, and the minor node must be in a connectable condition.

If FEPI is initialized before VTAM, and is instructed to acquire this node, it retries the VTAM OPEN request several times. Similarly, if a target application is unavailable, FEPI makes another attempt at session initiation. After this, the operator will need to intervene to establish connectivity.

Selection of FEPI session parameters

When FEPI establishes a session with a back-end system, it searches the VTAM LOGON mode (logmode) table for an entry that corresponds to the simulated device type specified on the FEPI INSTALL PROPERTYSET command used to define the pool to which the node-target connection belongs. If it finds such an entry, it uses it to set the parameters for the session. Suitable mode table entries for FEPI are in the LOGON mode table ISTINCLM. Table 3 on page 25 shows how entries in ISTINCLM correspond to FEPI device types.

DEVICE CVDA on FEPI INSTALL PROPERTYSET	Mode table entry in ISTINCLM	Session parameters
T3278M2	D4A32782	LU2 3278 model 2
T3278M3	D4A32783	LU2 3278 model 3
T3278M4	D4A32784	LU2 3278 model 4
T3278M5	D4A32785	LU2 3278 model 5
T3279M2	SNX32702	LU2 3279 model 2
T3279M3	SNX32703	LU2 3279 model 3
T3279M4	SNX32704	LU2 3279 model 4
T3279M5	SNX32705	LU2 3279 model 5
TPS55M2	SNX32702	LU2 PS/55, 24 lines
TPS55M3	SNX32703	LU2 PS/55, 32 lines
TPS55M4	SNX32703	LU2 PS/55, 43 lines
LUP	IBM3600	Secondary LU P (IMS protocol LU 0)
Note: The mode entries are fixed by FEPI; you cannot use any other entries.		

If *ISTINCLM* is defined as your default LOGON mode table, no additional definitions are required, and FEPI sessions use the characteristics that these entries specify. If you have defined a different default table, which does not contain the supplied entries, or if you want to associate a different set of characteristics with the names listed above (for example, class-of-service or pacing specifications), then you must provide the required entries in a customized mode table. This must be associated with the node via the *MODETAB* keyword of the VTAM APPL statement used to define the node to VTAM. For example:

```
DG4FEPI1 APPL ACBNAME=FEPI0001,MODETAB=mode-table-name
```

Notes:

1. If you choose to define your own mode table, it needs to contain only those entries that differ from set supplied in the default mode table (for example, *ISTINCLM*). If VTAM cannot find a given entry in the node-specific mode table, it automatically searches the system default table for an entry of the same name.
2. FEPI establishes the presentation space size of a terminal, based on the session parameters received in response to the session request, *not* on any fixed dimension implied by the device type specified for the pool (although the device type does establish a default value when a default *BIND* is received).
3. An externally initiated session (one started by the primary LU or by the operator through the *VARY LOGON* command) can specify any entry name in the mode table. If you expect to make use of external session initiation, it is advisable to specify the *DLOGMOD* keyword on the APPL statement used to define the node in question. This keyword identifies the mode table entry to be used in those cases where the session initiation request did not specify session parameters. It can be specified regardless of whether the *MODETAB* keyword is used. For example:

```
DG4FEPI1 APPL ACBNAME=FEPI0001,  
MODETAB=mode-table-name,DLOGMOD=mode-table-entry-name
```
4. If you define your own mode entries, ensure that all the parameters in an entry are appropriate. These logmode entries should be explicitly named in the APPL statements as described in step 3.

back-end configuration

Pacing of FEPI sessions

The pacing values used for FEPI sessions should be consistent with whatever installation standards are in effect for other LU2 and SLU P sessions in the network.

Back-end system configuration

No special configuration is needed for back-end systems, except that you must provide and manage LUs (simulated terminals) for FEPI use. These terminals are defined to the back-end CICS or IMS system just like real terminals. They can be explicitly defined or auto-installed as required. They do not need to be defined to VTAM in the back-end system, to which they appear as real terminals on that system. VTAM uses the various network definitions to determine how and where to route data; it can be routed locally, cross-domain, or cross-network. The LU name corresponds to the front-end node name. (Similarly, the VTAM applid of the back-end system corresponds to the applid in the FEPI target definition.) The diagram of the sample configuration in Figure 2 on page 31 illustrates these relationships.

If your back-end systems use the extended recovery facility (XRF), you must use their *generic* applids, rather than specific ones, in your FEPI target definitions. See “Using FEPI with XRF” on page 43.

CICS

For CICS back-end systems, acceptable terminal definitions (TYPETERMs) are:

- DFHLU2E2
- DFHLU2E3
- DFHLU2E4
- DFHLU2E5
- DFHLU2M2
- DFHLU2M3
- DFHLU2M4
- DFHLU2M5

These definitions match the VTAM mode table entries shown in Table 3 on page 25. You must create your own TYPETERMs for 3279 model 5 and PS/55 devices, if required, because no such definitions are supplied by CICS. If the back-end system is using CICS/MVS Version 2, you must create all your own TYPETERMs or copy them from the front-end system. For information about defining terminals to CICS, see the *CICS/ESA Resource Definition Guide*.

IMS

#

For terminals to be used by FEPI, the following settings are **required** on the TYPE or TERMINAL system definition macros:

- NAME must match the NODE name specified to and used by FEPI.
- MODETBL must specify the correct LOGMODE.

The following non-default settings are **recommended**. (FEPI will support the default settings as well.)

- Specify OPTIONS=OPTACK for more efficient communication.
- Specify OPTIONS=FORCRESP so transactions are run in response mode. (If you let this default, you might get non-response mode regardless of how the transactions are defined.)
- Specify OPTIONS=NORELRQ to make IMS ignore external requests for the node.
- Specify OPTIONS=BID to indicate that the VTAM BID command should always precede output messages that occur while between brackets.
- Specify OUTBUF=*nnn* to set a bigger output buffer than the default of 256.

#

```

#           The following example defines some IMS terminals for use by FEPI. You may need to
#           customize it for use in your own IMS environment.
#
#           TYPE UNITYPE=SLUTYPEP,MODETBL=IBM3600,                                x
#           OPTIONS=(OPTACK,FORCRESP,NORELRQ,BID),OUTBUF=512
#           TERMINAL NAME=IMSLUP01
#           NAME IMSLUP01
#           TERMINAL NAME=IMSLUP02
#           NAME IMSLUP02
#           TERMINAL NAME=IMSLUP03
#           NAME IMSLUP03
#           TERMINAL NAME=IMSLUP04
#           NAME IMSLUP04

```

For further information, see “IMS considerations” on page 130.

FEPI configuration

You **must** write:

- A setup program to define your FEPI nodes, targets, property sets, and pools.

You **may** also need to write:

- A monitoring program to handle unexpected events (including setup errors)
- Any common functions not provided by individual FEPI applications
- One or more global user exit programs
- Some specialized operator transactions, to simplify the control of FEPI resources.

See Appendix A, “Sample programs” on page 165 for details of the samples that are provided.

Writing configuration programs

FEPI programs are CICS applications, and so all aspects of CICS programming apply. For guidance about writing CICS application programs, see the *CICS/ESA Application Programming Guide*. For programming information, (including command formats, argument values, details on the translation of programs, and language considerations), see the *CICS/ESA Application Programming Reference*. Particularly relevant are the chapters in the *Application Programming Guide* about designing efficient applications and dealing with exception conditions.

The FEPI system programming commands are an extension of the EXEC CICS commands. They have similar names and similar functions. The FEPI commands also have similar keywords, but they are distinguished by having “FEPI” as a prefix. For system programming, the commands are:

Definition:

EXEC CICS FEPI INSTALL	Define communication resources
EXEC CICS FEPI ADD	Add resources to a pool
EXEC CICS FEPI DELETE	Remove targets or nodes from a pool
EXEC CICS FEPI DISCARD	Remove communication resources completely from FEPI.

Operations:

EXEC CICS FEPI INQUIRE	Query FEPI status and resources
EXEC CICS FEPI SET	Control FEPI resources.

Note that, when translating your programs, you must specify the FEPI option, which instructs the translator to process FEPI commands, but you do not need the SP option.

Your FEPI configuration programs can be AMODE(24) or AMODE(31)—that is, they can issue FEPI commands in either 24- or 31-bit addressing mode, and reside above or below the 16MB line.

Exception conditions

As with all CICS commands, FEPI commands may produce exception conditions that you can check using the RESP option, or capture using HANDLE CONDITION. Most FEPI command errors return INVREQ. The particular error in each case is uniquely identified by the RESP2 value. All the FEPI exception conditions and RESP2 values are listed in Chapter 9, "System programming reference" on page 69. There are copy books that contain declarations for the RESP2 values:

- DFHSZAPA for Assembler language
- DFHSZAPO for COBOL
- DFHSZAPP for PL/I
- DFHSZAPC for C/370.

For the system programming commands, errors are reported as unexpected events to the CSZX or other transient data queue, and to the FEPI message log CSZL, as well as by exception conditions on the command.

If there is an error, the command does nothing, and output values are not changed. Some commands operate on a list of resources; an error in one resource does not prevent the command from operating on the other resources in the list.

You can use EDF and CECI to debug FEPI programs. Because FEPI commands can be quite long, you will probably find the NAME field of CECI useful.

All resource names used by FEPI are a fixed length of 8 characters; they must be padded with blanks if necessary. For commands that use lists, make sure that the list field is a multiple of 8 characters long and that the number option is set correctly; neither the translator nor CECI checks these and you could get unpredictable results if they are wrong.

Writing setup programs

There are many considerations in designing setup programs, and so there is no single recommended way of writing them. On the distribution tape, there is:

- An Assembler language sample setup program with filename DFH0AZXS
- A COBOL sample setup program with filename DFH0VZXS
- A C/370 sample setup program with filename DFH0CZXS.

These programs install resources to make FEPI function with the other sample programs. They show you one way of writing setup programs. See "Setup" on page 170.

Your setup programs must:

- Install all node names that are available for FEPI.
- Install all targets that FEPI is permitted to access.
- Install properties. See "Organizing property sets" on page 18 for guidance on what choices to make. In defining the properties of connections in pools, the following options must be set:

Device attributes	DEVICE
Data handling	FORMAT, MAXFLENGTH, CONTENTION
Session management	BEGINSESSION, ENDSSESSION, INITIALDATA, STSN
Unexpected events	EXCEPTIONQ, UNSOLDATA, UNSOLDATAACK
Journaling	MSGJRNL, FJOURNALNUM

- Install pools
- Associate nodes and targets with the pools to define connections.

Note that, by default, FEPI resources are available for use as soon as they are installed or associated with a pool. For control, performance, or other reasons, you might want to override this; if so, you must provide a further program (or operations procedure) to bring the resources into service when you require them.

Many of the FEPI commands used by your setup program can use lists; using lists helps to improve performance. If some items in a list fail, errors (both programming errors and resource problems) are reported to your monitoring program, *not* to the setup program. If you want to track the errors in the setup program itself, without using the monitoring program, restrict your lists to a single item. Errors are then reported on the command itself.

In addition to a setup program, you may need a corresponding program to deal with deleting and discarding resources.

Running setup programs

The setup program is typically initiated by a program list table (PLT) program. Using this method, the setup program is run automatically at every CICS startup, including an XRF takeover. The steps are:

1. Write your setup program.
2. Define it to CICS, using RDO, and associate it with a transaction.

Note: You can define your setup program statically, or allow it to be installed automatically (autoinstalled) when it is invoked. For details of the CICS autoinstall facility for programs, see the *CICS/ESA Resource Definition Guide*.

3. Write a PLT program containing the command

```
EXEC CICS START TRANSID(tranid) INTERVAL(1)
```

where *tranid* is the ID of your setup transaction. (For programming information about writing PLT programs, see the *CICS/ESA Customization Guide*.)

4. Define your PLT program to CICS, and include it in the second part of the program list table post initialization (PLTPI) list. (For information about coding entries in the PLTPI list, see the *CICS/ESA Resource Definition Guide*.)

There may be a good reason for you to decide not to use the PLT to start the setup transaction. For example, you may want to have several, time-sensitive, setup programs, each having a corresponding discard program. If you decide not to use the PLT, you must arrange to start the setup transactions manually.

You should restrict access to the setup programs, because they are of a sensitive nature.

Varying the resources installed by the setup program

Unless your setup program contains some conditional logic, you always get the same set of FEPI resources installed. This may be exactly what you require, but if not, here are a few techniques that might prove useful.

Checking startup type

Your setup program can determine how the CICS system started by issuing an EXEC CICS INQUIRE SYSTEM STARTUP command. It could use this to install different sets of FEPI resources for warm and cold starts.

Recording the status of resources

If you install all your FEPI resources at CICS startup, and then alter their accessibility, consider writing a non-terminal transaction that runs frequently and uses the FEPI INQUIRE commands to determine the status of each FEPI resource. Write these to a *recoverable* temporary storage file. (You could, for example, use an XSZARQ global user exit program to log changes to FEPI resources.) At restart time, your setup program can read the file to determine the required access settings.

FEPI configuration

Using timed actions

You could take advantage of CICS automatic transaction initiation (ATI) at specified times to control FEPI resources. If you want to terminate FEPI access to another system at a specific time each day, schedule a transaction to run at the required time. When this transaction runs it can either make the required FEPI resources unavailable for access, or discard them. Because FEPI resources remain available for use by current tasks in this circumstance, this has no effect on existing FEPI users.

You could use timed initiation in a similar way to make FEPI resources available.

Using event handlers

Another way of controlling FEPI resources is to use the begin-session and end-session event handlers. (See “Other functions” on page 37.)

These handlers get invoked when a conversation starts and ends. Although they are primarily designed to handle signon and signoff to the back-end systems, you can take advantage of the fact that all FEPI functions are available to them. So you can use them to control access to back-end systems by either installing or discarding FEPI resources.

For example, suppose you want to ensure that no FEPI application is waiting for a connection to a back-end system. In the handlers, you issue FEPI INQUIRE POOL commands, and look at the WAITCONVNUM option, which returns the number of FEPI applications waiting for a connection. If this option exceeds a certain trigger value, issue FEPI commands to increase the number of connections (that is, add nodes, define new pools, and so on).

This technique can be extended to provide tuning of FEPI access to back-end systems.

Sample FEPI configuration

A sample configuration is given in Table 4 on page 32. Next, the target lists and node lists used in the sample are given. Then there are the definitions used to achieve the sample configuration. Figure 2 on page 31 is a diagrammatic representation of the sample configuration.

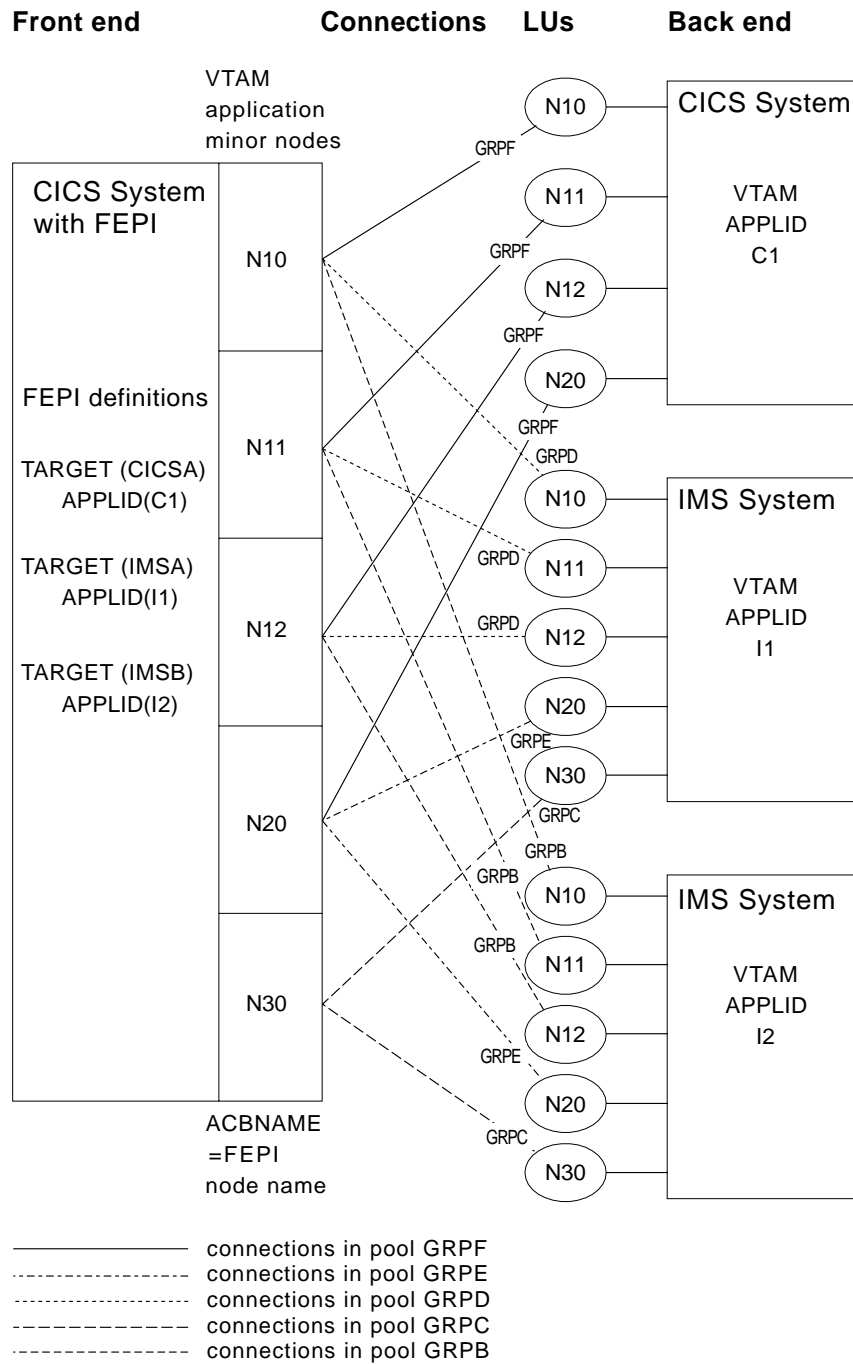

Figure 2. The sample FEPI configuration—a diagrammatic representation

Note that this is not the configuration the sample programs use; it illustrates as many aspects of configuration as possible.

Table 4. A sample FEPI configuration

Pool name	GRPB	GRPC	GRPD	GRPE	GRPF
Property set	SLUP	SLU2M3I	SLU2M3I	SLU2M2I	SLU2M2C
Target names	IMSB	IMSA IMSB	IMSA	IMSA IMSB	CICSA
Node names	N10 N11 N12	N30	N10 N11 N12	N20	N10 N11 N12 N20
Device type	LUP	T3278M3	T3278M3	T3278M2	T3278M2
Logmode name	IBM3600	D4A32783	D4A32783	D4A32782	D4A32782
Exceptional events queue name	IEXEPTP	IEXEPT2	IEXEPT2	IEXEPT2	CEXEPT2
Unsolicited-data transaction name or response	IUP	IU2	IU2	IU2	Negative
Begin-session transaction name	ISIP	ISI2	ISI2	ISI2	CSI2
End-session transaction name	none	IXI2	IXI2	IXI2	CXI2
STSN transaction name	ISTP	n/a	n/a	n/a	n/a
Initial inbound data	No	Yes	Yes	Yes	Yes

Sample lists

Here are the target lists and node lists used in the sample configuration, padded to eight bytes per item.

```

TLIST          'CICSA  IMSA  IMSB  '
TLISTA        'IMSA  '
TLISTB        'CICSA  '
TLISTC        'IMSA  IMSB  '
TLISTD        'IMSB  '
NLIST         'N10   N11   N12   N20   N30   '
NLISTA        'N10   N11   N12   '
NLISTB        'N20   '
NLISTC        'N30   '
NLISTD        'N10   N11   N12   N20   '
    
```

The following is the list of VTAM application names of the back-end CICS and IMS systems with which FEPI applications will communicate.

```

PLIST          'C1    I1    I2    '
    
```

Sample definitions

The following definitions illustrate the various possibilities when defining FEPI resources.

Define the back-end subsystems you want FEPI to access: This defines the logical names (targets) that FEPI uses to refer to back-end systems (in this case CICSA, IMSA, and IMSB as given in TLIST), and relates them to their VTAM names (C1, I1, and I2 as given in PLIST).

```

EXEC CICS FEPI INSTALL TARGETLIST(TLIST) TARGETNUM(3)
      APPLIST(PLIST)
    
```

Define the VTAM minor nodes available to FEPI: The names are N10, N11, N12, N20, and N30, as given in NLIST.

```

EXEC CICS FEPI INSTALL NODELIST(NLIST) NODENUM(5)
    
```

Define properties: This defines the characteristics of the connections.

SLU P connections:

```
EXEC CICS FEPI INSTALL PROPERTYSET(SLUP)
      LUP                      /* Device type (SLU P) */
      BEGINSSESSION(ISIP)      /* Begin session handler */
      STSN(ISTP)               /* STSN transaction */
      EXCEPTIONQ(IEXEPTP)     /* Exception report TD queue */
      UNSOLDATA(IUP)          /* Unsolicited-data transaction */
      NOTINBOUND               /* No "good morning" message */
```

SLU2 24 x 80 connections to IMS

```
EXEC CICS FEPI INSTALL PROPERTYSET(SLU2M2I)
      T3278M2                  /* Device type (3278 model 2, 24 x 80) */
      BEGINSSESSION(ISI2)     /* Begin session handler */
      EXCEPTIONQ(IEXEPT2)     /* Exception report TD queue */
      UNSOLDATA(IU2)          /* Unsolicited-data transaction */
      INBOUND                  /* Initial data */
      ENDSSESSION(IXI2)       /* End session handler */
```

SLU2 32 x 80 connections to IMS:

```
EXEC CICS FEPI INSTALL PROPERTYSET(SLU2M3I)
      T3278M3                  /* Device type (3278 model 3, 32 x 80) */
      BEGINSSESSION(ISI2)     /* Begin session handler */
      EXCEPTIONQ(IEXEPT2)     /* Exception report TD queue */
      UNSOLDATA(IU2)          /* Unsolicited-data transaction */
      INBOUND                  /* Initial data */
      ENDSSESSION(IXI2)       /* End session handler */
```

SLU2 24 x 80 connections to CICS:

```
EXEC CICS FEPI INSTALL PROPERTYSET(SLU2M2C)
      T3278M2                  /* Device type (3278 model 2, 24 x 80) */
      BEGINSSESSION(CSI2)     /* Begin session handler */
      EXCEPTIONQ(CEXEPT2)     /* Exception report TD queue */
      NEGATIVE                 /* Response to unsolicited data */
      INBOUND                  /* "Good morning" message */
      ENDSSESSION(CXI2)       /* End session handler */
```

Define the pools of connections: The pools define connections between targets and nodes; they specify which nodes can be used to access which target, and what properties the connection has.

```
EXEC CICS FEPI INSTALL POOL(GRPB) PROPERTYSET(SLUP)
      TARGETLIST(TLISTD) TARGETNUM(1)
      NODELIST(NLISTA) NODENUM(3)
EXEC CICS FEPI INSTALL POOL(GRPC) PROPERTYSET(SLU2M3I)
      TARGETLIST(TLISTC) TARGETNUM(2)
      NODELIST(NLISTC) NODENUM(1)
EXEC CICS FEPI INSTALL POOL(GRPD) PROPERTYSET(SLU2M3I)
      TARGETLIST(TLISTA) TARGETNUM(1)
      NODELIST(NLISTA) NODENUM(3)
EXEC CICS FEPI INSTALL POOL(GRPE) PROPERTYSET(SLU2M2I)
      TARGETLIST(TLISTC) TARGETNUM(2)
      NODELIST(NLISTB) NODENUM(1)
EXEC CICS FEPI INSTALL POOL(GRPF) PROPERTYSET(SLU2M2C)
      TARGETLIST(TLISTB) TARGETNUM(1)
      NODELIST(NLISTD) NODENUM(4)
```

Writing monitoring programs

You need a monitoring program to handle:

- Unexpected events reported by FEPI
- Errors in FEPI system programming commands.

FEPI reports these events by writing a record to a transient data (TD) queue. You can define pool-specific TD queues for FEPI, where information about events that relate to specific pools is reported. (There is also a common FEPI TD queue, CSZX, where events that do not relate to specific pools are reported.) Note that, if a pool-specific event occurs, and you have not defined a corresponding queue, information about the event is lost. Also, FEPI TD queues must be defined as 'not recoverable'; if a queue is 'recoverable', FEPI does not write to it, and discards any information about unexpected events.

Typically, you would arrange for the monitoring program to be triggered whenever an item is placed in a TD queue. (Define the queue with TRIGLEV=1.) A single monitoring program can service several queues, by using EXEC CICS ASSIGN QNAME to check which queue triggered it. According to the nature of the event, the monitoring program might simply write a message, log the event, or embark on a full conversation.

For example, using this method, whenever a session is lost, the monitoring program is invoked. The TD queue data provides information about what happened. Your monitoring program can obtain this in the usual way with EXEC CICS READQ TD. The following copy books describe the structure of the data:

- DFHSZAPA for Assembler language
- DFHSZAPO for COBOL
- DFHSZAPP for PL/I
- DFHSZAPC for C/370.

Your program may then choose to reestablish the lost session, to reinitialize, and so on. It may also set indicators for the application programs if contact with a target has been lost altogether.

Monitoring programs are written using the techniques and commands discussed in Part 3, "Application programming" on page 101. See also the overview of the sample monitoring program in "Monitor and unsolicited data-handler" on page 171.

Handling unexpected events

This section suggests some actions your monitoring program could take after various types of unexpected event. The type of event is indicated by the EVENTTYPE area in the TD queue record. In most cases, the EVENTVALUE area gives specific details of the failure; the values are the same as the RESP2 values listed in "RESP2 values" on page 187.

Events in CSZX TD queue records

INSTALLFAIL

A FEPI resource has failed to be installed. This is probably because you are trying to install a duplicate name. This may indicate either a logic error or a possible security violation.

Recommended action: Report possible application logic error, for investigation.

DISCARDFAIL

A FEPI resource has not been discarded. This is probably because you are trying to discard a nonexistent object. This may indicate a logic error.

Recommended action: Report possible application logic error, for investigation.

SETFAIL

A FEPI resource has rejected a SET request. This is probably because you are trying to manipulate a resource that does not exist. However, there is also the

possibility of rejection due to VTAM considerations. So SETFAIL may indicate either a logic error or a network failure.

Recommended action: Schedule a transaction to repeat the operation (if not a logic error).

ACQFAIL

A FEPI resource has failed to be acquired. This is probably because of a network failure, and so FEPI automatically retries the acquire request several times at intervals; the count in EVENTDATA shows whether there will be any more retries. However, there is also the possibility of an error in either the VTAM definition or the back-end system definition of the object.

Recommended action: After FEPI stops retrying, suggest investigating the condition of the resource from a VTAM viewpoint. The VTAM sense code describing the problem is in EVENTDATA. See the appropriate VTAM manual for more information. For nodes, this is the *VTAM Programming* manual; for connections, *VTAM Messages and Codes*. Further information is in the *SNA Formats* manual.

SESSION

An unsolicited bind was received, probably because of a CLSDST(PASS). See “Handling CLSDST(PASS)” on page 36.

Events in pool-specific TD queue records

SESSIONLOST

An active connection has failed. This is probably due to the back-end system failing. However, this error is also generated if an operator cancels an active connection.

Recommended action: Suggest that the operator:

- Investigate the condition of the connection from a VTAM viewpoint. The VTAM sense code that describes the problem is in EVENTDATA. See the *VTAM Messages and Codes* and *SNA Formats* manuals for more details.
- See whether the back-end system is still running.
- Check that the back-end system has not “closed” the FEPI simulated terminal.

SESSIONFAIL

A connection has failed to start. This is probably due to a setup inconsistency or to a failure of the back-end system, and so FEPI automatically retries the acquire request several times at intervals; the count in EVENTDATA shows whether there will be any more retries. However, this failure is also generated if an operator has canceled the connection.

Recommended action: After FEPI stops retrying, suggest the operator:

- Investigate the condition of the connection from a VTAM viewpoint. The VTAM sense code that describes the problem is in EVENTDATA. See the *VTAM Messages and Codes* and *SNA Formats* manuals for more details.
- See whether the back-end system is still running.
- Check that the back-end system has not “closed” the FEPI simulated terminal.
- Check that the terminal type definition in the back-end matches the FEPI device type.

ADDFAIL

An attempt to add a target or node to a pool has failed. The probable cause of this error is an attempt to add a resource that is already in the pool. This indicates a possible logic error.

Recommended action: Report possible application logic error, for investigation.

DELETEFAIL

An attempt to delete a target or node from a pool has failed. This is probably caused by an attempt to delete a resource that is not in the pool, indicating a possible logic error.

Recommended action: Report possible application logic error, for investigation.

Handling CLSDST(PASS)

A back-end system can end a network session with a VTAM CLSDST(PASS) request. This indicates that the back-end will reestablish a session with the front-end using a different PLU name (a *third-party* PLU). The front-end system detects reestablishment of the session by receiving an unsolicited bind request; so when the back-end system ends a session, it is important for it to indicate that an unsolicited bind is to be expected.

#

Note: To determine whether a lost session was caused by a CLSDST(PASS) request, a FEPI application can issue a FEPI INQUIRE CONNECTION command. If the value of LASTACQCODE is X'32020000', the back-end system issued a CLSDST(PASS) to unbind the session.

The three most likely scenarios are described in the following sections.

Unsolicited bind not expected

FEPI unconditionally rejects the bind request.

Third-party PLU name known and unsolicited bind expected

The prospective PLU names must be defined to FEPI as targets. You might need to restrict access to the pools that include these targets to make sure the connection is not already in use when the CLSDST(PASS) takes place. The simplest way to configure this is to define a pool containing the node and all the targets it can be placed in session with. Install all connections except the initial one with an ACQSTATUS of RELEASED so the back-end system can successfully acquire the session. No other special processing is required and no TD queue record is written in this case.

Third-party PLU name not known and unsolicited bind expected

The necessary resource definitions must be managed dynamically.

#

Note: Managing the resource definitions dynamically (described under “Conversation in progress”) is the only method that allows the conversation to persist across the CLSDST(PASS).

|
|

When FEPI receives the unsolicited bind, it writes a record to the CSZX TD queue, with an EVENTTYPE of SESSION, and with the third-party PLU name in the TARGET area. At this point the bind has not been accepted or rejected. A VTAM display for either the back-end or the front-end system would show the connection to be in a PSESST/B state. You are responsible for managing these TD queue records and making the necessary FEPI configuration updates so that processing can continue. If no action is taken, the session remains in this state until a VTAM VARY NET,TERM command is issued to terminate the session request.

|
|
|
|

There are two cases, according to whether or not there is a conversation in progress on the connection when the CLSDST(PASS) occurs. (This can be determined from the STATE option of the FEPI INQUIRE CONNECTION command.) In both cases, you need to determine which pool has the connection that the CLSDST(PASS) applies to, because the TD queue record does not report either the pool or the old target name. If the node is used in only one pool, the old target name can be found easily by browsing connections using FEPI INQUIRE CONNECTION; if not, use some other technique, such as the USERDATA option of the FEPI SET commands.

Conversation in progress: Nodes for which this kind of processing is required should be defined in pools containing only the node and the initial target, because of the nature of the processing involved.

The monitor program should:

1. Install a new pool with the same properties as the current one.
2. Install a new target whose PLU name is the third-party PLU name given in the TARGET area of the TD queue record.
3. Add the target to the new pool. This should be the only target in that pool.
4. Delete the node identified in the TD queue record from the pool in which it currently exists. If necessary, to ensure continuity, the monitor program can add another node to the pool before deleting the old node.
5. Add the node to the newly created pool. The new connection is now established.

When the session ends, the connection reverts to a RELEASED state. If necessary, use an end-session handler to perform any necessary cleanup, such as reversing the process described above.

The front-end application must also anticipate CLSDST(PASS) processing. See “Lost session” on page 129 for more details.

Conversation not in progress: The CLSDST(PASS) occurred as a result of trying to acquire a connection. The monitor program should:

1. Install a new target whose PLU name is the third-party PLU name given in the TARGET area of the TD queue record.
2. Add the target to the pool, specifying a desired connection acquire status of ACQUIRED. The new connection is now established.

If necessary, use an end-session handler to cleanup the dynamically defined targets. These connections always become RELEASED when the session ends and can be left for reuse, if required.

Writing operator transactions

You might find it useful to write some specialized operator transactions of your own to control FEPI resources. For more information, see “Controlling FEPI resources” on page 39.

Other functions

The other functions you might need to write for FEPI itself are the begin-session, end-session, and unsolicited-data handlers. These are extensions of the FEPI application programs, and are described in Part 3, “Application programming” on page 101. If you write them as common functions, you need to know what the application programs do. Alternatively, the application programmer may write them.

Global user exit programs

Two CICS global user exits are provided:

XSZBRQ Invoked before a FEPI command is executed
XSZARQ Invoked after a FEPI command is executed.

XSZBRQ is passed the parameters input to the command, and can be used to monitor commands, to bypass commands that violate installation conventions, or to change the parameters of a command, subject to the rules applying to global user exits. XSZARQ is passed the parameters output from the command.

For details of the FEPI global user exits, see “Global user exits” on page 63. For programming information about writing and using global user exit programs, see the *CICS/ESA Customization Guide*.

Chapter 6. FEPI operation

This chapter describes how FEPI operates. It includes information on controlling FEPI resources, performance, and shutdown. It also describes using FEPI with XRF and VTAM persistent sessions.

Controlling FEPI resources

The FEPI INQUIRE and SET functions can be carried out by a program, or by using the master terminal transaction, CEMT. You may find it useful to write some specialized operator transactions of your own.

The FEPI INQUIRE command (and its CEMT equivalent) tells you what resources are defined and their statuses. The only thing you cannot do directly is determine which nodes and targets are in a particular pool. Do this using CEMT to inquire about the connections in a particular pool:

```
CEMT I FECONNECTION POOL(poolname)
```

To do this from an application program, browse all connections and select those in the pool you want.

Here are the resource statuses of most interest:

SERVSTATUS

SERVSTATUS is used with connections, nodes, pools, and targets. It specifies the service status of the resource—that is, whether it can be used for a conversation. The service status can be set to `INSERVICE` to allow usage, or to `OUTSERVICE` to stop usage for any *new* conversation. Note that setting `OUTSERVICE` does not end any existing conversations that are using the resource; the status is `GOINGOUT` until the existing conversations end.

ACQSTATUS

ACQSTATUS is used with connections and nodes. It specifies the “acquire status” of the resource. For a connection, this means whether it should have a session established (bound) or ended (unbound). For a node, it means whether the VTAM ACB for the node should be opened or closed. The acquire status can be set to `ACQUIRED` (a status of `ACQUIRING` indicates that the acquisition has not yet been completed), or to `RELEASED`.

Setting `RELEASED` does not end any existing conversations that are using the resource; the acquire status is `RELEASING` until the existing conversations end. However, for connections, a conversation that is unowned and in a “pending” state (see “STATE” on page 41) is ended immediately if the acquire state is set to `RELEASED`; this means that connections being used by a failed application can be recovered.

`ACQUIRING` and `RELEASING` are shown as `BEING ACQUIRED` and `BEING RELEASED` by CEMT.

Network and other problems can cause connections to become stuck in a `RELEASING` or `ACQUIRING` state, in which case the operator might need to intervene using VTAM operator commands.

If a FEPI connection remains in a `RELEASING` state for longer than expected, try the following:

1. Note the node and target associated with the connection; use `CEMT INQUIRE FETARGET` to find the VTAM application name that the target represents.
2. Issue the VTAM command

```
D NET,E,ID=nodename
```

Controlling FEPI

to find out the state of network session associated with the connection.

3. Note the session status. See the *VTAM Programming* manual for an explanation of the status. If no session exists and a subsequent INQUIRE of the connection status using CEMT shows the state still as BEING RELEASED, there has been a system failure; you should collect diagnostic information.
4. If the session is in 'session takedown processing', you can use the VTAM command
D NET,SESSION
to find out what signals are needed to complete processing.
5. If you can resolve the problem using commands on the back-end system, attempt to do so.
6. If there is no other way to resolve the session status, you can use the VTAM command
V NET,TERM
to end the network procedure in progress. FEPI will then be able to complete processing.

It is not so easy to find out when an ACQUIRING state has persisted for too long. However, if you cannot determine why the session has not been established, follow the procedure described above. If no session is active for the connection, FEPI is currently waiting for the retry interval to expire. The system log should contain VTAM messages explaining why the session cannot be established. The LACQCODE option of CEMT INQUIRE FECONNECTION gives the reason code VTAM provided for the last session failure.

Also be sure to check that the node on which the connection depends is properly acquired; if not, resolve whatever problem is indicated by the LACQCODE option for the node.

Note that, under normal circumstances, after a FEPI FREE RELEASE command has been issued the session does not remain in RELEASED state, because FEPI automatically tries to reacquire the session. However, if a FEPI SET CONNECTION ACQSTATUS(RELEASED) command is issued before the FREE RELEASE, the session remains in RELEASED state.

LASTACQCODE

The INQUIRE CONNECTION or INQUIRE NODE commands can use the option LASTACQCODE (LACQCODE in CEMT), which returns the result of the last acquire request. This is the sense code from the last VTAM operation, where zero indicates success. For a full explanation of VTAM sense codes, see the appropriate VTAM manual: for nodes, this is *VTAM Programming*; for connections, *VTAM Messages and Codes*. Further information is in the *SNA Formats* manual.

INSTLSTATUS

INSTLSTATUS is used with connections, nodes, pools, and targets. It specifies whether the resource is installed, or is in the process of being discarded, waiting for the conversations that are using it to end.

WAITCONVNUM

WAITCONVNUM shows how many conversations are currently waiting to start using a connection or pool. If WAITCONVNUM is nonzero for significant periods of time, it might mean that you need to allocate extra resources to meet the demand. Or it might mean that applications are holding on to resources for too long.

STATE

STATE is used with connections. It shows the state of the conversation that is using a connection. See page 52 for the values that STATE can have.

If any of the “pending” states (PENDSTSN, PENDBEGIN, PENDDATA, PENDSTART, PENDFREE, PENDRELEASE, PENDUNSOL, or PENDPASS) is shown, it indicates that the conversation is unowned, pending the event or task shown. If a “pending” state persists, it is likely that the application has failed in some way; you should consider resetting the connection by issuing a FEPI SET CONNECTION RELEASED command.

Performance

You cannot tune FEPI itself—it is already optimized for speed of response. However, you can influence the performance of FEPI application programs.

FEPI runs under a separate CICS task control block (TCB) and CICS permits only *one* application program to issue a FEPI command at a time. This is a major influence on FEPI performance. Although many application programs can have FEPI commands being processed at any time, only one application can *issue* a FEPI command.

In a lightly loaded system, this means that CICS does not run FEPI until a command is issued. Thus, performance is impacted by the overhead of starting up the TCB so that the FEPI command can be processed. In a heavily loaded system, this overhead is not present, because the TCB is already active processing earlier FEPI commands. This is in contrast to a traditional CICS system, where a lightly loaded system may perform better than a heavily loaded one.

FEPI tries to minimize this overhead by issuing timer requests that ensure that the TCB is not inactive for more than one second.

There are three main principles that should be used in FEPI applications to provide the best performance:

1. Each FEPI command generates a CICS WAIT even if no network transmission is involved, and so the number of commands issued should be minimized.
2. Data transmission should be kept to a minimum.
3. Session disconnection should be avoided.

Techniques to use in application programs in support of these principles are given in “Performance” on page 133.

As to FEPI system programming, command usage can be reduced by using lists of resources on a command where possible. However, when a command using a list results in a VTAM operation, you could:

- “Flood” VTAM by requesting too many operations at once
- “Flood” the back-end system with requests for session initiation
- “Flood” the front-end system with started begin- or end-session transactions.

So you must carefully evaluate the benefits of using lists.

| Using CICS monitoring and statistics

CICS monitoring and statistics data can help with performance tuning and resource planning for applications that use FEPI.

Shutdown

Monitoring data

By default, CICS performance class monitoring records include the following data about the user task:

- The number and type of requests made to FEPI
- The time spent waiting for requests to FEPI to complete
- The number of requests to FEPI that are timed out.

For detailed information about the FEPI-related fields in performance class monitoring records, see the *CICS/ESA Performance Guide*. For information about using the DFHMCT TYPE=RECORD macro to control which FEPI fields are monitored, see the *CICS/ESA Resource Definition Guide*.

Statistics data

The standard CICS statistics reports contain data about usage of:

- FEPI pools
- FEPI connections
- FEPI targets.

To obtain the current statistics for a FEPI pool, connection, or target, a utility program can issue an EXEC CICS COLLECT STATISTICS command. For example, the command EXEC CICS COLLECT STATISTICS SET(pointer) POOL(GRPD) returns the current statistics for the 'GRPD' pool. To map the returned statistics, your utility program should include the appropriate CICS-supplied copybook:

DFHA22DS	FEPI pool statistics
DFHA23DS	FEPI connection statistics
DFHA24DS	FEPI target statistics.

The copybooks are supplied in COBOL, PL/I, and assembler language.

To cause all FEPI statistics to be written immediately to the SMF statistics data set, you can use either the EXEC CICS or the CEMT version of the PERFORM STATISTICS RECORD FEPI command.

For details of the CEMT COLLECT STATISTICS and PERFORM STATISTICS RECORD commands, see the *CICS/ESA CICS-Supplied Transactions*; for programming information about the equivalent EXEC CICS commands, see the *CICS/ESA System Programming Reference*.

To format and print FEPI-related statistics in the DFHSTATS data set, you can use the CICS-supplied utility program, DFHSTUP. To print only the FEPI statistics, specify the command parameter SELECT TYPE=FEPI. For information about how to use the DFHSTUP program, see the *CICS/ESA Operations and Utilities Guide*. For detailed information about fields in the FEPI statistics records, see the *CICS/ESA Performance Guide*.

Shutdown

FEPI shutdown is triggered as part of CICS shutdown—you cannot shut down FEPI alone. There are three forms of shutdown:

- Normal
- Immediate
- Forced.

Normal shutdown

A normal shutdown of CICS causes FEPI to shut down normally—active transactions are allowed to terminate. When all active conversations have ended, and all FEPI resources have been discarded, FEPI shuts down. While FEPI is shutting down, no *new* conversations can be started, but existing owned conversations continue. However, these cannot use the FEPI START or FEPI FREE PASS commands. Existing unowned conversations are ended immediately. Any FEPI transactions that you want to be able to start during CICS shutdown must be defined in the transaction list table (XLT).

If an end-session handler is invoked at the end of conversations, it is told that the session is to be ended because of CICS shutdown. The handler can choose to perform additional back-end operations that might be needed because of the shutdown. If you require this function, make sure the end-session handler transaction is defined in the transaction list table (XLT), and that it does not adversely affect the performance of CICS shutdown. (For details of how to define entries in the XLT, see the *CICS/ESA Resource Definition Guide*.)

CICS normal shutdown waits until FEPI shutdown has completed before continuing processing. So if you know when CICS shutdown is to occur, you should initiate FEPI DISCARD operations before starting CICS termination. Removing FEPI resources as they become inactive allows existing FEPI conversations to continue, but prevents new ones from starting. You could achieve the same effect by setting the status of FEPI resources to OUTSERVICE,RELEASED.

If shutdown is not proceeding, then before you force it to continue, consider carefully whether the problem is due to:

- A back-end system taking a long time to respond. In this case, do not attempt to speed things up—you may generate integrity errors in the back-end system.
- A FEPI failure. In this case, issue the following commands, pausing after each step to see whether CICS is still waiting:
 1. CEMT DISCARD FExxxx(*), to remove all FEPI resources
 2. CEMT SET FECONNECTION(*) OUTSERVICE RELEASED, to end any waiting conversations
 3. CEMT SET TASK(nnn) FORCE, to end any running FEPI transactions
 4. Attempt to issue VTAM VARY NET,INACT,FORCE commands from the system console to terminate connections.

If CICS shutdown still does not proceed, you cannot perform a warm shutdown. Try issuing a CEMT P SHUT IMMEDIATE command. If this fails, you must cancel CICS.

Immediate shutdown

An immediate shutdown of CICS immediately terminates FEPI. There is nothing you can do to influence this process.

Forced shutdown

A forced shutdown of CICS immediately terminates FEPI. There is nothing you can do to influence this process.

Using FEPI with XRF

This section discusses FEPI in a CICS extended recovery facility (XRF) environment. To understand it, you need to have read the *CICS/ESA 3.3 XRF Guide*, and to be familiar with CICS XRF VTAM USERVAR processing—the *VTAM Programming* manual contains relevant material.

Using FEPI with XRF

The effect of an XRF takeover of a CICS back-end system with which FEPI is in communication is described. Although IMS XRF processing is not discussed here, the same considerations apply.

XRF and VTAM

FEPI uses VTAM secondary LU support for communication and the simulated terminals defined to the back-end CICS system behave in a different way to real devices.

In an XRF environment, the simulated terminals in the back-end system cannot behave as VTAM class 1 terminals because there is no 3745/3725/3720 controller acting as the boundary network node (BNN). They behave like VTAM class 2 terminals, which is the default setting for CICS and IMS terminal definitions. Consequently, simulated terminals do not support VTAM XRF, and CICS XRF facilities are provided by tracking mechanisms that are explained in the *CICS/ESA 3.3 XRF Guide*.

When a FEPI connection is acquired, the back-end CICS generates a TCTTE (if one is not present already) using autoinstall. At this point, in a CICS XRF environment, the active CICS informs the alternate that a terminal has been defined. If the active is then taken over, the alternate knows which terminals are defined, and can take actions to recover the links.

As part of takeover processing, a VTAM BIND is issued to reestablish the session with each simulated terminal. However, FEPI also has detected that the connection has ended, and attempts to contact the (new active) back-end system by issuing a similar bind. This results in a **bind race**. The outcome of this bind race depends on the circumstances of the exchange. However, the bind issued by the new active CICS will probably be rejected, and the FEPI bind accepted. This results in DFHZCxxxx messages being produced during the takeover (see “Connections with a conversation—with data flow” on page 46). If FEPI reestablishes the connection, these messages can be ignored. You can remove these bind races by defining the back-end CICS terminal so it behaves as a VTAM class 3 terminal (no XRF support). To define the simulated terminals as class 3, specify RECOVOPTION=NONE in CICS, or BACKUP=NO in IMS.

FEPI resource definition and XRF

In an XRF environment, the applid specified on the FEPI INSTALL TARGETLIST command must be the *generic* applid of the back-end system. Specifying either the primary or secondary applid of the target results in processing errors. If you use the generic applid, FEPI is able to cater for the back-end system undergoing an XRF takeover.

However, you can define a pool that contains the specific applids of both the active and alternate systems. In this case, the alternate targets cannot be contacted until an XRF takeover has been performed. Similarly, the active targets cannot be contacted after takeover. If you define pools in this way (perhaps to provide backup support without XRF), you should manage the ACQUIRED–RELEASED status yourself, to minimize FEPI retry processing.

XRF takeover of front-end system

This section describes what happens when the CICS system running FEPI undergoes an XRF takeover.

Effect on back-end transactions

Each back-end transaction is abended, due to the loss of the simulated terminal—which is usually the principal facility for the task. Consequently, the ATNI (or equivalent) abend processing is unable to send the usual message indicating a transaction abend to the principal facility.

Transactions that attempt to handle terminal control errors should already be written to cope with this circumstance, and you should not need to alter them.

Effect on back-end terminals

FEPI is acting as the “terminal”, so an XRF takeover of the FEPI system results in the loss of the “terminal” in the back-end system. CICS takes the usual actions for the loss of a (real) terminal. There are three cases to consider:

“Terminals” without a conversation: If you are using autoinstall, the TCTTEs representing these “terminals” are deleted after a delay; if the delay is long enough, the alternate front-end CICS may reestablish the sessions before the TCTTEs are deleted.

“Terminals” with a conversation—no data flow: If you are using autoinstall, the TCTTEs representing these “terminals” are deleted after a delay; if the delay is long enough, the alternate front-end CICS may reestablish the sessions before the TCTTEs are deleted.

“Terminals” with a conversation—with data flow: These “terminals” are usually running a transaction when the “terminal” is lost. This results in the transaction being abended with the normal CICS abend code for a terminal failure (usually ‘ATNI’). The abend is usually accompanied by a DFHZCxxxx message indicating that the “terminal” has suffered an unrecoverable failure.

You may have to modify your node error program to prevent retry loops, but normally the default action (not to retry) is taken. When node error processing ends, if autoinstall is used, the “terminal” is deleted.

Effect on the alternate FEPI CICS system

The alternate FEPI CICS takes over operation of the failed CICS in the normal fashion. However, FEPI resources are not recovered automatically after an XRF takeover.

FEPI restarts at a late stage of takeover, after all RDO resources have been reinstalled. Nevertheless, when the second phase of the PLTPI list is entered, FEPI is ready to receive commands. Therefore, if you follow the recommendation to start your FEPI setup transaction from a PLTPI program, FEPI resources are reinstalled as part of the takeover. If you do *not* run your setup transaction in this way, then after a takeover you must arrange for it to be run manually, so that your FEPI resources are reinstalled.

However you handle resource definition in an XRF-environment, you must be prepared to cope with the possibility that FEPI resources have been manipulated in the failed CICS, so that the environment after takeover is not the same as that immediately before takeover. For example, resources may have been installed or deleted, or SERVSTATUS or ACQSTATUS values altered, after your setup transaction was run in the failed CICS.

XRF takeover of back-end system

This section describes what happens when the CICS back-end system with which FEPI is communicating undergoes an XRF takeover.

Effect on FEPI application programs

FEPI application programs are unable to distinguish between a loss of session due to an XRF takeover of the back-end system, and one due to a FEPI failure. In both cases, a typical RESP2 value of ‘215’ (‘Session lost’) is returned on the next FEPI command issued after the takeover has started. Alternatively, the application may get an indication of a state error, meaning that the command cannot be issued because the connection is not active. The application should *immediately* issue a FEPI FREE command to free the conversation.

If an end-session handler is active, it gets invoked, even though the conversation has ended.

If the application program believes that the back-end is undergoing an XRF takeover, it should reissue a FEPI ALLOCATE command for the back-end. When the takeover is complete, and FEPI has reestablished contact, the FEPI ALLOCATE completes successfully (together with any specified begin-session processing). If the TIMEOUT option is used, consider its setting in relation to how long you expect the alternate back-end system to take to complete takeover.

Using FEPI with VTAM persistent sessions

It is the responsibility of the application program to perform any processing in the new active back-end system necessitated by the XRF takeover.

Effect on FEPI connections

In general, FEPI successfully copes with the XRF takeover of a back-end system with which it is communicating. However, when the new active back-end system attempts to establish its terminal sessions, communication with FEPI may result in some strange terminal control messages. You should ignore these until FEPI has had time to contact the back-end system.

While FEPI is attempting to reestablish contact with the back-end system:

- Connections are in ACQUIRING state, with a last acquire code of (probably) X'320C0000'.
- Message DFHSZ4155I may be produced, with reason codes (typically X'320C0000' or X'81062900') showing that FEPI is attempting to reestablish contact with the back-end system.

There are three cases to consider:

Connections without a conversation: These connections reestablish contact with the new active back-end when the back-end's ACB is opened.

Connections with a conversation—no data flow: These connections reestablish contact with the new active back-end when the back-end's ACB is opened. You may get some messages in the back-end system indicating that the TCTTE was deleted and reinstalled.

Connections with a conversation—with data flow: These connections generate errors in the back-end system when it attempts to reestablish contact with the "terminal". You may see messages DFHZC3492E, DFHZC2411E, DFHZC3422E, DFHZC3437I, or DFHZC3462I being generated—all of which say that the standby back-end could not reestablish contact with the "terminal". However, as long as the conversation that was running on the connection has been freed, FEPI subsequently reestablishes contact and reinstalls the "terminal".

Using FEPI with VTAM persistent sessions

When creating FEPI applications, you need to be aware of the possible effects of the use of VTAM persistent sessions in the front- or back-end systems. For information about support for VTAM persistent session in CICS/ESA 4.1, see the *CICS/ESA Recovery and Restart Guide*.

Restart of front-end system using persistent sessions

Using persistent sessions in the front-end does not give FEPI any additional recoverability benefits. FEPI is always cold started; thus, to FEPI, the effect of restarting a front-end system for which persistent sessions support is enabled is indistinguishable from a cold start of CICS.

Restart of back-end system using persistent sessions

In the back-end system, there are terminal definitions that are used when the FEPI simulated terminals establish sessions with the target. These definitions may be hard-coded, or may be autoinstall model definitions. If the terminal definitions have been set up to use persistent session support, and the back-end system is restarted within the persistent session delay interval, the terminal sessions are recovered.

Effect on FEPI application programs

It is likely that FEPI application programmers have little say in the way that persistent session support is used in the back-end system. They therefore need to be aware of the different ways in which terminal sessions can be recovered, so that their applications cater for all possibilities. If the back-end (target) is a CICS/ESA 4.1 system, the way in which a session is recovered depends on the setting of the RECOVOPTION and RECOVNOTIFY options of the TYPETERM definition.

RECOVOPTION(SYSDEFAULT)

On restart within the persistent session delay interval, CICS selects the optimum procedure to recover a session.

For LU2, if the session is busy and CICS is in send mode, CICS sends an end bracket. If the session is busy and CICS is not in send mode, CICS sends an SNA CLEAR request to reset the conversation state.

If a FEPI conversation is in progress when the target system terminates, your application could see one of the following:

- A timeout on a RECEIVE, CONVERSE, or START command, while it waits for the target to restart.

Deal with this in the normal way for a timeout.

- A FEPI RECEIVE or CONVERSE command completes as a result of the end bracket sent by CICS. The RU on this data flow may be empty or may contain a user-defined message, depending on the value of the RECOVNOTIFY option.

Your application may need to perform some backout processing.

- An INVREQ response with a RESP2 value of 230 on a FEPI SEND, RECEIVE, CONVERSE, ISSUE, or START command, indicating that an SNA CLEAR was received.

Your application may need to perform some backout processing.

You must also consider the value specified for RECOVNOTIFY:

RECOVNOTIFY(MESSAGE)

A message (defined in the BMS maps DFHXRC3 and DFHXRC4) is sent to the "terminal". Your FEPI application must contain logic to deal with this data flow.

If there is no active conversation at the time of restart, the flow is received as unsolicited data at the FEPI front-end.

RECOVNOTIFY(TRANSACTION)

A transaction is initiated in the target. The default is the Good Morning transaction. Your application must contain logic to deal with this data flow.

If there is no active conversation at the time of restart, the flow is received as unsolicited data at the FEPI front-end.

RECOVNOTIFY(NONE)

The "terminal" is not notified that a restart has occurred. Your application need take no special action.

RECOVOPTION(CLEARCONV)

On restart within the persistent session delay interval, CICS sends an SNA CLEAR request to reset the conversation states. The CLEAR is sent only if the session was busy at the time of system restart. If a FEPI conversation is in progress when the target system terminates, your application could see one of the following:

- A timeout on a RECEIVE, CONVERSE, or START command, while it waits for the target to restart.

Deal with this in the normal way for a timeout.

- An INVREQ response with a RESP2 value of 230 on a FEPI SEND, RECEIVE, CONVERSE, ISSUE, or START command, indicating that an SNA CLEAR was received.

Your application may need to perform some backout processing.

You must also consider the value specified for RECOVNOTIFY. The possible values are as described above, for RECOVOPTION(SYSDEFAULT).

RECOVOPTION(RELEASESESS)

On restart within the persistent session delay interval, CICS sends an UNBIND request to release an active session. The request is sent only if the session was busy at the time of system restart.

If a FEPI conversation is in progress when the target system terminates, your application could see one of the following:

- A timeout on a RECEIVE, CONVERSE, or START command, while it waits for the target CICS to restart.
Deal with this in the normal way for a timeout.
- An INVREQ response with a RESP2 value of 215 on any FEPI command, indicating a 'session lost' condition.

Deal with this in the normal way for a session loss.

RECOVOPTION(UNCONDREL)

On restart within the persistent session delay interval, CICS sends an UNBIND request to release an active session. The request is sent whether or not the session was busy at the time of system restart.

If a FEPI conversation is in progress when the target system terminates, your application could see either of the symptoms described for RECOVOPTION(RELEASESESS).

RECOVOPTION(NONE)

Even if the system is restarted within the persistent session delay interval, the session is not recovered—it has no persistent session support.

Deal with this in the normal way for a session loss.

Chapter 7. Operator control

Two CICS-supplied transactions, CEMT and CETR, are extended to provide operator control of FEPI: you can use the CEMT INQUIRE, SET, and DISCARD commands to control FEPI resources such as nodes, targets, and pools; and the CETR transaction to control FEPI trace. You can also use VTAM commands to manage communication with target systems.

FEPI application programs, and the CICS resources they use, are controlled just like other CICS applications and resources.

CEMT—master terminal transaction

The CEMT transaction is extended by a range of commands that support FEPI. These commands, which are described below, work exactly like the CEMT commands described in the *CICS/ESA CICS-Supplied Transactions* manual—for example, in supporting resource selection by families (AB*, for example), lists (AB,CD,EF, for example), and by subdefining groups. Note that 4-character option names are used in the display.

See “Controlling FEPI resources” on page 39 for more information.

CEMT DISCARD

CEMT DISCARD

Function: DISCARD removes targets, nodes, pools, or property sets completely from FEPI.

Syntax

Press the Clear key to clear the screen. Type CEMT DISCARD (the minimum abbreviation is CEMT DISC), followed by any one of:

```
FENODE(nodename)  
FEPOOL(poolname)  
FEPROPSET(propsetname)  
FETARGET(targetname).
```

For example, `cent disc fen(fenode1)` removes the node *fenode1* from FEPI.

Typing ? at the beginning of either the first or second line gives a syntax prompt.



Options

FENode(nodename)

The name of the FEPI node to be discarded.

FEPOOL(poolname)

The name of the FEPI pool to be discarded.

FEPropset(propsetname)

The name of the FEPI property set to be discarded.

FETarget(targetname)

The name of the FEPI target to be discarded.

CEMT INQUIRE FECONNECTION

Function: Display information about FEPI connections.

Description: INQUIRE FECONNECTION displays information about the state of FEPI connections. A connection is identified by specifying the target and node. The results are given in order of target within the node. Family selection can be used for TARGET and NODE, but list selection cannot be used.

Input: Press the Clear key to clear the screen. There are two ways of commencing this transaction:

- Type CEMT INQUIRE FECONNECTION (the minimum abbreviation is CEMT I FEC). You get a display that lists the current status.
- Type CEMT INQUIRE FECONNECTION (CEMT I FEC) followed by as many of the other attributes as are necessary to limit the range of information that you require. For example, if you enter `cemt i fec p(pool15) acq`, the resulting display will show you the details of all FEPI connections in *pool15* on which sessions are bound.

You can tab to the highlighted fields and overtyping them with new values.

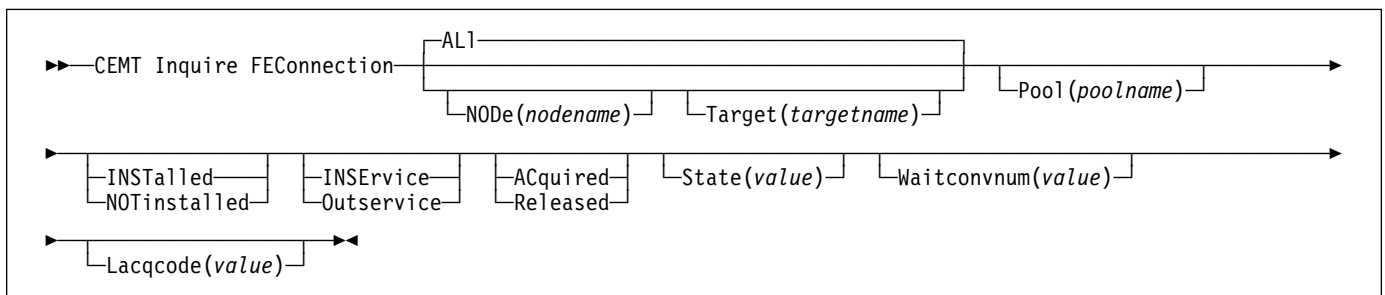

- ALI** is the default. Information about all connections is given, unless you specify a selection.
- NODe(nodename)** is the 8-character name of a node. Information is restricted to connections of which this node forms part.
- Target(targetname)** is the 8-character name of a target. Information is restricted to connections of which this target forms part.

- Pool(poolname)** displays the 8-character name of a pool of connections.
- Installed|Notinstalled** displays a value identifying the install state of the connection. The values are:
 - Installed** The connection is in a pool that has been defined by INSTALL and is available for use.
 - Notinstalled** The connection is in a pool, or involves a node or target that is being discarded, but is still in use.

Sample screen

```
CEMT IN FEC
STATUS: RESULTS - OVERTYPE TO MODIFY
Node(NODE1 ) Targ(TARGETA ) Pool(POOL5 ) Inst Inse Rele
Stat(NOCONV ) Wait(00000) Lacq(X'08570002')
Node(NODE1 ) Targ(TARGETB ) Pool(POOL5 ) Inst Inse Rele
Stat(NOCONV ) Wait(00000) Lacq(X'08570002')
Node(NODE1 ) Targ(TARGET3 ) Pool(POOL3 ) Inst Inse Rele
Stat(NOCONV ) Wait(00000) Lacq(X'08570002')
```

Figure 3. CEMT INQUIRE FECONNECTION screen

Displayed fields

- Node(value)** displays the 8-character name of a node identifying a connection.
- Target(value)** displays the 8-character name of a target identifying a connection.

- Inservice|Outservice** displays a value identifying the service state of the connection. The values are:
 - Inservice** The connection is in service and can be used in a conversation. If OUTSERVICE state has been requested but has not yet completed, a 'GOING OUT' message is shown.
 - Outservice** The connection is out of service and cannot be used for any conversation.

CEMT INQUIRE FECONNECTION

Acquired|Released

displays a value identifying whether a session on the connection is bound. The values are:

- Acquired** A session is bound on the connection. If RELEASED state has been requested but has not yet completed, a 'BEING RELEASED' message is shown. If this persists, you might need to use VTAM commands to recover the connection.
- Released** Sessions involving the connection have been unbound. If ACQUIRED state has been requested but has not yet completed, a 'BEING ACQUIRED' message is shown. If this persists, you might need to use VTAM commands to recover the connection.

State(value)

displays a 12-character value identifying the state of the conversation using the connection. The values are:

- APPLICATION** A normal application task owns the conversation
- BEGINSESSION** A begin-session handling task owns the conversation
- FREE** An end-session handling task owns the conversation, following a FEPI FREE command
- NOCONV** No conversation is active on the connection
- PENDBEGIN** A begin-session handling task has been scheduled
- PENDDATA** FEPI is waiting for inbound data, following a FEPI START command
- PENDFREE** An end-session handling task has been scheduled, following a FEPI FREE command
- PENDPASS** The conversation is unowned, following a FEPI FREE PASS command
- PENDRELEASE** An end-session handling task has been scheduled, following an unbind request
- PENDSTART** Inbound data having arrived, a task specified by FEPI START has been scheduled
- PENDSTSN** An STSN-handling task has been scheduled
- PENDUNSOL** An unsolicited-data handling task has been scheduled
- RELEASE** An end-session handling task owns the conversation, following an unbind request

STSN

An STSN-handling task owns the conversation

UNSOLDATA

An unsolicited-data handling task owns the conversation.

The "pending" states indicate the conversation is unowned, pending the event or task indicated. If a "pending" state persists, it is likely that the application has failed in some way; you should consider resetting the connection by issuing a CEMT SET FECONNECTION RELEASED command.

Waitconvnum(value)

displays a value identifying the number of conversations that are waiting to start using a connection. (If a conversation could use any one of several connections, it is counted as waiting on each one.)

Lacqcode(value)

displays a hexadecimal value indicating the result of the last acquire request for the node; that is, the sense code from the last VTAM REQSESS, a zero indicating success. For information about VTAM sense codes, see either the *VTAM Messages and Codes* or the *SNA Formats* manual.

CEMT INQUIRE FENODE

Function: Display information about a FEPI node.

Input: Press the Clear key to clear the screen. There are two ways of commencing this transaction:

- Type CEMT INQUIRE FENODE (the minimum abbreviation is CEMT I FEN). You get a display that lists the current status.
- Type CEMT INQUIRE FENODE (CEMT I FEN) followed by as many of the other attributes as are necessary to limit the range of information that you require. For example, if you enter `cemt i fen inst`, the resulting display will show you the details of all FEPI nodes that have been installed and are ready for use.

You can tab to the highlighted fields and overtype them with new values.

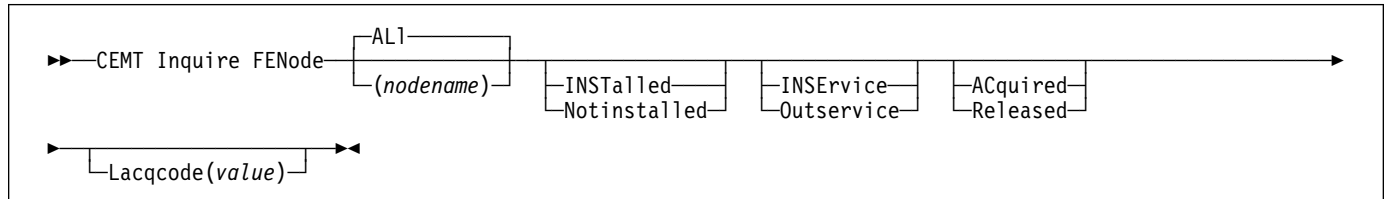

ALI

is the default. Information about all nodes is given, unless you specify a node.

nodename

is the 8-character name of the node to be queried.

Sample screen

```
CEMT IN FEN
STATUS: RESULTS - OVERTYPE TO MODIFY
Feno(NODE1 ) Inst Inse Acqu Lacq(X'00000000')
Feno(NODE2 ) Inst Inse Acqu Lacq(X'00000000')
Feno(NODE3 ) Inst Inse Acqu Lacq(X'00000000')
Feno(NODE4 ) Inst Inse Acqu Lacq(X'00000000')
```

Figure 4. CEMT INQUIRE FENODE screen

Displayed fields

Feno

indicates that this panel relates to an FENODE inquiry.

(value)

displays the 8-character name of a node.

Installed|Notinstalled

displays a value identifying the install state of the node. The values are:

Installed The node has been defined by INSTALL and is available for use.

Notinstalled The node is being discarded, but is still in use.

Inservice|Outservice

displays a value identifying the service state of the node. The values are:

Inservice The node is in service and can be used in a conversation. If OUTSERVICE state has been requested but has not yet completed, a 'GOING OUT' message is shown.

Outservice The node is out of service and cannot be used for any conversation.

Acquired|Released

displays a value identifying whether the state of the VTAM ACB for the node. The values are:

Acquired The VTAM ACB for the node is open and the VTAM 'set logon start' command has completed. If RELEASED state has been requested but has not yet completed, a 'BEING RELEASED' message is shown. If this persists, you might need to use VTAM commands to recover the node.

Released The VTAM ACB is closed. If ACQUIRED state has been requested but has not yet completed, a 'BEING ACQUIRED' message is shown. If this persists, you might need to use VTAM commands to recover the node.

Lacqcode(value)

displays a hexadecimal value indicating the result of the last acquire request for the node; that is, the sense code from the last VTAM OPEN ACB, a zero indicating success. For information about VTAM sense codes, see either the *VTAM Messages and Codes* or the *SNA Formats* manual.

CEMT INQUIRE FEPOOL

Function: Display information about the state of FEPI pools of connections.

Input: Press the Clear key to clear the screen. There are two ways of commencing this transaction:

- Type CEMT INQUIRE FEPOOL (the minimum abbreviation is CEMT I FEPO). You get a display that lists the current status.
- Type CEMT INQUIRE FEPOOL (CEMT I FEPO) followed by as many of the other attributes as are necessary to limit the range of information that you require. For example, if you enter `cemt i fepo inse`, the resulting display will show you the details of all FEPI pools that are in service and can be used by conversations.

You can tab to the highlighted 'service state' field and overtype it with a new value.

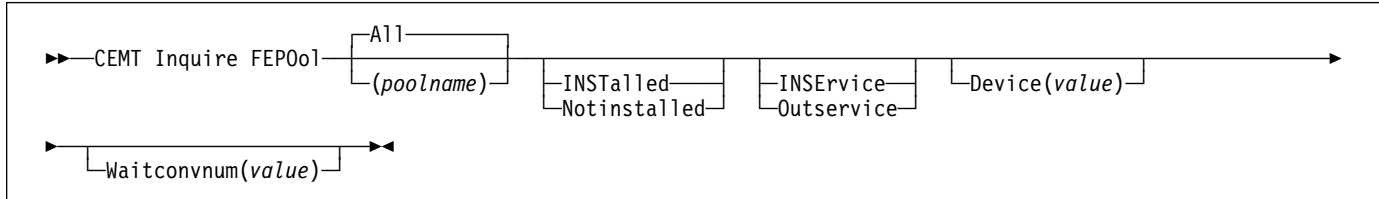

All is the default. Information about all pools is given, unless you specify a pool to be queried.

poolname

specifies the name of a pool of connections.

Sample screen

```
CEMT IN FEPO
STATUS: RESULTS -- OVERTYPE TO MODIFY
Fepo(P00L3 ) Inst Inse Devi(T3278M4 ) Wait(00000)
Fepo(P00L5 ) Inst Inse Devi(T3278M2 ) Wait(00000)
```

Figure 5. CEMT INQUIRE FEPOOL screen

Displayed fields

Fepo

indicates that this panel relates to an FEPOOL inquiry.

(value)

displays the 8-character name of a pool of connections.

Installed|Notinstalled

displays a value identifying the install state of the pool. The values are:

- Installed** The pool has been defined by INSTALL and is available for use.
- Notinstalled** The pool is being discarded, but is still in use.

Inservice|Outservice

displays a value identifying the service state of the pool. The values are:

- Inservice** The pool is in service and can be used in a conversation. If OUTSERVICE state has been requested but has not yet completed, a 'GOING OUT' message is shown.
- Outservice** The pool is out of service and cannot be used for any conversation.

Device(value)

displays a value identifying the mode of conversation and the type of device. The values are:

- T3278M2 SLU2 mode, 3278 Model 2
- T3278M3 SLU2 mode, 3278 Model 3
- T3278M4 SLU2 mode, 3278 Model 4
- T3278M5 SLU2 mode, 3278 Model 5
- T3279M2 SLU2 mode, 3279 Model 2B
- T3279M3 SLU2 mode, 3279 Model 3B
- T3279M4 SLU2 mode, 3279 Model 4B
- T3279M5 SLU2 mode, 3279 Model 5B
- TPS55M2 SLU2 mode, PS/55, 24 lines
- TPS55M3 SLU2 mode, PS/55, 32 lines
- TPS55M4 SLU2 mode, PS/55, 43 lines
- LUP SLU P mode, all cases

Waitconvnum(value)

displays a value identifying the number of conversations that are waiting to start using a connection in the pool.

CEMT INQUIRE FEPROPSET

Function: Display information about a set of FEPI properties.

Input: Press the Clear key to clear the screen. There are two ways of commencing this transaction:

- Type CEMT INQUIRE FEPROPSET (the minimum abbreviation is CEMT I FEPR). You get a display that lists all FEPI property sets that are currently installed.
- Type CEMT INQUIRE FEPROPSET (CEMT I FEPR) followed by the name of a particular property set. For example, if you enter `cemt i fepr (feprop1)`, the resulting display will show you whether or not the FEPI property set *feprop1* is installed. (If it is not installed, you get a 'NOT FOUND' response.)



All is the default. Information about all property sets is given, unless you specify a particular one.

propsetname

is the name of the property set to be queried.

Sample screen

```

CEMT IN FEPR
STATUS: RESULTS
Fepr (PROP1 )
Fepr (PROP2 )
Fepr (PROP3 )
Fepr (PROP4 )
  
```

Figure 6. CEMT INQUIRE FEPROPSET screen

Displayed fields

Fepr

indicates that this panel relates to an FEPROPSET inquiry.

(value)

displays the 8-character name identifying a property set.

CEMT INQUIRE FETARGET

Function: Display information about the state of FEPI targets.

Input: Press the Clear key to clear the screen. There are two ways of commencing this transaction:

- Type CEMT INQUIRE FETARGET (the minimum abbreviation is CEMT I FET). You get a display that lists the current status.
- Type CEMT INQUIRE FETARGET (CEMT I FET) followed by as many of the other attributes as are necessary to limit the range of information that you require. For example, if you enter `cemt i fet inse`, the resulting display will show you the details of all FEPI targets that are in service.

You can tab to the highlighted 'service state' field and overtype it with a new value.

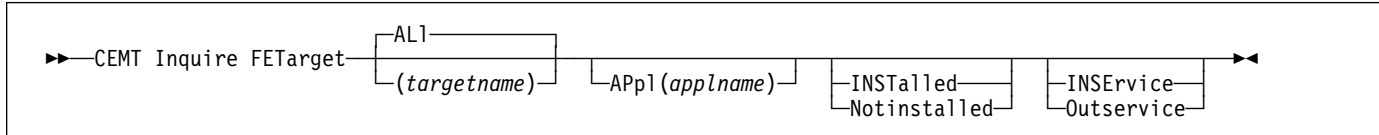

ALI
is the default. Information about all targets is given, unless you specify the target to be queried.

targetname
is the name of the target to be queried.

Sample screen

```
CEMT IN FET
STATUS: RESULTS - OVERTYPE TO MODIFY
Feta(TARGETA ) App1(APPL5 ) Inst Inse
Feta(TARGETB ) App1(APPL6 ) Inst Inse
Feta(TARGET1 ) App1(APPL1 ) Inst Inse
Feta(TARGET2 ) App1(APPL2 ) Inst Inse
Feta(TARGET3 ) App1(APPL3 ) Inst Inse
Feta(TARGET4 ) App1(APPL4 ) Inst Inse
```

Figure 7. CEMT INQUIRE FETARGET screen

Displayed fields

Feta
indicates that this panel relates to an FETARGET inquiry.

(value)
displays the 8-character name identifying a target.

App1(applname)
displays the 8-character VTAM application name of the back-end system that the target represents.

Installed|Notinstalled
displays a value identifying the install state of the target. The values are:

Installed The target has been defined by INSTALL and is available for use.

Notinstalled The target is being discarded, but is still in use.

Inservice|Outservice
displays a value identifying the service state of the target. The values are:

Inservice The target is in service and can be used in a conversation. If OUTSERVICE state has been requested but has not yet completed, a 'GOING OUT' message is shown.

Outservice The target is out of service and cannot be used for any conversation.

CEMT SET FECONNECTION

Function: Change the state of FEPI connections. Family selection can be used for TARGET and NODE, but list selection cannot be used.

Syntax

Press the Clear key to clear the screen. There are two ways of commencing this transaction:

- Type CEMT SET FECONNECTION (the minimum abbreviation is CEMT S FEC) with either TARGET(*targetname*) NODE(*nodename*) or ALL. You get a display that lists the current status, similar to that obtained by CEMT INQUIRE FECONNECTION. You can tab to the highlighted fields and overtype them with new values.
- Type CEMT SET FECONNECTION (CEMT S FEC) with either TARGET(*targetname*) NODE(*nodename*) or ALL, followed by one or more attribute settings that you want to change. For example, `cemt s fec al ac` causes sessions to be bound for all FEPI connections.

Typing ? at the beginning of either the first or second line gives a syntax prompt. Resetting the values takes effect immediately.

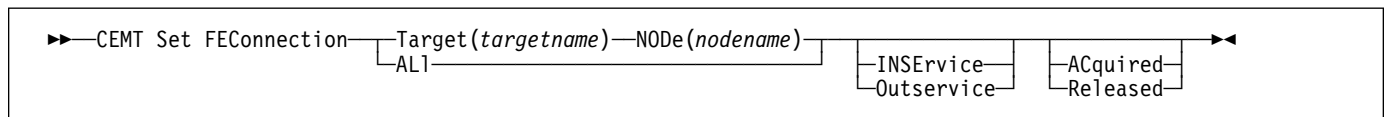

Options

ACquired

specifies that the connection is to have a session established (that is, 'bound'). The state is ACQUIRING until this is completed.

ALI

specifies that any change you request is made to all connections that you are authorized to access.

INService

specifies that the connection is in service and can be used in a conversation.

NODE(*nodename*)

specifies the 8-character name of the node identifying a connection.

Outservice

specifies that the connection is to be put out of service and not to be used for any new conversations, though existing conversations are unaffected. The service state is GOINGOUT until these conversations end.

Released

specifies that the connection is to have its session ended (that is, 'unbound'), when usage of the connection by all owned conversations ends. (An unowned conversation on the connection is ended immediately.) The state is RELEASING until this is completed.

Target(*targetname*)

specifies the 8-character name of the target identifying a connection.

CEMT SET FENODE

Function: Change the state of FEPI nodes.

Syntax

Press the Clear key to clear the screen. There are two ways of commencing this transaction:

- Type CEMT SET FENODE (the minimum abbreviation is CEMT S FEN) with either a *nodename* or ALL. You get a display that lists the current status, similar to that obtained by CEMT INQUIRE FENODE. You can tab to the highlighted fields and overwrite them with new values.
- Type CEMT SET FENODE (CEMT S FEN) with either a *nodename* or ALL, followed by one or more attribute settings that you want to change. For example, `cemt s fen al ac` causes the VTAM ACBs for all FEPI nodes to be opened, and 'set logon start' to be done.

Typing ? at the beginning of either the first or second line gives a syntax prompt. Resetting the values takes effect immediately.

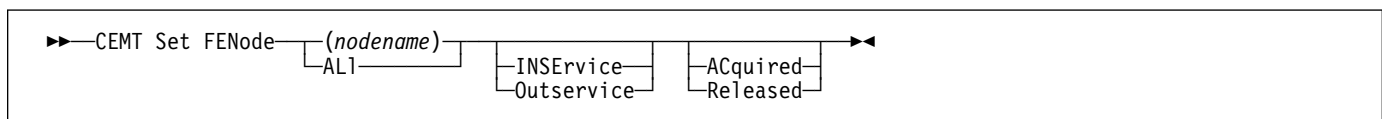

Options

ACquired

specifies that the VTAM ACB for the node should be opened, and 'set logon start' is to be done. The state is ACQUIRING until this is completed.

ALI

specifies that any change you request is made to all nodes that you are authorized to access.

INService

specifies that the node is in service and can be used in a conversation.

(nodename)

specifies the 8-character name of the node whose state is to be changed.

Outservice

specifies that the node is to be put out of service and not to be used for any new conversations, though existing conversations are unaffected. The service state is GOINGOUT until these conversations end.

Released

specifies that the VTAM ACB for the node is to be closed, when usage of the node by any conversation ends. The state is RELEASING until this is completed.

CEMT SET FEPOOL

Function: Change the state of FEPI pools of connections.

Syntax

Press the Clear key to clear the screen. There are two ways of commencing this transaction:

- Type CEMT SET FEPOOL (the minimum abbreviation is CEMT S FEPO) with either a *poolname* or ALL. You get a display that lists the current status, similar to that obtained by CEMT INQUIRE FEPOOL. You can tab to the highlighted 'service state' field and overtyping it with a new value.
- Type CEMT SET FEPOOL (CEMT S FEPO) with either a *poolname* or ALL, followed by a service state setting. For example, `cent s fepo fepool1 i` specifies that the *fepool1* pool is in service and available for use by a conversation.

Typing ? at the beginning of either the first or second line gives a syntax prompt. Resetting the values takes effect immediately.

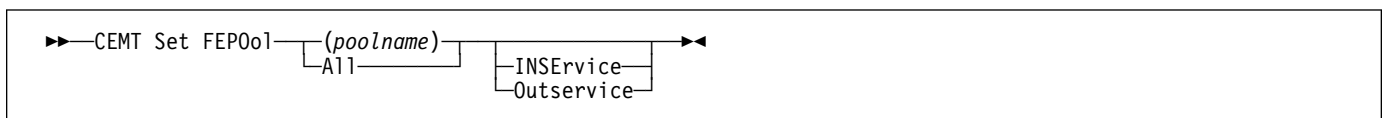

Options

All specifies that any change you request is made to all pools that you are authorized to access.

INService

specifies that the pool is in service and can be used in a conversation.

Outservice

specifies that the pool is to be put out of service and not be used for any new conversations, though existing conversations are unaffected. The service state is GOINGOUT until these conversations end.

(poolname)

specifies the pool of connections to be changed.

CEMT SET FETARGET

Function: Change the state of FEPI targets.

Syntax

Press the Clear key to clear the screen. There are two ways of commencing this transaction:

- Type CEMT SET FETARGET (the minimum abbreviation is CEMT S FET) with either a *targetname* or ALL. You get a display that lists the current status, similar to that obtained by CEMT INQUIRE FETARGET. You can tab to the highlighted 'service state' field and overwrite it with a new value.
- Type CEMT SET FETARGET (CEMT S FET) with either a *targetname* or ALL, followed by a service state setting. For example, `cemt s fet fetarg1 i` specifies that the *fetarg1* target is in service and available for use by a conversation.

Typing ? at the beginning of either the first or second line gives a syntax prompt. Resetting the values takes effect immediately.

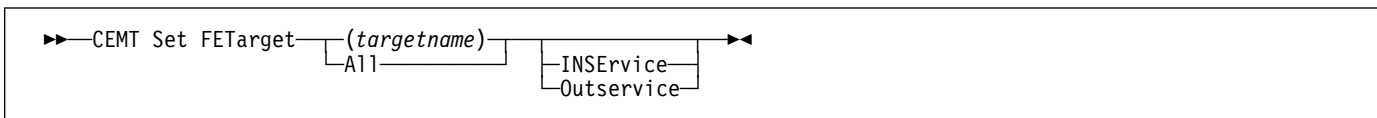

Options

All specifies that any change you request is made to all targets that you are authorized to access.

INService

specifies that the target is in service and can be used in a conversation.

Outservice

specifies that the target is out of service and cannot be used for any new conversations, though existing conversations are unaffected. The service state is GOINGOUT until these conversations end.

(targetname)

specifies the 8-character name of the target to be changed.

CETR—trace control transaction

You use the CETR transaction to control FEPI trace. The FEPI component code (on the CETR “Component Trace Options” panel) is ‘SZ’. Specify ‘SZ 1’ to turn on FEPI tracing.

For detailed information about the syntax of the CETR transaction, see the *CICS/ESA CICS-Supplied Transactions* manual. For information about using CETR in problem determination, see the *CICS/ESA Problem Determination Guide*.

VTAM commands

In addition to the resource control facilities provided by FEPI, you can use specific VTAM commands to manage communication with target systems. They are particularly useful where there are problems in acquiring or releasing sessions; see “ACQSTATUS” on page 39.

These commands are fully described in the *VTAM Operations* manual, but are summarized here. You can:

- Use the VTAM DISPLAY command to inquire about the status of the FEPI nodes (acting as SLUs) and the target

systems. It should normally be necessary to use this command only when you experience problems in communicating with a particular target. Note that to understand the displays you require some knowledge of how VTAM operates. VTAM messages are explained in the *VTAM Messages and Codes* manual.

- Use the VTAM VARY command to control the availability of resources within the network. In the case of FEPI, you can use it to force the closure of a node regardless of whether it is being used in an active conversation. This is achieved by making the VTAM node inactive. However, any pending request to change to a state of RELEASED or OUTSERVICE is able to complete. A subsequent VARY ACTIVE command makes the node available for use again (if its state is still INSERVICE).
- Use the VTAM VARY TERM command to terminate individual connections—that is, to end the session between a particular PLU (target) and SLU (FEPI) pair.
- Use the VTAM DISPLAY SESSIONS command to diagnose problems in establishing sessions. To use this command, you require an understanding of VTAM session processing.

Chapter 8. Customizing FEPI

This chapter outlines the customization features of FEPI. It contains:

- “Global user exits”
- “Journaling” on page 67.

It assumes that you are aware of the customization features of CICS/ESA 4.1 (programming information about these is in the *CICS/ESA Customization Guide* and the *CICS/ESA System Programming Reference*).

This chapter contains Product-sensitive Programming Interface information.

Global user exits

This section describes the two FEPI global user exits, **XSZBRQ** and **XSZARQ**. These exits behave in exactly the same manner as standard CICS global user exits.

XSZBRQ Invoked before a FEPI command is executed (but after the syntax of the command has been validated, and therefore after EDF processing).

XSZARQ Invoked immediately after a FEPI command has completed (before EDF processing).

Note that both the FEPI application programming *and* system programming commands cause XSZBRQ and XSZARQ to be invoked, but the latter do not provide the exit programs with any meaningful information.

You cannot use exit programming interface (XPI) calls or EXEC CICS commands in programs invoked from these exits.

The exits allow you to monitor the FEPI commands and data being processed; you can inhibit commands, and modify specific command options. You could use them for:

- Monitoring the issue of FEPI commands
- Load balancing
- External security on application programming commands.

XSZBRQ

XSZBRQ is invoked before a FEPI command is executed; the input parameters for the command are passed to the exit program. The majority of the information passed is read-only, but specific parameters can be updated. In addition, your exit program can decide whether the request is to be processed or bypassed. You could use XSZBRQ, for example, to log commands, to bypass commands that violate the conventions of your installation, or to reroute commands by changing their specified targets or pools.

XSZBRQ parameters you can modify

Your exit program can modify the settings of some of the parameters passed to it. However, if it does so, FEPI does not check the validity of the new value. The following parameters can be modified; no others can.

UEPSZSTT The ID of the transaction that is to continue a FEPI conversation (as supplied on the FEPI START command).

UEPSZSTM The ID of the terminal that is to continue a FEPI conversation (as supplied on the FEPI START command). (Set UEPSZSTM=X'00000000' to run non-terminal.)

UEPSZTIM The TIMEOUT value for FEPI ALLOCATE, RECEIVE, CONVERSE, and START commands.

UEPSZALP The POOL name supplied on the FEPI ALLOCATE or FEPI CONVERSE command.

UEPSZALT The TARGET name supplied on the FEPI ALLOCATE or FEPI CONVERSE command.

Together, UEPSZALP and UEPSZALT contain the information necessary to initiate a conversation.

Exit XSZBRQ

Invoked by FEPI before a FEPI command is executed (but after syntax and semantic checking).

Exit-specific parameters

UEPSZACT

A 2-byte field that identifies the command. The values are given in Table 5 on page 66.

UEPSZCNV

An 8-character field containing the conversation ID (CONVID) for the command. Applicable on FEPI ALLOCATE, SEND, RECEIVE, CONVERSE, EXTRACT, ISSUE, START, and FREE commands.

For an EXEC CICS FEPI ALLOCATE command without PASSCONVID, this field is set to nulls; if PASSCONVID is used, it contains the CONVID.

UEPSZALP

An 8-character field containing the name of the pool (POOL). Modifiable and applicable on FEPI ALLOCATE and CONVERSE commands.

UEPSZALT

An 8-character field containing the name of the target (TARGET). Modifiable and applicable on FEPI ALLOCATE and CONVERSE commands.

UEPSZTIM

Fullword binary field containing the time-out value (TIMEOUT). Modifiable and applicable on FEPI ALLOCATE, RECEIVE, CONVERSE, and START commands.

UEPSZSND

Address of the 'send' data-area (FROM). Applicable on FEPI CONVERSE and SEND commands.

UEPSZSNL

Fullword binary field containing the length of the 'send' data (FROMLENGTH, FLENGTH). Applicable on FEPI CONVERSE and SEND commands.

UEPSZSTT

A 4-character field containing the transaction ID (TRANSID). Modifiable and applicable on FEPI START commands.

UEPSZSTM

A 4-character field containing the terminal ID (TERMIN). Modifiable and applicable on FEPI START commands.

Exit XSZBRQ (continued)

	UEPSZSNK	A 1-bit flag field indicating whether data is in key stroke format (KEYSTROKE). Applicable on FEPI CONVERSE FORMATTED and SEND FORMATTED commands. It can contain the following values:
	UEPSZSNK_OFF	Not key stroke format.
	UEPSZSNK_ON	Key stroke format.
	UEPSZSNE	A 1-character field containing the key stroke escape character (ESCAPE). Applicable on FEPI CONVERSE FORMATTED and SEND FORMATTED commands.
Return codes	UERCNORM	Continue processing.
	UERCBYB	Do not process the request; return INVREQ to the application.
		Note: Your exit program cannot bypass events (like CICS shutdown or end-of-task).
XPI calls	Do not use any XPI calls.	

XSZARQ

XSZARQ is invoked immediately after a FEPI command has been executed; the exit program is passed the parameters that are output from the command. All of the information passed is read-only.

Exit XSZARQ

	Invoked by FEPI immediately after a FEPI command has been processed.	
Exit-specific parameters	UEPSZACN	A 2-byte field that identifies the command. The values are given in Table 5 on page 66.
	UEPSZCON	An 8-character field containing the conversation ID (CONVID) for the command. Applicable on FEPI ALLOCATE, SEND, RECEIVE, CONVERSE, EXTRACT, ISSUE, START, and FREE commands.
	UEPSZRP2	Fullword containing the response code for the command (RESP2).
	UEPSZRVD	Address of the 'receive' data-area (INTO). Applicable on FEPI RECEIVE, CONVERSE, and EXTRACT FIELD commands.
	UEPSZRVL	Fullword binary data field containing the length of the receive data (FLENGTH, TOFLENGTH). Applicable on FEPI RECEIVE, CONVERSE, and EXTRACT FIELD commands.
Return code	UERCNORM	Continue processing.
XPI calls	Do not use any XPI calls.	

The UEPSZACT and UEPSZACN exit-specific parameters

Both XSZBRQ and XSZARQ are passed a parameter (**UEPSZACT** for XSZBRQ, and **UEPSZACN** for XSZARQ) indicating the command or event being processed. Table 5. relates the hexadecimal values passed in UEPSZACT and UEPSZACN to the FEPI commands they represent.

Name	Setting (hex)	FEPI command or event
UEPSZNOA	820E	AP NOOP
UEPSZOAL	8210	ALLOCATE
UEPSZOCF	8212	CONVERSE FORMATTED
UEPSZOCD	8214	CONVERSE DATASTREAM
UEPSZOXC	8216	EXTRACT CONV
UEPSZOXF	8218	EXTRACT FIELD
UEPSZOXS	821A	EXTRACT STSN
UEPSZOFR	821C	FREE
UEPSZOSU	821E	ISSUE
UEPSZORF	8220	RECEIVE FORMATTED
UEPSZORD	8222	RECEIVE DATASTREAM
UEPSZOSF	8224	SEND FORMATTED
UEPSZOSD	8226	SEND DATASTREAM
UEPSZOST	8228	START
UEPSZSDN	8402	CICS normal shutdown
UEPSZSDI	8404	CICS immediate shutdown
UEPSZSDF	8406	CICS forced shutdown
UEPSZEOT	8408	CICS end-of-task
UEPSZNOS	840E	SP NOOP
UEPSZOQY	8422	INQUIRE PROPERTYSET
UEPSZOIY	8428	INSTALL PROPERTYSET
UEPSZODY	8430	DISCARD PROPERTYSET
UEPSZOQN	8442	INQUIRE NODE
UEPSZOTN	8444	SET NODE
UEPSZOIN	8448	INSTALL NODELIST
UEPSZOAD	844A	ADD POOL
UEPSZODE	844C	DELETE POOL
UEPSZODN	8450	DISCARD NODELIST
UEPSZOQP	8462	INQUIRE POOL
UEPSZOTP	8464	SET POOL
UEPSZOIP	8468	INSTALL POOL
UEPSZODP	8470	DISCARD POOL
UEPSZOQT	8482	INQUIRE TARGET
UEPSZOTT	8484	SET TARGET
UEPSZOIT	8488	INSTALL TARGETLIST
UEPSZODT	8490	DISCARD TARGETLIST
UEPSZOQC	84A2	INQUIRE CONNECTION
UEPSZOTC	84A4	SET CONNECTION

Note:

1 These events are generated internally by CICS; you cannot bypass them.

Using XMEOUT to control message output

You can use the XMEOUT global user exit, in the CICS message domain, to suppress or reroute FEPI messages. Note, however, that error conditions that generate a message also generate a transient data queue record. It is more efficient to handle such events using a monitoring program, through the TD queue, than by duplicating a message and then acting on it. See “Writing monitoring programs” on page 34.

For programming information about the XMEOUT exit, see the *CICS/ESA Customization Guide*.

Journaling

This section describes the format of FEPI journal records, and how to print them. For background information about CICS journaling, you should refer to the *CICS/ESA Operations and Utilities Guide*; for programming information, see the *CICS/ESA Customization Guide*.

FEPI journal operation

You can request FEPI to write inbound, outbound, or both inbound and outbound data to a specified CICS user journal; you cannot write to the system journal. This is done using the **MSGJRNL** and **FJOURNALNUM** options in your property set definitions.

Of the various reasons for using CICS journaling, the following are particularly relevant to FEPI processing:

- Creating audit trails
- Monitoring performance
- Controlling message security.

Table 6 shows the types of FEPI data that can be journaled.

FEPI command	Data flow	Type
SEND	Outbound	Data stream Formatted, screen image Formatted, key stroke
RECEIVE	Inbound	Data stream Formatted, screen image
CONVERSE	Outbound	Data stream Formatted, screen image Formatted, key stroke
CONVERSE	Inbound	Data stream Formatted, screen image
EXTRACT FIELD	Inbound	Extract field data

The records journaled by FEPI are identified in the usual way by module and function identifiers. These are listed in Table 7.

Identifier-type	Name	Value	Type of data
Module identifier	MODIDFEP	X'5D'	Identifies FEPI records in the journal
Function identifiers	FIDFEPIN FIDFEPOU	X'F0' X'F1'	Identifies FEPI inbound data Identifies FEPI outbound data

Journaling

In order to identify the conversation for which the data was journaled, FEPI provides a system prefix area in the journal record.

Printing FEPI journal records

You can manipulate FEPI journal records in any of the ways described in the *CICS/ESA Operations and Utilities Guide*; programming information about this is in the *CICS/ESA Customization Guide*. The following examples show ways in which you can use the CICS-supplied utility program, DFHJUP, to select FEPI records for printing.

```
—> Print all FEPI records
OPTION PRINT OFFSET=6,FLDTYP=X,VALUE=5D,FLDLEN=1,COND=E
—> Print all FEPI inbound records
OPTION PRINT OFFSET=5,FLDTYP=X,VALUE=F05D,FLDLEN=2,COND=E
—> Print all FEPI outbound records
OPTION PRINT OFFSET=5,FLDTYP=X,VALUE=F15D,FLDLEN=2,COND=E
—> Print all FEPI outbound records with data starting 'CEOT'
OPTION PRINT OFFSET=5,FLDTYP=X,VALUE=F15D,FLDLEN=2,COND=M
OPTION PRINT OFFSET=63,FLDTYP=C,VALUE=CEOT,FLDLEN=4,COND=E
—> Print all FEPI records to/from pool 'PPPPPPPP'
OPTION PRINT OFFSET=6,FLDTYP=X,VALUE=5D,FLDLEN=1,COND=M
OPTION PRINT OFFSET=35,FLDTYP=C,VALUE=PPPPPPPP,FLDLEN=8,COND=E
—> Print all FEPI inbound records from target 'TTTTTTTT'
OPTION PRINT OFFSET=5,FLDTYP=X,VALUE=F05D,FLDLEN=2,COND=M
OPTION PRINT OFFSET=43,FLDTYP=C,VALUE=TTTTTTTT,FLDLEN=8,COND=E
```

Chapter 9. System programming reference

This chapter describes the FEPI system programming commands that you use for FEPI configuration and operation. (Application programming commands such as ALLOCATE, CONVERSE, and EXTRACT are described in Chapter 16, "Application programming reference" on page 137.)

The FEPI system programming commands are:

```
ADD POOL
DELETE POOL
DISCARD NODELIST
DISCARD POOL
DISCARD PROPERTYSET
DISCARD TARGETLIST
INQUIRE CONNECTION
INQUIRE NODE
INQUIRE POOL
INQUIRE PROPERTYSET
INQUIRE TARGET
INSTALL NODELIST
INSTALL POOL
INSTALL PROPERTYSET
INSTALL TARGETLIST
SET CONNECTION
SET NODE
SET POOL
SET TARGET
SP NOOP
```

These commands are an addition to the system programming group of EXEC CICS commands (programming information about these is in the *CICS/ESA System Programming Reference*) and have the same features and properties. To use these commands, you should be familiar with:

- The format of EXEC CICS commands
- Input and output values, and CVDAs
- The use of the RESP, RESP2, and NOHANDLE options
- Security checking
- The use of INQUIRE and SET commands
- Browsing.

Brief notes on some of these topics are included here. For programming information about system programming commands, see the *CICS/ESA System Programming Reference*.

Command format

The general format of a command is:

EXEC CICS FEPI command option(argument)...

where:

command Is the command name (for example, ADD)
option Is an option name (for example, POOL)
argument Is the source or destination for data, as required for the specified option, that is passed to or returned from the command.

The way that you terminate the command is determined by the programming language that you use—COBOL, for example, requires an END-EXEC statement.

Arguments and data types

The text used to identify arguments in this book indicates the type of data represented by the argument and whether it is a value used by the command, or an area in which the command returns data. For example:

POOL(8-character data-value) says that the argument is, or identifies, a string of eight characters, and that the string is passed to the command as an input value.

ACQNUM(fullword binary data-area) says that the argument is a user-defined fullword data area in which the command can return a binary number as an output value.

Exceptionally, arguments that are lists have to be data areas, even though they are input values.

Errors and exception conditions

All FEPI commands support the RESP and RESP2 options to signal successful completion or an exception condition. Alternatively, you can use HANDLE CONDITION to trap errors.

Most FEPI command errors give the 'INVREQ' exception condition. The particular error in each case is uniquely identified by the RESP2 value.

Both RESP and RESP2 take, as an argument, the name of a user-defined fullword binary data area. Possible values of the RESP2 option are given in the description of each of the commands and a full list is given in "RESP2 values" on page 187. The following copy books provide declarations for the RESP2 values:

- DFHSZAPA for assembler language
- DFHSZAPO for COBOL
- DFHSZAPP for PL/I
- DFHSZAPC for C/370.

System programming reference

The following conditions and RESP2 values can occur for any system programming command:

Condition	RESP2	Meaning
INVREQ	10	Command bypassed by user exit.
INVREQ	11	FEPI not installed, or not active.
INVREQ	12	CICS shutting down, command not allowed.
INVREQ	13	FEPI unavailable.
INVREQ	14	FEPI busy or cannot get storage.
INVREQ	15	Unknown command.
INVREQ	16	Internal error.
INVREQ	17	FEPI cannot get storage for user exit.
INVREQ	18	Command failed through operator or system action.
NOTAUTH	100	Not authorized for this command.

If there is an error, the command does nothing, and the output arguments are not changed.

By their nature, some commands (for example, FEPI SET NODE INSERVICE) initiate a function and return before the function has completed. Errors in the execution of the function cannot be reported as an exception condition on the command. Such errors are reported by writing a record to a transient data (TD) queue and a message to the message log CSZL. See “Transient data queue records” on page 92 for details.

| **List processing:** Commands that operate on a list of resources can fail for some of the resources in the list, but succeed for others. If this happens, a ‘list error’ is returned on the command. A record is written to a TD queue for each of the resources for which the command failed.

| Even if the command fails for *all* of the resources in the list, it may still be partially successful if other parameters are valid. For example, a FEPI INSTALL POOL command installs a valid

| pool even if the array of node names specified on the NODELIST parameter does not exist.

Syntax notation

The notation used in this book to show the syntax of FEPI commands is the same as that used in the *CICS/ESA System Programming Reference*. See “CICS syntax notation used in this book” on page xi for details.

Translator options

Unlike other CICS system programming commands, the FEPI system programming commands do not need the ‘SP’ translator option. However, you do need to specify the ‘FEPI’ translator option.

INQUIRE and SET commands

The FEPI INQUIRE and SET commands work in the same way as other CICS INQUIRE and SET commands. They allow you to look at named FEPI resource definitions, browse sets of related definitions, and modify some of the defined values.

Other points

- FEPI commands can be issued in either 24-bit or 31-bit addressing mode, by programs that reside either above or below the 16MB line.
- No information is passed through the EXEC interface block (EIB) except that, as for all CICS commands, the EIBRESP, EIBRESP2, EIBFN, and EIBRCODE fields are set.

FEPI ADD POOL

Function: FEPI ADD POOL adds targets or nodes, or both, to an existing pool, thereby creating new connections in the pool. The targets or nodes must not be in the pool already. You can specify initial service and acquire states for these new connections. The command completes when the resources have been added to the pool but without waiting for the requested states to be achieved.

Syntax

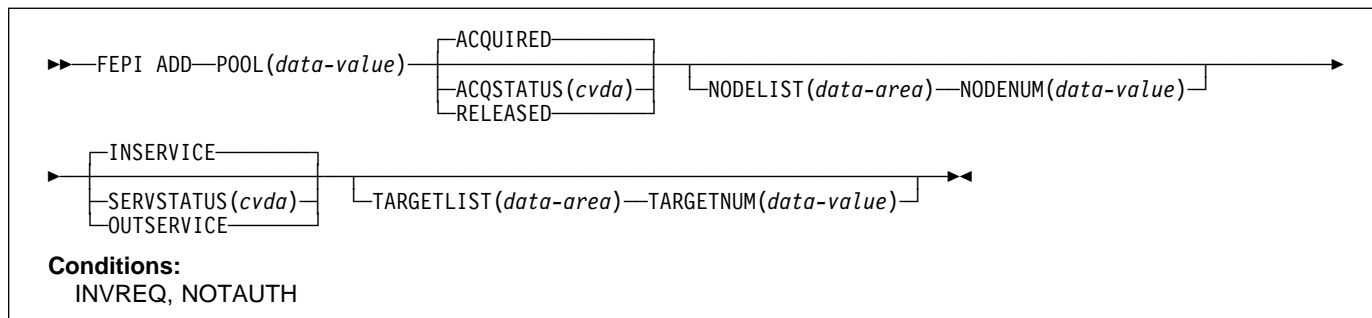

Options

ACQSTATUS(cvda)

specifies the initial acquire state of the connections being created. All the new connections have the same state. The relevant CVDA values are:

ACQUIRED The connections are to have sessions established (that is, be 'bound').

RELEASED The connections are not to have sessions established (that is, be left 'unbound').

NODELIST(data-area)

specifies a contiguous array of 8-character node names to be added to the pool. They must already be defined by FEPI INSTALL NODELIST, but can have any service state.

NODENUM(fullword binary data-value)

specifies the number of names in the NODELIST, in the range 0–256.

POOL(8-character data-value)

specifies the name of the pool to which the targets or nodes, or both, are being added.

SERVSTATUS(cvda)

specifies the initial service state of the connections being created. All the new connections have the same state. The relevant CVDA values are:

INSERVICE The connections are to be in service, and so can be used in a conversation.

OUTSERVICE The connections are to be out of service and cannot be used for any conversation.

TARGETLIST(data-area)

specifies a contiguous array of 8-character target names to be added to the pool. They must already be defined

by FEPI INSTALL TARGETLIST, but can be in any service state.

TARGETNUM(fullword binary data-value)

specifies the number of names in TARGETLIST, in the range 0–256.

Conditions

Condition	RESP2	Meaning
INVREQ	110	SERVSTATUS value not valid.
INVREQ	111	ACQSTATUS value not valid.
INVREQ	115	POOL name unknown.
INVREQ	116	TARGET name unknown.
INVREQ	117	NODE name unknown.
INVREQ	119	The command failed for one or more items in the list.
INVREQ	130	TARGETNUM value is out of range.
INVREQ	131	NODENUM value is out of range.
INVREQ	173	NODE name already exists in the specified pool.
INVREQ	174	TARGET name already exists in the specified pool.
INVREQ	175	Connection already exists.

FEPI DELETE POOL

Function: FEPI DELETE POOL removes targets or nodes, or both, from a specified pool, thereby removing connections from the pool. The targets or nodes must be in the pool already. The command completes immediately, without waiting for the necessary deletions to be achieved. When the connections are deleted, they are no longer defined to FEPI.

Syntax

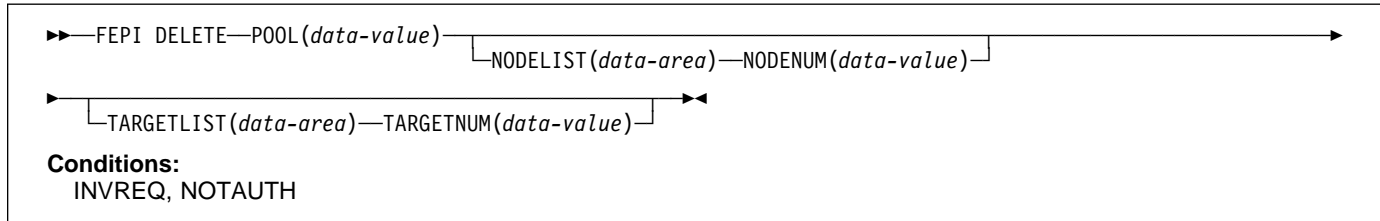

Options

NODELIST(data-area)

specifies a contiguous array of 8-character node names that are to be deleted from the pool.

NODENUM(fullword binary data-value)

specifies the number of names in the NODELIST, in the range 0–256.

POOL(8-character data-value)

specifies the name of the pool from which targets or nodes are to be removed.

TARGETLIST(data-area)

specifies a contiguous array of 8-character target names that are to be deleted from the pool.

TARGETNUM(fullword binary data-value)

specifies the number of names in TARGETLIST, in the range 0–256.

Conditions

Condition	RESP2	Meaning
INVREQ	115	POOL name unknown.
INVREQ	116	TARGET name unknown.
INVREQ	117	NODE name unknown.
INVREQ	119	The command failed for one or more items in the list.
INVREQ	130	TARGETNUM value out of range.
INVREQ	131	NODENUM value out of range.

FEPI DISCARD NODELIST

Function: FEPI DISCARD NODELIST removes nodes completely from FEPI. The state of each node to be discarded is set to OUTSERVICE RELEASED (see “FEPI SET NODE” on page 89). When this state is achieved, the node is deleted from any pool that it is in. The nodes are then discarded so that they are no longer defined to FEPI. The command completes immediately without waiting for the necessary service and acquire states to be achieved.

Syntax

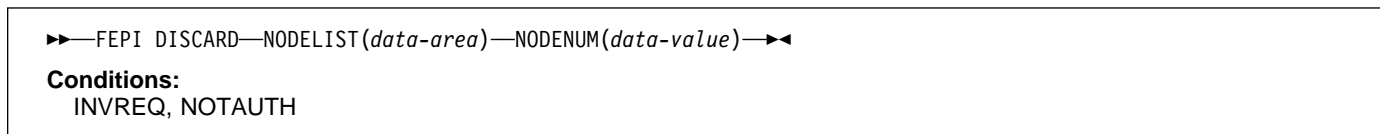

Options

NODELIST(data-area)

specifies a contiguous array of 8-character node names that are to be discarded.

NODENUM(fullword binary data-value)

specifies the number of names in NODELIST, in the range 1–256.

Conditions

Condition	RESP2	Meaning
INVREQ	117	NODE name unknown.
INVREQ	119	The command failed for one or more items in the list.
INVREQ	131	NODENUM value out of range.

FEPI DISCARD POOL

Function: FEPI DISCARD POOL removes a pool of connections completely from FEPI. The state of the connections in the pool is set to OUTSERVICE RELEASED (see “FEPI SET CONNECTION” on page 87), and the state of the pool is set to OUTSERVICE (see “FEPI SET POOL” on page 90). When these states have been achieved, the pool and its connections are discarded, so that they are no longer defined to FEPI. The command completes immediately, without waiting for the necessary service and acquire states to be achieved.

Syntax

```
►►—FEPI DISCARD—POOL(data-value)—◄◄
```

Conditions:
INVREQ, NOTAUTH

Options

POOL(8-character *data-value*)
specifies the name of the pool to be discarded.

Conditions

Condition	RESP2	Meaning
INVREQ	115	POOL name unknown.

FEPI DISCARD PROPERTYSET

Function: FEPI DISCARD PROPERTYSET removes a set of properties. The properties are discarded immediately so that they are no longer defined to FEPI, but any pool that was installed using the properties is not affected.

Syntax

```
►►—FEPI DISCARD—PROPERTYSET(data-value)—◄◄
```

Conditions:
INVREQ, NOTAUTH

Options

PROPERTYSET(8-character *data-value*)
specifies the name of the set of properties to be discarded.

Conditions

Condition	RESP2	Meaning
INVREQ	171	PROPERTYSET name unknown.

FEPI DISCARD TARGETLIST

Function: FEPI DISCARD TARGETLIST removes targets completely from FEPI. The state of the targets to be discarded is set to OUTSERVICE (see “FEPI SET TARGET” on page 91). When this state has been achieved, the targets are deleted from any pool they are in, and are then discarded, so that they are no longer defined to FEPI. The command completes immediately, without waiting for the necessary service and acquire states to be achieved.

Syntax

```
►►—FEPI DISCARD—TARGETLIST(data-area)—TARGETNUM(data-value)—◄◄
```

Conditions:
INVREQ, NOTAUTH

Options

TARGETLIST(*data-area*)
specifies a contiguous array of 8-character target names that are to be discarded.

Conditions

Condition	RESP2	Meaning
INVREQ	116	TARGET name unknown.
INVREQ	119	The command failed for one or more items in the list.
INVREQ	130	TARGETNUM value out of range.

TARGETNUM(fullword binary *data-value*)
specifies the number of names in TARGETLIST, in the range 1–256.

FEPI INQUIRE CONNECTION

Function: FEPI INQUIRE CONNECTION returns information about a FEPI connection. A connection is identified by specifying its target and node.

Syntax

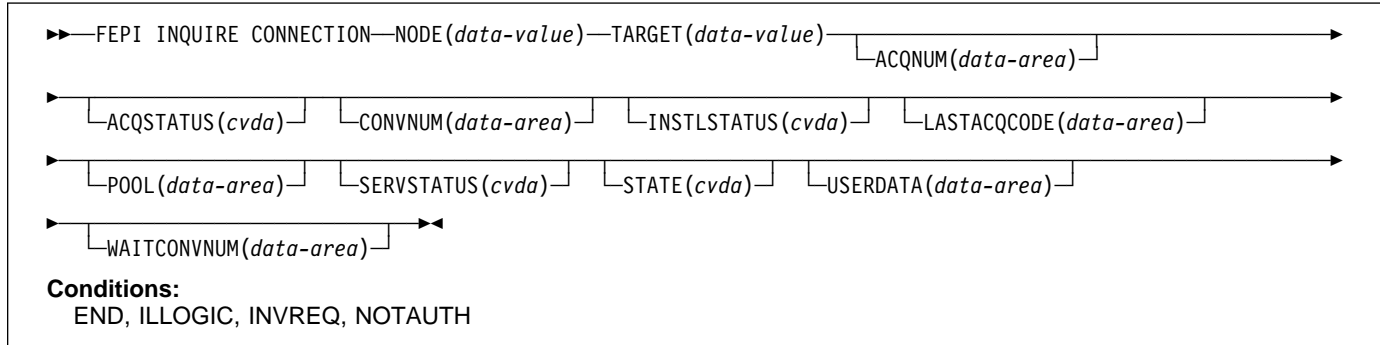

The following commands allow you to browse all FEPI connections. Read the information about browsing earlier in this book before using the browsing commands.

FEPI Browse CONNECTION

```
FEPI INQUIRE CONNECTION START
FEPI INQUIRE CONNECTION NEXTNODE|NEXTTARGET
NODE(8-character data-area)
TARGET(8-character data-area)
[The options are as for FEPI INQUIRE CONNECTION]
FEPI INQUIRE CONNECTION END
```

Conditions: INVREQ, NOTAUTH

The next connection for which information is returned depends on whether NEXTNODE or NEXTTARGET is specified. If NEXTNODE is specified, the information returned is for:

- The next node connected to the current target
- If there are no more nodes connected to the current target, then the first node connected to the next target.

If NEXTTARGET is specified, the information returned is for:

- The next target connected to the current node
- If there are no more targets connected to the current node, then the first target connected to the next node.

Options

ACQNUM(fullword binary data-area)

returns the number of times that the connection has been acquired.

ACQSTATUS(cvda)

returns the acquire state; that is, whether a session on the connection is bound or not. The relevant CVDA values are:

ACQUIRED The session is bound.

ACQUIRING A state of ACQUIRED has been requested but binding a session has not yet been completed.

RELEASED No session is bound.

RELEASING A state of RELEASED has been requested but unbinding the session has not yet been completed.

If ACQUIRING or RELEASING persist, the operator might need to intervene using VTAM commands to recover the connection.

CONVNUM(fullword binary data-area)

returns the number of conversations that have used the connection.

INSTLSTATUS(cvda)

returns the install state of the connection. The relevant CVDA values are:

INSTALLED The connection is in a pool defined by INSTALL and is available for use.

NOTINSTALLED The connection is in a pool, or involves a node or target that is being discarded but is still in use.

LASTACQCODE(fullword binary data-area)

returns the result of the last acquire request for the connection; that is, the sense code from the last VTAM REQSESS, zero indicating success.

Note: CLSDST(PASS)—X'32020000'—can be returned
in this field. This is the unbind flow received by CICS
during CLSDST(PASS) processing.

For details of VTAM sense codes, see the *VTAM Messages and Codes* manual, or *SNA Formats* manual.

NODE(8-character data-value/8-character data-area)

is the node identifying the connection.

POOL(8-character data-area)

returns the name of the pool that defines the connection.

SERVSTATUS(cvda)

returns the service state of the connection. The relevant CVDA values are:

- INSERVICE** The connection is in service and can be used in a conversation.
- OUTSERVICE** The connection is out of service and cannot be used for any new conversation, but a conversation using the connection is unaffected. The service state is GOINGOUT until any such conversation ends.
- GOINGOUT** A state of OUTSERVICE has been requested but the connection is still being used by some conversation.

STATE(cvda)

returns the state of the conversation using the connection. The relevant CVDA values are:

- NOCONV** No conversation is active on the connection.
- PENDSTSN** An STSN-handling task has been scheduled.
- STSN** An STSN-handling task owns the conversation.
- PENDBEGIN** A begin-session handling task has been scheduled.
- BEGINSESSION** A begin-session handling task owns the conversation.
- APPLICATION** A normal application task owns the conversation.
- PENDDATA** FEPI is waiting for inbound data, following a FEPI START command.
- PENDSTART** Inbound data having arrived, a task specified by FEPI START has been scheduled.
- PENDFREE** An end-session handling task has been scheduled, following a FEPI FREE command.
- FREE** An end-session handling task owns the conversation, following a FEPI FREE command.
- PENDRELEASE** An end-session handling task has been scheduled, following an unbind request.
- RELEASE** An end-session handling task owns the conversation, following an unbind request.
- PENDUNSOL** An unsolicited-data handling task has been scheduled.
- UNSOLDATA** An unsolicited-data handling task owns the conversation.

PENDPASS

The conversation is unowned, following a FEPI FREE PASS command.

The 'pending' states indicate that the conversation is unowned, pending the event or task indicated; the state ceases to be pending when a task issues a FEPI ALLOCATE PASSCONVID command. If a 'pending' state persists, it is likely that the application has failed in some way; you should consider resetting the connection by issuing FEPI SET CONNECTION RELEASED.

TARGET(8-character data-value/8-character data-area)

is the target identifying the connection.

USERDATA(64-character data-area)

returns the user data for the connection. If no user data has been set, nulls are returned.

WAITCONVNUM(fullword binary data-area)

returns the number of conversations that are waiting to start using the connection. Note that, if a conversation could use any one of several connections, it is counted as waiting on each one.

Conditions

Condition	RESP2	Meaning
ILLOGIC	1	For START: browse of this resource type is already in progress. For NEXT or INQUIRE: END was not issued.
END	2	For NEXT: all resource definitions have been retrieved.
INVREQ	116	TARGET name unknown.
INVREQ	117	NODE name unknown.
INVREQ	118	Connection unknown (TARGET and NODE names known, but not in a common pool).

FEPI INQUIRE NODE

Function: FEPI INQUIRE NODE returns information about a FEPI node.

Syntax

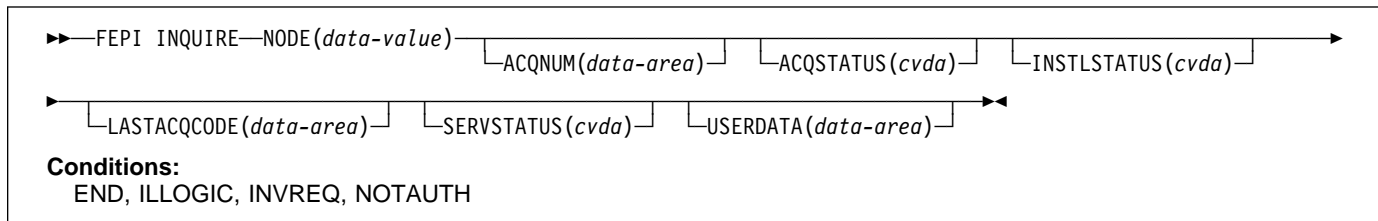

The following commands allow you to browse all FEPI NODE definitions. Read the information on browsing earlier in this book before using the browsing commands.

FEPI Browse NODE

```
FEPI INQUIRE NODE START
FEPI INQUIRE NODE(8-character data-area) NEXT
[The options are as for FEPI INQUIRE NODE]
FEPI INQUIRE NODE END
```

Options

ACQNUM(fullword binary data-area)

returns the number of times that the node has been acquired.

ACQSTATUS(*cvda*)

returns the acquire state—that is, whether the VTAM ACB is opened or closed. The relevant CVDA values are:

- ACQUIRED** The VTAM ACB for the node is open and 'set logon start' has completed.
- ACQUIRING** A state of ACQUIRED has been requested but opening the VTAM ACB for the node and issuing 'set logon start' has not yet been completed.
- RELEASED** Sessions on any connections involving the node have been unbound and the VTAM ACB has been closed.
- RELEASING** A state of RELEASED has been requested but closing the VTAM ACB for the node has not yet been completed.

If ACQUIRING or RELEASING persist, the operator might need to intervene using VTAM commands to recover the node.

INSTLSTATUS(*cvda*)

returns the install state of the node. The relevant CVDA values are:

- INSTALLED** The node has been defined by INSTALL and is available for use.

NOTINSTALLED The node is being discarded, but is still in use.

LASTACQCODE(fullword binary data-area)

returns the result of the last acquire request for the node; that is, the return code from the last VTAM OPEN ACB, zero indicating success. For details of VTAM return codes, see the *VTAM Programming* manual.

NODE(8-character data-value/8-character data-area)

is the name of the node.

SERVSTATUS(*cvda*)

returns the service state of the node. The relevant CVDA values are:

- INSERVICE** The node is in service and can be used in a conversation.
- OUTSERVICE** The node is out of service and cannot be used for any conversation.
- GOINGOUT** A state of OUTSERVICE has been requested but the node is still being used by a conversation.

USERDATA(64-character data-area)

returns the user data for the node. If no user data has been set, nulls are returned.

Conditions

Condition	RESP2	Meaning
ILLOGIC	1	For START: browse of this resource type is already in progress. For NEXT or END: START was not issued.
END	2	For NEXT: all resource definitions have been retrieved.
INVREQ	117	NODE name unknown.

FEPI INQUIRE POOL

Function: FEPI INQUIRE POOL returns information about a FEPI pool of connections.

Syntax

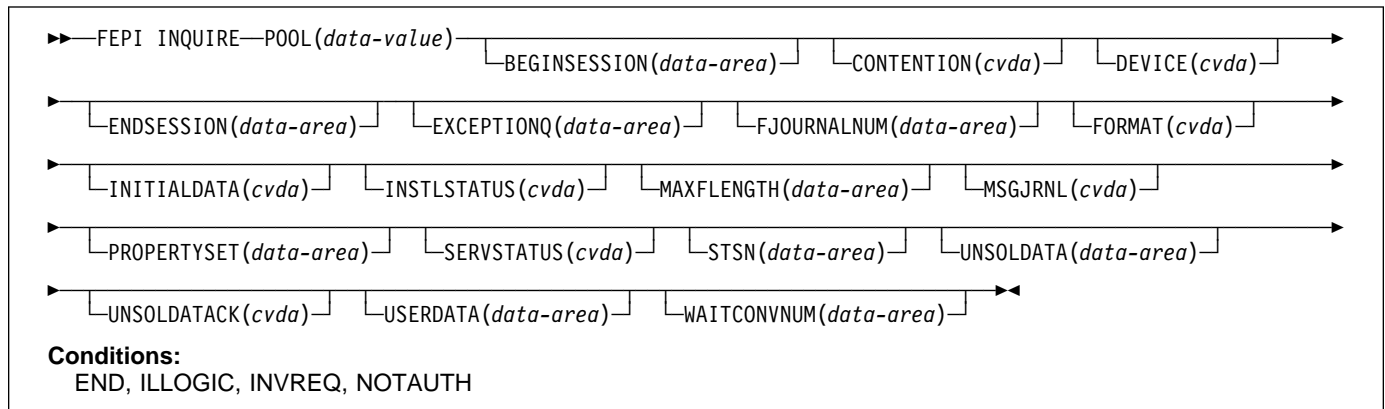

The following commands allow you to browse all FEPI POOL definitions. You should read the information on browsing earlier in this book before using the browsing commands.

FEPI Browse POOL

```
FEPI INQUIRE POOL START
FEPI INQUIRE POOL(8-character data-area) NEXT
[The options are as for FEPI INQUIRE POOL]
FEPI INQUIRE POOL END
```

Options

BEGINSESSION(4-character data-area)

returns the name of the transaction performing begin-session processing, or blanks if no transaction was specified.

CONTENTION(*cvda*)

returns a value that specifies what happens when a FEPI SEND command is issued and there is inbound data with 'begin bracket'. The relevant CVDA values are:

LOSE FEPI SEND command fails; a FEPI RECEIVE must be issued to get the inbound data.

WIN FEPI SEND command succeeds; inbound data is rejected with a negative response.

DEVICE(*cvda*)

returns a value that identifies the mode of conversation and the type of device. Defined values are:

T3278M2 SLU2 mode, 3278 Model 2
T3278M3 SLU2 mode, 3278 Model 3
T3278M4 SLU2 mode, 3278 Model 4
T3278M5 SLU2 mode, 3278 Model 5
T3279M2 SLU2 mode, 3279 Model 2B
T3279M3 SLU2 mode, 3279 Model 3B
T3279M4 SLU2 mode, 3279 Model 4B
T3279M5 SLU2 mode, 3279 Model 5B

TPS55M2 SLU2 mode, PS/55, 24 lines

TPS55M3 SLU2 mode, PS/55, 32 lines

TPS55M4 SLU2 mode, PS/55, 43 lines

LUP SLU P mode, all cases.

ENDSESSION(4-character data-area)

returns the name of the transaction performing end-session processing, or blanks if no transaction was specified.

EXCEPTIONQ(4-character data-area)

returns the name of the TD queue to which exceptional events are notified, or blanks if no queue was specified.

FJOURNALNUM(fullword binary data-area)

returns the number of the journal where data is to be logged.

FORMAT(*cvda*)

returns a value that identifies the data format. The relevant CVDA values are:

FORMATTED Formatted operation

DATASTREAM Data stream operation

NOTAPPLIC Option is not applicable for the specified pool.

INITIALDATA(*cvda*)

returns a value indicating whether initial inbound data is expected when a session is started. The relevant CVDA values are:

NOTINBOUND No inbound data expected

INBOUND Inbound data expected.

INSTLSTATUS(*cvda*)

returns the install state of the pool. The relevant CVDA values are:

INSTALLED The pool has been defined by INSTALL and is available for use.

FEPI INQUIRE POOL

NOTINSTALLED The pool is being discarded, but is still in use.

MAXLENGTH(fullword binary data-area)

returns the maximum length of data that can be returned on any FEPI RECEIVE, CONVERSE, or EXTRACT FIELD command for a conversation, or that can be sent by any FEPI SEND or CONVERSE command for a conversation.

MSGJRNL(cvda)

returns a value indicating whether journaling is performed for inbound and outbound data. The relevant CVDA values are:

NOMSGJRNL No journaling is to be performed.

INPUT Inbound data is journaled.

OUTPUT Outbound data is journaled.

INOUT Inbound and outbound data are journaled.

POOL(8-character data-value/8-character data-area)

is the name of the pool.

PROPERTYSET(8-character data-area)

returns the name of the set of properties with which the pool was installed.

SERVSTATUS(cvda)

returns the service state of the pool. The relevant CVDA values are:

INSERVICE The pool is in service and can be used in a conversation.

OUTSERVICE The pool is out of service and cannot be used for any conversation.

GOINGOUT A state of OUTSERVICE has been requested but the pool is still being used by some conversation.

STSN(4-character data-area)

returns the name of the transaction handling STSN data, or blanks if no transaction was specified.

UNSOLDATA(4-character data-area)

returns the name of the transaction handling unsolicited data (data received outside a conversation), or blanks if no transaction was specified.

UNSOLDATAACK(cvda)

if there is no unsolicited data processing, this indicates what acknowledgment FEPI gives to a BID. The relevant CVDA values are:

NEGATIVE Negative response X'0813', BID not accepted

POSITIVE Positive response, BID accepted and subsequent data is accepted and discarded

NOTAPPLIC Option is not applicable for the specified pool.

USERDATA(64-character data-area)

returns the user data for the pool. If no user data has been set, nulls are returned.

WAITCONVNUM(fullword binary data-area)

returns the number of conversations that are waiting to start using a connection in the pool.

Conditions

Condition	RESP2	Meaning
ILLOGIC	1	For START: browse of this resource type is already in progress. For NEXT or END: START was not issued.
END	2	For NEXT: all resource definitions have been retrieved.
INVREQ	115	POOL name unknown.

FEPI INQUIRE PROPERTYSET

Function: FEPI INQUIRE PROPERTYSET returns information about a FEPI property set.

Syntax

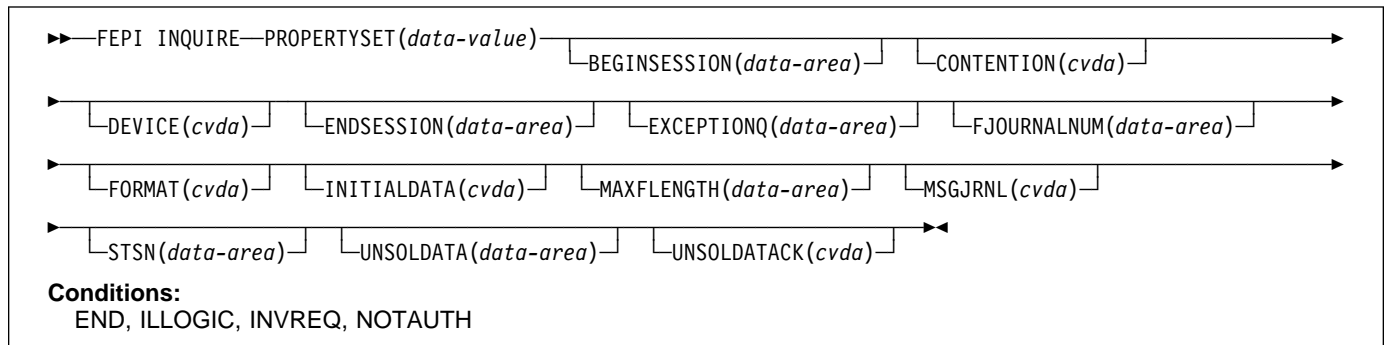

The following commands allow you to browse all FEPI PROPERTYSET definitions. You should read the information on browsing earlier in this book before using the browsing commands.

FEPI Browse PROPERTYSET

```
FEPI INQUIRE PROPERTYSET START
FEPI INQUIRE PROPERTYSET(8-character data-area) NEXT
[The options are as for FEPI INQUIRE PROPERTYSET]
FEPI INQUIRE PROPERTYSET END
```

Options

BEGINSESSION(4-character data-area)

returns the name of the transaction performing begin-session processing, or blanks if no transaction was specified.

CONTENTION(cvda)

returns a value that specifies what happens when a FEPI SEND command is issued and there is inbound data with 'begin bracket'. The relevant CVDA values are:

- LOSE** FEPI SEND command fails; a FEPI RECEIVE must be issued to get the inbound data.
- WIN** FEPI SEND command succeeds; inbound data is rejected with a negative response.

DEVICE(cvda)

returns a value that identifies the mode of conversation and the type of device. Defined values are:

- T3278M2** SLU2 mode, 3278 Model 2
T3278M3 SLU2 mode, 3278 Model 3
T3278M4 SLU2 mode, 3278 Model 4
T3278M5 SLU2 mode, 3278 Model 5
T3279M2 SLU2 mode, 3279 Model 2B
T3279M3 SLU2 mode, 3279 Model 3B
T3279M4 SLU2 mode, 3279 Model 4B

T3279M5 SLU2 mode, 3279 Model 5B

TPS55M2 SLU2 mode, PS/55, 24 lines

TPS55M3 SLU2 mode, PS/55, 32 lines

TPS55M4 SLU2 mode, PS/55, 43 lines

LUP SLU P mode, all cases.

ENDSESSION(4-character data-area)

returns the name of the transaction performing end-session processing, or blanks if no transaction was specified.

EXCEPTIONQ(4-character data-area)

returns the name of the TD queue to which exceptional events are notified, or blanks if no queue was specified.

FJOURNALNUM(fullword binary data-area)

returns the number of the journal where data is to be logged.

FORMAT(cvda)

returns a value that identifies the data format. The relevant CVDA values are:

- FORMATTED** Formatted operation
DATASTREAM Data stream operation
NOTAPPLIC Option is not applicable for the specified pool.

INITIALDATA(cvda)

returns a value indicating whether initial inbound data is expected when a session is started. The relevant CVDA values are:

- NOTINBOUND** No inbound data expected
INBOUND Inbound data expected.

MAXLENGTH(fullword binary data-area)

returns the maximum length of data that can be returned on any FEPI RECEIVE, CONVERSE, or EXTRACT FIELD command for a conversation, or that can be sent by any FEPI SEND or CONVERSE command for a conversation.

FEPI INQUIRE PROPERTYSET

MSGJRNL(cvda)

returns a value indicating whether journaling is performed for inbound and outbound data. The relevant CVDA values are:

NOMSGJRNL No journaling is to be performed.
INPUT Inbound data is journaled.
OUTPUT Outbound data is journaled.
INOUT Inbound and outbound data are journaled.

PROPERTYSET(8-character data-value/8-character data-area)

is the name of the set of properties.

STSN(4-character data-area)

returns the name of the transaction handling STSN data (SLU P mode only), or blanks if no transaction was specified.

UNSOLDATA(4-character data-area)

returns the name of the transaction handling unsolicited data (data received outside a conversation), or blanks if no transaction was specified.

UNSOLDATAACK(cvda)

indicates what acknowledgment FEPI gives to a BID, if there is no unsolicited-data processing. The relevant CVDA values are:

NEGATIVE Negative response X'0813', BID not accepted
POSITIVE Positive response, BID accepted and subsequent data is accepted and discarded
NOTAPPLIC Option is not applicable for the specified pool.

Conditions

Condition	RESP2	Meaning
ILLOGIC	1	For START: browse of this resource type is already in progress. For NEXT or END: START was not issued.
END	2	For NEXT: all resource definitions have been retrieved.
INVREQ	171	PROPERTYSET name unknown.

FEPI INQUIRE TARGET

Function: FEPI INQUIRE TARGET returns information about a FEPI target.

Syntax

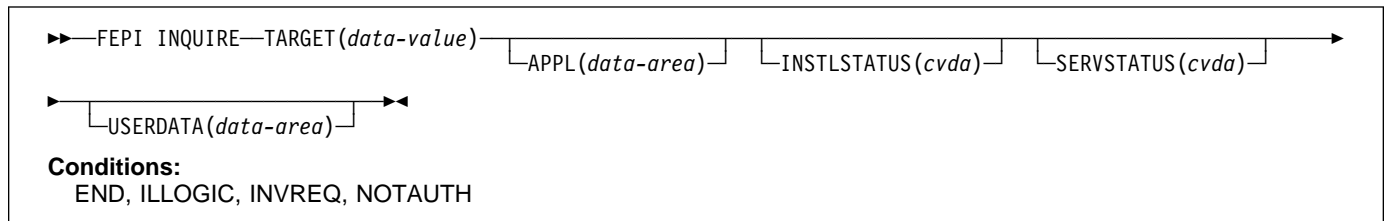

The following commands allow you to browse all FEPI TARGET definitions. Read the information on browsing earlier in this book before using the browsing commands.

FEPI Browse TARGET

```
FEPI INQUIRE TARGET START
FEPI INQUIRE TARGET(8-character data-area) NEXT
[The options are as for FEPI INQUIRE TARGET]
FEPI INQUIRE TARGET END
```

Conditions

Condition	RESP2	Meaning
ILLOGIC	1	For START: browse of this resource type is already in progress. For NEXT or END: START was not issued.
END	2	For NEXT: all resource definitions have been retrieved.
INVREQ	116	TARGET name unknown.

Options

APPL(8-character data-area)

returns the VTAM application name of the back-end system that the target system represents.

INSTLSTATUS(cvda)

returns the install state of the target. The relevant CVDA values are:

INSTALLED The target has been defined by INSTALL and is available for use.

NOTINSTALLED The target is being discarded but is still in use.

SERVSTATUS(cvda)

returns the service state of the target. The relevant CVDA values are:

INSERVICE The target is in service and can be used in a conversation.

OUTSERVICE The target is out of service and cannot be used for any conversation.

GOINGOUT A state of OUTSERVICE has been requested but the target is still being used by some conversation.

TARGET(8-character data-value/8-character data-area)

is the name of the target.

USERDATA(64-character data-area)

returns the user data for the target. If no user data has been set, nulls are returned.

FEPI INSTALL NODELIST

Function: FEPI INSTALL NODELIST defines new nodes to FEPI. You may specify initial service and acquire states for these new nodes. A node cannot be used for a conversation until it has been acquired, put in service, and added to a pool so that it is connected to a target. The command completes when the nodes have been defined without waiting for the requested states to be achieved.

Syntax

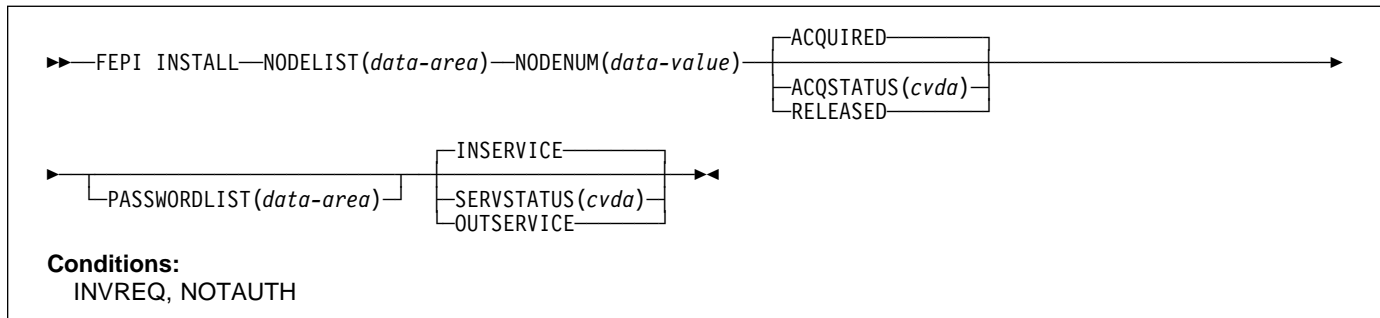

Options

ACQSTATUS(cvda)

specifies the initial acquire state of the nodes being defined. All nodes in the list have the same state. The relevant CVDA values are:

- ACQUIRED** The VTAM ACB for the node is to be opened and 'set logon start' is to be done.
- RELEASED** The VTAM ACB for the node is not to be opened.

Conditions

Condition	RESP2	Meaning
INVREQ	110	SERVSTATUS value not valid.
INVREQ	111	ACQSTATUS value not valid.
INVREQ	119	The command failed for one or more items in the list.
INVREQ	131	NODENUM value out of range.
INVREQ	163	NODE name not valid.
INVREQ	173	NODE name already exists.
INVREQ	176	The VTAM OPEN ACB failed.

NODELIST(data-area)

specifies a contiguous array of 8-character node names (that is, VTAM application minor node names in the front-end) to be defined. Names must not contain null characters (X'00'), leading blanks, or embedded blanks.

NODENUM(fullword binary data-value)

specifies the number of names in NODELIST, in the range 1–256.

PASSWORDLIST(data-value)

specifies a contiguous array of 8-character passwords. They correspond one-to-one with the node names in NODELIST. The passwords are those that VTAM requires to access the application minor nodes. They are not required if passwords are not used. You can use a value of 8 null characters (X'00') to indicate 'no password'.

SERVSTATUS(cvda)

specifies the initial service state of the nodes being defined. All nodes in the list have the same state. The relevant CVDA values are:

- INSERVICE** The nodes are in service and can be used in a conversation.
- OUTSERVICE** The nodes are out of service and cannot be used for any conversation.

FEPI INSTALL POOL

Function: FEPI INSTALL POOL defines a new pool of connections to FEPI. Any targets and nodes specified in the command are added to it, thereby creating new connections in the pool. You may specify an initial service state for the pool, and initial service and acquire states for any new connections. A pool cannot be used for a conversation until it has been put in service. The command completes when the pool has been created and any resources added; it does not wait for the requested states to be achieved.

Syntax

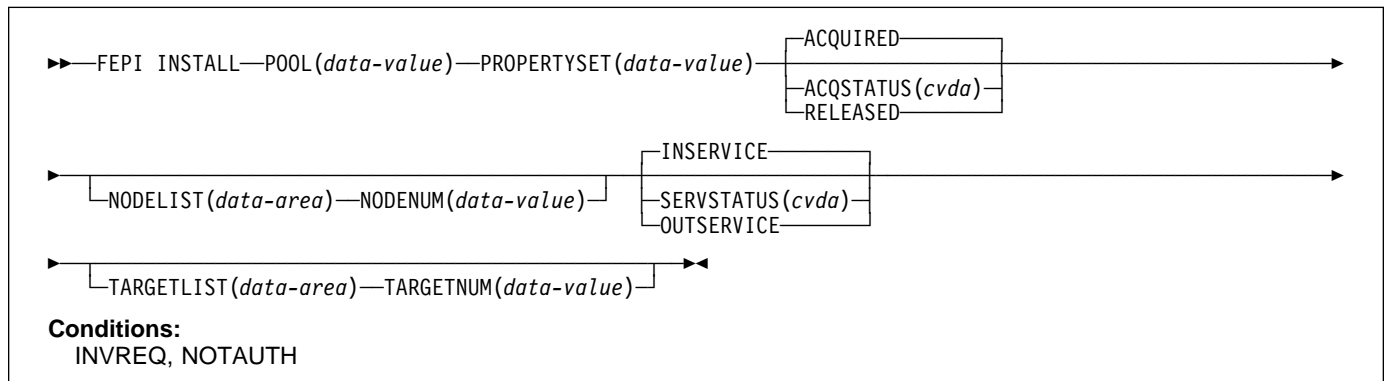

Options

ACQSTATUS(cvda)

specifies the initial acquire state of the connections being created. All the new connections have the same state. The relevant CVDA values are:

- ACQUIRED** The connections are to have sessions established (that is, 'bound').
- RELEASED** The connections are not to have sessions established (that is, left 'unbound').

NODELIST(data-area)

specifies a contiguous array of 8-character node names. They must already be defined by FEPI INSTALL NODELIST.

NODENUM(fullword binary data-value)

specifies the number of names in NODELIST, in the range 0–256.

POOL(8-character data-value)

specifies the name of the pool to be defined. The name must not contain null characters (X'00'), leading blanks, or embedded blanks.

PROPERTYSET(8-character data-value)

specifies the name of the set of properties for the pool, which must have been installed already.

SERVSTATUS(cvda)

specifies the initial service state of the pool being defined and of the connections being created. All the new connections have the same state. The relevant CVDA values are:

INSERVICE

The pool and any connections are in service and can be used in a conversation.

OUTSERVICE

The pool and any connections are out of service and cannot be used for any conversation.

TARGETLIST(data-area)

specifies a contiguous array of 8-character target names. They must already be defined by FEPI INSTALL TARGETLIST.

TARGETNUM(fullword binary data-value)

specifies the number of names in TARGETLIST, in the range 0–256.

Conditions

Condition	RESP2	Meaning
INVREQ	110	SERVSTATUS value not valid.
INVREQ	111	ACQSTATUS value not valid.
INVREQ	116	TARGET name unknown.
INVREQ	117	NODE name unknown.
INVREQ	119	The command failed for one or more items in the list.
INVREQ	130	TARGETNUM value out of range.
INVREQ	131	NODENUM value out of range.
INVREQ	162	POOL name not valid.
INVREQ	171	PROPERTYSET name unknown.
INVREQ	172	POOL name already exists.
INVREQ	175	The connection already exists.

FEPI INSTALL PROPERTYSET

Function: FEPI INSTALL PROPERTYSET defines a new set of properties to FEPI, which can be applied to any subsequently defined pool.

Syntax



Options

Note: Specifying a blank value for BEGINSESSION, ENDESESSION, EXCEPTIONQ, STSN, or UNSOLDATA has the same effect as omitting the option.

BEGINSESSION(4-character data-value)

specifies the name of the transaction to perform begin-session processing, immediately after a session has been established ('bound'). If omitted, there is to be no user-supplied begin-session processing.

CONTENTION(*cvda*)

specifies what happens when a FEPI SEND command is issued and there is inbound data with begin-bracket. The relevant CVDA values are:

LOSE The FEPI SEND command fails; a FEPI RECEIVE must be issued to get the inbound data.

WIN The FEPI SEND command succeeds; inbound data is rejected with a negative response.

DEVICE(*cvda*)

specifies the LU mode and device type that is to be simulated. The relevant CVDA values are:

T3278M2 SLU2 mode, 3278 Model 2
T3278M3 SLU2 mode, 3278 Model 3
T3278M4 SLU2 mode, 3278 Model 4
T3278M5 SLU2 mode, 3278 Model 5
T3279M2 SLU2 mode, 3279 Model 2B
T3279M3 SLU2 mode, 3279 Model 3B
T3279M4 SLU2 mode, 3279 Model 4B
T3279M5 SLU2 mode, 3279 Model 5B
TPS55M2 SLU2 mode, PS/55, 24 lines
TPS55M3 SLU2 mode, PS/55, 32 lines
TPS55M4 SLU2 mode, PS/55, 43 lines
LUP SLU P mode, all cases.

ENDESESSION(4-character data-value)

specifies the name of the transaction to perform end-session processing, when a conversation is ended (by a FEPI FREE command) or when a session is to be ended ('unbound'). If omitted, there is to be no user-supplied end-session processing.

EXCEPTIONQ(4-character data-value)

specifies the name of the TD queue to which pool-specific exceptional events are to be notified. If EXCEPTIONQ is omitted, there is to be no user-supplied exceptional event processing.

FJOURNALNUM(fullword binary data-value)

specifies the number of the journal where data is to be logged, in the range 2 through 99. If the value is zero or omitted, no journaling is done.

FORMAT(cvda)

specifies, for SLU2 mode, the data mode to be used. The relevant CVDA values are:

FORMATTED Formatted operation. Character attributes are not supported on outbound data and ignored on inbound data.

DATASTREAM Data stream operation.

This option is not valid for SLU P operation.

INITIALDATA(cvda)

specifies whether initial inbound data is expected when a session is started. The relevant CVDA values are:

NOTINBOUND No inbound data is expected.

INBOUND Inbound data is expected.

| If the target is a back-end IMS system, you should
| specify INBOUND. See page 122.

MAXLENGTH(fullword binary data-value)

specifies the maximum length of data that can be returned on any FEPI RECEIVE, CONVERSE, or EXTRACT FIELD command for a conversation, or that can be sent by any FEPI SEND or CONVERSE command for a conversation. This value helps FEPI use storage more efficiently, so should be set no larger than is necessary. It must be in the range 128–1 048 576. If MAXLENGTH is not specified, 4096 is used.

MSGJRNL(cvda)

specifies the required journaling of data to and from the back-end system. The relevant CVDA values are:

NOMSGJRNL No journaling

INPUT Journal inbound data

OUTPUT Journal outbound data

INOUT Journal inbound and outbound data.

PROPERTYSET(8-character data-value)

specifies the name of the set of properties to be defined. The name must not contain null characters (X'00'), leading blanks, or embedded blanks.

STSN(4-character data-value)

specifies the name of the transaction to be started to handle 'set and test sequence number' (STSN), for SLU P mode only. If omitted, there is to be no user-supplied STSN-handling; FEPI handles STSN automatically.

UNSOLDATA(4-character data-value)

specifies the name of the transaction to handle unsolicited data (data received outside a conversation). If omitted, there is to be no user-supplied unsolicited-data processing; FEPI treats unsolicited data as specified by UNSOLDATAACK.

UNSOLDATAACK(cvda)

if there is to be no unsolicited-data processing, this specifies what acknowledgment FEPI is to give to a BID. The relevant CVDA values are:

NEGATIVE Negative response X'0813', BID not accepted

POSITIVE Positive response, BID accepted and subsequent data is accepted and discarded.

Conditions

Condition	RESP2	Meaning
INVREQ	140	DEVICE value not valid.
INVREQ	141	CONTENTION value not valid.
INVREQ	142	INITIALDATA value not valid.
INVREQ	143	UNSOLDATAACK value not valid.
INVREQ	144	MSGJRNL value not valid.
INVREQ	150	FORMAT value not valid or is unsuitable for the LU mode and device type specified by the DEVICE value.
INVREQ	153	STSN name not valid or STSN is not allowed for the LU mode and device type specified by the DEVICE value.
INVREQ	154	BEGINSESSION name not valid.
INVREQ	155	UNSOLDATA name not valid.
INVREQ	156	EXCEPTIONQ name not valid.
INVREQ	157	FJOURNALNUM value not valid.
INVREQ	158	MAXLENGTH value not valid.
INVREQ	159	ENDSESSION name not valid.
INVREQ	160	PROPERTYSET name not valid.
INVREQ	170	PROPERTYSET name already exists.

FEPI INSTALL TARGETLIST

Function: FEPI INSTALL TARGETLIST defines new targets to FEPI. You can specify an initial service state for these new targets. A target cannot be used for a conversation until it has been put in service, and has been added to a pool so that it is connected to a node. The command completes when the targets have been installed without waiting for the requested states to be achieved.

Syntax

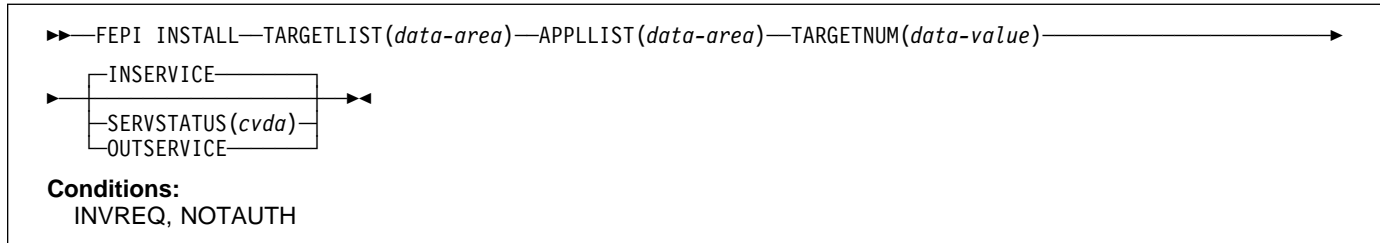

Options

APPLLIST(*data-area*)

specifies a contiguous array of 8-character primary logical unit (PLU) names. These are the VTAM application names (APPLID) of the back-end CICS or IMS systems with which FEPI applications are to communicate; they correspond one-to-one with the target names in TARGETLIST. The names must not contain null characters (X'00'), leading blanks, or embedded blanks.

Each name must be unique within the list; duplicate
names result in an INVREQ condition being returned.

| If a target specified in TARGETLIST is a CICS
| terminal-owning region that is a member of a VTAM
| generic resource group, you can specify in APPLLIST its
| generic resource name. This enables you to use the
| VTAM generic resource function to balance sessions
| across the available TORs. See "Workload balancing in
| a sysplex" on page 19.

SERVSTATUS(*cvda*)

specifies the initial service state of the targets being defined. All the targets in the list have the same state. The relevant CVDA values are:

INSERVICE The target is in service and can be used in a conversation.

OUTSERVICE The target is out of service and cannot be used for any conversation.

TARGETLIST(*data-area*)

specifies a contiguous array of 8-character target names to be defined. A target name is the logical FEPI front-end name of a back-end system. The names must not contain null characters (X'00'), leading blanks, or

embedded blanks. Each name must be unique within the
list; duplicate names result in an INVREQ condition being
returned.

TARGETNUM(*fullword binary data-value*)

specifies the number of names in TARGETLIST, in the range 1–256.

Conditions

Condition	RESP2	Meaning
INVREQ	110	SERVSTATUS value not valid.
INVREQ	119	The command failed for one or more items in the list.
INVREQ	130	TARGETNUM value out of range.
INVREQ	164	TARGET name not valid.
INVREQ	167	Application name not valid.
INVREQ	174	TARGET name already exists.
INVREQ	177	Application name already exists.

FEPI SET CONNECTION

Function: FEPI SET CONNECTION controls the use of FEPI connections. Lists may be used to set more than one connection at a time; all connections in the list are set to the same state. The command completes immediately, although the requested settings may not be achieved until later.

Syntax

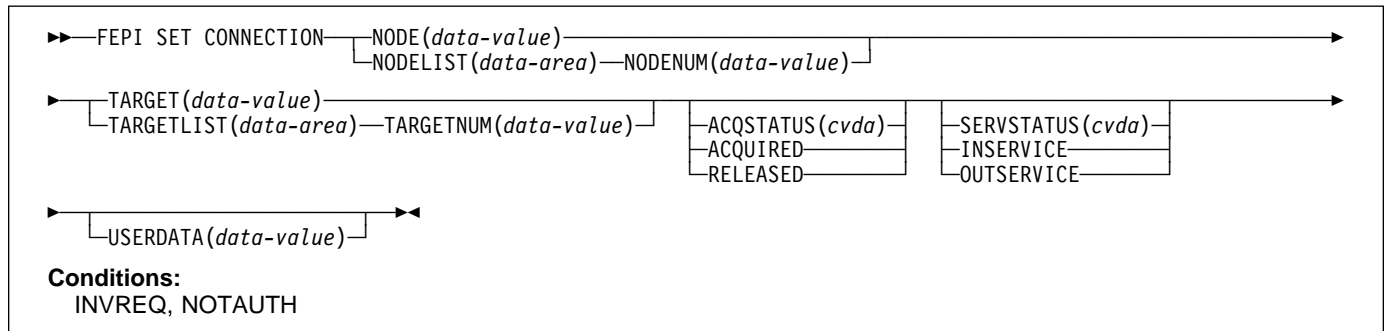

Options

ACQSTATUS(cvda)

specifies the acquire state of the connection; that is, whether a session should be established ('bound') or not ('unbound'). The relevant CVDA values are:

- ACQUIRED** The connection is to have a session established (that is, 'bound'). The state is ACQUIRING until this is completed.
- RELEASED** The connection is to have its session ended (that is, 'unbound') when usage of the connection by all owned conversations ends. However, if ownership of a conversation is relinquished by a FREE PASS command, a subsequent FREE RELEASE command must be issued before the session can be 'unbound' as a result of a SET CONNECTION RELEASED command. (An unowned conversation on the connection does not prevent the session from being ended immediately. See the STATE option of FEPI INQUIRE CONNECTION on page 75.) The state is RELEASING until this is completed.

If this option is not coded, the acquire state is not changed.

NODE(8-character data-value)

specifies the node name that identifies a connection.

NODELIST(data-area)

specifies a contiguous array of 8-character node names identifying connections.

NODENUM(fullword binary data-value)

specifies the number of node names in NODELIST, in the range 1–256.

SERVSTATUS(cvda)

specifies the service state of the connection; that is, whether the connection can be used for a conversation or not. The relevant CVDA values are:

- INSERVICE** Allows usage of the connection in a conversation.
- OUTSERVICE** Stops usage of a connection for any new conversation, although existing conversations are unaffected. The service state is GOINGOUT until these conversations end.

If this option is not coded, the service state is not changed.

TARGET(8-character data-value)

Specifies the target name that identifies a connection.

TARGETLIST(data-area)

specifies a contiguous array of 8-character target names identifying a connection or connections.

TARGETNUM(fullword binary data-value)

specifies the number of target names in TARGETLIST, in the range 1–256.

USERDATA(64-character data-value)

Specifies optional user data relating to the connections; it is not used by FEPI. It replaces any previous user data that was set.

Conditions

Condition	RESP2	Meaning
INVREQ	110	SERVSTATUS value not valid.
INVREQ	111	ACQSTATUS value not valid.
INVREQ	116	TARGET name unknown.
INVREQ	117	NODE name unknown.
INVREQ	118	Unknown connection (TARGET and NODE names are known but not connected in any pool).

FEPI SET CONNECTION

Condition	RESP2	Meaning
INVREQ	119	The command failed for one or more items in the list.
INVREQ	130	TARGETNUM value out of range.
INVREQ	131	NODENUM value out of range.

FEPI SET NODE

Function: FEPI SET NODE controls the use of FEPI nodes. Lists may be used to set more than one node at a time; all nodes in the list are set to the same state. The function completes immediately, although the requested settings may not be achieved until later.

Syntax

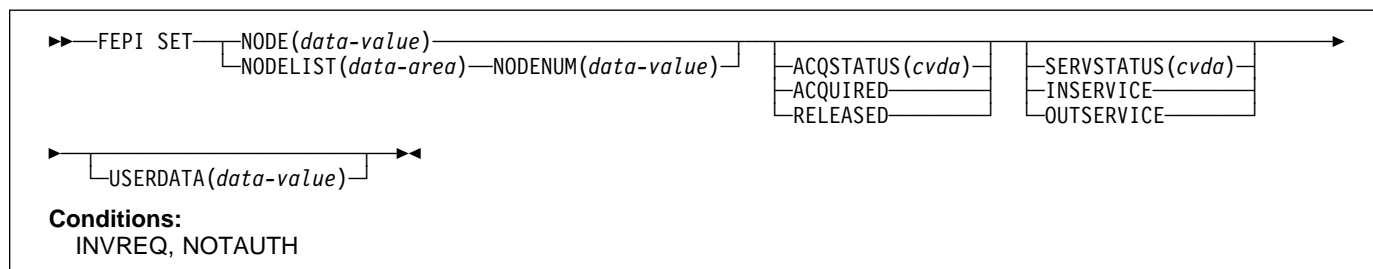

Options

ACQSTATUS(cvda)

specifies the acquire state of the node; that is, whether its VTAM ACB should be opened or closed. The relevant CVDA values are:

- ACQUIRED** The VTAM ACB for the node is to be opened and 'set logon start' is to be done. The state is ACQUIRING until this is completed.
- RELEASED** The VTAM ACB for the node is to be closed when usage of the node by any conversation ends. The state is RELEASING until this is completed.

If this option is not coded, the acquire state is not changed.

NODE(8-character data-value)

specifies the node to be set.

NODELIST(data-area)

specifies a contiguous array of 8-character node names to be set.

NODENUM(fullword binary data-value)

specifies the number of node names in NODELIST, in the range 1–256.

SERVSTATUS(cvda)

specifies the service state of the node; that is, whether the node can be used for a conversation or not. The relevant CVDA values are:

- INSERVICE** Allows usage of the node in a conversation.
- OUTSERVICE** Stops usage of a node for any new conversation, although existing conversations are unaffected. The service state is GOINGOUT until these conversations end.

If this option is not coded, the service state is not changed.

USERDATA(64-character data-value)

Specifies optional user data relating to the nodes; it is not used by FEPI. It replaces any previous user data that was set.

Conditions

Condition	RESP2	Meaning
INVREQ	110	SERVSTATUS value not valid.
INVREQ	111	ACQSTATUS value not valid.
INVREQ	117	NODE name unknown.
INVREQ	119	The command failed for one or more items in the list.
INVREQ	131	NODENUM value is out of range.
INVREQ	174	The VTAM OPEN ACB failed.

FEPI SET POOL

Function: FEPI SET POOL controls the use of FEPI pools. Lists may be used to set more than one pool at a time; all pools in the list are set to the same state. The function completes immediately, although the requested settings may not be achieved until later.

Syntax

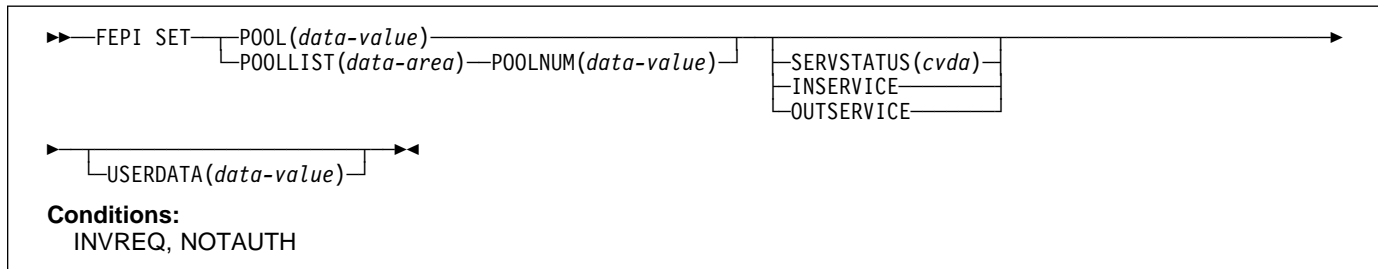

Options

POOL(8-character data-value)

specifies the pool to be set.

POOLLIST(data-area)

specifies a contiguous array of 8-character pool names to be set.

POOLNUM(fullword binary data value)

specifies the number of pool names in POOLLIST, in the range 1–256.

SERVSTATUS(cvda)

specifies the service state of the pool; that is, whether the pool can be used for a conversation or not. The relevant CVDA values are:

INSERVICE Allows usage of the pool in a conversation.

OUTSERVICE Stops usage of a pool for any new conversation, although existing conversations are unaffected. The service state is GOINGOUT until these conversations end.

If this option is not coded, the service state is not changed.

USERDATA(64-character data-value)

Specifies optional user data relating to the pools; it is not used by FEPI. It replaces any previous user data that was set.

Conditions

Condition	RESP2	Meaning
INVREQ	110	SERVSTATUS value not valid.
INVREQ	115	POOL name unknown.
INVREQ	119	The command failed for one or more items in the list.
INVREQ	132	POOLNUM value is out of range.

FEPI SET TARGET

Function: FEPI SET TARGET controls the use of FEPI targets. Lists may be used to set more than target at a time; all targets in the list are set to the same state. The function completes immediately, although the requested settings may not be achieved until later.

Syntax

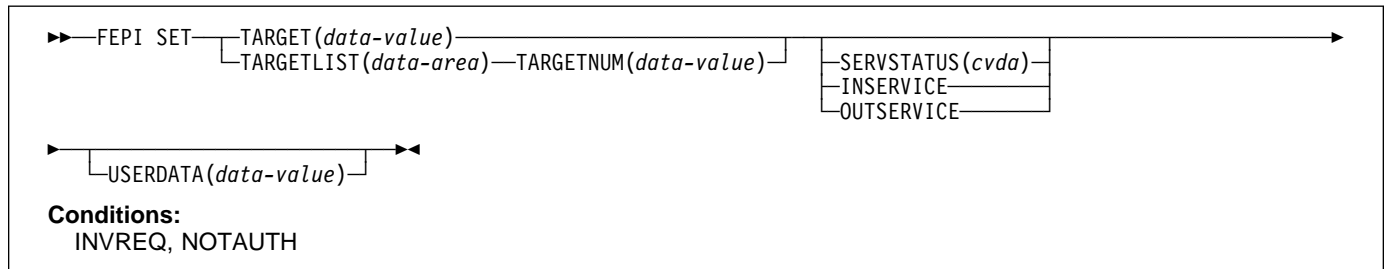

Options

SERVSTATUS(cvda)

specifies the service state of the target; that is, whether the target can be used for a conversation or not. The relevant CVDA values are:

INSERVICE Allows usage of the target in a conversation.

OUTSERVICE Stops usage of a target for any new conversation, although existing conversations are unaffected. The service state is GOINGOUT until these conversations end.

If this option is not coded, the service state is not changed.

TARGET(8-character data-value)

specifies the name of the target to be set.

TARGETLIST(data-area)

specifies a contiguous array of 8-character target names to be set.

TARGETNUM(fullword binary data-value)

specifies the number of target names in TARGETLIST, in the range 1–256.

USERDATA(64-character data-value)

Specifies optional user data relating to the targets; it is not used by FEPI. It replaces any previous user data that was set.

Conditions

Condition	RESP2	Meaning
INVREQ	110	SERVSTATUS value not valid.
INVREQ	116	TARGET name unknown.
INVREQ	119	The command failed for one or more items in the list.
INVREQ	130	TARGETNUM value is out of range.

FEPI SP NOOP

Function: FEPI SP NOOP has no effect.

Syntax

▶—FEPI SP NOOP—▶

Conditions:
INVREQ, NOTAUTH

Options: None.

Conditions: None specific to this command.

Transient data queue records

In response to various unexpected events, FEPI writes a record, describing the event and its circumstances, to a transient data (TD) queue. Such events include:

- Errors in functions initiated by a system programming command
- Errors for items in a list on a system programming command
- Events unrelated to any command.

If the event relates to a specific pool, the record is written to the queue specified by EXCEPTIONQ for that pool; if EXCEPTIONQ was not specified, no record is written. If the event does not relate to a specific pool, the record is written to queue CSZX. In all cases, if the appropriate TD queue does not exist or if it is not defined as non-recoverable, the record is lost.

The format of the record is as follows. The copy books DFHSZAPA, DFHSZAPO, DFHSZAPC, and DFHSZAPP (according to your programming language) provide declarations for this record structure.

DATATYPE	Fullword binary data-area
EVENTTYPE	CVDA
EVENTVALUE	Fullword binary data-area
EVENTDATA	8-character data-area
spare	4-character data-area
POOL	8-character data-area
TARGET	8-character data-area
NODE	8-character data-area
CONVID	8-character data-area
DEVICE	CVDA
FORMAT	CVDA
spare	8-character data-area.

Fields

CONVID(8-character data-area)

the conversation ID for which the event occurred; null if not applicable.

DATATYPE(fullword binary data-area)

identifies the type and structure of the data. A value of 2 indicates FEPI TD queue data.

DEVICE(cvda)

the device type of the conversation for which the event occurred (the values are as for FEPI INQUIRE POOL); zero if not applicable.

EVENTDATA(8-character data-area)

contains data about the event:

Event	Data
ACQFAIL	2 fullword binary numbers: <ul style="list-style-type: none"> • VTAM reason code • Count
SESSIONFAIL	2 fullword binary numbers: <ul style="list-style-type: none"> • VTAM reason code • Count
SESSIONLOST	2 fullword binary numbers: <ul style="list-style-type: none"> • VTAM reason code • Count
Others	Nulls

If the count is nonzero, it indicates the number of times the node acquire or session start has failed; it will be tried again. A zero count indicates that several failures have occurred and that there will be no further attempts to acquire the node or start the session.

EVENTTYPE(cvda)

indicates what the event was.

Exceptional events queued to common TD queue CSZX:

ACQFAIL	A node could not be acquired (its VTAM ACB could not be opened).
DISCARDFAIL	A resource in a list could not be discarded by FEPI DISCARD.
INSTALLFAIL	A resource in a list could not be installed by FEPI INSTALL.
SESSION	An unsolicited bind was received.
SETFAIL	A connection or resource in a list could not be set by FEPI SET or FEPI INSTALL.

Exceptional events queued to pool-specific TD queue:

ADDFAIL	A connection in a list could not be added to the pool by FEPI ADD.
DELETEFAIL	A connection in a list could not be deleted from the pool by FEPI DELETE.
SESSIONFAIL	Session could not be started.
SESSIONLOST	Active session was lost.

EVENTVALUE(fullword binary data area)

provides further information about the event. Values are:

Event	Value
ACQFAIL	0
ADDFAIL	The RESP2 value describing the failure, as given in the description of the FEPI ADD command
DELETEFAIL	The RESP2 value describing the failure, as given in the description of the FEPI DELETE command
DISCARDFAIL	The RESP2 value describing the failure, as given in the description of the FEPI DISCARD command
INSTALLFAIL	The RESP2 value describing the failure, as given in the description of the FEPI INSTALL command
SESSION	0
SESSIONFAIL	The RESP2 value describing the communication failure; it can be any of the RESP2 values in the range 182–199.
SESSIONLOST	The RESP2 value describing the communication failure; it can be any of the RESP2 values in the range 182–199.
SETFAIL	The RESP2 value describing the failure, as given in the description of the FEPI SET command

FORMAT(cvda)

the data format of the conversation for which the event occurred (the values being as for FEPI INQUIRE POOL); zero if not applicable.

NODE(8-character data-area)

the name of the node for which the event occurred; nulls if not applicable.

POOL(8-character data-area)

the name of the pool for which the event occurred; nulls if not applicable.

TARGET(8-character data-area)

the name of the target for which the event occurred; nulls if not applicable. For the SESSION event, it is the VTAM application name of the back-end system, rather than the FEPI target name.

spare

nulls.

TD queue records

Chapter 10. Problem determination

This chapter contains guidance information to help you identify the source of errors that affect your FEPI applications. For information about using CICS debugging tools, trace, and dump, see the *CICS/ESA Problem Determination Guide*.

This chapter contains Diagnosis, Modification or Tuning information.

Debugging FEPI applications

The CICS execution diagnostic facility (EDF) helps users of the EXEC CICS interface to step through the EXEC CICS commands of an application program. EDF can be used in just the same way to debug programs that use the EXEC CICS FEPI commands.

FEPI dump

CICS dump routines are available for FEPI. These routines are under the control of the usual CICS selection mechanisms.

You generate interpretation of the FEPI areas of a CICS dump by specifying the SZ keyword from within the interactive problem control system (IPCS). SZ can take the following values:

SZ value	What is printed
0	No FEPI areas are interpreted.
1	All FEPI areas are interpreted, excluding the stacks.
2	All FEPI areas are interpreted, including the stacks.

If you are looking at a FEPI problem, first ensure the SZ TCB is active, and the FEPI Resource Manager is running. Look at the kernel and dispatcher prints to verify their presence.

If the SZ TCB is present, and the FEPI Resource Manager is running, the problem is probably caused by a wait or an abend. In the case of a wait, the dispatcher and kernel prints should show where it is located.

After looking at any FEPI trace entries, you should direct your attention to the output of the 'SZ=2,IND' dump command. This displays all known FEPI control blocks and some of their interconnections. If you think a storage violation has occurred, use the dump storage manager options to display the contents of the FEPI storage subpools.

Here are some things that might help you identify a problem when you read the dump:

- Were any errors reported during interpretation? If so, this may indicate a corrupt address pointer or a broken chain.
- Follow all the pointers to associated control blocks (such as the conversation pointed to by the connection). Is this pointer correct? If not, this probably indicates corruption.
- Are there the expected numbers of nodes, targets, property sets, and pools? If not, this can indicate a broken chain or an unauthorized deletion.
- Does each pool contain the expected number of connections (that is, the number of nodes multiplied by the number of targets)? If not, this may indicate the failure of a FEPI ADD command.
- Has each node been successfully acquired? If not, there is the possibility of VTAM definition errors. The ACB and RPL may contain VTAM sense information—perhaps a VTAM major node is inactive.
- Is there successful communication with a target? If not, have APPLID and PASSWORD been correctly specified? If they are correct, is the back-end system running?

Problem determination

- Are there any queued ALLOCATE commands? If so, this indicates that there are not enough connections for the pool to process FEPI conversations without queuing. This may be acceptable, or not, depending on your configuration.
- Are the event handlers being run? If not, have they been correctly defined to CICS using RDO?
- Are the event handlers being recursively invoked? If so, this indicates a problem with a FEPI FREE command, a storage violation, or an internal logic error.
- Is information being correctly sent to the specified transient data queues? If not, are the queues defined as unrecoverable? Investigation of the DCT may help here.
- Are transactions being triggered from the TDQs? If not, are the transactions correctly defined to CICS?
- Is there a current conversation? If so, this conversation may be causing the error. Is the data correct? Is there any VTAM sense information in the RPL?
- Are the surrogate terminals correct? If not, the links between the nodes, pools, and targets may have become corrupted.
- Are FEPI SEND or FEPI RECEIVE commands failing due to state errors? If so, look at the conversation and see if the states are correct. If they are not, the conversation has become out of step with the VTAM flow.
- Is unexpected data being sent or received in formatted conversations? If so, there may be corrupt FEPI data. Look at FEPI's internal terminal character buffer.
- Look at the queues. Are there any requests that look as if they have got stuck? If so, the FEPI work chains may be corrupt. However, it may be simply that the flow to satisfy the requests has not yet happened. If you think it should have happened, there may be communication problems.
- Look at the FREE queue. The last VTAM event may be shown. If so, does it correspond with what you expected?
- Is the behavior of a pool correct? If not, it is possible that the property set used to define the pool is incorrect. However, if the property set is shown, it could have been re-created since the pool was defined—treat property set definitions with care.
- Are there any outstanding timer events that should have run? If so, this may indicate a chaining failure.
- Has a timer-dependent action been delayed? If so, this could indicate that the TIMEOUT parameter on the command was incorrect.
- Are you receiving all the data you expect? If not, have you set the correct end-of-flow condition on the FEPI RECEIVE (or CONVERSE) command?
- Are there many transactions waiting on FEPI? If so, either back-end systems are not responding, or the FEPI Resource Manager has failed.
- Has a VTAM dump been taken? If so, this may indicate a failure in one of the VTAM exits.

Using CICS dump facilities to investigate FEPI problems

This section describes how FEPI relates to the rest of CICS, and how its presence is revealed by the other CICS dump formatting commands.

The problem determination process for FEPI is driven from the usual CICS dump interpretation routines. The following sections describe what to look for in the major CICS areas.

Dispatcher

You should see a task (CSZI) running under the SZ task control block. (However, note that CSZI can run under the QR TCB while executing certain CICS functions, such as starting transactions and writing to transient data queues.) If CSZI is not present, then either FEPI is not in the system, or the FEPI Resource Manager has failed.

Application programs waiting for responses from the FEPI Resource Manager are shown as waiting on FEPI. (For details of FEPI waits, see the *CICS/ESA Problem Determination Guide*.)

Interval control

Any transactions that have been started by the FEPI Resource Manager, but not yet run, appear in the interval control section.

Kernel

In the kernel, you should find a running task named KETCB SZ representing the SZ TCB that FEPI uses. If KETCB SZ is not present, then either FEPI is not in the system, or the TCB has abended.

You should find the CSZI task either running or waiting. If CSZI is not present, then either FEPI is not in the system, or the FEPI Resource Manager has failed.

If an abend has occurred, the usual information is available. The location of the abend is indicated by the failing module, as follows:

- DFHESZ The application programming EXEC stub
- DFHEIQSZ The system programming EXEC stub
- DFHSZATR The FEPI adapter
- DFHSZRMP The FEPI Resource Manager.

Storage manager

Table 8 lists the CICS storage subpools used by FEPI. You can use the storage manager dump facilities to display the contents of these subpools. If you suspect a storage violation, a comparison of the contents of these subpools with the areas interpreted by a FEPI dump may show where the corruption has occurred.

Name	Type	Chained	Above or below 16MB line?	Usage
SZSPFCAC	Fixed	Yes	Below	ACBs
SZSPFCCD	Fixed	Yes	Any	Connections
SZSPFCCM	Fixed	Yes	Any	Common area
SZSPFCCV	Fixed	Yes	Any	Conversations
SZSPVUDA	VAR	Yes	Any	Various data areas
SZSPFCDS	Fixed	Yes	Any	Device support extensions
SZSPFCDT	Fixed	Yes	Any	Device-type control areas
SZSPFCNB	Fixed	Yes	Any	NIBs
SZSPFCND	Fixed	Yes	Any	Nodes
SZSPFCPD	Fixed	Yes	Any	Pools
SZSPFCPS	Fixed	Yes	Any	Property sets
SZSPFCRP	Fixed	Yes	Any	RPLs
SZSPFCRQ	Fixed	Yes	Any	Requests
SZSPFCSR	Fixed	Yes	Any	Surrogates
SZSPFCTD	Fixed	Yes	Any	Targets
SZSPFCWE	Fixed	Yes	Any	DQEs

FEPI trace

There are appropriate trace entries in the CICS trace table which are under the control of the usual CICS mechanisms. FEPI trace entries are listed in the *CICS/ESA Diagnosis Reference*.

FEPI generates exception and event trace entries—the latter under control of the 'SZ' component code. Points X'1200' through X'16FF' are defined for use by FEPI, although not all of these are used.

Taking trace entries

You control the taking of FEPI trace entries with the CETR SZ transaction, or the SET TRACETYPE SZ command. FEPI supports only one level of tracing—either all or nothing. At CICS initialization, you can specify the default levels of standard and special tracing by means of the STNTR, SPCTR, STNTRSZ, and SPCTRSZ system initialization parameters, which are described in the *CICS/ESA System Definition Guide*. Exception trace entries are always taken.

You can use the selection features of the CETR transaction to limit tracing to specific transactions. This is described in the *CICS/ESA CICS-Supplied Transactions* manual. If you do this, you can control the tracing of application programs, but the FEPI Resource Manager, running as the CSZI transaction, is unaffected, because trace selection is applied only at transaction start.

If you are using DFHTRAP under the guidance of IBM support, note that the FEPI Resource Manager runs under the SZ TCB. Therefore, do not do anything that could force an MVS task switch to any other TCB.

Interpreting FEPI trace entries

The first thing to consider is whether there are any exception trace entries. Their presence indicates that a problem has been detected, and (perhaps) that the appropriate action has been taken. Exception trace entries are either initialization errors or storage management errors.

Initialization errors result from checks made when CSZI starts, to prevent a second instance of the FEPI Resource Manager. Storage errors result from GETMAIN or FREEMAIN errors, and are usually caused by a lack of CICS storage.

The other trace entries are the usual module entry and exit traces, together with a few points indicating that important processing events have occurred (such as the FEPI Resource Manager becoming idle).

FEPI messages

Messages produced by FEPI have exactly the same format (DFHSZ...) as other CICS messages. They are all sent to the FEPI message log (the CSZL transient data queue); some are also sent to the operator.

FEPI messages are documented in the *CICS/ESA Messages and Codes* manual, and are also available through the CMAC transaction.

FEPI abends

FEPI does not (deliberately) issue either CICS transaction abends or MVS abends. However, an unexpected failure can occur in the following places:

- In a FEPI application program when INVREQ is returned
- In the EXEC stubs
- In the FEPI adapter
- In the FEPI Resource Manager transaction (CSZI) code
- In a VTAM exit routine.

These abends have different results, as shown in Table 9.

Point of failure	Result
Application	The usual transaction abend for the error condition.
EXEC stubs	The usual transaction abend for a failure within CICS management modules. An example of this is an 'operation' program check, which generates a CICS AKEA abend, which in turn generates an ASRA abend.
FEPI adapter	The usual transaction abend for a failure within CICS management modules. An example of this is an 'operation' program check, which generates a CICS AKEA abend, which in turn generates an ASRA abend.
FEPI Resource Manager	No direct effect on the application program, because the abend occurs under the CSZI Resource Manager task. This probably results in a DFHSZ4099E message (see "Message DFHSZ4099E"), and the failure of the Resource Manager. An example of this is an 'operation' program check, which generates a CICS AKEA abend, which in turn generates an ASRA abend. Any CICS FEPI transactions are left waiting on the FEPI_RQE resource (for details of FEPI waits, see the <i>CICS/ESA Problem Determination Guide</i>).
VTAM exit	A VTAM abend; a VTAM dump is taken. Because the exit lies within the FEPI Resource Manager, the CICS abend handling routines are activated to process a "normal" failure in the Resource Manager.

Restart

An abend in an application program, an EXEC stub, or the FEPI adapter affects only the active CICS task that issued the FEPI command; other FEPI programs continue as normal.

If an abend affects the SZ TCB, CICS makes that TCB unavailable for use, while keeping the other CICS TCBs active and accessible. This means that FEPI functions can be restored only by restarting the CICS system.

Message DFHSZ4099E

This message indicates that the abend exit routine within the FEPI adapter has trapped an abend within the FEPI Resource Manager.

As soon as an abend within the Resource Manager is detected, the FEPI state (in the FEPI static area) is set to 'Failed'. If possible, message DFHSZ4099E is issued, together with a SNAP dump, to indicate that FEPI has failed. However, in some circumstances it is not possible to issue DFHSZ4099E, and a system dump is generated instead.

Any FEPI transactions are left waiting on the FEPI_RQE resource (for details of FEPI waits, see the *CICS/ESA Problem Determination Guide*). These waits never get posted, so the transactions suspend. You must issue a CEMT FORCEPURGE command to remove these suspended transactions from the system.

Warning: It is strongly recommended that the CSZI transaction is initiated only as part of CICS system initialization. *Do not attempt to restart the CSZI transaction after a failure, other than by restarting CICS.*

Message DFHSZ4155I

This message indicates that a connection has ended, and gives a reason code taken from the VTAM control blocks. The reason code may be returned in the LASTACQCODE option of a CEMT or FEPI INQUIRE command, depending on the operation which generated DFHSZ4155I.

DFHSZ4155I does not always indicate a problem; if you took positive action to end the connection, DFHSZ4155I merely confirms that VTAM did as you requested. However, if the connection ended unexpectedly, the reason code tells you why.

To determine what the reason code means, refer to the *VTAM Programming* manual.

Reporting a FEPI problem to IBM

When reporting a problem to IBM Support, you need the following details of the CICS system in which FEPI is installed:

- All listings from the CICS job, including the CICS job log and JCL
- A print of all reports sent to the CSZL transient data queue
- A full system dump (including the CSA and LSQA)
- Any relevant transaction dumps
- All trace entries (you may need to recreate the problem with SZ trace active)
- A listing of the application program that detected the problem
- Listings of the programs used to configure your FEPI system
- Listings of any active CICS global user exit programs (not only the FEPI ones)
- Prints of user journals, if FEPI journaling was active when the problem occurred.

The following materials might also be required:

- A VTAM trace showing the data flows
- A trace of the back-end system showing what data streams were received from FEPI application programs
- A VTAM status display showing the status of FEPI connections
- Any dumps or logs produced by the back-end system.

Part 3. Application programming

This part of the book is primarily for application programmers and includes reference information for FEPI application programming commands.

- Chapter 11, “Basics” on page 103 introduces FEPI programming and the commands that are used.
- Chapter 12, “Key stroke and screen-image applications” on page 107 discusses the high-level interface for FEPI applications.
- Chapter 13, “Data stream applications” on page 115 describes the low-level interface for FEPI applications.
- Chapter 14, “Application design” on page 121 describes the programs comprising a FEPI application and various design aspects such as conversation ownership, handling errors, and specific requirements for CICS and IMS back-end systems.
- Chapter 15, “Specialized functions” on page 135 describes control functions, normally handled by FEPI, that can be taken over by FEPI applications.
- Chapter 16, “Application programming reference” on page 137 contains reference information for the FEPI commands that are used in application programs.

Chapter 11. Basics

This chapter introduces FEPI programming and the FEPI commands that you can use. Before reading this chapter you should be familiar with the FEPI concepts and facilities described in Chapter 1, “Introducing FEPI” and Chapter 2, “Functions and services.”

To write FEPI front-end applications, you need to know how to write programs in at least one of the programming languages that CICS supports. More importantly, you also need knowledge of data communication and protocols. And, if you will be accessing IMS back-end systems, you must also be familiar with using IMS and writing IMS applications.

The applications that you write using FEPI are normal CICS transactions with the familiar EXEC CICS commands. These FEPI applications use the FEPI subset of EXEC CICS application programming commands to:

- Allocate a connection from a pool
- Communicate with a back-end application using this connection
- Free the connection when finished.

Communication and conversations

Note: The highlighted terms in this section are defined in Chapter 2, “Functions and services” on page 7.

A FEPI application runs in a **front-end** CICS system and accesses applications in a **back-end** CICS or IMS system. FEPI lets it do this by simulating a terminal connected to the back-end system; this means that it has to act just like a real terminal and terminal operator.

The back-end systems are known as **targets** and the **connections** to them are arranged in **pools** that define the properties controlling communication. Targets, pools, and properties are defined by your system programmer, who can tell you which targets and pools to use and what properties they have.

When a connection has been established, on successful completion of a bind, the connection is **in session** and it can be allocated by FEPI for a **conversation** with the back-end system.

Conversations are the basis of all FEPI applications and, depending upon the needs of your application, may be used in several ways (see Chapter 14, “Application design” on page 121):

- A single conversation for all transactions on a back-end system
- A different conversation for each transaction or associated series of transactions
- A special conversation to handle unusual events.

The task that started the conversation owns it and other tasks cannot issue commands for it; however, the owning task can transfer ownership to another task. You can have as many conversations as you like at a time with various targets: they can be consecutive or, much more usefully, interleaved.

FEPI simulates a 3270-type terminal (SLU2 mode) for both CICS and IMS systems; it also supports the SLU P mode that is used by IMS for programmable terminals such as the 4700 family. The mode to be used, SLU2 or SLU P, is a property of the pool being used. Your application cannot change the mode of a conversation.

The data that you send and receive can be **formatted** or **data stream** and, as with mode, the data type is a property of the pool being used:

Formatted	A high-level data interface for SLU2 mode. The data sent by the FEPI application can be either key stroke format or screen-image format; data received by the application is in screen-image format.
Data stream	A low-level data interface for more sophisticated SLU2 mode applications and for use with SLU P mode. The data sent and received by the FEPI application is the data stream; applications using this format have access to some very specialized VTAM communication functions.

The same basic set of FEPI commands is used for all modes and data types and protocols, but the command options and keywords are generally different.

Structure and design

In addition to your main access program that handles communication with the back-end system, you may need to provide programs for other functions:

Begin session	Handle begin-session processing.
Unsolicited data	Handle unsolicited inbound data that arrives when there is no conversation.
End session	Handle end of conversation and end of session processing.

These functions could be combined in one program or implemented in separate programs with individual transaction names. There may be any number of each function, again according to your requirements and preferences. Suggestions about the various possibilities are given later.

As the application programmer, you will always write the main access programs. Sometimes the system programmer provides any special functions that are required; otherwise you would be responsible for these. Even if you are writing only the main access program, you need to be aware of what these special functions do and how they affect how you communicate with the back-end system. Because the use of these special functions is controlled by the pools that you use, you need to liaise with the system programmers or administrators who set them up.

Several different styles of access program are possible:

One-out one-in conversational

One program performs the complete conversation with the target and each conversation has a single transmission to and from the back-end system.

Conversational

One program performs the complete conversation with the target with multiple transmissions to and from the back-end system, waiting each time for the inbound data.

Pseudoconversational

Here, one program sends data to the target and requests CICS to start another program when the inbound data arrives.

The section beginning with Chapter 12, "Key stroke and screen-image applications" on page 107 and ending with Chapter 15, "Specialized functions" on page 135 describes the various features of writing application programs. A set of sample programs is available to help you to get started; these are supplied as source code on the distribution tape. For details, see Appendix A, "Sample programs" on page 165.

Programming

FEPI programs are CICS applications, so all aspects of CICS programming apply. For general information about writing CICS application programs, see the *CICS/ESA Application Programming Guide*. For programming information (including command formats, argument values, details on the translation of programs, and language considerations), see the *CICS/ESA Application Programming Reference*. Particularly relevant are the chapters in the *Application Programming Guide* about designing efficient applications and dealing with exception conditions.

The FEPI application programming commands are an extension of the EXEC CICS commands. They have similar names and similar functions. The FEPI commands also have similar keywords, but they are distinguished by having FEPI as a prefix. For application programming the commands are:

EXEC CICS FEPI ALLOCATE	Starts a conversation with a back-end system.
EXEC CICS FEPI FREE	Ends the conversation with a back-end system.
EXEC CICS FEPI REQUEST PASSTICKET	Requests the external security manager to supply a password substitute.
EXEC CICS FEPI SEND	Sends data to the back-end system.
EXEC CICS FEPI RECEIVE	Receives data from the back-end system.
EXEC CICS FEPI CONVERSE	Sends data to and receives data from the back-end system.
EXEC CICS FEPI ISSUE	Sends control data to the back-end system.
EXEC CICS FEPI EXTRACT	Gets field data and attributes, set-and-test sequence number (STSN) data, or information about a conversation.
EXEC CICS FEPI START	Schedules a CICS transaction to handle inbound data.

Note that, when translating your programs, you must specify the FEPI option; this instructs the translator to process FEPI commands.

Your FEPI application programs can be AMODE(24) or AMODE(31)—that is, they can issue FEPI commands in either 24- or 31-bit addressing mode, and reside above or below the 16MB line.

Exception conditions

As with all CICS commands, FEPI commands may produce exception conditions that you can check using the RESP option, or capture using HANDLE CONDITION. Most FEPI command errors return INVREQ. The particular error in each case is uniquely identified by the RESP2 value. All the FEPI exception conditions and RESP2 values are listed in Chapter 16, “Application programming reference” on page 137. There are copy books that contain declarations for the RESP2 values:

- DFHSZAPA for Assembler language
- DFHSZAPO for COBOL
- DFHSZAPP for PL/I
- DFHSZAPC for C/370.

If there is an error, the command does nothing, and output values are not changed. Note, however, that commands such as FEPI SEND may have transferred data before the condition is recognized.

You can use EDF and CECI to debug FEPI programs. Because FEPI commands can be quite long, you will probably find the NAME field of CECI useful.

Chapter 12. Key stroke and screen-image applications

This chapter discusses the key stroke and screen-image data interfaces for FEPI applications. The examples given in this chapter are confined to simple conversational applications. However, you can use this data interface whatever the application structure. See Chapter 14, "Application design" on page 121 for further possibilities together with full details of conversations, error handling, and system considerations.

The key stroke and screen-image data interface is suitable for a wide range of applications, and is simpler to use than the alternative data stream interface. However, there are certain types of application for which you cannot use screen-image data. For more details, see Chapter 13, "Data stream applications" on page 115.

You can send both key stroke and screen-image data in the same conversation. The inbound data format is the same for both: a screen-image, that you can also access field-by-field.

You must have general knowledge of data communication and protocols.

General sequence of commands

The following diagram illustrates the general sequence of FEPI commands that you use with key stroke and screen-image data. That is, a FEPI SEND, multiple FEPI RECEIVES that complete when all the data has been received, followed by another FEPI SEND.

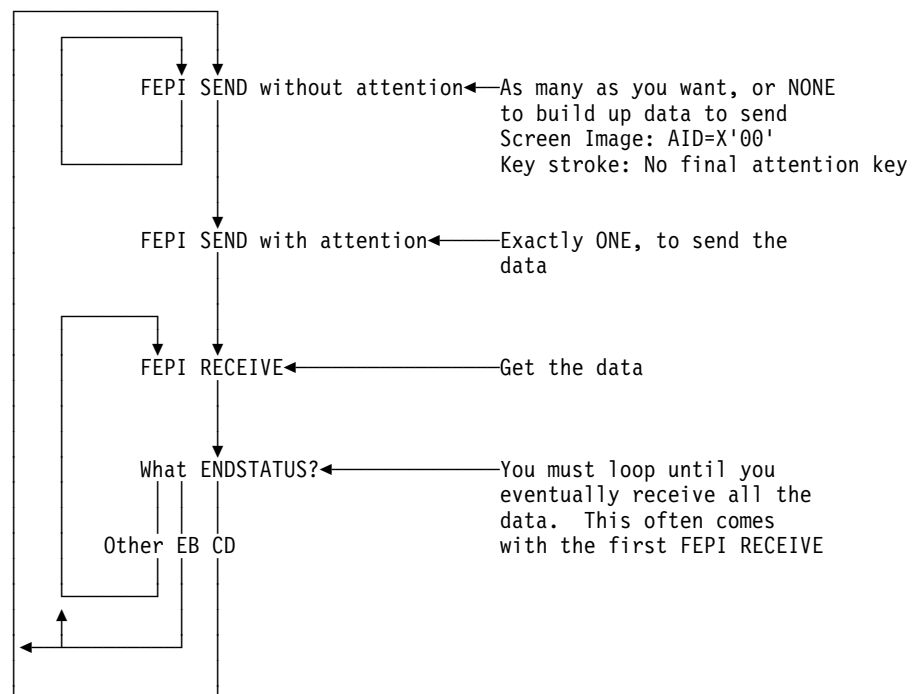

Note: The diagram does not show any processing of the data, nor where you might enter, or leave, the loop. This information is explained more fully in Chapter 14, "Application design" on page 121.

Sending key stroke data

Sending key strokes is the easiest way of sending data.

Your program acts in the same way as the keyboard operator, with FEPI letting the program “press keys” just as the operator does.

A sample program illustrates the techniques used; see “Key stroke CONVERSE” on page 174.

The data can contain any combination of data characters together with manipulative, special, and attention key values representing almost every keyboard key. Data characters are represented as themselves. Manipulative, special, and attention key values are represented by *escape* sequences, comprising an escape character followed by a 2-character code. For example, using '&' for the escape character, you might send the following sequence to insert AB in one field, type IJKL into another field, and press PF7 to complete the input operation:

```
&HO&T2&R1&INAB&RS&N4IJKL&EF&07
```

```
Home
  Tab, twice
    Cursor right
      Insert
        AB
          Reset
            Newline, 4 times
              IJKL
                Erase-EOF
                  PF7
```

If the sequence were in a character string named KEY-SCRIPT, you would send it with:

```
EXEC CICS FEPI SEND FORMATTED
      CONVID(...)
      KEYSTROKES
      FROM(KEY-SCRIPT)
      FLENGTH(30)
```

In full, the escape sequences are:

<i>Manipulative keys</i>	<i>Special keys</i>	<i>Attention keys</i>
&HO home	&IN insert	&AT attention
&Ln cursor left, n times	&DL delete	&An PAn (n = 1–3)
&Rn cursor right, n times	&RS reset	&nn PFnn (nn = 01–24, any leading 0 must be specified)
&Un cursor up, n times	&EF erase to end of field	&CL clear
&Dn cursor down, n times	&EI erase input	&CS cursor select (light pen)
&Tn tab, n times	&FM field mark	&EN enter
&Bn backtab, n times	&DU DUP	&ME end secure MSR
&Nn newline, n times	&ES escape character	
(n = 1–9)	&SO shift out	
	&SI shift in	
	&MS start secure MSR	

You can choose an alternative escape character.

Data characters must have values $\geq X'40'$, so nulls ($X'00'$) are not supported as such, although they can be generated using the erase or delete keys. Key strokes following an attempt to type into a protected field are ignored until RESET is keyed.

For magnetic stripe reader support, the sequence **&MS...data...&ME** represents passing a secure magnetic stripe card through the reader. Nonsecure cards have to be simulated by entering the data in the normal way.

The cursor position is set by your key strokes, rather than specifying where the cursor is placed. If your first key stroke is always the HOME key (&HO), you will have the cursor in a known starting position.

You can choose to send all the data with one command, or to use several commands to build up the data. The last (or only) command should have an attention key as its final key stroke, to actually send the data. There should be no other attention keys.

Alternatively, if you are not interested in the received data, you can ignore it by sending key strokes with multiple attention keys, as described in “Multiple attentions” on page 110.

Errors

Apart from communication errors caused externally, there are two likely sorts of error that you might get:

- Bad command sequencing; that is, you have issued a FEPI SEND when one was not expected. A FEPI SEND must **not** follow a FEPI SEND with a final attention key, or a FEPI RECEIVE that did not indicate ‘change direction’.
- Incorrect data; that is, your key strokes are improper. You may have:
 - Sent data, characters, or escape sequences that are not valid.
 - Got into an ‘input inhibited’ situation and not reset it.
 - Broken the rules for double-byte character set (DBCS) data.
 - Failed a validation test, if there are fields with one of the validation attributes.

Many of these data errors cannot be detected until the data is actually processed, because they depend on the previous data. This means that any key strokes preceding the error will already have taken effect—they cannot be removed by FEPI.

The FEPI SEND can also fail if, following end bracket, the back-end sends BID to send more data and your pool has CONTENTION(LOSE). You must then receive the new back-end data first.

Receiving field-by-field

Receiving data field-by-field is the easiest way of receiving data.

In the simplest case you would issue a FEPI RECEIVE command without specifying an INTO data area. FEPI gets the data from the back-end system and builds the resulting screen image internally. The cursor position is returned by the CURSOR option. Information about the number of lines, columns, and fields in the screen image is returned by the LINES, COLUMNS, and FIELDS options.

To get the data, you issue the FEPI EXTRACT FIELD command for each individual field that you want. As well as the data, you can find out the attribute settings for the field, and its length and position. The attribute values are defined in the DFHBMSCA copy book, as is used with BMS. You can issue as many FEPI EXTRACT FIELD commands as you need, for whichever fields you want. You can issue more than one for each field, for example, if you want to get the data and attributes separately. It is generally preferable to use the FIELDLOC option rather than FIELDNUM. There may be spurious attributes between each displayed field which make determining field numbers difficult.

A sample program illustrates the techniques used; see “Screen image RECEIVE and EXTRACT FIELD” on page 177.

Command completion

The FEPI RECEIVE command completes on 'end of chain'. This normally coincides with 'change direction' or 'end bracket', meaning that all data has been received. In some cases, however, back-end applications may send data to you in several sections (chains), each causing a screen update, so you must keep on receiving data until 'change direction' or 'end bracket' is indicated.

In all cases, the ENDSTATUS option is set to indicate what the completion conditions were. Where several conditions occur together, ENDSTATUS shows the most significant one. The values of ENDSTATUS and their associated meanings are shown in Table 10.

ENDSTATUS	Conditions			Next command expected
	End bracket	Change direction	End of chain	
EB	Y	-	Y	Any
CD	-	Y	Y	FEPI SEND or CONVERSE
LIC	-	-	Y	FEPI RECEIVE

Note: Y=Condition indicated.

When 'end bracket' is received, the session is in *contention state*, and either end may try to transmit data next. Some back-end systems use 'end bracket' in the middle of a series of transmissions to allow the terminal to break in if it wants, and they may use 'end bracket' instead of 'change direction' at the end of the flow. This is particularly true of IMS. CICS usually sends 'change direction' eventually, although it may send 'end bracket' indicators intermediately.

Using your knowledge of the back-end application and system, you must check the data that you have already received, to determine whether more data is to be expected or the transmission is complete. If more data is expected, you should issue another FEPI RECEIVE command; if the transmission is complete, it is the front-end application's turn to send data.

You should always use the TIMEOUT option on a FEPI RECEIVE command; see "Time-outs" on page 128.

Errors

Apart from communication errors caused externally, the most likely error you may get is due to bad command sequencing. That is, you have issued a FEPI RECEIVE when a FEPI SEND is expected. A FEPI RECEIVE must **not** follow a FEPI SEND without attention, or a FEPI RECEIVE that indicated 'change direction'.

Another likely error is 'previous SEND failed'. This may be an external communication error, or it may be that the back-end system has responded negatively—as IMS does, for example, if you try to run an unknown transaction. The sense data which you can get using FEPI EXTRACT CONV tells you which error it is, and, where the back-end system has responded negatively, you simply issue another FEPI RECEIVE to get the data.

Multiple attentions

In certain circumstances you might not have any interest in the immediate result of the data you send, but only in a later result, after you have sent more data. If this is the case, you can construct a single key stroke sequence, comprising all the sets of data to send, each with its own attention key, and then send the whole lot in one operation.

At each attention key, FEPI sends your data to the back-end system and receives the results internally, until 'change direction' or 'end bracket' is indicated. Then FEPI sends the next set of key strokes. Using multiple attentions improves performance but, if the intermediate results are not what you expect, FEPI has no way of knowing this and carries on sending your key strokes. This can lead to unexpected effects, or to the failure of the command with a data error. In the latter case, all the key strokes and back-end system interactions preceding the error have already taken effect and you may find it difficult to determine the state of the back-end system. Further, no time-out can be specified for the intermediate receives, and so, if there is a communication problem, your application may be suspended indefinitely.

If the last set of key strokes ends with an attention key, you **must** issue a FEPI RECEIVE command to get the final result. If the last set of key strokes does not end with an attention key, you can issue another FEPI SEND command, with yet more key strokes.

Sending screen-image data

Sending screen-image data is an alternative to sending key stroke data. In general, this would be the screen image that you received modified to reflect the changes that would be the result of an operator action. A sample COBOL program, DFH0VZTS, illustrates the techniques used; see "Screen image SEND and START" on page 175.

The data is exactly what you would expect: an image of the screen that you want to send. That is, 24 rows of 80 bytes (or whatever your screen size is) of data, corresponding byte-for-byte with the screen. For example, in a COBOL program containing this data description:

```

01  SCREEN-IMAGE  PIC X(1920).
01  SCREEN-FIELDS REDEFINES SCREEN-IMAGE.
05  LINE-1       PIC X(80).
05  FILLER       REDEFINES LINE-1.
10  FILLER       PIC X(20).
10  CUST-NO      PIC X(12).
10  FILLER       PIC X(48).
05  LINE-2       PIC X(80).
05  LINE-3       PIC X(80).
05  LINE-4       PIC X(80).
05  FILLER       REDEFINES LINE-4.
10  FILLER       PIC X(12).
10  CUST-NAME    PIC X(32).
10  FILLER       PIC X(36).

```

you would put the required data into the fields and send the screen image using:

```

EXEC CICS FEPI SEND FORMATTED
      CONVID(...)
      FROM(SCREEN-IMAGE) FLENGTH(1920)
      AID(PF2)

```

where AID specifies which attention key was pressed on the simulated terminal.

Data bytes are represented as themselves; you must set any nulls (X'00') that are needed to fill a field. In a protected field, the data bytes must be the same as in the current, simulated terminal buffer that FEPI holds. In the case of attribute bytes, it does not matter what values you put, because you have no control over their positions or settings, any more than a terminal operator does. However, if the value is X'01', FEPI sets the modified data tag (MDT) for the field, even if its data has not changed. (If the data has changed, FEPI sets the MDT automatically.)

You do not have to send a complete screen image. If your changes are confined to the first few lines, you need only send those few lines. The data you send is taken as starting from the top left position of the screen.

Key stroke and screen-image

Note: If you are using the C/370 programming language, remember that a screen image probably contains null characters. Take care if you are handling the screen image as a string.

The cursor position can be set using the CURSOR option.

You can choose to send all the data with one command, or to use several commands to build up the data. The last (or only) command must have an attention identifier (AID) specified, using the AID option, to send the data. The other commands must have an AID value of X'00'. Definitions for the AID values are in the DFHAID copy book, as is used with BMS.

#

Note: The COBOL and assembler versions of the DFHAID copybook are different. Therefore, you cannot simply copy unmodified SEND commands from the DFH0VZTS sample program, which is supplied in COBOL only, to a user-written assembler program.

Errors

The errors you can get are similar to those for key stroke data. Your screen-image data has other ways of being incorrect. In place of escape sequences not being valid, or 'input inhibited', you might have cursor or AID settings not valid, or changed data in a protected field. Many of these data errors cannot be detected until the data is actually processed. This means that some of the changes will have taken effect already—they cannot be removed by FEPI.

Receiving screen-image data

If you specify an INTO data area on a FEPI RECEIVE command, the data you receive is the screen image; 24 rows of 80 bytes (or whatever your screen size is) corresponding byte-for-byte with the screen. Data bytes are represented as themselves. In positions corresponding to attribute bytes, X'FF' appears.

You need only get the first few lines of the screen if that is all that you are interested in.

After you have processed the data, you will probably use the same screen image, modified as required, on a subsequent screen-image send.

Even though you got a screen image, you can use the FEPI EXTRACT FIELD command as well if you want, for any particular fields that you require, just as described in "Receiving field-by-field" on page 109. In particular, the FEPI EXTRACT FIELD command is the only way you can determine the value of the field attributes.

A sample program illustrates the techniques you can use; see "Key stroke CONVERSE" on page 174.

Note: If you are using the C/370 programming language, remember that a screen image probably contains null characters. Take care if you are handling the screen image as a string.

Command completion and errors

As far as completion and errors are concerned, a FEPI RECEIVE command with an INTO data area is just like one without. So, if you do not get 'change direction' or 'end bracket', you have to issue another FEPI RECEIVE command before you can send your screen image back, and even 'end bracket' might require further FEPI RECEIVE commands.

Extracting field data

It is not only after a FEPI RECEIVE command that you can issue a FEPI EXTRACT FIELD command. You can issue this command anywhere in the conversation to find out about the current screen image that FEPI holds for the simulated terminal.

This can be particularly useful where a FEPI SEND command has failed or given unexpected results, to discover what happened.

CONVERSE

FEPI CONVERSE can be used instead of a FEPI SEND with attention and the first (or only) FEPI RECEIVE. It is more efficient than issuing two separate commands and is allowed anywhere that FEPI SEND is allowed. The effects are exactly as if the two commands had been issued.

The ending conditions are identical to those for FEPI RECEIVE, unless you use the POOL option to get a temporary conversation. In this case, it ends on the first to occur of:

- 'Change direction' indicated
- 'End bracket' indicated,

and does not end at 'end of chain' alone.

Errors

You need to take into consideration which command is expected next:

- If the receive part of the FEPI CONVERSE command fails, the send will have already been done, and so a FEPI RECEIVE command is expected next.
- If the send part fails, the receive is not done, and, if the initial send was expected, a FEPI SEND or CONVERSE command is expected next.

Chapter 13. Data stream applications

This chapter discusses the low-level data stream interface for FEPI applications. The examples it contains are confined to simple conversational applications. However, you can use this data interface whatever the application structure; see Chapter 14, "Application design" for all the possibilities, together with details of conversations, error handling, and system considerations.

You need, or should use the data stream interface for the following types of applications:

- With pass-through; that is where the application passes data through, usually to the user's terminal, without doing anything to it.
- With SLU P.
- Where the formatted interface does not provide the detailed function that you need.
- For handling non-3270 LU2 devices.
- With non-response mode IMS transactions.

The 3270 data stream interface is especially useful when creating FEPI applications that require to do little or no manipulation of the inbound (screen) data, because it is already in a form suitable for sending to a real terminal. If interpretation or reformatting of the inbound data is required, however, it can be significantly more difficult to operate on a 3270 data stream.

An example of an application suited to the 3270 data stream interface is a pass-through program, as illustrated by the sample program "3270 data stream pass-through" on page 178. Such programs can also be used to determine the flows and screen layouts of back-end systems when you are developing FEPI applications that, for example, drive signon or menu selection sequences and manipulate screens or dialogs.

You **must** be fully conversant with the data stream and data stream protocols as detailed in the books in the following list, and with how the back-end system uses them:

- *3270 Data Stream Programming Reference*
- *3274 Functional Description*
- *SNA Formats*
- *VTAM Programming*
- *IMS/ESA Programming Guide for Remote SNA Systems*
- *IMS/VS Version 2 Programming Guide for Remote SNA Systems*.

The application program is entirely responsible for the integrity of the data stream that uses this interface. FEPI performs no checking or interpretation on the data stream that is sent to or received from the back-end system, and makes no attempt to manipulate data into RU sizes that the sender or receiver can handle; the application program must be prepared to handle whatever data is presented to it. For example, with SLU2 mode, it must be prepared to handle READ commands, and WRITE STRUCTURED FIELD commands, in addition to the normal WRITE commands.

#

General sequence of commands

The following diagram illustrates the general sequence of FEPI commands that you use with data stream. That is, a FEPI SEND, multiple FEPI RECEIVE commands that complete when all the data has been received, followed by another FEPI SEND.

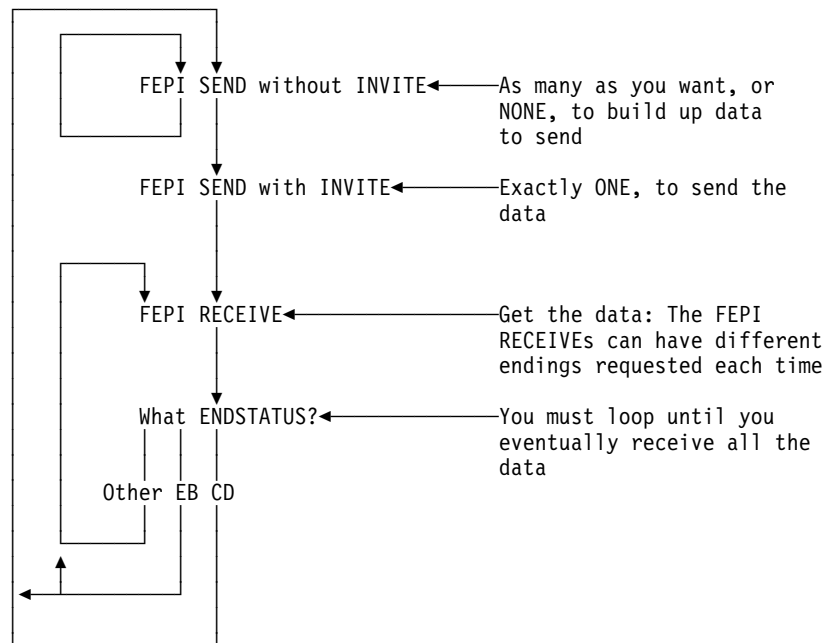

Note: The diagram does not show any processing of the data, nor where you might enter, or leave, the loop. This information is explained more fully in Chapter 14, “Application design” on page 121.

Receiving

You can choose whether to process data in small segments or all at once. Your choice depends upon various factors including:

- Processing convenience
- The amount of data that you expect
- The size of the data area that you can use
- What you are doing with the data
- How the back-end application operates
- Whether you want to handle responses (see Chapter 15, “Specialized functions” on page 135 for this feature).

The data is a standard inbound data stream, exactly as is sent to the simulated terminal from VTAM. It is quite possible that there will be occasions on which you will receive no data; for example, when the back-end system needs to set a protocol indicator.

Command completion

FEPI RECEIVE can be specified, or defaulted, to end in one of the following ways:

RU

- On the first to occur of:
- INTO data area full
 - End of request unit.

CHAIN

- On the first to occur of:
- INTO data area full
 - End of chain.

UNTILCDEB

On the first to occur of:

- INTO data area full
- End of chain with definite response request
- 'Change direction' indicated
- 'End bracket' indicated.

Note: Using UNTILCDEB is not recommended, because you may have the difficult task of splitting data back into its constituent chains in order to process it.

In all cases, the ENDSTATUS option is set to indicate what the completion conditions were. Where several conditions occur together, ENDSTATUS shows the most significant one. The values of ENDSTATUS and their associated meanings are shown in Table 11.

ENDSTATUS	Command options	Conditions					Next command expected
		End bracket	Change direction	End chain	End RU	INTO area full	
EB	RU, CHAIN, UNTILCDEB	Y	-	Y	Y	-	Any
CD	RU, CHAIN, UNTILCDEB	-	Y	Y	Y	-	FEPI SEND or CONVERSE
LIC	RU, CHAIN, UNTILCDEB	-	-	Y	Y	-	FEPI RECEIVE
RU	RU	-	-	-	Y	-	FEPI RECEIVE
MORE	RU, CHAIN, UNTILCDEB	-	-	-	-	Y	FEPI RECEIVE

Note: Y=Condition indicated.

FEPI RECEIVE commands must continue to be issued until 'change direction' or 'end bracket' is indicated. You cannot start sending data until all inbound data has been received. If an ENDSTATUS of MORE is indicated, the data stream is not necessarily self-contained and should not be processed until the remainder of the information is received. The value returned for REMFLENGTH *may* indicate how much more information is to come.

When 'end bracket' is received, the session is in *contention state*, and either end may try to transmit data next. Some back-end systems use 'end bracket' in the middle of a series of transmissions to allow the terminal to break in if it wants, and they may use 'end bracket' instead of 'change direction' at the end of the flow. This is particularly true of IMS. CICS usually sends 'change direction' eventually, although it may send 'end bracket' indicators intermediately.

Using your knowledge of the back-end application and system, you must check the data that you have already received, to find out whether more data is to be expected or the transmission is complete. If more data is expected, you should issue another FEPI RECEIVE command; if the transmission is complete, it is the front-end application's turn to send data.

A problem arises where the application is the pass-through type, because it does not look at the received data. There are various ways of handling this:

1. Request data conditionally from both ends—which cannot generally be done, and particularly not in the most typical case where the pass-through is directly to a front-end terminal.
2. Wait for data from both ends at once. This can be done where the pass-through is directly to a front-end terminal and the transaction is pseudoconversational for both CICS and FEPI. See "Started tasks" on page 124.
3. Ask each end at intervals if there is data waiting (for the back-end system by using FEPI RECEIVE with TIMEOUT); this is often not possible, as in the case where the pass-through is directly to a front-end terminal.
4. Forego a strict pass-through technique and check the data.

Data stream applications

5. Assume that a transmission with 'end bracket' and no data means that more data is to come.
6. Issue another FEPI RECEIVE with TIMEOUT in case more data is to come, which has the disadvantage of introducing a delay.

Note: The last two cases involve an element of risk because the wrong assumptions can be made.

You should always use the TIMEOUT option on a FEPI RECEIVE command; see "Time-outs" on page 128.

Errors

Apart from VTAM and back-end communication errors caused externally or, more probably, by errors in the outbound data stream that you sent previously, the most likely cause of an error condition is an incorrect sequence of commands. That is, you have issued a FEPI RECEIVE when a FEPI SEND is expected. A FEPI RECEIVE must **not** follow a FEPI SEND without INVITE, or a FEPI RECEIVE that indicated 'change direction'.

Another likely error is 'previous SEND failed'. This may be an external communication error, or it may be that the back-end system has responded negatively—as IMS does, for example, if you try to run an unknown transaction. The sense data which you can get using FEPI EXTRACT CONV tells you which error it is, and in the latter case you simply issue another FEPI RECEIVE to get the data.

See "3270 data stream pass-through" on page 178 and "SLU P pseudoconversational" on page 181 for sample programs illustrating some of the programming techniques.

Sending

You can choose to send an entire stream of data, or you can break it up into smaller units, finishing with a FEPI SEND with INVITE. INVITE indicates that this is the last data to send, and that inbound data should be expected next. The data is sent with 'last in chain' and 'change direction'. Otherwise, further FEPI SENDS are to be expected. It is the application program's responsibility to ensure that the amount of data sent on a request does not exceed the capacity of the receiving LU.

#

Errors

Apart from VTAM errors caused, most probably, by errors in the outbound data stream that you sent previously, the most likely cause of an error condition is an incorrect sequence of commands. That is, you have issued a FEPI SEND when one was not expected. A FEPI SEND must not follow a FEPI SEND with INVITE, or a FEPI RECEIVE that did not indicate 'change direction'.

The FEPI SEND can also fail if, following 'end bracket', the back-end system sends BID to send more data and your pool has CONTENTION(LOSE). You must then receive the new back-end data first.

See "3270 data stream pass-through" on page 178 and "SLU P pseudoconversational" on page 181 for sample programs illustrating some of the programming techniques.

CONVERSE

FEPI CONVERSE can be used instead of a FEPI SEND with INVITE and the first (or only) FEPI RECEIVE. It is more efficient than issuing two separate commands and is allowed anywhere that FEPI SEND is allowed. The effects are exactly as if the two commands had been issued.

The ending conditions are identical to those for FEPI RECEIVE, unless you use the POOL option to get a temporary conversation. In this case, it ends on the first to occur of:

- INTO data area full
- 'Change direction' indicated
- 'End bracket' indicated,

and **not** at 'end of chain' alone. Further, if there is any residual data to receive, it is lost.

With regard to errors, you need to take into consideration which command is expected next:

- If the receive part of the FEPI CONVERSE command fails, the send will have already been done, and so a FEPI RECEIVE command is expected next.
- If the send part fails, the receive is not done, and, if the initial send was expected, a FEPI SEND or CONVERSE command is expected next.

SLU2 mode considerations

It is necessary, when sending outbound 3270 data streams, to ensure that a three-byte prefix containing the attention identifier (AID) and cursor address is inserted at the front of the data. Similarly, the first two bytes of inbound data typically contain the 3270 command code and write control character (WCC). The lengths supplied or returned on the FEPI SEND, RECEIVE, or CONVERSE DATASTREAM commands include the length of the prefix.

AID values are the same as the CICS values and, in pass-through applications, can be taken from EIBAID. The cursor address however is a buffer address and **cannot** be taken from EIBCPOSN. 3270 buffer addresses can be 12-, 14-, or 16-bit addresses depending on the device. Twelve-bit addressing is the most difficult to convert to or from, but it is very common; an address conversion table and an algorithm are contained in the *3270 Information Display System 3274 Control Unit Reference Summary*.

The inbound 3270 command is most likely to be a WRITE or ERASE WRITE and is, therefore, followed by a WCC then orders and data. However, this is not guaranteed and the inbound command should be inspected to determine what it is, what, if anything, should follow it, and how it should be handled. For example, the application may choose to perform an EXEC CICS SEND TEXT from the inbound data and may, therefore, require to know whether to append the ERASE keyword. The various READ commands (such as READ BUFFER and READ MODIFIED) and all the WRITE STRUCTURED FIELD commands (a common one being READ PARTITION with QUERY) need special handling.

If you receive more than one chain (using the UNTILCDEB option), you have to find each inbound command yourself, so this is not recommended unless you know that the back-end system only sends a single chain.

For further information, refer to the *3270 Information Display System Data Stream Programmer's Reference*.

SLU P mode considerations

Two sample programs illustrate some of the programming techniques for SLU P mode. For details, see “SLU P pseudoconversational” on page 181 and “SLU P one-out one-in” on page 180.

Chapter 14. Application design

This chapter describes the programs comprising a FEPI application and the basic design aspects. It also discusses signon security, error handling, and system considerations, including performance.

Programs

The programs comprising a FEPI application are:

- Access
- Begin-session handler
- Unsolicited-data handler
- End-session handler.

Access program

The main purpose of an access program is to:

- Start a conversation, using FEPI ALLOCATE
- Communicate with the back-end application using FEPI SEND and RECEIVE or FEPI CONVERSE
- End the conversation using FEPI FREE.

It must also be able to handle exception cases such as edit errors, transactions that are not valid, or security violations, and it may need to manage signon/signoff sequences. It may also need to handle begin-session and end-session requirements, if special handlers are not provided. The SESSNSTATUS option of FEPI ALLOCATE tells you if a new session has been started, or if you are reusing an existing session.

For many FEPI applications, particularly where formatted data is used, the access program is not complex. However, you do need to be fully conversant with everything that the back-end application might do. Your application **must** behave just like the real terminal and operator, and you **must** send and receive data in the correct sequence. Within a conversation, any data received is passed to the application that owns the conversation; FEPI cannot determine whether it is the data or screen image that was expected or, for example, a message reporting an abnormal end. Although the FEPI application needs to handle these cases, the access program need not test for all possibilities. The suggested method is to test only for the expected data or screen image and use a special error-handling program if the test fails.

Other applications may require more sophisticated programming. In some cases, you not only have to understand all the displays and protocols of the back-end application, but must also be conversant with the detailed data stream protocols. Applications may have to be custom-written for each device and type of target that is to be supported.

Syncpoints are not needed and not applicable in FEPI because communication environments do not provide any recoverable units of work. It is up to you to provide the syncpoints and any recovery of data that you need. For particularly critical operations with the back-end applications, you may find that using "definite responses" is helpful; see "DRx responses" on page 135.

Begin-session handler

The begin-session handler transaction is started by FEPI when a connection is acquired. This transaction handles any functions that are required to initialize the session. Typical tasks are:

- Handling device queries.
- Handling any initial inbound data, or “good morning” message, following the bind.
- Signing on to the back-end system.

Device queries are sent by the back-end system (particularly CICS) if the terminal definitions so demand. You would normally reply ‘null’ (as illustrated by the begin-session sample program), or with some particular terminal properties that you want. Note, if you want to match the terminal properties to those of the real front-end terminal that an application is using, you cannot use a begin-session handler; each application will have to do its own begin-session handling.

When a back-end system sends a message after a successful bind, the connection should be in a pool where the INITIALDATA property is set to INBOUND. For SLU2, IMS always sends such a message; CICS may or may not do so depending on the way your system is defined. This extends the process of acquiring a connection to include receiving the data. Note that, if INBOUND is specified, the begin-session handler (or each application program, if there is no begin session handler) must issue a FEPI RECEIVE command to get the data and then send a suitable reply to the back-end system.

Remember that handling this initial data is just like handling any other back-end data: you must cope with whatever the back-end system may send, and handle and reply to it accordingly.

Security requirements in the back-end system might make it more appropriate for sign-on to be part of the access program. (Information about implementing signon security is on page 127.)

There is a sample begin-session handler program; see “Begin session” on page 173.

Unsolicited-data handler

The unsolicited-data handler transaction is started by FEPI if inbound data arrives on a connection for which there is no current conversation.

Unsolicited data can occur when:

- A target sends more data than the application expected.
- The access program times out, or the conversation is ended, before the data arrives.
- Asynchronous IMS output such as:
 - Message from previous input that could not be processed at the time of receipt by IMS
 - Reassignment of a logical terminal that has a message queued.

With IMS, this type of unsolicited data does not usually occur in SLU2 mode because IMS only sends messages in reply to explicit requests from the terminal.

- Asynchronous CICS output such as that sent by ATI.

The unsolicited data should all be received by the handler, even if it is only to be discarded. Otherwise, although FEPI eventually discards the data, it also ends and restarts the session, which is inefficient.

There is a sample unsolicited-data handler program; see “Monitor and unsolicited data-handler” on page 171.

End-session handler

The end-session handler transaction is started by FEPI when a conversation ends or a session is to be unbound. This could be used as follows:

- To set the session to a known state, perhaps by signing off from the back-end system, ready for the next conversation.
- When the conversation ends, to force (or prevent) unbind and the subsequent starting of a new session (overriding what the access program specified).
- To perform special action on CICS shutdown in the front-end system.

There is a sample end-session handler program; see “End-session handler” on page 179.

Note: The end-session handler transaction runs under the CICS region userid.

Application organization

This section discusses application styles, started tasks, and conversations.

The three application styles can be mixed as desired. If there are enough connections available, you can have as many conversations as you like at a time with various targets: they can be consecutive or, much more usefully, interleaved. For example, if you need data from four different applications, you could overlap the processing by sending all four requests for data before you start waiting for a response.

Application style

One-out one-in conversational

One transaction performs the complete conversation with the back-end application in a single send and receive operation. This is the simplest style, if the required data can be obtained from the back-end application in this way. The transaction can be reduced to a single FEPI CONVERSE command using a temporary conversation.

By freeing the connection between transmissions, the capacity of the connection is increased. However, this style only works where no setup is needed to run the back-end transaction and it does not depend on any prior communication. This is because, unless you have a very strict pool regime, you cannot generally guarantee which simulated terminal FEPI will use—it may not be the same one as in a previous conversation—or that you were the last user of the terminal. Further, if you receive unexpected results from the back-end transaction, you may not be able to recover. Therefore, you should only use this style where it does not matter if the back-end transaction runs or not, for example, for a simple inquiry. A one-out one-in conversational program is unlikely to be suitable for accessing CICS transactions or IMS conversational transactions.

See the sample program “SLU P one-out one-in” on page 180.

Conversational

One transaction performs the complete conversation with the back-end application using multiple send and receive operations and waiting for the inbound data to arrive. This style is used for a back-end application that requires several transmissions or complex setup. This style is simple, and if the network performance is good, the time spent waiting for inbound data may not be a problem.

See the sample program “Key stroke CONVERSE” on page 174.

Pseudoconversational

One transaction sends data to the back-end application, identifies another transaction that is to be started when the inbound data arrives, and ends. When inbound data arrives, FEPI starts the specified transaction which then receives the data. A typical technique is to have a transaction that, when started to receive inbound data, receives the data, sends the next piece of outbound data, issues FEPI START to start itself, and then ends.

The pseudoconversational style (use of FEPI START commands) results in significant CPU overheads in the front-end region. Further, since the use of FEPI START generates additional flows to and from the real terminal, response times are also significantly increased. As a consequence, FEPI START should be used sparingly when, for example, the receipt of the data from the back-end application takes a long time.

See the sample programs “Screen image SEND and START” on page 175 and “Screen image RECEIVE and EXTRACT FIELD” on page 177.

Started tasks

In the pseudoconversational case, the ‘receive’ program is started by FEPI as a CICS started task, with a start code of 'SZ' (for FEPI) which can be checked using EXEC CICS ASSIGN STARTCODE.

FEPI supplies **start data** that identifies the reason for starting the task and gives information about the FEPI resources, such as the node-target connection, the data mode and format, and the conversation ID involved. The program that processes the transaction issues EXEC CICS RETRIEVE to get this data (the CICS rules relating to transactions and start data apply; in particular, you must retrieve all of the start data to prevent multiple initiations). Copy books DFHSZAPA, DFHSZAPO, DFHSZAPC, and DFHSZAPP contain declarations of the start data structure. You can provide your own data to be included in the start data, so that your programs can communicate with each other about their processing state and so on.

The first thing such a program must do is get ownership of the conversation using the conversation ID from the start data; it should then use FEPI RECEIVE to get the actual data from the back-end. Then it can do whatever it likes: end the conversation, send more data to the back-end system (and start itself or a new task to receive the reply), and so on.

In addition to inbound data arriving, anything else that would cause a FEPI RECEIVE command to complete causes the ‘receive program’ to be started. This includes a ‘previous SEND failed’ error, and a response from the back-end system without any data. The FEPI RECEIVE that you issue shows these cases, as if FEPI START had not been used.

The program is also started if the time limit set by the FEPI START command expires, or if the session is lost. These cases are indicated by the value of EVENTTYPE, in the start data, being TIMEOUT or SESSIONLOST rather than DATA. They should be handled as if a FEPI RECEIVE command had caused the error.

If your ‘send’ program is associated with a front-end terminal, your FEPI START command would normally specify that the ‘receive’ program uses the same terminal. You should be aware that it is not possible for FEPI to guarantee that another transaction will not use the terminal while the inbound data is awaited. In the majority of cases, this does not happen or does not matter. If it does happen and it is critical (perhaps for security reasons), you can prevent user input at the terminal by issuing an EXEC CICS SET TERMINAL command specifying NEXTTRANSID(itran) before issuing FEPI START; remember to reset NEXTTRANSID to blank in the started task. *itran* is the name of a transaction that you provide which simply rejects any user input, and sets NEXTTRANSID(itran) again. If this is unacceptable, you must avoid using pseudoconversational applications.

The handlers mentioned on pages 122, 122 and 123 —begin-session, unsolicited data, end-session—are also CICS started tasks. Again, the start data (obtained with EXEC CICS RETRIEVE) tells you why the task was started and the identity of the conversation. The

started task must get ownership of the conversation so that it can continue the conversation and so that FEPI knows that the event is being handled.

Conversations

Your entire communication with a particular back-end transaction should be contained in a single FEPI conversation. This means that you remain in control of the communication; no other program can break in and you keep using the same simulated terminal. Only the task that started the conversation with FEPI ALLOCATE can use the conversation. It “owns” it and no other task can issue any command for it, not even FEPI EXTRACT CONV.

Conversational applications

In the simplest case, an access program starts a conversation with a FEPI ALLOCATE command specifying the pool of connections that is to be used. The command returns an identifier, the conversation ID, that is used to refer to the conversation subsequently. The program then issues a series of FEPI SEND, RECEIVE (and possibly other) commands for the conversation, each specifying the identifier, so that FEPI knows which conversation—and therefore which connection and target—the command is for. Finally, it ends the conversation with a FEPI FREE command. If it does not, the conversation is ended by FEPI when the task ends.

The FEPI FREE command should normally specify the HOLD option, so that the connection remains ready for use by another conversation. If the RELEASE option is used, or you leave the conversation to be freed by FEPI at the end of task, the session is ended, and a new one must be started for the next conversation; this is inefficient and, therefore, not recommended.

Started tasks

If the access program is pseudoconversational, after sending data it issues a FEPI START command to name the transaction that FEPI is to start when inbound data arrives. At this point the conversation becomes “unowned” and the first task can no longer use it. However, the conversation does not end; when data arrives, the conversation ID is passed to the started task and that task issues FEPI ALLOCATE with the PASSCONVID option to get ownership of the conversation. Only then can the started task use the conversation to receive the inbound data.

While the conversation is unowned, it can be acquired by any task that knows the conversation ID. Acquiring the connection cancels the pending start request, and the task that acquired ownership has to continue the conversation as if no FEPI START had been issued. This technique is useful in a pass-through application to a front-end terminal to handle contention between inbound data and terminal input. The application issues a FEPI START command, specifying the front-end terminal, and then returns to CICS specifying a ‘next’ transaction. Inbound data arriving first causes FEPI to start the transaction on the front-end terminal, which causes CICS to cancel its wait for terminal input; if terminal input arrives first, the application, after using EXEC CICS ASSIGN STARTCODE to determine why it was started, issues FEPI ALLOCATE with PASSCONVID which cancels the FEPI START request.

Getting ownership also applies to the tasks started by the various handlers. The conversation may have been started by some access program (end-session), or by FEPI itself (begin-session, unsolicited-data). Either way, you must still issue a FEPI ALLOCATE command with PASSCONVID, quoting the conversation ID, to get ownership and continue the conversation.

When a handler has finished processing, it must tell FEPI by issuing a FEPI FREE command for the conversation. For the begin-session handler, this should specify the HOLD option to indicate that the session is ready to be used; if RELEASE is used, the session is ended. The end-session and unsolicited-data handlers can use any of the options according to requirements.

Passing conversations

Besides using FEPI START to have a task for receiving data, any program or handler can explicitly give up ownership of its conversations so that another task can use them. You do this with the FEPI FREE command and the PASS option. Any task can then get ownership by using FEPI ALLOCATE with PASSCONVID and, if it maintains the command sequence, continue the conversation (for example, if the first task has issued a FEPI SEND with INVITE, the second task would have to issue a FEPI RECEIVE or, perhaps, a FEPI START). It is up to the two tasks to communicate between themselves, using the standard CICS methods (TS queue, COMMAREA, and so on), about the state of the conversation and its ID. FEPI does not offer any application programming facilities for this except that the new task can use FEPI EXTRACT CONV to determine details such as the data format.

If you do not employ a method of passing and saving the conversation across invocations of a pseudoconversational front-end transaction, and instead issue the default FREE command, you lose your connection to the back-end transaction, making it possible for another program to start a conversation and effectively “break into” the active transaction. This can cause the back-end application to abnormally end.

The only other method that can be used to ensure a unique relationship between front-end and back-end transactions, is to have FEPI pools containing a single FEPI node for each user. This ensures that you always get connected to the back-end transaction on the same terminal (FEPI node) to continue your conversation. However, this method can cause administrative problems where there are a large number of end users.

Temporary conversations

In a one-out one-in conversational application you can use a single FEPI CONVERSE command that combines an ALLOCATE–SEND–RECEIVE–FREE command sequence. This combination is selected by using the POOL option of FEPI CONVERSE rather than the CONVID option. In this case, the conversation is a *temporary* conversation that lasts only for the duration of the FEPI CONVERSE command. No conversation ID is returned by FEPI and no other commands can be issued for the conversation; you cannot even use FEPI EXTRACT FIELD to process the returned data.

As with all one-out one-in conversational applications, temporary conversations should be used with care. If more data is received than can be returned on the FEPI CONVERSE command (because, for example, the data is not what you expect), the excess is discarded and cannot be retrieved by the application. Data may be lost if the command fails and, because you cannot receive any more data or guarantee that your next conversation will use the same simulated terminal, it may be difficult to determine the state of the back-end system.

Notes:

1. Every conversation started with FEPI ALLOCATE has a unique conversation ID, as does every conversation started for a handler, except in the case of end-session when started after a FEPI FREE. In this case, the ID is the same as in the task issuing the FEPI FREE.

A task started when inbound data arrives gets the same conversation ID as the task that issued the FEPI START command.
2. The state of a conversation (whether, for example, it is owned by an access program, in a begin-session handler, waiting for inbound data, or being passed) is shown by the STATE option of the CEMT INQUIRE FECONNECTION command (page 52) or the FEPI INQUIRE CONNECTION command (page 74). This may be useful when you are debugging applications.
3. If your programs are written in C/370, do not handle conversation identifiers as strings; they may contain null characters.

Signon security

When signing on to a back-end system, FEPI applications can ask the external security manager (ESM) to supply a password substitute, or *PassTicket*. (For an explanation of why PassTickets are necessary, see page 11.)

How to use PassTickets

This section is an overview of how PassTickets work, and describes what you need to do to use them. For detailed information about PassTickets, see the *RACF System Administrator's Guide*.

1. To process PassTickets, the ESM uses keys, known as Secure Signon keys, that are shared by the front- and back-end systems. You must define a Secure Signon key for each target system with which FEPI communicates. For information about how to do this, RACF users should refer to the *RACF System Programmer's Guide*. Users of other ESMs should refer to the documentation for their product.
2. The end-user is verified by signing on to the front-end CICS in the usual way.
3. When he or she runs a transaction that uses FEPI, your application issues a FEPI REQUEST PASSTICKET command to obtain a PassTicket¹. A PassTicket is a secure representation of a password that can be used to sign on to the back-end system. It is valid for one use only, and is time-stamped. The userid for which the PassTicket is generated is that of the currently signed-on user. Your FEPI application can use an EXEC CICS ASSIGN command to check the userid of the currently signed-on user.
4. Your FEPI application uses the PassTicket and userid to perform a sign-on in the back-end system, just as if it were sending a password and userid. For example:

```
EXEC CICS FEPI SEND FORMATTED
                        CONVID(convid) FROM(CESN userid PassTicket)
                        FROMLENGTH(length_of_data)
```

It is the application's responsibility to provide the signon processing, because CICS cannot know either the type of back-end (CICS or IMS) or the back-end program being used for signon processing.

5. The back-end system uses an unchanged interface to perform the sign-on. Thus, a CICS system receiving a userid and a PassTicket can use its existing procedures to sign on the userid. RACF takes care of the fact that a PassTicket, rather than a password, is passed to it.

Note: If the PassTicket times out (because, for example, of a session failure), your application should generate another and try to sign on again. If signon continues to fail and the front- and back-ends are in different MVS systems, check that the TOD clocks are suitably synchronized. Too many failed signon attempts could result in the userid being revoked.

For information about using RACF with CICS, see the *CICS/ESA CICS-RACF Security Guide*.

Benefits

The advantages of using PassTickets are that:

- They provide a secure way of signing on to back-end systems. This is because:
 - They are valid for one use only and are timestamped—therefore, the potential damage caused by their being intercepted is minimal.
 - Passwords are not transmitted across the network.

¹ If EDF is being used the PassTicket is not displayed.

Application design

- FEPI applications do not have to store passwords (or ask users to reenter them) in order to sign on to back-end systems.
- No changes are required in the CICS or IMS back-end systems.
- System clocks in the front- and back-end systems do not need to be precisely synchronized (RACF compensates for variations up to plus or minus 5 minutes).

Requirements

- The front-end must be a CICS/ESA 4.1 system. The back-end can be an earlier-level CICS or IMS system.
- RACF Version 2 Release 1, or a functionally-equivalent external security manager, on both the front- and back-end systems.
- End-users must use the same userid in the back-end systems as in the front-end system.

Error handling

This section gives some general guidance on how to handle various error conditions, for example:

- Time-outs
- Session loss
- Previous send failed
- Communication errors
- Bypass by user exit
- Unknown conversation ID
- Operator/system action
- CICS shutdown.

FEPI does not recover any user data when an error condition is raised—data recovery, if needed, must be performed by the application program. In addition, the output option values on a command are not set if the command fails; your program should not be using these values in such cases.

The recommended way is that errors raised by FEPI commands should be handled by your application rather than letting CICS terminate the transaction abnormally. Errors and exceptions can be detected by using the RESP and RESP2 command options, or trapped using HANDLE CONDITION.

Time-outs

You should use time-outs with FEPI commands. If there is a problem with the connection to the back-end application, a program without time-outs may wait for ever, you may stop other applications running, and operator intervention may be needed.

Time-outs can be used with FEPI ALLOCATE, RECEIVE, START, and CONVERSE commands. In all cases, the timing applies only to the period that FEPI waits for a reply from the back-end system. As soon as anything is received from the back-end, FEPI stops the timer, and then waits for as long as is necessary to receive all the data that is required to complete the command. You **cannot** specify a time-out for FEPI SEND, because the command always completes immediately, without waiting for any data to be transmitted. Any delay or other problem is handled by the following FEPI RECEIVE command. The action to take on a time-out depends on the command that was used:

- For FEPI ALLOCATE, you could retry the initial command and then retry using a different pool or target before going into your error-handling routine.
- For FEPI RECEIVE, you can retry the command and, if that fails, handle the error as if the session with the back-end application had been lost.

- For FEPI START, the time-out is reported to the started task, and not as an error on the command. In other respects, however, it is the same as a FEPI RECEIVE time-out.
- For FEPI CONVERSE with a previously allocated conversation, it is exactly as if a FEPI SEND command and then a FEPI RECEIVE command were issued. That is, the time-out that you specify applies only to the 'receive' part of the command, and is treated and handled just like that for a FEPI RECEIVE.

For a temporary conversation, it is as if the command were preceded by a FEPI ALLOCATE and followed by a FEPI FREE, so in this case the time-out is applied to both the 'allocate' and 'receive' parts of the command. In this situation, if a time-out occurs, there is no indication as to which part caused it.

Lost session

If a FEPI application loses the session with the back-end application, it should free the conversation. Having done that, the application can take whatever action is required. A typical action would be to recover any data and restore the initial state before retrying the conversation or sending a message to the user.

The loss of a session can also occur because of CLSDST(PASS) processing (as discussed in "Handling CLSDST(PASS)" on page 36). If this is the case, you can find out when the session has been reestablished using the FEPI EXTRACT CONV command. You can then continue processing as required.

Previous SEND failed

This occurs on a FEPI RECEIVE and is indicated by RESP2=216. It may be an external communication error, or it may be that the back-end system has responded negatively (as IMS does, for example, if you try to run an unknown transaction). Use the FEPI EXTRACT CONV command to get the sense data describing the failure. If this indicates a negative response, you should reissue the FEPI RECEIVE to get the data. If it was not a negative response, it is equivalent to a lost session and the session cannot be recovered.

Communication errors

It is simplest to treat communication and network errors as a lost session, which avoids the need for detailed SNA error protocol handling. However, sophisticated applications may want to handle certain recoverable conditions, for example, SNA CLEAR received (RESP2=230).

Bypass by user exit

A command can be rejected by the FEPI global user exits (RESP2=10). Typically this would be because it violates the rules imposed by your system programmer. Check the rules with your system programmer.

Unknown conversation ID

Besides specifying the ID incorrectly, this is probably caused by the task that issued the command not owning the conversation, because:

- The conversation has been ended
- The conversation has been passed to another task
- FEPI ALLOCATE with PASSCONVID has not been issued.

If the error occurs on a FEPI ALLOCATE command with PASSCONVID, the conversation was probably not "unowned". Where the CONVID was obtained from FEPI start data, it is possible that between FEPI scheduling the task and it actually starting, a resource used by the conversation has been discarded, or CICS has started shutdown.

Operator/system action

An operator/system error occurs when the operator tries to cancel a FEPI transaction. If, as is likely, it is waiting for a FEPI command to be processed, it is the 'wait' for FEPI processing that is canceled, not the transaction.

When a FEPI command fails with an 'operator action' error (RESP2=18), first end all the active conversations and then end the transaction as soon as possible.

Shutdown

A normal CICS shutdown waits for currently active tasks to end, but does not allow new tasks to start. FEPI allows existing conversations to continue within a task but does not allow them to be passed to another task (because that task would never be started), nor does it allow new conversations to be started. Conversations that are "unowned" are ended immediately, because the tasks that would subsequently handle them would never be started. Therefore, FEPI START or FREE PASS commands issued during shutdown fail (RESP2=214); in this case the error-handling routine, after doing whatever housekeeping is required, should issue FEPI FREE to end the conversation. FEPI ALLOCATE commands issued during shutdown fail with RESP2=12.

You might need to take special action on the back-end system, for example, signing off, when the front-end application is going to shut down. For this reason, when conversations end during shutdown, the end-session handler is invoked with SHUTDOWN indicated in the EVENTVALUE field of the start data, so that the back-end system can be restored to a known state before FEPI ends; the FEPI FREE issued by the handler is treated as if RELEASE is specified. If you require this function, make sure the end-session handler is defined in the transaction list table (XLT), so that it can be started, and so that it does not adversely affect the performance of CICS shutdown. (The XLT is described in the *CICS/ESA Resource Definition Guide*.) Using an end-session handler is the only way to perform special processing on shutdown, because no notification of shutdown is given to normal active transactions and conversations.

An immediate CICS shutdown ends all conversations immediately, and commands in progress fail. No further FEPI commands can be issued, and no end-session handlers are started.

System considerations

You can think of FEPI as a "pipe" through which users access back-end transactions; any peculiarities that exist in the back-end system have to be allowed for in the FEPI application. IMS has special considerations and these are explained in the following text.

This section concludes with some notes about performance.

IMS considerations

It is essential that you are familiar with using IMS and writing IMS applications.

When designing access programs that have IMS as a target back-end system, careful consideration must be given to the differences between CICS and IMS under certain circumstances:

- Message protocols
- Use of response mode
- Beginning and end of session
- Effects of IMS restart and recovery features in a FEPI environment. (Because IMS is almost totally recoverable, this can present problems in the design of the FEPI application and some event handlers.)

Message protocols

- In SLU2 mode, IMS sends messages only in reply to explicit requests from the terminal. Therefore, unsolicited data will not usually occur; rather it will be available for the next FEPI conversation to receive. At the start of a FEPI conversation, you should first dequeue all such messages. However, unsolicited data can occur when requested data arrives after a FEPI conversation has been ended by, for example, a time-out.
- Take care if you use the IMS /SET command to preset a destination or put the transaction ID in the SPA to specify which IMS transaction to use next.
- If you are using Message Format Services (MFS), consider the following:
 - Physical paging or operator logical paging:
 - Whether paged output is deleted automatically by an input message or not.
 - for SLU2 mode, sending PA1 to request additional pages of paged output, and sending PA2 to remove paged output from the queue.
 - Unlocking the keyboard after MFS bypass.

Response mode

You are strongly recommended to run all your back-end IMS transactions in response mode
 # where messages to IMS from the (simulated) terminal are handled synchronously; that is,
 # each message from the terminal is processed by IMS and the reply is queued before a
 # further message from the terminal is allowed. This lets your front-end application be much
 simpler because data received will be the reply to the data just sent, and because the data
 stream flows from IMS are more straightforward; further, a separate FEPI conversation can
 be used for each IMS transaction and this allows much better use of the network (of course,
 you must use the same FEPI conversation throughout an IMS conversational transaction).

If you use non-response mode, the data stream flows may be more complex. If you send multiple messages to IMS, the application has to handle asynchronous messages from IMS and, to keep the same simulated terminal, has to use the same FEPI conversation all the time.

Check with your system programmer that the transactions to be used by FEPI are defined to run in response mode. This requires the terminals for FEPI to be defined either to force response mode or to use the setting for the transaction (which in turn should be defined as response mode).

Beginning of session

For SLU2, there is always initial data. You should:

- Dequeue all output messages by sending CLEAR and PA1 after each FEPI RECEIVE, until there are no more messages (there may be 'unsolicited' data as well as the initial data).
- If there is an IMS error message, end the session using FEPI FREE with the RELEASE option.

End of session

Application programs must be designed such that when a session is ended:

- An IMS conversation is not left active.
- An IMS /RCLSDST command is issued if appropriate.
- An IMS MFS bypass application is not left in bypass mode.
- Any preset destination has been reset.
- Any used test mode has been ended.
- No paged output message is left on the IMS message queue.
- All messages have been received.

Physically paged messages are removed from the queue automatically when the last page has been sent and, if they are recoverable, acknowledged. Operator logically-paged messages are not removed and require a PA2 (for SLU2 mode) or a NEXTMSG/NEXTMSGP control function (for SLU P mode) to be sent to IMS to remove the message from the queue if no input message is due.

IMS recovery

After a system failure, IMS recovers following a restart from the last checkpoint it took. This means that, if the failure occurs when IMS has committed a message to the input queue then, on restart, IMS requeues that message and schedules a transaction to process it. Similarly, IMS will requeue all output messages that it has committed to its output queues and not successfully sent.

When IMS fails, all sessions between FEPI and IMS are ended. This is reported to the FEPI application as a command error ('session lost'). A FEPI application should check this so that it can tidy up before ending and take the appropriate action (such as informing the operator).

FEPI attempts to regain lost connections and, therefore, when IMS restarts, any previously acquired connections are reestablished. If IMS has committed an input or output message, eventually there is going to be an output message to send. With the connection reacquired, IMS attempts to recover its position and ultimately to send any queued output messages to the FEPI node that carried the original FEPI conversation. The process of recovery in this situation is different for each of the two modes:

- **SLU P recovery**

When IMS tries to recover SLU P connections, it uses 'set and test sequence numbers' (STSN) in an attempt to resynchronize failed conversations. The STSN flow from IMS carries its version of the sequence numbers for the node being resynchronized. If there is an STSN handler specified, it is started. If not, FEPI responds POSITIVE, which effectively tells IMS that FEPI is satisfied with the sequence numbers sent. On receiving this, IMS sends all messages queued for the node. FEPI receives the messages, discards them and responds to IMS, completing the resynchronization.

- **SLU2 recovery**

The queued message is sent by IMS until there is a request from a front-end application, that application will receive the message as unexpected data interleaved with the data that it expects to receive. This problem can be handled in either of two ways:

1. By the application issuing a FEPI RECEIVE, with TIMEOUT, before starting its intended task or by dequeuing all output messages using CLEAR and PA1.
2. By the begin-session handler.

This situation becomes more complex if the back-end transaction is IMS conversational, because the front-end transaction has no way of knowing this, and the IMS conversation will still be active in the back-end system awaiting input.

The potential therefore exists for a front-end FEPI application to allocate a FEPI conversation on a node where an IMS conversation still exists on the back-end system. Any data flowing on this FEPI conversation is viewed by the front-end application as an exchange with a new back-end transaction, but it is viewed by IMS as the next input message to the existing conversation. To prevent this situation occurring, you can use the begin-session handler to issue the IMS /EXIT command, which has the effect of ending an active IMS conversation.

Where the possibility exists of a number of nodes with active IMS conversations following a restart, it is possible to use FEPI to obtain a connection to IMS and control the cleanup operation, from a single point. You do this by issuing, again from the appropriate handler:

- An IMS /DISPLAY command to display all active conversations
- The IMS /EXIT command to end all those attached to FEPI nodes.

In the event of a failure that unbinds all the FEPI connections to IMS, the recovery procedure is identical to that described here.

Performance

Use the following techniques to get the best performance from your FEPI applications; the main principles are to minimize the number of commands issued and the amount of data transmitted. Remember, however, that some of these techniques have drawbacks (as have been explained elsewhere), and some conflict with each other; you must choose the best balance to meet your needs.

General

- Use data area sizes that allow a send or receive to be completed with a single FEPI command.
- Use FEPI CONVERSE where possible. But remember that the send part of CONVERSE can fail for various reasons, so be sure to write your program so that it can issue a subsequent FEPI RECEIVE if necessary.
- The pseudoconversational style (use of FEPI START commands) results in significant CPU overheads in the front-end region. Further, since the use of FEPI START generates additional flows to and from the real terminal, response times are also significantly increased. As a consequence, FEPI START should be used sparingly when, for example, the receipt of the data from the back-end application takes a long time.
- Avoid ending sessions unnecessarily. Use the begin-session and end-session handlers to manage usage of the connections.
- Try to avoid operator dependency in exchanges with a back-end system.

Formatted data

- Unformatted screens (where the terminal character buffer contains no field attributes) require more processing than formatted screens. Where possible use formatted screens from the back-end systems.
- Not clearing a screen results in unnecessary data being transmitted to the back-end system.
- If, when data is received, only a small portion of the resultant screen is of interest, use FEPI EXTRACT FIELD to minimize the amount of data that needs to be transferred to the application.
- When using key stroke data, avoid issuing a FEPI CONVERSE, SEND, or RECEIVE for each attention operation; combine all the operations into one long string.
- When using key stroke data with an unformatted screen, use the HOME and ERASE-EOF keys to clear the screen rather than CLEAR, because the latter requires a network transmission.
- Use key stroke rather than screen-image data where possible, because much less data needs transferring from the application.

Chapter 15. Specialized functions

This chapter describes specialized control functions that are handled by FEPI but can be taken over by a FEPI application.

Set and test sequence number (STSN)

In SLU P mode, message sequence numbers are available in the data stream to allow message resynchronization. This can be demanded by a 'Set and Test Sequence Number' (STSN) request when a session is started.

The response that IMS requires, and that FEPI supplies if the system programmer has not defined a transaction to handle the STSN request, depends upon whether the STSN request showed 'SET' or 'TEST and SET':

For 'SET', the response is always 'TEST POSITIVE'.

For 'TEST and SET', the response is 'TEST POSITIVE' or 'TEST NEGATIVE'.

Any other response to STSN will cause the session to be unbound.

If an STSN handler is defined, it is started when session resynchronization is requested by the back-end system through an SNA STSN or SDT command. The back-end system sends an SNA STSN command indicating whether the last inbound message was in doubt or not; that is, whether a message had been sent by the back-end system but it had not logged the receipt of a response. The back-end system does not send an SNA STSN command if no traffic has been on the session since the latest cold start of the back-end system, but sends an SNA SDT command directly.

Like other handlers, the STSN handler is a CICS started task that uses EXEC CICS RETRIEVE to get the start data and FEPI ALLOCATE with PASSCONVID to get ownership of the conversation identified in that data. The STSN handler, which can use the FEPI EXTRACT STSN command to determine what response is needed, must use the FEPI ISSUE command to respond to the STSN.

FEPI normally does all the necessary STSN handling automatically, so an STSN handler is required only where you need to handle the sequence number information yourself. The FEPI SEND, FEPI RECEIVE, and FEPI CONVERSE commands return the current sequence numbers for you.

A sample program illustrates the techniques used. See "STSN handler" on page 182.

DRx responses

In all cases except those mentioned in the next paragraph, FEPI automatically gives a
 # positive DRx response when the inbound data indicates that a response is required. This
 # response flows on the next FEPI command (SEND, RECEIVE, CONVERSE, FREE, or
 # START).

The automatic response is not issued if the next command for a conversation is a FEPI
 # ISSUE CONTROL or a FEPI FREE PASS. Thus, if you want to send your own response,
 perhaps for added certainty or confirmation of particularly sensitive changes, you would do
 so using FEPI ISSUE CONTROL. The response type that is required can be determined
 from the RESPSTATUS option of FEPI RECEIVE and FEPI CONVERSE.

You can send your own responses with either formatted data or data stream. But do not use the following because they can cause FEPI to send responses automatically:

- Key stroke formatted data containing an attention key that is not the final key stroke
- FEPI CONVERSE with the POOL option to use a temporary conversation.

Specialized functions

If you respond negatively a back-end CICS system will discard the data but an IMS system will resend it.

SNA commands

The FEPI ISSUE command allows you to send various other SNA commands yourself. You should do this only if you have a particular requirement.

Chapter 16. Application programming reference

This chapter defines the FEPI application programming commands. (System programming commands such as INSTALL, INQUIRE, and SET are defined in Chapter 9, “System programming reference” on page 69.)

The FEPI application programming commands are:

```
ALLOCATE
AP NOOP
CONVERSE
EXTRACT
FREE
ISSUE
RECEIVE
REQUEST PASSTICKET
SEND
START
```

These commands are additions to the set of EXEC CICS commands that are available to application programmers, and they have the same features and properties as those commands. Some brief notes of these features and properties appear below; for details, refer to the programming information on the following subjects in the *CICS/ESA Application Programming Reference* manual:

- Command format
- Argument values, including programming-language considerations, and CVDA values
- RESP, RESP2, and NOHANDLE options
- LENGTH options.

Command format

The general format of a command is:

```
EXEC CICS FEPI command option(argument)...
```

where:

- command** Is the command name (for example, ALLOCATE).
- option** Is an option name (for example, POOL).
- argument** Is the source or destination for data, as required for the specified option, that is passed to or returned from the command.

The way that you end the command is determined by the programming language that you are using: COBOL, for example, requires an END-EXEC statement.

Arguments and data types

The text used to identify arguments in this book indicates the type of data represented by the argument and whether it is a value used by the command, or an area in which the command returns data. For example:

POOL(8-character data-value) says that the argument is, or identifies, a string of eight characters and that the string is passed to the command as an input value.

SIZE(fullword binary data-area) says that the argument is a user-defined fullword data area in which the command can return a binary number as an output value.

Errors and exception conditions

All FEPI commands support the RESP and RESP2 options to signal successful completion or an exception condition. Alternatively, you can use HANDLE CONDITION to trap errors.

Most FEPI command errors give the ‘INVREQ’ exception condition. The particular error in each case is uniquely identified by the RESP2 value.

If there is an error, the command does nothing and the output arguments are not changed. Note, however, that commands such as FEPI SEND may have transferred data before the condition is recognized.

Both RESP and RESP2 take, as an argument, the name of a user-defined fullword binary data area. Possible values of the RESP2 option are given in the description of each of the commands and a full list is given in “RESP2 values” on page 187. The following copy books provide declarations for the RESP2 values:

- DFHSZAPA for Assembler language
- DFHSZAPO for COBOL
- DFHSZAPP for PL/I
- DFHSZAPC for C/370.

The following conditions and RESP2 values can occur for any application programming command:

Condition	RESP2	Meaning
INVREQ	10	Command bypassed by user exit.
INVREQ	11	FEPI not installed, or not active.
INVREQ	12	CICS shutting down, command not allowed.
INVREQ	13	FEPI unavailable.
INVREQ	14	FEPI busy or cannot get storage.
INVREQ	15	Unknown command.
INVREQ	16	Internal error.
INVREQ	17	FEPI cannot get storage for user exit.
INVREQ	18	Command failed through operator or system action.

FEPI ALLOCATE PASSCONVID

Syntax notation

The notation used in this book to show the syntax of FEPI commands is the same as that used in the *CICS/ESA System Programming Reference*. See “CICS syntax notation used in this book” on page xi for details.

Translator options

You must specify the ‘FEPI’ translator option when you use FEPI commands.

Other points

- FEPI commands can be issued in either 24-bit or 31-bit addressing mode, by programs that reside either above or below the 16MB line.
- No information is passed through the EXEC interface block (EIB) except that, as for all CICS commands, the EIBRESP, EIBRESP2, EIBFN, and EIBRCODE fields are set.

FEPI ALLOCATE PASSCONVID

Function: FEPI ALLOCATE PASSCONVID acquires ownership of an existing unowned conversation.

Syntax

```
▶—FEPI ALLOCATE—PASSCONVID(data-value)—▶
```

Conditions:
INVREQ

Options

PASSCONVID(8-character data-value)

specifies the ID of the conversation.

Conditions

Condition	RESP2	Meaning
INVREQ	216	Error occurred on previous FEPI SEND.
INVREQ	240	Unknown conversation ID.

FEPI ALLOCATE POOL

Function: FEPI ALLOCATE POOL establishes a new FEPI conversation with a target application, acquiring a session from the named pool to use for the conversation. The conversation has the properties, particularly the mode (SLU2 or SLU P) and data format (data stream or formatted), specified for the pool that is used: some of the properties can be queried using FEPI EXTRACT CONV.

The command completes immediately if, in the named POOL, a suitable session has been established and is not in use. Otherwise the request waits for a session to become available. A time limit can be set for this wait.

Syntax

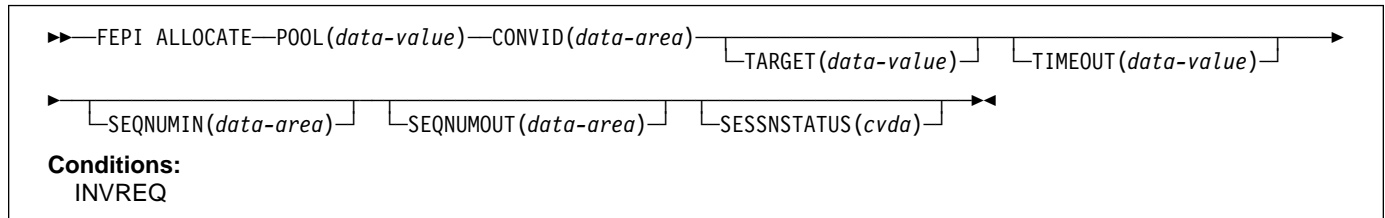

Options

CONVID(8-character data-area)

returns a unique identifier for the new conversation; this is the ID that must be quoted on all subsequent commands for the conversation.

POOL(8-character data-value)

specifies the name of the pool containing the target for the conversation.

SEQNUMIN(fullword binary data-area)

in SLU P mode, returns the current sequence number for inbound data. (SEQNUMIN has no significance in SLU2 mode.)

SEQNUMOUT(fullword binary data-area)

in SLU P mode, returns the current sequence number for outbound data. (SEQNUMOUT has no significance in SLU2 mode.)

SESSSTATUS(cvda)

returns a value that indicates whether the session being used for the conversation was newly-bound or not. The relevant CVDA values are:

NEWSSESSION
OLDSESSION

TARGET(8-character data-value)

specifies the name of the target. TARGET can be omitted if there is only one target in the pool or if all targets are suitable for the desired conversation.

TIMEOUT(fullword binary data-value)

specifies the maximum time in seconds that the command is to wait for a suitable session to become available. If TIMEOUT is not specified or the specified time is zero, the command is not timed out.

Conditions

Condition	RESP2	Meaning
INVREQ	30	POOL name unknown.
INVREQ	31	POOL name out of service.
INVREQ	32	TARGET name unknown.
INVREQ	33	TARGET name out of service.
INVREQ	34	TARGET name required but not specified.
INVREQ	36	No suitable session available and in service.
INVREQ	213	Command timed out.
INVREQ	241	TIMEOUT value negative or not valid.

FEPI AP NOOP

Function: FEPI AP NOOP has no effect.

Syntax



Options: None

Conditions: None specific to this command.

FEPI CONVERSE DATASTREAM

Function: FEPI CONVERSE DATASTREAM sends application data to and receives a reply from a target. The data supplied by the application must be a currently valid data stream appropriate to the mode of the conversation (SLU2 or SLU P); the data received into the application's data area is also data stream. Full details about the data are given in "Data formats" on page 160.

The conversation with the target can be one of two types:

Previously allocated

The conversation is specified by the CONVID option; it must be one that uses data-stream-type data. By default, the command completes when a whole chain of data has been received, although other ending conditions can be requested.

Temporary

The conversation is allocated from the pool specified by the POOL option and exists only for the duration of the command. The pool must be one that uses data-stream-type data.

The command first waits for a suitable session to become available (if there is not already one); then, after sending the data, it completes when 'change direction' or 'end bracket' is received.

A time limit can be set for this command. For more details of ending conditions, see "Ending status" on page 161.

Syntax: The syntax for each type of conversation is shown separately.

Previously allocated conversation

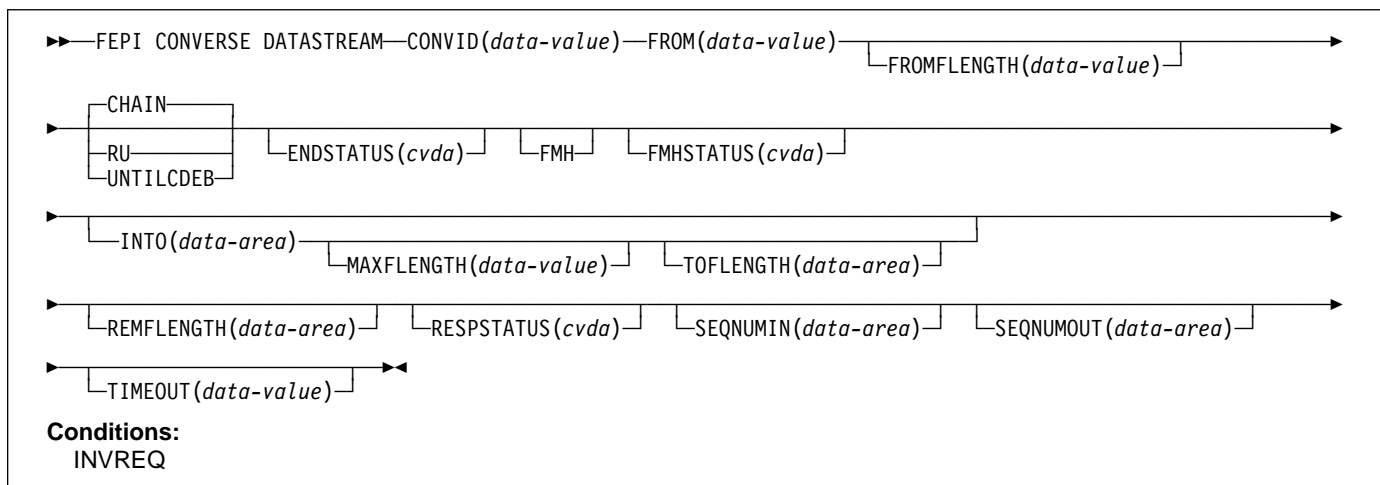

Temporary conversation

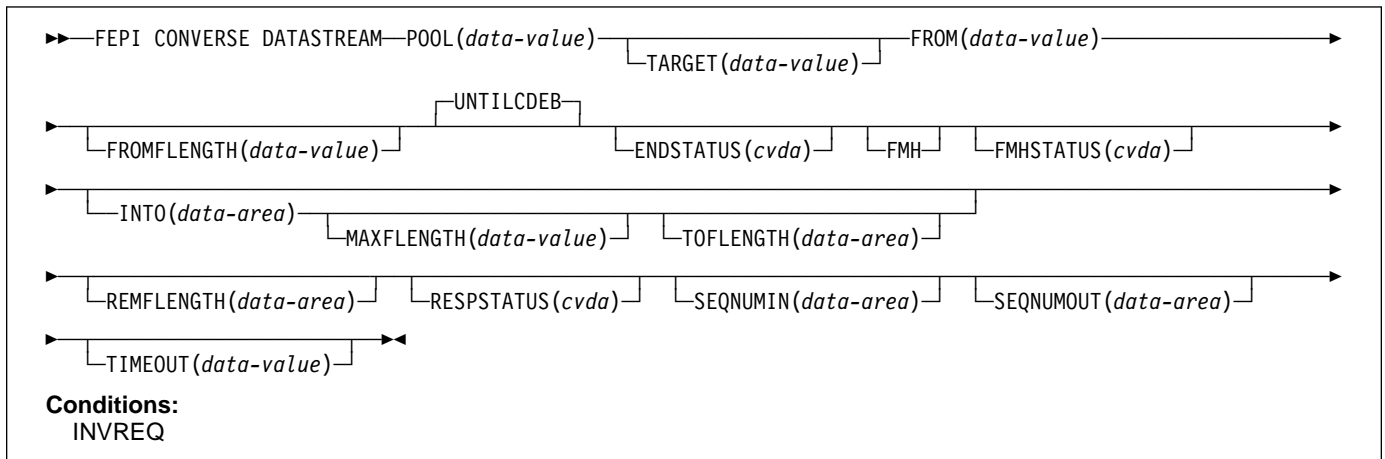

Options

CHAIN

specifies that the command should complete when a whole chain has been received. CHAIN is not allowed if the POOL option is specified.

CONVID(8-character data-value)

specifies the ID of the conversation to use. The conversation must be owned by the task issuing the command.

ENDSTATUS(cvda)

returns a value that indicates the ending status for the received data. The relevant CVDA values are:

Value	Meaning
CD	'Change direction' received.
EB	'End bracket' received.
LIC	'Last in chain' received.
RU	RU received.
MORE	The data area identified by the INTO option was too small to receive all the requested data.

For more details of ending status and how additional data is handled, see "Ending status" on page 161.

FMH

indicates that the data to send includes a function management header.

FMHSTATUS(cvda)

returns a value that indicates whether the received data contains a function management header. The relevant CVDA values are:

FMH
NOFMH

FROM(data-value)

specifies the data to send to the back-end application. Its length is specified by the FROMLENGTH option.

FROMLENGTH(fullword binary data-value)

specifies the length of the data to send; that is, the length of the data area identified by the FROM option. It must

not be zero or more than the maximum length allowed for the pool.

INTO(data-area)

specifies the data area in which the received data is to be returned. The length of the area is specified by the MAXLENGTH option, and the actual length of data written into the area is returned by the TOLENGTH option.

MAXLENGTH(fullword binary data-value)

specifies the maximum amount of data that can be returned; that is, the length of the data area identified by the INTO option. It must not be more than the maximum length allowed for the pool.

POOL(8-character data-value)

specifies the name of the pool containing the target for the conversation. Specifying POOL means that the conversation is a temporary one, that exists only for the duration of the FEPI CONVERSE. The CHAIN and RU options are not allowed, and the command completes when 'change direction' or 'end bracket' is received. If there is more data to receive than fits into the data area identified by the INTO option, the additional data is discarded.

REMLENGTH(fullword binary data-area)

returns the length, if known, of data remaining after filling the data area identified by the INTO option.

RESPSTATUS(cvda)

returns a value that indicates the type of response that is required at the back-end system. The relevant CVDA values are:

Value	Meaning
DEFRESP1	Definite response 1 required.
DEFRESP2	Definite response 2 required.
DEFRESP3	Definite response 1 and definite response 2 required.
NONE	No response required.

FEPI CONVERSE DATASTREAM

RU	Condition	RESP2	Meaning
specifies that the command should complete when a request unit has been received. RU is not allowed if the POOL option is specified.	INVREQ	213	Command timed out.
	INVREQ	215	Session lost.
	INVREQ	216	Error occurred on previous FEPI SEND.
	INVREQ	220	FEPI CONVERSE not allowed at this point in the conversation.
SEQNUMIN(fullword binary data-area) in SLU P mode, returns the current sequence number for inbound data, as at the completion of the command. (SEQNUMIN has no significance in SLU2 mode.)	INVREQ	224	Only FEPI ISSUE or FEPI FREE commands allowed at this point in the conversation.
SEQNUMOUT(fullword binary data-area) in SLU P mode, returns the current sequence number for outbound data, as at the completion of the command. (SEQNUMOUT has no significance in SLU2 mode.)	INVREQ	230	SNA CLEAR command received. ²
	INVREQ	231	SNA CANCEL command received. ²
	INVREQ	232	SNA CHASE command received. ²
	INVREQ	233	Exception response received.
	INVREQ	234	Exception request received.
	INVREQ	240	Conversation ID not owned by this task.
	INVREQ	241	TIMEOUT value negative or not valid.
TARGET(8-character data-value) specifies the name of the target. TARGET can be omitted if there is only one target in the pool or if all targets are suitable for the desired conversation.			
TIMEOUT(fullword binary data-value) specifies the maximum time in seconds that the command is to wait for the requested data to begin to arrive. If TIMEOUT is not specified or the specified time is zero, the command is not timed out.			
TOFLENGTH(fullword binary data-area) returns the actual length of data received in the data area identified by the INTO option.			
UNTILCDEB specifies that the command should complete when 'change direction' or 'end bracket' is received.			

Conditions

Condition	RESP2	Meaning
INVREQ	30	POOL name unknown.
INVREQ	31	POOL name out of service.
INVREQ	32	TARGET name unknown.
INVREQ	33	TARGET name out of service.
INVREQ	34	TARGET name required but not specified.
INVREQ	35	POOL name is unsuitable for temporary conversations. (It has CONTENTION(LOSE) or it has INITIALDATA(INBOUND) and no begin-session handler.)
INVREQ	36	No suitable session available and in service.
INVREQ	40	FROMFLENGTH value negative, zero, or more than the maximum allowed for the current pool.
INVREQ	50	Inbound data with 'begin bracket' to be received.
INVREQ	58	VTAM SEND failed.
INVREQ	60	MAXFLENGTH value negative, zero, or more than the maximum allowed for the current pool.
INVREQ	71	VTAM RECEIVE failed.
INVREQ	212	Conversation has wrong data format.

² For an explanation of this SNA command, see the *SNA Formats* manual, GA27-3136.

FEPI CONVERSE FORMATTED

Function: *The command is for SLU2 mode only.*

FEPI CONVERSE FORMATTED sends application data to and receives a reply from a target. The data supplied by the application must be formatted data, as key strokes (with a final attention character) or a screen image; the data received into the application's data area is a screen image. Full details about the data are given in "Data formats" on page 160.

The conversation with the target can be one of two types:

Previously allocated

The conversation is specified by the CONVID option; it must be one that uses formatted data. The command completes when 'last in chain', 'end bracket', or 'change direction' is received.

Temporary

The conversation is allocated from the pool specified by the POOL option and exists only for the duration of the command. The pool must be one that uses formatted data. In addition, the data must be sent in key stroke format.

The command first waits for a suitable session to become available (if there is not already one); it does not complete until 'end bracket' or 'change direction' is indicated.

A time limit can be set for this command. For more details of ending conditions, see "Ending status" on page 161.

Syntax: The syntax for each type of conversation is shown separately.

Previously allocated conversation

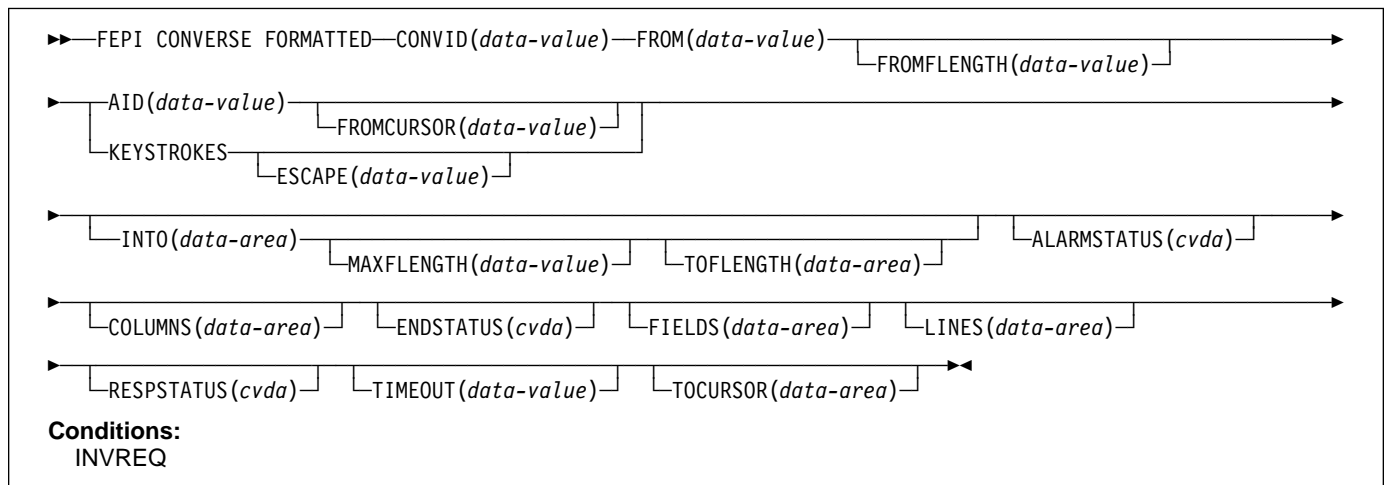

FEPI CONVERSE FORMATTED

Temporary conversation

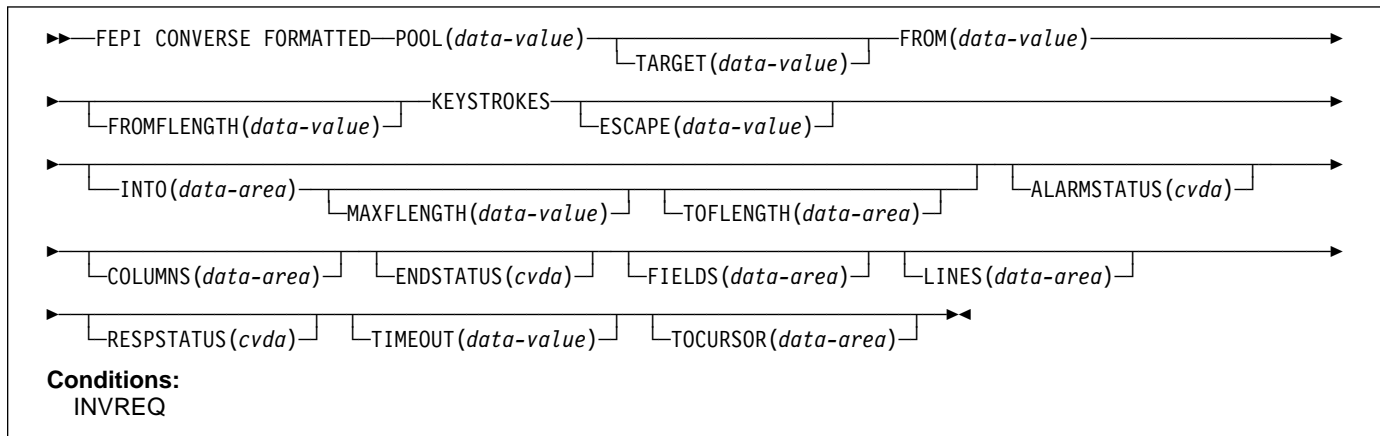

Options

AID(1-character data-value)

specifies the attention identifier value to send with the data. Specifying AID also indicates that the data to send is in screen-image format, as described in "Data formats" on page 160. The value must not be null (X'00'). AID, and therefore screen-image format data, is not allowed if POOL is specified.

- # Symbolic names for the AID values are available for the
- # supported languages in the language-specific DFHAID
- # copybooks.

ALARMSTATUS(cvda)

returns a value that indicates whether the received data sounded the alarm. The relevant CVDA values are:

ALARM
NOALARM

COLUMNS(fullword binary data-area)

returns the number of columns in the screen image.

CONVID(8-character data-value)

specifies the ID of the conversation to use. The conversation must be owned by the task issuing the command.

ENDSTATUS(cvda)

returns a value that indicates the ending status for the received data. The relevant CVDA values are:

Value	Meaning
CD	'Change direction' received
EB	'End bracket' received
LIC	'Last in chain' received.

For more details of ending status and how additional data is handled, see "Ending status" on page 161.

ESCAPE(1-character data-value)

for send data in key stroke format, specifies the escape character used to indicate character combinations representing special keys. You can use any value in the range X'40' through X'FE'. The default escape character is & (X'50').

FIELDS(fullword binary data-area)

returns the number of fields in the screen image.

FROM(data-value)

specifies the data to send to the back-end application. Its length is specified by the FROMLENGTH option. For send data in screen-image format, if the length is more than the screen image, the additional data is ignored; if it is less, the data is the first part of the screen image, and the last part of the screen image is not changed.

FROMCURSOR(fullword binary data-value)

for send data in screen-image format, specifies the position of the cursor, expressed as an offset from the start of the screen image; offset zero is the top left-hand corner of the screen. If FROMCURSOR is not specified, the cursor remains where it was positioned by the last inbound data.

FROMLENGTH(fullword binary data-value)

specifies the length of the data to send; that is, the length of the data area identified by the FROM option. It must not be zero or more than the maximum length allowed for the pool.

INTO(data-area)

specifies the data area in which the received data is to be returned. The length of the area is specified by the MAXLENGTH option, and the actual length of data written into the area is returned by the TOLENGTH option.

KEYSTROKES

specifies that the data to send is a sequence of key strokes (see "Data formats" on page 160).

LINES(fullword binary data-area)

returns the number of lines in the screen image.

MAXLENGTH(fullword binary data-value)

specifies the maximum amount of data that can be returned; that is, the length of the data area identified by the INTO option. It must not be more than the maximum length allowed for the pool.

POOL(8-character data-value)

specifies the name of the pool containing the target for the conversation. Specifying POOL means that the conversation is a temporary one, that exists only for the duration of the FEPI CONVERSE. You must also specify the KEYSTROKES option. If the length of the data area identified by the INTO option is less than the size of the screen image, the additional data is discarded.

RESPSTATUS(cvda)

returns a value that indicates the type of response that is required at the back-end system. The relevant CVDA values are:

Value	Meaning
DEFRESP1	Definite response 1 required.
DEFRESP2	Definite response 2 required.
DEFRESP3	Definite response 1 and definite response 2 required.
NONE	No response required.

TARGET(8-character data-value)

specifies the name of the target. TARGET can be omitted if there is only one target in the pool or if all targets are suitable for the desired conversation.

TIMEOUT(fullword binary data-value)

specifies the maximum time in seconds that the command is to wait for the requested data to begin to arrive. If TIMEOUT is not specified or the specified time is zero, the command is not timed out.

TOCURSOR(fullword binary data-area)

returns the position of the cursor in the received screen image, expressed as an offset from the start of the screen image; offset zero is the top left-hand corner of the screen.

TOFLENGTH(fullword binary data-area)

returns the actual length of data received in the data area identified by the INTO option.

| **Note:** On a FEPI CONVERSE FORMATTED command,
 | if MAXFLENGTH is less than the presentation space
 | size, TOFLENGTH returns the value defined in
 | MAXFLENGTH. If MAXFLENGTH is greater than the
 | presentation space size, TOFLENGTH returns the
 | presentation space size.

Conditions

Condition	RESP2	Meaning
INVREQ	30	POOL name unknown.
INVREQ	31	POOL name out of service.
INVREQ	32	TARGET name unknown.
INVREQ	33	TARGET name out of service.
INVREQ	34	TARGET name required but not specified.
INVREQ	35	POOL name is unsuitable for temporary conversations. (It has CONTENTION(LOSE) or it has INITIALDATA(INBOUND) and no begin-session handler.)
INVREQ	36	No suitable session available and in service.
INVREQ	40	FROMFLENGTH value negative, zero, or more than the maximum allowed for the current pool.
INVREQ	41	ESCAPE value not valid.
INVREQ	50	Inbound data with 'begin bracket' to be received.
INVREQ	51	AID value not valid.
INVREQ	52	Cursor position not valid.
INVREQ	53	Character values in send data not valid.
INVREQ	54	Attribute positions or values in send data not valid.
INVREQ	55	Key stroke escape sequence in send data is not valid.
INVREQ	56	Field validation (mandatory fill, mandatory enter, trigger) failed.
INVREQ	57	Input inhibited.
INVREQ	58	VTAM SEND failed.
INVREQ	59	DBCS data rules violated.
INVREQ	60	MAXFLENGTH value negative, zero, or more than the maximum allowed for the current pool.
INVREQ	71	VTAM RECEIVE failed.
# INVREQ	72	APARs PN68229 & PN71076: Documentation for PN68229 added on 19 June 1995. Documentation for PN71076 added on 18 August 1995.
#		RECEIVE FORMATTED processing found invalid, or unexpected data while interpreting the 3270 data stream for a WRITE, ERASE/WRITE, ERASE/WRITE ALTERNATE, or WRITE STRUCTURED FIELD command code.
INVREQ	210	Command not allowed for SLU P mode.
INVREQ	212	Conversation has wrong data format.
INVREQ	213	Command timed out.
INVREQ	215	Session lost.
INVREQ	216	Error occurred on previous FEPI SEND.
INVREQ	220	FEPI CONVERSE not allowed at this point in the conversation.
INVREQ	221	Data cannot be received because no AID or final attention key stroke specified.
INVREQ	224	Only FEPI ISSUE or FEPI FREE commands allowed at this point in the conversation.
INVREQ	230	SNA CLEAR command received. ³
INVREQ	231	SNA CANCEL command received. ³

| ³ For an explanation of this SNA command, see the *SNA Formats* manual, GA27-3136.

FEPI CONVERSE FORMATTED

Condition	RESP2	Meaning
INVREQ	232	SNA CHASE command received. ³
INVREQ	233	Exception response received.
INVREQ	234	Exception request received.
INVREQ	240	Conversation ID not owned by this task.
INVREQ	241	TIMEOUT value negative or not valid.

FEPI EXTRACT CONV

Function: FEPI EXTRACT CONV gets general information about a conversation.

Syntax

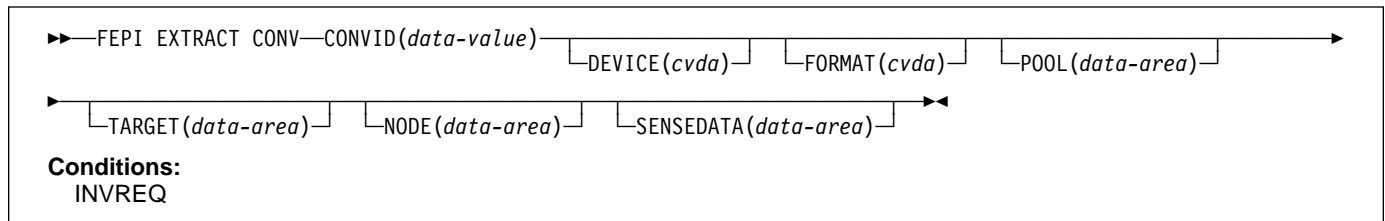

Options

CONVID(8-character data-value)

specifies the ID of the conversation for which information is wanted. The conversation must be owned by the task issuing the command.

Conditions

Condition	RESP2	Meaning
INVREQ	215	Session lost.
INVREQ	240	Conversation ID not owned by this task.

DEVICE(cvda)

returns a value that identifies the mode of conversation and the type of device. The relevant CVDA values are:

Value	Meaning
T3278M2	SLU2 mode, 3278 Model 2
T3278M3	SLU2 mode, 3278 Model 3
T3278M4	SLU2 mode, 3278 Model 4
T3278M5	SLU2 mode, 3278 Model 5
T3279M2	SLU2 mode, 3279 Model 2B
T3279M3	SLU2 mode, 3279 Model 3B
T3279M4	SLU2 mode, 3279 Model 4B
T3279M5	SLU2 mode, 3279 Model 5B
TPS55M2	SLU2 mode, PS/55, 24 lines
TPS55M3	SLU2 mode, PS/55, 32 lines
TPS55M4	SLU2 mode, PS/55, 43 lines
LUP	SLU P mode, all cases.

FORMAT(cvda)

in SLU2 mode, returns a value that identifies the data mode. The relevant CVDA values are:

DATASTREAM
FORMATTED

NODE(8-character data-area)

returns the node name.

POOL(8-character data-area)

returns the pool name.

SENSEDATA(fullword binary data-area)

returns the sense data associated with the last FEPI SEND, FEPI RECEIVE, or FEPI CONVERSE command for the conversation. If there is no sense data, zero is returned.

TARGET(8-character data-area)

returns the target name.

FEPI EXTRACT FIELD

Function: *The command is for SLU2 mode only, and for formatted data only.*

FEPI EXTRACT FIELD gets information about a field in the current character buffer of the simulated terminal. It can be issued at any point in the conversation. More than one FEPI EXTRACT FIELD command can be issued for a given field.

For information about field attributes and their values see *3270 Data Stream Programmer's Reference*. Symbolic names for the various attribute values are available in the DFHBMSCA copybook.

Syntax

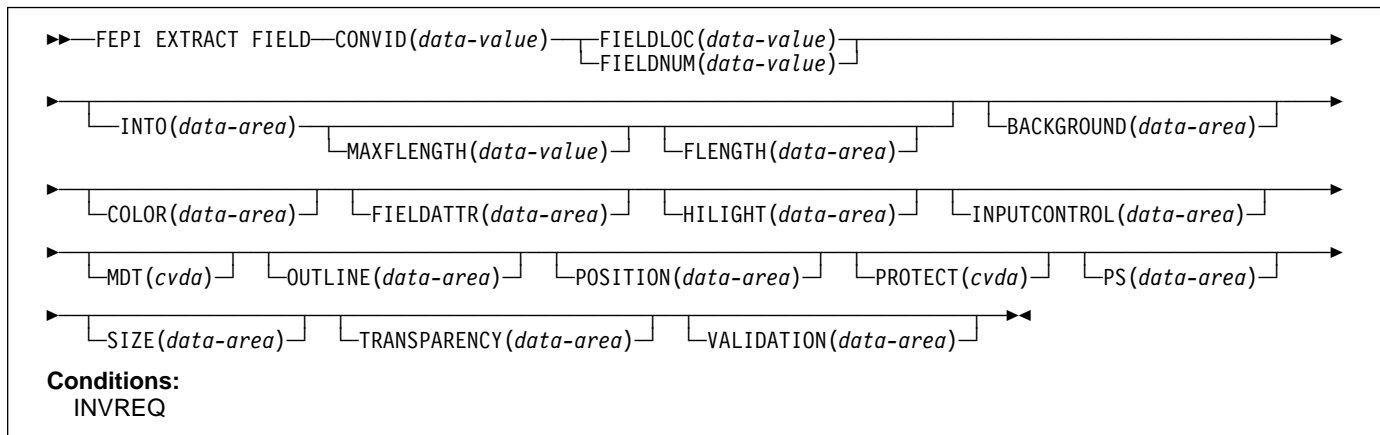

Options

BACKGROUND(1-character data-area)

returns the background color attribute of the field.

COLOR(1-character data-area)

returns the foreground color attribute of the field.

CONVID(8-character data-value)

specifies the ID of the conversation for which information is wanted. The conversation must be owned by the task issuing the command.

FIELDATTR(1-character data-area)

returns the 3270 field attribute of the field.

FIELDLOC(fullword binary data-value)

specifies the location of the required field expressed as an offset from the start of the screen image; offset zero is the top left-hand corner of the screen. The location can refer to any character position in the field, including its attribute byte.

FIELDNUM(fullword binary data-value)

specifies the location of the required field expressed as a field number counting from the top left-hand corner of the screen. The first field is number 1, and starts at the top-left hand corner of the screen, whether or not there is an attribute in that position. The last field ends at the bottom right-hand corner of the screen, and does not wrap back to the top.

FLENGTH(fullword binary data-area)

returns the actual length of data received in the data area identified by the INTO option.

HIGHLIGHT(1-character data-area)

returns the extended highlighting attribute of the field.

INPUTCONTROL(1-character data-area)

returns the DBCS input control attribute of the field.

INTO(data-area)

specifies the data area in which the data in the field is to be returned. The length of the area is specified by the MAXLENGTH option, and the actual length of data written into the area is returned by the FLENGTH option.

MAXLENGTH(fullword binary data-value)

specifies the maximum amount of data that can be returned; that is, the length of the data area identified by the INTO option. It must not be more than the maximum length allowed for the pool.

MDT(cvda)

returns a value that identifies the state of the modified data tag for the field. The relevant CVDA values are:

NOMDT
MDT

OUTLINE(1-character data-area)

returns the field outlining attribute of the field.

POSITION(fullword binary data-area)

returns the position of the field expressed as the offset of the first data byte from the start of the screen image; offset zero is the top left-hand corner of the screen.

PROTECT(cvda)

returns a value that indicates whether or not the field is protected. The relevant CVDA values are:

- UNPROTECTED
- PROTECTED

PS(1-character data-area)

returns the character set attribute of the field.

SIZE(fullword binary data-area)

returns the size of the field on the screen, excluding the field attribute byte, expressed as a number of bytes.

TRANSPARENCY(1-character data-area)

returns the transparency attribute of the field.

VALIDATION(1-character data-area)

returns the field validation attribute of the field.

Conditions

Condition	RESP2	Meaning
INVREQ	60	MAXLENGTH value negative, zero, or more than the maximum allowed for the current pool.
INVREQ	70	FIELDLOC or FIELDNUM value negative or not valid.
INVREQ	210	Command not allowed for SLU P mode.
INVREQ	212	Conversation has wrong data format.
INVREQ	224	Only FEPI ISSUE or FEPI FREE commands allowed at this point in the conversation.
INVREQ	240	Conversation ID not owned by this task.

FEPI EXTRACT STSN

Function: *The command is for SLU P mode only.*

FEPI EXTRACT STSN gets sequence number status information for a conversation.

Syntax

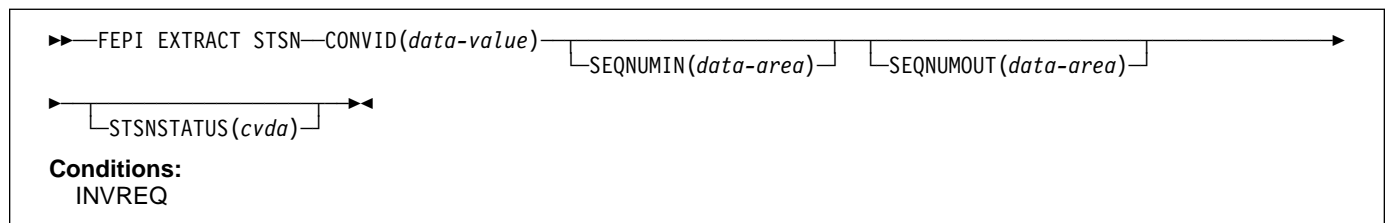

Options

CONVID(8-character data-value)

specifies the ID of the conversation for which information is wanted. The conversation must be owned by the task issuing the command.

SEQNUMIN(fullword binary data-area)

returns the current sequence number for inbound data.

SEQNUMOUT(fullword binary data-area)

returns the current sequence number for outbound data.

STSNSTATUS(cvda)

returns the current sequence-number set and test status. The relevant CVDA values are:

Value	Meaning
NOSTSN	No 'set' or 'test and set' issued.
STSNSET	'Set' sequence number issued.
STSNTEST	'Test and set' sequence number issued.

Conditions

Condition	RESP2	Meaning
INVREQ	211	Command not allowed for SLU2 mode.
INVREQ	240	Conversation ID not owned by this task.

FEPI FREE

Function: FEPI FREE ends a task's use and ownership of a conversation. The conversation may be ended completely, or may be passed to another task. The action depends on the processing state of the conversation:

- Begin session handler
- STSN handler
- Access program
- End session handler
- Unsolicited-data handler.

Syntax

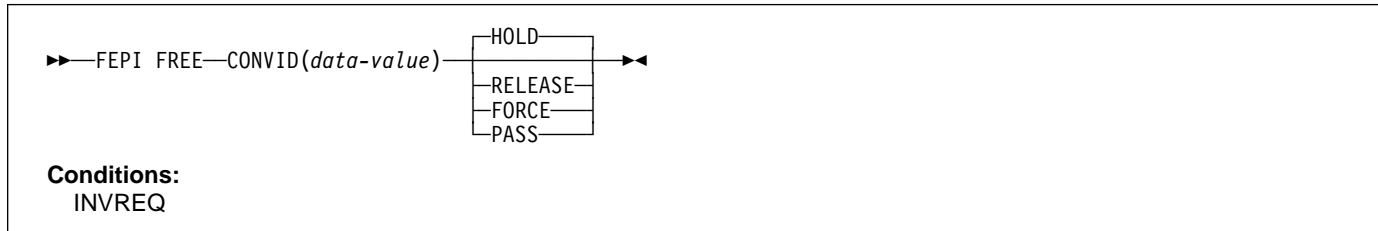

Options

CONVID(8-character data-value)

specifies the ID of the conversation to free. The conversation must be owned by the task issuing the command.

FORCE

tells FEPI what action to take. For all processing states of the conversation, FORCE instructs FEPI to end the conversation unconditionally, and to take the connection that it was using out of service immediately and, if possible, reset it.

HOLD

tells FEPI what action to take.

For the access program and the unsolicited-data handler, HOLD instructs FEPI to end the conversation and to retain the session for use by another conversation. However, this is subject to any end-session processing.

For the begin-session handler and the STSN handler, HOLD tells FEPI that begin-session or STSN processing has ended, and that the conversation is ready for the next processing state.

For the end-session handler, HOLD tells FEPI that end-session processing has ended, and instructs FEPI to end the conversation and to retain the session for use by another conversation. (If CICS shutdown is in progress, HOLD is the same as RELEASE.)

PASS

PASS

tells Front End Programming Interface what action to take. For all the processing states of the conversation, PASS specifies that the task is relinquishing ownership of the conversation so that another task can acquire it. FEPI regards this connection as still being used until such time as another task frees the connection without

using the PASS parameter. (PASS is not allowed if CICS shutdown is in progress.)

RELEASE

tells FEPI what action to take.

For the access program and the unsolicited-data handler, RELEASE instructs FEPI to end the conversation, and to release and unbind the session that it was using, thereby forcing a new session to be started next time the connection is used. However, this is subject to any end-session processing.

For the begin-session handler and the STSN handler, RELEASE tells FEPI that begin-session or STSN processing has ended, and instructs FEPI to end the conversation without proceeding to the next processing state, and to release and unbind the session that it was using, thereby forcing a new session to be started next time the connection is used. However, this is subject to any end-session processing.

For the end-session handler, RELEASE tells FEPI that end-session processing has ended, and instructs FEPI to end the conversation, and to release and unbind the session that it was using, thereby forcing a new session to be started next time the connection is used.

Note that, under normal circumstances, after a FEPI FREE RELEASE command has been issued the session does not remain in RELEASED state, because FEPI automatically tries to reacquire the session. However, if a FEPI SET CONNECTION ACQSTATUS(RELEASED) command is issued before the FREE RELEASE, the session remains in RELEASED state.

Conditions

Condition	RESP2	Meaning
INVREQ	214	CICS shutting down, conversation should be ended.
INVREQ	240	Conversation ID not owned by this task.

FEPI ISSUE

Function: FEPI ISSUE sends control data, such as standard responses and sense data, to the target system.

The command completes as soon as the corresponding VTAM SEND has been accepted.

Syntax

```
▶▶—FEPI ISSUE—CONVID(data-value)—CONTROL(cvda)—┐SENSEDATA(data-value)┘┐VALUE(cvda)┘▶▶
```

Conditions:
INVREQ

Options

CONTROL(*cvda*)

specifies what type of control data to send. The relevant CVDA values depend upon the data type and the mode of the conversation:

For all modes:

Value	Meaning
NORMALRESP	Send a normal response, as specified by the VALUE option.
EXCEPTRESP	Send an exception response, as specified by the VALUE option, and with the sense data specified by the SENSEDATA option.
ATTENTION	Send an attention (SNA 'signal' command X'00010000').
LUSTAT	Send an SNA 'LUSTAT' command with the sense data specified by the SENSEDATA option.

For data stream only:

Value	Meaning
CANCEL	Send an SNA 'cancel' command.

For SLU P mode only:

Value	Meaning
STSN	Send an SNA 'set and test sequence number' command.
RTR	Send an SNA 'ready to receive' command.

CONVID(8-character *data-value*)

specifies the ID of the conversation to use. The conversation must be owned by the task issuing the command.

SENSEDATA(fullword binary *data-value*)

specifies sense data to send to the target when the CONTROL is LUSTAT or EXCEPTRESP.

VALUE(*cvda*)

specifies the response type associated with the control data. The relevant CVDA values are determined by what is specified for the CONTROL option:

For EXCEPTRESP and NORMALRESP:

Value	Meaning
DEFRESP1OR2	Send definite response 1 or 2 as required.
DEFRESP1	Send definite response 1.
DEFRESP2	Send definite response 2.
DEFRESP3	Send definite response 1 and definite response 2.

For STSN:

Value	Meaning
POSITIVE	Send STSN positive response.
NEGATIVE	Send STSN negative response.
INVALID	Send STSN response not valid (this unbinds the session).
RESET	Send STSN reset response (this unbinds the session).
DEFRESP2	Send definite response 2.
DEFRESP3	Send definite response 1 and definite response 2.

For other controls:

None; the VALUE option is not used with the other controls.

Conditions

Condition	RESP2	Meaning
INVREQ	80	CONTROL value not valid.
INVREQ	81	VALUE value not valid: omitted when required, specified when not required, or unsuitable for the specified CONTROL value.
INVREQ	82	SENSEDATA value omitted when required or specified when not required.
INVREQ	90	Definite response type did not match what was required.
INVREQ	91	Only NORMALRESP or EXCEPTRESP are allowed at this point in the conversation.
INVREQ	92	Response to STSN SET was not POSITIVE.

FEPI RECEIVE DATASTREAM

Condition	RESP2	Meaning	Condition	RESP2	Meaning
INVREQ	93	Only FEPI ISSUE CONTROL(STSN) allowed at this point in the conversation.	INVREQ	216	Error occurred on previous FEPI SEND.
INVREQ	94	Only FEPI ISSUE CONTROL(STSN) or FEPI ISSUE CONTROL(NORMALRESP) allowed at this point in the conversation.	INVREQ	230	SNA CLEAR command received.
INVREQ	95	CONTROL value not allowed at this point in the conversation.	INVREQ	231	SNA CANCEL command received.
INVREQ	211	Option not allowed for SLU2 mode.	INVREQ	232	SNA CHASE command received.
INVREQ	215	Session lost.	INVREQ	233	Exception response received.
			INVREQ	234	Exception request received.
			INVREQ	240	Conversation ID not owned by this task.

FEPI RECEIVE DATASTREAM

Function: FEPI RECEIVE DATASTREAM receives data from a target and places the received data stream into the application's data area. Full details about the data are given in "Data formats" on page 160.

By default, FEPI RECEIVE DATASTREAM completes when a whole chain of data has been received. A time limit can be set for this command. For more details of ending conditions, see "Ending status" on page 161.

Syntax

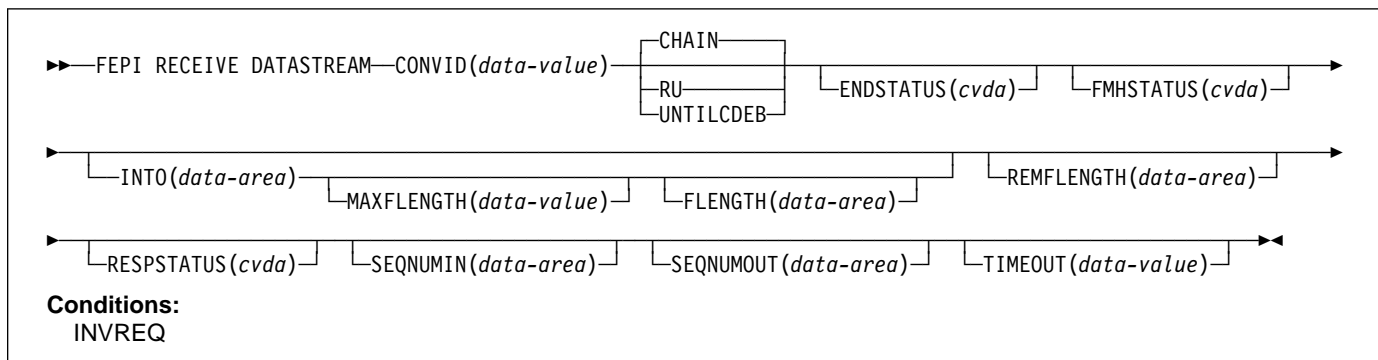

Options

CHAIN

specifies that the command should complete when a whole chain has been received.

CONVID(8-character data-value)

specifies the ID of the conversation to use. The conversation must be owned by the task issuing the command.

ENDSTATUS(cvda)

returns a value that indicates the ending status for the received data. The relevant CVDA values are:

Value	Meaning
CD	'Change direction' received.
EB	'End bracket' received
LIC	'Last in chain' received.
RU	RU received.
MORE	The data area identified by the INTO option was too small to receive all the requested data.

For more details of ending status and how additional data is handled, see "Ending status" on page 161.

FLENGTH(fullword binary data-area)

returns the actual length of data received in the data area identified by the INTO option.

FMHSTATUS(cvda)

returns a value that indicates whether the received data contains a function management header. The relevant CVDA values are:

FMH
NOFMH

INTO(data-area)

specifies the data area in which the received data is to be returned. The length of the area is specified by the MAXFLENGTH option, and the actual length of data written into the area is returned by the FLENGTH option.

MAXFLENGTH(fullword binary data-value)

specifies the maximum amount of data that can be returned; that is, the length of the data area identified by the INTO option. It must not be more than the maximum length allowed for the pool.

REMFLNGTH(fullword binary data-area)

returns the length, if known, of data remaining after filling the data area identified by the INTO option.

RESPSTATUS(cvda)

returns a value that indicates the type of response that is required at the back-end system. The relevant CVDA values are:

Value	Meaning
DEFRESP1	Definite response 1 required.
DEFRESP2	Definite response 2 required.
DEFRESP3	Definite response 1 and definite response 2 required.
NONE	No response required.

RU

specifies that the command should complete when a request unit has been received.

SEQNUMIN(fullword binary data-area)

in SLU P mode, returns the current sequence number for inbound data, as at the completion of the command. (SEQNUMIN has no significance in SLU2 mode.)

SEQNUMOUT(fullword binary data-area)

in SLU P mode, returns the current sequence number for outbound data, as at the completion of the command. (SEQNUMOUT has no significance in SLU2 mode.)

TIMEOUT(fullword binary data-value)

specifies the maximum time in seconds that the command is to wait for the requested data to begin to

arrive. If TIMEOUT is not specified or the specified time is zero, the command is not timed out.

UNTILCDEB

specifies that the command should complete when 'change direction' or 'end bracket' is received.

Conditions

Condition	RESP2	Meaning
INVREQ	60	MAXFLENGTH value negative or more than maximum allowed for the current pool.
INVREQ	71	VTAM RECEIVE failed.
INVREQ	212	Conversation has wrong data format.
INVREQ	213	Command timed out.
INVREQ	215	Session lost.
INVREQ	216	Error occurred on previous FEPI SEND.
INVREQ	221	FEPI RECEIVE not allowed at this point in the conversation.
INVREQ	224	Only FEPI ISSUE or FEPI FREE commands allowed at this point in the conversation.
INVREQ	230	SNA CLEAR command received.
INVREQ	231	SNA CANCEL command received.
INVREQ	232	SNA CHASE command received.
INVREQ	233	Exception response received.
INVREQ	234	Exception request received.
INVREQ	240	Conversation ID not owned by this task.
INVREQ	241	TIMEOUT value negative or not valid.

FEPI RECEIVE FORMATTED

Function: *This command is for SLU2 mode only.*

FEPI RECEIVE FORMATTED receives data from a target. The data received into the application's data area is a screen image. Full details about the data are given in "Data formats" on page 160.

FEPI RECEIVE FORMATTED completes after receiving the inbound data with 'last in chain', 'end bracket' or 'change direction' indicated. A time limit can be set for this command. For more details of ending conditions, see "Ending status" on page 161.

Syntax

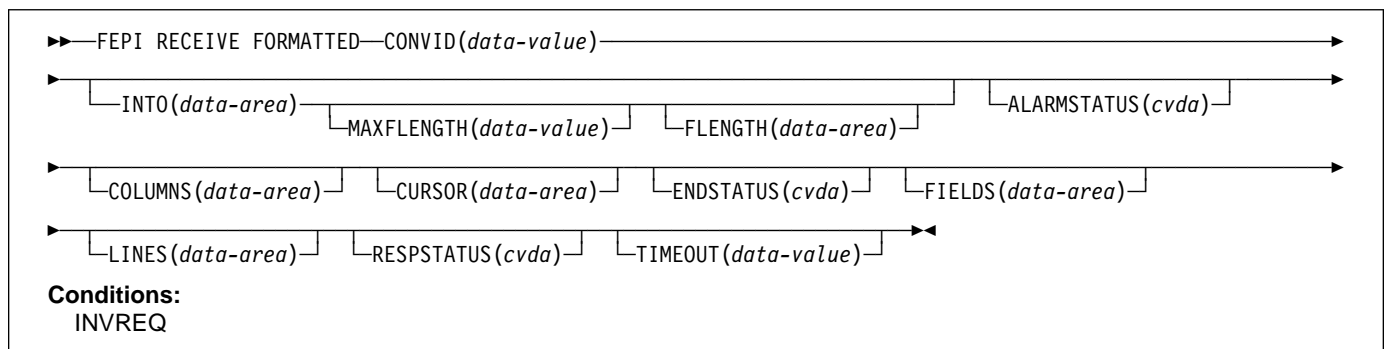

FEPI RECEIVE FORMATTED

Options

ALARMSTATUS(cvda)

returns a value that indicates whether the received data sounded the alarm. The relevant CVDA values are:

ALARM
NOALARM

COLUMNS(fullword binary data-area)

returns the number of columns in the screen image.

CONVID(8-character data-value)

specifies the ID of the conversation to use. The conversation must be owned by the task issuing the command.

CURSOR(fullword binary data-area)

returns the position of the cursor in the received screen image, expressed as an offset from the start of the screen image; offset zero is the top left-hand corner of the screen.

ENDSTATUS(cvda)

returns a value that indicates the ending status for the received data. The relevant CVDA values are:

Value	Meaning
CD	'Change direction' received.
EB	'End bracket' received
LIC	'Last in chain' received.

For more details of ending status and how additional data is handled, see "Ending status" on page 161.

FIELDS(fullword binary data-area)

returns the number of fields in the screen image.

FLENGTH(fullword binary data-area)

returns the actual length of data received in the data area identified by the INTO option.

INTO(data-area)

specifies the data area in which the received data is to be returned. The length of the area is specified by the MAXLENGTH option, and the actual length of data written into the area is returned by the FLENGTH option.

LINES(fullword binary data-area)

returns the number of lines in the screen image.

MAXLENGTH(fullword binary data-value)

specifies the maximum amount of data that can be returned; that is, the length of the data area identified by

the INTO option. It must not be more than the maximum length allowed for the pool.

RESPSTATUS(cvda)

returns a value that indicates the type of response that is required at the back-end system. The relevant CVDA values are:

Value	Meaning
DEFRESP1	Definite response 1 required.
DEFRESP2	Definite response 2 required.
DEFRESP3	Definite response 1 and definite response 2 required.
NONE	No response required.

TIMEOUT(fullword binary data-value)

specifies the maximum time in seconds that the command is to wait for the requested data to begin to arrive. If TIMEOUT is not specified or the specified time is zero, the command is not timed out.

Conditions

Condition	RESP2	Meaning
INVREQ	60	MAXLENGTH value negative or more than the maximum allowed for the current pool.
INVREQ	71	VTAM RECEIVE failed.
# INVREQ	72	APARs PN68229 & PN71076: Documentation for PN68229 added on 19 June 1995. Documentation for PN71076 added on 18 August 1995.
#		RECEIVE FORMATTED processing found invalid, or unexpected data while interpreting the 3270 data stream for a WRITE, ERASE/WRITE, ERASE/WRITE ALTERNATE, or WRITE STRUCTURED FIELD command code.
#		RECEIVE FORMATTED processing found invalid, or unexpected data while interpreting the 3270 data stream for a WRITE, ERASE/WRITE, ERASE/WRITE ALTERNATE, or WRITE STRUCTURED FIELD command code.
#		RECEIVE FORMATTED processing found invalid, or unexpected data while interpreting the 3270 data stream for a WRITE, ERASE/WRITE, ERASE/WRITE ALTERNATE, or WRITE STRUCTURED FIELD command code.
#		RECEIVE FORMATTED processing found invalid, or unexpected data while interpreting the 3270 data stream for a WRITE, ERASE/WRITE, ERASE/WRITE ALTERNATE, or WRITE STRUCTURED FIELD command code.
#		RECEIVE FORMATTED processing found invalid, or unexpected data while interpreting the 3270 data stream for a WRITE, ERASE/WRITE, ERASE/WRITE ALTERNATE, or WRITE STRUCTURED FIELD command code.
#		RECEIVE FORMATTED processing found invalid, or unexpected data while interpreting the 3270 data stream for a WRITE, ERASE/WRITE, ERASE/WRITE ALTERNATE, or WRITE STRUCTURED FIELD command code.
INVREQ	210	Command not allowed for SLU P mode.
INVREQ	212	Conversation has wrong data format.
INVREQ	213	Command timed out.
INVREQ	215	Session lost.
INVREQ	216	Error occurred on previous FEPI SEND.
INVREQ	221	FEPI RECEIVE not allowed at this point in the conversation.
INVREQ	224	Only FEPI ISSUE or FEPI FREE commands allowed at this point in the conversation.
INVREQ	230	SNA CLEAR command received.
INVREQ	231	SNA CANCEL command received.
INVREQ	232	SNA CHASE command received.
INVREQ	233	Exception response received.
INVREQ	234	Exception request received.
INVREQ	240	Conversation ID not owned by this task.
INVREQ	241	TIMEOUT value negative or not valid.

FEPI REQUEST PASSTICKET

Function: FEPI REQUEST PASSTICKET requests an external security manager (ESM) such as RACF to build a *PassTicket*. The *PassTicket* is a password substitute that your application can use to sign on to the back-end system associated with the conversation. For an explanation of how to use *PassTickets* to make your FEPI applications more secure, see “How to use *PassTickets*” on page 127.

Syntax

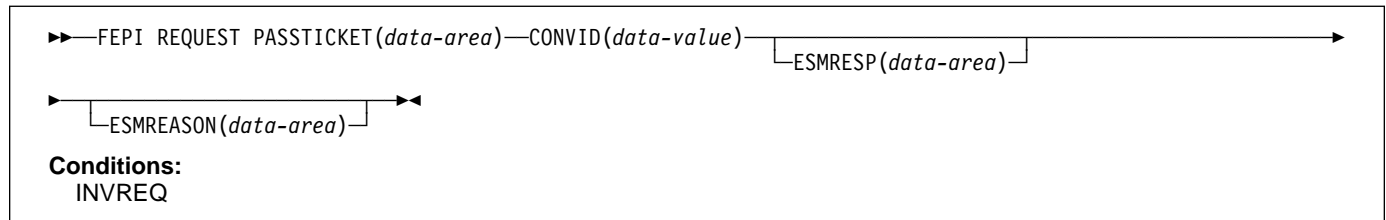

Options

CONVID(8-character data-value)

specifies the ID of the conversation with the back-end system for which a *PassTicket* is required.

ESMREASON(fullword binary data-area)

returns the reason code from the ESM.

ESMRESP(fullword binary data-area)

returns the response code from the ESM. For an explanation of the response and reason codes returned by RACF, see the *RACF Messages and Codes* manual.

PASSTICKET(8-character data-area)

returns the *PassTicket* generated by the ESM.

Conditions

Condition	RESP2	Meaning
INVREQ	240	Conversation ID not owned by this task.
INVREQ	250	Passticket not built successfully.
INVREQ	251	CICS ESM interface not initialized.
INVREQ	252	Unknown return code in ESMRESP from the ESM.
INVREQ	253	Unrecognized response from CICS security modules.
INVREQ	254	Function unavailable.

FEPI SEND DATASTREAM

Function: FEPI SEND DATASTREAM sends application data to a target. The data supplied by the application must be currently valid data stream appropriate to the mode of the conversation (SLU2 or SLU P). Full details about the data are given in "Data formats" on page 160.

The command completes as soon as the (first) VTAM SEND has been accepted.

Syntax

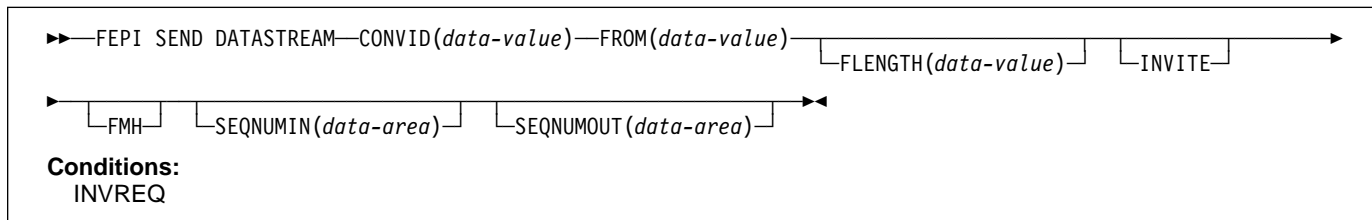

Options

CONVID(8-character data-value)

specifies the ID of the conversation to use. The conversation must be owned by the task issuing the command.

FMH

indicates that the data to send includes a function management header.

FLENGTH(fullword binary data-value)

specifies the length of the data to send; that is, the length of the data area identified by the FROM option. It must not be zero or more than the maximum length allowed for the pool.

FROM(data-value)

specifies the data to send to the back-end application. Its length is specified by the FLENGTH option.

INVITE

requests FEPI to send 'last in chain' and 'change direction' at the end of the data. This indicates that the data is complete, and that inbound data is expected next.

SEQNUMIN(fullword binary data-area)

in SLU P mode, returns the current sequence number for inbound data, as at the completion of the command. (SEQNUMIN has no significance in SLU2 mode.)

SEQNUMOUT(fullword binary data-area)

in SLU P mode, returns the current sequence number for outbound data, as at the completion of the command. (SEQNUMOUT has no significance in SLU2 mode.)

Conditions

Condition	RESP2	Meaning
INVREQ	40	FLENGTH value negative, zero, or more than maximum allowed for the current pool.
INVREQ	50	Inbound data with 'begin bracket' to be received.
INVREQ	58	VTAM SEND failed.
INVREQ	212	Conversation has wrong data format.
INVREQ	215	Session lost.
INVREQ	216	Error occurred on previous FEPI SEND.
INVREQ	220	FEPI SEND not allowed at this point in the conversation.
INVREQ	224	Only FEPI ISSUE or FEPI FREE commands allowed at this point in the conversation.
INVREQ	230	SNA CLEAR command received.
INVREQ	231	SNA CANCEL command received.
INVREQ	232	SNA CHASE command received.
INVREQ	233	Exception response received.
INVREQ	234	Exception request received.
INVREQ	240	Conversation ID not owned by this task.

FEPI SEND FORMATTED

Function: *This command is for SLU2 mode only.*

FEPI SEND FORMATTED sends application data to a target. The data supplied by the application must be formatted data, as key strokes or as a screen image. Full details about the data are given in “Data formats” on page 160.

The command completes as soon as the (first) VTAM SEND has been accepted.

Syntax

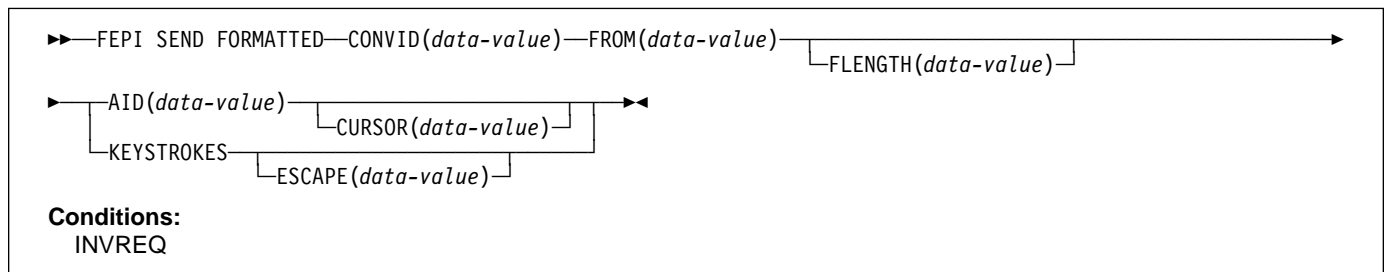

Options

AID(1-character data-value)

specifies the attention identifier value to send with the data. Specifying AID also indicates that the data to send is in screen-image format, as described in “Data formats” on page 160. A value of null (X'00') may be specified to indicate that no attention is to be sent, and that a further FEPI SEND is to follow.

- # Symbolic names for the AID values are available for the
- # supported languages in the language-specific DFHAID
- # copybooks.

CONVID(8-character data-value)

specifies the ID of the conversation to use. The conversation must be owned by the task issuing the command.

CURSOR(fullword binary data-value)

for send data in screen-image format, specifies the position of the cursor, expressed as an offset from the start of the screen image; offset zero is the top left-hand corner of the screen. If CURSOR is not specified, the cursor remains where it was positioned by the last inbound data.

ESCAPE(1-character data-value)

for send data in key stroke format, specifies the escape character used to indicate character combinations representing special keys. You can use any value in the range X'40' through X'FE'. The default escape character is & (X'50').

FLENGTH(fullword binary data-value)

specifies the length of the data to send; that is, the length of the data area identified by the FROM option. It must not be zero or more than the maximum length allowed for the pool.

FROM(data-value)

specifies the data to send to the back-end application. Its length is specified by the FLENGTH option. For send data in screen-image format, if the length is more than the screen image, the additional data is ignored; if it is less, the data is the first part of the screen image, and the last part of the screen image is not changed.

KEYSTROKES

specifies that the data to send is in key stroke format, a sequence of key strokes, as described in “Data formats” on page 160.

Conditions

Condition	RESP2	Meaning
INVREQ	40	FLENGTH value negative, zero, or more than the maximum allowed for the current pool.
INVREQ	41	ESCAPE value not valid
INVREQ	50	Inbound data with 'begin bracket' to be received.
INVREQ	51	AID value not valid.
INVREQ	52	Cursor position not valid.
INVREQ	53	Character values in send data not valid.
INVREQ	54	Attribute positions or values in send data not valid.
INVREQ	55	Key stroke escape sequence in send data not valid.
INVREQ	56	Field validation (mandatory fill, mandatory enter, trigger) failed.
INVREQ	57	Input inhibited.
INVREQ	58	VTAM SEND failed.
INVREQ	59	DBCS data rules violated.
INVREQ	210	Command not allowed for SLU P mode.
INVREQ	212	Conversation has wrong data format.
INVREQ	215	Session lost.
INVREQ	220	FEPI SEND not allowed at this point in the conversation.
INVREQ	224	Only FEPI ISSUE or FEPI FREE commands allowed at this point in the conversation.

FEPI START

Condition	RESP2	Meaning
INVREQ	230	SNA CLEAR command received.
INVREQ	231	SNA CANCEL command received.
INVREQ	232	SNA CHASE command received.
INVREQ	233	Exception response received.
INVREQ	234	Exception request received.
INVREQ	240	Conversation ID not owned by this task.

FEPI START

Function: FEPI START is used to relinquish control of a conversation and to specify a new transaction to be started when the next inbound data arrives. Up to 128 characters of user data can be passed to the transaction as part of the start data, as described in "Start data" on page 159 below.

Syntax

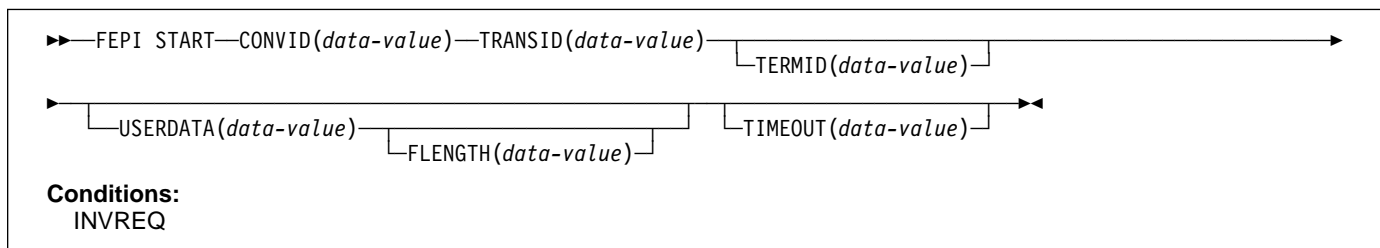

Options

CONVID(8-character data-value)

specifies the ID of the conversation to suspend. The conversation must be owned by the task issuing the command.

FLENGTH(fullword binary data-value)

specifies the length of the optional user data to pass to the transaction that is started; that is, the length of the data area identified by the USERDATA option. The FLENGTH value must not be greater than 128.

TERMINID(4-character data-value)

specifies the name of the terminal, if any, to be associated with the transaction that is started.

TIMEOUT(fullword binary data-value)

specifies the maximum time in seconds that FEPI is to wait for inbound data to begin to arrive before starting the transaction. If TIMEOUT is not specified or the specified time is zero, the command is not timed out.

TRANSID(4-character data-value)

specifies the name of the transaction that is to be started when the next inbound data arrives.

USERDATA(data-value)

specifies optional user data to pass to the transaction that is started, in addition to control information passed by FEPI. Its length is specified by the FLENGTH option.

Conditions

Condition	RESP2	Meaning
INVREQ	61	FLENGTH value negative or too large.
INVREQ	62	TRANSID name not valid.
INVREQ	63	TERMINID name not valid.
INVREQ	214	CICS shutting down, conversation should be ended.
INVREQ	215	Session lost.
INVREQ	216	Error occurred on previous FEPI SEND.
INVREQ	223	FEPI START not allowed at this point in the conversation.
INVREQ	224	Only FEPI ISSUE or FEPI FREE commands allowed at this point in the conversation.
INVREQ	230	SNA CLEAR command received.
INVREQ	231	SNA CANCEL command received.
INVREQ	232	SNA CHASE command received.
INVREQ	233	Exception response received.
INVREQ	234	Exception request received.
INVREQ	240	Conversation ID not owned by this task.
INVREQ	241	TIMEOUT value negative or not valid.

Start data

For various events, FEPI invokes a transaction, as a CICS started task, to handle the event. This may be in response to FEPI START, or to handle STSN, begin-session, end-session, or unsolicited-data. The transactions have a start code of 'SZ', as can be determined with the EXEC CICS ASSIGN command. FEPI provides start data which describes the event, and the conversation which is to be used to handle it. All of this data must be retrieved by the transaction using EXEC CICS RETRIEVE. The transaction can then gain access to the conversation identified in the data by using FEPI ALLOCATE PASSCONVID.

The structure for start data is shown below; the copy books DFHSZAPA, DFHSZAPO, DFHSZAPC, and DFHSZAPP (according to your programming language) provide declarations for this structure.

DATATYPE	Fullword binary data-area
EVENTTYPE	CVDA
EVENTVALUE	CVDA
EVENTDATA	8-character data-area
spare	4-character data-area
POOL	8-character data-area
TARGET	8-character data-area
NODE	8-character data-area
CONVID	8-character data-area
DEVICE	CVDA
FORMAT	CVDA
spare	8-character data-area
FLENGTH	Fullword binary data-area
USERDATA	128-character data area.

Fields

CONVID(8-character data-area)

the ID of the conversation for which the event occurred (this is the CONVID that should be used in FEPI ALLOCATE PASSCONVID).

DATATYPE(fullword binary data-area)

Type and structure of data. Value is 1 for FEPI start data.

DEVICE(cvda)

the device type of conversation for which the event occurred, values being as for FEPI EXTRACT CONV.

EVENTDATA(8-character data-area)

always nulls.

EVENTTYPE(cvda)

Indicates why the transaction was started. Values are:

Value	Event
BEGINSESSION	Begin-session to be handled
DATA	Inbound data arrived, following a FEPI START command
FREE	End-session transaction started to handle end of conversation as a result of a FEPI FREE request
SESSIONLOST	Active session lost while waiting for inbound data to arrive following a FEPI START command
STSN	Set and test sequence number (STSN) to be handled
TIMEOUT	Timed out waiting for inbound data to arrive following a FEPI START command
UNSOLDATA	Inbound data arrived outside a conversation.

EVENTVALUE(cvda)

A CVDA giving further information about event types FREE and RELEASE.

Values for FREE:

FORCE	A FEPI FREE FORCE command was issued.
HOLD	A FEPI FREE HOLD command was issued.
RELEASE	A FEPI FREE RELEASE command was issued.
SHUTDOWN	CICS is shutting down.
TASK	Conversation being freed by end-of-task.

The EVENTVALUE value is zero for all other event types.

FLENGTH(fullword binary data-area)

the length of the data in USERDATA.

FORMAT(cvda)

the data format of conversation for which the event occurred, values being as for FEPI EXTRACT CONV.

NODE(8-character data-area)

the name of the node for which the event occurred.

POOL(8-character data-area)

the name of the pool for which the event occurred.

TARGET(8-character data-area)

the name of the target for which the event occurred.

USERDATA(128-character data-area)

user data as specified on the FEPI START command.

spare

nulls.

Data formats

Outbound data

Data stream

The data is a standard outbound data stream, exactly as would be sent from the simulated terminal to VTAM.

Screen-image format, SLU2 mode

The data replaces, byte for byte, the data in the character buffer of the simulated terminal. Any data value is allowed. Data that goes into positions within a protected field must be identical to that in the field; data for positions occupied by an attribute byte is ignored. MDTs can be set forcibly for fields by setting the value in the attribute position to X'01'. (FEPI will set MDT automatically if data has changed.)

Key stroke format, SLU2 mode

The data can contain any combination of data characters together with manipulative, special, and attention key values. Data characters are represented by their EBCDIC code values in the range X'40'–X'FE', or by their DBCS code values of pairs of bytes in the range X'41'–X'FE', plus X'4040'. Manipulative, special, and attention key values are represented by *escape* sequences, comprising the escape character specified by the ESCAPE option and a 2-character code. Using '&' for the escape character, the escape sequences are:

Manipulative keys

&HO	home
&Ln	cursor left, n times
&Rn	cursor right, n times
&Un	cursor up, n times
&Dn	cursor down, n times
&Tn	tab, n times
&Bn	backtab, n times
&Nn	newline, n times (where n = 1–9)

Special keys

&IN	insert
&DL	delete
&RS	reset
&EF	erase to end of field
&EI	erase input
&FM	field mark
&DU	DUP
&ES	escape character
&MS	start secure MSR
&SO	shift out
&SI	shift in

Attention keys

&AT	attention
&An	PAn (n = 1–3)
&nn	PFnn (where nn = 01–24, leading 0 must be specified)
&CL	clear
&CS	cursor select (light pen)
&EN	enter
&ME	end secure MSR

Keys not listed and data characters below X'40' are not supported. Thus, nulls (X'00') are excluded—nulls can be generated by use of the erase or delete keys. Key strokes following an attempt to enter into a protected field are ignored until 'reset' is keyed.

For magnetic stripe reader support, the sequence &MS...data...&ME represents passing a secure magnetic stripe card through the reader. Nonsecure cards have to be simulated by using the corresponding key strokes.

Zero, one, or more than one, attention keys may be used. If an attention key is followed by data characters, FEPI does an implicit receive operation for each one until the back-end application unlocks the keyboard and sends 'change direction' or 'end bracket' (and FEPI responds positively to any definite response requests); then the subsequent key strokes are sent.

Inbound data

Data stream

The data is a standard inbound data stream, exactly as would be sent to the simulated terminal from VTAM.

Note that the received data is not complete if the command that received the data returned an ENDSTATUS of MORE.

Formatted, SLU2 mode

The data is the contents of the simulated terminal character buffer that FEPI holds. Data characters are represented by their EBCDIC or DBCS code values; positions corresponding to field attributes contain X'FF'.

Ending status

This describes in detail the conditions under which FEPI CONVERSE and FEPI RECEIVE commands complete, and how the completion condition is reported to the application.

The completion conditions for each command are:

FEPI CONVERSE DATASTREAM using a temporary conversation

On the first to occur of:

- INTO data area full
- 'change direction' indicated
- 'end bracket' indicated.

It does not end at 'end of chain' alone; if a definite response request is indicated on a chain, FEPI responds positively and continues receiving data.

FEPI CONVERSE DATASTREAM using a previously allocated conversation

As for FEPI RECEIVE DATASTREAM.

FEPI CONVERSE FORMATTED using a temporary conversation

on the first to occur of:

- 'change direction' indicated
- 'end bracket' indicated.

It does not end at 'end of chain' alone; if a definite response request is indicated on a chain, FEPI responds positively and continues receiving data.

FEPI CONVERSE FORMATTED using a previously allocated conversation

As for FEPI RECEIVE FORMATTED.

FEPI RECEIVE DATASTREAM

This can be specified or defaulted to end in one of the following ways:

RU

- on the first to occur of:
- INTO data area full
 - end of request unit.

CHAIN

- on the first to occur of:
- INTO data area full
 - 'end of chain'.

UNTILCDEB

- on the first to occur of:
- INTO data area full
 - 'end of chain' with definite response request
 - 'change direction' indicated
 - 'end bracket' indicated.

FEPI RECEIVE FORMATTED

At end of chain.

In all cases, ENDSTATUS is set to indicate the completion conditions and RESPSTATUS is set to indicate whether a response is required and, if so, the type of response. Where several conditions occur together, ENDSTATUS shows the most significant. The values and their meanings are shown in Table 12.

Table 12. ENDSTATUS values and associated meanings

ENDSTATUS	Commands						Conditions					Next command expected (except after CONVERSE with POOL)
	RECEIVE		CONVERSE without POOL		CONVERSE with POOL		End bracket	Change direction	End chain	End RU	INTO area full	
	DS	FM	DS	FM	DS	FM						
EB	X	X	X	X	X	X	Y	-	Y	Y	-	Any
CD	X	X	X	X	X	X	-	Y	Y	Y	-	FEPI SEND or CONVERSE
LIC	X	X	X	X	-	-	-	-	Y	Y	-	FEPI RECEIVE
RU	R	-	R	-	-	-	-	-	-	Y	-	FEPI RECEIVE
MORE	X	-	X	-	X	-	-	-	-	-	Y	FEPI RECEIVE

Note:
 DS=Datastream
 FM=Formatted
 X=Possible with command
 R=Possible with RU option of command
 Y=Condition indicated.

Appendix A. Sample programs

The SDFHSAMP library contains a set of sample programs (in source form), including two back-end application programs, that show many of the principles and techniques discussed in this book. Although the samples are copyrighted, you may use and copy them freely for educational purposes to help you write FEPI applications. This appendix gives an overview of these programs.

A subset of the sample programs is available in each of the supported programming languages. The programs and their names are given in Table 13.

Table 13. Sample programs and their names

Description	Transaction name	COBOL	Assembler	PL/I	C/370
Programs:					
Setup	CZXS	DFH0VZXS	DFH0AZXS		DFH0CZXS
Monitor and unsolicited data handler	CZUX	DFH0VZUX			
Begin-session handler	CZUC	DFH0VZUC			
3270 data stream pass-through	CZTD	DFH0VZTD	DFH0AZTD		
Key stroke CONVERSE	CZTK	DFH0VZTK		DFH0PZTK	DFH0CZTK
Screen image SEND and START	CZTS	DFH0VZTS			
Screen image RECEIVE and EXTRACT	CZTR	DFH0VZTR			
End-session handler	CZUU	DFH0VZUU			
SLU P, one-out, one-in	CZPS	DFH0VZPS	DFH0AZPS		
SLU P, pseudoconversational	CZPA	DFH0VZPA	DFH0AZPA		
STSN handler	CZQS	DFH0VZQS	DFH0AZQS		
Back-end CICS	CZBC		DFH0AZBC		
Back-end IMS	CZBI		DFH0AZBI		
Copy books:					
Customization data		DFH0BZCO	DFH0BZCA	DFH0BZCP	DFH0BZCC
Messages and other text		DFH0BZMO	DFH0BZMA	DFH0BZMP	DFH0BZMC
Key stroke map		DFH0BZ1O		DFH0BZ7P	DFH0BZ6C
Send/receive map		DFH0BZ2O			
Back-end CICS map			DFH0BZ3A		
SLU P, one-out, one-in map		DFH0BZ4O	DFH0BZ8A		
SLU P, pseudoconversational map		DFH0BZ5O	DFH0BZ9A		
Maps:					
Key stroke		DFH0MZ1		DFH0MZ7	DFH0MZ6
Send/receive		DFH0MZ2			
SLU P, one-out, one-in		DFH0MZ4	DFH0MZ8		
SLU P, pseudoconversational		DFH0MZ5	DFH0MZ9		
Back-end CICS			DFH0MZ3		

There are also some sample resource definitions:

Front-end CICS	DFH0IZRD
Back-end CICS	DFH0IZRC
Back-end IMS	DFH0IZRI
CICS TD queues	DFH0IZRQ

Table 14 shows you which samples illustrate which functions.

<i>Table 14. Functional cross-reference for sample programs</i>											
Functions	Samples (Last two letters of sample program name. See notes.)										
	TD	TK	TS	TR	PA	PS	QS	UC	UU	UX	XS
SLU2	X	X	X	X	X	X	X				
SLU P	X	X	X	X	X	X					
Data stream	X	X	X	X	X	X					
Screen-image	X	X	X	X							
Key stroke	X	X									
ALLOCATE	X	X	X	X							
ALLOCATE with PASSCONVID	X	X	X	X	X	X	X				
EXTRACT STSN	X										
EXTRACT FIELD	X	X									
SEND	X	X									
START	X	X									
RECEIVE	X	X	X	X							
CONVERSE	X	X	X								
CONVERSE with POOL	X										
ISSUE	X										
FREE	X	X	X	X	X	X	X	X			
FREE with PASS	X	X									
INSTALL	X										
ADD	X										
Start data	X	X	X	X	X						
TD queue data	X										
One-out one-in	X										
Conversational	X	X									
Pseudo-conversational	X	X	X								
Assembler language	X	X	X	X	X						
COBOL	X	X	X	X	X	X	X	X	X	X	X
C/370	X	X									
PL/I	X										
Notes:											
TD	Data stream										
TK	Key stroke										
TS	Screen image send/start										
TR	Screen image receive										
PA	SLU P pseudoconversational										
PS	SLU P one-out, one-in										
QS	STSN										
UC	Begin session										
UU	End session										
UX	Monitor, unsolicited data										
XS	Setup										
FEPI EXTRACT CONV, SET/INQUIRE/browse, and DELETE/DISCARD commands are not illustrated in the sample programs.											

COBOL II Sample Restrictions

The following COBOL II samples can only be compiled using the release 3 and later versions of the COBOL II compiler:

- DFH0VZUC
- DFH0VZUX
- DFH0VZPS
- DFH0VZPA

Installing the samples

The CICS front-end samples

All you have to do to get the samples running is customize them for your system. This means that you need to change at most three things:

- The customization data copy book, DFH0BZCx
- The setup program, DFH0xZXS
- The resource definitions, DFH0IZRx.

Then compile or assemble and link-edit all the samples (and their maps) that you want, as you would do for any CICS application program. Define them to your front-end system, using the examples in DFH0IZRD for the resource definitions that are needed; they are in the form required as input to the DFHCSDUP utility. Note that there is a separate resource group for each language because the transaction names used are the same for each programming language. You should have defined the necessary transient data (TD) queues when you installed FEPI itself. However, DFH0IZRQ provides sample definitions for them.

The CICS and IMS back-end samples

You need to assemble, link-edit, define, and install the appropriate back-end program and maps on your back-end system. For CICS, sample resource definitions are in DFH0IZRC. For IMS, sample resource definitions are in DFH0IZRI.

Note: When using the IMS back-end samples, ensure that you link-edit the back-end program with the IMS version of ASMTDLI (or the appropriate language module), and that you specify RMODE and AMODE as 24. (If you use the CICS version of ASMTDLI, the program will abend when executed in the IMS environment.)

Using the samples

The samples form an integrated set. The setup program provides the FEPI resource definitions that the other samples use. The monitor and the various handlers support and complement the access programs, to form a complete FEPI communication package, just as you need to provide. Remember, however, that these are samples designed for illustration purposes. Although they give a great deal of help, and include suggestions about writing FEPI programs, for any particular circumstance you must consider exactly what your requirements are.

The two back-end programs (one for CICS and one for IMS) provide applications for the front-end programs to access. The back-end CICS program is for access by the front-end SLU2 mode programs, and the back-end IMS program is for access by the front-end SLU P mode programs; no SLU2 mode access to IMS is provided. Although the back-end programs are supplied in source form, it is not necessary for you to understand the internal logic—only the external operations, as is the case for a “real” existing back-end application.

Sample programs

The FEPI sample front-end and back-end transactions assume that the datastream sent from the back-end application is received unaltered by the front-end application. For example, FEPI samples may perform unexpectedly if the datastreams are compressed after having been sent from the back-end application.

The back-end CICS program

This program is the CICS back-end application used by the FEPI sample programs.

Module name: DFH0AZBC

Transaction name: CZBC

Abend code: USZA

Map name: DFH0MZ3

Screen

```
CZBC                      Customer Inquiry
Please type a customer number in the range 1 to 9999, then Enter.
Customer Number . . . . .
Name . . . . . :
Balance . . . . . :
Address . . . . . :
Last Transaction Date . . :
F3=EXIT to CICS
```

Figure 8. CZBC transaction: customer inquiry

Overview

On the first invocation of the transaction, a map is sent to the terminal.

When there is input from the terminal, CICS invokes the transaction again. The customer data for the customer number from the input is found and sent to the terminal, and further input is awaited. PF3 or CLEAR ends the transaction.

Certain customer numbers cause special processing such as abends and delays, to show how a front-end application could manage such events. The valid customer numbers are:

0001-0005	Normal
0006	Delayed response
0007	Abend before send
0008	Abend after send.

Program logic

```

Main procedure:
  Set up exception condition handling:
    Map error - SEND_NEW_MAP
    CLEAR/PF3 - END_PROG
  Test COMMAREA
  If transaction not previously invoked
    Call SEND_NEW_MAP
  RECEIVE map
  If customer number not valid
    SEND message
    RETURN
  If customer type is 'ABEND before MAP'
    ABEND
  Build map with customer data
  If customer type is 'LONG DELAY'
    DELAY
  SEND map
  If customer type is 'ABEND after MAP'
    ABEND
  RETURN
SEND_NEW_MAP routine:
  SEND new map
  RETURN
END_PROG routine:
  Clear terminal
  RETURN

```

The back-end IMS program

This program is the IMS back-end application used by the FEPI sample programs.

Module name: DFH0AZBI

Transaction name: CZBI

Overview

This is a simple IMS back-end response mode program that is driven by input from a front-end FEPI application. It modifies the time stamp in the input message and returns the message to the front-end application.

IMS schedules this transaction when an input message is queued for it. It addresses the I/O PCB, DLI call function, and I/O area to build the parameter list for the GU call to retrieve the queued input message.

The time field of the input message is updated and the program then issues an ISRT call to place the message on the output queue. IMS then sends the output message to the front-end FEPI application.

Output messages from this program are all prefixed with a 5-byte function management header.

If any errors occur, the program ends with a nonzero return code.

Program logic

```

  GETMAIN storage areas for reentrancy
  Address PCB
  Issue GU call to get input message
  Use TIME to obtain system time
  Update I/O area
  Issue ISRT call to send output message
  RETURN

```

Description of the samples

Setup

This program installs the resources—property sets, nodes, targets, and pools—that are used by the FEPI sample programs.

Module names: DFH0VZXS, DFH0AZXS, DFH0CZXS

Transaction name: CZXS

Overview

The definitions of each of these resources are organized so that they can easily be changed. They are kept separate from the processing that does the installation, and there is no hard-coding of values in the CICS commands. There are four main tables, holding details of each resource type. This enables the resources to be changed by repeating sets of definitions which are in an easy-to-understand form. If desired, the program could be changed to obtain the resource definitions from a file.

The resources defined are:

Pool	Property set	Nodes	Targets
P00L1	PROPSET1	NODE1 NODE2 NODE3 NODE4 NODE5	TARGET1
P00L2	PROPSET2	NODE6 NODE7 NODE8 NODE9 NODE10	TARGET1
P00L3	PROPSET3	NODE1 NODE2 NODE3 NODE4 NODE5	TARGET2

You must customize these definitions to match the requirements of your system. If you do, you may also need to change the definitions in the sample customization constants copy book DFH0BZCx. You do not need to change any other samples—you need simply recompile them.

Each table is processed in turn. Nodes and targets are organized into lists for reasons of efficiency. Details of resource installation are written to the CICS log automatically by FEPI.

On completion, a message is sent. The setup program would typically be started by a PLT program, in which case the message goes to the CICS log. It can, however, be invoked from a terminal and, in this case, the message is sent to the terminal.

For clarity, error checking is minimal. In particular, the FEPI INSTALL commands do not check errors at all, because FEPI reports any errors that occur to the FEPI transient data queue, and they are then recorded by the sample monitor program.

Program logic

```

For each property set in table
  FEPI INSTALL PROPERTYSET
For each node in table
  Add node to list
FEPI INSTALL NODELIST
For each target in table
  Add target to list
FEPI INSTALL TARGETLIST
For each pool in table
  Start new lists of nodes and targets
  For each entry within pool definition
    If node, add details to node list
    If target, add details to target list
  FEPI INSTALL POOL with NODELIST and TARGETLIST
Send completion message
RETURN

```

Monitor and unsolicited data-handler

This program monitors unexpected events and handles unsolicited data for the FEPI sample programs.

Module name: DFH0VZUX

Transaction name: CZUX

TS queue name: MONITOR

Overview

This transaction handles:

- Unexpected events that are reported by FEPI to a TD queue, which triggers this transaction
- Unsolicited data from a back-end system, for which FEPI starts this transaction.

Because the event descriptions provided by FEPI and the processing required is basically the same for both cases, this common program is used.

ASSIGN STARTCODE is used to determine how the transaction was started, and ASSIGN QNAME to determine what TD queue triggered it. Details of the event are in the start data or the TD queue record as the case may be.

For illustrative purposes, all events are handled similarly by simply reporting their details to a TS queue named MONITOR, which can be browsed using CEBR. In practice, for any of the events you can do whatever extra or different processing you require, or (except for unsolicited data) you can ignore the event.

For unsolicited data, the conversation started by FEPI *must* be accessed so that FEPI knows that the data is being handled. The data itself should be received, or else FEPI ends and restarts the session. For illustration purposes, this program simply discards the data; in practice, you will probably want to process the data in some way.

However, if you did simply want to discard such data, you should specify no unsolicited-data handling and use the UNSOLDATAACK property to tell FEPI what action to take, as is done for SLU P mode by these samples.

The general format of the TS queue records is:

```
date time CZUX description
           Event type..ACQFAIL      Pool.....POOLNAME
           Target.....TGTNAME      Node.....NODENAME
           Device.....T3278M2      Event data..X'00000000'
           Format.....0             Event value.176
```

The actual details for each event vary. Events with similar details are grouped together for processing. The groups are:

- Unknown event—an event that is not recognized
- Unsolicited data
- Session lost
- Standard events—all other events.

The groups also determine any additional processing needed. Only unsolicited data needs any processing.

If any errors occur, they are reported to the TS queue.

Program logic

```
Main procedure:
  Determine how transaction was started using ASSIGN
  If started with data by FEPI
    RETRIEVE start data
  If triggered by TD queue
    READ the queue record
  Otherwise
    Report start code
    RETURN
TD-LOOP:
  Locate event type
  Locate device type
  Build description of event: event type, device type,
    format, event value, date/time, transaction
  Call UNKNOWN-EVENT, UNSOLDATA, STANDARD-EVENT, or
    SESSION-LOST according to event group
  If triggered by TD queue
    READ the next queue record
    If one exists, loop to TD-LOOP
  RETURN
UNKNOWN-EVENT routine:
  Write event details to TS queue: description and
    event value
UNSOLDATA routine:
  Write event details to TS queue: description, event
    type, pool, target, and node
  Access conversation using FEPI ALLOCATE with PASSCONVID
  FEPI RECEIVE unsolicited data
  Free conversation
  Handle data as required
STANDARD-EVENT routine:
  Write event details to TS queue: description, event
    type, pool, target, node, device, event data,
    format, and event value
SESSION-LOST routine:
  Write event details to TS queue: description, event
    type, pool, target, node, device, and format
```

Begin session

This program prepares sessions for use by the FEPI sample application programs.

Module name: DFH0VZUC

Transaction name: CZUC

TS queue name: SESSION

Overview

This transaction is started by FEPI when it begins a new session.

The conversation started by FEPI *must* be accessed so that FEPI knows that the event is being handled. The processing required depends on the data mode and type that the session uses (this is obtained from the start data), and whether the back-end system is IMS or CICS.

For SLU P mode (necessarily IMS), processing depends entirely on local requirements, and is typically used for handling security applications. For illustration purposes, this program simply gets and discards the initial data. Note that the setup for these samples does not specify a begin-session transaction for SLU P mode.

For SLU2 mode with CICS using formatted data, there is a CICS “good morning” message waiting. The message is received, and the back-end screen is cleared and left ready for a transaction ID to be entered.

For SLU2 mode with CICS using data stream, there may be a “read partition” request waiting which requires a reply—for example, if your pool has device T3279Mx or TPS55Mx specified, or if the logon mode table being used has “extended data stream” specified). Then there is a CICS “good morning” message to be received. A reply is sent to any “read partition” query request, the “good morning” message is received, and the back-end screen is cleared and left ready for a transaction ID to be entered.

For SLU2 mode with IMS, no processing is illustrated.

After the processing, the conversation is freed with the HOLD option, which leaves it ready for use by applications. A report is written to a TS queue named SESSION, which can be browsed using CEBR. The format of the TS queue records is:

```
date time CZUC Begin session completed
          RESP.....0           RESP2.....0
          Target.....TGNAME     Node.....NODENAME
          Pool.....POOLNAME
```

If any errors occur, a report is written to the TS queue, and the conversation is freed with the RELEASE option, so that the session is ended.

Program logic

```
Main procedure:
  RETRIEVE start data
  Access conversation using FEPI ALLOCATE with PASSCONVID
  Call PROCESS-LUP, PROCESS-FORMATTED, or
    PROCESS-DATASTREAM according to data mode and type
  Free conversation, keeping session
  Write event details to TS queue
  RETURN
PROCESS-LUP routine:
  FEPI RECEIVE initial data
  Handle data as required
PROCESS-FORMATTED routine:
  FEPI RECEIVE initial data
  Clear back-end screen and make ready for transaction ID
    to be entered, using FEPI CONVERSE
PROCESS-DATASTREAM routine:
  FEPI RECEIVE
  If 'read partition' query
    FEPI CONVERSE query reply and get acknowledgement
    FEPI RECEIVE initial data
  Clear back-end screen and make ready for transaction ID
    to be entered, using FEPI CONVERSE
```

Key stroke CONVERSE

This sample program demonstrates using FEPI to obtain information from a back-end transaction using the key stroke data format.

Module names: DFH0VZTK, DFH0PZTK, DFH0CZTK

Transaction name: CZTK

Map names: DFH0MZ1, DFH0MZ6, DFH0MZ7

Screen

```
CZTK                Customer Name and Address Inquiry
Please type a customer number in the range 1 through 9999, then Enter.
Customer Number . . . . .
                Name . . . . . :
                Address . . . . . :
                F3=EXIT to CICS
```

Figure 9. CZTK transaction: customer name and address inquiry

Overview

On the first invocation of the transaction, a map is sent to the front-end terminal.

When there is input from the front-end terminal, CICS invokes the transaction again. The customer number from the input is built into a key stroke sequence which runs a transaction at the back-end. The key strokes are sent and the results received using a FEPI ALLOCATE-CONVERSE-FREE command sequence. Information is extracted from the results and sent to the front-end terminal. Further input is then awaited.

When PF3 or CLEAR is received from the front-end terminal, the transaction ends. If there is an error, the front-end map is reset. These situations are detected using HANDLE CONDITION.

If the back-end sends a CICS message, it is sent on to the front-end terminal, and the transaction ends.

For clarity, error checking is minimal except for the FEPI commands. Note that the key stroke sequence used involves several attention keys, so that if the intermediate responses

are not what is expected, the effects are unpredictable. According to your requirements, it may be advisable to send each attention sequence individually and to check each time that the results are as expected.

Program logic

```

MAIN procedure:
  Test COMMAREA
  If transaction not previously invoked
    Call SEND-NEW-MAP
  Set up exception condition handling:
    Map error - SEND-NEW-MAP
    CLEAR/PF3 - END-PROG
  RECEIVE MAP from front-end terminal
  Build key stroke sequence to:
    clear back-end screen
    type transaction ID
    ENTER
    type the customer number
    ENTER
  FEPI ALLOCATE conversation with back-end
  FEPI CONVERSE to send key strokes to back-end and get
    the resulting screen image
  FEPI FREE conversation with back-end
  If CICS message received from back-end
    SEND message to front-end terminal
    RETURN
  Get customer information from back-end screen image
  Build data for front-end terminal map
  SEND map data to front-end terminal
  RETURN TRANSID(CZTK) with COMMAREA
SEND-NEW-MAP routine:
  SEND new map to front-end terminal
  RETURN TRANSID(CZTK) with COMMAREA
END-PROG routine:
  Clear front-end terminal
  RETURN

```

Screen image SEND and START

This sample program demonstrates using FEPI to send formatted data to a back-end transaction, and requesting a transaction to be started when the reply to the data arrives.

Module name: DFH0VZTS

Transaction name: CZTS

Map name: DFH0MZ2

Screen

```

CZTS                               Customer Name and Balance Inquiry
Please type a customer number in the range 1 through 9999, then Enter.
Customer number . . . . .
          Name . . . . . :
          Balance . . . . . :
          F3=EXIT to CICS

```

Figure 10. CZTS transaction: customer name and balance inquiry

Overview

This program is the SEND part of a SEND-RECEIVE pair of programs, the RECEIVE part being DFH0VZTR.

On the first invocation of this send transaction, a map is sent to the front-end terminal.

When there is input from the front-end terminal, CICS invokes this send transaction again. The customer number is extracted from the input. Using FEPI ALLOCATE a conversation is started with the back-end system. Then FEPI SEND with screen image data is used to start a back-end transaction. FEPI START is issued to specify that the receive transaction is to be started when the back-end system replies.

In due course, the receive transaction is started and XCTLs to this send transaction. The customer number can now be sent to the back-end using FEPI SEND with screen image data. FEPI START is again issued.

The receive transaction gets the results from the back-end transaction and sends them on to the front-end terminal.

When there is more input from the front-end terminal, CICS invokes this transaction again. FEPI ALLOCATE with PASSCONVID is issued to gain ownership of the conversation and the customer number is sent to the back-end as before. The cycle continues until PF3 or CLEAR is received. These are passed on to the receive transaction (using the FEPI START user data) and to the back-end transaction to indicate that it is to end.

Program logic

```
MAIN procedure:
  Test COMMAREA
  If transaction not previously invoked
    Call SEND-MAP
  If first customer number to process
    Call CONTINUE-CONVERSATION
  Set up exception condition handling:
    Map error - SEND-MAP
    PF3/CLEAR - CONTINUE-CONVERSATION
  RECEIVE MAP from front-end terminal
  If conversation not started
    Call INITIATE-CONVERSATION
  Else
    Call CONTINUE-CONVERSATION
SEND-MAP routine:
  SEND new map to front-end terminal
  RETURN TRANSID(CZTS) with COMMAREA
INITIATE-CONVERSATION routine:
  FEPI ALLOCATE conversation with back-end
  Build screen image to invoke back-end transaction
  FEPI SEND screen image to back-end
  FEPI START the receive transaction
  RETURN
CONTINUE-CONVERSATION routine:
  Unless first customer number
    Reaccess conversation with FEPI ALLOCATE PASSCONVID
  Build screen image to send customer number
  FEPI SEND screen image to back-end
  FEPI START the receive transaction
  RETURN
```

Screen image RECEIVE and EXTRACT FIELD

This sample program demonstrates using FEPI to get formatted data from a back-end transaction.

Module name: DFH0VZTR

Transaction name: CZTR

Map name: DFH0MZ2

Screen

See Figure 10 on page 175.

Overview

This program is the RECEIVE part of a SEND-RECEIVE pair of programs, the SEND part being DFH0VZTS.

This transaction is started by CICS either when data is received from the back-end transaction or if no data is received in the time set in the send transaction, as is determined from the start data obtained with RETRIEVE. The user data in the start data indicates whether the conversation is starting, continuing, or finishing.

A FEPI RECEIVE obtains the screen image from the back-end transaction and FEPI EXTRACT FIELD is used to obtain specific fields.

If the conversation is starting, control is passed to the send transaction using XCTL to allow an inquiry to be sent to the back-end transaction.

If the conversation is continuing, the results from the back-end are sent on to the front-end terminal. Access to the conversation is relinquished, and control is returned to CICS specifying that the send transaction is to be invoked when there is next user input.

If the conversation has finished, a message to that effect is sent to the front-end terminal. The conversation is freed and the transaction ends.

Program logic

```

MAIN procedure:
  RETRIEVE start data
  Reaccess conversation with FEPI ALLOCATE PASSCONVID
  If time out
    Call REPORT-PROBLEM
  FEPI RECEIVE back-end screen image
  If conversation ending (PF3 or CLEAR indicated)
    Call REPORT-PROBLEM
  If back-end problem
    (CICS message or back-end transaction message)
    Call REPORT-PROBLEM
  If conversation starting (user data has customer number)
    XCTL to program DFH0VZTS
  If conversation continuing
    Get interesting fields from back-end data using
      FEPI EXTRACT FIELD
    Build and send map to front-end terminal
    Release conversation using FEPI FREE PASS
    RETURN TRANSID(CZTS) with COMMAREA
REPORT-PROBLEM routine:
  SEND message to front-end terminal
  FEPI FREE conversation
  RETURN

```

3270 data stream pass-through

This sample program demonstrates using FEPI to pass-through 3270 data stream between a back-end application and a front-end terminal.

Module names: DFH0VZTD, DFH0AZTD

Transaction name: CZTD

Overview

On the first invocation of the transaction, a request is sent to the back-end system to start a transaction there. The response is sent on to the front-end terminal.

When there is input from the front-end terminal, CICS reinvoke the transaction. This input is sent on to the back-end system, using the FEPI CONVERSE command, and the resulting response is returned to the front-end terminal.

If there is an error, or the back-end system sends a CICS message, or PF3 is received from the front-end terminal, the transaction ends.

Program logic

```
Test COMMAREA
If transaction not previously invoked
  Build data stream request to start back-end transaction
  FEPI ALLOCATE conversation with back-end system
  FEPI CONVERSE data stream to and from back-end system
  SEND returned data stream to the front-end terminal
Else
  RECEIVE data stream from the front-end terminal
  Prepare data stream to send on to back-end system
  Reaccess conversation with FEPI ALLOCATE PASSCONVID
  FEPI CONVERSE data stream to and from back-end system
  SEND data stream to the front-end terminal
If error during processing
  SEND explanatory message
If continuing
  Release conversation using FEPI FREE PASS
  RETURN TRANSID(CZTD) with COMMAREA
Else (error, CICS message, or PF3)
  FEPI FREE conversation
  RETURN
```

End-session handler

This program cleans up sessions after use by FEPI sample application programs.

Module name: DFH0VZUU

Transaction name: CZUU

TS queue name: SESSION

Overview

This transaction is started by FEPI when an application ends a conversation or when a session is released.

The conversation passed by FEPI must be accessed so that FEPI knows that the event is being handled. The processing required depends entirely on local requirements. For illustration purposes, this program simply keeps the session for use by another conversation or lets it end, depending on the event type.

For end of conversation (EVENTTYPE=FREE in start data), processing could typically involve setting the session back to a known state (such as a clear back-end screen ready to accept a new transaction name), or handling security, or overriding the type of FREE used. Such processing would depend on the data mode and type that the session uses (which is obtained from the start data), whether the back-end system is CICS or IMS, and the type of FREE used (also obtained from the start data).

For end of session (EVENTTYPE=FREE and EVENTVALUE=RELEASE in start data), processing could typically involve handling security.

For both cases, there could be an indication (in EVENTVALUE in the start data) that CICS is shutting down, which might require alternative special processing. This transaction would have to be in the XLT to allow it to be started during shutdown.

After the processing, a report is written to a TS queue named SESSION, which can be browsed using CEBR. The format of the TS queue records is:

```
date time CZUU End-session handling completed
          RESP.....0          RESP2.....0
          Target.....TGTNAME    Node.....NODENAME
          Pool.....POOLNAME
```

Program logic

Main procedure:

```
RETRIEVE start data
Access conversation using FEPI ALLOCATE with PASSCONVID
Call PROCESS-RELEASE or PROCESS-FREE as appropriate
Write event details to TS queue
RETURN
```

PROCESS-RELEASE routine:

```
Handle as required
Free conversation, ending session
```

PROCESS-FREE routine:

```
Handle as required
Free conversation, keeping session
```

SLU P one-out one-in

This sample program demonstrates using FEPI to obtain information from a back-end IMS system, using SLU P mode and the FEPI CONVERSE command with the POOL option.

Module names: DFH0VZPS, DFH0AZPS

Transaction name: CZPS

Map names: DFH0MZ4, DFH0MZ8

Screen

```
CZPS          SLU P Sample Program.
IMS SLU P conversational sample program
This transaction will process a FEPI CONVERSE command to obtain time
and date from a back-end IMS system.
DATE       : 02/04/92
TIME       : 10:57:10
STATE      : Not started
F3=EXIT to CICS  ENTER=obtain time and date stamp from IMS
```

Figure 11. CZPS transaction: SLU P sample program

Overview

On the first invocation of the program, a map is sent to the front-end terminal.

When there is input from the front-end terminal, CICS reinvokes the program. A simple inquiry is made to the back-end system—for illustration purposes, it asks the time—and the answer is displayed on the front-end terminal. Because the inquiry requires only a one-out one-in exchange with the back-end system, a temporary conversation can be used, so the FEPI CONVERSE command with the POOL option is used.

When PF3 or CLEAR is received from the front-end terminal, the transaction ends. If there is an error, the front-end map is reset. These situations are detected using HANDLE CONDITION.

If the back-end system sends an IMS message, it is sent on to the front-end terminal and the transaction ends.

For clarity, error checking is minimal except for the FEPI commands.

Program logic

```
MAIN procedure:
  Test COMMAREA
  If transaction not previously invoked
    Call SEND-NEW-MAP
  Set up exception condition handling:
    Map error - SEND-NEW-MAP
    CLEAR/PF3 - END-PROG
  RECEIVE MAP from front-end terminal
  Build SLU P data stream to request time from back-end IMS
  system
  FEPI CONVERSE to send data stream to the back-end and get
  the message containing the time
  If IMS message received from back-end system
    SEND message to front-end terminal
    RETURN
  Build data for front-end terminal map
  SEND map data to front-end terminal
  RETURN TRANSID(CZPS) with COMMAREA
SEND-NEW-MAP routine:
  SEND new map
  RETURN TRANSID(CZPS) with COMMAREA
END-PROG routine:
  Clear front-end terminal
  RETURN
```

SLU P pseudoconversational

This sample program demonstrates using FEPI to obtain data from an IMS back-end transaction. It is in pseudoconversational style, using the FEPI START command to schedule itself when the results arrive.

Module names: DFH0VZPA, DFH0AZPA

Transaction name: CZPA

Map names: DFH0MZ5, DFH0MZ9

Screen

```

CZPA              SLUP Sample Program.
IMS SLUP Pseudoconversational sample program
This transaction will process SEND/START/RECEIVE requests with MFS
                specified, to a back-end IMS system.
                DATE   : 02/04/92
                TIME   : 10:58:50
                STATE  : Not Started
F3=EXIT to CICS  ENTER=obtain time and date stamp from IMS

```

Figure 12. CZPA transaction: SLU P pseudoconversational sample program

Overview

On the first invocation of the program, a map is sent to the front-end terminal.

When there is input from the front-end terminal, CICS invokes the program again. After establishing a conversation, an inquiry is sent to the back-end system. FEPI START is issued to start this program again when the results arrive. Meanwhile it returns to CICS, so releasing resources.

When the results arrive, FEPI starts the program again. The results are obtained using FEPI RECEIVE, and sent on to the front-end terminal. The conversation is freed and the program returns to CICS to await more input. If the back-end system sends an IMS message, it is sent on to the front-end terminal and the transaction ends.

When PF3 or CLEAR is received from the front-end terminal, the transaction ends. If there is an error, the front-end map is reset. These situations are detected using HANDLE CONDITION.

For clarity, error checking is minimal except for the FEPI commands.

Program logic

```
MAIN procedure:
  If started from terminal
    Test COMMAREA
    If transaction not previously invoked
      Call SEND-NEW-MAP
    Set up exception condition handling:
      Map error - SEND-NEW-MAP
      CLEAR/PF3 - END-PROG
    RECEIVE map from front-end terminal
    FEPI ALLOCATE conversation with back-end system
    Build SLU P data stream to request time
    FEPI SEND data stream to back-end system
    FEPI START transaction
    RETURN
  If started by FEPI
    RETRIEVE start data
    Reaccess conversation using FEPI ALLOCATE PASSCONVID
    If EVENTTYPE = data received
      FEPI RECEIVE data stream from back-end system
      FEPI FREE conversation
      If IMS message received
        SEND message to front-end terminal
        RETURN
      Build data for front-end terminal map
      SEND map to front-end terminal
      RETURN TRANSID(CZPA) with COMMAREA
    Otherwise (timeout or session loss)
      SEND map with message to front-end terminal
      RETURN (freeing conversation implicitly)
SEND-NEW-MAP routine:
  SEND new map
  RETURN TRANSID(CZPA) with COMMAREA
END-PROG routine:
  Clear front-end terminal
  RETURN
```

STSN handler

This program handles STSN processing for the FEPI sample application programs.

Module name: DFH0AZQS

Transaction name: CZQS

TS queue name: SESSION

Overview

This transaction is started by FEPI when a request for message resynchronization ('set and test sequence number', STSN) or a 'start data traffic' indication is received from a back-end IMS system.

The conversation passed by FEPI must be accessed so that FEPI knows that the event is being handled. The processing required depends on the STSN status, which is obtained using FEPI EXTRACT STSN.

For STSNSTATUS=NOSTSN, the transaction was started because 'start data traffic' arrived. A DR1 normal response must be sent.

For STSNSTATUS=STSNSET, a positive STSN response must be sent.

For STSNSTATUS=STSNTEST, processing would typically involve comparing saved sequence numbers with those received from the back-end IMS system to determine what response to send. The *IMS Customization Guide* gives advice on the appropriate action.

After the processing, the response is sent using FEPI ISSUE. A report is written to a TS queue named SESSION, which can be browsed using CEBR. The general format of the TS queue records is:

```
date time CZQS STSN processing completed
          Target.....TGTNAME      Node.....NODENAME
          Seqnumin....nnnn         Seqnumout...nnnn
          STSN status.XXXXXXX      Response...XXXXXXX
```

Program logic

Main procedure:

```
RETRIEVE start data
Access conversation using FEPI ALLOCATE with PASSCONVID
Get STSN status using FEPI EXTRACT STSN
Call NOSTSN, STSNSET, or STSNTEST
    according to STSN status
Send response using FEPI ISSUE CONTROL
Write event details to TS queue
Free conversation, keeping session
RETURN
```

NOSTSN routine:

```
Build DR1 normal response
```

STSNSET routine:

```
Build STSN positive response
```

STSNTEST routine:

```
Handle as required
Build required response
```

Sample programs

Appendix B. CVDA and RESP2 values

This appendix lists the CVDA and RESP2 values returned by FEPI commands.

CVDA and numeric values in alphabetic sequence

The following table lists the CVDA values used or returned by the FEPI commands. (See Table 16 on page 186 for the same values in numeric sequence.) For programming information about other CICS/ESA 3.3 CVDA values, see the *CICS/ESA System Programming Reference* manual.

ACQFAIL	515
ACQUIRED	69
ACQUIRING	71
ADDFAIL	519
ALARM	501
APPLICATION	559
ATTENTION	524
BEGINSESSION	510
CANCEL	526
CD	491
DATA	508
DATASTREAM	543
DEFRESP1	497
DEFRESP1OR2	528
DEFRESP2	498
DEFRESP3	499
DELETFAIL	520
DISCARDFAIL	513
EB	490
EXCEPTRESP	523
FMH	502
FORCE	342
FORMATTED	542
FREE	85
GOINGOUT	172
HOLD	163
INBOUND	547
INOUT	532
INPUT	226
INSERVICE	73
INSTALLED	550
INSTALLFAIL	512
INVALID	359
LIC	493
LOSE	544
LUP	541
LUSTAT	525
MDT	506
MORE	492
NEGATIVE	530
NEWSESSION	485
NOALARM	500
NOCONV	556
NOFMH	503
NOMDT	507

NOMSGJRNL	531
NONE	496
NORMALRESP	522
NOSTSN	487
NOTINBOUND	546
NOTINSTALLED	551
OLDSESSION	486
OUTPUT	227
OUTSERVICE	74
PENDBEGIN	558
PENDDATA	560
PENDFREE	86
PENDPASS	565
PENDRELEASE	562
PENDSTART	561
PENDSTSN	557
PENDUNSOL	564
POSITIVE	529
PROTECTED	504
RELEASE	563
RELEASED	70
RELEASING	549
RESET	290
RTR	527
RU	494
SESSION	372
SESSIONFAIL	517
SESSIONLOST	516
SETFAIL	514
SHUTDOWN	288
STSN	509
STSNSET	488
STSNTEST	489
TASK	233
TIMEOUT	511
TPS55M2	552
TPS55M3	553
TPS55M4	554
T3278M2	533
T3278M3	534
T3278M4	535
T3278M5	536
T3279M2	537
T3279M3	538
T3279M4	539
T3279M5	540
UNPROTECTED	505
UNSOLDATA	521
WIN	545

CVDA values

CVDAs and numeric values in numeric sequence

The following table lists the CVDA values used or returned by the FEPI commands. (See Table 15 on page 185 for the same values in alphabetic sequence.) For programming information about other CICS/ESA 3.3 CVDA values, see the *CICS/ESA System Programming Reference* manual.

69	ACQUIRED
70	RELEASED
71	ACQUIRING
73	INSERVICE
74	OUTSERVICE
85	FREE
86	PENDFREE
163	HOLD
172	GOINGOUT
226	INPUT
227	OUTPUT
233	TASK
288	SHUTDOWN
290	RESET
342	FORCE
359	INVALID
372	SESSION
485	NEWSESSION
486	OLDSESSION
487	NOSTSN
488	STSNSET
489	STSNTEST
490	EB
491	CD
492	MORE
493	LIC
494	RU
496	NONE
497	DEFRESP1
498	DEFRESP2
499	DEFRESP3
500	NOALARM
501	ALARM
502	FMH
503	NOFMH
504	PROTECTED
505	UNPROTECTED
506	MDT
507	NOMDT
508	DATA
509	STSN
510	BEGINSESSION
511	TIMEOUT
512	INSTALLFAIL
513	DISCARDFAIL
514	SETFAIL
515	ACQFAIL
516	SESSIONLOST
517	SESSIONFAIL
519	ADDFAIL
520	DELETFAIL
521	UNSOLDATA
522	NORMALRESP
523	EXCEPTRESP
524	ATTENTION
525	LUSTAT
526	CANCEL
527	RTR

528	DEFRESP1OR2
529	POSITIVE
530	NEGATIVE
531	NOMSGJRNL
532	INOUT
533	T3278M2
534	T3278M3
535	T3278M4
536	T3278M5
537	T3279M2
538	T3279M3
539	T3279M4
540	T3279M5
541	LUP
542	FORMATTED
543	DATASTREAM
544	LOSE
545	WIN
546	NOTINBOUND
547	INBOUND
549	RELEASING
550	INSTALLED
551	NOTINSTALLED
552	TPS55M2
553	TPS55M3
554	TPS55M4
556	NOCNV
557	PENDSTSN
558	PENDBEGIN
559	APPLICATION
560	PENDDATA
561	PENDSTART
562	PENDRELEASE
563	RELEASE
564	PENDUNSOL
565	PENDPASS

RESP2 values

Table 17 gives, in general terms, the meaning of the RESP2 values used by FEPI. These values are used in the EVENTVALUE area of FEPI transient data queue records and returned by the RESP2 option of FEPI commands. For details of the error conditions and related RESP2 values for each FEPI command, see the FEPI command definitions in Chapter 9, "System programming reference" and Chapter 16, "Application programming reference."

Declarations for the RESP2 values are provided in the following copy books:

- DFHSZAPA for Assembler language
- DFHSZAPO for COBOL
- DFHSZAPP for PL/I
- DFHSZAPC for C/370.

Table 17 (Page 1 of 2). RESP2 values

1	INQUIRE START, NEXT, or END command not valid here: START Browse of this resource type already in progress NEXT INQUIRE START not issued END INQUIRE START not issued.
2	All resource definitions have been retrieved.
10	Command bypassed by user exit.
11	FEPI not installed or not active.
12	CICS shutting down, command not allowed.
13	FEPI not available.
14	FEPI busy or cannot get storage.
15	Unknown command.
16	Internal problem.
17	FEPI cannot get storage for user exit parameters.
18	Command failed because of operator or system action.
30	POOL name not known.
31	POOL name out of service.
32	TARGET name not known.
33	TARGET name out of service.
34	TARGET name required but not specified.
35	Pool name is unsuitable for temporary conversations. It has CONTENTION(LOSE) or INITIALDATA(INBOUND) but no begin-session handler.
36	No suitable session available and in service.
40	[FROM]FLENGTH value is negative, zero, or more than MAXFLENGTH value for pool.
41	ESCAPE value not valid.
50	Inbound data with 'begin bracket' to be received.
51	Attention identifier (AID) not valid.
52	Cursor position not valid.
53	Code points in formatted data not valid.
54	Attribute positions or values in send data not valid.
55	Key stroke escape sequence in send data not valid.
56	Field validation (mandatory fill, mandatory enter, trigger) failed.
57	Input is inhibited.
58	VTAM SEND failed.
59	DBCS data rules violated.
60	MAXFLENGTH value negative, or greater than MAXFLENGTH value for pool.
61	FLENGTH value negative or greater than 128.
62	TRANSID name not valid.
63	TERMID name not valid.
70	FIELDLOC or FIELDNUM value negative or not valid.
71	VTAM RECEIVE failed.
#	INVREQ 72

Table 17 (Page 1 of 2). RESP2 values

#	APAR	
#	PN68229:	
#	Documentation	
#	for	
#	PN68229	
#	added	
#	on	
#	19	
#	June	
#	1995.	
#	RECEIVE	
#	FORMATTED	
#	processing	
#	found	
#	invalid,	
#	or	
#	unexpected	
#	data	
#	while	
#	interpreting	
#	the	
#	3270	
#	data	
#	steam	
#	for a	
#	WRITE	
#	ERASE/WRITE,	
#	ERASE/WRITE	
#	ALTERNATE,	
#	or	
#	WRITE	
#	STRUCTURED	
#	FIELD	
#	command	
#	code.	
	80	CONTROL value not valid.
	81	VALUE not valid: omitted when required; included when not required; or unsuitable for specified CONTROL.

RESP2 values

82	SENSEDATA option omitted when required, or specified when not required.
90	Definite response type did not match what was required.
91	Only NORMALRESP or EXCEPTRESP allowed at this point in conversation.
92	Response to STSN SET was not positive.
93	Only STSN allowed at this point in conversation.
94	Only STSN or NORMALRESP allowed at this point in conversation.
95	CONTROL value not allowed at this point in conversation.
100	Not authorized to issue command.
110	SERVSTATUS value not valid.
111	ACQSTATUS value not valid.
115	POOL name not known.
116	TARGET name not known.
117	NODE name not known.
118	Unknown connection (TARGET and NODE names known, but not in a common POOL).
119	Request failed for one or more items in list. Detailed errors reported to TD queue for monitor to handle.
130	TARGETNUM value negative, zero, or not valid.
131	NODENUM value negative, zero, or not valid.
132	POOLNUM value negative, zero, or not valid.
140	DEVICE value not valid.
141	CONTENTION value not valid.
142	INITIALDATA value not valid.
143	UNSOLDATAACK value not valid.
144	MSGJRNL value not valid.
150	FORMAT value not valid or unsuitable for specified device.
153	STSN name not valid or STSN unsuitable for specified device.
154	BEGINSESSION value not valid.
155	UNSOLDATA value not valid.
156	EXCEPTIONQ value not valid.
157	FJOURNALNUM value not valid.
158	MAXLENGTH value not valid.
159	ENDSESSION name not valid.
160	PROPERTYSET name not valid.
162	POOL name not valid.
163	NODE name not valid.
164	TARGET name not valid.
167	APPL name not valid.
170	PROPERTYSET name already exists.
171	PROPERTYSET name not known.
172	POOL name already exists.
173	NODE name already exists.
174	TARGET name already exists.
175	Connection already exists.
176	VTAM OPEN NODE failed.
177	VTAM APPLID already known.
182	Session unbound, unrecoverable.
183	Session unbound, recoverable.
184	Session unbound, error.
185	Session unbound, bind coming.
186	Session unbound.
187	Lost terminal.
188	CLEANUP, abnormal.
189	CLEANUP.
190	UNBIND error.
191	SETUP error.
192	SSCP error.
193	SLU error.
194	PLU error.
195	BIND error.
196	CINIT error.
197	REQSESS error.
198	REQSESS inhibited.
199	REQSESS not available.

210	Option not valid for SLU P.
211	Option not valid for SLU2.
212	Wrong data format for conversation.
213	Command has timed out.
214	CICS shutting down, conversation should be ended.
215	Session lost.
216	Error occurred on previous SEND command.
220	SEND or CONVERSE command not allowed at this point in conversation.
221	RECEIVE command not allowed at this point in conversation.
223	START command not allowed at this point in conversation.
224	Only ISSUE or FREE allowed at this point in conversation.
230	SNA CLEAR command received.
231	SNA CANCEL command received.
232	SNA CHASE command received.
233	Exception response received.
234	Exception request received.
240	Conversation ID unknown or not owned by task.
241	TIMEOUT value negative or not valid.
250	Passticket not built successfully.
251	CICS ESM interface not initialized.
252	Unknown return code in ESMRESP from the ESM.
253	Unrecognized response from CICS security modules.
254	Function unavailable.
259	No signed-on user.

Glossary

This glossary describes terms and abbreviations used in this book and words used with other than their everyday meaning. In some cases, a definition may not be the only one applicable to a term, but it gives the particular sense in which the word is used in this book.

This glossary includes only the most common 3270 and SNA terms. For other 3270 terms, refer to the glossary in *3270 Data Stream Programmer's Reference*. For other SNA terms, refer to the glossary in *SNA Technical Overview*.

For CICS terms not listed here, refer to the glossary in the *CICS/ESA 3.3 Facilities and Planning Guide*.

This glossary includes terms and definitions from the *IBM Dictionary of Computing*, published by McGraw-Hill. If you do not find the term you are looking for, refer to the index or the *Dictionary of Computing*.

A

ACB. In VTAM, an access method control block that links an application to VTAM.

access program. A user-provided part of a FEPI application that handles the main communications with application programs in CICS or IMS systems.

AID. (1) Attention identifier. (2) In CICS, automatic initiate descriptor.

APAR. Authorized program analysis report.

application. A program or suite of programs that do work. If an application uses FEPI, it is a FEPI application (also known as a terminal front-end program). In VTAM, *application* means programs that communicate directly using VTAM; in a FEPI environment, this means the back-end systems on one hand, and FEPI on the other.

application programming interface. The set of commands by which an application accesses CICS services.

attention identifier (AID). (1) A code in the inbound data stream that identifies the source or type of data that follows. (2) A character in a data stream indicating that the user has pressed a key, such as ENTER, that requests an action by the system.

ATI. Automatic transaction initiation.

authorized program analysis report (APAR). A report of a problem caused by a suspected defect in a current, unaltered release of a program.

automatic transaction initiation (ATI). The initiation of a CICS transaction by an internally generated request, for example, the issue of an EXEC CICS START command or

the reaching of a transient data trigger level. See the *CICS/ESA Application Programming Guide* manual.

B

back-end (system). The CICS or IMS system in which existing applications run. Equivalent to **partner system**. (See also **front-end (system)**.)

begin-session handler. A user-provided part of a FEPI application that handles begin-session processing.

begin bracket. See **bracket**.

between brackets. See **bracket** and **contention mode**.

bind. In SNA, to activate a session between logical units.

bind race. In SNA, a situation where two or more logical units (LUs) send bind requests to each other at the same time.

bracket. In SNA, one or more chains of request units (RUs) and their responses, which are exchanged between two LU-LU half-sessions and represent a transaction between them. A bracket must be completed before another bracket can start. Examples of brackets are data base inquiries and replies, update transactions, and remote job entry output sequences to work stations.

The duration of a bracket is shown by the begin-bracket and end-bracket indicators in the request headers of the first and last requests in the bracket. When a bracket is not in progress, the session is between brackets and is in **contention mode**.

buffer address. In 3270 data stream, the address of a location in the character buffer (screen image).

C

CECI. Command-level interpreter.

CEMT. A CICS-supplied transaction that invokes all the master terminal functions. These functions include inquiring and changing the value of parameters used by CICS, altering the status of system resources, terminating tasks, and shutting down CICS. See the *CICS/ESA CICS-Supplied Transactions* manual.

chain. In SNA, a group of one or more logically linked records (request units) that are transferred over a communication line. The ends of the chain are shown by the first-in-chain and last-in-chain indicators in the request headers of the first and last requests in the chain.

change direction protocol. In SNA, a data flow control protocol in which the sending logical unit (LU) stops sending

normal-flow requests, signals this fact to the receiving LU using the change-direction indicator (in the request header of the last request of the last chain), and prepares to receive requests.

CICS. Customer Information Control System.

command-level interpreter (CECI CECS). Enables CICS commands to be entered, syntax-checked, and executed interactively at a 3270 screen. See the *CICS/ESA Application Programming Guide* manual.

connection. A target-node pair in the same pool, between which a session can be established (bound), and which can then be used for communication.

contention mode. In data communication, a mode of transmission in which any station may transmit whenever the line is available. This occurs when a session is between brackets. If stations transmit simultaneously, protocols determine who wins the contention.

conversation. (1) In FEPI, a sequence of related data transmissions between a FEPI application and a particular back-end system. This is analogous to a CICS APPC conversation, but it is not the same as an IMS conversation, and it is not related to CICS conversational mode. (2) In distributed transaction processing, a sequence of exchanges over a session, delimited by SNA brackets. (3) A dialog between two programs in which each program alternately sends and receives data. (4) A dialog between CICS and a terminal user in which CICS alternately accepts input and responds.

Customer Information Control System (CICS). An IBM licensed program that enables transactions entered at remote terminals to be processed concurrently by user-written application programs. It includes facilities for building, using, and maintaining databases.

D

data stream. A continuous stream of data elements being transmitted, or intended for transmission, in character or binary-digit form, using a defined format.

DBCS. Double-byte character set.

DCT. Destination control table.

definite response. In SNA, a value on the form-of-response-requested field of the request header. The value directs the receiver of the request to return a response unconditionally, whether positive or negative, to that request.

destination control table (DCT). A table containing an entry for each extrapartition, intrapartition, and indirect transient data destination used in the system, or in connected CICS systems.

double-byte character set (DBCS). A set of characters in which each character is represented by two bytes. Languages, such as Japanese, which contain more symbols than can be represented by 256 code points require DBCS.

DRx response. Same as **definite response**.

E

EDF. Execution diagnostic facility.

end bracket. See **bracket**.

end session handler. A user-provided part of a FEPI application that handles end of conversation and end of session processing.

ESM. External security manager.

execution diagnostic facility (EDF). A CICS facility used for testing application programs interactively online, without making any modifications to the source program or to the program preparation procedure.

Extended Recovery Facility (XRF). A facility that increases the availability of CICS transaction processing, as seen by the end users. Availability is improved by having a second CICS system (the alternate system) ready to continue processing the workload, if and when particular failures that disrupt user services occur on the first system (the active system).

external security manager (ESM). A program, such as RACF, that performs security checking for CICS users and resources.

F

FEPI. Front End Programming Interface.

FMH. Function management header.

formatted data interface. In FEPI, a collective name for the keystroke and screen-image interfaces.

front-end (system). The CICS system in which the Front End Programming Interface (FEPI) runs to provide access to applications running on other systems. (See also **back-end (system)**.)

Front End Programming Interface (FEPI). An interface that enables you to write CICS application programs that access other CICS or IMS programs, providing a front end to those programs. The interface simulates the terminals that the other programs use.

function management header (FMH). In SNA, one or more headers, optionally present in the leading request units (RUs) of a chain, that contain control information.

G

global user exit. An event in CICS at which CICS can pass control to a user-supplied program and then resume control after the user program finishes. The exit is invoked on every occurrence of the event in CICS.

H

handler. In the CICS/ESA Front End Programming Interface (FEPI), a transaction initiated to handle specified events.

I

Information Management System (IMS). A data base/data communication system capable of managing complex data bases and terminal networks.

inbound. In FEPI and CICS, data received by a program from elsewhere. From the point-of-view of the back-end system, this data is outbound or output to a terminal.

initial data. A type of inbound data that arrives when a new session is bound. This is commonly called a "good morning" message.

ISC. CICS intersystem communication.

K

key stroke interface. The part of the Front End Programming Interface that allows a front-end application to specify a sequence of key stroke-like commands, used to define input to a back-end application.

L

last in chain. See **chain**.

LIC. Last in chain. See **chain**.

logical unit (LU). In SNA, a port through which an end user accesses the SNA network in order to communicate with another end user and through which the end user accesses the functions provided by system services control points.

LU. See **Logical unit (LU)**.

M

modified data tag (MDT). (1) An indicator, associated with each input or output/input field in a displayed record, that is set ON when data is keyed into the field. The modified data tag is maintained by the display device and can be used by the program using the field. (2) In 3270, a bit in each input field that, when set, causes that field to be transferred to the host system.

monitor. A user-provided program that handles unexpected events reported by FEPI.

MRO. CICS multiregion operation.

N

node. In VTAM, a named point in a network. In FEPI, a point (VTAM node) that is a secondary LU terminal simulated by FEPI. In other words, a node in FEPI is a simulated terminal.

non-response mode. In IMS, a mode of terminal operation that allows asynchronous operations between the terminal operator and the application program. Contrast with **response mode**.

no response. In SNA, a value in the form-of-response-requested field of the request header (RH) indicating that no response is to be returned to the request, whether or not the request is received and processed successfully.

O

outbound. In FEPI and CICS, data sent by a program to somewhere else. From the point-of-view of the back-end system, this data is inbound or input from a terminal.

P

partner. In CICS intercommunication, a transaction communicating with a remote transaction or system. In FEPI, this is equivalent to **back-end system**.

PLT. In CICS, the program list table.

PLTPI. In CICS, program list table post initialization.

PLU. Primary logical unit.

pool. In the CICS/ESA Front End Programming Interface (FEPI), a collection of **nodes** and **targets**.

presentation space. A portion of the device's buffer storage, allocated to a partition, that contains only display data that CICS sends to that partition.

primary logical unit (PLU). In SNA, the logical unit that contains the primary half-session. In a FEPI environment, the back-end systems are the PLUs.

program list table. In CICS, a list of programs to be executed at a specific phase of system initialization or termination.

Program Temporary Fix (PTF). A temporary solution or bypass of a problem diagnosed by IBM field engineering as the result of a defect in a current, unaltered release of the program. See authorized program analysis report (APAR).

property set. In the CICS/ESA Front End Programming Interface (FEPI), the definition of the characteristics of a **pool**.

PTF. Program temporary fix.

R

RACF. Resource Access Control Facility.

RDO. In CICS, resource definition online.

request header (RH). In SNA, control information preceding a request unit.

request unit (RU). In SNA, a message unit that contains control information such as a request code, or function management headers (FMHs), end-user data, or both. Synonymous with request. Each request unit belongs to a chain.

Resource Access Control Facility (RACF). A licensed program, provided by IBM, that provides for access control by identifying and by verifying the users to the system, authorizing access to protected resources, logging the detected unauthorized attempts to enter the system, and logging the detected accesses to protected resources.

resource definition online (RDO). A method of defining resources to CICS, in which resource definitions are created interactively with the CEDA transaction, or by using the CICS utility DFHCSDUP.

response. In SNA, a message that acknowledges receipt of a request.

response mode. (1) A mode in which a system can communicate with an end-user. (2) In IMS, a mode of terminal operation that synchronizes operations between the terminal operator and the application program. Contrast with **non-response mode**.

RU. Request unit.

S

screen-image interface. The part of the Front End Programming Interface that has a buffer with one byte for each screen position.

secondary logical unit (SLU). In SNA, the logical unit that contains the secondary half-session. In a FEPI environment, the FEPI system is the SLU, and the back-end CICS or IMS system is the PLU.

session. In SNA, that period during which programs or devices can communicate with each other.

set and test sequence number (STSN). In SNA, a communication protocol whereby transmissions can be checked.

setup program. A user-provided program that defines and inquires about FEPI resources, and performs housekeeping for the sessions.

SIT. System initialization table.

SLU. Secondary logical unit.

SLU P. An LU0 protocol defined by IMS as a protocol to communicate between a programmable workstation, such as a 4700, and IMS. IMS is the Primary Logical Unit (PLU) and the workstation is the Secondary Logical Unit (SLU) in the connection.

SLU2. An SLU using LU2 protocols, that is, the 3270 datastream protocol.

SMP/E. System Modification Program/Extended.

SNA. Systems Network Architecture.

STSN. Set and test sequence number.

STSN handler. A user-provided part of a FEPI application that handles STSN requests.

system initialization table (SIT). A CICS table that contains information to initialize and control system functions, module suffixes for selection of user-specified versions of CICS modules and tables, and information used to control the initialization process. You can generate several SITs, using the resource definition macro DFHSIT, and then use the SIT system initialization parameter to select the one that best meets your current requirements at initialization time.

System Modification Program/Extended (SMP/E). An IBM licensed program use to install software (for example, CICS/ESA) and software changes on MVS/ESA.

system programming interface. A subset of the CICS application programming interface that accesses special system-oriented CICS services.

T

target. In the CICS/ESA Front End Programming Interface (FEPI), the back-end CICS or IMS system to which FEPI appears as a secondary logical unit.

TCTTE. terminal control table terminal entry.

TD. Transient data.

temporary conversation. A FEPI conversation allocated from the pool specified by the POOL option that exists only for the duration of a FEPI CONVERSE command.

terminal control table terminal entry (TCTTE). In the CICS terminal control table (TCT), an entry for each terminal known to CICS.

terminal front-end program (FEPI application). A CICS application designed to use the front end programming interface (FEPI) to communicate with existing back-end applications.

transaction list table (XLT). CICS control table containing a list of transaction identifications. Depending on a system initialization specification that can be changed during system termination, the transactions in a particular XLT can be initiated from terminals during the first quiesce stage of system termination. During CICS execution the suffix of an XLT can be entered at the master terminal; the transactions in that XLT can then be enabled or disabled as a group.

transient data (TD). A CICS facility for temporarily saving data in the form of queues, called destinations. A TD destination is held either as a queue in a VSAM data set managed by CICS (intrapartition TD), or as a QSAM data set outside the CICS region.

U

unbind. In SNA, to deactivate a session between logical units.

unsolicited data. A type of inbound data that arrives on a connection where no FEPI conversation is active.

unsolicited-data handler. A user-provided part of a FEPI application that handles unsolicited inbound data.

V

Virtual Telecommunications Access Method (VTAM). A set of programs that maintain control of the communication between terminals and application programs.

W

write control character (WCC). (1) A control character that follows a write command in the 3270 data stream and provides control information for executing display and printer functions. (2) A character used with a write-type command to specify that a particular operation, or combination of operations, is to be performed at a display station or printer.

X

XLT. Transaction list table.

XRF. Extended Recovery Facility.

Numeric

3270 data stream. (1) The commands, control codes, orders, attributes, and data or structured fields for 3270 devices that are transmitted between an application program and a terminal. (2) Data being transferred from or to an allocated primary or tertiary device, or to the host system, as a continuous stream of data and 3270 Information Display System control elements in character form.

Index

Numerics

- 16MB line, AMODE setting for FEPI 27
- 3270 data stream
 - data formats 119
 - data-stream-level commands 8
 - glossary entry 193
 - list of books xiv
 - pass-through sample program 178
- 3278 device type 77
- 3279 device type 77

A

- abends 99
- access program 10, 121
 - glossary entry 189
- ACQFAIL event 35
- ACQNUM option
 - FEPI INQUIRE CONNECTION 74
 - FEPI INQUIRE NODE 76
- ACQSTATUS option
 - FEPI ADD 71
 - FEPI INQUIRE CONNECTION 74
 - FEPI INQUIRE NODE 76
 - FEPI INSTALL NODELIST 82
 - FEPI INSTALL POOL 83
 - FEPI SET CONNECTION 87
 - FEPI SET NODE 89
- ACQSTATUS, resource status 39
- Acquired
 - CEMT INQUIRE FECONNECTION 52
 - CEMT INQUIRE FENODE 53
- ACQUIRED option
 - CEMT SET FECONNECTION 57
 - CEMT SET FENODE 58
- ACQUIRED resource status 39
- ACQUIRING, resource status 39
- ADD POOL command 71
- ADDFAIL event 35
- addressing mode 27, 105
- AID (attention identifier), screen-image data 112
- ALARMSTATUS option
 - FEPI CONVERSE FORMATTED 144
 - FEPI RECEIVE FORMATTED 154
- ALL option
 - CEMT SET FECONNECTION 57
 - CEMT SET FENODE 58
 - CEMT SET FEPOOL 59
 - CEMT SET FETARGET 60
- ALLOCATE command 138
 - conversation 125
 - PASSCONVID 138
- ALLOCATE command (*continued*)
 - POOL 139
- ALLOCATE POOL 139
- AMODE setting
 - application programs 105
 - system programs 27
- analysis and planning 15
- AP NOOP 140
- APAR (Authorized Program Analysis Report) 5
 - glossary entry 189
- Appl
 - CEMT INQUIRE FETARGET 56
- APPL option
 - FEPI INQUIRE TARGET 81
- application minor nodes, VTAM 24
- application programming 101
 - commands 7, 137
 - components of FEPI programs 10, 121
 - conversational 123, 125
 - CVDA values 185, 186
 - data stream integrity 115
 - design 121
 - error handling
 - See error handling
 - FEPI use of 'application' x
 - general sequence of commands 107
 - IMS considerations 130
 - IMS response mode 131
 - interface, glossary entry 189
 - one-out one-in conversational 123
 - performance considerations 41, 133
 - pseudoconversational 124
 - RESP2 values 187
 - writing FEPI programs 105
- APPLLIST option
 - FEPI INSTALL TARGETLIST 86
- Assembler language
 - copybook 28, 137
 - sample programs 165
- ATI (automatic transaction initiation)
 - controlling FEPI resources 30
 - glossary entry 189
 - unsolicited data 122
- attention
 - general sequence of commands 107
 - keys 108, 160
 - multiple attentions 110
 - sending screen-image data 111
- authorized program analysis report (APAR)
 - See APAR (authorized program analysis report)
- automatic transaction initiation (ATI)
 - See ATI (automatic transaction initiation)

availability
 See *also* XRF (extended recovery facility)
 of network resources 24

B

back-end system 4
 CICS sample program 168
 configuration of 26
 glossary entry 189
 hardware and software requirements 5
 IMS considerations 130
 IMS sample programs 169
 in a CICSplex 19
 initial data 122
 message sent after a bind 122
 planning 15
 sample configuration 32
 XRF takeover 45
BACKGROUND option
 FEPI EXTRACT FIELD 148
begin-session handler 10
 application design 122
 defining to FEPI 18, 30
 glossary entry 189
 IMS considerations 131
 sample program 173
BEGINSESSION option
 FEPI INQUIRE POOL 77
 FEPI INQUIRE PROPERTYSET 79
 FEPI INSTALL PROPERTYSET 84
BEING ACQUIRED status 39
BEING RELEASED status 39
bind
 back-end system message after a bind 122
 communication and conversations 103
 device query 122
 glossary entry 189
 handling unsolicited binds with CLSDST(PASS) 35, 36
 introduction to FEPI resources 9
 removing bind races 44
 selection of FEPI session parameters 25
 XRF takeover 44
bind race, glossary entry 189
books from related libraries xiv
bracket
 glossary entry 189
bypass
 handling in application 129
 using in user exit 37

C

C/370 language
 copybook 28, 137
 nulls in screen image 112

C/370 language (*continued*)
 sample programs 165
card reader, sending key stroke data 108
CDSA storage requirements 19
CECI transaction
 debugging FEPI programs 28, 105
 glossary entry 189
CEMT transaction 49
 after FEPI failure 43
DISCARD 50
 glossary entry 189
INQUIRE FECONNECTION 51
INQUIRE FENODE 53
INQUIRE FEPOOL 54
INQUIRE FEPROPSET 55
INQUIRE FETARGET 56
SET FECONNECTION 57
SET FENODE 58
SET FEPOOL 59
SET FETARGET 60
CETR transaction 61, 98
CHAIN option
 FEPI CONVERSE DATASTREAM 141
 FEPI RECEIVE DATASTREAM 152
chain, receiving a 119
CICS (Customer Information Control System) 190
 back-end
 sample program 168
 terminal definitions 26
 CICS-supplied transactions 49
 default startup group list, DFHLIST 21, 22
 EXEC CICS command format 69, 137
 front-end, configuration of 23
 ISC and MRO considerations 3
 RDO group DFHFPEPI 21
 shutdown 42
 startup procedure 22
 TYPETERMs for CICS/MVS Version 2 26
 updating definitions 21, 23
CICSplex
 back-end systems in 19
CLSDST(PASS) 36
COBOL language
 copybook 28, 137
 example of sending screen-image data 111
 sample programs 165
COLLECT STATISTICS command 42
COLOR option
 FEPI EXTRACT FIELD 148
color support
 device attributes 18
 getting colors 148
 storage requirements 20
 VTAM configuration 24
COLUMNS option
 FEPI CONVERSE FORMATTED 144

COLUMNS option (*continued*)
 FEPI RECEIVE FORMATTED 154

command-level interpreter (CECI)
 See CECI transaction

command-level security 11, 22

commands
 application programming reference section 137
 CEMT DISCARD 50
 copy books for RESP2 values 28, 137
 CVDA values 185, 186
 data-stream-level 8, 115
 errors and exception conditions 28, 105
 format 69, 137
 formatted data 8
 general sequence 107, 116
 high-level FEPI 8
 introduction to FEPI commands 7
 key stroke interface 8, 107
 list of FEPI commands 9
 performance considerations 41
 RESP2 values 187
 screen-image interface 8, 107
 SNA 136
 specialized-level 8, 135
 storage requirements 19
 system programming 27, 69
 VTAM-level 8

communication
 error handling 129
 general considerations 103
 resources 103

conditions
 error and exception 69, 137

configuration
 16MB line 27
 AMODE setting 27
 example of 30
 of back-end CICS and IMS systems 26
 of CICS 23
 of FEPI
 coding of programs 27
 global user exits 37
 monitoring program 34
 sample 30
 setup program 28
 writing operator transactions 39

of VTAM
 application minor nodes 24
 ISTINCLM mode table 24
 session pacing values 26
 session parameters 24

planning 15
 programs, design of 27
 sample programs 30, 170

connection 9
 acquiring and releasing 39

connection (*continued*)
 controlling waits with event handlers 30
 determining contents of a pool 39
 glossary entry 190
 INQUIRE CONNECTION command 74
 sample configuration 33
 SET CONNECTION command 87
 storage requirements 19
 waiting in RELEASING state 39

contention mode 110, 117
 glossary entry 190

CONTENTION option
 FEPI INQUIRE POOL 77
 FEPI INQUIRE PROPERTYSET 79
 FEPI INSTALL PROPERTYSET 84

CONTROL option
 FEPI ISSUE 151

conventions used by FEPI
 node names 24
 pool names 18
 property set names 19
 syntax notation used in this book xi
 systems and data flow 7
 terminology used in this book ix

conversation ID 125

conversation identifier 125

conversations 103, 125
 design of conversational applications 123
 glossary entry 190
 ownership of 125
 passing conversations 126
 previously allocated 140, 143
 state of 40
 storage requirements 19
 temporary 126, 140, 143
 terminology x
 unknown conversation ID, error handling 129

CONVERSE
 data stream applications 119
 DATASTREAM 140
 FORMATTED 142
 key stroke and screen image applications 114

CONVID field
 start data 159
 TDQ record 92

CONVID option
 FEPI ALLOCATE POOL 139
 FEPI CONVERSE DATASTREAM 141
 FEPI CONVERSE FORMATTED 144
 FEPI EXTRACT CONV 147
 FEPI EXTRACT FIELD 148
 FEPI EXTRACT STSN 149
 FEPI FREE 150
 FEPI ISSUE 151
 FEPI RECEIVE DATASTREAM 152
 FEPI RECEIVE FORMATTED 154

- CONVID option (*continued*)
 - FEPI REQUEST PASSTICKET 155
 - FEPI SEND DATASTREAM 156
 - FEPI SEND FORMATTED 157
 - FEPI START 158
- CONVNUM option
 - FEPI INQUIRE CONNECTION 74
- CSZL transient data queue
 - command errors 28, 70
 - defining 21
- CSZX transient data queue
 - command errors 28, 93
 - defining 21
 - record format 92
 - reporting unexpected events 34
- CURSOR option
 - FEPI RECEIVE FORMATTED 154
 - FEPI SEND FORMATTED 157
- cursor setting 109, 112
- Customer Information Control System
 - See CICS (Customer Information Control System)
- customization
 - global user exits 63
 - journaling 67
- CVDA values 185
- CZBC transaction 168
- CZBI transaction 169
- CZPA transaction 181
- CZPS transaction 180
- CZQS transaction 182
- CZTD transaction 178
- CZTK transaction 174
- CZTR transaction 177
- CZTS transaction 175
- CZUC transaction 173
- CZUU transaction 179
- CZUX transaction 171
- CZXS transaction 170

D

- data formats
 - inbound data 160
 - journaling 67
 - start data 159
 - TD queue records 92
- data handling, using property set for 18, 28
- data stream applications 8
 - 3270 pass-through sample program 178
 - converse 119
 - data formats 160
 - data stream integrity 115
 - FEPI commands 7, 8
 - glossary entry 190
 - receiving 116
 - sending 118

- data stream applications (*continued*)
 - SLU P mode 120
 - SLU2 mode 119
 - writing 115
- DATATYPE field
 - start data 159
 - TDQ record 92
- DBCS (double-byte character set)
 - errors sending key stroke data 109
 - formatted, SLU2 mode 160
 - glossary entry 190
 - key stroke format 160
- DCT (destination control table)
 - defining transient data queues 21
 - glossary entry 190
- debugging 28, 95
 - See also error handling
- default CICS startup group list, DFHLIST 21, 22
- definite responses 121, 135
- definitions
 - for sample programs 165
 - sample 32
 - updating CICS 21
- DELETE POOL command 72
- DELETFAIL event 36
- design
 - access program 121
 - application organization 123
 - begin-session handler 122
 - end-session handler 123
 - programs 121
 - unsolicited-data handler 122
- destination control table (DCT)
 - See DCT (destination control table)
- Device
 - CEMT INQUIRE FEPOOL 54
- device attributes, using property set for 18, 28
- DEVICE field
 - start data 159
 - TDQ record 92
- DEVICE option
 - FEPI EXTRACT CONV 147
 - FEPI INQUIRE POOL 77
 - FEPI INQUIRE PROPERTYSET 79
 - FEPI INSTALL PROPERTYSET 84
- device query 122
- device-type, VTAM logon mode table entries 24
- DFHFEPI, RDO group 21, 22
- DFHLIST, default CICS startup group list 21, 22
- DFHSIT
 - See SIT (system initialization table)
- DFHSZ4099E message 99
- DFHSZ4155I message 100
- DFHSZAPA, copy book 28, 137
- DFHSZAPC, copy book 28, 137

- DFHSZAPO, copy book 28, 137
- DFHSZAPP, copy book 28, 137
- DISCARD command
 - NODELIST 72
 - POOL 73
 - PROPERTYSET 73
 - TARGETLIST 73
- DISCARDFAIL event 34
- distributed program link, shipping FEPI applications 23
- distribution tape 5
- double-byte character set
 - See DBCS (double-byte character set)
- DRx responses 121, 135
- dumps
 - FEPI 95

E

- ECDSA storage requirements 19
- EDF (Execution Diagnostic Facility)
 - debugging FEPI programs 28, 105
 - FEPI problem determination aids 95
 - glossary entry 190
- EIB (EXEC interface block) 70, 138
- end-session handler 10
 - application design 123
 - defining to FEPI 18, 30
 - glossary entry 190
 - IMS considerations 131
 - sample program 179
- ENDSESSION option
 - FEPI INQUIRE POOL 77
 - FEPI INQUIRE PROPERTYSET 79
 - FEPI INSTALL PROPERTYSET 84
- ENDSTATUS option
 - data stream 117
 - FEPI CONVERSE DATASTREAM 141
 - FEPI CONVERSE FORMATTED 144
 - FEPI RECEIVE DATASTREAM 152
 - FEPI RECEIVE FORMATTED 154
 - formatted data 110
- environmental requirements 5
- error handling 128
 - See also exception conditions
 - application programming commands 137
 - bad command sequencing 118
 - bypass by user exit 129
 - CONVERSE 114
 - general guidance 128
 - list of resources 29, 70
 - operator/system action 130
 - receiving data 110
 - receiving screen-image data 112
 - SEND failure 129
 - sending data
 - key stroke data 109
 - screen-image data 112

- error handling (*continued*)
 - session loss 129
 - shutdown 130
 - system programming commands 70
 - time-outs 128
 - unknown conversation ID 129
- ESCAPE option
 - FEPI CONVERSE FORMATTED 144
 - FEPI SEND FORMATTED 157
- escape sequences 108, 160
- ESM (external security manager) 22
 - See also RACF (Resource Access Control Facility)
 - glossary entry 190
 - PassTickets 11, 127
- ESMREASON option
 - FEPI REQUEST PASSTICKET 155
- ESMRESP option
 - FEPI REQUEST PASSTICKET 155
- EVENTDATA field
 - start data 159
 - TDQ record 92
- events, handling unexpected
 - See error handling
 - See unexpected events
- EVENTTYPE field
 - start data 159
 - TDQ record 93
- EVENTVALUE field
 - start data 159
 - TDQ record 93
- example of FEPI configuration 30
- exception conditions
 - See also error handling
 - application programs 105, 137
 - configuration programs 28
 - general considerations 28, 105
 - system programs 28, 69
- exception queues
 - See transient data queues
- exceptional events, handling
 - See unexpected events
- EXCEPTIONQ option
 - FEPI INQUIRE POOL 77
 - FEPI INQUIRE PROPERTYSET 79
 - FEPI INSTALL PROPERTYSET 84
- EXEC CICS command format
 - application programming 137
 - system programming 69
- EXEC interface block (EIB) 70, 138
- execution diagnostic facility (EDF)
 - See EDF (Execution Diagnostic Facility)
- exit programming interface (XPI) 63
 - with XSZARQ global user exit 65
 - with XSZBRQ global user exit 64
- exits, global user
 - See global user exits

- extended data stream
 - device attributes 18, 28
 - getting attributes 109, 112
 - storage requirements 20
 - VTAM configuration 24
- extended recovery facility (XRF)
 - See XRF (extended recovery facility)
- external security manager (ESM)
 - See ESM (external security manager)
- EXTRACT command
 - CONV 147
 - extracting field data 109, 113
 - FIELD 148
 - STSN 149

F

- Feno
 - CEMT INQUIRE FENODE 53
- FENODE option
 - CEMT DISCARD command 50
- FEPI
 - applications 121
 - CICS-supplied transactions 49
 - commands 69, 137
 - configuration 23
 - environmental requirements 5
 - functions and services 7
 - hardware requirements 5
 - how it fits into your system 4
 - installation 21
 - introduction 3
 - operator control 49
 - planning 5, 15
 - programming interface 7
 - resources 9
 - sample programs 165
 - setup program
 - sample program 170
 - software requirements 5
 - storage requirements 5
 - system integrity 5
 - translator option 70, 138
- FEPI commands
 - ADD POOL 71
 - ALLOCATE 138
 - ALLOCATE POOL 139
 - AP NOOP 140
 - application programming commands 137
 - CONVERSE DATASTREAM 140
 - CONVERSE FORMATTED 142
 - DELETE POOL 72
 - DISCARD NODELIST 72
 - DISCARD POOL 73
 - DISCARD PROPERTYSET 73
 - DISCARD TARGETLIST 73

- FEPI commands (*continued*)
 - EXTRACT CONV 147
 - EXTRACT FIELD 148
 - EXTRACT STSN 149
 - FREE 150
 - INQUIRE CONNECTION 74
 - INQUIRE NODE 76
 - INQUIRE POOL 77
 - INQUIRE PROPERTYSET 79
 - INQUIRE TARGET 81
 - INSTALL NODELIST 82
 - INSTALL POOL 83
 - INSTALL PROPERTYSET 84
 - INSTALL TARGETLIST 86
 - ISSUE 151
 - RECEIVE DATASTREAM 152
 - RECEIVE FORMATTED 153
 - REQUEST PASSTICKET 155
 - SEND DATASTREAM 156
 - SEND FORMATTED 157
 - SET CONNECTION 87
 - SET NODE 89
 - SET POOL 90
 - SET TARGET 91
 - SP NOOP 92
 - START 158
 - system programming commands 69
- FEPI configuration
 - coding of programs 27
 - addressing mode 27
 - exception conditions 28
 - system programming commands 27
 - translator option 27
 - debugging programs 28
 - example configuration 30
 - global user exits 37
 - monitoring program
 - sample program 171
 - triggering of 34
 - writing of 34
 - planning 5, 15
 - sample configuration 30
 - setup program
 - optional functions 28
 - required functions 28
 - running of 29
 - sample 170
 - writing operator transactions 39
- FEPI=YES|NO, system initialization parameter 22
- FEPIRESOURCE, resource identifier for RACF 22
- Fepo
 - CEMT INQUIRE FEPOOL 54
- FEPOOL option
 - CEMT DISCARD 50
- Fepo
 - CEMT INQUIRE FEPROPSET 55

FEPROPSET option
 CEMT DISCARD 50
 CEMT INQUIRE FEPROPSET 55
 Feta
 CEMT INQUIRE FETARGET 56
 FETARGET option
 CEMT DISCARD 50
 FIELDATTR option
 FEPI EXTRACT FIELD 148
 FIELDLOC option
 FEPI EXTRACT FIELD 148
 FIELDNUM option
 FEPI EXTRACT FIELD 148
 FIELDS option
 FEPI CONVERSE FORMATTED 144
 FEPI RECEIVE FORMATTED 154
 fields, getting data and attributes 109, 112
 FJOURNALNUM option
 FEPI INQUIRE POOL 77
 FEPI INQUIRE PROPERTYSET 79
 FEPI INSTALL PROPERTYSET 85
 FLENGTH field
 start data 159
 FLENGTH option
 FEPI EXTRACT FIELD 148
 FEPI RECEIVE DATASTREAM 152
 FEPI RECEIVE FORMATTED 154
 FEPI SEND DATASTREAM 156
 FEPI SEND FORMATTED 157
 FEPI START 158
 FMH option
 FEPI CONVERSE DATASTREAM 141
 FMHSTATUS option
 FEPI CONVERSE DATASTREAM 141
 FEPI RECEIVE DATASTREAM 152
 FORCE option
 FEPI FREE 150
 forced shutdown 43
 FORMAT field
 start data 159
 TDQ record 93
 format of data
 See data formats
 FORMAT option
 FEPI EXTRACT CONV 147
 FEPI INQUIRE POOL 77
 FEPI INQUIRE PROPERTYSET 79
 FEPI INSTALL PROPERTYSET 85
 formatted data 8
 performance 133
 programming 107
 RECEIVE and EXTRACT field sample program 177
 SEND and START sample program 175
 FREE 150
 FROM option
 FEPI CONVERSE DATASTREAM 141
 FEPI CONVERSE FORMATTED 144
 FEPI SEND DATASTREAM 156
 FEPI SEND FORMATTED 157
 FROMCURSOR option
 FEPI CONVERSE FORMATTED 144
 FROMFLENGTH option
 FEPI CONVERSE DATASTREAM 141
 FEPI CONVERSE FORMATTED 144
 front-end system 4
 configuration 23
 glossary entry 190
 hardware and software requirements 5
 XRF takeover 44
 function identifiers, journaling 67
 function shipping, restrictions on 23
 functions and services provided by FEPI 7

G
 generic resources, VTAM 19
 global user exits 63
 glossary entry 191
 introduction 37, 63
 XSZARQ
 exit-specific parameters 65
 overview 65
 return codes 65
 UEPSZACN parameter 66
 XPI calls 65
 XSZBRQ
 exit-specific parameters 64
 modifiable parameters 63
 overview 63
 return codes 64
 UEPSZACT parameter 66
 XPI calls 64
 glossary of terms and abbreviations 189
 GOINGOUT status 39
 good morning message 18, 122

H
 handler, glossary entry 191
 handling unexpected events
 See error handling
 See exception conditions
 See unexpected events
 hardware requirements 5
 HIGHLIGHT option
 FEPI EXTRACT FIELD 148
 HOLD option
 FEPI FREE 150

I

- immediate shutdown 43
- IMS (Information Management System)
 - considerations for application design 130
 - end of session 131
 - glossary entry 191
 - list of books xiv
 - message protocols 131
 - recovery 132
 - response mode 131
 - SLU P conversational sample program 180
 - SLU P recovery 132
 - SLU2 recovery 132
 - STSN handling 18, 135
 - sample program 182
 - terminal definitions 26
 - unsolicited-data handler 122
 - using MFS 131
- inbound data
 - 3270 data stream considerations 119
 - data format 160
 - initial data 18, 122
 - journaling 67
 - terminology x, 7
- INITIALDATA option
 - FEPI INQUIRE POOL 77
 - FEPI INQUIRE PROPERTYSET 79
 - FEPI INSTALL PROPERTYSET 85
- INPUTCONTROL option
 - FEPI EXTRACT FIELD 148
- INQUIRE command
 - CONNECTION 74
 - NODE 76
 - POOL 77
 - use in event handlers 30
 - PROPERTYSET 79
 - TARGET 81
- INQUIRE, CEMT
 - FECONNECTION 51
 - FENODE 53
 - FEPOOL 54
 - FEPROPSET 55
 - FETARGET 56
- Inservice
 - CEMT INQUIRE FECONNECTION 51
 - CEMT INQUIRE FENODE 53
 - CEMT INQUIRE FEPOOL 54
 - CEMT INQUIRE FETARGET 56
- INSERVICE option
 - CEMT SET FECONNECTION 57
 - CEMT SET FENODE 58
 - CEMT SET FEPOOL 59
 - CEMT SET FETARGET 60
- INSERVICE status 39
- INSTALL command
 - NODELIST 82
 - POOL 83
 - PROPERTYSET 84
 - TARGETLIST 86
- Installed
 - CEMT INQUIRE FECONNECTION 51
 - CEMT INQUIRE FENODE 53
 - CEMT INQUIRE FEPOOL 54
 - CEMT INQUIRE FETARGET 56
- INSTALLED status 40
- INSTALLFAIL event 34
- installing FEPI
 - defining security profiles 22
 - loading modules in the LPA 21
 - overview 21
 - planning considerations 5
 - RDO definitions 22
 - sample programs 167
 - starting CICS 22
 - updating CICS definitions
 - PLTPI list 23
 - supplied RDO group, DFHFPEPI 21
 - system initialization parameter, FEPI=YES|NO 22
 - transient data queues 21
- INSTLSTATUS option
 - FEPI INQUIRE CONNECTION 74
 - FEPI INQUIRE NODE 76
 - FEPI INQUIRE POOL 77
 - FEPI INQUIRE TARGET 81
- INSTLSTATUS, resource status 40
- integrity of FEPI system 5
- interactive problem control system (IPCS) 95
- INTO option
 - FEPI CONVERSE DATASTREAM 141
 - FEPI CONVERSE FORMATTED 144
 - FEPI EXTRACT FIELD 148
 - FEPI RECEIVE DATASTREAM 152
 - FEPI RECEIVE FORMATTED 154
- INVITE option
 - command sequence 116
 - FEPI SEND DATASTREAM 156
- IPCS (interactive problem control system) 95
- ISC (intersystem communication) 3
 - glossary entry 191
 - hardware requirements 5
- ISSUE 151
 - sending SNA commands 136
- ISTINCLM, LOGON mode table 24

J

- journaling 12, 67
 - use of property set for 19, 28

K

- key stroke and screen-image applications 8
 - CONVERSE 114
 - data formats 160
 - extracting field data 113
 - general sequence of commands 107
 - glossary entry 191
 - multiple attentions 110
 - performance considerations 133
 - receiving field-by-field 109
 - receiving screen-image data 112
 - sample programs
 - key stroke converse 174
 - screen image RECEIVE and EXTRACT 177
 - screen image SEND and START 175
 - sending key stroke data 108
 - sending screen-image data 111
 - writing 107
- KEYSTROKES option
 - FEPI CONVERSE FORMATTED 144
 - FEPI SEND FORMATTED 157

L

- Lacqcode
 - CEMT INQUIRE FECONNECTION 52
 - CEMT INQUIRE FENODE 53
- LACQCODE option
 - resource status 40
- LASTACQCODE option
 - FEPI INQUIRE CONNECTION 74
 - FEPI INQUIRE NODE 76
- LINES option
 - FEPI CONVERSE FORMATTED 144
 - FEPI RECEIVE FORMATTED 154
- Link Pack Area (LPA), loading FEPI modules into 21
- list of resources
 - benefits of using 41
 - errors 29, 70
- list processing 70
- logical unit (LU)
 - See LU (logical unit)
- LOGON mode table, VTAM 24
- LPA (Link Pack Area), loading FEPI modules into 21
- LU (logical unit)
 - See *also* SLU P
 - See *also* SLU2
 - See *also* terminal
 - glossary entry 191

M

- magnetic stripe reader, sending key stroke data to 108
- managing sessions, use of property set for 18, 28

- manipulative keys 108, 160
- manuals from related libraries xiv
- MAXFLENGTH option
 - FEPI CONVERSE DATASTREAM 141
 - FEPI CONVERSE FORMATTED 144
 - FEPI EXTRACT FIELD 148
 - FEPI INQUIRE POOL 78
 - FEPI INQUIRE PROPERTYSET 79
 - FEPI INSTALL PROPERTYSET 85
 - FEPI RECEIVE DATASTREAM 152
 - FEPI RECEIVE FORMATTED 154
- MDT (modified data tag) setting 111, 160
- MDT option
 - FEPI EXTRACT FIELD 148
- Message Format Services (MFS) 131
- message protocols (IMS) 131
- messages
 - format of FEPI messages 98
 - handling unexpected events 16
 - IMS protocols 131
 - message log, CSZL
 - See CSZL transient data queue
 - produced during XRF takeover 44
 - resynchronizing with STSN 135
 - terminology x
- MFS (Message Format Services) 131
- mode table, VTAM 24
- modified data tag (MDT) setting 111, 160
- module identifiers, journaling 67
- monitoring program
 - glossary entry 191
 - handling CLSDST(PASS) 37
 - sample program 171
 - triggering of 34
 - writing of 34
- monitoring, CICS
 - performance class records
 - FEPI-related fields 42
- MRO (multiregion operation)
 - AOR considerations for FEPI 23
 - general considerations 3
- MSGJRNL option
 - FEPI INQUIRE POOL 78
 - FEPI INQUIRE PROPERTYSET 79
 - FEPI INSTALL PROPERTYSET 85
- multiple attentions 110
- MVS/ESA
 - Integrity Programming Announcement 5

N

- naming conventions
 - network resources 24
 - nodes 15, 24
 - pools 18
 - property sets 19

naming conventions (*continued*)

- sample programs 7
- targets 15
- VTAM 24

network availability 24

no response, glossary entry 191

node

- acquiring and releasing 39
- CEMT INQUIRE FECONNECTION 51
- CEMT INQUIRE FENODE 53
- defining to VTAM 24
- definition of 9
- determining contents of a pool 39
- glossary entry 191
- INQUIRE NODE command 76
- name restrictions 24
- number of nodes 17
- sample node lists 32
- SET NODE command 89
- setup sample program 170
- storage requirements 19
- terminology x

NODE field

- start data 159
- TDQ record 93

NODE option

- CEMT SET FECONNECTION 57
- FEPI EXTRACT CONV 147
- FEPI INQUIRE CONNECTION 74
- FEPI INQUIRE NODE 76
- FEPI SET CONNECTION 87
- FEPI SET NODE 89

NODELIST option

- FEPI ADD 71
- FEPI DELETE 72
- FEPI DISCARD NODLIST 72
- FEPI INSTALL NODLIST 82
- FEPI INSTALL POOL 83
- FEPI SET CONNECTION 87
- FEPI SET NODE 89

nodename option

- CEMT SET FENODE 58

NODENUM option

- FEPI ADD 71
- FEPI DELETE 72
- FEPI DISCARD NODLIST 72
- FEPI INSTALL NODLIST 82
- FEPI INSTALL POOL 83
- FEPI SET CONNECTION 87
- FEPI SET NODE 89

non-response mode, glossary entry 191

normal shutdown 43

notation, syntax xi

Notinstalled

- CEMT INQUIRE FECONNECTION 51
- CEMT INQUIRE FENODE 53

Notinstalled (*continued*)

- CEMT INQUIRE FEPOOL 54
- CEMT INQUIRE FETARGET 56
- NOTINSTALLED status 40

O

one-out one-in conversational applications

- application design 123
- sample program 180

operator control

- commands 49
- FEPI trace 61
- operator/system action error 130
- transactions, user-written 39
- VTAM commands 61

operator/system action error 130

order of FEPI commands 107, 116

organizing pools 17

organizing property sets 18

outbound data

- 3270 data stream considerations 119
- data formats 160
- journaling 67
- terminology x, 7

OUTLINE option

- FEPI EXTRACT FIELD 148

Outservice

- CEMT INQUIRE FECONNECTION 51
- CEMT INQUIRE FENODE 53
- CEMT INQUIRE FEPOOL 54
- CEMT INQUIRE FETARGET 56

OUTSERVICE option

- CEMT SET FECONNECTION 57
- CEMT SET FENODE 58
- CEMT SET FEPOOL 59
- CEMT SET FETARGET 60

OUTSERVICE status 39

P

pacing of FEPI sessions 26

partner system

- See back-end system

PASS option

- FEPI FREE 150

pass-through

- contention state handling 117
- problem with received data 117
- sample program 178

PASSCONVID option

- FEPI ALLOCATE PASSCONVID 138
- getting ownership of conversations 126

passing conversations 126

PASSTICKET option

- FEPI REQUEST PASSTICKET 155

- PassTickets, for signon security 11, 127
- PASSWORDLIST option
 - FEPI INSTALL NODELIST 82
- PERFORM STATISTICS RECORD command 42
- performance
 - application programs 41
 - formatted data 133
 - key stroke and screen-image applications 133
 - of a CICSplex
 - using VTAM generic resources 19
 - optimization through application design 133
 - tuning using CICS monitoring data 42
 - tuning using CICS statistics data 42
- performance class monitoring records 42
- persistent sessions, VTAM
 - use of with FEPI 46
- PL/I language
 - copybook 28, 137
 - sample programs 165
- planning
 - back-end applications 15
 - configuration 5, 15
 - general considerations 5, 15
 - grouping of connections, for functional purposes 17
 - handling special events 16
 - installation 5
 - journaling requirements 16
 - names of nodes and targets 15
 - number of nodes 17
 - operator control requirements 15
 - organizing pools 17
 - organizing property sets 18
 - pools
 - using for control purposes 16
 - using for functional purposes 17
 - signon and signoff procedures 16
 - storage 19
- PLT (program list table) 23, 29
 - glossary entry 191
 - post initialization (PLTPI) 23
- PLTPI (program list table post initialization)
 - configuring CICS for FEPI 23
 - glossary entry 191
 - running setup programs 29
- PLU (primary logical unit)
 - See also back-end system
 - glossary entry 191
- Pool
 - CEMT INQUIRE FECONNECTION 51
 - CEMT INQUIRE FEPOOL 54
- POOL field
 - start data 159
 - TDQ record 93
- POOL option
 - FEPI ADD 71
 - FEPI ALLOCATE POOL 139
- POOL option (*continued*)
 - FEPI CONVERSE DATASTREAM 141
 - FEPI CONVERSE FORMATTED 145
 - FEPI DISCARD POOL 73
 - FEPI EXTRACT CONV 147
 - FEPI INQUIRE CONNECTION 74
 - FEPI INQUIRE POOL 78
 - FEPI INSTALL POOL 83
 - FEPI SET POOL 90
- POOLLIST option
 - FEPI SET POOL 90
- POOLNUM option
 - FEPI SET POOL 90
- pools
 - connections in 39
 - definition of 9
 - determining contents of a pool 39
 - glossary entry 191
 - INQUIRE POOL command 77
 - INSTALL POOL command 83
 - name restrictions 18
 - organizing pools 17
 - sample configuration 30
 - SET POOL command 90
 - setup sample program 170
 - storage requirements 19
 - transient data queues 21, 34
 - using for control reasons 16
 - using for functional reasons 17
- POSITION option
 - FEPI EXTRACT FIELD 148
- prerequisites, hardware and software 5
- presentation space 191
 - glossary entry 191
- previously allocated conversation 140, 143
- primary logical unit (PLU)
 - See also back-end system
 - glossary entry 191
- problem determination
 - See also error handling
 - See also exception conditions
 - abends 99
 - debugging 95
 - functions provided by FEPI 12
 - handling unexpected events 34
 - messages 98
 - reporting problems to IBM 100
 - shutdown not proceeding 43
 - trace 98
 - using CICS dumps 96
 - using FEPI dumps 95
- product tape 5
- program list table (PLT)
 - See PLT (program list table)
- program list table post initialization (PLTPI)
 - See PLTPI (program list table post initialization)

Program Temporary Fix (PTF)
 glossary entry 191
 programming commands
 See commands
 property set
 data handling 18, 28
 definition of 9
 device attributes 18, 28
 DISCARD PROPERTYSET command 73
 glossary entry 191
 INQUIRE PROPERTYSET command 79
 INSTALL PROPERTYSET command 84
 journaling 19, 28
 name restrictions 19
 organizing 18
 sample configuration 33
 session management 18, 28
 setup sample program 170
 storage requirements 19
 unexpected events 19, 28
 PROPERTYSET option
 FEPI DISCARD PROPERTYSET 73
 FEPI INQUIRE POOL 78
 FEPI INQUIRE PROPERTYSET 80
 FEPI INSTALL POOL 83
 FEPI INSTALL PROPERTYSET 85
 PROTECT option
 FEPI EXTRACT FIELD 149
 PS option
 FEPI EXTRACT FIELD 149
 PS/55
 FEPI device type 77
 TYPETERM 26
 pseudoconversational applications
 application design 124
 sample program 181
 PTF (Program Temporary Fix)
 glossary entry 192
 publications from related libraries xiv

Q

query, device 122
 queue, transient data
 See transient data queues

R

RACF (Resource Access Control Facility)
 general security considerations 22
 glossary entry 192
 list of books xiv
 RDO (resource definition online)
 definitions for sample programs 165
 glossary entry 192
 updating CICS definitions for FEPI 21

RDO (resource definition online) *(continued)*
 XRF considerations 44
 RECEIVE command
 completion 110, 116
 DATASTREAM 152
 error handling 110, 118
 FORMATTED 153
 receiving data
 data stream applications 116
 field-by-field 109
 screen-image 112
 reference section
 application programming 137
 operator commands 49
 system programming 69
 RELEASE option
 FEPI FREE 150
 Released
 CEMT INQUIRE FECONNECTION 52
 CEMT INQUIRE FENODE 53
 RELEASED option
 CEMT SET FECONNECTION 57
 CEMT SET FENODE 58
 RELEASED resource status 39
 RELEASING, resource status 39
 REMFLENGTH option
 FEPI CONVERSE DATASTREAM 141
 FEPI RECEIVE DATASTREAM 152
 reporting FEPI problems to IBM 100
 REQUEST PASSTICKET command 155
 request unit (RU)
 glossary entry 192
 receiving 116
 requirements, hardware and software 5
 Resource Access Control Facility (RACF)
 See RACF (Resource Access Control Facility)
 resource definition online (RDO)
 See RDO (resource definition online)
 resources
 benefits of using list of resources 41
 configuring 29
 definitions 9
 diagram showing relationship 9
 sample configuration 30
 status 39
 RESP2 values
 application programming commands 137
 system programming commands 69
 table of 187
 response mode 131
 response mode, glossary entry 192
 responses
 DRx responses 135
 RESPSTATUS option
 FEPI CONVERSE DATASTREAM 141
 FEPI CONVERSE FORMATTED 145

RESPSTATUS option (*continued*)
FEPI RECEIVE DATASTREAM 153
FEPI RECEIVE FORMATTED 154

restriction on use of DFH
in node names 24
in pool names 18
in property set names 19

return codes
application programming 137
system programming 70
user exits 64, 65
VTAM 40

RU option
FEPI CONVERSE DATASTREAM 142
FEPI RECEIVE DATASTREAM 153

S

sample FEPI configuration 30
sample programs 165
3270 data stream pass-through 178
begin session 173
CICS back-end 168
end-session handler 179
FEPI configuration 30
IMS back-end 169
installing of 167
introduction 7
key stroke CONVERSE 174
monitor and unsolicited data handler 171
naming conventions 7
one-out one-in 180
program descriptions and code 165
pseudoconversational 181
screen image RECEIVE and EXTRACT FIELD 177
screen image SEND and START 175
setup 170
SLU P one-out one-in 180
SLU P pseudoconversational 181
STSN handler 182
using the samples 167

sample resource definitions 32

screen-image applications

See key stroke and screen-image applications

screen-image interface 8, 192

See *also* key stroke and screen-image applications

data formats 160

RECEIVE and EXTRACT field sample program 177

SEND and START sample program 175

secondary logical unit (SLU)

glossary entry 192

terminals supported by FEPI 11

security

command-level 11, 22

handling violations with access program 121

restricting access to system programming commands 22

security (*continued*)

signoff 16

signon 11, 16, 121, 127

using PassTickets 11, 127

using RACF 22

SEND command

DATASTREAM 156

error handling 129

errors 109, 110, 118

FORMATTED 157

sending data

data stream applications 118

key stroke data 108

screen image 111

sense data 129

SENSEDATA option

FEPI EXTRACT CONV 147

FEPI ISSUE 151

SEQNUMIN option

FEPI ALLOCATE POOL 139

FEPI CONVERSE DATASTREAM 142

FEPI EXTRACT STSN 149

FEPI RECEIVE DATASTREAM 153

FEPI SEND DATASTREAM 156

SEQNUMOUT option

FEPI ALLOCATE POOL 139

FEPI CONVERSE DATASTREAM 142

FEPI EXTRACT STSN 149

FEPI RECEIVE DATASTREAM 153

FEPI SEND DATASTREAM 156

sequence number handling 135

sequence of FEPI commands 107, 116

SERVSTATUS option

FEPI ADD 71

FEPI INQUIRE CONNECTION 75

FEPI INQUIRE NODE 76

FEPI INQUIRE POOL 78

FEPI INQUIRE TARGET 81

FEPI INSTALL NODELIST 82

FEPI INSTALL POOL 83

FEPI INSTALL TARGETLIST 86

FEPI SET CONNECTION 87

FEPI SET NODE 89

FEPI SET POOL 90

FEPI SET TARGET 91

SERVSTATUS, resource status 39

session 192

begin-session

See begin-session handler

end-session

See end-session handler

loss of 129

management using property sets 18, 28

pacing values 26

parameters, selection of 24

SESSION event 35
 SESSIONFAIL event 35
 SESSIONLOST event 35
 set and test sequence number (STSN)
 See STSN (set and test sequence number)
 SET command
 CONNECTION 87
 NODE 89
 POOL 90
 TARGET 91
 SET, CEMT
 FECONNECTION 57
 FENODE 58
 FEPOOL 59
 FETARGET 60
 SETFAIL event 34
 setup program, for FEPI resources 9, 17, 170
 glossary entry 192
 sample program 170
 shutdown
 error handling 130
 of CICS 43
 of FEPI 43
 signon security 11, 16, 121, 127
 SIT (system initialization table)
 glossary entry 192
 SIT parameter, FEPI=YES|NO 22
 SIZE option
 FEPI EXTRACT FIELD 149
 SLU P 11
 begin-session sample 173
 data stream applications 120
 glossary entry 192
 IMS recovery 132
 one-out one-in sample program 180
 pseudoconversational sample program 181
 sample configuration 33
 sample programs 165
 STSN request 135
 SLU (secondary logical unit)
 glossary entry 192
 terminals supported by FEPI 11
 SLU P
 device attributes 18
 SLU2 11
 begin-session sample 173
 data stream applications 119
 device attributes 18
 glossary entry 192
 IMS recovery 132
 key stroke format 160
 sample configuration 33
 sample programs 165
 SMP/E (System Modification Program/Extended)
 glossary entry 192
 installing FEPI 5
 SNA (Systems Network Architecture)
 glossary entry 192
 list of books xiv
 sending commands 136
 software requirements 5
 special keys 108, 160
 specialized functions
 DRx responses 135
 SNA commands 136
 STSN 135
 START command 158
 failure during shutdown 130
 start data 124, 159
 started tasks 124
 State
 CEMT INQUIRE FECONNECTION 52
 STATE option
 FEPI INQUIRE CONNECTION 75
 STATE, resource status 41
 statistics, CICS
 FEPI-related
 COLLECT STATISTICS command 42
 PERFORM STATISTICS RECORD command 42
 storage planning 19
 stripe reader, sending key stroke data 108
 STSN (set and test sequence number) 10
 general considerations 135
 glossary entry 192
 sample program 182
 STSN handler
 defining to FEPI 28
 glossary entry 192
 STSN option
 FEPI INQUIRE POOL 78
 FEPI INQUIRE PROPERTYSET 80
 FEPI INSTALL PROPERTYSET 85
 syncpoints, use of in FEPI 121
 syntax notation xi, 70, 138
 system initialization table (SIT)
 See SIT (system initialization table)
 System Modification Program/Extended (SMP/E)
 See SMP/E (System Modification Program/Extended)
 system programming commands 27, 69
 Systems Network Architecture (SNA)
 See SNA (Systems Network Architecture)
 SZ, dump control keyword 95

T

takeover, XRF
 See XRF (extended recovery facility)
 target
 CEMT INQUIRE FECONNECTION 51
 definition of 9
 determining contents of a pool 39
 glossary entry 192

- target (*continued*)
 - INQUIRE TARGET command 81
 - naming conventions 15
 - sample target lists 32
 - SET TARGET command 91
 - setup sample program 170
 - storage requirements 19
- TARGET field
 - start data 159
 - TDQ record 93
- TARGET option
 - CEMT SET FECONNECTION 57
 - FEPI ALLOCATE POOL 139
 - FEPI CONVERSE DATASTREAM 142
 - FEPI CONVERSE FORMATTED 145
 - FEPI EXTRACT CONV 147
 - FEPI INQUIRE CONNECTION 75
 - FEPI INQUIRE TARGET 81
 - FEPI SET CONNECTION 87
 - FEPI SET TARGET 91
- TARGETLIST option
 - FEPI ADD 71
 - FEPI DELETE 72
 - FEPI DISCARD TARGETLIST 73
 - FEPI INSTALL POOL 83
 - FEPI INSTALL TARGETLIST 86
 - FEPI SET CONNECTION 87
 - FEPI SET TARGET 91
- TARGETNUM option
 - FEPI ADD 71
 - FEPI DELETE 72
 - FEPI DISCARD TARGETLIST 73
 - FEPI INSTALL POOL 83
 - FEPI INSTALL TARGETLIST 86
 - FEPI SET CONNECTION 87
 - FEPI SET TARGET 91
- tasks, started 124
- TD queue
 - See transient data queues
- temporary conversation 126
 - glossary entry 192
- TERMID option
 - FEPI START 158
- terminal
 - back-end definitions 26
 - simulated terminal usage 123
 - SLU P
 - See SLU P
 - SLU2
 - See SLU2
 - storage requirements 19
 - VTAM logon mode table entries 24
 - XRF environment 44
- terminology used in this book ix
- time-outs, error handling 128
- TIMEOUT option
 - FEPI ALLOCATE POOL 139
 - FEPI CONVERSE DATASTREAM 142
 - FEPI CONVERSE FORMATTED 145
 - FEPI RECEIVE DATASTREAM 153
 - FEPI RECEIVE FORMATTED 154
 - FEPI START 158
- TOCURSOR option
 - FEPI CONVERSE FORMATTED 145
- TOLENGTH option
 - FEPI CONVERSE DATASTREAM 142
 - FEPI CONVERSE FORMATTED 145
- trace control 61
- trace points 98
- transaction list table (XLT)
 - See XLT (transaction list table)
- transactions
 - CEMT
 - See CEMT transaction
 - CETR 61, 98
 - CZBC 168
 - CZBI 169
 - CZPA 181
 - CZPS 180
 - CZQS 182
 - CZTD 178
 - CZTK 174
 - CZTR 177
 - CZTS 175
 - CZUC 173
 - CZUU 179
 - CZUX 171
 - CZXS 170
- TRANSID option
 - FEPI START 158
- transient data queues
 - command errors 28
 - CSZL, for FEPI messages 21
 - CSZX, for unexpected events 21
 - defining to CICS 21
 - handling 34
 - planning 16
 - pool-specific 21, 34
 - records 92
 - sample program 171
 - unexpected event reporting 34
- translator options
 - application programming commands 138
 - FEPI option 27, 138
 - system programming commands 70
- TRANSPARENCY option
 - FEPI EXTRACT FIELD 149
- TYPETERMs for CICS back-end systems 26

U

UEPSZACN, exit-specific parameter for XSZARQ 66
UEPSZACT, exit-specific parameter for XSZBRQ 66
unbind, glossary entry 193
unexpected events 21
 See *also* error handling
 in CSZX TD queue 34
 in pool-specific TD queue 16, 35
 using event handlers 30
 using property set for 19, 28
unknown conversation ID, error handling 129
UNSOLDDATA option
 FEPI INQUIRE POOL 78
 FEPI INQUIRE PROPERTYSET 80
 FEPI INSTALL PROPERTYSET 85
UNSOLDDATAACK option
 FEPI INQUIRE POOL 78
 FEPI INQUIRE PROPERTYSET 80
 FEPI INSTALL PROPERTYSET 85
unsolicited data-handler
 sample program 171
unsolicited-data handler 10
 application design 122
 defining to FEPI 19, 28
 glossary entry 193
UNTILCDEB option
 FEPI CONVERSE DATASTREAM 142
 FEPI RECEIVE DATASTREAM 153
user exits
 See *global user exits*
USERDATA field
 start data 159
USERDATA option
 FEPI INQUIRE CONNECTION 75
 FEPI INQUIRE NODE 76
 FEPI INQUIRE POOL 78
 FEPI INQUIRE TARGET 81
 FEPI SET CONNECTION 87
 FEPI SET NODE 89
 FEPI SET POOL 90
 FEPI SET TARGET 91
 FEPI START 158

V

VALIDATION option
 FEPI EXTRACT FIELD 149
VALUE option
 FEPI ISSUE 151
VTAM (Virtual Telecommunications Access method)
 APPL statement 24
 application minor nodes 24
 BIND during XRF takeover 44
 CLSDST(PASS) 36
 commands 61

VTAM (Virtual Telecommunications Access method)

(continued)

 configuration of 24
 DISPLAY command 61
 DISPLAY SESSIONS command 61
 FEPI commands 7, 8
 generic resources 19
 ISTINCLM, supplied mode table 24
 list of books xiv
 LOGON mode table 24
 minor nodes, sample configuration 32
 naming conventions 24
 password protection 24
 persistent sessions 46
 program-to-program support 3
 releasing a connection 39
 session pacing values 26
 session parameters 24
 TYPETERMs for CICS/MVS Version 2 26
 VARY command 61
 VARY TERM command 61
 XRF considerations 44
VTAM persistent sessions
 use of with FEPI 46

W

Waitconvnum
 CEMT INQUIRE FECONNECTION 52
 CEMT INQUIRE FEPOOL 54
WAITCONVNUM option
 event handlers 30
 FEPI INQUIRE CONNECTION 75
 FEPI INQUIRE POOL 78
WAITCONVNUM resource status 40
WCC (write control character)
 handling 119
workload balancing
 in a CICSplex
 using VTAM generic resources 19
writing application programs 105
 See *also* application programming

X

XLT (transaction list table)
 application programming 130
 glossary entry 193
 operations 43
XPI (exit programming interface) 63
 with XSZARQ global user exit 65
 with XSZBRQ global user exit 64
XRF (extended recovery facility) 43
 See *also* availability
 back-end system configuration 26
 FEPI resource definition 44

XRF (extended recovery facility) *(continued)*

glossary entry 193

takeover of back-end CICS 45, 46

 effect on applications 45

 effect on FEPI connections 46

takeover of FEPI CICS 44, 45

 effect on alternate CICS 45

 effect on back-end terminals 45

 effect on back-end transactions 44

varying setup resources 29

VTAM considerations 44

XSZARQ, global user exit

 exit-specific parameters 65

 overview 65

 return codes 65

 UEPSZACN parameter 66

 XPI calls 65

XSZBRQ, global user exit

 exit-specific parameters 64

 modifiable parameters 63

 overview 63

 return codes 64

 UEPSZACT parameter 66

 XPI calls 64



Program Number: 5655-018



Printed in the United States of America
on recycled paper containing 10%
recovered post-consumer fiber.

SC33-1175-00



Spine information:



CICS/ESA

Front End Programming Interface User's Guide

Version 4 Release 1