



IBM Software Group

Software Expo 2005

INTRODUCCION A ITIL



@business on demand software

Mayo 2005

ITIL Defined

The Information Technology Infrastructure Library (ITIL)[®] is a framework of IT Best Practices defined in a series of books.

- ITIL documents industry best practice for IT Service Management
- ITIL is gaining worldwide momentum as an industry best practice for implementing key systems management disciplines.
- A list of the ITIL books can be found at:
<http://www.ogc.gov.uk>

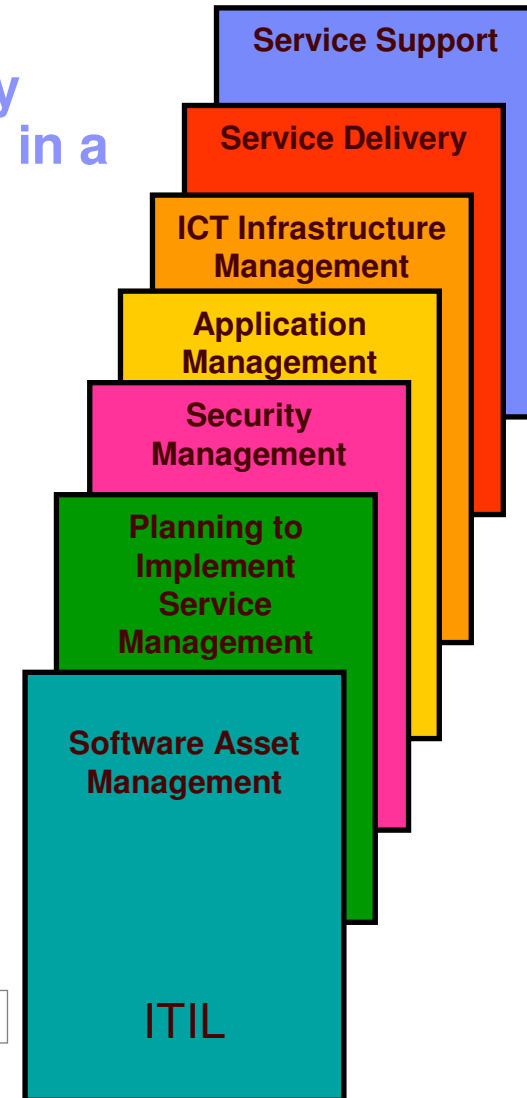



English

What is the itSMF?

The IT Service Management Forum (itSMF) is the only internationally recognised and independent organisation dedicated to IT Service Management. It is a not-for-profit organisation, wholly owned, and principally operated, by its membership.

The itSMF is a major influence on, and contributor to, industry "best practice" and Standards worldwide, working in partnership with a wide range of governmental and standards bodies worldwide.

Formed in the UK in 1991, there are now national chapters in an ever-increasing number of countries.

What are our aims?

- To develop and promote industry best practice in service management
- To engender professionalism within service management personnel
- To provide a vehicle for helping members improve service performance
- To provide members with a relevant forum in which to exchange information and share experiences with their peers on both sides of the industry

Who are our members?

Approximately 80% of the membership represents organizations striving to implement and sustain high quality IT Service Management solutions, with the remainder being organizations providing products and services to assist in those endeavours. Organisations range from large multi-nationals through small and medium local enterprises to individual consultants and cover both the public and private sectors.

What do we offer?

While, broadly speaking, all chapters offer very similar services, the range and sophistication does vary according to the



Stability in a Changing World

El marco de ITIL consiste en una serie de libros que documentan las mejores prácticas de la industria en Gestión de Servicios IT

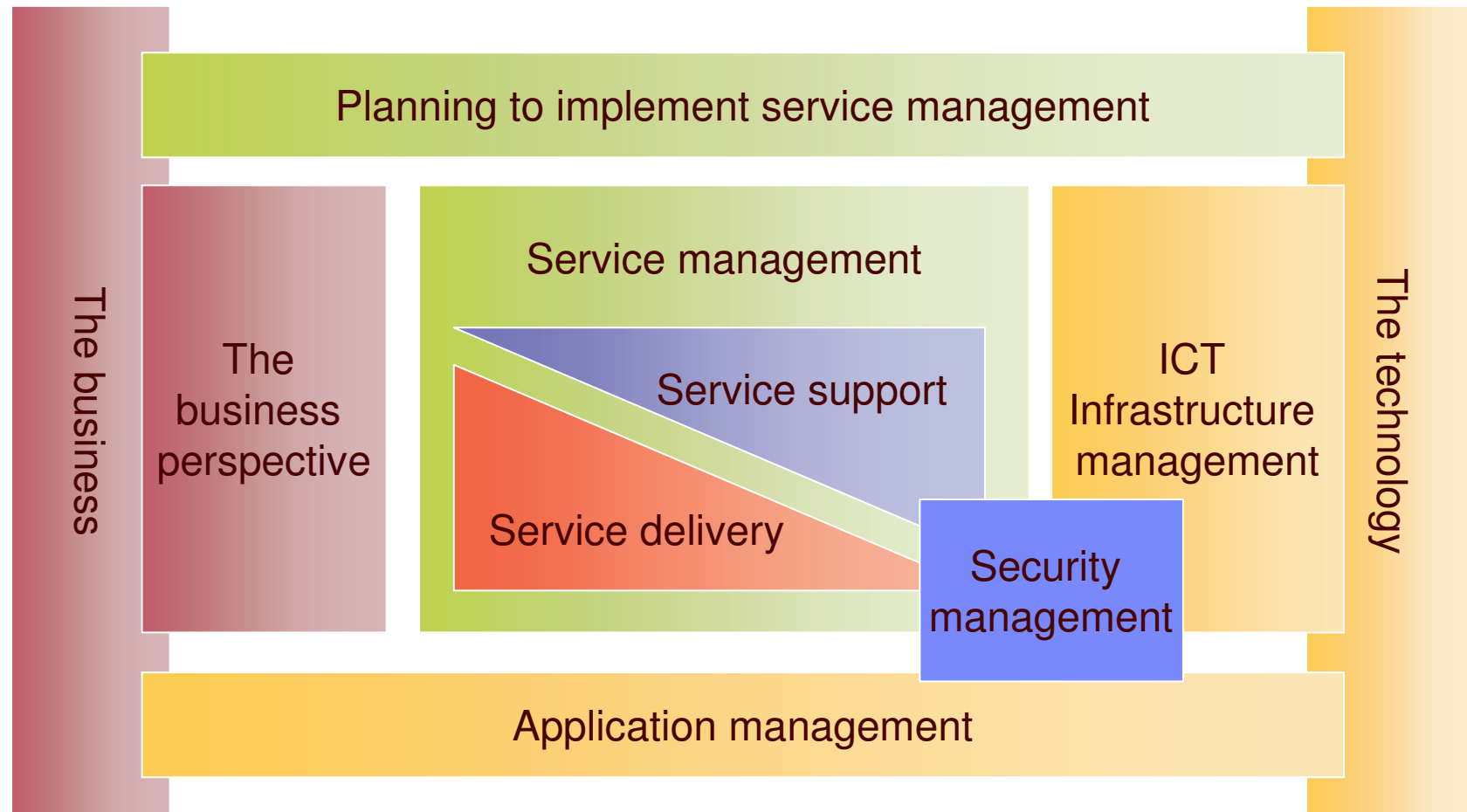

ITIL is a registered trademark of the OGC (the UK Government's Office of Government Commerce)

ITIL's Framework in Detail

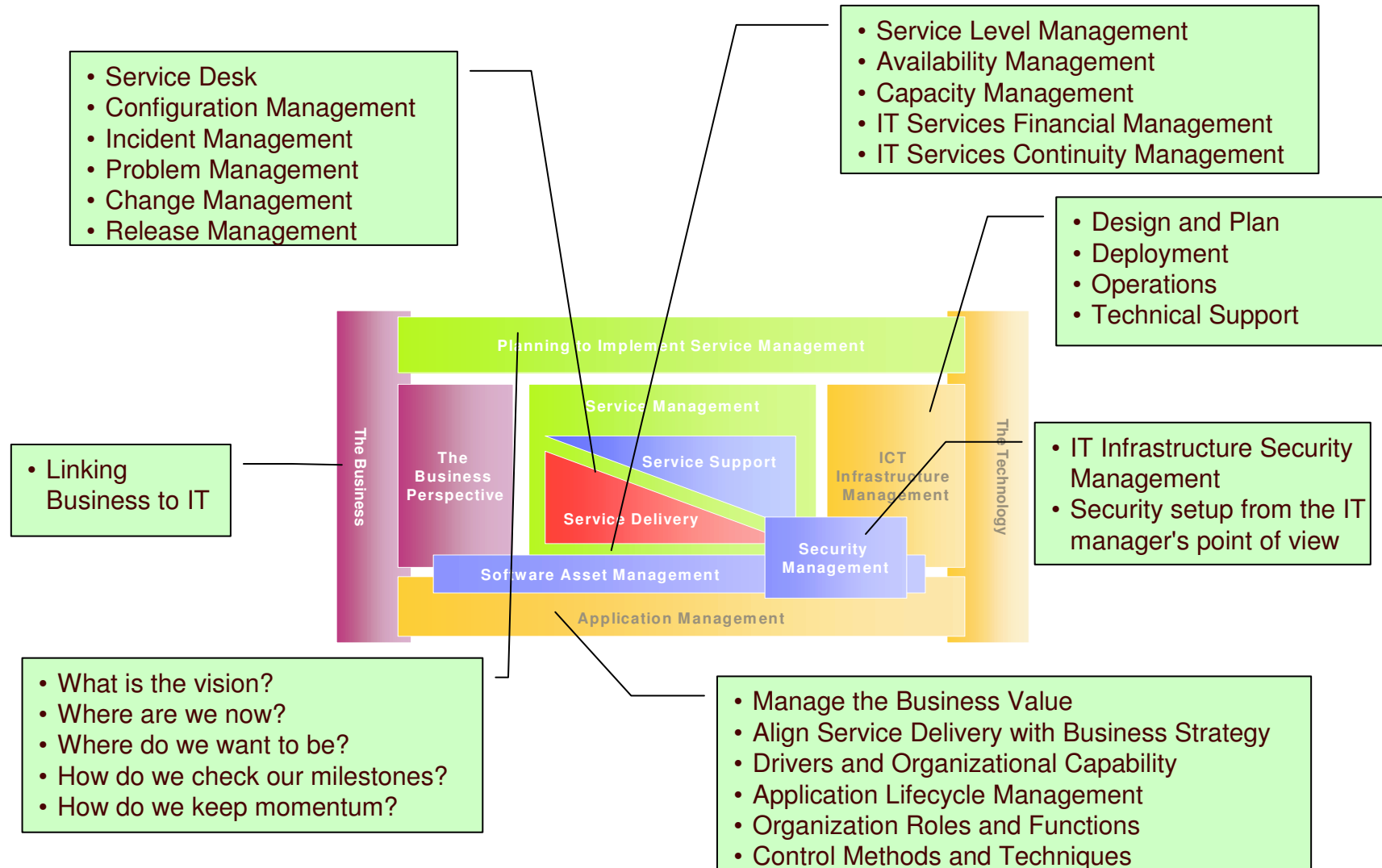

Implantación de best practices de IT Management (“Making ITIL Work”) requiere no solo conocimiento académico de las best practices o modelos

ITIL Design & implementation methods

What else do you need to

Service Management Implementation expertise

Integrated Process & Governance Models

ITIL Prioritizing & Diagnostic Techniques

ITIL Capability Maturity Model

Project management

Skilled & experienced IT management consultant

ITIL Tool Vendor Strategic Partnerships

ITIL is a registered trademark of the OGC (the UK Government's Office of Government Commerce)

Al final, el secreto de todas la implantaciones con éxito es la integración de organización, procesos, tecnología y datos

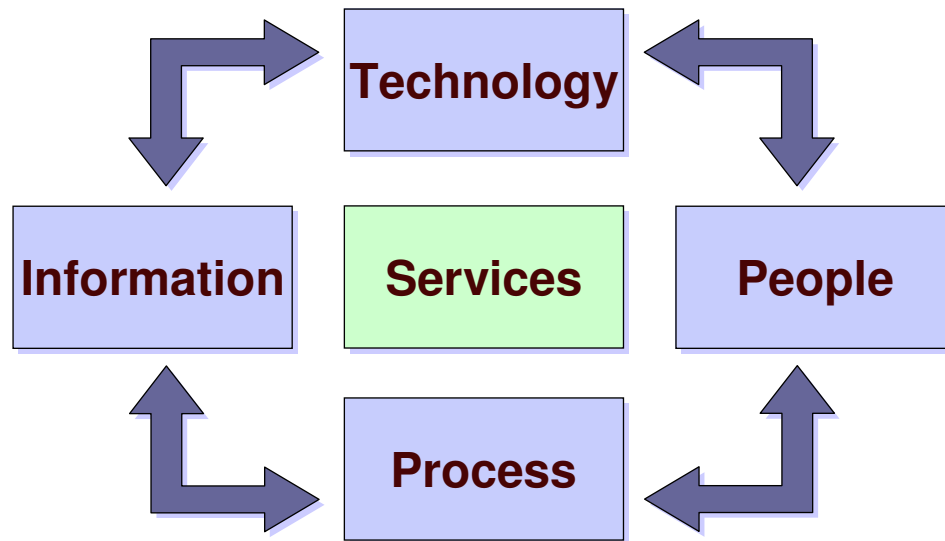

- Implantación planificada
- Acuerdo en objetivos realistas
- Planteamiento estructurado
- Confianza en las disciplinas de gestión de proyectos
- Compromiso a nivel ejecutivo

Gente bien gestionada, con la información correcta, ejecutando un proceso bien definido y soportado por tecnología adecuada, ofrecerán servicios de alta calidad al negocio que soportan





IBM Software Group

Relación de IBM con ITIL



@business on demand software

IBM proporciona servicios, asociados a implantación de ITIL, que van desde el diagnóstico, diseño e implantación, complementándose esta última con soluciones pre-empaquetadas que aceleran dicha implantación

■ Formación y certificación en ITIL

- Foundation
- Practitioners
- Service Manager

■ ITIL – Servicios de Consultoría

▶ *Servicios de Assessment*

- ITIL Self Assessment Workshops
- ITIL Process Maturity Matrices
- ITIL Assessments

▶ *Servicios de diseño*

- Estrategia de IT Management
- Definición del portfolio de Servicios
- Process Design
 - Diseño a alto nivel
 - Diseño detallado y desarrollo

■ ITIL Servicios de implantación

- Planificación e instalación de productos
- Desarrollo de código adaptado
- Adaptación de formularios y paneles
- Carga de datos
- Formación en productos

- ▶ IBM es partner con un número de vendedores cuyas herramientas/productos han sido validados por terceros y han sido valorados de forma que se ajustan al framework de ITIL

Tivoli software

Peregrine SYSTEMS

Remedy
a BMC Software company

■ ITIL Packaged Solutions

- IRM Accelerator (Full)
- IRM Accelerator for SMB



Peregrine SYSTEMS

Remedy
a BMC Software company

How ITIL Fits Within Tivoli and IBM

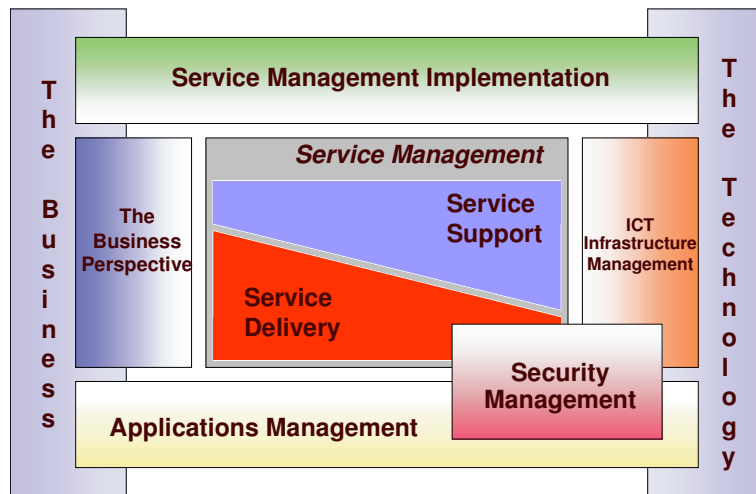

enables

Tivoli

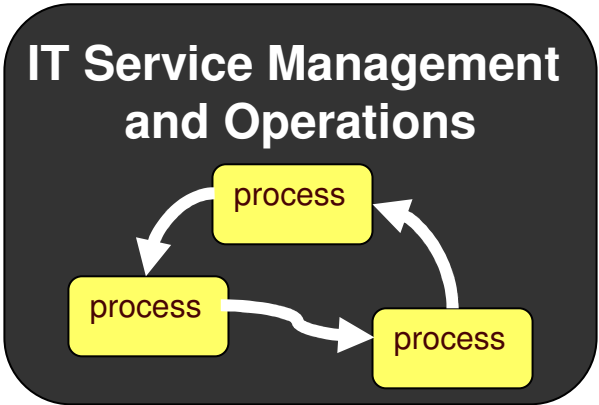

Autonomic computing

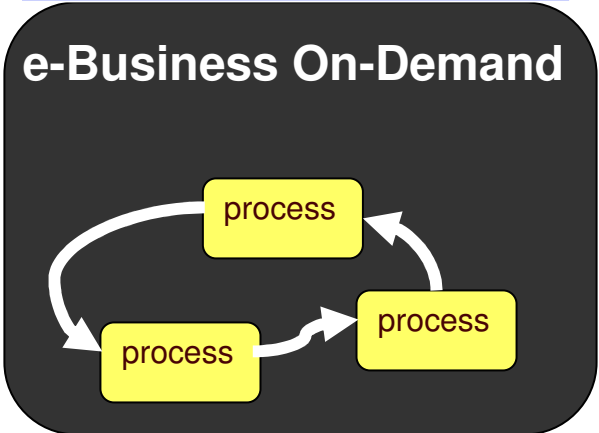

Workflow Models Using WBI Modeler

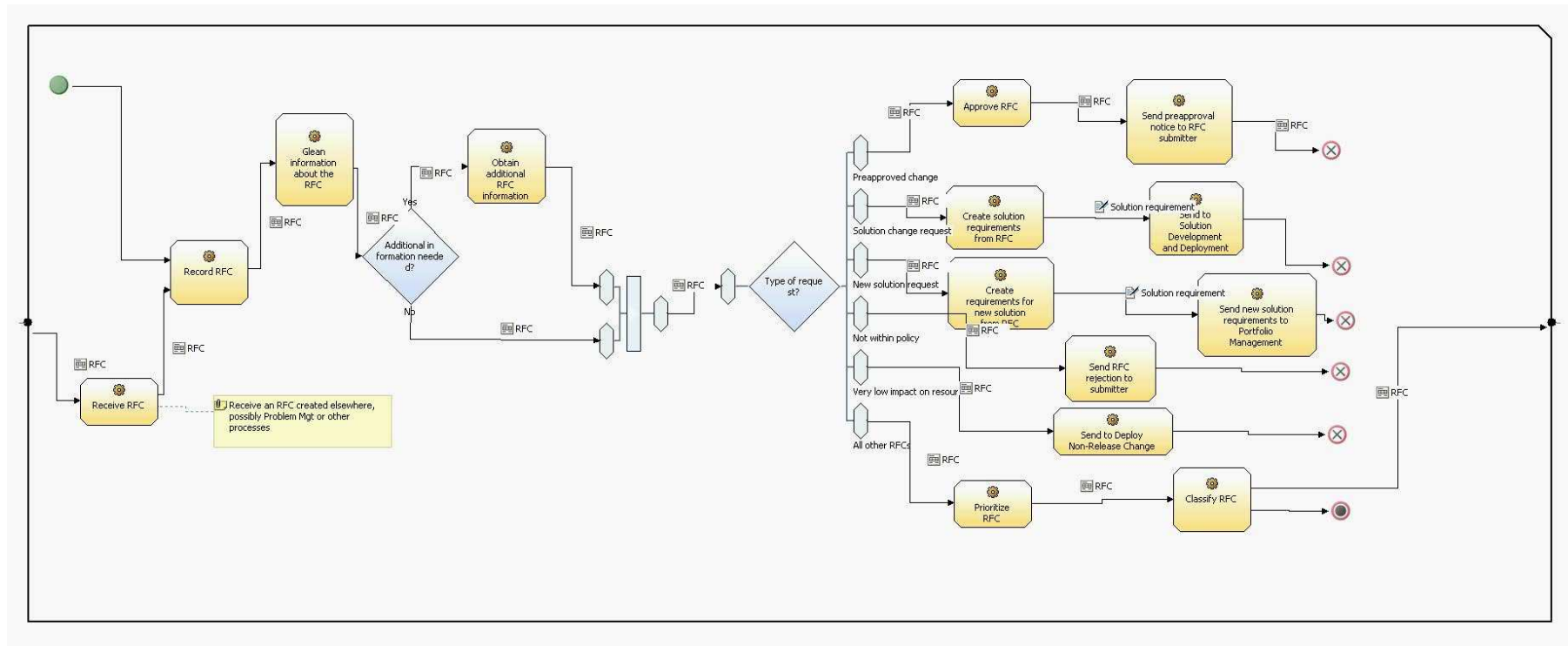

Process Reference Guide

File Edit View Go Bookmarks Tools Help

file:///c:/jlong/Projects/ITUP/itup%20site/Change%20Mgt/Assess%20Char

Search the web with L... Home Personal Toolbar Folder IBM

IT Unified Process

Getting Started Search Glossary Index Print Feedback

Overview
Processes
Roles
Workproducts
References
Additional resources

Assess Change

```

graph LR
    RFC1[RFC] --> A[Determine appropriate change mode for RFC]
    A -- RFC --> B[Schedule change assessment meeting]
    B -- RFC --> C[Collect change assessment data]
    B -- RFC --> D[Obtain change assessment from CAB]
    C -- RFC --> E[Perform change assessment]
    D -- RFC --> E
    E -- RFC --> F[Output RFC]
  
```

Description

The steps involved in this activity are the following:

1. The Change Manager schedules the RFC to be considered for approval. The approval will be according to the priority and categorization of the RFC, since different approval procedures may be used according to priority and category.

Done

IBM Tivoli's Strategy

1

Continue investing in a broad and deep set of IT infrastructure management products that automate IT tasks

2

Invest in a platform that enables the automation and integration of IT processes

3

Deliver a new set of process automation products based on best practices – that leverage a customer's existing investment in IBM Tivoli Software products

IBM Tivoli's Portfolio Linked To Processes

Existing Product Portfolio

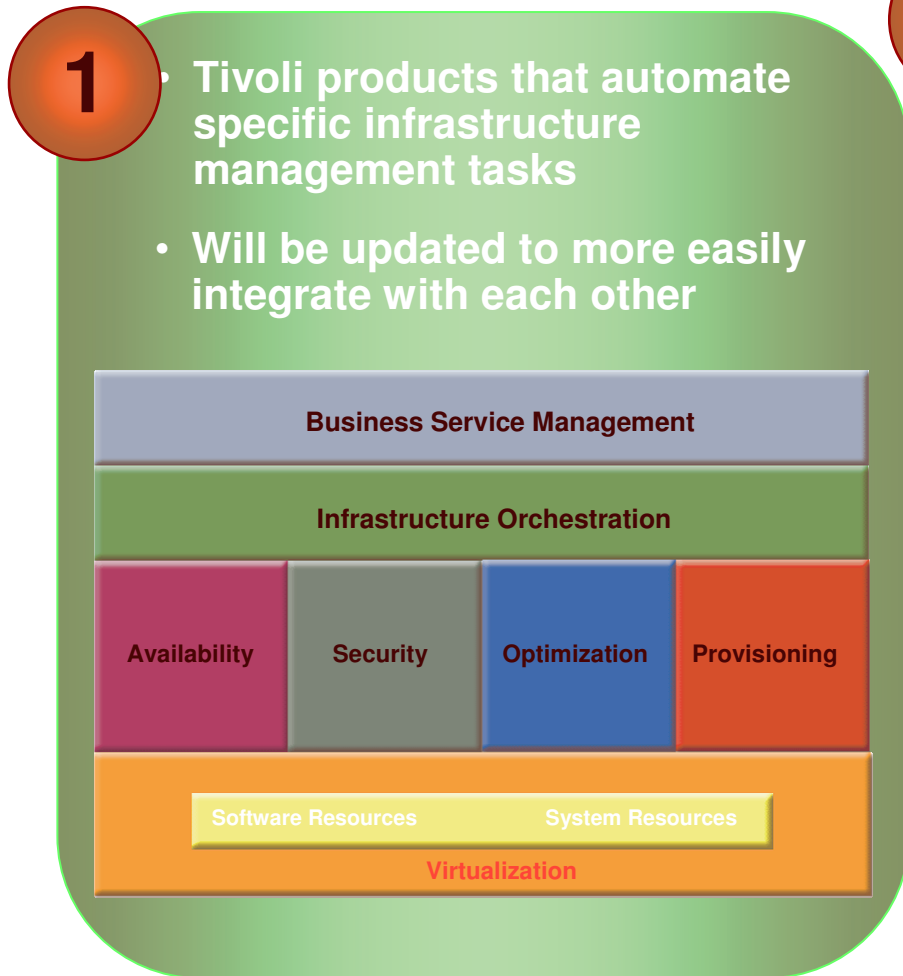

Additional Products

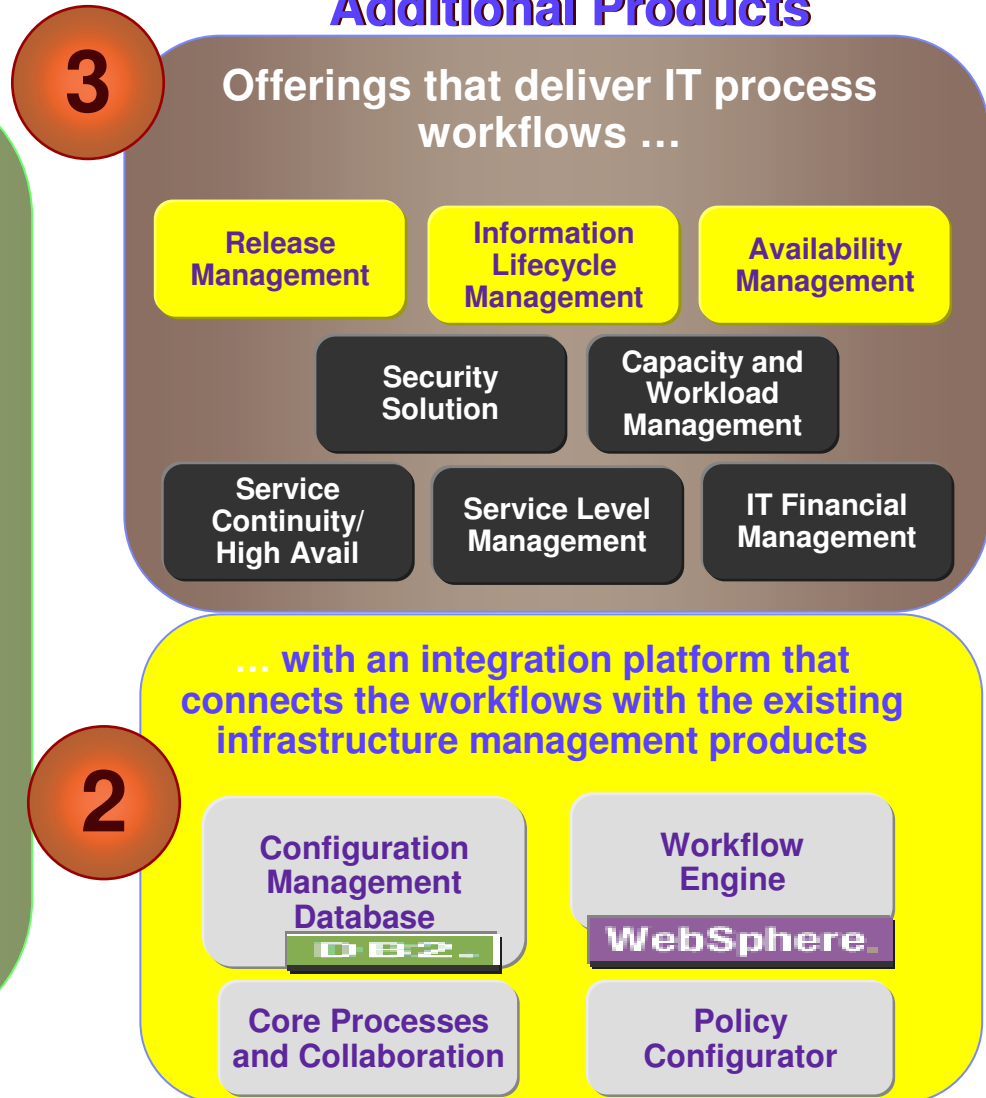

Leveraging IBM's On Demand Structure

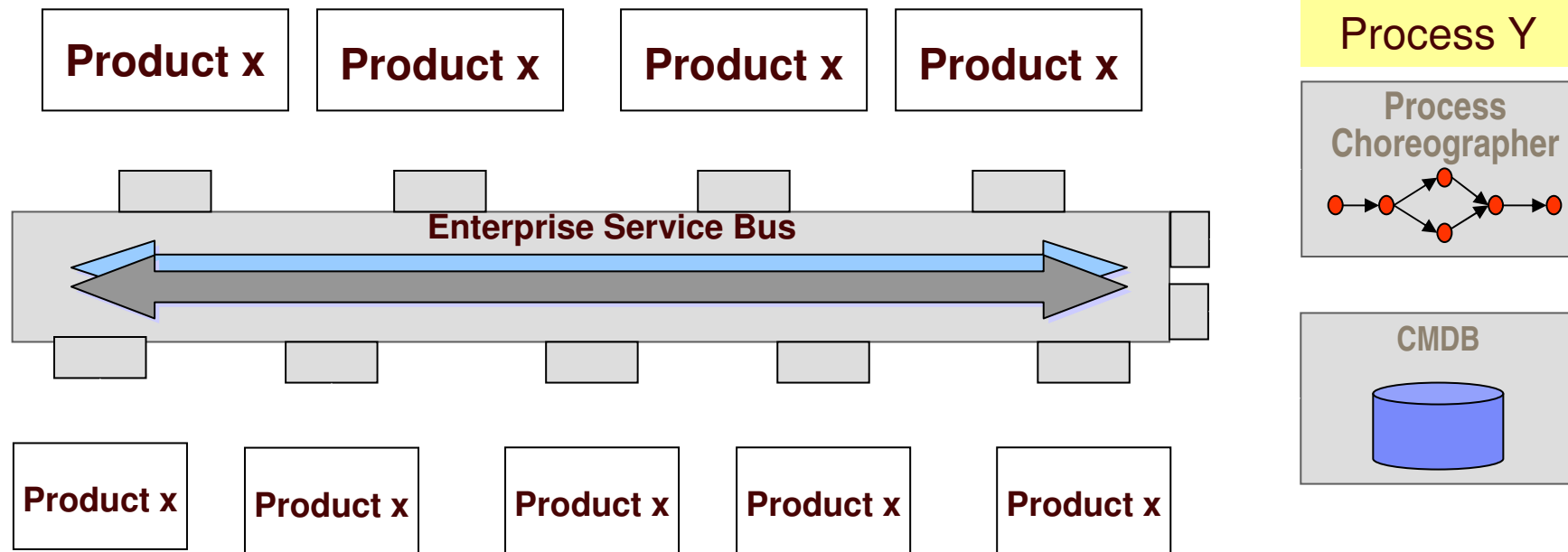

- A process automation offering makes a customer IT process more efficient and effective, and consists of:
 - A set of 2 or more products
 - Workflows running on WebSphere Process Choreographer
 - Linkages to a CMDB

Un Ecosistema abierto al resto de Proveedores

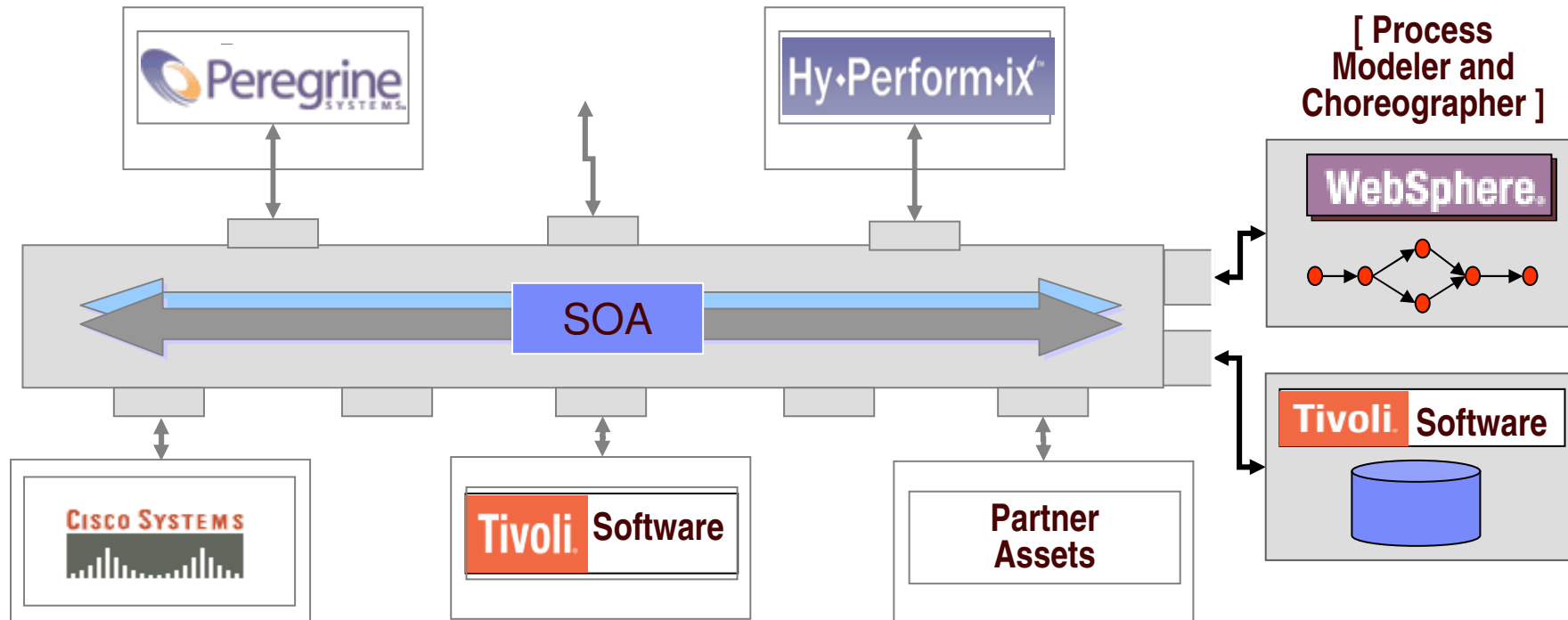

- Los Procesos se integrarán para todos los vendedores de herramientas
- Los Datos se integrarán y gestionarán a través de CCMDB
- La Automatización de Procesos se extiende a través de los límites anteriores
- Open Process Automation Library (OPAL)

The Future Of IBM IT Service Management

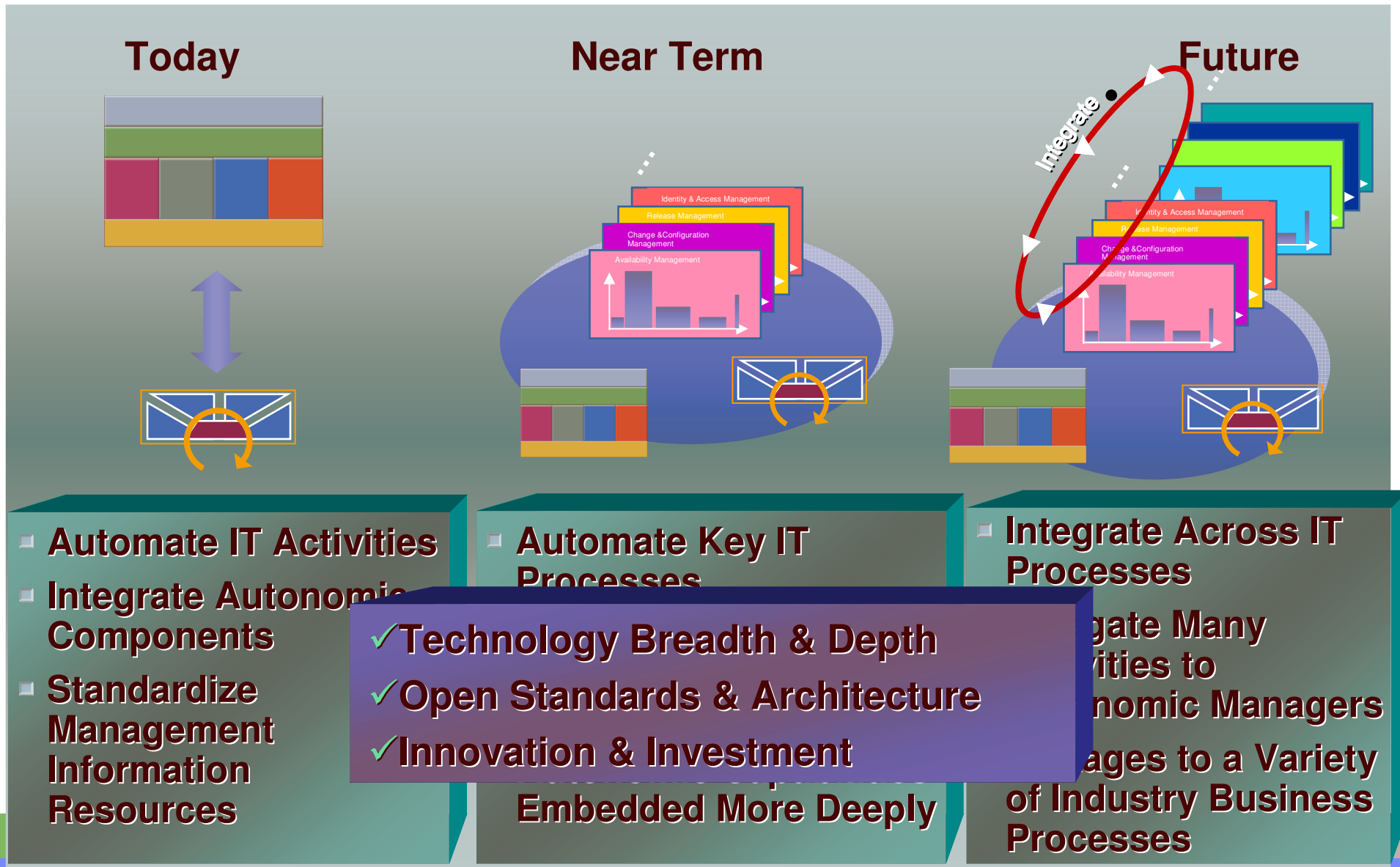

GRACIAS