

Requirements Discipline

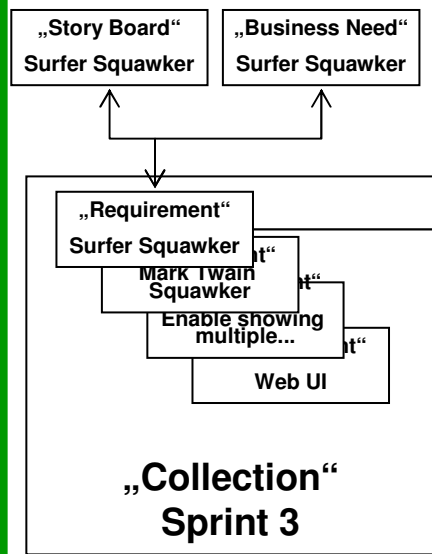

Development Discipline

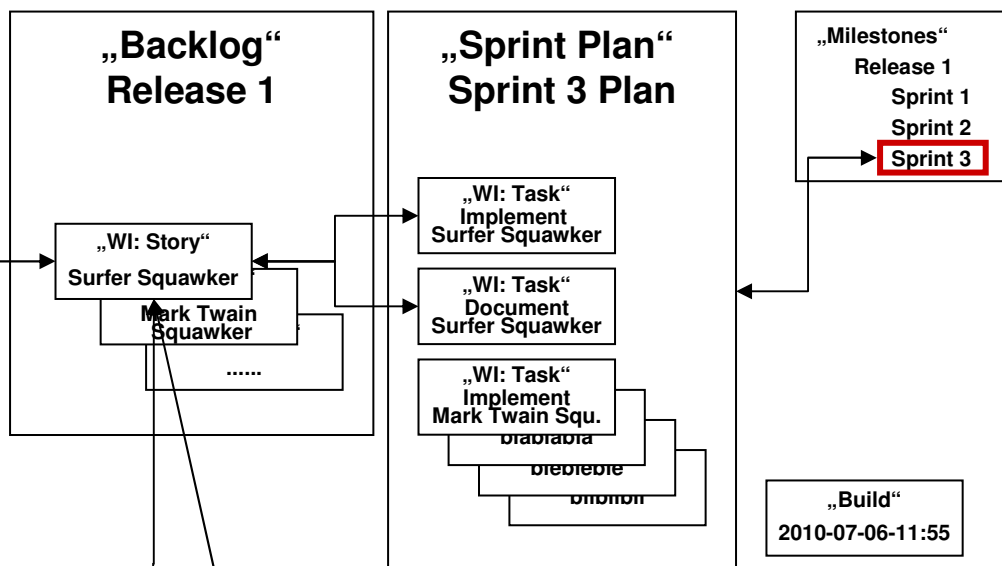

„WI Defect“
2010-07-06-11:55

Testing Discipline

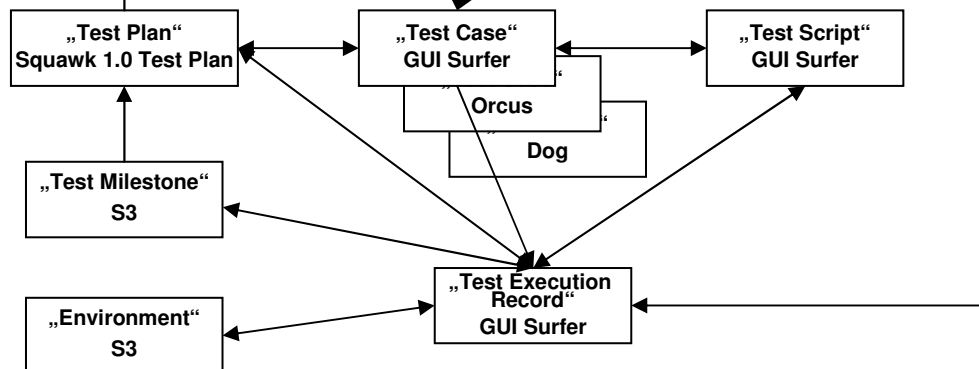

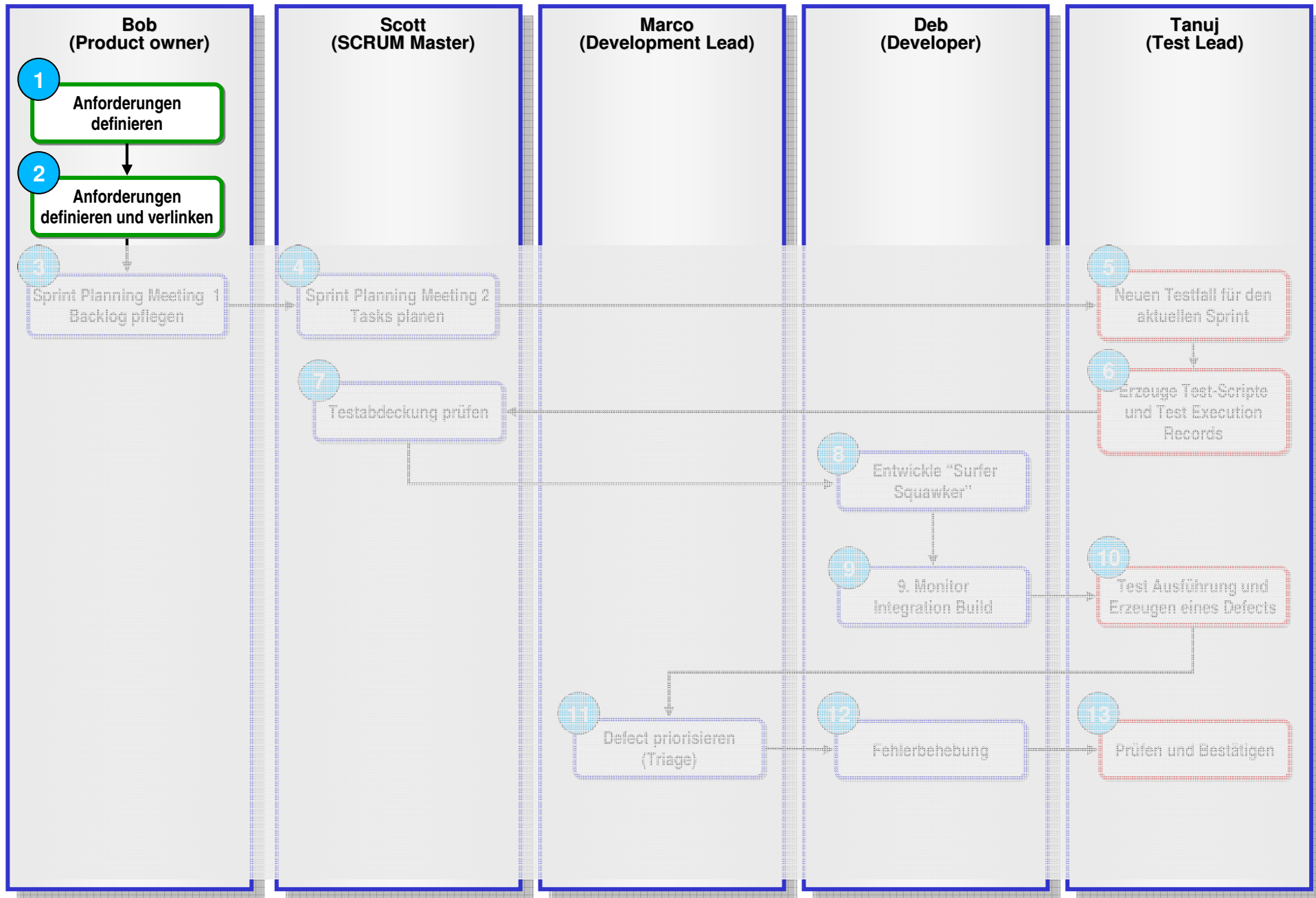

Rational Requirements Composer

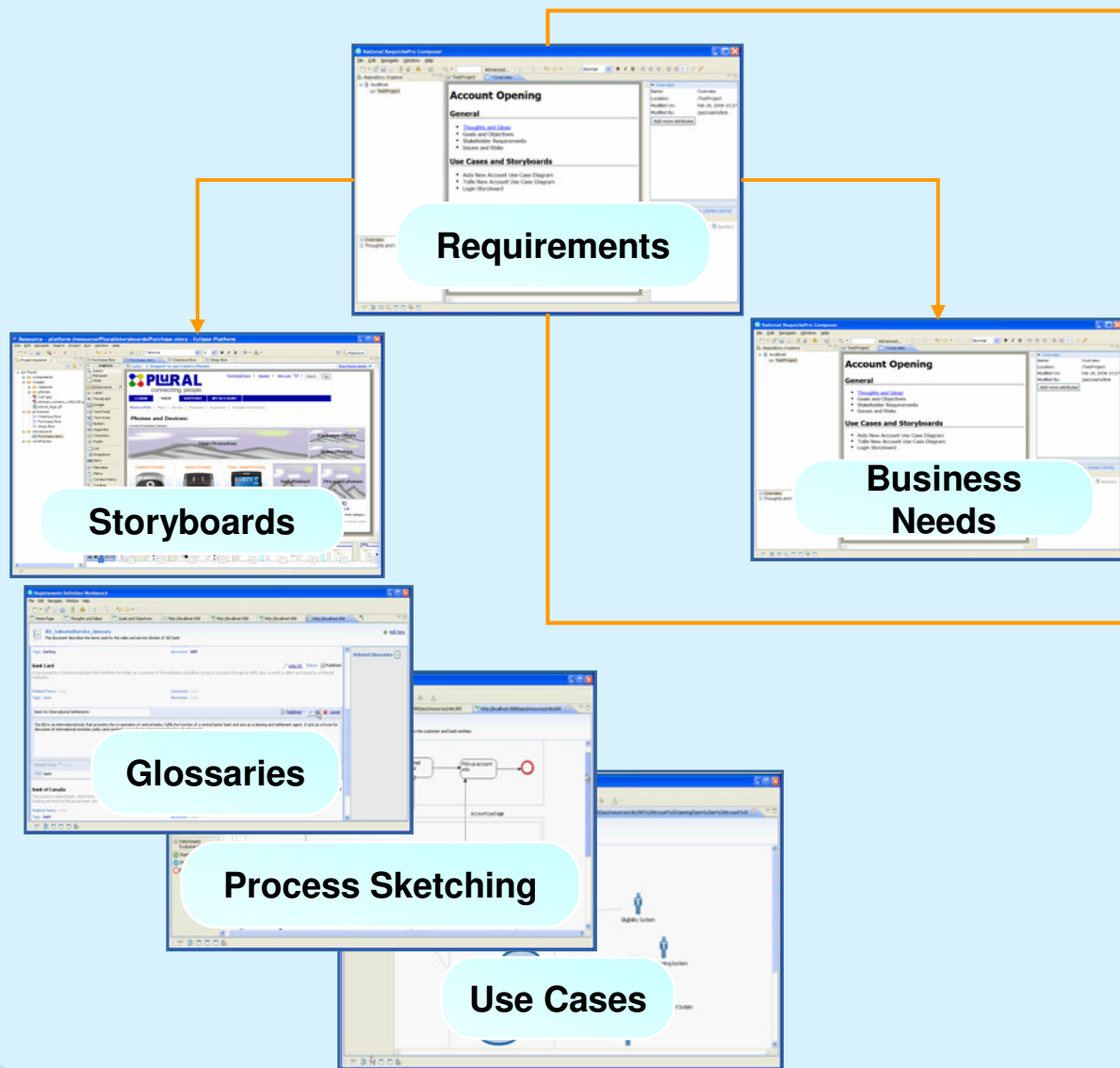

RTC Backlog

Story

RQM Testplan

Testfall

Demo Schritte 1 und 2

Requirements Discipline

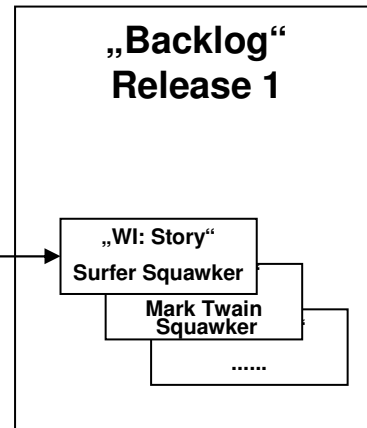
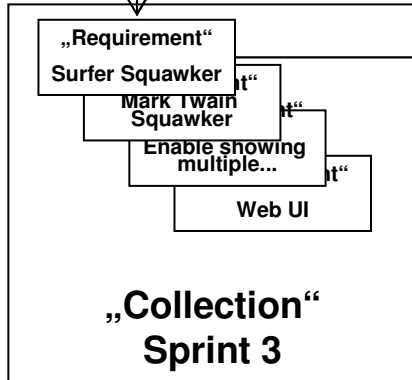
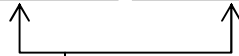
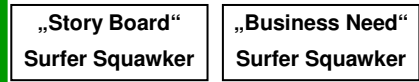

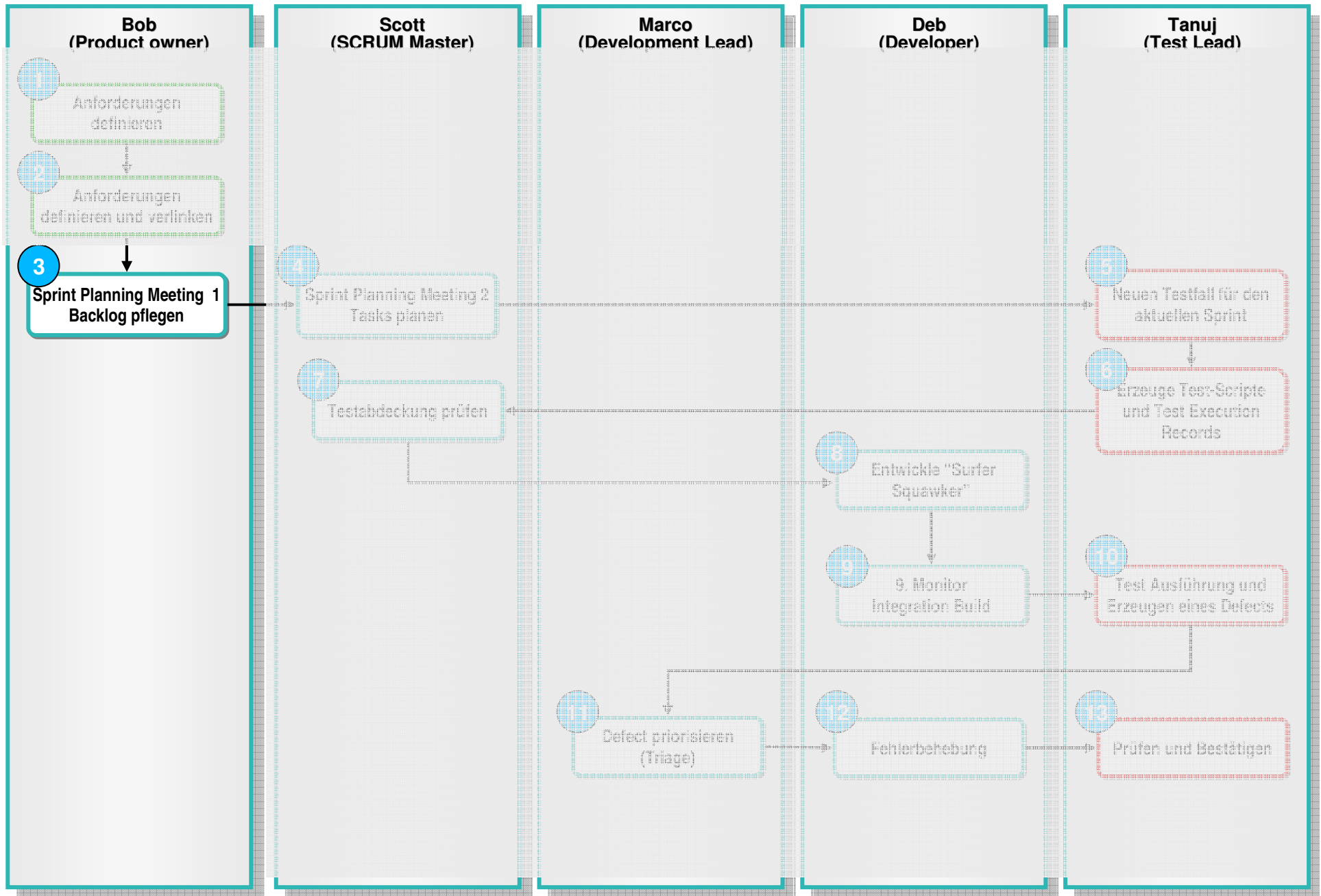

Plan- und Execution-Items

- RTC erlaubt Konfiguration von u.a.:

- ▶ Work Items
- ▶ Workflows

- Work-Items haben zwei Grundtypen:

- ▶ Execution-Item (Tasks)
Maßzahlen: Arbeitsaufwand (Tage, Stunden)
- ▶ Plan-Item: (Stories)
Maßzahl: Komplexität (Story Points)

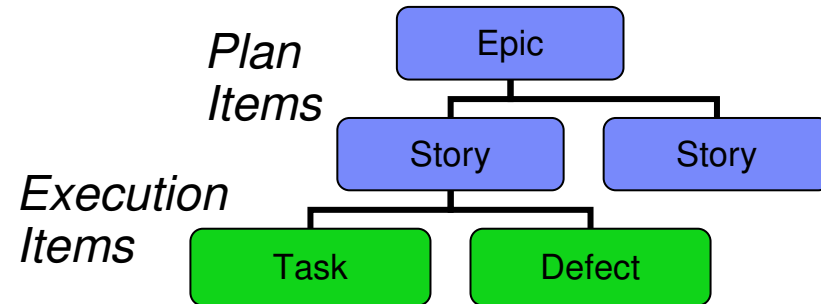

The screenshot shows the **Configuration** tool interface. On the left, a tree view lists various configuration categories. The **Top-Level Work Item Type** option is highlighted with a red box. On the right, the **Top-Level Work Item Types** panel is visible, showing a list of item types with checkboxes. The **Epic** and **Story** items are checked, while others are unchecked.

| Top-Level Work Item Types |
|---|
| <input type="checkbox"/> Adoption Item |
| <input type="checkbox"/> Defect |
| <input checked="" type="checkbox"/> Epic |
| <input type="checkbox"/> Impediment |
| <input type="checkbox"/> Retrospective |
| <input checked="" type="checkbox"/> Story |
| <input type="checkbox"/> Task |
| <input type="checkbox"/> Track Build Item |

Demo Schritte 3

Requirements Discipline

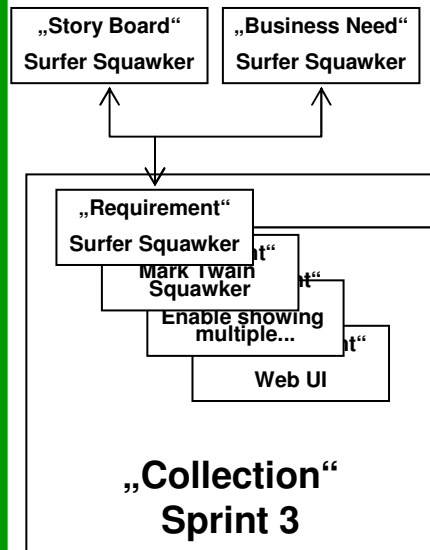

Development Discipline

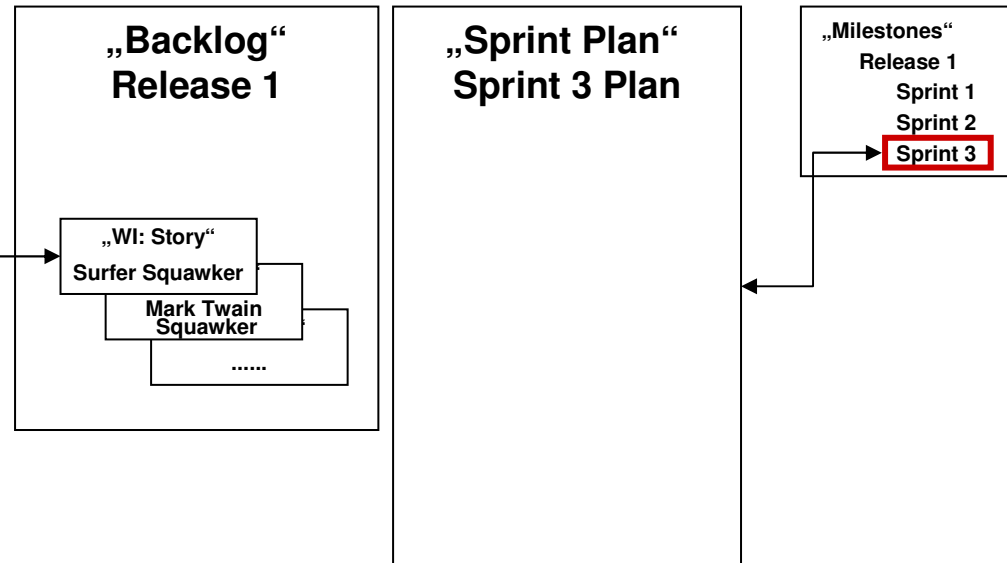

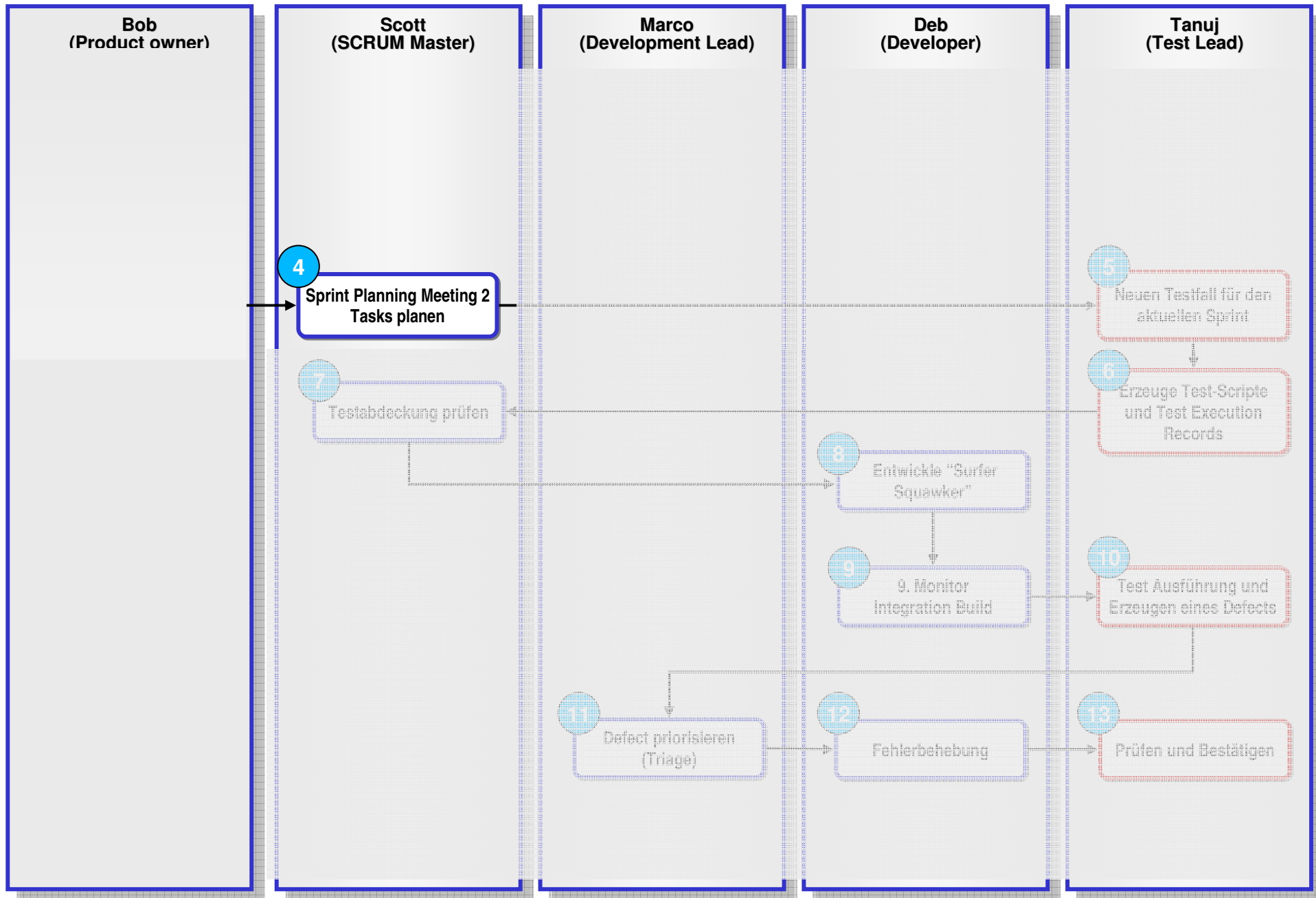

Plan-Typen

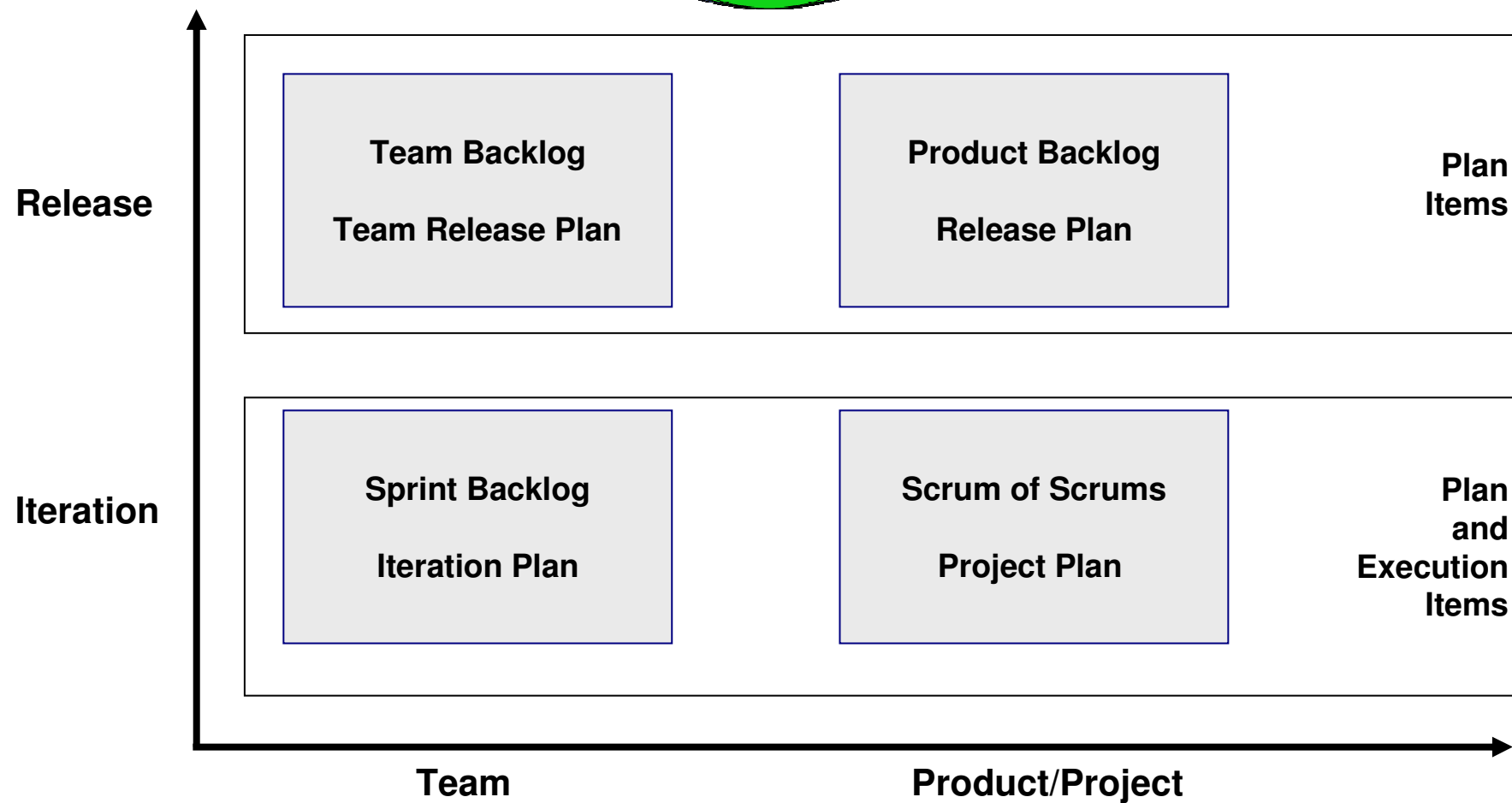
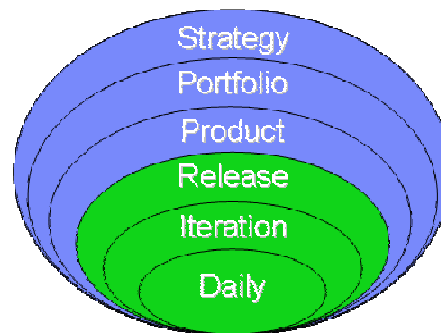



Demo Schritte

4

Requirements Discipline

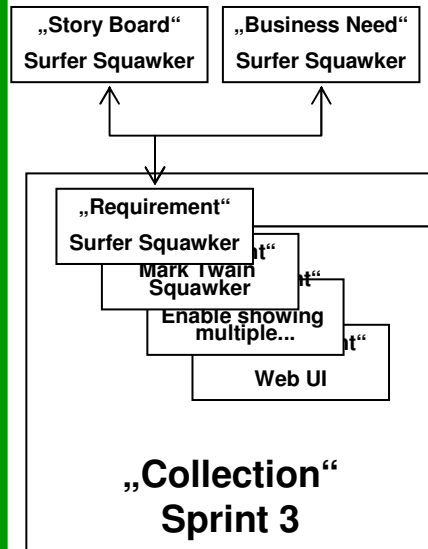

Development Discipline

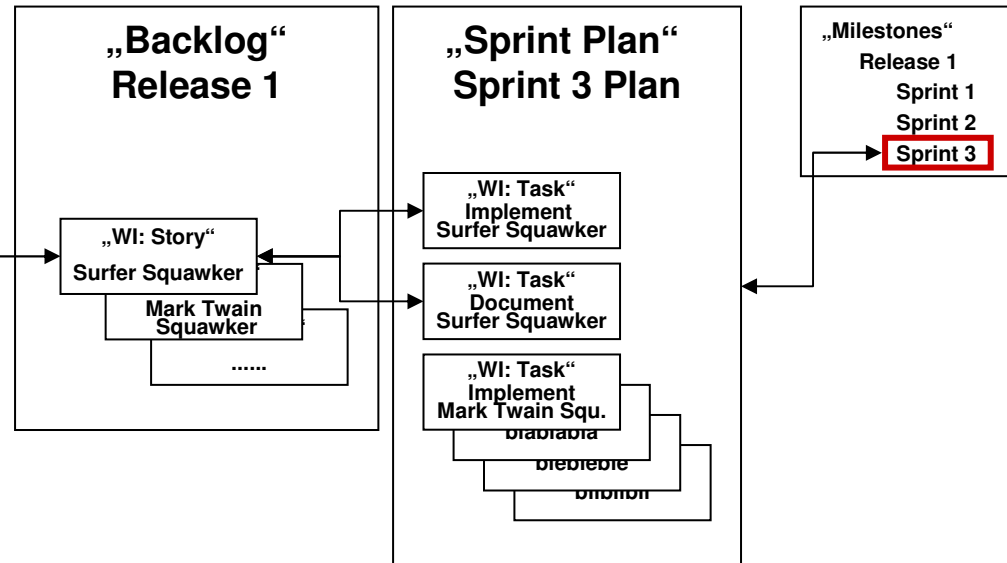

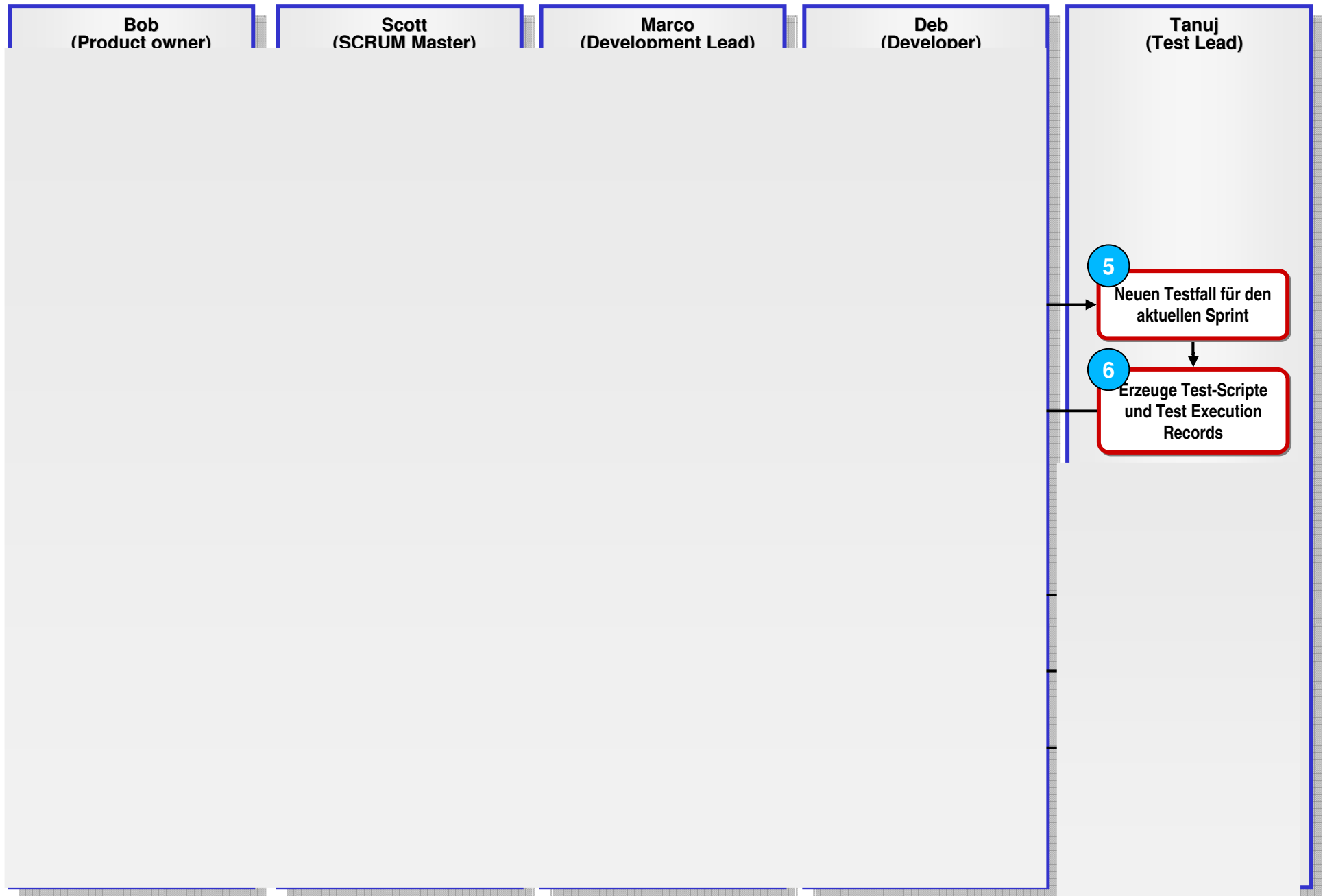

RQM Details

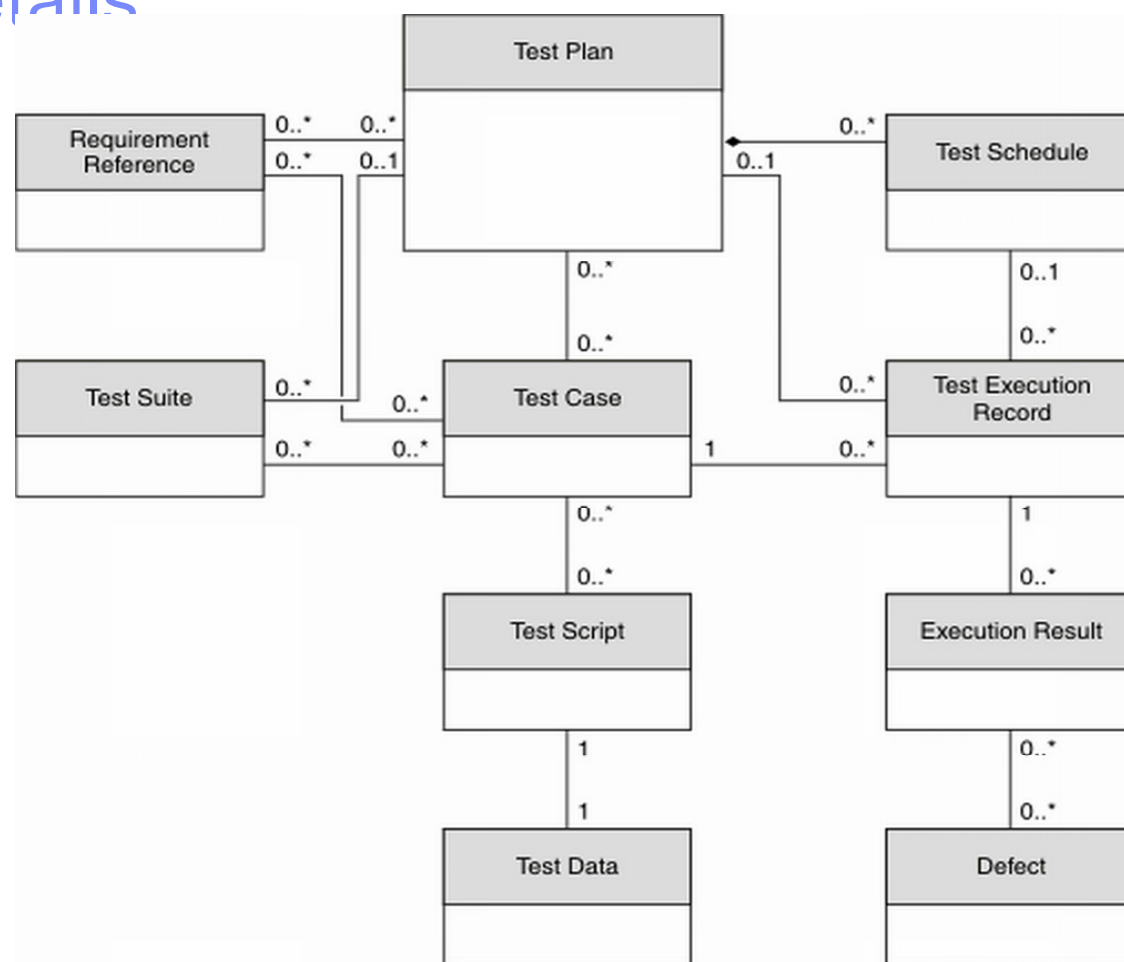
**Legend**

- 0..* Zero or more instances
- 1 Exactly one instance
- 0..1 No instances, or one instance (optional, may)
- ◄ Composition relationship



Demo Schritte 5 und 6

Requirements Discipline

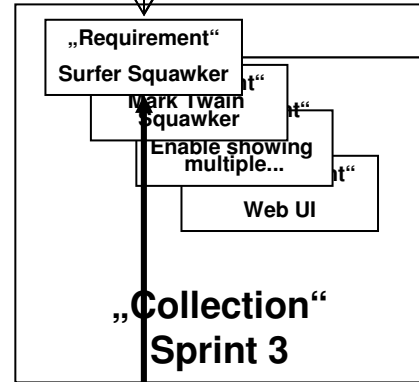
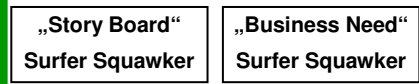

Development Discipline

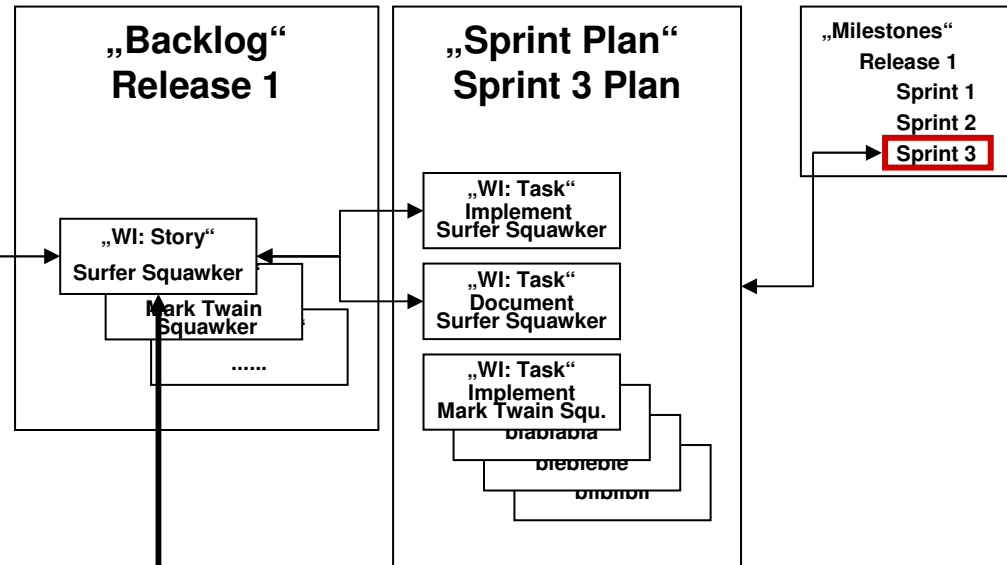

Testing Discipline

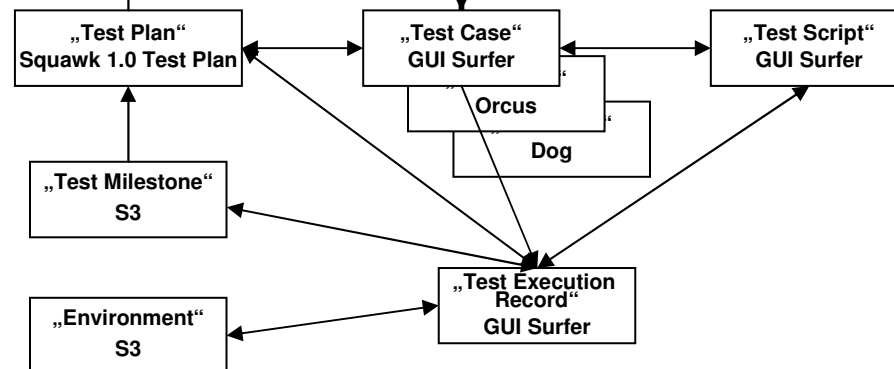

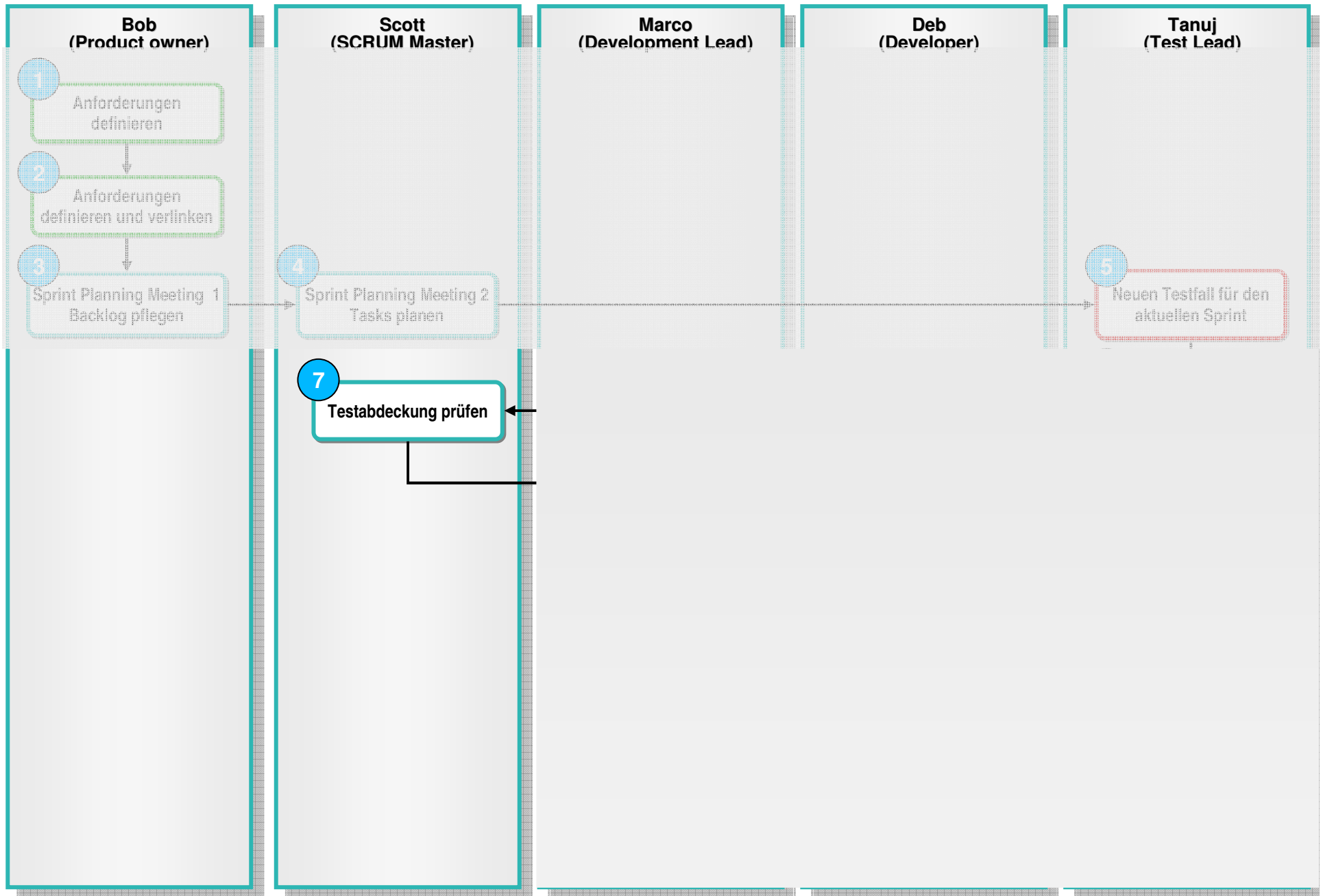

Demo Schritte 7

Requirements Discipline

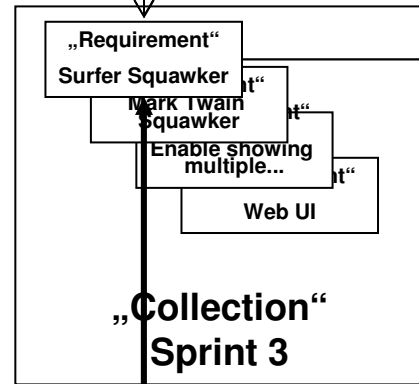
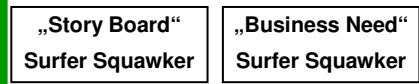

Development Discipline

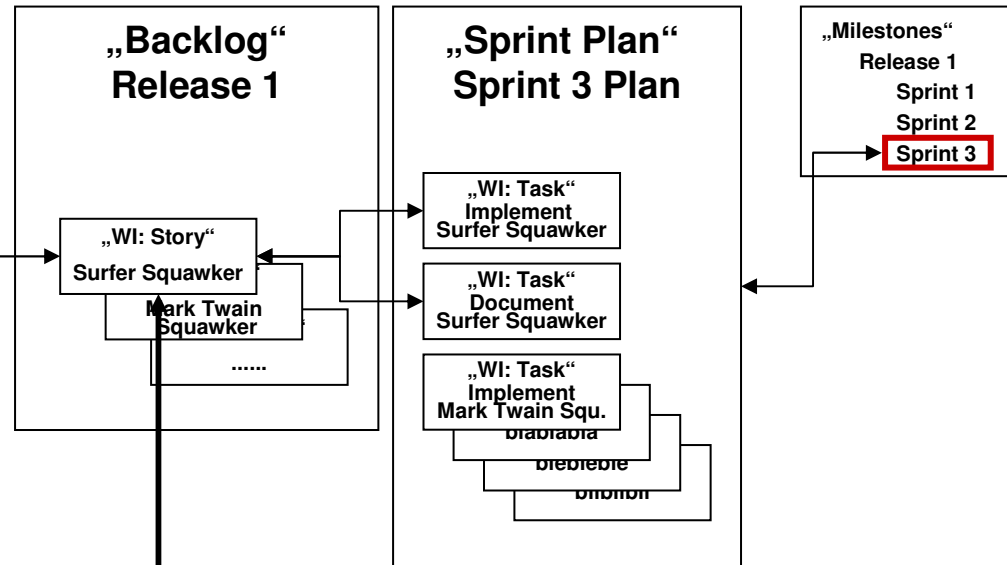

Testing Discipline

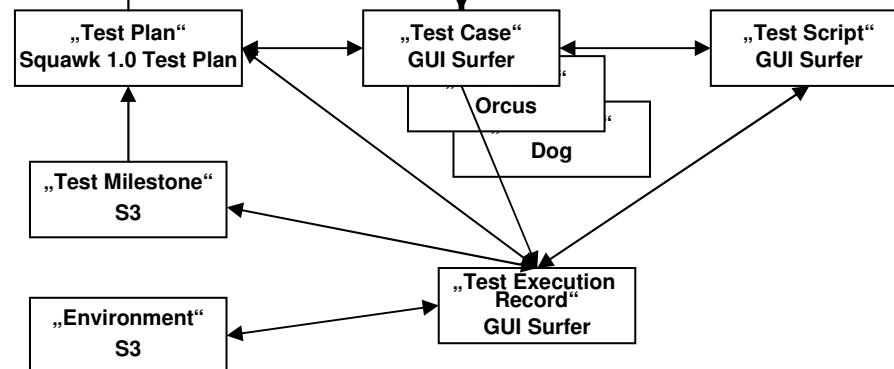

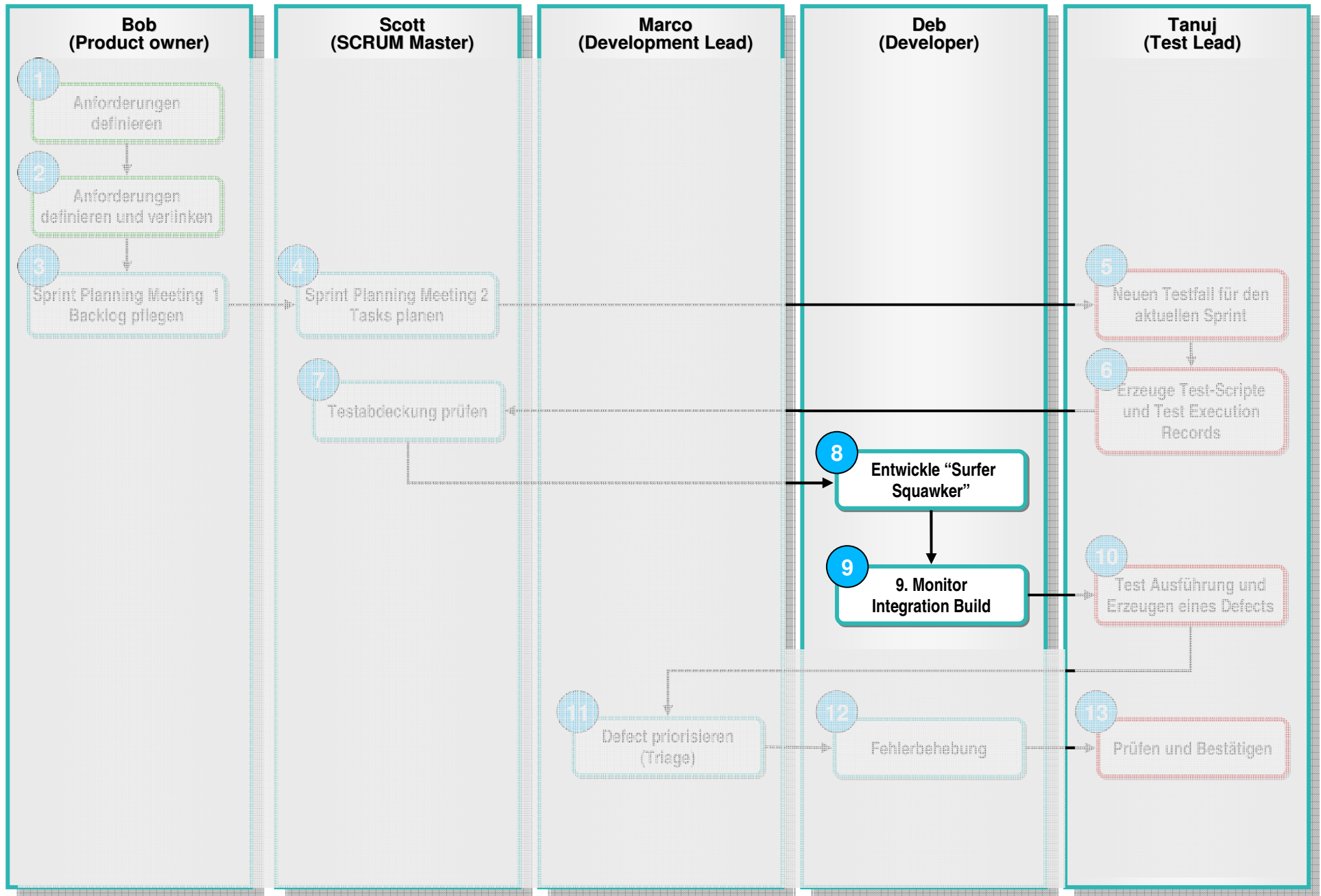

Konfigurationsmanagement im RTC

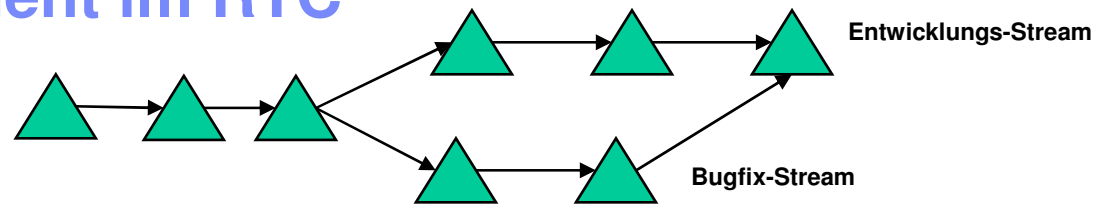

- **Workspace**
- **Change set**
- **Component**
- **Stream**

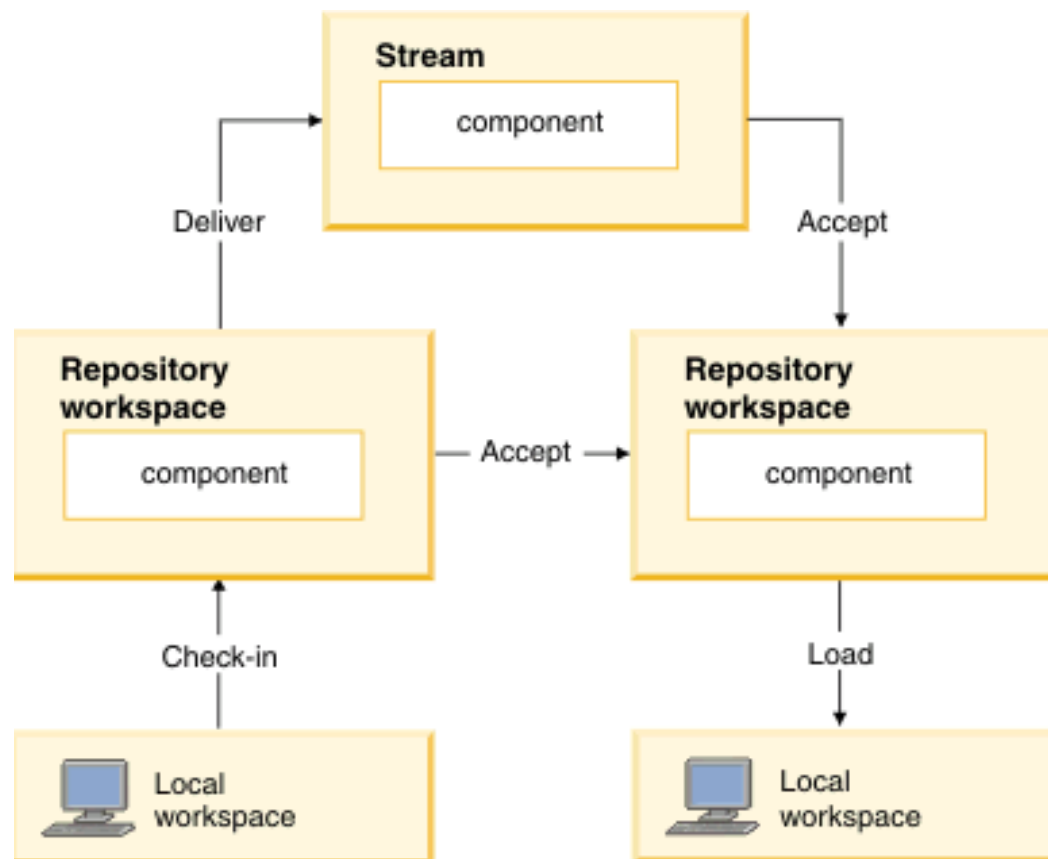

Build Management

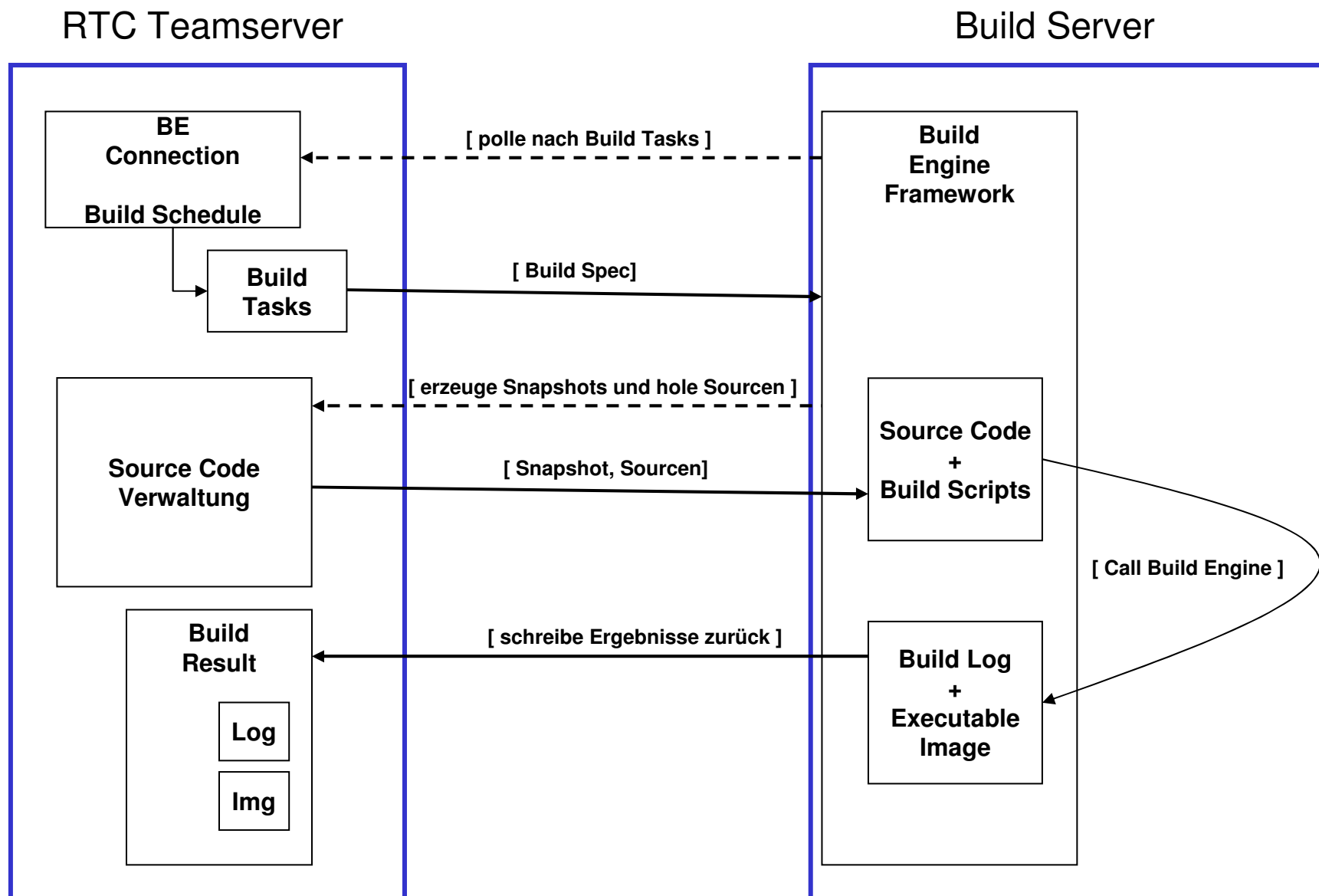



Demo Schritte 8 und 9

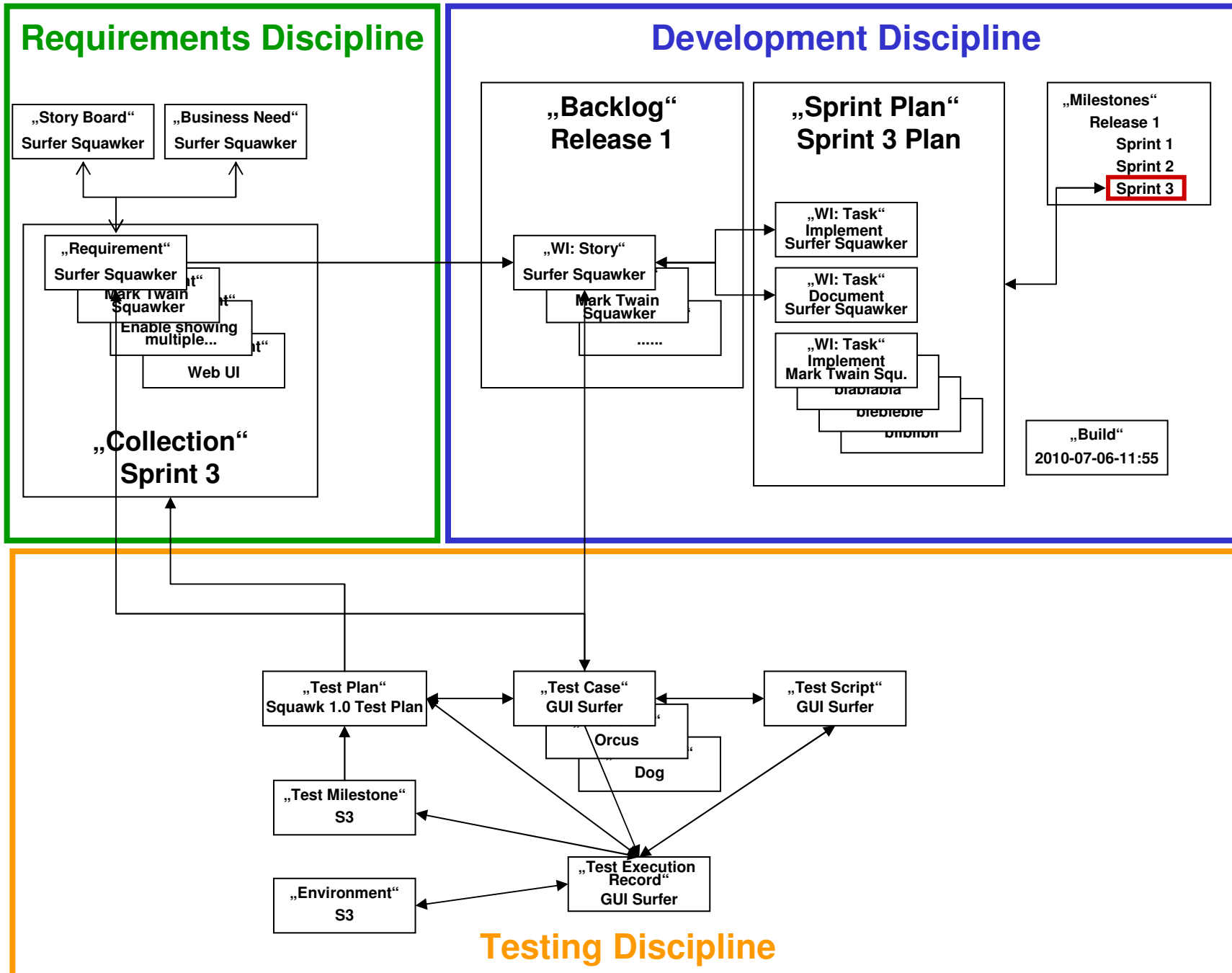

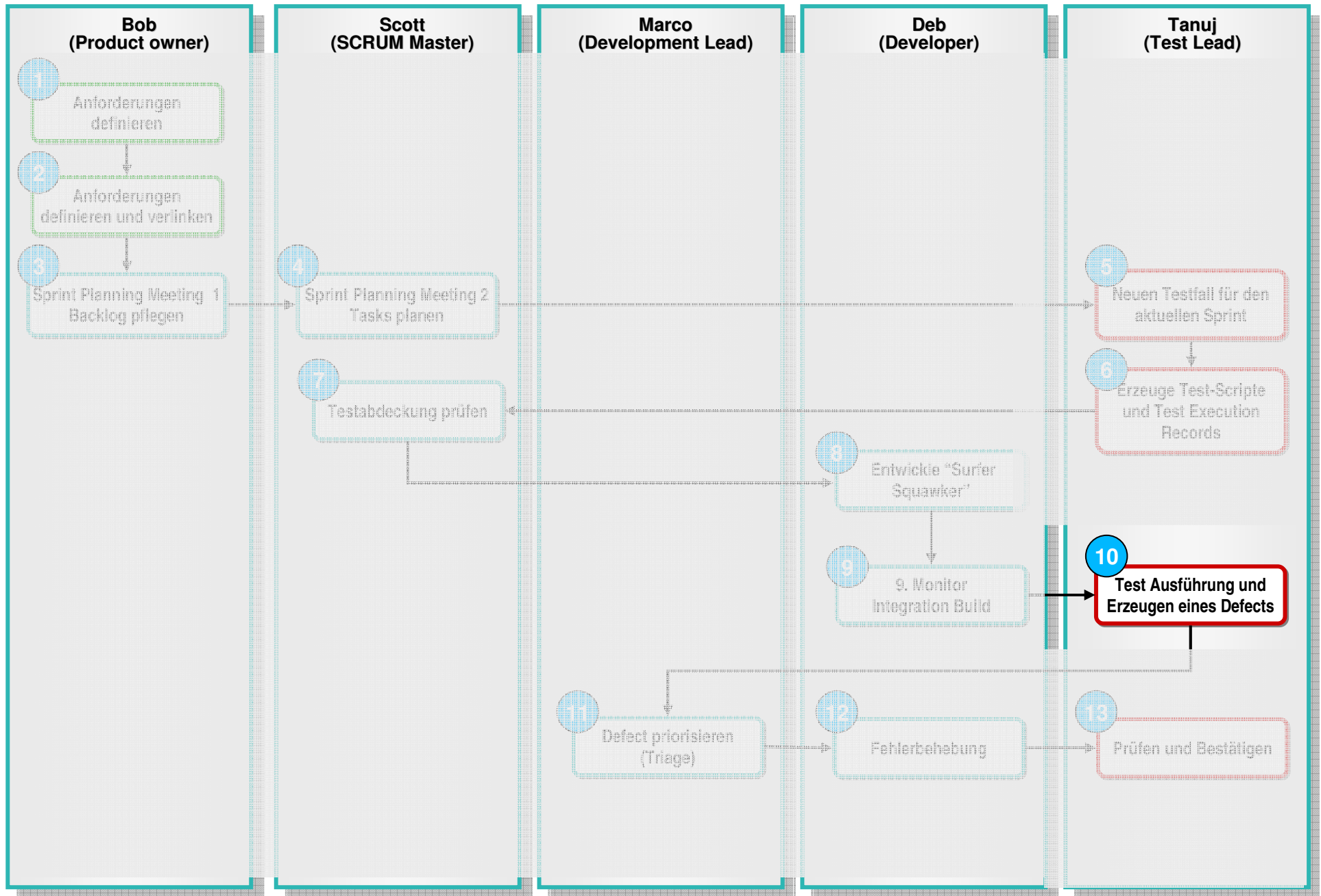

Demo Schritt 10

Requirements Discipline

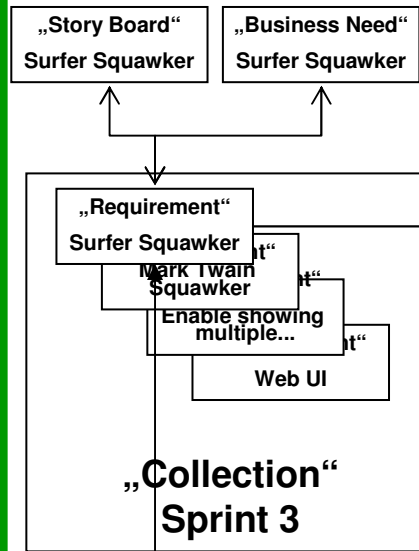

Development Discipline

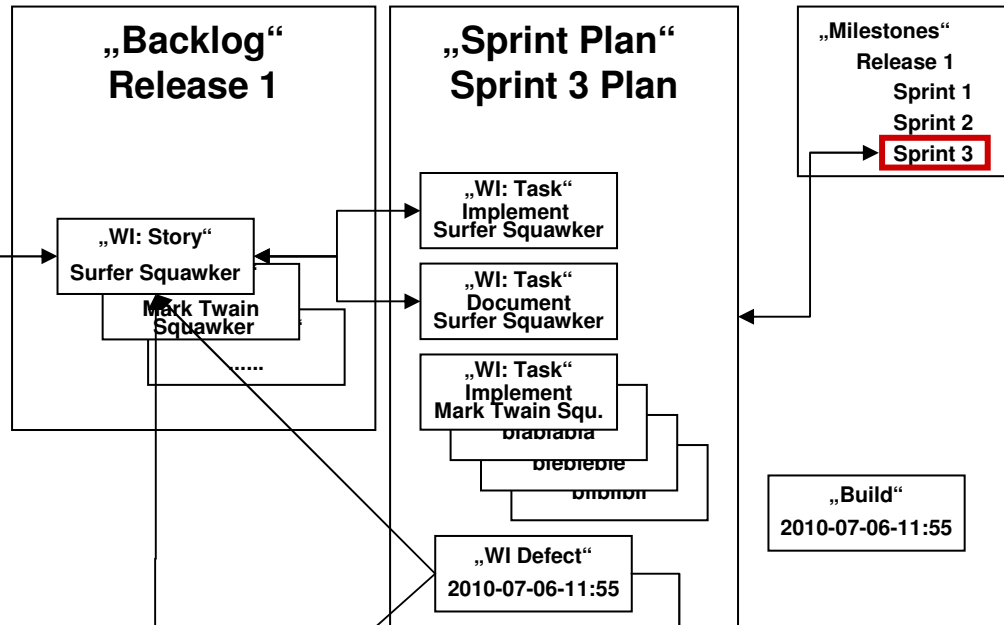

Testing Discipline

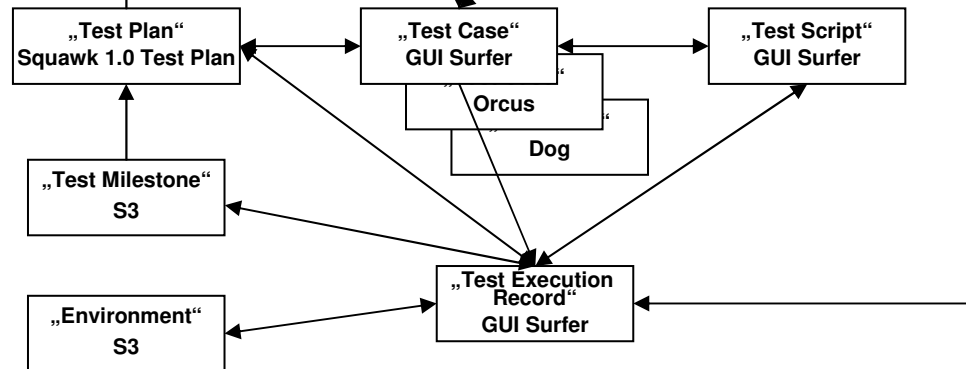

Demo Schritte 11, 12 und 13

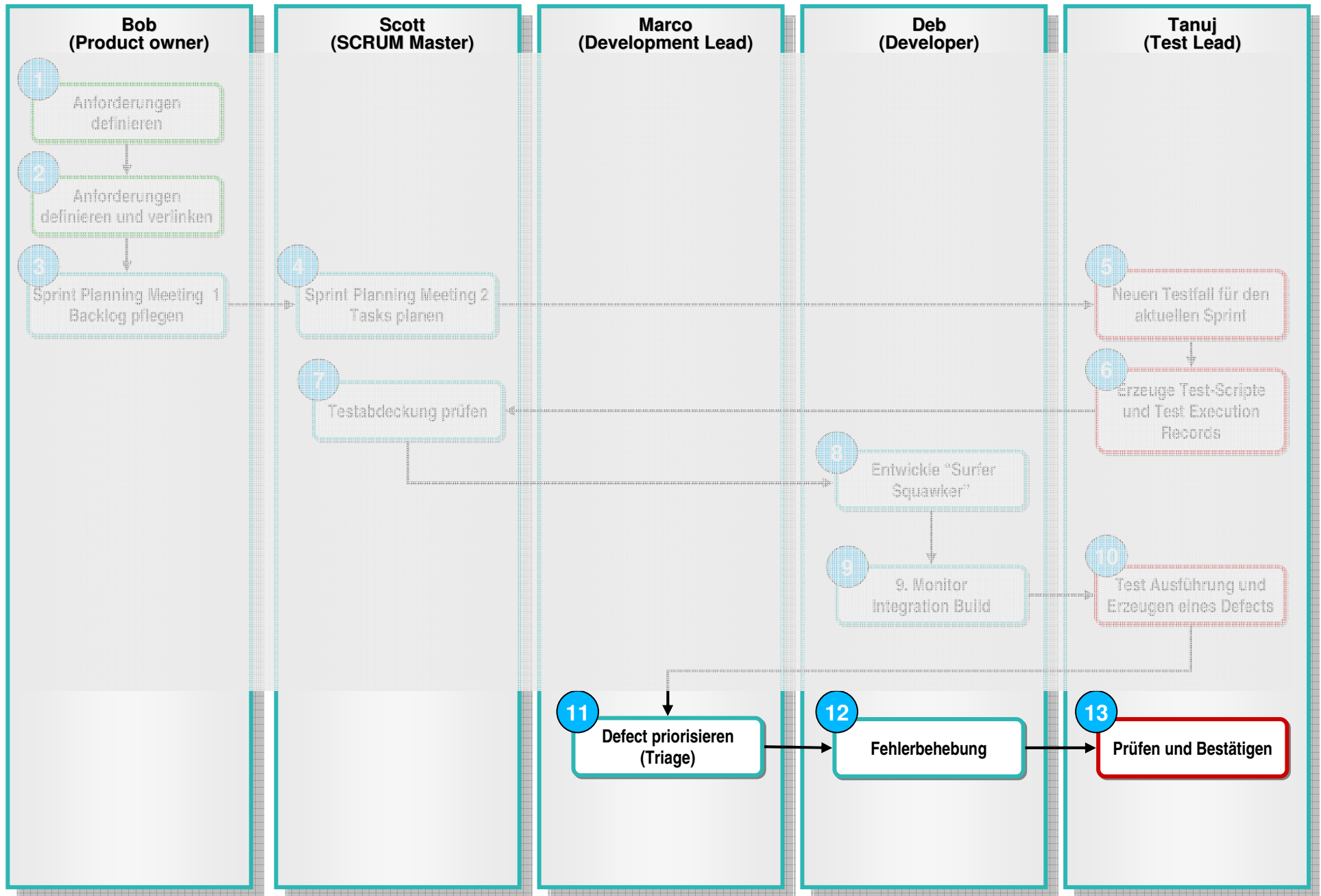

Requirements Discipline

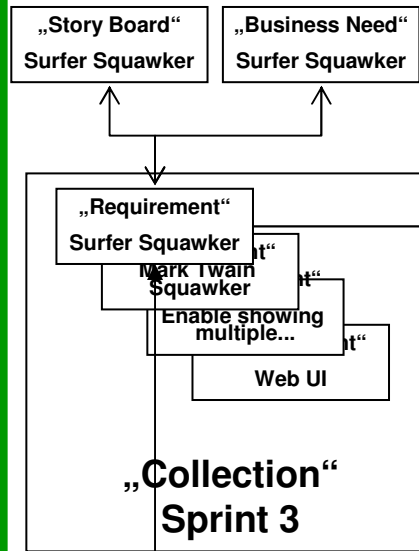

Development Discipline

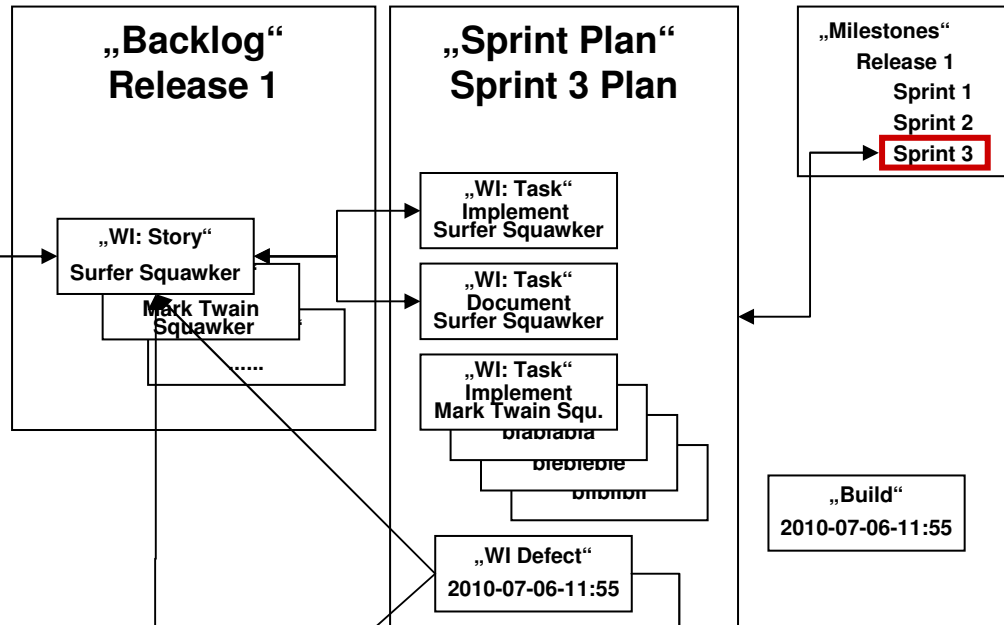

Testing Discipline

