

IMS



Application Programming: Design Guide

Version 9

IMS



Application Programming: Design Guide

Version 9

Note

Before using this information and the product it supports, be sure to read the general information under "Notices" on page 183.

Quality Partnership Program (QPP) Edition (December 2003) (Softcopy Only)

This QPP edition applies to Version 9 of IMS (product number 5655-J38) and to all subsequent releases and modifications until otherwise indicated in new editions.

© Copyright International Business Machines Corporation 1974, 2003. All rights reserved.

US Government Users Restricted Rights – Use, duplication or disclosure restricted by GSA ADP Schedule Contract with IBM Corp.

Contents

Figures	vii
Tables	ix
About This Book	xi
Summary of Contents	xi
Prerequisite Knowledge	xi
How to Use This Book	xii
How to Read Syntax Diagrams	xii
How to Send Your Comments	xv
Change Indicators	xv
Summary of Changes	xvii
Changes to the Current Edition of This Book for IMS Version 9	xvii
Changes to This Book for IMS Version 9	xvii
Library Changes for IMS Version 9	xvii
Chapter 1. Concepts and Terminology	1
Storing and Processing Information in a Database	1
A Look at the Tasks Ahead of You	7
Chapter 2. Introduction to Application Design	9
An Overview of Application Design	9
Identifying Application Data	11
Designing a Local View	16
Chapter 3. Analyzing IMS Application Processing Requirements	27
Deciding Your IMS Application's Requirements	27
Accessing Databases With Your IMS Application Program	28
Accessing Data: The Types of Programs You Can Write for Your IMS Application	31
IMS Programming Integrity and Recovery Considerations	38
Dynamic Allocation for IMS Databases	47
Chapter 4. Analyzing CICS Application Processing Requirements	49
Deciding Your CICS Application's Requirements	49
Accessing Databases With Your CICS Application Program	51
Writing a CICS Program to Access IMS Databases	52
Using Data Sharing for Your CICS Program	56
Scheduling and Terminating a PSB (CICS Online Programs Only)	57
Linking and Passing Control to Other Programs (CICS Online Programs Only)	57
Maximizing the Performance of Your CICS System	58
Programming Integrity and Database Recovery Considerations for Your CICS Program	58
Data Availability Considerations for Your CICS Program	63
Use of STAE or ESTAE and SPIE in IMS Batch Programs	64
Dynamic Allocation for IMS Databases	65
Chapter 5. Gathering Requirements for Database Options	67
Analyzing Data Access	67
Understanding How Data Structure Conflicts Are Resolved	74
Providing Data Security	83
Read Without Integrity	87

Chapter 6. Gathering Requirements for Message Processing Options	91
Identifying Online Security Requirements	91
Analyzing Screen and Message Formats	93
Gathering Requirements for Conversational Processing	95
Identifying Output Message Destinations	99
Chapter 7. Application Design for APPC	103
Overview of APPC and LU 6.2	103
Application Program Types	103
Application Objectives	105
Choosing Conversation Attributes	105
Conversation Type	106
Conversation State	107
Synchronization Level	107
Distributed Sync Point	108
Application Programming Interface for LU Type 6.2	112
LU 6.2 Partner Program Design	113
Chapter 8. Writing ODBA Application Programs	133
General Application Program Flow	134
Server Program Structure	137
DB2 Stored Procedures Use of ODBA	137
Chapter 9. Testing an IMS Application Program	139
What You Need to Test an IMS Program	139
Testing DL/I Call Sequences (DFSDDL0) Before Testing Your IMS Program	139
Using BTS II to Test Your IMS Program	140
Tracing DL/I Calls with Image Capture for Your IMS Program	140
Requests for Monitoring and Debugging Your IMS Program	145
What to Do When Your IMS Program Terminates Abnormally	158
Chapter 10. Testing a CICS Application Program	161
What You Need to Test a CICS Program	161
Testing Your CICS Program	161
Requests for Monitoring and Debugging Your CICS Program	166
What to Do When Your CICS Program Terminates Abnormally	167
Chapter 11. Testing an ODBA Application Program	169
Using the DL/I Test Program (DFSDDL0) Before Testing Your ODBA Program	170
Tracing DL/I Calls with Image Capture to Test Your ODBA Program	170
Using Image Capture with DFSDDL0 to Test Your ODBA Program	170
Running Image Capture Online	171
Retrieving Image Capture Data from the Log Data Set	171
Requests for Monitoring and Debugging Your ODBA Program	172
What to Do When Your ODBA Program Terminates Abnormally	172
Chapter 12. Documenting an Application Program	175
Documentation for Other Programmers	175
Documentation for Users	176
Appendix. IMS Spool API Overall Design	177
Design Concept	177
Performance Considerations	178
Application Coding Considerations	179
Notices	183

Programming Interface Information	185
Trademarks.	186
Product Names	186
Bibliography	187
IMS Version 9 Library	187
Index	189

Figures

1.	Medical Database Hierarchy	3
2.	Accounting Program's View of the Database	5
3.	Patient Illness Program's View of the Database	5
4.	Current Roster.	12
5.	Current Roster After Step 1	18
6.	Current Roster After Step 2	20
7.	Current Roster After Step 3	21
8.	Schedule of Courses	23
9.	Course Schedule After Step 1	23
10.	Instructor Skills Report.	24
11.	Instructor Skills After Step 1.	25
12.	Instructor Schedules	25
13.	Instructor Schedules Step 1	26
14.	Instructor Schedules Step 2	26
15.	Documenting User Task Descriptions: Current Roster Example	28
16.	Single Mode and Multiple Mode	40
17.	Current Roster Task Description	50
18.	Physical Employee Segment	75
19.	Employee Segment with Field-Level Sensitivity.	75
20.	Patient Hierarchy.	76
21.	Indexing a Root Segment.	78
22.	Indexing a Dependent Segment	79
23.	Patient and Inventory Hierarchies.	81
24.	Logical Relationships Example.	82
25.	Supplies and Purchasing Hierarchies	82
26.	Program B and Program C Hierarchies.	83
27.	Medical Database Hierarchy	84
28.	Sample Hierarchy	85
29.	Participants in Resource Recovery	109
30.	Two-Phase Commit Process with One Resource Manager	110
31.	Distributed Resource Recovery	111
32.	Flow of a Local IMS Synchronous Transaction When Sync_level=None	114
33.	Flow of a Local IMS Synchronous Transaction When Sync_level=Confirm	114
34.	Flow of a Local IMS Asynchronous Transaction When Sync_level=None	115
35.	Flow of a Local IMS Asynchronous Transaction When Sync_level=Confirm	115
36.	Flow of a Local IMS Conversational Transaction When Sync_level=None	116
37.	Flow of a Local IMS Command when Sync_level=None	116
38.	Flow of a Local IMS Asynchronous Command When Sync_level=Confirm	117
39.	Flow of a Message Switch When Sync_level=None.	117
40.	Flow of a Local CPI Communications Driven Program When Sync_level=None	118
41.	Flow of a Remote IMS Synchronous Transaction When Sync_level=None	119
42.	Flow of a Remote IMS Asynchronous Transaction When Sync_level=None	120
43.	Flow of a Remote IMS Asynchronous Transaction When Sync_level=Confirm	121
44.	Flow of a Remote IMS Synchronous Transaction When Sync_level=Confirm	122
45.	Standard DL/I Program Commit Scenario When Sync_level=Syncpt	123
46.	CPI-C Driven Commit Scenario When Sync_Level=Syncpt	124
47.	Standard DL/I Program U119 Backout Scenario When Sync_Level=Syncpt	125
48.	Standard DL/I Program U0711 Backout Scenario When Sync_Level=Syncpt	126
49.	Standard DL/I Program ROLB Scenario When Sync_Level=Syncpt	127
50.	Multiple Transactions in Same Commit When Sync_Level=Syncpt	128
51.	OS/390 Application Region's Connection to IMS DB	133
52.	DRA Uses One TCB per Thread.	137
53.	DB2 Stored Procedures Connection to IMS DB	138

54. DB2 Stored Procedures Relationships 138

Tables

1. How to Read Syntax Diagrams	xiii
2. Entities and Data Elements	11
3. Example of Data Elements Information Form	15
4. Single Occurrence of Class Aggregate	17
5. Multiple Occurrences of Class Aggregate	19
6. Course Schedule Data Elements	23
7. Instructor Skills Data Elements	24
8. Instructor Schedules Data Elements	25
9. Program and Database Options in IMS Environments	29
10. Processing Modes	40
11. The Data Your Program Can Access	51
12. Program and Database Options in the CICS Environments	51
13. Using Application Programs in APPC	105
14. Message Integrity of Conversations	129
15. Results of Processing When Integrity Is Compromised	129
16. Recovering APPC Messages	130
17. Tools You Can Use for Testing Your Program	161
18. Tools You Can Use for Testing Your Program	169

About This Book

This book is a guide for designing application programs for IMS™. It tells application programmers how to identify application data and analyze requirements for application processing. This book describes other tasks such as gathering requirements for database and message processing options and testing an application program.

This softcopy book is available only in PDF and BookManager formats. This book is available on the IMS Version 9 Licensed Product Kit (LK3T-7213). To get the most current versions of the PDF and BookManager® formats, go to the IMS Web site at www.ibm.com/ims and link to the Library page.

Summary of Contents

The chapters in this book are applicable in both the IMS and CICS® environments unless otherwise noted. Chapter content is as follows:

Introduction

Chapters 1 and 2 explain the basics for designing an application. The first chapter defines database concepts and terms, and the second chapter introduces the tasks of application design. These two introductory chapters also explain how to identify required application data and how to design a local view to describe that data.

Designing the Application

Chapters 3 through 6 describe the tasks involved in designing an application. These tasks include choosing the type of application program you need for both the IMS and CICS environments and gathering the information for the database administrator and system administrator.

Implementing the Design

Chapters 7 through 12 include considerations for using your application after the specifications have been developed. These considerations are using LU 6.2/APPC for distributing your application throughout the network, testing your application program after you have finished coding it, and documenting additional information about your program.

Prerequisite Knowledge

Before using this manual, you should understand basic IMS concepts and the IMS environments. IBM® offers a wide variety of classroom and self-study courses to help you learn IMS. For a complete list, see the IMS home page on the World Wide Web at: www.ibm.com/ims

You will also find descriptions of basic IMS concepts and the IMS environments at the above Web site.

If you are a CICS user, you should understand a similar level of information for CICS. The IMS concepts explained in this manual are limited to those concepts pertinent to designing application programs. You should also know how to use COBOL, PL/I, Assembler language, Pascal, or C language.

How to Use This Book

This book is one of several books documenting the IMS application programming task. This book is the introductory book. The complete package of application programming materials is as follows:

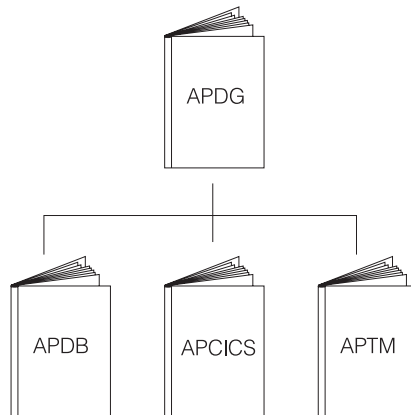

- *IMS Version 9: Application Programming: Design Guide (APDG)*, the book you are currently reading, is the introductory application programming book and is also the place to find information common to all of the application programming environments.
- *IMS Version 9: Application Programming: Database Manager (APDB)* describes how to write an application program to process a database using DLI calls. This book applies to both IMS and CICS environments.
- *IMS Version 9: Application Programming: EXEC DLI Commands for CICS and IMS (APCICS)* describes how to write an application program to process the database using EXEC DLI commands.
- *IMS Version 9: Application Programming: Transaction Manager (APTM)* describes how to write an application program to process messages using DC calls.

For definitions of terms used in this manual and references to related information in other manuals, please see *IMS Version 9: Master Index and Glossary*.

How to Read Syntax Diagrams

Each syntax diagram in this book begins with a double right arrow and ends with a right and left arrow pair. Lines that begin with a single right arrow are continuation lines. You read a syntax diagram from left to right and from top to bottom, following the direction of the arrows.

Conventions used in syntax diagrams are described in Table 1:

Table 1. How to Read Syntax Diagrams





Convention	Meaning
	<p>You must specify values A, B, and C. Required values are shown on the main path of a syntax diagram.</p>
	<p>You have the option to specify value A. Optional values are shown below the main path of a syntax diagram.</p>
	<p>You must specify value A, B, or C.</p>
	<p>You have the option to specify A, B, C, or none of these values.</p>
	<p>You have the option to specify A, B, C, or none of these values. If you don't specify a value, A is the default.</p>
	<p>You have the option to specify one, more than one, or none of the values A, B, or C. Any required separator for multiple or repeated values (in this example, the comma) is shown on the arrow.</p>
	<p>You have the option to specify value A multiple times. The separator in this example is optional.</p>
 <p>Name:</p>	<p>Sometimes a diagram must be split into fragments. The syntax fragment is shown separately from the main syntax diagram, but the contents of the fragment should be read as if they are on the main path of the diagram.</p>

Table 1. How to Read Syntax Diagrams (continued)

Convention	Meaning
Punctuation marks and numbers	Enter punctuation marks (slashes, commas, periods, parentheses, quotation marks, equal signs) and numbers exactly as shown.
Uppercase values	Keywords, their allowable synonyms, and reserved parameters, appear in uppercase letters for z/OS. Enter these values exactly as shown.
Lowercase values without italics	Keywords, their allowable synonyms, and reserved parameters, appear in lowercase letters for UNIX. Enter these values exactly as shown.
Lowercase values in italics (for example, <i>name</i>)	Supply your own text or value in place of the <i>name</i> variable.
b	A b symbol indicates one blank position.

Other conventions include the following:

- When entering commands, separate parameters and keywords by at least one blank if there is no intervening punctuation.
- Footnotes are shown by a number in parentheses, for example, (1).
- Parameters with number values end with the symbol #.
- Parameters that are names end with 'name'.
- Parameters that can be generic end with the symbol *.

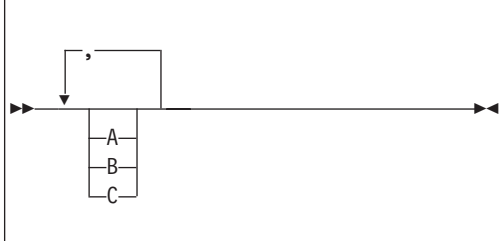
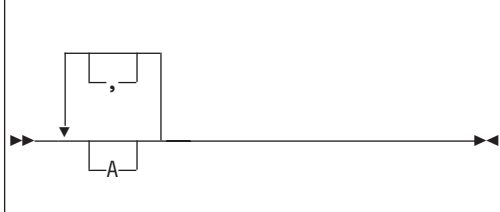
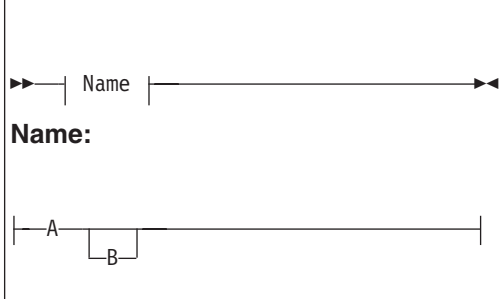
Example Syntax Diagram

Here is an example syntax diagram that describes the **hello** command.



Name:



Greeting:



Notes:

- 1 You can code up to three names.
- 2 Compose and add your own greeting (for example, how are you?).

According to the syntax diagram, these are all valid versions of the **hello** command:

```
hello  
hello name  
hello name, name  
hello name, name, name  
hello, your_greeting  
hello name, your_greeting  
hello name, name, your_greeting  
hello name, name, name, your_greeting
```

The space before the *name* value is significant. If you do not code *name*, you must still code the comma before *your_greeting*.

How to Send Your Comments

Your feedback is important in helping us provide the most accurate and highest quality information. If you have any comments about this book or any other IMS documentation, you can do one of the following:

- Go to the IMS home page at www.ibm.com/ims. There you will find an online feedback page where you can enter an submit comments.
- Send your comments by e-mail to imspubs@us.ibm.com. Be sure to include the name of the book, the part number of the book, the version of IMS, and, if applicable, the specific location of the text you are commenting on (for example, a page number or table number).

Change Indicators

Technical changes are indicated in this publication by a vertical bar (|) to the left of the changed text.

Summary of Changes

Changes to the Current Edition of This Book for IMS Version 9

This edition is a draft version of this book intended for use during the Quality Partnership Program (QPP). Contents of this book are preliminary and under development.

Changes to This Book for IMS Version 9

This book contains new technical information for IMS Version 9, as well as editorial changes. This book contains new information about:

- Program and database options in IMS environments

Library Changes for IMS Version 9

Changes to the IMS Library for IMS Version 9 include the addition of new titles, the change of one title, and a major terminology change.

New and Revised Titles

The following list details the major changes to the IMS Version 9 library:

- *IMS Version 9: HALDB Online Reorganization Guide and Reference*

The library includes a new book: *IMS Version 9: HALDB Online Reorganization Guide and Reference*. This book is available only in PDF and BookManager formats.

- *IMS Version 9: An Introduction to IMS*

The library includes a new book: *IMS Version 9: An Introduction to IMS*.

- The book formerly titled *IMS Version 8: IMS Java User's Guide* is now titled *IMS Version 9: IMS Java Guide and Reference*.

Terminology Changes

IMS Version 9 introduces new terminology for IMS commands:

type-1 command

A command, generally preceded by a leading slash character, that can be entered from any valid IMS command source. In IMS Version 8, these commands were called *classic* commands.

type-2 command

A command that is entered only through the OM API. Type-2 commands are more flexible and can have a broader scope than type-1 commands. In IMS Version 8, these commands were called *IMSplex* commands or *enhanced* commands.

Accessibility Enhancements

Accessibility features help a user who has a physical disability, such as restricted mobility or limited vision, to use software products. The major accessibility features in z/OS products, including IMS, enable users to:

- Use assistive technologies such as screen readers and screen magnifier software
- Operate specific or equivalent features using only the keyboard
- Customize display attributes such as color, contrast, and font size

User Assistive Technologies

Assistive technology products, such as screen readers, function with the IMS user interfaces. Consult the documentation of the assistive technology products for specific information when you use assistive technology to access these interfaces.

Accessible Documentation

Online documentation for IMS Version 9 is available in BookManager format, which is an accessible format. All BookManager functions can be accessed by using a keyboard or keyboard shortcut keys. BookManager also allows you to use screen readers and other assistive technologies. The BookManager READ/MVS product is included with the z/OS base product, and the BookManager Softcopy Reader (for workstations) is available on the IMS Licensed Product Kit (CD), which you can download from the Web at www.ibm.com.

Keyboard Navigation of the User Interface

Users can access IMS user interfaces using TSO/E or ISPF. Refer to the *z/OS V1R1.0 TSO/E Primer*, the *z/OS V1R1.0 TSO/E User's Guide*, and the *z/OS V1R1.0 ISPF User's Guide, Volume 1*. These guides describe how to navigate each interface, including the use of keyboard shortcuts or function keys (PF keys). Each guide includes the default settings for the PF keys and explains how to modify their functions.

Chapter 1. Concepts and Terminology

This section is an introduction to designing application programs. The first part explains some basic concepts about processing a database, and the second part gives an overview of the tasks covered in this information.

In this Section:

- “Storing and Processing Information in a Database”
- “A Look at the Tasks Ahead of You” on page 7

Storing and Processing Information in a Database

This section describes how storing data in a database is different from other ways of storing data. The advantages of storing and processing data in a database are that all of the data needs to appear only once and that each program must process only the data that it needs. One way to understand this is to compare three ways of storing data: in separate files, in a combined file, and in a database.

Storing Data in Separate Files

If you keep separate files of data for each part of your organization, you can ensure that each program uses only the data it needs, but you must store a lot of data in multiple places simultaneously. Problems with keeping separate files are:

- Redundant data takes up space that could be put to better use
- Maintaining separate files can be difficult and complex

Example: Suppose that a medical clinic keeps separate files for each of its departments, such as the clinic department, the accounting department, and the ophthalmology department:

- The clinic department keeps data about each patient who visits the clinic, such as:

- Identification number
- Name
- Address
- Illnesses
- Date of each illness
- Date patient came to clinic for treatment
- Treatment given for each illness
- Doctor that prescribed treatment
- Charge for treatment

- The accounting department also keeps information about each patient. The information that the accounting department might keep for each patient is:

- Identification number
- Name
- Address
- Charge for treatment
- Amount of payments

- The information that the ophthalmology department might keep for each patient is:

- Identification number

Name
Address
Illnesses relating to ophthalmology
Date of each illness
Names of members in patient's household
Relationship between patient and each household member

If each of these departments keeps separate files, each department uses only the data that it needs, but much of the data is redundant. For example, every department in the clinic uses at least the patient's number, name, and address. Updating the data is also a problem, because if a department changes a piece of data, the same data must be updated in each separate file. Therefore, it is difficult to keep the data in each department's files current. Current data might exist in one file while defunct data remains in another file.

Storing Data in a Combined File

Another way to store data is to combine all the files into one file for all departments to use. In the medical example, the patient record that would be used by each department would contain these fields:

Identification number
Name
Address
Illnesses
Date of each illness
Date patient came to clinic for treatment
Treatment given for each illness
Doctor that prescribed treatment
Charge for treatment
Amount of payments
Names of members in patient's household
Relationship between patient and each household member

Using a combined file solves the updating problem, because all the data is in one place, but it creates a new problem: the programs that process this data must access the entire file record to get to the part that they need. For example, to process only the patient's number, charges, and payments, an accounting program must access all of the other fields also. In addition, changing the format of any of the fields within the patient's record affects all the application programs, not just the programs that use that field.

Using combined files can also involve security risks, because all of the programs have access to all of the fields in a record.

Storing Data in a Database

Storing data in a database gives you the advantages of both separate files and combined files: all the data appears only once, and each program has access to the data that it needs. This means that:

- When you update a field, you do it in one place only.

- Because you store each piece of information only in one place, you cannot have an updated version of the information in one place and an out-of-date version in another place.
- Each program accesses only the data it needs.
- You can prevent programs from accessing private or secured information.

In addition, storing data in a database has two advantages that neither of the other ways has:

- If you change the format of part of a database record, the change does not affect the programs that do not use the changed information.
- Programs are not affected by how the data is stored.

Because the program is independent of the physical data, a database can store all the data only once and yet make it possible for each program to use only the data that it needs. In a database, what the data looks like when it is stored is different from what it looks like to an application program.

Database Hierarchies

In an IMS DB, a record is stored and accessed in a hierarchy. A hierarchy shows how each piece of data in a record relates to other pieces of data in the record. Figure 1 shows the hierarchy you can use to store the patient information as described in this section.

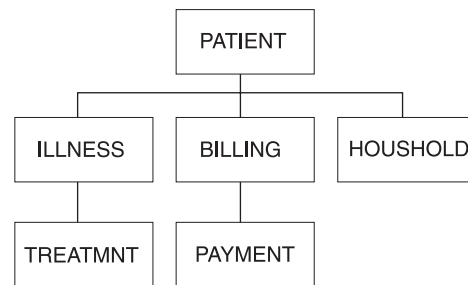

Figure 1. Medical Database Hierarchy

IMS connects the pieces of information in a database record by defining the relationships between the pieces of information that relate to the same subject. The result is a database hierarchy.

Example: In the medical database, the data that you are keeping is information about a particular patient. Information that is not associated with a particular patient is meaningless. For example, keeping information about a treatment given for a particular illness is meaningless if the illness is not associated with a patient. To be meaningful, ILLNESS, TREATMNT, BILLING, PAYMENT, and HOUSHOLD must always be associated with one of the clinic's patients.

You keep five kinds of information about each patient. The information about the patient's illnesses, billings, and household depends directly on the patient. Information about the patient's treatment depends on the patient's illness, and information about the patient's payments depends on the patient's billings.

Each piece of data represented in Figure 1 is called a *segment* in the hierarchy. Each segment contains one or more *fields* of information. The PATIENT segment,

for example, contains all the information that relates strictly to the patient: the patient's identification number, name, and address.

Definitions: A *segment* is the smallest unit of data that an application program can retrieve from the database. A *field* is the smallest unit of a segment.

The PATIENT segment in the medical database is the *root segment*. The segments below the root segment are the *dependents*, or children, of the root. For example, ILLNESS, BILLING, and HOUSHOLD are all children of PATIENT. ILLNESS, BILLING, and HOUSHOLD are called direct dependents of PATIENT; TREATMNT and PAYMENT are also dependents of PATIENT, but they are not direct dependents, because they are at a lower level in the hierarchy.

A *database record* is a single root segment (root segment *occurrence*) and all of its dependents. In the medical example, a database record is all of the information about one patient.

Definitions: A *root segment* is the highest-level segment. A dependent is a segment below a root segment. A root segment occurrence is a database record and all of its dependents.

Each database record has only one root segment occurrence, but it might have several occurrences at lower levels. For example, the database record for a patient contains only one occurrence of the PATIENT segment type, but it might contain several ILLNESS and TREATMNT segment occurrences for that patient.

Your Program's View of the Data

IMS uses two kinds of control blocks to enable application programs to be independent of your method of storing data in the database, the database description (DBD), and the database program communication block (DB PCB).

Database Description (DBD)

A *database description (DBD)* is a control block that describes the physical structure of the database. The DBD also defines the appearance and contents, or fields, that make up each of the segment types in the database.

For example, the DBD for the medical database hierarchy shown in Figure 1 on page 3 describes the physical structure of the hierarchy and each of the six segment types in the hierarchy: PATIENT, ILLNESS, TREATMNT, BILLING, PAYMENT, and HOUSHOLD.

Related Reading: For more information on generating DBDs, see *IMS Version 9: Utilities Reference: Database and Transaction Manager*.

Database Program Communication Block (DB PCB)

A *database program communication block (DB PCB)* defines an application program's view of the database. An application program often needs to process only some of the segments in a database. A PCB defines which of the segments in the database the program is allowed to access—which segments the program is sensitive to.

The data structures that are available to the program contain only segments that the program is sensitive to. The PCB also defines how the application program is allowed to process the segments in the data structure: whether the program can only read the segments, or whether it can also update them.

To obtain the highest level of data availability, your PCBs should request the fewest number of sensitive segments and the least capability needed to complete the task.

All the DB PCBs for a single application program are contained in a *program specification block* (PSB). A program might use only one DB PCB (if it processes only one data structure) or it might use several DB PCBs, one for each data structure.

Related Reading: For more information on generating PSBs, see *IMS Version 9: Utilities Reference: Database and Transaction Manager*.

Figure 2 illustrates the concept of defining a view for an application program. An accounting program that calculates and prints bills for the clinic's patients would need only the PATIENT, BILLING, and PAYMENT segments. You could define the data structure shown in Figure 2 in a DB PCB for this program.

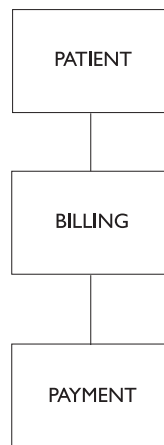

Figure 2. Accounting Program's View of the Database

A program that updates the database with information on patients' illnesses and treatments, in contrast, would need to process the PATIENT, ILLNESS, and TREATMNT segments. You could define the data structure shown in Figure 3 for this program.

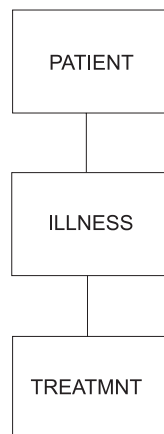

Figure 3. Patient Illness Program's View of the Database

Sometimes a program needs to process all of the segments in the database. When this is true, the program's view of the database as defined in the DB PCB is the same as the database hierarchy that is defined in the DBD.

An application program processes only the segments in a database that it requires; therefore, if you change the format of a segment that is not processed, you do not change the program. A program is affected only by the segments that it accesses. In addition to being sensitive to only certain segments in a database, a program can also be sensitive to only certain fields within a segment. If you change a segment or field that the program is not sensitive to, it does not affect the program. You define segment and *field-level* sensitivity during PSBGEN.

Definition: *Field-level* sensitivity is when a program is sensitive to only certain fields within a segment.

Related Reading: For more information, see *IMS Version 9: Administration Guide: Database Manager*.

Processing a Database Record

To process the information in the database, your application program communicates with IMS in three ways:

- Passing control—IMS passes control to your application program through an entry statement in your program. Your program returns control to IMS when it has finished its processing.

When you are running a CICS online program, CICS passes control to your application program, and your program schedules a PSB to make IMS requests. Your program returns control to CICS. If you are running a batch or BMP program, IMS passes control to your program with an existing PSB scheduled.

- Communicating processing requests—You communicate processing requests to IMS in one of two ways:
 - In IMS, you issue DL/I calls to process the database.
 - In CICS, you can issue either DL/I calls or EXEC DLI commands. EXEC DLI commands more closely resemble a higher-level language than do DL/I calls.
- Exchanging information using DL/I calls—Your program exchanges information in two areas:
 - A DL/I call reports the results of your request in a control block and the AIB communication block when using one of the AIB interfaces. For programs written using DL/I calls, this control block is the DB PCB. For programs written using EXEC DLI commands, this control block is the DLI interface block (DIB). The contents of the DIB reflect the status of the last DL/I command executed in the program. Your program includes a mask of the appropriate control block and uses this mask to check the results of the request.
 - When you request a segment from the database, IMS returns the segment to your I/O area. When you want to update a segment in the database, you place the new value of the segment in the I/O area.

An application program can read and update a database. When you update a database, you can replace, delete, or add segments. In IMS, you indicate in the DL/I call the segment you want to process, and whether you want to read or update it. In CICS, you can indicate what you want using either a DL/I call or an EXEC DLI command.

A Look at the Tasks Ahead of You

The following tasks are involved in developing an IMS application, and the programs that are part of the application.

Designing the Application

Application program design varies from place to place, and from one application to another. Therefore, this information does not try to cover the early tasks that are part of designing an application program. Instead, it covers only the tasks that you are concerned with after the early specifications for the application have been developed. These tasks are:

Analyzing Application Data Requirements

Two important parts of application design are defining the data that each of the business processes in the application requires and designing a local view for each of the business processes. Chapter 2, “Introduction to Application Design,” on page 9 explains these tasks.

Analyzing Application Processing Requirements

When you understand the business processes that are part of the application, you can analyze the requirements of each business process in terms of the processing that is available with different types of application programs. Chapter 3, “Analyzing IMS Application Processing Requirements,” on page 27 and Chapter 4, “Analyzing CICS Application Processing Requirements,” on page 49 explain the processing and application requirements that each type of program satisfies.

Gathering Requirements for Database Options

You then need to look at the database options that can most efficiently meet the requirements, and gather information about your application’s data requirements that relates to each of the options. Chapter 5, “Gathering Requirements for Database Options,” on page 67 explains these options and helps you gather information about your application that will be helpful to the database administrator in making informed decisions about database options.

Gathering Requirements for Message Processing Options

If your application communicates with terminals and other application programs, look at the message processing options and the requirements they satisfy. Chapter 6, “Gathering Requirements for Message Processing Options,” on page 91 explains the IMS message processing options and helps you to gather information about your application that is helpful in choosing message processing options.

Related Reading:

- For more information about designing a CICS application, see *CICS/ESA Application Programming Guide*.
- For more information about designing a Java™ application, see *IMS Version 9: IMS Java Guide and Reference*.

Developing Specifications

Developing specifications involves defining what your application will do, and how it will be done. This task depends completely on the specific application and your standards and so, is not described in this information.

Implementing the Design

When the specifications for each of the programs in the application are developed, you can structure and code the programs according to those specifications. The subtasks are:

Writing the Database Processing Part of the Program

When the program design is complete, you can structure and code your requests and data areas based on the programming specifications that have been developed.

Related Reading: The following books contain information about writing a program's database processing.

- *IMS Version 9: Application Programming: Database Manager*
- *IMS Version 9: Application Programming: EXEC DLI Commands for CICS and IMS*

Writing the Message Processing Part of the Program

If you are writing a program that communicates with terminals and other programs, you need to structure and code the message processing part of the program.

Related Reading: For more information about writing programs for message processing, see *IMS Version 9: Application Programming: Transaction Manager*.

Analyzing APPC/IMS Requirements

The LU 6.2 feature of IMS TM enables your application to be distributed throughout the network. Chapter 7, "Application Design for APPC," on page 103 tells how to use LU 6.2 and the IMS TM application programs. This section describes the considerations for modifying these application programs to communicate with other application programs and shows the results of conversations.

Testing an Application Program

When you finish coding your program, test it by itself and then as part of a system. Chapter 9, "Testing an IMS Application Program," on page 139 and Chapter 10, "Testing a CICS Application Program," on page 161 give you some guidelines.

Documenting an Application Program

Documenting a program continues throughout the project and is most effective when done incrementally. When the program is completely tested, information must be supplied to those who use and maintain your program. Chapter 12, "Documenting an Application Program," on page 175 gives you some suggestions about the information you should record about your program.

Chapter 2. Introduction to Application Design

Designing an application that meets the requirements of end users involves a variety of tasks and, usually, people from several departments. Application design begins when a department or business area communicates a need for some type of processing. Application design ends when each of the parts of the application system—for example, the programs, the databases, the display screens, and the message formats—have been designed.

In this Section:

- “An Overview of Application Design”
- “Identifying Application Data” on page 11
- “Designing a Local View” on page 16

An Overview of Application Design

The application design process varies from place to place and from application to application. The overview that is given in this section and the suggestions about documenting application design and converting existing applications are not the only way that these tasks are performed.

The purpose of this overview is to give you a frame of reference so that you can understand where the techniques and guidelines explained in this section fit into the process. The order in which you perform the tasks described here, and the importance you give to each one, depend on your settings. Also, the individuals involved in each task, and their titles, might differ depending on the site. The tasks are as follows:

- Establish your standards

Throughout the design process, be aware of your established standards. Some of the areas that standards are usually established for are:

- Naming conventions (for example, for databases and terminals)
- Formats for screens and messages
- Control of and access to the database
- Programming and conventions (for common routines and macros)

Setting up standards in these areas is usually an ongoing task that is the responsibility of database and system administrators.

- Follow your security standards

Security protects your resources from unauthorized access and use. As with defining standards, designing an adequate security system is often an ongoing task. As an application is modified or expanded, often the security must be changed in some way also. Security is an important consideration in the initial stages of application design.

Establishing security standards and requirements is usually the responsibility of system administration. These standards are based on the requirements of your applications.

Some security concerns are:

- Access to and use of the databases
- Access to terminals
- Distribution of application output
- Control of program modification

- Transaction and command entry

Related Reading: “Providing Data Security” on page 83 and “Identifying Online Security Requirements” on page 91 give some suggestions about the kind of information that you can gather concerning the security requirements for your application. This information can be helpful to database administration and system administration in implementing database and data communications security.

- Define application data

Identifying the data that an application requires is a major part of application design. One of the tasks of data definition is learning from end users what information will be required to perform the required processing. After you have listed the required data, you can name the data and document it. “Identifying Application Data” on page 11 describes these parts of data definition.

- Provide input for database design

To design a database that meets the requirements of all the applications that will process it, the database administrator (DBA) needs information about the data requirements of each application. One way to gather and supply this information is to design a local view for each of the business processes in your application. A local view is a description of the data that a particular business process requires.

Related Reading: “Designing a Local View” on page 16 explains how you can develop a conceptual data structure and analyze the relationships between the pieces of data in the structure for each business process in the application.

- Design application programs

When the overall application flow and system externals have been defined, you define the programs that will perform the required processing. Some of the most important considerations involved in this task are: standards, security requirements, privacy requirements, and performance requirements. The specifications you develop for the programs should include:

- Security requirements
- Input and output data formats and volumes
- Data verification and validation requirements
- Logic specifications
- Performance requirements
- Recovery requirements
- Linkage requirements and conventions
- Data availability considerations

In addition, you might be asked to provide some information about your application to the people responsible for network and user interface design.

- Document the application design process

Recording information about the application design process is valuable to others who work with the application now and in the future. One kind of information that is helpful is information about why you designed the application the way you did. This information can be helpful to people who are responsible for the database, your IMS system, and the programs in the application—especially if any part of the application must be changed in the future. Documenting application design is done most thoroughly when it is done during the design process, instead of at the end of it.

- Convert an existing application

One of the main aspects in converting an existing application to IMS is to know what already exists. Before starting to convert the existing system, find out everything you can about the way it works currently. For example, the following information can be of help to you when you begin the conversion:

- Record layouts of all records used by the application
- Number of data element occurrences for each data element
- Structure of any existing related databases

Identifying Application Data

Two important aspects of application design are identifying the application data and describing the data that a particular business process requires.

One of the steps of identifying application data is to thoroughly understand the processing the user wants performed. You need to understand the input data and the required output data in order to define the data requirements of the application. You also need to understand the business processes that are involved in the user's processing needs. Three of the tasks involved in identifying application data are:

- Listing the data required by the business process
- Naming the data
- Documenting the data

When analyzing the required application data, you can categorize the data as either an entity or a data element.

Definitions: An *entity* is anything about which information can be stored. A *data element* is the smallest named unit of data pertaining to an entity. It is information that describes the entity.

Example: In an education application, “students” and “courses” are both entities; these are two subjects about which you collect and process data. Table 2 shows some data elements that relate to the student and course entities. The entity is listed with its related data elements.

Table 2. Entities and Data Elements

Entity	Data Elements
Student	Student Name
	Student Number
Course	Course Name
	Course Number
	Course Length

When you store this data in an IMS database, groups of data elements are potential segments in the hierarchy. Each data element is a potential field in that segment.

Listing Data Elements

Example: To identify application data, consider a company that provides technical education to its customers. The education company has one headquarters office, called HQ, and several local education centers, called Ed Centers.

A class is a single offering of a course on a specific date at a particular Ed Center. One course might have several offerings at different Ed Centers; each of these is a separate class. HQ is responsible for developing all the courses that will be offered, and each Ed Center is responsible for scheduling classes and enrolling students for its classes.

Suppose that one of the education company's requirements is for each Ed Center to print weekly current rosters for all classes at the Ed Center. The current roster is to give information about the class and the students enrolled in the class. HQ wants the current rosters to be in the format shown in Figure 4.

CHICAGO			01/04/04		
TRANSISTOR THEORY		41837			
10 DAYS					
INSTRUCTOR(S): BENSON, R.J.			DATE: 01/14/04		
STUDENT	CUST	LOCATION	STATUS	ABSENT	GRADE
1.ADAMS, J.W.	XYZ	SOUTH BEND, IND	CONF		
2.BAKER, R.T.	ACME	BENTON HARBOR, MICH	WAIT		
3.DRAKE, R.A.	XYZ	SOUTH BEND, IND	CANC		
.					
.					
33.WILLIAMS, L.R.	BEST	CHICAGO, ILL	CONF		
CONFIRMED = 30					
WAIT-LISTED = 1					
CANCELED = 2					

Figure 4. Current Roster

To list the data elements for a particular business process, look at the required output. The current roster shown in Figure 4 is the roster for the class, “Transistor Theory” to be given in the Chicago Ed Center, starting on January 14, 2004, for ten days. Each course has a course code associated with it—in this case, 41837. The code for a particular course is always the same. For example, if Transistor Theory is also offered in New York, the course code is still 41837. The roster also gives the names of the instructors who are teaching the course. Although the example only shows one instructor, a course might require more than one instructor.

For each student, the roster keeps the following information: a sequence number for each student, the student's name, the student's company (CUST), the company's location, the student's status in the class, and the student's absences and grade. All the above information on the course and the students is input information.

The current date (the date that the roster is printed) is displayed in the upper right corner (01/04/04). The current date is an example of data that is output only data; it is generated by the operating system and is not stored in the database.

The bottom-left corner gives a summary of the class status. This data is not included in the input data. These values are determined by the program during processing.

When you list the data elements, abbreviating them is helpful, because you will be referring to them frequently when you design the local view.

The data elements list for current roster is:

EDCNTR Name of Ed Center giving class

DATE	Date class starts
CRSNAME	Name of course
CRSCODE	Course code
LENGTH	Length of course
INSTRS	Names of instructors teaching class
STUSEQ#	Student's sequence number
STUNAME	Student's name
CUST	Name of student's company
LOCTN	Location of student's company
STATUS	Student's status in class—confirmed, wait list, or cancelled
ABSENCE	Number of days student was absent
GRADE	Student's grade for the course

After you have listed the data elements, choose the major entity that these elements describe. In this case, the major entity is class. Although a lot of information exists about each student and some information exists about the course in general, together all this information relates to a specific class. If the information about each student (for example, status, absence, and grade) is not related to a particular class, the information is meaningless. This holds true for the data elements at the top of the list as well: The Ed Center, the date the class starts, and the instructor mean nothing unless you know what class they describe.

Naming Data Elements

Some of the data elements your application uses might already exist and be named. After you have listed the data elements, find out if any of them exist by checking with your database administrator (DBA).

Before you begin naming data elements, be aware of the naming standards that you are subject to. When you name data elements, use the most descriptive names possible. Remember that, because other applications probably use at least some of the same data, the names should mean the same thing to everyone. Try not to limit the name's meaning only to your application.

Recommendation: Use global names rather than local names. A *global name* is a name whose meaning is clear outside of any particular application. A *local name* is a name that, to be understood, must be seen in the context of a particular application.

One of the problems with using local names is that you can develop synonyms, two names for the same data element.

Example: In the current roster example, suppose the student's company was referred to simply as "company" instead of "customer". But suppose the accounting department for the education company used the same piece of data in a billing application—the name of the student's company—and referred to it as "customer". This would mean that two business processes were using two different names for the same piece of data. At worst, this could lead to redundant data if no one realized that "customer" and "company" contained the same data. To solve this, use a global name that is recognized by both departments using this data element. In

this case, “customer” is more easily recognized and the better choice. This name uniquely identifies the data element and has a specific meaning within the education company.

When you choose data element names, use qualifiers so that each name can mean only one thing.

Example: Suppose HQ, for each course that is taught, assigns a number to the course as it is developed and calls this number the “sequence number”. The Ed Centers, as they receive student enrollments for a particular class, assign a number to each student as a means of identification within the class. The Ed Centers call **this** number the “sequence number”. Thus HQ and the Ed Centers are using the same name for two separate data elements. This is called a *homonym*. You can solve the homonym problem by qualifying the names. The number that HQ assigns to each course can be called “course code” (CRSCODE), and the number that the Ed Centers assign to their students can be called “student sequence number” (STUSEQ#).

Definition: A *homonym* is one word for two different things.

Choose data element names that identify the element and describe it precisely. Make your data element names:

Unique	The name is clearly distinguishable from other names.
Self-explanatory	The name is easily understood and recognized.
Concise	The name is descriptive in a few words.
Universal	The name means the same thing to everyone.

Documenting Application Data

After you have determined what data elements a business process requires, record as much information about each of the data elements as possible. This information is useful to the DBA. Be aware of any standards that you are subject to regarding data documentation. Many places have standards concerning what information should be recorded about data and how and where that information should be recorded. The amount and type of this information varies from place to place. The following list is the type of information that is often recorded.

The descriptive name of the data element

Data element names should be precise, yet they should be meaningful to people who are familiar and also to those who are unfamiliar with the application.

The length of the data element

The length of the data element determines segment size and segment format.

The character format

The programmer needs to know if the data is alphanumeric, hexadecimal, packed decimal, or binary.

The range of possible values for the element

The range of possible values for the element is important for validity checking.

The default value

The programmer also needs the default value.

The number of data element occurrences

The number of data element occurrences helps the DBA to determine the required space for this data, and it affects performance considerations.

How the business process affects the data element

Whether the data element is read or updated determines the processing option that is coded in the PSB for the application program.

You should also record control information about the data. Such information should address the following questions:

- What action should the program take when the data it attempts to access is not available?
- If the format of a particular data element changes, which business processes does that affect? For example, if an education database has as one of its data elements a five-digit code for each course, and the code is changed to six digits, which business processes does this affect?
- Where is the data now? Know the sources of the data elements required by the application.
- Which business processes make changes to a particular data element?
- Are there security requirements about the data in your application? For example, you would not want information such as employees' salaries available to everyone?
- Which department owns and controls the data?

One way to gather and record this information is to use a form similar to the one shown in Table 3. The amount and type of data that you record depends on the standards that you are subject to. For example, Table 3 lists the ID number, data element name, length, the character format, the allowed, null, default values, and the number of occurrences.

Table 3. Example of Data Elements Information Form

ID #	Data Element Name	Length	Char. Format	Allowed Values	Null Values	Default Value	Number of Occurrences
5	Course Code	5 bytes	Hexa-decimal	0010090000	00000	N/A	There are 200 courses in the curriculum. An average of 10 are new or revised per year. An average of 5 are dropped per year.
25	Status	4 bytes	Alpha-numeric	CONF WAIT CANC	blanks	WAIT	1 per student
36	Student Name	20 bytes	Alpha-numeric	Alpha only	blanks	N/A	There are 3–100 students per class with an average of 40 per class.

A *data dictionary* is a good place to record the facts about the application's data. When you are analyzing data, a dictionary can help you find out whether a particular data element already exists, and if it does, its characteristics. With the DB/DC Data Dictionary, and its successor, DataAtlas (a part of the IBM VisualGen[®] Team Suite), you can determine online what segments exist in a particular database and what fields those segments contain. You can use either tool to create reports involving the same information.

Related Reading: For information on these products, see

- *OS/VS DB/DC Data Dictionary Applications Guide*
- *VisualGen V2R0.0 Introducing*
- *VisualGen: Running Application on MVS*

Designing a Local View

A *local view* is a description of the data that an individual business process requires. It includes the following:

- A list of the data elements
- A conceptual data structure that shows how you have grouped data elements by the entities that they describe
- The relationships between each of the groups of data elements

Definitions: A *data aggregate* is a group of data elements. When you have grouped data elements by the entity they describe, you can determine the relationships between the data aggregates. These relationships are called *mappings*. Based on the mappings, you can design a conceptual data structure for the business process. You should document this process as well.

Analyzing Data Relationships

When you analyze data relationships, you are developing conceptual data structures for the business processes in your application. This process, called *data structuring*, is a way to analyze the relationships among the data elements a business process requires, not a way to design a database. The decisions about segment formats and contents belong to the DBA. The information you develop is input for designing a database.

Data structuring can be done in many different ways. The method explained in this section is one example.

Grouping Data Elements into Hierarchies

The data elements that describe a data aggregate, the student, might be represented by the descriptive names STUSEQ#, STUNAME, CUST, LOCTN, STATUS, ABSENCE, and GRADE. We call this group of data elements the student data aggregate.

Data elements have values and names. In the student data elements example, the values are a particular student's sequence number, the student's name, company, company location, the student's status in the class, the student's absences, and grade. The names of the data aggregate are not unique—they describe all the students in the class in the same terms. The combined values, however, of a data aggregate occurrence are unique. No two students can have the same values in each of these fields.

As you group data elements into data aggregates and data structures, look at the data elements that make up each group and choose one or more data elements that uniquely identify that group. This is the data aggregate's *controlling key*, which is the data element or group of data elements in the aggregate that uniquely identifies the aggregate. Sometimes you must use more than one data element for the key in order to uniquely identify the aggregate.

By following the three steps explained in this section, you can develop a conceptual data structure for a business process's data. However, you are not developing the logical data structure for the program that performs the business process. The three steps are:

1. Separate repeating data elements in a single occurrence of the data aggregate.
2. Separate duplicate values in multiple occurrences of the data aggregate.
3. Group each data element with its controlling keys.

Step 1. Separating Repeating Data Elements: Look at a single occurrence of the data aggregate. Table 4 shows what this looks like for the class aggregate; the data element is listed with the class aggregate occurrence.

Table 4. Single Occurrence of Class Aggregate

Data Element	Class Aggregate Occurrence
EDCNTR	CHICAGO
DATE(START)	1/14/96
CRSNAME	TRANSISTOR THEORY
CRS CODE	41837
LENGTH	10 DAYS
INSTRS	multiple
STUSEQ#	multiple
STUNAME	multiple
CUST	multiple
LOCTN	multiple
STATUS	multiple
ABSENCE	multiple
GRADE	multiple

The data elements defined as multiple are the elements that repeat. Separate the repeating data elements by shifting them to a lower level. Keep data elements with their controlling keys.

The data elements that repeat for a single class are: STUSEQ#, STUNAME, CUST, LOCTN, STATUS, ABSENCE, and GRADE. INSTRS is also a repeating data element, because some classes require two instructors, although this class requires only one.

|
|
|
|
|

When you separate repeating data elements into groups, you have the structure shown in Figure 5 on page 18.

In that figure, the data elements in each box form an aggregate. The entire figure depicts a data structure. The data elements include Course aggregate, Student aggregate, and Instructor aggregate.

Figure 5 on page 18 shows these aggregates with the following keys indicated with leading asterisks (*):

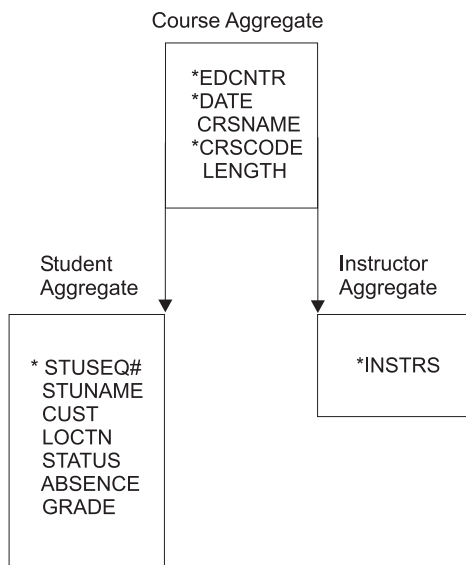

Figure 5. Current Roster After Step 1

Data Aggregate	Keys
Course aggregate	EDCNTR, DATE, CRSCODE
Student aggregate	EDCNTR, DATE, CRSCODE, STUSEQ#
Instructor aggregate	EDCNTR, DATE, CRSCODE, INSTRS

The asterisks in Figure 5 identify the key data elements. For the Class aggregate, it takes multiple data elements to identify the course, so you need multiple data elements to make up the key. The data elements that comprise the Class aggregate are:

- Controlling key element, STUSEQ#
- STUNAME
- CUST
- LOCTN
- STATUS
- ABSENCE

Along with these keys inherited from the root segment, Course aggregate:

- GRADE
- EDCNTR
- DATE
- CRSCODE

The data elements that comprise the Instructor aggregate are:

- Key element, INSTRS

Along with these Keys inherited from the root segment, Course aggregate:

- EDCNTR
- DATE
- CRSCODE

After you have shifted repeating data elements, make sure that each element is in the same group as its controlling key. INSTRS is separated from the group of data elements describing a student because the information about instructors is unrelated to the information about the students. The student sequence number does not control who the instructor is.

In the example shown in Figure 5 on page 18, the Student aggregate and Instructor aggregate are both dependents of the Course aggregate. A dependent aggregate's key includes the concatenated keys of all the aggregates above the dependent aggregate. This is because a dependent's controlling key does not mean anything if you don't know the keys of the higher aggregates. For example, if you knew that a student's sequence number was 4, you would be able to find out all the information about the student associated with that number. This number would be meaningless, however, if it were not associated with a particular course. But, because the key for the Student aggregate is made up of Ed Center, date, and course code, you can deduce which class the student is in.

Step 2. Isolating Duplicate Aggregate Values: Look at multiple occurrences of the aggregate—in this case, the values you might have for two classes. Table 5 shows multiple occurrences (2) of the same data elements. As you look at this table, check for duplicate values. Remember that both occurrences describe one course.

Table 5. Multiple Occurrences of Class Aggregate

Data Element List	Occurrence 1	Occurrence 2
EDCNTR	CHICAGO	NEW YORK
DATE(START)	1/14/96	3/10/96
CRSNAME	TRANS THEORY	TRANS THEORY
CRSCODE	41837	41837
LENGTH	10 DAYS	10 DAYS
INSTRS	multiple	multiple
STUSEQ#	multiple	multiple
STUNAME	multiple	multiple
CUST	multiple	multiple
LOCTN	multiple	multiple
STATUS	multiple	multiple
ABSENCE	multiple	multiple
GRADE	multiple	multiple

The data elements defined as multiple are the data elements that repeat. The values in these elements are not the same. The aggregate is always unique for a particular class.

In this step, compare the two occurrences and shift the fields with duplicate values (TRANS THEORY and so on) to a higher level. If you need to, choose a controlling key for aggregates that do not yet have keys.

In Table 5, CRSNAME, CRSCODE, and LENGTH are the fields that have duplicate values. Much of this process is intuitive. Student status and grade, although they can have duplicate values, should not be separated because they are not meaningful values by themselves. These values would not be used to identify a

particular student. This becomes clear when you remember to keep data elements with their controlling keys. When you separate duplicate values, you have the structure shown in Figure 6.

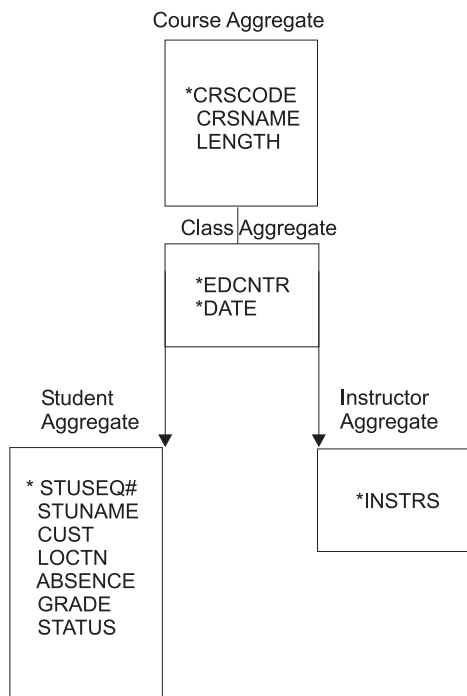

Figure 6. Current Roster After Step 2

Step 3. Grouping Data Elements with their Controlling Keys: This step is often a check on the first two steps. (Sometimes the first two steps have already done what this step instructs you to do.)

At this stage, make sure that each data element is in the group that contains its controlling key. The data element should depend on the full key. If the data element depends only on part of the key, separate the data element along with the partial (controlling) key on which it depends.

In this example, CUST and LOCTN do not depend on the STUSEQ#. They are related to the student, but they do not depend on the student. They identify the company and company address of the student.

CUST and LOCTN are not dependent on the course, the Ed Center, or the date, either. They are separate from all of these things. Because a student is only associated with one CUST and LOCTN, but a CUST and LOCTN can have many students attending classes, the CUST and LOCTN aggregate should be above the student aggregate.

Figure 7 on page 21 shows these aggregates and the following keys: Figure 7 on page 21 shows what the structure looks like when you separate CUST and LOCTN.

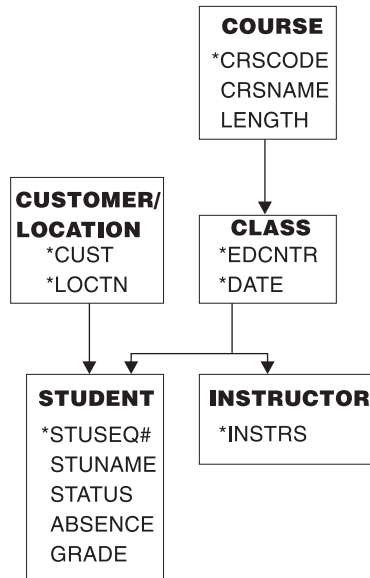

Figure 7. Current Roster After Step 3

Data Aggregate	Keys
Course aggregate	CRSCODE
Class aggregate	CRSCODE, EDCNTR, DATE
Customer aggregate	CUST, LOCTN
Student aggregate	(when viewed from the customer aggregate in Figure 7 instead of from the course aggregate, in Figure 6 on page 20) CUST, LOCTN, STUSEQ, CRSCODE, EDCNTR, DATE
Instructor aggregate	CRSCODE, EDCNTR, DATE, INSTRS

Deciding on the arrangement of the customer and location information is part of designing a database. Data structuring should separate any inconsistent data elements from the rest of the data elements.

Determining Mappings

When you have arranged the data aggregates into a conceptual data structure, you can examine the relationships between the data aggregates. A mapping between two data aggregates is the quantitative relationship between the two. The reason you record mappings is that they reflect relationships between segments in the data structure that you have developed. If you store this information in an IMS database, the DBA can construct a database hierarchy that satisfies all the local views, based on the mappings. In determining mappings, it is easier to refer to the data aggregates by their keys, rather than by their collected data elements.

The two possible relationships between any two data aggregates are:

- One-to-many

For each segment A, one or more occurrences of segment B exist. For example, each class maps to one or more students.

Mapping notation shows this in the following way:

Class ←————→ **Student**

- **Many-to-many**
Segment B has many A segments associated with it and segment A has many B segments associated with it. In a hierarchic data structure, a parent can have one or more children, but each child can be associated with only one parent. The many-to-many association does not fit into a hierarchy, because in a many-to-many association each child can be associated with more than one parent.

Related Reading: For more information about analyzing data requirements, see *IMS Version 9: Administration Guide: Database Manager*

Many-to-many relationships occur between segments in two business processes. A many-to-many relationship indicates a conflict in the way that two business processes need to process those data aggregates. If you use the IMS full-function database, you can solve this kind of processing conflict by using secondary indexing or logical relationships. “Understanding How Data Structure Conflicts Are Resolved” on page 74 explains how to use these tools.

The mappings for the current roster are:

- **Course** \longleftrightarrow **Class**
For each course, there might be several classes scheduled, but a class is associated with only one course.
- **Class** \longleftrightarrow **Student**
A class has many students enrolled in it, but a student might be in only one class offering of this course.
- **Class** \longleftrightarrow **Instructor**
A class might have more than one instructor, but an instructor only teaches one class at a time.
- **Customer/location** \longleftrightarrow **Student**
A customer might have several students attending a particular class, but each student is only associated with one customer and location.

Local View Examples

This section presents three more examples of designing a local view: The Schedule of Classes, the Instructor Skills Report, and the Instructor Schedules. It does not explain how to design a local view; it simply takes you through the examples. Each example shows the parts of designing a local view:

1. Gather the data. For each example, the data elements are listed and two occurrences of the data aggregate are shown. Two occurrences are shown because you need to look at both occurrences when you look for repeating fields and duplicate values.
2. Analyze the data relationships. First, group the data elements into a conceptual data structure using these three steps:
 - a. Separate repeating data elements in a single occurrence of the data aggregate by shifting them to a lower level. Keep data elements with their keys.
 - b. Separate duplicating values in two occurrences of the data aggregate by shifting those data elements to a higher level. Again, keep data elements with their keys.
 - c. Group data elements with their keys. Make sure that all the data elements within one aggregate have the same key. Separate any that do not.
3. Determine the mappings between the data aggregates in the data structure you have developed.

Schedule of Courses

HQ keeps a schedule of all the courses given each quarter and distributes it monthly. HQ wants the schedule to be sorted by course code and printed in the format shown in Figure 8.

COURSE SCHEDULE			
COURSE:	TRANSISTOR THEORY	COURSE CODE:	418737
LENGTH:	10 DAYS	PRICE:	\$280
<u>DATE</u>		<u>LOCATION</u>	
APRIL 14		BOSTON	
APRIL 21		CHICAGO	
.			
.			
NOVEMBER 18		LOS ANGELES	

Figure 8. Schedule of Courses

1. Gather the data. Table 6 lists the data elements and two occurrences of the data aggregate.

Table 6. Course Schedule Data Elements

Data Elements	Occurrence 1	Occurrence 2
CRSNAME	TRANS THEORY	MICRO PROG
CRSCODE	41837	41840
LENGTH	10 DAYS	5 DAYS
PRICE	\$280	\$150
DATE	multiple	multiple
EDCNTR	multiple	multiple

2. Analyze the data relationships. First, group the data elements into a conceptual data structure.
 - a. Separate repeating data elements in one occurrence of the data aggregate by shifting them to a lower level, as shown in Figure 9

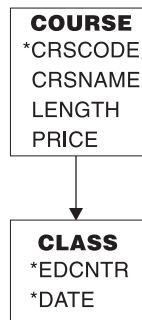

Figure 9. Course Schedule After Step 1

- b. Next, separate duplicate values in two occurrences of the data aggregate by shifting the data elements to a higher level. This data aggregate does not contain duplicate values.
- c. Group data elements with their controlling keys.

Data elements are grouped with their keys in the present structure. No changes are necessary for this step.

The keys for the data aggregates are as follows:

Data Aggregate	Keys
Course aggregate	CRSCODE
Class aggregate	CRSCODE, EDCNTR, DATE

- When you have developed a conceptual data structure, determine the mappings for the data aggregates.

The mapping for this local view is:

Course ←————→ **Class**

Instructor Skills Report

Each Ed Center needs to print a report showing the courses that its instructors are qualified to teach. The report format is shown in Figure 10.

INSTRUCTOR SKILLS REPORT		
<u>INSTRUCTOR</u>	<u>COURSE CODE</u>	<u>COURSE NAME</u>
BENSON, R. J.	41837	TRANS THEORY
MORRIS, S. R.	41837	TRANS THEORY
	41850	CIRCUIT DESIGN
	41852	LOGIC THEORY
.		
.		
REYNOLDS, P. W.	41840	MICRO PROG
	41850	CIRCUIT DESIGN

Figure 10. Instructor Skills Report

- Gather the data. Table 7 lists the data elements and two occurrences of the data aggregate.

Table 7. Instructor Skills Data Elements

Data Elements	Occurrence 1	Occurrence 2
INSTR	REYNOLDS, P.W.	MORRIS, S. R.
CRSCODE	multiple	multiple
CRSNAME	multiple	multiple

- Analyze the data relationships. First, group the data elements into a conceptual data structure.
 - Separate repeating data elements in one occurrence of the data aggregate by shifting to a higher level as shown in Figure 11 on page 25

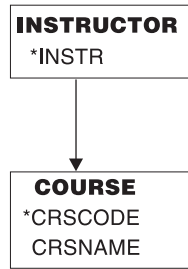

Figure 11. Instructor Skills After Step 1

- b. Separate any duplicate values in the two occurrences of the data aggregate.
No duplicate values exist in this data aggregate.
 - c. Group data elements with their keys.
All data elements are grouped with their keys in the current data structure.
There are no changes to this data structure.
3. Determine the mappings for the data aggregates.
The mapping for this local view is:
Instructor ←————→ **Course**

Instructor Schedules

HQ wants to produce a report showing the schedules for all the instructors.
Figure 12 shows the report format.

INSTRUCTOR SCHEDULES				
<u>INSTRUCTOR</u>	<u>COURSE</u>	<u>CODE</u>	<u>ED CENTER</u>	<u>DATE</u>
BENSON, R. J.	TRANS THEORY	41837	CHICAGO	1/14/96
MORRIS, S. R.	TRANS THEORY	41837	NEW YORK	3/10/96
	LOGIC THEORY	41852	BOSTON	3/27/96
	CIRCUIT DES	41840	CHICAGO	4/21/96
REYNOLDS, B. H.	MICRO PROG	41850	NEW YORK	2/25/96
	CIRCUIT DES	41850	LOS ANGELES	3/10.96

Figure 12. Instructor Schedules

- 1. Gather the data. Table 8 lists the data elements and two occurrences of the data aggregate.

Table 8. Instructor Schedules Data Elements

Data Elements	Occurrence 1	Occurrence 2
INSTR	BENSON, R. J.	MORRIS, S. R.
CRSNAME	multiple	multiple
CRSCODE	multiple	multiple
EDCNTR	multiple	multiple
DATE(START)	multiple	multiple

- 2. Analyze the data relationships. First, group the data elements into a conceptual data structure.
 - a. Separate repeating data elements in one occurrence of the data aggregate by shifting data elements to a lower level as shown in Figure 13 on page 26.

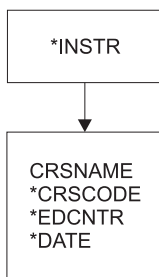

Figure 13. Instructor Schedules Step 1

- b. Separate duplicate values in two occurrences of the data aggregate by shifting data elements to a higher level as shown in Figure 14.
In this example, CRSNAME and CRSCODE can be duplicated for one instructor or for many instructors, for example, 41837 for Benson and 41850 for Morris and Reynolds.

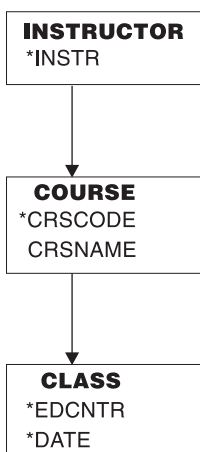
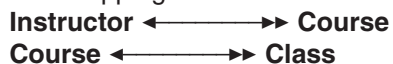

Figure 14. Instructor Schedules Step 2

- c. Group data elements with their keys.
All data elements are grouped with their controlling keys in the current data structure. No changes to the current data structure are required.
3. Determine the mappings for the data aggregates.
The mappings for this local view are:



An analysis of data requirements is necessary to combine the requirements of the three examples presented in this section and to design a hierarchic structure for the database based on these requirements.

Related Reading: For more information on analyzing data requirements, see *IMS Version 9: Administration Guide: Database Manager*.

Chapter 3. Analyzing IMS Application Processing Requirements

This section assumes you are writing application programs for IMS environments and explains the kinds of application programs that IMS supports and the requirements that each satisfies.

In this Section:

- “Deciding Your IMS Application’s Requirements”
- “Accessing Databases With Your IMS Application Program” on page 28
- “Accessing Data: The Types of Programs You Can Write for Your IMS Application” on page 31
- “IMS Programming Integrity and Recovery Considerations” on page 38
- “Dynamic Allocation for IMS Databases” on page 47

Related Reading: For information on writing CICS application programs, see Chapter 4, “Analyzing CICS Application Processing Requirements,” on page 49.

Deciding Your IMS Application’s Requirements

One of the steps of application design is to decide how the business processes, or tasks, that the end user wants performed can be best grouped into a set of programs that efficiently performs the required processing. To analyze processing requirements, consider:

When the task must be performed

- Will the task be scheduled unpredictably (for example, on terminal demand) or periodically (for example, weekly)?

How the program that performs the task is executed

- Will the program be executed online, where response time is crucial, or by batch job submission, where a slower response time is acceptable?

The consistency of the processing components

- Does the action the program is to perform involve more than one type of program logic? For example, does it involve mostly retrievals and only one or two updates? If so, you should consider separating the updates into a separate program.
- Does this action involve several large groups of data? If it does, it might be more efficient to separate the programs by the data they access.

Any special requirements about the data or processing

- | | |
|---------------------|--|
| Security | Should access to the program be restricted? |
| Recovery | Are there special recovery considerations in the program’s processing? |
| Availability | Does your application require high data availability? |
| Integrity | Do other departments use the same data? |

Answers to questions like these can help you decide on the number of application programs that the processing will require, and on the types of programs that perform the processing most efficiently. Although rules dealing with how many programs can most efficiently do the required processing do not exist, here are some suggestions:

- As you look at each programming task, examine the data and processing that each task involves. If a task requires different types of processing and has different time limitations (for example, daily as opposed to different times throughout the month), that task might be more efficiently performed by several programs.
- As you define each program, it is a good idea for maintenance and recovery reasons to keep it as simple as possible. The simpler a program is—the less it does—the easier it is to maintain, and to restart after a program or system failure. The same is true with data availability—the less data that is accessed, the more likely the data is to be available. The more limited the access requested, the more likely the data is to be available.

Similarly, if the data that the application requires is physically in one place, it might be more efficient to have one program do more of the processing than usual. These are considerations that depend upon the processing and the data of each application.

- Documenting each of the user tasks is helpful during the design process, and in the future when others will work with your application. Be sure you are aware of standards in this area. The kind of information that is typically kept is when the action is to be executed, a functional description, and requirements for maintenance, security, and recovery.

Example: For the current roster process described in “Listing Data Elements” on page 11, you might record the information shown in Figure 15. How frequently the program is run is determined by the number of classes (20) needed by the Education Center each week.

USER TASK DESCRIPTION

NAME: Current Roster

ENVIRONMENT: Batch **FREQUENCY:** 20 per week

INVOKING EVENT OR DOCUMENT: Time period (one week)

REQUIRED RESPONSE TIME: 24 hours

FUNCTION DESCRIPTION: Print weekly, a current student roster, in student number sequence for each class offered at the Education Center.

MAINTENANCE: Included in Education DB maintenance.

SECURITY: None.

RECOVERY: After a failure, the ability to start printing a particular class roster starting from a particular sequential student number.

Figure 15. Documenting User Task Descriptions: Current Roster Example

Accessing Databases With Your IMS Application Program

When designing your program, consider the type of database it must access. The type of database depends on the operating environment. The program types you can run and the different types of databases you can access in a DB batch, TM batch, DB/DC, DBCTL, or DCCTL environment are shown in Table 9 on page 29.

Table 9. Program and Database Options in IMS Environments

Environment	Type of Program You Can Run	Type of Database That Can Be Accessed	
DB Batch	DB Batch	Full function	
		DB2	
		GSAM MVS files	
TM Batch	TM Batch	DB2	
		GSAM	
		MVS files	
DB/TM	MPP	Full function	
		DEDB and MSDB	
		DB2®	
	JMP	Full function	
		DEDB	
	JBP	Full function	
		DEDB	
	IFP	Full function	DEDB and MSDB
			DB2
		BMP	Full function
DEDB and MSDB DB2 MVS files			
DBCTL	BMP (Batch-oriented)	Full function	
		DEDB	
		DB2	
		GSAM	
		MVS files	
	JBP	Full function	
		DEDB	

Table 9. Program and Database Options in IMS Environments (continued)

Environment	Type of Program You Can Run	Type of Database That Can Be Accessed
DCCTL	MPP	DB2
	IFP	DB2
	BMP	DB2
		GSAM

The types of databases that can be accessed are:

IMS Databases

There are two types of IMS databases: full-function and Fast Path.

– **Full-Function Databases**

Full-function databases are hierarchic databases that are accessed through Data Language I (DL/I) call interface and can be processed by these types of application programs: IFP, JMP, JBP, MPP, BMP, and DB batch. DL/I calls make it possible for IMS application programs to retrieve, replace, delete, and add segments to full-function databases.

JMP and JBP applications use JDBC to access full-function databases in addition to DL/I.

If you use data sharing, online programs and batch programs can access the same full-function database concurrently.

Full-function database types include: HDAM, HIDAM, HSAM, HISAM, SHSAM, and SHISAM.

– **Fast Path Databases**

Fast Path databases are of two types: MSDBs and DEDBs.

- **Main storage databases** (MSDBs) are root-segment-only databases that reside in virtual storage during execution.
- **Data entry databases** (DEDBs) are hierarchic databases that provide a high level of availability for, and efficient access to, large volumes of detailed data.

MPP, BMP, and IFP programs can access Fast Path databases. In the DBCTL environment, BMP programs can access DEDBs' but not MSDBs. JMP and JBP programs can access DEDBs' but not MSDBs.

DB2 Databases

DB2 databases are relational databases that can be processed by IMS batch, MPP, BMP, and IFP programs. An IMS application program might access only DL/I databases, both DL/I and DB2 databases, or only DB2 databases. Relational databases are represented to application programs and users as tables, and are processed using a relational data language called Structured Query Language (SQL).

Note: JMP and JBP programs cannot access DB2 databases.

Related Reading: For information on processing DB2 databases, see *DB2 UDB for z/OS and OS/390 Application Programming and SQL Guide*.

MVS Files

BMPs (in both the DB/DC and DBCTL environment) are the only type of online application program that can access MVS™ files for their input or output. Batch programs can also access MVS files.

GSAM Databases (Generalized Sequential Access Method)

Generalized Sequential Access Method (GSAM) is an access method that makes it possible for BMPs and batch programs to access a sequential MVS data set as a simple database. A GSAM database can be accessed by MVS or by IMS.

Accessing Data: The Types of Programs You Can Write for Your IMS Application

You must decide what type of program to use: batch programs, message processing programs (MPPs), IMS Fast Path programs (IFPs), batch message processing programs (BMPs), Java Message Processing (JMPs) or Java Batch Processing (JBPs). As Table 9 on page 29 shows, the types of programs you can use depend on whether you are running in the batch, DB/DC, or DBCTL environment.

The following sections explain the types of databases that the programs access, when the programs are used, and how to recover the programs.

DB Batch Processing

The following description of DB batch processing can help you decide if this batch program is appropriate for your application.

Data That a DB Batch Program Can Access

A DB batch program can access full-function databases, DB2 databases, GSAM databases, and MVS files. A DB batch program cannot access DEDBs or MSDBs.

Using DB Batch Processing

Batch programs are typically longer-running programs than online programs. You use a batch program when you have a large number of database updates to do or a report to print. Because a batch program runs by itself—it does not compete with any other programs for resources like databases—it can run independently of the control region. If you use data sharing, DB batch programs and online programs can access full-function databases concurrently. Batch programs:

- Typically produce a large amount of output, such as reports.
- Are not executed by another program or user. They are usually scheduled at specific time intervals (for example, weekly) and are started with JCL.
- Produce output that is not needed right away. The turnaround time for batch output is not crucial, as it usually is for online programs.

Recovering a DB Batch Program

Include checkpoints in your batch program to restart it in case of failure.

Issuing Checkpoints: Issue checkpoints in a batch program to commit database changes and provide places from which to restart your program. Issuing checkpoints in a batch program is important, because commit points do not occur automatically, as they do in MPPs, transaction-oriented BMPs, and IFPs.

Issuing checkpoints is particularly important in a batch program that participates in data sharing with your online system. Checkpoints free up resources for use by online programs. You should initially include checkpoints in all batch programs that you write. Even though the checkpoint support might not be needed then, it is

easier to incorporate checkpoints initially than to try to fit them in later. And it is possible that you might want to convert your batch program to a BMP or participate in data sharing. For more information on issuing checkpoints, see “Checkpoints in Batch Programs” on page 44.

To issue checkpoints (or other system service calls), you must specify an I/O PCB for your program. To obtain an I/O PCB, use the compatibility option by specifying `CMPAT=YES` in the `PSBGEN` statement in your program's `PSB`.

Related Reading: For more information on obtaining an I/O PCB, see *IMS Version 9: Application Programming: Database Manager*.

Recommendation: For `PSBs` used by DB batch programs, always specify `CMPAT=YES`.

Backing out Database Changes: The type of storage medium for the system log determines what happens when a DB batch program terminates abnormally. You can specify that the system log be stored on either DASD (direct access storage device) or tape.

System Log on DASD: If the system log is stored on DASD, using the `BKO` execution parameter you can specify that IMS is to dynamically back out the changes that the program has made to the database since its last commit point.

Related Reading: For information on using the `BKO` execution parameter, see *IMS Version 9: Installation Volume 2: System Definition and Tailoring*.

Dynamically backing out database changes has the following advantages:

- Data accessed by the program that failed is available to other programs immediately. If batch backout is used, other programs cannot access the data until the IMS Batch Backout utility has been run to back out the database changes.
- If data sharing is being used and two programs are deadlocked, one of the programs can continue processing. Otherwise, if batch backout is used, both programs fail.

IMS performs dynamic backout for a batch program when an IMS-detected failure occurs, for example, when a deadlock is detected. Logging to DASD makes it possible for batch programs to issue the `SETS`, `ROLB`, and `ROLS` system service calls. These calls cause IMS to dynamically back out changes that the program has made.

Related Reading: For information on the `SETS`, `ROLB`, and `ROLS` calls, see the section entitled “Recovering Databases and Maintaining Database Integrity” in either of the following books:

- *IMS Version 9: Application Programming: Database Manager*
- *IMS Version 9: Application Programming: EXEC DLI Commands for CICS and IMS*

System Log on Tape: If a batch application program terminates abnormally and the batch system log is stored on tape, you must use the IMS Batch Backout utility to back out the program's changes to the database.

TM Batch Processing

A TM batch program acts like a DB batch program with the following differences:

- It cannot access full-function databases, but it can access DB2 databases, GSAM databases, and MVS files.
- To issue checkpoints for recovery, you need not specify CMPAT=YES in your program's PSB. (The CMPAT parameter is ignored in TM batch.) The I/O PCB is always the first PCB in the list.
- You cannot dynamically back out a database because IMS does not own the databases.

Processing Messages: MPPs

The following description of a message processing program (MPP) can help you decide if this online program is appropriate for your application.

Data That an MPP Can Access

An MPP is an online program that can access full-function databases, DEDBs, MSDBs, and DB2 databases. Unlike BMPs and batch programs, MPPs cannot access GSAM databases. MPPs can only run in DB/DC and DCCTL environments.

Using an MPP

The primary purpose of an MPP is to process requests from users at terminals and from other application programs. Ideally, MPPs are very small, and the processing they perform is tailored to respond to requests quickly. They process messages as their input, and send messages as responses.

Definition: A *message* is data that is transmitted between any two terminals, application programs, or IMS systems. Each message has one or more segments.

MPPs are executed through transaction codes. When you define an MPP, you associate it with one or more transaction codes. Each transaction code represents a transaction the MPP is to process. To process a transaction, a user at a terminal enters a code for that transaction. IMS then schedules the MPP associated with that code, and the MPP processes the transaction. The MPP might need to access the database to do this. Generally, an MPP goes through these five steps to process a transaction:

1. Retrieve a message from IMS.
2. Process the message and access the database as necessary.
3. Respond to the message.
4. Repeat the process until no messages are forthcoming.
5. Terminate.

When an MPP is defined, a system administrator makes decisions about the program's scheduling and processing. For each MPP, a system administrator specifies:

- The transaction's priority
- The number of messages for a particular transaction code that the MPP can process in a single scheduling
- The amount of time (in seconds) in which the MPP is allowed to process a single transaction

Defining priorities and processing limits gives system administration some control over load balancing and processing.

Although the primary purpose of an MPP is to process and reply to messages quickly, it is flexible in how it processes a transaction and where it can send output

messages. For example, an MPP can send output messages to other terminals and application programs. See Chapter 5, "Gathering Requirements for Database Options," on page 67 for a description of some of the options available to MPPs.

Processing Messages: IFPs

The following description of an IMS Fast Path (IFP) program can help you decide if this online program is appropriate for your application.

Data That an IFP Can Access

An IFP is similar to an MPP: Its main purpose is to quickly process and reply to messages from terminals.

Like an MPP, an IFP can access full-function databases, DEDBs, MSDBs, and DB2 databases. IFPs can only be run in DB/DC and DCCTL environments.

Using an IFP

You should use an IFP if you need quick processing and can accept the characteristics and constraints associated with IFPs.

The main differences between IFPs and MPPs are as follows:

- Messages processed by IFPs must consist of only one segment. Messages that are processed by MPPs can consist of several segments.
- IFPs bypass IMS queuing, allowing for more efficient processing. Transactions that are processed by Fast Path's EMH (expedited message handler) are on a first-in, first-out basis.

IFPs also have the following characteristics:

- They run in **transaction response mode**. This means that they must respond to the terminal that sent the message before the terminal can enter any more requests.
- They process only **wait-for-input transactions**. When you define a program as processing wait-for-input transactions, the program remains in virtual storage, even when no additional messages are available for it to process.

Restrictions:

- An IMS program cannot send messages to an IFP transaction unless it is in another IMS system that is connected using Intersystem Communication (ISC).
- MPPs cannot pass conversations to an IFP transaction.

Recovering an IFP

IFPs must be defined as single mode. This means that a commit point occurs each time the program retrieves a message. Because of this, you do not need to issue checkpoint calls.

Batch Message Processing: BMPs

BMPs are application programs that can perform batch-type processing online and access the IMS message queues for their input and output. Because of this and because of the data available to them, BMPs are the most flexible of the IMS application programs.

The two types of BMPs are: **batch-oriented** and **transaction-oriented**. They are described in the following section s.

Batch Processing Online: Batch-Oriented BMPs

The following description of a batch message processing program can help you decide if this batch program is appropriate for your application.

Data a Batch-Oriented BMP Can Access: A batch-oriented BMP performs batch-type processing in any online environment. When run in the DB/DC or DCCTL environment, a batch-oriented BMP can send its output to the IMS message queue to be processed later by another application program. Unlike a transaction-oriented BMP, a batch-oriented BMP cannot access the IMS message queue for input.

In the DBCTL environment, a batch-oriented BMP can access full-function databases, DB2 databases, DEDBs, MVS files, and GSAM databases. In the DB/DC environment, a batch-oriented BMP can access all of these types of databases, as well as Fast Path MSDBs. In the DCCTL environment, this program can access DB2 databases, MVS files, and GSAM databases.

Using a Batch-Oriented BMP: A batch-oriented BMP can be simply a batch program that runs online. (Online requests are processed by the IMS DB/DC, DBCTL, or DCCTL system rather than by a batch system.) You can even run the same program as a BMP or as a batch program.

Recommendation: If the program performs a large number of database updates without issuing checkpoints, consider running it as a batch program so that it does not degrade the performance of the online system.

To use batch-oriented BMPs most efficiently, avoid a large amount of batch-type processing online. If you have a BMP that performs time-consuming processing such as report writing and database scanning, schedule it during non-peak hours of processing. This will prevent it from degrading the response time of MPPs.

Because BMPs can degrade response times, your response time requirements should be the main consideration in deciding the extent to which you will use batch message processing. Therefore, use BMPs accordingly.

Recovering a Batch-Oriented BMP: Issuing checkpoint calls is an important part of batch-oriented BMP processing, because commit points do not occur automatically, as they do in MPPs, transaction-oriented BMPs, and IFPs. Unlike most batch programs, a BMP shares resources with MPPs. In addition to committing database changes and providing places from which to restart (as for a batch program), checkpoints release resources that are locked for the program. For more information on issuing checkpoints, see "Checkpoints in Batch-Oriented BMPs" on page 43.

If a batch-oriented BMP fails, IMS and DB2 back out the database updates the program has made since the last commit point. You then restart the program with JCL. If the BMP processes MVS files, you must provide your own method of taking checkpoints and restarting.

Converting a Batch Program to a Batch-Oriented BMP: If you have IMS TM or are running in the DBCTL environment, you can convert a batch program to a batch-oriented BMP.

- If you have IMS TM, you might want to convert your programs for these reasons:
 - BMPs can send output to the message queues.
 - BMPs can access DEDBs and MSDBs.

- BMPs simplify program recovery because logging goes to a single system log. If you use DASD for the system log in batch, you can specify that you want dynamic backout for the program. In that case, batch recovery is similar to BMP recovery, except, of course, with batch you need to manage multiple logs.
- Restart can be done automatically from the last checkpoint without changing the JCL.
- If you are using DBCTL, you might want to convert your programs for these reasons:
 - BMPs can access DEDBs.
 - BMPs simplify program recovery because logging goes to a single system log. If you use DASD for the system log in batch, you can specify that you want dynamic backout for the program. In that case, batch recovery is similar to BMP recovery, except, of course, with batch you need to manage multiple logs.
- If you are running sysplex data sharing and you either have IMS TM or are using DBCTL, you might want to convert your program. This is because using batch-oriented BMPs helps you stay within the sysplex data-sharing limit of 32 connections for each OSAM or VSAM structure.

If you use data sharing, you can run batch programs concurrently with online programs. If you do not use data sharing, converting a batch program to a BMP makes it possible to run the program with BMPs and other online programs.

Also, if you plan to run your batch programs offline, converting them to BMPs enables you to run them with the online system, instead of waiting until the online system is not running. Running a batch program as a BMP can also keep the data more current.
- If you have IMS TM or are using DBCTL, you can have a program that runs as either a batch program or a BMP.

Recommendation: Code your checkpoints in a way that makes them easy to modify. Converting a batch program to a BMP or converting a batch program to use data sharing requires more frequent checkpoints. Also, if a program fails while running in a batch region, you must restart it in a batch region. If a program fails in a BMP region, you must restart it in a BMP region.

The requirements for converting a batch program to a BMP are:

- The program must have an I/O PCB. You can obtain an I/O PCB in batch by specifying the compatibility (CMPAT) option in the program specification block (PSB) for the program.

Related Reading: For more information on the CMPAT option in the PSB, see *IMS Version 9: Utilities Reference: System*.

- BMPs must issue checkpoint calls more frequently than batch programs.

See

Batch Message Processing: Transaction-Oriented BMPs

The following description of a transaction-oriented BMP can help you decide if this batch program is appropriate for your application.

Data a Transaction-Oriented BMP Can Access: Transaction-oriented BMPs can access MVS files, GSAM databases, DB2 databases, full-function databases, DEDBs, and MSDBs.

Unlike a batch-oriented BMP, a transaction-oriented BMP can access the IMS message queue for input and output, and it can only run in the DB/DC and DCCTL environments.

Using a Transaction-Oriented BMP: Unlike MPPs, transaction-oriented BMPs are not scheduled by IMS. You schedule them as needed and start them with JCL. For example, an MPP, as it processes each message, might send an output message giving details of the transaction to the message queue. A transaction-oriented BMP could then access the message queue to produce a daily activity report.

Typically, you use a transaction-oriented BMP to simulate direct update online: Instead of updating the database while processing its transactions, an MPP sends its updates to the message queue. A transaction-oriented BMP then performs the updates for the MPP. You can run the BMP as needed, depending on the number of updates. This improves response time for the MPP, and it keeps the data current. This can be more efficient than having the MPP process its transactions if the response time of the MPP is very important. One disadvantage in doing this, however, is that it splits the transaction into two parts which is not necessary.

If you have a BMP perform an update for an MPP, design the BMP so that, if the BMP terminates abnormally, you can reenter the last message as input for the BMP when you restart it. For example, suppose an MPP gathers database updates for three BMPs to process, and one of the BMPs terminates abnormally. You would need to reenter the message that the terminating BMP was processing to one of the other BMPs for reprocessing.

BMPs can process transactions defined as wait-for-input (WFI). This means that IMS allows the BMP to remain in virtual storage after it has processed the available input messages. IMS returns a QC status code, indicating that the program should terminate when one of the following occurs:

- The program reaches its time limit.
- The master terminal operator enters a command to stop processing.
- IMS is terminated with a checkpoint shutdown.

You specify WFI for a transaction on the WFI parameter of the TRANSACT macro during IMS system definition.

A batch message processing region (BMP) scheduled against WFI transactions returns a QC status code (no more messages) only for the following commands: /PSTOP REGION, /DBD, /DBR, or /STA.

Like MPPs, BMPs can send output messages to several destinations, including other application programs. See “Identifying Output Message Destinations” on page 99 for more information.

Recovering a Transaction-Oriented BMP: Like MPPs, with transaction-oriented BMPs, you can choose where commit points occur in the program. You can specify that a transaction-oriented BMP be single or multiple mode, just as you can with an MPP. If the BMP is single mode, issuing checkpoint calls is not as critical as in a multiple mode BMP. In a single mode BMP, a commit point occurs each time the program retrieves a message. For more information on issuing checkpoints in a BMP, see “Checkpoints in MPPs and Transaction-Oriented BMPs” on page 42.

Java Message Processing: JMPs

A JMP application program is similar to an MPP application program, except that JMP applications must be written in Java or object-oriented COBOL. Like an MPP application, a JMP application is started when there is a message in the message queue for the JMP application and IMS schedules the message for processing.

JMP applications can access IMS data or DB2 data using JDBC. JMP applications run in a JMP region that has a JVM (Java Virtual Machine). For more information about JMPs, see the *IMS Version 9: IMS Java Guide and Reference*.

Java Batch Processing: JBPs

A JBP application program is similar to a non-message-driven BMP application program, except that JBP applications must be written in Java or object-oriented COBOL.

JBP applications can access IMS data or DB2 data using JDBC. JBP applications run in a JMP region that has a JVM. For more information about JBPs, see the *IMS Version 9: IMS Java Guide and Reference*.

IMS Programming Integrity and Recovery Considerations

This section explains how IMS protects data integrity, and how you can plan ahead for program recovery. These topics assume some knowledge of IMS application programming. You might want to read this section after reading the IMS application programming book that is applicable for your environment.

How IMS Protects Data Integrity: Commit Points

When an online program accesses the database, it is not necessarily the only program doing so. IMS and DB2 make it possible for more than one application program to access the data concurrently without endangering the integrity of the data.

To access data concurrently while protecting data integrity, IMS and DB2 prevent other application programs from accessing segments that your program deletes, replaces, or inserts, until your program reaches a *commit point*. A commit point is the place in the program's processing at which it completes a unit of work. When a unit of work is completed, IMS and DB2 commit the changes that your program made to the database. Those changes are now permanent and the changed data is now available to other application programs.

What Happens at a Commit Point

When an application program finishes processing one distinct unit of work, IMS and DB2 consider that processing to be valid, even if the program later encounters problems. For example, an application program that is retrieving, processing, and responding to a message from a terminal constitutes a *unit of work*. If the program encounters problems while processing the next input message, the processing it has done on the first input message is not affected. These input messages are separate pieces of processing.

A commit point indicates to IMS that a program has finished a unit of work, and that the processing it has done is accurate. At that time:

- IMS releases segments it has locked for the program since the last commit point. Those segments are then available to other application programs.
- IMS and DB2 make the program's changes to the database permanent.

- The current position in all databases except GSAM is reset to the start of the database.

If the program terminates abnormally before reaching the commit point:

- IMS and DB2 back out all of the changes the program has made to the database since the last commit point. (This does not apply to batch programs that write their log to tape.)
- IMS discards any output messages that the program has produced since the last commit point.

Until the program reaches a commit point, IMS holds the program's output messages so that, if the program terminates abnormally, users at terminals and other application programs do not receive inaccurate information from the abnormally terminating application program.

If the program is processing an input message and terminates abnormally, the input message is **not** discarded if both of the following conditions exist:

1. You are not using the Non-Discardable Messages (NDM) exit routine.
2. IMS terminates the program with one of the following abend codes: U0777, U2478, U2479, U3303. The input message is saved and processed later.

Exception: The input message is discarded if it is not terminated by one of the abend codes previously referenced. When the program is restarted, IMS gives the program the next message.

If the program is processing an input message when it terminates abnormally, and you use the NDM exit routine, the input message might be discarded from the system regardless of the abend. Whether the input message is discarded from the system depends on how you have written the NDM exit routine.

Related Reading: For more information about the NDM exit routine, see *IMS Version 9: Customization Guide*.

- IMS notifies the MTO that the program terminated abnormally.
- IMS and DB2 release any locks that the program has held on data it has updated since the last commit point. This makes the data available to other application programs and users.

Where Commit Points Occur

A commit point can occur in a program for any of the following reasons:

- The program terminates normally. Except for a program that accesses Fast Path resources, normal program termination is always a commit point. A program that accesses Fast Path resources must reach a commit point before terminating.
- The program issues a Checkpoint call. Checkpoint calls are a program's means of explicitly indicating to IMS that it has reached a commit point in its processing.
- If a program processes messages as its input, a commit point might occur when the program retrieves a new message. IMS considers this commit point the start of a new unit of work in the program. Retrieving a new message is not always a commit point. This depends on whether the program has been defined as **single mode** or **multiple mode**.
 - If you specify single mode, a commit point occurs each time the program issues a call to retrieve a new message. Specifying single mode can simplify recovery, because you can restart the program from the most recent call for a new message if the program terminates abnormally. When IMS restarts the program, the program begins by processing the next message.
 - If you specify multiple mode, a commit point occurs when the program issues a Checkpoint call or when it terminates normally. At those times, IMS sends

the program's output messages to their destinations. Because multiple-mode programs contain fewer commit points than do single mode programs, multiple mode programs might offer slightly better performance than single-mode programs. When a multiple mode program terminates abnormally, IMS can only restart it from a checkpoint. Instead of reprocessing only the most recent message, a program might have several messages to reprocess, depending on when the program issued the last Checkpoint call.

Table 10 lists the modes in which the programs can run. Because processing mode is not applicable to batch programs and batch-oriented BMPs, they are not listed in the table. The program type is listed, and the table indicates which mode is supported.

Table 10. Processing Modes

Program Type	Single Mode Only	Multiple Mode Only	Either Mode
MPP			X
IFP	X		
Transaction-Oriented BMP			X

You specify single or multiple mode on the MODE parameter of the TRANSACT macro.

Related Reading: For information on the TRANSACT macro, see *IMS Version 9: Installation Volume 2: System Definition and Tailoring*.

See Figure 16 for an illustration of the difference between single-mode and multiple-mode programs. A single-mode program gets and processes messages, sends output, looks for more messages, and terminates if there are no more. A multiple-mode program gets and processes messages, sends output, but has a checkpoint before looking for more messages and terminating. For a single-mode program, the commit points are when the message is obtained and the program terminates. For multiple-mode, the commit point is at the checkpoint and when the program terminates.

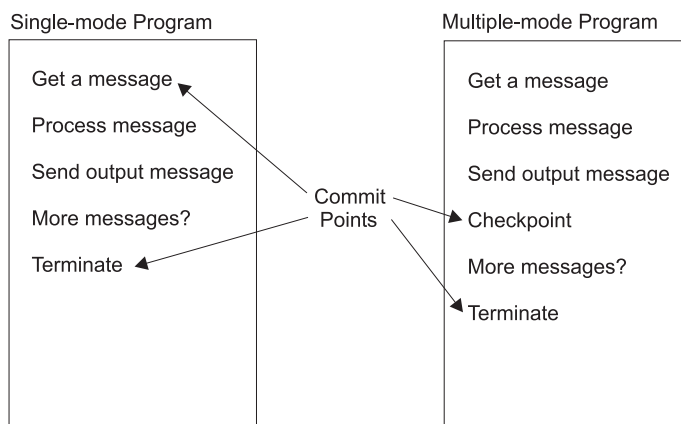

Figure 16. Single Mode and Multiple Mode

DB2 does some processing with multiple- and single-mode programs that IMS does not. When a multiple-mode program issues a call to retrieve a new message, DB2

performs an authorization check. If the authorization check is successful, DB2 closes any SQL cursors that are open. This affects the design of your program.

Related Reading: For more information on this topic, see *IMS Version 9: Application Programming: Transaction Manager*.

DB2's SQL COMMIT statement causes DB2 to make permanent changes to the database. However, this statement is valid only in TSO application programs. If an IMS application program issues this statement, it receives a negative SQL return code.

Planning for Program Recovery: Checkpoint and Restart

Recovery in an IMS application program that accesses DB2 data is handled by both IMS and DB2. IMS coordinates the process, and DB2 handles recovery of DB2 data.

Introducing Checkpoint Calls

Checkpoint calls indicate to IMS that the program has reached a commit point. They also establish places in the program from which the program can be restarted. IMS has symbolic Checkpoint calls and basic Checkpoint calls.

A program might issue only one type of Checkpoint call.

- MPPs and IFPs must use basic Checkpoint calls.
- BMPs and batch programs can use either symbolic Checkpoint calls or basic Checkpoint calls.

Programs that issue symbolic Checkpoint calls can specify as many as seven data areas in the program to be checkpointed. When IMS restarts the program, the Restart call restores these areas to the condition they were in when the program issued the symbolic Checkpoint call. Because symbolic Checkpoint calls do not support MVS files, if your program accesses MVS files, you must supply your own method of establishing checkpoints.

You can use symbolic Checkpoint for either Normal Start or Extended Restart (XRST).

Example: Typical calls for a Normal start would be as follows:

- XRST (I/O area is blank)
- CHKP (I/O area has checkpoint ID)
- Database Calls (including checkpoints)
- CHKP (final checkpoint)

Example: Typical calls for an Extended Restart (XRST) would be as follows:

- XRST (I/O area has checkpoint ID)
- CHKP (I/O area has new checkpoint ID)
- Database Calls (including checkpoints)
- CHKP (final checkpoint)

Related Reading: For more information on Checkpoint calls, see *IMS Version 9: Application Programming: Database Manager*.

The Restart call, which you must use with symbolic Checkpoint calls, provides a way of restarting a program after an abnormal termination. It restores the program's

data areas to the way they were when the program issued the symbolic Checkpoint call. It also restarts the program from the last checkpoint the program established before terminating abnormally.

All programs can use basic Checkpoint calls. Because you cannot use the restart call with the basic Checkpoint call, you must provide program restart. Basic Checkpoint calls do not support either MVS or GSAM files. IMS programs cannot use MVS Checkpoint and Restart. If you access MVS files, you must supply your own method of establishing checkpoints and restarting.

In addition to the actions that occur at a commit point, issuing a Checkpoint call causes IMS to:

- Inform DB2 that the changes your program has made to the database can be made permanent. DB2 makes the changes to DB2 data permanent, and IMS makes the changes to IMS data permanent.
- Write a log record containing the checkpoint identification given in the call to the system log, but only if the PSB contains a DB PCB. You can print checkpoint log records by using the IMS File Select and Formatting Print program (DFSERA10). With this utility, you can select and print log records based on their type, the data they contain, or their sequential positions in the data set. Checkpoint records are X'18' log records.

Related Reading: For more information about the DFSERA10 program, see *IMS Version 9: Utilities Reference: System*.

- Send a message containing the checkpoint identification that was given in the call to the system console operator and to the IMS master terminal operator.
- Return the next input message to the program's I/O area, if the program processes input messages. In MPPs and transaction-oriented BMPs, a Checkpoint call acts like a call for a new message.

Restriction: Do not specify CHKPT=EOV on any DD statement in order to take an IMS checkpoint because of unpredictable results.

When to Use Checkpoint Calls

Issuing Checkpoint calls is most important in programs that do not have built-in commit points. The decision about whether your program should issue checkpoints, and if so, how often, depends on your program. Generally, these programs should issue Checkpoint calls:

- Multiple-mode programs
- Batch-oriented BMPs (which can issue either SYNC or CHKP calls)
- Most batch programs
- Programs that run in a data sharing environment

You do not need to issue Checkpoint calls in:

- Single-mode BMP or MPP programs
- Database load programs
- Programs that access the database in read-only mode, as defined with the PROCOPT=GO option (during a PSBGEN), and are short enough to restart from the beginning
- Programs that have exclusive use of the database

Checkpoints in MPPs and Transaction-Oriented BMPs: The mode type of the program is specified on the MODE keyword of the TRANSACT macro during IMS system generation. The modes are single and multiple.

- **In single-mode programs**

In single mode programs (MODE=SNGL was specified on the TRANSACT macro during IMS system definition), a Get Unique to the message queue causes an implicit commit to be performed.

- **In multiple-mode programs**

In multiple-mode BMPs and MPPs, the only commit points are those that result from the Checkpoint calls that the program issues and from normal program termination. If the program terminates abnormally and it has not issued Checkpoint calls, IMS backs out the program's database updates and cancels the messages it created since the beginning of the program. If the program has issued Checkpoint calls, IMS backs out the program's changes and cancels the output messages it has created since the most recent checkpoint.

Consider the following when issuing Checkpoint calls in multiple-mode programs:

- How long it would take to back out and recover that unit of processing. The program should issue checkpoints frequently enough to make the program easy to back out and recover.
- How you want the output messages grouped. Checkpoint calls establish how a multiple-mode program's output messages are grouped. Programs should issue Checkpoint calls frequently enough to avoid building up too many output messages.

Depending on the database organization, issuing a Checkpoint call might reset your position in the database.

Related Reading: For more information about losing your position when a checkpoint is issued, see *IMS Version 9: Application Programming: Database Manager*.

Checkpoints in Batch-Oriented BMPs: Issuing Checkpoint calls in a batch-oriented BMP is important for several reasons:

- In addition to committing changes to the database and establishing places from which the program can be restarted, Checkpoint calls release resources that IMS has locked for the program.
- A batch-oriented BMP that uses DEDBs or MSDBs might terminate with abend U1008 if a SYNC or CHKP call is not issued before the application program terminates.
- If a batch-oriented BMP does not issue checkpoints frequently enough, it can be abnormally terminated, or it can cause another application program to be abnormally terminated by IMS for any of these reasons:
 - If a BMP retrieves and updates many database records between Checkpoint calls, it can tie up large portions of the databases and cause long waits for other programs needing those segments.

Exception: For a BMP with a processing option of GO or exclusive, IMS does not lock segments for programs. Issuing Checkpoint calls releases the segments that the BMP has locked and makes them available to other programs.

- The space needed to maintain lock information about the segments that the program has read and updated exceeds what has been defined for the IMS system. If a BMP locks too many segments, the amount of storage needed for the locked segments can exceed the amount of available storage. If this happens, IMS terminates the program abnormally. You must increase the program's checkpoint frequency before rerunning the program. The available storage is specified during IMS system definition.

Related Reading: For more information on specifying storage, see *IMS Version 9: Installation Volume 2: System Definition and Tailoring*.

You can limit the number of locks for the BMP by using the LOCKMAX=*n* parameter on the PSBGEN statement. For example, a specification of LOCKMAX=5 means the application cannot obtain more than 5000 locks at any time. The value of *n* must be between 0 and 255. When a maximum lock limit does not exist, 0 is the default. If the BMP tries to acquire more than the specified number of locks, IMS terminates the application with abend U3301.

Related Reading: For more information about this abend, see *IMS Version 9: Messages and Codes, Volume 1*.

Checkpoints in Batch Programs: Batch programs that update databases should issue Checkpoint calls. The main consideration in deciding how often to take checkpoints in a batch program is the time required to back out and reprocess the program after a failure. A general recommendation is one Checkpoint call every 10 or 15 minutes.

If you might need to back out the entire batch program, the program should issue the Checkpoint call at the very beginning of the program. IMS backs out the program to the checkpoint you specify, or to the most recent checkpoint, if you do not specify a checkpoint.

For a batch program to issue Checkpoint calls, it must specify the compatibility option in its PSB (CMPAT=YES). This generates an I/O PCB for the program, which IMS uses as an I/O PCB in the Checkpoint call.

Another important reason for issuing Checkpoint calls in batch programs is that, although they may currently run in an IMS batch region, they might later need to access online databases. This would require converting them to BMPs. Issuing Checkpoint calls in a BMP is important for reasons other than recovery—for example, to release database resources for other programs. So, you should initially include checkpoints in all batch programs that you write. Although the checkpoint support might not be needed then, it is easier to incorporate Checkpoint calls initially than to try to fit them in later.

To free database resources for other programs, batch programs that run in a data-sharing environment should issue Checkpoint calls more frequently than those that do not run in a data-sharing environment.

Specifying Checkpoint Frequency

You should specify checkpoint frequency in your program so that you can easily modify it when the frequency needs to be adjusted. You can do this by:

- Using a counter in your program to keep track of elapsed time, and issuing a Checkpoint call after a certain time interval.
- Using a counter to keep track of the number of root segments your program accesses, and issuing a Checkpoint call after a certain number of root segments.
- Using a counter to keep track of the number of updates your program performs, and issuing a Checkpoint call after a certain number of updates.

Data Availability Considerations

Your program might be unable to access data in a full-function database. This section describes the conditions for an unavailable database and the program calls that allow your program to manage data under these conditions.

Dealing with Unavailable Data

The conditions that make the database totally unavailable for both read and update are:

- The /LOCK command for a database was issued.
- The /STOP command for a database was issued.
- The /DBRECOVERY command was issued.
- Authorization for a database failed.

The conditions that make the database available only for read and not for update are:

- The /DBDUMP command has been issued.
- Database ACCESS value is RD (read).

In addition to unavailability of an entire database, other situations involving unavailability of a limited amount of data can also inhibit program access. One such example would be a failure situation involving data sharing. The active IMS system knows which locks were held by a sharing IMS system at the time the sharing IMS system failed. Although the active IMS system continues to use the database, it must reject access to the data which the failed IMS system locked upon failure. This situation occurs for both full-function and DEDB databases.

The two situations where the program might encounter unavailable data are:

- The program makes a call requiring access to a database that was unavailable at the time the program was scheduled.
- The database was available when the program was scheduled, but limited amounts of data are unavailable. The current call has attempted to access the unavailable data.

Regardless of the condition causing the data to be unavailable, the program has two possible approaches when dealing with unavailable data. The program can be **insensitive** or **sensitive** to data unavailability.

- When the program is insensitive, IMS takes appropriate action when the program attempts to access unavailable data.
- When the program is sensitive, IMS informs the program that the data it is attempting to access is not available.

If the program is insensitive to data unavailability, and attempts to access unavailable data, IMS aborts the program (3303 pseudo-abend), and backs out any updates the program has made. The input message that the program was processing is suspended, and the program is scheduled to process the input message when the data becomes available. However, if the database is unavailable because dynamic allocation failed, a call results in an AI (unable to open) status code.

If the program is sensitive to data unavailability and attempts to access unavailable data, IMS returns a status code indicating that it could not process the call. The program then takes the appropriate action. A facility exists for the program to initiate the same action that IMS would have taken if the program had been insensitive to unavailable data.

IMS does not schedule batch programs if the data that the program can access is unavailable. If the batch program is using block-level data sharing, it might

encounter unavailable data if the sharing system fails and the batch system attempts to access data that was updated but not committed by the failed system.

Scheduling and Accessing Unavailable Databases

By using the INIT, INQY, SETS, SETU, and ROLS calls, the program can manage a data environment where the program is scheduled with unavailable databases.

The INIT call informs IMS that the program is sensitive to unavailable data and can accept the status codes that are issued when the program attempts to access such data. The INIT call can also be used to determine the data availability for each PCB.

The INQY call is operable in both batch and online IMS environments. IMS application programs can use the INQY call to request information regarding output destination, session status, the current execution environment, the availability of databases, and the PCB address based on the PCBNAME. The INQY call is only supported via the AIB interface (AIBTDLI or CEETDLI using the AIB rather than the PCB address).

The SETS, SETU, and ROLS calls enable the application to define multiple points at which to preserve the state of full-function (except HSAM) databases and message activity. The application can then return to these points at a later time. By issuing a SETS or SETU call before initiating a set of DL/I calls to perform a function, the program can later issue the ROLS call if it cannot complete a function due to data unavailability.

The ROLS call allows the program to roll back its IMS full-function database activity to the state that it was in prior to a SETS or SETU call being issued. If the PSB contains an MSDB or a DEDB, the SETS and ROLS (with token) calls are invalid. Use the SETU call instead of the SETS call if the PSB contains a DEDB, MSDB, or GSAM PCB.

Related Reading: For more information on using the SETS and SETU calls with the ROLS call, see *IMS Version 9: Application Programming: Database Manager*.

The ROLS call can also be used to undo all update activity (database and messages) since the last commit point and to place the current input message on the suspend queue for later processing. This action is initiated by issuing the ROLS call without a token or I/O area.

Restriction: With DB2, you cannot use ROLS (with a token) or SETS.

Use of STAE or ESTAE and SPIE in IMS Programs

IMS uses STAE or ESTAE routines in the control region, the dependent (MPP, IFP, BMP) regions, and the batch regions. In the control region, STAE or ESTAE routines ensure that database logging and various resource cleanup functions are complete. In the dependent region, STAE or ESTAE routines are used to notify the control region of any abnormal termination of the application program or the dependent region itself. If the control region is not notified of the dependent region termination, resources are not properly released and normal checkpoint shutdown might be prevented.

In the batch region, STAE or ESTAE routines ensure that database logging and various resource cleanup functions are complete. If the batch region is not notified of the application program termination, resources might not be properly released.

Two important aspects of the STAE or ESTAE facility are that:

- IMS relies on its STAE or ESTAE facility to ensure database integrity and resource control.
- The STAE or ESTAE facility is also available to the application program.

Because of these two factors, be sure you clearly understand the relationship between the program and the STAE or ESTAE facility.

Generally, do not use the STAE or ESTAE facility in your application program. However, if you believe that the STAE or ESTAE facility is required, you must observe the following basic rules:

- When the environment supports STAE or ESTAE processing, the application program STAE or ESTAE routines always get control before the IMS STAE or ESTAE routines. Therefore, you must ensure that the IMS STAE or ESTAE exit routines receive control by observing the following procedures in your application program:
 - Establish the STAE or ESTAE routine only once and always before the first DL/I call.
 - When using the STAE or ESTAE facility, the application program should not alter the IMS abend code.
 - Do not use the RETRY option when exiting from the STAE or ESTAE routine. Instead, return a CONTINUE-WITH-TERMINATION indicator at the end of the STAE or ESTAE processing. If your application program specifies the RETRY option, be aware that IMS STAE or ESTAE exit routines will not get control to perform cleanup. Therefore, system and database integrity might be compromised.
 - For PL/I use of STAE and SPIE, see the description of IMS considerations in *Enterprise PL/I for z/OS and OS/390 Programming Guide*.
 - For PL/I, COBOL, and C/MVS, if you are using the AIBTDLI interface in a non-Language Environment[®] enabled system, you must specify NOSTAE and NOSPIE. However, in Language Environment Version 1.2 or later enabled environment, the NOSTAE and NOSPIE restriction is removed.
- The application program STAE or ESTAE exit routine must not issue DL/I calls (DB or TM) because the original abend might have been caused by a problem between the application and IMS. A problem between the application and IMS could result in recursive entry to STAE or ESTAE with potential loss of database integrity, or in problems taking a checkpoint. This also could result in a hang condition or an ABENDU0069 during termination.

Dynamic Allocation for IMS Databases

Use the dynamic allocation function to specify the JCL information for IMS databases in a library instead of in the JCL of each batch or online job.

Related Reading: For additional information on the definitions for dynamic allocation, see the description of the DFSMDA macro in *IMS Version 9: Utilities Reference: System*.

If you use dynamic allocation, do not include JCL DD statements for any database data sets that have been defined for dynamic allocation. Check with the DBA or comparable specialist to determine which databases have been defined for dynamic allocation.

Chapter 4. Analyzing CICS Application Processing Requirements

This section provides information for writing application programs in a CICS environment. See Chapter 3, “Analyzing IMS Application Processing Requirements,” on page 27 for the corresponding information on IMS application programming.

The following sections explain the kinds of programs CICS supports and the requirements that each satisfies.

In this Section:

- “Deciding Your CICS Application’s Requirements”
- “Accessing Databases With Your CICS Application Program” on page 51
- “Writing a CICS Program to Access IMS Databases” on page 52
- “Using Data Sharing for Your CICS Program” on page 56
- “Scheduling and Terminating a PSB (CICS Online Programs Only)” on page 57
- “Linking and Passing Control to Other Programs (CICS Online Programs Only)” on page 57
- “Maximizing the Performance of Your CICS System” on page 58
- “Programming Integrity and Database Recovery Considerations for Your CICS Program” on page 58
- “Data Availability Considerations for Your CICS Program” on page 63
- “Use of STAE or ESTAE and SPIE in IMS Batch Programs” on page 64
- “Dynamic Allocation for IMS Databases” on page 65

Deciding Your CICS Application’s Requirements

One of the steps of application design is to decide how the business processes, or tasks can be best grouped into a set of programs that will efficiently perform the required processing. Some of the considerations in analyzing processing requirements are:

When the task must be performed

- Will it be scheduled unpredictably (for example on terminal demand) or periodically (for example, weekly)?

How the program that performs the task is executed

- Will it be executed online, where response time is more important, or by batch job submission, where a slower response time is acceptable?

The consistency of the processing components

- Does this action the program is to perform involve more than one type of program logic? For example, does it involve mostly retrievals, and only one or two updates? If so, you should consider separating the updates into a separate program.
- Does this action involve several large groups of data? If it does, it might be more efficient to separate the programs by the data they access.

Any special requirements about the data or processing

Security Should access to the program be restricted?

Recovery Are there special recovery considerations in the program’s processing?

Integrity Do other departments use the same data?

Answers to questions like these can help you decide on the number of application programs that the processing will require, and on the types of programs that perform the processing most efficiently. Although rules dealing with how many programs can most efficiently do the required processing do not exist, here are some suggestions:

- As you look at each programming task, examine the data and processing that each task involves. If a task requires different types of processing and has different time limitations (for example, weekly as opposed to monthly), that task may be more efficiently performed by several programs.
- As you define each program, it is a good idea for maintenance and recovery reasons to keep programs as simple as possible. The simpler a program is—the less it does—the easier it is to maintain, and to restart after a program or system failure. The same is true with data availability—the less data that is accessed, the more likely the data is to be available; the more limited the data accessed, the more likely the data is to be available.

Similarly, if the data that the application requires is physically in one place, it might be more efficient to have one program do more of the processing than usual. These are considerations that depend on the processing and the data of each application.

- Documenting each of the user tasks is helpful during the design process, and in the future when others will work with your application. Be sure you are aware of the standards in this area. The kind of information that is typically kept is when the task is to be executed, a functional description, and requirements for maintenance, security, and recovery.

Example: For the Current Roster process described under “Listing Data Elements” on page 11, you might record the information shown in Figure 17. How frequently the program is run is determined by the number of classes (20) for which the Ed Center will print current rosters each week.

USER TASK DESCRIPTION	
NAME: Current Roster	
ENVIRONMENT: Batch	FREQUENCY: 20 per week
INVOKING EVENT OR DOCUMENT: Time period (one week)	
REQUIRED RESPONSE TIME: 24 hours	
FUNCTION DESCRIPTION: Print weekly, a current student roster, in student number sequence for each class offered at the Education Center.	
MAINTENANCE: Included in Education DB maintenance.	
SECURITY: None.	
RECOVERY: After a failure, the ability to start printing a particular class roster starting from a particular sequential student number.	

Figure 17. Current Roster Task Description

Accessing Databases With Your CICS Application Program

When designing your program, consider the type of data it must access. The type of data depends on the operating environment. The data from DL/I and DB2 databases, and MFS files, that is available to CICS online and IMS batch programs is shown in Table 11. Usage notes are also included.

Table 11. The Data Your Program Can Access

Type of Program	DL/I Databases	DB2 Databases	MVS Files
CICS Online	Yes ¹	Yes ²	Yes ³
DB Batch	Yes	Yes ³	Yes

Notes:

1. Except for Generalized Sequential Access Method (GSAM) databases. GSAM enables batch programs to access a sequential MVS data set as a simple database.
2. IMS does not participate in the call process.
3. Access through CICS file control or transient data services.

Also, consider the type of database your program must access. As shown in Table 12, the type of program you can write and database that can be accessed depends on the operating environment. Table 12 also includes usage notes.

Table 12. Program and Database Options in the CICS Environments

Environment ¹	Type of Program You Can Write	Type of Database That Can Be Accessed
DB Batch	DB Batch	DL/I Full-function DB2 ² GSAM MVS Files
DBCTL	BMP	DL/I Full-function DL/I DEDBs DB2 GSAM MVS Files
	CICS Online	DL/I Full-function DL/I DEDBs DB2 ² MVS Files (access through CICS file control or transient data services)

Notes:

1. A third CICS environment, referred to as remote DL/I, also exists. In this environment, a CICS system supports applications that issue DL/I calls but does not service the requests itself. It "function ships" the DL/I calls to another CICS system that is using DBCTL. For more information on remote DL/I, see *CICS IMS Database Control Guide*.
2. IMS does not participate in the call process.

The types of databases that can be accessed are:

Full-Function Databases

Full-function databases are hierarchic databases that are accessed through Data Language I (DL/I). DL/I calls enable application programs to retrieve, replace, delete, and add segments to full-function databases. CICS online and

BMP programs can access the same database concurrently (if participating in IMS data sharing); an IMS batch program must have exclusive access to the database (if not participating in IMS data sharing). See “Using Data Sharing for Your CICS Program” on page 56 for more details about when to use this environment.

All types of programs (batch, BMPs, and online) can access full-function databases.

Fast Path DEDBs

Data entry databases (DEDBs) are hierarchic databases for, and efficient access to, large volumes of detailed data. In the DBCTL environment, CICS online and BMP programs can access DEDBs.

DB2 Databases

DB2 databases are relational databases. Relational databases are represented to application programs and users as tables and are processed using a relational data language called Structured Query Language (SQL). DB2 databases can be processed by CICS online transactions, and by IMS batch and BMP programs.

Related Reading: For information on processing DB2 databases, see *DB2 UDB for z/OS and OS/390 Application Programming and SQL Guide*.

GSAM Databases

Generalized Sequential Access Method (GSAM) is an access method that enables BMPs and batch programs to access a “flat” sequential MVS data set as a simple database. A GSAM database can be accessed by MVS or CICS.

MVS Files

CICS online and IMS batch programs can access MVS files for their input, processing, or output. Batch programs can access MVS files directly; online programs must access them through CICS file control or transient data services.

Writing a CICS Program to Access IMS Databases

This section explains the following kinds of application programs that CICS users can write to process IMS databases:

- CICS online programs
- IMS batch programs
- IMS batch message processing (BMP) programs that are batch-oriented

As shown in Table 12 on page 51, the types of programs you can use depend on whether you are running in the DBCTL environment. Within the different environments, the type of program you write depends on the processing your application requires. Each type of program answers different application requirements.

Writing a CICS Online Program

The following description of a CICS online program can help you decide if an online program is appropriate for your application.

Data That a CICS Online Program Can Access

CICS online programs run in the DBCTL environment and can access IMS full-function databases, Fast Path DEDBs, DB2 databases, and MVS files.

Online programs that access IMS databases are executed in the same way as other CICS programs.

Using a CICS Online Program

An online program runs under the control of CICS, and it accesses resources concurrently with other online programs. Some of the application requirements online programs can answer are:

- Information in the database must be available to many users.
- Program needs to communicate with terminals and other programs.
- Programs must be available to users at remote terminals.
- Response time is important.

The structure of an online program, and the way it receives status information, depend on whether it is a call- or command-level program. However, both command- and call-level online programs:

- Schedule a PSB (for CICS online programs). A PSB is automatically scheduled for batch or BMP programs.
- Issue either commands or calls to access the database. Online programs cannot mix commands and calls in one logical unit of work (LUW).
- Optionally, terminate a PSB for CICS online programs.
- Issue an EXEC CICS RETURN statement when they have finished their processing. This statement returns control to the linking program. When the highest-level program issues the RETURN statement, CICS regains control and terminates the PSB if it has not yet been terminated.

Because an online application program can be used concurrently by several tasks, it must be quasi-reentrant.

An online program in the DBCTL environment can use many IMS system service requests.

Related Reading:

- For more information on writing these types of programs, see
 - *IMS Version 9: Application Programming: Database Manager* or
 - *IMS Version 9: Application Programming: EXEC DLI Commands for CICS and IMS*
- For more details about programming techniques and restrictions, see *CICS Application Programming Reference*.
- For a summary of the calls and commands an online program can issue, see
 - *IMS Version 9: Application Programming: Database Manager* or
 - *IMS Version 9: Application Programming: EXEC DLI Commands for CICS and IMS*

DL/I database or system service requests must refer to one of the program communication blocks (PCBs) from the list of PCBs passed to your program by IMS. The PCB that must be used for making system service requests is called the I/O PCB. When present, it is the first PCB in the list of PCBs.

For an online program in the DBCTL environment, the I/O PCB is optional. To use the I/O PCB, you must indicate this in the application program when it schedules the PSB.

Before you run your program, the program specification blocks (PSBs) and database descriptions (DBDs) the program uses must be converted to internal control block format using the IMS ACBGEN utility. (PSBs tell IMS an application

program's characteristics and use of data and terminals. DBDs tell IMS a database's physical and logical characteristics.)

Related Reading: For more information on performing an ACBGEN and a PSBGEN, see *IMS Version 9: Utilities Reference: System*.

Because an online program shares a database with other online programs, it may affect the performance of your online system. For more information on what you can do to minimize the effect your program has on performance, see "Maximizing the Performance of Your CICS System" on page 58.

Writing an IMS Batch Program

The following description of a batch program can help you decide if this program is appropriate for your application.

Data That a Batch Program Can Access

A batch program can access DL/I full-function, DB2, and GSAM databases, and MVS files. A batch program cannot access DEDBs or MSDBs, and it can run in the DBCTL environment.

Using a Batch Program

Batch programs typically run longer than online programs. If it is not participating in IMS data sharing, a batch program runs by itself and does not compete with other programs for database resources. Use a batch program to do a large number of database updates or when you want to print a report. Batch programs:

- Typically produce a large amount of output—for example, reports.
- Are not executed by another program or user. They are usually scheduled at specific time intervals (for example, weekly) and are started with JCL.
- Produce output that is not needed right away. The response time for batch output is not as important as it usually is for online programs.

The structure of a batch program and the way it receives status information depend on whether it is a command- or call-level program.

Related Reading: For more information on this topic, see:

- *IMS Version 9: Application Programming: EXEC DLI Commands for CICS and IMS*
- *IMS Version 9: Application Programming: Database Manager*

Unlike online programs, batch programs do not schedule or terminate PSBs. This is done automatically.

Batch programs can issue system service requests (such as checkpoint, restart, and rollback) to perform functions such as dynamically backing out database changes made by your program.

Related Reading: For a summary of the commands and calls, you can use in a batch program, see:

- *IMS Version 9: Application Programming: EXEC DLI Commands for CICS and IMS*
- *IMS Version 9: Application Programming: Database Manager*

When performing a PSBGEN, you must define the language of the program that will schedule the PSB. For your program to be able to successfully issue certain system service requests, such as a checkpoint or a rollback request, an I/O PCB must be

available for your program. To obtain an I/O PCB, specify CMPAT=YES in the PSBGEN statement. Make all batch programs sensitive to the I/O PCB so that checkpoints are easily introduced. Design all batch programs with checkpoint and restart in mind. Although the checkpoint support may not be needed initially, it is easier to incorporate checkpoints initially than to try to fit them in later. With checkpoints, it will be easier to convert batch programs to BMP programs or to batch programs that use data sharing.

Related Reading: For more information about obtaining an I/O PCB, see “Requesting an I/O PCB in Batch Programs” on page 59. For information on how to perform a PSBGEN, see *IMS Version 9: Utilities Reference: System*.

Converting a Batch Program to a Batch-Oriented BMP

If you are running in the DBCTL environment, you can convert a batch program to a batch-oriented BMP. Conversion to a BMP can be advantageous for these reasons:

- Logging is to the IMS log, which means that multiple logs are unnecessary.
- Automatic backout is available.
- Restart can be done automatically from the last checkpoint without changing the JCL.
- Concurrent access to databases is possible. If you are needing to run your batch programs offline, converting them to BMPs enables you to run them with the online system, instead of having to wait until the online system is not running. Running a batch program as a BMP can also keep the data more current.
- BMPs can access DEDBs.
- You can have a program that runs as either a batch or BMP program. However, because batch programs require fewer checkpoint calls than BMPs (except when data sharing), code Checkpoint calls in a way that makes them easy to modify. Also, if a program fails while running in a batch region, you must restart it in a batch region. If a program fails in a BMP region, you must restart it in a BMP region.
- If you are running sysplex data sharing, use of batch-oriented BMPs helps you stay within the sysplex data sharing limit of 32 connections for each OSAM or VSAM structure.

Requirements for converting a batch program to a BMP are:

- A BMP must have an I/O PCB. You can obtain an I/O PCB in batch by specifying the compatibility option in the program specification block (PSB) for the program.

Related Reading: For more information on the compatibility option in the PSB, see *IMS Version 9: Utilities Reference: System*.

- BMPs should issue Checkpoint calls more frequently than batch programs. However, batch programs in a data-sharing environment must also issue Checkpoint calls frequently.

Writing a Batch-Oriented BMP Program

The following description of a batch-oriented BMP program can help you decide if this program is appropriate for your application.

Data That a Batch-Oriented BMP Can Access

Batch-oriented batch message processing (BMP) programs can access full-function, DEDB, DB2, and GSAM databases and MVS files. Batch-oriented BMPs can be run only in a DBCTL environment.

Using a Batch-Oriented BMP

A batch-oriented BMP performs batch processing online. A batch-oriented BMP can be simply a batch program that runs online. You can even run the same program as a BMP or as a batch program.

Recommendations: If the program performs a large number of database updates without issuing checkpoint calls, it may be more efficient to run it as a batch program so that it does not degrade the performance of the online system.

To use batch-oriented BMPs most efficiently, avoid a large amount of batch-type processing online. If you have a BMP that performs time-consuming processing such as report writing and database scanning, schedule it during non-peak hours of processing.

Because BMPs can degrade response times, carefully consider the response time requirements as you decide on the extent to which you will use batch message processing. You should examine the trade-offs in using BMPs and use them accordingly.

Recovering a Batch-Oriented BMP

Issuing Checkpoint calls is an important part of batch-oriented BMP processing, because commit points do not occur automatically as they do in some other types of programs.

Unlike most batch programs, a BMP can share resources with CICS online programs using DBCTL. In addition to committing database changes and providing places from which to restart (as for a batch program), Checkpoint calls release resources locked for the program. For more information on issuing Checkpoint calls, see "Checkpoints in Batch-Oriented BMPs" on page 43.

If a batch-oriented BMP fails, IMS backs out the database updates the program has made since the last commit point. You must restart the program with JCL. If the BMP processes MVS files, you must provide your own method of taking checkpoints and restarting.

Using Data Sharing for Your CICS Program

If you use data sharing, your programs can participate in IMS data sharing. Under data sharing, CICS online and BMP programs can access the same DL/I database concurrently.

Batch programs in a data-sharing environment can access databases used by other batch programs, and by CICS and IMS online programs. With data sharing, you can share data directly and your program's requests need not go through a mirror transaction.

Related Reading: For more information on sharing a database with an IMS system, see *IMS Version 9: Administration Guide: System*.

Scheduling and Terminating a PSB (CICS Online Programs Only)

Before your online program issues any DL/I calls, it must indicate to IMS its intent to use a particular PSB by issuing either a PCB call or a SCHED command. In addition to indicating which PSB your program will use, the PCB call obtains the address of the PCBs in the PSB. When you no longer need a PSB, you can terminate it using the TERM request. The rest of this section describes the use of the TERM request and how it can affect your system.

In a CICS online program, you use a PCB call or SCHED command (for command-level programs) to obtain the PSB for your program. Because CICS releases the PSB your program uses when the transaction ends, your program need not explicitly terminate the PSB. Only use a terminate request if you want to:

- Use a different PSB
- Commit all the database updates and establish a logical unit of work for backing out updates
- Free IMS resources for use by other CICS tasks

A terminate request causes a CICS sync point, and a CICS sync point terminates the PSB. For more information about CICS recovery concepts, see the appropriate CICS publication.

Do not use terminate requests for other reasons because:

- A terminate request forces a CICS sync point. This sync point releases all recoverable resources and IMS database resources that were enqueued for this task.

If the program continues to update other CICS resources after the terminate request and then terminates abnormally, only those resources that were updated after the terminate request are backed out. Any IMS changes made by the program are not backed out.

- IMS lock management detects deadlocks that occur if two transactions are waiting for segments held by the other.

When a deadlock is detected, one transaction is abnormally terminated. Database changes are backed out to the last TERM request. If a TERM request or CICS sync point was issued prior to the deadlock, CICS does not restart the transaction.

Related Reading: For a complete description of transaction restart considerations, see *CICS Recovery and Restart Guide*.

- Issuing a terminate request causes additional logging.
- If the terminal output requests are issued after a terminate request and the transaction fails at this point, the terminal operator does not receive the message.

The terminal operator may assume that the entire transaction failed, and reenter the input, thus repeating the updates that were made before the terminate request. These updates were not backed out.

Linking and Passing Control to Other Programs (CICS Online Programs Only)

Use CICS to link your program to other programs without losing access to the facilities acquired in the linking program, as in the following examples:

- You could schedule a PSB and then link to another program using a LINK command. On return from that program, the PSB is still scheduled.
- Similarly, you could pass control to another program using the XCTL command, and the PSB remains scheduled until that program issues an EXEC CICS RETURN statement. However, when you pass control to another program using XCTL, the working storage of the program passing control is lost. If you want to retain the working storage for use by the program being linked to, you must pass the information in the COMMAREA.

Recommendation: To simplify your work, instead of linking to another program, you can issue all DL/I requests from one program module. This helps to keep the programming simple and easy to maintain.

Terminating a PSB or issuing a sync point affects the linking program. For example, a terminate request or sync point that is issued in the program that was linked causes the release of CICS resources enqueued in the linking program.

Maximizing the Performance of Your CICS System

When you write programs that share data with other programs (for example, a program that will participate in IMS data sharing or a BMP), be aware of how your program affects the performance of the online system. This section explains some things you can do to minimize the effect your program has on that performance.

A BMP program, in particular, can affect the performance of the CICS online transactions. This is because BMP programs usually make a larger number of database updates than CICS online transactions, and a BMP program is more likely to hold segments that CICS online programs need. Limit the number of segments held by a BMP program, so CICS online programs need not wait to acquire them.

One way to limit the number of segments held by a BMP or batch program that participates in IMS data sharing is to issue checkpoint requests in your program to commit database changes and release segments held by the program. When deciding how often to issue Checkpoint requests, you can use one or more of the following techniques:

- Divide the program into small logical units of work, and issue a Checkpoint call at the end of each unit.
- Issue a Checkpoint call after a certain number of DL/I requests have been issued, or after a certain number of transactions are processed.

In CICS online programs, release segments for use by other transactions to maximize the performance of your online system. (Ordinarily, database changes are committed and segments are released only when control is returned to CICS.) To more quickly free resources for use by other transactions, you can issue a TERM request to terminate the PSB. However, less processing overhead generally occurs if the PSB is terminated when control is returned to CICS.

Programming Integrity and Database Recovery Considerations for Your CICS Program

This section explains how IMS and CICS protect data integrity for CICS online programs, and how you can plan ahead for recovering batch and BMP programs.

How IMS Protects Data Integrity for Your Program (CICS Online Programs)

IMS protects the integrity of the database for programs that share data by:

- Preventing other application programs with update capability from accessing any segments in the database record your program is processing, until your program finishes with that record and moves to a new database record in the same database.
- Preventing other application programs from accessing segments that your program deletes, replaces, or inserts, until your program reaches a sync point. When your program reaches a sync point, the changes your program has made to the database become permanent, and the changed data becomes available to other application programs.

Exception: If PROCOPT=GO has been defined during PSBGEN for your program, your program can access segments that have been updated but not committed by another program.

- Backing out database updates made by an application program that terminates abnormally.

You may also want to protect the data your program accesses by retaining segments for the sole use of your program until your program reaches a sync point—even if you do not update the segments. (Ordinarily, if you do not update the segments, IMS releases them when your program moves to a new database record.) You can use the Q command code to reserve segments for the exclusive use of your program. You should use this option only when necessary because it makes data unavailable to other programs and can have an impact on performance.

Recovering Databases Accessed by Batch and BMP Programs

This section describes the planning you must do for recovering databases accessed by batch or BMP programs. CICS recovers databases accessed by CICS online programs in the same way it handles other recoverable CICS resources. For example, if an IMS transaction terminates abnormally, CICS and IMS back out all database updates to the last sync point.

For batch or BMP programs, do the following:

- Take checkpoints in your program to commit database changes and provide places from which your program can be restarted.
- Provide the code for or issue a request to restart your program.

You may also want to back out the database changes that have been made by a batch program that has not yet committed these changes.

To perform these tasks, you use system service calls, described in more detail in the appropriate application programming book for your environment.

Requesting an I/O PCB in Batch Programs

For your program to successfully issue any system service request, an I/O PCB must have been previously requested. See *IMS Version 9: Application Programming: Database Manager* for details on how to request an I/O PCB in your program.

Taking Checkpoints in Batch and BMP Programs

Taking checkpoints in batch and BMP programs is important for two reasons:

Recovery

Checkpoints establish places in your program from which your program could be restarted, in the event of a program or system failure. If your program abnormally terminates after issuing a Checkpoint request, database changes will be backed out to the point at which the Checkpoint request was issued.

Integrity

Checkpoints also commit the changes your program has made to the database.

In addition to providing places from which to restart your program and committing database changes, issuing Checkpoint calls in a BMP program or in a program participating in IMS data sharing releases database segments for use by other programs.

When a batch or BMP program issues a Checkpoint request, IMS writes a record containing a checkpoint ID to the IMS/ESA system log.

When your application program reaches a point during its execution where you want to make sure that all changes made to that point have been physically entered in the database, issue a Checkpoint request. If some condition causes your program to fail before its execution is complete, the database must be restored to its original state. The changes made to the database must be backed out so that the database is not left in a partially updated condition for access by other application programs.

If your program runs a long time, you can reduce the number of changes that must be backed out by taking checkpoints in your program. Then, if your program terminates abnormally, only the database updates that occurred after the checkpoint must be backed out. You can also restart the program from the point at which you issued the Checkpoint request, instead of having to restart it from the beginning.

Issuing a Checkpoint call cancels your position in the database.

Issue a Checkpoint call just before issuing a Get Unique call, which reestablishes your position in the database record after the checkpoint is taken.

The Kinds of Checkpoints You Can Use: The two kinds of checkpoint calls are: **basic** and **symbolic**. See Both kinds commit your program's changes to the database and establish places from which your program can be restarted:

Batch and BMP programs can issue basic Checkpoint calls using the CHKP call. When you use basic Checkpoint calls, you must provide the code for restarting the program after an abnormal termination.

Batch and BMP programs can also issue symbolic Checkpoint calls. You can issue a symbolic Checkpoint call by using the CHKP call. Like the basic Checkpoint call, the symbolic Checkpoint call commits changes to the database and establishes places from which the program can be restarted. In addition, the symbolic Checkpoint call:

- Works with the Extended Restart call to simplify program restart and recovery.
- Lets you specify as many as seven data areas in the program to be checkpointed. When you restart the program, the restart call restores these areas to the way they were when the program terminated abnormally.

Specifying a Checkpoint ID: Each Checkpoint call your program issues must have an identification, or ID. Checkpoint IDs must be 8 bytes in length and should contain printable EBCDIC characters.

When you want to restart your program, you can supply the ID of the checkpoint from which you want the program to be started. This ID is important because when your program is restarted, IMS then searches for checkpoint information with an ID matching the one you have supplied. The first matching ID that IMS encounters becomes the restart point for your program. This means that checkpoint IDs must be unique both within each application program and among application programs. If checkpoint IDs are not unique, you cannot be sure that IMS will restart your program from the checkpoint you specified.

One way to make sure that checkpoint IDs are unique within and among programs is to construct IDs in the following order:

- Three bytes of information that uniquely identifies your program.
- Five bytes of information that serves as the ID within the program, for example, a value that is increased by 1 for each Checkpoint command or call, or a portion of the system time obtained at program start by issuing the TIME macro.

Specifying Checkpoint Frequency: To determine the frequency of Checkpoint requests, you must consider the type of program and its performance characteristics.

In Batch Programs: When deciding how often to issue Checkpoint requests in a batch program, you should consider the time required to back out and reprocess the program after a failure. For example, if you anticipate that the processing your program performs will take a long time to back out, you should establish checkpoints more frequently.

If you might back out of the entire program, issue the Checkpoint request at the very beginning of the program. IMS backs out the database updates to the checkpoint you specify.

In a data-sharing environment, also consider the impact of sharing resources with other programs on your online system. You should issue Checkpoint calls more frequently in a batch program that shares data with online programs, to minimize resource contention.

It is a good idea to design all batch programs with checkpoint and restart in mind. Although the checkpoint support may not be needed initially, it is easier to incorporate Checkpoint calls initially than to try to fit them in later. If the Checkpoint calls are incorporated, it is easier to convert batch programs to BMP programs or to batch programs that use data sharing.

In BMP Programs: When deciding how often to issue Checkpoint requests in a BMP program, consider the performance of your CICS online system. Because these programs share resources with CICS online transactions, issue Checkpoint requests to release segments so CICS online programs need not wait to acquire them. "Maximizing the Performance of Your CICS System" on page 58 explains this in more detail.

Printing Checkpoint Log Records: You can print checkpoint log records by using the IMS File Select and Formatting Print Program (DFSERA10). With this utility, you can select and print log records based on their type, the data they contain, or their sequential positions in the data set. Checkpoint records are type 18 log records. *IMS Version 9: Utilities Reference: System* describes this program.

Backing Out Database Changes

If your program terminates abnormally, the database must be restored to its previous state and uncommitted changes must be backed out. Changes made by a BMP or CICS online program are automatically backed out. Database changes made by a batch program might or might not be backed out, depending on whether your system log is on DASD.

For a Batch Program: What happens when a batch program terminates abnormally and how you recover the database depend on the storage medium for the system log. You can specify that the system log is to be stored on either DASD or on tape.

When the system log is on DASD

You can specify that IMS is to dynamically back out the changes that a batch program has made to the database since its last commit point by coding BKO=Y in the JCL. IMS performs dynamic backout for a batch program when an IMS-detected failure occurs, such as when a deadlock is detected (for batch programs that share data).

DASD logging also makes it possible for batch programs to issue the rollback (ROLB) system service request, in addition to ROLL. The ROLB request causes IMS to dynamically back out the changes the program has made to the database since its last commit point, and then to return control to the application program.

Dynamically backing out database changes has the following advantages:

- Data accessed by the program that failed is immediately available to other programs. Otherwise, if batch backout is not used, data is not available to other programs until the IMS Batch Backout utility has been run to back out the database changes.
- If two programs are deadlocked, one of the programs can continue processing. Otherwise, if batch backout is not used, both programs will fail. (This applies only to batch programs that share data.)

Instead of using dynamic backout, you can run the IMS Batch Backout utility to back out changes.

When the system log is on tape

If a batch application program terminates abnormally and the system log is stored on tape, you must use the IMS Batch Backout utility to back out the program's changes to the database.

Related Reading: For more information, see *IMS Version 9: Utilities Reference: Database and Transaction Manager*.

For BMP Programs: If your program terminates abnormally, the changes the program has made since the last commit point are backed out. If a system failure occurs, or if the CICS control region or DBCTL terminates abnormally, DBCTL emergency restart backs out all changes made by the program since the last commit point. You need not use the IMS Batch Backout utility because DBCTL backs out the changes. If you need to back out all changes, you can use the ROLL system service call to dynamically back out database changes.

Restarting Your Program

If you issue symbolic Checkpoint calls (for batch and BMP programs), you can use the Extended Restart system service request (XRST) to restart your program after an abnormal termination. The XRST call restores the program's data areas to the way they were when the program terminated abnormally, and it restarts the program from the last Checkpoint request the program issued before terminating abnormally.

If you use basic Checkpoint calls (for batch and BMP programs), you must provide the necessary code to restart the program from the latest checkpoint in the event that it terminates abnormally.

One way to restart the program from the latest checkpoint is to store repositioning data in an HDAM database. Your program writes a database record containing repositioning information to the HDAM database. It updates this record at intervals. When the program terminates, the database record is deleted. At the completion of the XRST call, the I/O area always contains a checkpoint ID used by the restart. Normally, XRST will return the 8-byte symbolic checkpoint ID, followed by 4 blanks. If the 8-byte ID consists of all blanks, then XRST will return the 14-byte timestamp ID. Also, check the status code in the PCB. The only successful status code for an XRST call is a row of blanks.

Data Availability Considerations for Your CICS Program

Unfortunately, the data that a program needs to access may sometimes be unavailable. This section describes the situations where data is unavailable, whether a program is scheduled in these situations, and the functions your program might need to use when data is not available.

Unavailability of a Database

The conditions that make an entire database unavailable for both read and update are the following:

- A STOP command has been issued for the database.
- A DBRECOVERY (DBR) command has been issued for the database.
- DBRC authorization for the database has failed.

The conditions that make a database available for read but not for update are:

- A DBDUMP command has been issued for the database.
- The database access value is RD (read).

In a data-sharing environment, the command or error that created any of these conditions may have originated on the other system which is sharing data.

Whether a program is scheduled or whether an executing program can schedule a PSB when the database is unavailable depends on the type of program and the environment:

- A batch program

IMS does not schedule a batch program when one of the databases that the program can access is not available.

In a non-data sharing environment, DBRC authorization for a database may fail because the database is currently authorized to a DB/DC environment. In a data-sharing environment, a CICS or a DBCTL master terminal global command to recover a database or to dump a database may make the database unavailable to a batch program.

- An online or BMP program in the DBCTL environment.

When a program executing in this environment attempts to schedule with a PSB containing one or more full-function databases that are unavailable, the scheduling is allowed. If the program does not attempt to access the unavailable database, it can function normally. If it does attempt to access the database, the result is the same as when the database is available but some of the data in it is not available.

Unavailability of Some Data in a Database

In addition to the situation where the entire database is unavailable, there are other situations where a limited amount of data is unavailable. One example is a failure situation involving data sharing where the IMS system knows which locks were held by a sharing IMS at the time the sharing IMS system failed. This IMS system continues to use the database but rejects access to the data that the failed IMS system held locked at the time of failure.

A batch program, an online program, or a BMP program can be operating in the DBCTL environment. If so, the online or BMP programs may have been scheduled when an entire database was not available. The following options apply to these programs when they attempt to access data and either the entire database is unavailable or only some of the data in the database is unavailable.

Programs executing in these environments have an option of being sensitive or insensitive to data unavailability.

- When the program is insensitive to data unavailability and attempts to access unavailable data, the program fails with a 3303 abend. For online programs, this is a pseudo-abend. For batch programs, it is a real abend. However, if the database is unavailable because dynamic allocation failed, a call results in an AI (unable to open) status code.
- When the program is sensitive to data unavailability and attempts to access unavailable data, IMS returns a status code indicating that it could not process the request. The program can then take the appropriate action. A facility exists for the program to then initiate the same action that IMS would have taken if the program had been insensitive to unavailable data.

The program issues the INIT call or ACCEPT STATUS GROUP A command to inform IMS that it is sensitive to unavailable data and can accept the status codes issued when the program attempts to access such data. The INIT request can also be used to determine data availability for each PCB in the PSB.

The SETS or SETU and ROLS Functions

The SETS or SETU and ROLS requests allow an application to define multiple points at which to preserve the state of full-function databases. The application can then return to these points at a later time. By issuing a SETS or SETU request before initiating a set of DL/I requests to perform a function, the program can later issue the ROLS request if it cannot complete the function due possibly to data unavailability.

ROLS allows the program to roll back its IMS activity to the state prior to the SETS or SETU call.

Restriction: SETS or SETU and ROLS only roll back the IMS updates. They do not roll back the updates made using CICS file control or transient data.

Additionally, you can use the ROLS call or command to undo all database update activity since the last checkpoint.

Use of STAE or ESTAE and SPIE in IMS Batch Programs

This section describes using STAE or ESTAE and SPIE in an IMS batch program. For information on using these routines in CICS online programs, refer to CICS manuals.

IMS uses STAE or ESTAE routines in the IMS batch regions to ensure that database logging and various resource cleanup functions are completed. Two important aspects of the STAE or ESTAE facility are that:

- IMS relies on its STAE or ESTAE facility to ensure database integrity and resource control.
- The STAE or ESTAE facility is also available to the application program.

Because of these two factors, be sure you clearly understand the relationship between the program and the STAE or ESTAE facility.

Generally, do not use the STAE or ESTAE facility in your batch application program. However, if you believe that the STAE or ESTAE facility is required, you must observe the following basic rules:

- When the environment supports STAE or ESTAE processing, the application program STAE or ESTAE routines always get control before the IMS STAE or ESTAE routines. Therefore, you must ensure that the IMS STAE or ESTAE exit routines receive control by observing the following procedures in your application program:
 - Establish the STAE or ESTAE routine only once and always before the first DL/I call.
 - When using the STAE or ESTAE facility, the application program must not alter the IMS abend code.
 - Do not use the RETRY option when exiting from the STAE or ESTAE routine. Instead, return a CONTINUE-WITH-TERMINATION indicator at the end of the STAE or ESTAE processing. If your application program does specify the RETRY option, be aware that IMS STAE or ESTAE exit routines will not get control to perform cleanup. Therefore, system and database integrity may be compromised.
 - For PL/I use of STAE and SPIE, see the description of IMS considerations in *Enterprise PL/I for z/OS and OS/390 Programming Guide*.
 - For PL/I, COBOL, and C/MVS™, if you are using the AIBTDLI interface in a non-Language Environment enabled environment, you must specify NOSTAE or NOSPIE. However, in a Language Environment Version 1.2 or later enabled environment, the NOSTAE and NOSPIE restriction is removed.
- The application program STAE/ESTAE exit routine must not issue DL/I calls because the original abend may have been caused by a problem between the application and IMS. This would result in recursive entry to STAE/ESTAE with potential loss of database integrity or in problems taking a checkpoint.

Dynamic Allocation for IMS Databases

Use the dynamic allocation function to specify the JCL information for IMS databases in a library instead of in the JCL of each batch job or in the JCL for DBCTL. If you use dynamic allocation, do not include JCL DD statements for any database data sets that have been defined for dynamic allocation. Check with the database administrator (DBA) or comparable specialist at to determine which databases have been defined for dynamic allocation.

Related Reading: For more information on the definitions for dynamic allocation, see the DFSMDA macro in *IMS Version 9: Utilities Reference: System*.

Chapter 5. Gathering Requirements for Database Options

This section guides you in gathering information that the database administrator (DBA) can use in designing a database and implementing that design. After designing hierarchies for the databases that your application will access, the DBA evaluates database options in terms of which options will best meet application requirements. Whether these options are used depends on the collected requirements of the applications. To design an efficient database, the DBA needs information about the individual applications. This section describes the type of information that can be helpful to the DBA, how the information you are gathering relates to different database options, and the different aspects of your application that you need to examine.

In this Section:

- “Analyzing Data Access”
- “Understanding How Data Structure Conflicts Are Resolved” on page 74
- “Providing Data Security” on page 83
- “Read Without Integrity” on page 87

Analyzing Data Access

The DBA chooses a type of database, based on how the majority of programs that use the database will access the data. IMS databases are categorized according to the access method used. The following is a list of the types of databases that can be defined:

- HDAM (Hierarchical Direct Access Method)
- PHDAM (Partitioned Hierarchical Direct Access Method)
- HIDAM (Hierarchical Indexed Direct Access Method)
- PHIDAM (Partitioned Hierarchical Indexed Direct Access Method)
- MSDB (Main Storage Database)
- DEDB (Data Entry Database)
- HSAM (Hierarchical Sequential Access Method)
- HISAM (Hierarchical Indexed Sequential Access Method)
- GSAM (Generalized Sequential Access Method)
- SHSAM (Simple Hierarchical Sequential Access Method)
- SHISAM (Simple Hierarchical Indexed Sequential Access Method)

Important: PHDAM and PHIDAM are the partitioned versions of the HDAM and HIDAM database types, respectively. The corresponding descriptions of the HDAM and HIDAM database types therefore apply to PHDAM and PHIDAM in the following section s.

Some of the information that you can gather to help the DBA with this decision answers questions like the following:

- To access a database record, a program must first access the root of the record. How will each program access root segments?
 - Directly
 - Sequentially
 - Both

- The segments within the database record are the dependents of the root segment. How will each program access the segments within each database record?

Directly

Sequentially

Both

It is important to note the distinction between accessing a database record and accessing segments within the record. A program could access database records sequentially, but after the program is within a record, the program might access the segments directly. These are different, and can influence the choice of access method.

- To what extent will the program update the database?
 - By adding new database records?
 - By adding new segments to existing database records?
 - By deleting segments or database records?

Again, note the difference between updating a database record and updating a segment within the database record.

Direct Access

The advantage of direct access processing is that you can get good results for both direct and sequential processing. Direct access means that by using a randomizing routine or an index, IMS can find any database record that you want, regardless of the sequence of database records in the database.

IMS full function has four direct access methods.

- HDAM and PHDAM process data directly by using a randomizing routine to store and locate root segments.
- HIDAM and PHIDAM use an index to help them provide direct processing of root segments.

The direct access methods use pointers to maintain the hierarchic relationships between segments of a database record. By following pointers, IMS can access a path of segments without passing through all the segments in the preceding paths.

Some of the requirements that direct access satisfies are:

- Fast direct processing of roots using an index or a randomizing routine
- Sequential processing of database records with HIDAM and PHIDAM using the index
- Fast access to a path of segments using pointers

In addition, when you delete data from a direct-access database, the new space is available almost immediately. This gives you efficient space utilization; therefore, reorganization of the database is often unnecessary. Direct access methods internally maintain their own pointers and addresses.

A disadvantage of direct access is that you have a larger IMS overhead because of the pointers. But if direct access fulfills your data access requirements, it is more efficient than using a sequential access method.

Primarily Direct Processing: HDAM

Important: PHDAM is the partitioned version of the HDAM database type. The corresponding descriptions of the HDAM database type therefore apply to PHDAM in the following sections.

HDAM is efficient for a database that is usually accessed directly but sometimes sequentially. HDAM uses a randomizing routine to locate its root segments and then chains dependent segments together according to the pointer options chosen. The MVS access methods that HDAM can use are Virtual Storage Access Method (VSAM) and Overflow Storage Access Method (OSAM).

The requirements that HDAM satisfies are:

- Direct access of roots by root keys because HDAM uses a randomizing routine to locate root segments
- Direct access of paths of dependents
- Adding new database records and new segments because the new data goes into the nearest available space
- Deleting database records and segments because the space created by a deletion can be used by any new segment

HDAM Characteristics: An HDAM database:

- Can store root segments anywhere. Root segments do not need to be in sequence because the randomizing routine locates them.
- Uses a randomizing routine to locate the relative block number and root anchor point (RAP) within the block that points to the root segment.
- Accesses the RAPs from which the roots are chained in physical sequence. Then the root segments that are chained from the root anchors are returned. Therefore, sequential retrieval of root segments from HDAM is not based on the results of the randomizing routine and is not in key sequence unless the randomizing routine put them into key sequence.
- May not give the desired result for some calls unless the randomizing module causes the physical sequence of root segments to be in the key sequence. For example, a GU call for a root segment that is qualified as less than or equal to a root key value would scan in physical sequence for the first RAP of the first block. This may result in a not-found condition, even though segments meeting the qualification do exist.

For dependent segments, an HDAM database:

- Can store them anywhere
- Chains all segments of one database record together with pointers

An Overview of How HDAM Works: This section contains diagnosis, modification, or tuning information.

When a database record is stored in an HDAM database, HDAM keeps one or more RAPs at the beginning of each physical block. The RAP points to a root segment. HDAM also keeps a pointer at the beginning of each physical block that points to any free space in the block. When you insert a segment, HDAM uses this pointer to locate free space in the physical block. To locate a root segment in an HDAM database, you give HDAM the root key. The randomizing routine gives it the relative physical block number and the RAP that points to the root segment. The specified RAP number gives HDAM the location of the root within a physical block.

Although HDAM can place roots and dependents anywhere in the database, it is better to choose HDAM options that keep roots and dependents close together.

HDAM performance depends largely on the randomizing routine you use. Performance can be very good, but it also depends on other factors such as:

- The block size you use
- The number of RAPs per block
- The pattern for chaining together different segments. You can chain segments of a database record in two ways:
 - In hierarchic sequence, starting with the root
 - In parent-to-dependent sequence, with parents having pointers to each of their paths of dependents

To use HDAM for sequential access of database records by root key, you need to use a secondary index or a randomizing routine that stores roots in physical key sequence.

Direct and Sequential Processing: HIDAM

Important: PHIDAM is the partitioned version of the HIDAM database type. The corresponding descriptions of the HIDAM database type therefore apply to PHIDAM in the following sections.

HIDAM is the access method that is most efficient for an approximately equal amount of direct and sequential processing. The MVS access methods it can use are VSAM and OSAM. The specific requirements that HIDAM satisfies are:

- Direct and sequential access of records by their root keys
- Direct access of paths of dependents
- Adding new database records and new segments because the new data goes into the nearest available space
- Deleting database records and segments because the space created by a deletion can be used by any new segment

HIDAM can satisfy most processing requirements that involve an even mixture of direct and sequential processing. However, HIDAM is not very efficient with sequential access of dependents.

HIDAM Characteristics: For root segments, a HIDAM database:

- Initially loads them in key sequence
- Can store new root segments wherever space is available
- Uses an index to locate a root that you request and identify by supplying the root's key value

For dependent segments, a HIDAM database:

- Can store segments anywhere, preferably fairly close together
- Chains all segments of a database record together with pointers

An Overview of How HIDAM Works: This section contains diagnosis, modification, or tuning information.

HIDAM uses two databases. The primary database holds the data. An index database contains entries for all of the root segments in order by their key fields. For each key entry, the index database contains the address of that root segment in the primary database.

When you access a root, you supply the key to the root. HIDAM looks the key up in the index to find the address of the root and then goes to the primary database to find the root.

HIDAM chains dependent segments together so that when you access a dependent segment, HIDAM uses the pointer in one segment to locate the next segment in the hierarchy.

When you process database records directly, HIDAM locates the root through the index and then locates the segments from the root. HIDAM locates dependents through pointers.

If you plan to process database records sequentially, you can specify special pointers in the DBD for the database so that IMS does not need to go to the index to locate the next root segment. These pointers chain the roots together. If you do not chain roots together, HIDAM always goes to the index to locate a root segment. When you process database records sequentially, HIDAM accesses roots in key sequence in the index. This only applies to sequential processing; if you want to access a root segment directly, HIDAM uses the index, and not pointers in other root segments, to find the root segment you have requested.

Main Storage Database: MSDB

Use MSDBs to store the most frequently-accessed data. MSDBs are suitable for applications such as general ledger applications in the banking industry.

MSDB Characteristics: MSDBs reside in virtual storage, enabling application programs to avoid the I/O activity that is required to access them. The two kinds of MSDBs are terminal-related and non-terminal-related.

In a terminal-related MSDB, each segment is owned by one terminal, and each terminal owns only one segment. One use for this type of MSDB is an application in which each segment contains data associated with a logical terminal. In this type of application, the program can read the data (perhaps for reporting purposes), but cannot update it. A non-terminal-related MSDB stores data that is needed by many users during the same time period. It can be updated and read from all terminals (for example, a real time inventory control application, where reduction of inventory can be noted from many cash registers).

An Overview of How MSDBs Work:

Diagnosis, Modification or Tuning Information

MSDB segments are stored as root segments only. Only one type of pointer, the forward chain pointer, is used. This pointer connects the segment records in the database.

End of Diagnosis, Modification or Tuning Information

Data Entry Database: DEDB

DEDBs are designed to provide access to and efficient storage for large volumes of data. The primary requirement a DEDB satisfies is a high level of data availability.

DEDB Characteristics: DEDBs are hierarchic databases that can have as many as 15 hierarchic levels, and as many as 127 segment types. They can contain both direct and sequential dependent segments. Because the sequential dependent segments are stored in chronological order as they are committed to the database, they are useful in journaling applications.

DEDBs support a subset of functions and options that are available for a HIDAM or HDAM database. For example, a DEDB does not support indexed access (neither primary index nor secondary index), or logically related segments.

An Overview of How DEDBs Work:

Diagnosis, Modification or Tuning Information

A DEDB can be partitioned into multiple areas, with each area containing a different collection of database records. The data in a DEDB area is stored in a VSAM data set. Root segments are stored in the root-addressable part of an area, with direct dependents stored close to the roots for fast access. Direct dependents that cannot be stored close to their roots are stored in the independent overflow portion of the area. Sequential dependents are stored in the sequential dependent portion at the end of the area so that they can be quickly inserted. Each area data set can have up to seven copies, making the data easily available to application programs.

End of Diagnosis, Modification or Tuning Information

Sequential Access

When you use a sequential access method, the segments in the database are stored in hierarchic sequence, one after another, with no pointers.

IMS full-function has two sequential access methods. Like the direct access methods, one has an index and the other does not:

- HSAM only processes root segments and dependent segments sequentially.
- HISAM processes data sequentially but has an index so that you can access records directly. HISAM is primarily for sequentially processing dependents, and directly processing database records.

Some of the general requirements that sequential access satisfies are:

- Fast sequential processing
- Direct processing of database records with HISAM
- Small IMS overhead on storage because sequential access methods relate segments by adjacency rather than with pointers

The three disadvantages of using sequential access methods are:

- Sequential access methods give slower access to the right-most segments in the hierarchy, because HSAM and HISAM must read through all other segments to get to them.
- HISAM requires frequent reorganization to reclaim space from deleted segments and to keep the logical records of a database record physically adjoined.
- You cannot update HSAM databases. You must create a new database to change any of the data.

Sequential Processing Only: HSAM

HSAM is a hierarchic access method that can handle only sequential processing. You can retrieve data from HSAM databases, but you cannot update any of the data. The MVS access methods that HSAM can use are QSAM and BSAM.

HSAM is ideal for the following situations:

- You are using the database to collect (but not update) data or statistics.
- You only plan to process the data sequentially.

HSAM Characteristics: HSAM stores database records in the sequence in which you submit them. You can only process records and dependent segments sequentially, which means the order in which you have loaded them. HSAM stores dependent segments in hierarchic sequence.

An Overview of How HSAM Works:

Diagnosis, Modification or Tuning Information

HSAM databases are very simple databases. The data is stored in hierarchic sequence, one segment after the other, and no pointers or indexes are used.

End of Diagnosis, Modification or Tuning Information

Primarily Sequential Processing: HISAM

HISAM is an access method that stores segments in hierarchic sequence with an index to locate root segments. It also has an overflow data set. Store segments in a logical record until you reach the end of the logical record. When you run out of space on the logical record, but you still have more segments belonging to the database record, you store the remaining segments in an overflow data set. The access methods that HISAM can use are VSAM and OSAM.

HISAM is well-suited for:

- Direct access of record by root keys
- Sequential access of records
- Sequential access of dependent segments

The situations in which your processing has some of the above characteristics but where HISAM is not necessarily a good choice, occur when:

- You must access dependents directly.
- You have a high number of inserts and deletes.
- Many of the database records exceed average size and must use the overflow data set. The segments that overflow into the overflow data set require additional I/O.

HISAM Characteristics: For database records, HISAM databases:

- Store records in key sequence
- Can locate a particular record with a key value by using the index

For dependent segments, HISAM databases:

- Start each HISAM database record in a new logical record in the primary data set
- Store the remaining segments in one or more logical records in the overflow data set if the database record does not fit in the primary data set

An Overview of How HISAM Works:

Diagnosis, Modification or Tuning Information

HISAM does not immediately reuse space. When you insert a new segment, HISAM databases shift data to make room for the new segment, and this leaves unused space after deletions. HISAM space is reclaimed when you reorganize a

HISAM database.

_____ **End of Diagnosis, Modification or Tuning Information** _____

Accessing MVS Files through IMS: GSAM

GSAM enables IMS batch application programs and BMPs to access a sequential MVS data set as a simple database. The MVS access methods that GSAM can use are BSAM and VSAM. A GSAM database is an MVS data set record that is defined as a database record. The record is handled as one unit; it contains no segments or fields and the structure is not hierarchic. GSAM databases can be accessed by MVS, IMS, and CICS.

In a CICS environment, an application program can access a GSAM database from either a Call DL/I (or EXEC DLI) batch or batch-oriented BMP program. A CICS application cannot, however, use EXEC DLI to process GSAM databases; it must use IMS calls.

You commonly use GSAM to send input to and receive output from batch-oriented BMPs or batch programs. To process a GSAM database, an application program issues calls similar to the ones it issues to process a full-function database. The program can read data sequentially from a GSAM database, and it can send output to a GSAM database.

GSAM is a sequential access method. You can only add records to an output database sequentially.

Accessing IMS Data through MVS: SHSAM and SHISAM

Two database access methods give you simple hierarchic databases that MVS can use as data sets, SHSAM and SHISAM.

These access methods can be particularly helpful when you are converting data from MVS files to an IMS database. SHISAM is indexed and SHSAM is not.

When you use these access methods, you define an entire database record as one segment. The segment does not contain any IMS control information or pointers; the data format is the same as it is in MVS data sets. The MVS access methods that SHSAM can use are BSAM and QSAM. SHISAM uses VSAM.

SHSAM and SHISAM databases can be accessed by MVS access methods without IMS, which is useful during transitions.

Understanding How Data Structure Conflicts Are Resolved

The order in which application programs need to process fields and segments within hierarchies is frequently not the same for each application. When the DBA finds a conflict in the way that two or more programs need to access the data, three options are available to solve these problems. Each of the following options solves a different kind of conflict.

- When an application program does not need access to all the fields in a segment, or if the program needs to access them in a different order, the DBA can use **field level sensitivity** for that program. *Field-level sensitivity* makes it possible for an application program to access only a subset of the fields that a segment contains, or for an application program to process a segment's fields in an order that is different from their order in the segment.

- When an application program needs to access a particular segment by a field other than the segment’s key field, the DBA can use a **secondary index** for that database.
- When the application program needs to relate segments from different hierarchies, the DBA can use **logical relationships**. Using logical relationships can give the application program a logical hierarchy that includes segments from several hierarchies.

Using Different Fields: Field-Level Sensitivity

Field-level sensitivity applies the same kind of security for fields within a segment that segment sensitivity does for segments within a hierarchy: An application program can access only those fields within a segment, and those segments within a hierarchy to which it is sensitive.

Field-level sensitivity also makes it possible for an application program to use a subset of the fields that make up a segment, or to use all the fields in the segment but in a different order. If a segment contains fields that the application program does not need to process, using field-level sensitivity enables the program not to process them.

Example of Field-Level Sensitivity

Suppose that a segment containing data about an employee contains the fields shown in Figure 18. These fields are:

- Employee number: EMPNO
- Employee name: EMPNAME
- Birthdate: BIRTHDAY
- Salary: SALARY
- Address: ADDRESS

EMPNO	EMPNAME	BIRTHDAY	SALARY	ADDRESS
-------	---------	----------	--------	---------

Figure 18. Physical Employee Segment

A program that printed mailing labels for employees’ checks each week would not need all the data in the segment. If the DBA decided to use field-level sensitivity for that application, the program would receive only the fields it needed in its I/O area. The I/O area would contain the EMPNAME and ADDRESS fields. Figure 19 shows what the program’s I/O area would contain.

EMPNAME	ADDRESS
---------	---------

Figure 19. Employee Segment with Field-Level Sensitivity

Field-level sensitivity makes it possible for a program to receive a subset of the fields that make up a segment, the same fields but in a different order, or both.

Another situation in which field-level sensitivity is very useful is when new uses of the database involve adding new fields of data to an existing segment. In this situation, you want to avoid recoding programs that use the current segment. By

using field-level sensitivity, the old programs can see only the fields that were in the original segment. The new program can see both the old and the new fields.

Where Field-Level Sensitivity Is Specified

You specify field-level sensitivity in the PSB for the application program by using a sensitive field (SENFLD) statement for each field to which you want the application program to be sensitive.

Resolving Processing Conflicts in a Hierarchy: Secondary Indexing

Sometimes a database hierarchy does not meet all the processing requirements of the application programs that will process it. Secondary indexing can be used to solve two kinds of processing conflicts:

- When an application program needs to retrieve a segment in a sequence other than the one that has been defined by the segment's key field
- When an application program needs to retrieve a segment based on a condition that is found in a dependent of that segment

To understand these conflicts and how secondary indexing can resolve them, consider the examples of two application programs that process the patient hierarchy, shown in Figure 20. Three segment types in this hierarchy are:

- PATIENT contains three fields: the patient's identification number, name, and address. The patient number field is the key field.
- ILLNESS contains two fields: the date of the illness and the name of the illness. The date of the illness is the key field.
- TREATMNT contains four fields: the date the medication was given; the name of the medication; the quantity of the medication that was given; and the name of the doctor who prescribed the medication. The date that the medication was given is the key field.

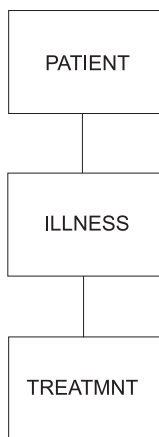

Figure 20. Patient Hierarchy

Using a Different Key

When an application program retrieves a segment from the database, the program identifies the segment by the segment's key field. But sometimes an application program needs to retrieve a segment in a sequence other than the one that has been defined by the segment's key field. Secondary indexing makes this possible.

Note: A new database type, the Partitioned Secondary Index (PSINDEX), is supported by the High Availability Large Database (HALDB). PSINDEX is the

partitioned version of the secondary index database type. The corresponding descriptions of the secondary index database type therefore apply to PSINDEX in the following section s.

Example: Suppose you have an online application program that processes requests about whether an individual has ever been to the clinic. If you are not sure whether the person has ever been to the clinic, you will not be able to supply the identification number for the person. But the key field of the PATIENT segment is the patient's identification number.

Segment occurrences of a segment type (for example, the segments for each of the patients) are stored in a database in order of their keys (in this case, by their patient identification numbers). If you issue a request for a PATIENT segment and identify the segment you want by the patient's name instead of the patient's identification number, IMS must search through all of the PATIENT segments to find the PATIENT segment you have requested. IMS does not know where a particular PATIENT segment is just by having the patient's name.

To make it possible for this application program to retrieve PATIENT segments in the sequence of patients' names (rather than in the sequence of patients' identification numbers), you can index the PATIENT segment on the patient name field and store the index entries in a separate database. The separate database is called a *secondary index database*.

Then, if you indicate to IMS that it is to process the PATIENT segments in the patient hierarchy in the sequence of the index entries in the secondary index database, IMS can locate a PATIENT segment if you supply the patient's name. IMS goes directly to the secondary index and locates the PATIENT index entry with the name you have supplied; the PATIENT index entries are in alphabetical order of the patient names. The index entry is a pointer to the PATIENT segment in the patient hierarchy. IMS can determine whether a PATIENT segment for the name you have supplied exists, and then it can return the segment to the application program if the segment exists. If the requested segment does not exist, IMS indicates this to the application program by returning a not-found status code.

Related Reading: For more information on HALDB, see *IMS Version 9: Administration Guide: Database Manager*.

Definitions: Three terms involved in secondary indexing are:

- The *pointer segment* is the index entry in the secondary index database that IMS uses to find the segment you have requested. In the previous example, the pointer segment is the index entry in the secondary index database that points to the PATIENT segment in the patient hierarchy.
- The *source segment* is the segment that contains the field that you are indexing. In the previous example, the source segment is the PATIENT segment in the patient hierarchy, because you are indexing on the name field in the PATIENT segment.
- The *target segment* is the segment in the database that you are processing to which the secondary index points; it is the segment that you want to retrieve.

In the previous example, the target segment and the source segment are the same segment—the PATIENT segment in the patient hierarchy. When the source segment and the target segment are different segments, secondary indexing solves the processing conflict.

The PATIENT segment that IMS returns to the application program's I/O area looks the same as it would if secondary indexing had not been used.

The key feedback area is different. When IMS retrieves a segment without using a secondary index, IMS places the concatenated key of the retrieved segment in the key feedback area. The concatenated key contains all the keys of the segment's parents, in order of their positions in the hierarchy. The key of the root segment is first, followed by the key of the segment on the second level in the hierarchy, then the third, and so on—with the key of the retrieved segment last.

But when you retrieve a segment from an indexed database, the contents of the key feedback area after the request are a little different. Instead of placing the key of the root segment in the left-most bytes of the key feedback area, DL/I places the key of the pointer segment there. Note that the term “key of the pointer segment,” as used here, refers to the key as perceived by the application program—that is, the key does not include subsequence fields.

Example: Suppose index segment A shown in Figure 21 is indexed on a field in segment C. Segment A is the target segment, and segment C is the source segment.

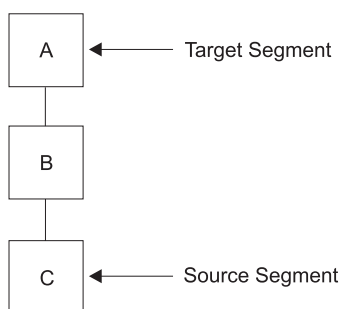

Figure 21. Indexing a Root Segment

When you use the secondary index to retrieve one of the segments in this hierarchy, the key feedback area contains one of the following:

- If you retrieve segment A, the key feedback area contains the key of the pointer segment from the secondary index.
- If you retrieve segment B, the key feedback area contains the key of the pointer segment, concatenated with the key of segment B.
- If you retrieve segment C, the key of the pointer segment, the key of segment B, and the key of segment C are concatenated in the key feedback area.

Although this example creates a secondary index for the root segment, you can index dependent segments as well. If you do this, you create an inverted structure: the segment you index becomes the root segment, and its parent becomes a dependent.

Example: Suppose you index segment B on a field in segment C. In this case, segment B is the target segment, and segment C is the source field. Figure 22 on page 79 shows the physical database structure and the structure that is created by the secondary index.

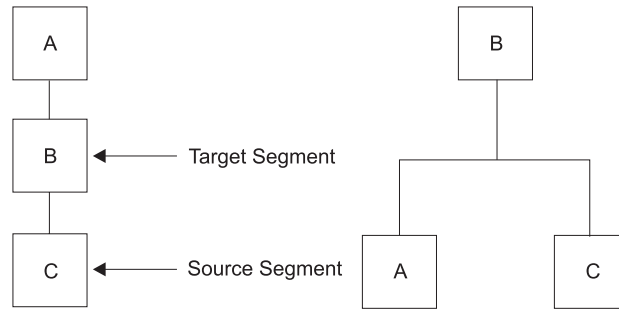

Figure 22. Indexing a Dependent Segment

When you retrieve the segments in the secondary index data structure on the right, IMS returns the following to the key feedback area:

- If you retrieve segment B, the key feedback area contains the key of the pointer segment in the secondary index database.
- If you retrieve segment A, the key feedback area contains the key of the pointer segment, concatenated with the key of segment A.
- If you retrieve segment C, the key feedback area contains the key of the pointer segment, concatenated with the key of segment C.

Retrieving Segments Based on a Dependent's Qualification

Sometimes an application program needs to retrieve a segment, but only if one of the segment's dependents meet a certain qualification.

Example: Suppose that the medical clinic wants to print a monthly report of the patients who have visited the clinic during that month. If the application program that processes this request does not use a secondary index, the program has to retrieve each PATIENT segment, and then retrieve the ILLNESS segment for each PATIENT segment. The program tests the date in the ILLNESS segment to determine whether the patient has visited the clinic during the current month, and prints the patient's name if the answer is yes. The program continues retrieving PATIENT segments and ILLNESS segments until it has retrieved all the PATIENT segments.

But with a secondary index, you can make the processing of the program simpler. To do this, you index the PATIENT segment on the date field in the ILLNESS segment. When you define the PATIENT segment in the DBD, you give IMS the name of the field on which you are indexing the PATIENT segment, and the name of the segment that contains the index field. The application program can then request a PATIENT segment and qualify the request with the date in the ILLNESS segment. The PATIENT segment that is returned to the application program looks just as it would if you were not using a secondary index.

In this example, the PATIENT segment is the target segment; it is the segment that you want to retrieve. The ILLNESS segment is the source segment; it contains the information that you want to use to qualify your request for PATIENT segments. The index segment in the secondary database is the pointer segment. It points to the PATIENT segments.

Creating a New Hierarchy: Logical Relationships

When an application program needs to associate segments from different hierarchies, logical relationships can make that possible. Logical relationships can solve the following conflicts:

- When two application programs need to process the same segment, but they need to access the segment through different hierarchies
- When a segment's parent in one application program's hierarchy acts as that segment's child in another application program

Accessing a Segment through Different Paths

Sometimes an application program needs to process the data in a different order than the way it is arranged in the hierarchy.

Example: An application program that processes data in a purchasing database also requires access to a segment in a patient database:

- Program A processes information in the patient database about the patients at a medical clinic: the patients' illnesses and their treatments.
- Program B is an inventory program that processes information in the purchasing database about the medications that the clinic uses: the item, the vendor, information about each shipment, and information about when and under what circumstances each medication is given.

Figure 23 on page 81 shows the hierarchies that Program A and Program B require for their processing. Their processing requirements conflict: they both need to have access to the information that is contained in the TREATMNT segment in the patient database. This information is:

- The date that a particular medication was given
- The name of the medication
- The quantity of the medication given
- The doctor that prescribed the medication

To Program B this is not information about a patient's treatment; it is information about the disbursement of a medication. To the purchasing database, this is the disbursement segment (DISBURSE).

Figure 23 on page 81 shows the hierarchies for Program A and Program B. Program A needs the PATIENT segment, the ILLNESS segment, and the TREATMNT segment. Program B needs the ITEM segment, the VENDOR segment, the SHIPMENT segment, and the DISBURSE segment. The TREATMNT segment and the DISBURSE segment contain the same information.

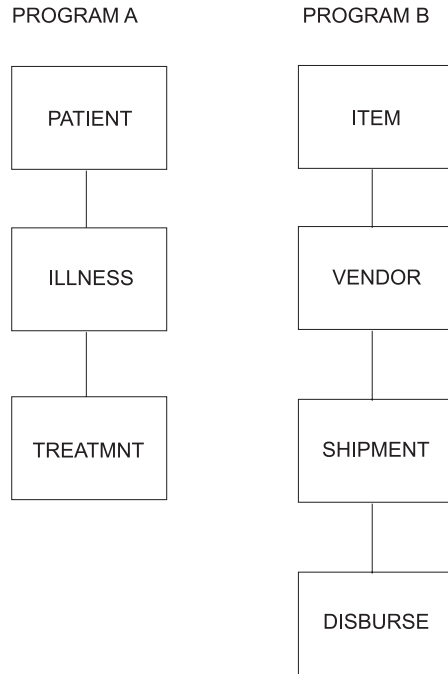

Figure 23. Patient and Inventory Hierarchies

Instead of storing this information in both hierarchies, you can use a logical relationship. A logical relationship solves the problem by storing a pointer from where the segment is needed in one hierarchy to where the segment exists in the other hierarchy. In this case, you can have a pointer in the DISBURSE segment to the TREATMNT segment in the medical database. When IMS receives a request for information in a DISBURSE segment in the purchasing database, IMS goes to the TREATMNT segment in the medical database that is pointed to by the DISBURSE segment. Figure 24 on page 82 shows the physical hierarchy that Program A would process and the logical hierarchy that Program B would process. DISBURSE is a pointer segment to the TREATMNT segment in Program A's hierarchy.

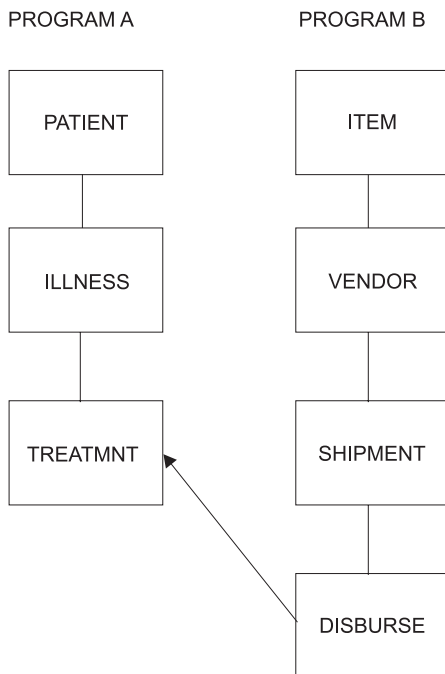

Figure 24. Logical Relationships Example

To define a logical relationship between segments in different hierarchies, you use a logical DBD. A logical DBD defines a hierarchy that does not exist in storage, but can be processed as though it does. Program B would use the logical structure shown in Figure 24 as though it were a physical structure.

Inverting a Parent-Child Relationship

Another type of conflict that logical relationships can resolve occurs when a segment's parent in one application program acts as that segment's child in another application program:

- The inventory program, Program B, needs to process information about medications using the medication as the root segment.
- A purchasing application program, Program C, processes information about which vendors have sold which medications. Program C needs to process this information using the vendor as the root segment.

Figure 25 shows the hierarchies for each of these application programs.

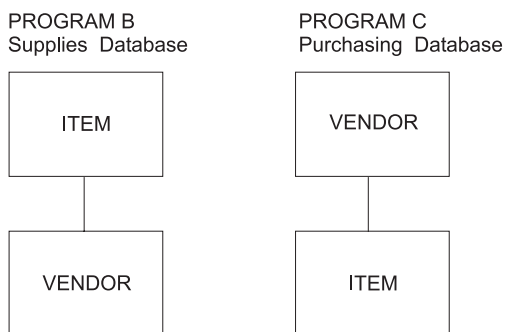

Figure 25. Supplies and Purchasing Hierarchies

Logical relationships can solve this problem by using pointers. Using pointers in this example would mean that the ITEM segment in the purchasing database would contain a pointer to the actual data stored in the ITEM segment in the supplies database. The VENDOR segment, on the other hand, would actually be stored in the purchasing database. The VENDOR segment in the supplies database would point to the VENDOR segment that is stored in the purchasing database.

Figure 26 shows the hierarchies of these two programs.

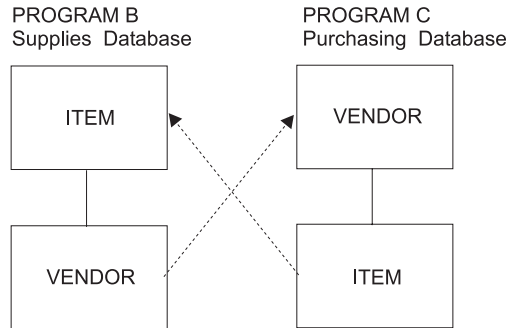

Figure 26. Program B and Program C Hierarchies

If you did not use logical relationships in this situation, you would:

- Keep the same data in both paths, which means that you would be keeping redundant data.
- Have the same disadvantages as separate files of data:
 - You would need to update multiple segments each time one piece of data changed.
 - You would need more storage.

Providing Data Security

If you find that some of the data in your application has a security requirement, an IMS application can provide security for that data in two ways:

- **Data sensitivity** is a way of controlling what data a particular program can access.
- **Processing options** are a way of controlling how a particular program can process data that it can access.

Providing Data Availability

Specifying segment sensitivity and processing options also affects data availability. You should set the specifications so that the PCBs request the fewest SENSEGS and limit the possible processing options. With data availability, a program can continue to access and update segments in the database successfully, even though some parts of the database are unavailable.

The SENSEG statement defines a segment type in the database to which the application program is sensitive. A separate SENSEG statement must exist for each segment type. The segments can physically exist in one database or they can be derived from several physical databases. If an application program is sensitive to a segment that is below the root segment, it must also be sensitive to all segments in the path from the root segment to the sensitive segment.

Related Reading: For more information on using field-level sensitivity for data security and using the SENSEG statement to limit the scope of the PCBs, see *IMS Version 9: Administration Guide: Database Manager*.

Keeping a Program from Accessing the Data: Data Sensitivity

An IMS program can only access data to which it is sensitive. You can control the data to which your program is sensitive on three levels:

- **Segment sensitivity** can prevent an application program from accessing all the segments in a particular hierarchy. Segment sensitivity tells IMS which segments in a hierarchy the program is allowed to access.
- **Field-level sensitivity** can keep a program from accessing all the fields that make up a particular segment. Field-level sensitivity tells IMS which fields within a particular segment a program is allowed to access.
- **Key sensitivity** means that the program can access segments below a particular segment, but it cannot access the particular segment. IMS returns only the key of this type of segment to the program.

You define each of these levels of sensitivity in the PSB for the application program. Key sensitivity is defined in the processing option for the segment. Processing options indicate to IMS exactly what a particular program may or may not do to the data. You specify a processing option for each hierarchy that the application program processes; you do this in the DB PCB that represents each hierarchy. You can specify one processing option for all the segments in the hierarchy, or you can specify different processing options for different segments within the hierarchy.

Segment sensitivity and field-level sensitivity are defined using special statements in the PSB.

Segment Sensitivity

You define what segments an application program is sensitive to in the DB PCB for the hierarchy that contains those segments.

Example: Suppose that the patient hierarchy shown in Figure 20 on page 76 belongs to the medical database shown in Figure 27. The patient hierarchy is like a subset of the medical database.

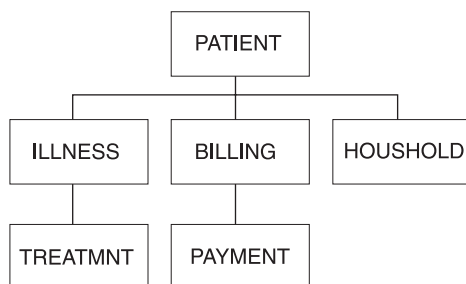

Figure 27. Medical Database Hierarchy

PATIENT is the root segment and the parent of the three segments below it: ILLNESS, BILLING, and HOUSHOLD. Below ILLNESS is TREATMNT. Below BILLING is PAYMENT.

To make it possible for an application program to view only the segments PATIENT, ILLNESS, and TREATMNT from the medical database, you specify in the DB PCB that the hierarchy you are defining has these three segment types, and that they

are from the medical database. You define the database hierarchy in the DBD; you define the application program's view of the database hierarchy in the DB PCB.

Field-Level Sensitivity

In addition to providing data independence for an application program, field-level sensitivity can also act as a security mechanism for the data that the program uses.

If a program needs to access some of the fields in a segment, but one or two of the fields that the program does not need to access are confidential, you can use field-level sensitivity. If you define that segment for the application program as containing only the fields that are not confidential, you prevent the program from accessing the confidential fields. Field-level sensitivity acts as a mask for the fields to which you want to restrict access.

Key Sensitivity

To access a segment, an application program must be sensitive to all segments at a higher level in the segment's path. In other words, in Figure 28, a program must be sensitive to segment B in order to access segment C.

Example: Suppose that an application program needs segment C to do its processing. But if segment B contains confidential information (such as an employee's salary), the program is not able to access that segment. Using key sensitivity lets you withhold segment B from the application program while giving the program access to the dependents of segment B.

When a sensitive segment statement has a processing option of K specified for it, the program cannot access that segment, but the program can pass beyond that segment to access the segment's dependents. When the program does access the segment's dependents, IMS does not return that segment; IMS returns only the segment's key with the keys of the other segments that are accessed.

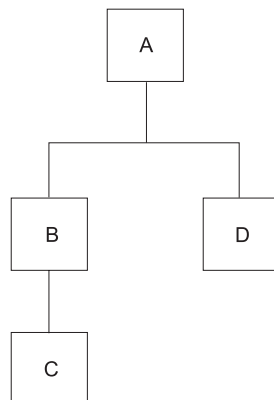

Figure 28. Sample Hierarchy

Preventing a Program from Updating Data: Processing Options

During PCB generation, you can use five options of the PROCOPT parameter (in the DATABASE macro) to indicate to IMS whether your program can read segments in the hierarchy, or whether it can also update segments. From most restrictive to least restrictive, these options are:

- G** Your program can read segments.
- R** Your program can read and replace segments.
- I** Your program can insert segments.

- D** Your program can read and delete segments.
- A** Your program needs all the processing options. It is equivalent to specifying G, R, I, and D.

Related Reading: For a thorough description of the processing options see, *IMS Version 9: Utilities Reference: System*.

Processing options provide data security because they limit what a program can do to the hierarchy or to a particular segment. Specifying only the processing options the program requires ensures that the program cannot update any data it is not supposed to. For example, if a program does not need to delete segments from a database, the D option need not be specified.

When an application program retrieves a segment and has any of the just-described processing options, IMS locks the database record for that application. If PROCOPT=G is specified, other programs with the option can concurrently access the database record. If an update processing option (R, I, D, or A) is specified, no other program can concurrently access the same database record. If no updates are performed, the lock is released when the application moves to another database record or, in the case of HDAM, to another anchor point.

The following locking protocol allows IMS to make this determination. If the root segment is updated, the root lock is held at update level until commit. If a dependent segment is updated, it is locked at update level. When exiting the database record, the root segment is demoted to read level. When a program enters the database record and obtains the lock at either read or update level, the lock manager provides feedback indicating whether or not another program has the lock at read level. This determines if dependent segments will be locked when they are accessed. For HISAM, the primary logical record is treated as the root, and the overflow logical records are treated as dependent segments.

Related Reading: For a special case involving HISAM delete byte with parameter ERASE=YES see, *IMS Version 9: Administration Guide: Database Manager*.

E and GO Processing Options

When using block-level or database-level data sharing for online and batch programs, you can use two additional processing options: E and GO.

Related Reading: For more information on database and block-level data sharing, see *IMS Version 9: Administration Guide: System*.

E option: With the E option, your program has exclusive access to the hierarchy or to the segment you use it with. The E option is used in conjunction with the options G, I, D, R, and A. While the E program is running, other programs cannot access that data, but may be able to access segments that are not in the E program's PCB.

GO option: When your program retrieves a segment with the GO option, IMS does not lock the segment. While the read without integrity program reads the segment, it remains available to other programs. This is because your program can only read the data (termed *read-only*); it is not allowed to update the database. Serialization between the program with PROCOPT=GO and any other update program does not occur; updates to the same data occur simultaneously.

If a segment has been deleted and another segment of the same type has been inserted in the same location, the segment data and all subsequent data that is returned to the application may be from a different database record.

A read-without-integrity program can also retrieve a segment even if another program is updating the segment. This means that the program need not wait for segments that other programs are accessing. If a read-without-integrity program reads data that is being updated by another program, and that program terminates abnormally before reaching the next commit point, the updated segments might contain invalid pointers. If an invalid pointer is detected, the read-without-integrity program terminates abnormally, unless the N or T options were specified with GO.

N option: When you use the N option with GO to access a full-function database or a DEDB, and the segment you are retrieving contains an invalid pointer, IMS returns a GG status code to your program. Your program can then terminate processing, continue processing by reading a different segment, or access the data using a different path. The N option must be specified as PROCOPT=GON, GON, or GONP.

T option: When you use the T option with GO and the segment you are retrieving contains an invalid pointer, the response from an application program depends on whether the program is accessing a full-function or Fast Path database.

For calls to full-function databases, the T option causes DL/I to automatically retry the operation. You can retrieve the updated segment, but only if the updating program has reached a commit point or has had its updates backed out since you last tried to retrieve the segment. If the retry fails, a GG status code is returned to your program.

For calls to Fast Path DEDBs, option T does not cause DL/I to retry the operation. A GG status code is returned. The T option must be specified as PROCOPT=GOT, GOT, or GOTP.

GOx and data integrity: For a very small set of applications and data, PROCOPT=GOx offers some performance and parallelism benefits. However, it does not offer application data integrity. For example, using PROCOPT=GOT in an online environment on a full-function database can cause performance degradation. The T option forces a re-read from DASD, negating the advantage of very large buffer pools and VSAM hiperspace for all currently running applications and shared data. For more information on the GOx processing option for DEDBs, see *IMS Version 9: Utilities Reference: System*.

Read Without Integrity

Database-level sharing of IMS databases provides for sharing of databases between a single update-capable batch or online IMS system and any number of other IMS systems that are reading data that are without integrity.

A GE status code might be returned to a program using PROCOPT=GOx for a segment that exists in a HIDAM database during CI splits.

In IMS, programs that use database-level sharing include PROCOPT=GOx in their DBPCBs for that data. For batch jobs, the DBPCB PROCOPTs establish the batch job's access level for the database. That is, a batch job uses the highest declared intent for a database as the access level for DBRC database authorization. In an online IMS environment, database ACCESS is specified on the DATABASE macro

during IMS system definition, and it can be changed using the /START DB ACCESS=RO command. Online IMS systems schedule programs with data availability determined by the PROCOPTs within those program PSBs being scheduled. That data availability is therefore limited by the online system's database access.

The PROCOPT=GON and GOT options (described in “E and GO Processing Options” on page 86) provide certain limited PCB status code retry for some recognizable pointer errors, within the data that is being read without integrity. In some cases, dependent segment updates, occurring asynchronously to the read-without-integrity IMS instance, do not interfere with the program that is reading that data without integrity. However, update activity to an average database does not always allow a read-without-integrity IMS system to recognize a data problem.

What Read Without Integrity Means

Each IMS batch or online instance has OSAM and VSAM buffer pools defined for it. Without locking to serialize concurrent updates that are occurring in another IMS instance, a read without integrity from a database data set fetches a copy of a block or CI into the buffer pool in storage. Blocks or CIs in the buffer pool can remain there a long time. Subsequent read without integrity of other blocks or CIs can then fetch more recent data. Data hierarchies and other data relationships between these different blocks or CIs can be inconsistent.

For example, consider an index database (VSAM KSDS), which has an index component and a data component. The index component contains only hierarchic control information, relating to the data component CI where a given keyed record is located. Think of this as the index component CI's way of maintaining the high key in each data component CI. Inserting a keyed record into a KSDS data component CI that is already full causes a CI split. That is, some portion of the records in the existing CI are moved to a new CI, and the index component is adjusted to point to the new CI.

Example: Suppose the index CI shows the high key in the first data CI as KEY100, and a split occurs. The split moves keys KEY051 through KEY100 to a new CI; the index CI now shows the high key in the first data CI as KEY050, and another entry shows the high key in the new CI as KEY100.

A program that is reading is without integrity, which already read the “old” index component CI into its buffer pool (high key KEY100), does not point to the newly created data CI and does not attempt to access it. More specifically, keyed records that exist in a KSDS at the time a read-without-integrity program starts might never be seen. In this example, KEY051 through KEY100 are no longer in the first data CI even though the “old” copy of the index CI in the buffer pool still indicates that any existing keys up to KEY100 are in the first data CI.

Hypothetical cases also exist where the deletion of a dependent segment and the insertion of that same segment type under a different root, placed in the same physical location as the deleted segment, can cause simple Get Next processing to give the appearance of only one root in the database. For example, accessing the segments under the first root in the database down to a level-06 segment (which had been deleted from the first root and is now logically under the last root) would then reflect data from the other root. The next and subsequent Get Next calls retrieve segments from the other root.

Read-only (PROCOPT=GO) processing does not provide data integrity.

Data Set Extensions

IMS instances with database-level sharing can open a database for read without integrity. After the database is opened, another program that is updating that database can make changes to the data. These changes might result in logical and physical extensions to the database data set. Because the read-without-integrity program is not aware of these extensions, problems with the RBA (beyond end-of-data) can occur.

Chapter 6. Gathering Requirements for Message Processing Options

One of the tasks of application design is providing information about your application's requirements to the people in charge of designing and administering your IMS system. This section describes the information you should provide, and why this information is important.

Restriction: This section applies to DB/DC and DCCTL environments only.

In this Section:

- "Identifying Online Security Requirements"
- "Analyzing Screen and Message Formats" on page 93
- "Gathering Requirements for Conversational Processing" on page 95
- "Identifying Output Message Destinations" on page 99

Identifying Online Security Requirements

Security in an online system means protecting the data from unauthorized use via terminals. It also means preventing unauthorized use of both the IMS system and the application programs that access the database. For example, you do not want a program that processes paychecks to be available to everyone who can access the system.

The security mechanisms that IMS provides are signon, terminal, and password security.

Related Reading: For an explanation of how to establish these types of security, see *IMS Version 9: Administration Guide: System*.

Limiting Access to Specific Individuals: Signon Security

Signon security is available through Resource Access Control Facility (RACF®) or a user-written security exit routine. With signon security, individuals who want to use IMS must be defined to RACF or its equivalent before they are allowed access.

When a person signs on to IMS, RACF or security exits verify that the person is authorized to use IMS before access to IMS-controlled resources is allowed. This signon security is provided by the /SIGN ON command. You can also limit the transaction codes and commands that individuals are allowed to enter. You do this by associating an individual's user identification (USERID) with the transaction codes and commands.

LU 6.2 transactions contain the USERID.

Related Reading: For more information on security, see *IMS Version 9: Administration Guide: Transaction Manager*.

Limiting Access for Specific Terminals: Terminal Security

Use terminal security to limit the entry of a transaction code to a particular terminal or group of terminals in the system. How you do this depends on how many programs you want to protect.

To protect a particular program, you can either authorize a transaction code to be entered from a list of logical terminals, or you can associate each logical terminal with a list of the transaction codes that a user can enter from that logical terminal. For example, you could protect the paycheck application program by defining the transaction code associated with it as valid only when entered from the terminals in the payroll department. If you wanted to restrict access to this application even more, you could associate the paycheck transaction code with only one logical terminal. To enter that transaction code, a user needs to be at a physical terminal that is associated with that logical terminal.

Restriction: If you are using the shared-queues option, static control blocks representing the resources needed for the security check need to be available in the IMS system where the security check is being made. Otherwise, the security check is bypassed.

Related Reading: For more information on shared queues, see *IMS Version 9: Administration Guide: Transaction Manager*.

Limiting Access to the Program: Password Security

Another way you can protect the application program is to require a password when a person enters the transaction code that is associated with the application program you want to protect. If you use only password security, the person entering a particular transaction code must also enter the password of the transaction before IMS processes the transaction.

If you use password security with terminal security, you can restrict access to the program even more. In the paycheck example, using password security and terminal security means that you can restrict unauthorized individuals within the payroll department from executing the program.

Restriction: Password security for transactions is only supported if the transactions that are needed for the security check are defined in the IMS system where the security check is being made. Otherwise, the security check is bypassed.

Allowing Access to Security Data: Authorization Security

RACF has a data set that you can use to store user-unique information. The AUTH call gives application programs access to the RACF data set security data, and a way to control access to application-defined resources. Thus, application programs can obtain the security information about a particular user.

How IMS Security Relates to DB2 Security

An important part of DB2 security is the authorization ID. The authorization ID that IMS uses for a program or a user at a terminal depends on the kind of security that is used and the kind of program that is running. For MPPs, IFPs, and transaction-oriented BMPs, the authorization ID depends on the type of IMS security:

- If signon is required, IMS passes the USERID and group name that are signed-on to DB2.
- If signon is not required, DB2 uses the name of the originating logical terminal as the authorization ID.

For batch-oriented BMPs, the authorization ID is dependent on the value specified for the BMPUSID= keyword in the DFSDCxxx PROCLIB member:

- If BMPUSID=USERID is specified, the value from the USER= keyword on the JOB statement is used.
- If USER= is not specified on the JOB statement, the program's PSB name is used.
- If BMPUSID=PSBNAME is specified, or if BMPUSID= is not specified at all, the program's PSB name is used.

Supplying Security Information

When you evaluate your application in terms of its security requirements, you need to look at each program individually. When you have done this, you can supply the following information to your security personnel.

- For programs that require signon security:
 - List the individuals who should be able to access IMS.
- For programs that require terminal security:
 - List the transaction codes that must be secured.
 - List the terminals that should be allowed to enter each of these transaction codes. If the terminals you are listing are already installed and being used, identify the terminals by their logical terminal names. If not, identify them by the department that will use them (for example, the accounting department).
- For programs that require password security:
 - List the transaction codes that require passwords.
- For commands that require security:
 - List the commands that require signon or password security.

Analyzing Screen and Message Formats

When an application program communicates with a terminal, an editing procedure translates messages from the way they are entered at the terminal to the way the program expects to receive and process them. The decisions about how IMS will edit your program's messages are based on how your data should be presented to the person at the terminal and to the application program. You need to describe how you want data from the program to appear on the terminal screen, and how you want data from the terminal to appear in the application program's I/O area. (The I/O area contains the segments being processed by the application program.)

To supply information that will be helpful in these decisions, you should be familiar with how IMS edits messages. IMS has two editing procedures:

- **Message Format Service (MFS)** uses control blocks that define what a message should look like to the person at the terminal and to the application program.
- **Basic edit** is available to all IMS application programs. Basic edit removes control characters from input messages and inserts the control characters you specify in output messages to the terminal.

Related Reading: For information on defining IMS editing procedures and on other design considerations for IMS networks, see *IMS Version 9: Administration Guide: Transaction Manager*.

An Overview of MFS

MFS uses four kinds of control blocks to format messages between an application program and a terminal. The information you gather about how you want the data formatted when it is passed between the application program and the terminal is contained in these control blocks.

The two control blocks that describe input messages to IMS are:

- The device input format (DIF) describes to IMS what the input message is to look like when it is entered at the terminal.
- The message input descriptor (MID) tells IMS how the application program expects to receive the input message in its I/O area.

By using the DIF and the MID, IMS can translate the input message from the way that it is entered at the terminal to the way it should appear in the program's I/O area.

The two control blocks that describe output messages to IMS are:

- The message output descriptor (MOD) tells IMS what the output message is to look like in the program's I/O area.
- The device output format (DOF) tells IMS how the message should appear on the terminal.

To define the MFS control blocks for an application program, you need to know how you want the data to appear at the terminal and in the application program's I/O area for both input and output.

Related Reading: For more information about how you define this information to MFS, see *IMS Version 9: Application Programming: Transaction Manager*.

An Overview of Basic Edit

Basic edit removes the control characters from an input message before the application program receives it, and inserts the control characters you specify when the application program sends a message back to the terminal. To format output messages at a terminal using basic edit, you need to supply the necessary control characters for the terminal you are using.

If your application will use basic edit, you should describe how you want the data to be presented at the terminal, and what it is to look like in the program's I/O area.

Editing Considerations in Your Application

Before you describe the editing requirements of your application, be sure that you are aware of your standards concerning screen design. Make sure that the requirements that you describe comply with those standards.

Provide the following information about your program's editing requirements:

- How you want the screen to be presented to the person at the terminal for the person to enter the input data. For example, if an airline agent wants to reserve seats on a particular flight, the screen that asks for this information might look like this:

FLIGHT#:
NAME:
NO. IN PARTY:

- What the data should look like when the person at the terminal enters the input message.
- What the input message should look like in the program's I/O area.
- What the data should look like when the program builds the output message in its I/O area.
- How the output message should be formatted at the terminal.
- The length and type of data that your program and the terminal will be exchanging.

The type of data you are processing is only one consideration when you analyze how you want the data presented at the terminal. In addition, you should weigh the needs of the person at the terminal (the human factors aspects in your application) against the effect of the screen design on the efficiency of the application program (the performance factors in the application program). Unfortunately, sometimes a trade-off between human factors and performance factors exists. A screen design that is easily understood and used by the person at the terminal may not be the design that gives the application program its best performance. Your first concern should be that you are following whatever are your established screen standards.

A terminal screen that has been designed with human factors in mind is one that puts the person at the terminal first; it is one that makes it as easy as possible for that person to interact with IMS. Some of the things you can do to make it easy for the person at the terminal to understand and respond to your application program are:

- Display a small amount of data at one time.
- Use a format that is clear and uncluttered.
- Provide clear and simple instructions.
- Display one idea at a time.
- Require short responses from the person at the terminal.
- Provide some means for help and ease of correction for the person at the terminal.

At the same time, you do not want the way in which a screen is designed to have a negative effect on the application program's response time, or on the system's performance. When you design a screen with performance first in mind, you want to reduce the processing that IMS must do with each message. To do this, the person at the terminal should be able to send a lot of data to the application program in one screen so that IMS does not have to process additional messages. And the program should not require two screens to give the person at the terminal information that it could give on one screen.

When describing how the program should receive the data from the terminal, you need to consider the program logic and the type of data you are working with.

Gathering Requirements for Conversational Processing

When you use *conversational processing*, the person at the terminal enters some information, and an application program processes the information and responds to the terminal. The person at the terminal then enters more information for an application program to process. Each of these interactions between the person at the terminal and the program is called a *step* in the conversation. Only MPPs can be conversational programs; Fast Path programs and BMPs cannot be conversational.

Definition: Conversational processing means that the person at the terminal can communicate with the application program.

What Happens in a Conversation

During a *conversation*, the person at the terminal enters a request, receives the information from IMS, and enters another request. Although it is not apparent to the person at the terminal, a conversation can be processed by several application programs or by one application program.

Definition: A conversation is a dialog between a person at a terminal and IMS through one or more application programs.

For a program to continue a conversation, the program must have the necessary information to continue processing. IMS stores data from one step of the conversation to the next in a scratch-pad area (SPA). When a program continues the conversation (the same program or a different one), IMS gives the program the SPA (scratch pad area) for the conversation associated with that terminal.

In the preceding airline example, the first program might save the flight number and the names of the people traveling, and then pass control to another application program to reserve seats for those people on that flight. The first program saves this information in the SPA. If the second application program did not have the flight number and names of the people traveling, it would not be able to do its processing.

Designing a Conversation

The first part of designing a conversation is to design the flow of the conversation. If the requests from the person at the terminal are to be processed by only one application program, you need only to design that program. If the conversation should be processed by several application programs, you need to decide which steps of the conversation each program is to process, and what each program is to do when it has finished processing its step of the conversation.

When a person at a terminal enters a transaction code that has been defined as conversational, IMS schedules the conversational program (for example, Program A) associated with that transaction code. When Program A issues its first call to the message queue, IMS returns the SPA that is defined for that transaction code to Program A's I/O area. The person at the terminal must enter the transaction code (and password, if one exists) only on the first input screen; the transaction code need not be entered during each step of the conversation. IMS treats data in subsequent screens as a continuation of the conversation started on the first screen.

After the program has retrieved the SPA, Program A can retrieve the input message from the terminal. After it has processed the message, Program A can either continue the conversation, or end it.

To continue the conversation, Program A can do any of the following:

- Reply to the terminal that sent the message.
- Reply to the terminal and pass the conversation to another conversational program, for example Program B. This is called a *deferred program switch*.

Definition: A deferred program switch means that Program A responds to the terminal and then passes control to another conversational program, Program B. After passing control to Program B, Program A is no longer part of the

conversation. The next input message that the person at the terminal enters goes to Program B, although the person at the terminal is unaware that this message is being sent to a second program.

Restriction: A deferred program switch is disallowed if the application is involved in an inbound protected conversation. The application will receive an X6 status code if it attempts to perform a deferred program switch in this environment.

- Pass control of the conversation to another conversational program without first responding to the originating terminal. This is called an *immediate program switch*.

Definition: An immediate program switch lets you pass control directly to another conversational program without having to respond to the originating terminal. When you do this, the program that you pass the conversation to must respond to the person at the terminal. To continue the conversation, Program B then has the same choices as Program A did: It can respond to the originating terminal and keep control, or it can pass control in a deferred or immediate program switch.

Restriction: An immediate program switch is disallowed if the application is involved in an inbound protected conversation. The application will be abended with a U711 if it attempts to perform an immediate program switch in this environment.

To end the conversation, Program A can do either of the following:

- Move a blank to the first byte of the transaction code area of the SPA and then return the SPA to IMS.
- Respond to the terminal and pass control to a nonconversational program. This is also called a deferred program switch, but Program A ends the conversation before passing control to another application program. The second application program can be an MPP or a transaction-oriented BMP that processes transactions from the conversational program.

Important Points about the SPA

When program A passes control of a conversation to program B, program B needs to have the data that program A saved in the SPA in order to continue the conversation. IMS gives the SPA for the transaction to program B when program B issues its first message call.

The SPA is kept with the message. When the truncated data option is on, the size of the retained SPA is the largest SPA of any transaction in the conversation.

Example: If the conversation starts with TRANA (SPA=100), and the program switches to a TRANB (SPA=50), the input message for TRANB will contain a SPA segment of 100 bytes. IMS adjusts the size of the SPA so that TRANB receives only the first 50 bytes.

Questions for Alan Smith

Version 5?! Also, I notice it is RTRUNC here and STRUNC in the ATM-AND - this same section is in both this and that book...should this be a shared file?

However, the IMS support that adjusts the size of the SPA does not exist in either IMS Version 5 or earlier systems. If TRANB is to execute on a remote MSC system

without this support, it will be passed a SPA of 100 bytes when it is only expecting 50 bytes. There are two ways to prevent this larger sized SPA from being sent to an IMS Version 5 or earlier system:

1. You could define TRANB on the local IMS system with the RTRUNC parameter on its TRANSACT macro, this forces the SPA to a size of 50 bytes when it is inserted by TRANA.
2. If you never use truncated data nor want to change the TRANSACT macros for remote transactions to specify RTRUNC, a specification is available to set the system-wide default for the truncated data option. The specification is TRUNC=Y|N in the DFSDCxxx PROCLIB member. You could set the system default to not save truncated data, and the SPA would be automatically truncated to a size of 50 bytes when it is inserted by TRANA.

Related Reading: For more information on how to structure a conversational program, see *IMS Version 9: Installation Volume 2: System Definition and Tailoring*.

Recovery Considerations in Conversations

Because a conversation involves several steps and can involve several application programs, consider the following items:

- One way you can make recovery easier is to design the conversation so that all the database updates are done in the last step of the conversation. This way, if the conversation terminates abnormally, IMS can back out all the updates because they were all made during the same step of the conversation. Updating the database during the last step of the conversation is also a good idea, because the input from each step of the conversation is available.
- Although a conversation can terminate abnormally during any step of the conversation, IMS backs out only the database updates and output messages resulting during the last step of the conversation. IMS does not back out database updates or cancel output messages for previous steps, even though some of that processing might be inaccurate as a result of the abnormal termination.
- Certain IMS system service calls can be helpful if the program determines that some of its processing was invalid. These calls include R0LB, SETS, SETU, and R0LS. The Roll Back call (R0LB) backs out all of the changes that the program has made to the database. R0LB also cancels the output messages that the program has created (except those sent with an express PCB) since the program's last commit point.

The SETS, or SETU, and R0LS (with a *token*) calls work together to allow the application program to set intermediate backout points within the call processing of the program. The application program can set up to nine intermediate backout points. Your program needs to use the SETS or SETU call to specify a token for each point. A subsequent R0LS call, using the same token, can back out all database changes and discard all nonexpress messages processed since that SETS or SETU call.

Definition: A token is a 4-byte identifier.

- The program can use an express PCB to send a message to the person at the terminal and to the master terminal operator. When the application program inserts messages using an express PCB, IMS waits until it has the complete message, rather than for the occurrence of a commit point, to transmit the message to its destination. (In this context, “insert” refers to a situation in which the application program sends the message and it is received by IMS; “transmit” refers to a situation in which IMS begins sending the message to its destination.) Therefore, when IMS has the complete message, it will be transmitted even if the program abnormally terminates. Messages sent with an express PCB are sent to

their final destinations even if the program terminates abnormally or issues a ROLB call. For more information about the express PCB, refer to “To Other Programs and Terminals.”

- To verify the accuracy of the previous processing, and to correct the processing that is determined to be inaccurate, you can use the Conversational Abnormal termination routine, DFSCONE0.

Related Reading: For more information on DFSCONE0, see *IMS Version 9: Customization Guide*.

- You can write an MPP to examine the SPA, send a message notifying the person at the terminal of the abnormal termination, make any necessary database calls, and use a user-written or system-provided exit routine to schedule it.

Identifying Output Message Destinations

An application program can send messages to another application program or to IMS terminals. To send output messages, the program issues a call and references the I/O PCB or an alternate PCB. The I/O PCB and alternate PCBs represent logical terminals and other application programs with which the application program communicates.

Definition: An *alternate PCB* is a data communication program communication block (DCPCB) that you define to describe output message destinations other than the terminal that originated the input message.

The Originating Terminal

To send a message to the logical terminal that sent the input message, the program uses an I/O PCB. IMS puts the name of the logical terminal that sent the message in the I/O PCB when the program receives the message. As a result, the program need not do anything to the I/O PCB before sending the message. If a program receives a message from a batch-oriented BMP or CPI Communications driven program, no logical terminal name is available to put into the I/O PCB. In these cases, the logical terminal name field contains blanks.

To Other Programs and Terminals

When you want to send an output message to a terminal other than, or in addition to, the terminal that sent the input message, you use an alternate PCB. You can set the alternate PCB for a specific logical terminal when the program's PSB is generated, or you can define the alternate PCB as being modifiable. A program can change the destination of a modifiable alternate PCB while the program is running, so you can send output messages to several alternate destinations.

The application program might need to respond to the originating terminal before the person at the originating terminal can send any more messages. This might occur when a terminal is in **response mode** or in **conversational mode**:

- **Response mode** can apply to a communication line, a terminal, or a transaction. When response mode is in effect, IMS does not accept any input from the communication line or terminal until the program has sent a response to the previous input message. The originating terminal is unusable (for example, the keyboard locks) until the program has processed the transaction and sent the reply back to the terminal.

If a response-mode transaction is processed, including Fast Path transactions, and the application does not insert a response back to the terminal through either the I/O PCB or alternate I/O PCB, but inserts a message to an alternate PCB

(program-to-program switch), the second or subsequent application program must respond to the originating terminal and satisfy the response. IMS will not take the terminal out of response mode.

If an application program terminates normally and does not issue an ISRT call to the I/O PCB, alternate I/O PCB, or alternate PCB, IMS sends system message DFS2082I to the originating terminal to satisfy the response for all response-mode transactions, including Fast Path transactions.

You can define communication lines and terminals as operating in response mode, not operating in response mode, or operating in response mode only if processing a transaction that is been defined as response mode. You specify response mode for communication lines and terminals on the TYPE and TERMINAL macros, respectively, at IMS system definition. You can define any transaction as a response-mode transaction; you do this on the TRANSACT macro at IMS system definition. Response mode is in effect if:

- The communication line has been defined as being in response mode.
- The terminal has been defined as being in response mode.
- The transaction code has been defined as response mode.
- **Conversational mode** applies to a transaction. When a program is processing a conversational transaction, the program must respond to the originating terminal after each input message it receives from the terminal.

In these processing modes, the program must respond to the originating terminal. But sometimes the originating terminal is a physical terminal that is made up of two components—for example, a printer and a display. If the physical terminal is made up of two components, each component has a different logical terminal name. To send an output message to the printer part of the terminal, the program must use a different logical terminal name than the one associated with the input message; it must send the output message to an alternate destination. A special kind of alternate PCB is available to programs in these situations; it is called an *alternate response PCB*.

Definition: An alternate response PCB lets you send messages when exclusive, response, or conversational mode is in effect. See the next section for more information.

Alternate Response PCB

The destination of an alternate response PCB must be a logical terminal—you cannot use an alternate response PCB to represent another application program. When you use an alternate response PCB during response mode or conversational mode, the logical terminal represented by the alternate response PCB must represent the same physical terminal as the originating logical terminal.

In these processing modes, after receiving the message, the application program must respond by issuing an ISRT call to one of the following:

- The I/O PCB.
- An alternate response PCB.
- An alternate PCB whose destination is another application program, that is, a program-to-program switch.
- An alternate PCB whose destination is an ISC link. This is allowed only for front-end switch messages.

Related Reading: For more information on front-end switch messages, see *IMS Version 9: Customization Guide*.

If one of these criteria is not met, message DFS2082I is sent to the terminal.

Express PCB

Consider specifying an alternate PCB as an *express PCB*. The express designation relates to whether a message that the application program inserted is actually transmitted to the destination if the program abnormally terminates or issues a ROLL, ROLB, or ROLS call. For all PCBs, when a program abnormally terminates or issues a ROLL, ROLB, or ROLS call, messages that were inserted but not made available for transmission are cancelled while messages that were made available for transmission are never cancelled.

Definition: An express PCB is an alternate response PCB that allows your program to transmit the message to the destination terminal earlier than when you use a nonexpress PCB.

For a nonexpress PCB, the message is not made available for transmission to its destination until the program reaches a commit point. The commit point occurs when the program terminates, issues a CHKP call, or requests the next input message and when the transaction has been defined with MODE=SNGL.

For an express PCB, when IMS has the complete message, it makes the message available for transmission to the destination. In addition to occurring at a commit point, it also occurs when the application program issues a PURG call using that PCB or when it requests the next input message.

You should provide the answers to the following questions to the data communications administrator to help in meeting your application's message processing requirements:

- Will the program be required to respond to the terminal before the terminal can enter another message?
- Will the program be responding only to the terminal that sends input messages?
- If the program needs to send messages to other terminals or programs as well, is there only one alternate destination?
- What are the other terminals to which the program must send output messages?
- Should the program be able to send an output message before it terminates abnormally?

Chapter 7. Application Design for APPC

Advanced Program-to-Program Communication (APPC) is IBM's preferred protocol for program-to-program communication. Application programs can be distributed throughout the network and communicate with each other in many hardware architectures and software environments.

This section describes the APPC function of IMS TM.

In this Section:

- "Overview of APPC and LU 6.2"
- "Application Program Types"
- "Application Objectives" on page 105
- "Choosing Conversation Attributes" on page 105
- "Conversation Type" on page 106
- "Conversation State" on page 107
- "Synchronization Level" on page 107
- "Distributed Sync Point" on page 108
- "Application Programming Interface for LU Type 6.2" on page 112
- "LU 6.2 Partner Program Design" on page 113

Related Reading: For more information on APPC, see:

- *IMS Version 9: Application Programming: Transaction Manager*, which includes specific information on APPC such as the application programming interface (API) and descriptions of the APSB and DPSB calls.
- *IMS Version 9: Administration Guide: Transaction Manager*, which includes an overview of APPC for LU 6.2 devices and CPI Communications concepts.

Overview of APPC and LU 6.2

APPC allows application programs using APPC protocols to enter IMS transactions from LU 6.2 devices. The LU 6.2 application program runs on an LU 6.2 device supporting APPC.

APPC creates an environment that allows:

- Remote LU 6.2 devices to enter IMS local and remote transactions
- IMS application programs to insert transaction output to LU 6.2 devices with no coding changes to existing application programs
- New application programs to make full use of LU 6.2 device facilities
- Data integrity provided by IMS and in LU 6.2 environments that do not have a distributed sync-point function

Application Program Types

APPC/IMS is part of IMS TM that uses the CPI communications interface to communicate with application programs. APPC/IMS supports the following types of application programs for LU 6.2 processing:

- Standard DL/I
- Modified standard DL/I
- CPI Communications driven

Standard DL/I Application Program

A standard DL/I application program does not issue any CPI Communications calls or establish any CPI-C conversations. This application program can communicate with LU 6.2 products that replace other LU-type terminals using the IMS API. A standard DL/I application program does not need to be modified, recompiled, or link-edited, and it executes as it currently does.

Modified Standard DL/I Application Program

A modified standard DL/I application program is a standard DL/I online IMS TM application program that uses both DL/I calls and CPI Communications calls. It can be an MPP, BMP, or IFP that can access full-function databases, DEDBs, MSDBs, and DB2 databases.

A modified standard DL/I application program uses CPI Communications (CPI-C) calls to provide support for an LU 6.2 and non-LU 6.2 mixed network. The same application program can be a standard DL/I on one execution, when the CPI Communications `ALLOCATE` verb is not issued, and a modified standard DL/I on a different execution when the CPI Communications `ALLOCATE` verb is issued.

A modified standard DL/I application program receives its messages using DL/I `GU` calls to the I/O PCB and issues output responses using DL/I `ISRT` calls. CPI Communications calls can also be used to allocate new conversations and to send and receive data for them.

Related Reading: For a list of the CPI Communications calls, see *Common Programming Interface Communications Reference*.

Use a modified standard DL/I application program when you want to use an existing standard DL/I application program to establish a conversation with another LU 6.2 device or the same network destination. The standard DL/I application program is optionally modified and uses new functions, new application and transaction definitions, and modified DL/I calls to initiate LU 6.2 application programs. Program calls and parameters are available to use the IMS-provided implicit API and the CPI Communications explicit API.

CPI Communications Driven Program

A CPI Communications driven application program uses `Commit` and `Backout` calls, and CPI Communications interface calls or LU 6.2 verbs for input and output message processing. This application program uses the CPI Communications explicit API, and can access full-function databases, DEDBs, MSDBs, and DB2 databases. An LU 6.2 device can activate a CPI Communications driven application program only by allocating a conversation.

Unlike a standard DL/I or modified standard DL/I application program, input and output message processing for a CPI Communications driven program uses APPC/MVS buffers and bypasses IMS message queueing. Because these application programs do not use the IMS message queue, they can control their own execution with the partner LU 6.2 system. An IMS `APSB` call enables you to allocate a PSB for accessing IMS databases and alternate PCBs.

The application program uses the Common Programming Interface Resource Recovery (CPI-RR) `SRRCMIT` verb to initiate an IMS sync point and the CPI-RR `SRRBACK` verb for backout. CPI Communications driven application programs use the CPI-RR calls to initiate IMS sync point processing prior to program termination.

A CPI Communications driven application program is able to:

- Access any type of database
- Receive and send large messages like the standard DL/I and modified standard DL/I application programs
- Control the flow of input and output with CPI Communications calls
- Allocate multiple conversations with partner LU 6.2 devices
- Cause synchronization with conversation partners
- Use the IMS implicit API (for example, IMS queue services)
- Use IMS services (for example, sync point at program termination) regardless of the API that is used

Application Objectives

Each application type has a different purpose, and its ease-of-use varies depending on whether the program is a standard DL/I, modified standard DL/I, or a CPI Communications driven application program. Table 13 on page 105 lists the purpose and ease-of-use for each application type (standard DL/I, modified standard DL/I, and PI-C driven). This information must be balanced with IMS resource use.

Table 13. Using Application Programs in APPC

Purpose of Application Program	Ease of Use		
	Standard DL/I Program	Modified Standard DL/I Program	PI-C Driven Program
Inquiry	Easy	Neutral	Very Difficult
Data Entry	Easy	Easy	Difficult
Bulk Transfer	Easy	Easy	Neutral
Cooperative	Difficult	Difficult	Desirable
Distributed	Difficult	Neutral	Desirable
High Integrity	Neutral	Neutral	Desirable
Client Server	Easy	Neutral	Very Difficult

Choosing Conversation Attributes

The LU 6.2 transaction program indicates how the transaction is to be processed by IMS. Two processing modes are available: **synchronous** and **asynchronous**.

Synchronous Conversation

A conversation is synchronous if the partner waits for the response on the same conversation used to send the input data.

Synchronous processing is requested by issuing the RECEIVE_AND_WAIT verb after the SEND_DATA verb. Use this mode for IMS response-mode transactions and IMS conversational-mode transactions.

Example:

```
MC_ALLOCATE TPN(MYTXN)
MC_SEND_DATA 'THIS CAN BE A RESPONSE MODE'
MC_SEND_DATA 'OR CONVERSATIONAL MODE'
MC_SEND_DATA 'IMS TRANSACTION'
MC_RECEIVE_AND_WAIT
```

For examples of transaction flow, see “LU 6.2 Flow Diagrams” on page 113.

Asynchronous Conversation

A conversation is asynchronous if the partner program normally deallocates a conversation after sending the input data. Output is sent to the TP name of DFSASYNC.

Asynchronous processing is requested by issuing the DEALLOCATE verb after the SEND_DATA verb. Use asynchronous processing for IMS commands, message switches, and non-response, non-conversational transactions.

Example:

```
MC_ALLOCATE TPN(OTHERTXN)
MC_SEND_DATA 'THIS MUST BE A MESSAGE SWITCH, IMS COMMAND'
MC_SEND_DATA 'OR A NON-RESP NON-CONV TRANSACTION'
MC_DEALLOCATE
```

For examples of transaction flow, see “LU 6.2 Flow Diagrams” on page 113.

Asynchronous Output Delivery

Asynchronous output is held on the IMS message queue for delivery. When the output is enqueued, IMS attempts to allocate a conversation to send this output. If this fails, IMS holds the output for later delivery. This delivery can be initiated by an operator command (/ALLOC), or by the enqueue of a new message for this LU 6.2 destination.

MSC Synchronous and Asynchronous Conversation

MSC remote application messages from both synchronous and asynchronous APPC conversations can be queued on the multiple systems coupling (MSC) link. These messages can then be sent across the MSC link to a remote IMS for processing.

For examples of transaction flow, see “LU 6.2 Flow Diagrams” on page 113.

Conversation Type

The APPC conversation type defines how data is passed on and retrieved from APPC verbs. It is similar in concept to file blocking and affects both ends of the conversation.

APPC supports two types of conversations:

Basic conversation

This low-conversation allows programs to exchange data in a standardized format. This format is a stream of data containing 2-byte length fields (referred to as LLs) that specify the amount of data to follow before the next length field. The typical data pattern is:

```
LL, data, LL, data
```

Each grouping of LL, data is referred to as a logical record. A basic conversation is used to send multiple segments with one verb and to receive maximum data with one verb.

Mapped conversation

This high-conversation allows programs to exchange arbitrary data records

in data formats approved by application programmers. One send verb results in one receive verb, and MVS and VTAM® handle the buffering.

Related Reading: For more information on basic and mapped conversations, see

- *Systems Network Architecture: LU 6.2 Reference: Peer Protocols* and
- *Systems Network Architecture: Transaction Programmer's Reference Manual for LU Type 6.2*

Conversation State

CPI Communications uses conversation state to determine what the next set of actions will be. Examples of conversation states are:

RESET	The initial state before communications begin.
SEND	The program can send or optionally receive.
RECEIVE	The program must receive or abort.
CONFIRM	The program must respond to a partner.

The basic rules for APPC verbs are:

- The program that initiates the conversation speaks first.
- Only one APPC verb can be outstanding at time.
- Programs take turns sending and receiving.
- The state of the conversation determines the verbs a program can issue.

Synchronization Level

The APPC synchronization level defines the protocol that is used when changing conversation states. APPC and IMS support the following `sync_level` values:

NONE	Specifies that the programs do not issue calls or recognize returned parameters relating to synchronization.
CONFIRM	Specifies that the programs can perform confirmation processing on the conversation.
SYNCPT	Specifies that the programs participate in coordinated commit processing on resources that are updated during the conversation under the RRS/MVS recovery platform. A conversation with this level is also called a protected conversation.

Allocating a conversation with `SYNCLVL=SYNCPT` requires the Resource Recovery Services (RRS/MVS) as the sync-point manager (SPM). RRS/MVS controls the commitment of protected resources by coordinating the commit or backout request with the participating owners of the updated resources, the resource managers. IMS is the resource manager for DL/I, Fast Path data, and the IMS message queues. The application program decides whether the data is to be committed or aborted and communicates this decision to the SPM. The SPM then coordinates the actions in support of this decision among the resource managers.

Related Reading: For more information on `SYNCLVL=SYNCPT`, see *IMS Version 9: Administration Guide: Transaction Manager*.

Distributed Sync Point

The Distributed Sync Point support enables IMS and remote application programs (APPC or OTMA) to participate in protected conversations with coordinated resource updates and recoveries. Before this support, IMS acted as the sync-point manager. In this new scenario, MVS manages the sync-point process on behalf of the conversation participants: the application program and IMS (now acting as a resource manager).

OS/390[®] implements a system resource recovery platform, the Resource Recovery Services/MVS (RRS/MVS). RRS/MVS supports the Common Programming Interface - Resource Recovery (CPI-RR), an element of the SAA[®] Common Programming Interface that defines resource recovery and provides for the coordinated management of resource recovery for both local *and* distributed resources. In addition to RRS/MVS, a communications resource manager (called APPC/PC for APPC/Protected Conversations) provides distribution of the recovery.

In the APPC environment, a protected conversation is initiated when the application program allocates an APPC conversation with SYNC_LEVEL=SYNCPT. Both IMS and APPC are resource managers in this scenario. In the OTMA environment, some additional code is required because OTMA is not a resource manager. The additional code needed is an OTMA adapter, IBM supplied or equivalent. This adapter indicates to IMS (in the OTMA message prefix) that this message is part of a protected conversation, and thus IMS and the adapter are participants in the coordinated commit process as managed by RRS/MVS.

Application programmers can now develop APPC application programs (local and remote) and remote OTMA application programs that use RRS/MVS as the sync-point manager, rather than IMS. This enhancement enables resources across multiple platforms to be updated and recovered in a coordinated manner.

Concepts

The Distributed Sync Point support entails:

- Changes in IMS that allow it to function as a resource manager under RRS/MVS
- Changes to the application program environment that support using applications in protected conversations
- Changes to some commands that aid the user

Introduction to Resource Recovery

Most customers maintain computer resources that are essential to the survival of their businesses. When these resources are updated in a controlled and synchronized manner, they are said to be **protected resources** or **recoverable resources**. These resources can all reside locally (on the same system) or be distributed (across nodes in the network). The protocols and mechanisms for regulating the updating of multiple protected resources in a consistent manner is provided in MVS with Resource Recovery Services/MVS (RRS/MVS).

Participants in Resource Recovery: As shown in Figure 29 on page 109 the Resource Recovery environment is composed of three participants:

- Sync-point manager
- Resource managers
- Application program

RRS/MVS is the **sync-point manager**, also known as the coordinator. The sync-point manager controls the commitment of protected resources by coordinating the commit request (or backout request) with the **resource managers**, the participating owners of the updated resources. These resource managers are known as participants in the sync-point process. IMS participates as a resource manager for DL/I, Fast Path, and DB2 data if this data has been updated in such an environment.

The final participant in this resource recovery protocol is the **application program**, the program accessing and updating protected resources. The application program decides whether the data is to be committed or aborted and relates this decision to the sync-point manager. The sync-point manager then coordinates the actions in support of this decision among the resource managers.

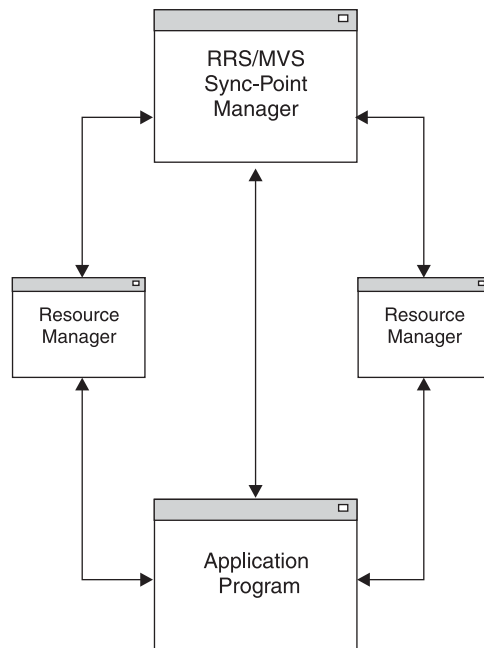

Figure 29. Participants in Resource Recovery

Two-Phase Commit Protocol: As shown in Figure 30 on page 110, the two-phase commit protocol is a process involving the sync-point manager and the resource manager participants to ensure that of the updates made to a set of resources by a third participant, the application program, either **all updates occur or none**. In simple terms, the application program decides to commit its changes to some resources; this commit is made to the sync-point manager that then polls all of the resource managers as to the feasibility of the commit call. This is the prepare phase, often called phase one. Each resource manager votes yes or no to the commit.

After the sync-point manager has gathered all the votes, phase two begins. If all votes are to commit the changes, then the phase two action is commit. Otherwise, phase two becomes a backout. System failures, communication failures, resource manager failures, or application failures are not barriers to the completion of the two-phase commit process.

The work done by various resource managers is called a **unit of recovery (UOR)** and spans the time from one consistent point of the work to another consistent

point, usually from one commit point to another. It is the unit of recovery that is the object of the two-phase commit process.

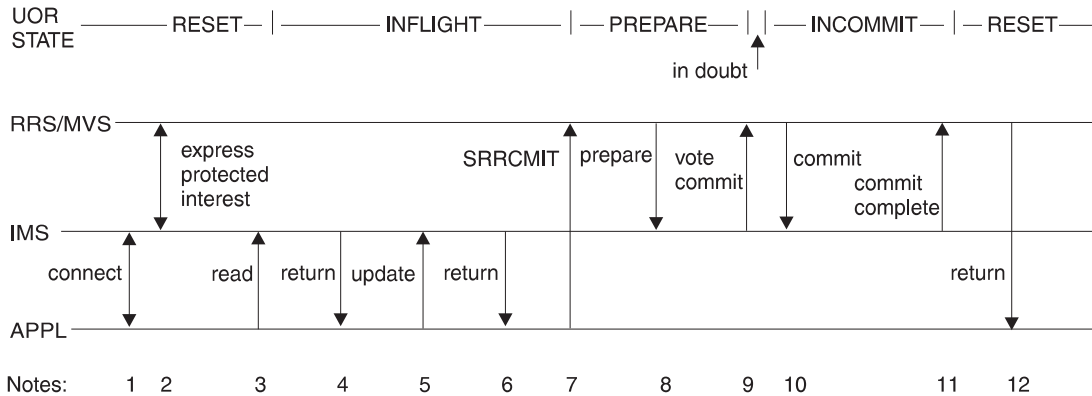

Figure 30. Two-Phase Commit Process with One Resource Manager

Notes:

1. The application and IMS make a connection.
2. IMS expresses protected interest in the work started by the application. This tells RRS/MVS that IMS will participate in the 2-phase commit process.
3. The application makes a read request to an IMS resource.
4. Control is returned to the application following its read request.
5. The application updates a protected resource.
6. Control is returned to the application following its update request.
7. The application requests that the update be made permanent via the SRRRCMIT call.
8. RRS/MVS calls IMS to do the prepare (phase 1) process.
9. IMS returns to RRS/MVS with its vote to commit.
10. RRS/MVS calls IMS to do the commit (phase 2) process.
11. IMS informs RRS/MVS that it has completed phase 2.
12. Control is returned to the application following its commit request.

Local Versus Distributed: The residence of the participants involved in the recovery process determines whether that recovery is considered local or distributed. In a **local** recovery scenario, all the participants reside on the same single system. In a **distributed** recovery scenario, the participants are scattered over multiple systems. Figure 31 on page 111 shows the communication between Resource Manager participants in a distributed resource recovery. There is no conceptual difference between a local and distributed recovery in the functions provided by RRS/MVS. However, to distribute the original sync-point manager's function to involve remote sync-point managers, a special resource manager is required. The APPC communications resource manager provides this support in the distributed environment.

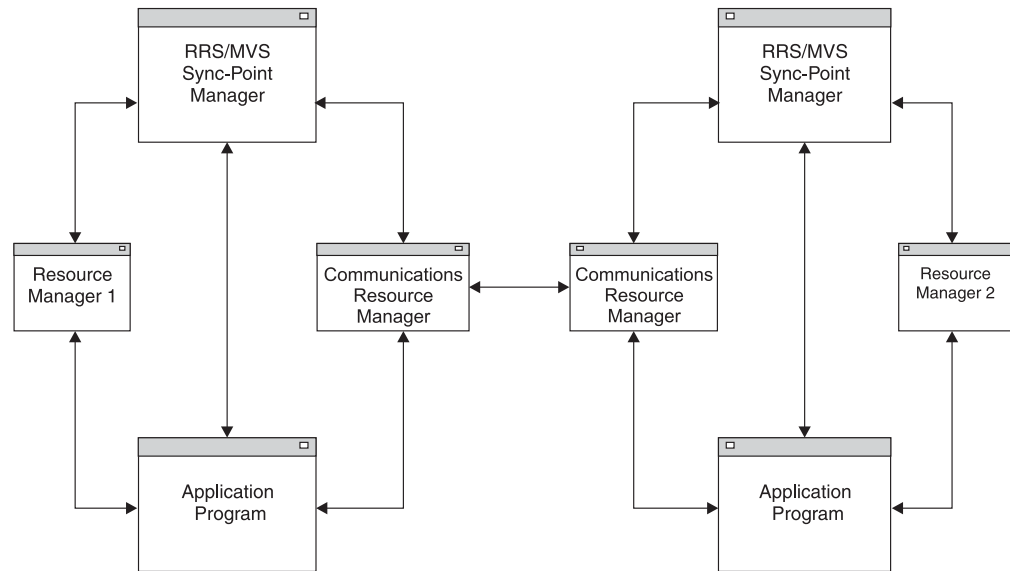

Figure 31. Distributed Resource Recovery

Summary of RRS/MVS Support

The objective of RRS/MVS is to provide a system resource recovery platform such that applications executing on MVS can have access to local and distributed resources and have system coordinated recovery management of these resources. The support includes:

- A sync-point manager to coordinate the two-phase commit process
- Implementation of the SAA Commit and Backout callable services for use by application programs
- A mechanism to associate resources with an application instance
- Services for resource manager registration and participation in the two-phase commit process with RRS/MVS
- Services to allow resource managers to express interest in an application instance and be informed of commit and backout requests
- Services to enable resource managers to obtain system data to restore their resources to consistent state
- A communications resource manager (called APPC/PC for APPC/Protected Conversations) so that distributed applications can coordinate their recovery with participating local resource managers

Restriction:

- Extended Recovery Facility (XRF)

Running protected conversations in an IMS-XRF environment does not guarantee that the alternate system can resume and resolve any unfinished work started by the active system. This process is not guaranteed because a failed resource manager must re-register with its original RRS system if the RRS is still available when the resource manager restarts. Only if the RRS on the active system is *not* available can an XRF alternate register with another RRS in the sysplex and obtain the incomplete unit of recovery data of the failing active.

Recommendation: Because IMS retains indoubt units-of-recovery indefinitely until they're resolved, a switch back to the original active system should be done as soon as possible to pickup unit of recovery information to resolve and

complete all the work of the resource managers involved. If this is not possible, the indoubt units-of-recovery can be resolved via commands.

- Remote Site Recovery (RSR)
Active systems tracked by a remote system in an RSR environment can participate in protected conversations, although it will be necessary to resolve indoubt units-of-recovery via commands if they should exist after a takeover to a remote site has been done. This is because the remote site is probably not part of the active sysplex and the new IMS cannot acquire unfinished unit-of-recovery information from RRS. IMS provides commands to interrogate protected conversation work and to resolve the unfinished unit-of-recovery if necessary.
- Batch and Non-Message Driven BMPs in a DBCTL Environment
Distributed Sync Point does not support the IMS batch environment. In a DBCTL environment, there are no inbound protected conversations possible. However, a BMP in a DBCTL environment can allocate an outbound protected conversation, which will be supported by Distributed Sync Point and RRS/MVS.

Impact on the Network

Network traffic will increase as a result of the conversation participants and the sync-point manager communicating with each other.

Application Programming Interface for LU Type 6.2

IMS application programs can use the IMS implicit LU 6.2 API to access LU 6.2 devices. This API provides compatibility with non-LU 6.2 device types so that the same application program can be used from both LU 6.2 and non-LU 6.2 devices. The API adds to the APPC interface by supplying IMS-provided processing for the application program. You can use the explicit CPI Communications interface for APPC functions and facilities for new or rewritten IMS application programs.

Implicit API

The implicit API accesses an APPC conversation indirectly. This API uses the standard DL/I calls (GU, ISRT, PURG) to send and receive data. It allows application programs that are not specific to LU 6.2 protocols to use LU 6.2 devices. The API uses new and changed DL/I calls (CHNG, INQY, SET0) to utilize LU 6.2. Using the existing IMS application programming base, you can write LU 6.2-specific applications using this API and not using the CPI Communications calls. Although the implicit API uses only some of the LU 6.2 capabilities, it can be a useful simplification for many applications. The implicit API also provides function outside of LU 6.2, like message queueing and automatic asynchronous message delivery.

IMS generates all CPI Communications calls under the implicit API. The application interaction is strictly with the IMS message queue.

The remote LU 6.2 system must be able to handle the LU 6.2 flows. APPC/MVS generates these flows from the CPI Communications calls issued by the IMS application program using the implicit API. An IMS application program can use the explicit API to issue the CPI Communications directly. This is useful with remote LU 6.2 systems that have incomplete LU 6.2 implementations, or that are incompatible with the IMS implicit API support. See the LU 6.2 data flow examples under "LU 6.2 Partner Program Design" on page 113.

The existing API is extended so that:

- Asynchronous LU 6.2 output is created by using alternate PCBs that reference LU 6.2 destinations. The DL/I CHNG call can supply parameters to specify an LU 6.2 destination. Default values are used for omitted parameters.
- An application program can retrieve the current conversation attributes such as the conversation type (basic or mapped), the sync_level (NONE, CONFIRM, or SYNCPT), and asynchronous or synchronous conversation.
- A terminal message switch can be used to and from LU 6.2 devices. See “LU 6.2 Partner Program Design” for a description of the message switch.

Explicit API

The explicit API (the CPI Communications API) can be used by any IMS application program to access an APPC conversation directly. IMS resources are available to the CPI Communications driven application program only if the application issues the APSB (Allocate_ PSB) call. The CPI Communications driven application program must use the CPI-RR SRRCMIT and SRRBACK verbs to initiate an IMS sync point or backout, or if SYNCLVL=SYNCPT is specified, to communicate the sync point decision to the RRS/MVS sync point manager.

Related Reading: For a description of the SRRCMIT and SRRBACK verbs, see *SAA CPI Resource Recovery Reference*.

LU 6.2 Partner Program Design

The flow of a transaction that is sent from an LU 6.2 device differs, depending on the conversation attributes and synchronization levels. Different results occur, and the partner system takes actions accordingly. The flow diagrams and the integrity tables in this section present these differences.

LU 6.2 Flow Diagrams

Figure 32 on page 114 through Figure 40 on page 118 show the flow between a synchronous or asynchronous LU 6.2 application program and an IMS application program in a single (local) IMS system.

Figure 41 on page 119 through Figure 44 on page 122 show the flow between a synchronous or asynchronous LU 6.2 application program in a single (local) IMS system and an IMS application program in a remote IMS system across a multiple systems coupling (MSC) link.

Figure 45 on page 123 and Figure 46 on page 124 show commit scenarios with SYNC_LEVEL=SYNCPT. Figure 47 on page 125 shows a backout scenario with SYNC_LEVEL=SYNCPT.

Differences in buffering and encapsulation of control data with user data may cause variations in the flows. The control data are the 3 returned fields from the Receive APPC verb: Status_received, Data_received, and Request_to_send_received. Any variations based on these differences will not affect the function or use of the flows.

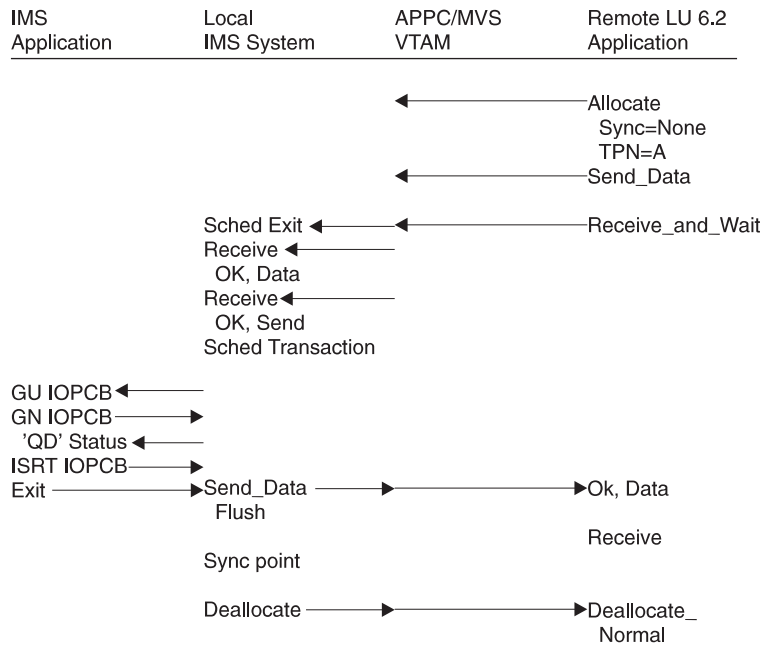

Figure 32. Flow of a Local IMS Synchronous Transaction When Sync_level=None

Figure 33 shows the flow of a local synchronous transaction when Sync_level is Confirm.

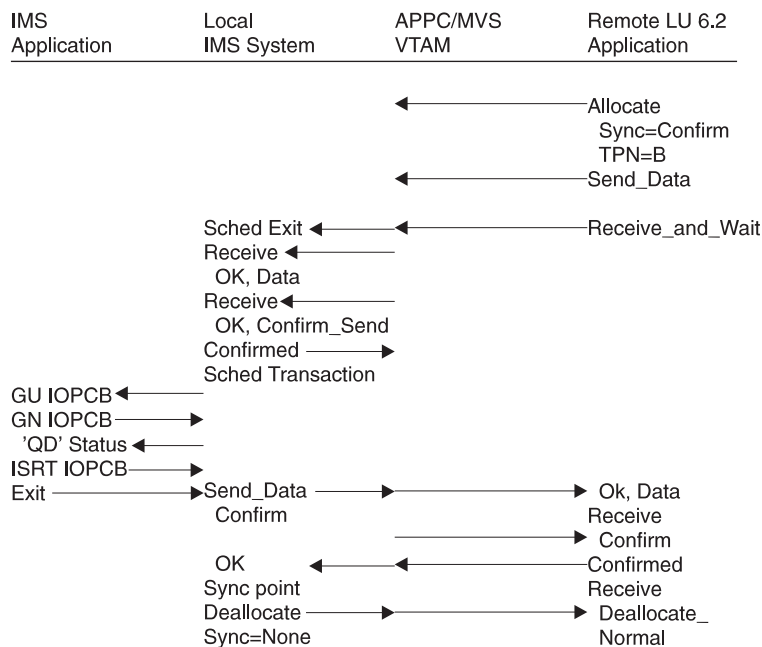

Figure 33. Flow of a Local IMS Synchronous Transaction When Sync_level=Confirm

Figure 34 on page 115 shows the flow of a local asynchronous transaction when Sync_level is None.

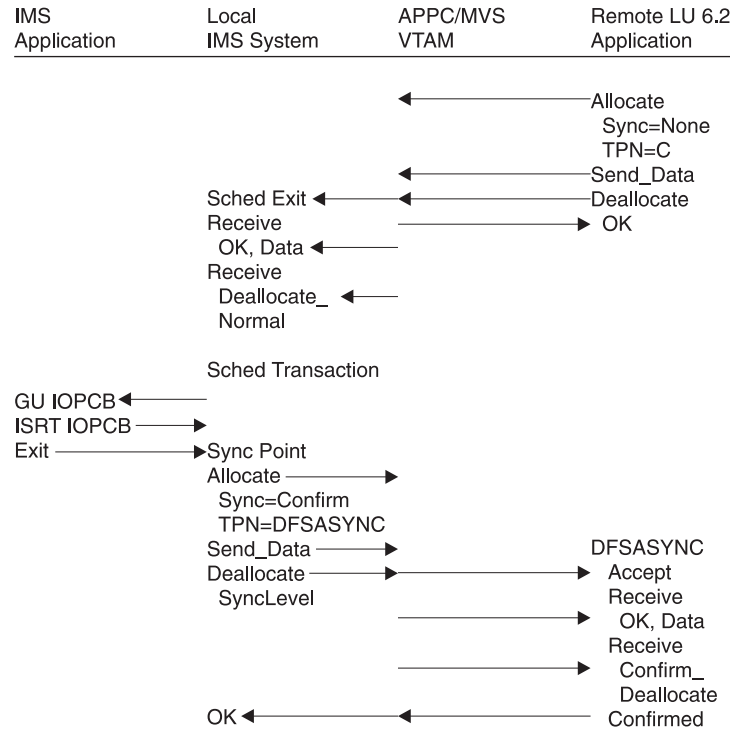

Figure 34. Flow of a Local IMS Asynchronous Transaction When Sync_level=None

Figure 35 shows the flow of a local asynchronous transaction when Sync_level is Confirm.

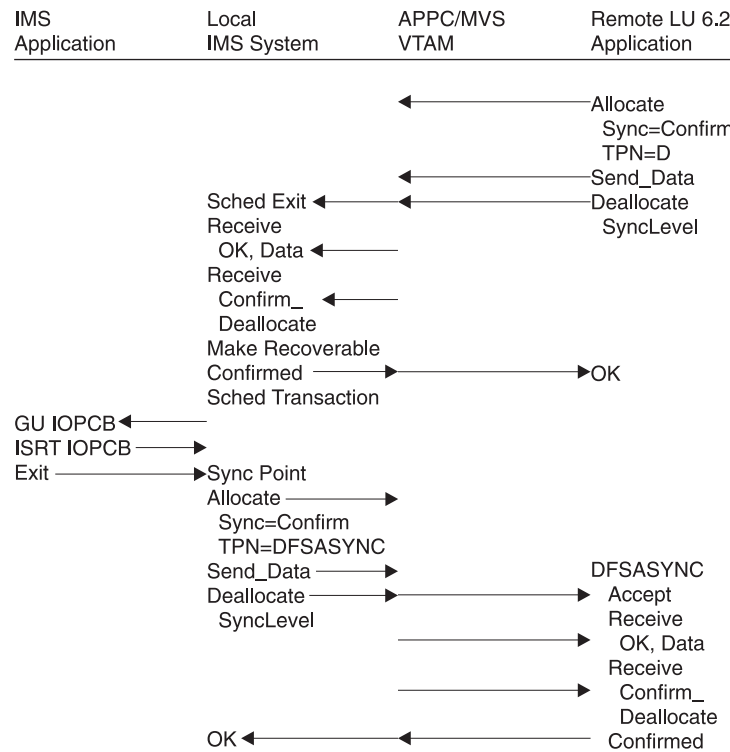

Figure 35. Flow of a Local IMS Asynchronous Transaction When Sync_level=Confirm

Figure 36 shows the flow of a local conversational transaction When Sync_level is None.

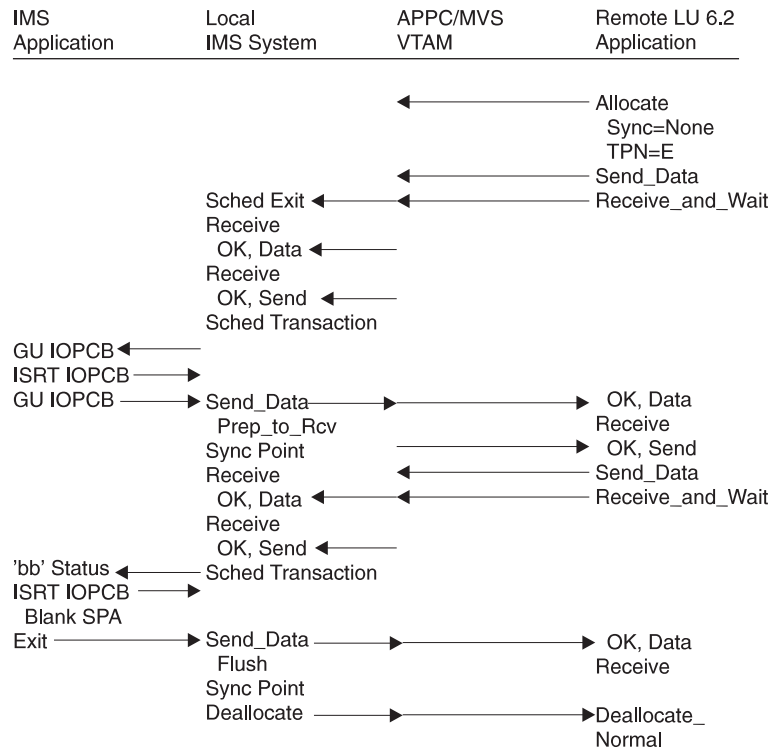

Figure 36. Flow of a Local IMS Conversational Transaction When Sync_level=None

Figure 37 shows the flow of a local IMS command when Sync_level is None.

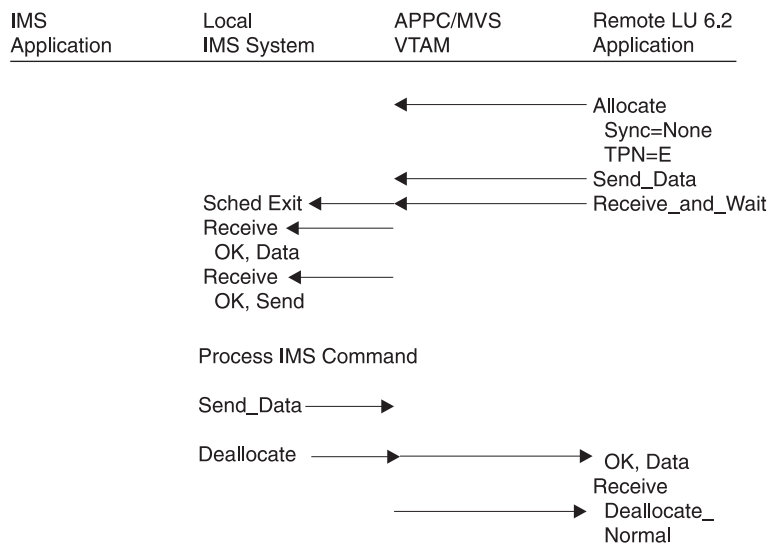

Figure 37. Flow of a Local IMS Command when Sync_level=None

Figure 38 on page 117 shows the flow of a local asynchronous command when Sync_level is Confirm.

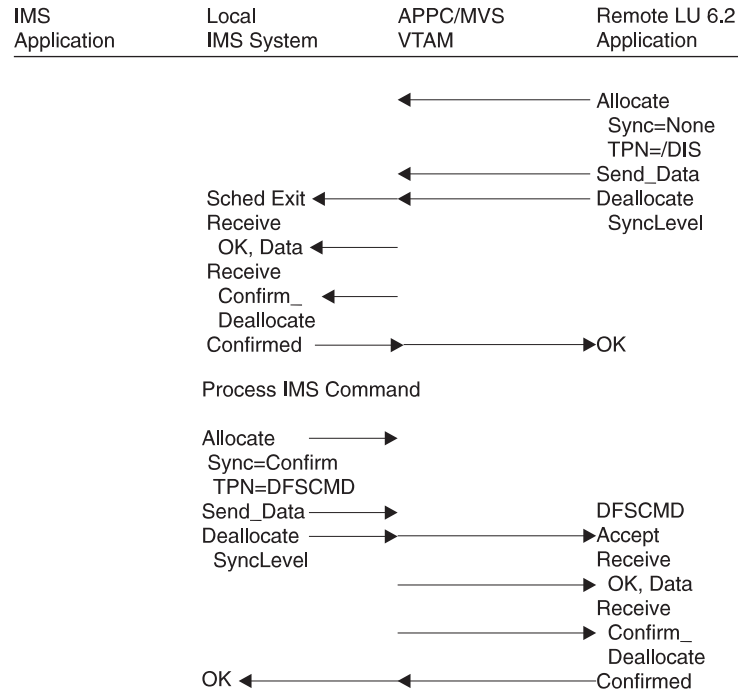

Figure 38. Flow of a Local IMS Asynchronous Command When Sync_level=Confirm

Figure 39 shows the flow of a message switch When Sync_level is None.

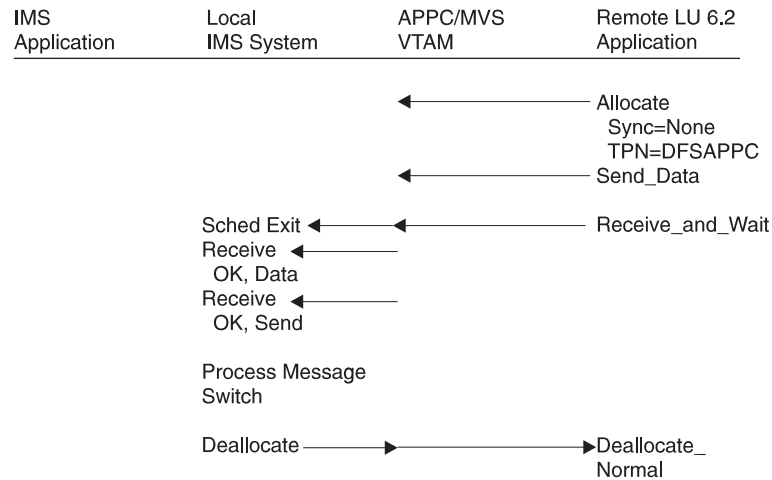

Figure 39. Flow of a Message Switch When Sync_level=None

Synchronous is used to verify that no error has occurred while processing DFSAPPC. If an error occurred, the error message returns before DEALLOCATE.

Figure 40 on page 118 shows the flow of a CPI-C driven program when Sync_level is None.

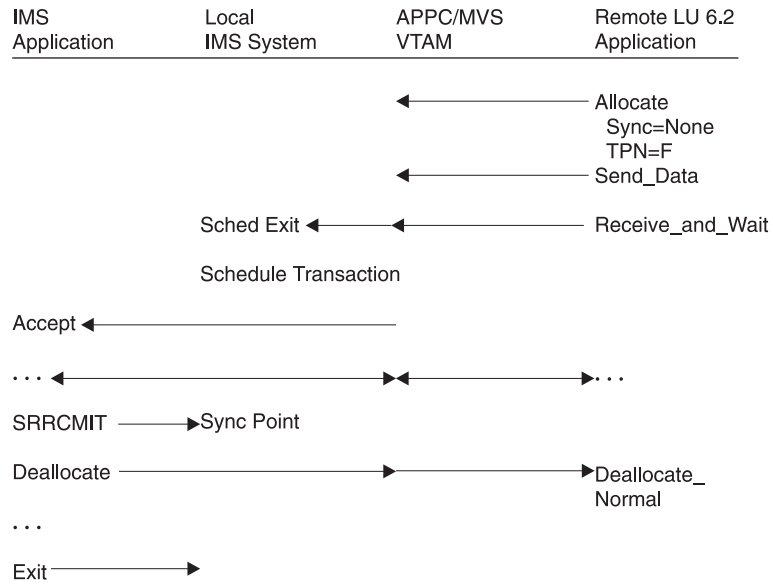

Figure 40. Flow of a Local CPI Communications Driven Program When Sync_level=None

Figure 41 on page 119 shows the flow of a remote synchronous transaction when Sync_level is None.

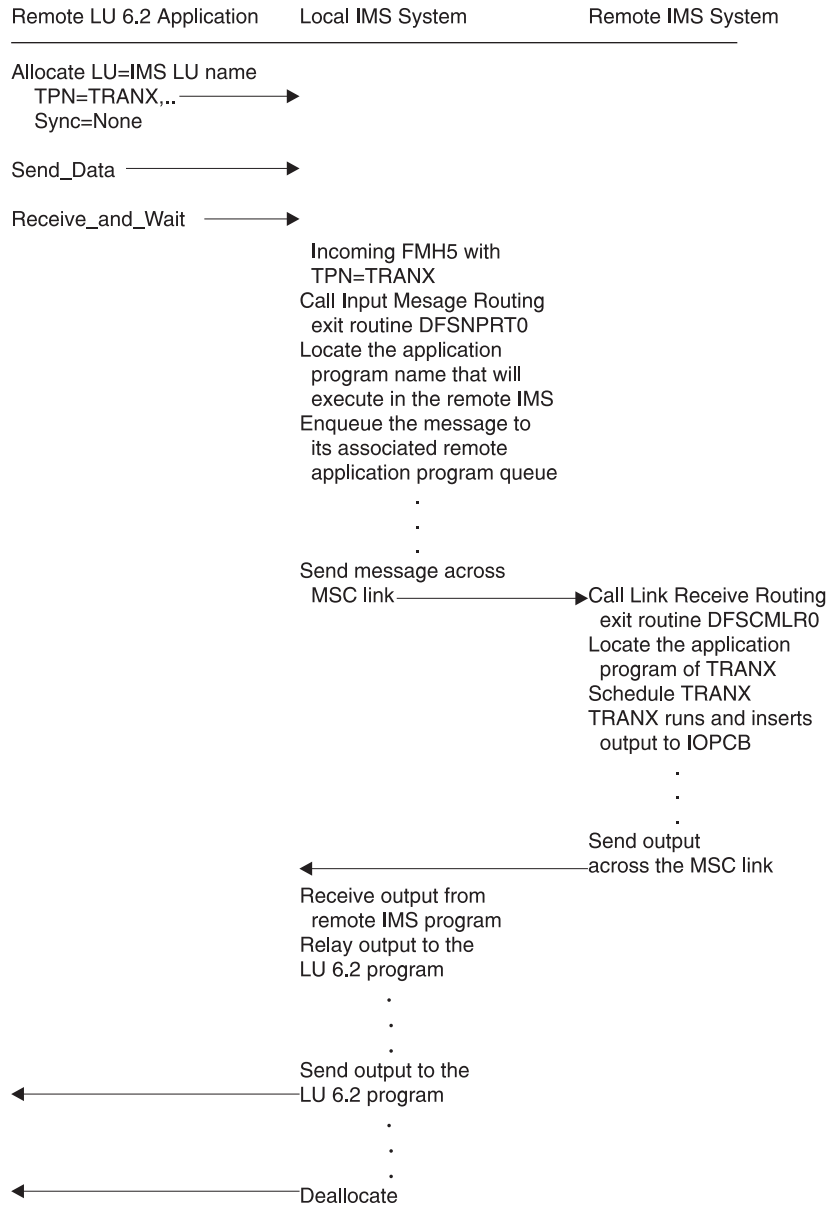

Figure 41. Flow of a Remote IMS Synchronous Transaction When Sync_level=None

Figure 42 on page 120 shows the flow of a remote asynchronous transaction when Sync_level is None.

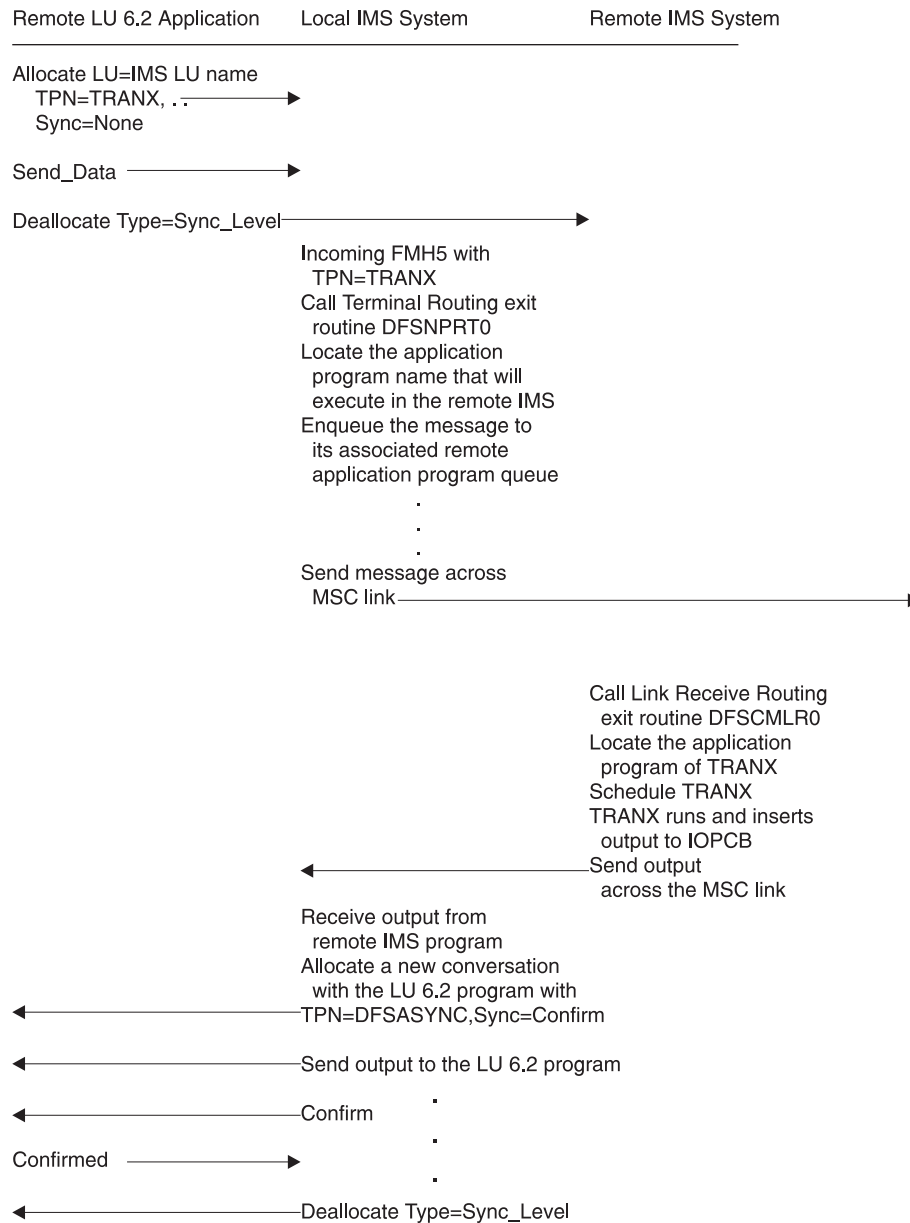

Figure 42. Flow of a Remote IMS Asynchronous Transaction When Sync_level=None

Figure 43 on page 121 shows the flow of a remote asynchronous transaction when Sync_level is Confirm.

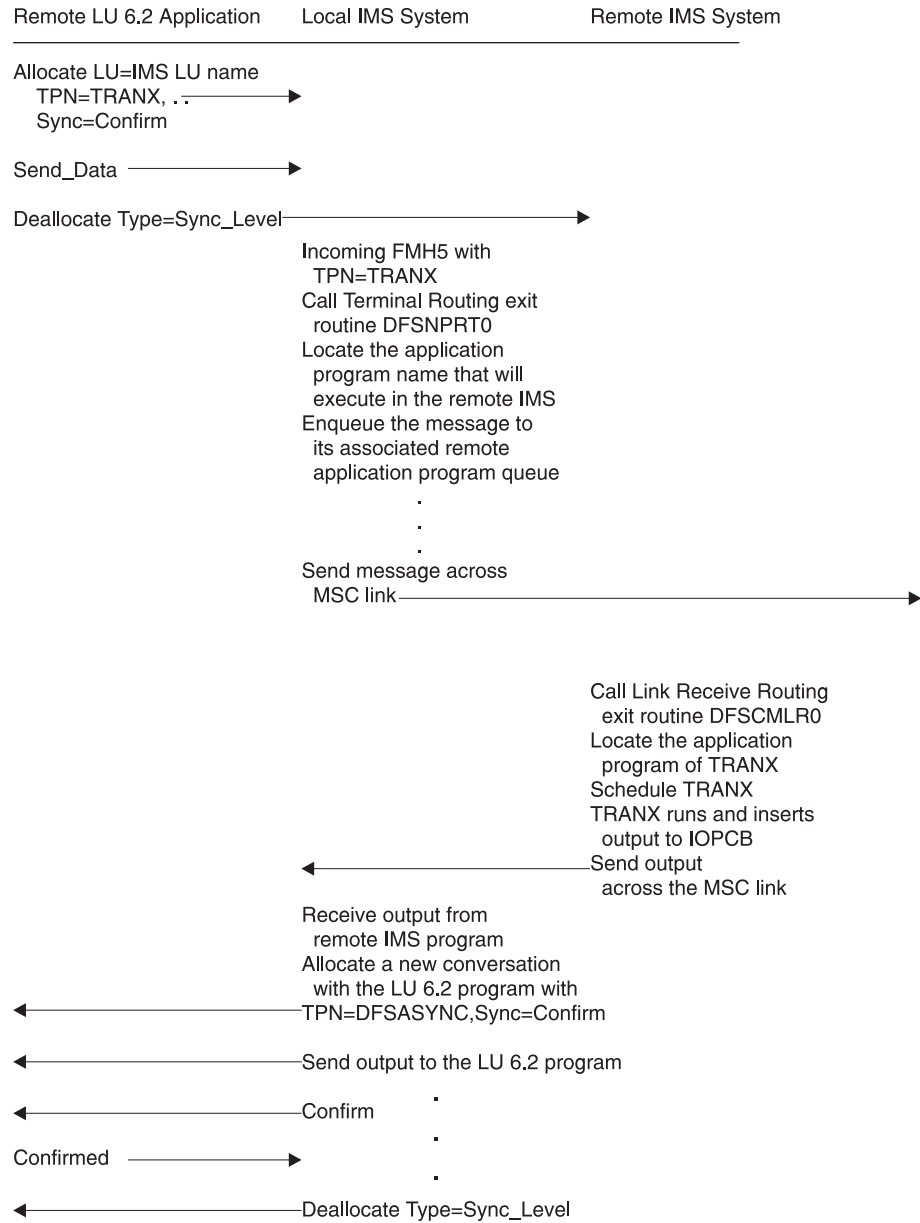

Figure 43. Flow of a Remote IMS Asynchronous Transaction When Sync_level=Confirm

Figure 44 on page 122 shows the flow of a remote synchronous transaction when Sync_level is Confirm.

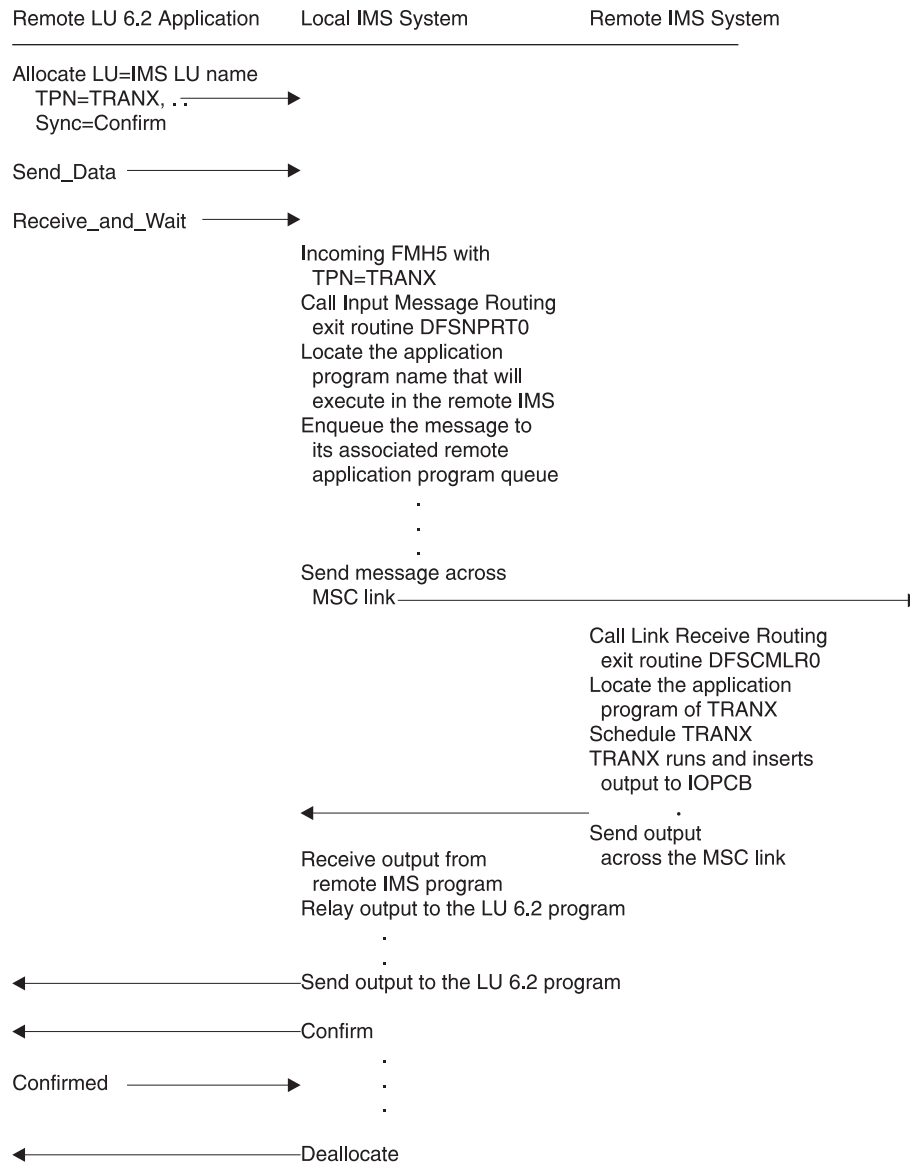

Figure 44. Flow of a Remote IMS Synchronous Transaction When Sync_level=Confirm

The scenarios shown in the following figures provide examples of the two-phase process for the supported application program types. The LU 6.2 verbs are used to illustrate supported functions and interfaces between the components. Only parameters pertinent to the examples are included. This does not imply that other parameters are not supported.

Figure 45 on page 123 shows a standard DL/I program commit scenario when Sync_Level is Syncpt.

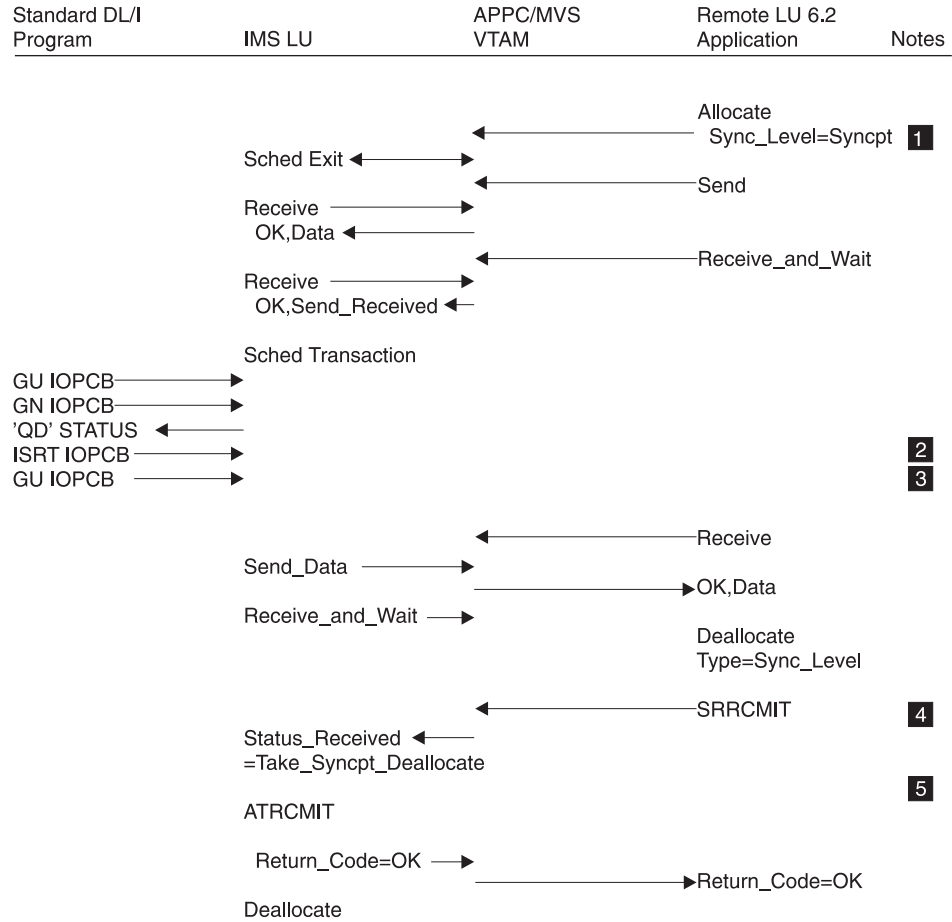

Figure 45. Standard DL/I Program Commit Scenario When Sync_Level=Syncpt

Notes:

- 1** Sync_Level=Syncpt triggers a protected resource update.
- 2** This application program inserts output for the remote application to the IMS message queue.
- 3** The GU initiates the transfer of the output.
- 4** The remote application sends a Confirmed after receiving data (output).
- 5** IMS issues ATRCMIT (equivalent to SRRCMIT) to start the two-phase process.

Figure 46 on page 124 shows a CPI-C driven commit scenario when Sync_Level is Syncpt.

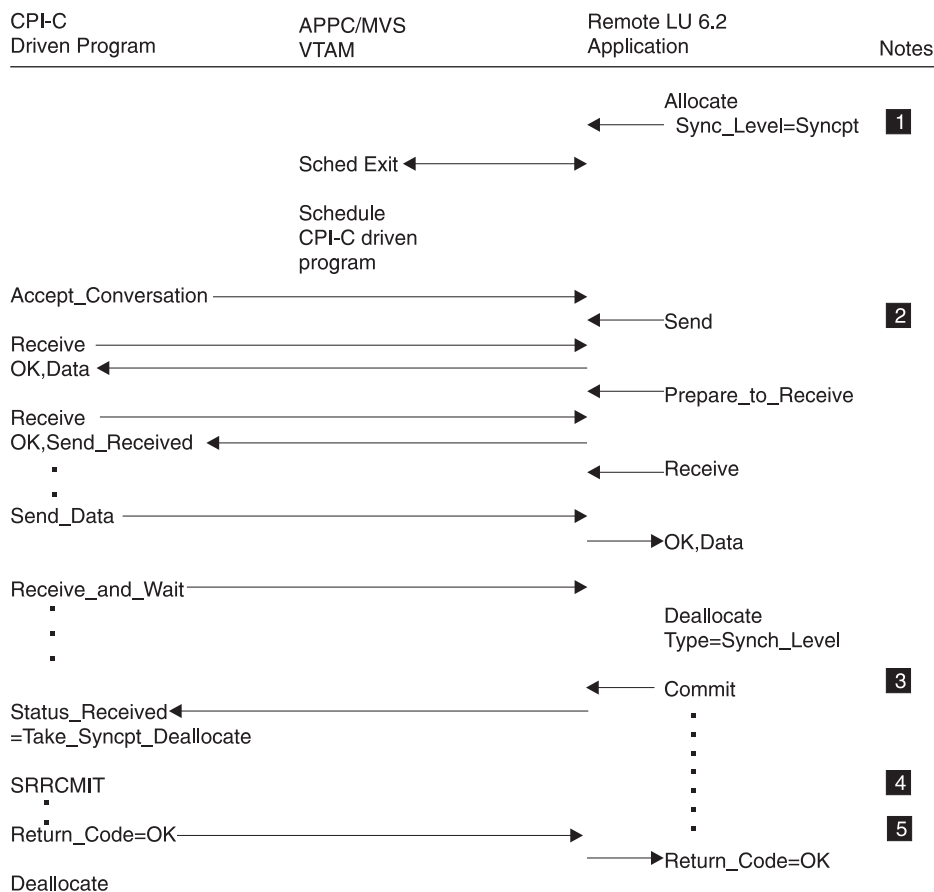

Figure 46. CPI-C Driven Commit Scenario When Sync_Level=Syncpt

Notes:

- 1** Sync_Level=Syncpt triggers a protected resource update.
- 2** The programs send and receive data.
- 3** The remote application decides to commit the updates.
- 4** The CPI-C program issues SRRCMIT to commit the changes.
- 5** The commit return code is returned to the remote application.

Figure 47 on page 125 shows a standard DL/I program backout scenario when Sync_Level is Syncpt.

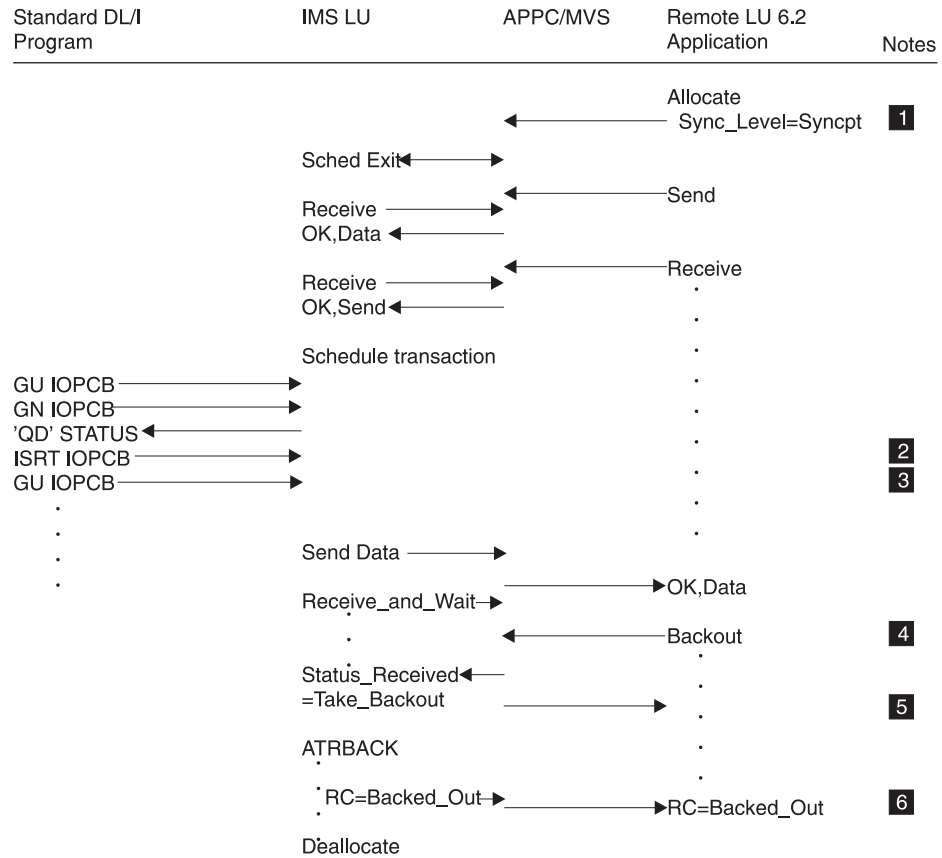

Figure 47. Standard DL/I Program U119 Backout Scenario When Sync_Level=Syncpt

Notes:

- 1** Sync_Level=Syncpt triggers a protected-resource update.
- 2** This application program inserts output for the remote application to the IMS message queue.
- 3** The GU initiates the transfer of the output.
- 4** The remote application decides to back out any updates.
- 5** IMS abends the application with a U119 to back out the application.
- 6** The backout return code is returned to the remote application.

Figure 48 on page 126 shows a standard DL/I program backout scenario when Sync_Level is Syncpt.

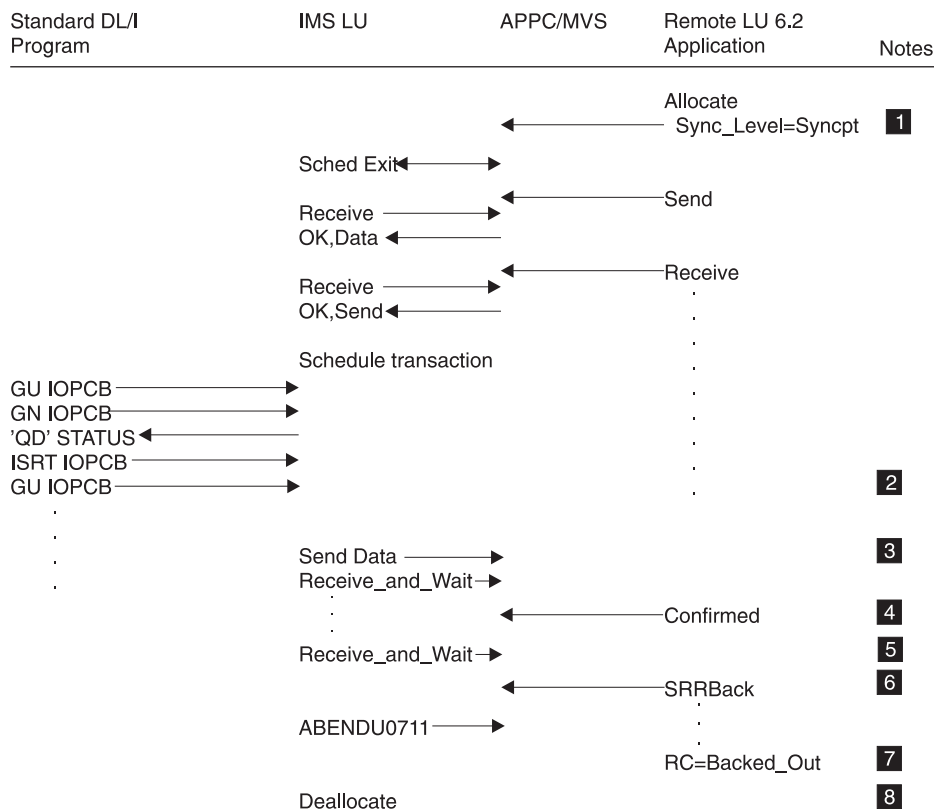

Figure 48. Standard DL/I Program U0711 Backout Scenario When Sync_Level=Syncpt

Notes:

- 1** Sync_Level=Syncpt triggers a protected-resource update.
- 2** This application program inserts output for the remote application to the IMS message queue.
- 3** The GU initiates the transfer of the output.
- 4** The remote application sends a Confirmed after receiving data (output).
- 5** IMS issues ATBRCVW on behalf of the DL/I application to wait for a commit or backout.
- 6** The remote application decides to back out any updates.
- 7** IMS abends the application with U0711 to back out the application.
- 8** The backout return code is returned to the remote application.

Figure 49 on page 127 shows a standard DL/I program ROLB scenario when Sync_Level is Syncpt.

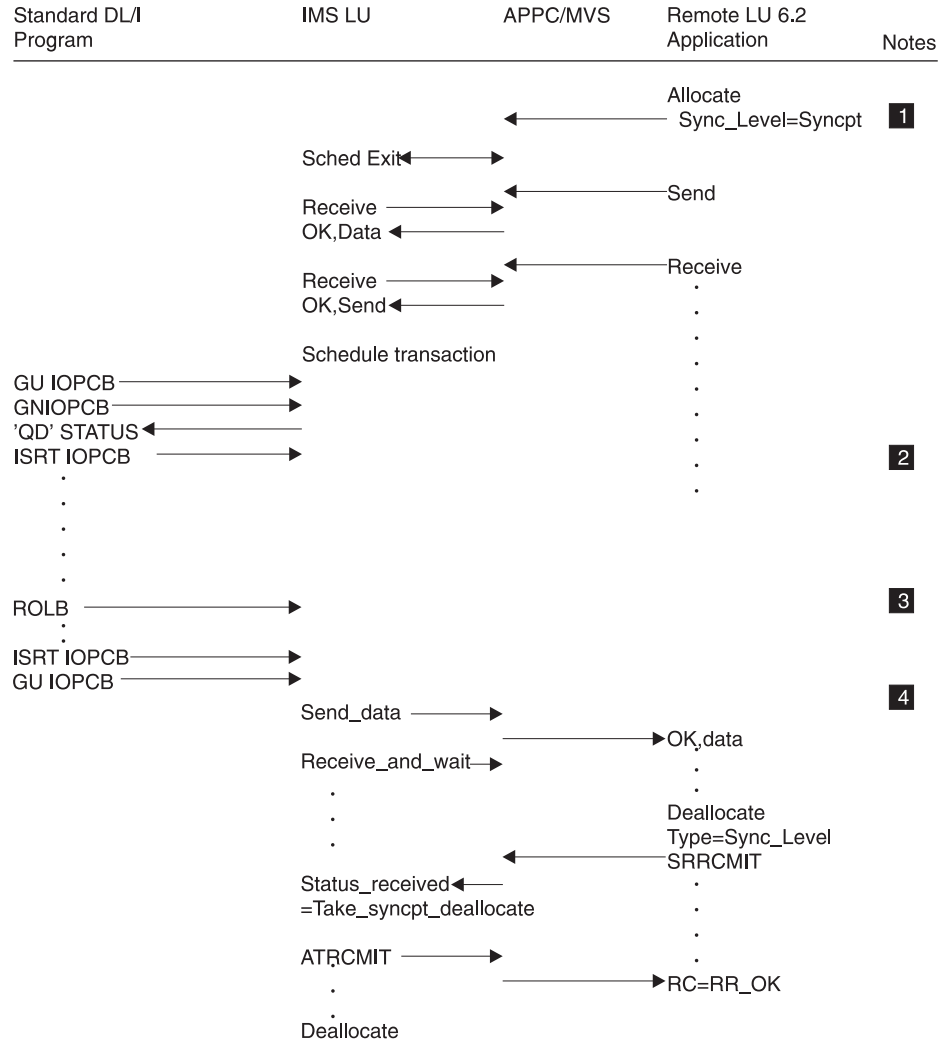

Figure 49. Standard DL/I Program ROLB Scenario When Sync_Level=Syncpt

Notes:

- 1** Sync_Level=Syncpt triggers a protected-resource update.
- 2** This application program inserts output for the remote application to the IMS message queue.
- 3** DL/I program issues a ROLB. ABENDU0711 with Return Code X'20' is issued.

Figure 50 on page 128 shows multiple transactions in the same commit when Sync_Level is Syncpt.

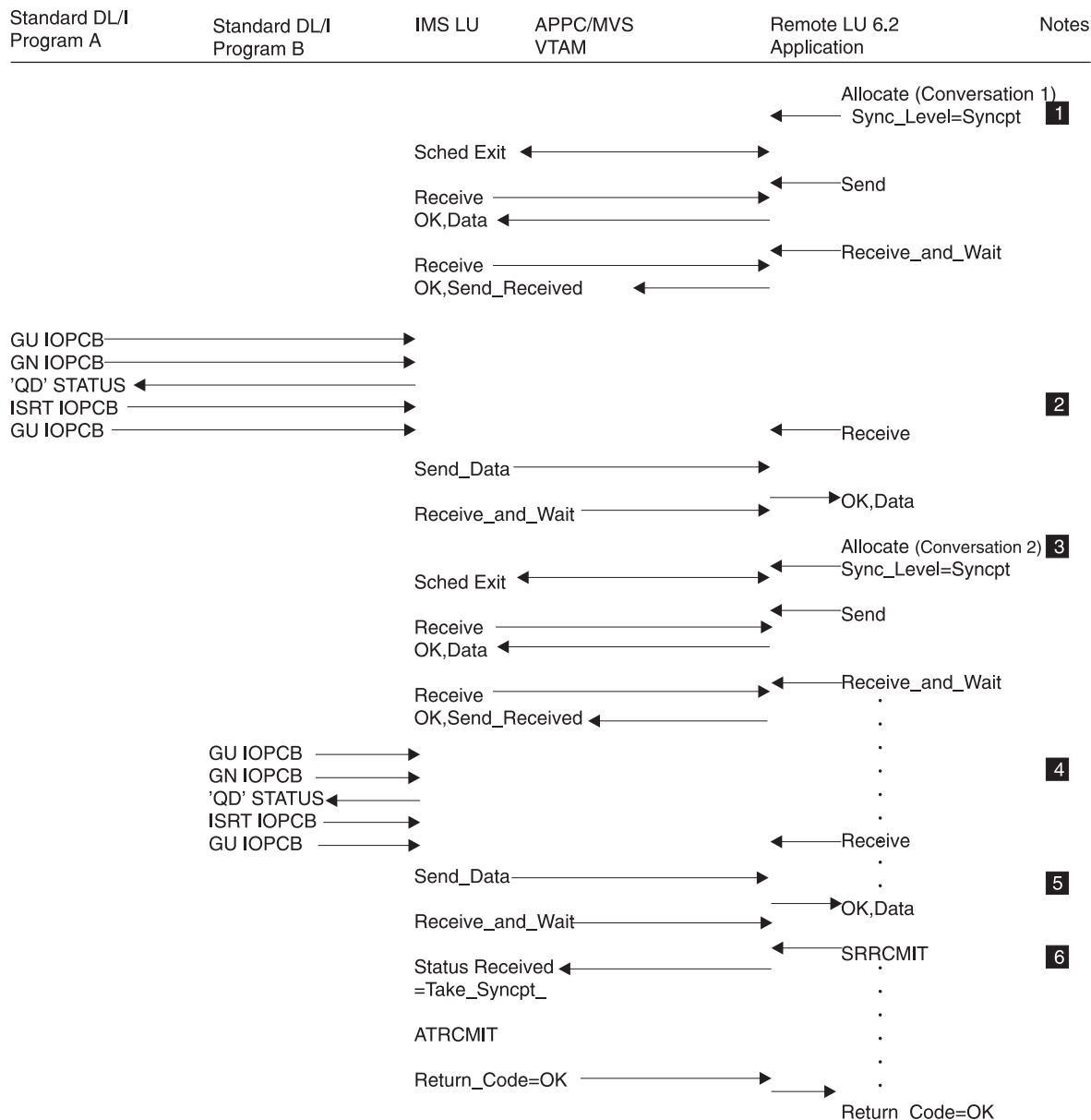

Figure 50. Multiple Transactions in Same Commit When Sync_Level=Syncpt

Notes:

- 1** An allocate with Sync_Level=Syncpt triggers a protected resource update with Conversation 1.
- 2** The first transaction provides the output for Conversation 1.
- 3** An allocate with Sync_Level=Syncpt triggers a protected resource update with Conversation 2.
- 4** The second transaction provides the output for Conversation 2.
- 5** The remote application issues SRRCMIT to commit both transactions.
- 6** IMS issues ATRCMIT to start the two-phase process on behalf of each DL/I application.

Integrity Tables

Table 14 shows the results, from the viewpoint of the IMS partner system, of normal conversation completion, abnormal conversation completion due to a session failure, and abnormal conversation completion due to non-session failures. These results apply to asynchronous and synchronous conversations and both input and output. This table also shows the outcome of the message, and the action that the partner system takes when it detects the failure. An example of an action, under "LU 6.2 Session Failure," is a programmable work station (PWS) resend.

Table 14. Message Integrity of Conversations

Conversation Attributes	Normal	LU 6.2 Session Failure ¹	Other Failure ²
Synchronous Sync_level=NONE	Input: Reliable Output: Reliable	Input: PWS resend Output: PWS resend	Input: Reliable Output: Reliable
Synchronous Sync_level=CONFIRM	Input: Reliable Output: Reliable	Input: PWS resend Output: Reliable	Input: Reliable Output: Reliable
Synchronous Sync_level=SYNCPT	Input: Reliable Output: Reliable	Input: PWS resend Output: Reliable	Input: Reliable Output: Reliable
Asynchronous Sync_level=NONE	Input: Ambiguous Output: Reliable	Input: Undetectable Output: Reliable	Input: Undetectable Output: Reliable
Asynchronous Sync_level=CONFIRM	Input: Reliable Output: Reliable	Input: PWS resend Output: Reliable	Input: Reliable Output: Reliable
Asynchronous Sync_level=SYNCPT	Input: Reliable Output: Reliable	Input: PWS resend Output: Reliable	Input: Reliable Output: Reliable

Notes:

1. A *session failure* is a network-connectivity breakage.
2. A *non-session failure* is any other kind of failure, such as invalid security authorization.
3. IMS resends asynchronous output if CONFIRM is lost; therefore, the PWS must tolerate duplicate output.

Table 15 shows the specifics of the processing windows when integrity is compromised (the message is either lost or its state is ambiguous). The table indicates the relative probability of an occurrence of each window and whether output is lost or duplicated.

A Sync_level value of NONE does not apply to asynchronous output, because IMS always uses Sync_level=CONFIRM for such output.

Table 15. Results of Processing When Integrity Is Compromised

Conversation Attributes	State of Window, before Accepting Transaction	Probability of Window State	Possible Action while Sending Response	Probability of Action while Sending Response
Synchronous Sync_level=NONE	ALLOCATE to PREPARE_TO_RECEIVE return	Medium	Can lose or send duplicate output.	Medium
Synchronous Sync_level=CONFIRM	PREPARE_TO_RECEIVE to PREPARE_TO_RECEIVE return	Small	CONFIRM to IMS receipt. Can cause duplicate output.	Small

Table 15. Results of Processing When Integrity Is Compromised (continued)

Conversation Attributes	State of Window ₁ before Accepting Transaction	Probability of Window State	Possible Action while Sending Response	Probability of Action while Sending Response
Synchronous Sync_level=SYNCPT	PREPARE_TO_ RECEIVE to PREPARE_TO_ RECEIVE return	Small	CONFIRM to IMS receipt. Can cause duplicate output.	Small
Asynchronous Sync_level=NONE	Allocate to Deallocate	High	CONFIRMED to IMS receipt. Can cause duplicate output.	Small
Asynchronous Sync_level=CONFIRM	PREPARE_TO_ RECEIVE to PREPARE_TO_ RECEIVE return	Small ²	CONFIRMED to IMS receipt. Can cause duplicate output.	Small
Asynchronous Sync_level=SYNCPT	PREPARE_TO_ RECEIVE to PREPARE_TO_ RECEIVE return	Small ²	CONFIRMED to IMS receipt. Can cause duplicate output.	

Notes:

1. The term *window* refers to a period of time when certain events can occur, such as the consequences described in this table.
2. Can be recoverable.

Table 16 indicates how IMS recovers APPC transactions across IMS warm starts, XRF takeovers, APPC session failures, and MSC link failures.

Table 16. Recovering APPC Messages

Message Type	IMS Warm Start (NRE or ERE)	XRF Takeover	APPC (LU 6.2) Session Fail	MSC LINK Failure
Local Recoverable Tran., Non Resp., Non Conversation - APPC Sync. Conv. Mode - APPC Async. Conv. Mode	Discarded (2) Recovered	Discarded (4) Recovered	Discarded (6) Recovered (1)	N/A (9) N/A (9)
Local Recoverable Tran., Conv. or Resp. mode - APPC Sync. Conv. Mode - APPC Async. Conv. Mode	Discarded (2) N/A (8)	Discarded (4) N/A (8)	Discarded (6) N/A (8)	N/A (9) N/A (8,9)
Local Non Recoverable Tran., - APPC Sync. Conv. Mode - APPC Async. Conv. Mode	Discarded (2) Discarded (2)	Discarded (4)	Discarded (6) Recovered (1)	N/A (9) N/A (9)
Remote Recoverable Tran., Non Resp., Non Conv. - APPC Sync. Conv. Mode - APPC Async. Conv. Mode	Discarded (2,5) Recovered	Discarded (3,5) Recovered	Recovered (1) Recovered (1)	Recovered (7) Recovered (7)
Remote Recoverable Tran., Conv. or Resp. mode - APPC Sync. Conv. Mode - APPC Async. Conv. Mode	Discarded (2,5) N/A (8)	Discarded (3,5) N/A (8)	Recovered (1) N/A (8)	Recovered (7) N/A (8)
Remote Non Recoverable Tran., - APPC Sync. Conv. Mode - APPC Async. Conv. Mode	Discarded (2,5) Discarded (2,5)	Discarded (3,5) Discarded (3,5)	Recovered (1) Recovered (1)	Recovered (7) Recovered (7)

Table 16. Recovering APPC Messages (continued)

Message Type	IMS Warm Start (NRE or ERE)	XRF Takeover	APPC (LU 6.2) Session Fail	MSC LINK Failure
--------------	--------------------------------	--------------	-------------------------------	---------------------

Notes:

1. This recovery scenario assumes the message was enqueued before failure; otherwise, the message is discarded.
2. The message is discarded during IMS warm-start processing.
3. The message is discarded when the MSC link is restarted and when the message is taken off the queue (for sending across the link).
4. The message is discarded when the message region is started and when the message is taken off the queue (for processing by the application program).
5. For all remote MSC APPC transactions, if the message has already been sent across the MSC link to the remote system when the failure occurs in the local IMS, the message is processed. After the message is processed by the remote application program and a response message is sent back to the local system, it is enqueued to the DFSASYNC TP name of the LU 6.2 device or program that submitted the original transaction.
6. At sync point, the User Message Control Error exit routine (DFSCMUX0) can prevent the transaction from being aborted and the output message can be rerouted (recovered).
For more information about this exit routine, see *IMS Version 9: Customization Guide*.
7. The standard MSC Link recovery protocol recovers all messages that are queued or are in the process of being sent across the MSC link when the link fails.
8. IMS conversational-mode and response-mode transactions cannot be submitted from APPC asynchronous conversation sessions. APPC synchronous conversation-mode must be used.
9. MSC link failures do not affect local transactions.

DFSAPPC Message Switch

DFSAPPC is an LU 6.2 descriptor that provides an IMS system service. It allows LU 6.2 application programs to send messages to the following:

- Application programs (transactions)
- IMS-managed local or remote LTERMs (message switches)
- LU name and TP name

Messages sent with the LTERM= option are directed to IMS-managed local or remote LTERMs. Messages sent without the LTERM= option are sent to the appropriate LU 6.2 application or IMS application program.

Because the LTERM can be an LU 6.2 descriptor name, the message is sent to the LU 6.2 application program as if an LU 6.2 device had been explicitly selected.

With DFSAPPC, message delivery is asynchronous. If a message is allocated and the allocate fails, the message is held on the IMS message queue until it can be successfully delivered.

Example: In the LU 6.2 conversation example, an IMS application issues a DFSAPPC message switch to its partner with the LU name FRED and TPN name REPORT. REPI is the user data.

```
DFSAPPC (TPN=REPORT LU=FRED) REP1
```

You can use a 17-byte network-qualified name in the LU= field.

Restriction: LU 6.2 architecture prohibits the use of the ALTRESP PCB on a CHNG call in an LU 6.2 conversation. The LU 6.2 conversation can only be associated with the IOPCB. The application sends a message on the existing LU 6.2

conversation (synchronous) or has IMS create a new conversation (asynchronous) using the IOPCB. Since there is no LTERM associated with an LU 6.2 conversation, only the IOPCB represents the original LU 6.2 conversation.

Related Reading: For more information about DFSAPPC, see *IMS Version 9: Administration Guide: Transaction Manager*.

Chapter 8. Writing ODBA Application Programs

This section describes the Open Database Access (ODBA) callable interface to IMS DB and presents information about how you write OS/390 application programs that use the interface. By using the ODBA interface, IMS DB databases can be accessed from environments that are outside the scope of IMS's control, such as DB2 stored procedures.

In this Section:

- “General Application Program Flow” on page 134
- “Server Program Structure” on page 137
- “DB2 Stored Procedures Use of ODBA” on page 137

The ODBA interface is not needed within IMS-controlled regions, such as MPRs, BMPs, or IFPs, for calls to locally-controlled databases.

The OS/390 application programs (hereafter called the ODBA application programs) run in a separate OS/390 address space that IMS regards as a separate region from the control region. The separate OS/390 address space hereafter is called the OS/390 application region.

The ODBA interface gains access to IMS DB through the Database Resource Adapter (DRA). The ODBA application programs (which can access any address space within the MVS they are running in) gain access to IMS DB databases through the ODBA interface. Figure 51 illustrates this concept and shows the relationship between the components of this environment.

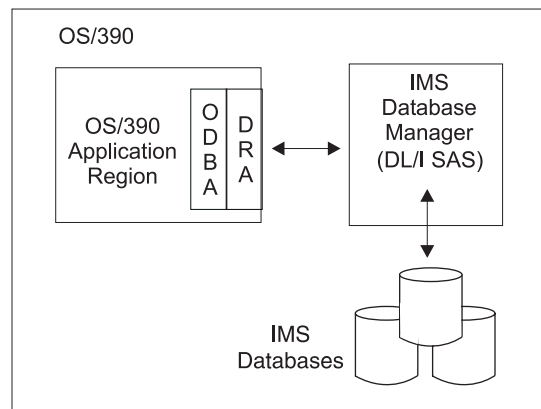

Figure 51. OS/390 Application Region's Connection to IMS DB

One OS/390 application region can connect to multiple IMS DBs and multiple OS/390 application regions can connect to a single IMS DB. The connection is similar to that of CICS to DBCTL.

Requirement: RRS/MVS is required; therefore, OS/390 Release 3 is the minimum level that can support the ODBA interface.

Related Reading: For a description of RRS and its uses, see *IMS Version 9: Administration Guide: Transaction Manager* for information on the Distributed Sync Point.

General Application Program Flow

OS/390 application programs issue DL/I calls using an application interface block (AIB). No other interface is supported.

Restriction: The ODBA interface does not support calls into batch DL/I regions.

Several conditions must be met for the AIB call to succeed:

1. If an AIB is not passed in the call, a U261 abend is issued.
2. If the AIB that is passed is not valid, a U476 abend is issued.
3. If the AIB that is passed is not large enough (264 bytes), the AIB return and reason codes are set to X'104' and X'228'.
4. If the AIB that is passed is not on a fullword boundary, the MVS system will return an abend S201.
5. If there are other internal problems with the call, other return and reason codes are passed back to the OS/390 application program. See *IMS Version 9: Messages and Codes, Volume 1* for a complete list of these return and reason codes.

The OS/390 must link edit with a language module (DFSCDLI0) or this module can be loaded into the OS/390 application region. The entry point for DFSCDLI0 is AERTDLI.

A simple example of the program flow of an OS/390 application program is:

1. Establish the application execution environment.
2. Allocate a PSB.
3. Perform DB calls.
4. Commit the changes.
5. Deallocate the PSB.
6. Terminate the connection.

Establishing the Application Execution Environment

The application execution environment must be initialized in the OS/390 application region. Use the CIMS INIT call to initialize the environment. If the optional DFSRNM2 field of the AIB contains a startup table ID, a connection to the IMS DB in the startup table is made. If the field is blank, connect to the IMS DB when you allocate a PSB.

The form of the connection call is:

```
CALL AERTDLI parmcount, CIMS, AIB
```

Where:

CIMS Is the required call function.

AIB Has the following fields:

AIBSFUNC

The subfunction is INIT. This field is mandatory.

AIBRSNM1

An optional field that provides an eye catcher identifier of the application server that is associated with the AIB. This field is 8 bytes.

AIBRSNM2

Provides the optional 4-byte startup table ID. The ID is optional if the call is issued as preconditioning only. If the ID is given, the OS/390 application region connects to the IMS DB specified in the DBCTLID parameter of the selected startup table.

Startup Table

The characteristics of the connection are determined from the DRA startup table. The startup table name is DFSxxxx0, where xxxx is the startup table ID that is used in the CIMS and APSB calls. Each startup table defines a combination of connection attributes, one of which is a subsystem ID of the IMS DB.

Related Reading: For more information about building a DRA startup table, see *IMS Version 9: Installation Volume 2: System Definition and Tailoring*.

Allocating a PSB

The APSB call, introduced for CPIC-driven programs, is used with the ODBA interface to allocate a PSB for the OS/390 application region. Security is checked before the call can succeed. See *IMS Version 9: Installation Volume 2: System Definition and Tailoring* for details. The APSB call is in the following form:

```
CALL AERTDLI parmcount, APSB, AIB
```

Where:

APSB Is the required call function.

AIB Is the name of the application interface block. The fields in the AIB must be filled in:

AIBRSNM1

Is the 8-character PSB name.

AIBRSNM2

Is the 4-byte startup table ID.

Several conditions must be met for the allocation request to succeed.

1. The PSB must exist and security checking through RACF must succeed.
2. A CIMS INIT call must have been successful.
3. RRS/MVS must be active when the APSB call is made.

Multiple PSBs can be active at the same time, which is typical for server environments. No token is specifically provided to identify which PSB is to be used for a given call to a given IMS DB, so the same AIB *must* be used for all calls to the same PSB instance (APSB, DB calls, DPSB). This enables multiple instances of the same PSB to be in use for the same IMS DB at the same time. The parallelism is controlled by the thread count specified in the startup table. The maximum number of threads and dependent regions supported by an IMS DB instance is 999.

Performing DB Calls

All DL/I calls, with a few exceptions, are supported through the AIB. The unsupported calls entail message handling (the IOPCB is available only for system calls), CKPT, ROLL, ROLB, and INQY PROGRAM. Alternate destination PCBs cannot be used. Both full-function databases and DEDBs are available.

Commit Changes

Synchronization is performed by issuing the distributed commit calls, SRRCMIT or ATRCMIT, or possibly their rollback forms of SRRBACK or ATRBACK. IMS sync-point calls are not allowed. Commit is effective for all RRS/MVS controlled resources in the MVS task.

Deallocating the PSB

The DPSB call is used when the work unit is complete. In the default case, a commit call must be issued before a DPSB call can be issued. No DL/I call, including system service calls, can be made between the commit and the DPSB call.

The DPSB call is in the following form:

```
CALL AERTDLI parmcount, DPSB, AIB
```

Where:

DPSB Is the required call function.

AIB Is the name of the application interface block. The following fields in the AIB must be filled in:

AIBRSNM1

Is the 8-character PSB name.

AIBSFUNC

Is an optional field. Set it to 'PREPbbbb' when you want to deallocate the PSB before initialization of commit processing and when the commit processing is provided from outside the application.

IMS performs phase 1 commit processing and returns control to the requestor, but holds the in-doubt work until RRS/MVS (the commit manager) requests full commit processing. An example is in DB2 Stored Procedures, where DB2 initializes commit processing on behalf of the procedure. See "DB2 Stored Procedures Use of ODBA" on page 137 for a discussion of this scenario.

Terminating the Connection

The termination call is in the following form:

```
CALL AERTDLI parmcount, CIMS, AIB
```

Where:

CIMS Is the required call function.

AIB Is the name of the application interface block. The following fields in the AIB must be filled in:

AIBSFUNC

Is a mandatory field whose value is TERM or TALL. Use TERM to sever a single IMS DB connection. Use TALL to sever all connections for this OS/390 application region and remove the DRA from the address space.

AIBRSNM1

Is an optional field that provides an eye catcher identifier of the application server associated with the AIB. This field is 8 bytes in length.

AIBRSNM2

When subfunction equals TERM, provides the 4-byte startup table ID used in a previous APSB call. Is not needed when the subfunction equals TALL.

Server Program Structure

The commit scope within the OS/390 application environment is all the work under the TCB from which the commit request is made to RRS/MVS. Server environments, therefore, need a separate TCB under which the individual client requests will be managed. Each TCB will map to a PST for thread handling.

Figure 52 shows an example TCB structure for a server environment.

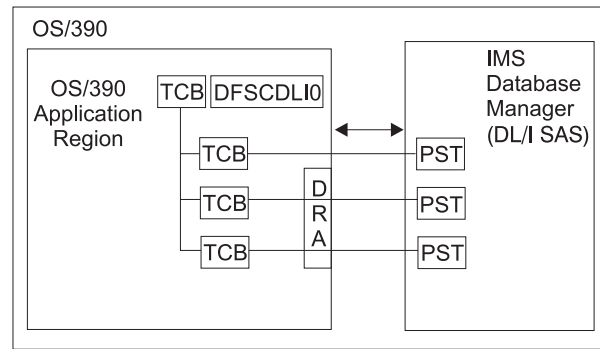

Figure 52. DRA Uses One TCB per Thread

Each connection to an IMS DB uses a thread under the TCB. When the APSB call is processed, a context is established and tied to the TCB. At commit time, all contexts for this TCB are committed or aborted by RRS/MVS.

Loading DFSCDLI0 rather than link editing is attractive when the OS/390 application region is a server supporting many clients with many instances of threads connected with the IMS DBs.

DB2 Stored Procedures Use of ODBA

DB2 Stored Procedures are a special case of the general server structure described in "Server Program Structure." Stored Procedures connecting to ODBA require DB2 Version 5 or later and must run in a work load manager (WLM)-managed stored procedures address space.

DB2 establishes the ODBA environment by issuing the INIT subcall for the stored procedure address space. Connection to a specific IMS DB occurs when the APSB call is issued.

Each stored procedure running in the stored procedure address space runs under its own TCB that was established by DB2 when the stored procedure is initialized. DB2 issues the commit call on behalf of the stored procedure when control is returned to DB2. Only the PREP subfunction of the DPSB call should be issued by the stored procedures themselves.

Figure 53 on page 138 illustrates the connection from a DB2 Stored Procedures address space to an IMS DB subsystem. This connection allows DL/I data to be

presented through an SQL interface, either locally to this DB2 or to DRDA[®] connected DB2s.

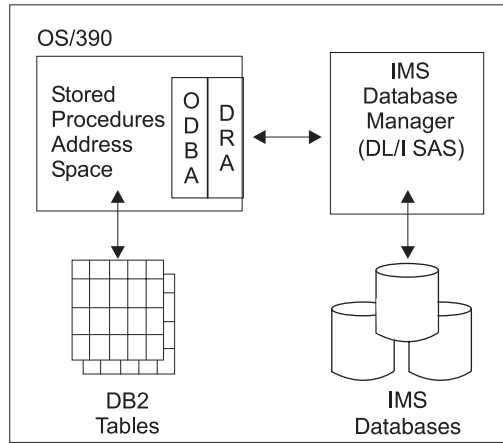

Figure 53. DB2 Stored Procedures Connection to IMS DB

Figure 54 illustrates the general relationships involved with using DB2 Stored Procedures and IMS DB together.

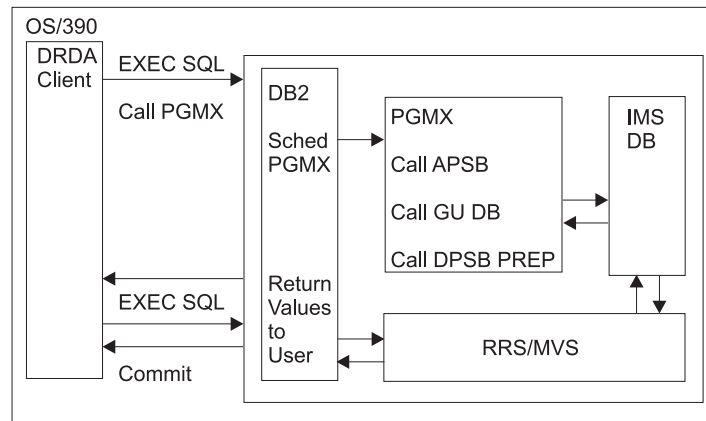

Figure 54. DB2 Stored Procedures Relationships

Chapter 9. Testing an IMS Application Program

This section tells you what is involved in testing an IMS application program (as a unit) and provides suggestions on how to do it. The purpose of this test, called a *program unit test*, is to ensure that the program correctly handles its input data, processing, and output test data.

The amount and type of testing you do depends on the individual program you are testing. Though no strict rules for testing are available, the guidelines offered in this section might be helpful.

In this Section:

- “What You Need to Test an IMS Program”
- “Testing DL/I Call Sequences (DFSDDL0) Before Testing Your IMS Program”
- “Using BTS II to Test Your IMS Program” on page 140
- “Tracing DL/I Calls with Image Capture for Your IMS Program” on page 140
- “Requests for Monitoring and Debugging Your IMS Program” on page 145
- “What to Do When Your IMS Program Terminates Abnormally” on page 158

What You Need to Test an IMS Program

Before you start testing your program, be aware of your established test procedures. To start testing, you need the following three items:

- Test JCL.
- A test database. Never test a program using a production database because the program, if faulty, might damage valid data.
- Test input data. The input data that you use need not be current, but it should be valid. You cannot be sure that your output data is valid unless you use valid input data.

The purpose of testing the program is to make sure that the program can correctly handle all the situations that it might encounter. To thoroughly test the program, try to test as many of the paths that the program can take as possible.

Recommendations:

- Test each path in the program by using input data that forces the program to execute each of its branches.
- Be sure that your program tests its error routines. Again, use input data that will force the program to test as many error conditions as possible.
- Test the editing routines your program uses. Give the program as many different data combinations as possible to make sure it correctly edits its input data.

Testing DL/I Call Sequences (DFSDDL0) Before Testing Your IMS Program

The DL/I test program, DFSDDL0, is an IMS application program that executes the DL/I calls you specify against any database.

Restriction: DFSDDL0 does not work if you are using a coordinator controller (CCTL).

An advantage of using DFSDDLTO is that you can test the DL/I call sequence you will use prior to coding your program. Testing the DL/I call sequence before you test the program makes debugging easier, because by the time you test the program, you know that the DL/I calls are correct. When you test the program, and it does not execute correctly, you know that the DL/I calls are not part of the problem if you have already tested them using DFSDDLTO.

For each DL/I call that you want to test, you give DFSDDLTO the call and any SSAs that you are using with the call. DFSDDLTO then executes and gives you the results of the call. After each call, DFSDDLTO shows you the contents of the DB PCB mask and the I/O area. This means that for each call, DFSDDLTO checks the access path you have defined for the segment, and the effect of the call. DFSDDLTO is helpful in debugging because it can display IMS application control blocks.

To indicate to DFSDDLTO the call you want executed, you use four types of control statements:

Status statements establish print options for DFSDDLTO's output and select the DB PCB to use for the calls you specify.

Comment statements let you choose whether you want to supply comments.

Call statements indicate to DFSDDLTO the call you want to execute, any SSAs you want used with the call, and how many times you want the call executed.

Compare statements tell DFSDDLTO that you want it to compare its results after executing the call with the results you supply.

In addition to testing call sequences to see if they work, you can also use DFSDDLTO to check the performance of call sequences.

Related Reading: For more details about using DFSDDLTO, and how to check call sequence performance, see:

- *IMS Version 9: Application Programming: Database Manager*
- *IMS Version 9: Application Programming: Transaction Manager*

Using BTS II to Test Your IMS Program

BTS II (Batch Terminal Simulator II) is a valuable tool for testing programs because you can use it to test call sequences. The documentation BTS II produces is helpful in debugging. You can also test online application programs without actually running them online.

Restriction: BTS II does not work if you are using a CCTL or running under DBCTL.

Related Reading: For information about how to use BTS II, refer to *BTS Program Reference/Operations Manual*.

Tracing DL/I Calls with Image Capture for Your IMS Program

The DL/I image capture program (DFSDLTR0) is a trace program that can trace and record DL/I calls issued by all types of IMS application programs.

Restriction: The image capture program does not trace calls to Fast Path databases.

You can run the image capture program in a DB/DC or a batch environment to:

Test your program

If the image capture program detects an error in a call it traces, it reproduces as much of the call as possible, although it cannot document where the error occurred, and cannot always reproduce the full SSA.

Produce input for DFSDDLTO

You can use the output produced by the image capture program as input to DFSDDLTO. The image capture program produces status statements, comment statements, call statements, and compare statements for DFSDDLTO.

Debug your program

When your program terminates abnormally, you can rerun the program using the image capture program, which can then reproduce and document the conditions that led to the program failure. You can use the information in the report produced by the image capture program to find and fix the problem.

Using Image Capture with DFSDDLTO

The image capture program produces the following control statements that you can use as input to DFSDDLTO:

Status statements

When you invoke the image capture program, it produces the status statement. The status statement it produces:

- Sets print options so that DFSDDLTO prints all call trace comments, all DL/I calls, and the results of all comparisons.
- Determines the new relative PCB number each time a PCB change occurs while the application program is executing.

Comments statement

The image capture program also produces a comments statement when you invoke it. The comments statements give:

- The time and date IMS started the trace
- The name of the PSB being traced

The image capture program also produces a comments statement preceding any call in which IMS finds an error.

Call statements

The image capture program produces a call statement for each DL/I call the application program issues. It also generates a CHKP call when it starts the trace and after each commit point or CHKP request.

Compare statements

The image capture program produces data and PCB comparison statements if you specify COMP on the TRACE command (if you run the image capture program online), or on the DLITRACE control statement (if you run the image capture program as a batch job).

Restrictions on Using Image Capture Output

The status statement of the image capture call is based on relative PCB position. When the PCB parameter LIST=NO has been specified, the status statement may need to be changed to select the PCB as follows:

- If all PCBs have the parameter LIST=YES, the status statement does not need to be changed.
- If all PCBs have the parameter LIST=NO, the status statement needs to be changed from the relative PCB number to the correct PCB name.

- If some PCBs have the parameter LIST=YES and some have the parameter LIST=NO, the status statement needs to be changed as follows:
 - The PCB relative position is based on all PCBs as if LIST=YES.
 - For PCBs that have a PCB name, the status statement can be changed to use the PCB name based on a relative PCB number.
 - For PCBs that have LIST=YES and no PCB name, change the relative PCB number to refer to the relative PCB number in the user list by looking at the PCB list using LIST=YES and LIST=NO.

Running Image Capture Online

When you run the image capture program online, the trace output goes to the IMS log data set. To run the image capture program online, you issue the IMS TRACE command from the IMS master terminal.

If you trace a BMP or an MPP and you want to use the trace results with DFSDDLTO, the BMP or MPP must have exclusive write access to the databases it processes. If the application program does not have exclusive access, the results of DFSDDLTO may differ from the results of the application program. When you trace a BMP that accesses GSAM databases, you must include an //IMSERR DD statement to get a formatted dump of the GSAM control blocks.

The following diagram shows the TRACE command format:

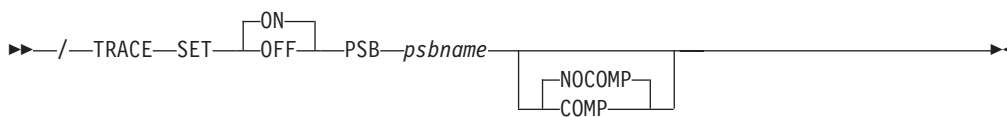

SET ON/OFF

Turns the trace on or off.

PSB *psbname*

Specifies the name of the PSB you want to trace. You can trace more than one PSB at the same time by issuing a separate TRACE command for each PSB.

COMP/NOCOMP

Specifies whether you want the image capture program to produce data and PCB compare statements to be used as input to DFSDDLTO.

Running Image Capture as a Batch Job

To run the image capture program as a batch job, you use the DLITRACE control statement in the DFSVSAMP DD data set. In the DLITRACE control statement, you specify:

- Whether you want to trace all of the DL/I calls the program issues or trace only a certain group of calls.
- Whether you want the trace output to go to:
 - A sequential data set that you specify
 - The IMS log data set
 - Both sequential and IMS log data sets

Format of DLITRACE Control Statement

The format of the DLITRACE control statement is:

**DLITRACE**

Invokes the trace. If this is the only parameter you specify, IMS uses default values for the remaining parameters.

LOG = YES|NO

Specifies whether you want IMS to route trace output to the IMS log. NO is the default.

DDNAME = anyname|DFSTROUT

Specifies the ddname of the sequential data set to which you want trace output sent. The default is DFSTROUT. However, if you specify LOG = YES, and you do not supply a value for the DDNAME parameter, IMS does not try to open the data set defined by DFSTROUT.

START = n|0

Gives the number of the first DL/I call in the program that you want traced. The value is a one- to eight-character hexadecimal number. If you do not supply a value, the trace starts with the first DL/I call in the program.

STOP = n|7FFFFFFF

Specifies the number of the last DL/I call in the program that you want traced. The value is a one- to eight-character hexadecimal number. The default and maximum is X'7FFFFFFF'.

COMP|NOCOMP

Specifies whether you want DFSDLTR0 to produce data and PCB comparison statements that are to be used as input to DFSDDLT0. NOCOMP is the default.

Notes:

1. DLITRACE must begin in column 1; the remainder of the parameters are nonpositional.
2. Each parameter can be used only once in the control statement.
3. Only one trace control statement is allowed for a program.

Example of DLITRACE

This example shows a DLITRACE control statement that:

- Traces the first 14 DL/I calls or commands that the program issues
- Sends the output to the IMS log data set
- Produces data and PCB comparison statements for DFSDDLT0, program

```
//DFSVSAMP DD *
DLITRACE LOG=YES,STOP=14,COMP
/*
```

Special JCL Requirements

Special JCL requirements are as follows:

//IEFRDER DD

If you want log data set output, this DD statement is required to define the IMS log data set.

//DFSTROUT DD|anyname

If you want sequential data set output, this DD statement is required to define that data set. If you want to specify an alternate ddname (anyname), specify it by using the DDNAME parameter on the DLITRACE control statement.

DCB parameters are required for this DD statement only when you want to use the output for problem determination and the program being traced abends. In this case, add the BLKSIZE=80 parameter to the DFSTROUT DD statement to ensure that all the generated output is written to the data set. Buffering the output may leave some of the traced data in the output buffers at abend time. If the BLKSIZE= parameter is not specified in the JCL for the DFSTROUT DD statement, the block size defaults to a system generated block size. The DCB parameters generated in the trace program are:

- RECFM=F
- LRECL=80

Notes on Using Image Capture

- If the program being traced issues CHKP and XRST calls, the checkpoint and restart information may not be directly reproducible when you use the trace output with DFSDDLTO.
- When you run DFSDDLTO in an IMS DL/I or DBB batch region with trace output, the results are the same as the application program's results, but only if the database has not been altered.

Retrieving Image Capture Data from the Log Data Set

If the trace output is sent to the IMS log data set, you can retrieve it by using utility DFSERA10 and a DL/I call trace exit routine, DFSERA50. DFSERA50 deblocks, formats, and numbers the image capture program records that are to be retrieved. To use DFSERA50, you must insert a DD statement defining a sequential output data set in the DFSERA10 input stream. The default ddname for this DD statement is TRCPUNCH. The statement must specify BLKSIZE=80.

Examples: You can use the following examples of DFSERA10 input control statements in the SYSIN data set to retrieve the image capture program data from the log data set:

- **Print all image capture program records:**

```
Column 1      Column 10
OPTION        PRINT OFFSET=5,VALUE=5F,FLDTYP=X
```

- **Print selected image capture program records by PSB name:**

```
Column 1      Column 10
OPTION        PRINT OFFSET=5,VALUE=5F,COND=M
OPTION        PRINT OFFSET=25,VLDTYP=C,FLDLEN=8,
              VALUE=psbname, COND=E
```

- **Format image capture program records (in a format that can be used as input to DFSDDLTO):**

```
Column 1      Column 10
OPTION        PRINT OFFSET=5,VALUE=5F,COND=M
OPTION        PRINT EXITR=DFSERA50,OFFSET=25,FLDTYP=C
              VALUE=psbname,FLDLEN=8,DDNAME=OUTDDN,COND=E
```

Point to remember: The DDNAME= parameter names the DD statement to be used by DFSERA50. The data set that is defined on the OUTDDN DD statement is used instead of the default TRCPUNCH DD statement. For this example, the DD is:

```
//OUTDDN DD ...,DCB=(BLKSIZE=80),...
```

Requests for Monitoring and Debugging Your IMS Program

You can use the following two requests to help you in debugging your program:

- The Statistics (STAT) call retrieves database statistics.
- The Log (LOG) call makes it possible for the application program to write a record on the system log.

The enhanced OSAM and VSAM STAT calls provide additional information for monitoring performance and fine tuning of the system for specific needs.

When the enhanced STAT call is issued, the following information is returned:

- OSAM statistics for each defined subpool
- VSAM statistics that also include hiperspace statistics
- OSAM and VSAM count fields that have been expanded to 10 digits

Retrieving Database Statistics: The STAT Call

Product-sensitive programming interface

This section contains product-sensitive programming interface information.

End of Product-sensitive programming interface

The STAT call is helpful in debugging a program because it retrieves IMS database statistics. It is also helpful in monitoring and fine tuning for performance. The STAT call retrieves OSAM database buffer pool statistics and VSAM database buffer subpool statistics.

Related Reading: For information on coding the STAT call, see the appropriate application programming book.

When you issue the STAT call, you indicate:

- An I/O area into which the statistics are to be returned.
- A statistics function, which is the name of a 9-byte area whose contents describe the type and format of the statistics you want returned. The contents of the area are defined as follows:
 - The first 4 bytes define the type of statistics desired (OSAM or VSAM).
 - The 5th byte defines the format to be returned (formatted, unformatted, or summary).
 - The remaining 4 bytes are defined as follows:
 - The normal or enhanced STAT call contains 4 bytes of blanks.
 - The extended STAT call contains the 4-byte parameter ' E1 ' (a 1-byte blank, followed by a 2-byte character string, and then another 1-byte blank).

Format of OSAM Buffer Pool Statistics

For OSAM buffer pool statistics, the values are possible for the stat-function parameter and for the format of the data that is returned to the application program. If no OSAM buffer pool is present, a GE status code is returned to the program.

DBASF: This function value provides the full OSAM database buffer pool statistics in a formatted form. The application program I/O area must be at least 360 bytes.

Three 120-byte records (formatted for printing) are provided as two heading lines and one line of statistics. The following diagram shows the data format.

```

    BLOCK   FOUND   READS   BUFF   OSAM   BLOCKS   NEW   CHAIN
    REQ   IN POOL  ISSUED   ALTS   WRITES  WRITTEN  BLOCKS  WRITES
    nnnnnnn nnnnnnnn  nnnnnn  nnnnnnn  nnnnnnn  nnnnnnnn  nnnnnn  nnnnnn

WRITTEN  LOGICAL   PURGE  RELEASE
AS NEW   CYL      REQ    REQ    ERRORS
          FORMAT
nnnnnnn  nnnnnnnn  nnnnnnnn  nnnnnnnn  nn/nn
    
```

BLOCK REQ

Number of block requests received.

FOUND IN POOL

Number of times the block requested was found in the buffer pool.

READS ISSUED

Number of OSAM reads issued.

BUFF ALTS

Number of buffers altered in the pool.

OSAM WRITES

Number of OSAM writes issued.

BLOCKS WRITTEN

Number of blocks written from the pool.

NEW BLOCKS

Number of new blocks created in the pool.

CHAIN WRITES

Number of chained OSAM writes issued.

WRITTEN AS NEW

Number of blocks created.

LOGICAL CYL FORMAT

Number of format logical cylinder requests issued.

PURGE REQ

Number of purge user requests.

RELEASE REQ

Number of release ownership requests.

ERRORS

Number of write error buffers currently in the pool or the largest number of errors in the pool during this execution.

DBASU: This function value provides the full OSAM database buffer pool statistics in an unformatted form. The application program I/O area must be at least 72 bytes. Eighteen fullwords of binary data are provided:

Word Contents

- 1 A count of the number of words that follow.
- 2-18 The statistic values in the same sequence as presented by the DBASF function value.

DBASS: This function value provides a summary of the OSAM database buffer pool statistics in a formatted form. The application program I/O area must be at

least 180 bytes. Three 60-byte records (formatted for printing) are provided. The following diagram shows the data format.

```
DATA BASE BUFFER POOL:  SIZE nnnnnn
                        REQ1 nnnnn REQ2 nnnnn READ nnnnn WRITES nnnnn LCYL nnnnn
                        PURG nnnnn OWNRR nnnnn ERRORS nn/nn
```

SIZE Buffer pool size.

REQ1 Number of block requests.

REQ2 Number of block requests satisfied in the pool plus new blocks created.

READ Number of read requests issued.

WRITES

Number of OSAM writes issued.

LCYL Number of format logical cylinder requests.

PURG Number of purge user requests.

OWNRR

Number of release ownership requests.

ERRORS

Number of permanent errors now in the pool or the largest number of permanent errors during this execution.

Format of VSAM Buffer Subpool Statistics

Because there might be several buffer subpools for VSAM databases, the STAT call is iterative when requesting these statistics. If more than one VSAM local shared resource pool is defined, statistics are retrieved for all VSAM local shared resource pools in the order in which they are defined. For each local shared resource pool, statistics are retrieved for each subpool according to buffer size.

The first time the call is issued, the statistics for the subpool with the smallest buffer size are provided. For each succeeding call (without intervening use of the PCB), the statistics for the subpool with the next-larger buffer size are provided.

If index subpools exist within the local shared resource pool, the index subpool statistics always follow statistics of the data subpools. Index subpool statistics are also retrieved in ascending order based on the buffer size.

The final call for the series returns a GA status code in the PCB. The statistics returned are totals for all subpools in all local shared resource pools. If no VSAM buffer subpools are present, a GE status code is returned to the program.

VBASF: This function value provides the full VSAM database subpool statistics in a formatted form. The application program I/O area must be at least 360 bytes. Three 120-byte records (formatted for printing) are provided as two heading lines and one line of statistics. Each successive call returns the statistics for the next data subpool. If present, statistics for index subpools follow the statistics for data subpools.

The following diagram shows the data format.

```
                BUFFER HANDLER STATISTICS
BSIZ NBUF RET RBA RET KEY ISRT ES ISRT KS BFR ALT  BGWRT SYN PTS
nnnK  nnn nnnnnnnn nnnnnnnn nnnnnnnn nnnnnnnn nnnnnnnn nnnnnnnn nnnnnnnn
```

```

          VSAM STATISTICS POOLID: xxxx
GETS  SCHBFR  FOUND  READS  USR WTS  NUR WTS  ERRORS
nnnnnnn nnnnnnnn nnnnnnnn nnnnnnnn nnnnnnnn nnnnnnnn nn/nn

```

POOLID

ID of the local shared resource pool.

BSIZ Size of the buffers in this VSAM subpool. In the final call, this field is set to ALL.

NBUF Number of buffers in this subpool. In the final call, this is the number of buffers in all subpools.

RET RBA

Number of retrieve-by-RBA calls received by the buffer handler.

RET KEY

Number of retrieve-by-key calls received by the buffer handler.

ISRT ES

Number of logical records inserted into ESDSs.

ISRT KS

Number of logical records inserted into KSDSs.

BFR ALT

Number of logical records altered in this subpool. Delete calls that result in erasing records from a KSDS are not counted.

BGWRT

Number of times the background-write function was executed by the buffer handler.

SYN PTS

Number of Synchronization calls received by the buffer handler.

GETS Number of VSAM GET calls issued by the buffer handler.

SCHBFR

Number of VSAM SCHBFR calls issued by the buffer handler.

FOUND

Number of times VSAM found the control interval already in the subpool.

READS

Number of times VSAM read a control interval from external storage.

USR WTS

Number of VSAM writes initiated by IMS.

NUR WTS

Number of VSAM writes initiated to make space in the subpool.

ERRORS

Number of write error buffers currently in the subpool or the largest number of write errors in the subpool during this execution.

VBASU: This function value provides the full VSAM database subpool statistics in a unformatted form. The application program I/O area must be at least 72 bytes. Eighteen fullwords of binary data are provided for each subpool:

Word Contents

1 A count of the number of words that follow.

2-18 The statistic values in the same sequence as presented by the VBASF function value, except for POOLID, which is not included in this unformatted form.

VBASS: This function value provides a summary of the VSAM database subpool statistics in a formatted form. The application program I/O area must be at least 180 bytes. Three 60-byte records (formatted for printing) are provided.

The following diagram shows the data format.

```
DATA BASE BUFFER POOL:  BSIZE nnnnnnn  POOLID xxxx  Type x
                        RRBA nnnnn  RKEY nnnnn  BFALT nnnnn  NREC nnnnn  SYN PTS nnnnn
                        NMBUFS nnn  VRDS nnnnn  FOUND nnnnn  VWTS nnnnn  ERRORS nn/nn
```

BSIZE Size of the buffers in this VSAM subpool.

POOLID

ID of the local shared resource pool.

TYPE Indicates a data (D) subpool or an index (I) subpool.

RRBA Number of retrieve-by-RBA requests.

RKEY Number of retrieve-by-key requests.

BFALT

Number of logical records altered.

NREC Number of new VSAM logical records created.

SYN PTS

Number of sync point requests.

NMBUFS

Number of buffers in this VSAM subpool.

VRDS Number of VSAM control interval reads.

FOUND

Number of times VSAM found the requested control interval already in the subpool.

VWTS Number of VSAM control interval writes.

ERRORS

Number of permanent write errors now in the subpool or the largest number of errors in this execution.

Format of Enhanced/Extended OSAM Buffer Subpool Statistics

The enhanced OSAM buffer pool statistics provide additional information generated for each defined subpool. Because there might be several buffer subpools for OSAM databases, the enhanced STAT call repeatedly requests these statistics. The first time the call is issued, the statistics for the subpool with the smallest buffer size is provided. For each succeeding call (without intervening use of the PCB), the statistics for the subpool with the next-larger buffer size is provided.

The final call for the series returns a GA status code in the PCB. The statistics returned are the totals for all subpools. If no OSAM buffer subpools are present, a GE status code is returned.

Extended OSAM buffer pool statistics can be retrieved by including the 4-byte parameter 'bE1b' following the enhanced call function. The extended stat call

returns all of the stats returned with the enhanced call, plus the stats on the coupling facility buffer invalidates, OSAM caching, and sequential buffering IMMED/SYNC read counts.

Restriction: The extended format parameter is supported by the DBESO, DBESU, and DBESF functions only.

DBESF: This function value provides the full OSAM subpool statistics in a formatted form. The application program I/O area must be at least 600 characters. For OSAM subpools, five 120-byte records (formatted for printing) are provided. Three of the records are heading lines and two of the records are lines of subpool statistics.

Example: The following shows the enhanced stat call format:

```

      B U F F E R   H A N D L E R   O S A M   S T A T I S T I C S   F I X O P T = X / X   P O O L I D :   x x x x
BSIZ  NBUFS      LOCATE-REQ  NEW-BLOCKS  ALTER- REQ  PURGE- REQ  FND-IN-POOL  BUFERS-SRCH  READ- REQ  BUFSTL-WRT
      PURGE-WRTS  WT-BUSY-ID  WT-BUSY-WR  WT-BUSY-RD  WT-RLSEOWN  WT-NO-BFRS  ERRORS
nn1K  nnnnnnnn  nnnnnnnnnn  nnnnnnnnnn  nnnnnnnnnn  nnnnnnnnnn  nnnnnnnnnn  nnnnnnnnnn  nnnnnnnnnn  nnnnnnnnnn
      nnnnnnnnnn  nnnnnnnnnn  nnnnnnnnnn  nnnnnnnnnn  nnnnnnnnnn  nnnnnnnnnn  nnnnnnnnnn  nnnnnnnn/nnnnnnn
    
```

Example: The following shows the extended stat call format:

```

      B U F F E R   H A N D L E R   O S A M   S T A T I S T I C S   S T G   C L S =   F I X O P T = N / N   P O O L I D :
BSIZ  NBUFS      LOCATE-REQ  NEW-BLOCKS  ALTER- REQ  PURGE- REQ  FND-IN-POOL  BUFERS-SRCH  READ- REQ  BUFSTL-WRT
      PURGE-WRTS  WT-BUSY-ID  WT-BUSY-WR  WT-BUSY-RD  WT-RLSEOWN  WT-NO-BFRS  ERRORS
nn1K  nnnnnnnn5  nnnnnnnnnn0  nnnnnnnnnn0  nnnnnnnnnn0  nnnnnnnnnn0  nnnnnnnnnn0  nnnnnnnnnn0  nnnnnnnnnn0  nnnnnnnnnn0
      nnnnnnnnnn  nnnnnnnnnn  nnnnnnnnnn  nnnnnnnnnn  nnnnnnnnnn  nnnnnnnnnn  nnnnnnnnnn  nnnnnnnn/nnnnnnn
CF-READS  EXPCTD-NF  CFWRT-PRI  CFWRT-CHG  STGCLS-FULL  XI-CNT  VECTR-XI  SB-SEQRD  SB-ANTICIP
nnnnnnnnn  nnnnnnnnnn  nnnnnnnnnn  nnnnnnnnnn  nnnnnnnnnn  nnnnnnnnnn  nnnnnnnnnn  nnnnnnnnnn  nnnnnnnnnn
    
```

FIXOPT

Fixed options for this subpool. Y or N indicates whether the data buffer prefix and data buffers are fixed.

POOLID

ID of the local shared resource pool.

BSIZ Size of the buffers in this subpool. Set to ALL for total line.¹

NBUFS

Number of buffers in this subpool. This is the total number of buffers in the pool for the ALL line.

LOCATE-REQ

Number of LOCATE-type calls.

NEW-BLOCKS

Number of requests to create new blocks.

ALTER-REQ

Number of buffer alter calls. This count includes NEW BLOCK and BYTALT calls.

PURGE-REQ

Number of PURGE calls.

FND-IN-POOL

Number of LOCATE-type calls for this subpool where data is already in the OSAM pool.

BUFERS-SRCH

Number of buffers searched by all LOCATE-type calls.

READ-REQS

Number of READ I/O requests.

BUFSTL-WRT

Number of single block writes initiated by buffer steal routine.

PURGE-WRTS

Number of blocks for this subpool written by purge.

WT-BUSY-ID

Number of LOCATE calls that waited due to busy ID.

WT-BUSY-WR

Number of LOCATE calls that waited due to buffer busy writing.

WT-BUSY-RD

Number of LOCATE calls that waited due to buffer busy reading.

WT-RLSEOWN

Number of buffer steal or purge requests that waited for ownership to be released.

WT-NO-BFRS

Number of buffer steal requests that waited because no buffers are available to be stolen.

ERRORS

Total number of I/O errors for this subpool or the number of buffers locked in pool due to write errors.

CF-READS

Number of blocks read from CF.

EXPCTD-NF

Number of blocks expected but not read.

CFWRT-PRI

Number of blocks written to CF (prime).

CFWRT-CHG

Number of blocks written to CF (changed).

STGGLS-FULL

Number of blocks not written (STG CLS full).

XI-CNTL

Number of XI buffer invalidate calls.

VECTR-XI

Number of buffers found invalidated by XI on VECTOR call.

SB-SEQRD

Number of immediate (SYNC) sequential reads (SB stat).

SB-ANTICIP

Number of anticipatory reads (SB stat).

Note: ¹ For the summary totals (BSIZ=ALL), the FIXOPT and POOLID fields are replaced by an OSM= field. This field is the total size of the OSAM subpool.

DBESU: This function value provides full OSAM statistics in an unformatted form. The application program I/O area must be at least 84 bytes. Twenty-one fullwords of binary data are provided for each subpool:

Word Contents

- 1** A count of the number of words that follow.
- 2-19** The statistics provided in the same sequence as presented by the DBESF function value.
- 20** The POOLID provided at subpool definition time.
- 21** The second byte contains the following fix options for this subpool:
- X'04' = DATA BUFFER PREFIX fixed
 - X'02' = DATA BUFFERS fixed
- The summary totals (word 2=ALL), for word 21, contain the total size of the OSAM pool.
- 22-30** Extended stat data in same sequence as on DBESF call.

DBESS: This function value provides a summary of the OSAM database buffer pool statistics in a formatted form. The application program I/O area must be at least 360 bytes. Six 60-byte records (formatted for printing) are provided. This STAT call is a restructured DBASF STAT call that allows for 10-digit count fields. In addition, the subpool header blocks give a total of the number of OSAM buffers in the pool.

The following shows the data format:

```
DATA BASE BUFFER POOL: NSUBPL nnnnnn NBUFS nnnnnnnn
  BLKREQ nnnnnnnnnn INPOOL nnnnnnnnnn READS nnnnnnnnnn
  BUFALT nnnnnnnnnn WRITES nnnnnnnnnn BLKWRT nnnnnnnnnn
  NEWBLK nnnnnnnnnn CHNWRT nnnnnnnnnn WRTNEW nnnnnnnnnn
  LCYLFM nnnnnnnnnn PURGRQ nnnnnnnnnn RLSERQ nnnnnnnnnn
  FRCWRT nnnnnnnnnn ERRORS nnnnnnnnn/nnnnnnnn
```

NSUBPL

Number of subpools defined for the OSAM buffer pool.

NBUFS

Total number of buffers defined in the OSAM buffer pool.

BLKREQ

Number of block requests received.

INPOOL

Number of times the block requested is found in the buffer pool.

READS

Number of OSAM reads issued.

BUFALT

Number of buffers altered in the pool.

WRITES

Number of OSAM writes issued.

BLKWRT

Number of blocks written from the pool.

NEWBLK

Number of blocks created in the pool.

CHNWRT

Number of chained OSAM writes issued.

WRTNEW

Number of blocks created.

LCYLFM

Number of format logical cylinder requests issued.

PURGRQ

Number of purge user requests.

RLSERQ

Number of release ownership requests.

FRCWRT

Number of forced write calls.

ERRORS

Number of write error buffers currently in the pool or the largest number of errors in the pool during this execution.

DBESO: This function value provides the full OSAM database subpool statistics in a formatted form for online statistics that are returned as a result of a /DIS P00L command. This call can also be a user-application STAT call. When issued as an application DL/I STAT call, the program I/O area must be at least 360 bytes. Six 60-byte records (formatted for printing) are provided.

Example: The following shows the enhanced stat call format:

```
OSAM DB BUFFER POOL:ID xxxx BSIZE nnnnnK NBUFnnnnnnn FX=X/X
  LCTREQ nnnnnnnnnn NEWBLK nnnnnnnnnn ALTREQ nnnnnnnnnn
  PURGRQ nnnnnnnnnn FNDIPL nnnnnnnnnn BFSRCH nnnnnnnnnn
  RDREQ  nnnnnnnnnn BFSTLW nnnnnnnnnn PURGWR nnnnnnnnnn
  WBSYID nnnnnnnnnn WBSYWR nnnnnnnnnn WBSYRD nnnnnnnnnn
  WRLSEO nnnnnnnnnn WNOBFR nnnnnnnnnn ERRORS nnnnn/nnnnn
```

Example: The following shows the extended stat call format:

```
OSAM DB BUFFER POOL:ID xxxx BSIZE nnnnnK NBUFnnnnnnn FX=X/X
  LCTREQ nnnnnnnnnn NEWBLK nnnnnnnnnn ALTREQ nnnnnnnnnn
  PURGRQ nnnnnnnnnn FNDIPL nnnnnnnnnn BFSRCH nnnnnnnnnn
  RDREQ  nnnnnnnnnn BFSTLW nnnnnnnnnn PURGWR nnnnnnnnnn
  WBSYID nnnnnnnnnn WBSYWR nnnnnnnnnn WBSYRD nnnnnnnnnn
  WRLSEO nnnnnnnnnn WNOBFR nnnnnnnnnn ERRORS nnnnn/nnnnn
  CFREAD nnnnnnnnnn CFEXPC nnnnnnnnnn CFWRPR nnnnn/nnnnn
  CFWRCH nnnnnnnnnn STGCLF nnnnnnnnnn XIINV  nnnnn/nnnnn
  XICLCT nnnnnnnnnn SBSEQR nnnnnnnnnn SBANTR nnnnn/nnnnn
```

POOLID

ID of the local shared resource pool.

BSIZE Size of the buffers in this subpool. Set to ALL for summary total line.¹

NBUF Number of buffers in this subpool. Total number of buffers in the pool for the ALL line.

FX= Fixed options for this subpool. Y or N indicates whether the data buffer prefix and data buffers are fixed.

LCTREQ

Number of LOCATE-type calls.

NEWBLK

Number of requests to create new blocks.

ALTREQ

Number of buffer alter calls. This count includes NEW BLOCK and BYTALT calls.

PURGRQ	Number of PURGE calls.
FNDIPL	Number of LOCATE-type calls for this subpool where data is already in the OSAM pool.
BFSRCH	Number of buffers searched by all LOCATE-type calls.
RDREQ	Number of READ I/O requests.
BFSTLW	Number of single-block writes initiated by buffer-steal routine.
PURGWR	Number of buffers written by purge.
WBSYID	Number of LOCATE calls that waited due to busy ID.
WBSYWR	Number of LOCATE calls that waited due to buffer busy writing.
WBSYRD	Number of LOCATE calls that waited due to buffer busy reading.
WRLSEO	Number of buffer steal or purge requests that waited for ownership to be released.
WNOBRF	Number of buffer steal requests that waited because no buffers are available to be stolen.
ERRORS	Total number of I/O errors for this subpool or the number of buffers locked in pool due to write errors.
CFREAD	Number of blocks read from CF.
CFEXPC	Number of blocks expected but not read.
CFWRPR	Number of blocks written to CF (prime).
CFWRCH	Number of blocks written to CF (changed).
STGCLF	Number of blocks not written (STG CLS full).
XIINV	Number of XI buffer invalidate calls.
XICLCT	Number of buffers found invalidated by XI on VECTOR call.
SBSEQR	Number of immediate (SYNC) sequential reads (SB stat).
SBANTR	Number of anticipatory reads (SB stat).

Note: ¹ For the summary totals (BSIZE=ALL), the FX= field is replaced by the OSAM= field. This field is the total size of the OSAM buffer pool. The POOLID is not shown.

Format of Enhanced VSAM Buffer Subpool Statistics

The enhanced VSAM buffer subpool statistics provide information on the total size of VSAM subpools in virtual storage and in hiperspace. All count fields are 10 digits.

Because there might be several buffer subpools for VSAM databases, the enhanced STAT call repeatedly requests these statistics. If more than one VSAM local shared resource pool is defined, statistics are retrieved for all VSAM local shared resource pools in the order in which they are defined. For each local shared resource pool, statistics are retrieved for each subpool according to buffer size.

The first time the call is issued, the statistics for the subpool with the smallest buffer size are provided. For each succeeding call (without intervening use of the PCB), the statistics for the subpool with the next-larger buffer size are provided.

If index subpools exist within the local shared resource pool, the index subpool statistics always follow the data subpools statistics. Index subpool statistics are also retrieved in ascending order based on the buffer size.

The final call for the series returns a GA status code in the PCB. The statistics returned are totals for all subpools in all local shared resource pools. If no VSAM buffer subpools are present, a GE status code is returned to the program.

VBESF: This function value provides the full VSAM database subpool statistics in a formatted form. The application program I/O area must be at least 600 bytes. For each shared resource pool ID, the first call returns five 120-byte records (formatted for printing). Three of the records are heading lines and two of the records are lines of subpool statistics.

The following shows the data format:

```

      B U F F E R   H A N D L E R   S T A T I S T I C S   /   V S A M   S T A T I S T I C S   F I X O P T = X / X / X   P O O L I D :   x x x x
BSIZ NBUFFRS HS-NBUF RETURN-RBA RETURN-KEY ESDS-INSRT KSDS-INSRT BUFFRS-ALT BKGRND-WRT SYNC-POINT ERRORS
      VSAM-GETS SCHED-BUFR VSAM-FOUND VSAM-READS USER-WRITS VSAM-WRITS HSRDS-SUCC HSWRT-SUCC HSR/W-FAIL
nn1K  nnnnnn  nnnnnn  nnnnnnnnnn  nnnnnnnnnn  nnnnnnnnnn  nnnnnnnnnn  nnnnnnnnnn  nnnnnnnnnn  nnnnnnnnnn  nnnnnn/nnnnnn
      nnnnnnnnnn  nnnnnnnnnn  nnnnnnnnnn  nnnnnnnnnn  nnnnnnnnnn  nnnnnnnnnn  nnnnnnnnnn  nnnnnnnnnn  nnnnnn/nnnnnn

```

FIXOPT

Fixed options for this subpool. Y or N indicates whether the data buffer prefix, the index buffers, and the data buffers are fixed.

POOLID

ID of the local shared resource pool.

BSIZ Size of the buffers in this subpool. Set to ALL for total line.¹

NBUFFRS

Number of buffers in this subpool. Total number of buffers in the VSAM pool that appears in the ALL line.

HS-NBUF

Number of hiperspace buffers defined for this subpool.

RETURN-RBA

Number of retrieve-by-RBA calls received by the buffer handler.

RETURN-KEY

Number of retrieve-by-key calls received by the buffer handler.

ESDS-INSRT

Number of logical records inserted into ESDSs.

KSDS-INSRT

Number of logical records inserted into KSDSs.

BUFFRS-ALT

Number of logical records altered in this subpool. Delete calls that result in erasing records from a KSDS are not counted.

BKGRND-WRT

Number of times the background write function was executed by the buffer handler.

SYNC-POINT

Number of Synchronization calls received by the buffer handler.

ERRORS

Number of write error buffers currently in the subpool or the largest number of write errors in the subpool during this execution.

VSAM-GETS

Number of VSAM Get calls issued by the buffer handler.

SCHED-BUFR

Number of VSAM Scheduled-Buffer calls issued by the buffer handler

VSAM-FOUND

Number of times VSAM found the control interval in the buffer pool.

VSAM-READS

Number of times VSAM read a control interval from external storage.

USER-WRITS

Number of VSAM writes initiated by IMS.

VSAM-WRITS

Number of VSAM writes initiated to make space in the subpool.

HSRDS-SUCC

Number of successful VSAM reads from hiperspace buffers.

HSWRT-SUCC

Number of successful VSAM writes from hiperspace buffers.

HSR/W-FAIL

Number of failed VSAM reads from hiperspace buffers/number of failed VSAM writes to hiperspace buffers. This indicates the number of times a VSAM READ/WRITE request from or to hiperspace resulted in DASD I/O.

Note: ¹ For the summary totals (BSIZ=ALL), the FIXOPT and POOLID fields are replaced by a VS= field and a HS= field. The VS= field is the total size of the VSAM subpool in virtual storage. The HS= field is the total size of the VSAM subpool in hiperspace.

VBESU: This function value provides full VSAM statistics in an unformatted form. The application program I/O area must be at least 104 bytes. Twenty-five fullwords of binary data are provided for each subpool.

Word Contents

1 A count of the number of words that follow.

- 2-23 The statistics provided in the same sequence as presented by the VBESF function value.
- 24 The POOLID provided at the time the subpool is defined.
- 25 The first byte contains the subpool type, and the third byte contains the following fixed options for this subpool:
 - X'08' = INDEX BUFFERS fixed
 - X'04' = DATA BUFFER PREFIX fixed
 - X'02' = DATA BUFFERS fixed

The summary totals (word 2=ALL) for word 25 and word 26 contain the virtual and hiperspace pool sizes.

VBESS: This function value provides a summary of the VSAM database subpool statistics in a formatted form. The application program I/O area must be at least 360 bytes. For each shared resource pool ID, the first call provides six 60-byte records (formatted for printing).

The following shows the data format:

```

VSAM DB BUFFER POOL:ID xxxx  BSIZE nnnnnnK  TYPE x  FX=X/X/X
RRBA  nnnnnnnnnn  RKEY    nnnnnnnnnn  BFALT  nnnnnnnnnn
NREC  nnnnnnnnnn  SYNC PT nnnnnnnnnn  NBUFS  nnnnnnnnnn
VRDS  nnnnnnnnnn  FOUND   nnnnnnnnnn  VWTS   nnnnnnnnnn
HSR-S nnnnnnnnnn  HSW-S   nnnnnnnnnn  HS NBUFS nnnnnnnn
HS-R/W-FAIL  nnnnn/nnnnn  ERRORS  nnnnnn/nnnnnn
    
```

POOLID

ID of the local shared resource pool.

BSIZE Size of the buffers in this VSAM subpool.

TYPE Indicates a data (D) subpool or an index (I) subpool.

FX Fixed options for this subpool. Y or N indicates whether the data buffer prefix, the index buffers, and the data buffers are fixed.

RRBA

Number of retrieve-by-RBA calls received by the buffer handler.

RKEY Number of retrieve-by-key calls received by the buffer handler.

BFALT

Number of logical records altered.

NREC Number of new VSAM logical records created.

SYNC PT

Number of sync point requests.

NBUFS

Number of buffers in this VSAM subpool.

VRDS Number of VSAM control interval reads.

FOUND

Number of times VSAM found the requested control interval already in the subpool.

VWTS Number of VSAM control interval writes.

HSR-S

Number of successful VSAM reads from hiperspace buffers.

HSW-S

Number of successful VSAM writes to hiperspace buffers.

HS NBUFS

Number of VSAM hiperspace buffers defined for this subpool.

HS-R/W-FAIL

Number of failed VSAM reads from hiperspace buffers and number of failed VSAM writes to hiperspace buffers. This indicates the number of times a VSAM READ/WRITE request to or from hiperspace resulted in DASD I/O.

ERRORS

Number of permanent write errors now in the subpool or the largest number of errors in this execution.

Writing Information to the System Log: The LOG Request

An application program can write a record to the system log by issuing the LOG call. When you issue the LOG request, you specify the I/O area that contains the record you want written to the system log. You can write any information to the log that you want, and you can use different log codes to distinguish between different types of information.

Related Reading: For information about coding the LOG request, see the appropriate application programming reference book.

What to Do When Your IMS Program Terminates Abnormally

When your program terminates abnormally, you can take the following actions to simplify the task of finding and fixing the problem:

- Record as much information as possible about the circumstances under which the program terminated abnormally.
- Check for certain initialization and execution errors.

If You Have a Problem

Many places have guidelines on what you should do if your program terminates abnormally. The suggestions given here are common guidelines:

- Document the error situation to help in investigating and correcting it. The following information can be helpful:
 - The program's PSB name
 - The transaction code that the program was processing (online programs only)
 - The text of the input message being processed (online programs only)
 - The call function
 - The name of the originating logical terminal (online programs only)
 - The contents of the PCB that was referenced in the call that was executing
 - The contents of the I/O area when the problem occurred
 - If a database call was executing, the SSAs, if any, that the call used
 - The date and time of day
- When your program encounters an error, it can pass all the required error information to a standard error routine. You should not use STAE or ESTAE routines in your program; IMS uses STAE or ESTAE routines to notify the control region of any abnormal termination of the application program. If you call your own STAE or ESTAE routines, IMS may not get control if an abnormal

termination occurs. For additional information about STAE or ESTAE routines, see “Use of STAE or ESTAE and SPIE in IMS Programs” on page 46.

- Online programs might want to send a message to the originating logical terminal to inform the person at the terminal that an error has occurred. Unless you are using a CCTL, your program can get the logical terminal name from the I/O PCB, place it in an express PCB, and issue one or more ISRT calls to send the message.
- An online program might also want to send a message to the master terminal operator giving information about the program’s termination. To do this, the program places the logical terminal name of the master terminal in an express PCB and issues one or more ISRT calls. (This is not applicable if you are using a CCTL.)
- You might also want to send a message to a printer so that you will have a hard-copy record of the error.
- You can send a message to the system log by issuing a LOG request.
- Some places run a BMP at the end of the day to list all the errors that have occurred during the day. If your shop does this, you can send a message using an express PCB that has its destination set for that BMP. (This is not applicable if you are using a CCTL.)

Finding the Problem

If your program does not run correctly when you are testing it or when it is executing, you need to isolate the problem. The problem might be anything from a programming error (for example, an error in the way you coded one of your requests) to a system problem. This section gives some guidelines about the steps that you, as the application programmer, can take when your program fails to run, terminates abnormally, or gives incorrect results.

Initialization Errors

Before your program receives control, IMS must have correctly loaded and initialized the PSB and DBDs used by your application program. Often, when the problem is in this area, you need a system programmer or DBA (or your equivalent specialist) to fix the problem. One thing you can do is to find out if there have been any recent changes to the DBDs, PSB, and the control blocks that they generate.

Execution Errors

If you do not have any initialization errors, check:

1. The output from the compiler. Make sure that all error messages have been resolved.
2. The output from the linkage editor:
 - Are all external references resolved?
 - Have all necessary modules been included?
 - Was the language interface module correctly included?
 - Is the correct entry point specified?
3. Your JCL:
 - Is the information that described the files that contain the databases correct? If not, check with your DBA.
 - Have you included the DL/I parameter statement in the correct format?
 - Have you included the region size parameter in the EXEC statement? Does it specify a region or partition large enough for the storage required for IMS and your program?
 - Have you declared the fields in the PCB masks correctly?

- If your program is an assembler language program, have you saved and restored registers correctly? Did you save the list of PCB addresses at entry? Does register 1 point to a parameter list of fullwords before issuing any DL/I calls?
- For COBOL and PL/I, are the literals you are using for arguments in DL/I calls producing the results you expect? For example, in PL/I, is the parameter count being generated as a half-word instead of a fullword, and is the function code producing the required 4-byte field?
- Use the PCB as much as possible to determine what in your program is producing incorrect results.

Chapter 10. Testing a CICS Application Program

This section tells you what is involved in testing a CICS application program as a unit and gives you some suggestions on how to do testing. This stage of testing is called *program unit test*. The purpose of program unit test is to test each application program as a single unit to ensure that the program correctly handles its input data, processing, and output data.

The amount and type of testing you do depends on the individual program. Though strict rules for testing are not available, the guidelines provided in this section might be helpful.

In this Section:

- “What You Need to Test a CICS Program”
- “Testing Your CICS Program”
- “Requests for Monitoring and Debugging Your CICS Program” on page 166
- “What to Do When Your CICS Program Terminates Abnormally” on page 167

What You Need to Test a CICS Program

When you are ready to test your program, be aware of your established test procedures before you start. To start testing, you need the following three items:

- Test JCL.
- A test database. When you are testing a program, do not execute it against a production database because the program, if faulty, might damage valid data.
- Test input data. The input data that you use need not be current, but it should be valid data. You cannot be sure that your output data is valid unless you use valid input data.

The purpose of testing the program is to make sure that the program can correctly handle all the situations that it might encounter.

To thoroughly test the program, try to test as many of the paths that the program can take as possible. For example:

- Test each path in the program by using input data that forces the program to execute each of its branches.
- Be sure that your program tests its error routines. Again, use input data that will force the program to test as many error conditions as possible.
- Test the editing routines your program uses. Give the program as many different data combinations as possible to make sure it correctly edits its input data.

Testing Your CICS Program

You can use different tools to test a program, depending on the type of program. Table 17 summarizes the tools that are available for Online DBCTL, Batch, and BMP programs.

Table 17. Tools You Can Use for Testing Your Program

Tool	Online (DBCTL)	Batch	BMP
Execution Diagnostic Facility (EDF)	Yes ¹	No	No

Table 17. Tools You Can Use for Testing Your Program (continued)

Tool	Online (DBCTL)	Batch	BMP
CICS Dump Control	Yes	No	No
CICS Trace Control	Yes	Yes	No
DFSDDLTO	No	Yes ²	Yes ²
DL/I Image Capture Program	Yes	Yes	Yes

Notes:

1. For online, command-level programs only.
2. For call-level programs only. (For a command-level batch program, you can use DL/I image capture program first, to produce calls for DFSDDLTO.)

Using the Execution Diagnostic Facility (Command-Level Only)

You can use the Execution Diagnostic Facility (EDF) to test command-level programs online. EDF can display EXEC CICS and EXEC DLI commands in online programs; it cannot intercept DL/I calls. (To test a call-level online program, you can use the CICS dump control facility or the CICS trace facility, described in the following section s.)

With EDF you can:

- Display and modify working storage; you can change values in the DIB.
- Display and modify a command before it is executed. You can modify the value of any argument, and then execute the command.
- Modify the return codes after the execution of the command. After the command has been executed, but before control is returned to the application program, the command is intercepted to show the response and any argument values set by CICS.

You can run EDF on the same terminal as the program you are testing.

Related Reading: For more information about using EDF, see “Execution (Command-Level) Diagnostic Facility” in *CICS Application Programming Reference*.

Using CICS Dump Control

You can use the CICS dump control facility to dump virtual storage areas, CICS tables, and task-related storage areas.

For more information about using the CICS dump control facility, see the CICS application programming reference manual that applies to your version of CICS.

Using CICS Trace Control

You can use the trace control facility to help debug and monitor your online programs in the DBCTL environment. You can use trace control requests to record entries in a trace table. The trace table can be located either in virtual storage or on auxiliary storage. If it is in virtual storage, you can gain access to it by investigating a dump; if it is on auxiliary storage, you can print the trace table. For more information about the control statements you can use to produce trace entries, see the information about trace control in the application programming reference manual that applies to your version of CICS.

Using the DL/I Test Program (DFSDDLTO)

See “Testing DL/I Call Sequences (DFSDDLTO) Before Testing Your IMS Program” on page 139 for a description of DFSDDLTO. DFSDDLTO can be used for testing batch or BMP programs.

Tracing DL/I Calls with Image Capture

DL/I image capture program (DFSDLTRO) is a trace program that can trace and record DL/I calls issued by batch, BMP, and online (DBCTL environment) programs. You can also use the image capture program with command-level programs, and you can produce calls for use as input to DFSDDLTO. You can use the image capture program to:

Test your program

If the image capture program detects an error in a call it traces, it reproduces as much of the call as possible, although it cannot document where the error occurred, and cannot always reproduce the full SSA.

Produce input for DFSDDLTO (DL/I test program)

You can use the output produced by the image capture program as input to DFSDDLTO. The image capture program produces status statements, comment statements, call statements, and compare statements for DFSDDLTO. For example, you can use the image capture program with a command-level program, to produce calls for DFSDDLTO.

Debug your program

When your program terminates abnormally, you can rerun the program using the image capture program. The image capture program can then reproduce and document the conditions that led to the program failure. You can use the information in the report produced by the image capture program to find and fix the problem.

Using Image Capture with DFSDDLTO

The image capture program produces the following control statements that you can use as input to DFSDDLTO:

Status statements

When you invoke the image capture program, it produces the status statement. The status statement it produces:

- Sets print options so that DFSDDLTO prints all call trace comments, all DL/I calls, and the results of all comparisons.
- Determines the new relative PCB number each time a PCB change occurs while the application program is executing.

Comments statement

The image capture program also produces a comments statement when you invoke it. The comments statements give:

- The time and date IMS started the trace
- The name of the PSB being traced

The image capture program also produces a comments statement preceding any call in which IMS finds an error.

Call statements

The image capture program produces a call statement for each DL/I call or EXEC DLI command the application program issues. It also generates a CHKP call when it starts the trace and after each commit point or CHKP request.

Compare statements

If you specify COMP on the DLITRACE control statement, the image capture program produces data and PCB comparison statements.

Running Image Capture Online

This section applies to a CICS (or CCTL) online program (running in the DBCTL environment only) or BMP programs (DBCTL environment). When you run the image capture program online, the trace output goes to the IMS log data set. To run the image capture program online, you issue the IMS TRACE command from the MVS console.

If you trace a BMP and you want to use the trace results with DFSDDLTO, the BMP must have exclusive write access to the databases it processes. If the application program does not have exclusive access, the results of DFSDDLTO may differ from the results of the application program.

The following diagram shows TRACE command format:

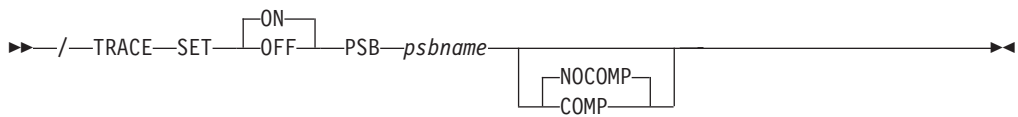

SET ON/OFF

Turns the trace on or off.

PSB psbname

Specifies the name of the PSB you want to trace. You can trace more than one PSB at the same time, by issuing a separate TRACE command for each PSB.

COMP/NOCOMP

Specifies whether you want the image capture program to produce data and PCB compare statements to be used with DFSDDLTO.

Running Image Capture in Batch

This section applies to batch programs. To run the image capture program as a batch job, you use the DLITRACE control statement in the DFSVSAMP DD data set. In the DLITRACE control statement you specify:

- Whether you want to trace all of the DL/I calls the program issues or trace only a certain group of calls.
- Whether you want the trace output to go to:
 - A sequential data set that you specify
 - The IMS log data set
 - Both sequential and IMS log data sets

The format of the DLITRACE control statement is: `i:8lunch`

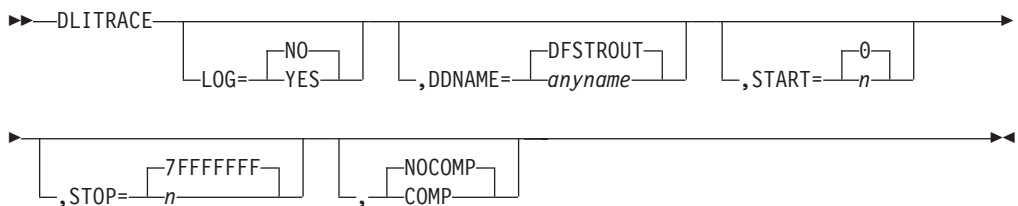

DLITRACE

Invokes the trace. If this is the only parameter you specify, IMS uses default values for the remaining parameters.

LOG = YES|NO

Specifies whether you want IMS to route trace output to the IMS log.

DDNAME = anyname|DFSTROUT

Specifies the ddname of the sequential data set to which you want trace output sent. The default is DFSTROUT; but if you specify LOG = YES, and you do not supply a value for the DDNAME parameter, IMS does not try to open the data set defined by DFSTROUT.

START = n|0

Gives the number of the first DL/I call in the program that you want traced. The value is a one- to eight-character hexadecimal number. If you do not supply a value, the trace starts with the first DL/I call in the program.

STOP = n|7FFFFFFF

Specifies the number of the last DL/I call in the program that you want traced. The value is a one- to eight-character hexadecimal number.

COMP|NOCOMP

Specifies whether you want the image capture program to produce data and PCB comparison statements to be used as input to the DFSDDLTO test program. NOCOMP is the default.

Notes:

1. DLITRACE must begin in column 1; the remainder of the parameters are nonpositional.
2. Each parameter may be used only once in the control statement.
3. Only one trace control statement is allowed for a program.

Example of DLITRACE

This example shows a DLITRACE control statement that:

- Traces the first 14 DL/I calls or commands that the program issues
- Sends the output to the IMS log data set
- Produces data and PCB comparison statements for DFSDDLTO

```
//DFSVSAMP DD *
DLITRACE LOG=YES,STOP=14,COMP
/*
```

Special JCL Requirements

The following are special JCL requirements:

//IEFRDER DD

If you want log data set output, this DD statement is required to define the IMS log data set.

//DFSTROUT DD|anyname

If you want sequential data set output, this DD statement is required to define that data set. If you want to specify an alternate DDNAME (anyname), it must be specified using the DDNAME parameter on the DLITRACE control statement.

The DCB parameters on the JCL statement are not required. The data set characteristics are:

- RECFM=F
- LRECL=80

Notes on Using Image Capture

- If the program being traced issues CHKP and XRST calls, the checkpoint and restart information may not be directly reproducible when you use the trace output with the DFSDDLTO.
- When you run DFSDDLTO in an IMS DL/I or DBB batch region with trace output, the results are the same as the application program's results provided the database has not been altered.

Retrieving Image Capture Data from the Log Data Set

If the trace output is sent to the IMS log data set, you can retrieve it by using utility DFSERA10 and a DL/I call trace exit routine, DFSERA50. DFSERA50 deblocks, formats, and numbers the image capture program records to be retrieved. To use DFSERA50, you must insert a DD statement defining a sequential output data set in the DFSERA10 input stream. The default ddname for this DD statement is TRCPUNCH. The card must specify BLKSIZE=80.

Examples: You can use the following examples of DFSERA10 input control statements in the SYSIN data set to retrieve the image capture program data from the log data set:

- **Print all image capture program records:**

```
Column 1      Column 10
OPTION        PRINT OFFSET=5,VALUE=5F,FLDTYP=X
```

- **Print selected image capture program records by PSB name:**

```
Column 1      Column 10
OPTION        PRINT OFFSET=5,VALUE=5F,COND=M
OPTION        PRINT OFFSET=25,VLDTYP=C,FLDLEN=8,
              VALUE=psbname, COND=E
```

- **Format image capture program records (in a format that can be used as input to DFSDDLTO):**

```
Column 1      Column 10
OPTION        PRINT OFFSET=5,VALUE=5F,COND=M
OPTION        PRINT EXITR=DFSERA50,OFFSET=25,FLDTYP=C
              VALUE=psbname,FLDLEN=8,DDNAME=OUTDDN,COND=E
```

The DDNAME= parameter is used to name the DD statement used by DFSERA50. The data set defined on the OUTDDN DD statement is used instead of the default TRCPUNCH DD statement. For this example, the DD appears as:

```
//OUTDDN DD ...,DCB=(BLKSIZE=80),...
```

Requests for Monitoring and Debugging Your CICS Program

You can use the following two requests to help you in debugging your program:

- The statistics (STAT) request retrieves database statistics. STAT can be issued from both call- and command-level programs. See "Retrieving Database Statistics: The STAT Call" on page 145 for a description of the STAT request.
- The log (LOG) request makes it possible for the application program to write a record on the system log. You can issue LOG as a command or call in a batch program; in this case, the record is written to the IMS log. You can issue LOG as a call or command in an online program in the DBCTL environment; in this case, the record is written to the DBCTL log. See "Writing Information to the System Log: The LOG Request" on page 158 for a description of the LOG request.

What to Do When Your CICS Program Terminates Abnormally

Whenever your program terminates abnormally, you can take some actions to simplify the task of finding and fixing the problem. First, you can record as much information as possible about the circumstances under which the program terminated abnormally; and second, you can check for certain initialization and execution errors.

If You Have a Problem

Many places have guidelines on what you should do if your program terminates abnormally. The suggestions given here are some common guidelines:

- Document the error situation to help in investigating and correcting it. Some of the information that can be helpful is:
 - The program's PSB name
 - The transaction code that the program was processing (online programs only)
 - The text of the input screen being processed (online programs only)
 - The call function
 - The terminal ID (online programs only)
 - The contents of the PCB or the DIB
 - The contents of the I/O area when the problem occurred
 - If a database request was executing, the SSAs or SEGMENT and WHERE options, if any, the request used
 - The date and time of day
- When your program encounters an error, it can pass all the required error information to a standard error routine.
- An online program might also want to send a message to the master terminal destination (CSMT) and application terminal operator, giving information about the program's termination.
- You can send a message to the system log by issuing a LOG request.

Finding the Problem

If your program does not run correctly when you are testing it or when it is executing, you need to isolate the problem. The problem might be anything from a programming error (for example, an error in the way you coded one of your requests) to a system problem. This section gives some guidelines about the steps that you, as the application programmer, can take when your program fails to run, terminates abnormally, or gives incorrect results.

Initialization Errors

Before your program receives control, IMS must have correctly loaded and initialized the PSB and DBDs used by your application program. Often, when the problem is in this area, you need a system programmer or DBA (or your equivalent specialist) to fix the problem. One thing you can do is to find out if there have been any recent changes to the DBDs, PSB, and the control blocks that they generate.

Execution Errors

If you do not have any initialization errors, check the following in your program:

1. The output from the compiler. Make sure that all error messages have been resolved.
2. The output from the linkage editor:
 - Are all external references resolved?

- Have all necessary modules been included?
 - Was the language interface module correctly included?
 - Is the correct entry point specified (for batch programs only)?
3. Your JCL:
 - Is the information that described the files that contain the databases correct? If not, check with your DBA.
 - Have you included the DL/I parameter statement in the correct format (for batch programs only)?
 - Have you included the region size parameter in the EXEC statement? Does it specify a region or partition large enough for the storage required for IMS and your program (for batch programs only)?
 4. Your call-level program:
 - Have you declared the fields in the PCB masks correctly?
 - If your program is an assembler language program, have you saved and restored registers correctly? Did you save the list of PCB addresses at entry? Does register 1 point to a parameter list of full words before issuing any DL/I calls?
 - For COBOL and PL/I, are the literals you are using for arguments in DL/I calls producing the results you expect? For example, in PL/I, is the parameter count being generated as a half word instead of a fullword, and is the function code producing the required 4-byte field?
 - Use the PCB as much as possible to determine what in your program is producing incorrect results.
 5. Your command-level program:
 - Did you use the FROM option with your ISRT or REPL command? If not, data will not be transferred to the database.
 - Check translator messages for errors.

Chapter 11. Testing an ODBA Application Program

This section tells you what is involved in testing an ODBA application program as a unit and gives you some suggestions on how to do testing. This stage of testing is called program unit test. The purpose of program unit test is to test each application program as a single unit to ensure that the program correctly handles its input data, processing, and output data. The amount and type of testing you do depends on the individual program. Though strict rules for testing are not available, the guidelines provided in this section might be helpful.

In this Section:

- “Using the DL/I Test Program (DFSDDLTO) Before Testing Your ODBA Program” on page 170
- “Tracing DL/I Calls with Image Capture to Test Your ODBA Program” on page 170
- “Using Image Capture with DFSDDLTO to Test Your ODBA Program” on page 170
- “Running Image Capture Online” on page 171
- “Retrieving Image Capture Data from the Log Data Set” on page 171
- “Requests for Monitoring and Debugging Your ODBA Program” on page 172
- “What to Do When Your ODBA Program Terminates Abnormally” on page 172

Be aware of your established test procedures before you start to test your program. To begin testing, you need the following items:

- A test JCL statement.
- A test database.

Always begin testing programs against test-only databases. Do not test programs against production databases. If the program is faulty it might damage or delete critical data.

- Test input data.

The input data that you use need not be current, but it should be valid data. You cannot be sure that your output data is valid unless you use valid input data.

The purpose of testing the program is to make sure that the program can correctly handle all the situations that it might encounter. To thoroughly test the program, try to test as many of the paths that the program can take as possible. For example:

Test each path in the program by using input data that forces the program to execute each of its branches. Be sure that your program tests its error routines. Again, use input data that will force the program to test as many error conditions as possible. Test the editing routines your program uses. Give the program as many different data combinations as possible to make sure it correctly edits its input data. Table 18 lists the tools you can use to test Online (IMSDB), Batch, and BMP programs.

Table 18. Tools You Can Use for Testing Your Program

Tool	Online (IMS DB)	Batch	BMP
DFSDDLTO	No	Yes ¹	Yes
DL/I Image Capture Program	Yes	Yes	Yes

Table 18. Tools You Can Use for Testing Your Program (continued)

Tool	Online (IMS DB)	Batch	BMP
Note: 1. For call-level programs only. (For a command-level batch program, you can use DL/I image capture program first, to produce calls for DFSDDLTO).			

Using the DL/I Test Program (DFSDDLTO) Before Testing Your ODBA Program

See “Testing DL/I Call Sequences (DFSDDLTO) Before Testing Your IMS Program” on page 139 for a description of DFSDDLTO. DFSDDLTO can be used for testing batch or BMP programs.

Tracing DL/I Calls with Image Capture to Test Your ODBA Program

The DL/I image capture program (DFSDDLTR0) is a trace program that can trace and record DL/I calls issued by batch, BMP, and online (IMS DB environment) programs. You can produce calls for use as input to DFSDDLTO. You can use the image capture program to:

- Test your program

If the image capture program detects an error in a call it traces, it reproduces as much of the call as possible, although it cannot document where the error occurred, and cannot always reproduce the full SSA.
- Produce input for DFSDDLTO (DL/I test program)

You can use the output produced by the image capture program as input to DFSDDLTO. The image capture program produces status statements, comment statements, call statements, and compare statements for DFSDDLTO. For example, you can use the image capture program with a ODBA application, to produce calls for DFSDDLTO.
- Debug your program

When your program terminates abnormally, you can rerun the program using the image capture program. The image capture program can then reproduce and document the conditions that led to the program failure. You can use the information in the report produced by the image capture program to find and fix the problem.

Using Image Capture with DFSDDLTO to Test Your ODBA Program

The image capture program produces the following control statements that you can use as input to DFSDDLTO:

- Status statements

When you invoke the image capture program, it produces the status statement. The status statement it produces:

 - Sets print options so that DFSDDLTO prints all call trace comments, all DL/I calls, and the results of all comparisons
 - Determines the new relative PCB number each time a PCB change occurs while the application program is running
- Comments statement

The image capture program also produces a comments statement when you run it. The comments statements give:

 - The time and date IMS started the trace

The name of the PSB being traced

The image capture program also produces a comments statement preceding any call in which IMS finds an error.

- Call statements

The image capture program produces a call statement for each DL/I call.

- Compare statements

If you specify COMP on the DLITRACE control statement, the image capture program produces data and PCB comparison statements.

Running Image Capture Online

This section applies to a CICS (or CCTL) online program (running in the IMS DB environment only) or BMP programs (IMS DB environment). When you run the image capture program online, the trace output goes to the IMS log data set. To run the image capture program online, you issue the IMS TRACE command from the MVS console. If you trace a BMP and you want to use the trace results with DFSDDLTO, the BMP must have exclusive write access to the databases it processes. If the application program does not have exclusive access, the results of DFSDDLTO may differ from the results of the application program. The following diagram shows TRACE command format:

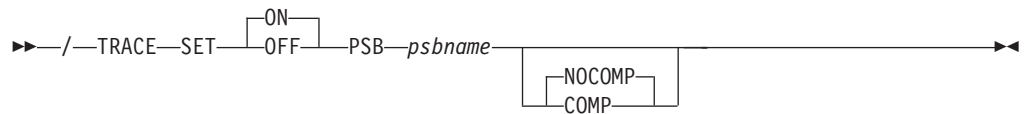

SET ON/OFF

Turns the trace on or off.

PSB *psbname*

Specifies the name of the PSB you want to trace. You can trace more than one PSB at the same time by issuing a separate TRACE command for each PSB.

COMP/NOCOMP

Specifies whether you want the image capture program to produce data and PCB compare statements to be used with DFSDDLTO.

Retrieving Image Capture Data from the Log Data Set

If the trace output is sent to the IMS log data set, you can retrieve it by using utility DFSERA10 and a DL/I call trace exit routine, DFSERA50. DFSERA50 deblocks, formats, and numbers the image capture program records to be retrieved. To use DFSERA50, you must insert a DD statement defining a sequential output data set in the DFSERA10 input stream. The default ddname for this DD statement is TRCPUNCH. The card must specify BLKSIZE=80.

Examples: You can use the following examples of DFSERA10 input control statements in the SYSIN data set to retrieve the image capture program data from the log data set:

- Print all image capture program records:

```

Column 1      Column 10
OPTION        PRINT OFFSET=5,VALUE=5F,FLDTYP=X
    
```

- Print selected image capture program records by PSB name:

```

Column 1      Column 10
OPTION        PRINT OFFSET=5,VALUE=5F,COND=M
OPTION        PRINT OFFSET=25,VLDTYP=C,FLDLLEN=8,
              VALUE=psbname, COND=E

```

- Format image capture program records (in a format that can be used as input to DFSDDLT0):

```

Column 1      Column 10
OPTION        PRINT OFFSET=5,VALUE=5F,COND=M
OPTION        PRINT EXITR=DFSERA50,OFFSET=25,FLDTYP=C
              VALUE=psbname,FLDLLEN=8,DDNAME=OUTDDN,COND=E

```

The DDNAME= parameter is used to name the DD statement used by DFSERA50. The data set defined on the OUTDDN DD statement is used instead of the default TRCPUNCH DD statement. For this example, the DD appears as:

```
//OUTDDN DD ...,DCB=(BLKSIZE=80),...
```

Requests for Monitoring and Debugging Your ODBA Program

You can use the following two requests to help you in debugging your program:

- The statistics (STAT) request retrieves database statistics. STAT can be issued from both call- and command-level programs. See “Retrieving Database Statistics: The STAT Call” on page 145 for a description of the STAT request.
- The log (LOG) request makes it possible for the application program to write a record on the system log. You can issue LOG as a command or call in a batch program; in this case, the record is written to the IMS log. You can issue LOG as a call or command in an online program in the IMS DB environment; in this case, the record is written to the IMS DB log. See “Writing Information to the System Log: The LOG Request” on page 158 for a description of the LOG request.

What to Do When Your ODBA Program Terminates Abnormally

Whenever your program terminates abnormally, you can take some actions to simplify the task of finding and fixing the problem.

First, you can record as much information as possible about the circumstances under which the program terminated abnormally; and second, you can check for certain initialization and execution errors.

If You Have a Problem

Many shops have guidelines on what you should do if your program terminates abnormally. The suggestions given here are some common guidelines:

- Document the error situation to help in investigating and correcting it. Some of the information that can be helpful is:
 - The program’s PSB name
 - The call function
 - The terminal ID (online programs only)
 - The contents of the PCB or the DIB
 - The contents of the I/O area when the problem occurred
 - If a database request was executing, the SSAs or SEGMENT and WHERE options, if any, the request used
 - The date and time of day
- When your program encounters an error, it can pass all the required error information to a standard error routine.

- You can send a message to the system log by issuing a LOG request.

Finding the Problem

If your program does not run correctly when you are testing it or when it is running, you need to isolate the problem. The problem might be anything from a programming error (for example, an error in the way you coded one of your requests) to a system problem. This section gives some guidelines about the steps that you, as the application programmer, can take when your program fails to run, terminates abnormally, or gives incorrect results.

Initialization Errors

Before your program receives control, IMS must have correctly loaded and initialized the PSB and DBDs used by your application program. Often, when the problem is in this area, you need a system programmer or DBA (or your equivalent specialist) to fix the problem. One thing you can do is to find out if there have been any recent changes to the DBDs, PSB, and the control blocks that they generate.

Running Errors

If you do not have any initialization errors, check the following in your program:

1. The output from the compiler. Make sure that all error messages have been resolved.
2. The output from the linkage editor:
 - Are all external references resolved?
 - Have all necessary modules been included?
 - Was the language interface module correctly included?
3. Your JCL. Is the information that described the files that contain the databases correct? If not, check with your DBA.

Chapter 12. Documenting an Application Program

This section provides guidelines for program documentation. The purposes for documenting an application program are described.

In this Section:

- “Documentation for Other Programmers”
- “Documentation for Users” on page 176

Many places establish standards for program documentation; make sure you are aware of your established standards.

Documentation for Other Programmers

Documenting a program is not something you do at the end of the project; your documentation will be much more complete, and more useful to others if you record information about the program as you structure and code it. Include any information that might be useful to someone else who must work with your program.

The reason you record this information is so that people who maintain your program know why you chose certain commands, options, call structures, and command codes. For example, if the DBA were considering reorganizing the database in some way, information about why your program accesses the data the way it does would be helpful.

A good place to record information about your program is in a data dictionary. You can use the DB/DC Data Dictionary, or its successor, DataAtlas (a part of the IBM VisualGen Team Suite), for this purpose.

Related Reading: For information on how to use these products to document a data processing environment: the application system, the programs, the programs' modules, and the IMS system, see

- *OS/VS DB/DC Data Dictionary Applications Guide*
- *Introducing VisualGen* or
- *VisualGen: Running Applications on MVS*

Information you can include for other programmers includes:

- Flowcharts and pseudocode for the program
- Comments about the program from code inspections
- A written description of the program flow
- Information about why you chose the call sequence you did, such as:
 - Did you test the call sequence using DFSDDLT0?
 - In cases where more than one combination of calls would have had the same results, why did you choose the sequence you did?
 - What was the other sequence? Did you test it using DFSDDLT0?
- Any problems you encountered in structuring or coding the program
- Any problems you had when you tested the program
- Warnings about what should not be changed in the program

All this information relates to structuring and coding the program. In addition, you should include the information described in “Documentation for Users” with the documentation for programmers.

Again, the amount of information you include and the form in which you document it depend upon you and your application. These documentation guidelines are provided as suggestions.

Documentation for Users

All the information listed in the “Documentation for Other Programmers” on page 175 relates to the design of the program. In addition to this, you should record information about how you use the program. The amount of information that users need and how much of it you should supply depends upon whom the users of the program are and what type of program it is.

At a minimum, include the following information for those who use your program:

- What one needs in order to use the program, for example:
 - For online programs, is there a password?
 - For batch programs, what is the required JCL?
- The input that one needs to supply to the program, for example:
 - For an MPP, what is the MOD name that must be entered to initially format the screen?
 - For a CICS online program, what is the CICS transaction code that must be entered? What terminal input is expected?
 - For a batch program, is the input in the form of a tape, or a disk data set? Is the input originally output from a previous job?
- The content and form of the program’s output, for example:
 - If it is a report, show the format or include a sample listing.
 - For an online application program, show what the screen will look like.
- For online programs, if decisions must be made, explain what is involved in each decision. Present the choices and the defaults.

If the people that will be using your program are unfamiliar with terminals, they will need a user’s guide also. This guide should give explicit instructions on how to use the terminal and what a user can expect from the program. The guide should contain discussions of what should be done if the task or program abends, whether the program should be restarted, or if the database requires recovery. Although you may not be responsible for providing this kind of information, you should provide any information that is unique to your application to whomever is responsible for this kind of information.

Appendix. IMS Spool API Overall Design

The IMS Spool API (application programming interface) is an expansion of the IMS application program interface that allows applications to interface directly to JES and create print data sets on the JES spool. These print data sets can then be made available to print managers and spool servers to serve the needs of the application.

This appendix describes the design of the Spool API and how an application program uses it.

In this Appendix:

- “Design Concept”
- “Performance Considerations” on page 178
- “Application Coding Considerations” on page 179

Related Reading: For more information about the Spool API, see

- *IMS Version 9: Application Programming: Transaction Manager* and
- *IMS Version 9: Application Programming: Database Manager*

Design Concept

The Spool API design provides the application program with the ability to create print data sets on the JES (job entry subsystem) spool using the standard DL/I call interface. The functions provided are:

- Definition of the data set output characteristics
- Allocation of the data set
- Insertion of lines of print into the data set
- Closing and deallocation of the data set
- Backout of uncommitted data within the limits of the JES interface
- Assistance in controlling an in-doubt print data set

The Spool API support uses existing DL/I calls to provide data set allocation information and to place data into the print data set. These calls are:

- The CHNG call. This call is expanded so that print data set characteristics can be specified for the print data set that will be allocated. The process uses the alternate PCB as the interface block associated with the print data set.
- The ISRT call. This call is expanded to perform dynamic allocation of the print data set on the first insert, and to write data to the data set. The data set is considered in-doubt until the unit of work (UOW) terminates. If possible, the sync point process deletes all in-doubt data sets for abending units of work and closes and deallocates data sets for normally terminating units of work.
- The SET0 call. This is a call, SET0 (Set Options), introduced by this support. Use this call to create dynamic output text units to be used with the subsequent CHNG call. If the same output descriptor is used for many print data sets, the overhead can be reduced by using the SET0 call to prebuild the text units necessary for the dynamic output process.

Related Reading: The use of the SET0 call is covered in more detail in *IMS Version 9: Application Programming: Transaction Manager*.

Start Up

Application programs can send data to the JES spool data sets using the same method that is used to send output to an alternate terminal. Use the DL/I call to change the output destination to a JES spool data set. Use the DL/I ISRT or PURG call to insert a message.

The options list parameter on the CHNG and SETO calls contains the data set printer processing options. These options direct the output to the appropriate Spool API data set. These options are validated for the DL/I call by the MVS™ Scheduler JCL Facility (SJF). If the options are invalid, error codes are returned to the application. To receive the error information, the application program specifies a feedback area in the CHNG or SETO DL/I call parameter list. If the feedback area is present, information about the options list error is returned directly to the application.

Performance Considerations

The Spool API interface uses MVS services within an IMS application while minimizing the performance impact of the MVS services on the other IMS transactions and services. For this reason, the spool API support places the print data directly on the JES spool at insert time instead of using the IMS message queue for intermediate storage. The processing of Spool API requests is performed under the TCB of the dependent region to ensure maximum usage of N-way processors. This design reduces the error recovery and JES job orientation problems.

JES Initiator Considerations

Because the dependent regions are normally long-running jobs, some of the initiator or job specifications might must be changed if the dependent region is using the Spool API. You might need to limit the amount of JES spool space used by the dependent region to contain the dynamic allocation and deallocation messages. For example, you can use the JOB statement MSGLEVEL to eliminate the dynamic allocation messages from the job log for the dependent region. You might be able to eliminate these messages for dependent regions executing as MVS started tasks.

Another initiator consideration is the use of the JES job journal for the dependent region. If the job step has a journal associated with it, the information for MVS checkpoint restart is recorded in the journal. Because IMS dependent regions cannot use MVS checkpoint restart, specify JOURNAL=NO for the JES2 initiator procedure and the JES3 class associated with the dependent regions execution class. You can also specify the JOURNAL= on the JES3 //MAIN statement for dependent regions executing as jobs.

Application Managed Text Units

The application can manage the dynamic descriptor text units instead of IMS. If the application manages the text units, overhead for parsing and text unit build can be reduced. Use the SETO call to have IMS build dynamic descriptor text units. After they are built, these text units can be used with subsequent CHNG calls to define the print characteristics for a data set.

To reduce overhead by managing the text units, the text units should be used with several change calls. An example of this is a wait-for-input (WFI) transaction. The same data set attributes can be used for all print data sets. For the first message processed, the application uses the SETO call to build the text units for dynamic

descriptors and a subsequent CHNG call with the TXTU= parameter referencing the prebuilt text units. For all subsequent messages, only a CHNG call using the prebuilt text units is necessary.

Be aware of the following: No testing has been done to determine the amount of overhead that might be saved using prebuilt text units.

BSAM I/O Area

The I/O area for spool messages can be very large. It is not uncommon for the area to be 32 KB in length. To reduce the overhead incurred with moving large buffers, IMS attempts to write to the spool data set from the application's I/O area. BSAM does not support I/O areas in 31-bit storage for SYSOUT files. If IMS finds that the application's I/O area is in 31-bit storage:

- A work area is obtained from 24-bit storage.
- The application's I/O area is moved to the work area.
- The spool data set is written from the work area.

If the application's I/O area can easily be placed in 24-bit storage, the need to move the I/O area can be avoided and possible performance improvements achieved.

Be aware of the following: No testing has been done to determine the amount of performance improvement possible.

Since a record can be written by BSAM directly from the application's I/O area, the area must be in the format expected by BSAM. The format must contain:

- Variable length records
- A Block Descriptor Word (BDW)
- A Record Descriptor Word (RDW)

Related Reading: For more information on the formats of the BDW and RDW, see *MVS/XA Data Administration Guide*. The format of the I/O area is described in more familiar IMS terms in *IMS Version 9: Application Programming: Transaction Manager*.

Application Coding Considerations

Your application can send data to a JES Spool or Print server using a print data set. This section describes this process and includes options for message integrity and recovering data when failures occur.

Print Data Formats

The IMS Spool API attempts to provide a transparent interface for the application to insert data to the JES spool. The data can be in line, page, IPDS™, AFPDS, or any format that can be handled by a JES Spool or Print server that processes the print data set. The IMS Spool API does not translate or otherwise modify the data inserted to the JES spool.

Message Integrity Options

The IMS Spool API provides support for message integrity. This is necessary because IMS cannot properly control the disposition of a print data set when:

- IMS abnormal termination does not execute because of a hardware or software problem.

- A dynamic deallocation error exists for a print data set.
- Logic errors are in the IMS code.

In these conditions, IMS might not be able to stop the JES subsystem from printing partial print data sets. Also, the JES subsystems do not support a two-phase sync point.

Print Disposition

The most common applications using Advanced Function Printing™ (AFP™) are TSO users and batch jobs. If any of these applications are creating print data sets when a failure occurs, the partial print data sets will probably print and be handled in a manual fashion. Many IMS applications creating print data sets can manage partial print data sets in the same manner. For those applications that need more control over the automatic printing by JES of partial print data sets, the IMS Spool API provides the following integrity options. However, these options alone might not guarantee the proper disposition of partial print data sets. These options are the **b** variable following the IAFP keyword used with the CHNG call.

b=0

Indicates no data set protection

This is probably the most common option. When this option is selected, IMS does not do any special handling during allocation or deallocation of the print data set. If this option is selected, and any condition occurs that prevents IMS from properly disposing the print data set, the partial data set probably prints and must be controlled manually.

b=1

Indicates SYSOUT HOLD protection

This option ensures that a partial print data set is not released for printing without a JES operator taking direct action. When the data set is allocated, the allocation request indicates to JES that this print data set be placed in SYSOUT HOLD status. The SYSOUT HOLD status is maintained for this data set if IMS cannot deallocate the data set for any reason. Because the print data set is in HOLD status, a JES operator must identify the partial data set and issue the JES commands to delete or print this data set.

If the print data set cannot be deleted or printed:

- Message DFS0012I is issued when a print data set cannot be deallocated.
- Message DFS0014I is issued during IMS emergency restart when an in-doubt print data set is found. The message provides information to help the JES operator find the proper print data set and effect the proper print disposition.

Some of the information includes:

- JOBNAME
- DSNAME
- DDNAME
- A recommendation on what IMS believes to be the proper disposition for the data set (for example, printing or deleting).

By using the Spool Display and Search Facility (SDSF), you can display the held data sets, identify the in-doubt print data set by DDNAME and DSNAME, and issue the proper JES command to either delete or release the print data set.

b=2

Indicates a nonselectable destination

This option prevents the automatic printing of partial print data sets. The IMS Spool API function requests a remote destination of IMSTEMP for the data set when the data set is allocated. The JES system must have a remote destination of IMSTEMP defined so that JES does not attempt to print any data sets that are sent to the destination.

If **b=2**, the name of the remote destination for the print data set must be specified in the destination name field of the call parameter list when the CHNG call is issued. When IMS deallocates the data set at sync point, and the data set prints, IMS requests that the data set be transferred to the requested final remote destination.

If the remote destination is not defined to the JES system, a dynamic allocation failure occurs. Because this remote destination is defined as nonselectable, and if IMS is unable to deallocate the print data set and control its proper disposition, the print data set remains associated with remote destination IMSTEMP when deallocated by MVS.

When an deallocation error occurs, message DFS0012I is issued to provide details of the deallocation error and help identify the print data set that requires operator action. When partial print data sets are left on this special remote destination, the JES operator can display all the print data sets associated with this JES destination to locate the data set that requires action. The **b=2** option simplifies the operator's task of locating partial print data sets.

Message Options

The third option on the IAFP keyword controls informational messages issued by the IMS Spool API support. These messages inform the JES operator of in-doubt data sets that need action.

c=0

Indicates that no DFS0012I or DFS0014I messages are issued for the print data set. You can specify **c=0** only if **b=0** is specified.

c=m

Indicates that DFS0012I and DFS0014I messages are issued if necessary. You can specify **c=m** or if **b=1** or if **b=2**, it is the default.

Option **c** does not affect issuing message DFS0013E.

IMS Emergency Restart: When IMS emergency restart is performed, DFS0014I messages might be issued if IMS finds that the proper disposition of a print data set is in-doubt, as a result of the restart. This message is only issued if the message option for the print data set was requested or **c=m** on the IAFP variable. When a DFS0014I message is received, a JES operator might need to find and properly dispose of the print data set. The DFS0014I message provides a recommended disposition (that is, deletion or printing).

Destination Name (LTERM) usage

The standard CHNG call parameter list contains a destination name field. For traditional message calls, this field contains the LTERM or transaction code that becomes the destination of messages sent via this alternate PCB. When ISRT calls are issued against the PCB, the data is sent to the LTERM or transaction.

However, the destination name field has no meaning to the IMS Spool API function unless **b=2** is specified following the IAFP keyword.

When **b=2** is specified:

- The name must be a valid remote destination supported by the JES system that receives the print data sets.
- If the name is not a valid remote destination, an error occurs during dynamic deallocation.

If any option other than **2** is selected, the name is not used by IMS.

The LTERM name appears in error messages and log records. Use a name that identifies the routine creating the print data set. This information can aid in debugging application program errors.

Notices

This information was developed for products and services offered in the U.S.A. IBM may not offer the products, services, or features discussed in this document in other countries. Consult your local IBM representative for information on the products and services currently available in your area. Any reference to an IBM product, program, or service is not intended to state or imply that only that IBM product, program, or service may be used. Any functionally equivalent product, program, or service that does not infringe any IBM intellectual property right may be used instead. However, it is the user's responsibility to evaluate and verify the operation of any non-IBM product, program, or service.

IBM may have patents or pending patent applications covering subject matter described in this document. The furnishing of this document does not give you any license to these patents. You can send license inquiries, in writing, to:

IBM Director of Licensing
IBM Corporation
North Castle Drive
Armonk, NY 10504-1785
U.S.A.

For license inquiries regarding double-byte (DBCS) information, contact the IBM Intellectual Property Department in your country or send inquiries, in writing, to:

IBM World Trade Asia Corporation
Licensing
2-31 Roppongi 3-chome, Minato-ku
Tokyo 106, Japan

The following paragraph does not apply to the United Kingdom or any other country where such provisions are inconsistent with local law:

INTERNATIONAL BUSINESS MACHINES CORPORATION PROVIDES THIS PUBLICATION "AS IS" WITHOUT WARRANTY OF ANY KIND, EITHER EXPRESS OR IMPLIED, INCLUDING, BUT NOT LIMITED TO, THE IMPLIED WARRANTIES OF NON-INFRINGEMENT, MERCHANTABILITY OR FITNESS FOR A PARTICULAR PURPOSE. Some states do not allow disclaimer of express or implied warranties in certain transactions, therefore, this statement may not apply to you.

This information could include technical inaccuracies or typographical errors. Changes are periodically made to the information herein; these changes will be incorporated in new editions of the publication. IBM may make improvements and/or changes in the product(s) and/or the program(s) described in this publication at any time without notice.

Any references in this information to non-IBM Web sites are provided for convenience only and do not in any manner serve as an endorsement of those Web sites. The materials at those Web sites are not part of the materials for this IBM product and use of those Web sites is at your own risk.

IBM may use or distribute any of the information you supply in any way it believes appropriate without incurring any obligation to you.

Licensees of this program who wish to have information about it for the purpose of enabling: (i) the exchange of information between independently created programs

and other programs (including this one) and (ii) the mutual use of the information which has been exchanged, should contact:

IBM Corporation
J46A/G4
555 Bailey Avenue
San Jose, CA 95141-1003
U.S.A.

Such information may be available, subject to appropriate terms and conditions, including in some cases, payment of a fee.

The licensed program described in this information and all licensed material available for it are provided by IBM under terms of the IBM Customer Agreement, IBM International Program License Agreement, or any equivalent agreement between us.

Any performance data contained herein was determined in a controlled environment. Therefore, the results obtained in other operating environments may vary significantly. Some measurements may have been made on development-level systems and there is no guarantee that these measurements will be the same on generally available systems. Furthermore, some measurement may have been estimated through extrapolation. Actual results may vary. Users of this document should verify the applicable data for their specific environment.

Information concerning non-IBM products was obtained from the suppliers of those products, their published announcements or other publicly available sources. IBM has not tested those products and cannot confirm the accuracy of performance, compatibility or any other claims related to non-IBM products. Questions on the capabilities of non-IBM products should be addressed to the suppliers of those products.

All statements regarding IBM's future direction or intent are subject to change or withdrawal without notice, and represent goals and objectives only.

This information is for planning purposes only. The information herein is subject to change before the products described become available.

This information contains examples of data and reports used in daily business operations. To illustrate them as completely as possible, the examples include the names of individuals, companies, brands, and products. All of these names are fictitious and any similarity to the names and addresses used by an actual business enterprise is entirely coincidental.

COPYRIGHT LICENSE:

This information contains sample application programs in source language, which illustrates programming techniques on various operating platforms. You may copy, modify, and distribute these sample programs in any form without payment to IBM, for the purposes of developing, using, marketing or distributing application programs conforming to the application programming interface for the operating platform for which the sample programs are written. These examples have not been thoroughly tested under all conditions. IBM, therefore, cannot guarantee or imply reliability, serviceability, or function of these programs. You may copy, modify, and distribute these sample programs in any form without payment to IBM for the purposes of developing, using, marketing, or distributing application programs conforming to IBM's application programming interfaces.

Each copy or any portion of these sample programs or any derivative work, must include a copyright notice as follows:

© (your company name) (year). Portions of this code are derived from IBM Corp. Sample Programs. © Copyright IBM Corp. _enter the year or years_. All rights reserved.

If you are viewing this information softcopy, the photographs and color illustrations may not appear.

Programming Interface Information

This book is intended to help the programmer design application programs. This book primarily documents General-use Programming Interface and Associated Guidance Information provided by IMS.

General-use programming interfaces allow the customer to write programs that obtain the services of IMS.

However, this book also documents Product-sensitive Programming Interface and Associated Guidance Information and Diagnosis, Modification or Tuning Information provided by IMS.

Product-sensitive programming interfaces allow the customer installation to perform tasks such as diagnosing, modifying, monitoring, repairing, tailoring, or tuning of IMS. Use of such interfaces creates dependencies on the detailed design or implementation of the IBM software product. Product-sensitive programming interfaces should be used only for these specialized purposes. Because of their dependencies on detailed design and implementation, it is to be expected that programs written to such interfaces may need to be changed to run with new product releases or versions, or as a result of service.

Product-sensitive Programming Interface and Associated Guidance Information is identified where it occurs, either by an introductory statement to a chapter or section or by the following marking:

Product-sensitive programming interface
Product-sensitive Programming Interface and Associated Guidance Information...
End of Product-sensitive programming interface

Diagnosis, Modification or Tuning Information is provided to help the programmer perform tasks such as diagnosing, modifying, monitoring, repairing, tailoring, or tuning of IMS.

Attention: Do not use this Diagnosis, Modification or Tuning Information as a programming interface.

Diagnosis, Modification or Tuning Information is identified where it occurs, either by an introductory statement to a chapter or section or by the following marking:

Product-sensitive programming interface

Diagnosis, Modification or Tuning Information...

End of Product-sensitive programming interface

Trademarks

The following terms are trademarks of the IBM Corporation in the United States or other countries or both:

Advanced Function Printing	Language Environment
AFP	MVS
BookManager	MVS/ESA
C/MVS	MVS/XA
CICS	OS/2
DATABASE 2	OS/390
DB2	RACF
IBM	VisualGen
IMS	VTAM
IPDS	z/OS
Language Reader	

Java and all Java-based trademarks and logos are trademarks or registered trademarks of Sun Microsystems, Inc., in the United States, other countries, or both.

Other company, product, and service names, which may be denoted by a double asterisk (**), may be trademarks or service marks of others.

Product Names

In this book, the following licensed programs have shortened names:

- “C/C++ for MVS/ESA” is referred to as either “C/MVS” or “C++/MVS”.
- “COBOL for MVS & VM” is referred to as “COBOL”.
- “DB2 for MVS/ESA” is referred to as “DB2”.
- “IBM DataAtlas for OS/2” is referred to as “DataAtlas”.
- “Language Environment for MVS & VM” is referred to as “Language Environment”.
- “PL/I for MVS & VM” is referred to as “PL/I”.

Bibliography

This bibliography includes all the publications cited in this book, including the publications in the IMS library.

BTS Program Reference/Operations Manual, SH20-5523

CICS Application Programming Guide, SC34-5993

CICS Application Programming Reference, SC34-5994

CICS IMS Database Control Guide, SC34-6010

CICS Transaction Server for z/OS Version 2.2 Information Center, SK3T-6945

CICS Messages and Codes, GC34-6003

CICS Recovery and Restart Guide, SC34-6008

Common Programming Interface Communications Reference, SC26-4399

DB2 UDB for z/OS and OS/390 Application Programming and SQL Guide, SC26-9933

VisualGen V2R0.0 Introducing, GH23-6570

MVS/XA Data Administration Guide, GC26-4140

Enterprise PL/I for z/OS and OS/390 Programming Guide, SC27-1457

OS/VS DB/DC Data Dictionary Applications Guide, SH20-9190

Systems Network Architecture: LU 6.2 Reference: Peer Protocols, SC31-6808

Systems Network Architecture: Transaction Programmer's Reference Manual for LU Type 6.2, GC30-3084

VisualGen: Running Applications on MVS, SH23-6550

SAA CPI Resource Recovery Reference, SC31-6821

ZES1-2334	APDG	<i>IMS Version 9: Application Programming: Design Guide</i>
ZES1-2335	APCICS	<i>IMS Version 9: Application Programming: EXEC DLI Commands for CICS and IMS</i>
ZES1-2336	APTM	<i>IMS Version 9: Application Programming: Transaction Manager</i>
ZES1-2337	BPE	<i>IMS Version 9: Base Primitive Environment Guide and Reference</i>
ZES1-2356	CR	<i>IMS Version 9: Command Reference</i>
ZES1-2338	CQS	<i>IMS Version 9: Common Queue Server Guide and Reference</i>
ZES1-2339	CSL	<i>IMS Version 9: Common Service Layer Guide and Reference</i>
ZES1-2340	CG	<i>IMS Version 9: Customization Guide</i>
ZES1-2341	DBRC	<i>IMS Version 9: DBRC Guide and Reference</i>
ZES1-2342	DGR	<i>IMS Version 9: Diagnosis Guide and Reference</i>
ZES1-2343	FAST	<i>IMS Version 9: Failure Analysis Structure Tables (FAST) for Dump Analysis</i>
ZES1-2345	OLR	<i>IMS Version 9: HALDB Online Reorganization Guide and Reference</i>
ZES1-2346	JGR	<i>IMS Version 9: IMS Java Guide and Reference</i>
ZES1-2347	IIV	<i>IMS Version 9: Installation Volume 1: Installation Verification</i>
ZES1-2348	ISDT	<i>IMS Version 9: Installation Volume 2: System Definition and Tailoring</i>
ZES1-2349	INTRO	<i>IMS Version 9: An Introduction to IMS</i>
ZES1-2351	MIG	<i>IMS Version 9: Master Index and Glossary</i>
ZES1-2352	MC1	<i>IMS Version 9: Messages and Codes, Volume 1</i>
ZES1-2353	MC2	<i>IMS Version 9: Messages and Codes, Volume 2</i>
ZES1-2354	OTMA	<i>IMS Version 9: Open Transaction Manager Access Guide and Reference</i>
ZES1-2355	OG	<i>IMS Version 9: Operations Guide</i>
GC17-7831	RPG	<i>IMS Version 9: Release Planning Guide</i>

IMS Version 9 Library

ZES1-2330	ADB	<i>IMS Version 9: Administration Guide: Database Manager</i>
ZES1-2331	AS	<i>IMS Version 9: Administration Guide: System</i>
ZES1-2332	ATM	<i>IMS Version 9: Administration Guide: Transaction Manager</i>
ZES1-2333	APDB	<i>IMS Version 9: Application Programming: Database Manager</i>

ZES1-2359	URDBTM	<i>IMS Version 9: Utilities Reference: Database and Transaction Manager</i>
ZES1-2360	URS	<i>IMS Version 9: Utilities Reference: System</i>

Supplementary Publications

GC17-7825	LPS	<i>IMS Version 9: Licensed Program Specifications</i>
ZES1-2357	SOC	<i>IMS Version 9: Summary of Operator Commands</i>

Publication Collections

LK3T-7213	CD	IMS Version 9 Softcopy Library
LK3T-7144	CD	IMS Favorites
LBOF-7789	Hardcopy and CD	Licensed Bill of Forms (LBOF): IMS Version 9 Hardcopy and Softcopy Library
SBOF-7790	Hardcopy	Unlicensed Bill of Forms (SBOF): IMS Version 9 Unlicensed Hardcopy Library
SK2T-6700	CD	OS/390 Collection
SK3T-4270	CD	z/OS Software Products Collection
SK3T-4271	DVD	z/OS and Software Products DVD Collection

Accessibility Titles Cited in this Book

SA22-7787		z/OS V1R1.0 TSO Primer
SA22-7794		z/OS V1R1.0 TSO/E User's Guide
SC34-4822		z/OS V1R1.0 ISPF User's Guide, Volume 1

Index

A

abend codes
 pseudo- 45
 S201 134
 U0069 47
 U0777 39
 U1008 43
 U119 125
 U2478 39
 U2479 39
 U261 134
 U3301 44
 U3303 39
 U476 134
 U711 97, 126

access methods
 DEDB 71
 description 67
 GSAM 74
 HDAM 69
 HIDAM 70
 HISAM 73
 HSAM 72
 MSDB 71
 PHDAM 67, 69
 PHIDAM 67, 70
 SHISAM 74
 SHSAM 74

access of
 IMS databases through MVS 74
 segments through different paths 80

Advanced Function Printing (AFP) 180

AFPDS and IMS Spool API 179

aggregates, data 16

AIB interface 6

AIBTDLI interface 47

allocation, dynamic 47

alternate PCBs 99

alternate response PCBs 99

analysis of
 processing requirements 27
 required application data 11
 user requirements 9

anchor point, root 69

API (application programming interface) for LU 6.2
 devices
 explicit API 113
 implicit API 112

APPC
 application program types for LU 6.2 devices 104
 APSB (allocate program specification block) 135
 basic conversation 106
 description 103
 DPSB (deallocate program specification block) 136
 LU 6.2 partner program design
 DFSAPPC message switch 131
 flow diagrams 113, 122

APPC (*continued*)
 LU 6.2 partner program design (*continued*)
 integrity after conversation completion 129
 mapped conversation 106
 RRS/MVS 133

application data
 analyzing required 11
 identifying 11

application design
 analyzing
 processing requirements 49
 the data a program must access 51
 user requirements 9, 11
 data dictionary, using 15
 DataAtlas 15
 DB/DC Data Dictionary 15
 debugging 182
 designing a local view 16
 documenting 10, 176
 overview 9
 Spool API interface 177

application program 109
 documentation 176
 test 139, 161
 TSO 41

application programming interface (API) 112

APSB (allocate program specification block) 113, 135

area, I/O 6

association, data 3

asynchronous conversation, description for LU 6.2
 transactions 106

AUTH call 92

authorization
 ID, DB2 92
 security 92

availability of data 5, 45, 63

B

back-out database changes 62

backout, dynamic 32

basic checkpoint 42, 60, 62

basic conversation, APPC 106

basic edit, overview of 94

Batch Backout utility 32

batch environment 30

batch message processing program.
 See BMP (batch message processing) program

batch programs
 converting to BMPs 35, 55
 databases that can be accessed 28, 51
 DB batch processing 31
 description 54
 differences from online 31, 54
 I/O PCB, requesting during PSBGEN 59
 issuing checkpoints 44, 59
 recovery 32, 59
 recovery of database 62

Batch Terminal Simulator II (BTS II) 140
 batch-oriented BMPs. 36
 BKO execution parameter 32
 block descriptor word (BDW), IMS Spool API 179
 BMP (batch message processing) program 36
 batch-oriented 36
 checkpoints in 43, 59
 converting batch programs to BMPs 55
 databases that can be accessed 35, 55
 description of 35, 55
 limiting number of locks with LOCKMAX=
 parameter 44
 recovery 35, 56
 databases that can be accessed 30, 51
 transaction-oriented
 checkpoints in 43
 databases that can be accessed 36
 recovery 37
 BTS II (Batch Terminal Simulator II) 140
 buffer pool, STAT call and OSAM 145
 buffer subpool, statistics for debugging
 enhanced STAT call and
 OSAM 149
 VSAM 147, 155

C

C/MVS 47
 CALL statement (DL/I test program) 140
 call-level programs, scheduling a PSB 57
 calls, DL/I 6
 CCTL (coordinator controller)
 restrictions
 when you encounter a problem 159
 with BTS II (Batch Terminal Simulator II) 140
 with DL/I test program 139
 with image capture 164
 checkpoint 60
 basic 41, 60
 calls, when to use 42
 frequency, specifying 44, 61
 IDs 60
 in batch programs 44, 61
 in batch-oriented BMPs 43, 61
 in MPPs 43
 in transaction-oriented BMPs 43
 issuing 31
 printing log records 61
 restart 43, 62
 summary of 41
 symbolic 41, 60
 CHKP (checkpoint) 41
 CHKPT=EOV 42
 CHNG system service call 177
 CICS 6
 CICS dump control 162
 CIMS 134
 classes schedule, example 23
 CMPAT=YES PSB specification 32
 COBOL 47

code
 course 12
 transaction 33
 codes abend 39
 commands, EXEC DLI 6
 COMMENTS statement 140
 commit points 31, 38
 commit points. 60
 COMPARE statement 140
 comparison of symbolic CHKP and basic CHKP 41
 concurrent access to full-function databases 31
 considerations in screen design 95
 CONTINUE-WITH-TERMINATION indicator 47
 continuing a conversation 96
 control, passing processing 6
 conventions, naming 9
 conversation attributes
 asynchronous 106
 MSC synchronous and asynchronous 106
 synchronous 105
 conversation state, rules for APPC verbs 107
 conversational mode
 description 100
 LU 6.2 transactions 105
 conversational processing
 abnormal termination of, precautions for 98
 deferred program switch 96
 designing a conversation 96
 DFSCONE0 98
 gathering requirements 95
 how to continue the conversation 96
 how to end the conversation 97
 immediate program switch 97
 overview 95
 passing the conversation to another program 96
 recovery considerations 98
 SPA 97
 use with alternate response PCBs 100
 using a deferred program switch to end the
 conversation 97
 what happens in a conversation 96
 conversations, preventing abnormal termination 98
 converting an existing application 10
 coordinator controller.
 See CCTL (coordinator controller)
 coordinator, sync-point 109
 course code 12
 CPI Communications driven application program for LU
 6.2 devices 104
 creation of
 a new hierarchy 79
 reports 15
 currency of data 2, 3
 current roster 11

D

data
 a program's view 4
 aggregate 16
 association 3

- data (*continued*)
 - documentation 14
 - elements, homonym 14
 - elements, isolating repeating 17
 - elements, naming 13
 - hierarchical relationships 3
 - integrity, how DL/I protects 59
 - keys 20
 - recording its availability 15
 - relationships, analyzing 16
 - structuring 16
 - unique identifier 14
- data availability
 - considerations 45, 63
 - levels 5
 - recording 15
- data currency 2, 3
- data definition 10
- data dictionary
 - DataAtlas 15, 175
 - DB/DC Data Dictionary 15, 175
 - documentation for other programmers 175
 - in application design 15
- data element
 - description 11
 - homonym 14
 - isolating repeating 17
 - listing 11
 - naming 13
 - synonym 13
- data elements, grouping into hierarchies 16
- data entity 11
- data entry database 30
- data mask 6
- data redundancy 1
- data sensitivity 4
- data sensitivity, defined 83
- data storage methods
 - combined file 2
 - in a database 2
 - separate files 1
- data structure 5
- data structure conflicts, resolving 74
- DataAtlas 15, 175
- database
 - access to 51
 - changes, backing out 62
 - description (DBD) 4
 - hierarchy 3
 - options 67
 - record, processing 6
 - recovery 59
 - unavailability 45, 63
- database and data communications security 10
- DATABASE macro 87
- database record 4
- database recovery
 - backing out database changes 62
 - checkpoints, description 59
 - restarting your program, description 62
- Database Resource Adapter (DRA) 133
- database statistics, retrieving 145
- database types
 - areas 30
 - DB2 30, 52
 - DEDB 30, 71
 - description 30
 - Fast Path 30
 - full-function 30
 - GSAM 31, 74
 - HDAM 69, 70
 - HISAM 73
 - HSAM 72
 - MSDB 30, 71
 - PHDAM 67, 69
 - PHIDAM 67, 70
 - relational 30
 - root-segment-only 30
 - SHISAM 74
 - SHSAM 74
- DB batch processing 31
- DB Control
 - DRA (Database Resource Adapter) 135
- DB Control DRA (Database Resource Adapter) 133
- DB PCB (database program communication block) 4
- DB/DC
 - Data Dictionary 15, 175
 - environment 30
- DB2
 - databases 30, 52
 - security 92
- DBASF, formatted OSAM buffer pool statistics 145
- DBASS, formatted summary of OSAM buffer pool statistics 146
- DBASU, unformatted OSAM buffer pool statistics 146
- DBCTL environment 30, 51
- DBCTLID parameter 135
- DBD (database description) 4
- DBESF, formatted OSAM subpool statistics 150
- DBESO, formatted OSAM pool online statistics 153
- DBESS, formatted summary of OSAM pool statistics 152
- DBESU, unformatted OSAM subpool statistics 151
- DCCTL environment 30
- deadlock, program 32
- debug a program, how to 159
- debug a program, How to 166
- DEDB (data entry database) 71
- DEDB (data entry database) and the PROCOPT operand 87
- deferred program switch 96
- definition
 - data 10
 - dependent segment 4
 - root segment 4
- dependent segment 4
- dependents
 - direct 30
 - sequential 30
- description, segment 3
- design of
 - an application 9

- design of (*continued*)
 - conversation 96
 - local view 16
 - designing
 - terminal screen 95
 - determination of mappings 21
 - device input format (DIF), control block 94
 - device output format (DOF), control block 94
 - DFSAPPC message switch 131
 - DFSCONE0 (Conversational Abnormal Termination exit routine) 98
 - DFSDDLTO (DL/I test program) 139
 - DFSDLTRO (DL/I image capture).
 - See DL/I image capture (DFSDLTRO) programs
 - DFSERA10 utility 166
 - DFSERA50 exit routine 166
 - DFSMDA macro 47
 - DIB (DLI interface block) 6
 - dictionary, data 15
 - DIF (device input format), control block 94
 - direct access methods
 - characteristics 68
 - HDAM 69
 - HIDAM 70
 - PHDAM 67, 69
 - PHIDAM 67, 70
 - types of 68
 - direct dependents 30
 - distributed commit calls
 - ATRBAC 136
 - ATRCMIT 136
 - RRS/MVS 136
 - SRRBACK 136
 - SRRCMIT 136
 - Distributed Sync Point 108
 - DL/I access methods
 - considerations in choosing 67
 - DEDB 71
 - direct access 68
 - GSAM 74
 - HDAM 69
 - HIDAM 70
 - HISAM 73
 - HSAM 72
 - MSDB 71
 - PHDAM 67, 69
 - PHIDAM 67, 70
 - sequential access 72
 - SHISAM 74
 - SHSAM 74
 - DL/I call trace 140
 - DL/I calls 6
 - DL/I calls, testing DL/I call sequences 139, 162
 - DL/I database
 - access to 51
 - description 51
 - DL/I image capture (DFSDLTRO) programs 163
 - DL/I options
 - field level sensitivity 75
 - logical relationships 79
 - secondary indexing 76
 - DL/I test program (DFSDDLTO)
 - call statements 140
 - checking program performance 140
 - comments statements 140
 - compare statements 140
 - control statements 140
 - description 140
 - status statements 140
 - testing DL/I call sequences 139, 162
 - DLITRACE control statement 164
 - documentation for users 176
 - documentation of
 - data 14
 - the application design process 10
 - DOF (device output format), control block 94
 - DPSB (deallocate program specification block) 136
 - DRA (Database Resource Adapter)
 - description 133
 - startup table 135
 - dump control, CICS 162
 - duplicate values, isolating 19
 - dynamic allocation 47, 65
 - dynamic backout 32
- ## E
- EBCDIC 60
 - EDF (Execution Diagnostic Facility) 162
 - editing
 - considerations in your application 94
 - messages
 - considerations in message and screen design 94
 - overview 93
 - elements
 - data, description 11
 - data, naming 13
 - emergency restart 181
 - EMH (expedited message handler) 34
 - end a conversation, how to 97
 - enhanced STAT call formats for statistics
 - OSAM buffer subpool 149
 - VSAM buffer subpool 155
 - entity, data 11
 - environments
 - DB/DC 30
 - DBCTL 30
 - DCCTL 30
 - options in 30, 51
 - program and database types 28
 - ERASE parameter 86
 - error
 - execution 159, 167
 - initialization 159, 167
 - ESTAE routines 46
 - example
 - current roster 11
 - field level sensitivity 75
 - instructor schedules 25
 - instructor skills report 24
 - local view 22

example (*continued*)
 logical relationships 80
 schedule of classes 23
 EXEC DLI commands 6
 Execution Diagnostic Facility (EDF) 162
 execution errors 159, 167
 existing application, converting an 10
 explicit API for LU 6.2 devices 113
 express PCBs 101
 Extended Restart 41, 62

F

Fast Path
 databases 30
 DEDB (data entry database) 71
 DEDB and the PROCOPT operand 87
 IFPs 34
 MSDB (main storage database) 30, 71
 field level sensitivity
 as a security mechanism 85
 defining 6
 description 75
 example 75
 specifying 76
 uses 75
 File Select and Formatting Print Program
 (DFSERA10) 42
 flow diagrams, LU 6.2
 CPI-C driven commit scenario 124
 DFSAPPC, synchronous SL=none 117
 DL/I program backout scenario 125, 126
 DL/I program commit scenario 123
 DL/I program ROLB scenario 126
 local CPI communications driven program,
 SL=none 118
 local IMS Command
 asynchronous SL=confirm 117
 local IMS command, SL=none 116
 local IMS conversational transaction, SL=none 116
 local IMS transaction
 asynchronous SL=confirm 115
 asynchronous SL=none 115
 synchronous SL=confirm 114
 synchronous SL=none 114
 multiple transactions in same commit 128
 remote MSC conversation
 asynchronous SL=confirm 121
 asynchronous SL=none 120
 synchronous SL=confirm 122
 synchronous SL=none 119
 frequency, checkpoint 44
 full-function databases
 and the PROCOPT operand 87
 how accessed, CICS 51
 how accessed, IMS 30

G

gather requirements
 for conversational processing 95

gather requirements
 for database options 67
 for message processing options 91
 Generalized Sequential Access Method (GSAM) 74
 GO processing option 43
 group data elements
 into hierarchies 16
 with their keys 20
 GSAM (Generalized Sequential Access Method)
 accessing GSAM databases 51
 database type 31
 description 74

H

HALDB (High Availability Large Database) 77
 HDAM (Hierarchical Direct Access Method) 69
 HIDAM (Hierarchical Indexed Direct Access
 Method) 70
 Hierarchical Direct Access Method (HDAM) 69
 Hierarchical Indexed Direct Access Method
 (HIDAM) 70
 Hierarchical Indexed Sequential Access Method
 (HISAM) 73
 Hierarchical Sequential Access Method (HSAM) 72
 hierarchy
 description 3
 grouping data elements 16
 High Availability Large Database (HALDB) 77
 HISAM (Hierarchical Indexed Sequential Access
 Method) 73
 homonym, data element 14
 HSAM (Hierarchical Sequential Access Method) 72

I

I/O area 6
 I/O PCB
 in different environments 53
 requesting during PSBGEN 59
 identification of
 recovery requirements 43
 identifying
 application data 11
 online security requirements 91
 output message destinations 99
 security requirements 83
 IDs, checkpoint 60
 IFP (IMS Fast Path) program
 databases that can be accessed 30
 differences from an MPP 34
 recovery 34
 restrictions 34
 image capture program
 CICS application program 163
 IMS application program 140
 immediate program switch 97
 implicit API for LU 6.2 devices 112
 IMS Fast Path (IFP) programs, description of 34
 INIT system service call 46
 initialization errors 159, 167

INQY system service call 46
 instructor
 schedules 25
 skills report 24
 integrity
 how DL/I protects data 59
 read without 87
 interface, AIB 6
 Introduction to Resource Recovery 108
 invalid processing and ROLB/SETS/ROLLS calls 98
 IPDS and IMS Spool API 179
 ISC (Intersystem Communication) 34
 isolation of
 duplicate values 19
 repeating data elements 17
 ISRT system service call 177
 issue checkpoints 31

J

Java Batch Processing (JBP)
 applications 38
 databases that can be accessed 30
 Java Message Processing (JMP)
 applications 38
 databases that can be accessed 30
 JBP (Java Batch Processing)
 applications 38
 databases that can be accessed 30
 JES Spool/Print server 179
 JMP (Java Message Processing)
 applications 38
 databases that can be accessed 30
 JOURNAL parameter 178

K

key sensitivity 85
 keys, data 20

L

limit access with signon security 91
 link to another online program 57
 LIST parameter 141
 listing data elements 11
 local view
 designing 16
 examples 22
 locking protocol 86
 LOCKMAX= parameter, BMP programs 44
 LOG call
 description 158
 use in monitoring 166
 log records
 type 18 61
 X'18' 42
 LOG system service call 172
 log, system 32
 logical relationships
 defining 82

logical relationships (*continued*)
 description 79
 example 80
 LTERM, local and remote 131
 LU 6.2 devices, signon security 91
 LU 6.2 partner program design
 DFSAPPC message switch 131
 flow diagrams 113
 integrity after conversation completion 129
 scenarios 122

M

macros
 DATABASE 87
 DFSMDA 47
 TRANSACT 37
 main storage database (MSDB) 71
 many-to-many mapping 22
 mapped conversation, APPC 107
 mappings, determining 21
 mask, data 6
 message
 input descriptor (MID), control block 94
 output 99
 output descriptor (MOD), control block 94
 processing options 91
 methods of data storage
 combined file 2
 database 2
 separate files 1
 MFS (Message Format Service)
 control blocks 94
 overview 94
 MID (message input descriptor), control block 94
 MOD (message output descriptor), control block 94
 mode
 multiple 43
 processing 40
 response 99
 single 43
 MODE parameter 40
 MPP (message processing program)
 databases that can be accessed 30, 33
 description 33
 executing 33
 MSDB (main storage database) 30, 71
 multiple mode 39, 43
 MVS files
 access to 31, 51
 description 52
 MVS Scheduler JCL Facility (SJF) 178

N

names of data elements 13
 naming conventions 9
 NDM (Non-Discardable Messages) routine 39
 network-qualified LU name 131
 NOSTAE and NOSPIE 47

O**ODBA**

- application execution environment
 - establishing 134, 137
- application programs
 - testing 169
 - writing 133
- APSB (allocate program specification block) 135
- CIMS 134
- DB2 Stored Procedures 137
- DPSB (deallocate program specification block) 136
- DRA (Database Resource Adapter) 133, 135
- RRS/MVS 133
 - server program 137
- ODBA (Open Database Access) 133
- one-to-many mapping 21
- online processing
 - databases that can be accessed 51
 - description 52, 53
 - linking and passing control to other applications 57
 - performance, maximizing 58
- online programs 33
- online security
 - password security 92
 - supplying information about your application 93
 - terminal 91
- OSAM buffer pool, retrieving statistics 145
- output messages, identifying destinations for 99

P**parameters**

- BKO 32
- DBCTLID 135
- ERASE 86
- JOURNAL 178
- LIST 141
- LOCKMAX 44
- MODE 40
- PROCOPT 85
- RTRUNC 98
- TRANSACT 40
- XTU 179
- WFI 37
- Partitioned Hierarchical Direct Access Method (PHDAM) 67, 69
- Partitioned Hierarchical Indexed Direct Access Method (PHIDAM) 67, 70
- Partitioned Secondary Index (PSINDEX) 77
- pass control of processing 6
- pass control to other applications 57
- password security 92, 93
- PCB (program communication block)
 - call 57
 - description 4
 - express 101
- performance
 - impact 178
 - maximizing online 58

- PHDAM (Partitioned Hierarchical Direct Access Method) 67, 69
- PHIDAM (Partitioned Hierarchical Indexed Direct Access Method) 67, 70
- physical structure of a database 4
- PL/I language 47
- position, reestablishing with checkpoint calls 43, 60
- primarily sequential processing 73
- print checkpoint log records, how to 61
- problem determination 159, 167
- process database records 6
- process of requests 6
- process of requirements, analyzing 27, 49
- processing mode 40
- processing options
 - A (all) 85
 - D (delete) 85
 - defined 83
 - E (exclusive) 86
 - G (get)
 - description and concurrent record access 86
 - general description 85
 - GO (read only)
 - description 87
 - invalid pointers and T and N options 87
 - N option 87
 - risks of GOx options 87
 - T option 87
 - I (insert) 85
 - K (key) 85
 - R (replace) 85
- PROCOPT parameter 85
- PROCOPT=GO 42
- program communication block (PCB) 4
- program deadlock 32
- program sensitivity 45
- program specification block (PSB) 4
- program switch
 - deferred 96
 - immediate 97
- program test 139
- program types, environments and database types 28
- program waits 43
- programs
 - DL/I image capture 163
 - DL/I test 139, 163
 - online 33
 - TM batch 32
- protected resources 108
- protocol, locking 86
- PSB (program specification block)
 - APSB (allocate program specification block) 113, 135
 - CMPAT=YES 32
 - description 4
 - DPSB (deallocate program specification block) 136
 - scheduling in a call-level program 57
- pseudo-abend 45
- PSINDEX (Partitioned Secondary Index) 77
- PURG system service call 178

Q

QC status code 37
 quantitative relationship between data aggregates 21

R

read access, specify with PROCOPT operand 85
 read without integrity 87
 read-only access, specify with PROCOPT operand 87
 record
 database processing 6
 database, description of 4
 record descriptor word (RDW), IMS Spool API 179
 recording
 data availability 15
 information about your program 175
 recoverable resources 108
 recovery
 considerations in conversations 98
 I/O PCB, requesting during PSBGEN 59
 identifying requirements 43
 in a batch-oriented BMP 35, 56
 in batch programs 32
 recovery of databases 62
 Recovery process
 distributed 110
 local 109
 Recovery, Resource 108
 redundant data 1
 reestablish position in database 43
 relational databases 30
 relationships
 between data elements 16
 data, hierarchical 3
 defining logical 82
 mapping data 22
 relationships between data aggregates 21
 remote DL/I 51
 repetitive data elements, isolating 17
 reply to the terminal in a conversation 96
 report of instructor schedules 25
 reports, creating 15
 requests, processing 6
 required application data, analyzing 11
 requirements, analyzing processing 27
 resolving data structure conflicts 74
 resource managers 109
 Resource Recovery
 application program 109
 Introduction to 108
 protected resources 108
 recoverable resources 108
 resource managers 109
 sync-point manager 109
 Resource Recovery Services/Multiple Virtual Storage (RRS/MVS)
 introduction to 108
 ODBA interface 133
 resources
 protected 108

resources (*continued*)
 recoverable 108
 security 9
 response mode, description 99
 restart your program
 code for, description 62
 with basic CHKP 43
 with symbolic CHKP 43
 restart, emergency 181
 Restart, Extended 41, 62
 retrieval of IMS database statistics 145
 RETRY option 47
 risks to security, combined files 2
 ROLB system service call 32, 62
 ROLL system service call 62
 ROLS system service call 32, 46, 64
 root anchor point 69
 root segment, definition 4
 roster, current 12
 routines
 DFSERA50 166
 ESTAE 46
 STAE 46
 RRS/MVS (Resource Recovery Services/Multiple Virtual Storage) 113, 133
 RTRUNC parameter 98

S

schedule a PSB, in a call-level program, how to 57
 schedule, classes example 23
 screen design considerations 95
 SDSF (Spool Display and Search Facility) 180
 secondary indexing
 description 76
 examples of uses 77
 Partitioned Secondary Index (PSINDEX) 77
 specifying 78
 security
 and the PROCOPT= operand 85
 database 83, 85
 field level sensitivity 85
 identifying online requirements 91
 key sensitivity 85
 of databases and data communications 10
 of resources 9
 password security 92
 risks of combined files 2
 segment sensitivity 84
 signon 91
 supplying information about your application 93
 terminal 91
 segment
 description 3
 preventing access to by other programs 59
 sensitivity 84
 sensitivity
 data 4
 field level 6, 85
 general description 83
 key 85

sensitivity (*continued*)
 program 45
 segment 84

sequential access methods
 characteristics of 72
 HISAM 73
 HSAM 72
 types of 72

sequential dependents 30

sequential processing only 72

SETO system service call 177

SETS system service call 32, 46, 64

SETU system service call 64

shared queues option 92

SHISAM (Simple Hierarchical Indexed Sequential Access Method) 74

SHSAM (Simple Hierarchical Sequential Access Method) 74

signon security 91, 93

simple HISAM (SHISAM) 74

simple HSAM (SHSAM) 74

single mode 34, 39, 43

SJF (Scheduler JCL Facility) 178

skills report, instructor 24

SPA (scratchpad area) 97

specification of
 field level sensitivity 76
 frequency, checkpoint 44

SPIE routine 47

SPM (sync-point manager) 107

Spool API application design 177

Spool Display and Search Facility (SDSF) 180

SQL (Structured Query Language) 30

STAE routines 46

STAT call
 formats for statistics
 OSAM buffer pool, STAT call 145
 OSAM buffer subpool, enhanced STAT call 149
 VSAM buffer subpool, enhanced STAT call 155
 VSAM buffer subpool, STAT call 147
 system service 172
 use in debugging 145, 166

statistics, database 145

status code, QC 37

STATUS statement 140, 163

storage of data
 in a combined file 2
 in a database 2
 in separate files 1

structure
 data 5
 physical, of a database 4

structure of data, methods 16

Structured Query Language (SQL) 30

summary of symbolic CHKP and basic CHKP 41

supply security information, how to 93

symbolic checkpoint
 description 41, 60
 IDs, specifying 60
 issuing 62
 restart 62

symbolic checkpoint (*continued*)
 restart with 43

sync_level values 107

sync-point manager (SPM) 107, 109

synchronous conversation, description for LU 6.2 transactions 105

synonym, data element 13

sysplex data-sharing 36

system log
 on tape 32
 storage 32

system service calls
 APSB (allocate program specification block) 135
 CHNG 177
 DPSB (deallocate program specification block) 136
 I/O PCB, requesting during PSBGEN 59
 INIT 46
 INQY 46
 ISRT 177
 LOG 158, 172
 PURG 178
 ROLB 32, 62
 ROLL 62
 ROLS 32, 46, 64
 SETO 177
 SETS 32, 46, 64
 SETU 64
 STAT 145, 172

system service requests, functions provided 54

T

take checkpoints, how to 59

terminal screen, designing 95

terminal security 91, 93

termination of a PSB, restrictions 57

termination, abnormal 39

test of application programs
 using BTS II 140
 using DFSDDLTO 162
 using DL/I test program 139
 what you need 139, 161

test of DL/I call sequences 139, 162

test, unit 139, 161

TM batch program 32

token, definition of 98

trace control facility 162

TRANSACT macro 40

transaction code 33

transaction response mode 34

transaction-oriented BMPs.
 See BMP (batch message processing) program

TSO application programs 41

two-phase commit process
 UOR 109

two-phase commit protocol 109

TXTU parameter 179

type 18 log record 61

U

unavailability of data 45, 63
 unique identifier, data 14
 unit of work 38
 unit test 139, 161
 UOR (unit of recovery) 109
 update access, specify with PROCOPT operand 86
 user requirements, analyzing 9
 utilities
 Batch Backout 32
 DFSERA10 61, 171
 File Select and Formatting Print program 42

V

values, isolating duplicate 19
 VBASF, formatted VSAM subpool statistics 147
 VBASS, formatted summary of VSAM subpool statistics 149
 VBASU, unformatted VSAM subpool statistics 148
 VBESF, formatted VSAM subpool statistics 155
 VBESS, formatted summary of VSAM subpool statistics 157
 VBESU, unformatted VSAM subpool statistics 156
 view of data, a program's 4
 view, local 22
 VisualGen 15
 VSAM buffer subpool, retrieving
 enhanced subpool statistics 155
 statistics 147, 155

W

wait-for-input (WFI)
 transactions 34, 37
 waits, program 43
 WFI parameter 37
 writing information to the system log 158

X

X'18' log record 42
 XRST (Extended Restart) 41



Program Number: 5655-J38

IBM Confidential
Printed in USA

ZES1-2334-00



Spine information:



IMS

Application Programming: Design Guide

Version 9