



IMS Version 8

Barbara Klein
bk@us.ibm.com



IMS Version 8

Providing Integrated e-business Solutions



Ideal for e-business

- ✓ Continuous Availability
- ✓ Systems Management
- ✓ Performance/Capacity
- ✓ Connectivity
- ✓ Application Development

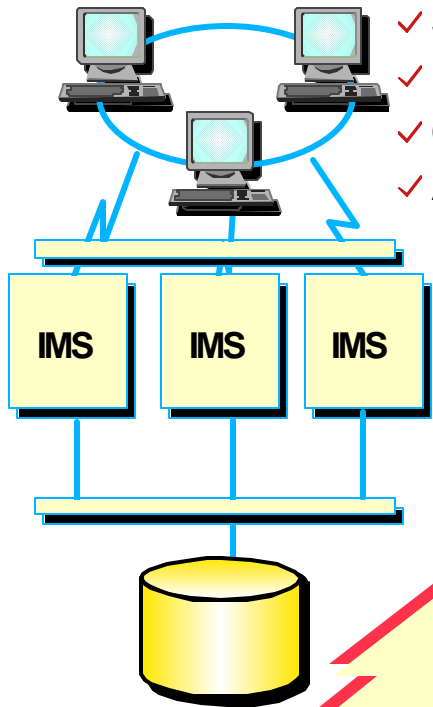

Enhancements

- Sysplex Terminal Management
- Sysplex-wide Resource Mgmt
- Sysplex-wide Operations with Single Point of Control
- Enhanced DB Recovery Ctrl
- Simplified Installation Process
- Enhanced Systems/Data Mgmt Tools
- Enhanced Java and XML

Benefits

- ✓ Enable Customer Growth
- ✓ Enhance Workload Balancing
- ✓ Increase Availability; Ease of Use
- ✓ Preserve Current Application Investment
- ✓ Enable New Applications

**Strategic Open Access
for S/390 and zSeries
Enterprise Servers**





e-business

IMS V8 Transaction Manager Enhancements



Availability/Recovery

- Sysplex Terminal Management
- APPC/OTMA Synchronous Shared Queues support
- APPC enhancements
- Shared Msg Queues and FP EMH CF Duplexing support

Performance/Capacity

- MSC FICON support
- CSA/VSCR enhancements

Systems Management

- Sysplex Wide Resource Manager
- Coordinated Online Change
- Single Image Operations Management
- Transaction Trace
- Syntax Checker

Application Development

- Java and XML enhancements
- Dynamic LE Runtime Parameters





IMS V8 Database Manager Enhancements



Availability/Recovery

- **IMS/DB2 Coordinated disaster recovery support**
- **DBRC Enhancements**
- **DB Image Copy 2 Enhancements**
- **Parallel Database Processing**
- **Batch RRS support**

Performance/Capacity

- **Fast Path DEDB Enhancements**
- **CSA/VSCR Enhancements**

Systems Management

- **Coordinated Online Change**
- **Single Image Operations Manager**
- **Syntax Checker**
- **Fast Path Shared VSO CF enhancements**

Application Development

- **Java enhancements**
- **Dynamic LE Runtime Parameters**





IMS V8 Common Storage Area (CSA)/Virtual Storage Constraint Relief (VSCR)



Relieves storage constraints with IMS using less local and common storage below 16M

- ▶ **Moves from local to above the 16M line:**
 - ✓ **System Program Status Tables**
 - ✓ **Code paths**





IMS V8 Dynamic LE Runtime Parameters



Eases Application development

- **Dynamically updates Language Environment (LE) runtime parameters for an IMS Transaction or Batch Message Program**
- **Makes it easier to use Debug Tool for application testing**
- **Done without requiring CEEROPT and CEEUOTP to be changed, reassembled, and relinked when parameters need to be changed**





e-business

IMS V8 Parallel DB Processing



Helps Reduce Recovery time for increased availability

- **Exploits Parallel TCB for Full Function DBs**
 - ▶ **Dynamic allocation, OPEN, CLOSE, EOVS**
 - ▶ **Faster processors with more engines**
 - ▶ **Provides for elapsed time improvement**
 - ▶ **Faster steady state response time**

The IBM logo, consisting of the letters 'IBM' in a bold, sans-serif font, with horizontal lines through the letters. It is positioned at the bottom left of the slide, partially overlapping a vertical blue gradient bar that also contains a faint image of a hand holding a mouse and a globe.

IBM



IMS V8 Batch Resource Recovery Service (RRS)



Simplifies and makes less error-prone operations and administration

- **Batch programs** can use MQSeries with coordinated commit
- **Full two phase commit** for batch programs accessing DB2 as well as IMS DB
- **Single unit of recovery ensured** for work propagating data to DB2 through 2-phase syncpoint process participation
- **IMS DProp V3R1 assist** in providing asynchronous, near real-time IMS-to-DB2

IBM



e-business

IMS V8 Image Copy 2 Enhancements



Eases Image Copy coordination and management

- **Multiple utility control statements** can be copied per execution
- **Group name support** names the datasets in one execution so can start and/or stop as a group
- **Single output data set** can be created for multiple image copies
- **DFSMSdss Optimize option** supported

The IBM logo, consisting of the letters 'IBM' in a bold, sans-serif font, with horizontal lines through the letters.



IMS V8 Database Recovery Control Enhancements



- **Automatic Recon Loss Notification** for quicker loss recovery
- **Eliminate abends** when authorizing database
- **RECON Command Authorization** controls RECON access/update via DBRC batch commands
- **16M RECON Record Size** helps users avoid problems caused by Recon Record size exceeding VSAM record size max
- **Prilog Compression** reduces overhead, improves performance





IMS V8/DB2 Coordinated Disaster Recovery



Aids in disaster recovery coordination in installations accessing DB2 via IMS

- **'eXtended Recovery Copy (XRC) tracking' added to IMS RSR**
- **Eases task synchronizing IMS and DB2 logs for disaster recovery**
- **Supports**
 - **IMS RSR For logs and (optionally) Databases**
 - **XRC for DB2 logs and boot strap data sets (BSDSs)**





e-business

IMS V8 Syntax Checker



Helps Reduce System Generation effort

- **New IMS ISPF application** which assists Systems Programmers in defining and maintaining the IMS parmlib members residing in the IMS PROCLIB
- **Parameter and value checking and detailed help text** at the parameter level tailored to the IMS version
- **Assists in moving from release to release** by identifying new parameters and obsolete parameters
- **Provide ability to ensure parameters are valid** prior to shutting down and restarting your IMS Control Regions.

The IBM logo, consisting of the letters 'IBM' in a bold, white, sans-serif font, set against a dark blue background. The logo is partially obscured by a vertical blue gradient bar on the left side of the slide.

IBM



IMS V8 Fast Path Data Entry Database Enhancements



- **DEDBs Greater than 240 Areas**
 - ▶ Increases capacity
 - ▶ Greater design flexibility
- **Non-recoverable DEDBs**
 - ▶ For use as work databases where recovery not required
 - ▶ Reduces log record/checkpoint info, thus improving IMS performance

The IBM logo, consisting of the letters 'IBM' in a white, bold, sans-serif font, set against a dark blue background.



e-business

IMS V8 Transaction Trace



Eases serviceability

Utilizes OS/390 and z/OS Transaction Trace facility for

- **Tracing a unit of work** through subsystems
- **Enabling show of flow** through components
- **Providing a consolidated place** to store tracking information
- **IMS Trace points** provided for
 - ▶ IMS Entry
 - ▶ IMS Exit
 - ▶ DL/I Entry
 - ▶ DL/I exit

The IBM logo, consisting of the letters 'IBM' in a bold, white, sans-serif font, set against a dark blue background.

IBM



IMS V8 APPC Enhancements



Improves APPC availability

- **Dynamically add/delete LU 6.2 descriptors for online change**
- **Use of another Logical Unit (LU) as an outbound LU for rerouting where resources are disabled**
- **Use a CPU-time limit for CPI-C (explicit) transactions to help prevent tying up of resources**
- **Synchronous Shared Queues support for enhanced workload distribution**

The IBM logo, consisting of the letters 'IBM' in a bold, white, sans-serif font, positioned at the bottom left of the slide. The background of the slide features a faint image of a globe and a hand holding a mouse, with a blue gradient at the bottom.



e-business

IMS V8 Synchronous Shared Queues support



- Provides for Sharing Messages between Sysplex Systems through IMS Queue Manager
 - MVS APPC programs
 - OTMA Clients (MQ, IMS Connect, ...)

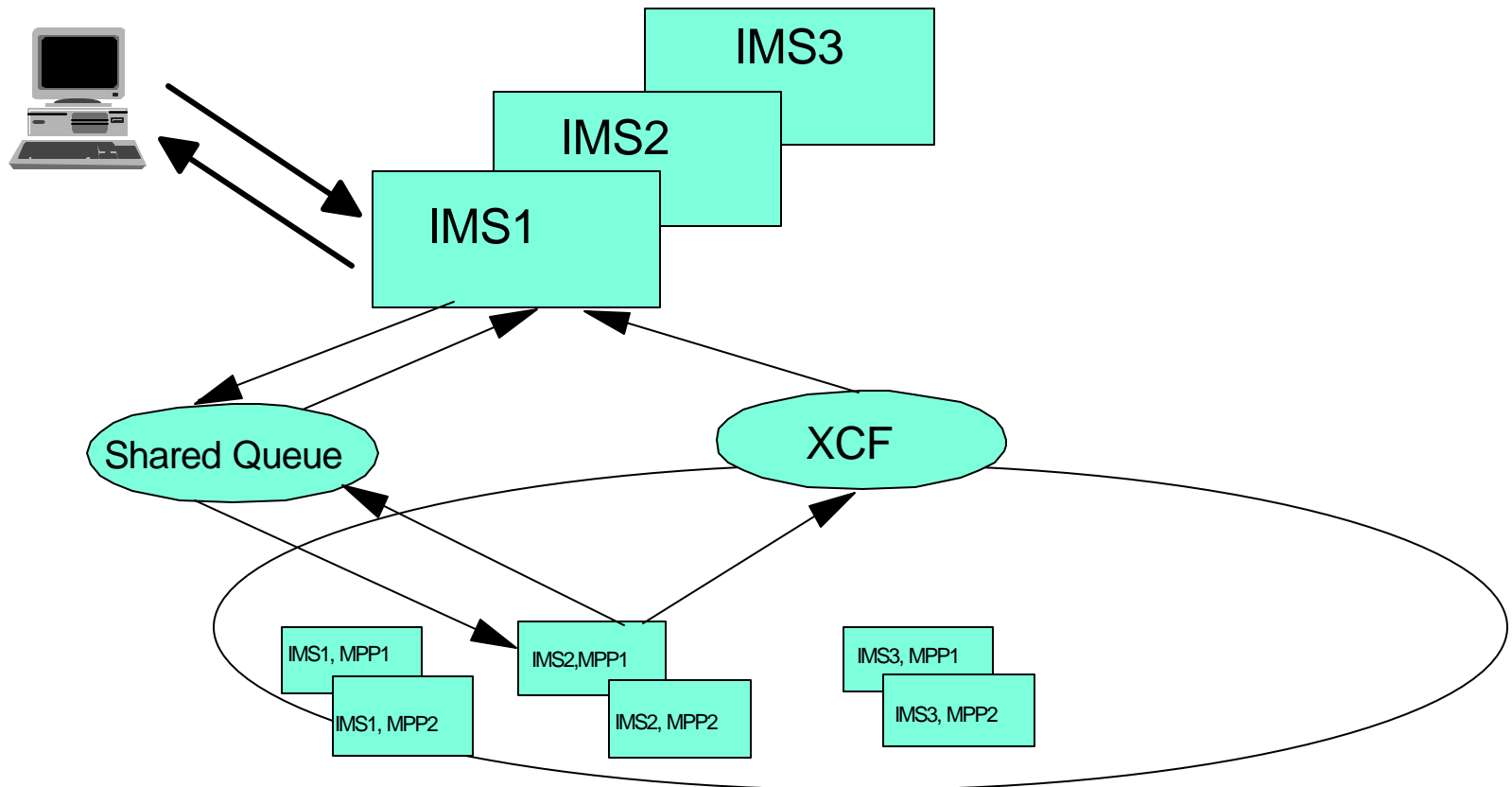

IBM



IMS Multiple Systems Coupling Fiber Connection Channel-to-Channel Support

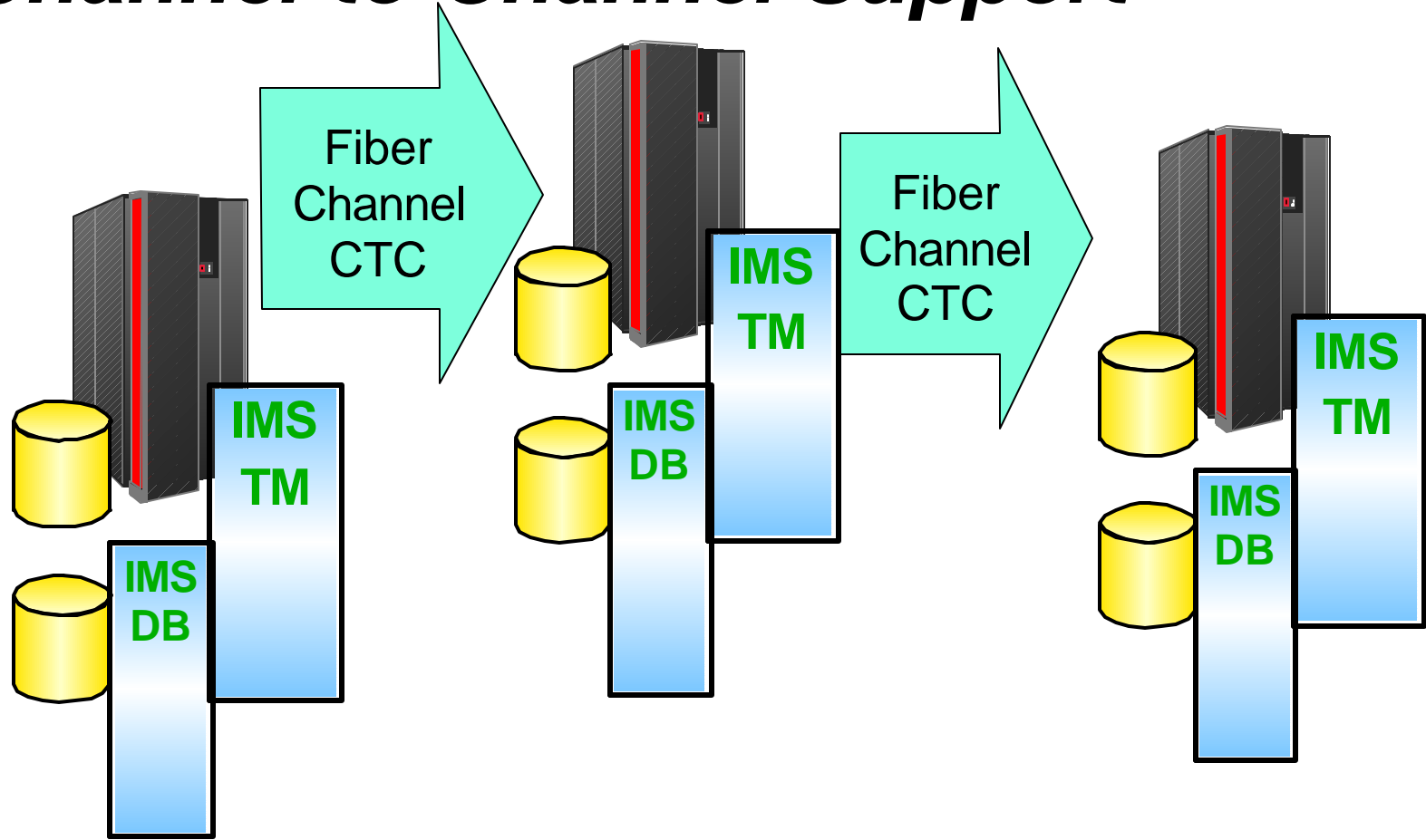

Providing Reliable, High Bandwidth Host-to-Host Communications Support between IMS systems.





IMS Sysplex Management Enhancements

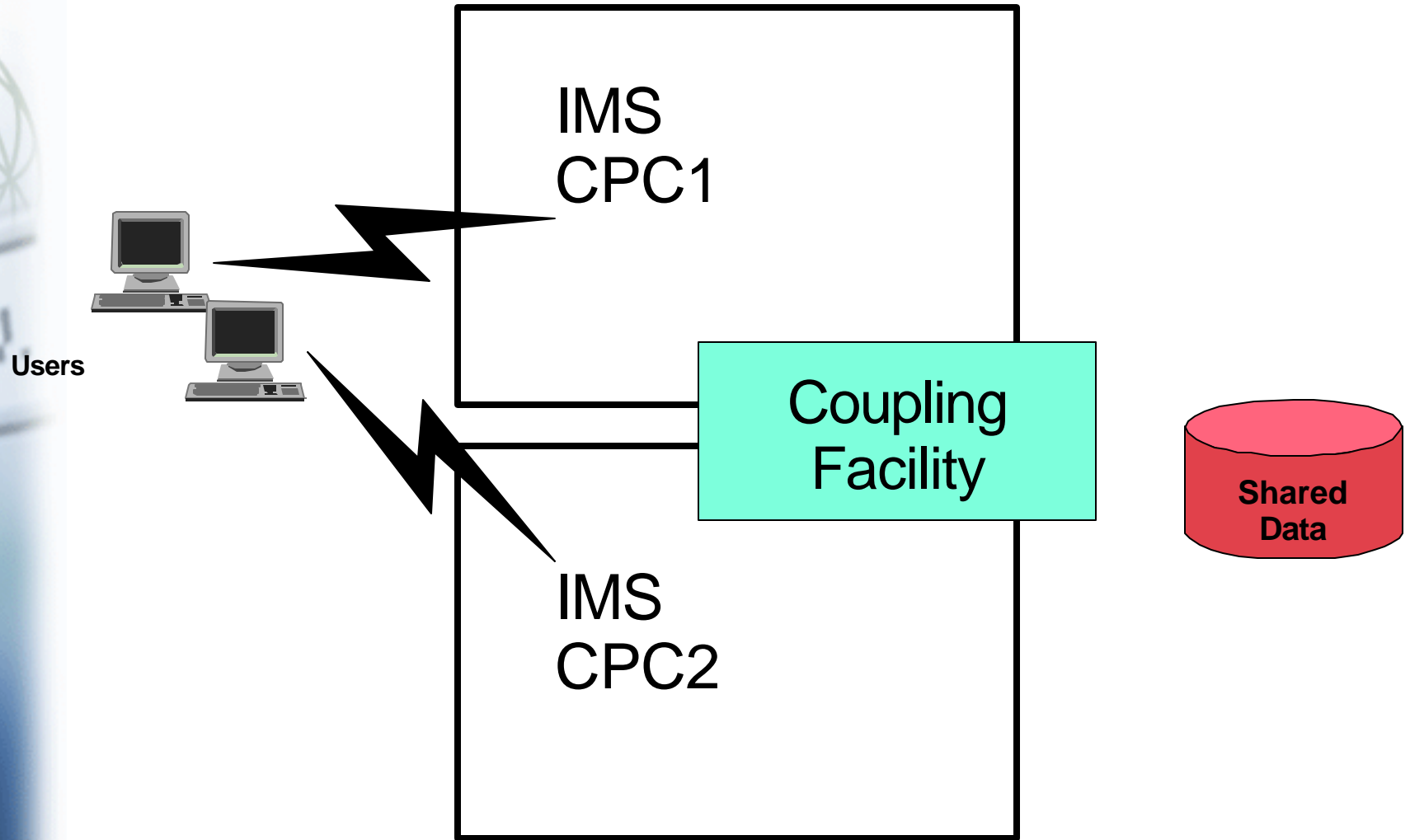



IMS in a Parallel Sysplex

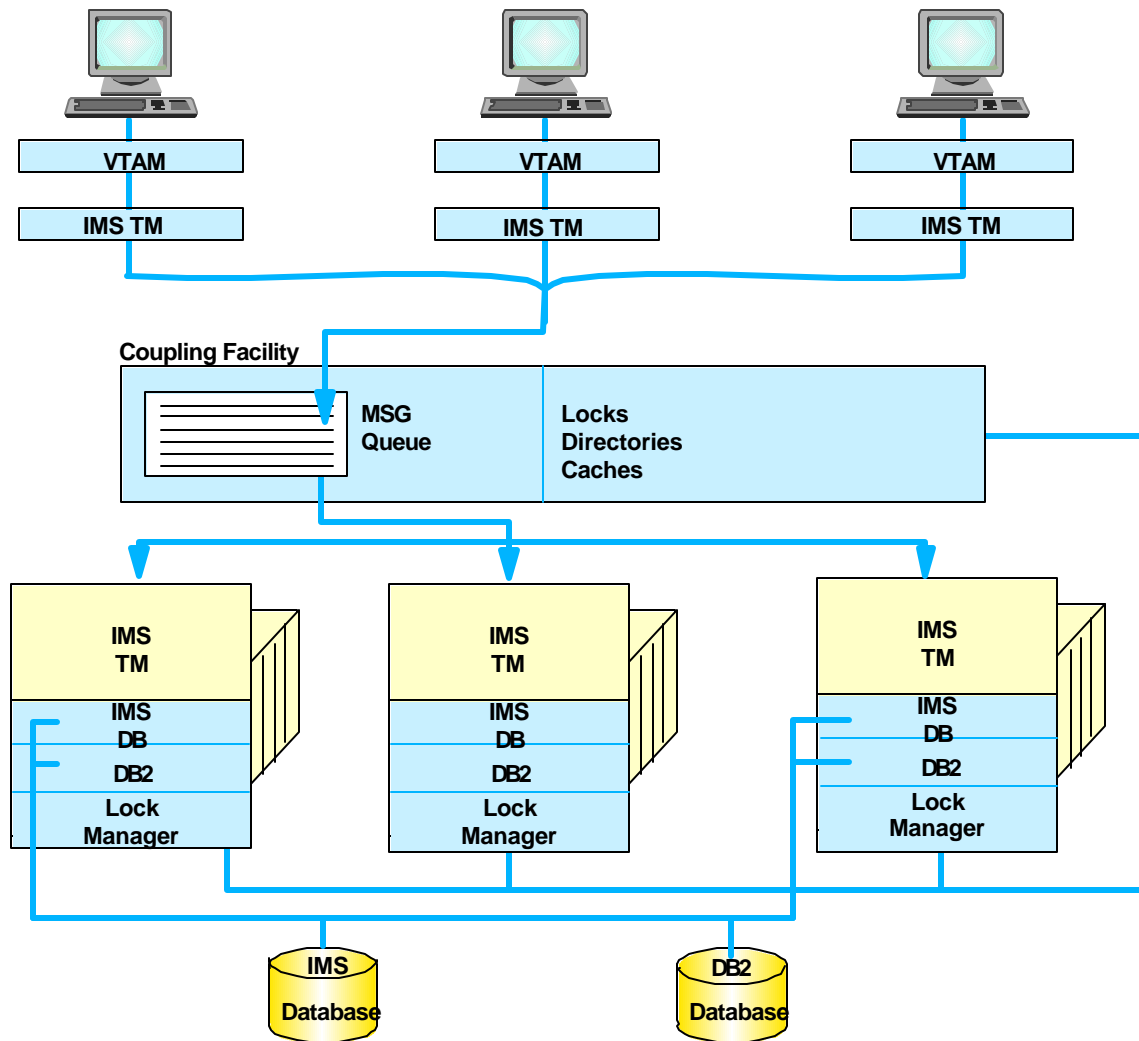

← Allocation of workstations

← Dynamic Workload Balancing

← Data Sharing
▸ IMS DB
▸ DB2

Easier access and management of enterprise applications and data



IMS Sysplex Management Coupling Facility Enhancements

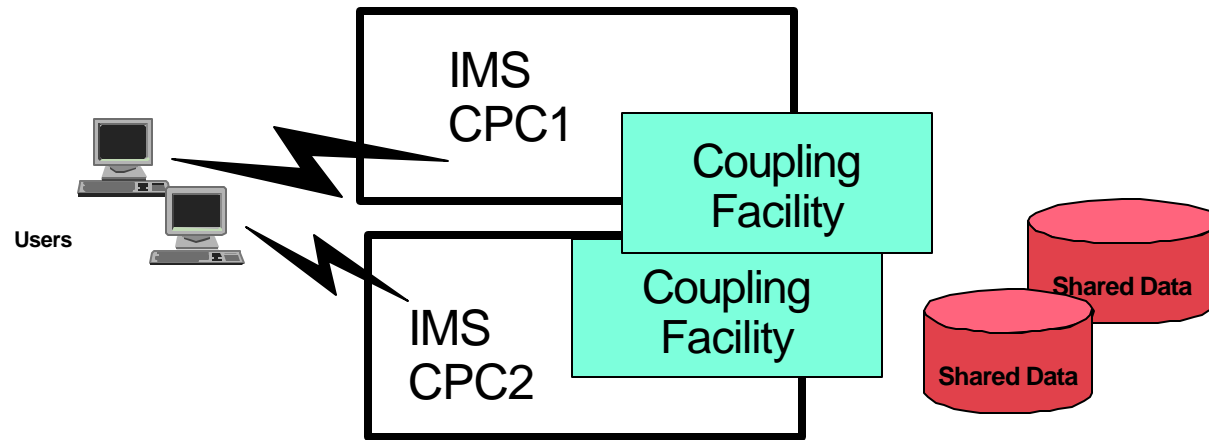

- **CF Duplexing for IMS Shared Queues and Fast Path (FP) Expedited Message Handler (EMH)**
- **CF Duplexing for IMS Data Sharing through IMS Resource Lock Manager (IRLM)**
- **IMS Fast Path Virtual Storage Option (VSO) CF support**
 - System Managed Duplexing
 - Automatic Altering
 - System Managed Rebuild



e-business

IMS Sysplex Management Requirements

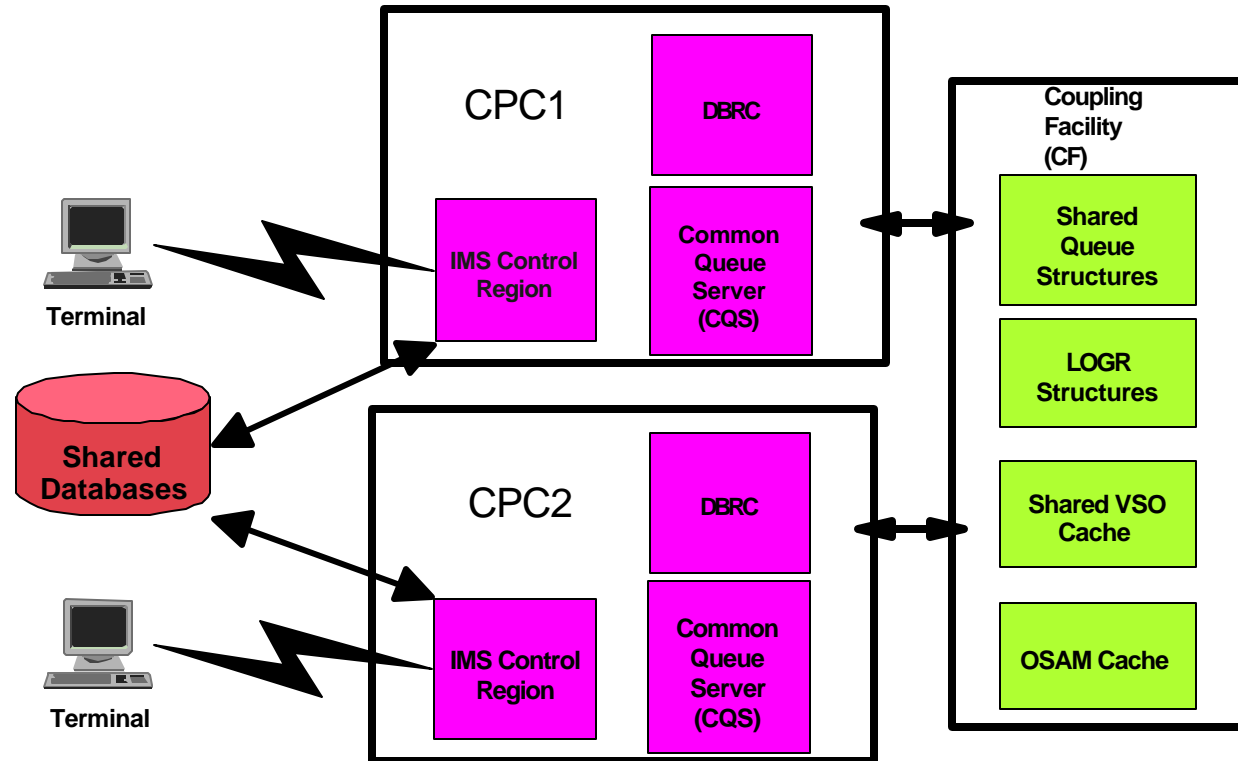

- PRESENT A SINGLE SYSTEM IMAGE ACROSS A SYSPLEX
- PROVIDE EASE OF USE THROUGH A SINGLE POINT OF CONTROL
- PROVIDE USERS THE ABILITY TO RESUME STATUS ON ANOTHER IMS IN THE SYSPLEX
- COORDINATE/MANAGE ONLINE CHANGE ACROSS THE IMSPLEX
- ADDITIONAL REQUIREMENTS

IBM



IMS V8 Sysplex Management Enhancements

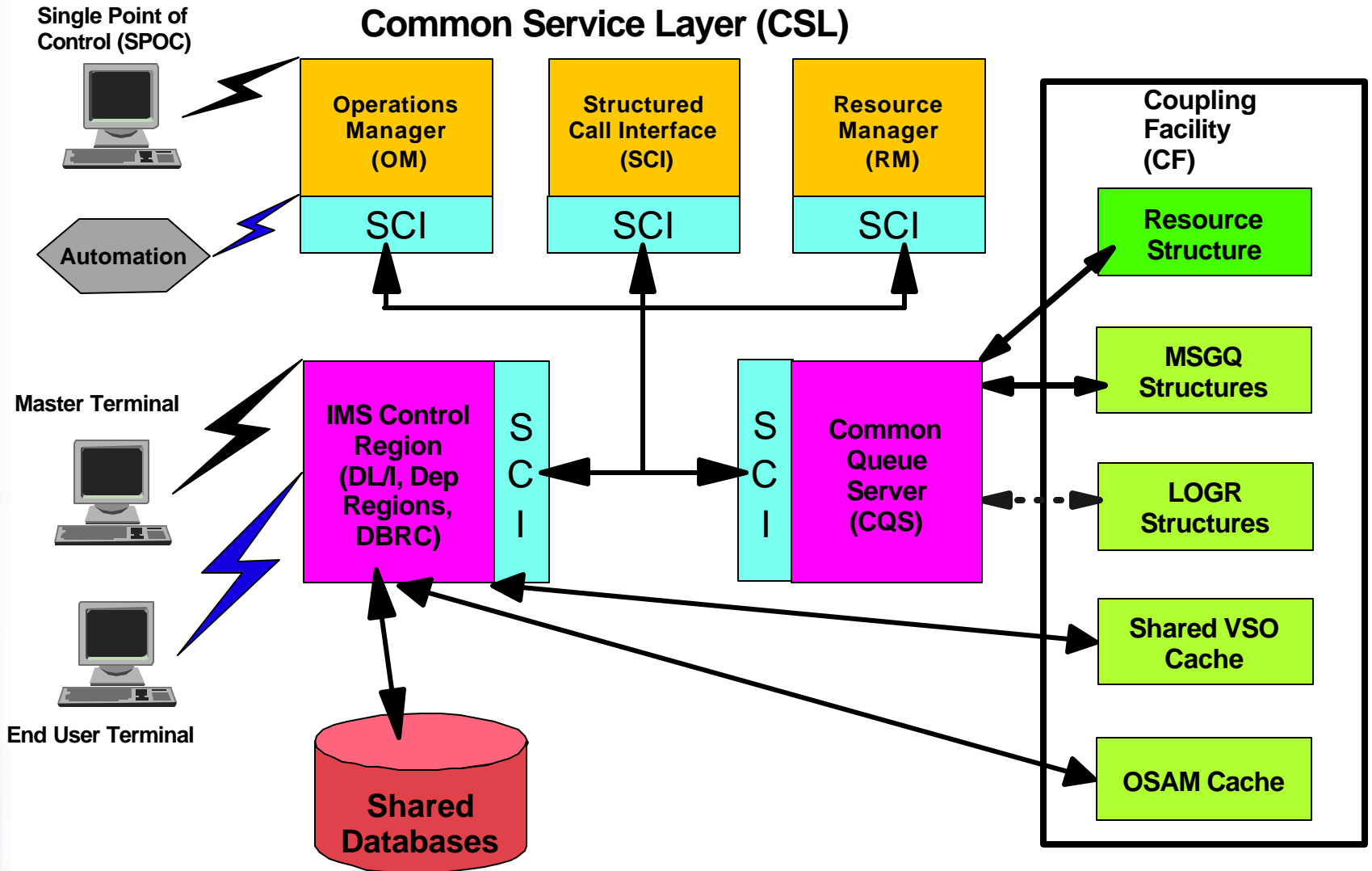

Structured Call Interface provides communication interface between IMS address spaces on same or across CPCs using XCF



IMS V8 Sysplex Operations Manager

Single Point of Control
(SPOC)
TSO/ISPF Application

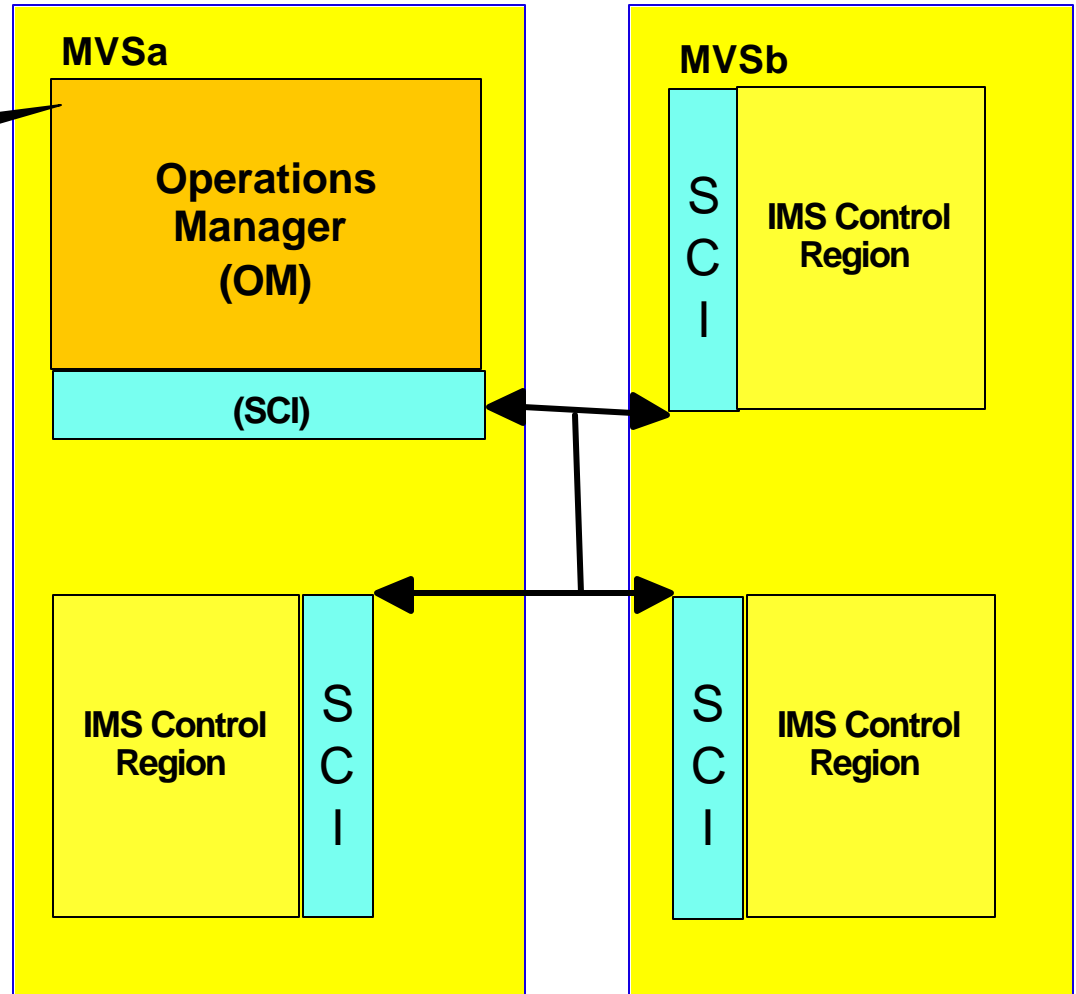

Operations Manager

- Routes Commands
- Provides an API
- Provides a SPOC and supporting TSO/ISPF Application for entering commands



IMS V8 Resource Manager



Provides a new IMS address space for

- **Coordination of online change across the IMS Sysplex**
- **Global management of IMS Terminal resources**
 - ▶ Enables a user to resume work on another IMS and to enforce single active user
 - ▶ Enforces single user signon in IMS Sysplex, if requested
 - ▶ Enables name uniqueness enforcement for message destinations





IMS V8 Coordinated Online Change



**Eases, manages, and automates change
across the IMS Sysplex.**

- Commands can be entered on one IMS
- Requests can be handled for coordinating change across all the IMSs in the IMS Sysplex
- Replaces manual coordination

The IBM logo, consisting of the letters 'IBM' in a bold, sans-serif font, positioned at the bottom left of the slide.

IBM



IMS V8 Sysplex Terminal Manager



Recovers terminal state information after a session reconnect, and allows the terminal user to log back onto another IMS after a failure.

- Allows VTAM to manage Generic Resource affinity while IMS can maintain VTAM terminal and user state data, if requested
- Enforces resource type consistency for message destinations and resource name uniqueness
- Supports global callable services for terminals/users, allowing user exits to obtain node and user information across IMS Sysplex
- Uses the Resource Manager to share VTAM terminal-related resources in the IMS Sysplex
- Autologons can be initiated from a single IMS in the Sysplex

The IBM logo, consisting of the letters 'IBM' in a bold, sans-serif font.

Java and XML

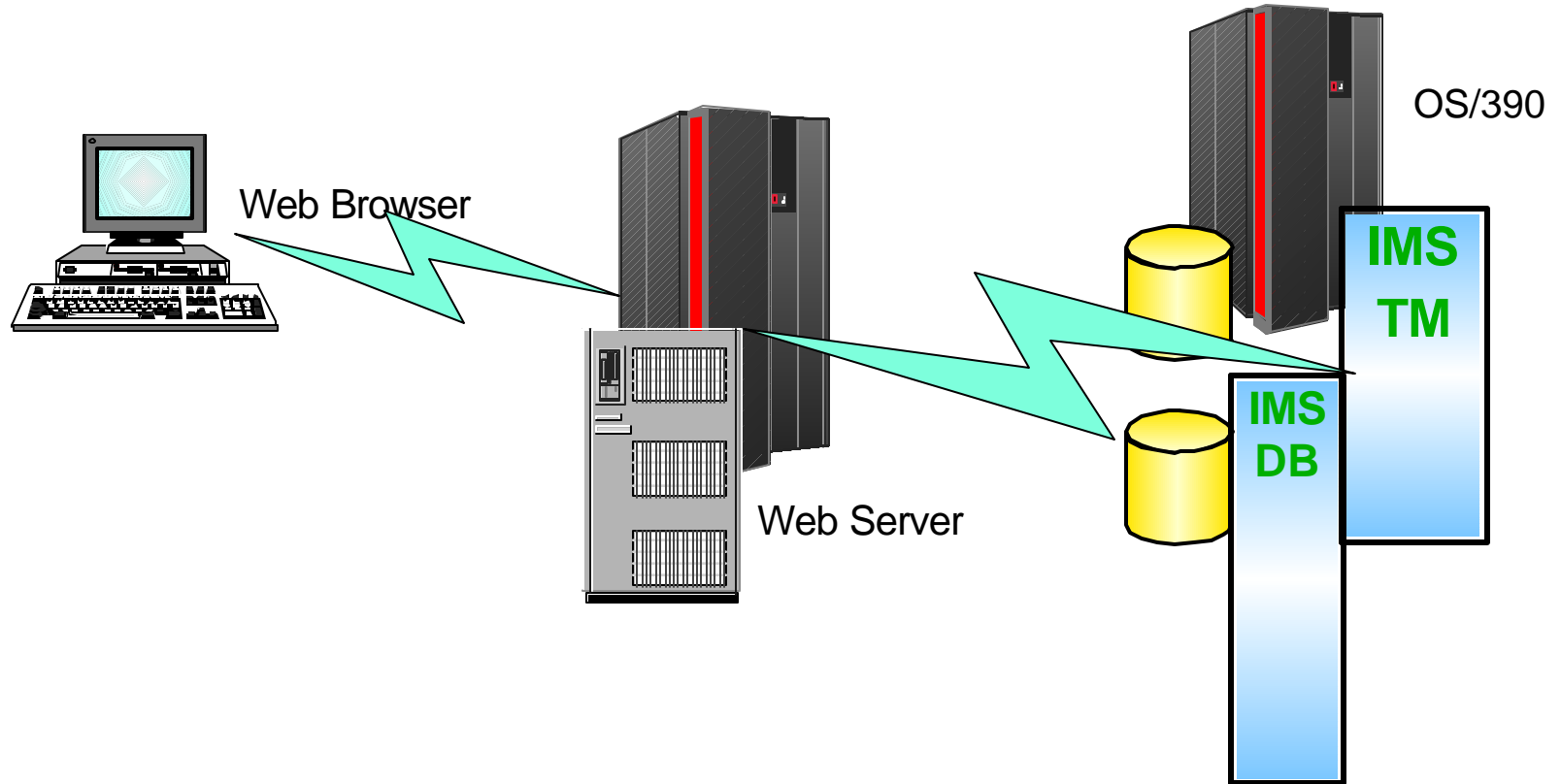

- For Connectivity to IMS Applications/Data
- For New IMS Application Development



Leveraging IMS Applications and Data

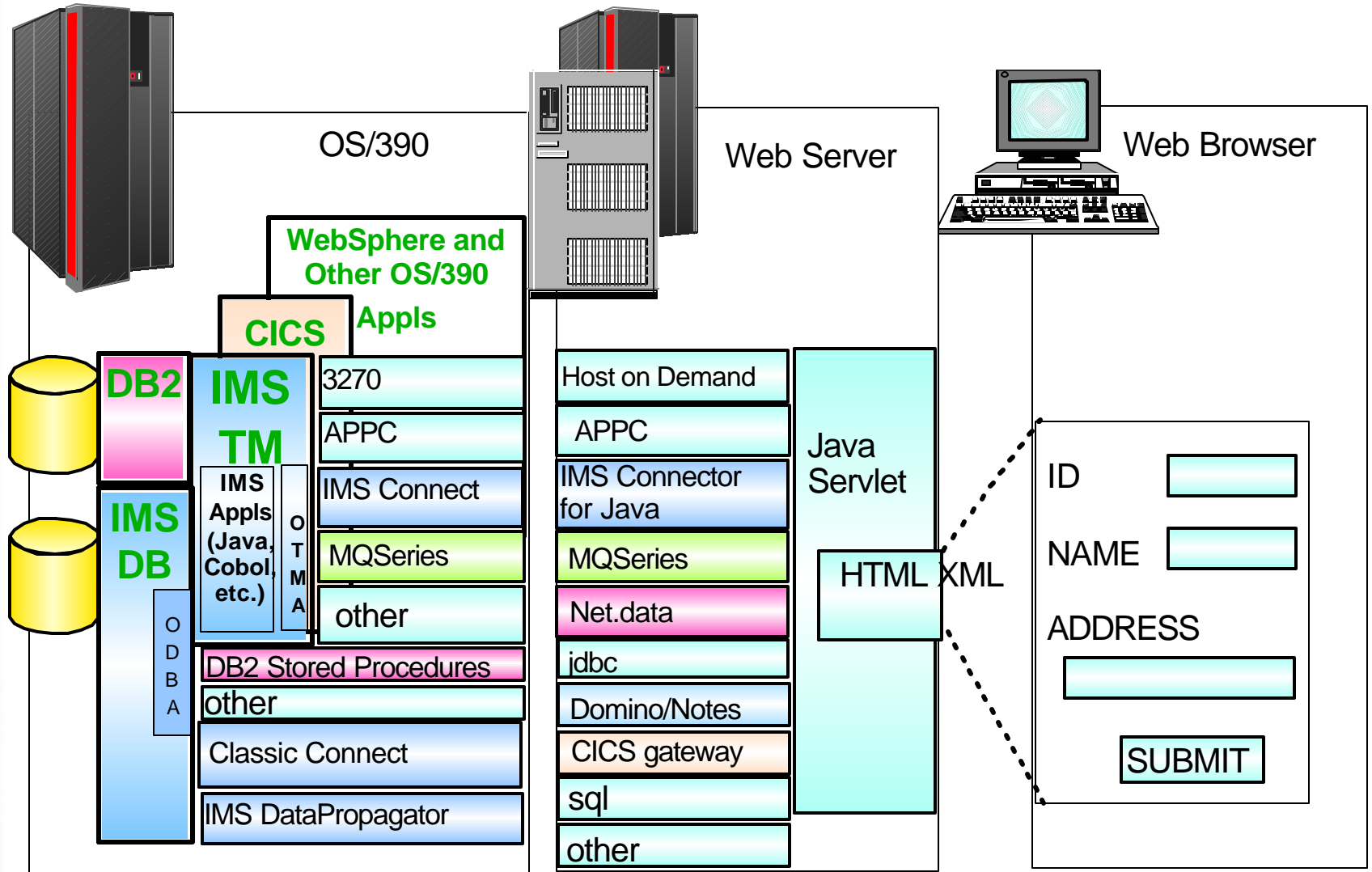



IMS Java for Integrated e-business Application Development



- ✓ **Application programmer productivity**
 - Java access to IMS input/output message queues
 - JDBC to access IMS DB and DB2 data
 - Java Compiler support in VisualAge for Java, Enterprise Edition/390 Version 2
 - Uses VisualAge tools for development
- ✓ **New Enhancements**
 - Java Dependent Region support for Scaleable Java Virtual Machine in IBM Developer Kit/390, Java 2 Technology Edition
 - JDBC access from additional environments
 - Java Standards enhancements





OS/390 WebSphere Application Server Using IMS Java Classes EJB/JDBC Access to IMS DB

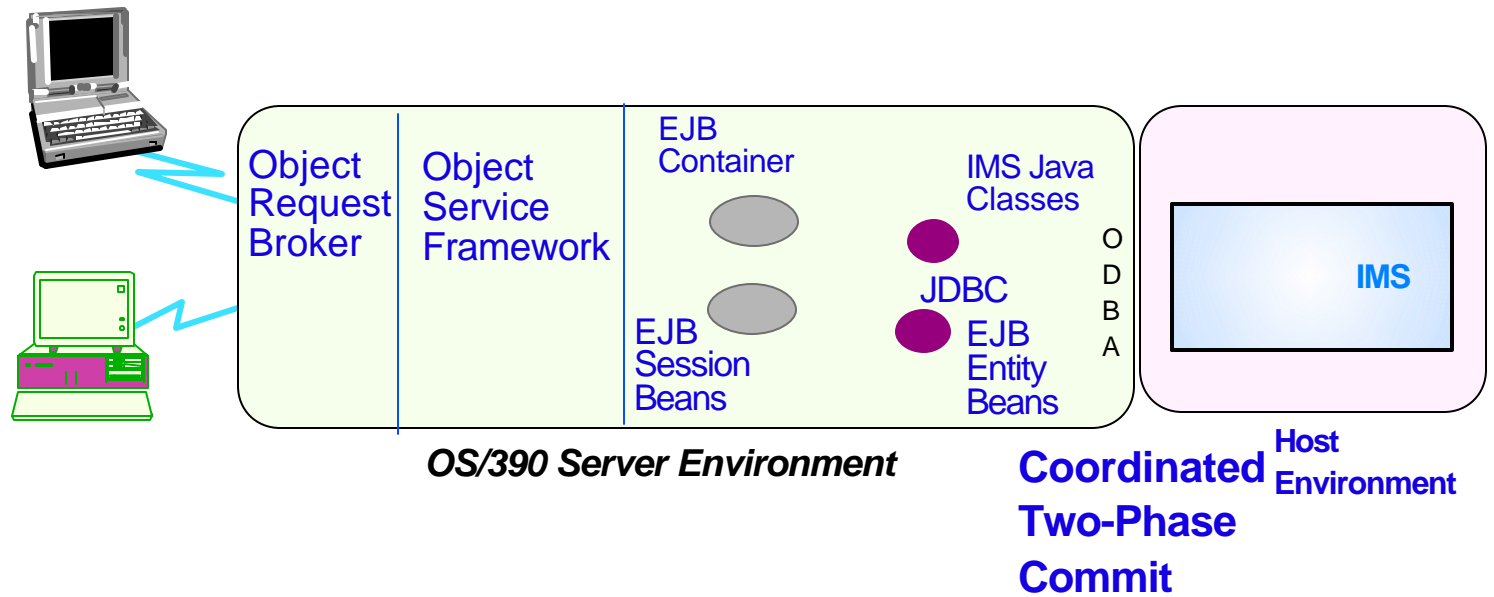

**To provide OS/390 WebSphere Application Server
Entity Bean access to IMS DB data**





e-business

XML and IMS



Processing XML Documents in New IMS Applications Today

- **Customers can write IMS C++ or IMS Java applications using the XML Toolkit for OS/390**
 - Tran code still must be EBCDIC, rest of data can be XML
 - Java/C++ program can invoke XML parser to convert to non-tagged data

Bridging XML and Existing IMS Applications Today

- **Using MQSeries Integrator**
 - Dictionary support for messages
 - Routing and processing based on message content
 - US Utility built cost-effective e-business infrastructure to IMS

XML and IMS Requirements

- **Processing XML Documents in new/changed IMS Cobol and PL/I applications using the XML Toolkit for OS/390**
- **Supporting SOAP(Simple Object Access Protocol)-compliant XML documents for Industry tooling and evolution to Web Services**
- **Transforming XML for existing IMS applications using Web Server and/or IMS Connect**
- **Using XML as an IMS Data Definition language**

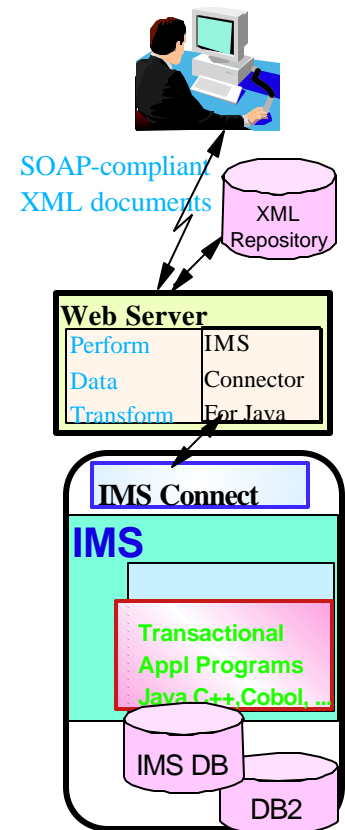



Also being provided through the IMS V7 Service process



IMS Transaction Manager

- Multiple Systems Coupling (MSC) Facility FICON Channel-To-Channel support
- Sysplex Coupling Facility (CF) enhanced support
 - CF Duplexing for IMS Shared Queues and Fast Path (FP) Expedited Message Handler (EMH)
- New Java Region Type for new Scaleable JVM

IMS Database Manager

- Sysplex Coupling Facility (CF) enhanced support
 - IMS Fast Path Virtual Storage Option (VSO) CF support
 - IMS DB Data Sharing support provided through IRLM
- JDBC support for DB2, CICS, and WebSphere
- Batch Remote Recovery Service (RRS) support





e-business

IMS V8 Software Prerequisites and Migration SPEs



IMS V8 MINIMUM RELEASE LEVELS

- OS/390 V2R10 (5647-A01) with DFSMS
 - ▶ RACF (included in separately orderable SecureWay Security Server), or equivalent, if security is used.
 - ▶ High Level Assembler Toolkit
- z/OS V1R2
 - ▶ Required for APPC/OTMA Synchronous Shared Qs
 - ▶ Required for MSC Ficon CTC support
 - ▶ Required for Shared Qs/EMH CF Duplexing support
 - ▶ Required for System Mgd Duplexing of VSO structures
 - ▶ Recommended for Resource Mgr and Coordinate OLC
 - ▶ Enhances usability for Sysplex Terminal Manager

DBRC Migration/Coexistence SPE

- on IMS V6
- on IMS V7

IBM



Packaging, Installation and IVP Enhancements



New IMS Packaging and Installation Process

- **SMP/E jobs removed from Install/IVP Dialog Process**
- **SMP/E Receive, Apply, Accept processing**
- **New Target and Distribution datasets**
- **No DFSJCLIN Job provided**

Installation Verification Program Enhancements

- **OM, RM, SCI, SPOC Sample Application**
- **Syntax Checker Sample Application**





Next Steps with IMS: Providing Integrated e-business Solutions



Ideal for e-business

- ✓ Continuous Availability
- ✓ Systems Management
- ✓ Performance/Capacity
- ✓ Connectivity
- ✓ Application Development

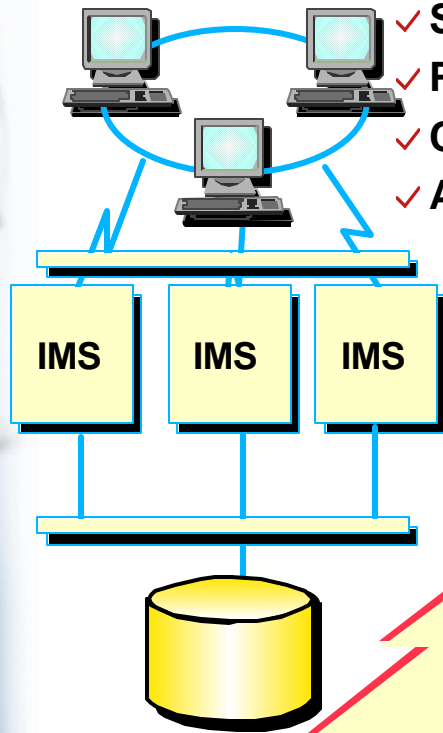

Enhancements

- Online Reorg
- Sysgen enhancements
- Sysplex Operations enhancements
- Sysplex Workload Distrib enhanced
- DB Recovery Ctrl Hi Perf/Avail
- Fast Path enhancements
- Virtual Storage enhancements
- MSC capacity enhancements
- Sysplex Terminal Mgt enhanced
- Enhanced XML

Benefits

- ✓ Enable Customer Growth
- ✓ Enhance Workload Balancing
- ✓ Increase Availability; Ease of Use
- ✓ Preserve Current Application Investment
- ✓ Enable New Applications

Strategic Open Access
for S/390 and zSeries
Enterprise Servers

