



DB2 and SOA Today

August 2007

DB2 track session 1

Information Management software

© 2006 IBM Corporation

- This is the Mainframe Technology Roadshow, highlighting DB2 and SOA. This agenda includes some introductory material, but we will be technical for most of the day, with current DB2 database administrators as the primary audience.

Agenda

- 1 DB2 and SOA today
- 2 Leveraging zIIP for DB2 workloads
- 3 DB2 for z/OS evolution in an SOA world
- 4 XML in DB2 for z/OS
- 5 A brave new world:
 Accessing DB2 for z/OS data in SOA
- 6 DB2 tools update: The key to optimized DB2 environments and reduced TCO
- Handouts for all road show sessions:

<http://www.ibm.com/software/os/zseries/roadshows/handouts/>



- **1 DB2 and SOA today:** DB2 for z/OS Version 8 supports a number of SOA capabilities, and this session will offer an update on how IBM customers are benefiting as they upgrade to Version 8 and fully exploit these rich functions. This session starts with an introduction to SOA to provide a level set, then looks at some current capabilities.
- **2 Leveraging zIIP for DB2 workloads:** IBM announced its new zIIP specialty engine offering in 2006. The zIIP is designed to help process certain DB2 related tasks at a reduced software license and processor cost. The workloads which benefit are distributed SQL access, parallel queries, and some utility processing. SAP customers are a good example. In this session, we will explain how you can start making use of the zIIP and which workloads qualify for the zIIP. We will also provide some measurements and best practices on how to maximize the usage of the zIIP.
- **3 DB2 for z/OS evolution in an SOA world:** This presentation will provide an overview of trends and directions of DB2 on z/OS. Special focus will be on SOA enablement and on DB2 9.
- **4 XML in DB2 for z/OS:** DB2 for z/OS provided an XML extender in DB2 Version 7, then added XML publishing functions in DB2 Version 8. DB2 9 provides extensive changes for pureXML. In this session we explain how to use XML with DB2 for z/OS and provide different usage scenarios including how to leverage XML data in an SOA.
- **5 A brave new world:** Accessing DB2 for z/OS data in an SOA: DB2 data and stored procedures can be accessed via Web services, or via Java programs using JDBC or SQLJ. Come learn about the benefits of each of these technologies, along with tips on how to select the right method for your requirements, and best practices in the deployment of each.
- **6 DB2 tools update:** The key to optimized DB2 environments and reduced TCO: DB2 tools can help you streamline database administration, reduce complexity by providing autonomic features that add capability and minimize error potential, and preserve investment in z/OS applications --all factors that help reduce total cost of ownership. Learn how DB2 tools can help optimize your current DB2 environment, assist in migrating to DB2 Version 8, and prepare for DB2 9. We'll also look at how tools can help you meet auditing requirements, address regulatory compliance issues, improve recovery and performance, and enhance your change management process.



IBM DB2 and SOA Today

1 DB2 and SOA today
Information as a Service

Delivering the Business Value of Information

DB2 for z/OS Development
IBM Silicon Valley Lab
San Jose, CA

Information Management software

SOA on your terms and our expertise

© 2006 IBM Corporation

- DB2 for z/OS Version 8 supports a number of SOA capabilities, and this session will offer an update on how IBM customers are benefiting as they upgrade to V8 and fully exploit these rich functions.

Innovation Requires a Business Centric View of SOA
Drive Innovation Priorities Through People, Process, and Information

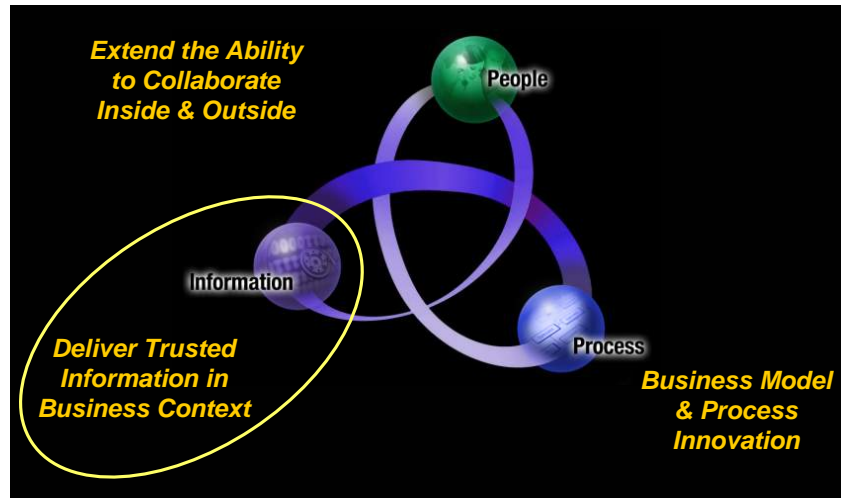

SOA has a number of key dimensions. Most of the time, we see the business centric view. The people focus must always be included. At other times, the business model and process are the focus. There is one more key focal point for SOA, and that is the information. Without all the legs of this stool, the platform is not stable.

SOA Executive Summit IBM

The Information Challenge

Information is in Silos... Trusted Information is Not Available

Today's business challenges mandate a fresh approach to managing information.

Globalization, M&As
Risk & Compliance,
Eroding Customer Loyalty,
Supply Chain Complexity,
Industry Transformations,
Cost Cutting...

Information Must Become a Strategic Asset

Managing information in silos has become obsolete.

Multiple Versions of the Truth
Inaccurate, Untimely
Inconsistent
Incomplete, Inaccessible
Out of Context...

60%+ of CEOs: Need to do a better job leveraging information

5X More Value creation by organizations effective at using Information as an Asset

70% of people's time can be spent searching for relevant information

Sources: IBM Attributes & Capabilities Study, 2005; Client Interviews 2004; IBM CFO Study, 2006

SOA on your terms and our expertise 5

- Critical business challenges are moving ineffective management of information from a chronic to an acute problem.
- Business initiatives, compliance, mandates, legislation, liability, connected supply and demand chains, and ever decreasing business cycles all depend on information
- Outsourcing, mergers and acquisitions, ERP / application consolidation, and data warehousing / business intelligence more expensive and difficult without effective information management
- *New technologies, standards and flexible architectures are now coming together to provide information in the context of business, during the course of business...*
- *Expertise has been honed to help develop innovative use of information and effective governance of information.*
- These forces include 1) emerging technologies, such as RFID and Telematics; 2) broader macro-economic trends, including new compliance requirements, mergers and acquisitions; and 3) the need to better leverage the avalanche of new data sources for competitive advantage.

Critical Business Initiatives Depend on Information Information Intense Business Problems

- **Master Data Management**
 - Single view of the customer and product
 - Gain control of disparate silos
- **Business Analysis and Discovery**
 - Deeper insight into buying behavior
 - Efficient, consumer driven supply chain
- **Business Transformation**
 - Partner collaboration
 - Real time information based decision
- **Worker Productivity**
 - Information accessible to every user when and where they need it... both structured and unstructured
- **Risk & Compliance**
 - Loss and Fraud prevention
 - Government regulations and taxes



SOA on your terms and our expertise

6

▶ Master Data Management

- - "We need to ensure data integrity between different systems." - CFO, North American Retailer
- - "Consistency of data between Finance and business is a top priority." - CFO, Large Asia Pacific Bank
- - Only 17% of Finance organizations have rationalized the number of data warehouses enterprisewide.

▶ Business Analysis and Discovery

- - "Becoming aware of some of the opportunities in other parts of the organization in a timely manner in order to assist or partner with them is a challenge." - VP Accounting, Worldwide Oil Exploration and Production
- - In the next 3 years, 47% of Finance organizations plan to adopt analytical tools for investigative and ad-hoc analytics.
- - In the next 3 years, 47% of Finance organizations plan to adopt data mining tools for predictive modeling.

▶ Business Performance & Process Innovation

- - "We have fragmented systems and inconsistent processes, which impact the integrity of information." - CFO, Large Asia Pacific Food Producer
- - 61% of CFOs and finance professionals place high importance on continuous process and business improvement. Yet, only 28% rate themselves as highly effective at it.
- - Only 35% of Finance organizations have increased the extent of common processes enterprise wide.
- - Only 14% of Finance organizations have pursued process simplification enterprise wide.
- - Only 12% of Finance organizations have expanded their use of functional best practices enterprise wide.
- - Only 27% of Finance organizations have reduced the number of finance common platforms enterprise wide.
- - Only 24% of Finance organizations have reduced the number of ERP instances enterprise wide.
- - In the next 3 years, 42% of Finance organizations plan to drive ownership and mapping of processes.
- - "We would be able to benefit right now from a technology platform that would allow commonality between units, improved quality of management and business information, and give us better ability to manage performance and forecast future results." - CFO, Large North American Bank
- - "Our number one challenge is to improve the integration and sharing of critical business information between businesses, operations and technical divisions." - Finance Operations Executive, Large North American Bank
- - "We would like to fully digitized performance reporting on the desktop, in real-time, for every executive and manager." - CFO, Large Asia Pacific Bank
- - "Lots of data. Not a lot of information." - CFO, North American Software Firm.
- - 69% of CFOs and finance professionals place high importance on measuring and monitoring business performance and place it at the top of their agenda. Yet, only 42% of these participants rate themselves as highly effective at it.
- - In the next 3 years, 47% of Finance organizations plan to adopt enterprise wide web-based reporting and/or portals.
- - In the next 3 years, 45% of Finance organizations plan to adopt enterprise wide BPM reporting/access, customized by organizational role.
- - In the next 3 years, 47% of Finance organizations plan to adopt enterprise resource planning (ERP) functionality for BPM.
- - CFOs would like to increase Finance's focus on decision support / performance management activities from 26% of their workload to 40%.
- - Only 38% of Finance organizations have implemented standard policies and business rules enterprise wide.
- - Only 27% of Finance organizations have rationalized finance budgeting / forecasting tools enterprise wide.

▶ Worker Productivity

- - "We would like to spend less energy in data collection and reporting, more in planning and control." - Finance Director, Leading European Provider of Custom Third-Party Warehouse Logistics
- - In the next 3 years, 44% of Finance organizations plan to create and populate knowledge management repositories.

▶ Risk & Compliance

- - "With margins shrinking, we are looking to move our culture from risk-averse to risk-managed." - CFO, Large Asia Pacific Bank
- - "We must install good control practices while keeping operation flexibility." - Director, Finance and Administration, Global Automobile Manufacturer
- - 61% of CFOs and finance professionals place high importance on leading finance-related compliance programs and strengthening the internal control environment. Yet, only 50% rate themselves as highly effective at it.
- - 47% of Finance organizations plan future use of analytical tools that are embedded in the actual work flow (e.g., automated real-time alerts).
- - 50% of Finance organizations plan future adoption of business activity monitoring with automated alerts embedded in operational dashboards.

Change And Improvement Have Been Daunting***Can Information Become a Service?***

- We have struggled with business flexibility for a long time, moving from applications as separate silos of data to integration across the enterprise.
- The latest challenges have been new silos for data warehouses, continuing demand for ownership in the business units, increasing mergers and acquisitions.
- How can the business information be more flexible to allow the enterprise – whether business or government – to be more flexible?

Service Oriented Architecture

Information as a Service is Key

You will waste your investment in SOA unless you have enterprise information that SOA can exploit.

Gartner, March 2005

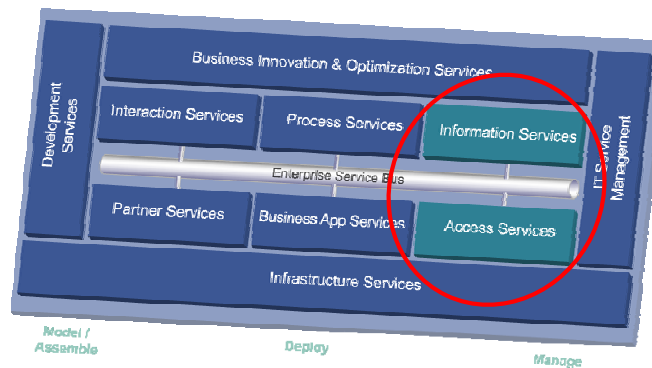

- The Service Oriented Architecture or SOA is the major initiative to increase business flexibility and agility. While the business focus is clear, the people focus is clear and the process focus is clear, sometimes we forget the information dimension of SOA. Two of the core services in SOA are
 - ▶ Information Services
 - ▶ Access Services
- I think of SOA as a stool with three legs:
 - ▶ Business or people
 - ▶ Process
 - ▶ Data
- To be stable, all three legs of the stool are required.

Information as a Service

Moving From a Project-Based to a Flexible Architecture

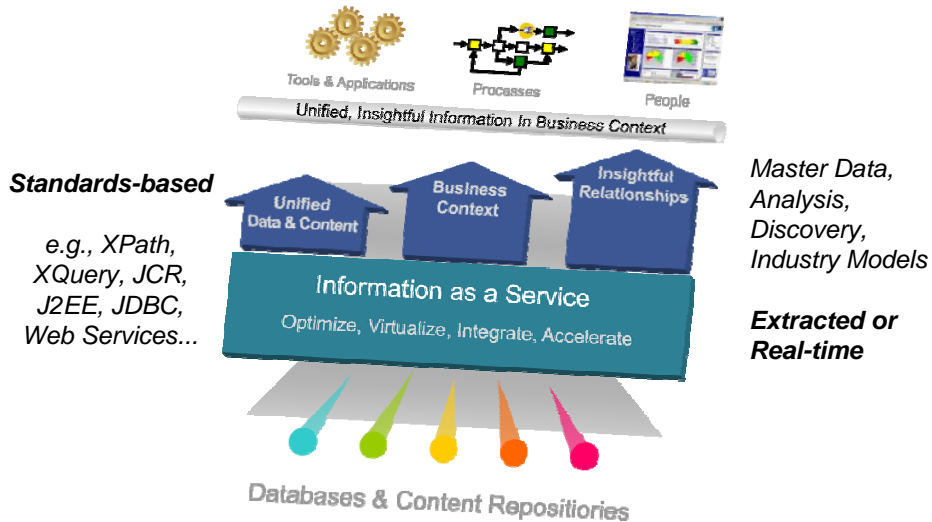

- Information as a Service (IaaS) is the process of moving the next step from a project-based or application based data architecture to a more flexible, agile data architecture.
- The base for the services is standards – formal international standards, committees, and consortia. Most of these standards are moving quickly.

Information as a Service**Moving From a Project-Based to a Flexible Architecture**

- **Deliver Information in Business Context**

In-context, In Line
Effectively Governed

- **Integrate Information**

Structured / Unstructured
Timely & Accurate
Manage Complexity

Open Standards

Flexible Infrastructure

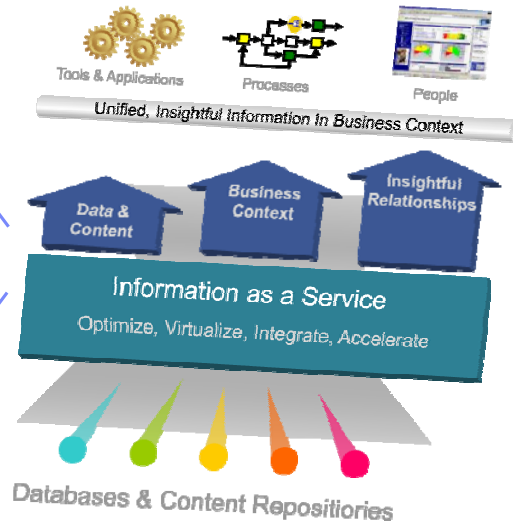

SOA on your terms and our expertise

10

- Deliver information in the business context: This means the right data, in the right context for this situation. Effective governance of the data becomes a process of master data management.
- Integrate the information – not just the structured information, but also the mass of information that now is on paper or images.

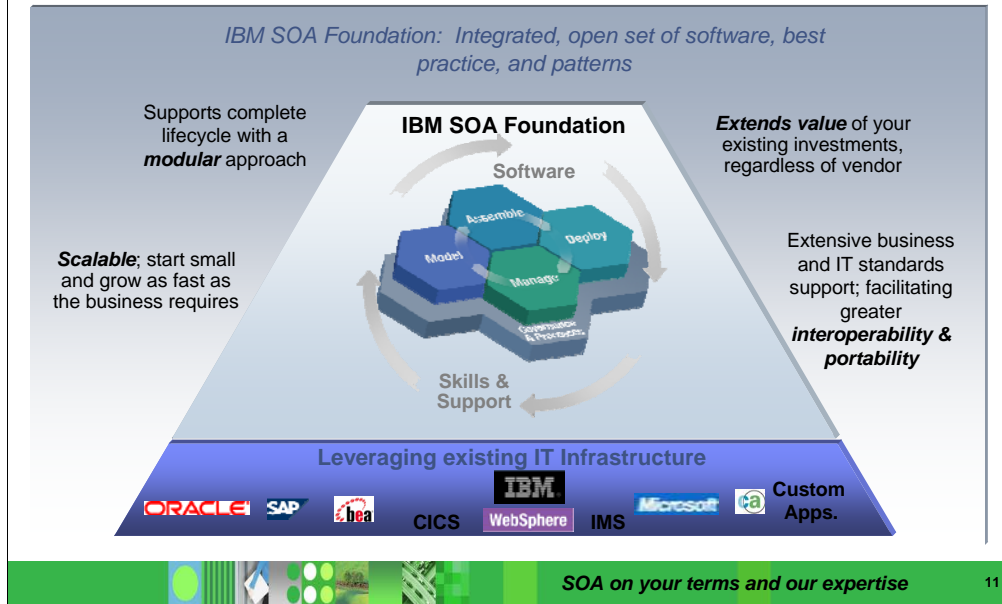
IBM SOA Foundation*Provides What You Need to Get Started with SOA*

- The IBM SOA Foundation supports this lifecycle and gives you what you need to get started with SOA. It is an integrated, open set of software, best practices and patterns. The components are modular allowing you to pick and choose the pieces you need to deliver an immediate impact while knowing that what you pick will work with pieces you add later on. The SOA Foundation is scalable allowing you to start small and grow as fast as your business requires. The SOA Foundation provides extensive support for business and IT standards; facilitating greater interoperability & portability between applications. It's important to emphasize again that this is in no way a replacement for your existing IT infrastructure and investments; it extend the value of the applications and business processes that are running your business today.

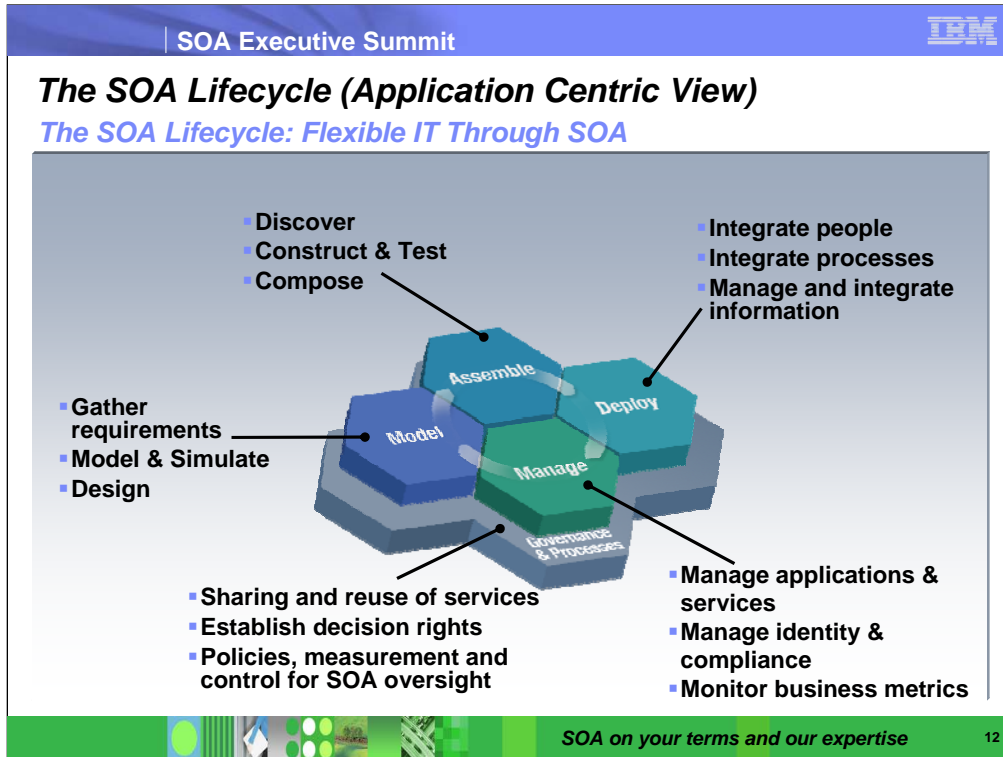

- 1) Approaching SOA in a business-centric way helps businesses pursue SOA the right way: by taking a project-based approach and demanding that each project deliver real business value on its own. 2) And the way that our customers have told us that they execute on SOA projects is to take a lifecycle approach to each project. This is the SOA Lifecycle that IBM introduced this past fall and which has been a guiding principle for successful SOA projects for much longer than that.
- They start in what we are calling the Model phase by gathering business requirements, designing, simulating, and optimizing their desired business processes. That way, they can make sure they are setting the right steps in motion before further action is taken.
- Once they have optimized the business processes, they implement it by combining newly created and re-used existing services to form composite applications.
- The assets are then deployed into a secure and integrated environment taking advantage of specialized services that provide support for integrating people, processes and information. This level of integration helps ensure that all the key elements of your company are connected and working together.
- Once deployed, customers manage and monitor the composite applications and underlying resources from both an IT and a business perspective. Information gathered during the Manage phase is used to gain real-time insight into business processes enabling better business decisions and feeding information back into the lifecycle for continuous process improvement. Underpinning all of these lifecycle stages is governance which provide guidance and oversight for the SOA project.

The SOA Lifecycle (Information Centric View)

The SOA Lifecycle Mapped to Information Needs

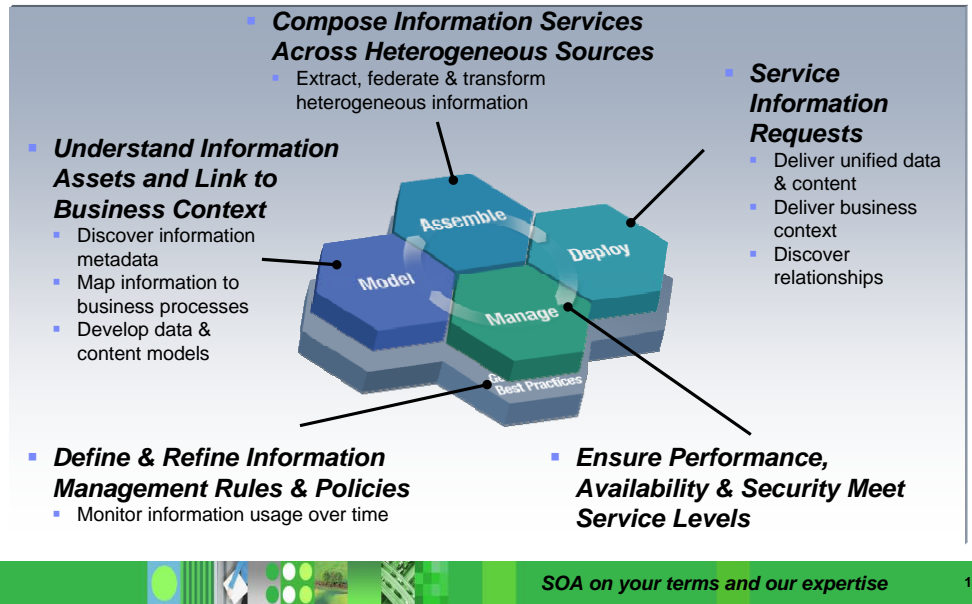

- Information as a Service: This is the information centric view of the SOA lifecycle. We'll work through the process cycle of
 - ▶ Model the data
 - ▶ Assemble the data
 - ▶ Deploy the data
 - ▶ Manage the data

SOA Executive Summit IBM

The SOA Lifecycle (Business Centric View)

Built on the SOA Lifecycle

- Deliver trusted information to provide *business insight* to enable innovation
- Enable *human and process interaction* with consistent levels of service
- Achieve greater efficiency and effectiveness with *business model innovation*

Recent studies of over 1900 customers showed SOA starting points of people, process, information or a combination of all three

SOA on your terms and our expertise 14

- A more business oriented path to SOA is the business centric approach, which is built upon the foundation provided by the SOA lifecycle. The business centric view of SOA looks beyond the technical capabilities of products within lifecycle stages and enables users to consider some less tangible SOA basics, such as the harmony required between people, process, and information exchange to make for efficient business practices. A business centric approach marries the technical capabilities identified in the SOA lifecycle to the needs of the business.
- Also REUSE & CONNECTIVITY (to be discussed later)

SOA Executive Summit IBM

IBM Information Management Software

Unparalleled Breadth and Depth

- **Deliver Information in Business Context**
 - Industry Models
 - Master Data Management
 - Entity Analytics
 - Discovery Services

500+ Clients
- **Integrate Information**
 - IBM Information Server
 - DB2 9

5,000+ Clients

Share Leaders

Information as a Service
Key to Service Oriented Architecture

Unified, Insightful Information in Business Context

No Other Vendor Delivers The Breadth and The Depth of Capabilities

Industry Models: Templates defined for a specific industry to structure/organize the data and processes to manage the data. Having industry models help companies get started more rapidly and use information across many applications and processes. The models are also designed with an enterprise (not a single application) in mind, so many processes can leverage the information asset. We've developed industry models for Telco, Retail (the basis for our RBIS solution...), Insurance, Banking (basis for Basel II solutions...).

Master Data Management: All businesses have core information... information about products, customers, employees... etc. - referred to often as reference data or master data. Master data has become very fragmented because its been buried in application silos; as a result a single view of the truth is elusive. Many forms of master data haven't been managed in a unified manner. Applications historically have captured tabular master data, e.g. product description or client address, but not free form, unstructured information, e.g. a picture of product or an image of a client policy. A unified view of master data is important. A unified view of master data can help speed product introductions, or manage optimize inventory levels in the case of product master data. A single view of the customer can help a company build targeted crm activities in the case of customer master data. We have acquired several assets here from companies like Trigo (product master data), DWL (customer master data)...that are now WebSphere Product Center and WebSphere Customer Center. Other technologies: integration software, analysis software, ...

Entity Analytics or Threat and Fraud Intelligence: Understanding the answer to questions like "Who is who?" and "Who knows who is critical". The answers to these questions apply to many industries: In identifying terrorists and criminals (law enforcement) In anti-money laundering schemes In retail - slip and fall scams, etc. or procurement fraud where vendors and buyers are related... In HR - who are you really hiring... are they related to some one you fired for theft? We acquired a company, SRD, who has specialized algorithms for this kind of analysis. This technology can factor into other solutions, e.g. Master Data.... getting a unified view of the client...

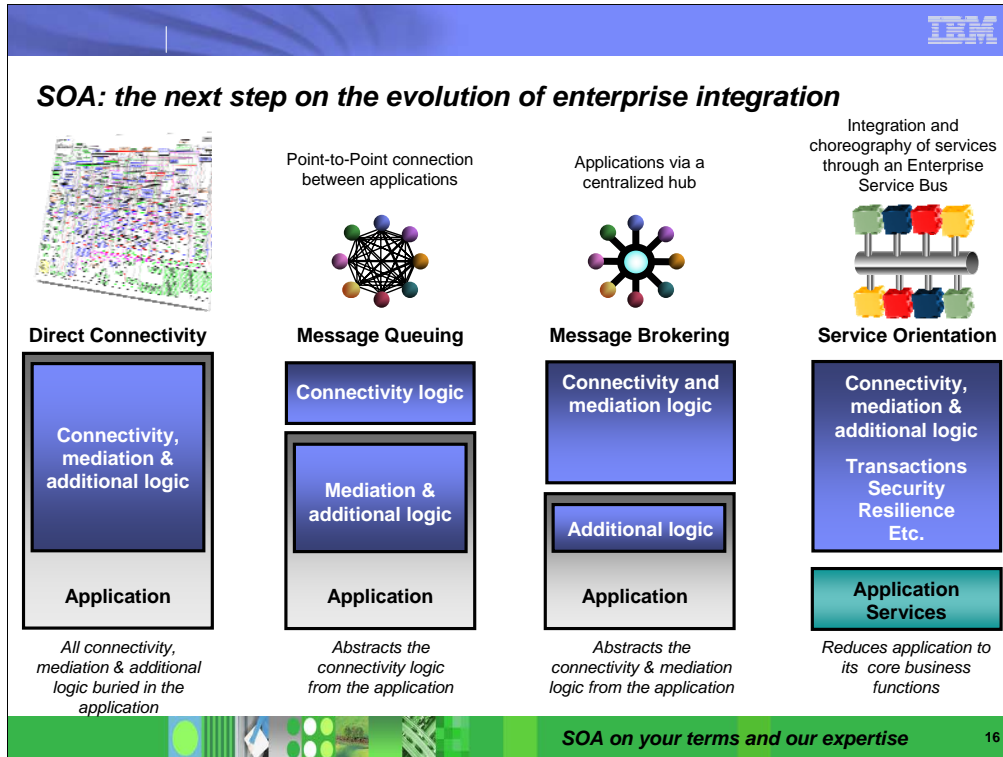

- Notes from prior page ... **Discovery Services:** This software searches information and helps add context to the search so the results are more relevant. Combines a real-time understanding of user intent and application context to optimize relevance of information that is delivered and includes predefined industry vocabularies. For instance, if an employee queries their 401K, we'll also know that they likely will want to see their stockplan contribution... or if a potential buyer searches for a certain type of product, they'll also want to see other products or link to other parts of the site... We can also do further analysis of trends on this. Understanding what information isn't linked to, or if linked to causes an exit from a website...etc... We have both organically grown software (OmniFind) and a recent acquisition here (iPhrase). There is core architecture here developed by our research team (UIMA ...unstructured information management architecture) that we recently provided to the open source community...
- Information Integration Services:** Information Server is software that consolidates information to create a new integrated database or "federates" information to provide a virtually integrated view of information. We can do this for both unstructured sources (e.g. emails, reports, images, in content management repositories etc) and structured information sources (e.g. erp data in DB2 or Oracle). As companies integrate, they also like to do quality scrubbing and some transformation to make it more usable along the way. Our software does this too. We have had significant organic development on this front for federation and acquired Ascential Software, with DataMirror and Princeton Softech in process.
- This has been a long process, moving from the various styles of silos of information, from direct connectivity from application to data, to add additional opportunities for redirection and reuse of the data, rather than needing separate sets of data.

SOA Scenarios: consuming the SOA foundation

Scenario Themes

IT Solution

1. Capitalize on new business opportunities

Take advantage of existing services and make new ones ubiquitously accessible



Service Orientation

2. Enhance responsiveness and customer service

Reduce transaction time and strengthen partner interactions



Service Oriented Integration

3. Extend collaboration efforts and information accessibility

Provide roll-based access to information for employees, customers, & partners



Aggregating User Interactions

4. Increase productivity

Automate process execution and easier change management



Business Process Management

5. Improve business agility and compliance

Create a single source of information for customers, partners & internal users



Managing & Connecting Information Services

7. Management & Security

Manage & Secure Business Process, Composite Applications, Web Services, etc.



Managing & Securing the SOA

SOA on your terms and our expertise

- These are the themes of the SOA scenarios.

SOA: 3 concepts at the core**1. Discovery**

- Where is the service?

**Discovery
UDDI****2. Description**

- What service does it offer?
- How do I use it?

**Description
WSDL****3. Messaging**

- Let's communicate!

**Messaging
SOAP**

- But now lets get down to the basics, the foundation of data and SOA. There are three key concepts.
 - ▶ Discovery: the process of finding a service.
 - ▶ Description of the service: telling an application what service is available and how to use it.
 - ▶ Messaging: describing how to communicate. We'll start with SOAP, and note the newer, lighter weight protocol, REST.
- Underlying almost all of the data is XML. We'll be talking about XML in the database a lot more today, primarily in session 4.

Anatomy of a Web Service

Standards-Based is key

- **UDDI** is used for discovery of the services which are available.
- **WSDL** is used to describe the function(s) that an application will be calling documenting in a standard way its entry points, parameters and output
- **XML** is used to carry the values of parameters and the outputs of the function
- **SOAP** is used as the messaging protocol that carries content (XML) over a network transport (typically HTML)
 - **REST** is a new lighter weight protocol used with some frameworks, such as Ruby on Rails.
- **HTML** is used as the network transport layer

Four key specifications form the Web Services stack:

- WSDL provides the description of the web service by specifying the collection of functions that a web service can perform, the inputs that these functions expect to receive and the type of output that a caller can expect to get back. Because WSDL is a standard, it can be interpreted by an application that needs to call the service automatically i.e. without a need for human intervention. There is no need to call the writer of the service, get a specification from him/her etc. Someone who wants to use the service simply needs to be able to get its WSDL.
- The data that is carried between the caller of a web service (web service consumer) and the web service itself (web service provider) is encoded using XML. Because XML allows for standard data representation, both web service consumer and the web service provider do not have to know or care about either the platform that each is running on or the programming language or application framework that each is using. For example, a consumer written in C# can call a web service written in Java in exactly the same way as a web service written in C#. As a matter of fact, the consumer never knows how a web service he is consuming is implemented.
- SOAP is a standard messaging protocol that is used to make a call to a web service and to bring the results back. SOAP is frequently described as an envelope which contains the XML payload.
- HTML is the most popular network transport for carrying SOAP messages for Web Services. It is popular because of its ability to traverse firewalls and because it is ubiquitous. Web Services allows for use of other protocols (e.g. MQ) but their use is quite rare.

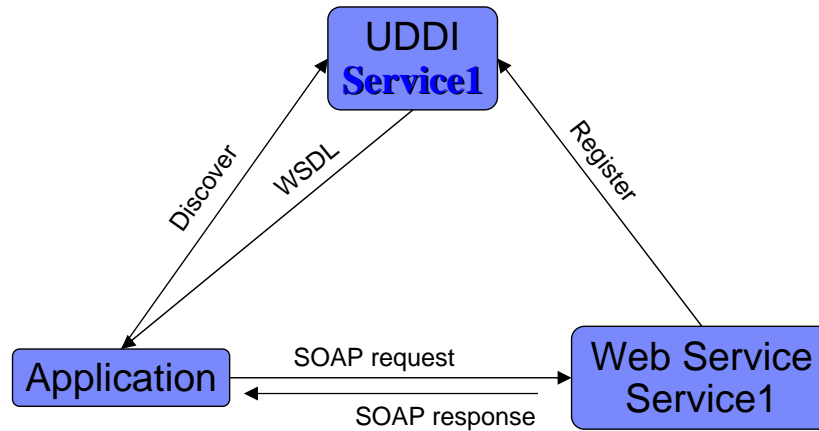
SOA: Web Services Interactions

- This is the process for defining a web service, finding the web service, then using the web service.

WSDL: Web Services Description Language

WSDL (Web Services Description Language) is a public description of the interfaces offered by a web service. Expressed in XML, it provides machine readable document that provides a calling application all of the information required to interact with a web service.

- WSDL is really at the very core of the Web Services architecture. It provides complete specification for the functionality exposed by a web service, all of the input and output formats and all other information required to communicate with a web service. It is expressed entirely in XML using a well known schema.
- WSDL describes services as a set of endpoints. WSDL can describe the 2 styles of Web Services: document-oriented or procedure-oriented. WSDL allows for a description of each individual message and operation and then binding them to a specific protocol (e.g. HTTP) to create an endpoint. A collection of endpoints is what defines a web service.

WSDL

A walk through an example

```
<?xml version="1.0" ?>
- <definitions name="TemperatureService"
  targetNamespace="http://www.xmethods.net/sd/TemperatureService.wsdl"
  xmlns:tns="http://www.xmethods.net/sd/TemperatureService.wsdl"
  xmlns:xsd="http://www.w3.org/2001/XMLSchema"
  xmlns:soap="http://schemas.xmlsoap.org/wsdl/soap/"
  xmlns="http://schemas.xmlsoap.org/wsdl/" >
- <message name="getTempRequest">
  <part name="zipcode" type="xsd:string" />
</message>
- <message name="getTempResponse">
  <part name="return" type="xsd:float" />
</message>
- <portType name="TemperaturePortType">
- <operation name="getTemp">
  <input message="tns:getTempRequest" />
  <output message="tns:getTempResponse" />
</operation>
</portType>
```

... (continued on the next page)

- This is an example of web services.

SOAP: Simple Object Access Protocol

Description for the rest for us

- Industry standard message format for sending and receiving data between a web services consumer and a web service provider
- SOAP messages are XML documents which have an envelope and:
 - Header (optional): contains information about the message such as date/time it was sent or security information
 - Body: contains the message itself
- Standard messaging protocol maintained by the W3C [XML Protocol Working Group](#).

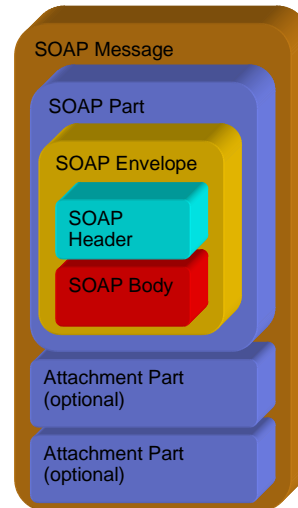

- This is the structure of SOAP or the Simple Object Access Protocol.
- SOAP is an industry standard message format for sending and receiving data between a web services consumer and a web service provider
- SOAP messages are XML documents which have an envelope and:
 - ▶ Header (optional): contains information about the message such as date/time it was sent or security information
 - ▶ Body: contains the message itself
- Standard messaging protocol maintained by the W3C [XML Protocol Working Group](#).

SOAP: Simple Object Access Protocol

Request Example

Call to a fictional web service to get details on product with product id=827635

```
<soap:Envelope xmlns:soap="http://schemas.xmlsoap.org/soap/envelope/">
  <soap:Body>
    <getProductDetails xmlns="http://warehouse.example.com/ws">
      <productID>827635</productID>
    </getProductDetails>
  </soap:Body>
</soap:Envelope>
```



SOAP: Simple Object Access Protocol

Response Example

Possible response to a request for product information:

```
<soap:Envelope xmlns:soap="http://schemas.xmlsoap.org/soap/envelope/">
  <soap:Body>
    <getProductDetailsResponse xmlns="http://warehouse.example.com/ws">
      <getProductDetailsResult>
        <productName>Toptimate 3-Piece Set</productName>
        <productID>827635</productID>
        <description>3-Piece luggage set. Black Polyester.</description>
        <price>96.50</price>
        <inStock>true</inStock>
      </getProductDetailsResult>
    </getProductDetailsResponse>
  </soap:Body>
</soap:Envelope>
```

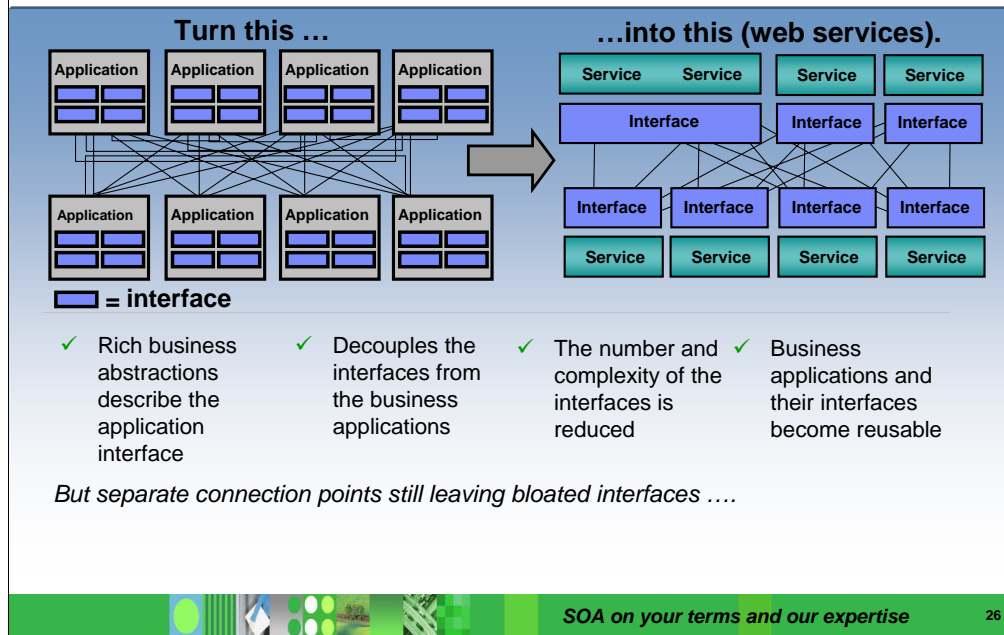
Web Services decouples interfaces from applications...



- So how does basic SOA decouple the interfaces from their applications?
- 1) SOA uses a programming model that allows a rich abstraction of both the business app and the interface.
- 2) By abstracting, the interfaces can be clearly separated from the business applications.
- 3) This enables you to reduce the number and complexity of those interfaces.
- 4) It allows you to reuse both the interfaces and the business applications.
- The problem is that you still have to build, find, and manage all of those interfaces somewhere.

The ESB shrinks those interfaces further

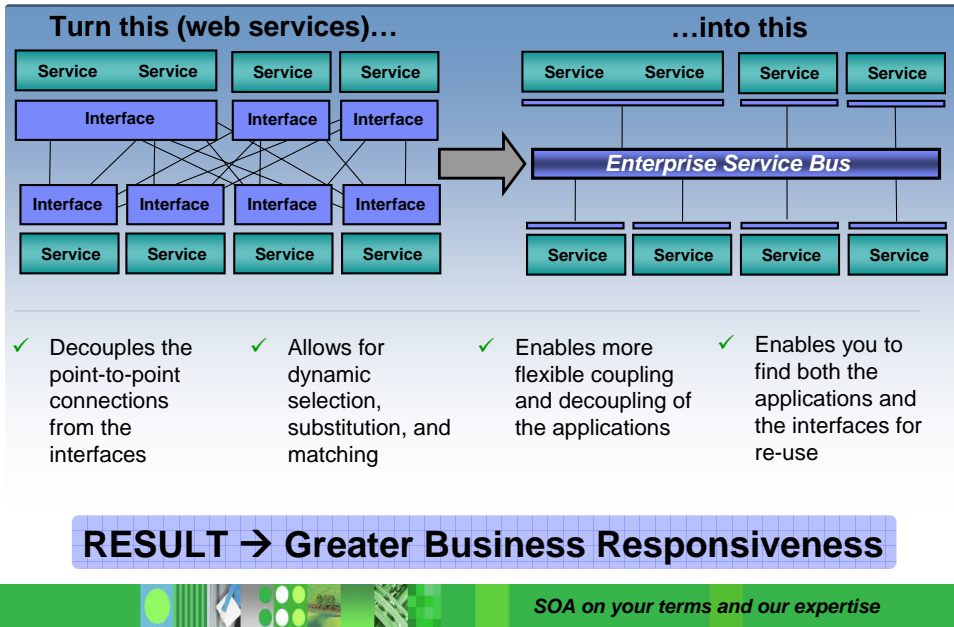

- The ESB shrinks the interfaces further.
 - 1) It virtualizes the interface, or in other words, it decouples the point-to-point connections from the interfaces themselves.
 - ✓ 2) The interfaces are put into a third party broker which helps you manage the interfaces better.
 - ✓ 3) This enables faster and more flexible coupling and decoupling of applications.
 - ✓ 4) Because you can find all of the applications and the interfaces, you can then reuse both.

Evolution of Business Solutions

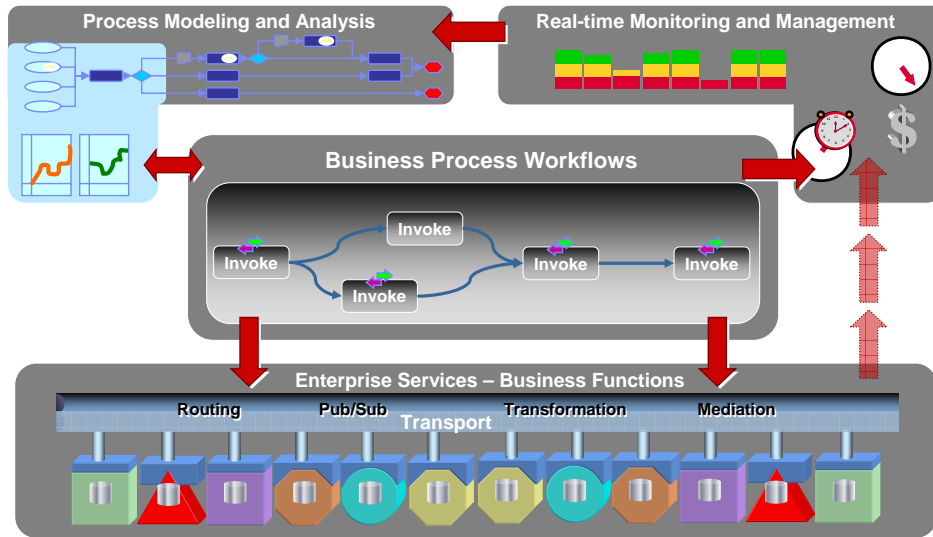

Distributed Resources: Modular Applications, Databases, Organizations, People

SOA on your terms and our expertise

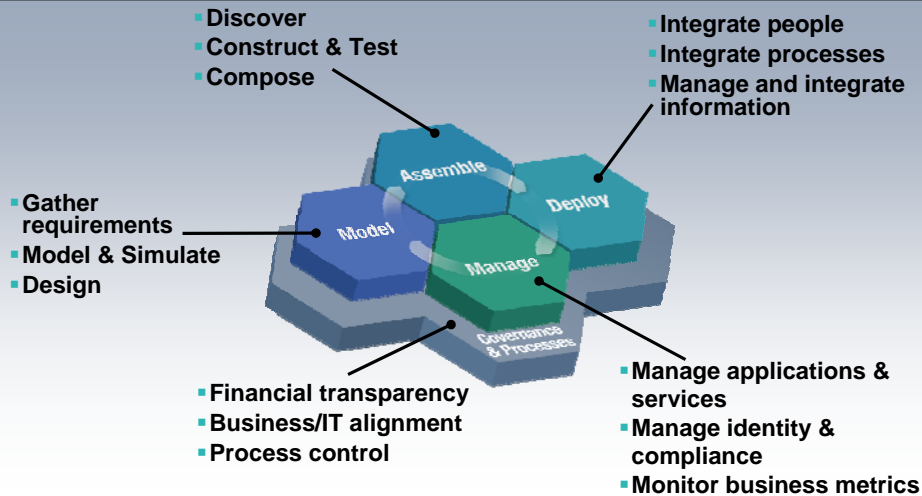
The SOA Lifecycle

- Customers think about SOA in terms of a lifecycle. They start in the Model phase by gathering business requirements and designing their business processes. Once they have optimized the business processes, they implement it by combining new and existing services. The assets are then deployed into a secure and integrated environment for integrating people, processes and information. Once deployed, customers manage and monitor from both an IT and a business perspective. Information gathered during the Manage phase is fed back into the lifecycle for continuous process improvement. Underpinning all of these lifecycle stages is governance which provides guidance and oversight for the SOA project.

SOA Executive Summit IBM

SOA Foundation

The diagram illustrates the SOA Foundation lifecycle stages and their supporting software products:

- Model:** WebSphere Business Modeler*, Rational Software Architect*
- Assemble:** WebSphere Integration Developer*, Rational Application Developer*
- Deploy:** WebSphere Process Server*, WebSphere ESB* & Message Broker*, WebSphere Partner Gateway & Adapters
- Manage:** WebSphere Business Monitor*, WebSphere Application Server & Extended deployment*, Tivoli Composite Application Manager*, Tivoli Identity & Access Manager * **New or Enhanced**

People: WebSphere Portal*, WebSphere Everyplace Deployment*, Workplace Collaboration Services*

Information: DB2, WebSphere Information Integrator*

SOA on your terms and our expertise 30

- The SOA Foundation is built with software that was carefully selected from a broader software portfolio. These are the specific, targeted software products that support each stage of the SOA lifecycle. They are interoperable and fully modular so you can select just what you need today with the comfort that it will work well with other additions you may want to make in the future.
- The IBM SOA Foundation delivers the capabilities you need to adopt SOA through a comprehensive architecture. These capabilities can be implemented on a build-as-you-go basis, and yet, because of the architecture and its service orientation, capabilities and project level solutions can be easily added as new requirements are addressed over time.
- Background: The SOA Reference Architecture shows the key capabilities that are required for comprehensive, enterprise wide SOA solutions.

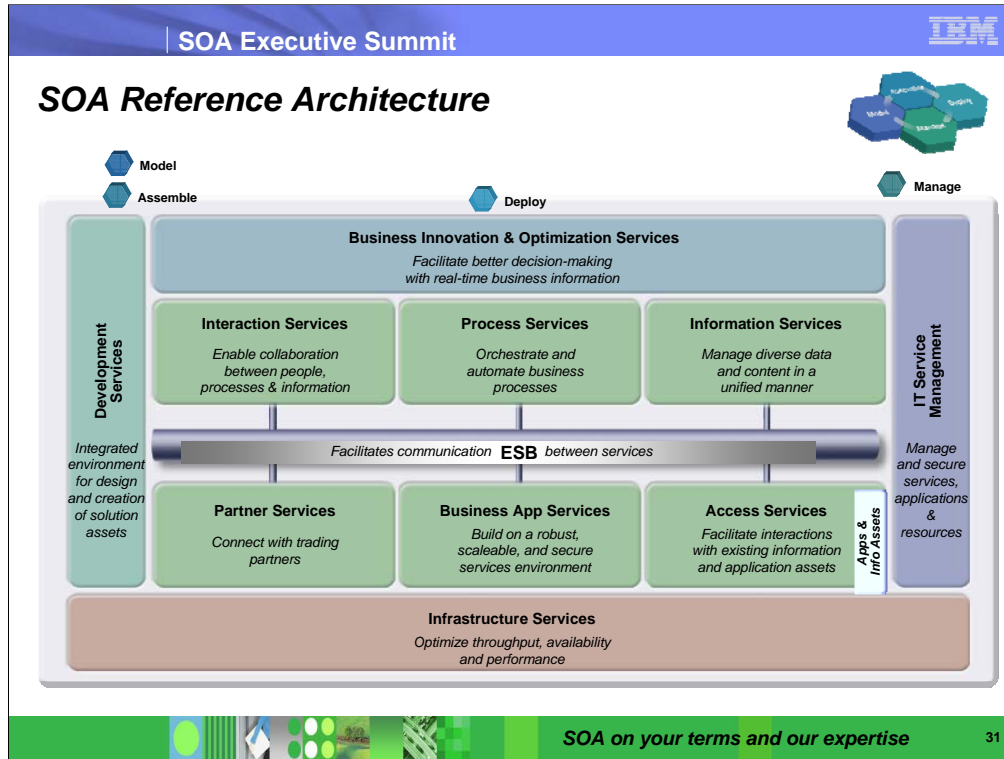

- Development Services** are an essential component of any comprehensive integration architecture. The SOA Architecture includes development tools, used to implement custom artifacts that leverage the infrastructure capabilities, and business performance management tools, used to monitor and manage the runtime implementations at both the IT and business process levels. Development tools allow people to efficiently complete specific tasks and create specific output based on their skills, their expertise, and their role within the enterprise. Business Analysts who analyze business process requirements need modeling tools that allow business processes to be charted and simulated. Software Architects need tool perspectives that allow them to model data, functional flows, system interactions, etc. Integration Specialists require capabilities that allow them to configure specific inter-connections in the integration solution. Programmers need tools that allow them to develop new business logic with little concern for the underlying platform. Yet, while it is important for each person to have a specific set of tool functions based on their role in the enterprise, the tooling environment must provide a framework that promotes joint development, asset management and deep collaboration among all these people. A common repository and functions common across all the developer perspectives (e.g. version control functions, project management functions, etc) are provided in the SOA Reference Architecture through a unified development platform.
- The **Business Innovation & Optimization Services** incorporate monitoring capabilities that aggregate operational and process metrics in order to efficiently manage systems and processes. Managing these systems requires a set of capabilities that span the needs of IT operations professionals and business analysts who manage the business operations of the enterprise. These capabilities are delivered through a set of comprehensive services that collect and present both IT and process-level data, allowing business dashboards, administrative dashboards, and other IT level displays to be used to manage system resources and business processes. Through these displays and services, it is possible for LOB and IT personnel to collaborate to determine, for example, what business process paths may not be performing at maximum efficiency, the impact of system problems on specific processes, or the relationship of system performance to business process performance. This collaboration allows IT personnel and assets to be tied more directly to the business success of the enterprise than they traditionally have been.
- One key feature of the SOA Reference Architecture is the linkage between the Development and the Business Innovation & Optimization Services. The ability to deliver runtime data and statistics into the development environment allows analyses to be completed that drive iterative process re-engineering through a continuous business process improvement cycle.
- At the core of the SOA Reference Architecture is the **Enterprise Service Bus**. This architectural construct delivers all the inter-connectivity capabilities required to leverage and use services implemented across the entire architecture. Transport services, event services, and mediation services are all provided through the ESB. Transport services provide the fundamental connection layer; event services allow the system to respond to specific stimuli that are part of a business process; and mediation services allow loose-coupling between interacting services in the system. The ESB is a key factor in enabling the service orientation of the SOA Reference Architecture to be leveraged in implementing service oriented solutions and can be implemented today to meet the quality of service requirements of any integration solution.
- The SOA Reference Architecture also contains a set of services that are oriented toward the integration of people, processes, and information. These services control the flow of interactions and data among people and automated application services in ways appropriate to the realization of a business process:
 - **Interaction Services** provide the capabilities required to deliver IT functions and data to end users, meeting the end-user's specific usage preferences.
 - **Process Services** provide the control services required to manage the flow and interactions of multiple services in ways that implement business processes.
 - **Information Services** provide the capabilities required to federate, replicate, and transform data sources that may be implemented in a variety of ways.

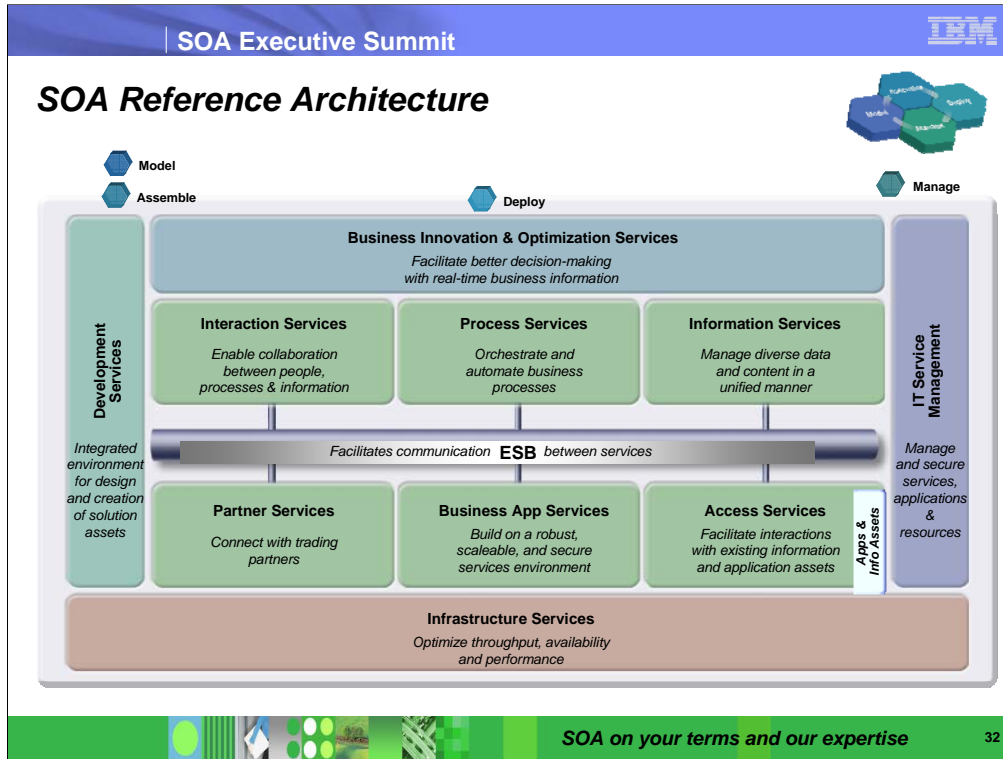

- Automated application services, implementations of business logic in automated systems, are a critical part of any integration architecture or solution. Many of these services are provided through existing applications; others are provided in newly implemented components; and others are provided through external connections to third party systems. Existing enterprise applications and enterprise data are accessible from the ESB through a set of access services. These **Access Services** provide the bridging capabilities between legacy applications, pre-packaged applications, enterprise data stores (including relational, hierarchical and nontraditional, unstructured sources such as XML and Text), etc and the ESB. Using a consistent approach, these access services expose the data and functions of the existing enterprise applications, allowing them to be fully re-used and incorporated into functional flows that represent business processes. Existing enterprise applications and data leverage the Business Application and Data Services of their operating environments such as CICS, IMS, DB2, etc. As these applications and data implementations evolve to become more flexible participants in business processes, enhanced capabilities of their underlying operating environments, for example support of emerging standards, can be fully utilized.
- The SOA Reference Architecture also contains a set of **Business Application Services** that provide runtime services required for new application components to be included in the integrated system. These application components provide new business logic required to adapt existing business processes to meet changing competitive and customer demands of the enterprise. Design and implementation of new business logic components for integration enables them to be fully re-useable, allowing them to participate in new and updated business processes over time. The Business Application Services include functions important to the traditional programmer for building maintainable, flexible, and re-useable business logic components.
- In many enterprise scenarios, business processes involve inter-actions with outside partners and suppliers. Integrating the systems of the partners and suppliers with those of the enterprise improves efficiency of the overall value chain. **Partner Services** provide the document, protocol, and partner management services required for efficient implementation of business-to-business processes and inter-actions.
- Underlying all these capabilities of the SOA Reference Architecture is a set of **Infrastructure Services** which provide security, directory, IT system management, and virtualization functions. The security and directory services include functions involving authentication and authorizations required for implementing, for example, single sign-on capabilities across a distributed and heterogeneous system.
- IT Services Management Services** include functions that relate to scale and performance, for example edge services and clustering services, and the virtualization capabilities allow efficient use of computing resources based on load patterns, etc. The ability to leverage grids and grid computing are also included in infrastructural services.
- While many of the Infrastructure and IT Service Management services perform functions tied directly to hardware or system implementations, others provide functions that interact directly with integration services provided in other elements of the architecture through the ESB. These interactions typically involve services related to security, directory, and I/T operational systems management.
- Wrap up:** The SOA Reference Architecture is a complete and comprehensive architecture that covers all the integration needs of an enterprise. Its services are well integrated and are delivered in a modular way, allowing SOA implementations to start at a small project level. As each additional project is addressed, new functions can be easily added, incrementally enhancing the scope of integration across the enterprise. In addition to supporting SOA strategies and solutions, the architecture itself is designed using principles of service orientation and function isolation.

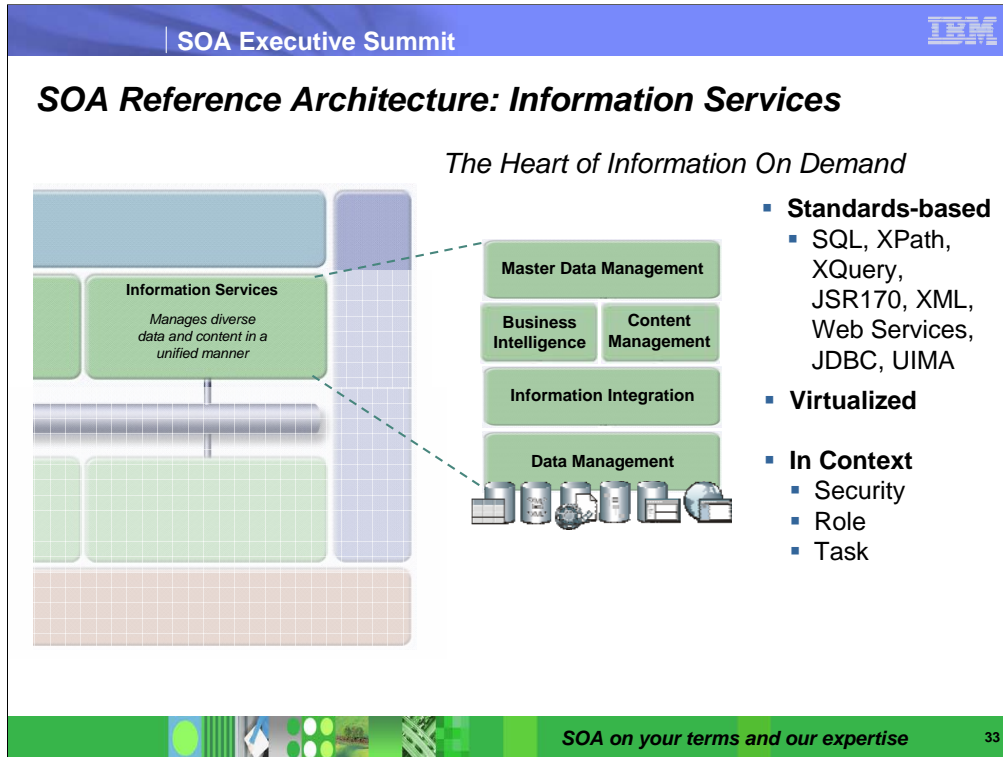

- Within the SOA Foundation we are going to look at the capabilities available for Information Composition.
- IBM Information Management portfolio provides key capabilities in the areas of:
 - Master Data Management (Product Information Management with WPC and Customer Data Integration with DWL)
 - Business Intelligence (e.g. DB2 AlphaBlox and DB2 Data Warehouse Edition)
 - Content Management (e.g. DB2 Content Manager)
 - Information Integration (with solutions for Enterprise Information Integration, Extract / Transform / Load, Enterprise Content Integration, Data Quality etc.), and
 - Data Management (including the DB2 UDB and Informix databases).
- These capabilities follow open standards where available and IBM is committed to contributing to the development of these standards including making donations of code and intellectual property such as the case with the Unstructured Information Management Architecture (UIMA) framework for Text Analytics recently released into the open source community.

DB2 and SOA

Exposing DB2 objects as Web Services

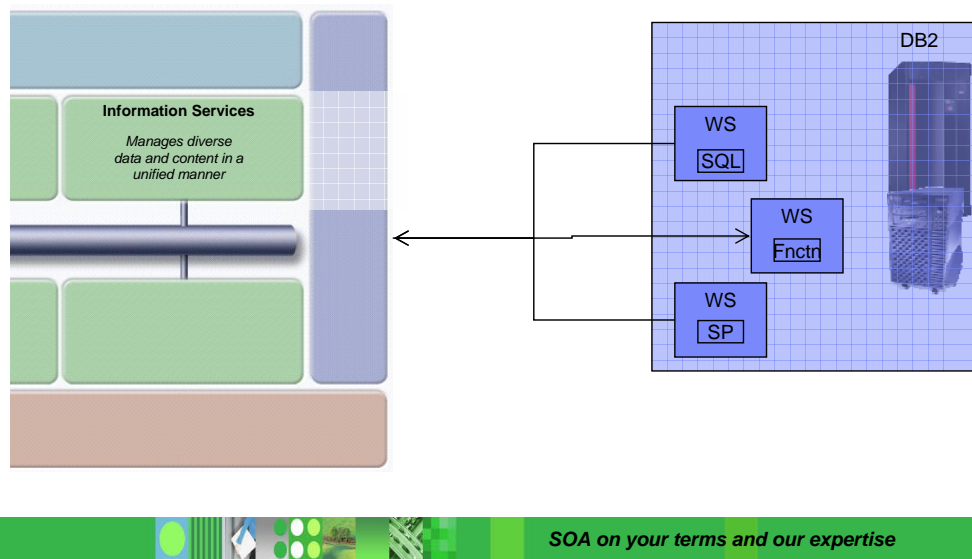

- Now let's move to a simple example of finding some DB2 objects and exposing them as web services. The DB2 objects are
 - ▶ SQL accessing tables in DB2
 - ▶ Stored procedures
 - ▶ Functions (user-defined or built-in)

DB2 and SOA

Exposing DB2 objects as Web Services

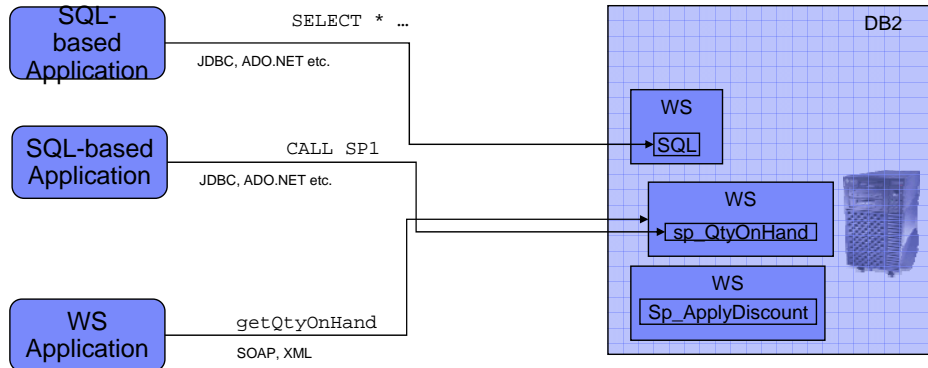

Exposing DB2 objects as Web Services

This applies to DB2 for z/OS and System i

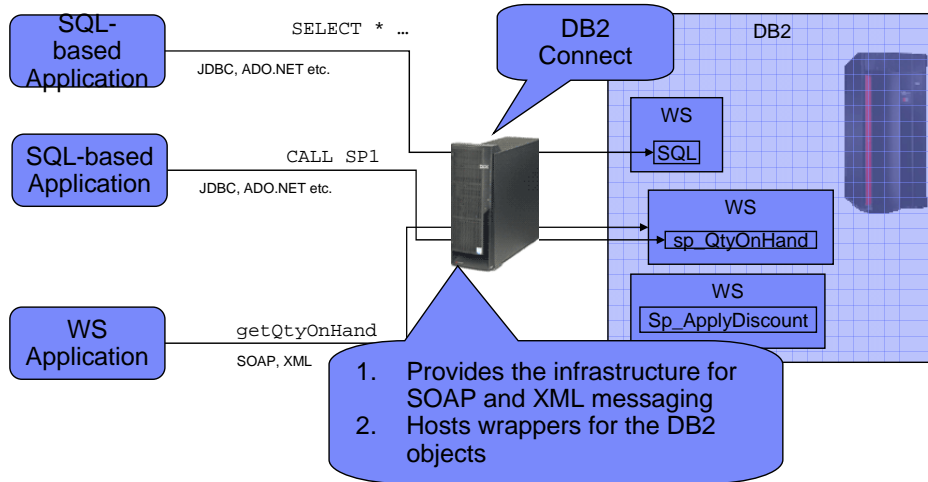

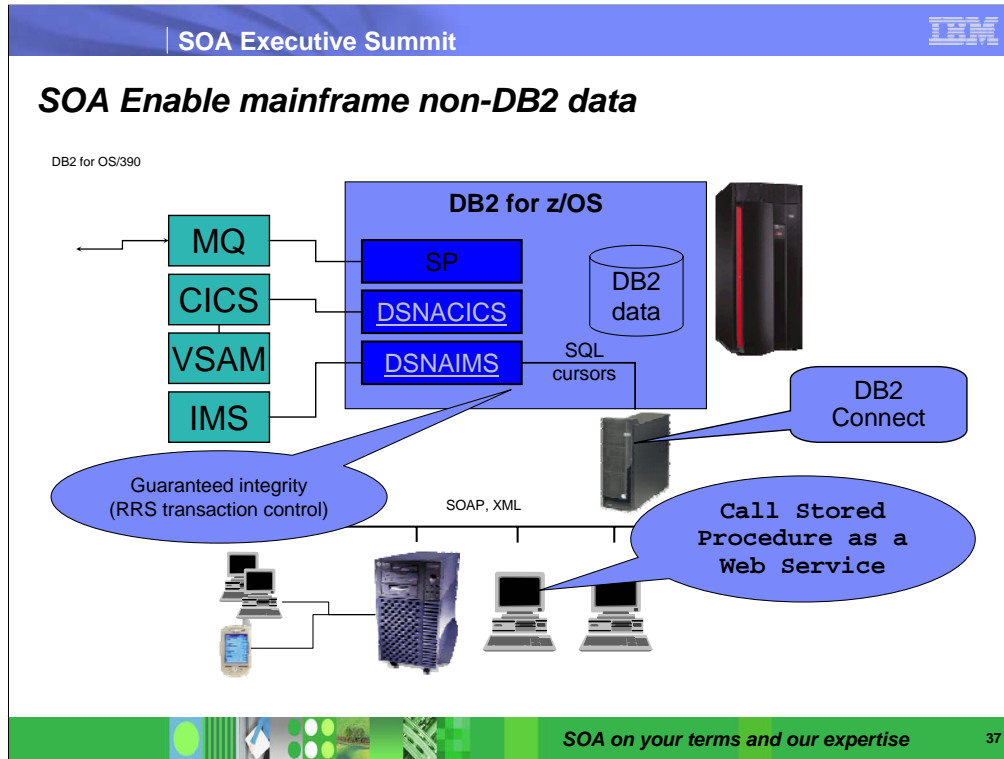

- In addition to providing access to relational data in DB2 family servers, DB2 Connect provides access to non-DB2 mainframe data. This access is provided by utilizing stored procedure function of DB2 for OS/390 and includes such popular data sources as VSAM files, CICS and IMS transactions and MQSeries queues.
- While there are other methods available for accessing these data sources from PC and web applications, DB2 Connect stored procedure method addresses the issues not addressed by the other methods. Because all access is provided through stored procedures, PC, UNIX and web application programmers do not need to be aware that data is being accessed or updated is not managed by DB2. Application programmers use very familiar stored procedure call and result set processing interfaces. The very same interfaces and methods that are used to access all relational data. Mainframe programmers and DBAs with skills in CICS, IMS, VSAM and MQSeries are responsible for building and managing access to these data sources. IBM provides documentation and samples for building stored procedures that access non-relational mainframe data.
- Also important is the fact that access to these data sources is transactional and data integrity is assured through the OS/390 RRS facility. For example, a DB2 stored procedure can update DB2 data and execute CICS and IMS transactions and be assured that if any of these operations was to fail the entire transaction would be rolled back.

DB2 and SOA

Consuming Web Services to get real time data

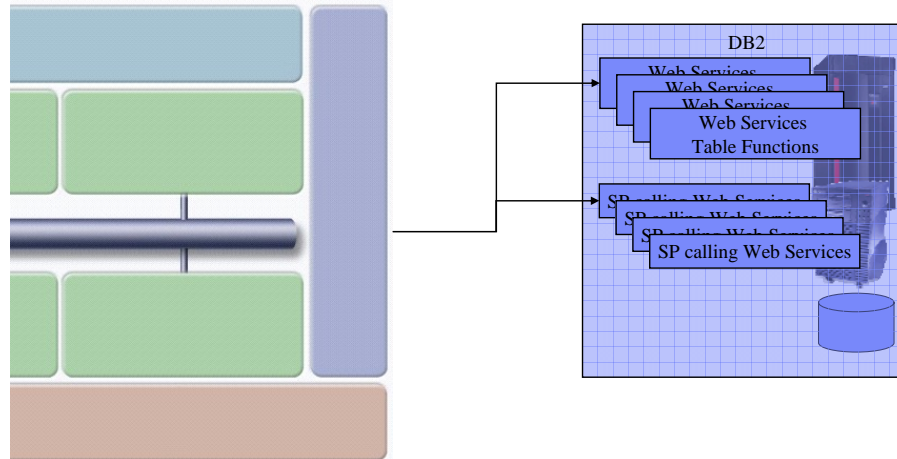

- We showed DB2 as a provider of information first, but DB2 can also be a consumer of web services. Here is a simple example of using web services within a DB2 function – either a table function or a stored procedure calling web services.

DB2 and SOA

Consuming Web Services to get real time data
Combining with DB2 information

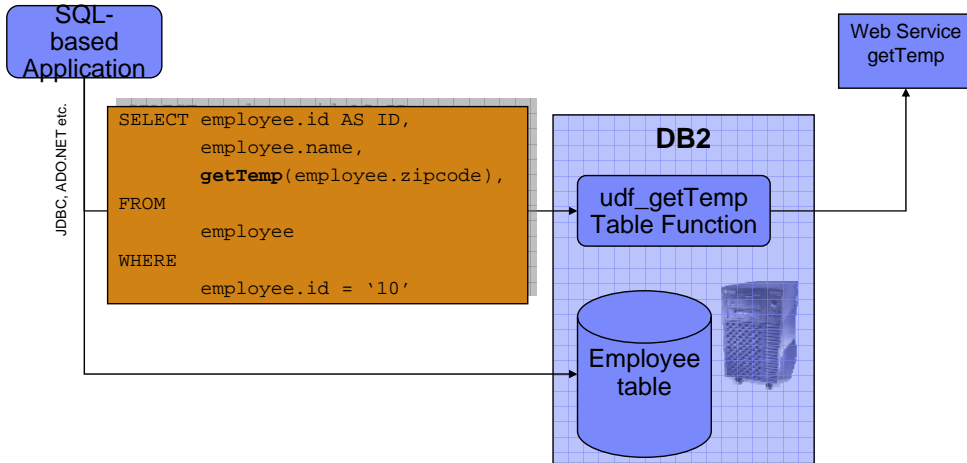

Information Services Are Key to SOA Solutions

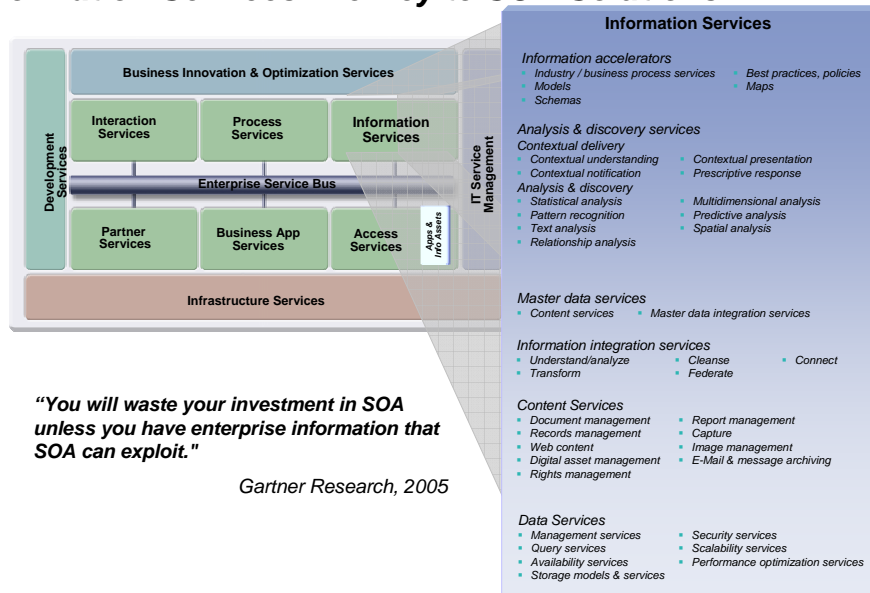

- **“You will waste your investment in SOA unless you have enterprise information that SOA can exploit.”**
 - ▶ Gartner Research, 2005
- Information services and access services are the key enablers for making the information more available to use and support SOA.
- The SOA Reference Architecture is a complete and comprehensive architecture that covers all the integration needs of an enterprise. Its services are well integrated and are delivered in a modular way, allowing SOA implementations to start at a small project level. As each additional project is addressed, new functions can be easily added, incrementally enhancing the scope of integration across the enterprise. In addition to supporting SOA strategies and solutions, the architecture itself is designed using principles of service orientation and function isolation.

Integrating XML Key to SOA

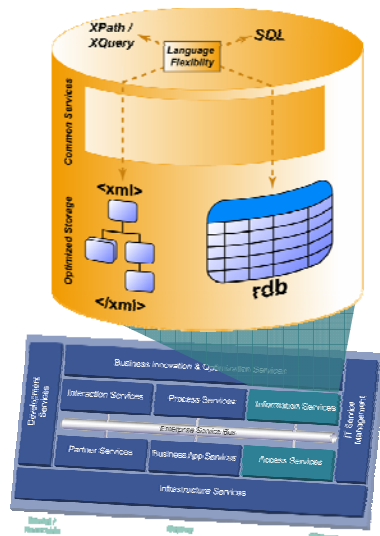

	Shred	CLOB	Stand-alone	Hybrid
Information Fidelity	✗	✓	✓	✓
Integration	✓	✗	✗	✓
Schema Flexibility	✗	=	✓	✓
Performance/Scale	=	✗	✗	✓
Programming Models	✗	✗	=	✓
Manageability	✓	✗	✗	✓

SOA on your terms and our expertise

41

- DB2 9 provides the best of both worlds, pureXML™ for native storage and integrating XML with object-relational. Performance, integrity, protection, and scale from the proven DB2 infrastructure with the flexibility of XML/XPath and relational/SQL. This overcomes the complexity & limitations of prior models (shred, CLOB, or XML only)
- IBM introduced a new generation data server with the availability of DB2 9. The explosive growth of XML based data standards in all industries means competitive advantage for those businesses that use it most effectively and efficiently. Client, policy and claims processing in Insurance; supply chain management in Retail; financial transactions and asset management in Banking; patient care in Healthcare; citizen service in Government; implementing Service Oriented Architectures (SOA) in Computing Software and Services - and many other processes across all industries - increasingly rely on information captured and exchanged in XML form. Our clients are increasingly managing XML format text documents in a content management system for proper governance and efficient use in the business process workflow. But few are realizing the full value of all the business data they possess that are in XML format.
- Early users of the pureXML feature of DB2 9 are taking advantage of the fact that data in XML format is well structured and can be queried via standard languages such as XPath and XQuery. By doing so they are bringing that data to bear in both transactional and analytic processes - with higher performance and lower development costs than previously possible with a relational database. The difference is that DB2 9 supports both relational (tabular) and XML (hierarchical) structures in the same database so that both can be easily, efficiently and securely managed, analyzed and delivered. Unlike other relational data servers - and previous versions of DB2 - pureXML eliminates the overhead of fitting the “square peg” XML tree structure into the “round hole” row and column relational structure.

Integrating XML

Key to SOA: Strong Client & Partner Feedback

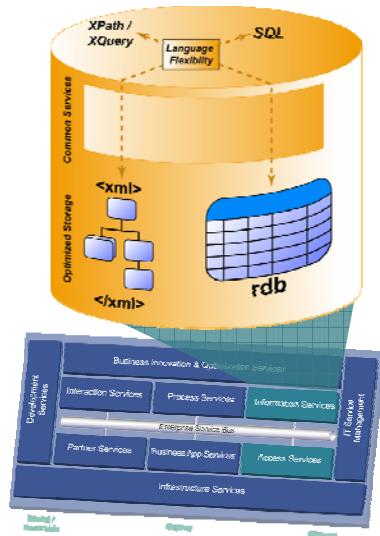

Work in Both Worlds

- Performance, integrity, protection, and scale from the proven DB2 infrastructure
- Flexibility of XML/XPath and relational/SQL
- Overcomes complexity & limitations of prior models (shred, CLOB, or XML only)

Learn More & Download

- ibm.com/software/db2zos

- There is a lot to learn and build upon. DB2 9 provides a solid XML base integrated into a robust DBMS. Whether you have relational data, XML data or hybrid data, you can integrate the information together.
- There is a new XML Guide in the DB2 library.
 - ▶ <http://publib.boulder.ibm.com/epubs/pdf/dsnxgk10.pdf>

SOA is a Team Sport

Different focus areas within SOA to meet customers' priorities

- Maximizing People Productivity within an SOA: *Delivered through a natural, intuitive, adaptive user experience*
- Business Process Management : *Understand, improve, and manage your business processes to enable rapid operational change*
- Information as a Service: *Achieve new levels of information flexibility, consistency & availability*
- IT Service Management: *Manage your IT infrastructure, to more effectively and efficiently deliver IT services*
- Business Driven Development: *Enable clients to govern the business process of software development*

- Here are some of the key lessons we have learned in SOA implementations.

DB2 9 for z/OS RedBooks & RedPapers

- Powering SOA with IBM Data Servers SG24-7259
- LOBs with DB2 for z/OS: SG24-7270
- Securing DB2 & MLS z/OS SG24-6480-01
- DB2 9 Technical Overview SG24-7330
- Enhancing SAP - DB2 9 SG24-7239
- Best practices SAP BI - DB2 9 SG24-6489-01
- DB2 9 Performance Topics SG24-7473
- DB2 9 Optimization Service Center SG24-7421
- Index Compression with DB2 9 for z/OS paper
- DB2 Stored Procedures SG24-7083 update

SOA on your terms and our expertise 44

▪ Six redbooks with substantial DB2 9 content are on the web, with two drafts being reviewed, one being written and and one more in the works for later this year. See the DB2 library for detailed information

<http://www.ibm.com/software/data/db2/zos/library.html>

▪ Powering SOA with IBM Data Servers, SG24-7259
<http://www.redbooks.ibm.com/abstracts/SG247259.html>

▪ LOBs with DB2 for z/OS: Stronger & Faster SG24-7270
<http://www.redbooks.ibm.com/abstracts/SG247270.html>

▪ Securing DB2 & MLS z/OS, SG24-6480-01
<http://www.redbooks.ibm.com/abstracts/sg246480.html>

▪ DB2 9 Technical Overview, SG24-7330
<http://www.redbooks.ibm.com/abstracts/SG247330.html>

▪ Enhancing SAP - DB2 9, SG24-7239,
<http://www.redbooks.ibm.com/abstracts/SG247239.html>

▪ Best practices SAP BI - DB2 9, SG24-6489-01,
<http://www.redbooks.ibm.com/abstracts/sg246489.html>

▪ DB2 9 Performance Topics, SG24-7473, in review, not on web yet
<http://www.redbooks.ibm.com/abstracts/SG247473.html>

▪ Index Compression with DB2 9 for z/OS, draft redpaper REDP4345
<http://www.redbooks.ibm.com/redpieces/abstracts/redp4345.html>

▪ DB2 9 Optimization Service Center, SG24-7421, being written

▪ DB2 for z/OS Stored Procedures: CALL & Beyond SG24-7083-01 update later

SOA and DB2 for z/OS Webliography:

- SOA from IBM
- The Value of the IBM System z and z/OS in Service-Oriented Architecture, redp4152
- The Value of the IBM System z and z/OS in the Design of a Service-Oriented Architecture, redp4190
- SOA Architecture Handbook for z/OS, SG24-7331
- SOA Solutions Using IBM Information Server, SG24-7402
- z/OS Getting Started: WebSphere Process Server and WebSphere Enterprise Service Bus V6, SG24-7378
- System z Strengths and Values, SG24-7333
- Powering SOA with IBM Data Servers, SG24-7259
- Best Practices of SOA Management, redp4233
- Information Management and SOA
- DeveloperWorks
- Architecture in Practice: toward SOA
- Interview with Jeff Josten



- **SOA from IBM** <http://www.ibm.com/jct09002c/isv/soa/resources.html>
<http://www.ibm.com/software/solutions/soa/>
- **The Value of the IBM System z and z/OS in Service-Oriented Architecture**
<http://www.redbooks.ibm.com/abstracts/redp4152.html?Open>
- **The Value of the IBM System z and z/OS in the Design of a Service-Oriented Architecture**
<http://www.redbooks.ibm.com/abstracts/redp4190.html?Open>
- **SOA Architecture Handbook for z/OS**
<http://www.redbooks.ibm.com/abstracts/sq247331.html?Open>
- **SOA Solutions Using IBM Information Server**
<http://www.redbooks.ibm.com/abstracts/sq247402.html?Open>
- **z/OS Getting Started: WebSphere Process Server and WebSphere Enterprise Service Bus V6** <http://www.redbooks.ibm.com/abstracts/sq247378.html?Open>
- **System z Strengths and Values** <http://www.redbooks.ibm.com/abstracts/sq247333.html?Open>
- **Powering SOA with IBM Data Servers, SG24-7259**
<http://www.redbooks.ibm.com/abstracts/sq247259.html?Open>
- **Best Practices of SOA Management** <http://www.redbooks.ibm.com/abstracts/redp4233.html?Open>
- **Information Management and SOA** <http://www.ibm.com/developerworks/db2/zones/webservices/>
- **DeveloperWorks** <http://www.ibm.com/developerworks/>
- **Architecture in Practice: toward SOA**
<http://www.ibm.com/developerworks/webservices/library/ws-soa-soi/>
<http://www.ibm.com/developerworks/webservices/library/ws-soa-soi2/>
<http://www.ibm.com/developerworks/architecture/library/ar-arprac2/>
- **Interview with Jeff Josten** <http://www.ibm.com/software/tivoli/features/ccr2/ccr2-2006-09/db2-for-zos.html>

IBM

<http://www.ibm.com/software/os/zseries/roadshows/handouts/>

Home | Products | Services & industry solutions | Support & downloads

Software > IBM software for System z >

System z Mainframe Technology Roadshows

Spark Innovation with New Mainframe Technology

- ✦ Invitation
- ✦ Track 1: The Modern Mainframe - at the Heart of Your Business
- ✦ Track 2: Application Development
- ✦ Track 3: DB2 Technology Update
- ✦ Track 4: Application Integration
- ✦ Track 5: System z IT Operations
- ✦ Track 6: CICS Application - System Development
- ✦ Track 7: IMS Technology Update
- ✦ Track 8: Business Integration

 [Invitation](#) (436KB)

Agenda - day 1

Track 1: The Modern Mainframe - at the Heart of Your Business

[Session 1 8:30 - 8:50 am Introduction to Next Generation Requirements](#) (PDF, 3MB)

[Session 2 8:50 - 9:20 am Specialized Offerings for Your](#)

Related links

- Mainframe servers
- XML Toolkit for zSeries
- Software Asset Management
- Software Migration Project Office
- Warranties,

SOA on your terms and our expertise

46

- Check though this web page for the presentations you are interested in and download them.

Related Presentations in other tracks:

- Delivering next generation solutions at the lowest cost
- Leveraging Specialty engines
- Hardware & Software update
- Consolidating data on System z
- Clustering
- Continuous Availability
- CICS
- IMS
- Rational
- WebSphere
- ...

Many of the other road show presentations are closely related to DB2.
Here are some examples of the topics.

Information as a Service Delivering the Business Value of Information

- **Visit our Web page**
www.ibm.com/informationondemand
- **Take our online self-assessment**
- **Take advantage of our Fast Start Services Offerings**



Information On Demand



Always available. Always complete. Always right.

Learn how to create business value through Information On Demand.

[Overview](#) | [Downloads](#) | [Events](#) | [Viewpoints](#) | [Industry](#)

[Product Offerings](#) | [Solutions Portfolio](#) | [Center of Excellence](#)