

Sterling Selling and Fulfillment Foundation



Drop Ship Option Pack

Release 9.1

Sterling Selling and Fulfillment Foundation



Drop Ship Option Pack

Release 9.1

Note

Before using this information and the product it supports, read the information in "Notices" on page 83.

Copyright

This edition applies to the 9.1 Version of IBM Sterling Selling and Fulfillment Foundation and to all subsequent releases and modifications until otherwise indicated in new editions.

© **Copyright IBM Corporation 1999, 2011.**

US Government Users Restricted Rights – Use, duplication or disclosure restricted by GSA ADP Schedule Contract with IBM Corp.

Contents

Chapter 1. Sterling Drop Ship Option Pack- An Overview	1	Configure the Chained Order Consolidation Template	29
Chapter 2. Sterling Drop Ship Option Pack Checklist	3	Chapter 13. Configure a Seller Organization as an Enterprise.	31
Chapter 3. Introduction to Sterling Drop Ship Option Pack Installation	7	Chapter 14. Assign the Role of a Seller to an Organization.	33
Chapter 4. Prerequisites to Installing Sterling Drop Ship Option Pack	9	Chapter 15. Assign the Role of a Buyer to a Seller Organization	35
Chapter 5. Install Sterling Drop Ship Option Pack in a UNIX Environment or a Linux Environment.	11	Chapter 16. Configure the Organization Code of a Seller.	37
Chapter 6. Load the Factory Defaults for Sterling Drop Ship Option Pack in Sterling Selling and Fulfillment Foundation	13	Chapter 17. Configure the Synchronized Dates Transaction Rule for a Seller	39
Chapter 7. Set Properties for Sterling Drop Ship Option Pack.	15	Configure the Synchronized Dates Transaction Rule For an SO	39
Chapter 8. Build the Enterprise Archive Package	17	Configure the Synchronized Dates Transaction Rule For a PO	39
Chapter 9. Drop Ship Purchase Order Lifecycle	19	Chapter 18. Configure Number of Transit Days for a Seller	41
Stages of a Drop Ship PO Fulfillment Cycle	20	Chapter 19. Create a Supplier	43
Creating a Drop Ship PO	20	Chapter 20. Configure a Supplier as a Vendor of the Seller Organization	45
Acknowledging a Drop Ship PO	20	Chapter 21. Configure a Supplier Organization as a Node	47
Shipping a Drop Ship PO.	21	Chapter 22. Configure a Supplier Organization as a Seller	49
Purging a Drop Ship PO	21	Chapter 23. Configure a Supplier's Inventory Attributes	51
Chapter 10. Define Event Handlers to Publish a Purchase Order and the Change Purchase Order	23	Chapter 24. Configure a Supplier's Catalog Attributes	53
Define the Event Handler of the Create Purchase Order Transaction	23	Chapter 25. Configuring the AS2 Communication Protocol for Drop Ship Option Pack	55
Define the Event Handler of the Change Purchase Order Transaction	23	Configuring Services to Send Documents from the Order Management System to Sterling B2B Integrator	55
Chapter 11. Configure the Modification Components for an Order	25		
Chapter 12. Configure Document Templates	27		
Configure the Default Chained Order Template	27		

Configuring Services to Receive Documents from Sterling B2B Integrator to the Order Management System 57

Chapter 26. Configuring a System Certificate in Sterling B2B Integrator for Drop Ship Option Pack 59

Chapter 27. Configuring an AS2 Profile in Sterling B2B Integrator for Drop Ship Option Pack 61

Chapter 28. Publishing a Chained Purchase Order 63

Chapter 29. Implementation: Publishing a Change Purchase Order 67

Chapter 30. Implementation: Receiving an Acknowledgement for a Drop Ship Order 69

Chapter 31. Implementation: Receiving an Advance Shipment Notice for a Drop Ship Order 73

Chapter 32. Implementation: Receiving Inventory Updates for a Drop Ship Order 75

Chapter 33. Implementation: Receiving an Invoice for a Drop Ship Order 77

Chapter 34. Sending a Remittance Advice 81

Notices 83

Index 87

Chapter 1. Sterling Drop Ship Option Pack- An Overview

Drop Ship fulfillment is a process in which a Seller takes orders from a customer, forwards these orders directly to a Supplier (either a manufacturer or a wholesaler), who then ships the items directly to the customer.

Sterling Drop Ship Option Pack is an integration solution between IBM® Sterling Selling and Fulfillment Foundation™ (On Premise) and the On Demand applications, which allows Sellers and Suppliers to manage and complete the drop ship process. The integration between Sterling On Premise Order Management, IBM Sterling Supplier Portal™, and IBM Sterling Supply Chain Visibility™ is achieved by using IBM Sterling B2B Collaboration Network™ and IBM Sterling Gentran® Integration Suite™, which has been renamed to IBM Sterling B2B Integrator. You can set up communication between the Order Management and the On Demand applications using Applicability Statement (AS2) or File Transfer Protocol (FTP).

When a customer places an order with a Seller, the Seller's Order Management system first verifies if the item can be shipped. If the ordered item has been defined as a drop ship item, based on the inventory information provided by the Suppliers, the Seller's Order Management system generates a chained Purchase Order (PO) for each Supplier, based on the customer's order. This chained PO is published to Sterling Supplier Portal through Sterling B2B Collaboration Network.

The Supplier, using Sterling Supplier Portal, acknowledges the PO if it can be fulfilled. The acknowledged PO is then sent to the Seller's Order Management system. Based on the Supplier's acknowledgement, the line status, order status, and estimated delivery date is updated in the Sales Order (SO).

After sending the acknowledgement, the Supplier picks and packs the ordered items from the warehouse, prints the Seller-branded packing slips, and ships the items to the customer. The Supplier then confirms the items and quantities that have been shipped to the customer. This Advance Shipment Notice (ASN) is sent to the Seller's Order Management system. In the Seller's Order Management system, the SO is updated with the line status and the order status.

After the order is fulfilled, the Seller sends a remittance advice to the Supplier.

All the documents published either by the Supplier or the Seller are copied to Sterling Supply Chain Visibility. The Seller can configure alerts for the drop ship orders in Sterling Supply Chain Visibility. The Seller can also run standard Key Performance Indicators reports in Sterling Supply Chain Visibility On-Demand to monitor individual or overall drop ship Suppliers' performance. For more information about configuring alerts and KPIs, refer to the *Sterling Supply Chain Visibility User Guide*.

Chapter 2. Sterling Drop Ship Option Pack Checklist

To utilize the features provided by Sterling Drop Ship Option Pack, you must perform certain tasks in the Applications Manager™ and Sterling Supplier Portal™ before you start using Sterling Drop Ship Option Pack. The following table provides a list of these tasks:

Task	Description	Refer To
Install Sterling Selling and Fulfillment Foundation	Ensure that you have successfully installed the Sterling Selling and Fulfillment Foundation, Release 8.0-HF44 (or higher)	<i>Selling and Fulfillment Foundation: Installation Guide</i>
Install Sterling Drop Ship Option Pack.	Ensure that you have successfully installed Sterling Drop Ship Option Pack.	Chapter 5, "Install Sterling Drop Ship Option Pack in a UNIX Environment or a Linux Environment," on page 11
Configure Sterling Drop Ship Option Pack.	Ensure that you have configured Drop Ship Option Pack.	<ul style="list-style-type: none"> Chapter 6, "Load the Factory Defaults for Sterling Drop Ship Option Pack in Sterling Selling and Fulfillment Foundation," on page 13 Chapter 7, "Set Properties for Sterling Drop Ship Option Pack," on page 15 Chapter 10, "Define Event Handlers to Publish a Purchase Order and the Change Purchase Order," on page 23 Chapter 8, "Build the Enterprise Archive Package," on page 17
Subscribe to Sterling B2B Collaboration Network	Ensure that both the Seller and Supplier have subscribed to the respective applications through Sterling B2B Collaboration Network.	Sterling Collaboration Overview Guide
Configure a Seller	Ensure that you have configured a Seller for Sterling Drop Ship Option Pack.	<ul style="list-style-type: none"> Chapter 16, "Configure the Organization Code of a Seller," on page 37 Chapter 13, "Configure a Seller Organization as an Enterprise," on page 31 Chapter 14, "Assign the Role of a Seller to an Organization," on page 33 Chapter 15, "Assign the Role of a Buyer to a Seller Organization," on page 35 Chapter 11, "Configure the Modification Components for an Order," on page 25 Chapter 12, "Configure Document Templates," on page 27 Chapter 17, "Configure the Synchronized Dates Transaction Rule for a Seller," on page 39 Chapter 18, "Configure Number of Transit Days for a Seller," on page 41

Task	Description	Refer To
Configure a Supplier	Ensure that you have configured a Supplier for Sterling Drop Ship Option Pack.	<ul style="list-style-type: none"> • Chapter 19, "Create a Supplier," on page 43 • Chapter 20, "Configure a Supplier as a Vendor of the Seller Organization," on page 45 • Chapter 22, "Configure a Supplier Organization as a Seller," on page 49 • Chapter 21, "Configure a Supplier Organization as a Node," on page 47 • Chapter 23, "Configure a Supplier's Inventory Attributes," on page 51 • Chapter 24, "Configure a Supplier's Catalog Attributes," on page 53
Configure sourcing rules	Ensure that you have defined the drop ship items by configuring the sourcing rules: <ul style="list-style-type: none"> • Define an item • Create a fulfillment type • Configure basic sourcing rules 	<i>Sterling Distributed Order Management: Configuration Guide</i>
Install Sterling B2B Integrator	<p>You must install Sterling B2B Integrator™ locally on your machine to facilitate the document flow from a Seller's Order Management system to Sterling Supplier Portal.</p> <p>Sterling B2B Integrator and Sterling Selling and Fulfillment Foundation must be installed in different database schemas. For more information about multitenant databases, see the <i>Selling and Fulfillment Foundation: Multitenant Enterprise Guide</i>.</p> <p>Note: Install Sterling B2B Integrator only if you are using Sterling B2B Integrator and the AS2 protocol to establish a communication between the Order Management system (On Premise) and the On Demand applications.</p>	Sterling B2B Integrator UNIX/Linux Non-Cluster Installation Guide
Integrate with Sterling B2B Integrator	<p>You must perform certain configurations in Sterling B2B Integrator so that the documents can flow seamlessly. The document types such as Purchase Order (PO), Acknowledgement, and so on flow from the Seller's Order Management system or Sterling Supplier Portal through Sterling B2B Collaboration Network using Applicability Statement 2 (AS2).</p> <p>Note: Perform these tasks only if you are using Sterling B2B Integrator and the AS2 protocol to establish a communication between the Order Management system (On Premise) and the On Demand applications.</p>	<ul style="list-style-type: none"> • Chapter 25, "Configuring the AS2 Communication Protocol for Drop Ship Option Pack," on page 55 • Chapter 26, "Configuring a System Certificate in Sterling B2B Integrator for Drop Ship Option Pack," on page 59 • Chapter 27, "Configuring an AS2 Profile in Sterling B2B Integrator for Drop Ship Option Pack," on page 61
Onboard a Supplier to a community	Ensure that you have onboarded a Supplier to a community through Sterling Supplier Portal.	Sterling Supplier Portal Sponsor User Guide

Task	Description	Refer To
Configure rules to receive inventory updates	Ensure that a Seller has configured the corresponding business rules when configuring a community, such that a drop ship Supplier can send the inventory updates.	Sterling Supplier Portal Sponsor User Guide
Upload inventory by a Supplier	Ensure that a Supplier sends the updated inventory for a drop ship order.	Sterling Supplier Portal Partner User Guide
Configure the document format	Ensure that a Sponsor has configured a community, such that the document format is Sterling XML. However, if the document format is either ANSI X.12 or EDIFACT, Sterling B2B Collaboration Network translates the incoming documents and outgoing documents into the required format.	Sterling Supplier Portal Sponsor User Guide

Chapter 3. Introduction to Sterling Drop Ship Option Pack Installation

You can install Sterling Drop Ship Option Pack in the Linux or UNIX environment. When installing Sterling Drop Ship Option Pack, follow the tasks in the sequence specified in the following table. The corresponding topic names are also listed in the table.

Task	Topic
-------------	--------------

1. Verify the prerequisites	
------------------------------------	--

	Chapter 4, "Prerequisites to Installing Sterling Drop Ship Option Pack," on page 9
--	--

2. Install Sterling Drop Ship Option Pack	
--	--

3. Load factory defaults	
---------------------------------	--

	Chapter 6, "Load the Factory Defaults for Sterling Drop Ship Option Pack in Sterling Selling and Fulfillment Foundation," on page 13
--	--

4. Set properties	
--------------------------	--

	Chapter 7, "Set Properties for Sterling Drop Ship Option Pack," on page 15
--	--

5. Build EAR	
---------------------	--

	Chapter 8, "Build the Enterprise Archive Package," on page 17
--	---

Chapter 4. Prerequisites to Installing Sterling Drop Ship Option Pack

Before installing Sterling Drop Ship Option Pack, ensure that the system requirements and software requirements that are listed in the following table are met:

System Requirement/Software Requirement	Minimum Supported Version
Sterling Selling and Fulfillment Foundation™	Release 8.5 later
IBM Sterling Gentrant Integration Suite™ /Sterling B2B Integrator™	Release 5.0 or later
Database Server Application Server Operation System	For the supported versions of these products, see the <i>Selling and Fulfillment Foundation: Installation Guide</i> for the Sterling Selling and Fulfillment Foundation release that you are installing.

For more information about installing Sterling B2B Integrator, refer to the *Sterling B2B Integrator UNIX/Linux Non-Cluster Installation Guide*.

Chapter 5. Install Sterling Drop Ship Option Pack in a UNIX Environment or a Linux Environment

About this task

Before installing Sterling Drop Ship Option Pack, ensure that the conditions listed in the topic, Chapter 4, "Prerequisites to Installing Sterling Drop Ship Option Pack," on page 9 are fulfilled.

This topic provides information about installing Sterling Drop Ship Option Pack in a UNIX or Linux environment. To install Sterling Drop Ship Option Pack in a UNIX or Linux environment, refer to your preinstallation checklist and then perform the following steps:

Procedure

1. Copy the SDS_Add-in.jar file from the FTP site to the <SETUP_DIR> directory. Ensure that the file transfer type is set to binary mode.
2. Navigate to the <INSTALL_DIR>/bin directory. <INSTALL_DIR> is the directory in which Sterling Selling and Fulfillment Foundation™ is installed.
3. Enter the following command:

```
./InstallService.sh <SETUP_DIR>/SDS_Add-in.jar
```

<SETUP_DIR> is the directory in which the SDS_Add-in.jar file is copied.

The "Deployment to application server successful" message is displayed, indicating that Sterling Drop Ship Option Pack has been installed.

After you have installed Sterling Drop Ship Option Pack, you must follow a sequence of tasks in order to use the solution. For more information about the task list, refer to the topic, Chapter 3, "Introduction to Sterling Drop Ship Option Pack Installation," on page 7.

Chapter 6. Load the Factory Defaults for Sterling Drop Ship Option Pack in Sterling Selling and Fulfillment Foundation

About this task

Before loading the factory defaults for Sterling Drop Ship Option Pack in Sterling Selling and Fulfillment Foundation™, ensure that you have done the following:

- Included the JDK directory in your system path.
- Set the <INSTALL_DIR> environment variable correctly.

Note: <INSTALL_DIR> is the directory in which Sterling Drop Ship and Sterling Selling and Fulfillment Foundation are installed.

To load the factory defaults in a UNIX environment or a Linux environment:

Procedure

1. Navigate to the <INSTALL_DIR>/resources directory, and open the `sds_fc_variable.properties` file.
2. Set the `SDSJMSComponent` property in the `sds_fc_variable.properties` file to the application server that is being used. This property can be set to any one of the following application servers:
 - For the JBoss® application server, set the value to `JBoss`.
 - For the Oracle WebLogic® Server, set the value to `Weblogic`.
 - For the IBM WebSphere® MQ® application server, set the value to `MQSeries®`.
3. Navigate to the <INSTALL_DIR>/bin directory. You can load the factory defaults in `install`, `overrideinstall`, or `nonconflictinginstall` mode. Perform one of these options as follows:

- To load the factory defaults in the Activated mode, run the following ant script:

```
<INSTALL_DIR>/Migration/apache-ant-1.7.1/bin/ant -f  
sds_load_defaults.xml install
```

In this mode, the newly provided events in the factory setup are automatically configured. However, validation is necessary to ensure that this does not affect the existing configurations. During validation, a validator throws an error if the event handlers are already configured. The error message contains information about the existing configuration that might get overwritten.

- To load the factory defaults in the Override mode, run the following ant script:

```
<INSTALL_DIR>/Migration/apache-ant-1.7.1/bin/ant -f  
sds_load_defaults.xml overrideinstall
```

In this mode, the event handlers are configured. However, if earlier configuration exists, then it is overridden.

- To load the factory defaults in the nonconflicting mode, run the following ant script:

```
<INSTALL_DIR>/Migration/apache-ant-1.7.1/bin/ant -f  
sds_load_defaults.xml nonconflictinginstall
```

In this mode, the event handlers are not configured. In such a scenario, you must manually define the event handlers for the Change Purchase Order transaction On Success event and Create Purchase Order transaction On Success event.

4. If you are using IBM Sterling Call Center and Store as your Order Management system, run the following ant script:

```
<INSTALL_DIR>/Migration/apache-ant-1.7.1/bin/ant -f sds_load_defaults.xml  
overrideCOMService
```

Results

See also:

- Chapter 10, “Define Event Handlers to Publish a Purchase Order and the Change Purchase Order,” on page 23

Chapter 7. Set Properties for Sterling Drop Ship Option Pack

You must set certain properties so that all the required services for Sterling Drop Ship Option Pack can run successfully. The SDSServer Integration Server is provided as part of factory setup, which must be started to invoke the required services. The following properties must be set in the `customer_overrides.properties` file.

- `SDSIncomingQueue`. This is the name of the queue in which the response message (Acknowledgement, Advance Shipment Notice, and Inventory updates) is received.
- `SDSOutgoingQueue`. This is the name of the queue in which the response message (Purchase Order and Change Purchase Order) is sent.
- `SDSProviderURL`. This is the provider Uniform Resource Locator (URL) of the JMS implementation and URL to use for Java Naming and Directory Interface (JNDI) lookups. Set this property as:
 - For IBM MQSeries®, set the property (for file system context) to `file:[drive:]/<pathname>`, and ensure that the directory exists in your environment.
 - For Oracle WebLogic Java™ Message Service (JMS), set the property to `t3://<DNS Server Name or IP Address>:<port>`.
 - For IBM WebSphere® JMS, set the property to `corbaloc::<DNS Server Name or IP Address>:<bootstrapport>`
- `SDSQCF`. This is the queue connection factory name, which is used to retrieve the queue connection factory from JNDI. A client uses a queue connection factory to create queue connections with a JMS provider.
- `SDSAlertType`. This is the alert type being raised when an exception occurs. This displays in the alert console, and can be used to filter particular types of alerts.

Chapter 8. Build the Enterprise Archive Package

After configuring Sterling Drop Ship Option Pack according to your business needs, build the Enterprise Archive (EAR) on your application server. For more information about building EAR, refer to the *Selling and Fulfillment Foundation: Installation Guide*.

Chapter 9. Drop Ship Purchase Order Lifecycle

Whenever a customer places an order, a Sales Order (SO) is created in the corresponding Seller's system. If it is a drop ship order, the SO is scheduled and moves to the Awaiting Chained Order Created status. The Create Chained Order time-triggered transaction then runs to create a drop ship Purchase Order (PO). This drop ship PO is published to Sterling Supplier Portal™ through Sterling B2B Collaboration Network and the published drop ship PO can be used by a drop ship Supplier.

Drop ship POs go through a wide range of statuses during their fulfillment cycles. Orders are processed through transactions that perform modifications to the orders and their related entities, such as acknowledgements and shipments. These transactions also determine how an order moves from one status to the next. Additionally, an order that is in a particular status must meet certain conditions for the application to determine which transaction should be processed next.

A drop ship PO's flow throughout its fulfillment cycle can be represented graphically by a pipeline. The pipeline determines the statuses in which the drop ship PO can exist, the transactions that can process the drop ship PO, and the conditions that the drop ship PO must go through in order to be fulfilled.

Implementers must create pipelines that are identical to the drop ship Purchase Order execution pipeline and Purchase Order Shipment pipeline in order to process orders of the drop ship PO document type within the Seller's Order Management system. Implementers can determine the pipeline used for the drop ship PO using the pipeline determination rule.

The following figure illustrates the drop ship Purchase Order execution pipeline. In this pipeline, Sellers review the drop ship PO.

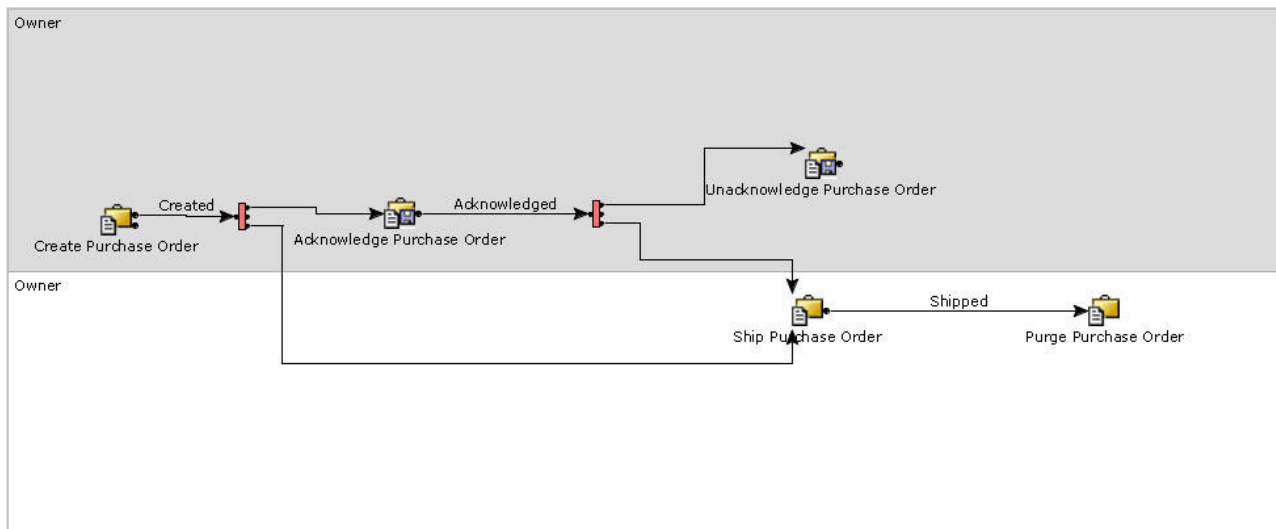

The following figure illustrates the Purchase Order Shipment pipeline. In this pipeline, Sellers review the shipment:

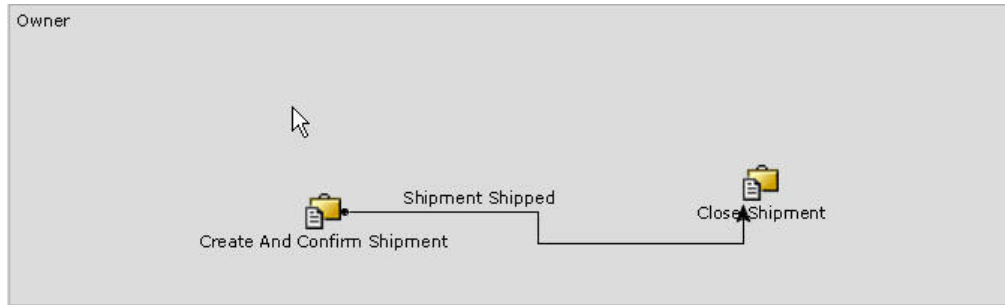

Stages of a Drop Ship PO Fulfillment Cycle

The stages of a drop ship PO fulfillment cycle consist of creating, acknowledging, shipping and purging a drop ship PO.

Creating a Drop Ship PO

Procedure

1. A PO is created on a Seller's system.
2. The Seller's system publishes the PO XML to a Supplier through Sterling B2B Collaboration Network.

Results

Note: No alert is impacted at this stage of the drop ship PO fulfillment flow.

Acknowledging a Drop Ship PO

About this task

The drop ship PO enters this stage of the pipeline only if the Supplier receiving the drop ship PO is configured to send an acknowledgement for an order.

Notes:

- Acknowledgement must be a part of the choreography configured in when creating a community. It is recommended that you create a community such that only one acknowledgement is allowed per order.
- A new status, Acknowledged, has been provided as a part of Statuses in the Purchase Order Execution Repository in Sterling Selling and Fulfillment Foundation™. Ensure that you have created a new pipeline that includes the newly created Acknowledged status.
- The SDS_PARTIAL_ACK alert is provided out-of-the-box for Sterling Drop Ship Option Pack.

The steps involved in acknowledging a drop ship PO are:

Procedure

1. After the Supplier acknowledges the order, the PO Acknowledgement XML is received by the Seller. The Supplier can send the PO acknowledgement either for the entire order or for only some order lines of the order.

2. The Acknowledge Purchase Order transaction changes the status to Acknowledged for the order lines and quantities for which the acknowledgement is received. The order lines and quantities for which the acknowledgement is not received remain in the Created status. The PO acknowledgement details may change because of the following reasons.
 - If the PO Change Request XML is sent to request PO Change from Sellers.
 - If a Supplier sends a partial acknowledgement for an order, the corresponding Seller requests either a PO Change or a PO Cancellation. If either the acknowledged quantity is less than the requested quantity or the acknowledged delivery date is beyond the requested delivery date, the acknowledgement is considered as a partial acknowledgement.

Results

After the drop ship PO is acknowledged, the Supplier ships the order.

Note: The Partial Acknowledgement alert is consolidated at the SO level, if the Supplier sends a partial acknowledgement for the order.

Shipping a Drop Ship PO

Procedure

1. The Supplier sends the Advance Ship Notice (ASN) XML to the Seller.
2. When the Seller's system receives the ASN, a shipment is created and the drop ship PO and SO are moved to the Shipped status.

Results

Note: No alert is impacted at this stage of the drop ship PO fulfillment flow.

Purging a Drop Ship PO

If you have included the stage, Purge, in the pipeline created for PO execution, the drop ship POs are purged after the time specified in the corresponding business rule by the Seller. This implies that the records for these orders have been moved from the database tables to the history tables. For more information about the order purge, refer to the *Selling and Fulfillment Foundation: Application Platform Configuration Guide*.

Note: No alert is impacted at this stage of the drop ship PO fulfillment flow.



Important: Ensure that all the open alerts are closed and purged before purging the drop ship PO.

Chapter 10. Define Event Handlers to Publish a Purchase Order and the Change Purchase Order

When the factory defaults are loaded in the non-conflicting mode, the event handlers are not implemented. In such a scenario, you must define the event handlers for the ON_SUCCESS event pertaining to the Create Purchase Order transaction and the Change Purchase Order transaction.

Define the Event Handler of the Create Purchase Order Transaction

Procedure

1. Launch the Sterling Selling and Fulfillment Foundation Applications Manager.
2. From the **Applications** menu, select **Application Platform**.
3. From the tree in the application rules side panel, select **Process Modeling**.
4. The Process Modeling window is displayed in the work area. Click the **Order** tab.
5. In the Process Types swimlane, right-click the **Purchase Order Execution** process type and select **Model Process**.
6. The Repository Details window in the work area is displayed. Click the **Transactions** tab.
7. The Transactions branch is displayed. Perform the following tasks:
 - a. Select the **Create Purchase Order** transaction.
 - b. The Transaction Detail window is displayed. Click the **Events** tab.
 - c. The Events panel is displayed. Select the **ON_SUCCESS** event and click  .
8. Click  .

The Event Handler Definition panel is displayed.

- d. In the Purchase Order Execution panel, click the **Actions** tab.
- e. The Actions branch is displayed. Expand the **SterlingDropShip** action group.
- f. Drag and drop Publish PO into the Event Handler Definition panel.



The event handler of the Create Purchase Order transaction is defined.

For more information about defining a transaction's event handler, refer to the *Selling and Fulfillment Foundation: Application Platform Configuration Guide*.

Define the Event Handler of the Change Purchase Order Transaction

Procedure

1. Launch the Sterling Selling and Fulfillment Foundation Applications Manager.
2. From the **Applications** menu, select **Application Platform**.
3. From the tree in the application rules side panel, select **Process Modeling**.
4. The Process Modeling window is displayed in the work area. Click the **Order** tab.
5. In the Process Types swimlane, right-click the **Purchase Order Execution** process type and select **Model Process**.

6. The Repository Details window and work area is displayed. Click the **Transactions** tab.
7. The Transactions branch is displayed. Perform the following tasks:
 - a. Select the **Change Purchase Order** transaction.
 - b. The Transaction Detail window is displayed. Click the **Events** tab.
 - c. The Events panel is displayed. Select the **ON_SUCCESS** event and click  .
The Event Handler Definition panel is displayed.
 - d. In the Purchase Order Execution panel, click the **Actions** tab.
 - e. The Actions branch is displayed. Expand the **SterlingDropShip** action group.
 - f. Drag and drop Publish Change PO into the Event Handler Definition panel.
8. Click  .
The event handler of the Change Purchase Order transaction is defined.
For more information about defining a transaction's event handler, refer to the *Selling and Fulfillment Foundation: Application Platform Configuration Guide*.

Chapter 11. Configure the Modification Components for an Order

Modification components determine which parts of a document can be modified, as well as in which status the modifications can be performed. Ensure that the modification rules and types for a Sales Order (SO) are identical to that of the Purchase Order (PO) so that if any modification is carried out on an SO, it is reflected in the corresponding PO too.

To configure modification components:

- For an SO, use the Distributed Order Management module in Sterling Selling and Fulfillment Foundation.
- For a PO, use the Supply Collaboration module in Sterling Selling and Fulfillment Foundation.

For more information about the modification components, refer to the *Sterling Distributed Order Management: Configuration Guide*.

Chapter 12. Configure Document Templates

A Seller must configure the following document templates to indicate how these must be used in the Drop Ship order fulfillment process type:

- Default Chained Order
- Chained Order Consolidation

Typically, templates are required in scenarios where an entity's particular set of attributes have to be considered for processing. You can determine which XML attributes and elements should be included or excluded from the master template XMLs for a given fulfillment process type in the Sterling Selling and Fulfillment Foundation Applications Manager.

Configure the Default Chained Order Template

About this task

A Seller must configure the attributes or elements in the Default Chained Order template XML for Sterling Drop Ship Option Pack solution so that these attributes or elements are copied to the chained Purchase Order created for a Supplier.

To configure the Default Chained Order template:

Procedure

1. Launch the Applications Manager.
2. From the **Applications** menu, select **Application Platform**.
3. In the tree in the application rules side panel that is displayed, click **Process Modeling**.
4. The Process Modeling window is displayed in the work area. Click the **Order** tab.
5. In the Process Types swimlane, right-click the **Order Fulfillment** process type, and select **Details**.
6. The Process Type Details window is displayed. Click the **Templates** tab.
7. The master templates that are available for the fulfillment process type you are working with are displayed as tabs. (These master templates are retrieved from the YFS_BASE_DOCUMENT_TYPE table.) Click the **Default Chained Order** tab.

The Default Chained Order template XML is loaded from the YFS_BASE_DOCUMENT_TEMPLATE table, and is combined with the template XML stored for this document type in the YFS_DOCUMENT_TEMPLATE table. Extended attributes are also added to the master template for each element that has extended attributes. The resulting XML is shown in hierarchical format in a tree.

8. Right-click the XML attributes or elements, and click  to include the attributes or elements in the Default Chained Order template XML for this process type.

Following are the recommended attributes in their corresponding elements, which should be included in the OrderLine root element of the Default Chained Order template XML:

- CarrierAccountNo
- CarrierServiceCode
- FreightTerms
- SCAC
- ShipNode

Item Element

- ItemDesc
- ItemID
- ItemShortDesc
- SupplierItem
- SupplierItemDesc
- UPCCode
- UnitOfMeasure

PersonInfoShipTo Element

- AddressLine1
- AddressLine2
- AddressLine3
- AddressLine4
- AddressLine5
- AddressLine6
- AlternateEmailID
- Beeper
- City
- Company
- Country
- DayFaxNo
- EveningPhone
- FirstName
- JobTitle
- LastName
- MiddleName
- MobileName
- OtherPhone
- PersonID
- State
- Suffix
- Title
- ZipCode

Notes Element

- AuditTransactionId
- ContactReference
- ContactTime
- ContactType
- ContactUser
- CustomerSatIndicator

- NoteText
- Priority
- ReasonCode

Order Dates Element

- ActualDate
- CommittedDate
- DateTypeId
- ExpectedDate
- RequestedDate

Schedules Element

- ExpectedDeliveryDate
- ExpectedShipmentDate
- Quantity

Configure the Chained Order Consolidation Template

About this task

A Seller must configure the attributes or elements in the Chained Order Consolidation template XML for Sterling Drop Ship Option Pack solution so that appropriate chained Purchase Order is created for order lines with different ship to addresses in a Sales Order. These attributes are supported by Sterling Supplier Portal™ at the header level.

To configure the Chained Order Consolidation template:

Procedure

1. Launch the Sterling Selling and Fulfillment Foundation Applications Manager.
2. From the **Applications** menu, select **Application Platform**.
3. In the tree in the application rules side panel that is displayed, click **Process Modeling**.
4. The Process Modeling window is displayed in the work area. Click the **Order** tab.
5. In the Process Types swimlane, right-click the **Order Fulfillment** process type, and select **Details**.
6. The Process Type Details window is displayed. Click the **Templates** tab.
7. The master templates that are available for the fulfillment process type you are working with are displayed as tabs. (These master templates are retrieved from the YFS_BASE_DOCUMENT_ TYPE table.) Click the **Chained Order Consolidation** tab.

The Chained Order Consolidation template XML is loaded from the YFS_BASE_DOCUMENT_TEMPLATE table, and is combined with the template XML stored for this document type in the YFS_DOCUMENT_TEMPLATE table. Extended attributes are also added to the master template for each element that has extended attributes. The resulting XML is shown in hierarchical format in the tree.

8. Right-click the XML attributes or elements, and click  to include the attributes or elements in the Chained Order Consolidation template XML for this process type.

Following are the recommended attributes in the OrderLine element, which should be included in the Chained Order Consolidation template XML

- CarrierAccountNo
- CarrierServiceCode
- SCAC
- ShipToKey
- FreightTerms

Note: If the CarrierServiceCode, FreightTerms, CarrierAccountNo, SCAC, and ShipToAddress attributes are different for different orderlines, the information pertaining to only the first order line is published in the chained Purchase Order (PO) at the header level.

Results

For more information about defining a process type's template, refer to the *Selling and Fulfillment Foundation: Application Platform Configuration Guide*.



Chapter 13. Configure a Seller Organization as an Enterprise

About this task

A Seller must be assigned the role of an Enterprise to define the organizations that interact within the enterprise. You can define the roles of a Seller when creating the corresponding Seller organization in the Sterling Selling and Fulfillment Foundation Applications Manager.

To configure a Seller as an Enterprise:

Procedure

1. Launch the Sterling Selling and Fulfillment Foundation Applications Manager.
2. From the **Applications** menu, select **Application Platform**.
3. From the tree in the application rules side panel, select **Participant Modeling > Participant Setup**.
4. The Organization Search window is displayed in the work area. Click .
5. The Create Organization dialog box is displayed. Enter values in the required fields, and select the **Organization Is An Enterprise** check box.
6. Click .

The Seller is assigned the role of an Enterprise.

For more information about defining the role of a Seller as an Enterprise, refer to the *Selling and Fulfillment Foundation: Application Platform Configuration Guide*.



Chapter 14. Assign the Role of a Seller to an Organization

About this task

An organization must be configured as a Seller so that the items can be sold to other enterprises. You can define the roles of an organization when creating the corresponding organization in the Sterling Selling and Fulfillment Foundation Applications Manager.

To assign the role of a Seller to an organization:

Procedure

1. Launch the Sterling Selling and Fulfillment Foundation Applications Manager.
2. From the **Applications** menu, select **Application Platform**.
3. From the tree in the application rules side panel, select **Participant Modeling > Participant Setup**.
4. The Organization Search window is displayed in the work area. Click .
5. The Create Organization dialog box is displayed. Enter values in the required fields.
6. Click .
7. The Organization Details window is displayed in the work area. Click the **Roles & Participation** tab.
8. In the **Roles** area that is displayed, select the **Seller** check box.
9. Click .

The organization is assigned a role of a Seller.

For more information about defining the role of an enterprise as a Seller, refer to the *Selling and Fulfillment Foundation: Application Platform Configuration Guide*.



Chapter 15. Assign the Role of a Buyer to a Seller Organization

About this task

A Seller must be assigned the role of a Buyer so that the items can be purchased from other enterprises. You can define the roles of the Seller when creating the Sponsor organization in the Sterling Selling and Fulfillment Foundation Applications Manager.

To assign the role of a Buyer to a Seller organization:

Procedure

1. Launch the Sterling Selling and Fulfillment Foundation Applications Manager.
2. From the **Applications** menu, select **Application Platform**.
3. From the tree in the application rules side panel, select **Participant Modeling > Participant Setup**.
4. The Organization Search window is displayed in the work area. Click .
5. The Create Organization dialog box is displayed. Enter values in the required fields.
6. Click .
7. The Organization Details window is displayed in the work area. Select the **Roles & Participation** tab.
8. In the **Roles** area that is displayed, select the **Buyer** check box.
9. Click .

The Seller has been assigned a role of a Buyer. For more information about defining the roles of a Seller as a Buyer, refer to the *Selling and Fulfillment Foundation: Application Platform Configuration Guide*.



Chapter 16. Configure the Organization Code of a Seller

About this task

The Organization Code of a Seller is provided when subscribing to . This code must be configured in Sterling Selling and Fulfillment Foundation so that Sterling Supplier Portal™ and Sterling Supply Chain Visibility™ can identify the Seller. You can configure the Sterling B2B Collaboration Network Organization Code of a Sterling Selling and Fulfillment Foundation Applications Manager. The custom common code type for configuring a Sterling B2B Collaboration Network Organization Code is provided as part of the factory setup.

To configure the Sterling B2B Collaboration Network Organization Code of a Seller:

Procedure

1. Launch the Sterling Selling and Fulfillment Foundation Applications Manager.
2. From the **Applications** menu, select **Application Platform**.
3. From the tree in the application rules side panel, select **Presentation > Custom Common Codes**.
4. The Custom Common Codes window is displayed in the work area. Double-click the **SCI_COMPANY_ID** custom common code type.
5. The Common Code Values dialog box is displayed. Click .
6. The IBM SCI Company ID Details dialog box is displayed. Perform the following steps:
 - a. In the **SCI Company ID*** box, enter the Sterling B2B Collaboration Network Organization Code, which is provided when a Seller subscribes to Sterling B2B Collaboration Network.
 - b. In the **Short Description*** box, enter the organization code. The organization code is provided when creating the Seller in Sterling Selling and Fulfillment Foundation.
 - c. In the **Long Description** box, enter the organization name. The organization name is provided when creating the Seller in Sterling Selling and Fulfillment Foundation.
 - d. Click .

Note: * indicates that the field is mandatory.

The Sterling B2B Collaboration Network Organization Code of the Seller is configured. For more information about custom common codes, refer to the *Selling and Fulfillment Foundation: Application Platform Configuration Guide*.

Chapter 17. Configure the Synchronized Dates Transaction Rule for a Seller



You must configure the Synchronized Dates transaction rule for both a Sales Order (SO) and a Purchase Order (PO). This will synchronize the requested dates and the expected ship dates for the Order Header, Order Line, and Order Line Schedules. The requested dates synchronize with the requested ship, requested delivery, and cancel dates on the order line or order header. The expected ship dates synchronize with the order schedules.

Configure the Synchronized Dates Transaction Rule For an SO

About this task

To configure the Synchronized Dates transaction rule for an SO:

Procedure

1. Launch the Sterling Selling and Fulfillment Foundation Applications Manager.
2. From the **Applications** menu, select **Distributed Order Management**.
3. Click  to load the Seller organization.
4. From the tree in the application rules side panel, select **Document Specific > Sales Order > Fulfillment > Transaction Specific Rules**.
5. The Transaction Rules window is displayed in the work area. Select the **Synchronize Dates Between Master Order Dates And Dates On Order Line And Schedules** check box.
6. Click .



The Synchronized Dates transaction rule is configured for the SO.

Configure the Synchronized Dates Transaction Rule For a PO

About this task

To configure the Synchronized Dates transaction rule for a PO:

Procedure

1. Launch the Sterling Selling and Fulfillment Foundation Applications Manager.
2. From the **Applications** menu, select **Supply Collaboration**.
3. Click  to load the Seller organization.
4. From the tree in the application rules side panel, select **Document Specific > Purchase Order > Fulfillment > Transaction Specific Rules**.
5. The Transaction Rules window is displayed in the work area. Select the **Synchronize Dates Between Master Order Dates And Dates On Order Line And Schedules** check box.
6. Click .

The Synchronized Dates transaction rule is configured for the PO.

Chapter 18. Configure Number of Transit Days for a Seller

Transit days indicate the maximum number of days required to deliver an item after the item has been shipped. You must configure transit days for a Seller because the expected shipment date pertaining to an order line schedule is calculated using the number of transit days.

For more information about transit days, refer to the *Selling and Fulfillment Foundation: Application Platform Configuration Guide*.

Chapter 19. Create a Supplier

A Seller must create a Supplier with a defined role for Sterling Drop Ship Option Pack. After you have created a Supplier, you must configure the Supplier first as a Node and then as a Seller for the drop ship hub.

You can create a Supplier in the Sterling Selling and Fulfillment Foundation Applications Manager. Remove the parent organization from the Supplier after marking the Supplier as a Seller in the Roles and Participation tab.

For more information about creating a Supplier, refer to the *Selling and Fulfillment Foundation: Application Platform Configuration Guide*.



Chapter 20. Configure a Supplier as a Vendor of the Seller Organization

About this task

You must configure a Supplier as a vendor of the Seller organization in order to establish a relationship between the Supplier and the Seller.

To configure a Supplier as a Vendor of the Seller organization:

Procedure

1. Launch the Sterling Selling and Fulfillment Foundation Applications Manager.
2. From the **Applications** menu, select **Supply Collaboration**.
3. From the tree in the application rules side panel, select **Cross Application > Vendor > Vendor Definitions**.
4. The Vendor Search window is displayed in the work area. Click .
5. The Vendor dialog box is displayed. Select the **Select An Existing Organization** radio button.
6. From the drop-down list that is enabled, select the required Supplier organization.
7. Enter the required values in other fields.
8. Click .

Note: The Supplier must enter the Organization Code as the Vendor ID when accepting the invitation to join the community. Otherwise, a chained Purchase Order (PO) will not be created in Sterling Supplier Portal™.

The Supplier is configured as a Vendor of the Seller organization. For more information about vendor definitions, refer to the *IBM Sterling Supply Collaboration Configuration Guide*.



Chapter 21. Configure a Supplier Organization as a Node

About this task

A Supplier can either be subscribed to Sterling Supplier Portal™ or can be Electronic Data Interchange-enabled. Irrespective of what the Supplier is subscribed to, you must configure the node type of the corresponding Supplier organization when creating the organization in the Sterling Selling and Fulfillment Foundation Applications Manager.

To configure the Supplier as a Node:

Procedure

1. Launch the Sterling Selling and Fulfillment Foundation Applications Manager.
2. From the **Applications** menu, select **Application Platform**.
3. From the tree in the application rules side panel, select **Participant Modeling > Participant Setup**.
4. The Organization Search window is displayed in the work area. Click .
5. The Create Organization dialog box is displayed. Enter the required values.
6. Click .
7. The Organization Details window is displayed in the work area. Click the **Roles & Participation** tab.
8. In the **Roles** area that is displayed, select the **Node** check box.
9. Click the **Node Attributes** tab.
10. From the **Node Type** drop-down list, select one of the following options:
 - Drop Ship: Select this if the Supplier is a drop ship Supplier.
11. Click .

Note: When creating the organization, ensure that you select the **Primary Enterprise** check box and the corresponding Seller organization from the drop-down list.

The Supplier is configured as a Node. For more information about configuring a Supplier as a Node, refer to the *Selling and Fulfillment Foundation: Application Platform Configuration Guide*.



Chapter 22. Configure a Supplier Organization as a Seller

About this task

A Supplier must be configured as a Seller so that the Supplier can be onboarded to the drop ship hub. You can define the role of a Supplier as a Seller when creating the corresponding Supplier organization in the Sterling Selling and Fulfillment Foundation Applications Manager.

To configure a Supplier as a Seller:

Procedure

1. Launch the Sterling Selling and Fulfillment Foundation Applications Manager.
2. From the **Applications** menu, select **Application Platform**.
3. From the tree in the application rules side panel, select **Participant Modeling > Participant Setup**.
4. The Organization Search window is displayed in the work area. Click .
5. The Create Organization dialog box is displayed. Enter the required values.
6. Click .
7. The Organization Details window is displayed in the work area. Click the **Roles & Participation** tab.
8. In the **Roles** area that is displayed, select the **Seller** check box.
9. Click the **Seller Attributes** tab that is displayed.
10. Select the **Requires Chained Orders** check box.
11. Click .

Note: When creating the organization, ensure that you select the **Primary Enterprise** check box and the corresponding Seller organization from the drop-down list.

The Supplier is configured as a Seller. For more information about configuring a Supplier as a Seller, refer to the *Selling and Fulfillment Foundation: Application Platform Configuration Guide*.



Chapter 23. Configure a Supplier's Inventory Attributes

About this task

A Supplier's inventory attributes must be configured such that the inventory is maintained within Sterling Selling and Fulfillment Foundation™. You can configure the inventory attributes of a Supplier either during the process of creating the corresponding Supplier organization or modifying the Supplier's details in the Sterling Selling and Fulfillment Foundation Applications Manager.

To configure the inventory attributes of a Supplier:

Procedure

1. Launch the Sterling Selling and Fulfillment Foundation Applications Manager.
2. From the **Applications** menu, select **Application Platform**.
3. From the tree in the application rules side panel, select **Participant Modeling > Participant Setup**.
4. The Organization Search window is displayed in the work area. Enter the search criteria, and click .
5. The search results are displayed in the Search Results panel. Double-click the Organization Code of the Supplier organization whose inventory attributes you want to configure.
6. The Organization Details window is displayed in the work area. Click the **Roles & Participation** tab.
7. Click the **Advanced Attributes** tab.
8. Perform the following steps in the area that is displayed:
 - a. Select the **Inventory Is Made Available To Sterling Selling and Fulfillment Foundation** radio button.
 - b. Select the **Inventory Organization Is** radio button, and select the Seller organization from the drop-down list.
9. Click .

The Supplier's inventory attributes are configured. For more information about configuring a Supplier's inventory attributes, refer to the *Selling and Fulfillment Foundation: Application Platform Configuration Guide*.

See also:

Chapter 19, "Create a Supplier," on page 43



Chapter 24. Configure a Supplier's Catalog Attributes

About this task

A Supplier's catalog attributes must be configured such that the catalog is maintained by the corresponding Seller. You can configure the catalog attributes of a Supplier either during the process of creating the corresponding Supplier organization or modifying the Supplier's details in the Sterling Selling and Fulfillment Foundation Applications Manager.

To configure the catalog attributes of a Supplier:

Procedure

1. Launch the Sterling Selling and Fulfillment Foundation Applications Manager.
2. From the **Applications** menu, select **Application Platform**.
3. From the tree in the application rules side panel, select **Participant Modeling > Participant Setup**.
4. The Organization Search window is displayed in the work area. Enter the search criteria, and click .
5. The search results are displayed in the Search Results panel. Double-click the Organization Code of the Supplier organization whose catalog attributes you want to configure.
6. The Organization Details window is displayed in the work area. Click the **Roles & Participation** tab.
7. Click the **Advanced Attributes** tab.
8. Click the **Catalog** tab.
9. In the area that is displayed, select the **Catalog Defined By** radio button, and select the Seller organization from the drop-down list.
10. Click .

The Supplier's catalog attributes are configured. For more information about configuring a Supplier's catalog attributes, refer to the *Selling and Fulfillment Foundation: Application Platform Configuration Guide*.

See also:

- Chapter 19, "Create a Supplier," on page 43
- Chapter 23, "Configure a Supplier's Inventory Attributes," on page 51

Chapter 25. Configuring the AS2 Communication Protocol for Drop Ship Option Pack

Only if you are using Sterling B2B Integrator™ and the Applicability Statement 2 (AS2) protocol to establish a communication between the Order Management system (On Premise) and the On Demand applications, must you configure certain services in Sterling B2B Integrator so that documents (Purchase Order, Change Purchase Order, and Remittance Advice) from the outbound queue of the Order Management system can be posted to the outbound folder from which the documents are picked up and sent to the Sterling Supplier Portal™ application. Similarly, documents (Acknowledgement, Advance Shipment Notice, Invoice and Inventory) that are posted to the inbound folder are in turn posted to the inbound queue of the Order Management system through Sterling B2B Collaboration Network.

The following sample services and business processes are provided as part of reference implementation data in Sterling B2B Integrator:

- S_CollectDocFromAS2InboundFolder
- S_CollectDocFromDOMOutboundQueue
- S_PutDocInAS2OutboundFolder
- S_PutDocInDOMInboundQueue
- BP_DocTransferFromQueueToAS2FS
- BP_DocTransferFromAS2FSToQueue

These services and business processes are bundled in the SDS_InstallBundle.jar file that is located at SDS_Add-in\etc\Integration\GIS folder. You must extract the SDS_InstallBundle.jar file to your local system and then import the JAR file in Sterling B2B Integrator so that the services and the business processes can be configured. For more information about importing these services and business processes in Sterling B2B Integrator, refer to the *Sterling B2B Integrator Manage Resources Guide*.

Configuring Services to Send Documents from the Order Management System to Sterling B2B Integrator

About this task

The S_CollectDocFromDOMOutboundQueue service picks a document from the outbound queue of the Order Management system, and calls the BP_DocTransferFromQueueToAS2FS business process internally. This business process in turn calls the S_PutDocInAS2OutboundFolder JMS adapter service internally, which posts the file to the outbound AS2 folder of the Seller's Sterling B2B Integrator.

The following services must be configured in to send out the documents from the Seller's Order Management system to the outbound AS2 folder:

- S_CollectDocFromDOMOutboundQueue

The following lists the fields whose values must be set for Drop Ship Option Pack when modifying the S_CollectDocFromDOMOutboundQueue service:

Field Description

Initial Context Factory

Set the value of this field to the initial context factory for the queue that you have selected.

Note: The value of the **Initial Context Factory** field is set to `com.sun.jndi.fscontext.ReffSContextFactory`. This value is applicable for queues in IBM MQSeries® only. Ensure that you modify the Initial Context Factory value based on the queue that you want to connect to.

URL Set the value of this field to the location of the bindings file pertaining to the queues configured for Drop Ship Option Pack. For example, `file:///SI_INSTALL_DIR/BINDING.FILE.LOCATION` can be the location of the bindings files. Here, `SI_INSTALL_DIR` is the directory in which is installed.

Remote Queue Name

Set the value of this field to the outbound queue of the Seller's Order Management system in which the documents (Purchase Order, Change Purchase Order and Remittance Advice) are posted to be sent to Sterling Supplier Portal and Sterling Supply Chain Visibility.

Remote Queue Connection Factory

Set the value of this field to the remote queue connection factory of the remote queues configured for Drop Ship Option Pack.

- **S_PutDocInAS2OutboundFolder**

The following lists the fields whose values must be set for Drop Ship Option Pack when modifying the `S_PutDocInAS2OutboundFolder` service:

Field Description

Extraction Folder

Set the value of this field to the location in which the outbound folder of the AS2 profile has been created in the Seller's Sterling B2B Integrator. For example, `SI_INSTALL_DIR/SI/as2partner/DROPSHIP_PARTNER_PROFILE/outbound` can be the location in which the outbound folder is located. Here, `SI_INSTALL_DIR` is the directory in which Sterling B2B Integrator is installed, and `DROPSHIP_PARTNER_PROFILE` is the Seller's profile created in Sterling B2B Integrator.

Collection Folder

Set the value of this field to the location in which the inbound folder of the AS2 profile has been created in the Seller's Sterling B2B Integrator. For example, `SI_INSTALL_DIR/SI/as2partner/DROPSHIP_PARTNER_PROFILE/inbound` can be the location in which the inbound folder is located. Here, `SI_INSTALL_DIR` is the directory in which Sterling B2B Integrator is installed, and `DROPSHIP_PARTNER_PROFILE` is the Seller's profile created in Sterling B2B Integrator.

Note: Ensure that both the services and the business processes are enabled so that these can be successfully run. For more information about configuring, editing, and enabling the services and business processes, refer to the following guides:

- *Sterling B2B Integrator Business Process Modeling Guide*
- *Sterling B2B Integrator Managing Services and Adapters Guide*

Configuring Services to Receive Documents from Sterling B2B Integrator to the Order Management System

The `S_CollectDocFromAS2InboundFolder` service picks a document from the inbound AS2 folder, and calls the `BP_DocTransferFromAS2FSToQueue` business process internally. This business process in turn calls the `S_PutDocInDOMInboundQueue` JMS adapter service, which puts the file in the inbound queue of the Order Management system. The `S_CollectDocFromAS2InboundFolder` service adds an appropriate message ID to the document so that the service in Drop Ship Option Pack can identify the document type.

The following services must be configured in for Drop Ship Option Pack:

- `S_CollectDocFromAS2InboundFolder`

The following lists the fields whose values must be set for Drop Ship Option Pack when modifying the `S_CollectDocFromAS2InboundFolder` service:

Field	Description
-------	-------------

Collection Folder	
--------------------------	--

	Set the value of this field to the location in which the inbound folder of the AS2 profile has been created in the Seller's . For example, <code>SI_INSTALL_DIR/SI/as2partner/DROPSHIP_PARTNER_PROFILE/inbound</code> can be the location in which the inbound folder is located. Here, <code>SI_INSTALL_DIR</code> is the directory in which is installed, and <code>DROPSHIP_PARTNER_PROFILE</code> is the Seller's profile created in Sterling B2B Integrator.
--	---

Extraction Folder	
--------------------------	--

	Set the value of this field to the location in which the outbound folder of the AS2 profile has been created in the Seller's Sterling B2B Integrator. For example, <code>SI_INSTALL_DIR/SI/as2partner/DROPSHIP_PARTNER_PROFILE/outbound</code> can be the location in which the outbound folder is located. Here, <code>SI_INSTALL_DIR</code> is the directory in which Sterling B2B Integrator is installed, and <code>DROPSHIP_PARTNER_PROFILE</code> is the Seller's profile created in Sterling B2B Integrator.
--	---

Note: In the reference implementation data, the `S_CollectDocFromAS2InboundFolder` service is not scheduled. If you want this service to run the scheduled activity of picking up the documents from the inbound AS2 folder at a certain time or time interval, such as every 2 hours, configure the schedules for this service based on a timer. For more information about configuring schedules based on a timer, refer to the *Sterling B2B Integrator Scheduling Guide*.

- `S_PutDocInDOMInboundQueue`

The following lists the fields whose values must be set for Drop Ship Option Pack when modifying the `S_PutDocInDOMInboundQueue` service:

Field	Description
-------	-------------

Initial Context Factory	
--------------------------------	--

	Set the value of this field to the initial context factory for the queue that you have selected.
--	--

Note: The value of the **Initial Context Factory** field is set to `com.sun.jndi.fscontext.ReffSContextFactory`. This value is applicable for

queues in IBM MQSeries® only. Ensure that you modify the Initial Context Factory value based on the queue that you want to connect to.

URL Set the value of this field to the location of the bindings file pertaining to the queues configured for Drop Ship Option Pack. For example, `file:///SI_INSTALL_DIR/BINDING.FILE.LOCATION` can be the location of the bindings folder. Here, `SI_INSTALL_DIR` is the directory in which Sterling B2B Integrator is installed.

Remote Queue Name

Set the value of this field to the inbound queue of the Seller's Order Management system in which the documents (Acknowledgement, Advance Shipment Notice, Invoice and Inventory) sent from Sterling Supplier Portal are posted.

Remote Queue Connection Factory

Set the value of this field to the remote queue connection factory of the remote queues configured in Drop Ship Option Pack.

Note: Ensure that both the services and the business processes are enabled so that these can be successfully run. For more information about configuring, editing, and enabling the services and business processes, refer to the following guides:

- *Sterling B2B Integrator Business Process Modelling Guide*
- *Sterling B2B Integrator Managing Services and Adapters Guide*

Chapter 26. Configuring a System Certificate in Sterling B2B Integrator for Drop Ship Option Pack

Applicability Statement 2 (AS2) is a protocol that uses digital certificates and encryption to transfer data securely and reliably over the Internet. Only if you are using Sterling B2B Integrator™ and the AS2 protocol to establish a communication between the Order Management system (On Premise) and the On Demand applications, you must create a System Certificate in Sterling B2B Integrator for the Seller's Order Management system, and share it with Sterling B2B Collaboration Network™. A corresponding System Certificate for Sterling B2B Collaboration Network must be created in Sterling B2B Integrator. These certificates are then exchanged and uploaded as trusted certificates in the corresponding applications. The Sterling B2B Collaboration Network System Certificate is uploaded as a trusted certificate in the Seller's Order Management system and the Seller's Order Management System certificate is uploaded as a trusted certificate in Sterling B2B Collaboration Network. These trusted certificate are used to create the corresponding AS2 profiles on the respective applications. In Sterling B2B Collaboration Network, the Seller is identified with the identifier (ID) provided when creating an AS2 profile configured in Sterling B2B Integrator.

For more information about configuring System Certificates, refer to the *IBM Sterling Standards Library: Using AS2 and the AS2 Edition Guide*.

Chapter 27. Configuring an AS2 Profile in Sterling B2B Integrator for Drop Ship Option Pack

Only if you are using Sterling B2B Integrator™ and the Applicability Statement 2 (AS2) protocol to establish a communication between the Order Management system (On Premise) and the On Demand applications, you must configure an AS2 profile in Sterling B2B Integrator.

An AS2 communication is established through Sterling B2B Integrator after the system certificate pertaining to Sterling B2B Integrator is exchanged with Sterling B2B Collaboration Network™, and the Sterling B2B Collaboration Network certificate is uploaded in Sterling B2B Integrator as a trusted certificate. The AS2 identifiers (ID) provided when creating the profiles are used to facilitate the document flow between the Seller's Order Management system and Sterling B2B Collaboration Network.

For more information about configuring AS2 profiles, refer to the *Sterling B2B Integrator Mailbox Guide*.

Chapter 28. Publishing a Chained Purchase Order

After a customer places an order, the corresponding Seller's Order Management system verifies the inventory and the availability of line items as per the Sales Order (SO). If an item in an order has to be sourced directly by a drop ship Supplier, a chained Purchase Order (PO) is created. This chained PO is published and sent to the Supplier subscribed to Sterling Supplier Portal™ through Sterling B2B Collaboration Network.

The following out-of-the-box Order XML is published and sent to Sterling Supplier Portal Supplier. The customer can customize this Order XML as per customer's business requirements.

```
<?xml version="1.0" encoding="UTF-16"?>

<Order BuyerOrganizationCode="" CarrierAccountNo="" CarrierServiceCode=""
ChainType="" CustCustPONo="" DocumentType="" EnterpriseCode="" FreightTerms=""
OrderDate="" OrderNo="" ReqCancelDate="" ReqDeliveryDate="" ReqShipDate=""
SCAC="" ScacAndService="" SellerOrganizationCode="" TaxExemptFlag=""
TaxJurisdiction="" TaxPayerId="" TermsCode="" VendorID="" Document="Order"
ReceiverEDIId="" SenderEDIId="" ReceivingNode="DROP_SHIP" DropShipNodeType="">

<References>

<Reference Name="" Value="" />

</References>

<OrderLines>

<OrderLine CarrierAccountNo="" CarrierServiceCode="" FreightTerms=""
PrimeLineNo="" ReqCancelDate="" SCAC="" ScacAndService="" SubLineNo=""
OrderedQty="" ReqShipDate="" ReqDeliveryDate="" LineIdentifier="">

<Item ItemShortDesc="" UnitOfMeasure="" ItemID="" CustomerItem=""
SupplierItem="" UPCCode="" ProductClass="" ItemDesc="" CustomerItemDesc=""/>

<LinePriceInfo UnitPrice="" />

<RequestedSchedules>

<RequestedSchedule EndShipDate="" EndDeliveryDate="" Quantity="" />

</RequestedSchedules>

</OrderLine>

</OrderLines>

<PersonInfoShipTo AddressLine1="" AddressLine2="" AddressLine3=""
AddressLine4="" AddressLine5="" AddressLine6="" AlternateEmailID="" Beeper=""
City="" Company="" Country="" DayFaxNo="" DayPhone="" Department="" EmailID=""
EveningFaxNo="" EveningPhone="" FirstName="" IsCommercialAddress="" JobTitle=""
LastName="" MiddleName="" MobilePhone="" OtherPhone="" PersonID="" State=""
Suffix="" TaxGeoCode="" Title="" ZipCode="" />

<PersonInfoBillTo AddressLine1="" AddressLine2="" AddressLine3=""
AddressLine4="" AddressLine5="" AddressLine6="" AlternateEmailID="" Beeper=""
City="" Company="" Country="" DayFaxNo="" DayPhone="" Department="" EmailID=""
```

```

EveningFaxNo="" EveningPhone="" FirstName="" IsCommercialAddress="" JobTitle=""
LastName="" MiddleName="" MobilePhone="" OtherPhone="" PersonID="" State=""
Suffix="" TaxGeoCode="" Title="" ZipCode="" />
</Order>

```

Note: When the inventory is available from two different Suppliers, and one Supplier is not able to fulfill the order, then two chained POs are created and published for one SO.

Solution

If the Schedule Order time-triggered transaction finds the inventory in a Drop Ship Node when verifying an inventory for a Sales Order, the Schedule Order time-triggered transaction assumes that a chained PO will be created to fulfill this order line. The order line is moved to the Awaiting Chained Order Creation status. The Create Chained Order time-triggered transaction is run for the SO, which picks up the order lines that are in the Awaiting Chained Order Creation status, and creates one chained PO for one SO belonging to one Supplier.

End-User Impact

A Supplier in Sterling Supplier Portal can view the PO, acknowledge it, and send an Advance Shipment Notice (ASN). The Supplier can send an invoice for the chained PO only if this task is configured in Sterling Supplier Portal when creating the community to which the Supplier belongs.

Implementation

The following sections explain the implementations required to publish a chained PO.

Implement the SDS_PublishDropShipPO Service

After the chained PO is created, the SDS_PublishDropShipPO service is invoked on the ON_SUCCESS event of the Create Purchase Order transaction. This service then publishes the chained PO to Sterling B2B Collaboration Network. Ensure that the value of the IsNodeType attribute is DROP_SHIP.

The following figure illustrates the SDS_PublishDropShipPO service:

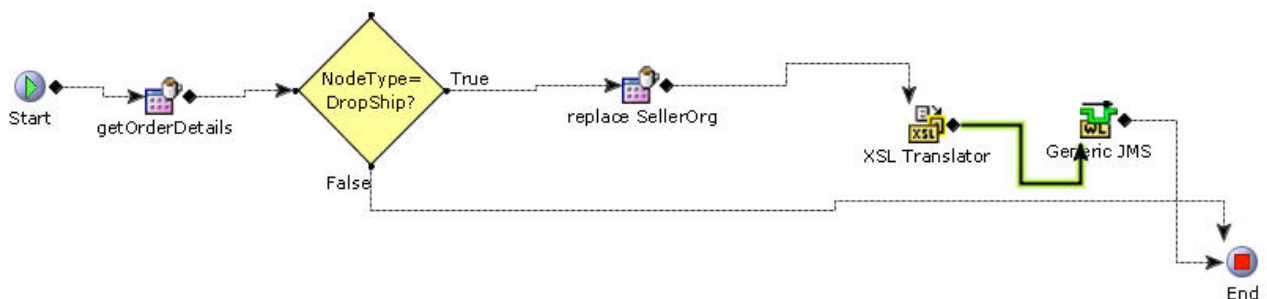

Configure the Schedule Order Time-Triggered Transaction

You must configure the Schedule Order time-triggered transaction for the Order Fulfillment Process type. For more information about time-triggered transactions,

refer to the *Selling and Fulfillment Foundation: Application Platform Configuration Guide*.

Configure the Chained Order Create Time-Triggered Transaction

You must configure the Chained Order Create time-triggered transaction for the Order Fulfillment Process type. For more information about transactions, refer to the *Selling and Fulfillment Foundation: Application Platform Configuration Guide*.

Chapter 29. Implementation: Publishing a Change Purchase Order

If a customer changes a Sales Order (SO), the changes are propagated to the corresponding chained Purchase Order (PO) and a Change Purchase Order is published and sent to the corresponding Sterling Supplier Portal™ Supplier through Sterling B2B Collaboration Network™.

The following out-of-the-box Change Order XML is published and sent to Sterling Supplier Portal Supplier. The customer can customize this Change Order XML as per customer's business requirements.

```
<?xml version="1.0" encoding="UTF-16"?>

<Order BuyerOrganizationCode="" CarrierAccountNo="" CarrierServiceCode=""
ChainType="" CustCustPONo="" DocumentType="" EnterpriseCode="" FreightTerms=""
OrderDate="" OrderNo="" ReqCancelDate="" ReqDeliveryDate="" ReqShipDate=""
SCAC="" ScacAndService="" SellerOrganizationCode="" TaxExemptFlag=""
TaxJurisdiction="" TaxPayerId="" TermsCode="" VendorID=""
Document="OrderChange" ReceiverEDIId="" SenderEDIId=""
ReceivingNode="DROP_SHIP" DropShipNodeType="">

<References>

<Reference Name="" Value="" />

</References>

<OrderLines>

<OrderLine CarrierAccountNo="" CarrierServiceCode="" FreightTerms=""
PrimeLineNo="" ReqCancelDate="" SCAC="" ScacAndService="" SubLineNo=""
OrderedQty="" ReqShipDate="" ReqDeliveryDate="" LineIdentifier="">

<Item ItemShortDesc="" UnitOfMeasure="" ItemID="" CustomerItem=""
SupplierItem="" UPCCode="" ProductClass="" ItemDesc="" CustomerItemDesc=""/>

<LinePriceInfo UnitPrice="" />

<RequestedSchedules>

<RequestedSchedule EndShipDate="" EndDeliveryDate="" Quantity="" />

</RequestedSchedules>

</OrderLine>

</OrderLines>

<PersonInfoShipTo AddressLine1="" AddressLine2="" AddressLine3=""
AddressLine4="" AddressLine5="" AddressLine6="" AlternateEmailID="" Beeper=""
City="" Company="" Country="" DayFaxNo="" DayPhone="" Department="" EmailID=""
EveningFaxNo="" EveningPhone="" FirstName="" IsCommercialAddress="" JobTitle=""
LastName="" MiddleName="" MobilePhone="" OtherPhone="" PersonID="" State=""
Suffix="" TaxGeoCode="" Title="" ZipCode="" />

<PersonInfoBillTo AddressLine1="" AddressLine2="" AddressLine3=""
AddressLine4="" AddressLine5="" AddressLine6="" AlternateEmailID="" Beeper=""
City="" Company="" Country="" DayFaxNo="" DayPhone="" Department="" EmailID=""
```

```

EveningFaxNo="" EveningPhone="" FirstName="" IsCommercialAddress="" JobTitle=""
LastName="" MiddleName="" MobilePhone="" OtherPhone="" PersonID="" State=""
Suffix="" TaxGeoCode="" Title="" ZipCode="" />
</Order>

```

Solution

The corresponding chained PO is automatically changed when an SO is changed by a Seller. The Change PO XML is published on the ON_SUCCESS event of the Change Purchase Order transaction for the drop ship order.

End-User Impact

A Supplier can view the Change PO and accept it in Sterling Supplier Portal.

Implementation

The AuditTransactionId= DONT_RAISE_EVENT condition is created before publishing a Change PO so that the Change PO is not published when the changeOrder API is called within the receiveOrderAcknowledgement API.

After the Change PO is created, the SDS_PublishDropShipChangePO service is invoked on the ON_SUCCESS event of the Change Purchase Order transaction so that the Change PO is published to Sterling B2B Collaboration Network. This service is called when AuditTransactionId= DONT_RAISE_EVENT is false, and NodeType=DROP_SHIP, ChainType=DROP_SHIP. The following figure illustrates the SDS_PublishDropShipChangePO service:

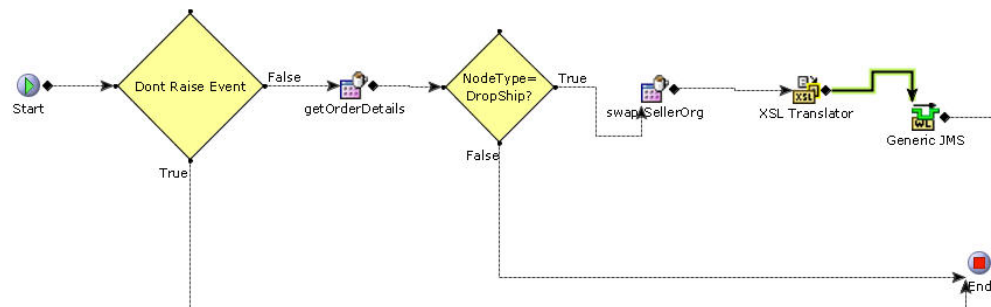

Chapter 30. Implementation: Receiving an Acknowledgement for a Drop Ship Order

A Seller can receive an acknowledgement for a drop ship Purchase Order (PO) from a Supplier if acknowledgement is a part of the choreography configured in [™] when creating the corresponding community. This PO acknowledgement is received by the Seller in the corresponding Order Management system, and the status of the PO is updated to Acknowledged. However, if the acknowledgement is a partial acknowledgement, an alert is raised on the Sales Order (SO). If it is a reject acknowledgement, the PO is cancelled. does not allow Suppliers to send over acknowledgement for a drop ship order.

Notes:

- A new status, Acknowledged, has been provided as a part of Statuses in the Purchase Order Execution Repository in . Ensure that you have created a new pipeline including the newly created Acknowledged status.
- The SDS_PARTIAL_ACK alert is provided out-of-the-box for Sterling Drop Ship.

Solution

When a Supplier sends an acknowledgement to a Seller's system through Sterling B2B Collaboration Network, the `receiveOrderAcknowledgement` API is called to handle the acknowledgement, which raises the `RECEIVED_ACKNOWLEDGEMENT` event. Based on the following cases, the status of the PO changes:

- In the case of a complete acknowledgement, the PO moves to the Acknowledged status. The status of the SO does not change.
- In the case of a rejected acknowledgement, the PO moves to the Cancelled status. The SO moves to the Unscheduled status and the `OrderLineSourcingCtrl/@SuppressSourcing` attribute is set to Y for the order so that the same Supplier is not considered while rescheduling the order.

If either the acknowledged quantity is less than the requested quantity or the acknowledged delivery date is beyond the requested delivery date, the acknowledgement is considered as a partial acknowledgement. A Partial acknowledgement for the PO can be accepted in two ways depending on the value of the `CancelQtyIfNotAcknowledged` flag in the input of the `receiveOrderAcknowledgement` API. By default, the value of this flag is set to Y. Following is a list of the default behaviour of the `receiveOrderAcknowledgement` API:

- The quantity that is not acknowledged gets cancelled on the PO.
- The quantity that is not acknowledged gets unscheduled on the SO.
- The `OrderLineSourcingCtrl` attribute on the SO gets updated so that when the order is scheduled again, it is scheduled for some other Supplier.
- An alert is raised.
- If the Supplier sends another acknowledgement with more quantity than the earlier quantity in the acknowledgement, the `receiveOrderAcknowledgement` API displays an error.

Note: The `receiveOrderAcknowledgement` API displays an error when the Supplier acknowledges an order before accepting a change PO that contains cancellation of the order.

However, after customization if the value of the `CancelQtyIfNotAck` flag is set to N, and the Supplier sends an acknowledgement for less than the ordered quantity, the `receiveOrderAcknowledgement` API exhibits the following behaviour:

- The ordered quantity is not cancelled on the PO.
- The ordered quantity does not get unscheduled on the SO.
- An alert is raised, specifying that the quantity that has been committed. On viewing this alert, a customer must perform one of the following tasks:
 - Accept the changes by changing the ordered quantity to the acknowledged quantity in the SO. In this scenario, the change PO is published.
 - Cancel the entire SO line. In this scenario, a change PO cancelling the order line is published.
 - Unschedule any unit of the ordered quantity from the Supplier. The unscheduled units are cancelled in the PO, and the `OrderLineSourcingCtrl` attribute on the SO gets updated.

Note: If the Supplier sends another acknowledgement after acknowledging completely with the acknowledged delivery dates same as the expected delivery dates, the `CancelQtyIfNotAcknowledged` flag must be set to N so that the unacknowledged quantity is not cancelled from the PO.

End-User Impact

A Seller can receive an acknowledgement for a drop ship PO. If it is a partial acknowledgement, the Seller can view the Partial Acknowledgement alert, and change the PO or cancel it.

Implementation

In order to receive an acknowledgement, the Acknowledge Purchase Order transaction, Unacknowledge Purchase Order transaction, and the `SDS_PARTIAL_ACK` exception type are configured in the Sterling Selling and Fulfillment Foundation Applications Manager. For more information about transactions and exception types, refer to the *Selling and Fulfillment Foundation: Application Platform Configuration Guide*.

The following services are run to implement the Receive an Acknowledgement feature:

- The `SDS_ReceiveOrderAcknowledgement` service obtains the acknowledgement XML from Sterling B2B Collaboration Network, and calls the `receiveOrderAcknowledgement` API. Before calling this API, an extended API component replaces the Sterling B2B Collaboration Network Organization Codes with the On Premise Organization Codes.

The following figure illustrates the `SDS_ReceiveOrderAcknowledgement` service:

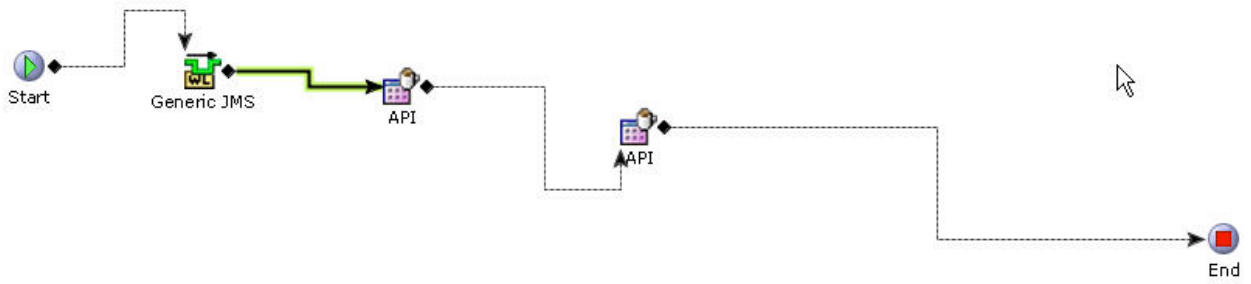

- The `SDS_CreateAlertForPartialAcknowledgement` service is called when the `receiveOrderAcknowledgement` API raises the `RECEIVED_ACKNOWLEDGEMENT` event. The Partial Acknowledgement alert is raised if a partial acknowledgement is received for a SO. The alert is consolidated at the order header level. The following figure illustrates the `SDS_CreateAlertForPartialAcknowledgement` service:

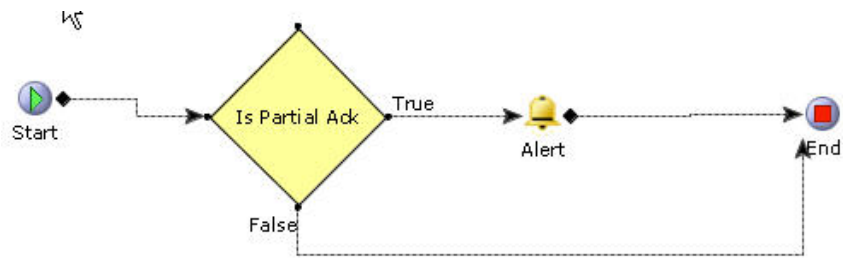

Chapter 31. Implementation: Receiving an Advance Shipment Notice for a Drop Ship Order

A Seller can receive an Advance Shipment Notice (ASN) for a drop ship Purchase Order (PO) from a Supplier if ASN is a part of the choreography that is configured in Sterling Supplier Portal™ when creating the corresponding community. This ASN is received by the Seller in the corresponding Order Management system, and the status of the PO is updated to either Shipped or Partially Shipped.

Solution

When a Supplier sends an ASN to a Seller's Order Management system through Sterling B2B Collaboration Network, the `confirmShipment` API is called for the PO. The PO and SO are moved to the Shipped status.

End-User Impact

None.

Implementation

The `SDS_ReceivePOASN` service receives the ASN XML from Sterling B2B Collaboration Network, and calls the `confirmShipment` API. The following figure illustrates the `SDS_ReceivePOASN` service:

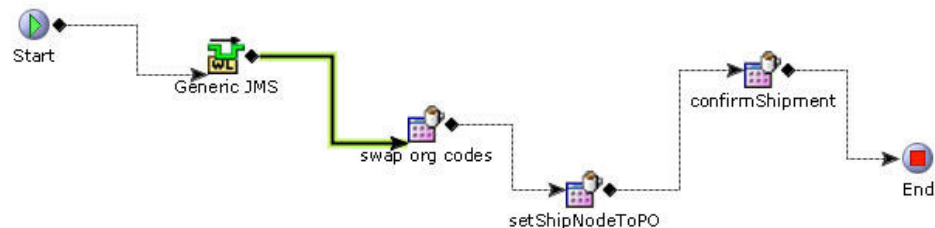

Chapter 32. Implementation: Receiving Inventory Updates for a Drop Ship Order

After a customer places an order, the corresponding Seller's Order Management system verifies the inventory and the availability of line items as per the order. Thus, to schedule the order, the Seller requires updates about the corresponding Supplier's inventory too. Sterling Supplier Portal™ provides a sample Excel sheet in which the Supplier enters the inventory information. This Excel sheet is parsed into an XML that is routed to the Seller's system through Sterling B2B Collaboration Network.

Solution

A Seller receives inventory updates from the corresponding Supplier, which provides visibility into the Supplier's inventory so that the order can be scheduled appropriately.

The following XML is sent by Sterling Supplier Portal to a Seller's Order Management system:

```
<?xml version="1.0" encoding="UTF-8"?>
<Shipment ActualShipmentDate="" BolNo=""
  BuyerOrganizationCode="" CarrierAccountNo=""
  CarrierServiceCode=""
  CommunityEDIDocType="" CommunityID=""
  Document="" DocumentType=""
  EnterpriseCode=""
  ExpectedDeliveryDate="" FreightTerms=""
  Modifyfts="" NumOfCartons=""
  NumOfPallets="" ProNo="" ReceiverEDIId=""
  ReceivingNode="" SCAC=""
  SellerOrganizationCode="" SenderEDIId=""
  ShipVia="" ShipmentNo="" ShipmentType=""
  TotalVolume="" TotalVolumeUOM="" TotalWeight="" TotalWeightUOM="">
  <Containers/>
    <FromAddress AddressLine1="" AddressLine2=""
      AddressLine3="" AddressLine4="" AddressLine5=""
      AddressLine6="" AlternateEmailID="" Beeper=""
      City="" Company="" Country="" DayFaxNo=""
      DayPhone="" Department="" EMailID="" EveningFaxNo=""
      EveningPhone="" FirstName="" JobTitle="" LastName=""
      MiddleName="" MobilePhone="" OtherPhone="" PersonID=""
      State="" Suffix="" Title="" ZipCode=""/>
    <ToAddress AddressLine1="" AddressLine2=""
      AddressLine3="" AddressLine4="" AddressLine5="" AddressLine6=""
      AlternateEmailID="" Beeper="" City="" Company=""
      Country="" DayFaxNo="" DayPhone="" Department=""
      EMailID="" EveningFaxNo="" EveningPhone="" FirstName=""
      JobTitle="" LastName="" MiddleName="" MobilePhone=""
      OtherPhone="" PersonID="" State="" Suffix="" Title="" ZipCode=""/>
  <ShipmentLines>
    <ShipmentLine ItemID="" LineIdentifier=""
      OrderNo="" PrimeLineNo="" ProductClass=""
      Quantity="" ShipmentLineNo="" ShipmentSubLineNo=""
      SubLineNo="" UnitOfMeasure=""/>
  </ShipmentLines>
</Shipment>
```

End-User Impact

None.

Implementation

The SDS_UpdateVendorInventory service reads the inventory XML obtained from Sterling B2B Collaboration Network, and calls the processAvailabilitySnapShot API along with the new inventory updates. The receiveInventoryUpdates XML updates the inventory in the Seller's system. The following figure illustrates the SDS_UpdateVendorInventory service:

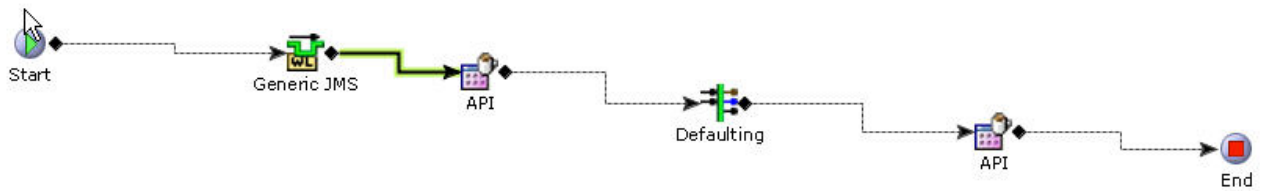

Chapter 33. Implementation: Receiving an Invoice for a Drop Ship Order

A Supplier sends an invoice to a Seller through Sterling Supplier Portal™. The invoice is sent in an XML format that is supported by Sterling Supplier Portal. Sterling B2B Collaboration Network copies this invoice XML to Sterling Supply Chain Visibility, and posts it to the Seller's mail box.

The following XML is sent by Sterling Supplier Portal to a Seller's Order Management system and copied to Sterling Supply Chain Visibility:

```
<MasterInvoice BuyerOrganizationCode="" CommunityEDIDocType="" CommunityID=""
DateInvoiced="" Document="" DocumentType="" EnterpriseCode="" LineTotal=""
MasterInvoiceNo="" MasterInvoiceType="" OrderNo="" OtherCharges="" PayByDate=""
ReceiverEDIId="" SellerOrganizationCode="" SenderEDIId="" ShipmentNo=""
TotalAmount="" TotalTax="">

<PersonInfoBillTo AddressLine1="" AddressLine2="" AddressLine3=""
AddressLine4="" AddressLine5="" AddressLine6="" AlternateEmailID="" Beeper=""
City="" Company="" Country="" DayFaxNo="" DayPhone="" Department="" EmailID=""
EveningFaxNo="" EveningPhone="" FirstName="" JobTitle="" LastName=""
MiddleName="" MobilePhone="" OtherPhone="" PersonID="" State="" Suffix=""
Title="" ZipCode=""/>

<PersonInfoRemitTo AddressLine1="" AddressLine2="" AddressLine3=""
AddressLine4="" AddressLine5="" AddressLine6="" AlternateEmailID="" Beeper=""
City="" Company="" Country="" DayFaxNo="" DayPhone="" Department="" EmailID=""
EveningFaxNo="" EveningPhone="" FirstName="" JobTitle="" LastName=""
MiddleName="" MobilePhone="" OtherPhone="" PersonID="" State="" Suffix=""
Title="" ZipCode=""/>

<HeaderChargeList>

<HeaderCharge ChargeAmount="" ChargeCategory="" ChargeName="" ChargePerUnit=""
ChargePercent="" IsDiscount="" Reference=""/>

</HeaderChargeList>

<TaxBreakupList>

<TaxBreakup Reference1="" Reference2="" Tax="" TaxName="" TaxPercentage=""/>

</TaxBreakupList>

<PaymentTerms>

<PaymentTerm DiscountDaysDue="" DiscountDueDate="" NetDays="" NetDueDate=""
TermsAmount="" TermsDateCode="" TermsDiscount="" TermsTypeCode=""/>

</PaymentTerms>

<OrderInvoiceList>

<OrderInvoice InvoiceNo="" OrderNo="">

<Order OrderDate="" TaxPayerId="">

<PriceInfo Currency="" EnterpriseCurrency=""/>

<References>

<Reference Name="" Value=""/>
```

```

</References>

</Order>

<Shipment ActualShipmentDate="" CarrierAccountNo="" CarrierServiceCode=""
Currency="" ProNo="" SCAC="" ShipVia="" ShipmentNo="">

<FromAddress AddressLine1="" AddressLine2="" AddressLine3="" AddressLine4=""
AddressLine5="" AddressLine6="" AlternateEmailID="" Beeper="" City=""
Company="" Country="" DayFaxNo="" DayPhone="" Department="" EMailID=""
EveningFaxNo="" EveningPhone="" FirstName="" JobTitle="" LastName=""
MiddleName="" MobilePhone="" OtherPhone="" PersonID="" State="" Suffix=""
Title="" ZipCode=""/>

<ToAddress AddressLine1="" AddressLine2="" AddressLine3="" AddressLine4=""
AddressLine5="" AddressLine6="" AlternateEmailID="" Beeper="" City=""
Company="" Country="" DayFaxNo="" DayPhone="" Department="" EMailID=""
EveningFaxNo="" EveningPhone="" FirstName="" JobTitle="" LastName=""
MiddleName="" MobilePhone="" OtherPhone="" PersonID="" State="" Suffix=""
Title="" ZipCode=""/>

</Shipment>

<LineDetails>

<LineDetail AlternateItemID="" CustomerItem="" ExtendedPrice="" ItemID=""
LineIdentifier="" OrderedQty="" PrimeLineNo="" ProductClass="" Quantity=""
SubLineNo="" SupplierBuyerItemDescription="" SupplierItem="" UCCCode=""
UnitOfMeasure="" UnitPrice="">

<LineChargeList>

<LineCharge ChargeCategory="" ChargeName="" ChargePerLine="" ChargePerUnit=""
ChargePercent="" IsDiscount="" Reference=""/>

</LineChargeList>

</LineDetail>

</LineDetails>

</OrderInvoice>

</OrderInvoiceList>

</MasterInvoice>

```

Implementation

The SDS_ReceiveInvoice service is provided as part of factory setup, which picks the invoice XML from Sterling B2B Collaboration Network. This service must be customized based on a customer's business requirements. The following figure illustrates the SDS_ReceiveInvoice service.

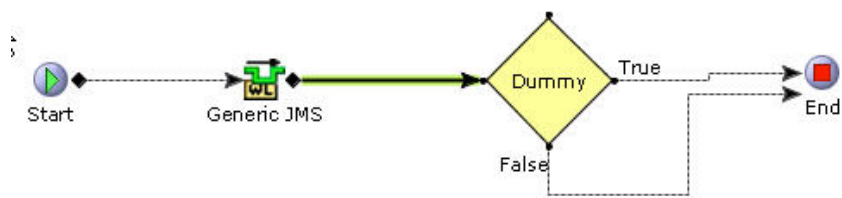

For more information about the APIs and services involved in implementing the Receive an Invoice feature, refer to the *Sterling Javadocs*.

Chapter 34. Sending a Remittance Advice

A Seller sends a remittance advice, also known as payment invoice, to a Supplier subscribed to Sterling Supplier Portal™. The remittance advice is sent in an XML format that is supported by Sterling Supplier Portal. Sterling B2B Collaboration Network copies this payment XML to the Sterling Supply Chain Visibility mail box.

The following XML is sent by a Seller's Order Management system to Sterling Supplier Portal and copied to Sterling Supply Chain Visibility. The API `recordExternalCharges` can be called in the Order Management system to generate this XML, which is then sent to On Demand through a configurable service:

```
<XMLWrapper>

<RecordExternalCharges AuditTransactionId="" BuyerOrganizationCode=""
CustomerPONo="" Document="Payment" DocumentType="" EnterpriseCode=""
ModificationReasonCode="" ModificationReasonText="" ModificationReference1=""
ModificationReference2="" ModificationReference3="" ModificationReference4=""
OrderHeaderKey="" OrderNo="" ReceiverEDIId="" SellerOrganizationCode=""
SenderEDIId="">

<PaymentMethod ChargeSequence="" CheckNo="" CheckReference=""
CreditCardExpDate="" CreditCardName="" CreditCardNo="" CreditCardType=""
CustomerAccountNo="" CustomerPONo="" DisplayCreditCardNo=""
DisplayPaymentReference1="" DisplaySvcNo="" MaxChargeLimit="" PaymentKey=""
PaymentReference1="" PaymentReference2="" PaymentReference3="" PaymentType=""
SvcNo="" UnlimitedCharges="">

<PaymentDetails AuditTransactionId="" AuthAvs="" AuthCode="" AuthReturnCode=""
AuthReturnFlag="" AuthReturnMessage="" AuthTime=""
AuthorizationExpirationDate="" AuthorizationID="" CVVAuthCode=""
ChargeType="Required" HoldAgainstBook="" InternalReturnCode=""
InternalReturnFlag="" InternalReturnMessage="" ProcessedAmount=""
Reference1="" Reference2="" RequestAmount="" RequestId="" RequestProcessed=""
TranRequestTime="" TranReturnCode="" TranReturnFlag="" TranReturnMessage=""
TranType=""/>

</PaymentMethod>

<Memo ChargeAmount="" Reference1=""/>

</RecordExternalCharges>

<XMLWrapper>
```

For more information about the APIs and services involved in implementing the Send a Remittance Advice feature, refer to the *Sterling Javadocs*.

Notices

This information was developed for products and services offered in the U.S.A.

IBM may not offer the products, services, or features discussed in this document in other countries. Consult your local IBM representative for information on the products and services currently available in your area. Any reference to an IBM product, program, or service is not intended to state or imply that only that IBM product, program, or service may be used. Any functionally equivalent product, program, or service that does not infringe any IBM intellectual property right may be used instead. However, it is the user's responsibility to evaluate and verify the operation of any non-IBM product, program, or service.

IBM may have patents or pending patent applications covering subject matter described in this document. The furnishing of this document does not grant you any license to these patents. You can send license inquiries, in writing, to:

IBM Director of Licensing

IBM Corporation

North Castle Drive

Armonk, NY 10504-1785

U.S.A.

For license inquiries regarding double-byte character set (DBCS) information, contact the IBM Intellectual Property Department in your country or send inquiries, in writing, to:

Intellectual Property Licensing

Legal and Intellectual Property Law

IBM Japan Ltd.

1623-14, Shimotsuruma, Yamato-shi

Kanagawa 242-8502 Japan

The following paragraph does not apply to the United Kingdom or any other country where such provisions are inconsistent with local law:

INTERNATIONAL BUSINESS MACHINES CORPORATION PROVIDES THIS PUBLICATION "AS IS" WITHOUT WARRANTY OF ANY KIND, EITHER EXPRESS OR IMPLIED, INCLUDING, BUT NOT LIMITED TO, THE IMPLIED WARRANTIES OF NON-INFRINGEMENT, MERCHANTABILITY OR FITNESS FOR A PARTICULAR PURPOSE. Some states do not allow disclaimer of express or implied warranties in certain transactions, therefore, this statement may not apply to you.

This information could include technical inaccuracies or typographical errors. Changes are periodically made to the information herein; these changes will be

incorporated in new editions of the publication. IBM may make improvements and/or changes in the product(s) and/or the program(s) described in this publication at any time without notice.

Any references in this information to non-IBM Web sites are provided for convenience only and do not in any manner serve as an endorsement of those Web sites. The materials at those Web sites are not part of the materials for this IBM product and use of those Web sites is at your own risk.

IBM may use or distribute any of the information you supply in any way it believes appropriate without incurring any obligation to you.

Licensees of this program who wish to have information about it for the purpose of enabling: (i) the exchange of information between independently created programs and other programs (including this one) and (ii) the mutual use of the information which has been exchanged, should contact:

IBM Corporation

J46A/G4

555 Bailey Avenue

San Jose, CA 95141-1003

U.S.A.

Such information may be available, subject to appropriate terms and conditions, including in some cases, payment of a fee.

The licensed program described in this document and all licensed material available for it are provided by IBM under terms of the IBM Customer Agreement, IBM International Program License Agreement or any equivalent agreement between us.

Any performance data contained herein was determined in a controlled environment. Therefore, the results obtained in other operating environments may vary significantly. Some measurements may have been made on development-level systems and there is no guarantee that these measurements will be the same on generally available systems. Furthermore, some measurements may have been estimated through extrapolation. Actual results may vary. Users of this document should verify the applicable data for their specific environment.

Information concerning non-IBM products was obtained from the suppliers of those products, their published announcements or other publicly available sources. IBM has not tested those products and cannot confirm the accuracy of performance, compatibility or any other claims related to non-IBM products. Questions on the capabilities of non-IBM products should be addressed to the suppliers of those products.

All statements regarding IBM's future direction or intent are subject to change or withdrawal without notice, and represent goals and objectives only.

All IBM prices shown are IBM's suggested retail prices, are current and are subject to change without notice. Dealer prices may vary.

This information is for planning purposes only. The information herein is subject to change before the products described become available.

This information contains examples of data and reports used in daily business operations. To illustrate them as completely as possible, the examples include the names of individuals, companies, brands, and products. All of these names are fictitious and any similarity to the names and addresses used by an actual business enterprise is entirely coincidental.

COPYRIGHT LICENSE:

This information contains sample application programs in source language, which illustrate programming techniques on various operating platforms. You may copy, modify, and distribute these sample programs in any form without payment to IBM, for the purposes of developing, using, marketing or distributing application programs conforming to the application programming interface for the operating platform for which the sample programs are written. These examples have not been thoroughly tested under all conditions. IBM, therefore, cannot guarantee or imply reliability, serviceability, or function of these programs. The sample programs are provided "AS IS", without warranty of any kind. IBM shall not be liable for any damages arising out of your use of the sample programs.

Each copy or any portion of these sample programs or any derivative work, must include a copyright notice as follows:

© IBM 2011. Portions of this code are derived from IBM Corp. Sample Programs. © Copyright IBM Corp. 2011.

If you are viewing this information softcopy, the photographs and color illustrations may not appear.

Trademarks

IBM, the IBM logo, and [ibm.com](http://www.ibm.com)[®] are trademarks or registered trademarks of International Business Machines Corp., registered in many jurisdictions worldwide. Other product and service names might be trademarks of IBM or other companies. A current list of IBM trademarks is available on the Web at "Copyright and trademark information" at <http://www.ibm.com/legal/copytrade.shtml>.

Adobe, the Adobe logo, PostScript, and the PostScript logo are either registered trademarks or trademarks of Adobe Systems Incorporated in the United States, and/or other countries.

IT Infrastructure Library is a registered trademark of the Central Computer and Telecommunications Agency which is now part of the Office of Government Commerce.

Intel, Intel logo, Intel Inside, Intel Inside logo, Intel Centrino, Intel Centrino logo, Celeron, Intel Xeon, Intel SpeedStep, Itanium, and Pentium are trademarks or registered trademarks of Intel Corporation or its subsidiaries in the United States and other countries.

Linux is a registered trademark of Linus Torvalds in the United States, other countries, or both.

Microsoft, Windows, Windows NT, and the Windows logo are trademarks of Microsoft Corporation in the United States, other countries, or both.

ITIL is a registered trademark, and a registered community trademark of the Office of Government Commerce, and is registered in the U.S. Patent and Trademark Office.

UNIX is a registered trademark of The Open Group in the United States and other countries.

Java and all Java-based trademarks and logos are trademarks or registered trademarks of Oracle and/or its affiliates.

Cell Broadband Engine is a trademark of Sony Computer Entertainment, Inc. in the United States, other countries, or both and is used under license therefrom.

Linear Tape-Open, LTO, the LTO Logo, Ultrium and the Ultrium Logo are trademarks of HP, IBM Corp. and Quantum in the U.S. and other countries.

Connect Control Center[®], Connect:Direct[®], Connect:Enterprise[™], Gentran[®], Gentran:Basic[®], Gentran:Control[®], Gentran:Director[®], Gentran:Plus[®], Gentran:Realtime[®], Gentran:Server[®], Gentran:Viewpoint[®], Sterling Commerce[™], Sterling Information Broker[®], and Sterling Integrator[®] are trademarks or registered trademarks of Sterling Commerce[™], Inc., an IBM Company.

Other company, product, and service names may be trademarks or service marks of others.

Index

C

- configure
 - SCN organization code 37
- configure seller
 - synchronized dates transaction rule 39
 - transit days 41
- creating supplier 43

D

- Drop Ship Option Pack
 - checklist 3
 - overview 1
- drop ship purchase order
 - lifecycle 19

G

- getting started
 - loading database factory defaults 13

I

- implementing Drop Ship Option Pack
 - publish chained purchase order 63
 - publish change purchase order 67
 - receive acknowledgement for drop ship order 69
 - receive ASN for drop ship order 73
 - receive inventory updates for drop ship order 75
 - receive invoice for drop ship order 77
 - send remittance advice 81
- install Drop Ship Option Pack
 - prerequisites 9
- installing Drop Ship Option Pack
 - building EAR 17
 - introduction 7
 - Linux/UNIX environment 11
- integration with Gentran Integration Suite
 - AS2 communication protocol 55
 - AS2 profile 61
 - system certificate 59
- invoice XML 77

M

- modelling supplier
 - configure catalog attributes 53
 - configure inventory attributes 51
 - configure supplier 47
 - create supplier 43

O

- onboarding seller
 - configure document templates 27
 - configure modification components 25

P

- payment XML 81
- pipeline
 - purchase order 19
 - purchase order shipment 20



Printed in USA