

# **Connect:Direct® for z/OS**

## **Facilities Guide**

**Version 4.7**

**Connect:Direct for z/OS Facilities Guide**  
**Version 4.7**  
**First Edition**

(c) Copyright 1998, 2008 Sterling Commerce, Inc. All rights reserved. Additional copyright information is located at the end of the release notes.

**STERLING COMMERCE SOFTWARE**

**\*\*\*TRADE SECRET NOTICE\*\*\***

THE CONNECT:DIRECT SOFTWARE ("STERLING COMMERCE SOFTWARE") IS THE CONFIDENTIAL AND TRADE SECRET PROPERTY OF STERLING COMMERCE, INC., ITS AFFILIATED COMPANIES OR ITS OR THEIR LICENSORS, AND IS PROVIDED UNDER THE TERMS OF A LICENSE AGREEMENT. NO DUPLICATION OR DISCLOSURE WITHOUT PRIOR WRITTEN PERMISSION. RESTRICTED RIGHTS.

This documentation, the Sterling Commerce Software it describes, and the information and know-how they contain constitute the proprietary, confidential and valuable trade secret information of Sterling Commerce, Inc., its affiliated companies or its or their licensors, and may not be used for any unauthorized purpose, or disclosed to others without the prior written permission of the applicable Sterling Commerce entity. This documentation and the Sterling Commerce Software that it describes have been provided pursuant to a license agreement that contains prohibitions against and/or restrictions on their copying, modification and use. Duplication, in whole or in part, if and when permitted, shall bear this notice and the Sterling Commerce, Inc. copyright notice. As and when provided to any governmental entity, government contractor or subcontractor subject to the FARs, this documentation is provided with RESTRICTED RIGHTS under Title 48 52.227-19. Further, as and when provided to any governmental entity, government contractor or subcontractor subject to DFARS, this documentation and the Sterling Commerce Software it describes are provided pursuant to the customary Sterling Commerce license, as described in Title 48 CFR 227-7202 with respect to commercial software and commercial software documentation.

These terms of use shall be governed by the laws of the State of Ohio, USA, without regard to its conflict of laws provisions. If you are accessing the Sterling Commerce Software under an executed agreement, then nothing in these terms and conditions supersedes or modifies the executed agreement.

Where any of the Sterling Commerce Software or Third Party Software is used, duplicated or disclosed by or to the United States government or a government contractor or subcontractor, it is provided with RESTRICTED RIGHTS as defined in Title 48 CFR 52.227-19 and is subject to the following: Title 48 CFR 2.101, 52.227-19, 227.7201 through 227.7202-4, FAR 52.227-14, and FAR 52.227-19(c)(1-2) and (6/87), and where applicable, the customary Sterling Commerce license, as described in Title 48 CFR 227-7202 with respect to commercial software and commercial software documentation including DFAR 252.227-7013, DFAR 252,227-7014, DFAR 252.227-7015 and DFAR 252.227-7018, all as applicable.

The Sterling Commerce Software and the related documentation are licensed either "AS IS" or with a limited warranty, as described in the Sterling Commerce license agreement. Other than any limited warranties provided, NO OTHER WARRANTY IS EXPRESSED AND NONE SHALL BE IMPLIED, INCLUDING THE WARRANTIES OF MERCHANTABILITY AND FITNESS FOR USE OR FOR A PARTICULAR PURPOSE. The applicable Sterling Commerce entity reserves the right to revise this publication from time to time and to make changes in the content hereof without the obligation to notify any person or entity of such revisions or changes.

Connect:Direct is a registered trademark of Sterling Commerce. Connect:Enterprise is a registered trademark of Sterling Commerce, U.S. Patent Number 5,734,820. All Third Party Software names are trademarks or registered trademarks of their respective companies. All other brand or product names are trademarks or registered trademarks of their respective companies.

---

Sterling Commerce, Inc.  
4600 Lakehurst Court Dublin, OH 43016-2000 \*  
614/793-7000

---

# Contents

|                                                                 |           |
|-----------------------------------------------------------------|-----------|
| <b>Chapter 1 About Connect:Direct for z/OS Facilities</b>       | <b>9</b>  |
| Connect:Direct for z/OS Documentation . . . . .                 | 10        |
| About This Guide . . . . .                                      | 10        |
| Task Overview . . . . .                                         | 10        |
| <b>Chapter 2 Activity Reporting System</b>                      | <b>11</b> |
| ARS and Connect:Direct . . . . .                                | 11        |
| Requesting ARS Reports . . . . .                                | 12        |
| Business Solutions Using ARS . . . . .                          | 12        |
| <b>Chapter 3 ARS Report Examples</b>                            | <b>15</b> |
| Connect:Direct Activity Report. . . . .                         | 15        |
| Connect:Direct Summary Report. . . . .                          | 17        |
| Connect:Direct Exception Report . . . . .                       | 19        |
| Connect:Direct Security Violations Report. . . . .              | 22        |
| Connect:Direct Function Reports . . . . .                       | 23        |
| Connect:Direct NonPDS Copy Report . . . . .                     | 23        |
| Connect:Direct PDS Copy Report. . . . .                         | 25        |
| Connect:Direct Run Job Report . . . . .                         | 27        |
| Connect:Direct Run Task Report . . . . .                        | 29        |
| Connect:Direct Submit Within a Process Report . . . . .         | 30        |
| <b>Chapter 4 Requesting ARS Reports Using Screens</b>           | <b>33</b> |
| Step 1—Requesting Reports Using ARS Screens . . . . .           | 33        |
| Accessing the ARS Screens Using the Connect:Direct IUI. . . . . | 33        |
| Accessing the ARS Screens . . . . .                             | 34        |
| ARS Report Options Screen . . . . .                             | 35        |
| ARS Connect:Direct Requirements Screen . . . . .                | 37        |
| ARS SAS Requirements Screen. . . . .                            | 38        |
| Displayed Job Stream Created from Screens. . . . .              | 39        |
| Step 2—Running the Job . . . . .                                | 40        |

---

**Chapter 5 Requesting Multiple ARS Reports or Scheduled Processing 41**

---

|                                                                 |    |
|-----------------------------------------------------------------|----|
| Sample Job Stream . . . . .                                     | 41 |
| Modifying the Sample Job Stream . . . . .                       | 42 |
| Job Stream Definitions . . . . .                                | 43 |
| Sample Connect:Direct Process That Submits Job Stream . . . . . | 45 |
| Routing Multiple Reports to an Output Data Set . . . . .        | 46 |

---

**Chapter 6 ARS Record Layouts 47**

---

|                                                     |    |
|-----------------------------------------------------|----|
| Description of an SAS Variable . . . . .            | 48 |
| Authorization Event Record . . . . .                | 49 |
| Change Process Termination Record . . . . .         | 49 |
| Copy Termination Record . . . . .                   | 51 |
| Delete Process Termination Record . . . . .         | 53 |
| Display Statistics Record . . . . .                 | 54 |
| Flush/Suspend Process Termination Record . . . . .  | 55 |
| PDS Member Copy Record . . . . .                    | 56 |
| Process Submit Statistics Record . . . . .          | 57 |
| Process Termination Record . . . . .                | 58 |
| Run Job Termination Record . . . . .                | 59 |
| Run Task Termination Record . . . . .               | 60 |
| Signon/Signoff Statistics Record . . . . .          | 61 |
| Start Connect:Direct Command Record . . . . .       | 62 |
| Stop Connect:Direct Statistics Record . . . . .     | 63 |
| Write to Operator (WTO) Statistics Record . . . . . | 63 |

---

**Chapter 7 Connect:Direct for z/OS Operator Interface 65**

---

|                                                                         |    |
|-------------------------------------------------------------------------|----|
| Invoking the Connect:Direct for z/OS Operator Interface . . . . .       | 65 |
| Using the Operator Interface . . . . .                                  | 66 |
| Sample Connect:Direct for z/OS CLISTs . . . . .                         | 66 |
| Rules for Setting Up Connect:Direct for z/OS CLISTs . . . . .           | 67 |
| Submitting Connect:Direct for z/OS Commands . . . . .                   | 68 |
| Examples . . . . .                                                      | 68 |
| CLIST with Command and No Parameters . . . . .                          | 68 |
| CLIST with Command and One Parameter . . . . .                          | 69 |
| CLIST with Command and Multiple Parameters . . . . .                    | 69 |
| CLIST with Command and %IF %ELSE %EIF . . . . .                         | 70 |
| Interpreting Connect:Direct for z/OS Operation Messages . . . . .       | 70 |
| Stopping Connect:Direct . . . . .                                       | 71 |
| Stopping a Connect:Direct/Plex Manager and All Servers . . . . .        | 71 |
| Stopping an Individual Connect:Direct/Plex Server . . . . .             | 71 |
| Understanding Connect:Direct for z/OS Tape Mount Messages . . . . .     | 71 |
| Tape Pre-mount Message . . . . .                                        | 72 |
| Tape Mount Messages . . . . .                                           | 72 |
| Setting Up Connect:Direct for z/OS Tape Pre-mount Messages . . . . .    | 72 |
| Setting Up Connect:Direct for z/OS Tape Mount Messages . . . . .        | 72 |
| Responding to Connect:Direct for z/OS Tape Pre-mount Messages . . . . . | 73 |
| Responding to Connect:Direct for z/OS Tape Mount Messages . . . . .     | 73 |

|                                                                 |           |
|-----------------------------------------------------------------|-----------|
| Tape Device Allocation . . . . .                                | 73        |
| Terminating the Tape Mount . . . . .                            | 74        |
| Verifying Volume Requests . . . . .                             | 74        |
| Handling Multivolume Files . . . . .                            | 74        |
| Connect:Direct for z/OS Messages on 3480 Display . . . . .      | 75        |
| <b>Chapter 8 Event Services Support</b>                         | <b>77</b> |
| Concepts and Components . . . . .                               | 77        |
| System Interfaces . . . . .                                     | 77        |
| System Advantages . . . . .                                     | 78        |
| <b>Chapter 9 Using Event Services Support</b>                   | <b>81</b> |
| Connect:Direct Event Services Support Architecture . . . . .    | 81        |
| ESS Data Flow Using CICS API . . . . .                          | 82        |
| Deciding What Event Data to Collect . . . . .                   | 83        |
| ESS Event Record Examples . . . . .                             | 84        |
| Using ESS with the CICS API . . . . .                           | 85        |
| Using ESS with the ESS User Exit . . . . .                      | 86        |
| System Architecture . . . . .                                   | 86        |
| Using the ESS Exit . . . . .                                    | 87        |
| <b>Chapter 10 Issuing Event Services Commands</b>               | <b>89</b> |
| EVENT SERVICES CREATE Command Format . . . . .                  | 89        |
| Required Parameters . . . . .                                   | 90        |
| Optional Parameters . . . . .                                   | 95        |
| Sample Command . . . . .                                        | 95        |
| EVENT SERVICES START Command Format . . . . .                   | 95        |
| Required Parameter . . . . .                                    | 96        |
| Optional Parameters . . . . .                                   | 96        |
| Sample Command . . . . .                                        | 96        |
| EVENT SERVICES STOP Command Format . . . . .                    | 97        |
| Required Parameter . . . . .                                    | 97        |
| Optional Parameter . . . . .                                    | 97        |
| EVENT SERVICES DISPLAY Command Format . . . . .                 | 97        |
| Required Parameters . . . . .                                   | 98        |
| Optional Parameter . . . . .                                    | 98        |
| <b>Chapter 11 Using ESS with the CICS API</b>                   | <b>99</b> |
| Configuring CICS . . . . .                                      | 99        |
| Driver Fields . . . . .                                         | 100       |
| Using the CICS API Option . . . . .                             | 101       |
| Linking DMQ012 . . . . .                                        | 102       |
| Using LASTSEQ . . . . .                                         | 103       |
| Reading an Event Record from the Transient Data Queue . . . . . | 104       |

**Chapter 12 Event Services Record Descriptions 105**

|                                        |     |
|----------------------------------------|-----|
| Event Record Type Attributes . . . . . | 105 |
| Event Record Types . . . . .           | 105 |
| Event Record Enhancements . . . . .    | 108 |

**Chapter 13 Spool Transfer Facility 109**

|                                     |     |
|-------------------------------------|-----|
| Spool Transfer Components . . . . . | 110 |
|-------------------------------------|-----|

**Chapter 14 Receiving Spool Output 111**

|                                   |     |
|-----------------------------------|-----|
| VTAM Printer Support . . . . .    | 111 |
| System Control . . . . .          | 112 |
| System Initialization . . . . .   | 112 |
| Printer Initialization . . . . .  | 112 |
| SYSOUT Data Set Ready. . . . .    | 112 |
| Printer Termination . . . . .     | 112 |
| System Termination . . . . .      | 112 |
| Connect:Direct API . . . . .      | 113 |
| CDVPSAPI . . . . .                | 113 |
| VPSSCDI . . . . .                 | 113 |
| Connect:Direct SIGNON . . . . .   | 113 |
| SIGNON Security . . . . .         | 114 |
| Process Names . . . . .           | 114 |
| CDPROCES . . . . .                | 115 |
| GENER . . . . .                   | 119 |
| Symbolic Definitions . . . . .    | 120 |
| Job and Jobstep Values . . . . .  | 120 |
| Printer File Attributes . . . . . | 120 |
| Customizing VPSSCDI . . . . .     | 120 |

**Chapter 15 Transferring Data to the JES Reader or Spool 123**

|                                             |     |
|---------------------------------------------|-----|
| Using the JES Reader or Spool. . . . .      | 123 |
| Dynamic Allocation . . . . .                | 123 |
| Checkpoint/Restart . . . . .                | 123 |
| Banner Page . . . . .                       | 124 |
| Sending Output to the JES Reader . . . . .  | 124 |
| Examples . . . . .                          | 124 |
| Using the READER Keyword . . . . .          | 124 |
| Using the SYSOPTS. . . . .                  | 125 |
| Sending Output to JES Spool Files . . . . . | 125 |
| Connect:Direct Banners . . . . .            | 125 |
| Banner After Restart . . . . .              | 126 |

|                                   |     |
|-----------------------------------|-----|
| Connect:Direct COPY Process ..... | 127 |
| Examples .....                    | 127 |
| Carriage Control .....            | 127 |
| Connect:Direct Syntax .....       | 128 |
| Symbolic Definitions .....        | 129 |
| SYSOUT Keyword .....              | 129 |
| Sample Process (CDTOJES) .....    | 132 |

|              |            |
|--------------|------------|
| <b>Index</b> | <b>135</b> |
|--------------|------------|

---





---

# About Connect:Direct for z/OS Facilities

Connect:Direct links technologies and moves information between networked systems and computers. It manages high-performance transfers by providing:

- ◆ Automation
- ◆ Reliability
- ◆ Efficient use of resources
- ◆ Application integration
- ◆ Ease of use

Connect:Direct software offers choices in communications protocols, hardware platforms, and operating systems. It provides the flexibility to move information among mainframes, midrange systems, desktop systems, and LAN-based workstations.

In addition to the core Connect:Direct product, the following facilities are provided to fill specific needs.

- ◆ The Activity Reporting System (ARS) works with Connect:Direct for z/OS to produce reports of Connect:Direct activity using the SAS System.
- ◆ The Console Operator interface enables you to issue all Connect:Direct for z/OS commands from a z/OS console by using a MODIFY command.
- ◆ Event Services Support (ESS) generates events asynchronously in Connect:Direct and can be used by external management and automated operations applications that require real-time notification of Connect:Direct activities.
- ◆ The Connect:Direct Spool Transfer facility enables you to transfer Job Entry Subsystem (JES) spool files by copying:
  - ◆ From JES Spool Files
  - ◆ To JES Print Queues
  - ◆ To JES Reader Queues

These facilities are the subject of this guide.

---

## Connect:Direct for z/OS Documentation

See the *Connect:Direct for z/OS Release Notes* for a complete list of the product documentation.

### About This Guide

The *Connect:Direct for z/OS Facilities Guide* is for programmers and network operations staff who install, configure, and maintain the Connect:Direct for z/OS product, and for operations staff who manage and monitor Process status and data transfer with Connect:Direct for mainframe platforms.

Depending on the facility being used, this manual assumes knowledge of the following components:

- ◆ IBM z/OS operating system
- ◆ Job Control Language (JCL)
- ◆ IBM Time Sharing Option/Interactive System Productivity Facility (TSO/ISPF)
- ◆ LRS VTAM Printer Support
- ◆ VPS/CDI option

For information about the z/OS operating system, refer to the IBM z/OS documentation. For information about a particular component or environment, refer to the library of manuals for the specific products.

### Task Overview

Connect:Direct for z/OS facilities include the following activities:

| <b>Task</b>                                                                                                                                                                       | <b>For More Information, See</b>                                                                                                                                                                                                                                    |
|-----------------------------------------------------------------------------------------------------------------------------------------------------------------------------------|---------------------------------------------------------------------------------------------------------------------------------------------------------------------------------------------------------------------------------------------------------------------|
| Planning and Using the Activity Reporting System                                                                                                                                  | Chapter 2, <i>Activity Reporting System</i><br>Chapter 3, <i>ARS Report Examples</i><br>Chapter 4, <i>Requesting ARS Reports Using Screens</i><br>Chapter 5, <i>Requesting Multiple ARS Reports or Scheduled Processing</i><br>Chapter 6, <i>ARS Record Layouts</i> |
| Issuing Connect:Direct commands from a z/OS console by using a MODIFY command                                                                                                     | Chapter 7, <i>Connect:Direct for z/OS Operator Interface</i>                                                                                                                                                                                                        |
| Generating events asynchronously in Connect:Direct for real-time notification of Connect:Direct activities on behalf of external management and automated operations applications | Chapter 8, <i>Event Services Support</i><br>Chapter 9, <i>Using Event Services Support</i><br>Chapter 10, <i>Issuing Event Services Commands</i><br>Chapter 11, <i>Using ESS with the CICS API</i><br>Chapter 12, <i>Event Services Record Descriptions</i>         |
| Transferring Job Entry Subsystem (JES) spool files                                                                                                                                | Chapter 13, <i>Spool Transfer Facility</i><br>Chapter 14, <i>Receiving Spool Output</i><br>Chapter 15, <i>Transferring Data to the JES Reader or Spool</i>                                                                                                          |

---

# Activity Reporting System

The Activity Reporting System (ARS) produces reports of Connect:Direct activity. While Connect:Direct itself produces statistics, ARS enables you to access more information and also provides sorting capabilities.

You can request ARS reports in three ways:

- ◆ Make requests through ARS screens using IBM Time Sharing Option/Interactive System Productivity Facility (TSO/ISPF)
- ◆ Request reports automatically through a Connect:Direct Process
- ◆ Schedule a batch job through a job scheduling subsystem

With ARS, you do not have to pass data to z/OS system management facilities (SMF) or write SAS requests to print Connect:Direct activity reports. Use ARS as a standard reporting format throughout a network for tracking Connect:Direct activity.

---

**Note:** ARS requires a SAS base running under z/OS. Connect:Direct for z/OS must be active in order to run ARS.

---

---

## ARS and Connect:Direct

Connect:Direct automatically collects statistical data about Connect:Direct activity and stores it in a data set. ARS can access this statistical data and produce the following reports for a selected time period:

- ◆ Connect:Direct Activity Report lists activity by Process step
- ◆ Connect:Direct Summary Report summarizes all activity
- ◆ Connect:Direct Exception Report lists all Process steps that do not complete successfully
- ◆ Connect:Direct Security Violations Report lists security violations by signon security failures, Process security failures, and data set access security failures
- ◆ Connect:Direct Function Reports provides the activity reports for the following types of Process steps:
  - ◆ Nonpartitioned Data Set (PDS) COPY

- ◆ PDS COPY
- ◆ RUN JOB
- ◆ RUN TASK
- ◆ Submit Within a Process

## Requesting ARS Reports

Following are two methods for requesting ARS reports:

- ◆ Through the ARS screens where you can create a job stream that requests reports. The screens automatically build the job or allow you to edit the sample report job stream.
- ◆ By using the sample JCL member that is provided with ARS.

---

## Business Solutions Using ARS

ARS is designed to provide data center management with additional tools to monitor and track Connect:Direct usage. Use the information in the reports to track attempted security violations, analyze capacity planning related data, examine Connect:Direct utilization, and isolate failed Connect:Direct Processes.

The following table describes how you can use ARS.

| Function               | Description                                                                                                                                                                                                                                                                                                                                                                        |
|------------------------|------------------------------------------------------------------------------------------------------------------------------------------------------------------------------------------------------------------------------------------------------------------------------------------------------------------------------------------------------------------------------------|
| Data Center Management | The data center manager wants to keep track of Connect:Direct activities performed. The Connect:Direct Activity Report lists all of the Process steps that occurred in this data center during a specified time period. The Connect:Direct NonPDS Copy Report and Connect:Direct PDS Copy Report provide additional information on all COPY steps performed.                       |
| Security Violations    | A system administrator requests a listing of any Connect:Direct-related security violations on a daily basis. The Connect:Direct Security Violations Report lists the following violations: <ul style="list-style-type: none"> <li>◆ Sign on security failures</li> <li>◆ Processes not run due to lack of authorization</li> <li>◆ Data set access security violations</li> </ul> |
| Capacity Planning      | The capacity planner at a data center needs to know how many bytes are transferring between this data center and other data centers and the total transmission times. The Connect:Direct Summary Report provides this type of information by remote data center for a specified time period.                                                                                       |

---

| <b>Function</b>            | <b>Description</b>                                                                                                                                                                                                                                                                                                                                                                                                                                                                                                                                                                                                      |
|----------------------------|-------------------------------------------------------------------------------------------------------------------------------------------------------------------------------------------------------------------------------------------------------------------------------------------------------------------------------------------------------------------------------------------------------------------------------------------------------------------------------------------------------------------------------------------------------------------------------------------------------------------------|
| Connect:Direct Utilization | <p>The data center administrator studies Connect:Direct utilization by examining how many application programs are submitted or invoked using Connect:Direct. The administrator uses this information with a job scheduling system to produce a comprehensive analysis of all jobs run at a data center.</p> <p>Two ARS reports provide this type of utilization summary.</p> <p>The Connect:Direct Run Job Report provides information about all jobs submitted by Connect:Direct.</p> <p>The Connect:Direct Run Task Report provides information about all programs executed under the control of Connect:Direct.</p> |
| Problem Isolation          | <p>The Connect:Direct Exception Report is an excellent tool for researching why a Process does not run. This report lists each failed Process for a requested time period along with the reason for the failure.</p>                                                                                                                                                                                                                                                                                                                                                                                                    |

---



---

# ARS Report Examples

This chapter explains the types of ARS reports available. The reports are as follows:

- ◆ Connect:Direct Activity Report
- ◆ Connect:Direct Summary Report
- ◆ Connect:Direct Exception Report
- ◆ Connect:Direct Security Violations Report
- ◆ Connect:Direct Function Reports:
  - ◆ Connect:Direct NonPDS Copy Report
  - ◆ Connect:Direct PDS Copy Report
  - ◆ Connect:Direct Run Job Report
  - ◆ Connect:Direct Run Task Report
  - ◆ Connect:Direct Submit Within a Process Report

You can request these reports in the following ways:

- ◆ Through ARS screens using TSO/ISPF
- ◆ Through a Connect:Direct Process that is defined to automatically request reports
- ◆ Through a pre-defined batch job stream that is run by a job scheduling subsystem

---

## Connect:Direct Activity Report

The Connect:Direct Activity Report lists Connect:Direct activity by Process step. The ARS software sorts the steps for each secondary node (SNODE) location by user ID and then by Process number, for a specified time period.

You can specify the start date and time and the stop date and time. Following is an example of the Connect:Direct Activity Report.

```

Connect:Direct ACTIVITY REPORT      (ARS00001)      17:12 WEDNESDAY, JUNE 24, 2005      1
NODE = CD.BOSTON
-----SNODE=CD.BOSTON-----
USERID      PROC      PROC      STEP      FUNCTION      ELAPSE      PNODE      CC      EXC      MSG      DATE
            #      NAME      NAME      TIME
ALPHA       46      COPY1     STEP01     COPY          0:00:01.89   CD.BOSTON   00000000      SCPA0001 06/17/2005
ALLEN       63      COPY2     STEP01     COPY          0:00:02.08   CD.CHICAGO  00000000      SRPA0001 06/17/2005
BETA        87      RUNJOB    LAB        RUNJOB        0:00:01.26   CD.CHICAGO  00000000      SRJA0001 06/17/2005
ETHAN       89      RUNJOB    SUBSTEP    RUNJOB        0:00:00.68   CD.JERSEY  00000000      SSJA0001 06/17/2005
LEWIS       9       RUNT      STEP1      RUNTASK       0:00:00.11   CD.JERSEY  00000000      SRTA0001 06/17/2005
LOUIS       95      SUB       SUBSTEP    SUBMIT        0:00:01.34   CD.JERSEY  00000008      SSUB0001 06/17/2005
MULLEN      96      COPY05    STEP1     COPY          0:00:01.57   CD.MIAMI    80013000      SCPA0001 06/17/2005
WARD        99      COPY05    STEP1     COPY          0:00:02.06   CD.MIAMI    80806000      SCPA0001 06/17/2005
WARREN      379     SUB       SUBSTEP    SUBMIT        0:00:00.96   CD.MIAMI    00000008      ***      SSUB005I 06/17/2005
-----SNODE=CD.JERSEY-----
JONES       544     RUNT      STEP1      RUNTASK       0:00:00.18   CD.BOSTON   80806000      ***      SRTA004I 06/18/2005
-----SNODE=CD.MIAMI-----
USERID      PROC      PROC      STEP      FUNCTION      ELAPSE      PNODE      CC      EXC      MSG      DATE
            #      NAME      NAME      TIME
ALLEN       413     COPY05    COPY01     COPY          0:00:06.96   CD.BOSTON   00000000      SCPA0001 06/17/2005
ALLEN       414     RUNTASK   LABRNJ2    RUNJOB        0:00:01.13   CD.BOSTON   00000000      SRJA0001 06/17/2005
BURNS       415     RUNT      STEP1      RUNTASK       0:00:00.28   CD.BOSTON   00000000      SRTA0001 06/17/2005
BURNS       418     SUB       SUBSTEP    SUBMIT        0:00:01.79   CD.BOSTON   00000000      SSUB0001 06/17/2005
GEORGE      420     PDSCOPY   COPY01     COPY          0:00:05.42   CD.BOSTON   00000000      SCPA0001 06/17/2005
JONES       421     PDSCOPY   COPY01     COPY          0:00:03.21   CD.BOSTON   00000008      ***      SDE5078I 06/17/2005
LISA        422     RUNJOB    LABRNJ2    RUNJOB        0:00:00.34   CD.BOSTON   80013000      ***      SVGS010I 06/17/2005
MILLER      425     RUNT      STEP1      RUNTASK       0:00:00.18   CD.BOSTON   80806000      ***      SRTA004I 06/17/2005
RYAN        426     SUB       SUBSTEP    SUBMIT        0:00:00.68   CD.BOSTON   00000008      ***      SSUB005I 06/17/2005
RYAN        427     RUNJOB    LABRNJ2    RUNJOB        0:00:00.39   CD.BOSTON   80013000      ***      SVSG010I 06/19/2005
RYAN        428     RUNJOB    LABRNJ2    RUNJOB        0:00:01.54   CD.BOSTON   00000000      ***      SRJA0001 06/19/2005
RYAN        429     RUN10     STEP1      RUNTASK       0:00:00.25   CD.BOSTON   80806000      ***      SRTA004I 06/19/2005
SMITH       430     RUN20     STEP1      RUNTASK       0:00:00.09   CD.BOSTON   00000000      SRJA0001 06/19/2005
SMITH       431     SUBACCT   SUBSTEP    SUBMIT        0:00:01.19   CD.BOSTON   00000004      ***      SBPA016I 06/19/2005
TURNER      432     SUBSTAT   SUBSTEP    SUBMIT        0:00:01.59   CD.BOSTON   00000008      ***      SPQG002I 06/19/2005
WARREN      433     SUBSALE   SUBSTEP    SUBMIT        0:00:02.47   CD.BOSTON   00000000      ***      SSUB0001 06/19/2005

```

The following table contains a description of the report fields.

| Report Field | Description                                                                                                                                  |
|--------------|----------------------------------------------------------------------------------------------------------------------------------------------|
| NODE         | Connect:Direct node where the statistics file is being examined.                                                                             |
| SNODE        | Connect:Direct secondary node.                                                                                                               |
| USERID       | Connect:Direct user ID.                                                                                                                      |
| PROC #       | Connect:Direct Process number.                                                                                                               |
| PROC NAME    | Connect:Direct Process name.                                                                                                                 |
| STEP NAME    | Name (or label) assigned to the Process step.                                                                                                |
| FUNCTION     | Connect:Direct activity. Valid Process steps are COPY, RUN JOB, RUN TASK, and SUBMIT (within a Process).                                     |
| ELAPSE TIME  | Function duration time in hh:mm:ss.hh format.                                                                                                |
| PNODE        | Connect:Direct primary node.                                                                                                                 |
| CC           | Connect:Direct completion code in hexadecimal format.                                                                                        |
| EXC          | Exception field is displayed "****" when a Process step does not complete successfully.                                                      |
| MSG ID       | Connect:Direct message ID.                                                                                                                   |
| DATE         | Date Connect:Direct activity began. Date format is mm/dd/yyyy. Process start date does not conform to the DATEFORM initialization parameter. |



## Connect:Direct Summary Report

The Connect:Direct Summary Report summarizes activity for the node containing the statistics file being examined. The report categorizes Connect:Direct activity by SNODE for a specified time period. The conclusion of the report includes a summary for all SNODEs.

Information includes:

- ◆ Total Process steps run
- ◆ Total COPY steps run
- ◆ Total RUN JOB steps run, and RUN JOB steps submitted at this node
- ◆ Total RUN TASK steps run, RUN TASK steps executed at this node
- ◆ Total SUBMIT (within a Process) steps run and number of Processes submitted at this node
- ◆ Number of successful steps and unsuccessful steps
- ◆ Total bytes tested, written, sent, and received by this node
- ◆ Total elapsed time for all Process steps in this time period
- ◆ Average time to complete a Process step
- ◆ Total elapsed time for all COPY steps
- ◆ Average time to complete a COPY step
- ◆ Effective send and receive rates

You can specify the start date and time and the stop date and time.

Following is an example of the Connect:Direct Summary Report

```

CD SUMMARY REPORT          (ARS00002)
NODE = CD.JERSEY
SNODE = ALL SNODES
FIRST FUNCTION BEGAN EXECUTING ON    06/17/2005 AT 10:07:03.28
LAST FUNCTION FINISHED EXECUTION ON  07/10/2005 AT 11:26:42.75
66 PROCESS STEPS WERE COMPLETED FOR THIS TIME PERIOD.
51 TOTAL COPY STEPS OR 77.3          % OF TOTAL STEPS RUN WERE COPIES
9 TOTAL RUNJOB STEPS OR 13.6         % OF TOTAL STEPS RUN WERE RUNJOBS
6 RUNJOBS WERE SUBMITTED ON CD.JERSEY
3 TOTAL RUNTASK STEPS OR 4.5         % OF TOTAL STEPS RUN WERE RUNTASKS
2 RUNTASKS WERE ATTACHED ON CD.JERSEY
3 TOTAL SUBMIT STEPS OR 4.5          % OF TOTAL STEPS RUN WERE SUBMITS
2 SUBMITS (WITHIN A PROCESS) ON CD.JERSEY
48 SUCCESSFUL STEPS OR 72.7          % OF TOTAL STEPS RUN COMPLETED WITH A ZERO RETURN CODE
18 UNSUCCESSFUL STEPS OR 27.3       % OF TOTAL STEPS RUN COMPLETED WITH A NON-ZERO RETURN CODE

13:22 FRIDAY, JUNE 19, 2005          2
CD SUMMARY REPORT          (ARS00002)
NODE = CD.JERSEY
SNODE = ALL SNODES
28,001,880          TOTAL BYTES WERE READ
28,019,820          TOTAL BYTES WERE SENT
28,250,480          TOTAL BYTES WERE WRITTEN
28,269,124          TOTAL BYTES WERE RECEIVED
0:26:23.98 WAS THE TOTAL "FUNCTION" TIME (SPENT PERFORMING FUNCTIONS)
0:00:24.00 WAS THE AVERAGE TIME TO COMPLETE A FUNCTION
0:26:06.91 WAS THE TOTAL "COPY" TIME (SPENT TRANSFERRING DATA)
0:00:30.72 WAS THE AVERAGE TIME TO COMPLETE A COPY
17.999 BYTES/SECOND = EFFECTIVE SEND RATE
18.16 BYTES/SECOND = EFFECTIVE RECEIVE RATE

```

The following table contains a description of the report fields.

| <b>Report Field</b>                        | <b>Description</b>                                                                                                                                                                                                      |
|--------------------------------------------|-------------------------------------------------------------------------------------------------------------------------------------------------------------------------------------------------------------------------|
| NODE                                       | Connect:Direct node where the statistics file is being examined.                                                                                                                                                        |
| SNODE                                      | Connect:Direct secondary node.                                                                                                                                                                                          |
| FIRST FUNCTION                             | Actual date/time that first Process step began executing during specified time period. Includes any step that started before specified time, but is under way or completes during the time period.                      |
| LAST FUNCTION                              | Actual date/time last Process step finished executing during specified time period. If a step started during specified time period but ended after requested stop time or stop date, it is not included in this report. |
| PROCESS STEPS COMPLETED                    | Total number of Process steps completed in time period.                                                                                                                                                                 |
| TOTAL COPY STEPS                           | Total number of COPY steps run.                                                                                                                                                                                         |
| % TOTAL STEPS RUN WERE COPIES              | Percentage of total steps run that are COPY steps.                                                                                                                                                                      |
| TOTAL RUNJOB STEPS                         | Total number of RUN JOB steps run.                                                                                                                                                                                      |
| % TOTAL STEPS RUN WERE RUNJOB              | Percentage of total steps run that are RUN JOB steps.                                                                                                                                                                   |
| # RUNJOBS SUBMITTED                        | Number of RUN JOB steps submitted to run at "NODE."                                                                                                                                                                     |
| TOTAL RUNTASK STEPS                        | Total RUN TASK steps run.                                                                                                                                                                                               |
| % TOTAL STEPS RUN WERE RUNTASKS            | Percentage of total steps run that are RUN TASK steps.                                                                                                                                                                  |
| # RUNTASKS ATTACHED                        | Number of RUN TASK steps that are attached on "NODE."                                                                                                                                                                   |
| TOTAL SUBMIT STEPS                         | Total number of SUBMIT steps run.                                                                                                                                                                                       |
| % TOTAL STEPS RUN WERE SUBMITS             | Percentage of total steps run that are SUBMIT (within a Process) steps.                                                                                                                                                 |
| # SUBMITS (WITHIN A PROCESS)               | Number of SUBMIT (within a Process) steps submitted to run at "NODE."                                                                                                                                                   |
| SUCCESSFUL STEPS                           | Total number of successful steps.                                                                                                                                                                                       |
| % OF TOTAL STEPS RUN WITH ZERO RETURN CODE | Percentage of total successful steps.                                                                                                                                                                                   |
| UNSUCCESSFUL STEPS                         | Total number of unsuccessful steps.                                                                                                                                                                                     |
| % OF TOTAL STEPS RUN WITH NON-ZERO RET CD  | Percentage of total unsuccessful steps.                                                                                                                                                                                 |
| TOTAL BYTES WERE READ                      | Total number of bytes read by "NODE."                                                                                                                                                                                   |
| TOTAL BYTES WERE SENT                      | Total number of bytes sent by "NODE."                                                                                                                                                                                   |

| <b>Report Field</b>                     | <b>Description</b>                                                                                                                                                                                        |
|-----------------------------------------|-----------------------------------------------------------------------------------------------------------------------------------------------------------------------------------------------------------|
| TOTAL BYTES WERE WRITTEN                | Total number of bytes written by "NODE."                                                                                                                                                                  |
| TOTAL BYTES WERE RECEIVED               | Total number of bytes received by "NODE."                                                                                                                                                                 |
| WAS TOTAL "FUNCTION" TIME               | Sum of elapsed times of all individual Process steps. The elapsed time for this calculation is the time period between when the step started and when the step completed.                                 |
| WAS AVERAGE TIME TO COMPLETE A FUNCTION | Total function time divided by number of Process steps run.                                                                                                                                               |
| WAS TOTAL "COPY" TIME                   | Sum of elapsed times for all individual COPY steps. The elapsed time for this calculation is the time period between when the step started and when the step completed.                                   |
| WAS AVERAGE TIME TO COMPLETE A COPY     | Total COPY time divided by the total number of COPY steps run.                                                                                                                                            |
| EFFECTIVE SEND RATE                     | Total bytes sent divided by elapsed time. For this calculation, the elapsed time is the time between when the first COPY step in the data set began and the last COPY step in the data set completed.     |
| EFFECTIVE RECEIVE RATE                  | Total bytes received divided by elapsed time. For this calculation, the elapsed time is the time between when the first COPY step in the data set began and the last COPY step in the data set completed. |

## Connect:Direct Exception Report

The Connect:Direct Exception Report lists Process steps that did not complete successfully for a specified time period. The ARS software sorts Process steps by SNODE, by user ID, and then by Process number. Each item in this report displays information unique to the executed Process step. For example, the type of information that is displayed for a failed COPY step differs from that of a failed RUN TASK step. A summary of all exception cases is listed at the conclusion of the report.

```

CD EXCEPTION REPORT (ARS00003) 17:12 WEDNESDAY, JUNE 24, 2005 1
NODE = CD.BOSTON
USERID PROC * PROC NAME STEP NAME EXCEPTION INFORMATION
***** *****
BYRAN 424 NONCOPY COPY01 ** NON-PDS COPY **
06/17/2005 PNODE = CD.BOSTON SNODE = CD.JERSEY
COMPLETION CODE = 00000008 MSG ID = SDE5708I
SENDING NODE ==> CD.JERSEY
SRC DSNAME ==> USERHLQ.NONPDS
RECEIVING NODE ==> CD.BOSTON
DEST DSNAME ==> USERHLQ.NEWNONPDS
CATALOG ERROR: CATALOG STRUCTURE OR NEW REQUEST FAILED
-----
JONES 421 PDSCOPY COPY01 ** PDS COPY **
06/17/2005 PNODE = CD.BOSTON SNODE = CD.JERSEY
COMPLETION CODE = 00000008 MSG ID = SDE5708I
SENDING NODE ==> CD.JERSEY
SRC DSNAME ==> USERHLQ.TESTPDS
RECEIVING NODE ==> CD.BOSTON
DEST DSNAME ==> USERHLQ.NEWPDS
CATALOG ERROR: CATALOG STRUCTURE OR NEW REQUEST FAILED
-----
MILLER 425 RUNJOB LABRNU2 ** RUNJOB **
06/17/2005 PNODE = CD.BOSTON SNODE = CD.JERSEY
COMPLETION CODE = 80013000 MSG ID = SVSG010I
DATASET CONTAINING JOB = USERHLQ.CNTLIMEMBER
INTENDED NODE FOR JOB SUBMISSION = CD.BOSTON
NON-VSAM OPEN ERROR OCCURRED
-----
SMITH 479 RUNT STEP1 ** RUNTASK **
06/17/2005 PNODE = CD.BOSTON SNODE = CD.JERSEY
COMPLETION CODE = 80806000 MSG ID = SRTA004I
PROGRAM NAME = ABCNAME
INTENDED NODE FOR PROGRAM EXECUTION = CD.JERSEY
Connect:Direct RUN TASK CANNOT FIND SPECIFIED TASK IN STEP LIBRARY
-----
WARD 499 SUB SUBSTEP ** SUBMIT **
06/17/2005 PNODE = CD.BOSTON SNODE = CD.JERSEY
COMPLETION CODE = 00000008 MSG ID = SSUB005I
DATASET CONTAINING PROCESS = THERE IS NO SUCH
LIBRARY AS THIS.(NOEXIST)
INTENDED NODE FOR PROCESS SUBMISSION = CD.JERSEY
UNABLE TO ALLOCATE DSN SPECIFIED IN SUBMIT STATEMENT

CD EXCEPTION REPORT (ARS00003) 17:12 WEDNESDAY, JUNE 24, 2005 3
NODE = CD.BOSTON
SUMMARY INFORMATION
*****
9 NON-SUCCESSFUL STEPS IN 17 PROCESS STEPS RUN OR
--> 52.9 % OF TOTAL PROCESS STEPS RUN COMPLETED WITH A NON-ZERO RETURN CODE
1 NON-SUCCESSFUL COPIES OF 3 COPY STEPS RUN OR
--> 33.3 % OF TOTAL COPY STEPS RUN COMPLETED WITH A NON-ZERO RETURN CODE
2 NON-SUCCESSFUL RUNJOBS IN 4 RUNJOB STEPS RUN OR
--> 60 % OF TOTAL RUNTASK STEPS RUN COMPLETED WITH A NON-ZERO RETURN CODE
3 NON-SUCCESSFUL SUBMITS IN 5 SUBMIT STEPS RUN OR
--> 60 % OF TOTAL SUBMIT STEPS RUN COMPLETED WITH A NON-ZERO RETURN CODE

```

You can specify the start date and time and the stop date and time. The following table contains a description of the report fields.

| Report Field      | Description                                                                                                               |
|-------------------|---------------------------------------------------------------------------------------------------------------------------|
| NODE              | Connect:Direct node where the statistics file is being examined.                                                          |
| USERID            | Connect:Direct user ID.                                                                                                   |
| PROC #            | Connect:Direct Process number.                                                                                            |
| PROC NAME         | Connect:Direct Process name.                                                                                              |
| STEP NAME         | Name (or label) assigned to the Process step.                                                                             |
| **function type** | Connect:Direct activity. Valid Process steps are PDS COPY, NONPDS COPY, RUN JOB, RUN TASK, and SUBMIT (within a Process). |
| mm/dd/yyyy        | Data Process step began executing.                                                                                        |

| <b>Report Field</b>                      | <b>Description</b>                                              |
|------------------------------------------|-----------------------------------------------------------------|
| PNODE                                    | Connect:Direct primary node.                                    |
| SNODE                                    | Connect:Direct secondary node.                                  |
| COMPLETION CODE                          | Connect:Direct completion code in hexadecimal format.           |
| MSG ID                                   | Connect:Direct message ID.                                      |
| SENDING NODE                             | (COPY) Sending Connect:Direct node location name.               |
| SRC DSNAME                               | (COPY) Source data set name.                                    |
| RECEIVING NODE                           | (COPY) Receiving Connect:Direct node location name.             |
| DEST DSNAME                              | (COPY) Destination data set name.                               |
| DATASET CONTAINING JOB                   | (RUNJOB) Data set containing job.                               |
| INTENDED NODE FOR JOB SUBMISSION         | (RUNJOB) Intended node location where the job is submitted.     |
| PROGRAM NAME                             | (RUNTASK) Program name.                                         |
| INTENDED NODE FOR PROGRAM EXECUTION      | (RUNTASK) Intended attach node where the program is run.        |
| DATASET CONTAINING PROCESS               | (SUBMIT) Data set containing Process.                           |
| INTENDED NODE FOR PROCESS SUBMISSION     | (SUBMIT) Intended node location where the Process is submitted. |
| message                                  | Error message for Connect:Direct message ID.                    |
| NON-SUCCESSFUL STEPS                     | Total number of unsuccessful Process steps.                     |
| PROCESS STEPS RUN                        | Total number of Process steps run.                              |
| % TOTAL PROCESS STEPS WITH NON-ZERO CODE | Percentage of Process steps unsuccessful.                       |
| NON-SUCCESSFUL COPIES                    | Number of unsuccessful COPY steps.                              |
| COPY STEPS RUN                           | Total number of COPY steps run.                                 |
| % TOTAL RUN JOB STEPS WITH NON-ZERO CODE | Percentage of RUN JOB steps unsuccessful.                       |
| NON-SUCCESSFUL RUNTASKS                  | Number of unsuccessful RUN TASK steps.                          |
| RUNTASK STEPS RUN                        | Total number of RUN TASK steps run.                             |
| % TOTAL RUNTASK STEPS WITH NON-ZERO CODE | Percentage of RUN TASK steps unsuccessful.                      |
| NON-SUCCESSFUL SUBMITS                   | Number of unsuccessful SUBMIT (within a Process) steps.         |

| Report Field                            | Description                                                 |
|-----------------------------------------|-------------------------------------------------------------|
| SUBMIT STEPS RUN                        | Total number of SUBMIT (within a Process) steps run.        |
| % TOTAL SUBMIT STEPS WITH NON-ZERO CODE | Percentage of SUBMIT (within a Process) steps unsuccessful. |

## Connect:Direct Security Violations Report

The Connect:Direct Security Violations Report lists the following types of violations for a specified time period:

- ◆ Signon security failures—This failure is caused by an invalid user ID or password that signed to Connect:Direct. Each violation is recorded.
- ◆ Process security failures—This failure is caused when a Process does not run due to an invalid security authorization. An example is a Process that does not run because the user is not defined in the Connect:Direct authorization file at the remote node.
- ◆ Data set access security failures—This failure is due to insufficient authority to access a data set.

A sample report follows:

| CD SECURITY VIOLATIONS REPORT |          | (ARS00004) |            |            | 17:12 WEDNESDAY, JUNE 24, 2005 2 |  |
|-------------------------------|----------|------------|------------|------------|----------------------------------|--|
| USERID                        | CC       | MSG ID     | DATE       | TIME       | VIOLATION TYPE                   |  |
| JONES                         | 00000008 | RACF095I   | 06/17/2005 | 10:34.30.5 | DATASET                          |  |
| SMITH                         | 00000008 | RACF095I   | 06/17/2005 | 10:49.21.1 | DATASET                          |  |
| MILLER                        | 00000008 | SAFA005I   | 06/17/2005 | 12:26.10.4 | SIGNON                           |  |
| BYRAN                         | 00000008 | RACF098I   | 06/17/2005 | 17:55.15.8 | SIGNON                           |  |
| BYRAN                         | 00000008 | RACF098I   | 06/17/2005 | 17:56.37.5 | SIGNON                           |  |
| BYRAN                         | 00000008 | RACF098I   | 06/17/2005 | 17:57.03.1 | SIGNON                           |  |
| GEORGE                        | 00000008 | SAFB004I   | 06/17/2005 | 19:00.30.2 | PROCESS                          |  |
| WARREN                        | 00000008 | SAFB004I   | 06/17/2005 | 20:00.30.2 | PROCESS                          |  |

You can specify the start date and time and the stop date and time.

Included in these reports are security message IDs generated by any security subsystem used with Connect:Direct. Security subsystems supported include:

- ◆ IBM Resource Access Control Facility (RACF)
- ◆ CA-ACF2 and CA-TOP SECRET by Computer Associates, Inc.

The following table contains a description of the report fields:

| Report Field | Description                                                      |
|--------------|------------------------------------------------------------------|
| NODE         | Connect:Direct node where the statistics file is being examined. |
| USERID       | Connect:Direct user ID that created security violation.          |
| CC           | Connect:Direct completion code in hexadecimal format.            |

| Report Field   | Description                                                               |
|----------------|---------------------------------------------------------------------------|
| MSG ID         | Security system message ID: Connect:Direct, ACF2, RACF, or TOP SECRET.    |
| DATE           | Date security violation occurred.                                         |
| TIME           | Time security violation occurred.                                         |
| VIOLATION TYPE | Type of security violation. Valid types are SIGNON, PROCESS, and DATASET. |

## Connect:Direct Function Reports

The Connect:Direct Function Reports provide detailed information about specific Process steps for a specified time period. The following reports are included:

- ◆ Connect:Direct NonPDS Copy Report
- ◆ Connect:Direct PDS Copy Report
- ◆ Connect:Direct Run Job Report
- ◆ Connect:Direct Run Task Report
- ◆ Connect:Direct Submit Within a Process Report

You can request the start date and time and the stop date and time when requesting one of the Connect:Direct Function Reports.

### Connect:Direct NonPDS Copy Report

The Connect:Direct NonPDS Copy Report provides information about COPY steps involving these transfers:

- ◆ NonPDS data set <-----> NonPDS data set
- ◆ NonPDS data set <-----> PDS data set member
- ◆ PDS data set member <-----> NonPDS data set

Following is an example of the Connect:Direct NonPDS Copy Report.

```

CD NON-PDS COPY REPORT      (ARS00005)                                17:12 WEDNESDAY, JUNE 24, 2005  1
NODE = CD.BOSTON
USERID  PROC #             PROC NAME  STEP NAME  TRANSMISSION INFORMATION
*****  *****          *****    *****
JONES   511                COPY05    COPY01    06/17/2005  PNODE = CD.BOSTON  SNODE = CD.JERSEY
TRANSMISSION TIME = 0:00:06.96      COMPLETION CODE = 00000000      MSG 10 = SCPA000I
COPY STEP SUCCESSFUL

=====
SENDING NODE ==>          CD.BOSTON  SRC DSNAME IS USERHLQ.OLDFILE1
BYTES READ   ==>          37200     DEST DSNAME IS USERHLQ.NEWFILE1
BLOCKS READ  ==>           12        RECEIVING NODE ==>          CD.JERSEY
RECS READ    ==>           0         BYTES WRITTEN ==>          37200
BYTES READ   ==>          37224     BLOCKS WRITTEN ==>          12
COMPRESSION% ==>         -0.1       RECS WRITTEN  ==>           0
VOLSER       ==>          ABC003     BYTES RECEIVED ==>         37224
                                           COMPRESSION%  ==>         -0.1
                                           VOLSER        ==>          PRD729

-----
MILLER    523                COPY07    COPY01    06/17/2005  PNODE = CD.BOSTON  SNODE = CD.MIAMI
TRANSMISSION TIME = 0:00:02.17      COMPLETION CODE = 00000000      MSG 10 = SCPA000I
COPY STEP SUCCESSFUL

=====
SENDING NODE ==>          CD.BOSTON  SRC DSNAME IS USERHLQ.SAMPFILE(MEMBER)
BYTES READ   ==>          1120     DEST DSNAME IS USERHLQ.COMPFILE
BLOCKS READ  ==>           1        RECEIVING NODE ==>          CD.MIAMI
RECS READ    ==>           0         BYTES WRITTEN ==>          1120
BYTES READ   ==>          1120     BLOCKS WRITTEN ==>           1
COMPRESSION% ==>         -0.2       RECS WRITTEN  ==>           0
VOLSER       ==>          DCM011     BYTES RECEIVED ==>         1120
                                           COMPRESSION%  ==>         -0.2
                                           VOLSER        ==>          PRD011

-----
-MILLER    523                COPY07    COPY01    06/17/2005  PNODE = CD.BOSTON  SNODE = CD.MIAMI
TRANSMISSION TIME = 0:00:00.87      COMPLETION CODE = 00000000      MSG 10 = SCPA000I
COPY STEP SUCCESSFUL

=====
SENDING NODE ==>          CD.BOSTON  SRC DSNAME IS USERHLQ.FILE01
BYTES READ   ==>           320     DEST DSNAME IS USERHLQ.FILE02
BLOCKS READ  ==>           1        RECEIVING NODE ==>          CD.MIAMI
RECS READ    ==>           0         BYTES WRITTEN ==>           320
BYTES READ   ==>           320     BLOCKS WRITTEN ==>           1
COMPRESSION% ==>         -0.6       RECS WRITTEN  ==>           0
VOLSER       ==>          PRD011     BYTES RECEIVED ==>           320
                                           COMPRESSION%  ==>         -0.6
                                           VOLSER        ==>          DCM011
    
```

This report includes all NonPDS COPY step transmissions for a specified time period. The ARS software sorts COPY information for each SNODE by user ID and then in ascending order by Process number. The following table contains a description of the report fields.

| Report Field      | Descriptions                                                                     |
|-------------------|----------------------------------------------------------------------------------|
| NODE              | Connect:Direct node where the statistics file is being examined                  |
| USERID            | Connect:Direct user ID                                                           |
| PROC #            | Connect:Direct Process number                                                    |
| PROC NAME         | Connect:Direct Process name                                                      |
| STEP NAME         | Name (or label) assigned to a COPY step                                          |
| mm/dd/yyyy        | Date COPY step began executing                                                   |
| PNODE             | Connect:Direct primary node                                                      |
| SNODE             | Connect:Direct secondary node                                                    |
| TRANSMISSION TIME | Elapsed time between when the COPY step started and when the COPY step completed |
| COMPLETION CODE   | Connect:Direct completion code in hexadecimal format                             |



| <b>Report Field</b> | <b>Descriptions</b>                                                                |
|---------------------|------------------------------------------------------------------------------------|
| MSG ID              | Connect:Direct message ID                                                          |
| message             | Short message for Connect:Direct message ID                                        |
| SRC DSNAME          | Source data set name                                                               |
| DEST DSNAME         | Destination data set name                                                          |
| REPORT FIELD        | Description of report                                                              |
| SENDING NODE        | Name of node sending the data set                                                  |
| RECEIVING NODE      | Name of node receiving the data set                                                |
| BYTES READ          | Number of bytes read by sending node                                               |
| BYTES WRITTEN       | Number of bytes written by receiving node                                          |
| BLOCKS READ         | Number of blocks read by sending node                                              |
| BLOCKS WRITTEN      | Number of blocks written by receiving node (either blocks or records is displayed) |
| RECS READ           | Number of records read by sending node                                             |
| RECS WRITTEN        | Number of records written by receiving node                                        |
| BYTES SENT          | Number of bytes sent by sending node                                               |
| BYTES RECEIVED      | Number of bytes received by receiving node                                         |
| COMPRESSION%        | Compression percentage for sending data set                                        |
| COMPRESSION%        | Compression percentage for receiving data set                                      |
| VOLSER              | Sending volume serial number                                                       |
| VOLSER              | Receiving volume serial number                                                     |

## Connect:Direct PDS Copy Report

The Connect:Direct PDS Copy Report provides information for each COPY step involving the following type of transfer:

◆ PDS data set <-----> PDS data set

Following is an example of the Connect:Direct PDS Copy Report.

```

                                17:12 WEDNESDAY, JUNE 24, 2005    1
                                (ARS00006)
                                CD PDS COPY REPORT
                                NODE = CD.BOSTON
USERID      PROC #    PROC NAME  STEP NAME  TRANSMISSION INFORMATION
*****      *****  *****  *****  *****
JONES       420      PDSCOPY   COPY01 06/17/2005  PNODE = CD.BOSTON SNODE = CD.JERSEY
TRANSMISSION TIME = 0:00:05.42  COMPLETION CODE = 00000000 MSGID = SCPA000I
COPY STEP SUCCESSFUL

=====
SENDING NODE      ==>    CD.BOSTON  SRC DSNAME IS USERHLQ.TESTPDS
BYTES READ        ==>    22240      DEST DSNAME IS USERHLQ.NEWPDS
BLOCKS READ       ==>    11          RECEIVING NODE ==>    CD.JERSEY
RECS READ         ==>    0           BYTES WRITTEN  ==>    22240
BYTES SENT        ==>    22262      BLOCKS WRITTEN ==>    11
COMPRESSION%      ==>    -0.1       RECS WRITTEN   ==>    0
VOLSER            ==>    ABC003     BYTES RECEIVED ==>    22262
                                COMPRESSION%   ==>    -0.1
                                VOLSER           ==>    ABC013
                                ABC005
                                ABC007
                                ABC009
                                ABC011

=====
                                MEMBER LIST
=====
                                MEMBER 1 TO MEMBER 1
                                MEMBER 2 TO MEMBER 2
                                MEMBER 3 TO MEMBER 3
                                MEMBER 4 TO MEMBER 4
                                MEMBER 5 TO MEMBER 5
                                MEMBER 6 TO MEMBER 6
                                MEMBER 7 TO MEMBER 7
                                MEMBER 8 TO MEMBER 8
                                MEMBER 9 TO MEMBER 9
                                MEMBER 10 TO MEMBER 10
                                MEMBER 11 TO MEMBER 11
                                MEMBER 12 TO MEMBER 12
    
```

This report lists all PDS COPY step transmissions by Process number for a specified time period. It lists sending data set members names with each destination data set member name.

We cannot guarantee the accuracy of the data in this report if you restart Connect:Direct using the TCQ=COLD initialization parameter during the time period specified. ARS uses the Process number in the statistics file to match PDS member names with a specific COPY step. Because a COLD restart begins numbering Processes from 1, ARS may not associate PDS member names correctly with the appropriate PDS Copy step.

The following table shows a description of the report fields.

| Report Field      | Description                                                                      |
|-------------------|----------------------------------------------------------------------------------|
| NODE              | Connect:Direct node where the statistics file is being examined                  |
| USERID            | Connect:Direct user ID                                                           |
| PROC #            | Connect:Direct Process number                                                    |
| PROC NAME         | Connect:Direct Process name                                                      |
| STEP NAME         | Name (or label) assigned to a COPY step                                          |
| mm/dd/yyyy        | Date COPY step began executing                                                   |
| PNODE             | Name of primary node                                                             |
| SNODE             | Name of secondary node                                                           |
| TRANSMISSION TIME | Elapsed time between when the COPY step started and when the COPY step completed |
| COMPLETION CODE   | Connect:Direct completion code in hexadecimal format                             |

| <b>Report Field</b> | <b>Description</b>                                                                 |
|---------------------|------------------------------------------------------------------------------------|
| MSG ID              | Connect:Direct message ID                                                          |
| message             | Short message for Connect:Direct message ID                                        |
| SRC DSNAME          | Source data set name                                                               |
| DEST DSNAME         | Destination data set name                                                          |
| SENDING NODE        | Name of node sending the data set                                                  |
| REPORT FIELD        | Description of report                                                              |
| RECEIVING NODE      | Name of node receiving the data set                                                |
| BYTES READ          | Number of bytes read by sending node                                               |
| BYTES WRITTEN       | Number of bytes written by receiving node                                          |
| BLOCKS READ         | Number of blocks read by sending node                                              |
| BLOCKS WRITTEN      | Number of blocks written by receiving node (either blocks or records is displayed) |
| RECS READ           | Number of records read by sending node                                             |
| RECS WRITTEN        | Number of records written by receiving node                                        |
| BYTES SENT          | Number of bytes sent by sending node                                               |
| BYTES RECEIVED      | Number of bytes received by receiving node                                         |
| COMPRESSION%        | Compression percentage for sending data set                                        |
| COMPRESSION%        | Compression percentage for receiving data set                                      |
| VOLSER              | Sending volume serial number                                                       |
| VOLSER              | Receiving volume serial number                                                     |
| MEMBER LIST         | List of sending member names and receiving member names.                           |

## Connect:Direct Run Job Report

The Connect:Direct Run Job Report lists the jobs that are submitted to the system for execution using the Connect:Direct RUN JOB statement. Jobs are listed for a specified time period. Following is an example of the Connect:Direct Run Job Report.

```

                                17:12 WEDNESDAY, JUNE 24, 2005   1
                                (ARS00007)
                                CD RUNJOB REPORT
                                NODE = CD.BOSTON
USERID      PROC #    PROC NAME  STEP NAME  RUNJOB INFORMATION
*****      *****  *****  *****  *****
JONES       414      ACCTJOB   STEP1 06/17/2005 PNODE = CD.BOSTON SNODE = CD.JERSEY
COMPLETION CODE = 00000000 MSG ID = SRJA000I
Connect:Direct RUN JOB FUNCTION COMPLETED SUCCESSFULLY
=====
DSNAME ==> USERHLQ.CNTL(MEMBER4)
JOB # ==> 1576
JOB SUBMITTED ON CD.BOSTON
-----
MILLER      422      PAYJOB   STEP00 06/17/2005 PNODE = CD.BOSTON SNODE = CD.JERSEY
COMPLETION CODE = 80013000 MSG ID = SVSG010I
NON-VSAM OPEN ERROR OCCURRED
=====
DSNAME ==> USERHLQ.CNTL(MEMBER6)
JOB # ==> 1576
INTENDED NODE FOR JOB SUBMISSION IS CD.BOSTON
-----
SMITH       427      STATUS   STEP03 06/17/2005 PNODE = CD.BOSTON SNODE = CD.JERSEY
COMPLETION CODE = 80013000 MSG ID = SVSG010I
NON-VSAM OPEN ERROR OCCURRED
=====
DSNAME ==> USERHLQ.CNTL(NOTHE)
JOB # ==> 1576
INTENDED NODE FOR JOB SUBMISSION IS CD.BOSTON
-----
SMITH       428      UPDATE   STEP01 06/17/2005 PNODE = CD.BOSTON SNODE = CD.JERSEY
COMPLETION CODE = 00000000 MSG ID = SRJA000I
Connect:Direct RUN JOB FUNCTION COMPLETED SUCCESSFULLY
=====
DSNAME ==> USERHLQ.CNTL(PRINT)
JOB # ==> 6713
JOB SUBMITTED ON CD.BOSTON
-----

```

The ARS software sorts all RUN JOB steps for each SNODE by userid and then in ascending order by Process number.

The following table contains a description of the report fields.

| Report Field     | Description                                                     |
|------------------|-----------------------------------------------------------------|
| NODE             | Connect:Direct node where the statistics file is being examined |
| USERID           | Connect:Direct user ID                                          |
| PROC #           | Connect:Direct Process number                                   |
| PROC NAME        | Connect:Direct Process name                                     |
| STEP NAME        | Name (or label) assigned to a RUN JOB step                      |
| mm/dd/yyyy       | Date RUN JOB step submitted to run                              |
| PNODE            | Connect:Direct primary node                                     |
| REPORT FIELD     | Description of report                                           |
| SNODE            | Connect:Direct secondary node                                   |
| COMPLETION CODE  | Connect:Direct completion code in hexadecimal format            |
| MSG ID           | Connect:Direct message ID                                       |
| message          | Short message for Connect:Direct message ID                     |
| DSNAME           | Data set name containing job stream to be submitted             |
| JOB #            | Number assigned to job by operating system                      |
| JOB SUBMITTED ON | Connect:Direct node where the job is submitted to run           |

## Connect:Direct Run Task Report

The Connect:Direct Run Task Report tracks all tasks (programs) for a specified time period that executed under the control of the Connect:Direct RUN TASK statement. Following is an example of the Connect:Direct Run Task Report.

```

                                17:12 WEDNESDAY, JUNE 24, 2005   1
                                (ARS00008)
                                CD RUNJOB REPORT
                                NODE = CD.BOSTON
USERID      PROC #      PROC NAME  STEP NAME  RUNTASK INFORMATION
*****      *****      *****
JONES       424        PAYROLL   STEP1 06/17/2005 PNODE = CD.BOSTON SNODE = CD.JERSEY
COMPLETION CODE = 80806000 MSG ID = SRTA004I
Connect:Direct RUN TASK CANNOT FIND SPECIFIED TASK IN STEP LIBRARY
=====
PROGRAM NAME ==> IDONTNO
INTENDED NODE FOR PROGRAM ATTACHMENT IS CD.BOSTON
-----
JONES       415        PAYJOB    STEP1 06/17/2005 PNODE = CD.BOSTON SNODE = CD.JERSEY
COMPLETION CODE = 00000000 MSG ID = SRTA000I
Connect:Direct RUN TASK FUNCTION SUCCESSFULLY COMPLETED
=====
PROGRAM NAME ==> IEFBR14
PROGRAM ATTACHED ON CD.BOSTON
-----
MILLER      425        RUNT     STEP1 06/17/2005 PNODE = CD.BOSTON SNODE = CD.JERSEY
COMPLETION CODE = 80806000 MSG ID = SRTA004I
Connect:Direct RUN TASK CANNOT FIND SPECIFIED TASK IN STEP LIBRARY
=====
PROGRAM NAME ==> IDONTNO
INTENDED NODE FOR PROGRAM ATTACHMENT IS CD.BOSTON
-----
SMITH       430        RUNT     STEP1 06/17/2005 PNODE = CD.BOSTON SNODE = CD.JERSEY
COMPLETION CODE = 00000000 MSG ID = SRTA000I
Connect:Direct RUN TASK FUNCTION SUCCESSFULLY COMPLETED
=====
PROGRAM NAME ==> IEFBR14
PROGRAM ATTACHED ON CD.BOSTON

```

The ARS software sorts all RUN TASK steps for each SNODE by userid and then in ascending order by Process number.

The following table contains a description of the report fields.

| Report Field    | Description                                                     |
|-----------------|-----------------------------------------------------------------|
| NODE            | Connect:Direct node where the statistics file is being examined |
| USERID          | Connect:Direct user ID                                          |
| PROC #          | Connect:Direct Process number                                   |
| PROC NAME       | Connect:Direct Process name                                     |
| STEP NAME       | Name (or label) assigned to a RUN TASK step                     |
| mm/dd/yyyy      | Date RUN TASK step attached and executed                        |
| PNODE           | Connect:Direct primary node                                     |
| REPORT FIELD    | Description of report                                           |
| SNODE           | Connect:Direct secondary node                                   |
| COMPLETION CODE | Connect:Direct completion code in hexadecimal format            |
| MSG ID          | Connect:Direct message ID                                       |
| message         | Short message for Connect:Direct message ID                     |

| Report Field        | Description                                                 |
|---------------------|-------------------------------------------------------------|
| PROGRAM NAME        | Name of program module attached                             |
| PROGRAM ATTACHED ON | Connect:Direct node where the task is attached and executed |

### Connect:Direct Submit Within a Process Report

The Connect:Direct Submit Within a Process Report lists Processes that are submitted to Connect:Direct for execution using the Connect:Direct Submit (within a Process) statement for a specified time period. Following is an example of the Connect:Direct Submit Within a Process Report.

```

17:12 WEDNESDAY, JUNE 24, 2005 1
CD SUBMIT WITHIN A PROCESS REPORT (ARS00009)
USERID PROC # PROC NAME STEP NAME SUBMIT INFORMATION
***** *****
LISA 418 SUB SUBSTEP 06/17/2005 PNODE = CD.BOSTON SNODE =CD.JERSEY
COMPLETION CODE = 80000000 MSG ID = SSUB000I
THE SUBMIT CONTROL BLOCK HAS BEEN SUCCESSFULLY CONSTRUCTED
=====
PROGRAM NAME ==> TESTHLQ.CD.DEVTEST PROC(LISA01)
PROCESS SUBMITTED ON CD.BOSTON
-----
LISA 426 SUB SUBSTEP 06/17/2005 PNODE = CD.BOSTON SNODE =CD.JERSEY
COMPLETION CODE = 00000008 MSG ID = SSUB005I
UNABLE TO ALLOCATE DSN SPECIFIED IN SUBMIT STATEMENT
=====
DSNAME ==> THERE IS NO SUCH LIBRARY AS THIS(NOEXIST)
INTENDED NODE FOR PROCESS SUBMISSION IS CD.BOSTON
-----
LISA 431 SUB SUBSTEP 06/17/2005 PNODE = CD.BOSTON SNODE =CD.JERSEY
COMPLETION CODE = 00000004 MSG ID = SBPA016I
DATA SET MEMBER NOT FOUND
=====
DSNAME ==> TESTHLQ.CD.DEVTEST PROC(NOMEMB)
INTENDED NODE FOR PROCESS SUBMISSION IS CD.BOSTON
-----
LISA 432 SUB SUBSTEP 06/17/2005 PNODE = CD.BOSTON SNODE =CD.JERSEY
COMPLETION CODE = 00000008 MSG ID = SPQG002I
SPECIFIED SNODE NOT AVAILABLE
=====
DSNAME ==> TESTHLQ.CD.DEVTEST PROC(NAME01)
INTENDED NODE FOR PROCESS SUBMISSION IS CD.BOSTON
-----
LISA 433 SUB SUBSTEP 06/17/2005 PNODE = CD.BOSTON SNODE =CD.JERSEY
COMPLETION CODE = 00000008 MSG ID = SSUB002I
THE SUBMIT CONTROL BLOCK HAS BEEN SUCCESSFULLY CONSTRUCTED
=====
DSNAME ==> TESTHLQ.CD.DEVTEST PROC(NAME01)
PROCESS SUBMITTED ON CD.BOSTON

```

The ARS software sorts all SUBMIT steps for each SNODE by userid and then in ascending order by Process number.

The following table contains a description of the report fields.

| Report Field | Description                                                     |
|--------------|-----------------------------------------------------------------|
| NODE         | Connect:Direct node where the statistics file is being examined |
| USERID       | Connect:Direct user ID                                          |
| PROC #       | Connect:Direct Process number                                   |
| PROC NAME    | Connect:Direct Process name                                     |

| <b>Report Field</b>  | <b>Description</b>                                                                         |
|----------------------|--------------------------------------------------------------------------------------------|
| STEP NAME            | Name (or label) assigned to a SUBMIT (within a Process) step                               |
| mm/dd/yyyy           | Date SUBMIT (within a Process) step ran                                                    |
| PNODE                | Connect:Direct primary node                                                                |
| REPORT FIELD         | Description of report                                                                      |
| SNODE                | Connect:Direct secondary node                                                              |
| COMPLETION CODE      | Connect:Direct completion code in hexadecimal format                                       |
| MSG ID               | Connect:Direct message ID                                                                  |
| message              | Short message for Connect:Direct message ID                                                |
| DSNAME               | Data set name containing the Connect:Direct Process.<br>Only available when SUBNODE=PNODE. |
| PROCESS SUBMITTED ON | Connect:Direct node where the Process was submitted to run                                 |





---

# Requesting ARS Reports Using Screens

This chapter explains how to request ARS statistical reports using ARS screens. Request these reports by completing the following two steps:

- ◆ Step 1—Request the ARS report using ARS screens
- ◆ Step 2—Run the job

ARS screens build a job stream to produce any of the ARS reports. For this reason, the screens are most useful in cases where you need individual reports instead of volume reports.

After ARS screens build the job stream and submit it to run, the job performs the following:

- ◆ Signs on to Connect:Direct
- ◆ Creates a temporary data set to hold the specified statistics
- ◆ Accesses the Connect:Direct statistics file and copies statistics to a temporary data set
- ◆ Executes the requested ARS report routine using the Connect:Direct statistics as input data
- ◆ Sends the report to the selected output location
- ◆ Deletes the temporary data set

---

## Step 1—Requesting Reports Using ARS Screens

The ARS screens prompt you to provide information that automatically builds the job discussed in Step 2 of this chapter. Certain information entered on these screens is retained between sessions to alleviate the need for entering identical information each time you request a report.

### Accessing the ARS Screens Using the Connect:Direct IUI

To access the ARS screens through the IUI, select the ADMIN option from the Primary Options Menu.

```

Connect:Direct PRIMARY OPTIONS MENU
CMD ==> ADMIN

SELECT ONE OF THE FOLLOWING:
CF - COPY A FILE *****
SB - SUBMIT A PREDEFINED PROCESS * *
DF - DEFINE A PROCESS USING ISPF EDIT * TODAY:1998.06.24*
SS - VIEW STATISTICS FOR A COMPLETED PROCESS * TIME: 09:20 *
MB - SUBMIT A BATCH TO Connect:Enterprise for z/OS * *
CP - CHANGE CHARACTERISTICS OF A PROCESS *****
DP - DELETE A NON-EXECUTING PROCESS
FP - FLUSH AN EXECUTING PROCESS
SP - VIEW DATA ABOUT AN EXECUTING PROCESS
PS - SUSPEND AN EXECUTING PROCESS
MSG - VIEW Connect:Direct MESSAGE TEXT
SW - SWAP AMONG CONCURRENT Connect:Direct SESSIONS
SD - VIEW/CHANGE YOUR Connect:Direct SIGNON INFORMATION DEFAULTS
NM - VIEW INFORMATION IN THE Connect:Direct NETWORK MAP
WHO - VIEW CHARACTERISTICS OF YOUR Connect:Direct IUI ENVIRONMENT
SPF - ENTER ISPF/PDF
AUTH - VIEW YOUR Connect:Direct FUNCTION AUTHORIZATION
MS - SIGN ON TO MULTIPLE Connect:DIRECT NODES CONCURRENTLY
ADMIN - PERFORM Connect:Direct ADMINISTRATIVE FUNCTIONS

```

From the Administrative Options Menu, select the ARS option.

```

View, Modify, Control, Delete, Secure+
-----
node.name          Connect:Direct ADMINISTRATIVE OPTIONS MENU
CMD ==>

SELECT ONE OF THE FOLLOWING:
ST - VIEW TYPE RECORD *****
IT - INSERT/UPDATE TYPE RECORD * *
DT - DELETE TYPE RECORD * TODAY:1998.06.24*
SU - VIEW USER AUTHORIZATION RECORD * TIME: 09:23 *
IU - INSERT/UPDATE USER AUTHORIZATION RECORD * *
DU - DELETE USER AUTHORIZATION RECORD *****
TS - VIEW Connect:Direct TASKS
TF - FLUSH A Connect:Direct TASK

MD - MODIFY Connect:Direct TRACE CHARACTERISTICS
C - ENTER A NATIVE Connect:Direct COMMAND
SN - TERMINATE Connect:Direct
ARS - ARS REPORTING FACILITY
NM - VIEW THE CONTENTS OF THE Connect:Direct NETWORK MAP
UNM - UPDATE THE Connect:Direct NETWORK MAP

INQ - INQUIRE ABOUT DTF INTERNAL STATUS
STAT - PERFORM STATISTICS FUNCTIONS

```

## Accessing the ARS Screens

In addition to the IUI, you can access the ARS screens by using one of following methods:

- ◆ Request the ARS option defined on the ISPF Primary Option Menu

- ◆ Request the TSO COMMAND Option (Option 6) from the ISPF Primary Option Menu and type the following.

```
ARS
```

- ◆ Type the following at the command line on any ISPF screen.

```
==> TSO %ARS
```

The following table contains a description of these ARS signon parameters.

| Parameters | Description of ARS Signon Parameters                                                      |
|------------|-------------------------------------------------------------------------------------------|
| TSO        | (optional) specifies a TSO command. Use it when accessing ARS from the ISPF command line. |
| ARS        | specifies the name of the CLIST that accesses the ARS screens.                            |

## ARS Report Options Screen

The ARS Report Options Screen in the following figure enables you to request the report, provide signon data, and specify the time period covered in the report.

If you already requested ARS reports using these screens and do not need to change any other data, you can bypass the remaining screens by typing SUB (submit) at the CMD field, then pressing Enter. This command automatically submits the job stream to run.

```

$cd.node          Connect:Direct - ARS REPORT OPTIONS
CMD ==>                                                  hh:mm

          AC - ACTIVITY                                PS - NON-PDS COPY
          SM - SUMMARY                                PO - PDS COPY
          EX - EXCEPTION                              RJ - RUNJOB
          SC - SECURITY                              RT - RUNTASK
                                                    SB - SUBMIT

REPORT TYPE ==>          EDIT JCL ==> (Y,N)

Connect:Direct SIGNON PARAMETERS
-----
USER ID      ==> $uid
PASSWORD    ==>
NETMAP NAME ==> $cd.netmap
TRANSPORT   ==> NET
COMMUNICATION ADDRESS ==> (      ,      )

REPORTING RANGE
-----
START DATE  ==>          START TIME ==>
STOP  DATE  ==>          STOP  TIME ==>
    
```

The following table contains a description of the screen fields.

| Field                 | Description                                                                                                                                                                                             |
|-----------------------|---------------------------------------------------------------------------------------------------------------------------------------------------------------------------------------------------------|
| REPORT TYPE           | Specifies the ARS report.                                                                                                                                                                               |
| EDIT JCL              | Specifies an option to edit JCL.                                                                                                                                                                        |
| USER ID               | Specifies the userid for signing on to Connect:Direct, if your security environment requires it. (optional)                                                                                             |
| PASSWORD              | Specifies the password needed to access Connect:Direct. (optional)                                                                                                                                      |
| NETMAP NAME           | Specifies the name of the Connect:Direct Network Map.                                                                                                                                                   |
| TRANSPORT             | Enables override of signon defaults for DMBATCH transport type.                                                                                                                                         |
| COMMUNICATION ADDRESS | Specifies port number and IP address with TRANSPORT=TCP.                                                                                                                                                |
| REPORTING RANGE       | Identifies the date, day or time period that you want the requested report to cover. (optional)<br><br>If all four fields are blank, the entire contents of the Connect:Direct statistics file is used. |

| Field                      | Description                                                                                                                                                                                                                                                                                                                                                                                                                                                                                                                                                                                                                                                                                                                                                                                                                                                                                                                                                                                                                                                                                                                                                                                          |
|----------------------------|------------------------------------------------------------------------------------------------------------------------------------------------------------------------------------------------------------------------------------------------------------------------------------------------------------------------------------------------------------------------------------------------------------------------------------------------------------------------------------------------------------------------------------------------------------------------------------------------------------------------------------------------------------------------------------------------------------------------------------------------------------------------------------------------------------------------------------------------------------------------------------------------------------------------------------------------------------------------------------------------------------------------------------------------------------------------------------------------------------------------------------------------------------------------------------------------------|
| START DATE or<br>STOP DATE | <p>Specifies the date or day that the statistics records are selected for the ARS report. You can specify the day (dd), month (mm), and year (yy for 2-digit year and yyyy for 4-digit year). Use periods or backslashes (\) to separate the components of a date value.</p> <p>You can specify the date (dd), month (mm), and year (yy) in one of the following formats: yymmdd or yyyyymmdd; yy/mm/dd or yyyy/mm/dd; yy.mm.dd or yyyy.mm.dd; mmddy or mmddy; mm/dd/yy or mm/dd/yyyy; mm.dd.yy or mm.dd.yyyy; or the Julian date, yyddd or yyyyddd; yy/ddd or yyyy/ddd; or yy.ddd or yyyy.ddd. If you only specify the date, the time defaults to 00:00.</p> <p>This date must have the same format as specified in the DATEFORM initialization parameter.</p> <p>You can also use day in these fields to indicate day of the week for which the statistics records are searched. Valid names include MOnday, TUesday, WEdnesday, THursday, FRiday, SAaturday, and SUnday.</p> <p>You can also specify TODAY, which searches for the statistics records today; or TOMORROW, which searches for statistics records the next day; or YESTER, which searches for statistics records for yesterday.</p> |
| START TIME or<br>STOP TIME | <p>Specifies the time of day in hours (hh), minutes (mm), and seconds (ss) when the statistics records are selected for the ARS report. Specify AM or PM. You can express the time of day using the 24-hour clock or the 12-hour clock. If you use the 24-hour clock, valid times are 00:00-24:00. If you use the 12-hour clock, you can express 1:00 hours as 1:00AM, and you can express 1:00 PM as 13:00 hours. If you do not use AM and PM, the 24-hour clock is assumed. You do not need to specify minutes and seconds.</p> <p>You can also specify NOON, which searches for the statistics records at noon, or MIDNIGHT, which searches for the statistics records at midnight.</p> <p>The default for the time is 00:00:00, the beginning of the day.</p> <p>If you do not specify START TIME and STOP TIME but you do specify the START DATE and STOP DATE, the time range default is 00:00 to 24:00.</p>                                                                                                                                                                                                                                                                                   |

## ARS Connect:Direct Requirements Screen

The ARS Connect:Direct Requirements screen in the following figure identifies specific job stream parameters for the job card and Connect:Direct-related information.

```

$cd.node          Connect:Direct - ARS (Job and File Requirements)
CMD ==>                                                hh:mm

UP TO 3 LINES FOR JOBCARD INFO
==> _____
==> _____
==> _____

STEPLIB DATA SET NAME FOR Connect:Direct PROGRAMS (OPTIONAL):
==> _____
==> _____

Connect:Direct PUBLIB PROCESS LIBRARIES (1 REQUIRED):
==> _____
==> _____

Connect:Direct MESSAGE DATA SET NAME (REQUIRED):
==> _____

UNIT SPECIFICATION FOR Connect:Direct TEMPORARY DATASET:
==> _____
    
```

The following table contains a description of the screen fields.

| Field                                             | Description                                                                                                                                                  |
|---------------------------------------------------|--------------------------------------------------------------------------------------------------------------------------------------------------------------|
| JOBCARD INFO                                      | Specifies typical job card information. Use the COND=(0,NE) for best results. This means that Step 2 of the job does not run if an error is found in Step 1. |
| STEPLIB DATA SET NAME FOR Connect:Direct PROGRAMS | Specifies the name of the library containing the Connect:Direct load modules. You can type two libraries in this section (optional).                         |
| Connect:Direct PUBLIC PROCESS LIBRARIES           | Specifies the name of the library containing Connect:Direct Processes.                                                                                       |
| Connect:Direct MESSAGE DATA SET NAME              | Specifies the name of the message data set containing the Connect:Direct messages.                                                                           |

### ARS SAS Requirements Screen

The ARS SAS Requirements screen in the following figure identifies specific JCL parameters for SAS-related information.

```

$cd.node          Connect:Direct - ARS (SAS Files and Output)
CMD ==>                                     hh:mm

SAS CATALOGED PROCEDURE (REQUIRED):
==> _____

DATASET NAME CONTAINING SAS ROUTINES (REQUIRED):
==> _____

ONE OF THE FOLLOWING MUST BE PROVIDED :

OUTPUT DATA SET NAME :
==> _____

OUTPUT (SYSOUT) CLASS :
==> _

```

The following table contains a description of the screen fields.

| Field                                 | Description                                                                                                                                                                                                                                                                                                                                                                                                                                                                                                                  |
|---------------------------------------|------------------------------------------------------------------------------------------------------------------------------------------------------------------------------------------------------------------------------------------------------------------------------------------------------------------------------------------------------------------------------------------------------------------------------------------------------------------------------------------------------------------------------|
| SAS CATALOGED PROCEDURE               | Identifies the name of the SAS cataloged procedure, which is a collection of JCL statements required to execute SAS for batch processing at your installation.                                                                                                                                                                                                                                                                                                                                                               |
| DATA SET NAME CONTAINING SAS ROUTINES | Specifies where the ARS routines (\$CD.MAPLIB) that interact with SAS are located.                                                                                                                                                                                                                                                                                                                                                                                                                                           |
| OUTPUT DATA SET NAME                  | You must preallocate the sequential data set designated in this field with the following attributes:<br>RECFM=FBA<br>LRECL=240<br>BLKSIZE=3120<br>If this field is left blank, you must specify the OUTPUT (SYSOUT) CLASS field.                                                                                                                                                                                                                                                                                             |
| OUTPUT (SYSOUT) CLASS                 | Specifies the SYSOUT class that automatically sends the output to a designated printer queue (optional). If you leave this field blank, you must specify the OUTPUT DATASET NAME field.<br><b>Note:</b> If you are requesting the Connect:Direct Summary report and routing it to a data set, ensure that the data set is empty. If the data set is not empty, this report is placed after the data already in the data set. The Connect:Direct Summary Report is automatically allocated with DISP=MOD instead of DISP=SHR. |

## Displayed Job Stream Created from Screens

After completing the ARS screens, ARS builds a job stream, as in the following example, based on what you entered on the screens. If you requested EDIT, ARS displays the job after completing the screens.

You can review the job stream before submitting it. Following is an example of the JCL which is generated using member CDARS from \$CD.ISPSLIB.

```
//JOBNAME JOB (ACCT), 'NAME', NOTIFY=TSOID,TIME=((1),
//REGION=1024K,MSGCLASS=X,CLASS=B
//*
//*
//DMBATCH EXEC PGM=DMBATCH,PARM='YYSLN'
//STEPLIB DD DISP=SHR,DSN=$CD.LINKLIB
//SYSUDUMP DD SYSOUT=*
//DMPUBLIB DD DISP=SHR,DSN=$CD.PROCESS
//DMMSGFIL DISP=SHR,DSN=$CD.MSG
//TEMPDSN DSN=&CDAPI,DISP=(NEW,PASS),UNIT=PTEMP,
// DCB=(DSORG=PS,RECFM=VBA,LRECL=4100,BLKSIZE=4104),
// SPACE=(4104,(70,13))
//DMPRINT DD SYSOUT=*
//SYSIN DD *
SIGNON USERID=(NAME,,) -
NETMAP=$CD.NETMAP TMPDD=TEMPDSN
SEL STAT WHERE (STARTT = (06/1/1998,12:00AM) -
STOPT = 07/1/1998,11:59PM) ) FILE

SIGNOFF
//*
//*
///SASTEP EXEC $SASPROC,
// OPTIONS='DQUOTE MACRO MACROGEN MERROR MISSING="- "'
//WORK DD UNIT=PTEMP,SPACE=(CYL,(20,10))
//NDMX0001 DD DISP=(OLD,DELETE),DSN=&CDAPI
//DMMSGFIL DD DISP=SHR,DSN=$CD.MSG
//FT20F001 DD DISP=SHR,DSN=$OUTPUT.DATASET.NAME
//SYSIN DD DISP=SHR,DSN=$CD.MAPLIB(ACTIVITY)
```

## Step 2—Running the Job

If you type COND=(0,NE) in the JOBCARD INFO field of the requirements screen, ARS bypasses Step 2 if Step 1 does not complete successfully.

When the job runs, it performs the following:

- ◆ Signs on to Connect:Direct
- ◆ Creates a temporary data set to hold the specified statistics
- ◆ Accesses the Connect:Direct statistics file and copies statistics to the temporary data set
- ◆ Executes the requested ARS report routine using the Connect:Direct statistics as input data
- ◆ Sends the report to the selected output location
- ◆ Deletes the temporary data set



---

# Requesting Multiple ARS Reports or Scheduled Processing

This chapter explains how to request ARS reports without using the ARS screens. You can:

- ◆ Submit multiple ARS reports at one time
- ◆ Submit ARS reports for scheduled processing

You can request ARS reports without using ARS screens by editing a sample job stream to specify processing requirements and report types. Also, when the output of a multiple report request is routed to a data set, some ARS report routines can require a minor edit change.

This chapter contains the following:

- ◆ Sample job stream with instructions for modifying it, and definitions of the parameters and SAS options used in the job stream
- ◆ Instructions for editing the sample Connect:Direct for z/OS Process that enables you to schedule the report requested
- ◆ Instructions for editing ARS report routines when multiple reports are routed to an output data set

---

## Sample Job Stream

The purpose of this section is to:

- ◆ Explain how to modify the sample job stream
- ◆ Define the parameters used in the job stream

The sample job stream is located in the data set named \$CD.JCL(ARSJCL).

## Modifying the Sample Job Stream

The following figure is a sample job stream. This job stream requests all of the ARS reports in one step. Make the following modifications of the sample job stream:

1. Modify the job card with the appropriate information.
2. Change \$CD.LINKLIB to the appropriate Connect:Direct load library name.
3. Change \$CD.PROCESS to the appropriate Connect:Direct Process library name.
4. Change all occurrences of \$CD.MSG to the Connect:Direct message data set name.
5. Change \$UID to your Connect:Direct user ID. Also add the password, if needed.
6. Change \$CD.NETMAP to your Network Map data set name.
7. Change all occurrences of \$UNITNAME to the valid unit name.
8. Change \$SASPROC to the name of the SAS cataloged procedure used at your installation.
9. Route the output to one of the two options:
  - ◆ Route to the SYSOUT class.
  - ◆ Change all occurrences of \$OUTPUT.DATASET.NAME to the name of the data set to which you route the output. Preallocate this data set as FBA with an LRECL of 240 and BLKSIZE of 3120. Ensure that the data set is empty before running this job. Complete the instructions in *Routing Multiple Reports to an Output Data Set* on page 46.

---

**Note:** This option is commented out in the sample job.

---

10. Change \$CD.MAPLIB to the name of the data set containing the SAS programs.

Following is an example of the ARSJCL member found in \$CD.CNTL.

```

//JOBNAMEX JOB (ACTNG), 'PRGRMR', NOTIFY=TSO, TIME=((1), COND=(0, NE),
// REGION=1024k, MSGCLASS=, CLASS=,
//*****
/* THIS JCL CAN BE EDITED TO CREATE A JOB STREAM THAT RUNS */
/* ARS INDEPENDENTLY OF THE ARS PANELS. IT IS SET UP TO */
/* PRODUCE MULTIPLE REPORTS. FOLLOW THE INSTRUCTIONS OUTLINED BELOW. */
/* */
/* 1) MODIFY JOB CARD WITH APPROPRIATE INFORMATION. */
/* 2) CHANGE %CD.LINKLIB TO BE THE NAME OF THE C:D LOAD LIBRARY. */
/* 3) CHANGE %CD.PROCESS TO BE THE NAME OF THE C:D PROCESS LIBRARY. */
/* 4) CHANGE ALL OCCURRENCES OF %CD.MSG TO THE NAME OF THE C:D */
/* MESSAGE DATA SET. */
/* 5) CHANGE %UID IN SIGNON CMD TO YOUR C:D USERID-ADD PSWD IF NEC. */
/* 6) CHANGE %CD.NETMAP TO YOUR NETWORK MAP DATA SET NAME. */
/* 7) CHANGE ALL OCCURRENCES OF %SUNITNAME TO VALID UNIT. */
/* 8) CHANGE %SASPROC TO THE NAME OF SAS CATALOGED PROCEDURE USED AT */
/* YOUR INSTALLATION. */
/* 9) ROUTE OUTPUT TO A SYSOUT CLASS (LOOK FOR FT20F001 DD) */
/* OR ... */
/* 9) CHANGE ALL %SOUTPUT.DATASET.NAME TO THE NAME OF THE DATA SET YOU */
/* HAVE CHOSEN TO ROUTE THE OUTPUT TO. THIS DATA SET SHOULD BE */
/* ALLOCATED AS FBA WITH AN LRECL OF 240 AND BLKSIZE OF 3120. */
/* THIS DATA SET SHOULD BE EMPTY BEFORE RUNNING THIS JOB. */
/* (DO NOT FORGET TO DELETE THE ASTERISK ON THIS LINE IN THE JOB */
/* AND PLACE IT ON THE LINE ABOVE BEFORE RUNNING.) */
/* */
/* A) BECAUSE THE SAS PROGRAMS ARE SET UP TO BE RUN INDIVIDUALLY, */
/* YOU MUST EDIT THE MEMBERS 'ACTIVITY' AND 'SECURITY' IN */
/* YOUR %CD.MAPLIB DATA SET IN THE FOLLOWING MANNER: */
/* */
/* CHANGE THE SAS STATEMENT ... */
/* PROC PRINTO NEW UNIT=20; TO ... */
/* */
/* PROC PRINTO UNIT=20; */
/* */
/* THIS WILL CAUSE THE OUTPUT FROM EACH REPORT TO APPEND TO */
/* THE END OF THE OUTPUT FILE RATHER THAN OVERLAY WHAT'S */
/* ALREADY THERE. */
/* */
/* 10) CHANGE %CD.MAPLIB TO THE NAME OF THE DATA SET CONTAINING */
/* THE SAS PROGRAMS. */
/* */
/* NOTE - IF YOU WOULD LIKE TO PUT SPECIFIC BOUNDARIES ON THE TIME */
/* SPAN TO BE REPORTED ON, MODIFY THE SEL STATISTICS COMMAND IN */
/* THE SYSIN STREAM OF THE DMBATCH STEP TO CONTAIN START AND STOP */
/* TIMES. AS IS, REPORTING WILL OCCUR ON THE ENTIRE STAT FILE. */
//*****
//DMBATCH EXEC PGM=DMBATCH, PARM='YYSLN'
//STEPLIB DD DSN=%CD.LINKLIB, DISP=SHR
//DMPUBLIB DD DSN=%CD.PROCESS, DISP=SHR
//DMMSGFIL DD DSN=%CD.MSG, DISP=SHR
//TEMPDSN DD DSN=%CDAPI, DISP=(NEW, PASS), DCB=(DSORG=PS,
// RECFM=VB, LRECL=4100, BLKSIZE=4104), SPACE=(4104, (70, 13)),
// UNIT=%SUNITNAME
//DMPRINT DD SYSOUT=*
//SYSPRINT DD SYSOUT=*
//SYSIN DD*
SIGNON USERID=(%UID) NETMAP=%CD.NETMAP TMPDD=TEMPDSN
SEL STAT WHERE () FILE
SIGNOFF
/*
/*
//SASTEP EXEC %SASPROC,
// OPTIONS='DQUOTE MACRO MACROGEN MERROR MISSING="-"'
//WORK DD UNIT=%SUNITNAME, SPACE=(CYL, (20, 10))
//NDMX0001 DD DISP=(OLD, DELETE), DSN=%CDAPI
//DMMSGFIL DD DISP=SHR, DSN=%CD.MSG
//SASPROGS DD DISP=SHR, DSN=%CD.MAPLIB
//FT20F001 DD SYSOUT=*
//FT20F001 DD DISP=MOD, DSN=%SOUTPUT.DATASET.NAME
//SYSIN DD *
%INCLUDE SASPROGS (ACTIVITY, SUMMARY, EXCEPT, SECURITY, NPDSCOPY, PDSCOPY,
RUNJOB, RUNTASK, SUBMIT);
/*

```

## Job Stream Definitions

The following table defines the parameters and SAS options for the sample job stream.

| <b>Report Field</b>   | <b>Definition</b>                                                                                                                                                                                                                                                                                                                                                                                                                                                                                                                                                      |
|-----------------------|------------------------------------------------------------------------------------------------------------------------------------------------------------------------------------------------------------------------------------------------------------------------------------------------------------------------------------------------------------------------------------------------------------------------------------------------------------------------------------------------------------------------------------------------------------------------|
| JOB CARD INFO         | Specifies the typical job card information. Use the COND=(0,NE) for best results. This means that the second step of the job does not run if an error occurs in the first step.                                                                                                                                                                                                                                                                                                                                                                                        |
| DMBATCH               | Specifies the program name of the Connect:Direct batch interface.                                                                                                                                                                                                                                                                                                                                                                                                                                                                                                      |
| STEPLIB               | Specifies the library containing the Connect:Direct load modules.                                                                                                                                                                                                                                                                                                                                                                                                                                                                                                      |
| DMPUBLIB              | Specifies the library containing the Connect:Direct Processes.                                                                                                                                                                                                                                                                                                                                                                                                                                                                                                         |
| DMMSGFIL              | Specifies the Connect:Direct message data set that accesses the Connect:Direct messages.                                                                                                                                                                                                                                                                                                                                                                                                                                                                               |
| TEMPDSN               | Specifies the temporary data set containing the extract from the Connect:Direct statistics file that is used as input to SAS. This is always specified as (NEW, PASS) so that when you create the data set, the extracted data is saved in it, and then passed on to the next step.                                                                                                                                                                                                                                                                                    |
| DMPRINT<br>(Optional) | Specifies where the job output from DMBATCH goes. This is useful if an error occurs in DMBATCH.                                                                                                                                                                                                                                                                                                                                                                                                                                                                        |
| SYSPRINT              | Specifies where the job execution messages goes.                                                                                                                                                                                                                                                                                                                                                                                                                                                                                                                       |
| SYSIN                 | Contains the Connect:Direct control statements to extract from the statistics file. You can represent SYSIN as a sequential data set, PDS member, or instream data set.                                                                                                                                                                                                                                                                                                                                                                                                |
| SASTEP                | Specifies the name of the SAS cataloged procedure used at your installation with the following options:<br>DQUOTE specifies that the system accepts double quotes.<br>MACRO specifies that the SAS macro library is available.<br>MACROGEN specifies that the system can print SAS macros.<br>MERROR specifies that a warning message is produced if a name is prefixed with a percent sign to indicate a SAS macro, but the name is not a valid SAS macro.<br>MISSING specifies that dashes (-) are inserted when a numeric character is missing in the report field. |
| WORK                  | Specifies the work area used by SAS for processing.                                                                                                                                                                                                                                                                                                                                                                                                                                                                                                                    |
| NDMX0001              | Specifies the temporary data set that contains the extract from the Connect:Direct statistics file. Specify the data set parameters (OLD, DELETE) so that the data set is deleted automatically after processing.                                                                                                                                                                                                                                                                                                                                                      |
| DMMSGFIL              | Specifies the name of the Connect:Direct message data set.                                                                                                                                                                                                                                                                                                                                                                                                                                                                                                             |
| SASPROGS              | Identifies the name of the data set containing the SAS routines to produce the reports. See %INCLUDE parameter in this table.                                                                                                                                                                                                                                                                                                                                                                                                                                          |
| FT20F001              | Specifies the DD statement used by SAS to route output. This DD statement can be either output to a data set or SYSOUT class. If it is to a data set, you must preallocate the data set, it must be sequential, and have the following attributes: RECFM=FBA; LRECL=240; BLKSIZE=3120.                                                                                                                                                                                                                                                                                 |

| Report Field | Definition                                                                                                                                                                                                                                                                                                                                                                                                                                                                                                                                                                                                                                                                                                                                                                  |
|--------------|-----------------------------------------------------------------------------------------------------------------------------------------------------------------------------------------------------------------------------------------------------------------------------------------------------------------------------------------------------------------------------------------------------------------------------------------------------------------------------------------------------------------------------------------------------------------------------------------------------------------------------------------------------------------------------------------------------------------------------------------------------------------------------|
| SYSIN        | Specifies SYSIN for SAS.                                                                                                                                                                                                                                                                                                                                                                                                                                                                                                                                                                                                                                                                                                                                                    |
| %INCLUDE     | <p>Contains a special SAS control statement that enables you to execute SAS programs that are stored separately from their JCL. The first name after SASPROGS identifies the DD name that references the location of the SAS programs. The requested ARS report routine names are placed inside of the parentheses:</p> <p>ACTIVITY specifies the Connect:Direct Activity Report<br/> EXCEPT specifies the Connect:Direct PDS Copy Report<br/> RUNJOB specifies the Connect:Direct Run Job Report.<br/> RUNTASK specifies the Connect:Direct Run Task Report.<br/> SECURITY specifies the Connect:Direct Security Violations Report.<br/> SUBMIT specifies the Connect:Direct Submit Within a Process Report.<br/> SUMMARY specifies the Connect:Direct Summary Report.</p> |

### Sample Connect:Direct Process That Submits Job Stream

The RPTPROC member in \$CD.SAMPLIB in the following figure contains a Connect:Direct Process that runs the job stream discussed in the previous section, *Modifying the Sample Job Stream* on page 42. You can set up the sample Process to run automatically on a specified time interval, by submitting this Process with the Connect:Direct SUBMIT command, specifying the STARTT parameter and RETAIN=YES parameter.

```

RPTPROC          -
* THIS PROCESS WILL SUBMIT FOR EXECUTION THE JCL TO RUN ARS
* CHANGE $SECONDARY.NODE TO THE DESIRED SNODE NAME FOR THE PROCESS
* CHANGE $TSOID TO YOUR TSO ID
* CHANGE $CD.CNTL(ARSJCL) TO THE DATA SET NAME CONTAINING THE JCL
*          TO RUN ARS

PROCESS          -
  SNODE=$SECONDARY.NODE -
  NOTIFY=$TSOID
STEPONE         -
  RUN JOB (      -
    DSN=$CD.CNTL(ARSJCL) -
  )

```

You need to modify the following items if you choose to use this sample Process.

1. Change \$SECONDARY.NODE to the appropriate SNODE.
2. Change \$TSOID to your TSO ID.
3. Change \$CD.CNTL(ARSJCL) to the data set name containing the job that runs ARS. (See STEPONE.)

For convenience, you may want to replace RPTPROC in your Connect:Direct Process library after editing it.

## Routing Multiple Reports to an Output Data Set

Complete this step only when you request multiple ARS report types in one job and the reports are sent to an output data set. The Connect:Direct Activity Report and Connect:Direct Security Violations Report require a minor edit change in the ARS routine if you include them in a multiple report request.

Before modifying the ARS routines, you may want to make a copy of the \$CD.MAPLIB, which contains all of the report routines. Use the first copy when you request only one report (in batch mode or using the ARS screens). The second copy can contain the modified routines for use when you make multiple report requests in a job.

You can report the ARS report routines using TSO. The routines are in the \$CD.MAPLIB. The following table lists the types of reports and the corresponding members in the \$CD.MAPLIB that require modification.

| Report Type                               | Member Name |
|-------------------------------------------|-------------|
| Connect:Direct Activity Report            | ACTIVITY    |
| Connect:Direct Security Violations Report | SECURITY    |

Modify the PROC PRINTTO statement listed in the members so that the output from one report appends rather than overlaying output from the previous report in the designated output file. Change the ARS report routine from:

```
PROC PRINTTO NEW UNIT=20
```

to:

```
PROC PRINTTO UNIT=20;
```

# ARS Record Layouts

This chapter contains the information you need to customize ARS reports. You can either modify the ARS reports or you can develop new reports. Examples include the following:

- ◆ Change ARS report headings, spacing, field titles, and output format
- ◆ Access additional information from the Connect:Direct statistics file to enhance ARS reports or to develop new reports

The ARS routines do not utilize all of the Connect:Direct fields in the Connect:Direct statistics records. To assist you in customizing reports, this chapter lists all of the Connect:Direct fields. The SAS Informat variables for these records are located in the \$CD.MAPLIB library. Access the information by the member names listed in the following table.

---

**Note:** Use the two character designations for records types when you browse the Connect:Direct statistics file.

---

| Member Name | Contents of Member                | Record Types                                                                                     |
|-------------|-----------------------------------|--------------------------------------------------------------------------------------------------|
| CDAER       | Authorization Event Record        | IU=INSert USER<br>UU=UPDate USER<br>SU=SElect USER<br>DU=DElete USER                             |
| CDCPTR      | Change Process Termination Record | CH=CHange PROCess                                                                                |
| CDCTR       | Copy Termination Record           | CT=COPIY                                                                                         |
| CDDPTR      | Delete Process Termination Record | DP=DElete PROCess                                                                                |
| CDDTR       | Display Statistics Record         | SP=SElect PROCess<br>DT=SElect TASK<br>FT=FLUSH TASK<br>SS=SElect STATistics<br>SN=SElect NETmap |
| CDFPTR      | Flush Process Termination Record  | FP=FLUSH PROCess                                                                                 |
| CDFMCR      | PDS Member Copy Record            | MC=PDS member COPIY                                                                              |

| Member Name | Contents of Member                        | Record Types                             |
|-------------|-------------------------------------------|------------------------------------------|
| CDPSSR      | Process Submit Statistics Record          | PS=SUBmit statement<br>SW=SUBmit command |
| CDPTR       | Process Termination Record                | PT=PROcEss                               |
| CDRJTR      | Run Job Termination Record                | RJ=RUN JOB                               |
| CDRTTR      | Run Task Termination Record               | RT=RUN TASK                              |
| CDSFR       | Signon/Signoff Statistics Record          | SI=SIGNON<br>SO=SIGNOFF                  |
| CSDSCR      | Start Connect:Direct Command Record       | SD=Start Connect:Direct                  |
| CDSTDCR     | Stop Connect:Direct Statistics Record     | ST=STOP CD                               |
| CDFWTOST    | Write to Operator (WTO) Statistics Record | WT=Write to Operator                     |

## Description of an SAS Variable

The SAS Informat variables for these records are located in the \$CD.MAPLIB library. An example of an SAS Informat variable is @5 SASFIELD PK1. Variable descriptions for this example are listed in the following table.

| Variable | Description                                                                                                                                                                                                                                                                                                                                                                                                                             |
|----------|-----------------------------------------------------------------------------------------------------------------------------------------------------------------------------------------------------------------------------------------------------------------------------------------------------------------------------------------------------------------------------------------------------------------------------------------|
| @n       | Identifies the position of the variable in the Connect:Direct statistics record (relative to 1). Always identified by an @.                                                                                                                                                                                                                                                                                                             |
| SASFIELD | Specifies the SAS name for the corresponding Connect:Direct field name. The SAS name variable must follow the position variable (@n).                                                                                                                                                                                                                                                                                                   |
| PK1      | Specifies the type and length of the SAS Informat variable used in the maps. The type variable must follow the name variable (SASFIELD).<br>Type variable used in the maps are:<br>HEX—numeric hexadecimal<br>IB—integer binary<br>PD—packed decimal<br>PIB—positive integer binary<br>PK—packed unsigned<br>\$n—standard character<br>\$CHAR—characters with blanks<br>\$HEX—character hexadecimal<br>\$VARYING—variable-length values |



---

## Authorization Event Record

The following table shows each field available in the Connect:Direct Authorization Event record. The CDAER member of the \$CD.MAPLIB library contains the SAS maps of the Connect:Direct statistics record.

| Field Names | Field Description                                                                                                        |
|-------------|--------------------------------------------------------------------------------------------------------------------------|
| AERECLN     | Length of this record.                                                                                                   |
| AERTYPE     | Record type indicates specific data in statistics record: IU=INSert; UU=UPDate USER; SU=SElect USER; and DU=DELeTe USER. |
| AERTIME     | Time that event was recorded in hh/mm/ss/tt format.                                                                      |
| AEDATE      | Date that event was recorded in Julian date format (yyyydddf).                                                           |
| AEPROCNM    | Process name.                                                                                                            |
| AEPROCNO    | Process number.                                                                                                          |
| AEUNODE     | User node of the submitter.                                                                                              |
| AEUID       | Userid of the submitter.                                                                                                 |
| AESTEP      | Step name or label.                                                                                                      |
| AESTIME     | Time that Process started in hh/mm/ss/tt format.                                                                         |
| AESDATE     | Date that Process started in Julian date format (yyyydddf).                                                              |
| AESCC       | Step completion code.                                                                                                    |
| AEMSGID     | Message ID.                                                                                                              |
| AESDSNL     | Length of data set name.                                                                                                 |
| AESDSN      | Source data set name.                                                                                                    |
| AESDSTYP    | Data set type (LIB, DSN).                                                                                                |
| AEEVENT     | Event code.                                                                                                              |
| AEEVENTQ    | Event code qualifier.                                                                                                    |

---

## Change Process Termination Record

The following table shows each field available in the Connect:Direct Change Process Termination record. The CDCPTR member of the \$CD.MAPLIB library contains the SAS maps of the Connect:Direct statistics record.

| <b>Field Names</b> | <b>Field Description</b>                                                     |
|--------------------|------------------------------------------------------------------------------|
| CHRECLN            | Length of this record.                                                       |
| CHRTYPE            | Record type – CH indicates the Change Process Termination Record.            |
| CHTIME             | Time that CHange PROCess command completed in hh/mm/ss/tt format.            |
| CHDATE             | Date that CHange PROCess command completed in Julian date format (yyyymmdd). |
| CHPROCNM           | Process name.                                                                |
| CHPROCNO           | Process number.                                                              |
| CHSTEP             | Step name or label.                                                          |
| CHUNODE            | User node ID of the submitter.                                               |
| CHUID              | Userid of the submitter.                                                     |
| CHSTIME            | Time that CHange PROCess command started in hh/mm/ss/tt format.              |
| CHSDATE            | Date that CHange PROCess command started in Julian date format (yyyymmdd).   |
| CHSCC              | Step completion code-displays normal completion code.                        |
| CHMSGID            | Message ID.                                                                  |
| CHRMNID            | Node where message routed.                                                   |
| CHRMUID            | Userid where message routed.                                                 |
| CHSCHTME           | Time that Process was scheduled in hh/mm/ss/tt format.                       |
| CHSCHDTE           | Date that Process was scheduled in Julian date format (yyyymmdd).            |
| CHSCHDAY           | Day that Process was scheduled.                                              |
| CHPRTY             | New Process priority in the Connect:Direct Transmission Control Queue (TCQ). |
| CHRETAIN           | Keeps copy in TCQ after execution.                                           |
| CHPROC             | ALL/PROCNAME/PROCNUMBER.                                                     |
| CHNDEST            | New destination node.                                                        |
| CHHOLD             | Process status in hold queue: Q=quiesce or I=immediate.                      |
| CHNPRTY            | New priority.                                                                |
| CHREL              | Release Processes=R.                                                         |
| CHRET              | Retain Processes=R.                                                          |

| Field Names | Field Description                                    |
|-------------|------------------------------------------------------|
| CHNRMNID    | New node ID messages to be routed.                   |
| CHNRMUID    | New userid messages to be routed.                    |
| CHNEWTME    | New scheduled time in hh/mm/ss/tt format.            |
| CHNEWDTE    | New scheduled date in Julian date format (yyyymmdd). |

## Copy Termination Record

The following table shows each field available in the Connect:Direct Copy Termination record. The CDCTR member of the \$CD.MAPLIB library contains the SAS maps of the Connect:Direct statistics record.

| Field Names | Field Description                                                       |
|-------------|-------------------------------------------------------------------------|
| CTRECLN     | Length of this record.                                                  |
| CTRTYPE     | Record type – CT indicates the Copy Termination record.                 |
| CTTIME      | Time that COPY step completed in hh/mm/ss/tt format.                    |
| CTDATE      | Date that COPY step completed in Julian date format (yyyymmdd).         |
| CTSTIME     | Time that COPY step started in hh/mm/ss/tt format.                      |
| CTSDATE     | Date that COPY step started in Julian date format (yyyymmdd).           |
| CTSCC       | Step completion code. Displays normal completion code.                  |
| CTMSGID     | Message ID.                                                             |
| CTPROCNM    | Process name.                                                           |
| CTPROCNO    | Process number.                                                         |
| CTSTEP      | Step name or label.                                                     |
| CTUNODE     | User node ID of the submitter.                                          |
| CTUID       | Userid of the submitter.                                                |
| CTPNODE     | Name of the node which is examining its Connect:Direct statistics file. |
| CTSNODE     | Name of the other node.                                                 |
| CTNODE      | This node is P(node) or S(node).                                        |
| CTFROM      | Direction of data: Snode to Pnode or Pnode to Snode                     |

| <b>Field Names</b> | <b>Field Description</b>                                                                                                                                                                |
|--------------------|-----------------------------------------------------------------------------------------------------------------------------------------------------------------------------------------|
| CTTRANS            | File translation. Includes: ASCII-TO-EBCDIC; EBCDIC-TO-ASCII; EBCDIC-TO-ASCII DIF; compressed; and compacted.                                                                           |
| CTTRANS2           | Transmission options. Includes: PDS-to-PDS copy; error originated on other node; sending PDS member to sequential DSN; sending DSN sequential DSN to PDS member; and COPY is restarted. |
| CTRUSZ             | Request/response unit (RU) size.                                                                                                                                                        |
| CTPACCT#           | Displacement to Pnode account data length.                                                                                                                                              |
| CTSACCT#           | Displacement to Snode account data length.                                                                                                                                              |
| CTINBYTE           | Number of bytes read from data set.                                                                                                                                                     |
| CTINRECN           | Number of records read from data set.                                                                                                                                                   |
| CTINBLK            | Number of blocks read from data set.                                                                                                                                                    |
| CTSBYTES           | Number of bytes sent.                                                                                                                                                                   |
| CTOBYTE            | Number of bytes written to data set.                                                                                                                                                    |
| CTOTRECN           | Number of records written to data set.                                                                                                                                                  |
| CTOTBLK            | Number of blocks written to data set.                                                                                                                                                   |
| CTRBYTES           | Number of bytes received.                                                                                                                                                               |
| CTNOKB             | Number of kilobytes sent.                                                                                                                                                               |
| CTNOMEMS           | Number of members sent.                                                                                                                                                                 |
| CTNOALIS           | Number of aliases sent.                                                                                                                                                                 |
| CTNOMEMX           | Number of members selected but not sent.                                                                                                                                                |
| CTNOALIX           | Number of aliases selected but not sent.                                                                                                                                                |
| CTNOMEMR           | Number of members received.                                                                                                                                                             |
| CTNOALIR           | Number of aliases received.                                                                                                                                                             |
| CTCMPTBL           | The compaction table name.                                                                                                                                                              |
| CTSDSTYP           | Source data set type: ESDS, KSDS, RRDS, PDS, SAM, or LIB.                                                                                                                               |
| CTSDISP1           | Source data set disposition status: O=OLD and S=SHR.                                                                                                                                    |
| CTSDISP2           | Source data set disposition normal termination: D=DELETE and K=KEEP.                                                                                                                    |
| CTSDISP3           | Source data set disposition abnormal termination: D=DELETE and K=KEEP.                                                                                                                  |
| CTSDSNL            | Length of the source data set name.                                                                                                                                                     |
| CTSDSN             | Source data set name.                                                                                                                                                                   |
| CTTYPE             | Type file key, if Type is specified in a Process step.                                                                                                                                  |

| Field Names | Field Description                                                                     |
|-------------|---------------------------------------------------------------------------------------|
| CTDDSTYP    | Destination data set type.                                                            |
| CTDDISP1    | Destination data set disposition status: M=MOD; N=NEW; O=OLD; and S=SHR.              |
| CTDDISP2    | Destination data set disposition normal termination: C=CATLG and K=KEEP.              |
| CTDDISP3    | Destination data set disposition abnormal termination: C=CATLG; K=KEEP; and D=DELETE. |
| CTDDSNL     | Length of destination data set name.                                                  |
| CTDDSN      | Destination data set name.                                                            |
| CTMEMBER    | Member name for PS to PO copies.                                                      |
| CTOMSGID    | Message ID from other node.                                                           |
| CTRNCOD     | Return code from other node.                                                          |
| CTNVTAMS    | Number of VTAM sends.                                                                 |
| CTNVTAMR    | Number of VTAM receives.                                                              |
| CTDSPVLR    | Displacement of receiving VOLSER list.                                                |
| CTDSPVLS    | Displacement of sending VOLSER list                                                   |
| CTTBOFS     | TCP buffer size used.                                                                 |
| CTV2BUFS    | V2 buffer size.                                                                       |
| CTNEGBF     | Negotiated V2 buffer size.                                                            |

## Delete Process Termination Record

The following table shows each field available in the Connect:Direct Delete Process Termination record. The CDDPTR member of the \$CD.MAPLIB library contains the SAS maps of the Connect:Direct statistics record.

| Field Names | Field Description                                                 |
|-------------|-------------------------------------------------------------------|
| DPRECLN     | Length of this record.                                            |
| DPRTYPE     | Record type—DP indicates the Delete Process Termination record.   |
| DPTIME      | Time that DELEte PROCess command completed in hh/mm/ss/tt format. |

| Field Names | Field Description                                                            |
|-------------|------------------------------------------------------------------------------|
| DPDATE      | Date that DELeTe PROCess command completed in Julian date format (yyydddff). |
| DPPROCNM    | Process name.                                                                |
| DPPROCNO    | Process number.                                                              |
| DPSTEP      | Step name or label.                                                          |
| DPUNODE     | User node iD of the submitter.                                               |
| DPUID       | Userid of the submitter.                                                     |
| DPSTIME     | Time that DELeTe PROCess command started in hh/mm/ss/tt format.              |
| DPSPDATE    | Date that DELeTe PROCess command started in Julian format (yyydddff).        |
| DPSCC       | Step completion code. Displays normal completion code.                       |
| DPMSGID     | Message ID.                                                                  |
| DPDPRNM     | Name of the deleted Process.                                                 |
| DPDPRNOP    | Number of the deleted Process.                                               |
| DPRMNID     | Route message node of deleted Process.                                       |
| DPRMUID     | Route message userid of deleted Process.                                     |

## Display Statistics Record

The following table contains each field available in the Connect:Direct Display Statistics record. The CDDTR member of the \$CD.MAPLIB library contains the SAS maps of the Connect:Direct statistics record.

| Field Name | Field Description                                                                                                                                       |
|------------|---------------------------------------------------------------------------------------------------------------------------------------------------------|
| DTRECLN    | Length of this record.                                                                                                                                  |
| DTRTYPE    | Record type indicates specific data in statistics record: SP=SELeCt PROCess; DT=SELeCt TASK; FT=FLUSH TASK; SS=SELeCt STATISTICS; and SN=SELeCt NETMAP. |
| DTTIME     | Time that command completed in hh/mm/ss/tt format.                                                                                                      |
| DTDATE     | Date that command completed in Julian date format (yyydddff).                                                                                           |
| DTPROCNM   | Process name.                                                                                                                                           |
| DTPROCNO   | Process number.                                                                                                                                         |

| Field Name | Field Description                                           |
|------------|-------------------------------------------------------------|
| DTSTEP     | Step name or label.                                         |
| DTUNODE    | User node ID of the submitter.                              |
| DTUID      | Userid of the submitter.                                    |
| DTSTIME    | Time that command started in hh/mm/ss/tt format.            |
| DTSDATE    | Date that command started in Julian date format (yyyydddf). |
| DTSCC      | Step completion code. Displays normal completion code.      |
| DTMSGID    | Message ID.                                                 |
| DTDFLNM    | Name of the displayed data set.                             |
| DTNVTAMS   | Number of VTAM sends.                                       |
| DTNVTAMR   | Number of VTAM receives.                                    |
| DTGETS     | Number of GETS.                                             |
| DTPUTS     | Number of PUTS.                                             |

## Flush/Suspend Process Termination Record

The following table shows each field available in the Connect:Direct Flush Process/Suspend Process Termination record. The CDFPTR member of the \$CD.MAPLIB library contains the SAS maps of the Connect:Direct statistics record.

| Field Names | Field Description                                                           |
|-------------|-----------------------------------------------------------------------------|
| FPRECLN     | Length of this record.                                                      |
| FPRTYPE     | Record type—FP indicates the Flush Process Termination record.              |
| FPTIME      | Time that FLUSH PROCess command completed in hh/mm/ss/tt format.            |
| FPDATE      | Date that FLUSH PROCess command completed in Julian date format (yyyydddf). |
| FPPROCNM    | Process name.                                                               |
| FPPROCNO    | Process number.                                                             |
| FPSTEP      | Step name or label.                                                         |
| FPUNODE     | User node ID of the submitter.                                              |
| FPUID       | Userid of the submitter.                                                    |

| Field Names | Field Description                                                        |
|-------------|--------------------------------------------------------------------------|
| FPSTIME     | Time that FLUSH PROCess command started in hh/mm/ss/tt format.           |
| FPSDATE     | Date that FLUSH PROCess command started in Julian date format (yyydddf). |
| FPSCC       | Step completion code. Displays normal completion code.                   |
| FPMMSGID    | Message ID.                                                              |
| FPDPRNM     | Name of the flushed Process.                                             |
| FPDPRNOP    | Number of the flushed Process.                                           |
| FPRMNID     | Route message node of flushed Process.                                   |
| FPRMUID     | Route message userid of flushed Process.                                 |

## PDS Member Copy Record

The following table shows each field available in the Connect:Direct PDS Member Copy record. The CDFMCR member of the \$CD.MAPLIB library contains the SAS maps of the Connect:Direct statistics record.

| Field Names | Field Description                                                    |
|-------------|----------------------------------------------------------------------|
| MCRECLN     | Length of this record.                                               |
| MCRTYPE     | Record type—MC indicates the PDS Member Copy record.                 |
| MCTIME      | Time that COPY step completed in hh/mm/ss/tt format.                 |
| MCDATE      | Date that COPY step completed in Julian date format (yyydddf).       |
| MCSTIME     | Time that member processing started in hh/mm/ss/tt format.           |
| MCSDATE     | Date that member processing started in Julian date format (yyydddf). |
| MCSCC       | Step completion code. Displays normal completion code.               |
| MCMMSGID    | Message ID.                                                          |
| MCPROCNM    | Process name.                                                        |
| MCPROCNO    | Process number.                                                      |
| MCSTEP      | Step name or label.                                                  |
| MCUNODE     | User node ID of the submitter.                                       |
| MCUID       | Userid of the submitter.                                             |



| Field Names | Field Description                                        |
|-------------|----------------------------------------------------------|
| MCPNODE     | The Pnode name for this Process.                         |
| MCSNODE     | The Snode name for this Process.                         |
| MCNODE      | This node is P(node) or S(node).                         |
| MCFROM      | Direction of data: P(node) to Snode or S(node) to Pnode. |
| MCTNAME     | Name of member on destination PDS.                       |
| MCFNAME     | Name of member on source PDS (if different).             |
| MCANAME     | Name of member for which node is an alias.               |
| MCNRECS     | The number of records.                                   |
| MCNBLKS     | The number of blocks.                                    |

## Process Submit Statistics Record

The following table shows each field available in the Connect:Direct Process Submit Statistics record. The CDPSSR member of the \$CD.MAPLIB library contains the SAS maps of the Connect:Direct statistics record.

| Field Names | Field Description                                                                                                     |
|-------------|-----------------------------------------------------------------------------------------------------------------------|
| PSSRECLN    | Length of this record.                                                                                                |
| PSSRTYPE    | Record type indicates specific data in statistics record: PS=SUBmit statement and SW=SUBmit command within a Process. |
| PSSCTIME    | Time that Process completed in hh/mm/ss/tt format.                                                                    |
| PSSCDATE    | Date that Process completed in Julian date format (yyyydddf).                                                         |
| PSSSTIME    | Time that Process started in hh/mm/ss/tt format.                                                                      |
| PSSSDATE    | Date that Process started in Julian date format (yyyydddf).                                                           |
| PSSSCC      | Step completion code. Displays normal completion code.                                                                |
| PSSMSGID    | Message ID.                                                                                                           |
| PSSPRCNM    | Process name.                                                                                                         |
| PSSPRCNO    | Process number.                                                                                                       |
| PSSSTEP     | Step name or label.                                                                                                   |
| PSSUNODE    | Submitter's symbolic node name.                                                                                       |

| Field Names | Field Description                                        |
|-------------|----------------------------------------------------------|
| PSSUID      | Userid of the submitter.                                 |
| PSSPNODE    | Pnode name for this Process.                             |
| PSSSNODE    | Snode name for this Process.                             |
| PSSNODE     | This node is P(node) or S(node).                         |
| PSSFROM     | Direction of data: P(node) to Snode or S(node) to Pnode. |
| PSSROSIZ    | The number of bytes in the Process.                      |
| PSSRMNID    | Route message userid of Process.                         |
| PSSFUNCD    | The function code for the SUBMIT.                        |
| PSSSYNTAX   | The syntax error in SUBmit command.                      |
| PSSPARSE    | The parse error in SUBmit command.                       |
| PSSPACT#    | Displacement to Pnode account data.                      |
| PSSSACT#    | Displacement to Snode account data.                      |
| PSSDSN#     | Displacement to data set name.                           |

## Process Termination Record

The following table shows each field available in the Connect:Direct Process Termination record. The CDPTR member of the \$CD.MAPLIB library contains the SAS maps of the Connect:Direct statistics record.

| Field Names | Field Description                                             |
|-------------|---------------------------------------------------------------|
| PTRECLN     | Length of this record.                                        |
| PTRTYPE     | Record type—PT indicates the Process Termination record.      |
| PTTIME      | Time that Process completed in hh/mm/ss/tt format.            |
| PTDATE      | Date that Process completed in Julian date format (yyyydddf). |
| PTSTIME     | Time that Process started in hh/mm/ss/tt format.              |
| PTSDATE     | Date that Process started in Julian date format (yyyydddf)    |
| PTSCC       | Step completion code. Displays normal completion code.        |
| PTMSGID     | Message ID.                                                   |
| PTPROCNM    | Process name.                                                 |

| Field Names | Field Description                                                 |
|-------------|-------------------------------------------------------------------|
| PTPROCNO    | Process number.                                                   |
| PTSTEP      | Step name or label.                                               |
| PTUNODE     | Submitter's symbolic node name.                                   |
| PTUID       | Userid of the submitter.                                          |
| PTPNODE     | Pnode name for this Process.                                      |
| PTSNODE     | Snode name for this Process.                                      |
| PTNODE      | This node is P(node) or S(node).                                  |
| PTFROM      | Direction of data: P(node) to Snode or S(node) to Pnode.          |
| PTUNPRNO    | Process number unique to submitter's node.                        |
| PTRMID      | Route message userid of Process.                                  |
| PTRMUID     | Userid where message is routed.                                   |
| PTSUBTME    | Time that Process was submitted in hh/mm/ss/tt format.            |
| PTSUBDTE    | Date that Process submitted in Julian date format (yyyymmdd).     |
| PTSCHTME    | Time that Process was scheduled in hh/mm/ss/tt format.            |
| PTSCHDTE    | Date that Process was scheduled in Julian date format (yyyymmdd). |
| PTSCHDAY    | Day Process was scheduled.                                        |
| PTSTMTN     | Number of statements.                                             |
| PTPRTY      | Process selection priority.                                       |

## Run Job Termination Record

The following table shows each field available in the Connect:Direct Run Job Termination record. The CDRJTR member of the \$CD.MAPLIB library contains the SAS maps of the Connect:Direct statistics record.

| Field Names | Field Description                                                  |
|-------------|--------------------------------------------------------------------|
| RJRECLN     | Length of this record.                                             |
| RJRTYPE     | Record type—RJ indicates the Run Job Termination record.           |
| RJTIME      | Time that RUN JOB step completed in hh/mm/ss/tt format.            |
| RJDATE      | Date that RUN JOB step completed in Julian date format (yyyymmdd). |

| Field Names | Field Description                                                |
|-------------|------------------------------------------------------------------|
| RJSTIME     | Time that RUN JOB step started in hh/mm/ss/tt format.            |
| RJSDATE     | Date that RUN JOB step started in Julian date format (yyyydddf). |
| RJSCC       | Step completion code. Displays normal completion code.           |
| RJMSGID     | Message ID.                                                      |
| RJPROCNM    | Process name.                                                    |
| RJPROCNO    | Process number.                                                  |
| RJSTEP      | Step name or label.                                              |
| RJUNODE     | Submitter's symbolic node name.                                  |
| RJUID       | Userid of the submitter.                                         |
| RJPNODE     | Pnode name for this Process.                                     |
| RJSNODE     | Snode name for this Process.                                     |
| RJNODE      | This node is P(node) or S(node).                                 |
| RJFROM      | Direction of data: P(node) to Snode or S(node) to Pnode.         |
| RJJOBNM     | Job name.                                                        |
| RJJOBNO     | Job number.                                                      |
| RJSYRCD     | System return code.                                              |
| RJDDSN      | Displacement to data set name.                                   |
| RJPACCT#    | Displacement to Pnode account data.                              |
| RJSACCT#    | Displacement to Snode account data.                              |

## Run Task Termination Record

The following table shows each field available in the Connect:Direct Run Task Termination record. The CDRTTR member of the \$CD.MAPLIB library contains the SAS maps of the Connect:Direct statistics record.

| Field Names | Field Description                                         |
|-------------|-----------------------------------------------------------|
| RTRECLN     | Length of this record.                                    |
| RTRTYPE     | Record type—RT indicates the Run Task Termination record. |
| RTTIME      | Time that RUN TASK step completed in hh/mm/ss/tt format.  |

| Field Names | Field Description                                                   |
|-------------|---------------------------------------------------------------------|
| RTDATE      | Date that RUN TASK step completed in Julian date format (yyyydddf). |
| RTSTIME     | Time that RUN TASK step started in hh/mm/ss/tt format.              |
| RTSDATE     | Date that RUN TASK step started in Julian date format (yyyydddf).   |
| RTSCC       | Step completion code. Displays normal completion code.              |
| RTMSGID     | Message ID.                                                         |
| RTPROCNM    | Process name.                                                       |
| RTPROCNO    | Process number.                                                     |
| RTSTEP      | Step name or label.                                                 |
| RTUNODE     | Submitter's symbolic node name.                                     |
| RTUID       | Userid of the submitter.                                            |
| RTPNODE     | Pnode name for this Process.                                        |
| RTSNODE     | Snode name for this Process.                                        |
| RTNODE      | This node is P(node) or S(node).                                    |
| RTFROM      | Direction of data: P(node) to Snode or S(node) to Pnode.            |
| RTMODNM     | Name of the RUN TASK program.                                       |
| RTSYSRTN    | System return code.                                                 |
| RTPARMLN    | Length of the parameter list.                                       |
| RTPACCT#    | Displacement to Pnode account data.                                 |
| RTSACCT#    | Displacement to Snode account data.                                 |

## Signon/Signoff Statistics Record

The following table shows each field available in the Connect:Direct Signon/Signoff Statistics record. The CDSFR member of the \$CD.MAPLIB library contains the SAS maps of the Connect:Direct statistics record.

| Field Names | Field Description                                                                                       |
|-------------|---------------------------------------------------------------------------------------------------------|
| SIRECLN     | Length of this record.                                                                                  |
| SIRTYPE     | Record type indicates specific data in the statistics record: SI=SIGNON command and SO=SIGNOFF command. |

| Field Names | Field Description                                                            |
|-------------|------------------------------------------------------------------------------|
| SITIME      | Time that SIGNON/SIGNOFF command completed in hh/mm/ss/tt format.            |
| SIDATE      | Date that SIGNON/SIGNOFF command completed in Julian date format (yyyymmdd). |
| SIUNODE     | User symbolic node ID.                                                       |
| SIUID       | Userid of the submitter.                                                     |
| SISCC       | Step completion code. Displays normal completion code.                       |
| SIMSGID     | Message ID.                                                                  |

## Start Connect:Direct Command Record

The following table shows each field available in the Start Connect:Direct Command record. The CDSDCR member of the \$CD.MAPLIB library contains the SAS maps of the Connect:Direct statistics record.

| Field Names | Field Description                                                                   |
|-------------|-------------------------------------------------------------------------------------|
| SDRECLN     | Length of this record.                                                              |
| SDRTYPE     | Record type—SD indicates the Start Connect:Direct Command record.                   |
| SDDTIME     | Time that Start Connect:Direct command completed in hh/mm/ss/tt format.             |
| SDDATE      | Date that Start Connect:Direct command completed in Julian date format (yyyymmdd).  |
| SDPROCNM    | Process name.                                                                       |
| SDPROCNO    | Process number.                                                                     |
| SDSTEP      | Step name or label.                                                                 |
| SDUNODE     | Submitter's symbolic node name.                                                     |
| SDUID       | Userid of the submitter.                                                            |
| SDSTIME     | Time that Start Connect:Direct command was issued in hh/mm/ss/tt format.            |
| SDSDATE     | Date that Start Connect:Direct command was issued in Julian date format (yyyymmdd). |
| SDSCC       | Step completion code. Displays normal completion code.                              |
| SDMSGID     | Message ID.                                                                         |

---

## Stop Connect:Direct Statistics Record

The following table shows each field available in the Stop Connect:Direct Statistics record. The CDSTDCR member of the \$CD.MAPLIB library contains the SAS maps of the Connect:Direct statistics record.

| Field Names | Field Description                                                                                                              |
|-------------|--------------------------------------------------------------------------------------------------------------------------------|
| TDRECLN     | Length of this record.                                                                                                         |
| TDRTYPE     | Record type—ST indicates the Stop Connect:Direct Statistics record.                                                            |
| TDTIME      | Time that STOP Connect:Direct command completed in hh/mm/ss/tt format.                                                         |
| TDDATE      | Date that STOP Connect:Direct command completed in Julian date format (yyydddf).                                               |
| TDPROCNM    | Process name.                                                                                                                  |
| TDPROCNO    | Process number.                                                                                                                |
| TDSTEP      | Step name or label.                                                                                                            |
| TDUNODE     | User node of the submitter.                                                                                                    |
| TDUID       | Userid of the submitter.                                                                                                       |
| TDSTIME     | Time that STOP Connect:Direct command was issued in hh/mm/ss/tt format.                                                        |
| TDSDATE     | Date that STOP Connect:Direct command was issued in Julian date format (yyydddf).                                              |
| TDSCC       | Step completion code. Displays normal completion code.                                                                         |
| TDSTOP      | Connect:Direct shutdown types: W=Step shutdown; X=Immediate shutdown; Y=Quiescent shutdown; and Z=Forced shutdown by an abend. |
| TDMSGID     | Message ID.                                                                                                                    |

---

## Write to Operator (WTO) Statistics Record

The following table shows each field available in the Connect:Direct WTO Statistics record. The CDFWTOST member of the \$CD.MAPLIB library contains the SAS maps of the Connect:Direct statistics record.

| <b>Field Names</b> | <b>Field Description</b>                                      |
|--------------------|---------------------------------------------------------------|
| WTRECLN            | Length of this record.                                        |
| WTRTYPE            | Record type—WT indicates the WTO Statistics record.           |
| WTCTIME            | Time that Process completed in hh/mm/ss/tt format.            |
| WTCDATE            | Date that Process completed in Julian date format (yyyydddf). |
| WTSTIME            | Time that function started in hh/mm/ss/tt format.             |
| WTSDATE            | Date that function started in Julian date format (yyyydddf).  |
| WTSCC              | Step completion code. Displays normal completion code.        |
| WTMSGID            | Message ID.                                                   |
| WTPROCNM           | Process name.                                                 |
| WTPROCNO           | Process number.                                               |
| WTSTEP             | Step name or label.                                           |
| WTUNODE            | Submitter's symbolic node name.                               |
| WTUID              | Userid of the submitter.                                      |
| WTPNODE            | The Pnode name for this Process.                              |
| WTSNODE            | The Snode name for this Process.                              |
| WTNODE             | This node is P(node) or S(node).                              |
| WTFROM             | Direction of data: P(node) to Snode or S(node) to Pnode.      |
| WTTASKNO           | Task number that issued the WTO.                              |



---

# Connect:Direct for z/OS Operator Interface

The Operator Interface enables you to issue all Connect:Direct for z/OS commands from a z/OS console by using a MODIFY command. The command results are displayed on the console.

This chapter explains how to:

- ◆ Invoke the Operator Interface
- ◆ Use the Operator Interface
- ◆ Interpret Connect:Direct operation error messages
- ◆ Stop Connect:Direct
- ◆ Conduct tape-handling procedures for Connect:Direct for z/OS

---

## Invoking the Connect:Direct for z/OS Operator Interface

You can access the Operator Interface after Connect:Direct initializes if you specify the Connect:Direct initialization parameters MCS.CLIST and MCS.SIGNON.

The syntax for the MCS.CLIST and MCS.SIGNON initialization parameters follows.

```
MCS.CLIST=console operator's CLIST library (dsn)
MCS.SIGNON=(SIGNON USERID=(userid,password) -
CASE=YES | NO-
NETMAP=network map file name)
```

An automatic signon is issued after the first Connect:Direct CLIST is invoked using the information in MCS.SIGNON. This session is active until you submit a CLIST that contains a Connect:Direct SIGNOFF command.

## Using the Operator Interface

You can create easy to remember customized Connect:Direct commands with the Operator Interface through a CLIST-type facility. The software supports symbolic substitution and CLIST-type parameters allowing you to alter Connect:Direct commands without changing the CLIST.

In a Connect:Direct/Plex, if you issue a console operator command to a Connect:Direct/Server, the console interface actually signs on to the Connect:Direct/Manager. As a result, any commands issued to Connect:Direct/Server are actually issued to the Connect:Direct/Manager, which is the only Connect:Direct/Plex member that accepts operator commands.

### Sample Connect:Direct for z/OS CLISTS

The Connect:Direct sample CLIST library, OPLIST on the distribution tape, contains the sample CLISTS included in the following table. Use these CLISTS to build customized Connect:Direct commands with symbolic parameters that allow you to customize the CLIST at submission time. Sample operator commands for each CLIST are listed in the comment section.

| CLIST Name | Command           | Description                                                                                                                                                                                                                                                                                                                                                                              |
|------------|-------------------|------------------------------------------------------------------------------------------------------------------------------------------------------------------------------------------------------------------------------------------------------------------------------------------------------------------------------------------------------------------------------------------|
| CMD        |                   | Provides a general format for requesting a Connect:Direct command.                                                                                                                                                                                                                                                                                                                       |
| DP         | DELETE PROCESS    | Shows six ways to delete a Process using this CLIST.                                                                                                                                                                                                                                                                                                                                     |
| DUMP       | STOP CD (Force)   | Stops Connect:Direct using the FORCE parameter and produces abnormal ending (abend) 4095 and a dump.                                                                                                                                                                                                                                                                                     |
| IPRM       | DISPLAY INITPARMS | Displays initialization parameters to the operator console. In a PLEX environment, it works as follows: <ul style="list-style-type: none"> <li>◆ Displays the global initialization parameters</li> <li>◆ Defaults to the manager's local initialization parameters</li> <li>◆ Allows the name of a server to display the server's global and local initialization parameters</li> </ul> |
| MSG        | SELECT MSG        | Shows a detail of the Connect:Direct message requested.                                                                                                                                                                                                                                                                                                                                  |
| NM         | SELECT NETMAP     | Displays entire NETMAP or it allows for one parameter – a node name.                                                                                                                                                                                                                                                                                                                     |
| RLSE       | CHANGE PROCESS    | Shows three ways to release a Process.                                                                                                                                                                                                                                                                                                                                                   |
| SIGNOFF    | SIGNOFF           | Signs the operator off Connect:Direct.                                                                                                                                                                                                                                                                                                                                                   |
| SIGNON     | SIGNON            | Connects the operator to Connect:Direct.                                                                                                                                                                                                                                                                                                                                                 |
| SP         | SELECT PROCESS    | Shows six ways to display Process status information.                                                                                                                                                                                                                                                                                                                                    |

| CLIST Name | Command           | Description                                                                                                                                                                                                                                                              |
|------------|-------------------|--------------------------------------------------------------------------------------------------------------------------------------------------------------------------------------------------------------------------------------------------------------------------|
| SS         | SELECT STATISTICS | Shows seven ways to select statistics for display.                                                                                                                                                                                                                       |
| STATS      | SELECT STATISTICS | Shows three ways to select statistics for display covering a specific time period.                                                                                                                                                                                       |
| STOP       | STOP CD           | Stops Connect:Direct using the STOP IMMEDIATE command. To perform an immediate shutdown in a PLEX environment from the operator console, issue the following command: F CD,STOP   CDPLEX. To stop a specific server, use this command:<br>F CD,STOP   WHERE(SERVER=name) |
| SUB        | SUBMIT PROCESS    | Shows two ways to submit a Process.                                                                                                                                                                                                                                      |
| SUSPEND    | SUSPEND PROCESS   | Shows four ways to suspend a Process.                                                                                                                                                                                                                                    |
| SWAP       | SWAP NODE         | Swaps operator to another node in a multiple session environment.                                                                                                                                                                                                        |
| TS         | SELECT TASK       | Shows active tasks.                                                                                                                                                                                                                                                      |
| VP         | VIEW PROCESS      | Displays a specific process.                                                                                                                                                                                                                                             |

## Rules for Setting Up Connect:Direct for z/OS CLISTS

The following rules apply when setting up an operator CLIST:

- ◆ All operator CLISTS must have a PROC record as the first record in the CLIST. The PROC record defines the parameters and keywords that are passed to the CLIST.
- ◆ You can stack multiple Connect:Direct commands in one CLIST, but you only need one PROC statement.
- ◆ A number between **0** and **24** (inclusive) must follow the PROC identifier. This number indicates the number of positional parameters used by the CLIST.
- ◆ Parameter names (one to eight characters each) that correspond to each positional parameter follow the number. If no positional parameters exist, specify PROC 0.
- ◆ If you define more than one positional parameter on the PROC statement, you do not need to specify trailing positional parameters in the command unless you also specify a keyword parameter.
- ◆ Use commas to indicate null values.
- ◆ A positional parameter is terminated by the first blank encountered.
- ◆ You can specify optional keyword parameters after the positional parameters. Enclose default values in parentheses after each keyword name.
- ◆ Use a hyphen (-) to indicate that a Connect:Direct command continues on the next line. An example follows.

```
PROC 1 PNUM
SELECT PROCESS WHERE ( -
    PNUM=&PNUM)
```

- ◆ You can use comments in the CLIST only if you include an asterisk (\*) in the first column.
- ◆ Sequence numbers are not allowed.

## Submitting Connect:Direct for z/OS Commands

Submit the Connect:Direct commands to the Operator Interface using a Connect:Direct for z/OS MODIFY command interface. This operator command lets you submit a CLIST containing Connect:Direct commands, and modify the Connect:Direct commands by substituting symbolic parameters with real values.

The command format is:

```
F jobname,clist [options]
```

The following table describes the parameters in the preceding command format:

| Parameter | Description                                                                                                                                                                                |
|-----------|--------------------------------------------------------------------------------------------------------------------------------------------------------------------------------------------|
| F         | The short form of the Connect:Direct for z/OS MODIFY command.                                                                                                                              |
| jobname   | The name on the job statement of the job stream that brings up the DTF.<br><b>Caution:</b> If jobname is a Connect:Direct/Server, the command is redirected to the Connect:Direct/Manager. |
| clist     | The name of the CLIST containing the Connect:Direct command.                                                                                                                               |
| options   | Optional positional and keyword parameters to be passed to the CLIST.                                                                                                                      |

## Examples

The following are CLIST examples and operator commands that submit the CLIST examples. As some examples show, you can use symbolic parameters to modify the Connect:Direct command at the time of submission. For example purposes, CDDTF is the jobname.

### CLIST with Command and No Parameters

In this example, the CLIST SELX contains one command and no parameters.

```
PROC 0
SEL PROC WHERE(Queue=EXEC)
```

To execute SELX, type the following operator command.

```
F CDDTF,SELX
```

When you issue the operator command, a Select Process command for Processes on the executing queue initiates. As a result, a list of these Processes is displayed.

## CLIST with Command and One Parameter

In this example, the CLIST SELQ contains one command and one positional parameter (SUBD).

```
PROC 1 SUBD
SEL PROC WHERE (QUEUE=&SUBD)
```

The following options present two ways to submit SELQ:

- ◆ When you issue the following command, TIMER (timer queue) is substituted for &SUBD. This command displays all Processes on the timer queue.

```
F CDDTF,SELQ TIMER
```

- ◆ When you issue the following command, ALL is substituted for &SUBD in the CLIST SELQ. This command displays all Processes on all queues.

```
F CDDTF,SELQ ALL
```

## CLIST with Command and Multiple Parameters

In this example, the CLIST SUB contains one command, two positional parameters (PROC and PARMS), and one keyword parameter (SNODE).

```
PROC 2 PROC PARMS SNODE (OTHER.NODE)
SUB PROC=&PROC SNODE=&SNODE &PARMS
```

The following options present four ways to execute SUB:

- ◆ When you issue the following command, PAYROLL is substituted for &PROC. This substitution causes the Process PAYROLL to be submitted.

```
F CDDTF, SUB PAYROLL
```

Because no SNODE is specified, the SNODE defaults to OTHER.NODE.

- ◆ When you issue the following command, CHECKS is substituted for &PROC and HOLD=YES is substituted for &PARMS. These cause the Process CHECKS to be submitted as a held Process.

```
F CDDTF, SUB CHECKS HOLD=YES
```

Because no SNODE is specified, the SNODE defaults to OTHER.NODE.

- ◆ When you issue this command, ORDERS is substituted for &PROC and CD.CHICAGO is substituted for &SNODE. These cause the Process ORDERS to be submitted to run in session with the secondary node called CD.CHICAGO.

```
F CDDTF, SUB ORDERS, , SNODE= (CD.CHICAGO)
```

Because PROC and PARMS are positional parameters, commas are required.

- ◆ When you issue the following command, CONFIRM is substituted for &PROC and HOLD=NO,STARTT=(FRIDAY,NOON) is substituted for &PARMS. These submit the Process CONFIRM so that it runs at noon on Friday.

```
F CDDTF, SUB CONFIRM HOLD=NO, STARTT= (FRIDAY, NOON)
```

The SNODE defaults to OTHER.NODE because no SNODE is specified.

### CLIST with Command and %IF %ELSE %EIF

In this example, the CLIST NM contains 1 command and 1 positional parameter.

```
PROC 1 NODE
  %IF &NODE = ,
  SEL NETMAP WHERE (NODE=*)
  %ELSE
  SEL NETMAP WHERE (NODE=&NODE)
  %EIF
```

If you enter no operands it will display the entire netmap. If you enter a particular node it will display just that node.

---

## Interpreting Connect:Direct for z/OS Operation Messages

Connect:Direct operation diagnostic messages are formatted into multiple lines so that errors and exception conditions are easy to read. Operator messages are sent to:

- ◆ The route code given in the Connect:Direct initialization parameters
- ◆ The ddname NDMLOG, if it is allocated

The COPY termination message (SVTM052I) is displayed in four lines, as follows:

- ◆ The first line shows the step label, the operation (COPY), the Process name and number, the associated node name, and the session class.
- ◆ The second line shows the FROM file name.
- ◆ The third line shows the TO file name.
- ◆ The fourth line shows the completion code and Connect:Direct message ID. If the COPY did not complete successfully, the first four positions of the last line contain the “####” flag.

When session errors occur, Connect:Direct formats the error message into two lines, as follows:

- ◆ The first line gives as much information as possible in the same format as the COPY termination message (Process name and number, and associated node name).
- ◆ The second line gives the text of the error message. The first four positions of the second line contain the “\*\*\*\*” flag.

The following example shows two Connect:Direct operation error messages following a COPY termination message.

```

SVTM052I STEP1 COPY PROCESS1 ( 126) PNODE=CD.NODE.A (002)
FROM SYSA.SAM.DATA.SET
TO SYSB.TEST.SAM.DATA.SET
#### COMPLETED 00000010/SCPA010I
SVTM045I PROCESS1 ( 126) PNODE=CD.NODE.A
**** RPLERRCK:CD/CD SESSION FAILURE
SVTM050I PROCESS1 ( 126) PNODE=CD.NODE.A
**** PROCESS INTERRUPTED:RECOVERY INITIATED

```

---

## Stopping Connect:Direct

To stop Connect:Direct for z/OS from the console, use the following command, which executes the STOP CLIST using the Operator Interface.

```
F jobname,STOP
```

### Stopping a Connect:Direct/Plex Manager and All Servers

To stop a Connect:Direct/Plex from the console, use the following command which executes the STOP CLIST using the Operator Interface:

```
F jobname,STOP [Q|S|I|R|F,] CDPLEX [,RECOVER]
```

### Stopping an Individual Connect:Direct/Plex Server

To stop a Connect:Direct/Plex Server from the console, use the following command which executes the STOP CLIST using the Operator Interface:

```
F jobname,STOP [Q|S|I|R|F,] WHERE(SERVER=name) [,RECOVER]
```

For more information, please refer to the Stopping Connect:Direct topic in the *Connect:Direct for z/OS Administration Guide*. For information on restarting Connect:Direct, see the *Connect:Direct for z/OS Installation Guide*.

---

## Understanding Connect:Direct for z/OS Tape Mount Messages

Connect:Direct for z/OS supports the transmission of tape files. Connect:Direct implements separate and distinct messages to control tape management, providing the greatest flexibility to operators in managing tape transfers. The following sections describe the three Connect:Direct tape messages.

## Tape Pre-mount Message

This optional message is issued prior to allocating a tape device. It tells you that Connect:Direct requires a specific volume on a specific device type. With this message, you can:

- ◆ Control the number of tape units available to Connect:Direct for tape transfers.
- ◆ Locate the volumes before the transfer occurs.

You are required to respond to this message when the required resources are available.

## Tape Mount Messages

These messages are also optional. The first message (WTO) is in the format of the z/OS mount message. The second message is issued as a WTOR to inform the operator to mount a specific volume on a specific device. The third message is issued only if TAPE.PREMOUNT=LIST. Message SVST00C is displayed listing all volume-serial numbers of the requested file. If you are unable to satisfy the specific request, you can reply CANCEL to cancel the request. This message is also used to drive the visual display devices attached to 3480-type devices.

---

**Note:** If you use tape silos in your environment, see the information on the Tapemount Exit in the chapter on using Connect:Direct exits in the *Connect:Direct for z/OS Administration Guide*. To prevent the Connect:Direct environment from locking up due to an outstanding tape mount request, the Connect:Direct tapemount exit provides an interface to StorageTek Tape Silo Software to query the silo to determine that all VOLS required for a tape file are present.

---

## Setting Up Connect:Direct for z/OS Tape Pre-mount Messages

To issue the Connect:Direct tape pre-mount messages, specify TAPE.PREMOUNT=YES|LIST in the Connect:Direct initialization parameter file. See the *Connect:Direct for z/OS Installation Guide* for details.

## Setting Up Connect:Direct for z/OS Tape Mount Messages

Issue the Connect:Direct tape mount messages in place of the z/OS mount message. The Connect:Direct mount messages consist of a z/OS-format mount message followed by a WTOR issued to the descriptor and route codes specified by the DESC.TAPE and ROUTCDE.TAPE.

You can suppress the Connect:Direct message by specifying ROUTCDE.TAPE=(0) in the initialization parameters. The defaults are DESC.TAPE=(2) ROUTCDE.TAPE=(5,11). If you suppress Connect:Direct tape mount messages, the standard z/OS mount messages are issued with related serialization during mount processing.

If you specify ROUTCDE.TAPE=(0), causing Connect:Direct not to issue the mount messages, then the normal z/OS mount message is issued when the dataset is opened. The z/OS mount processing holds an ENQ on the SYSZTIOT resource. This ENQ causes all other Connect:Direct Processes to hang at allocation, open, and deallocation until the tape is mounted.

If you use the Connect:Direct tape mount message, the tape already is on the tape drive at open time and z/OS mount processing does not hold the SYSZTIOT resource.



## Responding to Connect:Direct for z/OS Tape Pre-mount Messages

The following is the format of a Connect:Direct tape pre-mount message.

```
SVST000B - C:D REQUIRES VOL=SCRATCH TYPE=TAPE 6250/1600BPI
REPLY "GO" WHEN READY
```

To continue processing, reply GO to the message. While this message is outstanding, no unit is allocated. However, the session for this transfer request remains active.

## Responding to Connect:Direct for z/OS Tape Mount Messages

The following is the format of a Connect:Direct tape mount message issued during a specific tape request.

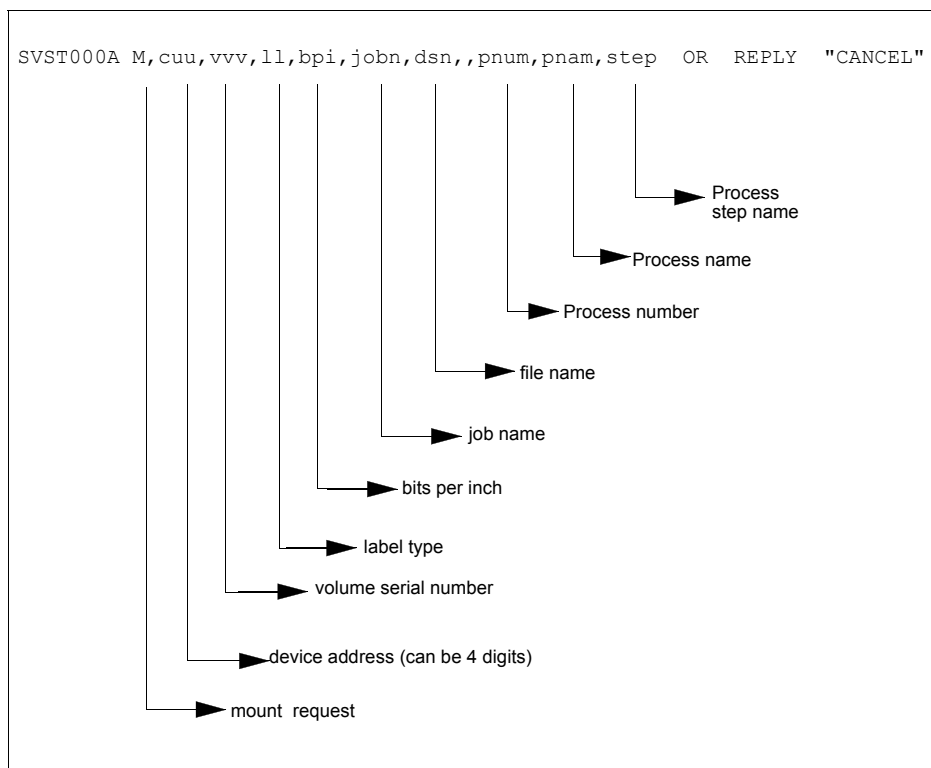

If no tape is available or if you want to end the copy, reply CANCEL to the tape mount message.

---

## Tape Device Allocation

After the GO reply to a pre-mount message, and following the pre-mount processing, Connect:Direct allocates a tape device using Defer mounting. If an allocation error occurs, and the

allocation error code is in the ALLOC.CODES parameter of the Connect:Direct initialization parameters, Connect:Direct retries the operation.

When device allocation completes successfully, Connect:Direct issues a z/OS-format Open mount message to allow tape management and visual display routines to process the request. The format of the message follows.

```
IEC501A M, cuu, volser, sl, , jobn, dsn, pnum, pnam, step
```

Following the IEC501A message, Connect:Direct issues a WTOR to allow you to mount the tape or cancel the request.

## Terminating the Tape Mount

A COPY step within a Process requiring a tape to be mounted causes the tape mount message to display. You can terminate the COPY step with a CANCEL reply. Any other reply causes Connect:Direct to reissue the mount message.

If you are using both the tape pre-mount message and the tape mount message, and want to cancel the request, reply GO to the tape pre-mount (SVST000B) and CANCEL to the tape mount message (SVST000A). If you do not want to terminate the copy step, the mount message disappears when the tape is mounted.

## Verifying Volume Requests

For standard label tapes, Connect:Direct for z/OS verifies the volume serial number for a specific volume request. If you mount the wrong volume, the following message is issued and the volume is dismounted.

```
SVST001I - D cuu, volser --- IS NOT THE REQUESTED VOLUME
```

You can mount the correct volume, or you can reply CANCEL to the reissued SVST000A mount message.

## Handling Multivolume Files

The Connect:Direct for z/OS mount message is issued only for the first volume of a file, when a multivolume file is requested. Subsequent mount requests causes a SYSZTIOT enqueue during end-of-volume processing.

To keep Connect:Direct from long waits while a second or subsequent volume is mounted, use UNIT=(unit,P) or UNIT=(unit,n) for the UNIT keyword of the COPY statement. For a description of the COPY statement, see the Connect:Direct Processes Web site at <http://www.sterlingcommerce.com/Documentation/processes/processhome.html>.

## Connect:Direct for z/OS Messages on 3480 Display

The 3480 tape drive has an 8-character display. Connect:Direct issues messages to this display concerning tape processing in the following manner:

- ◆ When a tape is to be dismounted, the first character position of the display contains a **D**. Positions 2–7 consist of the tape's volume serial number. Position eight contains an **N** if the tape is nonlabeled or an **S** if the tape has standard labels.
- ◆ When a tape is to be mounted, the first character position of the display contains an **M**. Positions 2–7 consist of the tape's volume serial number. Position eight contains an **N** if the tape is nonlabeled or an **S** if the tape has standard labels.
- ◆ When a tape is loaded, the first character position of the display is blank. Positions 2–7 consist of the tape's volume serial number. Position eight contains an **N** if the tape is nonlabeled or an **S** if the tape has standard labels.



---

# Event Services Support

Connect:Direct Event Services Support (ESS) implements an asynchronous, event-generation facility in Connect:Direct. ESS is designed for use by external management and automated operations applications that require real-time notification of Connect:Direct activities. ESS supports a publish or subscribe protocol with optional guaranteed event delivery and automated recovery.

Customer applications can register interest in receiving event data, and specify the types of event data the application receives through the new event services commands. ESS supports a general user exit point and an optional API for interface communication with user-written CICS automation applications.

---

## Concepts and Components

ESS provides real-time delivery of Connect:Direct event records to interested application interfaces. ESS is based on the existing Connect:Direct statistics facility and is designed to:

- ◆ Minimize the server-performance overhead for ESS processing
- ◆ Prevent adverse impact on Connect:Direct server reliability

ESS is a low-level Connect:Direct server technology that enables you to layer multiple APIs. An end-user application interfaces with the API rather than the low-level ESS core technology. This design enables future extension of ESS to support multiple application interface protocols and simultaneous publishing of the same event data to several event consumer applications.

## System Interfaces

ESS supports the event services exit and the CICS API interface.

An application can access event data through an ESS exit. A sample event exit (ESSEVX01) is in the sample library, and writes the event data to a predefined data set.

A CICS API initiates event processing by signing on to Connect:Direct through the current CICS API and issuing ESS commands. The CICS API provided with Connect:Direct writes event data to a CICS Transient Data Queue (TDQ). A sample program, DMQ249, shows how to read an event record from the TDQ.

## System Advantages

Building on the existing statistics facility has the following advantages:

### ◆ Event Definition

Because ESS event records are Connect:Direct statistics records, ESS does not restrict events to abnormal activities. This design enables ESS-enabled applications to initiate procedures based on either successful or unsuccessful Process statements.

### ◆ Historical Data Recovery

The Connect:Direct statistics file functions as the historical repository of ESS event data. ESS supports optional automated recovery of past event data if an event consumer application fails. Upon restart, ESS requests old event records from the statistics file.

The API automatically manages the restart point for an ESS-enabled application. This API tracks the last successfully delivered event record to a designated subscriber. Upon restart, the API resynchronizes event processing by issuing a SElect STATistics command to retrieve the historical event data and deliver it to the restarted event consumer.

### ◆ Event Record Types

The event record types give external applications greater visibility into Connect:Direct activities and improve the reliability and responsiveness of interface applications in a production environment. ESS supports several Connect:Direct event record types, including:

- ◆ **Process Initialization (PI)** occurs immediately prior to the execution of the first Process statement in a Process.
- ◆ **Step Start (CI, JI, TI)** events occur immediately prior to the execution of a COPY, RUN JOB, or RUN TASK statement.
- ◆ **COPY Step I/O Start (CE)** occurs immediately prior to the first COPY step I/O in a Process.
- ◆ **Queue Change (QW, QH, QE, QT)** events occur whenever a Process moves from one logical queue to another in the TCQ. The sample initialization parameters provided in the base Connect:Direct install the PARMLIB data set and specify STAT.EXCLUDE=(QE, QH, QT, QW). This specification prevents Connect:Direct from producing the queue change records. If you want queue change records, you must set this parameter appropriately.

See Chapter 12, *Event Services Record Descriptions*, for more information about Event Record Types.

ESS also supports basic event filtering. When an event consumer application registers interest in receiving events, the application can restrict the types of event data that it wants to receive. These options support the same filtering syntax as the SElect STATistics command. Following are two possible selections:

- ◆ A fault management application can request notification of COPY requests that did not complete normally, QH (Queue Hold) events or both. When such an event occurs, the fault management application can then poll Connect:Direct through SElect STATistics or SElect PROCess to investigate the problem further.
- ◆ An application can register interest in all events for a small group of mission-critical Processes.





---

# Using Event Services Support

ESS uses three main components to provide real-time information about Connect:Direct activities:

- ◆ Client application
- ◆ API
- ◆ Connect:Direct server

ESS can communicate with client application interfaces through the CICS API or through an ESS user exit.

The ESS architecture described in this chapter provides an overview of the system structure. Event data flows are presented in subsequent diagrams. A summary of each type of interface follows the discussion of system operation.

---

## Connect:Direct Event Services Support Architecture

The three main components of ESS interact to accomplish the following tasks:

- ◆ Define which events are reported to the client application
- ◆ Turn event services requests on and off
- ◆ Register event data
- ◆ Report event data

The following diagram details ESS with a CICS application using the Connect:Direct CICS API. The structure consists of the following components:

- ◆ The client application defines the event data requests and issues commands through a user-written program. The DMQ247 sample program demonstrates the method to issue the ESS CDNC commands.
- ◆ The API receives and passes event data and ESS CDNC commands to the Connect:Direct server, and maintains information for the guaranteed delivery feature.

- ◆ The Connect:Direct server is the Data Transmission Facility (DTF) that processes ESS CDNC commands and sends the requested event data to the client application through the API (DMQ012).

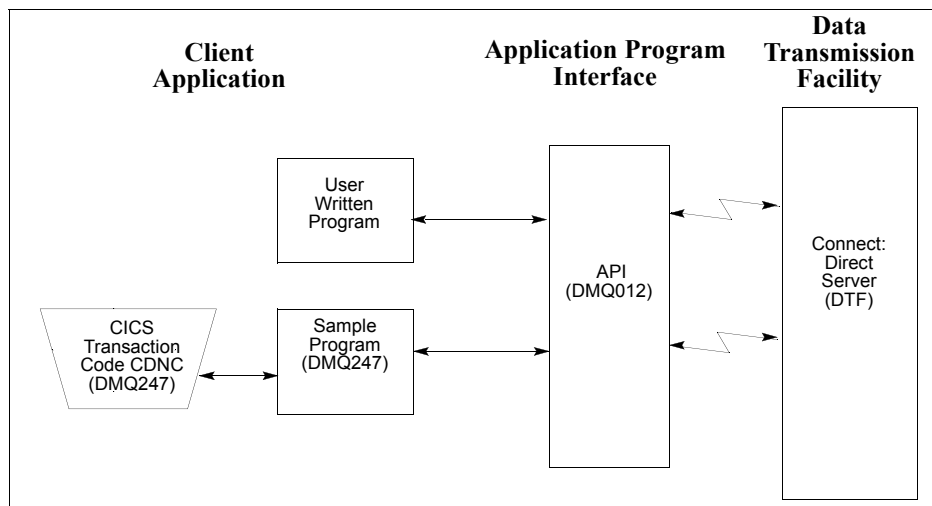

## ESS Data Flow Using CICS API

You define the event services environment by specifying the types of event data your application receives. These definitions are the event data requests that you issue through the DMQ247 program or a user-written program.

After you define the event data requests for your client application and activate your request by issuing the `EVENT SERVICES START` command, ESS processes the requested event data as follows:

- ◆ Upon receiving the `EVENT SERVICES START ID` parameter, the API (DMQ012) passes the command to the DTF through a VTAM session.
- ◆ When a requested event occurs, the DTF sends the event data to the API for distribution to the Transient Data Queue (TDQ).
- ◆ The event data is then available to the client application through the DMQ249 Sample Program. The DMQ249 program provides a way to read event data from the TDQ and processes the data for use by your application.

The following diagram illustrates the flow of event data from the DTF to the client application:

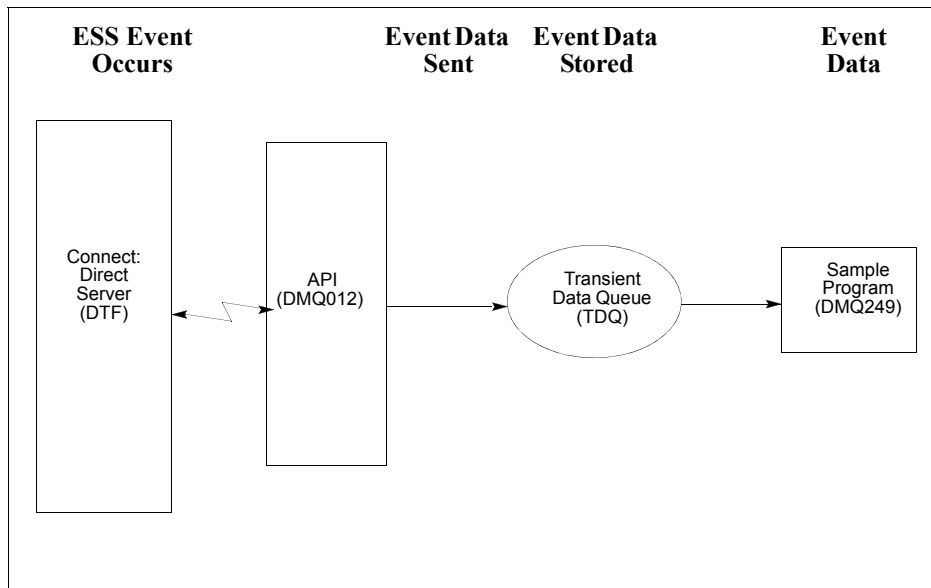

For additional information on Event Services commands, refer to Chapter 10, *Issuing Event Services Commands*.

## Deciding What Event Data to Collect

Deciding what event data to collect requires that you understand the types of data the ESS delivers and how you can use this data in your event consumer application. Although it is technically possible to request all event data for all Processes in the system, it is usually unnecessary and impractical to do so. Typically, an event consumer application is interested in a subset of event data.

---

**Note:** Statistics records excluded through the API STAT command or a DTF statistics exit, or by coding the DTF STAT.EXCLUDE initialization parameter, are not available to ESS.

---

The following are commonly requested event data:

- ◆ All event data for a particular Process or select group of Processes  
Requesting all event data gives the most detailed trace of Process execution. This information is useful during testing of an event consumer application. However, it is typically unnecessary after such an application goes into production.
- ◆ Major event data for a particular Process or select group of Processes  
This request is the most common subset specification. For normal production work, this request gives your application a sufficient trace of Process execution, and minimizes overhead for ESS processing and the processing of event records by your application.

- ◆ Subset of event data for a particular Process, set of Processes, or all Processes

For example, an application executes a procedure when a Connect:Direct Process terminates. In this case, it may be sufficient to register interest in PT (Process Termination) records only. As a second example, a fault reporting application needs CT (Copy Termination) statements that did not complete normally (signalling the failure of a Connect:Direct file transfer request).

## ESS Event Record Examples

The following examples show the ESS event records from a single Copy Process. The examples show the records produced from Process submittal until normal Process termination. The examples assume that no Connect:Direct commands affecting the Process [including the SElect PROCess command] are issued between Process submittal and termination.

- ◆ ESS Event Records Example 1 (No Retries)

In this example, the Process does not undergo a Process retry for any reason. The sequence of ESS event records produced by this Process are listed in the following table. These records are in sequential order.

| Record Type | Record Description           |
|-------------|------------------------------|
| PS          | Process submit               |
| QE          | Process moved to EXEC queue  |
| PI          | Process initiation           |
| CI          | COPY step statement start    |
| CE          | COPY step I/O start          |
| CT          | COPY termination             |
| NL          | Last statement (null step 1) |
| PT          | Process termination          |

- ◆ ESS Event Records Example 2 (One Retry)

This example shows the sequence of ESS records that are produced if the same Process undergoes a single Process retry. Connect:Direct commands are deliberately issued to suspend the Process and then release it for retry. As a result, the following record sequence includes the various operator commands required. The events are in sequential order.

| Record Type | Record Description          |
|-------------|-----------------------------|
| PS          | Process submit              |
| QE          | Process moved to EXEC queue |
| PI          | Process initiation          |

| Record Type | Record Description                                  |
|-------------|-----------------------------------------------------|
| CI          | COPY step statement start                           |
| CE          | COPY step I/O start                                 |
| FS          | Suspend Process command issued                      |
| CT          | COPY termination (as a result of requested SUSPEND) |
| QH          | Process moved to HOLD queue                         |
| CH          | Change Process command issued with RELEASE=Yes      |
| QE          | Process moved to EXEC queue                         |
| PI          | Process initiation                                  |
| CI          | COPY step start                                     |
| CE          | COPY I/O start                                      |
| CT          | COPY termination                                    |
| NL          | Last statement in Process end                       |
| PT          | Process termination                                 |

---

## Using ESS with the CICS API

The CICS API writes event data to the Transient Data Queue (TDQ). Your CICS application must include a program to read these event records from the TDQ and pass them to your application for processing.

Follow these steps to enable a CICS application for ESS:

1. Decide what event data your application requires. Refer to *Deciding What Event Data to Collect* on page 83 for additional information.
2. Verify that the Connect:Direct CICS API software is correctly installed and working. Refer to the Connect:Direct installation documentation for further information.
3. Create an ESS registration program. Include this program in the startup portion of your application. It must be called whenever your application wants to initiate event record collection. This program must perform the following:
  - ◆ Sign on to the Connect:Direct CICS API.
  - ◆ Issue the `EVENT SERVICES CREATE` command to register interest in receiving event data and to specify event record filter criteria.

- ◆ Specify the ID parameter to identify a subscriber name for your application. Specify the WHERE and ORWHERE parameters for your filtering criteria. Refer to *EVENT SERVICES CREATE Command Format* on page 89 for further information about event filter criteria.
  - ◆ Issue the EVENT SERVICES START command and specify the ID parameter to initiate event reception.
4. Create a customer interface program to read event records off the CICS TDQ and pass them to your application for processing. The sample interface program (DMQ249) demonstrates how to read an event record from the TDQ. Specifically, your application must issue an EXEC CICS READQ TD QUEUE instruction.
  5. Modify your application to process the ESS event records.
  6. Embed a call to the EVENT SERVICES STOP ID=subscriber\_name parameter in your application where you want to stop collecting event data.

---

## Using ESS with the ESS User Exit

You can execute Event Services commands through any existing Connect:Direct API such as CICS, ISPF, and DMBATCH. However, not all Connect:Direct APIs can process synchronous event data received from an EVENT SERVICES START command. In some cases, it is preferable not to have the Connect:Direct API process synchronous event data. The event services exit provides an alternative. Rather than passing synchronous event data back to the API that issued the EVENT SERVICES START (ESS) command, an exit processes the event data.

### System Architecture

The ESS exit acts as an extension to the Connect:Direct server. When a synchronous event occurs, Connect:Direct calls the event services exit. An event exit control block is passed for each event and contains the following:

- ◆ Address of the event record
- ◆ Flags indicating first or last call
- ◆ Fields for the user to indicate return code and message

DMEVEXCB, found in the sample library, maps the event exit control block. The sample exit, ESSEVX01, is also in the sample library.

The event services exit is called as a subtask from Connect:Direct so that the user code waiting for system services does not directly effect Connect:Direct processing. The sample exit (ESSEVX01) writes each event record to a predefined data set. You must modify ESSEVX01 to specify the name of your event exit data set, and you must define the data set to accommodate records up to 2048 bytes in length.

## Using the ESS Exit

Each record passed to the exit consists of a record header and an event record. DMMNHDR, which is in sample library, maps the record header. Members in the sample library also map the event records. See Chapter 12, *Event Services Record Descriptions*, to determine which member maps a particular event record.

The exit must reside in a load library accessible to the Connect:Direct server (DTF). Connect:Direct moves event data to storage below the 16M line before calling the event services exit. This step accommodates systems where I/O calls must be done below the line.

To use the ESS user exit, follow these steps:

1. Create an ESS exit program that can process the requested event records.
2. Decide what event data your application requires. Refer to *Deciding What Event Data to Collect* on page 83 for additional information.
3. Verify that your software is correctly installed and working.
4. Create an ESS registration program. Include this program in the startup portion of your application. It is called whenever your application wants to initiate event record collection. This program must accomplish the following:
  - ◆ Signon to Connect:Direct through the CICS API, the ISPF IUI, or DMBATCH.
  - ◆ Issue the EVENT SERVICES CREATE command to register interest in receiving event data and specify event record filter criteria.  
Specify the EXIT parameter to identify the name of your exit program, and the ID parameter to identify a subscriber name for your application. Specify the WHERE and ORWHERE parameters for your filtering criteria. Refer to *EVENT SERVICES CREATE Command Format* on page 89 for more information about event filter criteria.
  - ◆ Issue the EVENT SERVICES START command and specify the ID parameter to initiate event reception.
5. Embed a call to the EVENT SERVICES STOP ID=subscriber\_name parameter in your application where you want to stop collecting event data.

If the user application does not process records fast enough, the internal queue, which holds asynchronous events, becomes full. When the queue is full, event processing for this request ends, and Connect:Direct writes a WTOR message. To customize the internal queue size, specify the MAXQCNT parameter on the EVENT SERVICES CREATE command.





---

# Issuing Event Services Commands

The Event Services commands are the tools that enable you to determine what information your application receives, and to start and stop event notification. You can define the event data through an event services request. This chapter details how to use the EVENT SERVICES commands to create requests, start and stop event notification, and display event data.

This chapter describes the four commands that the Connect:Direct Event Services Support uses:

- ◆ EVENT SERVICES CREATE
- ◆ EVENT SERVICES START
- ◆ EVENT SERVICES STOP
- ◆ EVENT SERVICES DISPLAY

Each command description includes the function of the command and the command parameters.

---

## EVENT SERVICES CREATE Command Format

The EVENT SERVICES CREATE command enables you to create a new request for event data and define which data is sent to your application.

The EVENT SERVICES CREATE command uses the following format and parameters:

| Command                    | Parameters                                                                                          |
|----------------------------|-----------------------------------------------------------------------------------------------------|
| EVENT [SERVICES]<br>CREATE | <b>ID=</b> event-request-name                                                                       |
|                            | <b>WHERE</b> (CCODE PNAME PNUMBER STARTT STOPT USER SNODE TYPE <br>FNAME CASE LASTSEQ MAXQCNT EXIT) |
|                            | <b>ORWHERE</b> =(CCODE PNAME PNUMBER USER SNODE TYPE  FNAME)                                        |

## Required Parameters

The EVENT SERVICES CREATE command has two required parameters.

### **ID=event-request-name**

specifies a logical name for the event services request. This name is a text string of 1–16 characters. You can use any printable characters. You cannot use embedded blanks.

### **WHERE (CCODE = (condition, completion code)**

**PNAME = name | (list)**  
**PNUMBER = number | (list)**  
**STARTT = ([date | day] [,hh:mm:ssXM])**  
**STOPT = ([date | day] [,hh:mm:ssXM])**  
**USER = name | (list)**  
**SNODE = name | (list)**  
**TYPE = id | (list)**  
**FNAME = dsname | (list)**  
**CASE = YES | NO**  
**LASTSEQ=n**  
**MXQCNT=n**  
**EXIT=exitname)**

specifies selection criteria for event records.

You must specify at least one WHERE () subparameter, such as CCODE, PNAME, PNUMBER, or TYPE.

### **CCODE = (condition, completion code)**

specifies selection by completion code.

**condition** specifies a relationship to the completion code given in the subsequent positional parameter. The options for specifying condition are:

GT greater than  
 LT less than  
 EQ equal to  
 NE not equal to  
 GE greater than or equal to  
 LE less than or equal to

**completion** specifies a completion code value ranging from 1 to 2,147,483,647 so the RUN TASK can pass all values.

For example, if you specify CCODE = (GT,0), you see event records in which the step completion code is greater than zero, as long as the records also meet other specified criteria.

**PNAME = name | (list)**

specifies selection by Process name. Specify a list of Processes by enclosing them in parentheses. You can use a wild card character (\*) at the end of the name.

For example, if you specify PNAME=TEST\*, then all records with TEST in the first four characters of the Process name field are selected. Records having TEST, TEST123, and TESTX all satisfy the selection criterion.

**name** specifies the name of the Process to select.

**(list)** specifies a list of Process names to select. Enclose the list in parentheses. Separate Processes in the list with commas.

**PNUMBER = number | (list)**

specifies selection by Process number. To request a list of Processes, enclose them in parentheses. The range is 1–99999.

**number** specifies the number of the Process to select.

**(list)** specifies a list of Process numbers to select. Enclose the list in parentheses. Separate Processes in the list with commas.

**STARTT = ([date | day] [,hh:mm:ssXM])**

specifies selection by start date and time. Specify STARTT as a date and time prior to the current time. If you set this parameter, the event records retrieved from the statistics file begin with the date and time you specified and continue until the current time is reached. At that point, event records are processed as they occur.

---

**Note:** If you specify STARTT and LASTSEQ with the EVENT SERVICES START command, those values replace the values specified for these parameters in the EVENT SERVICES CREATE command. When you use the time specification in conjunction with the LASTSEQ parameter, you must include hours, minutes, seconds, and hundredths of seconds in the format hh:mm:ss.th.

---

**date** specifies the starting date from which event records are retrieved from the statistics file. You can specify the date in either Gregorian or Julian format.

If you use a Gregorian date format, set the DATEFORM initialization parameter to the appropriate date format. Otherwise, the date format defaults to the platform date format. You do not need to set the DATEFORM parameter for Julian date format.

The following table shows the acceptable date formats.

| Format    | DATEFORM Parameter | Date Format                                                             |
|-----------|--------------------|-------------------------------------------------------------------------|
| Gregorian | DATEFORM=MDY       | mmddy or mmddy<br>mm/dd/yy or mm/dd/yyyy<br>mm.dd.yy or mm.dd.yyyy      |
| Gregorian | DATEFORM=DMY       | ddmmy or ddmmyy<br>dd/mm/yy or dd/mm/yyyy<br>dd.mm.yy or dd.mm.yyyy     |
| Gregorian | DATEFORM=YMD       | yymmdd or yyyyymmdd<br>yy/mm/dd or yyyy/mm/dd<br>yy.mm.dd or yyyy.mm.dd |
| Gregorian | DATEFORM=YDM       | yyddmm or yyyyddmm<br>yy/dd/mm or yyyy/dd/mm<br>yy.dd.mm or yyyy.dd.mm  |
| Julian    | N/A                | yyddd or yyyyddd<br>yy/ddd or yyyy/ddd<br>yy.ddd or yyyy.ddd            |

---

**Note:** If RETAIN=Y, you cannot specify a date in the STARTT parameter of the initialization file.

---

**day** specifies the day of the week to select. Valid names include MONday, TUESday, WEDnesday, THURsday, FRIday, SATurday, and SUNday. You can also specify YESTER to retrieve event records created since yesterday, or TODAY to retrieve event records created today.

**hh:mm:ssXM** indicates the start time of day in hours (hh), minutes (mm), and seconds (ss) selected. XM indicates AM or PM. You can use the 24-hour clock or the 12-hour clock. If you use the 24-hour clock, valid times are 00:00-24:00. If you use the 12-hour clock, valid times are 00:00-12:00 and you must indicate AM or PM. For example, 01:00 hours on the 24 hour clock is expressed as 1:00AM on the 12 hour clock. If you do not specify AM or PM, Connect:Direct assumes the 24-hour clock. You do not need to specify minutes and seconds. You can also specify NOON to retrieve event records starting at noon, or MIDNIGHT to retrieve event records starting at midnight. The default for the time is 00:00:00, the beginning of the day.

If you do not specify the STARTT parameter, event processing begins with the current time.

**STOPT = ([date | day] [,hh:mm:ssXM])**

specifies when interest in event data ends.

**date** specifies the stop date when event processing ends. You can specify the date in either Gregorian or Julian format.

Refer to the STARTT subparameter on page 91 for a discussion of Gregorian and Julian date formats.

If you specify only the date, the time defaults to 24:00:00.

**day** specifies the day of the week to select. Valid values include MOnday, TUESday, WEDnesday, THursday, FRiday, SATurday, and SUnDay. You can also specify TODAY.

**hh:mm:ssXM** indicates the stop time of day in hours (hh), minutes (mm), and seconds (ss) to select. XM indicates AM or PM. You can use the 24-hour clock or the 12-hour clock. If you use the 24-hour clock, valid times are 00:00-24:00. If you use the 12-hour clock, valid times are 00:00-12:00 and you must indicate AM or PM. For example, 01:00 hours on the 24 hour clock is expressed as 1:00AM on the 12 hour clock. If you do not specify AM or PM, Connect:Direct assumes the 24-hour clock.

You do not need to specify minutes and seconds. You can also specify NOON to retrieve event records starting at noon, or MIDNIGHT to retrieve event records starting at midnight. The default time is 24:00:00, the end of the day.

If you do not specify the STOPT parameter, you must issue an EVENT SERVICES STOP command to stop event processing.

**USER = name | (list)**

limits the selected event records to those written for userids with the specified name. You can specify a list of names by enclosing them in parentheses. You can use wild card characters. For example, if you specify USER = SYSS\$, then records with SYSS\$ in the first four characters of the userid field are selected. Records having SYSS\$BOB, SYSS\$ADM, and SYSS\$0001 all satisfy this selection criterion. Userid names can be up to 64 characters in length and can contain lowercase characters.

**name** specifies the userid to select.

**(list)** specifies a list of userids to select. Enclose the list in parentheses. Separate userids in the list with commas.

**SNODE = name | (list)**

limits the selected event records to those written for Processes where the specified node name acted as SNODE. You can specify a list of names by enclosing them in parentheses. You can use wild card characters. For example, if you specify SNODE=DALLAS\$, then all records with DALLAS in the first six characters of the SNODE field are selected. Records having DALLAS.PROD, DALLAS.TEST, and DALLAS all satisfy this selection criterion. SNODE names can contain lowercase characters.

**name** specifies the SNODE to select.

**(list)** specifies a list of SNODES to select. Enclose the list in parentheses. Separate SNODES in the list with commas.

**TYPE = id | (list)**

specifies the event record types to select. Every event record that Connect:Direct generates has an associated record-type identifier. Each identifier is two characters long and indicates the event or function that generated the record. The identifier also indicates the record format and contents.

**id** specifies the event record type.

**(list)** specifies a list of event record types to select. Enclose the list in parentheses. Separate record types in the list with commas.

See Chapter 12, *Event Services Record Descriptions*, for a list of all event record type identifiers.

**FNAME=dsname | (list)**

limits the selected event records to those that contain the specified filename. The FNAME subparameter is valid for the following record types: Copy Termination (CT), Run Job (RJ), Start Connect:Direct (SD), and Submit within Process (SW).

**name** specifies the filename to select.

**(list)** specifies a list of filenames to select. Enclose the list in parentheses. Separate filenames in the list with commas.

The meaning of the filename within these records is unique for each record type. For example, the Run Job record contains the filename of the submitted JCL. Filenames can be up to 254 characters in length and can contain lowercase characters. Filenames must conform to your platform's naming conventions.

**CASE=YES | NO**

specifies whether lowercase or mixed-case data is permitted for the USER, SNODE, and FNAME subparameters. The CASE subparameter overrides the global CASE option defined at signon for the SELECT STATISTICS command.

**YES** changes the data in USER, SNODE, and FNAME to uppercase regardless of the actual data specified.

**NO** preserves the actual case entered for the USER, SNODE, and FNAME subparameters.

The CASE defaults to the setting defined in the session defaults, if nothing is specified.

**LASTSEQ=n**

specifies the last sequence number (for Restart capability) associated with the date/time stamp. Use it with the STARTT parameter. This information is provided by CICS when you issue a CREATE EVENT SERVICES REQUEST command for an event services request that finished abnormally. For additional information about how to use LASTSEQ, refer to *Using LASTSEQ* on page 103.

**MAXQCNT=n**

specifies the maximum number of elements that can reside in the internal event queue for this request. All events that match the WHERE criteria for this request are placed on an internal queue. If events occur faster than the API can process them, the queue can become full. If the queue becomes full, Connect:Direct terminates event services requests. You can

modify the queue size using MAXQCNT. Each queue element takes approximately 2K in storage. The default is **100**.

**EXIT=exitname**

specifies the name of an EVENT SERVICES OPTION exit. The sample exit ESSEVX01 is provided in the sample library. Event data is processed by an exit rather than the calling API, if EXIT is specified. Refer to *Using ESS with the ESS User Exit* on page 86 for information about the user exit.

## Optional Parameters

The following parameters are optional for the EVENT SERVICES CREATE command.

**ORWHERE(CCODE = (condition, completion code**

**PNAME = name | (list)**

**PNUMBER = number | (list)**

**USER = name | (list)**

**SNODE = name | (list)**

**TYPE = id | (list)**

**FNAME = dsname | (list)**

specifies which statistics records you want to examine.

The subparameters, such as CCODE, PNAME, PNUMBER, and TYPE, are optional, but you must specify at least one.

The parameters for the ORWHERE keyword are defined in the WHERE keyword section beginning on page 90.

## Sample Command

The following is an example of the EVENT SERVICES CREATE command.

```
EVENT CREATE ID=PROCESS_TERM WHERE (TYPE=PT)
```

---

## EVENT SERVICES START Command Format

The EVENT SERVICES START command enables you to start a specific notification request for event data. This command provides parameters where you can define what data (date, time, and sequence) is sent to your application.

The EVENT SERVICES START command uses the following format and parameters.

| Command                | Parameters                |
|------------------------|---------------------------|
| EVENT [SERVICES] START | ID=event-request-name     |
|                        | WHERE=(STARTT LASTSEQ     |
|                        | KEEPREC  ( for CICS only) |
|                        | TRACE) (CICS only)        |

## Required Parameter

The EVENT SERVICES START command has one required parameter.

**ID=event-request-name**

specifies the logical name of the event services request to start. Specify this name in a CREATE EVENT SERVICES command.

## Optional Parameters

The following parameter is optional for the EVENT SERVICES START command.

**WHERE(STARTT|LASTSEQ|KEEPREC|TRACE)**

sets restriction on event records meeting the following selection criteria.

**STARTT=([date|day][,hh:mm:ssXM])** specifies selection by designated starting date and time. STARTT must be a date and time prior to the current time. If you specify this parameter, the event records retrieved from the statistics file begins with the date and time you specified, and continues until the current time is reached. At that point, event records are processed as they occur.

For a complete explanation of the subparameters, refer to *EVENT SERVICES CREATE Command Format* on page 89.

**LASTSEQ=n** specifies the last sequence number (for Restart capability) associated with the date/time stamp. Use this parameter with the STARTT parameter. This information is provided by CICS when you issue a CREATE EVENT SERVICES REQUEST command for an event services request that finished abnormally. For additional information about how to use LASTSEQ, refer to *Using LASTSEQ* on page 103.

**KEEPREC (CICS-only)** specifies that the restart record created by Connect:Direct is kept, regardless of whether the event request completed abnormally or not. If KEEPREC is not specified, the restart record created by Connect:Direct is deleted if the event request completes normally. Refer to *Using LASTSEQ* on page 103 for more information about how to use the LASTSEQ parameter.

**TRACE (CICS-only)** specifies that every event record placed on the CICS TDQ is also written to the NDMTRACE temporary storage (TS) queue. You can use the NDMTRACE temporary storage queue to verify that EVENT records are flowing to the transient data queue.

## Sample Command

The following is an example of the EVENT SERVICES START command.

```
EVENT START ID=PROCESS_TERM
```



---

## EVENT SERVICES STOP Command Format

The EVENT SERVICES STOP command enables you to stop event notification for a specific event services request.

---

**Note:** The EVENT SERVICES STOP command stops event notification and deletes the event request from the system.

---

The EVENT SERVICES STOP command uses the following format and parameters.

| Command               | Parameters            |
|-----------------------|-----------------------|
| EVENT [SERVICES] STOP | ID=event-request-name |
|                       | IMMEDIATE             |

### Required Parameter

The EVENT SERVICES STOP command has one required parameter.

**ID=event-request-name**

specifies the logical name of the event services request to start. This name must match a name specified in a CREATE EVENT SERVICES command.

### Optional Parameter

The EVENT SERVICES STOP command has one optional parameter.

**IMMEDIATE**

indicates that no more event records can be sent. If you do not specify IMMEDIATE, all records on the internal EVENT queue are sent before the EVENT request is terminated.

---

## EVENT SERVICES DISPLAY Command Format

The EVENT SERVICES DISPLAY command enables you to display event data for a specific event services request. The EVENT SERVICES DISPLAY command uses the following format and parameter.

| Command                  | Parameter             |
|--------------------------|-----------------------|
| EVENT [SERVICES] DISPLAY | ID=event-request-name |

## Required Parameters

The EVENT SERVICES DISPLAY command has no required parameters.

## Optional Parameter

The EVENT SERVICES DISPLAY command has one optional parameter.

**ID=event-request-name**

specifies the logical name of the event services request to display. This name must match a name specified in a CREATE EVENT SERVICES command. If you do not specify this parameter, all event services requests are displayed.

---

# Using ESS with the CICS API

The Connect:Direct CICS interface enables you to use Connect:Direct through the Customer Information Control System (CICS) from local and remote sites. The system includes a set of nested menus, prompts for required information, online Help facilities, and monitoring features for current status.

---

## Configuring CICS

In addition to the Connect:Direct IUI, Sterling Commerce provides a facility that enables you to issue standard Connect:Direct commands from a CICS application program. You can use this interface for both terminal and non-terminal tasks. Following are two typical uses for this API:

- ◆ For terminal tasks, the API enables an installer to provide their own user interface to all or part of Connect:Direct or work with Connect:Direct from application programs using the CDNC transaction.
- ◆ For non-terminal tasks, the API enables an installer to write background transactions which programmatically issue Connect:Direct commands. The most typical sequence is SIGNON - SUBMIT - SIGNOFF. In this case, the SIGNON generates a SIGNON TYPE=CICS, and the SIGNOFF results in a cleanup operation of the signon table entry, temporary storage, and so forth.

To avoid having to sign on before each command and sign off after each command, the user application can pass a logical task number through the Q012TASK field. If Q012TASK is used, a user program can sign on once and issue multiple commands in pseudo-conversational mode. A signoff is only needed when the user application is terminating.

An example of the use of this facility is provided in member DMQ247 of the \$CD.SAMPLIB. This program enables you to type Connect:Direct commands on a screen and view the resulting return code, message number, message text, and Process number assigned to your Connect:Direct Process. In addition, the CICS application displays the name of the CICS Temporary Storage (TS) queue where the results of your command are stored, the count of items in the queue, and the maximum record length in the queue.

You must install both Connect:Direct and the Connect:Direct CICS interface, and they must be operating for the Connect:Direct CICS API to function.

The following components are required to use DMQ247.

| Component | Description                                           |
|-----------|-------------------------------------------------------|
| DMQ247    | The program source, written in assembly language      |
| DMQM98    | The BMS map used by DMQ247                            |
| DMQBMSTB  | A parsing macro used by DMQ247                        |
| DMQCA012  | A command-level COMMAREA passed to the CICS Interface |

A sample Connect:Direct API DRIVER screen follows. This screen shows data after the ESS registration program has signed on to the Connect:Direct CICS API driver and issued an EVENT SERVICES CREATE command.

```

CONNECT:Direct API DRIVER

COMMAND          EVENT SERVICES CREATE ID=MES00031 WHERE(MAXQCNT=998 LASTSEQ=1
                  STARTT=(02.14.2005,04:14:12.45) STOPT=(12.31.2041,24:00:00.00)
                  TYPE=(QE,QW,QH,QT,PI,CE,CT,PT,CI,RJ,RT,JI,TI,SW,DP) )

COMMAND RC       0000
COMMAND MSG ID   SOPM000I
COMMAND MSG      An EVENT REQUEST HAS COMPLETED NORMALLY
PROCESS NUMBER
TD EXIT COUNT
TS QUEUE NAME
TS MAX LRECL

EVENT RESTART DATA
WHERE(STARTT=(00000,00:00:00.00),LASTSEQ=000)

PF keys:  3 Exit   5 Signon  6 Command  7 Signoff

```

## Driver Fields

The following table describes the Driver fields:

| Field      | Description                                                            |
|------------|------------------------------------------------------------------------|
| COMMAND    | This 3-line field contains your API command.                           |
| COMMAND RC | This 4-character field contains the return code from your API Process. |

| Field              | Description                                                                                                                                                                                                                         |
|--------------------|-------------------------------------------------------------------------------------------------------------------------------------------------------------------------------------------------------------------------------------|
| COMMAND MSG ID     | This 8-character field contains the identification number of the message associated with your API Process.                                                                                                                          |
| COMMAND MSG        | This 64-character field contains the text of the message.                                                                                                                                                                           |
| PROCESS NUMBER     | This 6-character field contains the Process number assigned by the system to your API Process.                                                                                                                                      |
| TD EXIT COUNT      | This 6-character field contains the number of bytes indicating how much data is written by the exit module for your API Process.                                                                                                    |
| TS QUEUE NAME      | This 8-character field contains the name of the TS queue used during your API request.                                                                                                                                              |
| TS MAX LRECL       | This 4-character field contains the maximum logical record length in bytes of the TS queue.                                                                                                                                         |
| EVENT RESTART DATA | This 62-character field contains the DATE/TIME/SEQ of the last event record successfully received. Data is only displayed if an EVENT SERVICES CREATE command is issued and a previous event services request had ended abnormally. |

## Using the CICS API Option

To use the sample program, you must first change DMQ247 to issue a valid SIGNON command for your environment (the SIGNON command is defined near the end of the source module). Include a valid USERID, PASSWORD, and NODE. Before executing this program as a transaction, you must be signed on to CICS. Also observe the following items.

- ◆ Assemble DMQM98 and then DMQ247. Sample JCL is in the SAMPLIB. Assemble DMQM98 and DMQ247 as follows:
  - ◆ Use member ASMBMS to assemble DMQM98
  - ◆ Use member ASMCICS to assemble DMQ247
- ◆ Use the Connect:Direct Administrative (CDA) transaction to verify that the CICS Interface and the appropriate node are both active.
- ◆ Use transaction CDNC to get DMQM98 to display.
- ◆ The program checks for the presence of a communications area in the Exec Interface Block (EIB). If none is present, or if you press the **Clear** key, the DMQM98 map is sent and a RETURN TRANSID is performed to invoke the transaction again when you press **Enter**.
- ◆ If you pressed the **PF3** or **PF15** key, the program terminates.
- ◆ The DMQM98 map is received. If you pressed **PF5** or **PF17**, a Connect:Direct SIGNON request is generated and the results of the command are presented in the map.

- ◆ Following a successful signon (that is, the return code on DMQM98 after the SIGNON is zero), you can type a valid Connect:Direct command on the line provided in the DMQM98 map and press **PF6** or **PF18** to send the command to the Connect:Direct DTF. Command results are displayed when they are returned from the DTF.
- ◆ To signoff from the DTF, press **PF7** or **PF19**.

When you type a command through the DMQM98 screen, its length is determined and the address of the length and command are placed in the DMQCA012 communications area at label Q012CMDA. Program DMQ012 is then invoked through an EXEC CICS LINK command. When control returns to DMQ247, the DMQCA012 communications area contain the results of the command.

---

**Note:** The DMQ247 does not actually display the results of the issued command that are stored in CICS temporary storage. You can retrieve these records programmatically or view them using the CICS CEBR transaction.

---

Use the techniques in the DMQ247 sample program to issue any valid Connect:Direct command. Results of commands such as SELECT PROCESS and SELECT STATISTICS are written to CICS temporary storage; other commands can produce no output.

## Linking DMQ012

Access the API by linking program DMQ012 as follows.

```
EXEC CICS LINK PROGRAM('DMQ012') COMMAREA(Q012COMM)
      LENGTH(Q012CMLH) +
```

The COMMAREA Q012COMM is defined by macro DMQCA012 and is also provided in the sample library. A COBOL version of this record layout is provided as member DMQAPIC in the sample library. A brief description of each of the fields follows:

| Field    | Assembler Directive | Format | Description                                                                                                                                                                                                                                                        |
|----------|---------------------|--------|--------------------------------------------------------------------------------------------------------------------------------------------------------------------------------------------------------------------------------------------------------------------|
| Q012CMDA | DS                  | XL4    | Full word containing the address of the command to be issued to Connect:Direct. The command must be in the following format:<br>CMDLEN DS H<br>Length of CMDTEXT that Connect:Direct recognizes, not including length of CMDLEN.<br>CMDTEXT DS Cix<br>Command text |

| Field    | Assembler Directive | Format | Description                                                                                                                                                                                                                                                                              |
|----------|---------------------|--------|------------------------------------------------------------------------------------------------------------------------------------------------------------------------------------------------------------------------------------------------------------------------------------------|
| Q012RETC | DS                  | XL4    | Return code received after the command is invoked.<br>0: request completed successfully<br>1: C:D-CICS interface level error<br>2: C:D-CICS node level error<br>3: C:D-CICS signon level error<br>5: invalid COMMAREA or command passed to CICS API<br>8 and above: unsuccessful request |
| Q012TDCT | DS                  | XL4    | TDEXIT ITEM COUNT. The field contains the number of records received from the Connect:Direct DTF.                                                                                                                                                                                        |
| Q012TDMX | DS                  | XL2    | TDEXIT MAX ITEM SIZE - the maximum record size received from the Connect:Direct DTF.                                                                                                                                                                                                     |
| Q012PROC | DS                  | CL6    | Process number of the latest submitted Process.                                                                                                                                                                                                                                          |
| Q012TSKY | DS                  | CL8    | Temporary storage ID - the name of the CICS TS queue that contains the command output.                                                                                                                                                                                                   |
| Q012MSID | DS                  | CL8    | Message ID returned from the Connect:Direct for z/OS DTF.                                                                                                                                                                                                                                |
| Q012MSTX | DS                  | CL64   | Message Text returned from the Connect:Direct for z/OS DTF.                                                                                                                                                                                                                              |
| Q012DTE  | DS                  | PL4    | Date of the last event acknowledgment.                                                                                                                                                                                                                                                   |
| Q012TME  | DS                  | XL4    | Time of the last event acknowledgment.                                                                                                                                                                                                                                                   |
| Q012SEQ  | DS                  | XL2    | Sequence number of the last event acknowledgment.                                                                                                                                                                                                                                        |

Q012CMDA is the only required parameter you must set before linking to DMQ012. For optimum performance, follow the example of DMQ247 and initialize all fields before linking to DMQ012.

Any output generated by issuing the command is returned in a temporary storage queue. Your terminal ID is displayed as the last four characters in the unique TS queue name.

---

**Note:** DMQ012 requires that it run in CICS key. For the transaction that executes a program linking DMQ012, set the following parameters in the CEDA definitions (or in the RDO for that program):

TaskDataLoc:ANY

TaskDataKey:CICS

---

## Using LASTSEQ

All event records contain a unique timestamp that consists of date, time, and sequence number. Each EVENT SERVICES request is associated with an ID. The Connect:Direct CICS API creates a restart record for an ID when an EVENT SERVICES CREATE command is processed. After an

event record is successfully delivered to the Transient Data Queue, its timestamp is saved in the restart file. If event services processing ends abnormally, the restart record is retained. The restart record is also retained when you specify the `KEEPREC` (keep restart record) in the `EVENT START` statement.

When an `EVENT SERVICES CREATE` command is processed, the restart file is searched for a record matching the ID of the `CREATE`. If a match is found, the date, time, and sequence number of the last successfully delivered event record is returned. When you use the time specification in conjunction with the `LASTSEQ` parameter, you must include hours, minutes, seconds, and hundredths of seconds in the format `hh:mm:ss.th`.

If missed event data is required, you can use this information as the `STARTT` and `LASTSEQ` values as in the following example.

```
EVENT SERVICES START ID=id
WHERE (STARTT=(date,time) LASTSEQ=seq)
```

Event records beginning after this timestamp are processed.

---

## Reading an Event Record from the Transient Data Queue

The sample program `DMQ249` reads an ESS event record from the Transient Data queue. The sample program `DMQ249` is in `$CD.SAMPLIB`. You can use sample JCL `ASMCICS` to assemble `DMQ249`.

Each record passed to the user application consists of a record header and an event record. `DMMNHDR`, which is in the `Connect:Direct` sample library, maps the record header. Members in the sample library also map the event records. See Chapter 12, *Event Services Record Descriptions*, to determine which member maps a particular event record.



---

# Event Services Record Descriptions

ESS enables you to create ESS-enabled applications. This chapter provides reference information about event record types and attributes that help you create applications. For a list of statistics record types, refer to Chapter 10, *Using Connect:Direct Exits*, in the *Connect:Direct for z/OS Administration Guide*.

Assembler DSECT members are in the sample library. Access the information by the member names listed in the following table. Use the two-character designations for record types when you browse the Connect:Direct statistics file.

---

## Event Record Type Attributes

ESS has several statistics record types. This section summarizes the attributes of these record types.

Most record types have the following common attributes:

- ◆ Process name
- ◆ Process number
- ◆ Message ID
- ◆ Submitter's symbolic node name
- ◆ PNODE name for this Process
- ◆ SNODE name for this Process
- ◆ THISNODE (This node is P[node] or S[node].)

The following paragraphs detail the attributes of specific record types. For ease of reference, the information is grouped according to event type or enhancement type, and they are presented alphabetically.

## Event Record Types

Record type attributes for event records are described in the following paragraphs. The information is organized alphabetically by record type identifier.

**CI (COPY Step Initiation)**

This record is created immediately prior to the execution of any tasks associated with a COPY statement. The intent of this record is to capture the timing of such work as data set allocation prior to any I/O occurring. In addition to the common attributes, CI has the following individual attributes:

- COPY step start date/time
- Step name or label
- CI record retry count
- Transfer direction
- Source file name
- Destination file name
- Member name (when applicable)

**CE (COPY I/O Start)**

This record is created immediately prior to the first block of data transferred in a COPY statement. In addition to the common attributes, CE has the following individual attributes:

- COPY I/O start date/time
- Step name or label
- CE record retry count

**EI (Event Request Initiation)**

This record is created upon completion of a EVENT SERVICES START command.

---

**Note:** The common attributes for Process-related records do not apply to this record.

---

The following attributes apply to this event:

- Date/Time the command completed
- User ID of the user who issued the command
- Event services request ID
- Completion code for the command
- Command parameter string

**EL (Event Session Lost)**

This record is created when the Connect:Direct DTF is lost.

**ET (Event Request Stop)**

This record is created when an EVENT SERVICES STOP command completes.

---

**Note:** The common attributes for Process-related records do not apply to this record.

---

The following attributes apply to this event:

- Date/Time the command completed
- User ID of user who issued the command
- Event services request ID
- Completion code for the command

**JI (RUN JOB Start)**

This record is created immediately before the job specified by the RUN TASK statement is submitted. In addition to the common attributes, JI has the following individual attributes:

- RUN JOB start date/time
- Step name or label
- Job name
- JI record retry count

**QE (Process moved to EXEC queue)**

This record is created when a Process is moved to the execution queue. In addition to the common attributes, QE has the following individual attributes:

- Process execution start date/time
- QE record retry count

**PI (Process Initiation)**

This record is created immediately prior to when the first Process step is executed. In addition to the common attributes, PI has the following individual attributes:

- Queue change date/time
- Execution queue status value
- PI record retry count

**QH (Process moved to the HOLD queue)**

This record is created whenever a Process is moved to the Hold queue, either through some problem during Process execution or submission, a SUSPEND PROCESS command issued or a session failure. The reason for moving to the Hold queue is generally identified by the Hold queue status value. In addition to the common attributes, QH has the following individual attributes:

- Queue change date/time
- Hold queue status value
- QH record retry count

**QT (Process moved to the TIMER queue)**

This record is created whenever a Process is moved to the Timer queue, normally through a Process retry. In addition to the common attributes, QT has the following individual attributes:

- Queue change date/time
- Timer queue status value
- QT record retry count

**QW (Process moved to the WAIT queue)**

This record is created whenever a Process is moved to the Wait queue from the Hold or Timer queues. In addition to the common attributes, QW has the following individual attributes:

- Queue change date/time
- Wait queue status value
- QW record retry count

**TI (RUN TASK Initiation)**

This record is created immediately prior to the initiation of the task specified by the RUN TASK statement. In addition to the common attributes, TI has the following individual attributes:

- RUN TASK start date/time
- Step name or label
- Program name
- TI record retry count
- Date/time
- Process name and number
- Event name
- Event trigger
- Event type

## Event Record Enhancements

An enhancement to existing statistics records is described in the following paragraph.

**CT (COPY Termination) Record Enhancements**

The existing CT record is enhanced to include the following information:

- Total number of retries for the COPY step
- Total amount of data moved for all attempts of the COPY
- Type keywords specified in a COPY step to retrieve data set defaults for allocating the destination file

---

# Spool Transfer Facility

Connect:Direct Spool Transfer is an interface that enables you to transfer Job Entry Subsystem (JES) spool files in the following ways:

- ◆ Copy from JES Spool Files

The VPS/CDI option and the VPSSCDI program manage input from JES spool files. If a JES spool file is routed to a VPS printer owned by Connect:Direct, VPS copies the spool file to a disk file and invoke the Connect:Direct API to transfer the file within the Connect:Direct-defined network.

- ◆ Copy to JES Print Queues

Connect:Direct dynamically allocates a print file and writes the input file directly to the JES Spool.

- ◆ Copy to JES Reader Queues

Connect:Direct dynamically allocates an internal reader and writes the input file directly to the JES Reader.

For outbound transfers, this feature requires the following additional products from Levi, Ray & Schoup (LRS):

- ◆ VTAM Printer Support (VPS)
- ◆ VPS Connect:Direct Interface (VPS/CDI) Option

---

**Note:** For sending output to the JES reader, you do not need the VTAM Printer Support and VPS Connect:Direct Interface (VPS/CDI) Option components. See *Chapter 15, Transferring Data to the JES Reader or Spool*, for more information.

---

Connect:Direct Spool Transfer uses standard Connect:Direct facilities, which provide automation, reliability, management, interoperability, and security.

---

## Spool Transfer Components

The major components of Connect:Direct Spool Transfer are:

- ◆ VTAM Printer Support (VPS) System
- ◆ Application Program Interface (API)
- ◆ Data Transmission Facility (DTF)

The following diagram shows the relationship between these components. This chapter summarizes the function of each component.

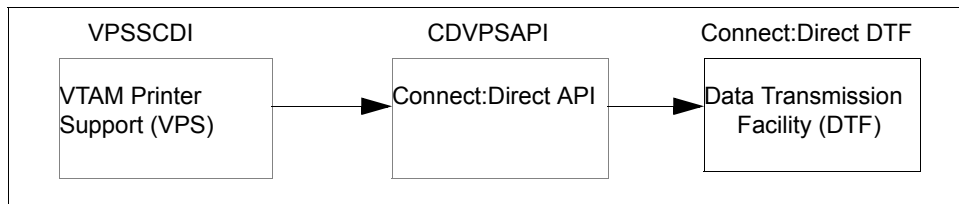

You implement Connect:Direct Spool Transfer by changing definitions in the VPS initialization. When a JES spool file is routed to a Connect:Direct virtual printer, VPS copies the spool file to disk and invokes Connect:Direct Spool Transfer to transfer the file within the Connect:Direct defined network.

## Receiving Spool Output

This chapter explains how VTAM Printer Support and the Connect:Direct API work together to distribute print files from JES Spool to Connect:Direct.

### VTAM Printer Support

Connect:Direct for z/OS uses VTAM Printer Support (VPS) to retrieve JES spool files for processing. Expansion of the VPS application includes Connect:Direct support for moving print files from the JES spool to any Connect:Direct node. The VPS module (VPSSCDI) directs spooled output from JES to the Connect:Direct API for file transfer.

The following diagram illustrates the flow of the print file through this process.

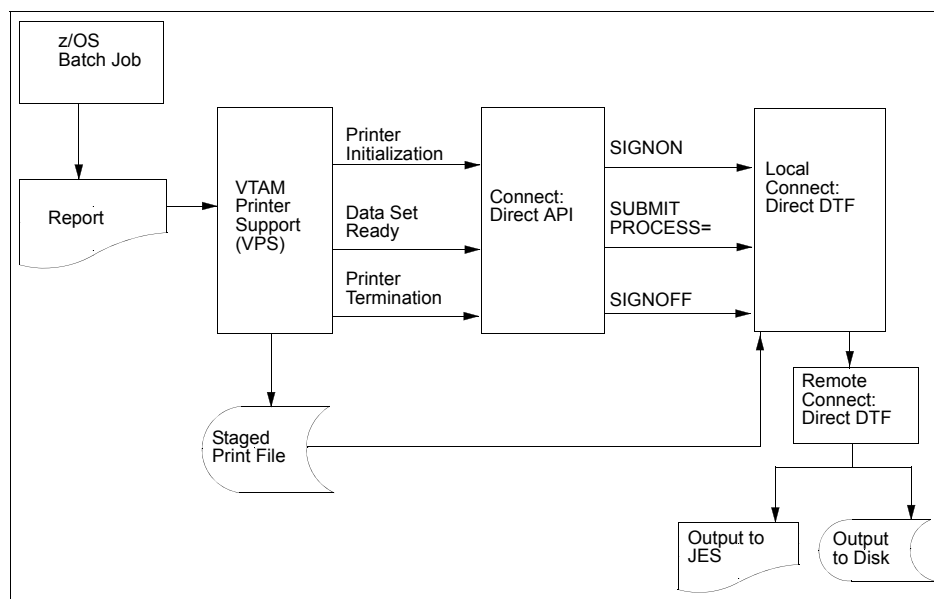

## System Control

VPS passes control to the Connect:Direct API at the following times:

- ◆ System initialization
- ◆ Printer initialization
- ◆ SYSOUT data set ready
- ◆ Printer termination
- ◆ System termination

You can change VPSSCDI to modify Connect:Direct control blocks prior to calling CDVPSAPI. Refer to *Customizing VPSSCDI* on page 120.

### System Initialization

When a JES spool file is routed to a Connect:Direct-defined printer, VPS first transfers control to the Connect:Direct API for printer initialization. This action causes the API to issue a SIGNON to the local DTF.

### Printer Initialization

Upon successful signon, VPS copies the print files to a disk file and passes this file to the Connect:Direct API.

### SYSOUT Data Set Ready

The Connect:Direct API then constructs a SUBMIT PROCESS command to pass printer attributes, data set name, and the submitter's user ID to the local DTF.

If the SUBMIT fails because the submitted Process could not be located or the specified SNODE is unavailable, the print file is returned to the JES print queue according to the values specified in the VPS printer requeue parameters. If the SUBMIT fails for any other reason, VPS deletes the staged data set, drains the Connect:Direct printer, and leaves the JES spool file in the JES queue for restart.

If the SUBMIT is successful, VPS releases ownership of the staged data set to Connect:Direct, and the JES spool file is removed from JES.

### Printer Termination

When no more JES files are printing to the Connect:Direct-defined printer, VPS calls the Connect:Direct API with a printer termination request.

### System Termination

The Connect:Direct API then sends a SIGNOFF command to the local DTF.



---

## Connect:Direct API

The Connect:Direct API (CDVPSAPI) communicates with the Data Transmission Facility through an application interface. CDVPSAPI signs on to the local DTF, submits a Process, and signs off of the local DTF.

### CDVPSAPI

The Connect:Direct module CDVPSAPI, part of the VPS interface, is distributed with Connect:Direct in SAMPLIB. This program is in source form so that you can assemble and link-edit when you install a new release of Connect:Direct VPS.

This program utilizes the VPS system log for reporting exception conditions and informational messages describing the Processes submitted to the local DTF. This log serves as one central point to determine the status of any print file controlled by VPS.

The CDVPSAPI program receives control from VPSSCDI and validates the function calls and control block fields passed by VPSSCDI. If a function executes successfully, the program returns a condition code of **0** (zero) to the VPSSCDI.

If a noncritical error occurs, CDVPSAPI returns a code of **4** to VPSSCDI to indicate that VPS requeues the print file according to VPS printer specifications.

If CDVPSAPI detects a critical error, it returns a code of **8** or greater, indicating that VPS can EDRAIN the printer.

A function call of PRINTER INITIALIZATION causes a SIGNON to be sent to the local DTF as defined in the network map specification for this printer.

A function call of DATA SET SYSOUT READY invokes the routines to validate the control blocks and build the Connect:Direct SUBMIT PROCESS command and send it to the local DTF.

A function call of PRINTER TERMINATION sends a SIGNOFF to the local DTF.

CDVPSAPI uses the Connect:Direct API interface module (DMCHLAPI) to communicate with the Data Transmission Facility.

### VPSSCDI

The VPS module VPSSCDI, the interface to Connect:Direct, is distributed as part of VPS. This program is in source form so that you can reassemble and link-edit it when you install a new release of VPS or Connect:Direct.

### Connect:Direct SIGNON

The SIGNON command uses the network map specification for the specified Connect:Direct printer.

If you do not have a network map override specified in the VPS printer definition table (CDNETMAP), the SIGNON command uses the DMNETMAP DD statement in the VPS startup JCL for the network map.

## SIGNON Security

The SIGNON command for CDVPSAPI does not pass a user id or password. If you are using the Stage 1 security exit, Connect:Direct extracts the user id associated with the VPS started task and puts the user id and a special password (assigned by the Stage 1 exit) into the UICB, a Connect:Direct user interface control block used for security.

If the Stage 1 processing is successful, the SIGNON command passes to the DTF, where the DTF Stage 2 security is invoked. The Stage 2 exit recognizes the special password, as assigned by the Stage 1 exit. All verification calls to the security system are by user id only.

If you are sending to a secured Connect:Direct, you can specify user id and password by adding the SNODEID specification to the Process. All Processes submitted by the VPS API have the security access level associated with the VPS job or started task, unless the security is overridden by PNODEID, SNODEID, and/or secure point-of-entry (SPOE) translation.

## Process Names

VPS print files are routed through the Connect:Direct network by specifying the SNODE keyword on the submitted Process. To provide flexibility, you can set up the VPS Connect:Direct printer either to submit a single Process name regardless of printer class or to submit a Process name with the printer output class appended to the name.

By appending the printer class to the name, one VPS/CDI printer can submit up to 36 different Process names, one for each printer class A–Z or 0–9. You can control the Process name being submitted with the VPS printer name and VPS printer definitions as follows:

- ◆ Define the CDSNODE in the VPS Printer Definition Table
- ◆ Define the CDPMBR in the VPS Printer Definition Table
- ◆ Use a VPS printer name of seven characters or less
- ◆ Use a VPS printer name of eight characters

This flexibility enables a VPS printer to submit Processes that send print files to one or more Connect:Direct SNODEs.

Use the following table to select the method that is best for your environment.

| Where to Code                   | Keyword | Requirements                                             | Results                                                       |
|---------------------------------|---------|----------------------------------------------------------|---------------------------------------------------------------|
| Use Default<br>(Do not code)    | None    | 1 to 7-character printer name                            | Process name is the VPS Printer name with the class appended. |
| Use Default<br>(Do not code)    | None    | 8-character printer name                                 | Process name is the VPS Printer name.                         |
| VPS Printer<br>Definition Table | CDSNODE | Value for CDSNODE<br>Process name specified in<br>CDPMBR | Process name is the printer name.<br>(Class is not appended.) |

| Where to Code                | Keyword           | Requirements                 | Results                                                                            |
|------------------------------|-------------------|------------------------------|------------------------------------------------------------------------------------|
| VPS Printer Definition Table | CDSNODE<br>CDPMBR | Value for CDSNODE and CDPMBR | Process name is the name specified in CDPMBR. (Class is not appended.)             |
| VPS Printer Definition Table | CDPMBR            | 8 characters                 | Process member name remains the same for all print files. (Class is not appended.) |
| VPS Printer Definition Table | CDPMBR            | Up to 7 characters           | Process name is the name specified in CDPMBR (Class is appended.)                  |

**Note:** Connect:Direct searches the Connect:Direct Process library for the Process name. You must define the Process names in the Process library.

For example, if you select CDPMBR=CDPROC and the output print class is **A**, Connect:Direct searches the Process library for the Process name of CDPROCA. If you select an output print class of **C** for the same printer, Connect:Direct searches for the Process name CDPROCC.

However, if you use an eight-character name such as CDPMBR=CDPROC01, the Process name for that printer is CDPROC01, regardless of the printer class.

## CDPROCES

The following sample Process is provided in the Install Process Library. This example shows all attributes that can pass from CDVPSAPI to the local Connect:Direct DTF in the SUBMIT statement. Any value of X'00' passed from VPS to CDVPSAPI is considered a null value, and the SUBMIT command does not pass the corresponding field to the Process. For example, if your printer output DD statement does not code COPIES, then the symbolic &COPIES is not passed in the SUBMIT command.

```

/* * * * * * * * * * * * * * * * * * * * * * * * * * * * * * * * * * */
/*
/*      C:D-ZOS JES SPOOL TRANSFER FACILITY SAMPLE PROCESS          */
/*
/*  CHANGE %CD.PROC TO THE Z/OS PROC LIBRARY THAT YOU HAVE        */
/*  INSTALLED THE PROC GENER INTO.  THE CONNECT:DIRECT           */
/*  INSTALLATION LOADED THIS MEMBER INTO YOUR                    */
/*  CONNECT:DIRECT PROCESS LIBRARY.                                */
/*
/* * * * * * * * * * * * * * * * * * * * * * * * * * * * * * * * * * */
CDPROCES PROC      SNODE=&SNODE,                -
                  &ADDR1=,                      /* ADDRESS LINE 1      */ -
                  &ADDR2=,                      /* ADDRESS LINE 1      */ -
                  &ADDR3=,                      /* ADDRESS LINE 1      */ -
                  &ADDR4=,                      /* ADDRESS LINE 1      */ -

```

Continued

```

&BLDG=,          /* BUILDING                */ -
&BURST=,        /* BURST=YES OR NO        */ -
&CHARS=,        /* CHAR ARRANGEMENT TABLE */ -
&CKPTL=,        /* CKPTLINE               */ -
&CKPTP=,        /* CKPTPAGE               */ -
&CKPTS=,        /* CKPTSEC                */ -
&CLASS=,        /* OUTPUT CLASS           */ -
&CMOD=,         /* COPY MODIFICATION MOD  */ -
&CMTTC=,        /* COPY MODULE TABLE REF */ -
&CNTL=,         /* DEFAULT SPACING        */ -
&COMPACT=,      /* COMPACTATION TABLE    */ -
&COPIES=,       /* OUTPUT NUMBER COPIES   */ -
&COPYG=,        /* COPY GROUP(S)          */ -
&DATCK=,        /* DATAK                  */ -
&DEFAULT=,      /* DEFAULT                 */ -
&DEPT=,         /* DEPARTMENT             */ -
&DEST=,         /* OUTPUT DESTINATION      */ -
&FCB=,          /* OUTPUT WTR FCB         */ -
&FLASH=,        /* FLASH FORMS OVERLAY    */ -
&FLSCT=,        /* FLASH FORMS OVERLAY CNT*/ -
&FMDEF=,        /* FORMDEF                 */ -
&FORM=,         /* OUTPUT FORM            */ -
&GROUPID=,     /* GROUPID                 */ -
&INDEX=,        /* INDEX                   */ -
&JACCT=,        /* JOB ACCOUNTING NUMBER  */ -
&JESDS=,        /* JESDS                   */ -
&JOBID=,        /* JES ASSIGNED JOB ID    */ -
&JOBNM=,        /* JOB NAME                */ -
&JPNAME=,      /* JOB PROGRAMMERS NAME   */ -
&JPROC=,        /* JOB PROC NAME           */ -
&JROOM=,        /* JOB PROGRAMMERS ROOM   */ -
&JSECL=,        /* SECURITY LABEL          */ -
&LINDEX=,       /* LININDEX                */ -
&LINECT=,      /* LINES PER PAGE         */ -
&NAME=,         /* NAME                    */ -
&NOTIFY1=,     /* 1ST NOTIFY ID         */ -
&NOTIFY2=,     /* 2ND NOTIFY ID         */ -
&NOTIFY3=,     /* 3RD NOTIFY ID         */ -
&NOTIFY4=,     /* 4TH NOTIFY ID         */ -
&OPTCD=,       /* OPTCD=J SPECIFIED     */ -
&PGDEF=,        /* PAGEDEF                 */ -
&PIMCT=,        /* PIMSG MSG-COUNT        */ -
&PIMSG=,        /* PIMSG                   */ -
&PRMODE=,      /* PRMODE                  */ -
&PRTY=,         /* PRTY                    */ -
&ROOM=,         /* ROOM                    */ -
&STEPDD=,      /* STEP DDNAME            */ -
&STEPNM=,      /* STEP NAME               */ -
&SUBNAME=,     /* SUBMITTERS NAME        */ -
&THRES=,       /* THRESHLD               */ -
&TITLE=,       /* TITLE                   */ -

```

Continued

```

&TRC=,          /* TRC                      */ -
&UCS=,          /* OUTPUT WTR UCS          */ -
&UDATA01=,     /* 1ST USERDATA           */ -
&UDATA02=,     /* 2ND USERDATA           */ -
&UDATA03=,     /* 3RD USERDATA           */ -
&UDATA04=,     /* 4TH USERDATA           */ -
&UDATA05=,     /* 5TH USERDATA           */ -
&UDATA06=,     /* 6TH USERDATA           */ -
&UDATA07=,     /* 7TH USERDATA           */ -
&UDATA08=,     /* 8TH USERDATA           */ -
&UDATA09=,     /* 9TH USERDATA           */ -
&UDATA10=,     /* 10TH USERDATA          */ -
&UDATA11=,     /* 11TH USERDATA          */ -
&UDATA12=,     /* 12TH USERDATA          */ -
&UDATA13=,     /* 13TH USERDATA          */ -
&UDATA14=,     /* 14TH USERDATA          */ -
&UDATA15=,     /* 15TH USERDATA          */ -
&UDATA16=,     /* 16TH USERDATA          */ -
&ULIB1=,       /* 1ST USERLIB LIBRARY    */ -
&ULIB2=,       /* 2ND USERLIB LIBRARY    */ -
&ULIB3=,       /* 3RD USERLIB LIBRARY    */ -
&ULIB4=,       /* 4TH USERLIB LIBRARY    */ -
&ULIB5=,       /* 5TH USERLIB LIBRARY    */ -
&ULIB6=,       /* 6TH USERLIB LIBRARY    */ -
&ULIB7=,       /* 7TH USERLIB LIBRARY    */ -
&ULIB8=,       /* 8TH USERLIB LIBRARY    */ -
&VPSDSN=,      /* VPS PRINTER STAGED DSN */ -
&WRITER=,      /* OUTPUT WRITER NAME     */ -
&WTR=,         /* OUTPUT WTR NAME (OLD)  */ -
&OUTDSN=&SUBNAME..&JOBNM..&JOBID..&STEPNM..&STEPDD
/* * * * * * * * * * * * * * * * * * * * * * * * * * * * * * * * * */
/* COPY FILE STAGED BY VPSSCDI                                     */
/* * * * * * * * * * * * * * * * * * * * * * * * * * * * * * * * * */
STEP01 COPY FROM(PNODE -
          DSN=&VPSDSN -
          DISP=SHR ) -
          CKPT=10M -
          COMPRESS EXT -
        TO(SNODE -
          DSN=&OUTDSN -
          DISP=(NEW,CATLG,DELETE) )
/* * * * * * * * * * * * * * * * * * * * * * * * * * * * * * * * * */
/* DELETE FILE STAGED BY VPSSCDI                                     */
/* * * * * * * * * * * * * * * * * * * * * * * * * * * * * * * * * */
STEP02 IF (STEP01 = 0) THEN
STEP03 RUN TASK (PGM=DMRTDYN -
          PARM=(C"ALLOC DSN=&VPSDSN,DISP=(OLD,DELETE) " -
          F'-1' -
          C"UNALLOC DSN=&VPSDSN"))
          EIF
/* * * * * * * * * * * * * * * * * * * * * * * * * * * * * * * * * */
/* EXECUTE PROC GENER TO PRINT THE OUTPUT FILE                       */
/* * * * * * * * * * * * * * * * * * * * * * * * * * * * * * * * * */
STEP04 RUN TASK (PGM=DMRTSUB -
          PARM=("DSN=$CD.PROC(Gener),DISP=SHR", -
          "ADDR1 &ADDR1", -
          "ADDR2 &ADDR2", -
          "ADDR3 &ADDR3", -
          "ADDR4 &ADDR4", -
          "BLDG &BLDG", -

```

Continued

|          |            |   |
|----------|------------|---|
| "BURST   | &BURST",   | - |
| "CHARS   | &CHARS",   | - |
| "CKPTL   | &CKPTL",   | - |
| "CKPTP   | &CKPTP",   | - |
| "CKPTS   | &CKPTS",   | - |
| "CLASS   | &CLASS",   | - |
| "CMOD    | &CMOD",    | - |
| "CMTTC   | &CMTTC",   | - |
| "CNTL    | &CNTL",    | - |
| "COMPACT | &COMPACT", | - |
| "COPIES  | &COPIES",  | - |
| "COPYG   | &COPYG",   | - |
| "DATCK   | &DATCK",   | - |
| "DEFAULT | &DEFAULT", | - |
| "DEPT    | &DEPT",    | - |
| "DEST    | &DEST",    | - |
| "FCB     | &FCB",     | - |
| "FLASH   | &FLASH",   | - |
| "FLSCT   | &FLSCT",   | - |
| "FMDEF   | &FMDEF",   | - |
| "FORM    | &FORM",    | - |
| "GROUPID | &GROUPID", | - |
| "INDEX   | &INDEX",   | - |
| "INPUT   | &OUTDSN",  | - |
| "JACCT   | &JACCT",   | - |
| "JESDS   | &JESDS",   | - |
| "JOBID   | &JOBID",   | - |
| "JOBNM   | &JOBNM",   | - |
| "JPNAME  | &JPNAME",  | - |
| "JPROC   | &JPROC",   | - |
| "JROOM   | &JROOM",   | - |
| "JSECL   | &JSECL",   | - |
| "LINDEX  | &LINDEX",  | - |
| "LINECT  | &LINECT",  | - |
| "NAME    | &NAME",    | - |
| "NOTIFY1 | &NOTIFY1", | - |
| "NOTIFY2 | &NOTIFY2", | - |
| "NOTIFY3 | &NOTIFY3", | - |
| "NOTIFY4 | &NOTIFY4", | - |
| "OPTCD   | &OPTCD",   | - |
| "PGDEF   | &PGDEF",   | - |
| "PIMCT   | &PIMCT",   | - |
| "PIMSG   | &PIMSG",   | - |
| "PRMODE  | &PRMODE",  | - |
| "PRTY    | &PRTY",    | - |
| "ROOM    | &ROOM",    | - |
| "STEPDD  | &STEPDD",  | - |
| "STEPNM  | &STEPNM",  | - |
| "SUBNAME | &SUBNAME", | - |
| "THRES   | &THRES",   | - |
| "TITLE   | &TITLE",   | - |
| "TRC     | &TRC",     | - |
| "UCS     | &UCS",     | - |
| "UDATA01 | &UDATA01", | - |
| "UDATA02 | &UDATA02", | - |
| "UDATA03 | &UDATA03", | - |

Continued

```

"UDATA04  &UDATA04",      -
"UDATA05  &UDATA05",      -
"UDATA06  &UDATA06",      -
"UDATA07  &UDATA07",      -
"UDATA08  &UDATA08",      -
"UDATA09  &UDATA09",      -
"UDATA10  &UDATA10",      -
"UDATA11  &UDATA11",      -
"UDATA12  &UDATA12",      -
"UDATA13  &UDATA13",      -
"UDATA14  &UDATA14",      -
"UDATA15  &UDATA15",      -
"UDATA16  &UDATA16",      -
"ULIB1    &ULIB1",        -
"ULIB2    &ULIB2",        -
"ULIB3    &ULIB3",        -
"ULIB4    &ULIB4",        -
"ULIB5    &ULIB5",        -
"ULIB6    &ULIB6",        -
"ULIB7    &ULIB7",        -
"ULIB8    &ULIB8",        -
"VPSDSN   &VPSDSN",      -
"WRITER   &WRITER",      -
"WTR      &WTR",         -
)) SNODE
EXIT

```

## GENER

The following sample JCL is provided in the Install Process Library. This example is the GENER job that is submitted by DMRTSUB in STEP 04 of the preceding Process example. Because it runs on the SNODE, it shows how you can print files back into the JES spool at the remote site.

If Connect:Direct Spool Transfer is enabled at the remote site, you can use Connect:Direct to transfer output back into the JES spool. Refer to *Sending Output to the JES Reader* on page 124.

```

//&JOBNM    JOB (00000), &PGMR, PRTY=12, TIME=(10),
//REGION=4096K, MSGLEVEL=(1,1), MSGCLASS=X
//*
//STEP01   EXEC PGM=IEBGENER
//SYSPRINT DD SYSOUT=*
//SYSIN    DD DUMMY
//SYSUT1   DD DSN=&INPUT,
//          DISP=(OLD,DELETE,KEEP)
//SYSUT2   DD SYSOUT=&CLASS, COPIES=&COPIES, DEST=&DEST
//

```

---

**Caution:** When you use this JCL to test your own VPS, a print loop can occur if you use the symbolic &DEST on the same VPS system from which you submitted the print job.

---

---

## Symbolic Definitions

This section identifies the parameters that can be passed to the Process submitted by the Connect:Direct API.

### Job and Jobstep Values

The following table lists the job and jobstep values.

| Parameter | Definition                             |
|-----------|----------------------------------------|
| &JACCT    | Job accounting number                  |
| &JOBID    | JOB ID assigned by JES                 |
| &JOBNM    | JOB name                               |
| &JPNAME   | Name of the programmer                 |
| &JPROC    | Procedure name                         |
| &JROOM    | Room number of the programmer          |
| &JSECL    | Security label                         |
| &STEPDD   | DD name of the print file DD statement |
| &STEPNM   | Process step name                      |
| &SUBNAME  | User ID of the submitter               |
| &VPSSDSN  | Printer staged data set                |

### Printer File Attributes

Refer to *SYSOUT Keyword* on page 129 for the available parameters and associated symbolic names for print file attributes passed by the VPSSCDI interface program. Any non-zero attributes for a printer file cause the corresponding symbolic name to be generated on the SUBMIT command created by the Connect:Direct interface program, CDVPSAPI. You can reference these symbolic names in the Connect:Direct Process you are submitting.

---

## Customizing VPSSCDI

VPSSCDI creates the control blocks that the Connect:Direct API uses to build the SIGNON, SUBMIT, and SIGNOFF commands. Any customized validation or modification to the Connect:Direct control blocks is done at this point.



You can change printer values to reflect the destination environment. For example, you can change the destination name to a printer name at your location.

You can perform security or usage validation by validating any fields and either continuing the processing or returning to VPS with the appropriate return code settings.

The VPS return code settings are:

- ◆ RC=00 Normal execution continues.
- ◆ RC=04 Print file is requeued per VPS printer specifications.
- ◆ RC=08 The printer is EDRAINed.

---

**Note:** Do not change VPS control blocks.

---



---

# Transferring Data to the JES Reader or Spool

Connect:Direct Spool Transfer enables you to transfer data from any Connect:Direct node to the JES reader or the JES spool. You can route job control language (JCL) statements to the JES reader or output files to the JES spool.

This chapter explains how to use Connect:Direct Spool Transfer to transfer data to the JES reader.

---

## Using the JES Reader or Spool

By transferring data to the JES reader, any Connect:Direct node can send z/OS JCL to the JES reader. Unlike the Connect:Direct RUN JOB, this feature enables z/OS JCL to reside at the location executing the Process on any media that Connect:Direct supports.

The RUN JOB Security Exit, which provides a standard interface for security verification of job streams before they are submitted, is fully supported. For additional information on the RUN JOB Security Exit, see the *Implementing Security* chapter in the *Connect:Direct for z/OS Administration Guide*.

### Dynamic Allocation

Connect:Direct Spool Transfer uses dynamic allocation (SVC 99) to allocate the JES spool file. You can also use the OUTADD and OUTDEL macros to allocate an OUTPUT DD reference statement dynamically.

### Checkpoint/Restart

Connect:Direct Spool Transfer supports the checkpoint/restart facility of Connect:Direct. Connect:Direct takes a checkpoint at the *top of form* of the page printed after the checkpoint interval. *Top of form* is one of the following:

- ◆ X'F1' for ASA carriage control
- ◆ X'8B' for machine carriage control
- ◆ LINECT (line count) if NOCC or the TOF=X'xx' is specified in the Process

## Banner Page

You can print a Connect:Direct banner page at the beginning of each print report. For information on how to use this feature, refer to *Connect:Direct Banners* on page 125.

---

## Sending Output to the JES Reader

Use Connect:Direct syntax to transfer data to the JES reader. To initiate this transfer, specify the keyword, `READER`, in the `COPY TO` Process statement for Connect:Direct nodes that have enabled Spool transfer. Keyword and parameter definitions are in the section, *Connect:Direct Syntax* on page 128.

Some older releases of Connect:Direct do not support the `READER` keyword. Use the `SYSOPTS` parameter `OUTPUT=READER` for such nodes. Keyword and parameter definitions are in *Connect:Direct Syntax* on page 128.

## Examples

You can adapt the following Process language examples to output JCL into the JES reader. These examples are in the Sample Library.

### Using the `READER` Keyword

The following sample Process (`CDTORDR2`) uses the `READER` keyword to output JCL into the JES reader.

```

CDTORDR2 PROCESS      SNODE=xx.xxx.xxxxxx      -
STEP01  COPY FROM(PNODE      -
                DSN=SAMPLE.JCL.LIB(JCL)      -
                DISP=SHR      -
                )      -
                TO(SNODE      -
                READER      -
                )
EXIT

```

## Using the SYSOPTS

The following sample Process (CDTORDR1) uses SYSOPTS to output JCL into the JES reader.

```

CDTORDR1  PROCESS  SNODE=xx.xxxx.xxxxxx      -
STEP01    COPY FROM(PNODE                    -
          DSN=SAMPLE.JCL.LIB(JCL)          -
          DISP=SHR                          -
        )                                    -
          TO(SNODE                            -
          DSN=NULLFILE                      -
          DISP=RPL                          -
          SYSOPTS="OUTPUT=READER"          -
        )
EXIT

```

---

## Sending Output to JES Spool Files

You can also use Connect:Direct syntax to direct files transferred through Connect:Direct directly to the JES2/JES3 spool.

Copying a file into the JES spool is controlled through the SYSOUT=(...,...) keyword on the COPY TO Process statement. Keyword and parameter definitions are in *Connect:Direct Syntax* on page 128.

You can specify all keywords available on the z/OS JCL SYSOUT DD statement within the Connect:Direct SYSOUT=(...) Process keyword. The format of all subparameters within the Connect:Direct SYSOUT=(...) follows the rules in the *OS/390 JCL Reference Guide* for that keyword.

---

**Note:** You cannot use SYSOUT=class because the Connect:Direct feature *requires* that you specify all subparameters within parentheses. Refer to page 127 for examples using this keyword.

---



---

## Connect:Direct Banners

You can print a Connect:Direct banner page at the beginning of each print report. If you selected the checkpoint/restart option for the file transfer, the word RESTARTED is added to the banner page during restart.

Select this option by coding the BANNER=(...) subparameter of the SYSOUT=(...) Process keyword. Banner values are supplied in pairs of literal = value. One banner line is printed for each supplied pair. Keyword and parameter definitions are in *Connect:Direct COPY Process* on page 127.

If the value contains a character other than 0–9 or A–Z, you must enclose it in quotation marks. For example, PROGRAMMER=John Doe must be specified as PROGRAMMER="John Doe". JOBNAME=OS/400 must be specified as JOBNAME="OS/400".

You can use literals of 1–25 characters. Literals longer than 25 characters are truncated. Values can be 1–30 characters. Values longer than 30 characters are truncated. If the literal or value contains a character other than 0–9 or A–Z, you must enclose it in quotation marks.

In the following example, three banner data lines are printed. JUNK is ignored because it is not paired with a value.

```
BANNER= (PROGRAMMER=&JPNAME, JOBNAME=&JOBNM,           -
          SUBMITTER=&SUBNAME, STEPNAME=&STEPNM,         -
          DDNAME=&STEPDD, JUNK)
```

Assuming that the symbolics are set to the values defined previously, the following example is generated.

```
***** C O N N E C T : D I R E C T *****
***** C O N N E C T : D I R E C T *****
***** C O N N E C T : D I R E C T *****
***** C O N N E C T : D I R E C T *****
****  PROGRAMMER          JOHN DOE          ****
****  JOBNAME             JOHN1X           ****
****  SUBMITTER           JOHN1            ****
****  STEPNAME            STEP1            ****
****  DDNAME              SYSUT2           ****
***** C O N N E C T : D I R E C T *****
***** C O N N E C T : D I R E C T *****
***** C O N N E C T : D I R E C T *****
***** C O N N E C T : D I R E C T *****
```

## Banner After Restart

The following example illustrates the banner that prints if the job is restarted.

```
***** C O N N E C T : D I R E C T *****
***** C O N N E C T : D I R E C T *****
***** C O N N E C T : D I R E C T *****
***** C O N N E C T : D I R E C T *****
*****          R E S T A R T E D          *****
****  PROGRAMMER          JOHN DOE          ****
****  JOBNAME             JOHN1X           ****
****  SUBMITTER           JOHN1            ****
****  STEPNAME            STEP1            ****
****  DDNAME              SYSUT2           ****
*****          R E S T A R T E D          *****
***** C O N N E C T : D I R E C T *****
***** C O N N E C T : D I R E C T *****
***** C O N N E C T : D I R E C T *****
***** C O N N E C T : D I R E C T *****
```

## Connect:Direct COPY Process

The Connect:Direct COPY Process controls the printing of the output data set by specifying key values within the new Process keyword SYSOUT=(...) or by using the SYSOPTS=(SYSOUT=(...)) for platforms other than z/OS.

### Examples

The following sample Process shows the simplest form of a COPY Process. SYSOUT=A is not a valid value in this example. You must put all subparameters in parentheses, and you must set CLASS to the output class assigned to the print file.

```

TESTP  PROCESS  SNODE=
STEP01 COPY     FROM (DSN=NAME, DISP=SHR)           -
                        TO (SYSOUT= (CLASS=A)         -
                            )
                        )
END
```

The next example is an alternative way to code the same Process. In this example, the CLASS= parameter is not required because of the additional parentheses in the first parenthetical group of the SYSOUT keyword. This example corresponds to the syntax of the SYSOUT DD statement.

```

TESTP  PROCESS  SNODE=
STEP01 COPY     FROM (DSN=NAME, DISP=SHR)           -
                        TO (SYSOUT= ((A, writer-name, form-name), ...) -
                            )
                        )
END
```

The following example uses the SYSOUT= keyword and its subparameters within the SYSOPTS keyword.

```

TESTP  PROCESS  SNODE=
STEP01 COPY     FROM (DSN=NAME, DISP=SHR)           -
                        TO (DSN=NULLFILE            -
                            SYSOPTS="(SYSOUT= (CLASS=A) )" -
                            )
                        )
END
```

### Carriage Control

The input file DCB RECFM specification determines carriage control. If RECFM is VA, VBA, FA, FBA, or UA, ASA carriage control is assigned (ASA is also the default). If RECFM is VM, VBM, FM, FBM, or UM, then machine carriage control is assigned.

You can optionally override the specification by defining the NOCC, LINECT, and TOF parameters in the SYSOUT keyword CC=. Keyword and parameter definitions are in the following section, *Connect:Direct Syntax* on page 128.

The following example shows how to override carriage control specifications.

```

TESTP   PROCESS  SNODE=
STEP01  COPY     FROM (DSN=NAME, DISP=SHR)           -
                                     TO (SYSOUT=(CLASS=A,   -
                                     CC=(NOCC, LINECT=n, TOF=x 'F1' ) ) -
                                     )
END

```

## Connect:Direct Syntax

All keywords and parameters of the COPY TO statement that support Spool Transfer are defined in this section. The table provided in the Symbolics Definitions section identifies where the parameters of the SYSOUT=(...) keyword are documented. For detailed information on other keywords and parameters, see the Connect:Direct Processes Web site at <http://www.sterlingcommerce.com/Documentation/processes/processhome.html>.

| Keyword                                                            | Description                                                                                                                                                                                                                                                                                                                                                                                                                                                                                                                                                                                                                                                                                                                                                                             |
|--------------------------------------------------------------------|-----------------------------------------------------------------------------------------------------------------------------------------------------------------------------------------------------------------------------------------------------------------------------------------------------------------------------------------------------------------------------------------------------------------------------------------------------------------------------------------------------------------------------------------------------------------------------------------------------------------------------------------------------------------------------------------------------------------------------------------------------------------------------------------|
| READER                                                             | Specifies the output data set that is directed to the JES reader.                                                                                                                                                                                                                                                                                                                                                                                                                                                                                                                                                                                                                                                                                                                       |
| SYSOUT=(...)                                                       | Controls the printing of the output data set.                                                                                                                                                                                                                                                                                                                                                                                                                                                                                                                                                                                                                                                                                                                                           |
| BANNER=<br>(‘literal 1’ = value1[, ‘literal 2’ =<br>value2[,...]]) | Specifies the banner values in pairs of literal = value. One banner line is printed for each supplied pair. A literal without a corresponding value is ignored.<br><br>You can use literals of 1–25 characters. Literals greater than 25 characters are truncated. You can use a value size of 1–30 characters. Values greater than the 30 characters are truncated.<br><br>If the name or value contains a character other than 0–9 or A–Z, you must enclose it in quotation marks.                                                                                                                                                                                                                                                                                                    |
| CC=( <u>A</u>   <u>M</u>  NOCC LINECT= <u>n</u>  TOF= <u>x</u> )   | Overrides carriage control supplied by the input file DCB RECFM.<br><b>A</b> (for ASA) is assigned if RECFM is VA, VBA, FA, FBA, or UA. It is also the default if carriage control is not specified.<br><b>M</b> (for machine) is assigned if RECFM is VM, VBM, FM, FBM, or UM.<br><b>NOCC</b> identifies the file as having no carriage control. If you specify NOCC, you must also specify LINECT and TOF.<br><b>LINECT=<u>nnn</u></b> identifies the number of lines printed per page. The default is <b>55</b> .<br><b>TOF=<u>X’F1’</u></b> identifies the hex character that is inserted in the print line at the interval specified in the LINECT parameter. The hex character specified by the TOF parameter indicates to skip to the top of form. The default is <b>X’F1’</b> . |
| SYSOPTS=“...”                                                      | <b>OUTPUT=READER</b> specifies that the output data set is directed to the JES reader.<br><b>SYSOUT=(class=<u>class</u>)(class,<u>writer-name</u>,<u>form-name</u>)</b> specifies that the output data set is directed to the JES spool files on platforms other than z/OS.                                                                                                                                                                                                                                                                                                                                                                                                                                                                                                             |



---

## Symbolic Definitions

This section lists the parameters that you can pass to JES from the Connect:Direct API.

### SYSOUT Keyword

The following table lists the subparameter fields for the SYSOUT keyword. The table identifies the format for the parameter, the VPS symbolic name, and identifies where the parameter is documented.

The *As Documented by* column states where you can find additional information about the parameters. *Spool Transfer* indicates that the parameter is documented in this book. References to JCL parameters indicate that additional information is available in the JCL documentation.

| Parameter | Format                                                        | VPS Symbolic Name           | As Documented by       |
|-----------|---------------------------------------------------------------|-----------------------------|------------------------|
| ADDRESS=  | ('address line1',address line2',address line3, address line4) | &ADDR1,&ADDR2,&ADDR3,&ADDR4 | SYSOUT DD              |
| BANNER=   | ('literal 1' = value1, 'literal 2' = value2,...)              |                             | Spool Transfer         |
| BUILDING= | 'building identification'                                     | &BLDG                       | OUTPUT DD              |
| BURST=    | Yes or No                                                     | &BURST                      | OUTPUT DD & SYSOUT DD  |
| CC=       | ASA or Machine or NOCC                                        |                             | Spool Transfer         |
| CHARS=    | (tablename,tablename...)                                      | &CHARS                      | OUTPUT DD & SYSOUT DD  |
| CKPTLINE= | nnnnn                                                         | &CKPTL                      | OUTPUT DD              |
| CKPTPAGE= | nnnnn                                                         | &CKPTP                      | OUTPUT DD              |
| CKPTSEC=  | nnnnn                                                         | &CKPTS                      | OUTPUT DD              |
| CLASS=    | class                                                         | &CLASS                      | OUTPUT DD              |
| COMPACT=  | compaction-table-name                                         | &COMPACT                    | OUTPUT DD              |
| COMSETUP= | name                                                          |                             | OUTPUT DD              |
| CONTROL=  | PROGRAM<br>SINGLE<br>DOUBLE<br>TRIPLE                         | &CNTL                       | OUTPUT DD              |
| COPIES=   | nnn<br>(,(group value,group value,...))                       | &COPIES<br>&COPYG           | SYSOUT DD<br>OUTPUT DD |

| <b>Parameter</b> | <b>Format</b>                                | <b>VPS Symbolic Name</b> | <b>As Documented by</b>  |
|------------------|----------------------------------------------|--------------------------|--------------------------|
| DATAACK=         | BLOCK<br>UNBLOCK<br>BLKCHAR<br>BLKPDS        | &DATCK                   | OUTPUT DD                |
| DEFAULT=         | Yes or No                                    | &DEFAULT                 | OUTPUT DD                |
| DEPT=            | 'department identification'                  | &DEPT                    | OUTPUT DD                |
| DEST=            | destination<br>(nodename,userid)             | &DEST                    | SYSOUT DD &<br>OUTPUT DD |
| DPAGELBL=        | Yes or No                                    |                          | OUTPUT DD                |
| FCB=             | fcb-name<br>(fcb-name,align   verify)        | &FCB                     | SYSOUT DD &<br>OUTPUT DD |
| FLASH=           | (overlay-name,count)<br>(,count)             | &FLASH<br>&FLSCT         | SYSOUT DD &<br>OUTPUT DD |
| FORMDEF=         | membername                                   | &FMDEF                   | OUTPUT DD                |
| FORMS=           | form-name                                    | &FORM                    | OUTPUT DD                |
| GROUPIX=         | output-group                                 | &GROUPIX                 | OUTPUT DD                |
| HOLD=            | Yes or No                                    |                          | SYSOUT DD                |
| INDEX=           | nn                                           | &INDEX                   | OUTPUT DD                |
| JESDS=           | ALL<br>JCL<br>LOG<br>MSG                     | &JESDS                   | OUTPUT DD                |
| JOBNAME=         | job name                                     | &JOBNM                   | Spool Transfer           |
| LINDEX           | nn                                           | &LINDEX                  | OUTPUT DD                |
| LINECT=          | nnn                                          | &LINECT                  | OUTPUT DD                |
| MODIFY=          | module-name<br>(module-name,trc)             | &CMOD<br>&CMTTC          | SYSOUT DD &<br>OUTPUT DD |
| NAME=            | name of output separator                     | &NAME                    | OUTPUT DD                |
| NOTIFY=          | node.userid<br>(node.userid,node.userid,...) | &NOTIFY1-4               | OUTPUT DD                |
| OPTJ=            | Yes or No                                    | &OPTCD                   | Spool Transfer           |
| OUTBIN=          | nnnnn                                        |                          | OUTPUT DD                |
| OUTDISP=         | (normal,abnormal)                            |                          | OUTPUT DD                |
| OUTPUT=          | (reference)                                  |                          | SYSOUT DD                |

| <b>Parameter</b> | <b>Format</b>                                              | <b>VPS Symbolic Name</b>   | <b>As Documented by</b> |
|------------------|------------------------------------------------------------|----------------------------|-------------------------|
| PAGEDEF=         | membername                                                 | &PGDEF                     | OUTPUT DD               |
| PIMSG=           | (yes,msg-count)<br>(no,msg-count)                          | &PIMSG<br>&PIMCT           | OUTPUT DD               |
| PRMODE=          | line<br>page<br>process-mode                               | &PRMODE                    | OUTPUT DD               |
| PRTY=            | nnn                                                        | &PRTY                      | OUTPUT DD               |
| ROOM=            | 'room identification'                                      | &ROOM                      | OUTPUT DD               |
| SYSAREA=         | Yes<br>No                                                  |                            | OUTPUT DD               |
| SYSOUT=          | (class)<br>(class,writer-name,<br>form-name)               | &CLASS<br>&WRITER<br>&FORM | SYSOUT DD               |
| THRESHLD=        | nnnnnnnn                                                   | &THRES                     | OUTPUT DD               |
| TITLE=           | 'description of output'                                    | &TITLE                     | OUTPUT DD               |
| TOF=             | X'F1'                                                      |                            | Spool Transfer          |
| TRC=             | Yes<br>No                                                  | &TRC                       | OUTPUT DD               |
| UCS=             | character-set-code<br>(character-set-code,fold,<br>verify) | &UCS                       | OUTPUT DD<br>SYSOUT DD  |
| USERDATA=        | ('user data description',<br>'user data description',...)  | &UDATA01-16                | OUTPUT DD               |
| USERLIB=         | ('library name 1',<br>'library name 2',...)                | &ULIB1-8                   | OUTPUT DD               |
| WRITER=          | name                                                       | &WRITER                    | OUTPUT DD               |

## Sample Process (CDTOJES)

The following sample Process shows all attributes that you can specify within the SYSOUT=(...) keyword. This sample Process is provided in the Sample Library.

```

/* * * * * * * * * * * * * * * * * * * * * * * * * * * * * * * * * * * * * * * * * */
/*                                                                                               */
/*           * * *   S A M P L E   P R O C E S S   * * *                                       */
/*                                                                                               */
/*           C:D-ZOS JES SPOOL TRANSFER FACILITY SAMPLE PROCESS                               */
/*           INPUT FROM JES SPOOL TRANSFER FACILITY                                         */
/*           OUTPUT TO VPS CONTROLLED PRINTER                                              */
/*                                                                                               */
/* * * * * * * * * * * * * * * * * * * * * * * * * * * * * * * * * * * * * * * * * */
CDTOJES  PROC  SNODE=&SNODE,
&ADDR1=,    /* ADDRESS LINE 1          */ -
&ADDR2=,    /* ADDRESS LINE 1          */ -
&ADDR3=,    /* ADDRESS LINE 1          */ -
&ADDR4=,    /* ADDRESS LINE 1          */ -
&BLDG=,     /* BUILDING                */ -
&BURST=,    /* BURST=YES OR NO        */ -
&CHARS=,    /* CHAR ARRANGEMENT TABLE */ -
&CKPTL=,    /* CKPTLINE                */ -
&CKPTP=,    /* CKPTPAGE                */ -
&CKPTS=,    /* CKPTSEC                 */ -
&CLASS=,    /* OUTPUT CLASS            */ -
&CMOD=,     /* COPY MODIFICATION MOD   */ -
&CMTTC=,    /* COPY MODULE TABLE REF  */ -
&CNTRL=,    /* DEFAULT SPACING         */ -
&COMPACT=,  /* COMPACTATION TABLE     */ -
&COPIES=,   /* OUTPUT NUMBER COPIES   */ -
&COPYG=,    /* COPY GROUP(S)           */ -
&DATCK=,    /* DATAACK                 */ -
&DEFAULT=,  /* DEFAULT                  */ -
&DEPT=,     /* DEPARTMENT              */ -
&DEST=,     /* OUTPUT DESTINATION      */ -
&FCB=,      /* OUTPUT WTR FCB         */ -
&FLASH=,    /* FLASH FORMS OVERLAY    */ -
&FLSCT=,    /* FLASH FORMS OVERLAY CNT*/ -
&FMDEF=,    /* FORMDEF                 */ -
&FORM=,     /* OUTPUT FORM             */ -
&GROUPID=,  /* GROUPID                 */ -
&INDEX=,    /* INDEX                   */ -
&JACCT=,    /* JOB ACCOUNTING NUMBER   */ -
&JESDS=,    /* JESDS                   */ -
&JOBID=,    /* JES ASSIGNED JOB ID    */ -
&JOBNM=,    /* JOB NAME                */ -
&JPNAME=,   /* JOB PROGRAMMERS NAME   */ -
&JPROC=,    /* JOB PROC NAME           */ -
&JROOM=,    /* JOB PROGRAMMERS ROOM   */ -
&JSECL=,    /* SECURITY LABEL          */ -

```

*Continued*

```

&LINDEX=,          /* LINDEX                */ -
&LINECT=,          /* LINES PER PAGE        */ -
&NAME=,            /* NAME                   */ -
&NOTIFY1=,         /* 1ST NOTIFY ID         */ -
&NOTIFY2=,         /* 2ND NOTIFY ID         */ -
&NOTIFY3=,         /* 3RD NOTIFY ID         */ -
&NOTIFY4=,         /* 4TH NOTIFY ID         */ -
&OPTCD=,           /* OPTCD=J SPECIFIED     */ -
&PGDEF=,           /* PAGEDEF                */ -
&PIMCT=,           /* PIMSG MSG-COUNT       */ -
&PIMSG=,           /* PIMSG                  */ -
&PRMODE=,          /* PRMODE                 */ -
&PRTY=,            /* PRTY                   */ -
&ROOM=,            /* ROOM                   */ -
&STEPDD=,          /* STEP DDNAME            */ -
&STEPNM=,          /* STEP NAME              */ -
&SUBNAME=,         /* SUBMITTERS NAME       */ -
&THRES=,           /* THRESHLD              */ -
&TITLE=,           /* TITLE                  */ -
&TOF=X'F1',        /* ASA TOP OF FORM       */ -
&TRC=,             /* TRC                    */ -
&UCS=,             /* OUTPUT WTR UCS        */ -
&UDATA01=,         /* 1ST USERDATA          */ -
&UDATA02=,         /* 2ND USERDATA          */ -
&UDATA03=,         /* 3RD USERDATA          */ -
&UDATA04=,         /* 4TH USERDATA          */ -
&UDATA05=,         /* 5TH USERDATA          */ -
&UDATA06=,         /* 6TH USERDATA          */ -
&UDATA07=,         /* 7TH USERDATA          */ -
&UDATA08=,         /* 8TH USERDATA          */ -
&UDATA09=,         /* 9TH USERDATA          */ -
&UDATA10=,         /* 10TH USERDATA         */ -
&UDATA11=,         /* 11TH USERDATA         */ -
&UDATA12=,         /* 12TH USERDATA         */ -
&UDATA13=,         /* 13TH USERDATA         */ -
&UDATA14=,         /* 14TH USERDATA         */ -
&UDATA15=,         /* 15TH USERDATA         */ -
&UDATA16=,         /* 16TH USERDATA         */ -
&ULIB1=,           /* 1ST USERLIB LIBRARY   */ -
&ULIB2=,           /* 2ND USERLIB LIBRARY   */ -
&ULIB3=,           /* 3RD USERLIB LIBRARY   */ -
&ULIB4=,           /* 4TH USERLIB LIBRARY   */ -
&ULIB5=,           /* 5TH USERLIB LIBRARY   */ -
&ULIB6=,           /* 6TH USERLIB LIBRARY   */ -
&ULIB7=,           /* 7TH USERLIB LIBRARY   */ -
&ULIB8=,           /* 8TH USERLIB LIBRARY   */ -
&VPSSDN=,          /* VPS PRINTER STAGED DSN */ -
&WRITER=,          /* OUTPUT WRITER NAME     */ -
&WTR=,             /* OUTPUT WTR NAME (OLD)  */ -
/* * * * * * * * * * * * * * * * * * * * * * * * * * * * * * * * * * * * * * * * * */

```

Continued

```

/* COPY FILE FROM VPS STAGED DATASET INTO JES SPOOL */
/* DESTINATION HAS BEEN CHANGED TO A VPS CONTROLLED PRINTER. */
/* BANNER PAGE WILL BE PRODUCED. */
/* * * * * * * * * * * * * * * * * * * * * * * * * * * * * */
STEP01 COPY FROM( PNODE -
                DSN=&VPSDSN -
                DISP=SHR ) -
                CKPT=1M -
                COMPRESS EXT -
                TO( SNODE -
                  SYSOUT=(CLASS=&CLASS,COPIES=&COPIES,DEST=&DEST -
                    BANNER=(PROGRAMMER=&JPNAME,JOBNAME=&JOBNM, -
                      SUBMITTER=&SUBNAME,STEPNAME=&STEPNM, -
                        DDNAME=&STEPDD),JOBNAME=&JOBNM) -
                    )
/* * * * * * * * * * * * * * * * * * * * * * * * * * * * * */
/* DELETE VPS STAGE INPUT FILE */
/* * * * * * * * * * * * * * * * * * * * * * * * * * * * * */
STEP02 IF (STEP01 = 0) THEN
STEP03 RUN TASK (PGM=DMRTDYN -
                PARM=(C"ALLOC DSN=&VPSDSN,DISP=(OLD,DELETE) " -
                  F'-1' -
                  C"UNALLOC DSN=&VPSDSN"))
                EIF
                EXIT `

```

## Symbols

\$HLQ.AR.S.MAPLIB

contents 47

DMAER member 49

DMCPTR member 49

DMCTR member 51

DMDPTR member 53

DMDTR member 54

DMFMCR member 56

DMFPTR member 55

DMFWTOST member 63

DMPSSR member 57

DMPTR member 58

DMRJTR member 59

DMRTTR member 60

DMSDCR member 62

DMSFR member 61

DMSTDCR member 63

%INCLUDE 45

## A

Activity Reporting System (ARS)

business solutions 12

description 15

example 15

field descriptions 16

in conjunction with Connect:Direct 11

tracking Connect:Direct activities 12

ALLOC.CODES initialization parameter 74

Application Program Interface (API) 99, 102, 110

ARS Reports

customizing 47

methods of requesting 11, 15

multiple reports

job stream definitions 43

routing to output data sets 46

sample job stream 41

sample Process to submit job stream 46

requesting 15

ARS Reports (continued)

requesting through a Process 11

requesting through a scheduling subsystem 11

requesting through screens 33

using 11

ARS Screens, accessing 34

ARS screens

accessing 34

accessing through IUI 33

Connect:Direct Requirements

example 37

field descriptions 38

Report Options

example 35

field descriptions 36

SAS Requirements

example 38

field descriptions 39

signon parameters 35

using 33

Authorization Event record 49

Automatic signon 65

## B

Banners

after restart 126

coding 125

Business solutions 12

## C

Capacity planning 12

Carriage control 127

CDNC commands 81

CDNC transaction 99

CDPROCES 115

CDVPSAPI 113

Change Process command 66

Change Process Termination record 49

Checkpoint 123

CICS

- API command 86
- API Driver screen 100
- API interface
  - create ESS registration program 87
  - event data 85, 87
  - using ESS with 86
  - verify software installation 85, 87
- create ESS registration program 85
- EXEC CICS READQ TD QUEUE command 86

CLASS 127

clist 68

CLISTs, setting up for Connect:Direct for z/OS 67

COMMAND MSG ID field 101

COMMAND RC field 100

Commands 65, 66, 68

- EVENT SERVICES CREATE
  - example 95
  - format 89
  - with ESS CICS API 85
- EVENT SERVICES DISPLAY
  - format 97
  - parameters 98
- EVENT SERVICES START
  - ESS CICS API 86
  - example 96
  - format 95
- EVENT SERVICES STOP, format 97
- EXEC CICS LINK 102
  - submitting 68

COMMAREA 100, 102

Components

- Connect:Direct API 113
- diagram 110
- JES Spool Transfer
  - Application Program Interface 110
  - Data Transmission Facility 110
  - VTAM Printer Support 110
- VTAM printer support 111

Connect:Direct

- commands
  - issuing 102
  - issuing from CICS 99

- Connect:Direct (continued)
  - Event Services Support
    - advantages 78
    - architecture 81
    - concepts 77
    - interfaces 77
    - utilization 13
- Connect:Direct for z/OS
  - Operation error messages 70
  - Operator interface 66, 68
- COPY I/O start (CE)
  - description 106
  - type attributes 106
- COPY process 127
- COPY step initiation (CI)
  - description 106
  - type attributes 106
- COPY termination (CT)
  - description 108
  - event record enhancements 108
- Copy termination message 70
- Copy Termination record 51
- Customizing ARS Reports 47

## D

Data center management 12

Data format 87, 104

Data recovery 78

Data set access security failures 22

DATA SET NAME CONTAINING SAS  
ROUTINES 39

Dates
 

- how Connect:Direct processes 91
- specifying 91

Delete Process command 66

Delete Process Termination record 53

DESC.TAPE initialization parameter 72

Display Statistics record 54

DMBATCH 44

DMMNHDR 87, 104



DMMSGFIL 44  
 DMPRINT 44  
 DMPUBLIB 44  
 DMQ012 linking 102  
 DMQ247 processing 101  
 DMQ249 86  
 DMQM98 processing 101  
 DTF 110

## E

EIB (Exec interface block) 101

Entry fields

- COMMAND 100
- COMMAND MSG 101
- COMMAND MSG ID 101
- COMMAND RC 100
- EVENT RESTART DATA 101
- PROCESS NUMBER 101
- TD EXIT COUNT 101
- TS MAX LRECL 101
- TS QUEUE NAME 101

Error messages 70

ESS CICS API 85

ESS registration program 85, 87

ESS user exit 86

Event data

- filtering 83, 85, 87
- reading 104
- what data to collect 83

Event definition 78

Event enhancements

- COPY termination 108
- event records 108

Event filtering 78, 83, 85, 87

Event record enhancements 108

Event record type attributes 105

Event request initiation (EI)

- description 106
- type attributes 106

Event request stop (ET)

- description 106
- type attributes 106

EVENT RESTART DATA 101

EVENT SERVICES CREATE

- format 89
- parameters
  - ID 90
  - ORWHERE 95
  - WHERE 90

EVENT SERVICES DISPLAY

- format 97
- ID parameter 98

EVENT SERVICES START

- example 96
- format 95
- parameters 96

EVENT SERVICES STOP

- CICS API interface 86, 87
- format 97
- parameters 97

Event Services Support

- interface 81, 85
- output data format 87, 104

Event session lost (EL)

- description 106
- type attributes 106

Examples

- Activity Report 15
- ARS Connect:Direct Requirements screen 37
- ARS Report Options screen 35
- ARS SAS Requirements screen 38
- Connect:Direct for z/OS 68
- Exception Report 20
- Non-PDS Copy Report 24
- PDS Copy Report 26
- Run Job Report 28
- Run Task Report 29
- Security Violations Report 22
- Submit Within a Process Report 30
- Summary Report 17

Exception Report

- description 19
- example 20
- field descriptions 20
- problem isolation 13

Exception Report (continued)  
use 11

Exec Interface Block (EIB) 101

## F

F jobname command 68, 71

### Field descriptions

- Activity Report 16
- ARS Connect:Direct Requirements screen 38
- ARS Report Options screen 36
- ARS SAS Requirements screen 39
- Exception Report 20
- Non-PDS Copy Report 24
- PDS Copy Report 26
- Run Job Report 28
- Run Task Report 29
- Security Violations Report 22
- Submit Within a Process Report 30
- Summary Report 17

### Fields

- COMMAND MSG ID 101
- COMMAND RC (return code) 100
- EVENT RESTART DATA 101
- PROCESS NUMBER 101
- TD EXIT COUNT 101
- TS MAX LRECL 101
- TS QUEUE NAME 101

Flush Process/Suspend Process Termination record 55

FT20F001 44

### Function Reports

- description 11, 23
- Non-PDS Copy Report 23
- PDS Copy Report 23
- Run Job Report 23
- Run Task Report 23
- Submit Within a Process Report 23
- types of 11, 23

## G

GENER JCL 119

## H

HOLD queue (QH)  
description 107

HOLD queue (QH) (continued)  
type attributes 107

## I

Initialization parameters 65, 72, 74

Interfaces 81, 85

## J

### JES

- overview 109
- print queues 109
- reader 124
- reader queues 109
- spool transfer components 110

### Job stream

- definitions 43
- modifying for multiple reports 42
- producing ARS reports 33
- SAS options 43
- submitting 45
- submitting to create reports 40
- viewing from screen 39

JOB CARD INFO 38, 44

jobname 68

## M

MCS.CLIST initialization parameter 65

MCS.SIGNON initialization parameter 65

MESSAGE DATA SET NAME 38

Messages 70, 71, 72, 73, 75

### Multiple reports

- job stream definitions 43
- modifying the sample job stream 42
- routing to an output data set 46
- sample job stream 41
- sample Process to submit job stream 45

## N

NDMX0001 44

Non-PDS Copy Report  
description 23  
example 24

Non-PDS Copy Report (continued)  
 field descriptions 24

## O

Operation error messages 70

### Operations

input from JES spool files 109  
 input to JES print queues 109  
 input to JES reader queues 109

Operator interface 66, 68

invoking 65  
 using with Connect:Direct for z/OS 66

OPLIST sample library, z/OS 66

options 68

Output 87, 104

data sets 46  
 to JES spool files 125  
 to the JES reader 123

OUTPUT (SYSOUT) CLASS 39

## P

### Parameters

CASE 94  
 CCODE 90  
 EXIT 95  
 FNAME 94  
 ID 90  
 KEEPREC 96  
 LASTSEQ 94, 96  
 MAXQCNT 94  
 ORWHERE 86, 87, 95  
 PNAME 91  
 PNUMBER 91  
 SNODE 93  
 STARTT 91, 96  
 STOPT 93  
 TRACE 96  
 TYPE 94  
 USER 93  
 WHERE 86, 87, 90, 96

Parameters, for SYSOUT 129

### PDS Copy Report

description 25  
 example 26

PDS Copy Report (continued)  
 field descriptions 26

PDS Member Copy record 56

Problem isolation 13

Process flow diagram 111

### Process initiation (PI)

description 107  
 type attributes 107

### Process language samples

using READER keyword 124  
 using SYSOPTS 125

Process moved to EXEC queue (QE) 107

Process names 114

PROCESS NUMBER field 101

Process security failures 22

Process Submit Statistics record 57

Process Termination record 58

PUBLIC PROCESS LIBRARIES 38

## Q

Queue 104

## R

READER 124

Record types 105

Restart 123

ROUTCDE.TAPE initialization parameter 72

### Run Job Report

description 27  
 example 28  
 field descriptions 28

RUN JOB security exit 123

### RUN JOB start (JI)

attributes 107  
 description 107

Run Job Termination record 59

### RUN TASK initiation (TI)

description 108  
 type attributes 108

Run Task Report  
 description 29  
 example 29  
 field descriptions 29

Run Task Termination record 60

## S

Sample CLISTs, Connect:Direct for z/OS 66

Sample JCL, GENER 119

Sample Process to submit job stream 45

Sample Processes  
 CDPROCES 115  
 CDTOJES 132  
 copyfile 127

Samples

CICS API 78  
 DMQ249 interface program 86  
 ESS event records 84  
 ESSEVX01 86  
 event exit 77  
 event filtering 78  
 EVENT SERVICES CREATE 95  
 trace of ESS records 84

SAS

Informat variables 47, 48  
 location of maps 47

SAS CATALOGED PROCEDURE 39

SASPROGS 44

SASTEP 44

Screens

ARS Connect:Direct Requirements 37  
 ARS Report Options 35  
 ARS SAS Requirements 38

Security subsystems

CA-ACF2 22  
 IBM Resource Access Control Facility 22

Security violations 12

Security Violations Report

description 11, 22  
 example 22  
 field descriptions 22  
 types of failures reported 22  
 use 12

Select Process command 66

Select Statistics command 66

Signoff command 65

SIGNON 113

Signon command 66

Signon security failures 22

Signon, automatic 65

Signon/Signoff Statistics record 61

Start Connect:Direct Command record 62

START DATE 37

START TIME 37

STEPLIB 44

STEPLIB DATA SET NAME 38

Stop Connect:Direct (Force) command, z/OS 66

Stop Connect:Direct Command record 63

STOP DATE 37

STOP TIME 37

Stopping Connect:Direct, Connect:Direct for z/OS 71

Submit Process command 66

Submit Within a Process Report

description 30  
 example 30  
 field descriptions 30

Summary Report

capacity planning 12  
 description 17  
 example 17  
 field descriptions 17  
 use 12

Suspend Process command 66

Swap Node command 66

Symbolic 68

Symbolic definitions

job and jobstep values 120  
 printer file attributes 120  
 SYSOUT keyword 129

SYSIN 44, 45

SYSOPTS 125

SYSOUT 125, 127  
 SYSPRINT 44  
 System architecture  
   diagram 81  
   Event Services Support 81

System control  
   printer initialization 112  
   printer termination 112  
   SYSOUT data set ready 112  
   system initialization 112  
   system termination 112

System Management Facility 11

## T

Tape Mount messages 71, 72, 73  
 Tape Premount messages 72, 73  
 TAPE.PREMOUNT initialization parameter 72

TD EXIT COUNT field 101

TEMPDSN 44

Time Sharing Option 11

TIMER queue (QT)  
   description 108  
   type attributes 108

Transient data  
   data flow diagram 83  
   ESS data flow 82  
   queue 85, 86, 104

TS MAX LRECL field 101

TS QUEUE NAME field 101

Type attributes  
   COPY I/O start 106  
   COPY step initiation 106  
   event request initiation 106  
   event request stop 106  
   event session lost 106  
   HOLD queue 107  
   Process initiation 107  
   Process moved to EXEC queue 107  
   RUN JOB start 107  
   RUN TASK initiation 108  
   TIMER queue 108  
   WAIT queue 108

## V

VPS  
   diagram 110  
   initialization 110

VPSSCDI 109, 111, 113

## W

WAIT queue (QW)  
   description 108  
   type attributes 108

WORK 44

Write to Operator (WTO) Statistics record 63

WTO (Write to operator) 72

WTOR (Write to operator with reply) 72, 74

## Z

z/OS MODIFY command 65

z/OS Modify command 68

