

IBM Sterling Gentrans:Server for UNIX - Workstation

Getting Started Guide

Version 6.2



Copyright

This edition applies to the 6.2 Version of IBM® Sterling Gentran:Server® for UNIX - Workstation and to all subsequent releases and modifications until otherwise indicated in new editions.

Before using this information and the product it supports, read the information in *Notices* on page N-1.

Licensed Materials - Property of IBM

IBM® Sterling Gentran:Server® for UNIX - Workstation

© Copyright IBM Corp. 1991, 2011. All Rights Reserved.

US Government Users Restricted Rights - Use, duplication or disclosure restricted by GSA ADP Schedule Contract with IBM Corp.

Table of Contents

About this Guide

▶ Introduction	viii
▶ Supported Configurations	x
▶ Chapter Content	xi
▶ Product Installation	xii
▶ Related Publications	xiii

Installing Sterling Gentran:Server

Overview

▶ Introduction	1-2
▶ Stages of Installation	1-3

Procedures

▶ How to Install Sterling Gentran:Server for UNIX - Workstation	1-4
▶ How to Install MDAC 2.8 Components	1-8
▶ Sterling Gentran:Server Standards	1-10
▶ How to Convert Existing Data	1-11

Setting Up Communications

Overview

▶ Introduction	2-2
▶ What Is the Communications Toolkit?	2-3
▶ COMM Subdirectory Structure	2-5
▶ The Communications Toolkit Setup Process	2-9

Procedures

▶ How to Set Up Asynchronous Communications	2-10
▶ How to Set Up Bisynchronous Communications	2-12
▶ How to Start Up Cleo A+	2-14
▶ How to Start Up Cleo 3780Plus	2-17
▶ Start-Up Procedure Examples	2-19

Troubleshooting

▶ Communications Session Error Recovery	2-21
▶ Cleo 3780Plus Troubleshooting	2-26
▶ Connecting to Other VANs and Directly to Trading Partners	2-27

Introducing Sterling Gentran:Server

- ▶ Introduction3-2
- ▶ Sterling Gentran:Server Features3-4
- ▶ Sterling Gentran:Server Architecture3-6
- ▶ Running Multiple Sessions3-7
- ▶ File Name Conventions3-11

Using Sterling Gentran:Server

- ▶ Introduction4-2
- Starting and Exiting**
 - ▶ How to Start Sterling Gentran:Server4-3
 - ▶ How to Exit Sterling Gentran:Server4-4
- The Sterling Gentran:Server User Interface**
 - ▶ Overview4-5
 - ▶ The Main Window4-6
 - ▶ Main Window Menus4-8
 - ▶ The Main Window Toolbar4-10
 - ▶ How to Use the Sterling Gentran:Server Interface4-11
 - ▶ How to Use the On-line Help4-12
 - ▶ The File Browser4-14
 - ▶ How to Use the File Browser4-16
 - ▶ How to Change Print Properties4-19
- Setting Default Values**
 - ▶ Overview4-20
 - ▶ Set Up Directories Dialog Box4-22
 - ▶ How to Change the Default Workstation Directories4-24

Working with Application Integration

- Overview**
 - ▶ Introduction5-2
 - ▶ Working in Workstation5-3
- Dialog Boxes**
 - ▶ Select Map and File Definitions Files to Check out Dialog Box5-4
 - ▶ Select Map Files to Check in Dialog Box5-6
 - ▶ Select TBL/TPL Files to Check In Dialog Box5-8
 - ▶ Select File Definition to Check in Dialog Box5-9
 - ▶ Select Map and File Definition Files to Unlock Dialog Box5-11
- Procedures**
 - ▶ How to Check Out and View Maps and File Definitions5-13

- ▶ How to Save Changes to Working Files5-16
- ▶ How to Unlock Master Files and Delete Working Copies5-18
- ▶ How to Check In Maps and Translation Objects5-21
- ▶ How to Check In File Definitions5-25

Notices

Glossary

Index

About this Guide

Content	▶ Introduction	viii
	▶ Supported Configurations	x
	▶ Chapter Content	xi
	▶ Product Installation	xii
	▶ Related Publications	xiii

Introduction

Welcome Welcome to the IBM® Sterling Gentran:Server® for UNIX - Workstation electronic data interchange (EDI) and electronic commerce (EC) software.

Who should use this guide

This guide is for the following audiences:

- Administrators responsible for installing and configuring EDI or EC application software
- Users of the IBM® Sterling Gentran:Server® for UNIX - Workstation product

Use this table to determine which chapters are for you.

If you are...	Then refer to...
An administrator	Chapter 1-2
Using Sterling Gentran:Server for the first time	Chapters 3-5
A user and you are upgrading from Sterling Gentran:Server 5.4	Chapters 3-5
A user and you are upgrading from Sterling Gentran:Server 5.3 or prior version	Chapters 3-6

Reference

See the [Chapter Content](#) topic for a description of each chapter.

Note

This guide documents procedures for the Application Integration system.

Required skills

This guide assumes that you are familiar with basic Windows concepts and commands, including:

- ▶ How to navigate and operate within the Windows environment
- ▶ How to use DOS commands and the DOS window within the Windows desktop

Product packaging

Your IBM® Sterling Gentran:Server® for UNIX - Workstation package should include the following items:

- ▶ A CD containing the IBM® Sterling Gentran:Server® for UNIX - Workstation software and the Communications Toolkit
- ▶ A CD containing the Sterling Gentran:Server EDI Standards
- ▶ A CD containing the Sterling Gentran:Server online documentation
- ▶ The *IBM® Sterling Gentran:Server® for UNIX - Workstation Getting Started Guide*

WARNING

If additional installation instructions came with your Sterling Gentran:Server shipment, those instructions take precedence over the instructions listed here.

Supported Configurations

Hardware specifications

Each workstation computer needs the following resources for you to install and run IBM® Sterling Gentran:Server® for UNIX - Workstation version 6.2.

- ▶ A CD-ROM drive
- ▶ Microsoft Windows XP® SP2
- ▶ Windows 7
- ▶ A minimum of 1 GB of free disk space

Note

Your Windows operating system may require updates to work correctly. Check the following Microsoft web site to determine and download the latest service packs for your operating system:

<http://www.microsoft.com/windows/downloads/default.asp>

Chapter Content

Description of content

This table describes the content of the chapters within the *IBM® Sterling Gentran:Server® for UNIX - Workstation Getting Started Guide*.

Chapter Title	Description
About this Guide	This preface describes the purpose and content of this guide. It describes the supported hardware and software configurations.
Chapter 1 - Installing IBM® Sterling Gentran:Server® for UNIX - Workstation	Explains how to install IBM® Sterling Gentran:Server® for UNIX - Workstation version 6.2 into a new directory.
Chapter 2 - Setting Up Communications	Explains how to set up communications using CLEO software.
Chapter 3 - Introducing Sterling Gentran:Server	Describes the basic architecture of the Sterling Gentran:Server software.
Chapter 4 - Using Sterling Gentran:Server	Explains how to start and exit Sterling Gentran:Server, describes the user interface, and explains how to set default values for your system.
Chapter 5 - Working with Application Integration	Contains procedures for working with Application Integration system files in Workstation. Includes instructions for checking out, saving, and checking in files.
Glossary	Sterling Gentran:Server and industry-related terms.

Product Installation

In this guide

This guide explains how to install and configure:

- ▶ IBM® Sterling Gentran:Server® for UNIX - Workstation version 6.2
- ▶ Online documentation for Sterling Gentran:Server
- ▶ The Sterling Gentran:Server Standards
- ▶ The Communications Toolkit

Note

These instructions apply only to new installations of IBM® Sterling Gentran:Server® for UNIX - Workstation.

Installation options

You can install each option separately after installing the core Sterling Gentran:Server software. This table lists the CD containing each option and the instructions for installing the option.

To install the...	Use...
XML Translation Extension	the core installation CD. Note This option is installed during the core product installation. The serial number you enter validates your purchase of the XML Translation Extension.
HIPAA features	the core installation CD. Note The installation process asks if you want to install optional HIPAA features for Sterling Gentran:Server.
Extensions	the documentation shipped with other options or add-on software for installation instructions.

Related Publications

Sterling Gentran:Server documentation

This table describes additional documentation for the Sterling Gentran:Server software.

Document	Description
<i>IBM® Sterling Gentran:Server® for UNIX Upgrade and Data Conversion Guide</i>	Instructions for upgrading from previous versions of IBM® Sterling Gentran:Server® for UNIX and IBM® Sterling Gentran:Server® for UNIX - Workstation. Also includes instructions for converting the files that are part of the upgrade.
<i>IBM® Sterling Gentran:Server® for UNIX Installation Checklist</i>	Description of the recommended sequence in which you should install and configure system components.
<i>IBM® Sterling Gentran:Server® for UNIX Getting Started Guide</i>	Instructions for installing the Sterling Gentran:Server software and performing setup tasks, such as setting up security. Instructions for starting and exiting Sterling Gentran:Server and for setting preferences and default values. Also includes instructions for checking files in and out and saving files.
<i>IBM® Sterling Gentran:Server® for UNIX Application Integration User Guide</i>	Instructions for performing mapping and translation tasks using the Sterling Gentran:Server Application Integration system.
<i>IBM® Sterling Gentran:Server® for UNIX HIPAA Compliance and NCPDP User Guide</i>	Instructions for mapping and translating NCPDP files with the Application Integration system.
<i>IBM® Sterling Gentran:Server® for UNIX GENCOD User Guide</i>	Instructions for mapping and translating GENCOD files with the Application Integration system.
<i>IBM® Sterling Gentran:Server® for UNIX VDA User Guide</i>	Instructions for mapping and translating VDA files with the Application Integration system.

Document	Description
<i>IBM® Sterling Gentran:Server® for UNIX Technical Reference Guide</i>	Describes processes, lists command-line commands in alphabetical order, and describes file record layouts and data type formats.
<i>IBM® Sterling Gentran:Server® for UNIX - EC Workbench Data Flow Administration Guide</i>	User instructions for configuring data flows using the Sterling Gentran:Server software.
<i>IBM® Sterling Gentran:Server® for UNIX - Process Control Manager Data Flow Administration Guide</i>	User instructions for configuring data flows using the Sterling Gentran:Server software.
<i>IBM® Sterling Gentran:Server® for UNIX Maintenance and Troubleshooting Guide</i>	Instructions for maintaining your Sterling Gentran:Server installation. Also provides troubleshooting information to help determine the cause and solution of problems that may occur.
<i>IBM® Sterling Gentran:Server® for UNIX - Workstation Maintenance and Troubleshooting Guide</i>	Instructions for maintaining your workstation installation. Also provides troubleshooting information to help determine the cause and solution of problems that may occur.
<i>IBM® Sterling Gentran:Server® for UNIX with ADD User Guide</i>	Instructions for configuring and using the Advanced Data Distribution system.
<i>IBM® Sterling Gentran:Server® for UNIX XML Translation User Guide</i>	Instructions for mapping and translating XML files with the Application Integration system.

Document	Description
<i>IBM® Sterling Gentran:Server® for UNIX with ADD FTP Daemon User Guide</i>	Instructions for configuring and using the FTP Daemon tool with IBM® Sterling Gentran:Server® for UNIX with ADD.
Online Help	Context-sensitive help screens describing the Sterling Gentran:Server dialog boxes and features. Also includes procedures for using the mapping and translation and the data flow administration software.

Installing Sterling Gentran:Server

Content	Overview	
	▶ Introduction	2
	▶ Stages of Installation	3
	Procedures	
	▶ How to Install Sterling Gentran:Server for UNIX - Workstation	4
	▶ How to Install MDAC 2.8 Components	8
	▶ Sterling Gentran:Server Standards	10
	▶ How to Convert Existing Data	11

Overview

Introduction

Chapter contents This chapter contains instructions for installing IBM® Sterling Gentran:Server® for UNIX - Workstation version 6.2 into a new directory structure.

Key terms This table describes key terms used in this chapter.

Term	Description
default	A value that is automatically assigned if the user enters no value.
Windows computer	A PC that uses the Windows operating system. For IBM® Sterling Gentran:Server® for UNIX - Workstation, the operating system can be: <ul style="list-style-type: none">▶ Microsoft Windows XP® SP2▶ Microsoft Windows 7

Stages of Installation

Stage Table

This table describes the stages of the installation process for IBM® Sterling Gentran:Server® for UNIX - Workstation. Detailed instructions for completing each stage are contained in the sections that follow.

Stage	Description
1	Installation of Sterling Gentran:Server into the default directories, or into a new directory created and named by you, and installation of the Communications Toolkit
2	Installation of Microsoft Data Access Components
3	Installation of Sterling Gentran:Server EDI Standards
4	Installation of the Sterling Gentran:Server online documentation
5	Installation of Acrobat Reader version 4.0 or higher with search function
6	<p>Conversion of existing data, if upgrading from a previous version</p> <p>Reference See the <i>IBM® Sterling Gentran:Server® for UNIX Upgrade and Data Conversion Guide</i> for more information.</p>

XML installation

The XML translation option is installed on your computer automatically if your company purchased the option.

Procedures

How to Install Sterling Gentran:Server for UNIX - Workstation

Introduction This topic explains how to install IBM® Sterling Gentran:Server® for UNIX - Workstation software onto a Windows computer from the CD.

Procedure Use the following procedure to install Sterling Gentran:Server.

Step	Action
1	Close all programs running on your computer.
2	<p>Insert the installation CD into the CD-ROM drive of your PC.</p> <p>The Welcome dialog box is displayed.</p> <p>Click Next to continue.</p> <p>Comment</p> <p>If the Welcome dialog box is not displayed, then you can do the following to start the installation.</p> <p>Select Run from the Start menu in the Run dialog box, type the following command where <drive> represents the letter assigned to your CD-ROM drive, then click OK.</p> <p>Example</p> <pre><drive>:\setup</pre>
3	<p>Enter the following information and click Next:</p> <ul style="list-style-type: none"> ▶ User Name ▶ Company Name ▶ Install XML

(Contd) Step	Action
4	<p>Select the Destination Folder for the installation. You can browse to a destination folder or choose to keep the default destination folder displayed.</p> <p>Select Next to continue.</p> <p>Comments You can type into the Browse dialog a path that Setup will create during installation. If the pathname contains a folder that does not exist, Sterling Gentran:Server displays the prompt: Do you want to the folder to be created?"</p> <p>Be sure that the path you specify contains no spaces, and no punctuation other than a backslash (\) between directories.</p> <p>WARNING If you have an earlier version of Sterling Gentran:Server installed, be sure to use a different root directory for your Sterling Gentran:Server 6.2 software.</p>
5	<p>Select Program Folder.</p> <p>Default is Server Gentran Server Workstation 6.2.</p> <p>Click Next to continue.</p>
6	<p>Review the setup information.</p> <p>Click Install to begin the installation.</p>
7	<p>Do you want to install the Microsoft Data Access Components (MDAC)?</p> <ul style="list-style-type: none"> ▶ If YES, GO TO topic How to Install MDAC 2.8 Components in this chapter. ▶ If NO (you already have MDAC), clear the checkbox and continue to the next step. <p>Note You must have MDAC to use the Sterling Gentran:Server EDI Standards database. The minimum version required is 2.1sp1a. This MDAC installation process installs version 2.8.</p>

(Contd) Step	Action
4	<p>Select the Destination Folder for the installation. You can browse to a destination folder or choose to keep the default destination folder displayed.</p> <p>Select Next to continue.</p> <p>Comments You can type into the Browse dialog a path that Setup will create during installation. If the pathname contains a folder that does not exist, Sterling Gentran:Server displays the prompt: Do you want to the folder to be created?"</p> <p>Be sure that the path you specify contains no spaces, and no punctuation other than a backslash (\) between directories.</p> <p>WARNING If you have an earlier version of Sterling Gentran:Server installed, be sure to use a different root directory for your Sterling Gentran:Server 6.2 software.</p>
5	<p>Select Program Folder.</p> <p>Default is Server Gentran Server Workstation 6.2.</p> <p>Click Next to continue.</p>
6	<p>Review the setup information.</p> <p>Click Install to begin the installation.</p>
7	<p>Do you want to install the Microsoft Data Access Components (MDAC)?</p> <ul style="list-style-type: none"> ▶ If YES, GO TO topic How to Install MDAC 2.8 Components in this chapter. ▶ If NO (you already have MDAC), clear the checkbox and continue to the next step. <p>Note You must have MDAC to use the Sterling Gentran:Server EDI Standards database. The minimum version required is 2.1sp1a. This MDAC installation process installs version 2.8.</p>

(Contd) Step	Action
8	<p>Click Finish to complete setup.</p> <p>Comment You will need to decide if you want to restart your computer now or later.</p> <p>System Response Setup displays the Sterling Gentran:Server 6.2 dialog box</p>

How to Install MDAC 2.8 Components

Introduction

To read the EDI standards provided with Sterling Gentran:Server, you must have Microsoft Data Access Components (MDAC) 2.1sp1a or higher installed on each PC or client. MDAC includes ActiveX® Data Objects (ADO), and OLE DB. Data-driven client/server applications use these components to integrate information from a variety of sources.

If you do not already have MDAC on the PC, you must install it before you install the EDI standards. This topic explains how to install MDAC.

Installing MDAC

Use this procedure to install MDAC 2.8 on a PC.

Step	Action	
1	Use this table to determine your first action.	
	IF you are ...	THEN...
	Continuing from the PC setup program	Leave the I would like to install Microsoft MDAC 2.8 check box selected on the Setup Complete dialog box. Click Finish and GO TO Step 5.
	Installing MDAC after exiting the PC setup program	Continue with Step 2.
2	Insert the installation CD into the CD-ROM drive of the PC computer.	
3	Select Run from the Windows Start menu.	
	System Response Windows displays the Run dialog box.	

(Contd) Step	Action
4	Type the following command in the Run dialog box and click OK . <drive>:\mdac_typ.exe where <drive> is your CD-ROM drive. System Response The system response is dependent on your operating system.
5	Click Next .
6	Click Finish .
7	Click Close . System Response Setup displays the Sterling Gentran:Server Setup complete dialog box, which asks whether you want to reboot the PC now or later.
8	Click Finish to complete setup.

Sterling Gentran:Server Standards

**Installing the
Standards
Database**

Use the Sterling Gentran:Server EDI Standards documentation to install the Sterling Gentran:Server EDI Standards.

How to Convert Existing Data

Introduction If you are upgrading from an earlier version of Sterling Gentran:Server, you need to convert your existing data.

Reference Refer to the *IBM® Sterling Gentran:Server® for UNIX Upgrade and Data Conversion Guide* for detailed instructions.

Setting Up Communications

Content**Overview**

- ▶ Introduction 2
- ▶ What Is the Communications Toolkit? 3
- ▶ COMM Subdirectory Structure 5
- ▶ The Communications Toolkit Setup Process 9

Procedures

- ▶ How to Set Up Asynchronous Communications 10
- ▶ How to Set Up Bisynchronous Communications 12
- ▶ How to Start Up Cleo A+ 14
- ▶ How to Start Up Cleo 3780Plus 17
- ▶ Start-Up Procedure Examples 19

Troubleshooting

- ▶ Communications Session Error Recovery 21
 - ▶ Cleo 3780Plus Troubleshooting 26
 - ▶ Connecting to Other VANs and Directly to Trading Partners 27
-

Overview

Introduction

The Communications Toolkit

The Communications Toolkit enables Sterling Gentran:Server to use Cleo A+® or Cleo 3780Plus® communication software to access a Value-Added Network (VAN).

Among other services, VANs provide store-and-forward messaging in a dial-on-demand environment. This means that the VAN stores files in a mailbox until the recipient to whom they are addressed dials into the VAN and picks them up.

When to use the Communications Toolkit

Use the Communications Toolkit if you connect to the Commerce Net®, Advantis®, or GEIS® networks, and you use or plan to use either Cleo A+ or Cleo 3780Plus.

What do I need to buy?

The Communications Toolkit is included with IBM® Sterling Gentran:Server® for UNIX - Workstation and IBM® Sterling Gentran:Server® for UNIX.

However, Cleo A+ and Cleo 3780Plus are not part of the Sterling Gentran:Server product; you must purchase Interface Systems' Cleo A+ or Cleo 3780Plus communication software.

How to activate the Communications Toolkit

To activate the toolkit functions, you need to configure the Communications Toolkit and then install the Cleo software.

Communications Toolkits files are included in the Sterling Gentran:Server host CD and are installed automatically with the Sterling Gentran:Server host software.

In this chapter

This chapter provides instructions for setting up the toolkit.

What Is the Communications Toolkit?

Command scripts IBM provides command scripts for the third-party communication packages, Cleo 3780Plus and Cleo A+. The scripts control the processes of:

- ▶ Dialing the VAN
- ▶ Logging in
- ▶ Transmitting waiting files
- ▶ Receiving any files waiting on the VAN
- ▶ Logging off
- ▶ Exiting

Supported VANs This table describes the VANs and protocols supported by the Communications Toolkit.

VAN	Supported Protocols
IBM® Sterling Information Broker® (IBM)	Asynchronous-ASCII Bisynchronous
Advantis (IBM)	Asynchronous-Xmodem Bisynchronous
GEIS (General Electric Information System)	Asynchronous-Xmodem Bisynchronous

Toolkit parts There are two primary parts to the Communications Toolkit provided with Sterling Gentran:Server:

- ▶ Cleo A+ scripts and configuration files
- ▶ Cleo 3780Plus scripts and configuration files

Cleo software **Cleo A+**

Interface Systems' Cleo A+ is an asynchronous communications package that uses sophisticated scripting to handle various types of communications. It supports several file transfer methods, including ASCII, Xmodem, Ymodem,

Zmodem, Kermit, and ANSI CLEAR. It can also perform as an FTP tool, using SLIP, PPP, Telnet, or local modes.

Cleo 3780Plus

Interface Systems' Cleo 3780Plus is a bisynchronous communications package that uses scripting to handle various types of communications. It supports 2780/3780 bisync protocols by using a piece of hardware to convert ASCII data to EBCDIC data for transmission and EBCDIC data to ASCII data upon receipt of the EBCDIC data.

WARNING

The scripts in the Communications Toolkit expect to find the Cleo software in a specific directory relative to the Sterling Gentran:Server directories. To prevent complications, install the Cleo software *after* you install and set up Sterling Gentran:Server and the Communications Toolkit.

COMM Subdirectory Structure

Diagram The following diagram illustrates the directory structure required by the Communications Toolkit. Installation of Sterling Gentran:Server automatically installs the Communications Toolkit files for you.

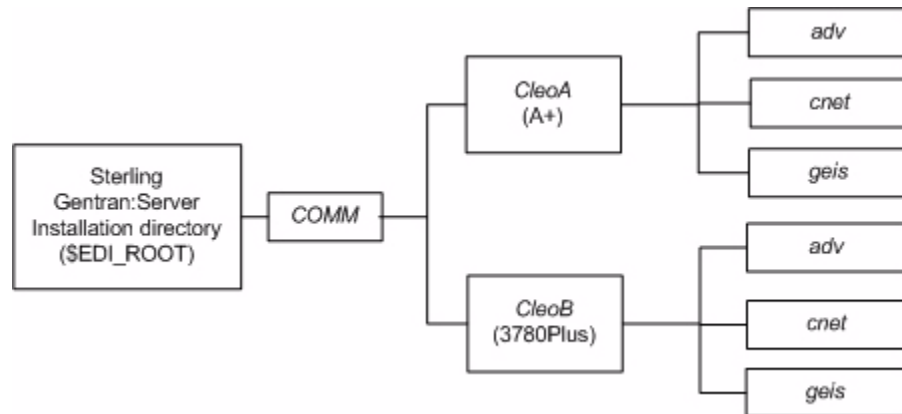

Location of communication scripts and configuration files

The Cleo communications script and configuration files reside in subdirectories of the COMM CleoA or CleoB subdirectory of the Server directory.

Directory	Contents
Server/COMM/CleoA (A+)	Holds Cleo A+ asynchronous package
Server/COMM/CleoB (3780Plus)	Holds Cleo 3780Plus bisynchronous package

VAN subdirectories

Under the CleoA and CleoB subdirectories, each VAN has its own subdirectory:

- ▶ *cnet* for Sterling Information Broker
- ▶ *adv* for Advantis
- ▶ *geis* for GEIS.

Subdirectory contents

The *adv*, *cnet*, and *geis* subdirectories contain files that enable the communications application to communicate with the corresponding VAN.

You should use the subdirectory appropriate to your network to hold the outbound file <van>s that you are transmitting to the VAN.

Note

You should place files you are sending in the communications subdirectory before a session. For example, to send a file to Advantis via an asynchronous communication session, place the file in Server/COMM/CleoA/adv/adv.s.

During a session, the system places the inbound file <van>.r.000 in the communication subdirectory. This file contains any files received during a communications session.

Important files

This table lists the important files that the Communications Toolkit uses or creates.

Filename	Description
<van>.cfg	A configuration file specific to the VAN indicated in the file name.
edilog.fil	A log file produced by each bisynchronous Advantis session. WARNING The program overwrites this file after each session. To save this file, you must copy or move it to another location.
advmsg.fil	A file containing messages produced by each bisynchronous Advantis session. WARNING The program overwrites this file after each session. To save this file, you must copy or move it to another location.

(Contd) Filename	Description
<van>*.job	<p>Cleo job file for connecting to the supported networks. The individual files connect as follows:</p> <ul style="list-style-type: none"> ▶ <i>cnetsr.job</i> - Sterling Information Broker via the CompuServe network local access nodes. ▶ <i>advsr.job</i> - IBM Advantis network ▶ <i>geissr.job</i> - GEIS network
<van>.log	A log file specific to the last connection made to the indicated VAN.
<van>.mon	A monitor file specific to the last connection made to the indicated VAN.
<van>.ovr	A data translation file that provide protocol transfer information that Cleo requires.
cnet.rpts	A file containing Sterling Information Broker reports.
<van>s	<p>The user data file to be sent to the network. Must be placed in the directory for the specific VAN before connecting to the VAN.</p> <p>WARNING</p> <p>You must move or delete this file after completing the session successfully.</p> <p>Sterling Gentran:Server will send a duplicate transmission unless this file is overwritten or deleted before the next session.</p> <p>Sterling Gentran:Server may overwrite the file if you do not move it before the next session. The file will then be unavailable to retransmit data.</p>

(Contd) Filename	Description
<van>r.nnn	<p>The user data file that Sterling Gentran:Server receives from the VAN. The first file received has an extension of .000. If the file is moved from the VAN directory before another file arrives, the next file received also has an extension of .000.</p> <p>WARNING</p> <p>The file extension is incremented by one with the receipt of each new file unless the prior version is moved or deleted before the session. If your site uses automated file processing, it may not recognize the incremented file.</p>
geisrpt.*	<p>A session log report generated by GEIS under 3780Plus or AllSync.</p> <p>WARNING</p> <p>The program overwrites this file after each session. To save this file, you must copy or move it to another location.</p>

The Communications Toolkit Setup Process

Process flow This diagram shows the flow of the setup process required to prepare the Communications Toolkit to work with Sterling Gentran:Server.

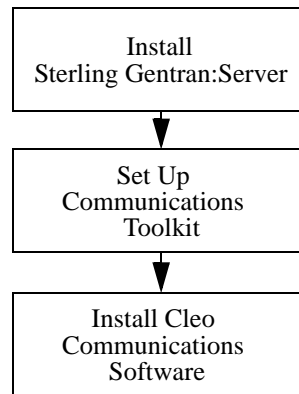

Procedures

How to Set Up Asynchronous Communications

Introduction

This topic contains the procedures for setting up asynchronous communications using VAN scripts that are located in the COMM directory structure. Follow the instructions for the VAN to which you are connecting.

Microcom Network Protocol (MNP)

The Microcom Network Protocol (MNP) enables error correction during transmissions. It is particularly important when connecting to Sterling Information Broker.

Modifying the VAN configuration file

Your Cleo A+ VAN configuration file (*cnet.cfg*, *adv.cfg*, or *geis.cfg*) contains all or most of the required network configurations. However, you may have hardware issues that require you to modify the file.

This table lists the environment parameters you may need to modify. The Parameter column lists the name of the parameter and the related file.

Parameter	Description
Modem Initialization (<i>modeminit.cfg</i>)	This parameter normally contains the async factory default setting for your modem. To use another setting, check the AT commands in your modem user guide. Usually, the setting & F0 sets up most asynchronous modems in standard asynchronous mode.
Port (<i>device.cfg</i>)	This is the port to which the modem is installed. <ul style="list-style-type: none"> ▶ If you use DOS or Windows, you may use COM2 or a similar setting. ▶ If you use UNIX, you may use <i>/dev/tty3</i> or a similar setting.
Port Speed (<i>speed.cfg</i>)	This parameter identifies to Cleo the baud rate of the port so that Cleo knows how fast to write to the port. This is NOT the dial-up connection speed or the modem baud rate.

(Contd) Parameter	Description								
Terminal Type (<i>terminal.cfg</i>)	The terminal type is usually VT100 or VT220, depending on the terminal type to be emulated. Refer to the Cleo documentation for more information.								
Dial Initialization	This is the most important configuration parameter. It is used to set the unique configuration that a particular VAN expects. Use the following table to guide you in setting this parameter.								
	<table border="1"> <thead> <tr> <th data-bbox="737 659 940 709">VAN</th> <th data-bbox="940 659 1427 709">Dial-Initialization Settings</th> </tr> </thead> <tbody> <tr> <td data-bbox="737 709 940 842">Sterling Information Broker</td> <td data-bbox="940 709 1427 842"> <ul style="list-style-type: none"> ▶ MNP error correction protocol ▶ Software Flow Control (also known as XON/XOFF Flow Control) </td> </tr> <tr> <td data-bbox="737 842 940 1016">Advantis</td> <td data-bbox="940 842 1427 1016"> <ul style="list-style-type: none"> ▶ MNP error correction protocol ▶ Hardware Flow Control (RTS/CTS) ▶ FTP: Xmodem (in addition to the MNP protocol) </td> </tr> <tr> <td data-bbox="737 1016 940 1379">GEIS</td> <td data-bbox="940 1016 1427 1379"> <ul style="list-style-type: none"> ▶ Either Hardware Flow Control (RTS/CTS) or Software Flow Control <p>CAUTION If you use Software Flow Control, make sure the Dial Init and FLOWCONTROL setting in the configuration file are compatible.</p> <ul style="list-style-type: none"> ▶ FTP: Xmodem </td> </tr> </tbody> </table>	VAN	Dial-Initialization Settings	Sterling Information Broker	<ul style="list-style-type: none"> ▶ MNP error correction protocol ▶ Software Flow Control (also known as XON/XOFF Flow Control) 	Advantis	<ul style="list-style-type: none"> ▶ MNP error correction protocol ▶ Hardware Flow Control (RTS/CTS) ▶ FTP: Xmodem (in addition to the MNP protocol) 	GEIS	<ul style="list-style-type: none"> ▶ Either Hardware Flow Control (RTS/CTS) or Software Flow Control <p>CAUTION If you use Software Flow Control, make sure the Dial Init and FLOWCONTROL setting in the configuration file are compatible.</p> <ul style="list-style-type: none"> ▶ FTP: Xmodem
	VAN	Dial-Initialization Settings							
	Sterling Information Broker	<ul style="list-style-type: none"> ▶ MNP error correction protocol ▶ Software Flow Control (also known as XON/XOFF Flow Control) 							
	Advantis	<ul style="list-style-type: none"> ▶ MNP error correction protocol ▶ Hardware Flow Control (RTS/CTS) ▶ FTP: Xmodem (in addition to the MNP protocol) 							
GEIS	<ul style="list-style-type: none"> ▶ Either Hardware Flow Control (RTS/CTS) or Software Flow Control <p>CAUTION If you use Software Flow Control, make sure the Dial Init and FLOWCONTROL setting in the configuration file are compatible.</p> <ul style="list-style-type: none"> ▶ FTP: Xmodem 								
Sterling Information Broker	<ul style="list-style-type: none"> ▶ MNP error correction protocol ▶ Software Flow Control (also known as XON/XOFF Flow Control) 								
Advantis	<ul style="list-style-type: none"> ▶ MNP error correction protocol ▶ Hardware Flow Control (RTS/CTS) ▶ FTP: Xmodem (in addition to the MNP protocol) 								
GEIS	<ul style="list-style-type: none"> ▶ Either Hardware Flow Control (RTS/CTS) or Software Flow Control <p>CAUTION If you use Software Flow Control, make sure the Dial Init and FLOWCONTROL setting in the configuration file are compatible.</p> <ul style="list-style-type: none"> ▶ FTP: Xmodem 								

How to Set Up Bisynchronous Communications

Introduction

This topic contains the procedure for setting up bisynchronous communications using VAN scripts that are located in the COMM directory structure. Follow the instructions for the VAN to which you are connecting.

Editing the configuration file

Your Cleo 3780Plus VAN configuration file (*cnet.cfg*, *adv.cfg*, or *geis.cfg*) contains all or most of the required network configurations. However, you may have hardware issues that require you to modify the file.

The parameter settings that sometimes need to be increased are:

- ▶ Wait Limit
- ▶ Retransmission Limit

Important

The configuration file does not contain any labels. Consult the Cleo documentation to determine which lines to edit within the file.

Use this procedure to edit the configuration file for Sterling Information Broker, Advantis, and GEIS.

Step	Action
1	Open the VAN Configuration File in a text editor.
2	Set the Wait Limit as needed.
3	Set the Retransmission limit as needed.
4	Initiate a Cleo session so you can test communications to the VAN.
5	<p>Check whether a completion status of '0' was returned.</p> <ul style="list-style-type: none"> ▶ If the status was 0, you are finished editing the configuration file. ▶ If a non-zero was returned, use the <van>.log and <van>.mon files to troubleshoot. <p>Reference See the topic Cleo 3780Plus Troubleshooting for more information.</p>

Editing the job file

Use this procedure to edit the job file for cnet bisync communications.

Step	Action
1	Open the job file in a text editor.
2	<p>Set the dialing command.</p> <p>Example AUTODIAL n-<i>nnn</i>-<i>nnn</i>-<i>nnnn</i> T60 R3</p> <p>Where</p> <p><i>n-<i>nnn</i>-<i>nnn</i>-<i>nnnn</i></i> is the connection telephone number</p> <p>T60 is the time in seconds to wait for a connection to complete</p> <p>R3 is the number of times to retry a connection attempt.</p> <p>Comment We recommend that you use the default time and retry settings.</p>
3	<p>Set mailbox ID and password. You must set it in three separate places:</p> <pre>KEY \$\$REQ ID=<i>xxxxx</i>R BID='<i>nnnnnnn</i>' -x</pre> <pre>KEY \$\$REQ ID=<i>xxxxx</i>D BID='<i>nnnnnnn</i>' -x</pre> <pre>KEY \$\$ADD ID=<i>xxxxx</i>D BID='<i>nnnnnnn</i>' -x</pre> <p>Where</p> <p><i>xxxxx</i> is the five character network mailbox ID</p> <p><i>nnnnnnn</i> is the seven digit password.</p> <p>Warning These are the only changes to the job file approved by IBM. Any other changes will NOT be supported by IBM Customer Support.</p>

How to Start Up Cleo A+

Description

Interface Systems' Cleo A+ is an asynchronous communications package that uses sophisticated scripting to handle various types of communications. It supports several file transfer methods, including raw ASCII, Xmodem, Ymodem, Zmodem, Kermit, and ANSI CLEAR. It can also perform as an FTP tool, using SLIP, PPP, Telnet, or local modes.

Cleo A+ start-up command

The Cleo A+ start-up command consists of the command to execute the application A+ and several parameters. The two most important parameters are the job file and tokens, which are explained below.

The rest of the information that you can place in the start-up command is identified within the *job* file. A log file is generated automatically.

.job file

This parameter identifies the job file to use for the session. The job file determines how Cleo manages a communication session. There is a separate job file for each VAN which ends with the extension *.job*. For example, the Advantis job file is *advsr.job*.

This table lists the job file that corresponds to each supported VAN.

VAN Async (COMM/CleoA/.)	Job File
Sterling Information Broker via CompuServe	.cnetsr.job
Advantis Expedite/Async	.advsr.job
GEIS EDI*Express	.geissr.job

Tokens A **token** is a piece of information that is passed to a job, such as the VAN telephone number or your VAN ID. The token parameter identifies the tokens to be passed to the job as it is running.

This table lists the available A+ tokens for each VAN.

VAN	Token Number	Description
Advantis	1	Telephone/modem access number. (n- <u>nnn</u> - <u>nnn</u> - <u>nnnn</u>)
	2	IBM Network Account ID.
	3	IBM Network User ID.
	4	IBM Network Password.
	5	Information Exchange Network Account ID.
	6	Information Exchange Network User ID.
	7	Information Exchange Network Password.
Sterling Information Broker	1	Telephone/modem access number. (n- <u>nnn</u> - <u>nnn</u> - <u>nnnn</u>)
	2	Mailbox ID. (Sxxxx)
	3	Mailbox password. (nnnnnnn)
	4	Mailbox Application ID obtained from network support. (EDIx)
	5	Report slot ID. (xxx)
	6	Data slot ID. (xxx)
	7	Node access host. (compu)
GEIS	1	Telephone/modem access number. (n- <u>nnn</u> - <u>nnn</u> - <u>nnnn</u>)
	2	GEIS Network User Number.
	3	GEIS Network User Password.
	4	Last three digits of the GEIS User Number.

**Example start-up
command**

```
A+ jobfile=./cnet/cnetsr.job "tokens=18005551212 SX999 1234567 EDIx R D mci"
```

How to Start Up Cleo 3780Plus

Description Interface Systems' Cleo 3780Plus is a bisynchronous communications package that uses scripting to handle various types of communications. It supports 2780/3780 bisync protocols by using a piece of hardware to convert ASCII data to EBCDIC data for transmission and EBCDIC data to ASCII data upon reception of the EBCDIC data.

Cleo 3780Plus start-up command

The Cleo 3780Plus start-up command consists of the Cleo command 3780Plus' along with several other parameters. These are required parameters:

Parameter	Description	
-d	Identifies the device or communications port to use this session.	
-j	Identifies the <i>.job</i> file to run.	
	VAN Bisync (COMM/CleoB/..)	Job File
	Sterling Information Broker	<i>.cnetsr.job</i>
	Advantis Expedite/Direct	<i>.advsr.job</i>
	GEIS EDI*Express	<i>.geissr.job</i>
-k	Used to pass the tokens to the <i>.job</i> file as it is running.	

You can use the following optional parameters in the start-up command.

Parameter	Description
-c	Identifies the configuration file to use. The <i>.job</i> file includes this information.
-LO	Directs Cleo to generate a new log for the session if one does not exist in the COMM directory or overwrite an existing one. This command is recommended.

Note

The log is not required. However, IBM Customer Support personnel must have the log to assist you in troubleshooting any communication difficulties you may encounter.

GEIS and Advantis tokens

This table lists the available 3780Plus or AllSync tokens for GEIS and Advantis.

Note

To control startup of bisynchronous communications for Sterling Information Broker, you need to edit the job file instead of using tokens.

Reference

See the [How to Set Up Bisynchronous Communications](#) topic in this chapter.

VAN	Token Number	Description
Advantis	1	Connection telephone number.
	2	IBM Network Account ID.
	3	IBM Network User ID.
	4	IBM Network Password.
	5	Information Exchange Network Account ID.
	6	Information Exchange Network User ID.
	7	Information Exchange Network Password.
GEIS	1	Connection telephone number.
	2	GEIS Network User Number.
	3	GEIS Network User Password.
	4	Last three digits of the GEIS User Number.

Example start-up command

```
3780Plus -d /dev/tty03 -j ./geis/geissr.job -k 18005551212 GEISID GEISPSWDnnn -LO
```

Start-Up Procedure Examples

Introduction

Communications is not a Sterling Gentran:Server application and the procedures to start communications can vary from environment to environment. Once communications are set up, you use the same commands to start it regardless of the platform.

Initiating communications through automated procedures

The communications toolkit has certain expectations regarding file placement. You can automate processes to move the file to and from the VAN directories. You can also automate the start-up process using *.bat* files created in DOS or Windows, or shell scripts created in UNIX or open systems.

Examples

The following examples show what you can implement into an automated communications procedure.

DOS or Windows Users .BAT File Example

```
copy C:\Server\ediout?.fil C:\Server\comm\cleoa\cnet\cnets
del C:\Server\ediout?.fil
cd \Server\comm\cleoa
aplus jobfile=.\cnet\cnetsr.job "tokens=5551212 SX999 1234567 EDIx R D mci"
copy C:\Server\comm\cleoa\cnet\cnetr C:\Server\comm\cleoa\ediin?.fil
del C:\Server\comm\cleoa\cnet\cnetr
```

UNIX Systems Users Shell Example

```
cp/Server/ediout?.fil /Server/comm/cleoa/cnet/cnets
rm/Server/ediout?.fil
cd/Server/comm/cleoa
A+ jobfile=./cnet/cnetsr.job "tokens=5551212 SX999 1234567 EDIx R D mci"
***error recovery procedures ie; if $? =gt 0 ...****
```

```
cp /Server/comm/cleoa/cnet/cnetr /Server/edliin?.fil
```

```
rm /Server/comm/cleoa/cnet/cnetr
```

**Example start-up
command**

```
3780Plus -d /dev/tty03 -j ./geis/geissr.job -k 18005551212 GEISID GEISPSWD -LO
```

Troubleshooting

Communications Session Error Recovery

Introduction

With communications applications, failures can occur. The communications scripts developed by IBM are designed to handle common communications errors.

Error messages and end codes

The communications script files (<van>sr.job files), have an “error Fall Thru” section. This section lists the messages that the Cleo application writes to the .log file. Each time a session error occurs, the .job file posts a relevant error message to the log and returns an end code when it exits the Cleo application. You can use this end code in a shell script (UNIX) or .bat file (DOS/Windows) to decide whether communications ended successfully. An end code of 0 indicates success and a non-zero value indicates a failure. The various end code values indicate why the failure occurred.

Sterling Information Broker Async end codes

This table describes the possible end codes generated by a Cleo application in Async (A+) mode and the meaning of each.

Sterling Information Broker Async (A+)	
End Code	Meaning
0	Session successful; continue processing.
Non-zero values:	Require further examination
35	Error occurred during dial attempts; connection never established.
50	Error occurred at some point during the logon process to the network. Connection established to communication node but no session established with host.
60	Error occurred while attempting to transmit your outbound data to the network; resend data.
70	Error occurred while attempting to receive inbound data or reports from the network; any data to be sent during that session was NOT sent; retry may be required.

**Sterling
Information
Broker Bisync
end codes**

This table describes the possible end codes generated by a Cleo application in Bisync (3780Plus) mode and the meaning of each.

Sterling Information Broker Bisync (3780Plus)	
End Code	Meaning
0	Session successful; continue processing.
Non-zero values:	Requires further examination
35	Error occurred during dial attempts; connection never established.
40	Error occurred during receive process for inbound data or reports from the network; retry may be required.
50	Error may have occurred at some point during transmittal of 'request cards', 'add' card', or outbound data file; retry may be required.

**Advantis
Expedite/Direct
Async end codes**

This table describes the possible end codes generated by a Cleo application in Async (A+) mode and the meaning of each.

Advantis Expedite/Direct Async (A+)	
End Code	Meaning
0	Session successful; continue processing.
Non-zero values:	Requires further examination
35	Error occurred during dial attempts; connection never established.
40	Error occurred during logon process; session never established communication to Advantis network, even though connection was made.
50	Error occurred during transmittal of outbound data to Advantis network.
55	Error occurred during transmittal of outbound flat file data to Advantis network.

(Contd) Advantis Expedite/Direct Async (A+)	
End Code	Meaning
60	Error occurred during reception of inbound data from Advantis network; retry may be needed.
65	Although data may have been collected by communications, Advantis may not recognize this because the session failed after the data was received; they may send duplicate data in following session.
70	Logoff process failed and Advantis may not have collected or acknowledged your receipt of data.

**Advantis
Expedite/Direct
Bisync end
codes**

This table describes the possible end codes generated by a Cleo application in Bisync (3780Plus) mode and the meaning of each.

Advantis Expedite/Direct Bisync (3780Plus)	
End Code	Meaning
0	Session successful; continue processing.
Non-zero values:	Requires further examination
35	Error occurred during dial attempts; connection never established.
40	Error occurred during logon process; session never established communication to Advantis network even though connection was made.
50	Error occurred during transmittal of data.
55	Error occurred during transmittal of 'receive' and 'receive log' commands occurred, or acknowledgment from Advantis never received.
60	Error occurred during receive process for inbound data file or reports from Advantis.

**GEIS
EDI*Express
Async end codes**

This table describes the possible end codes generated by a Cleo application in Async (A+) mode and the meaning of each.

GEIS EDI*Express Async (A+)	
End Code	Meaning
0	Session successful; continue processing.
Non-zero values:	Require further examination
35	Error occurred during dial attempts; connection never established.
40	Error occurred during logon process; session never established communication to GEIS network, even though connection was made.
50	Error occurred during transmittal of commands associated with sending outbound data to Advantis network; data never sent.
55	Error occurred during transmittal of outbound data to GEIS network.
60	Error occurred during transmittal of receive commands for inbound data from GEIS network.
65	Error occurred during reception of data from GEIS network.
70	Error occurred during logoff.

**GEIS
EDI*Express
Bisync end
codes**

This table describes the possible end codes generated by a Cleo application in Bisync (3780Plus) mode and the meaning of each.

GEIS EDI*Express Bisync (3780Plus)	
End Code	Meaning
0	Session successful; continue processing.
Non-zero values:	Requires further examination
35	Error occurred during dial attempts; connection never established.
40	Error occurred during logon process; session never established communication to GEIS network even though connection was made.
50	Error occurred during transmittal of commands associated with sending outbound data to Advantis network; data was never sent.
55	Error occurred during transmittal of outbound data to GEIS network.
60	Error occurred during transmittal of receive commands for inbound data from GEIS network, or failure occurred receiving data from GEIS network.
65	Error occurred during transmission of *EOS command; session may not even be recorded on GEIS network side.

Cleo 3780Plus Troubleshooting

Introduction

This section offers possible solutions to three of the most common situations. See your Cleo documentation for further information.

Problem and solution table

This table lists common problems and solutions.

Problem	Possible Solution
During a RECEIVE process, you encounter a WAIT error.	Increase the Wait Limit parameter in the Cleo configuration file (cnet.cfg, adv.cfg, or geis.cfg).
During a SEND process, you encounter a RETRAN error.	Increase the Retransmission Limit parameter in the Cleo configuration file (cnet.cfg, adv.cfg, or geis.cfg).
At any point in the session, you encounter a BIDLMT error.	<p>Check the documentation for your modem and verify that it can handle synchronous communications, then try again.</p> <p>If the problem continues, contact IBM Customer Support for information and assistance.</p> <p>Note The BIDLMT error can occur when you attempt to connect to a bisynchronous line at a speed other than that of the line. For example, if you attempt to connect to a 9600 bisynchronous line at 2400 baud.</p>

Connecting to Other VANs and Directly to Trading Partners

Introduction

If you need to connect to a trading partner directly or to a VAN that is not supported by the Communications Toolkit, you will need to create a Cleo communications script to connect to the VAN. You may also need to create a configuration file.

About creating communications scripts

Scripts are usually created as ASCII text files, which you do not need to compile.

Cleo 3780Plus

The Cleo 3780Plus communications application software enables an ASCII system to emulate a 2780 or 3780 terminal. With 3780Plus, you can transmit and receive data from any system that supports the 2780 or 3780 bisynchronous protocols.

The scripting facility in Cleo 3780Plus is relatively simple to use. However, you must understand the session protocol that the remote system requires.

Basic Cleo 3780Plus commands

The table below lists some *basic* Cleo commands and descriptions. See your Cleo 3780Plus documentation for more detailed information.

Command	Description
AUTODIAL tel# Txx Rxx	<p>Used to dial remote system modems for a communications connection.</p> <ul style="list-style-type: none"> ▶ tel# = The number to connect to. ▶ Txx = The timer delay for waiting for an answer from the remote modem. ▶ Rxx = The retry parameter for number of attempts to retry if the dial attempt fails.
KEY msg -ENRX	<p>Used to send a user a specified message. Often used to send commands such as a system logon to a remote system. Unless otherwise specified, Cleo automatically transmits an End of Transmission (EOT) character when the message transmission is complete.</p> <p>The switches that follow the command are used for protocol and translation functions.</p> <ul style="list-style-type: none"> ▶ -E = Suppress an EOT character after the message is transmitted. ▶ -X = Suppress an End of Text (ETX) character as well as an EOT character after the message is sent. ▶ -N = Send non-transparent data from the message through “as is” (no translation). ▶ -R = Suppress inter-record separators from the transmitted message.
TEXT path/filename - ENRX	<p>Used to transmit specified files to the remote system. The switches that follow the command (-ENRX) are used for protocol and translation functions. See descriptions above.</p>

(Contd) Command	Description
RECEIVE path/filename - NX	<p>Used to receive files from the remote system to a specified path and filename. A received EOT character terminates the command. A received ETX character causes Cleo to terminate the write to the specified file and start writing into an incremented filename. Depending on the user filename, Cleo may overwrite the previous data in the specified file.</p> <p>Switches:</p> <ul style="list-style-type: none"> ▶ -X = Ignore incoming ETX characters ▶ -N = Allow transparent data to be received “as is” (no translation)
VOICE	<p>Hangs up the phone and terminates a session. Usually, the command to terminate the Cleo 3780Plus application (QUIT) follows this command.</p>

Suggestions

- ▶ Reference the 3780Plus documentation to learn about the many other session script commands, startup options, and other functions not discussed in this appendix.
- ▶ Make sure you are familiar with all the options on the commands before you use them.
- ▶ Use the 3780.LOG file to review sessions for errors that may have occurred during the previous communications sessions.
- ▶ There is a Monitor file you can use as a line scope to determine what is being transferred to and from your system. This monitor is in EBCDIC Hexadecimal code. There is a conversion chart in the 3780Plus documentation that may help you read this trace.

Cleo A+

Cleo A+ enables users to transmit and receive files from systems that support asynchronous file transfer protocols. You can run sessions interactively or use scripts you have written to perform unattended functions. Several configuration options are available for file transfer: ASCII, Xmodem, Ymodem, Zmodem, Kermit, ANSI, and FTP (slip, ppp, telnet).

The scripting facility in Cleo 3780Plus is relatively simple to use. However, you must understand the session protocol that the remote system requires. A+ allows use of environment variables, user-defined variables, and the ability to control file naming during a session.

Basic Cleo A+ commands

This table includes descriptions of *basic* Cleo A+ commands used to start a dialup, send commands to a remote system, receive files, send files, and terminate the connection. See your CleoA+ documentation for more detailed information.

Command	Description
AUTODIAL tel# Txx Rxx	<p>Used to dial remote system modems for a communications connection.</p> <ul style="list-style-type: none"> ▶ tel# = The number to connect to ▶ Txx = The timer delay for waiting for an answer from the remote modem ▶ Rxx = The retry parameter for number of attempts to retry if the dial attempt fails
KEY msg -NTR	<p>Used to send a user a specified message. Often used to send commands such as a system logon to a remote system. Unless otherwise specified, Cleo automatically transmits a CR character when the message transmission is complete.</p> <p>The switches that follow the command are used for protocol and translation functions.</p> <ul style="list-style-type: none"> ▶ -N= Send non-transparent data from the message through “as is” (no translation). ▶ -T= Force message through the translation table. ▶ -R= Suppress carriage return (CR) from the end of the transmitted message.
SEND path/filename / remote filename -TN	<p>Used to transmit specified files to the remote system. The remote filename parameter is used to send the same filename to the remote system. The switches that follow the command (-TN) are used for translation functions.</p> <ul style="list-style-type: none"> ▶ -T= Force message through the translation table. ▶ -N= Send non-transparent data from the message through “as is” (no translation).

(Contd) Command	Description
RECEIVE path/filename - NT	<p>Used to receive files from the remote system to a specified path and filename. Depending on the file transfer type you are using, when the receive is complete, A+ attempts to write to the specified file or into an incremented filename. A+ may overwrite the previous data in the specified file, depending on the filename.</p> <p>Switches:</p> <ul style="list-style-type: none"> ▶ -N= Allow transparent data to be received “as is” (no translation). ▶ -T= Force the outbound data through the translation table.
VOICE	<p>Hangs up the phone and terminates a session. Usually, the command to terminate the Cleo 3780Plus application (QUIT) follows this command.</p>

Suggestions

- ▶ Reference the A+ documentation to learn about the many other session script commands, startup options, and other functions not discussed in this appendix.
- ▶ Make sure you are familiar with all the options on the commands before you use them.
- ▶ Use the A+.LOG file to review sessions for errors that may have occurred during the previous communications sessions.

Configuration file

Depending on your trading partner requirements, you may need to create a configuration file. The important thing to remember is that the settings defined in the configuration file that pertain to your system or your modem should always be in sync with each other. Be sure to talk to staff at the remote site to determine its requirements for connection. Never assume anything will work. Even if you guess on how to establish the connection you will still need to determine the session protocol. Talk to your remote staff!

Extended Communications Support Services (ECS)

If you do not have the resources required to develop the communications or configuration file, IBM offers consulting services to create, maintain, install, and test communications. Contact IBM Customer Support and ask for communications support for information.

Introducing Sterling Gentran:Server

Content

- ▶ Introduction 2
- ▶ Sterling Gentran:Server Features 4
- ▶ Sterling Gentran:Server Architecture 6
- ▶ Running Multiple Sessions 7
- ▶ File Name Conventions 11

Introduction

Welcome Welcome to Sterling Gentran:Server, the electronic data interchange (EDI) software that makes it easy to manage data exchanges between you and your trading partners. The heart of EDI is the translation of data into and out of formats that are intelligible to computerized data management systems.

Sterling Gentran:Server enables you to exchange data with your trading partners. When you send application data, Sterling Gentran:Server converts your data into EDI standard formats that can be understood by your trading partners. When you receive data in a standardized format, Sterling Gentran:Server translates the data into a format your application can understand.

You can use Sterling Gentran:Server to describe your applications, edit standards, maintain trading partnership information, and generate translation “maps,” which are sets of instructions for translating data.

Note

If your company purchased the XML translation option, you can also exchange data in XML format. See the *IBM® Sterling Gentran:Server® for UNIX XML User Guide* for more information.

In this chapter This chapter contains background information about Sterling Gentran:Server that you should know before beginning to use the software.

Key terms This table describes key terms used in this chapter.

Term	Description
application	The business software generating the business information that you are sending or receiving electronically.
default	A value that is automatically assigned.
EDI	Electronic Data Interchange. Application-to-application transfer of key business transaction information in a standard or XML format via a computer-to-computer communication link.
EDI standard	A format to regulate syntax, structure, and content of transaction data.

(Contd) Term	Description
map	A file that contains the relationships between: <ul style="list-style-type: none"> ▶ The segments and elements of a standard EDI document and the data fields in your application ▶ The elements in an XML document and the data fields in your application, EDI standard document, or in another XML document ▶ The segments and elements of two different standards ▶ The records and fields of two different applications
master directory	The directory on a PC that stores your master files.
master file	The version of a map that Sterling Gentran:Server uses to process data.
standard format	A format intelligible to computerized data management systems.
temporary file	A file on the client that Sterling Gentran:Server uses during editing and compiling.
trading partner	The company, division, or group with which you are exchanging business data electronically.
Trading Partnership	An arrangement to exchange information in a specific document type with a specific trading partner and using a particular standard version.
working file	A file that is stored in the user working directory on the client while the user has it checked out for editing.
working file directory	The directory created on the client to hold the files that a user is editing.

Sterling Gentran:Server Features

Introduction This summary lists the features Sterling Gentran:Server provides for your translation needs.

Product versions There are two basic versions of Sterling Gentran:Server:

- ▶ IBM® Sterling Gentran:Server® for UNIX - Workstation, which runs on a PC
- ▶ IBM® Sterling Gentran:Server® for UNIX, which runs on a client/server architecture

Sterling Gentran:Server Workstation architecture The Workstation architecture provides:

- ▶ A Windows® interface.
- ▶ All files and processing on one machine.
- ▶ Single-user configuration; no file-sharing or security limitations.
- ▶ Standard Sterling Gentran:Server functions.

Multiple Help sources Sterling Gentran:Server provides Help through:

- ▶ Wizards to guide you through the key record-creation processes.
- ▶ Online Help with task-oriented content.
- ▶ Documentation provided on CD-ROM for online access.

Automated functions The following features automate many tasks for you.

Archiving

- ▶ Stores and retrieves both EDI and user-defined data
- ▶ Tracks key EDI activities; provides reports and audit trails of translations

Functional Acknowledgments

- ▶ Handles inbound and outbound functional acknowledgments and reconciliation
- ▶ Provides status information for each document

Task Scheduler

- ▶ Runs processes such as upload and download, translation, communications, and other tasks in a totally unattended mode

Mappers The Application Integration system is available in Sterling Gentran:Server.

Sterling Gentran:Server Architecture

Introduction This topic describes the IBM® Sterling Gentran:Server® for UNIX - Workstation architecture.

Description All Sterling Gentran:Server files are installed on a PC. The PC stores the data, houses the user interface, and runs the processes.

Advantages The Workstation architecture provides the following advantages:

- ▶ Allows users familiar with PCs to quickly learn how to use the Sterling Gentran:Server interface
- ▶ Provides a single-user control over data and processes

Running Multiple Sessions

Definition A **session** is a single instance of the Sterling Gentran:Server application running in a window on your desktop.

Sterling Gentran:Server does not limit you to a single session; you can run more than one instance of IBM® Sterling Gentran:Server® for UNIX client software or IBM® Sterling Gentran:Server® for UNIX - Workstation at the same time. Each time you start Sterling Gentran:Server on your desktop, you start a new session. Each session runs in a different window. Running multiple sessions enables you to perform different Sterling Gentran:Server tasks in each window.

How many sessions can you run?

You can run:

- Up to four sessions of the IBM® Sterling Gentran:Server® for UNIX client software at the same time on one Windows desktop
- Up to four sessions of IBM® Sterling Gentran:Server® for UNIX - Workstation at the same time on one Windows desktop
- IBM® Sterling Gentran:Server® for UNIX - Workstation and IBM® Sterling Gentran:Server® for UNIX client software at the same time on one desktop.

Example

You run three simultaneous sessions of the Sterling Gentran:Server client software for the host1 and environment XYZ combination:

- Session 1, view a file with the File Browser
- Session 2, search for a Trading Partnership record
- Session 3, create a new category

Performance limitations

Each additional session you start degrades performance. Opening too many sessions at once can cause the client to lock.

Login requirements for UNIX

When you start another Sterling Gentran:Server session for a host and environment that is running on your desktop, you must use the same User Name and Password to log onto the new session.

If you want to start a session for a different host or environment, you can use a different User Name and Password.

Process and session limits

If you open multiple sessions on your desktop, the sessions can be for the:

- ▶ Same host and environment (IBM® Sterling Gentran:Server® for UNIX)
- ▶ Same host and different environments (IBM® Sterling Gentran:Server® for UNIX)
- ▶ Different hosts and environments (IBM® Sterling Gentran:Server® for UNIX)
- ▶ Combination of IBM® Sterling Gentran:Server® for UNIX - Workstation sessions and IBM® Sterling Gentran:Server® for UNIX sessions.

This table shows the limitations on running processes in multiple sessions.

Process	Limitations
File Browser	None. Multiple windows permitted in each session.
Trading Partnership Maintenance	None. Multiple windows permitted in each session.
Process Control Manager	Once in a session for each host/environment combination.
SAP Configuration (if purchased)	Once in a session for each host/environment combination.
Archive	Once in a session for each host/environment combination.
EC Workbench server	One client session for each host/environment combination. You can run EC Workbench multiple times as long as each Client session is for a different host/environment combination.
Translation	One client session for each host/environment. You can run translation multiple times as long as each session is for a different host/environment combination.
Map Compilation	One client session at a time.
Mapping	None. Multiple windows permitted in each session

If a process has session limitations and is already running, Sterling Gentran:Server displays a message to let you know that the process is busy and asks that you try again later.

File locking

Sterling Gentran:Server locks certain files to prevent you from editing the same file in multiple sessions. If you attempt to edit a file that you are editing in another session, Sterling Gentran:Server displays a message to let you know that the file is in use.

Sterling Gentran:Server locks these files when you open them for editing:

- Maps
- Trading Partner record
- Group Organization record
- Interchange Organization record

Exceptions

Locking does not apply to:

- Files edited in the File Browser
- Trading Partnership Category files
- Trading Partnership Contact files

Note

If the same non-DISAM file is edited in two different parallel sessions, the last changes saved overwrite earlier changes from another session.

Caution

Never use the File Browser to edit a DISAM (*.dat and *.idx pair) file. Doing so will corrupt the file.

Report, log and local temporary files

Sterling Gentran:Server keeps the report files, log files, and local temporary files for each host and environment in different directories.

The system creates a directory named **rpt** for the report and log files under the directory where the Sterling Gentran:Server client software is installed. The local temporary working files are stored in the **lcltmp** directory.

For each host and environment, the system creates a subdirectory under the **rpt** and **lcltmp** directories. The subdirectory is named for the environment and host name (environment+hostname) logged in to for the session.

Example

The Sterling Gentran:Server client software is installed in D:\gentran. The system creates subdirectories for the report files and for the local temporary files:

- ▶ D:\gentran\rpt
- ▶ D:\gentran\lcltmp

You start a session, logging in to the 60test environment on the host hpd350. Sterling Gentran:Server creates subdirectories for the session:

- ▶ D:\gentran\61testhpd350
- ▶ D:\gentran\rpt\61testhpd350
- ▶ D:\gentran\lcltmp\61testhpd350

Sterling Gentran:Server stores the session report and log files in D:\gentran\rpt\61testhpd350 and stores the session local temporary files in D:\gentran\lcltmp\61testhpd350.

You open a session for a different environment and host, 2XF on hpd001. Sterling Gentran:Server creates new subdirectories for the report and local temporary files:

- ▶ D:\gentran\2XFhpd001
- ▶ D:\gentran\rpt\2XFhpd001
- ▶ D:\gentran\lcltmp\2XFhpd001

Note

If the host or environment name contains special characters (such as *, ?, <, or >), the system converts the special characters to underscores (_). For example, the host name hp<200> is converted to hp_200_.

File Name Conventions

Introduction This topic describes the file name conventions and limitations you must follow when you name a Sterling Gentran:Server file or directory.

Directory and path name length Directory names can be up to 63 characters in length, not counting the slash or backslash character used to separate a directory name from a subdirectory name.

The total maximum for a path, file name, and file name extension is 128 characters.

Validation When you save or open a file, Sterling Gentran:Server checks the length of the file name and the characters used in the file name. If the file name exceeds the maximum length or if the file name includes an invalid character, Sterling Gentran:Server displays a message to alert you of the problem.

File name length

This table lists length restrictions of the file names of specific types of Sterling Gentran:Server files:

File Type	Maximum Length of Name
Map	60 (plus 4-character extension)
File definition	60 (plus 4-character extension)
Application description	60 (plus 4-character extension)
Implementation guide	60 (plus 4-character extension)
Input file	60 (plus 4-character extension)
Output file	60 (plus 4-character extension)
Mapping table	60 (plus 4-character extension)
Script	14 characters
Data manager	4 characters
Data manager pattern	15 characters
Transaction Register	9 characters
Queue	8 characters

Character limitations

This table lists the characters that Sterling Gentran:Server does not allow in a file name.

Character	Description
\	Backslash (reserved for separating directory, subdirectory, and file names)
/	Slash (reserved for separating directory, subdirectory, and file names)
*	Asterisk
“	Double quotation mark
‘	Forward single quotation mark
’	Backward single quotation mark
<	Less-than sign
>	Greater-than sign
	Vertical bar
	Spaces
@	“At” sign
&	“Ampersand” character
(Open round bracket
)	Closed round bracket
;	Semi-colon
:	Colon
?	Question mark
\$	Dollar sign

Using Sterling Gentran:Server

Content	▶ Introduction	2
	Starting and Exiting	
	▶ How to Start Sterling Gentran:Server	3
	▶ How to Exit Sterling Gentran:Server	4
	The Sterling Gentran:Server User Interface	
	▶ Overview	5
	▶ The Main Window	6
	▶ Main Window Menus	8
	▶ The Main Window Toolbar	10
	▶ How to Use the Sterling Gentran:Server Interface	11
	▶ How to Use the On-line Help	12
	▶ The File Browser	14
	▶ How to Use the File Browser	16
	▶ How to Change Print Properties	19
	Setting Default Values	
	▶ Overview	20
	▶ Set Up Directories Dialog Box	22
	▶ How to Change the Default Workstation Directories	24

Introduction

In this chapter

This chapter contains general information about the Sterling Gentran:Server interface. It describes the menus and Toolbar of the Main Window and includes instructions for:

- ▶ Starting and exiting Sterling Gentran:Server
- ▶ Using menus, toolbar buttons, and dialog boxes
- ▶ Using the File Browser to edit text, EDI, and NCPDP files
- ▶ Choosing printing properties
- ▶ Setting Sterling Gentran:Server preferences and default values

Key terms

This table describes key terms used in this chapter.

Term	Description
check box	A square to the left of an option in a dialog. When the option is selected, the square contains an X. You click the check box to change whether the option is selected.
default	A value that is automatically assigned.
master directory	The directory on a PC that stores your master files.
menu	A list of related commands.
menu bar	The row of menu names that runs across the top of a window.
option button	A round button used to select one option from a mutually exclusive set of options.
push-button	A symbol or icon that initiates some action when you click it.
text box	A box into which you enter alphanumeric text to provide data needed by Sterling Gentran:Server.
Toolbar	A bar of buttons used to start commands.

Starting and Exiting

How to Start Sterling Gentran:Server

Introduction This topic explains how to start Sterling Gentran:Server.

Note

You can run up to four sessions of Sterling Gentran:Server on the same desktop at once.

Procedure Follow this procedure to start Sterling Gentran:Server.

Step	Action
1	Click the Windows Start menu.
2	Select the Sterling Gentran:Server program icon from the Programs menu. System Response Sterling Gentran:Server displays the copyright dialog box.
3	Click OK . System Response Sterling Gentran:Server displays the Main Window.

Reference

See the *How to Set TP Administration Preferences* topic in the *IBM® Sterling Gentran:Server® for UNIX Application Integration User Guide* for instructions on setting Trading Partnership Administration Preferences.

How to Exit Sterling Gentran:Server

Introduction This topic explains how to exit Sterling Gentran:Server.

Before you exit Any files that are checked out when you exit the application remain checked out and unavailable for other users to edit. Before you exit Sterling Gentran:Server, be sure to check in any files that you no longer need.

Reference

See [How to Check In Maps and Translation Objects](#) and [How to Check In File Definitions](#) in the [Working with Application Integration](#) chapter.

Procedure Select **Exit** from the **File** menu.

Note

If you are running multiple sessions on your desktop, you must exit each session.

System Response

Sterling Gentran:Server exits.

The Sterling Gentran:Server User Interface

Overview

Introduction

Sterling Gentran:Server features on the client use the Windows environment. To use Sterling Gentran:Server, you must be familiar with using a personal computer and with Windows functions and terminology, including the following:

- The terminology used to describe mouse and cursor actions; for example, opening, clicking, scrolling
- The terminology used to describe Windows-specific attributes, such as dialog boxes, buttons, and check boxes.

User interface

The user interface for all versions of Sterling Gentran:Server includes:

- Screens that use the familiar Windows interface.
 - Graphical tree organization of trading partnership records to make setup and maintenance easier.
 - Graphic displays of mapping components and relationships.
-

The Main Window

Introduction This topic explains the items you see on the Sterling Gentran:Server Main Window.

Reference

Refer to your Windows documentation for detailed explanations of Windows terms and functions.

Main Workstation window

This illustration shows the major parts of the main window for Sterling Gentran:Server.

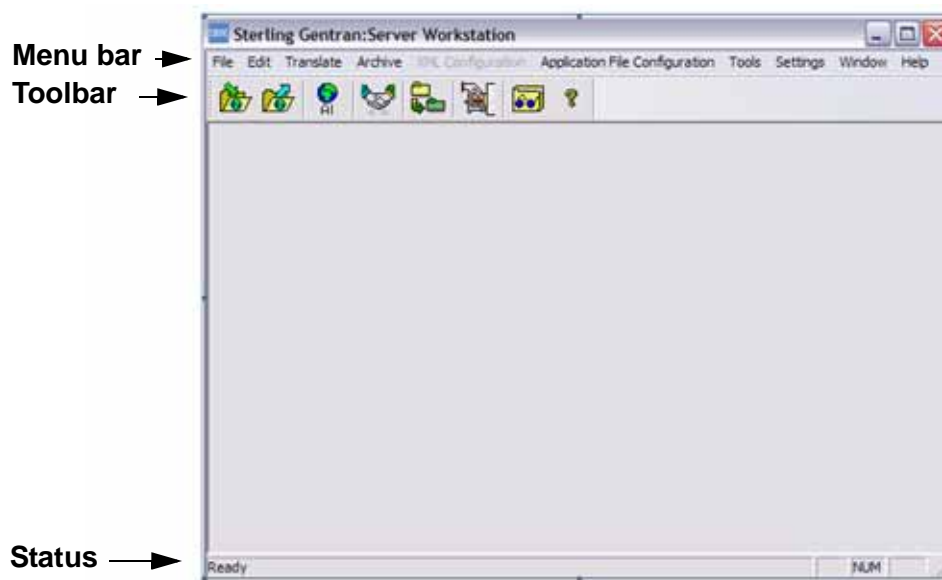

Parts of the window

This table describes the parts of the main Sterling Gentran:Server window.

Part	Function
Menu bar	Opens menus to display commands.
Toolbar	Starts commands from a set of buttons.
Status bar	Displays a status message, prompt, or toolbar button description.

Main Window Menus

Introduction You can start all Sterling Gentran:Server features and functions from the menus of the Sterling Gentran:Server Main Window.

**Workstation
Main Window
menus**

This table describes the menus of the Workstation Main Window.

Menu	Used to...
File Menu	<ul style="list-style-type: none"> ▶ Check in a file ▶ Check out a file ▶ Unlock a file ▶ Open the Print Setup dialog box ▶ Exit the Main Window
Edit Menu	<ul style="list-style-type: none"> ▶ Start a mapping editor ▶ Start the Trading Partnership Administration system
Translate	<ul style="list-style-type: none"> ▶ Open the Translate Documents dialog box ▶ Generate a translation report.
Archive	<ul style="list-style-type: none"> ▶ Set archiving parameters ▶ Open an archive ▶ Purge an archive ▶ Load and unload archived files ▶ Create new archives
XML Configuration (if you purchased the XML translation option)	<ul style="list-style-type: none"> ▶ Open the XML Element Configuration window ▶ Start the XML Trading Partnership Rules wizard ▶ Open the XML TP Cross Reference dialog box.
Application File Configuration	<ul style="list-style-type: none"> ▶ Start the Application File Trading Partnership Rules wizard ▶ Open the Application File TP Cross Reference dialog box.

(Contd) Menu	Used to...
Tools	<ul style="list-style-type: none">▶ Set up and Run scheduled tasks▶ Run Standard Version Conversion▶ Start the File Browser▶ Open the Run a Command dialog box to run a command line program
Settings	Specify default directories for your Sterling Gentran:Server files
Window	<ul style="list-style-type: none">▶ Display or hide the Toolbar▶ Display or hide the Status Bar
Help	<ul style="list-style-type: none">▶ Open the Help Contents or Index▶ Display information about using Help▶ Display version information for Sterling Gentran:Server

The Main Window Toolbar









Introduction

The Sterling Gentran:Server Toolbar consists of several buttons that you can use to quickly access Sterling Gentran:Server systems, tools, and optional features.

The specific buttons displayed on your toolbar depend upon the Sterling Gentran:Server product and options your company purchased. This topic describes the most common buttons. Your toolbar may include additional buttons for optional features.

The Main Window Toolbar

To execute a command with a toolbar button, click the appropriate button.

Click this...	To do this...
	Check in files.
	Check out files.
	Open the Application Integration mapping editor.
	Open the Trading Partnership Administration system.
	Open the Translate Documents dialog box or generate a translation report.
	Start an archiving option.
	Open the File Browser text editor.
	Display Help for the current window.

How to Use the Sterling Gentran:Server Interface

Introduction This topic explains how to use the Sterling Gentran:Server menus, toolbars, dialog boxes, and other interface features.

Using the Toolbar To start a feature or system from the Toolbar, click the appropriate Toolbar button.

Note

For information about a Toolbar button, place the pointer on the button to display the button name and then refer to the Status Bar for the button function.

Using the Status Bar The status bar displays information, descriptions, or instructions for the active window, item on a dialog box, toolbar button, or command. You may see a status such as “Ready” for a window, an instruction such as “Enter record ID” for a text box on a dialog box, or “File Browser” for a Toolbar button.

To use the Status Bar, move the pointer to the window, box, or button that you want to check and then read the text displayed on the Status Bar.

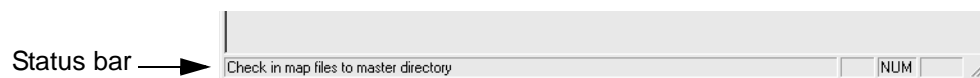

Using dialog boxes You enter information within a dialog box by:

- ▶ Typing in text boxes
- ▶ Selecting items from list boxes
- ▶ Clicking check boxes, options, or push buttons.

To move to the desired box or button, use either the mouse or the keyboard.

- ▶ When using the mouse, move the mouse pointer to the desired box or button and click to select the box or button.
- ▶ When using the keyboard, press TAB to move to the next box or button or press SHIFT+TAB to move to the previous box or button.

How to Use the On-line Help

Introduction

Sterling Gentran:Server provides Help information to guide you through commands and procedures. Sterling Gentran:Server Help files explain many topics: parts of the active window, commands, dialogs, and procedures for using specific features to perform a task.

Getting Help

You can access Help several ways. The methods available depend on the window you have displayed.

To start Help from...	Do this...
The menu bar	Select a command or topic from the Help menu.
The toolbar	Click the Help button on the toolbar for information about the currently displayed dialog box or window.
Any window	Press F1 for information about the window.
A dialog box	Click the Help button on the active dialog box for related help information.

Using the Help menu

To learn how to use Help, select **Using Help** from the Help menu.

The Contents command from the Help menu displays a list of Help topics that you can choose from. You can access Help information for the topics in different ways; you can use the menus at the top of the **Help** window, or you can use the buttons under the menus to search for a topic. You can print and edit Help information.



Using the Help toolbar button

On major windows, you can get window-level Help by clicking the **Help** button on the toolbar.

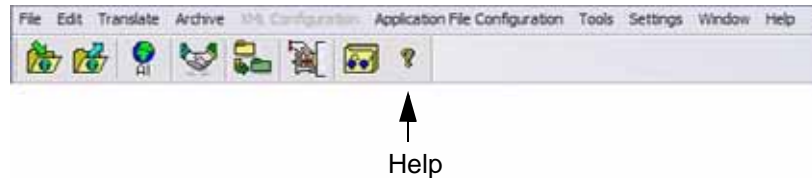

Using the Help buttons on dialog boxes

You can get Help for any dialog box that displays the **Help** button. Click **Help** for more information.

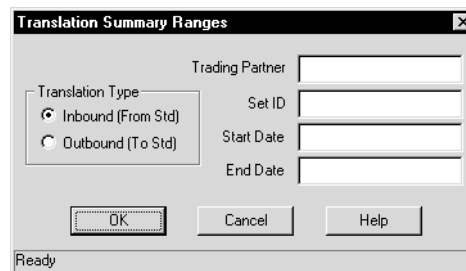

Exiting Help

You can close the **Help** window when you are finished with it. To close **Help**, select **Exit** on the File menu of the Help system menu bar.

The File Browser

Introduction

The File Browser is a Sterling Gentran:Server tool that enables you to open and edit text, EDI, and NCPDP files. It contains basic text-editing features, such as copying, cutting, pasting, finding, and replacing text.

When to use

You can use the File Browser to open and edit:

- Text files, such as batch files (*.bat) and configuration files (*.cfg)
- EDI files
- NCPDP files

Note

When you open an EDI file in the File Browser, Sterling Gentran:Server runs the **edifmat** command on the file before displaying it. The **edifmat** command replaces the segment terminators in the file with new line terminators so that the format is easier to read.

CAUTION

Never use the file browser to edit a disam file. Doing so will corrupt the file.

The File Browser window

This illustration shows the File Browser window.

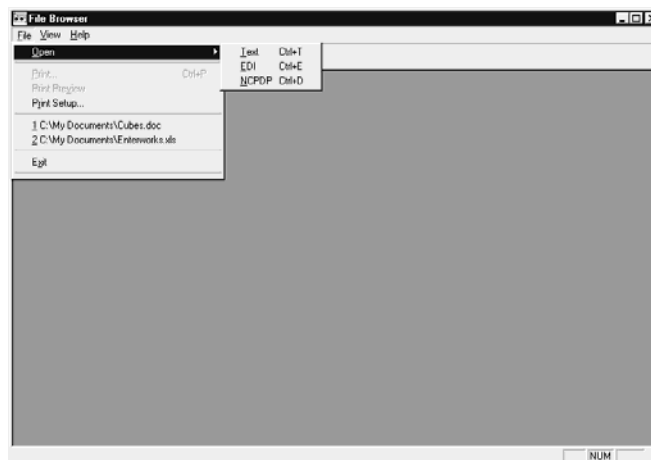

**Parts of the File
Browser window**

This table describes the parts and functions of the File Browser window.

Part	Function
Menu bar	Opens menus to display commands.
Toolbar	Starts commands from a set of buttons.
Status bar	Displays a status message, prompt, or toolbar button description.

How to Use the File Browser

Introduction

This topic explains how to start and exit the File Browser, open a file, and use the File Browser editing commands to modify a file.

Starting the File Browser

To start the File Browser, do one of the following:

- Click the File Browser button on the Main Window toolbar.
 - Select **Start File Browser** from the Tools menu.
-

Opening a file

There are two ways to open a file in the File Browser: from the Toolbar or from the File menu.

Method 1 - Toolbar button.

Step	Action
1	Click the Open button on the File Browser toolbar. System Response The File Browser displays the Open dialog box.
2	Select Text File , EDI File , or NCPDP File to indicate the type of file you want to open. CAUTION Never use the file browser to edit a disam file. Doing so will corrupt the file.
3	Click OK . System Response The File Browser displays the standard Open dialog box.
4	Browse to the folder and file you want to open.
5	Click OK .

(Contd) Step	Action	
6	IF you open...	THEN the File Browser...
	an EDI file	displays the Enter EDI Format Parameter dialog box. Continue with Step 7.
	a text file	displays the text file. You are finished.
	a NCPDP file	runs the edifmat command on the file you selected and displays the file in a newline terminated format. You are finished.
7	Select the option on the Enter EDI Format Parameter dialog box to specify the format you want applied to the data. System Response The system runs the edifmat command on the file you selected and displays the file in a newline terminated format.	

Method 2 - File menu

Select **Open** from the File menu and then select **Text**, **EDI**, or **NCPDP** from the cascading menu.

Editing a file in the File Browser

This table describes how to edit, print, and save a file in the File Browser.

IF you want to...	Then...
Insert characters	Click at the insertion point and type the characters.
Copy selected text to the clipboard	Click Copy on the Edit menu.
Paste text on the clipboard into the document	Click at the insertion point and then click Paste on the Edit menu.
Select the entire document	Click Select All on the Edit menu.
Search for characters, words, or phrases	Click Find on the Edit menu. Then, enter the search string.

(Contd) IF you want to...	Then...
Search for the next occurrence of a search item	Click Find Next on the Edit menu.
Replace selected text	Click Replace on the Edit menu. Then type the replacement text.
Print the document	Click Print on the File Menu.
Save the changes to the document	Click Save on the File menu.
Save a copy of the document under a new path or name	Click Save As on the File menu. and enter the new path and file name.

Exiting the File Browser

To close the File Browser, do one of the following:

- ▶ Select **Exit** from the File menu.
 - ▶ Click the close button on the File Browser window.
-

How to Change Print Properties

Introduction This topic explains how to open the Print Setup dialog box from within Sterling Gentran:Server. Check your Microsoft documentation for details on how to use the window.

Background When you print any of the reports that Sterling Gentran:Server generates, the program prints the report on the default printer, using the default font style and size specified for that printer. You can use the Microsoft Print Setup dialog box to specify print properties for the default printer for the client.

Your selections affect all printing (except printing of compiler messages) in Sterling Gentran:Server until you quit or change them. If you want to set these defaults and keep them between Sterling Gentran:Server sessions, use the **Printers** utility in the Windows **Control Panel**.

Opening the Print Setup window Follow this procedure to open the Print Setup dialog box from within Sterling Gentran:Server.

Step	Action
1	Click File on either the Main, Application Integration Main, Application Editor, or Standard/IG Editor menu bar.
2	Click Print Setup on the File menu.

Adjusting print properties Depending upon the font style and size, some parts of the report may not appear on the output (This may be a problem with fonts larger than 12 point). To correct, change the default font style or size. The methods of changing the default font style and size vary according to your PC.

Depending upon the aspect ratio of the report, you could also try printing landscape instead of portrait.

Setting Default Values

Overview

In this section

This section explains how to set the basic directory for the Application Integration system and default values you want your system to use.

Reference

See the *Setting Preferences and Default Values* section in the *IBM® Sterling Gentran:Server® for UNIX Application Integration User Guide* for information about setting preferences and default values for the Application Integration system.

Default directories

The Set Up Directories dialog box enables you to define the default directories that Sterling Gentran:Server will use to store your Sterling Gentran:Server files on your PC or client.

When to set the values

We recommend that you set your default directory and map display values before you create your first map. However, you can set or change the map display options at any time.

Where to go next

Use this table to locate the instructions for setting particular types of preferences.

IF you want to customize...	THEN select...
<i>Workstation</i>	
The default directories your system uses to store Sterling Gentran:Server files	How to Change the Default Workstation Directories
<i>Application Integration</i>	
All the Application Integration system preferences	<i>How to Set the Application Integration Preferences in the IBM® Sterling Gentran:Server® for UNIX Application Integration User Guide.</i>
The list of date and time formats that you can use in map fields	<i>How to Set the Application Date/Time Formats in the IBM® Sterling Gentran:Server® for UNIX Application Integration User Guide.</i>
The default date format for all date fields used in a map	<i>How to Set the Default Date Formats in the IBM® Sterling Gentran:Server® for UNIX Application Integration User Guide.</i>
Which map component descriptions are displayed	<i>How to Customize Component Display Options in the IBM® Sterling Gentran:Server® for UNIX Application Integration User Guide.</i>
Foreground and background colours of map components	<i>How to Customize Component Colors in the IBM® Sterling Gentran:Server® for UNIX Application Integration User Guide</i>
Font type, style, or size used in map displays	<i>How to Customize Global Fonts in the IBM® Sterling Gentran:Server® for UNIX Application Integration User Guide.</i>
How map links are displayed	<i>How to Customize the Display of Links in the IBM® Sterling Gentran:Server® for UNIX Application Integration User Guide.</i>
How the map version number is incremented	<i>How to Customize the Auto-increment Map Version in the IBM® Sterling Gentran:Server® for UNIX Application Integration User Guide.</i>

Set Up Directories Dialog Box

Introduction

The Set Up Directories dialog box enables you to define the default directories that Sterling Gentran:Server will use to store your Sterling Gentran:Server files on your PC.

Sterling Gentran:Server Workstation

This illustration shows the Set Up Directories dialog box for IBM® Sterling Gentran:Server® for UNIX - Workstation.

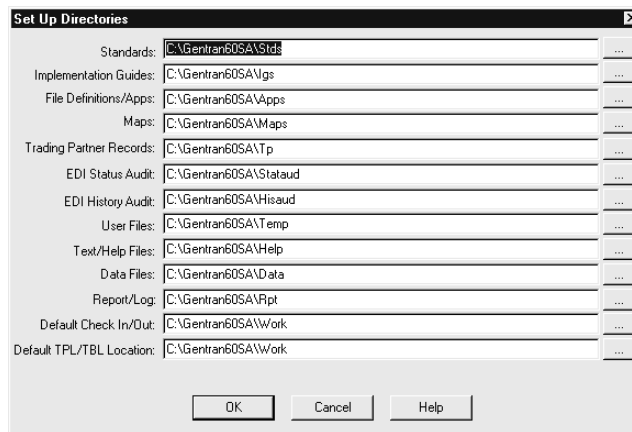

Fields and functions

This table lists the fields of the Workstation Set Up Directories dialog box and their functions.

Field	Function
Standards	Stores a list of available standards.
Implementation Guide	Stores implementation guides (.igs).
File Definitions/Apps	Stores file definitions (.ddfs).
Maps	Stores map files and translation objects.
Trading Partner Records	Stores Trading Partnership files.
EDI Status Audit	Stores the status audit files that Sterling Gentran:Server generates.
EDI History Audit	Stores the history audit files that Sterling Gentran:Server generates.
User Files	Stores your user files.
Text/Help Files	Stores text files and the Sterling Gentran:Server Help files.
Data Files	Stores your data files.
Report/Log	Contains the reports and log files that Sterling Gentran:Server generates.
Default Check In/Out	Serves as the default working directory for files.
Default TPL/TBL Location	Serves as the default working directory for translation objects (compiled maps).

How to Change the Default Workstation Directories

Introduction You can change the default directories for the Sterling Gentran:Server files from the values set at installation.

Changing Workstation directories

Use this procedure to change a directory path for the Sterling Gentran:Server Workstation files.

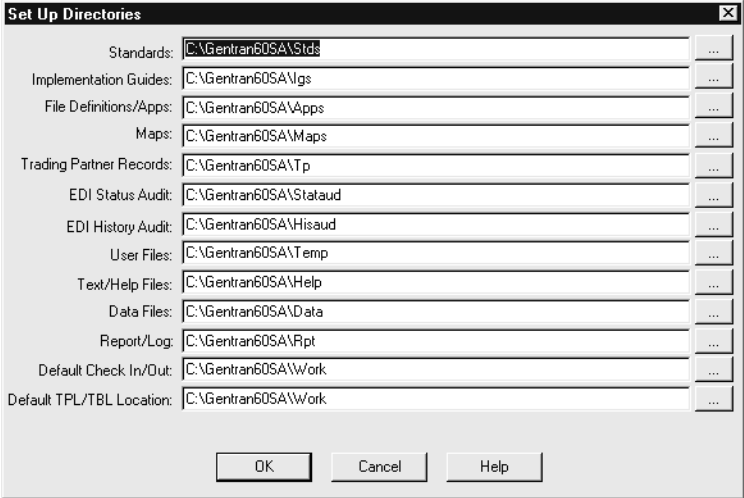
Step	Action
1	Click Settings on the menu bar.
2	<p>Click Set Up Directories on the Settings menu.</p> <p>System Response The system displays the Set Up Directories dialog box.</p> 
3	Click in the appropriate text box.
4	<p>Delete the current path and type the new path, or edit the existing path as appropriate.</p> <p>Note You can use the browse button to the right of the box to browse for the path.</p>
5	Click OK to save your changes.

Working with Application Integration

Content	Overview
	▶ Introduction 2
	▶ Working in Workstation 3
	Dialog Boxes
	▶ Select Map and File Definitions Files to Check out Dialog Box 4
	▶ Select Map Files to Check in Dialog Box 6
	▶ Select TBL/TPL Files to Check In Dialog Box 8
	▶ Select File Definition to Check in Dialog Box 9
	▶ Select Map and File Definition Files to Unlock Dialog Box 11
	Procedures
	▶ How to Check Out and View Maps and File Definitions 13
	▶ How to Save Changes to Working Files 16
	▶ How to Unlock Master Files and Delete Working Copies 18
	▶ How to Check In Maps and Translation Objects 22
	▶ How to Check In File Definitions 26

Overview

Introduction

In this chapter This chapter contains information about working in Workstation and accessing and returning files.

Key terms This table describes the key terms used in this chapter.

Term	Description
check in	The act of returning a copy of a file from your working directory to the master directory, making it available to other users.
check out	The act of copying a file from the master directory to your working directory, making the file unavailable to other users.
lock	The act of making a file unavailable to other users. A file is locked once it is checked out.
unlock	The act of making a file available to other users. A file is unlocked once it is checked in.

Working in Workstation

Introduction IBM® Sterling Gentran:Server® for UNIX - Workstation uses numerous data files such as maps, translation objects (.TPL files), file definitions (.ddf files), and Trading Partnership records.

This section explains how to work with files in Sterling Gentran:Server.

Master directory Sterling Gentran:Server stores the master files (maps, translation objects, file definitions, etc.) on the PC in the master directory specified for the file type. You specify the master directories in the Set Up Directories dialog box, which is available from the main Sterling Gentran:Server window under the Settings menu.

File checkout When you want to edit a master file, you must check it out. When you **check out** a map file to edit it, Sterling Gentran:Server moves a copy of the file to the working directory and retains the original file in the master directory.

Working directory Sterling Gentran:Server stores your working files (copies of checked out maps and file definitions) in the working directory on the PC. This enables you to modify a checked-out map without affecting the original file. You specify the working directories in the Set Up Directories dialog box, which is available from the Sterling Gentran:Server Settings menu.

Map check in When you **check in** a map file, Sterling Gentran:Server transfers a copy of the file from your working directory to the master directory. If the map file is one that you checked out, Workstation replaces the map in the master directory with the working copy. The working copy becomes the new master file for the map. Sterling Gentran:Server lets you to choose to keep or remove the copy of the file in your working directory.

Dialog Boxes

Select Map and File Definitions Files to Check out Dialog Box

Introduction This topic describes the following dialog boxes:

- ▶ Select Map Files to Check out
- ▶ Select File Definition Files to Check out

Purpose The Select <filename> to Check out dialog box is used to move a copy of a file from the master directory to a working directory on the PC. Maps, and their associated TPL files, and file definitions files can be checked out.

Example check out dialog box

The same dialog box format is used to check out file definition files.

This illustration shows the Select Map Files to Check out dialog box.

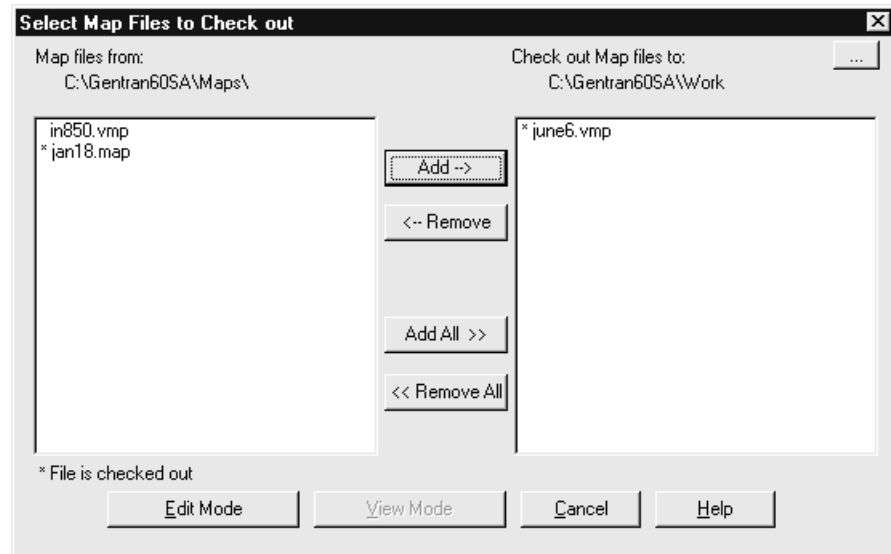

Fields and functions

This table lists the fields of the Select Map Files to Check Out and Select File Definition Files to Check out dialog box and their functions.

Field	Function
...files from	<p>Displays the name of the master directory.</p> <p>The list below the name displays the names of the files in the master directory. An asterisk next to a name indicates that the file is currently checked out.</p>
Check out <filename> files to	<p>Displays the name of the default working directory on your PC. This is the directory to which Sterling Gentran:Server copies the file.</p> <p>The list below the directory name displays the names of the working files in the working directory.</p> <p>Note You can use the browse button to select a different directory.</p>
Add	Adds the name of the selected file to the list of files in the working directory.
Remove	Removes the name of the file from the working directory check out list.
Add All	Adds the names of all the files in the master directory to the working directory.
Remove All	Removes the names of all the files from the working directory check out list.
Edit Mode	Checks out the files so that you can edit them. Copies the files that you added to the Check out <filename> files to list and moves the copies into the working directory.
View Mode	View Mode is unavailable in Workstation.

Select Map Files to Check in Dialog Box

Introduction This topic describes the Select Map Files to Check in dialog box.

Purpose The Select Map Files to Check in dialog box is used to move the saved working file from your working directory to the master directory. The system replaces the master file with the map you check in. The following files can be checked in:

- map files
- associated TPL files

Example check in dialog box

This illustration shows the Select Map Files to Check in dialog box.

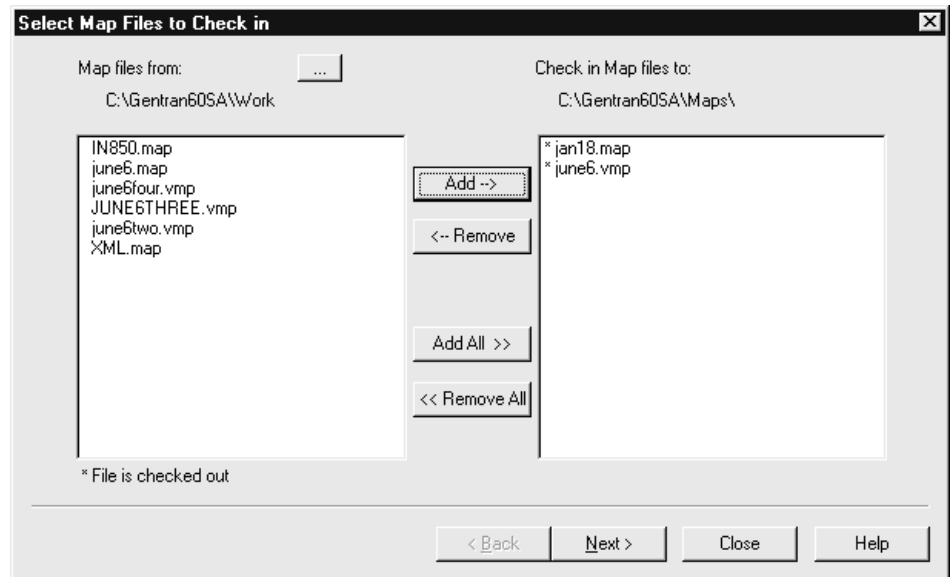

Fields and functions

This table lists the fields of the Select Map Files to Check in dialog box and their functions.

Field	Function
Map files from	<p>Displays the name of the working directory on your PC.</p> <p>The list below the name displays the names of the maps in the working directory.</p> <p>Note You can use the browse button to select a different directory.</p>
Check in Map files to	<p>Displays the name of the master directory for maps on your PC. This is the directory to which Sterling Gentran:Server copies the map file.</p> <p>The list below the directory name displays the names of the maps in the master directory.</p>
Add	Adds the name of the selected map to the list of maps in the master directory.
Remove	Removes the name of the map from the master directory check in list.
Add All	Adds the names of all the maps in the working directory to the master directory.
Remove All	Removes the names of all the maps from the master directory check in list.

Select TBL/TPL Files to Check In Dialog Box

Introduction The Select TBL/TPL Files to Check In dialog box is used to select the translation objects (compiled maps) you want to check in.

Illustration This illustration shows the Select TBL/TPL Files to Check In dialog box.

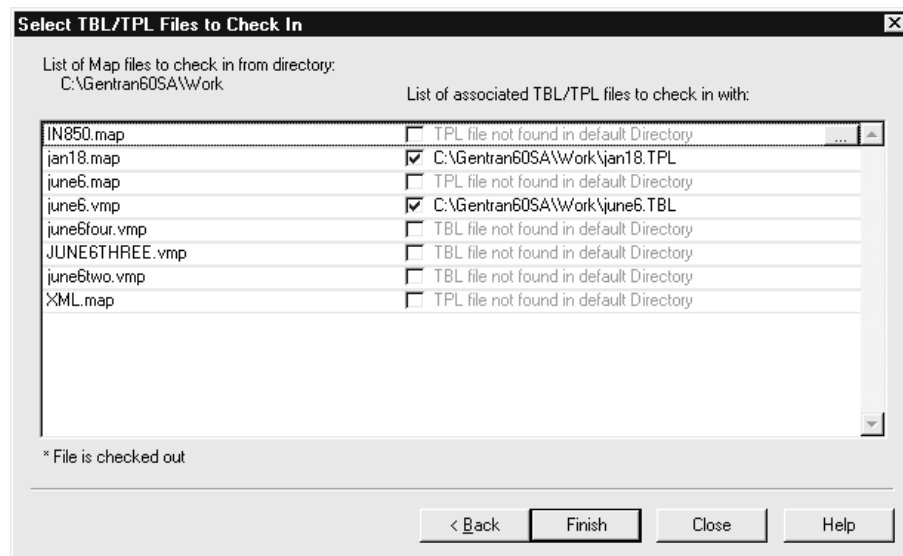

Fields and functions This table lists the fields of the Select TBL/TPL to Check In dialog box and their functions.

Field	Function
List of Map files to check in from directory	Displays the name of the working directory on your PC. The list below the name displays the names of the maps you are checking in.
List of associated TBL/TPL files to check in with	Displays the names of the translation objects associated with the maps you are checking in.
Finish	Saves your changes and checks in the maps and translation objects you selected.

Select File Definition to Check in Dialog Box

Introduction The Select File Definition Files to Check in dialog box is used to move a working copy of a file definition file (.ddf) from your working directory to the master directory for file definitions.

Illustration This illustration shows the Select File Definition Files to Check in dialog box.

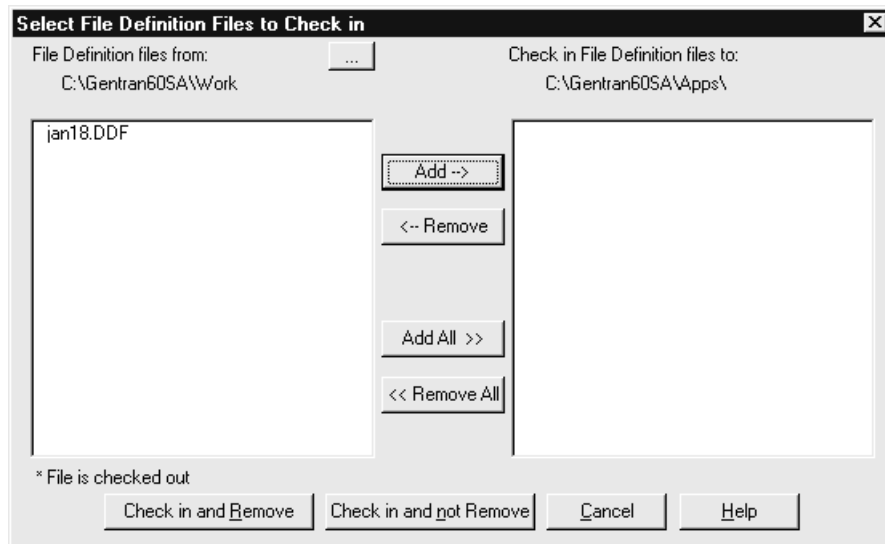

Note

When you check in a file, the system converts the filename to lowercase letters. UNIX client/server versions require that the filenames are lowercase.

Fields and functions

This table lists the fields of the Select File Definitions to Check in dialog box and their functions.

Field	Function
File Definition files from	<p>Displays the name of the working directory.</p> <p>The list below the name displays the names of the file definition files in the working directory. An asterisk next to a name indicates that the file is currently checked out.</p> <p>Note You can use the browse button to select a different directory.</p>
Check in File Definition files to	<p>Displays the name of the master directory for file definition files. This is the directory to which Sterling Gentran:Server copies the file.</p> <p>The list below the directory name displays the names of the file definition files in the master directory.</p>
Add	Adds the name of the selected file definition file to the list of file definition files in the master directory.
Remove	Removes the name of the file definition file from the master directory check in list.
Add All	Adds the names of all the file definition files in the working directory to the master directory.
Remove All	Removes the names of all the file definition files from the master directory check in list.
Check in and Remove	Saves your changes, starts moving the file definition files, and deletes the working copies from the working directory.
Check in and not Remove	Saves your changes, starts moving the file definition files, and retains the working copies in the working directory.

Select Map and File Definition Files to Unlock Dialog Box

Introduction This topic describes the following dialog boxes:

- ▶ Select Map Files to Unlock
- ▶ Select File Definition Files to Unlock

Purpose The **unlock** dialog box is used to remove the lock from the master file when you do not want to save changes to a file in your working directory. The following files can be unlocked:

- ▶ map files
- ▶ file definitions files

Example unlock dialog box

The same dialog box format is used to unlock file definition files.

This illustration shows the Select Map Files to Unlock dialog box.

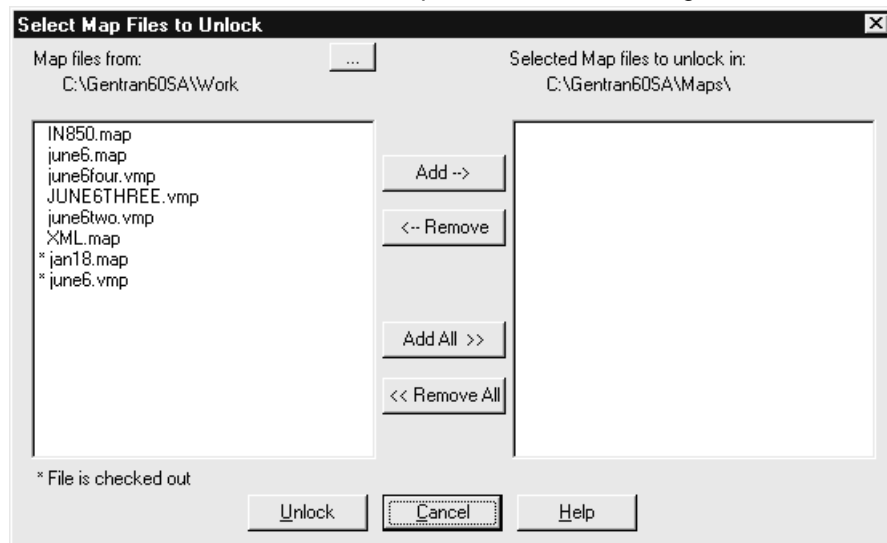

Fields and functions

This table lists the fields of the Select Map Files to Unlock dialog box and their functions.

Field	Function
...files from	<p>Displays the name of the working directory.</p> <p>The list below the name displays the names of the files in the working directory. An asterisk next to a name indicates that the file is currently checked out.</p> <p>Notes You can use the browse button to select a different directory.</p>
Selected <filename> files to unlock in	<p>Displays the name of the master directory for the files. This is the directory to which Sterling Gentran:Server copies the file.</p> <p>The list below the directory name displays the names of the files in the master directory.</p>
Add	Adds the name of the selected file to the list of files in the master directory.
Remove	Removes the name of the file from the master directory unlock list.
Add All	Adds the names of all the files in the working directory to the master directory.
Remove All	Removes the names of all the files from the master directory unlock list.
Unlock	Unlocks the file or files you have selected

Procedures

How to Check Out and View Maps and File Definitions

Introduction This topic explains how to check out a file.

What happens when you check out a file When you check out a file in Sterling Gentran:Server, Sterling Gentran:Server copies the file from the master directory to the working directory on the PC.

Checking out a map or file definition

Use this procedure to check out a map or a file definition file in Workstation.

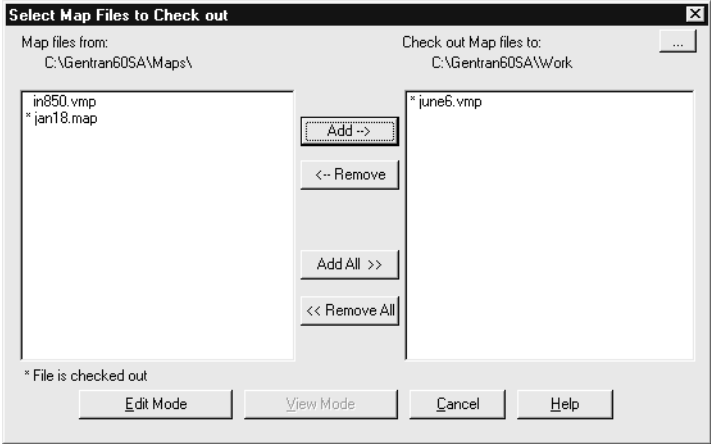
Step	Action
1	<p>Select Check Out from the Sterling Gentran:Server Main File menu and click the type of file you want to check out.</p> <ul style="list-style-type: none"> ▶ Map ▶ File Definition File <p>System Response Sterling Gentran:Server displays the Select <filename> Files to Check out dialog box.</p>  <p>Notes An asterisk next to a file name indicates that the file is already checked out. The View Mode button is unavailable in Workstation.</p>
2	<p>Check the name of the default directory to which the system will copy checked out files. Do you want to check out files to a different directory?</p> <ul style="list-style-type: none"> ▶ If YES, click the directory button and browse to the directory; continue with the next step. ▶ If NO, continue with the next step.

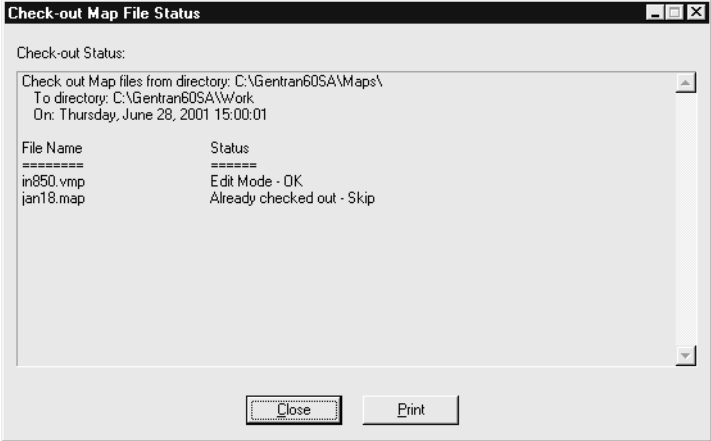
(Contd) Step	Action	
3	Use this table to determine your next step.	
	IF you want to check out... a single file	THEN... Select the file you want to check out from the list in the left pane and click Add . Repeat this step for each additional file you want to check out.
4	all the available files	Click Add All .
5	<p>Click Edit Mode.</p> <p>System Response Sterling Gentran:Server displays the Check-out <filename> File Status dialog box.</p> 	
6	<p>Do you want to print the information displayed on the Check-out <filename> File Status dialog box?</p> <ul style="list-style-type: none"> ▶ If YES, click the Print. ▶ If NO, click Close. 	

How to Save Changes to Working Files

Introduction

If an Application Integration system map file is open, you can save changes on the PC:

- ▶ To the open file
- ▶ To the working copy of a map (but not to the original map)

Note

You can also save the map files by using a new file name.

Reference

To replace an original map with a working copy of the map that you have modified, see [How to Check In Maps and Translation Objects](#) in this chapter.

Saving changes to an open file

Use this procedure to save changes to an open file.

Procedure

Click **Save** on the **File** menu.

System Response

Sterling Gentran:Server updates the file.

Saving to a new file name

Use this procedure to save an open working map file to a new file name in the working directory.

CAUTION

You cannot use this procedure to save a working map file to the master directory.

Step	Action
1	Click Save As on the File menu. System Response Sterling Gentran:Server displays the Save As dialog box.
2	Type the new file name for the copy of the map. Note You cannot save a map file to another directory, but you can save it under a new file name. Reference See How to Check In Maps and Translation Objects in this chapter to replace a master map file with a modified working copy.
3	Click OK . System Response Sterling Gentran:Server saves a copy of the map under the new name.

How to Unlock Master Files and Delete Working Copies

Introduction

If you do not want to save changes to a file in your working directory, you can use the Sterling Gentran:Server Unlock function to remove the lock from the master file and delete the working copy of the file. This procedure explains how to use the Unlock function.

CAUTION

When you unlock a master file, you lose all changes you made to the working file. Use this procedure only if you want to delete the working file.

Procedure

Use this procedure to unlock a master file and delete a working file.

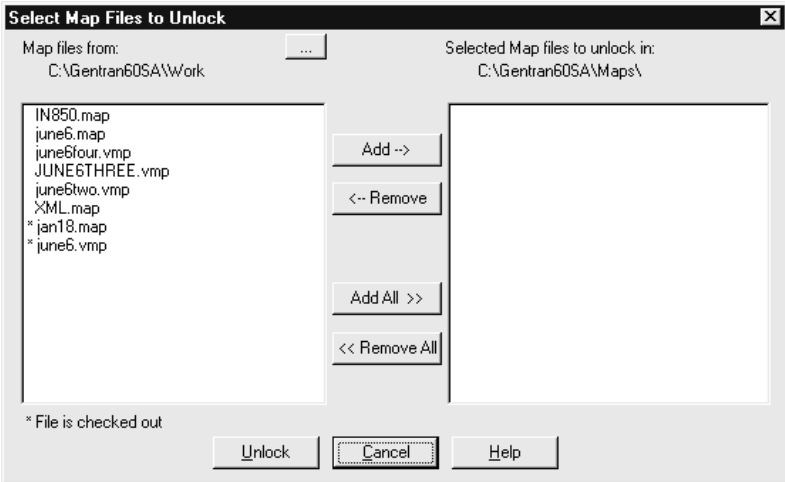
Step	Action
1	<p>Select Unlock from the File menu and click the type of file you want to unlock:</p> <ul style="list-style-type: none"> ▶ Map ▶ File Definition File <p>System Response Sterling Gentran:Server displays the Select <filename> Files to Unlock dialog box.</p> 

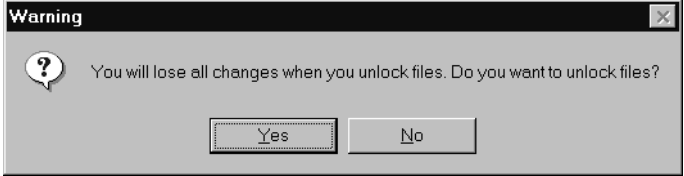
(Contd) Step	Action	
2	Use this table to determine your next step.	
	IF you want to unlock...	THEN...
	a single file	Select the file you want to remove from the list of available files in the left box and click Add . System Response Sterling Gentran:Server moves the selected file to the selected files to unlock list.
all the available files	Click Add All . System Response Sterling Gentran:Server moves all the files to the selected files to unlock list.	
3	Click Unlock . System Response Sterling Gentran:Server displays this dialog box. <div data-bbox="686 1115 1365 1289" style="border: 1px solid black; padding: 5px; margin: 10px 0;">  <p>A warning dialog box with a question mark icon. The text reads: "Warning. You will lose all changes when you unlock files. Do you want to unlock files?" There are two buttons at the bottom: "Yes" and "No".</p> </div>	

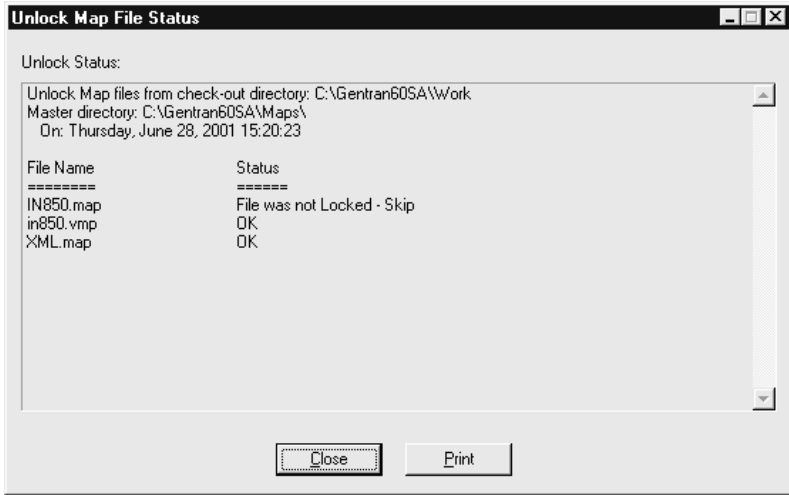
(Contd) Step	Action
4	<p>Do you want to continue?</p> <ul style="list-style-type: none"> ▶ If YES, click Yes. ▶ If NO, click No. <p>System Response If you clicked Yes, Sterling Gentran:Server displays the Unlock <filename> File Status dialog box.</p> 
5	<p>Do you want to print the information displayed on the Unlock <filename> File Status dialog box?</p> <ul style="list-style-type: none"> ▶ If YES, click the Print. ▶ If NO, click Close.

How to Check In Maps and Translation Objects

Introduction This topic explains how to check in maps and the translation objects (TPL files) associated with them.

What happens when you check in a file When you are satisfied that a working map and translation object produces the results you expect, you **check in** the working file. When you check in a working file, the system copies the file from the working directory to the master directory, replacing the original file. The working file becomes the new map or translation object. You can choose to leave a copy of the file in the working directory or remove it.

Maps The procedure for checking in maps differs from that for checking in other files because you can check in multiple maps at the same time.

You can check in a compiled working map or an uncompiled working map.

- If you compile a working map before you check it in, the Check In function moves the compiled map to the master directory.
- If you move an uncompiled working map, you must compile it in the master directory; otherwise, the translator will not recognize the changes.

Checking in maps and translation objects

Use this procedure to check in a map and translation object.

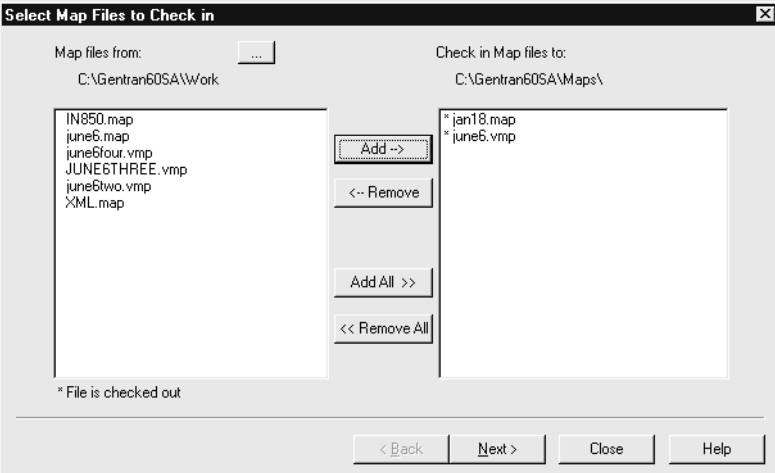
Step	Action						
1	<p>Select Check In from the Sterling Gentran:Server Main File menu and click Map.</p> <p>System Response Sterling Gentran:Server displays the Select Map Files to Check in dialog box.</p> 						
2	<p>Use this table to determine your next step.</p> <table border="1" data-bbox="618 1205 1419 1556"> <thead> <tr> <th data-bbox="618 1205 1024 1262">IF you want to check in...</th> <th data-bbox="1024 1205 1419 1262">THEN...</th> </tr> </thead> <tbody> <tr> <td data-bbox="618 1262 1024 1507">a single map</td> <td data-bbox="1024 1262 1419 1507"> <p>Select the map you want to check in from the list in the left pane and click Add.</p> <p>Repeat this step for each additional map you want to check in.</p> </td> </tr> <tr> <td data-bbox="618 1507 1024 1556">all the available maps</td> <td data-bbox="1024 1507 1419 1556">Click Add All.</td> </tr> </tbody> </table>	IF you want to check in...	THEN...	a single map	<p>Select the map you want to check in from the list in the left pane and click Add.</p> <p>Repeat this step for each additional map you want to check in.</p>	all the available maps	Click Add All .
IF you want to check in...	THEN...						
a single map	<p>Select the map you want to check in from the list in the left pane and click Add.</p> <p>Repeat this step for each additional map you want to check in.</p>						
all the available maps	Click Add All .						

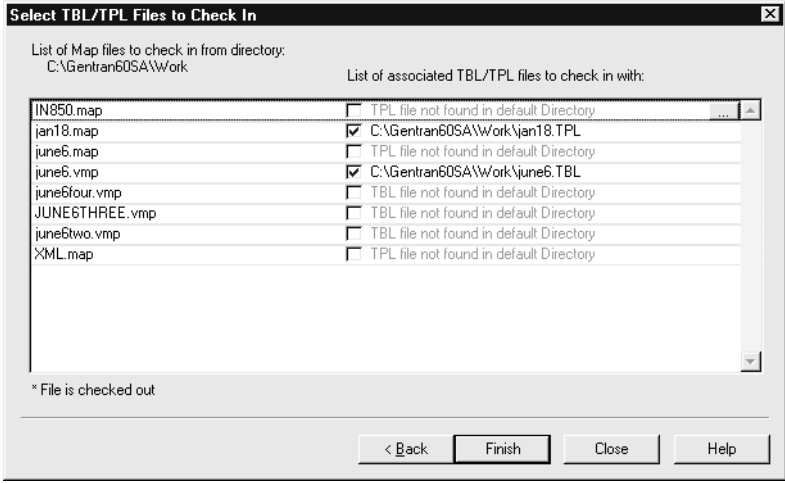
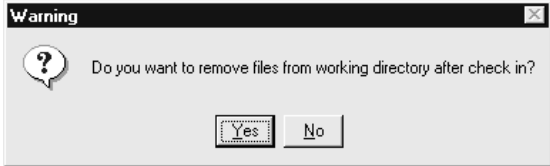
(Contd) Step	Action
3	<p>Click Next.</p> <p>System Response Sterling Gentran:Server searches for the associated translation object files in the default Table Location directory and displays the results in the Select TBL/TPL Files to Check In dialog box.</p> 
4	<p>Do you want Sterling Gentran:Server to search for the translation object in a different directory?</p> <ul style="list-style-type: none"> ▶ If YES, click the browse button next to specify the directory; continue with next step. ▶ If NO, continue with Step 5.
5	<p>Do you want to check in the translation object associated with the map you are checking in?</p> <ul style="list-style-type: none"> ▶ If YES, make sure that the check box next to the translation object is selected and then click Finish. ▶ If NO, clear the check box and then click Finish. <p>System Response Sterling Gentran:Server displays this dialog box.</p> 

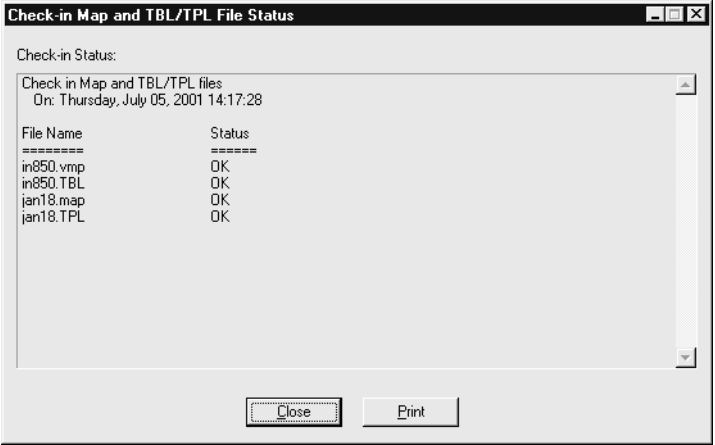
(Contd) Step	Action
6	<p>Do you want to remove the copies of the working files from the working directory after the files are checked in?</p> <ul style="list-style-type: none"> ▶ If YES, click the Yes button. ▶ If NO, click the No button. <p>System Response The system displays the Check-in Map and TBL/TPL File Status dialog box.</p> 
7	<p>Do you want to print the information displayed on the Check-in <filename> Status dialog box?</p> <ul style="list-style-type: none"> ▶ If YES, click the Print. ▶ If NO, click Close.

How to Check In File Definitions

Introduction

When you are satisfied with a file definition file, you **check in** the working file. When you check in a working file, the system copies the file from the working directory to the master directory, replacing the original file. The working file becomes the new file definition. You can choose to leave a copy of the file in the working directory or remove it.

Checking in a file definition

Use this procedure to check in a file definition file.

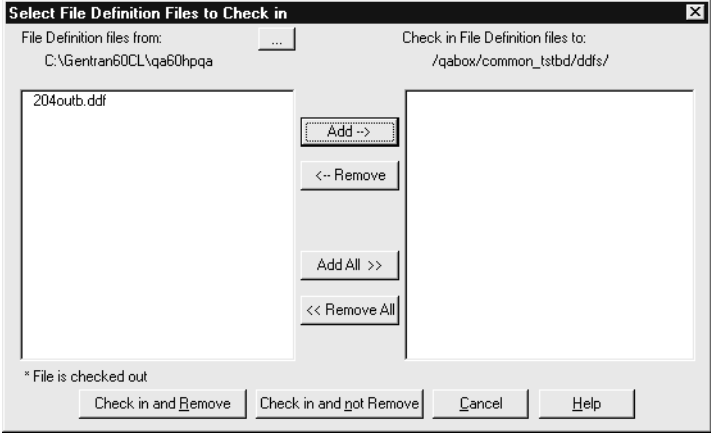
Step	Action
1	<p>Select Check In from the Sterling Gentran:Server Main File menu and click File Definition File.</p> <p>System Response Sterling Gentran:Server displays the Select File Definition File to Check in dialog box.</p> 

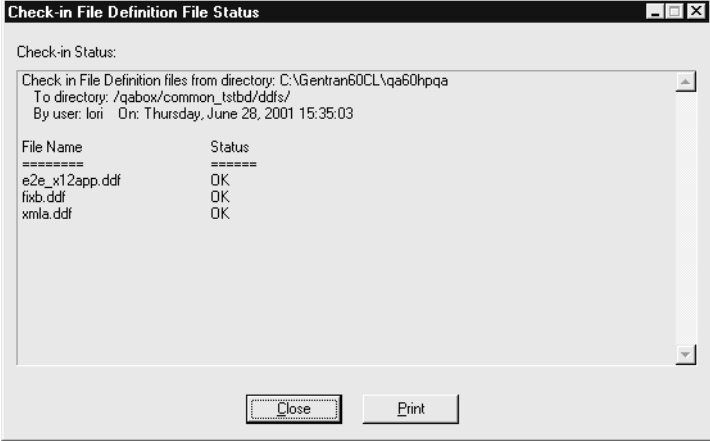
(Contd) Step	Action	
2	Use this table to determine your next step.	
	IF you want to check in...	THEN...
	a single file definition file	Select the file definition file you want to check in from the list in the left pane and click Add . Repeat this step for each additional file you want to check in.
all the available file definition files	Click Add All .	
3	Use this table to determine your next step.	
	IF you want to...	THEN click...
	Remove the working files from the working directory after they are checked in	Check in and Remove
Leave the working files in the working directory after they are checked in	Check in and not Remove	
<p>System Response Sterling Gentran:Server displays the Check-in File Definition File Status dialog box.</p> 		

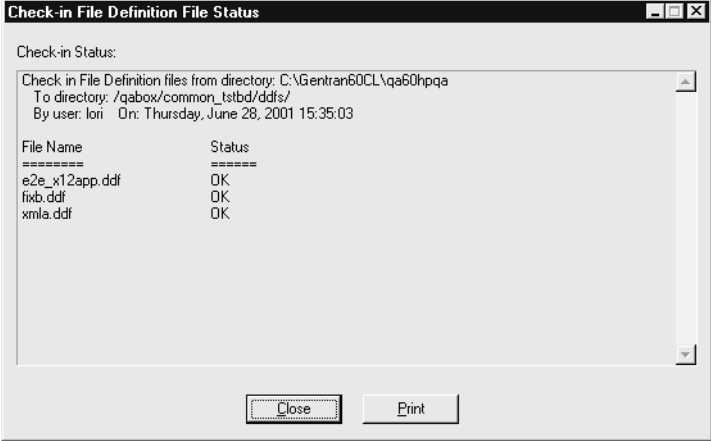
(Contd) Step	Action	
2	Use this table to determine your next step.	
	IF you want to check in...	THEN...
	a single file definition file	Select the file definition file you want to check in from the list in the left pane and click Add . Repeat this step for each additional file you want to check in.
	all the available file definition files	Click Add All .
3	Use this table to determine your next step.	
	IF you want to...	THEN click...
	Remove the working files from the working directory after they are checked in	Check in and Remove
	Leave the working files in the working directory after they are checked in	Check in and not Remove
	<p>System Response Sterling Gentran:Server displays the Check-in File Definition File Status dialog box.</p> 	

(Contd) Step	Action
4	Do you want to print the information displayed on the Check-in <filename> Status dialog box? <ul style="list-style-type: none">▶ If YES, click Print.▶ If NO, click Close.

Notices

This information was developed for products and services offered in the U.S.A.

IBM may not offer the products, services, or features discussed in this document in other countries. Consult your local IBM representative for information on the products and services currently available in your area. Any reference to an IBM product, program, or service is not intended to state or imply that only that IBM product, program, or service may be used. Any functionally equivalent product, program, or service that does not infringe any IBM intellectual property right may be used instead. However, it is the user's responsibility to evaluate and verify the operation of any non-IBM product, program, or service.

IBM may have patents or pending patent applications covering subject matter described in this document. The furnishing of this document does not grant you any license to these patents. You can send license inquiries, in writing, to:

IBM Director of Licensing

IBM Corporation

North Castle Drive

Armonk, NY 10504-1785

U.S.A.

For license inquiries regarding double-byte character set (DBCS) information, contact the IBM Intellectual Property Department in your country or send inquiries, in writing, to:

Intellectual Property Licensing

Legal and Intellectual Property Law

IBM Japan Ltd.

1623-14, Shimotsuruma, Yamato-shi

Kanagawa 242-8502 Japan

The following paragraph does not apply to the United Kingdom or any other country where such provisions are inconsistent with local law:

INTERNATIONAL BUSINESS MACHINES CORPORATION PROVIDES THIS PUBLICATION "AS IS" WITHOUT WARRANTY OF ANY KIND, EITHER EXPRESS OR IMPLIED, INCLUDING, BUT NOT LIMITED TO, THE IMPLIED WARRANTIES OF NON-INFRINGEMENT, MERCHANTABILITY OR FITNESS FOR A PARTICULAR PURPOSE. Some states do not allow disclaimer of express or implied warranties in certain transactions, therefore, this statement may not apply to you.

This information could include technical inaccuracies or typographical errors. Changes are periodically made to the information herein; these changes will be incorporated in new editions of the publication. IBM may make improvements and/or changes in the product(s) and/or the program(s) described in this publication at any time without notice.

Any references in this information to non-IBM Web sites are provided for convenience only and do not in any manner serve as an endorsement of those Web sites. The materials at those Web sites are not part of the materials for this IBM product and use of those Web sites is at your own risk.

IBM may use or distribute any of the information you supply in any way it believes appropriate without incurring any obligation to you.

Licensees of this program who wish to have information about it for the purpose of enabling: (i) the exchange of information between independently created programs and other programs (including this one) and (ii) the mutual use of the information which has been exchanged, should contact:

IBM Corporation

J46A/G4

555 Bailey Avenue

San Jose, CA__95141-1003

U.S.A.

Such information may be available, subject to appropriate terms and conditions, including in some cases, payment of a fee.

The licensed program described in this document and all licensed material available for it are provided by IBM under terms of the IBM Customer Agreement, IBM International Program License Agreement or any equivalent agreement between us.

Any performance data contained herein was determined in a controlled environment. Therefore, the results obtained in other operating environments may

vary significantly. Some measurements may have been made on development-level systems and there is no guarantee that these measurements will be the same on generally available systems. Furthermore, some measurements may have been estimated through extrapolation. Actual results may vary. Users of this document should verify the applicable data for their specific environment.

Information concerning non-IBM products was obtained from the suppliers of those products, their published announcements or other publicly available sources. IBM has not tested those products and cannot confirm the accuracy of performance, compatibility or any other claims related to non-IBM products. Questions on the capabilities of non-IBM products should be addressed to the suppliers of those products.

All statements regarding IBM's future direction or intent are subject to change or withdrawal without notice, and represent goals and objectives only.

This information is for planning purposes only. The information herein is subject to change before the products described become available. This information contains examples of data and reports used in daily business operations. To illustrate them as completely as possible, the examples include the names of individuals, companies, brands, and products. All of these names are fictitious and any similarity to the names and addresses used by an actual business enterprise is entirely coincidental.

COPYRIGHT LICENSE:

This information contains sample application programs in source language, which illustrate programming techniques on various operating platforms. You may copy, modify, and distribute these sample programs in any form without payment to IBM, for the purposes of developing, using, marketing or distributing application programs conforming to the application programming interface for the operating platform for which the sample programs are written. These examples have not been thoroughly tested under all conditions. IBM, therefore, cannot guarantee or imply reliability, serviceability, or function of these programs. The sample programs are provided "AS IS", without warranty of any kind. IBM shall not be liable for any damages arising out of your use of the sample programs.

Each copy or any portion of these sample programs or any derivative work, must include a copyright notice as follows:

© IBM 2011. Portions of this code are derived from IBM Corp. Sample Programs.

© Copyright IBM Corp. 2011.

If you are viewing this information softcopy, the photographs and color illustrations may not appear.

Trademarks

IBM, the IBM logo, and ibm.com are trademarks or registered trademarks of International Business Machines Corp., registered in many jurisdictions

worldwide. Other product and service names might be trademarks of IBM or other companies. A current list of IBM trademarks is available on the Web at "[Copyright and trademark information](http://www.ibm.com/legal/copytrade.shtml)" at www.ibm.com/legal/copytrade.shtml.

Adobe, the Adobe logo, PostScript, and the PostScript logo are either registered trademarks or trademarks of Adobe Systems Incorporated in the United States, and/or other countries.

IT Infrastructure Library is a registered trademark of the Central Computer and Telecommunications Agency which is now part of the Office of Government Commerce.

Intel, Intel logo, Intel Inside, Intel Inside logo, Intel Centrino, Intel Centrino logo, Celeron, Intel Xeon, Intel SpeedStep, Itanium, and Pentium are trademarks or registered trademarks of Intel Corporation or its subsidiaries in the United States and other countries.

Linux is a registered trademark of Linus Torvalds in the United States, other countries, or both.

Microsoft, Windows, Windows NT, and the Windows logo are trademarks of Microsoft Corporation in the United States, other countries, or both.

ITIL is a registered trademark, and a registered community trademark of the Office of Government Commerce, and is registered in the U.S. Patent and Trademark Office.

UNIX is a registered trademark of The Open Group in the United States and other countries.

Java and all Java-based trademarks and logos are trademarks or registered trademarks of Oracle and/or its affiliates.

Cell Broadband Engine is a trademark of Sony Computer Entertainment, Inc. in the United States, other countries, or both and is used under license therefrom.

Linear Tape-Open, LTO, the LTO Logo, Ultrium and the Ultrium Logo are trademarks of HP, IBM Corp. and Quantum in the U.S. and other countries.

Connect Control Center®, Connect:Direct®, Connect:Enterprise, Gentran®, Gentran:Basic®, Gentran:Control®, Gentran:Director®, Gentran:Plus®, Gentran:Realtime®, Gentran:Server®, Gentran:Viewpoint®, Sterling Commerce™, Sterling Information Broker®, and Sterling Integrator® are trademarks or registered trademarks of Sterling Commerce, Inc., an IBM Company.

Other company, product, and service names may be trademarks or service marks of others.

Glossary

Adobe Reader	An Adobe program designed to read and display Portable Document Format (PDF) documents. Older versions were called Acrobat Reader.
application	The business software generating the business information that you are sending or receiving electronically.
check in	The act of returning a copy of a file from your working directory to the master directory, making it available to other users.
check out	The act of copying a file from the master directory to your working directory, making the file unavailable to other users.
default	A value that is automatically assigned.
DNS	Domain Name Services.
EDI	Electronic Data Interchange. Application-to-application transfer of key business transaction information in a standard or XML format via a computer-to-computer communication link.
EDI standard	A format to regulate syntax, structure, and content of transaction data.
GENCOD	The GENCOD standard was developed by the French National Numbering Organization GENCOD-EAN France. The GENCOD standard is used mainly in France within the retail market by some major retailers and manufacturers.

HIPAA	Health Insurance Portability and Accounting Act.
lock	The act of making a file unavailable to other users. A file is locked once it is checked out.
map	A file that contains the relationships between: <ul style="list-style-type: none">▶ The segments and elements of a standard EDI document and the data fields in your application,▶ The elements in an XML document and the data fields in your application, EDI standard document, or in another XML document,▶ The segments and elements of two different standards, or▶ The records and fields of two different applications.
master directory	The directory on a PC or on a server that stores your master files.
master file	The version of a file that Sterling Gentran:Server uses to process data.
MDAC	Microsoft Data Access Components.
NCPDP	National Council of Prescription Drug Programs.
PCM	Process Control Manager.
standard format	A format intelligible to computerized data management systems.
temporary file	A file on the client that Sterling Gentran:Server uses during editing and compiling.

trading partner	The company, division, or group with which you are exchanging business data electronically.
Trading Partnership	An arrangement to exchange information in a specific document type with a specific trading partner and using a particular standard version.
unlock	The act of making a file available to other users. A file is unlocked once it is checked in.
user directory	The directory on the server that temporarily holds the files being transferred from a client working directory to the master directory on the server.
VAN	Value Added Network.
VDA	Verband der Deutschen Automobilindustrie. A German group responsible for a range of different standards in the automobile industry.
working file directory	The directory created on the client to hold the files that a user is editing.
XML	Extensible Markup Language. Describes a class of data objects called XML documents, and partially describes the behavior or computer programs which process them.

Index

A

application description
 length of file name 3-12
 Asynchronous communications
 setting up 2-26

B

bisynchronous communications
 setting up 2-12

C

check in 5-3
 checking in
 File 5-3
 file definitions 5-25
 maps 5-21
 maps and translation objects 5-21
 translation objects 5-21
 checking out 5-13
 file 5-13
 file definitions 5-13
 maps 5-13
 TBL/TPL files 5-4
 Cleo 3780Plus
 Communications Toolkit 2-3
 troubleshooting 2-26
 Cleo A+
 Communications Toolkit 2-3
 Communications Toolkit 2-1
 Cleo 3780Plus 2-3
 Cleo 3780Plus troubleshooting 2-26
 Cleo A+ 2-3
 Comm subdirectory structure 2-5
 communicating with VANs 2-2
 connecting to VANs and directly to trading
 partners 2-27
 overview 2-2
 parts and functions 2-3
 setting up asynchronous communications 2-26
 configuration file
 van 2-10
 Connecting to Miscellaneous VANs and Directly to
 Trading Partners 2-27

D

data manager
 length of file name 3-12
 data manager pattern
 length of file name 3-12
 deleting
 working copies 5-18
 directory name length 3-11

E

editing a file 4-17

F

File Browser 4-14, 4-16, 4-17
 caution for using 3-9
 exiting 4-18
 opening a file 4-16
 saving a file 4-18
 starting 4-16
 when to use 4-14
 file check out 5-3
 in Workstation 5-3
 file definition
 checking in 5-25
 checking out 5-13
 length of file name 3-12
 unlocking 5-18
 File name
 character restrictions 3-13
 conventions 3-11
 invalid characters 3-13
 length 3-12
 validation 3-11

I

implementation guide
 length of file name 3-12
 input file
 length of file name 3-12
 ISAM files
 editing caution 3-9

M

Main Window buttons 4-10
 map

- checking in 5-3
- checking out 5-13
- length of file name 3-12
- unlocking 5-18
- mapping table
 - length of file name 3-12
- master directory 5-3
- master file
 - unlocking 5-18
- Microcom Network Protocol 2-10
- modifying
 - VAN configuration files 2-10

O

- On-line Help
 - using 4-12
- output file
 - length of file name 3-12

Q

- queue
 - length of file name 3-12

S

- saving a file 4-18
 - file definition 5-16
 - maps 5-16
- script
 - length of file name 3-12
- Select File Definition Files to Check in dialog box 5-9
- Select File Definition Files to Unlock dialog box 5-11
- Select Map Files to Check in dialog box 5-6
- Select Map Files to Check out dialog box 5-4
- Select Map Files to Unlock dialog box 5-11
- Select TBL/TPL Files to Check In dialog box 5-8

- setting up
 - bisynchronous communications 2-12
- Status Bar
 - using 4-11

T

- TBL/TPL
 - checking out 5-4
- Toolbar 4-10
 - using 4-11
- transaction register
 - length of file name 3-12
- translation object
 - checking in 5-21

U

- unlocking
 - file definitions 5-18
 - maps 5-18
 - master files 5-18
- using
 - on-line help 4-12
 - Status Bar 4-11
 - Toolbar 4-11

V

- Value-Added Network (VAN)
 - Communications Toolkit 2-2

W

- Window 4-14
- working copy
 - deleting 5-18
- working directory 5-3
- working file
 - saving 5-16