

IBM Sterling Gentran:Server for UNIX

Getting Started Guide

Version 6.2



Copyright

This edition applies to the 6.2 Version of IBM® Sterling Gentran:Server® for UNIX and to all subsequent releases and modifications until otherwise indicated in new editions.

Before using this information and the product it supports, read the information in *Notices* on page N-1.

Licensed Materials - Property of IBM

IBM® Sterling Gentran:Server® for UNIX

© Copyright IBM Corp. 1991, 2016. All Rights Reserved.

US Government Users Restricted Rights - Use, duplication or disclosure restricted by GSA ADP Schedule Contract with IBM Corp.

Table of Contents

About this Guide

▶ Introduction	viii
▶ Supported Configurations	xi
▶ Chapter Content	xiv
▶ Product Installation	xvi
▶ Optional Products	xvii
▶ Related Publications	xviii

Installing Sterling Gentran:Server On the UNIX Host

Overview

▶ Introduction	1-2
--------------------------	-----

Preparing for Installation

▶ Overview	1-4
▶ How to Create an Administrative User	1-5
▶ How to Create a Sterling Gentran:Server User	1-7

Installing the Software on the UNIX Host

▶ Overview	1-9
▶ How to Load Security Installation Files	1-10
▶ How to Install Security Administration Software	1-12
▶ How to Load Sterling Gentran:Server Host Installation Files	1-19
▶ How to Install the Sterling Gentran:Server Host Software	1-21
▶ How to Load and Install the XML Translation Option	1-27

Setting Up Sterling Gentran:Server Security

▶ Overview	1-30
▶ Sterling Gentran:Server Directories and Permissions	1-31
▶ How to Start and Exit Security Administration	1-32
▶ How to Add a New Environment Record	1-35
▶ How to Add a User Record	1-39
▶ Environment Access	1-46
▶ How to Assign Access to an Environment and Its Functions	1-51

Starting Sterling Gentran:Server Processes

▶ How to Start Sterling Gentran:Server on the Host	1-54
--	------

Setting Up Windows Clients

- ▶ Overview2-2
- ▶ How to Install the Client Software2-4
- ▶ How to Install MDAC 2.8 Components2-11
- ▶ How to Install Sterling Gentran:Server Standards2-13
- ▶ How to Edit the Windows Hosts File2-18
- ▶ How to Identify the Host to DNS2-19
- ▶ How to Install Optional Components2-20

Setting Up Communications

Overview

- ▶ Introduction3-2
- ▶ What Is the Communications Toolkit?3-3
- ▶ COMM Subdirectory Structure3-5
- ▶ The Communications Toolkit Setup Process3-9

Procedures

- ▶ How to Set Up Asynchronous Communications3-10
- ▶ How to Set Up Bisynchronous Communications3-12
- ▶ How to Start Up Cleo A+3-14
- ▶ How to Start Up Cleo 3780Plus3-17
- ▶ Start-Up Procedure Examples3-19

Troubleshooting

- ▶ Communications Session Error Recovery3-21
- ▶ Cleo 3780Plus Troubleshooting3-26
- ▶ Connecting to Other VANs and Directly to Trading Partners3-27

Introducing Sterling Gentran:Server

- ▶ Introduction4-2
- ▶ Sterling Gentran:Server Features4-5
- ▶ Sterling Gentran:Server for UNIX Client/Server Strategy4-7
- ▶ Running Multiple Sessions4-11

Using Sterling Gentran:Server

- ▶ Introduction5-2

Starting and Exiting

- ▶ How to Start Sterling Gentran:Server5-4
- ▶ How to Change Your Password (UNIX Version)5-6
- ▶ How to Exit Sterling Gentran:Server5-8

The Sterling Gentran:Server User Interface

- ▶ Overview5-9
- ▶ The Main Window5-10
- ▶ Main Window Menus5-12
- ▶ The Main Window Toolbar5-14
- ▶ How to Use the Sterling Gentran:Server Interface5-15
- ▶ How to Use the On-line Help5-16
- ▶ The File Browser5-18
- ▶ How to Use the File Browser5-20
- ▶ How to Change Print Properties5-23

Setting Default Values

- ▶ Overview5-24
- ▶ Set Up Directories Dialog Box5-26
- ▶ How to Change Client Default Directories5-28

Working with Application Integration

Overview

- ▶ Introduction6-2
- ▶ Working in Sterling Gentran:Server6-3

Dialog Boxes

- ▶ Select Map and File Definitions Files to Check out Dialog Box6-7
- ▶ Select Map Files to Check in Dialog Box6-9
- ▶ Select TBL/TPL Files to Check In Dialog Box6-11
- ▶ Select File Definition to Check in Dialog Box6-12
- ▶ Select Map and File Definition Files to Unlock Dialog Box6-14

Procedures

- ▶ How to Check Out and View Maps and File Definitions6-16
- ▶ How to Save Changes to Working Files6-20
- ▶ How to Unlock Master Files and Delete Working Copies6-22
- ▶ How to Copy a Translation Object to the Host User Directory6-26
- ▶ How to Check In Maps and Translation Objects6-27
- ▶ How to Check In File Definitions6-31

Client Descriptions

- ▶ Tracking TableA-1

Installing Sterling Gentran:Server Extension

- ▶ Verifying System RequirementsB-1
- ▶ How to Upgrade from Prior VersionsB-3
- ▶ How to Install the Configuration ClientB-4
- ▶ How to Load the SAP Extension Host Installation FilesB-6

- ▶ How to Install the SAP Extension onto the Host B-8
- ▶ How to Convert Version 5.x Flows to the 6.2 Format B-9
- ▶ NOTES B-11

Glossary

Notices

Index

About this Guide

Contents

- ▶ Introduction viii
- ▶ Supported Configurations xi
- ▶ Chapter Content xvi
- ▶ Product Installation xviii
- ▶ Optional Products xix
- ▶ Related Publications xxi

Introduction

Welcome Welcome to the IBM® Sterling Gentran:Server® for UNIX electronic data interchange (EDI) and electronic commerce (EC) software.

Who should use this guide

This guide is for the following audiences:

- Administrators responsible for installing and configuring EDI or EC application software
- Users of the Sterling Gentran:Server product

Use this table to determine which chapters are for you.

If you are...	Then refer to...
An administrator	Chapter 1-3
Using Sterling Gentran:Server for the first time	Chapters 4-6
A user and you are upgrading from Sterling Gentran:Server 5.4	Chapters 4-6
A user and you are upgrading from Sterling Gentran:Server 5.3 or prior version	Chapters 4-6

Reference

See the [Chapter Content](#) topic for a description of each chapter.

Required skills

This guide assumes that you are familiar with basic Windows concepts and commands, including:

- How to navigate and operate within the Windows environment
- How to use DOS commands and the DOS window within the Windows desktop

A knowledge of UNIX is also needed to successfully install and set up this product. IBM® Sterling Gentran:Server® for UNIX is a client/server product that allows EDI users to use Windows client computers to access programs and data on the UNIX host. This guide assumes you are familiar with basic UNIX concepts and commands, including:

- How UNIX identifies users and associates them into groups
- File ownership
- How to change the current directory
- How to set environment variables
- How to start and stop UNIX processes
- How to run UNIX scripts

Product packaging

Your IBM® Sterling Gentran:Server® for UNIX package should include the following items:

- The Host software CD
- The Client software CD
- A CD containing the Sterling Gentran:Server EDI Standards
- A CD containing the Sterling Gentran:Server online documentation
- The *IBM® Sterling Gentran:Server® for UNIX Getting Started Guide*

Notes

If your company purchased IBM® Sterling Gentran:Server® Extension for SAP R/3, then your package should also include:

- The Installation Card for Sterling Gentran:Server Extension
- The SAP Host software CD
- The SAP Client software CD

WARNING

If additional installation instructions came with your Sterling Gentran:Server shipment, those instructions take precedence over the instructions listed here.

**Sterling
Gentran:Server
products**

This guide provides instructions for installing the following IBM® Sterling Gentran:Server® for UNIX products:

- ▶ IBM® Sterling Gentran:Server® for UNIX
- ▶ IBM® Sterling Gentran:Server® for UNIX with ADD

The title of the *Installation Checklist* included with your software indicates which product you purchased.

**Sterling
Gentran:Server
utilities**

Depending on which level of Sterling Gentran:Server your company purchased, the following utilities may be included:

- ▶ Communications Toolkit
- ▶ Life Cycle

Communications Toolkit

The Communications Toolkit is included in the IBM® Sterling Gentran:Server® for UNIX. The toolkit scripts are automatically installed when you install IBM® Sterling Gentran:Server® for UNIX. If you want to use the Communications Toolkit, you must first install and configure Sterling Gentran:Server, then set up the toolkit.

Reference

See the [Setting Up Communications](#) chapter in this guide.

Life Cycle

IBM® Sterling Gentran:Server® for UNIX - Process Control Manager include the Life Cycle data tracking utility. Life Cycle requires additional database software. Life Cycle must be set up on the UNIX host by someone familiar both with your site database and with UNIX.

Reference

See the *IBM® Sterling Gentran:Server® for UNIX - Process Control Manager Data Flow Administration Guide* or the *IBM for UNIX - EC Workbench Data Flow Administration Guide* for detailed requirements and for instructions for setting up the Life Cycle tracking utility.

Supported Configurations

Introduction This topic describes the hardware and software configurations supported by IBM® Sterling Gentran:Server® for UNIX.

Windows client Each Windows client must have:

- A CD-ROM drive
- Microsoft Windows XP® SP2
- Windows 7
- A minimum of 1GB of free disk space

Note

Your Windows operating system may require updates to work correctly. Check the following Microsoft web site to determine and download the latest service packs for your operating system:

<http://www.microsoft.com/windows/downloads/default.asp>

UNIX host The UNIX host computer must have:

- A minimum of 100 MB free disk space
- A minimum of 500 MB memory
- Additional disk space for customer data, archives, etc.

WARNING

For IBM® Sterling Gentran:Server® for UNIX, the UNIX host *must* include the Korn shell.

Operating systems This table lists the operating systems minimum requirements on the supported Sterling Gentran:Server platforms.

Hardware Platform	Operating System and Version
HP 9000	HPUX 11.31
IBM RS6000	A minimum of AIX 5.3
SUN	A minimum of Solaris 10 (SPARC only)

Patches

Hewlett-Packard provides service patches to their operating systems. You may need the service patches if you experience problems with message queues, the dynamic loader, performance, or the translator. We recommend that you check the Hewlett-Packard web site, or contact your Hewlett-Packard representative to obtain the most recent information about service patches.

Networking requirements

Your Sterling Gentran:Server installation must satisfy the following networking requirements.

- ▶ Appropriate software for the EDI administrator to access the UNIX command line (Telnet or an x-emulation package).
- ▶ TCP/IP connectivity between UNIX host and Windows client computers.

Lifecycle requirements

The Sterling Gentran:Server Life Cycle auditing facility interfaces with most versions of:

- ▶ Informix
- ▶ Oracle
- ▶ Sybase

Contact IBM Customer Support to verify that a particular version of a database is supported.

This table lists, by vendor, the software that may be required to run Life Cycle.

Vendor	Required Software	Description
Informix	ESQL/C Openline	Embedded SQL precompiler
	I-SQL Openline	SQL statement interpreter
	Informix Standard Engine (SE)	Standard database engine
Oracle	PRO*C	Embedded SQL precompiler for C source code
	Oracle RDBMS	Database server
	PL/SQL	SQL statement interpreter
Sybase	Sybase SQL Server	Database server
	Open Client/C	Necessary libraries to communicate with Sybase
	Embedded SQL/C	Embedded SQL precompiler for C source code

Note

Check with your database vendor for current requirements.

Chapter Content

Description of content

This table describes the content of the chapters within the *IBM® Sterling Gentran:Server® Getting Started Guide*.

Chapter Title	Description
About this Guide	This preface describes the purpose and content of this guide. It describes the supported hardware and software configurations.
Chapter 1 - Installing Sterling Gentran:Server on the UNIX Host	This chapter explains how to set up a new installation of Sterling Gentran:Server on a UNIX host computer. The procedures include: <ul style="list-style-type: none"> ▶ preparing for installation ▶ installing Sterling Gentran:Server on the host ▶ setting up the Sterling Gentran:Server Security Administration utility.
Chapter 2 - Setting Up Windows Clients	This chapter explains how to install and set up client software for Sterling Gentran:Server on the Windows client computers.
Chapter 3 - Setting Up Communications	This chapter explains how to install and set up client software for Sterling Gentran:Server on the Windows client computers.
Chapter 4 - Introducing Sterling Gentran:Server	Describes the basic architecture of the Sterling Gentran:Server software.
Chapter 5 - Using Sterling Gentran:Server	Explains how to start and exit Sterling Gentran:Server, describes the user interface, and explains how to set default values for your system.
Chapter 6 - Working with Application Integration	Contains procedures for working with Sterling Gentran:Server Application Integration system files. Includes instructions for checking out, saving, and checking in files.

(Contd) Chapter Title	Description
Appendix A - Client Descriptions	Contains a table designed to help track serial numbers, IP addresses, and descriptions of your client PCs.
Glossary	Sterling Gentran:Server and industry-related terms.

Product Installation

Installation process

We automated most of the installation process on both the UNIX host and the Windows client.

- ▶ The host installation process prompts you for the necessary environment variables. The process collects the variables in a file that you can copy into scripts or attach to the profile of the appropriate user.
- ▶ The client installation process helps configure the Sterling Gentran:Server connection to the UNIX host. The client installation now includes the ability to install online versions of the Sterling Gentran:Server documentation.

Note

This guide contains an additional procedure for setting up client/host communication for networks that use Domain Name Services (DNS).

Installation Checklist

The *Installation Checklist* contains the following features:

- ▶ Flow diagram of the installation process.
- ▶ Places to record all of the information you need during the installation process.

We recommend that you keep the *Installation Checklist* with you for reference throughout the installation process.

Optional Products

- Introduction** There are several options available for IBM® Sterling Gentran:Server® for UNIX 6.2. They include:
- ▶ XML Translation extension (available for purchase)
 - ▶ Health Insurance Portability and Accountability Act (HIPAA) features (available to all customers)
 - ▶ Extensions (such as IBM® Sterling Gentran:Server® Extension for SAP R/3)
- These options are installed automatically on the client. Access is limited, however, to only those options that have been installed on the UNIX host.

- Installing options** You can install each option separately after installing the core Sterling Gentran:Server software. This table lists the CD containing the option and the instructions for installing the option.

To install the...	Use...
XML Translation Extension	<p>the core installation CD.</p> <p>Note You need to supply the serial number to install the XML Translation Extension.</p> <p>Reference See the How to Load and Install the XML Translation Option topic in this guide.</p>
HIPAA features	<p>the <i>IBM® Sterling Gentran:Server® for UNIX HIPAA Compliance and NCPDP User Guide</i>.</p> <p>Reference See the How to Add a New Environment Record topic in this guide.</p>
Extensions	<p>the documentation shipped with other options or add-on software for installation instructions.</p>

Related Publications

Sterling Gentran:Server documentation

This table describes additional documentation for the Sterling Gentran:Server software.

Document	Description
<i>IBM® Sterling Gentran:Server® for UNIX Upgrade and Data Conversion Guide</i>	Instructions for upgrading from previous versions of IBM® Sterling Gentran:Server® for UNIX and IBM® Sterling Gentran:Server® for UNIX - Workstation. Also includes instructions for converting the files that are part of the upgrade.
<i>IBM® Sterling Gentran:Server® for UNIX Installation Checklist</i>	Description of the recommended sequence in which you should install and configure system components.
<i>IBM® Sterling Gentran:Server® for UNIX - Workstation Getting Started Guide</i>	Instructions for installing the IBM® Sterling Gentran:Server® for UNIX - Workstation software and performing setup tasks. Instructions for starting and exiting Sterling Gentran:Server and for setting preferences and default values. Also includes instructions for checking files in and out and saving files.
<i>IBM® Sterling Gentran:Server® for UNIX Application Integration User Guide</i>	Instructions for performing mapping and translation tasks using the Sterling Gentran:Server Application Integration system.
<i>IBM® Sterling Gentran:Server® for UNIX HIPAA Compliance and NCPDP User Guide</i>	Instructions for mapping and translating NCPDP files with the Application Integration system.
<i>IBM® Sterling Gentran:Server® for UNIX GENCOD User Guide</i>	Instructions for mapping and translating GENCOD files with the Application Integration system.
<i>IBM® Sterling Gentran:Server® for UNIX VDA User Guide</i>	Instructions for mapping and translating VDA files with the Application Integration system.

Document	Description
<i>IBM® Sterling Gentran:Server® for UNIX Technical Reference Guide</i>	Describes processes, lists command-line commands in alphabetical order, and describes file record layouts and data type formats.
<i>IBM® Sterling Gentran:Server® for UNIX - EC Workbench Data Flow Administration Guide</i>	User instructions for configuring data flows using the Sterling Gentran:Server software.
<i>IBM® Sterling Gentran:Server® for UNIX - Process Control Manager Data Flow Administration Guide</i>	User instructions for configuring data flows using the Sterling Gentran:Server software.
<i>IBM® Sterling Gentran:Server® for UNIX Maintenance and Troubleshooting Guide</i>	Instructions for maintaining your Sterling Gentran:Server installation. Also provides troubleshooting information to help determine the cause and solution of problems that may occur.
<i>IBM® Sterling Gentran:Server® for UNIX - Workstation Maintenance and Troubleshooting Guide</i>	Instructions for maintaining your workstation installation. Also provides troubleshooting information to help determine the cause and solution of problems that may occur.
<i>IBM® Sterling Gentran:Server® for UNIX with ADD User Guide</i>	Instructions for configuring and using the Advanced Data Distribution system.
<i>IBM® Sterling Gentran:Server® for UNIX XML Translation User Guide</i>	Instructions for mapping and translating XML files with the Application Integration system.

Document	Description
<i>IBM® Sterling Gentran:Server® for UNIX with ADD FTP Daemon User Guide</i>	Instructions for configuring and using the FTP Daemon tool with IBM® Sterling Gentran:Server® for UNIX with ADD.
Online Help	Context-sensitive help screens describing the Sterling Gentran:Server dialog boxes and features. Also includes procedures for using the mapping and translation and the data flow administration software.

Installing Sterling Gentran:Server On the UNIX Host

Contents	Overview	
	▶ Introduction	2
	Preparing for Installation	
	▶ Overview	4
	▶ How to Create an Administrative User	5
	▶ How to Create a Sterling Gentran:Server User	7
	Installing the Software on the UNIX Host	
	▶ Overview	9
	▶ How to Load Security Installation Files	10
	▶ How to Install Security Administration Software	12
	▶ How to Load Sterling Gentran:Server Host Installation Files	19
	▶ How to Install the Sterling Gentran:Server Host Software	21
	▶ How to Load and Install the XML Translation Option	27
	Setting Up Sterling Gentran:Server Security	
	▶ Overview	30
	▶ Sterling Gentran:Server Directories and Permissions	31
	▶ How to Start and Exit Security Administration	32
	▶ How to Add a New Environment Record	35
	▶ How to Add a User Record	39
	▶ Environment Access	46
	▶ How to Assign Access to an Environment and Its Functions	51
	Starting Sterling Gentran:Server Processes	
	▶ How to Start Sterling Gentran:Server on the Host	54

Overview

Introduction

Chapter contents

This chapter contains instructions for installing Sterling Gentran:Server in a new environment.

WARNING

This installation method creates new, empty data files. Do not use this method to upgrade an existing Sterling Gentran:Server environment because it will overwrite existing data.

Reference

See the *IBM® Sterling Gentran:Server® for UNIX Upgrade and Data Conversion Guide* for information about upgrading to a new version of Sterling Gentran:Server.

Stages of Installation

When installing Sterling Gentran:Server, you must install at least one copy of the Security Administration utility and one copy of the Sterling Gentran:Server host installation software onto UNIX hosts on your network. The Security Administration and Sterling Gentran:Server installations must be on the same host. You must also load the Sterling Gentran:Server client software onto each Windows client computer that will access the Sterling Gentran:Server software.

This table describes the stages of a new installation process for Sterling Gentran:Server. Detailed instructions for completing each stage are contained in the rest of this manual.

Reference

See the *IBM® Sterling Gentran:Server® for UNIX Upgrade and Data Conversion Guide* for information about upgrading to a new version of Sterling Gentran:Server.

Stage	Description
1	Prepare for installation: <ul style="list-style-type: none"> ▶ Create an administrative user to own and load the Security Administration utility. ▶ Create a Sterling Gentran:Server user to own the Sterling Gentran:Server host installation and processes.

(Contd) Stage	Description
2	Install Sterling Gentran:Server on the host: <ul style="list-style-type: none">▶ Load the Security Administration installation files into a temporary area on the UNIX host computer.▶ Install the Sterling Gentran:Server Security Administration utility.▶ Load the Sterling Gentran:Server host installation files into a temporary area on the UNIX host computer.▶ Install the Sterling Gentran:Server host software, including any options.
3	Configure the environment security for the Sterling Gentran:Server installation.
4	Configure the user security for the Sterling Gentran:Server installation.
5	Start the Sterling Gentran:Server processes on the UNIX host.
6	Install Sterling Gentran:Server on the Windows client.

Preparing for Installation

Overview

In this section

This section contains procedures you must perform before installing the Sterling Gentran:Server host and client software.

Before you begin

Use this table as a checklist to determine whether you are ready to install Sterling Gentran:Server.

Done	Item
	Make sure that you have: <ul style="list-style-type: none">▶ An <i>Installation Checklist</i>▶ The host software CD▶ The client software CD▶ The IBM® Sterling Gentran® Standards CD▶ The online documentation CD▶ Any optional software that you want to install at this time
	Complete the <i>Installation Checklist</i> , and keep it with you when performing the procedures in this chapter.

How to Create an Administrative User

Introduction If different users perform separate parts of the installation, each user must have the same permissions and belong to the same group.

Recommendations

We recommend that you create an administrative user and use that login to install the Security Administration utility software, configure Sterling Gentran:Server security, and start the security processes.

We recommend that you also create a separate Sterling Gentran:Server user for each Sterling Gentran:Server installation. If you have an older version of Sterling Gentran:Server on the same machine, you must create a new user profile to run the new version of Sterling Gentran:Server. The Sterling Gentran:Server user should have access to Sterling Gentran:Server, but not to administrative functions. For instructions, see the [How to Create a Sterling Gentran:Server User](#) topic in this chapter.

Procedure Use this procedure to create an administrative user to install and own the Security Administration software, start the processes, and configure security.

Comment

Depending on how system security is handled at your site, a system administrator may have to create this user for you.

Step	Action
1	Log on to the UNIX host as root.
2	Create a UNIX user login. Example gsadmin
3	Create a group containing the new user. Example gsuser

(Contd) Step	Action
4	<p>Create a directory to contain the Sterling Gentran:Server Security Administration utility. Set ownership of this directory to the user and group you created in Steps 2 and 3.</p> <p>Comment For the Sterling Gentran:Server Security Administration utility to work properly, the user must be the owner or a member of the group that owns the Sterling Gentran:Server Security directory.</p>
5	<p>Are you installing Sterling Gentran:Server for UNIX?</p> <ul style="list-style-type: none"> ▶ If YES, give the administrator at privileges to allow the administrator to start scripts. <p>WARNING The Sterling Gentran:Server data flow software will work properly only if the user has the ability to start scripts.</p> <p>Comment Permission to start at jobs is maintained in the <i>at.allow</i> or <i>at.deny</i> files. These files are normally found in <i>/usr/admin/cronq</i> or <i>/usr/lib/cron</i>, depending on the version of UNIX you are running.</p>
6	<p>Give the administrator cron privileges to allow the administrator to start cron jobs.</p> <p>WARNING The Sterling Gentran:Server Scheduler requires cron privileges to function.</p> <p>Comment Permission to start cron jobs is maintained in the <i>cron.allow</i> or <i>cron.deny</i> files. These files are normally found in <i>/usr/admin/cronq</i> or <i>/usr/lib/cron</i>. The actual location may vary, depending on the version of the UNIX system you are running.</p>

How to Create a Sterling Gentran:Server User

Introduction You should create a separate Sterling Gentran:Server user login to each environment and that you use that login to start the Sterling Gentran:Server processes within that environment.

Procedure Use this procedure to create a Sterling Gentran:Server user to install and run the Sterling Gentran:Server installation.

Comment

Depending on how system security is handled at your site, a system administrator may have to create this user.

Step	Action
1	Log on to the UNIX host as root.
2	Create a UNIX user login. Example gsprod
3	Add the user to the group containing the administrative login. Example gsuser
4	Create a directory for the Sterling Gentran:Server installation. Set ownership of this directory to the user and group you created in Steps 2 and 3. WARNING Do not use spaces or other punctuation within the directory name.

(Contd) Step	Action
5	<p>Are you installing IBM® Sterling Gentran:Server® for UNIX ?</p> <ul style="list-style-type: none">▶ If YES, give the user at privileges. This allows the administrator to start scripts. <p>WARNING</p> <p>The Sterling Gentran:Server data flow software will work properly only if you have privileges to start scripts.</p> <p>Comment</p> <p>Permission to start at jobs is maintained in the <i>at.allow</i> or <i>at.deny</i> files. These files are normally stored in <i>/usr/admin/cronq</i> or <i>/usr/lib/cron</i>. The location is dependent on which version of the UNIX system you are running.</p>
6	<p>Give the user cron privileges to allow the user to start cron jobs.</p> <p>WARNING</p> <p>The Sterling Gentran:Server Scheduler requires cron privileges to function.</p> <p>Comment</p> <p>Permission to start cron jobs is maintained in the <i>cron.allow</i> or <i>cron.deny</i> files. These files are normally found in <i>/usr/admin/cronq</i> or <i>/usr/lib/cron</i>. The location is dependent on which version of the UNIX system you are running.</p>

Installing the Software on the UNIX Host

Overview

In this section This section explains how to load Sterling Gentran:Server from the installation CD into the proper directories on the UNIX host computer.

Installation Checklist We recommend that you keep the *Installation Checklist* with you for reference throughout the installation process.

The *Installation Checklist* contains the following features:

- Flow diagram of the installation process.
 - Places to record all of the information you need during the installation process.
-

How to Load Security Installation Files

Introduction

During installation, you must run a transfer program to copy the compressed software files from the installation CD into the proper directories on the UNIX host computer. This topic explains how to use the transfer program to read the security installation files from a CD in a Windows client computer into a temporary directory on the UNIX host.

Before you begin

Before you begin loading the Sterling Gentran:Server security installation files onto the UNIX host computer, you must have a UNIX login to install and own the Security Administration utility.

References

See the [How to Create an Administrative User](#) topic in this chapter for detailed instructions on creating this login.

Copying installation files from the CD

Use this procedure to copy the security installation files from a CD-ROM drive on the Windows client computer to the UNIX host.

Note

Before you begin, verify that

- ▶ The connection between the Windows client and the UNIX host supports TCP/IP.
- ▶ The Windows client computer is connected to the UNIX host.

Step	Action
1	Insert the Sterling Gentran:Server host installation CD into a CD-ROM drive in the Windows client.
2	<ul style="list-style-type: none"> ▶ For Window 7, click Start > All Programs > Accessories, and then click on the Command Prompt. ▶ For Windows XP, click Start > All Programs > Accessories - XP, and then click on the Command Prompt.
3	Change directories to the CD-ROM drive on the Windows computer.

(Contd) Step	Action
4	<p>Type the following command to copy the security installation files from the CD to a temporary area on the UNIX host.</p> <pre>ftpprod security <host> <path> <user> <password></pre> <p>Where</p> <ul style="list-style-type: none">▶ <host> is the system name for the UNIX host▶ <path> is the path to a temporary directory (The ftpprod process creates the directory if necessary)▶ <user> is the user login for the administrative user you created▶ <password> is the user password for the administrative user
5	<p>Press ENTER.</p> <p>System Response</p> <p>The transfer program displays information about the transfer process. The message “Files transferred” indicates that the process completed successfully.</p>
6	<p>Close the DOS window.</p>
7	<p>Continue to How to Install Security Administration Software to install the security software from the temporary directory.</p>

How to Install Security Administration Software

Introduction

The Sterling Gentran:Server Security Administration utility controls the Sterling Gentran:Server software. Run the `secsetup.sh` script to install the software for this utility into the appropriate directories on the UNIX host.

The `secsetup.sh` script

- reads the installation files
- installs them into the specified location on the UNIX host
- temporarily sets the UNIX environment variables that the security software needs
- places those variables into a file that you can include in scripts and UNIX users' profiles.

This topic explains how to run `secsetup.sh` to install the security software files into a security administration directory. It also explains how to add the environment variables into the security administrator profile.

Before you begin

Use this checklist to ensure that you are ready to begin installing the Sterling Gentran:Server Security Administration utility onto the UNIX host computer.

Done	Task
	<p>Log onto the UNIX host machine as the administrative user that was set up to install and own the security administration installation.</p> <p>Reference See the How to Create an Administrative User topic in this chapter for detailed instructions on creating this user.</p>
	<p>Verify that the compressed security installation files reside in a temporary directory on the UNIX host that this login is accessing.</p> <p>Reference See the How to Load Security Installation Files topic in this chapter for detailed instructions.</p>

CAUTION

During the setup process, the setup program prompts you for a required environment variable if it is not set. If the setup program finds a value for a required environment variable, it continues to the next step without displaying a prompt.

Installing the Security Administration utility

Use this procedure to install the Sterling Gentran:Server Security Administration utility on the UNIX host computer. Refer to the completed *Installation Checklist* as needed.

Step	Action
1	<p>Log onto the UNIX host as the administrative user that will install and own this installation.</p> <p>WARNING</p> <p>You must log on as the user who will own the security directories and start the security processes. Using another login will result in conflicts with permissions.</p> <p>Do <i>not</i> log on as root. The root login is unable to run the installation program.</p> <p>Reference</p> <p>See the topic How to Create an Administrative User in this chapter for instructions.</p>
2	<p>Change directories to the temporary directory.</p> <p>Example</p> <pre>cd temp</pre>
3	<p>Give yourself “execute” privileges for the secsetup.sh script file. This gives you permission to run the script.</p> <p>Example</p> <pre>chmod +x secsetup.sh</pre>
4	<p>Type the following command at the UNIX prompt and then press ENTER:</p> <pre>./secsetup.sh</pre> <p>System Response</p> <p>The secsetup.sh script displays information about the installation process and prompts you to enter a value for SADMIN_ROOT.</p>

(Contd) Step	Action
5	<p>Type the complete path you want secsetup.sh to use when installing the security utility and press ENTER.</p> <p>Example /usr1/gentran/security</p> <p>System Response The secsetup.sh script displays the path entered and prompts you to confirm that the path is correct.</p>
6	<p>Is the path displayed correct?</p> <ul style="list-style-type: none"> ▶ If YES, type y and press ENTER. ▶ If NO, type n and press ENTER. The secsetup.sh script again prompts you to enter a value for SADMIN_ROOT. Return to Step 5. <p>System Response The secsetup.sh script prompts you for the complete path to the <i>vvtermcap</i> file.</p>
7	<p>Do you want to use the <i>vvtermcap</i> file supplied by IBM?</p> <ul style="list-style-type: none"> ▶ If YES, press ENTER to accept the default path. <p>Note We recommend that you accept the default. Use another file only if your system requires a proprietary terminal emulator.</p> <ul style="list-style-type: none"> ▶ If NO, type the path to where your proprietary <i>vvtermcap</i> file is stored, and press ENTER. (Contact your system administrator if you do not know the path.) <p>System Response The secsetup.sh script displays the path entered for the <i>vvtermcap</i> file and prompts you to confirm that value.</p>

(Contd) Step	Action
8	<p>Is the displayed VVTERMCAP value correct?</p> <ul style="list-style-type: none"> ▶ If YES, type y and press ENTER. ▶ If NO, type n and press ENTER. The secsetup.sh script prompts you a second time to enter a value for VVTERMCAP. Return to Step 7. <p>System Response The secsetup.sh script prompts you for a value for the VVTERM environment variable.</p> <p>Comment This value reflects the terminal emulation setting to use for Sterling Gentran:Server. It normally equals the TERM environment variable value set in your profile.</p>
9	<p>Do you want to use the default value, which sets VVTERM to the same value as TERM?</p> <ul style="list-style-type: none"> ▶ If YES, then press ENTER. ▶ If NO, type the value you want to use for VVTERM, and press ENTER. <p>Comment A common value is vt100.</p> <p>System Response The secsetup.sh script displays the value entered and prompts you to confirm the value.</p>
10	<p>Is the displayed VVTERM value correct?</p> <ul style="list-style-type: none"> ▶ If YES, type y and press ENTER. ▶ If NO, type n, and press ENTER. The secsetup.sh script prompts you to enter a value for VVTERM a second time. Return to Step 9. <p>System Response The secsetup.sh script prompts you for a value for the NAMEBROKER environment variable.</p>
11	<p>Type the system name for the UNIX computer that will run the broker process that controls this security installation.</p> <p>System Response The secsetup.sh script displays the value entered and prompts you to confirm the value.</p>

(Contd) Step	Action
12	<p>Is the displayed NAMEBROKER value correct?</p> <ul style="list-style-type: none"> ▶ If YES, type y and press ENTER. ▶ If NO, type n and press ENTER. The secsetup.sh script prompts you a second time to enter a value for NAMEBROKER. Return to Step 11. <p>System Response The secsetup.sh script displays status messages and lists the path to the file that contains the environment variables.</p>
13	<p>View the installation log to confirm that the installation completed successfully.</p> <p>Comment The system creates the installation log (<i>secsetup.log</i>) in the directory where you started the secsetup.sh script.</p>
14	<p>Do you want to install another copy of the Security Administration utility to control a second Sterling Gentran:Server environment?</p> <ul style="list-style-type: none"> ▶ If YES, then return to Step 1 and repeat this procedure. ▶ If NO, then continue with the next procedure, Adding environment variables to the owner profile. <p>Note You can use a single security installation to control multiple Sterling Gentran:Server environments on the same UNIX host machine. Each UNIX host machine running Sterling Gentran:Server must have a security installation.</p>

Adding environment variables to the owner profile

Use this procedure to add the environment variables saved by **secsetup.sh** into the profile of the security administrator.

Step	Action
1	<p>If you logged off of the UNIX host, log back on as the administrative user.</p> <p>Reference See the How to Create an Administrative User topic in this guide for instructions.</p>
2	<p>Change directories to the home directory for the administrative user.</p>

(Contd) Step	Action
3	Use a text editor to open the profile (<i>.profile</i> or <i>.login</i>) of the administrative user. Reference See the documentation provided with the text editor for more information about opening files.
4	Open a second session on the UNIX host while keeping the first session open.
5	Open the <i>gentran.security.vars</i> file and add the last set of values to the end of the profile. CAUTION The installation process appends new values at the end of the <i>gentran.security.vars</i> file each time you run <i>secsetup.sh</i> using the same UNIX login. Depending on the size of the file and the text editor you are using, it may be easier to locate the values that you need to copy by printing the file first.
6	Save the modified profile.
7	Log the administrative user off the system.
8	Log onto the system again as the administrative user. System Response The system sets the environment variables for the administration user using the values from the edited profile.

How to Load Sterling Gentran:Server Host Installation Files

Introduction

During installation, you must run a transfer program to copy the compressed software files from the installation CD into the proper directories on the UNIX host computer. This topic explains how to use the transfer program to read the installation files from a CD in a Windows client computer into a temporary directory on the UNIX host.

Before you begin

Before you begin loading the Sterling Gentran:Server installation files onto the UNIX host computer, you must have a UNIX login to install and own the Security Administration utility.

IMPORTANT

You must load the Security Installation files and install the Security Administration software before loading the Sterling Gentran:Server Host installation files.

References

See the [How to Create an Administrative User](#) topic in this chapter for detailed instructions on creating this login.

Copying installation files from the CD

Use this procedure to copy the installation files from a CD-ROM drive on the Windows client computer to the UNIX host.

Note

Before you begin, verify that

- ▶ The connection between the Windows client and the UNIX host supports TCP/IP
- ▶ The Windows client computer is connected to the UNIX host.

Step	Action
1	Insert the Sterling Gentran:Server host installation CD into a CD-ROM drive in the Windows client.
2	<ul style="list-style-type: none"> ▶ For Window 7, click Start > All Programs > Accessories, and then click on the Command Prompt. ▶ For Windows XP, click Start > All Programs > Accessories - XP, and then click on the Command Prompt.

(Contd) Step	Action
3	Change directories to the CD-ROM drive on the Windows computer. Example D:
4	Type the following command to transfer installation files from the CD to a temporary area on the UNIX host: <pre>ftpprod <product> <host> <path> <user> <password></pre> Where <ul style="list-style-type: none"> ▶ <product> is the product code for the Sterling Gentran:Server you purchased. Use the following value, add=IBM® Sterling Gentran:Server® for UNIX with ADD ▶ <host> is the system name for the UNIX host ▶ <path> is the path to a temporary directory (The ftpprod process will create the directory if necessary) ▶ <user> is the user login for the administrative user you created ▶ <password> is the user password for the administrative user Example <pre>ftpprod add sun2 /usr/gentran/temp secuser secpassword</pre>
5	Press ENTER. System Response The transfer program displays information about the transfer process. The message "Files transferred" indicates that the process completed successfully.
6	Close the DOS window.
7	Continue to How to Install the Sterling Gentran:Server Host Software to install the security software from the temporary directory.

How to Install the Sterling Gentran:Server Host Software

Introduction

You run the `setup.sh` script to install the Sterling Gentran:Server host software into the appropriate directories on the UNIX host.

The `setup.sh` script reads the installation files and installs them into the specified location on the UNIX host. This script also sets temporary values for some of the UNIX environment variables that the Sterling Gentran:Server software needs. The installation script places those variables into a file that you can include in scripts and UNIX users' profiles.

This topic explains how to run `setup.sh` to install the Sterling Gentran:Server software files into a directory and then add the environment variables into the administration user profile or to scripts.

IMPORTANT

Before you install the Sterling Gentran:Server host software, you must complete the following tasks: load the Security Installation files; install the Security Administration software; and load Sterling Gentran:Server host software files

Before you begin

Use this checklist to determine that you are ready to install Sterling Gentran:Server onto the UNIX host computer.

Done	Task
	Verify that you created a Sterling Gentran:Server user to own the environment and the processes run within it.
	Verify that you correctly installed a copy of the Security Administration utility to control the Sterling Gentran:Server environment.

CAUTION

During the setup process, the setup program prompts you for a required environment variable if it is not set. If the setup program finds a value for a required environment variable, it continues to the next step without displaying a prompt.

Installing the Sterling Gentran:Server software

Use this procedure to install the Sterling Gentran:Server software onto the UNIX host computer. Refer to the completed *Installation Checklist* as needed.

Step	Action
1	<p>Log on to the UNIX host as the Sterling Gentran:Server user that owns the host software.</p> <p>WARNING</p> <p>You must log on as the user who will own the Sterling Gentran:Server environment. Using another login will result in conflicts with permissions.</p> <p>Do <i>not</i> log on as root. The root login is unable to run the installation program.</p> <p>Reference</p> <p>See the topic How to Create a Sterling Gentran:Server User for instructions on this task.</p>
2	<p>Change directories to the temporary directory you used as the path in the ftpprod in Step 5 of "How to Load Sterling Gentran:Server Host Files."</p>
3	<p>Give "execute" privileges for the setup.sh script file so it can be run by the Sterling Gentran:Server user.</p> <p>Example</p> <pre>chmod +x setup.sh</pre>
4	<p>Type the following command and press ENTER.</p> <pre>./setup.sh</pre> <p>System Response</p> <p>The setup.sh script displays information about the installation process and prompts you to provide the product key for the Sterling Gentran:Server product you want to install.</p>
5	<p>Type the product key and press ENTER.</p> <p>System Response</p> <p>The setup.sh script prompts you for the path to the location where Sterling Gentran:Server will be installed.</p>

Note: If you are installing on the SunOS/Solaris platform, only SPARC is supported. If you attempt to install on x86 or x86-64, the system will respond positively ("Version xx.x meets or exceeds our minimum requirements") but the install will fail with an error message.

(Contd) Step	Action
6	<p>Type the complete path to where you want setup.sh to install the Sterling Gentran:Server software and press ENTER.</p> <p>Example /usr1/gentran/edi</p> <p>System Response The setup.sh script displays the path you entered and prompts you to confirm that the path is correct.</p>
7	<p>Is the displayed path correct?</p> <ul style="list-style-type: none"> ▶ If YES, type y and press ENTER. ▶ If NO, type n and press ENTER. The setup.sh script prompts you a second time to enter a value for EDI_ROOT and ENV_ROOT. Return to Step 6. <p>System Response The setup.sh script prompts you for the complete path to the <i>vvtermcap</i> file.</p>
8	<p>Do you want to use the <i>vvtermcap</i> file supplied by IBM?</p> <ul style="list-style-type: none"> ▶ If YES, press ENTER to accept the default path. <p>Note We recommend that you accept the default. Use another file only if your system requires a proprietary terminal emulator.</p> <ul style="list-style-type: none"> ▶ If NO, type the path to where your proprietary <i>vvtermcap</i> file is stored and press ENTER. (Your system administrator can provide this path if you need it.) <p>System Response The setup.sh script displays the path entered for the <i>vvtermcap</i> file and prompts you to confirm that value.</p>
9	<p>Is the displayed VVTERMCAP value correct?</p> <ul style="list-style-type: none"> ▶ If YES, type y and press ENTER. ▶ If NO, type n and press ENTER. The setup.sh script prompts you a second time to enter a value for VVTERMCAP. Return to Step 8. <p>Comment This value reflects the terminal emulation setting to use for Sterling Gentran:Server, and normally is the same as the value for the TERM environment variable as set in your profile.</p>

(Contd) Step	Action
10	<p>Do you want to install in the <filename> directory?</p> <ul style="list-style-type: none"> ▶ If YES, type y and press ENTER. ▶ If NO, type n and the directory you want to use. Press ENTER. <p>System Response The setup.sh script runs. It creates directories, installs the EDI software, and creates empty data files. After all files are installed, the installation validation program verifies that Sterling Gentran:Server can run successfully. Validation collects the validated environment variable settings in a file, and creates a log file that records any problems detected.</p> <p>Note The validation stage lasts several minutes for the lowest product level. This stage lasts longer for higher product levels.</p> <p>Eventually, the setup.sh script displays status messages and lists the path to the file that contains the environment variables.</p>
11	<p>View the installation log to confirm that the installation completed successfully.</p> <p>Comment The system creates the installation log (<i>setup.log</i>) in the directory where you started setup.sh.</p>
12	<p>Continue with the next procedure, Adding environment variables to the owner profile.</p>

Adding environment variables to the owner profile

Use this procedure to add the required environment variables saved by `secsetup.sh` and by `setup.sh` into the profile of the environment owner.

Note

This procedure requires you to open two sessions on the UNIX host.

Step	Action
1	<p>If you logged off the UNIX host, log back onto the UNIX host as the Sterling Gentran:Server user created to own this environment.</p> <p>Reference See the How to Create a Sterling Gentran:Server User topic for instructions.</p>
2	Change directories to the home directory for the Sterling Gentran:Server user.
3	Use any text editor to open the profile (<code>.profile</code> or <code>.login</code>) of the Sterling Gentran:Server user.
4	Open a second session on the UNIX host while keeping the first session open.
5	<p>Log onto the second session as the Sterling Gentran:Server user.</p> <p>Comment You can make the rest of this procedure easier to perform by resizing the session windows side-by-side.</p>
6	Change directories in the second session to the home directory of the owner of the security installation.
7	<p>Open the <code>gentran.security.vars</code> file and copy the command that sets NAMEBROKER from the last set of values.</p> <p>CAUTION The installation process appends new values at the end of the <code>gentran.security.vars</code> file each time you run <code>secsetup.sh</code> using the same UNIX login.</p> <p>Comment Depending on the size of the file and the text editor you are using, it may be easier to locate the values that you need to copy by printing the file first.</p>
8	Paste the NAMEBROKER command into the profile in the first session window.

(Contd) Step	Action
9	From the <i>gentran.security.vars</i> file in the second session window, copy the command that sets <code>SADMIN_ROOT</code> .
10	Paste the <code>SADMIN_ROOT</code> command into the profile in the first session window.
11	Change directories in the second session window to the home directory for the Sterling Gentran:Server user.
12	<p>Open the <i>gentran.server.vars</i> file and copy the environment variables.</p> <p>WARNING The installation process appends new values at the end of the <i>gentran.server.vars</i> file each time you run <code>setup.sh</code> using the same UNIX login.</p> <p>Comment Depending on the size of the file and the text editor you are using, it may be easier to locate the values that you need to copy by printing the file first.</p>
13	Paste the commands at the end of the profile in the first session.
14	Save the modified profile.
15	<p>Log the Sterling Gentran:Server user off of both sessions and then log this user back on to the host again.</p> <p>System Response The system sets the environment variables for the Sterling Gentran:Server user using the values from the edited profile.</p>
16	<p>Do you want to install the optional XML Translation extension?</p> <ul style="list-style-type: none"> ▶ If YES, see How to Load and Install the XML Translation Option for further instructions. ▶ If NO, continue to the next step.
17	<p>Do you want to install another copy of the Sterling Gentran:Server software?</p> <ul style="list-style-type: none"> ▶ If YES, then repeat the previous procedure, Installing the Sterling Gentran:Server software. ▶ If NO, then you are ready to set up security for your new installation. Continue with the section, Setting Up Sterling Gentran:Server Security.

How to Load and Install the XML Translation Option

Introduction

To install the optional XML translation extension, you copy the compressed software files from the installation CD into a temporary directory on the host, and then run the installation script `xmlsetup.sh` to install the software into the appropriate directory on the host.

Note

The XML translation extension is automatically installed on the Windows client computer. It cannot be accessed until this installation process is completed on the host computer, however.

Before you begin

You must first install the core Sterling Gentran:Server software before you can install the optional XML extension. See [How to Install the Sterling Gentran:Server Host Software](#) for instructions.

CAUTION

During the setup process, the setup program prompts you for a required environment variable, if the variable has not been set. If the setup program finds a value for a required environment variable, it continues to the next step without displaying a prompt.

Procedure

Use this procedure to load and install the optional XML translation extension.

Step	Action
1	<p>Log on to the UNIX host as the Sterling Gentran:Server user that owns this environment.</p> <p>WARNING</p> <p>You must log on as the user who owns the Sterling Gentran:Server environment. Using another login will result in conflicts with permissions.</p> <p>Do <i>not</i> log on as root. The root login is unable to run the installation program.</p> <p>Reference</p> <p>See the topic How to Create a Sterling Gentran:Server User for instructions on this task.</p>
2	<p>Insert the Sterling Gentran:Server host installation CD into a CD-ROM drive in the Windows client.</p>

(Contd) Step	Action
3	<ul style="list-style-type: none"> ▶ For Window 7, click Start > All Programs > Accessories, and then click on the Command Prompt. ▶ For Windows XP, click Start > All Programs > Accessories - XP, and then click on the Command Prompt.
4	Change directories to the CD-ROM drive on the Windows computer. Example D:\
5	Type the following command to transfer XML installation files from the CD to a temporary area on the UNIX host: <pre>ftpprod xml <host> <path> <user> <password></pre> Where <ul style="list-style-type: none"> ▶ <host> is the system name for the UNIX host ▶ <path> is the path to a temporary directory (The ftpprod process will create the directory if necessary) ▶ <user> is the user login for the administrative user you created ▶ <password> is the user password for the administrative user Example <pre>ftpprod xml sun2 /usr/gentran/tempxml secuser secpassword</pre>
6	Press ENTER. System Response The transfer program displays information about the transfer process. The message “Files transferred” indicates that the process completed successfully.
7	On the UNIX host, change directories to the temporary directory specified by <path> in Step 6.
8	Give “execute” privileges for the xmlsetup.sh script file so it can be run by the Sterling Gentran:Server user. Example <pre>chmod +x xmlsetup.sh</pre>

(Contd) Step	Action
9	<p>Type the following command and press ENTER.</p> <pre>./xmlsetup.sh</pre> <p>System Response The xmlsetup.sh script displays information about the installation process. The system then prompts you to enter the serial number for your XML Translation software.</p>
10	<p>At the prompt, type values for the EDI_ROOT and ENV_ROOT environment variables.</p> <p>Example /edibox1/server61/ediproduct</p> <p>System Response The system displays this prompt: Is this correct: [value for variables] (y/n)</p>
11	<p>Do you want to run the validation program?</p> <ul style="list-style-type: none"> ▶ If YES, type y at the prompt and continue with Step 14. ▶ If NO, type n at the prompt to complete the installation process.
12	<p>View the installation log to confirm that the installation completed successfully.</p> <p>Comment The system creates the installation log (<i>xmlsetup.log</i>) in the directory where you started xmlsetup.sh.</p>

Setting Up Sterling Gentran:Server Security

Overview

In this section

This section explains how to use the Security Administration utility to:

- ▶ Set up each newly-installed Sterling Gentran:Server environment.
 - ▶ Set up the Sterling Gentran:Server users for each newly-configured environment.
-

Sterling Gentran:Server Directories and Permissions

Directory names

The Security Administration Utility is installed into the directory you specified for the `SADMIN_ROOT` environment variable. The directory `SADMIN_ROOT` contains the following subdirectories:

Subdirectory	Contents
broker	Executable and database files for the NAMEBROKER
admin	Security Administration executable files
db	Security Administration database files
temp	Security Administration temporary files

Directory permissions

This table shows the recommended read (r), write (w), execute (x), and no permission (-) file permissions for the Security Administration directories.

Directory	Permission Group		
	Owner	Group	User/Other
broker	r w x	r w x	---
admin	r w x	r w x	---
db	r w x	r w x	---
temp	r w x	r w x	---

How to Start and Exit Security Administration

Login screen Enter the security administrator password on the Security Administration login screen.

Before you begin Before you attempt to start Security Administration, check with your UNIX administrator to ensure that you have the appropriate file permissions to the Security Administration directories.

Starting Security Administration

Use this procedure to start Security Administration.

Step	Action						
1	Go to the UNIX command line.						
2	Use this table to determine your next action.						
	<table border="1"> <thead> <tr> <th>IF the Security Administration subdirectory <i>security/admin</i> is...</th> <th>THEN...</th> </tr> </thead> <tbody> <tr> <td>In your path</td> <td>Enter the command: secadmin</td> </tr> <tr> <td>Not in your path</td> <td>Change to the <i>admin</i> subdirectory. Enter the command: secadmin</td> </tr> </tbody> </table>	IF the Security Administration subdirectory <i>security/admin</i> is...	THEN...	In your path	Enter the command: secadmin	Not in your path	Change to the <i>admin</i> subdirectory. Enter the command: secadmin
IF the Security Administration subdirectory <i>security/admin</i> is...	THEN...						
In your path	Enter the command: secadmin						
Not in your path	Change to the <i>admin</i> subdirectory. Enter the command: secadmin						
	<p>System Response The system displays the Security Administration login screen.</p>						
3	<p>Type the security administrator password in the Password field and press ENTER.</p> <p>System Response The system displays the Main Menu.</p> <p>CAUTION If you are logging in for the first time, the password is ADMIN. You should change this password immediately after logging in. See the topic <i>How to Change the Security Administrator Password</i> in the <i>Security Administration Overview</i> chapter of the <i>IBM® Sterling Gentran:Server® for UNIX Maintenance and Troubleshooting Guide</i>.</p>						

If you forget your password

If you forget your security administrator password, you must call IBM Customer Support to reset it.

Exiting Security Administration

Use this procedure to exit Security Administration.

Step	Action
1	Press Esc twice to return to the Main Menu.
2	Press x to exit.

Example

This illustration shows how to exit Security Administration.

To exit Security Administration press X

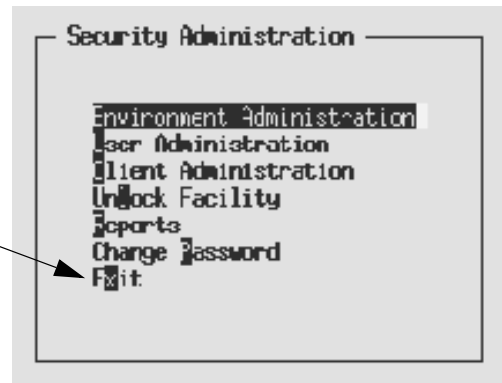

How to Add a New Environment Record

Introduction To create a new environment on a host, you enter all of the new environment data into a blank Environment Administration screen. Security Administration copies required files from the *db* subdirectory into the new environment record.

Before you begin Make sure you are logged on to the Security Administration utility as the UNIX user who installed the Sterling Gentran:Server Security Administration utility. This ensures that you have the appropriate permissions for the security directories.

Procedure Use this procedure to add an environment record.

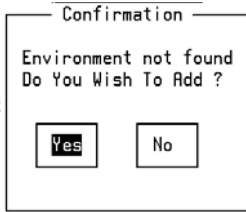
Step	Action
1	Select Environment Administration from the Security Administration Main Menu to display the Environment Administration screen.
2	Type the name of the new environment in the Environment field.
3	Press ENTER. System Response The system displays the prompt "Environment not found. Do You Wish to Add?" 
4	Select Yes and press ENTER to continue. System Response Security Administration enters the name from Step 2 into the Environment field of the Environment Administration screen.

(Contd) Step	Action
5	<p>Type the complete path to <code>\$EDI_ROOT</code> into the first field on the Environment Administration screen and then press ENTER.</p> <p>WARNING</p> <p>The path of the root directory must be unique to the environment. All other paths may either be unique or shared among two or more environments.</p> <p>System Response</p> <p>Security Administration creates appropriate entries for all of the other fields, basing them on the root directory you enter.</p> <div data-bbox="691 793 1365 1050" style="border: 1px solid black; padding: 5px; margin: 10px 0;"> <pre>Environment Administration ----- Environment: srv60ADD Root Directory: /home/gentran/srv60ADD Standards/Codes: /home/gentran/srv60ADD/stds/ Implement Guides: /home/gentran/srv60ADD/igs/ App/DDF Files: /home/gentran/srv60ADD/apps/ Maps: /home/gentran/srv60ADD/maps/ Trading Partner: /home/gentran/srv60ADD/tp/ EDI History Audit: /home/gentran/srv60ADD/edihist/ Data: /home/gentran/srv60ADD/data/ HIPAA Features[Y/N]: N</pre> </div> <p style="text-align: center;"><ESC>-Exit F1-Help F10-Save</p>
6	<p>Check the path in every field on the Environment Administration screen and edit them if necessary.</p>
7	<p>Do you want to enable Sterling Gentran:Server features that support the Health Insurance Portability and Accountability Act (HIPAA)?</p> <ul style="list-style-type: none"> ▶ If YES, type Y in the HIPAA Features field. ▶ If NO, type N in the HIPAA Features field. <p>Reference</p> <p>See the <i>IBM® Sterling Gentran:Server® for UNIX HIPAA Compliance and NCPDP User Guide</i> for information about the HIPAA features of Sterling Gentran:Server.</p>
8	<p>Press F10 to save the record.</p> <p>Comment</p> <p>Press ESC+0 if your terminal emulator is set to vt100.</p>

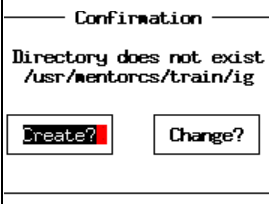
(Contd) Step	Action		
9	Use this table to determine your next action.		
	IF...	THEN Security Administration...	AND you should...
	All the directories you specified exist	Saves the environment record and refreshes the screen	Add another environment or exit the screen.
	Either the root or temporary directory is not unique	Displays an error message	Correct the record by typing a unique directory path name in the Root Directory or Temporary field.
A specified directory does not exist	Displays a confirmation panel for each directory that does not exist  <p style="text-align: center;">Confirmation</p> <p>Directory does not exist /usr/mentorcs/train/ig</p> <p><input type="button" value="Create?"/> <input type="button" value="Change?"/></p>	Select Create to create the directory or select Change to specify another directory.	

CAUTION

Security Administration automatically creates the parent directories when you choose to create the subordinate directory.

**Example of
completed
Environment
Administration
screen**

The following is an example of a completed Environment Administration screen. For field descriptions, see the *The Environment Administration Screen* topic in the *IBM® Sterling Gentran:Server® for UNIX Maintenance and Troubleshooting Guide*.

```
Environment Administration

Environment:          13.test
<root Directory:    /13/home/srvr/60test
Standards/Codes:    /13/home/srvr/60test/etds/
Implement Guides:   /13/home/srvr/60test/:gs/
App/TMF Files:     /13/home/srvr/60test/apps/
Acps:               /13/home/srvr/60test/naps/
Trading Partner:    /13/home/srvr/60test/tp/
EII History Audit:  /13/home/srvr/60test/edihist/
Data:               /13/home/srvr/60test/date/
HIPAA Features(Y/N): Y
```

<ESC>-Exit F1-Help F3-Delete F10-Save

How to Add a User Record

Introduction

You can add a new user record by doing one of the following:

IF you...	THEN...
Need to build your user ID records	Enter all user information into the blank fields on the User Administration screen.
Do not have an existing user ID record that is similar to the one you need	Enter all user information into the blank fields on the User Administration screen.
Have an existing user ID record that is similar to the one you need	Copy the entire user record, including all the environmental-level and function-level access permissions, and modify it as necessary.

Entering new user information on blank panels

Use this procedure to add a new user record.

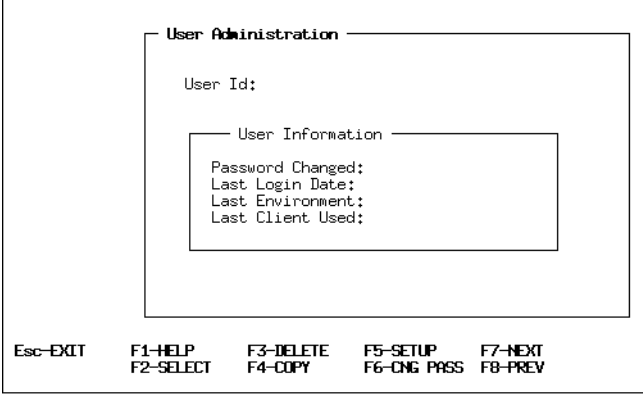
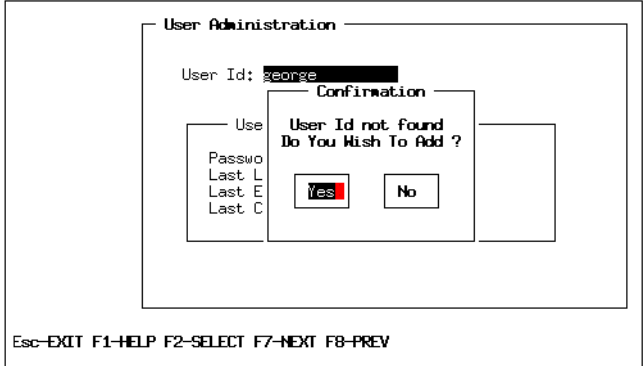
Step	Action
1	<p>Select User Administration from the Main Menu.</p> <p>System Response The system displays the User Administration screen.</p> 
2	<p>Type the new user ID in the User ID field and then press ENTER.</p> <p>Comment The field accepts up to 15 alphanumeric characters. Do not use spaces or any punctuation.</p> <p>System Response If the user ID does not exist, the system displays the following panel:</p> 

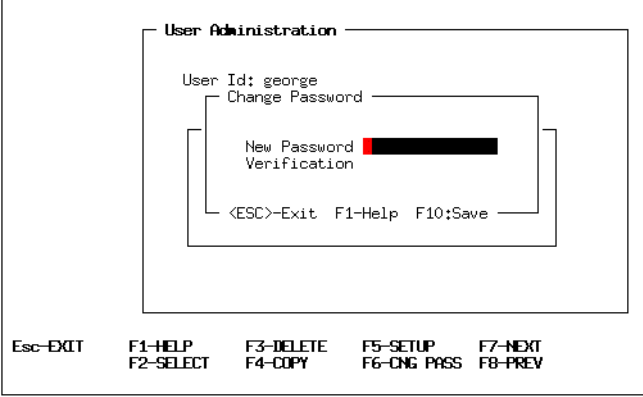
(Contd) Step	Action
3	<p>Select Yes to add the new user ID.</p> <p>System Response The system displays the Change Password panel. This panel is used to set the user's initial password.</p> 
4	<p>Type the password you want to assign to this user in the New Password field and then press ENTER.</p> <p>Comment The field accepts up to 15 alphanumeric characters. Do not use spaces or any punctuation.</p>
5	<p>Type the password again in the Verification field.</p>
6	<p>Press F10.</p> <p>Comment Press ESC-0 if your terminal emulator is vt100.</p> <p>WARNING If the password entered in the New Password field does not match the password entered in the Verification field, Security Administration displays the message "Verification error - Retry." Press Esc to remove the error message from your display. Retype the password in the New Password and Verification fields.</p>

(Contd) Step	Action	
7	Use this table to determine your next action.	
	IF you...	THEN...
	Do not need to create more users	Continue with the topic How to Assign Access to an Environment and Its Functions .
	Need to create more users and some of the users need the same access to the environment	Continue with the topic How to Assign Access to an Environment and Its Functions . Suggestion After you set all security access for this user, use the procedure Copying a user record to create new users with the same access.
	Need to create more users and all of the users need different environment access	Repeat Steps 1 through 6 for each additional user.

Copying a user record

Use this procedure to copy a user record.

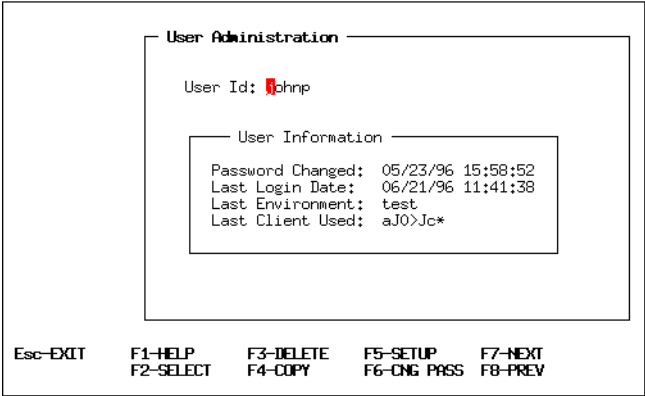
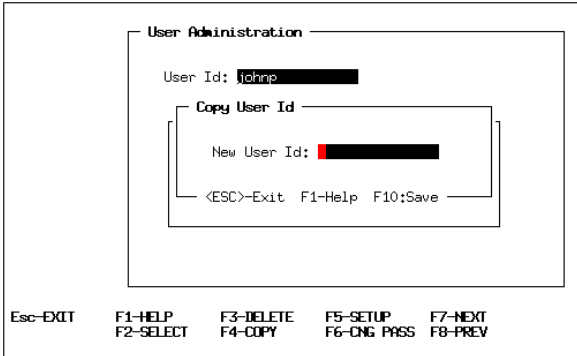
Step	Action
1	Select User Administration from the Main Menu.
2	<p>Press F2 and choose the user ID from the choice list.</p> <p>Comment Press ESC-2 if your terminal emulator is vt100.</p> <p>System Response The system displays the user information.</p>  <p>The screenshot shows a terminal window titled "User Administration". Inside, it displays "User Id: johnp" with a cursor at the end. Below this is a box titled "User Information" containing the following text: "Password Changed: 05/23/96 15:58:52", "Last Login Date: 06/21/96 11:41:38", "Last Environment: test", and "Last Client Used: aJ0>Jc*". At the bottom of the terminal window, there is a row of function key shortcuts: Esc-EXIT, F1-HELP, F2-SELECT, F3-DELETE, F4-COPY, F5-SETUP, F6-CHG PASS, F7-NEXT, and F8-PREV.</p>
3	<p>Press F4.</p> <p>Comment Press ESC-4 if your terminal emulator is vt100.</p> <p>System Response The system displays the Copy User ID panel.</p>  <p>The screenshot shows the same terminal window as in step 2, but now with a "Copy User Id" panel overlaid. The panel contains "New User Id:" followed by a red cursor and a blacked-out area. Below the panel, it shows the shortcuts "<ESC>-Exit", "F1-Help", and "F10:Save". The bottom row of function key shortcuts remains the same as in the previous screenshot.</p>

(Contd) Step	Action
4	<p>On the Copy User ID panel, type the ID of the new user in the New User ID field.</p> <p>Comment The field accepts up to 15 alphanumeric characters. Do not use spaces or any punctuation.</p>
5	<p>Press F10.</p> <p>Comment Press <code>ESC-0</code> if your terminal emulator is vt100.</p> <p>System Response The system displays the Change Password panel.</p> <div data-bbox="737 814 1313 1167" style="border: 1px solid black; padding: 10px; margin: 10px auto; width: fit-content;"> <pre> User Administration ----- User Id: george Change Password ----- New Password ██████████ Verification ----- <ESC>-Exit F1-Help F10:Save </pre> <p style="font-size: small; margin-top: 5px;"> Esc-EXIT F1-HELP F3-DELETE F5-SETUP F7-NEXT F2-SELECT F4-COPY F6-CNG PASS F8-PREV </p> </div>
6	<p>In the New Password field, type the password you want to assign to this user and press ENTER.</p>
7	<p>Type the password again in the Verification field.</p>
8	<p>Press F10.</p> <p>Comment Press <code>ESC-0</code> if your terminal emulator is vt100.</p> <p>WARNING If the password you typed in the New Password field does not match the password you typed in the Verification field, Security Administration displays the message “Verification error - Retry.” Press <code>Esc</code> to remove the error message from your display and then retype the password in the New Password and Verification fields.</p>

Comment

After you create the new user ID record, you can modify it as needed. See the topic [How to Assign Access to an Environment and Its Functions](#) in this chapter for instructions.

Environment Access

Introduction

You can assign a single environment to any number of user IDs. You can also assign a number of environments to a single user ID. After assigning an environment to a user, select the function groups of the environment and assign an access code to each function in each group.

Function levels and classifications

Environments have two function groups: **editor** and **program**.

Editor group

The editor functions enable the user to modify files.

Editor functions have three access levels:

- No access (user has no access to the function or the files)
- View-only access (user can only view files)
- Full access (user has access to all capabilities of editor, such as viewing, copying, editing, loading, unloading, and renaming files)

Program Group

Program functions are executable programs.

Program functions have two access levels:

- Full access (user can run the program)
- No access (user cannot run the program)

Screens used to assign environment level access

These screens are used to assign the environment and function-level access:

- User Environment Administration
- User Function Administration

Descriptions of these two screens follow this topic.

User Environment Administration screen

This illustration shows the User Environment Administration screen.



Purpose

The User Environment Administration screen is used to assign an environment to a user ID.

Fields and functions

This table describes the fields of the User Environment Administration screen and their functions.

Field	Function
User ID	The characters that identify the user record to the system.
Environment	The name of the environment to which the user ID is granted access.

Function keys

This table lists the function keys on the User Environment Administration screen and their functions.

Key	Function
ESC	Exits the screen. Comment Press <code>ESC-ESC</code> if your terminal emulator is vt100.
F1	Displays Help information. Comment Press <code>ESC-1</code> if your terminal emulator is vt100.

(Contd) Key	Function
F2	Displays a list of all possible choices for the field that contains the cursor. Comment Press <code>ESC-2</code> if your terminal emulator is vt100.
F6	Displays a list of values already assigned to the field that contains the cursor. Comment Press <code>ESC-6</code> if your terminal emulator is vt100.

User Function Administration screen

This illustration shows the User Function Administration screen (Program function group) for IBM® Sterling Gentran:Server® for UNIX - EC Workbench.

```

User Function Administration
-----
User ID:      mle
Environment:  13_60
Function Group: Editors

      Function Description                Type  Access
-----
Archive Retrieval                       E      F
Check In, Check Out Files                E      F
File Browser                             E      F
Trading Partner Preferences Settings     E      F
Trading Partner Editor                   E      F

<ESC>-EXIT  F1-HELP  F3-NO ACCESS FOR ALL  F5-VIEW FOR ALL  F7-NEXT
              F4-FULL ACCESS FOR ALL  F8-PREV  F10-SAVE

```

Purpose The purpose of this screen is to assign the type of access the user is to have to each function in the environment.

Fields and functions This table describes the fields of the User Function Administration screen and their functions.

Field	Function
User ID	The characters that identify the user record to the system.
Environment	The name of the environment to which the user ID is granted access.
Function Group	The predefined name of the function group (Editors or Programs).
Function Description	The predefined functions within the function group.
Type	The function type: <ul style="list-style-type: none"> ▶ E = Editor ▶ N = Non-Editor
Access	The access code: <ul style="list-style-type: none"> ▶ F = Full access ▶ N = No access ▶ V = View-only access

Function keys This table lists the function keys on the User Function Administration screen and their functions.

Key	Function
ESC	Exits the screen.
F1	Displays Help information.
F3	Denies access for every function (places an N in every field.)
F4	Grants access for every function (Places an F in every field.)

(Contd) Key	Function
F5	Grants view-only access for every editor function (Places a V in every access field.) This option is not available for Programs.
F7	Displays this screen for the next User ID.
F8	Displays this screen for the previous User ID.
F10	Saves the information you entered.

How to Assign Access to an Environment and Its Functions

Procedure Use this procedure to assign access to an environment.

Step	Action
1	Select User Administration from the Main Menu.
2	<p>Press F2 and select the user ID from the list displayed.</p> <p>Comment Press ESC-2 if your terminal emulator is vt100.</p> <p>System Response The system displays the User Information screen.</p> <div data-bbox="695 926 1333 1318" style="border: 1px solid black; padding: 10px; margin: 10px auto; width: fit-content;"> <pre> User Administration ----- User Id: jhnp User Information ----- Password Changed: 05/23/96 15:58:52 Last Login Date: 06/21/96 11:41:38 Last Environment: test Last Client Used: aJ0>Jc* </pre> <p style="text-align: center; font-size: small;"> Esc-EXIT F1-HELP F3-DELETE F5-SETUP F7-NEXT F2-SELECT F4-COPY F6-CHG PASS F8-PREV </p> </div>

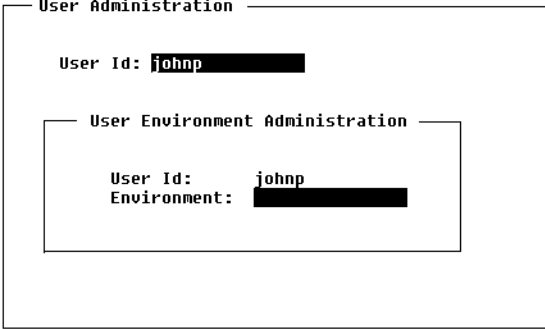
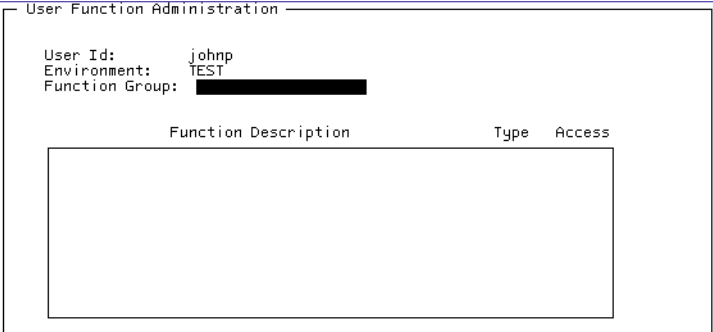
(Contd) Step	Action
<p>3</p>	<p>Press F5 to set up the user environment.</p> <p>Comment Press ESC-5 if your terminal emulator is vt100.</p> <p>System Response The system displays the User Environment Administration screen.</p> 
<p>4</p>	<p>Press F2 and choose the environment you want to assign to this user or type the name of the environment in the field.</p> <p>Comment Press ESC-2 if your terminal emulator is vt100.</p> <p>Comment To view a list of environments already assigned to this user, press F6. Press ESC-6 if your terminal emulator is vt100.</p>
<p>5</p>	<p>Press ENTER.</p> <p>System Response Because this is a new environment for this user, Security Administration displays the User Function Administration screen so that you can assign function-level access to the user ID for this environment.</p> 

(Contd) Step	Action
6	Press F2 and choose the function group. Comment Press ESC-2 if your terminal emulator is vt100.
7	Press ENTER. System Response The system displays the function group and descriptions. Note that these are predefined and you cannot edit them. <div style="border: 1px solid black; padding: 10px; margin: 10px 0;"> <pre> User Function Administration ----- User ID: mle Environment: 13_60 Function Group: Editors Function Description Type Access ----- Archive Retrieval E F Check In, Check Out Files E F File Browser E F Trading Partner Preferences Settings E F Trading Partner Editor E F </pre> </div> <p><ESC>-EXIT F1-HELP F3-NO ACCESS FOR ALL F5-VIEW FOR ALL F7-NEXT F4-FULL ACCESS FOR ALL F8-PREV F10-SAVE</p>
8	In the Access column, enter the access code you want to assign this user or press a function key to assign the same access to all the functions. Comment The valid access codes are: <ul style="list-style-type: none"> ▶ N=No access ▶ F=Full access
9	Press F10. System Response Security Administration refreshes the screen so you can choose and set up the next function group assignments.
10	Do you want to set up another function group assignment? <ul style="list-style-type: none"> ▶ If YES, GO TO Step 6. ▶ If NO, press Esc twice to return to the User Environment Administration screen. The system retains the user ID. Comment Press ESC-0 if your terminal emulator is vt100.

Starting Sterling Gentran:Server Processes

How to Start Sterling Gentran:Server on the Host

Introduction You must start processes on the UNIX host in order to test the connection of the client to the EDI installations and verify that the Sterling Gentran:Server environment is set up correctly. This topic describes the procedure you must perform to correctly start the processes that control your Sterling Gentran:Server installation.

Starting processes

Use this procedure to start processes on the host computer.

CAUTION

The installation process for Sterling Gentran:Server turns off the s-bit (also known as the “set-userID/set-group-ID” bit). If your environment normally turns on the s-bit, it must be restored before you start the Sterling Gentran:Server processes.

WARNING

Make sure that you are logged into the host as the owner of the environment for which you want to start the processes.

Step	Action
1	If you have not already done so, log on as the owner of the environment whose processes you want to start.
2	Change directory to the root of the host environment.
3	Type the command ps -ef grep ltb_server at the UNIX command line to check whether the broker process is running on the host.
4	Is the broker running on the host? <ul style="list-style-type: none"> ▶ If YES, GO TO Step 6. ▶ If NO, login as owner of security and enter the following command to start the broker process. <pre>\$SADMIN_ROOT/broker/startnb.sh</pre>

(Contd) Step	Action	
5	Is the Korn shell in use? <ul style="list-style-type: none"> ▶ If YES, continue with next step. ▶ If NO, enter the following command to start the Korn shell. ksh -m 	
6	Type the following commands as owner of the host software to start the mhs_server and mhp_server processes in the affected environment. <pre>cd \$EDI_ROOT startrpc.sh</pre>	
7	Use this table to determine your next step.	
	IF...	THEN...
	You need to create another Sterling Gentran:Server environment on this host	Repeat the instructions in the following sections: <ul style="list-style-type: none"> ▶ Preparing for Installation ▶ Installing the Software on the UNIX Host ▶ Setting Up Sterling Gentran:Server Security ▶ Starting Sterling Gentran:Server Processes
You are finished creating environments on this host	Continue with the Setting Up Windows Clients chapter in this guide.	

Setting Up Windows Clients

Contents

- ▶ Overview 2
- ▶ How to Install the Client Software 4
- ▶ How to Install MDAC 2.8 Components 11
- ▶ How to Install Sterling Gentrans:Server Standards 13
- ▶ How to Edit the Windows Hosts File 18
- ▶ How to Identify the Host to DNS 19
- ▶ How to Install Optional Components 20

Overview

Introduction This chapter explains how to set up a Sterling Gentran:Server client computer.

Before You Begin Use this table to determine whether you are ready to install Sterling Gentran:Server.

Done	Task
	<p>Install the Security Administration utility and the Sterling Gentran:Server host software.</p> <p>Reference See the Installing Sterling Gentran:Server On the UNIX Host chapter in this guide for instructions.</p>
	<p>Use the Security Administration utility to:</p> <ul style="list-style-type: none">▶ Set up the Sterling Gentran:Server environment.▶ Set up the Sterling Gentran:Server users.▶ Give each user appropriate access to the environment. <p>Reference See the chapter Installing Sterling Gentran:Server On the UNIX Host in this guide for instructions.</p>
	<p>Start Sterling Gentran:Server processes on the host.</p> <p>Reference See the Installing Sterling Gentran:Server On the UNIX Host chapter in this guide for instructions.</p>
	<p>Complete the installation checklist. Keep the checklist with you as a reference throughout the procedure.</p>

**Client setup
process**

This table describes the stages in the setup process for a Sterling Gentran:Server client.

Stage	Description
1	Install the Sterling Gentran:Server client software.
2	Install Microsoft Data Access Components.
3	Install IBM® Sterling Gentran® Standards.
4	Edit the Windows Hosts file or identify the host to DNS.
5	Install the Sterling Gentran:Server online documentation.
6	Set Trading Partnership Administration preferences. Reference See the <i>Setting Preferences and Default Values</i> section in the <i>Application Integration Basics</i> chapter of the <i>IBM® Sterling Gentran:Server® for UNIX Application Integration User Guide</i> .

How to Install the Client Software

Use this procedure to install Sterling Gentran:Server on each client computer.

Step	Action
1	Close all programs running on the client computer.
2	Insert the installation CD into the CD-ROM drive of the client computer.
3	<p>Did the installation program start automatically and display the Welcome dialog box?</p> <ul style="list-style-type: none"> ▶ If YES, GO TO to Step 6. ▶ If NO, continue to the next step.
4	<p>Select Run from the Start menu.</p> <p>System Response Setup displays the Run dialog box.</p>
5	<p>Type the following command in the Run dialog box, then click OK:</p> <p><drive>:\setup</p> <p>where <drive> represents the drive letter of the CD-ROM drive</p> <p>System Response Setup displays the Welcome dialog box.</p>
6	<p>Click Next to continue.</p> <p>System Response Setup displays the Registration dialog box.</p>
7	<ul style="list-style-type: none"> ▶ Enter your name and company. ▶ Select Client Id ▶ Click Next. <p>Note You must complete all three fields to continue.</p> <p>WARNING</p> <p>Use a different Client Id on each client computer. Sterling Gentran:Server controls access by Client Id and will not allow a second login of an active number. If you accidentally assign a Client Id twice, you must reinstall Sterling Gentran:Server on the second client and assign an unused Client Id.</p> <p>System Response Setup displays the Choose Destination Location dialog box.</p>

(Contd) Step	Action								
8	<p>Do you want to change the directory where Sterling Gentran:Server is installed?</p> <ul style="list-style-type: none"> ▶ If NO, click Next and GO TO Step 11. ▶ If YES, click Browse and continue with the next step. <p>WARNING If you have an earlier version of Sterling Gentran:Server, use a different root directory for your Sterling Gentran:Server 6.2 software. If you install version 6.2 on top of a previous installation, you will lose existing data on the client.</p>								
9	<p>Browse to the directory into which you want to install Sterling Gentran:Server. If the directory does not exist, type into the Browse box a path for Setup to create during installation. Click OK.</p> <p>WARNING Do not use spaces in the path you specify.</p> <p>System Response</p> <table border="1" data-bbox="418 1003 1427 1476"> <thead> <tr> <th data-bbox="418 1003 930 1062">IF the directory...</th> <th data-bbox="930 1003 1427 1062">THEN...</th> </tr> </thead> <tbody> <tr> <td data-bbox="418 1062 930 1220">Already contains a copy of Sterling Gentran:Server</td> <td data-bbox="930 1062 1427 1220">Setup prompts you to confirm that you want to install into this directory and overwrite the existing files. Click Yes and GO TO Step 14.</td> </tr> <tr> <td data-bbox="418 1220 930 1350">Does not yet exist</td> <td data-bbox="930 1220 1427 1350">Setup prompts you to confirm that you want to create this directory. GO TO Step 10.</td> </tr> <tr> <td data-bbox="418 1350 930 1476">Exists, but does not contain a copy of Sterling Gentran:Server</td> <td data-bbox="930 1350 1427 1476">Setup displays the Select Program Folder dialog box. GO TO Step 15.</td> </tr> </tbody> </table>	IF the directory...	THEN...	Already contains a copy of Sterling Gentran:Server	Setup prompts you to confirm that you want to install into this directory and overwrite the existing files. Click Yes and GO TO Step 14.	Does not yet exist	Setup prompts you to confirm that you want to create this directory. GO TO Step 10.	Exists, but does not contain a copy of Sterling Gentran:Server	Setup displays the Select Program Folder dialog box. GO TO Step 15.
IF the directory...	THEN...								
Already contains a copy of Sterling Gentran:Server	Setup prompts you to confirm that you want to install into this directory and overwrite the existing files. Click Yes and GO TO Step 14.								
Does not yet exist	Setup prompts you to confirm that you want to create this directory. GO TO Step 10.								
Exists, but does not contain a copy of Sterling Gentran:Server	Setup displays the Select Program Folder dialog box. GO TO Step 15.								
10	<p>Confirm that you want to create the directory.</p> <p>System Response The Destination Folder field displays the selected location.</p>								

(Contd) Step	Action								
11	<p>Click Next to accept the destination folder.</p> <p>System Response Use this table to determine the system response.</p> <table border="1" data-bbox="423 520 1427 961"> <thead> <tr> <th data-bbox="423 520 930 575">IF the directory...</th> <th data-bbox="930 520 1427 575">THEN...</th> </tr> </thead> <tbody> <tr> <td data-bbox="423 575 930 709">Already contains a copy of Sterling Gentran:Server</td> <td data-bbox="930 575 1427 709">Setup prompts you to confirm that you want to install into this directory. Continue with Step 15.</td> </tr> <tr> <td data-bbox="423 709 930 835">Does not yet exist</td> <td data-bbox="930 709 1427 835">Setup prompts you to confirm that you want to create this directory. Continue with Step 12.</td> </tr> <tr> <td data-bbox="423 835 930 961">Exists, but does not contain a copy of Sterling Gentran:Server</td> <td data-bbox="930 835 1427 961">Setup displays the Select Program Folder dialog box. GO TO Step 15.</td> </tr> </tbody> </table>	IF the directory...	THEN...	Already contains a copy of Sterling Gentran:Server	Setup prompts you to confirm that you want to install into this directory. Continue with Step 15.	Does not yet exist	Setup prompts you to confirm that you want to create this directory. Continue with Step 12.	Exists, but does not contain a copy of Sterling Gentran:Server	Setup displays the Select Program Folder dialog box. GO TO Step 15.
IF the directory...	THEN...								
Already contains a copy of Sterling Gentran:Server	Setup prompts you to confirm that you want to install into this directory. Continue with Step 15.								
Does not yet exist	Setup prompts you to confirm that you want to create this directory. Continue with Step 12.								
Exists, but does not contain a copy of Sterling Gentran:Server	Setup displays the Select Program Folder dialog box. GO TO Step 15.								
12	Click Yes to continue.								
13	<p>Click Next to accept the destination.</p> <p>System Response Setup displays the Select Program Folder dialog box.</p>								
14	<p>Do you want to change the Program Folder to which Setup will add program icons?</p> <ul style="list-style-type: none"> ▶ If NO, click Next. ▶ If YES, type a new folder name or select one from the existing Folders list and click Next. <p>System Response Setup displays the Sub-Directory Name prompt.</p> 								

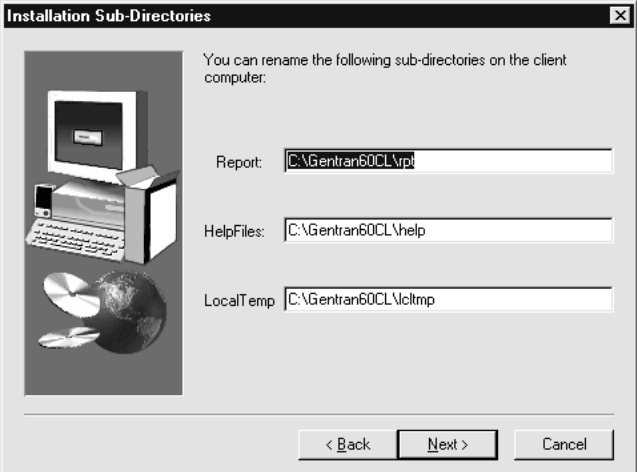
(Contd) Step	Action
15	<p>Do you want to accept the default sub-directory names?</p> <ul style="list-style-type: none"> ▶ If YES, click Yes and GO TO Step 18. <p>System Response Setup displays the Add IP Address dialog box.</p> <ul style="list-style-type: none"> ▶ If NO, click No to display the Installation Sub-Directories dialog box and continue with the next step.
16	<p>Enter the <i>Report</i>, <i>HelpFiles</i>, and <i>LocalTemp</i> sub-directories to which you are installing the Sterling Gentran:Server files.</p> <p>When you are finished, click Next to accept your changes.</p> <p>WARNING Do not use spaces in the paths you specify.</p> <p>Example</p>  <p>Note All other subdirectories reside on the UNIX host and therefore cannot be changed in this process.</p> <p>System Response Setup displays the Add IP Address dialog box.</p>

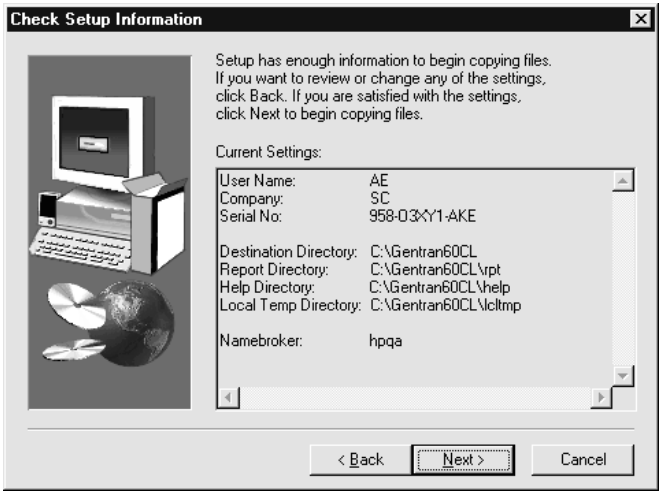
(Contd) Step	Action
17	<p>Does the displayed list of UNIX hosts contain the IP address of the host that is running NAMEBROKER (ltb_server)?</p> <ul style="list-style-type: none"> ▶ If YES, click Next and GO TO Step 20. <p>System Response Setup displays the Namebroker dialog box.</p> <ul style="list-style-type: none"> ▶ If NO, click Add, click Next, and then continue with the next step. <p>System Response Setup displays a dialog box to add an IP address.</p>
18	Type the missing address into the Server IP Address field, then press Tab to move the cursor to the Host Name field.
19	Type the system name for the host into the Hostname field, then click Add .
20	<p>Double-click on the IP address and name of the host that is running NAMEBROKER (ltb_server) through which you want the user to log on to Sterling Gentran:Server.</p> <p>Comment This selection should match the name and address you entered on the checklist for the NAMEBROKER.</p> <p>System Response Setup displays the selected host information in the Namebroker field.</p>
21	<p>Click Next to continue.</p> <p>System Response Setup displays the Check Setup information dialog box.</p> 

(Contd) Step	Action
22	<p>Are the displayed current settings correct?</p> <ul style="list-style-type: none"> ▶ If YES, click Next to continue. ▶ If NO, click Back until you find the dialog you must change. Make your changes, then click Next until you return to the Check Setup Information dialog box. Click Next to continue. <p>System Response Setup displays progress information as it installs the software.</p> <p>WARNING The Setup script displays warning messages if it cannot copy one or more Sterling Gentran:Server files to the destination. Write down each message before you click OK to dismiss it.</p>
23	<p>Did the Setup program display any warning messages during the installation process?</p> <ul style="list-style-type: none"> ▶ If YES, click Exit and continue to the next step. ▶ If NO, Setup displays the View Readme File dialog box. GO TO Step 25.
24	<p>Are any programs running on the client other than the Sterling Gentran:Server Setup program?</p> <ul style="list-style-type: none"> ▶ If YES, then close those programs and return to Step 4. ▶ If NO, call IBM Customer Support with a list of the warning messages.
25	<p>Do you want to install Microsoft Data Access Components (MDAC)?</p> <ul style="list-style-type: none"> ▶ If YES, GO TO the topic How to Install MDAC 2.8 Components in this chapter. ▶ If NO, clear the checkbox and continue to the next step. <p>Note You must have MDAC to use the IBM® Sterling Gentran:Server® EDI Standards database. The minimum version required is 2.1sp1a. This MDAC installation process installs version 2.8.</p>
26	<p>Click Finish.</p> <p>System Response Setup finishes copying files to your computer and displays restart options.</p>
27	<p>Do you want to let Setup restart the client computer now?</p> <ul style="list-style-type: none"> ▶ If YES, click Yes, I want to restart my computer now and remove any disks from the client disk drive. ▶ If NO, click No, I will restart my computer later.
28	<p>Click Finish to complete setup.</p>

How to Install MDAC 2.8 Components

Introduction

To read the EDI standards provided with IBM® Sterling Gentrans:Server® for UNIX, you must have Microsoft Data Access Components (MDAC) 2.1sp1a or higher installed on each PC or client. MDAC include ActiveX® Data Objects (ADO), and OLE DB.

If you do not already have MDAC on the client, you must install it before you install the EDI standards. This topic explains how to install MDAC.

Installing MDAC

Use this procedure to install MDAC 2.8 on a client.

Step	Action	
1	Use this table to determine your first action.	
	IF you are ...	THEN...
	Continuing from the client setup program	Leave the I would like to install Microsoft MDAC 2.8 check box selected on the Setup Complete dialog box. Click Finish and GO TO Step 5.
	Installing MDAC after exiting the client setup program	Continue with Step 2.
2	Insert the installation CD into the CD-ROM drive of the client computer.	
3	Select Run from the Windows Start menu. System Response Windows displays the Run dialog box.	

(Contd) Step	Action
4	<p>Type the following command in the Run dialog box and click OK.</p> <p><drive>:\mdac_typ.exe</p> <p>where <drive> is your CD-ROM drive.</p> <p>System Response Your system loads the Microsoft Data Access Components 2.6 Setup program and displays the Microsoft Data Access Components 2.6 Setup dialog box.</p>
5	<p>Select the checkbox on the End User License Agreement of the Microsoft Data Access Components 2.6 Setup dialog box to accept the terms of the licensing agreement; then click Next.</p> <p>System Response Setup displays the Microsoft Data Access Components 2.6 Setup dialog box.</p>
6	Click Next .
7	Click Finish .
8	<p>Click Close.</p> <p>System Response Setup displays the Sterling Gentran:Server Setup complete dialog box, which asks whether you want to reboot the client now or later.</p>
9	<p>Do you want to restart the client now?</p> <ul style="list-style-type: none"> ▶ If YES, click Yes. Remove any disks from the client disk drives. ▶ If NO, click No.
10	Click Finish to complete setup.

How to Install Sterling Gentran:Server Standards

System requirements

The amount of hard disk space required to use the Sterling Gentran:Server EDI Standards database depends on the following:

- New install (run from EDI Standards CD)
Approximately 10 MB of hard disk space to install the EDI Standards database to run from the CD.
- New install (install on hard drive)
Approximately 300 MB of hard disk space to install the EDI Standards database to run from your hard drive.

Note

For a 64 bit client installation, the odbc32.exe must be run after EDI Standards CD is installed, to register the standards DB.

Before you begin

You must install Microsoft Data Access Components (MDAC) 2.1sp1a or higher before you install Sterling Gentran:Server EDI Standards.

Caution

Install Sterling Gentran:Server before you install the EDI Standards database.

Note

If you have already set up this machine to run EDI standards from the CD-ROM drive, you only have to exchange the old standards CD for the most current Standards CD. You do *not* have to complete the installation procedure below.

Updated versions included

Please refer to the readme.txt file provided on the Sterling Gentran:Server Standards CD for the most current information about the standards.

For fast access, install the Sterling Gentran:Server EDI Standards database on your hard drive. This requires approximately 10 MB of free space for the temporary installation files and 300 MB for the EDI Standards database. You can also access the Sterling Gentran:Server Standards database directly from the CD-ROM.

The Sterling Gentran:Server EDI Standards database is updated periodically, produced on CD-ROM separate from products, and available at your request (usually on a quarterly basis).

**Additional
standards
included**

The Standard CD also contains folders for NCPDP and VDA standard templates. See the *IBM® Sterling Gentran:Server® for UNIX HIPAA Compliance and NCPDP User Guide* and the *IBM® Sterling Gentran:Server® for UNIX VDA User Guide* for instructions on how to copy the templates.

Installing the Standards Database

Complete the following steps to install the EDI Standards database:

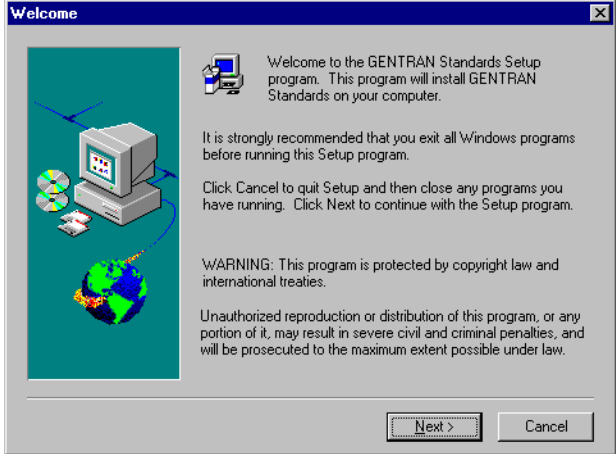
Step	Action
1	Close all programs on your computer.
2	Insert the Sterling Gentran:Server Standards CD into your CD-ROM drive.
3	Select Run from the Start menu.
4	<p>Type <drive>:\I386\setup.exe</p> <p>Where: <drive> is your CD-ROM drive (for example, D:\ or E:\)</p> <p>System Response Setup prepares the wizard that guides you through the install program. This may take several seconds. When the wizard is ready, the system displays the Welcome dialog box.</p> 

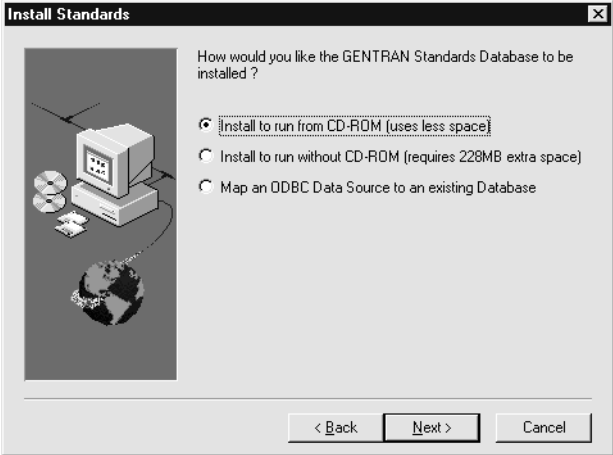
(Contd) Step	Action		
5	<p>Click Next> to continue the Setup program.</p> <p>System Response Setup displays the Install Standards dialog box.</p> 		
6	Use the following table to determine your next action.		
	IF you select...	THEN...	AND...
	Install to run from the CD-ROM	Click Next> to install the EDI Standards database.	Proceed with Step 7.
	Install to run without CD-ROM	<p>Click Next> to install the EDI Standards database.</p> <p>System Response The system displays the Standards Destination dialog box.</p>	<p>Type the destination or click Browse and select where you want the EDI Standards database to be stored. Proceed with Step 7.</p> <p>Note At least 300 MB must be available. If there is insufficient space available on the drive you specified, you will be prompted to select another location or increase the amount of space available in the target directory.</p>

(Contd) Step	Action	
7	Use the table to determine your next step.	
	IF you...	THEN...
	Accept the default	Click Next
	Specify a new data source name	Type the name in the field and the Click Next .
	System Response The system displays the prompt: Setup is ready to install Sterling Gentran:Server Standards. Would you like to proceed?	
8	Click Yes to install Sterling Gentran:Server Standards.	
	Note If you receive messages that a .DLL is currently in use, click Ignore to continue the installation. You receive these messages when a service (like the SQL Executive service) is running in the background. The system will still install the EDI Standards database correctly. System Response Setup displays a message indicating that the EDI Standards database installation is complete.	
9	Click OK .	

How to Edit the Windows Hosts File

Introduction This topic explains how to edit a Windows hosts file to specify the broker process (NAMEBROKER) after you have finished running Setup.

WARNING

Perform this procedure only if Setup did not add a NAMEBROKER entry in the *hosts* file.

Procedure Use this procedure to identify the namebroker by adding it to the Windows *hosts* file.

Step	Action
1	<p>Open the <i>hosts</i> or <i>host.sam</i> file using any text editor.</p> <p>Note hosts are located in the following directory: C:\Windows\System32\drivers\etc</p> <p>Comment If the <i>hosts</i> file does not exist, look for the file <i>hosts.sam</i>. Save the edited file as both <i>hosts</i>, and <i>hosts.sam</i>.</p>
2	<p>Type the IP address and host name of the server on which the Sterling Gentran:Server host program was installed. Use the following format:</p> <p><IPAddress> <hostname> NAMEBROKER</p> <p>Note Separate the fields with spaces or tabs.</p>
3	<p>Save and close the updated <i>hosts</i> file.</p> <p>Note You must reboot the computer to activate this change.</p>

How to Identify the Host to DNS

Introduction The network at your installation must be able to identify the host that is running the broker process.

Many networks use the Windows *hosts* file to determine the IP addresses and host names of all host computers. Setup allows you to add addresses and names to the *hosts* file.

There are several ways in which you can identify the host that is running the broker process. This topic describes one way—by adding the name of the host running the Sterling Gentran:Server broker process to Domain Name Services (DNS). This method assumes that you have the NAMEBROKER environment variable set. You do not have to use this method if you prefer to use another.

Note

The DNS ignores the *hosts* file. Instead, it uses environment variables such as those set in the *autoexec.bat* file.

Procedure Use this procedure to add the broker process to the client computer *autoexec.bat* file. This will allow the DNS to identify the Sterling Gentran:Server host.

Step	Action
1	Open the <i>autoexec.bat</i> file in a DOS text editor.
2	Set the NAMEBROKER environment variable to the name of the UNIX host on which you will run Sterling Gentran:Server. Example set NAMEBROKER=<machine name> Where <machine name> is the system name for the UNIX host. Your system administrator can provide this information.
3	Save your changes to the <i>autoexec.bat</i> file.
4	Reboot the client computer to apply the changes.

How to Install Optional Components

**XML translation
option**

See the [How to Load and Install the XML Translation Option](#) topic for instructions on installing the XML translation option on the host.

Setting Up Communications

Contents	Overview
	▶ Introduction 2
	▶ What Is the Communications Toolkit? 3
	▶ COMM Subdirectory Structure 5
	▶ The Communications Toolkit Setup Process 9
	Procedures
	▶ How to Set Up Asynchronous Communications 10
	▶ How to Set Up Bisynchronous Communications 12
	▶ How to Start Up Cleo A+ 14
	▶ How to Start Up Cleo 3780Plus 17
	▶ Start-Up Procedure Examples 19
	Troubleshooting
	▶ Communications Session Error Recovery 21
	▶ Cleo 3780Plus Troubleshooting 26
	▶ Connecting to Other VANs and Directly to Trading Partners 27

Overview

Introduction

The Communications Toolkit

The Communications Toolkit enables Sterling Gentran:Server to use Cleo A+® or Cleo 3780Plus® communication software to access a Value-Added Network (VAN).

Among other services, VANs provide store-and-forward messaging in a dial-on-demand environment. This means that the VAN stores files in a mailbox until the recipient to whom they are addressed dials into the VAN and picks them up.

When to use the Communications Toolkit

Use the Communications Toolkit if you connect to the Commerce Net®, Advantis®, or GEIS® networks, and you use or plan to use either Cleo A+ or Cleo 3780Plus.

What do I need to buy?

The Communications Toolkit is included with IBM® Sterling Gentran:Server® for UNIX - Workstation and IBM® Sterling Gentran:Server® for UNIX.

However, Cleo A+ and Cleo 3780Plus are not part of the Sterling Gentran:Server product; you must purchase Interface Systems' Cleo A+ or Cleo 3780Plus communication software.

How to activate the Communications Toolkit

To activate the toolkit functions, you need to configure the Communications Toolkit and then install the Cleo software.

Communications Toolkits files are included in the Sterling Gentran:Server host CD and are installed automatically with the Sterling Gentran:Server host software.

In this chapter

This chapter provides instructions for setting up the toolkit.

What Is the Communications Toolkit?

Command scripts IBM provides command scripts for the third-party communication packages, Cleo 3780Plus and Cleo A+. The scripts control the processes of:

- ▶ Dialing the VAN
- ▶ Logging in
- ▶ Transmitting waiting files
- ▶ Receiving any files waiting on the VAN
- ▶ Logging off
- ▶ Exiting

Supported VANs This table describes the VANs and protocols supported by the Communications Toolkit.

VAN	Supported Protocols
IBM® Sterling Information Broker® (IBM)	Asynchronous-ASCII Bisynchronous
Advantis (IBM)	Asynchronous-Xmodem Bisynchronous
GEIS (General Electric Information System)	Asynchronous-Xmodem Bisynchronous

Toolkit parts There are two primary parts to the Communications Toolkit provided with Sterling Gentran:Server:

- ▶ Cleo A+ scripts and configuration files
- ▶ Cleo 3780Plus scripts and configuration files

Cleo software **Cleo A+**

Interface Systems' Cleo A+ is an asynchronous communications package that uses sophisticated scripting to handle various types of communications. It supports several file transfer methods, including ASCII, Xmodem, Ymodem,

Zmodem, Kermit, and ANSI CLEAR. It can also perform as an FTP tool, using SLIP, PPP, Telnet, or local modes.

Cleo 3780Plus

Interface Systems' Cleo 3780Plus is a bisynchronous communications package that uses scripting to handle various types of communications. It supports 2780/3780 bisync protocols by using a piece of hardware to convert ASCII data to EBCDIC data for transmission and EBCDIC data to ASCII data upon receipt of the EBCDIC data.

WARNING

The scripts in the Communications Toolkit expect to find the Cleo software in a specific directory relative to the Sterling Gentran:Server directories. To prevent complications, install the Cleo software *after* you install and set up Sterling Gentran:Server and the Communications Toolkit.

COMM Subdirectory Structure

Diagram The following diagram illustrates the directory structure required by the Communications Toolkit. Installation of Sterling Gentran:Server automatically installs the Communications Toolkit files for you.

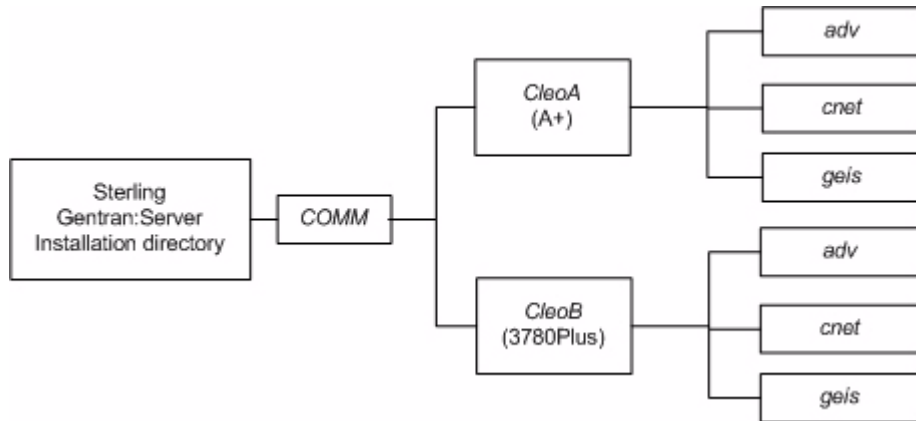

Location of communication scripts and configuration files

The Cleo communications script and configuration files reside in subdirectories of the COMM CleoA or CleoB subdirectory of the Server directory.

Directory	Contents
Server/COMM/CleoA (A+)	Holds Cleo A+ asynchronous package
Server/COMM/CleoB (3780Plus)	Holds Cleo 3780Plus bisynchronous package

VAN subdirectories

Under the CleoA and CleoB subdirectories, each VAN has its own subdirectory:

- ▶ *cnet* for Sterling Information Broker
- ▶ *adv* for Advantis
- ▶ *geis* for GEIS.

Subdirectory contents

The *adv*, *cnet*, and *geis* subdirectories contain files that enable the communications application to communicate with the corresponding VAN.

You should use the subdirectory appropriate to your network to hold the outbound file <van>s that you are transmitting to the VAN.

Note

You should place files you are sending in the communications subdirectory before a session. For example, to send a file to Advantis via an asynchronous communication session, place the file in Server/COMM/CleoA/adv/adv.s.

During a session, the system places the inbound file <van>.r.000 in the communication subdirectory. This file contains any files received during a communications session.

Important files

This table lists the important files that the Communications Toolkit uses or creates.

Filename	Description
<van>.cfg	A configuration file specific to the VAN indicated in the file name.
edilog.fil	A log file produced by each bisynchronous Advantis session. WARNING The program overwrites this file after each session. To save this file, you must copy or move it to another location.
advmsg.fil	A file containing messages produced by each bisynchronous Advantis session. WARNING The program overwrites this file after each session. To save this file, you must copy or move it to another location.

(Contd) Filename	Description
<van>*.job	<p>Cleo job file for connecting to the supported networks. The individual files connect as follows:</p> <ul style="list-style-type: none"> ▶ <i>cnetsr.job</i> - Sterling Information Broker via the CompuServe network local access nodes. ▶ <i>advsr.job</i> - IBM Advantis network ▶ <i>geissr.job</i> - GEIS network
<van>.log	A log file specific to the last connection made to the indicated VAN.
<van>.mon	A monitor file specific to the last connection made to the indicated VAN.
<van>.ovr	A data translation file that provide protocol transfer information that Cleo requires.
cnet.rpts	A file containing Sterling Information Broker reports.
<van>s	<p>The user data file to be sent to the network. Must be placed in the directory for the specific VAN before connecting to the VAN.</p> <p>WARNING</p> <p>You must move or delete this file after completing the session successfully.</p> <p>Sterling Gentran:Server will send a duplicate transmission unless this file is overwritten or deleted before the next session.</p> <p>Sterling Gentran:Server may overwrite the file if you do not move it before the next session. The file will then be unavailable to retransmit data.</p>

(Contd) Filename	Description
<van>r.nnn	<p>The user data file that Sterling Gentran:Server receives from the VAN. The first file received has an extension of .000. If the file is moved from the VAN directory before another file arrives, the next file received also has an extension of .000.</p> <p>WARNING</p> <p>The file extension is incremented by one with the receipt of each new file unless the prior version is moved or deleted before the session. If your site uses automated file processing, it may not recognize the incremented file.</p>
geisrpt.*	<p>A session log report generated by GEIS under 3780Plus or AllSync.</p> <p>WARNING</p> <p>The program overwrites this file after each session. To save this file, you must copy or move it to another location.</p>

The Communications Toolkit Setup Process

Process flow This diagram shows the flow of the setup process required to prepare the Communications Toolkit to work with Sterling Gentran:Server.

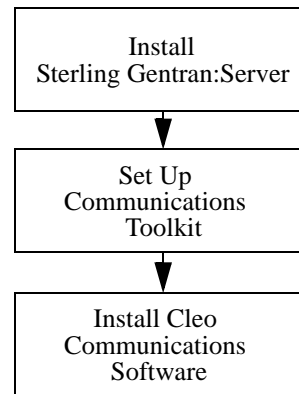

Procedures

How to Set Up Asynchronous Communications

Introduction

This topic contains the procedures for setting up asynchronous communications using VAN scripts that are located in the COMM directory structure. Follow the instructions for the VAN to which you are connecting.

Microcom Network Protocol (MNP)

The Microcom Network Protocol (MNP) enables error correction during transmissions. It is particularly important when connecting to Sterling Information Broker.

Modifying the VAN configuration file

Your Cleo A+ VAN configuration file (*cnet.cfg*, *adv.cfg*, or *geis.cfg*) contains all or most of the required network configurations. However, you may have hardware issues that require you to modify the file.

This table lists the environment parameters you may need to modify. The Parameter column lists the name of the parameter and the related file.

Parameter	Description
Modem Initialization (<i>modeminit.cfg</i>)	This parameter normally contains the async factory default setting for your modem. To use another setting, check the AT commands in your modem user guide. Usually, the setting & F0 sets up most asynchronous modems in standard asynchronous mode.
Port (<i>device.cfg</i>)	This is the port to which the modem is installed. <ul style="list-style-type: none"> ▶ If you use DOS or Windows, you may use COM2 or a similar setting. ▶ If you use UNIX, you may use <i>/dev/tty3</i> or a similar setting.
Port Speed (<i>speed.cfg</i>)	This parameter identifies to Cleo the baud rate of the port so that Cleo knows how fast to write to the port. This is NOT the dial-up connection speed or the modem baud rate.

(Contd) Parameter	Description	
Terminal Type (<i>terminal.cfg</i>)	The terminal type is usually VT100 or VT220, depending on the terminal type to be emulated. Refer to the Cleo documentation for more information.	
Dial Initialization	This is the most important configuration parameter. It is used to set the unique configuration that a particular VAN expects. Use the following table to guide you in setting this parameter.	
	VAN	Dial-Initialization Settings
	Sterling Information Broker	<ul style="list-style-type: none"> ▶ MNP error correction protocol ▶ Software Flow Control (also known as XON/XOFF Flow Control)
	Advantis	<ul style="list-style-type: none"> ▶ MNP error correction protocol ▶ Hardware Flow Control (RTS/CTS) ▶ FTP: Xmodem (in addition to the MNP protocol)
	GEIS	<ul style="list-style-type: none"> ▶ Either Hardware Flow Control (RTS/CTS) or Software Flow Control <p style="margin: 0;">CAUTION</p> <p style="margin: 0;">If you use Software Flow Control, make sure the Dial Init and FLOWCONTROL setting in the configuration file are compatible.</p> <ul style="list-style-type: none"> ▶ FTP: Xmodem

How to Set Up Bisynchronous Communications

Introduction

This topic contains the procedure for setting up bisynchronous communications using VAN scripts that are located in the COMM directory structure. Follow the instructions for the VAN to which you are connecting.

Editing the configuration file

Your Cleo 3780Plus VAN configuration file (*cnet.cfg*, *adv.cfg*, or *geis.cfg*) contains all or most of the required network configurations. However, you may have hardware issues that require you to modify the file.

The parameter settings that sometimes need to be increased are:

- ▶ Wait Limit
- ▶ Retransmission Limit

Important

The configuration file does not contain any labels. Consult the Cleo documentation to determine which lines to edit within the file.

Use this procedure to edit the configuration file for Sterling Information Broker, Advantis, and GEIS.

Step	Action
1	Open the VAN Configuration File in a text editor.
2	Set the Wait Limit as needed.
3	Set the Retransmission limit as needed.
4	Initiate a Cleo session so you can test communications to the VAN.
5	<p>Check whether a completion status of '0' was returned.</p> <ul style="list-style-type: none"> ▶ If the status was 0, you are finished editing the configuration file. ▶ If a non-zero was returned, use the <van>.log and <van>.mon files to troubleshoot. <p>Reference See the topic Cleo 3780Plus Troubleshooting for more information.</p>

Editing the job file

Use this procedure to edit the job file for cnet bisync communications.

Step	Action
1	Open the job file in a text editor.
2	<p>Set the dialing command.</p> <p>Example AUTODIAL n-<i>nnn</i>-<i>nnn</i>-<i>nnnn</i> T60 R3</p> <p>Where <i>n-<i>nnn</i>-<i>nnn</i>-<i>nnnn</i></i> is the connection telephone number T60 is the time in seconds to wait for a connection to complete R3 is the number of times to retry a connection attempt.</p> <p>Comment We recommend that you use the default time and retry settings.</p>
3	<p>Set mailbox ID and password. You must set it in three separate places:</p> <pre>KEY \$\$REQ ID=<i>xxxxx</i>R BID='<i>nnnnnnn</i>' -x KEY \$\$REQ ID=<i>xxxxx</i>D BID='<i>nnnnnnn</i>' -x KEY \$\$ADD ID=<i>xxxxx</i>D BID='<i>nnnnnnn</i>' -x</pre> <p>Where <i>xxxxx</i> is the five character network mailbox ID <i>nnnnnnn</i> is the seven digit password.</p> <p>Warning These are the only changes to the job file approved by IBM. Any other changes will NOT be supported by IBM Customer Support personnel.</p>

How to Start Up Cleo A+

Description

Interface Systems' Cleo A+ is an asynchronous communications package that uses sophisticated scripting to handle various types of communications. It supports several file transfer methods, including raw ASCII, Xmodem, Ymodem, Zmodem, Kermit, and ANSI CLEAR. It can also perform as an FTP tool, using SLIP, PPP, Telnet, or local modes.

Cleo A+ start-up command

The Cleo A+ start-up command consists of the command to execute the application A+ and several parameters. The two most important parameters are the job file and tokens, which are explained below.

The rest of the information that you can place in the start-up command is identified within the *job* file. A log file is generated automatically.

.job file

This parameter identifies the job file to use for the session. The job file determines how Cleo manages a communication session. There is a separate job file for each VAN which ends with the extension *.job*. For example, the Advantis job file is *advsr.job*.

This table lists the job file that corresponds to each supported VAN.

VAN Async (COMM/CleoA/.)	Job File
Sterling Information Broker via CompuServe	.cnetsr.job
Advantis Expedite/Async	.advsr.job
GEIS EDI*Express	.geissr.job

Tokens A **token** is a piece of information that is passed to a job, such as the VAN telephone number or your VAN ID. The token parameter identifies the tokens to be passed to the job as it is running.

This table lists the available A+ tokens for each VAN.

VAN	Token Number	Description
Advantis	1	Telephone/modem access number. (n- <u>nnn</u> - <u>nnn</u> - <u>nnnn</u>)
	2	IBM Network Account ID.
	3	IBM Network User ID.
	4	IBM Network Password.
	5	Information Exchange Network Account ID.
	6	Information Exchange Network User ID.
	7	Information Exchange Network Password.
Sterling Information Broker	1	Telephone/modem access number. (n- <u>nnn</u> - <u>nnn</u> - <u>nnnn</u>)
	2	Mailbox ID. (Sxxxx)
	3	Mailbox password. (nnnnnnn)
	4	Mailbox Application ID obtained from network support. (EDIx)
	5	Report slot ID. (xxx)
	6	Data slot ID. (xxx)
	7	Node access host. (compu)
GEIS	1	Telephone/modem access number. (n- <u>nnn</u> - <u>nnn</u> - <u>nnnn</u>)
	2	GEIS Network User Number.
	3	GEIS Network User Password.
	4	Last three digits of the GEIS User Number.

**Example start-up
command**

```
A+ jobfile=./cnet/cnetsr.job "tokens=18005551212 SX999 1234567 EDIx R D mci"
```

How to Start Up Cleo 3780Plus

Description Interface Systems' Cleo 3780Plus is a bisynchronous communications package that uses scripting to handle various types of communications. It supports 2780/3780 bisync protocols by using a piece of hardware to convert ASCII data to EBCIDIC data for transmission and EBCIDIC data to ASCII data upon reception of the EBCIDIC data.

Cleo 3780Plus start-up command

The Cleo 3780Plus start-up command consists of the Cleo command 3780Plus' along with several other parameters. These are required parameters:

Parameter	Description	
-d	Identifies the device or communications port to use this session.	
-j	Identifies the <i>.job</i> file to run.	
	VAN Bisync (COMM/CleoB/..)	Job File
	Sterling Information Broker	<i>.cnetsr.job</i>
	Advantis Expedite/Direct	<i>.advsr.job</i>
	GEIS EDI*Express	<i>.geissr.job</i>
-k	Used to pass the tokens to the <i>.job</i> file as it is running.	

You can use the following optional parameters in the start-up command.

Parameter	Description
-c	Identifies the configuration file to use. The <i>.job</i> file includes this information.
-LO	Directs Cleo to generate a new log for the session if one does not exist in the COMM directory or overwrite an existing one. This command is recommended.

Note

The log is not required. However, IBM Customer Support personnel must have the log to assist you in troubleshooting any communication difficulties you may encounter.

GEIS and Advantis tokens

This table lists the available 3780Plus or AllSync tokens for GEIS and Advantis.

Note

To control startup of bisynchronous communications for Sterling Information Broker, you need to edit the job file instead of using tokens.

Reference

See the [How to Set Up Bisynchronous Communications](#) topic in this chapter.

VAN	Token Number	Description
Advantis	1	Connection telephone number.
	2	IBM Network Account ID.
	3	IBM Network User ID.
	4	IBM Network Password.
	5	Information Exchange Network Account ID.
	6	Information Exchange Network User ID.
	7	Information Exchange Network Password.
GEIS	1	Connection telephone number.
	2	GEIS Network User Number.
	3	GEIS Network User Password.
	4	Last three digits of the GEIS User Number.

Example start-up command

```
3780Plus -d /dev/tty03 -j ./geis/geissr.job -k 18005551212 GEISID GEISPSWDnnn -LO
```

Start-Up Procedure Examples

Introduction

Communications is not a Sterling Gentran:Server application and the procedures to start communications can vary from environment to environment. Once communications are set up, you use the same commands to start it regardless of the platform.

Initiating communications through automated procedures

The communications toolkit has certain expectations regarding file placement. You can automate processes to move the file to and from the VAN directories. You can also automate the start-up process using *.bat* files created in DOS or Windows, or shell scripts created in UNIX or open systems.

Examples

The following examples show what you can implement into an automated communications procedure.

DOS or Windows Users .BAT File Example

```
copy C:\Server\ediout?.fil C:\Server\comm\cleoa\cnet\cnets
del C:\Server\ediout?.fil
cd \Server\comm\cleoa
aplus jobfile=.\cnet\cnetsr.job "tokens=5551212 SX999 1234567 EDIx R D mci"
copy C:\Server\comm\cleoa\cnet\cnetr C:\Server\comm\cleoa\ediin?.fil
del C:\Server\comm\cleoa\cnet\cnetr
```

UNIX Systems Users Shell Example

```
cp/Server/ediout?.fil /Server/comm/cleoa/cnet/cnets
rm/Server/ediout?.fil
cd/Server/comm/cleoa
A+ jobfile=./cnet/cnetsr.job "tokens=5551212 SX999 1234567 EDIx R D mci"
***error recovery procedures ie; if$? =gt 0 ...****
```

```
cp /Server/comm/cleoa/cnet/cnetr /Server/edliin?.fil
```

```
rm /Server/comm/cleoa/cnet/cnetr
```

**Example start-up
command**

```
3780Plus -d /dev/tty03 -j ./geis/geissr.job -k 18005551212 GEISID GEISPSWD -LO
```

Troubleshooting

Communications Session Error Recovery

Introduction

With communications applications, failures can occur. The communications scripts developed by IBM are designed to handle common communications errors.

Error messages and end codes

The communications script files (<van>sr.job files), have an “error Fall Thru” section. This section lists the messages that the Cleo application writes to the .log file. Each time a session error occurs, the .job file posts a relevant error message to the log and returns an end code when it exits the Cleo application. You can use this end code in a shell script (UNIX) or .bat file (DOS/Windows) to decide whether communications ended successfully. An end code of 0 indicates success and a non-zero value indicates a failure. The various end code values indicate why the failure occurred.

Sterling Information Broker Async end codes

This table describes the possible end codes generated by a Cleo application in Async (A+) mode and the meaning of each.

Sterling Information Broker Async (A+)	
End Code	Meaning
0	Session successful; continue processing.
Non-zero values:	Require further examination
35	Error occurred during dial attempts; connection never established.
50	Error occurred at some point during the logon process to the network. Connection established to communication node but no session established with host.
60	Error occurred while attempting to transmit your outbound data to the network; resend data.
70	Error occurred while attempting to receive inbound data or reports from the network; any data to be sent during that session was NOT sent; retry may be required.

**Sterling
Information
Broker Bisync
end codes**

This table describes the possible end codes generated by a Cleo application in Bisync (3780Plus) mode and the meaning of each.

Sterling Information Broker Bisync (3780Plus)	
End Code	Meaning
0	Session successful; continue processing.
Non-zero values:	Requires further examination
35	Error occurred during dial attempts; connection never established.
40	Error occurred during receive process for inbound data or reports from the network; retry may be required.
50	Error may have occurred at some point during transmittal of 'request cards', 'add' card', or outbound data file; retry may be required.

**Advantis
Expedite/Direct
Async end codes**

This table describes the possible end codes generated by a Cleo application in Async (A+) mode and the meaning of each.

Advantis Expedite/Direct Async (A+)	
End Code	Meaning
0	Session successful; continue processing.
Non-zero values:	Requires further examination
35	Error occurred during dial attempts; connection never established.
40	Error occurred during logon process; session never established communication to Advantis network, even though connection was made.
50	Error occurred during transmittal of outbound data to Advantis network.
55	Error occurred during transmittal of outbound flat file data to Advantis network.

(Contd) Advantis Expedite/Direct Async (A+)	
End Code	Meaning
60	Error occurred during reception of inbound data from Advantis network; retry may be needed.
65	Although data may have been collected by communications, Advantis may not recognize this because the session failed after the data was received; they may send duplicate data in following session.
70	Logoff process failed and Advantis may not have collected or acknowledge your receipt of data.

**Advantis
Expedite/Direct
Bisync end
codes**

This table describes the possible end codes generated by a Cleo application in Bisync (3780Plus) mode and the meaning of each.

Advantis Expedite/Direct Bisync (3780Plus)	
End Code	Meaning
0	Session successful; continue processing.
Non-zero values:	Requires further examination
35	Error occurred during dial attempts; connection never established.
40	Error occurred during logon process; session never established communication to Advantis network even though connection was made.
50	Error occurred during transmittal of data.
55	Error occurred during transmittal of 'receive' and 'receive log' commands occurred, or acknowledgment from Advantis never received.
60	Error occurred during receive process for inbound data file or reports from Advantis.

**GEIS
EDI*Express
Async end codes**

This table describes the possible end codes generated by a Cleo application in Async (A+) mode and the meaning of each.

GEIS EDI*Express Async (A+)	
End Code	Meaning
0	Session successful; continue processing.
Non-zero values:	Require further examination
35	Error occurred during dial attempts; connection never established.
40	Error occurred during logon process; session never established communication to GEIS network, even though connection was made.
50	Error occurred during transmittal of commands associated with sending outbound data to Advantis network; data never sent.
55	Error occurred during transmittal of outbound data to GEIS network.
60	Error occurred during transmittal of receive commands for inbound data from GEIS network.
65	Error occurred during reception of data from GEIS network.
70	Error occurred during logoff.

**GEIS
EDI*Express
Bisync end
codes**

This table describes the possible end codes generated by a Cleo application in Bisync (3780Plus) mode and the meaning of each.

GEIS EDI*Express Bisync (3780Plus)	
End Code	Meaning
0	Session successful; continue processing.
Non-zero values:	Requires further examination
35	Error occurred during dial attempts; connection never established.
40	Error occurred during logon process; session never established communication to GEIS network even though connection was made.
50	Error occurred during transmittal of commands associated with sending outbound data to Advantis network; data was never sent.
55	Error occurred during transmittal of outbound data to GEIS network.
60	Error occurred during transmittal of receive commands for inbound data from GEIS network, or failure occurred receiving data from GEIS network.
65	Error occurred during transmission of *EOS command; session may not even be recorded on GEIS network side.

Cleo 3780Plus Troubleshooting

Introduction

This section offers possible solutions to three of the most common situations. See your Cleo documentation for further information.

Problem and solution table

This table lists common problems and solutions.

Problem	Possible Solution
During a RECEIVE process, you encounter a WAIT error.	Increase the Wait Limit parameter in the Cleo configuration file (cnet.cfg, adv.cfg, or geis.cfg).
During a SEND process, you encounter a RETRAN error.	Increase the Retransmission Limit parameter in the Cleo configuration file (cnet.cfg, adv.cfg, or geis.cfg).
At any point in the session, you encounter a BIDLMT error.	<p>Check the documentation for your modem and verify that it can handle synchronous communications, then try again.</p> <p>If the problem continues, contact IBM Customer Support for information and assistance.</p> <p>Note The BIDLMT error can occur when you attempt to connect to a bisynchronous line at a speed other than that of the line. For example, if you attempt to connect to a 9600 bisynchronous line at 2400 baud.</p>

Connecting to Other VANs and Directly to Trading Partners

Introduction

If you need to connect to a trading partner directly or to a VAN that is not supported by the Communications Toolkit, you will need to create a Cleo communications script to connect to the VAN. You may also need to create a configuration file.

About creating communications scripts

Scripts are usually created as ASCII text files, which you do not need to compile.

Cleo 3780Plus

The Cleo 3780Plus communications application software enables an ASCII system to emulate a 2780 or 3780 terminal. With 3780Plus, you can transmit and receive data from any system that supports the 2780 or 3780 bisynchronous protocols.

The scripting facility in Cleo 3780Plus is relatively simple to use. However, you must understand the session protocol that the remote system requires.

Basic Cleo 3780Plus commands

The table below lists some *basic* Cleo commands and descriptions. See your Cleo 3780Plus documentation for more detailed information.

Command	Description
AUTODIAL tel# Txx Rxx	<p>Used to dial remote system modems for a communications connection.</p> <ul style="list-style-type: none"> ▶ tel# = The number to connect to. ▶ Txx = The timer delay for waiting for an answer from the remote modem. ▶ Rxx = The retry parameter for number of attempts to retry if the dial attempt fails.
KEY msg -ENRX	<p>Used to send a user a specified message. Often used to send commands such as a system logon to a remote system. Unless otherwise specified, Cleo automatically transmits an End of Transmission (EOT) character when the message transmission is complete.</p> <p>The switches that follow the command are used for protocol and translation functions.</p> <ul style="list-style-type: none"> ▶ -E = Suppress an EOT character after the message is transmitted. ▶ -X = Suppress an End of Text (ETX) character as well as an EOT character after the message is sent. ▶ -N = Send non-transparent data from the message through “as is” (no translation). ▶ -R = Suppress inter-record separators from the transmitted message.
TEXT path/filename - ENRX	<p>Used to transmit specified files to the remote system. The switches that follow the command (-ENRX) are used for protocol and translation functions. See descriptions above.</p>

(Contd) Command	Description
RECEIVE path/filename - NX	<p>Used to receive files from the remote system to a specified path and filename. A received EOT character terminates the command. A received ETX character causes Cleo to terminate the write to the specified file and start writing into an incremented filename. Depending on the user filename, Cleo may overwrite the previous data in the specified file.</p> <p>Switches:</p> <ul style="list-style-type: none"> ▶ -X = Ignore incoming ETX characters ▶ -N = Allow transparent data to be received “as is” (no translation)
VOICE	<p>Hangs up the phone and terminates a session. Usually, the command to terminate the Cleo 3780Plus application (QUIT) follows this command.</p>

Suggestions

- ▶ Reference the 3780Plus documentation to learn about the many other session script commands, startup options, and other functions not discussed in this appendix.
- ▶ Make sure you are familiar with all the options on the commands before you use them.
- ▶ Use the 3780.LOG file to review sessions for errors that may have occurred during the previous communications sessions.
- ▶ There is a Monitor file you can use as a line scope to determine what is being transferred to and from your system. This monitor is in EBCDIC Hexadecimal code. There is a conversion chart in the 3780Plus documentation that may help you read this trace.

Cleo A+

Cleo A+ enables users to transmit and receive files from systems that support asynchronous file transfer protocols. You can run sessions interactively or use scripts you have written to perform unattended functions. Several configuration options are available for file transfer: ASCII, Xmodem, Ymodem, Zmodem, Kermit, Ansi, and FTP (slip, ppp, telnet).

The scripting facility in Cleo 3780Plus is relatively simple to use. However, you must understand the session protocol that the remote system requires. A+ allows use of environment variables, user-defined variables, and the ability to control file naming during a session.

Basic Cleo A+ commands

This table includes descriptions of *basic* Cleo A+ commands used to start a dialup, send commands to a remote system, receive files, send files, and terminate the connection. See your CleoA+ documentation for more detailed information.

Command	Description
AUTODIAL tel# Txx Rxx	<p>Used to dial remote system modems for a communications connection.</p> <ul style="list-style-type: none"> ▶ tel# = The number to connect to ▶ Txx = The timer delay for waiting for an answer from the remote modem ▶ Rxx = The retry parameter for number of attempts to retry if the dial attempt fails
KEY msg -NTR	<p>Used to send a user a specified message. Often used to send commands such as a system logon to a remote system. Unless otherwise specified, Cleo automatically transmits a CR character when the message transmission is complete.</p> <p>The switches that follow the command are used for protocol and translation functions.</p> <ul style="list-style-type: none"> ▶ -N= Send non-transparent data from the message through “as is” (no translation). ▶ -T= Force message through the translation table. ▶ -R= Suppress carriage return (CR) from the end of the transmitted message.
SEND path/filename / remote filename -TN	<p>Used to transmit specified files to the remote system. The remote filename parameter is used to send the same filename to the remote system. The switches that follow the command (-TN) are used for translation functions.</p> <ul style="list-style-type: none"> ▶ -T= Force message through the translation table. ▶ -N= Send non-transparent data from the message through “as is” (no translation).

(Contd) Command	Description
RECEIVE path/filename - NT	<p>Used to receive files from the remote system to a specified path and filename. Depending on the file transfer type you are using, when the receive is complete, A+ attempts to write to the specified file or into an incremented filename. A+ may overwrite the previous data in the specified file, depending on the filename.</p> <p>Switches:</p> <ul style="list-style-type: none"> ▶ -N= Allow transparent data to be received “as is” (no translation). ▶ -T= Force the outbound data through the translation table.
VOICE	<p>Hangs up the phone and terminates a session. Usually, the command to terminate the Cleo 3780Plus application (QUIT) follows this command.</p>

Suggestions

- ▶ Reference the A+ documentation to learn about many other session script commands, startup options, and other functions not discussed in this appendix.
- ▶ Make sure you are familiar with all the options on the commands before you use them.
- ▶ Use the A+.LOG file to review sessions for errors that may have occurred during the previous communications sessions.

Configuration file

Depending on your trading partner requirements, you may need to create a configuration file. The important thing to remember is that the settings defined in the configuration file that pertains to your system or your modem should always be in sync with each other. Be sure to talk to staff at the remote site to determine its requirements for connection. Never assume anything will work. Even if you guess on how to establish the connection you will still need to determine the session protocol. Talk to your remote staff!

Extended Communications Support Services (ECS)

If you do not have the resources required to develop the communications or configuration file, IBM offers consulting services to create, maintain, install, and test communications. Contact IBM Customer Support and ask for communications support for information.

Introducing Sterling Gentran:Server

Content

- ▶ Introduction 2
- ▶ Sterling Gentran:Server Features 5
- ▶ Sterling Gentran:Server for UNIX Client/Server Strategy 7
- ▶ Running Multiple Sessions 11

Introduction

Welcome Welcome to Sterling Gentran:Server, the electronic data interchange (EDI) software that makes it easy to manage data exchanges between you and your trading partners. The heart of electronic data interchange is the translation of data into and out of formats that are intelligible to computerized data management systems.

Sterling Gentran:Server enables you to exchange data with your trading partners. When you send application data, Sterling Gentran:Server converts your data into EDI standard formats that can be understood by your trading partners. When you receive data in a standardized format, Sterling Gentran:Server translates the data into a format your application can understand.

You use Sterling Gentran:Server to describe your applications, edit standards, maintain trading partnership information, and generate translation “maps,” which are sets of instructions for translating data.

Note

If your company purchased the XML translation option, you can also exchange data in XML format. See the *IBM® Sterling Gentran:Server® for UNIX XML User Guide* for more information.

In this chapter This chapter contains background information about Sterling Gentran:Server that you should know before beginning to use the software.

Key terms This table describes key terms used in this chapter.

Term	Description
application	The business software generating the business information that you are sending or receiving electronically.
client	The computer in a client/server network that acts as the interface between the user and the server.
client/server	A computer network architecture in which data is stored and processing is performed on the server, which users access through the interface provided on the client.
default	A value that is automatically assigned.

(Contd) Term	Description
EDI	Electronic Data Interchange. Application-to-application transfer of key business transaction information in a standard or XML format via a computer-to-computer communication link.
EDI standard	A format to regulate syntax, structure, and content of transaction data.
map	A file that contains the relationships between: <ul style="list-style-type: none"> ▶ The segments and elements of a standard EDI document and the data fields in your application ▶ The elements in an XML document and the data fields in your application, EDI standard document, or in another XML document ▶ The segments and elements of two different standards ▶ The records and fields of two different applications
master directory	The directory on a server that stores your master files.
master file	The version of a map that Sterling Gentran:Server uses to process data.
server	The computer in a client/server network that performs the major system security, data storage, and computing tasks.
standard format	A format intelligible to computerized data management systems.
temporary file	A file on the client that Sterling Gentran:Server uses during editing and compiling.
trading partner	The company, division, or group with which you are exchanging business data electronically.
Trading Partnership	An arrangement to exchange information in a specific document type with a specific trading partner and using a particular standard version.
user directory	The directory on the server that temporarily holds the files being transferred from a client working directory to the master directory on the server.

(Contd) Term	Description
working file	A file that is stored in the user working directory on the client while the user has it checked out for editing.
working file directory	The directory created on the client to hold the files that a user is editing.

Sterling Gentran:Server Features

Introduction This summary lists the features Sterling Gentran:Server provides for your translation needs.

Product versions There are two basic versions of Sterling Gentran:Server:

- ▶ IBM® Sterling Gentran:Server® for UNIX - Workstation, which runs on a PC
- ▶ IBM® Sterling Gentran:Server® for UNIX, which runs on a client/server architecture

Sterling Gentran:Server for UNIX architecture The client/server architecture provides:

- ▶ An interface with a Windows look and feel.
- ▶ UNIX computing power for processing-intensive tasks.
- ▶ Multi-user capability.
- ▶ System and file security.
- ▶ Availability of optional products.

Multiple Help sources Sterling Gentran:Server provides Help through:

- ▶ Wizards to guide you through the key record-creation processes.
- ▶ Online Help with task-oriented content.
- ▶ Documentation provided on CD-ROM for online access.

Automated functions The following features automate many tasks for you.

Archiving

- ▶ Stores and retrieves both EDI and user-defined data
- ▶ Tracks key EDI activities; provides reports and audit trails of translations

Functional Acknowledgments

- ▶ Handles inbound and outbound functional acknowledgments and reconciliation
- ▶ Provides status information for each document

Task Scheduler

- ▶ Runs processes such as upload and download, translation, communications, and other tasks in a totally unattended mode

Mappers

The mapper available in Sterling Gentran:Server 6.2 is the Application Integration system.

Sterling Gentran:Server for UNIX Client/Server Strategy

Introduction This topic describes the IBM® Sterling Gentran:Server® for UNIX client/server architecture.

Description A Sterling Gentran:Server installation consists of a UNIX server (host computer) connected by a network to one or more client PCs. The server provides data, security, and translation processing, while the client computers provide the user interface, mapping tools, and the trading partnership maintenance module.

Advantages The client/server architecture provides the following advantages:

- ▶ A user interface with a Windows look and feel to allow users familiar with PCs to quickly learn how to use the Sterling Gentran:Server interface
- ▶ UNIX computing power for processing-intensive tasks such as performing translation, without the expense of a UNIX box for every user
- ▶ A true multi-user system that allows only one user to edit a file at a time, but also allows other users view-only access to locked files
- ▶ Increased system and file security.

Architecture This illustration and accompanying table show the major components of the Sterling Gentran:Server client/server architecture.

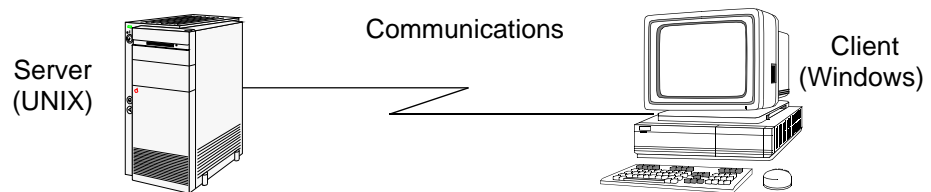

Where components reside

This table shows which Sterling Gentran:Server components reside on the server and which on the client.

	Server	Client	Server or Client
Programs	<ul style="list-style-type: none"> ▶ Translator ▶ Archiver ▶ Security ▶ Utilities 	<ul style="list-style-type: none"> ▶ Mapper (Application Integration system) editors ▶ Compiler ▶ Archive viewer ▶ Trading partner maintenance 	
Data	<ul style="list-style-type: none"> ▶ Maps and translation objects ▶ Trading partner records and associated files 	<ul style="list-style-type: none"> ▶ Temporary files 	<ul style="list-style-type: none"> ▶ Standard files (Application Integration system)

Environments

Environments are installations of the Sterling Gentran:Server software on the UNIX server. Usually, each installation is dedicated to a certain purpose. They are physically represented as branches in the directory tree structure and can be created for many purposes. They can be especially useful for providing a place to test changes without affecting normal activity.

Examples

Some examples of environments created for specific purposes follow.

Installations based on the activity performed:

- ▶ Development
- ▶ Testing
- ▶ Production

Installations based on the document generated:

- ▶ Purchase orders
- ▶ Invoices

Installations based on the industry of the trading partner:

- ▶ Automotive
- ▶ Aerospace
- ▶ Medical

Security

Within each installation, the system administrator can assign different levels of access to a user for each of the major functions within Sterling Gentran:Server.

Levels of access

This table describes the different levels of access.

Level of Access	Description
Full Access	Gives you permission to view, copy, rename, load, unload, and edit files.
View	Gives you permission to view files, but not to alter them.
No Access	Prevents you from using an editor, viewing files, or running a program.

Example

By creating separate environments (installations) and assigning appropriate permissions, system administrators can assign users access appropriate to the work they perform. For example, a system administrator might have Full Access permission in all environments, while a user whose job is to process reports may have only View permission in the production environment and No Access permissions in all other environments.

Functional areas

This table shows the basic functional areas and types of access that the system administrator may assign you.

Note

Each of the editors functional areas may be collectively set to one of three types of access. Each of the programs functional areas may be collectively set to one of two types of access.

Functional Area		Types of Access
Editors	Archive Retrieval	Full Access
	File Browser	View-only
	Trading Partner Preferences Settings	No Access
	Trading Partner Editor	No Access

(Contd) Functional Area		Types of Access
Programs	Process Control Manager	Full Access
	Archive load/unload/create/ purge	No Access
	TP/org/category/contact load/ unload/create	
	Run Program: D-ISAM File Operations	
	Server Workbench	
	Schedule Tasks to Run Automatically	
	Run Tools	
	Run Inbound and Outbound Translation	

Running Multiple Sessions

Definition A **session** is a single instance of the Sterling Gentran:Server application running in a window on your desktop.

Sterling Gentran:Server does not limit you to a single session; you can run more than one instance of IBM® Sterling Gentran:Server® for UNIX client software or IBM® Sterling Gentran:Server® for UNIX - Workstation at the same time. Each time you start Sterling Gentran:Server on your desktop, you start a new session. Each session runs in a different window. Running multiple sessions enables you to perform different Sterling Gentran:Server tasks in each window.

How many sessions can you run?

You can run:

- Up to four sessions of the IBM® Sterling Gentran:Server® for UNIX client software at the same time on one Windows desktop
- Up to four sessions of IBM® Sterling Gentran:Server® for UNIX - Workstation at the same time on one Windows desktop
- IBM® Sterling Gentran:Server® for UNIX - Workstation and IBM® Sterling Gentran:Server® for UNIX client software at the same time on one desktop.

Example

You run three simultaneous sessions of the IBM® Sterling Gentran:Server® for UNIX client software for the host1 and environment XYZ combination:

- Session 1, view a file with the File Browser
- Session 2, search for a Trading Partnership record
- Session 3, create a new category

Performance limitations

Each additional session you start degrades performance. Opening too many sessions at once can cause the client to lock.

Login requirements for UNIX

When you start another Sterling Gentran:Server session for a host and environment that is running on your desktop, you must use the same User Name and Password to log onto the new session.

If you want to start a session for a different host or environment, you can use a different User Name and Password.

Process and session limits

If you open multiple sessions on your desktop, the sessions can be for the:

- ▶ Same host and environment (IBM® Sterling Gentran:Server® for UNIX)
- ▶ Same host and different environments (IBM® Sterling Gentran:Server® for UNIX)
- ▶ Different hosts and environments (IBM® Sterling Gentran:Server® for UNIX)
- ▶ Combination of IBM® Sterling Gentran:Server® for UNIX - Workstation sessions and IBM® Sterling Gentran:Server® for UNIX sessions.

This table shows the limitations on running processes in multiple sessions.

Process	Limitations
File Browser	None. Multiple windows permitted in each session.
Trading Partnership Maintenance	None. Multiple windows permitted in each session.
Process Control Manager	Once in a session for each host/environment combination.
SAP Configuration	Once in a session for each host/environment combination.
Standard Version Conversion	Once in a session for each host/environment combination.
Archive	Once in a session for each host/environment combination.
EC Workbench	One client session for each host/environment combination. You can run EC Workbench multiple times as long as each Client session is for a different host/environment combination.
Translation	One client session for each host/environment. You can run translation multiple times as long as each session is for a different host/environment combination.
Map Compilation	One client session at a time.
Mapping	None. Multiple windows permitted in each session

If a process has session limitations and is already running, Sterling Gentran:Server displays a message to let you know that the process is busy and asks that you try again later.

File locking

Sterling Gentran:Server locks certain files to prevent you from editing the same file in multiple sessions. If you attempt to edit a file that you are editing in another session, Sterling Gentran:Server displays a message to let you know that the file is in use.

Sterling Gentran:Server locks these files when you open them for editing:

- Maps
- Trading Partner record
- Group Organization record
- Interchange Organization record

Exceptions

Locking does not apply to:

- Files edited in the File Browser
- Trading Partnership Category files
- Trading Partnership Contact files

Note

If the same non-DISAM file is edited in two different parallel sessions, the last changes saved overwrite earlier changes from another session.

Caution

Never use the File Browser to edit an DISAM file. Doing so will corrupt the file.

Report, log and local temporary files

Sterling Gentran:Server keeps the report files, log files, and local temporary files for each host and environment in different directories.

The system creates a directory named **rpt** for the report and log files under the directory where the Sterling Gentran:Server client software is installed. The local temporary working files are stored in the **lcltmp** directory.

For each host and environment, the system creates a subdirectory under the **rpt** and **lcltmp** directories. The subdirectory is named for the environment and host name (environment+hostname) logged in to for the session.

Example

The Sterling Gentran:Server client software is installed in D:\gentran. The system creates subdirectories for the report files and for the local temporary files:

- D:\gentran\rpt
- D:\gentran\lcltmp

You start a session, logging in to the 60test environment on the host hpd350. Sterling Gentran:Server creates subdirectories for the session:

- D:\gentran\61testhpd350
- D:\gentran\rpt\61testhpd350
- D:\gentran\lcltmp\61testhpd350

Sterling Gentran:Server stores the session report and log files in D:\gentran\rpt\61testhpd350 and stores the session local temporary files in D:\gentran\lcltmp\61testhpd350.

You open a session for a different environment and host, 2XF on hpd001. Sterling Gentran:Server creates new subdirectories for the report and local temporary files:

- D:\gentran\2XFhpd001
- D:\gentran\rpt\2XFhpd001
- D:\gentran\lcltmp\2XFhpd001

Note

If the host or environment name contains special characters (such as *, ?, <, or >), the system converts the special characters to underscores (_). For example, the host name hp<200> is converted to hp_200_.

Using Sterling Gentran:Server

Content	▶ Introduction	2
	Starting and Exiting	
	▶ How to Start Sterling Gentran:Server	4
	▶ How to Change Your Password (UNIX Version)	6
	▶ How to Exit Sterling Gentran:Server	8
	The Sterling Gentran:Server User Interface	
	▶ Overview	9
	▶ The Main Window	10
	▶ Main Window Menus	12
	▶ The Main Window Toolbar	14
	▶ How to Use the Sterling Gentran:Server Interface	15
	▶ How to Use the On-line Help	16
	▶ The File Browser	18
	▶ How to Use the File Browser	20
	▶ How to Change Print Properties	23
	Setting Default Values	
	▶ Overview	24
	▶ Set Up Directories Dialog Box	26
	▶ How to Change Client Default Directories	28

Introduction

In this chapter

This chapter contains general information about the Sterling Gentran:Server interface. It describes the menus and Toolbar of the Main Window and includes instructions for:

- ▶ Starting and exiting Sterling Gentran:Server
- ▶ Using menus, toolbar buttons, and dialog boxes
- ▶ Using the File Browser to edit text, EDI, and NCPDP files
- ▶ Changing your password (UNIX version only)
- ▶ Choosing printing properties
- ▶ Setting Sterling Gentran:Server preferences and default values

Key terms

This table describes key terms used in this chapter.

Term	Description
check box	A square to the left of an option in a dialog. When the option is selected, the square contains an X. You click the check box to change whether the option is selected.
default	A value that is automatically assigned.
master directory	The directory on a PC or on a server that stores your master files.
menu	A list of related commands.
menu bar	The row of menu names that runs across the top of a window.
option button	A round button used to select one option from a mutually exclusive set of options.
push-button	A symbol or icon that initiates some action when you click it.
server	The computer in a client/server network that performs the major system security, data storage, and computing tasks.

(Contd) Term	Description
text box	A box into which you enter alphanumeric text to provide data needed by Sterling Gentran:Server.
Toolbar	A bar of buttons used to start commands.

Starting and Exiting

How to Start Sterling Gentran:Server

Introduction This topic explains how to start Sterling Gentran:Server.

Note

You can run up to four sessions of Sterling Gentran:Server on the same desktop at once.

Starting Sterling Gentran:Server

Follow this procedure to start and log on to Sterling Gentran:Server.

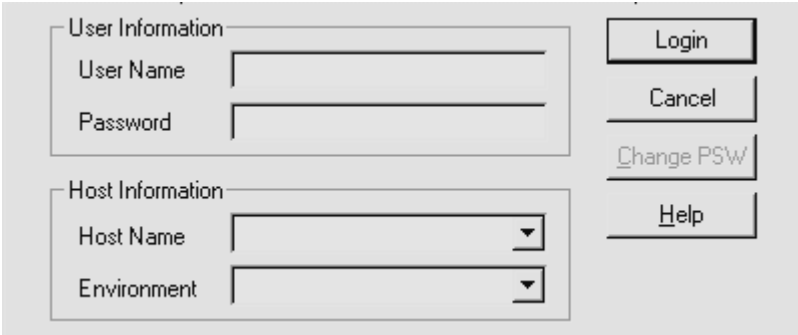
Step	Action
1	Select the Windows Start menu.
2	<p>Select the Sterling Gentran:Server program icon from the Programs menu.</p> <p>System Response Sterling Gentran:Server displays the Login window.</p> 
3	<p>Type your user name into the User Name box.</p> <p>Note When you start another Sterling Gentran:Server session for the same host and environment that is running on your desktop, you must use the same User Name and Password to log onto the new session.</p> <p>If you want to start a session for a different host or environment, use a different User Name and Password.</p>

(Contd) Step	Action
4	Type your Sterling Gentran:Server user password into the Password box.
5	Select the host server from the Host Name drop-down list.
6	Select an environment from the Environment drop-down list.
7	Click Login .
8	Click Continue . System Response Sterling Gentran:Server displays the main window and logs you into the selected host and environment. Note The Main menu title bar displays the name of the host and environment.

Reference

See the *How to Set TP Administration Preferences* topic in the *IBM® Sterling Gentran:Server® for UNIX Application Integration User Guide* for instructions on setting Trading Partnership Administration Preferences.

How to Change Your Password (UNIX Version)

Introduction This topic explains how to change your user password for Sterling Gentran:Server.

Note

If you use IBM® Sterling Gentran:Server® for UNIX - Workstation, you do not have a password.

Procedure Use this procedure to change your Sterling Gentran:Server password.

Step	Action
1	Click the Start menu.
2	Select the Sterling Gentran:Server program icon from the Programs menu. System Response Sterling Gentran:Server displays the Login window.
3	Type your user name into the User Name box.
4	Type your Sterling Gentran:Server user password into the Password box.
5	Select a Host Name from the drop-down list.
6	Select an environment from the Environment drop-down list.
7	Click Login . System Response Sterling Gentran:Server enables the Change PSW button.

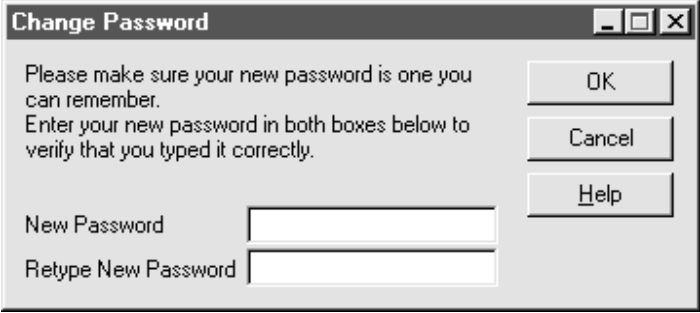
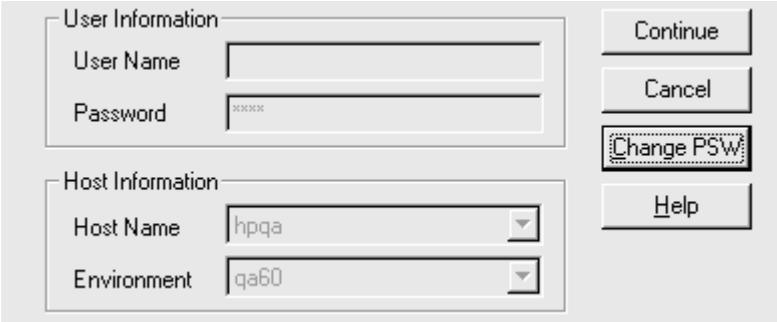
(Contd) Step	Action
8	<p>Click Change PSW.</p> <p>System Response Sterling Gentran:Server displays the Change Password dialog box.</p> 
9	<p>Type the new password into both the New Password and Retype New Password text boxes. Click OK.</p> <p>System Response The system displays the Login dialog box.</p> 
10	<p>Click Continue.</p> <p>System Response Sterling Gentran:Server logs you in, changes your password, and displays the main window.</p>

How to Exit Sterling Gentran:Server

Introduction This topic explains how to exit Sterling Gentran:Server.

Before you exit Any files that are checked out when you exit the application remain checked out and unavailable for other users to edit. Before you exit Sterling Gentran:Server, be sure to check in any files that you no longer need.

Reference

See [How to Check In Maps and Translation Objects](#) and [How to Check In File Definitions](#) in the [Working with Application Integration](#) chapter or [How to Check In Compiled Maps](#), [How to Check In IG/Application Description Files](#) and [How to Check In Synonym and Thesaurus List Files](#) for instructions.

Procedure Select **Exit** from the **File** menu.

Note

If you are running multiple sessions on your desktop, you must exit each session.

System Response

Sterling Gentran:Server logs off of the host computer and exits.

The Sterling Gentran:Server User Interface

Overview

Introduction

Sterling Gentran:Server features on the client use the Windows environment. To use Sterling Gentran:Server, you must be familiar with using a personal computer and with Windows functions and terminology, including the following:

- The terminology used to describe mouse and cursor actions; for example, opening, clicking, scrolling
- The terminology used to describe Windows-specific attributes, such as dialog boxes, buttons, and check boxes.

User interface

The user interface for all versions of Sterling Gentran:Server includes:

- Screens that use the familiar Windows interface.
 - Graphical tree organization of trading partnership records to make setup and maintenance easier.
 - Graphic displays of mapping components and relationships.
-

The Main Window

Introduction This topic explains the items you see on the Sterling Gentran:Server Main Window.

Reference

Refer to your Windows documentation for detailed explanations of Windows terms and functions.

Main UNIX Window

This illustration shows an example of the Main Window for Sterling Gentran:Server.

Note

This illustration displays many of the options available with Sterling Gentran:Server. However, you will only see the options your company purchased.

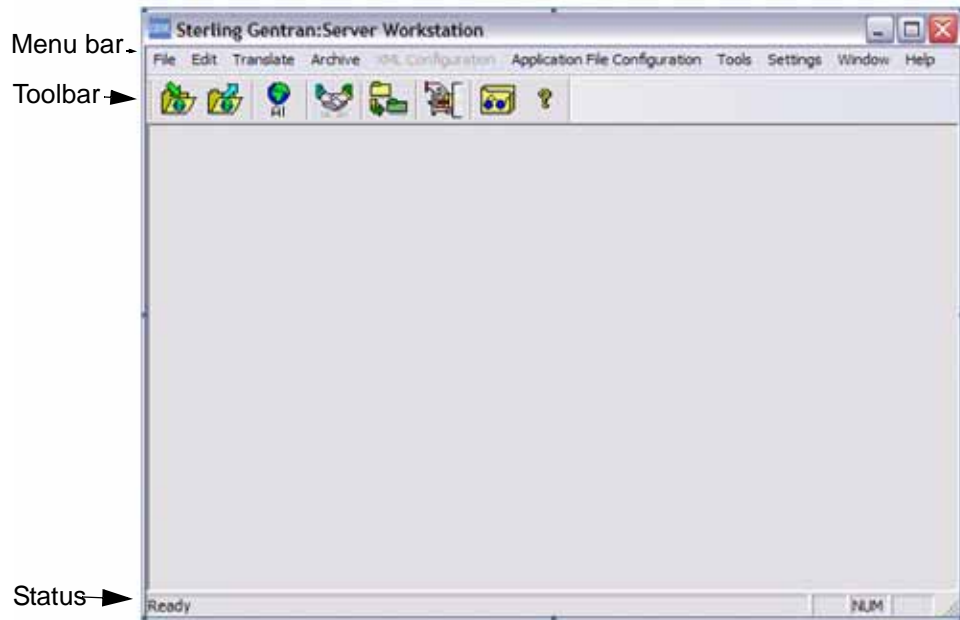

Parts of the window

This table describes the parts of the main Sterling Gentran:Server window.

Part	Function
Menu bar	Opens menus to display commands.
Toolbar	Starts commands from a set of buttons.
Status bar	Displays a status message, prompt, or toolbar button description.

Main Window Menus

Introduction

You can start all Sterling Gentran:Server features and functions from the menus of the Sterling Gentran:Server Main Window.

UNIX Client/ Server Main Window menus

This table describes the menus of the UNIX Client/Server Main Window.

Menu	Used to...
File Menu	<ul style="list-style-type: none"> ▶ Check in a file ▶ Check out a file ▶ Unlock a file ▶ Copy compiled maps (.tbl and .tpl) to User Directory on host ▶ Open the Print Setup dialog box ▶ Exit the Main Window
Edit Menu	<ul style="list-style-type: none"> ▶ Start a mapping editor (Application Integration) ▶ Start the Trading Partnership Administration system
Translate	<ul style="list-style-type: none"> ▶ Open the Translate Documents dialog box ▶ Generate a translation report.
Archive	<ul style="list-style-type: none"> ▶ Set archiving parameters ▶ Open an archive ▶ Purge an archive ▶ Load and unload archived files ▶ Create new archives
XML Configuration (if you purchased the XML translation option)	<ul style="list-style-type: none"> ▶ Open the XML Element Configuration window ▶ Start the XML Trading Partnership Rules wizard ▶ Open the XML TP Cross Reference dialog box.

(Contd) Menu	Used to...
Application File Configuration	<ul style="list-style-type: none"> ▶ Start the Application File Trading Partnership Rules wizard ▶ Open the Application File TP Cross Reference dialog box.
Tools	<ul style="list-style-type: none"> ▶ Test host connection ▶ Open the Task Scheduler to schedule a task ▶ Run scheduled tasks ▶ Run Standard Version Conversion ▶ Start the File Browser ▶ Open the Run a Command dialog box to run a command line program ▶ Start optional system (such as the Process Control Manager or Workbench on a host) or an extension
Settings	Specify default directories for your Sterling Gentran:Server files
Window	<ul style="list-style-type: none"> ▶ Display or hide the Toolbar ▶ Display or hide the Status Bar
Help	<ul style="list-style-type: none"> ▶ Open the Help Contents or Index ▶ Display information about using Help ▶ Display version information for Sterling Gentran:Server

The Main Window Toolbar









Introduction

The Sterling Gentran:Server Toolbar consists of several buttons that you can use to quickly access Sterling Gentran:Server systems, tools, and optional features.

The specific buttons displayed on your toolbar depend upon the Sterling Gentran:Server product and options your company purchased. This topic describes the most common buttons. Your toolbar may include additional buttons for optional features.

The Main Window Toolbar

To execute a command with a toolbar button, click the appropriate button.

Click this...	To do this...
	Check in files.
	Check out files.
	Open the Application Integration mapping editor.
	Open the Trading Partnership Administration system.
	Open the Translate Documents dialog box or generate a translation report.
	Start an archiving option.
	Start the Process Control Manager system.
	Open the File Browser text editor.
	Display Help for the current window.

How to Use the Sterling Gentran:Server Interface

Introduction This topic explains how to use the Sterling Gentran:Server menus, toolbars, dialog boxes, and other interface features.

Using the Toolbar To start a feature or system from the Toolbar, click the appropriate Toolbar button.

Note

For information about a Toolbar button, place the pointer on the button to display the button name and then refer to the Status Bar for the button function.

Using the Status Bar

The status bar displays information, descriptions, or instructions for the active window, item on a dialog box, toolbar button, or command. You may see a status such as “Ready” for a window, an instruction such as “Enter record ID” for a text box on a dialog box, or “File Browser” for a Toolbar button.

To use the Status Bar, move the pointer to the window, box, or button that you want to check and then read the text displayed on the Status Bar.



Using dialog boxes

You enter information within a dialog box by:

- ▶ Typing in text boxes
- ▶ Selecting items from list boxes
- ▶ Clicking check boxes, options, or push buttons.

To move to the desired box or button, use either the mouse or the keyboard.

- ▶ When using the mouse, move the mouse pointer to the desired box or button and click to select the box or button.
- ▶ When using the keyboard, press **TAB** to move to the next box or button or press **SHIFT+TAB** to move to the previous box or button.

How to Use the On-line Help

Introduction

Sterling Gentran:Server provides Help information to guide you through commands and procedures. Sterling Gentran:Server Help files explain many topics: parts of the active window, commands, dialogs, and procedures for using specific features to perform a task.

Getting Help

You can access Help several ways. The methods available depend on the window you have displayed.

To start Help from...	Do this...
The menu bar	Select a command or topic from the Help menu.
The toolbar	Click the Help button on the toolbar for information about the currently displayed dialog box or window.
Any window	Press F1 for information about the window.
A dialog box	Click the Help button on the active dialog box for related help information.

Using the Help menu

To learn how to use Help, select **Using Help** from the Help menu.

The Contents command from the Help menu displays a list of Help topics that you can choose from. You can access Help information for the topics in different ways; you can use the menus at the top of the **Help** window, or you can use the buttons under the menus to search for a topic. You can print and edit Help information.



Using the Help toolbar button

On major windows, you can get window-level Help by clicking the **Help** button on the toolbar.

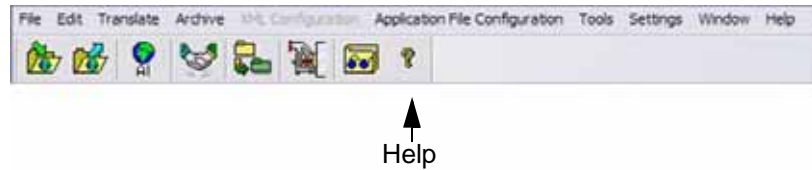

Using the Help buttons on dialog boxes

You can get Help for any dialog box that displays the **Help** button. Click **Help** for more information.

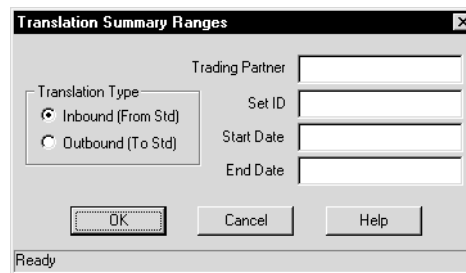

Exiting Help

You can close the **Help** window when you are finished with it. To close **Help**, select **Exit** on the File menu of the Help system menu bar.

The File Browser

Introduction

The File Browser is a Sterling Gentran:Server tool that enables you to open and edit text, EDI, and NCPDP files. It contains basic text-editing features, such as copying, cutting, pasting, finding, and replacing text.

When to use

You can use the File Browser to open and edit:

- Text files, such as batch files (*.bat) and configuration files (*.cfg)
- EDI files
- NCPDP files

Note

When you open an EDI file in the File Browser, Sterling Gentran:Server runs the **edifmat** command on the file before displaying it. The **edifmat** command replaces the segment terminators in the file with new line terminators so that the format is easier to read.

CAUTION

Never use the file browser to edit a disam file. Doing so will corrupt the file.

The File Browser window

This illustration shows the File Browser window.

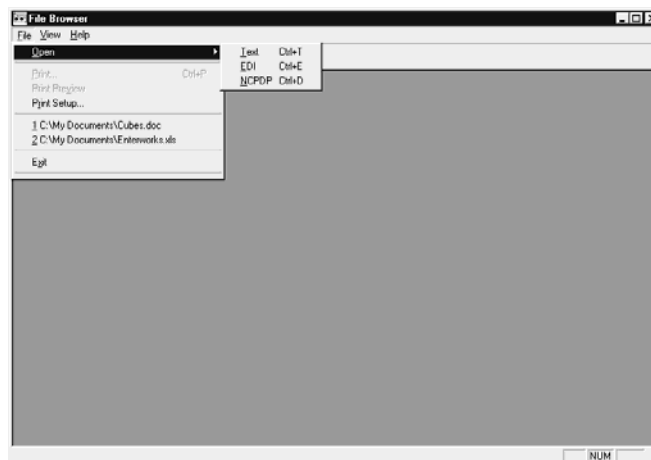

**Parts of the File
Browser window**

This table describes the parts and functions of the File Browser window.

Part	Function
Menu bar	Opens menus to display commands.
Toolbar	Starts commands from a set of buttons.
Status bar	Displays a status message, prompt, or toolbar button description.

How to Use the File Browser

Introduction This topic explains how to start and exit the File Browser, open a file, and use the File Browser editing commands to modify a file.

Starting the File Browser

To start the File Browser, do one of the following:

- Click the File Browser button on the Main Window toolbar.
 - Select **Start File Browser** from the Tools menu.
-

Opening a file

There are two ways to open a file in the File Browser: from the Toolbar or from the File menu.

Method 1 - Toolbar button.

Step	Action
1	Click the Open button on the File Browser toolbar. System Response The File Browser displays the Open dialog box.
2	Select Text File , EDI File , or NCPDP File to indicate the type of file you want to open. CAUTION Never use the file browser to edit a disam file. Doing so will corrupt the file.
3	Click OK . System Response The File Browser displays the standard Open dialog box.
4	Browse to the folder and file you want to open.
5	Click OK .

(Contd) Step	Action	
6	IF you open...	THEN the File Browser...
	an EDI file	displays the Enter EDI Format Parameter dialog box. Continue with Step 7.
	a text file	displays the text file. You are finished.
	a NCPDP file	runs the edifmat command on the file you selected and displays the file in a newline terminated format. You are finished.
7	Select the option on the Enter EDI Format Parameter dialog box to specify the format you want applied to the data. System Response The system runs the edifmat command on the file you selected and displays the file in a newline terminated format.	

Method 2 - File menu

Select **Open** from the File menu and then select **Text**, **EDI**, or **NCPDP** from the cascading menu.

Editing a file in the File Browser

This table describes how to edit, print, and save a file in the File Browser.

IF you want to...	Then...
Insert characters	Click at the insertion point and type the characters.
Copy selected text to the clipboard	Click Copy on the Edit menu.
Paste text on the clipboard into the document	Click at the insertion point and then click Paste on the Edit menu.
Select the entire document	Click Select All on the Edit menu.
Search for characters, words, or phrases	Click Find on the Edit menu. Then, enter the search string.

(Contd) IF you want to...	Then...
Search for the next occurrence of a search item	Click Find Next on the Edit menu.
Replace selected text	Click Replace on the Edit menu. Then type the replacement text.
Print the document	Click Print on the File Menu.
Save the changes to the document	Click Save on the File menu.
Save a copy of the document under a new path or name	Click Save As on the File menu. and enter the new path and file name.

Exiting the File Browser

To close the File Browser, do one of the following:

- ▶ Select **Exit** from the File menu.
 - ▶ Click the close button on the File Browser window.
-

How to Change Print Properties

Introduction This topic explains how to open the Print Setup dialog box from within Sterling Gentran:Server. Check your Microsoft® documentation for details on how to use the window.

Background When you print any of the reports that Sterling Gentran:Server generates, the program prints the report on the default printer, using the default font style and size specified for that printer. You can use the Microsoft Print Setup dialog box to specify print properties for the default printer for the client.

Your selections affect all printing (except printing of compiler messages) in Sterling Gentran:Server until you quit or change them. If you want to set these defaults and keep them between Sterling Gentran:Server sessions, use the **Printers** utility in the Windows **Control Panel**.

Opening the Print Setup window Follow this procedure to open the Print Setup dialog box from within Sterling Gentran:Server.

Step	Action
1	Click File on either the Main, Application Integration Main, Application Editor, or Standard/IG Editor menu bar.
2	Click Print Setup on the File menu.

Adjusting print properties Depending upon the font style and size, some parts of the report may not appear on the output (This may be a problem with fonts larger than 12 point). To correct, change the default font style or size. The methods of changing the default font style and size vary according to your PC.

Depending upon the aspect ratio of the report, you could also try printing landscape instead of portrait.

Setting Default Values

Overview

In this section

This section explains how to set the basic directory and the Application Integration system preferences and default values you want your system to use.

Reference

See the *Setting Preferences and Default Values* section in the *IBM® Sterling Gentran:Server® for UNIX Application Integration User Guide* for information about setting preferences and default values for the Application Integration system.

Default directories

The Set Up Directories dialog box enables you to define the default directories that Sterling Gentran:Server will use to store your Sterling Gentran:Server files on your PC or client. If you are using IBM® Sterling Gentran:Server® for UNIX, your system administrator will set the default directories for the server during installation. The server directories appear on the screen, but can't be changed.

When to set the values

We recommend that you set your default directory and map display values before you create your first map. However, you can set or change the map display options at any time.

Where to go next

Use this table to locate the instructions for setting particular types of preferences.

IF you want to customize...	THEN select...
<i>Client</i>	
The default directories your system uses to store Sterling Gentran:Server files	How to Change Client Default Directories
<i>Application Integration</i>	
All the Application Integration system preferences	<i>How to Set the Application Integration Preferences in the IBM® Sterling Gentran:Server® for UNIX Application Integration User Guide.</i>
The list of date and time formats that you can use in map fields	<i>How to Set the Application Date/Time Formats in the IBM® Sterling Gentran:Server® for UNIX Application Integration User Guide.</i>
The default date format for all date fields used in a map	<i>How to Set the Default Date Formats in the IBM® Sterling Gentran:Server® for UNIX Application Integration User Guide.</i>
Which map component descriptions are displayed	<i>How to Customize Component Display Options in the IBM® Sterling Gentran:Server® for UNIX Application Integration User Guide.</i>
Foreground and background colours of map components	<i>How to Customize Component Colors in the IBM® Sterling Gentran:Server® for UNIX Application Integration User Guide</i>
Font type, style, or size used in map displays	<i>How to Customize Global Fonts in the IBM® Sterling Gentran:Server® for UNIX Application Integration User Guide.</i>
How map links are displayed	<i>How to Customize the Display of Links in the IBM® Sterling Gentran:Server® for UNIX Application Integration User Guide.</i>
How the map version number is incremented	<i>How to Customize the Auto-increment Map Version in the IBM® Sterling Gentran:Server® for UNIX Application Integration User Guide.</i>

Set Up Directories Dialog Box

Introduction

The Set Up Directories dialog box enables you to define the default directories that Sterling Gentran:Server will use to store your Sterling Gentran:Server files on your client.

Sterling Gentran:Server

This illustration shows the Set Up Directories dialog box for Sterling Gentran:Server. Note that the Host directories are not available for editing. Your system administrator sets these during installation.

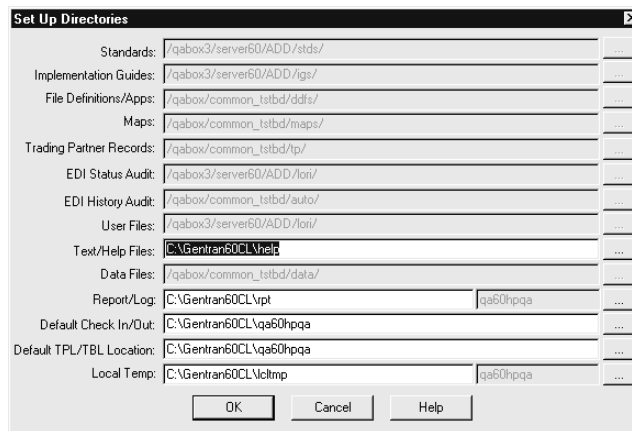

Fields and functions

This table lists the fields of the UNIX Set Up Directories dialog box and their functions.

Field	Function
Standards	Stores a list of available standards. This directory is located on the host.
Implementation Guide	Stores implementation guides (.igs). This directory is located on the host.
File Definitions/Apps	Stores file definitions (.ddfs). This directory is located on the host.
Maps	Stores map files and translation objects. This directory is located on the host.
Trading Partner Records	Stores Trading Partnership files. This directory is located on the host.
EDI Status Audit	Stores the status audit files that Sterling Gentran:Server generates. This directory is located on the host.
EDI History Audit	Stores the history audit files that Sterling Gentran:Server generates. This directory is located on the host.
User Files	Stores your user files. This directory is located on the host.
Text/Help Files	Stores text files and the Sterling Gentran:Server Help files. This directory is located on the client.
Data Files	Stores your data files. This directory is located on the server.
Report/Log	Contains the reports and log files that Sterling Gentran:Server generates. This directory is located on the client.
Default Check In/Out	Serves as the default working directory for files. This directory is located on the client.
Default TPL/TBL Location	Serves as the default working directory for translation objects (compiled maps). This directory is located on the client.
Local Temp	Serves as the default working directory. This directory is located on the client.

How to Change Client Default Directories

Introduction

You can change the default directories for the Sterling Gentran:Server files on the client from the values set at installation. You cannot change the default directories on the host with this procedure.

Reference

See the chapter *Environment Administration* in the *IBM® Sterling Gentran:Server® for UNIX Maintenance and Troubleshooting Guide*.

How to change a directory path

Use this procedure to change a default directory path for files on the client.

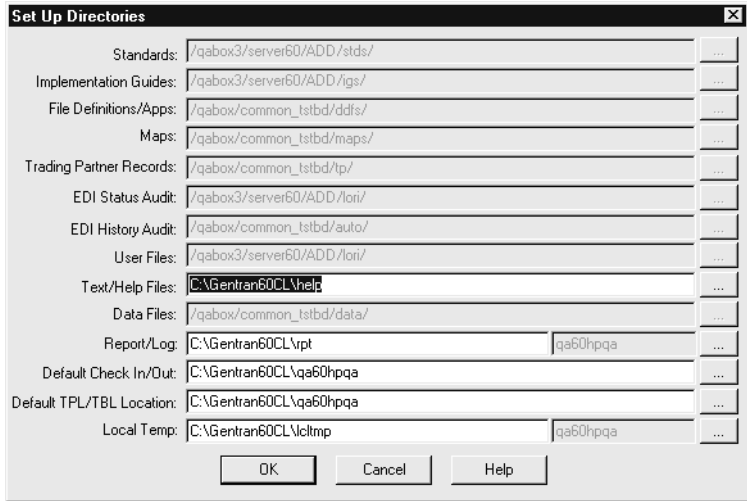
Step	Action
1	Click Settings on the menu bar.
2	<p>Click Set Up Directories on the Settings menu.</p> <p>System Response The system displays the Set Up Directories dialog box, showing the default directories for each type of file on the client. The directories on the server are not active.</p> 
3	Click in the appropriate text box.

(Contd) Step	Action
4	Delete the current path and type the new path, or edit the existing path. Note You can use the browse button to the right of the box to browse for the path.
5	Click OK to save your changes.

Working with Application Integration

Content	Overview
	▶ Introduction 2
	▶ Working in Sterling Gentran:Server 3
	Dialog Boxes
	▶ Select Map and File Definitions Files to Check out Dialog Box 7
	▶ Select Map Files to Check in Dialog Box 9
	▶ Select TBL/TPL Files to Check In Dialog Box 11
	▶ Select File Definition to Check in Dialog Box 12
	▶ Select Map and File Definition Files to Unlock Dialog Box 14
	Procedures
	▶ How to Check Out and View Maps and File Definitions 16
	▶ How to Save Changes to Working Files 20
	▶ How to Unlock Master Files and Delete Working Copies 22
	▶ How to Copy a Translation Object to the Host User Directory 26
	▶ How to Check In Maps and Translation Objects 27
	▶ How to Check In File Definitions 31

Overview

Introduction

In this chapter This chapter contains information about working in Sterling Gentran:Server and accessing and returning files.

Key terms This table describes the key terms used in this chapter.

Term	Description
check in	The act of returning a copy of a file from your working directory to the master directory, making it available to other users.
check out	The act of copying a file from the master directory to your working directory, making the file unavailable to other users.
lock	The act of making a file unavailable to other users. A file is locked once it is checked out.
unlock	The act of making a file available to other users. A file is unlocked once it is checked in.

Working in Sterling Gentrans:Server

Background

Sterling Gentrans:Server uses numerous data files such as maps, translation objects (TPL files), file definitions, and Trading Partnership records. Sterling Gentrans:Server installations control access to data files through environments, master files and working files, and through checking out and checking in master files.

Access rights

Sterling Gentrans:Server provides a security utility. A system administrator uses this utility to assign each user the appropriate access rights for each of the Sterling Gentrans:Server installations (environments). Within each installation, the system administrator can assign different levels of access to a user for each of the following functional areas:

- Editing maps and file definitions
- Editing archived files
- Editing Trading Partnership records and related files (contact records, organization records, TRADACOMS supplemental files, and category records)
- Running the translator
- Using the Run Program tool

This table shows the different levels of access that can be assigned to a function.

Access Type	Permissions
Full	View, copy, rename, load, unload, and edit files
View	View, copy, rename, load, and unload files, but not to edit them
No Access	None

Master files

Each installation contains **master files**.

A master file is the original, source version available to all users for viewing, and to one user at a time for editing.

Working files

When you check out a master file to view or edit, Sterling Gentran:Server copies the file and transfers the working copy from the Host to your client check out (working files) directory.

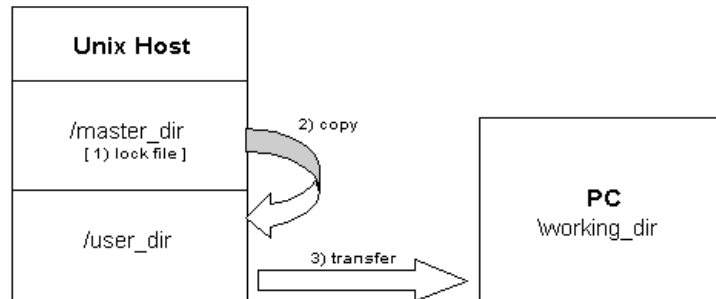
Check out files for Gentran Server for Unix in V6.0

You can check out a file to any directory on your client, but the default directory is the one specified in the Set Up Directories dialog box.

File checkout

When you want to access a master file to edit, you must check it out. When you check out a file to edit, the system locks the file so that other users cannot modify it while you have it checked out.

Other users with proper permissions still can view the master file or use it in a translation even while you are editing your working copy of the master file.

Note

Within the file directories, an asterisk precedes the name of any file that is currently checked out. This means it is locked. Even if you have Full Access, you can only open the file for viewing.

Checking in

Before any other user can edit a file that you have checked out, you must check the file in.

When you check in a file, Sterling Gentran:Server transfers a copy of the file from your client PC to the user directory on the Host. When the transfer is complete, Sterling Gentran:Server:

- copies the file from the Host user directory to the Host master directory
- removes the copy from the Host user directory.

Check in files for Gentran Server for Unix in V6.0

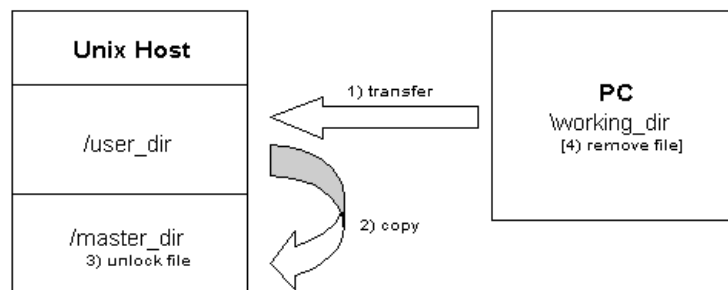

When you check in a file, Sterling Gentran:Server lets you choose to keep or remove the copy of the file on your PC.

Illustration This illustration shows how file access can be controlled under Sterling Gentran:Server.

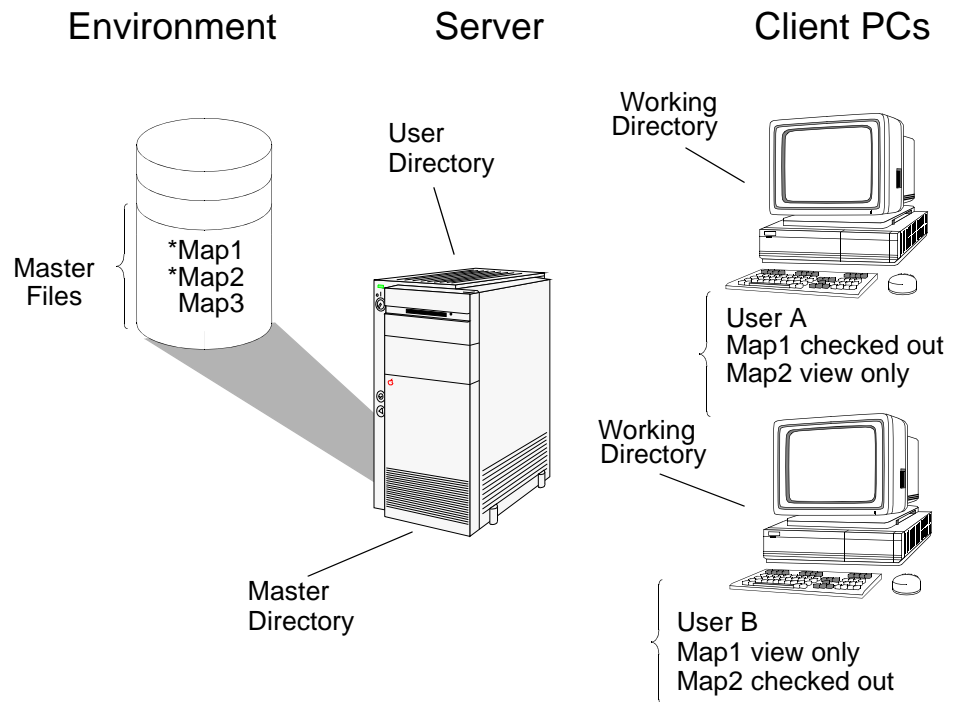

Dialog Boxes

Select Map and File Definitions Files to Check out Dialog Box

Introduction This topic describes the following dialog boxes:

- Select Map Files to Check out
- Select File Definition Files to Check out

Purpose The Select <filename> to Check out dialog box is used to move a copy of a file from the master directory to a working directory on the PC. Maps, and their associated TPL files, and file definitions files can be checked out.

Example check out dialog box

The same dialog box format is used to check out file definition files.

This illustration shows the Select Map Files to Check out dialog box.

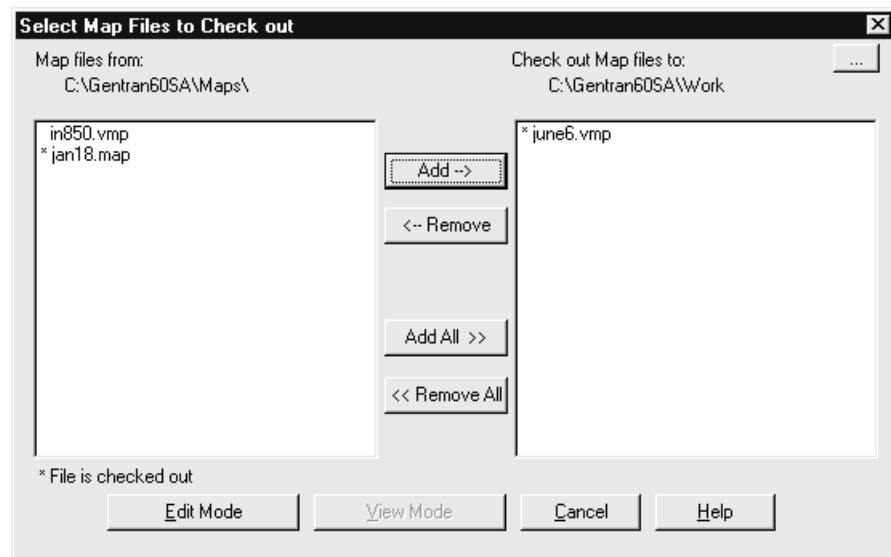

Fields and functions

This table lists the fields of the Select Map Files to Check Out and Select File Definition Files to Check out dialog box and their functions.

Field	Function
...files from	<p>Displays the name of the master directory.</p> <p>The list below the name displays the names of the files in the master directory. An asterisk next to a name indicates that the file is currently checked out.</p>
Check out <filename> files to	<p>Displays the name of the default working directory on your PC. This is the directory to which Sterling Gentran:Server copies the file.</p> <p>The list below the directory name displays the names of the working files in the working directory.</p> <p>Note You can use the browse button to select a different directory.</p>
Add	Adds the name of the selected file to the list of files in the working directory.
Remove	Removes the name of the file from the working directory check out list.
Add All	Adds the names of all the files in the master directory to the working directory.
Remove All	Removes the names of all the files from the working directory check out list.
Edit Mode	Checks out the files so that you can edit them. Copies the files that you added to the Check out <filename> files to list and moves the copies into the working directory.
View Mode	<p>Checks out the files so that you can view them. Copies the files that you added to the Check out <filename> files to list and moves the copies into the working directory.</p> <p>Note This button is not available in IBM® Sterling Gentran:Server® for UNIX - Workstation.</p>

Select Map Files to Check in Dialog Box

Introduction This topic describes the Select Map Files to Check in dialog box.

Purpose The Select Map Files to Check in dialog box is used to move the saved working file from your working directory to the master directory. The system replaces the master file with the map you check in. The following files can be checked in:

- map files
- associated TPL files

Example check in dialog box

This illustration shows the Select Map Files to Check in dialog box.

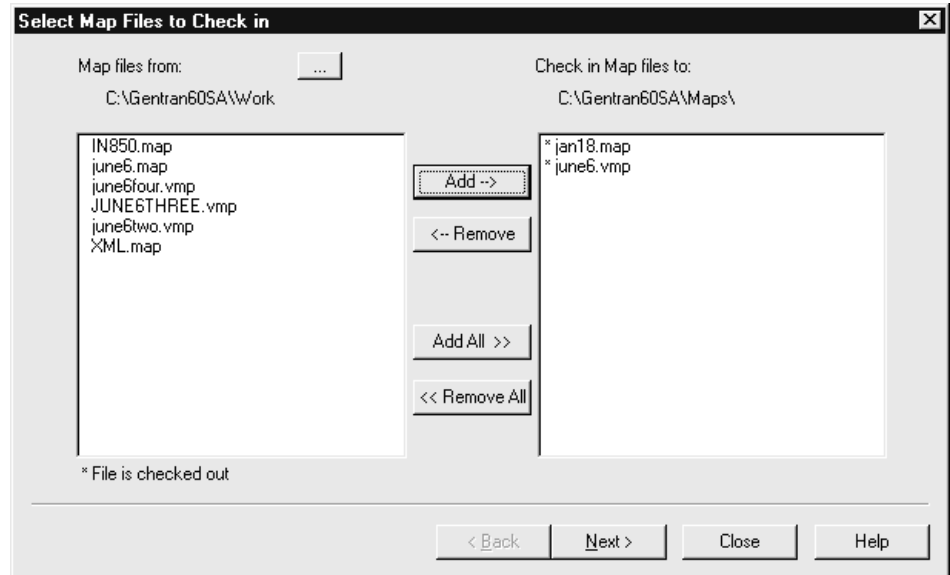

Fields and functions

This table lists the fields of the Select Map Files to Check in dialog box and their functions.

Field	Function
Map files from	<p>Displays the name of the working directory on your PC.</p> <p>The list below the name displays the names of the maps in the working directory.</p> <p>Note You can use the browse button to select a different directory.</p>
Check in Map files to	<p>Displays the name of the master directory for maps on your PC. This is the directory to which Sterling Gentran:Server copies the map file.</p> <p>The list below the directory name displays the names of the maps in the master directory.</p>
Add	Adds the name of the selected map to the list of maps in the master directory.
Remove	Removes the name of the map from the master directory check in list.
Add All	Adds the names of all the maps in the working directory to the master directory.
Remove All	Removes the names of all the maps from the master directory check in list.
Next	Flags the maps to be checked in and displays the Select TBL/TPL Files to Check In dialog box.

Select TBL/TPL Files to Check In Dialog Box

Introduction The Select TBL/TPL Files to Check In dialog box is used to select the translation objects (compiled maps) you want to check in.

Illustration This illustration shows the Select TBL/TPL Files to Check In dialog box.

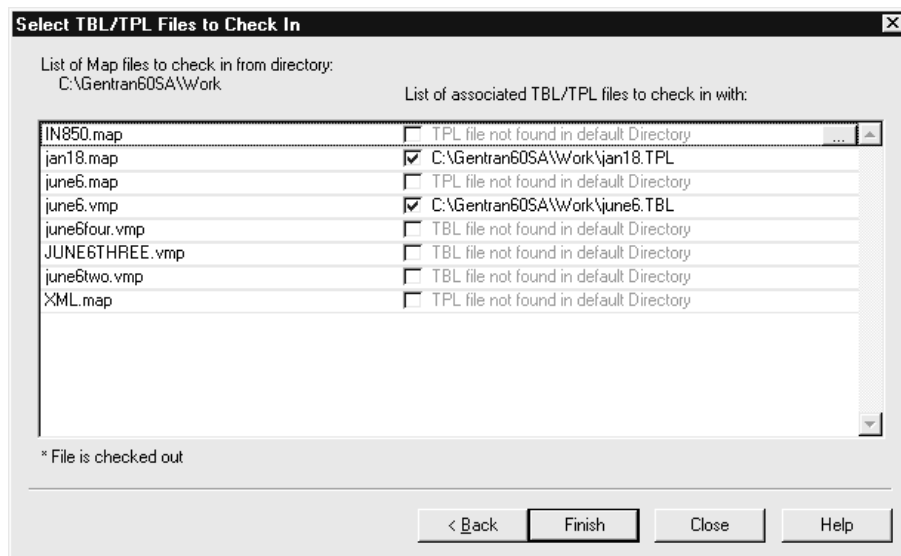

Fields and functions This table lists the fields of the Select TBL/TPL to Check In dialog box and their functions.

Field	Function
List of Map files to check in from directory	Displays the name of the working directory on your PC. The list below the name displays the names of the maps you are checking in.
List of associated TBL/TPL files to check in with	Displays the names of the translation objects associated with the maps you are checking in.
Finish	Saves your changes and checks in the maps and translation objects you selected.

Select File Definition to Check in Dialog Box

Introduction The Select File Definition Files to Check in dialog box is used to move a working copy of a file definition file (DDF) from your working directory to the master directory for file definitions.

Illustration This illustration shows the Select File Definition Files to Check in dialog box.

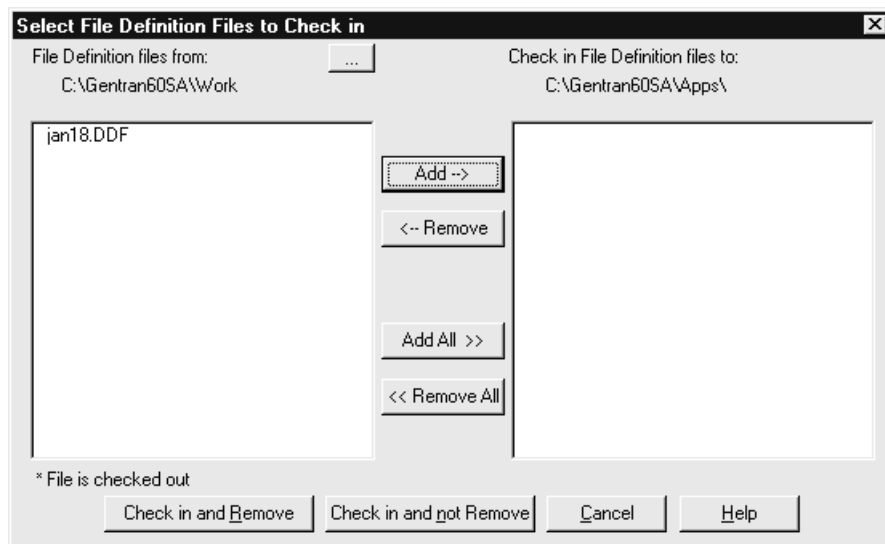

Fields and functions

This table lists the fields of the Select File Definitions to Check in dialog box and their functions.

Field	Function
File Definition files from	<p>Displays the name of the working directory.</p> <p>The list below the name displays the names of the file definition files in the working directory. An asterisk next to a name indicates that the file is currently checked out.</p> <p>Note You can use the browse button to select a different directory.</p>
Check in File Definition files to	<p>Displays the name of the master directory for file definition files. This is the directory to which Sterling Gentran:Server copies the file.</p> <p>The list below the directory name displays the names of the file definition files in the master directory.</p>
Add	Adds the name of the selected file definition file to the list of file definition files in the master directory.
Remove	Removes the name of the file definition file from the master directory check in list.
Add All	Adds the names of all the file definition files in the working directory to the master directory.
Remove All	Removes the names of all the file definition files from the master directory check in list.
Check in and Remove	Saves your changes, starts moving the file definition files, and deletes the working copies from the working directory.
Check in and not Remove	Saves your changes, starts moving the file definition files, and retains the working copies in the working directory.

Select Map and File Definition Files to Unlock Dialog Box

Introduction This topic describes the following dialog boxes:

- ▶ Select Map Files to Unlock
- ▶ Select File Definition Files to Unlock

Purpose The **unlock** dialog box is used to remove the lock from the master file when you do not want to save changes to a file in your working directory. The following files can be unlocked:

- ▶ map files
- ▶ file definitions files

Example unlock dialog box

The same dialog box format is used to unlock file definition files.

This illustration shows the Select Map Files to Unlock dialog box.

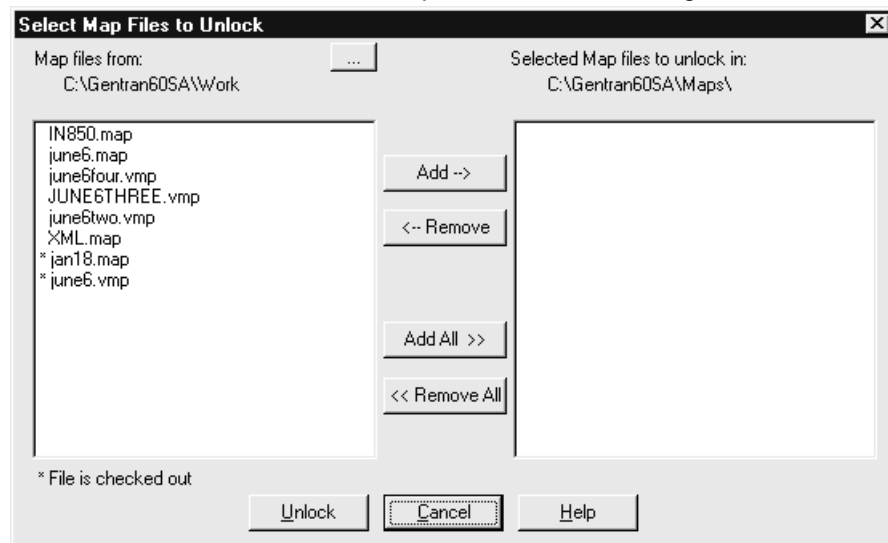

Fields and functions

This table lists the fields of the Select Map Files to Unlock dialog box and their functions.

Field	Function
...files from	<p>Displays the name of the working directory.</p> <p>The list below the name displays the names of the files in the working directory. An asterisk next to a name indicates that the file is currently checked out.</p> <p>Notes You can use the browse button to select a different directory.</p>
Selected <filename> files to unlock in	<p>Displays the name of the master directory for the files. This is the directory to which Sterling Gentran:Server copies the file.</p> <p>The list below the directory name displays the names of the files in the master directory.</p>
Add	Adds the name of the selected file to the list of files in the master directory.
Remove	Removes the name of the file from the master directory unlock list.
Add All	Adds the names of all the files in the working directory to the master directory.
Remove All	Removes the names of all the files from the master directory unlock list.
Unlock	Unlocks the file or files you have selected

Procedures

How to Check Out and View Maps and File Definitions

Introduction This topic explains how to check out a file.

What happens when you check out a file

When you check out a file, Sterling Gentran:Server transfers a copy of the file from the Host to the client PC working directory. If you have Full Access permission, Sterling Gentran:Server locks the file on the host so that other users cannot edit it. If you have View privileges, Sterling Gentran:Server does not lock the file.

You can check out a file to any directory. The default directory is the one specified in the Setup Directories dialog box.

If Sterling Gentran:Server locks the file when you check it out, other users cannot check it out to edit it. You must check in the file to release the lock so that another user can access it.

Checking out and viewing maps

Use this procedure to check out a map.

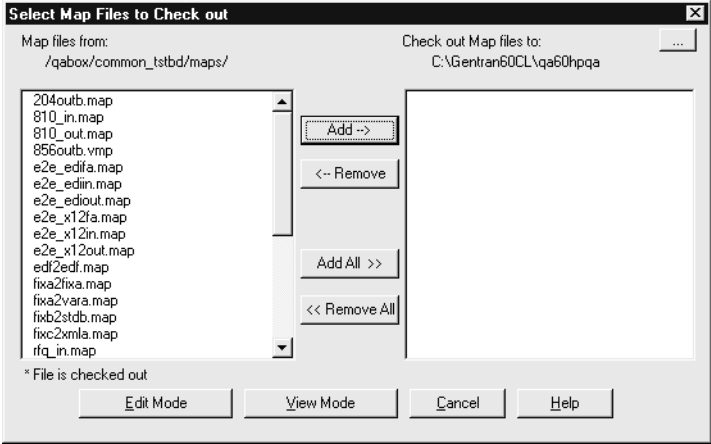
Step	Action						
1	Open the Sterling Gentran:Server Main window.						
2	<p>Select Check Out from the File menu and then click Map.</p> <p>System Response The system displays the Select Map Files to Check Out dialog box.</p>  <p>Note An asterisk preceding a file name means that the file is checked out. Even if you have Full access, you can only open the file for viewing.</p>						
3	<p>Use this table to determine your next step.</p> <table border="1" data-bbox="618 1346 1421 1675"> <thead> <tr> <th data-bbox="618 1346 1003 1402">IF you want to check out ...</th> <th data-bbox="1003 1346 1421 1402">THEN...</th> </tr> </thead> <tbody> <tr> <td data-bbox="618 1402 1003 1619">a map</td> <td data-bbox="1003 1402 1421 1619"> Select the map you want to check out from the list and click Add. Repeat this step for each additional map you want to check out. </td> </tr> <tr> <td data-bbox="618 1619 1003 1675">all the available maps</td> <td data-bbox="1003 1619 1421 1675">Click Add All.</td> </tr> </tbody> </table>	IF you want to check out ...	THEN...	a map	Select the map you want to check out from the list and click Add . Repeat this step for each additional map you want to check out.	all the available maps	Click Add All .
IF you want to check out ...	THEN...						
a map	Select the map you want to check out from the list and click Add . Repeat this step for each additional map you want to check out.						
all the available maps	Click Add All .						

(Contd) Step	Action
4	<p>Do you want to edit the files you are checking out?</p> <ul style="list-style-type: none"> ▶ If YES, click Edit Mode. (This locks the master files.) ▶ If NO, click View Mode. <p>System Response Sterling Gentran:Server displays the Checkout Files Status dialog box. This dialog box lists the files to be checked out and the status of the process.</p> 
5	<p>Do you want to print the information displayed on the Check-out Map File Status dialog box?</p> <ul style="list-style-type: none"> ▶ If YES, click Print. ▶ If NO, click Close.

Checking out a file definition

Use this procedure to check out a file definitionfile.

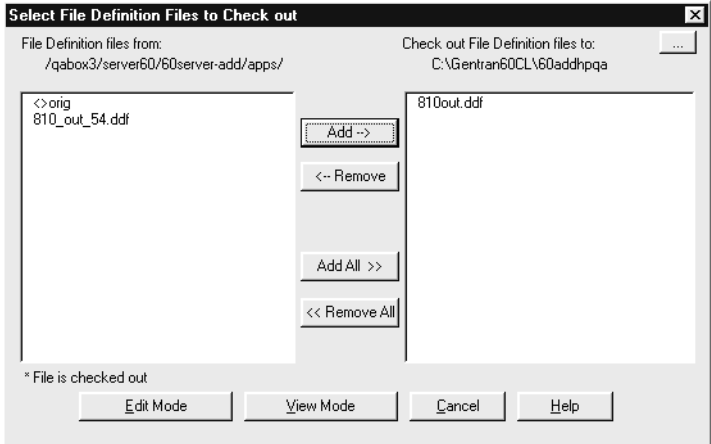
Step	Action						
1	Open the Sterling Gentran:Server Main window.						
2	<p>Select Check out from the File menu and then click File Definition.</p> <p>System Response The system displays the Select File Definition Files to Check out dialog box.</p>  <p>Note An asterisk preceding a file name means the file is checked out.</p>						
3	<p>Use the following table to determine your next step.</p> <table border="1"> <thead> <tr> <th>IF you want to check out...</th> <th>THEN...</th> </tr> </thead> <tbody> <tr> <td>a single file definition file</td> <td> <p>Select the file definition file you want to check out from the left pane, then click Add.</p> <p>Repeat this step for each additional file you want to check out.</p> </td> </tr> <tr> <td>all the available file definition files</td> <td>Click Add All.</td> </tr> </tbody> </table>	IF you want to check out...	THEN...	a single file definition file	<p>Select the file definition file you want to check out from the left pane, then click Add.</p> <p>Repeat this step for each additional file you want to check out.</p>	all the available file definition files	Click Add All .
IF you want to check out...	THEN...						
a single file definition file	<p>Select the file definition file you want to check out from the left pane, then click Add.</p> <p>Repeat this step for each additional file you want to check out.</p>						
all the available file definition files	Click Add All .						
4	<p>Do you want to edit the files you are checking out?</p> <ul style="list-style-type: none"> ▶ If YES, click Edit Mode to move a copy of the file to your working directory (This locks the master files). ▶ If NO, click View Mode. 						

How to Save Changes to Working Files

Introduction

If an Application Integration system map file is open, you can save changes on the PC:

- ▶ To the open file
- ▶ To the working copy of a map (but not to the original map)

Note

You can also save the map files by using a new file name.

Reference

To replace an original map with a working copy of the map that you have modified, see [How to Check In Maps and Translation Objects](#) in this chapter.

WARNING

For example, if you are creating a new map in the Application Integration system using the XXX.vmp as a guide, then save the new map using the file name XXY.map or XXXa.map.

Sterling Gentran:Server does not recognize map extensions. When you check in a working map to the master directory, it overwrites any existing map file that has the same file name, regardless of the extension.

Saving changes to an open file

Use this procedure to save changes to an open file.

Procedure

Click **Save** on the **File** menu.

System Response

Sterling Gentran:Server updates the file.

Saving to a new file name

Use this procedure to save an open working map file to a new file name in the working directory.

CAUTION

You cannot use this procedure to save a working map file to the master directory.

Step	Action
1	Click Save As on the File menu. System Response Sterling Gentran:Server displays the Save As dialog box.
2	Type the new file name for the copy of the map. Note You cannot save a map file to another directory, but you can save it under a new file name. Reference See How to Check In Maps and Translation Objects in this chapter to replace a master map file with a modified working copy.
3	Click OK . System Response Sterling Gentran:Server saves a copy of the map under the new name.

How to Unlock Master Files and Delete Working Copies

Introduction

If you do not want to save changes to a file in your working directory, you can use the Sterling Gentran:Server Unlock function to remove the lock from the master file and delete the working copy of the file. This procedure explains how to use the Unlock function.

CAUTION

When you unlock a master file, you lose all changes you made to the working file. Use this procedure only if you want to delete the working file.

Procedure

Use this procedure to unlock a master file and delete a working file.

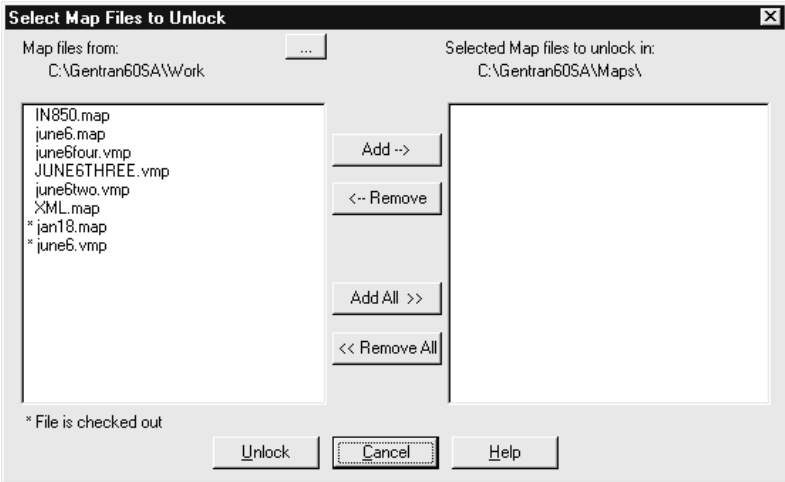
Step	Action
1	<p>Select Unlock from the File menu and click the type of file you want to unlock:</p> <ul style="list-style-type: none"> ▶ Map ▶ File Definition File <p>System Response Sterling Gentran:Server displays the Select <filename> Files to Unlock dialog box.</p> 

(Contd) Step	Action	
2	Use this table to determine your next step.	
	IF you want to unlock...	THEN...
	a single file	Select the file you want to remove from the list of available files in the left box and click Add . System Response Sterling Gentran:Server moves the selected file to the selected files to unlock list.
all the available files	Click Add All . System Response Sterling Gentran:Server moves all the files to the selected files to unlock list.	
3	Click Unlock . System Response Sterling Gentran:Server displays this dialog box. <div data-bbox="688 1083 1365 1257" style="border: 1px solid black; padding: 5px; margin: 10px auto; width: fit-content;"> <p style="margin: 0;">Warning ✕</p> <p style="margin: 0;">? You will lose all changes when you unlock files. Do you want to unlock files?</p> <p style="margin: 0; text-align: center;"> <input type="button" value="Yes"/> <input type="button" value="No"/> </p> </div>	

(Contd) Step	Action	
2	Use this table to determine your next step.	
	IF you want to unlock...	THEN...
	a single file	Select the file you want to remove from the list of available files in the left box and click Add . System Response Sterling Gentran:Server moves the selected file to the selected files to unlock list.
all the available files	Click Add All . System Response Sterling Gentran:Server moves all the files to the selected files to unlock list.	
3	Click Unlock . System Response Sterling Gentran:Server displays this dialog box. <div data-bbox="688 1083 1365 1255" style="border: 1px solid black; padding: 5px; margin: 10px auto; width: fit-content;"> <p style="margin: 0;">Warning ✕</p> <p style="margin: 0;">? You will lose all changes when you unlock files. Do you want to unlock files?</p> <p style="margin: 0; text-align: center;"> <input type="button" value="Yes"/> <input type="button" value="No"/> </p> </div>	

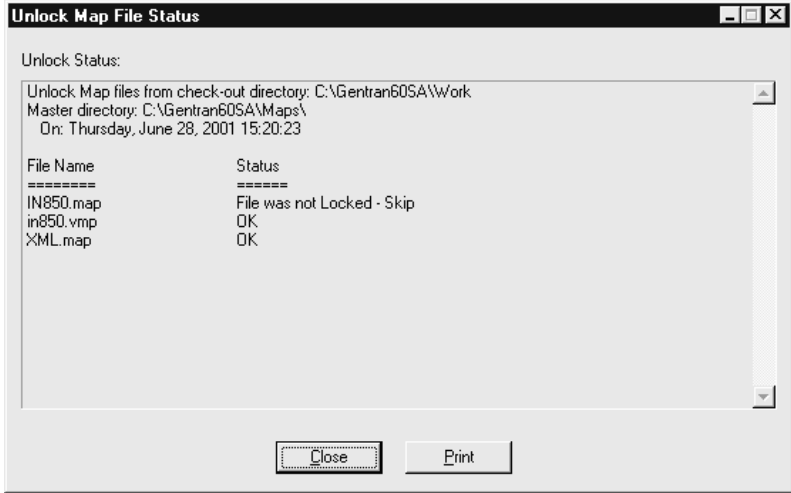
(Contd) Step	Action
4	<p>Do you want to continue?</p> <ul style="list-style-type: none"> ▶ If YES, click Yes. ▶ If NO, click No. <p>System Response If you clicked Yes, Sterling Gentran:Server displays the Unlock <filename> File Status dialog box.</p>  <p>The screenshot shows a dialog box titled "Unlock Map File Status". It contains the following text: "Unlock Status:", "Unlock Map files from check-out directory: C:\Gentran60SA\Work", "Master directory: C:\Gentran60SA\Maps\", and "On: Thursday, June 28, 2001 15:20:23". Below this is a table with two columns: "File Name" and "Status". The table lists three files: "IN850.map" with status "File was not Locked - Skip", "in850.vmp" with status "OK", and "XML.map" with status "OK". At the bottom of the dialog are two buttons: "Close" and "Print".</p>
5	<p>Do you want to print the status report?</p> <ul style="list-style-type: none"> ▶ If YES, click the Print. ▶ If NO, click Close.

How to Copy a Translation Object to the Host User Directory

Introduction

After you compile a new map to create translation object, you can copy the translation object to the Host user directory for testing with the translator.

Copying a translation object to the host user directory

Use this procedure to copy a translation object to the Host user directory.

Step	Action
1	Open the Sterling Gentran:Server Main Window.
2	Select Copy .TBL/.TPL file to User Directory... System Response Sterling Gentran:Server displays a dialog box for you to select the file you want to copy.
3	Select the translation object (TPL file) and click Open . System Response Sterling Gentran:Server copies the file to the User Directory on the Host.

How to Check In Maps and Translation Objects

Introduction This topic explains how to check in maps and the translation objects (TPL files) associated with them.

What happens when you check in a file When you check in a file, Sterling Gentran:Server transfers a copy of the file from the working directory on your PC to the user directory on the Host. You can choose whether to keep or remove the copy of the file that is on your PC.

After the file has been transferred, Sterling Gentran:Server:

- copies the file from the user directory to the master directory
- removes the copy from the user directory
- unlocks the master file so that others can access it

Maps The procedure for checking in maps differs from that for checking in other files, because you can check in multiple maps at the same time.

You can check in a compiled working map or an uncompiled working map.

- If you compile a working map before you check it in, the Check In function moves the compiled map to the master directory.
- If you move an uncompiled working map, you must compile it in the master directory; otherwise, the translator will not recognize the changes.

Checking in maps and translation objects

Use this procedure to replace a map in the master directory with a modified working map.

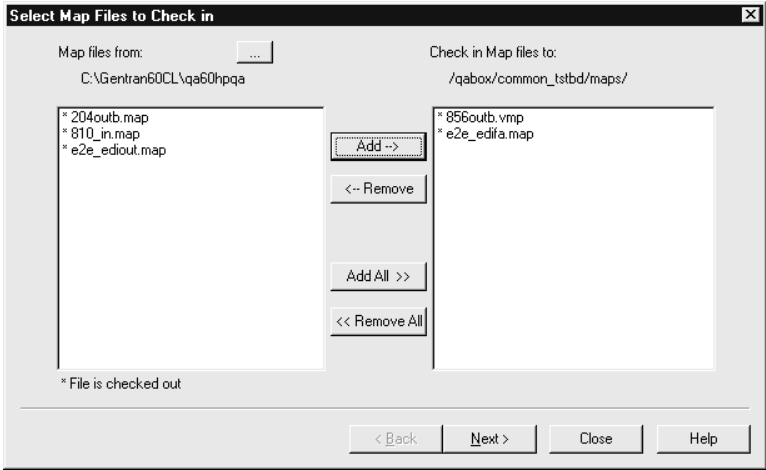
Step	Action
1	<p>Click Check In from the Main File menu and select Map as the type of file to check in.</p> <p>System Response The system displays the Select Map Files to Check in dialog box.</p>  <p>Note The list on the left shows only the maps that are in your working directory.</p> <p>WARNING For example, if you are creating a new map in the Application Integration system using the XXX.vmp as a guide, then save the new map using the file name XXY.map or XXXa.map. Sterling Gentran:Server does not recognize map extensions. When you check in a working map to the master directory, it overwrites any existing map file that has the same file name, regardless of the extension.</p>

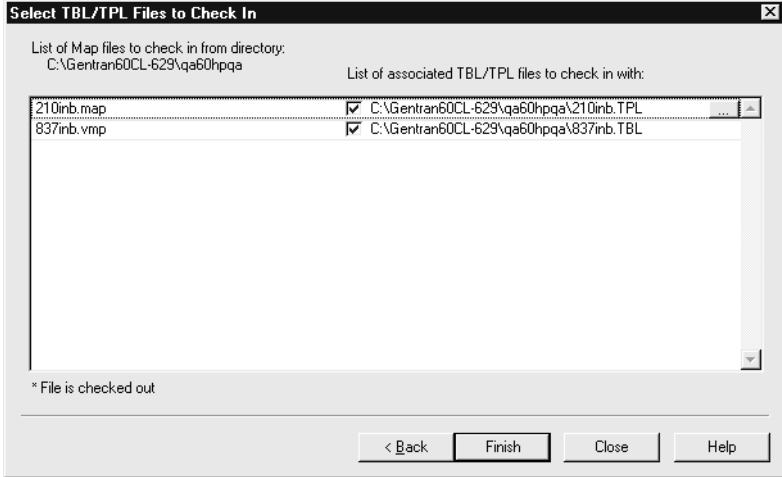
(Contd) Step	Action	
2	Use this table to determine your next step.	
	IF you want to...	THEN...
	Check in a map	Select the map you want to check in from the list and click Add . Repeat this step for each additional map you want to check in.
	Check in all the available maps	Click Add All .
3	<p>Click Next.</p> <p>System Response Sterling Gentran:Server displays the Select TBL/TPL Files to Check In dialog box.</p> 	
4	<p>Do you want to check in the translation objects (compiled maps) associated with the maps you selected?</p> <ul style="list-style-type: none"> ▶ If YES, select the check box next to the name of the translation object. ▶ If NO, clear the check box from the translation objects that you do not want to check in. 	

(Contd) Step	Action
5	Click Finish . System Response The system moves the selected files from the working directory on the client to the user directory on the Host. After the files have been transferred successfully, the system moves them from the user directory to the master directory and unlocks the master files.

How to Check In File Definitions

Introduction

When you are satisfied with a file definition file, you **check in** the working file. When you check in a working file, the system copies the file from the working directory to the master directory, replacing the original file. The working file becomes the new file definition. You can choose to leave a copy of the file in the working directory or remove it.

Checking in a file definition

Use this procedure to check in a file definition file.

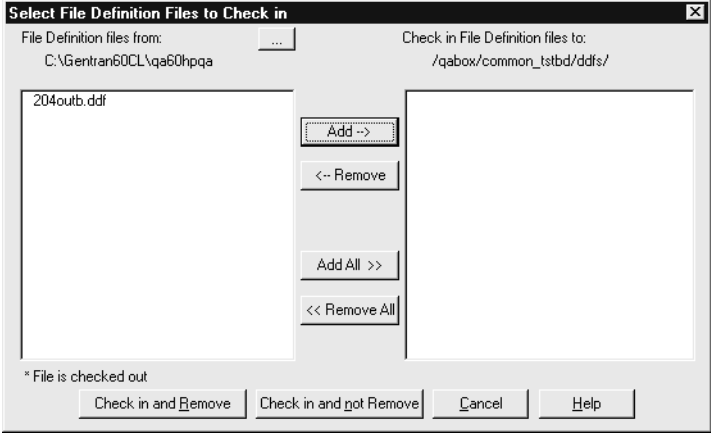
Step	Action
1	<p>Select Check In from the Sterling Gentran:Server Main File menu and click either File Definition File</p> <p>System Response Sterling Gentran:Server displays the Select File Definition File <filename> to Check in dialog box.</p> 

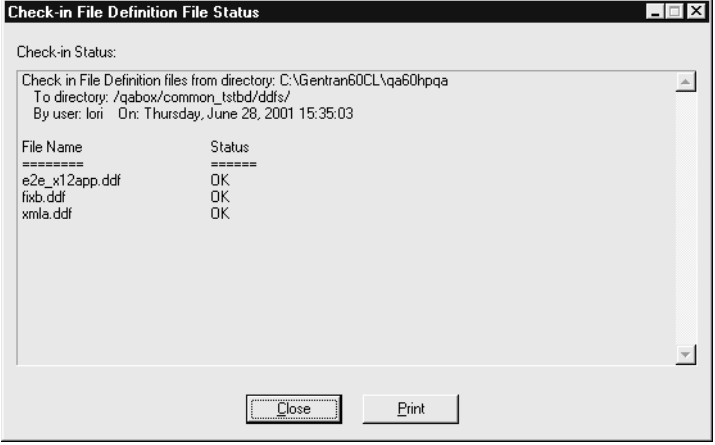
(Contd) Step	Action	
2	Use this table to determine your next step.	
	IF you want to check in...	THEN...
	a single file definition file	Select the file definition file you want to check in from the list in the left pane and click Add . Repeat this step for each additional file you want to check in.
all the available file definition files	Click Add All .	
3	Use this table to determine your next step.	
	IF you want to...	THEN click...
	Remove the working files from the working directory after they are checked in	Check in and Remove
Leave the working files in the working directory after they are checked in	Check in and not Remove	
<p>System Response Sterling Gentran:Server displays the Check-in File Definition File Status dialog box.</p> 		

(Contd) Step	Action
4	Do you want to print the information displayed in the Check-in File Definition File Status report? <ul style="list-style-type: none"><li data-bbox="630 464 899 495">▶ If YES, click Print.<li data-bbox="630 506 899 537">▶ If NO, click Close.

Installing Sterling Gentran:Server Extension

These instructions explain how to install IBM® Sterling Gentran:Server® Extension for SAP R/3 onto your Sterling Gentran:Server computer.

Verifying System Requirements

Operating systems

This table lists the operating systems required on the supported Sterling Gentran:Server platforms.

Hardware Platform	Operating System and Version
HP 9000	HP-UX 11.31
IBM RS6000	A minimum or AIX 5.3
SUN	Solaris 10

Patches

Hewlett-Packard provides service patches to their operating system. For the most recent information, check the Hewlett-Packard Web Site, or contact your Hewlett-Packard representative.

**Pre-installation
checklist**

The following pre-installation checklist details items you need to install the extension software. Verify that you have met the requirements and check each box as you complete each item.

Checkbox	Pre-Installation Checklist
	Verify that IBM® Sterling Gentran:Server® for UNIX version 6.2 is installed on this UNIX system.
	Identify the name of the directory containing the Sterling Gentran:Server software.
	Verify that you have the correct media containing the extension software.
	Identify the device name of the drive you are using to install the media.
	Verify that SAP system R/3 is installed.
	Verify that the SAP-supplied Remote Call Function (RFC) programs rfcexec and startRFC are located on your UNIX system. These are included on the SAP distribution CD RFCSDK.
	Verify that SAP TCP/IP services entries are defined in the <code>/etc/services</code> file on your UNIX system.

How to Upgrade from Prior Versions

Introduction If you are upgrading from version 5.2.1, 5.3, or 5.4 to version 6.2 of Sterling Gentran:Server, and Sterling Gentran:Server Extension, complete this procedure.

Procedure Use this procedure to upgrade to version 6.2.

Step	Action
1	Back up your 5.2.1, 5.3, or 5.4 software and data.
2	If you have not already done so, install IBM® Sterling Gentran:Server® for UNIX 6.2.
3	Install the 6.2 SAP Configuration client software
4	Load the 6.2 SAP host installation files.
5	If you have not already done so, convert your data from your current version to version 6.2. Reference See the <i>IBM® Sterling Gentran:Server® for UNIX Upgrade and Data Conversion Guide</i> for instructions.
6	Copy the mysql tables from your current installation to your 6.2 installation as follows: <ul style="list-style-type: none"> ▶ Go to the SAP Extension installation directory. ▶ Run this command: cp_mysql.sh
7	At this prompt, "Is this the correct setting for OLD_EDI_ROOT," type n .
8	At this prompt, "Enter the value for OLD_EDI_ROOT (Server 5.x)," type the EDI_ROOT value for the 5.2.1/5.3/5.4 installation.
9	At this prompt, "Is this the correct setting for NEW_EDI_ROOT (Server 6.2)," type y to confirm the value or n to specify a new value.

How to Install the Configuration Client

Introduction The SAP Configuration client is used to define and maintain the routing information between Sterling Gentran:Server and the SAP system.

Before you begin Before you begin loading the SAP Configuration client software, ensure that Sterling Gentran:Server is installed onto the host and client computers.

Procedure Use this procedure to install the SAP Configuration client onto your Sterling Gentran:Server client computer.

Step	Action
1	Insert the Sterling Gentran:Server Extension CD into the CD-ROM drive on the client computer.
2	<p>Select Run from the Start menu. In the Run dialog box, enter the following command where "e" represents the letter assigned to the CD-ROM drive, then click OK:</p> <p>e:\Client\setup</p> <p>System Response Setup displays the Welcome dialog box.</p>
3	<p>Click Next to continue.</p> <p>System Response Setup displays the Choose Destination Location dialog box.</p>
4	<p>Does IBM® Sterling Gentran:Server® for UNIX 6.2 exist in the destination folder listed?</p> <ul style="list-style-type: none"> ▶ If YES, click Next to accept the destination folder for your SAP Extension. ▶ If NO, browse to the folder that contains IBM® Sterling Gentran:Server® for UNIX 6.2 <p>Note You must install the SAP client software into the folder that has your Sterling Gentran:Server client software.</p> <p>System Response Setup displays the Sterling Gentran:Server Extension Setup dialog box, which displays the current settings for installation.</p>

(Contd) Step	Action
5	Click Next to accept the installation settings. System Response Setup displays the SAP Client Installation dialog box.
6	Click Continue to install the client software. System Response Setup installs the software and then displays the SAP Client Installation Complete dialog box.
7	Do you want to restart your computer now? <ul style="list-style-type: none">▶ If YES, select the Yes, I want to restart my computer now option. Recommendation You should restart your computer. <ul style="list-style-type: none">▶ If NO, select the No, I will restart my computer later option.
8	Click Finish to complete the installation of the SAP Configuration client.

How to Load the SAP Extension Host Installation Files

Introduction

During installation you must run a transfer program to copy compressed software files from a compact disc into the proper directories on the UNIX host computer. This topic explains how to use the transfer program to read the installation files from a compact disc in a Windows client computer into the temporary directory on the UNIX host.

Before you begin

Before you begin loading the SAP 6.2 extension installation files onto the UNIX host computer, you must have created a UNIX login to install and own the Sterling Gentran:Server installation.

Copying installation files from the compact disc

Use this procedure to copy the installation files to the UNIX host from a CD-ROM drive on a Windows client computer.

Comment

The connection between the Windows client and the UNIX host must support TCP/IP.

The Windows client computer must be able to connect to the UNIX host.

Step	Action
1	Insert the Sterling Gentran:Server Extension installation CD into a CD-ROM drive in a Windows client that is connected to the UNIX host.
2	From the Start menu, point to Programs and select MS-DOS Prompt . System Response Windows opens an MS-DOS Prompt window.
3	In the MS-DOS window, change directories to the CD-ROM drive on the Windows computer.
4	In the MS-DOS window, change directories to the host operating system platform. Example: cd Host\HP cd Host\IBM cd Host\SUN

(Contd) Step	Action
5	<p>Enter the following command to copy the SAP extension installation files to the host.</p> <pre>ftpprod <host> <path> <user> <password></pre> <p>Where</p> <ul style="list-style-type: none">▶ <host> is the system name for the UNIX host▶ <path> is the path on the UNIX host to temporarily transfer the installation files to <p>Note This path will be created for you, if permissions allow.</p> <ul style="list-style-type: none">▶ <user> is the user login for the EDI user you created▶ <password> is the user password for the EDI user <p>System Response The ftpprod script displays messages about the transfer process. When the process is complete, the script displays “Files transferred.”</p>
6	Close the DOS window.
7	Continue with the next topic, How to Install the SAP Extension onto the Host .

How to Install the SAP Extension onto the Host

Introduction To install the SAP extension, you run the `sh ./sapsetup.sh` script to install the software into the appropriate directories on the UNIX host.

Before you begin You must first install the core Sterling Gentran:Server software before you can install the SAP extension.

Installing on the UNIX host computer Use this procedure to install the SAP extension onto the UNIX host computer.

Step	Action
1	On the UNIX host computer, make sure the copied SAP Installation files are in the temporary directory you specified earlier.
2	<p>Change directories to the temporary directory from the previous procedure and enter the following command to unpack the installation files and start the installation process.</p> <pre>sh ./sapsetup.sh</pre> <p>System Response The installation program displays status messages about the ongoing process of the installation. The installation program will give you a message that the process completed successfully.</p> <p>Note The installation program may prompt you to enter values for environmental variables that are not set up. When prompted, type in the missing value and press Enter. Confirm the value you entered by typing y. If you want to specify another value, type n. Press Enter again. The installation program continues.</p>

How to Convert Version 5.x Flows to the 6.2 Format

Introduction

When you install the SAP extension software, modifications are made to the flowmgr.exe, which gives you the *option* of opening your existing 5.x flows and saving them in the 6.2 format. This topic explains how to convert your existing 5.x flows to the 6.2 format.

Why convert 5.x flows

Converting 5.x flows to the 6.2 format enables you to use the new functionality for flows in IBM® Sterling Gentran:Server® for UNIX version 6.2. Also, in converting the 5.x flows, you are ensured that the flows contain core product script changes.

NOTE

Converting 5.x flows to the 6.2 format is an option. These flows will continue to work as is in Sterling Gentran:Server if you decide not to convert.

When to convert a 5.x flow

Convert an existing 5.x flow to the 6.2 format the first time you open it in the Process Control Manager.

Procedure

Use the following procedure to convert existing 5.x flow to the 6.2 formats.

Step	Action
1	<p>Edit the flow in the Process Control Manager.</p> <p>System Response The system displays the prompt: “You have chosen to edit a flow from previous version. Do you want to convert the flow to the current version? If you click Yes, existing scripts are converted to the current version using default values for the new option. If you click No, existing scripts remain unchanged.”</p>

Step	Action
2	<p>Do you want to convert the flow to the current version?</p> <ul style="list-style-type: none"> ▶ If YES, click Yes and continue with next step. <p>System Response Sterling Gentran:Server reads the existing 5.x fields and populates the 6.2 specific fields with default values.</p> <p>Sterling Gentran:Server displays the Flow Edit dialog box.</p> <ul style="list-style-type: none"> ▶ If NO, click No and continue with Step 5. <p>System Response Sterling Gentran:Server displays the Flow Edit dialog box.</p>
3	<p>Do you want to modify the default values for the new fields?</p> <ul style="list-style-type: none"> ▶ If YES, select the tab that contains the field you want to modify and then modify the field; continue with the next step. ▶ If NO, GO TO Step 6.
4	<p>Do you want to modify another field under a different tab?</p> <ul style="list-style-type: none"> ▶ If YES, return to Step 3. ▶ If NO, GO TO Step 6.
5	<p>Do you want to view the 5.x flow values?</p> <ul style="list-style-type: none"> ▶ If YES, click each tab you want to view and then GO TO Step 7. ▶ If NO, GO TO Step 7.
6	Click OK to save your changes.
7	Click Cancel to close the Flow Edit dialog box.



Upgrading from a previous version of SAP Extension

sapcnvrt. The script `sapcnvrt.sh` can be used to migrate data configuration files from previous versions of the Sterling Gentran:Server SAP Extension. The script requires the installation directories location of the current and previous versions of the Sterling Gentran:Server for Unix, and a path to the previous versions ODBC ini file. There is an optional parameter to indicate if duplicate records can be overwritten. This script should be run from the `$EDI_ROOT` directory of the new Sterling Gentran:Server for Unix installation. As a result of running the script, the `sap_intp`, `sap_outtp`, and `sap_route` ISAM files will be populated with the records from the previous Sterling Gentran:Server SAP Extension corresponding tables.

Command Usage

Usage:

```
sapcnvrt.sh <old_install_dir> <old_odbcini> <new_install_dir> [-o|-no]
```

Where,

- `old_install_dir` is the path to old environment's root install directory (e.g. `/old/edi/root`)
 - `old_odbc_ini` is the path to old environment's ODBC ini file (e.g. `/old/edi/root/odbc/odbc.ini`)
 - `new_install_dir` is the path to new environment's root install directory (e.g. `/new/edi/root`)
 - `-o` overwrites duplicate records
 - `-no` do NOT overwrite duplicate records (default)
-

Note: The database in the source SAP Extension must be started prior to running `sapcnvrt`. Otherwise, the program will not be able to export from the database.

NOTES

Glossary

Adobe Reader	An Adobe program designed to read and display Portable Document Format (PDF) documents. Older versions were known as Acrobat Reader.
application	The business software generating the business information that you are sending or receiving electronically.
check in	The act of returning a copy of a file from your working directory to the master directory, making it available to other users.
check out	The act of copying a file from the master directory to your working directory, making the file unavailable to other users.
client	The computer in a client/server network that acts as the interface between the user and the server.
client/server	A computer network architecture in which data is stored and processing is performed on the server, which users access through the interface provided on the client.
default	A value that is automatically assigned.
DNS	Domain Name Services.

EDI Electronic Data Interchange.

Application-to-application transfer of key business transaction information in a standard or XML format via a computer-to-computer communication link.

EDI standard A format to regulate syntax, structure, and content of transaction data.

GENCOD The GENCOD standard was developed by the French National Numbering Organization GENCOD-EAN France. The GENCOD standard is used mainly in France within the retail market by some major retailers and manufacturers.

HIPAA Health Insurance Portability and Accounting Act.

lock The act of making a file unavailable to other users. A file is locked once it is checked out.

map A file that contains the relationships between:

- ▶ The segments and elements of a standard EDI document and the data fields in your application,
- ▶ The elements in an XML document and the data fields in your application, EDI standard document, or in another XML document,
- ▶ The segments and elements of two different standards, or
- ▶ The records and fields of two different applications.

master directory The directory on a PC or on a server that stores your master files.

master file The version of a file that Sterling Gentran:Server uses to process data.

MDAC Microsoft Data Access Components.

NCPDP	National Council of Prescription Drug Programs.
PCM	Process Control Manager.
server	The computer in a client/server network that performs the major system security, data storage, and computing tasks.
standard format	A format intelligible to computerized data management systems.
temporary file	A file on the client that Sterling Gentran:Server uses during editing and compiling.
trading partner	The company, division, or group with which you are exchanging business data electronically.
Trading Partnership	An arrangement to exchange information in a specific document type with a specific trading partner and using a particular standard version.
unlock	The act of making a file available to other users. A file is unlocked once it is checked in.
user directory	The directory on the server that temporarily holds the files being transferred from a client working directory to the master directory on the server.
VAN	Value Added Network.
VDA	Verband der Deutschen Automobilindustrie. A German group responsible for a range of different standards in the automobile industry.

working file directory

The directory created on the client to hold the files that a user is editing.

XML

Extensible Markup Language. Describes a class of data objects called XML documents, and partially describes the behavior or computer programs which process them.

Notices

This information was developed for products and services offered in the U.S.A.

IBM may not offer the products, services, or features discussed in this document in other countries. Consult your local IBM representative for information on the products and services currently available in your area. Any reference to an IBM product, program, or service is not intended to state or imply that only that IBM product, program, or service may be used. Any functionally equivalent product, program, or service that does not infringe any IBM intellectual property right may be used instead. However, it is the user's responsibility to evaluate and verify the operation of any non-IBM product, program, or service.

IBM may have patents or pending patent applications covering subject matter described in this document. The furnishing of this document does not grant you any license to these patents. You can send license inquiries, in writing, to:

IBM Director of Licensing

IBM Corporation

North Castle Drive

Armonk, NY 10504-1785

U.S.A.

For license inquiries regarding double-byte character set (DBCS) information, contact the IBM Intellectual Property Department in your country or send inquiries, in writing, to:

Intellectual Property Licensing

Legal and Intellectual Property Law

IBM Japan Ltd.

1623-14, Shimotsuruma, Yamato-shi

Kanagawa 242-8502 Japan

The following paragraph does not apply to the United Kingdom or any other country where such provisions are inconsistent with local law:

INTERNATIONAL BUSINESS MACHINES CORPORATION PROVIDES THIS PUBLICATION "AS IS" WITHOUT WARRANTY OF ANY KIND, EITHER EXPRESS OR IMPLIED, INCLUDING, BUT NOT LIMITED TO, THE IMPLIED WARRANTIES OF NON-INFRINGEMENT, MERCHANTABILITY OR FITNESS FOR A PARTICULAR PURPOSE. Some states do not allow disclaimer of express or implied warranties in certain transactions, therefore, this statement may not apply to you.

This information could include technical inaccuracies or typographical errors. Changes are periodically made to the information herein; these changes will be incorporated in new editions of the publication. IBM may make improvements and/or changes in the product(s) and/or the program(s) described in this publication at any time without notice.

Any references in this information to non-IBM Web sites are provided for convenience only and do not in any manner serve as an endorsement of those Web sites. The materials at those Web sites are not part of the materials for this IBM product and use of those Web sites is at your own risk.

IBM may use or distribute any of the information you supply in any way it believes appropriate without incurring any obligation to you.

Licensees of this program who wish to have information about it for the purpose of enabling: (i) the exchange of information between independently created programs and other programs (including this one) and (ii) the mutual use of the information which has been exchanged, should contact:

IBM Corporation

J46A/G4

555 Bailey Avenue

San Jose, CA__95141-1003

U.S.A.

Such information may be available, subject to appropriate terms and conditions, including in some cases, payment of a fee.

The licensed program described in this document and all licensed material available for it are provided by IBM under terms of the IBM Customer Agreement, IBM International Program License Agreement or any equivalent agreement between us.

Any performance data contained herein was determined in a controlled environment. Therefore, the results obtained in other operating environments may

vary significantly. Some measurements may have been made on development-level systems and there is no guarantee that these measurements will be the same on generally available systems. Furthermore, some measurements may have been estimated through extrapolation. Actual results may vary. Users of this document should verify the applicable data for their specific environment.

Information concerning non-IBM products was obtained from the suppliers of those products, their published announcements or other publicly available sources. IBM has not tested those products and cannot confirm the accuracy of performance, compatibility or any other claims related to non-IBM products. Questions on the capabilities of non-IBM products should be addressed to the suppliers of those products.

All statements regarding IBM's future direction or intent are subject to change or withdrawal without notice, and represent goals and objectives only.

This information is for planning purposes only. The information herein is subject to change before the products described become available. This information contains examples of data and reports used in daily business operations. To illustrate them as completely as possible, the examples include the names of individuals, companies, brands, and products. All of these names are fictitious and any similarity to the names and addresses used by an actual business enterprise is entirely coincidental.

COPYRIGHT LICENSE:

This information contains sample application programs in source language, which illustrate programming techniques on various operating platforms. You may copy, modify, and distribute these sample programs in any form without payment to IBM, for the purposes of developing, using, marketing or distributing application programs conforming to the application programming interface for the operating platform for which the sample programs are written. These examples have not been thoroughly tested under all conditions. IBM, therefore, cannot guarantee or imply reliability, serviceability, or function of these programs. The sample programs are provided "AS IS", without warranty of any kind. IBM shall not be liable for any damages arising out of your use of the sample programs.

Each copy or any portion of these sample programs or any derivative work, must include a copyright notice as follows:

© IBM 2016. Portions of this code are derived from IBM Corp. Sample Programs.

© Copyright IBM Corp. 2016.

If you are viewing this information softcopy, the photographs and color illustrations may not appear.

Trademarks

IBM, the IBM logo, and ibm.com are trademarks or registered trademarks of International Business Machines Corp., registered in many jurisdictions

worldwide. Other product and service names might be trademarks of IBM or other companies. A current list of IBM trademarks is available on the Web at "[Copyright and trademark information](http://www.ibm.com/legal/copytrade.shtml)" at www.ibm.com/legal/copytrade.shtml.

Adobe, the Adobe logo, PostScript, and the PostScript logo are either registered trademarks or trademarks of Adobe Systems Incorporated in the United States, and/or other countries.

IT Infrastructure Library is a registered trademark of the Central Computer and Telecommunications Agency which is now part of the Office of Government Commerce.

Intel, Intel logo, Intel Inside, Intel Inside logo, Intel Centrino, Intel Centrino logo, Celeron, Intel Xeon, Intel SpeedStep, Itanium, and Pentium are trademarks or registered trademarks of Intel Corporation or its subsidiaries in the United States and other countries.

Linux is a registered trademark of Linus Torvalds in the United States, other countries, or both.

Microsoft, Windows, Windows NT, and the Windows logo are trademarks of Microsoft Corporation in the United States, other countries, or both.

ITIL is a registered trademark, and a registered community trademark of the Office of Government Commerce, and is registered in the U.S. Patent and Trademark Office.

UNIX is a registered trademark of The Open Group in the United States and other countries.

Java and all Java-based trademarks and logos are trademarks or registered trademarks of Oracle and/or its affiliates.

Cell Broadband Engine is a trademark of Sony Computer Entertainment, Inc. in the United States, other countries, or both and is used under license therefrom.

Linear Tape-Open, LTO, the LTO Logo, Ultrium and the Ultrium Logo are trademarks of HP, IBM Corp. and Quantum in the U.S. and other countries.

Connect Control Center®, Connect:Direct®, Connect:Enterprise, Gentran®, Gentran:Basic®, Gentran:Control®, Gentran:Director®, Gentran:Plus®, Gentran:Realtime®, Gentran:Server®, Gentran:Viewpoint®, Sterling Commerce™, Sterling Information Broker®, and Sterling Integrator® are trademarks or registered trademarks of Sterling Commerce, Inc., an IBM Company.

Other company, product, and service names may be trademarks or service marks of others.

Index

A

access
 rights 6-3
 type of 6-3
 admin 1-31
 Asynchronous communications
 setting up 3-26
 at privileges 1-6, 1-8

B

bisynchronous communications
 setting up 3-12
 broker 1-31

C

check in
 in UNIX 6-27
 checking in
 file definitions 6-31
 in UNIX 6-5
 maps 6-27
 translation objects 6-27
 checking out 6-16
 file definitions 6-16
 file in UNIX 6-16
 maps 6-16
 TBL/TPL files 6-7
 Cleo 3780Plus
 Communications Toolkit 3-3
 troubleshooting 3-26
 Cleo A+
 Communications Toolkit 3-3
 client 2-4
 client descriptions A-1
 client installation
 installation 2-4
 Communications Toolkit
 Cleo 3780Plus 3-3
 Cleo 3780Plus troubleshooting 3-26
 Cleo A+ 3-3
 Comm subdirectory structure 3-5
 communicating with VANs 3-2
 connecting to VANs and directly to trading
 partners 3-27
 overview 3-2

 parts and functions 3-3
 setting up asynchronous communications 3-26
 compiled map 6-26
 configuration file
 van 3-10
 Connecting to Miscellaneous VANs and Directly to
 Trading Partners 3-27
 copying
 translation object 6-26
 cron privileges 1-6, 1-8

D

db 1-31
 deleting
 working copies 6-22

E

EDI administrative user 1-5
 EDI user 1-7
 editing a file 5-21
 editor functions 1-46
 environment 1-7
 Environment Administration screen
 example of completed 1-38
 environment record
 adding 1-35
 displaying 1-32

F

File Browser 5-18, 5-20, 5-21
 caution for using 4-13
 exiting 5-22
 opening a file 5-20
 saving a file 5-22
 starting 5-20
 when to use 5-18
 file checkout
 in UNIX 6-4
 file definition
 checking in 6-31
 checking out 6-16
 unlocking 6-22
 viewing 6-19
 function access
 levels 1-46

H

host computer 4-7
 host nam 2-18
 hosts file 2-18

I

implementation guide
 viewing 6-19
 installation
 checklist 1-4, 1-22
 Installation Checklist 1-4
 IP address 2-18
 ISAM files
 editing caution 4-13

L

log in screen 1-32

M

Main Window buttons 5-14
 map
 checking out 6-16
 unlocking 6-22
 viewing 6-17
 master file
 unlocking 6-22
 master files
 in UNIX 6-3
 Microcom Network Protocol 3-10
 modifying
 VAN configuration files 3-10

N

NAMEBROKER 2-18
 networking requirements *TOC-xii*

O

On-line Help
 using 5-16

P

password
 security administrator 1-33
 what to do if forgotten 1-33
 pre-installation checklist, *B-2*
 program functions 1-46

R

requirements
 networking *TOC-xii*
 root 1-7, 1-14, 1-22, 1-27

S

saving a file 5-22
 file definition 6-20
 maps 6-20
 Security Administration
 exiting 1-34
 starting 1-32
 Select File Definition Files to Check in dialog box 6-12
 Select File Definition Files to Unlock dialog box 6-14
 Select Map Files to Check in dialog box 6-9
 Select Map Files to Check out dialog box 6-7
 Select Map Files to Unlock dialog box 6-14
 Select TBL/TPL Files to Check In dialog box 6-11
 setting up
 bisynchronous communications 3-12
 Status Bar
 using 5-15
 system requirements,
 verifying, *B-1*

T

TBL/TPL
 checking out 6-7
 temp 1-31
 Toolbar 5-14
 using 5-15
 translation object
 checking in 6-27
 copying to host user directory 6-26

U

UNIX
 check in 6-27
 checking in 6-5
 file check out 6-4
 master files 6-3
 working files 6-4
 unlocking
 file definitions 6-22
 maps 6-22
 master files 6-22
 user
 assigning access to an environment 1-51
 User Environment Administration screen 1-47
 fields and functions 1-47
 function keys 1-47
 User Function Administration screen 1-48
 fields and functions 1-49
 function keys 1-49

user record
 adding 1-39
 copying 1-43
 entering a new 1-40
using
 on-line help 5-16
 Status Bar 5-15
 Toolbar 5-15

V

Value-Added Network (VAN)
 Communications Toolkit 3-2
verifying system requirements, *B-1*

viewing
 file definitions 6-19
 implementation guide 6-19
 maps 6-17

W

Window 5-18
working copy
 deleting 6-22
working file
 saving 6-20
working files
 in UNIX 6-4

