



IBM Software Group

# It's How We Put It Together That's Sets Us Apart

*Jim Gideon*

**System z Software Sales**

[jgideon@us.ibm.com](mailto:jgideon@us.ibm.com)

**+770.858.8932**



***System z: The coolest place  
in the datacenter!***

# Trademarks

- The following are trademarks of the International Business Machines Corporation in the United States and/or other countries. For a complete list of IBM Trademarks, see [www.ibm.com/legal/copytrade.shtml](http://www.ibm.com/legal/copytrade.shtml)
  - ▶ AS/400, CICS, DB2, Domino, E-business logo, ESCON, eServer, FICON, IBM, IBM Logo, IMS, iSeries, Lotus, MVS, Notes, OS/390, pSeries, Rational, RS/6000, S/390, Tivoli, VM/ESA, VSE/ESA, WebSphere, xSeries, z/OS, zSeries, z/VM
- The following are trademarks or registered trademarks of other companies
  - ▶ Linux is a registered trademark of Linus Torvalds
  - ▶ Java and all Java-related trademarks and logos are trademarks of Sun Microsystems, Inc., in the United States and other countries
  - ▶ UNIX is a registered trademark of The Open Group in the United States and other countries.
  - ▶ Microsoft, Windows and Windows NT are registered trademarks of Microsoft Corporation.
  - ▶ SET and Secure Electronic Transaction are trademarks owned by SET Secure Electronic Transaction LLC.
  - ▶ Intel is a registered trademark of Intel Corporation
  - ▶ \* All other products may be trademarks or registered trademarks of their respective companies.
- **Notes:**
  - Performance is in Internal Throughput Rate (ITR) ratio based on measurements and projections using standard IBM benchmarks in a controlled environment. The actual throughput that any user will experience will vary depending upon considerations such as the amount of multiprogramming in the user's job stream, the I/O configuration, the storage configuration, and the workload processed. Therefore, no assurance can be given that an individual user will achieve throughput improvements equivalent to the performance ratios stated here.
  - IBM hardware products are manufactured from new parts, or new and serviceable used parts. Regardless, our warranty terms apply.
  - All customer examples cited or described in this presentation are presented as illustrations of the manner in which some customers have used IBM products and the results they may have achieved. Actual environmental costs and performance characteristics will vary depending on individual customer configurations and conditions.
  - This publication was produced in the United States. IBM may not offer the products, services or features discussed in this document in other countries, and the information may be subject to change without notice. Consult your local IBM business contact for information on the product or services available in your area.
  - All statements regarding IBM's future direction and intent are subject to change or withdrawal without notice, and represent goals and objectives only.



# Setting the scene: Mainframe Design Philosophy

- **General, multi-purpose commercial computer, designed to use *all* resources efficiently**
  - ▶ Balanced design, optimized to run “Mixed workloads” especially OLTP  
vs Uni- or personal- use
  - ▶ Software designed to run together
  - ▶ Streamlined labor requirements  
Best practices have evolved
  - ▶ The **more** workload, the more **mixed** the workload, the better



# What is System z technology?

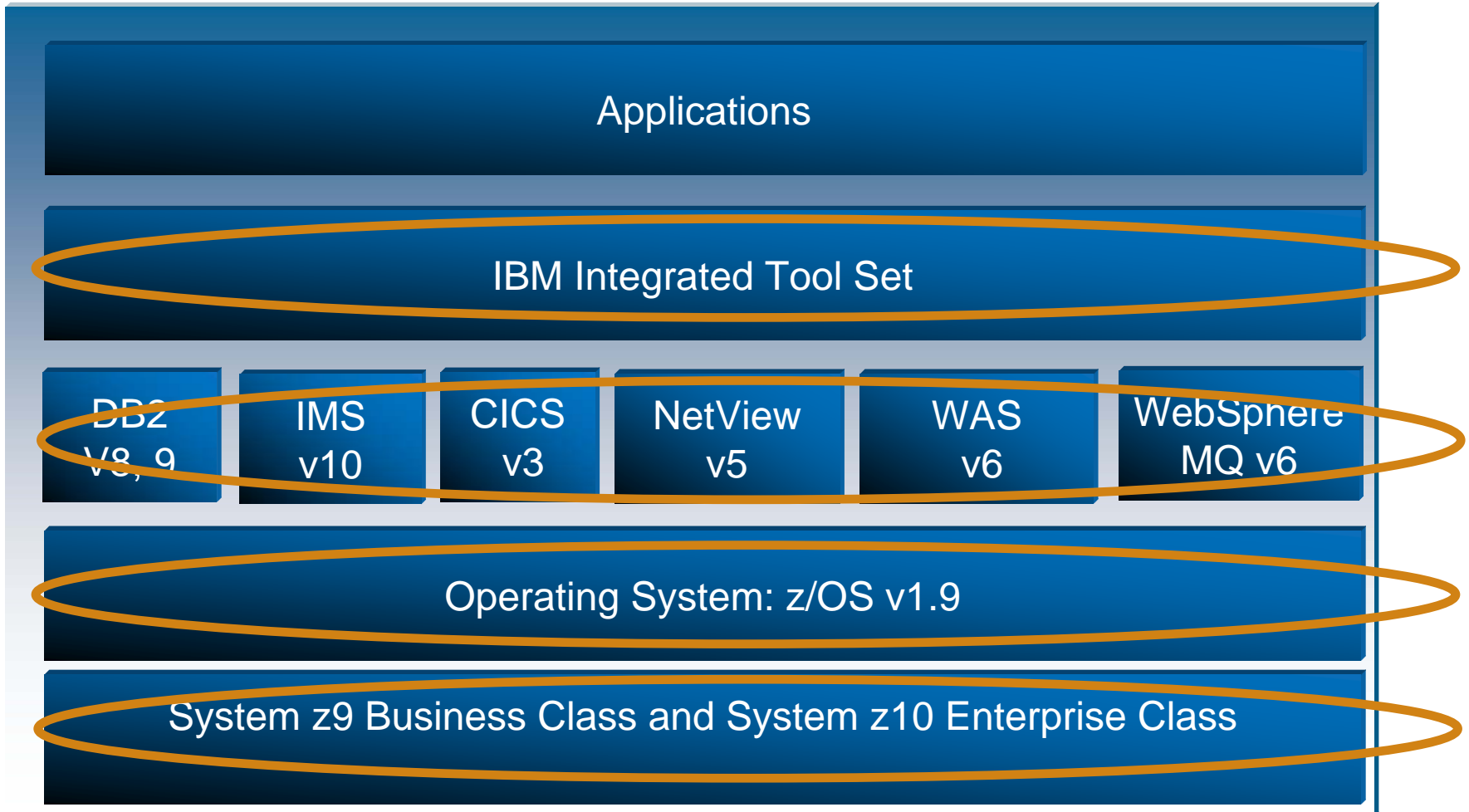

## Availability – Think of Application Availability!

- **99.999% Available ( less than 5 minutes a year)**
  - ▶ Most People think of Hardware.
- **We talk about application availability**
- **Reduced unplanned availability**
  - ▶ Reliability of HW, including executing every instruction 2X
  - ▶ Storage Protect keys
  - ▶ z/OS architecture of Address Spaces – One program can't bring another one down
  - ▶ Automation Tools
- **Planned outage reduction if not elimination**
  - ▶ Upgrade z/OS and Middleware without bringing the system down
    - Requires a Sysplex
  - ▶ Middleware, you can upgrade the application on the fly



# System z Continuous Availability

Single System



- Built In Redundancy
- Capacity Upgrade on Demand
- Capacity Backup
- Hot Pluggable I/O
- Concurrent LIC updates

Parallel Sysplex

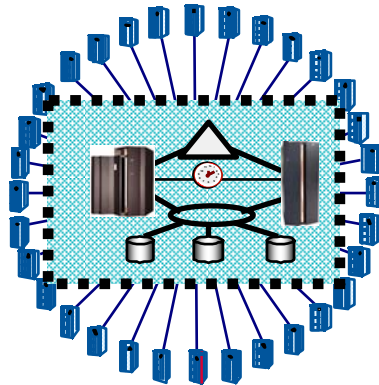

1 to 32 Systems

- Addresses Planned/Unplanned HW/SW Outages
- Flexible, Nondisruptive Growth
  - Capacity beyond largest CEC
  - Scales better than SMPs
- Dynamic Workload/Resource Management

GDPS

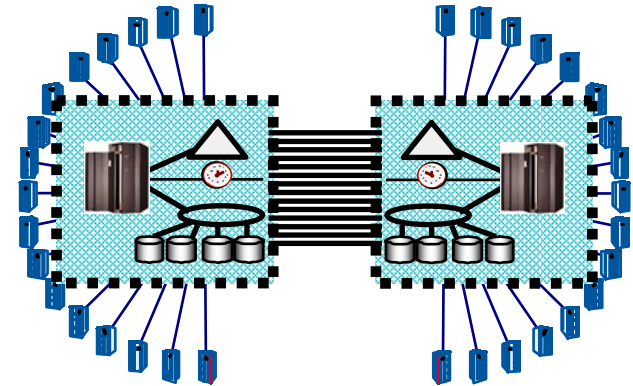

Site 1

Site 2

- **Addresses Site Failure/Maintenance**
- **Sync/Async Data Mirroring**
  - Eliminates Tape/Disk SPOF
  - No/Some Data Loss
- **Application Independent**

# System z is known for continuous availability

Availability Rankings - selected platforms

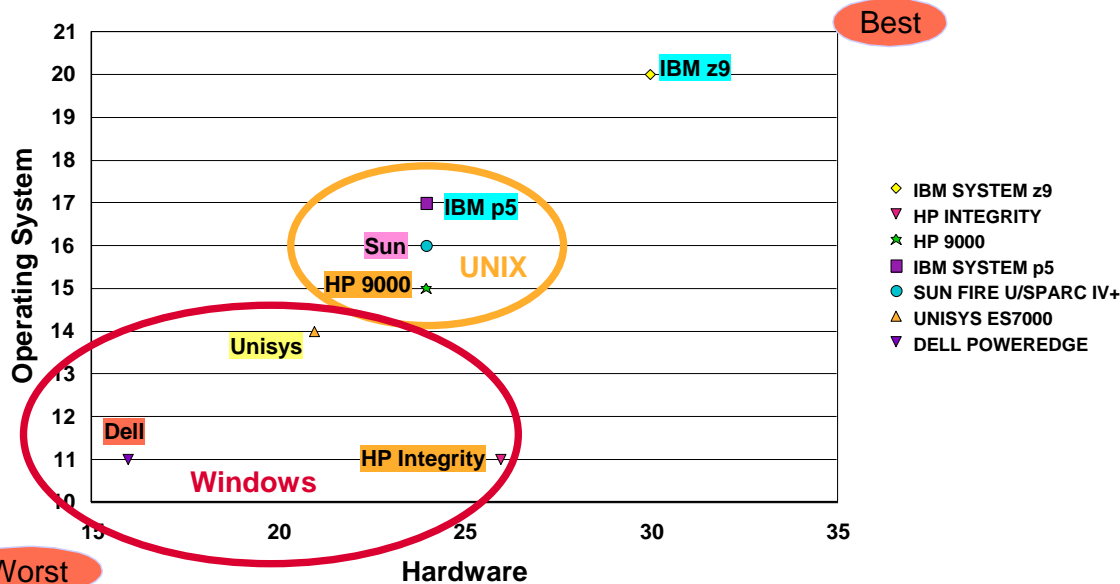

Source: Gartner, Server Scorecard Evaluation Model version 2, May 2006

- System z plus DB2 has the **lowest requirement for planned outages** in the industry
- System z with GDPS has the **best tolerance to disaster outages** in the industry
- System z has the **best Application Availability** in the industry
- System z provides **Industry leading Reliability**

“The IBM mainframe platform retains industry-leading availability characteristics even for single-system instances. For example, standard service availability commitments from tier one service providers in commercial data center outsourcing agreements suggest that the mainframe is delivering 99.9% to 99.99% scheduled availability versus 99.5% for distributed server platforms in non-clustered configurations.”

Source: Forrester, 2005 Mainframe Market Outlook, February 4, 2005

“The Parallel Sysplex zSeries environment was selected as the best way to meet our high demands for reliability, security and availability.” Nikolai Matveev, Chief Engineer, Surgutneftegas

# Scalability and Performance

## ■ Hardware

- ▶ Growth in capacity from a small BC machine from up to 4 processors to a z10 with 54 availability processors
- ▶ System assist processors for I/O
- ▶ Large memory
- ▶ Intelligent Resource Director
- ▶ Parallel Sysplex – Up to 32 complexes connected

## ■ z/OS

- ▶ Intelligent Workload Manager
- ▶ Priority scheduling of workload based on business rules

## ■ Middleware (IMS, DB2 and CICS)

- ▶ Priority schedule of transactions based on business rules from WLM
- ▶ Very large buffer pools for data





# z/OS: Prioritizing work across images in a server - IRD

*"Intelligent Resource Director (IRD)" further differentiates z/OS with its ability to manage resources across multiple partitions in a server*

*PR/SM, IRD and WLM work together to ensure that the resources of the server are correctly balanced to enable work to complete within stated policy goals*

**MORE**

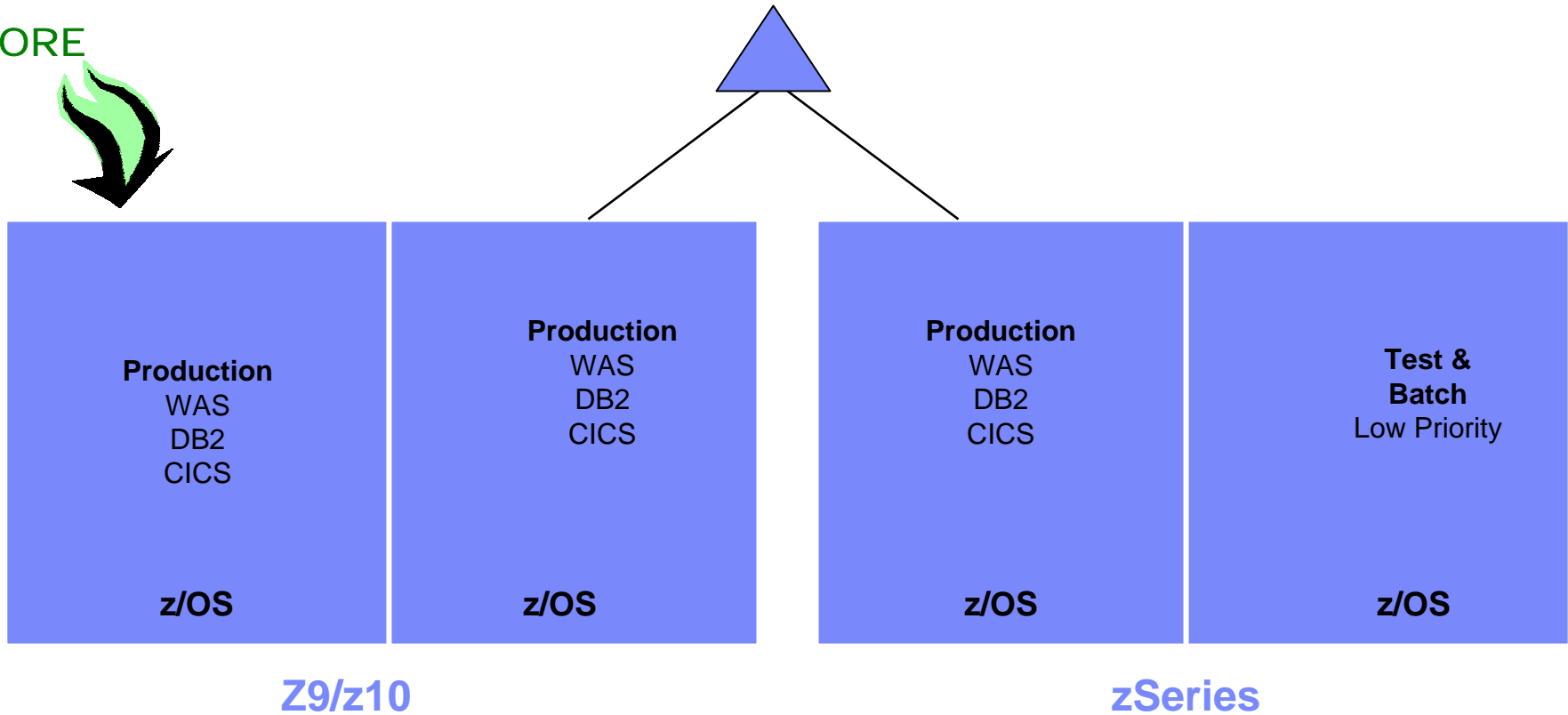

*Processor resources, data bandwidth and I/O queueing decisions are perfectly balanced across the server to manage diverse workloads within the parameters of stated business goals*



# Relative single system capacity

*There's more to performance than just processing power*

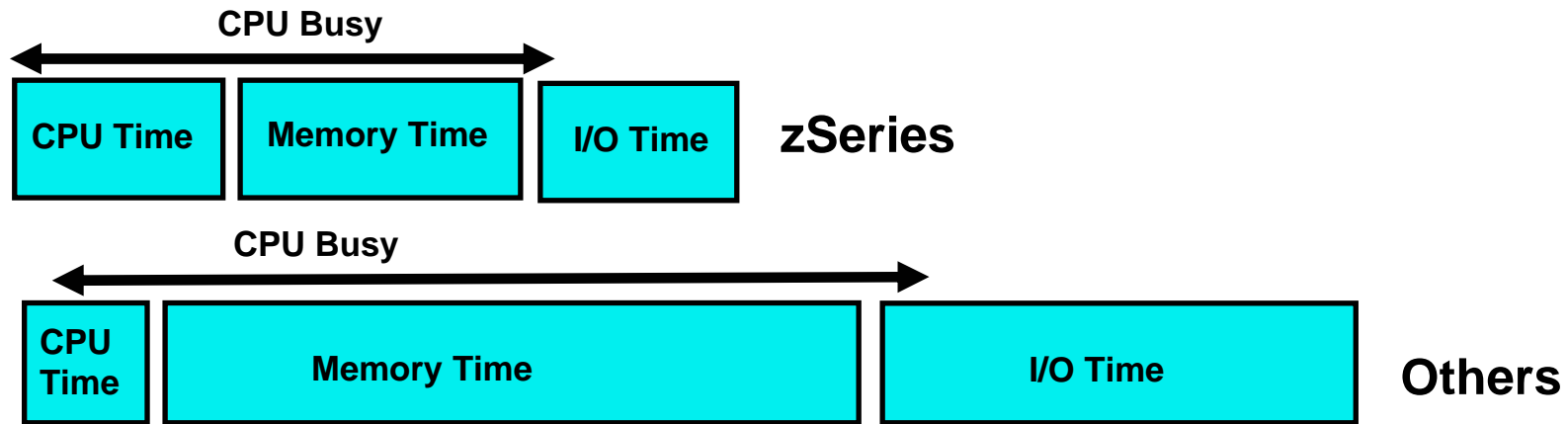

*Data intensive workloads like large databases, transaction processing, object-oriented code and context switching potentially run better on zSeries servers.*

# The largest System z benchmark ever

Near-Linear Scalability with DB2 for z/OS with No Partitioning Required

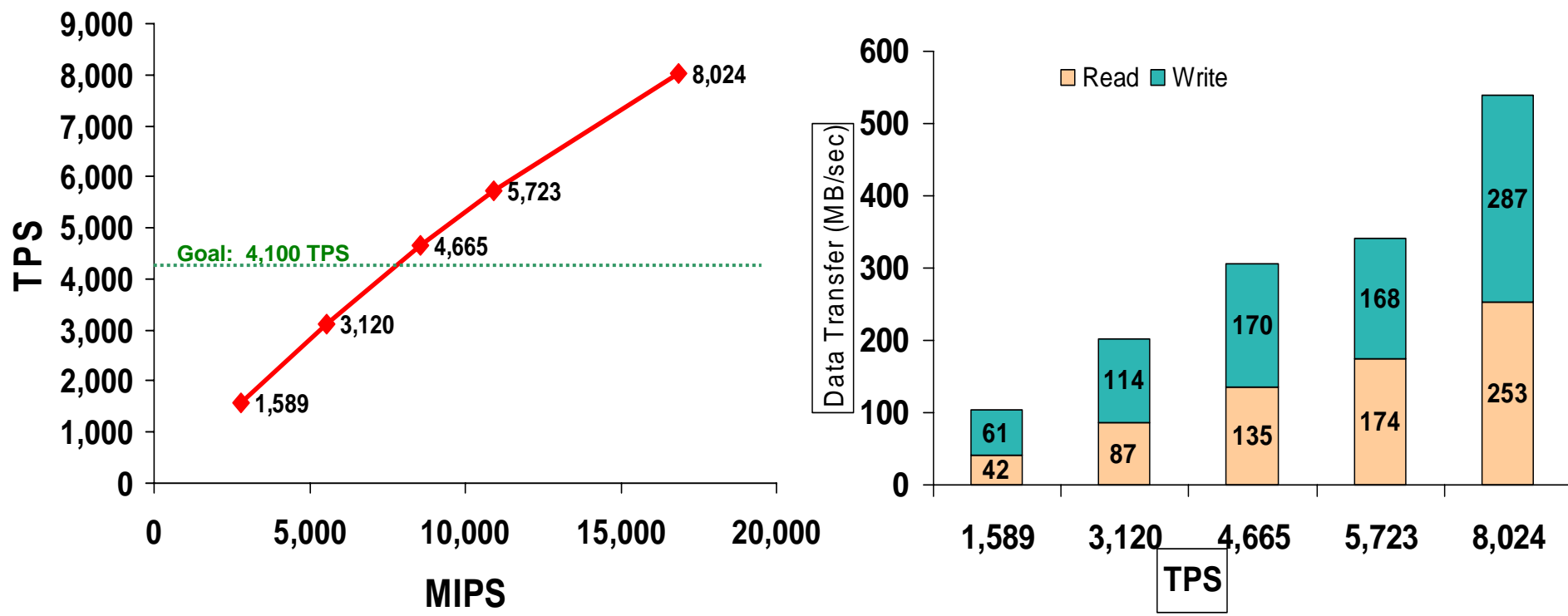

# Rock solid Security, best in industry! Begins with RACF

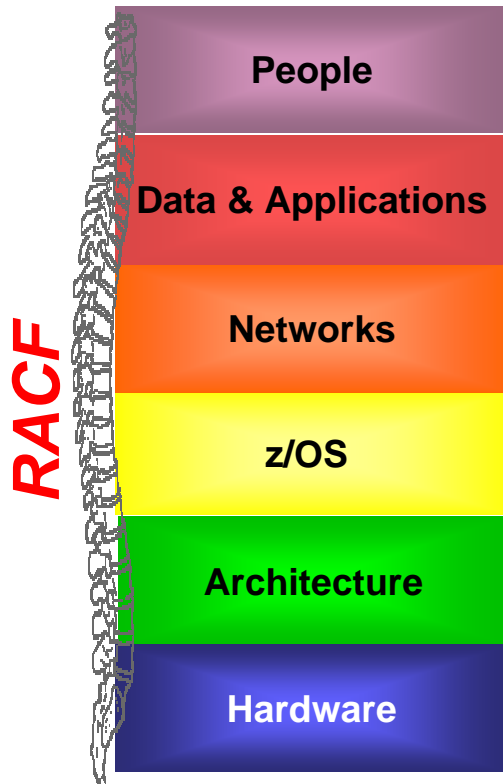
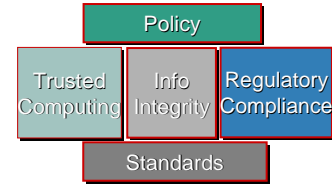

- Identity management, privacy,
- Application and database security through RACF
- CICS, MQ, IMS,WAS secured transactions
- RACF, Secured communications, PKI support
- Storage protect key, workload isolation, hipersockets, error recovery
- Hardware assisted encryption, Geographically Dispersed Parallel Sysplex ( GDPS)



Proven security, integrated throughout the stack

# Security in Depth

Runaway workloads

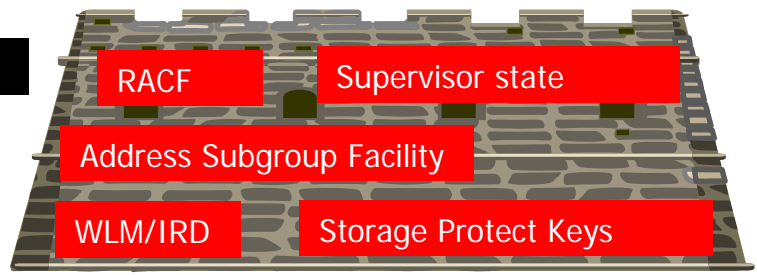
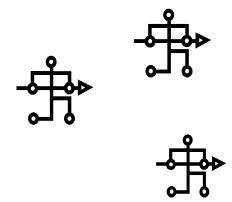

## FIPS 104-2 Certified

## E4 Security Certified

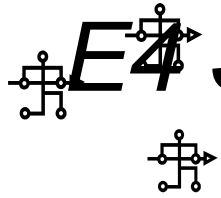

Buffer Overflows

Non authorized programs

Network security

Communication Server

Physical security

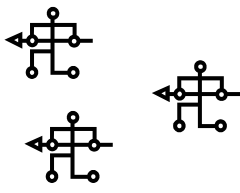

Trojan Horses

Network attacks

Viruses

Denial of Service



# Strong Security Needs Many Elements

Crypto Cards



Tape encryption



TS1120

Multilevel security

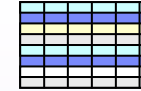

System z SMF



Consul Insight



Consul System z Tools



DB2 Audit Management Expert



## Compliance and Audit

## Data Privacy



## Extended Enterprise

Tivoli Identity Manager



Tivoli Federated Identity Mgr



## Platform Infrastructure

Common Criteria Ratings

Support for standards

RACF



Provides audit, authorization, authentication and access

Communications Server



Network intrusion detection

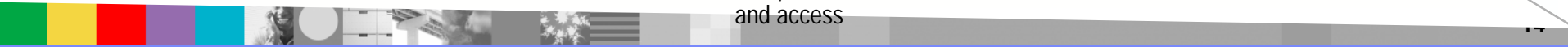

# System z virtualization leads the industry

- Virtualization creates the illusion that each user has their own private machine
  - ▶ Technology in z/VM, PR/SM, concept of LPARs, MVS address-spaces
- Virtualization enables the OS to maximize utilization
  - ▶ z/VM significantly reduces costs by reducing the total hardware (less memory and CPU) needed for any workload and also simplifying operation
- These 2 advantages enable massive **Server consolidation**
  - ▶ And also quick and easy provisioning
- LPARs enable sub-capacity pricing

## ***Other platforms are way behind: E.g. compared with VMWare***

- ▶ z/VM supports many more virtual CPUs and has no theoretical limit for number of guests
- ▶ z/VM supports virtual machines with 128 GB of memory
- ▶ z/VM customers over-commits memory 200-400% in production
- ▶ z/VM environment maximizes and balances utilization of memory, CPU and I/O to reduce the amount of hardware required



# System z Virtualization Architecture

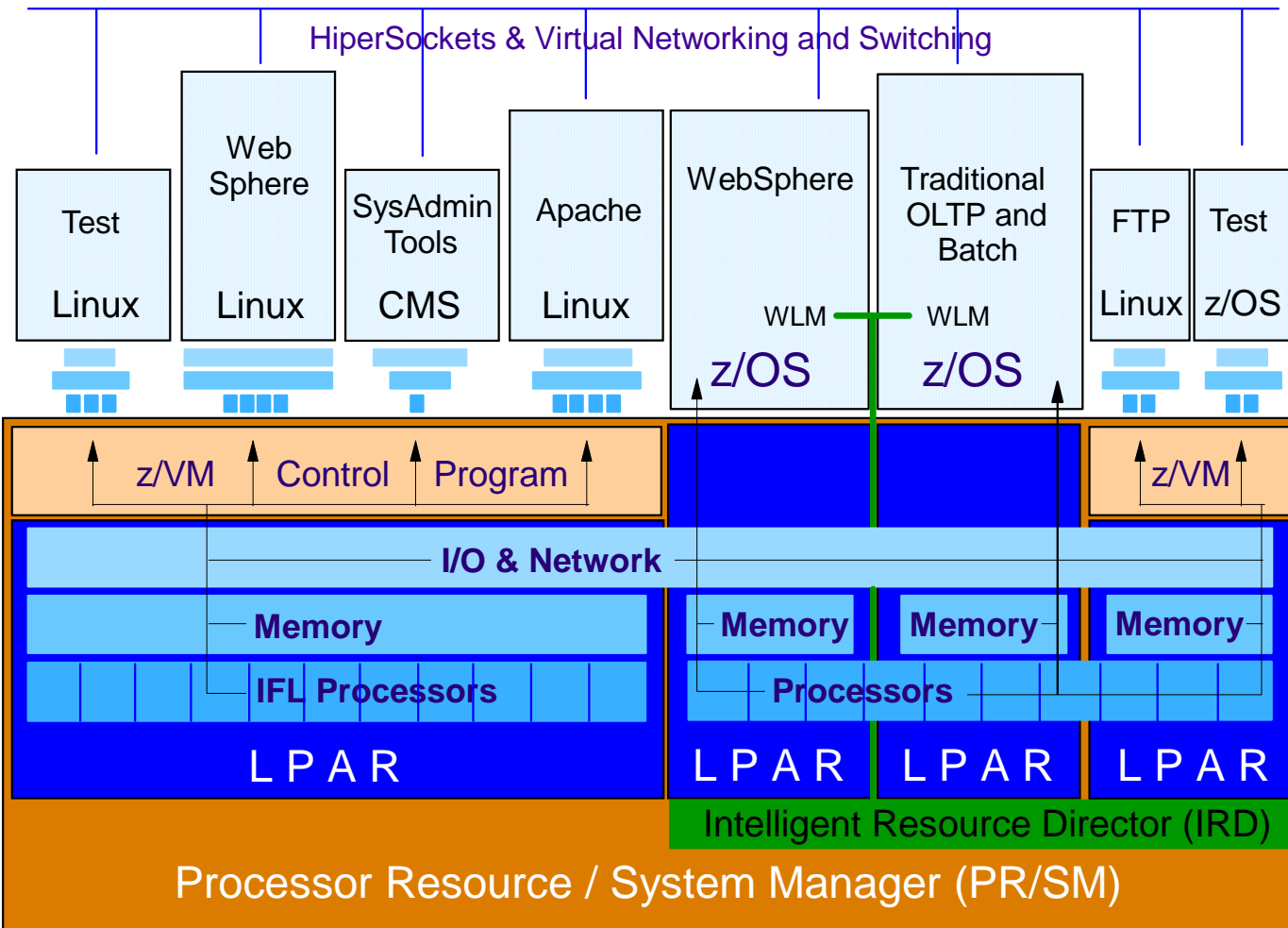

- Multi-dimensional virtualization technology
  - ▶ zSeries provides logical (LPAR) and software (z/VM) partitioning
  - ▶ PR/SM enables highly scalable virtual server hosting for LPAR *and* z/VM virtual machine environments
  - ▶ IRD coordinates allocation of CPU and I/O resources among z/OS and non-z/OS LPARs\*

\* Excluding non-shared resources Like Integrated Facility for Linux processors





# Hub for Data and SOA

“Co-location” has many major technical benefits

- Transactional Capabilities
  - ▶ (2PC, Compensation)
- State Management (DB2)
- Performance
  - ▶ Network bandwidth/latency
- Work Load Management
- Policy Management
- Problem Determination
- Deployment & Version Control
- Logging/Audit
- Scale/Clustering

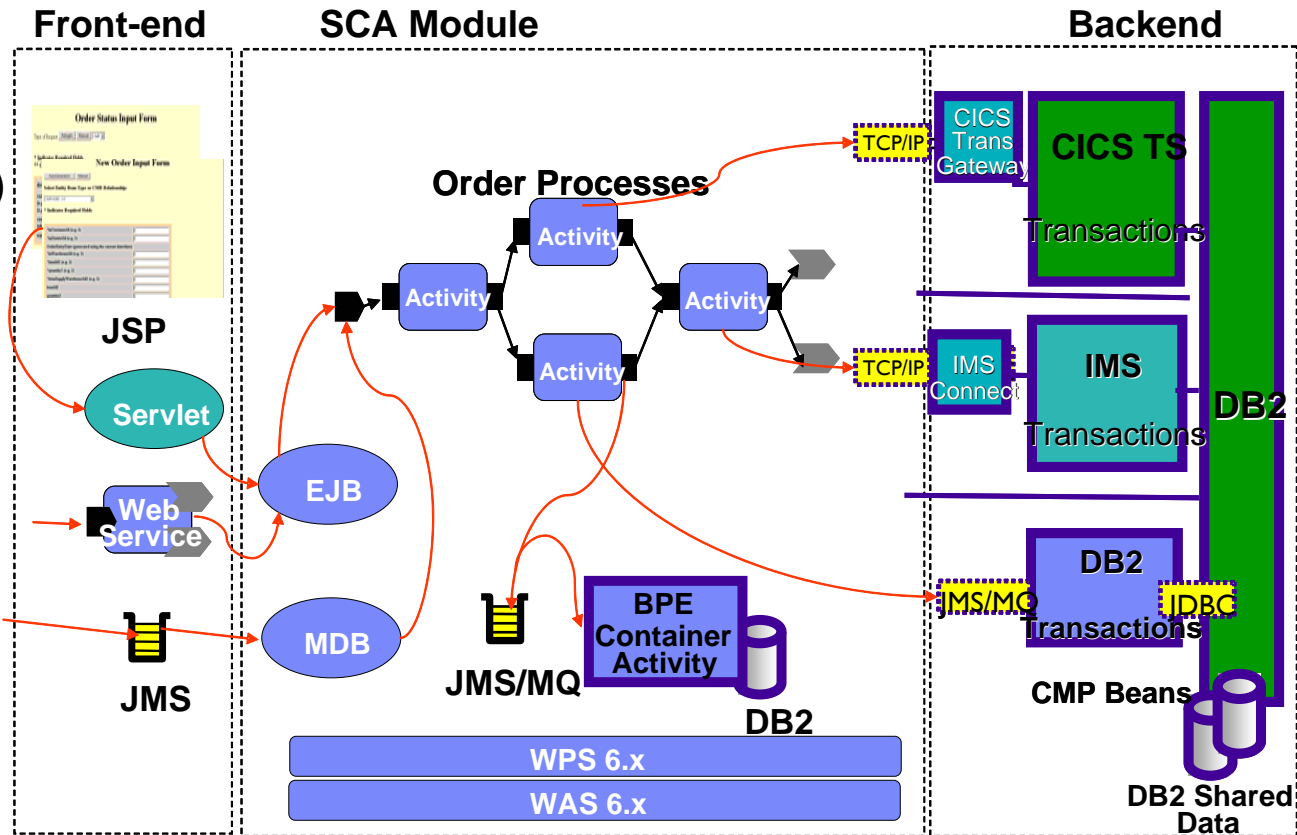

# Why centralize the DB on the mainframe?

1. scalability
  - high data throughput
  - very large DB size
2. availability
  - 24 by 7
  - real-time update
  - resiliency
3. security and protection

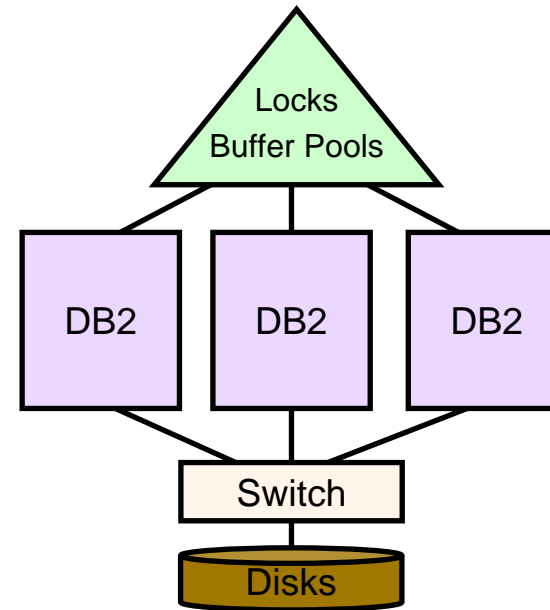

- Single system image
- High speed centralized lock manager in coupling facility
- Shared data, not partitioned
- Easy to add more processors

# Oracle RAC: Lock Management Overhead

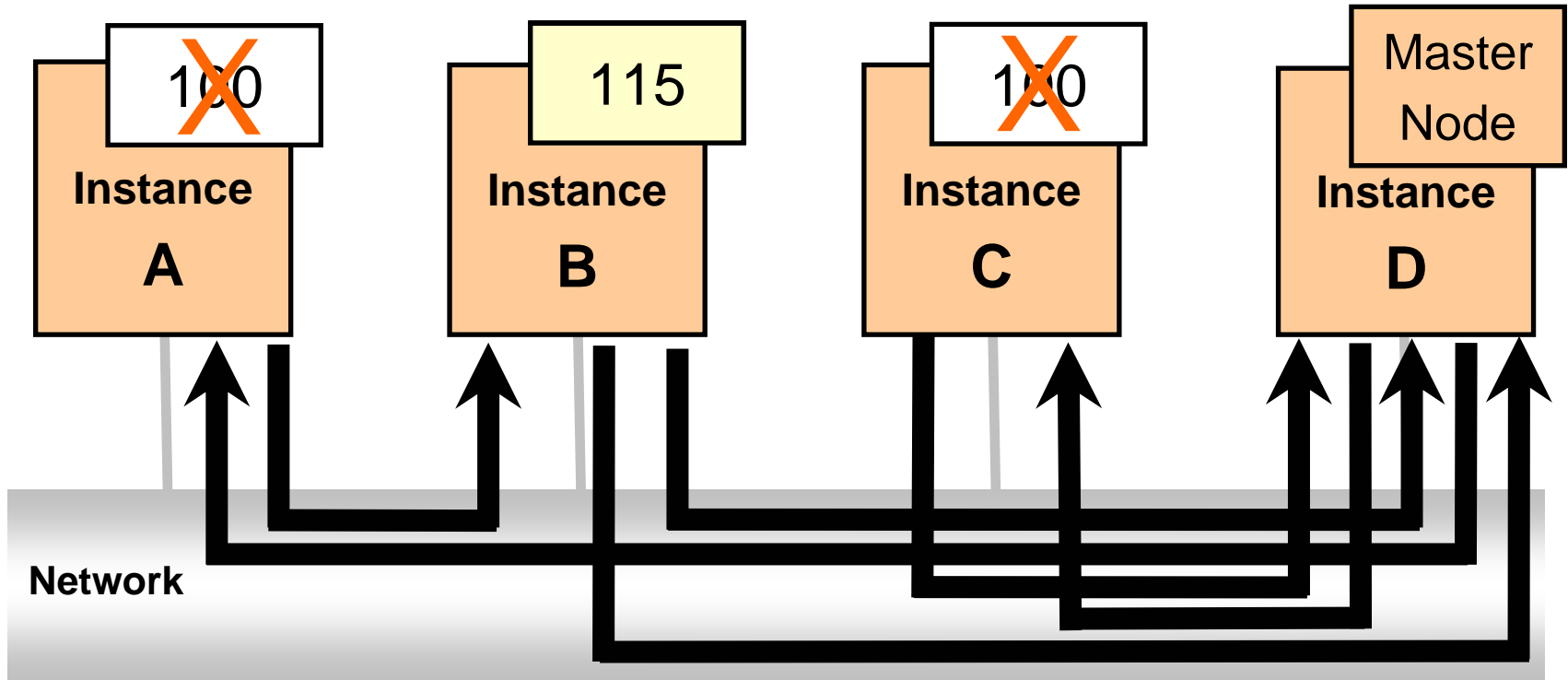

**Lock Assume**

7. B Updates local copy

**Inter-node connections: 6**

**In a cluster with 4 nodes, an update operation may need 6 network connections and two in-memory calls (not shown).**

# What is System z technology?

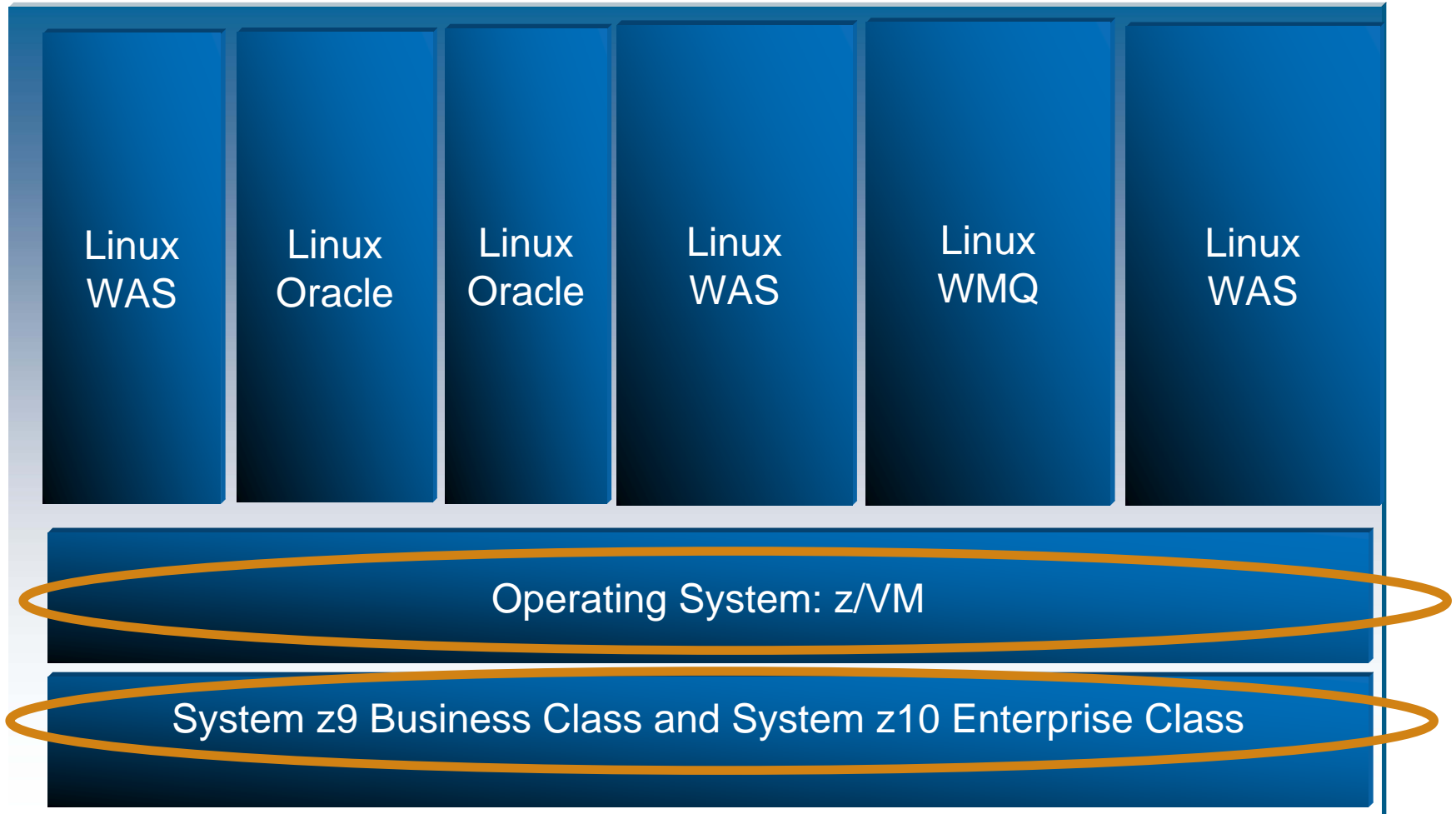

# How does the Mainframe do it (drive TCO down) ?

## Hardware

- Specialty processors (IFL, zAAP and zIIP) discounted 90%
- Disaster Recovery processors discounted 98%
- Growing customers may upgrade installed MIPS without cost
- Up to 336 I/O offload processors at feature prices
- Requires less power, cooling and floor space

## Software

- MLC per incremental MIP / MSU goes down as system gets larger
- One-time charges are per processor for IFL (at Intel rate)
- No charge for software on zIIP and zAAP
- Sub-capacity pricing, Sysplex aggregation, zNALC, technology dividend

## People

- Requires significantly less operational staff to manage the installation

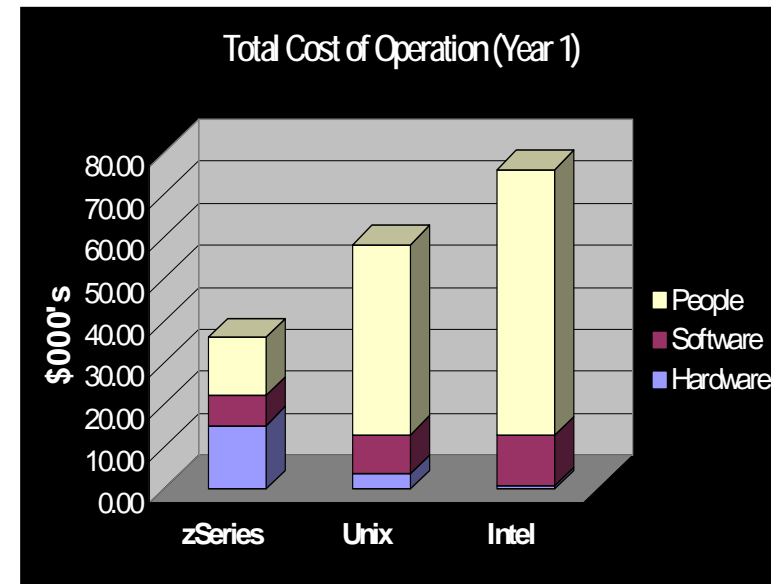

# Top 3 Pains for Customers with Mainframes\*

**Question: What is the largest inhibitor to the growth in usage of the mainframe in your organization?**

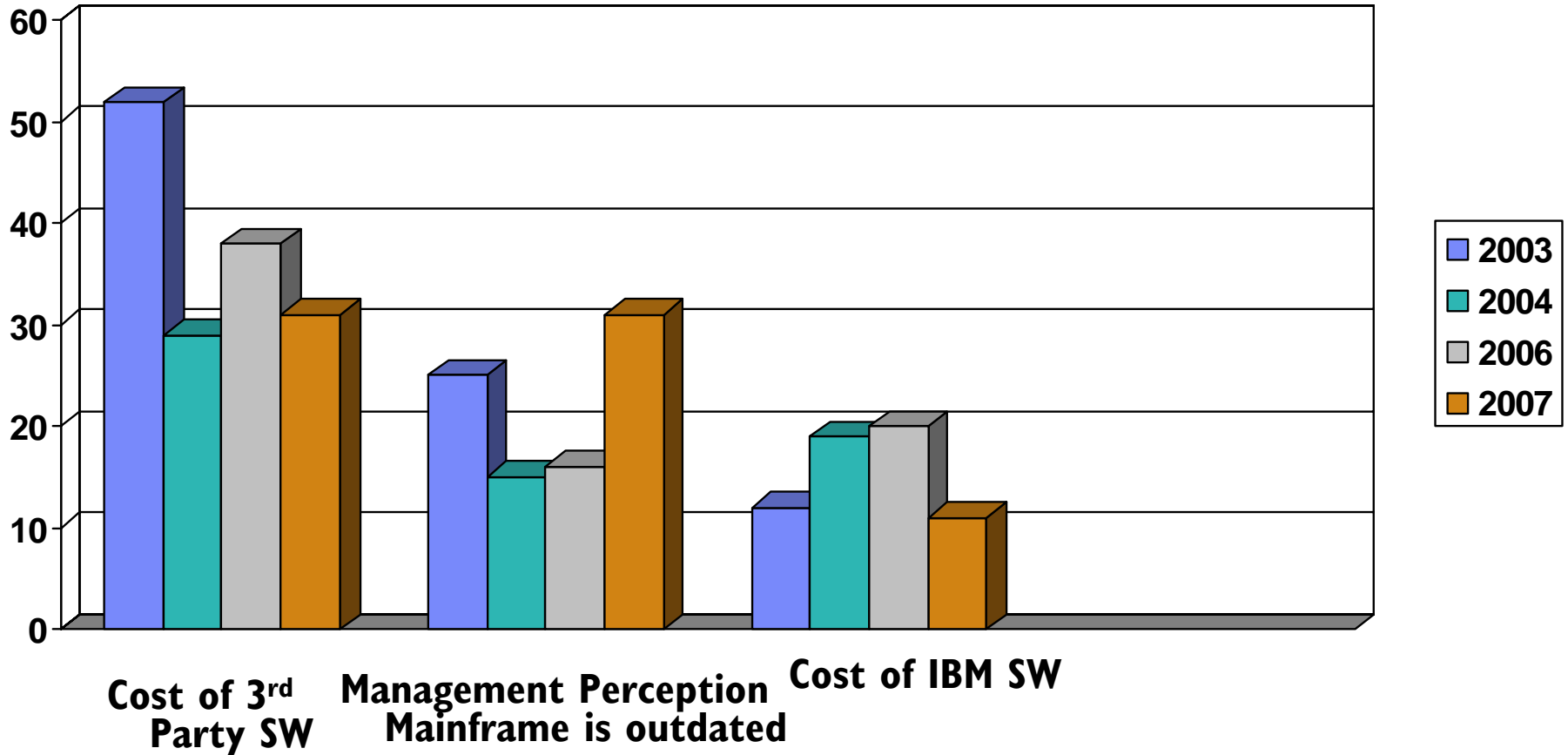

\* Gartner Data Center Conference survey - January 2007



# The Value is in the zStack

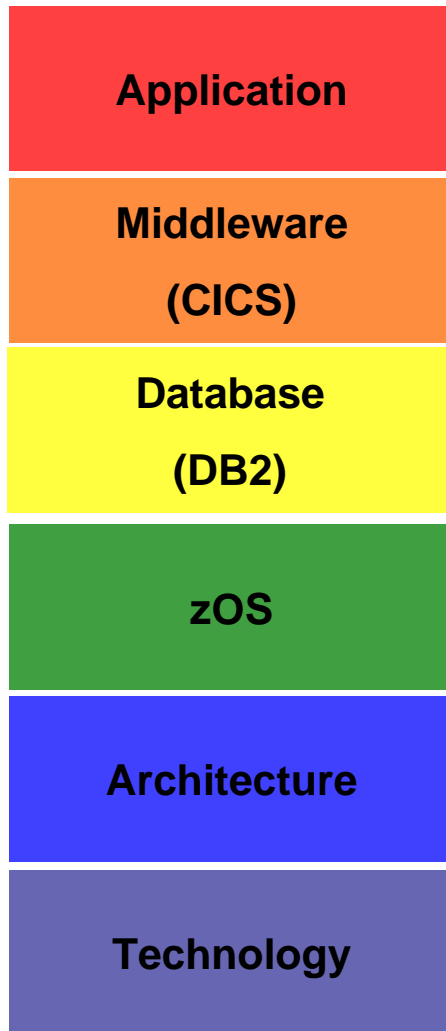

- It's not just a collection of technologies
- It's \$100 Billion+ dollar investment in an integrated stack ...
- Designed to achieve business objectives in demanding customer environments

Thank you

