

IMS Performance Update
IMS-1683A

Kevin Hite, IBM
khite@us.ibm.com

IBM Software
Information On Demand 2011



Please Note:

IBM's statements regarding its plans, directions, and intent are subject to change or withdrawal without notice at IBM's sole discretion.

Information regarding potential future products is intended to outline our general product direction and it should not be relied on in making a purchasing decision.

The information mentioned regarding potential future products is not a commitment, promise, or legal obligation to deliver any material, code or functionality. Information about potential future products may not be incorporated into any contract. The development, release, and timing of any future features or functionality described for our products remains at our sole discretion.

Performance is based on measurements and projections using standard IBM benchmarks in a controlled environment. The actual throughput or performance that any user will experience will vary depending upon many factors, including considerations such as the amount of multiprogramming in the user's job stream, the I/O configuration, the storage configuration, and the workload processed. Therefore, no assurance can be given that an individual user will achieve results similar to those stated here.



Information On Demand 2011

Acknowledgements and Disclaimers:



Availability. References in this presentation to IBM products, programs, or services do not imply that they will be available in all countries in which IBM operates.

The workshops, sessions and materials have been prepared by IBM or the session speakers and reflect their own views. They are provided for informational purposes only, and are neither intended to, nor shall have the effect of being, legal or other guidance or advice to any participant. While efforts were made to verify the completeness and accuracy of the information contained in this presentation, it is provided AS-IS without warranty of any kind, express or implied. IBM shall not be responsible for any damages arising out of the use of, or otherwise related to, this presentation or any other materials. Nothing contained in this presentation is intended to, nor shall have the effect of, creating any warranties or representations from IBM or its suppliers or licensors, or altering the terms and conditions of the applicable license agreement governing the use of IBM software.

All customer examples described are presented as illustrations of how those customers have used IBM products and the results they may have achieved. Actual environmental costs and performance characteristics may vary by customer. Nothing contained in these materials is intended to, nor shall have the effect of, stating or implying that any activities undertaken by you will result in any specific sales, revenue growth or other results.

© Copyright IBM Corporation 2011. All rights reserved.

— U.S. Government Users Restricted Rights - Use, duplication or disclosure restricted by GSA ADP Schedule Contract with IBM Corp.

IBM, the IBM logo, ibm.com, Information Management, IMS, CICS, WebSphere Application Server and z/OS are trademarks or registered trademarks of International Business Machines Corporation in the United States, other countries, or both. If these and other IBM trademarked terms are marked on their first occurrence in this information with a trademark symbol (® or ™), these symbols indicate U.S. registered or common law trademarks owned by IBM at the time this information was published. Such trademarks may also be registered or common law trademarks in other countries. A current list of IBM trademarks is available on the Web at "Copyright and trademark information" at www.ibm.com/legal/copytrade.shtml

Other company, product, or service names may be trademarks or service marks of others.



Information On Demand 2011

Agenda:



- Performance Evaluation Process & Environment
- IMS Version 12 Base Performance Evaluations
- IMS Version 12 Performance Evaluations: New functions and Enhancements
- Performance Evaluation Highlights



Information On Demand 2011

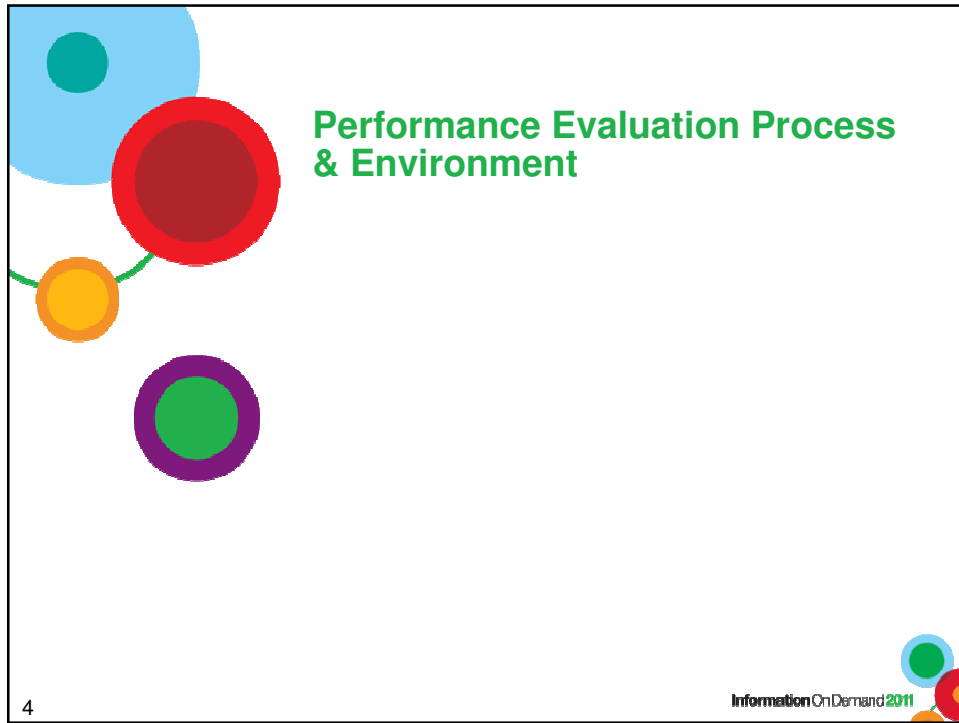

Performance Evaluation Process & Environment

4

Information On Demand 2011

The diagram features a central title 'Performance Evaluation Process & Environment' in green. To the left, there are four overlapping circles: a large light blue one at the top, a smaller yellow one below it, a large red one to the right of the yellow one, and a purple one with a green center at the bottom. A thin green line connects the yellow and red circles. In the bottom right corner, there is a small logo consisting of three overlapping circles (green, blue, red) and the text 'Information On Demand 2011'. The number '4' is in the bottom left corner.

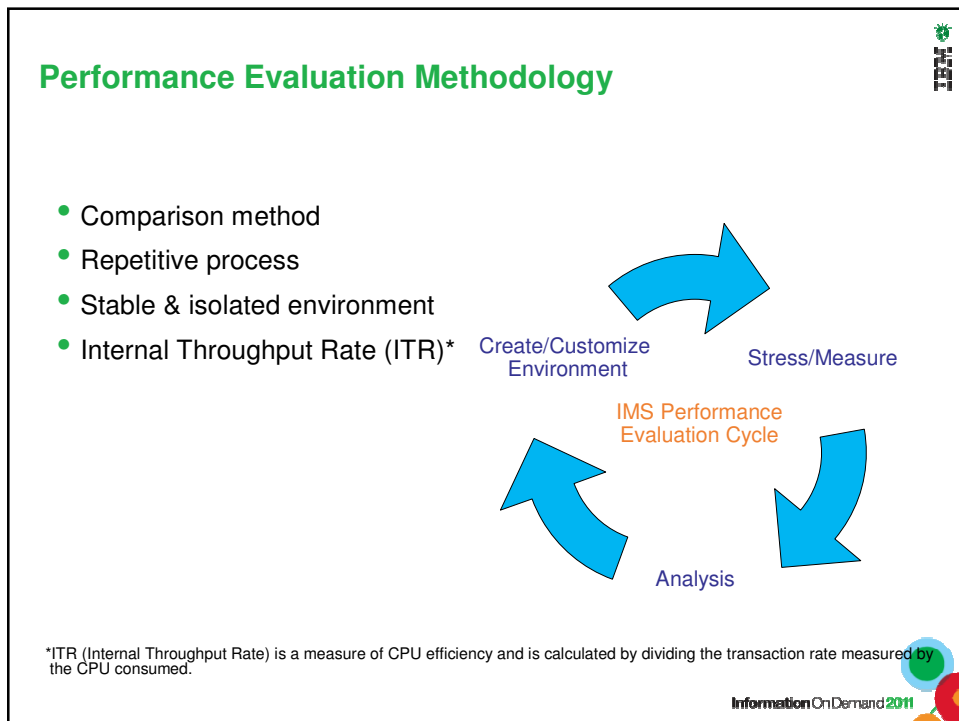

Performance Evaluation Methodology

- Comparison method
- Repetitive process
- Stable & isolated environment
- Internal Throughput Rate (ITR)*

Create/Customize Environment → Stress/Measure → Analysis → Create/Customize Environment

IMS Performance Evaluation Cycle

*ITR (Internal Throughput Rate) is a measure of CPU efficiency and is calculated by dividing the transaction rate measured by the CPU consumed.

Information On Demand 2011

The diagram is titled 'Performance Evaluation Methodology' in green. It lists four bullet points: 'Comparison method', 'Repetitive process', 'Stable & isolated environment', and 'Internal Throughput Rate (ITR)*'. To the right, a circular flow diagram shows three blue arrows forming a cycle: 'Create/Customize Environment' at the top, 'Stress/Measure' on the right, and 'Analysis' at the bottom. The text 'IMS Performance Evaluation Cycle' is written in orange in the center of the cycle. In the top right corner, there is a small green gear icon with the letters 'IBM' below it. In the bottom right corner, there is a small logo with three overlapping circles (green, blue, red) and the text 'Information On Demand 2011'.

Performance Environment



- Processor
 - IBM System z10 Enterprise Class (2097 E64)
 - IBM zEnterprise System z196 (2817)
- DASD 8300 & 8700 FICON Channels
- Internal CFs, CFCC Levels 15 & 16
- VTAM and CTC ESCON channel speed = 17 MB/sec
 - (CTC FICON 60-170 MB/sec)
- TCP/IP OSA card speed = 128 MB/sec (1 Gb/sec)
- Workloads include Full Function Warehouse, Fast Path Banking, and BMP workloads



IBM System z10 Enterprise Class (2097 E64)



IBM zEnterprise System z196 (2817)



IMS Version 12 Base Performance Evaluations

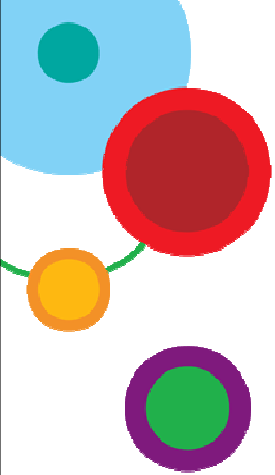

7

**IMS Version 12 Base Performance Evaluations -
Fast Path Base Evaluation**



- z10 - 2 two way sysplex environment with 2 General Purpose engines each
- Single Image IMS on 1 dedicated LPAR with TPNS on its own dedicated LPAR
- TPNS simulating 4,000 clients

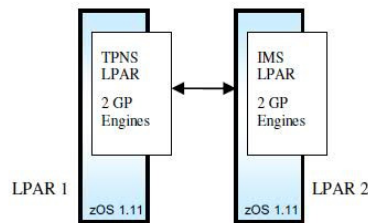

Information On Demand 2011



**IMS Version 12 Base Performance Evaluations -
Fast Path Base Evaluation**



- The results of the ITR comparison between IMS V11 and IMS V12 demonstrate the latest IMS release maintains its current performance and CPU efficiency
- IMS V11 FPB64=N vs. IMS V12 FPB64=N comparisons show a 1.9% reduction in ITR for IMS V12
- IMS V12 FPB64=Y show an increased ITR of <1%
 - Functional enhancement made to the FPB64=Y to optionally allow subpool expansion/compression

Information On Demand 2011



IMS Version 12 Base Performance Evaluations - Full Function with HALDB Base Evaluation



- 2 LPARS with 3 General Purpose engines each
- Single Image IMS on 1 dedicated LPAR with TPNS on its own dedicated LPAR
- TPNS simulating 4,000 clients
- DS8000 model 8700 DASD connected via 8 FICON channel paths

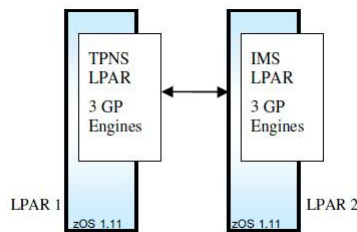

Information On Demand 2011



IMS Version 12 Base Performance Evaluations - Full Function with HALDB Evaluation



- The results show that the Internal Throughput Rate (ITR) comparisons of the IMS Version 11 and IMS Version 12 Full Function with HALDB workload demonstrate equal or better performance for the IMS V12 environment

Full Function Base Evaluation				
	IMS V11	IMS V12	Delta	Delta %
ETR (Tran/Sec)	1,543.43	1,548.26	4.83	0.31%
CPU%	82.47%	82.61%	0.14	0.17%
ITR (Tran/Sec)	1,871.43	1874.10	2.68	.14% Improvement

Information On Demand 2011



IMS Version 12 Base Performance Evaluations - Full Function HALDB Shared Message Queues (SMQ) Base Evaluation



- 2 LPARS with 2 General Purpose engines each and 2 zIIP processors on the IMS LPAR
 - With IMS V12 and subsequent releases, IMS SMQ or Shared IMS Fast Path Message Queues environments can processes eligible work on System Z Integrated Information Processors (zIIP)
- Single Image IMS on 1 dedicated LPAR with TPNS on its own dedicated LPAR
- TPNS simulating 4,000 clients
- DS8000 model 8700 DASD connected via 8 FICON channel Paths

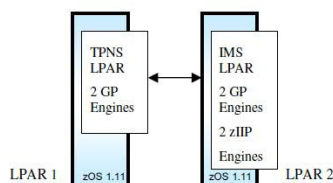

Information On Demand 2011



IMS Version 12 Base Performance Evaluations - Full Function HALDB Shared Message Queues (SMQ) Base Evaluation



- The results show that the Internal Throughput Rate (ITR) comparison of the IMS V11 and IMS V12 Full Function HALDB SMQ workload demonstrate minimal improvement for IMS V12

Full Function SMQ Base Evaluation				
	IMS V11	IMS V12	Delta	Delta %
ETR (Tran/Sec)	1028.69	1031.91	3.22	0.31%
CPU%	80.64%	80.85%	0.21	0.26%
zIIP%	4.23%	5.39%	1.16	27.42%
ITR (Tran/Sec)	1275.66	1276.33	.67	0.05%

Information On Demand 2011



**IMS Version 12 Base Performance Evaluations -
Banking BMP Base Evaluation**



- The goals for the Banking BMP base measurements were focused on the total elapsed time required to execute a set of banking like BMPs
- 1 LPARS with 3 General Purpose engines
- Single Image IMS on 1 dedicated LPAR
- DS8000 model 8700 DASD connected via 8 FICON channel Paths

Information On Demand 2011



**IMS Version 12 Base Performance Evaluations -
Full Function HALDB Shared Message Queues (SMQ) Base Evaluation**



- The results of the Banking BMP comparison between IMS V11 and IMS V12 demonstrate the latest IMS release maintains its current performance and CPU efficiency

	Elapsed Time (sec)	CPU Busy %	EXCP #	CSA Below 16MB Key 7	Task CPU Time	ECSA Above 16MB Key 7
IMS V11	76	7.88	41	204K	7.39	49.5M
IMS V12	78	7.69	42	208K	7.39	49.5M

Information On Demand 2011



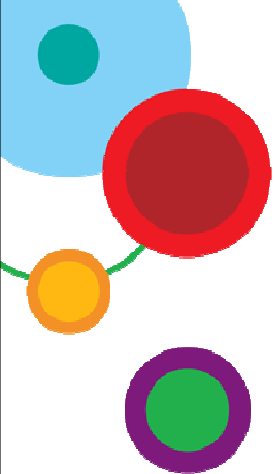

Performance Evaluations: IMS Version 12 Enhanced Logger with 64 bit Buffering

16

Information On Demand 2011

IMS Version 12 Enhanced Logger with 64 bit Buffering

- Online and System Log Data Sets are now enhanced to allow
 - the IMS log buffer storage to move above the 2 gigabyte boundary by utilizing 64 bit buffering
 - the IMS log data sets to be striped

Information On Demand 2011





IMS Version 12 Enhanced Logger with 64 bit Buffering

OLDS Logging Using Sequential Access Method (SAM) Striping (74KB Log Data Size) on DS8700

Scenario	Transaction Rate (Tran/sec)	PA OLDS (Writes/sec)
No Stripes	2133	154 MB/sec
2 Stripes	3162	228 MB/sec
4 Stripes	3825	277 MB/sec
6 Stripes	4536	329 MB/sec
8 Stripes	4908	354 MB/sec

Side Note:
DASD Type 8700 provides 1/3 logging rate improvement over the 8300 DASD type

 Information On Demand 2011



IMS Version 12 Enhanced Logger with 64 bit Buffering

- Using a sample workload generating 74KB per transaction, SAM striping helps V12 logging bandwidth
- 354 MB/sec IMS V12 OLDS logging rate was achieved using SAM striping (8 stripes with 74KB log data size per transaction)
- The ECSA Virtual Storage Constraint Relief, (VSCR) with 2,516 64-bit log buffers was 64MB
- 35% logging rate improvement was observed using DS8700 vs DS8300 volumes (DS8300 4-stripe, 74KB log data size setup achieved a logging rate of 205MB/sec)

 Information On Demand 2011

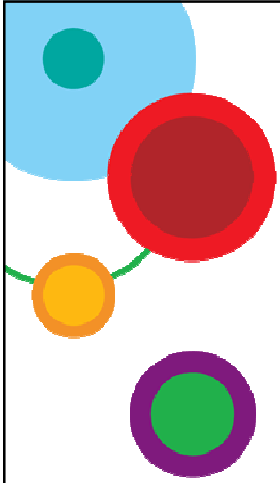

Performance Evaluations: IMS Version 12 Logging WADS Enhancement

Information On Demand 2011

20

IMS Version 12 Logger Enhancements - WADS

- New WADS Channel Program now conforms to E-C-K-D architecture providing greater efficiency and reduces channel program operations

IMS V11 (top) & IMS V12 (Bottom)

STORAGE GROUP	DEV	DEVICE	NUMBER	VOLUME	PAV	LCU	ACTIVITY RATE	AVG RESP TIME	AVG IOPS	AVG CMR	AVG DB DLY	AVG PEND TIME	AVG DISC TIME	AVG CONN TIME	% DEV CONN	% DEV UTIL	% DEV RESV	AVG NUMBER ALLOC	% ANY ALLOC	% MT PEND
2400	33909	31164	S24500	1.0H	0028	1143.49	.384	.000	.025	.000	.179	.001	.204	23.32	23.42	0.0	1.0	100.0	0.0	
2400	33909	31164	S24500	1.0H	0028	1163.02	.344	.000	.028	.000	.184	.001	.159	18.47	18.60	0.0	1.0	100.0	0.0	

	IMS Version 11	IMS Version 12
WADS AVG RespTime	.384	.344
% Improvement (Resp Time)	--	10.41%

WADS Response Time comparison table

- Note: This improvement is expected to have a significant positive impact on global and metro mirroring

Information On Demand 2011

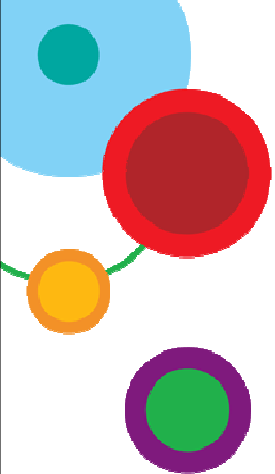

Performance Evaluations: IMS Version 12 Fast Path 64 Bit Buffer Manager Enhancement

22

Information On Demand 2011

IMS Version 12 Fast Path 64 Bit Buffer Manager Enhancement



- IMS V12 enhancement to the Fast Path 64 bit buffer manager introduces
 - subpool expansion and compression
 - reduced ECSA usage
 - code length reduction and removal
 - enhanced QUERY POOL command improving both performance and manageability
- IMS Fast Path subpools are expanded prior to wait-for-buffer conditions
- IMS Fast Path subpools are compressed when the storage is no longer needed

Information On Demand 2011

IMS Version 12 Fast Path 64 Bit Buffer Manager Enhancement

- Fast Path Banking Workload
- 2 LPARS with 6 General Purpose engines each
- Single Image IMS on 1 dedicated LPAR with TPNS on its own dedicated LPAR
- DS8000 model 8700 DASD connected via 8 FICON channel Paths

The diagram illustrates two Logical Partitions (LPARs) connected to each other. LPAR 1 on the left contains a TPNS LPAR with 6 General Purpose (GP) Engines. LPAR 2 on the right contains an IMS LPAR with 6 GP Engines. Both LPARs are running zOS 1.11. A double-headed arrow indicates communication between the two LPARs.

Information On Demand 2011

IMS Version 12 Fast Path 64 Bit Buffer Manager Enhancement

- Observations
 - As workload requirement for FP Buffers increased the total number of FP Buffers in the pool expanded
 - As workload requirement for FP Buffers decreased the total number of FP Buffers in the pool compressed
 - Total ECSA requirements adjusted as workload requirements adjusted.

Time	Event	Transactions Rate/Sec	Total # of Buffers	Total ECSA Usage
08:24:30	3K Clients Executing	9,025	536	747K
08:24:33	Open 1K More Clients			
08:24:33	4K Clients Executing	12,380	1,406	1279K
08:27:35	Close All Clients			
08:37:42	Clients are Quiescing	3,018	1,290	1279K
09:00:17	All Clients are stopped	0	1,000	1092K

Information On Demand 2011

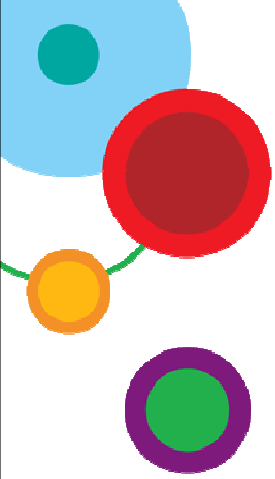

Performance Evaluations: IMS V12 DRD with RDDS and Repository

26

Information On Demand 2011

IMS V12 DRD with RDDS and Repository

- IMS Repository support for selected DRD resources (transactions, routing codes, program directories, database directories, and descriptors for these) provides a single centralized store for resource definitions in an IMSplex
- IMS Repository simplifies the management of resource definitions and eliminates manual import and the multiple Resource Definition Data Sets (RDDS) for each IMS

Information On Demand 2011

IMS V12 DRD with RDDS and Repository



- RDDS vs. Repository for a single image IMS
 - Measurements compare RDDS vs. Repository for IMPORT and EXPORT commands for 135,000 resource definitions for a Single IMS
 - AUTOIMPORT +1 minute
 - IMPORT command +1 minute
 - EXPORT command +16 minutes

DB	15000
DB Index	15000
PGM Batch	
PGM TP	30000
TRAN	60000
RTCODE	15000
Total Resources	135000

IMS Version 12 RDDS vs Repository (REPO) with 135K definitions

	RDDS	REPO	Delta
EXPORT CMD	00:00.54	15:55.41	15:54.87
IMPORT CMD	25:21.82	26:40.19	01:18.37
AUTOIMPORT	01:09.96	02:19.36	01:19.40

RDDS vs Repository Single Image Analysis



IMS V12 DRD with RDDS and Repository



- Comparison of elapsed time for a Repository AUTOIMPORT of 135,000 resource definitions to a 3 way IMS system

3 Way IMS Version 12 Sysplex Repository AUTOIMPORT with 135k definitions

	Start command issued at same time for all 3 IMS regions		
	IMS 1	IMS 2	IMS 3
Start Time	11:12:17.14	11:12:17.14	11:10:08.92
End Time	11:15:49.37	11:15:49.52	11:13:28.96
Elapsed Time (individual)	3 min 32 sec	3 min 32 sec	3 min 20 sec



IMS V12 DRD with RDDS and Repository



- Observations

- The IMS V12 AUTOIMPORT into the IMS Repository took roughly 1 minute longer than the AUTOIMPORT time with IMS V11 RDDS
- The IMS V12 IMPORT into the IMS Repository took roughly 1 minute longer than the IMPORT time with IMS V11 RDDS
- IMS V12 EXPORT elapsed time in comparison to IMS V11 was roughly 16 minutes longer
- Users should find that the manageability aspects of the Repository outweigh the increase in total elapsed time for these commands



Performance Evaluations: IMS Version 12 Full Function Dynamic Buffer Pool

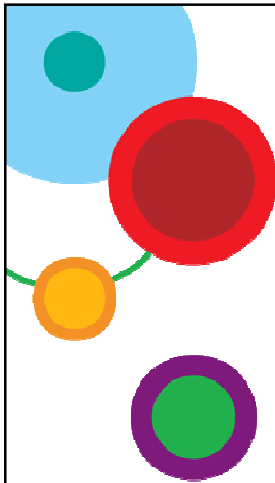

IMS Version 12 Full Function Dynamic Buffer Pool



- New IMS online commands are provided to dynamically managing (add, change, and delete) Full Function database OSAM and VSAM buffer pools without taking the system down
- As transaction volume grows, the number of I/Os would be increased; but if the buffer pool size is increased, less I/Os are needed

Information On Demand 2011



IMS Version 12 Full Function Dynamic Buffer Pool



- Two scenarios were used to evaluate the impact of issuing the UPDATE POOL command
 - Single Image IMS Full Function workload with 128 MPP regions at approximately 850 transactions/sec
 - Single Image IMS Full Function workload with 128 MPP regions and 4 BMPs at approximately 850 transactions/sec

Information On Demand 2011



IMS Version 12 Full Function Dynamic Buffer Pool



- UPD POOL for OSAM vs VSAM vs a combination of OSAM & VSAM in the same run with Full Function workload

Single Image IMS Full Function workload with 128 MPP regions			
	OSAM	VSAM	OSAM & VSAM
Tran Rate before UPD POOL	851.3 tx/sec	852.2 tx/sec	852.6 tx/sec
Tran Rate During UPD POOL	846.3 tx/sec	628.1 tx/sec	632.9 tx/sec
Total time to process UPD POOL (sec)	.7 sec	16 sec	.7 sec / 17 sec
CPU busy % Before/During/After UPD	36.2% / 36.2% / 36.2%	36.7% / 29.2% / 37.1%	35.7% / 28.6% / 36.4%
Transit execution time	44 msec	43 msec	41 msec
DBBP latch conflict (OSAM only)	44.8/sec	--	43.5/sec

Full Function Dynamic Buffer Pool Impact Analysis



IMS Version 12 Full Function Dynamic Buffer Pool (BMP)



- UPD POOL for OSAM vs VSAM vs a combination of OSAM & VSAM in the same run with 128 MPPs & 4 BMPs

Single Image IMS Full Function workload with 128 MPP regions & 4 BMPs			
	OSAM	VSAM	OSAM & VSAM
Tran Rate before UPD POOL	852.2 tx/sec	852.7 tx/sec	852.6 tx/sec
Tran Rate During UPD POOL	850.1 tx/sec	603.7 tx/sec	605.5 tx/sec
Total time to process UPD POOL (sec)	.7 sec	36 sec	.7 sec / 36 sec
CPU busy % Before/During/After UPD	40.9% / 42.5% / 36.4%	33.5% / 29.4% / 37.4%	41.1% / 22.1% / 37.2%
Transit execution time	42 msec	43 msec	43 msec
DBBP latch conflict (OSAM only)	43.9/sec	--	42.5/sec

Full Function Dynamic Buffer Pool with BMPs Impact Analysis



IMS Version 12 Full Function Dynamic Buffer Pool



- For both scenarios we observed
 - Approximately 26%~29% transaction rate impact to the online system during the command execution against the VSAM data base resource pool
 - Approximately 1% transaction rate impact when the command was issued against our OSAM buffer pools
- Even with the impact to the transaction rate, the UPDATE POOL command provides a convenient way make buffer pool changes to your online system depending on your systems demands



Performance Evaluations: IMS Version 12 Synchronous Shared Queues Enhancement

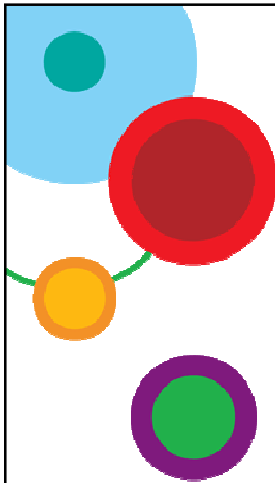

IMS Version 12 Synchronous Shared Queues Enhancement



- New support for using z/OS® cross-system coupling facility (XCF) for communicating between a front-end IMS and a back-end IMS in a shared-queue group for APPC synchronous conversations or OTMA send-then-commit (CM1) transactions with a synchronization level of NONE or CONFIRM
- In these situations, IMS is the synchronization point manager instead of z/OS Resource Recovery Services (RRS)

Information On Demand 2011



IMS Version 12 Synchronous Shared Queues Enhancement



- Both the OTMA and APPC evaluations used three LPARs one for TPNS, one for the Front End (FE) IMS and one for the Back End (BE) IMS

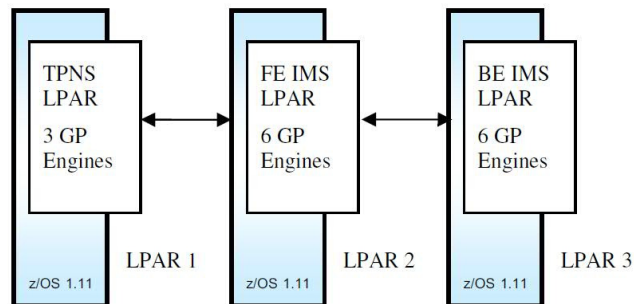

Information On Demand 2011



IMS Version 12 Synchronous Shared Queues Enhancement-OTMA



- 63% ITR Path-length improvement For SYNCLVL=NONE using XCFIMS

V12 OTMA Sync. SQ Enhancement (SYNCLVL=NONE)

	CM1/SL0		Delta	%
	AOS=Y	AOS=X		
ITR	3,910.50	6,375.60	2,465.10	63.04%
FE CPU	37.64%	14.24%	-23.40	-62.18%
BE CPU	91.91%	70.10%	-21.81	-23.74%

RRS (AOS=Y) vs. XCF (AOS=X) ITR Comparison

Information On Demand 2011



IMS Version 12 Synchronous Shared Queues Enhancement-OTMA



- 81% ITR Path-length improvement For SYNCLVL=CONFIRM using XCFIMS

V12 OTMA Sync. SQ Enhancement (SYNCLVL=CONFIRM)

	CM1/SL1		Delta	%
	AOS=Y	AOS=X		
ITR	4,072.24	7,363.85	3,291.62	80.83%
FE CPU	45.04%	20.62%	-24.42	-54.21%
BE CPU	87.00%	65.31%	-21.69	-24.93%

RRS (AOS=Y) vs. XCF (AOS=X) ITR Comparison

Information On Demand 2011



IMS Version 12 Synchronous Shared Queues Enhancement - OTMA



- For SYNCLVL=NONE, when splitting the workload between the IMS Front End and Back End, the path-length (ITR) improved by 27%

V12 OTMA Sync. SQ Enhancement (SYNCLVL=NONE) Split				
	CM1/SLO		Delta	%
	AOS=Y	AOS=X		
Total ITR	5,440.74	6,906.66	1,465.92	26.94%
FE CPU	79.64%	68.09%	-11.55	-14.51%
BE CPU	16.68%	10.43%	-6.25	-37.46%

RRS (AOS=Y) vs XCF (AOS=X) ITR Comparison Split



IMS Version 12 Synchronous Shared Queues Enhancement-APPC



- Significant performance gains in the APPC Sync. SMQ enhancements.
- An average of 78% reduction in CPU utilization for BE and FE IMS
- 35% reduction IFP region occupancy demonstrating quicker transaction transit times
 - 8 IFPs used with 57.13% region occupancy for AOS=Y and 42.12% for AOS=B

IMS V12 APPC Synchronous Shared Queues Enhancement			
	AOS=Y	AOS=B	Delta (Delta %)
ETR	1521	1938	417 (21.51%)
ITR	3135.44	7100.20	3964.73 (126.45%)
FE CPU	59.59%	33.66%	-25.93 (-77.03)
BE CPU	37.43%	20.93%	-16.5 (-78.83%)

RRS (AOS=Y) vs APPC (AOS=B) ITR Comparison



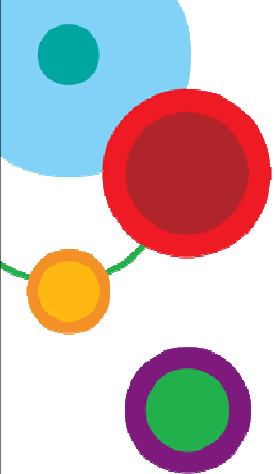

Performance Evaluations: IMS V12 IMS Connect to IMS Connect Enhancement

44

Information On Demand 2011

IMS V12 IMS Connect to IMS Connect Enhancement

- The IMS™ Connect to IMS Connect function introduces the concept of *IMS-to-IMS TCP/IP communications*: two IMS systems communicating with each other across an Internet Protocol network without the requirement of a third-party application to relay the TCP/IP messages between multiple instances of IMS TCP/IP servers (IMS Connect)
- IMS-to-IMS TCP/IP communications supports both the Multiple Systems Coupling (MSC) and Open Transaction Manager Access (OTMA) components of IMS

Information On Demand 2011

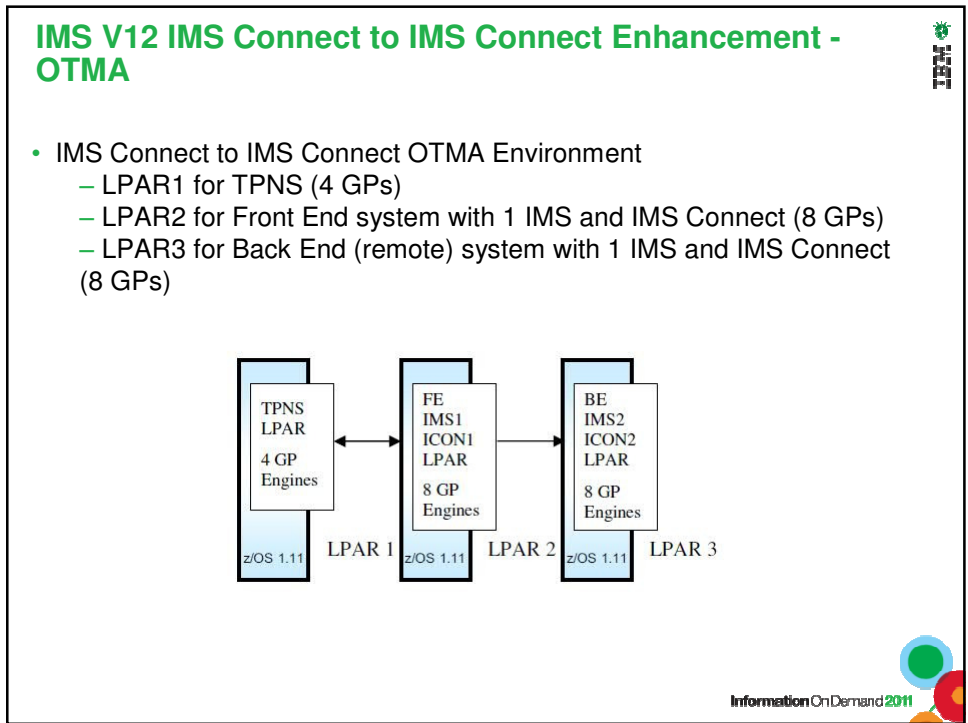
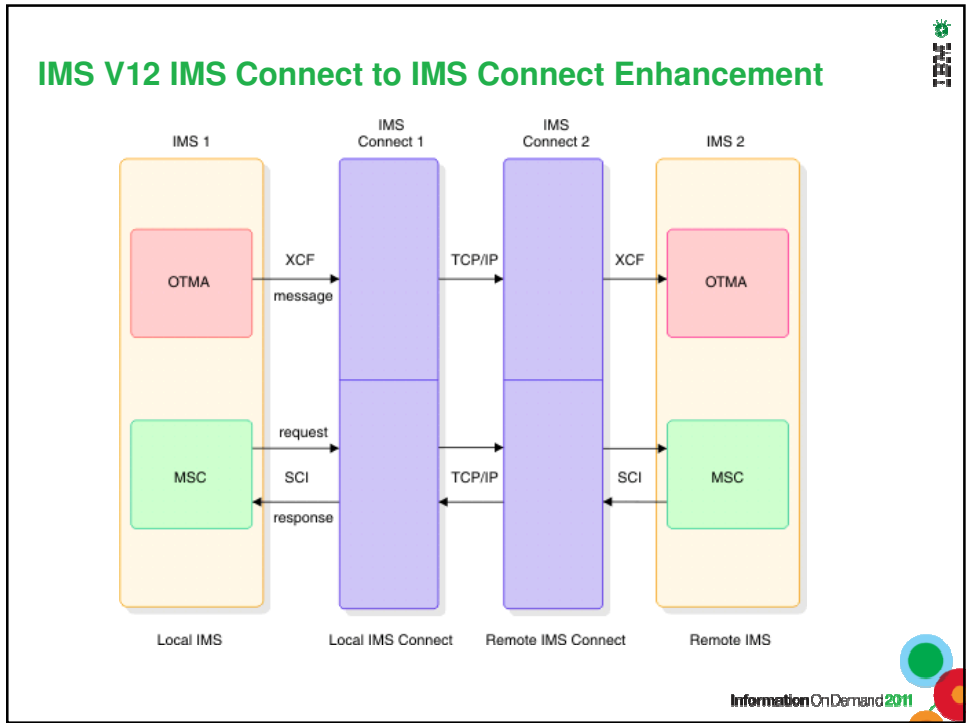

IMS V12 IMS Connect to IMS Connect Enhancement - OTMA



- TPNS drove transactions that issued CHNG and ISRT ALTPCB calls from local application running in 132 MPP regions
- OTMA one-way asynchronous messages distributed among 120 OTMA descriptors to remote site

Information On Demand 2011



IMS V12 IMS Connect to IMS Connect Enhancement - OTMA



- IMS Connect to IMS Connect OTMA Results:

	ICON-ICON OTMA (Send Only)
ETR (sending)	9,570 tx/sec
CPU	81%
ITR (sending)	11,815 tx/sec

IMS Connect to IMS Connect OTMA Benchmark Evaluation

Information On Demand 2011



IMS V12 MSC TCP/IP Enhancement



- The benchmark for the MSC TCP/IP evaluation tested an even distribution of transactions across 32 MSC links to compare
 - VTAM Links
 - TCP/IP Links
- Environment
 - 3 GPs for TPNS simulating 8,000 clients
 - 4 GPs for Front-End (FE) IMS with 32 MSC Links (ESCON CTC)
 - 8 GPs for Back-End (BE) IMS with 64 MPP regions, 32 transactions

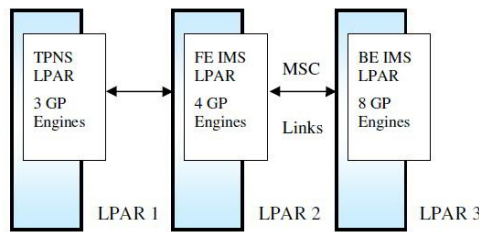

Information On Demand 2011



IMS Version 12 MSC TCPIP Achieves Over 10,500 tx/sec



- Observations
 - Over 10,500 transactions per second achieved with IMS V12 MSC TCPIP

IMS Version 12 MSC TCPIP 16K Buffers (1K message size)	
	TCPIP
ETR	10,587.57
ITR	19,155.22
FE CPU	80.52%
BE CPU	55.27%

MSC TCPIP Benchmark Evaluation

IMS Version 12 MSC VTAM 16K Buffers (1K message size)	
	VTAM
ETR	9,303.86
ITR	16,070.58
FE CPU	81.14%
BE CPU	57.89%

MSC VTAM Benchmark Evaluation

Information On Demand 2011





IMS Version 12 MSC Conclusions

- TCP/IP has a higher bandwidth than VTAM even though TCP/IP has more components to go through (i.e. local and remote SCIs and IMS Connects)
- In the zOS communications server, TCP/IP uses considerable less resources than VTAM. This is believed to be due to a simpler routing technique and less layering
- IMS Connect and SCI have good performance

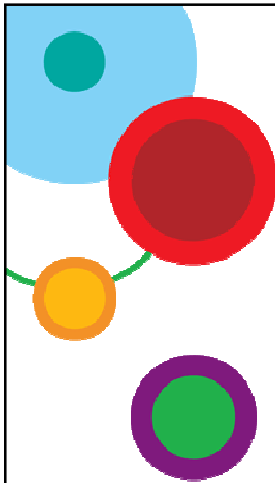

Performance Evaluations: IMS Version 12 Fast Path Secondary Index (FPSI)





IMS Version 12 Fast Path Secondary Index (FPSI)

- FP Secondary Index support provides the infrastructure to enable secondary indexing support for IMS FP data entry databases (DEDBs)
- Allows FP DEDBs to be accessed through secondary key sequence
- IMS automatically performs index maintenance
- Hierarchical indexed sequential access method (HISAM) and simple hierarchical indexed sequential access method (SHISAM) database structures are supported







IMS Version 12 Fast Path Secondary Index (FPSI)

- **Scenario 1** compares when Fast Path Secondary Indexes are defined to a database but not used to determine the performance impact
 - With FPSI defined but not used, there is no significant performance impact

	DEDB with 0 secondary indexes	DEDB with 2 secondary indexes	DEDB with 4 secondary indexes
ETR (UTI=50)	265	265	265
CPU	14.2%	15.3%	15.6%
ITR	1866	1732	1699
Proc. Tm (sec)	.012	.011	.012
DLI Stats. (per second)			
GHU	529 (2.33%)	529 (2.33%)	529 (2.33%)
GHN	10,584 (46.51%)	10,584 (46.51%)	10,585 (46.51%)
REPL	11,113 (48.84%)	11,113 (48.84%)	11,114 (48.84%)

Fast Path Secondary Index (FPSI) Impact Analysis





IMS Version 12 FPSI DEDB vs HDAM

- **Scenario 2** compares DEDB with 2 secondary indexes with HDAM databases with 2 secondary indexes

 Information On Demand 2011



IMS Version 12 FPSI DEDB vs HDAM

	HDAM with 2 secondary indexes	DEDB with 2 secondary indexes	Delta
ETR (UTI=25)	526	471	-55 (10%)
CPU	34%	19%	-15% (-44%)
ITR	1547	2479	+932 (+60%)
I/O Activity (per second)			
Main DB	6542	3693	
Secidx-1	156	136	
Secidx-2	157	135	
DLI Stats. (per second)			
GHU	1,168 (4.47%)	1,006 (4.67%)	
GHN	11,625 (44.53%)	10,398 (44.43%)	
ISRT	29 (0.11%)	25 (0.11%)	
DLET	30 (0.11%)	27 (0.12%)	
REPL	12,206 (46.75%)	10,917 (46.83%)	

Fast Path Secondary Index (FPSI) Comparing HDAM vs DEDB both with 2 secondary indices

 Information On Demand 2011

IMS Version 12 FPSI DEDB vs HDAM



- Scenario 2 Observations
 - DEDB with 2 secondary indexes demonstrated a 60% ITR improvement compared with the same workload against HDAM databases with 2 secondary indexes

Information On Demand 2011



Performance Evaluations: IMS V12 OTMA ACEE Reduction

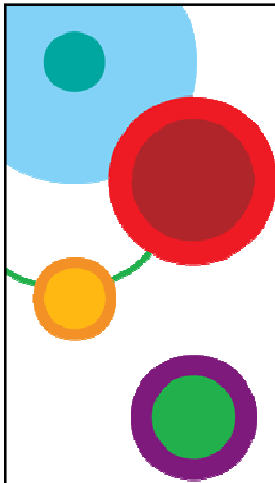

59

Information On Demand 2011





IMS V12 OTMA ACEE Reduction

- OTMA Access Control Environment Element (ACEE) enhancements reduce the ACEE storage needed to run IMS and provide a better security environment for running OTMA transactions

OTMA ACEE Reduction 3K TCP/IP Clients

3K TCP/IP Clients	IMS V11	IMS V12	Delta
CPU	73%	73%	--
ITR	17,532	17,539	--
SUBPOOL 249 (MB)	6.8	1.9	-4.9 (72%)
# of ACEEs	9,000	3,000	-6,000

OTMA ACEE Reduction 10K TCP/IP Clients

10K TCP/IP Clients	IMS V11	IMS V12	Delta
CPU	73%	73%	
ITR	17,542	17,539	
SUBPOOL 249 (MB)	22.5	6.7	-15.8 (70%)
# of ACEEs	30,000	10,000	-20,000

Information On Demand 2011



IMS V12 OTMA ACEE Reduction

- Expect significantly reduced EPVT usage for the IMS control region when many TMEMBERS have the same user IDs
 - Observed 70% EPVT subpool 249 reduction for IMS V12 over IMS V11
 - Greater EPVT subpool 249 savings is expected as the number of OTMA clients increase

Information On Demand 2011



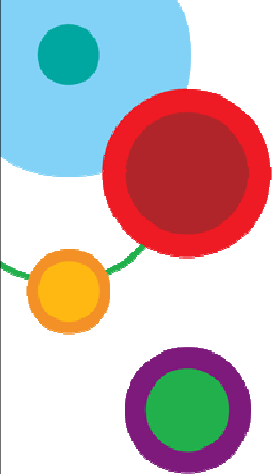

Performance Evaluations: CICS-DBCTL Open Thread Support

62

Information On Demand 2011





CICS-DBCTL Open Thread Support

- With CICS V4R2 and IMS 12
 - DBCTL requests in CICS are now threadsafe
 - The CICS-DBCTL TRUE runs on an L8 TCB
 - Supported from IMS version 12 with APAR PM31420 applied

Information On Demand 2011

CICS-DBCTL Open Thread Support

- Improved throughput:
 - if QR TCB currently running at around 100% CPU
 - CICS DBCTL TRUE runs on an L8 TCB
 - Concurrency (threadsafe/required) programs then continue on the L8 TCB
- Performance tests:
 - Application processing:
 - code below performed 2 times
 - SQL SELECT call
 - DLI PSB schedule
 - DLI GU call
 - run business logic
 - syncpoint call
 - CICS TS V4.2 compared with CICS TS V4.1
 - for both threadsafe and non-threadsafe applications

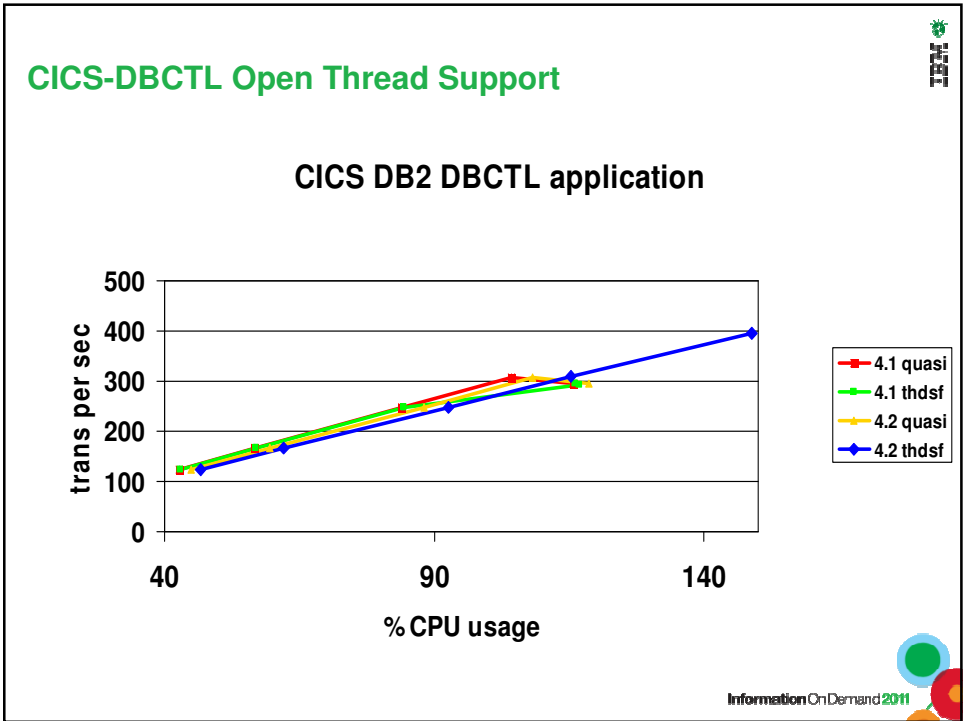
CICS-DBCTL Open Thread Support



- Reduced CPU:
 - for threadsafe tasks running on an L8 TCB
 - L8/QR/L8 TCB switch to run CICS-DBCTL TRUE not required
- Performance tests:
 - Application processing:
 - code below performed 10 times
 - SQL SELECT call
 - DLI PSB schedule call (first time through only)
 - DLI GU call
 - minimal business logic
 - CICS TS V4.2 compared with CICS TS V4.1
 - for both threadsafe and non-threadsafe applications

Information On Demand 2011



CICS-DBCTL CPU benefits



Millisecs of CPU per transaction

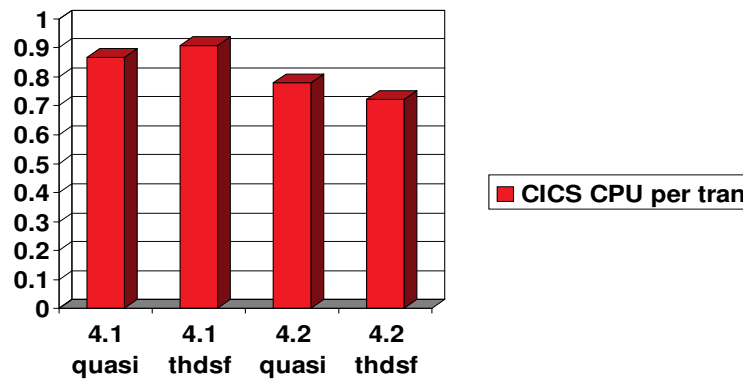

Information On Demand 2011



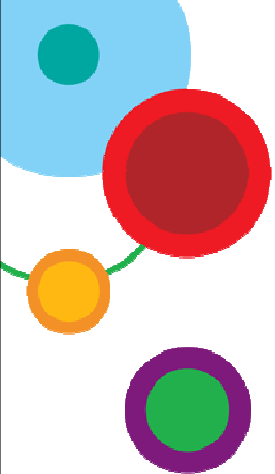

Performance Evaluations: IMS V12 Fast Path High Volume Benchmark

68

Information On Demand 2011

IMS V12 Fast Path High Volume Benchmark

- Environment
 - IBM zEnterprise System z196 (2817)
 - Single IMS LPAR with 7 general purpose processors driven from a separate TPNS LPAR with 4 general processors
 - 48 active IMS Fast Path (IFP) Regions
 - 30,000 terminals - (Terminal Network is simulated by executing TPNS using SNA protocol on separate processors)
 - VTAM internal trace disabled

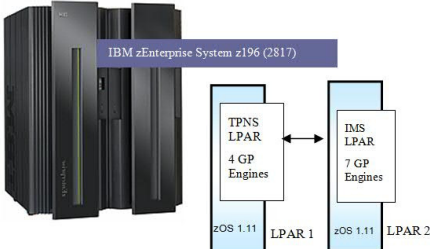



Information On Demand 2011

IMS V12 Fast Path High Volume Benchmark

- Observations

Single Image IMS V12 Fast Path High Stress	
ETR	46,004
CPU Busy %	74.88%
ITR	61,437



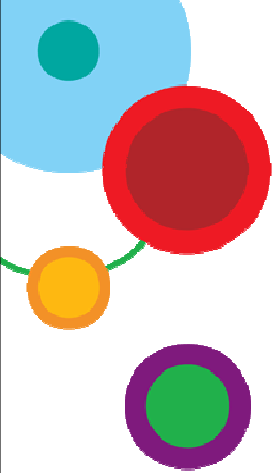

Performance Evaluations: IMS V11 Open Database



71

IMS V11 Open Database

- IMS Open Database provides a standards-based direct interface (Java EE and JDBC) to IMS data from TCP/IP-enabled Windows®, Linux®, HP-UX, Sun Solaris, AIX®, zLinux, and z/OS® platforms
- IMS Open Database provides an integrated distributed data access solution, helping you to integrate IMS assets with other products and platforms across your enterprise and the internet



IMS V11 Open Database

Type 4 scenario used both Single LPAR and cross LPAR scenarios with RRS=Y and RRS=N

Single LPAR Configuration

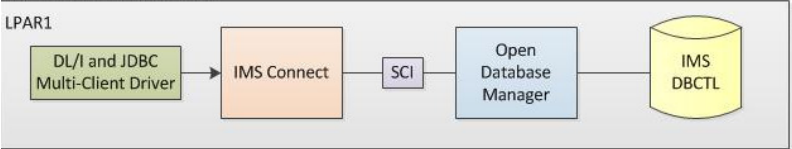

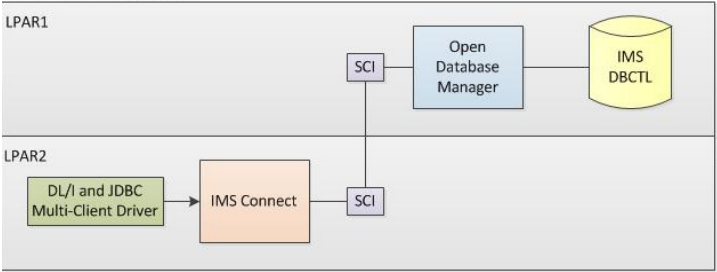
Cross LPAR Configuration







IMS V11 Open Database

	Single LPAR with RRS=Y	Cross LPAR with RRS=Y	Single LPAR with RRS=N	Cross LPAR with RRS=N
ETR	3320	3448	4098	4308
CPU (LPAR 1)	90.56%	70.36%	91.53%	70.64%
CPU (LPAR 2)	N/A	47.70%	N/A	57.02%

 Information On Demand 2011



IMS V11 Open Database

- The Type 2 scenario used 50 JMP regions using the FP2 workload that was rewritten using the IMS Universal Database Drivers for DL/I and JDBC
- Tested on
 - z196
 - z/OS V1R12
 - DS8700
 - Java SDK 6.0.1

	IMS V11	IMS V12	% delta
ETR	9,325.92	9,389.91	0.69%
ITR1 (GCP)	9,455.94	9,567.83	1.18%
ITR2 (GCP+zIIP)	14,461.71	14,501.95	0.28%
GCP	98.63%	98.13%	-0.51%
zIIP	13.28%	14.66%	10.39%
Service Time / Tran (ms)	5.52	5.55	0.59%
Service Units / Tran	26.78	26.57	-0.78%

 Information On Demand 2011

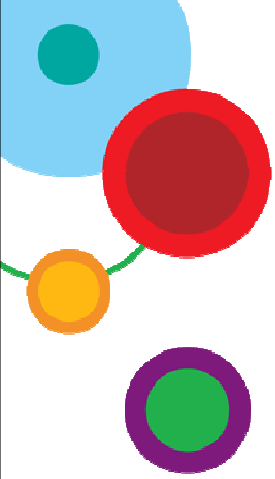

IMS Performance Evaluation Highlights

76

Information On Demand 2011

IMS Performance Evaluation Highlights





- Customers migrating from IMS V11 to IMS V12 should expect equivalent performance in some cases and significant improvements in others depending on the environment
- IMS V12 approaches 4 billion transactions a day, achieving over 46,000 transactions per second in a single image Fast Path environment
- 40-50% ITR improvement (CPU efficiency) with IMS V12 APPC/OTMA Synchronous Shared Queues Enhancement with XCF when compared with the same environments using RRS
- 60% ITR improvement was demonstrated for IMS V12 DEDB with (FPSI) over the equivalent workload using HDAM data base with 2 secondary indices

Information On Demand 2011

IMS Performance Evaluation Highlights



- Logging rates over 350 MB/sec were achieved using the IMS V12 Logger with 64-bit virtual buffering and Sequential Access Method (SAM) striping
- Virtual Storage Constraint Relief, (VSCR) – IMS V12 demonstrated significant ECSA savings, in our sample 64MB, with the use of 64-bit log buffers
- Customers that are logging bandwidth constrained can significantly improve transaction throughput rates and can reduce their batch time (BMP) windows, we have observed gains of twice the throughput in our environment
- Device response time reduced by up to 10% with the enhanced channel program for the IMS V12 WADS devices in comparison to IMS V11 WADS response time rates
- IMS V12 MSC TCPIP Achieves over 10,500 Transactions per second as baseline benchmark number
- Negligible increased processing cost for all the base function measurements

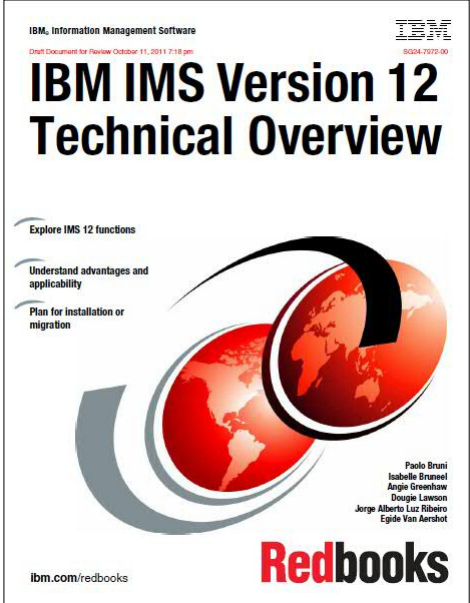

IMS 12 Redbook Announcement



- Just released!
- Discusses all IMS 12 capabilities from a user perspective
- Draft available for free download at <http://www.redbooks.ibm.com>



An Introduction to IMS – Second Edition



- Updated to include IMS 10, IMS 11 and IMS 12 functions
- Available for pre-order
- Will ship December 2011

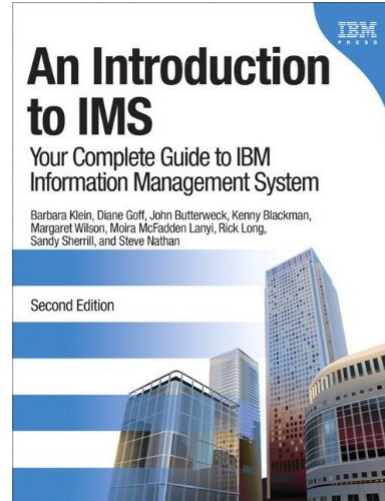

Information On Demand 2011



IMS 12 Performance White Paper is Available



- Detailed results of our internal performance tests
- Environment, functions tested, MIPS and throughput results
- Available for download at www.ibm.com/ims



IMS Version 12 Performance Evaluation Summary

Maintaining superior performance with greater efficiency

IMS Performance Evaluation Team (IBM Silicon Valley Laboratory)
September 2011

Author: Hiram K. Neat

Contributors: Richard Antikoff, Cedric Chen, Manover Dawoodbey, Kevin Hsu, Claudia Ho, Hsiung Tang, Jasdeep Singh, David Vigners, Ya Ying Wang, Mark Zabarth

Abstract

The latest release of one of the most widely used data base and transaction managers, IMS Version 12, exemplifies efficiency. IMS V12 adds a significant amount of critical functionality without any additional overhead. Fast Path Secondary Indexing, DFSMS Extended-Formatted Sequential Logging, Full Function Dynamic Buffer Pools, ICON to ICON Communication, and Fast Path 64-Bit Buffer Expansion/Compression. With its optimized modules IMS V12 proves to demonstrate equal or better CPU efficiency by comparison. This paper illustrates the performance characteristics of the newly enhanced IMS product and the additional functionality now provided therein.

The information provided in this paper was obtained at the IBM Silicon Valley Laboratory and is intended for migration and capacity planning purposes.

© IBM 2011
Software Group
San Jose

Information On Demand 2011





Thank You! Your Feedback is Important to Us

- Access your personal session survey list and complete via SmartSite
 - Your smart phone or web browser at: iodsmartsite.com
 - Any SmartSite kiosk onsite
 - Each completed session survey increases your chance to win an Apple iPod Touch with daily drawing sponsored by Alliance Tech

