

z/VSE Connectors Update

Ingo Franzki
Alina Glodowski

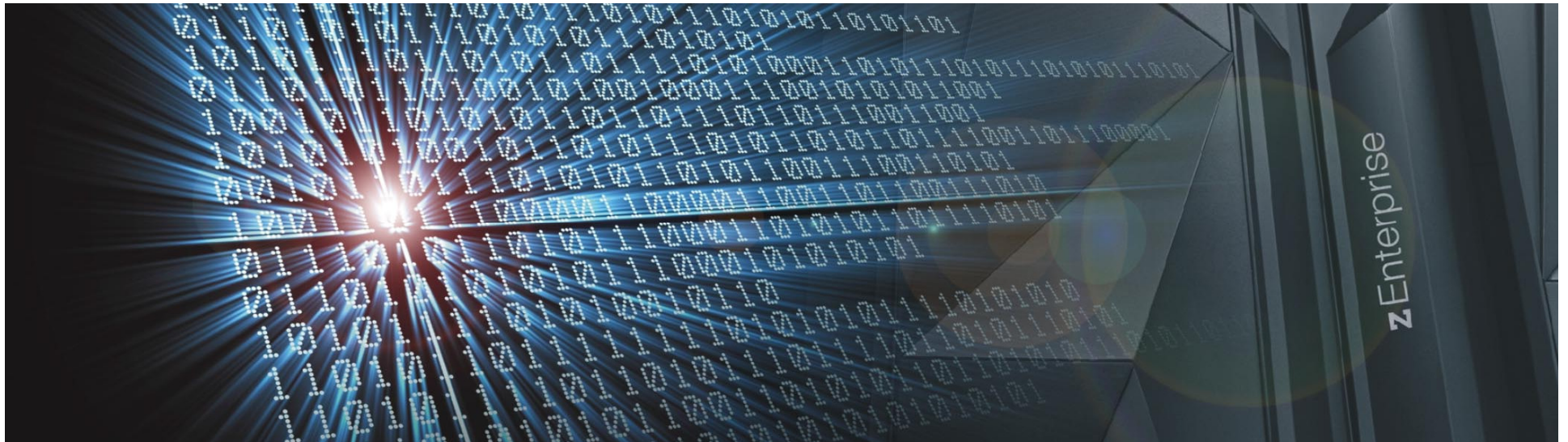

<http://www.ibm.com/zVSE>

<http://twitter.com/IBMzVSE>

Trademarks

The following are trademarks of the International Business Machines Corporation in the United States, other countries, or both.

Not all common law marks used by IBM are listed on this page. Failure of a mark to appear does not mean that IBM does not use the mark nor does it mean that the product is not actively marketed or is not significant within its relevant market.

Those trademarks followed by ® are registered trademarks of IBM in the United States; all others are trademarks or common law marks of IBM in the United States.

For a complete list of IBM Trademarks, see www.ibm.com/legal/copytrade.shtml:

*, AS/400®, e business (logo)®, DBE, ESCO, eServer, FICON, IBM®, IBM (logo)®, iSeries®, MVS, OS/390®, pSeries®, RS/6000®, S/30, VM/ESA®, VSE/ESA, WebSphere®, xSeries®, z/OS®, zSeries®, z/VM®, System i, System i5, System p, System p5, System x, System z, System z9®, BladeCenter®

The following are trademarks or registered trademarks of other companies.

Adobe, the Adobe logo, PostScript, and the PostScript logo are either registered trademarks or trademarks of Adobe Systems Incorporated in the United States, and/or other countries.

Cell Broadband Engine is a trademark of Sony Computer Entertainment, Inc. in the United States, other countries, or both and is used under license therefrom.

Java and all Java-based trademarks are trademarks of Sun Microsystems, Inc. in the United States, other countries, or both.

Microsoft, Windows, Windows NT, and the Windows logo are trademarks of Microsoft Corporation in the United States, other countries, or both.

Intel, Intel logo, Intel Inside, Intel Inside logo, Intel Centrino, Intel Centrino logo, Celeron, Intel Xeon, Intel SpeedStep, Itanium, and Pentium are trademarks or registered trademarks of Intel Corporation or its subsidiaries in the United States and other countries.

UNIX is a registered trademark of The Open Group in the United States and other countries.

Linux is a registered trademark of Linus Torvalds in the United States, other countries, or both.

ITIL is a registered trademark, and a registered community trademark of the Office of Government Commerce, and is registered in the U.S. Patent and Trademark Office.

IT Infrastructure Library is a registered trademark of the Central Computer and Telecommunications Agency, which is now part of the Office of Government Commerce.

* All other products may be trademarks or registered trademarks of their respective companies.

Notes:

Performance is in Internal Throughput Rate (ITR) ratio based on measurements and projections using standard IBM benchmarks in a controlled environment. The actual throughput that any user will experience will vary depending upon considerations such as the amount of multiprogramming in the user's job stream, the I/O configuration, the storage configuration, and the workload processed. Therefore, no assurance can be given that an individual user will achieve throughput improvements equivalent to the performance ratios stated here.

IBM hardware products are manufactured from new parts, or new and serviceable used parts. Regardless, our warranty terms apply.

All customer examples cited or described in this presentation are presented as illustrations of the manner in which some customers have used IBM products and the results they may have achieved. Actual environmental costs and performance characteristics will vary depending on individual customer configurations and conditions.

This publication was produced in the United States. IBM may not offer the products, services or features discussed in this document in other countries, and the information may be subject to change without notice. Consult your local IBM business contact for information on the product or services available in your area.

All statements regarding IBM's future direction and intent are subject to change or withdrawal without notice, and represent goals and objectives only.

Information about non-IBM products is obtained from the manufacturers of those products or their published announcements. IBM has not tested those products and cannot confirm the performance, compatibility, or any other claims related to non-IBM products. Questions on the capabilities of non-IBM products should be addressed to the suppliers of those products.

Prices subject to change without notice. Contact your IBM representative or Business Partner for the most current pricing in your geography.

Notice Regarding Specialty Engines (e.g., zIIPs, zAAPs and IFLs):

- Any information contained in this document regarding Specialty Engines ("SEs") and SE eligible workloads provides only general descriptions of the types and portions of workloads that are eligible for execution on Specialty Engines (e.g., zIIPs, zAAPs, and IFLs). IBM authorizes customers to use IBM SE only to execute the processing of Eligible Workloads of specific Programs expressly authorized by IBM as specified in the "Authorized Use Table for IBM Machines" provided at http://www.ibm.com/systems/support/machine_warranties/machine_code/aut.html ("AUT").
- No other workload processing is authorized for execution on an SE.
- IBM offers SEs at a lower price than General Processors/Central Processors because customers are authorized to use SEs only to process certain types and/or amounts of workloads as specified by IBM in the AUT.

Agenda

- **Connector Updates with z/VSE 5.1 + PTFs**
 - z/VSE Database Connector

- **Connector Updates with z/VSE 5.2**
 - SNMP Monitoring Agent enhancements
 - IPv6 enablement of Connectors
 - LDAP Tools
 - Web Services (SOAP) enhancements
 - POWER XEM Support

- **Summary**

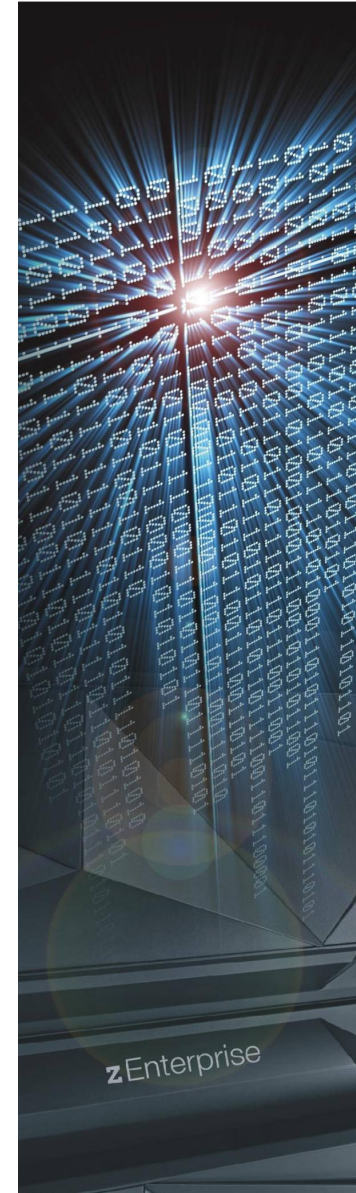

Options for using Databases with z/VSE applications

▪ DB2/VSE or DB2/VM Server

- Local database residing in z/VSE or z/VM
- Lacks support of modern SQL functionality
- Only quite old SQL level supported

▪ DB2/VSE Client Edition

- Remote database (on Linux, Windows, Unix)
- Communication via DRDA protocol
- Same old SQL level supported as DB2/VSE Server
- Can not use modern SQL functionality provided by DB2 LUW
- Can only access remote DB2 databases
 - Other databases (e.g. MS SQL Server, Oracle, etc) can only be accessed through IBM InfoSphere Federation Server

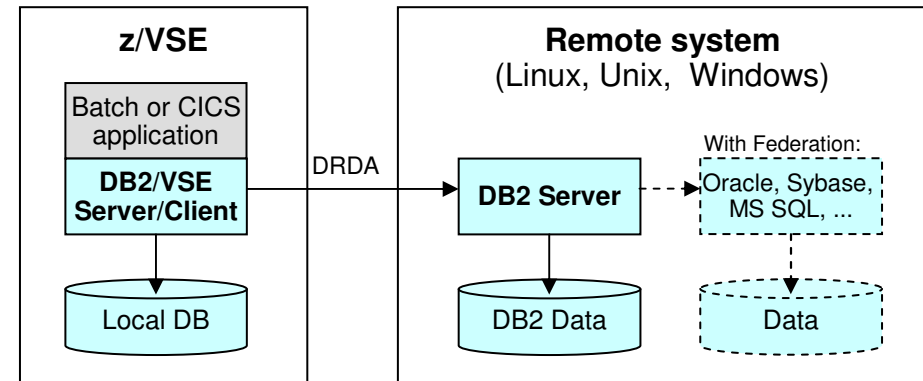

▪ VSAM Redirector

- Primarily used to keep Databases in sync with VSAM data
- Also allows migration from VSAM to database

▪ **New with z/VSE 5.1 + PTFs:** z/VSE Database Call Level Interface

- Allows z/VSE applications to access a relational database on any suitable database server
 - IBM DB2, IBM Informix, Oracle, MS SQL Server, MySQL, etc.
- Utilize advanced database functions and use SQL statements provided by modern database products



z/VSE V5.1 + PTFs: z/VSE Database Call Level Interface (DBCLI)

- **Allows z/VSE applications to access a relational database on any suitable database server**
 - IBM DB2, IBM Informix, Oracle, MS SQL Server, MySQL, etc.
 - The database product must provide a JDBC driver that supports JDBC V3.0 or later
- **Utilize advanced database functions and use SQL statements provided by modern database products**

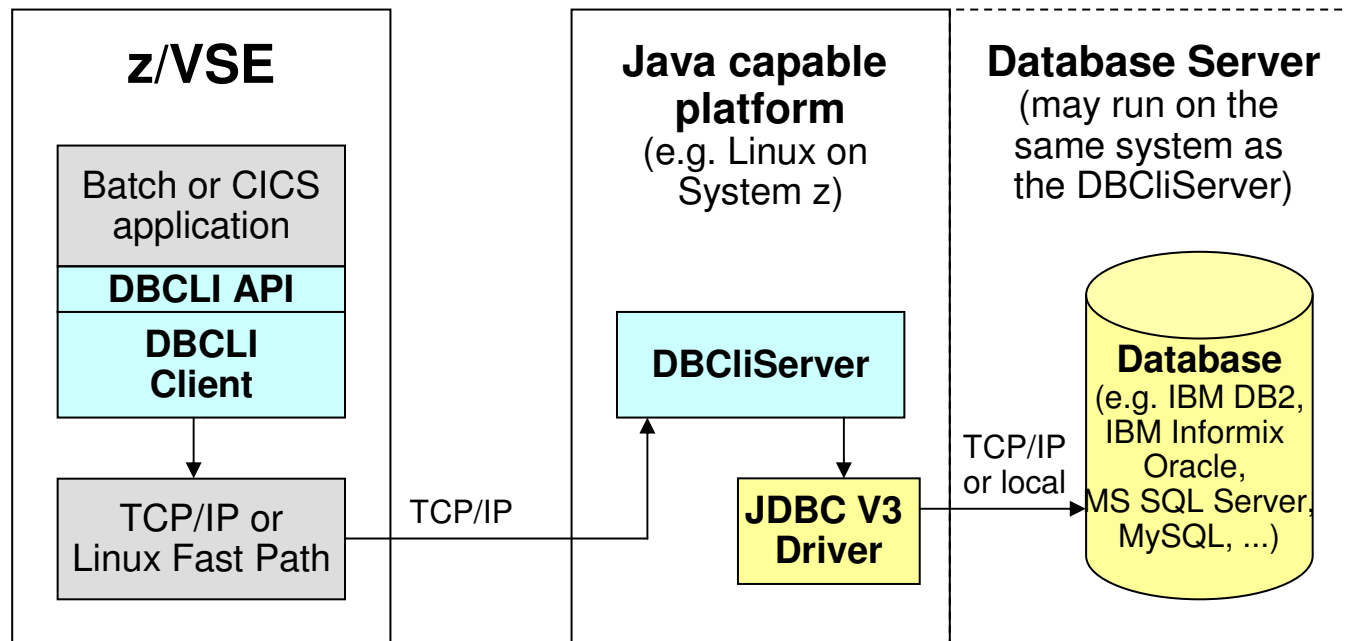

z/VSE V5.1 + PTFs: z/VSE Database Call Level Interface (DBCLI)

- **The z/VSE Database Call Level Interface provides a programming interface (API)**
 - Call interface for use with [COBOL](#), [PL/1](#), [Assembler](#), [C](#) and [REXX](#)
 - Can be used in [Batch](#) as well as in [CICS TS](#) applications
 - Supports LE enabled as well as non-LE environments (Assembler, REXX)

- **It provides callable functions for**
 - [Initializing](#) and [Terminating](#) the API Environment
 - [Connecting](#) and [Disconnecting](#) to/from the DBCLI Server and the Database
 - [Executing](#) SQL Statements
 - Retrieving [query results](#) through cursors
 - Handling of [Logical Units of Work \(Transactions\)](#)
 - Retrieving [Database Meta Data](#)

- **Additional enhancement via PTFs:**
 - [Connection Pooling for CICS](#)

- **The API is not compatible with DB2/VSE's EXEC DB2 preprocessor interface**
 - But it provides similar functions
 - The API is similar to the ODBC programming interface

- **A COBOL example is provided to show how DBCLI can be used in your applications**



Agenda

- **Connector Updates with z/VSE 5.1 + PTFs**
 - z/VSE Database Connector

- **Connector Updates with z/VSE 5.2**
 - SNMP Monitoring Agent enhancements
 - IPv6 enablement of Connectors
 - LDAP Tools
 - Web Services (SOAP) enhancements
 - POWER XEM Support

- **Summary**

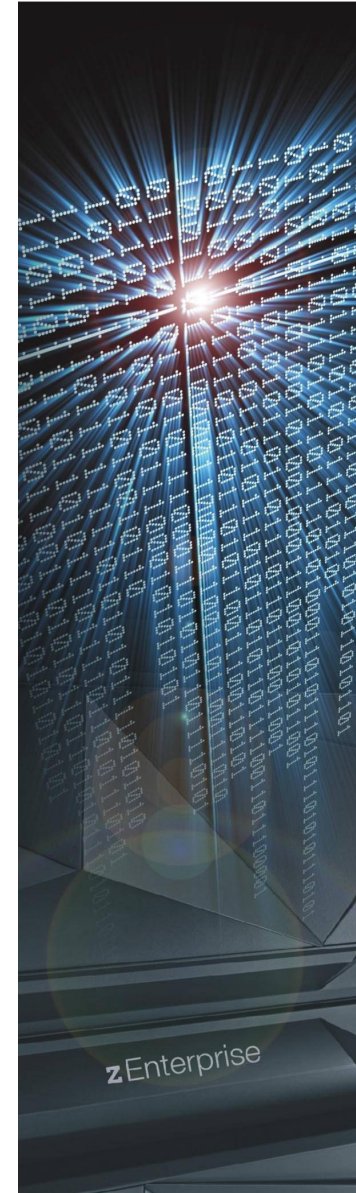
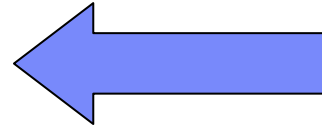

z/VSE 5.2: z/VSE SNMP Monitoring Agent enhancements

- **With z/VSE 4.3 we introduced the z/VSE Monitoring Agent**

- It responds to all SNMP Version 1 requests

- **SNMP Security:**

- The **community string** acts as a 'password'
- The community string is part of each SNMP packet
- Agents only accept SNMP requests if the **community string matches**
- SNMP protocol is not encrypted, the community string **visible each packet**

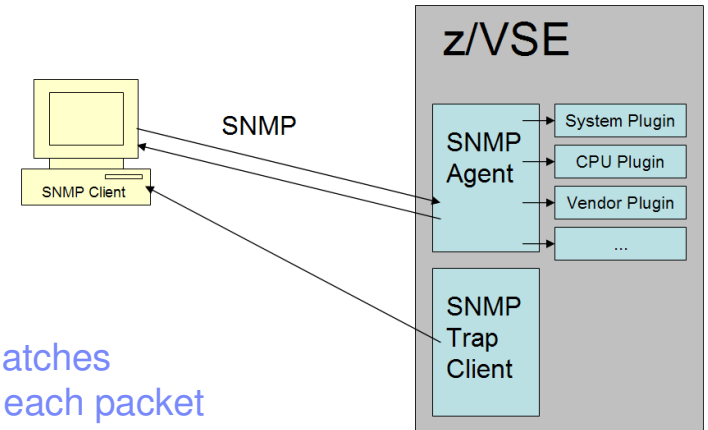

- **To enhance the security of the z/VSE Monitoring Agent, an IP filter has been added:**

- Only if the source IP of an incoming packet matches a rule set the packet will be processed

- **Example:**

- * ALLOWED IPS (IP FILTER)
- * WHEN AT LEAST ONE IP IS SPECIFIED HERE, THE MONITORING AGENT WILL
- * ONLY ALLOW CONNECTIONS FROM THE ALLOWED IPS AND DISCARD CONNECTIONS
- * FROM IPS, WHICH ARE NOT SPECIFIED HERE
- * (ATTENTION: IF YOU SPECIFY IPV6 ADDRESSES, YOU HAVE TO USE THE LONG
- * FORM)

ALLOWEDIP = '192.168.1.5'

ALLOWEDIP = '192.168?.9'

ALLOWEDIP = '10.0.0.*'

ALLOWEDIP = '2001:0db8:0000:09d3:0000:8a2e:0070:7342'

ALLOWEDIP = '2001:0db8:0000:0000:0000:8a2e:*



z/VSE 5.2: IPv6 enabled Connectors

The following components have been IPv6 enabled with z/VSE 5.2

- **e-business Connectors**

- VSE Connector Server and Client
- VSE Script Server and Client
- VSAM Redirector Server
- Database Connector (already IPv6 capable in z/VSE 5.1)
- VSE HTTP Client
- VSE SOAP Client
- VSE LDAP Client

- **SNMP Monitoring Agent and Trap Client**

- **VTAPE**

- II Dialogs dealing with VTAPE

- **CICS Listener (enhanced listener)**

→ **IPv6 support is implemented in a way, that it can transparently run with any TCP/IP stack:**

- If the TCP/IP stack supports IPv6, then you can use IPv6 addresses.
- If the TCP/IP stack supports only IPv4, then you can use IPv4 addresses only.
- If the TCP/IP stack supports both (dual stack), then IPv6 and IPv4 addresses can be used.



Available TCP/IP Stacks in z/VSE

- **TCP/IP for VSE/ESA 1.5(F)**
 - IPv4 only
 - IPv6 support pending
 - Standard applications (IPv4 capable)

- **IPv6/VSE V1.1**
 - The IPv6/VSE product contains 2 TCP/IP stacks
 - IPv6 Stack
 - Provides support for the IPv6 protocol
 - IPv6 application programming interfaces (APIs)
 - IPv6-enabled applications
 - Supports IPv6 only, no IPv4
 - IPv4 Stack
 - Provides support for the IPv4 protocol
 - IPv4 application programming interfaces (APIs)
 - IPv4-enabled applications
 - Supports IPv4 only, no IPv6
 - Dual stack support through coupling of both stacks

- **Fast Path to Linux on System z (LFP)**
 - No full 'Stack', provides Socket APIs only
 - IPv4 and IPv6 (since zVSE 5.1) support (dual stack)
 - Available in z/VM and LPAR (since z/VSE 5.1) environment
 - No applications provided

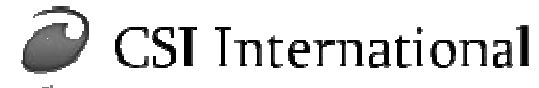

IPv6/VSE is a registered trademark of Barnard Software, Inc



Available Socket APIs

API	Programming languages	Standard / Proprietary	SSL Support	IPv6 Support	Stack support
LE/C Socket API	C	Standard BSD Sockets, mostly compatible with z/OS and other distributed systems (e.g. Unix, Linux, Windows, Mac, ...)	Yes	since z/VSE 5.1, IPv6/VSE and LFP only	TCP/IP for VSE/ESA, IPv6/VSE, LFP
EZA APIs - EZASMI - EZASOCKET	Assembler COBOL, PL/1, Assembler	Standard BSD Sockets, mostly compatible with z/OS	Yes	since z/VSE 4.2 with IPv6/VSE, since z/VSE 5.1 with LFP, too	TCP/IP for VSE/ESA, IPv6/VSE, LFP
CSI SOCKET Macro	Assembler	CSI proprietary	No	No (IPv6/VSE and LFP support IPv6 extensions)	TCP/IP for VSE/ESA, BSI*, LFP* *) Not all features supported
CSI Preprocessor API (EXEC TCP)	COBOL, PL/1, Assembler	CSI proprietary	No	No	TCP/IP for VSE/ESA (BSI provides conversion tool for EXEC TCP to EZA for COBOL programs)
CSI BSD Socket API	C, Assembler (COBOL, PL/1)	BSD-like socket API with limited standard compatibility CSI proprietary	Yes	No	TCP/IP for VSE/ESA
IBM REXX Sockets	REXX	Standard BSD Sockets	Yes	No	TCP/IP for VSE/ESA, BSI, LFP (internally uses LE/C Sockets)
CSI REXX Sockets	REXX	CSI proprietary	No	No	TCP/IP for VSE/ESA

TCP/IP Stack independent Socket APIs

▪ TCP/IP Stack independent Socket APIs typically consists of 2 parts

- A generic part (provided by IBM as part of z/VSE)
- A vendor specific part (provided by the vendor or IBM)

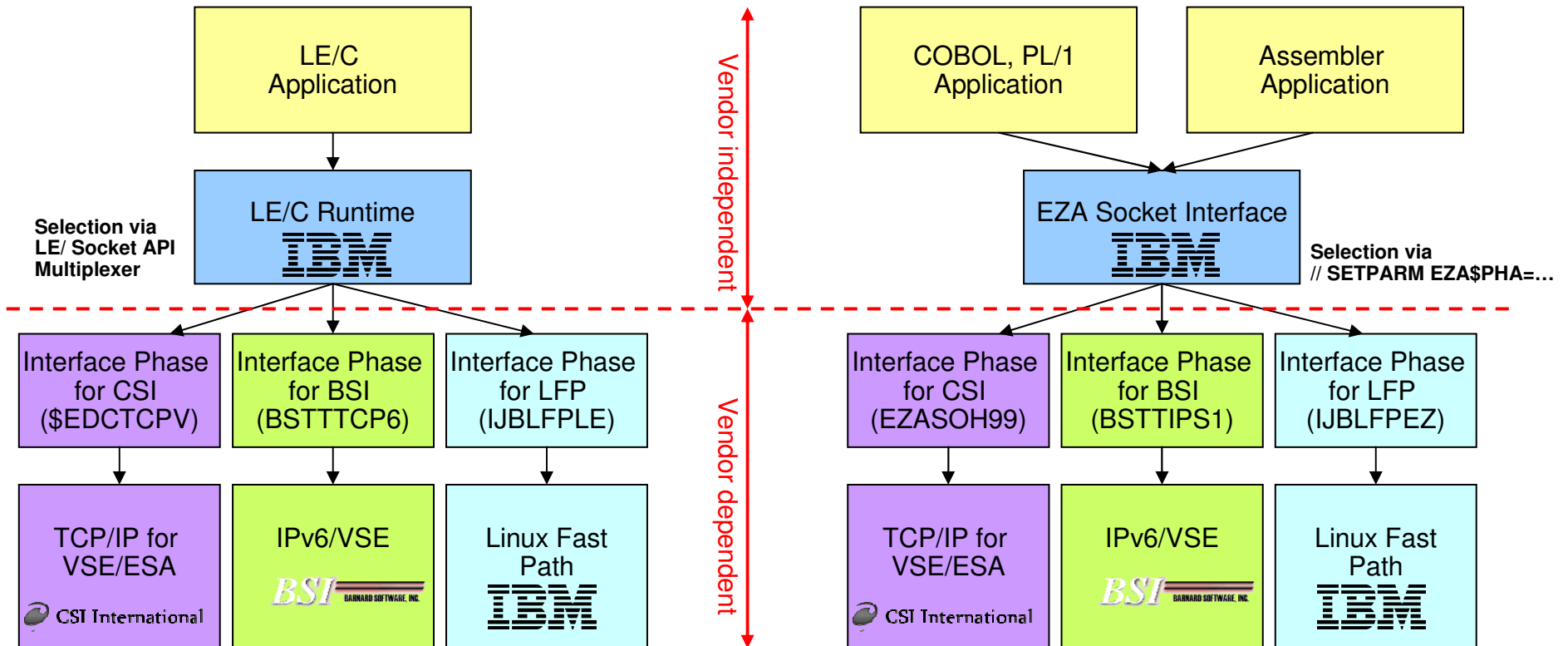

Adding IPv6 support to socket applications

▪ Prerequisite:

- Your application uses a Socket API that supports IPv6:
 - [LE/C or EZA](#)
 - or CSI SOCKET Macro with BSI or LFP

▪ How to make you application work with any of the 3 stacks

- **Either:** Detect the TCP/IP stack vendor and version you are working with
- **Or:** Implement it in a way that works with all stacks

▪ Possible situations:

- **IPv4-only stack** (e.g. CSI stack, BSI IPv4 stack, LFP on z/VSE 4.3)
 - Supports IPv4 only, no IPv6 addresses accepted
 - New IPv6 related socket calls may not be available
- **IPv6-only stack** (e.g. BSI IPv6 stack)
 - Supports IPv6 only, no IPv4 addresses accepted
 - You can connect to IPv6 endpoints only
 - Supports the new IPv6 related socket calls
- **Dual stack** (e.g. BSI IPv6 stack coupled with BSI IPv4 stack, LFP since z/VSE 5.1)
 - Supports both IPv4 and IPv6
 - Supports the new IPv6 related socket calls

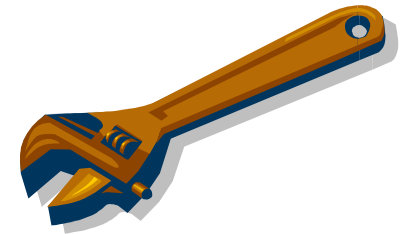

z/VSE 5.2: LDAP Tools

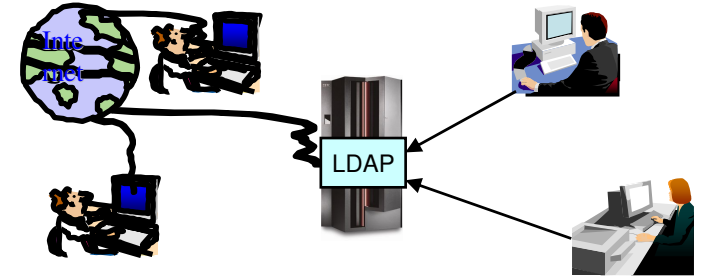

- **LDAP = Lightweight Directory Access Protocol**
- **z/VSE 4.2 added support for Sign-on using LDAP**
 - LDAP API implements a C language application interface to LDAP based on RFC 1823
 - The LDAP API implementation can be found in PRD1.BASE and it is referred to as IESLDAPH.H in z/VSE 4.2 System as C language header file
- **z/VSE V5.2 is now designed to give clients the flexibility to inspect and administrate the LDAP directory on the LDAP server from within the z/VSE system**
- **Batch tools are provided that support these LDAP functions on the LDAP directory:**
 - **LDAP search** to perform a search using specified filters
 - **LDAP add** to add an entry
 - **LDAP modify** to modify an entry
 - **LDAP delete** to delete one or more entries



z/VSE 5.2: LDAP Search Sample

```
// JOB LDAP
// EXEC IESLDSRC
host=ldapHostName
basedn=cn=Manager,dc=maxcrc,dc=com
filter=(dn:cn=Peter Hofmann,ou=People,dc=maxcrc)
psw=secret
/*
```



```
// JOB FIND
// EXEC IESLDSRC
host=ldapHostName
port=123
basedn= ou=database,o=ibm
filter=(sn=glodow*)
attr=email
attr=TelephoneNumber
/*
```



```
#-----
dn: uid=109043724,c=de,ou=database,o=ibm
email: stev.glodowski@de.ibm.com
email: glodowsk@de.ibm.com
TelephoneNumber: 49-7031-16- xxxxxx
#-----
dn: uid=155446724,c=de,ou=database,o=ibm
TelephoneNumber: 49-(0)7031-16- xxxxxx
email: alina.glodowski@de.ibm.com
#-----
```

z/VSE 5.2: LDAP Modify Sample

```
// JOB MODIFY
// EXEC IESLDMDF
host=ldapHostName
binddn=cn=Manager,dc=crc,dc=com
ignoreError=1
ldif
dn:cn=Peter Ho,ou=People,dc=crc,dc=com
changetype:add
-
dn:cn=Peter Ho,ou=People,dc=crc,dc=com
changetype:add
-
dn:uid=user001, ou=People,dc=crc,dc=com
changetype:add
objectclass:inetOrgPerson
cn: User
sn: First
/*
```

```
// JOB MODIFY
// EXEC IESLDMDF
host=ldapHostName
binddn=cn=Manager,dc=ibm,dc=us
ldif
dn:uid=user001,ou=users,o=ibm,c=us
changetype:modify
replace:departmentNumber
departmentNumber:DEP001
-
dn:uid=user001,ou=users,o=ibm,c=us
changetype:modify
delete:departmentNumber
-
dn:uid=user001,ou=users,o=ibm,c=us
changetype:modrdn
newrdn: uid=user008
deleteoldrdn: 1
/*
```

z/VSE 5.2: Web Services (SOAP) enhancements

- z/VSE V5.2 is designed support the **literal encoding style**, in addition to the already supported **SOAP-encoding style**
 - RPC-type Web Services using encoded style
 - **New:** RPC-type Web Services using **literal style**
 - Arrays/Lists support
 - Better support for data types conversion

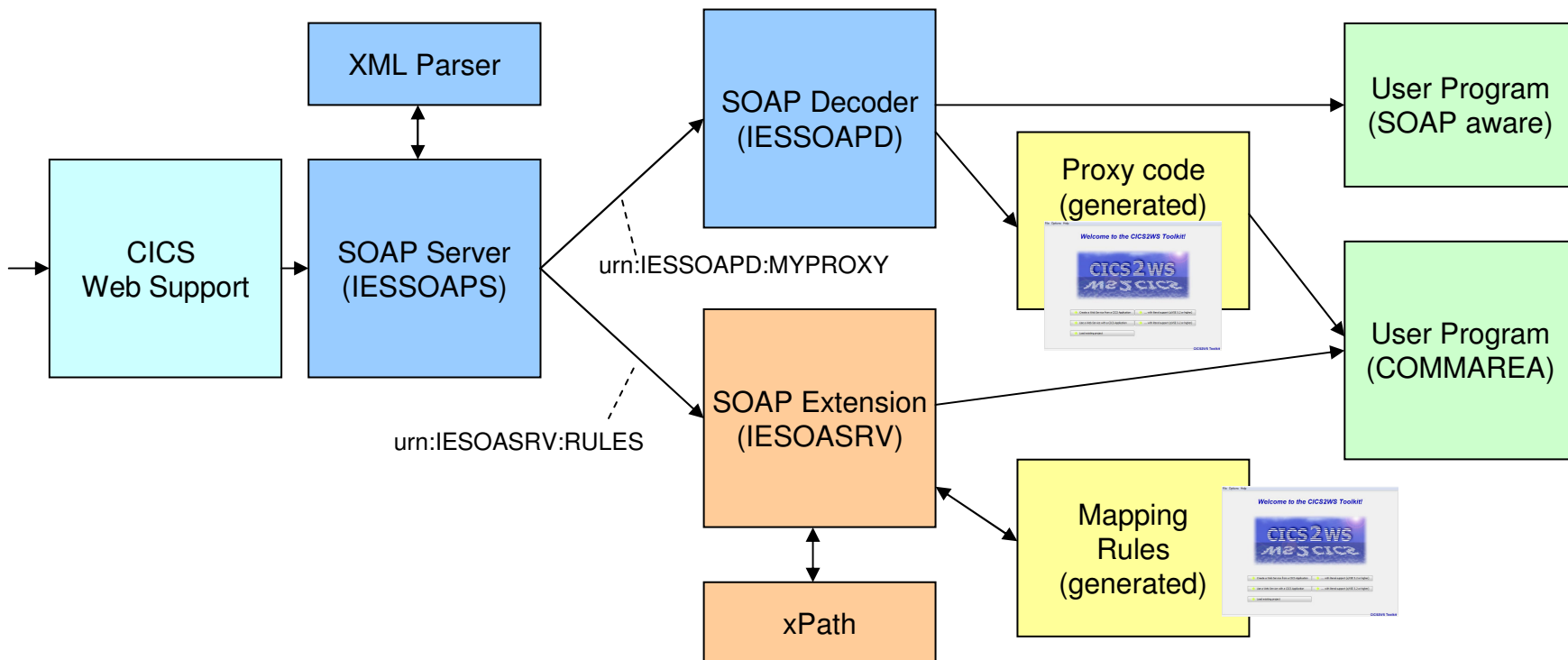

z/VSE 5.2: CICS2WS Tool



z/VSE 5.2: CICS2WS Tool

File Options Help

WSDL Check Choose Operation Authentication Code Creation

Service Information

Service Name:

WSDL File Location:

WSDL Information

Content	COMMAREA name	Type	Length	IDP	Amount	Occur field name
Operations						
changeDate	(SoapAction: 'changeDat...					
getBirthdays	(SoapAction: 'getBirtha...					
Input Parameters						
S T year	year	int	4		1	
Output Parameters						
C T getBirthdaysReturn	ArrayOfBirthdays	ArrayOfBirthdays (Name...	-70		1	
C T person	person	Person (Namespace: 'htt...	70		-1	
S T name	name	string	60		1	
S T birthda			10		1	
getDate	(SoapAction: 'getDate')					
setDate	(SoapAction: 'setDate')					

This WSDL type is an array. You need to define size.

Move Up Move Down Action...

Use the context menu to change names and lengths of parameters to enable the desired method for use. Finally, select a method.

Save Project Back Next Cancel Help

z/VSE 5.2: CICS2WS Tool

File Options Help

WSDL Check Choose Operation Authentication Code Creation

Service Information

Service Name: TestDateRPCLiteralService

WSDL File Location: C:\Users\IBM_ADMIN\Desktop\TestDateRPCLiteral.wsdl

WSDL Information

Content	COMMAREA name	Type	Length	IDP	Amount	Occur field name
Operations						
changeDate	(SoapAction: 'changeDat...					
getBirthdays	(SoapAction: 'getBirthda...					
Input Parameters						
year	year	int	4		1	
Output Parameters						
getBirthdaysReturn	ArrayOfBirthdays	ArrayOfBirthdays (Name...	-70		1	
person	person	Person (Namespace: htt...	70		-1	
name		string	60		1	
birthd...		private	10		1	
getDate						
setDate						

Context Menu:

- Expand Subtree
- Collapse Subtree
- Make array fix length
- Make array variable length
- Change occurs field name
- Change Commarea Name

Move Up Move Down Action...

Use the context menu to change names and lengths of parameters to enable the desired method for use. Finally, select a method.

Save Project Back Next Cancel Help

z/VSE 5.2: CICS2WS Tool: Variable Length List

File Options Help

WSDL Check Choose Operation Authentication Code Creation

Service Information

Service Name: TestDateRPCLiteralService

WSDL File Location: C:\Users\IBM_ADMIN\Desktop\TestDateRPCLiteral.wsdl

WSDL Information

Content	COMMAREA name	Type	Length	IDP	Amount	Occur field name
Operations						
changeDate	(SoapAction: 'changeDat...					
getBirthdays	(SoapAction: 'getBirthda...					
Input Parameters						
year	year	int	4		1	
Output Parameters						
getBirthdaysReturn	ArrayOfBirthdays	ArrayOfBirthdays (Name...	6930		1	
person	person	Person (Namespace: 'htt...	70		-2	PERSONOCCFLD
name	name	string	60		1	
birthday	birthday	private	10		1	
getDate	(SoapAction: 'getDate')					
setDate	(SoapAction: 'setDate')					

Move Up Move Down Action...

Use the context menu to change names and lengths of parameters to enable the desired method for use. Finally, select a method.

Save Project Back Next Cancel Help

z/VSE 5.2: CICS2WS Tool: Copybook

File Options Help

WSDL Check Choose Operation Authentication Code Creation

Generate Copybook

ASM Copybook
 Cobol Copybook
 PL/I copybook

Save Copybook

```
1 Copybook.  
3 year PIC 9(9) COMP.  
3 ArrayOfBirthdays.  
5 PERSONOCCFLD PIC 9(9) COMP.  
5 person OCCURS 1 TO 10 DEPENDING ON PERSONOCCFLD.  
7 name PIC X(40).  
7 birthday PIC X(10).
```

Generate Assembler Rules Code

RULES Name: MYRULES

Service Name: TestDateRPCLiteralService

Service URL: http://localhost:9080/CICS2WS-test00/services/TestDateRPCLiteral

Target Namespace: http://tests

SOAP Action: getBirthdays

Create Code

Choose your code type to save a copybook, then create your Assembler Proxy Code.

Save Project Back Finish Cancel Help

z/VSE 5.2: CICS2WS Tool: More Information

- Setup CICS Web Support

- „How To Use Web Services With z/VSE“

<ftp://public.dhe.ibm.com/eserver/zseries/zos/vse/pdf3/HowToUseWebServicesWithzVSE.pdf>

- CICS2WS Tool

- IBM.com/zVSE → Downloads → CICS2WS Toolkit

<http://www-03.ibm.com/systems/z/os/zvse/downloads/#cics2ws>

- Web Services with z/VSE

- [IBM.com/zVSE](http://www.ibm.com/zvse) → Documentation → Documents & articles → e-business → Web Services (SOAP) with z/VSE

<http://www-03.ibm.com/systems/z/os/zvse/documentation/ebusiness.html#soap>

z/VSE 5.2: VSE/POWER's eXtended Event Messages (XEM) support

- **As of z/VSE 4.3 and 5.1, VSE/POWER can generate the following notification messages for a SAS (Spool Access Support) application:**
 - **Job Generation message 1Q5HI (JGM):**
Informs that the job, submitted via SAS interface, has generated another job as punch output with DISP=I
 - **Job Completion message 1Q5DI (JCM):**
Informs that the job, submitted via SAS interface, has completed
 - **Output Generation message 1Q5RI (OGM):**
Is generated each time when the job, submitted via SAS interface, has created LST or PUN entry, and this entry became ready for processing
- **With these notification messages, a Job Scheduler application can control the whole lifetime of a job:**
 - Job Submission
 - Job Generation (DISP=I)
 - Job Completion
 - Output Generation

z/VSE 5.2: VSE/POWER's eXtended Event Messages (XEM) support

- **With z/VSE 5.2 VSE/POWER adds support for eXtended Event Messages (XEM)**
 - VSE/POWER generates such event messages whenever a POWER entry is created, altered, deleted, etc.
 - Regardless how and by whom the entry was initially created
- **Previous notification messages (JGM, JCM, OGM) can only be requested through a SAS application on job creation**
 - XEM messages are independent on the creator of the entry
- **With XEM support, an application can 'monitor' all activities on VSE/POWER entries**
- **Example:**
 - An application monitors a specific LST class and processes each entry in this class that became dispatchable
 - Kind of like the 'Auto Event Processing' of TCP/IP for VSE
- **Benefits:**
 - XEM avoids polling for new matching entries

z/VSE 5.2: VSE/POWER's eXtended Event Messages (XEM) support

The Java-based Connector exploits XEM messages:

- **XEM messages can be requested and retrieved through the `VSEPower.monitorEvents()` method**
 - For each event, an instance of class `VSEPowerEvent` is passed to the application
 - The application can check the attributes of the event and the affected POWER entry and perform further actions with it

- **An example is provided in source that shows how to use the XEM support**
 - See `PowerEventProcessor.java` in the samples directory
 - The examples shows how to monitor a set of LST and Pun classes
 - For each dispatchable entry in that classes a certain action is performed
 - E.g. Download it from VSE and FTP it to an FTP server
 - Once the action has been performed the entry is deleted or set to DISP=L, dependent on its disposition (DISP=D or K)



Agenda

- **Connector Updates with z/VSE 5.1 + PTFs**
 - z/VSE Database Connector

- **Connector Updates with z/VSE 5.2**
 - SNMP Monitoring Agent enhancements
 - IPv6 enablement of Connectors
 - LDAP Tools
 - Web Services (SOAP) enhancements
 - POWER XEM Support

- **Summary**

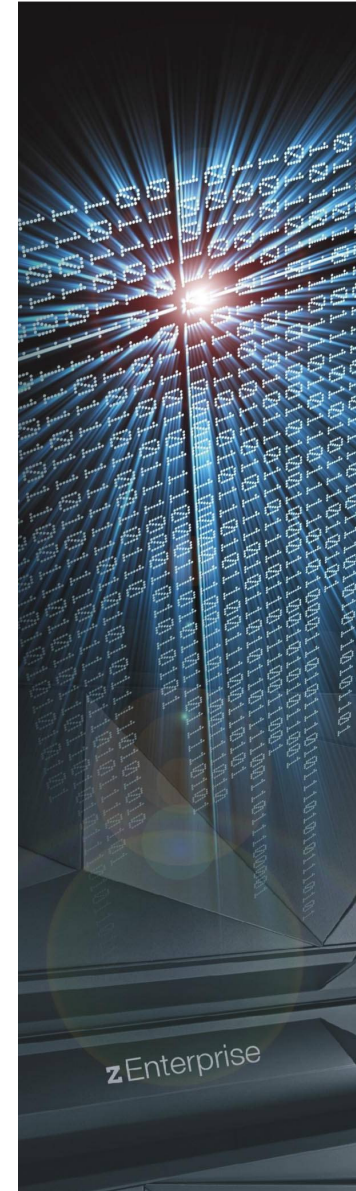
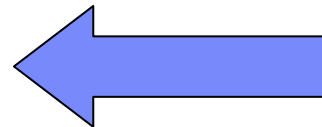

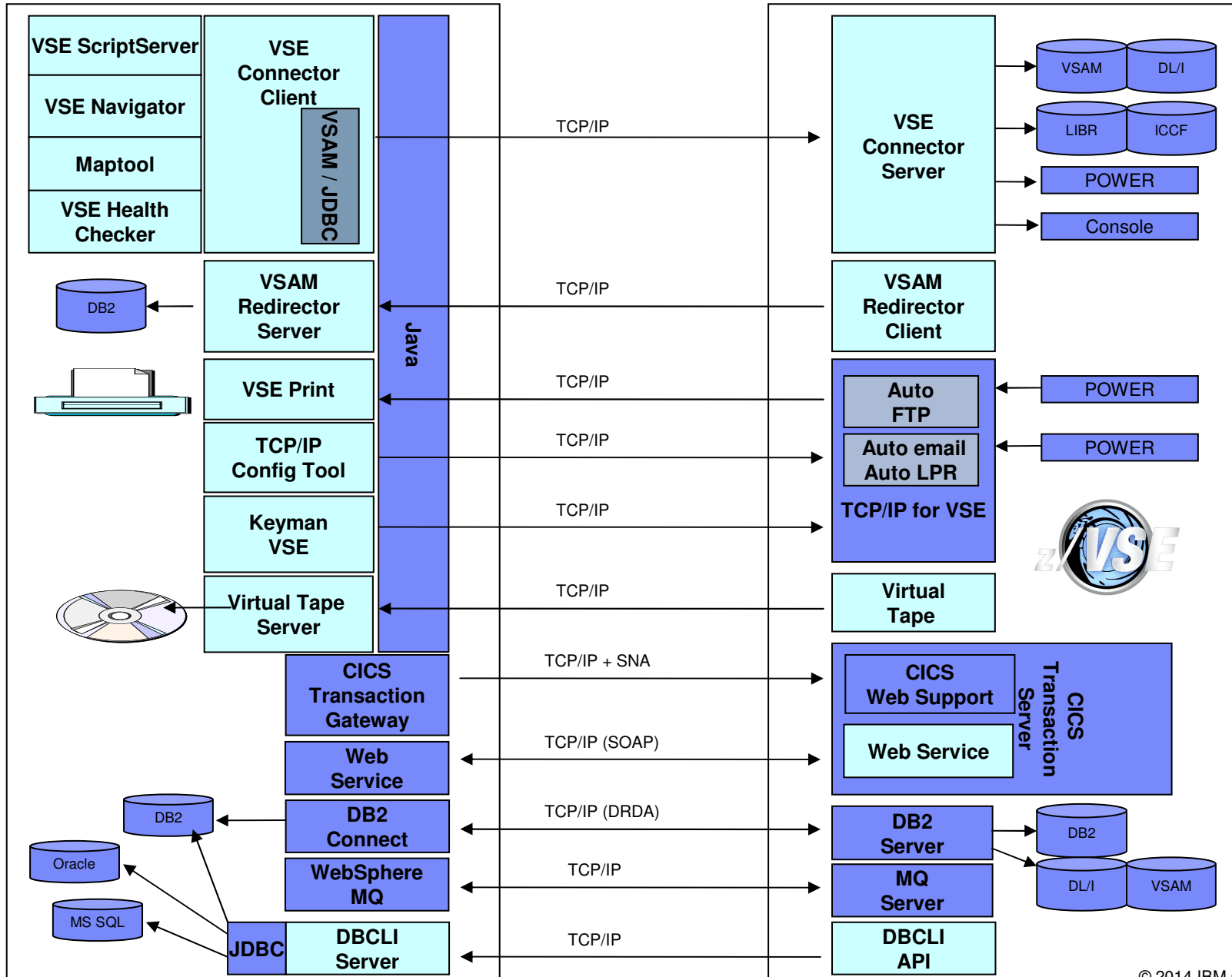

z/VSE Tools & Connector - Downloads

- IBM offers a huge set of tools available on the z/VSE Homepage

<http://ibm.com/zvse/downloads>

- Most tools are 'as is', at no additional charge.
- Connector components (part of z/VSE and officially supported) are also available here
- Information about the Connector Components can be found here:

<http://ibm.com/zvse/products/connectors.html>

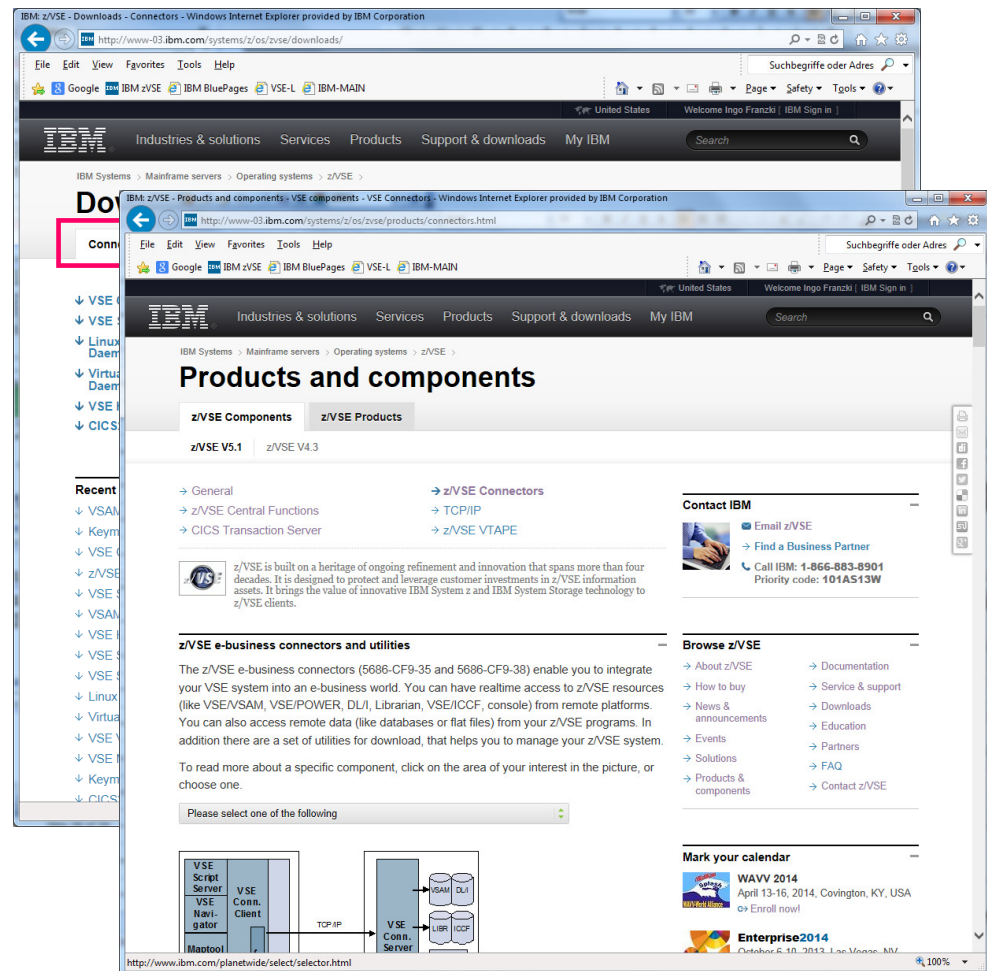

The screenshot displays the IBM z/VSE website's 'Downloads' section. The browser window title is 'IBM z/VSE - Downloads - Connectors - Windows Internet Explorer provided by IBM Corporation'. The address bar shows the URL <http://www-03.ibm.com/systems/z/os/zvse/downloads/>. The page content includes a navigation menu with 'Industries & solutions', 'Services', 'Products', 'Support & downloads', and 'My IBM'. The main heading is 'Products and components'. Below this, there are tabs for 'z/VSE Components' and 'z/VSE Products'. A list of components is shown, including 'z/VSE V5.1' and 'z/VSE V4.3'. A section titled 'z/VSE e-business connectors and utilities' provides information about integrating z/VSE into an e-business world. A diagram at the bottom illustrates the architecture, showing a 'VSE Script Server' and 'VSE Navigator' connected to a 'VSE Conn. Client', which in turn connects via 'TCP/IP' to a 'VSE Conn. Server' that interfaces with 'SAM', 'DLI', 'LIBR', and 'ICCF'.

Thank You



Questions

Please forward your questions or remarks to

zvse@de.ibm.com
ifranzki@de.ibm.com
alina.glodowski@de.ibm.com

z/VSE Live Virtual Classes

z/VSE @ <http://www.ibm.com/zvse/education/>

LINUX + z/VM + z/VSE @ <http://www.vm.ibm.com/education/lvc/>

Read about upcoming LVCs on @ <http://twitter.com/IBMzVSE>

Join the LVC distribution list by sending a short mail to alina.glodowski@de.ibm.com

