

IBM z/VSE



# Planning

*Version 5 Release 1*



IBM z/VSE



# Planning

*Version 5 Release 1*

**Note:** Before using this information and the product it supports, be sure to read the general information under “Notices” on page xiii.

This edition applies to Version 5 Release 1 of IBM z/Virtual Storage Extended (z/VSE), Program Number 5609-ZV5, and to all subsequent releases and modifications until otherwise indicated in new editions.

This edition replaces SC34-2635-01.

Order publications through your IBM representative or the IBM branch office serving your locality. Publications are not stocked at the addresses given below.

A form for readers' comments is provided at the back of this publication. If the form has been removed, address your comments to:

IBM Deutschland Research & Development GmbH  
Department 3248  
Schoenaicher Strasse 220  
D-71032 Boeblingen  
Federal Republic of Germany

You may also send your comments by FAX or via the Internet:

Internet: [s390id@de.ibm.com](mailto:s390id@de.ibm.com)  
FAX (Germany): 07031-16-3456  
FAX (other countries): (+49)+7031-16-3456

When you send information to IBM, you grant IBM a non-exclusive right to use or distribute the information in any way it believes appropriate without incurring any obligation to you.

© Copyright IBM Corporation 1984, 2013.

US Government Users Restricted Rights – Use, duplication or disclosure restricted by GSA ADP Schedule Contract with IBM Corp.

# Contents

<b>Figures</b> . . . . .	<b>ix</b>
--------------------------	-----------

<b>Tables</b> . . . . .	<b>xi</b>
-------------------------	-----------

<b>Notices</b> . . . . .	<b>xiii</b>
--------------------------	-------------

Trademarks . . . . .	xiii
----------------------	------

<b>Accessibility</b> . . . . .	<b>xv</b>
--------------------------------	-----------

Using Assistive Technologies . . . . .	xv
--	----

Documentation Format . . . . .	xv
--------------------------------	----

<b>About This Publication</b> . . . . .	<b>xvii</b>
---	-------------

Who Should Use This Publication . . . . .	xvii
---	------

How to Use This Publication . . . . .	xvii
---------------------------------------	------

Where to Find More Information. . . . .	xvii
---	------

<b>Summary of Changes</b> . . . . .	<b>xix</b>
-------------------------------------	------------

<b>Chapter 1. How to Run z/VSE 5.1</b> . . . . .	<b>1</b>
--	----------

Advantages When Running z/VSE in LPAR mode. . . . .	1
---	---

Advantages when Running z/VSE under z/VM . . . . .	2
--	---

The z/VSE Supervisor . . . . .	2
--------------------------------	---

The z/VSE Turbo Dispatcher . . . . .	2
--------------------------------------	---

CPU Balancing via the SYSDEF TD Command . . . . .	3
---	---

<b>Chapter 2. z/VSE 5.1 Hardware Support</b> . . . . .	<b>5</b>
--	----------

Server Support . . . . .	6
--------------------------	---

Servers Supported by z/VSE 5.1. . . . .	6
---	---

Logical Partitions and LCSS Support . . . . .	6
---	---

Adapter Interruptions Support . . . . .	7
---	---

Support for Dynamic Starting/Stopping of CPUs in an LPAR. . . . .	7
---	---

Signal Quiesce (Signal Shutdown) Support . . . . .	7
--	---

Spanned Channels . . . . .	8
----------------------------	---

Device Address Support Of Up to X'FFFF' . . . . .	9
---	---

Hardware Crypto and CPACF Support . . . . .	11
---	----

Communication Adapter Support . . . . .	12
---	----

FICON Express Features . . . . .	12
----------------------------------	----

OSA Express Features . . . . .	12
--------------------------------	----

Disk Device Support . . . . .	16
-------------------------------	----

Overview of Disk Features Supported by z/VSE . . . . .	17
--	----

Maximum Volume and Minidisk Sizes . . . . .	18
---	----

Parallel Access Volume (PAV) Support . . . . .	18
--	----

Fibre-Channel-Attached SCSI Disk Support. . . . .	19
---	----

SAN Volume Controller (SVC) Support . . . . .	19
---	----

Storwize V7000 Midrange Disk System Support . . . . .	20
---	----

XIV Storage System Support. . . . .	20
-------------------------------------	----

FlashCopy Support. . . . .	20
----------------------------	----

Remote Mirroring and Copy (RMC) Feature . . . . .	21
---	----

Large Volume Support (LVS) and How it is Used . . . . .	22
---	----

By VSE/VSAM . . . . .	22
-----------------------	----

Tape Device Support . . . . .	23
-------------------------------	----

Overview of Tape Drives/Libraries Supported by z/VSE . . . . .	24
--	----

IBM TS1140, TS1130, TS1120, and 3592 J1A Tape Drives . . . . .	26
--	----

TS3400 Autoloader Tape Library . . . . .	27
--	----

IBM TotalStorage 3590/3592 Tape Drives . . . . .	27
--	----

IBM TotalStorage 3490E Tape Drive . . . . .	29
---	----

IBM TS7680 ProtecTIER Deduplication Gateway . . . . .	31
---	----

for System z . . . . .	31
------------------------	----

IBM TS7700 Virtualization Engine . . . . .	32
--	----

IBM TS3500/3584 UltraScalable Tape Library . . . . .	34
--	----

IBM TotalStorage 3494 Tape Library . . . . .	35
--	----

IBM TotalStorage 3494 VTS (Virtual Tape Server) . . . . .	35
---	----

How z/VSE Supports Tape Libraries . . . . .	35
---	----

Virtual Tape Support . . . . .	37
--------------------------------	----

Channel-Related Support . . . . .	38
-----------------------------------	----

Dynamic I/O Handling . . . . .	38
--------------------------------	----

FICON Express, FICON Express2, FICON Express4, and FICON Express8 . . . . .	38
---	----

ESCON. . . . .	38
----------------	----

IBM Enterprise Systems Connection Director (ESCD). . . . .	39
--	----

IBM 9035 ESCON Channel Protocol Converter. . . . .	39
--	----

Devices Not Supported by z/VSE 5.1. . . . .	40
---	----

Programs No Longer Shipped With z/VSE 5.1. . . . .	41
--	----

<b>Chapter 3. z/VSE 5.1 Base and Optional Programs</b> . . . . .	<b>43</b>
--	-----------

z/VSE 5.1 Base Programs. . . . .	43
----------------------------------	----

Base Programs Shipped on the Extended Base . . . . .	43
--	----

Tape. . . . .	43
---------------	----

Base Programs Included in z/VSE 5.1 . . . . .	44
---	----

Where Do the Base Programs Reside? . . . . .	46
--	----

Base Programs That Require Special Attention. . . . .	47
---	----

Further Information . . . . .	48
-------------------------------	----

z/VSE 5.1 Optional Programs . . . . .	48
---------------------------------------	----

<b>Chapter 4. System Organization and Concepts.</b> . . . . .	<b>51</b>
---	-----------

Minimum System Configuration . . . . .	51
--	----

z/VSE System Size . . . . .	52
-----------------------------	----

Storage Support and Layout. . . . .	53
-------------------------------------	----

Real Storage Support . . . . .	53
--------------------------------	----

Virtual Storage Support . . . . .	53
-----------------------------------	----

Address Spaces, Data Spaces, and Virtual Disks . . . . .	55
--	----

Allocating I/O Control Blocks Above 16 MB Line . . . . .	55
--	----

Allocating DL/I PSBs, HD Buffers, Routines, Above 16 MB Line . . . . .	56
--	----

Shared and Private Areas. . . . .	56
-----------------------------------	----

Static and Dynamic Partitions . . . . .	56
---	----

GETVIS Areas . . . . .	57
------------------------	----

Partition IDs and Address Space IDs . . . . .	57
---	----

Summary of System Characteristics and Capabilities . . . . .	58
--	----

Predefined System Environments . . . . .	59
--	----

Selecting a Predefined Environment . . . . .	59
--	----

Environment Characteristics. . . . .	60
--------------------------------------	----

Storage Layout of Predefined Environment A . . . . .	60
--	----

Storage Layout of Predefined Environment B . . . . .	62
Storage Layout of Predefined Environment C . . . . .	64
Page Data Set Definitions. . . . .	66
PASIZE Considerations . . . . .	67
Program SIZE Restrictions . . . . .	67
Using Memory Objects in the 64-Bit Address Space	67
Storage Allocation During System Startup . . . . .	69
Loading Phases into the SVA . . . . .	71
Running z/VSE With More Than 255 Tasks. . . . .	71
Activating the Support for More Tasks . . . . .	71
Attaching Tasks . . . . .	71
How to Display the Status of Subtask Allocation	72
IPL Storage Allocation Parameters . . . . .	72
IPL Supervisor Parameters Command . . . . .	72
IPL SYS Command . . . . .	73
IPL SVA Command . . . . .	73
IPL Commands and Storage Values . . . . .	73
IPL Storage Values for Predefined Environments	75
Real Storage Allocation . . . . .	76
IPL SYS Command RSIZE . . . . .	76
JCL SETPFIX Statement . . . . .	76
Additional Considerations . . . . .	76
Startup Processing after IPL . . . . .	76
Storage Allocation for Static Partitions . . . . .	76
Startup Overview of Predefined Environments . . . . .	77
Static Partition Allocations for Predefined Environments. . . . .	78
Static Partition Allocations for Predefined Environment A . . . . .	78
Static Partition Allocations for Predefined Environment B . . . . .	79
Static Partition Allocations for Predefined Environment C . . . . .	79
Predefined Dynamic Partition Support . . . . .	80
Dynamic Class Table . . . . .	80
Startup Profile . . . . .	80
CICS Transaction Server and VSE/ICCF Interrelationship. . . . .	80
Concepts and Partition Layout . . . . .	81
VSE/ICCF Interactive Partition Layout and Characteristics . . . . .	82
Displaying Storage Layout Information . . . . .	83
<b>Chapter 5. Installing z/VSE 5.1 . . . . .</b>	<b>85</b>
Overview . . . . .	85
How to Install z/VSE 5.1. . . . .	86
Initial Installation . . . . .	86
FSU from z/VSE 4.2.x, z/VSE 4.3.x, or z/VSE 5.1.x to z/VSE 5.1.2. . . . .	86
Comparison Of an Initial Installation With an FSU Release Upgrade . . . . .	86
Shipment of z/VSE 5.1 . . . . .	87
Shipment of z/VSE 5.1 on Distribution Tapes . . . . .	87
Shipment of z/VSE 5.1 on CD-ROM . . . . .	88
Downloading of z/VSE 5.1 Via the Internet. . . . .	89
Considerations for LE/VSE and the VSE C Language Run-Time Support . . . . .	89
TCP/IP Considerations . . . . .	89
DB2 Considerations . . . . .	89
VTAM Considerations . . . . .	89
VTAM Passwords . . . . .	89

Initial Installation of z/VSE 5.1 . . . . .	90
z/VSE Input/Output Configuration Program (IOCP) . . . . .	90
The Initial Installation Process . . . . .	90
Planning Steps for Initial Installation . . . . .	91
Installing z/VSE 5.1 via FSU . . . . .	92
Required Status of Current System . . . . .	92
Restrictions for System Modifications. . . . .	92
DB2 Server for VSE 7.5 . . . . .	93
VSE/VSAM Space Considerations for a Release Upgrade or Service Refresh via an FSU . . . . .	93
Performing the FSU . . . . .	94
Installing the DB2 Server for VSE or DB2 Server for VSE Client Edition . . . . .	94
Installing z/VSE Optional Programs . . . . .	94
Further Installation and Customization Tasks . . . . .	94
Installation Tasks . . . . .	94
Customization Tasks . . . . .	95
VTAM 4.2 Storage Requirements . . . . .	95
VTAM 31-Bit I/O Buffer Support . . . . .	95
SVA Size . . . . .	95
Data Space Sizes for VTAM . . . . .	96
Verifying Storage Allocations and Buffer Definitions. . . . .	98

**Chapter 6. Migrating From Earlier Releases . . . . . 99**

Ways of Performing the Migration. . . . .	99
Overview of the Migration Steps . . . . .	99
Migration Programs and Utilities You Can Use . . . . .	101
Overview of IESBLDUP . . . . .	101
Additional Possible Migration Items. . . . .	101
Migrating From Releases Older Than z/VSE 4.2.x . . . . .	102
Migrating User-Defined System Information . . . . .	103
Explanations to Sample Jobs . . . . .	105
z/VSE-Supplied CICS CSD TYPETERM Definitions . . . . .	105
User-Defined and Modified CICS Parameter Tables . . . . .	106
Migrating Device Definitions . . . . .	106

**Chapter 7. Files and Libraries . . . . . 109**

Standard Label Procedures . . . . .	109
System Files . . . . .	110
System File Assignments . . . . .	110
Requirements for VSE/POWER Files . . . . .	110
VSE/ICCF DTSFILE . . . . .	112
System Work Files. . . . .	112
VSE Control File . . . . .	112
BSM Control File . . . . .	113
LDAP Mapping File . . . . .	113
Text Repository File . . . . .	113
Online Messages File . . . . .	113
Message Routing File. . . . .	113
Other System Files. . . . .	114
Defining Work Files on a Virtual Disk . . . . .	115
Predefined z/VSE Libraries. . . . .	116
VSE Libraries . . . . .	116
IJSYSRS Library . . . . .	118
Space Allocations for Master Catalog in Environments A, B, C. . . . .	119

PRD1 and PRD2 Libraries . . . . .	119
PRD1 Library . . . . .	120
PRD2 Library . . . . .	120
SYSDUMP Library . . . . .	122
PRIMARY Library . . . . .	122
CRYPTO Library . . . . .	123
VSE/ICCF Libraries . . . . .	123
Planning for Private Files . . . . .	124
VSE/VSAM Files . . . . .	124
Non-VSE/VSAM Files . . . . .	124
Creating Standard Labels for Non-VSE/VSAM User Files . . . . .	125
Planning for Private VSE Libraries . . . . .	125
General Recommendations . . . . .	125
Libraries in VSE/VSAM Space . . . . .	125
Libraries in Non-VSE/VSAM Space . . . . .	125

## Chapter 8. Running z/VSE Under VM 127

Introduction . . . . .	127
Summary of z/VSE and VM Operating Environments . . . . .	128
VM Mode V=V . . . . .	128
VM Linkage Support . . . . .	128
Initial Program Load (IPL) . . . . .	129
Performing an IPL From an FCP-Attached SCSI Disk . . . . .	129
Performing an IPL From a Non-SCSI Disk . . . . .	130
Using z/VSE System Activity Dialogs . . . . .	132
Defining a z/VSE Virtual Machine . . . . .	132
Defining a VM Directory Entry . . . . .	132
Defining a CMS Profile EXEC . . . . .	134
Defining a CMS Profile to IPL a SCSI Device . . . . .	136
Defining a z/VSE Console . . . . .	136
Defining Shared Minidisks . . . . .	138
Using SCSI Disks Via the VM-Emulated FBA Support . . . . .	139
Using System Parameter IJBVMID . . . . .	139
Processor Resource/Systems Manager Support . . . . .	140
SQL/DS Guest Sharing Support . . . . .	140

## Chapter 9. z/VSE e-business Connectors and Tools 141

Choosing Between 2-Tier and 3-Tier Environments . . . . .	142
Overview of Available Connectors and Tools . . . . .	142
How the VSE Connector Components Are Installed . . . . .	145
Implementing the DB2-Based Connector . . . . .	146
Initial Installation or FSU . . . . .	147
FSU from z/VSE 4.2.x, z/VSE 4.3.x, or z/VSE 5.1.x to z/VSE 5.1.2 . . . . .	147
Enabling the DB2 Server for VSE . . . . .	148
Summary of the Steps Required to Install the Sample Database . . . . .	149
Use of Installation Member ARISIVAR.Z . . . . .	150

## Chapter 10. TCP/IP and Networking Support. 153

TCP/IP for VSE/ESA Support. . . . .	153
Function Overview . . . . .	153
Installing TCP/IP for VSE/ESA . . . . .	154
TCP/IP for VSE/ESA Startup . . . . .	154

Customizing TCP/IP for VSE/ESA . . . . .	155
Migration Considerations for TCP/IP for VSE/ESA. . . . .	155
IPv6/VSE Support. . . . .	155
Function Overview . . . . .	155
Installing IPv6/VSE . . . . .	156
Installing the Product Key and Customer Number . . . . .	157
IPv6/VSE Startup . . . . .	157
Migration Considerations for IPv6/VSE . . . . .	157
TCP/IP Socket Interfaces Support . . . . .	157
LE/VSE Support for TCP/IP Socket Interfaces Support for the TCP/IP EZA Socket Application Programming Interfaces . . . . .	158
OSA Express QDIO and Non-QDIO Support . . . . .	158
Using OSA Express in QDIO Mode . . . . .	158
Using OSA Express in Non-QDIO Mode . . . . .	158
Using OSA/SF to Manage/Customize the Adapter Environment . . . . .	159
HiperSockets Support . . . . .	160
Exploiting the Queue-I/O Assist Function . . . . .	161
TCP/IP Layer 2 (Data Link Layer) Support . . . . .	161
Virtual LAN (VLAN) Support . . . . .	162
OSA Express for zBX (IEDN) Support . . . . .	162
Linux Fast Path Support. . . . .	163
z/VSE - z/VM IP Assist Support . . . . .	165

## Chapter 11. Using Data Spaces and Virtual Disks. 167

Data Space Support . . . . .	167
Requirements . . . . .	167
1 MB Frame Support for Data Spaces . . . . .	169
Virtual Disk Support . . . . .	169
Requirements . . . . .	169
Where to Use Virtual Disks. . . . .	170
Where Not to Use Virtual Disks . . . . .	170
Performance Considerations for Virtual Disks . . . . .	171
Further Planning Information for Data Spaces and Virtual Disks . . . . .	171
Storage Considerations . . . . .	171
Command and Macro Support . . . . .	171
Examples of Virtual Disk Usage . . . . .	172
Creating a VSE Library that Resides on a Virtual Disk . . . . .	173
Label Area on Virtual Disk . . . . .	173
Improving Virtual Storage Management for Application Programs . . . . .	175
Linkage Stack Functions. . . . .	175
Callable Cell Pool Services . . . . .	175

## Chapter 12. Dynamic Partition Support 177

Dynamic Partition Support Summary . . . . .	177
System Support for Dynamic Partitions. . . . .	177
Which Programs Can Run in Dynamic Partitions? . . . . .	178
Restrictions of Dynamic Partitions . . . . .	179
Planning for Implementation . . . . .	179
Dynamic Class Tables and Dynamic Classes . . . . .	179
Number of Dynamic Partitions Supported. . . . .	180
Customizing Dynamic Partition Support . . . . .	180

Predefined Dynamic Partition Support . . . . .	181
The Predefined Dynamic Class Table . . . . .	182
The Predefined Startup Profiles . . . . .	184
Partition Standard Labels for Dynamic Partitions	184

**Chapter 13. Tailoring System Startup 185**

Components of the Startup Facility . . . . .	185
IPL Procedure . . . . .	186
JCL Startup Procedures and Jobs . . . . .	186
Startup Program DTRISTR1 . . . . .	186
Procedure \$COMVAR . . . . .	186
Procedure CPUVARn . . . . .	187
Startup Modes . . . . .	187
Considerations for Tailoring System Startup . . . . .	188
Tasks for Tailoring System Startup . . . . .	189

**Chapter 14. Tailoring the Interactive Interface . . . . . 191**

Overview of the Interactive Interface . . . . .	191
z/VSE User Profiles . . . . .	191
Interactive Interface Panels . . . . .	192
Panel Hierarchies for Predefined Users . . . . .	193
z/VSE Application Profiles . . . . .	193
Dialogs for Interactive Interface Tailoring . . . . .	194
General Planning Considerations for the Interactive Interface . . . . .	195
Example of Profile-Driven System Views . . . . .	196

**Chapter 15. Setting Up Your CICS Environment. . . . . 197**

Overview. . . . .	197
Major Characteristics of the CICS Transaction Server . . . . .	197
Overview on CICS Skeletons and Tables . . . . .	198
CICS Transaction Server User Profiles . . . . .	199
CICS Transaction Server Monitoring and Statistics Support . . . . .	199
Installing a Second CICS Transaction Server . . . . .	200
Environment Characteristics . . . . .	200
Planning for the Second CICS Transaction Server . . . . .	201
DFH0STAT Considerations . . . . .	203
Activating the APPC Support . . . . .	204
Using the CICS Report Controller to Control/Print Reports . . . . .	204
z/VSE's Implementation of the Report Controller . . . . .	204
Transient Data Queues Used by the Report Controller . . . . .	205

**Chapter 16. Console Support . . . . . 207**

Console Types and Functions Supported . . . . .	207
Supported Console Functions . . . . .	208
Console Types (Logical Level) . . . . .	208
3270 Console Support . . . . .	209
3270 System Console Activation . . . . .	210
Modes of Operation . . . . .	210
Console Definitions . . . . .	210
Macro IJBDEF . . . . .	212
Console Selection and Assignment . . . . .	214

Overview. . . . .	214
IPL System Console Selection . . . . .	215
Message Flow and Message Logging . . . . .	215
Routing Rules . . . . .	215
Recovery Conditions and Actions. . . . .	216
Communicating with the Operator . . . . .	217
Command Processing . . . . .	217
Command Authorization . . . . .	217
New and Changed Commands . . . . .	218
VM/VSE Linkage Functions . . . . .	218
Operating z/VSE from a CMS Console. . . . .	218
Using REXX/VSE for Console Automation . . . . .	220
VSE/POWER Console Considerations . . . . .	220
Command Authorization . . . . .	220
ECHO Support for User Consoles . . . . .	220
Message Prefix Changes. . . . .	220
VSE/ICCF Command Authorization. . . . .	220
JCL Command Authorization . . . . .	221
Security Considerations for the Master Console . . . . .	221
STXIT OC Macro Extensions . . . . .	221
Migration Considerations Related to Console Support . . . . .	222
Initial Program Load (IPL) . . . . .	222
VM Linkage Functions . . . . .	222
Message Prefix Changes. . . . .	222

**Chapter 17. Data Compression Support. . . . . 223**

VSE/VSAM Data Compression Support . . . . .	223
VSE/VSAM Backup/Restore . . . . .	224
VTAM Data Compression Support . . . . .	224
Introducing the CSRCMPSC Programming Interface . . . . .	224

**Chapter 18. Security and Encryption Support. . . . . 227**

Introduction. . . . .	228
History of Security Changes . . . . .	229
Activating BSM or ESM Security Support . . . . .	230
Overview of Security-Support Implementation . . . . .	230
Issuing BSM Security Server Commands . . . . .	232
What BSM Security Provides . . . . .	232
Sign-On (Log-On) Security . . . . .	233
CICS and General Resource Security . . . . .	234
Resource Classes For WebSphere MQ for z/VSE and Other Programs . . . . .	235
BSM Post-Processing Installation Exit BSTXX01 Access Control for z/VSE Resources Defined in DTSECTAB . . . . .	236
Migrating CICS Transaction Security Definitions	237
Creating/Maintaining User Profile Definitions . . . . .	237
Generating BSM Cross Reference Reports . . . . .	238
LDAP Sign-On Support . . . . .	238
Access Control for VSE/POWER Spool Entries . . . . .	239
Support for Logging and Reporting . . . . .	239
Encryption Support . . . . .	240
Support for Crypto Cards . . . . .	240
Support for SSL . . . . .	241
Support for Server and Client Authentication	241
Support for Hardware-Based Tape Encryption	242



Encryption Using the Encryption Facility for z/VSE . . . . .	242
Encryption Using the Encryption Facility for z/VSE OpenPGP . . . . .	243
<b>Chapter 19. Application Development Support . . . . .</b>	<b>245</b>
Programming Language Support . . . . .	245
Integrating Online Applications into the Interactive Interface . . . . .	246
Tailoring Compile Skeletons . . . . .	246
Support of REXX/VSE . . . . .	249
Introduction . . . . .	249
Initialization . . . . .	249
Characteristics of REXX/VSE . . . . .	250
Benefits of the REXX Language . . . . .	250
REXX/VSE Application Enabling Platform . . . . .	251
Running a REXX Program . . . . .	253
Compatibility of REXX/VSE . . . . .	254
Further Information . . . . .	254
Note on VSE/POWER Application Programs . . . . .	254
Adding a User-Written Application to CICS . . . . .	254
Redefining IDs for System Transactions. . . . .	256
<b>Chapter 20. Storage and Tuning Recommendations . . . . .</b>	<b>257</b>
Performance Analysis Process . . . . .	258
z/VSE Exploitation Overview . . . . .	259
Virtual Storage Constraint Relief (VSCR) . . . . .	259
VSE/VSAM Multiple LSR Pools . . . . .	261
CICS Data Tables . . . . .	263
z/VSE Virtual Disks . . . . .	263
General Release Transition Hints . . . . .	265
IPL Commands . . . . .	265
NPARTS Definition . . . . .	266
JCL Statements and AR Commands . . . . .	266
General Recommendations for Allocating Virtual Storage . . . . .	266
SVA Considerations . . . . .	267
VTOC Considerations . . . . .	267
ECKD Devices . . . . .	267
FBA Devices. . . . .	268
VSE Libraries . . . . .	268
System File Placement . . . . .	268
Parallel Page I/O and Page Data Set Extents . . . . .	269
Recommendations for Using DASD Sharing and Lock Files . . . . .	269
File Placement Specifics . . . . .	270
Recommendations for VSE/POWER. . . . .	270
Scheduling VSE/POWER Jobs in Dynamic Partitions. . . . .	271
Recommendations for VTAM . . . . .	271
Recommendations for the CICS Transaction Server . . . . .	272
Buffers for VSE/VSAM Files Accessed from a CICS Partition . . . . .	272

<b>Chapter 21. System Authorization Facility (SAF) and its External Security Interface (RACROUTE) . . . . .</b>	<b>273</b>
System Authorization Facility (SAF) . . . . .	273
z/VSE-Related SAF Changes . . . . .	273
Planning to Use the SAF Router Exit ICHRTX00 . . . . .	274
<b>Appendix A. Startup Procedures . . . . .</b>	<b>275</b>
List of IPL, JCL, and Label Procedures . . . . .	275
Example of an IPL Procedure . . . . .	276
<b>Appendix B. z/VSE Disk Layouts (DOSRES, SYSWK1) . . . . .</b>	<b>277</b>
IBM 3380 Disks. . . . .	278
DOSRES ----- IBM 3380 Disk . . . . .	278
SYSWK1 ----- IBM 3380 Disk . . . . .	279
IBM 3390 Disks. . . . .	280
DOSRES ----- IBM 3390 Disk . . . . .	280
SYSWK1 ----- IBM 3390 Disk . . . . .	282
IBM FBA (and SCSI) Disks . . . . .	283
DOSRES ----- IBM FBA (and SCSI) Disks . . . . .	283
SYSWK1 ----- IBM FBA (and SCSI) Disks . . . . .	284
<b>Appendix C. Dialogs of the Interactive Interface . . . . .</b>	<b>285</b>
<b>Appendix D. Additional z/VSE Applications . . . . .</b>	<b>291</b>
<b>Appendix E. Reserved Names of the Interactive Interface . . . . .</b>	<b>293</b>
<b>Appendix F. z/VSE Skeletons and REXX/VSE Procedures . . . . .</b>	<b>295</b>
Startup Skeletons . . . . .	295
Skeletons for e-business Connectors Support . . . . .	296
Skeletons for the CICS Transaction Server . . . . .	297
Skeletons for Using RPG II With the CICS Transaction Server. . . . .	298
Skeletons for Job Accounting . . . . .	298
Skeletons for Libraries . . . . .	299
Skeletons for VSE/POWER. . . . .	299
Skeletons for VSE/ICCF. . . . .	299
Skeletons for Network Definitions . . . . .	299
Skeletons for the Linux Fast Path (LFP). . . . .	300
Skeleton for a Virtual LAN (VLAN) . . . . .	300
Skeletons for the Capacity Measurement Tool (CMT). . . . .	300
Skeletons for Compiling Programs That Use the TCP/IP Preprocessor. . . . .	301
Delete Skeletons . . . . .	301
Skeletons for Debugging . . . . .	301
Resource Definition and other Skeletons . . . . .	302
Skeletons for Workstation File Transfer Support . . . . .	303
REXX/VSE Procedures . . . . .	304
<b>Appendix G. Devices Supported . . . . .</b>	<b>307</b>
Disk Devices . . . . .	307

Tape Devices . . . . .	308
IBM TotalStorage Tape Libraries . . . . .	308
Printers . . . . .	308
Channel-Attached Printers . . . . .	308
SNA LU 6.2 Attached Printers . . . . .	309
Advanced Function Printing Family, SNA-Attached . . . . .	309
Advanced Function Printing Family, LU1 . . . . .	309
Advanced Function Printing Family, SNA-Token Ring Attached . . . . .	310
Advanced Function Printing Family, Channel-Attached . . . . .	310
Terminal Printers and Channel-Attached Line Printers . . . . .	310

Display Stations . . . . .	311
Communication Control Units . . . . .	311
Communication Adapters . . . . .	311
Reader/Punch Devices . . . . .	312
Personal Computers . . . . .	312
3270 Terminal Emulation . . . . .	312

**Glossary . . . . . 313**

**Index . . . . . 331**

---

## Figures

1. Access to a Shared Tape Drive . . . . .	30	12. Sample PROFILE EXEC for Two z/VSE Guest Machines (in REXX) . . . . .	135
2. Connection Between a Processor and I/O Control Unit via an ESCD Device . . . . .	39	13. Access Path to Shared VM Minidisks . . . . .	138
3. Storage Layout of Predefined Environment A . . . . .	61	14. TCP/IP Startup Skeleton SKTCPSTR . . . . .	154
4. Storage Layout of Predefined Environment B . . . . .	63	15. The Difference Between Address Spaces and Data Spaces . . . . .	168
5. Storage Layout of Predefined Environment C . . . . .	65	16. Predefined Dynamic Class Table (DTR\$DYNC.Z). . . . .	183
6. Using Memory Objects in the 64-Bit Address Space . . . . .	68	17. Default Startup Profile STDPROF . . . . .	184
7. Address Space Layout and Related IPL Parameters . . . . .	70	18. Default Startup Profile PWSPROF. . . . .	184
8. CICS Transaction Server - VSE/ICCF Partition Layout . . . . .	82	19. Example of a Selection Panel . . . . .	193
9. Example of a z/VSE IPL Process (\$IPLESA) From a SCSI Disk . . . . .	130	20. Example of a FULIST . . . . .	194
10. Example of a z/VSE IPL Procedure (\$IPLESA) From a Non-SCSI Disk . . . . .	131	21. Profile-Driven System Views . . . . .	196
11. Example of a VM Directory . . . . .	133	22. Logical Structure of BSM Security Support . . . . .	233
		23. Example of an IPL Procedure (for Environment A). . . . .	276



---

## Tables

1. Encryption Support Available With System z Servers . . . . .	11	34. Allocations for PRD1 and PRD2 Library . . . . .	121
2. FICON Support Available With System z Servers . . . . .	12	35. SYSDUMP Library Allocation . . . . .	122
3. OSA Express4S Features Available With System z Servers. . . . .	12	36. VSE/ICCF Libraries . . . . .	123
4. OSA Express3 Features Available With System z Servers. . . . .	13	37. Summary of System Functions Supported for VM Mode V=V . . . . .	128
5. OSA Express2 Features Available With System z Servers. . . . .	13	38. Available z/VSE e-business Connectors and Tools . . . . .	142
6. OSA Express Features Available With System z Servers . . . . .	13	39. Restrictions of Dynamic Partitions . . . . .	179
7. CHPID Types Supported by OSA Express4S, OSA Express3, OSA Express2, and OSA Express Features . . . . .	14	40. Tasks for Tailoring System Startup . . . . .	189
8. IBM Disk Feature Support . . . . .	17	41. z/VSE Predefined User Profiles . . . . .	191
9. Maximum Volume/Minidisk Sizes . . . . .	18	42. CICS Skeletons and Tables . . . . .	198
10. Tape Drives Supported by z/VSE . . . . .	24	43. System Files and Disk Space Needed for Second Predefined CICS Transaction Server . . . . .	202
11. Tape Libraries Supported by z/VSE . . . . .	25	44. Supported Console Functions . . . . .	208
12. Defining/Adding IBM 3480/3490 Tape Devices	29	45. Supported Console Types (Logical Level)	209
13. Characteristics of IBM 3490/3490E Tape Devices . . . . .	30	46. Predefined PF-Key Settings . . . . .	210
14. Base Programs Included in z/VSE 5.1 . . . . .	44	47. Compile Skeletons in VSE/ICCF Library 2	248
15. Location of z/VSE Base Programs . . . . .	46	48. Checklist for Exploiting z/VSE Capabilities	261
16. Optional Programs for z/VSE 5.1 . . . . .	48	49. z/VSE Virtual Disk Functionality . . . . .	264
17. z/VSE 5.1 System Characteristics and Capabilities . . . . .	58	50. IPL, JCL, and Label Procedures for Initial Installation . . . . .	275
18. Predefined Environments: VSIZE, Number of Address Spaces and Partitions . . . . .	59	51. Minimum Cylinders/Blocks Required, per Disk Type, for Environments A, B, C. . . . .	277
19. Values of PASIZE, NPARTS, Data Space, and GETVIS for z/VSE Predefined Environments . . . . .	59	52. DOSRES Layout for an IBM 3380 Disk	278
20. IPL Commands and Storage Values . . . . .	74	53. SYSWK1 Layout for an IBM 3380 Disk	279
21. IPL Storage Values as Set for Predefined Environments . . . . .	75	54. DOSRES Layout for an IBM 3390-1 Disk	280
22. Skeletons and Procedures for Storage Allocation (Static Partitions) . . . . .	76	55. SYSWK1 Layout for an IBM 3390-1 Disk	282
23. Startup Overview of z/VSE Predefined Environments . . . . .	77	56. DOSRES Layout for an FBA (and SCSI) Disk	283
24. Storage Values for Static Partitions (Environment A) . . . . .	78	57. SYSWK1 Layout for an FBA (and SCSI) Disk	284
25. Storage Values for Static Partitions (Environment B) . . . . .	79	58. Dialogs of the Interactive Interface . . . . .	285
26. Storage Values for Static Partitions (Environment C) . . . . .	79	59. Additional z/VSE Applications . . . . .	291
27. Characteristics of the Predefined VSE/ICCF Interactive Partitions . . . . .	83	60. Startup Skeletons . . . . .	295
28. Comparing Initial Installation against FSU	86	61. Skeletons for e-business Connectors Support	296
29. Mapping of CICS Parameter Table Names to CSD TYPETERM Definitions . . . . .	105	62. Skeletons for the CICS Transaction Server	297
30. Procedures for System File Assignments	110	63. Skeletons for Using RPG II With the CICS Transaction Server . . . . .	298
31. Examples of DBLK Sizes and Default DBLK	111	64. Skeletons for Job Accounting . . . . .	298
32. Overview of VSE Libraries and Sublibraries	116	65. Skeletons for Libraries . . . . .	299
33. Allocations for the Master Catalog in Environments A, B, and C . . . . .	119	66. Skeletons for VSE/POWER . . . . .	299
		67. Skeletons for VSE/ICCF . . . . .	299
		68. Skeletons for Network Definitions . . . . .	299
		69. Skeletons for the Linux Fast Path (LFP)	300
		70. Skeleton for a Virtual LAN (VLAN) . . . . .	300
		71. Skeletons for the Capacity Measurement Tool (CMT) . . . . .	300
		72. Skeletons for Compiling Programs That Use the TCP/IP Preprocessor. . . . .	301
		73. Delete Skeletons . . . . .	301
		74. Skeletons for Debugging . . . . .	301
		75. Resource Definition and other Skeletons	302
		76. Skeletons for Workstation File Transfer Support . . . . .	303
		77. REXX/VSE Procedures . . . . .	304



---

## Notices

References in this publication to IBM products, programs, or services do not imply that IBM intends to make these available in all countries in which IBM operates. Any reference to an IBM product, program, or service is not intended to state or imply that only that IBM product, program, or service may be used. Any functionally equivalent product, program, or service that does not infringe any of the intellectual property rights of IBM may be used instead of the IBM product, program, or service. The evaluation and verification of operation in conjunction with other products, except those expressly designated by IBM, are the responsibility of the user.

IBM may have patents or pending patent applications covering subject matter in this document. The furnishing of this document does not give you any license to these patents. You can send license inquiries, in writing, to the IBM Director of Licensing, IBM Corporation, North Castle Drive, Armonk, NY 10504-1785, U.S.A.

Any pointers in this publication to non-IBM websites are provided for convenience only and do not in any manner serve as an endorsement. IBM accepts no responsibility for the content or use of non-IBM websites specifically mentioned in this publication or accessed through an IBM website that is mentioned in this publication.

Licensees of this program who wish to have information about it for the purpose of enabling: (i) the exchange of information between independently created programs and other programs (including this one) and (ii) the mutual use of the information which has been exchanged, should contact:

IBM Deutschland GmbH  
Dept. M358  
IBM-Allee 1  
71139 Ehningen  
Germany

Such information may be available, subject to appropriate terms and conditions, including in some cases payment of a fee.

---

## Trademarks

IBM, the IBM logo, and [ibm.com](http://ibm.com) are trademarks or registered trademarks of International Business Machines Corp., registered in many jurisdictions worldwide. Other product and service names might be trademarks of IBM or other companies. A current list of IBM trademarks is available on the web at "Copyright and trademark information" at [www.ibm.com/legal/copytrade.shtml](http://www.ibm.com/legal/copytrade.shtml).

Adobe, the Adobe logo, PostScript, and the PostScript logo are either registered trademarks or trademarks of Adobe Systems Incorporated in the United States, and/or other countries.

Linux is a registered trademark of Linus Torvalds in the United States, other countries, or both.

Microsoft, Windows, Windows NT, and the Windows logo are trademarks of Microsoft Corporation in the United States, other countries, or both.

UNIX is a registered trademark of The Open Group in the United States and other countries.

Java and all Java-based trademarks and logos are trademarks or registered trademarks of Oracle and/or its affiliates.

IPv6/VSE is a registered trademark of Barnard Software, Inc.



---

## Accessibility

Accessibility features help a user who has a physical disability, such as restricted mobility or limited vision, to use software products successfully. The major accessibility features in z/VSE enable users to:

- Use assistive technologies such as screen readers and screen magnifier software
- Operate specific or equivalent features using only the keyboard
- Customize display attributes such as color, contrast, and font size

---

## Using Assistive Technologies

Assistive technology products, such as screen readers, function with the user interfaces found in z/VSE. Consult the assistive technology documentation for specific information when using such products to access z/VSE interfaces.

---

## Documentation Format

The publications for this product are in Adobe Portable Document Format (PDF) and should be compliant with accessibility standards. If you experience difficulties when you use the PDF files and want to request a web-based format for a publication, you can either write an email to [s390id@de.ibm.com](mailto:s390id@de.ibm.com), or use the Reader Comment Form in the back of this publication or direct your mail to the following address:

IBM Deutschland Research & Development GmbH  
Department 3282  
Schoenaicher Strasse 220  
D-71032 Boeblingen  
Federal Republic of Germany

In the request, be sure to include the publication number and title.

When you send information to IBM, you grant IBM a nonexclusive right to use or distribute the information in any way it believes appropriate without incurring any obligation to you.



---

## About This Publication

This publication describes the Service Upgrade of IBM® z/VSE Version 5 Release 1 from a planning point of view.

---

## Who Should Use This Publication

The publication is intended for those who plan, administer, and maintain a z/VSE system. A knowledge of z/VSE and the z/VSE base programs is required.

---

## How to Use This Publication

The information in this publication is primarily meant to help you plan for installation and daily system use. Much of this involves *tailoring* your system to meet your particular data processing needs.

---

## Where to Find More Information

This publication documents new and changed functions that result from installing the Service Upgrade of z/VSE 5.1. The *z/VSE Release Guide* provides an overview of *all* changes and the functions that are new with the Service Upgrade of z/VSE 5.1.

### **z/VSE Home Page**

z/VSE has a home page on the World Wide Web, which offers up-to-date information about VSE-related products and services, new z/VSE functions, and other items of interest to VSE users.

You can find the z/VSE home page at

<http://www.ibm.com/systems/z/os/zvse/>

You can also find VSE User Examples (in zipped format) at

<http://www.ibm.com/systems/z/os/zvse/downloads/samples.html>



---

## Summary of Changes

These are the enhancements that have been made available via the *June 2013* Service Upgrade of z/VSE 5.1:

- z/VSE now supports the configurable Crypto Express4S technology in both IBM Common Cryptographic Architecture (CCA) and accelerator modes. See “Hardware Crypto and CPACF Support” on page 11
- z/VSE now supports the OSA Express4S 1000BASE-T technology that is provided by the zEnterprise EC12 server. See “OSA Express Features” on page 12.
- z/VSE now supports the IBM System Storage® TS1140 Tape Drive. See Table 10 on page 24.
- Media types MEDIA11 (CSTB), MEDIA12 (CSTC), and MEDIA13 (CSTD) are now supported. See Table 10 on page 24 and Table 11 on page 25.
- The *Database Call Level Interface* has been extended to include *connection pooling*. See Table 38 on page 142.

These are the enhancements made available via the *June 2012* Service Upgrade of z/VSE 5.1:

- IBM System Storage Tape Controller 3592 Model C07 is a new high-performance tape controller that can be used to attach 3592 Model E05 (TS1120) or 3592 Model E06 (TS1130) Tape Drives, or a TS3500/3584 UltraScalable Tape Library. See Table 10 on page 24 and Table 11 on page 25.
- The *Database Call Level Interface* is a database connector that allows z/VSE applications to access a database server that runs on a platform other than z/VSE. See Table 38 on page 142.

These are the new items and changes that were delivered *at General Availability of z/VSE 5.1*:

- The IBM servers that are supported by z/VSE 5.1 no longer offer the *basic mode* of operation.
- Since preferred paths are no longer supported for SCSI disks, Table 8 on page 17 has been updated accordingly.
- A table has been introduced that provides a summary of the maximum sizes of each type of volume or minidisk. See “Maximum Volume and Minidisk Sizes” on page 18.
- z/VSE supports the *IBM Storwize® V7000* midrange disk and the *IBM XIV® Storage System* high-end open disk system. See “Disk Device Support” on page 16.
- z/VSE supports the *Copy Export* feature, which is provided by the Model TS7740 of the TS7700 Virtualization Engine. It allows you to “copy export” selected logical volumes to an offsite location, to be used for disaster recovery. See “IBM TS7700 Model TS7740 (With Copy Export Feature)” on page 33.
- z/VSE supports *multi-cluster grid* configurations for the TS7700 Virtualization Engine. See “IBM TS7700 Multi-Cluster Grid Support” on page 33.

- The layouts of the predefined environments A, B, and C have been changed. This included a table that showed the additional settings for PASIZE, NPARTS, data space allocation, and SVA GETVIS size, that are different for each z/VSE predefined environment. See “Predefined System Environments” on page 59.
- 64-bit virtual addressing support now allows you to create and manage *memory objects* in a 64-bit address space. See “Using Memory Objects in the 64-Bit Address Space” on page 67.
- A table has been included that shows the space allocated in the DOSRES/SYSWK1 master catalog on 3380, 3390, and 3390-FAT disks, in environments A, B, and C. See Table 33 on page 119.
- The VSE Monitoring Agent has been enhanced to allow SNMP Version 1 “traps” to be sent to SNMP monitors from COBOL, PL/I, and C programs, and CICS<sup>®</sup> transactions, via the SNMP Trap Client API. See Table 38 on page 142.
- GDPS<sup>®</sup> support is new. A GDPS Client can collect availability data from your z/VSE systems and send this data to a central GDPS K-System. See Table 38 on page 142.
- The instructions on how to configure OSA Express<sup>®</sup> and HiperSockets<sup>™</sup> devices have been moved from Chapter 10, “TCP/IP and Networking Support,” on page 153 to the *z/VSE Administration*.
- The instructions on how to define OAT entries and install an SNA image using OSA/SF have been moved from Chapter 10, “TCP/IP and Networking Support,” on page 153 to the *z/VSE SNA Networking Support, SC34-2626*.
- Instructions are provided on how to install and customize IPv6/VSE. See “IPv6/VSE Support” on page 155.
- z/VSE now supports the *Layer 2* (the Data Link Layer) of the OSI (*Open Systems Interconnection*) TCP/IP model. See “TCP/IP Layer 2 (Data Link Layer) Support” on page 161.
- z/VSE now allows you to configure one or more *Virtual LANs* (VLANs). See “Virtual LAN (VLAN) Support” on page 162.
- z/VSE can now participate in an Intra-Ensemble Data Network (IEDN) using OSA Express for zBX. See “OSA Express for zBX (IEDN) Support” on page 162.
- The Linux Fast Path now supports *IPv6* that allows 128-bit (16-byte) IP addresses. See “Linux Fast Path Support” on page 163.
- A table has been included that showed the minimum number of cylinders or blocks that are required to install z/VSE on a 3380, 3390, or FBA disk for each z/VSE environment. See Table 51 on page 277.
- The information about the “IBM RAMAC Family” and also the “Cache Functions for ECKD<sup>™</sup> Disks” has been removed. If you still require this information, refer to an earlier edition of this publication.

**Note:** For an overview of *all* the items introduced with z/VSE 5.1 (including the two service upgrades described above), refer to the *z/VSE Release Guide*.

---

## Chapter 1. How to Run z/VSE 5.1

How you run a z/VSE system depends on many aspects. One of the major aspects is the hardware you use. This chapter is intended as an overview of the different ways of how you can run z/VSE.

You can run this version of z/VSE on any of the IBM System z servers that are listed in “Server Support” on page 6. On these servers, you can run z/VSE either:

- In logical partitioned (**LPAR**) mode under PR/SM™.
- As a guest system under **any supported z/VM release**.

Each method of running z/VSE has its advantages, some of which are listed below.

This chapter contains these main topics:

- “Advantages When Running z/VSE in LPAR mode”
- “Advantages when Running z/VSE under z/VM” on page 2
- “The z/VSE Supervisor” on page 2
- “The z/VSE Turbo Dispatcher” on page 2
- “CPU Balancing via the SYSDEF TD Command” on page 3

### Related Topics:

For details of how to ...	Refer to ...
run z/VSE with more than 255 tasks	“Running z/VSE With More Than 255 Tasks” on page 71.
use physical addresses of up to X'FFFF'	“Device Address Support Of Up to X'FFFF'” on page 9.
run z/VSE with a Linux Fast Path	“Linux Fast Path Support” on page 163.

---

## Advantages When Running z/VSE in LPAR mode

- Partitions (LPARs) are independent from each other.
- Shared I/O units possible.

Depending on the server type, **PR/SM** (Processor Resource/Systems Manager) provides a maximum of 60 logical partitions. Each logical partition can be used to run a single operating system such as z/VSE.

For more information about PR/SM and LPAR mode, refer to the *Processor Resource/Systems Manager, Planning Guide* of your IBM System z server.

### Advantages when Running z/VSE under z/VM

- Shared I/O units possible.
- Flexible communication between guest systems.
- Flexible use of terminals.
- Flexible configuration setup.
- Advanced data base integrity.
- Exploitation of expanded storage.
- Broad range of CMS applications.

z/VM V5.4 and later supports the *z/VM mode* LPAR on IBM System z10™ and later platforms. Multiple types of processor can be defined in the same z/VM mode LPAR, including:

- Central Processor (CP)
- Integrated Facility for Linux (IFL)

This means that you can run z/VSE and Linux on System z guests in the *same* LPAR. The *Linux Fast Path* takes advantage of this feature (as described in “Linux Fast Path Support” on page 163).

For further details about running under z/VM, refer to the z/VM publication *Running Guest Operating Systems*, SC24-6115.

---

### The z/VSE Supervisor

From z/VSE V4R1.0 onwards, z/VSE is delivered with *one supervisor only*, which is the standard supervisor \$A\$SUPI. This supervisor supports up to 1024 devices.

To generate a supervisor and listing, you can install the generation feature and generate a supervisor. However, you cannot modify the generation options. For further details, refer to “Regenerating the Supervisor” in the *z/VSE Administration*.

z/VSE:

- Executes in z/Architecture® mode only.
- Supports up to 32 GB processor storage.

z/VSE supports 64-bit virtual address spaces for user applications. The size of a data space remains restricted to 2 GB.

---

### The z/VSE Turbo Dispatcher

The Turbo Dispatcher is the only dispatcher supported by z/VSE, and is always active.

The Turbo Dispatcher support is available for uniprocessors *and* multiprocessors. The Turbo Dispatcher can utilize multiprocessors by distributing the workload across several processors (CPUs), enabling them to work in parallel and thus increase the overall throughput of a z/VSE system.

Partition balancing allows the operator to specify a relative share of CPU time for any static partition and any dynamic class of a balanced group. This allows a more refined control of workload distribution.



**Note:** The z/VSE Turbo Dispatcher can **exploit up to 3-way** processors and in some cases up to 4-way processors (with the known workloads of today) and **tolerates up to 10-way** processors.

The Turbo Dispatcher provides:

- The same partition balancing support for a uniprocessor as described above for a multiprocessor environment.
- Planning information, by showing to what extent a workload running on the uniprocessor would be able to exploit the CPUs of a multiprocessor.

---

## CPU Balancing via the SYSDEF TD Command

You can use *CPU balancing* to reduce the multiprocessing overhead. When CPU balancing is enabled, the Turbo Dispatcher only selects the number of CPUs that are required for the *current* workload.

CPU balancing might reduce the overhead or performance-degradation for I/O-intensive workloads that are running in *one* partition only (the remaining partitions are idle) and when multiple CPUs are active. For example, you could use CPU balancing to restrict an I/O-intensive batch job to one CPU.

Using SYSDEF parameters, you can specify the interval after which the current CPU utilization is recalculated. You can also specify a percentage value (threshold) of CPU utilization, above or below which certain CPUs are activated or quiesced/stopped.

z/VSE provides *two* options for CPU balancing:

- *CPU Balancing via the STOPQ (Quiesce) Parameter:*
  - Using the SYSDEF TD,INT=...,STOPQ process, you can *quiesce* a CPU.
  - If a CPU is *quiesced*, it will no longer receive work units. I/O interrupts are disabled.
  - If the CPU-utilization falls below a specified threshold value, CPU balancing will *automatically* quiesce CPUs. The quiesce of CPUs depends upon the overall CPU-utilization and a specified time-interval.
  - You are recommended to use CPU balancing via the quiesce parameter for LPAR environments and most z/VM<sup>®</sup> guests.
- *CPU Balancing via the STOP Parameter:*
  - Using the SYSDEF TD,INT=...,STOP process, you can manage the available CPUs via the start/stop process. This depends upon the CPU-utilization of a given workload.
  - If a workload has a lower utilization than a specified *threshold* value, only CPUs that are required to run the workload will stay active. Other CPUs will be stopped. CPUs will be restarted when the workload requires more CPU-cycles than the threshold value.
  - Any CPU known to z/VSE (irrespective of whether the CPU is active, inactive or quiesced) can be used for CPU balancing.
  - CPU balancing via the stop parameter might be useful in z/VM 5.4 (or later) environments, since z/VM *guest shares* can be better exploited in this type of environment.

*Scenario for Using the SYSDEF TD Command:*

## Running z/VSE

1. Assume the interval is 10 seconds, the *threshold value* is 50 (that is, 50%), and *three* CPUs are active. After the 10-second interval has been passed, the Turbo Dispatcher checks if any CPUs need to be added or quiesced:
  - As long as the current CPU utilization stays below 50%, only *one* CPU will be active (the other two CPUs are *quiesced*).
  - If the current CPU utilization increases to 50% or higher, the second CPU will be activated.
  - If the current CPU utilization increases to 100% or higher, the third CPU will be activated.
  - If the current CPU utilization decreases to below 100%, the third CPU will again be quiesced.
2. Now assume that the threshold value is 70 (that is, 70%). In this case:
  - If the current CPU utilization increases to 70% or higher, the second CPU will be activated.
  - If the current CPU utilization increases to 140% or higher, the third CPU will be activated.

For details of the SYSDEF TD and QUERY TD commands, including the parameters that you specify with the SYSDEF TD command – INT, THR, START, STOPQ and STOP – refer to “Job Control and Attention Routine” in the *z/VSE System Control Statements*.

---

## Chapter 2. z/VSE 5.1 Hardware Support

This chapter describes the hardware and related programs that are supported by z/VSE 5.1.

It contains these main topics:

- “Server Support” on page 6
- “Device Address Support Of Up to X'FFFF'” on page 9
- “Hardware Crypto and CPACF Support” on page 11
- “Communication Adapter Support” on page 12
- “Disk Device Support” on page 16
- “Tape Device Support” on page 23
- “Virtual Tape Support” on page 37
- “Channel-Related Support” on page 38
- “Devices Not Supported by z/VSE 5.1” on page 40
- “Programs No Longer Shipped With z/VSE 5.1” on page 41

### Related Topics:

For details of ...	See ...
<i>display station</i> support	“Display Stations” on page 311.
<i>all</i> the devices that are supported	Appendix G, “Devices Supported,” on page 307.
HiperSockets support	“HiperSockets Support” on page 160.
Intra-Ensemble Data Network (IEDN) support	“OSA Express for zBX (IEDN) Support” on page 162.

---

# Server Support

## Servers Supported by z/VSE 5.1

z/VSE 5.1 supports these **IBM System z** servers:

- **IBM zEnterprise® EC12** (zEC12).
- **IBM zEnterprise 196** (z196).
- **IBM zEnterprise 114** (z114).
- **IBM System z10 Enterprise Class** (z10 EC).
- **IBM System z10 Business Class** (z10 BC).
- **IBM System z9® Enterprise Class** (z9 EC).
- **IBM System z9 Business Class** (z9 BC).

### Notes:

1. z/VSE Version 4 was the last version of z/VSE to support the following servers:
  - **zSeries® 890** (z890)
  - **zSeries 990** (z990)
  - **zSeries 800** (z800)
  - **zSeries 900** (z900)
2. z/VSE Version 3 was the last version of z/VSE to support the following servers:
  - **IBM S/390® Multiprise 3000**
  - **IBM S/390 Parallel Enterprise Server - Generation 5 and Generation 6**

## Logical Partitions and LCSS Support

z/VSE 5.1 supports:

- **Up to 60 LPARs** (Logical Partitions) in which z/VSE can run on these IBM servers:
  - zEC12
  - z196
  - z10 EC
- **Up to 30 LPARs** (Logical Partitions) in which z/VSE can run on these IBM servers:
  - z114
  - z10 BC
  - z9 BC
- **Up to four Logical Channel Subsystems (LCSS):**
  - The zEC12, z196, z10 EC, and z9 EC support up to 4 LCSSs.
  - The z114, z10 BC, and z9 BC support up to 2 LCSS.
  - With multiple LCSSs, up to 1024 channels can be attached.
  - Any single instance of z/VSE is limited to:
    - 256 channels.
    - 1024 devices.

## Adapter Interruptions Support

### Notes:

1. The term “FICON® Express” is used for all “FICON Express” features (“FICON Express”, “FICON Express2”, and later).
2. The term “OSA Express” is used for all “OSA Express” features (“OSA Express”, “OSA Express2”, and later).

High performance adapter interrupt handling is available with:

- HiperSockets (CHPID type IQD).
- OSA Express in QDIO mode (CHPID types OSD and OSX).
- FICON Express (CHPID type FCP).

**Note:** Adapter interrupt handling was first introduced with HiperSockets. Starting with the z990, this efficient technique for handling I/O interrupts was also introduced for CHPID types OSD and FCP.

## Support for Dynamic Starting/Stopping of CPUs in an LPAR

z/VSE allows you to start CPUs in that were not online at IPL. These can be either:

- CPUs that were in a “standby” state at IPL.
- CPUs that were added to the z/VSE LPAR profile after IPL.

Note that z/VSE uses the term *CPU* to refer to *Central Processors* (CPs).

Using the HMC/SE “Logical Processor Add” task, you can add CPUs to an LPAR after IPL. This feature is available on IBM z10 and later platforms. When CPUs are added to an LPAR, z/VSE *automatically* updates its CPU configuration.

You can then use the:

- SYSDEF TD, STARTSBY=*cpuaddr* command to set CPUs that are in a “standby” state to an “online” state and start these CPUs.
- SYSDEF TD, STOPSBY=*cpuaddr* command to change the CPU state from “online” to “standby”.

These functions allow you to exploit z10 and later technology and update the CPU configuration depending on workload needs.

**Note:** “Standby” CPUs do not consume any CPU share of their LPAR. For details of how CPU share is distributed, refer to *Processor Resource/Systems Manager™ Planning Guide* for your processor.

For details of how to use the SYSDEF TD command to dynamically start/stop CPUs, refer to the *z/VSE System Control Statements*.

## Signal Quiesce (Signal Shutdown) Support

A *signal quiesce* (also referred to as *signal shutdown*) requests an end-of-program execution for a z/VSE system that has been enabled for signal quiesce.

To configure z/VSE for signal quiesce, you use the QUIESCE parameter of the IPL SYS control statement.

If a disruptive operation (for example, an IML or IPL) is performed via a *Service Element* (SE) or *Hardware Management Console* (HMC) panel, the SE or HMC will generate a *signal-quiesce event*. Under z/VM, a signal-quiesce event can be triggered

for a guest using a SIGNAL SHUTDOWN command. The signal-quietse event instructs an active z/VSE to quietse (stop) processing:

1. When a signal-quietse event is received, z/VSE issues message 0W01D:  
0W01D DO YOU WANT TO CONTINUE SYSTEM SHUTDOWN (WILL BE FORCED AFTER TIMEOUT)?  
REPLY 'YES' TO ENTER HARD WAIT STATE OR 'NO'
2. If the operator replies “YES”, the system will enter a disabled-wait state and set a unique hard-wait code.  
If the operator replies “NO” or does not reply at all, the system will wait for a predefined time-interval only, after which it continues to process the disruptive operation.

Signal quietse is designed to be mainly used with *console automation* programs which can initiate a *controlled system shutdown* as a response to message 0W01D.

**Note:** z/VSE does **not** provide controlled shutdown processing!

- For further details of the IPL SYS QUIESCE parameter, refer to “Initial Program Load” in the *z/VSE System Control Statements*.
- If you run z/VSE under z/VM, also refer to the *z/VM CP Commands and Utilities Reference*. This publication describes the SIGNAL SHUTDOWN command and its impact on z/VM Guest operating systems.

## Spanned Channels

A z/VSE image in a single LPAR can use FICON Express and OSA Express features defined across multiple LCSSs.

Spanned Channels also allow z/VSE to use HiperSockets (described in “HiperSockets Support” on page 160) that link LPARs or virtual servers using different Logical Channel Subsystems (LCSSs).

## Device Address Support Of Up to X'FFFF'

From z/VSE 4.3 onwards, z/VSE supports device addresses (that is, *physical addresses*) of up to X'FFFF'. This support is implemented as follows:

- z/VSE applications, messages, commands, and so on, do not address a device by the physical address (**pcuu**), but instead by the *VSE address* (**cuu**).
- VSE addresses are in the range from X'000' to X'FFF'.
- To each physical address (pcuu) there is a corresponding VSE address (cuu).
- If the physical address is less than or equal to X'FFF', the VSE address (cuu) is equal to the physical address (pcuu).
- If the physical address is higher than X'FFF' (and therefore outside the range of VSE addresses), the physical address (pcuu) and VSE address (cuu) will be different.

CP commands (under z/VM) always use *physical addresses*.

z/VSE jobs, commands, dialogs, and messages use *VSE addresses*. However, in specified cases (for example, when using the QUERY I/O command) *physical addresses* might be used.

**Note! Throughout the z/VSE documentation, the term *address of a device* (used on its own) always refers to the *VSE address*.**

Because z/VSE supports physical addresses of up to X'FFFF', personnel in the computing center must no longer provide a z/VSE-specific configuration. This is especially helpful in mixed IT environments consisting of z/VSE, z/VM, Linux on System z, and z/OS operating systems.

If you perform a *Fast Service Upgrade* to z/VSE 5.1 from z/VSE 4.3, your z/VSE system already uses physical and VSE addresses and therefore no special actions are required.

If you perform a *Fast Service Upgrade* to z/VSE 5.1 from z/VSE 4.2.x, your z/VSE system is *not affected* by the implementation of physical addresses of up to X'FFFF'. This is because in your previous system, the physical and VSE addresses *were the same*. However, after the FSU has completed you can use the *Hardware Configuration: Unit Address List* dialog to add devices with a physical address higher than X'FFF'.

If you perform an *initial installation* of z/VSE, the implementation of physical addresses of up to X'FFFF' is relatively straightforward:

1. During the installation procedure you have to respond to messages with the variable "pcuu" by entering a physical address in the range X'0000' to X'FFFF'.
2. During the IPL of z/VSE, the system will sense the physical addresses that are available in the z/VSE I/O configuration.
3. The IPL automatically assigns a VSE address to each physical address.
4. After initial installation is complete, you can change the assignment of physical addresses to z/VSE addresses that was done automatically during the initial installation of z/VSE.

The *Hardware Configuration: Unit Address List* dialog (Fast Path **241**) lists the physical addresses and their corresponding VSE addresses. This is described in "Using the Configure Hardware Dialog" in the *z/VSE Administration*.

**Note:** To change the VSE address of a device using this dialog, you must:

1. Delete the entry for the device.
2. Re-add the device with a new VSE address but with the *same* physical address.

### Rules That Apply When Assigning Device Addresses:

- You should not use physical addresses that are higher than X'FFF' for virtual and dummy devices (POWER<sup>®</sup> dummy devices, virtual tapes, and virtual disks).
- SCSI system disks are *always* restricted to device addresses that are X'FFF' or lower.
- When assigning VSE addresses, ensure you follow the rules that might apply for physical addresses.

Here are some examples that illustrate the use of VSE addresses and physical addresses:

- This example defines an FCP device with physical address 1FA0 and corresponding VSE address FA0.  

```
ADD 1FA0 AS FA0,FCP
```
- This second defines eight 3380 devices with addresses 130 through 137.  

```
ADD 130:137,3380
```
- This third example defines six FCP devices with addresses 1120 through 1125 and maps them to six VSE addresses 120 through 125.  

```
ADD 1120..1125 AS 120..125,FCP
```
- This fourth example defines the same six FCP devices as in the previous example, but using a slightly different syntax.  

```
ADD 1120:1125 AS 120:125,FCP
```

To obtain the *VSE address* of a device that corresponds to a physical address, you can use the QUERY IO command. For example, to display the VSE address (cuu) of a tape drive that has the physical address (pcuu) 3A61, you would enter at the z/VSE console:

```
QUERY IO,CUU=3A61
AR 0015  VSE ADDR  PHYSICAL ADDR  DEVICE INFORMATION
AR 0015      A61           3A61    TAPE
AR 0015 1140I  READY
```

The VSE address shown above is A61.

You can similarly use the QUERY IO command to obtain the *physical address* of a device that corresponds to a VSE address. On the console, the PF11 key has also been assigned for this purpose. You simply position the cursor under the first character of a VSE address and press PF11. A QUERY IO CUU=*nnn* command is then automatically displayed in the command line, ready to be executed. For details, refer to the *z/VSE Operation*.

For further examples of using physical addresses of up to X'FFFF', refer to the:

- description of the ADD command in the *z/VSE System Control Statements*.
- examples of defining OSA Express and HiperSockets devices that are provided in Chapter 10, "TCP/IP and Networking Support," on page 153.
- examples of configuring SCSI disks that are provided in "Configuring Your System to Use SCSI Disks" in the *z/VSE Administration*, SC34-2627 (these examples illustrate the use of *dialogs* to add devices).



For further details about how to use the QUERY I0 command, refer to “Job Control and Attention Routine” in the *z/VSE System Control Statements*.

## Hardware Crypto and CPACF Support

z/VSE provides hardware-based encryption support either via crypto cards, or via crypto functions that are provided on the processor itself (CPACF).

- Encryption that is provided *via crypto cards* requires either a:
  - Crypto Express2 card or equivalent (where the term “hardware crypto support” is the short-form for *Hardware Encryption Assist support*).
  - PCIxCC card or equivalent
  - PCI Cryptographic Accelerator (PCICA) card or equivalent.

These crypto cards help to increase the throughput in a TCP/IP network using SSL (Secure Sockets Layer).

- Encryption that is provided *via the processor itself* is based upon the CPACF (*CP Assist for Cryptographic Function*) feature. CPACF is:
  - Designed to accelerate symmetric cryptographic operations.
  - A no-charge hardware feature which z/VSE tests-for at IPL-time.
  - Used transparently by SSL.

z/VSE tests for these crypto cards at IPL time. Table 1 provides a summary of the encryption support that is available with various System z servers.

*Table 1. Encryption Support Available With System z Servers*

	z9	z10	z196 / z114	zEC12
PCICA Card	No	No	No	No
PCIxCC Card	No	No	No	No
Crypto Express2 in (CCA) Coprocessor or Accelerator Mode	Yes	Yes	No	No
Crypto Express3 in (CCA) Coprocessor or Accelerator Mode	No	Yes	Yes	Yes
Crypto Express4S in (CCA) Coprocessor or Accelerator Mode	No	No	No	Yes
"On Processor" CPACF	Yes	Yes	Yes	Yes

For further details about Hardware Crypto support, refer to “Implementing Hardware Cryptographic Support” in the *z/VSE Administration*.

## Communication Adapter Support

This topic describes the *communication adapters* and related programs that are supported by z/VSE 5.1.

**Notes:**

1. The term “FICON Express” is used for all “FICON Express” features (“FICON Express”, “FICON Express2”, and later).
2. The term “OSA Express” is used for all “OSA Express” features (“OSA Express”, “OSA Express2”, and later).

This topic contains these sub-topics:

- “FICON Express Features”
- “OSA Express Features”

**Related Topics:**

For details of ...	See ...
<ul style="list-style-type: none"> <li>• HiperSockets support</li> <li>• Linux Fast Path support</li> <li>• Virtual LAN (VLAN) support</li> <li>• Intra-Ensemble Data Network support</li> </ul>	Chapter 10, “TCP/IP and Networking Support,” on page 153.

## FICON Express Features

FICON Express offers two modes of operation, both of which are supported by z/VSE:

- Native FICON and FICON Channel-to-Channel (CTC) traffic (CHPID type FC).
- Fibre Channel Protocol traffic (CHPID type FCP).

**Note:** z/VSE does not support zHPF (CHPID type FC).

*Table 2. FICON Support Available With System z Servers*

	z9	z10	z196 / z114	zEC12
FICON Express	Yes	No	No	No
FICON Express2	Yes	No	No	No
FICON Express4	Yes	Yes	Yes	Yes
FICON Express8	No	Yes	Yes	Yes
FICON Express8s	No	No	Yes	Yes

## OSA Express Features

OSA Express offers various features, as shown in Table 3, Table 4 on page 13, Table 5 on page 13, and Table 6 on page 13.

*Table 3. OSA Express4S Features Available With System z Servers*

Feature	z9	z10	z196 / z114	zEC12
1000BASE-T 2-ports per CHPID	No	No	Yes	Yes
Gigabit Ethernet (LX and SX) 2-ports per CHPID	No	No	Yes	Yes

*Table 3. OSA Express4S Features Available With System z Servers (continued)*

Feature	z9	z10	z196 / z114	zEC12
10 Gigabit Ethernet (LR and SR) 1-port per CHPID	No	No	Yes	Yes

OSA Express offers various features, as shown in Table 4, Table 5, and Table 6.

*Table 4. OSA Express3 Features Available With System z Servers*

Feature	z9	z10	z196 / z114	zEC12
Gigabit Ethernet (LX and SX) 4-ports and 2 CHPIDs	No	Yes	Yes	Yes
10 Gigabit Ethernet LR 2-ports and 2 CHPIDs	No	Yes	Yes	Yes
1000BASE-T Ethernet 4-port and 2 CHPIDs	No	Yes	Yes	Yes

**Notes:**

1. OSA Express3 GbE and 1000BASE-T Ethernet features are available with four ports and two CHPIDs. This means, two ports (Port-0 and Port-1) per CHPID.
2. The OSA Express3 10 GbE feature is available with two ports and two CHPIDs. This means, one port per CHPID.

*Table 5. OSA Express2 Features Available With System z Servers*

Feature	z9	z10	z196 / z114	zEC12
Gigabit Ethernet (LX and SX)	Yes	Yes	Yes	No
10 Gigabit Ethernet LR	Yes	Yes	No	No
1000BASE-T Ethernet	Yes	Yes	Yes	No

*Table 6. OSA Express Features Available With System z Servers*

Feature	z9	z10	z196 / z114	zEC12
Gigabit Ethernet (LX and SX)	Yes	No	No	No
Fast Ethernet	Yes	No	No	No
1000BASE-T Ethernet	Yes	No	No	No

You can configure your OSA Express adapter with various CHPID types. The CHPID type determines how the OSA Express adapter will be used.

Table 7 on page 14 describes the CHPID types you can configure.

## Communication Adapters

Table 7. CHPID Types Supported by OSA Express4S, OSA Express3, OSA Express2, and OSA Express Features

CHPID Type	OSA Express4S, OSA Express3, OSA Express2, or OSA Express Feature	Where Used
OSC	<ul style="list-style-type: none"> <li>• 1000BASE-T Ethernet</li> </ul>	OSA-ICC (for emulation of TN3270E and non-SNA DFT 3270).
OSD	<ul style="list-style-type: none"> <li>• 1000BASE-T Ethernet</li> <li>• Gigabit Ethernet</li> <li>• 10 Gigabit Ethernet</li> </ul>	Queue Direct Input/Output (QDIO) architecture: TCP/IP traffic when Layer 3 (uses IP address) and Protocol-independent when Layer 2 (uses MAC address).
OSE	<ul style="list-style-type: none"> <li>• 1000BASE-T Ethernet</li> </ul>	The adapter executes in non-QDIO mode, and can be used for: <ul style="list-style-type: none"> <li>• SNA connections</li> <li>• APPN connections</li> <li>• TCP/IP links</li> </ul>
OSN	<ul style="list-style-type: none"> <li>• 1000BASE-T Ethernet</li> <li>• Gigabit Ethernet</li> </ul>	OSA-Express for NCP: Appears to z/VSE as a device-supporting channel data link control (CDLC) protocol. Enables Network Control Program (NCP) channel-related functions, such as loading and dumping to NCP. Available on <b>System z9</b> and later, and <b>OSA Express2</b> and later. Not supported on OSA-Express4S GbE features.
OSX	<ul style="list-style-type: none"> <li>• 10 Gigabit Ethernet</li> </ul>	OSA-Express for zBX. Provides connectivity and access control to the intraensemble data network (IEDN) from z196 and later to Unified Resource Manager functions. Available on <b>z196 CEC</b> and later, and <b>OSA Express3</b> and later.

The CHPID types shown in Table 7 are now explained in more detail in the topics that now follow.

### OSA Express Integrated Console Controller

The OSA Express Integrated Console Controller (OSA-ICC) support is integrated into the z9 and later servers. This support is available via the *1000BASE-T Ethernet* feature (CHPID type **OSC**).

The *Open Systems Adapter-Express Integrated Console Controller* (OSA-ICC) function supports the emulation of:

- TN3270E (RFC 2355)
- Non-SNA DFT 3270

Using OSA-ICC, you can avoid the need for an external console controller (such as an IBM 2074 or 3174). For further details, refer to *OSA-ICC User's Guide*, SA22-7990.

### OSA Express in QDIO Mode

*QDIO mode* (CHPID type **OSD**) is used for fast data-transmission via TCP/IP.

z/VSE supports up to:

- 640 TCP/IP connections per dedicated CHPID.
- 640 total connections across multiple LPARs using a shared or spanned CHPID.

For further information, see “Using OSA Express in QDIO Mode” on page 158.

### OSA Express in Non-QDIO Mode

z/VSE supports using an OSA Express adapter in *non-QDIO mode* by emulating a S/390 Open Systems Adapter 2 (OSA-2) adapter. To emulate an OSA-2 adapter, the OSA Express CHPID Type is set to **OSE** in *SNA and TCP/IP mode*.

“OSA Express QDIO and Non-QDIO Support” on page 158 provides further information on using an OSA Express adapter in QDIO and non-QDIO modes, and also using the *Open Systems Adapter Support Facility (OSA/SF)*.

For further information, see “Using OSA Express in Non-QDIO Mode” on page 158.

### OSA Express for NCP

**OSN** is the short form for “Open Systems Adapter for NCP”. When using OSA Express in OSN mode (CHPID type **OSN**), the OSA Express appears to z/VSE as if it were an ESCON® channel connected to a 374x communication controller.

The OSA Express in OSN mode therefore allows you to configure, manage, and operate your NCPs as if they were running in an ESCON-attached 3745 communication controller.

As a result, you no longer require IBM 3745 hardware. For further details, refer to the *z/VSE SNA Networking Support*.

### OSA Express for zBX

OSA-Express for zBX (CHPID type **OSX**) provides connectivity and access control to the intraensemble data network (IEDN) from z196 and later to Unified Resource Manager functions.

For further information, see “OSA Express for zBX (IEDN) Support” on page 162.

## Disk Device Support

This topic describes the *disk devices* and related programs that are supported by z/VSE 5.1.

It contains these sub-topics:

- “Overview of Disk Features Supported by z/VSE” on page 17
- “Maximum Volume and Minidisk Sizes” on page 18
- “Parallel Access Volume (PAV) Support” on page 18
- “Fibre-Channel-Attached SCSI Disk Support” on page 19
- “SAN Volume Controller (SVC) Support” on page 19
- “Storwize V7000 Midrange Disk System Support” on page 20
- “XIV Storage System Support” on page 20
- “FlashCopy Support” on page 20
- “Remote Mirroring and Copy (RMC) Feature” on page 21
- “Large Volume Support (LVS) and How it is Used By VSE/VSAM” on page 22

### Related Topics:

For details of how to ...	Refer to this topic in the <i>z/VSE Administration ...</i>
use the <i>Interactive Interface</i> to add a disk device	“Configuring Disk, Tape, and Printer Devices”.
configure your z/VSE system to use Fibre-Channel-attached SCSI (Small Computer System Interface) disks	“Configuring Your System to Use SCSI Disks”.
configure your z/VSE system to use <i>Parallel Access Volume</i> (PAV) support	“Configuring Your System to Use PAV”.

### Notes:

1. The IBM 3380 Model A disk device (or an equivalent-sized VM minidisk) is not supported for the initial installation and FSU of z/VSE. However, this model can still be used as data devices.
2. Also check Appendix B, “z/VSE Disk Layouts (DOSRES, SYSWK1),” on page 277 to ensure that the disks you plan to use for the installation of your selected z/VSE Environment have sufficient space.
3. z/VSE can be IPL'd with more than 1024 devices defined to the z/VSE system in, for example, the IOCDs or in the z/VM guest definition. However, z/VSE can only use 1024 devices. If more devices are available, you must use the DEL command to delete devices until only 1024 devices remain.
4. For details of size considerations when using VSAM data, refer to the *VSE/VSAM User's Guide and Application Programming*.
5. The various models of the IBM 3390, that are attached via a control unit to a z/VSE system, can still be used with this version and release of z/VSE. However, for details you must refer to an earlier edition of this publication.
6. 3390 (or 3380) ECKD disk devices also include custom-sized volumes that were defined within DS6000™, DS8000®, or ESS disk controllers.

## Overview of Disk Features Supported by z/VSE

Table 8 provides you with a “quick reference” summary of the features that are supported by disk devices and operating-system versions.

Table 8. IBM Disk Feature Support

Feature	DS8000 <sup>1</sup>	DS6000 <sup>2</sup>	ESS <sup>3</sup>	Supported by z/VSE ...
System z Channel Attachment:				
FICON	Yes	Yes	Yes	3.1 and later
FCP-attached SCSI disks	Yes	Yes	Yes <sup>4</sup>	3.1 and later
ESCON	Yes	No	Yes	3.1 and later
Preferred Path (ECKD only) <sup>5</sup>	No	Yes	No	3.1 and later
ECKD Format				
3380	Yes	Yes	Yes	3.1 and later
3390	Yes	Yes	Yes	3.1 and later
Large Volume Support (65520 cyl)	Yes	Yes	Yes	4.1 and later
PAV Support	Yes	Yes	Yes	4.2 and later
FlashCopy <sup>®</sup> Support	Yes	Yes	Yes	3.1 and later
NOCOPY option	Yes	Yes	Yes	3.1 and later
Dataset Copy	Yes	Yes	Yes <sup>6</sup>	3.1 and later
FlashCopy SE (Space Efficient)	Yes	No	No	4.2 and later
FlashCopy Consistency Group support	Yes	No	No	4.3 and later
Remote Mirror and Copy (RMC) Feature	Yes	Yes	Yes <sup>7</sup>	
RMC Metro Mirror	Yes	Yes	Yes	3.1 and later (ICKDSF) <sup>8</sup>
Global Copy	Yes	Yes	Yes	3.1 and later (ICKDSF) <sup>8</sup>
Global Mirror	Yes	Yes	Yes	3.1 and later (ICKDSF) <sup>8</sup>
Full Disk Encryption	Yes	No	No	3.1 and later <sup>9</sup>
SSD (Solid <sup>®</sup> State Disk) <sup>10</sup>	Yes	No	No	4.1 and later
Automatic Volume Expansion	Yes	No	No	Not supported
Extended Address Volumes (greater than 65520 cyl)	Yes	No	No	Not supported

### Notes:

1. The full name is IBM System Storage DS8000.
2. The full name is IBM System Storage DS6000. This storage system is EOM (“End of Marketing”).
3. The full name is IBM TotalStorage Enterprise Storage Server<sup>®</sup>. This storage system is EOM (“End of Marketing”).
4. The ESS 750 does not support FCP-attached SCSI disks.
5. For *ECKD disks*, the preferred path will be used as long the path is available. If an error in the preferred path occurs, the alternate path will then be used. From z/VSE 5.1 onwards, preferred paths are *not* supported for SCSI disks.
6. The ESS provides FlashCopy and FlashCopy Version 2 (“FlashCopy 2”). Dataset Copy requires FlashCopy 2.

7. The ESS provides copy functions via the Peer-to-Peer Remote Copy (PPRC) and PPRC V2 capabilities. These functions are included in the RMC feature of the DS8000 and DS6000.
8. Only the modes shown in Table 8 on page 17 are supported by z/VSE and only via the ICKDSF component.
9. Provides encryption support using Encrypting Disks and supported key manager software. Full Disk Encryption provides the ability to encrypt data “at rest” on a DS8000. The Full Disk Encryption disk drive sets are optional to the DS8000 series. Full Disk Encryption is transparent to z/VSE applications.
10. SSD support is transparent to z/VSE applications. For performance considerations, refer to the IBM System Storage Homepage:  
<http://www.ibm.com/systems/storage/disk/ds8000/index.html>

## Maximum Volume and Minidisk Sizes

Table 9 shows the maximum permitted volume and minidisk sizes.

Table 9. Maximum Volume/Minidisk Sizes

Device	Device Type Code	Max. (CYL)	Max. (GB)
ECKD Models (z/VSE in LPAR Mode or as z/VM Guest)	3380	3,339	2
	3390	262,668 <sup>1</sup>	223 <sup>1</sup>
FBA minidisk (z/VSE as z/VM Guest)	–	–	2
FCP-attached SCSI device	FBA-SCSI	–	24 <sup>2</sup>

### Notes:

1. For z/VSE, restricted to 65,520 cylinders (54 GB).
2. For VSE/VSAM files, restricted to 16 GB.

## Parallel Access Volume (PAV) Support

*Parallel Access Volume (PAV)* is an optional licensed feature on the IBM System Storage DS6000/DS8000/ESS series.

Parallel access volumes:

- Are managed by creating *multiple* addresses for a *single* logical device.
- Allow your z/VSE system to access volumes *in parallel*.
- Enable more than one I/O operation to be processed for a *single* logical device.
- Represent a significant performance improvement by the storage unit over traditional I/O processing.
- Can significantly reduce device queue delays to busy devices (all I/O operations are normally processed from a single queue).
- Allow your system to access a single volume from a single z/VSE host with multiple concurrent requests.

For further details, refer to “Configuring Your System to Use PAV” in the *z/VSE Administration*.



## Fibre-Channel-Attached SCSI Disk Support

The objective of z/VSE Small Computer System Interface (SCSI) disk support is to offer customers more storage choices as well as help lower Total Cost of Ownership (TCO). Therefore, selected SCSI disks can be attached, in addition to Extended Count-Key-Data (ECKD) and Fixed Block Architecture (FBA) disks. Fibre-Channel-attached SCSI disks appear to z/VSE as FBA disks.

### Notes:

1. Only SCSI disks that are contained within the IBM Storwize V7000, XIV Storage System, SAN Volume Controller, System Storage DS8000, DS6000, and ESS Model F20, 800, and 800 Turbo are qualified for this support.
2. z/VSE supports a maximum of approximately 100 SCSI disks during IPL. The actual number of supported devices might be less depending upon your system configuration.

The IBM System Storage *SAN Volume Controller* (SVC) is also qualified to be used with z/VSE's SCSI support. SVC is described in "SAN Volume Controller (SVC) Support."

The z/VSE SCSI-FCP support is designed to be transparent to z/VSE components and subsystems, vendor interfaces, and user-written programs. This support includes both operating system components and files containing user data.

The IBM System z Fibre Channel Protocol (FCP) channels are designed to allow customers to attach industry-standard SCSI disk devices. A typical topology might consist of:

- One or more FCP channels.
- A switch (such as the IBM 2109).
- A controller, containing one or more ports and one or more SCSI devices.

FCP channels are available through FICON Express, FICON Express2, FICON Express4, or FICON Express8 adapters that have been configured with CHPID type FCP.

For further details, refer to "Configuring Your System to Use SCSI Disks" in the *z/VSE Administration*.

## SAN Volume Controller (SVC) Support

The IBM System Storage *SAN Volume Controller* (SVC) consists of the:

- SAN Volume Controller (SVC) Storage Engine 2145.
- SAN Volume Controller (SVC) Software V4.2 or later.

The SVC handles the device-specific requirements for whatever collection of disk-storage devices a client has attached to the SVC. The SVC can be attached to a storage network to provide a "virtualized pool" of storage that is shared by all hosts. It helps to reduce complexity and cost-of-storage, and also provides enhanced copy services. These copy services are controlled by the SVC software, not by the z/VSE operating system.

z/VSE support for the SVC allows z/VSE to access FCP-SCSI disks in IBM System Storage disk subsystems, including DS8000, DS6000, DS4000® and ESS series, as well as disk subsystems from other manufacturers that are supported by the SVC.

z/VSE supports the SVC via its *SCSI device driver*. In addition to IBM System Storage qualified for use with z/VSE FCP-SCSI support, any FCP-SCSI disk device supported by the SVC can now be used.

For further details, refer to the *SAN Home Page* which you can find at:

<http://www-03.ibm.com/systems/storage/software/virtualization/svc/>

### Storwize V7000 Midrange Disk System Support

The *IBM Storwize V7000* is a midrange disk offering built on IBM System SAN Volume Controller (SVC) technology. It can be attached through Fibre Channel (FC) switches to z/VSE using Fibre Channel Protocol (FCP) sub-channels.

z/VSE supports Storwize V7000 (SCSI) devices for system use (IPLable z/VSE<sup>®</sup> system devices) and as data devices in both an LPAR and a z/VM guest environment.

z/VSE supports Storwize V7000 using the functionality that is provided by the *z/VSE SCSI device driver*. Details are provided in the chapter “Configuring Your System to Use SCSI Disks” in the *z/VSE Administration*.

z/VSE's Storwize V7000 support is available with z/VSE V4.2 and later.

### XIV Storage System Support

The *IBM XIV Storage System* is a high-end open disk system which can be attached through FC switches to z/VSE using FCP sub-channels.

z/VSE supports XIV (SCSI) devices for system use (IPLable z/VSE system devices) and as data devices in both an LPAR and a z/VM guest environment. This support eliminates the need for z/VSE to access XIV devices through the SVC.

z/VSE supports XIV using the functionality that is provided by the *z/VSE SCSI device driver*. Details are provided in the chapter “Configuring Your System to Use SCSI Disks” in the *z/VSE Administration*.

z/VSE's XIV support is available with z/VSE V4.2 and later.

### FlashCopy Support

IBM System Storage FlashCopy technology is a *point-in-time* copy capability that can be used to help reduce planned application outages caused by backups and other data copy activities. It is available with the DS8000, DS6000, and ESS servers.

FlashCopy is designed to enable data to be copied in the background, then make both source and copied data available to users almost immediately.

z/VSE supports the following selected FlashCopy functions:

- The NOCOPY option, which leads to greater efficiency when copying from disk to tape. The NOCOPY function can be used to copy most, or all, of the data directly from the source to tape *without* the need to first copy all of the physical data to an intermediate target copy.
- *Dataset Copy*, which offers a new level of granularity. It allows more efficient use of disk capacity. It can also reduce background completion times because FlashCopy no longer needs to be performed at the volume level when only a

dataset copy is required. With Dataset Copy, the source and target volumes may be different sizes. It also allows the copied data to reside at a different location on the source and target volumes.

**Note:** Because a VSAM “dataset” is a complex entity consisting of a catalog entry and one or more data extents which can reside on different volumes, VSAM files are **not** candidates for the Dataset Copy function.

- *Elimination of the LSS Constraint*, which can help simplify administration and capacity planning for FlashCopy. Source and target volumes can now span logical subsystems within a storage server.
- *Multiple Relationship FlashCopy*, which offers new flexibility. It allows up to 12 target volumes to be created from one source volume in a single FlashCopy operation. Multiple target volumes can be used for testing, backup, and other applications.
- *IBM FlashCopy SE feature*, which is optional licensed hardware feature of the DS8000 series. It allocates storage space on an “as needed” basis by only using space on a target volume when it actually copies tracks from the source volume to the target volume. For a source volume without much write activity during the duration of the FlashCopy SE relation, the target volume might therefore consume significantly less physical space than the source volume.
- *FlashCopy Consistency Group support*, which is available with the ESS, DS6000, and DS8000 storage subsystems. It can be used when applications have their data spread over multiple volumes.
  - This support uses the IXFP SNAP command with parameter FREEZE, followed by IXFP DDSR command with parameter THAW.
  - ICKDSF supports the PPRC FREEZE and PPRC RUN commands. Note that these commands have the same functionality as the IXFP SNAP command with the FREEZE parameter, and the IXFP DDSR command with the THAW parameter.

z/VSE does **not** support the following FlashCopy functions:

- Incremental FlashCopy.
- Persistent FlashCopy Relationship.
- Inband Commands over a Remote Mirror link.

For details of how to:

- use FlashCopy support, including the *IBM FlashCopy SE* and *Consistency Group FlashCopy* features, refer to “Performing a FlashCopy” in the *z/VSE Administration*.
- take a snapshot of *VSE/VSAM files*, refer to “Performing an IDCAMS SNAP (FlashCopy)” in the *VSE/VSAM User’s Guide and Application Programming*.

## Remote Mirroring and Copy (RMC) Feature

z/VSE supports the RMC feature via the ICKDSF component. ICKDSF supports these RMC modes:

- RMC Metro Mirror
- Global Copy
- Global Mirror

### Large Volume Support (LVS) and How it is Used By VSE/VSAM

The large volume support (LVS) is the ability to define custom-sized 3390 ECKD logical volumes (referred to as “custom volumes”) ranging in size from 1 to 65,520 cylinders for use by an operating system such as z/VSE. These large volumes help to improve disk utilization by allowing you to consolidate multiple smaller disk volumes into a single large volume. They can be defined in a DS8000, DS6000, and ESS.

You can use Large Volumes with a size of up to 65,520 cylinders.

Custom-sized volumes are reported to the *z/VSE host system* as:

- 3390-3 devices when their size is between 1 and 3,339 cylinders.
- 3390-9 devices when their size is between 3,340 and 65,520 cylinders.

A large volume has the following characteristics:

z/VSE device type: ECKD  
Number of cylinders: Up to 65520  
Number of tracks per cylinder: 15

**How LVS Is Used By VSE/VSAM:** You can define VSE/VSAM space and catalogs on large volumes (DASDs) in this way:

#### Big DASD Volumes

For any ECKD DASDs that has a size of at least *64K tracks*, VSE/VSAM space and catalogs can be defined on the first *10,017 cylinders*.

- By default, up to a maximum of 10,017 cylinders will be used.
- Any cylinders beyond 10,017 cannot be used by VSE/VSAM as *Big DASD*.
- Big DASD volumes are shown in LISTCAT as BIG-3390.

#### Fat DASD Volumes

For any ECKD DASDs that has a size of at least *64K tracks*, VSE/VSAM space and catalogs can be defined on the first *65,520 cylinders*.

- By specifying the FATDASD parameter, up to a maximum of 65,520 cylinders will be used.
- Any cylinders beyond 65,520 cannot be used by VSE/VSAM.
- Fat DASD volumes are shown in LISTCAT as FAT-3390.

For details of the VSE/VSAM support for large DASDs, refer to the *VSE/VSAM User's Guide and Application Programming*.

## Tape Device Support

This topic describes the *tape devices* that are supported by z/VSE 5.1.

It contains these sub-topics:

- “Overview of Tape Drives/Libraries Supported by z/VSE” on page 24
- “IBM TS1140, TS1130, TS1120, and 3592 J1A Tape Drives” on page 26
- “TS3400 Autoloader Tape Library” on page 27
- “IBM TotalStorage 3590/3592 Tape Drives” on page 27
- “IBM TotalStorage 3490E Tape Drive” on page 29
- “IBM TS7680 ProtecTIER Deduplication Gateway for System z” on page 31
- “IBM TS7700 Virtualization Engine” on page 32
- “IBM TS3500/3584 UltraScalable Tape Library” on page 34
- “IBM TotalStorage 3494 Tape Library” on page 35
- “IBM TotalStorage 3494 VTS (Virtual Tape Server)” on page 35
- “How z/VSE Supports Tape Libraries” on page 35

### Related Topics:

For details of how to ...	Refer to ...
use the <i>Interactive Interface</i> to add a tape drive, including specifying the tape mode (encrypted, buffered write, compacted)	“Configuring Disk, Tape, and Printer Devices” in the <i>z/VSE Administration</i> .
configure a tape library for use with z/VSE's <i>Tape Library Support</i> (TLS)	“Implementing Tape Library Support” in the <i>z/VSE Administration</i> .
<ul style="list-style-type: none"> <li>• add a tape drive to the IPL startup using the ADD statement</li> <li>• assign a tape drive to a system logical unit using the ASSGN statement</li> <li>• specify the tape mode (encrypted, buffered write, compacted, and so on) using the ASSGN statement</li> <li>• perform tape library functions (for example issue a LIBSERV MOUNT or LIBSERV EJECT command)</li> </ul>	<i>z/VSE System Control Statements</i> .
encrypt tapes using encryption-capable tape drives	“Configuring for Hardware-Based Tape Encryption” in the <i>z/VSE Administration</i> .
backup/export to encrypted tapes using the <i>Interactive Interface</i>	“Backing Up and Restoring Data” in the <i>z/VSE Operation</i> .
setup and configure the TS3400 autoloader	technical article “Overview of IBM System Storage TS1120 Tape Controller Support for System Storage TS3400 Tape Library”, which you can find in the “Documentation” section of the <i>z/VSE Homepage</i> (whose URL is given in “Where to Find More Information” on page xvii).

## Tape Devices

### Overview of Tape Drives/Libraries Supported by z/VSE

Table 10 provides you with a “quick reference” summary of the current *tape drive* devices that are supported by z/VSE.

Table 10. Tape Drives Supported by z/VSE

Tape Drive	Can be Used With Tape Controllers	Capacity <sup>1</sup> / Media	Recording Format <sup>2</sup>	Supported by z/VSE		
				4.2	4.3	5.1
TS1140 (3592 Model E07) Encryption <sup>3</sup>	C06, C07 <sup>4</sup>	3200 GB (MEDIA11/12)	2176 Track EEFMT4			x
		1500 GB (MEDIA9/10)	2176 Track EEFMT4			x
		400 GB (MEDIA13)	2176 Track EEFMT4			x
TS1140 (3592 Model E07) <sup>3</sup>	C06, C07 <sup>4</sup>	3200 GB (MEDIA11/12)	2176 Track EFMT4			x
		1500 GB (MEDIA9/10)	2176 Track EFMT4			x
		400 GB (MEDIA13)	2176 Track EFMT4			x
TS1130 (3592 Model E06) Encryption <sup>3</sup>	C06, C07 <sup>4</sup>	700 GB (MEDIA9/10)	1152 Track EEFMT3	x	x	x
		300 GB (MEDIA5/6)	1152 Track EEFMT3	x	x	x
		60 GB (MEDIA7/8)	1152 Track EEFMT3	x	x	x
TS1130 (3592 Model E06) <sup>3</sup>	C06, C07 <sup>4</sup>	700 GB (MEDIA9/10)	1152 Track EFMT3	x	x	x
		300 GB (MEDIA5/6)	1152 Track EFMT3	x	x	x
		60 GB (MEDIA7/8)	1152 Track EFMT3	x	x	x
TS1120 (3592 Model E05) Encryption	C06, C07 <sup>4</sup> , J70	700 GB (MEDIA9/10)	896 Track EEFMT2	x	x	x
		300 GB (MEDIA5/6)	896 Track EEFMT2	x	x	x
		60 GB (MEDIA7/8)	896 Track EEFMT2	x	x	x
TS1120 (3592 Model E05)	C06, C07 <sup>4</sup> , J70	700 GB (MEDIA9/10)	896 Track EFMT2	x	x	x
		300 GB (MEDIA5/6)	896 Track EFMT2	x	x	x
		60 GB (MEDIA7/8)	896 Track EFMT2	x	x	x
3592 Model J1A	C06, J70	300 GB (MEDIA5/6)	512 Track EFMT1	x	x	x
		60 GB (MEDIA7/8)	512 Track EFMT1	x	x	x
TS3400 Tape Library (Autoloader) containing up to two TS1120 tape drives	C06	(see info. for TS1120) / MEDIA5 - MEDIA10	896 Track	x	x	x
3590 Model H	A50, A60	30 to 60 GB	384 Track	x	x	x
3590 Model E	A50, A60	20 to 40 GB	256 Track	x	x	x
3590 Model B	A50, A60	10 to 20 GB	128 Track	x	x	x
3490E	A10, A20	800 MB	36 Track	x	x	x
3490	A01, A02	200 MB	18 Track	x	x	x
3480	A22	200 MB	18 Track	x	x	x

#### Notes:

1. The TS1140 is also referred to as the 3592 Model E07. The TS1130 is also referred to as the 3592 Model E06. The TS1120 is also referred to as the 3592 Model E05.

1. If data compaction is used, the capacity is increased by a ratio of 3.
2. z/VSE uses the highest possible recording format for the tape drive. If you are using a lower recording format, the hardware will automatically adapt to this lower recording format.
3. z/VM provides guest toleration support for the TS1130 and TS1140 on supported releases of z/VM Version 5. This support allows you to attach a TS1130 or TS1140 to guest operating systems that support them, including guest access to the tape drive's encryption capabilities. For the VM control program, you require the PTFs for APAR VM64459. If your environment requires RMS, you require the PTFs for APAR VM64458 for the RMS component of DFSMS/VM FL221.
4. The C07 tape controller only supports FICON attachments.
5. MEDIA6, MEDIA8, MEDIA10, and MEDIA12 are 3592 WORM (write-once read-many) tapes.
6. z/VSE supports the automatic cartridge loader (ACL) of tape drive devices, which forces the automatic processing of more than one cartridge mounted on the same tape drive before switching to an alternate tape drive. See also "Characteristics of IBM 3490/3490E Tape Devices" on page 30.

Table 11 provides you with a "quick reference" summary of the current *tape library* devices that are supported by z/VSE.

Table 11. Tape Libraries Supported by z/VSE

Tape Library	Can be Used With Tape Controllers	Capacity <sup>1</sup> / Media <sup>2</sup>	Recording Format	Supported By z/VSE		
				4.2	4.3	5.1
TS7680 ProtecTIER® Deduplication Gateway for System z <sup>3</sup>	C06	Virtual 3592 / CST5			x	x
TS7700 Virtualization Engine <sup>4</sup> (Single Cluster Grid or Multi Cluster Grid <sup>5</sup> ), which includes these models: <ul style="list-style-type: none"> <li>• TS7720 disk-only<sup>6</sup></li> <li>• TS7740 with Copy Export facility<sup>7</sup> (z/VSE 5.1 and later)</li> </ul>	See info. for tape drives	Virtual 3490E / CST1		x	x	x
		400 MB up to 4 GB	36 Track	x	x	x
		800 MB up to 4 GB	36 Track	x	x	x
TS3500/3584 UltraScalable Tape Library	J70 / C06, C07 <sup>8</sup>	3592 / CST5 - CSTA		x	x	x
		3592 / CSTB - CSTD				x
3494 with Virtual Tape Server (VTS)	See info. for tape drives	Virtual 3490E / CST1		x	x	x
		400 GB	36 Track	x	x	x
		800 GB	36 Track	x	x	x
3494 Tape Library	A60	3490E / CST1		x	x	x
		3590 / CST3		x	x	x
	J70, C06	3592 / CST5 - CSTA		x	x	x

### Notes:

1. If data compaction is used, the capacity is increased by a ratio of 3.
2. The entries CST1 to CSTD correspond to the media types MEDIA1 to MEDIA13.
3. The TS7680 provides a disk-only virtual tape solution. The TS7680 will emulate an IBM tape library and 3592 Model J1A tape drives.
4. The TS7700 Virtualization Engine *Release 1.6 and later* provides WORM support via its logical tape volumes (3490E). See “IBM TS7700 Support for WORM Cartridges” on page 33.
5. The TS7700 *Release 1.5 and later* can be used in Single- or Multi-Cluster Grid configurations. This is supported by z/VSE 5.1 and later. See “IBM TS7700 Multi-Cluster Grid Support” on page 33.
6. The TS7700 *Release 1.5 and later* includes the model IBM TS7720 which is *disk-only*. See “IBM TS7700 Model TS7720” on page 33.
7. The TS7700 *Release 1.5 and later* includes the model IBM TS7740 with its *Copy Export* feature (used for performing a disaster recovery). This feature is supported by z/VSE 5.1 and later. See “IBM TS7700 Model TS7740 (With Copy Export Feature)” on page 33.
8. The C07 tape controller only supports FICON attachments.

## IBM TS1140, TS1130, TS1120, and 3592 J1A Tape Drives

The IBM System Storage TS1140, TS1130, TS1120, and 3592 J1A tape drives can be:

- Used in stand-alone mode.
- Integrated in an IBM TotalStorage Tape Library.

The cartridge capacities and recording formats that you can use with these tape drives are shown in Table 10 on page 24. These cartridges are available in

- Rewritable formats.
- WORM (Write Once Read Many) formats.

WORM cartridges are designed to provide non-alterable, non-rewritable tape media for long-term records retention. When the tape drive detects a WORM cartridge, the tape drive prevents overwrite or changes to existing customer data. New data can be appended to existing data until the capacity of the cartridge is reached.

### Tape Encryption Supported by the IBM TS1130 and TS1120

Using the tape encryption support provided by the IBM System Storage TS1130 or TS1120 tape drives or later, you can write the data in encrypted format to the tape. The IBM *Encryption Key Manager* (EKM) component for the Java™ platform is used to manage the encryption keys that are used in key negotiation between the Encryption key Manager (EKM) and the tape drive.

The EKM can be downloaded and installed on a Java-based platform.

An application running on a z/VSE host can therefore issue a request to encrypt the data stored on a tape. This request is initiated using an appropriate Mode setting in the ASSGN statement. The EKM and tape drive communicate via the TCP/IP protocol.

---

2. The TS1130 is also referred to as the 3592 Model E06. The TS1120 is also referred to as the 3592 Model E05.



Re-keying support is available via the REKEY parameter of the JCL KEKL statement. This support enables you to re-encrypt the data key of an already-encrypted tape using new encryption keys.

For further details, refer to “Implementing Hardware-Based Encryption” in the *z/VSE Administration*.

## TS3400 Autoloader Tape Library

From z/VSE Version 3 Release 1 Modification Level 2 onwards, z/VSE supports the TS3400 tape library as an *autoloader* operating in AUTO mode. In AUTO mode, as soon as a cartridge is unloaded from the drive, the next unused cartridge is loaded.

The TS3400 autoloader tape library supports up to **two** IBM System Storage TS1120 (3592 Model E05) tape drives. These are added in z/VSE as stand-alone TPA (Tape Products Architecture) devices.

The TS3400 contains two *cartridge magazines* that each hold up to nine tapes. The lower magazine can be configured to use up to three slots as *I/O slots*. This can be done using either the TS3400 Operator Panel, or using the Web Interface.

For details of how to:

- add TS1120 (3592 Model E05) tape drives as stand-alone TPA devices, refer to “Configuring a Disk, Tape, or Printer Device” in the *z/VSE Administration*.
- setup and configure the TS3400 autoloader, refer to the technical article “Overview of IBM System Storage TS1120 Tape Controller Support for System Storage TS3400 Tape Library”, which you can find in the “Documentation” section of the *z/VSE Homepage* (whose URL is given in “Where to Find More Information” on page xvii).

## IBM TotalStorage 3590/3592 Tape Drives

The 3590/3592 tape drives can be:

- Used in stand-alone mode.
- Attached to an IBM TotalStorage Tape Library.

The cartridge capacities and recording formats that you can use with 3590/3592 tape drives are shown in Table 10 on page 24.

### Programming Aspects

The z/VSE device support for IBM 3590/3592 is similar to the IBM 3480/3490 device support, with the following exceptions that could affect user programs:

- TPA devices do not support READ BACKWARD CCWs.
- A CCW, READ PREVIOUS, is provided as a replacement for READ BACKWARD.

If you issue a READ BACKWARD CCW, z/VSE error recovery transforms it into a READ PREVIOUS CCW, but at the expense of performance degradation.

The standard HDR2 label has been changed to accommodate six digits, instead of the last 5 digits of the device serial number, which were moved into the HDR2 label record for other devices.

To ensure proper error recovery, applications waiting for device end or channel end on an IBM 3590/3592 are posted at device end. Note that rewind or

positioning commands can cause excessive wait times, and thus degrade performance.

### IBM 3590/3592 Tape Modes

The TPA architecture allows various *tape mode* settings. For the 3590/3592 you can choose between:

'00' to '0C' (unbuffered and/or encryption and/or compaction)

'20' to '2C' (buffered and/or encryption and/or compaction)

The default is Mode X'08'.

For details of how to use the ASSGN statement and tape-mode settings, refer to the *z/VSE System Control Statements*.

### IPL and JCL Support

The IBM 3590/3592 will be properly recognized during IPL, if it is attached and operational. If the device is not attached and operational, the IBM 3590/3592 can be added by specifying a tape device type in the type of ADD statement:

```
ADD cuu,TPA[,mode]
```

In this second example, the *tape device type* is simply TPA:

```
ADD 580,TPA,2B
```

In this third example, the *tape device type* is TPA896 which contains more precise information about the tape device and its track format (TPA896 corresponds to an IBM 3592 E05 with encryption mode):

```
ADD 580,TPA896,2B
```

**Note:** From z/VSE 4.3 onwards, you *cannot* ADD a TPA tape drive with tape mode '05' or with a tape mode that includes '05' in its calculation (such as '25'). If you have specified one of these tape modes in a previous z/VSE release, during an initial installation or FSU of z/VSE you will receive an appropriate error message.

JCL allows you to assign IBM 3590/3592 tape drives using one of these methods:

- By specifying the cuu directly:

```
ASSGN SYSxxx,cuu
```

- By specifying the tape device type TPA with which the device (cuu) was added during IPL:

```
ASSGN SYSxxx,TPAnnn
```

where TPAnnn can be TPA, TPAT128, TPAT264, and so on for the different tape device types and their corresponding track formats.

JCL also allows LIBSERV MOUNT commands for IBM 3590/3592 tape drive units in tape libraries (such as the IBM 3494). If several tape-device types are contained in a tape library and a UNIT parameter has not been specified, JCL will select a tape drive that is able to process the specified tape volumes.

Data compaction is handled as specified during IPL in the ADD statement, or as set with the JCL ASSGN statement. Volume, header and trailer labels are not compacted.

For details of how to specify tape device types, refer to “Job Control and Attention Routine” in the *z/VSE System Control Statements*.

## IBM TotalStorage 3490E Tape Drive

z/VSE supports IBM 3490E tape drive devices. The IBM 3490E with its control unit Models A10/20 (including B20/B40), D41/42, and C10/C11/C22 is a double-density follow-on device to the IBM 3480/3490 tape subsystem. The models of the IBM 3490E have a standard cartridge capacity of up to 1200MB/400MB (with or without compaction through the IDRC feature). The cartridge capacity with the IDRC feature installed is dependent on the compaction ratio. All models of the IBM 3490E can read IBM 3480/3490 cartridges but not vice versa.

**Note:** IDRC means Improved Data Recording Capability.

### Considerations for Adding an IBM 3490E/3490/3480 Tape Device

At IPL time, the IBM 3490E, IBM 3490, and IBM 3480 are treated differently which is shown in the following table. The table also applies when defining an IBM 3490E, IBM 3490, or IBM 3480 tape device during initial installation.

Table 12. Defining/Adding IBM 3480/3490 Tape Devices

Tape Device	To be defined or added as 3490E	To be defined or added as 3490	To be defined or added as 3480
IBM 3480			x
IBM 3480 with IDRC feature		x	
IBM 3490			x
IBM 3490 with IDRC feature		x	
IBM 3490E	x		

If a tape drive is operational at IPL time, it is sensed and is recognized correctly whether it is installed with or without the IDRC feature. If a tape drive is **not** operational at IPL time, you have to use one of the following commands to set the correct IDRC capability in the device list:

```
ADD cuu,3480,mode
ADD cuu,3490,mode
ADD cuu,3490E,mode
```

For details of how to use the ASSGN statement and mode settings, refer to the *z/VSE System Control Statements*.

**Note:** The IBM 3480 and IBM 3490 Model D31/D32 have the IDRC feature as an **optional** feature only. The other models of the IBM 3490 and IBM 3490E include the IDRC feature as a **standard** feature.

### 3480-XF and 3480-2 XF Recording Format Compatibility

When using these tape devices, you must observe the following:

An IBM 3490E uses the **3480-2 XF** recording format. This format is different from the format of the IBM 3480 and IBM 3490 tape subsystems. They use the **3480-XF** recording format.

**Note:** The 3480-2 XF recording format is an enhanced capability format with 36-track bidirectional recording (for IBM 3490E tape devices) compared to 18-track recording format 3480-XF (for IBM 3480/3490 tape devices).

- Cartridges created on an IBM 3490E can **only** be read on IBM 3490E tape devices.

## Tape Devices

- IBM 3490E tape devices can read cartridges created on an IBM 3480 or IBM 3490 tape device.
- All IBM 3490 can be attached to an ESCON channel if they have the 4.5 MB/sec ESCON feature with a 2MB buffer or if they have the 9MB/sec ESCON feature with an 8MB buffer installed.

For the system support of the automatic cartridge loader of the IBM 3490E, IBM 3490, and IBM 3480 tape devices, see the topic “Summary of Support for IBM 3490 and IBM 3490E Tape Drives.”

### Access to a Shared Tape Drive

You can share an IBM 3490E, 3490, or 3480 tape drive, for example, between two CPUs. Only one of these CPUs, however, can “own” the device at a particular time. Two operator commands, **ONLINE** and **OFFLINE**, allow controlled access to the shared device. Figure 1 is a simplified example:

Whenever the operator issues an ONLINE command for an IBM 3480, 3490 or

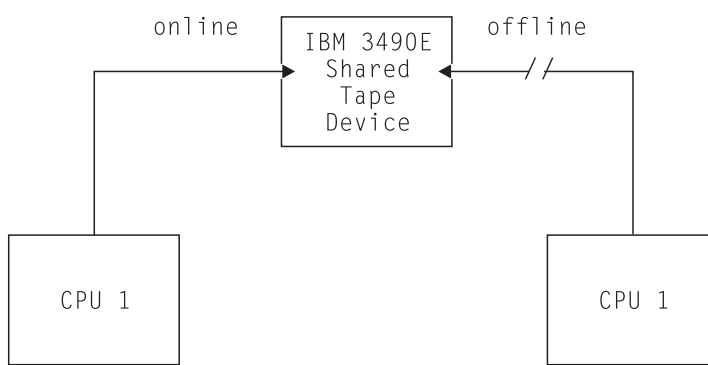

Figure 1. Access to a Shared Tape Drive

3490E tape (cartridge) device, the tape device is being dedicated to that CPU. However, if the tape device is already in use by another CPU, a message indicates this status. No other CPU can access this tape device until the operator releases the device with the OFFLINE command. Under “ONLINE” and “OFFLINE”, the *z/VSE System Control Statements* describes the ONLINE and OFFLINE commands in detail.

### Summary of Support for IBM 3490 and IBM 3490E Tape Drives

Following is a summary of the VSE support for IBM 3490 and IBM 3490E tape (cartridge) devices.

#### Characteristics of IBM 3490/3490E Tape Devices:

Table 13. Characteristics of IBM 3490/3490E Tape Devices

	IBM 3490 A01/A02 (see Note 1) B02/B04	IBM 3490 D31/D32	IBM 3490E A10/A20 (see Note 1) B20/B40	IBM 3490E D41/D42 C10/C11/C22 C1A/C2A F00/F01/F11/F1A (see Note 3)
Number of tracks	18	18	36	36
IDRC	standard	optional	standard	standard

Table 13. Characteristics of IBM 3490/3490E Tape Devices (continued)

	IBM 3490 A01/A02 (see Note 1) B02/B04	IBM 3490 D31/D32	IBM 3490E A10/A20 (see Note 1) B20/B40	IBM 3490E D41/D42 C10/C11/C22 C1A/C2A F00/F01/F11/F1A (see Note 3)
IDRC disable switch	YES	YES	not applicable	not applicable
Automatic Cartridge Loader	standard	optional	standard	(see Note 4)
Performance Enhancement Function (see Note 2)	not applicable	not applicable	standard	optional
Buffer Size (MB)	2	2	8	2
ESCON Adapter	optional	optional	optional	optional
Parallel Adapter	optional	standard	optional	standard

**Notes:**

1. The IBM 3490E Models A01/A02 and A10/A20 do not include channel attachment as standard equipment. Channel adapter type and quantity must be specified at initial order.
2. This function uses an 8MB buffer and an increased speed compactor. An instantaneous data rate of up to 9MB/sec is provided on ESCON channels.
3. Models C1A and C2A of the IBM 3490E are included in the IBM 3494. For the z/VSE support of the IBM 3494 refer to "IBM TotalStorage 3494 Tape Library" on page 35.
4. For the models C11, C22, C1A, and C2A, it is standard and for the models D41/D42 it is optional. For the model C10 it is not applicable.

**IBM TS7680 ProtecTIER Deduplication Gateway for System z**

The IBM *TS7680 ProtecTIER Deduplication Gateway for System z* (referred to simply as the TS7680) provides users with an optimal disk-based solution for System z applications that traditionally use tape, and is designed to simplify tape processing operations.

Like the IBM System Storage TS7720 Virtualization Engine, the TS7680 provides a *disk-only virtual tape solution*. It does this by emulating an IBM tape library with 3592 Model J1A tape drives and JA (Media 5) media.

- The TS7680 appears to the z/VSE host as an automated tape library (and not as a virtual tape library).
- Logical 3592 J1A drives must be added during IPL as TPA device type.
- Only 3590 emulation mode is supported for 3592 Model J1A tape drives residing in a TS7680.

## Tape Devices

For high availability, the TS7680 supports *two* nodes, where each node consists of a:

- C06 tape control unit
- TS7650G server

Each of the two nodes supports up to 128 virtual tape drives (8 logical control units with 16 devices per logical control unit).

The capacity of a TS7680 logical volume (100 GB) is less than the capacity of a JA (MEDIA5) physical cartridge (300 GB). However, the TS7680 provides up to one million logical volumes per system.

Logical volumes are defined in the TS7680 via the *IBM ProtectTIER Manager* GUI, but do not take up any disk space until written by the z/VSE host. A scalability of up to 1 PB of useable capacity is possible per system.

If you perform a QT cuu command for this tape device, the TS7680 will be shown as being a DISK-ONLY (a similar example for the TS7720 is shown in “IBM TS7700 Model TS7720” on page 33).

## IBM TS7700 Virtualization Engine

The IBM *TS7700 Virtualization Engine* is a mainframe virtual-tape solution that is designed to optimize tape processing. Deploying this innovative subsystem may help reduce batch processing time, total cost of ownership and management overhead.

The TS7700 Virtualization Engine offers:

- The definition of up to 16 physical TS1120 or TS1130 tape drives with the TS7740.
- A maximum of 256 virtual tape drives and 2 million logical volumes.
- Web-based management tools.
- Encryption support based on the TS1120 and TS1130 tape drives with the TS7740.

From z/VSE 5.1 onwards, the TS7700 in Multi-Cluster Grid mode is supported.

### IBM TS7700 Support for BVIR

z/VSE supports the BVIR (*Bulk Volume Information Retrieval*) function for use with the TS7700 Virtualization Engine.

For details of the BVIR support, refer to this URL:

<http://www-03.ibm.com/support/techdocs/atmastr.nsf/WebIndex/WP101094>

## IBM TS7700 Support for WORM Cartridges

WORM cartridges are designed to provide non-alterable, non-rewritable tape media for long-term records retention. When the tape drive detects a WORM cartridge, the tape drive prevents overwrite or changes to existing customer data. New data can be appended to existing data until the capacity of the cartridge is reached.

- The TS7700 Virtualization Engine provides support for WORM cartridges via its *logical tape volumes* (3490E). When WORM is active, any attempt to modify a previously-written user data record of a logical 3490E WORM volume will be rejected.
- A logical 3490E volume will be designated as WORM when it is first mounted and written from load point.
- You can define/indicate logical volumes to be WORM volumes via the provided Web/GUI interface.

## IBM TS7700 Model TS7720

The IBM TS7700 Virtualization Engine model TS7720 is a *disk-cache only* configuration (it does *not* attach to a “physical” tape library).

To support the TS7720, z/VSE provides this additional information:

- Using the QT cuu command, you can see if a member of the TS7700 family is a tapeless TS7720 Virtualization Engine. The parameter DISK-ONLY is displayed together with the other details.
- The JCL LIBSERV LQUERY command and the LBSERV LQUERY macro call can be used to obtain information about the percentage of cache that is currently being used.

For further details, see “Job Control and Attention Routine” in the *z/VSE System Control Statements*.

## IBM TS7700 Model TS7740 (With Copy Export Feature)

The IBM TS7740 Virtualization Engine is a model of the TS7700 Virtualization Engine family that:

- Includes a disk cache configuration.
- Attaches to a “physical” TS3500 tape library for back-end processing.

The model TS7740 includes the *Copy Export* feature, that allows you to “Copy Export” a copy of selected data to an offsite location for *disaster recovery* (DR) purposes.

For further details of how to implement the Copy Export feature, refer to “Implementing Tape Library Support” in the *z/VSE Administration*.

## IBM TS7700 Multi-Cluster Grid Support

From z/VSE 5.1 onwards, z/VSE provides support for *multi-cluster grid configurations* of the TS7700 Virtualization Engine:

- A *TS7700 Grid* refers to two or more physically separate TS7700 clusters that are connected via a customer-supplied TCP/IP network.
- Logical volume attributes and data can be replicated across the clusters in a Grid. Any data replicated between the clusters is accessible through any other cluster in a Grid configuration.
- Through remote volume access, you can reach any virtual volume through any virtual device, even if a replication has not been made.

## Tape Devices

z/VSE differentiates between a *composite library* and a *distributed library*:

- A *composite library* is a logical image of the grid which is presented to the host.
- A *distributed library* is one cluster in a grid.

By setting up *policies* on the TS7700 Virtualization Engines, you define where and when you want to have multiple copies of your data. You may also specify, for certain kinds of data, for example, test data, that you do not need a secondary or tertiary copy.

*Outboard Policy Management* is *not* supported by z/VSE hosts that are attached to a TS7700 Virtualization Engine. Therefore you must use the TS7700 Virtualization Engine *Management Interface* (MI) to perform, for example, these tasks:

- Define your pools and constructs.
- Define data classes.
- Insert logical volumes into groups.
- Modify logical volumes.

A Grid configuration looks like a single storage subsystem to the hosts. For both single- and multi-cluster configurations, the entire subsystem appears as a *single tape library* to the attached hosts. This is referred to as a *composite library* with underlying *distributed libraries*. Distributed libraries are not seen from the host.

z/VSE will provide additional information in existing AOMs (asynchronous operator messages). For example, AOMs now specify whether a message originates from a cluster or a composite library. Here are two examples of AOM messages:

```
AOMAP00I LIBRARY INFORMATION CUU=0C9F, LIB=BARR88,CLUSTER=01
```

```
AOMAP00I LIBRARY INFORMATION CUU=0C9F, LIB=BARR88,COMPOSITE
```

For details of how to implement multi-cluster grid support, refer to the IBM Redbook which you can find at this URL:

<http://www.redbooks.ibm.com/redbooks/pdfs/sg247712.pdf>

## IBM TS3500/3584 UltraScalable Tape Library

The attachment of System z hosts to the TS3500/3584 Tape Library via the *Enterprise Library Controller (ELC)* takes advantage of the TS3500/3584 Tape Library's support of the IBM TotalStorage 3592 Tape Drive Models J1A and E05.

In Open system environments, you can use in the same TS3500/3584 Tape Library:

- IBM TotalStorage LTO (Linear Tape-Open) Tape sub-systems.
- IBM TotalStorage 3592 Tape Drive Models J1A and E05.

The TS3500/3584 tape library supports:

- System z via the IBM 3953 Tape System, which enables System z hosts to access the TS3500/3584 tape library cartridge inventory and allows connection to 3592 J1A and TS1120 tape drives.
- Up to four 3953 tape systems, allowing for up to eight VTS subsystems per physical library.

For further details of TS3500/3584 support, refer to the *z/VSE Administration*.



## IBM TotalStorage 3494 Tape Library

The IBM TotalStorage 3494 Tape Library is an intermediate automated tape library dataserer. It automates the retrieval, storage, and control of IBM 3490E, IBM 3590, and IBM 3592 cartridge tapes.

The 3494 Tape Library addresses data retention and business continuity requirements. It supports 3490E, 3590 and 3592 tape drives with high capacity or short length rewritable media, as well as 3592 WORM media. A single 3494 Tape Library can be shared across multiple platforms.

With the support of the IBM 3590 and IBM 3592, the IBM 3494 may contain devices of more than one device type.

## IBM TotalStorage 3494 VTS (Virtual Tape Server)

The IBM TotalStorage 3494 VTS support is designed to help reduce operating costs and improve the overall performance of the tape library processing.

To help improve performance, the 3494 VTS subsystem writes virtual 3490E volumes to a tape volume cache on a high-speed RAID disk buffer. It then stacks the virtual volumes on high-capacity 3592 or 3590 cartridges.

The 3494 VTS can help reduce batch processing time, reduce the Total Cost of Ownership, and management cost. A single 3494 VTS can also be shared across multiple platforms.

## How z/VSE Supports Tape Libraries

z/VSE supports IBM tape libraries in LPAR mode, via LCDD, and as a VSE Guest Server.

### Tape Library Support (TLS) in LPAR Mode

The TLS in LPAR mode allows IBM tape libraries to be supported through the channel command interface.

Existing Library Control Device Driver (z/VSE in LPAR mode) and VGS (where z/VSE runs under VM) tape library support is based on the XPCC/APPC communication protocol.

The support in LPAR mode is easier to use and more extendable than earlier tape library support.

For compatibility reasons, the LCDD interface can still be used with tape library support in LPAR mode. However, the LCDD support is not enhanced. For example, LCDD support does not include 3592 tape drives.

For further details of tape library support in LPAR mode, refer to the *z/VSE Administration*.

### VGS (VSE Guest Server) Support

The capabilities of the VM component DFSMS/VM RMS extend the IBM tape library support to z/VSE guests running under z/VM.

The DFSMS/VM RMS component provides library control through the host channel attachment of the tape library.

DFSMS/VM provides a z/VSE Guest Server (VGS) virtual machine to facilitate the z/VSE-guest usage of CMS interfaces. The z/VSE API for the tape library is the main programming interface for controlling the library through VGS.

For further details, refer to *DFSMS/VM RMS User's Guide and Reference*, SC35-0141.

### z/VSE Macros and Parameters Used With Tape Libraries

The z/VSE support consists of the following major functions:

- Support of Parameter ATL in IPL SYS Command  
The ATL (automatic tape library) parameter is required to activate the appropriate tape library support for the tape library during startup.
- LIBSERV Command/Statement  
The LIBSERV command/statement is provided for specifying all information for mounting, maintaining, and detaching tape volumes on a tape library. Refer to the *z/VSE System Control Statements* under "LIBSERV" for a description of the LIBSERV command/statement.
- LBSEVR Macro  
The LBSEVR macro provides the application programming interface (API) which allows to write applications that can access volumes of the tape library. Refer to the *z/VSE System Macros Reference* under "LBSEVR Macro" for the syntax and a description of the LBSEVR macro and the *z/VSE System Macros User's Guide* under "Example for a LBSEVR MOUNT Request" for programming examples.

---

## Virtual Tape Support

A virtual tape is intended to be transparent to applications and to provide you with the ability to read from or write to a virtual tape in the same way as if it were a physical tape. For technical and performance reasons, the full range of the capabilities of a physical tape has not been implemented in z/VSE.

In z/VSE, a virtual tape is a file (or dataset) containing a tape image. A virtual tape can be:

- A VSE/VSAM **ESDS** file on the z/VSE host side.
- A **remote** file on the server side; for example, a Linux, UNIX, or Windows file. To access such a remote virtual tape, a **TCP/IP** connection is required between z/VSE and the remote system.

You **cannot** use virtual tapes with the hardware-based tape encryption support (described in “Tape Encryption Supported by the IBM TS1130 and TS1120” on page 26).

For details of how to use virtual tapes, refer to “Implementing Virtual Tape Support” in the *z/VSE Administration*.

## Channel-Related Support

### Dynamic I/O Handling

z/VSE provides for improved I/O handling through the dynamic channel subsystem. The channel subsystem supports:

- Dynamic path selection (DPS)
- Dynamic path reconnection (DPR)
- Up to 256 channels
- Up to 8 paths to a single device.

z/VSE supports DPS for all devices with multiple paths and DPR for all devices which support DPR.

With dynamic I/O handling, the cuu does not specify channel and unit address but instead the device address as generated via IOCP (Input/Output Configuration Program) for the device. In z/VSE, a device address can be between 0000 and FFFF.

In such an environment, channels are transparent to z/VSE. They are defined via IOCP, as described in “z/VSE Input/Output Configuration Program (IOCP)” on page 90.

### FICON Express, FICON Express2, FICON Express4, and FICON Express8

FICON is an abbreviation for (Native Fiber CONnection) channel support.

z/VSE supports devices that are attached to the server via both FICON and ESCON channels.

## ESCON

### ESCON Channels

Some **IBM 3174 controllers** have ESCON channel interfaces for SNA and non-SNA control units.

### ESCON Channel-to-Channel

Through VTAM and TCP/IP, z/VSE supports the ESCON CTC connection between two processors or servers.

### ESCON Multiple Image Facility (EMIF)

ESCON Multiple Image Facility allows for a more flexible utilization of resources, such as ESCON channel sharing between PR/SM logical partitions, less channel connections, and common usage of channels and peripheral devices.

## IBM Enterprise Systems Connection Director (ESCD)

z/VSE supports the following Enterprise Systems Connection Director (ESCD) devices:

- IBM 9032
- IBM 9033

The ESCD devices provide dynamic ESCON connections. The various models of the IBM 9032 support up to 124 *ports*, where port means an attachment for ESCON channels or control units. The IBM 9033 supports a minimum of 8 and a maximum of 16 ports. The ports can be Light Emitting Diode (LED) or Extended Distance Feature (XDF) or both.

When controlled from z/VSE, the device is recognized during IPL. The Error Recovery Procedure (ERP) handles all errors reported by solicited and unsolicited interrupts of that device. The following example illustrates the connection between a processor and the I/O control unit via an ESCD device:

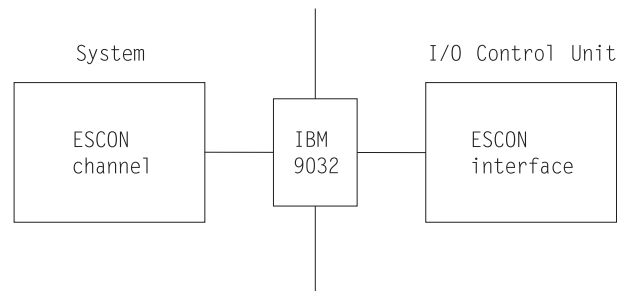

Figure 2. Connection Between a Processor and I/O Control Unit via an ESCD Device

When you run z/VSE under z/VM, you can make use of ESCON manager functions. In a z/VSE system in LPAR mode, ESCON directors have to be controlled through their operator console.

## IBM 9035 ESCON Channel Protocol Converter

z/VSE supports the IBM 9035 ESCON Channel Protocol Converter. It lets you attach an ESCON control unit to parallel channels.

### Devices Not Supported by z/VSE 5.1

These IBM devices are **not** supported *from z/VSE 4.1 onwards*:

#### Disks Devices

- 0671
- 3370
- 3375
- 3995
- 9332
- 9335
- 9336
- 9345.

#### Notes:

1. As a result of the withdrawal of the 9345 support, a Fast Service Upgrade (FSU) from a 9345 device is not supported.
2. FBA devices can still be used with z/VSE as “generic FBA” devices.

#### Tape Devices

- 2440
- 3422
- 3424
- 9346
- 9347
- 9348

#### Network Communications Devices

- CETI
- SDLC ICA
- BSC ICA
- 2701
- 2703
- 3705
- 3720
- 3725

#### Other Devices

- 3540
- 3881
- 3886
- 3890
- 3895

**Note:** These devices can be ADDED, but *cannot* be configured using the Interactive Interface:

- 3745-130
- 3745-210
- 3745-310
- 3745-410
- 3745-610

---

## Programs No Longer Shipped With z/VSE 5.1

No programs have been dropped with z/VSE 5.1.





---

## Chapter 3. z/VSE 5.1 Base and Optional Programs

This chapter describes the base and optional products available with z/VSE 5.1.

It contains these main topics:

- “z/VSE 5.1 Base Programs”
- “z/VSE 5.1 Optional Programs” on page 48

The *Program Directory*, which is shipped with z/VSE, provides additional details about base and optional programs such as the Modification Level, the Program ID, the Component ID and the Component Level Code (CLC).

---

### z/VSE 5.1 Base Programs

As shipped, z/VSE consists of a number of base programs as listed in Table 14 on page 44. Most of these programs are shipped on the z/VSE base tape, some of them on the Extended Base Tape as indicated in Table 14 on page 44 and further explained below.

The program number for ordering z/VSE (including all base programs) is 5609-ZV5. Refer to “Shipment of z/VSE 5.1” on page 87 for additional details.

#### Base Programs Shipped on the Extended Base Tape

Some of the z/VSE 5.1 base programs are shipped on the Extended Base Tape. These programs are in most cases not installed automatically as further explained below:

- **LE/VSE DBCS Locales**

LE/VSE is one of the base components on the z/VSE base tape. However, the *LE/VSE DBCS Locales* component is shipped on the *Extended Base Tape*. You require this component you use a language that requires the Double Byte Character Set. If you need this component, you must install it separately using the dialog for optional program installation. Refer also to “Considerations for LE/VSE and the VSE C Language Run-Time Support” on page 89.

- **DB2 Server for VSE 7.5 or DB2 Server for VSE Client Edition 7.5**

During initial installation you are asked whether you want install the *DB2 Server for VSE*. If you answer with YES, you must mount the Extended Base Tape for automatic installation. If you respond with NO or in case of an FSU, you can install this program later using the dialog for optional program installation. You can separately install the *DB2 Server for VSE Client Edition* using the dialog for optional program installation.

The Extended Base Tape includes the **DataPropagator Relational Capture** additional DB2® program related to the *DB2 Server for VSE* and *DB2 Server for VSE Client Edition*. If you want to use this program, you must install it separately using the dialog for optional program installation.

The z/VSE shipment includes an extra tape containing the **DB2 Server for VSE Help**. This component must be installed using the corresponding DB2 installation support. Refer also to “Use of Installation Member ARISIVAR.Z” on page 150.

- **VSE Connectors Workstation Code**

## Base Programs

The VSE Connectors Workstation Code component is shipped on the Extended Base Tape. If you want to use this program, you must install it separately using the dialog for optional program installation. It includes all code that can be installed *on a workstation*.

- **IPv6/VSE**

The IPv6/VSE component is shipped on the Extended Base Tape. If you want to use this program, you must install it separately using the dialog for optional program installation.

## Base Programs Included in z/VSE 5.1

Table 14. Base Programs Included in z/VSE 5.1

z/VSE 5.1 Base Programs	Program Number	Version Release	Extended Base Tape	Comment
VSE Central Functions including: VSE Advanced Functions VSE/SP Unique Code VSE/POWER VSE/ICCF VSE/VSAM VSE/Fast Copy REXX/VSE OSA/SF VSE Connector Server Encryption Facility for z/VSE LE/VSE	5686-CF9 – – – – – – – – – – –	9.1 – – – – – – – – – – 1.4.8		see Note 1 see Note 2 see Note 3 see Note 4 see Note 5 see Note 6 see Note 7 see Note 8 see Note 9 see Note 10 see Note 11
VTAM®	5686-065	4.2		see Note 12
CICS Transaction Server for VSE/ESA	5648-054	1.1.1		see Note 13
TCP/IP for VSE/ESA	5686-A04	1.5		see Note 14
IPv6/VSE	5686-BS1	1.1	yes	see Note 15
DB2 Server for VSE DB2 Server for VSE Client Edition DB2 DataPropagator Relational Capture DB2 Server for VSE Help	5697-F42	7.5 7.5 7.4 7.5	yes yes yes (*)	see Note 16
VSE Connectors Workstation Code	5686-CF9-38 51P	9.1	yes	see Note 17
OS/390® API	5686-CF9	9.1	yes	see Note 18
High Level Assembler for VSE	5696-234	1.6		see Note 19
DITTO/ESA for VSE	5648-099	1.3		see Note 20
EREP	5656-260	3.5		see Note 21
ICKDSF	5747-DS2	1.17		see Note 22

### Explanations to Table 14:

(\*) The *DB2 Server for VSE Help* component is shipped on a separate tape (**not** the Extended Base Tape).

For details about the programs shipped on the Extended Base Tape refer to “Base Programs Shipped on the Extended Base Tape” on page 43.

### Notes:

1. **VSE/Advanced Functions** provides basic system control and includes the supervisor and system programs such as the Librarian and the Linkage Editor.
2. **VSE/SP Unique Code** provides productivity support such as the Interactive Interface and workstation related support.
3. **VSE/POWER** (VSE/Priority Output Writers, Execution Processors and Input Readers) provides spooling support and networking control.
4. **VSE/ICCF** (VSE/Interactive Computing and Control Facility) provides interactive partition support and support for VSE/ICCF libraries.
5. **VSE/VSAM** (VSE/Virtual Storage Access Method) provides data management support.
6. **VSE/Fast Copy** is a utility program providing fast copy support for data on disk or tape devices.
7. **REXX/VSE** provides programming language support. Refer to “Support of REXX/VSE” on page 249 for details.
8. **OSA/SF for VSE/ESA** (Open Systems Adapter Support Facility) provides support for customizing and managing Open Systems Adapters. Refer to “Using OSA/SF to Manage/Customize the Adapter Environment” on page 159 for further details.
9. **VSE Connector Server** also includes the VSE/VSAM CLI (Call Level Interface) and the VSE/VSAM Redirector Client.
10. The **Encryption Facility for z/VSE** can be used to encrypt and decrypt files, VSE Library members, and complete backups that were made using any z/VSE backup utility. The optional program *Encryption Facility for z/VSE OpenPGP* also supports the OpenPGP standard. Refer to “Encryption Using the Encryption Facility for z/VSE” on page 242 for details.
11. **LE/VSE** (IBM Language Environment for VSE/ESA) provides a language environment for high-level language applications. It supports COBOL, PL/I, and C. The VSE C Language Run-Time Support is a subset of it, and provides an environment to run applications written in the C programming language. Refer to “Considerations for LE/VSE and the VSE C Language Run-Time Support” on page 89 for further details. The *LE/VSE DBCS Locales* component is shipped on the Extended Base Tape.
12. **VTAM** (Virtual Telecommunications Access Method) provides display station and networking control support.
13. **CICS Transaction Server for VSE/ESA** provides transaction processing support.
14. **TCP/IP for VSE/ESA** provides a set of protocols by which computers can communicate with any other computer that runs an operating system with a TCP/IP implementation. Refer to “TCP/IP for VSE/ESA Support” on page 153 for further details.
15. **IPv6/VSE** is a native implementation of Transmission Control Protocol/Internet Protocol (TCP/IP) and provides an *IPv6 solution* for z/VSE. IPv6/VSE has been licensed from *Barnard Software, Incorporated*. It is shipped on the Extended Base Tape. Refer to “IPv6/VSE Support” on page 155.
16. **DB2 Server for VSE** and **DB2 Server for VSE Client Edition** provide advanced, relational database management and DB2 stored procedures support for z/VSE. The *DataPropagator Relational Capture* option of the DB2 Server for VSE is also available on the Extended Base Tape. An extra tape is also provided including the *DB2 Server for VSE Help* component.
17. The **VSE Connectors Workstation Code** is shipped on the Extended Base Tape. You can install it separately using the dialog for optional program installation. It includes all code that can be installed *on a workstation*. However,

## Base Programs

you can also download *individual* members (for example, the VSE Connector Client, Virtual Tape Server, VSAM Redirector Server, and VSE Script Server) via the *VSE Homepage*.

18. The **OS/390 API** consists of a set of macros that can be used within z/VSE to emulate z/OS supervisor calls (SVCs). However, the OS/390 API is normally for use by *Vendors only*. Its use requires a high level of technical knowledge. It is shipped on the Extended Base Tape.
19. **High Level Assembler for VSE** provides enhanced programming language support at the assembler level.
20. **DITTO/ESA for VSE** (Data Interfile Transfer, Testing and Operations Utility) provides support for moving data fast from one media to another.
21. **EREP** (Environmental Record Editing and Printing) belongs to basic system control and provides diagnostics support.
22. **ICKDSF** (Device Support Facilities) belongs to basic system control and provides support for maintaining devices such as disks and tapes.

## Where Do the Base Programs Reside?

After initial installation, the base programs reside in the system libraries listed below:

Table 15. Location of z/VSE Base Programs

z/VSE System Sublibrary	Contains ...
IJSYSRS.SYSLIB	<ul style="list-style-type: none"> <li>• VSE Central Functions including:               <ul style="list-style-type: none"> <li>VSE/Advanced Functions</li> <li>VSE/SP Unique Code</li> <li>VSE/POWER</li> <li>VSE/ICCF</li> <li>VSE/VSAM</li> <li>VSE/Fast Copy</li> <li>Encryption Facility for z/VSE</li> </ul> </li> <li>• ICKDSF (Device Support Facilities)</li> </ul>
PRD1.BASE	VSE Central Functions including: <ul style="list-style-type: none"> <li>• OSA/SF</li> <li>• REXX/VSE</li> <li>• VSE Connector Server</li> </ul> The other base programs included in PRD1.BASE are: <ul style="list-style-type: none"> <li>VTAM</li> <li>CICS Transaction Server for VSE/ESA</li> <li>TCP/IP for VSE/ESA</li> <li>High Level Assembler for VSE</li> <li>DITTO/ESA for VSE</li> <li>EREP</li> </ul>
PRD1.MACLIB	VSE/Advanced Functions Macros VSE/VSAM Macros VSE/POWER Macros
PRD2.SCEEBASE	LE/VSE
PRD2.DB2750	DB2 Server for VSE

Table 15. Location of z/VSE Base Programs (continued)

z/VSE System Sublibrary	Contains ...
PRD2.DB2750C	DB2 Server for VSE Client Edition
PRD2.ASN740	DB2 DataPropagator Relational Capture
PRD2.GEN1	VSE/Advanced Functions Generation feature.
PRD2.PROD	VSE Connectors Workstation Code component.
PRD2.TCPIPB	IPv6/VSE
PRD2.OS390	OS/390 API

## Base Programs That Require Special Attention

This concerns the following base programs:

### 1. LE/VSE

This program is automatically installed into library **PRD2.SCEEBASE**. LE/VSE is always available as one of the VSE Central Functions. Refer to “Considerations for LE/VSE and the VSE C Language Run-Time Support” on page 89 for details.

The *LE/VSE DBCS Locales* component is shipped on the Extended Base Tape and must be installed like a z/VSE optional program.

### 2. TCP/IP for VSE/ESA

This program is automatically installed into **PRD1.BASE**. There are different levels of functionality available which is further discussed under “TCP/IP for VSE/ESA Support” on page 153.

### 3. DB2 Server for VSE or DB2 Server for VSE Client Edition

The *DB2 Server for VSE* is not installed automatically but on request into default sublibrary **PRD2.DB2750**. Similarly, the *DB2 Server for VSE Client Edition* is not installed automatically but separately on request into default sublibrary **PRD2.DB2750C**. The related *DataPropagator Relational Capture* option must be installed separately (default sublibrary **PRD2.ASN740**). The *DB2 Server for VSE Help* component is to be installed during DB2 customization. Except for the *DB2 Server for VSE Help* component, which is shipped on a separate tape, the other two programs are shipped on the Extended Base Tape. Refer also to Chapter 9, “z/VSE e-business Connectors and Tools,” on page 141.

### 4. VSE Connectors Workstation Code component

The **VSE Connectors Workstation Code** component is shipped on the Extended Base Tape and must be installed separately. The VSE Connectors Workstation Code consists of:

- IESDDMCW.W (VisualAge® Generator Client Interface)
- IESINCON.W (VSE Connector Client)
- IESSCRPT.W (VSE Script Server)
- IESVSMRD.W (VSAM Redirector Server)
- VTAPESRV.W (Virtual Tape Server)

The default sublibrary is **PRD2.PROD**. You can also install the code contained in these W-Books from the downloads section of the VSE home page:

<http://www.ibm.com/systems/z/os/zvse/downloads/>

## Further Information

Further details about the contents of system libraries are provided in Chapter 7, "Files and Libraries," on page 109 and with regard to optional programs in Table 16. To know the contents of the system libraries is important for tasks such as applying service which is discussed in detail in the *z/VSE System Upgrade and Service*.

## z/VSE 5.1 Optional Programs

z/VSE optional programs must be installed separately. They are not part of the initial installation process.

Table 16 lists optional programs for z/VSE available when this publication made available. IBM may have announced other optional programs since then. Consult the *Program Directory*, which is shipped with z/VSE, for the latest information on optional programs or contact your IBM representative.

From z/VSE 4.3 onwards, CICS/VSE (Program Number 5686-026) is no longer shipped on the Extended Base Tape. Therefore, all references to CICS/VSE have been removed from this publication.

Table 16 also shows the default sublibrary displayed by z/VSE for selection when installing an optional program. Instead of using the default system sublibrary, you may select your own private sublibrary. The approximate space requirements in cylinders (for an IBM 3390) and FBA blocks (for IBM FBA disk devices) are shown as well. Note that these are approximate values for the English version of a program.

Table 16. Optional Programs for z/VSE 5.1

z/VSE 5.1 Optional Programs	Program Number	Version Release	Sublibrary	Cylinders (IBM 3390)	FBA Blocks
VSE/Access Control-Logging and Reporting (VSE/ACLR) - Note 1	5746-XE7	1.2.1	PRD2.PROD	1	194
ACF/NCP	5648-063	7.8.1	PRD2.COMM	37	35165
ACF/SSP	5686-064	4.8.1	PRD2.COMM2	37	35940
AFP Font Collection	5648-B33	2.1.0	PRD2.PROD	(Note 2)	(Note 2)
CCCA/VSE	5686-A07	2.1.0	PRD2.PROD	11	10864
CICSVR/VSE	5686-011	1.2.0	PRD2.PROD	7	6026
COBOL for VSE/ESA	5686-068	1.1.0	PRD2.PROD	13	11932
C for VSE/ESA	5686-A01	1.1.0	PRD2.DBASE	14	13078
DB2 Server for VSE	5697-F42	7.5.0	PRD2.DB2750	61	59490
DB2 Server for VSE Client Edition		7.5.0	PRD2.DB2750C	46	45492
DB2 Control Center VSE		7.3.0	PRD2.CCF730	17	16082
DB2 Data Restore VSE		7.3.0	PRD2.RCV730	5	3900
QMF for VSE		7.2.0	PRD2.PROD	25	24594
DB2 DataPropagator Relational Capture (Note 3)		7.4.0	PRD2.ASN740	8	7626
DFSORT/VSE	5746-SM3	3.4.0	PRD2.PROD	5	4064
Debug Tool VSE	5686-A02	1.1.0	PRD2.PROD	10	9398

Table 16. Optional Programs for z/VSE 5.1 (continued)

z/VSE 5.1 Optional Programs	Program Number	Version Release	Sublibrary	Cylinders (IBM 3390)	FBA Blocks
DL/I VSE	5746-XX1	1.12.0	PRD2.DBASE (PROD) PRD2.DLI1C0G (GEN)	7 14	6711 12770
Encryption Facility for z/VSE OpenPGP	5686-CF9	1.2.0	PRD2.PROD	1	762
EP	5735-XXB	1.14.0	PRD2.COMM2	1	748
GDDM					
GDDM/IMD	5668-801	2.1.3	PRD2.PROD	5	4794
GDDM/IVU	5668-723	1.1.3	PRD2.PROD	2	1902
GDDM/PGF	5668-812	2.1.3	PRD2.PROD	5	4734
GDDM/VSE	5686-057	3.2.0	PRD2.PROD	49	48180
High Level Assembler Toolkit	5696-234	1.6.0	PRD2.PROD	28	26276
OGL/370	5688-191	1.1.0	PRD2.AFP	5	4346
PL/I for VSE/ESA	5686-069	1.1.0	PRD2.PROD	11	10210
PPFA/370	5688-190	1.1.0	PRD2.AFP	2	1690
PSF/VSE	5686-040	2.2.1	PRD2.AFP	6	5886
DOS/VS RPG II	5746-RG1	1.3.0	PRD2.PROD	4	3078
Rational COBOL Runtime for z/VSE	5648-F66	7.5.0	PRD2.DBASE	38	33810
SDF II VSE	5746-XXT	1.6.0 (Note 4)	PRD2.PROD	29	27540
WebSphere MQ for z/VSE	5655-U97	3.0.0	PRD2.MQSERIES	19	18258
X.25 NPSI	5688-035	3.9.0	PRD2.COMM	5	4598

**Notes:**

1. Although VSE/Access Control-Logging and Reporting is installed in PRD2.PROD, you must copy the phases DSPLLOG and \$SVALOG to the system sublibrary IJSYSRS.SYSLIB before it can be used.
2. The values depend on the fonts required for a particular installation. The complete AFP Font Collection requires about 990 cylinders on an IBM 3390 or 947620 FBA blocks.
3. The *DB2 Server for VSE* and *DB2 Server for VSE Client Edition* (as well as the *DataPropagator Relational Capture* option) are shipped as base programs on the Extended Base Tape. However, some of the programs and components that belong to the DB2 support must be ordered separately as z/VSE optional programs such as the *Control Center for VSE*, *Data Restore for VSE*, and *QMF™ for VSE*. Refer also to the “Base Programs Shipped on the Extended Base Tape” on page 43. For the latest information, consult the *z/VSE 5.1 Program Directory*.
4. SDF II VSE runs with the CICS Transaction Server.





---

## Chapter 4. System Organization and Concepts

After initial installation, z/VSE will reside on two disk volumes named **DOSRES** and **SYSWK1**. These two volumes contain the system files and libraries required by z/VSE. The layout of DOSRES and SYSWK1 is predefined and depends on the disk device type used. The detailed layouts are shown in Appendix B, “z/VSE Disk Layouts (DOSRES, SYSWK1),” on page 277.

Chapter 5, “Installing z/VSE 5.1,” on page 85 provides information on what is to be considered prior to installing z/VSE.

**Note:** Depending on your configuration and workload it may be required for performance reasons to move system files to additional disk volumes, for example, page data set extents. If doing so, ensure that no file overlap occurs.

This chapter describes how z/VSE is organized together with the underlying concepts in these main topics:

- “Minimum System Configuration”
- “z/VSE System Size” on page 52
- “Storage Support and Layout” on page 53
- “Summary of System Characteristics and Capabilities” on page 58
- “Predefined System Environments” on page 59
- “Using Memory Objects in the 64-Bit Address Space” on page 67
- “Storage Allocation During System Startup” on page 69
- “Loading Phases into the SVA” on page 71
- “Running z/VSE With More Than 255 Tasks” on page 71
- “IPL Storage Allocation Parameters” on page 72
- “Real Storage Allocation” on page 76
- “Startup Processing after IPL” on page 76
- “Static Partition Allocations for Predefined Environments” on page 78
- “Predefined Dynamic Partition Support” on page 80
- “CICS Transaction Server and VSE/ICCF Interrelationship” on page 80
- “Displaying Storage Layout Information” on page 83

---

### Minimum System Configuration

z/VSE 5.1 requires the following minimum system configuration:

- 32 MB of processor (real) storage.
- Two disk volumes, DOSRES and SYSWK1, providing the minimum space specified in Table 51 on page 277. This includes a page data set of 256 MB (predefined environment A) *providing* a partition data set is being used (for details, see “Page Data Set Considerations” on page 54).
  - For predefined environment B, 256 MB are additionally required for the page data set on DOSRES.
  - For predefined environment C, 1792 MB are additionally required for the page data set on DOSRES.
  - For predefined environments B and C, additional data space for the master catalog is defined on SYSWK1.

## System Organization and Concepts

- The volumes must be of the same device type.
- The volumes must be of the same device model.
- For 3390 disks, one of the following must be true:
  - *Both* volumes must be smaller than 4370 cylinders.
  - *Both* volumes must be larger than 4370 cylinders and smaller than or equal to 10017 cylinders (BIG-3390 disks).
  - *Both* volumes must be larger than 10017 cylinders (FAT-3390 disks).

See also “z/VSE System Size.”

- A tape device. For details, see “Shipment of z/VSE 5.1 on Distribution Tapes” on page 87.
- A system printer. This may be a channel-attached or adapter-attached printer controlled by VSE/POWER or a local terminal printer controlled by CICS. A terminal printer should have a minimum speed of 300 lines per minute.
- A display station. This can be a terminal or programmable workstation of any supported type.
- A non-SNA connected system console. This can be either:
  - The Integrated Console of a server.
  - Any display station supported as system console.
  - An OSA-ICC connected terminal.

### Notes:

1. The IBM 3380 Models A and D **cannot** be used for initial installation of z/VSE 5.1 since the available space is too small. The installation of z/VSE 5.1 requires at least 1770 cylinders on the installation volumes.
2. The IBM 3390 Model 1 can only be used for environment A. For environments B and C, the additional space provided by Model 3 or later is required.

---

## z/VSE System Size

For installation, z/VSE requires a minimum of two disk volumes (DOSRES and SYSWK1) of the same device type. The total system size (required space on DOSRES and SYSWK1) of:

- Predefined environment A is about 1022 MB (which includes a page data set of 256 MB).
- Predefined environment B is about 1278 MB (which includes a page data set of 512 MB).
- Predefined environment C is about 2814 MB (which includes a page data set of 2 GB).

**Note:** If you wish to use a page data set, you *cannot* select an environment C to install z/VSE on a:

- 3380 volume
- FBA-SCSI volume under z/VM
- Virtual FBA under z/VM

For details, see Table 51 on page 277.

For the predefined environments, about 86 MB of free library space are available in the VSE/VSAM master catalog. This applies if no Generation Feature and no optional programs have been installed.

The predefined environment C can only be installed on disks that are larger than, or equivalent in size to, the IBM 3390-3 or FBA-SCSI disk.

## Storage Support and Layout

### Real Storage Support

- z/VSE can support a maximum of 32 GB of processor (real) storage.
- Environment C can run on 2 GB or more of real storage without the use of a page data set.

### Virtual Storage Support

Virtual storage is used up by:

- private areas
- shared areas
- data spaces
- memory objects.

The *private area* is the space between the end of the Shared Virtual Area (24-Bit), up to the address space limit or the beginning of the Shared Virtual Area (31-Bit). If your system uses the 64-bit address space via *memory objects*, the private area includes the *extended private area* as shown in Figure 6 on page 68.

*Shared areas* are shared among all address spaces. These areas include the supervisor and the shared virtual areas (SVA 24-Bit and SVA 31-Bit) and may include shared partitions. If your system uses the 64-bit address space via *memory objects*, the shared area includes the *extended shared area* as shown in Figure 6 on page 68.

*Data spaces* usually hold data. A data space can also be defined to hold a virtual disk. Details about these system resources are provided on the following pages.

*Memory objects* hold data, and are contiguous ranges of virtual addresses that are allocated by programs as a number of *application pages* (1 MB multiples on a 1 MB boundary). Your VSIZE must include the size of any memory objects.

The maximum value of virtual storage (VSIZE) that z/VSE can support depends on the capacity of the installation's page data set devices. Up to 15 extents can be specified for a page data set, and an entire volume may be used for one extent. For more details, refer to the *z/VSE System Control Statements*.

The *actual usable* VSIZE on a z/VSE system depends on a number of factors: for example, the type of workload, the system setup, and the available processor capacity. The most limiting factor, however, is the size of the processor (real) storage since the paging rate should not exceed an acceptable level.

As an example, some practical values are given:

#### Processor Storage

##### Concurrently Usable VSIZE

#### 512 MB

About 1.6 GB to about 3.2 GB

**2 GB** About 6 GB to about 12 GB

**4 GB** About 12 GB to about 20 GB

#### General Rules You Can Apply:

## System Organization and Concepts

1. For processor storage sizes of 2 GB or less, you are recommended to specify a VSIZE value that is 3 to 6 times the available processor (real) storage.
2. For processor storage sizes above 2 GB, you are recommended to specify a VSIZE value that is 3 to 4/5 times the available processor (real) storage.
3. If you wish to use *memory objects*, you must include their size in your VSIZE calculation. In this case, the maximum VSIZE is 90 GB (the theoretical maximum size of one virtual address space). VSIZE includes the sizes of the 24-bit and 31-bit SVAs, together with the size of the Private Area containing all allocated address spaces and memory objects.
4. These general rules are intended as guidelines only. Usually, you would define a VSIZE that meets your requirements for partition allocation, data spaces, and memory objects.

### Page Data Set Considerations

For performance reasons, consider using a separate volume for the page data set.

You will require a *large page data set* if you are using a large VSIZE. Initializing a large page data set on ECKD devices will take a relatively long time. You might wish to allocate the page data set extents on FBA or FBA-SCSI disks, since these do not need to be initially formatted.

**VSE Without a Page Data Set:** If you have a processor with large storage, you might be able to configure your system so that it does not use a page data set. Therefore, VSE **without** a page data set is configured as follows:

- The system is initialized by an option in the IPL supervisor command: **NOPDS**. See also “IPL Supervisor Parameters Command” on page 72.
- VSIZE must not be specified; it is calculated by the system from the processor storage available for VSE and the specified VIO size:  
$$\text{VSIZE} = \text{processor storage} - \text{VIO}$$

The value of VSIZE will depend upon either the real storage size of your processor, or the storage size of your z/VSE virtual machine under VM.

If the processor size is sufficiently large, z/VSE will avoid creating and formatting a page data set during initial installation.

The initial installation process checks whether the processor storage size is sufficient to accommodate both:

- All virtual storage.
- The real storage required by the system.

The virtual storage size is the sum of the specified values for VSIZE and VIO. If the processor storage available is sufficient, the DPD commands are ignored and no page data set is created. In addition, message 0I35I is issued:

```
0I35I  PROCESSOR STORAGE LARGER THAN VIRTUAL STORAGE - DPD COMMAND IGNORED
```

## Address Spaces, Data Spaces, and Virtual Disks

In addition to **address spaces** (in which static and dynamic partitions reside and the programs executed in them), z/VSE supports also data spaces.

A **data space** is an area in virtual storage like an address space but contains data only. It can have a maximum size of up to 2 GB. A data space can also be used as a **virtual disk** for holding temporary files.

Chapter 11, “Using Data Spaces and Virtual Disks,” on page 167 provides further details about data spaces and virtual disks.

## Allocating I/O Control Blocks Above 16 MB Line

The IODEV parameter of the *Tailor IPL Procedure: Supervisor Parameters* dialog specifies the number of Input/Output (I/O) devices the z/VSE supervisor will support. The IODEV parameter also determines the shared addressing area in which various I/O control blocks will be allocated by the z/VSE supervisor.

Using the IODEV parameter, you can instruct the z/VSE supervisor to allocate various Input/Output (I/O) control blocks in the *31-bit* shared addressing area (below the 2 GB bar) instead of in the *24-bit* shared addressing area (below the 16 MB line). This makes space available in the 24-bit shared addressing area (below the 16 MB line) for other uses, and should improve z/VSE I/O performance.

You can set IODEV to either:

- **1024**, which means the z/VSE supervisor will allocate I/O control blocks in the 31-bit shared area. This is the *default* value.
- **1023**, which means the z/VSE supervisor will allocate I/O control blocks in the 24-bit shared area (as in previous z/VSE releases). This provides compatibility for Vendor programs that will only run when I/O control blocks are allocated in the 24-bit shared area.

**Note:** If you run z/VSE with IODEV set to 1024, any Vendor-supplied programs that have *not* been modified so they address control blocks moved to the 31-bit shared area *will no longer work!* In such situations, contact the appropriate Vendor.

If you perform an *initial installation* of z/VSE, IODEV will be set to 1024.

If you perform a *Fast Service Upgrade (FSU)* of z/VSE, IODEV will be set to the value in the z/VSE system *from which* the FSU was done. However, after performing an FSU you can manually change the value of IODEV.

From z/VSE 4.3 onwards, z/VSE also *automatically* allocates VSAM I/O control blocks above the 16 MB line. This is independent of the value of IODEV.

### Allocating DL/I PSBs, HD Buffers, Routines, Above 16 MB Line

You can instruct DL/I to allocate PSBs and HD buffers above the 16 MB line using the DLZACT TYPE=CONFIG control statement:

- To allocate PSBs above the 16 MB line you set parameter PSBLOC=ANY.
- To allocate HD buffers above the 16 MB line you set parameter HMODE=ANY.

Starting with DL/I Release 1.12, when running in an *online* environment DL/I also loads its action modules above the 16 MB line. When running in a *batch* environment, DL/I continues to load its action modules below the 16 MB line.

The DL/I action modules might also be loaded into the SVA-high. In this case, the action modules will be accessed via the SVA (both in the online and batch environments).

**Note:** Vendor-supplied programs that have *not* been enabled for 31-bit addressing *might not work!* In such situations, contact the appropriate Vendor.

For further details about allocating DL/I PSBs and HD buffers above the 16 MB line, refer to the *DL/I Release Guide*, SC33-6211-06.

### Shared and Private Areas

The supervisor distinguishes two types of virtual areas: shared and private.

#### Shared Areas

Some areas are shared among all address spaces. They are provided for code and data that must be directly accessible to several or all partitions. These areas include the supervisor and the shared virtual areas (SVA 24-Bit and SVA 31-Bit) and may include shared partitions.

#### Private Areas

The space between the end of the SVA (24-Bit) up to the address space limit or the beginning of the SVA (31-Bit) is available as private area.

Figure 4 on page 63 illustrates this concept further.

### Static and Dynamic Partitions

Partitions always reside in an address space. The number of partitions and address spaces depends on the predefined environment chosen during initial installation.

#### Static Partitions

Once defined, static partitions are always existent and occupy virtual storage. This is in contrast to dynamic partitions as shown later. z/VSE supports a maximum of 12 static partitions. An address space may include more than one static partition but only one may cross the 16 MB line.

## Dynamic Partitions

You can define up to between 150 and 200 dynamic partitions in addition to a maximum of 12 static partitions. The actual number of dynamic partitions that can be specified and used depends on the server, the system configuration, the job profiles, and the workload. Dynamic partitions allow you to exploit the available virtual storage up to the VSIZE maximum available. Each dynamic partition occupies an address space of its own. Contrary to static partitions, z/VSE creates and activates dynamic partitions as they are needed for jobs intended to run in a dynamic partition. Also, it releases the occupied space when a dynamic partition finishes processing. For further details, refer to Chapter 12, “Dynamic Partition Support,” on page 177.

## GETVIS Areas

Certain functions require virtual storage dynamically during program execution. z/VSE maintains three GETVIS (Get Virtual Storage) areas for this purpose located within an address space:

- System GETVIS area
- Partition GETVIS area
- Dynamic space GETVIS area

Figure 7 on page 70 shows the location of these areas. “GETVIS Areas” in the *z/VSE Guide to System Functions* provides additional details about the GETVIS areas and their layout.

## Partition IDs and Address Space IDs

z/VSE assigns for each ID (identification) of a **static** partition a **default** address space ID as follows:

Partition ID	Address Space ID
<b>BG</b>	0
<b>F1</b>	1
<b>F2</b>	2
<b>:</b>	<b>:</b>
<b>FA</b>	A
<b>FB</b>	B

The following rules apply:

1. If an ALLOC command does not include an address space ID, z/VSE uses the defaults. You can change the defaults by explicitly defining an address space ID in the ALLOC command, but it is recommended to use the defaults.
2. The BG partition **must** always reside in address space 0.

For **dynamic** partitions the address space ID is identical with the partition ID; C1, for example. It is assigned automatically according to the definitions in the dynamic class table.

## Summary of System Characteristics and Capabilities

Table 17. z/VSE 5.1 System Characteristics and Capabilities

Characteristic	Capability
Real storage maximum	32 GB
VSIZE maximum	90 GB (see Note 1)
Number of virtual address spaces	number of static partitions plus number of dynamic partitions
Maximum size of a virtual address space	2 GB
VTAM in a private address space	YES
VSE/POWER in a private address space	YES
Number of static partitions	max. 12
Number of dynamic partitions	max. 150-200 (NPARTS-12, SYS command)
31-bit addressing	YES
64-bit (real and virtual) addressing	YES (see Note 2)
Access registers	YES
Data spaces	YES
Virtual disks	YES
Linkage stack	YES
Callable cell pool services	YES
Space switching	YES
Subsystem storage protection	YES
Location of SVA areas	low (24-bit) high (31-bit)
Hardware data compression	YES
Max. number of devices	1024 (see Note 3)
Dynamic channel subsystem	YES
ESCON/FICON/FCP channels	YES
z/Architecture support	YES
S/390 Architecture support	NO
Runs under z/VM	YES
VM linkage support	All (including IUCV)

**Notes:**

1. The appropriate VSIZE for a z/VSE system is also discussed under “Virtual Storage Support” on page 53.
2. For 64-bit virtual addressing, see “Using Memory Objects in the 64-Bit Address Space” on page 67.
3. During IPL, z/VSE can support more than 1024 devices.



## Predefined System Environments

To ease your planning and installation efforts, z/VSE provides three predefined environments as shown in Table 18.

### Selecting a Predefined Environment

During initial installation, you *must* choose one of the predefined environments (A, B, or C) as the basis for your system. If none of these environments meets your needs, select the most suitable one and tailor it according to your requirements.

Before you install your system, be sure to read the information given here. *By carefully planning your system's initial environment you may considerably reduce any tailoring effort required later.*

Note that you can install a second CICS Transaction Server with predefined **Environments B and C only**.

Table 18. Predefined Environments: VSIZE, Number of Address Spaces and Partitions

Predefined Environment	Virtual Storage (VSIZE)	Number of Address Spaces	Number of Partitions	Characteristics
A	256 MB	12+dyn	12+dyn	Entry System
B	512 MB	12+dyn	12+dyn	Medium System
C	2 GB	12+dyn	12+dyn	Large System

#### Notes:

1. The term “dyn” is the *number of dynamic partitions*. This is calculated as the total number of partitions (NPARTS), minus the 12 static partitions.
2. The maximum VSIZE possible (xx GB) for a z/VSE system depends on various factors, explained under “Virtual Storage Support” on page 53.

You must also consider the additional settings for PASIZE, NPARTS, data space allocation, and SVA GETVIS size, that are different for each z/VSE predefined environment. These are shown in Table 19.

Table 19. Values of PASIZE, NPARTS, Data Space, and GETVIS for z/VSE Predefined Environments

	Environment A	Environment B	Environment C
PASIZE	50 MB	150 MB	512 MB
NPARTS	60	80	120
Data Space Allocation	20 MB	40 MB	256 MB
SVA GETVIS 31	6 MB	10 MB	20 MB

### Environment Characteristics

Predefined environments A, B, and C offer static and dynamic partitions. Both environments include 12 predefined static partitions (12 is the maximum possible).

The abbreviation **dyn** in Table 18 on page 59 indicates that dynamic partitions are supported. Each dynamic partition occupies an address space of its own. The maximum number of dynamic partitions that can be activated is:

- 48 for environment A
- 68 for environment B
- 108 for environment C

These values are determined by NPARTS (explained below) minus the number of static partitions. However, the number of dynamic partitions that can actually be active at the same time also depends on the virtual storage (VSIZE) available and the number of dynamic partitions specified for each class in the dynamic class table. NPARTS is an IPL SYS command parameter and defines the maximum number of partitions (static and dynamic) that can be specified.

The shared virtual area (SVA) is split into a 24-bit and a 31-bit area.

Figure 3 on page 61 shows the system layout of environment A, Figure 4 on page 63 of environment B, and Figure 5 on page 65 of environment C.

### Storage Layout of Predefined Environment A

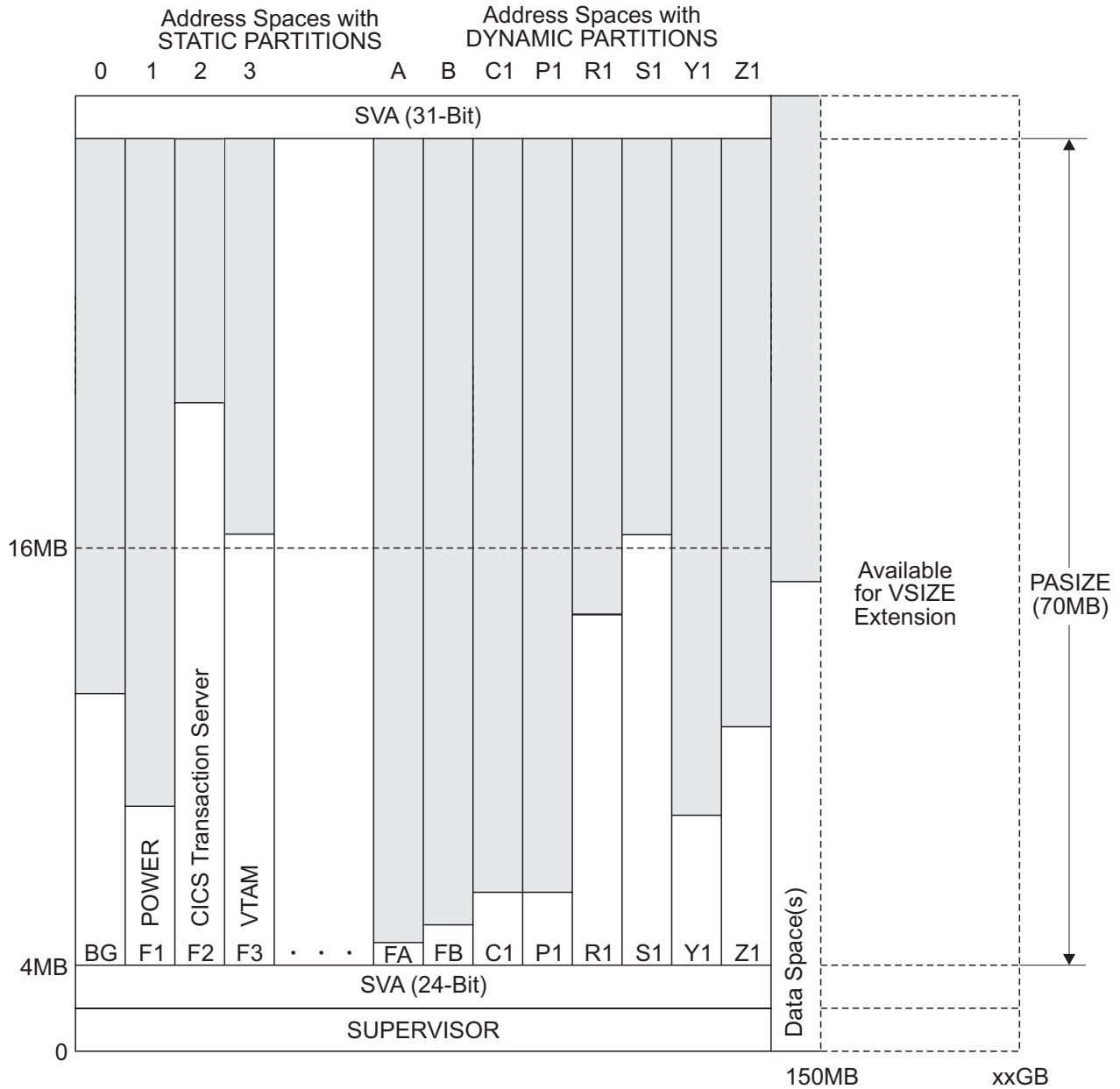

Figure 3. Storage Layout of Predefined Environment A

**Explanations:**

- Environment A offers a default system with a VSIZE of 256 MB and a maximum of 60 partitions, 12 static and 48 dynamic partitions (NPARTS=48). The VSIZE of 256 MB is divided into about:
  - 170.5 MB for static partitions
  - 49.5 MB for dynamic partitions
  - 4 MB for supervisor and SVA (24-bit)
  - 12 MB for SVA (31-bit)
  - 20 MB for data spaces (VTAM applications and label area)

The dynamic partitions shown in Figure 3 (1 partition of each class active) are an example and have the following storage values (as specified in the predefined dynamic class table DTR\$DYNC):

## System Organization and Concepts

- 1 MB (for 1 C-class partition)
- 1 MB (for 1 P-class partition)
- 8 MB (for 1 R-class partition)
- 15 MB (for 1 S-class partition)
- 5 MB (for 1 Y-class partition)
- 5 MB (for 1 Z-class partition)

This combination occupies 35 MB of the available 49.5 MB.

A detailed description of DTR\$DYNC is given under “The Predefined Dynamic Class Table” on page 182.

2. The default PASIZE is 50 MB resulting in an address space size of about 66 MB for supervisor and SVAs.
3. The areas for the SVAs (shared virtual areas) and the supervisor are shared by all address spaces.
4. Besides the CICS Transaction Server, VSE/ICCF also resides in the F2 partition.
5. VTAM resides in a private address space (F3) but VTAM applications need not reside in the same address space.
6. 20 MB are reserved for data spaces (VTAM applications and label area on virtual disk). This value is defined in the ALLOC procedure (skeleton SKALLOCA). Refer to the *z/VSE Administration* under “Skeletons for Static Partition Allocations” for further details about ALLOC and SKALLOCA.
7. The FB partition is reserved for the z/VSE security support. After initial installation, the Security Server of the BSM (Basic Security Manager) runs in the FB partition. Chapter 18, “Security and Encryption Support,” on page 227 provides further details.
8. The F7 partition is reserved for TCP/IP.
9. After initial installation, the F8 partition is reserved for a second CICS Transaction Server.

## Storage Layout of Predefined Environment B

This environment provides a default system with a VSIZE of 512 MB and a maximum of 80 partitions 12 static and 68 dynamic partitions (NPARTS=80). The VSIZE is divided into about:

- 357 MB for static partitions
- 95 MB for dynamic partitions
- 4 MB for supervisor and SVA (24-bit)
- 16 MB for SVA (31-bit)
- 40 MB for data spaces (VTAM applications and label area)

The default value for PASIZE is 150 MB, resulting in an address space size of about 170 MB for supervisor and SVAs.

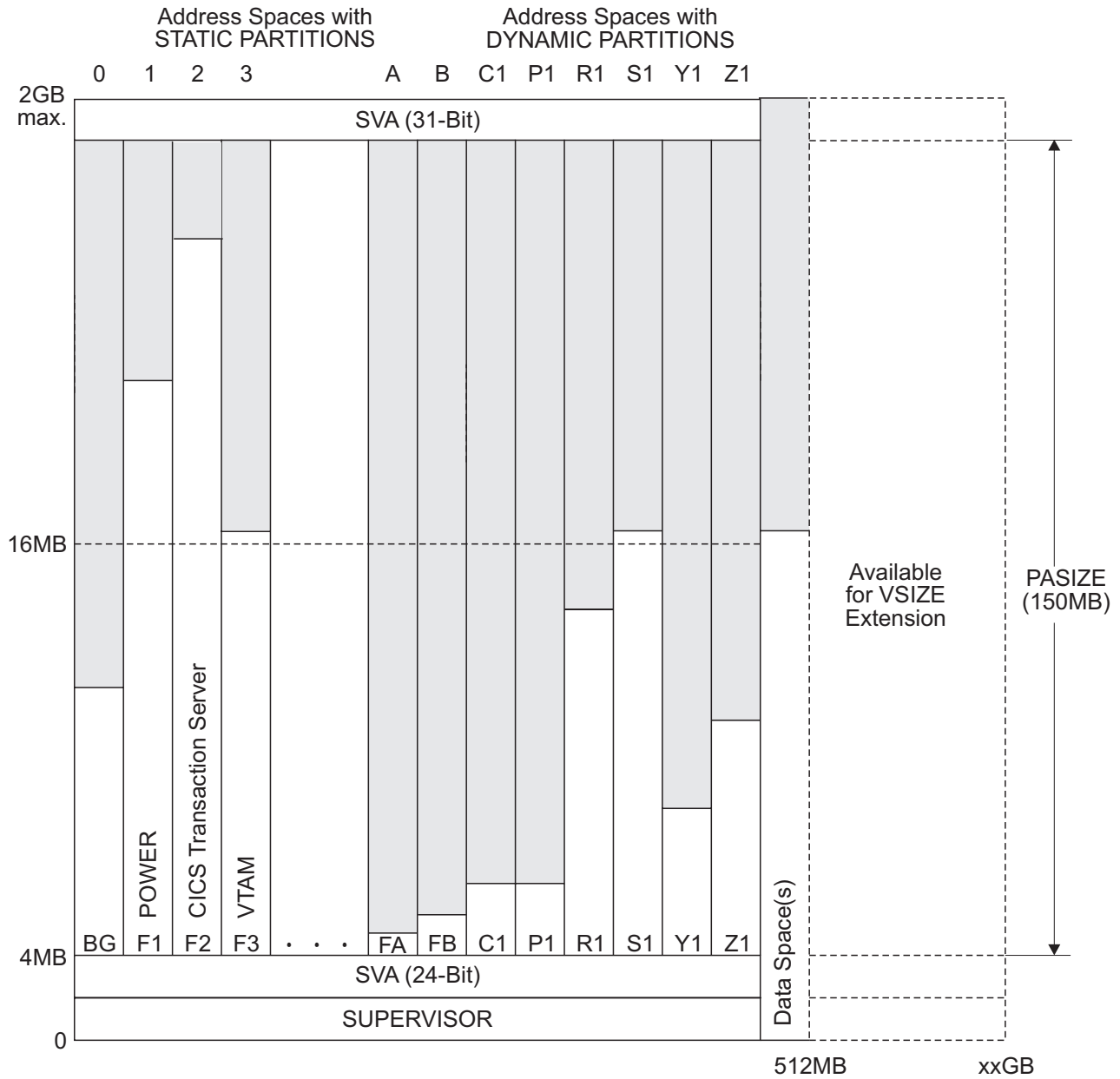

Figure 4. Storage Layout of Predefined Environment B

**Explanations:**

- The dynamic partitions shown in Figure 4 (1 partition of each class active) are an example and have the following storage values (as specified in the predefined dynamic class table, DTR\$DYNC):

- 1 MB (for 1 C-class partition)
- 1 MB (for 1 P-class partition)
- 8 MB (for 1 R-class partition)
- 15 MB (for 1 S-class partition)
- 5 MB (for 1 Y-class partition)
- 5 MB (for 1 Z-class partition)

This combination occupies 35 MB of the available 95 MB.

## System Organization and Concepts

A detailed description of DTR\$DYNC is given under “The Predefined Dynamic Class Table” on page 182.

2. The SVA and supervisor areas are shared by all address spaces.
3. Besides the CICS Transaction Server, VSE/ICCF also resides in the F2 partition.
4. VTAM resides in a private address space (F3) but VTAM applications need not reside in the same address space.
5. 40 MB are reserved for data spaces (VTAM applications and label area on virtual disk). This value is defined in the ALLOC procedure (skeleton SKALLOCB). Refer to the *z/VSE Administration* under “Skeletons for Static Partition Allocations” for further details about ALLOC and SKALLOCB.
6. The FB partition is reserved for the z/VSE security support. After initial installation, the Security Server of the BSM (Basic Security Manager) runs in the FB partition. Chapter 18, “Security and Encryption Support,” on page 227 provides further details.
7. The F7 partition is reserved for TCP/IP.
8. After initial installation, the F8 partition is reserved for a second CICS Transaction Server.

## Storage Layout of Predefined Environment C

This environment provides a default system with a VSIZE of 2 GB and a maximum of 120 partitions (12 static and 108 dynamic partitions (NPARTS=120)). The VSIZE is divided into about:

- 1041 MB for static partitions
- 721 MB for dynamic partitions
- 4 MB for supervisor and SVA (24-bit)
- 26 MB for SVA (31-bit)
- 256 MB for data spaces (VTAM applications and label area)

The default value for PASIZE is 512 MB, resulting in an address space size of about 528 MB for supervisor and SVAs.

If you wish to use *memory objects* in the 64-bit address space (above the 2 GB bar), you must increase VSIZE accordingly.

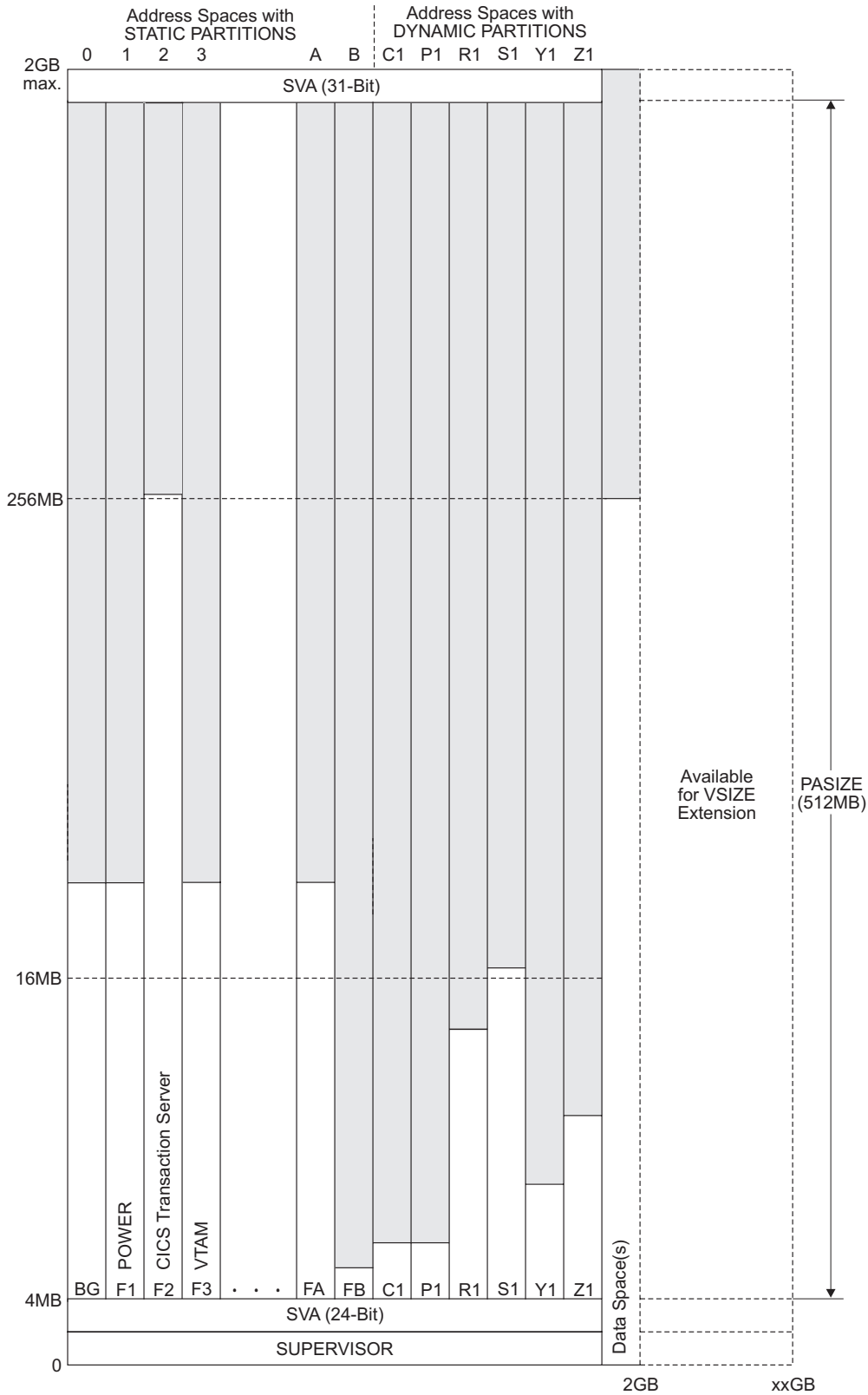

Figure 5. Storage Layout of Predefined Environment C

Explanations:

## System Organization and Concepts

1. The dynamic partitions shown in Figure 5 on page 65 (1 partition of each class active) are an example and have the following storage values (as specified in the predefined dynamic class table, DTR\$DYNC):

- 1 MB (for 1 C-class partition)
- 1 MB (for 1 P-class partition)
- 8 MB (for 1 R-class partition)
- 15 MB (for 1 S-class partition)
- 5 MB (for 1 Y-class partition)
- 5 MB (for 1 Z-class partition)

This combination occupies 35 MB of the available 721 MB.

A detailed description of DTR\$DYNC is given under “The Predefined Dynamic Class Table” on page 182.

2. The SVA and supervisor areas are shared by all address spaces.
3. Besides the CICS Transaction Server, VSE/ICCF also resides in the F2 partition.
4. VTAM resides in a private address space (F3) but VTAM applications need not reside in the same address space.
5. 256 MB are reserved for data spaces (VTAM applications and label area on virtual disk). This value is defined in the ALLOC procedure (skeleton SKALLOCC). Refer to the *z/VSE Administration* under “Skeletons for Static Partition Allocations” for further details about ALLOC and SKALLOCC.
6. The FB partition is reserved for the z/VSE security support. After initial installation, the Security Server of the BSM (Basic Security Manager) runs in the FB partition. Chapter 18, “Security and Encryption Support,” on page 227 provides further details.
7. The F7 partition is reserved for TCP/IP.
8. After initial installation, the F8 partition is reserved for a second CICS Transaction Server.

## Page Data Set Definitions

The two predefined page data set extents reside on the system disk DOSRES. For all predefined environments, the system keeps a minimum of 256 MB. This is also the total size of the page data set for predefined environment A. The additional 1792 MB for the page data set of predefined environment C are included in the definition for the second extent. Details on the DOSRES layout, including the page data set, are provided under Appendix B, “z/VSE Disk Layouts (DOSRES, SYSWK1),” on page 277.

### Notes:

1. In case of high paging rates, it is recommended to move both extents to a separate volume. In this way, you can improve performance because of a better I/O distribution. You specify or redefine page data set extents with the DPD parameter of the *Tailor IPL Procedure* dialog.
2. The 150 MB minimum reserved for the page data set on DOSRES are not accessible via dialog. To reuse them, especially if you either moved the page data set to another volume or if you run with more real storage, the *Tailor IPL Procedure* dialog (Page Data Set Definition) offers PF6=FREE. After pressing the key, the space can be reused by other dialogs.
3. If you wish to use a page data set with environment C, check the space requirements described in Table 51 on page 277.



## PASIZE Considerations

With PASIZE you define the maximum size available as private area in an address space. This area is available for partition allocation. The size of an address space is the sum of:

PASIZE + size of shared areas 24-bit and 31-bit

The resulting value must be equal or smaller 2 GB.

You should limit the PASIZE to the maximum value required for the largest partition in a single address space or to the sum of all partitions in one address space (whatever is larger) since this also reduces the amount of storage needed by the system for storage management.

The current settings for PASIZE for each z/VSE predefined environment are shown in Table 19 on page 59.

## Program SIZE Restrictions

The size (defined via the SIZE parameter of the EXEC statement or the SIZE command) of a program running in a partition that crosses the 16 MB line is restricted as follows:

16 MB - (xx + shared areas 24-bit)

where xx is the partition GETVIS size required by z/VSE which must be  $\geq 48$  KB (the minimum of 48 KB must be available below 16 MB). The resulting value is further reduced if additional static partitions reside in an address space or by the dynamic space GETVIS area in case of a dynamic partition.

A program, however, can load additional phases above 16 MB into the partition GETVIS area by using the CDLOAD macro (if 31-bit addressing is used).

### Considerations for the BG Partition

The minimum storage allocation for the BG partition is 6 MB. This value should not be reduced.

---

## Using Memory Objects in the 64-Bit Address Space

The *64-bit address space* provides you with a vastly increased amount of virtual storage than was previously available with only the first 2 GB of virtual storage. This should help you to meet the demands of growing applications and workloads.

The 64-bit address space is a virtual address space that is supported by 64-bit addresses. However:

- z/VSE does not support the full range of a 64-bit address space.
- The size of a 64-bit address space is limited by the maximum value of VSIZE, which is currently 90 GB.

The 2 GB address in the 64-bit address space is marked by a virtual line referred to as the *2 GB bar* (or simply *the bar*). This is shown in Figure 6 on page 68.

## System Organization and Concepts

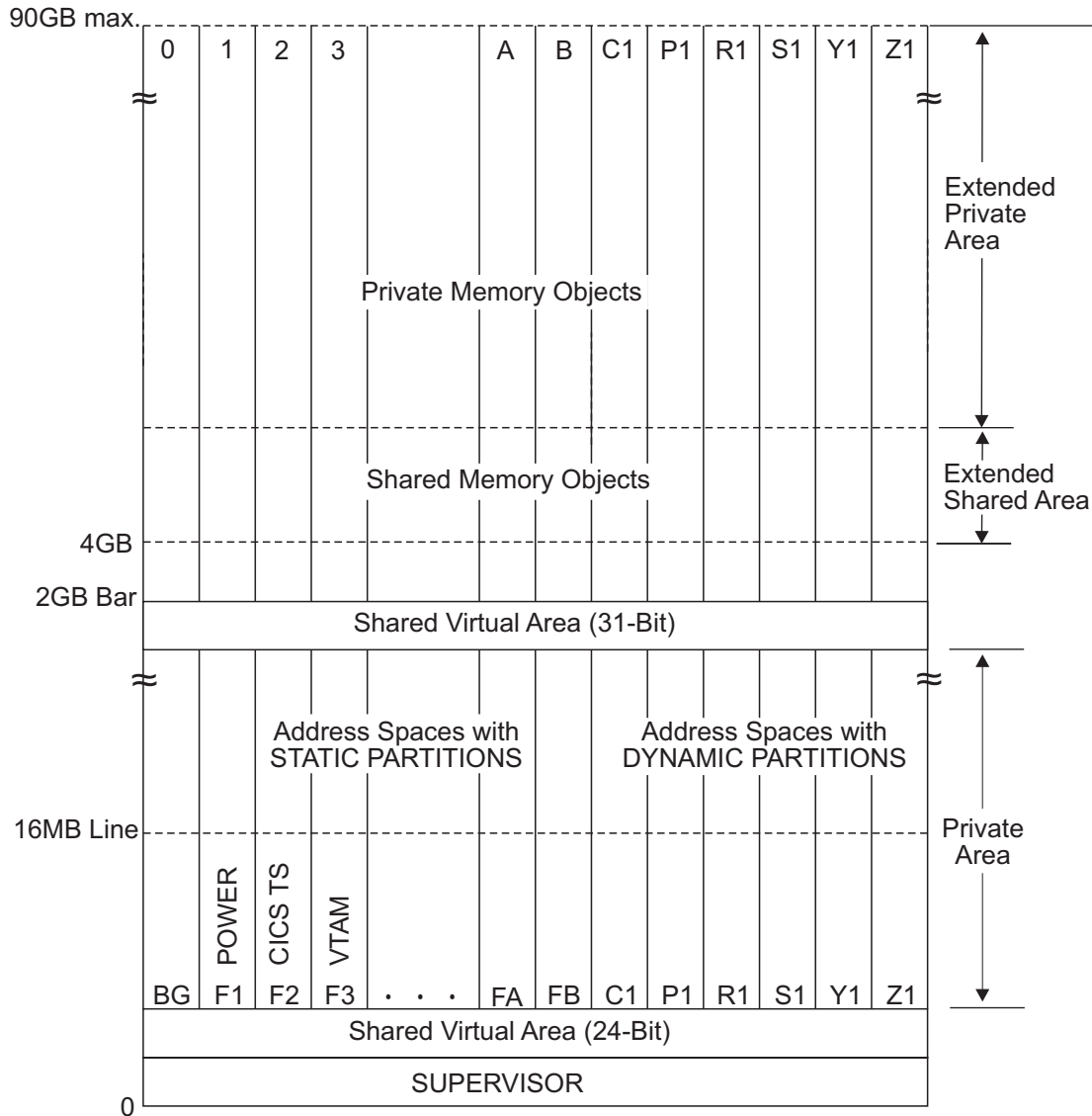

Figure 6. Using Memory Objects in the 64-Bit Address Space

As shown in Figure 6, virtual storage above the bar is organized as *memory objects* that can be created by programs:

- A memory object is a multiple of 1 MB “chunks” of virtual storage.
- Each memory objects starts on a megabyte boundary.
- z/VSE's use of memory objects is based upon the z/OS implementation of 64-bit memory objects.
- Memory objects can be allocated for *data* only.
- Programs cannot run in the virtual storage area above the bar.
- Only *allocated* memory objects are used in the calculation of the current VSIZE usage.

As shown in Figure 6, there are two types of memory object:

- *Private memory objects*, which are allocated in the *Extended Private Area*.
- *Shared memory objects*, which are allocated in the *Extended Shared Area*.

Using the EXCP macro and 64-bit buffers, I/O operations on DASD (ECKD) devices can also be performed via private memory objects.

When an “abnormal program end” (ABEND) occurs, if OPTION MODUMP or STDOPT MODUMP=YES is active then z/VSE will create a *memory object dump* of 4 KB either side of the failing address. Memory objects can also be included in a stand-alone dump. For details, refer to the *z/VSE Diagnosis Tools*.

For further details of how to use assembler instructions and manage storage in the 64-bit address space, refer to “Using the 64-Bit Address Space” in the *z/VSE Extended Addressability*.

---

### Storage Allocation During System Startup

The z/VSE system startup sequence consists of two parts:

1. The processing of the IPL (initial program load) procedure.
2. The processing of JCL startup procedures and jobs.

It is during the processing of these procedures that z/VSE allocates storage and defines the storage layout as requested. For conceptual details about system startup refer to Chapter 13, “Tailoring System Startup,” on page 185.

The following figure shows the IPL commands and parameters as related to the subareas of an address space. These commands and parameters are part of the IPL procedure. z/VSE provides predefined IPL procedures. A sample is shown under Appendix A, “Startup Procedures,” on page 275.

## System Organization and Concepts

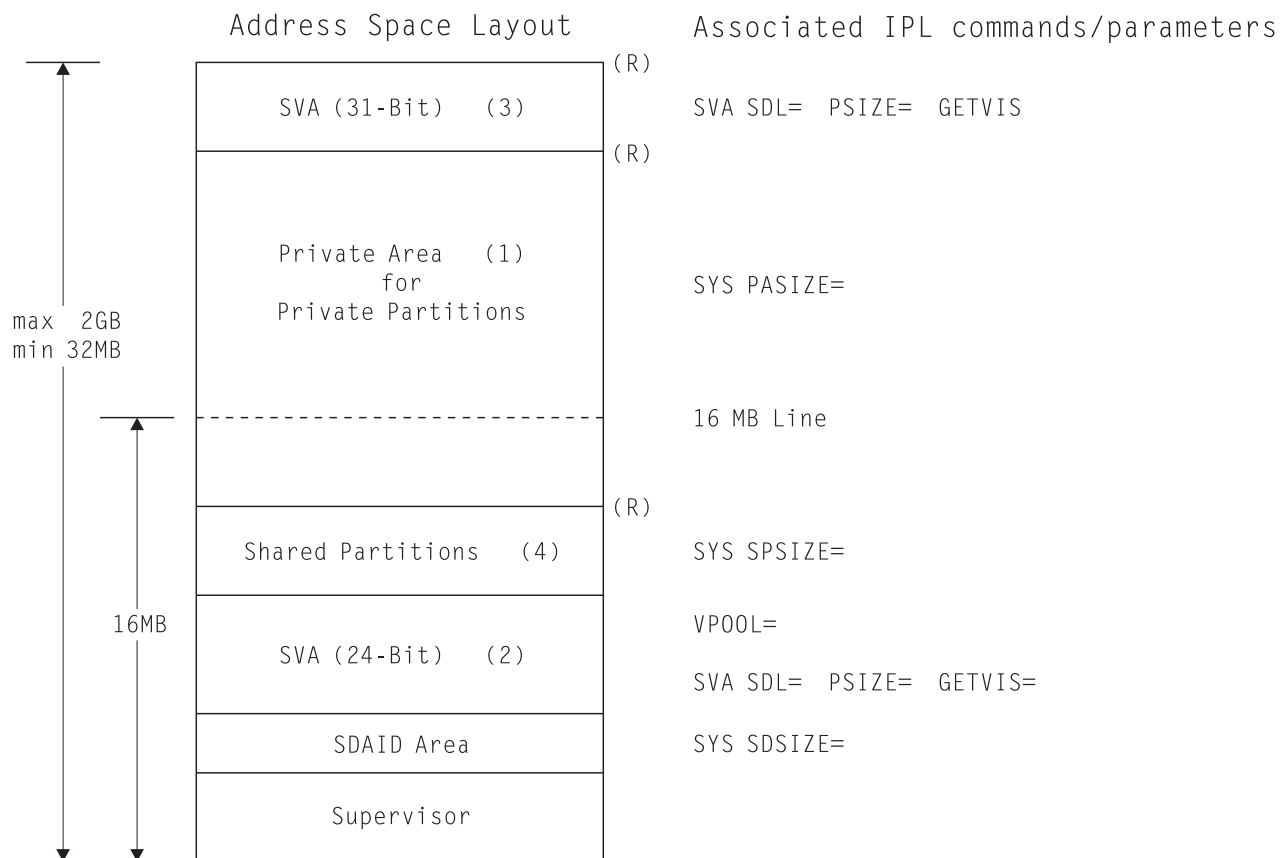

Figure 7. Address Space Layout and Related IPL Parameters

- (1) The private area includes:
  - Partition GETVIS area (static or dynamic partition)
  - Program area
  - Dynamic space GETVIS area (dynamic partition)
- (2) The SVA (24-Bit) includes:
  - VPOOL (virtual pool)
  - SLA (system label area)
  - System GETVIS area
  - VLA (virtual library area)
  - SDL (system directory list)
- (3) The SVA (31-Bit) includes:
  - System GETVIS area
  - VLA (virtual library area)
- (4) Not existing in predefined environments.
- Note on **SLA** (SVA 24-Bit):  
This area includes control information for label processing (12 KB for the whole system and an additional 8 KB for each static partition).  
Note on the **SVA** command:  
Although the SVA command is shown twice in Figure 7, in the IPL procedure only **one** SVA command is present. This single SVA command defines space for both the SVA (31-Bit) and the SVA (24-Bit) as described in the *z/VSE System Control Statements* under “SVA”.

- (R) identifies storage boundaries. At these boundaries rounding may occur up to the next 1 MB value. “Storage Management” in the *z/VSE Guide to System Functions* provides further details about address space and partition layout.

---

## Loading Phases into the SVA

z/VSE loads system phases that must reside in the shared virtual area (SVA) automatically into this area of virtual storage during system startup. Phases that are to be loaded can be defined in load lists.

Under “Loading Phases into the SVA”, the *z/VSE Guide to System Functions* provides background information and describes what is to be considered when loading user phases into the SVA and which tasks are involved.

---

## Running z/VSE With More Than 255 Tasks

Before z/VSE 4.2, a maximum of **255** VSE tasks were supported. This number included 32 tasks reserved for system usage and all partition main tasks (the number of partition main tasks is defined with the IPL SYS *NPARTS* parameter).

From z/VSE 4.2 onwards, z/VSE supports up to **512** tasks. This number still includes the 32 tasks reserved for system usage and all partition main tasks. The additional tasks might help you to:

- Increase CICS workloads.
- Consolidate z/VSE systems.

After you have installed z/VSE, the default maximum number of tasks remains **255**. z/VSE therefore provides various options to configure and use the support for up to 512 tasks.

## Activating the Support for More Tasks

You activate the “more tasks” support via the SYSDEF JCL command using parameter *NTASKS*. You must enter this command at z/VSE startup (ASI) from the BG partition.

Using parameter *TASKS* on the SYSDEF command you determine a system-wide default-mode for attaching tasks:

- *TASKS=ANY* will allow z/VSE to use any task-ID.
- *TASKS=OLD* tells z/VSE to use task-IDs below X'0100' only.

## Attaching Tasks

The tasks that you additionally define are in the task-ID range X'0100' to X'nnnn', where *nnnn* is the hexadecimal value of *NTASKS* that you defined using the SYSDEF command. You can use these additionally-defined tasks to *attach sub-tasks*.

The main tasks of static and dynamic partitions are still taken from within the range X'0021' to X'mmmm', where *mmmm* is the hexadecimal sum of:

- The number of system tasks (32), *plus*
- The maximum number of partitions defined at IPL-time (SYS *NPARTS*=).

After you have activated “more tasks” support, z/VSE determines at JCL EXEC time whether “new” task-IDs (X'0100' and above) can be used by z/VSE when attaching sub-tasks.

## System Organization and Concepts

A “new” task-ID (if available) is used with any sub-task attachment in the partition providing:

- You have not specified TASKS=OLD on the EXEC statement, *and*
- Either:
  - TASKS=ANY is the default from the SYSDEF command, *or*
  - You have specified TASKS=ANY on the JCL EXEC statement.

### How to Display the Status of Subtask Allocation

Using the (JCL/AR) QUERY SYSTEM command, you can display:

- What has been specified with the SYSDEF SYSTEM command.
- How many sub-tasks are currently allocated.

For details, refer to “Job Control and Attention Routines” in the *z/VSE System Control Statements*.

---

## IPL Storage Allocation Parameters

This topic describes the IPL parameters related to **storage allocation**. The values for these parameters can be changed with the *Tailor IPL Procedure* dialog described in the *z/VSE Administration* under “Tailoring the IPL Procedure”.

Refer to Table 55 on page 282 for IPL storage values.

For a detailed description of each IPL command and its parameters refer to the *z/VSE System Control Statements*.

### IPL Supervisor Parameters Command

#### NOPDS

Defines that the system is to operate without a page data set. You cannot specify both, NOPDS and VSIZE. Only one of these parameters is allowed. Refer to “Migrating From Releases Older Than z/VSE 4.2.x” on page 102 for further details about NOPDS.

#### VSIZE

Defines the total virtual storage size of a z/VSE system.

Note that the size of the page data set must correspond to VSIZE+VIO. The value for VSIZE must be sufficient to accommodate all of the following of your z/VSE system:

- ADDRESS SPACES (including shared areas, static and dynamic partitions). Note that the shared areas have to be added only once for all address spaces.
- DATA SPACES (including virtual disks if used).
- You must also consider that z/VSE itself requires virtual storage for system management tasks. As a rule of thumb, z/VSE requires about 4 KB for managing 1 MB of virtual storage (VSIZE).

Note that VSIZE cannot be specified together with NOPDS. In a system with no page data set (NOPDS), z/VSE calculates the VSIZE as follows: processor storage available minus the value specified for VIO.

**VIO** Defines the virtual I/O area which can be considered as an extension of the page data set and is used as system work area.

#### VPOOL

Defines storage needed to exchange data with the VIO area.

### IODEV

Defines the number of I/O devices that the z/VSE supervisor supports. This can be either 1023 or 1024. IODEV also determines where various I/O control blocks will be allocated by the z/VSE supervisor. See “Allocating I/O Control Blocks Above 16 MB Line” on page 55.

## IPL SYS Command

### PASIZE

Defines the maximum size of the private area (available for the allocation of private partitions) within an address space. The system will decrease the PASIZE to the largest possible value if necessary.

**RSIZE** Defines the storage that can be allocated for the real execution of programs (the maximum available for ALLOC R definitions).

### SDSIZE

Defines the size of a shared area for system monitor functions such as provided by the SDAID program.

### SPSIZE

Defines the storage to be reserved for shared partitions.

## IPL SVA Command

**PSIZE** Defines additional PSIZE space in the SVA (24-Bit) and SVA (31-Bit) areas. PSIZE reserves space for SVA eligible phases loaded via the SET SDL command. It also increases the size of the VLA (virtual library area).

### GETVIS

Defines additional system GETVIS space in the SVA (24-Bit) and SVA (31-Bit) areas. z/VSE automatically reserves system GETVIS space for its own requirements.

**SDL** Defines the number of entries in the system directory list to be reserved for user phases and SVA-eligible phases of z/VSE which are not automatically loaded during IPL.

## IPL Commands and Storage Values

The following table shows the possible range of IPL storage values and the defaults chosen by the system if necessary. The leftmost column identifies the related **IPL command**. For the predefined environments, z/VSE allocates storage according to the values shown in Table 21 on page 75.

## System Organization and Concepts

Table 20. IPL Commands and Storage Values

IPL Command	Parameter	Attribute	Storage Value	
SUPERVISOR	VSIZE (see Note 1)	maximum minimum default	xxGB 32MB 32MB	
	VIO	maximum minimum default	128MB VPOOL value 512KB	
	VPOOL	maximum minimum default	16MB 64KB 256KB	
	IODEV (see Note 2)	maximum minimum default	1024 0 1023	
SYS	PASIZE (see Note 3)	maximum minimum default	2048MB 64KB 256KB	
	RSIZE	maximum minimum default	16MB 0KB 64KB	
	SDSIZE	maximum minimum default	256KB 0KB 64KB	
	SPSIZE	maximum minimum default	16MB 0KB 0KB	
SVA	PSIZE (see Note 4)	maximum minimum default	<b>24Bit</b>	<b>31Bit</b>
			16MB 0KB 1MB	2048MB 0KB 0KB
	GETVIS (see Note 4)	maximum minimum default	<b>24Bit</b>	<b>31Bit</b>
			16MB 0KB 0MB	2048MB 0KB 0KB

### Notes:

- For an explanation of the maximum VSIZE value (xx GB) refer to “Virtual Storage Support” on page 53.
- If IODEV is less than or equal to 1023, I/O control blocks are allocated in the 24-bit SVA. If you specify IODEV equal to 1024, I/O control blocks are allocated in the 31-bit SVA. For further details, see “Allocating I/O Control Blocks Above 16 MB Line” on page 55.
- 2048 MB (2 GB) is the theoretical maximum size of an address space. The storage available for PASIZE, however, is 2048 MB minus the size of the shared areas.  
The minimum PASIZE is 6 MB if the VSIZE is equal or larger than 256 MB, and 1 MB if the VSIZE is smaller than 256 MB.



In a system without a page data set (NOPDS), no VSIZE can be specified. The system uses the processor storage size to calculate the minimum value for the PASIZE.

- Although the default value is 0 KB, the system acquires and occupies storage needed for system tasks.

## IPL Storage Values for Predefined Environments

The following table shows the IPL storage values as set for predefined environments A and B. The leftmost column identifies the related **IPL command**.

Table 21. IPL Storage Values as Set for Predefined Environments

		ENVIRONMENTS		
		A	B	C
S U P P O S I T I O N	VSIZE	256MB	512MB	2GB
	VIO	512KB	512KB	512KB
	VPOOL	64KB	64KB	64KB
S Y S	PASIZE	50MB	150MB	512MB
	RSIZE	64KB	64KB	64KB
	SDSIZE	96KB	96KB	96KB
	SPSIZE	0KB	0KB	0KB
S V A	PSIZE (24) PSIZE (31) (see Notes)	652KB 6MB	652KB 6MB	652KB 6MB
	GETVIS (24) GETVIS (31) (see Notes)	768KB 6MB	768KB 10MB	768KB 20MB

### Notes:

- The values for PSIZE and GETVIS are the values predefined for the SVA (24-Bit) and SVA (31-Bit) areas. These values are added by the system to its own requirements.
- If your installation uses 31-bit addressing, you must define storage values for the SVA (31-bit) area according to your requirements. Refer to the IPL SVA command in the *z/VSE System Control Statements* under “SVA” for details.
- To get the current SVA storage values displayed, you can use the *Display Storage Layout* dialog. The dialog is described in detail in the *z/VSE Administration* under “Using the Display Layout Dialog”.

### Real Storage Allocation

#### IPL SYS Command RSIZE

The IPL SYS command RSIZE specifies the amount of real storage that may be allocated for the execution of programs in real mode in static partitions. It is the maximum size available for ALLOC R definitions. The RSIZE default of 64 KB is sufficient for static partitions. If dynamic partitions are to be used for programs running in real mode, you must increase the RSIZE.

**Note:** It is recommended to use ALLOC R definitions **only** if programs are to be executed in real mode (EXEC program,REAL). Whenever a program needs real storage to PFIX pages, the SETPFIX statement should be used.

#### JCL SETPFIX Statement

The JCL SETPFIX statement sets storage limits per partition for fixing pages (PFIX).

The shipped startup jobs and JCL startup procedures for the predefined environments include SETPFIX statements where page fixing is needed. The values specified for SETPFIX are assigned permanently and are shown in Table 24 on page 78 and Table 25 on page 79.

If you have job streams with programs that PFIX pages, you should use the JCL SETPFIX statement in the job directly to have storage temporarily assigned for the duration of the job.

**Note:** For a single partition, an ALLOC R specification and a SETPFIX specification (BELOW) are mutually exclusive. Refer to the *z/VSE System Control Statements* under "ALLOC" and under "SETPFIX" for details.

#### Additional Considerations

The size of the shared areas (supervisor, SVA 24-Bit, shared partitions) is taken from the real storage available. If your real storage size is relatively small, it might be that in exceptional cases the remaining size for ALLOC R is not sufficient to execute programs in real mode.

---

### Startup Processing after IPL

Once IPL processing is complete, various JCL procedures are processed mainly for allocating space to static partitions and starting them.

#### Storage Allocation for Static Partitions

For the predefined environments, the following skeletons (stored in VSE/ICCF library 59) and procedures are provided for allocating storage to static partitions.

*Table 22. Skeletons and Procedures for Storage Allocation (Static Partitions)*

Name	Environment	Description
SKALLOCA	A	Skeleton
SKALLOCB	B	Skeleton
SKALLOCC	C	Skeleton
ALLOC	A, B, C	Procedure for running system
ALLOCBSX	A, B, C	Procedure for basic startup

## Startup Overview of Predefined Environments

The following table provides an overview for the predefined environments about page data set extent books, partition allocation and startup, and the JCL startup procedures, jobs, and skeletons associated with it.

Table 23. Startup Overview of z/VSE Predefined Environments

	ENVIRONMENT A	ENVIRONMENT B	ENVIRONMENT C
Partitions (see Note 1)	12 Static 28 Dynamic	12 Static 48 Dynamic	12 Static 108 Dynamic
Address Spaces	12/48	12/68	12/108
VSIZE (in MB) and related Page Data Set Extent Books (see Note 2)	256 PDSxxxx0/2	512 PDSxxxx0/2	2048 PDSxxxx0/2
Partition Allocation Procedure: Skeletons: (see Note 3)	ALLOC SKALLOCA	ALLOC SKALLOCB	ALLOC SKALLOCC
BG Startup	Procedures: \$0JCL, USERBG Skeletons: SKJCL0, SKUSERBG		
F1 Startup (VSE/POWER)	Procedures: \$1JCL Skeletons: SKJCL1		
VSE/POWER Autostart Procedures: Skeletons:	POWSTRTA SKPWSTRT	POWSTRB SKPWSTRT	POWSTRC SKPWSTRT
F2 Startup (CICS TS, ICCF)	Procedure: \$2JCL Startup Job: CICSICCF Skeletons: SKJCL2, SKCICS		
F3 Startup (VTAM)	Procedure: \$3JCL Startup Job: VTAMSTRT Skeletons: SKJCL3, SKVTAM		
F4 Startup	Procedure: \$4JCL Skeleton: SKJCL4		
F5 Startup	Procedure: \$5JCL Skeleton: SKJCL5		
F6 - FA Startup	Procedure: \$6JCL - \$AJCL Skeletons: SKJCL6 - SKJCLA		
FB Startup (Security Server)	Procedure: \$BJCL Skeleton: SKJCLB		
Dynamic Partition Startup	Profile: STDPROF/PWSPROF Skeleton: SKJCLDYN		
Library Definitions	Procedure: LIBDEF Skeleton: SKLIBCHN		

### Notes:

1. The maximum number of partitions (static plus dynamic) that can be active is defined with the NPARTS parameter of the IPL SYS command. The current settings for NPARTS for each z/VSE predefined environment are shown in Table 19 on page 59.

## System Organization and Concepts

2. Listed are the names of the Z-books stored in IJSYSRS.SYSLIB. Such a Z-book contains the DPD commands specifying the page data set extents. xxxx represents the disk device type (such as 3390) on which the page data set extents reside.
3. During initial installation, z/VSE changes the procedure name for partition allocation automatically to ALLOC. This procedure is active once initial installation has been completed.

---

## Static Partition Allocations for Predefined Environments

The following tables reflect the storage values allocated to the static partitions of the predefined environments. z/VSE provides skeletons (SKALLOCx) for changing these values. Refer to “Skeletons for Static Partition Allocations” in the *z/VSE Administration* for details about the skeletons provided. For details about the ALLOC command used to allocate virtual and real storage, refer to the *z/VSE System Control Statements* under “ALLOC”.

For Table 24 and Table 25 on page 79 the following applies:

- The SETPFIX values are defined in the corresponding JCL procedure for partition startup and in the startup jobs.
- All other storage values are defined through the ALLOC procedure active after initial installation has been completed.

### Static Partition Allocations for Predefined Environment A

Environment A provides 12 address spaces with 12 static partitions. Additionally, environment A provides support for dynamic partitions as described under “Predefined Dynamic Partition Support” on page 80.

Table 24. Storage Values for Static Partitions (Environment A)

Address Space	Partition	Initial ALLOC	Virtual SIZE	Partition GETVIS	Program	SETPFIX below/above
0	BG	6M	1280K	4864K	---	---
1	F1	6M	1500K	4500K	POWER	200K
2	F2	50M	2M	48M	CICS TS ICCF	144K
3	F3	15M	600K	14760K	VTAM	424K/300K
4	F4	20M	2M	18M	---	---
5	F5	1024K	768K	256K	---	---
6	F6	512K	256K	256K	---	---
7	F7	20M	1M	19M	TCP/IP	900K/2100K
8	F8	50M	2M	48M	---	---
9	F9	512K	256K	256K	---	---
A	FA	512K	256K	256K	---	---
B	FB	1M	512K	512K	Security Server	---

## SETPFIX Details

### Notes:

1. Each OSA Express link causes TCP/IP to acquire 1 MB SETPFIX storage above if more than 16 MB real storage is available. 2100 KB is sufficient for 2 links.
2. To activate the SETPFIX limit above, you must modify the appropriate startup jobs for TCP/IP and VTAM.

## Static Partition Allocations for Predefined Environment B

Environment B provides 12 address spaces with 12 static partitions. Partitions F2, F3, F4, F7, and F8 cross the 16 MB line making use of the 31-bit addressing support. Besides static partitions, environment B supports also dynamic partitions as described under “Predefined Dynamic Partition Support” on page 80.

Table 25. Storage Values for Static Partitions (Environment B)

Address Space	Partition	Initial ALLOC	Virtual SIZE	Partition GETVIS	Program	SETPFIX below/above
0	BG	10M	1280K	8960K	---	---
1	F1	30M	1500K	29220K	POWER	200K
2	F2	50M	2M	48M	CICS TS ICCF	144K
3	F3	15M	600K	14760K	VTAM	424K/300K
4	F4	20M	2M	18M	---	---
5	F5	5M	768K	4352K	---	---
6	F6	50M	1M	49M	---	---
7	F7	20M	1M	19M	TCP/IP	900K/2100K
8	F8	150M	2M	148M	---	---
9	F9	5M	1M	4M	---	---
A	FA	5M	1M	4M	---	---
B	FB	1M	512K	512K	Security Server	---

Refer also to “SETPFIX Details.”

After initial installation, partition F8 is reserved for a second CICS Transaction Server.

## Static Partition Allocations for Predefined Environment C

Environment C provides 12 address spaces with 12 static partitions. Partitions F2, F4, and F8 cross the 16 MB line making use of the 31-bit addressing support. Besides static partitions, environment C also supports dynamic partitions, as described under “Predefined Dynamic Partition Support” on page 80.

Table 26. Storage Values for Static Partitions (Environment C)

Address Space	Partition	Initial ALLOC	Virtual SIZE	Partition GETVIS	Program	SETPFIX below/above
0	BG	32M	1280K	31488K	---	---
1	F1	32M	1500K	32268K	POWER	200K

## System Organization and Concepts

Table 26. Storage Values for Static Partitions (Environment C) (continued)

Address Space	Partition	Initial ALLOC	Virtual SIZE	Partition GETVIS	Program	SETPFIX below/above
2	F2	256M	2M	254M	CICS TS ICCF	144K
3	F3	15M	600K	14760K	VTAM	424K/300K
4	F4	32M	2M	30M	---	---
5	F5	32M	1M	31M	---	---
6	F6	32M	1M	31M	---	---
7	F7	32M	1M	31M	TCP/IP	900K/2100K
8	F8	512M	2M	510M	---	---
9	F9	32M	1M	31M	---	---
A	FA	32M	1M	31M	---	---
B	FB	2M	512K	1536K	Security Server	---

Refer also to “SETPFIX Details” on page 79.

After initial installation, partition F8 is reserved for a second CICS Transaction Server.

---

## Predefined Dynamic Partition Support

z/VSE provides a dynamic class table and default startup profiles (procedures) for dynamic partition support.

### Dynamic Class Table

The dynamic class table (DTR\$DYNC) is activated for predefined environments A and B. You can modify the table or create new tables with the *Maintain Dynamic Partitions* dialog. z/VSE supports multiple dynamic class tables.

### Startup Profile

z/VSE provides default startup profiles (STDPROF and PWSPROF) for the use of predefined dynamic partitions. To maintain and catalog such a profile, use skeleton SKJCLDYN described in the *z/VSE Administration* under “Cataloging JCL Startup Procedures”.

For further details, refer to “Predefined Dynamic Partition Support” on page 181.

---

## CICS Transaction Server and VSE/ICCF Interrelationship

## Concepts and Partition Layout

The following list provides an overview of the CICS Transaction Server and VSE/ICCF interaction, operation, and partition layout:

- VSE/ICCF runs as a subtask system under the primary CICS Transaction Server.
- VSE/ICCF resides below 16 MB and is loaded and initialized during CICS Transaction Server startup in the partition GETVIS area.
- VSE/ICCF, including the VSE/ICCF interactive partitions, requires about 3.5 MB of virtual storage below 16 MB. As shipped, this value is taken from the GETVIS space below 16 MB reserved for the CICS Transaction Server partition (size value).
- During CICS Transaction Server startup, VSE/ICCF is initialized via the initialization program DTSPSTI. To restart VSE/ICCF during production, transaction I\$ST is available. This may be necessary to implement VSE/ICCF configuration changes which is possible via the VSE/ICCF generation table. The name of the default generation table (DTSIGEN) has then to be specified as parameter for transaction I\$ST.

The table DTSIGEN must be assembled and cataloged in a VSE/ICCF regeneration run as described in the chapter “Regenerating the Supervisor, VSE/POWER, or VSE/ICCF” in the *z/VSE Administration*.

z/VSE provides table DTSIGENM for generating larger interactive partitions if needed.

- Together with the CICS Transaction Server, VSE/ICCF can run in a dynamic partition.
- For VSE/ICCF shutdown, the command /ICCFEND and transaction I\$SH are available.
- VSE/ICCF transaction programs have been converted from CICS macro to CICS command level.
- The DSA storage limit (EDSALIM) for the CICS Transaction Server above the 16 MB limit is set to:
  - 25 MB for predefined environment A.
  - 25 MB for predefined environment B when the CICS TS runs in partition F2.
  - 120 MB for predefined environment B when the CICS TS runs in partition F8.
  - 200 MB for predefined environment C when the CICS TS runs in partition F2.
  - 450 MB for predefined environment C when the CICS TS runs in partition F8.

For environment B, the value can be increased about 35 MB for F2 and 135 MB for F8. For environment C, the value can be increased to about 240 MB for F2 and 490 MB for F8.

In a z/VSE system with several CICS Transaction Servers only one can include VSE/ICCF. Figure 8 on page 82 shows the layout of the CICS - ICCF partition (F2).

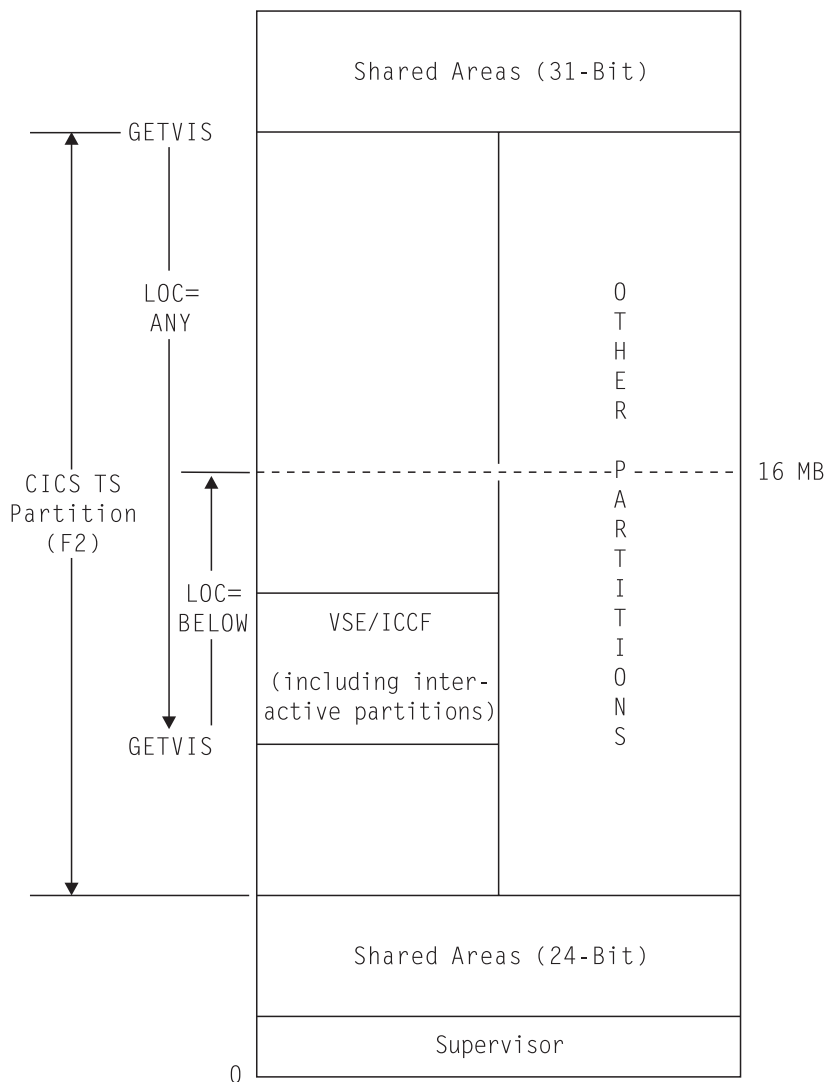

Figure 8. CICS Transaction Server - VSE/ICCF Partition Layout

## VSE/ICCF Interactive Partition Layout and Characteristics

The Interactive Interface uses **interactive partitions** that are allocated within VSE/ICCF in the CICS TS partition (F2).

Table 27 on page 83 shows the characteristics of the predefined VSE/ICCF interactive partitions. You can change their size through the VSE/ICCF generation table DTSIGEN or DTSIGENM, as described in the chapter “Regenerating the Supervisor, VSE/POWER, or VSE/ICCF” in the *z/VSE Administration*.

If you increase the size of the existing interactive partitions or add partitions, you should also make a corresponding increase in the size of the F2 partition.

Note that you should **not**

- Add a second class I partition. Some functions of the Interactive Interface use class I. These functions should *not* be performed concurrently.
- Decrease the size of any partition, though you may be tempted to save 24-Bit storage.



- Remove all class A and B partitions. The Interactive Interface requires at least one partition of each class.

To improve Interactive Interface performance, you should also consider regenerating VSE/ICCF, for example, to increase the number of DTSFILE buffers.

*Table 27. Characteristics of the Predefined VSE/ICCF Interactive Partitions*

Interactive Partition	Class	Minimum Size	Used By
1	I	1024K	Interactive Interface
2	A	384K	Interactive Interface
3	A	384K	Interactive Interface
4	A,B	512K	Interactive Interface
5	A,B	512K	Interactive Interface

---

## Displaying Storage Layout Information

Before you start modifying the storage and partition layout of your system, you should use the *Display Storage Layout* dialog to get the real and virtual storage values of your current system. The dialog is described in detail in the *z/VSE Administration*.



---

## Chapter 5. Installing z/VSE 5.1

This chapter describes the installation of z/VSE 5.1. It contains these main topics:

- “Overview”
- “Shipment of z/VSE 5.1” on page 87
- “Considerations for LE/VSE and the VSE C Language Run-Time Support” on page 89
- “TCP/IP Considerations” on page 89
- “DB2 Considerations” on page 89
- “VTAM Considerations” on page 89
- “Initial Installation of z/VSE 5.1” on page 90
- “Installing z/VSE 5.1 via FSU” on page 92
- “Installing the DB2 Server for VSE or DB2 Server for VSE Client Edition” on page 94
- “Installing z/VSE Optional Programs” on page 94
- “Further Installation and Customization Tasks” on page 94
- “VTAM 4.2 Storage Requirements” on page 95

---

### Overview

The following IBM disk types are supported for the initial installation of z/VSE 5.1:

- 3380 ECKD (with a minimum of 1770 cylinders)
- 3390 ECKD
- FBA

The minimum number of cylinders or blocks that are required to install z/VSE on a 3380, 3390, or FBA disk for each z/VSE environment is shown in Table 51 on page 277.

#### Notes:

1. The device types 3380 and 3390 can also be devices defined in the:
  - IBM DS8000 / DS6000
  - IBM TotalStorage ESS
  - IBM RAMAC Array family
2. The FBA disk device can be either:
  - An FCP-attached SCSI disk in z/VSE.
  - A z/VM emulated FBA disk or an FBA minidisk.

### How to Install z/VSE 5.1

- When you install z/VSE the first time, you must perform an **initial installation**.
- If you have already installed a z/VSE 4.2.x, z/VSE 4.3.x, or z/VSE 5.1.x system, you can perform a *Release Upgrade* through an **FSU** (Fast Service Upgrade).

### Initial Installation

This is the standard method if you install z/VSE for the first time or if your current system does not fulfill the requirements for an FSU. Refer to “Initial Installation of z/VSE 5.1” on page 90 for an overview of the initial installation process.

The *z/VSE Installation* provides a step-by-step description for performing an initial installation.

### FSU from z/VSE 4.2.x, z/VSE 4.3.x, or z/VSE 5.1.x to z/VSE 5.1.2

The great advantage of an FSU is the fact that your migration effort is reduced to a minimum. The FSU uses your current system as installed on DOSRES and SYSWK1 and upgrades it to the z/VSE 5.1 level by replacing IBM code as follows:

- z/VSE base programs.
- VSE/ICCF members provided by IBM.
- The online messages file.

An FSU is used to perform:

- Release upgrades (for example, from z/VSE 4.3.x to z/VSE 5.1)
- Service refreshes (for example, from z/VSE 5.1.0 to z/VSE 5.1.2).

User libraries, hardware configuration tables, and other installation-unique data are not changed by the FSU.

An FSU does not install or update z/VSE optional programs or programs shipped on the Extended Base Tape. If you want to add or update such programs you can do so after FSU completion.

You perform an FSU by using the *Fast Service Upgrade* dialog. This chapter provides planning information and discusses important aspects of an FSU (refer also to “Installing z/VSE 5.1 via FSU” on page 92). The *z/VSE System Upgrade and Service* describes the FSU dialog in detail.

### Comparison Of an Initial Installation With an FSU Release Upgrade

Table 28 provides an overview of the advantages and disadvantages comparing the two installation methods.

Table 28. Comparing Initial Installation against FSU

	Initial Installation	FSU
<b>Eligible for:</b>	All users	z/VSE 4.2.x, z/VSE 4.3.x, and z/VSE 5.1.x users
<b>Requirements:</b>	No special requirements	(see “Required Status of Current System” on page 92)
<b>Hardware configuration:</b>	Can be migrated  (which must be requested)	Kept as is

Table 28. Comparing Initial Installation against FSU (continued)

	Initial Installation	FSU
User profiles, selection panels, application profiles:	Can be migrated (which must be requested)	Kept as is (only system data on DOSRES and SYSWK1 replaced)
User-specific data:	Access to VSE/VSAM data must be re-established  VSE/ICCF user libraries must be restored	Kept as is  For example: System layout, VSE/VSAM data, VSE/ICCF file, etc.  System startup is to be adapted
z/VSE optional programs:	Must be installed	Should be refreshed
Additional IBM or non-IBM programs:	Must be installed	Should be refreshed
User application programs:	Must be re-established (update of VSE/VSAM catalogs, CICS tables, etc.)	Kept as is (recompile may be necessary)
System Modifications:	Possible	(see "Restrictions for System Modifications" on page 92)

## Shipment of z/VSE 5.1

z/VSE 5.1 is delivered in the following three ways:

- **As distribution tapes.** Either:
  - Three IBM 3590 distribution tapes (128 tracks).
  - Three IBM 3592 distribution tapes (512 tracks).
- **As a CD-ROM.**
- **Via the Internet** (using IBM's **ShopzSeries**).

These three possible ways to ship z/VSE are now described.

### Shipment of z/VSE 5.1 on Distribution Tapes

This Service Refresh of z/VSE 5.1 is shipped on **three** distribution tapes as follows:

- One **base tape**.
- One **extended base tape**.
- One **extra tape** for the *DB2 Server for VSE Help* component.

The base tape is labeled **Z/VSE5.1.2-YY**, the extended base tape has the label **Z/VSE5.1.2-XBASE**. For the tape containing the *DB2 Server for VSE Help* component, refer to the z/VSE 5.1 Program Directory.

The "X" identifies the latest modification level of the current release. IBM provides Multicultural Support for z/VSE. "YY" is the language indicator:

EN for English  
KA for Kanji (Japanese)

**Note:** You receive additional tapes if you have ordered z/VSE optional programs.

### Extended Base Tape

The extended base tape for z/VSE 5.1 includes the following programs and components:

- DB2 Server for VSE
- DB2 Server for VSE Client Edition
- IPv6/VSE
- DataPropagator Relational Capture
- LE/VSE DBCS Locales
- VSE Connectors Workstation Code

Programs shipped on the Extended Base Tape are not installed automatically. Exceptions are the **DB2 Server for VSE** or the **DB2 Server for VSE Client Edition**, for which you are asked during initial installation (but not during an FSU). If you answer with YES, you must mount the tape and the program you choose is then installed automatically.

**Installing Programs from the Extended Base Tape:** From an installation point of view, programs and components on the Extended Base Tape are to be treated as z/VSE optional programs. They have to be installed using the *Install Program(s) from Tape* dialog as described in the *z/VSE Installation*. You reach this dialog by first selecting the *Install Programs -V2 Format* dialog.

### Extra Tape

This tape contains only one component: the *DB2 Server for VSE Help*. For installation details, refer to “Use of Installation Member ARISIVAR.Z” on page 150. Note that you cannot install this component like a z/VSE optional program.

For details of how to obtain and use the above z/VSE 5.1 distribution tapes, refer to the *z/VSE Installation*.

## Shipment of z/VSE 5.1 on CD-ROM

There are two CD-ROMs that can be used directly at your workstation. The first CD-ROM is labelled VSE\_BASE\_CDR\_YYY and contains these files in virtual tape format:

- VSE512YY.AWS
- VSE512XB.AWS
- DB2SERVE.AWS
- READM512.TXT

The second CD-ROM contains the file VSE512OP.AWS in virtual tape format, which contains the optional products.

The above files contain the contents of the three tapes described in “Shipment of z/VSE 5.1 on Distribution Tapes” on page 87.

The “YYY” part of the label VSE\_BASE\_CDR\_YYY refers to the language used, where ENU is for English.

For details of how to obtain and use the above z/VSE 5.1 CD-ROM, refer to the *z/VSE Installation*.

## Downloading of z/VSE 5.1 Via the Internet

If you download from the Internet, the tape image files are in zipped format. These zipped files contain the contents of the three tapes described in “Shipment of z/VSE 5.1 on Distribution Tapes” on page 87.

**Note:** It is currently not possible to download Japanese tape image files via the internet.

For details of how to obtain and use the above z/VSE 5.1 zipped files, refer to the *z/VSE Installation*.

## Considerations for LE/VSE and the VSE C Language Run-Time Support

LE/VSE is a z/VSE base program. This means, you receive LE/VSE as one of the VSE Central Functions. LE/VSE is installed automatically (during initial installation) into sublibrary PRD2.SCEEBASE.

The VSE C Language Run-Time Support is also one of the VSE Central Functions. It enables you to run applications compiled with the *C for VSE/ESA* compiler.

## TCP/IP Considerations

TCP/IP for VSE/ESA is installed automatically into sublibrary PRD1.BASE. Refer to “Installing TCP/IP for VSE/ESA” on page 154 and “Customizing TCP/IP for VSE/ESA” on page 155 for further details.

Note that some components require that TCP/IP is up and running before they can be started. For example, the DB2 connector support.

## DB2 Considerations

Refer to Chapter 9, “z/VSE e-business Connectors and Tools,” on page 141 for installation details of the DB2 Server for VSE or the DB2 Server for VSE Client Edition.

## VTAM Considerations

### VTAM Passwords

You receive VTAM *Version 4 Release 2* with z/VSE 5.1. VTAM consists of three different levels. When you ordered VTAM, you had to specify one of these levels. With the z/VSE distribution tapes, you also receive a unique VTAM password customized for your site.

For initial installation, z/VSE uses a predefined password and no action on your side is necessary. However, when initial installation is complete and you tailor your system, you must activate your own VTAM password by modifying skeleton SKVTAM stored in VSE/ICCF library 59. Proceed as follows:

- Copy the skeleton into your primary VSE/ICCF library.
- Use the copy of the skeleton to modify the VTAM password.
- Submit the skeleton for processing.

## Installing z/VSE

For further introductory information refer to the *VTAM Overview*, for further technical details refer to the *VTAM Network Implementation Guide*.

VTAM storage requirements are discussed under “VTAM 4.2 Storage Requirements” on page 95.

---

## Initial Installation of z/VSE 5.1

**Note:** For the latest information on installing z/VSE, consult the *Program Directory* shipped with z/VSE 5.1.

You must plan for initial installation as well as for the subsequent customization and tailoring steps. After initial installation, you can use the Interactive Interface to customize and tailor z/VSE for your particular needs.

Any preparatory steps, like defining and planning your system requirements or loading the Input/Output Configuration Data Set (IOCDS), should be completed before you install z/VSE.

### z/VSE Input/Output Configuration Program (IOCP)

The *Input/Output Configuration Program (IOCP)* describes the I/O configuration (IOCDS) of your System z server. IOCDS is an abbreviation for *Input/Output Control Dataset*. The stand-alone version of IOCP is shipped with System z. You must first run the stand-alone version in order to generate an IOCDS for your server. As input, you can also use an already-customized IOCDS that was generated on another server.

The online version of IOCP is automatically installed during initial installation of z/VSE. You can use this online version of IOCP to:

- Create a new IOCDS, when you change your hardware configuration.
- Define and validate the IOCP macro instructions, when preparing to install a new server.

Use skeleton SKIOCPCN (available in VSE/ICCF library 59) as a base for configuration changes.

For detailed information about IOCP, consult the IOCP publication of your server.

### The Initial Installation Process

The initial installation process is divided into three installation parts and should take about two hours to complete. The three installation parts consist of:

1. Initializing the system disks by using the program Device Support Facilities. The system disks, named DOSRES and SYSWK1, are reserved for use by z/VSE.
2. Transferring z/VSE from its distribution tapes to disk and starting up the system for the first time.
3. Using dialogs of the Interactive Interface to provide z/VSE with specific information vital to the operation of your system.

The first two parts can be done using either an “automatic” installation or a “manual” installation. The automatic installation initializes your disk devices, places the Volume Table of Contents (VTOC), and restores the system library IJSYSRS.SYSLIB. A predefined customization table shipped with the z/VSE installation tape provides the required values.



## Planning Steps for Initial Installation

The following planning steps are required:

1. Define your hardware configuration and collect related information like device types and addresses.

At initial installation, z/VSE supports up to 1024 input/output devices. If more than 1024 input/output devices exist, these additional devices will be ignored by the device sensing process. After initial installation, z/VSE can support more than 1024 I/O devices during IPL providing you add these devices using the *Hardware Configuration* dialog.

The following devices must be ADDED:

- Channel-attached devices like disk and tape devices, printers, and communication controllers.
  - Local non-SNA terminals. Each terminal attached requires one IPL ADD command. This may be a constraint. However it can be removed by using local SNA terminals and VTAM.
2. Determine the predefined environment (A, B, or C) that fits your needs best. Note that if you want to install the *DB2 Server for VSE*, you must choose predefined environment B or C.
  3. Decide whether you want to do migration during initial installation or later. Refer to Chapter 6, “Migrating From Earlier Releases,” on page 99 for further details.
  4. Decide whether you want to install the *DB2 Server for VSE* during initial installation or later.
  5. Decide whether you want to configure TCP/IP during initial installation or later.
  6. Determine whether you want to run your system with security active. With security active, you can control and restrict the access to resources such as files and libraries. Refer to Chapter 18, “Security and Encryption Support,” on page 227 for further details.
  7. Determine the procedure name for the FCB (Forms Control Buffer) or UCB (Universal Character Set Buffer) to be used for your system printer.

To simplify initial installation, z/VSE includes a master procedure (\$ASIPROC) and a predefined **customization table**.

### Master Procedure \$ASIPROC

z/VSE includes an \$ASIPROC (TYPE=INSTALL) for initial installation. It selects the IPL and JCL procedures for initial installation according to the following list of IBM disk devices that can be used as DOSRES and SYSWK1 devices:

3380 (with a minimum of 1770 cylinders)  
 3390  
 FBA-SCSI  
 FBA

An FBA device reflects the generalized fixed blocked architecture (GFBA) disk layout, which is used by:

- Minidisks or virtual disks under z/VM, or z/VM emulated-FBA disks.
- SCSI FCP-attached disks, as described in “Configuring Your System to Use SCSI Disks” in the *z/VSE Administration*.

Related information is provided in Appendix A, “Startup Procedures,” on page 275 and in Appendix B, “z/VSE Disk Layouts (DOSRES, SYSWK1),” on page 277.

### Customization Table

To automate installation, z/VSE uses a predefined customization table. The table relieves the operator from entering commands and responses during the installation process. This minimizes the possibility of entering wrong or incorrect information and reduces the overall time required for the initial installation of z/VSE.

A message asks the user whether "automated installation" is wanted. A "NO" response enables the operator to enter all required information manually at the console. This may be necessary if a review of the customization table shows that the predefined values and parameters defined there do not fit your system's requirements.

---

## Installing z/VSE 5.1 via FSU

This topic provides planning details for the installation of z/VSE 5.1.2 through a Release Upgrade or Service Refresh via an FSU (Fast Service Upgrade). A Release Upgrade via an FSU is possible if you currently have a:

- z/VSE 4.3.x system.
- z/VSE 4.2.x system.
- z/VSE 5.1.x system.

### Required Status of Current System

Your current system **must** have the standard (shipped) system layout of a z/VSE 5.1.x, z/VSE 4.3.x, or z/VSE 4.2.x system, including the z/VSE library structure and VSE/VSAM catalogs. This is because the following libraries must be present for FSU: IJSYSRS, PRD1, and PRD2. Note that if you have combined or renamed these libraries and sublibraries, the FSU job stream will not work without modification.

**Note:** The FSU uses sublibrary PRD2.SAVE as save library. Therefore, you should not store any phases in it except for FCBs and UCBs.

### Restrictions for System Modifications

You **cannot** use the FSU to modify your system. For example, you cannot:

- Use different disk device types from those you are using presently (for example, if you have installed your system on IBM 3380 and now want to use IBM 3390 or SCSI disk devices).
- Use an FSU to change your system from another language to English.
- Use an FSU to change your system from English to Kanji.
- Switch from the 2-digit subarea naming convention to the 4-digit subarea naming convention.

In each of these cases, you have to do an **initial installation**.

Also note that:

- You **cannot** use the FSU to change your environment, for example from environment B to C.
- An FSU will **not change** your environment to any of the layouts described in "Predefined System Environments" on page 59.

However, using the provided skeletons, you can perform a change of environment *after* the FSU is complete.

## DB2 Server for VSE 7.5

z/VSE 5.1 includes the DB2 Server for VSE 7.5 and the DB2 Server for VSE Client Edition 7.5, either of which you can install from the Extended Base Tape.

In case of z/VSE 4.2.x or z/VSE 4.3.x, the FSU allows you to select the automatic installation of the DB2 Server for VSE 7.5 or the DB2 Server for VSE Client Edition 7.5.

**Note:** Although the DB2 Server for VSE 7.5 was also included in z/VSE 4.3.x, you might wish to install the most up-to-date copy containing the latest fixes.

## VSE/VSAM Space Considerations for a Release Upgrade or Service Refresh via an FSU

This concerns VSE/VSAM space that must be available on **DOSRES** and **SYSWK1** for the system libraries **PRD1** and **PRD2**. The DOSRES and SYSWK1 layouts are shown in Appendix B, “z/VSE Disk Layouts (DOSRES, SYSWK1),” on page 277.

### PRD1 and PRD2 Libraries

#### Library Blocks Required for the PRD1 LIBRARY:

- To perform an FSU from:
  - z/VSE 4.3.x to z/VSE 5.1, you require about 21,800 more library blocks.
  - z/VSE 4.2.x to z/VSE 5.1, you require about 22,200 more library blocks.
- To perform a Service Refresh of z/VSE 5.1, you require about 500 more library blocks.

#### Library Blocks Required for the PRD2 LIBRARY:

- To perform an FSU from:
  - z/VSE 4.3.x to z/VSE 5.1, you require about 15,500 more library blocks.
  - z/VSE 4.2.x to z/VSE 5.1, you require about 16,500 more library blocks.
- To perform a Service Refresh of z/VSE 5.1, you require about 500 more library blocks.

**You are strongly recommended to check that the space required for the additional library blocks is available in the VSE/VSAM master catalog.** If there is *not* enough space available, the FSU might fail during stage 2 and it *will be difficult to recover from such an error situation.*

To find out about the VSE/VSAM space available on DOSRES and SYSWK1 of your old system, you can use one of the following methods:

- The SHOW SPACE function of the *Display or Process a Catalog, Space* dialog.
- The VSE/VSAM LISTCAT command.

Check whether the values in your VSE/VSAM user catalog are sufficient. Refer to the corresponding disk layouts in Appendix B, “z/VSE Disk Layouts (DOSRES, SYSWK1),” on page 277 for details.

### Performing the FSU

After completing the above planning steps, you can now perform the *Fast Service Upgrade*. The *z/VSE System Upgrade and Service* provides details of:

- Which libraries are updated during an FSU.
- Error-recovery procedures from errors caused by space problems.
- The tailoring tasks you should perform when the FSU is completed.

---

### Installing the DB2 Server for VSE or DB2 Server for VSE Client Edition

Refer to Chapter 9, “z/VSE e-business Connectors and Tools,” on page 141 for details on installing the *DB2 Server for VSE* either during initial installation or after an FSU.

You can separately install the *DB2 Server for VSE Client Edition* using the dialog for optional program installation.

---

### Installing z/VSE Optional Programs

You install optional programs after initial installation or FSU by using dialogs. It is recommended to use the dialogs since they support selective installation from tape. z/VSE provides dialogs for installing optional programs that are shipped in either the Version 2 (V2) or the Version 1 (V1) format. Most IBM programs you can order for z/VSE are V2 programs. Such programs are shipped in the library format introduced with VSE/Advanced Functions Version 2. **All z/VSE optional programs are distributed in the V2 format.**

For installation, select first the *Install Programs - V2 Format* dialog and then the *Install Program(s) from Tape* dialog. Refer to the *z/VSE Installation* for further details.

---

## Further Installation and Customization Tasks

### Installation Tasks

#### Installing z/VSE under VM

Basically, an initial installation of z/VSE on a VM system works just like an installation in LPAR mode. Before installing z/VSE, you must first prepare the VM host as described in Chapter 8, “Running z/VSE Under VM,” on page 127.

#### Installing the Generation Feature

The z/VSE distribution tape or cartridge contains source code which provides generation capability for the supervisor. The installation of this code is optional. To install the source code, z/VSE provides the *Install Generation Feature* dialog. With the installed source code you can:

- Generate a listing of the supervisor.
- Regenerate the supervisor to include your own macros.

## Customization Tasks

Once you have installed z/VSE, a number of customization tasks may be required to tailor z/VSE to your specific needs. For example:

### Adding a Second CICS Transaction Server

z/VSE offers a second predefined CICS Transaction Server. It is designed for use as a “production” system, providing an adequate base for running your applications. The primary CICS Transaction Server offers Interactive Interface support through VSE/ICCF, which the second CICS Transaction Server does not have.

Refer to “Installing a Second CICS Transaction Server” on page 200 for details.

---

## VTAM 4.2 Storage Requirements

VTAM 4.2, which is part of z/VSE, has specific storage requirements as discussed below.

### VTAM 31-Bit I/O Buffer Support

From z/VSE 3.1 plus PTF onwards, the VTAM I/O buffers (IOBUF) can use 31-bit system GETVIS storage, instead of 24-bit system GETVIS storage. Using 31-bit I/O buffers, you can increase your communication workloads.

To take advantage of this support, you must:

- Specify IOBUF31=YES (from z/VSE 4.1 onwards, the default) in VTAM startup book ATCSTR00.B contained in library PRD2.CONFIG.
- Ensure you have enough copy blocks defined, as otherwise VTAM startup might fail.
  - For local non-SNA terminals, such as terminals used under VM, moving I/O buffers in 31-bit storage requires about 4 copy blocks for each terminal.
  - Depending on the number of local non-SNA terminals you have in your z/VSE system, the default number of copy blocks (1500) might not be sufficient.
  - To change the default number of copy blocks, use the IPL SYS BUFSIZE command.

### SVA Size

The size of the SVA as shipped is:

```
SVA PSIZE=(652K,6M),SDL=700,GETVIS=(768K,6M)
```

This value must be increased if user programs or vendor programs are additionally loaded into the SVA. The above values cover all base programs including the High Level Assembler, REXX, CICS, VTAM, TCP/IP, and LE/VSE where about 1 MB is left in the SVA (31-bit) area for user purposes.

## Data Space Sizes for VTAM

### 1. General Requirements

VTAM requires 1 MB for initialization and in addition 1 MB for each partition running VTAM applications. This would mean, for example, if VSE/POWER with PNET and a VTAM line is used:

1 MB for VTAM, 1 MB for VSE/POWER, and 1 MB for CICS

That is, in an environment with VSE/POWER and PNET, 3 MB are needed as minimum. Without VSE/POWER and PNET, 2 MB is the minimum since CICS always needs VTAM. The first data space (1 MB) is used by VTAM itself, the second data space is created when the ACB for CICS is opened. If there are VTAM user applications active, for each partition running such applications, 1 MB has to be added.

### 2. Maximum Value for VTAM Data Spaces

There is a maximum size for VTAM data spaces which may be specified either through the DFSIZE operand of the SYSDEF statement or by the DSPACE parameter of the EXEC job control statement. VTAM expands data spaces in 1 MB increments up to this specified limit.

The DFSIZE is a global value for all VTAM applications (but only VTAM applications), private usage of data spaces is not affected. The value specified in the EXEC JCL statement is only for the related application and it overrides the DFSIZE specification. If DFSIZE is smaller than 1 MB, VTAM will take 1 MB.

The IBM provided settings are: VTAM, CICS and VSE/POWER have a DSPACE parameter of 2 MB. DFSIZE is not used. The maximum of 2 MB will be sufficient in most cases; if many different request unit sizes (RU sizes) are used, we recommend to change the maximum size to 3 MB.

The DSPACE parameter in the VTAM startup job limits the size for the VTAM data space that supports the VTAM Control Point application. It does not set a maximum for data spaces that VTAM gets for the support of other applications. It is the maximum value of data space VTAM can obtain for itself from the z/VSE system data space pool. The DSPACE parameter in an application startup job limits the value of data space which can be used by VTAM to support this specific application.

### 3. How VTAM uses Data Spaces

The default size allocated is 1 MB for each partition. From the first 1 MB data space, 0.25 MB is used for data space management, the remainder is also divided into 0.25 MB segments and is reclaimed as needed. There are two major considerations when trying to estimate the size needed for VTAM data spaces:

- a. The range of sizes of the request units (RU) being received by applications in the partition.
- b. The number of RUs that have to be queued because the application does not have RECEIVE RPLs issued to read incoming RUs.

There are 10 possible different RU size groups. Each group will obtain a 0.25 MB segment when the first RU of this size is queued. The groups have the following size limits (in hexadecimal):

GROUP	1	2	3	4	5	6	7	8	9	10
SIZE (upper limit)	78	F8	1F8	3F8	7F8	FF8	1FF8	7DF8	FBF8	10108

3 MB of data space would allow to have RUs of all 10 groups (0.25 MB would be left). A data space of 2 MB would allow 7 groups, a 1 MB data space could only have 3 different groups. If one 0.25 MB segment is filled up with RUs not being processed (which means the RUs are not received), the related segment will be extended by another 0.25 MB segment if further RUs need to be stored for this group. The first 0.25 MB segment reclaimed is not freed till VTAM is shut down; additionally used segments for a certain group are freed if no longer used. This means that the maximum size of the data space needed for VTAM and its applications varies and VTAM extends dynamically.

#### 4. Detailed Calculation

Minimum size used = 1 + N1 + N2 + N3 (MB)

where N1 is the number of VTAM applications using RUs with sizes of 3 different groups

N2 is the number of VTAM applications using RUs with sizes of 4 to 7 different groups

N3 is the number of VTAM applications using RUs with sizes of 7 to 10 different groups

The above minimum size is the minimum value that should be specified in the DSIZE operand of the SYSDEF command.

#### 5. How to Verify the Settings

The total amount of storage available for data spaces is limited through the DSIZE parameter of the SYSDEF command. The predefined environment A has a DSIZE value of 15 MB, predefined environment B has one of 20 MB, and predefined environment C has one of 256 MB.

In case data compression is used, 2 MB of data space are needed additionally. This data space may extend by another 2 MB if needed. The DSIZE parameter should be increased accordingly if data compression is used.

The value of DSIZE should be the sum of all VTAM related data spaces, virtual disks, and private data spaces used in the system. We recommend to start with a higher DSIZE value than calculated and adjust the value according to the space actually used. The QUERY DSPACE command displays the usage of data spaces. For details, refer to the *z/VSE System Control Statements*, SC34-2637.

#### 6. Changing the Data Space Size

If the maximum value of the data space size used by VTAM needs to be changed, the related EXEC statement has to be modified:

```
// EXEC ISTINCVT,SIZE=ISTINCVT,PARM='CUSTNO=...',DSPACE=2M
```

This change is in VTAMSTRT - use skeleton SKVTAM. For the other VTAM applications proceed accordingly.

If the global value is to be used, change the SYSDEF command in the ALLOC procedure using the related skeleton SKALLOCx where x is the environment character A, B, or C.

**Note:** Do not add the SYSDEF command to your IPL procedure, the subsequently called ALLOC procedure will reset such a specification. If you need it in the IPL procedure, for example if you use a virtual disk for the label area, be sure that you have the same values specified in the ALLOC procedure or that you have deleted the SYSDEF command there.

### Verifying Storage Allocations and Buffer Definitions

It is recommended to check storage allocations and buffer definitions and adjust them if necessary. The following commands are useful for finding out the current system values.

#### 1. System Information

```
GETVIS F3
```

Shows the usage of the 24-Bit and 31-Bit GETVIS area in the VTAM partition F3.

```
MAP F3
```

Displays allocation information about VTAM partition F3.

#### 2. VTAM Information

```
D NET,BFRUSE
```

Displays information about all the buffers and the usage of the 24-Bit and 31-Bit system GETVIS area.

```
D NET,VTAMOPTS
```

Displays information about all startup options.

```
D NET,STATS,TYPE=VTAM
```

Displays information about the VTAM network.

```
D NET,STORUSE,DSPNAME=*
```

Displays information about all data spaces accessed by VTAM.

```
D NET,STORUSE,APPL=appl-name
```

Displays information about the data space accessed by VTAM for the application identified by appl-name.

```
D NET,STORUSE,POOL=*
```

Displays usage information about all VTAM storage pools.

```
D NET,VTAMOPTS,OPT=IOBUF31
```

Displays whether or not I/O buffer usage above the 16 MB line is active (for 31-bit GETVIS).



---

## Chapter 6. Migrating From Earlier Releases

This chapter provides an overview of how to migrate your z/VSE system to z/VSE 5.1.

The migration involves transferring z/VSE **hardware configuration** and **user profile** data stored in the VSE/ICCF DTSFILE and the z/VSE control file to the z/VSE 5.1 system. In addition, there are various migration tasks to be done depending on your system setup and the z/VSE version and release you are currently using.

This chapter contains these main topics:

- “Ways of Performing the Migration”
- “Overview of the Migration Steps”
- “Migration Programs and Utilities You Can Use” on page 101
- “Additional Possible Migration Items” on page 101
- “Migrating From Releases Older Than z/VSE 4.2.x” on page 102
- “Migrating User-Defined System Information” on page 103
- “z/VSE-Supplied CICS CSD TYPETERM Definitions” on page 105

**Note:** This chapter does not apply if you are performing a *service refresh* from one modification level to a later modification level of the *same* z/VSE release.

---

### Ways of Performing the Migration

Existing VSE system information can be migrated to z/VSE 5.1 as follows:

1. Migrating during initial installation

In this way, you can migrate hardware information as well as VSE.CONTROL.FILE and VSE/ICCF DTSFILE information. This means that you need as input for initial installation a copy of the DTSFILE and the control file of your **old system** on separate tape volumes. Refer to “Overview of the Migration Steps” for an outline of the tasks involved.

2. Migrating after initial installation

This method is not recommended since it allows you to migrate VSE.CONTROL.FILE and DTSFILE information but **not** your hardware information.

---

### Overview of the Migration Steps

To migrate to z/VSE 5.1, you need:

- A backup copy on tape of your current VSE/ICCF DTSFILE created with the VSE/ICCF utility program DTSUTIL. It is recommended to use the *Backup/Restore Library Objects* dialog. The volume serial number of the tape must be ICCF01.
- A VSE/VSAM backup copy on tape (must be of the same device type as used for initial installation) of your current VSE.CONTROL.FILE created with the REPRO command (which **must** be used). The following should be specified:
  - RECORD FORMAT=variable-length blocked records
  - BLOCK SIZE=4000

## Migrating

Following is a job stream with the *VSE/VSAM REPRO* command. You can create a similar job stream by using the *Display and Process a File* dialog and select option 4 (COPY).

```
* $$ JOB JNM=COPYCNTL,CLASS=A,DISP=D,NTFY=YES
// JOB COPYCNTL COPY 'VSE.CONTROL.FILE'
// DLBL COPYIN,'VSE.CONTROL.FILE',,VSAM, X
      CAT=VSESPUC
// TLBL COPYOUT,'REPRO.CNTRL.FILE',,CF0001
// ASSGN SYS005,cuu
// EXEC IDCAMS,SIZE=AUTO
  REPRO INFILE (COPYIN) -
        OUTFILE (COPYOUT -
                ENVIRONMENT (BLOCKSIZE (4000 ) -
                            RECORDFORMAT (VARBLK) -
                            STDLABEL -
                            PRIMEDATADEVICE (2400) REW)) -
        NOREUSE
/*
/&
* $$ E0J
```

In the job stream example, the volume serial number is CF0001 which must be used.

The tapes you use for backup must be of the same type as the distribution tape(s) you received. Refer to “Backing Up and Restoring Data” in the *z/VSE Operation* for information on how to create backup copies.

You can migrate your

hardware configuration and

your user profiles (up to 199 VSE/ICCF users and their library names)

by answering 'YES' to the migration question displayed on the system console during initial installation. Keep in mind that the migration performed during initial installation is a *predefined migration*. If you want to migrate **after initial installation**, you can use the migration utility IESBLDUP introduced under “Migration Programs and Utilities You Can Use” on page 101 to migrate the control file information.

After migration you must do the following:

- Assemble and catalog the migrated hardware tables. You do this by invoking the *Hardware Configuration* dialog in your newly installed system. Devices which are no longer supported by the *z/VSE* dialogs or which are not identified uniquely are displayed on the *Unidentified Device List* panel. Verify the migrated tables and execute the function by pressing PF5 (PROCESS).
- Validate and process the migrated VTAM startup options and VTAM APPLIDs. You do this by invoking the dialogs *Maintain Startup Options* and *Maintain VTAM Application Names*.
- Users that were migrated during initial installation using either the MIGRAT Job or using the IESBLDUP utility, must be given a security definition. To do so, you use the administrator fast path **282** (*BSM Group Maintenance*) to add the migrated users to their corresponding security groups. For details, refer to the chapter “Protecting Resources via BSM Dialogs” in the *z/VSE Administration*.

---

## Migration Programs and Utilities You Can Use

z/VSE provides a number of migration programs and utilities to help you perform migration. You can use:

- The utility program *IESBLDUP* to migrate user profile information to the new system. The utility can be used, for example, if you did not migrate this information during initial installation. “Overview of *IESBLDUP*” provided an overview of this utility program.
- The dialogs of the Interactive Interface to back up and restore libraries and VSE/VSAM files. Refer to the *z/VSE Operation* for details.
- VSE/POWER's POFFLOAD facility to save and later reload jobs and output in the VSE/POWER queues. Refer to “POFFLOAD: Writing Queue Entries to Tape and Restoring” in the *VSE/POWER Administration and Operation* for details.
- The program *BSTADMIN* to migrate your CICS transaction security definitions. Refer to “Migrating CICS Transaction Security Definitions” in the *z/VSE Administration*.

### Overview of *IESBLDUP*

The utility program *IESBLDUP* helps z/VSE users migrate old VSE control file data such as user profiles, application profiles, and selection panels (but not VSE/ICCF user libraries) to the new system.

To do this, you must first create copies of the following resources on your old system:

- A copy of the VSE control file.
- A copy of the VSE/ICCF *DTSFILE*.

*IESBLDUP* uses these files as input and updates the user profile information of the new VSE control file. In addition, it creates the job *DTRMIGR*, and places *DTRMIGR* into the VSE/POWER reader queue. Job *DTRMIGR* is automatically processed and invokes the VSE/ICCF utility *DTSUTIL* to:

- Add new user profiles to the new VSE/ICCF *DTSFILE*.
- Alter VSE/ICCF *DTSFILE* options that are incompatible with VSE/ESA Version 1.

*IESBLDUP* must run in a batch partition controlled by VSE/POWER.

**Note:** You can also use *IESBLDUP* to create a *status report* of your system's users. Such a report lists all user-IDs and related data defined in the VSE control file and VSE/ICCF *DTSFILE*. It thus provides valuable information for maintaining user profiles and data.

The *z/VSE Installation* provides a detailed description of the *IESBLDUP* program.

---

## Additional Possible Migration Items

When migrating to z/VSE 5.1, you should consider these possible additional migration items:

- Depending upon whether you have implemented the latest BSM security concepts or not, you might have to migrate file *VSE.BSTCNTL.FILE*. To do so, you use the skeleton *SKBSTSAV* contained in ICCF library 59. For further details, refer to “Migrating CICS Transaction Security Definitions” in the *z/VSE Administration*, SC34-2627.

## Migrating

- VSE/POWER 9.1 (as part of z/VSE 5.1) cannot coexist with previous levels of VSE/POWER in a shared spooling environment. All systems must be of the same level.
- If you are currently using LDAP-enabled user-IDs in your z/VSE system, you might need to migrate the user mappings contained in the LDAP mapping file of your previous z/VSE system. For details, refer to “Maintaining User Profiles in an LDAP Environment” in the *z/VSE Administration*, SC34-2627.
- You can install the latest VSE Java Parts for z/VSE 5.1 on your workstations either from the Extended Base Tape which is used to ship the VSE Connectors Workstation Code component, or via the “downloads” section of the *z/VSE Home Page*:

<http://www.ibm.com/servers/eserver/zseries/zvse/downloads/>

These are the components you might need to install:

- VSE Connector Client
- VSE Script Server
- VSE Redirector Server
- VTAPE Server

For further details, refer to “How the VSE Connector Components Are Installed” on page 145

- If you are currently using any of these downloadable components, check you have the latest versions:
  - VSE Navigator
  - VSAM Maptool
  - TCP/IP Configuration Dialog
  - VSEPrint Utility
  - Keyman/VSE
  - VSE Heath Checker
  - VSE System Class Library
  - CICS2WS Toolkit
  - WebSphere® MQ Client for VSE

These components are obtainable from the *z/VSE Home Page* (the URL is given above).

For a description of *all* new and changed functions which might involve further migration items, refer to the *z/VSE Release Guide*, SC34-2636

---

## Migrating From Releases Older Than z/VSE 4.2.x

For information about how to migrate from a VSE release that is older than z/VSE 4.2.x, refer to:

- The edition of the *VSE Planning* that was supplied with that older VSE release.
- The edition of the *VSE Installation* that was supplied with that older VSE release.
- The information contained in “Migrating CICS Transaction Security Definitions” of the current *z/VSE Administration*.

## Migrating User-Defined System Information

The system sublibrary (IJSYSRS.SYSLIB) of your z/VSE system may include user-defined system information. Examples of such information are:

- FCB- and UCB-image phases of your own stored by the IBM standard names.
- Label information.
- Private SVA load lists.

Any such information is lost if you simply perform **initial installation**. To avoid this, proceed as outlined below.

**Note:** Numbers within parentheses in front of individual statements refer to additional information under “Explanations to Sample Jobs” on page 105.

### 1. Produce a backup copy of sublibrary PRD2.SAVE

This step assumes that you had defined and processed your FCB- and UCB-image phases, using the Interactive Interface of z/VSE as described in the *z/VSE Administration*. In that case, these phases were saved in the sublibrary PRD2.SAVE of your system. Perform this step on your current VSE system.

To produce the backup, either use the *Backup/Restore Library Objects* dialog with *Backup VSE Library on Tape* or run a job similar to the sample below.

```
// JOB BACKUP PRD2.SAVE SUBLIBRARY
// MTC REW, cuu
// EXEC LIBR
(1) BACKUP S=PRD2.SAVE TAPE=cuu
/*
/ &
```

This step saves all control information stored in your PRD2.SAVE library.

If, because of a locally defined procedure, this control information is not stored in the sublibrary PRD2.SAVE, produce a backup of the system sublibrary. The corresponding BACKUP statement would be:

```
BACKUP S=IJSYSRS.SYSLIB TAPE=cuu
```

As concerns label information stored on the system residence volume, ensure that your original load procedures are stored in a sublibrary on a private volume.

### 2. Edit your JCL ASI and label procedures

Do this after having performed the first system startup with the newly installed refresh release. This is a multi-step process as follows:

- Restore the sublibrary PRD2.SAVE into a separate sublibrary. Either use the *Backup/Restore Library Objects* dialog with *Restore VSE Library from Tape* or run a job similar to the sample below.

```
// JOB RESTORE PRD2.SAVE
// MTC REW, cuu
// EXEC LIBR, PARM='MSHP'
(2) RESTORE S=PRD2.SAVE:PRD2.SAVEOLD TAPE=cuu DATE=OLD
/*
/ &
```

If there was a need to backup your system sublibrary, replace the librarian RESTORE command by a number of selective restore requests. Each of your restore requests would have to specify the generic name of the procedures that are to be restored. The librarian RESTORE command is described in your *z/VSE System Control Statements* under “RESTORE”.

- Select VSE/ICCF command mode.

- c. Punch, into your primary VSE/ICCF library, the startup procedures that you want to migrate. To do this, use the LIBRP command as shown:

```
LIBRP PRD2.SAVEOLD vsemembername.PROC iccfmembername
```

If you have used the default names for your z/VSE startup procedures, you may have to issue such a request for each of the following procedures:

**ALLOC** If you changed the partition allocations.

**\$0JCL** If you changed the startup procedure for BG.

**\$1JCL** If you changed the startup procedure for the VSE/POWER partition.

**POWSTRT**

If you changed the VSE/POWER autostart procedure.

**Any of \$2JCL through \$BJCL**

If you changed the startup procedures for partition F2 through FB.

**STDLABEL and STDLABUP**

Get the new label procedures and edit them to get your own label definitions into the procedures.

Use the corresponding names of your own choice if you have not used the IBM standard names.

- d. Ensure that IBM supplied specifications relating to new support (if any) will be included in the procedures that are to be migrated.
- e. Verify your changes – on a test system, if possible.  
Perform step 3 on a test system rather than on your system for normal operation and subsequently start up the test system.
- f. Return the edited procedures to the sublibrary from which they were punched into your VSE/ICCF library.

Use LIBRC macro requests to accomplish this. The macro works in a way similar to the LIBRP macro but in reverse direction.

**3. Restore the procedures to the system sublibrary**

Copy the edited procedures to the system sublibrary. Use a job similar to the one shown below:

```
// JOB COPY PROCEDURES
// EXEC LIBR,PARM='MSHP'
CONNECT S=PRD2.SAVEOLD:IJSYSRS.SYSLIB
(3) COPY vsemembername.PROC REPLACE=YES DATE=OLD
/*
/&
```

**4. Restore the FCB and UCB-image phases**

If you use the interactive interface, do an administrator fast path selection of **3722** and provide the required control information.

If you do not use the interactive interface, run a job similar to the one below:

```
// JOB RESTORE FCB PHASES
// MTC REW, cuu
// EXEC LIBR,PARM='MSHP'
(4) RESTORE PRD2.SAVE.$$BFCB*.PHASE : IJSYSRS.SYSLIB -
    TAPE=cuu REPLACE=YES DATE=OLD
(5) RESTORE PRD2.SAVE.$$BUCB*.PHASE : IJSYSRS.SYSLIB -
    TAPE=cuu REPLACE=YES DATE=OLD
/*
/&
```

**5. Make the changes effective**

IPL the modified system to make the changes effective.

## Explanations to Sample Jobs

- (1) Replace the tape-drive address (TAPE=cuu) by the address of the tape drive on which you mounted the backup tape. Use an unlabeled scratch tape.
- (2) You may replace PRD2.SAVEOLD by the qualified name of an existing sublibrary of your own choice to temporarily store the information you want to migrate.  
  
Replace the tape-drive address by the address of the tape drive on which you mounted the backup tape.
- (3) You must submit one such statement for each distinct (generic) member name.
- (4) This librarian step restores the previously saved FCB-image phases. The IBM supplied FCB-image phases are overwritten. In the command, replace the tape drive address by the address of the tape drive on which you mounted the backup tape.
- (5) This step is not required if your printer automatically loads the correct image into its UCB from internal storage, such as does the IBM 4248, for example.

---

## z/VSE-Supplied CICS CSD TYPETERM Definitions

The Interactive Interface dialogs store the terminal definitions for VTAM users in the **CICS System Definition (CSD)** file.

There is no TCT support available with the CICS Transaction Server. A CICS terminal definition in the CSD consists of two parts:

The type terminal definition (DEFINE TYPETERM).

The terminal definition (DEFINE TERMINAL).

**One** CICS parameter table has **two** corresponding CSD TYPETERM definitions. One is for SNA, the other one for non-SNA definitions. Table 29 lists the VSE/SP Version 4 CICS table names and the migrated z/VSE CSD TYPETERM definitions provided as models.

*Table 29. Mapping of CICS Parameter Table Names to CSD TYPETERM Definitions*

Table name	CSD non-SNA	CSD SNA	Remarks
D3178	VSE32782	VSELU2A	DSCRS = 24,80 PAGE (AUDALARM)
D3179	VSE32792	VSELU2E	(COLOR EXTDS HILIGHT)
D3277	VSE3277	VSELU2A	DPGES = 24,80 PAGE (AUDALARM)
D32782	VSE32782	VSELU2A	DSCRS = 24,80 PAGE (AUDALARM)
D32783	VSE32783	VSELU2B	ASCRS = 32,80
D32784	VSE32784	VSELU2C	ASCRS = 43,80
D32785	VSE32785	VSELU2D	ASCRS = 27,132
D3279S2A	VSE32782	VSELU2A	-
D3279S2B	VSE32792	VSELU2E	(COLOR EXTDS HILIGHT)
D3279S3A	VSE32783	VSELU2B	ASCRS = 32,80
D3279S3B	VSE32793	VSELU2F	ASCRS = 32,80 (COLOR EXTDS HILIGHT)

Table 29. Mapping of CICS Parameter Table Names to CSD TYPETERM Definitions (continued)

Table name	CSD non-SNA	CSD SNA	Remarks
D3279S3G	VSE3279G	VSELU2G	ASCRS = 32,80 (COLOR EXTDS HILIGHT PS)
D32792X	VSE32782	VSELU2A	-
D32793X	VSE32783	VSELU2B	ASCRS = 32,80
D3290	VSE3290	VSELU2I	ASCRS = 62,160
D5550	VSE5555	VSELU2H	(COLOR EXTDS HILIGHT PS KATAKANA SOSI OUTLINE)
P3262	VSEDSCP	VSELU3	DPGES = 24,80 AUTOPAGE
P3268	VSEDSCP	VSESCS	—
P3287	VSEDSCP	VSELU3	—
P3287C	VSEDSCP	VSESCS	—
P3289	VSEDSCP	VSELU3	—
P5210	VSEDSCP	VSESCS	—
P555X	VSE3278	VSELU2	(PS OUTLINE SOSI)

## User-Defined and Modified CICS Parameter Tables

For user-defined and modified CICS parameter tables the z/VSE migration program defines new TYPETERM definitions (during initial installation). These definitions are stored into a CSD group with the group name VSETYPE1. The group VSETYPE1 is exclusively used by z/VSE.

## Migrating Device Definitions

When you log on with the user-ID POST and have selected *migration* during initial installation, your previously made hardware configurations are checked by the migration program.

Depending on how many devices you had defined in your previous system, this step may take some time. Do **not** interrupt this process after the message has been displayed:

```
INPUT ACCEPTED. PLEASE WAIT.
```

For devices that are no longer supported under z/VSE you get an *Unidentified Device List* panel. In this panel, the unsupported device addresses are displayed with question marks. If you get this panel, redefine or delete the devices which show question marks. The following message also appears on the *Unidentified Device List* panel:

```
JOB HAS BEEN SUBMITTED AND FILED AS CSDMIGR
```

This job is stored in VSE/ICCF library 10.

For information about how to continue, refer to “Completing Initial Installation” in the *z/VSE Installation*.

To migrate your previously configured hardware, you must at least once enter the *Hardware Configuration* dialog. Select fast path 241 to get to the *Unit Address List* panel. The system may display another unidentified device list for devices which



are not defined uniquely. You can define or delete them using the dialog. Once you press **PF5** (PROCESS), your hardware specifications are stored in the CICS CSD File.



---

## Chapter 7. Files and Libraries

This chapter describes the files and libraries that are used with z/VSE. It contains these main topics:

- “Standard Label Procedures.”
- “System Files” on page 110.
- “Predefined z/VSE Libraries” on page 116.
- “VSE Libraries” on page 116.
- “VSE/ICCF Libraries” on page 123.
- “Planning for Private Files” on page 124.
- “Planning for Private VSE Libraries” on page 125.

---

### Standard Label Procedures

Labels and the information they contain serve to identify and describe files stored on disk devices, or, less frequently, stored on tape. In this context, a library is considered to be a file. In a job stream, label information is provided through DLBL and EXTENT statements for disk devices, and files on tape are identified through a TLBL statement. The following publications provide background information on file and label processing:

*z/VSE System Macros User's Guide*  
*z/VSE Guide to System Functions*  
*z/VSE System Control Statements*

As outlined below, z/VSE uses three standard procedures for maintaining label information in the system's label information area. The area itself is divided into the subareas STDLABEL and PARSTD. STDLABEL identifies the **system** standard subarea and PARSTD the **partition** standard subarea. Both, STDLABEL and PARSTD are parameters of the JCL OPTION statement.

z/VSE provides and uses the following standard label procedures:

- **STDLABEL.PROC**

This procedure is automatically created during initial installation. It is based on the disk device type (of DOSRES and SYSWK1) you use for installation, and it contains labels for all **non-VSE/VSAM** system files.

The startup procedure for the BG partition (\$0JCL) executes STDLABEL.PROC. You should modify STDLABEL.PROC only if you extend a system file, for example.

- **STDLABUP.PROC**

This procedure is used for labels of **VSE/VSAM** system files only. These are labels for files that:

- Are created automatically during installation.
- You define using the Interactive Interface.

When you use the dialogs for defining or deleting VSE/VSAM files, the jobs created by the dialog automatically update the STDLABUP procedure.

**Note:** If you define VSE/VSAM files without using the Interactive Interface (but through editing job streams), you should not use EXTENT statements. The reason is that all these files are deleted from STDLABUP.PROC when you use the Interactive Interface for file creation next time.

## Standard Label Procedures

The STDLABEL procedure executes STDLABUP.PROC.

- **STDLABUS.PROC**

z/VSE provides the STDLABUS skeleton in VSE/ICCF library 59. You can use this skeleton to include standard labels for non-VSE/VSAM user files.

The STDLABEL procedure executes the STDLABUS.PROC.

z/VSE initially provides a dummy STDLABUS procedure in IJSYSRS. “Creating Standard Labels for Non-VSE/VSAM Files” in the *z/VSE Administration* describes how to use the supplied skeleton (STDLABUS) to create labels for non-VSE/VSAM files.

---

## System Files

System files reside on the system disks DOSRES and SYSWK1 and are discussed on the following pages.

Appendix B, “z/VSE Disk Layouts (DOSRES, SYSWK1),” on page 277 shows the layouts of DOSRES and SYSWK1 for all the disk device types supported for initial installation.

## System File Assignments

z/VSE supplies procedures which contain the assignments for key system files. These are automatically invoked by the startup job stream and by other z/VSE job streams. You should change them only if you move the corresponding files.

*Table 30. Procedures for System File Assignments*

PROCEDURE:	ASSIGNMENT:	FOR:
DTRICCF.PROC	SYS010	VSE/ICCF DTSFILE
DTRPOWR.PROC	SYS000 to SYS002	VSE/POWER
DTRINFOA.PROC	SYS016 to SYS017	Info/Analysis work files
DTRCICST.PROC	SYS018	CICS SD files
	SYS001 to SYS002	Work files for DTSANALS to recover DTSFILE

## Requirements for VSE/POWER Files

### VSE/POWER Queue File

The disk space requirements for the VSE/POWER queue file on DOSRES (VSE.POWER.QUEUE.FILE) are directly related to the number of queue file entries you plan to hold at one time. For an extension of the queue file, free space is provided right after the queue file location on DOSRES.

Refer to “Estimating Disk Space for the VSE/POWER Spool Files” in the *VSE/POWER Administration and Operation* for more information.

For performance reasons, it is recommended that the VSE/POWER queue file resides in the partition GETVIS area in storage. This must be reflected in the value specified for the partition size. The storage copy of the Queue File is placed into the VSE/POWER partition GETVIS-31 storage, as soon as the partition ALLOC provides GETVIS space beyond the 16 MB line.

## VSE/POWER Data File

Table 31 shows possible allocations for the VSE/POWER data file on SYSWK1 (VSE.POWER.DATA.FILE). These values are shown for the disk devices supported for initial installation. The DBLK (data block) size corresponds to the physical record size of the data file on disk. The DBLK influences the VSE/POWER spooling performance and is a parameter of the VSE/POWER generation macro (for details, refer to the chapter “Regenerating the Supervisor, VSE/POWER, or VSE/ICCF” in the *z/VSE Administration*).

It is possible to extend the data file during a WARM start of VSE/POWER. For details, refer to the *z/VSE Administration*.

Table 31. Examples of DBLK Sizes and Default DBLK

Device Type	DBLK (Sizes in Bytes)	DBLK/Track	Bytes/Track Used	Minimum 80-Cards/DBLK	Minimum 132-Lines/DBLK	Default DBLK used by VSE/POWER (in Bytes)
3380	3860	11	42460	44	28	7476
	4276	10	42760	49	31	
	6356	7	44492	73	45	
	7476	6	44856	85	54	
	11476	4	45904	131	82	
	15476	3	46428	176	111	
	23476	2	46952	267	168	
3390	4566	11	50226	52	32	7548
	5726	9	51534	65	41	
	7548	7	52836	86	54	
	10796	5	53980	123	78	
	13682	4	54728	156	98	
	18452	3	55356	210	132	
	27998	2	55886	319	200	
SCSI (FBA)	4096	---	---	46	29	7680
	7680	---	---	87	54	
	15360	---	---	174	109	
	23040	---	---	261	164	
	30720	---	---	349	219	

The default value of DBLK as used in the pregenerated IPWPOWER phase, is about 7500 for the common disk device types. You can use the DBLK operand of the VSE/POWER generation macro, or the SET DBLK statement in the VSE/POWER startup procedure to modify the DBLK value which is to be activated with a COLD startup.

The maximum DBLK value for CKD and FBA disk devices is 65024 bytes.

### Notes:

1. If you use shared spooling, consider the following:
  - Place the queue and data files on separate shared disks and not on the same actuator as the lock file.

## System Files

- Define multiple extent data files on multiple actuators.
2. The *z/VSE Administration* under “Extending VSE/POWER Files” explains how to extend the space reserved for the VSE/POWER files. Only do this, however, when absolutely necessary. Incorrect specifications will most likely cause startup problems.
  3. The optimal performance is reached if you use the highest allocation values for the DBLK size, as shown in Table 31 on page 111.

## VSE/ICCF DTSFILE

The VSE/ICCF DTSFILE includes the VSE/ICCF libraries (file ICCFLIBRARY on SYSWK1). Refer to “VSE/ICCF Libraries” on page 123 for further details about these libraries.

## System Work Files

Note that it is possible to place workfiles on a virtual disk. Refer to “Defining Work Files on a Virtual Disk” on page 115 for details.

The following is important for system work files:

- All work files are allocated in VSAM-managed space including, for example:
  - The VSE/ICCF work files IKSYS11 to IKSYS54.
  - A standard SORT work file (SORTWK1) for which you should ensure that the allocation is sufficient for your sort requirements.
  - The work files IJSYS01 to IJSYS07 for use by compilers.
- All work file labels are part of the system standard labels (procedure STDLABUP.PROC). Refer also to “Standard Label Procedures” on page 109.

### Notes:

1. Files defined implicitly by the system, such as SORTWK1, cannot be redefined (EXTENTs) through the Interactive Interface. They can be changed only by editing the job stream.
2. If system work files are defined on virtual disk, you must also define a user catalog for them on the same virtual disk.

## VSE Control File

The VSE control file (VSE.CONTROL.FILE) is the central repository file for system access information for the Interactive Interface and CICS TS. It contains records such as:

- User profile records
- Selection panel records
- Application profile records
- Synonym records
- News records (messages displayed to users after they sign on)

The user profile information provides coordination between VSE/ICCF and the Interactive Interface.

Shareoption 4, which allows multiple write access, is required.

The control file is also accessed by the Basic Security Manager (BSM). Only one control file can be part of the system.

## BSM Control File

The BSM control file (VSE.BSTCNTL.FILE) is used by the *Basic Security Manager* (BSM) for security information (security settings and resource profiles). The BSM control file (introduced with z/VSE V3R1.1) allows you to protect not only CICS transactions, but also CICS RSL resources, applications, and facilities.

The use of the BSM control file succeeds the previous method of protecting CICS transactions using the table DTSECTXN. If you wish to protect your CICS transactions using BSM resource profiles, you must migrate any CICS transaction data from tables DTSECTXN and DTSECTXM to the BSM control file.

For details of the latest BSM security, how to migrate CICS TS security data to the BSM control file, and how to administer CICS/general resources using BSM commands/dialogs, refer to the *z/VSE Administration*, SC34-2627.

## LDAP Mapping File

The *LDAP mapping file* is a VSAM KSDS file that is used to store user-ID mappings. It is automatically defined during the installation of z/VSE. The LDAP mapping file contains:

- Records containing user-IDs that are to be used for *LDAP-authentication*, in which a mapping of a long-user-ID (used in the LDAP environment) to a short-user-ID (used in z/VSE) is done. These user-IDs are referred to as being *LDAP-enabled*.
- Records containing user-IDs that are not used for LDAP-authentication (for example, the SYSA user-ID). These user-IDs are referred to as being *not LDAP-enabled*, and these users can sign on to z/VSE even if the LDAP server is not operational.

For further details, refer to “Maintaining User Profiles in an LDAP Environment” in the *z/VSE Administration*, SC34-2627.

## Text Repository File

The text repository file (VSE.TEXT.REPSTORY.FILE) contains Interactive Interface information such as HELP text and messages which the Interactive Interface dialogs display. You can redefine this system file using skeleton SKRSTRFL.

## Online Messages File

The online messages file (VSE.MESSAGES.ONLINE) must be in the VSE/VSAM master catalog. It contains console messages which may be issued by z/VSE component programs. Via the *System Console* dialog, you can request an explanation of a console message online at your display station. You can redefine this system file using skeleton SKOMERST.

## Message Routing File

The messages routing file (VSE.MESSAGE.ROUTING.FILE) supports the exchange of messages between the system and its Interactive Interface users. Messages sent by the system to a user are stored in this file. They can be retrieved by the user after notification.

When a user retrieves a message, it is deleted from the file. If a user is not signed on, the system keeps any messages for that user in the file until a sign on is performed. To avoid a possible overflow, the administrator may need to sign on for a user who is not working with the system.

## System Files

You can redefine this system file by using as an example the related job steps in source members VSAMDEFS.Z and VSAMINIT.Z.

## Other System Files

The remaining predefined system files on DOSRES and SYSWK1 are listed below.

### Non-VSE/VSAM System Files

DOS.LABEL.FILE.CPUID	(on DOSRES)
INFO.ANALYSIS.DUMP.MGNT.FILE	(on SYSWK1)
INFO.ANALYSIS.EXT.RTNS.FILE	(on SYSWK1)
VTAM.TRACE.FILE	(on SYSWK1)
VSESP.JOB.MANAGER.FILE	(on SYSWK1)
VSE.HARDCOPY.FILE	(on SYSWK1)
VSE.RECORDER.FILE	(on SYSWK1)
VSE.SYSTEM.HISTORY.FILE	(on DOSRES)
VSE.POWER.ACCOUNT.FILE	(on SYSWK1)
VSE.POWER.DATA.FILE	(on SYSWK1)
VSE.POWER.QUEUE.FILE	(on DOSRES)
WORK.HIST.FILE	(on SYSWK1)
ICCF.LIBRARY	(on SYSWK1)
CU37XX.LOAD.FILE	(on SYSWK1)
PAGING.DATA.SET.ONE	(on DOSRES)
PAGING.DATA.SET.TWO	(on DOSRES)

### Note on CICS Journaling

z/VSE provides predefined (non-VSE/VSAM) system files on DOSRES for journaling, which is optional, as follows:

#### For primary CICS Transaction Server:

CICS.SYSTEM.LOG.A  
CICS.SYSTEM.LOG.B  
CICS.USER.JOURNAL.A  
CICS.USER.JOURNAL.B

#### For secondary CICS Transaction Server:

CICS2.SYSTEM.LOG.A  
CICS2.SYSTEM.LOG.B  
CICS2.USER.JOURNAL.A  
CICS2.USER.JOURNAL.B

Refer also to “Overview on CICS Skeletons and Tables” on page 198.

### VSE/VSAM System Files

VSE/VSAM system files reside in the VSE/VSAM user catalog, **except** for the VSE.MESSAGES.ONLINE file which resides in the master catalog. The workfiles defined in the catalogs are not listed.

VSAM.MASTER.CATALOG  
VSAM.COMPRESS.CONTROL  
VSESP.USER.CATALOG  
DFHTEMP  
CICS.CSD  
CICS.RSD  
CICS.TD.INTRA  
CICS.DUMPA  
CICS.DUMPB  
CICS.AUXTRACE  
CICS.DBDCICCS.DFHDMFA  
CICS.DBDCICCS.DFHDMFB  
CICS.GCD  
CICS.LCD



```

PTF.FILE
VSE.CONTROL.FILE
VSE.BSTCNTL.FILE
VSE.LDAP.USER.MAPPING
VSE.TEXT.REPSTORY.FILE
VSE.MESSAGES.ROUTING.FILE
VSE.ONLINE.PROB.DET.FILE
VSE.VSAM.RECORD.MAPPING.DEFS
VSE.CICREX.FP01.DIR
VSE.CICREX.FP02.DIR
VSE.CICREX.FP01.FILE01
VSE.CICREX.FP02.FILE01
VSE.EZACICS.CONFIG
VSE.EZACICS.CACHE
VSE.MESSAGES.ONLINE

```

## Defining Work Files on a Virtual Disk

z/VSE offers skeleton **SKWRKFIL** in VSE/ICCF library 59 to define system work files on a virtual disk. You can create a virtual disk using the *Hardware Configuration* dialog which supports the device type FBAV for virtual disks.

The system startup must reflect the size of the virtual disk in the DSPACE settings.

Skeleton **SKWRKFIL** modifies and catalogs procedure **IESWORK** which is executed during system startup. Procedure **IESWORK** defines a user catalog (**VSEWKUC**) on the virtual disk, defines the model cluster for SAM ESDS files, and redefines the labels for the following work files:

```

IJSYS01 - IJSYS07
IKSYS21 - IKSYS24
IKSYS31 - IKSYS34
IKSYS41 - IKSYS44
IKSYS51 - IKSYS54
SORTWK1

```

The whole virtual disk is dedicated to the user catalog **VSEWKUC**.

### Implementation Details

For size flexibility, the work files are allocated in VSAM space. The size required for the virtual disk depends on the amount of partitions active at a time using work files, for example the number of partitions with compile jobs, and the average size of the work file needed. A supervisor assembly for example will need a lot of space, more than 40 MB which is 81920 blocks.

The virtual disk must be defined in the IPL procedure and the **VDISK** command must be active in the **\$0JCL** procedure. The **IESWORK** procedure must also be included in the **\$0JCL** procedure. Skeleton **SKJCL0** has comments where to add the procedure call and the **VDISK** command. To make sure that the DSPACE settings are correct, the **SKALLOCx** skeleton has to be considered for changing the size.

After defining the virtual disk, use the *Tailor IPL Procedure* dialog for increasing the **VSIZE** in the IPL procedure. Run skeletons **SKALLOCx** and **SKJCL0** to increase the DSPACE value and to modify the system startup by invoking the **IESWORK** procedure.

The size of the virtual disk must be defined individually for each z/VSE system. Suggested is a minimum of 81920 blocks which means a minimum of 40 MB.

The FSU keeps the work files in the **VSESPUC** catalog on real disk. Also, during initial installation the work files are on real disk.

## Predefined z/VSE Libraries

This topic discusses the predefined libraries shipped with z/VSE. z/VSE distinguishes two types of libraries:

### VSE Libraries

### VSE/ICCF Libraries

Predefined VSE libraries reside on the system disks DOSRES and SYSWK1 in the files:

VSE.SYSRES.LIBRARY	(BAM on DOSRES)
VSE.PRD1.LIBRARY	(VSAM in Master Catalog)
VSE.PRD2.LIBRARY	(VSAM in Master Catalog)
VSE.PRIMARY.LIBRARY	(VSAM in User Catalog)
VSE.CRYPTO.LIBRARY	(VSAM in Master Catalog)
VSE.DUMP.LIBRARY	(VSAM in Master Catalog)

You may refer to Appendix B, “z/VSE Disk Layouts (DOSRES, SYSWK1),” on page 277 for the DOSRES and SYSWK1 layout as shipped with z/VSE.

VSE/ICCF libraries reside in the VSE/ICCF DTSFILE:

ICCF.LIBRARY	(on SYSWK1)
--------------	-------------

## VSE Libraries

Table 32 lists the VSE libraries and sublibraries predefined for z/VSE.

z/VSE includes the following **system** libraries: **IJSYSRS**, **PRD1**, **PRD2**, **SYSDUMP**, and **CRYPTO**.

The **PRIMARY** library is a **private** library, but it is included here because it is created during initial installation of z/VSE.

Table 32. Overview of VSE Libraries and Sublibraries

Library	Sublibraries	Type of Space	Creation Time
IJSYSRS	SYSLIB	Non-VSAM	stand-alone restore (initial installation)
PRD1	BASE BASED	VSAM	initial installation
PRD1	MACLIB MACLIBD	VSAM	initial installation
PRD2	CONFIG	VSAM	initial installation
PRD2	SAVE	VSAM	initial installation
PRD2	COMM	VSAM	initial installation
PRD2	COMM2	VSAM	initial installation

Table 32. Overview of VSE Libraries and Sublibraries (continued)

Library	Sublibraries	Type of Space	Creation Time
PRD2	DBASE	VSAM	initial installation
PRD2	AFP	VSAM	initial installation
PRD2	PROD	VSAM	initial installation
PRD2	TCPIPB	VSAM	initial installation
PRD2	DFHDOC	VSAM	initial installation
PRD2	DB2750 DB2750C DB2STP SCEEBASE SCEEBASD	VSAM	initial installation
PRD2	DLI1A0 * ASN740 * CCF730 * RCV730 *	VSAM	installation of program(s)
PRD2	DUMP	VSAM	archive for dumps
PRD2	OSASF	VSAM	initial installation
SYSDUMP	BG F1 through FB DYN	VSAM	initial installation
PRIMARY	\$\$C	VSAM	initial installation
PRIMARY	SUF	VSAM	initial installation
PRD2	GEN1 * GEN1D *	VSAM	generation feature installation
CRYPTO	KEYRING	VSAM	initial installation

**Notes:**

1. The libraries marked (\*) are **not** defined during the initial installation of z/VSE.
2. The z/VSE base programs and optional programs installed in these sublibraries are listed in Table 14 on page 44 and Table 16 on page 48. Sublibraries with a D at the end are required for PTF application.

### IJSYSRS Library

z/VSE allocates space for IJSYSRS on the DOSRES volume. As shown above, IJSYSRS has only one sublibrary, named **SYSLIB**. IJSYSRS and IJSYSRS.SYSLIB are also referred to as **system library**. **IJSYSRS.SYSLIB** contains the following base programs:

- VSE Central Functions including:
  - VSE/SP Unique Code
  - VSE/Advanced Functions
  - VSE/POWER
  - VSE/VSAM
  - VSE/ICCF
  - VSE/Fast Copy
- ICKDSF (Device Support Facilities)

IJSYSRS is intended for those base programs which provide hardware and functional support for starting up the system. You should:

1. **Not** copy members into it, *except* for the following:
  - IPL or JCL procedures (must be in IJSYSRS for startup)
  - FCBs and UCBs
  - User exits (such as IPL and JCL exit programs)
2. **Not** move this library or change its size.
3. **Not** create another sublibrary within the library.

#### Service Aspects of IJSYSRS

Any of your own members that you catalog into IJSYSRS may be affected by a *system refresh* for z/VSE. Because of this, you should also catalog a copy of them into PRD2.SAVE. PRD2.SAVE is created during initial installation and later used for FSU only (Fast Service Upgrade). For a detailed description of the service aspects, refer also to the *z/VSE System Upgrade and Service* under “General Service Concept for z/VSE”.

#### Notes:

1. A system refresh is also referred to as a *Fast Service Upgrade (FSU)*.
2. IBM supplied members which you modify by using specific IBM supplied skeletons or dialogs may automatically be saved in PRD2.SAVE (for example, skeletons for tailoring startup procedures).
3. If you **modify other IBM supplied** members of IJSYSRS, **save neither** a copy of the original member **nor** your changed version in **PRD2.SAVE**. If you want to save copies of the original member and your changed version, you should create another VSE sublibrary and catalog them there.

It is **your responsibility** to check whether service has been applied to the IBM-supplied members that you have modified. Also, you must ensure that the members work correctly when you have modified them.

## Backup/Restore Aspects of IJSYSRS

Refer to the description of the BACKUP and RESTORE command in the *z/VSE Guide to System Functions* under “Backup a SYSRES File, Library, Sublibrary, or Member” and under “Restore a SYSRES File, Library, Sublibrary, or a Member”.

## Space Allocations for Master Catalog in Environments A, B, C

For the three possible z/VSE installation environments, Table 33 shows the allocations of space for DOSRES (D) and SYSWK1 (S) in the master catalog. The allocations are listed as the starting block/track, followed by the number of blocks/tracks.

For example, in Table 33 the entry (S) 975, 2550 under the heading 3390 means that 2550 tracks are allocated on volume SYSWK1 on a 3390 disk, starting at track 975. The 2550 tracks are allocated in environments A, B, and C.

Table 33. Allocations for the Master Catalog in Environments A, B, and C

Environment	Disk	FBA		3380		3390 or 3390-FAT	
		Start Block	Number of Blocks	Start Track	Number of Tracks	Start Track	Number of Tracks
A, B, C	DOSRES	125,952	172,032	3165	2730	3,135	2,520
	SYSWK1	64,512	168,960	1035	2715	975	2,550
	SYSWK1	489,472	468,992	9,270	2820	8,790	3,960
	SYSWK1	1,097,728	409,600	12,090	1,170	12,750	1,425
	SYSWK1			13,620	2,115	14,700	1,980
B only	SYSWK1	1,507,380	703,488	15,735	10,800	16,680	15,000
C only	SYSWK1	1,507,380	2,110,464	15,735	21,600	16,680	30,000

## PRD1 and PRD2 Libraries

The PRD1 and PRD2 libraries are allocated on DOSRES and SYSWK1. During initial installation, z/VSE allocates them in VSE/VSAM space. This VSE/VSAM space is owned by the VSE/VSAM master catalog. On the condition that the master catalog has sufficient space available, PRD1 and PRD2 will be extended automatically as soon as they are full.

The extensions will be done according to the values given in Table 34 on page 121. Secondary allocations are done on the same volume and must start on a cylinder boundary. If you run out of VSE/VSAM space, use the *Display or Process a Catalog, Space* dialog to define new space to the master catalog. The defined space should be a multiple of the size of the secondary allocations provided in Table 34 on page 121. A primary allocation is required for a new volume if the old volume is full. As shown in Table 34 on page 121, the initial allocation depends on the disk device type you are using.

**Note:** If you use 3380 disk devices, extend the space of the VSE/VSAM master catalog for PRD1 and PRD2 before installing any additional programs.

### PRD1 Library

PRD1 contains the macros and base programs of z/VSE that are not required to be in IJSYSRS. It includes the sublibraries **BASE** (BASED) and **MACLIB** (MACLIBD). Note that you should **not** move library PRD1, or change its size, or add another sublibrary to it.

**PRD1.BASE** contains:

VSE Central Functions including:

OSA/SF for VSE/ESA

REXX/VSE

VSE Connector Server

The other programs included in PRD1.BASE are:

VTAM

CICS Transaction Server for VSE/ESA

TCP/IP for VSE/ESA

High Level Assembler for VSE

DITTO/ESA for VSE

EREP

**PRD1.MACLIB** contains:

VSE/Advanced Functions macros

VSE/POWER macros

VSE/VSAM macros

### PRD2 Library

PRD2 includes the following sub-libraries:

#### CONFIG

Contains installation-unique members that are not required in IJSYSRS.

These include:

- Members created during initial installation.
- Members created when you use the Interactive Interface (for example, CICS TS tables and VTAM startup books).
- Members that will not be changed during an FSU.

This sublibrary is not used when you apply service. You should **not** change the name of this sublibrary.

#### GEN1 (GEN1D)

These sublibraries are optional and contain the VSE/Advanced Functions Generation Feature when installed. You should **not** change the name of this sublibrary.

**SAVE** Contains mainly system procedures (PROCs) and is for FSU only. For adding members to IJSYSRS and PRD2.SAVE, refer to "Service Aspects of IJSYSRS" on page 118.

#### DUMP

Contains the archives of dumps.

**AFP, ASN740, CCF730, COMM, COMM2, DBASE, DB2750, DB2750C, DB2STP, DFHDOC, DLI1A0, PROD, SCEEBASE, (SCEEBASD), RCV730, and TCPIPB**

These are default sublibraries for z/VSE optional and base programs

(except for DB2STP which is a working library). Some of these libraries (marked with an asterisk in Table 32 on page 116) do not exist after initial installation. They are created later when the programs are actually installed.

**Note:** The following **base** programs are installed in **PRD2** sublibraries:

- DB2 Server for VSE is installed in PRD2.DB2750.
- DB2 Server for VSE Client Edition is installed in PRD2.DB2750C.
- LE/VSE is installed in PRD2.SCEEBASE.

Table 16 on page 48 lists the z/VSE optional programs and the corresponding default sublibraries. Besides the predefined sublibraries, you can define additional sublibraries in PRD2 for z/VSE optional programs or other VSE licensed programs. It is recommended, however, that you create separate VSE user libraries for your own application programs.

### Space Allocations for PRD1 and PRD2

Table 34 shows the total initial allocations for PRD1, PRD2, and the OME file for the disk devices supported for initial installation. Note that a value without a qualifier means library blocks. In case of FBA disk devices, one library block has a size of 1024 bytes (1KB) including 2 FBA blocks of 512 bytes each. In case of (E)CKD disk devices (3380 and 3390), the number of tracks is shown in the table in addition to the values for library blocks.

Table 34. Allocations for PRD1 and PRD2 Library

Disk Device	System-Provided VSE/VSAM Space		PRD1 Allocations in Library Blocks/Tracks		PRD2 Allocations in Library Blocks/Tracks	
	in Blocks/Tracks	in Library Blocks	Primary Allocation	Secondary Allocation	Primary Allocation	Secondary Allocation
3380	10380	319100	21212	10606	10606	21673
	692 Cyl.		690 Trks.	345 Trks.	345 Trks.	705 Trks.
3390	11010	360100	19624	9812	10793	21586
	734 Cyl.		600 Trks.	300 Trks.	330 Trks.	660 Trks.
FBA	809984 Blks.	404992	20480	10240	10240	20480

**Note:** For details of the VSE/VSAM data space that z/VSE allocates for the master catalog in environments A, B, and C, see Table 33 on page 119.

In some cases, the amount of space predefined for PRD2 may not be sufficient. To extend PRD2, define additional VSE/VSAM data space in the master catalog, for example, if you:

- Install a large number of z/VSE optional programs.
- Install additional VSE licensed programs in PRD2.

If you install z/VSE optional programs using the Interactive Interface dialog, the dialog scans the tape and prints information about the required space for each optional program.

#### Notes:

1. The Librarian command **LD** (List Directory) provides useful space information about libraries.
2. The predefined allocations for PRD2 may be checked using the *File and Catalog Management* dialogs.

## SYSDUMP Library

From z/VSE 5.1 onwards, during an initial installation of z/VSE the SYSDUMP library will be defined in the master catalog. The allocation of the dump library in VSAM is shown in Table 35.

The space allocation for the *master catalog* (for each of the three possible z/VSE installation environments) is shown in Table 33 on page 119.

The size of the VSE.DUMP.LIBRARY is as follows:

Table 35. SYSDUMP Library Allocation

	FBA	3380	3390
Primary	81920	1800	1800
Secondary	81920	1800	1800

SYSDUMP is the VSE system library that is used for storing partition dumps and data space dumps. It includes one sublibrary for each static partition and a single sublibrary for all dynamic partitions.

If you have not performed an initial installation of z/VSE 5.1 or later (and therefore your SYSDUMP library is still located in BAM space), you might have to reallocate the file *VSE.DUMP.LIBRARY* with a larger size in any of the following situations:

- You store many dumps in the SYSDUMP library.
- Your partitions are larger than 50 MB in size.
- Your z/VSE system uses the large partitions allocated for environment C.

To extend the dump library, you can use the skeleton SKDMPEXT which is stored in VSE/ICCF library 59.

If you use the Info/Analysis program to view dumps from other systems, you should reallocate this library to meet this requirement. “The Dump Library” in the *z/VSE Guide for Solving Problems* has information about working with the SYSDUMP library.

For environment C, you must extend the dump library so that it can hold a dump of the largest partition (512 MB).

## PRIMARY Library

The PRIMARY library is a **private** library and includes sublibraries intended for environments which do not use VSE/ICCF and its libraries. z/VSE creates a PRIMARY library during initial installation including:

- A common sublibrary for the exchange of data among different users named PRIMARY.\$\$C.
- A sublibrary named PRIMARY.SUF used as intermediate storage for PTFs requested from the IBM service server.

The PRIMARY library is located in VSE/VSAM space and defined in the VSE/VSAM user catalog (VSESPUC). It will include PRIMARY sublibraries defined for individual users and which are named **PRIMARY.userid**. Primary sublibraries can be created for individual users (if they are authorized in their user profile) through the:



- *Maintain Primary Sublibraries* dialog which submits a job for creating/deleting PRIMARY sublibraries.
- *IESUPDCF* batch utility described in “Maintaining User Profiles (Batch)” in the *z/VSE Administration*.

If security is active, PRIMARY sublibraries are specially protected as described in the *z/VSE Administration* under “Access Control for Libraries”.

### Size of the PRIMARY Library

The initial allocation values are as follows:

Disk Type	Allocation in Blocks/Tracks	
	Primary	Secondary
FBA	5120	10240
3380	75	225
3390	75	225

### CRYPTO Library

This library is required by the Secure Sockets Layer (SSL) support for storing keys and certificates. The library is protected by an entry in the security table DTSECTAB.

The CRYPTO library has the same initial allocation values as shown above for the PRIMARY library.

---

## VSE/ICCF Libraries

The VSE/ICCF DTSFILE is allocated with approximately 40MB and defines 199 VSE/ICCF libraries and users during initial installation. These libraries are also referred to as *program development* libraries.

Table 36 shows the VSE/ICCF libraries and their use. Note that some libraries are reserved for z/VSE. The members that z/VSE ships in these libraries take up approximately 20% of the space reserved for the DTSFILE. After allocating a library for each user, determine the total requirement for the DTSFILE. Compare this to the default allocation. If the space is insufficient, you should extend the file.

For information on how to extend the DTSFILE, refer to the *z/VSE Administration* under “Using Skeleton SKDTSEXT”. It describes how to use the skeleton *SKDTSEXT* for this task.

Table 36. VSE/ICCF Libraries

Library	Type	Contents	Usage
1	Private	VSE/ICCF administrative library. Contents shipped with VSE/ICCF.	system
2	Common	Common library. Macros and procedures. VSE/ICCF and z/VSE code members.	system
3 - 6	Public	Empty.	user
7	Private	Empty.	user
8	Private	Default primary library for operator profile.	user
9	Private	Default primary library for programmer profile.	user
10	Private	Default primary library for administrator profile.	user

Table 36. VSE/ICCF Libraries (continued)

Library	Type	Contents	Usage
11 - 49	Private	Empty.	user
50 - 58	Public	Reserved for z/VSE.	system
59	Public	z/VSE job streams, skeletons, CICS TS tables, and sample programs for the workstation file transfer support.	system
60 - 67	Public	Reserved for z/VSE.	system
68	Public	z/VSE members for Personal Computer tasks.	system
69	Public	Reserved for z/VSE.	system
70 - 199	Private	Empty.	user

For information about changing the characteristics of the DTSFILE, refer to the chapter “Regenerating the Supervisor, VSE/POWER, or VSE/ICCF” in the *z/VSE Administration*.

**Note:** The *Program Development Library* dialog helps you access and use VSE/ICCF libraries. For detailed information about this dialog, refer to the *VSE/ESA Programming and Workstation Guide* under “Handling VSE/ICCF Library Members”.

---

## Planning for Private Files

A private file is a user-owned file which is separate and distinct from system files.

### VSE/VSAM Files

With the *File and Catalog Management* dialog, you can define files (or libraries) in VSAM-managed space. These files have the following characteristics:

- The space is defined as a VSE/VSAM cluster.
- A secondary allocation allows for dynamic extension.
- Secondary extents are *not* dynamically reclaimed when they are empty.

“Overview of File and Catalog Management Dialogs” in the *z/VSE Administration* explains how to use the *File and Catalog Management* dialog.

### Non-VSE/VSAM Files

Although it is recommended to work with VSE/VSAM files, you can define files for other access methods such as SAM and DAM. If you use such access methods, consult the following publications:

- z/VSE System Macros Reference*
- z/VSE System Macros User's Guide*

## Creating Standard Labels for Non-VSE/VSAM User Files

When using dialogs for VSE/VSAM file definition, z/VSE automatically adds standard labels to the procedure `STDLABUP`.

For non-VSE/VSAM files, you can use the skeleton `STDLABUS` to create standard labels as described in the *z/VSE Administration* under “Creating Standard Labels for Non-VSAM User Files”.

## Planning for Private VSE Libraries

A private library is a user-owned library which is separate and distinct from the system library.

PRIMARY sublibraries belong to private libraries. However, they are discussed under VSE system libraries (“PRIMARY Library” on page 122) since the PRIMARY library is created by z/VSE during initial installation.

## General Recommendations

*It is recommended that you create separate user libraries and sublibraries for your applications instead of using system library PRD2.*

This keeps those libraries independent of any future changes that IBM service may make to PRD2. In addition, separate libraries offer you more flexibility with regard to size and organization.

You can define VSE user libraries either in VSAM-managed space or in space that is not managed by VSAM. In either case, you must define at least one *sublibrary* before a new library can be used. This is a requirement of the Librarian, described in the *z/VSE Guide to System Functions* under “The Librarian Program”, which controls all VSE libraries in your system.

## Libraries in VSE/VSAM Space

The same applies as stated for “VSE/VSAM Files” on page 124.

After defining a library, you must add its name to the library definition chain using a `LIBDEF` command for the partition needed.

## Libraries in Non-VSE/VSAM Space

z/VSE provides **skeletons** to define, extend, and delete libraries in space **not** managed by VSE/VSAM. These skeletons are described in the *z/VSE Administration*.

You can allocate both multi-extent and multi-volume user libraries. When you define a multi-volume library, you must use the same disk device type. After defining a library, you must add its name to the library definition chain using a `LIBDEF` command for the partition needed.

**Note:** The *z/VSE System Control Statements* describes the `LIBDEF` command in detail. A detailed description of the Librarian program is given in the *z/VSE Guide to System Functions*.

## Private Libraries

---

## Chapter 8. Running z/VSE Under VM

The term VM in this chapter stands for **z/VM**.

### Notes:

1. Use the information in this chapter together with the *z/VM Version 5, Running Guest Operating Systems*, SC24-6115.
2. Table 37 on page 128 provides a summary of the major aspects you should consider when installing z/VSE under VM; you should use this figure together with Table 17 on page 58. The *z/VSE Installation* describes in detail how to install a z/VSE system under VM.
3. Refer also to “Advantages When Running z/VSE in LPAR mode” on page 1 for details on running z/VSE as multiple preferred guest under VM.

This chapter contains these main topics:

- “Introduction”
- “Summary of z/VSE and VM Operating Environments” on page 128
- “VM Linkage Support” on page 128
- “Initial Program Load (IPL)” on page 129
- “Using z/VSE System Activity Dialogs” on page 132
- “Defining a z/VSE Virtual Machine” on page 132
- “Using System Parameter IJBVMID” on page 139
- “Processor Resource/Systems Manager Support” on page 140
- “SQL/DS Guest Sharing Support” on page 140

### Related Topics:

For details of how to ...	Refer to ...
use the <i>z/VM Queue-I/O Assist</i> function (also called “passthru”) to provide OSA Express and HiperSockets performance improvements	“Exploiting the Queue-I/O Assist Function” on page 161
install and run the <i>Linux Fast Path</i> function (which exploits the <i>z/VM-mode LPAR</i> )	<ul style="list-style-type: none"><li>• “Linux Fast Path Support” on page 163 (which provides an overview)</li><li>• <i>z/VSE TCP/IP Support</i></li></ul>

---

## Introduction

z/VSE can only run as a guest system under **z/VM Version 5 Release 4 or later**.

In an environment where z/VSE runs under VM, you can:

- Log on to VM using the ID and password defined for the z/VSE virtual machine. Your terminal can then serve as the z/VSE console.
- Dial into the z/VSE system and use the functions provided by the Interactive Interface.
- Log on to CMS and interact with z/VSE. z/VSE provides the VM/VSE Interface, which allows CMS users of VM to work with z/VSE systems concurrently. This is discussed under “VM/VSE Linkage Functions” on page 218.

In this chapter, **virtual machine console** refers to a console that is defined for each VM guest system. **z/VSE console** refers to a console that is used to control the operation of a z/VSE system.

---

## Summary of z/VSE and VM Operating Environments

Table 37 summarizes some of the major items you should consider when planning to install z/VSE under VM.

**Note:** Irrespective of which z/VM version you are using, you are strongly recommended to define sufficient storage in the virtual guest machine so that your z/VSE will run *without paging* (that is, as a NOPDS system). As a result, only z/VM will perform paging.

Since z/VSE can run as a guest system under z/VM Version 5 Release 4 (or later), the *only VM mode that is available* is:

V=V (Virtual=Virtual)

### VM Mode V=V

If z/VSE runs as a V=V guest, double paging (VM and z/VSE) will occur if z/VSE has a page data set (PDS).

Table 37. Summary of System Functions Supported for VM Mode V=V

System Function	Support
VM Paging	YES
VSE Paging	
PDS (Page Data Set) - VSE Paging	YES
NOPDS (No Page Data Set) - VSE Paging	NO
VM CCW Translation	YES
VSE CCW Translation	YES
VSE Real Size	≥32MB (real from DEF STOR)
VSE Virtual Size	xxGB (virtual from VSIZE definition)

#### Notes:

1. z/VSE does not page in case of a NOPDS system.
2. Refer to “Virtual Storage Support” on page 53 for a description of the maximum VSIZE (xxGB) possible. Note that VSIZE cannot be specified for a NOPDS system.

---

## VM Linkage Support

If you want to submit jobs from VM to a z/VSE guest system, you should have the VM/VSE Interface Routines installed. Specific commands are then available for cross-system communication. Refer to “VM/VSE Linkage Functions” on page 218 for details.

The VM/VSE interface routines must be installed through skeleton SKVMVSE. Under “Installing VM/VSE Interface Routines”, the *z/VSE Installation* describes in detail the installation of the interface routines.

---

## Initial Program Load (IPL)

**Related Topic:**

- “Defining a CMS Profile to IPL a SCSI Device” on page 136

Initial installation of z/VSE as a VM guest machine involves two IPLs.

1. **The first IPL** (IPL cuu) is from the distribution tape and loads the stand-alone environment including the required utility programs for installation.
2. **The second IPL** depends upon whether the IPL is performed from a SCSI disk or a non-SCSI disk, as described below.

### Performing an IPL From an FCP-Attached SCSI Disk

FCP-attached SCSI disks cannot be sensed. Therefore, if SCSI disks are to be included in the I/O configuration, you must add them using the Interactive Interface *Hardware Configuration* dialog.

An exception to the above is if you use FCP-attached SCSI disks as your system residence disks. The connection path information from the first installation step is used to update the IPL procedure.

The second IPL is then performed automatically using the information provided during the initial installation (the first IPL).

Figure 9 on page 130 shows an example of an IPL process from a SCSI disk when running z/VSE under VM.

```

0I04I IPLDEV=X'608',VOLSER=DOSRES,CPUID=FF0000032064
      FCP=X'C00',WWPN=5005076300C69A76,LUN=574500000000
0J01I IPL=$IPLESA ,JCL=$$JCL
$$A$SUPI,VSIZE=2048M,VIO=512K,VPOOL=64K,LOG,IODEV=1024
      * During initial installation, ADD statements
      * are added for the devices attached. They
      * also reflect definitions made in the VM
      * directory shown later. For example:
      ADD 080,3270 (Terminal for DIAL function)
      ADD 01F,3270 (z/VSE system console)
      ADD 00C,3505
      ADD 00D,3525
      ADD 00E,3262
      ADD 1BA0:1BAA AS BA0:BAA,FCP
      ADD 1D10:1D12 AS D10:D12,ECKD
      ADD 1D14:1D15 AS D14:D15,ECKD
:
:
      * The following ADD statements are predefined
      * and are required by z/VSE:
ADD FDF,FBAV          VIRTUAL DISK LABEL AREA, DO NOT DELETE
ADD FEC,3505          POWER DUMMY READER, DO NOT DELETE
ADD FED,2520B2        POWER DUMMY PUNCH, DO NOT DELETE
ADD FEE,PRT1          POWER DUMMY PRINTER, DO NOT DELETE
ADD FEF,PRT1          POWER DUMMY PRINTER, DO NOT DELETE
ADD FFA,3505          ICCF INTERNAL READER, DO NOT DELETE
ADD FFC,3505          ICCF DUMMY READER, DO NOT DELETE
ADD FFD,2520B2        ICCF DUMMY PUNCH, DO NOT DELETE
ADD FFE,PRT1          ICCF DUMMY PRINTER, DO NOT DELETE
ADD FFF,CONS          DUMMY CONSOLE, DO NOT DELETE
:
:
DEF SCSI,FBA=608,FCP=C00,WWPN=5005076300C69A76,LUN=5745000000000000
DEF SCSI,FBA=609,FCP=C00,WWPN=5005076300C69A76,LUN=5746000000000000
0S45I SCSI DEVICE 609 CONSISTS OF 09765632 BLOCKS, 09756789 BLOCKS ARE
AVAILABLE, 651 BLOCKS ARE UNUSED
:
:

```

Figure 9. Example of a z/VSE IPL Process (\$IPLESA) From a SCSI Disk

Because of device sensing, you should attach the devices to be used by z/VSE *before* the sense IPL. If you do not, you must later modify the IPL procedure created.

Detach devices you do *not* want in the z/VSE IPL procedure (for example, CMS minidisks or MAINT's 190 minidisk) or delete them later via the *Tailor IPL Procedure* dialog.

## Performing an IPL From a Non-SCSI Disk

The second IPL from disk (DOSRES) is done by the system automatically. This IPL is known as the *sense* IPL. z/VSE uses device sensing to automatically define:

- Each device attached to z/VSE.
- Each device defined in the VM directory entry for z/VSE.

The sensed devices are used to update the IPL procedure. Figure 10 on page 131 shows an example of an IPL procedure for running z/VSE under VM.



```

01F $$A$SUPI,VSIZE=264M,VIO=512K,VPOOL=64K,LOG,IODEV=1024
* During initial installation, ADD statements
* are added for the devices attached. They
* also reflect definitions made in the VM
* directory shown later. For example:
  ADD 080,3270 (Terminal for DIAL function)
  ADD 01F,3270 (z/VSE system console)
  ADD 00C,3505
  ADD 00D,3525
  ADD 00E,3262
  ADD A181 AS 18A,3480,00
  ADD 1300 AS 306,3277
  ADD 1302:1303 AS 307:308,3277
  ADD 1BA0:1BAA AS BA0:BAA,FCP
  ADD 1D10:1D12 AS D10:D12,ECKD
  ADD 1D14:1D15 AS D14:D15,ECKD
:
* The following ADD statements are predefined
* and are required by z/VSE:
ADD FDF,FBAV
ADD FEC,3505          POWER DUMMY READER, DO NOT DELETE
ADD FED,2520B2       POWER DUMMY PUNCH, DO NOT DELETE
ADD FEE,PRT1         POWER DUMMY PRINTER, DO NOT DELETE
ADD FEF,PRT1         POWER DUMMY PRINTER, DO NOT DELETE
ADD FFA,3505         ICCF INTERNAL READER, DO NOT DELETE
ADD FFC,3505         ICCF DUMMY READER, DO NOT DELETE
ADD FFD,2520B2       ICCF DUMMY PUNCH, DO NOT DELETE
ADD FFE,PRT1         ICCF DUMMY PRINTER, DO NOT DELETE
ADD FFF,CONS         DUMMY CONSOLE, DO NOT DELETE
* Other IPL Commands
SET ZONE=WEST/00/00
DEF SYSCAT=DOSRES
DEF SYSREC=SYSWK1
SYS BUF$SIZE=1500
SYS NPARTS=60
SYS DASDFP=YES
SYS SEC=NO
SYS PASIZE=70M
SYS SPSIZE=0K
SYS BUFLD=YES
SYS SERVPART=FB
SYS TRKHLD=12
DPD VOLID=DOSRES,CYL=414,NCYL=44,TYPE=N,DSF=N
DPD VOLID=DOSRES,CYL=458,TYPE=N,DSF=N
SVA SDL=700,GETVIS=(768K,6M),PSIZE=(652K,6M)

```

Figure 10. Example of a z/VSE IPL Procedure (\$IPLISA) From a Non-SCSI Disk

Because of device sensing, you should attach the devices to be used by z/VSE *before* the sense IPL. If you do not, you must later modify the IPL procedure created.

Detach devices you do *not* want in the z/VSE IPL procedure (for example, CMS minidisks or MAINT's 190 minidisk) or delete them later via the *Tailor IPL Procedure* dialog.

## Using z/VSE System Activity Dialogs

The Interactive Interface provides two dialogs that display general information about current system activity. These are the *Display System Activity* and the *Display Channel and Device Activity* dialogs. With them, you can monitor information such as CPU use, paging, and I/O activity.

When using these dialogs for a z/VSE guest machine, note that:

- All data is valid, except for data displayed as the number of events per second (for example, SIO/Sec).
- The information describes z/VSE activity only.

The percentage of CPU use shows how much time (VTIME) the guest virtual machine has consumed. It does *not* include the time used by CP to service z/VSE (TTIME-VTIME).

Refer to the z/VSE *Operation* under “Dialogs for Displaying System Status” for how to use the dialog.

---

## Defining a z/VSE Virtual Machine

### Defining a VM Directory Entry

Each guest system running under VM requires a *directory entry* that defines the virtual machine's configuration and operating characteristics. For the z/VSE system volumes DOSRES and SYSWK1, VM requires unique volume IDs if they are shared by two or more z/VSE guest systems running under VM.

Figure 11 on page 133 shows a sample VM directory entry for a z/VSE system named *VSEESA1*. The letters to the left of the figure are used here as reference points for various statements. They are not part of the actual directory entry.

**Note:** When you install z/VSE under VM, z/VSE will automatically sense the devices defined in the VM directory for its configuration. If you have any devices not supported under VM, you can bypass device sensing by adding the EML operand in the IPL ADD statements of z/VSE.

```

(A) USER VSEESA1 password 1024M 8G G
(B) OPTION MAINTCCW QUICKDSP
(C) MACHINE ESA 2
(D) CPU 0 CPUID 0xxxxx NODEDICATE
    CPU 1 CPUID 1xxxxx
(E) IPL 24A0 PARM AUTOLOG
(F) ACCOUNT ### SYSPROG
(G)   DEDICATE 244 704
    DEDICATE 245 705
(H)   CONSOLE 009 3270 T OPERATOR
(I)   SPECIAL 080 3270
      .
      .
      SPECIAL 01F 3270
(J)   SPOOL   00C 3505 A
    SPOOL   00D 3525 A
    SPOOL   00E 3262 A
    SPOOL   05E 4248 A
      .
      .
      * Link to optional disks as needed....
      * Link to Executable CMS Code

(K)   LINK MAINT 190 190 RR
      .
      * Link to Program Products (Y Disk)

      LINK MAINT 19E 19E RR
(L)   MDISK 240 3390 1 1112 VSADOS MWV
    MDISK 241 3390 1 1112 VSASY1 MWV
    MDISK 242 3390 1 1112 USER01 MWV
    MDISK 243 3390 1 1112 USER02 MWV

```

Figure 11. Example of a VM Directory

The statements in the directory define the following:

- A USER** defines the:
- Name and password of the z/VSE guest.
  - Virtual storage size (1024M or 1G) for the z/VSE guest when logging on to VM (this is the real storage for z/VSE itself).
  - Maximum virtual storage (8G) size that can be defined for the z/VSE guest after logging on. This is therefore the maximum size for VM.
  - User class G (general) is available.
- B OPTION** defines:
- MAINTCCW authorizes the z/VSE guest to initialize disk devices (use diagnostic CCWs).
  - QUICKDSP causes a virtual machine to be added to the dispatch list immediately when it has work to do, without waiting in the eligible list.
- C MACHINE** defines the virtual machine mode (which must be ESA). 2 defines the maximum number of processors that can be active.
- D CPU** defines the processors that can be active.
- E IPL** defines automatic IPL to be performed with specified device address.
- F ACCOUNT** defines an account number and a distribution identification.
- G DEDICATE** specifies that a real disk device is to be dedicated to this z/VSE guest (VSEESA1).

- H** **CONSOLE** defines the virtual machine console. In the statement:
- 009 is the virtual address of the console.
  - 3270 defines the terminal type of the virtual machine console.
  - T defines the spool class.
  - OPERATOR defines the secondary VM user. If the primary user (VSEESA1) is disconnected, the VM user OPERATOR will receive all CP messages for the z/VSE virtual machine. The secondary user also can send CP commands to the disconnected z/VSE virtual machine.

- I** **SPECIAL** defines a virtual device with device type and address to the z/VSE system. Terminal addresses do *not* have to be real devices on the system.

When you define a terminal as SPECIAL, you can use the address to dial into the z/VSE system. You should ensure that you have a sufficient number of addresses defined as SPECIAL for users who require the DIAL function.

Devices defined in this manner are added to the z/VSE IPL procedure through device sensing.

- J** **SPOOL** defines virtual unit record devices. One entry is required for each unit record device.

- K** **LINK** defines a link to a device that belongs to another user.

- L** **MDISK** defines an extent on a disk device to be owned by VSEESA1. The extent assigned with the statement becomes the user's minidisk.

In case of FBA minidisks, the total number of blocks must be a multiple of the number of blocks per access position for the device type. "Multiple of access position" means cylinder boundary and its values should be obtained from the related device documentation.

For further LINK and MDISK information, refer to "Defining Shared Minidisks" on page 138.

### Defining a CMS Profile EXEC

If you want additional options to be executed during startup, you can define a CMS PROFILE EXEC for the z/VSE user-ID. To do so, you must define a CMS profile EXEC for a z/VSE guest system, you must first define a CMS 191 minidisk for the z/VSE guest system for holding the profile.

Note that the sample PROFILE EXEC below is set for two user-IDs. VSEA is a z/VSE system with 1024 MB and VSEB a z/VSE system with 8 GB.

```

/*
--Next line sets variable n1 to hex '15' to separate commands
*/
n1='15'x                               /*linend character*/
parse value diag(8,'QUERY USERID') with userid . node (n1)
'CP SET RUN ON'
'CP SP RDR CONT'
if userid='VSEA' then cpcom='CP DEF STOR 1024M'
else cpcom='CP DEF STOR 8G'
cpcom = cpcom ,
        || n1 || 'CP TERM CONM 3270 BRE GUEST' ,

        || n1 || 'CP IPL 240 CLEAR'
address command cpcom
say 'IPL failed, RC=' RC
exit rc

```

Figure 12. Sample PROFILE EXEC for Two z/VSE Guest Machines (in REXX)

Be sure that the last concatenated command is the IPL command for z/VSE.

You can have the following CP commands in the PROFILE EXEC. Note that if you do not want to use a PROFILE EXEC, you can enter these commands from CP mode.

- **SET RUN ON** – Allows you to activate the Attention key (causing a read of a CP command) without stopping the virtual machine.
- **SPOOL READER CONT** – Ignores intermediate end-of-file indications or CLOSE requests for virtual readers. Reading is continuous, with all end-of-file indicators ignored until all files spooled to the virtual machine are read. If this option is not in effect, a unit exception is reflected to the virtual machine at the end of each spooled file.
- **DEF STOR n..nM** – The DEF STOR command can be used to acquire the maximum amount of virtual storage specified in the directory entry for the z/VSE virtual machine.
- **TERM CONMODE 3270** – Specifies full screen operation mode of the virtual machine console. This command is required if you use a shared z/VSE console in 3270 mode (see “Defining a Shared Console” on page 137).
- **TERM BREAKIN GUEST** – Prevents CP messages from being displayed on the z/VSE console.
- **IPL cuu LOADPARM** – This is the IPL statement for z/VSE. You should replace **cuu** with the address of DOSRES. *This must be the last CP command in the PROFILE EXEC.*

If you use the TERM CONMODE 3270 command in the PROFILE EXEC, you should combine it with other CP commands into a single command line. This is because TERM CONMODE 3270 causes CMS to terminate. If it is on a separate command line, other commands in the PROFILE EXEC will not be executed.

Combining the commands into a single command line ensures that they are read from the CP console stack when CMS terminates. To combine (concatenate) commands, you can use the coding technique shown in Figure 12.

For further details about using a CMS PROFILE EXEC, refer to the VM documentation.

## Defining a CMS Profile to IPL a SCSI Device

If your system resource disk is an FBA-SCSI device, you must provide the following definitions in your CMS profile:

```
'CP DEF STOR 32M'  
'CP TERM CONMODE 3270'  
'CP SET LOADDEV PORT 50050763 00C69A76 LUN 560A0000 00000000' (see '1')  
'CP I C02 ' (see '2')
```

1. The SET LOADDEV command is required in order to specify the:
  - Port (WWPN) that is used to access the DOSRES SCSI disk.
  - Logical unit number of the DOSRES SCSI disk.
2. For the IPL or load address, you specify the FCP device that is used to attach the DOSRES SCSI disk. For further information, refer to the Chapter “Configuring Your System to Use SCSI Disks” in the *z/VSE Administration*.

## Defining a z/VSE Console

The CONSOLE control statement in a directory entry specifies the *virtual machine* console for that user. In the z/VSE – VM environment, the way you define the z/VSE console (the *system* console) depends in part on the following considerations:

1. Will z/VSE and VM have separate consoles?
2. Will the z/VSE console support VM operations?
3. Will z/VSE be logged on manually or autologged?
4. Will the z/VSE console be disconnected?
5. Will the virtual machine run disconnected?

The rest of this topic explains three possible ways to define the z/VSE console.

**Note:** VM's *autolog* facility can be used to automatically IPL one or more z/VSE virtual machines without operator intervention. The virtual machine is logged on in disconnected mode. The same restrictions that apply to any disconnected virtual machine also apply to virtual machines logged on with the autolog facility.

When VM autologs a z/VSE virtual machine, the correct IPL and JCL procedures for z/VSE are selected through the automated startup facility.

### Defining a Dedicated Console

A VM installation can dedicate (reserve) one of its terminals for use as the z/VSE console. Doing this means that the z/VSE operator can work from this device as if it were a console for a stand-alone z/VSE system.

In “Defining a VM Directory Entry” on page 132 you can use a DEDICATE statement to specify that the real device at 01F (or a terminal at another address) is to be used as the z/VSE console.

To use a dedicated z/VSE console, the following must be considered:

1. The device specified in the DEDICATE statement must not be enabled before the z/VSE virtual machine is logged on.

If it has been enabled, you can disable it using the command:

```
CP DISABLE cuu
```

where **cuu** is the address of the real device.

2. If the z/VSE system is not automatically IPLed, you must log on the z/VSE virtual machine and perform an IPL from a VM terminal. This must be a *different* terminal from the one specified in the DISABLE command.

You can, if you wish, disconnect the z/VSE virtual machine after IPL completes.

### Defining a Shared Console

Instead of defining a dedicated console for z/VSE, you can operate the system from a *shared* console. In this environment, the *same* VM terminal used to log on and IPL the z/VSE virtual machine is also used as the z/VSE console.

To use a shared console:

1. From a VM terminal, log on using the ID and password defined for the z/VSE virtual machine.
2. Enter the following CP commands *after* you IPL CMS but *before* you IPL z/VSE:

```
CP SP RDR CONT
CP SET RUN ON
CP TERM CONMODE 3270
CP TERM BREAKIN GUEST
```

Besides manually entering these commands in CP mode, you can also make them a part of a PROFILE EXEC that you define for the z/VSE virtual machine. "Defining a CMS Profile EXEC" on page 134 shows how to do this.

3. IPL z/VSE. The z/VSE console screen will be displayed.
4. If you want to return to VM from the z/VSE console, press the **PA1** key. This puts the screen in CP mode.
5. To return to the z/VSE console from CP mode, enter the command **B** (for **CP BEGIN**).
6. When you are done using the z/VSE console, enter the following command in the command line at the bottom of the console screen:

```
* CP DISC
```

### Defining a Disconnected Console

You can also define the z/VSE console as a *disconnected* console. The z/VSE console may or may not be active (displayed at a terminal) at any given time.

To define the z/VSE console to operate in disconnect mode:

1. Define the virtual machine console in the z/VSE directory entry. For example, the directory entry could be:

```
CONS 009 3215
```

2. In the directory entry, define the device to be used for the z/VSE console with a **SPECIAL** statement. For example:

```
SPECIAL 2FF 3215
```

The address specified here should be the *highest* one used in the directory entry's **SPECIAL** statements. This minimizes the chance that a user later will dial into the z/VSE guest machine and get the z/VSE console by mistake.

3. Have an **ADD** statement in the IPL procedure for z/VSE that uses the same device address as in the **SPECIAL** statement. For example:

```
ADD 2FF,3277
```

4. Have an **ASSGN** statement similar to the following in the JCL ASI procedure for the BG partition:

```
ASSGN SYSLOG,2FF
```

After z/VSE is IPLed, this statement re-assigns the terminal at 2FF as the z/VSE console.

To use the disconnected console:

1. From a VM terminal, log on using the ID and password defined for the z/VSE virtual machine.
2. IPL z/VSE.
3. Once IPL is complete, you can disconnect the z/VSE virtual machine and use the terminal for other purposes.
4. Whenever you want to use the z/VSE console, enter the following command from a VM terminal:  
**DIAL xxxxxxxx 2FF**  
where xxxxxxxx is the user-ID of the z/VSE virtual machine. The z/VSE console will be displayed at the terminal.
5. When you are done using the z/VSE console, enter the following command in the command line at the bottom of the console screen:  
**\* CP RESET 2FF**

### Defining Shared Minidisks

Under VM, shared disk devices (DASD Sharing) must be defined as minidisks in the VM directory entry for each guest system that is to access them. VM provides multiple access to the same devices through MDISK and LINK definitions. Figure 13 shows an example where MDISK and LINK definitions create *one* access path to DASDs.

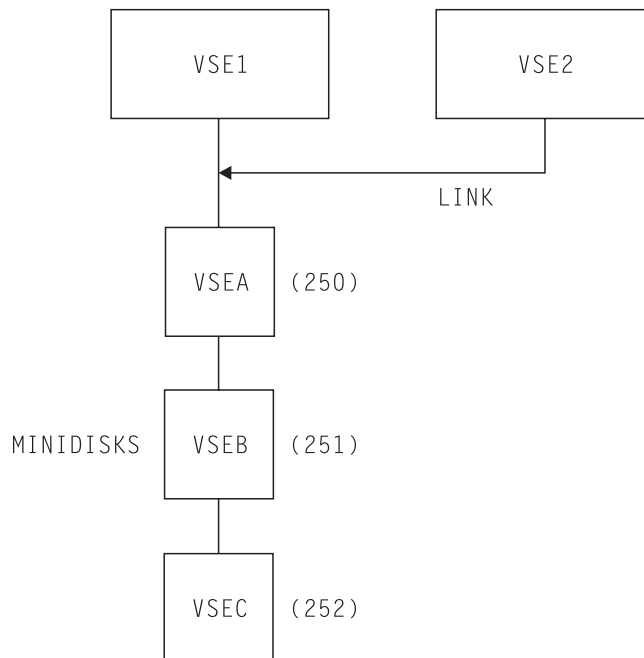

Figure 13. Access Path to Shared VM Minidisks

The MDISK definition of the device on which the lock file resides requires access mode **MWV**. This indicates that a write link is given to the disk and that the CP virtual RESERVE/RELEASE function is used in the I/O operation of that disk.

For performance reasons in a shared system environment, the VSE Lock file should be put on a VM virtual disk or at least on a VM minidisk.



For details about DASD sharing in general, refer to the *z/VSE Guide to System Functions* under “DASD Sharing with Multiple VSE Systems”.

## Using SCSI Disks Via the VM-Emulated FBA Support

If you use SCSI disks via VM's emulated FBA-support, these SCSI disks:

- Appear to z/VSE as **9336 Model 20 FBA** disks.
- Are used by z/VSE as disks of type **FBA** (for example, in z/VSE dialogs).

If you define a *second path* to a SCSI disk using ADD PATH on a z/VM CP SET EDEVICE command, you required z/VM APAR VM64784.

Since z/VSE SCSI support is *not* required in order to access VM-emulated FBA disks, these disks can be used by VSE releases prior to z/VSE 3.1.

### Restrictions

z/VSE supports emulated FBA disks (fullpack or partial minidisks) with these restrictions:

- The VTOC of an FBA disk for use by z/VSE or VSE/ESA should **not** be placed at the end of the volume, *except* when the last block is a multiple of 8\*777 blocks.
- If the size of the disk is not a multiple of 8\*777 blocks, the VTOC should be placed below the highest multiple number of 8\*777 blocks that fit into the total number of defined blocks. This is due to the fact that DASD file protection is set to “On” in z/VSE.
- The FBA disks must not exceed a size of 2 GB.
- VSAM can only use the first 2 GB of an emulated FBA disk.

---

## Using System Parameter IJBVMID

z/VSE provides the “implicitly-defined” symbolic system parameter **IJBVMID**:

- When running z/VSE under z/VM, IJBVMID contains the 8-byte z/VM user-ID (padded to the right with blanks).
- When running z/VSE natively, IJBVMID contains eight blank characters.

**Note:** “Implicitly-defined” means that z/VSE provides IJBVMID without requiring any action by the user.

In a conditional JCL job, you can check the value of **IJBVMID** and then act accordingly. For example:

```
// IF IJBVMID = 'PROD' THEN
// EXEC PROC=INITPROD
// IF IJBVMID = 'TEST' THEN
// EXEC PROC=INITTEST
```

---

## Processor Resource/Systems Manager Support

The Processor Resource/Systems Manager (PR/SM) allows you to run multiple preferred guest systems under VM as outlined under “Advantages When Running z/VSE in LPAR mode” on page 1.

---

## SQL/DS Guest Sharing Support

### Notes:

1. This support relates to DB2 and SQL/DS applications.
2. The guest sharing support requires the *DB2 Server for VSE* program.

The support is provided for a VM environment with z/VSE guest systems. It allows you to run DB2 (or SQL/DS) applications in different VM systems, either under VM or under a z/VSE guest system, and share one or more DB2 (or SQL/DS) data bases. A data base must be installed on a VM system.

The support requires that during IPL z/VSE is initialized as a z/VSE guest system under VM. You must tailor the IPL procedure accordingly (VSE APPC/VM specification). z/VSE provides the *Tailor IPL Procedure* dialog as described in the *z/VSE Administration*. Since guest sharing is based on APPC/VM, fixed areas in real storage are required. The amount of PFIX storage needed depends on the number of communication paths. The required PFIX storage can be estimated by the number of links per partition, multiplied by 32KB. For page fixing, use the SETPFIX statement to reserve space for each partition (batch or CICS) that accesses VM databases.

If you are using guest sharing, the z/VSE guest system must have the following entry in the VM directory:

```
OPTION MAXCONN nn
```

The value of MAXCONN is based on the estimated number of APPC/VM links required to be established between the z/VSE guest systems and the VM database machines. This number can be estimated as follows:

```
MAXCONN = NUMBER OF CICS LINKS (involved in guest sharing)
          + NUMBER OF BATCH LINKS
          + NUMBER OF DATABASE MINIDISKS
          + SPARE
```

The support is activated if the IPL procedure includes the required SET XPCC commands (created using the *Tailor IPL Procedure* dialog) or by loading the DB2 phase for activation into the SVA.

## Chapter 9. z/VSE e-business Connectors and Tools

This chapter describes the z/VSE e-business connectors and tools you can use to allow Web browsers to access data stored on the z/VSE host.

It contains these main topics:

- “Choosing Between 2-Tier and 3-Tier Environments” on page 142
- “Overview of Available Connectors and Tools” on page 142
- “How the VSE Connector Components Are Installed” on page 145
- “Implementing the DB2-Based Connector” on page 146

### Related Topics:

For details of how to ...	Refer to this topic(s) in the <i>z/VSE e-business Connectors User's Guide</i> :
implement 2-tier and 3-tier environments for e-business connectors and tools	“Overview of 2- and 3-Tier Environments”
perform <i>data mapping</i> (that is, map <b>VSE/VSAM data</b> into a <b>relational structure</b> so that it can be accessed in a DB2 relational database environment)	“Mapping VSE/VSAM Data to a Relational Structure”
implement the VSE Connector Client and the VSE Connector Server	“Installing and Operating the Java-Based Connector”
install and use the VSAM Redirector Connector	“Installing the VSAM Redirector Connector”
install and use the Database Call Level Interface	“Installing the Database Call Level Interface” and “Using the Database Call Level Interface to Access Data”
install and use the VSE Script Connector	“Installing the VSE Script Connector” and “Using the VSE Script Connector for non-Java Access”
implement Web services and SOAP in your z/VSE system	“Using SOAP for Inter-Program Communication”
collect “trap” data from your batch jobs, COBOL, PL/I and C programs, and CICS transactions	“Collecting Data via the VSE Monitoring Agent”
allow availability-data to be collected and sent to a central GDPS ( <i>Geographically Dispersed Parallel Sysplex</i> <sup>®</sup> ) K-System	“Using GDPS Support for High Availability”

## Choosing Between 2-Tier and 3-Tier Environments

The support for e-business connectors and tools is based on a 2-tier or 3-tier environment:

- In 2-tier environments, the Web client and z/VSE host communicate directly with each other.
  - In 3-tier environments, the Web client or non-Java client, and z/VSE host communicate with each other via an intermediate tier called the *middle-tier*. This middle-tier can be either a:
    - “physical” middle-tier (in which the WebSphere Application Server runs under Linux, AIX®, or Windows on a middle-tier server, such as an xSeries® or pSeries® server).
    - “logical” middle-tier (in which the WebSphere Application Server runs under *Linux on System z* on the z/VSE host).
  - The 2-tier environment is not the typical environment under which you will develop *your own* Java programs, since it is not:
    - part of the IBM *Application Framework for e-business* (it does not, for example, use the IBM WebSphere Application Server on the middle-tier).
    - secured by the state-of-the-art security services (firewall, and so on) provided by the IBM Application Framework for e-business.
- The 2-tier environment is generally suitable for your *intranet* solutions only.
- The DB2-based connector can **only** be used in a 3-tier environment.

## Overview of Available Connectors and Tools

Table 38 lists the connectors and tools you can use together with z/VSE. If you wish to download any of the tools that have a “Yes” entry in the column “Download From VSE Homepage?”, you must start your Web browser and go to URL:

<http://www.ibm.com/servers/eserver/zseries/zvse/downloads/>

Table 38. Available z/VSE e-business Connectors and Tools

Tool	Description	Shipped With VSE?	Download From VSE Homepage?	Prerequisites
VSE Connector Client	Provides the VSE Java Beans class library, together with extensive online help, Javadoc, and coding samples for all kinds of Java programs (such as small applications, servlets, applets, and EJBs).	IESINCON.W in PRD2.PROD (after installation from Extended Base Tape)	Yes	Java 1.4 or later
VSAM Redirector Server	Enables you to use your existing application programs (e.g. COBOL programs) without any changes, to work with data on any Java-enabled platform. Provides a Java-based server which communicates with the VSAM Redirector Client on VSE.	IESVSMRD.W in PRD2.PROD (after installation from Extended Base Tape)	Yes	Java 1.5 or later

Table 38. Available z/VSE e-business Connectors and Tools (continued)

Tool	Description	Shipped With VSE?	Download From VSE Homepage?	Prerequisites
Database Call Level Interface	A <i>database connector</i> that allows z/VSE applications to access a relational database on any suitable database server. Therefore, z/VSE customers have the flexibility of being able to choose a database server (IBM DB2, Oracle, Microsoft SQL Server, MySQL, and so on) that runs on a platform other than z/VSE. CICS applications can also benefit from <i>connection pooling</i> , which keeps and reuses <i>existing</i> database connections for Database Call Level Interface (DBCLI) applications running under the CICS Transaction Server for VSE/ESA V1.1. This can be especially beneficial for short-lived, CICS DBCLI applications that run frequently.	IESDBSRV.W in PRD2.PROD (after installation from Extended Base Tape)	Yes	Java 1.5 or later
VSE Navigator	A graphical user interface for use by the VSE systems programmer. Provides access to VSE file systems and VSE operator console. Comfortable mechanism for job creation, submission, and scheduling. Allows you to display system activity, monitor VSAM space usage, display label information, system tasks, and so on.	No	Yes	<ul style="list-style-type: none"> <li>• Java 1.5 or later</li> <li>• VSE Connector Client</li> </ul>
VSE Health Checker	A graphical user interface for use by the VSE systems programmer. Provides retrieval, display, and analysis, of VSE system data. You can use this tool to obtain a summary of the “health” of your VSE system.	No	Yes	<ul style="list-style-type: none"> <li>• Java 1.5 or later</li> <li>• VSE Connector Client</li> </ul>
VSE Virtual Tape Server	The server-part of the VSE Virtual Tape functionality. A virtual tape is represented by a file in AWSTAPE format, which can be either a VSE/VSAM file or a file on any Java-enabled platform.	VTAPESRV.W in PRD2.PROD (after installation from Extended Base Tape)	Yes	Java 1.5 or later
VSE Script Server	Allows access to VSE functions and data from any kind of platform, Java and non-Java. VSEScript interprets and executes batch files (VSE script files), which contain commands to be executed on VSE.	No	Yes	<ul style="list-style-type: none"> <li>• Java 1.5 or later</li> <li>• VSE Connector Client</li> </ul>
VSE/VSAM JDBC Driver	A JDBC driver to issue SQL queries against VSAM files. Is part of the VSE Connector Client.	IESINCON.W in PRD2.PROD (after installation from Extended Base Tape)	Yes	Part of VSE Connector Client

## e-business Connectors and Tools

Table 38. Available z/VSE e-business Connectors and Tools (continued)

Tool	Description	Shipped With VSE?	Download From VSE Homepage?	Prerequisites
VSE Web Services	Provides a SOAP server and a SOAP client, running in CICS on the basis of CICS Web Support. The server allows a Web service that is implemented as CICS program, to be called from any kind of Web service client (Apache, AXIS, Microsoft .Net, C#, and so on). The client can call any Web service on, e.g., a WebSphere.	IESINCON.W in PRD2.PROD (after installation from Extended Base Tape)	Yes	Part of the VSE Connector Client
VSAM Maptool	Provides a Java-based dialog to generate VSAM data maps as they are used by the VSE/ESA e-business connectors and the IDCAMS function RECMAP. Maps can be either created by the user or imported from a VSE system, from an XML file, or from a COBOL copy book.	No	Yes	<ul style="list-style-type: none"> <li>• Java 1.5 or later</li> <li>• VSE Connector Client</li> </ul>
VSE Print Utility	A Java-based dialog to format and print VSE/POWER listings on PC or LAN-attached printers. Transfers the listings via AUTOFTP.	No	Yes	<ul style="list-style-type: none"> <li>• All VSE releases with TCP/IP</li> <li>• Java 1.5 or later</li> </ul>
JConVSE	Provides a Java-based dialog to automate your VSE jobs via an automated operator console. It is event or timer driven and is fully customizable.	No	Yes	<ul style="list-style-type: none"> <li>• Java 1.5 or later</li> <li>• VSE Connector Client</li> </ul>
JDataMig	Provides a Java application to read data from a VSAM file and write the data to a database, to spreadsheet format, or HTML.	No	Yes	<ul style="list-style-type: none"> <li>• Java 1.5 or later</li> <li>• VSE Connector Client</li> </ul>
Java class library with VSE-specific tasks for Apache ANT	Provides a programming interface for creating Apache ANT scripts for communicating with a VSE system. For details, see <a href="http://ant.apache.org">http://ant.apache.org</a>	No	Yes	<ul style="list-style-type: none"> <li>• Java 1.5 or later</li> <li>• VSE Connector Client</li> </ul>
Keyman/VSE	A VSE-specific SSL key management tool. It can directly upload generated RSA keys and certificates to VSE, and keep the server-side keyring in sync with client-side keyring files.	No	Yes	<ul style="list-style-type: none"> <li>• Java 1.5 or later</li> <li>• VSE Connector Client</li> </ul>
CICS2WS	A development tool that helps you to implement Web Services using your existing CICS programs.	No	Yes	Java 1.5 or later
VSE System Java class library	Provides a Java programming interface for VSE operator commands.	No	Yes	<ul style="list-style-type: none"> <li>• Java 1.5 or later</li> <li>• VSE Connector Client</li> </ul>

Table 38. Available z/VSE e-business Connectors and Tools (continued)

Tool	Description	Shipped With VSE?	Download From VSE Homepage?	Prerequisites
VSE Monitoring Agent	(1) Uses the SNMP Trap Client to send SNMP Version 1 "traps" to SNMP monitors from batch jobs. (2) Uses the SNMP Trap Client API to send SNMP Version 1 "traps" to SNMP monitors from COBOL, PL/I, and C programs, and CICS transactions.	IESMASNM.PHASE in PRD1.BASE	No	VSE Connector Client (if parts of GDPS Client run on Linux or Windows)
GDPS Client	Allows z/VSE system availability-data to be collected and sent to a central GDPS ( <i>Geographically Dispersed Parallel Sysplex</i> ) K-System running under z/OS.	IESGDPSC.PHASE in PRD1.BASE	No	<ul style="list-style-type: none"> <li>VSE Connector Client (if parts of GDPS Client run on Linux or Windows)</li> <li>a GDPS K-System running on z/OS</li> </ul>

## How the VSE Connector Components Are Installed

During **Initial Installation** or **FSU**, the following components are installed on your z/VSE system:

- Connector components that are installed into **PRD1.BASE** and are delivered on the **Base Tape**:
  - VSE Connector Server, which runs in a dynamic partition of z/VSE and is required for the Java-based connector support.
  - VSE/VSAM Redirector Client, which enables VSE programs to access data on remote systems, in real-time.
  - VSAM Call Level Interface, which provides access to VSE/VSAM data when using the DB2-based connector support.
  - VSE Monitoring Agent and plug-ins, which enable you to monitor your z/VSE systems using standard monitoring interfaces.
- Connector components that are installed into **PRD2.PROD** and are delivered on the **Extended Base Tape**. You can install these components onto any Java-enabled **workstations** of your choice. Alternatively, you can download these components from the VSE Home page:
  - VSE Connector Client, which provides the Java-based connector support on the middle-tier and the client side.
  - VSAM Redirector Server, which enables VSE programs to access data on remote systems, in real-time.
  - Database Call Level Interface that allows z/VSE applications to access a relational database on any suitable database server. Therefore, z/VSE customers have the flexibility of being able to choose a database server that runs on a platform other than z/VSE.
  - Virtual Tape Server, which allows you to create virtual tape files on a workstation.
  - VSE Script Server, which provides access to the z/VSE host from any Java or non-Java platform.

## e-business Connectors and Tools

- VisualAge Generator Client Interface, which provides access to the z/VSE host from the IBM *VisualAge Generator*.

**Note:** If you have *already installed* the Connector components on your PC or workstation, you must *reinstall* the versions of these components that are shipped with z/VSE 5.1.

In addition, the *DB2 Server for VSE 7.5* is installed from the Extended Base Tape into sublibrary **PRD2.DB2750** if requested during Initial Installation. It is the main component on the host side of the DB2-based connector, and runs in a dynamic z/VSE partition.

In case of an FSU, the DB2 Server for VSE may be installed after the FSU, or during the FSU using the appropriate processing control switch. You should, however, be aware that the DB2 Version might be different from the one installed with the previous release. Refer to “FSU from z/VSE 4.2.x, z/VSE 4.3.x, or z/VSE 5.1.x to z/VSE 5.1.2” on page 147 for further details.

You can also install the *DB2 Server for VSE Client Edition* from the Extended Base Tape after the FSU or initial installation. However, the *DB2 Server for VSE Client Edition* is not sufficient for use with the DB2-based connector since the DB2 Server for VSE Client Edition does not allow DB2 Stored Procedures to be run on z/VSE.

---

## Implementing the DB2-Based Connector

### Notes:

1. A DB2 Server for VSE is required for use with the DB2-based connector. The DB2 Server for VSE Client Edition does not allow DB2 Stored Procedures to be run on z/VSE.
2. Throughout this topic, the term *DB2 Server for VSE* is used for both the *DB2 Server for VSE* **and** the *DB2 Server for VSE Client Edition*. You enable and configure the *DB2 Server for VSE Client Edition* in a similar way as you enable and configure the *DB2 Server for VSE*.

In a DB2 relational database environment, the DB2-based connector provides access to this data stored on the z/VSE host:

- VSE/VSAM data
- DB2 data
- DL/I data

The access from a client to VSE/VSAM, DL/I, or DB2 data stored on the z/VSE host is via the middle-tier. The connection from the client to the middle tier is via TCP/IP, from the middle tier to the host via DRDA<sup>®</sup> (Distributed Relational Database Architecture<sup>™</sup>) using TCP/IP (or APPC), where DRDA is the communication protocol and TCP/IP the carrier protocol.

For details and examples of how the DB2-based connector is used to access data on the z/VSE host, refer to the chapter “Using the DB2-Based Connector to Access Data” in the *z/VSE e-business Connectors User’s Guide*

On the z/VSE host, the main component for the DB2-based connector support is the *DB2 Server for VSE 7.5* (or *DB2 Server for VSE Client Edition 7.5*) which runs per default in a **dynamic partition of class S**. By setting up a DB2 environment with the DB2 Server for VSE, you have the whole range of supported DB2 functions



available at your installation. This also includes a DB2 sample database. A DB2 Server for VSE is required for use with the DB2-based connector.

The DB2 Server for VSE Client Edition does not allow DB2 Stored Procedures to be run on z/VSE.

For the processing of *Stored Procedures*, which actually perform the access to VSE/VSAM and DL/I data, a **Stored Procedure Server** is defined. This server runs per default in a **dynamic partition of class R**.

## Initial Installation or FSU

The installation process for the *DB2 Server for VSE* is different for an Initial Installation compared to an FSU from z/VSE 4.2.x, z/VSE 4.3.x or z/VSE 5.1.x to z/VSE 5.1.2.

During the Initial Installation process, the following message appears on the console screen:

```
IESI0063D DB2 IS REQUIRED FOR THE DB2-BASED CONNECTORS. DO YOU WANT
          TO INSTALL DB2 NOW? YES/NO
```

If you respond with YES, you must mount the **Extended Base Tape** (during processing of job DB2REST) and install the DB2 Server for VSE (restored) into sublibrary PRD2.DB2750.

**Note:** This topic does not apply if you are performing a *service refresh* since different modification levels still use the same DB2 system.

## FSU from z/VSE 4.2.x, z/VSE 4.3.x, or z/VSE 5.1.x to z/VSE 5.1.2

The FSU dialog allows the installation of the *DB2 Server 7.5*. Note that an existing DB2 Server is *not* deleted and that your system may then include more than one DB2 Server. z/VSE 5.1.2 therefore provides the delete job DELDB274 to delete DB2/BASE 7.4.0.

Procedure USERBG includes the EXEC IVALPKEY statement to enable the *DB2 Server for VSE*. This statement must be activated after FSU completion via skeleton SKUSERBG available in VSE/ICCF library 59.

Refer to “DB2 Server for VSE 7.5” on page 93 for further FSU details.

If you have already installed a previous version of DB2 on your current system, a migration from your current DB2 to the *DB2 Server for VSE* is required to make use of the DB2-based connector support. For migration details, refer to the *Program Directory* of the *DB2 Server for VSE*.

**Note:** This topic does not apply if you are performing a *service refresh* from one modification level to another modification level of the *same* release, since different modification levels still use the same DB2 system.

## Enabling the DB2 Server for VSE

To use the *DB2 Server for VSE* or *DB2 Server for VSE Client Edition*, you must first enable it via a **key**. You have two choices: you use the trial key provided (giving you access for 90 days) or use the key you get when buying a DB2 license. The startup procedure **USERBG** (skeleton SKUSERBG) includes the following (inactive) statement with the trial key:

```
EXEC IVALPKEY,PARM='PRODUCT=DB2 KEY=0000-1111-2222-3333-4444CUSTINF*  
0=C111-111-111'
```

where the asterisk (\*) in the last position of the first line is the continuation character (column 72) and the second line continues at column 16.

You can use the statement as it is and just activate it via skeleton SKUSERBG available in VSE/ICCF library 59. This allows you to use the *DB2 Server for VSE* or *DB2 Server for VSE Client Edition* **for a trial period of 90 days**. After that time, you must replace the KEY and CUSTINFO information with the data you receive when buying a DB2 license. Otherwise, access to DB2 is denied. In case of a validation error, message 0S38I is displayed.

The trial period allows you to test the support provided via the DB2-based connector and access VSE/VSAM and DL/I data as well as using the DB2 sample data base available with the *DB2 Server for VSE* or *DB2 Server for VSE Client Edition*.

Once the trial period is activated by IVALPKEY, it is valid for 90 days. This is independent of the installation of the *DB2 Server for VSE*. If DB2 is installed 40 days later, for example, it can be used for 50 days only.

In case you decide not to use DB2 after the trial period, you can use the delete job DELDB275 (available in VSE/ICCF library 59) to remove the *DB2 Server for VSE 7.5* from your system. The job also deletes the *DataPropagator Relational Capture* component if installed. The delete job for the *DB2 Server for VSE 7.4* is DELDB274.

### Enabling the DB2 Server for VSE with a separate job:

You can run a separate job to activate the *DB2 Server for VSE* or *DB2 Server for VSE Client Edition* without using the EXEC IVALPKEY statement in the startup procedure USERBG (though this is recommended). A sample job is shown below. It uses as example the key for the trial period and must be run each time an IPL is performed **before** the *DB2 Server for VSE* is started.

```
* $$ JOB JNM=IVALTRY,DISP=L,CLASS=0  
// JOB IVALTRY  
// LIBDEF *,SEARCH=(PRD2.CONFIG,PRD2.SCEEBASE,PRD2.PROD,PRD2.DBASE)  
EXEC IVALPKEY,PARM='PRODUCT=DB2 KEY=0000-1111-2222-3333-4444CUSTINF*  
0=C111-111-111'  
  
/&  
* $$ E0J
```

The EXEC IVALPKEY statement must be processed before each DB2 startup. Otherwise, DB2 cannot be activated.

## Summary of the Steps Required to Install the Sample Database

### Notes:

1. The steps described in this topic are for the installation of the sample database for the DB2 Server for VSE only, and *not for the DB2 Server for VSE Client Edition*.
2. For details of how to configure your system for the DB2 Server for VSE Client Edition, refer to the relevant DB2 documentation.

This topic provides a summary of the tasks required for setting up a running DB2 environment on the host side for accessing VSE/VSAM, DL/I, and DB2 data stored on the host. It is assumed that the *DB2 Server for VSE* has already been restored (installed) into sublibrary PRD2.DB2750.

1. Customize CICS TS so that it has access to the DB2 Server for VSE.
2. Customize TCP/IP so that your workstations are set up to use the DB2-based connector.
3. Customize the DB2 Server for VSE and the DB2 sample database for use by the DB2-based connector.  
Skeletons provided: **SKDB2VAR** (including member ARISIVAR.Z; refer to "Use of Installation Member ARISIVAR.Z" on page 150 for details).
4. Set up your z/VSE environment for use with DRDA (Distributed Relational Database Architecture) support.  
Skeleton provided: **SKDB2VAR**.
5. Set up the DB2 Stored Procedure Server.  
Skeleton provided: **SKDB2SPS**.
6. Set up for DB2 Stored Procedures.  
Skeletons provided: see steps 7 and 8.
7. Customize the DB2-based connector for VSE/VSAM data access.  
Skeletons provided: **SKCRESTP**, **SKCPSTP**, **SKVSSAMP**.
8. Customize the DB2-based connector for DL/I data access.  
Skeletons provided: **SKDLISTP**, **SKDLICMP**, **SKDLISMP**.
9. Start DB2, and then start the DB2 Stored Procedure Server by placing the job DB2START in your VSE/POWER reader queue.  
Skeleton provided: **SKDB2STR**.
10. Establish a connection between your Web client and the z/VSE host, by installing and configuring DB2 Connect on your middle-tier platform.

For details of the above tasks, refer to:

- "Customizing the DB2-Based Connector" in the *z/VSE e-business Connectors User's Guide*.
- The Program Directory for the *DB2 Server for VSE*, which complements this information with the DB2 details needed to understand how DB2 is set up, and how it must be installed.
- The *DB2 System Administration* and the *DB2 Database Administration* publications of the *DB2 Server for VSE*, which provide further details for setting up a DB2 environment.

### Use of Installation Member ARISIVAR.Z

The parameters provided by ARISIVAR.Z determine the setup of your *DB2 Server for VSE* and the DB2 sample database provided. The DB2 Job Manager uses in addition job list control tables to control the installation process. Member ARISIVAR.Z has three parts:

- Preparation Steps

The preparation steps are always required, for an installation as well as for a migration (where migration means that you already have installed an earlier DB2 version). The job list control table used is ARISITBP.

- Installation Steps

The job list control table used for installation is ARISITBI.

- Migration Steps

The job list control table used for migration is ARISITBM.

There are mandatory and optional steps. Depending on how you want to set up your *DB2 Server for VSE*, you may decide to not perform some of the optional steps. Note that this chapter and the *z/VSE e-business Connectors User's Guide* do not discuss migration steps. If you need to perform a migration, consult the *Program Directory* of the *DB2 Server for VSE*.

ARISIVAR.Z is shipped in two formats which differ in content. The original ARISIVAR is shipped as Z-Book in PRD2.DB2750 and covers the whole range of DB2 definitions and functions available. In addition, VSE/ICCF library 59 provides skeleton **SKDB2VAR**. SKDB2VAR renames the original ARISIVAR.Z into ARISIVAR.ORIG and creates a new ARISIVAR.Z.

This new ARISIVAR.Z creates a **DB2 entry environment** for testing the connectors and the DB2 sample database provided. It is recommended to first create this less complex DB2 environment to ensure that the newly provided functions work correctly at your installation. Note that the skeleton assumes an IBM 3380 disk device for storage allocations. If you use a different disk device type, you must change these allocations accordingly (especially in case of FBA devices).

After successful testing, you may set up a more complex DB2 environment according to your requirements.

For a complete and detailed description of ARISIVAR.Z, its parameters and related control tables, refer to the *Program Directory* of the *DB2 Server for VSE*.

#### Submitting Skeleton SKDB2VAR

When submitted, skeleton SKDB2VAR performs the following major tasks:

- Defines for DB2 a separate disk volume (variable --V001--) and the related VSE/VSAM user catalog SQLCAT.
- Renames the original ARISIVAR.Z to ARISIVAR.ORIG.
- Catalogs the new ARISIVAR.Z into PRD2.DB2750.
- Places the startup job for the DB2 Job Manager (DB2JMGR) into the VSE/POWER reader queue.
- Places the startup job for DRDA (DB2DRDA) into the VSE/POWER reader queue.
- Places the startup job for the Stored Procedure Server (SPSERVER) into the VSE/POWER reader queue.

## Starting and Processing ARISIVAR.Z

Note that the processing of ARISIVAR.Z is controlled by the **DB2 Job Manager**.

You start the Job Manager by releasing the job **DB2JMGR** in the VSE/POWER reader queue (placed there by skeleton SKDB2VAR). You must release the Job Manager once for each step: Preparation, Installation (or Migration).

As described in detail in the *Program Directory* for the *DB2 Server for VSE*, ARISIVAR.Z processes many parameters, globals and variables, to define DB2 characteristics and resources.

Major definitions include, for example:

- The DB2 sample database **SQLDS** which is defined on volume --V001-- (variable in skeleton SKDB2VAR).
- The **DB2 Server for VSE Help** component, the installation of which is controlled by the following variable:

```
ARIS7ZJZ HELP      YES
```

It is recommended that you install this component since it provides the help information for the *DB2 Server for VSE*. When this variable is processed, you are requested to mount the corresponding tape. This is the fourth tape (the extra tape) of the distribution tapes you received. You must replace the variable --V003-- with the cuu of the device on which you mount the tape.

- The creation of DB2 (work)files such as **BINDFILE**, **BINDWFILE**, and **SQLGLOB**.
- The setting of **CICS TS** parameters as required for a DB2 environment.



---

## Chapter 10. TCP/IP and Networking Support

This chapter introduces z/VSE's TCP/IP and networking support. z/VSE offers two TCP/IP solutions:

- *TCP/IP for VSE/ESA*, which provides an *IPv4 solution* and is licensed from *Connectivity Systems Incorporated*.
- *IPv6/VSE*, which provides an *IPv4 solution* and *IPv6 solution* and is licensed from *Barnard Software, Incorporated*.

It contains these main topics:

- “TCP/IP for VSE/ESA Support”
- “IPv6/VSE Support” on page 155
- “TCP/IP Socket Interfaces Support” on page 157
- “OSA Express QDIO and Non-QDIO Support” on page 158
- “HiperSockets Support” on page 160
- “Exploiting the Queue-I/O Assist Function” on page 161
- “TCP/IP Layer 2 (Data Link Layer) Support” on page 161
- “Virtual LAN (VLAN) Support” on page 162
- “OSA Express for zBX (IEDN) Support” on page 162
- “Linux Fast Path Support” on page 163
- “z/VSE - z/VM IP Assist Support” on page 165

---

### TCP/IP for VSE/ESA Support

*TCP/IP for VSE/ESA* is a native implementation of Transmission Control Protocol/Internet Protocol (TCP/IP) for z/VSE and provides an *IPv4 solution* for z/VSE. TCP/IP for VSE/ESA is licensed from *Connectivity Systems Incorporated*.

TCP/IP for VSE/ESA provides the functions and the support described in detail in the *z/VSE TCP/IP Support*.

#### Function Overview

With TCP/IP for VSE/ESA you can, for example:

- Implement *Secure Sockets Layer (SSL)* security, including *client authentication*. This is described in detail in the *z/VSE Administration*.
- Implement *HiperSockets* and *Hardware Crypto* support. For details, refer to “HiperSockets Support” on page 160.
- Transfer files to or from z/VSE using the File Transfer Protocol (FTP).
- Permit PC users access to server applications using TN3270.
- Logon to remote hosts using the Telnet protocol.
- Write (or port) TCP/IP applications to your z/VSE host using the socket interface.
- Print files from the VSE/POWER LST queue directly on any TCP/IP-attached printer or print workstation or LAN files on any VSE/POWER-attached printer.
- Use z/VSE as a Web server for corporate Intranets or for the Internet.

## TCP/IP for VSE/ESA

Per default, TCP/IP for VSE/ESA is shipped enabled for **demonstration mode**, which allows a customer to try the product in a functionally very limited way. This mode is not suited for any production purposes.

To be able to use all the functions of TCP/IP for VSE/ESA, TCP/IP must be enabled **via a key** to be ordered from IBM. The complete set of TCP/IP functions (except for the NFS and GPS features) is also referred to as **Application Pak**. For details on the functions provided, refer to the *z/VSE TCP/IP Support, SC34-2640*.

## Installing TCP/IP for VSE/ESA

TCP/IP for VSE/ESA is automatically installed as part of z/VSE. After initial installation or FSU, TCP/IP for VSE/ESA resides in library PRD1.BASE and is available in **demonstration mode**.

If you finally decide not to use TCP/IP for VSE/ESA, run delete job DELTCPIP (provided in VSE/ICCF library 59) to remove the product from your system.

## TCP/IP for VSE/ESA Startup

### Partition Considerations

As shipped, z/VSE provides partition F7 with the storage values required for running TCP/IP for VSE/ESA:

ALLOC	SIZE	GETVIS	
20M	1M	19M	Environment A
20M	1M	19M	Environment B
32M	1M	31M	Environment C

TCP/IP for VSE/ESA can run in these predefined environments (A, B, and C). It can also run in a dynamic partition.

### Startup Job Stream

Here is an example of a startup job stream:

```
* $$ JOB JNM=TCPSTRT2,CLASS=7,DISP=K
* $$ LST CLASS=A DISP=D
:
// SETPFIX LIMIT=(400K)
// SETPFIX LIMIT=(,2100K)
:
// EXEC IPNET,SIZE=IPNET,PARM='ID=00,INIT=IPINIT00',DSPACE=2M
/&
* $$ EOJ
```

Figure 14. TCP/IP Startup Skeleton SKTCPSTR

### Notes:

1. Each OSA Express link causes TCP/IP to acquire 1 MB SETPFIX storage above if more than 16 MB real storage is available. 2100 KB is sufficient for 2 links.
2. If the TELNET Daemon Support is used with TCP/IP for VSE/ESA, a DSPACE value of 2 MB is recommended on the EXEC IPNET statement.



## Customizing TCP/IP for VSE/ESA

### Installing the Product Key and Customer Number

TCP/IP for VSE/ESA is the product that is licensed from *Connectivity Systems Incorporated* that currently supports IPv4 only (and not IPv6).

You must install the product key and your customer number before you can use TCP/IP for VSE/ESA in **production mode**. You do this by running two assembler jobs of which examples are provided in the *z/VSE TCP/IP Support*.

TCP/IP uses this information during startup of the TCP/IP partition to enable those TCP/IP functions you are authorized to use according to your product key and customer number.

### Using the TCP/IP Configuration Dialog (on the Host Side)

The z/VSE dialog for configuring TCP/IP on the host side is described in detail in the *z/VSE TCP/IP Support*. This dialog supports the creation of the startup member IPINIT00.L for use with TCP/IP for VSE/ESA (which supports IPv4 only).

This dialog cannot be used together with the IPv6/VSE product (which is described in “IPv6/VSE Support”).

## Migration Considerations for TCP/IP for VSE/ESA

Refer to the *z/VSE TCP/IP Support* for a detailed discussion of TCP/IP migration items.

## IPv6/VSE Support

*IPv6/VSE* is a native implementation of Transmission Control Protocol/Internet Protocol (TCP/IP) and provides both an *IPv6 solution* and *IPv4 solution* for z/VSE. IPv6/VSE has been licensed from *Barnard Software, Incorporated*.

### Function Overview

Using IPv6, the IP address space is expanded from 32-bit addresses (4-byte) as used in IPv4 to *128-bit addresses* (16-byte) as used in IPv6. As a result, there is a virtually unlimited number of IP addresses available for the foreseeable future.

This addressing capability, together with simplified address configuration and management, makes IPv6 a critical component in the evolution of e-business (network connectivity) and the next-generation internet.

*IPv6/VSE* provides:

- IPv4 and IPv6 TCP/IP stacks.
- IPv4 and IPv6 application programming interfaces (APIs).
- IPv4- and IPv6-enabled applications.

The *IPv6 TCP/IP stack of IPv6/VSE* can be run concurrently with an IPv4 TCP/IP stack within *one* z/VSE system. This is referred to as *dual stack support*. The IPv6 TCP/IP stack runs in a separate partition using its own stack ID.

Dual stack support addresses both performance and reliability aspects:

- Existing IPv4 applications continue to run unchanged using the IPv4 TCP/IP stack, thus protecting and leveraging existing investments. For example, since

IPv6/VSE does not support SSL you can continue to use your existing Hardware Crypto and SSL implementations (that both use an IPv4 TCP/IP stack).

- An application can connect to both the IPv4 and IPv6 network *simultaneously*. With the implementation of dual stack support, a single IPv6-enabled CICS transaction or batch application can communicate with partners via either the IPv4 or IPv6 network.
- New IPv6-enabled applications can be gradually introduced using the IPv6 stack of IPv6/VSE.

IBM provides extensions that can be used with IPv6/VSE. They include the:

- LE/VSE C socket interface
- EZASMI macro interface
- EZASOKET call interface

**Note:** These extensions and their external interfaces might describe more functionality than is actually provided by the IPv6/VSE program. Therefore, you should check the IPv6/VSE documentation for such exceptions.

IPv6/VSE provides a wide range of IPv6-enabled applications which can run outside the IPv6/VSE stack partition: for example, support for TN3270/TN3270E terminal sessions and TN3270E printer sessions. For the most recent details of applications provided by IPv6/VSE, refer to the Home Page of Barnard Software, Incorporated at:

<http://www.bsiopti.com>

## Installing IPv6/VSE

IPv6/VSE is a *base program* that is provided on the Extended Base Tape. The space requirements are shown in Table 16 on page 48.

After initial installation or FSU, you can install IPv6/VSE from the Extended Base Tape into sublibrary PRD2.TCPIP. Before you can use IPv6/VSE, you must obtain an installation key.

You can use IPv6/VSE together with TCP/IP for VSE/ESA in the same z/VSE system providing both programs are installed in separate libraries. However, if you wish to:

- Only use IPv6/VSE, run job DELTCPIP (provided in VSE/ICCF library 59) to remove TCP/IP for VSE/ESA from your z/VSE system.
- Only use TCP/IP for VSE/ESA, run job DELIPV6 (provided in VSE/ICCF library 59) to remove IPv6/VSE from your z/VSE system.

Note that z/VSE does not provide any dialogs for configuring IPv6/VSE on the z/VSE host (as it does for TCP/IP for VSE/ESA). The details of how to install IPv6/VSE are therefore provided:

- In the *z/VSE TCP/IP Support, SC34-2640*.
- At this URL:  
<http://www.ibm.com/systems/z/os/zvse/documentation/#tcpip>

## Installing the Product Key and Customer Number

You must install the product key and your customer number before you can use IPv6/VSE in your z/VSE system.

IPv6/VSE uses this information during startup of the IPv6/VSE partition to enable those IPv6/VSE functions you are authorized to use according to your product key and customer number.

## IPv6/VSE Startup

### Partition Considerations

As shipped, z/VSE provides partition F7 with the storage values required for running IPv6/VSE:

ALLOC	SIZE	GETVIS	
20M	1M	19M	Environment A
20M	1M	19M	Environment B
32M	1M	31M	Environment C

IPv6/VSE can run in these predefined environments (A, B, and C). It can also run in a dynamic partition.

### Startup Job Streams

z/VSE provides two sample startup jobs for your use:

- SKIPV4ST, a startup job for IPv4 using IPv6/VSE.
- SKIPV6ST, a startup job for IPv6 using IPv6/VSE.

You must tailor these sample jobs to suit your requirements (they are stored in VSE/ICCF library 59).

## Migration Considerations for IPv6/VSE

Refer to the *z/VSE TCP/IP Support* for a detailed discussion of IPv6/VSE migration items.

## TCP/IP Socket Interfaces Support

The TCP/IP socket interfaces support described here can be used with both *TCP/IP for VSE/ESA* and *IPv6/VSE*.

For details of this support, refer to the *z/VSE TCP/IP Support*.

## LE/VSE Support for TCP/IP Socket Interfaces

LE/VSE offers a C application programming interface (API) for TCP/IP sockets. This API for client/server communication across TCP/IP networks is compatible to the socket API of z/OS®.

IBM also provides IPv6-related functions that can be used with the *LE/VSE C Run-Time Socket API*.

## Support for the TCP/IP EZA Socket Application Programming Interfaces

For TCP/IP socket application programming, z/VSE provides the:

- EZASMI macro interface for HLASM programs.
- EZASOKET call interface for COBOL, PL/I and HLASM programs.
- IPv4- and IPv6-related functions of the *EZA Socket API*.

These interfaces are mostly compatible with the corresponding z/OS interfaces.

---

## OSA Express QDIO and Non-QDIO Support

This topic contains these sub-topics:

- “Using OSA Express in QDIO Mode”
- “Using OSA Express in Non-QDIO Mode”
- “Using OSA/SF to Manage/Customize the Adapter Environment” on page 159

### Using OSA Express in QDIO Mode

When an OSA Express adapter is configured as CHPID type **OSD** or **OSX**, it uses *QDIO (Queued Direct I/O) architecture*:

- QDIO mode is used for fast data-transmission via TCP/IP.
- The QDIO architecture allows a highly efficient data transfer since it eliminates the need for conventional I/O and interrupt processing. This results in accelerated TCP/IP data packet transmission.

The QDIO architecture is implemented by the z/VSE QDIO network driver. It is used for all z/VSE devices that have been configured with z/VSE device type **OSAX**.

The z/VSE QDIO network driver supports:

- TCP/IP Layer 2 and Layer 3.
- IPv4 and IPv6 protocols.

The TCP/IP configuration for OSAX device types is provided by:

- TCP/IP for VSE/ESA.
- IPv6/VSE.

Layer 2 and IPv6 support is provided by *IPv6/VSE*.

For details of how to use an OSA Express adapter in QDIO mode, refer to “Configuring an OSA Express Adapter” in the *z/VSE Administration*.

### Using OSA Express in Non-QDIO Mode

When an OSA Express adapter is configured as CHPID type **OSE** (*non-QDIO mode*) it emulates an *Open Systems Adapter (OSA-2)* adapter:

- This provides backwards compatibility for your VTAM applications.
- This provides backwards compatibility for any TCP/IP application that use the OSA-2 interface.

CHPID type **OSE** devices are configured with z/VSE device type **OSA**.

The TCP/IP configuration for devices with z/VSE device type **OSA** is provided by:

- TCP/IP for VSE/ESA.
- IPv6/VSE.

For details of how to configure an OSA Express device in non-QDIO mode, refer to “Configuring an OSA Express Adapter” in the *z/VSE Administration*.

## Using OSA/SF to Manage/Customize the Adapter Environment

*z/VSE* provides the *Open Systems Adapter Support Facility* (OSA/SF) for customizing and managing the OSA Express adapter environment. For example, you require OSA/SF to define the ports of OSA Express features (CHPID type OSE) that support two ports per CHPID.

OSA/SF is shipped as part of *z/VSE* and is automatically installed into the *z/VSE* sublibrary PRD1.BASE. It requires an additional sublibrary, PRD2.OSASF, for storing and processing data and work files.

Before you can use OSA/SF, you must prepare *z/VSE* so that you can run OSA/SF jobs in static or dynamic partitions of *z/VSE*. OSA/SF includes the following jobs (available in VSE/ICCF library 59):

### OSA/SF Job:

#### Explanation:

#### IOAMAIN

This job must be active in order to use OSA/SF. It must be running when submitting OSA/SF commands but also when using the GUI.

#### IOACMD

This job runs the command EXEC for submitting OSA/SF commands from the host (*z/VSE*).

To use the jobs IOAMAIN and IOACMD, you must prepare them as follows:

1. Modify them as required for your environment.
2. Submit them to the VSE/POWER reader queue.
3. Release them as needed for an OSA/SF task.

You can communicate with OSA/SF through:

- A supported workstation
- OSA/SF commands

To use OSA/SF on a supported workstation, you must first download from the *z/VSE* host the necessary files to create the *OSA/SF Graphical User Interface* (GUI) on your workstation:

- You can use the OSA/SF GUI for any supported workstation configuration and management task.
- Instead of using the OSA/SF GUI, you can manage and customize an OSA adapter by submitting OSA/SF commands from the host (*z/VSE*). All the tasks done from the OSA/SF GUI can also be done by submitting OSA/SF commands.

**Note:** OSA/SF does not support CHPID type OSX devices.

For details of how to:

- Define OAT entries,

- Install an SNA image using OSA/SF, refer to the *z/VSE SNA Networking Support*.

---

## HiperSockets Support

HiperSockets “network within the box” functionality allows high speed any-to-any connectivity among operating system images without requiring any physical cabling.

Each HiperSockets:

- Is defined via a HiperSockets channel path identifier (CHPID type **IQD**).
- Simulates a TCP/IP network (a LAN) with a specific server.

z/VSE supports *HiperSockets spanned channels* (HiperSockets that connect LPARs via different Logical Channel Subsystems).

HiperSockets uses the *QDIO (Queued Direct I/O) architecture*. Therefore, HiperSockets devices are:

- Defined using z/VSE device type OSAX.
- Implemented in the z/VSE QDIO network driver (which is also used for CHPID type OSD and OSX devices).

For HiperSockets, the z/VSE QDIO network driver supports:

- TCP/IP Layer 3
- IPv4 and IPv6 protocols.

The TCP/IP configuration for OSAX device types is provided by:

- TCP/IP for VSE/ESA.
- IPv6/VSE.

IPv6 support is provided by *IPv6/VSE*.

Real LANs have a maximum frame size predefined by the architecture. With HiperSockets you can define the maximum frame size for each of the four possible HiperSockets yourself.

The following *Redbook* provides planning and implementation information, as well as setup examples:

- *zSeries HiperSockets*, SG24-6816.
- You can order hardcopy Redbooks®, as well as view, download, or search for Redbooks at the following Web site:

[www.redbooks.ibm.com](http://www.redbooks.ibm.com)

If you run z/VSE under z/VM, you can also use *virtual HiperSockets*. For details of HiperSockets support under VM, refer to the corresponding z/VM documentation.

For details of how to configure a HiperSockets device, refer to “Configuring a HiperSockets Device” in the *z/VSE Administration*.

---

## Exploiting the Queue-I/O Assist Function

The z/VM function *queue-I/O assist* (QIOASSIST) provides performance improvements for V=V guests using real adapters and real networking devices that use the Queued Direct I/O (QDIO) facility.

z/VSE exploits the queue-I/O assist function for:

- OSA Express devices (CHPID type **OSD**).
- HyperSockets devices (CHPID type **IQD**).

To use the queue-I/O assist (QIOASSIST) function in z/VSE, use the z/VM CP command:

```
SET QIOASSIST ON
```

After you have enabled the queue-I/O assist function, each z/VSE DEFINE LINK,TYPE=OSAX command will then *automatically* exploit the queue-I/O assist function.

If you do not wish to use the queue-I/O assist (QIOASSIST) function in z/VSE, disable it using this z/VM CP command:

```
SET QIOASSIST OFF
```

Other z/VM CP commands you might use are:

- CP QUERY QIOASSIS to show if the queue-I/O assist function is enabled.
- CP QUERY VIRTUAL OSA to show if an adapter is running with the queue-I/O assist function.

### Summary of Requirements for Using the Queue-I/O Assist function:

- z/VM must be Version 5 Release 4 or later.
- z/VM must be running in an LPAR and not as a z/VM guest.
- The queue-I/O assist function must be *globally* enabled via the SET QIOASSIT ON ALL command.
- The virtual machine must be enabled via the SET QIOASSIST ON command.
- The adapters and networking devices must not be attached to the virtual machine via either the:
  - NOQIOASSIT option of the CP ATTACH command.
  - System directory DEDICATE statement.

For further details on how to use the queue-I/O assist function, refer to the z/VM V5R4 CP Commands and Utilities Reference, SC24-6081-07 or later.

---

## TCP/IP Layer 2 (Data Link Layer) Support

Layer 2 is the Data Link Layer of the OSI (*Open Systems Interconnection*) TCP/IP model. From z/VSE 5.1 onwards, z/VSE allows Layer 2 in addition to Layer 3 (IP Layer) mode. Layer 2 mode provides you with additional connectivity options:

- In a Layer 3 configuration, the TCP/IP stack uses IP packets that include IP addresses to determine source and destination.
- In a Layer 2 configuration, the TCP/IP stack uses Ethernet frames that include MAC addresses to determine source and destination.

## TCP/IP Layer 2 (Data Link Layer)

The use of both modes is transparent to TCP/IP applications. Layer 3 is the default mode for z/VSE devices of type OSAX (OSA Express, HiperSockets) and is supported by TCP/IP for VSE/ESA and IPv6/VSE. It is the only mode that could be used prior to z/VSE V5.1.

IPv6/VSE V1.1 adds Layer 2 support for OSA Express devices (CHPID type OSD or OSX) when used in an IPv6 link. Layer 2 has to be specified explicitly in the IPv6/VSE configuration.

Layer 2 support extends the capabilities of your z/VM guest environment:

- You can now include a z/VM VSWITCH into your z/VSE IPv6 configuration and, when accessing the IEDN through a z/VM VSWITCH, you can use IPv6 links in addition to IPv4 links.
- Layer 2 support also allows you to share a z/VM VSWITCH with operating systems that require Layer 2 for protocol independent traffic.

For details of how to define TCP/IP Layer 2 links, refer to:

<http://www.ibm.com/systems/z/os/zvse/documentation/#tcpip>

---

## Virtual LAN (VLAN) Support

A *virtual LAN* allows a physical network to be divided administratively into separate logical networks. These logical networks operate as if they are physically independent of each other.

z/VSE provides VLAN support for OSA Express (CHPID type OSD and OSX) and HiperSockets devices.

- In a Layer 3 configuration, VLANs can be transparently used by IPv6/VSE and TCP/IP for VSE/ESA.
- If you wish to configure VLANs for OSA-Express (CHPID type OSD and OSX) devices in a Layer 2 configuration that carries IPv6 traffic, you require IPv6/VSE.

For details of how to configure a VLAN, refer to the *z/VSE TCP/IP Support*, SC34-2640.

---

## OSA Express for zBX (IEDN) Support

OSA-Express for zBX (CHPID type **OSX**) provides connectivity and access control to the *Intra-Ensemble Data Network (IEDN)* from z196 and z114 to *Unified Resource Manager* functions.

An *Intra-Ensemble Data Network (IEDN)* provides connectivity between:

- A zEnterprise CEC (Central Electrical Complex) or later and System z<sup>®</sup> Blade Center Extensions (zBXs).
- Two or more zEnterprise CECs or later.

IEDN requires *OSA Express for zBX* devices (CHPID type **OSX**) and VLAN (at least GLOBAL VLAN) support. VLAN support is described in *z/VSE TCP/IP Support*, SC34-2640.

In addition to the OSA Express for zBX support in z/VSE, you must also configure z/VSE within your IEDN using *Unified Resource Manager* functions. For details, refer to the relevant *Unified Resource Manager* documentation.



OSA Express for zBX uses the *QDIO (Queued Direct I/O) architecture*. Therefore, OSA Express for zBX devices are:

- Defined using z/VSE device type OSAX.
- Implemented in the z/VSE QDIO network driver (which is also used for CHPID type OSD and IQD devices).

OSA Express for zBX devices can be used with:

- TCP/IP Layer 2 and Layer 3.
- IPv4 and IPv6 protocols.

The TCP/IP configuration is the same as for all other OSAX device types.

z/VSE can participate in an IEDN using either:

- OSA Express for zBX devices (z/VSE 5.1 and later) either in an LPAR or z/VM guest environment. This requires VLAN (at least Global VLAN) support.
- z/VM VSWITCH and OSDSIM mode in a z/VM guest environment (z/VSE 4.2 and later).
- If using a z/VM VSWITCH environment, you are recommended to only use the VLAN support provided by z/VM VSWITCH.

For further details about IEDN support, refer to the chapter “Participating in an Intra-Ensemble Data Network” in the *z/VSE Administration*.

---

## Linux Fast Path Support

This topic provides an overview of the *Fast Path to Linux on System z function*, referred to simply as the *Linux Fast Path (LFP)*.

The *Linux Fast Path (LFP)* allows selected TCP/IP applications running under z/VSE to communicate with a TCP/IP stack on Linux *without* using a TCP/IP stack on z/VSE. In addition to your own applications, *z/VSE e-business Connectors* can run on Linux on System z and be accessed via a Linux Fast Path. For example:

- VSE Connector Client
- DB/2 Connect
- WebSphere MQ Client
- WebSphere MQ Server
- VSE Script Server
- VSE Virtual Tape Server
- VSAM Redirector Server

The Linux Fast Path can be run in either a *z/VM environment* or an *LPAR environment*:

- If you run Linux Fast Path (LFP) in a z/VM environment, both z/VSE and Linux on System z run in the *same* z/VM-mode LPAR on an IBM System z10 or later server. An IUCV connection is used between z/VSE and Linux on System z.
- If you run Linux Fast Path (LFP) in an LPAR environment, both z/VSE and Linux on System z run in their own LPARs on a zEnterprise server. A HiperSockets connection is used between z/VSE and Linux on System z. LFP requires the *HiperSockets Completion Queue* function that is available with zEnterprise.

**Notes:**

## Linux Fast Path

1. If you run LFP in a z/VM environment, it is *not* a technical requirement that you run the Linux Fast Path in a z/VM-mode LPAR. However, you are recommended to do so in order to reduce TCO. This is because Linux on System z will primarily run on the faster/cheaper IFL (Integrated Linux Facility) processors whereas z/VSE will run on standard processors. Otherwise, both Linux on System z and z/VSE will run on standard processors which might result in higher software costs.
2. If you run LFP in an LPAR environment, Linux on System z will primarily run on the faster/cheaper IFL (Integrated Linux Facility) processors, whereas z/VSE will run on standard processors.

*The information that now follows applies to both IUCV and HiperSockets connections.*

All socket requests will be transparently forwarded to a Linux on System z system. The LFP daemon (lfpd) must run on Linux on System z. This daemon fulfills all socket requests by forwarding them to the Linux TCP/IP stack.

The Linux Fast Path function is *not* intended to replace an existing TCP/IP stack on z/VSE being used to communicate with a remote server. LFP only provides TCP/IP socket APIs for programs running on z/VSE:

- These APIs are compatible with existing APIs and enable existing socket programs to run unchanged using the LFP.
- Other than the basic socket API, no other tools (for example, FTP server or FTP client) are provided.
- You still require a TCP/IP stack on z/VSE in order to run FTP servers/daemons, TELNET servers, LPR/LPD, and so on.

z/VSE applications that run with an LFP can use both:

- IPv6, that allows 128-bit (16-byte) IP addresses (from z/VSE 5.1 onwards).
- IPv4, that allows 32-bit (4-byte) IP addresses.

A z/VSE system can connect to an LFP daemon running on Linux on System z that was shipped before z/VSE 5.1 became available. However:

- None of the IPv6 functions and options will be available. If an attempt is made to either invoke an IPv6 function or use an IPv6 option, this attempt will be rejected with an appropriate error message.
- If you wish to use LFP in an LPAR environment (via a HiperSockets connection), you must upgrade your z/VSE system and the LFP daemon (lfpd) on Linux on System z to include HiperSockets support.

For details of:

- the prerequisites and restrictions when using a Linux Fast Path
- the communication flow when using a Linux Fast Path
- how to set up, configure, and use a Linux Fast Path
- the IPv4- and IPv6-related functions of the *EZA Socket API*

refer to the *z/VSE TCP/IP Support*, SC34-2640.

---

## z/VSE - z/VM IP Assist Support

z/VSE - z/VM IP Assist (referred to in its short form as *z/VSE VIA*) allows selected TCP/IP applications running under z/VSE to communicate via a Linux Fast Path with a z/VM guest that provides all the services the Linux Fast Path requires.

Therefore, you are not required to:

- install and maintain a Linux system in a z/VM guest
- use a TCP/IP stack on z/VSE

For example, your z/VSE TCP/IP applications can use a Linux Fast Path to access a database server installed on a non-z/VSE operating system running on an IBM zEnterprise BladeCenter® Extension (zBX).

To use z/VSE VIA, you must:

- Configure a z/VSE VIA guest image using the SCPDATA operand of the z/VM LOADDEV directory control statement.
- Configure the z/VSE VIA guest image to have two CMS minidisks.
  - The *configuration disk* contains the LFPD daemon configuration files and the SENDERS.ALLOWED file. This disk must be linked during z/VM startup by the LOADDEV directory entry.
  - The *data disk* contains trace files written if a trace has been started. This disk can be linked during z/VM startup or when the trace is started.
- Configure one or more Linux Fast Path daemons that will be run by the z/VSE VIA guest image.

For details of:

- the prerequisites and restrictions when using z/VSE VIA
- the communication flow when using z/VSE VIA
- how to set up, configure, and use z/VSE VIA

refer to the *z/VSE TCP/IP Support*, SC34-2640.



---

## Chapter 11. Using Data Spaces and Virtual Disks

This chapter introduces and provides planning information for the capabilities and the support of:

**Data Spaces**

**Virtual Disks**

In general, these capabilities allow for more “data in memory” which reduces the number of physical input/output (I/O) operations to disk devices. This provides better response times for online applications and better elapsed times for applications running in batch. These advantages require, however, that **sufficient real storage** is available. Refer to “z/VSE Exploitation Overview” on page 259 for additional details about “data in memory”.

Consult the *z/VSE Extended Addressability* for details and information about planning and writing application programs that make use of these capabilities.

This chapter contains these main topics:

- “Data Space Support”
- “Virtual Disk Support” on page 169
- “Further Planning Information for Data Spaces and Virtual Disks” on page 171
- “Examples of Virtual Disk Usage” on page 172
- “Improving Virtual Storage Management for Application Programs” on page 175

---

### Data Space Support

#### Requirements

Data spaces are data-only spaces that can hold up to 2 GB of data. A data space can be considered as an area in virtual storage like an address space. Unlike an address space, however, a data space can **only** contain data.

It does not contain shared areas as the following diagram shows:

## Data Space Support

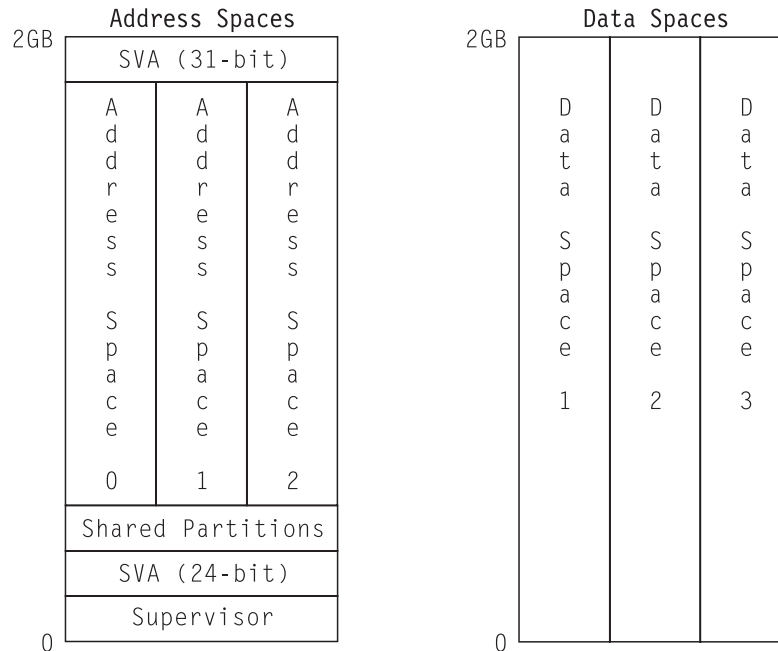

Figure 15. The Difference Between Address Spaces and Data Spaces

By using data spaces, you move data closer to a program since the data also resides in virtual storage and not on disk. Data Spaces are an extremely flexible solution to problems related to accessing large amounts of data. They also provide integrity and isolation for the data they contain in much the same way as address spaces provide integrity and isolation for code and data they contain. z/VSE includes macros allowing you to write programs to create, control, and delete data spaces as required.

### Notes:

1. Only programs in 31-bit addressing mode can create data spaces and access data located above the 16 MB line in a data space.
2. Programs in 24-bit addressing mode can access data located below the 16 MB line in a data space.

z/VSE data spaces have the following characteristics:

- Program code cannot execute in a data space. But a program can reside in a data space as nonexecutable code.
- Data spaces cannot contain shared areas or control blocks.
- The owner of a data space is the task that creates the data space.
- Programs accessing data spaces must be in access register (AR) mode. Note that most supervisor services cannot be called in AR mode. For example, it is not possible to issue an I/O request from or to a data space.
- Data spaces improve data sharing capabilities for:
  - Selected users (SCOPE=ALL)
  - System wide (SCOPE=COMMON)
- Only key 0 programs can create data spaces of TYPE=ALL or COMMON.

z/VSE data spaces are a subset of the MVS™ data space support and are implemented via MVS compatible interfaces and concepts such as source code compatible macro expansions.

## 1 MB Frame Support for Data Spaces

The 1 MB frame support (also referred to as “large page support” or “1 MB page support”) allows 1 MB of virtual storage to be backed with 1 MB frames in processor storage. This means, the virtual storage can be viewed as being “fixed” because paging does not occur. The 1 MB frame support is available:

- on IBM z10 and z196 platforms
- in *LPAR mode* only.

z/VSE uses 1 MB frame support for *data spaces*. Long-running applications accessing data spaces frequently might benefit from improved CPU utilization. 1 MB frame support for data spaces might help you to exploit large processor storage to a greater extent. z/VSE implements this support *transparently*:

- In order to take advantage of z/VSE's 1 MB frame support, you are *not* required to perform any actions.
- z/VSE decides internally when and how data spaces will be backed with 1 MB frames. Therefore, a data space can consist of both “fixed” and “pageable” virtual storage.
- If the z/VSE system runs out of processor storage, one or more 1 MB frames used for backing data spaces will be made available again for use by the system. This is true for the time during which the data space application is active. To avoid this occurring in the future, you might wish to increase the amount of processor storage before the next re-IPL of your z/VSE system.

The default size of a data space (DFSIZE) is 960 KB. All data spaces that you define with a maximum size of *at least 960 KB* will benefit from 1 MB frame support providing there is sufficient processor storage available.

### Related Topics:

For details of ...	See these command descriptions in the <i>z/VSE System Control Statements</i>
how to configure data space support	<ul style="list-style-type: none"> <li>• SYSDEF DSPACE</li> </ul>
how 1 MB frames for data spaces are currently being used in your z/VSE system	<ul style="list-style-type: none"> <li>• MAP REAL</li> <li>• QUERY DSPACE</li> <li>• QUERY MEMOBJ</li> <li>• QUERY SYSTEM</li> </ul>

---

## Virtual Disk Support

### Requirements

With the virtual disk support it is possible to have (temporary) data reside in virtual storage (in a data space) and not on a real disk device. Each virtual disk resides in its own separate data space. A virtual disk in z/VSE has been implemented by emulating an FBA (Fixed Block Architecture) disk device. You can use it like a real FBA device, without being required to change code in your applications. In addition, applications running in different partitions on the same z/VSE system can share virtual disks like real disk devices.

Since data can be accessed at memory speed, response times for transactions and throughput for jobs and applications accessing such data may improve significantly.

With z/VSE, you can define up to 128 virtual disks.

### Where to Use Virtual Disks

Since virtual disks are not permanent, they should be used for files that easily can be recovered in case of loss (because of a power failure, for instance). These include:

- **Temporary work files or test files**

All types of temporary work files can be used on a virtual disk. These can be work files for compilers, sort programs, and so on. See also skeleton SKWRKFIL.

- **VSE/VSAM space and user catalogs**

As with a real disk, the space on a virtual disk can be split between VSE/VSAM space and other files. If you have VSE/VSAM files on a virtual disk, note that:

1. A VSE/VSAM user catalog for files on a virtual disk *must* also reside on a virtual disk. This is also true for VSE/VSAM workfiles.
2. A multi-volume file *must* be completely allocated either on virtual disks or on real disks. It cannot be allocated on both.
3. You should use the BACKUP and RESTORE functions of VSE/VSAM to move VSE/VSAM objects between virtual disks and real disks, if, for example, VSE/VSAM test files are to be created on a virtual disk.

- **VSE libraries**

You can place VSE libraries into VSE/VSAM or non-VSE/VSAM space on a virtual disk. To reduce real I/O requests to frequently-used applications or data, copy them to the virtual disk by using the librarian program LIBR. Refer also to “Creating a VSE Library that Resides on a Virtual Disk” on page 173.

“z/VSE Virtual Disks” on page 263 provides further details about when and where to use virtual disks.

### Where Not to Use Virtual Disks

Since virtual disks are volatile, they cannot be used for data that must be kept if the system goes down or for data that is needed during system startup. Therefore, do **not** use a virtual disk to hold files such as the following:

- Control file
- LDAP mapping file
- BSM control file
- Text repository file
- CSD file
- Page data sets
- System recorder file
- System history file
- Hardcopy file
- VSE/VSAM master catalog

A z/VSE virtual disk cannot be shared among z/VSE systems. It can, however, be shared by different partitions on the same z/VSE system.



## Performance Considerations for Virtual Disks

Virtual disks in data spaces are subject to the same paging rules as virtual storage for address spaces. To benefit from virtual disks, you must have sufficient real (processor) storage available to avoid a possible paging bottleneck. If the real storage available is insufficient, I/O requests to real disks are replaced by I/O requests to the page data set.

---

## Further Planning Information for Data Spaces and Virtual Disks

### Storage Considerations

With the AR and JCL command **SYSDEF** you define the maximum amount of virtual storage that can be allocated to data spaces. However, the specified storage may not always be available for data spaces. The system may use it also for allocating partitions if required. The storage specified for **SYSDEF** is taken from the value specified for **VSIZE**. Consequently, you have to increase the **VSIZE** definition to accommodate the storage requirements for data spaces (and virtual disks) as follows:

- Add the size of all data spaces that might be used concurrently and needed besides those needed for virtual disks.

**Note:** For each data space, virtual storage is allocated in multiples of 32KB. For example, if you define a data space of 40KB, the available **VSIZE** decreases by 64KB although the usable data space size is 40KB.

- Add the size of all virtual disks that might be used *concurrently*.

Add the resulting value to your current **VSIZE**.

Once you have determined the total value for **VSIZE**, it may be necessary to increase the current size of your page data set (defined through the IPL **DPD** command).

You can change both, **VSIZE** and **DPD** values, through the *Tailor IPL Procedure* dialog.

## Command and Macro Support

### Data Space Commands

Consult the *z/VSE System Control Statements* under “**SYSDEF**”, “**QUERY**”, and “**MAP**” for a detailed description of the commands listed below.

- **SYSDEF** command
 

With the **SYSDEF** command you define the maximum amount of virtual storage which may be allocated to data spaces (and virtual disks) if available. Optionally, it allows you to specify values such as the default size of a data space and the maximum number of data spaces.
- **QUERY** and **MAP** command
  - With the **QUERY** command you can display information about data spaces and their characteristics.
  - With the **MAP** command you can display the amount of virtual storage allocated to data spaces.

### Data Space Macros

Consult the *z/VSE System Macros Reference* for a detailed description of the macros listed below.

- **ALESERV** macro  
A program uses the “ALESERV” macro to control the data space entries in the access list.
- **ATTACH ALCOPY** macro  
A program uses the “ATTACH ALCOPY” macro to transfer data space information to a subtask to be attached.
- **DSPSERV** macro  
A program uses the “DSPSERV” macro to create, delete, and control data spaces.
- **SDUMPX** macro  
A program uses the “SDUMPX” macro to dump storage from a data space.
- **SYSSTATE** macro  
A program uses the “SYSSTATE” macro to set and test the address space control (ASC) mode.

### Virtual Disk Commands and Macros

Consult the *z/VSE System Control Statements* for a detailed description of the commands and the *z/VSE System Macros Reference* for a detailed description of the macro listed below.

- **ADD** command  
With the “ADD” command, you add a virtual disk (device type FBAV) to z/VSE in the same way as a real disk device.  
The *Hardware Configuration* dialog supports virtual disks through device type FBAV.
- **VDISK** command  
With the “VDISK” command, issued from the BG partition, you create the data space required for a virtual disk.
- **VOLUME** command  
With the “VOLUME” command, you can retrieve information about existing virtual disks.
- **GETVCE** macro  
A program can use the “GETVCE” macro to retrieve device characteristics of a virtual disk.
- **QUERY** command  
With the “QUERY” command, you can display data space limits and other data space characteristics.

---

## Examples of Virtual Disk Usage

Following are two examples of virtual disk usage:

1. “Creating a VSE Library that Resides on a Virtual Disk” on page 173.
2. “Label Area on Virtual Disk” on page 173.

## Creating a VSE Library that Resides on a Virtual Disk

The following steps are an example of how to create and use a VSE library on a virtual disk:

1. Define a virtual disk in the IPL startup procedure with the command:

```
ADD 234,FBAV
```

You can use the *Tailor IPL Procedure* dialog to add the command.

2. Catalog the following procedure (named VDISK) into a sublibrary so that you can run it any time required.

The procedure defines a library on a virtual disk with address 234 and a size of 3000 blocks. As a next step, it copies macros (A-Books) into the virtual library. These macros, it is assumed, are accessed frequently by compile jobs.

```
// VDISK UNIT=234,BLKS=3840
// DLBL MYLIB,'MY.TEMP.LIBRARY'
// EXTENT SYS019,,1,0,10,3000
// ASSGN SYS019,234
// EXEC LIBR
DEF L=MYLIB
DEF S=MYLIB.MYSUBLIB
CONN S=PRD1.MACLIB:MYLIB.MYSUBLIB
COPY MAP*.A
/*
```

3. You can activate the procedure from the BG partition with:

```
EXEC PROC=VDISK
```

4. It is recommended that the labels are not included in the standard label procedure (STDLABEL) and that temporary LIBDEF statements are submitted with the jobs accessing the virtual library.

## Label Area on Virtual Disk

### Notes:

1. From z/VSE 4.1 onwards, the label area *must* reside on virtual disk. The default cuu used is **FDF**. It cannot reside on a real disk.
2. Do not delete the ADD FDF,FBAV statement in the IPL procedure since it is required for system startup. The same applies to the VDISK statement in the \$0JCL procedure:
 

```
// VDISK UNIT=FDF,BLKS=2880,VOLID=VDIDLA,USAGE=DLA
```
3. You can use your own cuu address for the label area. If you *do* use a different cuu address, you must change the VDISK statement in the \$0JCL procedure accordingly.

Labels are used to identify files and libraries and are stored in the system's label information area. This area is located on a disk device (DOSRES). For each first-time access (OPEN) to a file or library a search for the corresponding label on disk is required. In great numbers, such search operations for label information can become time-consuming and degrade performance.

The search time for labels can be reduced considerably by moving the label area from disk into virtual storage. This is done by defining a **virtual disk** for holding the label area. Note that a virtual disk is a temporary storage media, that is, the data stored on it is lost in case of a system restart (IPL). Since the label area and its content are recreated with each startup, this should cause no problem. It requires, however, that the procedures run during startup for the label area reflect the latest status of the system's label information.

### Planning Information

It is necessary to check whether your VSIZE value is large enough for the SYSDEF definition to accommodate the virtual disk. If you have to increase the VSIZE, it may be required to increase the size of the page data set as well. Page data set extents are defined through DPD commands. Both, the VSIZE specification and the DPD commands are part of the IPL startup procedure and you can modify them using the *Tailor IPL Procedure* dialog.

Since the layout of a virtual disk reflects an FBA disk device, the system allocates blocks (of 512 bytes each) for the label area. The allocation of a virtual disk is done in multiples of 960 blocks. This means that this value is also the minimum size possible for the label area. If the value specified for BLKS in the VDISK statement is equal or lower than 960, the system always allocates 960 blocks. 960 blocks provide space for about 3000 labels. This is an average value, however, which may be higher or lower depending on such parameters as the number of partitions and the number of labels stored in each subarea.

The maximum size supported for the label area is 2880 blocks.

### Background Information for Label Area Size

The label processing routine uses a 90-byte table to maintain 2KB label subareas. These 2KB label subareas (also called label area segments) are the allocation units to store label information records. The table can thus handle 720 (8 times 90) 2KB subareas.

Each 2KB subarea is mapped to four 512-bytes FBA blocks. This results in a maximum of 2880 (4 times 720) FBA blocks. Two FBA blocks are required for the VOL1 label residing at the very beginning of the virtual disk. These two FBA blocks cannot be used to store label information – actually four FBA blocks, because label processing considers four consecutive FBA blocks as one allocation unit. Therefore, a maximum of 2876 (4 times 719) blocks are available to store label information. This value can be decreased by the VTOC which resides at the very end of the virtual disk. Eight FBA blocks are the minimum (and the default if USAGE=DLA has been specified in the VDISK command) to hold the VTOC.

Each 2KB allocation unit holds a maximum of 19 label records in case of sequential or VSE/VSAM files (or 24 label records in case of tape files). Hence, under the assumption that we deal with sequential or VSE/VSAM files and that each 2 KB label subarea is filled up completely, 13661 (19 times 719) labels can be stored.

However, this is a theoretical upper limit. The real upper limit depends on:

- The number of active partitions using partition labels (temporary, permanent, or free-usage).
- The number of labels stored for each label group (such as BG permanent labels).

If, for example, we have 100 dynamic partitions, each writing one temporary and one permanent partition label, then we have 200 labels occupying 200 label subareas (from a total of 712). If, on the other hand, we have 5 dynamic partitions, each writing 40 temporary partition labels, then we have 200 labels occupying only 15 label subareas.

9000 labels is a reasonable average value for a label area with the maximum size of 2880 blocks.

Theoretically, you can define a much larger virtual disk than the 2880 blocks supported for the label area and use the additional space for storing other data.

However, this is not recommended and it is preferable to define a separate virtual disk for holding the label area only.

### Where to Find Further Information

For a detailed description of the ADD, DLA, SYSDEF, and VDISK commands or statements, refer to the *z/VSE System Control Statements*.

For a detailed description of skeleton SKJCL0, refer to the *z/VSE Administration* under “Skeletons for Starting Up BG Partition”. This publication also describes the *Tailor IPL Procedure* dialog under “Tailoring the IPL Procedure”.

---

## Improving Virtual Storage Management for Application Programs

Additional programming enhancements are available which further improve virtual storage management for application programs.

These enhancements include:

- Linkage stack functions
- Callable cell pool services

“Linkage Stack Functions” and “Callable Cell Pool Services” in the *z/VSE Extended Addressability* describe these enhancements in detail. The following paragraphs provide introductory information.

### Linkage Stack Functions

The linkage stack is an area of protected storage that the system gives to a program to save status information in case of a branch or a program call. Each VSE task has its own linkage stack available for all programs running under this task.

The saved status information includes the contents of the 16 general purpose registers (GRPs), the 16 access registers (ARs), the PSW (program status word), and other relevant system information. Instructions are available to branch and save and to return and restore the saved information, as well as to access the linkage stack entries and their contents.

The linkage stack support is required when using the callable cell pool services introduced below.

### Callable Cell Pool Services

Cell pool services are available through the CALL macro interface. The services can be used to manage virtual storage located in the primary address space, any other address space, or in data spaces.

A cell pool is an area of virtual storage that is subdivided into fixed-sized areas of storage called **cells**. A cell pool contains an anchor, at least one extent, and any number of cells of the same size. You define these resources and their size by calling the cell pool services through the CALL macro.

You obtain the virtual storage for the cell pool through either the GETVIS or the DSPSERV macro.



---

## Chapter 12. Dynamic Partition Support

This chapter provides planning information relevant if you want to use dynamic partitions at your installation. Before you read this chapter you should be familiar with the concept of dynamic partitions as described under “Static and Dynamic Partitions” on page 56.

It contains these main topics:

- “Dynamic Partition Support Summary”
- “Planning for Implementation” on page 179
- “Predefined Dynamic Partition Support” on page 181
- “Partition Standard Labels for Dynamic Partitions” on page 184

---

### Dynamic Partition Support Summary

This topic provides a summary of the system support provided by z/VSE for dynamic partitions. It mentions items such as dialogs, skeletons, and statements needed to implement, modify, or operate dynamic partitions. It refers to other publications for details where appropriate.

This topic mentions also the restrictions which apply to dynamic partitions with regard to static partitions. For example, not all system programs that run in static partitions can also be run in dynamic partitions.

### System Support for Dynamic Partitions

The system support for dynamic partitions includes:

- Predefined Environments A, B, and C, which support dynamic partitions as described under “Predefined System Environments” on page 59. z/VSE provides a dialog (*Maintain Dynamic Partitions*) and skeletons to implement and tailor dynamic partitions. Refer to “Planning for Implementation” on page 179.
- Support of multiple dynamic class tables to easily change the setup of a dynamic partitions environment.
- Dialogs and commands for operating and controlling dynamic partitions:
  - *Display System Activity* dialog for displaying dynamic partition activities. Refer to the *z/VSE Operation* under “Displaying System Activity” for details.
  - *Display Storage Layout* dialog for displaying dynamic partition and dynamic GETVIS area layout. Refer to “Displaying System Status and Storage Information” in the *z/VSE Administration* for details.
  - Extended VSE/POWER commands for dynamic partition control:
    - PLOAD DYNC,ID=n (where n identifies the dynamic class table)
    - PDISPLAY DYNC
    - PDISPLAY STATUS
    - PVARV

Refer to “Loading a Dynamic Class Table (Format 3)”, “Format 8: PDISPLAY DYNC,ALL”, “Format 3: Displaying Varied Status Information”, and “PVARV: Dis-/Enabling Exit Routines, Task Trace, or Dynamic Classes” in the *VSE/POWER Administration and Operation* for details about the above commands.

## Dynamic Partitions

- Label option CLASSTD for storing labels in the dynamic partitions label subarea. Refer to the the *z/VSE System Control Statements* under "OPTION" for details.
- The extended SDAID and DUMP programs for handling dynamic partitions. Refer to the *z/VSE Diagnosis Tools* and *z/VSE Guide for Solving Problems* for details.

The following commands have either been extended for dynamic partition support or are restricted in their use for dynamic partitions. Refer to the *z/VSE System Control Statements* for details.

ASSGN  
DVCDN/DVCUP  
EXEC  
HOLD  
LIBDEF  
LIBLIST  
LISTIO  
MAP  
PRTY (affected by MSECS value)  
PRTYIO  
RSTRT  
SET  
START  
STATUS  
STOP

### Which Programs Can Run in Dynamic Partitions?

The z/VSE programs listed in Table 14 on page 44 **can run** in dynamic partitions **except** for the following:

- VSE/POWER

The z/VSE optional programs listed in Table 16 on page 48 **can run** in dynamic partitions **except** for the following:

- ACF/NCP
- ACF/SSP
- EP
- DL/I DOS/VS can run but the MPS restart support is not available.
- GDDM<sup>®</sup> can run except for the batch print utilities.
- NetView<sup>®</sup> FTP can run, but for file transfer with dynamic allocation the VSE partition component must run in a static partition.
- SDF II VSE

**Applications** of the following z/VSE base and optional programs run in dynamic partitions if they observe the general restrictions listed in Table 39 on page 179:

- CICS Transaction Server
- VSE/VSAM
- VTAM
- DL/I DOS/VS
- DL/I VSE
- DB2 Server for VSE



**Note:** You should also consult the *Program Directory*, which is part of the z/VSE shipment, for the latest information about programs being able to run in dynamic partitions.

## Restrictions of Dynamic Partitions

There are certain system restrictions to be observed when using dynamic instead of static partitions. They are shown in Table 39:

Table 39. Restrictions of Dynamic Partitions

Items	Static Partitions	Dynamic Partitions
Partition balancing	only for balanced partitions	always balanced within one dynamic class
Storage protection	unique storage keys (PIK=storage key)	unique storage keys within one address space
Real execution	YES	NO (virtual only)
Checkpoint/Restart	YES	NO
VMCF support	YES	YES
XECB support	YES (same address space)	NO

Programs can PFIx pages in static as well as in dynamic partitions.

---

## Planning for Implementation

### Dynamic Class Tables and Dynamic Classes

The characteristics and attributes of dynamic partitions are defined in one or more **dynamic class tables**. Such a table is stored in the system sublibrary IJSYSRS.SYSLIB under the member name DTR\$DYNn.Z. **DTR\$DYNC.Z** is the name of the default table shipped with z/VSE.

You activate a dynamic class table through the VSE/POWER PLOAD DYNC,ID=n command. VSE/POWER creates a dynamic partition if a job for a dynamic class has been submitted and retrieves the partition parameters defined for that class from the active table.

For dynamic partitions you can define up to 23 dynamic classes per table. For defining these classes you can use the letters C, D, E, and G through Z. Note that you cannot use the characters A, B, F, and 0 through 9. The maximum number of dynamic partitions that can be specified per class is 32.

### Multiple Dynamic Class Tables

You can define up to 36 dynamic class tables to be able to easily change the setup of a dynamic partition environment. The name of a table must be DTR\$DYNn.Z, where n can be any character from 0 - 9 to A - Z. z/VSE supports multiple dynamic class tables through the *Maintain Dynamic Partitions* dialog.

### Number of Dynamic Partitions Supported

z/VSE supports up to **12 static partitions** and in addition you can define up to **150-200 dynamic partitions**. Following is some background information about the maximum number of partitions supported.

The supervisor supports a maximum of 512 VSE/Advanced Functions tasks. This limitation also exists with dynamic partitions. VSE/Advanced Functions tasks are classified into system tasks, maintasks and subtasks. A number of these tasks are reserved for z/VSE component programs.

A partition corresponds to a maintask. The number of static and dynamic partitions that can be activated concurrently on a z/VSE system is determined by the IPL command `SYS NPARTS=nnn`:

- The z/VSE system is generated for 12 static partitions, so *nnn* minus 12 dynamic partitions can be allocated at the same time. This depends upon the availability of other system resources, such as virtual storage.
- Even with the support (introduced with z/VSE 4.2) for up to 512 activated tasks, the number of system tasks and maintasks on a z/VSE system is still limited to 255.

This results in a maximum value of about 150-200 for the number of dynamic partitions possible. But this is more or less a theoretical value and the *reasonable* number of allocated partitions depends also on your:

- Server
- System configuration
- Customer environment
- Job profile

### Customizing Dynamic Partition Support

All predefined environments **A**, **B**, and **C** contain dynamic partition support, as described under “Predefined Dynamic Partition Support” on page 181. No further tailoring effort is required.

You are recommended to select the environment A, B, or C which best suits your requirement for dynamic partition support. You can easily change the number of dynamic partitions by tailoring or creating an environment with dynamic partitions:

- Tailor the IPL Procedure
- Catalog the JCL Startup Procedure
- Tailor the VSE/POWER Startup Procedure
- Define or tailor a Dynamic Class Table
- Verify a Dynamic Class Table
- Activate a Dynamic Class Table

After completing these tasks and performing IPL, you can submit and process jobs in dynamic partitions. z/VSE provides the:

- *Maintain Dynamic Partitions* dialog for creating a dynamic class table.
- *Tailor IPL Procedure* dialog for tailoring the IPL procedure.
- Skeleton SKJCLDYN for cataloging the JCL startup procedure for dynamic partitions.
- Skeleton SKPWSTRT for tailoring the VSE/POWER startup procedure.

Instead of tailoring the VSE/POWER startup procedure, you can have the operator activate the dynamic partition support via the VSE/POWER *PLOAD* command.

- VSE/POWER *PLOAD DYNC, ID=n, VERIFY* command to “debug” a dynamic class table before it is actually loaded and used.

The *z/VSE Administration* describes in detail the dialogs and skeletons mentioned above. “Dynamic Partition Support” in the *VSE/POWER Administration and Operation* describes the dynamic partition support as implemented and supported by VSE/POWER including VSE/POWER commands. This includes information also important for making planning decisions.

### Further Tailoring Information

Your modifications in the dynamic class table may result in further changes to environment A, B, or C, as outlined below.

- If you need more virtual storage, you have to increase the values for:
  - VSIZE (virtual storage size)
  - DPD (page data set extents)

You may also have a need to increase the total number of partitions and thus change the value for:

- NPARTS

These are all parameters of the IPL procedure which you can tailor with the *Tailor IPL Procedure* dialog.

- Since VSE/POWER controls dynamic partitions, its storage requirements increase with the number of dynamic partitions to be handled. For each additional dynamic partition VSE/POWER requires:
  - About 2KB to be reserved through the SETPFIX command.
  - About 10KB to 15KB partition GETVIS space, assuming 3 spooled devices (1 RDR, 2 PRT/PUN) per dynamic partition and the default DBLK size.

The VSE/POWER values depend mainly on

- the number of spooled and actually used devices per dynamic partition.
- the DBLK value of the VSE/POWER generation macro.

For detailed values, refer to “Planning for VSE/POWER” in the *VSE/POWER Administration and Operation*.

In addition, at IPL time, for each dynamic partition defined in the NPARTS parameter, the system GETVIS area is extended by about 4KB. Since this must be real space, the total SETPFIX value for static partitions is reduced correspondingly.

---

## Predefined Dynamic Partition Support

### The Predefined Dynamic Class Table

The dynamic class table provided (named DTR\$DYNC) defines 57 dynamic partitions:

- 9 partitions with 1 MB (class C)
- 32 partitions with 1 MB (class P)
- 3 partitions with 8 MB (class R)
- 2 partitions with 15 MB (class S)
- 8 partitions with 5 MB (class Y)
- 3 partitions with 5 MB (class Z)

The number of dynamic partitions that can be active at the same time is limited by two parameters:

- The VSIZE available for dynamic partitions.
  - For predefined environment A, the VSIZE is 150 MB; about 39 MB of this space is available for dynamic partitions.
  - For predefined environment B, the VSIZE is 264 MB; about 58 MB of this space is available for dynamic partitions.
  - For predefined environment C, the VSIZE is 2 GB; about 735 MB of this space is available for dynamic partitions.

For further VSIZE details, refer to:

- “Storage Layout of Predefined Environment A” on page 60
- “Storage Layout of Predefined Environment B” on page 62
- “Storage Layout of Predefined Environment C” on page 64
- The number of dynamic partitions which can be active at the same time. This depends on the NPARTS definition.
  - For predefined environment A, the IPL SYS command defines NPARTS=40 as system maximum; 12 of these are static partitions, leaving 28 for dynamic partitions.
  - For predefined environment B, the IPL SYS command defines NPARTS=60 as system maximum; 12 of these are static partitions, leaving 48 for dynamic partitions.
  - For predefined environment C, the IPL SYS command defines NPARTS=120 as system maximum; 12 of these are static partitions, leaving 108 for dynamic partitions.
  - Figure 3 on page 61 shows the storage layout for environment A, including dynamic partitions.
  - Figure 4 on page 63 shows the storage layout for environment B, including dynamic partitions.
  - Figure 5 on page 65 shows the storage layout for environment C, including dynamic partitions.

**Note:** Class P is intended for z/VSE workstation platform users. For performance reasons, class P has its own startup profile (PWSPROF) shown under “The Predefined Startup Profiles” on page 184.

In Figure 16 on page 183, the character **v** (or another character) identifies column beginning and end. All numeric values are right-bound, but text is left bound. The table also includes the addresses for the VSE/POWER spooled reader, printer, and punch devices for each dynamic class. For the reader only 1 device is allowed; for the printer and punch devices you can specify additional devices (up to 14 in one row and separated by commas).

```

          CLASS  ALLOC  SIZE  SP-GETV LUBS  PROFILE  MAX-P  ENABLED
-----V-----VVVV-----VVVVV-----VVVV-----VVV-----VVVVVVVV-----VV-----V-----
CLASS=   C         1    500   128    50  STDPROF  09      Y
          POWER SPOOLED DEVICES
-----V-----V-----V-----V-----V-----V-----V-----V-----V-----
READER=  FEC
PRINTERS= FEE
PUNCHES= FED
-----V-----VVVV-----VVVVV-----VVVV-----VVV-----VVVVVVVV-----VV-----V-----
CLASS=   P         1    512   128    50  PWSPROF  32      Y
          POWER SPOOLED DEVICES
-----V-----V-----V-----V-----V-----V-----V-----V-----V-----
READER=  FEC
PRINTERS= FEE
PUNCHES= FED
-----V-----VVVV-----VVVVV-----VVVV-----VVV-----VVVVVVVV-----VV-----V-----
CLASS=   R         8   1024   128    50  STDPROF  03      Y
          POWER SPOOLED DEVICES
-----V-----V-----V-----V-----V-----V-----V-----V-----V-----
READER=  FEC
PRINTERS= FEE
PUNCHES= FED
-----V-----VVVV-----VVVVV-----VVVV-----VVV-----VVVVVVVV-----VV-----V-----
CLASS=   S        15   1024   128    50  STDPROF  02      Y
          POWER SPOOLED DEVICES
-----V-----V-----V-----V-----V-----V-----V-----V-----V-----
READER=  FEC
PRINTERS= FEE
PUNCHES= FED
-----V-----VVVV-----VVVVV-----VVVV-----VVV-----VVVVVVVV-----VV-----V-----
CLASS=   Y         5   1024   128    50  STDPROF  08      Y
          POWER SPOOLED DEVICES
-----V-----V-----V-----V-----V-----V-----V-----V-----V-----
READER=  FEC
PRINTERS= FEE
PUNCHES= FED
-----V-----VVVV-----VVVVV-----VVVV-----VVV-----VVVVVVVV-----VV-----V-----
CLASS=   Z         5   1024   128    50  STDPROF  03      Y
          POWER SPOOLED DEVICES
-----V-----V-----V-----V-----V-----V-----V-----V-----V-----
READER=  FEC
PRINTERS= FEE
PUNCHES= FED

```

Figure 16. Predefined Dynamic Class Table (DTR\$DYNC.Z)

**Note:** When modifying the table it is recommended to use the dialog and not edit the existing table. If, for any reason, you edit the table you should be aware that when using the dialog later it may no longer work correctly.

The columns have the following meaning:

**CLASS**

Specifies the class which is also used to create the partition ID.

**ALLOC**

Specifies in MB the virtual storage of a partition within a class: *maximum program size + partition GETVIS area* and includes the dynamic space GETVIS area. The theoretical maximum is 2046 MB.

**SIZE**

Specifies in KB the maximum program size. This is the amount of contiguous virtual storage reserved for program execution.

**SP-GETV**

Specifies in KB the size of the dynamic space GETVIS area which is located below 16 MB. The minimum required is 128KB.

**LUBS**

Specifies the number of programmer logical units allocated to each dynamic partition within a dynamic class. The maximum is 255.

## Dynamic Partitions

### PROFILE

Specifies the name of the JCL procedure processed when a dynamic partition is activated. (The name must follow the standard naming conventions for phases).

### MAX-P

Specifies the maximum number of dynamic partitions that can be activated within a class. It can range from 1 to 32.

### ENABLED

Specifies whether a dynamic partition can be activated via the PLOAD DYNC, ID=n command of VSE/POWER.

## The Predefined Startup Profiles

The default startup profiles (STDPROF and PWSPROF) for dynamic partitions are shown below. To maintain and catalog such a procedure, use skeleton SKJCLDYN.

```
CATALOG STDPROF.PROC DATA=YES REPLACE=YES
// LIBDEF DUMP,CATALOG=SYSDUMP.DYN,PERM
// OPTION NODUMP
// EXEC PROC=LIBDEF
ASSGN SYSIN,FEC
ASSGN SYSPCH,FED
ASSGN SYSLST,FEE
ASSGN SYSLNK,DISK,VOL=DOSRES,SHR          SYSTEM LINK FILE
ASSGN SYS001,DISK,VOL=SYSWK1,SHR          SYSTEM WORK FILE 1
ASSGN SYS002,DISK,VOL=SYSWK1,SHR          SYSTEM WORK FILE 2
ASSGN SYS003,DISK,VOL=SYSWK1,SHR          SYSTEM WORK FILE 3
ASSGN SYS004,DISK,VOL=SYSWK1,SHR          SYSTEM WORK FILE 4
/+
```

Figure 17. Default Startup Profile STDPROF

For better performance, you may replace the LIBDEF statement in STDPROF with one that specifies less sublibraries as, for example, in profile PWSPROF. This profile is intended for dynamic class P to be used with the programmable workstation support.

```
CATALOG PWSPROF.PROC DATA=YES REPLACE=YES
ASSGN SYSIN,FEC
ASSGN SYSPCH,FED
ASSGN SYSLST,FEE
/+
```

Figure 18. Default Startup Profile PWSPROF

---

## Partition Standard Labels for Dynamic Partitions

Partition standard labels can also be specified for dynamic partitions (// OPTION PARSTD). They are searched instead of the CLASSTD labels, but will be automatically removed from the system when the dynamic partition is UNBATCHed at the end of the VSE/POWER job.

The // OPTION PARSTD statement for a dynamic partition can be specified only in the partition where the labels are used and not from the BG partition.

---

## Chapter 13. Tailoring System Startup

z/VSE provides an *automated startup* facility for performing a fast and efficient system startup. This is sometimes also referred to as ASI (automated system initialization). In most cases, no operator intervention is required, except for IPL (initial program load). You may use the procedures and jobs of the startup facility as shipped by IBM, or you can tailor them to meet the needs of your installation.

### Related Information

This chapter helps you plan startup requirements for your installation. For detailed information about startup procedures and jobs and how to tailor them, refer to “Tailoring IPL and System Startup” in the *z/VSE Administration*.

“Starting the System” in the *z/VSE Guide to System Functions* provides additional startup information about topics such as interrupting IPL processing for modifications, loading phases into the SVA, or creating a \$ASIPROC master procedure.

### Notes:

1. During initial installation, you must specify the predefined environment you want to use. Refer to “Predefined System Environments” on page 59 for details about the predefined environments provided. Careful planning of your system's environment may considerably reduce any tailoring effort needed later.
2. If you use z/VSE as shipped by IBM, the startup procedures provided with the system are processed during startup. These procedures create a system with the partition layout of the predefined environment selected.
3. If you wish, you may also create your own startup procedures instead of using or modifying the ones supplied by IBM.

This chapter contains these main topics:

- “Components of the Startup Facility”
- “Startup Modes” on page 187
- “Considerations for Tailoring System Startup” on page 188
- “Tasks for Tailoring System Startup” on page 189

---

## Components of the Startup Facility

The main components of the Startup facility are:

- IPL procedure.
- JCL startup procedures and jobs.
- Startup program *DTRISTR*.
- Procedures *CPUVARn* and *\$COMVAR*.

### IPL Procedure

The name of your system's original IPL procedure is determined by the disk device type on which you install z/VSE. For example, for a system that resides on an IBM 3390, z/VSE uses initially IPL procedure *\$IPL90*.

During initial installation, the IPL procedure selected is renamed to *\$IPLESA*. This is the name that appears on the screen when you use the *Tailor IPL Procedure* dialog, for example, to change IPL parameters.

### JCL Startup Procedures and Jobs

After IPL successfully completes, the JCL startup procedure for the BG partition is called. For initial installation, the name is *\$0JCL790* (for the example outlined under "IPL Procedure" before). The second digit identifies the partition and the last two digits the disk device type. During initial installation, the procedure is renamed to *\$0JCL*.

The procedure calls various other procedures and releases jobs necessary for specific startup tasks. This includes the startup program *DTRISTR*, which determines the startup mode used by the system (WARM, for example).

### Startup Program DTRISTR

The startup program *DTRISTR* determines the startup mode for *each* static partition. This decision is based on system status analysis and the startup request (if any) made by the operator.

*DTRISTR* is activated by the JCL startup procedure for the BG partition (*\$0JCL*). At that time, the system variables of *CPUVARn* (see below) still reflect the status of the last shutdown, or the last startup if no shutdown was performed.

*DTRISTR* analyzes the information stored in *CPUVARn* for each static partition. In addition, *DTRISTR* issues messages that allow the operator to intervene if requested and select a particular startup mode. After deciding on the startup modes, *DTRISTR* sets the system variables in *CPUVARn* accordingly. The JCL startup procedures retrieve these variables to initiate the correct startup procedures and jobs.

### Procedure \$COMVAR

*\$COMVAR* is a CPU-independent procedure where the CPU ID and number are stored. It is used to determine the CPU number of the CPU where the startup is to be performed.

The default *\$COMVAR* procedure is set to a single system environment. In a DASD sharing environment with two or more CPUs, you *must* modify *\$COMVAR* to identify the different CPUs in use. In addition, each CPU requires its own *CPUVARn* procedure.

z/VSE provides skeleton *SKCOMVAR* for tailoring such an environment. The skeleton is described in detail in the *z/VSE Administration* under "Skeleton for Tailoring *\$COMVAR* Procedure".



## Procedure CPUVARn

A CPUVARn procedure consists of SETPARM statements that contain system variables. These variables describe the system and reflect each partition's status. For a each CPU, one procedure is required. n is the CPU number. The name of the default procedure shipped is CPUVAR1.

A CPUVARn procedure is used to save system information such as:

- **Use of Partitions** – This information shows which partitions are used and which programs run in the partitions.
- **Partition Status** – A partition can be either active or inactive. For example, if a partition shows status ACTIVE at startup time, it indicates that the previous shutdown was not successful.
- **Outstanding Requests** – z/VSE functions may request a certain partition startup mode. For example, a COLD start is requested for the VSE/POWER partition after the VSE/POWER queues have been extended.
- **Results of Status Analysis and Operator Requests** – The startup program DTRISTRTR updates system variables according to these requests.
- **Synchronization Points** – Synchronization points can be used to define how partitions interact during startup. For example, a synchronization point in one partition may trigger further processing in another partition.
- **System Environment** – This is the environment that was selected at initial installation.

**Note:** As described in the *z/VSE System Utilities* under “DTRSETP Utility”, the DTRSETP utility program helps you create and modify CPUVARn procedures.

---

## Startup Modes

z/VSE provides several startup modes to be able to react properly to a specific system status. The startup modes are:

- **WARM** – A WARM startup is performed by the system if the last shutdown was completed successfully. The system is in normal, re-usable condition.
- **RECOV** – A RECOV (recovery) startup is performed by the system if the last shutdown of one or more partitions could not be completed successfully or if no shutdown was performed at all.
- **COLD** – A COLD startup is performed or should be selected by the operator if, for example, there is a need to reformat the VSE/POWER queues. This means, however, that the jobs in the VSE/POWER reader queue are lost unless they are saved and reloaded afterwards. The *z/VSE Operation* under “Offloading and Loading VSE/POWER Queues” describes how to save and reload user jobs. System jobs are reloaded automatically.
- **BASIC** – A BASIC startup is performed or should be selected by the operator when the system does not start as normally required due to an error condition like exhausted VSE/VSAM space or VTAM buffer space.

A BASIC startup gives you a “basic” system with the original system tables active. *Your modifications are ignored.* During a BASIC startup, the operator is requested to specify up to three terminal addresses. These terminals are activated and allow interactive correction of errors.

- **MINI** – A MINI startup is performed or should be selected by the operator if library problems exist or library maintenance is necessary. MINI starts three partitions only, BG, F1 (VSE/POWER), and FB (Security Server).

## System Startup

z/VSE allows the operator to interrupt startup processing if requested via the IPL load parameter. The operator can then request a COLD, BASIC, or MINI start and override the startup modes selected by the system. *Startup modes WARM and RECOV can only be selected by the system.*

During a WARM or RECOV startup, a startup mode is selected individually for every partition of the system. This means that during startup, partitions may be started in different modes.

If startup mode is BASIC or MINI, only a certain set of partitions is started (all in BASIC or MINI mode). If the operator selects COLD, COLD is used as startup mode for all the partitions of the system.

### Notes:

1. These five startup modes have been developed for z/VSE. They are not identical to the startup modes defined by CICS.
2. During startup, CICS selects its startup mode from the restart data set. Only specifying a BASIC or COLD startup mode forces CICS to perform a cold start.
3. The *z/VSE Guide for Solving Problems* under “System Startup Modes Available” describes system conditions that should be handled with COLD, BASIC and MINI starts.

---

## Considerations for Tailoring System Startup

The following should be considered if you plan to tailor your system's startup:

- The startup procedures and jobs are written in the job control language (JCL). Functions such as conditional job control, symbolic parameters, and nested procedures are used. These functions are described in detail in the *z/VSE Guide to System Functions* under “Controlling Jobs”.
- Procedures CPUVARn and \$COMVAR mainly contain JCL SETPARM statements. For details about SETPARM statements, refer to “SETPARM” in the *z/VSE System Control Statements*.
- Table 40 on page 189 shows the skeletons that z/VSE provides in VSE/ICCF library 59 for startup tailoring tasks. The *z/VSE Administration* under “Tailoring IPL and System Startup” lists the contents of these skeletons and has detailed information about changing them.

When you change startup skeletons, do *not* use the original members. Copy them to your primary VSE/ICCF library and apply your changes to the copied versions. Test these changed versions carefully. It is your responsibility that the changed startup is error free and runs correctly.

- You should *not* change the following:
  - \$nJCLBSX and all related procedures and jobs for BASIC startup.
  - \$nJCLMIN and all related procedures for MINI startup.

This ensures that you can still perform a BASIC or MINI startup if problems arise. This may be your only chance to correct an error.

## Tasks for Tailoring System Startup

Table 40 shows the tasks that are involved in tailoring your system's startup. You may perform some or all of these tasks, depending on the scope of your changes. "Tailoring IPL and System Startup" in the *z/VSE Administration* has detailed information about the tailoring tasks and instructions on how to perform them. That information is not repeated in this chapter.

Table 40. Tasks for Tailoring System Startup

TASK	SKELETON(S) USED
Modify IPL procedure	(See Note 1)
Modify allocations for static partitions (see Notes 2 and 3)	SKALLOCA
Modify BG partition startup (see Note 3)	SKJCL0, SKUSERBG
Modify VSE/POWER partition startup (See Note 3)	SKJCL1, SKPWSTRT
Modify other partition startups (see Note 3 for SKJCLx and SKLIBCHN)	SKJCLx, SKLIBCHN, SKVTAM, SKCICS
Define CPU IDs in a DASD-sharing environment	SKCOMVAR
Add jobs to load list for VSE/POWER reader queue for a COLD start	SKCOLD
Create sample job for loading jobs into VSE/POWER reader queue	SKLOAD
Create a startup job for a dynamic partition	SKJCLDYN

### Notes:

- The Interactive Interface provides the *Tailor IPL Procedure* dialog for this task.
- You usually modify just one of the skeletons available in VSE/ICCF library 59 for partition allocations:
  - SKALLOCA = 12 static partitions (12 address spaces)
  - SKALLOCB = 12 static partitions (12 address spaces)
  - SKALLOCC = 12 static partitions (12 address spaces)
 These skeletons reflect the predefined environments provided. Refer to "Predefined System Environments" on page 59 for details.
- After you have modified the startup skeleton(s) mentioned, use skeleton *SKENVSEL* to catalog them. *SKENVSEL* is also a member of VSE/ICCF library 59.

## System Startup

---

## Chapter 14. Tailoring the Interactive Interface

This chapter describes how you can tailor the *Interactive Interface*. It contains these main topics:

- “Overview of the Interactive Interface”
- “Dialogs for Interactive Interface Tailoring” on page 194
- “General Planning Considerations for the Interactive Interface” on page 195

---

### Overview of the Interactive Interface

The Interactive Interface makes it easier to access and use system functions. Through *selection panels*, you can select dialogs for specific tasks that you want to perform (define files or backup libraries, for example).

Appendix C, “Dialogs of the Interactive Interface,” on page 285 lists the dialogs that z/VSE ships as part of the Interactive Interface.

### z/VSE User Profiles

In z/VSE, a *user profile* defines a system user to the Interactive Interface. At initial installation, z/VSE creates the user profiles shown in Table 41.

User profiles are stored in the VSE.CONTROL.FILE.

Table 41. z/VSE Predefined User Profiles

User-ID	Password	Function
SYSA	SYSA	Model system administrator
PROG	PROG	Model programmer
OPER	OPER	Model operator
POST	BASE	User to complete initial installation
CICSUSER	CICSUS	CICS default user
DBDCCICS	DBDCCI	CICS partition user (F2)
PRODCICS	PRODCI	CICS partition user (F8)
FORSEC	FORSEC	Model administrator (SECURITY=YES)
\$SRV	\$SRV	Model for problem determination
VCSRV	VCSRV	Connector Server partition user
CNSL	CNSL	Model for CICS TS console user

For security reasons, you are forced during the first logon to change the above passwords except for users DBDCCICS and PRODCICS.

You can use the user-IDs **SYSA**, **PROG**, and **OPER** as models to define your own profiles for an administrator, programmer, or system operator. You should not use them for daily operation, because they may be affected if you later install a system refresh.

**POST** is a reserved user-ID. It is used *only* during initial installation for performing special tasks. You should *not* use it for any other tasks.

## Tailoring the Interactive Interface

**CICSUSER** is a default user-ID required for CICS Transaction Server startup. It performs security checks for terminal users that are not signed on.

**DBDCICS** and **PRODCICS** are partition user-IDs required for the startup of the primary and secondary CICS Transaction Server.

**FORSEC** is a user-ID required for system startup if **SECURITY=YES** has been selected during initial installation. This user-ID is defined in **DTSECTAB** as well as in the **VSE.CONTROL.FILE**.

**\$SRV** allows access to a default panel hierarchy for problem determination.

**VCSRVR** is the partition user required for the Connector Server startup. It does not have an initial selection panel and can therefore not be used for sign-on.

**CNSL** is a console user-ID for the CICS Transaction Server. This ID is defined with all security transaction classes, which allows all transactions to be executed on the system or Interactive Interface consoles.

The *z/VSE Administration* has further details on user profiles.

## Interactive Interface Panels

The Interactive Interface has several types of panels:

- Selection Panels

A selection panel displays up to nine options from which you can choose one. Each option represents either a dialog or another selection panel. The options on the panel are numbered. You make your selection by entering the appropriate number at the bottom of the panel.

Figure 19 on page 193 shows an example of a selection panel.

- Data Entry Panels

The dialogs use data entry panels to obtain information about the task you are performing. You enter the input in particular fields on the panel. For example, if you are restoring a library, you enter the tape drive address.

- Function Lists (FULISTs)

A FULIST is a special type of data entry panel. It displays a list of items that you can process. It also displays options that you use to process the items. Each option corresponds to a specific number. You enter the number of the option you want to perform next to the item you want to process.

Figure 20 on page 194 shows an example of a FULIST.

- HELP Panels

From most panels, you can press **PF1** to display a HELP panel. The HELP panel provides an explanation about the task you are performing.

A HELP panel often provides information about a message that the system displays. For example, if you enter incorrect data, the system displays a message. If you press **PF1**, the HELP panel may explain the error.

## Panel Hierarchies for Predefined Users

A *panel hierarchy* refers to the complete set of selection panels that are available to a user. z/VSE supplies separate panel hierarchies for the predefined users SYSA, PROG, OPER, and \$SRV which you can use as models for your own panel hierarchies.

## z/VSE Application Profiles

z/VSE provides an *application profile* for each dialog in the Interactive Interface. This profile defines execution parameters for the dialog. The application profiles defined for Interactive Interface dialogs are important to you when creating your own selection panels and panel hierarchies. Appendix C, "Dialogs of the Interactive Interface," on page 285 lists the application profile names for the dialogs of the Interactive Interface.

**Note:** z/VSE also provides a number of applications that are not included in the Interactive Interface. You can also include these applications, which are listed in Appendix D, "Additional z/VSE Applications," on page 291, in selection panels that you create.

```

IESADMSL.IESEADM          z/VSE FUNCTION SELECTION          APPLID: DBDCCICS
Enter the number of your selection and press the ENTER key:

    1 Installation
    2 Resource Definition
    3 Operations
    4 Problem Handling
    5 Program Development
    6 Command Mode
    7 CICS Supplied Transactions

PF1=HELP          3=SIGN OFF          6=ESCAPE(U)
                  9=Escape(m)

==> _

```

Figure 19. Example of a Selection Panel

## Tailoring the Interactive Interface

```
IESFILFL1          DISPLAY OR PROCESS A FILE          Page 1 of 3
CATALOG:  VESP.USER.CATALOG          VESPUC

OPTIONS:  1 = SHOW    2 = SORT    3 = PRINT    4 = COPY    5 = DELETE
          6 = VERIFY  7 = LOAD

OPT      FILE ID          FILE      FILE  FILE
          FILE ID          NAME      TYPE  ADDR
-        CICS.CSD          DFHCSD   B    1
-        CICS.DBDCICIS.DFHDMFA  DFHDMFA B    1
-        CICS.DBDCICIS.DFHDMFB  DFHDMFB B    1
-        CICS.DUMPA          DFHDMPA B    1
-        CICS.DUMPB          DFHMPB  B    1
-        CICS.GCD           DFHGCD  B    1
-        CICS.LCD           DFHLCD  B    1
-        CICS.RSD           DFHRS   B    1
-        CICS.TD.INTRA       DFHNTRA B    1
-        DEFAULT.MODEL.ESDS.SAM *NONE*  B    1
-        DFHTEMP            DFHTEMP B    1

PF1=HELP    2=REFRESH  3=END    4=RETURN
             8=FORWARD  9=PREFIX

LOCATE FILE ID ==> _____
```

Figure 20. Example of a FULIST

## Dialogs for Interactive Interface Tailoring

Although z/VSE ships three panel hierarchies, these may not accurately reflect your specific system environment. Through dialogs, you can change the appearance of the Interactive Interface so that it reflects your environment and your users.

The following dialogs, described in detail in the *z/VSE Administration*, are available for Interactive Interface tailoring:

1. **Maintain User Profiles** dialog to define users to the system.

Every user of the Interactive Interface has a *user profile record* that specifies:

- User-ID and password
- z/VSE information
- CICS information
- VSE/ICCF information

**Note:** To maintain large numbers of user profiles, you can use the batch utility IESUPDCF. This utility is described under “Maintaining User Profiles via Batch Program IESUPDCF” in the *z/VSE Administration*.

2. **Maintain Selection Panels** dialog to create your own selection panels.

The system uses *selection panel records* to build and maintain selection panels. z/VSE ships records for each selection panel in the Interactive Interface. The record specifies the:

- Name of the selection panel.
- Choices (selections) on the panel.
- Panel or application corresponding to each selection.

3. **Maintain Application Profiles** dialog to define your CICS applications to the system and access them from the Interactive Interface.

An *application profile record* defines a CICS application to the Interactive Interface. The record contains execution information about the application such as:



- The name of the application.
  - How the application is initiated.
  - The name you use to activate the application.
  - Specifications for terminal input and input data.
4. *Maintain Synonyms* dialog to define names (synonyms) for selection panels and applications.

With the *Maintain Synonyms* dialog, you can also create character strings that users can enter for accessing dialogs and applications. Users can enter such synonyms (which are easier to remember than number strings) from any selection panel of the Interactive Interface or from selection panels that you create.

The records for user profiles, selection panels, Interactive Interface applications, and synonyms are part of the z/VSE control file (*VSE.CONTROL.FILE*) on DOSRES (in the VSE/VSAM user catalog).

### Notes:

1. The panel *User Interface Tailoring* offers in addition the following dialogs which are not directly related to Interactive Interface tailoring and which are described in the *z/VSE Administration*:
  - Maintain PRIMARY Sublibraries*
  - Customize z/VSE Workstation Platform*
2. REXX/VSE programs are provided which allow you to generate your selection panel and/or application profile definitions in one z/VSE system, and then load these into a second z/VSE system. For details, refer to the *z/VSE Administration*.

---

## General Planning Considerations for the Interactive Interface

After you install your system, you must define profiles for each user of the Interactive Interface. Remember that you can use the SYSA, PROG, and OPER profiles that z/VSE defines as models for various users. Do *not* use POST.

You should carefully consider who can access the dialogs for user interface tailoring. For example, only one person should maintain user profiles and have access to the *Maintain User Profiles* dialog. You may want some application programmers to be able to maintain application profiles.

You should probably use the Interactive Interface for some time before changing it. As you and other users work with the system, compare the default panels and panel hierarchies of the Interactive Interface with the distribution of tasks and responsibilities in your company. Remember that you can:

- Modify selection panels and thus the structure of the hierarchy.
- Change access rights in the programmer and operator profiles.
- Add applications to the structure.

If you decide to create your own selection panels and panel hierarchies, there are several things you should consider. You should *not* build a panel hierarchy of more than nine levels. Beyond the ninth level, the END key always returns you to the selection panel at level eight. You can have selection panels and applications in different places within the panel hierarchy. You do not necessarily have to recreate an entire set of panels. You can create an initial selection panel and display this panel when the user signs on. From this selection panel, you can invoke different Interactive Interface panels which the user needs.

### Example of Profile-Driven System Views

When you create a user profile, you define what a specific user sees of the entire system. Figure 21 is a simple example of how a system could look to several users, each of whom has a different profile. Note that all of these users sign on to the system from the same panel. What is defined in their user profiles, however, causes the system to show each of them something different.

The payroll clerk's profile specifies that an application is to be invoked when this

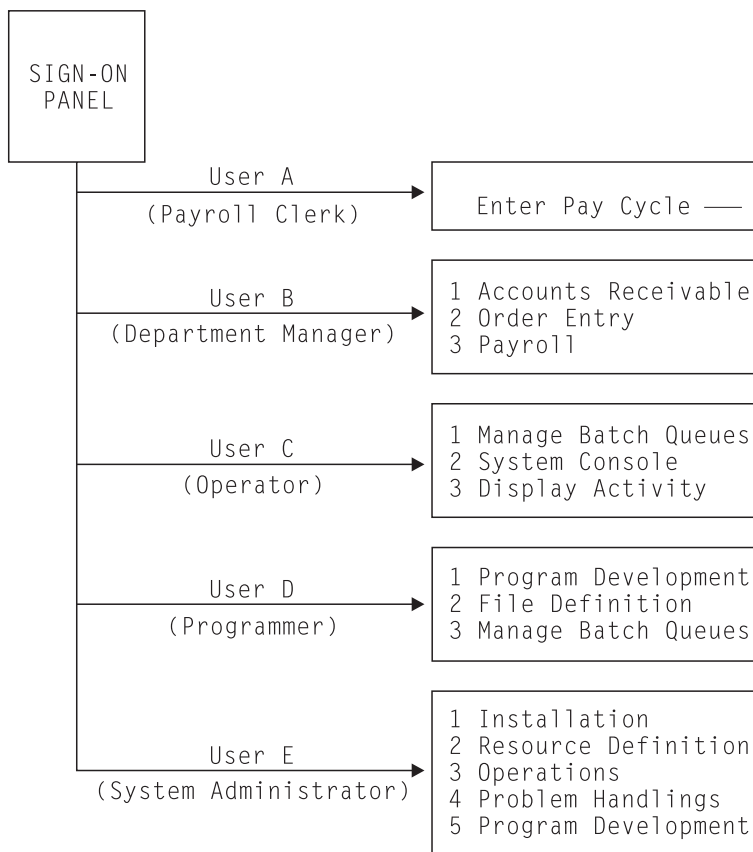

Figure 21. Profile-Driven System Views

user signs on. Access to other system functions is not possible. At sign on, the system finds the corresponding application profile and then invokes the application.

Unlike the payroll clerk, the department manager needs access to several applications. This user's profile contains the name of a selection panel that offers options for these applications.

The operator, programmer, and system administrator have access to selected z/VSE system functions.

---

## Chapter 15. Setting Up Your CICS Environment

This chapter describes how you can set up your CICS environment. It contains these main topics:

- “Overview”
- “Major Characteristics of the CICS Transaction Server”
- “Overview on CICS Skeletons and Tables” on page 198
- “CICS Transaction Server User Profiles” on page 199
- “CICS Transaction Server Monitoring and Statistics Support” on page 199
- “Installing a Second CICS Transaction Server” on page 200
- “DFH0STAT Considerations” on page 203
- “Activating the APPC Support” on page 204
- “Using the CICS Report Controller to Control/Print Reports” on page 204

---

### Overview

z/VSE provides in partition F2 the **CICS Transaction Server for VSE/ESA**.

As shipped, z/VSE also provides support for the installation of a **second** (predefined) **CICS Transaction Server** in partition F8 during the initial installation of z/VSE. However, this support is provided for the Environments B and C only.

The second CICS Transaction Server requires that you select **predefined environment B or C** for initial installation.

---

### Major Characteristics of the CICS Transaction Server

The CICS Transaction Server provides new functions that improve application and system programming, system management, and the reliability and integrity of your system. Key benefits include:

- Exploitation of ESA/390 subsystem storage protection.
- Extensive virtual storage constraint relief with more space below 16 MB for user applications.
- System management enhancements including Resource Definition Online (RDO) for files.
- Shared data tables for improved performance and availability.
- Support for CICS Web Support (CWS), CICS 3270 Bridge, and REXX for CICS.
- Support for SSL (Secure Sockets Layer) and ECI (External Call Interface).

For details, refer to the corresponding *CICS Transaction Server V1R1.1* documentation.

## Overview on CICS Skeletons and Tables

Table 42 shows for the predefined CICS systems the available skeletons and tables. The figure allows you to identify quickly the differences and the requirements for the:

- Primary CICS Transaction Server which is available after initial installation and which is running in partition F2.
- Secondary CICS Transaction Server which must be installed separately (default partition F8) as described under “Installing a Second CICS Transaction Server” on page 200.

The source code of all the skeletons, tables, and members provided is available in **VSE/ICCF library 59**.

Table 42. CICS Skeletons and Tables

Skeletons/Tables	Primary CICS TS (DBDCCICS)	Secondary CICS TS (PRODCICS)
Startup Skeleton	SKCICS	SKCICS2
Resource Definition Skeleton	—	SKPREPC2
Destination Control Table	DFHDCTSP	DFHDCTC2
Monitoring/Statistics Table	DFHDMFSP	—
File Control Table	DFHFCTSP *	DFHFCTC2 *
Journal Control Table	DFHJCTSP	—
Processing Program Table	—	—
Program Control Table	—	—
Program List Table (startup)	DFHPLTPI	DFHPLTP2
Program List Table (shutdown)	DFHPLTSD (see Note)	DFHPLTS2
System Initialization Table	DFHSITSP	DFHSITC2
Temporary Storage Table	DFHTSTSP	—
Terminal Control Table	—	—
Transaction List Table	DFHXLTP	DFHXLTP
Sign-on Table	—	—

(\*) These tables are migrated into the CSD during initial installation or FSU.

**Note:** DFHPLTSD includes a minimum support for statistics to be printed at shutdown. This support is invoked if DFH0STAT has been activated in DFHPLTSD.

The following source books for CSD definitions are available in IJSYSRS.SYSLIB:

```

IESWPPT.Z      Program definitions for workstations
IESWPPTL.Z    Program definitions for workstations (Multicultural Support)
IESZPPT.Z     Program definitions for Interactive Interface
IESZPPTI.Z   Program definitions for Interactive Interface-VSE/ICCF
IESZPPTL.Z   Program definitions for Interactive Interface-VSE/ICCF
              (Multicultural Support)
IESWPCT.Z     Transaction definitions for workstations
IESZPCT.Z     Transaction definitions for Interactive Interface
IESZFCT.A     File definitions
IESZTCT.Z    Terminal and console definitions
IESCSEZA.Z   CICS Listener definitions

```

CEECCSD.Z	LE/VSE Base definitions
IBMCCSD.Z	PL/I Run-Time definitions
IGZCCSD.Z	COBOL Run-Time definitions
EDCCCS.D.Z	C Run-Time definitions

The following source books for CSD definitions are available in PRD2.SCEEBASE:

CEETICS.D.Z	Set USESVACOPY(YES) for LE/VSE Base
EDCTICS.D.Z	Set USESVACOPY(YES) for C Run-Time

The following source book for CSD definitions is available in PRD1.BASE:

IPNCSD.Z	TCP/IP definitions
----------	--------------------

### Autoinstall Exit

Autoinstall exits are used for VTAM terminal definitions according to predefined models.

The autoinstall exit member for the CICS Transaction Server is IESZATDX. This exit member is available as a skeleton of the same name in VSE/ICCF library 59.

## CICS Transaction Server User Profiles

A user profile defines a user to z/VSE. It includes user-ID and password for signing on to the system. z/VSE includes the following predefined CICS user profiles for the CICS Transaction Server:

- DBDCCICS  
This is the user-ID for the primary CICS Transaction Server. and is required for startup. This name is also used as CICS Region Prefix to identify this CICS Transaction Server and the transactions belonging to it, as defined for the security manager (for example, BSM).
- PRODCICS  
This is the user-ID for the secondary CICS Transaction Server. and is required for startup. This name is also used as CICS Region Prefix to identify this CICS Transaction Server and the transactions belonging to it, as defined for the security manager (for example, BSM).
- CICSUSER  
This is a default user-ID required for CICS Transaction Server startup. It performs security checking for users that are not signed on.
- CNSL  
This is a default user-ID that allows all CICS transactions to run on the system console.

Refer to “z/VSE User Profiles” on page 191 for additional profile information.

## CICS Transaction Server Monitoring and Statistics Support

Statistical and monitoring data is written to data sets of the Data Management Facility (DMF). This data can be used for subsequent processing by the new monitoring utility program, **DFHMNDUP**. DMF requires a partition of its own.

To show the different ways of how to use the commands EXEC CICS INQUIRE and EXEC CICS COLLECT STATISTICS, a set of programs (**DFH0STAT**) for producing CICS statistics is part of the CICS Transaction Server. DFH0STAT provides CICS Transaction Server statistics at shutdown. Also refer to “DFH0STAT Considerations” on page 203.

### Skeletons for Monitoring and Statistics Support

The following skeletons are provided for the monitoring and statistics support:

#### DFHMNDUP

Monitoring support CICS Transaction Server.

#### DFHMOLS

Monitoring support CICS Transaction Server.

#### SKDMFPR

Print statistics CICS Transaction Server.

#### SKDMFST

Startup monitoring partition CICS Transaction Server.

#### SKJOBDMF

Job accounting (DMF records).

#### SKJOURN

Format journal data sets for CICS Transaction Server.

---

## Installing a Second CICS Transaction Server

This topic introduces the installation of a second CICS Transaction Server. For a detailed description of the required installation steps, refer to the *z/VSE Administration*.

The installation support provides the following skeletons in VSE/ICCF library 59:

**SKCICS2** (for defining startup)

**SKPREPC2** (for defining resources)

For an overview on the skeletons and tables provided, refer to “Overview on CICS Skeletons and Tables” on page 198.

## Environment Characteristics

The support defines a secondary CICS Transaction Server, named PRODCICS, for use in a production environment. PRODCICS is defined to communicate with DBDCCICS, the primary CICS Transaction Server, via **MRO** (Multi-Region Option). Refer to the *z/VSE Administration* for the customization tasks involved.

The two CICS systems can also communicate via ISC (Inter-System Communication). In case of an ISC connection, the two CICS systems can run on the same server or on different servers. For further ISC information, you may also refer to “Activating the APPC Support” on page 204.

Note that the second CICS Transaction Server can run in a dynamic partition as well.

The environment has the following characteristics:

- The two CICS Transaction Servers share the VSE.CONTROL.FILE. Therefore, the user definitions and applications stored in this file are known to and available for both CICS systems.
- The installation support provided assumes that you use the autoinstall function to define terminals and terminal printers for both CICS systems. For that reason, VTAM must be up and running.

- The second CICS Transaction Server will have an Interactive Interface without the services dependent on VSE/ICCF. This means that your use of the Interactive Interface is restricted to the following functions:
  - Sign on to and sign off from the system.
  - Select and control the processing of CICS applications.
  - Work with the Online Problem Determination (OLPD) tool.
  - Work with the Workstation File Transfer Support.
  - Work with the following dialogs:
    - Inspect Message Log
    - Display Channel and Device Activity
    - Display System Activity
    - Display Storage Layout
    - Display Active Users/Send Message
  - Work with most of the functions of the *Manage Batch Queues*
  - Work with the dialogs for maintaining user profiles, selection panels, and application profiles. VSE/ICCF information, however, cannot be changed.

## Planning for the Second CICS Transaction Server

### Virtual Storage Requirements

These are the storage values defined for the second CICS Transaction Server, which is assumed to run in partition F8.

- For environment A:

```
ALLOC F8=50M  
SIZE F8=2M  
CICS EDSALIM = 50M
```

- For environment B:

```
ALLOC F8=150M  
SIZE F8=2M  
CICS EDSALIM = 120M
```

- For environment C:

```
ALLOC F8=512M  
SIZE F8=2M  
CICS EDSALIM = 450M
```

Note that these are default values. The values required depend on the size of the applications you are going to run. The minimum value required is 30M.

If required, adjust the partition values by using skeleton SKALLOCB or SKALLOCC. The SETPFIX value is set by the startup procedure provided (skeleton SKCICS2).

If you reduce the default value for ALLOC, you must also reduce the value for EDSALIM in the DFHSIT.

### Disk Storage Requirements for System Files

While some system files are shared between the two CICS Transaction Servers, others must be defined additionally for the second CICS Transaction Server.

The following files are shared with DBDCCICS, the primary CICS Transaction Server:

```
CICS.CSD
CICS.DBDCCICS.DFHDMFA
CICS.DBDCCICS.DFHDMFB
PC.HOST.TRANSFER.FILE
VSE.CONTROL.FILE
VSE.TEXT.REPSTORY.FILE
VSE.MESSAGE.ROUTING.FILE
```

The system files to be defined for the second CICS Transaction Server are shown in Table 43. Initially, you should reserve the amount of space shown.

z/VSE provides skeleton **SKPREPC2** to define these system files.

*Table 43. System Files and Disk Space Needed for Second Predefined CICS Transaction Server*

File Name	IBM-Provided File Identifier	File Type		Remarks
DFHRSD	CICS2.RSD	VSAM KSDS		See Note 1
DFHNTRA	CICS2.TD.INTRA	VSAM ESDS		See Note 1
DFHTEMP	CICS2.DFHTEMP	VSAM ESDS		See Note 1
DFHGCD	CICS2.GCD	VSAM KSDS		
DFHLCD	CICS2.LCD	VSAM KSDS		
DFHDMPA	CICS2.DUMPA	VSAM ESDS		
DFHDMPB	CICS2.DUMPB	VSAM ESDS		
DFHAUXT	CICS2.AUXTRACE	VSAM ESDS		
IESPRB	CICS2.ONLINE.PROB.DET.FILE	VSAM ESDS		
Approximate Amount of Disk Space Required				
	Number of FBA Blocks	Number of Tracks (full cylinders)		Approx. Number of Megabytes (MB)
		IBM 3380	IBM 3390	
VSAM Space	24,000	390	360	12
Journal Files (see Note 2)	12,032	240	240	6

All files are ready for use after skeleton SKPREPC2 has been run.

#### Notes:

1. The file is created dynamically when required. It is released again (on user request) when it is no longer needed.
2. Possibly, your second CICS Transaction Server needs system journal files (DFHJCTxx). The size of a system journal file and of any CICS user journal file that you might want to use, is workload dependent. For guidance about journal file sizes, refer to the appropriate CICS documentation. Add the size of the planned journal files to your disk space requirements.



For CICS journal files, refer also to "Note on CICS Journaling" under "Non-VSE/VSAM System Files" on page 114.

### Startup Considerations for a Dynamic Partition

The startup program DTRISTRTR processes and sets variables in CPUVARn (shipped as CPUVAR1) such as XSTATxx or XMODxx only for static partitions. This means, it ignores these parameters if your second CICS Transaction Server runs in a dynamic partition. However, you can use the concept of controlling startup via SETPARM variables in CPUVARn by coding your own CICS startup procedure.

### CICS Control Tables

For the second CICS Transaction Server, z/VSE provides a set of tables as listed in Table 42 on page 198. In general, these predefined tables need not be modified except for adding your own applications and resources. Minor changes are to be made to the DFHSIT of the primary CICS (DBDCCICS) if the two CICS Transaction Servers are to communicate with each other via MRO or ISC as described in the *z/VSE Administration* under "Installation Tasks for a Second CICS Transaction Server".

**Note:** If you use a page data set with an Environments B or C, ensure that the default allocations for CICS Journal files (SKJOUR2) used with the second CICS Transaction Server do not overlap with the page data set!

---

## DFH0STAT Considerations

DFH0STAT uses EXEC CICS COLLECT STATISTICS to retrieve statistical information. You should be aware, however, of the following restrictions when using DFH0STAT:

1. If a CEMT PERF STAT RESET is issued or the "statistics collection interval" has expired or midnight is reached (all statistics information is written to DMF), the counter fields for most resources are reset. DFH0STAT cannot collect these numbers. Therefore, you should consider to set interval statistics collection STATRCD=OFF to avoid a counter reset.  
But be aware that by doing so you will lose any interval statistics information with DFHSTUP.
2. If an autoinstalled resource like a terminal or a program is removed from a CICS partition, all statistics information is written to the DMF before deleting the resource control blocks. Deletion of these control blocks means also deleting all counters for it. A subsequent usage of DFH0STAT will **not** show any counters for this resource. When running DFHSTUP against the DMF dataset, all of the information will be shown.
3. If an uncontrolled shutdown occurs, DFH0STAT in DFHPLTSD will **not** produce any output. DFHSTUP may not show the last activities but all the previous ones.

Refer also to Note 1 for Table 42 on page 198.

Because of the restrictions outlined above, it may be the better solution for a production system to use DFHSTUP (instead of DFH0STAT) for collecting statistics information.

### Definition of DFH0STAT, DFH\$STAS and DFH\$STCN

## Installing Second CICS TS

All three programs have to be defined with EXECKEY=CICS if DFH0STAT is put into the DFHPLTSD. Programs defined in DFHPLTSD run under CICS control in CICS mode.

DFHPLTSD is available as skeleton in VSE/ICCF library 59.

---

## Activating the APPC Support

APPC (advanced program-to-program communication) is important for programs such as the VSE/ESA Distributed Workstation Feature.

To activate the APPC support, the DFHSITSP for the CICS Transaction Server must be re-assembled with ISC=YES. DFHSITC2, the initialization table for the second CICS Transaction Server is shipped with ISC=YES and must not be re-assembled.

ISC=YES enables the APPC connection between the CICS system in the host and a workstation with the VSE/ESA Distributed Workstation Feature installed.

For further details about the tasks involved in activating the APPC support, consult the *VSE/ESA Distributed Workstation Feature - User's Guide (OS/2 Support)* or the Windows version of this publication. The publications are available online via the z/VSE home page.

---

## Using the CICS Report Controller to Control/Print Reports

The CICS Report Controller is available with the **CICS Transaction Server**.

It allows users to control and print information (*reports*) created by both online applications and batch programs. See the corresponding CICS documentation for details.

During system startup, the Report Controller is automatically activated and made available through the *CICS Supplied Transactions* panel of the Interactive Interface.

The following publications are available for the CICS Transaction Server:

*CICS TS Report Controller Planning Guide*

*CICS TS Report Controller User*

### z/VSE's Implementation of the Report Controller

The system initialization table (DFHSITSP) that z/VSE provides for the *primary CICS Transaction Server* contains the following entry for the Report Controller:

**SP00L=(YES,A,A)**

**YES** specifies that the Report Controller is part of the CICS system. **A,A** mean that its ID is SYSCICSA and its default class is A.

The DFHSITxx for a *secondary CICS Transaction Server* includes:

**SP00L=(YES,B,A)**

The DFHSITxx for a *third CICS Transaction Server* includes:

**SP00L=(YES,C,A)**

The security setup for the CICS Transaction Server *Report Controller* uses the latest BSM security concept. For details of the CICS Report Controller, refer to the *CICS TS Security Guide*, SC33-1942-03 or later.

### Transient Data Queues Used by the Report Controller

In z/VSE, the Report Controller makes use of two transient data queues:

- **CSPA**

This queue holds audit information about:

- Reports printed on a printer and
- Changes made to the characteristics or status of reports.

When CICS is shut down, this information is forwarded to SYSLST and automatically printed.

- **CSPW**

Action messages for a print task (such as a forms change request) and severe error messages are routed to CSPW.

As defined in DFHDCTSP, the final destination of these messages can either be a terminal or a file. The default for z/VSE is the system console.

If you wish, you can route the messages to any other terminal by changing the terminal ID specified in IEP1 of DFHDCTSP. You also can use IEP2 to hold the messages in a file. This file then can be manipulated via option 4 (Transient data queue selection) of the selection panel for CEMS.

**Note:** If you hold the messages in a file, be sure to print or delete them from time to time. If you do not, transient data space may gradually fill up.



---

## Chapter 16. Console Support

This chapter describes the *console support* provided by z/VSE. It contains these main topics:

- “Console Types and Functions Supported”
- “3270 Console Support” on page 209
- “Console Selection and Assignment” on page 214
- “Message Flow and Message Logging” on page 215
- “Communicating with the Operator” on page 217
- “Command Processing” on page 217
- “VM/VSE Linkage Functions” on page 218
- “Using REXX/VSE for Console Automation” on page 220
- “VSE/POWER Console Considerations” on page 220
- “VSE/ICCF Command Authorization” on page 220
- “JCL Command Authorization” on page 221
- “Security Considerations for the Master Console” on page 221
- “STXIT OC Macro Extensions” on page 221
- “Migration Considerations Related to Console Support” on page 222

---

### Console Types and Functions Supported

The following types of consoles are supported by z/VSE:

#### **Integrated Console**

An integrated console allows to operate z/VSE from the console used on servers to control and maintain the configuration of the server.

#### **3270 Console**

This is the existing z/VSE full-screen system console support based on a local non-SNA 3270 terminal. This console is optional when the Integrated Console is used in connection with one of the following consoles:

Interactive Interface master console

CMS master console

NetView master console.

The functions, presentation characteristics, and performance have been significantly improved.

#### **Line Mode Console**

This is the existing Line Mode system console based on a virtual 3215 printer-keyboard. Its use is only meaningful in an environment where z/VSE runs under VM. The functions and presentation characteristics are unchanged.

#### **Interactive Interface Consoles**

These consoles replace the former VSE/ICCF-based consoles. Their capabilities, presentation characteristics, and performance have been improved in such a way that they can effectively replace the 3270 system console

## Console

### CMS Consoles

This is the existing facility, supported by the VM/VSE Interface Routines to operate a z/VSE guest system from a CMS console of VM. This support has been extended to dynamic partitions and to optionally route master console traffic to a predefined CMS user-ID (SYSECHO command).

## Supported Console Functions

The functions supported by the various types of consoles are shown in Table 44.

Table 44. Supported Console Functions

Console Functions	Integrated Console	3270 System Console	Line Mode Console	Interactive Interface Console	CMS Console
Interact with IPL	yes	yes	yes	no	no
Receive messages	yes	yes	yes	yes	yes
Enter message replies	yes	yes	yes	yes	yes
Enter system commands	yes	yes	yes	yes	yes
Receive command responses	yes	yes	yes	yes	yes
PF-Keys	(Note 1)	yes	(Note 2)	yes	(Note 2)
Extended Attributes	(Note 1)	yes	(Note 2)	yes	(Note 2)
Redisplay Hardcopy File	yes	yes	yes	yes	yes
Message Explanation, Help	no	yes	no	yes	no
Multiple User Support	no	no	no	yes	yes

### Notes:

1. Presentation features are controlled by the Support Element (SE) implementation.
2. Presentation features are controlled by VM.

## Console Types (Logical Level)

On a logical level, z/VSE distinguishes between system, master, and user consoles. Table 45 on page 209 shows the combinations that are possible.

### System Console

The system console is identified by being assigned the logical unit name **SYSLOG**. The 3270 system console, the Line Mode console, or the Integrated Console may be used for this purpose. Its function is taken over automatically by the Integrated Console, if available, and if the SYSLOG device fails. The system console is used to IPL the system and operates after IPL like a master console (3270 or Line Mode) or as a console of the "last resort" (Integrated Console). It has master console authorization and a user can reply to all outstanding messages and enter all system commands.

### Master Console

A z/VSE system may have several master consoles active. Each master console receives all system messages which are not routed exclusively to a specific console, and it can reply to all outstanding messages and enter all system commands. After IPL, a 3270 system console or a Line Mode system console also operates as a master console.

**User Console**

User consoles differ from master consoles with respect to their input capability and/or to the scope of messages routed to them. The following cases are possible:

1. Limited output with full input capability.  
The console receives only messages related to jobs submitted with a matching ECHO/ECHOU option or to programs invoked directly from the console, but the console is authorized for all system commands and replies and has full REDISPLAY capability. The typical user is a system administrator.
2. Limited output with restricted input capability.  
The console receives limited output as in the first case, but may only enter a restricted set of system commands and only reply to the messages it receives. REDISPLAY is also limited to messages and inputs routed to or entered from the console. The typical user is a program developer.
3. Restricted input capability with full output.  
The console receives all messages that are also routed to master consoles and has full REDISPLAY capability, but may only enter a restricted set of system commands and only reply to messages that are specifically routed to it. This console is typical for users that need to monitor system activity as, for example, in a printer room.

“Console Selection and Assignment” on page 214 describes how system, master, and user consoles are assigned.

*Table 45. Supported Console Types (Logical Level)*

Console Type	Integrated Console	3270 System Console	Line Mode Console	Interactive Interface Console	CMS Console
System Console	yes	yes	yes	no	no
Master Console	no	yes	yes	yes	yes
User Console	no	no	no	yes	yes

---

## 3270 Console Support

3270-type terminals are supported as:

- System console
- Master and user consoles (Interactive Interface consoles)

For the 3270 system console, a local non-SNA terminal is needed. But since the Integrated Console can also be used for this purpose, the 3270 system console is optional.

The functional characteristics of all 3270 consoles are identical, and their presentation characteristics depend only on the capabilities of the terminal model used.

## 3270 System Console Activation

The 3270 system console becomes active at IPL time when the console is identified as IPL communication device, or as soon as the system recognizes an ASSGN SYSLOG,cuu for the console device.

### Activation of Interactive Interface Consoles

An Interactive Interface console becomes active when a user selects the *Console* dialog. The console type is determined by the user type and by user profile options. Refer also to "Console Selection and Assignment" on page 214.

### Dropped Console Printer Support

The support of a console printer, in connection with a 3270 system console, has been dropped.

## Modes of Operation

You can operate 3270-type consoles in the following modes:

- Console mode (C)  
The messages are displayed in the order as they are being generated by the system.
- Redisplay mode (R)  
Messages no longer visible on the screen can be redisplayed. The messages can be retrieved selectively or displayed sequentially as stored on the Hardcopy file.
- Explanation mode (E)  
This mode allows to display z/VSE message explanations. The display format is identical to the format used in the *z/VSE Messages and Codes*.
- Help mode (H)  
Help information is available for explaining panel functions and local messages.

## Console Definitions

Console definitions consist of definitions for:

- PF keys
- Panel data
- Local messages
- Operation characteristics

These definitions are predefined and shipped as phase \$IJBDEF in library IJSYSRS.SYSLIB. Table 46 shows the default PF-key settings for 3270-type consoles as shipped with z/VSE. PF-key settings are candidates for user modifications and are therefore discussed in more detail.

Table 46. Predefined PF-Key Settings

Type	Key	Mode	Text	Command / Variable
PFKEY	1	C	'1=HLP'	'%HELP'
PFKEY	2	C	'2=CPY'	'%COPY "?CL'
PFKEY	3	C	'3=END'	'%END'
PFKEY	4	C	'4=RTN'	'%RETURN'
PFKEY	5	C	'5=DEL'	'%DELETE "?CL","?IN'
PFKEY	6	C	'6=DELS'	'%DELETE "?CL","SYSTEM'
PFKEY	7	C	'7=RED'	'%REDISPLAY "?IN'



Table 46. Predefined PF-Key Settings (continued)

Type	Key	Mode	Text	Command / Variable
PFKEY	8	C	'8=CONT'	'%CONTINUE'
PFKEY	9	C	'9=EXPL'	'%EXPLAIN "?TK'
PFKEY	10	C	'10=HLD'	'%CHANGE "HOLD'
PFKEY	11	C	'11=PCUU'	'%EXCUU "?CL'
PFKEY	12	C	'12=RTRV'	'%RETRIEVE'
PFKEY	ENTER	C	'INPUT'	'?IN'
PFKEY	CLEAR	C	'CLEAR'	'%CLEAR'
PFKEY	1	R	'1=HLP'	'%HELP'
PFKEY	2	R	'2=CPY'	'%COPY "?CL'
PFKEY	3	R	'3=END'	'%REDISPLAY E'
PFKEY	4	R	' '	"
PFKEY	5	R	' '	"
PFKEY	6	R	'6=CNCL'	'%REDI C'
PFKEY	7	R	'7=BWD'	'%REDI "?CL";"B,"?IN'
PFKEY	8	R	'8=FWD'	'%REDI "?CL";"F,"?IN'
PFKEY	9	R	'9=EXPL'	'%EXPLAIN "?TK'
PFKEY	10	R	'10=INP'	'?IN'
PFKEY	11	R	'11=PCUU'	'%EXCUU "?CL'
PFKEY	12	R	'12=INFO'	'%CHANGE INFO'
PFKEY	ENTER	R	'REDISPLY'	'%REDI "?CL";"?IN'
PFKEY	CLEAR	R	'CLEAR'	'%CLEAR'
PFKEY	1	E	'1=HLP'	'%HELP'
PFKEY	2	E	'2=CPY'	'%COPY "?CL'
PFKEY	3	E	'3=END'	'%END'
PFKEY	4	E	' '	"
PFKEY	5	E	' '	"
PFKEY	6	E	' '	"
PFKEY	7	E	'7=BWD'	'%BACKWARD'
PFKEY	8	E	'8=FWD'	'%FORWARD'
PFKEY	9	E	'9=EXPL'	'%EXPLAIN "?TK'
PFKEY	10	E	'10=INP'	'?IN'
PFKEY	ENTER	E	'EXPLAIN'	'%EXPLAIN "?TK'
PFKEY	CLEAR	E	'CLEAR'	'%CLEAR'
PFKEY	1	H	'1=HLP'	'%HELP'
PFKEY	2	H	' '	"
PFKEY	3	H	'3=END'	'%END'
PFKEY	4	H	' '	"
PFKEY	5	H	' '	"
PFKEY	6	H	' '	"
PFKEY	7	H	'7=BWD'	'%BACKWARD'

Table 46. Predefined PF-Key Settings (continued)

Type	Key	Mode	Text	Command / Variable
PFKEY	8	H	'8=FWD'	'%FORWARD'
PFKEY	9	H	' '	"
PFKEY	10	H	'10=INP'	'?IN'
PFKEY	ENTER	H	'HELP'	'%HELP'
PFKEY	CLEAR	H	'CLEAR'	'%CLEAR'

## Macro IJBDEF

Macro IJBDEF is used for defining and modifying console definitions. The macro can be of type:

### DSECT

Creates a DSECT of the definition table

### PANEL

Defines a panel entry in definition table

### PFKEY

Defines a PF-key entry in definition table

**MSG** Defines a message text entry in definition table

### DEFAULT

Selects operation characteristics and message colors

**GEN** Starts the table generation process

As shown in Table 46 on page 210, for type PFKEY the following parameters can be specified:

1. PF-key number (1 through 12), or ENTER, or CLEAR.
2. Mode (C=Console, R=Redisplay, E=Explanation, H=Help).
3. Descriptive text (up to 12 characters).
4. Command string which may include variables.

For PFKEY, the following command and variable characteristics apply:

- A command may be a local command (to invoke a local console function) or a VSE command to be sent to the system.
- Only one local command is allowed and it must be the first item in the string.
- Local commands are not echoed like system commands.
- Local commands may be entered from the input line. For example, requesting a message explanation:  

```
%EXPLain 1Q15
```
- The following variables can be used with local commands:  

```
?CL (insert screen message line number pointed to by cursor)
?TK (insert token (message ID) pointed to by cursor)
?IN (insert input from the input line without trailing blanks)
```
- Variables are only substituted when being defined with PFKEY (but not when entered in the input line).

## Modifying PF-Key Settings

PF-key settings (and other console definitions) can be changed separately for the 3270 system console by assembling member IJBDEF, and for all Interactive Interface consoles (not for individual users) by assembling member IESEDEF.

Under “Tailoring Console Definitions”, the *z/VSE Administration* describes in detail macro IJBDEF, member IJBDEF, and the tasks involved for modifying console definitions.

## Modifying Color Settings

The support offers additional IJBDEF DEFAULT specifications for the colors of messages and input lines displayed on the console as follows:

```
IJBDEF DEFAULT,msgtype,color
```

*msgtype* may be:

- IMSG** Information message
- RMSG**  
Immediate command response
- PMSG**  
Prompt message, needing a reply
- AMSG**  
Action message
- EMSG**  
System failure message
- LMSG**  
RED L response (redisplay)
- HMSG**  
RED H response (redisplay)
- EINP** Echoed console input

*color* may be: 00, F0 through FF, with the same color conventions already supported for panel fields. Refer to the *z/VSE Administration* for details.

Currently reserved bytes in the default table generated by IJBDEF are used to store the new color specifications. These bytes are currently generated to contain X'00', and remain X'00' if the corresponding DEFAULT specification was omitted or specifies X'00'.

The implemented algorithm replaces the standard colors generated by the console routers, if the corresponding byte in the default table contains a non-zero value. This ensures that standard colors continue to be displayed for existing versions of the default table.

Modules IJBDEF and IESEDEF, which contain standard console definitions for the system console and the Interactive Interface consoles, remain unchanged. The new DEFAULT definitions must be explicitly added to obtain the desired alternate colors.

---

## Console Selection and Assignment

### Overview

#### Initial Installation

The initial installation procedure contains an ADD command for a dummy system console with predefined device address:

```
ADD FFF,CONS
```

IPL may thus select as the **system console** for installation the Integrated Console with device address FFF (for cuu), depending on the IPL load parameter.

#### Performing IPL

During IPL, the **system console** is assigned to the Integrated Console, or to the 3270 or Line Mode console. Which console is finally selected depends on the following:

- IPL load parameter.
- Device availability.
- Console device specification in the IPL procedure.
- I/O interrupt received from a console device.

For further details refer to “IPL System Console Selection” on page 215.

#### Running System

After IPL, the **system console** may be re-assigned at any time by changing the SYSLOG assignment:

```
ASSGN SYSLOG,cuu
```

1. **Master consoles** can be requested and are assigned as follows:
  - For Interactive Interface users defined in their profiles as type 1 with full console output option or type 2 with full input and output options, by selecting the CONSOLE dialog. Refer to the chapter “Maintaining User Profiles via Dialogs” in the *z/VSE Administration* for details.
  - One CMS master consoles (for operating z/VSE from VM) through the SYSECHO ON command.

Typically, most messages are then routed to one or more of these master consoles. The system console, when assigned to the Integrated Console, is then used for critical messages only which cannot be routed to any other master console. When the system console is assigned to a 3270 or Line Mode console, it continues to receive all message traffic not routed to NetView.

2. **User consoles** can be requested and are assigned as follows:
  - For Interactive Interface users defined in their profiles as type 1 with limited console output option or type 2 with limited input and/or output options, by selecting the CONSOLE dialog.
  - CMS user consoles by logging on to VM. Such a user has limited operating capabilities for z/VSE.

## IPL System Console Selection

IPL supports the Integrated Console as system console (in addition to a 3270 or Line Mode system console). The basic selection rules are:

1. If a console type is specified in the IPL load parameter, then the system will route the messages to that device. This can be the Integrated Console or a local console. Local console means in this case 3270 or Line Mode console.
  - a. If a local console is requested or the Integrated Console is not available, the system will route messages to the local console specified in the ASI IPL procedure.
  - b. If that device is not available or not operational, the system will wait for an interrupt from a local console.
2. If a system is IPLed without specification of a device type in the IPL load parameter, the system will route messages to a local console (3270 or Line Mode console).
  - a. The system selects first the console specified in the ASI IPL procedure.
  - b. If this device is not operational, the system waits for an interrupt from a local console.

### The IPL Load Parameter

To support the Integrated Console, the following IPL load parameter specifications have been introduced:

**Console type** which specifies whether the messages are to be routed to an Integrated Console or to a local console.

**IPL message suppression code** which may be used to request message suppression and command logging during IPL.

**IPL prompting code** which may be used to request a prompting for IPL parameters (this is identical to the former IPLSTOP function). How to use this function is described in detail in the *z/VSE Guide to System Functions* under "Starting the System".

**Startup mode prompting code** which may be used to request prompting for a startup mode such as BASIC or MINI.

For a detailed description of the available operands of the IPL load parameter refer to the *z/VSE System Control Statements* under "The IPL Load Parameter".

## Message Flow and Message Logging

### Routing Rules

When multiple consoles are concurrently active, messages and DOM (Delete Operator Message) requests are routed to a selected subset of these consoles according to the following routing criteria:

- Messages or responses destined for a specific console are routed to that console if it is active. This is the only criteria for **user consoles** with limited input capability.
- Messages that are (also) destined for **master consoles** are routed to them based on matching routing codes, message level, and automation option.

## Console

The automation option, activated for selected messages by operator-automation products, is taken into account only when at least one automation console, like the NetView console, is active and eligible for the message.

- **Master console** messages that cannot be delivered to any active master console are routed to the **Integrated Console** if active.
- DOM requests are routed to all eligible consoles, based on a matching DOM option defined for each console.

Note that the above routing rules do not apply for messages originating from Interactive Partitions if these messages are intercepted by VSE/ICCF and are displayed exclusively on a VSE/ICCF user terminal.

## Recovery Conditions and Actions

Recovery conditions and actions are summarized below:

- When a task terminates, messages issued by the task and awaiting a reply or action are removed from the "hold" state, and a corresponding DOM request is routed to eligible consoles. Incomplete messages are suppressed. All consoles activated by the terminating task are deactivated.
- When a console is deactivated or suspended, the system does not wait any longer for messages to be received or replied to by that console. All messages that are only waiting to be routed to that console are deleted but logged when applicable. Messages that are to be routed exclusively to that console and need a reply cause the originating task(s) to be canceled. Other console messages which require an operator action or a reply remain pending.
- When a console with full output capability is activated or resumed, it receives all pending messages eligible for it before delivery of current messages begins.

## Logging Messages on the Hardcopy File

All normal message traffic is logged by default on the Hardcopy File. Exceptions are DOM and message explanation requests, as well as redisplay commands and responses. Optionally, logging may also be suppressed (through the HCLOG command) for messages that are routed exclusively to user consoles with limited input capability and for the replies to such messages. Hardcopy file records include message routing information and the name of the originating console for commands and replies.

## Security Aspects

The console support ensures that **user consoles** with limited input capability can only reply to and redisplay messages that were routed to them. For other commands, console authorization checking is performed.

When z/VSE security (access control) is active, the system determines the user-ID and the authority level of inputs submitted by a **master console** on behalf of other users (for example, CMS users) and uses this information for authorization checking.

---

## Communicating with the Operator

The following macros are available for application programs to communicate with the operator. They allow to submit messages or command responses, receive replies and control the disposition of submitted messages.

### WTO (WTOR)

The WTO (Write to Operator) and WTOR (Write to Operator with Reply) macros support functions such as:

- Specification of message text lines by addresses.
- Concatenation of multiple WTOs to a single logical message of arbitrary length.
- Routing to a specified console.
- Specification of a correlation token for command responses.
- Identification of the console replying to a WTOR.
- Writing of log-only messages.

Both macros are compatible with the MVS/ESA macros of the same name. Compatibility with the previous level of WTO and WTOR is also preserved.

**DOM** The DOM (Delete Operator Message) macro allows you to delete a submitted message or to mark it as deletable when the condition that caused the message no longer exists.

For a detailed description of these macros, their syntax and their operands, refer to "WTO Macro", "WTOR", and "DOM Macro" in the *z/VSE System Macros Reference*. Under "WTO, WTOR, DOM Usage Examples", the *z/VSE System Macros User's Guide* provides coding examples exemplifying how to use these macros in application programs.

---

## Command Processing

### Command Authorization

Commands are classified into three categories:

- **Restricted commands** which can be entered from system or master consoles only.
- **Semi-restricted commands** which can be entered from user consoles with limited input capability depending on certain argument values as follows:
  1. Partition related commands that are accepted only when an ECHO or ECHOU option for the originating console is effective for the job currently running in the specified partition (ECHO scope).  
The ECHO or ECHOU option is to be specified in the VSE/POWER \* \$\$ JOB statement.
  2. Commands that are accepted from user consoles with limited input capability in "query format only".
- **General-use commands** that may be entered from any console.

For example, most AR (Attention Routine) commands are restricted and can be entered only from a console with full input capability except for the commands listed below:

**CANCEL**  
ECHO scope

## Console

<b>GETVIS</b>	General use
<b>MAP</b>	General use
<b>MSG</b>	ECHO scope
<b>MSECS</b>	Query only
<b>PAUSE</b>	ECHO scope
<b>PRTY</b>	Query only
<b>PRTYIO</b>	Query only
<b>STATUS</b>	General use
<b>VOLUME</b>	General use

### Further Information

Consult the following publications for command details including their classification:

*z/VSE System Control Statements*  
*VSE/POWER Administration and Operation*  
*VSE/ICCF Administration and Operation*

## New and Changed Commands

The *z/VSE System Control Statements* describes these commands in detail. For a summary of the new and changed commands, refer to “Summary of Changes” in the *z/VSE System Control Statements*.

---

## VM/VSE Linkage Functions

### Operating z/VSE from a CMS Console

As in previous releases, a CMS user of VM can submit jobs to z/VSE guests through the **SUBVSE** interface routine. The **VSECMD** interface routine for operating z/VSE guests from VM has been generalized.

The interface routines **VSEREP**, **VSECP** and **VSEMSG** have been dropped since their functions are also covered by **VSECMD** now.

The *z/VSE Operation* describes in detail the command level of the interface routines.

### Requirements

To use the VM/VSE linkage functions, the following requirements must be met:

- The VM/VSE interface routines must first be installed through skeleton SKVMVSE. This task is described in detail in the *z/VSE Installation* under “How to Install the VM/VSE Interface”.
- The IPL startup procedure of a z/VSE guest must include **VMCF=YES** in the IPL **SYS** command.



## Planning Details

### 1. SUBVSE Interface/Command

SUBVSE allows a CMS user to submit jobs to z/VSE guests. The record length is restricted to a maximum of 80 characters.

For the ECHO function the following applies:

- ECHO is now supported as an option in the VSE/POWER \* \$\$ JOB statement and must be coded explicitly like other output routing options such as LDEST or PDEST. The FOR and ECHO arguments for SUBVSE have therefore been dropped.
- If the ECHO or ECHOU option is specified for a submitted job, all messages related to the processing of that job are routed to the console of the ECHO user-ID. If no z/VSE console is active for that user-ID, the messages are routed to the CMS console with that user-ID (typically the job submitter).

Messages that are sent to a CMS user and need a reply can then be answered with VSECMD provided the user is authorized for the reply.

Master authorization is required for selected messages that are also routed to master consoles.

### 2. VSECMD Interface/Command

VSECMD allows CMS users to operate z/VSE guests and is the only way of submitting console input (command or reply) to a z/VSE guest, including redisplay commands for the Hardcopy file.

To ensure that VSECMD works properly, z/VSE user-IDs and CMS user-IDs of VM should be unique. If identical user-IDs exist, they must identify the same person and cannot be used concurrently to access z/VSE console functions from both, CMS and z/VSE.

To ensure z/VSE integrity and security, master console authority for CMS users should be implemented as follows:

- Perform IPL of z/VSE with SEC=YES in the IPL SYS command.
- Define CMS users requiring z/VSE master console authority in the z/VSE access control table DTSECTAB with MCONS=YES and/or AUTH=YES. The *z/VSE Administration* describes DTSECTAB and its parameters in detail.

Implementing the system as described above ensures that:

- A user with "master" authority can enter any command and reply to any outstanding message (whether or not it was routed to the own CMS user-ID).
- A user without "master" authority can only enter a subset of commands and reply to most messages that were routed to the own CMS user-ID, based on the ECHO or ECHOU option of a submitted job.

Since not all console traffic is recorded on the Hardcopy file (as described under "Logging Messages on the Hardcopy File" on page 216), some previous user inputs or z/VSE messages may be missing in the redisplay response. The CMS console log may be used to maintain a complete record of all CMS sessions, including all message traffic with z/VSE guests.

### 3. Two additional VM/VSE functions are provided through commands:

- The SYSECHO command can be used to route all z/VSE master console messages to a CMS user-ID specified in the command. This support can be exploited to automate z/VSE operations via a CMS program.
- The \* CP command can be used to allow z/VSE operators with master authority to submit VM CP commands and receive the associated responses.

"SYSECHO" and "\* CP" in the *z/VSE System Control Statements* describe in detail the commands SYSECHO and \* CP.

---

### Using REXX/VSE for Console Automation

REXX/VSE offers a feature called REXX/VSE Console Automation. The support helps to automate console operation by handling one or more z/VSE console sessions from a REXX program. z/VSE console commands can be imbedded into a REXX program and commands can be retrieved.

The following types of commands are supported:

- Attention routine (AR) commands
- Console redisplay commands
- VSE/POWER, VSE/ICCF, CICS, VTAM, and SQL/DS commands.

The *REXX/VSE Reference* provides a detailed description of the REXX/VSE Console Automation.

---

### VSE/POWER Console Considerations

#### Command Authorization

All VSE/POWER commands are accepted from the system or a master console. From a user console, only selected commands or command variations are accepted. The *VSE/POWER Administration and Operation* provides details about VSE/POWER commands and their usage with the various console types.

#### ECHO Support for User Consoles

New ECHO or ECHOU parameters have been introduced for the VSE/POWER \***\$\$ JOB** statement. They allow to specify whether job-related system console messages are to be routed to a given user console.

The system checks first for an active z/VSE user console matching the specified user-ID. If no such console exists and z/VSE runs under VM, an attempt is made to route the message to a CMS console with that user-ID. If this is not successful, the message is ignored or, if a user reply is required, the job is canceled.

The former ECHO parameter of the JCL // JOB statement is no longer supported.

#### Message Prefix Changes

A job related message shows the prefix of the partition in which the job was actually executed. In former releases, such messages showed the prefix of the VSE/POWER partition (F1).

---

### VSE/ICCF Command Authorization

All VSE/ICCF commands are accepted from a master console. From a user console, only the following commands are accepted:

```
/DISPLAY  
/MAP  
/USERS
```

---

## JCL Command Authorization

The following JCL commands are accepted from a master console only:

ALLOC  
DVCDN  
DVCUP  
HOLD  
JCLEXIT  
MSECS  
NPGR  
PRTY  
ROD  
SET  
SIZE  
START  
STOP  
UCS  
UNBATCH

---

## Security Considerations for the Master Console

For security and integrity reasons the assignment of **master console** authority to CMS users can be controlled by assigning only to selected users this authority level. The following steps are required:

1. Perform IPL of z/VSE with SEC=YES in the IPL SYS command.
2. Define master console users with MCONS=YES or AUTH=YES in the VSE.CONTROL.FILE via the *Maintain User Profile* dialog. Refer to the *z/VSE Administration* for details on the dialog.

A user with MCONS=YES is authorized to submit input which requires master console authority.

---

## STXIT OC Macro Extensions

The OC (operator communications) exit of the STXIT macro has been extended by the operand MSGPARM.

MSGPARM indicates that control information (routing and correlation parameters) is accepted from the MSG command. They are to be passed to the save area of the OC exit. For a detailed description of the macro, refer to the *z/VSE System Macros Reference* under “STXIT Macro”.

---

## Migration Considerations Related to Console Support

### Initial Program Load (IPL)

#### IPL Load Parameter

To support the Integrated Console, the format and contents of the IPL load parameter has changed. The old format (IPLSTOP) is no longer supported. Refer to the *z/VSE System Control Statements* under “The IPL Load Parameter” for details about the format of the IPL load parameter.

#### IPL Communication Device

If your system console is an **Integrated Console**, the source of your IPL commands may be your IPL ASI procedure, or you may interactively enter the IPL commands at the Integrated Console.

#### Interrupting and Restarting IPL

When your system console is an **Integrated Console**, you must use the IPL load parameter if you want to interrupt and restart IPL (for modifications). Refer to the *z/VSE Guide to System Functions* under “Interrupt IPL Processing for Modifications” for details.

### VM Linkage Functions

#### VM/VSE Interface Routines

The interface routines VSEREP, VSECP, and VSEMSG are no longer available. Their functions are covered by VSECMD now. Refer to “VM/VSE Linkage Functions” on page 218 for further details.

#### ECHO Support

The ECHO parameter for the current SUBVSE support in the JCL // JOB statement is no longer supported. Instead, the ECHO parameter can be specified in the VSE/POWER \* \$\$ JOB statement. This means that jobs must be submitted via VSE/POWER, if job messages are to be routed to a CMS user console.

### Message Prefix Changes

The reply ID field of the message prefix added by the system to all console messages is extended from 3 to 4 digits. Programs that process console messages (for automation purposes, for example) and depend on the length of the reply ID must be adapted accordingly.

IPL uses for its messages the prefix 0 (prefix of the BG partition).

---

## Chapter 17. Data Compression Support

Data compression provides advantages such as the saving of disk space, reduced number of I/O operations, and reduced channel utilization. In a network it means faster data transmission and lower line costs.

z/VSE provides support for data compression (and expansion) through:

1. The hardware instruction CMPSC which is available on all the servers that are listed in “Server Support” on page 6.
2. The CSRCMPSC macro which will use the hardware instruction if available; otherwise it simulates the CMPSC instruction. The CSRCMPSC macro is compatible with the MVS macro of the same name.

It is transparent to an application which of the two functions actually performs compression. IPL detects whether a processor supports instruction CMPSC and IPL message 0J76I informs about the compression support available.

A CMPSC application can only run if the hardware instruction is supported. A CSRCMPSC application, however, runs with the CMPSC hardware instruction if supported; if not supported the CSRCMPSC macro simulates the CMPSC instruction.

With z/VSE, you can exploit data compression as follows:

1. Using the data compression support provided by **VSE/VSAM** for ESDS, KSDS, and VRDS files. This support is available on the VSE/VSAM command level as well as through the VSE/VSAM dialogs of the Interactive Interface. Further details are provided below.
2. Using the **VTAM** data compression support as introduced below.
3. Writing or using CSRCMPSC applications as introduced below.
4. Writing or using CMPSC applications as described in the *ESA/390 Data Compression (SA22-7208)*.

This chapter contains these main topics:

- “VSE/VSAM Data Compression Support”
- “VTAM Data Compression Support” on page 224
- “Introducing the CSRCMPSC Programming Interface” on page 224

---

### VSE/VSAM Data Compression Support

VSE/VSAM uses the CSRCMPSC interface to provide compression support for KSDS, VRDS, and ESDS files. To be eligible for compression, a VSE/VSAM file should at least have a size of 5 MB. The average record length of such a file should be at least 40 bytes. For a KSDS file the record length (minus key length and key offset) must be greater than 40 bytes.

Data compression takes place on the record level. When a record is loaded into a file it is compressed; when the record is read from the file it is expanded again.

You request data compression for a VSE/VSAM cluster (file) in the IDCAMS command DEFINE CLUSTER with the parameter:

COMPRESS

## Data Compression

Control information for compression and expansion is kept in a dictionary. This dictionary is built by VSE/VSAM when loading the cluster and added to the CCDS (Compression Control Data Set). Any VSE/VSAM catalog including clusters that are to be compressed must have a CCDS defined. The reserved name for a CCDS is VSAM.COMPRESS.CONTROL.

The VSE/VSAM dialog *Define a New File* supports data compression parameters and the dialog *Define a New User Catalog* supports the creation of a CCDS. The dialogs are described in detail in the *z/VSE Administration* under “Managing VSE/VSEAM Files and Catalogs”.

Consult the *VSE/VSAM User's Guide and Application Programming* and *VSE/VSAM Commands* for further details about the VSE/VSAM data compression support and its related parameters.

### VSE/VSAM Backup/Restore

Currently, VSE/VSAM Backup/Restore supports the COMPACT option. It creates a compressed backup copy of a file via software compaction.

It is not recommended to specify the COMPACT option for the BACKUP run of a cluster defined with the COMPRESS parameter. There would be little gain with regard to compression but considerable consumption of CPU time.

#### Compression Prediction Tool

A measure for compressibility is the *compression ratio*, which is the ratio of the length of the data in uncompressed format to the length in compressed format.

The compression prediction tool IKQCPRED can compute the anticipated compression ratio for one or more data sets residing in the same VSE/VSAM catalog. Further details about the tool are provided in the *VSE/VSAM User's Guide and Application Programming*.

---

## VTAM Data Compression Support

VTAM data compression enables you to reduce the amount of data being exchanged between LUs in multiple-domain environments (and APPN environments), thus improving response time for LU-LU sessions and reducing traffic over the lines. VTAM supports static and dynamic compression algorithms. With the CMPMIPS start option it is possible to control the amount of CPU cycles spent for compression and better balance CPU time and compression effectiveness.

Refer to the VTAM publications *VTAM Network Implementation Guide* and *VTAM Resource Definition Reference* for further details.

---

## Introducing the CSRCMPSC Programming Interface

Macro CSRCMPSC is available for writing applications making use of the z/VSE data compression support. The algorithm used is the Ziv-Lempel method where frequently occurring substrings are represented by index entries in a dictionary. This dictionary must be passed to z/VSE with the CSRCMPSC macro call.

Macro CSRCMPSC has two control parameters:

- CBLOCK

Specifies a 36-byte input/output area which contains parameter information for compression (and expansion) such as compression dictionaries, source and target areas, and associated lengths.

- RETCODE

Specifies a fullword output variable or register for storing the return code.

Refer to the *z/VSE System Macros Reference* under “CSRCMPSC Macro” and *z/VSE System Macros User’s Guide* under “Compressing and Expanding Data” for further details about this support.





---

## Chapter 18. Security and Encryption Support

This chapter discusses z/VSE security support that is based upon the use of the *Basic Security Manager* (BSM) and encryption services.

It contains these main topics:

- “Introduction” on page 228
- “History of Security Changes” on page 229
- “Activating BSM or ESM Security Support” on page 230
- “Overview of Security-Support Implementation” on page 230
- “Issuing BSM Security Server Commands” on page 232
- “What BSM Security Provides” on page 232
- “Migrating CICS Transaction Security Definitions” on page 237
- “Creating/Maintaining User Profile Definitions” on page 237
- “Generating BSM Cross Reference Reports” on page 238
- “LDAP Sign-On Support” on page 238
- “Access Control for VSE/POWER Spool Entries” on page 239
- “Support for Logging and Reporting” on page 239
- “Encryption Support” on page 240

### Related Topics:

For details of how to ...	Refer to this topic(s) in the <i>z/VSE Administration</i> , <b>SC34-2627</b> :
implement security support	“Implementing z/VSE Security Support”
define user profiles	“Maintaining User Profiles via Dialogs” and “Maintaining User Profiles via Batch Program IESUPDCF”
define user profiles so they can be used in an LDAP environment	“Maintaining User Profiles in an LDAP Environment”
protect CICS transactions, PCT, DCT, FCT, JCT, and TST entries, CICS applications, and other resources	“Protecting Resources via BSM Dialogs” and “Protecting Resources via BSTADMIN Commands”
protect operands contained in JCL statements	“Using the Tailor-IPL-Procedure Dialog to Tailor Security Parameters” and “Using BSM Dialogs to Protect JCL Operands”
protect z/VSE libraries, sub-libraries, members, and files	“Customizing/Activating DTSECTAB-Based Security”
propagate VSE/POWER security between VSE/POWER subsystems	“Propagation of VSE/POWER Security Identification”
operate a z/VSE system that has an “active” DTSECTAB-based security system	“Operating a DTSECTAB-Based Security System”
log and report security events using the <i>Data Management Facility</i> (DMF) and the <i>VSE/Access Control-Logging and Reporting</i> (ACLR) program	“Logging and Reporting the Security Events”

## Security/Encryption

For details of how to ...	Refer to this topic(s) in the <i>z/VSE Administration</i> , SC34-2627:
implement hardware cryptography	"Implementing Hardware Cryptographic Support"
set up your z/VSE system to use Secure Sockets Layer (SSL)	"Preparing Your System to Use SSL"
configure your z/VSE system for SSL <i>server authentication</i>	"Configuring for Server Authentication"
implement <i>client authentication</i> in the Java-based connector	"Configuring for Client Authentication"
encrypt tapes using an <i>encryption-capable tape drive</i>	"Implementing Hardware-Based Tape Encryption"
implement the <i>software-based</i> encryption of files, library members, and backups	"Implementing the Encryption Facility for z/VSE" and "Implementing the Encryption Facility for z/VSE OpenPGP"
protect your CICS transaction security using table DTSECTXN	"Protecting CICS Transactions with Access Control Table DTSECTXN"
migrate access-control data contained in table DTSECTXN to the BSM control file	"Migrating CICS Transaction Security Definitions"
convert TRANSEC values from CICS/VSE into entries in table DTSECTXN	"Migrating CICS/VSE Security Information to the CICS TS"

### Other Related Topic:

For details of how to ...	Refer to ....
implement z/VSE security in a <i>TCP/IP environment</i>	<i>z/VSE TCP/IP Support</i> , SC34-2640.

---

## Introduction

z/VSE offers two ways of implementing security at a customer's installation:

- Using the Basic Security Manager (**BSM**) included in z/VSE.
- Installing an External Security Manager (**ESM**).

The BSM provides basic security support and is part of z/VSE. It is ready for customization after initial installation.

As an alternative to using the BSM, z/VSE allows you to use an ESM. This is usually a priced vendor product and must be installed separately. An ESM is for users who require more functionality and flexibility in their security implementation than the BSM provides.

The major characteristics of an ESM are:

- It maintains its own user and resource data base for security checking.
- It is activated during startup with the ESM parameter in the IPL SYS command.

An ESM is described in its own set of publications.

The centralized control of z/VSE security processing is done by the *System Authorization Facility* (SAF). Vendors or customers that want to use the SAF directly find an introduction under Chapter 21, "System Authorization Facility (SAF) and

its External Security Interface (RACROUTE),” on page 273.

---

## History of Security Changes

- The security changes introduced with VSE/ESA 2.4 were mainly due to the replacement of CICS/VSE by the *CICS Transaction Server for VSE/ESA*.
- The security changes introduced with z/VSE 3.1.1 provided additional support for CICS resource security, applications and facilities, using the Basic Security Manager (BSM) and the *BSM control file* (VSE.BSTCNTL.FILE).
- Also introduced with z/VSE 3.1.1:
  - The BSM control file replaced the use of file DTSECTXN for controlling access to CICS transactions.
  - Migration programs were provided for you to migrate your security-related transaction data from DTSECTXN to the BSM control file.
- The security changes introduced with z/VSE 4.1 provided a logging and reporting facility for the BSM resources that are controlled via RACROUTE requests (for example, when CICS issues a RACROUTE request to check the authority of users to use a specific CICS transaction):
  - This logging and reporting facility uses the *Data Management Facility* (DMF) that is provided with the CICS Transaction Server for VSE/ESA.
  - The DMF collects SMF records, and writes them to a data set.
  - You can then use the BSM Report Writer to create your own reports of these SMF records.
- The security changes introduced with z/VSE 4.2:
  - Enhance the BSM logging facility so that you can specify logging at the access-level and logging of security-relevant BSTADMIN commands.
  - Enable user profiles to be used in an *LDAP environment*. This means:
    - Company-wide user-IDs and passwords can be used (that is, for z/VSE and other applications).
    - User-IDs can be longer than the previous z/VSE-restriction of four-to-eight characters.
    - Passwords can be longer than the previous z/VSE-restriction of one-to-eight characters. Password strength can also be enforced so that only complex passwords (that is, passwords containing mixed-case plus numeric and/or special characters) are allowed.
- The security changes introduced with z/VSE 4.3:
  - The ability to generate *BSM Cross Reference reports*, using either a dialog or by running the *BSM Cross Reference facility* from the console. These reports help administrators control the profile definitions in the BSM control file (BSTCNTL). In particular, these reports can be used to check that a deleted user-ID has been removed from *all* access lists and groups.
  - The use of the *Data Management Facility* (DMF) to log and generate reports of access attempts to resources protected by DTSECTAB. Previously, you could only use ACLR for this purpose.
    - The DMF collects SMF records for DTSECTAB, and writes them to a data set.
    - You can then use the BSM Report Writer to create your own reports of these SMF records.
  - The including of *DTSECTAB resources* in the BSM auditing function. The BSM uses SMF records for logging and reporting. It now writes such SMF records for access-attempts to DTSECTAB resources (for example, z/VSE files or librarian members).

- The automatic linking to a dialog for adding/updating an LDAP user-ID, during the process to add/update a VSE user-ID.

---

## Activating BSM or ESM Security Support

### Basic Security Manager (BSM):

The BSM is *always activated* during startup (independent of the SEC setting in the IPL SYS command) in order to provide:

- Sign-on security (signing-on via the Interactive Interface or the CICS Transaction Server), and
- CICS transaction security.

Note, that for this support the DFHSIT must include SEC=YES (which is the default). If you reset it to SEC=NO, you will have no CICS security at all, not even sign-on security.

During initial installation you are asked whether you want to run your system with "security on". If you respond with YES, this will set in the IPL SYS command SEC=(YES,NOTAPE), which also provides access control for resources defined in DTSECTAB.

### External Security Manager (ESM):

After installing an **ESM**, you must define the name of the ESM initialization routine in the ESM parameter of the IPL SYS command. If the ESM you have installed requires a server partition, specify the partition ID in the SERVPART parameter of the IPL SYS command or use the default partition FB.

Consult in addition your ESM documentation for further implementation and customization steps that may be required on the z/VSE side.

z/VSE always checks for the ESM setting first. If the parameter is specified in the IPL SYS command, the ESM is activated, otherwise the BSM.

---

## Overview of Security-Support Implementation

- The IPL SYS command contains the following security parameters.

```
SEC=NO
SEC=YES
SEC=(YES,JCL)
SEC=(YES,NOTAPE)
SEC=(YES,NOTAPE,JCL)
SEC=RECOVER
ESM=name
SERVPART=partition
```

– These parameters are modified using the *Tailor IPL Procedure* dialog.

– For a detailed description of the IPL SYS command, refer to the *z/VSE System Control Statements*.

- Initial Installation

During initial installation you are asked whether you want to run your system with "security on".

– If you respond with YES, this will set SEC=(YES,NOTAPE) in the IPL SYS command. This also provides access control for resources defined in DTSECTAB.

- If you respond with NO during initial installation and want to activate security later, you can later use the *Tailor IPL Procedure* dialog to change SEC=NO into SEC=YES, SEC=(YES,JCL), SEC=(YES,NOTAPE), or SEC=(YES,NOTAPE,JCL). However, security activation also requires additional z/VSE modifications to be done manually. To avoid this effort and if you definitely plan to implement security later, it is recommended to proceed as follows:
  - Respond with YES to the security question during initial installation. This prepares and initializes the system for security activation and avoids later customization work.
  - You can now use the IPL SYS command and specify SEC=NO if you want to run your system without table DTSECTAB security for the time being (DTSECTAB includes resource definitions only, except for the predefined users DUMMY and FORSEC). With SEC=YES you can at any time switch security on. No further customization effort is required except including your own entries in DTSECTAB.

If you use the option JCL, the system will perform JCL security checking using *JCL resource profiles*. For details, see “Protecting Resource via BSM Dialogs” in the *z/VSE Administration*.

- Security Server Partition

BSSINIT is the common security initialization routine for the BSM or an ESM. BSSINIT initializes and starts partition FB as BSM server partition unless another partition than FB has been specified in the IPL SYS command (SYS SERVPART=xx).

To avoid any problems and additional customization work, it is recommended **not** to switch the predefined partition (FB) in which the Security Server runs after installation. If there is a need for a switch, you should plan it very carefully. You must select a static partition which is not controlled by VSE/POWER and modify the VSE/POWER startup procedure accordingly. The partition used must have the same priority as the default partition FB.

Refer also to “Issuing BSM Security Server Commands” on page 232.

- RSL Security available with the BSM

Using the BSM support that is available from z/VSE V3R1.1 onwards, you can use RSL (Resource Security Level) security to control access to CICS resources such as:

- Files
- Programs
- Transactions
- Temporary storage
- Transient data queues
- Journals

- You can also use a program (BSTSAVER) to recreate the contents of your BSM control file using BSTADMIN commands. This is useful if you wish to create backup/safety copies of your BSM control file, or if you wish to migrate this file from one z/VSE release to a later one. For details, refer to the chapter “Migrating CICS Transaction Security Definitions” in the *z/VSE Administration*.
- The CICS transaction security keys in the *Maintain User Profiles* dialog are only valid if you are still using the DTSECTXN table to protect your CICS transactions. If you have migrated your CICS transaction definitions to the BSM control file, you must maintain BSM groups instead of CICS transaction security keys.
- A sequence of FSUs from a release/modification level of z/VSE that is earlier than V3R1.1 will establish transaction security that is based upon the use of

table DTSECTXN. You are responsible for migrating table DTSECTXN to the BSM control file, which is described in the *z/VSE Administration*.

- Problem Solving in a Security Environment

In case of problem recovery, for example during the implementation and test phase, there may be a need to run your system without the security support active. If such a situation occurs, you can specify `SEC=RECOVER` in the `IPL SYS` command. Note, however, that this switches off security completely (including sign-on and CICS transaction security) *leaving your system unprotected!*

---

## Issuing BSM Security Server Commands

The Security Server provides a set of commands to control its operation and display server status information. These commands can be entered from the system console through:

```
MSG xx,DATA=command
```

where `xx` indicates the selected server partition (default FB) and **command**, the command to be used. Refer to the *z/VSE Operation* for details.

---

## What BSM Security Provides

The support provided by the Basic Security Manager (BSM) can be grouped as follows:

- Sign-on (log-on) security, using the VSE control file (VSE.CONTROL.FILE).
- CICS and general resource security (including CICS transaction security), using the BSM control file (VSE.BSTCNTL.FILE).
- Access control for resources defined in table DTSECTAB (z/VSE libraries, sub-libraries, members, and files).
- CICS transaction security, using table DTSECTXN.

### Notes:

1. The use of DTSECTXN has been replaced by the BSM control file.
2. z/VSE will use any definitions that you have in table DTSECTXN in preference to your definitions in the BSM control file.
3. If you continue to use table DTSECTXN, you will not benefit from future changes that IBM might make to the resource profiles stored in the BSM control file.

Figure 22 on page 233 shows, in a simplified form, the basic security support that the BSM provides.

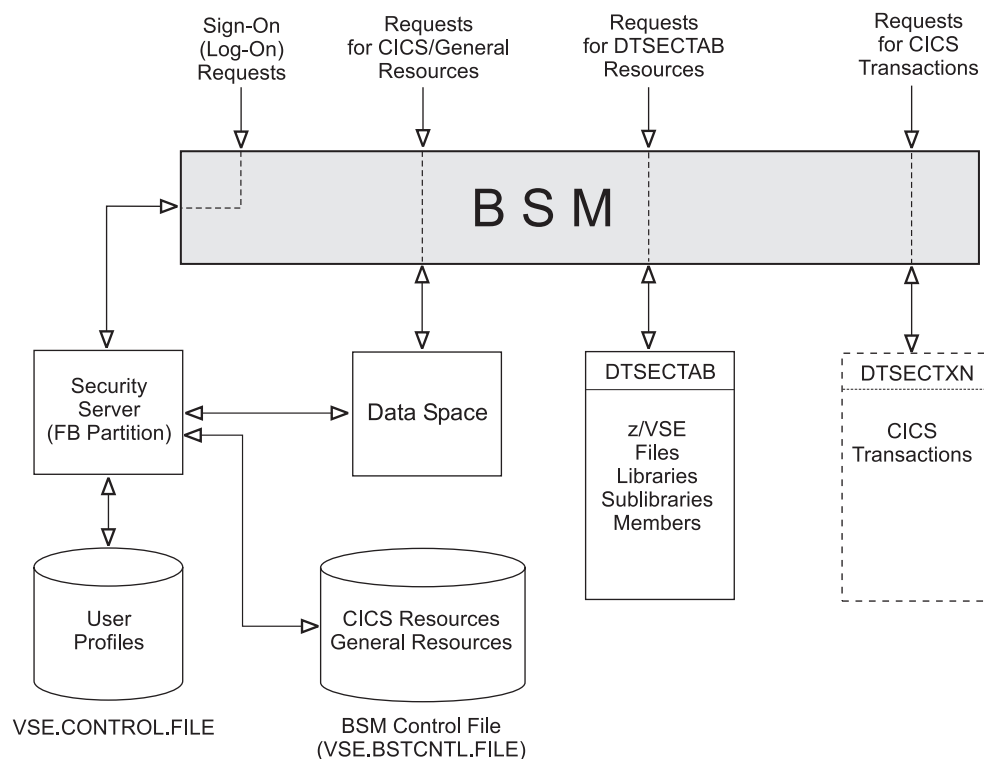

Figure 22. Logical Structure of BSM Security Support

In addition, the BSM:

- Displays violation messages on the system console.
- Logs resource-accesses that are initiated via RACROUTE calls and via access attempts to resources protected via DTSECTAB (z/VSE libraries, sub-libraries, members, and files). To do so, the BSM uses the *Data Management Facility (DMF)* supplied with the CICS Transaction Server for VSE/ESA.
- Provides the *Report Writer*, which you can use to create reports of the output (consisting of SMF records) that is created by the DMF dump utility.

As an alternative to using the DMF to log accesses to DTSECTAB-protected resources, you can use the IBM program *VSE/Access Control-Logging and Reporting (VSE/ACLR)* (which you can purchase).

## Sign-On (Log-On) Security

This security check is related to user-ID and password. It is also referred to as user identification and user authentication. This check is done when:

- Signing-on to z/VSE or LDAP via the Interactive Interface (you must enter user-ID and password).

This check is always done independent of the security setting in the IPL SYS command, with the exception of IPL SYS=RECOVER in which case no password checking is done.

- Submitting a batch job.

This checking requires that security for DTSECTAB is on: SEC=YES in the IPL SYS command.

User-ID and password are submitted using either a:

- VSE/POWER Job statement





## Resource Classes For WebSphere MQ for z/VSE and Other Programs

From *WebSphere MQ for z/VSE* Version 3 onwards, the Basic Security Manager (BSM) provides resource classes for protecting MQSeries® resources.

To make use of this support, you must have installed APAR PM02556, which is supplied with the WebSphere MQ for z/VSE.

In addition, the BSM provides resource classes for CICS and other programs.

For further details, refer to “Resources Classes Stored in the BSM Control File” in the *z/VSE Administration*.

### BSM Post-Processing Installation Exit BSTXX01

If using BSM, you might need to extend the security checking of the BSM using your own logic. Therefore, you might wish to change the:

- Return code triple of the RACROUTE request.
- Contents of result areas as provided by EXTRACT requests.

The BSM provides the installation exit BSTXX01 to allow modifications immediately before returning to SAF. To use it, you have to build a phase with the name BSTXX01 and catalog it in IJSYSRS.SYSLIB.

For related information, see also Chapter 21, “System Authorization Facility (SAF) and its External Security Interface (RACROUTE),” on page 273.

These are the contents of the BSTXX01 interface:

```
AMODE 31
RMODE ANY
```

Input:

```
R1 : address of area that contains:
    +0 address of SAFF
    +4 R1 contents to be returned to SAF
      (e.g. result area address)
    +8 R15 contents to be returned to SAF
```

Output:

```
The customer created phase BSTXX01 is responsible for
restoring the registers.
```

Register

```
0,2-13 as on entry
1 value from input area or explicit return value
  from customer BSTXX01 code
15 if the customer wants to change the return code
  then the new return code, else the value from
  input area
```

### Access Control for z/VSE Resources Defined in DTSECTAB

You can run a batch job or program in a z/VSE partition or a VSE/ICCF interactive partition. If such a job or program accesses resources, these resources can be protected by defining them in DTSECTAB. The origin of the user-ID and password is either the VSE/POWER JOB statement or the JCL ID statement. Refer to “Sign-On (Log-On) Security” on page 233 for further details.

The following resources can be defined in DTSECTAB:

- Files
- VSE Libraries
- VSE Sublibraries
- VSE Members

Access control for such resources is active if the security setting in the IPL SYS command is SEC=YES and the resource to be accessed is defined in DTSECTAB.

#### Access Control Table DTSECTAB

From VSE/ESA 2.4 onwards, user entries are no longer included in DTSECTAB. All security-related user information is part of the user's profile stored in the VSE.CONTROL.FILE. An exception are the predefined users FORSEC and DUMMY. They are required by z/VSE for startup processing and are the only user definitions included in DTSECTAB.

Following is an example of a typical DTSECTAB resource entry - in this case for a library:

```
DTSECTAB TYPE=LIB,  
          NAME=PRIVATE.TEST.LIB1  
          ACC=(1-8),  
          UACC=CON,  
          LOG=(1-8)
```

All users can access library PRIVATE.TEST.LIB1 with access right CON (Connect). In addition, any user who has specified one or more of access control classes 1-8 can access the library with the access right (Read, Update, Alter) assigned to a class.

As shipped, z/VSE provides a predefined DTSECTAB which includes definitions of system-provided resources that need to be protected. The DTSECTAB source is available as skeleton DTSECTRC in VSE/ICCF library 59. Use this skeleton to modify DTSECTAB as required for your installation.

#### Notes:

1. You define entries in DTSECTAB with the DTSECTAB macro which is described in detail in the *z/VSE Administration*.
2. To modify DTSECTAB, copy skeleton DTSECTRC from VSE/ICCF library 59 to your private VSE/ICCF library. Use always this copy if there is a need to change DTSECTAB. You create a new (updated) DTSECTAB by submitting skeleton DTSECTRC from your private VSE/ICCF library.

---

## Migrating CICS Transaction Security Definitions

Up to z/VSE V3R1.1, CICS transaction security was provided for the CICS TS via the access control table DTSECTXN. This table is used to define CICS transactions and their security class. The security class authorizes particular users to access a transaction.

From z/VSE V3R1.1 onwards, CICS transaction security is provided by the *BSM control file* (VSE.BSTCNTL.FILE):

- If you are using a release of z/VSE that has CICS transaction security based upon the use of table DTSECTXN, you are strongly recommended to migrate table DTSECTXN to the BSM control file.
- If you have TRANSEC information that is used with CICS/VSE, you can use the *CICS/VSE Security Migration Aid* and then skeleton SKSECTX2 of ICCF library 59 to migrate your TRANSEC definitions to a CICS TS system that uses the BSM control file.

For further information, see “Migrating CICS Transaction Security Definitions” and “Migrating CICS/VSE Security Information to the CICS TS” in the *z/VSE Administration*.

---

## Creating/Maintaining User Profile Definitions

User profiles are stored in the VSE.CONTROL.FILE.

You can use the *Maintain User Profiles* dialog or the batch utility IESUPDCF to create or maintain user profiles.

**Maintain User Profiles dialog:** The major security parameters you can define with this dialog are:

- User-ID
- Password
- Programmer name
- Transaction security keys (1 to 64)

If you have performed:

- an initial installation of z/VSE 5.1
- an FSU to z/VSE 5.1 from a VSE system in which you *had already migrated* your security definitions to the latest BSM security

then the transaction security keys are no longer used. Instead of using the transaction security keys, you must use the TCICSTRN resource class and user groups to protect your CICS transactions. For details, refer to the *z/VSE Administration*.

If you have performed an FSU from a VSE system where you *have not migrated* your security definitions to the latest BSM security, you can use these transaction security keys (1 to 64) to control access to a CICS transaction defined in DTSECTXN. For details, refer to the chapter “Protecting CICS Transactions with Access Control Table DTSECTXN” in the *z/VSE Administration*.

- Access control classes (1-32) for the resources that can be defined in DTSECTAB:
  - Files
  - Libraries
  - Sublibraries
  - Members

## Security/Encryption

Access rights for the 32 access control classes:

- 1 = Connect
- 2 = Read
- 3 = Update
- 4 = Alter

Note that a blank (no specification) means **no access**.

- Other security-related specifications for a user on this panel are READ DIRECTORY and B-TRANSIENTS.
- The panel USER AUTHORIZATION (of the *Maintain User Profiles* dialog) allows further specifications that are related to security. They allow the system administrator to limit or expand the authorization a user has when working with the system and its resources.

For details about creating/maintaining user profile definitions, refer to “Maintaining User Profiles via Dialogs” in the *z/VSE Administration*.

## Generating BSM Cross Reference Reports

You can generate *BSM Cross Reference reports* using either the:

- BSM Cross Reference facility (BSTXREF).
- BSM Cross Reference Report dialog.

You can use BSM Cross Reference reports to control the profile definitions in the *BSM control file* (VSE.BSTCNTL.FILE). In particular, these reports are useful when deleting a user-ID. After deleting a user-ID from the VSE Control File (VSE.CONTROL.FILE), you can then use BSM Cross Reference reports to check if data for this user-ID still exists in the access lists and groups stored in the *BSM control file*.

For details about BSM Cross Reference reports, refer to “Maintaining User Profiles via Dialogs” in the *z/VSE Administration*.

---

## LDAP Sign-On Support

The LDAP sign-on support enables users to sign on to z/VSE using long, “company-wide” (corporate) user-IDs and passwords. The user-ID and password are authenticated using an LDAP server that is reachable via the TCP/IP network. The LDAP server is installed on the company network.

This use of “company-wide” user-IDs connects z/VSE with the *centralized* management of user-IDs. As a result, password-rules and password-renewal can be enforced via the LDAP server.

LDAP authorization is designed to integrate z/VSE into “Identity Management Systems”, such as IBM Tivoli® products, or systems-based on the *Microsoft Active Directory* that support LDAP authentication.

An LDAP sign-on overcomes the previous limitations in z/VSE that:

- VSE/ICCF user-IDs could be up to 4 characters long.
- CICS user-IDs could be between 4 and 8 characters long.
- Passwords could be up to 8 characters long.

Using an LDAP sign-on:

- User-IDs and passwords can *both* be up to 64 characters long.
- Users can be forced to use *complex* passwords. For example, passwords might have to contain a mixture of numerical and alphabetical characters, and/or upper and lower case characters.
- A *centralized* management of “company-wide” user-IDs and passwords within a company is possible. Each user can be forced to change his/her password that is used on *all* systems within a predefined time period (for example, every 12 weeks).

The major advantage of a centralized *Identity Management System* is that all updates for employees (enabling/disabling passwords, granting/revoking access, and so on) can be performed on *one* location. For example, if an employee leaves a company, the *company's administrator* must only revoke access for the person's user-IDs in the Identity Management System (typically, the LDAP server). This means, that the revoked user-IDs can no longer be used for signing on to z/VSE without the need for the *z/VSE administrator* to perform any further actions.

For further information, refer to “Maintaining User Profiles in an LDAP Environment” in the *z/VSE Administration*. General information about LDAP and Identity Management Systems can also be found on the internet using any standard Search Engine.

---

## Access Control for VSE/POWER Spool Entries

VSE/POWER security has been improved by providing spool access protection for entries in the RDR, LST, PUN, and XMT queues. The support requires the specification of SEC=YES in the IPL SYS command and SECAC=SYS in the SET statement of the VSE/POWER startup procedure.

Spool access protection can be further controlled at the entry level with the SECAC operand in the JOB, LST, and PUN statements.

The support is available with the BSM as well as with an ESM.

Refer to the *VSE/POWER Administration and Operation* for further details.

---

## Support for Logging and Reporting

The BSM supports the logging and reporting of system activity:

- The z/VSE optional program *VSE/Access Control-Logging and Reporting (VSE/ACLR)* is used to log and report-on authorized and non-authorized accesses to the system and to the resources defined in *DTSECTAB* (VSE libraries, sub-libraries, members, and files).
- The BSM uses **SMF** (System Management Facility) records together with the **DMF** (Data Management Facility) to log RACROUTE requests and (optionally) access attempts to resources protected by *DTSECTAB*. This data is written to a VSAM data set.

**Note:** If you use logging with DMF, for performance reasons you should specify parameter OS390 in the EXEC BSTADMIN statement. This is required so that BSTADMIN can communicate *directly* with the DMF partition. The first statement should therefore look like this:

```
EXEC BSTADMIN,OS390
```

## Security/Encryption

- The BSM also logs security-relevant BSTADMIN commands. To use this support in an environment with *no batch security active* (SYS SEC=NO), a BSTADMIN command (USERID) is provided to identify the issuing of BSTADMIN commands.
- The DMF is supplied as part of the CICS Transaction Server for VSE/ESA.
- You can use the *BSM Report Writer* to create your own reports of the SMF records that the DMF collects in a data set.
- CICS violation messages, which are required to alert the operator of security-critical events, are displayed on the system console (in addition to being logged by the DMF).

An ESM must provide its own logging and reporting facilities.

For details of the VSE/ACLR program and the use of the DMF, refer to “Logging/Reporting Security Events” in the *z/VSE Administration*.

---

## Encryption Support

z/VSE provides encryption support that is based upon the use of *Secure Sockets Layer* (SSL).

### Support for Crypto Cards

Crypto cards are plugged into an *Adjunct Processor* (AP), which is seen as an extension to the CPU. Once plugged into the system, a Crypto card is identified as follows:

- An eight-character serial number.
- A two-digit Adjunct Processor (AP) number.
- A CHPID number.

There is no need to change any applications already using SSL. Existing applications that use SSL *automatically* benefit from this transparent use of Crypto cards. During system initialization (IPL), z/VSE senses the hardware and recognizes the Crypto support, if installed.

Existing applications that use SSL *automatically* benefit from this transparent use of Crypto cards. For example, applications such as:

- CICS Web Support (CWS)
- VSE/POWER PNET
- z/VSE e-business connectors
- WebSphere MQ for z/VSE
- Secure FTP
- Secure Telnet

When z/VSE runs as a guest under z/VM, the Crypto support must be defined to the system in the *VM Directory Entry*.

For further information, see “Implementing Hardware Cryptographic Support” in the *z/VSE Administration*.

## Support for SSL

The z/VSE support for Secure Sockets Layer (SSL) includes details of how you can:

- activate *TCP/IP for VSE/ESA* in order to have access to *all TCP/IP functions*, including SSL support,
- create a *Client Keyring File* that can be used for storing keys and certificates used by client and server authentication,
- download and customize the *Keyman/VSE* tool (which can be used for most of the activities concerning SSL keys and certificates),
- get started with SSL using the IBM-supplied *Keyring Set* (for testing and learning purposes).

For further information, see “Preparing Your System to Use SSL” in the *z/VSE Administration*.

## Support for Server and Client Authentication

For most applications, *server authentication* provides a sufficient level of SSL security, and means that a server certificate is provided by the server (in this case, the z/VSE host) to authenticate the server to clients.

When configuring your z/VSE system for server authentication, you can use server certificates that are either signed by:

- your own root certificate (*self-signed*), or
- signed by a *Certificate Authority (CA)* such as the Thawte Corporation.

You must also configure *each* VSE Connector Server installation in order to implement server authentication. It is important to understand that you cannot have both SSL-mode and non-SSL-mode connections using the *same* VSE Connector Server. However you can, of course, run multiple VSE Connector Servers in different partitions on the z/VSE host, and with or without SSL.

If client authentication is required (in addition to server authentication), a *client certificate* is provided by clients to authenticate the client to the server.

To implement client authentication in your Java-based connector, you must configure for client authentication:

- *Each* VSE Connector Client installed on Web clients of a 2-tier environment.
- The VSE Connector Client installed on the middle-tier of a 3-tier environment.
- The VSE Connector Server.

You can also introduce access checking on client certificates via *z/VSE user-IDs* that have been assigned to these client certificates. The client certificates belong to either CICS clients or VSE Connector Clients. Therefore using client certificates, you can control the access rights from:

- CICS clients to z/VSE host resources.
- VSE Connector Clients to z/VSE host resources.

For further information, see “Configuring for Server Authentication” and “Configuring for Client Authentication” in the *z/VSE Administration*.

### Support for Hardware-Based Tape Encryption

You can encrypt tapes using the hardware-based encryption facilities provided by an *encryption-capable* tape drive. An example of an *encryption-capable* tape drive is the IBM TotalStorage 3592 Model E05<sup>3</sup>.

Before you can use this type of tape encryption, you must have installed and configured an encryption-capable tape drive and tape controller.

The hardware-based tape encryption uses the *Encryption Key Manager (EKM)*, which must be running on a Java platform. The EKM is a common-platform Java application that is used to generate and protect AES (Advanced Encryption Standard) keys. Upon request, the EKM generates AES keys to be used for encryption, and protects these keys using RSA key pairs.

You can use the

- Attention Routine (AR) **QT** command to display the encryption details of a tape device that is attached to your z/VSE system,
- LIBR utility to read the contents of an encrypted tape.

For further information, see “Implementing Hardware-Based Tape Encryption” in the *z/VSE Administration*.

### Encryption Using the Encryption Facility for z/VSE

The need to be able to create *secure* archived copies of business data is a critical security concern. Encrypting data that can be recovered at any time offers a high degree of privacy protection from unwanted access. The *Encryption Facility for z/VSE* (referred to simply as the *EF for z/VSE*) makes use of:

- System z crypto and compression hardware, and
- key management based on the *Keyman/VSE utility* (which is downloadable from the VSE Homepage).

The EF for z/VSE is a *software-based* encryption facility. Depending on the kind of processor and the type of cryptographic hardware that you have installed, the EF for z/VSE uses hardware-accelerated crypto support for encryption and decryption.

The EF for z/VSE provides encryption for:

- single SAM files,
- VSAM files,
- VSE Library members,
- complete backups that were made using any z/VSE backup utility (such as IDCAMS, LIBR, POFFLOAD) or a vendor product.

Encrypted data can be exchanged between different operating systems:

- The EF for z/VSE can read encrypted files that were created by the:
  - Encryption Facility for z/OS,
  - Encryption Facility for z/OS Client (*z/OS Java Client*).
- Both the Encryption Facility for z/OS and z/OS Java Client can read encrypted files that were created by the EF for z/VSE.

---

3. The IBM TotalStorage 3592 Model E05 has been renamed to the IBM System Storage TS1120.



You can also perform an encryption/decryption of data on *platforms other than z/VSE or z/OS*.

You can choose between *two* methods for encrypting data:

- *Passphrase-based encryption*, which is the simplest method since it does not require any key-generation or key-handling. On systems without TCP/IP for VSE/ESA or with other TCP/IP stacks, you can *only* use passphrase-based encryption.
- *Public-key encryption*, which requires the use of Keyman/VSE to either generate private and public keys, or to import public keys.

Public-key encryption guarantees that although multiple sites can *encrypt* data, only *one single site* is able to *decrypt* the data. This is because private keys, which are used for decryption, are never (intentionally) distributed between systems. Therefore, public-key encryption is *more secure* (but also more restrictive) than passphrase-based encryption.

However, if you wish to create local backups which *do not leave* the encryption site, public-key encryption is relatively easy to implement.

For further details, refer to the chapter “Implementing the Encryption Facility for z/VSE” in the *z/VSE Administration*.

## Encryption Using the Encryption Facility for z/VSE OpenPGP

*OpenPGP* is a standard protocol for ensuring the integrity of data that can be exchanged between trusted partners. It is designed to help provide data integrity through:

- Data encryption using either a randomly-generated symmetric session key or a password.
- OpenPGP certificates for the exchange of key information that can provide the data integrity service.

The *Encryption Facility for z/VSE OpenPGP* (referred to simply as the *EF for z/VSE OpenPGP*) offers the same functionality as the EF for z/VSE (described in “Encryption Using the Encryption Facility for z/VSE” on page 242), but *also* offers support for OpenPGP.

It therefore provides the:

- IJBEFVSE utility, which is the same as the utility used by the EF for z/VSE.
- IJBEFPGP utility for OpenPGP encryption processing.

For further details, refer to the chapter “Implementing the Encryption Facility for z/VSE OpenPGP” in the *z/VSE Administration*.



---

## Chapter 19. Application Development Support

z/VSE provides a number of programming functions to help you develop online and batch applications. These include functions for creating and editing source code, translating, compiling, and testing it.

The functions listed below, described in other chapters of this publication or documented in other z/VSE publications, reflect the broad range of the z/VSE application development support:

- Chapter 11, “Using Data Spaces and Virtual Disks,” on page 167 for details on data spaces and virtual disk support.
- *z/VSE Guide to System Functions* under “Linking Programs” for Linkage Editor and under “The Librarian Program” for Librarian details.
- *z/VSE Administration* for details about related dialogs such as the the *Create Application Job Streams* dialog.
- *z/VSE System Macros User’s Guide* and *z/VSE System Macros Reference* for the system support provided through assembler macros.
- z/VSE programming and workstation support described in the:  
*VSE/ESA Programming and Workstation Guide*

This chapter contains these main topics:

- “Programming Language Support”
- “Integrating Online Applications into the Interactive Interface” on page 246
- “Tailoring Compile Skeletons” on page 246
- “Support of REXX/VSE” on page 249
- “Note on VSE/POWER Application Programs” on page 254
- “Adding a User-Written Application to CICS” on page 254
- “Redefining IDs for System Transactions” on page 256

---

### Programming Language Support

For programming you can use any programming language supported by z/VSE. The High Level Assembler for VSE, REXX/VSE, and LE/VSE (IBM Language Environment for VSE/ESA) are part of the z/VSE base.

For introductory information on REXX/VSE, refer to “Support of REXX/VSE” on page 249. For introductory information on LE/VSE, refer to “Considerations for LE/VSE and the VSE C Language Run-Time Support” on page 89.

The following programming languages are available as z/VSE optional programs:

COBOL for VSE/ESA  
C for VSE/ESA  
PL/I for VSE/ESA  
DOS/VS RPG II

**Notes:**

## Application Development

1. From z/VSE V4R3.0 onwards, DOS/VS RPG II supports CICS Transaction Server for VSE/ESA online applications only. To use this support, you must install PTF UK58484 (for APAR PM16528), which is supplied together with these information APARs:

- II14447 (information/steps for enabling on z/VSE 4.2)
- II14452 (information/steps for enabling on z/VSE 4.3)

See also “Skeletons for Using RPG II With the CICS Transaction Server” on page 298.

2. VS FORTRAN is also supported but it is not a z/VSE optional program.
3. COBOL for VSE/ESA, C for VSE/ESA, and PL/I for VSE/ESA provide together with LE/VSE an advanced COBOL, C, and PL/I programming environment.

For all three languages the following features are available:

- Alternate Function feature comprising the compiler only.
- Full Function feature comprising the compiler and interactive debugger. Note that the debugger covers all three languages and is needed only once in the system.
- Enterprise Workstation feature which provides the workstation development environment IBM VisualAge for COBOL/PL/I Professional Edition (no offering available for C for VSE/ESA).

LE/VSE and its programming languages C, COBOL, and PL/I do not support VSE/ICCF interactive partitions. It is generally recommended to use dynamic partitions for programs written in these languages.

4. For the High Level Assembler for VSE the optional feature High Level Assembler Toolkit for VSE is available. It provides:
  - An interactive debug facility.
  - A disassembler converting object code into source statements.
  - A set of structured programming macros to simplify coding and better understand complex control flows.
5. The new z/VSE optional program CICS Command Level Conversion Aid for VSE (CCCA/VSE) helps you migrate your online and batch DOS/VS COBOL applications into COBOL for VSE/ESA applications.

---

## Integrating Online Applications into the Interactive Interface

Be aware that you can integrate an online application into z/VSE's Interactive Interface. For details about the required tailoring of the Interactive Interface, refer to Chapter 14, “Tailoring the Interactive Interface,” on page 191, and also to “Adding a User-Written Application to CICS” on page 254.

---

## Tailoring Compile Skeletons

z/VSE provides compile skeletons for the following programming languages:

- High Level Assembler for VSE
- COBOL for VSE/ESA
- C for VSE/ESA
- PL/I for VSE/ESA
- DOS/VS RPG II
- VS FORTRAN

In addition, z/VSE provides skeletons for the:

- Relational database management system SQL/DS and DB2.
- Creation of HTML templates.
- Use of DL/I.

Note that from z/VSE 3.1 onwards, the *DB2 Server for VSE* is provided as a base program.

These skeletons must first be tailored to reflect your programming environment. After tailoring, you can use them to compile online programs, BMS (Basic Mapping Support) map definitions, batch programs, and batch subroutines. z/VSE uses the tailored job streams if you select the **COMPILE** option of the *Program Development Library* dialog to submit a VSE/ICCF library member for assembly or compilation.

The system administrator should plan who will be allowed to use the compile skeletons stored in VSE/ICCF library 2. The administrator can do one of two things:

1. Give some or all application programmers the skeletons and have them tailor them for their own needs. In this case, the administrator would copy skeletons from VSE/ICCF library 2 into a VSE/ICCF library which programmers can access.
2. Leave the skeletons in VSE/ICCF library 2 and tailor them for the entire system. This allows the administrator to set standards for compile jobs and have every programmer use them.

When the COMPILE option is selected, the system searches for the correct compile skeleton in the following order:

1. User's primary library.
2. User's secondary library.
3. VSE/ICCF library 2.

Table 47 on page 248 lists the name and function of each compile skeleton provided by z/VSE. The naming convention is as follows:

**C\$\$xyyy**, **C\$Qxyyy**, and **C\$Dxyyy**

where:

- Q identifies the skeletons provided for use with the DB2 Server for VSE.
- D identifies the skeletons provided for use with DL/I.

xx can be:

CN (for C for VSE/ESA)  
CV (for COBOL for VSE/ESA)  
PV (for PL/I for VSE/ESA)  
AS (for High Level Assembler for VSE)  
RP (for RPG II)  
FO (for VS FORTRAN)

yyy can be:

ONL for online program  
BAT for batch program  
SUB for batch subroutine  
MAP for BMS map definition

## Application Development

HTML templates can be created from BMS maps. Maps of type HTML are stored in sublibrary PRD2.DFHDOC.

Under “Tailoring Compile Skeletons”, the *z/VSE Administration* has examples of compile skeletons and describes the modifications that are required.

Table 47. Compile Skeletons in VSE/ICCF Library 2

Member Name	Function
C\$\$ASONL	High Level Assembler for VSE online program.
C\$\$ASBAT	High Level Assembler for VSE batch program.
C\$\$ASSUB	High Level Assembler for VSE batch subroutine.
C\$\$ASMAP	High Level Assembler for VSE BMS map definition.
C\$\$CNONL	C for VSE/ESA online program.
C\$\$CNBAT	C for VSE/ESA batch program.
C\$\$CNSUB	C for VSE/ESA batch subroutine.
C\$\$CNMAP	C for VSE/ESA BMS map definition
C\$\$COMAP	COBOL for VSE/ESA BMS map definition.
C\$\$CVONL	COBOL for VSE/ESA online program.
C\$\$CVBAT	COBOL for VSE/ESA batch program.
C\$\$CVSUB	COBOL for VSE/ESA batch subroutine.
C\$\$FOBAT	VS FORTRAN batch program.
C\$\$FOSUB	VS FORTRAN batch subroutine.
C\$\$PLMAP	PL/I for VSE/ESA BMS map definition.
C\$\$PVONL	PL/I for VSE/ESA online program.
C\$\$PVBAT	PL/I for VSE/ESA batch program.
C\$\$PVSUB	PL/I for VSE/ESA batch subroutine.
C\$\$RPONL	DOS/VS RPG II online program.
C\$\$RPBAT	DOS/VS RPG II batch program.
C\$\$RPMAP	DOS/VS RPG II BMS map definition.
C\$\$RPSUB	DOS/VS RPG II batch subroutine.
C\$DASBAT	High Level Assembler for VSE batch program (for DL/I applications).
C\$DASONL	High Level Assembler for VSE online program (for DL/I applications).
C\$DASSUB	High Level Assembler for VSE batch subroutine (for DL/I applications).
C\$DCVBAT	COBOL for VSE/ESA batch program (for DL/I applications).
C\$DCVONL	COBOL for VSE/ESA online program (for DL/I applications).
C\$DCVSUB	COBOL for VSE/ESA batch subroutine (for DL/I applications).
C\$DPVBAT	PL/I for VSE/ESA batch program (for DL/I applications).
C\$DPVONL	PL/I for VSE/ESA online program (for DL/I applications).
C\$DPVSUB	PL/I for VSE/ESA batch subroutine (for DL/I applications).
C\$QASONL	High Level Assembler for VSE online program (for DB2 applications).

Table 47. Compile Skeletons in VSE/ICCF Library 2 (continued)

Member Name	Function
C\$QASBAT	High Level Assembler for VSE batch program (for DB2 applications).
C\$QASSUB	High Level Assembler for VSE batch subroutine (for DB2 applications).
C\$QCNONL	C for VSE/ESA online program (for DB2 applications).
C\$QCNBAT	C for VSE/ESA batch program (for DB2 applications).
C\$QCN SUB	C for VSE/ESA batch subroutine (for DB2 applications).
C\$QCVONL	COBOL for VSE/ESA online program (for DB2 applications).
C\$QCVBAT	COBOL for VSE/ESA batch program (for DB2 applications).
C\$QCVSUB	COBOL for VSE/ESA batch subroutine (for DB2 applications).
C\$QFOBAT	VS FORTRAN batch program (for DB2 applications).
C\$QFOSUB	VS FORTRAN batch subroutine (for DB2 applications).
C\$QPVONL	PL/I for VSE/ESA online program (for DB2 applications).
C\$QPVBAT	PL/I for VSE/ESA batch program (for DB2 applications).
C\$QPVSUB	PL/I for VSE/ESA batch subroutine (for DB2 applications).

---

## Support of REXX/VSE

### Introduction

REXX/VSE is a partial implementation for z/VSE of the Level 2 SAA (Systems Application Architecture<sup>®</sup>) REXX language.

REXX is a very versatile programming language. A REXX program consists of REXX language instructions that the REXX Interpreter translates directly. A program can also contain commands that the host environment executes.

One advantage of the REXX language in general is its similarity to ordinary English. This similarity makes it easy to read and write a REXX program. REXX has simple syntax rules and you can use uppercase, lowercase, or mixed case. There are no restrictions about columns in which you can type.

**Note:** Before a REXX program can be executed, you must store it into a VSE sublibrary with member type PROC (procedure). REXX programs can run in any partition of z/VSE.

### Initialization

During startup, REXX/VSE phases are loaded into the SVA with the statements:

```
SET SDL
LIST=$$SVAREXX
```

These statements are part of the BG startup procedure \$0JCL. This procedure also initializes REXX/VSE by activating the startup program ARXLINK.

### Characteristics of REXX/VSE

REXX/VSE provides:

- A selected subset of REXX functions of REXX/MVS.
- REXX/MVS compatible programming and customization services.
- z/VSE unique external functions and host command environments.

REXX/VSE offers both the

- REXX Interpreter that provides interpretation of REXX programs, and the
- REXX/370 Library that provides execution of compiled REXX programs.

**Note:** z/VSE does not support the compilation of REXX programs. This must be done on either a VM or z/OS system where the compiler for SAA REXX/370, Program Number 5695-013, is required.

### Benefits of the REXX Language

#### Ease of Use

REXX is a general purpose programming language that has the usual structured-programming instructions such as IF, SELECT, DO WHILE, and LEAVE. This allows programs and algorithms to be written in a clear and structured way.

REXX is easy to use by both computer professionals and by "casual" general users. It is a language that provides powerful character and arithmetical abilities in a simple framework. The values that REXX manipulates are in the form of character strings. There are no data types to be declared. In order to manage the data as naturally as you would manipulate words on a page or with a text editor, REXX has a rich set of character manipulation functions and built-in parsing with many options.

#### New System Management Capabilities for z/VSE

REXX offers capabilities as a language for general use, as well as for z/VSE system command programming. REXX/VSE can be used to tailor the z/VSE operating system by using the REXX language instead of the z/VSE conditional job control language. You can use REXX/VSE in the z/VSE batch environment for:

- z/VSE operation automation
- Substitution and parameterization for job execution
- Direct communication to the z/VSE system console
- Input/output (I/O) operations to z/VSE libraries and sequential data sets
- Dynamic creation and execution of z/VSE job streams
- VSE/POWER job submission and controlling
- VSE/POWER queue element manipulation
- VSE/POWER command execution
- Automated console operation.

REXX/VSE is particularly suitable for:

- Command procedures
- Rapid batch program development
- Prototyping
- Personal utilities.



## Performance Improvements Due to Including the REXX/370 Library

A REXX program may be interpreted line-for-line, which provides the advantage of easy debugging. When a REXX program has been completed, it could be compiled on a VM or z/OS system. The REXX/370 Library provides significant benefits when executing compiled programs on z/VSE. The benefits include improved performance, reduced system load, and portability of compiled programs.

## REXX/VSE Application Enabling Platform

### Accessing z/VSE Resources

REXX/VSE provides the EXECIO command which is compatible with the EXECIO command of REXX on z/OS. You may use EXECIO to control input/output (I/O) operations to and from:

- VSE library members
- Sequential files
- SYSIPT (input only)
- SYSLST (output only).

EXECIO can read and write data on the program stack or in REXX variables (for example into a stem) directly. You can use EXECIO for I/O tasks such as copying information to and from a data set, to add, delete or update information. A REXX program can read information from a data set to the data stack for serialized processing or to a list of REXX variables for random processing. A program can write information from the data stack or from a list of REXX variables.

z/VSE provides the VSAMIO command to access VSAM data from REXX/VSE. Refer to the *REXX/VSE Reference* for further details.

### VSE/POWER Interface

You may switch to the VSE/POWER host command environment via ADDRESS POWER to retrieve and store VSE/POWER queue entries. You may also send VSE/POWER commands and retrieve the corresponding output via the OUTTRAP function.

The retrieval and storing of data in the LST and PUN queues of VSE/POWER includes options to:

- Handle print control characters for LST queue entries.
- Retrieve all parts of a segmented output entry.
- Retrieve only a certain part of an entry.
- Append records to an existing output queue entry.
- Specify disposition, priority, user information, the number of copies, and user-defined output operands for entries stored in the LST or PUN queue.

### Creating and Executing z/VSE Job Streams Dynamically

By using the character string manipulation functions of REXX, you can dynamically create z/VSE job streams and store them into a VSE sublibrary, a sequential file, or into the program stack. In the latter case, when the REXX program exits and returns to job control, job control executes all JCL statements that have been left in the program stack.

### Submitting and Controlling VSE/POWER Jobs

By using the VSE/POWER host command PUTQE, you may submit a VSE/POWER job to another partition and optionally wait a specified number of seconds until the job has been started and completed. The OUTTRAP function provides you with a job completion message and maximum or last return code and other useful information about the submitted job. The VSE/POWER job to be submitted may reside in a VSE sublibrary or in a list of REXX variables.

### Issuing JCL Commands

A JCL command issued by a REXX batch program is immediately executed and a return code is provided. Input/output data can be exchanged via REXX "compound variables", called stems. Thus, REXX can loop on JCL commands and make very efficient use of the JCL conditional job control support.

### Calling Batch Programs

The following functions are available:

- The called batch program can **read** input data from REXX. Within REXX the data is supplied using "compound variables", called stems. This is transparent to the batch program and can be used to replace previous data input via JCL.
- A batch program can also **write** output data to REXX stems using a service routine. This increases the possibilities for subsequent processing of output data created by user programs.
- Parameters can be passed in the same way as previously done via JCL. In addition, REXX provides a standard parameter list for COBOL, PL/I, and C/VSE. With it, multiple parameters can be passed and modified by the called program.

### Issuing z/VSE Librarian and VSE/VSAM IDCAMS Commands

Such commands are executed immediately and return codes are provided. Input/output data can be exchanged using REXX stems.

### Communicating with User Consoles

For messages and replies the REXX instructions SAY and PULL are available allowing interactive communication in line mode.

### REXX/VSE Console Automation

REXX/VSE console automation is based on the console support of z/VSE. The support helps to automate console operation and provides an easy-to-use z/VSE console command environment that allows to activate or deactivate one or more z/VSE console sessions. z/VSE console commands can be imbedded into a REXX program to issue z/VSE console commands and retrieve command responses. The following types of commands are supported:

- Attention routine (AR) commands.
- Console redisplay commands.
- VSE/POWER, VSE/ICCF, CICS, VTAM, and DB2 commands.

A *Console Application Framework* is included to demonstrate how to exploit REXX/VSE console automation in the most beneficial way.

A REXX CPU monitor checks for critical performance values in z/VSE partitions and issues console messages if user-defined limits have been exceeded.

### Performing Data Stack Services

REXX/VSE provides a data stack and related commands compatible to REXX/MVS. You can use these commands to create or delete data stacks or query information about the stack, for example, the number of elements in the stack.

### REXX/VSE Socket API

REXX/VSE provides the function SOCKET to implement the SOCKET API for communication between network applications. With VSE/ESA 2.7, the SOCKET function has been enhanced to write SSL-enabled socket applications in REXX/VSE.

### Extending the Programming Capabilities of REXX/VSE

You can write your own external functions and subroutines to extend the programming capabilities of REXX/VSE. You can write such functions or subroutines in REXX or in any programming language that supports the system-dependent interface of REXX/VSE. You can also group frequently used external functions and subroutines into a function package. This allows quicker access but they must all be link-edited into a phase.

Interfaces to external functions, subroutines, and functions packages are compatible with REXX on z/OS.

## Running a REXX Program

A REXX program is a **program written in the REXX language**. A REXX program runs in the dynamic or static partition of the invoking job stream. REXX/VSE itself is mostly SVA (shared virtual area) resident and is shared by all z/VSE partitions.

A REXX program may reside in any z/VSE sublibrary. The name of that library member is the program name and the member type must be PROC (procedure); for example, MYPROG.PROC. The sublibrary in which the program is stored must be included in the current LIBDEF chain.

### Job Control Extension to Invoke a REXX Program

A new operand, named **REXX**, has been introduced for the job control EXEC statement/command to invoke REXX programs. For example:

```
// EXEC REXX=prog_name,SIZE=size_operand,PARM='parm_list'
```

For a detailed syntax and operand description, refer to the EXEC statement/command in the *z/VSE System Control Statements* under “EXEC”.

Usually, a VSE/POWER job must be submitted to invoke a REXX program. However, you can also invoke a REXX program by using the programming services of REXX/VSE. These services let application programs written in assembler or high-level languages interface to REXX/VSE.

### Leaving Data on the Stack

If you call a REXX program (through an EXEC statement), you can leave z/VSE JCL statements on the stack and z/VSE can then process these statements. This means you can insert JCL statements or data into the current job stream.

### Compatibility of REXX/VSE

Compatibility exists in the following areas:

- The REXX language is consistent across the SAA environments.
- REXX/VSE provides a subset of functions compatible with REXX on z/OS.
- EXECIO and stack services are compatible to REXX on z/OS.
- The function provided by the REXX/370 Library is identical on z/VSE, z/OS, and z/VM.

### Further Information

The following publications describe REXX/VSE and its functions in detail:

- *REXX/VSE Reference*
- *REXX/VSE User's Guide*
- *IBM Compiler and Library for SAA REXX/370, User's Guide and Reference.*

The REXX/VSE homepage can be accessed via:

<http://www-1.ibm.com/servers/eserver/zseries/zvse/support/rexx/rexxhome.html>

---

### Note on VSE/POWER Application Programs

Application programs which communicate with VSE/POWER via the SPOOL-macro support must run in the same private address space as VSE/POWER or in a partition in the shared area. The macros XECBTAB, XPOST, and XWAIT belong to the SPOOL-macro support.

However, it is recommended to use the XPCC macro support instead because application programs using this support can run in any private address space.

---

### Adding a User-Written Application to CICS

This topic summarizes the tasks required to add a user-written, online application (transaction) to your z/VSE system. Note that both the system administrator and the programmer each perform several of the tasks. *To ensure system integrity, a programmer should not be allowed to do all of them.*

You might also find it useful to read the information contained in the appendix "Programming experience" of the IBM Redbook *Introduction to the New Mainframe: z/VSE Basics*. This appendix includes sections describing "Interlanguage communication (ILC)", "programming with other products", and "fourth-generation-language programming and z/VSE".

In the following list:

- The tasks which the programmer performs are based on the default programmer profile (PROG) that is shipped with z/VSE.
- It is assumed that the source code for the application resides in a VSE/ICCF library.

Adding a user-written **online application** to CICS normally involves:

1. Defining a new VSE sublibrary for the program and maps (**Administrator**). This task is optional. An existing sublibrary can also be used. If so, the next two steps can be skipped.
2. Copying the skeleton for the compiler from VSE/ICCF library 2 to your primary VSE/ICCF library. Refer to Table 47 on page 248 for a list of the skeletons provided (**Administrator** or **Programmer**).
3. Tailoring the compile skeleton to include the name of the new sublibrary for the program and maps (**Administrator** or **Programmer**).
4. Compiling/assembling the program and maps using the Interactive Interface. (**Programmer**).
5. Reviewing the VSE/POWER LST queue to see if the compile/assemble was successful (**Programmer**).
6. Defining any required VSE/VSAM data files (**Administrator**).
7. If necessary, loading the new files (**Programmer**).
8. Defining the programs, transactions, and any maps to CICS using Resource Definition Online commands. The transaction ID for RDO is CEDA (**Administrator**).

Note that for program testing, the administrator can activate transactions, programs, and maps using the command:

```
CEDA INSTALL GROUP(name)
```

Once the program has been tested, the administrator can modify the system startup to include the application by entering the command:

```
CEDA ADD GROUP(name) LIST(VSELIST)
```

VSELIST is the name of the group list shipped by z/VSE. To use RDO (transaction CEDA) in your system, you need to add the following to DFHSITSP:

```
GRPLIST=VSELIST
```

9. Defining the data files to CICS by modifying the FCT in VSE/ICCF library 59 (**Administrator**).
10. Assembling the new FCT (**Administrator**).
11. Changing the CICS startup job stream to include the new user sublibrary that was defined in Step 3 (**Administrator**). This can be done by:
  - a. Copying the skeleton *SKCICS* from VSE/ICCF library 59,
  - b. Making the change, and
  - c. Submitting the skeleton for processing.
12. Activating the FCT by shutting down and then restarting CICS with a COLD start or use CEDA to define the FCT entry (**Administrator**).
13. Using CEMT to check that the data files are open and available. (**Administrator**).
14. Defining the program to the Interactive Interface using the application profile function (**Administrator**).
15. Creating a selection panel that includes the program as a selection (**Administrator**).  
Note that at this time any HELP panels for the program could be added via the Interactive Interface.
16. Defining a profile for a user who works with the new program (**Administrator**).
17. Signing on as the new user to test the user and application profiles and the new selection panel (**Administrator** or **Programmer**).

### Redefining IDs for System Transactions

z/VSE provides several transaction IDs that may conflict with your own transaction ID names. If you want to use your own transaction IDs, you can override the following IDs of z/VSE:

- OLPD
- USER
- HELP
- PF1
- PF3
- PF13
- PF15

OLPD activates the *Online Problem Determination* function. USER displays active users. The HELP and PF key transactions return a user from native CICS mode to the Interactive Interface. To use any of these IDs for your own transactions, you can do one of the following:

1. Select the *Invoke CEDA* dialog from the *CICS Supplied Transactions* panel, and redefine the z/VSE definition of the transaction ID.
2. If you use SKCSDFIL to define transaction IDs, change IESZPCT.Z and run DFHCSDUP.

SKCSDFIL redefines the IBM-supplied parts of the CICS Transaction Server for VSE/ESA's CSD file. It uses IESZPCTZ which includes the seven transaction IDs listed above. Do *not*, however, override any of the other IDs defined by z/VSE. If you do, the Interactive Interface may not work correctly, and functions that you use could have unpredictable results.

In addition, do *not* override transaction IDs that are reserved for CICS.

---

## Chapter 20. Storage and Tuning Recommendations

This chapter provides general information concerning:

- The performance analysis process.
- The exploitation of z/VSE features, including Virtual Storage Constraint Relief and Data In Memory.
- Other factors that influence performance.

Performance information is also available on the Internet via the z/VSE home page at:

<http://www.ibm.com/servers/eserver/zseries/zvse/documentation/performance.html>

**Note:** The information provided in this chapter about z/VSE performance aspects is of a more general nature. For more specific details, contact your IBM representative who will be glad to provide further information about z/VSE and its performance characteristics.

This chapter contains these main topics:

- “Performance Analysis Process” on page 258
- “z/VSE Exploitation Overview” on page 259
- “IPL Commands” on page 265
- “JCL Statements and AR Commands” on page 266
- “General Recommendations for Allocating Virtual Storage” on page 266
- “VTOC Considerations” on page 267
- “VSE Libraries” on page 268
- “System File Placement” on page 268
- “Parallel Page I/O and Page Data Set Extents” on page 269
- “Recommendations for Using DASD Sharing and Lock Files” on page 269
- “Recommendations for VSE/POWER” on page 270
- “Recommendations for VTAM” on page 271
- “Recommendations for the CICS Transaction Server” on page 272

### Related Topics:

For details of how to ...	Refer to ...
to display status and storage information of your z/VSE and CICS systems	“Displaying System Status and Storage Information” in the <i>z/VSE Administration</i>
collect z/VSE activity in a CICS environment.	“Collecting Additional z/VSE Activity Data” in the <i>z/VSE Administration</i>
collect data and report-on system activity using the VSE Navigator	“Using VSE Java Beans to Implement Java Programs” in the <i>z/VSE e-business Connectors User’s Guide</i> .
collect data from your z/VSE systems using the VSE Monitoring Agent	“Collecting Data via the VSE Monitoring Agent” in the <i>z/VSE e-business Connectors User’s Guide</i> .

### Performance Analysis Process

Whenever a performance problem is encountered, a structured and logical analysis is important to solve the problem as fast as possible. To this end, you should follow the outline provided on the following pages and ask the following questions:

- Where in the system does the problem occur?
- What has been changed (if the problem did not occur before)?
- When and with which application does the problem occur?
- What actions do I need to take for I/O related problems?

#### *Where in the system does the problem occur?*

1. For hardware and software related problems:
  - Are the performance related ECs (Engineering Changes) and PTFs (Program Temporary Fixes) installed?
2. For microcode and software setup:
  - Are the VM assists active?
  - Are the VM guest parameters properly set?
  - Are all traces switched off?
  - Is DEBUG off?
3. For problems related to the system configuration:
  - What is the CPU utilization?
  - What is the paging rate?
4. For I/O related problems:
  - Use performance monitoring tools for a detailed problem analysis.
  - Is minidisk caching active?

#### *What has been changed (if the problem did not occur before)?*

- Was there any change in the system, workload, or partition setup?
- Has any new software release from IBM or from another supplier been installed?
  - Which new release was installed?
  - Do PTFs for this release exist?
  - Can I temporarily deactivate the software or even remove it?
  - Can I reproduce the problem?

#### *When and with which application does the problem occur?*

- Already in single thread?
- Only under heavy system load?
- Only when specific other applications are running?
- Which particular job step or transaction is affected?
- Did the problem exist before? If not, what has been changed?

#### *What actions do I need to take for I/O related problems?*

- Did the number of I/Os increase compared to the former situation?
- Did the duration of the I/Os increase?
- Check the capacity guidelines for device and channel utilizations and the number of actuators and paths.



Consider that z/VSE supports dynamic I/O handling, which includes dynamic path select (DPS) and dynamic path reconnect (DPR).

- Tune the software with regard to I/O as follows:
  - Check the VSE/VSAM file definitions.
    - Use more or larger I/O buffers, especially for a z/VSE system with more private space.
  - Are other disk device types used without re-checking the following?
    - The VSE/VSAM CI (control interval) sizes for data and index. The layout of the VSE/VSAM LSR buffers.
- Check your minidisk caching settings, and adjust if required.
- Increase the multiprogramming level (I/O concurrency). This can be done by using additional partitions.
- Use faster I/O subsystems such as the IBM TotalStorage DS8000, DS6000, or ESS (Enterprise Storage Server) family.
  - If you emulate an IBM 3380 or 3390 disk device on an IBM TotalStorage DS8000, DS6000, or ESS, ensure that your ADD statement specifies:
 

```
ADD cuu,ECKD
```

## z/VSE Exploitation Overview

By supporting 31-bit addressing, z/VSE provides significant performance benefits. These benefits include primarily:

- **Virtual Storage Constraint Relief** below 16 MB
- **Data In Memory**

### Virtual Storage Constraint Relief (VSCR)

Starting with the **CICS Transaction Server V1R1.1**, most of the CICS nucleus and control blocks have been moved above the 16 MB line.

Starting with z/VSE 4.1, you can also use VTAM IOBUF31 to obtain shared storage relief below the 16 MB line. For details, see “VTAM 31-Bit I/O Buffer Support” on page 95.

### Data In Memory (DIM)

Data In Memory is a proven concept (introduced first with MVS) to keep more data in virtual (and real) storage. By reducing I/O operations to disk devices, Data In Memory can provide significant reductions in the number of physical I/O operations and thus improve transaction response times besides a reduction in CPU time. The number of reduced I/O operations also allows to drive an ESA-capable processor for a given transaction response time to higher CPU utilization, if this is preferred. z/VSE supports Data In Memory by:

- The ability to assign large VSE/VSAM buffer areas above the 16 MB line. This can include up to 15 CICS and 16 batch VSE/VSAM LSR buffer pools.
- CICS data tables
- z/VSE data spaces
- Virtual disk support

CICS data tables are a valuable means to also reduce the required CPU-time of a given transaction by keeping a rapidly accessible copy of records in storage thus bypassing VSE/VSAM record management.

## Storage and Tuning

To really benefit from Data In Memory, it is mandatory that the appropriate amount of processor (real) storage is available. Otherwise, file I/Os for a partition are replaced by paging-I/Os with potentially big disadvantages for CICS production environments.

### Increased Overall Capacity

Increased z/VSE system capacity is made possible by the following enhancements:

- Dynamic partitions
- More address spaces
- More total virtual storage
- Larger real storage
- Virtual Storage Constraint Relief
- Data In Memory

### Recommendations for the CICS Transaction Server

With z/VSE you can freely select the number of CICS partitions you want to use. There is enough real storage supported for any number of CICS partitions. On the other hand, you are no more forced to split up your CICS production system for capacity reasons into several CICS partitions and use CICS MRO transaction routing and/or function shipping. In addition, the CICS Transaction Server provides shared data tables. Refer to “CICS Data Tables” on page 263 for details.

Unchanged **24-bit CICS applications** benefit from the fact that the system moves VSE/VSAM control blocks and VSE/VSAM buffers above the 16 MB line thus freeing space below 16 MB. Specifying more data buffers or using CICS data tables may further improve the response times, if I/O operations to disk devices can be avoided.

**31-bit CICS applications** will effectively no longer be storage constrained by the size of programs. Together with the other enhancements such as VSE/VSAM buffer restructuring, the efficient exploitation of ESA-capable processors is possible.

Through the increased capacity of CICS for all types of applications, the cost of today's complex communication configurations with several CICS partitions and MRO or ISC can now be reduced in certain cases.

To benefit from the higher capacity and from more Data In Memory to reduce I/Os, it is definitely required that the appropriate amount of processor (real) storage is provided, in order not to replace file I/Os with page I/Os.

For debugging applications, you may consider to set storage protection ON and increase the size of the trace area.

### Setting Up More Batch Partitions

To obtain higher batch throughput, you can set up more batch partitions. This may require a rearrangement of batch jobs to exploit possible parallelism. In any case, you have to check that no I/O bottleneck is created, especially that the batch I/Os are spread across enough disk devices. By using the PRTYIO command, make sure that your online production gets higher priority in the I/O subsystem.

With z/VSE, **batch programs** will especially benefit from the reduced numbers of I/Os to disk devices by using virtual disks for workfiles. the batch throughput increase for such type of jobs will be up to 30% and more, depending for example on the degree of I/O activity to the workfiles.

## Recommendations for z/VSE Exploitation

You can:

- Save I/Os by implementing the concept of Data In Memory.
- Speed up those I/Os by using fast cached I/O subsystems, such as the IBM TotalStorage DS8000, DS6000, and ESS disk families, or the Internal Disk of the IBM Multiprise 3000 servers.
- More overlap of I/Os by setting up more partitions and tasks concurrently.

The above list covers the opportunities z/VSE offers to reduce the dependency from the I/O speed. In order to fully exploit z/VSE, check your installation by using the checklist provided under Table 48.

Table 48. Checklist for Exploiting z/VSE Capabilities

Item	I/O savings for	CPU-time savings for
More/larger VTAM buffers	–	Buffer expansions
More/larger VSE/VSAM buffers (NSR, LSR) for permanent user data on disk devices	READs	Setup of I/O I/O Interference LSR search
CICS Data Tables (VSE/VSAM LSR KSDS) CICS Transaction Server	READs (full key) (imprecise key)	Setup of I/O I/O Interference VSE/VSAM code
Virtual disks for temporary/work data	READs WRITEs	I/O Interference
Using data spaces	READs WRITEs	I/O Interference
More applications resident	READs	Setup of I/O I/O interference program load code
Applications more generous with regard to virtual storage	READs WRITEs (temp)	Setup of I/O I/O interference application code

## VSE/VSAM Multiple LSR Pools

Multiple LSR pools are a big step forward in improving VSE/VSAM file accesses. Up to 15 LSR pools can be allocated for CICS (and 16 for batch partitions). They provide tuning improvements, such as:

- Separation of heavily used files.  
Such files may be "unfriendly" to each other (stealing buffers or dominating a subpool during BROWSE, for example).
- Grouping of files; for example by application, work shift, or usage frequency.
- Separation of data and index-CIs (of different files) so that data and index CIs do not compete in the same subpool.
- Full freedom to select optimal data and index-CI sizes (without regarding CI-sizes of other LSR files).
- Smaller subpools for faster searches are possible. This avoids long subpool searches (CPU-time) with a low chance of a hit ratio increase if:

## Storage and Tuning

- Shared with many other files.
- More subpools with less buffers per subpool (uses less CPU-time).

Overall, you get the following performance benefits:

Reduction of VSE/VSAM I/Os (with the same subpool sizes), or even a higher reduction of the VSE/VSAM I/Os (with larger subpool sizes) at the cost of some CPU-time.

VSE/VSAM supports up to 15 (sub)pools both for data and index buffers, which is exploited by the **CICS Transaction Server** and must be specified via Resource Definition Online (RDO).

z/VSE customers can exploit very large LSR buffer pools through VSE/VSAM buffer hashing. For details, refer to the *VSE/VSAM User's Guide and Application Programming*.

### Tuning of Multiple LSR Pools

In order to properly tune multiple LSR pools (in the CICS DFHFCT TYPE=SHRCTL and the VSE/VSAM BLDVRP definitions) you should be aware of the following:

- Independent of the LSR buffers being able to reside above the 16 MB line, the VSE/VSAM control blocks per LSR pool are above the 16 MB line:

Size in partition GETVIS per LSR pool

$$\begin{aligned} &= 2128 + 72 \times \text{no. of subpools} + 108 \times \text{no. of buffers in pool} \\ &\quad + (920 + \text{max. key length}) \times \text{STRNO} \end{aligned}$$

The optimal settings for the performance relevant parameters are characterized by:

- LSR pools: Define only as many as required.
- STRNO: Do not largely oversize STRNOs.

For a single LSR pool, the maximum STRNO was and remains 255. Assuming the same workload, you may for all your pools require only a few more STRNOs (since they are shared less) compared to the number you had before for a single pool.

- KEYLEN: Specify correctly.

If you specify as KEYLEN the maximum of all the KSDS files in the pertinent pool, CICS need not determine that value at startup time.

Furthermore, use the provided CICS LSR hit ratio statistics with the I/Os and the number of hits per CI-size (subpool) for each pool to optimize the number of buffers per subpool as follows:

Increase number until hit ratio does no more increase sensibly.

Decrease number until hit ratio does no more decrease sensibly.

For further details refer to “Buffers for VSE/VSAM Files Accessed from a CICS Partition” on page 272.

## CICS Data Tables

As described in the CICS documentation, CICS data tables can be viewed as a data look-aside within CICS virtual storage for full-key READs of VSE/VSAM LSR defined KSDS files. In addition, the CICS Transaction Server also supports imprecise (generic) keys:

- Also imprecise key (GENERIC, GTEQ, BROWSE).
- Directly sharable between CICS TS partitions.
- Function shipping only required for updates from other CICS TS systems.

For the CICS Transaction Server, normal VSE/VSAM LSR services are only required in the following cases:

- If a READ record is not in the table.
- For UPDATE requests.

The performance benefits of CICS data tables are the fast and efficient access to data, caused by:

- Shorter path length compared to access records via VSE/VSAM.
- Less I/Os to disk devices if sufficient number of records are loaded into virtual storage (and enough processor storage is available).

A noticeable reduction in CICS DSA (dynamic storage area) use is caused by the decrease in transaction residency time. All factors together result in improved transaction response times and throughput.

**Note:** Use CICS data tables before you increase VSE/VSAM LSR subpools to a much higher number than you used before.

## z/VSE Virtual Disks

Consult also Chapter 11, “Using Data Spaces and Virtual Disks,” on page 167 when planning for virtual disks.

z/VSE virtual disks are a versatile means to redirect I/O requests for disk devices to virtual storage (z/VSE data spaces). Thus, if enough processor (real) storage is available, the number of physical I/O accesses to disk devices can be significantly reduced.

Naturally, this concept can be applied only to data which need not reside on a permanent storage medium.

The following table provides an overview of such types of “workfiles” in the widest sense, ranging from “real” workfiles, via test files, via reproducible, short living files, up to copies of permanent data on real disk devices, such as read only, or even read intensive copies of user data.

All items shown in Table 49 on page 264 apply in principle for both, batch and CICS partitions, although batch is the primary usage area.

Table 49. z/VSE Virtual Disk Functionality

Function	Created / Maintained
Compiler work areas	IJSYS01 to IJSYS07
Link-edit work areas (option CATAL)	SYSLNK
SORT work areas	SORTWK1 to SORTWK9
DTSANALS work areas	IJSYS02
CSP work files	CSP.USER.WORK.VSAM
Test/work SAM and VSE/VSAM files	
Test/work libraries	
Reproducible input/output files across jobs/job steps. For example, for: - Batch production - DL/I reorganization	SYSIPT, SYSPCH
Read only user files (see Note below)	Copied from real disk
Read only libraries. For example, for: - PSF/VSE fonts - RPG II CICS applications	Copied from real disk  Cannot be made resident
Read intensive user files	Copied from real disk, real disk updates by applications
Read intensive libraries	Copied from real disk, real disk updates by applications

**Note:** Apart from the read intensive items, all the functionality shown in Table 49 do **not** require any change in the application itself. You only have to take care for the updates on the real disk device, and to initially load the data onto the virtual disk. Put CICS TEMP STORAGE AUX (if used in spite of MAIN) on virtual disk only if the applicability has been evaluated (for example, if TS AUX is only used for recreatable data).

### Virtual Disk Usage Hints

In order to optimally exploit the z/VSE virtual disk support, consider the following usage rules:

- Do not grossly overcommit your real storage with virtual disks.
- When selecting the type of files for virtual disks:
  - Prefer READ intensive over WRITE intensive files.
  - Prefer those files with the smallest I/O blocking.
- Define your virtual disks as small as possible.
- Reuse virtual disk extents as much as possible.
- If the data is no more required, release a complete virtual disk via DVCDN cuu and VDISK UNIT=cuu,BLKS=0. This avoids that in the long run unused data is unnecessarily paged out and paged in again.
- Do not load large virtual disks (for example, with VSE/VSAM Backup/Restore) during production. Loading virtual disks larger than the unused real storage will cause page-outs.
- Under z/VM, the VSE Lock file should be on a VM virtual disk or at least on a VM minidisk.

## General Release Transition Hints

When migrating to a new z/VSE release, consider the following general performance rules:

- Adapt your hardware resources (processor power, real storage) to the intended degree of:
  - Increased concurrency of active partitions/tasks.
  - Data In Memory exploitation.

Increase both items in a controlled manner, in order to gain most benefit of both for your specific environment.

- Start with moving VSE/VSAM buffers for 24-bit transactions above 16 MB. Before going further, observe the results for storage relief.
- Continue by exploiting Data In Memory:
  - Enlarged VSE/VSAM buffers above 16 MB.
  - CICS data tables.
  - Virtual disks.

If batch is running side by side with online production, prefer to tune virtual disks **after** you have tuned your CICS environment.

- Other usage of data spaces in addition to virtual disks.
- Relink/Recompile your application programs for 31-bit addressing.

Also refer to the LE/VSE performance-related information contained in these publications: *LE/VSE Customization Guide*, *LE/VSE Programming Guide*, and *LE/VSE Programming Reference*.

- Check your assembler programs for 31-bit conformance before compiling for 31-bit with the High Level Assembler.

---

## IPL Commands

The following IPL commands influence storage consumption and can affect performance:

- ADD
  - SHR (DASD sharing by multiple CPUs)
  - ECKD (when emulating 3380/3390 disk devices on a DS8000, DS6000, or ESS)
- DPD (location and size of the page data sets)
- SYS (system parameters)
  - JA
  - DASDFP
  - CHANQ
  - NPARTS
  - PASIZE
  - SDSIZE
  - SPSIZE
  - BUFSIZE
  - SEC
  - TRKHLD

For details about these commands refer to “ADD”, “DPD”, and “SYS” in the *z/VSE System Control Statements*.

## Storage and Tuning

### Notes:

1. Do not define a disk device as shared (SHR) unless you use DASD sharing.
2. Specifying TYPE=NORMAL in the ASI (\$ASIPROC) *master procedure* avoids the overhead of device sensing during IPL. For information about this parameter, refer to the *z/VSE Guide to System Functions* under “The ASI Master Procedure”.

## NPARTS Definition

You should not define much more partitions for NPARTS than you actually need. The upper limit that you should specify is the maximum number of concurrently active partitions (static plus dynamic). Specifying a higher value for NPARTS requires one additional task and 4 KB shared space for each dynamic partition.

---

## JCL Statements and AR Commands

You should consider the following statements and commands in terms of performance or storage consumption:

- **ALLOC**
- **SIZE**
- **PRTY**  
(set partition priorities)
- **PRTYIO**  
(set I/O priorities per partition)
- **MSECS**  
(partition balancing time)
- **SIZE**  
(parameter on EXEC card)
- **LIBDEF**
- **GETVIS**

---

## General Recommendations for Allocating Virtual Storage

Adhere to the following rules when allocating virtual storage:

- All allocations should be multiples of:
  - 4 KB for SIZE and SETPFIX
  - 64 KB for VPOOL, VIO, and ALLOC
- Do not specify a greater value for VSIZE and PASIZE than actually needed. This helps you keep the tables for system management as small as possible.
- Specify SPSIZE as small as possible. This shared space can only be used for shared partitions and should not be higher than the sum of all required shared partition sizes.
- Specify VPOOL=64K in the IPL procedure.

The VPOOL is the address area for the (larger) VIO area. To estimate the size of the necessary VIO area use the following values:

### Linkage Editor

64 KB



**For Each CICS System**

128 KB

The VIO value influences the total size of the page data set and must thus be reflected in the DPD command.

- Specify SIZE=AUTO in the EXEC statement whenever possible. As a result, a value is taken needed to load the largest phase with the same first 4 characters of the phase specified in the EXEC statement.

You cannot specify SIZE=AUTO for VSE programs which dynamically expand program storage into dynamic storage without using GETVIS requests. Such programs are the Linkage Editor, the Librarian and IBM Compilers.

Use the GETVIS command to display the GETVIS size available.

**SVA Considerations**

Place only those phases into the SVA-24 which are effectively used in a reentrant way by several tasks and partitions. This is especially true for user phases placed into the SVA via a SET SDL command. SVA-31 is not critical since sufficient GETVIS and PSIZE storage is available.

From z/VSE 4.3 onwards, changes have been made that should result in a significant reduction in the amount of SVA-24 required for z/VSE system phases:

- Most VSE/VSAM phases are allocated in the **SVA-31** (the *31-bit* shared addressing area below the 2 GB bar) instead of the **SVA-24** (the *24-bit* shared addressing area below the 16 MB line).
- Other Input/Output (I/O) control blocks are allocated in the **SVA-31** instead of in the **SVA-24**. However, this allocation is controlled via the IODEV parameter. For further details, see “Allocating I/O Control Blocks Above 16 MB Line” on page 55.

---

**VTOC Considerations****ECKD Devices**

After initial installation (automatic) the size of the VTOC is as follows for the ECKD disk devices IBM 3380 and 3390:

DASD: Tracks:

3380	4	(provides space for 212 entries)
3390	4	(provides space for 206 entries)

The number of tracks can be increased up to 15 (1 cylinder) without the danger that an overlap occurs. You specify the number of tracks in the **INIT** command of the *Device Support Facilities* program (ICKDSF). You must subtract 11 tracks from the current VTOC beginning and start initialization there to get a VTOC size of 15 tracks.

### FBA Devices

After initial installation (automatic) the size of the VTOC is as follows for an FBA disk device:

DASD: CISIZE:

FBA 8192 (provides space for 228 entries)

The CISIZE of 8192 provides a performance optimum. It is at the same time the maximum and cannot be increased. This means that if a larger VTOC is required, an extension at that location (in the middle of the disk) is not possible since it would cause an overlap.

The *z/VSE Installation* shows the format of the INIT commands. Appendix B, “z/VSE Disk Layouts (DOSRES, SYSWK1),” on page 277 describes the DOSRES and SYSWK1 layouts for the disk devices supported for installation.

---

### VSE Libraries

You should consider the following for performance reasons:

1. Periodically backing up and restoring VSE libraries improves search performance. Note that reorganization of scattered members is only done when *entire* libraries are restored. A MINI startup can be used for this task and allows a restore of the entire library.
2. The Restore and Copy/Move functions of the librarian are faster if the target library is uniquely assigned.
3. Check the LIBDEF sequence. To optimize sublibrary access, the most frequently accessed sublibraries should come first.
4. After the installation of z/VSE, it is recommended to increase the size of the dump library and move it to a different volume. For the library definitions, refer to LIBRDEFS.Z in IJSYSRS.SYSLIB.

---

### System File Placement

The following recommendations regard file placement:

1. Consider splitting the Page Data Set and placing the extents (of about equal size) on different volumes.
2. In case of high SPOOL utilization, you should move the VSE/POWER data file away from the system disk onto a private disk device.  
You should also consider defining the data file with more than one extent and place each extent on a different actuator.
3. A lock file is needed *only* when sharing disk devices. It should be on a disk device (such as a VM virtual disk) that has low usage and contains no other system files.
4. Concurrently active data files should be placed adjacent to one another, if (for any reason) they are located at the same address.

---

## Parallel Page I/O and Page Data Set Extents

Within page management, there exists a device queue for every page data set device. This allows the overlapping of page I/O operations if the extents are on different disk devices.

The virtual storage of a partition is distributed across all available page data set extents. If you modify the page data set layout, you should distribute your page data set across several extents on separate disk devices. To optimize segment distribution, select extents of about equal size.

If your system uses the system-defined page data set, move it for performance reasons to a different volume.

---

## Recommendations for Using DASD Sharing and Lock Files

When you share disk devices (DASD sharing), you can reduce the overhead as far as possible by adhering to the following rules:

- Put non-shared data on non-shared disk devices.  
This is a general rule which does not only bring performance benefits, but also is reasonable for non-performance reasons.
- Avoid, whenever possible, to add disk devices as cuu,SHR.
- Only specify as many CPUs as needed in the DLF NCPU parameter, in order to speed up lock file I/Os.  
Increasing the total size of the lock file (NCYLS) to 2 or more cylinders may reduce the I/Os by increased “hashing hits”.
- Lock File location:  
Put the z/VSE lock file, if possible, on a separate volume (in LPAR mode). Under VM, use a VM virtual disk, or at least a separate VM minidisk for the lock file. Place only other data (if at all) on the lock file if it is rarely accessed. If possible, select a string that is not highly utilized. The reason is that:
  - RESERVE/RELEASE is being used by the VSE lock manager.
  - RESERVE/RELEASE locks a complete volume.
- Lock File volume:  
If all z/VSE systems sharing the same lock file run under the same VM systems, you can use one of the following as lock file volume:
  - A VM virtual disk
  - A separate VM minidisk
 Instead of using the above and when running on different servers, you may use as lock file volume one of the following:
  - A cached IBM 3380
  - A cached IBM 3390
- Placing the lock file on a SCSI FCP-attached FBA Disk:  
If you want to allocate a lock file on a SCSI disk, you must install a unique FCP adapter for each VSE system that shares the lock file. Each VSE system must access the lock file via its unique FCP adapter. This is necessary because the hardware does not reserve the SCSI disk (using RESERVE command) per FCP cuu, but instead per FCP adapter.

**Warning!:** If the VSE systems sharing the lock file also share the same FCP adapter to access the SCSI disk, the lock file and the data to be protected may be destroyed.

**Notes:**

1. You cannot define the lock file on an FCP SCSI-attached DOSRES or SYSWK1 disk, or on another IPL device. The IPL checks for the IPL device.
2. You should not establish a multipath connection to an FCP SCSI-attached device on which the lock file resides. If more than one connection to this device exists, the IPL will reject the DLF command for this SCSI device. If a DEF/SYSDEF command for the lock file device is entered after the DLF command, the FCP device driver will reject this command.
3. If the z/VSE system enters hardwait, a release of the lock file is attempted in order to prevent other VSE systems being affected that share the lock file.
4. During an IPL, the SCSI FCP device where the lock file resides is released unconditionally.
5. If you use a VM virtual disk, you should ensure that the size of your lock disk (including the VTOC) is a multiple of (777 x 8) blocks.

## File Placement Specifics

For the following types of files it is performance-wise beneficial to place them (if non-shared) on non-shared volumes:

VSE/VSAM files and catalogs  
VSE libraries

Apart from standard device contention, it is irrelevant from a performance point-of-view where the following files (if non-shared) are located, be it on non-shared or shared devices (without the lock file):

SAM, DAM, and ISAM files  
VSE/POWER files

In other words, it is performance-wise not beneficial to move such a file from a shared to a non-shared volume (except the shared volume would also contain the lock file or the shared device would have too much device contention).

For further information on DASD sharing, refer to the *z/VSE Guide to System Functions* under “DASD Sharing with Multiple VSE Systems”.

---

## Recommendations for VSE/POWER

The following recommendations apply only for experienced users which are able to perform these steps outside the daily production work. As shipped, VSE/POWER is running in partition F1.

- Select SETPFIX as small as possible.  
During VSE/POWER shutdown, you get statistics (representative workload needed) about the maximum number of pages fixed. During normal processing, you can use the D STATUS command to get statistics.  
Use the value provided and reduce SETPFIX for F1 to that size.
- In general, try to reduce the partition GETVIS size and the SIZE allocation.

For further information refer to “Processor- and Virtual Storage Requirements” in the *VSE/POWER Administration and Operation*.

## Scheduling VSE/POWER Jobs in Dynamic Partitions

If a job can be processed in a dynamic partition, then it is recommended that you run the job in a dynamic partition. There is only a minimal overhead for a VSE/POWER job if it is run in a dynamic partition instead of a static partition.

If you follow this recommendation, then you will “conserve” your static partitions, which are limited in number. Remember that with static partitions, you can:

- Use the PRTYIO command for explicitly setting and changing I/O priorities.
- Run all types of programs.

Also note that if you have extremely short VSE/POWER jobs that you frequently run, it is recommended to run them in static partitions.

### VSE/POWER DBLK Size

The maximum DBLK size for VSE/POWER is 65024 bytes. The number of SIOs to the VSE/POWER data file depends on the DBLK size specified. The affected buffers are allocated as follows:

- One for each data file extent in real space (SETPFIX) of the VSE/POWER partition.
- One for each spooled device (used by spooled partitions) in the partition GETVIS area of the VSE/POWER partition.

The default value of DBLK used by VSE/POWER is about 7500 bytes. You can specify another value using the DBLK operand of the VSE/POWER generation macro. For details, refer to the chapter “Regenerating the Supervisor, VSE/POWER, or VSE/ICCF” in the *z/VSE Administration*. For an overview on DBLK sizes, refer to Table 31 on page 111.

In general, a DBLK size of half the track size is recommended. This is possible with z/VSE 3.1, since VSE/POWER 7.1 allows the VSE/POWER Queue File virtual storage copy to be above the 16 MB line.

---

## Recommendations for VTAM

The following recommendation apply for the partition in which VTAM is running. As shipped, VTAM is running in partition F3.

- Use SIZE=AUTO.
- Specify IOBUF31=YES in your VTAM startup job.
- Try to reduce the VTAM buffer sizes.

To find out about buffer sizes use the command D NET,BFRUSE after a peak hour of operation. The size of the buffer areas can be reduced as long as MAX USED is lower than the values allocated during VTAM startup. The storage for VTAM buffers is taken from the data space defined in the startup job VTMSTRT (skeleton SKVTAM). Adapt the DSPACE parameter in the // EXEC ISTINCVT... statement accordingly.

For more information about buffers and their sizes, refer to the *VTAM Resource Definition Reference*, and the document *Estimating Storage for VTAM*.

---

### Recommendations for the CICS Transaction Server

The following recommendations apply for a partition in which the CICS Transaction Server is running. The CICS Transaction Server is installed automatically into partition F2 during the installation of z/VSE.

- Make only those programs resident in CICS which really need to be there. During CICS shutdown or on request, you get statistics which tell you how often a program has been fetched from the library.
- If many non-resident, small programs are loaded frequently, you should consider making them resident and have them densely packed (via ALT) to avoid wasting virtual storage.
- The use of VSAM LSR (Local Shared Resources) is beneficial (at the cost of some CPU-time) to reduce I/Os and virtual storage. No general rules can be given since it is workload dependent. But you should follow LSR rules to avoid using more virtual storage than actually needed; for each opened LSR VSE/VSAM file only 3.5 KB will be needed instead of 7 KB for each NSR file.

For information further on how to tune the CICS Transaction Server, refer to the *CICS TS Performance Guide*, SC33-1667.

### Buffers for VSE/VSAM Files Accessed from a CICS Partition

Using the Local Shared Resources (LSR) facility of VSE/VSAM is the default. However, the number of buffers set up by CICS and the default sizes of these buffers may not be adequate to achieve an acceptable performance. You may want to do some performance optimization in this area. As a first step, analyze the CICS shutdown statistics after a peak production period with defaulted number of buffers and their sizes. The section VSAM SHARED RESOURCES STATISTICS provides the information you need. A high number of I/O requests waiting for a buffer of a specific size indicates that the number of available buffers of this size is too low. To achieve an acceptable performance, you can do the following:

1. Adjust the sizes of the control intervals (CIs) of your files. Check your LISTCAT output to see which CI sizes VSE/VSAM selected for the index component of your file. If necessary, redefine your file and select CI sizes such that they are close to or identical with the standard CI sizes as listed below:
  - 512
  - 1,024
  - 2,048
  - 4,096 (or any multiple of 4,096 up to 32,768)
2. Try to keep the number of different control-interval sizes small. The smaller this number is, the better will be your performance.
3. Define the number and sizes of buffers, the maximum key length and the total string number for VSE/VSAM LSR (local shared resources). Use skeleton SKSHRCTL for this task and follow the description provided by the skeleton.
4. Reassemble and catalog the file control table (skeleton DFHFCTSP in VSE/ICCF library 59) of your CICS subsystem after having activated the /INCLUDE SKSHRCTL statement.

For a detailed description of the DFHFCT macro with TYPE=SHRCTL, refer to the *CICS Resource Definition Guide*.

---

## Chapter 21. System Authorization Facility (SAF) and its External Security Interface (RACROUTE)

This chapter describes the *System Authorization Facility* (SAF) and its *External Security Interface* (RACROUTE). It contains these main topics:

- “System Authorization Facility (SAF)”
- “z/VSE-Related SAF Changes”
- “Planning to Use the SAF Router Exit ICHRTX00” on page 274

---

### System Authorization Facility (SAF)

The System Authorization Facility (SAF) of z/VSE provides centralized control for security processing through a system service called the SAF router. The resource manager components and subsystems (for example, the CICS Transaction Server for VSE/ESA) call the SAF router as part of the security decision-making functions in their processing, such as access control checking and authorization-related checking.

To use the SAF router, a resource management component or subsystem issues a RACROUTE call (macro) which invokes the SAF router. Once invoked, the SAF router first calls an optional installation exit routine and then the Basic Security Manager (BSM) or an External Security Manager (if one is installed and active on the system).

The SAF provided with z/VSE was ported from OS/390. Although z/VSE and OS/390 are based on the same S/390 platform, there are differences. The following topic points out the z/VSE SAF deviations from the OS/390 SAF and its interfaces.

---

### z/VSE-Related SAF Changes

The external interfaces of the SAF are documented in the following **OS/390** books:

- *SecureWay Security Server, External Security Interface, (RACROUTE) Macro Reference*, GC28-1922-07
- *SecureWay Security Server RACF<sup>®</sup>, Data Areas*, SY27-2640-08

These books are included as part of the z/VSE documentation on CD-ROM.

The RACROUTE macro is the interface to RACF (Resource Access Control Facility) or another security manager for OS/390 and z/VSE resource managers. The macro descriptions in the publication listed above define this interface. This does not imply, however, that both the OS/390 and z/VSE operating systems support all the functions allowed by the interface. Rather, it defines the macros and keywords that are available for OS/390 and z/VSE resource managers to implement security for data and other resources.

The main deviations of z/VSE from OS/390 are summarized below:

- The independent RACF system macros are not supported by z/VSE.
- The RACF SVCs are not part of the z/VSE RACROUTE support.
- No cross-memory mode is supported; use only HASN=PASN=SASN.
- z/VSE does not know APF libraries. The APF authorization is mapped to valid subsystems and z/VSE authorizations.

## SAF and RACROUTE

- The SAF router exit ICHRTX01 is not supported by z/VSE.
- The SAF support for OpenEdition MVS is not provided with z/VSE. The callable service router and its exit IRRSXT00 are also not part of the z/VSE SAF.
- The ACEE address fields TCBSENV and ASXBSENV are not available with z/VSE. For external security products the services
  - `MODFLD FIELD=ACCEPTR`, and
  - `GETFLD FIELD=ACCEPTR`are provided to support an equivalent behavior.
- IHAACEE has been changed to indicate z/VSE specific authorizations.
- To use the z/VSE SAF service, `RELEASE=1.9` up to 2.2 has to be specified for the RACROUTE requests.

**Note:** You are strongly recommended to *only* use the SAF-related macros that have been shipped in these libraries:

- PRD1.MACLIB
- PRD2.GEN1 (if you have installed the Generation Feature).

---

## Planning to Use the SAF Router Exit ICHRTX00

If you require a *security exit*, you can use the SAF router exit ICHRTX00.

To use exit ICHRTX00, you must:

1. Catalog the exit as member ICHRTX00.PHASE in system library IJSYSRS.SYSLIB. This phase will then be loaded into the system GETVIS area (GETVIS SVA) during SAF initialization at IPL time. It is not part of the system directory list (SDL).
2. Activate a new copy of ICHRTX00, by performing an IPL.

For further details, refer to the OS/390 publications listed under “z/VSE-Related SAF Changes” on page 273. But when using these publications, also take into account the z/VSE-specific changes described in “z/VSE-Related SAF Changes” on page 273.



## Appendix A. Startup Procedures

### List of IPL, JCL, and Label Procedures

This appendix lists the names of the IPL, JCL, and label procedures shipped with z/VSE in system library IJSYSRS.SYSLIB.

Table 50. IPL, JCL, and Label Procedures for Initial Installation

IPL Procedures	JCL Procedures	Label Procedures
\$IPLE80	\$0JCL780	STDLAB80
\$IPLE90	\$0JCL790	STDLAB90
\$IPLEGF	\$0JCL7GF	STDLABGF
	\$1JCL780	
	⋮	
	\$2JCL780	
	⋮	
	\$3JCL780	
	⋮	
	\$4JCL780	
	⋮	
	\$5JCL780	
	⋮	
	\$xJCL780	

**Note:** z/VSE uses these procedures only once for initial installation.

The name of a procedure is determined by the disk device type used for DOSRES and SYSWK1. The following naming conventions apply for the procedures:

- The last two characters identify the type of disk device on which DOSRES and SYSWK1 reside. Appendix B, “z/VSE Disk Layouts (DOSRES, SYSWK1),” on page 277 shows the layout of DOSRES and SYSWK1 for each disk device type supported for initial installation. Procedures are provided for initial installation for the following disk device types:

80 = IBM 3380  
 90 = IBM 3390  
 GF = GFBA (Minidisks and SCSI)

The characters GF indicate that this is the generalized layout for FBA disk devices (GFBA). This layout is used by minidisks under z/VM, and SCSI disks.

- In a running system, after installation, the procedures have been renamed as follows:
  - IPL procedure: \$IPLESA
  - JCL procedures: \$0JCL, \$1JCL, \$2JCL, and so on.
  - Label procedure: STDLABEL

## IPL, JCL, and Label Procedures

Procedure STDLABEL calls procedures STDLABUP and STDLABUS.

It might be useful to have printouts available of those procedures which are relevant for your system. Such a printout can help you identify the original contents of a procedure in case of a system startup problem because of user modifications. This should be done right after initial installation.

You can use the VSE/ICCF **LIBRP** command to copy a procedure from the system library IJSYSRS.SYSLIB to your primary VSE/ICCF library. From it, print the procedure using the *Program Development Library* dialog.

---

### Example of an IPL Procedure

Figure 23 shows the statements of IPL procedure \$IPLE90, required for the initial installation of a z/VSE system on an IBM 3390 disk device. After initial installation, z/VSE completes the procedure and renames it to \$IPLESA.

```
01F,$$A$SUPI,VSIZE=256M,VP00L=64K,IODEV=1024,VI0=512K
ADD FDF,FBAV VIRTUAL DISK FOR LABEL AREA
ADD FEC,3505
ADD FFC,3505 ICCF DUMMY DEVICE DON'T DELETE
ADD FFA,3505 ICCF DUMMY DEVICE DON'T DELETE
ADD FED,2520B2
ADD FFD,2520B2 ICCF DUMMY DEVICE DON'T DELETE
ADD FEE,PRT1
ADD FEF,PRT1
ADD FFE,PRT1 ICCF DUMMY DEVICE DON'T DELETE
ADD FFF,CONS DEDICATED CONSOLE DON'T DELETE
DEF SYSCAT=DOSRES,SYSREC=SYSWK1
SYS DASDFP=YES
SYS JA=YES
SYS SPSIZE=0K
SYS NPARTS=40
SYS PASIZE=30M
DPD VOLID=DOSRES,CYL=398,NCYL=36,DSF=N
DPD VOLID=DOSRES,CYL=434,DSF=NO
SVA PSIZE=(652K,6M),SDL=700,GETVIS=(768K,6M)
```

Figure 23. Example of an IPL Procedure (for Environment A)

## Appendix B. z/VSE Disk Layouts (DOSRES, SYSWK1)

The figures in this appendix show the space that is reserved on DOSRES and SYSWK1 for z/VSE.

### Notes:

1. The UNUSED SPACE and END.VTOC may be **different**, depending on the DASD model you use. For information on the exact disk capacity of your DASD model, refer to the hardware description of your respective DASD model.
2. You are recommended to place the VTOC in the middle of the disk device.
3. MCAT means that this space belongs to the VSE/VSAM master catalog, UCAT that it belongs to the VSE/VSAM user catalog.

### Layout Depending on Environment Selected

In the following tables, the space reserved for holding the page data sets is open ended. To avoid overlaps, especially with the page data sets, you should not put any files in the reserved space area.

If you select predefined environment B during initial installation, an **enlarged** page data set of 512 MB (compared to 256 MB for predefined environment A) is active. The UNUSED SPACE area will thus be reduced by 256 MB.

If you select predefined environment C during initial installation, an **enlarged** page data set of 1792 MB (compared to 256 MB for predefined environment A) is active. The UNUSED SPACE area will thus be reduced by 1792 MB.

The minimum number of cylinders or blocks (as rounded values) for the three environments and for 3380, 3390, and FBA disks, are:

*Table 51. Minimum Cylinders/Blocks Required, per Disk Type, for Environments A, B, C*

3380	DOSRES (Minimum Cylinders)	SYSWK1 (Minimum Cylinders)
Environment A	853	1,114
Environment B	1,291	1,834
Environment C	3,921 <sup>1</sup>	2,554
3390	DOSRES (Minimum Cylinders)	SYSWK1 (Minimum Cylinders)
Environment A	758	1,112
Environment B	1,117	2,112
Environment C	3,271	3,112
FBA	DOSRES (Minimum Blocks)	SYSWK1 (Minimum Blocks)
Environment A	860,000	1,510,000
Environment B	1,366,000	2,211,000
Environment C	4,518,000 <sup>2</sup>	3,618,000

## DOSRES and SYSWK1 Layouts

### Notes:

1. If you wish to use a page data set, you *cannot* install your z/VSE system with environment C on a 3380 disk! A 3380 disk is limited to a size of 3339 cylinders.
2. If you wish to use a page data set, you *cannot* install your z/VSE system with environment C on a FBA-SCSI or virtual FBA disk that is controlled by z/VM! Both of these types of disk are limited to a size of 2 GB.

## IBM 3380 Disks

### DOSRES ----- IBM 3380 Disk

Table 52. DOSRES Layout for an IBM 3380 Disk

START TRACK	NUMBER TRACKS	START CYL	START HEAD	FILE IDENTIFICATION
1	959	0	1	VSE.SYSRES.LIBRARY
1005	8	67	0	VSE.POWER.QUEUE.FILE
1010	7	67	8	U N U S E D S P A C E
1020	120	68	0	VSAM.MASTER.CATALOG
1140	2010	76	0	VSAM.DATA.SPACE.DOSRES(UCAT) %DOS.WORKFILE.SYSLNK VSE.CONTROL.FILE VSE.BSTCNTL.FILE VSE.LDAP.USER.MAPPING VSE.TEXT.REPSTORY.FILE VSE.ONLINE.PROB.DET.FILE VSE.MESSAGE.ROUTING.FILE VSE.PRIMARY.LIBRARY %DOS.WORKFILE.SYS001.RECOVER CICS.AUTO.STATS.A CICS.AUTO.STATS.B CICS.TD.INTRA DFHTEMP CICS.CSD CICS.RSD CICS.GCD CICS.LCD CICS.DBDCCICS.DFHDMFA CICS.DBDCCICS.DFHDMFB PTF.FILE
3150	11	210	0	RESERVED FOR VTOC (UNUSED)
3161	4	210	11	RECOMMEN.VTOC
3165	2725	211	0	VSAM.DATA.SPACE.DOSRES (MCAT) VSE.PRD1.LIBRARY VSE.PRD2.LIBRARY VSE.MESSAGES.ONLINE
5895	60	393	0	CICS.SYSTEM.LOG.A
5955	60	397	0	CICS.SYSTEM.LOG.B
6015	60	401	0	CICS.USER.JOURNAL.A
6075	60	405	0	CICS.USER.JOURNAL.B
6135	75	409	0	VSE.SYSTEM.HISTORY.FILE

Table 52. DOSRES Layout for an IBM 3380 Disk (continued)

START TRACK	NUMBER TRACKS	START CYL	START HEAD	FILE IDENTIFICATION
6210	660	414	0	PAGING.DATA.SET.ONE
6870	5925	395	0	PAGING.DATA.SET.TWO (ENV A)
6870	12510	834	0	PAGING.DATA.SET.TWO (ENV B)
12795	13500	853	0	U N U S E D S P A C E (ENV A)
19380	6915	1292	0	U N U S E D S P A C E (ENV B)
26295	60	1753	0	CICS2.SYSTEM.LOG.A
26355	60	1757	0	CICS2.SYSTEM.LOG.B
26415	60	1761	0	CICS2.USER.JOURNAL.A
26475	60	1765	0	CICS2.USER.JOURNAL.B
26535	15	1769	0	RESERVED FOR END.VTOC

**Notes:**

1. This layout is valid for all native or emulated devices that are at least 1770 cylinders in size.
2. You must move the journaling files for a second CICS to a different location if your page dataset resides on DOSRES and if you are using environment C. The same applies if you have increased VSIZE to a value larger than the predefined value for environment B. For details of how to define CICS journaling files, see the skeleton SKJOUR2 in ICCF library 59.
3. For environment C, there are *no* possible PAGING.DATA.SET.TWO and UNUSED SPACE file identifications.

**SYSWK1 ----- IBM 3380 Disk**

Table 53. SYSWK1 Layout for an IBM 3380 Disk

START TRACK	NUMBER TRACKS	START CYL	START HEAD	FILE IDENTIFICATION
1	959	0	1	SYS.NEW.RES
960	75	64	0	WORK.HIST.FILE
1035	2715	69	0	VSAM.DATA.SPACE.SYSWK1 (MCAT)
3750	150	250	0	VSESP.USER.CATALOG
3900	975	260	0	VSAM.DATA.SPACE.SYSWK1 (UCAT)
				%DOS.WORKFILE.SYS001
				to
				%DOS.WORKFILE.SYS007
				%DOS.WORKFILE.SYS002.RECOVER
				%DOS.WORKFILE.SYS001.SORT
				%WORK.FILE.N11
				to
				%WORK.FILE.N54
				CICS.DUMPA
				CICS.DUMPB
				CICS.AUXTRACE
4875	11	325	0	RESERVED FOR VTOC (UNUSED)
4886	4	325	11	RECOMMEN.VTOC
4890	1800	326	0	ICCF.LIBRARY
6690	2025	446	0	VSE.POWER.DATA.FILE
8715	90	581	0	VSE.POWER.ACCOUNT.FILE
8805	15	587	0	VSESP.JOB.MANAGER.FILE

## DOSRES and SYSWK1 Layouts

Table 53. SYSWK1 Layout for an IBM 3380 Disk (continued)

START TRACK	NUMBER TRACKS	START CYL	START HEAD	FILE IDENTIFICATION
8820	75	588	0	VSE.HARDCOPY.FILE
8895	60	593	0	VSE.RECORDER.FILE
8955	75	597	0	VSE.ALT.HISTORY.FILE
9030	3	602	0	INFO.ANALYSIS.DUMP.MGNT.FILE
9033	12	602	3	U N U S E D S P A C E
9045	1	603	0	INFO.ANALYSIS.EXT.RTNS.FILE
9046	14	603	1	U N U S E D S P A C E
9060	30	604	0	VTAM.TRACE.FILE
9090	180	606	0	CU37XX.LOAD.FILE
9270	2820	618	0	VSAM.DATA.SPACE.SYSWK1 (MCAT)
12090	1170	806	0	VSAM.DATA.SPACE.SYSWK1 (MCAT)
13260	360	884	0	U N U S E D S P A C E
13620	2115	908	0	VSAM.DATA.SPACE.SYSWK1 (MCAT)
15735	10800	1049	0	VSAM.DATA.SPACE.SYSWK1 (MCAT) Environment B
15735	21600	1049	0	VSAM.DATA.SPACE.SYSWK1 (MCAT) Environment C

### Notes:

1. This layout is valid for all native or emulated devices that are at least 1770 cylinders in size.
2. There are several DASD models of this disk device. For all of them, the space requirement and file location for z/VSE are the same. Environments B and C include an enlarged **Page Data Set** (264 MB total size for environment B, and 2048 MB total size for environment C). UNUSED SPACE and END.VTOC depend on the model of the disk device you use and on the size of the Page Data Set. Remember that it is recommended to place the VTOC in the middle of the disk device.

## IBM 3390 Disks

### DOSRES ----- IBM 3390 Disk

Table 54. DOSRES Layout for an IBM 3390-1 Disk

START TRACK	NUMBER TRACKS	START CYL	START HEAD	FILE IDENTIFICATION
1	899	0	1	VSE.SYSRES.LIBRARY
945	7	63	0	VSE.POWER.QUEUE.FILE
952	8	63	7	U N U S E D S P A C E
960	120	64	0	VSAM.MASTER.CATALOG
1080	2040	72	0	VSAM.DATA.SPACE DOSRES (UCAT) %DOS.WORKFILE.SYSLNK VSE.CONTROL.FILE VSE.BSTCNTL.FILE VSE.LDAP.USER.MAPPING VSE.TEXT.REPSTORY.FILE VSE.ONLINE.PROB.DET.FILE VSE.MESSAGE.ROUTING.FILE

Table 54. DOSRES Layout for an IBM 3390-1 Disk (continued)

START TRACK	NUMBER TRACKS	START CYL	START HEAD	FILE IDENTIFICATION
				VSE.PRIMARY.LIBRARY %DOS.WORKFILE.SYS001.RECOVER CICS.AUTO.STATS.A CICS.AUTO.STATS.B CICS.TD.INTRA DFHTEMP CICS.CSD CICS.RSD CICS.GCD CICS.LCD CICS.DBDCCICS.DFHDMFA CICS.DBDCCICS.DFHDMFB PTF.FILE
3120	11	208	0	RESERVED FOR VTOC (UNUSED)
3131	4	208	11	RECOMMEN.VTOC
3135	2520	209	0	VSAM.DATA.SPACE.DOSRES (MCAT) VSE.PRD1.LIBRARY VSE.PRD2.LIBRARY VSE.MESSAGES.ONLINE
5655	60	377	0	CICS.SYSTEM.LOG.A
5715	60	381	0	CICS.SYSTEM.LOG.B
5775	60	385	0	CICS.USER.JOURNAL.A
5835	60	389	0	CICS.USER.JOURNAL.B
5895	75	393	0	VSE.SYSTEM.HISTORY.FILE
5970	540	398	0	PAGING.DATA.SET.ONE
6510	4965	434	0	PAGING.DATA.SET.TWO (ENV A)
6510	10470	434	0	PAGING.DATA.SET.TWO (ENV B)
6510	10470	434	0	PAGING.DATA.SET.TWO (ENV C)
11475	4725	467	0	U N U S E D S P A C E (ENV A)
16980	4725	1132	0	U N U S E D S P A C E (ENV B)
50010	--	3334	0	U N U S E D S P A C E (ENV C)
16200	60	1080	0	CICS2.SYSTEM.LOG.A
16260	60	1084	0	CICS2.SYSTEM.LOG.B
16320	60	1088	0	CICS2.USER.JOURNAL.A
16380	60	1092	0	CICS2.USER.JOURNAL.B

**Note:** You must move the journaling files for a second CICS to a different location if your page dataset resides on DOSRES and if you are using environment C. The same applies if you have increased VSIZE to a value larger than the predefined value for environment B. For details of how to define CICS journaling files, see the skeleton SKJOUR2 in ICCF library 59.

**SYSWK1 ----- IBM 3390 Disk**

Table 55. SYSWK1 Layout for an IBM 3390-1 Disk

START TRACK	NUMBER TRACKS	START CYL	START HEAD	FILE IDENTIFICATION
1	899	0	1	SYS.NEW.RES
900	75	60	0	WORK.HIST.FILE
975	2550	65	0	VSAM.DATA.SPACE.SYSWK1 (MCAT)
3525	150	235	0	VSESP.USER.CATALOG
3675	840	245	0	VSAM.DATA.SPACE.SYSWK1 (UCAT)
				%DOS.WORKFILE.SYS001
				to
				%DOS.WORKFILE.SYS007
				%DOS.WORKFILE.SYS002.RECOVER
				%DOS.WORKFILE.SYS001.SORT
				%WORK.FILE.N11
				to
				%WORK.FILE.N54
				CICS.DUMPA
				CICS.DUMPB
				CICS.AUXTRACE
4515	11	301	0	RESERVED FOR VTOC (UNUSED)
4526	4	301	11	RECOMMEN.VTOC
4530	1800	302	0	ICCF.LIBRARY
6330	1920	422	0	VSE.POWER.DATA.FILE
8250	90	550	0	VSE.POWER.ACCOUTN.FILE
8340	15	556	0	VSESP.JOB.MANAGER.FILE
8355	60	557	0	VSE.HARDCOPY.FILE
8415	60	561	0	VSE.RECORDER.FILE
8475	75	565	0	VSE.ALT.HISTORY.FILE
8550	3	570	0	INFO.ANALYSIS.DUMP.MGNT.FILE
8553	12	570	3	U N U S E D S P A C E
8565	1	571	0	INFO.ANALYSIS.EXT.RTNS.FILE
8566	14	571	1	U N U S E D S P A C E
8580	30	572	0	VTAM.TRACE.FILE
8610	180	574	0	CU37XX.LOAD.FILE
8790	3960	586	0	VSAM.DATA.SPACE.SYSWK1 (MCAT)
12750	1425	850	0	VSAM.DATA.SPACE.SYSWK1 (MCAT)
14175	525	945	0	U N U S E D S P A C E
14700	1980	980	0	VSAM.DATA.SPACE.SYSWK1 (MCAT)
16680	15000	1112	0	VSAM.DATA.SPACE.SYSWK1 (MCAT)
				Environment B
16680	30000	1112	0	VSAM.DATA.SPACE.SYSWK1 (MCAT)
				Environment C

**Note:** There are several DASD models of this disk device. For all of them, the space requirement and file location for z/VSE are the same. Environments B and C include an enlarged **Page Data Set** (264 MB total size for environment B, and 2048 MB total size for environment C). UNUSED SPACE and END.VTOC depend on the model of the disk device you use and on the size of the Page Data Set. Remember that it is recommended to place the VTOC in the middle of the disk device.



## IBM FBA (and SCSI) Disks

**Note:** This layout is also used for FBA devices defined as VM virtual disks. These VM virtual disks are used under z/VM.

### DOSRES ----- IBM FBA (and SCSI) Disks

Table 56. DOSRES Layout for an FBA (and SCSI) Disk

START BLOCK	NUMBER of BLOCKS	FILE IDENTIFICATION
2	59390	VSE.SYSRES.LIBRARY
59904	1024	VSE.POWER.QUEUE.FILE
60928	3072	VSAM.MASTER.CATALOG
64000	61440	VSAM.DATA.SPACE.DOSRES (UCAT) %DOS.WORKFILE.SYSLNK VSE.CONTROL.FILE VSE.BSTCNTL.FILE VSE.LDAP.USER.MAPPING VSE.TEXT.REPSTORY.FILE VSE.ONLINE.PROB.DET.FILE VSE.MESSAGE.ROUTING.FILE VSE.PRIMARY.LIBRARY %DOS.WORKFILE.SYS001.RECOVER CICS.AUTO.STATS.A CICS.AUTO.STATS.B CICS.TD.INTRA DFHTEMP CICS.CSD CICS.RSD CICS.GCD CICS.LCD CICS.DBDCCICS.DFHDMFA CICS.DBDCCICS.DFHDMFB PTF.FILE
125440	64	VTOC
125504	448	UNUSED SPACE
125952	172032	VSAM.DATA.SPACE.DOSRES (MCAT) VSE.PRD1.LIBRARY VSE.PRD2.LIBRARY VSE.MESSAGES.ONLINE
297984	3072	CICS.SYSTEM.LOG.A
301056	3072	CICS.SYSTEM.LOG.B
304128	3072	CICS.USER.JOURNAL.A
307200	3072	CICS.USER.JOURNAL.B
310272	5120	VSE.SYSTEM.HISTORY.FILE
315392	50176	PAGING.DATA.SET.ONE
365568	475904	PAGING.DATA.SET.TWO (ENV A)
365568	1001920	PAGING.DATA.SET.TWO (ENV B)
365568	4158144	PAGING.DATA.SET.TWO (ENV C)
482560		U N U S E D S P A C E (ENV A)
958464	3072	CICS2.SYSTEM.LOG.A
961536	3072	CICS2.SYSTEM.LOG.B
964608	3072	CICS2.USER.JOURNAL.A
967680	3072	CICS2.USER.JOURNAL.B

## SYSWK1 ----- IBM FBA (and SCSI) Disks

Table 57. SYSWK1 Layout for an FBA (and SCSI) Disk

START BLOCK	NUMBER of BLOCKS	FILE IDENTIFICATION
2	59390	SYS.NEW.RES
59392	5120	WORK.HIST.FILE
64512	168960	VSAM.DATA.SPACE.SYSWK1 (MCAT)
233472	3072	VSESP.USER.CATALOG
236544	69632	VSAM.DATA.SPACE.SYSWK1 (UCAT)
		%DOS.WORKFILE.SYS001
		to
		%DOS.WORKFILE.SYS007
		%DOS.WORKFILE.SYS002.RECOVER
		%DOS.WORKFILE.SYS001.SORT
		%WORK.FILE.N11
		to
		%WORK.FILE.N54
		CICS.DUMPA
		CICS.DUMPB
		CICS.AUXTRACE
306176	64	VTOC
306240	448	UNUSED SPACE
306688	69632	ICCF.LIBRARY
376320	89088	VSE.POWER.DATA.FILE
465408	2048	VSE.POWER.ACCOUNT.FILE
467456	128	VSESP.JOB.MANAGER.FILE
467584	5248	VSE.HARDCOPY.FILE
472832	1024	VSE.RECORDER.FILE
473856	5120	VSE.ALT.HIST.FILE
478976	192	INFO.ANALYSIS.DUMP.MGNT.FILE
479168	64	INFO.ANALYSIS.EXT.RTNS.FILE
479232	1024	VTAM.TRACE.FILE
480256	9216	CU37XX.LOAD.FILE
489472	468992	VSAM.DATA.SPACE.SYSWK1 (MCAT)
958464	139264	VSAM.DATA.SPACE.SYSWK1 (UCAT)
1097728	409600	VSAM.DATA.SPACE.SYSWK1 (MCAT)
1507380	703488	VSAM.DATA.SPACE.SYSWK1 (MCAT)
		Environment B
1507380	2110464	VSAM.DATA.SPACE.SYSWK1 (MCAT)
		Environment C

**Note:** There are several DASD models of this disk device. For all models of this disk device the space requirement and file location for z/VSE are the same. Environments B and C include an enlarged **Page Data Set** (264 MB total size for environment B, and 2048 MB total size for environment C). UNUSED SPACE and END.VTOC depend on the model of the disk device you use and on the size of the Page Data Set. Remember that it is recommended to place the VTOC in the middle of the disk device.

---

## Appendix C. Dialogs of the Interactive Interface

### Related Topic:

- Chapter “Fast Paths and Synonyms for Dialogs” in the *z/VSE Administration*.

This appendix lists the dialogs that are available from selection panels of the Interactive Interface. If you wish, you can invoke these dialogs from selection panels that you create and add to the Interactive Interface.

In Table 58:

- **z/VSE Selection** is the name that is used for a dialog in a selection panel of the Interactive Interface.
- **Default for** shows where the dialog appears in the default panel hierarchies:
  - **A** = hierarchy for **SYSA** (type 1 user)
  - **O** = hierarchy for **OPER** (type 2 user)
  - **P** = hierarchy for **PROG** (type 2 user)
  - **S** = hierarchy for **SSRV** (type 2 user)

A, O, and P identify the default panel hierarchies available for a system administrator (SYSA), an operator (OPER), and a programmer (PROG). S, which stands for service (SSRV), identifies a default panel hierarchy which provides access to a selected set of standard dialogs for problem determination. This panel hierarchy is mainly intended for IBM personnel doing remote problem determination for a user site via a data link connecting the user installation with an IBM Support Center, for example. But the SSRV panel hierarchy can also be used for local problem determination.
- **Application Profile** is the name you would specify for the dialog when creating your own selection panels.
- **VSE/ICCF Partition** shows if a particular dialog uses a VSE/ICCF interactive partition. If so, the requirements for the partition's class (A, B, and I) and size are shown. If a dialog does not require a VSE/ICCF interactive partition, all user types (1, 2, or 3) can access it. If a dialog requires a partition, both type 1 and type 2 users can access it, unless otherwise indicated. Type 3 users (general users) cannot access the dialog.
- **Concurrent Execution** indicates how many users can execute a dialog at the same time. For example:
  - Any number of users can concurrently execute the *Command Mode* dialog.
  - Only one user at a time can execute the *Configure Hardware* dialog.
  - Two users can concurrently execute the *Back Up a File* dialog.

Note that the number of allowed concurrent users is based on the initial partition layout for VSE/ICCF. You can increase the number of class A or B partitions to allow concurrent access for more users.

Table 58. Dialogs of the Interactive Interface

z/VSE Selection	Default for	Application Profile	VSE/ICCF Partition	Concurrent Execution
Analyze and Apply PTFs	A	IESS\$PHT	I, 1024K	1 user only
Apply PTFs	A	IESS\$PHJ	I, 1024K	1 user only
Archive All ICCF Libraries on Tape	A, P, O	IESS\$SAR	B, 512K	2 users

## Interactive Interface Dialogs

Table 58. Dialogs of the Interactive Interface (continued)

z/VSE Selection	Default for	Application Profile	VSE/ICCF Partition	Concurrent Execution
Back Up a File	A, P, O	IESU\$DMF	B, 512K	2 users
Back Up a User Catalog to Disk	A, O	IESC\$BUD	B, 512K	2 users
Back Up a User Catalog to Tape	A, O	IESC\$BUT	B, 512K	2 users
Back Up a Volume	A, P, O	IESU\$DMV	B, 512K	2 users
Back Up History File	A, O	IESS\$BAC	B, 512K	2 users
Back Up the DT\$FILE (all ICCF Libraries)	A, P, O	IESS\$SAL	B, 512K	2 users
Back Up the Master Catalog to Disk	A, O	IESC\$BMD	B, 512K	2 users
Back Up the Master Catalog to Tape	A, O	IESC\$BMT	B, 512K	2 users
Back Up VSAM File	A, P, O	IESD\$BAC	B, 512K	2 users
Back Up VSE Library on Tape	A, O	IESS\$LSV	B, 512K	2 users
BSM Cross Reference Report	A	IESBXRPT		1 user only
BSM Group Maintenance	A	IESBSGRP		1 user only
BSM Security Rebuild	A	IESBSREB		1 user only
Catalog Printer UCB	A	IEST\$UCB	B, 512K	2 users
Change Nicknames	A	IESS\$CNN	I, 1024K	1 user only
Command Mode (use ICCF in native mode)	A, P	IESNICCF		Any number of users
Configure Hardware	A	IESA\$HDW	I, 1024K	1 user only
Console (see Note 6)	A, P, O, S	IESDC		Any number of users
Copy a File	A, P, O	IESU\$FCF	B, 512K	2 users
Copy a Volume	A, P, O	IESU\$FCV	B, 512K	2 users
Create Application Job Stream	A, P	IESP\$EXE	B, 512K	2 users
Create Standalone Dump Program on Tape	A, P, S	IESP\$AIA	B, 512K	2 users
Create Standalone Dump Program on Disk	A, P, S	IESP\$AIK	B, 512K	2 users
Customize z/VSE Workstation Platform	A	IESWPM		1 user only
Define Transaction Security (DTSECTXN) (see Note 7)	A	IESC\$SEC	I, 1024K	1 user only
Defragmentation of the History File	A	IESSCMP	I, 1024K	1 user only
Display Active Users/Send Message (see Note 6)	A, P, O, S	IESUSER		Any number of users
Display Channel and Device Activity	A, O	IESDS		Any number of users
Display CICS TS Storage Layout	A, O	IESDSA		Any number of users
Display Storage Layout	A, O	IESSTRGL		Any number of users
Display System Activity (see Note 6)	A, P, O	IESDA		Any number of users
Display VTOC	A	IESLVTOC	B, 512K	Any number of users

Table 58. Dialogs of the Interactive Interface (continued)

z/VSE Selection	Default for	Application Profile	VSE/ICCF Partition	Concurrent Execution
Down-Level Check (system refresh installation)	A	IES\$FSD	I, 1024K (see Note 1)	1 user only
Enter News	A, P, O	IESNEWS		1 user only
Export-Disconnect a User Catalog	A, O	IESC\$EXP	B, 512K	2 users
Export ICCF Library Members to Tape	A, P, O	IES\$EXP	B, 512K	2 users
Export VSAM File	A, P, O	IESD\$EXP	B, 512K	2 users
File and Catalog Management (see Note 2)	A, P	IESVSAM	B, 512K (see Note 1)	Any number of users
FlashCopy VSAM Catalog/Files	A, O	IESC\$SNP	I, 1024K	1 user only
Format ICCF Dump Data	A, P, S	IESP\$FDM	B, 512K	2 users
FSU Installation (system refresh installation)	A	IES\$FSI	I, 1024K	1 user only
FSU Preparation	A	IES\$FSR	I, 1024K	1 user only
Import-Connect a User Catalog	A, O	IESC\$IMP	B, 512K	2 users
Import ICCF Library Member	A, P, O	IES\$IMP	B, 512K	2 users
Import VSAM File	A, P, O	IESD\$IMP	B, 512K	2 users
Inspect Dump Management Output	A, P, S	IESDUMPV		Any number of users
Inspect Message Log	A, P, S	IESMLOG		Any number of users
Install Generation Feature	A	IESI\$GLI	I, 1024K	1 user only
Install Program(s) from Tape	A	IESI\$OPI	I, 1024K	1 user only
Install Programs - V1 Format	A	IESI\$ODI	I, 1024K	1 user only
Invoke CEDA	A	IESCEDA		Any number of users
Invoke CEMS (Report Controller – administrator functions)	A, O	IESCEMS		Any number of users
Invoke CEOS (Report Controller – programmer subset)	P	IESCEOS		Any number of users
Invoke CEMT	A, P, O	IESCEMT		Any number of users
List and Process User Files in Host Transfer File	A	IESIWS0		Any number of users
Look Up PTF/APAR (see Note 3)	A, P, S	IES\$RLP	I, 1024K	1 user only
Maintain APPL Profiles	A	IESBSAPP		1 user only
Maintain Application Profiles (see Note 4)	A	IESAPM/M2		1 user only
Maintain Certificate - User ID List	A	IESC\$AUT	I, 1024K	1 user only
Maintain DCT Profiles	A	IESBSDCT		1 user only
Maintain Dynamic Partitions	A	IESC\$DYN	I, 1024K	1 user only
Maintain FACILITY Profiles	A	IESBSFAC		1 user only
Maintain FCT Profiles	A	IESBSFCT		1 user only
Maintain JCT Profiles	A	IESBSJCT		1 user only
Maintain LDAP User Profiles	A	IESLUP		1 user only

## Interactive Interface Dialogs

Table 58. Dialogs of the Interactive Interface (continued)

z/VSE Selection	Default for	Application Profile	VSE/ICCF Partition	Concurrent Execution
Maintain PCT Profiles	A	IESBSPCT		1 user only
Maintain PPT Profiles	A	IESBSPPT		1 user only
Maintain Printer FCB	A	IESU\$FCB	I, 1024K	1 user only
Maintain PRIMARY Sublibraries	A	IESSTM		1 user only
Maintain Selection Panels (see Note 4)	A	IESSPM/M2		1 user only
Maintain Synonyms	A, P, O	IESSYN		Any number of users
Maintain Transaction Profiles	A	IESBSTRN		1 user only
Maintain TST Profiles	A	IESBSTST		1 user only
Maintain User Profiles (see Note 4)	A	IESUPM	I, 1024K	1 user only
Maintain VTAM Application Names	A	IESC\$APP	I, 1024K	1 user only
Maintain VTAM Startup Options	A	IESC\$ACT	I, 1024K	1 user only
Maintain Workstation Platform	A	IESWPM		Any number of users
Manage Batch Queues	A, P, O, S	IESBQU		Any number of users
Move Files from Host Transfer File to ICCF	A	IESIWS5		Any number of users
Move Files from Host Transfer File to VSAM	A	IESIWS3		Any number of users
Move ICCF Members to Host Transfer File	A	IESIWS4		Any number of users
Move VSAM Files to Host Transfer File	A	IESIWS2		Any number of users
Online Problem Determination	A, P, S	IESOLPD		Any number of users
PC File Transfer	A	IESIWS7		Any number of users
Personalize History File	A	IESA\$LB	I, 1024K	1 user only
Prepare for Installation	A	IESI\$PRI	I, 1024K	1 user only
Print IPL Diagnostics	A, P, S	IESP\$AII	B, 512K	2 users
Print SDAID Tape	A, P, S	IESP\$AID	B, 512K	2 users
Print Service Document	A	IESS\$LST	I, 1024K	1 user only
Print Stand-Alone Dump	A, P, S	IESP\$SAD	B, 512K	2 users
Program Development Library (see Note 5)	A, P, O	IESLIBXX	A, 384K	4 users
Remove FlashCopy Relation	A	IESU\$FCD	B, 512K	2 users
Remove PTF Records from History File	A	IESS\$PHR	I, 1024K	1 user only
Remove Standalone Dump Program from Disk	A, P, S	IESP\$AIR	B, 512K	2 users
Restore a File	A, P, O	IESU\$RSF	B, 512K	2 users
Restore a Member of an ICCF Library	A, P, O	IESS\$RME	B, 512K	2 users
Restore a User Catalog from Disk	A, O	IESC\$RUD	B, 512K	2 users

Table 58. Dialogs of the Interactive Interface (continued)

z/VSE Selection	Default for	Application Profile	VSE/ICCF Partition	Concurrent Execution
Restore a User Catalog from Tape	A, O	IESC\$RUT	B, 512K	2 users
Restore a Volume	A, P, O	IESU\$RSV	B, 512K	2 users
Restore History File	A, O	IESS\$RHS	B, 512K	2 users
Restore One ICCF Library	A, P, O	IESS\$RON	B, 512K	2 users
Restore the DTSFILE (all ICCF Libraries)	A, P, O	IESS\$RAL	B, 512K	2 users
Restore the Master Catalog from Disk	A, O	IESC\$RMD	B, 512K	2 users
Restore the Master Catalog from Tape	A, O	IESC\$RMT	B, 512K	2 users
Restore VSAM File	A, P, O	IESD\$RES	B, 512K	2 users
Restore VSE Library from Tape	A, O	IESS\$LRS	B, 512K	2 users
Retrace (retrace entire System History File, see Note 3)	A, P, S	IESS\$RRP	I, 1024K	1 user only
Retrace APARs	A, P, S	IESS\$RAP	I, 1024K	1 user only
Retrace Component ID	A, P, S	IESS\$ROP	I, 1024K	1 user only
Retrace Components	A, P, S	IESS\$RCP	I, 1024K	1 user only
Retrace Members	A, P, S	IESS\$RMP	I, 1024K	1 user only
Retrace Products	A, P, S	IESS\$RPP	I, 1024K	1 user only
Retrace PTFs	A, P, S	IESS\$RFP	I, 1024K	1 user only
Retrieve Message	A, P, O, S	IESIMSG		Any number of users
Scan Dump Files on Tape	A, P, S	IESP\$SCT	B, 512K	2 users
Scan Dump Files on Disk	A, P, S	IESP\$SCD	B, 512K	2 users
Scan VSE Library Backup Tape	A, O	IESS\$SRS	B, 512K	2 users
Storage Dump Management	A, P, S	IESP\$IDH	I, 1024K	1 user only
Tailor IPL Procedure	A	IEST\$MAS	I, 1024K	1 user only
TCP/IP Configuration	A	IESC\$TCP	I, 1024K	1 user only
Verify Location of Involved Serviced Files	A	IESS\$LOC	I, 1024K	1 user only

**Notes:**

1. CICS builds and uses a temporary VSE/ICCF partition for this dialog.
2. If a user has authority to define VSE/VSAM files and manage catalogs, the application IESVSAM provides access to 6 functions:
  - a. *Display or Process a File*
  - b. *Define a New File*
  - c. *Define a Library*
  - d. *Define an Alternate Index or Name*
  - e. *Display or Process a Catalog, Space*
  - f. *Define a New User Catalog*
  - The last two functions are not shown to a user who has no authority to manage catalogs. Selections 2 through 4 are not accessible to users with no authority to define VSE/VSAM files.

## Interactive Interface Dialogs

- For a FAT 3390 disk, the backend for the DEFINE SPACE function will run in VSE/ICCF Class I,1024K, For all other disks and functions, VSE/ICCF Class B,512K will be used.
3. The *Look Up PTF/APAR* and *Retrace* dialogs listed in this appendix are accessed via the *Retrace History File* panel.

The panel hierarchy for an administrator also allows access to the dialogs via the *IBM Service* panel. These dialogs are identical in function to those accessed from the *Retrace History File* panel. The only difference is that their application names end in *S*, not *P* (IESS\$RAS instead of IESS\$RAP, for example).

If you wish to include an option for a *Retrace* dialog in a selection panel that you create, you can specify either application name for the dialog.

4. To work with this dialog, a user must have special authorization to be defined in the user profile.
5. The following functions of the *Program Development Library* dialog use a VSE/ICCF interactive partition: SUBMIT, PRINT, and COMPILE.
6. These dialogs have no timeout set due to conversational programming.
7. This dialog has been retained for migration purposes only.



## Appendix D. Additional z/VSE Applications

z/VSE provides a number of applications that are not included as options in selection panels of the Interactive Interface. If you wish, you can invoke one or more of these applications from selection panels that you create.

In Table 59:

- **Function** lists the function provided by an application.
- **Application Profile** is the name you would specify when adding an application to your own selection panels.
- **VSE/ICCF Partition** shows if a particular dialog uses a VSE/ICCF interactive partition. If so, the requirements for the partition's class and size are shown. If a dialog does not require a VSE/ICCF interactive partition, all user profile types (1, 2, or 3) can access it. If a dialog requires a partition, both type 1 and type 2 users can access it, unless otherwise indicated. Type 3 users cannot access the dialog.
- **Concurrent Execution** indicates how many users can execute an application at the same time.

Note that the number of concurrent users shown for these applications is based on the initial partition layout for VSE/ICCF. You can increase the number of class B partitions to allow concurrent access for more users.

If you use an application which requires an optional program:

- The optional program must be installed.
- If the optional program has a user-ID and password for sign-on, you should define the Interactive Interface user-ID and password to the optional program. For example, if USER1 is the Interactive Interface user-ID which uses the SDF/CICS application, USER1 and its password must be known to SDF/CICS.

Table 59. Additional z/VSE Applications

Function	Application Profile	VSE/ICCF Partition	Concurrent Execution
CEMT Perform Shutdown	IESCMT01		Any number of users
CEMT Perform Shutdown Immediate	IESCMT02		Any number of users
CEMT Perform Shutdown Immediate Dump	IESCMT03		Any number of users
Display Channel and Device Activity (see Note 1)	IESLS		Any number of users
Display LST Queue	IESLST		Any number of users
Display PUN Queue	IESPUN		Any number of users
Display RDR Queue	IESRDR		Any number of users
Display System Activity (see Note 1)	IESLA		Any number of users
Display XMT Queue	IESXMT		Any number of users
Interactive Structured Query Language (ISQL)	IESISQL		Any number of users
Shut Down ISQL Resource Manager	IESSQLT		Any number of users
Start ISQL Resource Manager	IESSQLS		Any number of users
Invoke CEDB (Resource Definition Online)	IESCEDB		Any number of users
Invoke CEDC (Resource Definition Online)	IESCEDC		Any number of users

## Additional z/VSE Applications

Table 59. Additional z/VSE Applications (continued)

Function	Application Profile	VSE/ICCF Partition	Concurrent Execution
Invoke DITTO/ESA for VSE (see Note 2)	IESDITTO		Any number of users
Invoke Librarian in an Interactive Partition	IESLIBR	B, 512K	2 users
Query Management Facility™ (QMF)	IESQMF		Any number of users
QMF / Trace	IESQMFT		Any number of users
Screen Definition Facility (SDF/CICS)	IESSDF		Any number of users

### Notes:

1. When creating your own selection panels, specify IESLS or IESLA for the application name if you want to change the system defaults for refreshing the screen. If you do not want to change the defaults, use IESDS or IESDA instead. The z/VSE dialogs are listed in Table 58 on page 285.
2. This dialog has no timeout set due to conversational programming.

---

## Appendix E. Reserved Names of the Interactive Interface

z/VSE uses certain prefixes when assigning names for the following resources:

- VSE libraries, sublibraries, and members
- VSE/ICCF
  - Library members
  - Files (in DLBL statements)
- CICS
  - Programs
  - Maps and map sets
  - Transaction IDs
  - Temporary storage queue IDs
  - Transient data queues
  - Files
- Selection panels
- Application profiles
- Message prefixes

When you name any of these items for your own use, you should not use the reserved prefixes listed below to avoid duplicate names.

The following prefixes are reserved:

I\$  
IE  
INW  
DTR  
DTS  
VSE

In addition, all names with \$ in the second or fourth position are reserved:

X\$X\$XXX

CICS uses the following transaction IDs:

HELP  
OLPD  
USER  
ICCF  
PF1  
PF3  
PF13  
PF15



---

## Appendix F. z/VSE Skeletons and REXX/VSE Procedures

As the name implies, skeletons are usually incomplete jobs that you cannot immediately submit for execution. Instead, they contain parameters and variables that you must specify to create jobs for your specific system. They also contain comments that describe JCL statements and variables and explain how you make the necessary changes.

To use a skeleton, you should copy it from its original VSE/ICCF library into a VSE/ICCF library that you own. You can then edit the copy and make the necessary changes.

This appendix also includes a list of REXX/VSE procedures you can use.

This appendix contains these main topics:

- “Startup Skeletons”
- “Skeletons for e-business Connectors Support” on page 296
- “Skeletons for the CICS Transaction Server” on page 297
- “Skeletons for Using RPG II With the CICS Transaction Server” on page 298
- “Skeletons for Job Accounting” on page 298
- “Skeletons for Libraries” on page 299
- “Skeletons for VSE/POWER” on page 299
- “Skeletons for VSE/ICCF” on page 299
- “Skeletons for Network Definitions” on page 299
- “Skeletons for the Linux Fast Path (LFP)” on page 300
- “Skeleton for a Virtual LAN (VLAN)” on page 300
- “Skeletons for the Capacity Measurement Tool (CMT)” on page 300
- “Skeletons for Compiling Programs That Use the TCP/IP Preprocessor” on page 301
- “Delete Skeletons” on page 301
- “Skeletons for Debugging” on page 301
- “Resource Definition and other Skeletons” on page 302
- “Skeletons for Workstation File Transfer Support” on page 303
- “REXX/VSE Procedures” on page 304

---

### Startup Skeletons

Table 60. Startup Skeletons

Member Name	Library	Use
SKALLOCA	59	Allocate static partitions for Environment A.
SKALLOCB	59	Allocate static partitions for Environment B.
SKALLOCC	59	Allocate static partitions for Environment C.
SKCOLD	59	Add jobs to the load list for the RDR queue for a COLD startup.
SKCOMVAR	59	Define CPU IDs in a DASD-sharing environment.
SKENVOVW	59	Overview of procedures for tailoring system startup.

## z/VSE Skeletons

Table 60. Startup Skeletons (continued)

Member Name	Library	Use
SKENVSEL	59	Include jobs created by startup skeletons into a single job.
SKJCL0	59	Start BG partition.
SKBGSTRT	59	Startup for BG.
SKJCL1-SKJCLB	59	Start partitions F1 through FB.
SKJCLDYN	59	Start dynamic partition (dynamic partition profile).
SKLIBCHN	59	Define library search chains.
SKLOAD	59	Create job for loading jobs into VSE/POWER reader queue.
SKPWSTRT	59	Startup job for VSE/POWER.
SKTCPSTR	59	Startup job for TCP/IP.
SKIPV4ST	59	Startup job for TCP/IP Version 4, licensed from Connectivity Systems Incorporated.
SKIPV6ST	59	Startup job for TCP/IP Version 6 (IPv6/VSE), licensed from Barnard Software Incorporated.
SKUSERBG	59	Release jobs CICSICCF and VTAMSTRT.
SKVCSSTJ	59	Startup job for Connector Server.
SKVTAM	59	Startup job for VTAM.
SKVTASTJ	59	Startup job for Virtual Tape Data Handler.

## Skeletons for e-business Connectors Support

Table 61. Skeletons for e-business Connectors Support

Member Name	Library	Use
SKCPSTP	59	Compile and link sample stored procedure.
SKCRESTP	59	Create sample stored procedure DB2 connector.
SKDB2SPS	59	Catalog stored procedure server job.
SKDB2STR	59	DB2 server startup job.
SKDB2VAR	59	Define and initialize the DB2 sample database.
SKDLICMP	59	Compile sample stored procedure for DL/I access.
SKDLISMP	59	Define and initialize DL/I sample database.
SKDLISTP	59	Create sample stored procedures to access DL/I data.
SKRDCFG	59	Set up VSE/VSAM Redirector.
SKVCSCAT	59	Connector Server, catalog VCS configuration members.
SKVCSCFG	59	Connector Server, main configuration member.
SKVCSLIB	59	Connector Server, library configuration member.
SKVCSPLG	59	Connector Server, plugin configuration member.
SKVCSSSL	59	Connector Server, SSL configuration member.
SKVCSSTJ	59	Connector Server, startup job.
SKVCSUSR	59	Connector Server, user security configuration member.
SKVSSAMP	59	Define VSAM connector sample data.
SKLDCFG	59	LDAP Configuration
SKSOAPOP	59	VSE SOAP Engine Configuration

## Skeletons for the CICS Transaction Server

Refer also to Table 42 on page 198 - it shows the major skeletons and tables for a CICS environment.

Table 62. Skeletons for the CICS Transaction Server

Member Name	Library	Use
DFHAUXPR	59	Print CICS Transaction Server AUXTRACE file.
DFHAUXB	59	Define auxiliary trace file B for the CICS Transaction Server (PRODCICS, DBDCCICS).
DFHCNV	59	Conversion table for CICS Web Support.
DFHDCTSP	59	Sample destination control table.
DFHDMFSP	59	Sample monitoring/statistics table.
DFHFCTSP	59	Sample file control table.
DFHJCTSP	59	Sample journal control table.
DFHMNDUP	59	Monitoring support for CICS Transaction Server.
DFHMOLS	59	Monitoring support for CICS Transaction Server.
DFHPLTPI	59	Sample program list table (startup).
DFHPLTSD	59	Sample program list table (shutdown).
DFHSITSP	59	Sample system initialization table.
DFHTSTSP	59	Sample temporary storage table.
DFHWBEP	59	Sample exit for CWS (CICS Web Support).
DFHXLTP	59	Sample transaction list table.
DFHOSTAT	59	Sample program print statistics.
IESZATDX	59	Autoinstall exit for CICS Transaction Server.
IESZNEP	59	Node error program for CICS Transaction Server.
IESZNEPS	59	Sample error program for CICS Transaction Server.
IESZNEPX	59	Sample node error program for CICS Transaction Server.
SKCICMD	59	Sample program issue GETVISxx,RESET
SKCICS	59	Startup job for CICS Transaction Server with IUI and ICCF.
SKCICSLI	59	Define CICS Listener file.
SKCICCLD	59	CICS cold start, clearing LCD and GCD.
SKCIDTRA	59	Print internal trace from dump in dump library.
SKCITMP	59	Redefine and/or increase CICS temporary storage (DFHTEMP) or correct it if corrupted.
SKCONSII	59	Define console for Interactive Interface.
SKCSDFC2	59	Update CSD file for secondary CICS Transaction Server.
SKCICS2	59	Startup job for a secondary CICS Transaction Server in partition F8.
SKPREPC2	59	Preparation job for a secondary CICS Transaction Server in partition F8.
DFHJCTC2	59	Sample Journal Control Table for a secondary CICS Transaction Server.
SKCSDFIL	59	Perform an upgrade of the CICS CSD file.
SKDFHDUP	59	Print transaction dump of CICS Transaction Server.

## z/VSE Skeletons

Table 62. Skeletons for the CICS Transaction Server (continued)

Member Name	Library	Use
SKDMFPR	59	Print statistics for CICS Transaction Server.
SKDMFST	59	Startup monitoring partition.
SKEXCIAS	59	HLASM translation sample for batch client.
SKEXCICN	59	C translation sample for batch client.
SKEXCICV	59	COBOL translation sample for batch client.
SKEXCIPV	59	PL/I translation sample for batch client.
SKEXITDA	59	Sample user exit program for saving activity data.
SKEXIT1	59	Sample sign-on exit.
SKGCDFIL	59	Global catalog redefinition.
SKJOURN	59	Define/format journal data sets.
SKJOUR2	59	Define/format journal data sets for second CICS Transaction Server.
SKLCDFIL	59	Local catalog redefinition.

---

## Skeletons for Using RPG II With the CICS Transaction Server

See also “Using RPG II With the CICS Transaction Server” in the *z/VSE Administration*, SC34-2627.

Table 63. Skeletons for Using RPG II With the CICS Transaction Server

Member Name	Library	Use
RPGINST	59	<ul style="list-style-type: none"><li>• Define the PRD2.RPGII sublibrary.</li><li>• Catalog CICS/VSE BMS map structures and R-type members.</li><li>• Linkedit the CICS/VSE RPGII translator.</li></ul>
RPGSAMPL	59	Catalog CICS/VSE-supplied RPG sample applications.

---

## Skeletons for Job Accounting

Table 64. Skeletons for Job Accounting

Member Name	Library	Use
SKJADACC	59	Extended job accounting.
SKJADOFF	59	Extended job accounting offload.
SKJADPRT	59	Extended job accounting reporting.
SKJOBACC	59	Standard job accounting.
SKJOBDMF	59	Extended job accounting reporting routine.



## Skeletons for Libraries

Table 65. Skeletons for Libraries

Member Name	Library	Use
LIBRSTAT	59	Librarian STATE request.
SKLIBDEF	59	Define VSE user library in non-VSAM managed space.
SKLIBDEL	59	Delete VSE user library in non-VSAM managed space.
SKLIBEXT	59	Extend VSE user library in non-VSAM managed space.

## Skeletons for VSE/POWER

Table 66. Skeletons for VSE/POWER

Member Name	Library	Use
SKPWRBSC	59	Define POWER BSC lines and work stations.
SKPWRDAT	59	Dynamic extension of VSE/POWER data file (which permits a VSE/POWER warm start).
SKPWRGEN	59	Generate VSE/POWER.
SKPWRNDT	59	Create PNET network definition table (SSL support).
SKPWRSNA	59	Define SDLC work stations.
SKPWSTRT	59	Startup job for VSE/POWER.
SKPWREXT	59	Extend or relocate VSE/POWER files.
SKPWRDMP	59	Create dump of the VSE/POWER spool file.

## Skeletons for VSE/ICCF

Table 67. Skeletons for VSE/ICCF

Member Name	Library	Use
SKDTSEXT	59	Extend VSE/ICCF DTSFILE.
SKICFFMT	59	Format VSE/ICCF DTSFILE.
SKICFGEN	59	Generate VSE/ICCF.
SKICFRST	59	Selective restore of DTSFILE from the z/VSE installation tape or cartridge.
SKREORG	59	VSE/ICCF file reorganization.

## Skeletons for Network Definitions

Table 68. Skeletons for Network Definitions

Member Name	Library	Use
SKAPPN	59	Define VSE/VSAM clusters for VTAM APPN.
SKDTRNET	59	Create resource definitions for installing and operating a z/VSE system in a network.
SKNCPLD	59	Load 37xx from CKD device using ACF/SSP.
SKNCPCLF	59	Create NCP load module file.
SKNCPST	59	Set up NCP configurable station.

## z/VSE Skeletons

Table 68. Skeletons for Network Definitions (continued)

Member Name	Library	Use
SKNCPSAL	59	Define the Subarea Link.
SKNCPWKF	59	Create NCP workfile.
SKVTMMOD	59	Create VTAM Logon Mode table.
SKVTMUSS	59	Create VTAM USS table.

---

## Skeletons for the Linux Fast Path (LFP)

Table 69. Skeletons for the Linux Fast Path (LFP)

Member Name	Library	Use
SKLFPACT	59	Contains JCL statements to activate the LFP Socket Interface.
SKLFPSTA	59	Start an LFP Instance.
SKLFPSTO	59	Stop an LFP Instance.
SKLFPPLST	59	List active LFP instances.
SKLFPINF	59	Obtain information about an active LFP instance.

---

## Skeleton for a Virtual LAN (VLAN)

Table 70. Skeleton for a Virtual LAN (VLAN)

Member Name	Library	Use
SKOSACFG	59	Contains JCL statements and parameters to configure a VLAN and load phase IJBOCONF containing your specifications into sublibrary PRD2.CONFIG.

---

## Skeletons for the Capacity Measurement Tool (CMT)

Table 71. Skeletons for the Capacity Measurement Tool (CMT)

Member Name	Library	Use
SKCMT	59	Catalogs the procedure CMTLAB.PROC which contains DLBLs for the CMT data files, and catalogs the procedure CMTSTART.PROC to start the CMT measurement.
SKCMTINI	59	Initializes the CMT data files. This should ONLY be done before the first start of the CMT measurement!
SKCMTREP	59	Extracts the SCRT89 records from the CMT data files written by the CMT, and writes them into a VSAM ESDS dataset for further processing using the SCRT.

## Skeletons for Compiling Programs That Use the TCP/IP Preprocessor

Table 72. Skeletons for Compiling Programs That Use the TCP/IP Preprocessor

Member Name	Library	Use
SKTCPLON	59	Compile PL/I online programs that use the TCP/IP for VSE/ESA preprocessor.
SKTCPLBA	59	Compile PL/I batch programs that use the TCP/IP for VSE/ESA preprocessor.
SKTCCOON	59	Compile COBOL online programs that use the TCP/IP for VSE/ESA preprocessor.
SKTCCOBA	59	Compile COBOL batch programs that use the TCP/IP for VSE/ESA preprocessor.

## Delete Skeletons

Table 73. Delete Skeletons

Member Name	Library	Use
DELCICS	59	Delete CICS Transaction Server.
DELCOBII	59	Delete VS COBOL II.
DELCONN	59	Delete the VSE Connectors Workstation Code component
DELDB275	59	Delete DB2 Server for VSE 7.5
DELDIT	59	Delete DITTO for VSE.
DELHLASM	59	Delete High Level Assembler.
DELIPV6	59	Delete IPv6/VSE.
DELLECOB	59	Delete LE/VSE COBOL.
DELLELOC	59	Delete LE DBCS locales.
DELLEPLI	59	Delete LE/VSE PL/I.
DELOS390	59	Delete OS 390 API.
DELREXX	59	Delete REXX/VSE.
DELTCPIP	59	Delete TCP/IP for VSE/ESA.
DELVTM	59	Delete VTAM.

## Skeletons for Debugging

Table 74. Skeletons for Debugging

Member Name	Library	Use
SKDMPINI	59	Initialize Info/Analysis work files.
SKDMPMGR	59	Sample dump file manager procedure.
SKPWRDMP	59	Generate a dump of the VSE/POWER spool files.
SKSDBRA	59	Run SDAID branch trace with area definition.
SKSDBRJ	59	Run SDAID branch trace with jobname definition.
SKSDGTVA	59	Run SDAID GETVIS trace with area definition.
SKSDGTVJ	59	Run SDAID GETVIS trace with jobname definition.

## z/VSE Skeletons

Table 74. Skeletons for Debugging (continued)

Member Name	Library	Use
SKSDINSA	59	Run SDAID instruction trace with area definition.
SKSDINSJ	59	Run SDAID instruction trace with jobname definition.
SKSDIOA	59	Run SDAID I/O interrupt trace with area definition.
SKSDIOJ	59	Run SDAID I/O interrupt trace with jobname definition.
SKSDPGCA	59	Run SDAID program check trace with area definition.
SKSDPGCJ	59	Run SDAID program check trace with jobname definition.
SKSDPGMA	59	Run SDAID program load trace with area definition.
SKSDPGMJ	59	Run SDAID program load trace with jobname definition.
SKSDSTA	59	Run SDAID storage alteration trace with area definition.
SKSDSTJ	59	Run SDAID instruction trace with jobname definition.
SKSDSVCA	59	Run SDAID SVC trace with area definition.
SKSDSVCJ	59	Run SDAID SVC trace with jobname definition.
SKSUPDMP	59	Sample for suppressing dumps.
SKSYSDMP	59	Dump SYSWK1 volume.
SKVSDMPD	59	Run utility program DOSVSDMP to create a Standalone Dump Program on a CKD or FBA disk device.
SKVMSNP	59	Activate VSE/VSAM SNAP dump.
SKVTAMBU	59	Run SDAID VTAM buffer trace.
SKVTAMIO	59	Run SDAID VTAM I/O trace.
TPRINT	59	Print VTAM trace.

## Resource Definition and other Skeletons

Table 75. Resource Definition and other Skeletons

Member Name	Library	Use
DTSECTRC	59	Create access control table DTSECTAB.
IESBLDUP	59	Migrate user profiles.
IESELOGO	59	Change z/VSE Online panel and related functions.
IESUPDCF	59	Batch program for user profile maintenance.
JOBEXIT	59	Sample for dummy job exit.
JOBXSAMP	59	Sample job exit program.
SKARCHIV	59	Create user product-ID and component-ID entry for System History file.
SKASMOPT	59	High Level Assembler default OPTIONS sample to use WORKFILES
SKBOOTST	59	Create IPL bootstrap records for IJSYSTR1 on volume SYSWK1.
SKCCERT	59	Sample client certificate.
SKDMPEXT	59	Extend the system dump library.
SKEDECKX	59	Setting up an exit for the High Level Assembler for VSE to process E-Decks.
SKIESBLD	59	Create access control table DTSECTAB.
SKIOPCPN	59	IOCP configuration sample.
SKJMGRIN	59	Job manager file initialization.

Table 75. Resource Definition and other Skeletons (continued)

Member Name	Library	Use
SKLDCFG	59	Enable LDAP authentication.
SKLE370	59	Update the CICS CSD file for the VSE C Language Run-Time Support.
SKOMERST	59	Selective restore of online message file from z/VSE installation tape or cartridge.
SKREFRE	59	Restore member DTRIHIST.Z from z/VSE installation tape.
SKRSTRFL	59	Restore member IESTRFL.V from z/VSE installation tape.
SKRXPRTF	59	REXX printlog automation sample, first usage.
SKRXPRTL	59	REXX printlog automation sample, repeated usage.
SKSHRCTL	59	VSE/VSAM shared resource definition for DFHFCT.
SKSRVMOD	59	Sample APAR for object deck.
SKSRVPHS	59	Sample APAR for a phase.
SKSRVSCN	59	Sample job for scanning a phase.
SKSRVSRC	59	Sample APAR for source code.
SKSSLKEY	59	Catalog keyring set into CRYPTO.KEYRING sublibrary (SSL support).
SKSUPASM	59	Regenerate the supervisor.
SKTERSE	59	Sample for using TERSE utility.
SKUNDO	59	Remove user correction from a phase.
SKVMVSE	59	Punch VM/VSE modules to VM user.
SKVSAMDC	59	Define VSE/VSAM compression control data set.
SKVTAPE	59	Define VSE/VSAM file for virtual tape support.
SKWRKFIL	59	Define system work files on a Virtual Disk.
STDLABUS	59	Create standard labels for your files.
TLSDEF	59	Customization options for 3494 TLS (Tape Library Support).

## Skeletons for Workstation File Transfer Support

Table 76. Skeletons for Workstation File Transfer Support

Member Name	Library	Use
INWAMSA	59	Sample program (Assembler) for application interface to Host Transfer File.
INWAPIA	59	Sample program (Assembler) for application interface to Host Transfer File.
INWDAT1	59	File used by the Move Utility exit routines.
INWDAT2	59	File used by the Move Utility exit routines.
INWDESC1	59	Descriptor record used for Move Utility exit routines.
INWDESC2	59	Descriptor record used for Move Utility exit routines.
INWEXTA1	59	Sample exit routine (Assembler) for Move Utilities.
INWEXTA2	59	Sample exit routine (Assembler) for Move Utilities.
INWEXTC1	59	Sample exit routine (COBOL) for Move Utilities.
INWPATOE	59	Procedure for converting ASCII to EBCDIC.
INWPENG3	59	Translation table Euro support.
INWPETOA	59	Procedure for converting EBCDIC to ASCII.

## z/VSE Skeletons

Table 76. Skeletons for Workstation File Transfer Support (continued)

Member Name	Library	Use
INWPERC3	59	Translation table Euro support.
INWPGER3	59	Translation table Euro support.
INWPITL3	59	Translation table Euro support.
INWPMS	59	Translate PC file transfer messages.
INWPMSXX	59	Translation of prefix.
INWSPN3	59	Translation table Euro support.
INWPUK3	59	Translation table Euro support.
INWSAMA1	59	Sample program (Assembler) for a transfer operation with a SEND command.
INWSAMA2	59	Sample program (Assembler) for a transfer operation with a RECEIVE command.
INWSAMC1	59	Sample program (COBOL) for a transfer operation with a SEND command.
INWSAMC2	59	Sample program (COBOL) for a transfer operation with a RECEIVE command.
INWSAMP1	59	Sample program (PL/I) for a transfer operation with a SEND command.
INWSAMP2	59	Sample program (PL/I) for a transfer operation with a RECEIVE command.
INWSCRA	59	Map for program defined by INWSAMA1.
INWSCRC	59	Map for program defined by INWSAMC1.
INWSCRIP	59	Map for program defined by INWSAMP1.
SKIWSTF	59	Create the Host Transfer File.

## REXX/VSE Procedures

Table 77. REXX/VSE Procedures

Member Name	Library	Use
DMPMGR.PROC	IJSYSRS.SYSLIB	Dump file manager (Librarian, VSE/POWER).
IESWAITR.PROC	IJSYSRS.SYSLIB	Program synchronization (VSE/POWER, Console).
REXDFHDU.PROC	IJSYSRS.SYSLIB	Print routine for CICS transaction dumps.
REXXPRTL.PROC	IJSYSRS.SYSLIB	Hardcopy file manager (Console, Job Control).
REXXCO.PROC	PRD1.BASE	Monitoring console (Console).
REXXDOM.PROC	PRD1.BASE	Delete operator messages (Console automation).
REXXSCAN.PROC	PRD1.BASE	Scan job messages (Console automation).
REXXJMGR.PROC	PRD1.BASE	Job manager.
REXXEVNT.PROC	PRD1.BASE	Event handler (Console automation).
REXXCPUM.PROC	PRD1.BASE	Monitoring system load (Console).
REXXSAA.PROC	PRD1.BASE	Interactive REXX (Console).
REXXWAIT.PROC	PRD1.BASE	Start VSE/POWER job (VSE/POWER).
REXXSPCE.PROC	PRD1.BASE	Serialize VSE/POWER jobs (Console automation).
REXXSTOP.PROC	PRD1.BASE	Stop REXXCXIT (Console automation).

Table 77. REXX/VSE Procedures (continued)

Member Name	Library	Use
REXXASM.PROC	PRD1.BASE	Compile, link, and start assembler program (Job Control, Linkage Editor).
REXXSSDL.PROC	PRD1.BASE	Load phase and display load information.
REXXVSAM.PROC	PRD1.BASE	Open VSAM file and write records (Console automation).
SKRXPRT	59	Allows the hardcopy file to be managed and printed.
UPCNTLAP.PROC	IJSYSRS.SYSLIB	Update application profile records in the VSE Control File (IESCNTL).
UPCNTLSP.PROC	IJSYSRS.SYSLIB	Update selection panel records in the VSE Control File (IESCNTL).





---

## Appendix G. Devices Supported

This chapter provides an overview of the IBM devices supported by z/VSE. The devices are listed by type and number. Model information is given only if it is of significance. Almost all of the devices listed in this chapter can be defined to z/VSE by using the *Hardware Configuration* dialog. Devices which are compatible to other devices may not show up in the *Hardware Configuration* dialog. Such a device must be defined by selecting the device it is compatible with.

You may be interested in devices that are not listed but which may be used with z/VSE. Whenever you have a question of this kind or require further details about a listed device, contact your IBM marketing representative.

**Note:** IBM may have announced other devices as supported by z/VSE after this publication was made available. Contact your IBM marketing representative for the latest list of devices supported.

For details on the **servers** supported by z/VSE, refer to “Server Support” on page 6.

---

### Disk Devices

z/VSE supports the following types of disk devices:

- FBA (Fixed Block Architecture)
- ECKD (Extended-Count-Key-Data)

You can use a combination of FBA and ECKD disk devices in your hardware configuration.

For initial installation, you need two disk devices (volumes) of the same device type and with the same capacity.

The following table shows all disk devices supported by z/VSE.

CKD/ECKD Devices
IBM 3380 <sup>1</sup>
IBM 3390 <sup>2</sup>
IBM TotalStorage Enterprise Storage Server (ESS)
IBM TotalStorage DS6000 Series
IBM TotalStorage DS8000 Series

FBA Devices
Generic FBA Devices <sup>3</sup>
FCP-Attached SCSI Devices on IBM TotalStorage: <ul style="list-style-type: none"><li>• Enterprise Storage Server</li><li>• DS6000</li><li>• DS8000</li></ul>

<sup>1</sup> The IBM 3380 Model A is supported as data device but not as system device for initial installation.

## Devices Supported

- <sup>2</sup> Dependent on the model, the IBM 3390 is supported in 3390 (ECKD) mode and in 3380 track compatibility mode. It can be attached to a parallel channel or to an ESCON channel through an IBM 3990 Model 2, 3, or 6 control unit. When running in 3380 track compatibility mode, it cannot be attached to an ESCON channel.
- <sup>3</sup> DAM is not supported for this device type.

---

## Tape Devices

Tape Device	Track/Cartridge
IBM 3420	9 Track (Reel)
IBM 3430	Cartridge
IBM 3480	Cartridge
IBM 3490	Cartridge
IBM 3490E	Cartridge
IBM 3590	Cartridge
IBM 3592 Model J1A	Cartridge
IBM TS1120 (3592 Model E05)	Cartridge
IBM TS1130 (3592 Model E06)	Cartridge
IBM TS3400 Autoloader	Cartridge

---

## IBM TotalStorage Tape Libraries

Tape Library
IBM 3494
IBM 3494 with Virtual Tape Server (VTS)
IBM TS3500 / 3584
IBM TS3500 / 3584 with Virtual Tape Server (VTS)
IBM TS7700 Virtualization Engine
IBM TS7680 ProtecTIER Deduplication Gateway for System z

---

## Printers

### Channel-Attached Printers

Printer
IBM 3800 Models 3, 6, 8
<b>Note:</b> The IBM 3800 Model 8 is only supported in Asia Pacific countries.

## SNA LU 6.2 Attached Printers

These printers are supported via the optional licensed programs PSF/VSE.

Printer
IBM 3820
IBM 3820 Remote PrintManager™ and PSF/2 Distributed Print Function
IBM 3935

## Advanced Function Printing Family, SNA-Attached

These printers are supported via the z/VSE optional program PSF/VSE. All of them have the Remote PrintManager and PSF/2 Distributed Print Function installed.

Printer
IBM 3825
IBM 3835 Models 001 and 002
IBM 3827
IBM 3828
IBM 3829
IBM 3900

## Advanced Function Printing Family, LU1

Printer	Model
IBM 3812	
IBM 3816	
IBM 4019	PSF/2 Distributed Print Function
IBM 4224	Models 201, 202, 2C2, 2E2, 2E3 (AA001 and higher)
IBM 4028	
IBM 4029	PSF/2 Distributed Print Function
IBM 4230	
IBM 4234	Model 011 (A0030 and higher)
IBM 3912	Model NS1
IBM 3916	Model NS1
IBM 3930	Models 02S and 02D

## Advanced Function Printing Family, SNA-Token Ring Attached

Printer
IBM 3935

## Advanced Function Printing Family, Channel-Attached

These printers are supported via the z/VSE optional program PSF/VSE.

Printer	Model
IBM 3800	Models 3, 6, 8
IBM 3825	
IBM 3835	Models 001 and 002
IBM 3827	
IBM 3828	
IBM 3829	
IBM 3831	
IBM 3900	
IBM 3935	

## Terminal Printers and Channel-Attached Line Printers

The "C" indicates a channel-attached line printer.

A local terminal printer can function like a system printer via the CICS Report Controller Feature. When used in this manner, the terminal printer should have a minimum speed of 300 lines per minute.

Printer	Printer (continued)
IBM 1403 (C)	IBM 3289 (both)
IBM 3200	IBM 4019
IBM 3203 (C)	IBM 4224
IBM 3211 (C)	IBM 4234
IBM 3262 (C)	IBM 4245 (C)
IBM 3268	IBM 4248 (C)
IBM 3284	IBM 5553
IBM 3286	IBM 5557
IBM 3287	IBM 6252
IBM 3288 (supported like an IBM 3800)	IBM 6262 (C)

### Notes:

1. The printers 3284, 3286, 3287, 4224, 4234, and 4245 are no longer supported as console printers.
2. The following Pennant printers are supported by the optional program PSF/VSE 2.2.1:  
3112, 3116, 3130, 3160, 6400, 6408, and 6412.

---

## Display Stations

A selection of display stations supported by z/VSE is shown below. The *Hardware Configuration* dialog displays the characteristics a display station must have in order to be defined via the Interactive Interface.

### Notes:

1. Local display stations are supported by VTAM.
2. All of the devices below can be used in emulated mode.
3. The 2074 console support eliminates the need for a non-SNA 3174 controller.

Display Station	Display Station (continued)
IBM 3178	IBM 3277
IBM 3179	IBM 3278
IBM 3180	IBM 3279
IBM 3191	IBM 3472
IBM 3192	IBM 5540
IBM 3193	IBM 5555
IBM 3194	IBM 5560
IBM 3197	

---

## Communication Control Units

z/VSE supports devices that can be attached to IBM servers via their integrated communication adapters or subsystem controllers/adapters or to the following local and remote communication control units.

For control units supported by TCP/IP for VSE/ESA, refer to the *z/VSE TCP/IP Support*.

Control Unit	Description
IBM 3172	Interconnect Controller
IBM 3174	Local and Remote Terminal Control Unit
IBM 3274	Terminal Control Unit
IBM 3276	Terminal Control Unit
IBM 3745	Communication Controller
IBM 3791	Local Communication Controller

---

## Communication Adapters

z/VSE supports the communication adapters listed below.

Adapter	Description
OSA-Express3	Open Systems Adapter Express 3
OSA-Express2	Open Systems Adapter Express 2
OSA-Express	Open Systems Adapter Express

## Devices Supported

For details of the z/VSE support for the above adapters, see Chapter 10, “TCP/IP and Networking Support,” on page 153.

---

## Reader/Punch Devices

z/VSE supports the following Reader/Punch devices:

Reader/Punch Device	Description
IBM 2520	Needed for VSE/POWER without blank card
IBM 2540	Needed for VM as default device
IBM 3505	Needed for VSE/POWER with blank card (or for VM virtual addresses)
IBM 3525	Needed for VSE/POWER as virtual device

---

## Personal Computers

### 3270 Terminal Emulation

z/VSE supports any workstation as a **3270 display station**, provided that the workstation supports 3270 terminal emulation via a suitable adapter and the corresponding emulation control program. The workstation is connected and defined to z/VSE like a normal 3270 display station: as a local or as a remote SNA or non-SNA workstation.

**Further Information:**

- The publications that are supplied with your hardware devices.
- *VSE/ESA Programming and Workstation Guide*, for details on Workstation File Transfer Support.
- *AIX RISC System/6000 Command Reference*, for a description of the XFER command.

---

## Glossary

If you do not find the term you are looking for, refer to the index of this book or to the *IBM*

*Glossary of Computing Terms* at:

<http://www.ibm.com/ibm/terminology>

The glossary includes definitions with:

- Symbol \* where there is a one-to-one copy from the IBM Dictionary of Computing.
- Symbol (A) from the *American National Dictionary for Information Processing Systems*, copyright 1982 by the Computer and Business Equipment Manufacturers Association (CBEMA). Copies may be purchased from the American National Standards Institute, 1430 Broadway, New York, New York 10018. Definitions are identified by the symbol (A) after the definition.
- Symbols (I) or (T) from the *ISO Vocabulary - Information Processing* and the *ISO Vocabulary - Office Machines*, developed by the International Organization for Standardization, Technical Committee 97, Subcommittee 1. Definitions of published segments of the vocabularies are identified by the symbol (I) after the definition; definitions from draft international standards, draft proposals, and working papers in development by the ISO/TC97/SC1 vocabulary subcommittee are identified by the symbol (T) after the definition, indicating final agreement has not yet been reached among participating members.

**\* Access Control - Logging and Reporting**

An IBM licensed program used to log access to protected data and to print selected formatted reports on such access.

**access control table (DTSECTAB)**

A table used by the system to verify a user's right to access a certain resource.

**access method**

A program, that is, a set of commands (macros), to define files or addresses and to move data to and from them; for example VSE/VSAM or VTAM.

**\* account file**

A direct access file maintained by VSE/POWER to hold the accounting information it generates and the programs that it controls.

**\* ACF** Advanced Communications Function.

**ACF/NCP**

See *NCP*.

**ACF/SSP**

See *SSP*.

**ACF/VTAM**

See *VTAM*.

**addressing mode (AMODE)**

A program attribute that refers to the address length that a program is prepared to handle on entry. Addresses may be either 24 bits or 31 bits in length. In 24-bit addressing mode, the processor treats all virtual addresses as 24-bit values; in 31-bit addressing mode, the processor treats all virtual addresses as 31-bit values. Programs with an addressing mode of ANY can receive control in either 24-bit or 31-bit addressing mode.

**address space**

A range of up to two gigabytes of contiguous virtual storage addresses that the system creates for a user. Unlike a data space, an address space contains user data **and** programs, as well as system data and programs, some of which are common to all address spaces. Instructions execute in an address space (not a data space). Contrast with *data space*.

**\* Advanced Communications Function (ACF)**

A group of IBM licensed programs, principally VTAM programs, TCAM, NCP and SSP that use the concepts of Systems Network Architecture (SNA), including distribution of function and resource sharing.

**Advanced Function Printing (AFP)**

A group of IBM licensed programs that support APA printers.

**\* advanced peer-to-peer networking (APPN)**

Data communications support that routes data in a network between two or more APPC systems that do not need to be adjacent.

**advanced program-to-program communication (APPC)**

A synonym for logical unit (LU) 6.2 and its implementations.

\* **AFP** Advanced Function Printing.

\* **American National Standard Code for Information Interchange (ASCII)**

The standard code, using a coded character set consisting of 7-bit coded characters (8 bits including parity check), that is used for information interchange among data processing systems, data communication systems, and associated equipment. The ASCII set consists of control characters and graphic characters. (A)

**AMODE**

Addressing mode.

\* **APA** All points addressable.

\* **APAR**

Authorized program analysis report.

\* **APPC**

Advanced program-to-program communications.

\* **application profile**

A control block in which the system stores the characteristics of one or more application programs.

\* **application program**

A program written for or by a user that applies directly to the user's work, such as a program that does inventory control or payroll. See also *batch program* and *online application program*.

\* **APPN**

Advanced peer-to-peer networking.

\* **ASCII**

American National Standard Code for Information Interchange.

**ASI (automated system initialization) procedure**

A set of control statements which specifies values for an automatic system initialization.

\* **assemble**

To translate an assembly language program into an object program. (T)

\* **assembler**

A computer program that converts assembly language instructions into object code.

**assembler language**

A programming language whose instructions are usually in one-to-one correspondence with machine instructions and allows to write macros.

**attention routine (AR)**

A routine of the system that receives control when the operator presses the Attention key. The routine sets up the console for the input of a command, reads the command, and initiates the system service requested by the command.

\* **authorized program analysis report (APAR)**

A request for a correction of a problem caused by a defect in a current unaltered release of a program.

\* **automated system initialization (ASI)**

A function that allows control information for system startup to be cataloged for automatic retrieval during system startup.

**background partition**

An area of virtual storage in which programs are executed under control of the system. By default, the partition has a processing priority lower than any of the existing foreground partitions.

**backup copy**

A copy, usually of a file or a library member, that is kept in case the original file or library member is unintentionally changed or destroyed.

**batch processing**

Serial processing of computer programs. Pertaining to the technique of executing a set of computer programs such that each is completed before the next program of the set is started. (A)

**batch program**

A program that is processed in series with other programs and therefore normally processes data without user interaction.

**bits per second (bps)**

In serial transmission, the instantaneous bit speed with which a device or channel transmits a character.

**block** Usually, a block consists of several records of a file that are transmitted as a unit. But



- if records are very large, a block can also be part of a record only. On an FBA disk, a block is a string of 512 bytes of data.
- \* **bps** Bits per second.
  - \* **BSC** Binary synchronous communication.
  - \* **cache**  
A high-speed buffer storage that contains frequently accessed instructions and data; it is used to reduce access time.
- cache storage**  
A random access electronic storage in selected storage controls used to retain frequently used data for faster access by the channel. For example, the IBM 3990 Model 3 contains cache.
- \* **catalog**  
A directory of files and libraries, with reference to their locations. A catalog may contain other information such as the types of devices in which the files are stored, passwords, blocking factors. (I) (A) To store a library member such as a phase, module, or book in a sublibrary.  
See also *VSE/VSAM catalog*.
  - \* **cataloged procedure**  
A set of control statements placed in a library and retrievable by name.
- cell pool**  
An area of virtual storage obtained by an application program and managed by the callable cell pool services. A cell pool is located in an address space or a data space and contains an anchor, at least one extent, and any number of cells of the same size.
- Central Processing Complex**  
A segment of the physical resources of a system configuration.
- central processing unit (CPU)**  
The hardware component that interprets and executes instructions. Synonym for *processor*.
- \* **channel adapter**  
A communication controller hardware unit used to attach the controller to a data channel.
  - \* **channel-attached**  
Pertaining to attachment of devices directly by data channels (I/O channels)
- to a computer. Contrast with *link-attached*.  
Synonymous with *locally attached*.
- channel-to-channel connection (CTC)**  
A function that allows data to be exchanged (1) under the control of VSE/POWER between two virtual VSE machines running under VM or (2) under the control of VTAM between two processors.
- channel subsystem**  
A feature of Enterprise Systems Architecture that provides extensive additional channel (I/O) capabilities over the System/370.
- CICS Transaction Server for VSE/ESA**  
This is the successor system to CICS/VSE.
- \* **CICS/VSE**  
Customer Information Control System/VSE. No longer shipped on the Extended Base Tape.
- CKD device**  
Count-key-data device.
- class** In VSE/POWER, a group of jobs that either come from the same input device or go to the same output device.
- \* **CMS**  
Conversational monitor system.
- COBOL**  
Common business-oriented language.
- common business-oriented language (COBOL)**  
A high-level programming language based on English used primarily for business application programs.
- \* **communication adapter**  
A circuit card with associated software that enables a processor, controller, or other device to be connected to a network.
  - \* **communication controller**  
A device that directs the transmission of data over the data links of a network; its operation may be controlled by a program executed in a processor to which the controller is connected or it may be controlled by a program executed within the device. (T) A type of communication control unit whose operations are controlled by one or more programs stored and executed in the unit. It

manages the details of line control and the routing of data through a network.

**\* compile**

To translate a source program into an executable program (an object program). See also *assembler*.

**compiler**

A program used to compile.

**control program**

A program to schedule and supervise the running of programs in a system.

**control unit**

See *communication controller*. Synonymous with *controller*.

**\* conversational monitor system (CMS)**

A virtual machine operating system that provides general interactive time sharing, problem solving, and program development capabilities.

**\* corrective service**

The installation of a PTF or an APAR fix that corrects a specific problem.

**count-key-data (CKD) device**

A disk device that stores data in the record format: count field, key field, data field. The count field contains, among others, the address of the record in the format: cylinder, head (track), record number and the length of the data field. The key field, if present, contains the record's key or search argument. CKD disk space is allocated by tracks and cylinders. Contrast with *FBA disk device*. See also *extended count-key-data device*.

**\* CPU** Central processing unit.

**CTC** Channel-to-channel connection.

**CUT (control unit terminal) mode**

IBM PCs operating in CUT mode make not use of the extended data stream facility. Contrast with *DFT mode*.

**\* DASD**

Direct access storage device.

**DASD sharing**

An option that lets independent computer systems use common data on shared disk devices.

**database**

A set of data available online that is

organized by a common system and used for a common purpose.

**\* data block (DBLK)**

In VSE/POWER, the unit of transfer for spooling job input and job output.

**Data Interfile Transfer, Testing and Operations/ESA for VSE (DITTO/ESA for VSE)**

A z/VSE base program that provides file-to-file services for card I/O, tape, and disk devices.

**Data Language/I (DL/I)**

A database access language used with CICS/VSE and CICS TS.

**\* data management**

A major function of the operating system. It involves organizing, storing, locating, and retrieving data.

**data security**

See *access control*.

**data set**

See *file*.

**data space**

A range of up to two gigabytes of contiguous virtual storage addresses that a program can directly manipulate through ESA/370 instructions. Unlike an address space, a data space can hold only user data; it does not contain shared areas, system data or programs. Instructions do not execute in a data space, although a program can reside in a data space as non-executable code. Contrast with *address space*.

**\* DBLK**

Data block.

**\* dedicated (disk) device**

A device that cannot be shared among users.

**default value**

A value assumed by the program when no value has been specified by the user.

**\* device address**

The identification of an input/output device by its channel and unit number. In data communication, the identification of any device to which data can be sent or from which data can be received.

**\* device class**

The generic name for a group of device

- types; for example, all display stations belong to the same device class. Contrast with *device type*.
- \* **Device Support Facilities (DSF)**  
See *ICKDSF*.
  - \* **device type code**  
The four- or five-digit code to be used for defining an I/O device to a computer system.
- DFT mode**  
Distributed function terminal (DFT) mode.
- \* **dialog**  
In an interactive system, a series of related inquiries and responses similar to a conversation between two people. For z/VSE, a set of panels that can be used to complete a specific task; for example, defining a file.
- direct access**  
Accessing data on a storage device using their address and not their sequence. This is the typical access on disk devices as opposed to magnetic tapes. Contrast with *sequential access*.
- \* **Direct access storage device (DASD)**  
A device in which access time is effectively independent of the location of the data.
- directory**  
A table of identifiers and references to the corresponding items of data. (I) (A) In VSE, specifically, the index for the program libraries. See also *library directory*.
- disk operating system residence volume (DOSRES)**  
The disk volume on which the system sublibrary IJSYSRS.SYSLIB is located including the programs and procedures required for system startup.
- disk sharing**  
An option that lets independent computer systems use common data on shared disk devices.
- display station**  
A display screen with attached keyboard for communication with the system or a network. See also *terminal*.
- disposition**  
A means of indicating to VSE/POWER how job input and output is to be handled. A job may, for example, be deleted or kept after processing.
- distributed function terminal (DFT) mode**  
IBM PCs operating in DFT mode make use of the extended data stream facility allowing simultaneous host sessions by using screen windows.
- \* **distribution tape**  
A magnetic tape that contains, for example, a preconfigured operating system like z/VSE. This tape is shipped to the customer for program installation.
  - \* **DITTO/ESA for VSE**  
Data Interfile Transfer, Testing and Operations/ESA for VSE.
- DL/I** Data Language/I.
- DOSRES**  
Disk operating system residence volume.
- double-byte character set (DBCS)**  
A character set which allows Korean, Japanese, and Chinese languages to be internally represented by two bytes per character.
- \* **DSF** Device Support Facilities.
- dummy device**  
A device address with no real I/O device behind it. Input and output for that device address are spooled on disk.
- \* **dump**  
Data that has been dumped. (T) To record, at a particular instant, the contents of all or part of one storage device in another storage device. Dumping is usually for the purpose of debugging. (T)
  - \* **duplex**  
Pertaining to communication in which data can be sent and received at the same time.
- dynamic class table**  
Defines the characteristics of dynamic partitions.
- dynamic partition**  
A partition created and activated on an 'as needed' basis that does not use fixed static allocations. After processing, the occupied space is released. Contrast with *static partition*.

**\* dynamic partition balancing**

A VSE facility that allows the user to specify that two or more or all partitions of the system should receive about the same amount of time on the processing unit.

**EBCDIC**

Extended binary-coded decimal interchange code.

**ECKD device**

Extended count-key-data device.

**emulation**

The use of programming techniques and special machine features that permit a computer system to execute programs written for another system or for the use of I/O devices different from those that are available.

**\* emulation program (EP)**

An IBM control program that allows a channel-attached 3705 or 3725 communication controller to emulate the functions of an IBM 2701 Data Adapter Unit, or an IBM 2703 Transmission Control.

**Enterprise Systems Architecture (ESA)**

See *ESA/390*.

**Environmental Record Editing and Printing (EREP) program**

A z/VSE base program that makes the data contained in the system recorder file available for further analysis.

**EREP program**

Environmental Record Editing and Printing program.

**ESCON Channel (Enterprise Systems Connection Channel)**

A serial channel, using fiber optic cabling, that provides a high-speed connection between host and control units for I/O devices. It complies with the ESA/390 I/O Interface.

**ESDS** Entry-sequenced data set. See *entry-sequenced file*.

**exit** A routine, normally user-supplied, that receives control from the system when a certain event occurs (abnormal-end exit, for example).

**extended addressability**

See *31-bit addressing*. The ability of a

program to use virtual storage that is outside the address space in which the program is running. Generally, instructions and data reside in a single address space - the primary address space. However, a program can have data in address spaces other than the primary or in data spaces. (The instructions remain in the primary address space, whilst the data can reside in another address space or in a data space.) To access data in other address spaces, a program must use access registers (ARs) and execute in access register mode (AR mode).

**extended binary-coded decimal interchange code (EBCDIC)**

A coded character set consisting of 8-bit coded characters.

**extended count-key-data (ECKD) device**

A disk storage device that has a data transfer rate faster than some processors can utilize. A specialized channel program is needed to convert ordinary CKD channel programs for use with an ECKD device.

**FASTCOPY**

See *VSE/Fast Copy*.

**fast service upgrade (FSU)**

A service function of z/VSE for the installation of a refresh release without regenerating control information such as library control tables.

**FBA disk device**

Fixed-block architecture disk device.

**\* FCB** Forms control buffer.

**\* FCOPY**

See *VSE/Fast Copy*.

**\* FCP** See *Fibre Channel Protocol*.

**\* file** A named set of records stored or processed as a unit. (T) Synonymous with *data set*.

**\*fibre-channel connection (FICON)**

A fibre-channel communication protocol designed for IBM mainframe computers and peripherals.

**\*Fibre Channel Protocol (FCP)**

The serial SCSI command protocol used on fibre-channel networks.

**\*FICON**

See *fibre-channel connection*.

**fixed-block architecture (FBA) disk device**

A disk device that stores data in blocks of fixed size. These blocks are addressed by block number relative to the beginning of the file. Contrast with *CKD device*.

**\* foreground partition**

A space in virtual storage in which programs are executed under control of the system. By default, a foreground partition has a higher processing priority than the background partition.

**\* forms control buffer (FCB)**

In the 3800 Printing Subsystem, a buffer for controlling the vertical format of printed output.

**FSU** Fast service upgrade.

**FULIST (Function LIST)**

A type of selection panel that displays a set of files and/or functions for the choice of the user.

**\* GB** Gigabyte.

**\* generate**

To produce a computer program by selecting subsets of skeletal code under the control of parameters. (A)

**generation**

See *macro generation*.

**generation feature**

An IBM licensed program order option used to tailor the object code of a program to user requirements.

**\* GETVIS space**

Storage space within a partition or the shared virtual area, available for dynamic allocation to programs.

**gigabyte (GB)**

1 024MB or 1 073 741 824 bytes.

**guest system**

A data processing system that runs under control of another (host) system.

**\* half-duplex**

In data communication, pertaining to transmission of data in only one direction at a time. Contrast with *duplex*.

**hardcopy file**

A system file on disk, used to log all lines of communication between the system

and the operator at the system console, to be printed on request.

**hard wait**

The condition of a processor when all operations are suspended. System recovery from a hard wait is impossible without performing a new system startup.

**\* hardware**

All or part of the physical components of an information processing system, such as computers or peripheral devices. (T) (A) Contrast with *software*.

**\* help panel**

A display of information provided by the system in response to a user's help request.

**High Level Assembler for VSE**

A programming language providing enhanced assembler programming support. It is a base program of z/VSE.

**host mode**

In this operating mode, a PC can access a VSE host. For programmable workstation functions, the Move Utilities of VSE can be used.

**\* host processor**

In a network, the processing unit in which resides the access method for the network. In an SNA network, the processing unit that contains a system services control point (SSCP).

**\* host system**

The controlling or highest level system in a data communication configuration.

**host transfer file (HTF)**

Used by the Workstation File Transfer Support of z/VSE as an intermediate storage area for files that are sent to and from IBM Personal Computers.

**ICCF** See *VSE/ICCF*.

**ICKDSF (Device Support Facilities)**

A z/VSE base program that supports the installation, use, and maintenance of IBM disk devices.

**index** In data management, a table used to locate the records of a file.

**\* initial program load (IPL)**

The process of loading system programs and preparing the system to run jobs.

**\* input/output control system (IOCS)**

A group of routines provided by IBM for handling transfer of data between main storage and auxiliary storage devices.

**integrated console**

In z/VSE, the Support Element console available on ES/9000 servers that operates as the z/VSE system console. The integrated console is typically used during IPL and for recovery purposes when no other console is available.

**intelligent workstation**

See *programmable workstation*.

**interactive**

A characteristic of a program or system that alternately accepts input and then responds. An interactive system is conversational, that is, a continuous dialog exists between user and system. Contrast with *batch*.

**interactive interface**

A system facility which controls how different users see and work with the system by means of user profiles. When signing on, the interactive interface makes available those parts of the system authorized by the profile. The interactive interface has sets of selection- and data-entry panels through which users communicate with the system.

**interactive partition**

An area of virtual storage for the purpose of processing a job that was submitted interactively via VSE/ICCF.

**Interactive User Communication Vehicle (IUCV)**

Programming support available in a VSE supervisor for operation under z/VM. The support allows a user to communicate with other users or with CP in the same way he would with a non-preferred guest.

**interface**

A shared boundary between two hardware or software units, defined by common functional or physical characteristics. It might be a hardware component or a portion of storage or registers accessed by several computer programs.

**I/O (input/output)**

See *input* and *output*.

**IOCS** Input/output control system.

**\* IPL** Initial program load.

**IUCV** Interactive User Communication Vehicle.

**\* JCL** Job control language.

**JECL** Job entry control language.

**job accounting**

A system function that lists how much every job step uses of the different system resources.

**\* job accounting interface**

A function that accumulates accounting information for each job step that can be used for charging usage of the system, planning new applications, and supervising system operation more efficiently.

**\* job accounting table**

An area in the supervisor where accounting information is accumulated for the user.

**job control language (JCL)**

A language that serves to prepare a job or each job step of a job to be run. Some of its functions are: to identify the job, to determine the I/O devices to be used, set switches for program use, log (or print) its own statements, and fetch the first phase of each job step.

**job control statement**

A particular statement of JCL.

**job entry control language (JECL)**

A control language that allows the programmer to specify how VSE/POWER should handle a job.

**job stream**

The sequence of jobs as submitted to an operating system.

**Kanji** A set of symbols used in Japanese ideographic printing. Every symbol is represented by two bytes.

**KB** Kilobyte.

**key-sequenced file**

A VSE/VSAM file whose records are loaded in key sequence and controlled by an index. Records are retrieved and stored by keyed access or by addressed access, and new records are inserted in the file in key sequence.

- \* **kilobyte (KB)**  
1024 bytes.
- KSDS** Key-sequenced data set. See *key-sequenced file*.
- label** An identification record for a tape or disk volume, or for a file on such a volume. In assembler programming, a named instruction generally used for branching.
- label information area**  
An area on a disk to store label information read from job control statements or commands. Synonymous with *label area*.
- \* **LAN** Local area network.
- \* **language translator**  
A general term for any assembler, compiler, or other routine that accepts statements in one language and produces equivalent statements in another language.
- \* **librarian**  
The set of programs that maintains, services, and organizes the system and private libraries.
- library**  
See *VSE library* and *VSE/ICCF library*.
- \* **library block**  
A block of data stored in a sublibrary.
- \* **library directory**  
The index that enables the system to locate a certain sublibrary of the accessed library.
- \* **library member**  
The smallest unit of data that can be stored in and retrieved from a sublibrary.
- \* **licensed program**  
A separately priced program and its associated materials that bear an IBM copyright and are offered to customers under the terms and conditions of the IBM Customer Agreement (ICA).
- \* **line printer**  
A device that prints a line of characters as a unit. (I) (A)
- \* **linkage editor**  
A program used to create a phase (executable code) from one or more independently translated object modules, from one or more existing phases, or from both. In creating the phase, the linkage editor resolves cross references among the modules and phases available as input. The program can catalog the newly built phases.
- linkage stack**  
An area of protected storage that the system gives to a program to save status information in case of a branch or a program call.
- link-edit**  
To create a loadable computer program by having the linkage editor process compiled (assembled) source programs.
- local area network (LAN)**  
A data network located on the user's premises in which serial transmission is used for direct data communication among data stations. (T)
- local shared resources (LSR)**  
A VSE/VSAM option activated by three extra macros to share control blocks among files.
- \* **lock file**  
In a shared disk environment under VSE, a system file on disk used by the sharing systems to control their access to shared data.
- \* **logging**  
The recording of data about specific events.
- logical partition**  
In LPAR mode, a subset of the server unit hardware that is defined to support the operation of a system control program.
- logical record**  
A user record, normally pertaining to a single subject and processed by data management as a unit. Contrast with *physical record* which may be larger or smaller.
- logical unit (LU)**  
A name used in programming to represent an I/O device address.
- \* **logical unit name**  
In programming, a name used to represent the address of an input/output unit.
- logical unit 6.2**  
A SNA/SDLC protocol for

communication between programs in a distributed processing environment. LU 6.2 is characterized by

1. a peer relationship between session partners,
2. efficient utilization of a session for multiple transactions,
3. comprehensive end-to-end error processing, and
4. a generic

application program interface (API) consisting of structured verbs that are mapped into a product implementation.

**logo** A trademark or other art work that is associated with a firm or product. A logo often appears as the first screen of an interactive program.

#### **LPAR mode**

Logically partitioned mode. The CP mode that is available on the Configuration (CONFIG) frame when the PR/SM feature is installed. LPAR mode allows the operator to allocate the hardware resources of the server unit among several logical partitions.

**LSR** Local shared resources.

\* **LU** Logical unit.

#### **macro (macro instruction)**

In assembler programming, a user-invented assembler statement that causes the assembler to process a set of statements defined previously in the macro definition. A sequence of VSE/ICCF commands defined to cause a sequence of certain actions to be performed in response to one request.

#### **macro generation**

An assembler operation by which a macro instruction gets replaced in the program by the statements of its definition. It takes place before assembly.

#### \* **main task**

The main program within a partition in a multiprogramming environment.

#### \* **maintain system history program (MSHP)**

A program used for automating and controlling various installation, tailoring, and service activities for a VSE system.

#### **major node**

In VTAM, a set of minor nodes that can be activated as a group. See *node* and *minor node*.

#### **master console**

In z/VSE, one or more consoles that receive all system messages, except for those that are directed to one particular console. Contrast with the *user console* which receives only those messages that are specifically directed to it, for example messages issued from a job that was submitted with the request to echo its messages to that console. The operator of a master console can reply to all outstanding messages and enter all system commands.

\* **MB** Megabyte.

#### \* **megabyte (MB)**

1 024 KB or 1 048 576 bytes.

#### \* **member**

The smallest unit of data that can be stored in and retrieved from a sublibrary. See also *library member*.

#### **message**

In VSE, a communication sent from a program to the operator or user. It can appear on a console, a display terminal or on a printout. In telecommunication, a logical set of data being transmitted from one node to another.

#### \* **migrate**

To move to a changed operating environment, usually to a new release or version of a system.

#### \* **minor node**

In VTAM programs, a uniquely-defined resource within a major node. See *node* and *major node*.

**mode** A method of operation. See also *ESA mode*.

#### \* **module**

A program unit that is discrete and identifiable with respect to compiling, combining with other units, and loading; for example, the input to, or output from an assembler, compiler, linkage editor, or executive routine. (A)

#### \* **MSHP**

Maintain system history program.



## MVS/ESA

Multiple Virtual Storage/Enterprise Systems Architecture.

\* **NCP** Network Control Program.

\* **nest** To incorporate a structure or more structures of one kind into a structure of the same kind. For example, to nest one loop (the nested loop) within another loop or to nest one subroutine (the nested subroutine) within another subroutine. (T)

## NetView

A z/VSE optional program used to monitor a network, manage it, and diagnose its problems.

## network

An arrangement of nodes (data stations) and connecting branches. The assembly of equipment through which connections are made between data stations.

### \* **network address**

In SNA, an address, consisting of subarea and element fields, that identifies a link, link station, or NAU. Subarea nodes use network addresses; peripheral nodes use local addresses. The boundary function in the subarea node to which a peripheral node is attached transforms local addresses to network addresses and vice versa. See also *network name*.

## Network Control Program (NCP)

An IBM licensed program that provides communication controller support for single-domain, multiple-domain, and interconnected network capability. Its full name is ACF/NCP.

## networking

Making use of the services of a network program.

## network name

1. In SNA, the symbolic identifier by which users refer to a NAU, link, or link station. See also *network address*. 2. In a multiple-domain network, the name of the APPL statement defining a VTAM application program. This is its network name which must be unique across domains.

### \* **node**

In SNA, an end point of a link or junction common to two or more links in a network. Nodes can be distributed to host

processors, communication controllers, cluster controllers, or terminals. Nodes can vary in routing and other functional capabilities. In VTAM programs, a point in a network defined by a symbolic name. Synonymous with *network node*. See *major node* and *minor node*.

### \* **node name**

In VTAM programs, the symbolic name assigned to a specific major or minor node during network definition.

### \* **node type**

In SNA, a designation of a node according to the protocols it supports and the network addressable units (NAUs) it can contain.

## nonprogrammable workstation (NPWS)

A workstation that does not have processing capability and that does not allow the user to change its functions. Contrast with *programmable workstation*.

## NPWS

Nonprogrammable workstation.

### \* **object code**

Output from a compiler or assembler which is itself executable machine code or is suitable for processing to produce executable machine code. (A)

## object module (program)

A program unit that is the output of an assembler or compiler and is input to a linkage editor.

## online application program

An interactive program used at display stations. When active, it waits for data. Once input arrives, it processes it and sends a response to the display station or to another device.

## online processing

Processing by which the input data enters the computer directly from a display station and the output data is transmitted directly to the display station.

### \* **operating system**

Software that controls the execution of programs and that may provide services such as resource allocation, scheduling, input/output control, and data management. Although operating systems

are predominantly software, partial hardware implementations are possible.  
(T)

**optical reader/sorter**

A device that reads hand written or machine printed symbols on a voucher and, after having read the voucher, can sort it into one of the available stacker-select pockets.

**optional program**

An IBM licensed program that a user can install on z/VSE by way of available installation-assist support.

**OS/2 (Operating System/2®)**

An IBM operating system that runs on IBM personal computers with appropriate microprocessors.

**page** In a virtual storage system, the unit of code or data or both which is transferred between processor storage and the page data set (PDS) as needed for processing. To transfer pages between processor storage and the page data set.

**page data set (PDS)**

One or more extents of disk storage in which pages are stored when they are not needed in processor storage.

**\* page fixing**

Marking a page so that it is held in processor storage until explicitly released. Until then, it cannot be paged out.

**\* page pool**

The set of page frames available for paging virtual-mode programs.

**panel** The complete set of information shown in a single display on a terminal screen. Scrolling back and forth through panels is like turning publication pages. See also *selection panel*.

**partition**

A division of the virtual address area available for running programs. See also *dynamic partition*, *static partition*.

**\* partition balancing, dynamic**

A VSE facility that allows the user to specify that two or more or all partitions of the system should receive about the same amount of time on the server.

**\* PDS** Page data set.

**\* phase**

The smallest complete unit of executable code that can be loaded into virtual storage.

**\* physical record**

The amount of data transferred to or from auxiliary storage. Synonymous with *block*.

**\* PL/I** A programming language that is designed for use in a wide range of commercial and scientific computer applications.

**PNET** Programming support available with VSE/POWER; it provides for the transmission of selected jobs, operator commands, messages, and program output between the nodes of a network.

**POWER**

See *VSE/POWER*.

**\* preventive service**

The installation of one or more PTFs on a VSE system to avoid the occurrence of anticipated problems.

**Print Services Facility™ (PSF)/VSE**

An access method that provides support for the advanced function printers.

**priority**

A rank assigned to a partition or a task that determines its precedence in receiving system resources.

**private area**

The part of an address space that is available for the allocation of private partitions. Its maximum size can be defined during IPL. Contrast with *shared area*.

**\* private library**

A user-owned library that is separate and distinct from the system library.

**\* private partition**

Any of the system's partitions that are not defined as shared. See also *shared partition*.

**procedure**

See *cataloged procedure*.

**\* processing**

The performance of logical operations and calculations on data, including the temporary retention of data in processor storage while this data is being operated upon.

**\* processor**

In a computer, a functional unit that interprets and executes instructions. A processor consists of at least an instruction control unit and an arithmetic and logic unit. (T)

**Processor Resource/System Manager**

A feature of certain servers that allows the processor storage and resources to be divided into multiple logical processors.

**processor storage**

The storage contained in one or more processors and available for running machine instructions. Synonymous with *real storage*.

**profile**

A description of the characteristics of a user or a computer resource.

**\* programmable workstation**

A workstation that has some degree of processing capability and that allows the user to change its functions. Contrast with *nonprogrammable workstation*.

**\* programmer logical unit**

A logical unit available primarily for user-written programs. See also *logical unit name*.

**program service**

The customer- or program-related IBM service of correcting design or implementation errors via APARs and PTFs.

**program temporary fix (PTF)**

A solution or by-pass of one or more problems documented in APARs. PTFs are distributed to IBM customers for preventive service to a current release of a program.

**protocol**

In SNA, the set of rules for requests and responses between communicating nodes that want to exchange data.

**PR/SM**

Processor Resource/Systems Manager.

**PSF/VSE**

Print Services Facility/VSE.

**\* PTF** Program temporary fix.

**\* PU** Physical unit.

**\* queue**

A line or list formed by items in a system waiting for service; for example, tasks to be performed or messages to be transmitted in a network. To arrange in, or form a queue.

**\* queue file**

A direct access file maintained by VSE/POWER that holds control information for the spooling of job input and job output.

**real address**

The address of a location in processor storage.

**real mode**

A processing mode in which a program may not be paged. Contrast with *virtual mode*.

**real storage**

See *processor storage*.

**record** A set of related data or words, treated as a unit. See *logical record*, *physical record*.

**\* remote job entry (RJE)**

Submission of jobs through an input unit that has access to a computer through a data link.

**residency mode (RMODE)**

A program attribute that refers to the location where a program is expected to reside in virtual storage. RMODE 24 indicates that the program must reside in the 24-bit addressable area (below 16 megabytes), RMODE ANY indicates that the program can reside anywhere in 31-bit addressable storage (above or below 16 megabytes).

**\* restore**

To write back onto disk data that was previously written from disk onto an intermediate storage medium such as tape.

**REXX/VSE**

A general-purpose programming language which is particularly suitable for command procedures, rapid batch program development, prototyping, and personal utilities.

**\* RJE** Remote job entry.

**RMODE**

Residency mode.

**\* routine**

A program, or part of a program, that may have some general or frequent use. (T)

**\* RPG II**

A commercially oriented programming language specifically designed for writing application programs intended for business data processing.

**SCSI (Small Computer System Interface)**

A standard hardware interface that enables a variety of peripheral devices to communicate with one another.

**SDL** System directory list.

**security**

See *access control*.

**\* selection panel**

A displayed list of items from which a user can make a selection. Synonymous with *menu*.

**sense** Determine, on request or automatically, the status or the characteristics of a certain I/O or communication device.

**sequential access**

The serial retrieval of records in their entry sequence or serial storage of records with or without a premeditated order. Contrast with *direct access*.

**sequential access method (SAM)**

A data access method that writes to and reads from an I/O device record after record (or block after block). On request, the support performs device control operations such as line spacing or page ejects on a printer or skip a certain number of tape marks on a tape drive.

**\* sequential file**

A file in which records are processed in the order in which they are entered and stored.

**shared area**

An area of storage that is common to all address spaces in the system. z/VSE has two shared areas:

1. The shared area (24 bit) is allocated at the start of the address space and contains the supervisor, the SVA (for system programs and the system GETVIS area), and the shared partitions.

2. The shared area (31 bit) is allocated at the end of the address space and contains the SVA (31 bit) for system programs and the system GETVIS area.

**shared disk option**

An option that lets independent computer systems use common data on shared disk devices.

**\* shared partition**

A partition allocated for a program that provides services for and communicates with programs in other partitions of the system's virtual address spaces.

**\* shared spooling**

A function that permits the VSE/POWER account file, data file, and queue file to be shared among several computer systems with VSE/POWER.

**\* shared virtual area (SVA)**

A high address area that contains a system directory list (SDL) of frequently used phases, resident programs that can be shared between partitions, and an area for system support.

**\* skeleton**

A set of control statements, instructions, or both, that requires user-specific information to be inserted before it can be submitted for processing.

**\* SNA** Systems Network Architecture.

**\* SNA network**

The part of a user-application network that conforms to the formats and protocols of SNA.

**source member**

A library member containing source statements in any of the programming languages supported by VSE.

**\* source program**

A program that a particular translator can accept. (T) Contrast with *object module*.

**\* source statement**

A statement written in symbols of a programming language.

**\* spool access support**

A function of VSE/POWER that allows user programs or subsystems running on VSE system to access the spool files of VSE/POWER.

**\* spool file**

1. A file that contains output data saved for later processing. 2. One of three VSE/POWER files on disk: queue file, data file, and account file.

**\* spooling**

The use of disk storage as buffer storage to reduce processing delays when transferring data between peripheral equipment and the processors of a computer. In VSE, this is done under the control of VSE/POWER.

**SQL/DS**

Structured Query Language/Data System.

**stand-alone program**

A program that runs independently of (not controlled by) the VSE system.

**startup**

The process of performing IPL of the operating system and of getting all subsystems and application programs ready for operation.

**static partition**

A partition, defined at IPL time and occupying a defined amount of virtual storage that remains constant. Contrast with *dynamic partition*.

**storage dump**

See *dump*.

**submit**

A VSE/POWER function that passes a job to the system for processing.

**\* subsystem**

A secondary or subordinate system, usually capable of operating independently of, or asynchronously with, a controlling system. (T)

**\* supervisor**

The part of a control program that coordinates the use of resources and maintains the flow of processor operations.

**supervisor mode**

See *ESA mode*.

**\* SVA** Shared virtual area.

**SYSRES**

System residence file.

**\* system console**

A console, usually equipped with a

keyboard and display screen for control and communication with the system.

**system directory list (SDL)**

A list containing directory entries of frequently-used phases and of all phases resident in the SVA. The list resides in the SVA.

**\* system file**

A file used by the operating system, for example, the hardcopy file, the recorder file, the page data set.

**system logical unit**

A logical unit available primarily for operating system use. See also *logical unit name*.

**\* system recorder file**

The file used to record hardware reliability data. Synonymous with *recorder file*.

**system residence file (SYSRES)**

The z/VSE system sublibrary IJSYSRS.SYSLIB that contains the operating system. It is stored on the system residence volume DOSRES.

**system sublibrary**

The sublibrary that contains the operating system. It is stored on the system residence volume (DOSRES).

**Systems Network Architecture (SNA)**

The description of the logical structure, formats, protocols, and operational sequences for transmitting information units through and controlling the configuration and operation of networks.

**\* tailor**

A process that defines or modifies the characteristics of the system.

**\* task** The basic unit of synchronous program execution. A task competes with other tasks for system resources such as processing time and I/O channels.

**\* TCT** Terminal control table.

**\* telecommunication**

Transmission of data between computer systems over telecommunication lines and between a computer system and remote devices.

**\* terminal**

A point in a system or network at which

data can either enter or leave. (A) Usually a display screen with a keyboard.

**terminal control table (TCT)**

A control block in which the system stores information about the characteristics and modes of operation of the terminals defined to the system.

**token ring**

A network configuration where series of attaching devices are connected by unidirectional transmission links to form a closed path. Tokens are passed from adapter to adapter.

**trace** To record a series of events as they occur. A record of specified events during the run of a program. A program to produce such a record.

**\* track**

A circular path on the surface of a disk on which information is recorded and from which recorded information is read. Smallest unit of physical disk space.

**\* transaction**

In a batch or remote batch entry, a job or job step. In CICS, one or more application programs that can be used by a display station operator. A given transaction can be used concurrently from one or more display stations. The execution of a transaction for a certain operator is also referred to as a task. A given task can relate only to one operator.

**UCB** Universal character set buffer.

**user console**

In z/VSE, a console that receives only those system messages that are specifically directed to it. These are, for example, messages that are issued from a job that was submitted with the request to echo its messages to that console. Contrast with *master console*.

**\* user exit**

A programming service provided by an IBM software product that may be requested during the execution of an application program for the service of transferring control back to the application program upon the later occurrence of a user-specified event.

**\* utility program**

A computer program in general support

of computer processes; for example, a diagnostic program, a trace program, or a sort program. (T) Synonymous with *service program*. A program designed to perform an everyday task such as copying data from one storage device to another. (A)

**virtual address**

An address that refers to a location in virtual storage. It is translated by the system to a processor storage address when the information stored at the virtual address is to be used.

**virtual address area**

The virtual range of available program addresses.

**\* virtual address space**

A subdivision of the virtual address area available to the user for the allocation of private, nonshared partitions.

**virtual disk**

A range of up to two gigabytes of contiguous virtual storage addresses that a program can use as workspace. Although the virtual disk exists in storage, it appears as a real FBA disk device to the user program. All I/O operations directed to a virtual disk are intercepted and the data to be written to, or read from, the disk is moved to or from a data space.

Like a data space, a virtual disk can hold only user data; it does not contain shared areas, system data or programs. Unlike an address space or a data space, data is not directly addressable on a virtual disk. To manipulate data on a virtual disk, the program has to perform I/O operations.

**\* virtual I/O area (VIO)**

An extension of the page data set used by the system as intermediate storage, primarily for control data.

**\* virtual machine (VM)**

A functional simulation of a computer system and its associated devices.

**\* virtual mode**

The operating mode of a program which may be paged.

**virtual storage**

Addressable space image for the user

from which instructions and data are mapped into processor (real) storage locations.

**z/VM** z/Virtual Machine.

**volume**

A data carrier that is mounted and demounted as a unit, for example, a reel of tape or a disk pack. (I) Some disk units have no demountable packs. In that case, a volume is the portion available to one read/write mechanism.

**volume ID**

The volume serial number, which is a number in a volume label assigned when a volume is prepared for use by the system.

**volume table of contents (VTOC)**

A table on a disk volume that describes every file on it.

**VRDS** Variable-length relative-record data set.

**VSAM**

See *VSE/VSAM*.

**VSE (Virtual Storage Extended)**

A system that consists of a basic operating system and any IBM supplied and user-written programs required to meet the data processing needs of a user. VSE and the hardware it controls form a complete computing system. Its current version is called z/VSE.

**VSE/Advanced Functions**

A program that provides basic system control and includes the supervisor and system programs such as the Librarian and the Linkage Editor.

**VSE/ESA Turbo Dispatcher**

A facility of z/VSE that allows to exploit multiprocessor systems (also called CEC: Central Electronic Complexes). Each CPU within such a CEC has access to the shared virtual areas of z/VSE: supervisor, shared areas (24-bit), and shared areas (31-bit). The CPUs have equal rights which means that any CPU may receive interrupts and work units are not dedicated to any specific CPU.

**\* VSE/Fast Copy (VSE/Fast Copy Data Set program)**

A program for fast copy data operations from disk to disk and dump/restore

operations via an intermediate dump file on magnetic tape or disk.

**\* VSE/ICCF (VSE/Interactive Computing and Control Facility)**

A program that serves as interface, on a time-slice basis, to authorized users of terminals linked to the system's processor.

**VSE/ICCF library**

A file composed of smaller files (libraries) including system and user data which can be accessed under the control of VSE/ICCF.

**VSE library**

A collection of programs in various forms and storage dumps stored on disk. The form of a program is indicated by its member type such as source code, object module, phase, or procedure. A VSE library consists of at least one sublibrary which can contain any type of member.

**\* VSE/POWER**

A program primarily used to spool input and output. The program's networking functions enable a VSE system to exchange files with or run jobs on another remote server.

**VSE/VSAM (VSE/Virtual Storage Access Method)**

An IBM access method for direct or sequential processing of fixed and variable length records on disk devices.

**VSE/VSAM catalog**

A file containing extensive file and volume information that VSE/VSAM requires to locate files, to allocate and deallocate storage space, to verify the authorization of a program or an operator to gain access to a file, and to accumulate use statistics for files.

**\* VSE/VSAM managed space**

A user-defined space on disk placed under the control of VSE/VSAM.

**VTAM (Virtual Telecommunications Access Method)**

A z/VSE base program that controls communication and the flow of data in an SNA network. It provides single-domain, multiple-domain, and interconnected network capability; it supports application programs and subsystems (VSE/POWER, for example).

\* **VTAM application program**

A program that has opened an ACB to identify itself to VTAM and can now issue VTAM macro instructions.

\* **VTOC**

Volume table of contents.

**workstation**

See *programmable* and *nonprogrammable workstation*.

**Workstation File Transfer Support**

Enables the exchange of data between IBM Personal Computers (PCs) linked to a z/VSE host system where the data is kept in intermediate storage. PC users can retrieve that data and work with it independently of z/VSE.

**X.25** In data communication, a recommendation of the CCITT that defines the interface between data terminal equipment and packet switching networks.

**X.25 NCP Packet Switching Interface (NPSI)**

An IBM licensed program that allows SNA programs to communicate with SNA equipment or non-SNA equipment over packet-switched data networks. In addition, the product may be used to attach native X.25 equipment to SNA host systems without a packet network. See also *Recommendation X.25 (Geneva 1980)*.

**z/Virtual Machine (z/VM)**

An IBM program providing operating system support. Among other services, it manages the resources of a single computer so that multiple computing systems seem to exist. Each of those virtual machines is the functional equivalent of an IBM computer system.

**z/VSE (z/Virtual Storage Extended)**

The most advanced VSE system currently available.

**31-bit addressing**

Provides addressability for address spaces and data spaces of up to 2 gigabytes.



---

# Index

## Special characters

(IEDN) support 162  
\$ASIPROC master procedure 91  
\$COMVAR procedure 186  
\$IJBIXFP, phasename of FlashCopy support 20  
\$IPL procedures 186  
\$IPL90 procedure 276  
\$SRV user-ID 191  
\$SRV, dialogs for user 285

## Numerics

1 MB frame support 169  
1 MB page support 169  
10 Gigabit Ethernet (10 GbE) support (OSA Express2) 12  
1000BASE-T Ethernet 12  
16 MB line (above), allocating DL/I PSBs, HD buffers, routines 56  
16 MB line (above), allocating I/O control blocks 55  
31-bit addressing  
    callable cell pool services 175  
    linkage stack functions 175  
    storage layout required 62, 64  
3270 console support 209  
3270 terminal emulation 312  
3380 disk layouts 278  
3390 disk layouts 280  
3480-2 XF recording format 29  
3480-XF recording format 29  
3494 tape library 35  
3494 virtual tape server (VTS) support 35  
34xx tape devices 29  
3590/3592 tape drives 27  
3592 J1A WORM, 60 GB, 300 GB media (support for) 26  
3592 Model J1A tape drive support for 26  
64-bit address space 67  
64-bit address space and memory objects 67  
64-Bit processing 2  
90xx enterprise systems connection director 39

## A

access control for resources 236  
access control table DTSECTAB 236  
access to a shared tape drive 30  
accessibility xv  
ACF/NCP, optional program 48  
ACF/SSP, optional program 48  
adapter interruptions support 7  
adapter-interruption facility for OSA Express 12  
adding a user-written application 254

additional z/VSE applications 291  
address space, 64-bit 67  
address spaces 53, 167  
Advanced Function Printing 309  
AFP Font Collection, optional program 48  
AFP, sublibrary of PRD2 120  
ALLOC procedure 76  
allocated storage for predefined environments 78  
allocation of storage (IPL) 69  
allocation, partition second CICS Transaction Server 201  
allocations for static partitions 78  
ALLOCBSX procedure 76  
APPC support 204  
application development support 245  
    adding a user written application 254  
    additional z/VSE applications 291  
    compile skeletons 246  
    compiler and languages 245  
    REXX/VSE support 249  
    VSE/POWER programs using SPOOL macros 254  
    workstation support 245  
application profiles 193  
application profiles provided by z/VSE 291  
AR commands 266  
ARISIVAR.Z, DB2 installation member 150  
ASI (automated system initialization) 185  
ASN740, sublibrary of PRD2 120  
assembler 245, 246  
assignments for system files 110  
ATL (automatic tape library) 36  
ATM 12  
autolog facility of VM 136  
automatic cartridge loader 30  
automatic cartridge loader, tape drives 24  
automatic IPL under VM 136

## B

base programs included in z/VSE 43  
BASE, sublibrary of PRD1 120  
Basic Security Manager 230  
    installation exit BSTXX01 235  
basic security support 232  
BASIC startup mode 187  
Big DASD 22  
BSM 230  
BSM Cross Reference facility (BSTXREF) 238  
BSM Cross Reference Report dialog 238  
BSM Cross Reference reports 238  
BSTXX01, BSM installation exit 235  
buffer hashing, VSE/VSAM 261

buffers, VSE/VSAM 272  
BVIR (Bulk Volume Information Retrieval) function 32

## C

C for VSE/ESA programming language 246  
C for VSE/ESA, optional program 48  
C\$xxxxx, compile skeletons 246  
C\$Qxxxxx, compile skeletons 246  
callable cell pool services 175  
Capacity Measurement Tool (CMT), skeletons for 300  
cataloging startup members 189  
CCCA/VSE, optional program 48, 245  
cell pool services 175  
changing  
    Interactive Interface 191  
    system startup 185  
channel  
    channel-to-channel support 38  
    protocol converter 39  
CICS 3270 Bridge 197  
CICS data tables 263  
CICS environment, overview 197  
CICS resource security 234  
CICS skeletons and tables 198  
CICS transaction security 237  
CICS Transaction Server  
    activating the APPC support 204  
    autoinstall exit 198  
    characteristics 197  
    DFH0STAT considerations 203  
    files for second CICS Transaction Server 202  
    installing second CICS Transaction Server 200  
    monitoring support 199  
    performance information 272  
    planning for second CICS Transaction Server 201  
    RACROUTE macro 273  
    Report Controller 204  
    restrictions second CICS Transaction Server 200  
    skeletons and tables 198  
    statistics support 199  
    System Authorization Facility (SAF) 273  
    user profiles 199  
CICS Web Support (CWS) 197  
CICSUSER user-ID 191  
CICSVR/VSE, optional program 48  
CKD minidisks (z/VM) 132  
classes for interactive partitions 82  
client certificates (SSL) 227  
CMS profile EXEC 134  
CMS profile to IPL a SCSI device 136  
CNSL user-ID 191

- COBOL for VSE/ESA programming language 246
- COBOL for VSE/ESA, optional program 48
- COLD startup mode 187
- COMM, sublibrary of PRD2 120
- COMM2, sublibrary of PRD2 120
- command processing, console support 217
- communicating with the operator (WTO, WTOR, DOM) 217
- communication control units, list of supported 311
- compile skeletons 246
- component IDs of programs in z/VSE 43
- compression prediction tool 224
- CONFIG, sublibrary of PRD2 120
- configured hardware 106
- connector support 141
  - ARISIVAR.Z, DB2 installation member 150
  - Database Call Level Interface 142
  - DB2-based connector 146
  - DB2-based connector support, skeletons 149
  - e-business 141
  - GDPS support 142
  - Java-based connector 142
  - SOAP protocol 142
  - SSL Client Authentication 142
  - VSAM Redirector Connector 142
  - VSE Monitoring Agent 142
  - VSE Script Connector 142
- console definitions, 3270 console support 210
- console selection and assignment 214
- console selection at IPL 215
- console support 207
  - 3270 console support 209
  - command processing 217
  - communicating with the operator (WTO, WTOR, DOM) 217
  - console definitions, 3270 console support 210
  - console selection and assignment 214
  - console selection at IPL 215
  - console types (logical level) 208
  - console types and functions 207
  - IJBDEF macro, modifying console definitions 212
  - master console 208
  - message flow and message logging 215
  - migration considerations 222
  - modes of operation, 3270 console support 210
  - modifying color settings 213
  - new and changed commands 218
  - security considerations 221
  - system console 208
  - user console 208
  - VM/VSE linkage functions 218
- console types (logical level) 208
- console types and functions 207
- console under VM 136
- contents of the extended base tape 88

- Control Center for VSE 48
- control file 112, 194
- Copy Export feature, of TS7700 model TS7740 Virtualization Engine 33
- CP-assisted cryptographic function (CPACF) 11
- CPU balancing 3
- CPUVARn procedure 187
- creating
  - panel hierarchies 195
  - standard labels for non-VSAM files 125
  - VSE user libraries 123
- Crypto Express2 card 11
- Crypto Express3 card 11
- Crypto Express4S card 11
- CSD file 105
- CSDMIGR, job for migration 106
- CSPA and CSPW, transient data queues 205
- CSRCMPSC programming interface, data compression 224
- customization table 92
- Customize z/VSE Workstation Platform dialog 194

**D**

- DASD sharing 186
  - lock file hints 269
  - SKCOMVAR, define CPU IDs 189
  - under performance aspects 269
- DASD Sharing 138
- data
  - entry panels 192
  - in memory 167
- data compression 223
  - CSRCMPSC programming interface 224
  - hardware instruction CMPSC 223
  - macro CSRCMPSC 223
  - VSE/VSAM support 223
  - VTAM support 224
- data in memory (DIM) 259
- Data Link Layer (Layer 2), of OSI TCP/IP model 161
- Data Restore for VSE 48
- data spaces
  - commands 171
  - macros 172
  - storage considerations 171
  - support for 55, 167
- Database Call Level Interface 142
- DataPropagator Relational Capture 43, 47
- DB2 Control Center for VSE 48
- DB2 Data Restore for VSE 48
- DB2 QMF/VSE 48
- DB2 Server for VSE 47
  - guest sharing support 140
- DB2 Server for VSE Client Edition 43, 47
- DB2 Server for VSE Client Edition, enabling via key 148
- DB2 Server for VSE Client Edition, installation member ARISIVAR.Z 150

- DB2 Server for VSE Client Edition, trial period 148
- DB2 Server for VSE Help 47
- DB2 Server for VSE, customization 149
- DB2 Server for VSE, enabling via key 148
- DB2 Server for VSE, installation member ARISIVAR.Z 150
- DB2 Server for VSE, installation/FSU 147
- DB2 Server for VSE, skeletons 149
- DB2 Server for VSE, trial period 148
- DB2-based connector support 146
- DB2-based connector support, skeletons 149
- DB2750, sublibrary of PRD2 120
- DB2750C, sublibrary of PRD2 120
- DB2STP, sublibraries of PRD2 120
- DBASE, sublibrary of PRD2 120
- DBDCCICS user-ID 191
- DBLK default values, VSE/POWER 111
- debug skeletons 301
- Debug Tool, optional program 48
- dedicated console under VM 136
- default
  - sublibraries for base programs 43
- Define Transaction Security dialog 237
- defining
  - CMS profile exec for z/VSE guest machine 134
  - DTSECTAB entries 236
  - DTSECTXN entries 237
  - resource security 234
  - system console under VM 136
  - transaction IDs 256
  - transaction security 237
  - VM directory entry for z/VSE guest 132
  - VSE user libraries 123
- Defining Work Files on a Virtual Disk 115
- delete skeletons 301
- device sensing
  - VM considerations 130
  - when migrating 99
- devices not supported 40
- devices supported 307
- DFSORT/VSE, optional program 48
- dialogs for
  - creating VSE user libraries 123
  - customizing workstation platform 194
  - defining transaction security 237
  - displaying system status 132
  - hardware configuration 307
  - install generation feature 94
  - maintaining dynamic partitions 179
  - maintaining primary sublibraries 194
  - maintaining synonyms 194
  - tailoring IPL procedure 69
  - tailoring the Interactive Interface 194
  - tailoring the IPL procedure 185
  - user \$SRV 285
  - user OPER 285
  - user PROG 285
  - user SYSA 285
- dialogs of the Interactive Interface 285

- directory entry for z/VSE guest 132
- disability xv
- disconnected console under VM 137
- disk devices
  - support 16
- disk devices, list of supported 307
- disk features
  - overview table 17
- disk layouts, DOSRES and SYSWK1 277
- disk storage, second CICS Transaction Server 202
- displaying storage layout information 83
- DL/I PSBs, HD buffers, routines, allocating above 16 MB line 56
- DL/I VSE, optional program 48
- DLI1A0, sublibrary of PRD2 120
- DOM macro 217
- DOS/VS RPG II, optional program 48
- DOSRES layout for FBA (including SCSI) disk 283
- DOSRES layouts 277
- downloading an IOCDS 90
- DS6000 series, support for 17
- DS8000 series, support for 17
- DTRCICST procedure 110
- DTRICCF procedure for DTSFILE 110
- DTRINFOA procedure 110
- DTRISTR, program for startup 186
- DTRPOWR procedure 110
- DTRSETP utility program 187
- DTRSYSWK procedure 110
- DTSECTAB access control table 236
- DTSECTXN macro 237
- DTSECTXN security table 237
- DTSFILE 112, 123
- dual stack support 155
- dump library 122
- duplicate transaction IDs 256
- dynamic
  - class tables 181
  - connections 39
  - partitions 57
  - space GETVIS area 57
- dynamic partitions
  - dynamic class table 179
  - dynamic classes 179
  - dynamic partition support 177
  - partition standard labels for 184

**E**

- e-buiness connectors 141
- e-buiness tools 141
- ECI (External Call Interface) 197
- EMIF support 38
- emulated FBA disks for SCSI 139
- emulation (3270) 312
- Encryption Facility for z/OS 242
- Encryption Facility for z/OS Client 242
- Encryption Facility for z/VSE 242
  - passphrase-based encryption 242
  - public-key encryption 242
- Encryption Facility for z/VSE OpenPGP 48, 243
- encryption support
  - REKEY parameter 26

- encryption support (*continued*)
  - tape encryption 26
- Enterprise Storage Servers (ESS) support 17
- Enterprise Systems Connection Director 39
- environment, second CICS 200
- environments, predefined 59
- EP, optional program 48
- ES/9000 servers 90
- ESCD support 39
- ESCON
  - CTC (Channel-to-Channel) 38
  - ESCON Channel Protocol Converter 39
  - Multiple Image Facility 38
- eServer zSeries servers 6
- ESM 230
- ESS models 750 17
- examples of
  - a fulist 193
  - a selection panel 193
- extended base tape 88
- Extended Base Tape 44
- External Security Manager 230
- EZA socket APIs 158
- EZA TCP/IP programming interface 158

## F

- Fast Ethernet 12
- Fast Path to Linux on System z 163
- Fast Path to Linux on System z, skeletons for 300
- Fast Service Upgrade (FSU) 92
- Fat DASD 22
- FBA minidisks (z/VM) 132
- fibre-channel-attached SCSI disks, support for 19
- FICON Express support 12
- FICON Express8 / Express4 / Express2, and Ficon Express support 12
- file placement 268
- FlashCopy Consistency Group support, for DS8000 series 20
- FlashCopy SE, of DS8000 series 20
- FlashCopy support, DS8000, DS6000, and ESS servers 20
- FORSEC user-ID 191
- FORTTRAN programming language 246
- frame support (1 MB) for data spaces 169
- FSU, installing z/VSE 5.1 92
- FULIST panels 192

## G

- GDDM, optional program 48
- GDPS support 142
- GEN1, sublibrary of PRD2 120
- generating
  - Input/Output Configuration Program (IOCP) 90
- generation feature 94
- GETVIS
  - areas 57

- GETVIS (*continued*)
  - storage management 57
- Gigabit Ethernet 12
- Gigabit Ethernet (GbE) support (OSA Express2) 12
- Global VLAN 162
- group VSETYPE1 106
- guest sharing support 140
- guest system, z/VSE under VM 127

## H

- hardware
  - 3494 tape library 35
  - adapter interruptions support 7
  - card devices 312
  - channel protocol converter support 39
  - communication control units 311
  - configuration dialog 307
  - CPACF support 11
  - Crypto Express2 card 11
  - Crypto Express3 card 11
  - Crypto Express4S card 11
  - crypto support 11, 153
  - disk devices, list of supported 307
  - display stations, list of supported 311
  - logical partition (LPAR) and LCSS support 6
  - PCIXCC card 11
  - PCs 312
  - Personal System/2 312
  - printers, list of supported 308
  - PS/2 312
  - server support 6
  - support 5
  - tape devices 308
  - tape encryption support 26
  - tape libraries, list of supported 308
  - TS3500/3584 tape library 34
  - volume and minidisk maximum sizes 18
  - workstations 312
- hardware crypto support 11, 153
- hardware data compression 223
- HELP panels 192
- hierarchy of Interactive Interface panels 193
- High Level Assembler Toolkit for VSE 245
- High Level Assembler for VSE 245, 246
- High Level Assembler Toolkit 48
- Hipersockets 153
- HiperSockets
  - support overview 160
- HiperSockets support 160

**I**

- I/O control blocks, allocating above 16 MB line 55
- I\$SH, transaction 81
- I\$ST, transaction 81
- IDs for system files 277
- IESBLDUP utility program 101

- IJBDEF macro, modifying console definitions 212
- IJBVMID parameter 139
- IJSYSRS, system library 116, 118
- IJSYSRS.SYSLIB system sublibrary 46
- initial installation 90
  - \$ASIPROC master procedure 91
  - customization table 92
  - migrating from earlier release 99
  - planning for 90
  - under VM 129
- Input/Output Configuration Program
  - downloading an IOCDS 90
  - generating an IOCP 90
  - Input/Output configuration data set 90
  - installing 90
  - skeleton SKIOPCPN 90
  - support 90
- Input/Output Configuration Program batch program 90
- installation, of z/VSE 85
- installation, planning for
  - contents of the extended base tape 88
  - installation through initial installation 90
  - planning for LE/VSE and the VSE C Run-Time Support 89
  - shipment of z/VSE 5.1 87
  - VTAM considerations 89
- installing
  - optional programs 94
  - second CICS Transaction Server 200
  - under VM 127
- installing z/VSE 5.1 via FSU 92
- Integrated Console Controller (OSA-ICC) support 14
- Interactive Interface
  - application profiles 193
  - dialogs for tailoring 194
  - dialogs of 285
  - panel hierarchies 193
  - tailoring 191
  - types of panels 192
  - user profiles 191
- interactive partitions 82
- Intra-Ensemble Data Network (IEDN) 12
- IOCDS (data set) 90
- IOCP batch program 90
- IODEV parameter 55
- IPL of a SCSI device 136
- IPL procedure \$IPL90 276
- IPL procedures 129, 186, 275
- IPv6 support 155
- IPv6/VSE 155
- IPv6/VSE program 46
- IUCV 58

## J

- Java-based connector support 142
- JCL (Job Control Language)
  - procedures 275
  - startup procedures 186
  - statements and AR commands 266

- JConVSE 142
- JDataMig 142
- job stream skeletons provided by z/VSE 295
- journaling, assignments for system files 110

## K

- Keyman/VSE 142

## L

- label area in virtual storage 173
- label area on virtual disk
  - planning information 174
- label procedures 275
- Large DASD 22
- Large Volume Support (LVS) 22
- Layer 2 (Data Link Layer), of OSI TCP/IP model 161
- LDAP sign-on security 233, 238
- LE/VSE base program
  - planning for LE/VSE and the VSE C Run-Time Support 89
- LE/VSE DBCS Locales 47
- librarian program 121
- libraries
  - for z/VSE 116
  - IJSYSRS 116, 118
  - PRD1 116, 120
  - PRD2 116, 120
  - PRIMARY 122
  - skeletons for non-VSAM libraries 299
  - SYSDUMP 122
  - VSE user libraries 123
  - VSE/ICCF 123
- library blocks 121
- library space for PRD2 121
- linkage stack functions 175
- Linux Fast Path
  - overview 163
- Linux Fast Path (LPF), skeletons for 300
- Linux Fast Path (LPF), support for 163
- lock file hints 269
- log-on security 233
- logical partition (LPAR) and LCSS support 6
- logical partitioned (LPAR) mode 1
- LPAR mode 1
- LPAR Mode and tape libraries 35

## M

- macros
  - for communicating with the operator 217
  - for data spaces 172
  - for virtual disks 172
- Maintain Application Profiles dialog 194
- Maintain Dynamic Partitions dialog 179
- Maintain PRIMARY Sublibraries dialog 194
- Maintain Selection Panels dialog 194
- Maintain Synonyms dialog 194

- Maintain User Profiles dialog 194
- master console 208
- memory objects 53
- memory objects in 64-bit address space 67
- memory objects, including in stand-alone dumps 67
- message flow and message logging 215
- message routing file 113
- migrating
  - DTRMIGR, migration job 101
  - during initial installation 99
  - IESBLDUP, utility program 101
  - TCT definitions into CSD 105
  - to latest z/VSE 99
  - utilities 101
- migration
  - of hardware configuration 99
  - of user profile 99
  - special considerations 99
- migration considerations, console support 222
- MINI startup mode 187
- minidisks (z/VM) 132
- minidisks under VM 138
- mode
  - LPAR mode 1
  - VM mode 128
- modes of operation, 3270 console support 210
- modifying
  - compile skeletons 246
  - Interactive Interface 191, 194
  - system startup 185
- MQSeries resource classes 235
- Multicultural Support 87
- multiple dynamic class tables 179
- multiple LSR pools 261

## N

- names reserved for the system 293
- network definitions, skeletons for 299
- new and changed commands 218
- non-QDIO mode 158
- non-QDIO mode, OSA Express 158
- NOPDS (no page data set) 53
- not shipped, programs 41
- not supported, list of devices 40
- NPARTS definition 266
- number of dynamic partitions supported 180

## O

- OGL/370, optional program 48
- Open Systems Interconnection (OSI) TCP/IP model 161
- OPER user-ID 191
- OPER, dialogs for user 285
- operating environment
  - procedure for multiple-processor environment 186
  - selecting at installation 59
- operator console under VM 136
- optional programs 48

- optional programs (*continued*)
  - version 1 format 94
  - version 2 format 94
- OS/390 API 44, 46
- OSA Express
  - 1000BASE-T Ethernet 12
  - ATM 12
  - Fast Ethernet 12
  - Gigabit Ethernet 12
  - Intra-Ensemble Data Network (IEDN) 12
  - non-QDIO architecture 158
  - OSA Express2 adapter 158
  - OSA/SF program 159
  - QDIO architecture 158
  - Queue-I/O Assist (QIOASSIST) function 161
  - Token Ring 12
- OSA Express in non-QDIO mode 15
- OSA Express in OSN mode 15
- OSA Express in QDIO mode 15
- OSA Express Integrated Console Controller (OSA-ICC) support 14
- OSA Express, in non-QDIO mode 158
- OSA Express, OSA Express 2 adapters 158
- OSA Express2 10 Gigabit Ethernet (10 GbE) support 12
- OSA Express2 Gigabit Ethernet (GbE) support 12
- OSA Express4s support 12
- OSA Express4s, OSA Express3, OSA Express2, OSA Express 12
- OSA-2 adapter, emulated via OSA Express adapter 158
- OSA-ICC support 14
- OSI TCP/IP model, Layer 2 (Data Link Layer) 161
- overview of
  - additional z/VSE applications 291
  - dialogs of the Interactive Interface 285
  - reserved names 293
  - skeletons provided 295

## P

- page data set 277
- page data set considerations 54
- page I/O 269
- page printers 310
- panels of the Interactive Interface 192
- Parallel Access Volume (PAV) support 18
- parallel page I/O 269
- partition
  - allocations, predefined environments 78
  - GETVIS area 57
  - layout 56
- partition standard labels for dynamic partitions 184
- partitions, system
  - interactive partitions for VSE/ICCF 82
  - predefined environments 59, 78
  - standard labels 109

- partitions, system (*continued*)
  - status at startup 187
- PCIXCC card 11
- performance considerations 257
  - allocating virtual storage 266
  - analysis process 258
  - DASD sharing and lock file hints 269
  - file placement 268
  - file placement specifics 270
  - for virtual disks 171
  - IPL commands 265
  - JCL statements and AR commands 265
  - lock file 270
  - parallel page I/O 269
  - VSAM buffers, shared 272
  - VSAM files for CICS application 272
  - VSE libraries 268
  - VSE/POWER DBLK size 271
  - VSE/POWER partition 270
  - VTAM partition 271
  - z/VSE exploitation overview 259
- Personal Computers
  - Personal System/2 312
  - PS/2 312
  - supported devices 312
- Personal Computers, supported 312
- PL/I for VSE/ESA programming language 246
- PL/I for VSE/ESA, optional program 48
- planning for
  - access control 236
  - CICS Transaction Server 197
  - console support 207
  - data spaces 167
  - dynamic partition support 177
  - for files 124
  - for libraries 125
  - hardware 5
  - installation 85
  - installing z/VSE under VM 127
  - migration from earlier releases to latest z/VSE 99
  - security support 227
  - storage considerations 257
  - system startup 185
  - tailoring the interactive interface 191
  - tuning the system 257
  - virtual disks 169
  - VSE user libraries 123
- POST user-ID 191
- PPFA/370, optional program 48
- PR/SM 1
- PR/SM feature 140
- PRD1, system library 116, 120
- PRD1.BASE system sublibrary 46
- PRD1.MACLIB system sublibrary 46
- PRD2 library space 121
- PRD2, system library 116, 120
- PRD2.ASN740 system sublibrary 46
- PRD2.DB2750 system sublibrary 46
- PRD2.DB2750C system sublibrary 46
- PRD2.GEN1, system sublibrary 46
- PRD2.OS390, system sublibrary 46
- PRD2.PROD, system sublibrary 46
- PRD2.SCEEBASE system sublibrary 46
- PRD2.TCPIPB, system sublibrary 46

- predefined
  - dynamic class table 181
  - dynamic partition support 80
  - environment A 60
  - environment B 62
  - environment C 64
  - environments 59
  - environments, real storage allocation 76
  - ENVIRONMENTS, STARTUP OVERVIEW 77
  - using memory objects 67
- PRIMARY library size 123
- PRIMARY sublibraries 122
- printer support 308
- private areas 53, 56
- PROD, sublibrary of PRD2 120
- PRODCICS user-ID 191
- PROFILE EXEC under VM 134
- profile-driven system views 196
- profiles for
  - dialogs and applications 193
  - users 191
- profiles for z/VSE applications 291
- PROG user-ID 191
- PROG, dialogs for user 285
- program development support 245
- programming language support 245
- programming languages
  - C for VSE/ESA 246
  - COBOL for VSE/ESA 246
  - DOS/VS RPG II 246
  - High Level Assembler for VSE 246
  - PL/I for VSE/ESA 246
  - VS FORTRAN 246
- programs
  - included in z/VSE 43
  - optional programs 48
- protocol converter 39
- PSF/VSE, optional program 48
- punched card devices, list of supported 312

## Q

- QDIO adapter-interruption facility 12
- QDIO architecture 158
- QMF/VSE 48
- Queue-I/O Assist (QIOASSIST) function 161

## R

- RACROUTE macro 273
- Rational COBOL Runtime for z/VSE 48
- RCV730, sublibrary of PRD2 120
- reader/punch devices, list of supported 312
- real storage
  - allocation, predefined environments 76
  - support 53
- recompiling modules 99
- recording format (3480-2 XF) 29
- recording format (3480-XF) 29
- RECOV startup mode 187

- redefining transaction IDs 256
- remote mirroring support, DS8000/DS6000/ESS series 21
- Report Controller Feature
  - implementation in z/VSE 204
  - SIT entry 204
  - transient data queues CSPA and CSPW 205
- reserved names in the system 293
- resource definition skeletons 302
- resource security 234
- REXX for CICS 197
- REXX/VSE procedures 295, 304
- REXX/VSE programming language
  - benefits 250
  - characteristics 250
  - compatibility of 254
  - console automation 252
  - overview 249
  - REXX operand in EXEC
    - statement/command 253
  - REXX/370 library 251
  - running a REXX program 253
  - support 249
  - system management capabilities 250
  - VSE/POWER interface 251
- RPG II, using with CICS Transaction Server
  - skeletons
    - for RPG II with CICS Transaction Server 298
- RPG programming language 246

## S

- S/390 adapters 311
- SAN Volume Controller (SVC) support 19
- SAVE, sublibrary of PRD2 120
- SCEEBASE, sublibrary of PRD2 120
- SCSI disk support
  - CMS Profile to IPL a SCSI device 136
  - DOSRES disk layout 283
  - emulated FBA disks 139
  - SYSWK1 disk layout 284
  - using SCSI disks via VM-emulated FBA support 139
- SCSI disks, support for 19
- SDF II VSE, optional program 48
- Secure Sockets Layer (SSL) 153
- Secure Sockets Layer (SSL) support 227
- security server partition 230
- security support 227
  - access control for resources 236
  - access control for VSE/POWER spool entries 239
  - Basic Security Manager (BSM) 230
  - basic security support 232
  - BSM installation exit BSTXX01 235
  - CICS resource security 234
  - CICS transaction security 237
  - Define Transaction Security dialog 237
  - DTSECTAB access control table 236
  - DTSECTXN security table 237
  - External Security Manager (ESM) 230

- security support (*continued*)
  - implementing security 230
  - IPL SYS command 228
  - LDAP sign-on security 233, 238
  - log-on security 233
  - logging and reporting 239
  - resource security 234
  - security server commands 232
  - security server partition 230
  - sign-on security 233
  - System Authorization Facility (SAF) 228
  - transaction security 237
  - user profile definitions 237
- security table DTSECTXN 237
- selection panels 192, 193
- servers supported 6
  - System z z10 BC 6
  - System z z10 EC 6
  - System z z9 BC 6
  - System z z9 EC 6
  - z9-109 6
  - zEnterprise 196 6
- SETPARM statements for system variables 187, 188
- setting up a second CICS Transaction Server 95
- shared
  - areas 56
  - console under VM 137
  - minidisks under VM 138
  - tape drive 30
  - VSE/VSAM buffers 272
- sign-on security 233
- signal quiesce event 7
- signal quiesce support 7
- signal shutdown support 7
- size of PRIMARY library 123
- SKALLOCA, allocating static partitions 76
- SKALLOCB, allocating static partitions 76
- SKALLOCC, allocating static partitions 76
- SKALLOCCx, skeletons for allocating partitions 189
- SKCICS, skeleton for defining CICS and VSE/ICCF startup 189
- SKCOLD, skeleton for loading VSE/POWER queues 189
- SKCOMVAR, skeleton for defining CPU IDs 189
- SKDTSEXT, skeleton for extending DTSECTXN 112
- skeletons
  - C\$\$xxxxx, compile skeletons 246
  - C\$Dxxxxx, compile skeletons 246
  - C\$Qxxxxx, compile skeletons 246
  - for Capacity Measurement Tool (CMT) 300
  - for CICS Transaction Server 297
  - for compiling with TCP/IP preprocessor 301
  - for debugging 301
  - for deleting programs 301
  - for e-business Connectors Support 296

- skeletons (*continued*)
  - for Fast Path to Linux on System z 300
  - for libraries 299
  - for Linux Fast Path (LFP) 300
  - for network definitions 299
  - for resource definition 302
  - for startup 295
  - for tailoring system startup 189
  - for Virtual LAN (VLAN) 300
  - for VSE/ICCF 299
  - for VSE/POWER 299
  - for VTAM 299
  - for Workstation File Transfer Support 303
  - job accounting 298
  - SKALLOCA, allocating static partitions 76
  - SKALLOCB allocating static partitions 76
  - SKALLOCC, allocating static partitions 76
  - SKALLOCCx, allocating partitions 189
  - SKCICS, defining CICS and VSE/ICCF startup 189
  - SKCOLD, loading VSE/POWER queues 189
  - SKCOMVAR, defining CPU IDs 189
  - SKDTSEXT, extending DTSECTXN 112
  - SKENVSEL, cataloging startup members 189
  - SKIOPCPN (for IOCP) 90
  - SKJCL0, JCL startup procedure for BG 189
  - SKJCL1, starting VSE/POWER 189
  - SKJCLDYN, skeleton for dynamic partition startup 189
  - SKLIBCHN, defining library search chains 189
  - SKLOAD, loading VSE/POWER queues 189
  - SKPWSTRT, starting VSE/POWER 189
  - SKUSERBG, starting BG 189
  - SKVTAM, starting VTAM 189
  - STDLABUS, creating labels for non-VSAM files 125
  - SKENVSEL, skeleton for cataloging startup members 189
  - SKIPV4ST, IPv6/VSE startup sample 157
  - SKIPV6ST, IPv6/VSE startup sample 157
  - SKJCL0, skeleton for BG startup procedure 189
  - SKJCL1, skeleton for starting VSE/POWER 189
  - SKJCLDYN, skeleton for dynamic partition startup 189
  - SKJOURN, CICS journal data sets 114
  - SKLIBCHN, skeleton for defining library search chains 189
  - SKLOAD, skeleton for loading VSE/POWER queues 189
  - SKPWSTRT, skeleton for starting VSE/POWER 189

- SKRCFSEC skeleton (protect reports via the BSM) 204
  - SKTCPSTR, TCP/IP startup skeleton 154
  - SKUSERBG, skeleton for starting BG 189
  - SKVMVSE, skeleton 128
  - SKVTAM, skeleton for starting VTAM 189
  - SKWRKFIL skeleton 115
  - SNA LU 6.2 attached printers 309
  - SOAP protocol 142
  - SORT work file 112
  - space for PRD2 121
  - spanned channels 8
  - SQL/DS
    - guest sharing support 140
  - SSL (Secure Sockets Layer) 197
  - SSL Client Authentication 142, 153
  - standard labels, defining 109, 125
  - startup
    - overview 77
    - partition allocations 78
    - skeletons 295, 296
  - startup jobs 186
  - startup modes
    - BASIC 187
    - COLD 187
    - MINI 187
    - RECOV 187
    - WARM 187
  - static partition allocations 78
  - static partitions 56
  - status of partitions at startup 187
  - status report of system users 101
  - STDLABEL procedure 109
  - STDLABUP procedure 109
  - STDLABUS procedure 109
  - STDLABUS, skeleton for creating labels 125
  - storage allocation
    - during IPL 69
    - predefined environments 78
    - shared and private storage areas 56
  - Storwize V7000, midrange disk system 20
  - summary of
    - system capabilities 58
  - supporting application development 254
  - SVA, loading phases into 71
  - synchronization points used for startup 187
  - SYSA user-ID 191
  - SYSA, dialogs for user 285
  - SYSDUMP, system library 122
  - SYSDUMP, VSE library 122
    - and environment C 122
  - SYSLIB, sublibrary of IJSYSRS 118
  - system
    - capabilities (summary) 58
    - console under VM 136
    - environment, second CICS 200
    - environment, selecting at initial installation 59
    - file assignments 110
    - GETVIS area 57
    - startup tailoring 185
  - system (*continued*)
    - transaction IDs, redefining 256
    - transactions 256
    - tuning 257
    - work files 112
  - System Authorization Facility (SAF) 228, 273
  - system console 208
  - system disk layouts, DOSRES and SYSWK1 277
  - system startup
    - \$COMVAR procedure 186
    - components of the Startup facility 185
    - considerations for tailoring 188
    - CPUVARn procedure 187
    - DTRSETP utility program 187
    - facility supplied by z/VSE 185
    - IPL procedure 186
    - JCL startup procedures 186
    - modes 187
    - program DTRISTR 186
    - SETPARM statements 187
    - skeletons for tailoring 189
    - startup jobs 186
    - tailoring 59, 185
    - tasks for tailoring 189
  - System Storage DS6000 Series, support for 17
  - System Storage DS8000 Series, support for 17
  - System z servers 6
  - SYSWK1 layout for FBA (including SCSI) disk 284
  - SYSWK1 layouts 277
- ## T
- tailoring
    - compile skeletons 246
    - Interactive Interface 191, 194
    - IPL procedure 185
    - system startup 185
  - tape
    - devices, list of supported 308
  - tape drives 3590/3592 27
  - tape drives/libraries
    - overview table 24
  - tape encryption 26
  - tape libraries
    - 3494 35
    - 3494 virtual tape server (VTS) 35
    - how used 35
    - in LPAR mode 35
    - model TS7720 disk-only 33
    - TS3500/3584 UltraScalable 34
    - TS7680 ProtecTIER Deduplication Gateway 31
    - TS7700 model TS7740 (with Copy Export feature) 33
    - TS7700 Virtualization Engine 32
    - VGS (VSE Guest Server) support 36
  - tape library 3494 35
  - tape library support 308
  - tape library TS3500/3584 34
  - tasks for
    - tailoring system startup 189
  - tasks, increasing 71
  - tasks, more than 255 71
  - TCP/IP for VSE/ESA 153
    - customizing TCP/IP 155
    - dual stack support 155
    - EZA socket APIs 158
    - EZA TCP/IP programming interface 158
    - function overview 153, 155
    - Hardware Crypto support 153
    - Hipersockets support 153
    - installation of IPv6/VSE 156
    - installation of TCP/IP 154
    - IPv6 support 155
    - IPv6 TCP/IP stack 155
    - IPv6/VSE startup 157
    - Layer 2 (Data Link Layer) 161
    - migration considerations 155, 157
    - Open Systems Interconnection (OSI) TCP/IP model 161
    - preprocessor, skeletons for compiling with 301
    - Secure Sockets Layer (SSL) 153
    - SSL Client Authentication 153
    - startup 154
    - TCP/IP socket interfaces 157
  - TCP/IP for VSE/ESA Configuration Dialog 142
  - TCP/IP preprocessor, skeletons for compiling with 301
  - TCPIP, sublibrary of PRD2 120
  - TCT definitions 105
  - terminal emulation 312
  - terminals supported by z/VSE 311
  - text repository file 113
  - Token Ring 12
  - tools
    - JConVSE 142
    - JDataMig 142
    - Keyman/VSE 142
    - TCP/IP for VSE/ESA Configuration Dialog 142
    - VSAM Maptool 142
    - VSE Health Checker 142
    - VSE Navigator 142
    - VSE Print Utility 142
    - VSE Script 142
    - VSE Web Services 142
    - VSE/VSAM JDBC Driver 142
  - TotalStorage 3494 tape library, support for 35
  - TotalStorage 3590/3592 tape drives 27
  - TotalStorage ESS support 17
  - TotalStorage TS3500/3584 tape library, support for 34
  - TPA (Tape Products Architecture) 27
  - transaction I\$ST 81
  - transaction IDs, duplicate 256
  - transaction security 237
  - transient data queues CSPA and CSPW 205
  - TS1120 and TS1130 WORM, 60 GB, 300 GB, 700 GB media (support for) 26
  - TS1120 tape drive
    - support for 26
  - TS1130 tape drive
    - support for 26

- TS3400 autoloader 27
- TS3500/3584 tape library 34
- TS7650G server 31
- TS7680 ProtecTIER Deduplication Gateway 31
- TS7700 Virtualization Engine
  - overview 32
  - support for BVIR (Bulk Volume Information Retrieval) 32
  - support for WORM cartridges) 33
- TS7720 model disk-only 33
- TS7740 model of TS7700 Virtualization Engine (with Copy Export feature) 33
- tuning the system 257
  - allocating virtual storage 266
  - file placement 268
  - parallel page I/O 269
  - VSAM files for CICS application 272
  - VSE libraries 268
  - VSE/POWER DBLK size 271
  - VSE/POWER partition 270
  - VTAM partition 271
- Turbo Dispatcher 2
- TYPETERM definition 105, 106

## U

- uniprocessor environment, advantages of using the Turbo Dispatcher 2
- user
  - ID 191
  - interface tailoring 194
  - libraries 123
- user console 208
- user profile 191
- user-written application, adding to your system 254

## V

- VGS (VSE Guest Server) support for tape libraries 36
- virtual console under VM 136
- Virtual Disk, Defining Work Files 115
- virtual disks
  - commands and macros 172
  - performance considerations 171
  - requirements 169
  - restrictions 170
  - storage considerations 171
  - support 263
  - support for 55, 169
  - usage hints 264
  - where to use 170
- Virtual LAN (VLAN), skeletons for 300
- virtual LAN (VLAN), used by IPv6/VSE 162
- virtual LAN (VLAN), used by TCP/IP for VSE/ESA 162
- virtual machine, z/VSE under VM 127
- virtual storage constraint relief (VSCR) 259
- virtual storage support 53
- virtual storage, label information area in 173

- Virtual Tape
  - implementation 37
  - overview 37
  - support 37
- virtual tape server (VTS) support for 3494 35
- Virtual Tape support 37
- virtual tapes, support for 37
- VM
  - defining a console for z/VSE guest 136
  - directory entry for z/VSE guest 132
  - displaying status of z/VSE guest machine 132
  - installation of z/VSE guest 129
  - minidisks for z/VSE guest 138
  - PROFILE EXEC for z/VSE guest 134
  - SQL/DS guest sharing support 140
  - support for z/VSE guest machines 127
- VM directory 132
- VM linkage support 128
- VM-emulated FBA support (SCSI disks) 139
- VM/VSE Interface 127
- VM/VSE linkage functions 218
- volume and minidisk sizes, maximum 18
- VSAM I/O control blocks 55
- VSAM Maptool 142
- VSAM Redirector Connector 142
- VSE C Language Run-Time Support 89
- VSE Connectors Workstation Code component 46, 47
- VSE Health Checker 142
- VSE Java Parts, installing latest versions 101
- VSE libraries
  - considerations for tuning 268
  - IJSYSRS 116
  - PRD1 116, 120
  - PRD2 116, 120
  - SYSDUMP 122
- VSE Monitoring Agent 142
- VSE Navigator 142
- VSE Print Utility 142
- VSE Script 142
- VSE Script Connector 142
- VSE Web Services 142
- VSE/Access Control-Logging and Reporting, optional program 48
- VSE/ICCF
  - DTSFILE 112, 123
  - I\$ST transaction 81
  - library contents 123
  - partitions 82
  - skeletons 299
- VSE/POWER
  - access control for spool entries 239
  - application programs using SPOOL macros 254
  - data files 110
  - DBLK size 271
  - predefined files 110
  - queue file 110
  - shared spooling 111
  - skeletons 299

- VSE/POWER (*continued*)
  - tuning partition size 270
  - XPCC macro support 254
- VSE/VSAM
  - buffers, shared 272
  - compression prediction tool 224
  - compression support 223
  - defined on Big DASD 22
  - defined on Large DASD 22
  - multiple LSR pools 261
  - support of Large DASD 22
- VSE/VSAM data compression support 223
- VSE/VSAM JDBC Driver 142
- VSE/VSAM support of Large DASD 22
- VSE.CONTROL.FILE 112
- VSE.MESSAGE.ROUTING.FILE 113
- VSE.TEXT.REPSTORY.FILE 113
- VSETYPE1 group 106
- VSIZE of predefined environments 59
- VTAM
  - data compression support 224
  - passwords 89
  - skeletons 299
  - tuning partition size 271
- VTOC considerations for CKD, ECKD, and FBA devices 267

## W

- W-Books for VSE Connector 47
- WARM startup mode 187
- WebSphere MQ for z/VSE 48
- WebSphere MQ for z/VSE
  - resource classes 235
- work files 112
- Work Files on a Virtual Disk 115
- Workstation File Transfer Support
  - personal computers supported 312
  - skeletons 303
- workstation support 245
- WORM 3592, support for 26
- WORM support 33
- WORM support, for logical tape volumes (3490E) 32
- WTO (WTOR) macro 217

## X

- X.25 NPSI, optional program 48
- XIV Storage System 20

## Z

- z/OS Java Client 242
- z/VM 127
  - HiperSockets support 160
- z/VSE
  - adding a user-written application 254
  - address spaces 57
  - base programs 43
  - CICS environment 197
  - components of the Startup facility 185
  - control file 99, 112, 194



- z/VSE (*continued*)
  - CPU balancing 3
  - data space support 167
  - defining a console under VM 136
  - dialogs of the Interactive Interface 285
  - directory entry under VM 132
  - dynamic partitions 57
  - hardware support 5
  - IESBLDUP utility program 101
  - installation under VM 127, 129
  - IPL procedures 275
  - JCL procedures 275
  - label procedures 275
  - libraries 116
  - LPAR mode 1
  - message routing file 113
  - migration utilities 101
  - minidisks under VM 138
  - optional programs 48
  - partition layout 56
  - performance considerations 257
  - predefined environments 59
  - procedures for standard labels 109
  - PROFILE EXEC under VM 134
  - real storage support 53
  - reserved names 293
  - running as a guest under VM 127
  - security support 227
  - skeletons, overview 295
  - standard labels 109
  - static partitions 56
  - supervisor modes 59
  - system and user libraries 116
  - system file assignments 110
  - system status dialogs 132
  - tailoring system startup 185
  - text repository file 113
  - transaction IDs 256
  - Turbo Dispatcher 2
  - under VM 127
  - use of CICS Report Controller 204
  - virtual disk support 169
  - virtual storage support 53
  - VM/VSE Interface 127
  - with Fast Path to Linux on System
    - z 163
  - with Linux Fast Path 163
  - with z/VSE - z/VM IP Assist (z/VSE VIA) 165
- z/VSE - z/VM IP Assist (z/VSE VIA), support for 165
- z/VSE e-business Connectors 141
- z/VSE VIA (z/VSE - z/VM IP Assist), support for 165
- z10 BC servers 6
- z10 EC servers 6
- z9 BC servers 6
- z9 EC servers 6
- zEnterprise 196 servers 6
- zSeries 800 servers 6
- zSeries 890 servers 6
- zSeries 900 servers 6
- zSeries 990 servers 6
- zSeries servers 160



---

## Readers' Comments — We'd Like to Hear from You

IBM z/VSE  
Planning  
Version 5 Release 1

Publication No. SC34-2635-02

We appreciate your comments about this publication. Please comment on specific errors or omissions, accuracy, organization, subject matter, or completeness of this book. The comments you send should pertain to only the information in this manual or product and the way in which the information is presented.

For technical questions and information about products and prices, please contact your IBM branch office, your IBM business partner, or your authorized remarketer.

When you send comments to IBM, you grant IBM a nonexclusive right to use or distribute your comments in any way it believes appropriate without incurring any obligation to you. IBM or any other organizations will only use the personal information that you supply to contact you about the issues that you state on this form.

Comments:

Thank you for your support.

Submit your comments using one of these channels:

- Send your comments to the address on the reverse side of this form.
- Send a fax to the following number: +49-7031-163456
- Send your comments via email to: [s390id@de.ibm.com](mailto:s390id@de.ibm.com)
- Send a note from the web page: <http://www.ibm.com/systems/z/os/zvse/>

If you would like a response from IBM, please fill in the following information:

\_\_\_\_\_

Name

\_\_\_\_\_

Address

\_\_\_\_\_

Company or Organization

\_\_\_\_\_

Phone No.

\_\_\_\_\_

Email address



Fold and Tape

Please do not staple

Fold and Tape



NO POSTAGE  
NECESSARY  
IF MAILED IN THE  
UNITED STATES

# BUSINESS REPLY MAIL

FIRST-CLASS MAIL PERMIT NO. 40 ARMONK, NEW YORK

POSTAGE WILL BE PAID BY ADDRESSEE

IBM Deutschland Research & Development GmbH  
Department 3248  
Schoenaicher Strasse 220  
71032 Boeblingen  
Germany



Fold and Tape

Please do not staple

Fold and Tape





Product Number: 5609-ZV5

Printed in USA

SC34-2635-02

