

Introduction to IBM Wave for z/VM Management

Intelligent Visualization – Simplified Monitoring – Unified Management

Eduardo Oliveira
eduardoc@us.ibm.com

Ernest Horn
ehorn@us.ibm.com

Ivan Dobos
ivan.dobos@sk.ibm.com



WAVV – Covington, KY
April 13-16, 2014



IBM System z Tiger Team: News



IBM

Trademarks

The following are trademarks of the International Business Machines Corporation in the United States and/or other countries.

DirMaint	OMEGAMON*	System z*
HiperSockets	Performance Toolkit for VM	System z10*
IBM*	RACF*	zEnterprise*
IBM (logo)*	REXX	z/VM*

* Registered trademarks of IBM Corporation

The following are trademarks or registered trademarks of other companies.

Adobe, the Adobe logo, PostScript, and the PostScript logo are either registered trademarks or trademarks of Adobe Systems Incorporated in the United States, and/or other countries.

Cell Broadband Engine is a trademark of Sony Computer Entertainment, Inc. in the United States, other countries, or both and is used under license therefrom.

Intel, Intel logo, Intel Inside, Intel Inside logo, Intel Centrino, Intel Centrino logo, Celeron, Intel Xeon, Intel SpeedStep, Itanium, and Pentium are trademarks or registered trademarks of Intel Corporation or its subsidiaries in the United States and other countries.

IT Infrastructure Library is a registered trademark of the Central Computer and Telecommunications Agency which is now part of the Office of Government Commerce.

ITIL is a registered trademark, and a registered community trademark of the Office of Government Commerce, and is registered in the U.S. Patent and Trademark Office.

Java and all Java based trademarks and logos are trademarks or registered trademarks of Oracle and/or its affiliates.

Linear Tape-Open, LTO, the LTO Logo, Ultrium, and the Ultrium logo are trademarks of HP, IBM Corp. and Quantum in the U.S. and

Linux is a registered trademark of Linus Torvalds in the United States, other countries, or both.

Microsoft, Windows, Windows NT, and the Windows logo are trademarks of Microsoft Corporation in the United States, other countries, or both.

OpenStack is a trademark of OpenStack LLC. The OpenStack trademark policy is available on the [OpenStack website](#).

TEALEAF is a registered trademark of Tealeaf, an IBM Company.

Windows Server and the Windows logo are trademarks of the Microsoft group of countries.

Worklight is a trademark or registered trademark of Worklight, an IBM Company.

UNIX is a registered trademark of The Open Group in the United States and other countries.

* Other product and service names might be trademarks of IBM or other companies.

Notes:

Performance is in Internal Throughput Rate (ITR) ratio based on measurements and projections using standard IBM benchmarks in a controlled environment. The actual throughput that any user will experience will vary depending upon considerations such as the amount of multiprogramming in the user's job stream, the I/O configuration, the storage configuration, and the workload processed. Therefore, no assurance can be given that an individual user will achieve throughput improvements equivalent to the performance ratios stated here.

IBM hardware products are manufactured from new parts, or new and serviceable used parts. Regardless, our warranty terms apply.

All customer examples cited or described in this presentation are presented as illustrations of the manner in which some customers have used IBM products and the results they may have achieved. Actual environmental costs and performance characteristics will vary depending on individual customer configurations and conditions.

This publication was produced in the United States. IBM may not offer the products, services or features discussed in this document in other countries, and the information may be subject to change without notice. Consult your local IBM business contact for information on the product or services available in your area.

All statements regarding IBM's future direction and intent are subject to change or withdrawal without notice, and represent goals and objectives only.

Information about non-IBM products is obtained from the manufacturers of those products or their published announcements. IBM has not tested those products and cannot confirm the performance, compatibility, or any other claims related to non-IBM products. Questions on the capabilities of non-IBM products should be addressed to the suppliers of those products.

Prices subject to change without notice. Contact your IBM representative or Business Partner for the most current pricing in your geography.

This information provides only general descriptions of the types and portions of workloads that are eligible for execution on Specialty Engines (e.g., zIIPs, zAAPs, and IFLs) ("SEs"). IBM authorizes customers to use IBM SE only to execute the processing of Eligible Workloads of specific Programs expressly authorized by IBM as specified in the "Authorized Use Table for IBM Machines" provided at www.ibm.com/systems/support/machine_warranties/machine_code/aut.html ("AUT"). No other workload processing is authorized for execution on an SE. IBM offers SE at a lower price than General Processors/Central Processors because customers are authorized to use SEs only to process certain types and/or amounts of workloads as specified by IBM in the AUT.

Agenda – Advanced z/VM Systems Management

- Today's Challenges
- IBM Wave for z/VM
- Benefits
- Fit in Portfolio
- Test Drive Environment
- IBM Wave Tiger Team
- IBM Wave Jumpstart
- Features and Architectural Overview
- Demo
- Q&A



Today's Challenges

- IT management is striving to achieve operational efficiencies and reduce spend on daily management
- Administrators need to become more self sufficient through self service, administration needs to be easier and simpler
- Organizations need better control of configuration and change management especially in a virtualized environment
- IT organizations want to accelerate their migration efforts to cloud and need tools that can help them get started quickly
- Internal and external IT customers expect even faster responsiveness due to ever changing business dynamics
- Faced with reduced budgets, IT management must extend the reach of their existing IT staff to do more with less without sacrificing quality



What is IBM Wave for z/VM?

IBM recently acquired CSL International, and with that its flagship product CSL Wave, now known as IBM Wave for z/VM v1.1 (IBM Wave). In this session we will discuss IBM Wave and how one can leverage it to simplify the administration of z/VM and Linux on z environments, and drive more productivity.



IBM Wave for z/VM

Empowered Virtualization Management

5648-AE1 1.1. IBM Wave for z/VM
5648-AE2 1.1. IBM Wave for z/VM S&S

IBM Wave enables the **management of the entire Enterprise** and its multiple z/VM guests **across LPARs and CECs**. Using the Enterprise Viewer and IBM Wave functions such as Projects and Grouping, one can cross manage multiple instances by custom attributes to match specific business needs!



IBM Wave for z/VM V1.1 (IBM Wave)

- IBM Wave is a new virtualization management product for z/VM[®] and Linux[®] virtual servers that uses visualization to dramatically automate and simplify administrative and management tasks
- Enhanced Enterprise Linux Server (ELS*) solution is also available with IBM Wave for z/VM
- New! Jumpstart Services to help customers get started with IBM Wave
- Read the announcement [here!](http://www-01.ibm.com/common/ssi/cgi-bin/ssialias?subtype=ca&infotype=an&supplier=897&letternum=ENUS214-027)
 - <http://www-01.ibm.com/common/ssi/cgi-bin/ssialias?subtype=ca&infotype=an&supplier=897&letternum=ENUS214-027>
- General availability - February 28th, 2014

Supported IBM System z[®] processors: IBM System z10[®] Enterprise Class (z10 EC[™]), IBM System z10 Business Class[™] (z10 BC[™]) and later

Supported z/VM versions/releases:

- z/VM 6.3
- z/VM 6.2
- z/VM 5.4



****Enterprise Linux Server is an integrated solution comprised of Hardware, Hypervisor, Memory, Easy to Use Virtualization Management and 3 years Service and Support designed to get customers including FIEs started with low cost scalable computing environment***

IBM Wave for z/VM

Helps Simplify and Automate Virtualization Management
For z/VM and Linux virtual servers

- Automate, simplify management and monitor virtual servers and resources-all from a single dashboard
- Perform complex virtualization tasks in a fraction of the time compared to manual execution
- Provision virtual resources (Servers, Network, Storage) to accelerate the transformation to cloud infrastructure
- Supports advanced z/VM[®] management capabilities such as Live Guest Relocation with a few clicks
- Delegate responsibility and provide more self service capabilities to the appropriate teams

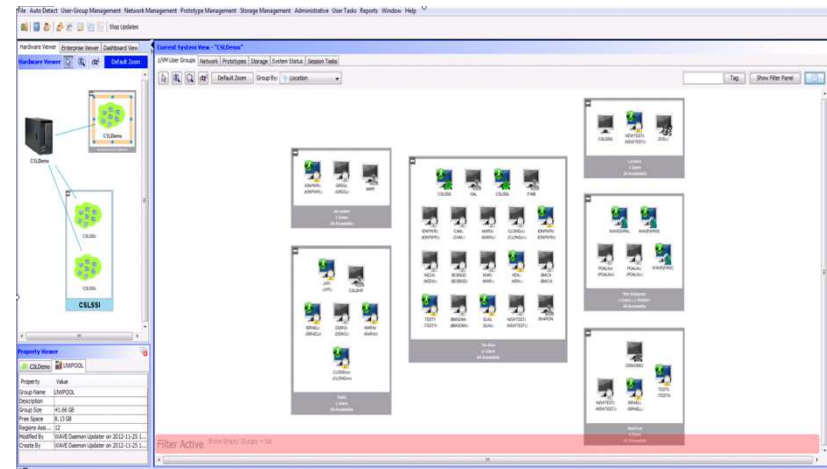

A simple, intuitive virtualization management tool providing management, provisioning, and automation for a z/VM environment supporting Linux[®] virtual servers

Extend the Reach of Skills with IBM Wave for z/VM

Intelligent Visualization



- Shorten the learning curve needed to manage complex environments
- Organize and simplify management of z/VM and virtual Linux servers
- View servers and storage utilization graphically; understand the status of system resources with Intelligent icons
- Reduce unnecessary steps using highly customizable views
- Graphical or tabular displays with layered drill down
- Make existing staff more self-sufficient

Simplified Monitoring

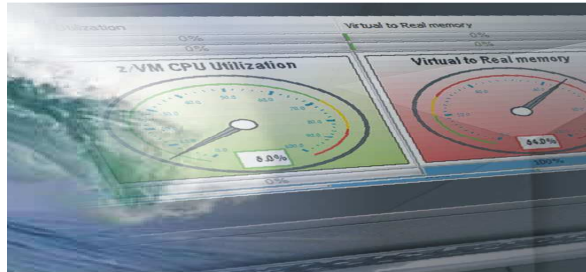

- Monitor the status of z/VM systems through an innovative interface
- Monitor performance of CPU, paging devices, spool disks and more;
- Use agentless discovery to detect an accurate view of your environment
- Use advanced filters, tagging, layout and layer selection to make monitoring and management more meaningful
- Complements IBM OMEGAMON® XE used for in-depth performance monitoring

Unified Management



- Manage your system from a single point of control
- Assign and delegate administrative access with role based assignments
- Provision, clone, and activate virtual resources . Define and control virtual network and storage devices
- Perform management tasks such as live guest relocation
- Annotate resources for additional policy based management
- Execute complex scripts with a single mouse click

IBM Wave Intelligent Visualization

Quickly Understand the Status of System Resources

- **Get a current and accurate view of your managed environment**
 - Network Topology
 - Centralized view of the entire network topology per z/VM System, view Virtual LANS (VLANS)
 - Annotate network topology view to identify external resources - routers, switches, etc
 - Linux Servers
 - View performance gauges for all z/VM systems from one screen:
 - See resource consumption by guest or type
 - CPU, Virtual to Real, Paging, Spool
 - Storage
 - Visual representation of all storage resources

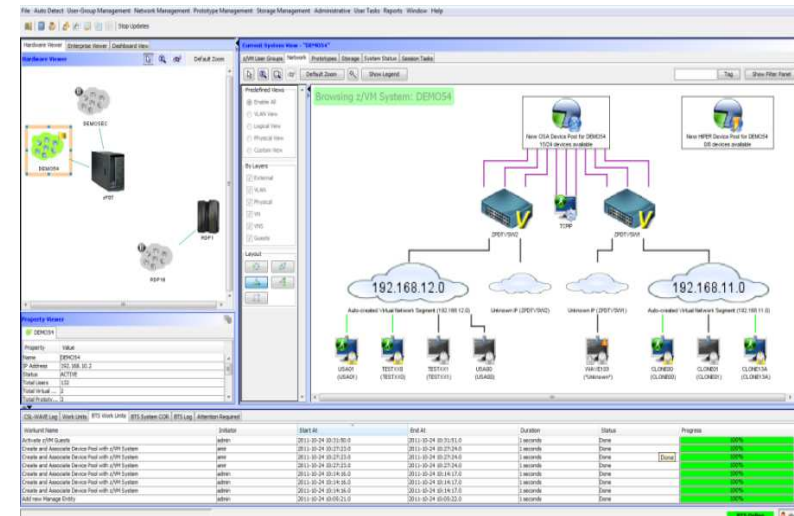

- **Visualize and control virtual resources**
 - Views can be graphical or easily switched to tabular mode
 - View relationships between resources easily and graphically
 - View the entire environment graphically and easily zoom in
- **Advanced filters, tagging, layout and layer based views for every display**

Intelligent Visualization

Mapping Attached Storage to Guests and Storage Controllers

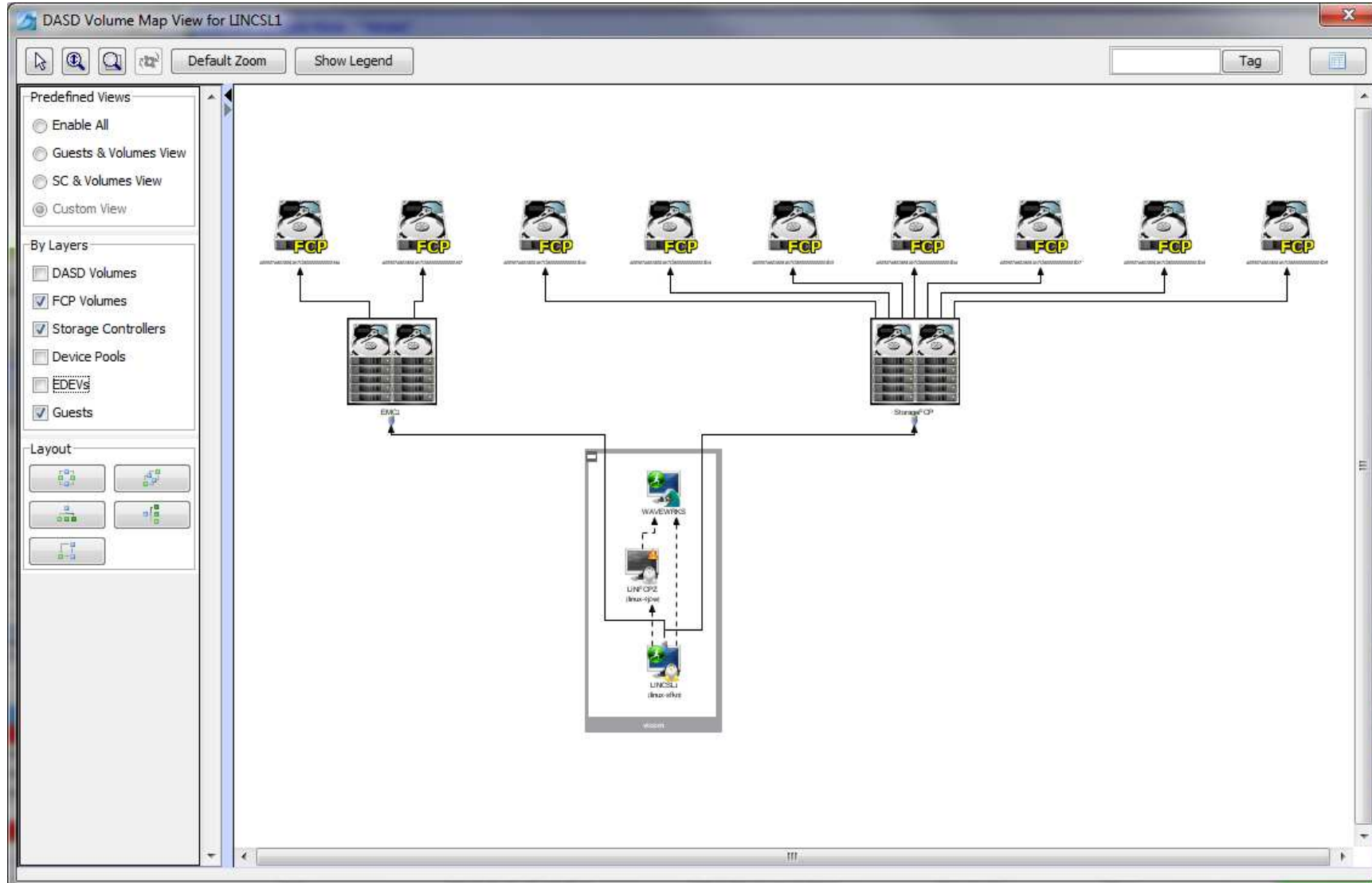

IBM Wave Simplified Monitoring

Automatic Detection and Monitoring of Resources

- **Agentless Resource Discovery**
 - Discover, manage and monitor z/VM resources and their relationships across multiple LPARs and CECs
 - Identify resource and relationship changes; reflect current environment in the user interface
- **Monitoring**
 - Allows the state of resources to be observed; icons show additional content for the resources
 - Use graphical and tabular displays with layered drill down to hone in on only the resources you need to view
 - Perform ongoing monitoring of changes that occur after initial auto-detection
- **Reporting**
 - Automatically generate charts like pie charts to report on utilization and more
 - All table-based views can be exported to a CSV file for import into other applications

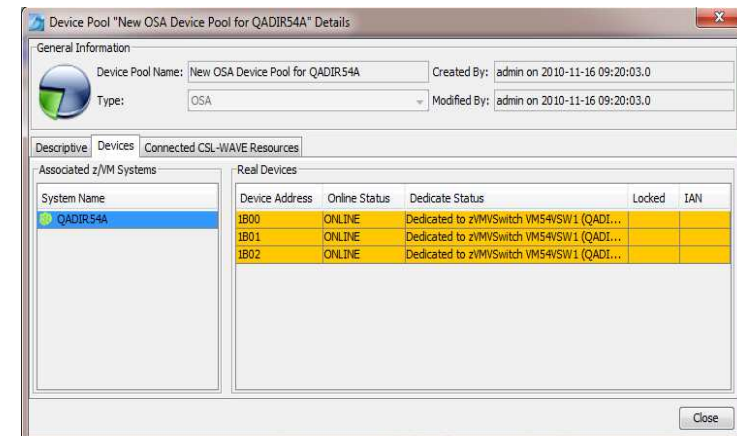

Performance Resource Monitoring

At a Glance Status of all z/VM instances

CSL-WAVE 3.1.0 (WAVESERV Hostname: N/A, IP Address: 192.168.1.183)

File Auto Detect User-Group Management Network Management Prototype Management Storage Management Administrative User Tasks Reports Window Help

Stop Updates

Hardware Viewer Enterprise Viewer Dashboard View

Enterprise Dashboard View

Enterprise Status Viewer

Filter selection

CPC = *

Clear Go

Property Viewer

3 (vicom) LINCSL2 (vicom)

Property	Value
Name	LINCSL2
Status	Inactive
Eligible	Yes
Group	USER-LOCAL
Type	Linux
Distribution	SLES 11 - 64 Bit
1st IP Address	10.100.0.45
Project	N/A
Functionality	N/A

z/VM System Name	CPU Utilization	Virtual to Real memory	Page Space Utilization	Spool Space Utilization
ETPGVBJ	z/VM CPU Utilization: 0.0%	Virtual to Real memory: 52.0%	z/VM Page Space Utilization: 0.0%	z/VM Spool Space Utilization: 1.0%
vicom	z/VM CPU Utilization: 0.0%	Virtual to Real memory: 141.0%	z/VM Page Space Utilization: 1.0%	z/VM Spool Space Utilization: 22.0%

CSL-WAVE Log Work Units BTS Work Units BTS System COR BTS Log Attention Required

Workunit Name	Initiator	Start At	End At	Duration	Status	Progress
Init z/VM Guests for CSL-WAVE	amir	2012-05-28 18:53:28.0	2012-05-28 18:54:36.0	1:08 minutes	Done	100%
Init z/VM Guests for CSL-WAVE	amir	2012-05-28 18:53:10.0	2012-05-28 18:53:14.0	4 seconds	Error	
Refresh Linux Data for z/VM Guests	amir	2012-05-28 18:52:00.0	2012-05-28 18:52:32.0	32 seconds	Done	100%
Refresh Linux Data for z/VM Guests	amir	2012-05-28 18:48:53.0	2012-05-28 18:51:23.0	2:30 minutes	Done	100%
Refresh Linux Data for z/VM Guests	amir	2012-05-28 15:16:15.0	2012-05-28 15:16:41.0	26 seconds	Done	100%
Create New FCP Volume Group	amir	2012-05-24 21:18:29.0	2012-05-24 21:20:04.0	1:35 minutes	Done	100%
Create New FCP Volume Group	amir	2012-05-24 21:15:26.0	2012-05-24 21:15:32.0	6 seconds	Error	
Create New FCP Volume Group	amir	2012-05-24 20:43:32.0	2012-05-24 20:45:03.0	1:31 minutes	Done	100%
Init z/VM Guests for CSL-WAVE	amir	2012-05-24 19:33:37.0	2012-05-24 19:34:34.0	57 seconds	Done	100%
Sync NFS Servers	amir	2012-05-24 19:12:45.0	2012-05-24 19:12:47.0	2 seconds	Done	100%

BTS Online amir

Performance Resource Monitoring

At a Glance Drill down to Virtual Memory Detail

Current Real and Virtual Memory Values

Type	Size	Ratio Display
Total Real Memory	7000M	7000
Total Virtual Memory	6020M	6020

Virtual to Real Ratio

86%

Virtual Memory Utilization for All Guests - Last Updated: 08:45:24 EDT WEDNESDAY 06/19/13

Name	Type	Memory (MB)	VDisks (MB)	Total (MB)	% Used
CSLSSI2	CMS	1200	0	1200	19%
CSLSSI1	CMS	1200	0	1200	19%
NEWTEST1	Linux	128	500	628	10%
ISRAEL0	Linux	128	0	128	2%
TEMPO	Linux	128	0	128	2%
IONPWR2	Linux	128	0	128	2%
IONPWR1	Linux	128	0	128	2%
WAVEWRKC	CSL-WAVE	32	0	32	0%
WAVEWRKL	CSL-WAVE	32	0	32	0%
WAVEWRKS	CSL-WAVE	32	0	32	0%

Include IBM Service Machines

Virtual Memory Usage Distribution (By Guest)

Virtual Memory Usage Distribution (By Type)

IBM Wave Unified Management

Managing the Entire Pool of Resources Intuitively

- **Simplification**

- Simplify the process of performing a function across multiple z/VM or Linux systems

- **Manage Networks**

- Centralized, layer based customizable view of the entire z/VM network topology
- Define and control all network devices such as VSWITCHes and guest LANs

- **Manage Storage**

- Manage devices and device pools

- **Provision Resources**

- Clone resources and virtual servers, apply scripts for more customization
- Install Linux on virtual machines
- Adding attached storage to z/VM Guests using IBM Wave's Manage Storage Wizard
- Activate/Deactivate servers in an ordered fashion

- **Improve Policy Management**

- Use reminder notes attached to icons to provide advisory and policy notices

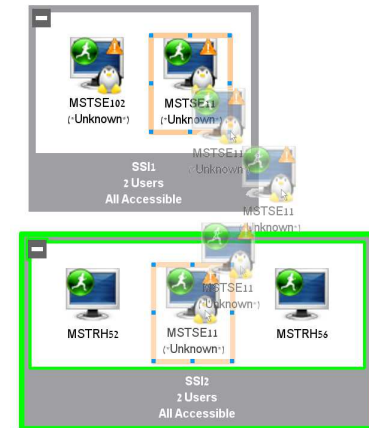

Simplify Systems Management Tasks

Provision resources quickly and easily

CSL-WAVE 3.2.0 (WAVESERV Hostname: cslserv13, IP Address: 192.168.39.77)

File Auto Detect User-Group Management Network Management Prototype Management User Tasks Reports Window Help

Hardware Viewer Enterprise Viewer Dashboard View

Hardware Viewer Default Zoom

ATSEC12

CSLVM13

Property Viewer

Property	Value
Name	CSLRHEL
Status	Inactive
Eligible	Yes
Group	USER-LOCAL
Type	Linux
Distribution	RedHat 6 - 64 Bit
1st IP Address	192.168.39.75
Project	DMV
Functionality	N/A

CSL-WAVE Log BTS Work Units BTS System COR. BTS Le

WAVESRV Time	User
2014-01-28 17:08:41	dmvuser
2014-01-28 17:09:39	dmvuser

Waiting for user input

BTS Online dmvuser 5:11 PM

Benefits	IBM Wave for z/VM Capabilities
<ul style="list-style-type: none"> ✓ Gain efficiencies in virtualization management ✓ Work with a current, accurate and complete view of your managed z/VM environment 	<ul style="list-style-type: none"> ▪ IBM Wave provides a high level view of performance, storage usage, networks at a glance with built-in reporting ▪ By providing an up to date, accurate view of the IT environment through its “agentless discovery” organizations can plan, change and optimize their virtualized resources accurately ▪ IBM Wave enables automation of management tasks and can incorporate scripts.
<ul style="list-style-type: none"> ✓ Simplify administrative, operations and systems functions ✓ Enable improved self service to reduce costs 	<ul style="list-style-type: none"> ▪ Optimize z/VM capabilities by simplifying and automating management tasks that could otherwise take hours and require significant z/VM knowledge, (includes complicated tasks as LGR, Server Cloning, Storage provisioning, etc.).
<ul style="list-style-type: none"> ✓ Respond quickly to changing business needs ✓ Reduce errors with appropriate delegation 	<ul style="list-style-type: none"> ▪ Make common management tasks accessible to more user roles ▪ Easily delegate administrative capabilities to the appropriate users ▪ Enforce segregation policies at the individual administrator as well as the group level ▪ Set scope and permissions to match business requirements

Benefits	IBM Wave for z/VM Capabilities
<ul style="list-style-type: none"> ✓ Improve service levels ✓ Easily respond to changing requirements. ✓ Reduce time spent on administrative efforts 	<ul style="list-style-type: none"> ▪ Offers easy, convenient access to performance and management information –at a glance ▪ Helps you quickly and easily administer and provision resources like servers, storage, user accounts. ▪ Tag resources with meaningful notes to help enforce installation defined rules.
<ul style="list-style-type: none"> ✓ Easily manage virtualized environments ✓ Simplify and accelerate your journey to cloud 	<ul style="list-style-type: none"> ▪ Lets you provision new servers (bare metal installations) and easily clone Linux virtual servers and other resources ▪ Scripts allow customization of a golden master. ▪ Support early virtualization steps needed to get to a private cloud.
<ul style="list-style-type: none"> ✓ Create audit trails of IBM Wave users' activities 	<ul style="list-style-type: none"> ▪ List tasks and status requested by the users with respect to their scope. ▪ Log each operation that changes the system including logon and logoff to provide an audit trail. The logs may be then routed to a centralized logging mechanism for further filtering or processing.
<ul style="list-style-type: none"> ✓ Simplify your administration ✓ Extend the reach of your existing IT staff 	<ul style="list-style-type: none"> ▪ IBM Wave automates a sequence of VM commands, reducing steps needed to complete common administrative and management tasks—and improve consistency. ▪ IBM Wave helps your team manage additional servers even if you do not have a deep expert skills bench available.

Cloud Computing - Based on Virtualization and Standardization

To position the various technologies in this space, we need to first understand that Cloud computing is a journey beginning with virtualization and consolidation of environments and ending with workload pattern-based deployment of IT services.

This is not always a step-wise progression. Some clients may require advanced cloud capabilities from the start, while others will begin by optimizing their virtualization foundation and then gradually move to cloud.

Others require capabilities from the beginning and may start with entry or advanced cloud solutions.

Not all customers will want/need to get to the final step!

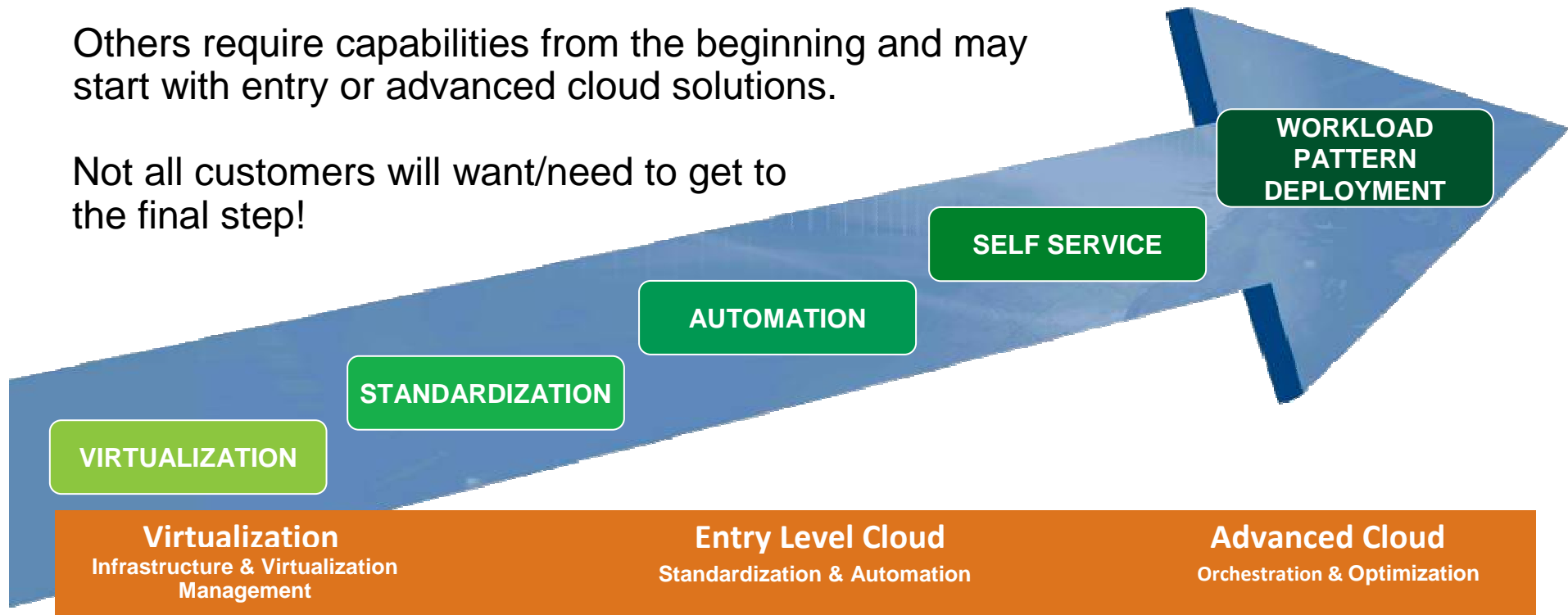

How IBM Wave fits into the Cloud Blueprint

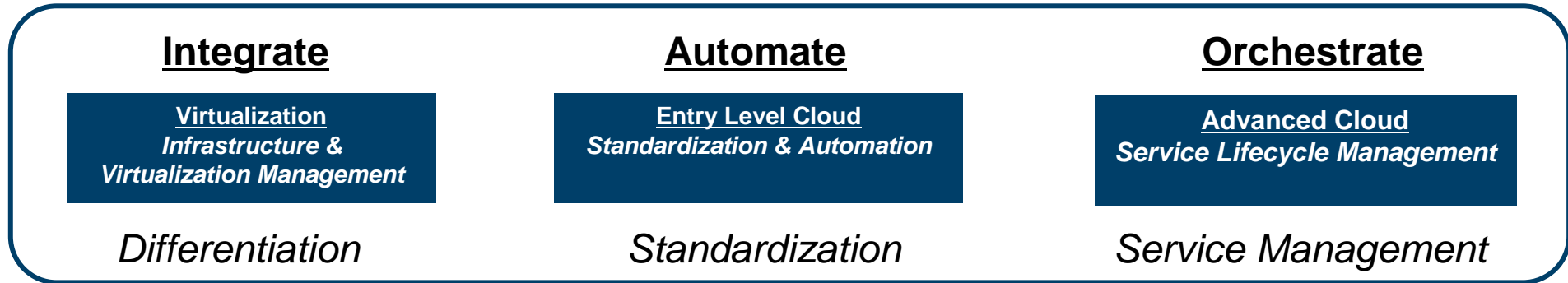

- Rapid deployment of Linux virtual servers for less than \$1 a day
- Industry leading "gold standard" security for tenant isolation
- Elastic scaling achieved by dynamically adjustable capacity at sustained performance
- Simplified and empowered virtualization management with IBM Wave

- Automated provisioning and de-provisioning
- Pool standardized virtualized building blocks
- Plug-and-play capacity across hardware generations
- Capture and catalog virtual images in the data center
- Automated methods for faster delivery of services with higher levels of control

- Integrated virtualization management with IT service delivery processes
- Self-service provisioning
- Automated service lifecycle management including dynamic instantiation of cloud services
- Pay for use
- Optimize IT resources to reinvent business processes

z/VM
IBM Wave for z
Linux on IBM System®

xCAT
SmartCloud Entry*

Cloud Ready for Linux on System z
SmartCloud Provisioning*
SmartCloud Orchestrator*

* System z support currently in development

Learn More with IBM Wave Client Hands on Experience

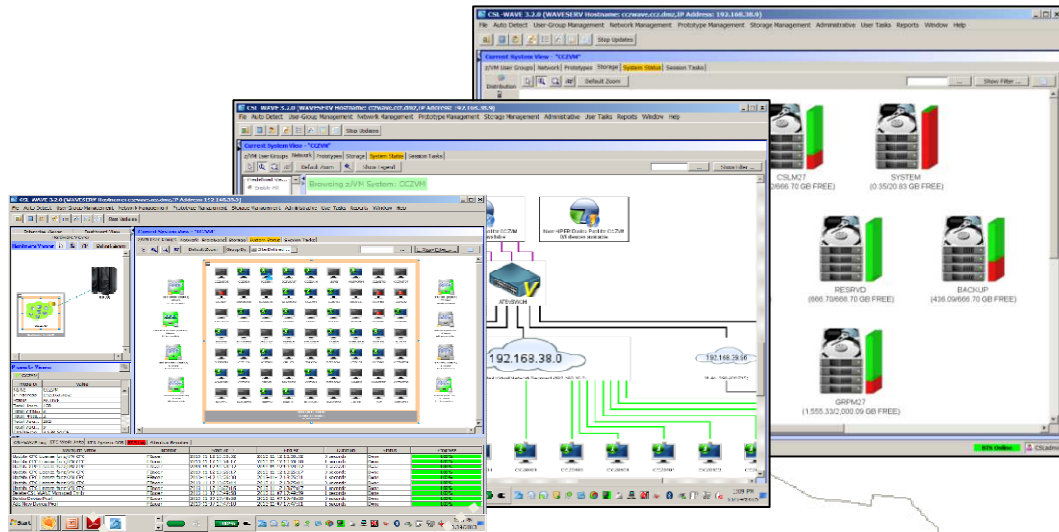

IBM Advanced Technical Support
Washington Systems Center
Gaithersburg, MD



Client Sites Worldwide

Hands on IBM Wave Environment now available

- Client hands-on experience using IBM Wave on a IBM zEnterprise EC12 (zEC12)
- Secure remote access from client site to zEC12 in Gaithersburg, MD
- Accessible 24 hours a day, 7 days a week (except for occasional planned outages)
- Guided exercises provide hands on experience with IBM Wave
- Contact your representative to get started today



zGrowth IBM Wave for z/VM TIGER TEAM – WW Coverage



**Marty Horan,
Manager**

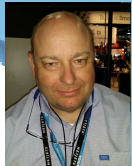

**Ernest Horn
Ernest Horn**



**Eduardo Oliveira,
Team lead**

Ivan Dobos



Luis Ramos



STG Lab Services – IBM Wave Jumpstart Services for zEnterprise

- This Jumpstart service can help to accelerate your IBM Wave implementation.
- This service offering provides planning, installation, and usage assistance.
- We tailor the installation to your environment and provide skills transfer by reviewing common use cases of the interface with your support staff.

Key Features:

- This service helps accelerate the implementation and ROI with IBM Wave
- Assistance in planning the implementation by those who have implemented and used for several years
- Provide recommendations on integration and configuration in your environment
- Demonstrate how to implement custom REXX™ Execs with IBM Wave to extend functionality
- Integration with your AD for authentication
- Demonstration and review of common IBM Wave use cases with your staff in a workshop setting
- Demonstrate how to enable existing Linux servers to be managed by IBM Wave
- The Jumpstart is usually typically complete in one week depending upon the size of the deployment

Target Audiences:

- zEnterprise z/VM and Linux Administrators
- Existing and First in Enterprise customers
- Organization who want augment the System z support staff with less experienced IT professionals

Business Drivers:

- Reduced staff z/VM experience requirements
- Increased IT staff productivity
- Reduce systems management costs

Contact:

- stgls@us.ibm.com for questions specific to this service.

Our System z experts have years of experience in working with IBM Wave

IBM Wave for z/VM Features and Architectural Overview

IBM System z Tiger Team: News



Feature overview - Automation and simplification

- View the entire server farm laid out graphically
- Ordered Activation/Deactivation of servers
- Execution of customer's REXX as part of the cloning process to allow local z/VM customization
- Run Linux shell scripts against dynamically grouped/filtered servers, as IBM Wave for z/VM background tasks, listing the results for each selected server - All via the GUI
- Run REXX EXECs against any virtual object with customized parameters and results listing - All via the GUI
- WAVECLI – A CLI for IBM Wave for z/VM actions that can be utilized from Linux shell scripts or Windows Batch files
- Access Linux on System z guests directly from the GUI using SSH, 3270 or CLC– No hostnames or IP addresses to remember, simply right-click on the server and select the desired access

Feature overview - Provisioning

- Sophisticated guests cloning including Cross System Clone (across LPARs and CPCs)
- Ability to customize the first boot of a cloned server (before TCP/IP is initialized)
- Simple creating and manipulation of Vswitches and Guest LANs
- Connect/disconnect guests to Vswitches or Guest LANs via the GUI
- Storage management and provisioning at the z/VM and Linux levels (including LVM support)
- Automatic handling of Real or Dedicated devices via IBM Wave for z/VM's user defined Device Pool

Feature overview – Graphical control

- Rich GUI with graphical views of all managed objects
- Advanced filters, tagging, layouts and layers for every display
- Multiple objects may be selected

Feature overview – Auto-detection

- Agentless technology
- Automatic initial detection of all virtual server farms components (servers, prototypes, networks, network devices and storage)
- Any changes to the system, done by any IBM Wave component or user are immediately propagated to all GUI users
- Ongoing monitoring of changes made outside of IBM Wave for z/VM after the initial auto-detection

Feature overview – Network support

- Centralized, layer based view of the entire network topology per z/VM system
- Define and control all network devices such as VSwitches and guest LANs
- Manipulation of servers-to-network connect/disconnect using GUI
- Support for VLAN usage
- Management of VSwitches with protocol layer 2 or 3
- Customize network topology view with external resources such as routers, LPARs etc.

IBM Wave Architecture

Client

- The Client can run on Microsoft® Windows®, running Java™ 1.7
- Graphic interpretation of the TVP through communication with WAVESRV using Point-and-Click and Drag-and-Drop operations

WAVESRV

- This server (virtual or physical) hosts the application database and Background Task Scheduler
- One BTS server can manage many Target Virtualization Platforms.

TVP

- The Target Virtualization Platform (TVP) represents the hypervisor which hosts the virtual guests that are managed.
- The BTS utilizes the TVP API to query and perform changes to the TVP and hosted virtual guests.

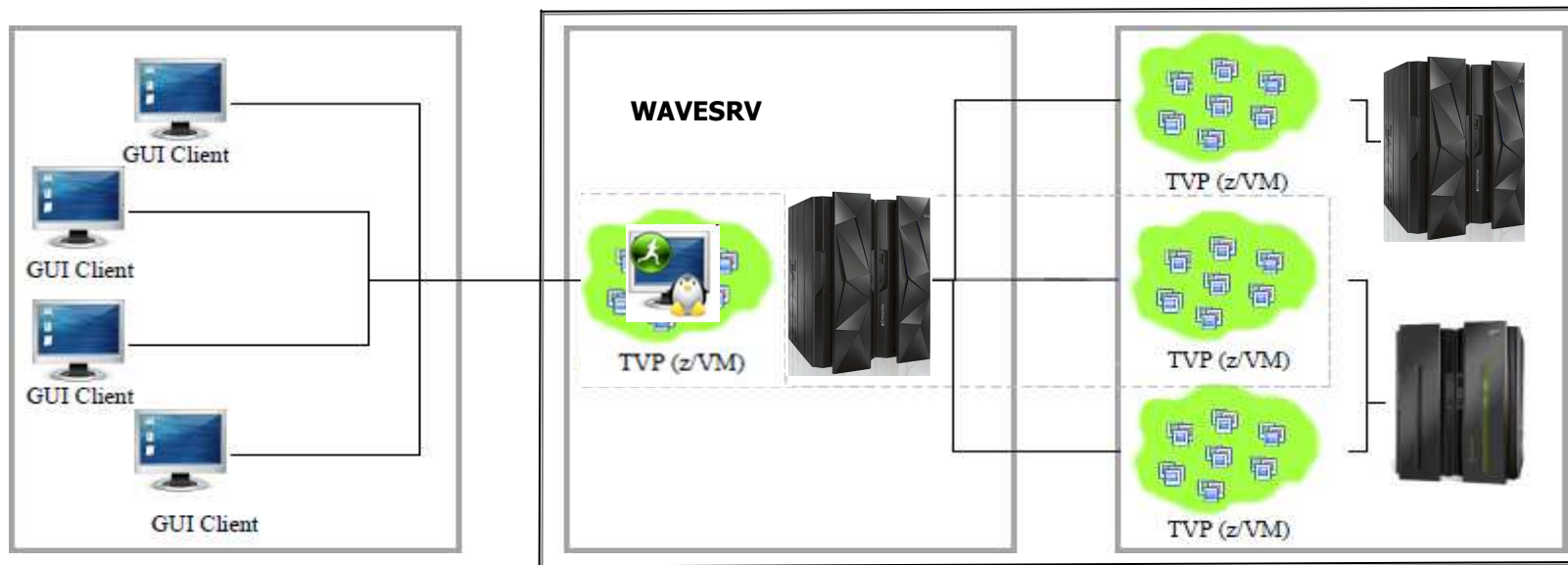

IBM Wave Requirements

Client

- Windows 7 Workstation
- Internet Explorer or Firefox
- Java Runtime 1.7 with Web Start Support
- PuTTY or equivalent telnet/SSH client

WAVESRV

- z/VM Guest or LPAR
- RHEL 6 or SLES 11
- MySQL V12.22 or higher
- Java SE Runtime 1.7
- Apache

TVP

- IBM System z10® or later
- z/VM V5.4, V6.2 or higher with Systems Management API configured
- IBM Directory Maintenance for z/VM (DirMaint™) or equivalent
- Performance Toolkit for VM™ (Perfkit, optional but suggested)

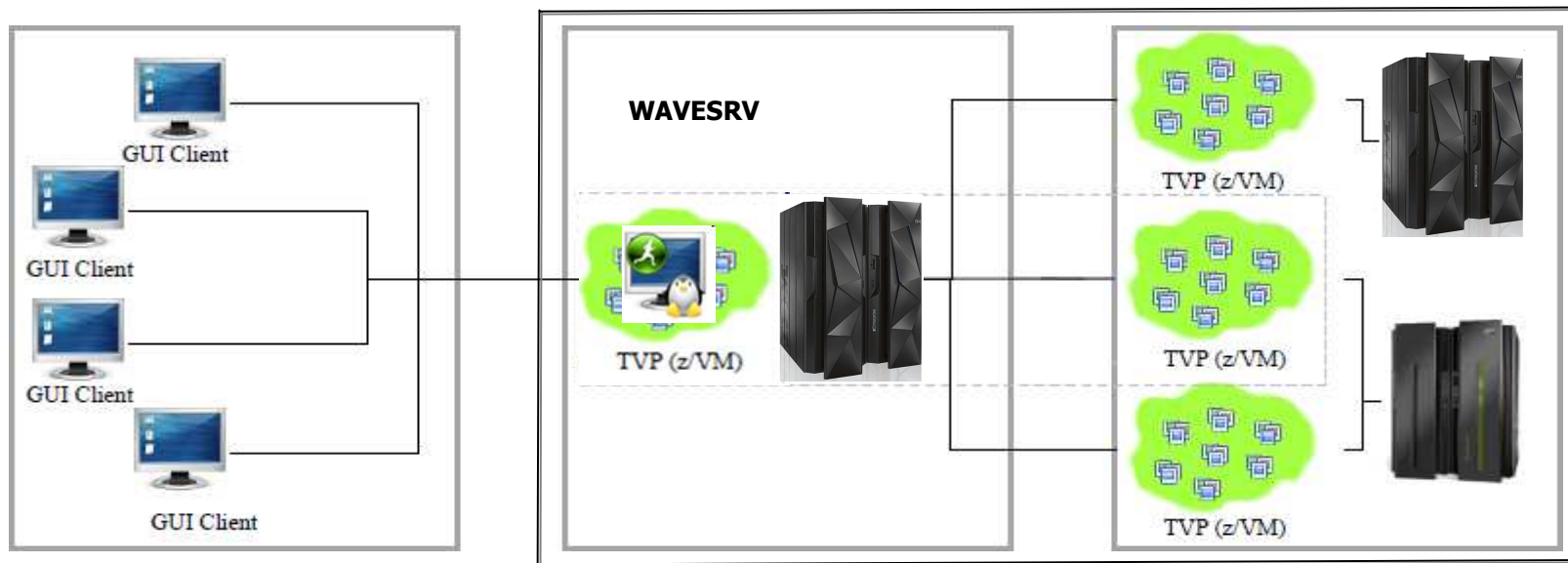

IBM Wave for z/VM: Tier 1- GUI

CSL-WAVE 3.2.0 (WAVESERV Hostname: N/A, IP Address: 9.12.7.89)

File Auto Detect User-Group Management Network Management Prototype Management Storage Management Administrative User Tasks Reports Window Help

Stop Updates

Enterprise Viewer Dashboard View

Hardware Viewer

Property Viewer

Property	Value
Name	IIS02VM4
IP Address	9.12.5.59
Status	ACIIVE
Total Users	139
Total Vir...	3
Total Pro...	2
Total Vol...	5842
Total Vol...	3

Current System View - "IIS02VM4"

z/VM User Groups Network Prototypes Storage **System Status** Session Tasks

Predefined Views

- Enable All
- VLAN View
- Logical View
- Physical View
- Custom View

By Layers

- External
- VLAN
- Physical
- VM
- VNS
- Guests

Layout

Workunit Name	Initiator	Start At	End At	Duration	Status	Progress
Update z/VM Prototype Aspect For z/VM System	richard	2014-01-07 08:15:57	2014-01-07 08:15:59	2 seconds	Done	100%
Update z/VM Network Aspect For z/VM System	richard	2014-01-07 08:15:52	2014-01-07 08:15:55	3 seconds	Done	100%
Update z/VM Guest Aspect For z/VM System	richard	2014-01-07 08:15:47	2014-01-07 08:15:50	3 seconds	Done	100%
Assign Directory for z/VM System	richard	2014-01-07 08:15:44	2014-01-07 08:15:45	1 seconds	Done	100%
Create and Associate Device Pool with z/VM System	richard	2014-01-07 08:15:39	2014-01-07 08:15:39	0 seconds	Done	100%
Create and Associate Device Pool with z/VM System	richard	2014-01-07 08:15:39	2014-01-07 08:15:39	0 seconds	Done	100%
Create and Associate Device Pool with z/VM System	richard	2014-01-07 08:15:39	2014-01-07 08:15:39	0 seconds	Done	100%
Create and Associate Device Pool with z/VM System	richard	2014-01-07 08:15:39	2014-01-07 08:15:40	1 seconds	Done	100%

CSL-WAVE Log BIS Work Units BIS System COR **BIS 2** Attention Required

BIS Online liyong

IBM Wave for z/VM: Tier 2 – WAVESRV server

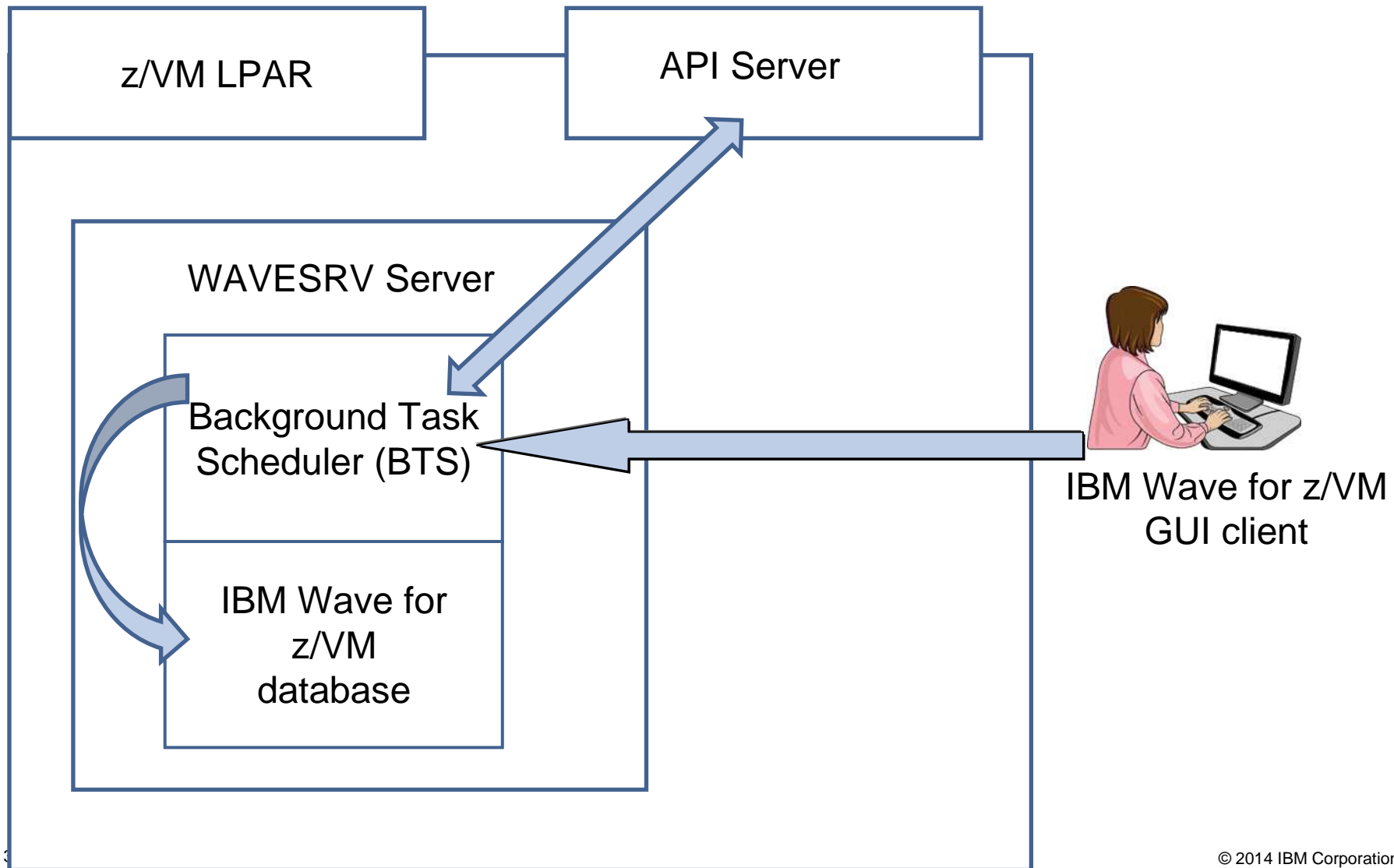

IBM Wave for z/VM WAVESRV server foundation

- **Background Task Scheduler (BTS)**
 - Employs Work Unit processing architecture for BTS worker threads
- **Knowledge Base**
 - Keeps track of the managed system components and their associated metadata
- **Common Output Repository (COR)**
 - Stores output generated by each BTS work unit
- **Message Brokers**
 - Efficiently moves messages across all system components
- **Security Enforcer**
 - Controls the scope and permission of every user action
- **Device Management**
 - Simple and automatic control of all virtual and real/dedicated devices

IBM Wave for z/VM: Tier 3 – Target Virtualization Platform (TVP)

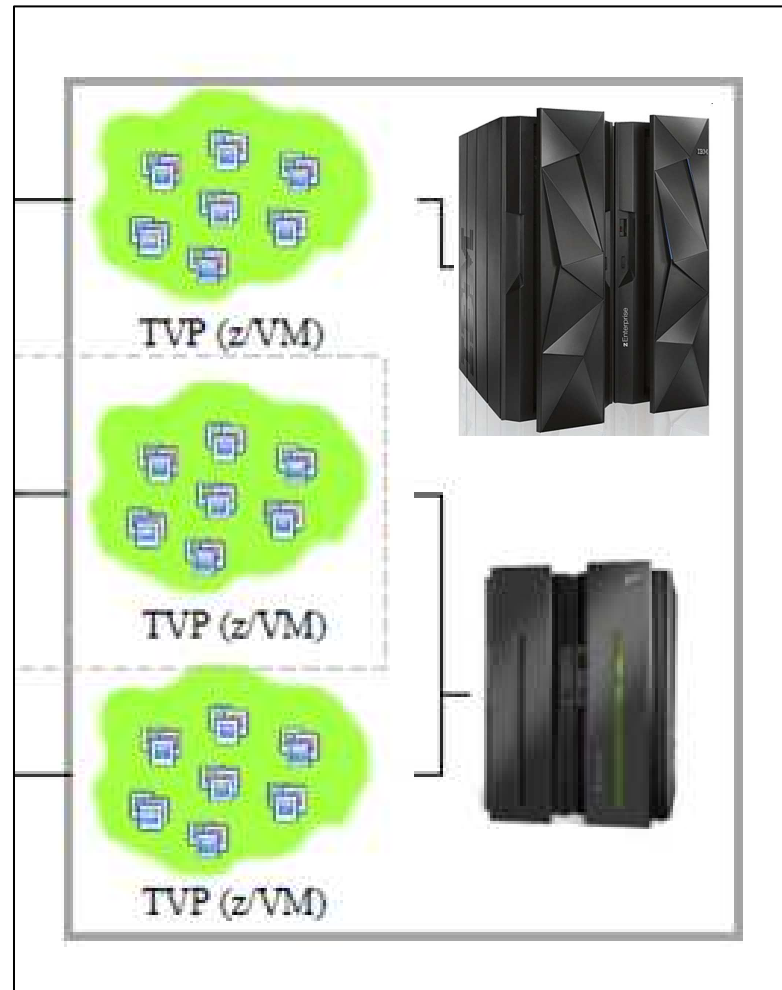

IBM Wave for z/VM Target Virtualization Platform (TVP)

- IBM Wave utilizes the SMAPI interface in order to mediate requests from the BTS and the GUI Client.
- Specific functions executed on the z/VM System using the following Service Machines:
 - **WAVEWRKS**
 - The Short Service Machine executes various compiled REXX EXECs to interact with the z/VM environment
 - **WAVEWRKL**
 - The Long Service Machine provides an additional thread of execution to run longer scripts or executes some directory manager commands
 - **WAVEWRKC**
 - This Cross-System Cloning Service Machine is used to stream minidisks from a source z/VM system to a target z/VM system during cloning actions.
- As part of the auto-detection process when adding a new z/VM System to IBM Wave management, these 3 service machines are created and started on the z/VM System automatically.

IBM Wave Operational Model

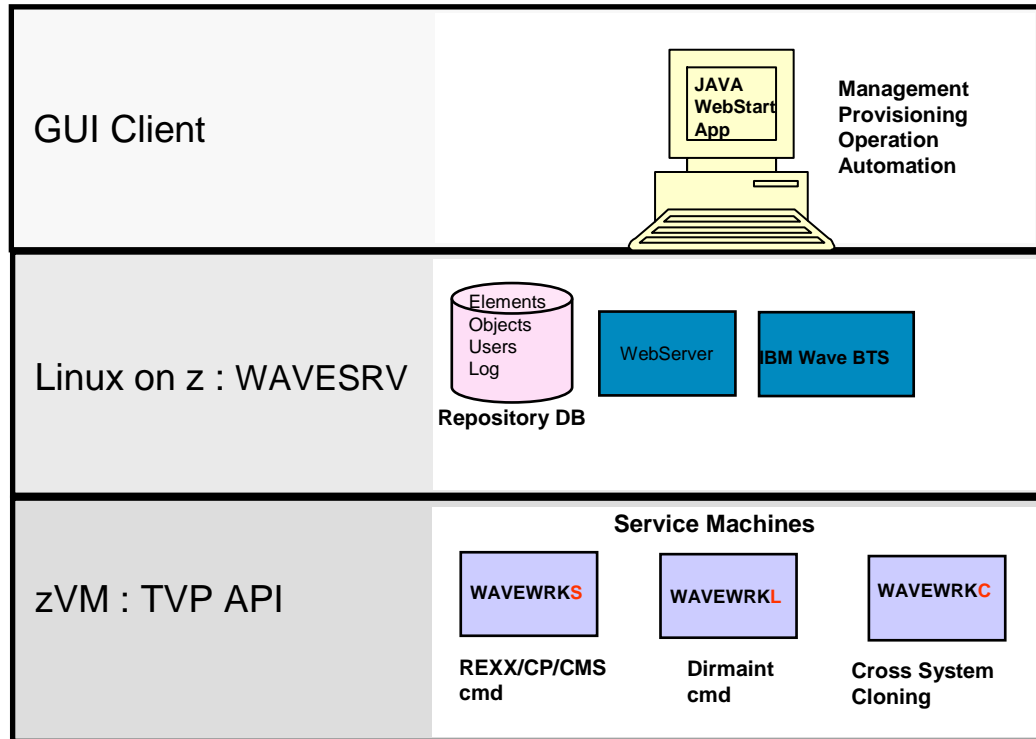

Scope

- Physical Servers
 - zVM instances, Virtual Linux Server Objects
 - Virtual Networks (Guest LANs/VSwitches)
 - Virtual-servers-to-Virtual Networks Connections
 - Storage Volumes/Groups
-
- Elements
 - Objects
 - Users
 - Log
-
- WAVEWRKS – REXX executables, CP/CMS commands
 - WAVEWRKL – Directory Manager commands
 - WAVEWRKC – Cross System Clone feature

Planning and Design

- **Sizing**
 - **1GB RAM**
 - **Filesystems:**
 - /boot 100MB (approx. 100 Cyls)
 - / 2GB (approx. 3000 Cyls)
 - /var 3GB (approx. 4500 Cyls)
- **Sizing the log space areas**
 - By default, logs are stored in /var
 - configure the /var filesystem as a logical volume under LVM so it can be extended when needed
- **Location of WAVESRV server**

The server is implemented as a virtual server within a z/VM LPAR.

Sample directory entry for the WAVESRV virtual server

USER WAVESRV <Password Here> 1G 2G GC

CPU 00

IPL CMS

MACHINE ESA 4

OPTION QUICKDSP

CONSOLE 0009 3215

NICDEF 0800 TYPE QDIO LAN SYSTEM <GLAN/VSWITCH Name here>

SPOOL 000C 3505 A

SPOOL 000D 3525 A

SPOOL 000E 1403 A

LINK MAINT 0190 0190 RR

LINK MAINT 019D 019D RR

LINK MAINT 019E 019E RR

MDISK 0191 3390 1 3 <DASD Volume Name here> - This is a CMS minidisk

MDISK 0150 3390 1 3000 <DASD Volume Name here> - This minidisk will be used for „/“

MDISK 0151 3390 1 4500 <DASD Volume Name here> - This minidisk will be used for „/var“

MDISK 0152 3390 1 200 <DASD Volume Name here> - This minidisk will be used for swap

IBM Wave Systems Management Task Example

Add Disk Space To A Virtual Server

Without IBM Wave

1. Find requested disk space
2. Create disk definition
3. Activate definition
4. Connect storage to virtual server
5. Mount device
6. Create a File System

View Storage at a Glance

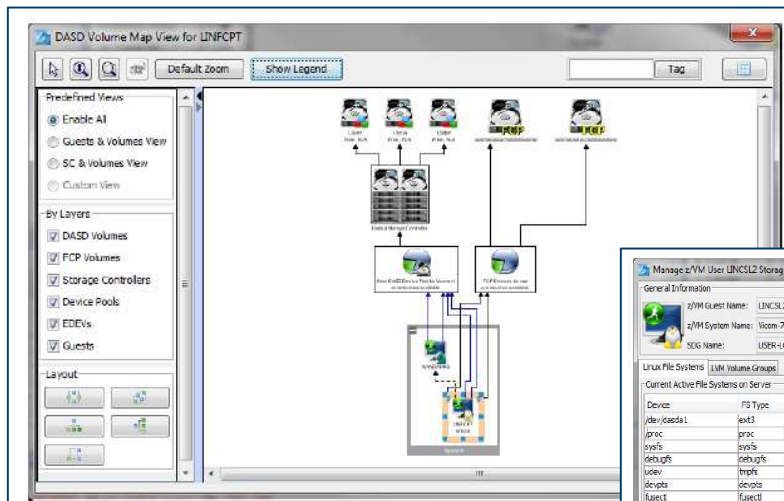

With IBM Wave

1. Open the “Add Storage” form
2. Fill the storage capacity requested
3. Press the “Go” button

Benefits:

- ✓ Reduce reliance on scarce skills
- ✓ Respond faster to IT customer needs
- ✓ Reduce costs
- ✓ Empower team to do more independently
- ✓ Simplify management
- ✓ Accurately depict current environment
- ✓ Reduce manual procedure errors
- ✓ Avoid problematic situations downstream

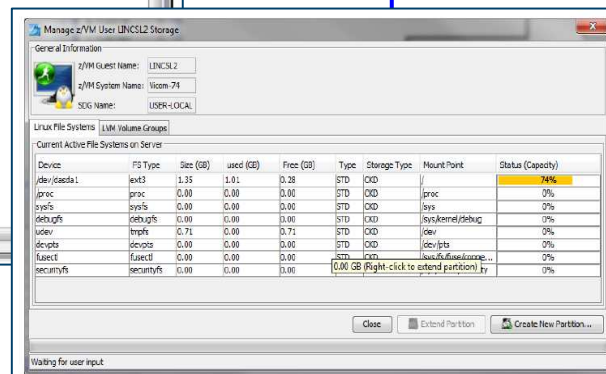

IBM Wave Systems Management Task Example: Clone a Virtual Machine

Without IBM Wave

1. Determine if required resources exist
2. Create clone VM definition
3. Define clone VM resources
4. Create copies of private VM resources (server)
5. Create copies of private VM resources (disk)
6. Customize clone VM
7. Authorize clone VM access / VSwitch Access
8. Add clone to management groups
9. Activate clone
10. Configure the network
11. Run middleware configuration scripts
12. Monitor and report on cloning operation.

With IBM Wave

1. Open the “Clone” form
2. Fill in the needed information
3. Press the “Go” Button

Benefits:

- ✓ Reduce time for a highly complex task
- ✓ Reduce costs
- ✓ Reduce reliance on scarce skills
- ✓ Improve speed to clone
- ✓ Simplify management
- ✓ Reduce errors associated with manual procedures
- ✓ No need to monitor every step of the process



Clone a Linux Virtual Server

IBM Wave Systems Management Task Example

Live Guest Relocation

Without IBM Wave

- Using manual control program commands

Task	Task Steps
Log into both z/VM instances	Login PBCVMA Login PBCVMB
Find out which instance has the running guest	q HTTP2 in PBCVMA q HTTP2 in PBCVMB
Verify the guest can be moved	vmrelo test HTTP2 to PBCVMB
Move the guest	vmrelo move HTTP2 to PBCVMB
Log out of both z/VM instances	Logoff PBCVMA Logoff PBCVMB

With IBM Wave

- Using the GUI's Drag-and-Drop techniques
- Or Execute via menu selection

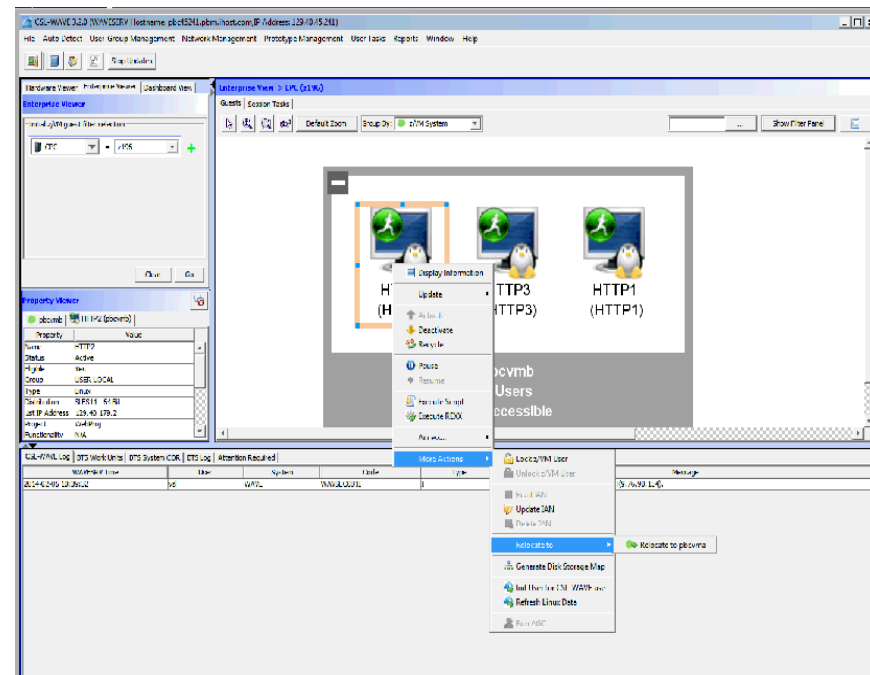

IBM Wave for z/VM Tested Productivity Savings*

IBM Wave is designed to help automate and improve the productivity of many administrative tasks. Tests were run on a zEnterprise processor both with and without the IBM Wave interface**.

Tasks	Manual Times in seconds	With IBM Wave Times in seconds	Reduction in time
Clone a Guest Linux Server	576	29	95%
Activate/deactivate a guest	65	10	85%
Add a virtual switch	88	20	77%
Execute scripts for a guest	96	18	81%
Monitor z/VM	30	13	58%
Live guest migration	95	13	87%

*These are sample task timings conducted by the IBM Competitive Project Office. Manual test times assumed a base knowledge of z/VM and assume no additional scripting. Individual test results may vary.

**Tests used a zEnterprise 196.model 2817-H10 running z/VM 6.3 with 6 cores shared by LPARS in the test. Each z/VM has 128G of memory.

Enterprise Linux Server features IBM Wave for z/VM

Enterprise Linux Server includes IBM zEnterprise® hardware, hardware maintenance, IBM virtualization and management software components and software support & subscription.

■ Hardware options

- IBM zEnterprise server
- 32 GB memory
- Connectivity
- S&S

■ Virtualization software

- IBM z/VM Version 6
- z/VM basic features:
 - Dirmaint™, RACF®, Performance Toolkit for VM™, RSCS
- NEW! IBM Wave for z/VM** included can be snapped out
- 3-5 years S&S
- **Note:** Linux ordered from Red Hat or SUSE

Enterprise Linux Server

Includes IFLs, memory, I/O adapters, z/VM software including 3-to-5 years of S&S, and maintenance

Solution Edition for Enterprise Linux

Acquire incremental Linux CPUs (IFLs), memory, z/VM software and 3-5 years of subscription and support, and maintenance.



¹ 28-32 GB memory on zBC12, 24 GB memory per core up to 5 IFLs on z114.

Summary- Overall Benefit of IBM Wave for z/VM:

- ✓ Simplify the administrative and management of virtualized servers all from a single dashboard
- ✓ Reduce the time it takes to perform complex virtualization management tasks
- ✓ Extend the reach of existing skills to manage even the most complex tasks like live guest relocation
- ✓ Improve the quality and consistency of operations with a current and accurate view of your system using IBM Wave discovery
- ✓ Reduce risk of errors by delegating management scope to the appropriate teams
- ✓ Accelerate virtualization steps like virtual server cloning and provisioning to make the transformation to cloud easier



IBM Wave for z/VM Pre-Recorded Demo or Live Demo or Slides Guided Demo

IBM System z Tiger Team: News



IBM Wave for z/VM – Demo (16min 45sec)
<http://www.youtube.com/watch?v=N3L5IJKisrY>

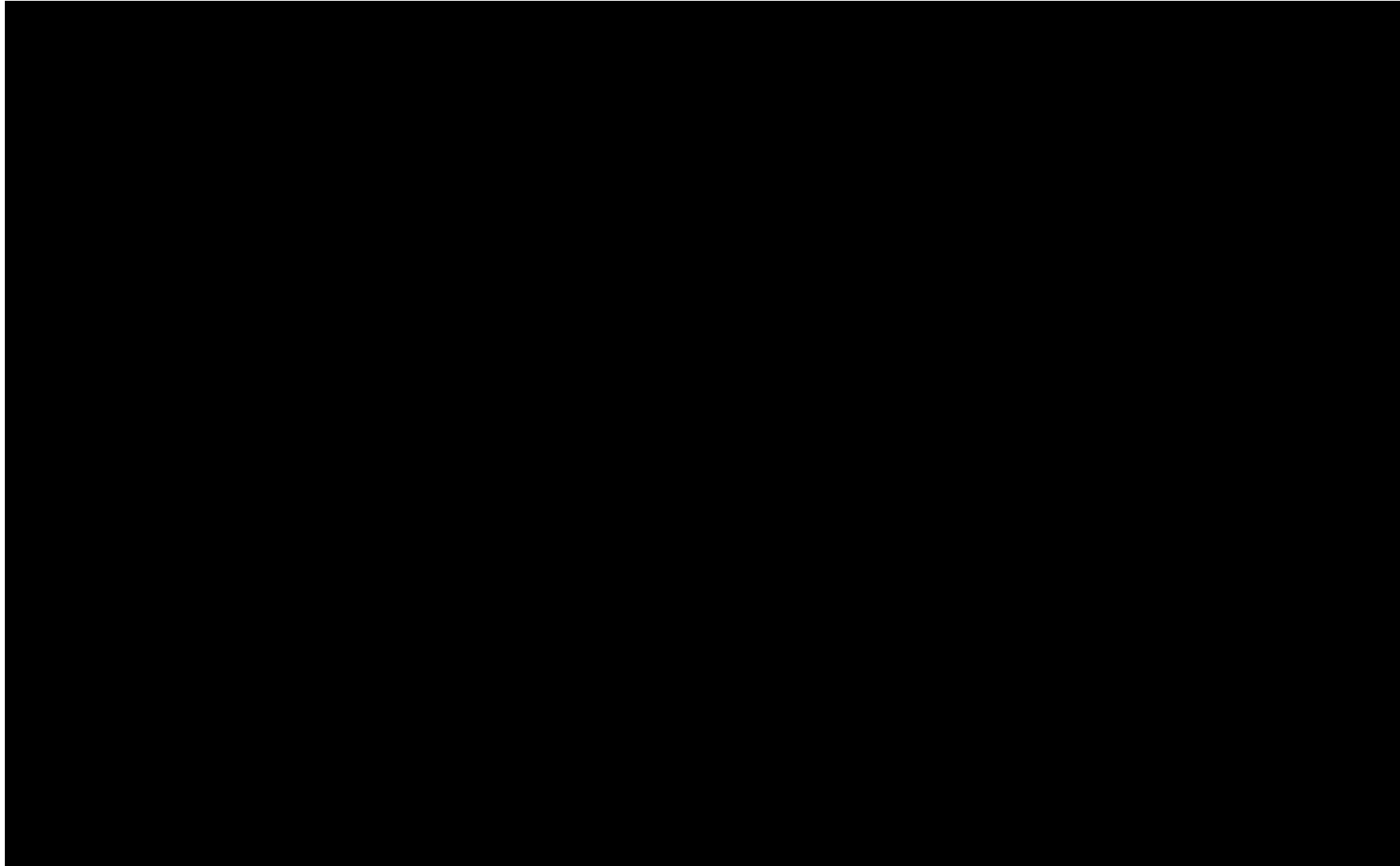

The screenshot displays the IBM Wave for z/VM viewer interface. At the top, there is a **Title Bar** with the window title "IBM Wave for z/VM 3.3.0 (WAVESERV Hostname: N/A, IP Address: 9...)". Below it is a **Menu Bar** with options: File, Auto Detect, User-Group Management, Network Management, Page Management, Administrative, User Tasks, Reports, Window, Help. A **Tool Bar** is located below the menu bar, containing icons for various functions and a "Stop Updates" button.

The main content area is titled "Current System View - 'VMLINUX2'" and shows a grid of **z/VM environment viewers**. Each viewer is represented by a green icon and a text label indicating the environment name, user count, and accessibility. The viewers shown are:

- IBM-CORP (VMLINUX2): 0 Users, All Accessible
- IBM-ENR (VMLINUX2): 4 Users, All Accessible
- IBM-SWAPI (VMLINUX2): 1 Users, All Accessible
- IBM-COM (VMLINUX2): 37 Users, All Accessible
- USER-LOCAL (VMLINUX2): 10 Users, All Accessible
- IBM-SYSTEM (VMLINUX2): 5 Users, All Accessible
- WAVE-INTERNAL (VMLINUX2): 4 Users, All Accessible
- IBM-DIRM (VMLINUX2): 3 Users, All Accessible
- IBM-UTIL (VMLINUX2): 1 Users
- IBM-WNA (VMLINUX2): 26 Users
- IBM-SEG (VMLINUX2): 12 Users

On the left side, there is a **Property Viewer** for the selected "VMLINUX2" environment. It lists the following properties:

Property	Value
Name	VMLINUX2
IP Address	9.12.4.4
Status	ACTIVE
Total Users	131
Total Virtual ...	4
Total Prototy...	0
Total Volume...	29
Total Volume ...	5
BASE P...	14.77 GB

At the bottom of the interface is the **IBM Wave for z/VM viewer** status bar, which includes a log table and a "Status Bar" label. The log table shows the following entries:

WAVESERV Time	User	System	Code	Type	Message
2014-01-21 10:56:15	lydie	WAVE	WAVSEC001I	I	Administrator lydie logged in from LYD1401(9.80.41.236).
2014-01-21 11:40:24	lydie	WAVE	WAVBTS006I	I	BTS Workunit 103611: was deleted.

The status bar also indicates "SSL Enabled" and shows the user "lydie" logged in.

CSL-WAVE 3.2.0 (WAVESERV Hostname: cslserv13, IP Address: 192.168.39.77)

File Auto Detect User-Group Management Network Management Prototype Management Storage Management Administrative User Tasks Reports Window Help

Stop Updates

Hardware Viewer Enterprise Viewer Dashboard View

Hardware Viewer Default Zoom

ATSEC12

CSLVM13

Property Viewer

Property	Value
Name	CSLVM13
IP Address	192.168.39.78
Status	ACTIVE
Total Users	130
Total Virtual ...	3
Total Prototy...	1
Total Volumes	23
Total Volume ...	3
DASD Free St...	764.95 GB

Current System View - "CSLVM13"

z/VM User Groups Network Prototypes Storage **System Status** Session Tasks

Default Zoom Group By: Project

Wave Test Drive
2 Users (+1 Hidden)
All Accessible

No Project Assigned
127 Users
All Accessible

Arrange Items

Add New Project

Collapse All

Expand All

CSL-WAVE Log BTS Work Units BTS System COR **BTS Log** Attention Required

Workunit Name	Initiator	Start At	End At	Duration	Status	Progress
Delete z/VM Guests	fred	2014-01-27 19:34:14	2014-01-27 19:36:22	2:08 minutes	Done	100%
Update All z/VM Aspects	sean	2014-01-27 18:41:02	2014-01-27 18:44:48	3:46 minutes	Done	100%
Conditional DASD update	fred	2014-01-27 18:37:03	2014-01-27 18:37:56	53 seconds	Done	100%
Create New FCP Partition	fred	2014-01-27 18:10:29	2014-01-27 18:11:16	47 seconds	Done	100%
Assign WWPNs to Storage Controller	sean	2014-01-27 18:05:54	2014-01-27 18:05:55	1 seconds	Done	100%
Update z/VM Storage Aspect	sean	2014-01-27 18:04:29	2014-01-27 18:04:43	14 seconds	Done	100%
Conditional DASD update	fred	2014-01-27 17:28:52	2014-01-27 17:29:45	53 seconds	Done	100%
Delete z/VM Guests	fred	2014-01-27 17:10:34	2014-01-27 17:11:02	28 seconds	Done	100%

BTS Online csladmin 4:54 PM

CSL-WAVE 3.2.0 (WAVESERV Hostname: cslserv13, IP Address: 192.168.39.77)

File Auto Detect User-Group Management Network Management Prototype Management Storage Management Administrative User Tasks Reports Window Help

Stop Updates

Hardware Viewer Enterprise Viewer Dashboard View

Hardware Viewer Default Zoom

ATSEC12

CSLVM13

Current System View - "CSLVM13"

z/VM User Groups Network Prototypes Storage System Status Session Tasks

Default Zoom Group By: Project Tag Show Filter Panel

Add New Project

General Information

Name: DMV

Description: California Department of Motor Vehicles

Contact Information

Contact Name: Ernie Horn

Contact Phone: 123-456-07890

Contact EMail: ernie.horn@dmv.ca.gov

Organizational Information

Project Team: DMV

Project Department: DMV

CSL-WAVE Information

Created By:

Last Modified By:

Add Close

No Project Assigned
127 Users
All Accessible

Property Viewer

Property	Value
Name	CSLVM13
IP Address	192.168.39.78
Status	ACTIVE
Total Users	130
Total Virtual ...	3
Total Prototy...	1
Total Volumes	23
Total Volume ...	3
DASD Free St	764.95 GB

CSL-WAVE Log BTS Work Units BTS System COR **BTS Log** Attention Required

Workunit Name	Initiator	Start At	End At	Duration	Status	Progress
Delete z/VM Guests	fred	2014-01-27 19:34:14	2014-01-27 19:36:22	2:08 minutes	Done	100%
Update All z/VM Aspects	sean	2014-01-27 18:41:02	2014-01-27 18:44:48	3:46 minutes	Done	100%
Conditional DASD update	fred	2014-01-27 18:37:03	2014-01-27 18:37:56	53 seconds	Done	100%
Create New FCP Partition	fred	2014-01-27 18:10:29	2014-01-27 18:11:16	47 seconds	Done	100%
Assign WWPNs to Storage Controller	sean	2014-01-27 18:05:54	2014-01-27 18:05:55	1 seconds	Done	100%
Update z/VM Storage Aspect	sean	2014-01-27 18:04:29	2014-01-27 18:04:43	14 seconds	Done	100%
Conditional DASD update	fred	2014-01-27 17:28:52	2014-01-27 17:29:45	53 seconds	Done	100%
Delete z/VM Guests	fred	2014-01-27 17:10:34	2014-01-27 17:11:02	28 seconds	Done	100%

BTS Online csladmin

5:02 PM

CSL-WAVE 3.2.0 (WAVESERV Hostname: cslserv13, IP Address: 192.168.39.77)

File Auto Detect User-Group Management Network Management Prototype Management Storage Management Administrative User Tasks Reports Window Help

Stop Updates

Hardware Viewer Enterprise Viewer Dashboard View

Hardware Viewer Default Zoom

ATSEC12

CSLVM13

Property Viewer

CSLVM13

Property	Value
Name	CSLVM13
IP Address	192.168.39.78
Status	ACTIVE
Total Users	130
Total Virtual ...	3
Total Prototy...	1
Total Volumes	23
Total Volume ...	3
DASD Free St...	264.95 GB

Current System View - "CSLVM13"

z/VM User Groups Network Prototypes Storage **System Status** Session Tasks

Default Zoom Group By: Project

DMV
0 Users

Assigned
127 Users
All Accessible

Wave Test Drive
2 Users (+1 Hidden)
All Accessible

Add CSL-WAVE Project

WAVE Project DMV added successfully.

OK

CSL-WAVE Log BTS Work Units BTS System COR **BTS Log** Attention Required

Workunit Name	Initiator	Start At	End At	Duration	Status	Progress
Delete z/VM Guests	fred	2014-01-27 19:34:14	2014-01-27 19:36:22	2:08 minutes	Done	100%
Update All z/VM Aspects	sean	2014-01-27 18:41:02	2014-01-27 18:44:48	3:46 minutes	Done	100%
Conditional DASD update	fred	2014-01-27 18:37:03	2014-01-27 18:37:56	53 seconds	Done	100%
Create New FCP Partition	fred	2014-01-27 18:10:29	2014-01-27 18:11:16	47 seconds	Done	100%
Assign WWPNs to Storage Controller	sean	2014-01-27 18:05:54	2014-01-27 18:05:55	1 seconds	Done	100%
Update z/VM Storage Aspect	sean	2014-01-27 18:04:29	2014-01-27 18:04:43	14 seconds	Done	100%
Conditional DASD update	fred	2014-01-27 17:28:52	2014-01-27 17:29:45	53 seconds	Done	100%
Delete z/VM Guests	fred	2014-01-27 17:10:34	2014-01-27 17:11:07	38 seconds	Done	100%

BTS Online csladmin

5:02 PM

CSL-WAVE 3.2.0 (WAVESERV Hostname: cslserv13, IP Address: 192.168.39.77)

File Auto Detect User-Group Management Network Management Prototype Management Storage Management Administrative User Tasks Reports Window Help

Stop Updates

Hardware Viewer Enterprise Viewer Dashboard View

Hardware Viewer Default Zoom

ATSEC12

CSLVM13

Current System View - "CSLVM13"

z/VM User Groups Network Prototypes Storage System Status Session Tasks

Default Zoom Group By: Project Tag Show Filter Panel

ATSEC12

CSLRHEL
(cslrhel13.ccz.dmz)

No Project Assigned
127 Users
All Accessible

Wave Test Drive
2 Users (+)
All Accessible

Wave Test Drive
DMV
Users

Display Information
Update
Status
Activate
Deactivate
Recycle
Pause
Resume
Send Message
Execute Script
Access...
Cloning...
Install...
More Actions

Update Information
Assign Distribution
Assign Project
Assign Custom Attribute
Assign Account
Remove Account
Assign Functionality
Assign Default z/VM System

Property Viewer

Property	Value
Name	CSLRHEL
Status	Active
Eligible	Yes
Group	USER-LOCAL
Type	Linux
Distribution	RedHat 6 - 64 Bit
1st IP Address	192.168.39.75
Project	Wave Test Drive
Functionality	N/A

CSL-WAVE Log BTS Work Units BTS System COR **BTS Log** Attention Required

Workunit Name	Initiator	Start At	End At	Duration	Status	Progress
Delete z/VM Guests	fred	2014-01-27 19:34:14	2014-01-27 19:36:22	2:08 minutes	Done	100%
Update All z/VM Aspects	sean	2014-01-27 18:41:02	2014-01-27 18:44:48	3:46 minutes	Done	100%
Conditional DASD update	fred	2014-01-27 18:37:03	2014-01-27 18:37:56	53 seconds	Done	100%
Create New FCP Partition	fred	2014-01-27 18:10:29	2014-01-27 18:11:16	47 seconds	Done	100%
Assign WWPNs to Storage Controller	sean	2014-01-27 18:05:54	2014-01-27 18:05:55	1 seconds	Done	100%
Update z/VM Storage Aspect	sean	2014-01-27 18:04:29	2014-01-27 18:04:43	14 seconds	Done	100%
Conditional DASD update	fred	2014-01-27 17:28:52	2014-01-27 17:29:45	53 seconds	Done	100%
Delete z/VM Guests	fred	2014-01-27 17:10:34	2014-01-27 17:11:02	28 seconds	Done	100%

BTS Online csladmin

5:03 PM

CSL-WAVE 3.2.0 (WAVESERV Hostname: cslserv13, IP Address: 192.168.39.77)

File Auto Detect User-Group Management Network Management Prototype Management Storage Management Administrative User Tasks Reports Window Help

Stop Updates

Hardware Viewer Enterprise Viewer Dashboard View

Hardware Viewer Default Zoom

ATSEC12

CSLVM13

Current System View - "CSLVM13"

z/VM User Groups Network Prototypes Storage System S

Default Zoom Group By: IP

SLES00 (SLES00)

Wave Test Drive
1 Users (+1 Hidden)
All Accessible

RHEL

DMV
1 Users
All Accessible

No Project Assigned
127 Users
All Accessible

Property Viewer

Property	Value
Name	CSLVM13
IP Address	192.168.39.78
Status	ACTIVE
Total Users	130
Total Virtual ...	3
Total Prototy...	1
Total Volumes	23
Total Volume ...	3
DASD Free St...	264.95 GB

Administrative

- Site Management
 - Toggle Single User Mode
 - Backup CSL-WAVE Database
 - Restore CSL-WAVE Database
- Manage CSL-WAVE Users
- Manage CSL-WAVE User Profiles
- Project Manager
- View Logged in Users
- View WRS Elements
- BTS Manager
- Send Message
- Broadcast Mesasge to CSL-WAVE Users
- Recycle Service Machines
- Recycle API Server
- Manage Parameters

CSL-WAVE Log BTS Work Units BTS System COR **BTS Log** Attention Required

Workunit Name	Initiator	Start At	End At	Duration	Status	Progress
Assign Project to z/VM Guests	csladmin	2014-01-28 17:03:10	2014-01-28 17:03:12	2 seconds	Done	100%
Delete z/VM Guests	fred	2014-01-27 19:34:14	2014-01-27 19:36:22	2:08 minutes	Done	100%
Update All z/VM Aspects	sean	2014-01-27 18:41:02	2014-01-27 18:44:48	3:46 minutes	Done	100%
Conditional DASD update	fred	2014-01-27 18:37:03	2014-01-27 18:37:56	53 seconds	Done	100%
Create New FCP Partition	fred	2014-01-27 18:10:29	2014-01-27 18:11:16	47 seconds	Done	100%
Assign WWPNS to Storage Controller	sean	2014-01-27 18:05:54	2014-01-27 18:05:55	1 seconds	Done	100%
Update z/VM Storage Aspect	sean	2014-01-27 18:04:29	2014-01-27 18:04:43	14 seconds	Done	100%
Conditional DASD update	fred	2014-01-27 17:28:52	2014-01-27 17:29:45	53 seconds	Done	100%

BTS Online csladmin

5:03 PM

CSL-WAVE 3.2.0 (WAVESERV Hostname: cslserv13, IP Address: 192.168.39.77)

File Auto Detect User-Group Management Network Management Prototype Management Storage Management Administrative User Tasks Reports Window Help

Hardware Viewer Enterprise Viewer Dashboard View

Hardware Viewer Default Zoom

Current System View - "CSLVM13"

z/VM User Groups Network Prototypes Storage System Status Session Tasks

Default Zoom Group By: Project Tag Show Filter Panel

CSL-WAVE User Manager

Some of the active CSL-WAVE Users are super users

Existing Users

Name	WA	SLA	NA	Status	Description	Created By	Created On	Modified By	Modified On	Loc...	IAN
CLIUser	<input type="checkbox"/>	<input type="checkbox"/>	<input type="checkbox"/>	Active		WAVEinit	2007-12-13 13:1...	WAVEinit	2009-09-03 21:5...		
csladmin	<input checked="" type="checkbox"/>	<input checked="" type="checkbox"/>	<input checked="" type="checkbox"/>	Active		WAVEinit	2014-01-07 11:3...	WAVEinit	2014-01-28 16:5...		
fred	<input checked="" type="checkbox"/>	<input checked="" type="checkbox"/>	<input checked="" type="checkbox"/>	Active		csladmin	2014-01-07 12:0...	csladmin	2014-01-27 11:4...		
richard	<input checked="" type="checkbox"/>	<input checked="" type="checkbox"/>	<input checked="" type="checkbox"/>	Active		sean	2014-01-21 11:0...	sean	2014-01-21 11:1...		
sean	<input checked="" type="checkbox"/>	<input checked="" type="checkbox"/>	<input checked="" type="checkbox"/>	Active		csladmin	2014-01-07 12:0...	csladmin	2014-01-27 14:2...		
WAVE Daemon Updater	<input type="checkbox"/>	<input type="checkbox"/>	<input type="checkbox"/>	Active		WAVEinit	2000-01-01 00:0...	WAVEinit	2007-09-23 13:1...		
waveadmin	<input type="checkbox"/>	<input type="checkbox"/>	<input type="checkbox"/>	Active	Dummy User for active dir...	WAVEinit	2007-12-13 13:1...	WAVEinit	2007-12-24 14:3...		
WAVEBTSAttReq	<input type="checkbox"/>	<input type="checkbox"/>	<input type="checkbox"/>	Active	Initial WAE user for the A...	WAVEinit	2007-12-13 13:1...	WAVEinit	2009-09-03 21:5...		
WAVEBTSMsgListen	<input type="checkbox"/>	<input type="checkbox"/>	<input type="checkbox"/>	Active	Initial WAE user for the M...	WAVEinit	2007-12-13 13:1...	WAVEinit	2012-01-23 08:3...		
WAVEBTScheduler	<input type="checkbox"/>	<input type="checkbox"/>	<input type="checkbox"/>	Active	Initial WAE user for the s...	WAVEinit	2007-12-13 13:1...	WAVEinit	2007-12-13 22:1...		
WAVEinit	<input type="checkbox"/>	<input type="checkbox"/>	<input type="checkbox"/>	Active	temp user to initiate the c...	WAVEinit	2000-01-01 00:0...	WAVEinit	2007-09-23 13:1...		

Filter

Active Regular Users Site Level Administrators

Suspended CSL-WAVE Administrators Network Administrators

Reset

Review Scopes and Permissions Add New CSL-WAVE User Close

Assigned users visible

Property Viewer

CSLVM13

Property	Value
Name	CSLVM13
IP Address	192.168.39.78
Status	ACTIVE
Total Users	130
Total Virtual ...	3
Total Prototy...	1
Total Volumes	23
Total Volume ...	3
DASD Free St...	764.95 GB

CSL-WAVE Log BTS Work Units BTS System COR **BTS Log** Attention Required

Workunit Name	Initiator	Start At	End At	Duration	Status	Progress
Assign Project to z/VM Guests	csladmin	2014-01-28 17:03:10	2014-01-28 17:03:12	2 seconds	Done	100%
Delete z/VM Guests	fred	2014-01-27 19:34:14	2014-01-27 19:36:22	2:08 minutes	Done	100%
Update All z/VM Aspects	sean	2014-01-27 18:41:02	2014-01-27 18:44:48	3:46 minutes	Done	100%
Conditional DASD update	fred	2014-01-27 18:37:03	2014-01-27 18:37:56	53 seconds	Done	100%
Create New FCP Partition	fred	2014-01-27 18:10:29	2014-01-27 18:11:16	47 seconds	Done	100%
Assign WWPNS to Storage Controller	sean	2014-01-27 18:05:54	2014-01-27 18:05:55	1 seconds	Done	100%
Update z/VM Storage Aspect	sean	2014-01-27 18:04:29	2014-01-27 18:04:43	14 seconds	Done	100%
Conditional DASD update	fred	2014-01-27 17:28:52	2014-01-27 17:29:45	53 seconds	Done	100%

Updating entries for WAVE Messaging Manager

BTS Online csladmin

5:04 PM

CSL-WAVE 3.2.0 (WAVESERV Hostname: cslserv13, IP Address: 192.168.39.77)

File Auto Detect User-Group Management Network Management Prototype Management Storage Management Administrative User Tasks Reports Window Help

Stop Updates

Hardware Viewer Enterprise Viewer Dashboard View

Hardware Viewer Default Zoom

Current System View - "CSLVM13"

z/VM User Groups Network Prototypes Storage System Status Session Tasks

Default Zoom Group By: Project

Tag Show Filter Panel

CSL-WAVE User Manager

Some of the active CSL-WAVE U

Name	WA	SLA
CLIUser	<input type="checkbox"/>	<input type="checkbox"/>
csladmin	<input checked="" type="checkbox"/>	<input checked="" type="checkbox"/>
fred	<input checked="" type="checkbox"/>	<input checked="" type="checkbox"/>
richard	<input checked="" type="checkbox"/>	<input checked="" type="checkbox"/>
sean	<input checked="" type="checkbox"/>	<input checked="" type="checkbox"/>
WAVE Daemon Updater	<input type="checkbox"/>	<input type="checkbox"/>
waveadmin	<input type="checkbox"/>	<input type="checkbox"/>
WAVEBTSattReq	<input type="checkbox"/>	<input type="checkbox"/>
WAVEBTSmsgListen	<input type="checkbox"/>	<input type="checkbox"/>
WAVEBTSscheduler	<input type="checkbox"/>	<input type="checkbox"/>
WAVEinit	<input type="checkbox"/>	<input type="checkbox"/>

Filter

Active Regular Users Suspended CSL-WAVE Administrators

Create New CSL-WAVE User

Actions

General Details User Type Scope and Permissions

User Details

User Name: dmvuser

Password: ●●●

Confirm: ●●●

Security Question: Who is the governor?

Answer: ●●●●●●

AD USER

Change Password on Next Login

Description: DMV User

Created by:

Last modified by:

User Status

Active A-Suspend

Reset

Create Cancel Add New CSL-WAVE User Close

Modified By	Modified On	Loc...	IAN
WAVEinit	2009-09-03 21:5...		
WAVEinit	2014-01-28 16:5...		
admin	2014-01-27 11:4...		
an	2014-01-21 11:1...		
admin	2014-01-27 14:2...		
WAVEinit	2007-09-23 13:1...		
WAVEinit	2007-12-24 14:3...		
WAVEinit	2009-09-03 21:5...		
WAVEinit	2012-01-23 08:3...		
WAVEinit	2007-12-13 22:1...		
	2007-09-23 13:1...		

Assigned users visible

CSL-WAVE Log BTS Work Units BTS System COR BTS Log Attention Required

Workunit Name	Initiator	Start At	End At	Duration	Status	Progress
Assign Project to z/VM Guests	csladmin	2014-01-28 17:03:10	2014-01-28 17:03:12	2 seconds	Done	100%
Delete z/VM Guests	fred	2014-01-27 19:34:14	2014-01-27 19:36:22	2:08 minutes	Done	100%
Update All z/VM Aspects	sean	2014-01-27 18:41:02	2014-01-27 18:44:48	3:46 minutes	Done	100%
Conditional DASD update	fred	2014-01-27 18:37:03	2014-01-27 18:37:56	53 seconds	Done	100%
Create New FCP Partition	fred	2014-01-27 18:10:29	2014-01-27 18:11:16	47 seconds	Done	100%
Assign WWPNS to Storage Controller	sean	2014-01-27 18:05:54	2014-01-27 18:05:55	1 seconds	Done	100%
Update z/VM Storage Aspect	sean	2014-01-27 18:04:29	2014-01-27 18:04:43	14 seconds	Done	100%
Conditional DASD update	fred	2014-01-27 17:28:52	2014-01-27 17:29:45	53 seconds	Done	100%

BTS Online csladmin

5:05 PM

CSL-WAVE 3.2.0 (WAVESERV Hostname: cslserv13.IP Address: 192.168.39.77)

File Auto Detect User-Group Management Network Management Prototype Management Storage Management Administrative UserTasks Reports Window Help

Hardware Viewer Enterprise Viewer Dashboard View

Hardware Viewer Default Zoom

Current System View - "CSLVM13"

z/VM User Groups Network Prototypes Storage System Status Session Tasks

Default Zoom Group By: Project

Tag Show Filter Panel

CSL-WAVE User Manager

Some of the active CSL-WAVE Users are super users

Existing Users

Name	WA	SLA	NA	Status	Description	Created By	Created On	Modified By	Modified On	Loc...	IAN
CLIUser	<input type="checkbox"/>	<input type="checkbox"/>	<input type="checkbox"/>	Active		WAVEinit	2007-12-13 13:1...	WAVEinit	2009-09-03 21:5...		
csladmin	<input checked="" type="checkbox"/>	<input checked="" type="checkbox"/>	<input checked="" type="checkbox"/>	Active		WAVEinit	2014-01-07 11:3...	WAVEinit	2014-01-28 16:5...		
fred	<input checked="" type="checkbox"/>	<input checked="" type="checkbox"/>	<input checked="" type="checkbox"/>	Active		csladmin	2014-01-07 12:0...	csladmin	2014-01-27 11:4...		
richard	<input checked="" type="checkbox"/>	<input checked="" type="checkbox"/>	<input checked="" type="checkbox"/>	Active		sean	2014-01-21 11:0...	sean	2014-01-21 11:1...		
sean	<input checked="" type="checkbox"/>	<input checked="" type="checkbox"/>	<input checked="" type="checkbox"/>	Active		csladmin	2014-01-07 12:0...	csladmin	2014-01-27 14:2...		
WAVE Daemon Updater	<input type="checkbox"/>	<input type="checkbox"/>	<input type="checkbox"/>	Active		WAVEinit	2000-01-01 00:0...	WAVEinit	2007-09-23 13:1...		
waveadmin	<input type="checkbox"/>	<input type="checkbox"/>	<input type="checkbox"/>	Active	Dummy User for active dir...	WAVEinit	2007-12-13 13:1...	WAVEinit	2007-12-24 14:3...		
WAVEBTSAttReq	<input type="checkbox"/>	<input type="checkbox"/>	<input type="checkbox"/>	Active	Initial WAE user for the A...	WAVEinit	2007-12-13 13:1...	WAVEinit	2009-09-03 21:5...		
WAVEBTSMsgListen	<input type="checkbox"/>	<input type="checkbox"/>	<input type="checkbox"/>	Active	Initial WAE user for the M...	WAVEinit	2007-12-13 13:1...	WAVEinit	2012-01-23 08:3...		
WAVEBTScheduler	<input type="checkbox"/>	<input type="checkbox"/>	<input type="checkbox"/>	Active	Initial WAE user for the s...	WAVEinit	2007-12-13 13:1...	WAVEinit	2007-12-13 22:1...		
WAVEinit	<input type="checkbox"/>	<input type="checkbox"/>	<input type="checkbox"/>	Active	temp user to initiate the c...		2000-01-01 00:0...		2007-09-23 13:1...		
dmvuser	<input type="checkbox"/>	<input type="checkbox"/>	<input type="checkbox"/>	Active	DMV User	csladmin	2014-01-28 17:0...	csladmin	2014-01-28 17:0...		

Filter: Active Suspended

- Update CSL-WAVE User
- Clone this CSL-WAVE User
- Lock CSL-WAVE user
- Unlock CSL-WAVE user
- Read IAN
- Update IAN
- Delete IAN
- Copy scopes and permissions to selected users...

Review Scopes and Permissions Add New CSL-WAVE User Close

Property Viewer

CSLVM13

Property	Value
Name	CSLVM13
IP Address	192.168.39.78
Status	ACTIVE
Total Users	130
Total Virtual ...	3
Total Prototy...	1
Total Volumes	23
Total Volume ...	3
DASD Free St...	764.95 GB

CSL-WAVE Log

Workunit Name	Assign Project to z/VM Guests	Delete z/VM Guests	Update All z/VM Aspects	Conditional DASD update	Create New FCP Partition	Assign WPPNs to Storage Controller	Update z/VM Storage Aspect	Conditional DASD update
fred	sean	fred	fred	sean	sean	sean	fred	fred
2014-01-27 19:34:14	2014-01-27 18:41:02	2014-01-27 18:37:03	2014-01-27 18:10:29	2014-01-27 18:05:54	2014-01-27 18:04:29	2014-01-27 17:28:52		
2014-01-28 17:03:12	2014-01-27 19:36:22	2014-01-27 18:44:48	2014-01-27 18:37:56	2014-01-27 18:11:16	2014-01-27 18:05:55	2014-01-27 18:04:43	2014-01-27 17:28:45	
2 seconds	2:08 minutes	3:46 minutes	53 seconds	47 seconds	1 seconds	14 seconds	53 seconds	
Done	Done	Done	Done	Done	Done	Done	Done	
100%	100%	100%	100%	100%	100%	100%	100%	

Assigned users visible

BTS Online csladmin

5:05 PM

CSL-WAVE 3.2.0 (WAVESERV Hostname: cslserv13, IP Address: 192.168.39.77)

File Auto Detect User-Group Management Network Management Prototype Management Storage Management Administrative User Tasks Reports Window Help

Stop Updates

Current System View - "CSLVM13"

z/VM User Groups Network Prototypes Storage System Status Session Tasks

Group By: Project Tag Show Filter Panel

CSL-WAVE User Manager

Some of the active CSL-WAVE U

Name	WA	SLA
CLIUser	<input type="checkbox"/>	<input type="checkbox"/>
csladmin	<input checked="" type="checkbox"/>	<input checked="" type="checkbox"/>
fred	<input checked="" type="checkbox"/>	<input checked="" type="checkbox"/>
richard	<input checked="" type="checkbox"/>	<input checked="" type="checkbox"/>
sean	<input checked="" type="checkbox"/>	<input checked="" type="checkbox"/>
WAVE Daemon Updater	<input type="checkbox"/>	<input type="checkbox"/>
waveadmin	<input checked="" type="checkbox"/>	<input checked="" type="checkbox"/>
WAVEBTSattReq	<input type="checkbox"/>	<input type="checkbox"/>
WAVEBTSMsgListen	<input type="checkbox"/>	<input type="checkbox"/>
WAVEBTSScheduler	<input type="checkbox"/>	<input type="checkbox"/>
WAVEinit	<input type="checkbox"/>	<input type="checkbox"/>
dmvuser	<input type="checkbox"/>	<input type="checkbox"/>

Filter:

Active
 Regular Users
 Suspended
 CSL-WAVE Administrators

Update CSL-WAVE User dmvuser

Actions: General Details User Type Scope and Permissions

Current Permissions:

System	Permission Type	Entry Value	Permissions

Buttons: Delete Permission, Add Permission, Update, Close

Modified By	Modified On	Loc...	IAN
AVEinit	2009-09-03 21:5...		
AVEinit	2014-01-28 16:5...		
admin	2014-01-27 11:4...		
an	2014-01-21 11:1...		
admin	2014-01-27 14:2...		
AVEinit	2007-09-23 13:1...		
AVEinit	2007-12-24 14:3...		
AVEinit	2009-09-03 21:5...		
AVEinit	2012-01-23 08:3...		
AVEinit	2007-12-13 22:1...		
	2007-09-23 13:1...		
admin	2014-01-28 17:0...		

Buttons: Add New CSL-WAVE User, Close, Reset

Assigned users visible

Workunit Log

Workunit Name	Initiator	Start At	End At	Duration	Status	Progress
Assign Project to z/VM Guests	csladmin	2014-01-28 17:03:10	2014-01-28 17:03:12	2 seconds	Done	100%
Delete z/VM Guests	fred	2014-01-27 19:34:14	2014-01-27 19:36:22	2:08 minutes	Done	100%
Update All z/VM Aspects	sean	2014-01-27 18:41:02	2014-01-27 18:44:48	3:46 minutes	Done	100%
Conditional DASD update	fred	2014-01-27 18:37:03	2014-01-27 18:37:56	53 seconds	Done	100%
Create New FCP Partition	fred	2014-01-27 18:10:29	2014-01-27 18:11:16	47 seconds	Done	100%
Assign WWPNs to Storage Controller	sean	2014-01-27 18:05:54	2014-01-27 18:05:55	1 seconds	Done	100%
Update z/VM Storage Aspect	sean	2014-01-27 18:04:29	2014-01-27 18:04:43	14 seconds	Done	100%
Conditional DASD update	fred	2014-01-27 17:28:52	2014-01-27 17:29:45	53 seconds	Done	100%

BTS Online | User: csladmin | 5:05 PM

CSL-WAVE 3.2.0 (WAVESERV Hostname: cslserv13, IP Address: 192.168.39.77)

File Auto Detect User-Group Management Network Management Prototype Management Storage Management Administrative User Tasks Reports Window Help

Stop Updates

Hardware Viewer Enterprise Viewer Dashboard View

Hardware Viewer Default Zoom

Current System View - "CSLVM13"

z/VM User Groups Network Prototypes Storage System Status Session Tasks

Default Zoom Group By: Project

Tag Show Filter Panel

CSL-WAVE User Manager

Update CSL-WAVE User dmvuser

Some of the active users

Existing Users

Name	CLUser
csladmin	
fred	
richard	
sean	
WAVE Daemon Updater	
waveadmin	
WAVEBTSAtReq	
WAVEBTSMsgListen	
WAVEBTSScheduler	
WAVEinit	
dmvuser	

Filter

Active Regular

Suspended CSL-WAVE

Add CSL-WAVE Permission

Permission Scope

z/VM System Scope Type Project Scope Value *

Permissions

<input checked="" type="checkbox"/> Activate	<input checked="" type="checkbox"/> Clone	<input checked="" type="checkbox"/> Assign Distribution	<input type="checkbox"/> Assign Project	<input checked="" type="checkbox"/> Browse Console
<input checked="" type="checkbox"/> CLC	<input checked="" type="checkbox"/> Delete	<input checked="" type="checkbox"/> Connect	<input checked="" type="checkbox"/> Create Like	<input checked="" type="checkbox"/> Create Prototype
<input checked="" type="checkbox"/> Deactivate	<input checked="" type="checkbox"/> Init for CSL-WAVE	<input checked="" type="checkbox"/> Disconnect	<input checked="" type="checkbox"/> Display	<input checked="" type="checkbox"/> Execute REXX
<input checked="" type="checkbox"/> Execute Script	<input checked="" type="checkbox"/> Recycle	<input checked="" type="checkbox"/> Linux Console	<input checked="" type="checkbox"/> Lock/Unlock	<input checked="" type="checkbox"/> Manage Storage
<input checked="" type="checkbox"/> Pause	<input type="checkbox"/> Set Account	<input checked="" type="checkbox"/> Remove Inconsistent	<input checked="" type="checkbox"/> Resume	<input checked="" type="checkbox"/> SSH
<input checked="" type="checkbox"/> Send Message		<input checked="" type="checkbox"/> Status	<input type="checkbox"/> Transfer to SDG	<input checked="" type="checkbox"/> Update

Permit All Deny All Clear All

Cancel Add permission

Update Close Add New CSL-WAVE User Close

Assigned users visible

CSL-WAVE Log BTS Work Units BTS System COR **BTS Log** Attention Required

Workunit Name	Initiator	Start At	End At	Duration	Status	Progress
Assign Project to z/VM Guests	csladmin	2014-01-28 17:03:10	2014-01-28 17:03:12	2 seconds	Done	100%
Delete z/VM Guests	fred	2014-01-27 19:34:14	2014-01-27 19:36:22	2:08 minutes	Done	100%
Update All z/VM Aspects	sean	2014-01-27 18:41:02	2014-01-27 18:44:48	3:46 minutes	Done	100%
Conditional DASD update	fred	2014-01-27 18:37:03	2014-01-27 18:37:56	53 seconds	Done	100%
Create New FCP Partition	fred	2014-01-27 18:10:29	2014-01-27 18:11:16	47 seconds	Done	100%
Assign WWPNs to Storage Controller	sean	2014-01-27 18:05:54	2014-01-27 18:05:55	1 seconds	Done	100%
Update z/VM Storage Aspect	sean	2014-01-27 18:04:29	2014-01-27 18:04:43	14 seconds	Done	100%
Conditional DASD update	fred	2014-01-27 17:28:52	2014-01-27 17:29:45	53 seconds	Done	100%

BTS Online csladmin 5:06 PM

CSL-WAVE 3.2.0 (WAVESERV Hostname: cslserv13, IP Address: 192.168.39.77)

File Auto Detect User-Group Management Network Management Prototype Management Storage Management Administrative User Tasks Reports Window Help

Stop Updates

Hardware Viewer Enterprise Viewer Dashboard View

Hardware Viewer Default Zoom

Current System View - "CSLVM13"

z/VM User Groups Network Prototypes Storage System Status Session Tasks

Default Zoom Group By: Project Tag Show Filter Panel

CSL-WAVE User Manager

Update CSL-WAVE User dmvsuser

Some of the active users

Existing Users

Name
CLIUser
csladmin
fred
richard
sean
WAVE Daemon Updater
waveadmin
WAVEBTSAttReq
WAVEBTSMsgListen
WAVEBTS Scheduler
WAVEInit
dmvsuser

Filter

Active Regular

Suspended CSL-WAVE

Add CSL-WAVE Permission

Permission Scope

z/VM System	Scope Type	Scope Value
*	Project	DMV

Permissions

z/VM User		
<input checked="" type="checkbox"/> Activate	<input checked="" type="checkbox"/> Add	<input checked="" type="checkbox"/> Assign Distribution
<input checked="" type="checkbox"/> CLC	<input checked="" type="checkbox"/> Clone	<input checked="" type="checkbox"/> Connect
<input checked="" type="checkbox"/> Deactivate	<input checked="" type="checkbox"/> Delete	<input checked="" type="checkbox"/> Disconnect
<input checked="" type="checkbox"/> Execute Script	<input checked="" type="checkbox"/> Init for CSL-WAVE	<input checked="" type="checkbox"/> Linux Console
<input checked="" type="checkbox"/> Pause	<input checked="" type="checkbox"/> Recycle	<input checked="" type="checkbox"/> Remove Inconsistent
<input checked="" type="checkbox"/> Send Message	<input type="checkbox"/> Set Account	<input checked="" type="checkbox"/> Status
<input type="checkbox"/> Assign Project	<input checked="" type="checkbox"/> Browse Console	<input checked="" type="checkbox"/> Create Like
<input checked="" type="checkbox"/> Create Prototype	<input checked="" type="checkbox"/> Create Prototype	<input checked="" type="checkbox"/> Execute REXX
<input checked="" type="checkbox"/> Manage Storage	<input checked="" type="checkbox"/> SSH	<input checked="" type="checkbox"/> Update
<input checked="" type="checkbox"/> Update	<input type="checkbox"/> Transfer to SDG	

Buttons: Permit All, Deny All, Clear All, Cancel, Add permission, Update, Close, Add New CSL-WAVE User, Close

Assigned users visible

CSL-WAVE Log

Workunit Name	Initiator	Start At	End At	Duration	Status	Progress
Assign Project to z/VM Guests	csladmin	2014-01-28 17:03:10	2014-01-28 17:03:12	2 seconds	Done	100%
Delete z/VM Guests	fred	2014-01-27 19:34:14	2014-01-27 19:36:22	2:08 minutes	Done	100%
Update All z/VM Aspects	sean	2014-01-27 18:41:02	2014-01-27 18:44:48	3:46 minutes	Done	100%
Conditional DASD update	fred	2014-01-27 18:37:03	2014-01-27 18:37:56	53 seconds	Done	100%
Create New FCP Parition	fred	2014-01-27 18:10:29	2014-01-27 18:11:16	47 seconds	Done	100%
Assign WWPNs to Storage Controller	sean	2014-01-27 18:05:54	2014-01-27 18:05:55	1 seconds	Done	100%
Update z/VM Storage Aspect	sean	2014-01-27 18:04:29	2014-01-27 18:04:43	14 seconds	Done	100%
Conditional DASD update	fred	2014-01-27 17:28:52	2014-01-27 17:29:45	53 seconds	Done	100%

BTS Online csladmin

5:07 PM

CSL-WAVE 3.2.0 (WAVESERV Hostname: cslserv13, IP Address: 192.168.39.77)

File Auto Detect User-Group Management Network Management Prototype Management Storage Management Administrative User Tasks Reports Window Help

Hardware Viewer Enterprise Viewer Dashboard View

Hardware Viewer Default Zoom

Current System View - "CSLVM13"

z/VM User Groups Network Prototypes Storage System Status Session Tasks

Default Zoom Group By: Project

Tag Show Filter Panel

CSL-WAVE User Manager

Some of the active CSL-WAVE U

Name	WA	SLA
CLUser	<input type="checkbox"/>	<input type="checkbox"/>
csladmin	<input checked="" type="checkbox"/>	<input checked="" type="checkbox"/>
fred	<input checked="" type="checkbox"/>	<input checked="" type="checkbox"/>
richard	<input checked="" type="checkbox"/>	<input checked="" type="checkbox"/>
sean	<input checked="" type="checkbox"/>	<input checked="" type="checkbox"/>
WAVE Daemon Updater	<input type="checkbox"/>	<input type="checkbox"/>
waveadmin	<input type="checkbox"/>	<input type="checkbox"/>
WAVEBTSAttReq	<input type="checkbox"/>	<input type="checkbox"/>
WAVEBTSMsgListen	<input type="checkbox"/>	<input type="checkbox"/>
WAVEBTS Scheduler	<input type="checkbox"/>	<input type="checkbox"/>
WAVEinit	<input type="checkbox"/>	<input type="checkbox"/>
dmvuser	<input type="checkbox"/>	<input type="checkbox"/>

Filter

Active Regular Users

Suspended CSL-WAVE Administrators

Update CSL-WAVE User dmvuser

Actions

General Details User Type Scope and Permissions

Current Permissions

System	Permission Type	Entry Value	Permissions
*	Project	DMV	Execute Script, Update, Manage Stora...

Modified By Modified On Loc... IAN

AVeinit	2009-09-03 21:5...		
AVeinit	2014-01-28 16:5...		
admin	2014-01-27 11:4...		
an	2014-01-21 11:1...		
admin	2014-01-27 14:2...		
AVeinit	2007-09-23 13:1...		
AVeinit	2007-12-24 14:3...		
AVeinit	2009-09-03 21:5...		
AVeinit	2012-01-23 08:3...		
AVeinit	2007-12-13 22:1...		
admin	2007-09-23 13:1...		
admin	2014-01-28 17:0...		

Delete Permission Add Permission Reset

Update Close

Add New CSL-WAVE User Close

Assigned users visible

Property Viewer

CSLVM13

Property	Value
Name	CSLVM13
IP Address	192.168.39.78
Status	ACTIVE
Total Users	130
Total Virtual ...	3
Total Prototy...	1
Total Volumes	23
Total Volume ...	3
DASD Free St...	264.95 GB

CSL-WAVE Log BTS Work Units BTS System COR **BTS Log** Attention Required

Workunit Name	Initiator	Start At	End At	Duration	Status	Progress
Assign Project to z/VM Guests	csladmin	2014-01-28 17:03:10	2014-01-28 17:03:12	2 seconds	Done	100%
Delete z/VM Guests	fred	2014-01-27 19:34:14	2014-01-27 19:36:22	2:08 minutes	Done	100%
Update All z/VM Aspects	sean	2014-01-27 18:41:02	2014-01-27 18:44:48	3:46 minutes	Done	100%
Conditional DASD update	fred	2014-01-27 18:37:03	2014-01-27 18:37:56	53 seconds	Done	100%
Create New FCP Partition	fred	2014-01-27 18:10:29	2014-01-27 18:11:16	47 seconds	Done	100%
Assign WWPNs to Storage Controller	sean	2014-01-27 18:05:54	2014-01-27 18:05:55	1 seconds	Done	100%
Update z/VM Storage Aspect	sean	2014-01-27 18:04:29	2014-01-27 18:04:43	14 seconds	Done	100%
Conditional DASD update	fred	2014-01-27 17:28:52	2014-01-27 17:28:45	53 seconds	Done	100%

BTS Online csladmin

5:07 PM

CSL-WAVE 3.2.0 (WAVESERV Hostname: cslserv13, IP Address: 192.168.39.77)

File Auto Detect User-Group Management Network Management Prototype Management Storage Management Administrative User Tasks Reports Window Help

Stop Updates

Hardware Viewer Enterprise Viewer Dashboard View

Hardware Viewer Default Zoom

Current System View - "CSLVM13"

z/VM User Groups Network Prototypes Storage System Status Session Tasks

Default Zoom Group By: Project Tag Show Filter Panel

CSL-WAVE User Manager

Update CSL-WAVE User dmvuser

Some of the active users

Existing Users

Name
CLIUser
csladmin
fred
richard
sean
WAVE Daemon Updater
waveadmin
WAVEBTSAttReq
WAVEBTSMsgListen
WAVEBTSScheduler
WAVEinit
dmvuser

Filter

Active Regular

Suspended CSL-WAVE

Add CSL-WAVE Permission

Permission Scope

z/VM System	Scope Type	Scope Value
*	DASDGroup	CSLGRP

Permissions

DASD Group

Add To Linux

Execute REXX

Lock/Unlock

Permit All Deny All Clear All

Cancel Add permission

Update Close Add New CSL-WAVE User Close

Assigned users visible

CSL-WAVE Log BTS Work Units BTS System COR **BTS Log** Attention Required

Workunit Name	Initiator	Start At	End At	Duration	Status	Progress
Assign Project to z/VM Guests	csladmin	2014-01-28 17:03:10	2014-01-28 17:03:12	2 seconds	Done	100%
Delete z/VM Guests	fred	2014-01-27 19:34:14	2014-01-27 19:36:22	2:08 minutes	Done	100%
Update All z/VM Aspects	sean	2014-01-27 18:41:02	2014-01-27 18:44:48	3:46 minutes	Done	100%
Conditional DASD update	fred	2014-01-27 18:37:03	2014-01-27 18:37:56	53 seconds	Done	100%
Create New FCP Parition	fred	2014-01-27 18:10:29	2014-01-27 18:11:16	47 seconds	Done	100%
Assign WWPNs to Storage Controller	sean	2014-01-27 18:05:54	2014-01-27 18:05:55	1 seconds	Done	100%
Update z/VM Storage Aspect	sean	2014-01-27 18:04:29	2014-01-27 18:04:43	14 seconds	Done	100%
Conditional DASD update	fred	2014-01-27 17:28:52	2014-01-27 17:29:45	53 seconds	Done	100%

BTS Online csladmin

5:07 PM

CSL-WAVE 3.2.0 (WAVESERV Hostname: cslserv13, IP Address: 192.168.39.77)

File Auto Detect User-Group Management Network Management Prototype Management Storage Management Administrative User Tasks Reports Window Help

Stop Updates

Hardware Viewer Enterprise Viewer Dashboard View

Hardware Viewer Default Zoom

ATSEC12

CSLVM13

Property Viewer

CSLVM13

Property	Value
Name	CSLVM13
IP Address	192.168.39.78
Status	ACTIVE
Total Users	130
Total Virtual ...	3
Total Prototy...	1
Total Volumes	23
Total Volume ...	3
DASD Free St	264.95 GB

Current System View - "CSLVM13"

z/VM User Groups Network Prototypes Storage **System Status** Session Tasks

Default Zoom Group By: Project

SLES00
(SLES00)

Wave Test Drive
1 Users (+1 Hidden)
All Accessible

CSLRHEL
(cslrhel13.ccz.dmz)

DMV
1 Users
All Accessible

No Project Assigned
127 Users
All Accessible

CSL-WAVE Log BTS Work Units BTS System COR **BTS Log** Attention Required

Workunit Name	Initiator	Start At	End At	Duration	Status	Progress
Assign Project to z/VM Guests	csladmin	2014-01-28 17:03:10	2014-01-28 17:03:12	2 seconds	Done	100%
Delete z/VM Guests	fred	2014-01-27 19:34:14	2014-01-27 19:36:22	2:08 minutes	Done	100%
Update All z/VM Aspects	sean	2014-01-27 18:41:02	2014-01-27 18:44:48	3:46 minutes	Done	100%
Conditional DASD update	fred	2014-01-27 18:37:03	2014-01-27 18:37:56	53 seconds	Done	100%
Create New FCP Partition	fred	2014-01-27 18:10:29	2014-01-27 18:11:16	47 seconds	Done	100%
Assign WWPNs to Storage Controller	sean	2014-01-27 18:05:54	2014-01-27 18:05:55	1 seconds	Done	100%
Update z/VM Storage Aspect	sean	2014-01-27 18:04:29	2014-01-27 18:04:43	14 seconds	Done	100%
Conditional DASD update	fred	2014-01-27 17:28:52	2014-01-27 17:28:45	53 seconds	Done	100%

BTS Online csladmin 5:08 PM

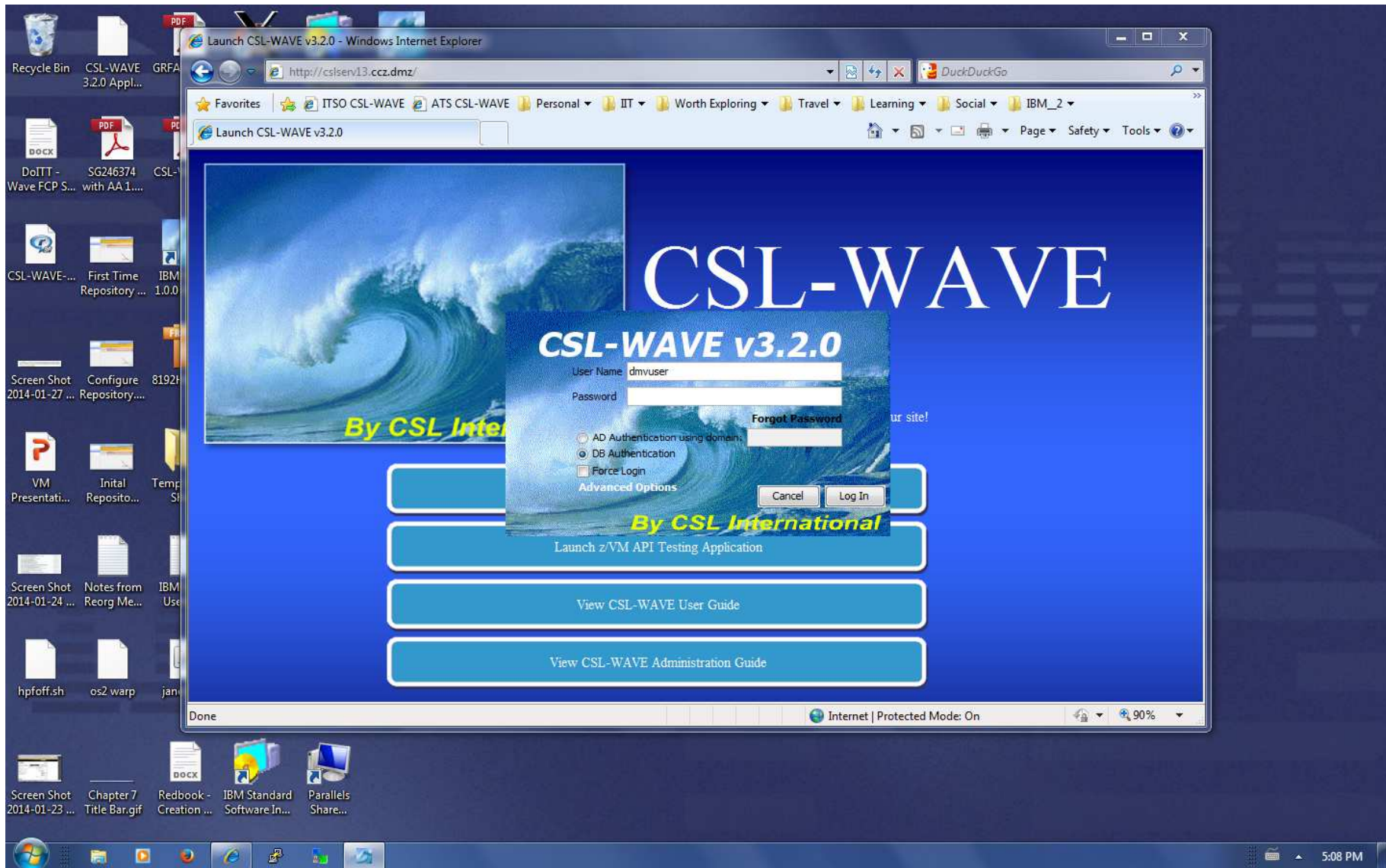

CSL-WAVE 3.2.0 (WAVESERV Hostname: cslserv13, IP Address: 192.168.39.77)

File Auto Detect User-Group Management Network Management Prototype Management UserTasks Reports Window Help

Stop Updates

Hardware Viewer Enterprise Viewer Dashboard View

Hardware Viewer Default Zoom

ATSEC12

CSLVM13

Property Viewer

CSLVM13

Property	Value
Name	CSLVM13
IP Address	192.168.39.78
Status	ACTIVE
Total Users	1
Total Virtual ...	3
Total Prototy...	0
Total Volumes	23
Total Volume ...	1
DASD Free St	249.81GB

Current System View - "CSLVM13"

z/VM User Groups Network Prototypes System Status Session Tasks

Default Zoom Group By: Site Defined Groups

USER-LOCAL (CSLVM13)
1 Users
All Accessible

WAVE-INTERNAL (CSLVM13)
0 Users

CSL-WAVE Log BTS Work Units BTS System COR **BTS Log** Attention Required

WAVESRV Time	User	System	Code	Type	Message
2014-01-28 17:08:41	dmvuser	WAVE	WAVSEC00II	I	Regular User dmvuser logged in from ADMINIB-2I8EROC(10.211.55.4).

BTS Online dmvuser 5:09 PM

CSL-WAVE 3.2.0 (WAVESERV Hostname: cslserv13, IP Address: 192.168.39.77)

File Auto Detect User-Group Management Network Management Prototype Management User Tasks Reports Window Help

Stop Updates

Hardware Viewer Enterprise Viewer Dashboard View

Hardware Viewer Default Zoom

ATSEC12

CSLVM13

Property Viewer

Property	Value
Name	CSLRHEL
Status	Active
Eligible	Yes
Group	USER-LOCAL
Type	Linux
Distribution	RedHat 6 - 64 Bit
1st IP Address	192.168.39.75
Project	DMV
Functionality	N/A

Current System View - "CSLVM13"

z/VM User Groups Network Prototypes System Status Session Tasks

Default Zoom Group By: Site Defined Groups Tag Show Filter Panel

WAVE-INTERNAL (CSLVM13)
0 Users

CSLRHEL
(cslrhel13.ccz.dmz)

USER-LOCAL (CSLVM13)
1 Users
All Accessible

CSL-WAVE Log BTS Work Units BTS System COR **BTS Log** Attention Required

WAVESRV Time	User	System	Code	Type	Message
2014-01-28 17:08:41	dmvuser	WAVE	WAVSEC00 II	I	Regular User dmvuser logged in from ADMINIB-ZI8EROC(10.211.55.4).

BTS Online dmvuser

5:09 PM

CSL-WAVE 3.2.0 (WAVESERV Hostname: cslserv13, IP Address: 192.168.39.77)

File Auto Detect User-Group Management Network Management Prototype Management User Tasks Reports Window Help

Hardware Viewer Enterprise Viewer Dashboard View

Hardware Viewer Default Zoom

Current System View - "CSLVM13"

z/VM User Groups Network Prototypes System Status Session Tasks

Default Zoom Group By: Site Defined Groups

Tag Show Filter Panel

ATSEC12

CSLVM13

WAVE-INTERNAL (CSLVM13)
0 Users

CSL (cslrhel1)

USER-LOCAL
1 U
All Acc

- Display Information
- Update
- Status
- Activate
- Deactivate
- Recycle
- Pause
- Resume
- Send Message
- Execute Script
- Access...
- Cloning...
- Install...
- More Actions

Property Viewer

Property	Value
Name	CSLRHEL
Status	Active
Eligible	Yes
Group	USER-LOCAL
Type	Linux
Distribution	RedHat 6 - 64 Bit
1st IP Address	192.168.39.75
Project	DMV
Functionality	N/A

CSL-WAVE Log | BTS Work Units | BTS System COR | **BTS Log** | Attention Required

WAVESRV Time	User	System	Code	Type	Message
2014-01-28 17:08:41	dmvuser	WAVE	WAVSEC001I	I	Regular User dmvuser logged in from ADMINIB-ZI8EROC(10.211.55.4).

BTS Online dmuser 5:09 PM

CSL-WAVE 3.2.0 (WAVESERV Hostname: cslserv13, IP Address: 192.168.39.77)

File Auto Detect User-Group Management Network Management Prototype Management User Tasks Reports Window Help

Stop Updates

Hardware Viewer Enterprise Viewer Dashboard View

Hardware Viewer Default Zoom

ATSEC12

CSLVM13

Current System View - "CSLVM13"

z/VM User Groups Network Prototypes System Status Session Tasks (1)

Default Zoom Group By: Site Defined Groups

Tag Show Filter Panel

Deactivate z/VM Users (1/1) Selected

Deactivate the following z/VM Users

Name	System	Act. Level	Status
<input checked="" type="checkbox"/> CSLRHEL	CSLVM13	1	Ready

Select All Deselect All Toggle Selection Show Filtering Parallel

With the following Shutdown Options:

Issue "shutdown -h" with timeout

Force z/VMuser logoff

Use Activation Levels

Hide Cancel Go

Waiting for user input

Property Viewer

CSLVM13 CSLRHEL (CSLVM13)

Property	Value
Name	CSLRHEL
Status	Active
Eligible	Yes
Group	USER-LOCAL
Type	Linux
Distribution	RedHat 6 - 64 Bit
1st IP Address	192.168.39.75
Project	DMV
Functionality	N/A

CSL-WAVE Log BTS Work Units BTS System COR **BTS Log** Attention Required

WAVESRV Time	User	System	Code	Type	Message
2014-01-28 17:08:41	dmvuser	WAVE	WAVSEC00II	I	Regular User dmvuser logged in from ADMINIB-ZI8EROC(10.211.55.4).

BTS Online dmvuser

5:09 PM

CSL-WAVE 3.2.0 (WAVESERV Hostname: cslserv13, IP Address: 192.168.39.77)

File Auto Detect User-Group Management Network Management Prototype Management User Tasks Reports Window Help

Stop Updates

Hardware Viewer Enterprise Viewer Dashboard View

Hardware Viewer Default Zoom

ATSEC12

CSLVM13

Hardware Viewer Property Viewer

CSLVM13 CSLRHEL (CSLVM13)

Property	Value
Name	CSLRHEL
Status	Active
Eligible	Yes
Group	USER-LOCAL
Type	Linux
Distribution	RedHat 6 - 64 Bit
1st IP Address	192.168.39.75
Project	DMV
Functionality	N/A

Current System View - "CSLVM13"

z/VM User Groups Network Prototypes System Status Session Tasks

Default Zoom Group By: Site Defined Groups

WAVE-INTERNAL (CSLVM13)
0 Users

CSLRHEL
(cslrhel13.ccz.dmz)

USER-LOCAL (CSLVM13)
1 Users
All Accessible

CSL-WAVE Log BTS Work Units BTS System COR **BTS Log** Attention Required

WAVESRV Time	User	System	Code	Type	Message
2014-01-28 17:08:41	dmvuser	WAVE	WAVSEC00II	I	Regular User dmvuser logged in from ADMINIB-2I8EROC(10.211.55.4).

BTS Online dmvuser

5:09 PM

CSL-WAVE 3.2.0 (WAVESERV Hostname: cslserv13, IP Address: 192.168.39.77)

File Auto Detect User-Group Management Network Management Prototype Management User Tasks Reports Window Help

Hardware Viewer Enterprise Viewer Dashboard View

Hardware Viewer Default Zoom

Current System View - "CSLVM13"

z/VM User Groups Network Prototypes System Status Session Tasks

Default Zoom Group By: Site Defined Groups Tag Show Filter Panel

ATSEC12

CSLVM13

WAVE-INTERNAL (CSLVM13)
0 Users

CSLRHEL (cslrhel13.c)

USER-LOCAL
1 User
All Access

Property Viewer

Property	Value
Name	CSLRHEL
Status	Inactive
Eligible	Yes
Group	USER-LOCAL
Type	Linux
Distribution	Red-Hat 6 - 64 Bit
1st IP Address	192.168.39.75
Project	DMV
Functionality	N/A

CSL-WAVE Log BTS Work Units BTS System COR **BTS Log** Attention Required

WAVESERV Time	User	System	Code	Type	Message
2014-01-28 17:08:41	dmvuser	WAVE	WAVSEC001I	I	Regular User dmvuser logged in from ADMINIB-2I8EROC(10.211.55.4).
2014-01-28 17:09:39	dmvuser	CSLVM13	WAVUSR015I	I	z/VM user CSLRHEL deactivated successfully.

BTS Online dmvuser

5:10 PM

CSL-WAVE 3.2.0 (WAVESERV Hostname: cslserv13, IP Address: 192.168.39.77)

File Auto Detect User-Group Management Network Management Prototype Management User Tasks Reports Window Help

Stop Updates

Hardware Viewer Enterprise Viewer Dashboard View

Hardware Viewer Default Zoom

Property Viewer

Property	Value
Name	CSLRHEL
Status	Inactive
Eligible	Yes
Group	USER-LOCAL
Type	Linux
Distribution	RedHat 6 - 64 Bit
1st IP Address	192.168.39.75
Project	DMV
Functionality	N/A

CSL-WAVE Log BTS Work Units BTS System COR BTS U

WAVESRV Time	User
2014-01-28 17:08:41	dmvuser
2014-01-28 17:09:39	dmvuser

Clone z/VM Guest CSLRHEL in z/VM System CSLVM13 (3/3) Selected

New Clone information

CSC Information

Target z/VM System Name:

New Clone Parameters

Number of clones: Basename for clones: New Password: Verify new password:

New Storage Group:

Clone the following users

Name	Hostname	System	ATS395	Virtual Network 2	Virtual Network 3	Status
<input checked="" type="checkbox"/> LICENSE0	LICENSE0	CSLVM13	192.168.39.67			Ready
<input checked="" type="checkbox"/> LICENSE1	LICENSE1	CSLVM13	192.168.39.68			Ready
<input checked="" type="checkbox"/> LICENSE2	LICENSE2	CSLVM13	192.168.39.69			Ready

Total Storage Needed: 62.5 GB

Network Configuration FCP Configuration Optional Configuration

Network Information

Virtual Segment	Virtual Network	Network	Default GW	Port type
<input checked="" type="checkbox"/> ATS395	SYSTEM.CSLVSWCH (z/VM VSwitch)	192.168.39.64	<input checked="" type="checkbox"/>	N/A

Waiting for user input

BTS Online dmuser 5:11 PM

CSL-WAVE 3.2.0 (WAVESERV Hostname: cslserv13, IP Address: 192.168.39.77)

File Auto Detect User-Group Management Network Management Prototype Management UserTasks Reports Window Help

Stop Updates

Hardware Viewer Enterprise Viewer Dashboard View

Hardware Viewer Default Zoom

ATSEC12

CSLVM13

Property Viewer

Property	Value
Name	CSLRHEL
Status	Inactive
Eligible	Yes
Group	USER-LOCAL
Type	Linux
Distribution	Red-Hat 6 - 64 Bit
1st IP Address	192.168.39.75
Project	DMV
Functionality	N/A

Current System View - "CSLVM13"

z/VM User Groups Network Prototypes System Status Session Tasks

Default Zoom Group By: Site Defined Groups

WAVE-INTERNAL (CSLVM13)
0 Users

LICENSE0 (LICENSE0)

LICENSE1 (LICENSE1)

LICENSE2 (LICENSE2)

CSLRHEL (cslrhel13.ccz.dmz)

USER-LOCAL (CSLVM13)
4 Users
All Accessible

Workunit Name	Initiator	Start At	End At	Duration	Status	Progress
Clone z/VM Guest CSLRHEL (CSLVM13) -> LICENSE2 (CSLVM13)	dmvuser	2014-01-28 17:12:57			Active	16%
Clone z/VM Guest CSLRHEL (CSLVM13) -> LICENSE1 (CSLVM13)	dmvuser	2014-01-28 17:11:55			Active	50%
Clone z/VM Guest CSLRHEL (CSLVM13) -> LICENSE0 (CSLVM13)	dmvuser	2014-01-28 17:11:49	2014-01-28 17:12:45	56 seconds	Done	100%
Conditional DASD update	dmvuser	2014-01-28 17:11:41			Active	55%
Deactivate z/VM Guests	dmvuser	2014-01-28 17:09:38	2014-01-28 17:09:40	2 seconds	Done	100%
Assign Project to z/VM Guests	csladmin	2014-01-28 17:03:10	2014-01-28 17:03:12	2 seconds	Done	100%
Delete z/VM Guests	fred	2014-01-27 19:34:14	2014-01-27 19:36:22	2:08 minutes	Done	100%
Unlodge All z/VM Connect	cesn	2014-01-27 18:41:02	2014-01-27 18:44:48	3:46 minutes	Done	100%

BTS Online dmvuser 5:13 PM

CSL-WAVE 3.2.0 (WAVESERV Hostname: cslserv13, IP Address: 192.168.39.77)

File Auto Detect User-Group Management Network Management Prototype Management User Tasks Reports Window Help

Stop Updates

Hardware Viewer Enterprise Viewer Dashboard View

Hardware Viewer Default Zoom

ATSEC12

CSLVM13

Property Viewer

Property	Value
Name	CSLVM13
IP Address	192.168.39.78
Status	ACTIVE
Total Users	1
Total Virtual ...	3
Total Prototy...	0
Total Volumes	23
Total Volume ...	1
DASD Free St...	749.81 GB

Current System View - "CSLVM13"

z/VM User Groups Network Prototypes System Status Session Tasks

Default Zoom Group By: Site Defined Groups

Tag Show Filter Panel

WAVE-INTERNAL (CSLVM13)
0 Users

USER-LOCAL (CSLVM13)
4 Users
All Accessible

LICENSE0 (LICENSE0)

LICENSE1 (LICENSE1)

LICENSE2 (LICENSE2)

CSLRHEL (cslrhel13.ccz.dmz)

Workunit Name	Initiator	Start At	End At	Duration	Status	Progress
Clone z/VM Guest CSLRHEL (CSLVM13) -> LICENSE2 (CSLVM13)	dmvuser	2014-01-28 17:12:57	2014-01-28 17:13:58	1:01 minutes	Done	100%
Clone z/VM Guest CSLRHEL (CSLVM13) -> LICENSE1 (CSLVM13)	dmvuser	2014-01-28 17:11:55	2014-01-28 17:13:20	1:25 minutes	Done	100%
Clone z/VM Guest CSLRHEL (CSLVM13) -> LICENSE0 (CSLVM13)	dmvuser	2014-01-28 17:11:49	2014-01-28 17:12:45	56 seconds	Done	100%
Conditional DASD update	dmvuser	2014-01-28 17:11:41	2014-01-28 17:13:45	2:04 minutes	Done	100%
Deactivate z/VM Guests	dmvuser	2014-01-28 17:09:38	2014-01-28 17:09:40	2 seconds	Done	100%
Assign Project to z/VM Guests	csladmin	2014-01-28 17:03:10	2014-01-28 17:03:12	2 seconds	Done	100%
Delete z/VM Guests	fred	2014-01-27 19:34:14	2014-01-27 19:36:22	2:08 minutes	Done	100%
Loadable All z/VM Attach...	lean	2014-01-27 18:41:02	2014-01-27 18:44:48	3:46 minutes	Done	100%

BTS Online dmuser

5:14 PM

CSL-WAVE 3.2.0 (WAVESERV Hostname: cslserv13, IP Address: 192.168.39.77)

File Auto Detect User-Group Management Network Management Prototype Management UserTasks Reports Window Help

Stop Updates

Hardware Viewer Enterprise Viewer Dashboard View

Hardware Viewer Default Zoom

ATSEC12

CSLVM13

Property Viewer

Property	Value
Name	LICENSE0
Status	Inactive
Eligible	Yes
Group	USER-LOCAL
Type	Linux
Distribution	Red-Hat 6 - 64 Bit
1st IP Address	192.168.39.67
Project	DMV
Functionality	N/A

Current System View - "CSLVM13"

z/VM User Groups Network Prototypes System Status Session Tasks

Default Zoom Group By: Site Defined Groups

WAVE-INTERNAL (CSLVM13)
0 Users

USER-LOCAL (CSLVM13)
4 Users
All Accessible

LICENSE1 (LICENSE1)

LICENSE0 (LICENSE0)

LICEN (LICEN)

CSLRHEL (cslrhel13.ccz.dmz)

- Update
- Activate
- Deactivate
- Recycle
- Pause
- Resume
- Send Message
- Execute Script
- More Actions

CSL-WAVE 3.2.0 (WAVESERV Hostname: cslserv13, IP Address: 192.168.39.77)

File Auto Detect User-Group Management Network Management Prototype Management User Tasks Reports Window Help

Stop Updates

Hardware Viewer Enterprise Viewer Dashboard View

Hardware Viewer Default Zoom

ATSEC12

CSLVM13

Current System View - "CSLVM13"

z/VM User Groups Network Prototypes System Status Session Tasks (1)

Default Zoom Group By: Site Defined Groups

Tag Show Filter Panel

z/VM User Activation (3/3) Selected

Activate the following z/VM Users

Name	System	Act. Level	Status
<input checked="" type="checkbox"/> LICENSE2	CSLVM13	1	Ready
<input checked="" type="checkbox"/> LICENSE1	CSLVM13	1	Ready
<input checked="" type="checkbox"/> LICENSE0	CSLVM13	1	Ready

Select All Deselect All Toggle Selection Show Filtering Parallel

With the Following Options:

Use Activation Levels

Wait Threshold: 600 Seconds

Timeout Action: Continue Activation Stop Activation

Consider Guests as active when TCP/IP is reachable

Hide Cancel Go

Waiting for user input

CSL-WAVE Log BTS Work Units BTS System COR **BTS User** Attention Required

Workunit Name	Initiator	Status	Progress
Clone z/VM Guest CSLRHEL (CSLVM13) -> LICENSE2 (CSLVM13)	dmvuser	Done	100%
Clone z/VM Guest CSLRHEL (CSLVM13) -> LICENSE1 (CSLVM13)	dmvuser	Done	100%
Clone z/VM Guest CSLRHEL (CSLVM13) -> LICENSE0 (CSLVM13)	dmvuser	Done	100%
Conditional DASD update	dmvuser	Done	100%
Deactivate z/VM Guests	dmvuser	Done	100%
Assign Project to z/VM Guests	csladmin	Done	100%
Delete z/VM Guests	fred	Done	100%
Update All z/VM Attachments	jean	Done	100%

Property Viewer

CSLVM13 LICENSE2 (CSLVM13) Li...

Property	Value
Name	LICENSE0
Status	Inactive
Eligible	Yes
Group	USER-LOCAL
Type	Linux
Distribution	RedHat 6 - 64 Bit
1st IP Address	192.168.39.67
Project	DMV
Functionality	N/A

CSL-WAVE Log BTS Work Units BTS System COR **BTS User** Attention Required

BTS Online dmvuser

5:14 PM

CSL-WAVE 3.2.0 (WAVESERV Hostname: cslserv13, IP Address: 192.168.39.77)

File Auto Detect User-Group Management Network Management Prototype Management User Tasks Reports Window Help

Stop Updates

Hardware Viewer Enterprise Viewer Dashboard View

Hardware Viewer Default Zoom

Current System View - "CSLVM13"

z/VM User Groups Network Prototypes System Status Session Tasks (1)

Default Zoom Group By: Site Defined Groups

Tag Show Filter Panel

ATSEC12

CSLVM13

License2 (License2)

Property Viewer

Property	Value
Name	LICENSE0
Status	Inactive
Eligible	Yes
Group	USER-LOCAL
Type	Linux
Distribution	RedHat 6 - 64 Bit
1st IP Address	192.168.39.67
Project	DMV
Functionality	N/A

z/VM User Activation (3/3) Selected

Activate the following z/VM Users

Name	System	Act. Level	Status
<input checked="" type="checkbox"/> LICENSE2	CSLVM13	1	Ready
<input checked="" type="checkbox"/> LICENSE1	CSLVM13	1	Ready
<input checked="" type="checkbox"/> LICENSE0	CSLVM13	1	Ready

Select All Deselect All Toggle Selection Show Filtering Parallel

With the Following Options:

Use Activation Levels

Wait Threshold: 600 Seconds

Timeout Action: Continue Activation Stop Activation

Consider Guests as active when TCP/IP is reachable

Hide Cancel Go

Waiting for user input

Workunit Name	Initiator	Status	Progress
Clone z/VM Guest CSLRHEL (CSLVM13) -> LICENSE2 (CSLVM13)	dmvuser	Done	100%
Clone z/VM Guest CSLRHEL (CSLVM13) -> LICENSE1 (CSLVM13)	dmvuser	Done	100%
Clone z/VM Guest CSLRHEL (CSLVM13) -> LICENSE0 (CSLVM13)	dmvuser	Done	100%
Conditional DASD update	dmvuser	Done	100%
Deactivate z/VM Guests	dmvuser	Done	100%
Assign Project to z/VM Guests	csladmin	Done	100%
Delete z/VM Guests	fred	Done	100%
Linkdate All z/VM Appar...	cean	Done	100%

CSL-WAVE Log BTS Work Units BTS System COR **BTS Log** Attention Required

BTS Online dmvuser

5:14 PM

CSL-WAVE 3.2.0 (WAVESERV Hostname: cslserv13, IP Address: 192.168.39.77)

File Auto Detect User-Group Management Network Management Prototype Management User Tasks Reports Window Help

Stop Updates

Hardware Viewer Enterprise Viewer Dashboard View

Hardware Viewer Default Zoom

ATSEC12

CSLVM13

Property Viewer

LICENSE0 (CSLVM13) LICENSE1 (CSLVM...)

Property	Value
Name	LICENSE1
Status	Active
Eligible	Yes
Group	USER-LOCAL
Type	Linux
Distribution	RedHat 6 - 64 Bit
1st IP Address	192.168.39.68
Project	DMV
Functionality	N/A

Current System View - "CSLVM13"

z/VM User Groups Network Prototypes System Status Session Tasks

Default Zoom Group By: Site Defined Groups

WAVE-INTERNAL (CSLVM13)
0 Users

LICENSE2
(LICENSE2)

LICENSE0
(LICENSE0)

LICENSE1
(LICENSE1)

CSLRHEL
(cslrhel13.ccz.dmz)

USER-LOCAL (CSLVM13)
4 Users
All Accessible

Workunit Name	Initiator	Start At	End At	Duration	Status	Progress
Activate z/VM Guests	dmvuser	2014-01-28 17:14:36	2014-01-28 17:14:40	4 seconds	Done	100%
Clone z/VM Guest CSLRHEL (CSLVM13) -> LICENSE2 (CSLVM13)	dmvuser	2014-01-28 17:12:57	2014-01-28 17:13:58	1:01 minutes	Done	100%
Clone z/VM Guest CSLRHEL (CSLVM13) -> LICENSE1 (CSLVM13)	dmvuser	2014-01-28 17:11:55	2014-01-28 17:13:20	1:25 minutes	Done	100%
Clone z/VM Guest CSLRHEL (CSLVM13) -> LICENSE0 (CSLVM13)	dmvuser	2014-01-28 17:11:49	2014-01-28 17:12:45	56 seconds	Done	100%
Conditional DASD update	dmvuser	2014-01-28 17:11:41	2014-01-28 17:13:45	2:04 minutes	Done	100%
Deactivate z/VM Guests	dmvuser	2014-01-28 17:09:38	2014-01-28 17:09:40	2 seconds	Done	100%
Assign Project to z/VM Guests	csladmin	2014-01-28 17:03:10	2014-01-28 17:03:12	2 seconds	Done	100%
Delete z/VM Guests	fred	2014-01-27 19:34:14	2014-01-27 19:36:22	2:08 minutes	Done	100%

BTS Online dmvuser 5:18 PM

CSL-WAVE 3.2.0 (WAVESERV Hostname: cslserv13, IP Address: 192.168.39.77)

File Auto Detect User-Group Management Network Management Prototype Management User Tasks Reports Window Help

Stop Updates

Hardware Viewer Enterprise Viewer Dashboard View

Hardware Viewer Default Zoom

ATSEC12

CSLVM13

Current System View - "CSLVM13"

z/VM User Groups Network Prototypes System Status Session Tasks

Default Zoom Group By: Site Defined Groups

Tag Show Filter Panel

WAVE-INTERNAL (CSLVM13)
0 Users

LICENSE0 (LICENSE0)

LICENSE2 (LICENSE2)

CSLRHEL (cslrhel13.ccz.dmz)

USER-LOCAL (CSLVM13)
4 Users
All Accessible

Property Viewer

LICENSE0 (CSLVM13) LICENSE1 (CSLVM...)

Property	Value
Name	LICENSE1
Status	Active
Eligible	Yes
Group	USER-LOCAL
Type	Linux
Distribution	RedHat 6 - 64 Bit
1st IP Address	192.168.39.68
Project	DMV
Functionality	N/A

CSL-WAVE Log BTS Work Units BTS System COR **BTS Log** Attention Required

Workunit Name	Initiator	Start At	End At	Duration	Status	Progress
Activate z/VM Guests	dmvuser	2014-01-28 17:14:36	2014-01-28 17:14:40	4 seconds	Done	100%
Clone z/VM Guest CSLRHEL (CSLVM13) -> LICENSE2 (CSLVM13)	dmvuser	2014-01-28 17:12:57	2014-01-28 17:13:58	1:01 minutes	Done	100%
Clone z/VM Guest CSLRHEL (CSLVM13) -> LICENSE1 (CSLVM13)	dmvuser	2014-01-28 17:11:55	2014-01-28 17:13:20	1:25 minutes	Done	100%
Clone z/VM Guest CSLRHEL (CSLVM13) -> LICENSE0 (CSLVM13)	dmvuser	2014-01-28 17:11:49	2014-01-28 17:12:45	56 seconds	Done	100%
Conditional DASD update	dmvuser	2014-01-28 17:11:41	2014-01-28 17:13:45	2:04 minutes	Done	100%
Deactivate z/VM Guests	dmvuser	2014-01-28 17:09:38	2014-01-28 17:09:40	2 seconds	Done	100%
Assign Project to z/VM Guests	csladmin	2014-01-28 17:03:10	2014-01-28 17:03:12	2 seconds	Done	100%
Delete z/VM Guests	fred	2014-01-27 19:34:14	2014-01-27 19:36:22	2:08 minutes	Done	100%

CSL-WAVE 3270 Display-only Linux Console
CSL-WAVE 3270 Linux Console
SSH Access
CLC Access

BTS Online dmvuser

5:18 PM

CSL-WAVE 3.2.0 (WAVESERV Hostname: cslserv13, IP Address: 192.168.39.77)

File Auto Detect User-Group Management Network Management Prototype Management User Tasks Reports Window Help

Stop Updates

Hardware Viewer Enterprise Viewer Dashboard View

Hardware Viewer Default Zoom

ATSEC12

CSLVM13

Property Viewer

LICENSE0 (CSLVM13) LICENSE1 (CSLVM...)

Property	Value
Name	LICENSE1
Status	Active
Eligible	Yes
Group	USER-LOCAL
Type	Linux
Distribution	RedHat 6 - 64 Bit
1st IP Address	192.168.39.68
Project	DMV
Functionality	N/A

Current System View - "CSLVM13"

z/VM User Groups Network Prototypes System Status Session Tasks

Default Zoom Group By: Site Defined Groups

Tag Show Filter Panel

LICENSE0 (LICENSE0)

LICENSE1 (LICENSE1)

CSLRHEL (cslrhl13.ccz.dmz)

USER-LOCAL (CSLVM13)
4 Users
All Accessible

SSH to LICENSE1

Login Credentials

User Name: root

Password: ●●●●●●

Interface: 192.168.39.68

Connection Options

Set this connection as default

Use Public key Authentication

Cancel Login

Waiting for user input

CSL-WAVE Log BTS Work Units BTS System COR **BTS Log** Attention Required

Workunit Name	Initiator	Start At	End At	Duration	Status	Progress
Activate z/VM Guests	dmvuser	2014-01-28 17:14:36	2014-01-28 17:14:40	4 seconds	Done	100%
Clone z/VM Guest CSLRHEL (CSLVM13) -> LICENSE2 (CSLVM13)	dmvuser	2014-01-28 17:12:57	2014-01-28 17:13:58	1:01 minutes	Done	100%
Clone z/VM Guest CSLRHEL (CSLVM13) -> LICENSE1 (CSLVM13)	dmvuser	2014-01-28 17:11:55	2014-01-28 17:13:20	1:25 minutes	Done	100%
Clone z/VM Guest CSLRHEL (CSLVM13) -> LICENSE0 (CSLVM13)	dmvuser	2014-01-28 17:11:49	2014-01-28 17:12:45	56 seconds	Done	100%
Conditional DASD update	dmvuser	2014-01-28 17:11:41	2014-01-28 17:13:45	2:04 minutes	Done	100%
Deactivate z/VM Guests	dmvuser	2014-01-28 17:09:38	2014-01-28 17:09:40	2 seconds	Done	100%
Assign Project to z/VM Guests	csladmin	2014-01-28 17:03:10	2014-01-28 17:03:12	2 seconds	Done	100%
Delete z/VM Guests	frad	2014-01-27 19:34:14	2014-01-27 19:36:22	2:08 minutes	Done	100%

BTS Online dmvuser

5:19 PM

CSL-WAVE 3.2.0 (WAVESERV Hostname: cslserv13, IP Address: 192.168.39.77)

File Auto Detect User-Group Management Network Management Prototype Management User Tasks Reports Window Help

Stop Updates

Hardware Viewer Enterprise Viewer Dashboard View Current System View - "CSLVM13"

Hardware Viewer

Property Viewer

Property	Value
Name	LICENSE1
Status	Active
Eligible	Yes
Group	USER-LOCAL
Type	Linux
Distribution	RedHat 6 - 64 Bit
1st IP Address	192.168.39.68
Project	DMV
Functionality	N/A

192.168.39.68 - PuTTY

Tag Show Filter Panel

LICENSE0 (LICENSE0)

LICENSE1 (LICENSE1)

CSLRHEL (cslrhel13.ccz.dmz)

USER-LOCAL (CSLVM13)
4 Users
All Accessible

PuTTY Security Alert

WARNING - POTENTIAL SECURITY BREACH!

The server's host key does not match the one PuTTY has cached in the registry. This means that either the server administrator has changed the host key, or you have actually connected to another computer pretending to be the server.

The new rsa2 key fingerprint is:
ssh-rsa 2048 f9:04:4d:b0:ac:17:99:4c:fb:26:33:50:46:a6:71:a4

If you were expecting this change and trust the new key, hit Yes to update PuTTY's cache and continue connecting. If you want to carry on connecting but without updating the cache, hit No.

If you want to abandon the connection completely, hit Cancel. Hitting Cancel is the ONLY guaranteed safe choice.

Yes No Cancel

CSL-WAVE Log BTS Work Units BTS System COR **BTS Log** Attention Required

Workunit Name	Initiator	Start At	End At	Duration	Status	Progress
Activate z/VM Guests	dmvuser	2014-01-28 17:14:36	2014-01-28 17:14:40	4 seconds	Done	100%
Clone z/VM Guest CSLRHEL (CSLVM13) -> LICENSE2 (CSLVM13)	dmvuser	2014-01-28 17:12:57	2014-01-28 17:13:58	1:01 minutes	Done	100%
Clone z/VM Guest CSLRHEL (CSLVM13) -> LICENSE1 (CSLVM13)	dmvuser	2014-01-28 17:11:55	2014-01-28 17:13:20	1:25 minutes	Done	100%
Clone z/VM Guest CSLRHEL (CSLVM13) -> LICENSE0 (CSLVM13)	dmvuser	2014-01-28 17:11:49	2014-01-28 17:12:45	56 seconds	Done	100%
Conditional DASD update	dmvuser	2014-01-28 17:11:41	2014-01-28 17:13:45	2:04 minutes	Done	100%
Deactivate z/VM Guests	dmvuser	2014-01-28 17:09:38	2014-01-28 17:09:40	2 seconds	Done	100%
Assign Project to z/VM Guests	csladmin	2014-01-28 17:03:10	2014-01-28 17:03:12	2 seconds	Done	100%
Relate z/VM Guests	frad	2014-01-27 19:34:14	2014-01-27 19:36:22	2:08 minutes	Done	100%

BTS Online dmuser 5:19 PM

CSL-WAVE 3.2.0 (WAVESERV Hostname: cslserv13, IP Address: 192.168.39.77)

File Auto Detect User-Group Management Network Management Prototype Management User Tasks Reports Window Help

Stop Updates

Hardware Viewer Enterprise Viewer Dashboard View Current System View - "CSLVM13"

Hardware Viewer

Property Viewer

LICENSE0 (CSLVM13)

Property	Value
Name	LICENSE1
Status	Active
Eligible	Yes
Group	USER-LOCAL
Type	Linux
Distribution	RedHat 6 - 64 Bit
1st IP Address	192.168.39.68
Project	DMV
Functionality	N/A

```

** Welcome to the CSL-WAVE test drive **
-----
[root@LICENSE1 ~]# ifconfig
eth0    Link encap:Ethernet  HWaddr 02:00:00:00:00:7A
        inet addr:192.168.39.68  Bcast:192.168.39.79  Mask:255.255.255.240
        inet6 addr: fe80::200:0:100:7a/64 Scope:Link
        UP BROADCAST RUNNING NOARP MULTICAST  MTU:1492  Metric:1
        RX packets:89 errors:0 dropped:0 overruns:0 frame:0
        TX packets:69 errors:0 dropped:0 overruns:0 carrier:0
        collisions:0 txqueuelen:1000
        RX bytes:6984 (6.8 KiB)  TX bytes:8880 (8.6 KiB)

lo      Link encap:Local Loopback
        inet addr:127.0.0.1  Mask:255.0.0.0
        inet6 addr: ::1/128 Scope:Host
        UP LOOPBACK RUNNING  MTU:16436  Metric:1
        RX packets:0 errors:0 dropped:0 overruns:0 frame:0
        TX packets:0 errors:0 dropped:0 overruns:0 carrier:0
        collisions:0 txqueuelen:0
        RX bytes:0 (0.0 b)  TX bytes:0 (0.0 b)

[root@LICENSE1 ~]#
    
```

LICENSE2 (LICENSE0)

LICENSE1 (LICENSE1)

CSLRHEL (cslrhel13.ccz.dmz)

USER-LOCAL (CSLVM13)

4 Users

All Accessible

CSL-WAVE Log BTS Work Units BTS System COR **BTS Log** Attention Required

Workunit Name	Initiator	Start At	End At	Duration	Status	Progress
Activate z/VM Guests	dmvuser	2014-01-28 17:14:36	2014-01-28 17:14:40	4 seconds	Done	100%
Clone z/VM Guest CSLRHEL (CSLVM13) -> LICENSE2 (CSLVM13)	dmvuser	2014-01-28 17:12:57	2014-01-28 17:13:58	1:01 minutes	Done	100%
Clone z/VM Guest CSLRHEL (CSLVM13) -> LICENSE1 (CSLVM13)	dmvuser	2014-01-28 17:11:55	2014-01-28 17:13:20	1:25 minutes	Done	100%
Clone z/VM Guest CSLRHEL (CSLVM13) -> LICENSE0 (CSLVM13)	dmvuser	2014-01-28 17:11:49	2014-01-28 17:12:45	56 seconds	Done	100%
Conditional DASD update	dmvuser	2014-01-28 17:11:41	2014-01-28 17:13:45	2:04 minutes	Done	100%
Deactivate z/VM Guests	dmvuser	2014-01-28 17:09:38	2014-01-28 17:09:40	2 seconds	Done	100%
Assign Project to z/VM Guests	csladmin	2014-01-28 17:03:10	2014-01-28 17:03:12	2 seconds	Done	100%
Relate z/VM Guests	frad	2014-01-27 19:34:14	2014-01-27 19:36:22	2:08 minutes	Done	100%

Updating entries for Personalization Manager

BTS Online dmuser

CSL-WAVE 3.2.0 (WAVESERV Hostname: cslserv13, IP Address: 192.168.39.77)

File Auto Detect User-Group Management Network Management Prototype Management User Tasks Reports Window Help

Stop Updates

Hardware Viewer Enterprise Viewer Dashboard View

Hardware Viewer Default Zoom

ATSEC12

CSLVM13

Current System View - "CSLVM13"

z/VM User Groups Network Prototypes System Status Session Tasks

Default Zoom Group By: Site Defined Groups

Tag Show Filter Panel

WAVE-INTERNAL (CSLVM13)
0 Users

LICENSE0 (LICENSE0)

LICENSE2 (LICENSE2)

CSLRHEL (cslrhel13.ccz.dmz)

USER-LOCAL (CSLVM13)
4 Users
All Accessible

- Display Information
- Update
- Status
- Activate
- Deactivate
- Recycle
- Pause
- Resume
- Send Message
- Execute Script
- Access...
- Cloning...
- Install...
- More Actions

Property Viewer

LICENSE0 (CSLVM13) LICENSE1 (CSLVM...)

Property	Value
Name	LICENSE1
Status	Active
Eligible	Yes
Group	USER-LOCAL
Type	Linux
Distribution	RedHat 6 - 64 Bit
1st IP Address	192.168.39.68
Project	DMV
Functionality	N/A

CSL-WAVE Log BTS Work Units BTS System COR **BTS Log** Attention Required

Workunit Name	Initiator	Start At	End At	Duration	Status	Progress
Activate z/VM Guests	dmvuser	2014-01-28 17:14:36	2014-01-28 17:14:40	4 seconds	Done	100%
Clone z/VM Guest CSLRHEL (CSLVM13) -> LICENSE2 (CSLVM13)	dmvuser	2014-01-28 17:12:57	2014-01-28 17:13:58	1:01 minutes	Done	100%
Clone z/VM Guest CSLRHEL (CSLVM13) -> LICENSE1 (CSLVM13)	dmvuser	2014-01-28 17:11:55	2014-01-28 17:13:20	1:25 minutes	Done	100%
Clone z/VM Guest CSLRHEL (CSLVM13) -> LICENSE0 (CSLVM13)	dmvuser	2014-01-28 17:11:49	2014-01-28 17:12:45	56 seconds	Done	100%
Conditional DASD update	dmvuser	2014-01-28 17:11:41	2014-01-28 17:13:45	2:04 minutes	Done	100%
Deactivate z/VM Guests	dmvuser	2014-01-28 17:09:38	2014-01-28 17:09:40	2 seconds	Done	100%
Assign Project to z/VM Guests	csladmin	2014-01-28 17:03:10	2014-01-28 17:03:12	2 seconds	Done	100%
Delete z/VM Guests	frad	2014-01-27 16:34:14	2014-01-27 16:36:22	2:08 minutes	Done	100%

BTS Online dmvuser 5:19 PM

CSL-WAVE 3.2.0 (WAVESERV Hostname: cslserv13, IP Address: 192.168.39.77)

File Auto Detect User-Group Management Network Management Prototype Management UserTasks Reports Window Help

Stop Updates

Hardware Viewer Enterprise Viewer Dashboard View

Hardware Viewer Default Zoom

ATSEC12

CSLVM13

Property Viewer

Property	Value
Name	LICENSE1
Status	Active
Eligible	Yes
Group	USER-LOCAL
Type	Linux
Distribution	Red-Hat 6 - 64 Bit
1st IP Address	192.168.39.68
Project	DMV
Functionality	N/A

Current System View - "CSLVM13"

z/VM User Groups Network Prototypes System Status Session Tasks

Default Zoom Group By: Site Defined Groups

3270 connection to LICENSE1

Enter VM User Password

Enter Password:

Use LogonBY

LogonBY User :

LogonBY Password :

Cancel Login

LICENSE0 (LICENSE0)

LICENSE1 (LICENSE1)

CSLRHEL (cslrhel13.ccz.dmz)

USER-LOCAL (CSLVM13)
4 Users
All Accessible

Workunit Name	Initiator	Start At	End At	Duration	Status	Progress
Activate z/VM Guests	dmvuser	2014-01-28 17:14:36	2014-01-28 17:14:40	4 seconds	Done	100%
Clone z/VM Guest CSLRHEL (CSLVM13) -> LICENSE2 (CSLVM13)	dmvuser	2014-01-28 17:12:57	2014-01-28 17:13:58	1:01 minutes	Done	100%
Clone z/VM Guest CSLRHEL (CSLVM13) -> LICENSE1 (CSLVM13)	dmvuser	2014-01-28 17:11:55	2014-01-28 17:13:20	1:25 minutes	Done	100%
Clone z/VM Guest CSLRHEL (CSLVM13) -> LICENSE0 (CSLVM13)	dmvuser	2014-01-28 17:11:49	2014-01-28 17:12:45	56 seconds	Done	100%
Conditional DASD update	dmvuser	2014-01-28 17:11:41	2014-01-28 17:13:45	2:04 minutes	Done	100%
Deactivate z/VM Guests	dmvuser	2014-01-28 17:09:38	2014-01-28 17:09:40	2 seconds	Done	100%
Assign Project to z/VM Guests	csladmin	2014-01-28 17:03:10	2014-01-28 17:03:12	2 seconds	Done	100%
Delete z/VM Guests	frad	2014-01-27 19:34:14	2014-01-27 19:36:22	2:08 minutes	Done	100%

BTS Online dmvuser 5:19 PM

CSL-WAVE 3.2.0 (WAVESERV Hostname: cslserv13, IP Address: 192.168.39.77)

File Auto Detect User-Group Management Network Management Prototype Management UserTasks Reports Window Help

Stop Updates

Hardware Viewer Enterprise Viewer Dashboard View

Hardware Viewer Default Zoom

ATSEC12

CSLVM13

Property Viewer

LICENSE0 (CSLVM13) LICENSE1 (CSLVM13)

Property	Value
Name	LICENSE1
Status	Active
Eligible	Yes
Group	USER-LOCAL
Type	Linux
Distribution	Red-Hat 6 - 64 Bit
1st IP Address	192.168.39.68
Project	DMV
Functionality	N/A

Current System View - "CSLVM13"

z/VM User Groups Network Prototypes System Status Session Tasks

Default Zoom

Linux Console for LICENSE1

Key Pad

```

17:20:14 * MSG FROM WAVESRVS: WAVE-3270 SESSION ACTIVATED SUCCESSFULLY
root
Login incorrect
login: root
root
Password: cslwave
Last login: Tue Jan 28 17:19:12 from 9.82.37.222
*
*   IBM Advanced Technical Support (ATS)
*   System z Applied Technologies Lab
*   Red Hat Enterprise Linux Server 6.4
*
** Welcome to the CSL-WAVE test drive **
*
[root@LICENSE1 ~]#
                    
```

Go Break (^C)

Progress

100%
100%
100%
100%
100%
100%
100%
100%
100%

CSL-WAVE Log BTS Work Units BTS System COR **BTS Log** Attention Required

Workunit Name	Initiator	Start Time	End Time	Duration	Status
Activate z/VM Guests	dmvuser				
Clone z/VM Guest CSLRHEL (CSLVM13) -> LICENSE2 (CSLVM13)	dmvuser				
Clone z/VM Guest CSLRHEL (CSLVM13) -> LICENSE1 (CSLVM13)	dmvuser				
Clone z/VM Guest CSLRHEL (CSLVM13) -> LICENSE0 (CSLVM13)	dmvuser				
Conditional DASD update	dmvuser				
Deactivate z/VM Guests	dmvuser				
Assign Project to z/VM Guests	csladmin	2014-01-28 17:03:10	2014-01-28 17:03:12	2 seconds	Done
Deleata z/VM Guests	frad	2014-01-27 19:34:14	2014-01-27 19:36:22	2:02 minutes	Done

BTS Online dmvuser

5:20 PM

CSL-WAVE 3.2.0 (WAVESERV Hostname: cslserv13.IP Address: 192.168.39.77)

File Auto Detect User-Group Management Network Management Prototype Management UserTasks Reports Window Help

Stop Updates

Hardware Viewer Enterprise Viewer Dashboard View

Hardware Viewer Default Zoom

ATSEC12

CSLVM13

Property Viewer

LICENSE1 (CSLVM13)

Property	Value
Name	LICENSE1
Status	Active
Eligible	Yes
Group	USER-LOCAL
Type	Linux
Distribution	Red-Hat 6 - 64 Bit
1st IP Address	192.168.39.68
Project	DMV
Functionality	N/A

CSL-WAVE Log BTS Work Units BTS System COR

Workunit Name

Activate z/VM Guests

Clone z/VM Guest CSLRHEL (CSLVM13) -> LICENSE2 (CSLVM13)

Clone z/VM Guest CSLRHEL (CSLVM13) -> LICENSE1 (CSLVM13)

Clone z/VM Guest CSLRHEL (CSLVM13) -> LICENSE0 (CSLVM13)

Conditional DASD update

Deactivate z/VM Guests

Assign Project to z/VM Guests

Delete z/VM Guests

Display LICENSE1 Details

General Information

z/VM Guest Name: LICENSE1

z/VM System Name: CSLVM13

SDG Name: USER-LOCAL

Data z/VM View zLinux View Performance View Custom Attributes

z/VM Performance Data

Linux Performance Data

CPU

Memory

1,857.54 MB Free

143.70 MB Used

Swap (7384383488...)

7,042.30 MB Free

Load Average

	1 Minute	5 Minutes	15 Minutes
0.0	0.01	0.0	0.0

Cache

Type	Amount
Buffers	17.14 MB
Cache	63.50 MB

Tasks (71 total)

Status	Amount
Running	1
Sleeping	70
Stopped	0
Zombie	0

Processes

Process Name	PID	User	Prio.	Nice	Virtual	Resident	Share	Status	% CPU	% Memory	Time
top	1698	root	20	0	2.87 KB	1.16 KB	952	R	0.3	0.1	0:00.01
init	1	root	20	0	3.17 KB	1.62 KB	1.32 KB	S	0.0	0.1	0:00.25
kthreadd	2	root	20	0	0	0	0	S	0.0	0.0	0:00.00
migration/0	3	root	RT	0	0	0	0	S	0.0	0.0	0:00.00
ksftirnd/0	4	root	20	0	0	0	0	S	0.0	0.0	0:00.01

Update

Close IAN

Waiting for user input

Progress

100%
100%
100%
100%
100%
100%
100%
100%

BTS Online dmuser

5:23 PM

CSL-WAVE 3.2.0 (WAVESERV Hostname: cslserv13, IP Address: 192.168.39.77)

File Auto Detect User-Group Management Network Management Prototype Management User Tasks Reports Window Help

Stop Updates

Hardware Viewer Enterprise Viewer Dashboard View

Hardware Viewer Default Zoom

ATSEC12

CSLVM13

Property Viewer

LICENSE1 (CSLVM13)

Property	Value
Name	LICENSE1
Status	Active
Eligible	Yes
Group	USER-LOCAL
Type	Linux
Distribution	RedHat 6 - 64 Bit
1st IP Address	192.168.39.68
Project	DMV
Functionality	N/A

CSL-WAVE Log BTS Work Units BTS System COR BTS U

Workunit Name

Activate z/VM Guests

Clone z/VM Guest CSLRHEL (CSLVM13) -> LICENSE2 (CSLVM13)

Clone z/VM Guest CSLRHEL (CSLVM13) -> LICENSE1 (CSLVM13)

Clone z/VM Guest CSLRHEL (CSLVM13) -> LICENSE0 (CSLVM13)

Conditional DASD update

Deactivate z/VM Guests

Assign Project to z/VM Guests	dmvuser	2014-01-28 17:03:10	2014-01-28 17:03:10	2 seconds	Done
Assign Project to z/VM Guests	csladmin	2014-01-28 17:03:10	2014-01-28 17:03:12	2 seconds	Done
Deactivate z/VM Guests	frad	2014-01-27 19:34:14	2014-01-27 19:36:22	2:08 minutes	Done

Display LICENSE1 Details

General Information

z/VM Guest Name: LICENSE1

z/VM System Name: CSLVM13

SDG Name: USER-LOCAL

Data z/VM View zLinux View Performance View Custom Attributes

File System Information (df -ah)

Device	FS Type	Size (GB)	used (GB)	Free (GB)	Type	Mount Point	Status (Capacity)
/dev/dasdc1	ext4	6.77	2.37	4.05	STD	/	35%
proc	proc	0.00	0.00	0.00	STD	/proc	0%
sysfs	sysfs	0.00	0.00	0.00	STD	/sys	0%
devpts	devpts	0.00	0.00	0.00	STD	/dev/pts	0%
tmpfs	tmpfs	0.98	0.00	0.98	STD	/dev/shm	0%
/dev/mapper/optvg-optiv	ext4	6.77	0.14	6.28	LVM	/opt	2%

Network Information (ifconfig -all)

Device	MAC Address	IP Address	Status
eth0	02:00:00:00:00:7A	192.168.39.68	ONLINE
lo		127.0.0.1	ONLINE

Routing Information (route)

Destination	Gateway	Mask	Flags	Metric	Ref	Use	Interface	Reachable
192.168.39...	*	255.255.255.240	U	0	0	0	eth0	N/A
link-local	*	255.255.0.0	U	1002	0	0	eth0	N/A
default	192.168.39.65	0.0.0.0	UG	0	0	0	eth0	Reachable

Uptime Information

Uptime: up 7 min

Close IAN

Waiting for user input

Progress

100%
100%
100%
100%
100%
100%
100%
100%

BTS Online dmuser

5:24 PM

CSL-WAVE 3.2.0 (WAVESERV Hostname: cslserv13, IP Address: 192.168.39.77)

File Auto Detect User-Group Management Network Management Prototype Management User Tasks Reports Window Help

Stop Updates

Hardware Viewer Enterprise Viewer Dashboard View

Hardware Viewer Default Zoom

ATSEC12

CSLVM13

Property Viewer

LICENSE1 (CSLVM13)

Property	Value
Name	LICENSE1
Status	Active
Eligible	Yes
Group	USER-LOCAL
Type	Linux
Distribution	RedHat 6 - 64 Bit
1st IP Address	192.168.39.68
Project	DMV
Functionality	N/A

Workunit Name

Activate z/VM Guests

Clone z/VM Guest CSLRHEL (CSLVM13) -> LICENSE2 (CSLVM13)

Clone z/VM Guest CSLRHEL (CSLVM13) -> LICENSE1 (CSLVM13)

Clone z/VM Guest CSLRHEL (CSLVM13) -> LICENSE0 (CSLVM13)

Conditional DASD update

Deactivate z/VM Guests

Assign Project to z/VM Guests

Delete z/VM Guests

CSL-WAVE Log BTS Work Units BTS System COR

Waiting for user input

Display LICENSE1 Details

General Information

z/VM Guest Name: LICENSE1

z/VM System Name: CSLVM13

SDG Name: USER-LOCAL

Data z/VM View zLinux View Performance View Custom Attributes

```

USER LICENSE1 XXXXXXXX 2G G
*
* CSL-WAVE RHEL MASTER IMAGE (192.168.38.11)
*
ACCOUNT 67YC ATSZLAB
COMMAND SET PF12 RETR BACK
COMMAND SET PF11 RETR FORW
COMMAND SET RUN ON
IPL CMS PARM AUTOOCR
IUCV ANY PRIORITY MSGLIMIT 2000
IUCV ALLOW
MACHINE ESA
OPTION APPLMON
CONSOLE 0009 3215 T
NICDEF AC00 TYPE QDIO LAN SYSTEM CSLYSWCH
SPOOL 000C 2540 READER *
SPOOL 000D 2540 PUNCH A
SPOOL 000E 1403 A
*
LINK MAINT 0190 0190 RR
LINK MAINT 019D 019D RR
LINK MAINT 019E 019E RR
LINK TCPMAINT 0592 0592 RR
LINK LNXMaint 0191 0191 RR
LINK LNXMaint 0192 0192 RR
LINK WAVEWRKS 0399 0399 RR
MDISK 0200 3390 6679 10016 CSL005 MR
MDISK 0300 3390 16695 10016 CSL005 MR
MDISK 0900 3390 26711 3338 CSL004 MR
MDISK 0901 3390 1 6678 CSL006 MR
*DVOPT LNK0 LOG1 RCM1 SMS0 NPW1 LNGAMENG PWC20140128 CRC+F
    
```

Close IAN

Progress

100%
100%
100%
100%
100%
100%
100%
100%
100%
100%

BTS Online dmuser

5:24 PM

CSL-WAVE 3.2.0 (WAVESERV Hostname: cslserv13, IP Address: 192.168.39.77)

File Auto Detect User-Group Management Network Management Prototype Management User Tasks Reports Window Help

Stop Updates

Hardware Viewer Enterprise Viewer Dashboard View

Hardware Viewer Default Zoom

ATSEC12

CSLVM13

Property Viewer

LICENSE1 (CSLVM13)

Property	Value
Name	LICENSE1
Status	Active
Eligible	Yes
Group	USER-LOCAL
Type	Linux
Distribution	RedHat 6 - 64 Bit
1st IP Address	192.168.39.68
Project	DMV
Functionality	N/A

CSL-WAVE Log BTS Work Units BTS System COR BTS U

Workunit Name

Activate z/VM Guests

Clone z/VM Guest CSLRHEL (CSLVM13) -> LICENSE2 (CSLVM13)

Clone z/VM Guest CSLRHEL (CSLVM13) -> LICENSE1 (CSLVM13)

Clone z/VM Guest CSLRHEL (CSLVM13) -> LICENSE0 (CSLVM13)

Conditional DASD update

Deactivate z/VM Guests

Assign Project to z/VM Guests

Delete z/VM Guests

dmvuser 2014-01-28 17:03:10 2014-01-28 17:03:10 2 seconds Done

csladmin 2014-01-28 17:03:10 2014-01-28 17:03:12 2 seconds Done

lfad 2014-01-27 19:34:14 2014-01-27 19:36:22 2:08 minutes Done

Progress

100%
100%
100%
100%
100%
100%
100%
100%
100%
100%

BTS Online dmuser

5:24 PM

Display LICENSE1 Details

General Information

z/VM Guest Name: LICENSE1

z/VM System Name: CSLVM13

SDG Name: USER-LOCAL

Data z/VM View zLinux View Performance View Custom Attributes

Guest Meta Data

Distribution: RedHat 6 - 64 Bit Project: DMV Details

Functionality: N/A (Activation Level 1) Prototype: N/A

Description: Original Guest: N/A

Default z/VM System: CSLVM13 Locker: N/A

z/VM Data

z/VM System	Status	Connectable	SDG	Eligible	Profile	CPUs	Mem. Min	Mem. Max	Disk Space	Auth Class	Account
CSLVM13	Active	Yes	USER-LOCAL	Yes		1	2000 MB	2000 MB	20.83 GB	G	67YC

Connection Availability from This Work Station

IP Address	VNS Name	Virtual Network Name	Status
192.168.39.68	ATS395	CSLVSCH	Reachable

Update

Created By: dmuser on 2014-01-28 17:11:50

Last Modified By: WAVEinit on 2014-01-28 17:16:33

Close IAN

Waiting for user input

CSL-WAVE 3.2.0 (WAVESERV Hostname: cslserv13, IP Address: 192.168.39.77)

File Auto Detect User-Group Management Network Management Prototype Management UserTasks Reports Window Help

Stop Updates

Hardware Viewer Enterprise Viewer Dashboard View

Hardware Viewer Default Zoom

ATSEC12

CSLVM13

Current System View - "CSLVM13"

z/VM User Groups Network Prototypes System Status Session Tasks

Default Zoom Group By: Site Defined Groups

Tag Show Filter Panel

WAVE-INTERNAL (CSLVM13)
0 Users

LICENSE2 (LICENSE2)

LICENSE0 (LICENSE0)

- Lock z/VM User
- Unlock z/VM User
- Read IAN
- Update IAN
- Delete IAN
- Init User for CSL-WAVE use
- Refresh Linux Data
- Run AGC
- Manage Storage
- Generate Disk Storage Map
- Execute REXX
- Delete

Display Information
Update
Status
Activate
Deactivate
Recycle
Pause
Resume
Send Message
Execute Script
Access...
Cloning...
Install...
More Actions

Property Viewer

LICENSE1 (CSLVM13)

Property	Value
Name	LICENSE1
Status	Active
Eligible	Yes
Group	USER-LOCAL
Type	Linux
Distribution	Red-Hat 6 - 64 Bit
1st IP Address	192.168.39.68
Project	DMV
Functionality	N/A

CSL-WAVE Log BTS Work Units BTS System COR **BTS Log** Attention Required

Workunit Name	Initiator	Start At	End At	Duration	Status	Progress
Activate z/VM Guests	dmvuser	2014-01-28 17:14:36	2014-01-28 17:14:40	4 seconds	Done	100%
Clone z/VM Guest CSLRHEL (CSLVM13) -> LICENSE2 (CSLVM13)	dmvuser	2014-01-28 17:12:57	2014-01-28 17:13:58	1:01 minutes	Done	100%
Clone z/VM Guest CSLRHEL (CSLVM13) -> LICENSE1 (CSLVM13)	dmvuser	2014-01-28 17:11:55	2014-01-28 17:13:20	1:25 minutes	Done	100%
Clone z/VM Guest CSLRHEL (CSLVM13) -> LICENSE0 (CSLVM13)	dmvuser	2014-01-28 17:11:49	2014-01-28 17:12:45	56 seconds	Done	100%
Conditional DASD update	dmvuser	2014-01-28 17:11:41	2014-01-28 17:13:45	2:04 minutes	Done	100%
Deactivate z/VM Guests	dmvuser	2014-01-28 17:09:38	2014-01-28 17:09:40	2 seconds	Done	100%
Assign Project to z/VM Guests	csladmin	2014-01-28 17:03:10	2014-01-28 17:03:12	2 seconds	Done	100%
Delete z/VM Guests	frad	2014-01-27 19:34:14	2014-01-27 19:36:22	2:08 minutes	Done	100%

BTS Online dmvuser

5:24 PM

CSL-WAVE 3.2.0 (WAVESERV Hostname: cslserv13, IP Address: 192.168.39.77)

File Auto Detect User-Group Management Network Management Prototype Management User Tasks Reports Window Help

Stop Updates

Hardware Viewer Enterprise Viewer Dashboard View

Hardware Viewer Default Zoom

ATSEC12

CSLVM13

Current System View - "CSLVM13"

z/VM User Groups Network Prototypes System Status Session Tasks

Default Zoom Group By: Site Defined Groups

Tag Show Filter Panel

Manage z/VM User LICENSE1 Storage

General Information

z/VM Guest Name: LICENSE1

z/VM System Name: CSLVM13

SDG Name: USER-LOCAL

Linux File Systems LVM Volume Groups

Current Active File Systems on Server

Device	FS Type	Size (GB)	used (GB)	Free (GB)	Type	Storage Type	Mount Point	Status (Capacity)
/dev/dasdc1	ext4	6.77	2.37	4.05	STD	DASD	/	35%
proc		0.00	0.00	0.00	STD	DASD	/proc	0%
sysfs	sysfs	0.00	0.00	0.00	STD	DASD	/sys	0%
devpts	devpts	0.00	0.00	0.00	STD	DASD	/dev/pts	0%
tmpfs	tmpfs	0.98	0.00	0.98	STD	DASD	/dev/shm	0%
/dev/mapper/optvg-optv	ext4	6.77	0.14	6.28	LVM	DASD	/opt	2%
none	binfmt_misc	0.00	0.00	0.00	STD	DASD	/proc/sys/fs/binfmt...	0%
sunrpc	rpc_pipefs	0.00	0.00	0.00	STD	DASD	/var/lib/nfs/rpc_pip...	0%

Close Extend Partition Create New Partition...

Waiting for user input

Property Viewer

LICENSE1 (CSLVM13)

Property	Value
Name	LICENSE1
Status	Active
Eligible	Yes
Group	USER-LOCAL
Type	Linux
Distribution	Red-Hat 6 - 64 Bit
1st IP Address	192.168.39.68
Project	DMV
Functionality	N/A

CSL-WAVE Log BTS Work Units BTS System COR **BTS Log** Attention Required

Workunit Name	Initiator	Start At	End At	Duration	Status	Progress
Activate z/VM Guests	dmvuser	2014-01-28 17:14:36	2014-01-28 17:14:40	4 seconds	Done	100%
Clone z/VM Guest CSLRHEL (CSLVM13) -> LICENSE2 (CSLVM13)	dmvuser	2014-01-28 17:12:57	2014-01-28 17:13:58	1:01 minutes	Done	100%
Clone z/VM Guest CSLRHEL (CSLVM13) -> LICENSE1 (CSLVM13)	dmvuser	2014-01-28 17:11:55	2014-01-28 17:13:20	1:25 minutes	Done	100%
Clone z/VM Guest CSLRHEL (CSLVM13) -> LICENSE0 (CSLVM13)	dmvuser	2014-01-28 17:11:49	2014-01-28 17:12:45	56 seconds	Done	100%
Conditional DASD update	dmvuser	2014-01-28 17:11:41	2014-01-28 17:13:45	2:04 minutes	Done	100%
Deactivate z/VM Guests	dmvuser	2014-01-28 17:09:38	2014-01-28 17:09:40	2 seconds	Done	100%
Assign Project to z/VM Guests	csladmin	2014-01-28 17:03:10	2014-01-28 17:03:12	2 seconds	Done	100%
Delete z/VM Guests	frad	2014-01-27 19:34:14	2014-01-27 19:36:22	2:08 minutes	Done	100%

BTS Online dmvuser

5:24 PM

IBM Wave for z/VM Q&A



Frequently Asked Questions

Q1: How does IBM Wave for z/VM fit in the System z portfolio?

A1: IBM Wave for z/VM provides the graphical interface that simplifies and helps to manage z/VM resources and provision Linux on System z virtual servers. It fully abstracts and visualizes virtual and physical resources to enable system programmers and system administrators to manage z/VM environments.

Q2: How do Cloud and Smarter Infrastructure (Tivoli) products complement IBM Wave for z/VM?

A2: IBM Wave for z/VM interacts with z/VM and Linux guest virtual machines. There are no programming interfaces between IBM Wave for z/VM and Tivoli products at this time. However, to the extent that other products affect the environment, IBM Wave for z/VM will detect and adapt to those changes dynamically. For example, if Tivoli Provisioning Manager creates and provisions a new virtual machine, IBM Wave for z/VM will automatically detect that virtual machine and allow it to be managed. In general, IBM Wave for z/VM fills a gap that Tivoli products do not address, rounding out the suite of systems management tools available for z/VM from IBM. The Tivoli product portfolio provides complementary monitoring, automation and orchestration capabilities that further enhance the z/VM and Linux environments managed by IBM Wave for z/VM.

Frequently Asked Questions (*cont.*)

Q3: What is the positioning of IBM Wave for z/VM with xCAT and OpenStack?

A3: IBM Wave for z/VM enables system programmers and system administrators to manage z/VM environments using an intuitive graphical user interface. For many clients, it may offer a complete solution and eliminate the need to implement additional capabilities. xCAT enables clients to create a rudimentary z/VM-based cloud environment. As an open source tool, it may be enhanced by community development over time. OpenStack is an open source effort that is the basis of IBM's cloud strategy and will provide the foundation for future cloud offerings from IBM. At this time there is no upgrade path to an environment based on OpenStack from either IBM Wave for z/VM or xCAT.

Q4: What is the positioning of IBM Wave for z/VM with Omegamon XE on z/VM and Linux?

A4: Both IBM Wave for z/VM and Omegamon XE on z/VM and Linux provide real-time monitoring of virtual server (z/VM) resources. But with Omegamon XE on z/VM and Linux, you have the ability to get additional performance metrics from each individual Linux guest environment and a historical view of all monitoring data. IBM Wave for z/VM is not a substitute for Omegamon XE on z/VM and Linux and we expect customers to use both products in their environment. In addition, Omegamon XE on z/VM and Linux is part of the overall IBM Tivoli Monitoring and OMEGAMON infrastructure - allowing you to monitor performance of servers and systems on multiple platforms throughout your enterprise.

Frequently Asked Questions (*cont.*)

Q5: Is IBM Wave for z/VM mutually exclusive with the SmartCloud suite of products that provide cloud management software?

A5: No, we envision both to be used in customer environments. IBM Wave for z/VM provides virtualization management which would be used by the system programming and system administration staff to manage the z/VM environment, as well as project managers and application developers. The SmartCloud suite of products (SmartCloud Entry, SmartCloud Provisioning, SmartCloud Orchestrator) would be used by cloud administrators and end-users to provide cloud management and allow end-users to deploy workloads in their cloud environment.

Q6: What is the difference between virtualization management and cloud management?

A6: Virtualization management focuses on managing the entire pool of virtualized resources including operational oversight, monitoring, usability and availability through a single application management console. This is also known as hypervisor management. Cloud management on the other hand, focuses on providing capabilities to deploy and manage a cloud environment in a virtualized infrastructure. These capabilities include automated self-service provisioning and deprovisioning of system resources (server, storage, network) for workload deployment and visibility to performance metrics of these virtual machines. Advanced capabilities include workflow orchestration to manage the process for usage approvals and track resource utilization for billing and metering.

Thank You!



IBM System z Tiger Team:

