



WAVV 2007

z/VSE Version 4 News and Views

G. M. (Jerry) Johnston
Senior Advisor – Boeblingen Lab
p798000@us.ibm.com

Trademarks

Trademarks

The following are trademarks of the International Business Machines Corporation in the United States and/or other countries. For a complete list of IBM Trademarks, see www.ibm.com/legal/copytrade.shtml: AS/400, DBE, e-business logo, ESCO, eServer, FICON, IBM, IBM Logo, iSeries, MVS, OS/390, pSeries, RS/6000, S/30, VM/ESA, VSE/ESA, Websphere, xSeries, z/OS, zSeries, z/VM

The following are trademarks or registered trademarks of other companies

Lotus, Notes, and Domino are trademarks or registered trademarks of Lotus Development Corporation
Java and all Java-related trademarks and logos are trademarks of Sun Microsystems, Inc., in the United States and other countries
LINUX is a registered trademark of Linux Torvalds
UNIX is a registered trademark of The Open Group in the United States and other countries.
Microsoft, Windows and Windows NT are registered trademarks of Microsoft Corporation.
SET and Secure Electronic Transaction are trademarks owned by SET Secure Electronic Transaction LLC.
Intel is a registered trademark of Intel Corporation
* All other products may be trademarks or registered trademarks of their respective companies.

NOTES:

Performance is in Internal Throughput Rate (ITR) ratio based on measurements and projections using standard IBM benchmarks in a controlled environment. The actual throughput that any user will experience will vary depending upon considerations such as the amount of multiprogramming in the user's job stream, the I/O configuration, the storage configuration, and the workload processed. Therefore, no assurance can be given that an individual user will achieve throughput improvements equivalent to the performance ratios stated here.

IBM hardware products are manufactured from new parts, or new and serviceable used parts. Regardless, our warranty terms apply.

All customer examples cited or described in this presentation are presented as illustrations of the manner in which some customers have used IBM products and the results they may have achieved. Actual environmental costs and performance characteristics will vary depending on individual customer configurations and conditions.

This publication was produced in the United States. IBM may not offer the products, services or features discussed in this document in other countries, and the information may be subject to change without notice. Consult your local IBM business contact for information on the product or services available in your area.

All statements regarding IBM's future direction and intent are subject to change or withdrawal without notice, and represent goals and objectives only.

Information about non-IBM products is obtained from the manufacturers of those products or their published announcements. IBM has not tested those products and cannot confirm the performance, compatibility, or any other claims related to non-IBM products. Questions on the capabilities of non-IBM products should be addressed to the suppliers of those products.

Prices subject to change without notice. Contact your IBM representative or Business Partner for the most current pricing in your geography.

References in this document to IBM products or services do not imply that IBM intends to make them available in every country.

Any proposed use of claims in this presentation outside of the United States must be reviewed by local IBM country counsel prior to such use.

The information could include technical inaccuracies or typographical errors. Changes are periodically made to the information herein; these changes will be incorporated in new editions of the publication. IBM may make improvements and/or changes in the product(s) and/or the program(s) described in this publication at any time without notice.

Any references in this information to non-IBM Web sites are provided for convenience only and do not in any manner serve as an endorsement of those Web sites. The materials at those Web sites are not part of the materials for this IBM product and use of those Web sites is at your own risk.



z/VSE Heritage

40+ Years of IBM Mainframe & VSE Evolution

§ S/360->S/370->4300->9370->ES9000->S/390->zSeries->z9

§ **DOS/360**->DOS/VS->DOS/VSE->(SSX)->VSE/SP
->VSE/ESA V1->VSE/ESA V2->z/VSE V3->**zVSE V4**

§ S/360 Model 30

- 30 KIPS (.03 MIPS)
- 16 - 64 KB

§ **System z9 BC**

- 26-480 MIPS (1-way)
- 8 - 64 GB

§ **z/VSE V4.1**

- Batch and OLTP
- SOA
- still lovable

§ DOS/360

- 1 batch partition
- basic, but lovable

1960s

1970s

1980s

1990s

2000s

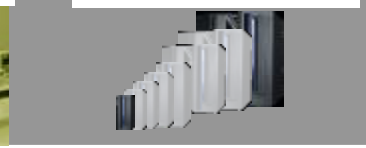

Recent VSE History

Capacity
Quality
z/OS Affinity
Interoperability

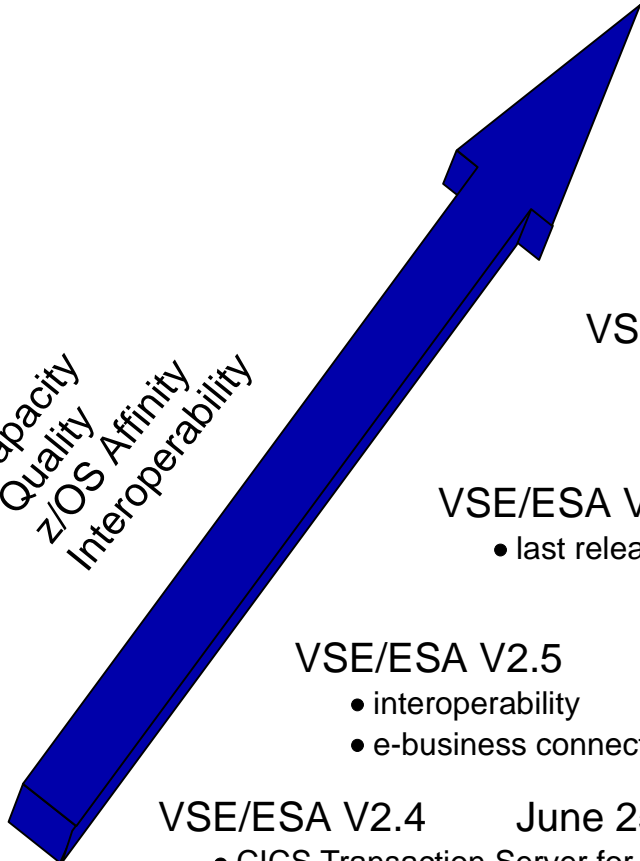

z/VSE V4.1 March 16, 2007

- z/Architecture only
- 64-bit real addressing
- MWLC full & sub-cap pricing



z/VSE V3.1* March 4, 2005

- zSeries features, FCP/SCSI
- 31-bit mode only

VSE/ESA V2.7 March 14, 2003

- enhanced interoperability
- ALS2 servers only



VSE/ESA V2.6 Dec 14, 2001

- last release to support pre-G5 servers

VSE/ESA V2.5 Sept 29, 2000

- interoperability
- e-business connectors

VSE/ESA V2.4 June 25, 1999

- CICS Transaction Server for VSE/ESA
- e-business



Changes since WAVV 2006

- § 03/31/2006 - EoS for VSE/ESA V2.6 effective
- § 04/27/2006 - IBM System z9 EC and z9 BC Announcement (incl z9 EC sub-cap models)
- § 04/27/2006 - z/VSE V4.1 Preview
- § 07/21/2006 - z/VSE V3.1.2 (service update and consolidation) available
- § 08/29/2006 - SOD for z/VSE support of TS1120 encrypting tape drive
- § 11/11/2006 - TCP/IP for VSE/ESA V1.5 Service Pak E
- § 01/09/2007 - z/VSE Version 4 Release 1 Announcement
- § 01/09/2007 - Midrange Workload License Charge (MWLC) for z/VSE V4
- § 02/06/2007 - z/VM Version 5 Release 3 Announcement
- § **02/28/2007 - EoS for VSE/ESA V2.7 effective**
- § **03/16/2007 - z/VSE V4.1 General Availability**
- § 03/16/2007 - SecureFTP PTF available
- § 04/18/2007 - IBM System z9 EC and z9 BC Enhancements
- § 05/18/2007 - IBM TS1120 encrypting tape PTF (for z/VSE V4.1) available

z/VSE Status

VSE Version and Release	Marketed	Supported	End of Support
z/VSE V4.1	Yes	Yes	tbd
z/VSE V3.1	Yes	Yes	tbd
VSE/ESA V2.7	No	No	02/28/2007



z/VSE Version 4 Release 1



z/VSSE Version 4 Release 1

§ Preview 4/27/2006

§ Announce 1/9/2007

§ **General Availability 3/16/2007**

§ **z/Architecture mode only**

- 64-bit *real* addressing (31-bit *virtual* addressing)
 - up to 8 GB real processor storage
- IBM System z9 EC and z9 BC servers
- IBM eServer zSeries 990, 890, 900, and 800 servers

§ **Capacity Measurement Tool (CMT)**

- fulfills SOD from July 2005

§ **New MWLC pricing metrics (z9 EC and z9 BC only)**

- Improved price/performance with full-capacity MWLC price points
- Sub-capacity MWLC option for added price/performance

§ **Encryption enhancements**

- CPACF enhancements (AES-128)
- Configurable Crypto Express2 (new accelerator option)
- Secure FTP
- TS1120 encrypting tape



z/VSSE Version 4 Release 1 (cont.)

§ IBM System Storage

- TS1120 encrypting tape
- TS7700 Virtualization Engine
- TS3500 Tape Library
- SOD for TS3400 Tape Library
- DS6000/DS8000 64K cylinder ECKD volumes

§ TCP/IP for VSE/ESA V1.5 Service Pack E enhancements, including

- TCP/IP stack
- Performance
- FTP
- Security and SSL
 - SecureFTP
 - CPACF AES-128
 - Crypto Express2 2048-bit RSA keys (card required)
- Message Logging
- Telnet
- eMail
- BSE/C Socket API



z/VSE Version 4 Release 1 (cont.)

§ SOA and Interoperability

- VTAPE interface to Tivoli® Storage Manager (TSM) to backup VSE data
- VSAM Capture Exit
- upgrade to JDK 1.5 (Java5) standard

§ Component changes

- ACF/VTAM V4.2 31-bit buffers
- BSM security logging and reporting
- VSE/POWER enhancements
- LE/VSE enhancements and z/OS affinity

§ Miscellaneous

- Single Supervisor
- SDAID

§ FSU from z/VSE V3.1 and VSE/ESA V2.7

§ Requires z/VM V5.2 (or later) if running under VM



IBM System z9 Exploitation

Functions	z/VSE V4.1	z/VSE V3.1 (Note 1)
z/Architecture mode only	Yes	No
64-bit <i>real</i> addressing (up to 8 GB proc storage)	Yes	No
Fibre Channel Protocol (FCP) for SCSI Disks	Yes	Yes
CP Assist for Cryptographic Function (CPACF)	Yes	Yes
Crypto Express2 (SSL clear key encryption assist)	Yes	Yes
HiperSockets™ (including spanned HiperSockets)	Yes	Yes
FICON Express2™ & FICON Express4™	Yes	Yes
OSA Express2 (incl 10Gb and Gb ethernet)	Yes	Yes
OSA Integrated Console Controller (OSA-ICC)	Yes	Yes
Up to 60 LPARs and 4 LCSSs	Yes	Yes

z/VSE Support for Mainframe Servers

IBM Servers	z/VSE V4.1	z/VSE V3.1 (Note 1)
IBM System z9 Enterprise Class (formerly z9-109)	Yes	Yes
IBM System z9 Business Class (z9 BC)	Yes	Yes
IBM eServer zSeries 990, 890, 900, 800	Yes	Yes
S/390® Parallel Enterprise Server™ G5/G6	No	Yes
S/390® Multiprise® 3000	No	Yes
S/390® Parallel Enterprise Server™ G1/2/3/4	No	No
S/390® Multiprise® 2000	No	No

z/VSE support for IBM System Storage



IBM System Storage	DS6000	ESS 750, 800, 800Turbo	DS8000. DS8000 Turbo
ESCON	Not Avail	Yes	Yes
FICON	Yes	Yes	Yes
FCP/SCSI	Yes	Yes	Yes

z/VSE support for IBM TS1120 Tape Drive Encryption

§ IBM System Storage TS1120 - first encrypting tape drive

- Standard feature on new TS1120 tape drives
- Supports “traditional” and “encrypted” modes of operation
 - encryption “disabled” unless otherwise specified
- Implements data encryption using AES-256 encryption
- Data is compressed *then* encrypted – no change in media utilization
- Encryption performed with minimal (< 1% data rate performance impact)



TS1120
500 GB
100 MB/sec

§ z/VSE V4.1 supports Systems Managed Encryption

- Support available via PTF after z/VSE V4.1 GA
- SOD for z/VSE V3.1

**Encryption Key
Manager**

§ IBM Encryption Key Manager (EKM) for Java platform™

- Runs on z/OS, AIX, Linux (incl System z), i5/OS, HP, Sun, & Windows
- Secure TCP/IP connection between EKM and TS1120
- Stores and manages labels and key encrypting keys
- Supplies data encrypting keys to TS1120 on request
- TS1120 encrypts files using data encrypting key
- TS1120 stores encrypted data encrypting key on cartridge
 - data encryption key can be encrypted using two different key encryption keys



Overview of Encryption Key Manager for Tape Encryption - key generation, communication and key storage

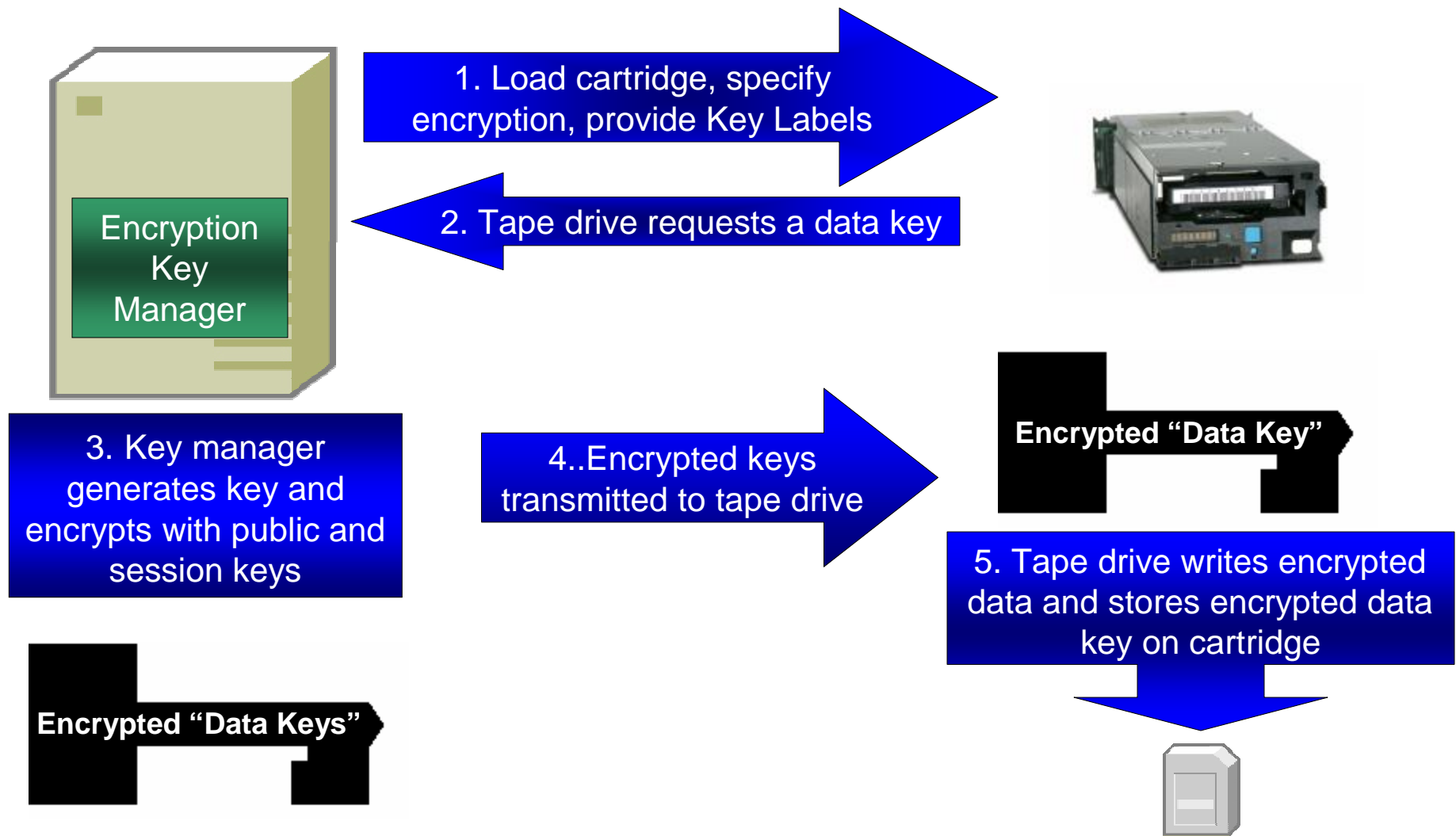

z/VSE Comparison

§ z/VSE V3.1* (GA 3/2005)

- **ESA/390 (31-bit) mode only**
 - up to 2GB real processor storage
 - System z9 EC *and* z9 BC
 - zSeries 990, 890, 900, 800
 - **Multiprise 3000 & S/390 G5/G6**
- GMLC, GOLC, zELC, TWLC, etc.
- HiperSockets
- CPACF
- Crypto Express2 (configurable)
- FCP/SCSI disks & NPIV
 - DS8000, DS6000, ESS
- FICON Express2 & 4
- OSA Express2
- 31-bit buffers for ACF/VTAM (via PTF)
- **SOD for TS1120 encrypting tape**

§ z/VSE V4.1 (GA Planned 3/2007)

- **z/Architecture (64-bit) mode only**
 - **up to 8 GB real processor storage**
 - System z9 EC *and* z9 BC
 - zSeries 990, 890, 900, 800
- **MWLC Pricing Metric (z9 only)**
 - **Full-capacity and sub-capacity mode**
- HiperSockets
- CPACF + **enhancements**
- Crypto Express2 (configurable)
- FPC/SCSI disk & NPIV + **point-to-point**
 - DS8000, DS6000, ESS
- FICON Express2 & 4
- OSA Express2
- 31-bit buffers for ACF/VTAM
- TS1120 encrypting tape

Introducing a New Price Metric for z/VSE V4



Summary of z/VSE Price Metrics

IBM Servers	z/VSE V4.1	z/VSE V3.1 (Note 1)
IBM System z9 Enterprise Class – z9 EC (formerly z9-109)	MWLC (may be flat WLC)	GMLC, ELC, flat WLC
IBM System z9 Business Class – z9 BC	MWLC (A01 is zELC)	TWLC (A01 is zELC)
IBM eServer zSeries 990 and 900	GMLC, ELC, flat WLC	GMLC, ELC, flat WLC
IBM eServer zSeries 890	TWLC (110 is zELC)	TWLC (110 is zELC)
IBM eServer zSeries 800	zELC	zELC
S/390® Parallel Enterprise Server™ G5/G6	not applicable	GMLC, ELC, flat WLC
S/390® Multiprise® 3000	not applicable	GOLC

Midrange Workload License Charge (MWLC)

- § Requires current hardware (IBM System z9 EC or z9 BC) *and* z/VSE V4
 - exception: z9 BC Capacity Setting A01 remains zELC

- § VSE Central Functions + 12 IBM middleware products are eligible

– 5686 CF8	VSE Central Functions		
– 5696 234	HLASM	– 5686 068	IBM COBOL for VSE/ESA
– 5648 054	CICS TS for VSE/ESA V1	– 5686 A01	IBM C for VSE/ESA
– 5686 065	ACF/VTAM® VSE/ESA V4	– 5686 069	IBM PL/1 for VSE/ESA
– 5686 A04	TCP/IP for VSE/ESA V1.5	– 5746 SM3	IBM DFSORT/VSE V3
– 5648 099	DITTO/ESA® for VSE	– 5746 XX1	DL/I VSE
– 5697 F42	DB2 Server for VSE & VM	– 5686 A06	MQSeries® for VSE/ESA

- § Full-capacity and sub-capacity MWLC options

- full-capacity mode offers improved price/performance compared to GOLC, zELC, and TWLC alternatives
- additional price/performance possible through sub-capacity mode

- § Structured to help address new growth opportunities



MWLC Sample Stack vs. TWLC and FWLC

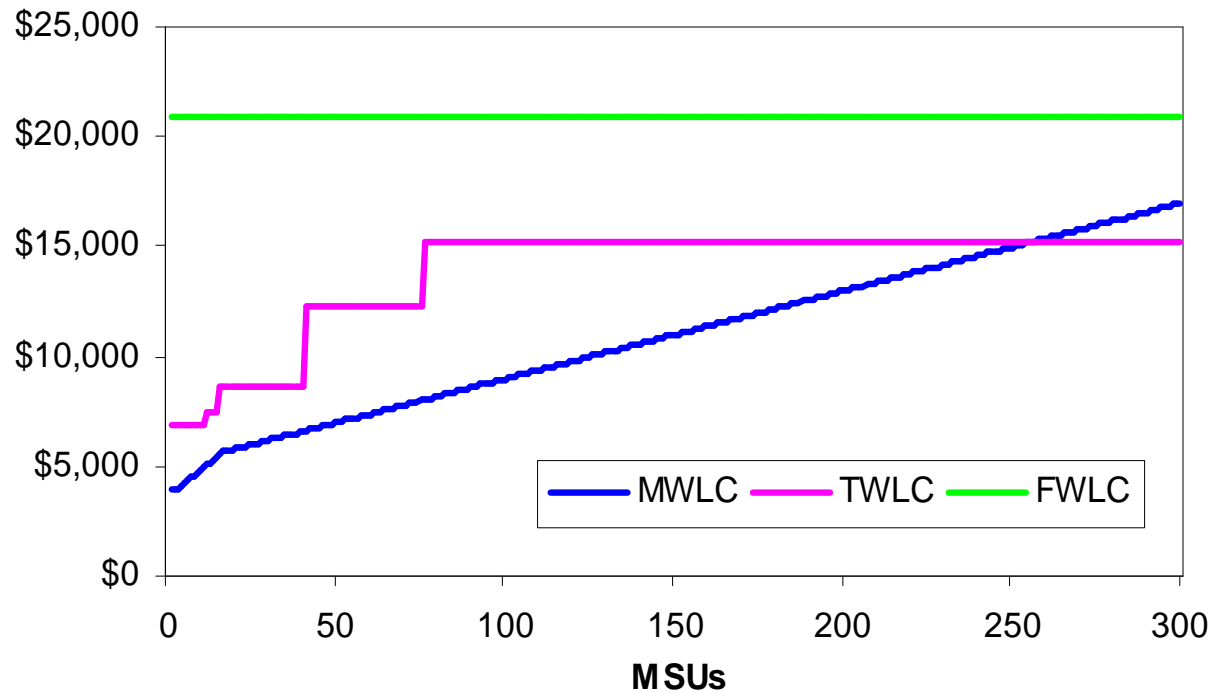

- § Customers may choose between MWLC/TWLC or MWLC/FWLC as appropriate to their machine
- § Additional price/performance may be possible with sub-capacity mode

*Sample software stack includes: VSE CF V8, HLASM, VTAM, DITTO, COBOL

*Prices subject to change without notice; all prices shown in USD

What is sub-capacity?



Full-Capacity Pricing Metric relies on the total rated capacity (measured in MSUs) of the MACHINE where a product executes.

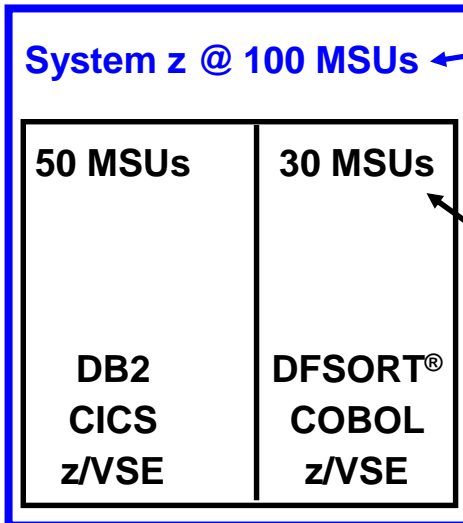

Sub-Capacity Pricing Metric relies on the utilization (based on peak 4-hour rolling average each month) of the LPAR(s) or guest Virtual Machines where a product executes.

Generic sub-capacity example

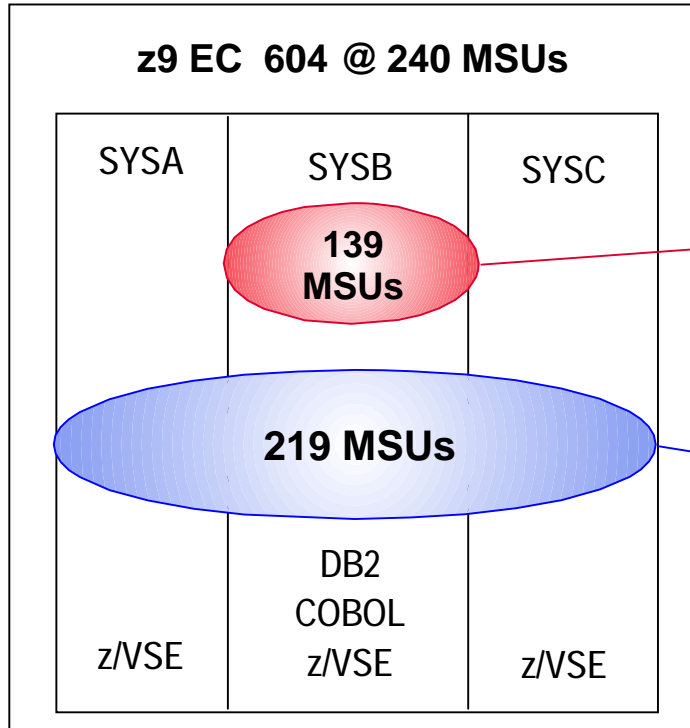

Product	Sub-Cap MSUs
DB2	139 MSUs
COBOL	139 MSUs
z/VSE	219 MSUs

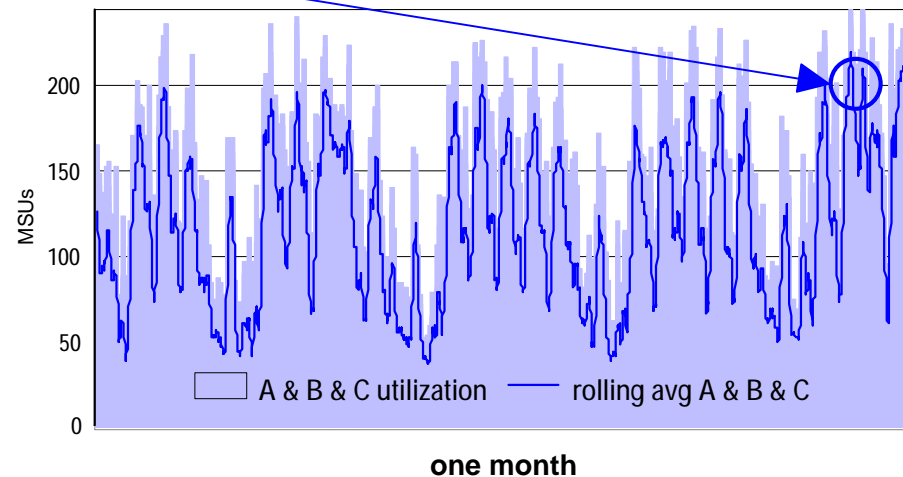
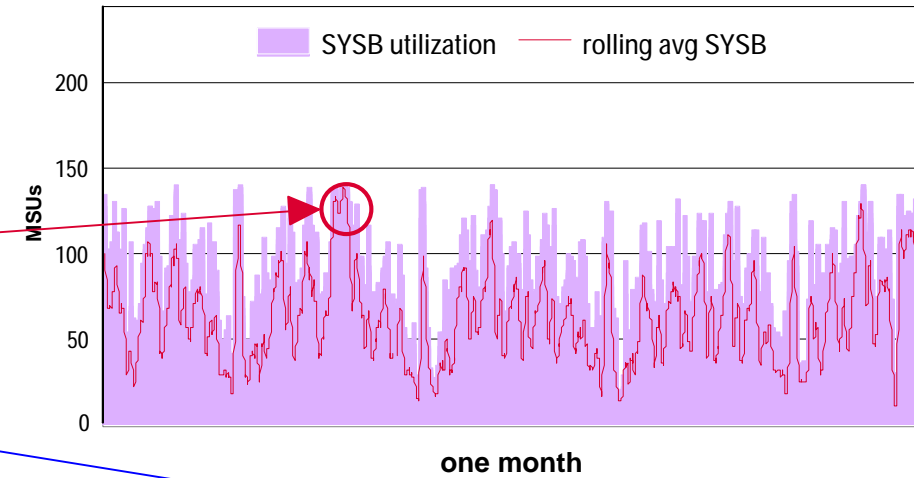

New z9 Opportunities with MWLC



§ More MSUs for the same, or slightly lower, IBM software \$

- More capacity for future growth, workload spikes, seasonal factors, emergencies, etc.
 - disconnect hardware growth from software charges
 - grow into capacity gradually with a 1 MSU level of granularity
- IBM software \$ respond to normal cyclicality
- Isolate middleware products to reduce software costs (depending on workload)
 - examine workload to identify where you might limit product use to specific LPARs (or VM guests)
 - limit LPAR (or VM guest) utilization to control software costs (optional)
 - expand production LPARs (or VM guests) without impacting other LPARs (or VM guests)
- Add IFL(s) and Linux-based IBM middleware to the mix for new workloads

§ Pick the server that best meets your needs

- High end and midrange z9 servers are no longer priced differently

§ Consolidate servers in large accounts

- Consolidate remote, vulnerable VSE workloads onto LPARs on System z9 EC servers primarily running z/OS at HQ

§ The same MSUs for lower IBM software \$



z/VSE Integration

Customer Application Portfolio:

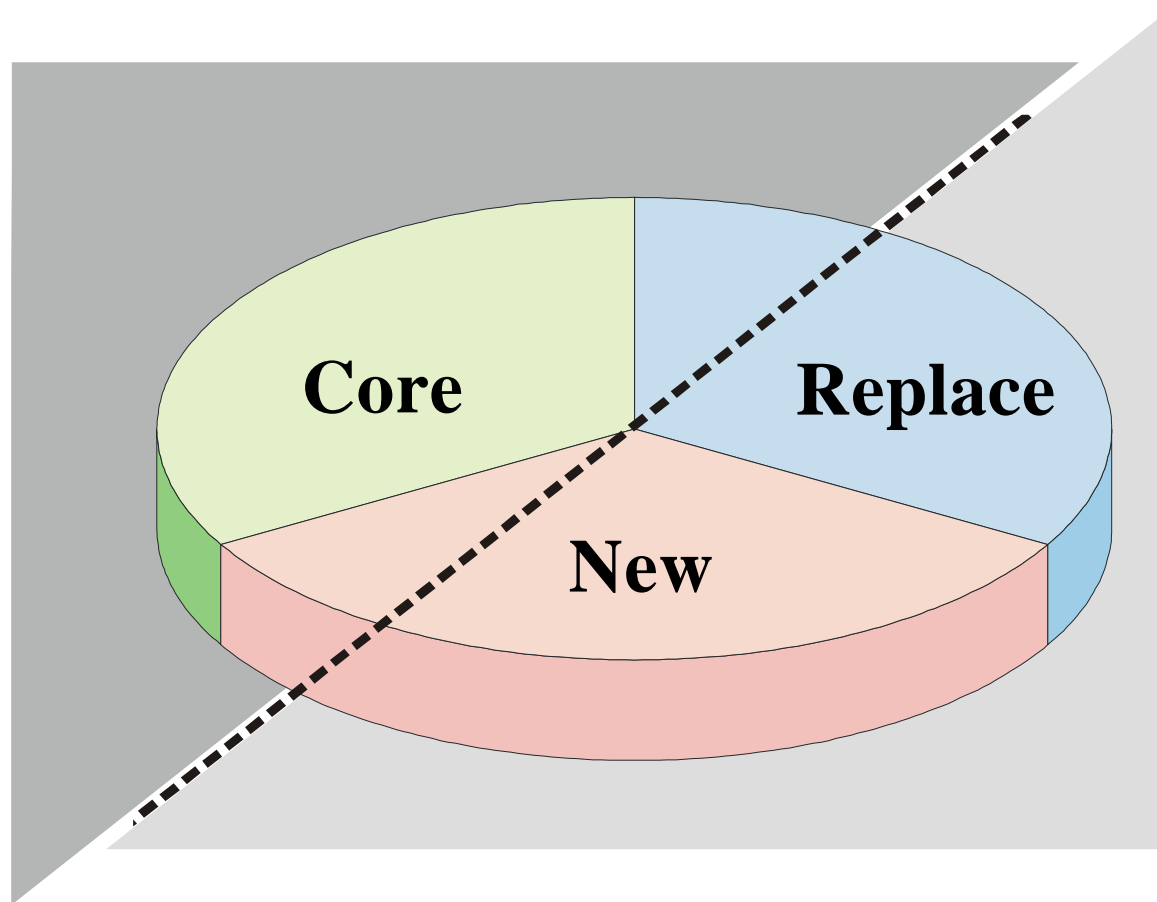

Note: Pie arbitrarily divided into thirds. Percent of applications
In each category is unique to each customer

Integrating z/VSE into the IT network

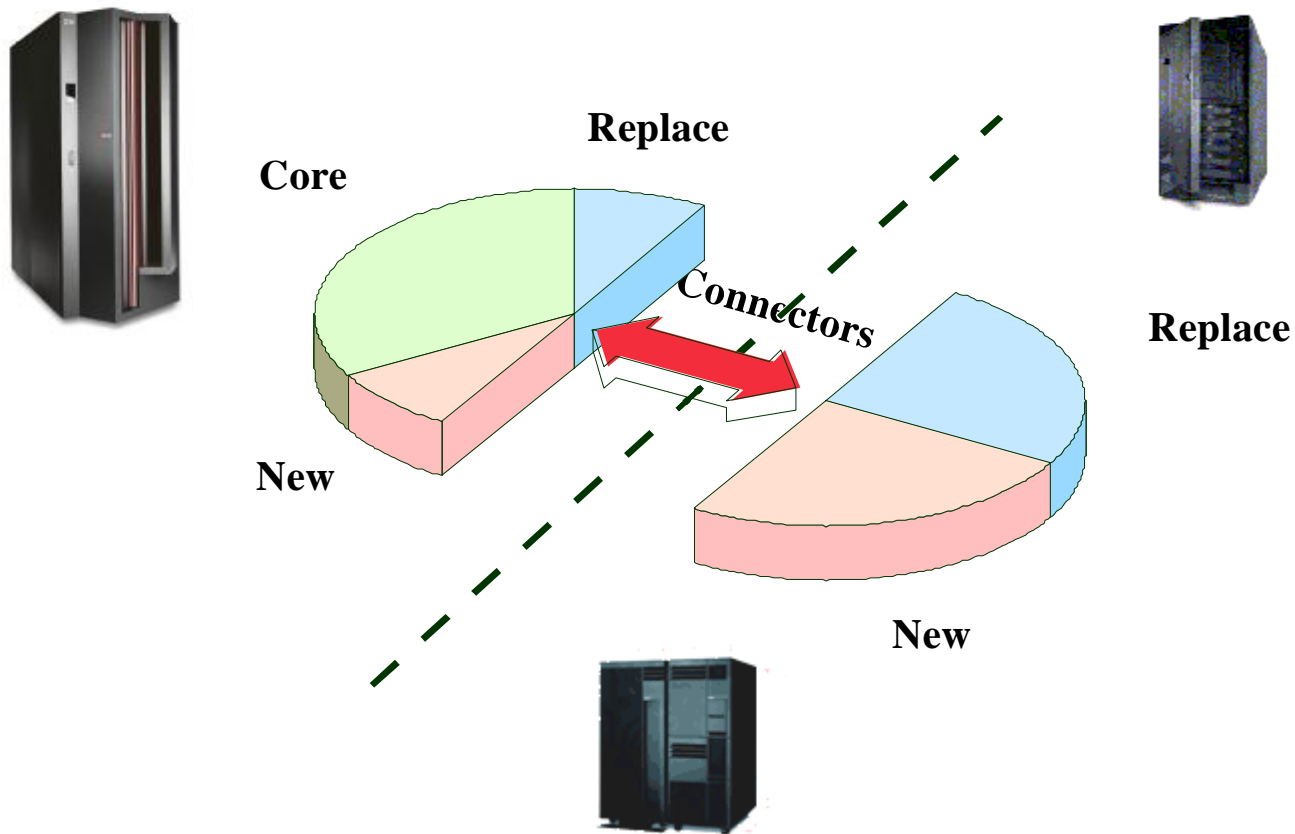

Hybrid model

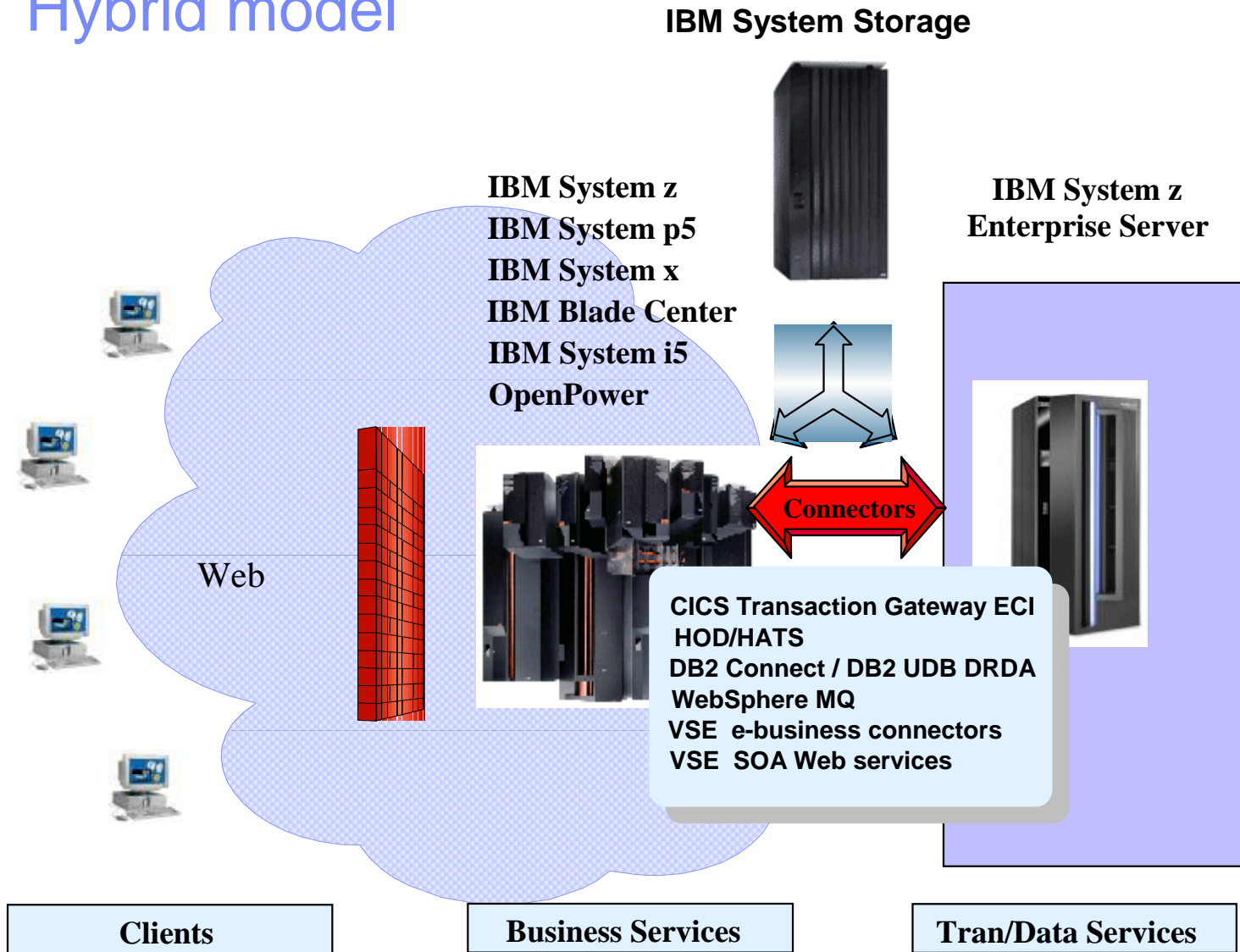

Think *inside* the box

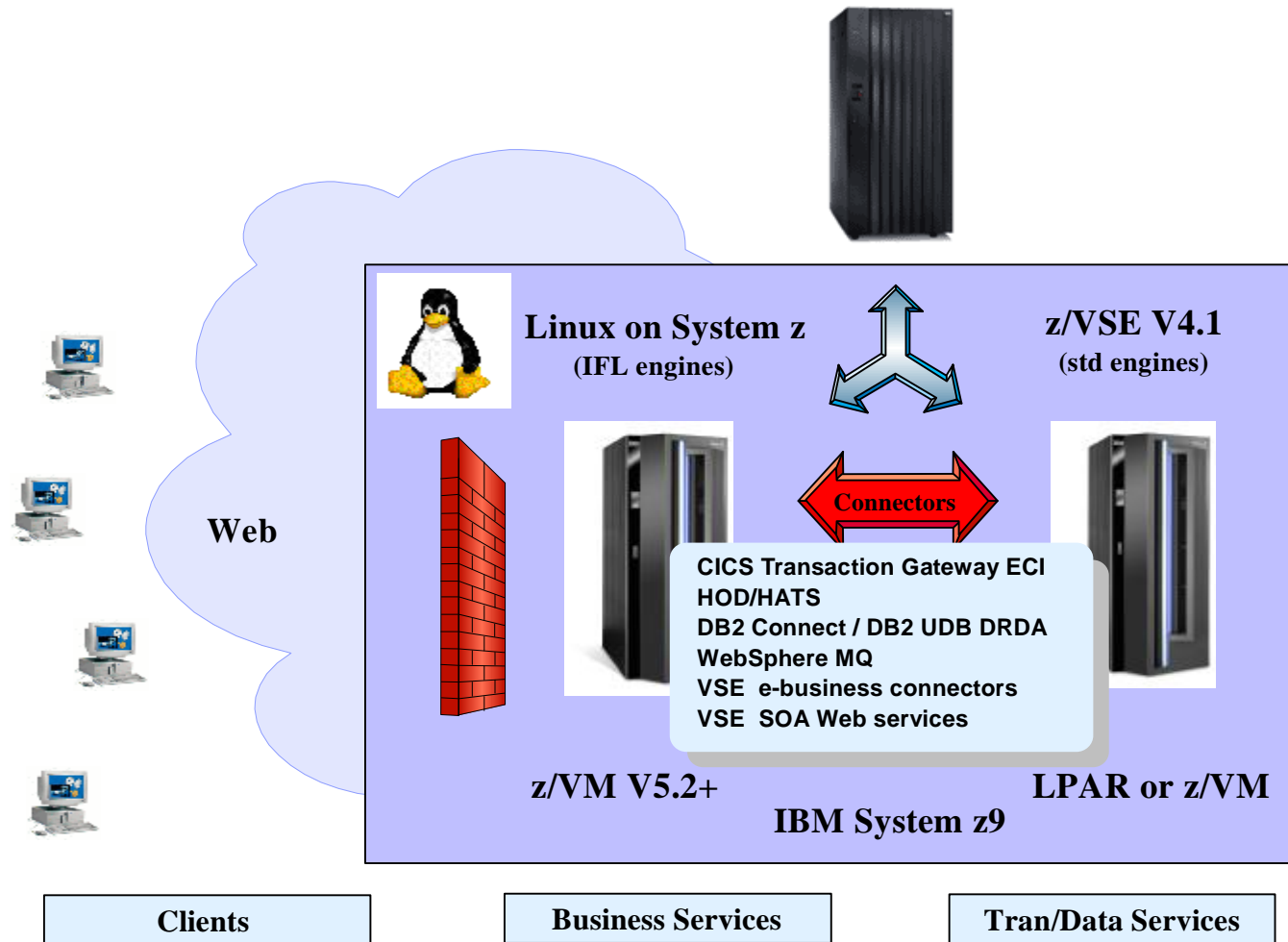

VSAM Connector

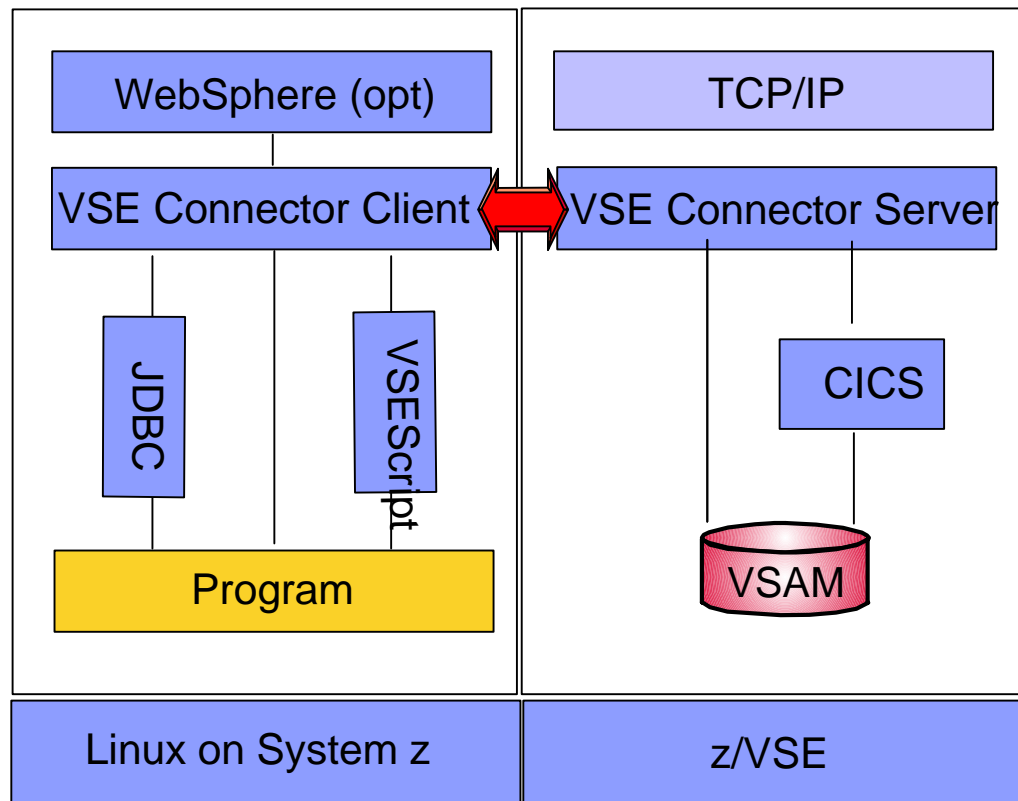

VSE/VSAM Redirector

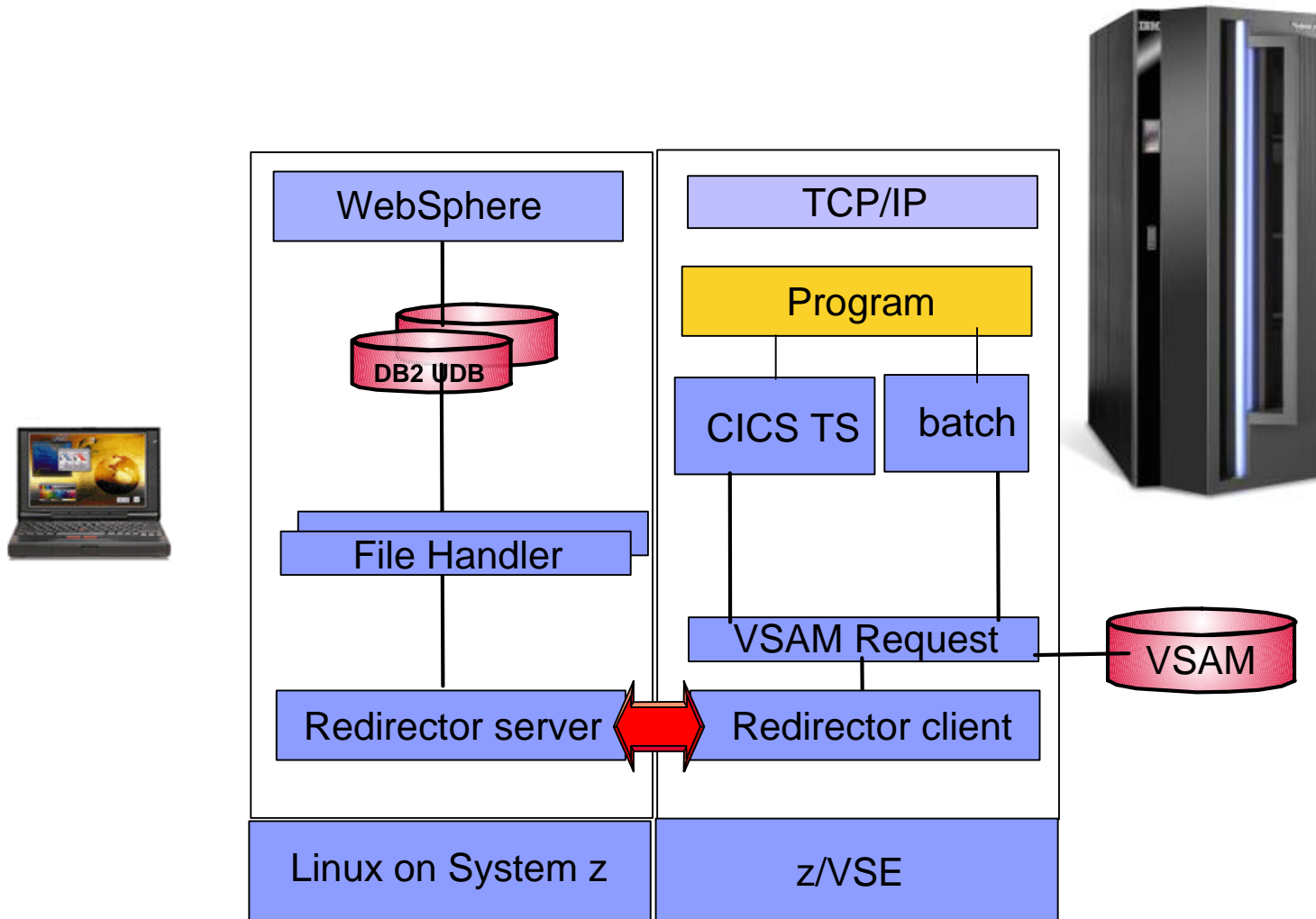

z/VSE SOA and Interoperability

Connector Functions	z/VSE V4.1	z/VSE V3.1 (Note 1)
VSE Connectors (no additional charge)		
SOA Web Services, i.e. SOAP and XML	Yes	Yes
VSAM Redirector	Yes	Yes
VSAM, POWER, Librarian, ICCF lib, console	Yes	Yes
VSE Script and DL/1	Yes	Yes
DB2 Stored Procedures for VSAM and DL/1	Yes	Yes
IBM Middleware (priced)		
CICS Transaction Gateway ECI	Yes	Yes
Host on Demand / Host Application Transformation	Yes	Yes
DB2 Connect/DB2 UDB (DB2 Server for VSE PRPQ)	Yes	Yes
WebSphere MQ (VSE Client no charge)	Yes	Yes



z/VSE V4 and Linux on System z

VSE Customer Environment

- § Mixed servers (System z, System p, System x, System i, and competitive)
- § CICS and batch programs on VSE
- § VSAM data on VSE (plus some DB2, DL/I, or ISV database)
- § Relational data bases (DB2, Oracle, etc.) on distributed platforms
- § Data exchange via FTP

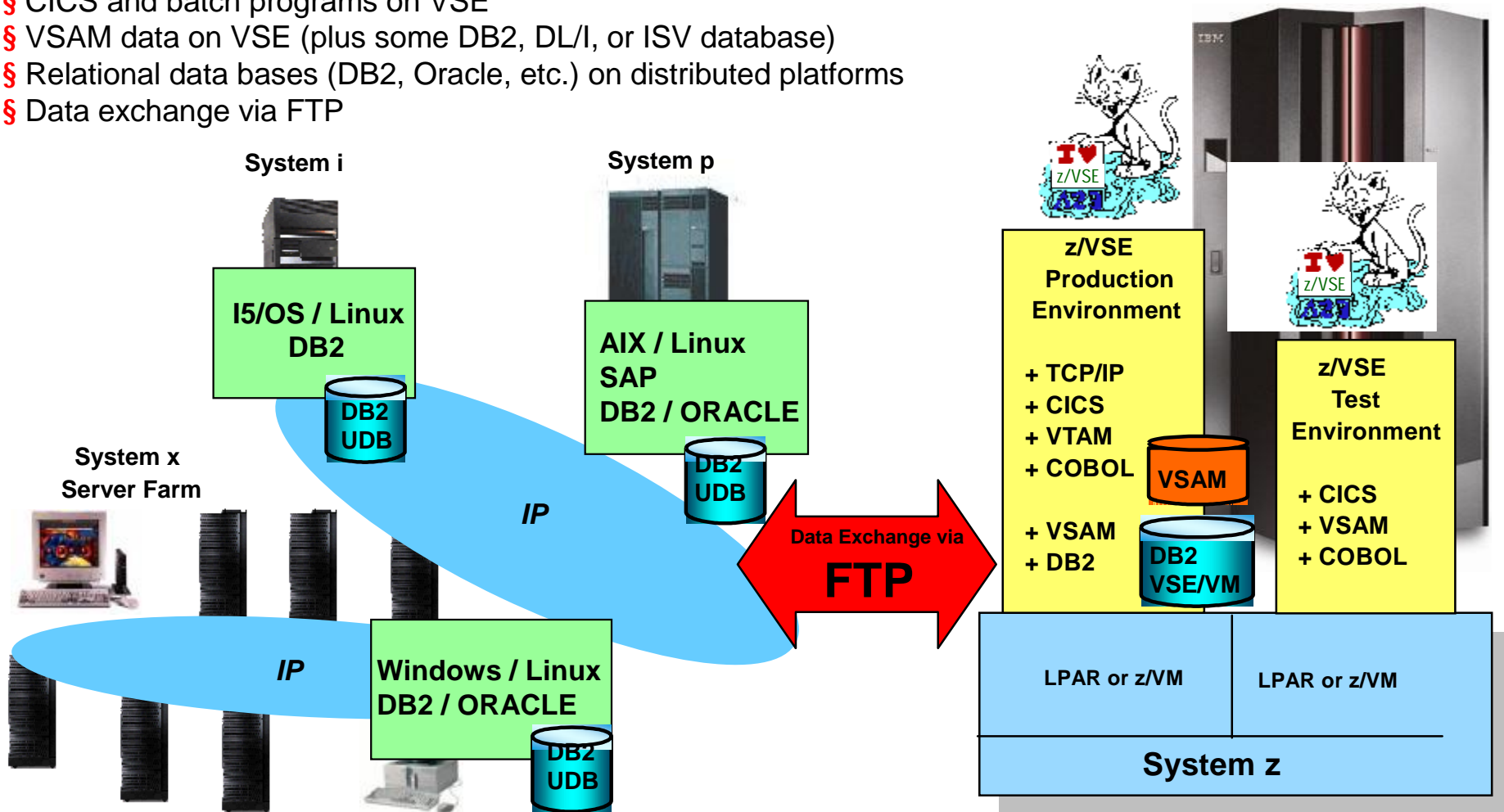

Most important requirement: Access to new applications!

Scenario 1: DB2 UDB (64-bit) for VSE Customers

Data consolidation and data warehouse solutions with DB2 UDB on System z

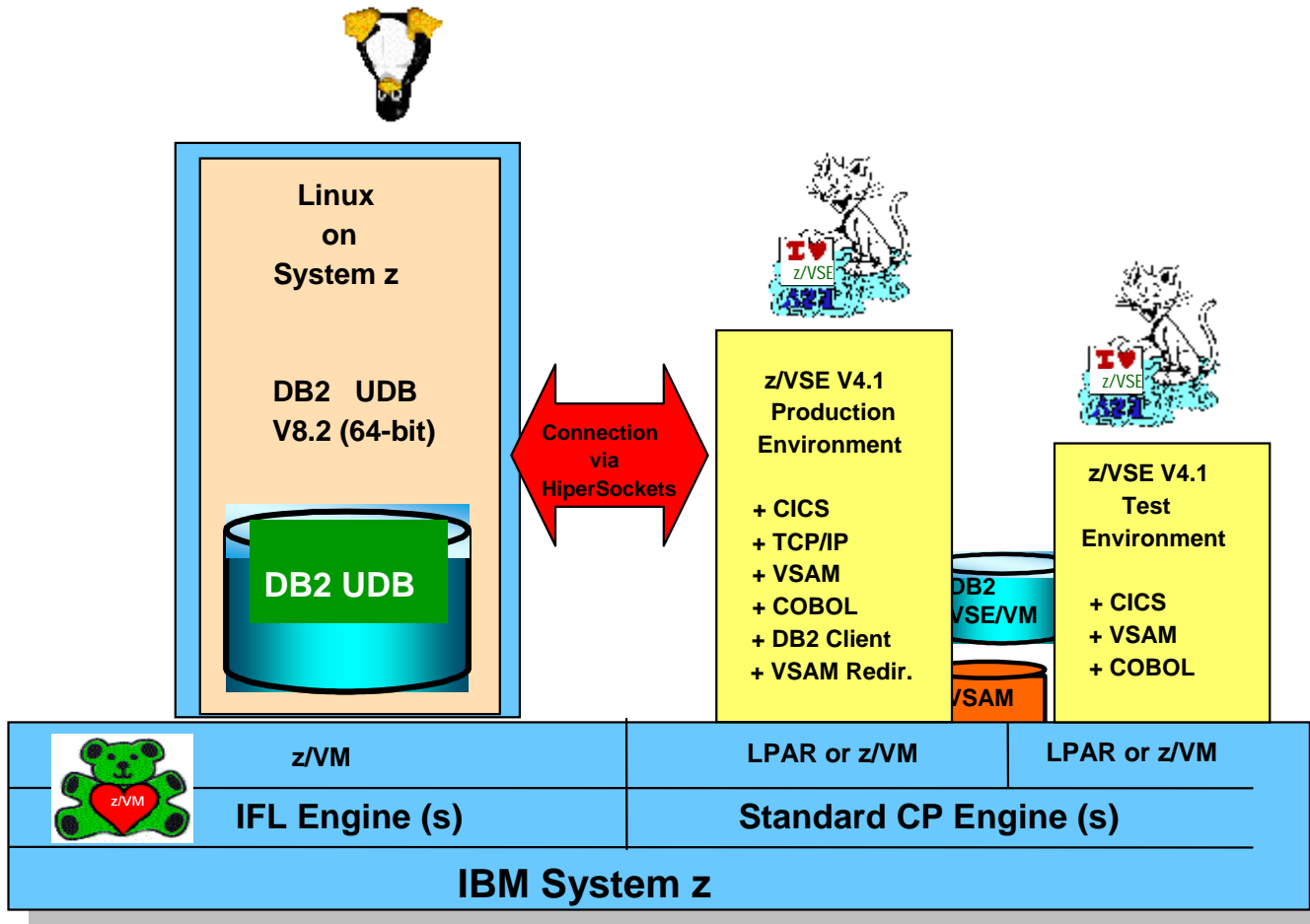

Scenario 2: „Webification“ of VSE Applications

Web enable existing applications with Internet / Intranet frontend

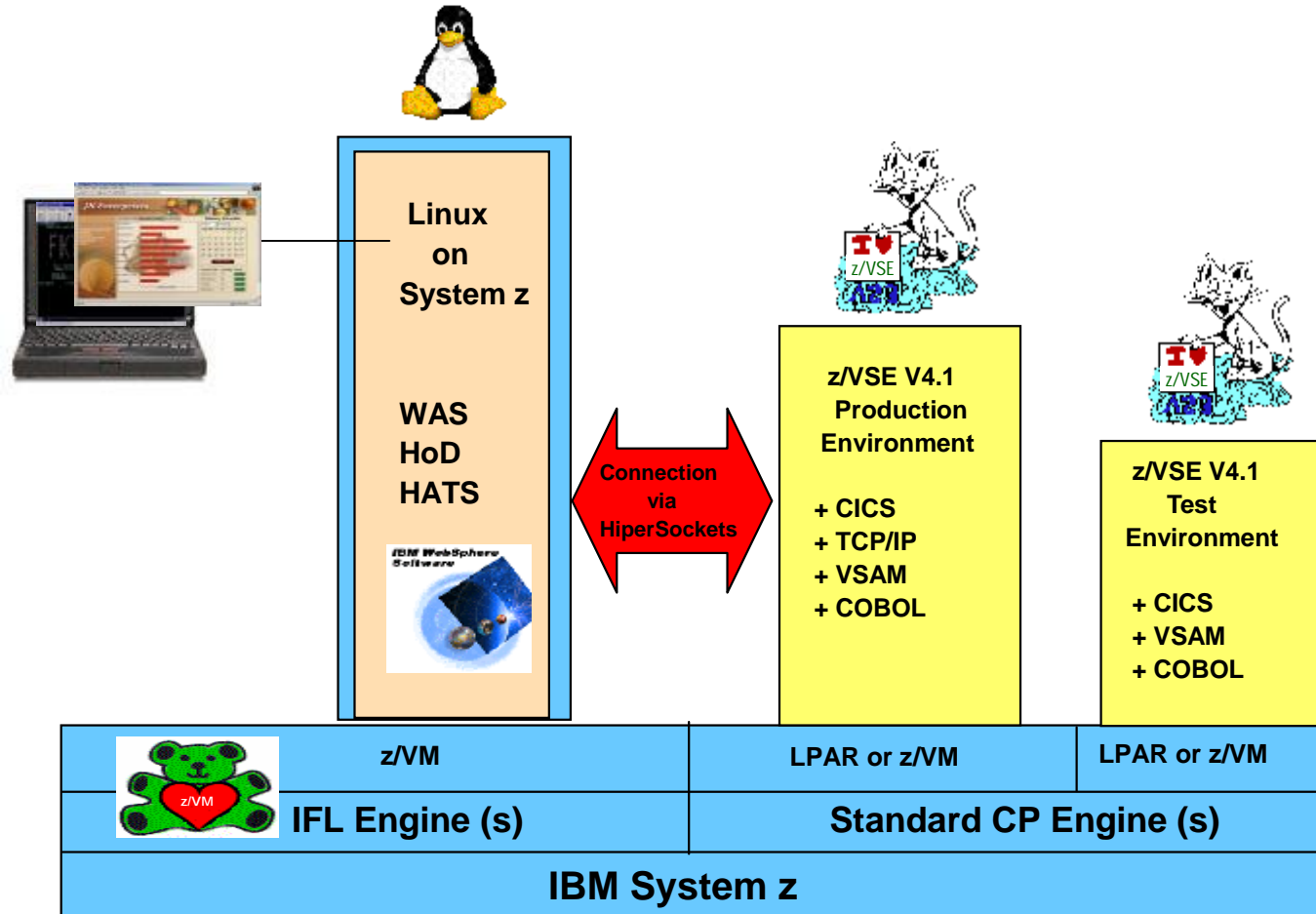

Scenario 3: WebSphere Portal for VSE Customers

Portal for administration and integration of employees / customers / partners

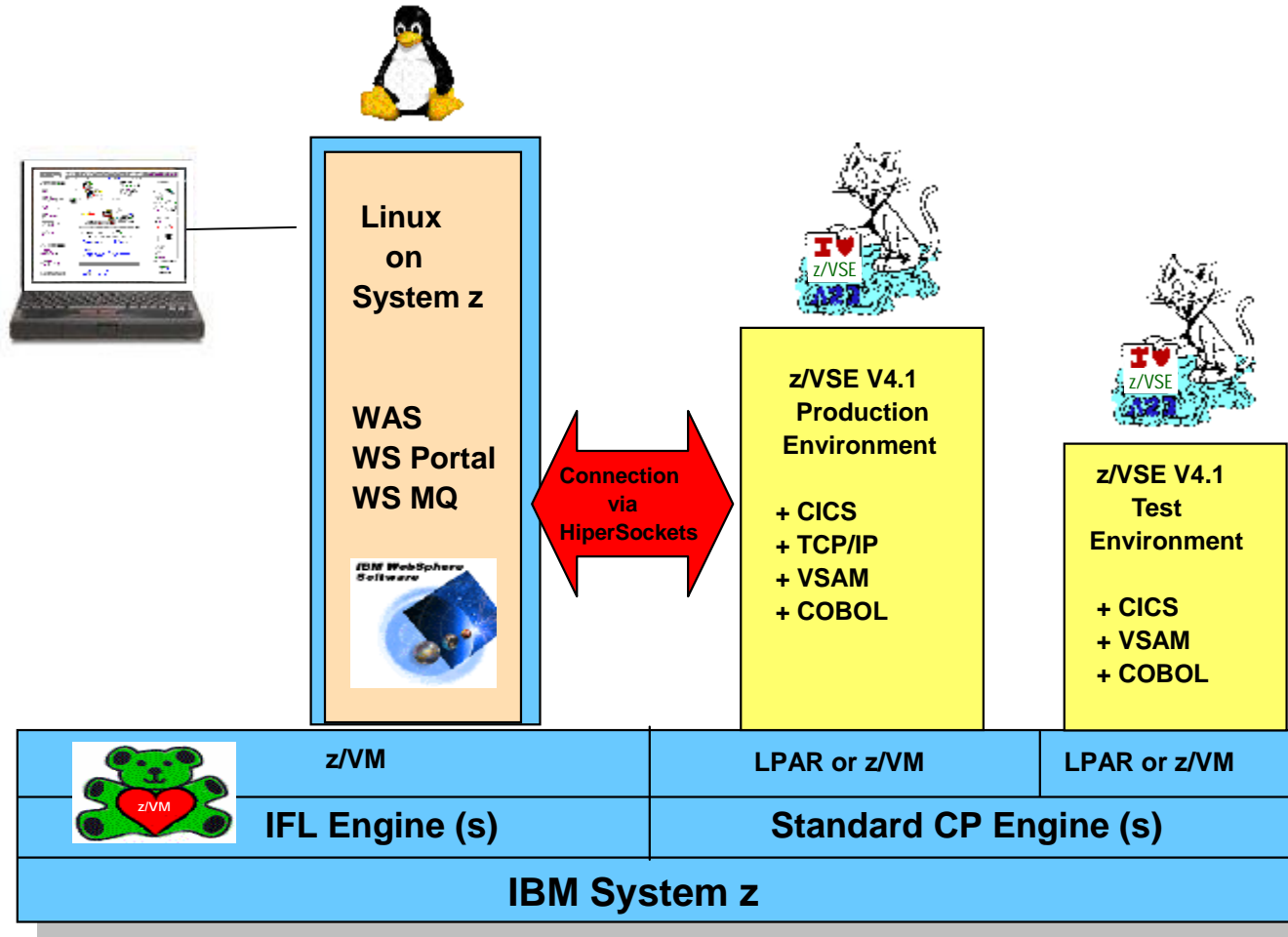

Scenario 4: Network Infrastructure Simplification

3745/46 (NCP) and TN3270 replacement with Linux on System z

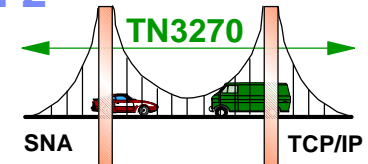

Easy, high-value transition

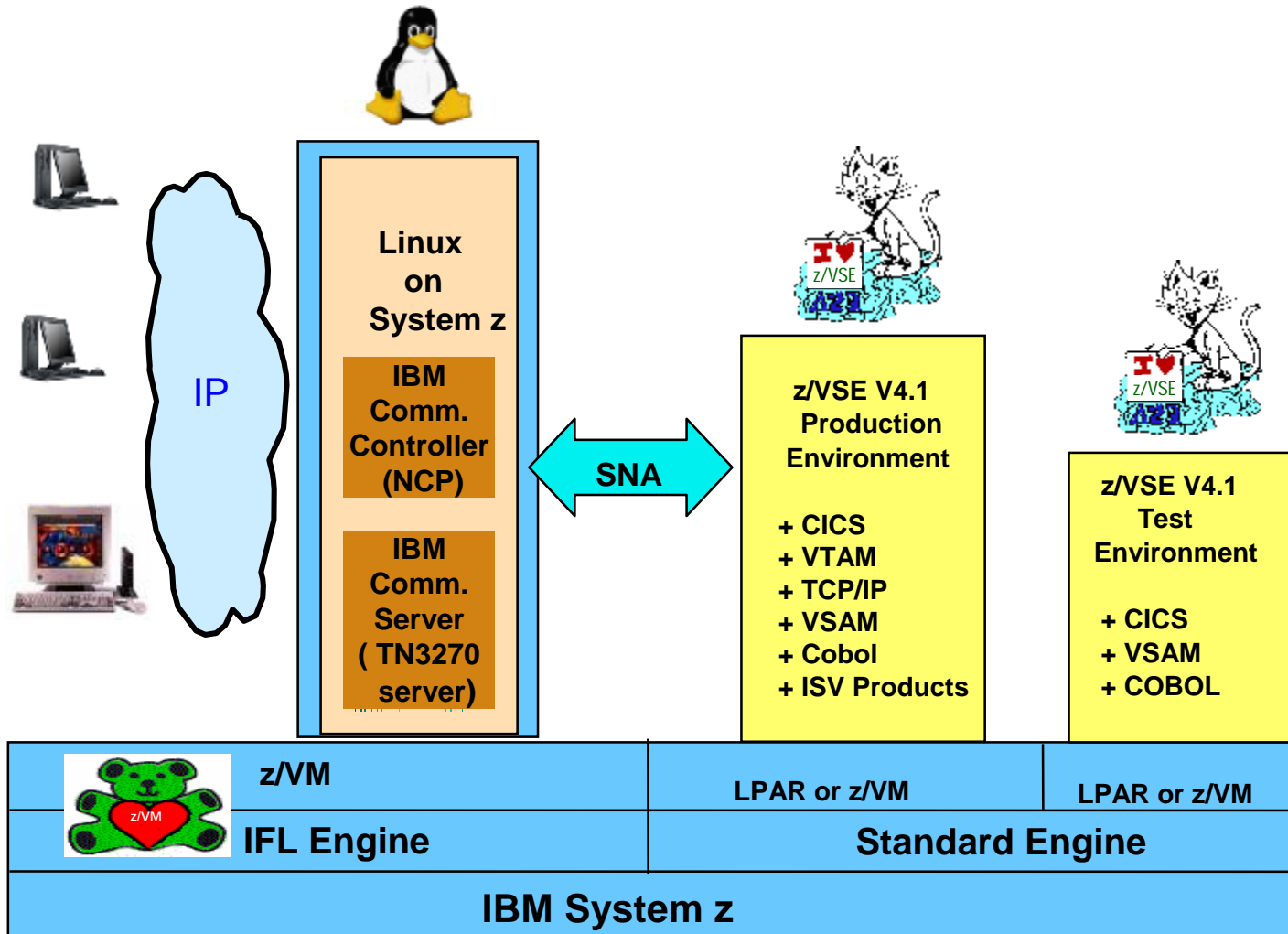

Scenario 5: Application Development for VSE

Modern, Cross Platform Application Development Environment



PC/Workstation

VisualAge Generator EGL Plug-in for VSE *

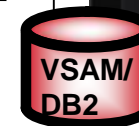
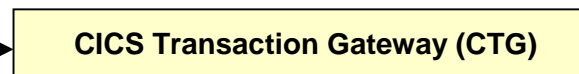
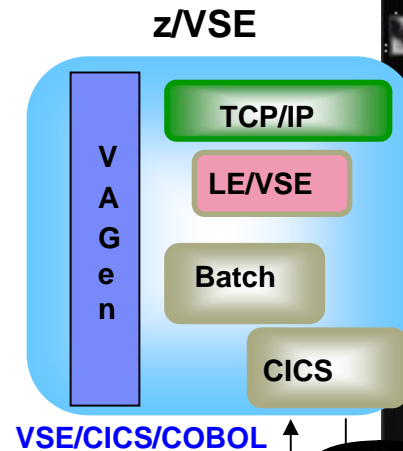
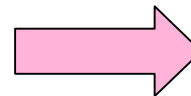
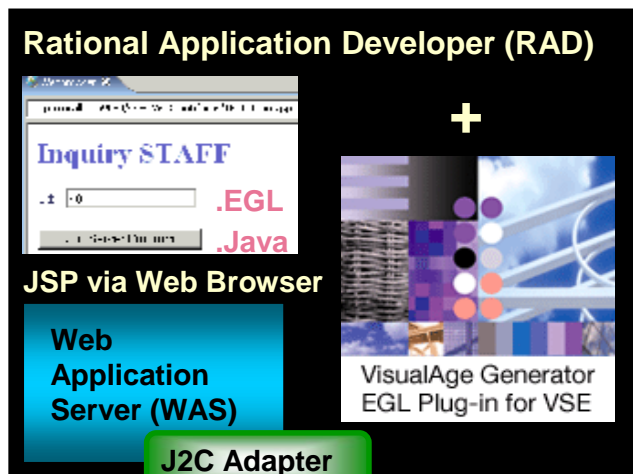

- § WebSphere Application Server – the integration platform
- § Enterprise Generation Language (EGL), Visual Age Generator
- § Java™ 2 Platform, Enterprise Edition (J2EE) connection Architecture (J2C/JCA)
- § Java Server Pages (JSP), as Front-End representation technology

Scenario 6: Backup/Restore Concepts for VSE

Integrate z/VSE with TSM on Linux on System z

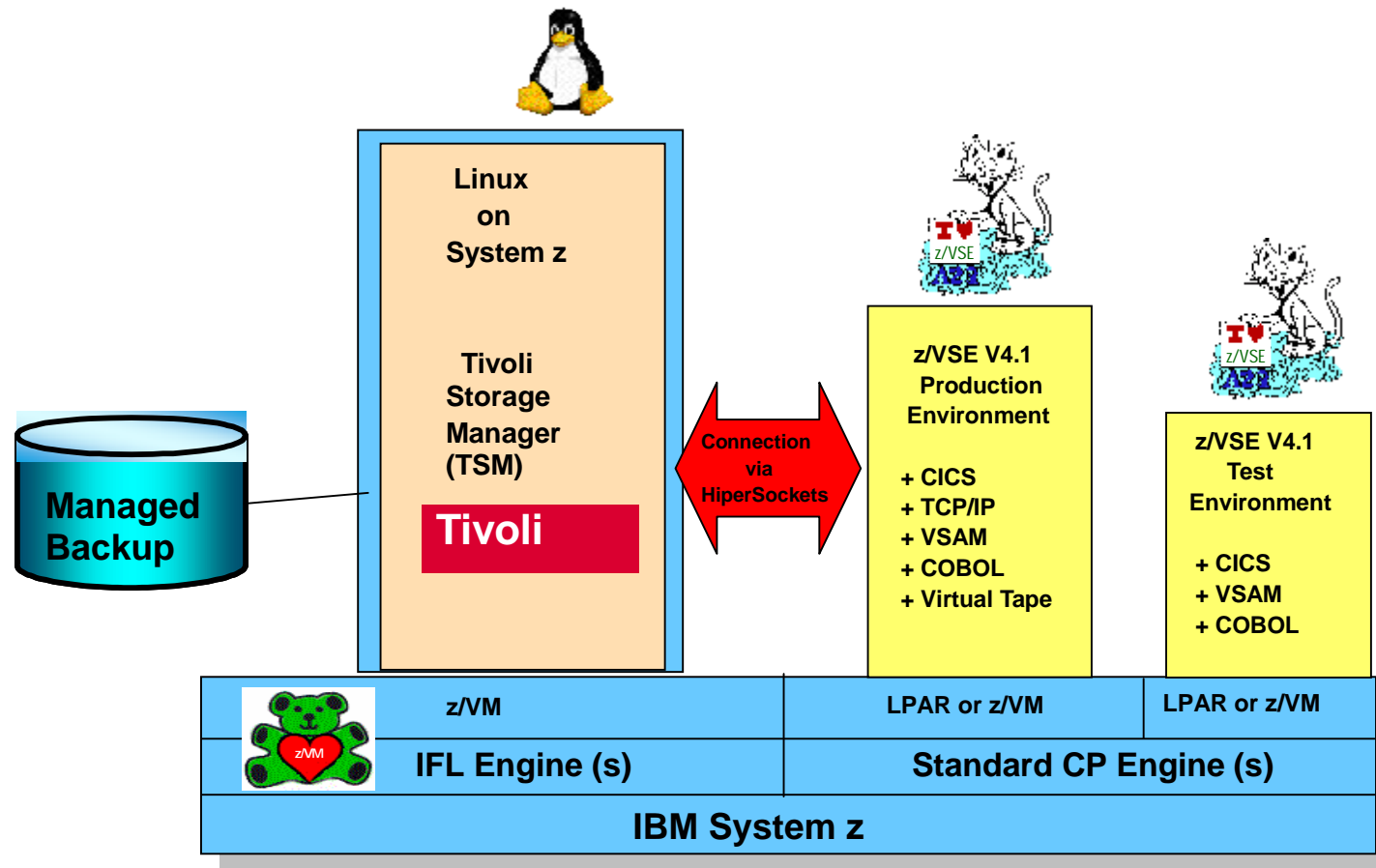

Linux Advantages for z/VSE Customers

§ Linux applications based on IBM Middleware

- WebSphere Application Server
- DB2 UDB
- Lotus® Domino™
- Communications Server
- advanced Application Development tools

§ Linux-based open source and/or ISV applications

- Linux on System z exploits 64-bit capabilities
- Complement 31-bit core VSE applications

§ Integrate Linux and z/VSE solutions

- Linux access to core z/VSE applications and data
- z/VSE access to new Linux applications and data

§ Infrastructure simplification

- Consolidate existing distributed servers
- TCO benefits of Linux and System z

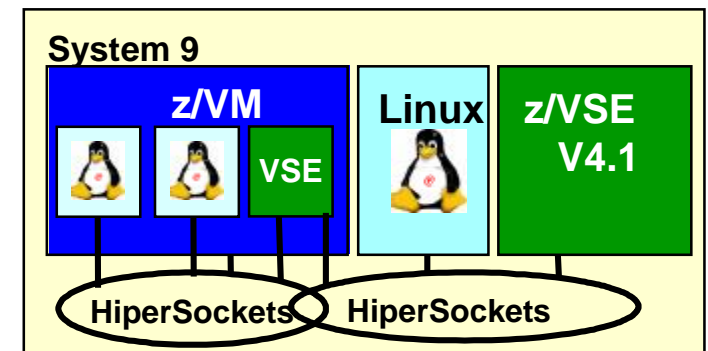
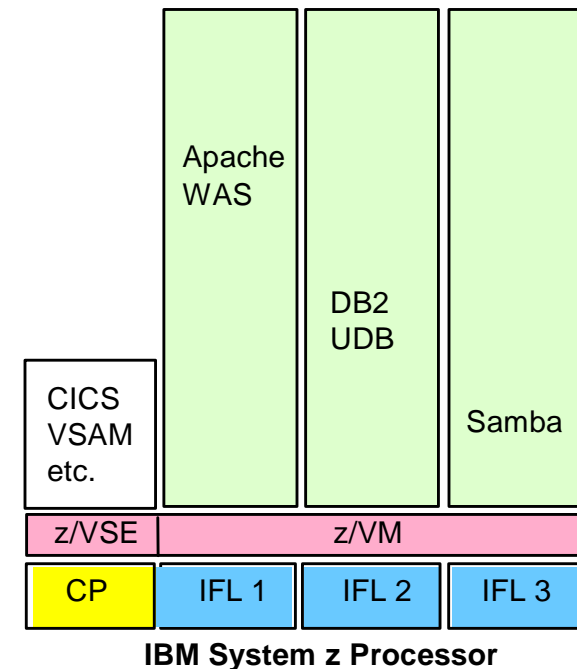

Exploiting the System z Platform

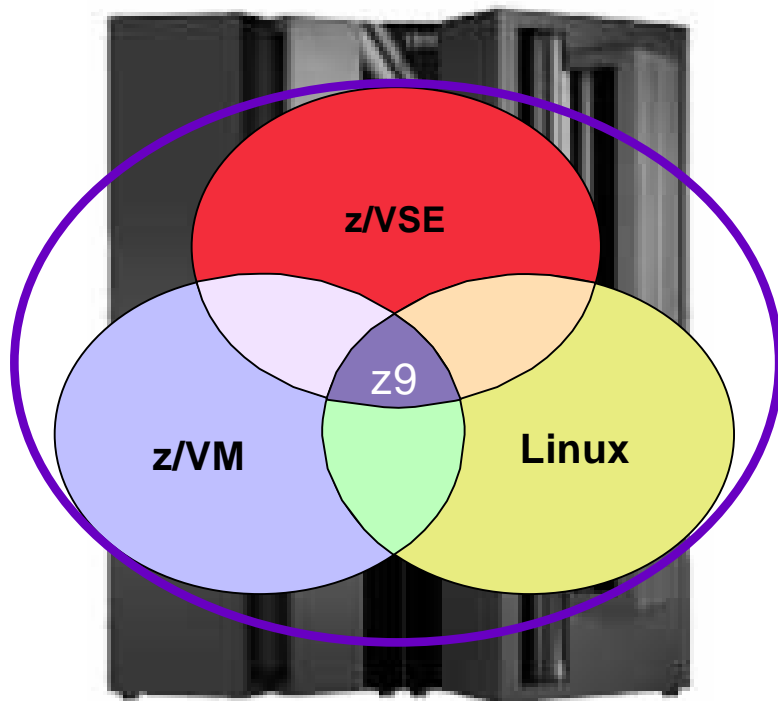

§ **z/VSE** *designed to provide*

- protection of core IT investments
- robust, secure enterprise server
- cost-effective solutions
- interoperability with network/servers
- z/OS affinity

§ **Linux on System z**

- large portfolio of new applications
- platform for IBM middleware
- infrastructure simplification
- massive scalability

§ **z/VM** *designed to provide*

- highly flexible, secure
- robust, industrial strength
- multiple VSE and Linux images
- designed to exploit System z

z/VSE V4 and Linux on System z

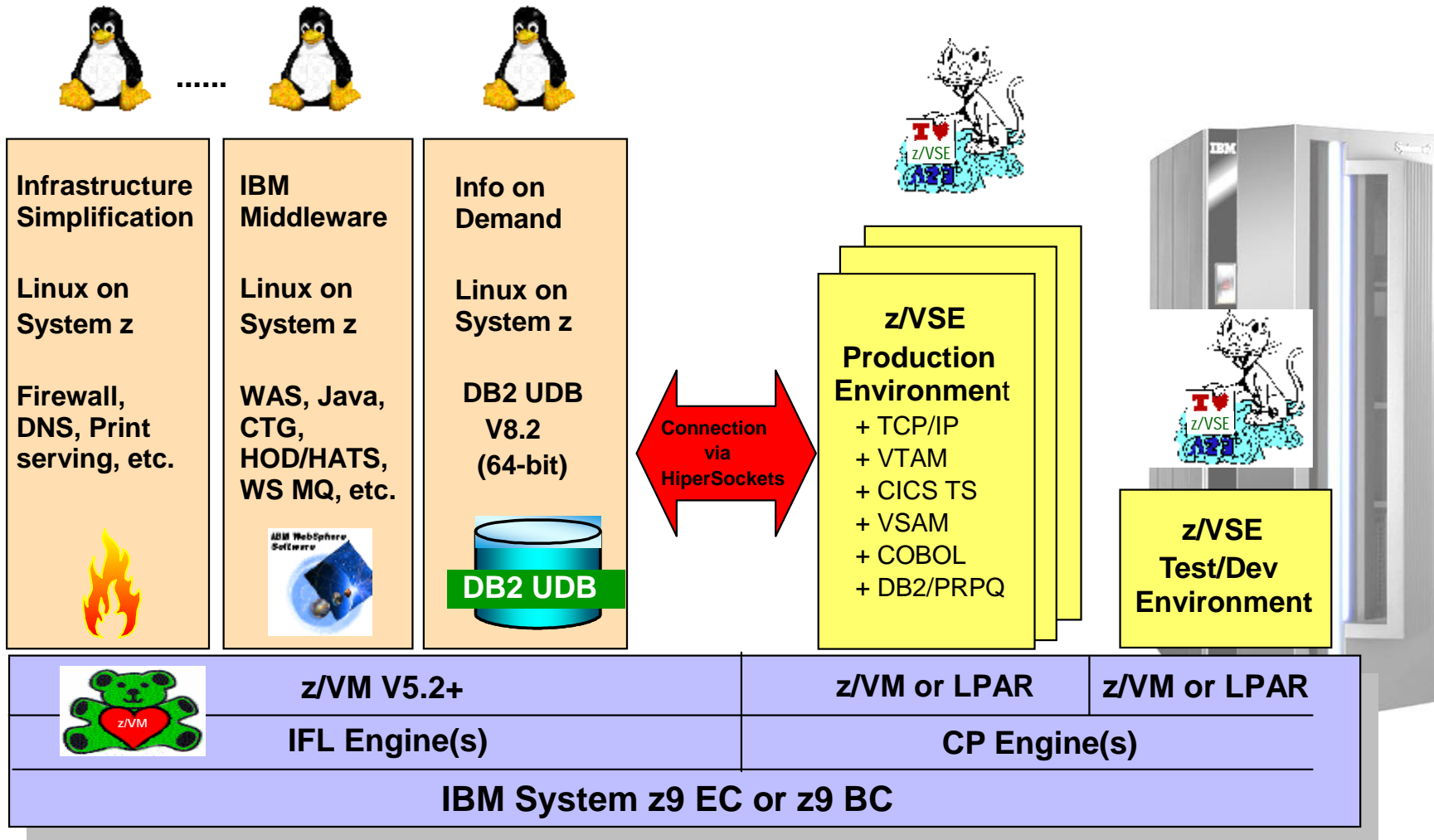



Summary/Wrap-up

z/VSE Version 4 Release 1

§ Announce 1/9/2007 (Preview 4/29/2006)

§ **General Availability 3/16/2007**

§ **z/Architecture (64-bit) mode only**

- Up to 8 GB real processor storage
- System z9 EC *and* z9 BC
- zSeries 990, 890, 900, 800

§ **New MWLC pricing metrics (z9 only)**

- Low full capacity price points
- Sub-capacity option

§ **Encryption enhancements**

- CPACF enhancements (AES-128)
- Crypto Express2 (configurable)
- TS1120 encrypting tape
- SecureFTP

§ **SOA and interoperability**

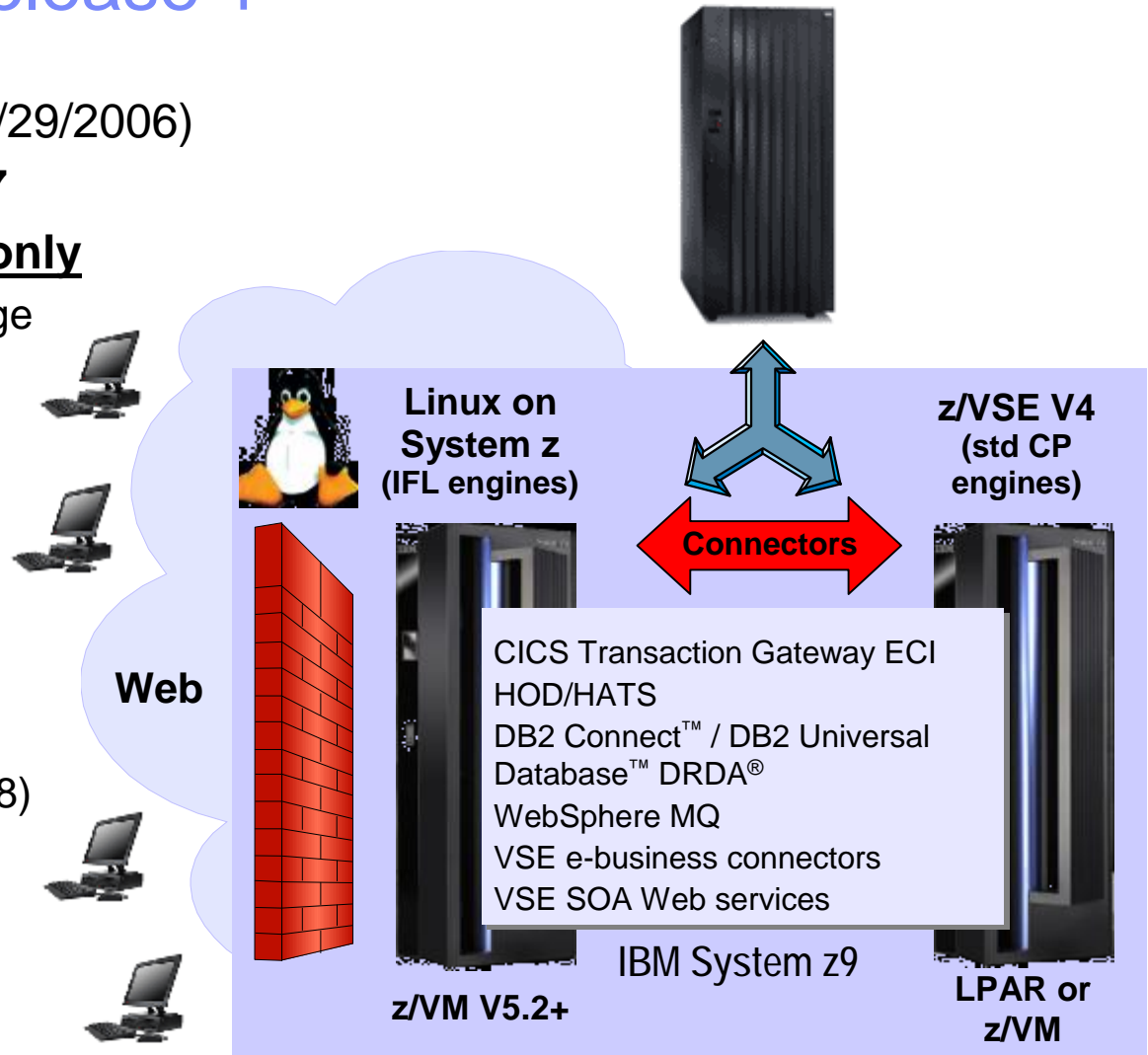

z/VSE V4 and Linux on System z

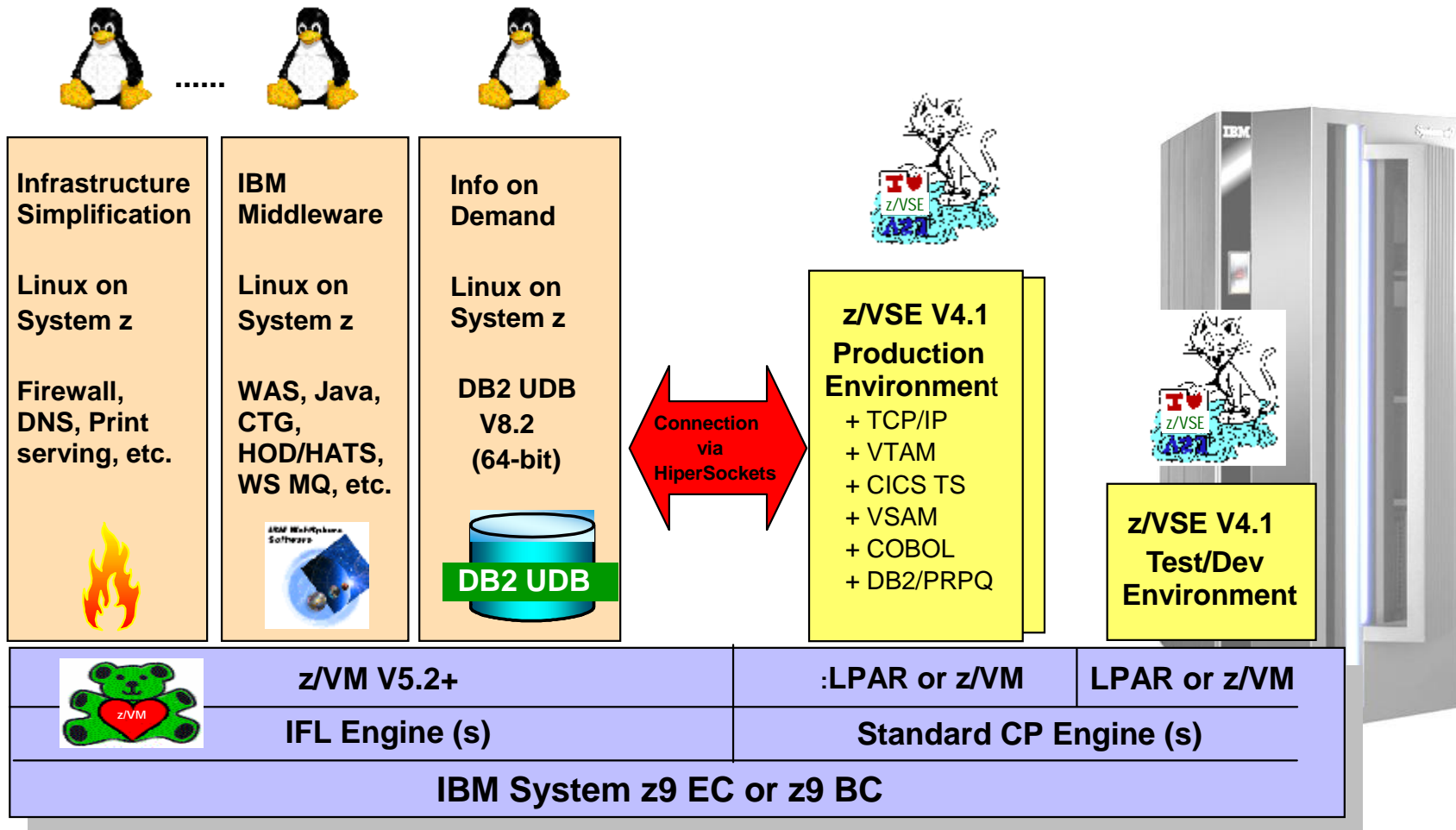

z/VSE “PIE” Strategy

- § Help **P**rotect existing customer investments in core z/VSE programs, data, equipment, IT skills, *plus* business processes, end user training
 - Modernize, i.e. extend z/VSE resources to Web
 - Exploit IBM servers, storage, and software
 - z/OS affinity
- § Help **I**ntegrate z/VSE with the rest of IT, based on open and industry standards
 - VSE connectors and SOA Web services
 - IBM middleware
- § Help **E**xpand solutions with Linux on System z
 - Linux as preferred platform for new workloads
 - leverage existing core VSE investments
 - low cost, low risk, fast time-to-market
 - New line-of-business applications
 - Low TCO and infrastructure simplification



z/VSE Directions

§ Protect

- basic hardware support and selective exploitation
 - IBM System z9 (incl 64-bit real memory, CPACF, Crypto Express2, FICON Express4, etc.)
 - IBM TotalStorage (incl DS8000 Turbo, TS1120 encryption, IBM 3400 tape library, etc.)
- value
 - availability / integrity / reliability / security
 - continuity / stability / z/OS affinity
 - ease-of-use / maintainability / serviceability
 - lower total cost of ownership (TCO) / flexible terms and conditions
 - specific customer requests (WAVV, GSE, individuals, etc. requirements)

§ Integrate

- connectivity based on open and industry standards
- network integration (including VSE Connectors & SOA web services)

§ Extend

- integrate / new workloads exploit capabilities of Linux on IBM System z
- low risk, low cost, fast time-to-market

Thanks for listening



Your friends, the VSE development team

