



WAVV 2004 Conference



CICS Web Support: Access to CICS Applications from the Web

Robin Gemmell
(gemmell@uk.ibm.com)

Chattanooga, 30 April - 4 May 2004

Trademarks

- The following terms are trademarks of International Business Machines Corporation in the United States and/or other countries:

AIX	DB2	OS/390	VisualAge
CICS	MVS/ESA	VSE/ESA	
CICS/VSE	OS/2	VTAM	

- Java and Solaris are trademarks of Sun Microsystems, Inc
- Windows, Windows 95, Windows 98, Windows 2000, and Windows NT are trademarks of Microsoft Corporation, Inc
- Other company, product, and service names may be trademarks or service marks of others

Agenda

- What is CICS Web Support?
- CICS Web Support architecture
- Enabling CICS Web Support
- Writing CICS Web Applications
- Running 3270-based transactions with CICS Web Support
- Further Information and Summary

Agenda

- **What is CICS Web Support?**
- CICS Web Support architecture
- Enabling CICS Web Support
- Writing CICS Web Applications
- Running 3270-based transactions with CICS Web Support
- Further Information and Summary

What is CICS Web Support?

- Set of services that enables direct connection from a Web browser to CICS Transaction Server for VSE/ESA
- Enables access to CICS Application Programs and Transactions
- Formerly known as the CICS Web Interface
- New API 's provided for "Web aware" applications
- Delivered in CICS Transaction Server for VSE/ESA V1.1.1

What is CICS Web Support?

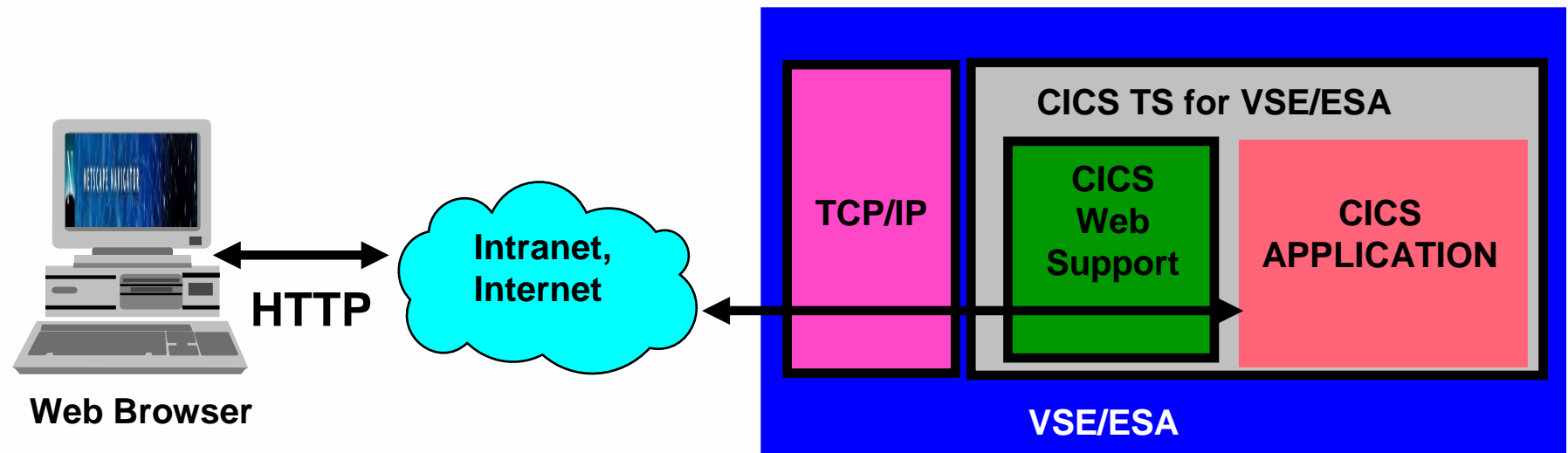

- Web browser access to CICS Applications and Transactions
- Direct connection - no intermediate gateways or servers
- Standard HTTP protocol used over TCP/IP
- *Secure Sockets Layer support available with VSE/ESA V2.6*

Relationship to the CICS Transaction Gateway

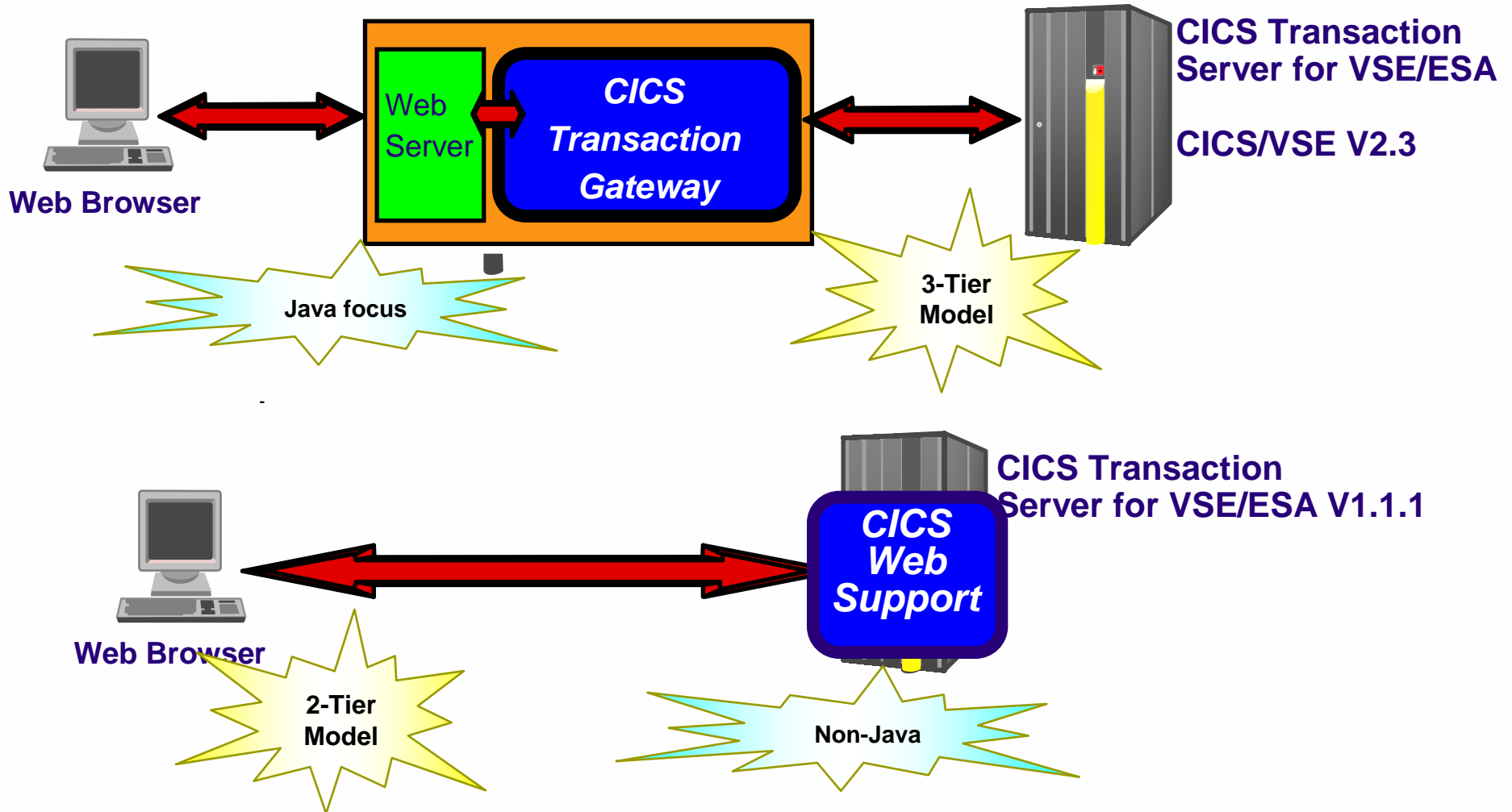

What is CICS Web Support?

- CICS Application program to be invoked specified in URL
- Default URL format:

f <http://hostid:port/converter/alias/program?optional-token>

hostid is the IP address or DNS name of the CICS region
port is the configured listening port number
converter is the name of the program for Decode & Encode processing
- "CICS" if no converter
alias is the transaction id of the alias transaction
- "CWBA" is the supplied alias
program is the name of the CICS application program to be invoked
optional-token is optional data to be passed with the request

- Example URL:

f <http://cicstest.ibm.com:1080/cics/cwba/webpgm1>

Agenda

- What is CICS Web Support?
- **CICS Web Support architecture**
- Enabling CICS Web Support
- Writing CICS Web Applications
- Running 3270-based transactions with CICS Web Support
- Further Information and Summary

CICS Web Support Architecture

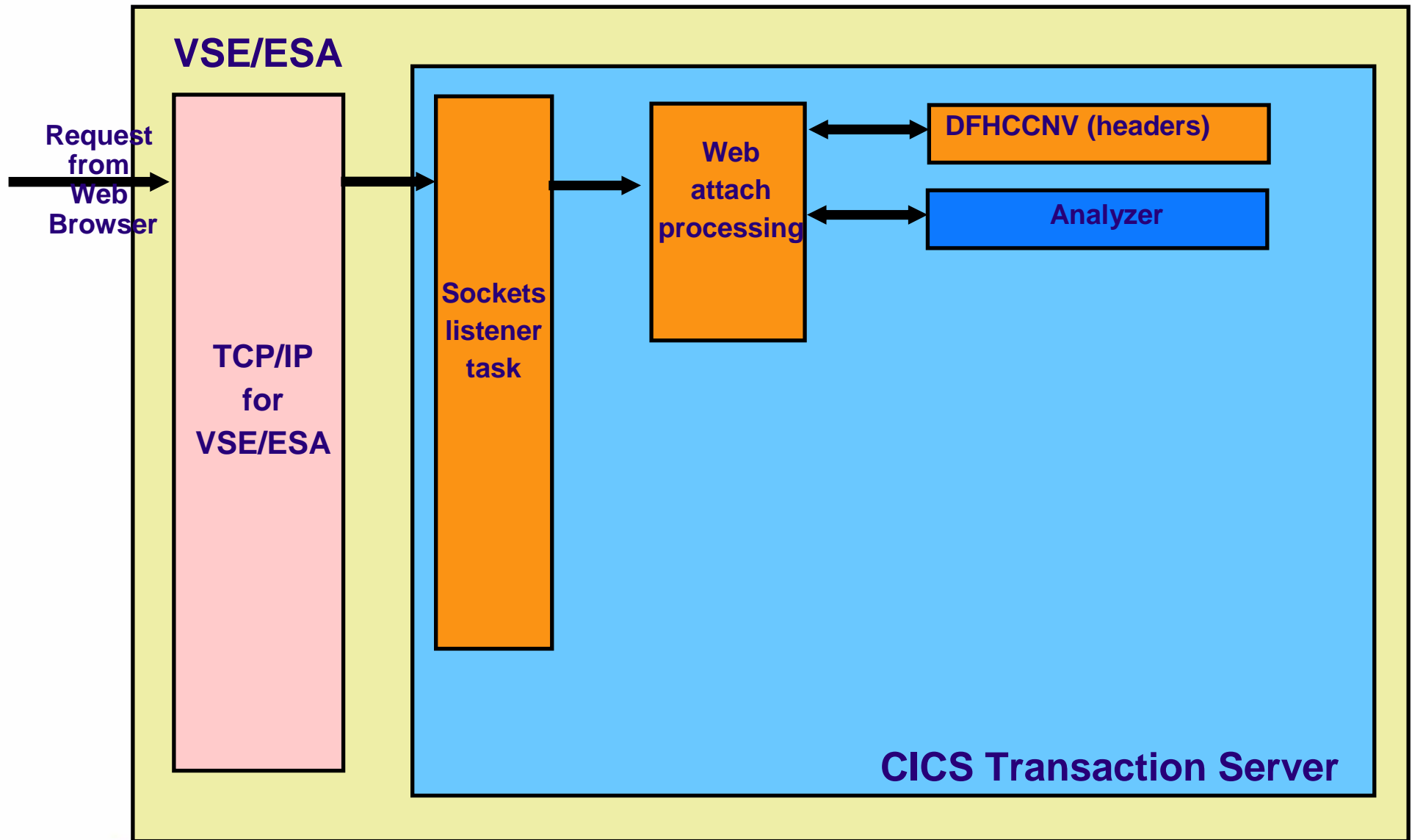

CICS Web Support Architecture

■ The **Analyzer**:

- f* Parses the incoming request
- f* Determines resources and context for Alias transaction
- f* Specifies codepage conversion for body of http request
- f* User Replaceable Module

■ The supplied default Analyzer:

- f* Provides ISO-8859-01 codepage conversation
- f* Supports the default CWS URL format
-<http://hostid:port/converter/alias/program?optional-token>

■ The supplied Analyzer programs:

- f* DFHWBADX -----> Assembler
- f* DFHWBAHX -----> C
- f* DFHWBALX -----> PL/I
- f* DFHWBAOX -----> COBOL

CICS Web Support Architecture

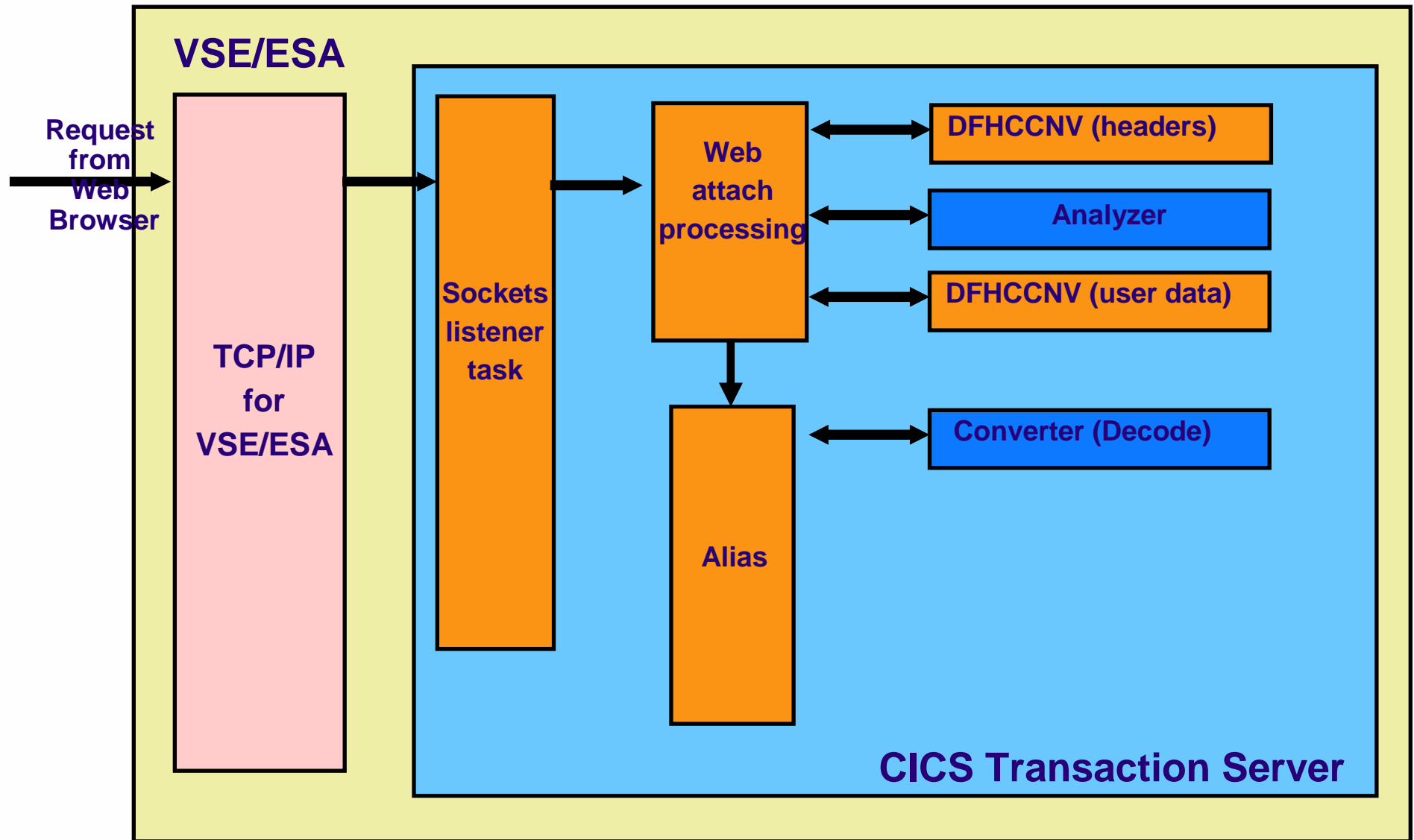

CICS Web Support Architecture

■ The Converter

f Provides **Decode** and **Encode** functions

■ **Decode** invoked *before* request passed to CICS application

f Maps inbound HTTP request to application COMMAREA

■ **Encode** invoked *after* CICS application has processed request

f Maps application COMMAREA to outbound HTTP response

■ Converter is optional

CICS Web Support Architecture

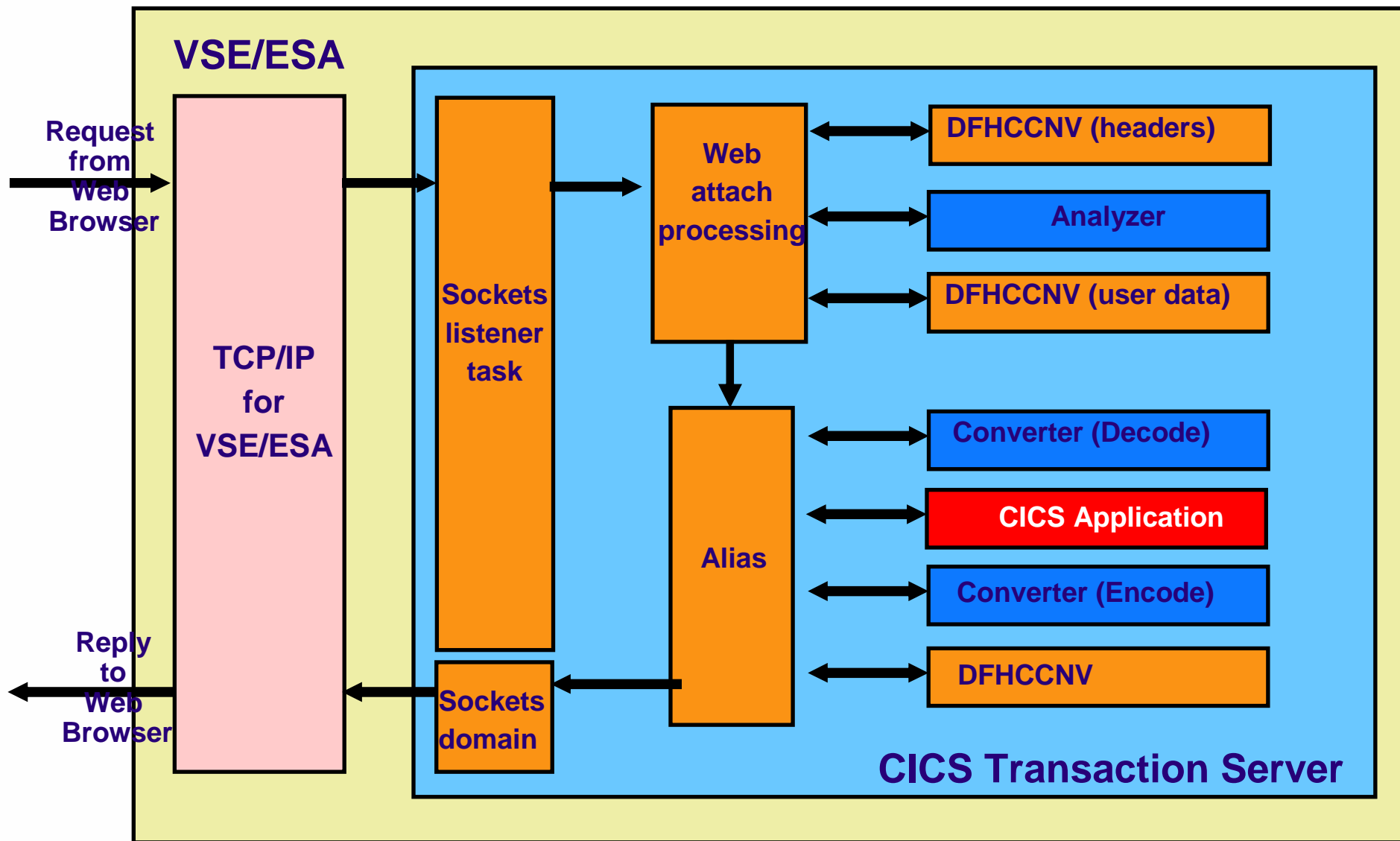

CICS Web Support Architecture

Accessing existing COMMAREA based applications

- Converter used to shield applications from HTTP and HTML

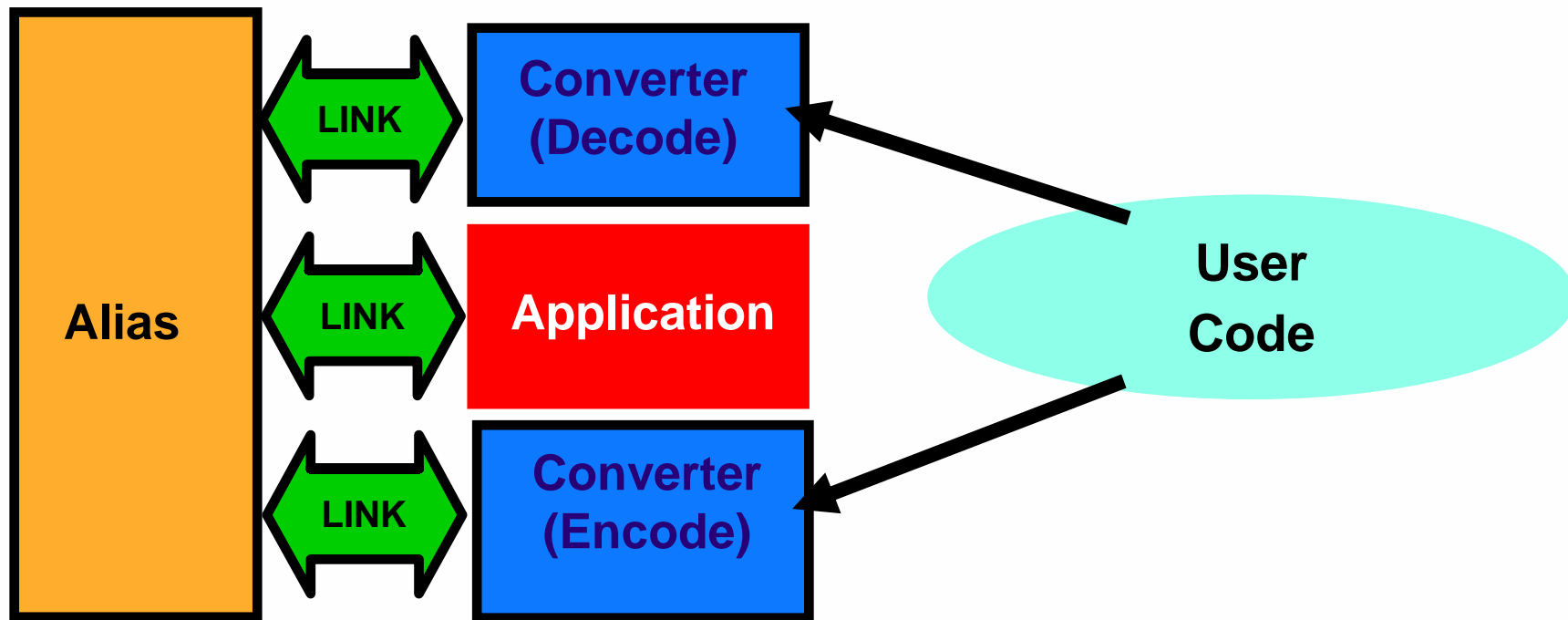

CICS Web Support Architecture

Accessing new CICS "Web aware" Applications

- The picture becomes simpler using the new API's....

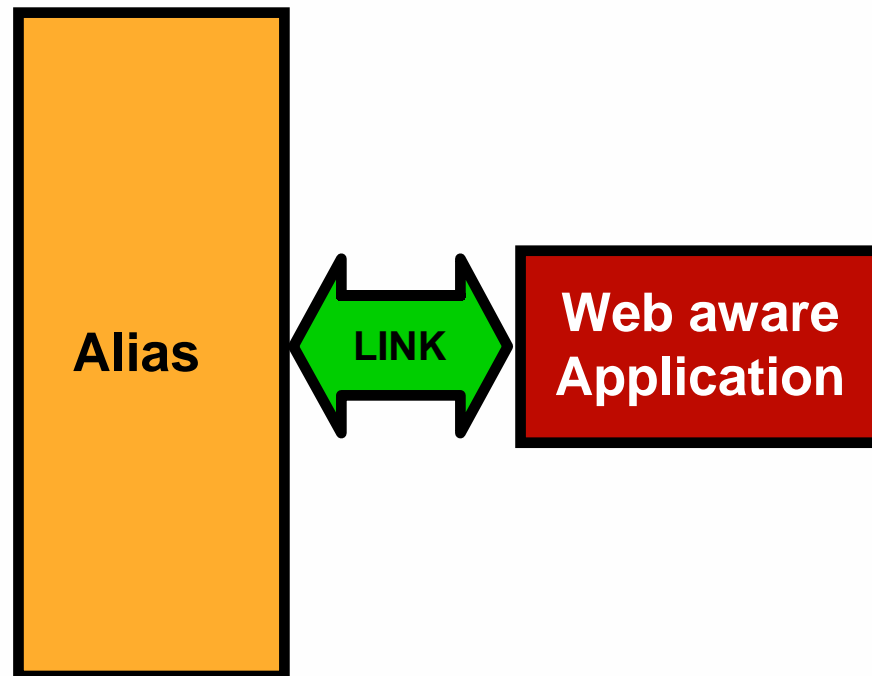

- NB: "Web aware" applications need to understand HTTP

CICS Web Support Architecture

Accessing 3270-based transactions

- Uses the 3270 Bridge support
- Some limitations

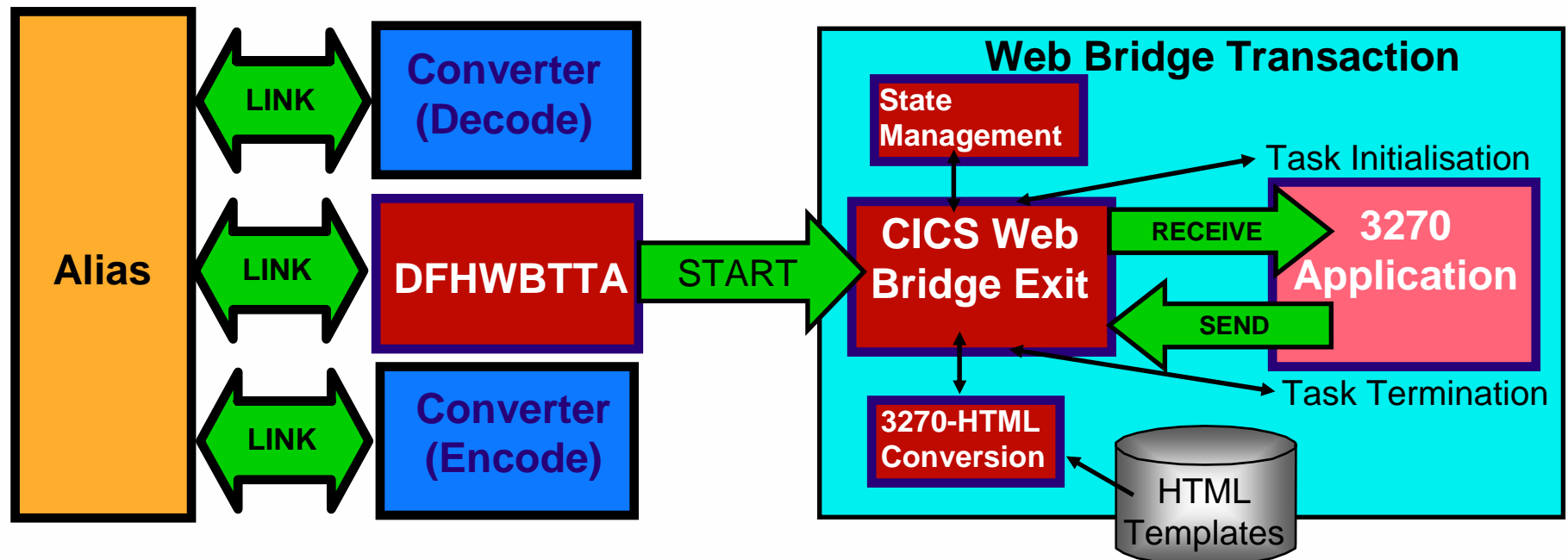

Example URL > <http://cics1.ibm.com:1080/cics/cwba/dfhwbtt/ceci>

Agenda

- What is CICS Web Support?
- CICS Web Support architecture
- **Enabling CICS Web Support**
- Writing CICS Web Applications
- Running 3270-based transactions with CICS Web Support
- Further Information and Summary

DFHSIT requirements

- Specify that TCP/IP services are required
 - f* TCPIP=YES
- Specify Web 3270 bridge parameters
 - f* WEBDELAY=(n,m)
 - n = time transaction remains in terminal wait before being terminated
 - m = time during which state data is kept for a transaction
- Increase EDSA storage
 - f* by at least 2M for TCPIP services
 - f* 1M per active Web connection
- Additional SIT parameters if using SSL
 - f* ENCRYPTION=WEAK|NORMAL|STRONG
 - f* KEYFILE=*name*
 - f* SSLDELAY= *number*

Resource Definitions

- Define at least one TCPIP SERVICE
 - f* Specifies IP address, port number, name of the analyzer
 - f* Also specifies level of SSL support and SSL certificate
 - f* Sample specified in DFH\$SOT
- Install supplied RDO group DFHWEB
 - f* Contains definitions for CWS transactions and programs
- Define any required DOCTEMPLATES
 - f* Required if using new DOCUMENT API

Other Requirements

- Define a conversion table using DFHCNV macros
 - f* For HTTP conversion between ASCII and EBCDIC
 - f* Example DFHCNV table:

```
DFHCNV TYPE=INITIAL
*
DFHCNV TYPE=ENTRY,RTYPE=PC,RNAME=DFHQBHH,USREXIT=NO,
      SRVERCP=037,CLINTCP=8859-1
DFHCNV TYPE=SELECT
DFHCNV TYPE=FIELD,OFFSET=0,DATATYP=CHARACTER,DATALEN=32767,
      LAST=YES
*
DFHCNV TYPE=ENTRY,RTYPE=PC,RNAME=DFHQBUD,USREXIT=NO,
      SRVERCP=037,CLINTCP=8859-1
DFHCNV TYPE=SELECT
DFHCNV TYPE=FIELD,OFFSET=0,DATATYP=CHARACTER,DATALEN=32767,
      LAST=YES
*
DFHCNV TYPE=FINAL
END
```

- Configure TCP/IP for VSE/ESA

Other Considerations

■ Security

- f* Transactions that compose CICS Web Support
- f* Running Web transactions with end-user specified Userid
- f* Use of Secure Sockets Layer (SSL)
- f* TCP/IP VSE/ESA security facilities

■ Operational Support

- f* DFHWBEP - Web Error Program
- f* SPI and CEMT commands

COMMAND	SPI	CEMT
CREATE DOCTEMPLATE		
CREATE TCPIP SERVICE		
DISCARD DOCTEMPLATE		
DISCARD TCPIP SERVICE		
INQUIRE DOCTEMPLATE		
INQUIRE TCPIP		
INQUIRE TCPIP SERVICE		
INQUIRE WEB		
SET TCPIP		
SET TCPIP SERVICE		
SET WEB		

Agenda

- What is CICS Web Support?
- CICS Web Support architecture
- Enabling CICS Web Support
- **Writing CICS Web Applications**
- Running 3270-based transactions with CICS Web Support
- Further Information and Summary

The new Web API's

■ WEB API

f HTTP protocol

EXEC CICS WEB EXTRACT

EXEC CICS WEB STARTBROWSE

EXEC CICS WEB READNEXT

EXEC CICS WEB ENDBROWSE

EXEC CICS WEB READ

EXEC CICS WEB RECEIVE

EXEC CICS WEB WRITE

EXEC CICS WEB SEND

EXEC CICS WEB RETRIEVE

■ TCP/IP API

f Sockets protocol

EXEC CICS EXTRACT TCPIP

EXEC CICS EXTRACT CERTIFICATE

■ DOCUMENT API

f HTML,XML, etc

EXEC CICS DOCUMENT CREATE

EXEC CICS DOCUMENT INSERT

EXEC CICS DOCUMENT SET

EXEC CICS DOCUMENT RETRIEVE

The new Web API's....

■ EXEC CICS WEB

- f* Retrieve components of the inbound HTTP request
- f* Construct HTTP headers to be returned in HTTP response
- f* Select a document for delivery as the body of the response

■ EXEC CICS EXTRACT TCPIP

- f* Retrieve TCP/IP information

■ EXEC CICS EXTRACT CERTIFICATE

- f* Retrieve information from the client certificate

■ EXEC CICS DOCUMENT

- f* Create and manipulate "Documents"
 - Can be made up of both text and binary elements
 - Can contain templates, symbols and bookmarks
 - Bookmarks can be used to insert data at specific points
 - Documents can be imbedded
 - Codepage information stored with document

New WEB API's....Processing HTTP Requests

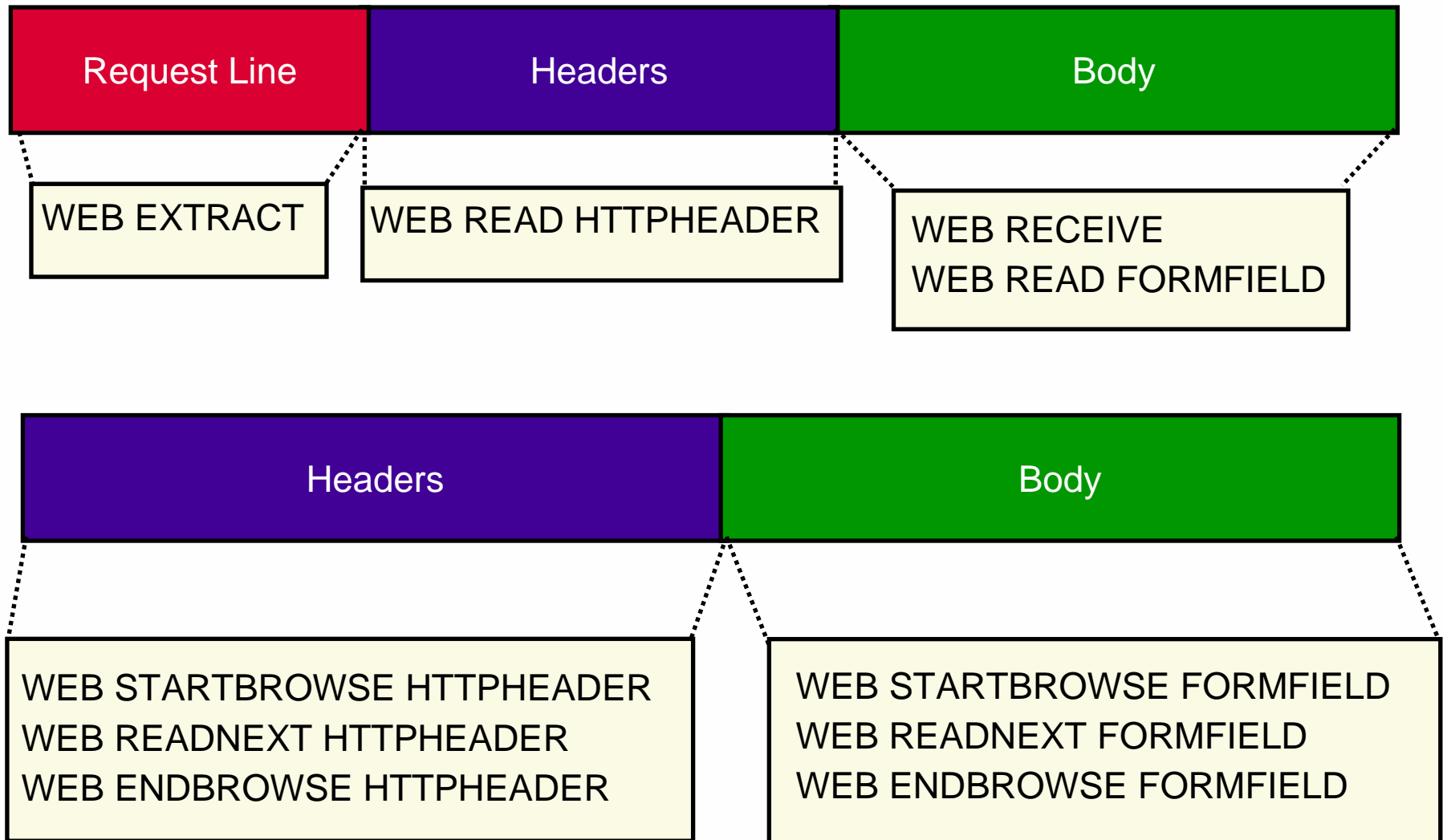

New WEB API's....Processing HTTP Responses

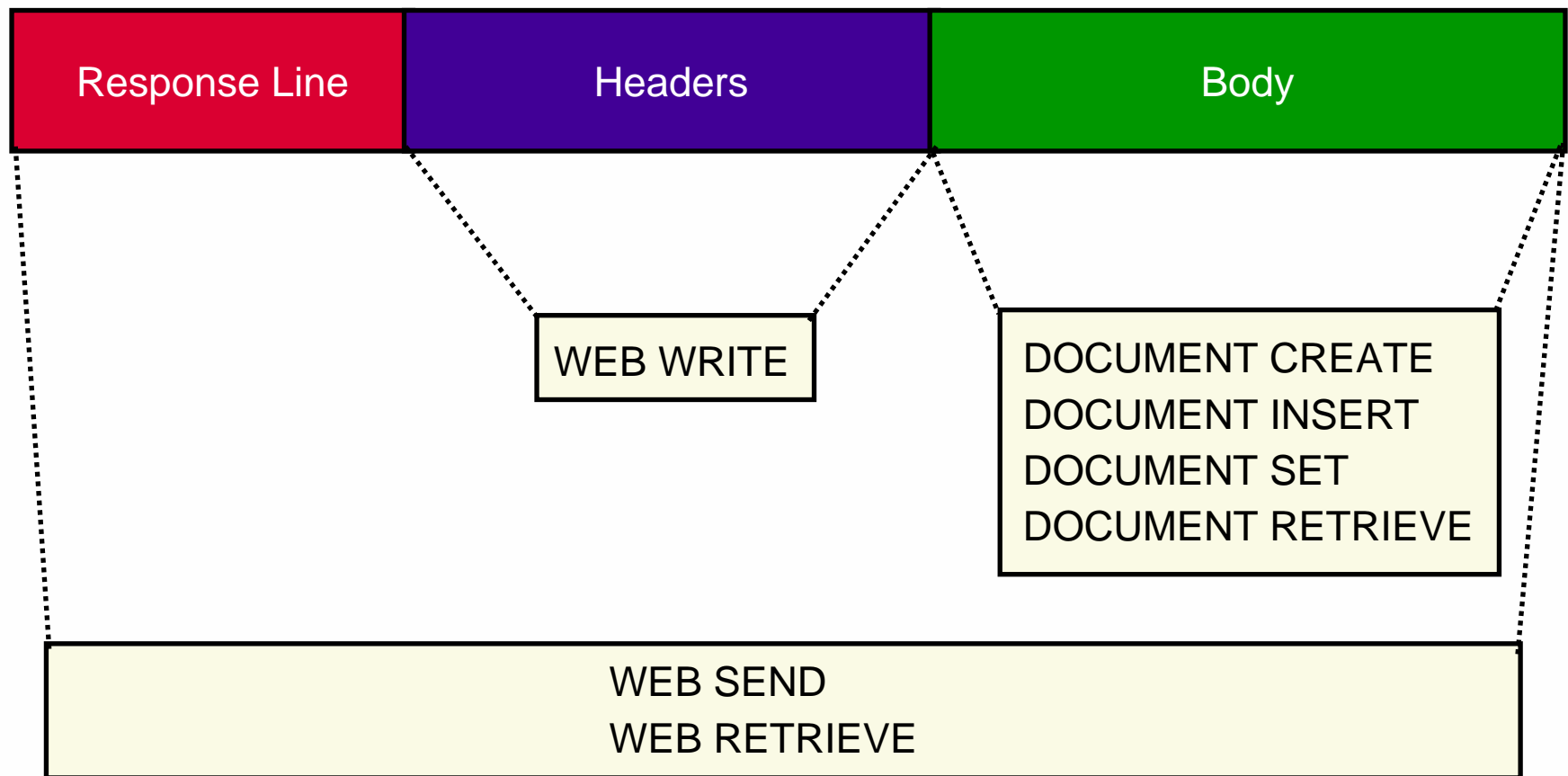

Document Templates

- Templates specified by DOCTEMPLATE resource, can be...
 - f* VSE sub-library member, CICS file, TS queue, TD queue
 - f* Load module, Exit program
- HTML example:

```
<html>
<head>
<title>Address Book</title>
</head>
<body>
<center>
<h1>&person;</h1><br>
&house_number; &street;<br>
&town;<br>
&zip;<br>
&person; can be reached on &home_number; at home or &work_number; during office hours <br>
</center>
</body>
</html>
```
- Example symbol list for the above would be a single string:

"**person=Barney Rubble&house_number=2&street=Stoney
Lane&town=Bedrock&zip=&home_number=911&work_number=123-456** "

Document Templates...after substitution

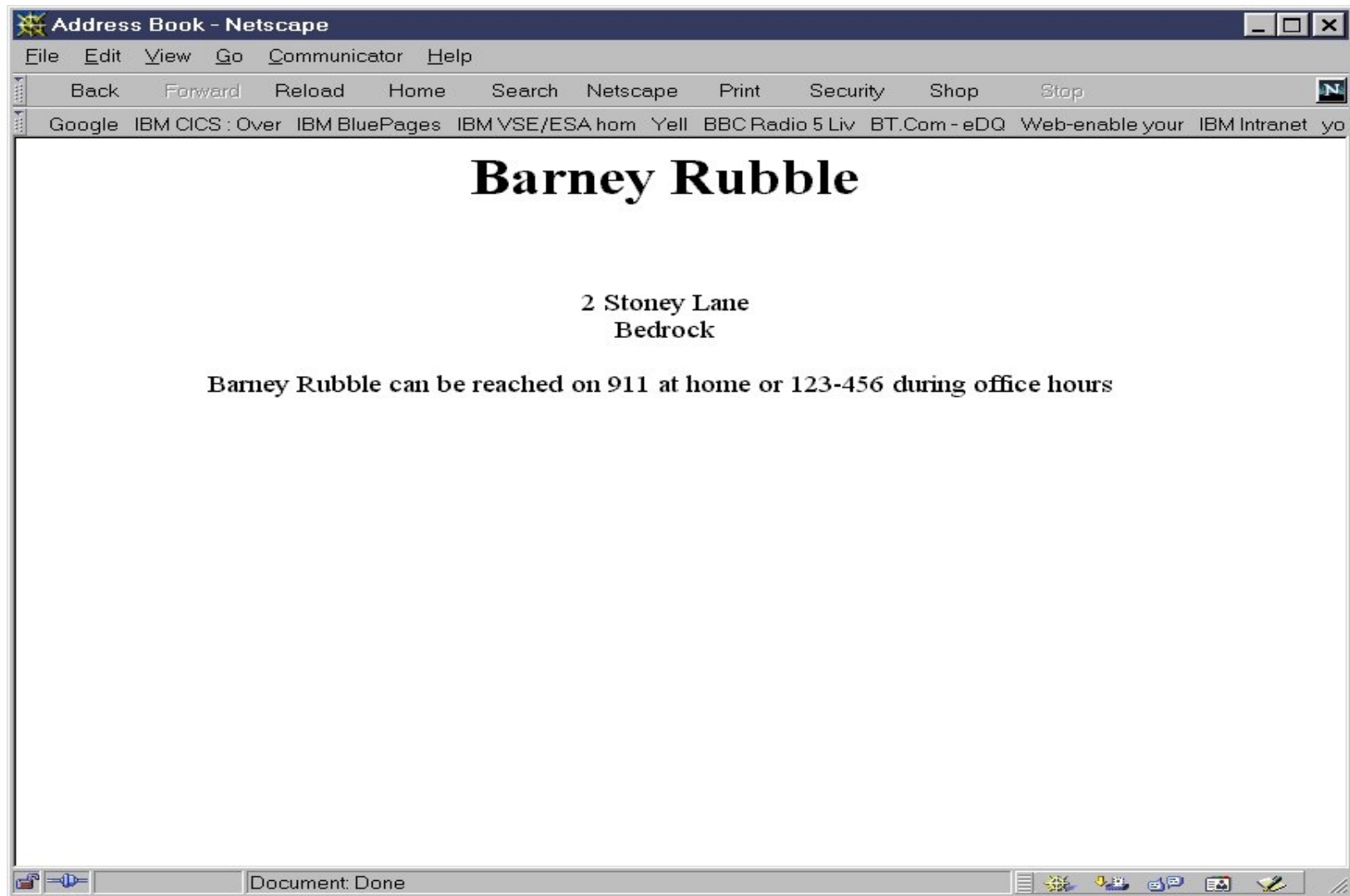

Web API's - code example

- * Create document from existing HTML template

```
EXEC CICS DOCUMENT CREATE DOCTOKEN(DOCTKN)
      TEMPLATE('TEMPL1')
```

- * Get Server TCP/IP address

```
EXEC CICS EXTRACT TCPIP
      SERVERADDR(SRVRADDR) SADDRLENGTH(ADDRL)
```

- * Get Client TCP/IP address

```
EXEC CICS EXTRACT TCPIP
      CLIENTADDR(CLNTADDR) CADDRLENGTH(ADDRL)
```

- * Insert both addresses into document

```
EXEC CICS DOCUMENT INSERT DOCTOKEN(DOCTKN)
      TEXT(DOCTXT) LENGTH(DOCTXTL)
```

- * Add footer to document from existing HTML template

```
EXEC CICS DOCUMENT INSERT DOCTOKEN(DOCTKN)
      TEMPLATE('TEMPL2')
```

- * Send completed document

```
EXEC CICS WEB SEND DOCTOKEN(DOCTKN) CLNTCODEPAGE('iso-8859-1')
```

- * Terminate program

```
EXEC CICS RETURN
```

```
ADDRL      DC F'15'
DOCTXTL    DC F'70'
DOCTKN     DC CL16
DOCTXT     DS 0CL
SRVRTXT    DC C'<p> Server Address: '
SRVRADDR   DS CL15
SRVRTXT    DC C'<p> Client Address: '
CLNTADDR   DS CL15
```

Web API's - Templates example

Document Template - TEMPL1

```
<html>
<head>
<title>Simple CWS Demo</title>
</head>
<body>
<h1>Following info produced via the EXEC CICS EXTRACT, DOCUMENT and WEB API's</h1>
```

Web API's - code example

```
* Create document from existing HTML template
EXEC CICS DOCUMENT CREATE DOCTOKEN(DOCTKN)
      TEMPLATE('TEMPL1')
* Get Server TCP/IP address
EXEC CICS EXTRACT TCPIP
      SERVERADDR(SRVRADDR) SADDRLENGTH(ADDRL)
* Get Client TCP/IP address
EXEC CICS EXTRACT TCPIP
      CLIENTADDR(CLNTADDR) CADDRLENGTH(ADDRL)
* Insert both addresses into document
EXEC CICS DOCUMENT INSERT DOCTOKEN(DOCTKN)
      TEXT(DOCTXT) LENGTH(DOCTXTL)
* Add footer to document from existing HTML template
EXEC CICS DOCUMENT INSERT DOCTOKEN(DOCTKN)
      TEMPLATE('TEMPL2')
* Send completed document
EXEC CICS WEB SEND DOCTOKEN(DOCTKN) CLNTCODEPAGE('iso-8859-1')
* Terminate program
EXEC CICS RETURN
```

```
ADDRL      DC F'15'
DOCTXTL    DC F'70'
DOCTKN     DC CL16
DOCTXT     DS 0CL
SRVRTXT    DC C'<p> Server Address: '
SRVRADDR   DS CL15
SRVRTXT    DC C'<p> Client Address: '
CLNTADDR   DS CL15
```

Web API's - code example

```
* Create document from existing HTML template
EXEC CICS DOCUMENT CREATE DOCTOKEN(DOCTKN)
      TEMPLATE('TEMPL1')
* Get Server TCP/IP address
EXEC CICS EXTRACT TCPIP
      SERVERADDR(SRVRADDR) SADDRLENGTH(ADDRL)
* Get Client TCP/IP address
EXEC CICS EXTRACT TCPIP
      CLIENTADDR(CLNTADDR) CADDRLENGTH(ADDRL)
* Insert both addresses into document
EXEC CICS DOCUMENT INSERT DOCTOKEN(DOCTKN)
      TEXT(DOCTXT) LENGTH(DOCTXTL)
* Add footer to document from existing HTML template
EXEC CICS DOCUMENT INSERT DOCTOKEN(DOCTKN)
      TEMPLATE('TEMPL2')
* Send completed document
EXEC CICS WEB SEND DOCTOKEN(DOCTKN) CLNTCODEPAGE('iso-8859-1')
* Terminate program
EXEC CICS RETURN
```

```
ADDRL      DC F'15'
DOCTXTL    DC F'70'
DOCTKN     DC CL16
DOCTXT     DS 0CL
SRVRTXT    DC C'<p> Server Address: '
SRVRADDR   DS CL15
SRVRTXT    DC C'<p> Client Address: '
CLNTADDR   DS CL15
```

Web API 's - Templates example

Document Template - TEMPL2

```
<p><hr>  
<p>Foot of simple CICS Web Support API demo page  
</body>  
</html>
```

Web API's - code example

- * Create document from existing HTML template
EXEC CICS DOCUMENT CREATE DOCTOKEN(DOCTKN)
TEMPLATE('TEMPL1')
- * Get Server TCP/IP address
EXEC CICS EXTRACT TCPIP
SERVERADDR(SRVRADDR) SADDRLENGTH(ADDRL)
- * Get Client TCP/IP address
EXEC CICS EXTRACT TCPIP
CLIENTADDR(CLNTADDR) CADDRLENGTH(ADDRL)
- * Insert both addresses into document
EXEC CICS DOCUMENT INSERT DOCTOKEN(DOCTKN)
TEXT(DOCTXT) LENGTH(DOCTXTL)
- * Add footer to document from existing HTML template
EXEC CICS DOCUMENT INSERT DOCTOKEN(DOCTKN)
TEMPLATE('TEMPL2')
- * Send completed document
EXEC CICS WEB SEND DOCTOKEN(DOCTKN) CLNTCODEPAGE('iso-8859-1')
- * Terminate program
EXEC CICS RETURN

ADDRL DC F'15'
DOCTXTL DC F'70'
DOCTKN DC CL16
DOCTXT DS 0CL
SRVRTXT DC C'<p> Server Address: '
SRVRADDR DS CL15
SRVRTXT DC C'<p> Client Address: '
CLNTADDR DS CL15

Web API's - Example output

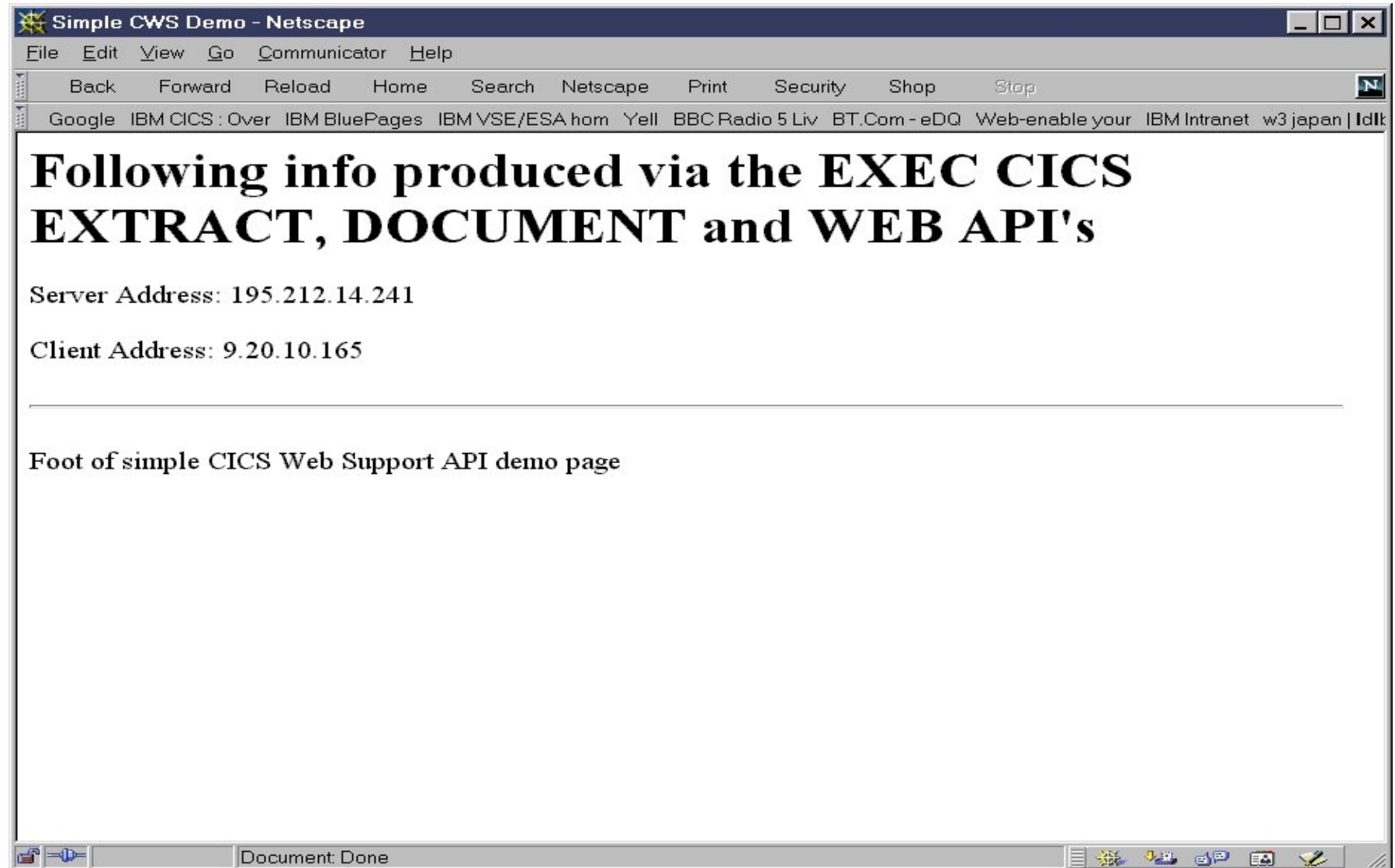

Agenda

- What is CICS Web Support
- CICS Web Support architecture
- Enabling CICS Web Support
- Writing CICS Web applications
- **Running 3270-based transactions with CICS Web Support**
- Further Information and Summary

Running 3270 based transactions - Architecture

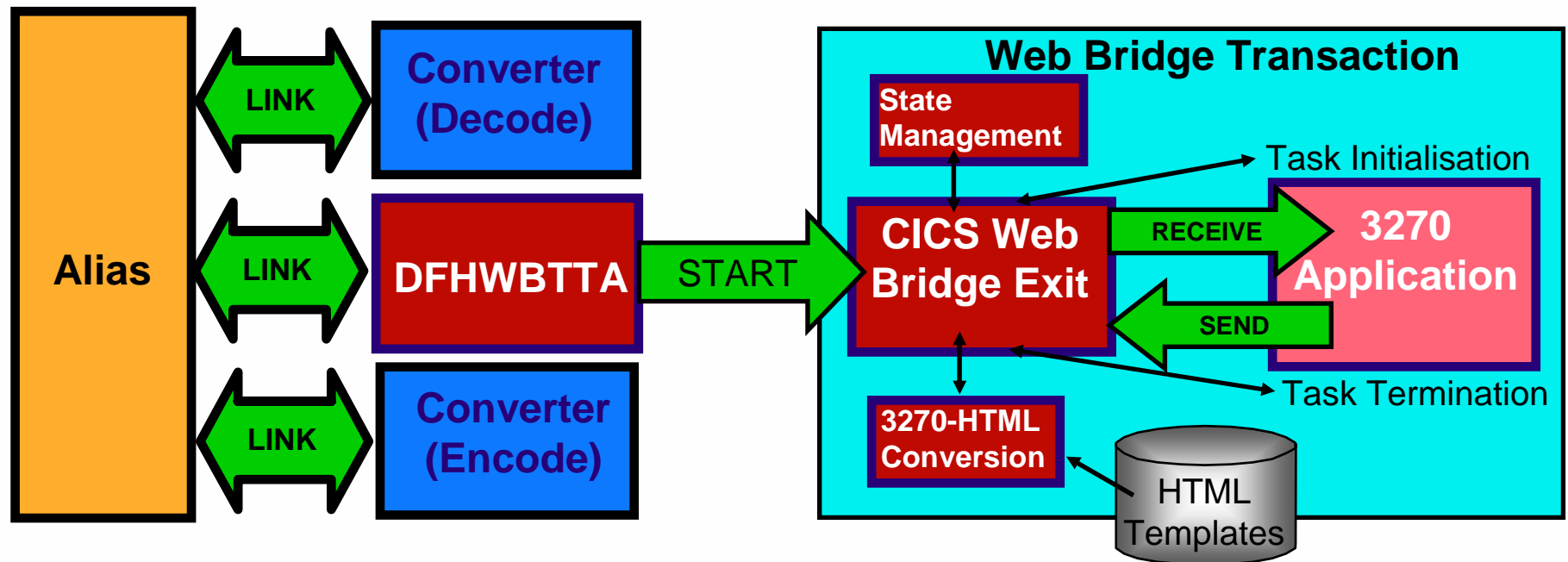

Example URL > <http://cics1.ibm.com:1080/cics/cwba/dfhwbttta/ceci>

Creating HTML for BMS applications

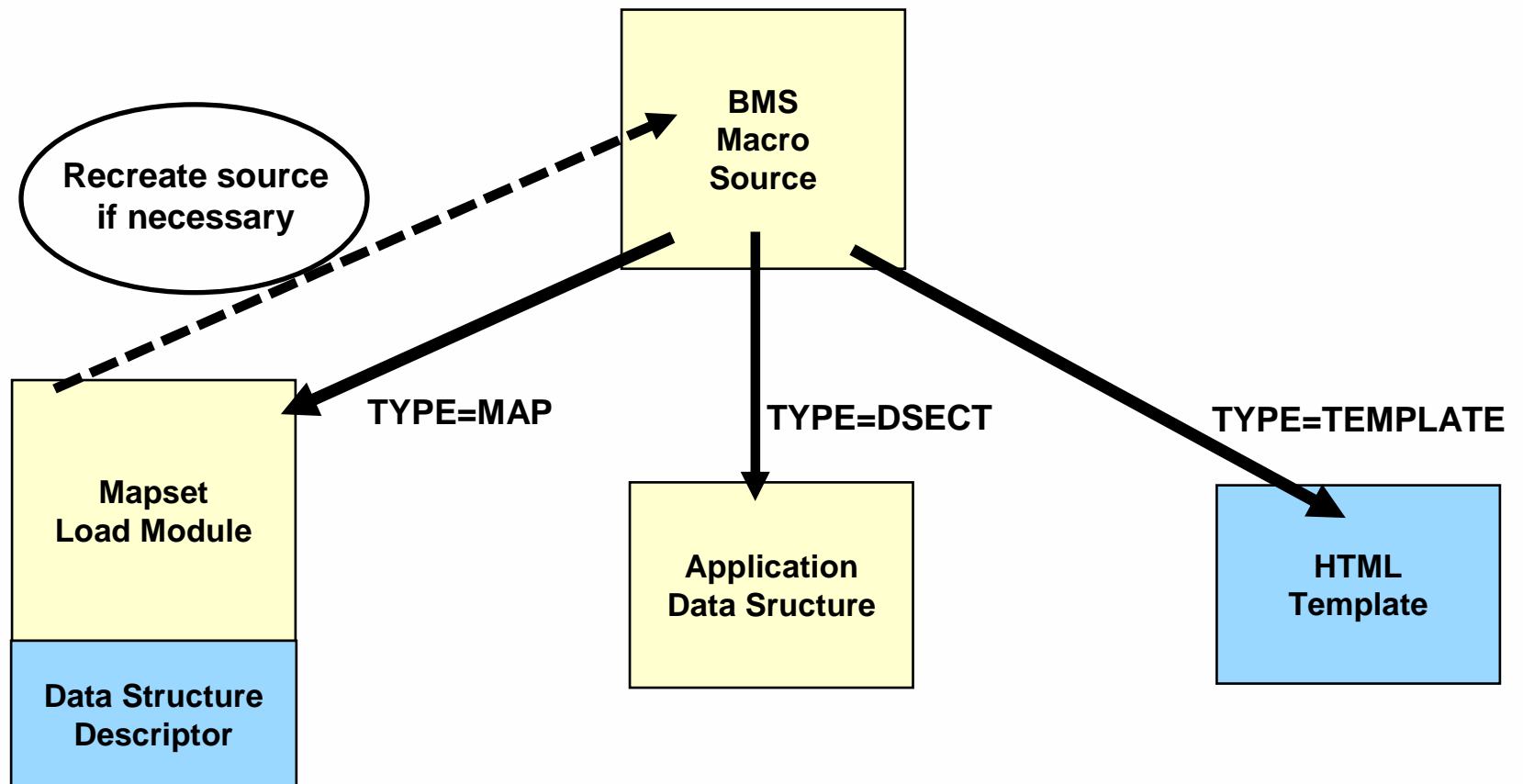

Creating HTML for BMS applications....

A template generated by the standard method contains...

- Constants and input fields from the map
- Buttons to represent:
 - f* ENTER key
 - f* PA1, PA2, PA3 keys
 - f* Program function keys PF1 to PF24
 - f* HTML Reset
- Hidden variables
 - f* For handling conversations/pseudoconversations
 - f* For holding name of map field where cursor is set
- JavaScript
 - f* Function to set the cursor position to a specific field
 - f* Exception handler for tracking cursor movement

Customising HTML for BMS applications

- Customise via CICS supplied macros
- Edit the generated HTML
- Run time customisation via use of Converter
 - f* Input (Decode)
 - e.g. change AID, change cursor position
 - f* Output (Encode)
 - e.g. add timestamp

Customising HTML for BMS applications....

Customising via the DFHMDX macro.....

- Defines customization macros used for template creation
- Is invoked from DFHMSX
- Can be used to
 - f* Suppress HTML Reset
 - f* Change or suppress PF keys and associated text
 - f* Provide an HTML title or masthead graphic
 - f* Change the background
 - f* Modify BMS colours
 - f* Suppress parts of the BMS map
 - f* Add Web browser control functions, e.g. JavaScript

Customising HTML for BMS applications....

Customising via the DFHWBOUT macro

- Add invocations of DFHWBOUT to BMS source
- Can be used to
 - f* Add HTML header information
 - f* Add text to HTML page that is not part of BMS map
 - f* Add Web browser control functions, e.g. JavaScript

Examples - DFHMDX & DFHWBOUT

*** Set default PF keys for all maps and mapsets**

```
DFHMSX
DFHMDX MAPSET=*,MAP=*,
      PF1='Help',PF3='Exit',PF4='Save',PF9='Messages'
```

*** Change title and PF4 for all maps in mapset DFHWB0**

```
DFHMDX MAPSET=DFHWB0,MAP=*,
      TITLE='CICS Web Support - Demo Application',
      PF4='Messages'
```

*** Add text that appears only on the HTML page**

```
DFHWBOUT '<p>This text illustrates the use of the DFHWBOUT macro,'
DFHWBOUT ' which can be used to output text that only appears'
DFHWBOUT ' in HTML templates and not in the corresponding BMS map.'
```

*** Add HTML header information to the HTML page**

```
DFHWBOUT '<meta name="author" content="E Phillips Oppenheim">'
DFHWBOUT '<meta name="owner" content="epoppenheim@xxx.com">'
DFHWBOUT '<meta name="review" content="20000314">'
```

HTML for non-BMS applications

- Default presentation...
 - Page produced in fixed width font
 - Supplied Headers and Footers
 - f* Mandatory HTML page elements
 - f* Input buttons (ENTER, PF Keys, etc)

- Customisation...
 - Provide replacement header and footer templates
 - Use a converter for customisation at run time
 - f* Input (Decode)
 - e.g. change AI D, change cursor position
 - f* Output (Encode)
 - e.g. add timestamp

3270 based transactions - limitations

- The CICS Web Bridge supports
 - f* Terminal Control -> SEND, CONVERSE, RECEIVE
 - f* Mimimum BMS and SEND TEXT
- The following restrictions have been removed by PTF UQ69745:
 - f* No dynamic modification of attribute bytes
 - f* Multiple SEND MAPs for one screen not supported
 - f* Cannot mix BMS and non-BMS SEND commands
 - f* Structured fields not supported
 - f* Lightpen emulation not supported
 - f* Must use same map on a RECEIVE following a SEND

Accessing Existing CICS Transactions...non-BMS



Accessing Existing CICS Applications...BMS

BMS application - 3270 screen.....

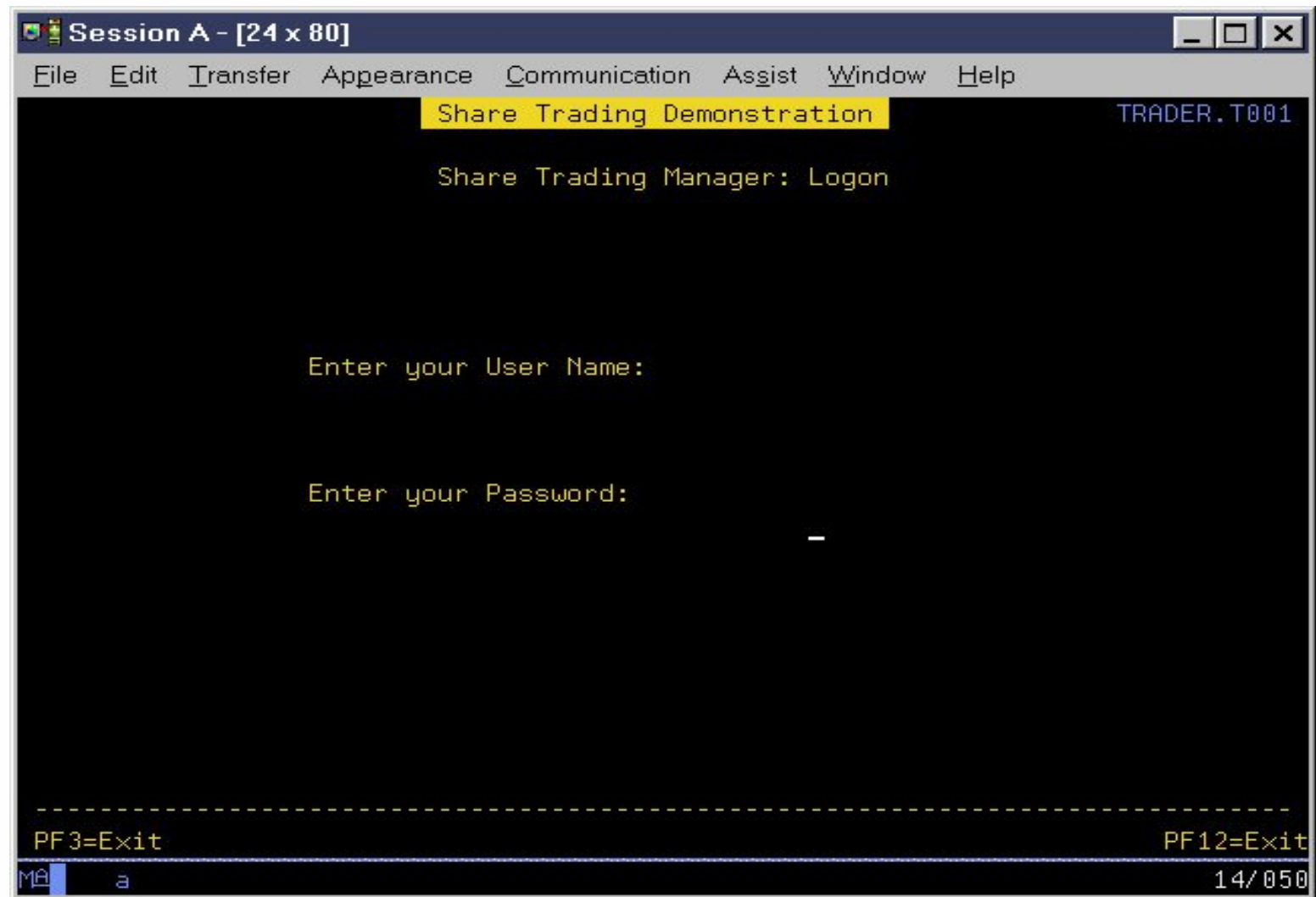

Accessing Existing CICS Applications...BMS

BMS application - default Web browser appearance.....

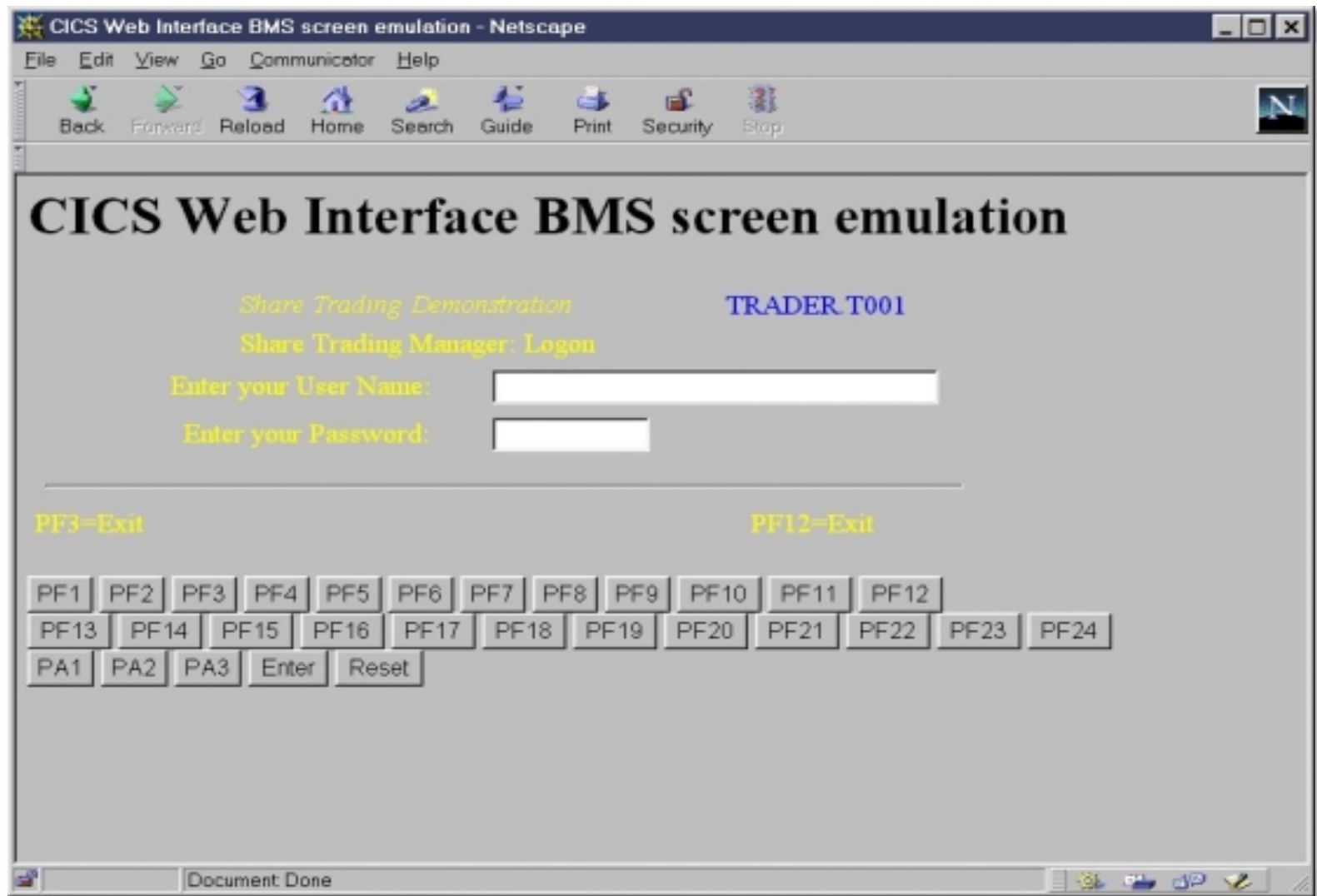

Accessing Existing CICS Applications...BMS

BMS application - customised.....

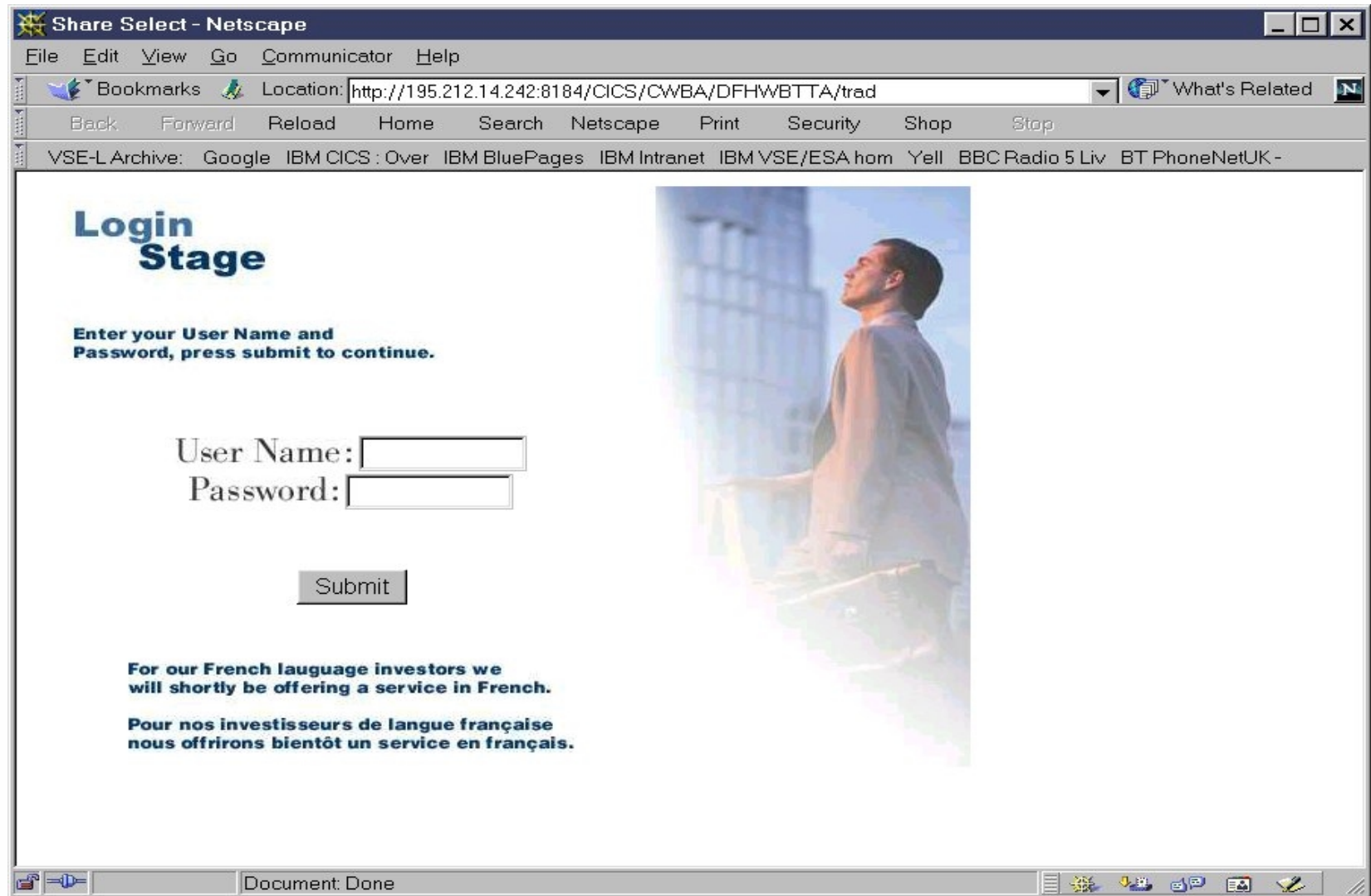

Agenda

- What is CICS Web Support?
- CICS Web Support architecture
- Enabling CICS Web Support
- Writing CICS Web applications
- Running 3270-based transactions with CICS Web Support
- **Hints & Tips**
- Further Information and Summary

Hints & Tips

- Apply PQ33097 - Set SOCKETCLOSE parm to '0' instead of 'NO'

Agenda

- What is CICS Web Support?
- CICS Web Support architecture
- Enabling CICS Web Support
- Writing CICS Web applications
- Running 3270-based transactions with CICS Web Support
- Hints & Tips
- **Further Information and Summary**

Further Information

■ Web Sites

f CICS (main site)

-<http://ibm.com/cics>

f CICS Transaction Server for VSE/ESA

-<http://ibm.com/cics/platforms/cicsvse/>

f CICS (SupportPacs)

-<http://ibm.com/cics/txppacs/>

f VSE/ESA

-<http://www.s390.ibm.com/vse>

f Redbooks

-<http://www.redbooks.ibm.com>

Further Information....

■ Publications

Title	Number
CICS Transaction Server for VSE/ESA V1.1.1 product publications	
Internet Guide	SC34-5765
Enhancements Guide	GC34-5763
External Interfaces Guide	SC33-1669
IBM Redbooks	
CICS Transaction Server for VSE/ESA: CICS Web Support	SG24-5997
Revealed! Architecting Web Access to CICS	SG24-5466
Getting Started with TCP/IP for VSE/ESA V1.4	SG24-5626
e-business Solutions for VSE/ESA	SG24-5662

f Accessible from the CICS and IBM Redbooks Web sites

Further Information...

■ Announcement Letters

f CICS Transaction Server for VSE/ESA V1.1.1: 200-293

f VSE/ESA V2.6: 201-325

f VSE/ESA V2.7: 203-043

Summary

CICS Web Support....

- Access to CICS Application programs and transactions from standard Web Browsers
- Direct connection
- Standard HTTP protocol used
- Secure Sockets Layer supported
- New APIs to enable creation of new Web aware applications
- Provided with CICS Transaction Server for VSE/ESA V1.1.1



WAVV 2004 Conference



CICS Web Support: Access to CICS Applications from the Web

Robin Gemmell
(gemmell@uk.ibm.com)

Chattanooga, April 30 – May 4 2004

Appendix

APPENDIX

HTTP Request



- **Request Line** : method absolute_path http_version CRLF
POST /bin/cgi HTTP/1.0

- **Headers**: headername: value CRLF
Accept: image/jpeg
Content-length: 44

- **Null Line**: single CRLF delimits end of headers

- **Body**: URL encoded forms data : name=value pairs
field1=stringa&field2=stringb&field3=stringc

HTTP Response

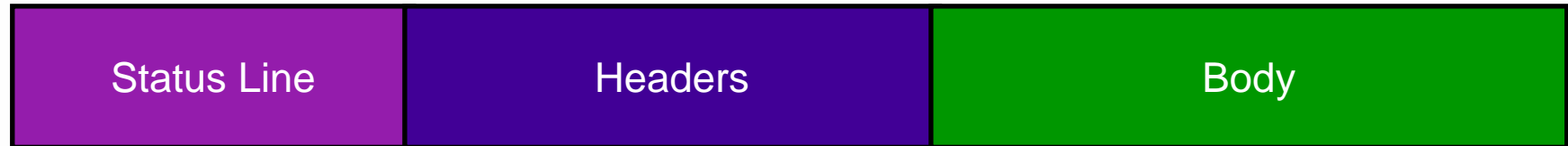

- **Status Line:** HTTP_version status_code text CRLF
HTTP/1.0 200 Document follows

- **Headers:** headername: value CRLF
Content-type: text/html
Content-length: 46
Last-modified: Wed, 04 Oct 2000 08:45:00 GMT

- **Null Line:** single CRLF delimits end of headers

- **Body:** HTML tags and text
<html><title>A Sample</title><h1>Sample 1</h1></html>