

IBM VSE/Enterprise Systems Architecture



# Installation

*Version 2 Release 7 Modification Level 2*



IBM VSE/Enterprise Systems Architecture



# Installation

*Version 2 Release 7 Modification Level 2*

**Note!**

Before using this information and the product it supports, be sure to read the general information under "Notices" on page xi.

**Eighth Edition (March 2004)**

This edition applies to Version 2 Release 7 Modification Level 2 of IBM Virtual Storage Extended/Enterprise Systems Architecture, (VSE/ESA) Program Number 5690-VSE, and to all subsequent releases and modifications until otherwise indicated in new editions.

Order publications through your IBM representative or the IBM branch office serving your locality. Publications are not stocked at the addresses given below.

A form for readers' comments is provided at the back of this publication. If the form has been removed, address your comments to:

IBM Deutschland Entwicklung GmbH  
Department 3248  
Schoenaicher Strasse 220  
D-71032 Boeblingen  
Federal Republic of Germany

You may also send your comments by FAX or via the Internet:

Internet: [s390id@de.ibm.com](mailto:s390id@de.ibm.com)  
FAX (Germany): 07031-16-3456  
FAX (other countries): (+49)+7031-16-3456

When you send information to IBM, you grant IBM a non-exclusive right to use or distribute the information in any way it believes appropriate without incurring any obligation to you.

© Copyright International Business Machines Corporation 1984, 2004. All rights reserved.

US Government Users Restricted Rights – Use, duplication or disclosure restricted by GSA ADP Schedule Contract with IBM Corp.

---

# Contents

<b>Figures</b> . . . . .	<b>vii</b>
<b>Tables</b> . . . . .	<b>ix</b>
<b>Notices</b> . . . . .	<b>xi</b>
Trademarks and Service Marks . . . . .	xii
<b>About This Book</b> . . . . .	<b>xiii</b>
Who Should Use This Book . . . . .	xiii
How to Use This Book . . . . .	xiii
Accessing Dialogs . . . . .	xiv
Conventions Used in This Book . . . . .	xiv
Where to Find More Information . . . . .	xiv
<b>Summary of Changes</b> . . . . .	<b>xv</b>

---

## Installation Overview and Preparation . . . . . 1

### Chapter 1. Overview of VSE/ESA Installation . . . . . 3

Automatic Initial Installation – When to Use . . . . .	3
Manual Initial Installation – When to Use . . . . .	3
Graphical Overview of an Initial Installation . . . . .	4
Descriptive Overview of an Initial Installation . . . . .	5
Filling in an Installation Worksheet . . . . .	6
Overview of the VSE/ESA Base Tapes or Files . . . . .	7
Default Values for Automatic Initial Installation . . . . .	9
How to Proceed if Automatic Initial Installation Fails . . . . .	9

### Chapter 2. Basic Information for Installation . . . . . 11

Predefined Environments Shipped with VSE/ESA . . . . .	11
IBM Supplied Supervisor . . . . .	11
Minimum Hardware Requirements . . . . .	12
Knowing Your Hardware Setup – the Hardware Configuration List . . . . .	13
Volume Table of Contents (VTOC) . . . . .	14
Disk Devices Used for Initial Installation . . . . .	14
Special Considerations for IBM 3390 Disk Devices . . . . .	15
Migration During Initial Installation . . . . .	15
Restrictions for Migration During Initial Installation . . . . .	17
Installing VSE/ESA Using an Integrated Console . . . . .	17
How to Access an Integrated Console . . . . .	18
Disconnecting the System Console . . . . .	18

---

## Installation Parts 1 and 2 – Short Description (for Experienced Users) 19

### Chapter 3. Short Description for Experienced VSE/ESA Users . . . . . 21

Installation Part 1 . . . . .	21
Installation Part 2 . . . . .	22
Defining Local Non-SNA VTAM Display Terminals . . . . .	23
Defining Local SNA VTAM Display Terminals . . . . .	23
Cataloging Hardware Information . . . . .	24
Cataloging ASI IPL Procedure . . . . .	24
Cataloging VTAM Startup Information . . . . .	24
Building the List of Jobs . . . . .	24
Running Job Manager Controlled Jobs . . . . .	24

---

## Installation Part 1 – Detailed Description . . . . . 31

### Chapter 4. Automatic Installation Part 1 – Native and VM. . . . . 33

Preparatory Tasks (for Automatic Installation) . . . . .	33
Downloading the Input/Output Configuration Data Set . . . . .	33
Performing Automatic Installation . . . . .	34
Step 1 – Performing an IPL from Tape . . . . .	34
Step 2 – Starting Automatic Installation . . . . .	35

### Chapter 5. Manual Installation Part 1 – Native . . . . . 39

Preparatory Tasks (Manual/Native) . . . . .	39
Downloading the Input/Output Configuration Data Set . . . . .	39
Step 1 – Performing an IPL from Tape (Manual/Native) . . . . .	40
Step 2 – Starting Installation (Manual/Native) . . . . .	41
Step 3 – Initializing Disks and Placing the VTOC (Manual/Native) . . . . .	42
Initializing Disks (VTOC in the Middle of Volume) . . . . .	43
Initializing Disks (VTOC at the End of Volume) . . . . .	44
Initializing IBM Disk Devices as Data DASDs . . . . .	45
Step 4 – Restoring the System Library IJSYSRS (Manual/Native) . . . . .	46
Step 5 – Performing an IPL from DOSRES (Manual/Native) . . . . .	48

### Chapter 6. Manual Installation Part 1 – Under VM . . . . . 55

Preparatory Tasks (Manual/Under VM) . . . . .	55
Step 1 – Performing an IPL from Tape (Manual/Under VM) . . . . .	55
Step 2 – Starting Installation (Manual/Under VM) . . . . .	56
Step 3 – Initializing Disks and Placing the VTOC (Manual/Under VM) . . . . .	57

Initializing Disks (VTOC in the Middle of Volume) . . . . .	58
Initializing Disks (VTOC at End of Volume) . . . . .	59
Initializing IBM Disk Devices as Data DASDs . . . . .	60
Step 4 – Restoring the System Library IJSYSRS (Manual/Under VM) . . . . .	62
Step 5 – Performing an IPL from DOSRES (Manual/Under VM) . . . . .	64

---

## Installation Part 2 – Detailed Description . . . . . 71

### Chapter 7. Installation Part 2 - Native and VM . . . . . 73

Job Stream Processing . . . . .	73
Running the Install Program for VSE/ESA . . . . .	73
Defining User Terminals . . . . .	74
Cataloging Hardware Information . . . . .	76
Cataloging ASI IPL Procedure . . . . .	76
Cataloging VTAM Startup Information . . . . .	76
Building the List of Jobs . . . . .	76
Running Job Manager Controlled Jobs . . . . .	77
Creating Print Buffers for a System Printer . . . . .	77
Starting a Printer Controlled by VSE/POWER . . . . .	81
Restoring System History File . . . . .	82
Defining VSAM Catalogs, Space, and Clusters . . . . .	82
Defining Libraries and Sublibraries . . . . .	82
Restoring VSE/ICCF DTSFILE . . . . .	83
Punching Install Information to VSE/ICCF DTSFILE . . . . .	83
Installing VSE/ESA Base Macros . . . . .	83
Installing LE/VSE . . . . .	83
Restoring Language-Dependent Members . . . . .	83
Restoring Language-Dependent VSE/ICCF Members . . . . .	83
Installing VSE/ESA Base Programs . . . . .	84
Initializing and Loading VSE/VSAM Files . . . . .	84
Initializing Work Files for Info/Analysis . . . . .	84
Performing Migration (optional) . . . . .	84
Installing DB2 . . . . .	86
Cataloging Members into VSE System Libraries . . . . .	86
Configuring TCP/IP (Optional) . . . . .	86
Telecommunications Access Method and CICS/ICCF Startup . . . . .	89

---

## Installation Part 3 – Description for All Users . . . . . 93

### Chapter 8. Installation Part 3 - Native and VM . . . . . 95

Completing Initial Installation (Non-Migration) . . . . .	96
Completing Initial Installation (Migration) . . . . .	97
Personalizing the History File . . . . .	98
Completing the Hardware Tables . . . . .	99
Activating the VTAM Password . . . . .	102
Users Who Want to Use a System with Security Active . . . . .	102
Additional Considerations . . . . .	103

Updating Hardware Tables After Initial Installation . . . . .	103
Migrating Old TCTs into the CICS Transaction Server CSD File . . . . .	103
Changing Passwords for VSE/ESA User IDs . . . . .	104

---

## Optional Installation Tasks . . . . . 107

### Chapter 9. Doing Optional Installation Tasks - Native and VM . . . . . 109

Deleting VSE/ESA Programs You Do Not Need . . . . .	109
Overview of the Generation Feature . . . . .	110
When to Install the Generation Feature . . . . .	110
Installing VSE/ESA Generation Feature . . . . .	111
Installing the Generation Feature after Service Has Been Installed . . . . .	111
Overview of Installing Additional Programs . . . . .	112
Installing a Program from the VSE/ESA Extended Base Tape . . . . .	112
Installing Additional VSE Programs . . . . .	113
Installing Non-IBM Programs under VSE/ESA . . . . .	113
Using Installation Dialogs for Additional VSE Programs . . . . .	114
Additional Considerations . . . . .	114
Having Multiple Program Versions on Your System . . . . .	114
Installing Additional VSE Programs . . . . .	115
Prepare for Installation Dialog . . . . .	116
Install Program(s) from Tape Dialog . . . . .	118
Installing Programs without a Program List (Panel INS\$OPI3) . . . . .	121
Reinstalling Programs . . . . .	122
Installing Programs in Version 1 Format . . . . .	122
Additional Considerations . . . . .	122
Install Programs - V1 Format Dialog . . . . .	123

### Chapter 10. Installing VM/VSE Interface Routines – VM Only . . . . . 125

What Are the VM/VSE Interface Routines? . . . . .	125
Functions Supported by the VM/VSE Interface . . . . .	125
Overview to VM/VSE Interface Routines . . . . .	126
How to Install the VM/VSE Interface . . . . .	126
List of Installation Tasks . . . . .	126

### Appendix A. Overview of the Job Manager . . . . . 129

Special Considerations for Installation Dialogs . . . . .	129
Job Manager Commands . . . . .	129
Tips and Hints for Error Handling . . . . .	130

### Appendix B. Migrating More than 199 VSE/ICCF Users or More than 199 VSE/ICCF Libraries . . . . . 133

### Appendix C. Migrating to a New Release . . . . . 135

VSE/ESA Migration Utility IESBLDUP . . . . .	135
Introducing the IESBLDUP Utility . . . . .	135

Planning and Concept Information . . . . .	136	Preparing for Initial Installation or FSU. . . . .	150
Using the IESBLDUP Utility . . . . .	137	Uploading the Base Tape to VSAM for FSU via	
Migrating to VSE/ESA 2.7 . . . . .	140	Virtual Tape . . . . .	151
The Control Statement . . . . .	145	Installing Additional Products. . . . .	152
Recovering from Migration Errors . . . . .	148	Additional Information for Receiving VSE/ESA	
		from the Internet . . . . .	152
<b>Appendix D. Preparing for Initial</b>		<b>Glossary . . . . .</b>	<b>155</b>
<b>Installation or FSU from Virtual Tape . 149</b>		<b>Index . . . . .</b>	<b>163</b>
Preparing the Installation . . . . .	149		
Preparing the Virtual Tape Files on the			
Workstation . . . . .	149		





---

## Figures

1. Graphical Overview of the Initial Installation Process . . . . .	4
2. Example of Job ICFSAV . . . . .	16
3. Example of Job REPROCMT . . . . .	17
4. Panel - VSE/ESA Online . . . . .	95
5. VSE Naming Convention for VTAM Resources	96
6. Panel - Complete Initial Installation . . . . .	98
7. Panel - Unidentified Device List . . . . .	100
8. Hardware Configuration: Unit Address List (Information Added) . . . . .	101
9. Hardware Configuration : Catalog Startup Members . . . . .	102
10. Prepare for Installation Dialog . . . . .	116
11. Panel - Virtual Tape: Specify the Data Set (VSAM) . . . . .	118
12. Panel - Virtual Tape: Specify the Data Set (Remote System) . . . . .	118
13. Panel - Install Additional Programs from Tape	119
14. VSE/ESA Skeleton SKVMVSE . . . . .	127
15. Example Job for Backing Up the VSE Control File . . . . .	140
16. Job Stream Example for Migrating from VSE/SP or Previous VSE/ESA System . . . . .	142
17. Job Stream Example for Migrating from DOS/VSE. . . . .	142
18. Job Stream Example for Status Report	143
19. Example for a Status Report Output . . . . .	143
20. Restoring the VSE Control File. . . . .	148



---

## Tables

1. Installation Parts . . . . .	5	10. Procedure Names for UCBs . . . . .	79
2. Worksheet for Initial Installation . . . . .	6	11. LUCB Attention Commands . . . . .	80
3. Contents of the VSE/ESA Base Tapes/Files . . . . .	8	12. VSE/ESA Predefined User Profiles . . . . .	104
4. Predefined Values for Disk Devices . . . . .	9	13. Delete Jobs for VSE/ESA Programs . . . . .	109
5. Predefined Environments . . . . .	11	14. Space Requirements for PRD2.GEN1 . . . . .	110
6. Minimum Hardware Requirements for Installing VSE/ESA 2.7. . . . .	12	15. Layout of a Distribution Tape . . . . .	113
7. List of Local SNA and Non-SNA Control Units . . . . .	74	16. Modules and Phases of the VM/VSE Interface . . . . .	126
8. Default Printer Train/Belt Combinations . . . . .	78	17. Abend Job Names for Job Manager Processing . . . . .	130
9. Procedure Names for FCBs . . . . .	78	18. File Names of Tape Images . . . . .	149



---

## Notices

References in this publication to IBM products, programs, or services do not imply that IBM intends to make these available in all countries in which IBM operates. Any reference to an IBM product, program, or service is not intended to state or imply that only that IBM product, program, or service may be used. Any functionally equivalent product, program, or service that does not infringe any of the intellectual property rights of IBM may be used instead of the IBM product, program, or service. The evaluation and verification of operation in conjunction with other products, except those expressly designated by IBM, are the responsibility of the user.

IBM may have patents or pending patent applications covering subject matter in this document. The furnishing of this document does not give you any license to these patents. You can send license inquiries, in writing, to the IBM Director of Licensing, IBM Corporation, North Castle Drive, Armonk, NY 10504-1785, U.S.A.

Any pointers in this publication to non-IBM Web sites are provided for convenience only and do not in any manner serve as an endorsement. IBM accepts no responsibility for the content or use of non-IBM Web sites specifically mentioned in this publication or accessed through an IBM Web site that is mentioned in this publication.

Licensees of this program who wish to have information about it for the purpose of enabling: (i) the exchange of information between independently created programs and other programs (including this one) and (ii) the mutual use of the information which has been exchanged, should contact:

IBM Deutschland GmbH  
Department 0790  
Pascalstr. 100  
70569 Stuttgart  
Germany

Such information may be available, subject to appropriate terms and conditions, including in some cases payment of a fee.

---

## Trademarks and Service Marks

The following terms, are trademarks of International Business Machines Corporation in the United States, or other countries, or both:

Advanced Function Printing	PR/SM
AFP	RAMAC
CICS	RS/6000
CICS/VSE	S/390
DB/2	S/390 Parallel Enterprise Server
ECKD	SP
Enterprise Storage Server	System/370
Enterprise Systems Architecture/390	System/390
Enterprise System/3090	SQL/DS
Enterprise System/9000	TotalStorage
ESCON	VM/ESA
eServer	VSE/ESA
IBM	VTAM
Language Environment	z/Architecture
Multiprise	z/OS
OS/390	zSeries
Processor Resource/Systems Manager	z/VM

---

## About This Book

This manual describes how to install the operating system VSE/Enterprise Systems Architecture (VSE/ESA).

---

## Who Should Use This Book

This manual is intended for people who:

- Install VSE/ESA.
- Install additional VSE/ESA programs, for example VSE/ESA optional programs.

Such people should be familiar with basic hardware operations and VSE functions.

---

## How to Use This Book

This book has several sections. The first section has a brief planning introduction for installing a VSE/ESA system and gives an overview of the installation. You should read this section before you start the installation.

The other sections describe how to install VSE/ESA:

Initial installation consists of **three installation parts**. Installation part 1 and installation part 2 are described twice:

1. For experienced users who only wish a subset of system prompts and system messages required for installation.
2. For users who wish detailed installation information.

Installation part 3 is described once for all users.

When you are instructed to **enter** a response, type in the data and then press the **ENTER (END/ENTER)** key. Depending on the task, you use the:

- System console, or an
- Integrated console, or a
- User terminal.

For the initial installation of VSE/ESA, you use a system console or an integrated console. In the printed version of this manual:

- System messages displayed during initial installation are shown in uppercase and in a different font. Not all of the messages are shown, but this book lists enough messages to let you check that the task is completing correctly. The following is an example of how system messages are illustrated:

```
BG 0000 IESI0059D ENTER A 3270 ADDRESS (CUU) OR "END"
```

- The responses you enter are printed in boldface. In this book, the responses you must enter are shown in uppercase. Variables, which you must replace, are in lowercase. The variables are usually described to the right of or before the response. The following is an example of how responses are shown when using the system console:

```
0 cuu (where cuu is a 3270 terminal address)
```

You can, of course, use either uppercase or lowercase when actually entering input.

## Accessing Dialogs

To help you access a dialog, this book uses *sequences* which show the selection panel name and selection number you must enter to display the Interactive Interface dialog. If you want to install the Generation Feature, for example, start with the *VSE/ESA Function Selection* panel and select:

- 1 (Installation)
- 3 (Install Generation Feature)

Administrator Fast Path: 13	Synonym Default: _____ Yours:
--------------------------------	----------------------------------

### Using Fast Path

As shown above, the left box under a dialog sequence contains the *Fast Path* for a selection. This facility allows you to go directly to a dialog without working through the entire panel hierarchy. To use fast path, you enter all the numbers you would enter on the individual panels in the hierarchy on a single selection panel.

In addition to fast path, the right box under a dialog sequence may contain a synonym that you can select. In the example shown before, no default synonym is given, but you can create your own synonym for it using the *Maintain Synonyms* dialog. This is a task that you do after initial installation, and it is described in the IBM manual *VSE/ESA Administration*, SC33-6705.

## Conventions Used in This Book

Additional instructions or exceptions for particular users are shown in a box with an appropriate heading, for example:

### CKD Device Users

This box then shows system information or requests that are valid for CKD device users only.

If the heading of the box applies to you, follow the instructions in the box.

## Where to Find More Information

VSE/ESA is described in a set of manuals called the *VSE/ESA library*. References to some of these manuals occur here.

The IBM manuals *VSE/ESA Planning*, SC33-6703, and *VSE/ESA Release Guide*, SC33-6718 provide more details about VSE/ESA 2.7, its programs and functions.

### VSE/ESA Home Page

VSE/ESA has a home page on the World Wide Web, which offers up-to-date information about VSE-related products and services, new VSE/ESA functions, and other items of interest to VSE users.

You can find the VSE/ESA home page at:

<http://www.ibm.com/servers/eserver/zseries/os/vse/>



---

## Summary of Changes

Starting with VSE/ESA 2.7.2, VSE/ESA is shipped on either three tapes, on CD-ROMs, or you can download it from the Internet.

For details, refer to “Overview of the VSE/ESA Base Tapes or Files” on page 7 and Appendix D, “Preparing for Initial Installation or FSU from Virtual Tape,” on page 149.

Whenever the term VM is used, it means both: VM/ESA as well as z/VM.



---

# Installation Overview and Preparation

VSE/Enterprise Systems Architecture (VSE/ESA) is a pre-generated system that is easy to install. Initial installation can be done in about two hours.

Installation tasks fall into four different categories:

**1. Initial Installation of VSE/ESA**

This is the only installation task which is required for all users. An initial installation consists of three “parts”. When you have finished initial installation, you have the VSE/ESA base programs installed.

**2. Installation of the VSE/ESA Generation Feature**

You only need to install the VSE/ESA Generation Feature, if the options of the pre-generated supervisor are not adequate for your needs. This task is “optional” and described in Chapter 9, “Doing Optional Installation Tasks - Native and VM,” on page 109.

**3. Installation of the VSE/ESA Extended Base Tape**

The VSE/ESA Extended Base Tape contains base programs which are not installed automatically during initial installation. They are treated as optional programs and must be installed using the corresponding dialog. This task is described in “Overview of Installing Additional Programs” on page 112.

**4. Installation of Additional VSE Programs**

VSE/ESA supports the installation of additional VSE programs, such as VSE/ESA optional programs. This task is “optional” and described in “Overview of Installing Additional Programs” on page 112.

***Installation of the VM/VSE Interface:***

If you install VSE/ESA under VM, you also may want to install the VM/VSE Interface, which is a set of VSE phases and CMS modules. These phases and modules provide functions for working with one or more VSE/ESA guest systems from CMS. This task is “optional” and described in Chapter 10, “Installing VM/VSE Interface Routines – VM Only,” on page 125.

***Installation of IBM Service:***

It also may be necessary to install service at certain times. Thus, you may want to install a VSE/ESA 2.7 refresh or install Problem Temporary Fixes (PTFs). VSE/ESA’s Interactive Interface has dialogs that help you apply service. For instructions on how to install service, refer to the IBM manual *VSE/ESA System Upgrade and Service*, SC33-6702.

## Installation Overview and Preparation

---

## Chapter 1. Overview of VSE/ESA Installation

You have the possibility to choose between an **automatic** installation and a **manual** installation. The automatic installation (in part 1) mainly allows for better usability, by reducing the complexity and the number of IPLs needed during installation.

---

### Automatic Initial Installation – When to Use

VSE/ESA 2.7 uses a predefined customization table containing the information required to perform an automatic installation. “Default Values for Automatic Initial Installation” on page 9 shows the predefined values that are used. You **cannot** change the default values.

If you choose automatic installation, the system handles specific installation tasks for you:

- Initialization of disk devices (DOSRES and SYSWK1)
- Placement of a VTOC in the middle of disk pack
- Restore of the VSE/ESA system library
- Automatic IPL from DOSRES

This means that you do not have to type in ICKDSF INIT UNIT commands with values for the system disks DOSRES and SYSWK1 and the allocation for the Volume Table of Contents (VTOC). Moreover, VSE/ESA handles any related system prompts that gather information regarding the disk devices.

**It is recommended that you select the automatic installation in part 1, since this way excludes errors of typing or of setup.** But there may be reasons for you not to use the automatic installation process. In this case, you have the option to select “manual” installation. See “Manual Initial Installation – When to Use” below.

---

### Manual Initial Installation – When to Use

Unlike automatic installation, manual installation means that you have to do the tasks described above *manually*.

Reasons for choosing the manual installation process may be:

- You want to use values other than the default values recommended for initial installation.
- You want to initialize more than two disk devices at initial installation.
- You use disk devices which have never been initialized before.
- You use disk devices which previously have been used on a system other than VSE.
- You change disk devices from emulation mode to native mode.
- You want to use disk layouts other than the default ones, (for example, more page data sets to a different disk).

## Graphical Overview of an Initial Installation

The following picture gives you an overview of initial installation. As you see, initial installation consists of three parts. **Installation part 1** is separately described for users who:

- Use automatic installation support
- Install VSE/ESA native (manually)
- Install VSE/ESA under VM (manually)

The installation parts 2 and 3 are mainly the same for all three installation types. If there are differences, there are boxes marking them.

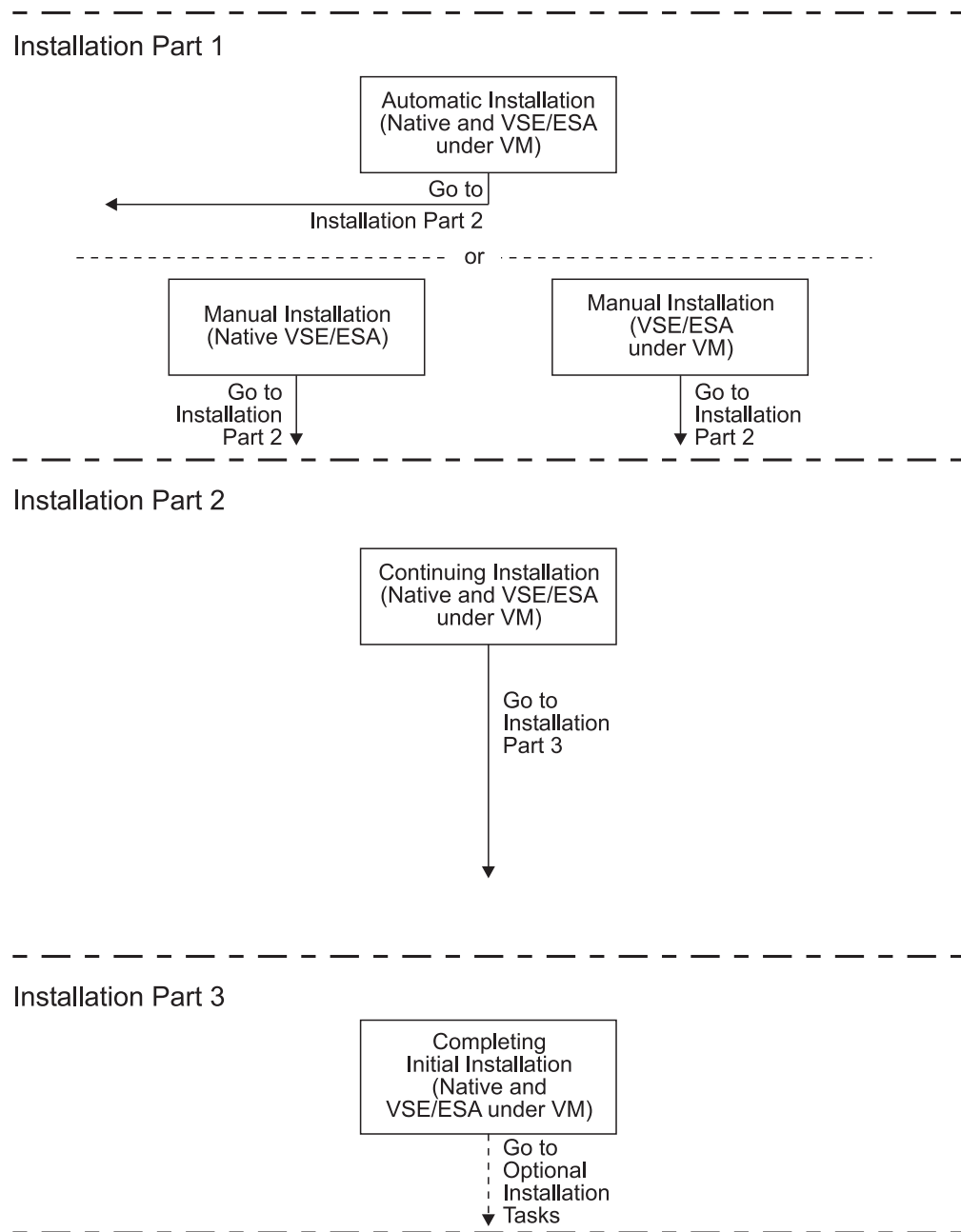

Figure 1. Graphical Overview of the Initial Installation Process

## Descriptive Overview of an Initial Installation

The table below describes the graphical view shown on the previous page. Every installation part consists of a number of steps.

Table 1. Installation Parts

Installation Part 1 consists of:	Installation Part 2 consists of:	Installation Part 3 consists of:
<ul style="list-style-type: none"> <li>• Performing an IPL from tape</li> <li>• Initializing disk devices</li> <li>• Placing the Volume Table of Contents (VTOC)</li> <li>• Restoring system library IJSYSRS</li> <li>• Performing an IPL from DOSRES</li> </ul>	<p><b>Decision tasks:</b></p> <ul style="list-style-type: none"> <li>• Deciding on migration</li> <li>• Selecting a system environment</li> <li>• Selecting security</li> <li>• Creating print buffer</li> <li>• Starting up a printer</li> </ul> <p><b>Main jobs that run:</b></p> <p><b>LFCBLINK</b>     Creating FCB and UCB for printer</p> <p><b>HISTREST</b>     Restoring the system history file</p> <p><b>VSAMDEFS</b>     Defining VSE/VSAM catalogs</p> <p><b>LIBRDEFS</b>     Defining VSE/VSAM libraries</p> <p><b>ICCFREST</b>     Restoring the VSE/ICCF DTSFILE</p> <p><b>ICCFLOAD</b>     Adding system information to the VSE/ICCF DTSFILE</p> <p><b>MACREST</b>     Installing separate base macros</p> <p><b>LEREST</b>     Restoring LE code</p> <p><b>NLLIBRES</b>     Restoring language-dependent members</p> <p><b>NLICFRES</b>     Restoring language-dependent VSE/ICCF members into DTSFILE</p> <p><b>BASEREST</b>     Installing VSE/ESA base programs</p> <p><b>VSAMINIT</b>     Initializing and loading VSAM clusters</p> <p><b>DUMPINIT</b>     Initializing Info/Analysis work files</p> <p><b>MIGRAT</b>     Migrating VSE/ESA user IDs and hardware tables (optional)</p> <p><b>DTRMIGR</b>     Adding ICCF user IDs</p> <p><b>DB2REST</b>     Installing DB2 (optional)</p> <p><b>SAVEMEMB</b>     Cataloging members into PRD2.CONFIG and PRD2.SAVE</p> <p><b>TCPIPCFG</b>     Configuring TCP/IP (optional)</p> <p><b>TPSTART</b>     Preparing VTAM and CICS</p> <p><b>CLEANUP</b>     Completing initial installation processing</p> <p><b>CICSBSX</b>     Starting basic CICS</p> <p><b>VTAMBSX</b>     Starting basic VTAM</p>	<ul style="list-style-type: none"> <li>• Signing on to VSE/ESA (user ID: POST)               <ul style="list-style-type: none"> <li>– Entering naming convention</li> <li>– Entering personalized data</li> </ul> </li> <li>• Signing on to VSE/ESA (user ID: SYSA)               <ul style="list-style-type: none"> <li>– Completing Hardware Tables</li> </ul> </li> <li>• Changing passwords</li> <li>• Performing an IPL to make the changes active</li> </ul>

## Filling in an Installation Worksheet

Fill in this worksheet as you plan for and before you begin initial installation. It will help you remember the device addresses and the device types that are requested from you during initial installation. Write in the device addresses, the device types, and the information **you are using**. DOSRES and SYSWK1 are the default disk devices used during installation. If you use more than two disk devices, you can also add the device information for these disk devices.

Table 2. Worksheet for Initial Installation

Disk Device Information			
	Device Address	Device Type	Device Type Code
DOSRES			
SYSWK1			
Telecommunication Access Method Information			
	Terminal Address (number 1)	Terminal Address (number 2)	Terminal Address (number 3)
VTAM:			
Control Unit Information			
SNA Control Unit: YES/NO	Address of Control Unit:		Attached Terminal Type:
Address of Terminal:	Address of Terminal:		Address of Terminal:
Predefined Environment Information			
Environment (A, B):		Security Selected: YES/NO	
Printer Information			
Printer Device Address:		Printer Class:	
FCB or UCB Information			
Procedure Name for UCBs:		Procedure Name for FCBs:	
Tape or Cartridge Device Information			
	Tape/Cartridge Device Address	Tape/Cartridge Device Type	Tape/Cartridge Device Type Code
Tape/Cartridge			
Migrate Hardware and control file (optional)			
DB2 installation information (optional)			
TCP/IP configuration information (optional)			



---

## Overview of the VSE/ESA Base Tapes or Files

VSE/ESA 2.7.2 is delivered on the following media:

- three IBM 3480 compressed (compacted with IDRC) tapes,
- three IBM 3590 tapes (128 tracks)
- CD-ROM
- via Internet

The distribution tapes are labeled:

- VSE/ESA2.7.x-YY
- VSE/ESA2.7.x-XBASE
- VSE/ESA DB2 Help

**Note:** The “x” in the tape ID shows the latest modification level of the current release. IBM provides National Language Support (NLS) for VSE/ESA. “YY” is the language indicator for the language used. “YY” can be:

- EN for English
- GE for German
- KA for Kanji
- SP for Spanish

The CD is labeled VSE\_BASE\_CDR\_YYY and contains the following files that are in virtual tape format:

- VSEBAS27.AWS
- VSEBAE27.AWS
- DB2VSEHE.AWS

**Note:** “YYY” is the language indicator for the language used. “YYY” can be:

- ENU for English
- DEU for German
- ESP for Spanish

If you download VSE/ESA from the Internet, the tape image files are in zipped format. The file names of the unzipped files are as follows:

- VSE27xYY.AWS
- VSE27xB.AWS
- DB2HELP.AWS

The first two tapes and the files on the first CD are needed for initial installation. Their contents are listed in Table 3 on page 8. The third tape, or the file DB2VSEHE on the CD which contains the DB2 Server for VSE Help component, is optional and is used only by customers who install DB2.

## Overview of Base Tapes/Files

Table 3. Contents of the VSE/ESA Base Tapes/Files

External Label/File Names	Contents
<b>Tape:</b> VSE/ESA2.7.x-YY <b>CD:</b> VSEBAS27.AWS <b>Internet:</b> VSE27xYY.AWS	<ul style="list-style-type: none"> <li>• Stand-alone utilities including Device Support Facilities; system library (IJSYSRS.SYSLIB) backup.</li> <li>• VSE/ICCF DTSFILE backup</li> <li>• Library backup of base product libraries (PRD1.MACLIB)</li> <li>• LE/VSE</li> <li>• VSE/ICCF DTSFILE containing language-dependent members. Library backup of language libraries.</li> <li>• Language-Dependent Members</li> <li>• Generation Feature</li> <li>• VSE/VSAM backup of on-line message explanation file</li> <li>• PRD1.BASE</li> </ul>
<b>Tape:</b> VSE/ESA2.7.x-XBASE <b>CD:</b> VSEBAE27.AWS <b>Internet:</b> VSE27xB.AWS	<ul style="list-style-type: none"> <li>• DB2 Server for VSE</li> <li>• DataPropagator Relational Capture</li> <li>• CICS/VSE 2.3</li> <li>• LE/VSE DBCS Locales</li> <li>• OS/390 API</li> </ul>

### Notes:

1. If you have ordered VSE/ESA optional programs, you receive one or more optional program tapes or CDs.
2. For a detailed description of the VSE/ESA base tape or CD layout, refer to *VSE/ESA System Upgrade and Service*.
3. If VSE/ESA is delivered on CD or electronically (downloaded from the internet), you must copy the Base Tape to a real tape for an initial installation. For details, see the copy job in “Using a Remote Tape Image on a Workstation to Copy the Base Tape to Real Tape” on page 150.
4. If you are running VSE/ESA on an IBM S/390 Multiprise 3000, you can use the files as emulated tape directly for FSU or initial installation.

## Default Values for Automatic Initial Installation

As stated, automatic initial installation does the following for you:

- It initializes two disk devices (DOSRES and SYSWK1), and assumes default values for placing the Volume Table of Contents (VTOC) in the middle of the disk packs.
- It has predefined system library allocations.

Refer to Table 4 for the predefined values that are used during automatic initial installation. These are the same values that are suggested when you perform a “manual” installation.

Table 4. Predefined Values for Disk Devices

Disk Device Type	VTOC Value for DOSRES	VTOC Value for SYSWK1	Type of Disk	Allocation of VSE System Library
generalized FBA (9336)	125504,228,8192	306624,228,8192	FBA	59134 (blocks)
9345	243,11,4	359,11,4	ECKD	1064 (tracks)
3380	210,11,4	325,11,4	3380	959 (tracks)
3390	208,11,4	301,11,4	ECKD <sup>(1)</sup> 3380 <sup>(2)</sup>	899 <sup>(1)</sup> (tracks) 959 <sup>(2)</sup> (tracks)

**Note:** <sup>1</sup> in 3390 mode  
<sup>2</sup> in 3380 track compatibility mode

## How to Proceed if Automatic Initial Installation Fails

If an error condition occurs during the automatic initial installation, the following message appears on your screen:

```
BG 0000 SA09I  SELECT ONE OF THE FOLLOWING PROGRAMS, OR TYPE END
BG 0000 SA10D  FASTCOPY, RESTORE, ICKDSF, DITTO, REIPL
```

In this case, you can fix your problem and either:

- Continue manually without performing a new IPL of the installation tape, or
- Rewind your installation tape and perform a new IPL from it. Select automatic or manual installation once more.

If you have specified a printer during initial installation (which is recommended), you can consult your printer output for a complete list of messages, since most of the messages are suppressed on the system console.

## Installation Overview and Preparation

---

## Chapter 2. Basic Information for Installation

Before you begin to install VSE/ESA, you should consult the IBM manual *VSE/ESA Planning*. It gives you an overview of the main VSE/ESA functions, supported hardware, and information on general planning considerations, such as:

- System organization and concepts
- Migration to VSE/ESA 2.7
- Hardware support
- VSE/ESA under VM
- Tailoring system start-up
- Storage and tuning recommendations.

When you receive VSE/ESA, be sure to check the *Program Directory* for additional new information. Also, you may request the *Preventive Service Planning (PSP) bucket* from IBM. It contains any recent installation information.

---

### Predefined Environments Shipped with VSE/ESA

The following section lists the predefined environments shipped with VSE/ESA. During initial installation you are asked to select one of these environments. Therefore, please make yourself familiar with the characteristics of these environments, as shown in the following figure. All predefined environments run with supervisor mode ESA.

Table 5. Predefined Environments

Predefined Environment	Virtual Storage	Address Spaces	Partitions	Characteristics
A	150 MB	12+dynamic partitions	12+dynamic partitions	Entry system
B	264 MB	12+dynamic partitions	12+dynamic partitions	Large system

---

### IBM Supplied Supervisor

VSE/ESA supports the **ESA mode supervisor** only. `$$A$SUPX` is used, regardless of running VSE/ESA native or under VM. During initial installation, IPL procedure `$IPLESA` is created.

You may want to generate your own supervisor if the supervisor provided by VSE/ESA does not meet your requirements.

## Minimum Hardware Requirements

### Minimum Hardware Requirements

The following table lists the minimum configuration required for initial installation of VSE/ESA 2.7.

Table 6. Minimum Hardware Requirements for Installing VSE/ESA 2.7

Minimum Hardware Requirements					
A Processor	Two Disk Devices	A System Console	A Magnetic Tape or Cartridge Device	A Printer	A Local Terminal
With at least 16MB processor storage.	Of same device type.  Of disk space at least 916 MB for environment A, and 1030 MB for environment B in total.	Any supported terminal or workstation.  (Non-SNA or integrated console.)	Supporting 3480 compressed cartridges (compacted with IDRC), or 3590 (128-track).	Either controlled by VSE/POWER, or a terminal printer controlled by CICS, supporting at least 300 lines per minute.  Channel- or adapter-attached.	Supporting 24x80 character screen format, with at least 10 Program Function keys (See Note 1).
Disk Devices Supported			Processors Supported		
IBM TotalStorage Enterprise Storage Server IBM RAMAC Array Family IBM 3380 (except Model A) IBM 3390 IBM 9345 All generalized FBA disk devices (See Note 2)			In general, VSE/ESA supports <b>uniprocessors</b> and <b>multiprocessors</b> of the following IBM processor series: <ul style="list-style-type: none"> <li>• IBM @server zSeries 800 (z800)</li> <li>• IBM @server zSeries 900 (z900)</li> <li>• IBM @server zSeries 990 (z990)</li> <li>• IBM S/390 Multiprise 3000</li> <li>• IBM S/390 Parallel Enterprise Server - Generation 6</li> <li>• IBM S/390 Parallel Enterprise Server - Generation 5</li> </ul> (See Note 3)		
<p><b>Note:</b></p> <p>(1) Terminals with a screen format larger than 24x80 (the IBM 3278-5, for example) are supported. However, the Interactive Interface only uses the first 24x80 screen positions.</p> <p>(2) These disk devices are supported for initial installation. The IBM 3370 Model 2, IBM 3380 Model A, and the IBM 3375 disk devices are supported as <b>data volumes</b> only.</p> <p>The listed disk devices are supported for all predefined environments and are large enough to hold the page data set extents (264MB).</p> <p>(3) VSE/ESA 2.7 does not support the z/Architecture (64-bit) capabilities of the z800, z900, z990, or equivalent 64-bit servers. These servers are supported in 31-bit mode.</p>					

## Knowing Your Hardware Setup – the Hardware Configuration List

VSE/ESA offers two possibilities for defining your hardware configuration:

1. During initial installation, it uses **device sensing** to automatically:
  - Define each device attached to VSE/ESA (for example, a tape attached as 181).
  - Sense all devices and add the sensed devices to the IPL procedure (for VSE/ESA running under VM).

Because of device sensing, you should attach (or define) the devices to be used by VSE/ESA **before** the sense IPL. The IPL procedure will be automatically created and updated.

2. If initial installation is complete, there will be no automatic device sensing. If you want to modify your hardware configuration, you can use an Interactive Interface dialog.

**Note:** Any devices that will be used for initial installation have to be operational and ready.

Prior to installation, you should prepare a list of all the devices in your hardware configuration. Creating such a device list may be of value to you when performing initial installation. If you are already a VSE/ESA user, you can use the *Hardware Configuration* dialog (Fast Path: 241) to create a hardware configuration list of your existing system. This can be used later as base for your new hardware setup.

The information you need corresponds to the parameters of the ADD command (described in the manual *VSE/ESA System Control Statements*). For each channel-attached device in your hardware configuration, you should record the following:

1. Device address (cuu)
2. Device type (for example IBM 3390 disk device)
3. Device type code (for example ECKD for an IBM 3390 disk device)
4. Mode (some devices require a mode specification of two, three, or four digits)

Also, you should note if:

- A tape can be physically attached (switched) to two adjacent channels.
- A disk device can be physically attached (switched) to up to four adjacent channels.
- A disk device can be shared by two or more systems.

At initial installation, up to **254** devices are supported. After completion of initial installation, up to 1024 devices are supported when you use supervisor \$A\$SUPL. To activate this supervisor, you must modify the IPL procedure accordingly. To do so, you can use the *Tailor IPL Procedure* dialog, as described in the IBM manual *VSE/ESA Administration* under "Tailoring the IPL Procedure".

Most I/O devices, such as disks and tapes, are attached via control units. For disk and tape devices, each address configured for a control unit counts as **one** I/O device for VSE/ESA. This is true even if no device physically exists for a configured address. For terminals, you must distinguish between SNA and non-SNA terminals:

- Terminals attached to a non-SNA control unit are handled in the same way as tape and disk devices. Each terminal counts as one I/O device.

## Preparing a Hardware Configuration List

- Terminals attached to an SNA control unit or a communication controller do not count individually. VSE/ESA only considers the SNA communication controller or control unit as an I/O device, not the terminals attached to it.

*VSE/ESA Administration* and *VSE/ESA Networking Support* provide further details about hardware configuration and the dialogs available for defining devices.

---

## Volume Table of Contents (VTOC)

A VTOC is mandatory for every disk volume you will use. It shows the contents of each disk. That is, it contains the start block/track and the extent information of every file that is loaded onto the disk and the start block/track of all unused space. When you initialize your disk devices manually, you have to know where to place the VTOC. Before doing so, consider the following:

In VSE/ESA, you have several choices for the location of the VTOC for each system disk:

- About in the middle of the disk device.

**Note:** For **better system performance** it is recommended that you place the VTOC about in the middle of the disk device.

- At the end of the disk device.
- Anywhere on the disk device, provided that this space is **not** used by system files.

More information on how to reduce VTOC space is in the topic “Storage and Tuning Recommendations” in the IBM manual *VSE/ESA Planning*.

**Note:** If you install VSE/ESA on VM minidisks, make sure that you have specified enough space for them. In case of FBA on minidisks, make sure the number of blocks is a multiple of 4\*777, especially if the VTOC is put at the end of the volume. It is recommended not to use the FBAVTOC(END) syntax, but to put the VTOC at a location that is described in “Initializing Disks (VTOC at End of Volume)” on page 59.

---

## Disk Devices Used for Initial Installation

In general, two volumes of the **same device type** and of the **same model** are recommended for initial installation. You cannot use one IBM 3380 volume and one IBM 3390 volume, for example. Also, you should not use one IBM 3380-K and one IBM 3380-J disk device, for example.

The first volume always has the ID **DOSRES**. The second volume always has the ID **SYSWK1**.

**Note:** DOSRES and SYSWK1 may *not* have enough space for all the VSE/ESA optional programs you want to install. In this case, you may need additional disk devices.

During manual installation, you are asked to initialize disks (DOSRES and SYSWK1) and to place the Volume Table of Contents (VTOC). To do so, you must know the command to initialize the disks. You also should know why it is important to place a VTOC either in the middle or at the end of the disks.



**More Information**

- See Table 6 on page 12 for a list of the supported disk devices.
- Under “Appendix B. VSE/ESA Disk Layouts (DOSRES, SYSWK1)”, the manual *VSE/ESA Planning* provides the disk layouts of DOSRES and SYSWK1.
- See the IBM manual *Device Support Facilities User’s Guide and Reference* for a detailed description of the INIT command.

**Special Considerations for IBM 3390 Disk Devices**

If you used the IBM 3390 disk in 3380 track compatibility mode in a previous VSE system and now want to use it in 3390 mode, you have to perform the step described below **before** you initialize the two disks. You also must move all data off the device before switching the mode. **All mode switches reformat the device.** For detailed information on mode switching, refer to the IBM manual *Using IBM 3390 Direct Access Storage in a VSE Environment*.

Use the SETMODE parameter of the INSTALL command to specify the volume’s operating mode.

- The default for the SETMODE parameter is **3390**.
- Specifying **SETMODE(3390)** formats a 3390 disk for 3390 mode.
- Specifying **SETMODE(3380)** formats the 3390 disk for 3380 track compatibility mode.

**Migration During Initial Installation**

If you want to upgrade to VSE/ESA 2.7 from an earlier version of VSE/ESA, you can migrate the following:

- Hardware configuration, and
- User profiles (for up to 199 VSE/ICCF users).

If you want to do this, answer **YES** to the migration question shown on page 73.

Please note that you can migrate your hardware configuration only during initial installation. This is completed successfully even if you have more than 199 VSE/ICCF users. Also, the easiest way to migrate your user profiles is during initial installation.

If you want to migrate **more** than 199 VSE/ICCF users or **more** than 199 VSE/ICCF libraries, refer to page 133.

## Migration During Initial Installation

**Before you migrate your system, make sure you have the following available:**

- Backup of the VSE/ICCF DTSFILE from your previous system. You can use the *Backup/Restore Library Objects* dialog to do the backup (or the VSE/ICCF utility program DTSUTIL). The volume serial number for the tape must be ICCF01. For an example, refer to Figure 2.
- Copy of the VSE control file of your previous system. This is done by the VSE/VSAM REPRO command. The volume serial number for the tape must be CF0001. For an example, refer to Figure 3 on page 17.
- Backup of all user data that resided on previous system volumes.

**Note:** The tapes you use for the copy can be 3480, or 3480 compressed. However, you must use 3590 tapes if your VSE/ESA distribution tapes are of the type 3590.

Remember that the migration performed during initial installation is for the above mentioned items only.

```
* $$ JOB JNM=ICFSAV,DISP=D,PRI=3, C
* $$ NTFY=YES, C
* $$ LDEST=*, C
* $$ CLASS=C
// JOB ICFSAV BACKUP ICCF LIBRARY
// LIBDEF PHASE,SEARCH=PRD1.BASE
* THIS FUNCTION CAN ONLY RUN IF ICCF IS NOT RUNNING, BECAUSE
* THE DTSFILE IS ACCESSED. /DISC THE DTSFILE AND
* THEN CONTINUE. IF NOT POSSIBLE, CANCEL THIS JOB.
// PAUSE
* THIS FUNCTION USES A TAPE FOR OUTPUT
* MOUNT LABELED TAPE WITH VOLUME ID=ICCF01 ON DEVICE D50
* THEN CONTINUE. IF NOT POSSIBLE CANCEL THIS JOB.
// PAUSE
// TLBL DTSBKUP,,,ICCF01
// ASSGN SYS005,D50,00
// EXEC PROC=DTRICCF
// EXEC DTSUTIL
BACKUP
/*
/&
* $$ EOJ
```

Figure 2. Example of Job ICFSAV

```
* $$ JOB JNM=REPROCNT,CLASS=A,DISP=D,NTFY=YES
// JOB REPROCMT COPY CONTROL FILE
// DLBL COPYIN,'VSE.CONTROL.FILE',,VSAM, X
      CAT=VSESPUC
// TLBL COPYOUT,'VSE.CONTROL.FILE',,CF0001
// ASSGN SYS005,D50
// EXEC IDCAMS,SIZE=AUTO
      REPRO INFILE (COPYIN) -
          OUTFILE (COPYOUT -
              ENVIRONMENT (BLOCKSIZE (4000 ) -
                  RECORDFORMAT (VARBLK) -
                  STDLABEL -
                  PRIMEDATADEVICE (2400) REW)) -
          NOREUSE
/*
/ &
* $$ E0J
```

Figure 3. Example of Job REPROCMT

### More Information

The following IBM manuals provide more information on performing a migration:

- To produce the backup/copy tapes for migrating to VSE/ESA, refer to *VSE/ESA System Utilities* under “Backups Required from Your Old System”.
- To migrate your system after initial installation, refer to *VSE/ESA Planning* and *VSE/ESA System Utilities*.

## Restrictions for Migration During Initial Installation

Migration of hardware tables is **not possible** if either of the following is true:

1. You want to switch to the 4-digit naming convention that allows you to support more than 255 sub-areas. In this case, a complete initial installation is required.
2. You use BTAM in your current system, because BTAM-ES is no longer supported and you **cannot migrate** the hardware definition. Therefore, you **must answer NO** when prompted if you want to migrate your configuration data during initial installation.

Of course you can migrate the user definitions in the control file, but you may do this after initial installation in a separate step.

---

## Installing VSE/ESA Using an Integrated Console

An IBM S/390 or zSeries processor has a function called *integrated console*. If you have chosen an integrated console as your VSE/ESA console, you would typically use it for installation on a hardware environment **without locally attached Non-SNA terminals**.

For details about the integrated console support, refer to the IBM manual *VSE/ESA Operation*.

### How to Access an Integrated Console

The following example shows how to access an integrated console from an IBM @server zSeries processor. For more details, refer to the operating procedure manual shipped with your IBM @server zSeries processor.

To access the integrated processor console, proceed as follows:

1. Select the CPC Image, you want to IPL
2. From the CPC Recovery selection menu, select LOAD
3. On the panel that is displayed, you are prompted for a device address and a LOAD parameter (PARM). Enter the required address and specify **I**. **I** indicates that you perform an IPL with an integrated console.
4. The "Operating System Messages" icon is flashing. To be able to communicate with VSE/ESA, double click on the icon.
5. The VSE system console is displayed on your screen. You can now enter VSE/ESA commands. Type the VSE/ESA command and select SEND COMMAND.

---

### Disconnecting the System Console

VSE/ESA lets you switch the system console to a VTAM or a CICS terminal. This requires the definition of a dummy device. The following command, contained in the shipped IPL procedures, defines such a device: **ADD FFF,CONS**

You can disconnect your system console with the command: **OPERATE DISC**

This means that the device is released from system console status and can be used as a VTAM or a CICS terminal. No system messages appear on the screen after the system console has been disconnected. Note that the DISC option only is accepted if the hard copy file is open at the time the command is issued.

To return to the system console, terminate your VTAM or CICS application and press **ENTER**. If that is not possible, switch off the terminal and switch it on again. This will reconnect the system console.

When you use VSE/ESA under VM, you have to use the following command to disconnect the system console: **\* CP DISC**

However, this command does not apply to a VSE/ESA dedicated console.

For detailed information about the system console types and the way to start or shut down a VSE/ESA system, refer to the IBM manual *VSE/ESA Operation*.

---

## Installation Parts 1 and 2 – Short Description (for Experienced Users)

Experienced VSE/ESA users can use this chapter to install VSE/ESA.

This part only lists system prompts and a subset of system messages for a VSE/ESA installation. Basic operational tasks (like performing an IPL) are not explained in this chapter. Also possible error messages or other exceptional installation situations are not described here.

If you are a new VSE/ESA user, you may refer to “Installation Part 1 – Detailed Description” on page 31 and proceed as described there.

Please see also “Filling in an Installation Worksheet” on page 6. It helps you define the values that are required for initial installation.



---

## Chapter 3. Short Description for Experienced VSE/ESA Users

The installation shown in this chapter describes an **automatic** VSE/ESA initial installation for installing VSE/ESA native or under VM. Only the minimum system prompts and messages are shown. Users whose installation deviates from this “standard installation”, should turn to “Installation Part 1 – Detailed Description” on page 31.

---

### Installation Part 1

1. **Mount the cartridge/tape labeled VSE/ESA2.7.X-YY. Do not reposition or dismount the tape or cartridge until you have instructions to do so.**
2. **Perform an IPL from tape.**

After having performed an IPL, the system waits for an interrupt from the console. Press **ENTER** to continue.

3. **Start the automatic installation process.**

Make sure that you have not more than 254 devices turned on at initial installation. If you install a native VSE/ESA, make sure that the time-of-day clock is set. In case of an error situation, refer to page 41.

The first system prompt that appears on your system console **after** you have done an IPL from the VSE/ESA tape is the following:

```
BG 0000 SI01D DO YOU WANT TO DO AN AUTOMATIC INSTALLATION (YES/NO?)
```

**0 YES**

```
BG 0000 SA02D IF YOU WANT A LISTING, SPECIFY CUU OF PRINTER, ELSE (ENTER)
```

**0 cuu**

```
BG 0000 SI02D ENTER CUU OF DOSRES
```

**0 cuu**

```
BG 0000 SI03D ENTER CUU OF SYSWK1
```

**0 cuu**

Before the automatic installation process is started, you will receive the following information messages:

```
BG 0000 SI08I DOSRES IS cuu, DEVICE TYPE xxxx  
BG 0000 SI09I SYSWK1 IS cuu, DEVICE TYPE xxxx
```

where *cuu* and device type *xxxx* show the sensed values (or values that you have entered). With the following message, you have the opportunity to start or redefine the automatic installation part:

```
BG 0000 SI10D START WITH AUTOMATIC INSTALLATION (YES/NO?)
```

**0 YES**

The job processing that now takes place takes some time to complete. Several system messages inform you on the installation progress. When the automatic installation part 1 has finished, you will receive the following message:

```
BG 0000 SA17W ***** END OF STAND ALONE PROCESSING *****
```

The system now performs an automatic IPL from DOSRES.

### Installation Part 2

Because the VSE.CONTROL.FILE does not exist yet, you will get the following message:

```
FB 0011 // JOB SECSERV
          DATE xx/xx/xxxx, CLOCK yy/yy/yy
FB 0074 4228I FILE IJSYSCT  OPEN  ERROR X'B4'(180) CAT=..N/A..
          (OPNCT-20) VOLUME 'DOSRES' NOT OWNED BY VSAM
FB 0074 4228I FILE IESCNTL  OPEN  ERROR X'B4'(180) CAT=VSESPUC ( 4,AD, 2)
          (OPNHC-10) RC X'00000004' FROM CATLG
FB 0074 BST300E THE II CONTROL FILE COULD NOT BE OPENED.
FB 0075 1J017I CRYPTO HARDWARE NOT INSTALLED OR NOT DEFINED.
BG 0000 BST001I BASIC SECURITY MANAGER INITIALIZED
```

The error messages are only informational, processing continues and the VSE/ESA INSTALL program runs.

```
BG 0001 1Q47I  BG INSTALL xxxxx FROM (SYSA), TIME=hh:mm:ss
BG 0000 // JOB INSTALL VSE/ESA INSTALL PROGRAM
BG 0000 IESI0077D DO YOU WANT TO MIGRATE YOUR CONFIGURATION DATA FROM
          A PREVIOUS VSE VERSION (VTAM ONLY)? YES/NO
```

**0 xxx**

You now have the option to install DB2 and to configure TCP/IP during your initial installation. If you do not want to install DB2 now, you can do so later on.

```
BG 0000 IESI0063D DB2 IS REQUIRED FOR THE DB2-BASED CONNECTORS. DO YOU
          WANT TO INSTALL DB2 NOW? YES/NO
```

**0 xxx**

```
BG 0000 IESI0051D DO YOU WANT TO CONFIGURE TCP/IP FOR INITIAL STARTUP? YES/NO
```

**0 xxx**

#### Note

In addition to TCP/IP, you must also define VTAM terminals for initial startup of CICS.

You are now asked to select one of the predefined environments that are shipped with VSE/ESA. For more information about the predefined environments, refer to "Predefined Environments Shipped with VSE/ESA" on page 11.

```
BG 0000 IESI0078 SELECT AN ENVIRONMENT OUT OF A OR B.
```

**0 x**

```
BG 0000 IESI0079D DO YOU WANT TO RUN YOUR SYSTEM WITH SECURITY ON? YES/NO
```

**0 xxx**

```
BG 0000 IESI0062D CHECK YOUR ANSWERS. DO YOU WANT TO CONTINUE ? YES/NO
```

**0 YES**



**Users Installing under VM**

If you install VSE/ESA under VM and access the system via the CP DIAL command, you must answer **NO** to the next message, because a DIALED terminal appears to VSE as a local non-SNA device.

```
BG 0000 IESI0065D IS THE LOCAL CONTROL UNIT AN SNA CU ? YES/NO
```

```
0 xxx
```

**Defining Local Non-SNA VTAM Display Terminals**

Local non-SNA VTAM users must define at least one, but not more than three, local VTAM display terminals. If you plan to use TCP/IP, you must also define VTAM terminals for initial startup of CICS.

**Note:** You must specify the terminal addresses in **ascending** order. If you do not enter them in the correct order, the system will generate the start-up books for VTAM incorrectly.

```
BG 0000 IESI0064I DEFINE UP TO 3 LOCAL VTAM TERMINALS
BG 0000 IESI0059D ENTER A 3270 ADDRESS (CUU) OR "END"
```

```
0 cuu
```

```
BG 0000 IESI0059D ENTER A 3270 ADDRESS (CUU) OR "END"
```

```
0 cuu
```

```
BG 0000 IESI0059D ENTER A 3270 ADDRESS (CUU) OR "END"
```

```
0 cuu
```

If you enter a third 3270 address, the terminal definition session ends.

```
BG 0000 IESI0062D CHECK YOUR ANSWERS. DO YOU WANT TO CONTINUE ? YES/NO
```

```
0 YES
```

```
BG 0000 EOJ INSTALL MAX.RETURN CODE=xxxx
```

Continue with "Cataloging Hardware Information" on page 24.

**Defining Local SNA VTAM Display Terminals**

You have selected VTAM with a local SNA control unit. You will define your control unit and at least one, but not more than three, local 3270 display terminals. If you use TCP/IP, you must also define VTAM terminals for initial startup of CICS.

**Note:** You must specify the terminal addresses in **ascending order**. If you do not enter the terminal addresses in the correct order, you get the error message IESI0076A.

```
BG 0000 IESI0071D ENTER ADDRESS OF 3270 CONTROL UNIT: CUU
```

```
0 cuu
```

```
BG 0000 IESI0066I DEFINE TERMINAL TYPE ATTACHED TO THIS CONTROL UNIT
BG 0000 IESI0067D ENTER 24x80, 32x80, 43x80
```

```
0 nnnnn
```

## Short Description of Installation Parts 1 and 2

```
BG 0000 IESI0064I DEFINE UP TO 3 LOCAL VTAM TERMINALS
```

```
BG 0000 IESI0073D ENTER ADDRESS OF A 3270 TERMINAL  
(2 TO 33) OR "END"
```

0 xx

```
BG 0000 IESI0073D ENTER ADDRESS OF A 3270 TERMINAL  
(2 TO 33) OR "END"
```

0 xx

```
BG 0000 IESI0073D ENTER address OF A 3270 TERMINAL  
(2 TO 33) OR "END"
```

0 xx

After the third address is entered, the terminal definition session ends.

```
BG 0000 IESI0062D CHECK YOUR ANSWERS. DO YOU WANT TO CONTINUE ? YES/NO
```

0 YES

```
BG 0000 EOJ INSTALL MAX.RETURN CODE=xxxx
```

## Cataloging Hardware Information

The job **DTRIHARD** catalogs hardware information from the IPL procedure.

```
BG 0001 1Q47I BG DTRIHARD nnnnn FROM LOCAL , TIME=hh:mm:ss  
BG 0000 // JOB DTRIHARD CATALOG HARDWARE RELATED INFORMATION  
BG 0000 EOJ DTRIHARD MAX.RETURN CODE=xxxx
```

## Cataloging ASI IPL Procedure

The job **DTRIASI** catalogs the ASI IPL procedure.

```
BG 0001 1Q47I BG DTRIASI nnnnn FROM LOCAL , TIME=hh:mm:ss  
BG 0000 // JOB DTRIASI CATALOG ASI IPL PROCEDURE  
BG 0000 EOJ DTRIASI MAX.RETURN CODE=xxxx
```

## Cataloging VTAM Startup Information

The job **DTRIVTAM** runs for **VTAM users** only. It catalogs VTAM start-up information.

```
BG 0001 1Q47I BG DTRIVTAM nnnnn FROM LOCAL , TIME=hh:mm:ss  
BG 0000 // JOB DTRIVTAM CREATE VTAM STARTUP BOOK ...  
BG 0000 EOJ DTRIVTAM MAX.RETURN CODE=xxxx
```

## Building the List of Jobs

The job **DTRIJB LD** builds the list of jobs that will run.

```
BG 0001 1Q47I BG DTRIJB LD nnnnn FROM LOCAL , TIME=hh:mm:ss  
BG 0000 // JOB DTRIJB LD BUILD ORDERED JOB LIST  
BG 0000 EOJ DTRIJB LD MAX.RETURN CODE=xxxx
```

## Running Job Manager Controlled Jobs

Do not cancel any of the following jobs, which are running under the control of Job Manager.

The job **LFCBLINK** creates procedures for FCBs and UCBs.

```
BG 0001 1Q47I BG LFCBLINK nnnnn FROM (SYSA) , TIME=hh:mm:ss  
BG 0000 // JOB LFCBLINK  
BG 0000 * EXECUTE THE PROCEDURE FOR THE FORMS CONTROL BUFFER THAT YOU  
BG 0000 * WANT LOADED INTO YOUR PRINTER OR IF NOT REQUIRED EXECUTE THE
```

## Short Description of Installation Parts 1 and 2

```
BG 0000 * PROCEDURE FOR THE CHARACTER SET BUFFER YOU WANT LOADED INTO
BG 0000 * YOUR PRINTER. IF NEITHER IS REQUIRED REPLY "0 (END/ENTER)".
BG 0000 // PAUSE
BG 0000
```

If you accept the default UCB and FCB, reply:

0

If you do not want to use the default UCB and FCB, refer to "Creating Print Buffers for a System Printer" on page 77.

### Restoring System History File

The job **HISTREST** restores the system history file.

```
BG 0001 1Q47I BG HISTREST nnnnn FROM (SYSA) , TIME=hh:mm:ss
BG 0000 // JOB HISTREST RESTORE SYSTEM HISTORY FILE
DATE xx/xx/xxxx,CLOCK yy/yy/yy
BG 0000 EOJ HISTREST MAX.RETURN CODE=xxxx
DATE xx/xx/xxxx,CLOCK yy/yy/yy,DURATION zz/zz/zz
```

### Defining VSAM Catalogs, Space, and Clusters

The job **VSAMDEFS** defines the VSAM master catalog, a VSAM user catalog, VSAM space, and clusters. The error message 4228I is expected and can be ignored.

```
BG 0001 1Q47I BG VSAMDEFS nnnnn FROM (SYSA) , TIME=hh:mm:ss
BG 0000 // JOB VSAMDEFS - DEFINE VSAM MCAT, UCAT SPACE AND CLUSTERS
BG 0000 * THIS JOB WILL DEFINE THE VSAM MASTER CATALOG, A USER CATALOG,
BG 0000 * VSAM DATA SPACE, AND VSAM CLUSTERS. FIRST TIME EXECUTION
BG 0000 * WILL RESULT IN A VSAM OPEN ERROR X'B4' (180) ON FILE IJSYSCT.
BG 0000 4228I FILE IJSYSCT OPEN ERROR X'B4'(180) CAT=..N/A..
(IKQOPNCT) VOLUME 'DOSRES' NOT OWNED BY VSAM
BG 0000 EOJ VSAMDEFS MAX.RETURN CODE=0000
```

### Defining Libraries and Sublibraries

The job **LIBRDEFS** defines the necessary libraries and sublibraries for VSE/ESA.

```
BG 0001 1Q47I BG LIBRDEFS nnnnn FROM (SYSA) , TIME=hh:mm:ss
BG 0000 // JOB LIBRDEFS DEFINE LIBRARIES AND SUBLIBRARIES
BG 0000 EOJ LIBRDEFS MAX.RETURN CODE=0000
```

### Restoring VSE/ICCF DTSFILE

The job **ICCFREST** restores the VSE/ESA-supplied VSE/ICCF DTSFILE.

```
BG 0001 1Q47I BG ICCFREST nnnnn FROM (SYSA) , TIME=hh:mm:ss
BG 0000 // JOB ICCFREST RESTORE THE VSE/ESA ICCF DTSFILE
BG 0000 K237I LIBRARY REALLOCATION FROM nnnn TO nnnn
BG 0000 K236I USER REALLOCATION FROM nnnn TO nnnn
BG 0000 EOJ ICCFREST MAX.RETURN CODE=xxxx
```

### Punching Install Information to VSE/ICCF DTSFILE

The job **ICCFLOAD** adds required system information to the VSE/ESA supplied VSE/ICCF DTSFILE.

```
BG 0001 1Q47I BG ICCFLOAD nnnnn FROM (SYSA) , TIME=hh:mm:ss
BG 0000 // JOB ICCFLOAD PUNCH INSTALL INFO TO ICCF LIBRARY
BG 0000 K246I AT LEAST ONE DTSUTIL COMMAND FAILED
BG 0000 EOJ ICCFLOAD MAX.RETURN CODE=xxxx
```

### Installing Separate VSE/ESA Base Macros

The job **MACREST** installs separate macros into PRD1.MACLIB.

## Short Description of Installation Parts 1 and 2

```
BG 0001 1Q47I BG MACREST nnnnn FROM (SYSA) , time=hh:mm:ss
BG 0000 // JOB MACREST - RESTORE SUB-LIBRARY PRD1.MACLIB
DATE xx/xx/xxxx,CLOCK yy/yy/yy
```

### Installing LE/VSE

The job **LEREST** installs LE/VSE into the sublibrary PRD2.SCEEBASE.

```
BG 0001 1Q47I BG LEREST nnnnn FROM (SYSA) , TIME=hh:mm:ss
BG 0000 // JOB LEREST - RESTORE LE/VSE LIBRARY PRD2.SCEEBASE
:
:
BG 0000 EOJ LEREST MAX.RETURN CODE=xxxx
```

### Restoring Language-Dependent Members

The job **NLLIBRES** restores national language-dependent members from tape into IJSYSRS.SYSLIB.

```
BG 0001 1Q47I BG NLLIBRES nnnnn FROM (SYSA) , TIME=hh:mm:ss
BG 0000 // JOB NLLIBRES - RESTORE LANGUAGE DEPENDENT MEMBERS INTO SYSLIB
DATE xx/xx/xxxx,CLOCK yy/yy/yy
BG 0000 EOJ NLLIBRES MAX.RETURN CODE=xxxx
DATE xx/xx/xxxx,CLOCK yy/yy/yy,DURATION zz/zz/zz
```

### Restoring Language-Dependent VSE/ICCF Members

The job **NLICFRES** restores national language-dependent VSE/ICCF members from tape into the VSE/ICCF DTSFILE.

```
BG 0001 1Q47I BG NLICFRES nnnnn FROM (SYSA) , TIME=hh:mm:ss
BG 0000 // JOB NLICFRES - RESTORE LANGUAGE DEPENDENT MEMBERS INTO DTSFILE
DATE xx/xx/xxxx,CLOCK yy/yy/yy
BG 0000 EOJ NLICFRES MAX.RETURN CODE=xxxx
DATE xx/xx/xxxx,CLOCK yy/yy/yy,DURATION zz/zz/zz
```

### Installing VSE/ESA Base Programs

The job **BASEREST** installs the VSE/ESA sublibrary PRD1.BASE.

**Note:** This job takes several minutes. Do not cancel this job.

```
BG 0001 1Q47I BG BASEREST nnnnn FROM (SYSA) , TIME=hh:mm:ss
BG 0000 // JOB BASEREST - RESTORE SUB-LIBRARY PRD1.BASE
DATE xx/xx/xxxx,CLOCK yy/yy/yy
BG 0000 * *****
BG 0000 * RESTORING PRD1 - THIS STEP WILL TAKE SEVERAL MINUTES
BG 0000 * *****
BG 0000 EOJ BASEREST MAX.RETURN CODE=xxxx
DATE xx/xx/xxxx,CLOCK yy/yy/yy,DURATION zz/zz/zz
```

### Initializing and Loading VSE/VSAM Files

The job **VSAMINIT** initializes and loads VSAM files that are needed by VSE/ESA.

**Notes:**

1. This job takes several minutes. Do not cancel this job.
2. During this job, the control file is opened which activates full security support of the Basic Security Manager.

```
BG 0001 1Q47I BG VSAMINIT nnnnn FROM (SYSA) , TIME=hh:mm:ss
BG 0000 // JOB VSAMINIT - INITIALIZE AND LOAD VSAM FILES
BG 0000 EOJ VSAMINIT MAX.RETURN CODE=xxxx
```

### Initializing Work Files for Info/Analysis

The job **DUMPINIT** initializes the Info/Analysis work files.

```
BG 0001 1Q47I BG DUMPINIT nnnnn FROM (SYSA) , TIME=hh:mm:ss
BG 0000 // JOB DUMPINIT - INITIALIZE INFO/ANALYSIS WORK FILES
BG 0000 EOJ DUMPINIT MAX.RETURN CODE=xxxx
```

## Short Description of Installation Parts 1 and 2

The next step is only performed if you answered **YES** earlier to the question whether you want to migrate your previous VSE system to VSE/ESA 2.7.

### Performing Migration (optional)

```
BG 0000 // JOB MIGRAT  MIGRATE VSE USER IDS AND HARDWARE TABLES
          DATE xx/xx/xxxx,CLOCK yy/yy/yy
BG 0000 * PLEASE MOUNT YOUR BACKUP TAPE CONTAINING THE DTSFILE
BG 0000 *   ON TAPE DRIVE cuu
BG 0000 *
BG 0000 * IF YOU HAVE MORE THAN ONE BACKUP TAPE FOR THE DTSFILE:
BG 0000 * -----
BG 0000 * THE DTSUTIL RESTORE STEP WILL PROMPT YOU TO MOUNT THE SECOND BACKUP
BG 0000 * TAPE (MESSAGE 4140A NO ALTERNATE DRIVE ASSIGNED).
BG 0000 * AFTER MOUNTING THE SECOND DTSUTIL BACKUP TAPE REPLY "NEWTAP" TO
BG 0000 * ABOVE MESSAGE.
BG 0000 * WHILE THE RESTORE CONTINUES PLEASE ENTER
BG 0000 * "PAUSE BG" (AR COMMAND).
BG 0000 * THIS WILL STOP PROCESSING AFTER THE
BG 0000 * RESTORE STEP. THE NEXT STEP WHICH IS IESBLDUP NEEDS THE FIRST
BG 0000 * DTSUTIL BACKUP TAPE AGAIN. THAT MEANS WHEN THE PAUSE IS
BG 0000 * ACTIVE, MOUNT THE FIRST DTSFILE BACKUP TAPE TO CONTINUE.
BG 0000 * CONTINUE ONLY IF THE CONTROL FILE IS CLOSED, SEE ABOVE MESSAGES.
BG 0000 // PAUSE PLEASE READ ABOVE TEXT, WHEN TAPE READY, REPLY "0 (END/ENTER)"
```

The job will close the Control File and reopen it after successful completion.

Mount the tape containing the backup of the VSE/ICCF DTSFILE (of your previous VSE system) on the specified tape drive. You should have created the backup before starting initial installation. After you have mounted the tape, enter:

0

```
BG 0000 1T20I SYSxxx HAS BEEN ASSIGNED TO cuu (TEMP)
BG 0000 IESU0020A MOUNT CONTROL FILE TAPE ON 'cuu', PRESS ENTER WHEN READY
BG 0000 OR ENTER 'CANCEL' TO CANCEL JOB
```

On the specified tape drive, mount the tape containing the VSE/VSAM copy of the control file from your previous VSE system. After you have mounted the tape, enter:

0

```
BG 0000 EOJ MIGRAT MAX.RETURN CODE=xxxx
BG 0001 1Q47I  BG DTRMIGR nnnnn FROM LOCAL, TIME=hh:mm:ss
BG 0000 // JOB DTRMIGR  UPDATE ICCF DTSFILE
BG 0000 EOJ DTRMIGR MAX.RETURN CODE=xxxx
```

### Installing DB2 (optional)

The job **DB2REST** is only performed if you answered **YES** when asked if you want to install DB2.

```
BG 0001 1Q47I  BG DB2REST nnnnn FROM (SYSA) , TIME=hh:mm:ss
BG 0000 // JOB DB2REST  - INSTALL DB2/VSE
          DATE xx/xx/xxxx, CLOCK yy/yy/yy
BG 0000 * *****
BG 0000 * *
BG 0000 * *   THIS JOB INSTALLS DB2/VSE...7.x.0 FROM THE EXTENDED BASE
BG 0000 * *   TAPE.
BG 0000 * *   PLEASE MOUNT THE TAPE LABELED  VSE/ESA2.X.X-XBASE
BG 0000 * *   ON TAPE DRIVE cuu
BG 0000 * *   AND REPLY "(END/ENTER)" TO CONTINUE
BG 0000 * *   (ENTER '// GOTO NEXT' IN CASE YOU DO NOT WANT TO RUN THE JOB)
BG 0000 * *
BG 0000 * *****
BG-0000 // PAUSE
```

## Short Description of Installation Parts 1 and 2

### Dismount/Mount the VSE/ESA Cartridge/Tape

1. Dismount the VSE/ESA cartridge/tape labeled *VSE/ESA2.7.X-YY*.
2. Mount the VSE/ESA cartridge/tape labeled *VSE/ESA2.7.X-XBASE*. Reply END/ENTER to continue.

```
0
BG 0000 EOJ DB2REST MAX.RETURN CODE=xxxx
```

### Cataloging Members into VSE System Libraries

```
BG 0001 1Q47I BG SAVEMEMB nnnnn FROM (SYSA) , TIME=hh:mm:ss
BG 0000 // JOB SAVEMEMB CATALOG MEMBERS INTO PRD2.CONFIG AND PRD2.SAVE
BG 0000 EOJ SAVEMEMB MAX.RETURN CODE=xxxx
```

### Configuring TCP/IP (Optional)

```
BG 0001 1Q47I BG TCPIPCFG 00019 FROM (SYSA) , TIME=hh:mm:ss
BG 0000 // JOB TCPIPCFG - CONFIGURE TCP/IP
DATE dd/mm/yyyy, CLOCK hh/mm/ss
BG 0000 * *****
BG 0000 * *
BG 0000 * * THIS JOB WILL START A CONFIGURATION DIALOG TO SETUP AN
BG 0000 * * INITIAL STARTUP FOR TCP/IP. BG 0000 * *
BG 0000 * *****
```

⋮

Refer to “Configuring TCP/IP (Optional)” on page 86 for more details of the job processing.

### Telecommunications Access Method and CICS/ICCF Startup

```
BG 0001 1Q47I BG TPSTART nnnnn FROM (SYSA), TIME=hh:mm:ss
BG 0000 // JOB TPSTART START ICCF, CICS AND VTAM (IF APPLICABLE)
```

```
BG 0000 1S47I PRELEASE RDR,VTAMSTRT
```

⋮

```
BG 0001 1Q47I F3 VTAMSTRT nnnnn FROM (SYSA), TIME=hh:mm:ss
F3 0003 // JOB VTAMSTRT START UP VTAM
```

⋮

```
BG 0000 1S47I PRELEASE RDR,CICSICCF
```

```
BG 0001 1Q47I F2 CICSICCF nnnnn FROM (SYSA), TIME=hh:mm:ss
F2 0002 // JOB CICSICCF CICS/ICCF STARTUP
```

⋮

```
F3 0024 IST093I VTMAPPL ACTIVE
```

```
F3 0024 IST093I VTMSNA ACTIVE
```

```
F3 0024 IST093I VTMSNA ACTIVE
```

⋮

```
F3 0024 IST093I VTMA1 ACTIVE
```

```
F3 0024 IST093I VTMA2 ACTIVE
```

⋮

```
F3 0024 IST093I VTMSW1 ACTIVE
```

```
F3 0024 IST020I VTAM INITIALIZATION COMPLETE FOR V4R2
```

(additional SESSION SETUP messages may be displayed)

```
BG 0000 EOJ TPSTART MAX.RETURN CODE=xxxx
```

## Completion of Initial Installation Processing

The job **CLEANUP** completes initial installation processing. Messages from job **CLEANUP** may be displayed, together with messages from the **CICS/ICCF** startup job.

```

BG 0001 1Q47I  BG CLEANUP nnnnn FROM (SYSA), TIME=hh:mm:ss
BG 0000 // JOB CLEANUP
BG 0000 * BASE INSTALL PROCESSING IS NOW FINISHED.
BG 0000 * COMPLETION OF THE INSTALL PROCESS MUST
BG 0000 * BE PERFORMED USING THE VSE/ESA DIALOGS.

BG 0000 EOJ CLEANUP  MAX.RETURN CODE=xxxx

:

F2 0002 DFHPA1101  DBDCCICS DFHSITSP IS BEING LOADED.
F2 0002 DFHPA1108  DBDCCICS DFHSITSP HAS BEEN LOADED. (GENERATED AT: MM/DD=
                xx/xx HH:MM= yy:yy).
F2 0002 DFHPA1100  DBDCCICS OVERRIDE PARAMETERS FROM JCL EXEC STATEMENT:

F2 0002 DFHPA1927  DBDCCICS APPLID=DBDCCICS,START=COLD,EDSALIM=14M,SI

F2 0002 DFHPA1102  DBDCCICS OVERRIDE PARAMETERS FROM SYSIPT:
F2 0002 DFHPA1927  DBDCCICS SIT=SP,STATRCD=OFF,MXT=20,NEWSIT=YES

F2 0002 DFHPA1103  DBDCCICS END OF FILE ON SYSIPT.
F2 0002 DFHTR0103  TRACE TABLE SIZE IS 256K
F2 0002 DFHSM0122I DBDCCICS Limit of DSA storage below 16MB is n,nnnK.
F2 0002 DFHSM0123I DBDCCICS Limit of DSA storage above 16MB is nnM.
F2 0002 DFHSM0113I DBDCCICS Storage protection is not active.
F2 0082 DFHDM0101I DBDCCICS CICS is initializing.
F2 0083 DFHXS1100I DBDCCICS Security initialization has started.
F2 0083 DFHWB0109I DBDCCICS Web domain initialization has started.
F2 0083 DFHS00100I DBDCCICS Sockets domain initialization has started.
F2 0083 DFHDH0100I DBDCCICS Document domain initialization has started.
F2 0083 DFHSI1500  DBDCCICS CICS startup is in progress for CICS Transaction
                Server Version 1.1.1
F2 0083 DFHXS1105  DBDCCICS Resource profiles for class TCICSTRN have been
                built.
F2 0083 DFHXS1103I DBDCCICS Default security for userid CICSUSER has been
                established.
F2 0083 DFHSI1501I DBDCCICS Loading CICS nucleus.
:
F2 0083 DFHXS1101I DBDCCICS Security initialization has ended.
F2 0083 DFHWB0110I DBDCCICS Web domain initialization has ended.
F2 0083 DFHS00101I DBDCCICS Sockets domain initialization has ended.
F2 0083 DFHMN0105I DBDCCICS Using default Monitoring Control Table.
F2 0083 DFHMN0110I DBDCCICS CICS Monitoring is inactive.
F2 0083 DFHDH0101I DBDCCICS Document domain initialization has ended.
F2 0083 DFHSI1502I DBDCCICS CICS startup is Cold.
F2 0083 DFHSI1503I DBDCCICS Terminal data sets are being opened.
F2 0083 DFHDU0304I DBDCCICS Transaction Dump Data set DFHDMPA opened.
F2 0083 DFHCP0101I DBDCCICS CPI initialization has started.
F2 0083 DFHPR0104I DBDCCICS Partner resource manager initialization has
                started.
F2 0083 DFHFC0100I DBDCCICS File Control initialization has started.
F2 0083 DFHFC0101I DBDCCICS File Control initialization has ended.
F2 0083 DFHTD0100I DBDCCICS Transient Data initialization has started.
F2 0083 DFHAI0101I DBDCCICS AITM initialization has started.
F2 0083 DFHTD0101I DBDCCICS Transient Data initialization has ended.
F2 0083 DFHTS0100I DBDCCICS Temporary Storage initialization has started.
F2 0083 DFHTS0102I DBDCCICS About to format the temporary storage data set
                (104 control intervals).
F2 0083 DFHTS0101I DBDCCICS Temporary Storage initialization has ended.
F2 0083 DFHCP0102I DBDCCICS CPI initialization has ended.
F2 0083 DFHPR0105I DBDCCICS Partner resource manager initialization has ended.

```

## Short Description of Installation Parts 1 and 2

```
F2 0083 DFHAI0102I DBDCCICS AITM initialization has ended.
F2 0083 DFHSI1511I DBDCCICS Installing group list VSELIST .
F2 0083 DFHFC0208I DBDCCICS
      LSR pool 1 is being built dynamically by CICS because the following
      are not defined: 'CI SIZE' 'STRINGS' 'MAXKEYLENGTH' . A delay is
      possible.
BG 0000 1S47I PRELEASE RDR,CICSICCF
F2 0083 DFHAP1203I DBDCCICS Language Environment for VSE/ESA is being
      initialized.
F2 0083 CEE3550I LE/VSE C/VSE Run-Time initialized
F2 0083 CEE3551I LE/VSE COBOL Run-Time initialized
F2 0083 CEE3552I LE/VSE PL/I Run-Time initialized
F2 0083 DFHWP1007 DBDCCICS Initializing CICS Web environment.
F2 0083 DFHWP1008 DBDCCICS CICS Web environment initialization is complete.
F2 0083 DFHSI8430I DBDCCICS About to link to PLT programs during the third
      stage of initialization.
F2 0085 K002I BEGIN ICCF INITIALIZATION
F2 0085 K042I VSE ACCESS CONTROL NOT ACTIVE, VSE/ICCF ACCESS CONTROL ACTIVE
F2 0085 K481I DYNAMIC FILE SPACE INITIALIZATION BYPASSED
F2 0085 K001I DEVICE TYPE IS nnn
F2 0085 K088I HI FILE RECORDS=      nnn,nnn (nn%)
F2 0083 K029I ICCF INITIALIZATION COMPLETED
F2 0083 DFHSI8434I DBDCCICS Control returned from PLT programs during the
      third stage of initialization.
F3 0003 IST899I RETRY OF AUTOLOGON(S) TO VTAM1.DBDCCICS IN PROGRESS
F2 0083 DFHSI1517 DBDCCICS Control is being given to CICS.
```

**Once message DFHSI1517 appears, the system is available. Turn to "Installation Part 3 – Description for All Users" on page 93 to continue.**



---

## Installation Part 1 – Detailed Description

Installation part 1 consists of a number of steps. As shown in Figure 1 on page 4 you can decide on performing these steps automatically or manually. When you use the automatic way, only those steps marked with an asterisk (\*) require interaction on your part:

- Performing an IPL from tape (\*)
- Initializing disk devices
- Placing the Volume Table of Contents (VTOC)
- Restoring system library IJSYSRS
- Performing an IPL from DOSRES

Please see also “Filling in an Installation Worksheet” on page 6. It helps you prepare the values that are required for initial installation.

If you are an experienced VSE/ESA user, you may turn to Chapter 3, “Short Description for Experienced VSE/ESA Users,” on page 21 and install VSE/ESA as described there.



---

## Chapter 4. Automatic Installation Part 1 – Native and VM

When you install VSE/ESA 2.7, the first prompt that is displayed on your system console asks you if you want to do an automatic installation of VSE/ESA. If you answer YES to this question, specific installation tasks are automatically handled for you. The required values are taken from a customization table which is supplied on your VSE/ESA installation tape. You cannot change the default values.

Please make sure that you know the automatic installation process and the default values that are used. You should therefore refer to Chapter 1, “Overview of VSE/ESA Installation,” on page 3, which is a **MUST READ** chapter.

The following sections describe preparatory tasks that you have to do to ensure that the automatic installation process runs smoothly.

---

### Preparatory Tasks (for Automatic Installation)

When you install VSE/ESA native on a processor, you must perform the steps described in the next sections. You also follow these steps if you install VSE/ESA on a processor with Processor Resource/Systems Manager (PR/SM) in LPAR mode. For information on PR/SM, consult the manual *S/390 Processor Resource/Systems Manager Planning Guide*, GA22-7236.

#### Important Information

Note that the example shows you how to perform an IPL using an IBM @server zSeries 900 (z900) processor. *This is just an example.* For detailed information on how to perform an IPL on your processor, refer to the respective operating procedure manual.

### Downloading the Input/Output Configuration Data Set

**Before you start to install VSE/ESA, make sure that the Input/Output Configuration Data Set (IOCDS) is correctly loaded on your processor.** The Input/Output Configuration Program (IOCP) describes a system’s I/O configuration (using the IOCDS) to the Central Processor Unit (CPU).

For details on the Input/Output Configuration Program (IOCP), consult the IBM manuals shipped with your processor, for example:

- *IOCP User’s Guide and ESCON CTC Reference, S/390, GC38-0401*
- *Stand-Alone Input/Output Configuration Program, S/390 Generation 5/Generation 6, Multiprise 3000, GC38-0458*
- *Processor Resource/Systems Manager Planning Guide, GA22-7236*
- *IOCP User’s Guide, IBM eServer zSeries, SB10-7029*
- *Stand-Alone IOCP, IBM eServer zSeries, SB10-7032*
- *Processor Resource/Systems Manager Planning Guide, IBM eServer zSeries, SB10-7033*

#### VSE/ESA Input/Output Configuration Program

When you install VSE/ESA, you **automatically** install the **VSE/ESA IOCP batch program**. You need the VSE/ESA batch IOCP to create a new IOCDS when you change the hardware configuration. You also need it to define and validate the

## Automatic Installation Part 1 – Native and VM

IOCP macro instructions if you prepare for the installation of a new processor. Use skeleton SKIOPCN (available in VSE/ICCF library 59) as a base for configuration changes.

### Performing Automatic Installation

Mount the cartridge/tape labeled *VSE/ESA2.7.X-YY*. Do not reposition or dismount the cartridge/tape until you have instructions to do so.

#### Step 1 – Performing an IPL from Tape

##### Users Installing on a z900 Processor

On a z900 processor, you are using the "Support Element Workplace" to perform a LOAD. A load resets a system or logical partition, to prepare it for loading an operating system, and then loads the operating system. (Other systems may refer to a load as an initial program load or IPL.) On the CPC Recovery Task List on the right side of the support element workplace, double-click on the Load Icon. The Load window is displayed:

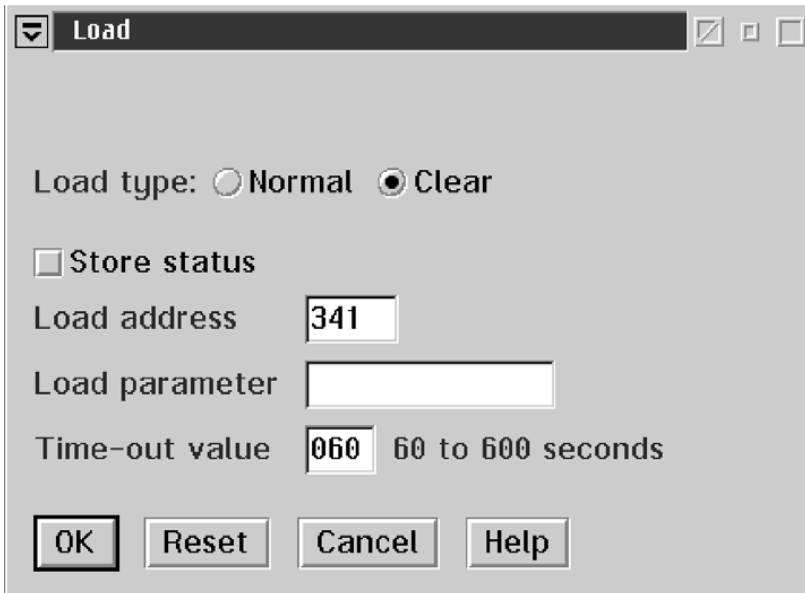

Fill in the information about load type, load address, and load parameter, and click OK. For more information about the load parameter, refer to the manual *VSE/ESA System Control Statements*, under "IPL Load Parameter". For more information on the other parameters, see the operating procedure manual for your particular processor. A confirmation window is displayed where you can verify the provided information. If the information is correct, select the YES push button to perform the load. A progress window is displayed which indicates the progress of the load and the result. When the load has successfully completed, click OK to close the window. Otherwise, follow the directions or any messages that may be displayed to determine the problem and correct it.

Continue with "Step 2 – Starting Automatic Installation" on page 35.

**Users Installing VSE/ESA Under VM**

To make your VM system ready for the automatic initial installation of VSE/ESA, you have to perform the following steps:

Ensure that your processor is running in mode ESA: **SET MACH ESA**.

To define the console mode, enter in CP mode:

**TERM CON 3270**

To define terminals to VM, enter in CP mode:

**DEF GRAF cuu** (*cuu* – terminal address)

Repeat this command for every terminal you want to define, if you have not yet defined the terminals in your VM directory.

Please note that you have to define at least one terminal.

You have to define *at least* 16 MB of storage, (the maximum storage value depends on your VM system). Enter the following in CP mode:

**DEF STOR xxxM** (Replace *xxx* with the value you want to specify.)

To perform an IPL, enter in CP mode:

**IPL cuu** (*cuu* - address of tape drive with VSE/ESA tape)

After having typed in all parameters, press **ENTER**.

Continue with “Step 2 – Starting Automatic Installation.”

**Step 2 – Starting Automatic Installation**

After having performed an IPL, the system waits for an interrupt from the console. Press **ENTER** to continue.

Make sure that you have not more than 254 devices turned on at initial installation. If you install VSE/ESA native, make sure that the time-of-day clock is set. In case of an error situation, refer to page 41.

The first system prompt that appears on your system console **after** you have done an IPL from the VSE/ESA tape is the following:

BG 0000 SI01D DO YOU WANT TO DO AN AUTOMATIC INSTALLATION (YES/NO)?

**0 YES**

**Answer YES if you want to do an automatic installation. As described before, VSE/ESA then handles part 1 of the initial installation automatically for you. You must specify only a few values to start the automatic installation process.**

If you answer NO to this system prompt, you have to turn to Chapter 5, “Manual Installation Part 1 – Native,” on page 39 or Chapter 6, “Manual Installation Part 1 – Under VM,” on page 55 and proceed as described there.

## Automatic Installation Part 1 – Native and VM

This chapter describes installation part 1, assuming that you have answered **YES** to the above system prompt.

You are now asked whether you want a listing of the automatic installation process. The listing that you receive, if you specify a printer, contains all messages and system prompts necessary for installation. **Therefore, it is recommended to specify a printer.** Note that you can specify a printer only at this time during automatic installation.

For ease of use, nearly all of the messages issued during automatic initial installation are suppressed on your system console.

```
SA02D IF YOU WANT A LISTING, SPECIFY CUU OF PRINTER, ELSE (ENTER)
```

```
0 cuu (cuu - address of printer)
```

Otherwise, enter **0** to continue.

**Note:** If the printer cannot be sensed, messages SA04I, SA05I, and SA06D are issued, asking for the correct device type.

Now the system asks you for the addresses of DOSRES and SYSWK1:

```
BG 0000 SI02D ENTER CUU OF DOSRES
```

```
0 cuu (cuu - address of DOSRES)
```

```
BG 0000 SI03D ENTER CUU OF SYSWK1
```

```
0 cuu (cuu - address of SYSWK1)
```

### If Device Type Cannot be Sensed

If the system cannot sense the device type of DOSRES or SYSWK1, the following messages are issued:

```
BG 0000 SI04I FOLLOWING DEVICE TYPES ARE SUPPORTED:  
BG 0000 SI05I list of supported DASD
```

Message SI05I displays a list of the supported device types. Select the device type that you want to use and answer the following system prompt:

```
BG 0000 SI06D ENTER DEVICE TYPE OF DOSRES/SYSWK1
```

```
0 xxxx (xxxx - Specify the device type you use)
```

Please note that the device type you use must be one of the supported device types shown in message SI05I. If you specify a device type that does not match the displayed device types, you receive an error message. You again are asked to enter cuu of DOSRES and SYSWK1.

Before the automatic installation process is started, you will receive the following information messages:

```
BG 0000 SI08I DOSRES IS cuu, DEVICE TYPE xxxx  
BG 0000 SI09I SYSWK1 IS cuu, DEVICE TYPE xxxx
```

where cuu and xxxx show the address and device types of your DOSRES and SYSWK1.

```
BG 0000 SI10D START WITH AUTOMATIC INSTALLATION (YES/NO?)
```

0 YES

With this message, you have the opportunity to confirm your input and start or redefine the automatic installation process.

If you answer NO, restart with message SI01D once more.

From now on, the automatic installation process runs. Your disk devices are initialized, the VTOC is created in the middle of the disk packs, and the system library is restored.

**This process takes some time to complete. Do not hit any key to interrupt this process.**

During the automatic installation process, the system informs you from time to time about the processing status. System messages such as the following appear on your screen:

```
BG 0000 SI20I  FORMATTING OF DOSRES IN PROGRESS
BG 0000 SI20I  FORMATTING OF SYSWK1 IN PROGRESS
...
BG 0000 L306I  RESTORE OF LIBRARY IJSYSR1 IN PROGRESS
...
BG 0000 L326I  RESTORE COMPLETE FOR LIBRARY IJSYSR1
```

When the automatic installation is finished, the following message appears:

```
BG 0000 SA17W  ***** END OF STAND ALONE PROCESSING *****
```

The system now performs an automatic IPL from DOSRES.

**You can turn to “Installation Part 2 – Detailed Description” on page 71 and continue installing VSE/ESA.** If exceptional conditions occur, refer to pages 49 through 51.

## Installation Overview and Preparation



---

## Chapter 5. Manual Installation Part 1 – Native

This chapter provides installation instructions for installing a native VSE/ESA system **using manual support**.

---

### Preparatory Tasks (Manual/Native)

When you install VSE/ESA native on a processor, you must perform the steps described in the next sections. You also follow these steps if you install VSE/ESA on a processor with Processor Resource/Systems Manager (PR/SM) in LPAR mode. For information on PR/SM, consult the manual *S/390 Processor Resource/Systems Manager Planning Guide*, GA22-7236.

#### Important Information

Note that the example shows you how to perform an IPL using an IBM @server zSeries 900 (z900) processor. *This is just an example*. For detailed information on how to perform an IPL on your processor, refer to the respective operating procedure manual.

### Downloading the Input/Output Configuration Data Set

The Input/Output Configuration Program (IOCP) describes a system's I/O configuration to the Central Processor Unit (CPU). **Before you start to install VSE/ESA, make sure that the Input/Output Configuration Data Set (IOCDS) is correctly loaded on your processor.**

For details on the Input/Output Configuration Program (IOCP), consult the IBM manuals shipped with your processor, for example:

- *IOCP User's Guide and ESCON CTC Reference*, S/390, GC38-0401
- *Stand-Alone Input/Output Configuration Program*, S/390 Generation 5/Generation 6, Multiprise 3000, GC38-0458
- *Processor Resource/Systems Manager Planning Guide*, GA22-7236
- *IOCP User's Guide*, IBM eServer zSeries, SB10-7029
- *Stand-Alone IOCP*, IBM eServer zSeries, SB10-7032
- *Processor Resource/Systems Manager Planning Guide*, IBM eServer zSeries, SB10-7033

#### VSE/ESA Input/Output Configuration Program

When you install VSE/ESA, you **automatically** install the **VSE/ESA IOCP batch program**. You need the VSE/ESA batch IOCP to create a new IOCDS when you change the hardware configuration. You also need it to define and validate the IOCP macro instructions if you prepare for the installation of a new processor. Use skeleton SKIOPCPN (available in VSE/ICCF library 59) as a base for configuration changes.

### Step 1 – Performing an IPL from Tape (Manual/Native)

Mount the cartridge/tape labeled *VSE/ESA2.7.X-YY*. Do not reposition or dismount the cartridge/tape until you have instructions to do so.

#### Example for Installing on a z900 Processor

On a z900 processor, you are using the "Support Element Workplace" to perform a LOAD. A load resets a system or logical partition, to prepare it for loading an operating system, and then loads the operating system. (Other systems may refer to a load as an initial program load or IPL.) On the CPC Recovery Task List on the right side of the support element workplace, double-click on the Load Icon. The Load window is displayed:

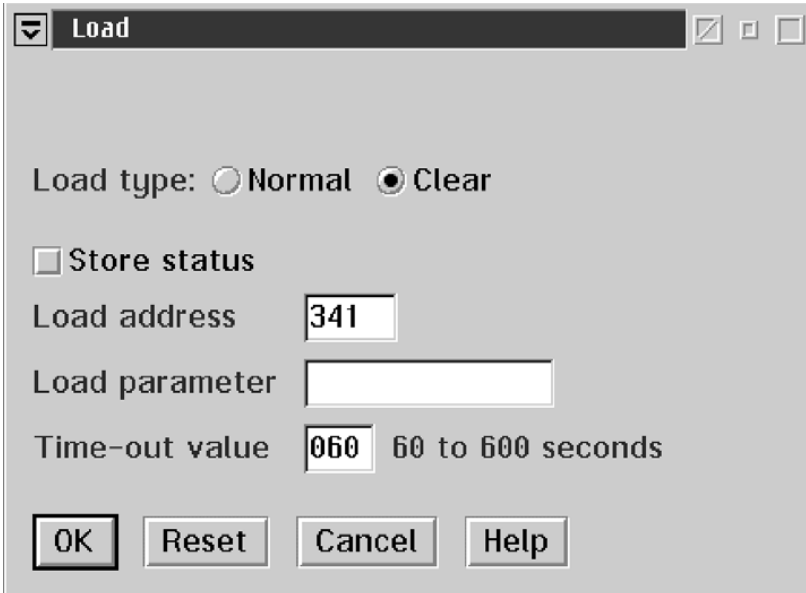

The screenshot shows a window titled "Load" with a dropdown arrow on the left and standard window controls on the right. The window contains the following elements:

- Load type:** Two radio buttons, "Normal" (unselected) and "Clear" (selected).
- Store status:** A checkbox that is currently unchecked.
- Load address:** A text input field containing the value "341".
- Load parameter:** An empty text input field.
- Time-out value:** A text input field containing "060", followed by the text "60 to 600 seconds".
- Buttons:** Four buttons are located at the bottom: "OK", "Reset", "Cancel", and "Help".

Fill in the information about load type, load address, and load parameter, and click OK. For more information about the load parameter, refer to the manual *VSE/ESA System Control Statements*, under "IPL Load Parameter". For more information on the other parameters, see the operating procedure manual for your particular processor. A confirmation window is displayed where you can verify the provided information. If the information is correct, select the YES push button to perform the load. A progress window is displayed which indicates the progress of the load and the result. When the load has successfully completed, click OK to close the window. Otherwise, follow the directions or any messages that may be displayed to determine the problem and correct it.

Continue with "Step 2 – Starting Installation (Manual/Native)" on page 41.

## Step 2 – Starting Installation (Manual/Native)

After having performed an IPL, the system waits for an interrupt from the console. Press **ENTER** to continue.

### Time-of-Day Clock

If the TOD (time-of-day) clock is not set, the system displays the following messages:

```
BG 0000 0I18D ENTER SET CMD
BG 0000      THE DATE VALUE FORMAT IS MM/DD/YYYY
```

**Enter the SET DATE command, no other command is accepted.**

**For DATE=** mm is month, dd is day, yyyy is year.

**For CLOCK=** hh is hour, mm is minutes, ss is seconds.

**SET DATE=mm/dd/yyyy,CLOCK=hh/mm/ss**

```
BG 0000 0I19A ENABLE SETTING OF TOD CLOCK
```

Processing continues with message SI01D.

### More I/O Devices Than Supported

If you have more than 254 devices turned on, you receive the following message:

```
BG 0000 0J74D SUPERVISOR GENERATED FOR 254 DEVICES - nnnn DEVICES PRESENT
ENTER DEL COMMAND FOR UNNEEDED DEVICES
BG-0000
```

In this case you must delete the additional devices, since VSE/ESA only accepts up to 254 I/O devices during initial installation. Please identify devices which you do not need for your installation process, and use the IPL DEL command to delete the devices.

**No other IPL command than the IPL DEL command is accepted.** If you enter any other command, the system prompts you again:

```
BG 0000 0I60D ENTER DEL COMMAND
```

Enter the following:

```
0 DEL cuu1:cuu2
```

Refer to the IBM manual *VSE/ESA System Control Statements* for more information on the DEL command.

Processing continues with message SI01D.

The first system prompt that appears on your system console **after** you have done an IPL from the VSE/ESA tape is the following:

```
BG 0000 SI01D DO YOU WANT TO DO AN AUTOMATIC INSTALLATION (YES/NO)?
```

**0 NO**

## Performing an IPL from Tape (Manual/Native)

Answer **NO** to do a manual installation.

```
BG 0000 SA01I ***** STAND ALONE PROGRAMS LOADED *****
BG 0000 SA02D IF YOU WANT A LISTING,SPECIFY CUU OF PRINTER, ELSE (ENTER)
```

**0**

If you want a listing, specify the **cuu** of the printer (for example, **0 00e**). Otherwise enter **0**. If the printer cannot be sensed, messages SA04I, SA05I, and SA06D are issued, asking for the correct device type.

You are now requested to specify the device type of the printer.

```
BG 0000 SA03D DEVICE TYPE IS xxxxyy. ACCEPT (ENTER) OR SPECIFY ALTERNATE TYPE
```

If this is the device type that you want to specify, enter:

**0**

For a complete list of the device type codes possible, including those for PRT1, refer to the manual *VSE/ESA System Control Statements*. It contains a figure showing all device type codes supported.

```
BG 0000 SA08D SYSTEM DATE IS mm/dd/yyyy. ACCEPT DATE (ENTER) OR SPECIFY
DATE MM/DD/YYYY
```

**0 mm/dd/yyyy**

(mm - month)

(dd - day)

(yyyy - year)

If you want to change the date, you must enter two digits for month and day, and four digits for year, separated by a slash. Otherwise enter **0**.

```
BG 0000 SA09I SELECT ONE OF THE FOLLOWING PROGRAMS, OR TYPE END
BG 0000 SA10D FASTCOPY, RESTORE, ICKDSF, DITTO, REIPL
```

**0 ICKDSF**

```
BG 0000 ICKDSF-VSE DEVICE SUPPORT FACILITIES 17.0 TIME
BG 0000 xx/xx/xx MM/DD/YYYY
BG 0000 ENTER INPUT COMMAND:
```

The next input requested, is an INIT UNIT command.

---

## Step 3 – Initializing Disks and Placing the VTOC (Manual/Native)

For VSE/ESA installation, you need to initialize two disk devices, **DOSRES** and **SYSWK1**. You first initialize the volume **DOSRES** and continue with **SYSWK1**. Enter the command for the respective disk type.

**Note:** You can initialize as many data volumes as you need and give them individual names.

In addition, you have to place the VTOC. You may choose to place the VTOC in the middle of the disk pack or at the end of it.

If the Device Support Facilities Program is to initialize either a new CKD disk or a CKD disk that was used under another operating system (for example, z/OS or OS/390), the program must validate and rewrite the home address and record 0 on each track of the disk.

In these cases, additional parameters of the INIT command (VALIDATE, CHECK) are required to initialize the disks correctly. Otherwise, you may have problems later, when you IPL the restored system. Note that validate may not be available for all disk devices.

You should review the INIT command in detail, especially if one of the following is true:

- The disks have never been initialized.
- The disks have been previously used on a system other than VSE.
- You are changing from emulation mode to disk native mode.

### Initializing Disks (VTOC in the Middle of Volume)

The following section lists the recommended VTOC locations. These commands place the VTOC almost in the middle of the disk devices. Note that there are **different locations for DOSRES and SYSWK1**. Therefore you must enter two different commands, one for DOSRES and one for SYSWK1. Replace **cuu** with the respective disk address.

If the INIT command exceeds 70 characters on your screen, use a dash (-) as the continuation character. The system will then ask you for additional information.

More information on how to reduce VTOC space is in the topic “Storage and Tuning Recommendations” in the IBM manual *VSE/ESA Planning*. The predefined values are sufficient for up to 230 labels.

FBA device:

```
0 INIT UNIT(cuu) NVFY NOMAP PURGE FBAVTOC(125504,228,8192) VOLID(DOSRES)
0 INIT UNIT(cuu) NVFY NOMAP PURGE FBAVTOC(306624,228,8192) VOLID(SYSWK1)
```

IBM 3380 (CKD device):

```
0 INIT UNIT(cuu) NVFY NOMAP PURGE DOSVTOC(210,11,4) VOLID(DOSRES)
0 INIT UNIT(cuu) NVFY NOMAP PURGE DOSVTOC(325,11,4) VOLID(SYSWK1)
```

IBM 3390 (ECKD device):

```
0 INIT UNIT(cuu) NVFY NOMAP PURGE DOSVTOC(208,11,4) VOLID(DOSRES)
0 INIT UNIT(cuu) NVFY NOMAP PURGE DOSVTOC(301,11,4) VOLID(SYSWK1)
```

IBM 9345 (ECKD device):

```
0 INIT UNIT(cuu) NVFY NOMAP PURGE DOSVTOC(243,11,4) VOLID(DOSRES)
0 INIT UNIT(cuu) NVFY NOMAP PURGE DOSVTOC(359,11,4) VOLID(SYSWK1)
```

After you entered the appropriate input command, respond with U to the following message, to proceed with command processing:

```
BG 0000 ICK003D REPLY U TO ALTER VOLUME cuu CONTENTS, ELSE T
```

```
0 U
```

## Initializing Disks (Manual/Native)

### Additional Messages

If you install on previously used disk devices, the system may issue the following messages:

```
ICK001D CONFIRM PURGING OF UNEXPIRED DATA SETS, REPLY U TO PURGE, ELSE T
```

```
0 U
```

```
ICK019D CONFIRM PURGING OF ALL VSAM FILES, REPLY U TO PURGE, ELSE T
```

```
0 U
```

```
BG 0000 ICK01313I VOLUME CONTAINS nn ALTERNATE TRACKS -- nn AVAILABLE.  
BG 0000 ICK01314I VTOC IS LOCATED AT CCHH=X'nnnn nnnn' AND IS nn TRACKS.  
BG 0000 ICK00001I FUNCTION COMPLETED, HIGHEST CONDITION CODE WAS nn  
ENTER INPUT/COMMAND:
```

To exit ICKDSF command processing and to return to the stand-alone utility selection, enter:

```
0 END
```

Continue with “Step 4 – Restoring the System Library IJSYSRS (Manual/Native)” on page 46.

## Initializing Disks (VTOC at the End of Volume)

Enter the following to initialize the system volumes. Replace **cuu** with the respective disk address.

If the INIT command exceeds 70 characters on your screen, use a dash (-) as the continuation character. The system will then ask you for additional information.

For CKD disks (IBM 3380, except Model A) and ECKD disks (IBM 3390, 9345):

```
0 INIT UNIT(cuu) NVFY NOMAP PURGE DOSVTOC(END) VOLID(DOSRES)  
0 INIT UNIT(cuu) NVFY NOMAP PURGE DOSVTOC(END) VOLID(SYSWK1)
```

Respond with U to the following message, to proceed with command processing:

```
BG 0000 ICK003D REPLY U TO ALTER VOLUME cuu CONTENTS, ELSE T
```

```
0 U
```

```
BG 0000 ICK01313I VOLUME CONTAINS nn ALTERNATE TRACKS -- nn AVAILABLE.  
BG 0000 ICK01314I VTOC IS LOCATED AT CCHH=X'nnnn nnnn' AND IS nn TRACKS.
```

```
BG 0000 ICK00001I FUNCTION COMPLETED, HIGHEST CONDITION CODE WAS nn  
ENTER INPUT/COMMAND:
```

To exit ICKDSF command processing and to return to the stand-alone utility selection, enter:

```
0 END
```

Continue with “Step 4 – Restoring the System Library IJSYSRS (Manual/Native)” on page 46.

## Initializing IBM Disk Devices as Data DASDs

VSE/ESA allows you to use the following disk devices only as data DASDs, **not** as system devices.

IBM 3370-2  
 IBM 3375  
 IBM 3380 (Model A)

Note that if you are using an FBA as data device, the details on the previous page about the VTOC location must be considered (multiple of 777).

To initialize these disk devices, issue the following command and replace **xxxxxx** by a valid **other than** DOSRES and SYSWK1. Replace **cuu** by the respective disk address.

**Note:** If the INIT command exceeds 70 characters on your screen, use a dash (-) as the continuation character. The system will then ask you for additional information.

For IBM 3370 (FBA device):

```
0 INIT UNIT(cuu) NVFY NOMAP PURGE FBAVTOC(END) VOLID(xxxxxx)
```

For IBM 3375 (CKD device):

```
0 INIT UNIT(cuu) NVFY NOMAP PURGE DOSVTOC(END) VOLID(xxxxxx)
```

For IBM 3380 (CKD device):

```
0 INIT UNIT(cuu) NVFY NOMAP PURGE DOSVTOC(END) VOLID(xxxxxx)
```

After you entered the appropriate input command, respond with U to message ICK003D, to proceed with command processing.

```
BG 0000 ICK003D REPLY U TO ALTER VOLUME cuu CONTENTS, ELSE T
```

```
0 U
```

```
BG 0000 ICK01313I VOLUME CONTAINS nn ALTERNATE TRACKS -- nn AVAILABLE.  

  BG 0000 ICK01314I VTOC IS LOCATED AT CCHH=X'nnnn nnnn' AND IS nn TRACKS.
```

```
BG 0000 ICK00001I FUNCTION COMPLETED, HIGHEST CONDITION CODE WAS nn  

  ENTER INPUT/COMMAND:
```

To exit ICKDSF command processing and to return to the stand-alone utility selection, enter:

```
0 END
```

### Step 4 – Restoring the System Library IJSYSRS (Manual/Native)

This task restores the system library IJSYSRS (IJSYSR1) from tape. The following system prompts and messages appear:

```
BG 0000 SA09I  SELECT ONE OF THE FOLLOWING PROGRAMS, OR TYPE END
BG 0000 SA10D  FASTCOPY, RESTORE, ICKDSF, DITTO, REIPL
```

**0 RESTORE**

```
BG 0000 SA11D  SPECIFY ADDRESS OF INPUT DEVICE  CUU
```

**0 cuu** (cuu - tape drive address where VSE/ESA tape is mounted)

```
BG 0000 SA03D  DEVICE TYPE IS xxxxyy. ACCEPT (ENTER) OR SPECIFY ALTERNATE TYPE
```

**0**

You may get the following message:

```
BG 0000 SA13D  TAPE MODE IS XX. ACCEPT (ENTER) OR SPECIFY ALTERNATE MODE YY
```

**0**

Always accept the default when you restore the contents of the SYSRES volume, regardless what type of tape unit you use.

```
BG 0000 SA15D  FOR TAPE LABEL CHECKING SPECIFY // TLBL, ELSE (ENTER)
```

**0**

```
BG 0000 SA16D  SPECIFY ADDRESS OF SYSRES DISK  CUU
```

**0 cuu** (cuu - address of DOSRES)

```
BG 0000 SA03D  DEVICE TYPE IS xxxxyy. SPECIFY ALTERNATE TYPE, OR ACCEPT (ENTER)
```

**0**

```
BG 0000 L302A  ENTER YES TO RESTORE SYSRES FILE IJSYSR1 OR NO TO SKIP
                TO NEXT SYSRES
```

**0 YES**

```
BG 0000 L315I  ORIGINAL FILE ID= VSE.SYSRES.LIBRARY
L316A ENTER YES TO KEEP OR NO TO RESPECIFY THE SYSRES FILE ID
```

**0 YES**

You **must** answer **NO** to the following prompt:

```
BG 0000 L309I  ORIGINAL ALLOCATION= xxxx  ....
BG 0000 L310A  ENTER YES TO KEEP OR NO TO RESPECIFY THE ALLOCATION
```

**0 NO**

Now use the values in this table to answer to the next system prompt:

Disk Device Type	Allocation Value (xxxxx)
For 3380 (all models)	959
For 3390 (in 3390 mode)	899
For 3390 (in 3380 track compatibility mode)	959
For generalized FBA disks	59134
For 9345 (all models)	1064



## Restoring System Library (Manual/Native)

```
BG 0000 L312I MINIMUM ALLOCATION= xxx ....
BG 0000 L304I ENTER THE DESIRED ALLOCATION AS NUMBER OF ....
BG 0000 L313A ALLOC=
```

**0 xxxxx**

```
BG 0000 L329A ENTER YES TO RESTORE ALL SUBLIBRARIES OR NO FOR
      SELECTIVE RESTORE
```

**0 YES**

```
BG 0000 L338I SUMMARY OF RESTORE PARAMETERS:
BG 0000 L318I FILE NAME = IJSYSR1
BG 0000 L319I FILE ID = VSE.SYSRES.LIBRARY.xxx
BG 0000 L321I ALLOCATION= xxxx ....
BG 0000 L344I START= ..... - END= ....
BG 0000 L327I RESTORE ALL SUBLIBRARIES
BG 0000 L322A ENTER YES IF THE SPECIFICATION IS CORRECT OR NO TO RESPECIFY
```

**0 YES**

### Restarting the Restore

If you restart this step and you get the following message (where xxxxxxx is the file name),

```
BG 0000 L324I EQUAL FILE ID IN VTOC xxxxxxx ...
BG 0000 L319I FILE ID=id
BG 0000 L330A TYPE CANCEL OR DELETE
```

you should enter:

**0 DELETE**

### CKD Device Users

The system displays the following message:

```
BG 0000 L300I FORMATTING OF LIBRARY IJSYSR1 IN PROGRESS
```

```
BG 0000 L306I RESTORE OF LIBRARY IJSYSR1 IN PROGRESS
BG 0000 L325I RESTORE OF SUBLIBRARY IJSYSR1.SYSLIB IN PROGRESS
BG 0000 L326I RESTORE COMPLETE FOR LIBRARY IJSYSR1
BG 0000 SA09I SELECT ONE OF THE FOLLOWING PROGRAMS, OR TYPE END
BG 0000 SA10D FASTCOPY, RESTORE, ICKDSF, DITTO, REIPL
```

**0 END**

```
BG 0000 SA17W ***** END OF STAND ALONE PROCESSING *****
```

System Library IJSYSRS is now restored.

### Step 5 – Performing an IPL from DOSRES (Manual/Native)

This step uses a VSE/ESA-supplied IPL procedure. The correct IPL procedure is chosen automatically, based on the disk type and CPU mode. VSE/ESA selects the appropriate options for your system.

Usually, you do not have to add devices during this task. The IPL program for VSE/ESA uses device sensing to automatically define the devices on the system. Therefore, you should power on the devices which you need defined during IPL. Please be aware that for initial installation, only up to **254** devices are allowed. If your environment includes more than 254 devices, you have to identify the devices that you do **not** need for installing the system and **exclude** them from the installation process.

There are several alternatives for excluding the devices:

1. You may power off any devices which you do not want to be sensed.
2. If you decide not to power off the devices, the system senses all operational devices. It then displays the number of devices sensed and asks you to use the **IPL DEL** command to delete the additional devices.

This only works for up to 1024 devices, which is the maximum number of devices that are supported by VSE/ESA. Any devices above the number of 1024 have to be powered off in any case. (Page 13 has more information.)

3. You can use an IOCDS that contains 254 (or 1024) devices.

If not all necessary information can be sensed, you are asked to define these devices when you complete the initial installation ( Chapter 8, "Installation Part 3 - Native and VM," on page 95).

If a device is needed for the minimum configuration and it cannot be sensed, you are asked to enter command **IPL ADD** for that device.

**Note:** You should have either a system printer **or** a terminal printer attached to your system. This is recommended even though the system does not check for the presence of a printer. If you only have terminal printers attached, VSE/ESA must be up and running in order to get the VSE system printer output sent to a terminal printer.

#### Perform an IPL from DOSRES.

According to the type of processor you use, perform the IPL as described under "Step 1 – Performing an IPL from Tape (Manual/Native)" on page 40. Note that the example there shows you how to IPL using an IBM @server zSeries 900 processor. *This is just an example.* If you use a different processor, refer to the operating procedure manual for your processor.

After having performed an IPL, the system waits for an interrupt from the console. Press **ENTER** to continue.

```
BG 0000 0I04I IPLDEV=X'cuu',VOLSER=DOSRES,CPUID=xxxxxxxxxxxx
BG 0000 0J01I IPL=$IPLExx ,JCL=$$JCL7xx
BG 0000 $$A$SUPX,VSIZE=nnM,VPOOL=nnnK,VIO=nnnK
BG 0000 0I30I DATE=xx/xx/xxxx,CLOCK=yy/yy/yy,ZONE=nnnn/00/00
BG 0000 THE DATE VALUE FORMAT IS MM/DD/YYYY

BG 0000 0J47I CHANNEL SUBSYSTEM: nnnn DEVICE(S) FOUND OPERATIONAL.
BG 0000 ...
BG 0000 ...
BG 0000 ADD FDF,FBAV
```

## Performing an IPL from DOSRES (Manual/Native)

```
BG 0000 ADD FEC,3505
BG 0000 ADD FFC,3505 ICCF DUMMY DEVICE DON'T DELETE
BG 0000      ...
BG 0000      ...(additional devices added)
BG 0000      ...
BG 0000 ADD FFF,CONS      DUMMY CONSOLE DON'T DELETE
BG 0000 DEF SYSCAT=DOSRES,SYSREC=SYSWK1
```

### Time-of-Day Clock

If the TOD (time-of-day) clock is not set, the system displays the following messages:

```
BG 0000 0I18D ENTER SET CMD
BG 0000      THE DATE VALUE FORMAT IS MM/DD/YYYY
```

Enter the SET DATE command.

**For DATE=** *mm* is month, *dd* is day, *yyyy* is year.

**For CLOCK=** *hh* is hour, *mm* is minutes, *ss* is seconds.

**SET DATE=mm/dd/yyyy,CLOCK=hh/mm/ss**

```
BG 0000 0I19A ENABLE SETTING OF TOD CLOCK
```

Enable the setting of the TOD clock via the enable TOD switch, the hardware selection menu, or mode select option.

For more information, refer to the appropriate hardware manual.

### More I/O Devices than Supported

If you have more than 254 I/O devices turned on, you receive the following message:

```
BG 0000 0J74D SUPERVISOR GENERATED FOR 254 DEVICES - nnnn DEVICES PRESENT
      ENTER DEL COMMAND FOR UNNEEDED DEVICES
```

In this case you must delete the additional devices, since VSE/ESA only accepts up to 254 I/O devices during initial installation. Please identify devices which you do not need for your installation process, and use the DEL command to delete the devices. **Make sure that you do not delete essential hardware devices, such as the disk volume SYSWK1.**

```
0 DEL cuu1:cuu2
```

Refer to the IBM manual *VSE/ESA System Control Statements* for more information on the DEL command.

Native installation continues in "Installation Part 2 – Detailed Description" on page 71.

## Performing an IPL from DOSRES (Manual/Native)

### Insufficient System Configuration

If you get the following messages, follow these instructions.

```
BG 0000 IESI0101I INSUFFICIENT SYSTEM CONFIGURATION FOR
          INITIAL INSTALLATION
BG 0000 IESI0102A SPECIFY IPL ADD COMMAND FOR xxxxxxxxxx
```

The system checks whether the minimum hardware configuration for initial installation is available. If some devices are not sensed, the system displays the above messages. The second message (IESI0102A) is displayed for each required device that was not sensed. xxxxxxxxxx is the specific device type. It can be:

```
TAPE DEVICE
CICS TERMINAL/LOCAL SNA CONTROL UNIT
01 DASD DEVICE - TYPE AS SYSRES
```

Remember that you only need two disk volumes (DOSRES and SYSWK1) for the minimum configuration. The disk type of the unidentified but required disk must be of the same type as DOSRES.

Enter one IPL ADD command for **each** required device type that was not sensed (tape, terminal/control unit, disk).

**0 ADD cuu,device-type** (cuu - device address)

As an example, suppose that the system displays the following messages:

```
BG 0000 IESI0102A SPECIFY IPL ADD COMMAND FOR CICS
BG 0000          TERMINAL/LOCAL SNA CONTROL UNIT
```

You would add the address of at least one terminal/local SNA control unit. For instance, you might enter:

**0 ADD 380,3277**

```
BG 0000 0J10I IPL RESTART POINT BYPASSED
```

### Duplicate Volume Identifiers Found

If you get the following message, follow these instructions.

```
BG 0000 IESI0120I VOLID xxxxxx FOUND ON FOLLOWING ADDRESSES (CUU):
BG 0000          cuu1 cuu2 ...
```

The system checks the volume identifiers (VOLIDs) of all disks. This is to ensure that the VOLIDs for VSE/ESA (DOSRES, SYSWK1) are unique. If two disks have the same VOLID, the system displays the above message, where *xxxxxx* is the VOLID that is duplicated. Following the message is a list of the disk addresses with the same VOLID (*cuu1, cuu2 ...*).

For DOSRES, VSE/ESA automatically uses the address of the disk that was IPLed as DOSRES. The system displays the following message:

```
BG 0000 IESI0123I DASD WITH ADDRESS xxx WILL BE USED AS DOSRES
```

For VOLID SYSWK1, the system displays the following message:

```
BG 0000 IESI0121D ENTER ADDRESS OF DASD TO BE USED AS SYSWK1: CUU
```

Enter the address (*cuu*) of the disk device you are using for VSE/ESA installation.

**0 cuu** (*cuu* - disk address of SYSWK1)

All other disk devices with the same VOLID are set in *device down* status. The system displays the following message:

```
BG 0000 IESI0124I FOLLOWING DEVICE(S) WILL BE SET IN DEVICE DOWN STATUS:
GB 0000          cuu1 cuu2...
```

The message is followed by a list of the disk addresses that are set in *device down* status (*cuu1, cuu2 ...*).

```
BG 0000 SYS NPARTS=xx
BG 0000 SYS DASDFP=YES
BG 0000 SYS SEC=NO
BG 0000 SYS PASIZE=nnM
BG 0000 SYS SPSIZE=nK
BG 0000 SYS BUFLD=YES
BG 0000 SYS SERVPART=FB

BG 0000 DPD VOLID=DOSRES,CYL=xxx,NCYL=xx,TYPE=N,DSF=N
BG 0000 0I52I PDS EXT 01 ON cuu:          LOW          HIGH
BG 0000          CC HH:          xxx          x          xxx          xx4
BG 0000          PAGE NUMBER:          x          xxxxx
BG 0000 DPD VOLID=DOSRES,CYL=xxx,TYPE=N,DSF=N
BG 0000 0I52I PDS EXT 02 ON cuu:          LOW          HIGH
BG 0000          CC HH:          xxx          x          xxx          xx
BG 0000          PAGE NUMBER:          xxxxx          xxxxx
BG 0000          VIO START PAGE NUMBER:          xxxxx
BG 0000 DLA NAME=AREA1,VOLID=DOSRES,CYL=xx,NCYL=x,DSF=N
BG 0000 0I52I LABEL AREA ON cuu:          LOW          HIGH
BG 0000          CC HH:          xx          x          xx          xx
BG 0000 SVA SDL=nnn,GETVIS=(nnnK,nM),PSIZE=(nnnK,nM)
BG 0000 0J24I DASD SHARING SUPPORT RESET
BG 0000 0J62I ACTUAL CHANQ IS nnn
BG 0000 0J83I ACTUAL SYSTEM TIME ZONE=EAST/00/00
```

## Performing an IPL from DOSRES (Manual/Native)

```
BG 0000 0J69I ACTUAL SIZE OF PRIVATE AREA IS nnM
BG 0000      31-BIT SYSTEM GETVIS AREA ROUNDED BY 692K
BG 0000 0J73I ACTUAL NUMBER OF USER SDL ENTRIES IS xxx
AR 0030 VMCF10I VM/VSE INTERFACE INITIALIZED

BG 0000 0J39I ACTUAL BUFSIZE IS nnnn
BG 0000 0J76I software/hardware COMPRESSION INITIALIZED
BG 0000
0I26I $$BFCB23 LOADED                CUU=xxx
BG 0000 0I20I IPL COMPLETE FOR system identification
BG 0000      SUPVR USERID IS: .....
```

### Additional Messages

Some systems also may display the following messages:

```
BG 0000 4301I NO FORMAT 1 LABEL FOUND IJSYSCN SYSREC=xxx SYSWK1
BG 0000 1I94I HARD COPY OPEN FAILED, HC=CREATE FORCED
```

```
BG 0000 ALLOC BG=xxxxK
BG 0000      SIZE  BG=xxxxK
:
:      (additional ALLOC and SIZE statements)
:
```

Because the VSE.CONTROL.FILE does not exist yet, you will get the following message:

```
FB 0011 // JOB SECSERV
      DATE xx/xx/xxxx, CLOCK yy/yy/yy
FB 0074 4228I FILE IJSYSCT  OPEN  ERROR X'B4'(180) CAT=..N/A..
      (OPNCT-20) VOLUME 'DOSRES' NOT OWNED BY VSAM
FB 0074 4228I FILE IESCNL  OPEN  ERROR X'B4'(180) CAT=VSESPUC (4,AD,2)
      (OPNHC-10) RC X'00000004' FROM CATLG
FB 0074 BST300E THE II CONTROL FILE COULD NOT BE OPENED.
```

This error message is only informational and processing continues.

```
BG 0000 STOP
F1 0001 // JOB POWSTART
```

### If Second or Additional IPL from Disk

If you restart this step, you may get messages concerning the VSE/POWER QUEUE.FILE, DATA.FILE, or ACCOUNT.FILE, such as:

```
F1 0001 4733D EQUAL FILE ID IN VTOC ...
```

Enter:

**1 DELETE**

```
:
```

```
DATE xx/xx/xxxx, CLOCK yy/yy/yy
```

```
F1 0001 1Q20I AUTOSTART IN PROGRESS
F1 0001 1R75I  BG AUTOSTARTED
F1 0001 1R75I  F2 AUTOSTARTED
F1 0001 1R75I  F3 AUTOSTARTED
F1 0001 1R75I  F4 AUTOSTARTED
F1 0001 1R75I  F5 AUTOSTARTED
```

## Performing an IPL from DOSRES (Manual/Native)

```
F1 0001 1R88I  OK
F1 0001 1Q12I  VSE/POWER 6.7.0 INITIATION COMPLETED
F1 0001 1Q34I  F3 WAITING FOR WORK
F1 0001 1Q34I  F2 WAITING FOR WORK
F1 0001 1Q34I  F4 WAITING FOR WORK
F1 0001 1Q34I  F5 WAITING FOR WORK
BG 0000 * *****
BG 0000 *
BG 0000 *          INSTALLATION OF          *
BG 0000 * *****
BG 0000 *
BG 0000 *          VSE/ESA 2.7.0          xx/xx/xxxx *
BG 0000 *
BG 0000 * *****
BG 0000 * LICENSED MATERIALS - PROPERTY OF IBM *
BG 0000 * 5686-066 AND OTHER MATERIALS (C) COPYRIGHT*
BG 0000 * IBM CORP. 2002 AND OTHER DATES *
BG 0000 * ALL RIGHTS RESERVED. *
BG 0000 * US GOVERNMENT USERS RESTRICTED RIGHTS - *
BG 0000 * USE, DUPLICATION OR DISCLOSURE *
BG 0000 * RESTRICTED BY *
BG 0000 * GSA ADP SCHEDULE CONTRACT WITH IBM CORP. *
BG 0000 * *****
BG 0000 *
BG 0000 * *****
F3 0003 // JOB STARTF3
          DATE xx/xx/xxxx, CLOCK yy/yy/yy
F2 0002 // JOB STARTF2
          DATE xx/xx/xxxx, CLOCK yy/yy/yy
F4 0004 // JOB STARTF4
          DATE xx/xx/xxxx, CLOCK yy/yy/yy
F5 0005 // JOB STARTF5
          DATE xx/xx/xxxx, CLOCK yy/yy/yy
F3 0003 1N90I  EOP WAS FORCED BY EOJ
F3 0003 EOJ STARTF3
          DATE xx/xx/xxxx, CLOCK yy/yy/yy, DURATION  zz/zz/zz
F3 0001 1Q34I  F3 WAITING FOR WORK
F2 0002 1N90I  EOP WAS FORCED BY EOJ
F2 0002 EOJ STARTF2
          DATE xx/xx/xxxx, CLOCK yy/yy/yy, DURATION  zz/zz/zz
F2 0001 1Q34I  F2 WAITING FOR WORK
F4 0004 1N90I  EOP WAS FORCED BY EOJ
F4 0004 EOJ STARTF4
          DATE xx/xx/xxxx, CLOCK yy/yy/yy, DURATION  zz/zz/zz
F4 0001 1Q34I  F4 WAITING FOR WORK
F5 0005 1N90I  EOP WAS FORCED BY EOJ
F5 0005 EOJ STARTF5
          DATE xx/xx/xxxx, CLOCK yy/yy/yy, DURATION  zz/zz/zz
F5 0001 1Q34I  F5 WAITING FOR WORK
BG 0000 1S47I  PRELEASE RDR, INSTALL
BG 0000 1N90I  EOP WAS FORCED BY EOJ
BG 0000 EOJ BGINIT  MAX.RETURN CODE=xxxx
          DATE xx/xx/xxxx,CLOCK yy/yy/yy,DURATION  zz/zz/zz
```

### Continuing Installation

To continue installation, refer to "Installation Part 2 – Detailed Description" on page 71.

## Performing an IPL from DOSRES (Manual/Native)



---

## Chapter 6. Manual Installation Part 1 – Under VM

This chapter gives instructions for installing VSE/ESA under VM. The information in this chapter supplements the information available in the following VM manuals which provide detailed information about planning for VSE/ESA guest systems and using them:

- *z/VM, Version 3 Release 1.0, Running Guest Operating Systems, SC24-5950.*
- *z/VM, Version 4 Release 1.0, Running Guest Operating Systems, SC24-5997.*
- *z/VM, Version 4 Release 2.0, Running Guest Operating Systems, SC24-5997-01.*
- *z/VM, Version 4 Release 3.0, Running Guest Operating Systems, SC24-5997-02.*

---

### Preparatory Tasks (Manual/Under VM)

To install VSE/ESA under VM, the VSE/ESA guest system must be known to VM. If you initialize the disk under VM, dedicate the disk (by the CP ATTACH command) to your user ID before you start initialization. You can use disk devices as dedicated disks or as minidisks.

There is a number of planning and preparation tasks you have to do before you start installing VSE/ESA under VM. Please make sure that you have read “Planning for Running VSE/ESA under VM” in the IBM manual *VSE/ESA Planning*.

You can install and use VSE/ESA as a guest system under any supported version of VM. In this combined environment, you can do the following:

- Log on to VM using the ID and password defined for the VSE/ESA guest system. Your terminal then can serve as the VSE/ESA console.
- Dial into the VSE/ESA system and use the functions provided by the Interactive Interface. If your VM system has the VM/Pass-Through Facility (a VM optional program) installed, you can quickly switch between CMS and VSE/ESA environments.
- Log on to CMS and interact with VSE/ESA. VSE/ESA provides the VM/VSE Interface, which allows CMS users to operate VSE/ESA systems. This is described in Chapter 10, “Installing VM/VSE Interface Routines – VM Only,” on page 125.
- Make sure that your processor is running in ESA mode (SET MACH ESA).

#### Note:

In this chapter, *virtual machine console* refers to a device that is defined for every VM user. *VSE/ESA console* refers to the VSE/ESA system console that is used to control operation of VSE/ESA.

---

### Step 1 – Performing an IPL from Tape (Manual/Under VM)

**Mount the cartridge/tape labeled VSE/ESA2.7.X-YY. Do not reposition or dismount the cartridge/tape until you are told to do so.**

To define the console mode, enter in CP mode:

**TERM CON 3270**

## Performing IPL from Tape (Manual/Under VM)

To define terminals to VM, enter in CP mode:  
**DEF GRAF cuu** (*cuu* - terminal address).

Repeat this command for every terminal you want to define, if you have not yet defined the terminals in your VM directory. Please note that you have to define at least one terminal.

You have to define *at least* 16 MB of storage. (The maximum storage value is 2 GB). Enter the following in CP mode:

**DEF STOR xxxM** (Replace *xxx* with the value you want to specify.)

To perform an IPL, enter in CP mode:  
**IPL cuu** (*cuu* - address of tape drive with VSE/ESA tape)

After having typed in all parameters, press **ENTER**.

---

## Step 2 – Starting Installation (Manual/Under VM)

After having performed an IPL, the system waits for an interrupt from the console. Press **ENTER** to continue.

### More I/O Devices Than Supported

If you have more than 254 devices turned on, you receive the following message:

```
BG 0000 0J74D SUPERVISOR GENERATED FOR 254 DEVICES - nnnn DEVICES PRESENT
      ENTER DEL COMMAND FOR UNNEEDED DEVICES
```

In this case you must delete the additional devices, since VSE/ESA only accepts up to 254 I/O devices during initial installation. Please identify devices which you do not need for your installation process, and use the IPL DEL command to delete the devices.

**No other IPL command than the IPL DEL command is accepted.** If you enter any other command, the system prompts you again:

```
BG 0000 0I60D ENTER DEL COMMAND
```

Enter the following:

```
0 DEL cuu1:cuu2
```

Refer to the IBM manual *VSE/ESA System Control Statements* for more information on the DEL command.

Processing continues with message SI01D.

The first system prompt that appears on your system console **after** you have done an IPL from the VSE/ESA tape is the following:

```
BG 0000 SI01D DO YOU WANT TO DO AN AUTOMATIC INSTALLATION (YES/NO) ?
```

**0 NO**

Answer **NO** to continue with manual installation.

## Performing IPL from Tape (Manual/Under VM)

```
BG 0000 SA01I ***** STAND ALONE PROGRAMS LOADED *****
BG 0000 SA02D IF YOU WANT A LISTING, SPECIFY CUU OF PRINTER, ELSE (ENTER)
```

0

If you want a listing, specify the **cuu** of the printer (for example, **0 00e**). If the printer cannot be sensed, messages SA04I, SA05I, and SA06D are issued, asking for the correct device type.

You are now requested to specify the device type of the printer.

```
BG 0000 SA03D DEVICE TYPE IS xxxxyy. ACCEPT (ENTER) OR SPECIFY ALTERNATE TYPE
```

If this is the device type that you want to specify, enter:

0

For a complete list of the device type codes possible, including those for PRT1, refer to the manual *VSE/ESA System Control Statements*. It contains a figure showing all device type codes supported.

```
BG 0000 SA08D SYSTEM DATE IS mm/dd/yyyy. ACCEPT DATE (ENTER) OR SPECIFY
DATE MM/DD/YYYY
```

If you want to change the date, you must enter two digits for month and day, and four digits for the year, separated by a slash. Otherwise enter **0**.

**0 mm/dd/yyyy**

```
BG 0000 SA09I SELECT ONE OF THE FOLLOWING PROGRAMS, OR TYPE END
BG 0000 SA10D FASTCOPY, RESTORE, ICKDSF, DITTO, REIPL
```

**0 ICKDSF**

```
BG 0000 ICKDSF-VSE DEVICE SUPPORT FACILITIES 17.0 TIME
BG 0000 xx/xx/xxxx MM/DD/YYYY
BG 0000 ENTER INPUT COMMAND:
```

The next input requested is an INIT UNIT command, as shown under “Initializing Disks (VTOC in the Middle of Volume)” on page 58.

---

### Step 3 – Initializing Disks and Placing the VTOC (Manual/Under VM)

For VSE/ESA installation, you need to initialize two disk devices, **DOSRES** and **SYSWK1**. You first initialize the volume **DOSRES** and continue with **SYSWK1**. Enter the command for the respective disk type.

**Note:** You can initialize as many data volumes as you need and give them individual names.

In addition, you have to place the VTOC. You may choose to place the VTOC in the middle of the disk pack or at the end of it.

If the Device Support Facilities Program is to initialize a new CKD disk or a CKD disk that was used under another operating system (for example z/OS or OS/390), the program must validate and rewrite the home address and record 0 on each track of the disk.

## Initializing Disks (Manual/Under VM)

In these cases, additional parameters of the INIT command (VALIDATE, CHECK) are required to initialize the disks correctly. Otherwise, you may later have problems when you IPL the restored system. Please note that validate may not be available for all disk devices.

You should review the INIT command in detail, especially if one of the following is true:

- The disks have never been initialized.
- The disks have been previously used on a system other than VSE.
- You are changing from emulation mode to disk native mode.

## Initializing Disks (VTOC in the Middle of Volume)

The following section lists recommended VTOC locations for the various supported disk devices. There is no difference between initializing a disk as dedicated disk or as a minidisk.

Note that there are **different locations for DOSRES and SYSWK1**. Therefore you must enter two different commands, one for DOSRES and one for SYSWK1. Replace **cuu** with the respective disk address. More information on how to reduce VTOC space is in topic "Storage and Tuning Recommendations" in the IBM manual *VSE/ESA Planning*. The predefined values are sufficient for up to 230 labels.

**Note:** If the INIT command exceeds 70 characters on your screen, use a dash (–) as the continuation character. The system will then ask you for additional information.

FBA device (9336):

```
0 INIT UNIT(cuu) NVFY NOMAP PURGE FBAVTOC(125504,228,8192) VOLID(DOSRES)
0 INIT UNIT(cuu) NVFY NOMAP PURGE FBAVTOC(306624,228,8192) VOLID(SYSWK1)
```

IBM 3380 (CKD device):

```
0 INIT UNIT(cuu) NVFY NOMAP PURGE DOSVTOC(210,11,4) VOLID(DOSRES)
0 INIT UNIT(cuu) NVFY NOMAP PURGE DOSVTOC(325,11,4) VOLID(SYSWK1)
```

IBM 3390 (ECKD device):

```
0 INIT UNIT(cuu) NVFY NOMAP PURGE DOSVTOC(208,11,4) VOLID(DOSRES)
0 INIT UNIT(cuu) NVFY NOMAP PURGE DOSVTOC(301,11,4) VOLID(SYSWK1)
```

IBM 9345 (ECKD device):

```
0 INIT UNIT(cuu) NVFY NOMAP PURGE DOSVTOC(243,11,4) VOLID(DOSRES)
0 INIT UNIT(cuu) NVFY NOMAP PURGE DOSVTOC(359,11,4) VOLID(SYSWK1)
```

After you entered the appropriate input command, respond with U to the following message, to proceed with command processing:

```
BG 0000 ICK003D REPLY U TO ALTER VOLUME cuu CONTENTS, ELSE T
```

```
0 U
```

### Additional Messages

If you install on previously used disk devices, the system may issue the following messages:

```
ICK001D CONFIRM PURGING OF UNEXPIRED DATA SETS, REPLY U TO PURGE, ELSE T
```

```
0 U
```

```
ICK019D CONFIRM PURGING OF ALL VSAM FILES, REPLY U TO PURGE, ELSE T
```

```
0 U
```

```
BG 0000 ICK01313I VOLUME CONTAINS nn ALTERNATE TRACKS -- nn AVAILABLE.  
BG 0000 ICK01314I VTOC IS LOCATED AT CCHH=X'nnnn nnnn' AND IS nn TRACKS.  
BG 0000 ICK00001I FUNCTION COMPLETED, HIGHEST CONDITION CODE WAS nn  
ENTER INPUT/COMMAND:
```

To exit ICKDSF command processing and to return to the stand-alone utility selection, enter:

```
0 END
```

Continue with “Step 4 – Restoring the System Library IJSYSRS (Manual/Under VM)” on page 62.

## Initializing Disks (VTOC at End of Volume)

Enter the following to initialize the system volumes. Replace **cuu** with the respective disk address.

### Notes:

1. If the INIT command exceeds 70 characters on your screen, use a dash (–) as the continuation character. The system will then ask you for additional information.
2. Initializing FBA minidisks with the VTOC at the end of the disk pack is the same as initializing dedicated disks with the VTOC at the end of the disk pack.

## Initializing Disks (Manual/Under VM)

For FBA disks (IBM 9336):

```
0 INIT UNIT(cuu) NVFY NOMAP PURGE FBAVTOC(END) VOLID(DOSRES)
0 INIT UNIT(cuu) NVFY NOMAP PURGE FBAVTOC(END) VOLID(SYSWK1)
```

For FBA minidisks or dedicated disks, make sure the number of blocks of the disk is a multiple of the so called actuator file which is 4\*777 in case of a 9336. If the number of blocks is not a multiple, placing the VTOC at the end of the volume may lead to problems because the system cannot read the VTOC.

The DASDFP operand of the IPL SYS command also influences VTOC reading. As shipped, it is set to YES and requires a multiple of 4\*777 in case of FBAVTOC(END). If it is set to NO (DASDFP=NO), FBAVTOC(END) can be used without ensuring a multiple of 4\*777 (at the cost of file protection).

Example:

For a dedicated 9336 Model 10 for example, DSF will put the VTOC at location 920051–920115, where 920115 is not at actuator boundary. It is recommended in this case to put the VTOC at location 919904–919968, where 919968 is 1084 x 777. The corresponding INIT command would be:

```
0 INIT UNIT(cuu) NVFY NOMAP PURGE FBAVTOC(919904, 228, 8192)
VOLID(DOSRES)
0 INIT UNIT(cuu) NVFY NOMAP PURGE FBAVTOC(919904, 228, 8192)
VOLID(SYSWK1)
```

For CKD disks (IBM 3380, except Model A) and ECKD disks (IBM 3390, 9345):

```
0 INIT UNIT(cuu) NVFY NOMAP PURGE DOSVTOC(END) VOLID(DOSRES)
0 INIT UNIT(cuu) NVFY NOMAP PURGE DOSVTOC(END) VOLID(SYSWK1)
```

Respond with U to the following message, to proceed with command processing:

```
BG 0000 ICK003D REPLY U TO ALTER VOLUME cuu CONTENTS, ELSE T
```

```
0 U
```

```
BG 0000 ICK01313I VOLUME CONTAINS nn ALTERNATE TRACKS -- nn AVAILABLE.
BG 0000 ICK01314I VTOC IS LOCATED AT CCHH=X'nnnn nnnn' AND IS nn TRACKS.
BG 0000 ICK00001I FUNCTION COMPLETED, HIGHEST CONDITION CODE WAS nn
ENTER INPUT/COMMAND:
```

To exit ICKDSF command processing and to return to the stand-alone utility selection, enter:

```
0 END
```

Continue with “Step 4 – Restoring the System Library IJSYSRS (Manual/Under VM)” on page 62.

## Initializing IBM Disk Devices as Data DASDs

VSE/ESA allows you to use the following disk devices only as data DASDs, **not** as system devices.

```
IBM 3370-2
IBM 3375
IBM 3380 (Model A)
FBA (generalized)
```

## Initializing Disks (Manual/Under VM)

Note that if you are using an FBA as data device, the details on the previous page about the VTOC location FBAVTOC(END) must be considered (multiple of 4\*777).

To initialize these disk devices, issue the following command and replace **xxxxxx** by a valid **other than** DOSRES and SYSWK1. Replace **cuu** by the respective disk address.

**Note:** If the INIT command exceeds 70 characters on your screen, use a dash (-) as the continuation character. The system will then ask you for additional information.

For IBM 3370 (FBA device):

```
0 INIT UNIT(cuu) NVFY NOMAP PURGE FBAVTOC(END) VOLID(xxxxxx)
```

For IBM 3375 (CKD device):

```
0 INIT UNIT(cuu) NVFY NOMAP PURGE DOSVTOC(END) VOLID(xxxxxx)
```

For IBM 3380 (CKD device):

```
0 INIT UNIT(cuu) NVFY NOMAP PURGE DOSVTOC(END) VOLID(xxxxxx)
```

After entering the appropriate input command, respond with U to the following message, to continue with command processing.

```
BG 0000 ICK003D REPLY U TO ALTER VOLUME cuu CONTENTS, ELSE T
```

```
0 U
```

```
BG 0000 ICK01313I VOLUME CONTAINS nn ALTERNATE TRACKS -- nn AVAILABLE.  
BG 0000 ICK01314I VTOC IS LOCATED AT CCHH=X'nnnn nnnn' AND IS nn TRACKS.
```

```
BG 0000 ICK00001I FUNCTION COMPLETED, HIGHEST CONDITION CODE WAS nn  
ENTER INPUT/COMMAND:
```

To exit ICKDSF command processing and to return to the stand-alone utility selection, enter:

```
0 END
```

### Step 4 – Restoring the System Library IJSYSRS (Manual/Under VM)

This task restores the system library IJSYSRS (IJSYSR1) from cartridge/tape. The following system prompts and messages appear:

```
BG 0000 SA09I  SELECT ONE OF THE FOLLOWING PROGRAMS, OR TYPE END
BG 0000 SA10D  FASTCOPY, RESTORE, ICKDSF, DITTO, REIPL
```

**0 RESTORE**

```
BG 0000 SA11D  SPECIFY ADDRESS OF INPUT DEVICE  CUU
```

**0 cuu** (cuu - tape drive address where VSE/ESA tape is mounted)

```
BG 0000 SA03D  DEVICE TYPE IS xxxxyy. ACCEPT (ENTER) OR SPECIFY ALTERNATE TYPE
```

**0**

You may get the following message:

```
BG 0000 SA13D  TAPE MODE IS XX. ACCEPT (ENTER) OR SPECIFY ALTERNATE MODE YY
```

**0**

Always accept the default when you restore the contents of the SYSRES volume, regardless what type of tape unit you use.

```
BG 0000 SA15D  FOR TAPE LABEL CHECKING SPECIFY // TLBL, ELSE (ENTER)
```

**0**

```
BG 0000 SA16D  SPECIFY ADDRESS OF SYSRES DISK  CUU
```

**0 cuu** (cuu - address of DOSRES)

```
BG 0000 SA03D  DEVICE TYPE IS xxxxyy. SPECIFY ALTERNATE TYPE, OR ACCEPT (ENTER)
```

**0**

```
BG 0000 L302A  ENTER YES TO RESTORE SYSRES FILE IJSYSR1 OR NO TO SKIP
                TO NEXT SYSRES
```

**0 YES**

```
BG 0000 L315I  ORIGINAL FILE ID= VSE.SYSRES.LIBRARY
L316A  ENTER YES TO KEEP OR NO TO RESPECIFY THE SYSRES FILE ID
```

**0 YES**

You **must** answer **NO** to the following prompt:

```
BG 0000 L309I  ORIGINAL ALLOCATION= xxxx  ....
BG 0000 L310A  ENTER YES TO KEEP OR NO TO RESPECIFY THE ALLOCATION
```

**0 NO**

Now use the values in this table to answer to the next system prompt:

Disk Device Type	Allocation Value (xxxxx)
For 3380 (all models)	959
For 3390 (in 3390 mode)	899
For 3390 (in 3380 track compatibility mode)	959
For FBA (all models)	59134
For 9345 (all models)	1064



## Restoring System Library (Manual/Under VM)

```
BG 0000 L312I MINIMUM ALLOCATION= xxx ....
BG 0000 L304I ENTER THE DESIRED ALLOCATION AS NUMBER OF ....
BG 0000 L313A ALLOC=
```

**0 xxxxx**

```
BG 0000 L329A ENTER YES TO RESTORE ALL SUBLIBRARIES OR NO FOR
      SELECTIVE RESTORE
```

**0 YES**

```
BG 0000 L338I SUMMARY OF RESTORE PARAMETERS:
BG 0000 L318I FILE NAME = IJSYSR1
BG 0000 L319I FILE ID = VSE.SYSRES.LIBRARY
BG 0000 L321I ALLOCATION= xxxx ....
BG 0000 L344I START= ..... - END= ....
BG 0000 L327I RESTORE ALL SUBLIBRARIES
BG 0000 L322A ENTER YES IF THE SPECIFICATION IS CORRECT OR NO TO RESPECIFY
```

**0 YES**

### Restarting the Restore

If you restart this step and you get the following message (xxxxxxx is the file name),

```
BG 0000 L324I EQUAL FILE ID IN VTOC xxxxxxxx ...
BG 0000 L319I FILE ID=id
BG 0000 L330A TYPE CANCEL OR DELETE
```

you should enter:

**0 DELETE**

### CKD Device Users

The system displays the following message:

```
BG 0000 L300I FORMATTING OF LIBRARY IJSYSR1 IN PROGRESS
```

```
BG 0000 L306I RESTORE OF LIBRARY IJSYSR1 IN PROGRESS
BG 0000 L325I RESTORE OF SUBLIBRARY IJSYSR1.SYSLIB IN PROGRESS
BG 0000 L326I RESTORE COMPLETE FOR LIBRARY IJSYSR1
BG 0000 SA09I SELECT ONE OF THE FOLLOWING PROGRAMS, OR TYPE END
BG 0000 SA10D FASTCOPY, RESTORE, ICKDSF, DITTO, REIPL
```

**0 END**

```
BG 0000 SA17W ***** END OF STAND ALONE PROCESSING *****
```

You must enter **0**. The system displays the message:

```
CP ENTERED; DISABLED WAIT PSW'000E...'
```

System Library IJSYSRS is now restored.

### Step 5 – Performing an IPL from DOSRES (Manual/Under VM)

This step uses a VSE/ESA-supplied IPL procedure. The correct IPL procedure is automatically chosen, based on the disk type and CPU mode. VSE/ESA selects the appropriate options for your system.

Usually, you do not have to add devices during this task. The IPL program for VSE/ESA uses device sensing to automatically define the devices on the system. Please be aware that for initial installation, only up to **254** devices are allowed. If your environment includes more than 254 devices, you have to identify the devices that you do **not** need for installing the system and **exclude** them from the installation process.

There are several alternatives for excluding the devices:

1. You may power off any devices which you do not want to be sensed.
2. If you decide not to power off the devices, the system senses all operational devices. It then displays the number of devices sensed and asks you to use the **IPL DEL** command to delete the additional devices.

This only works for up to 1024 devices, which is the maximum number of devices that VSE/ESA supports. Any devices above the number of 1024 have to be powered off in any case (page 13 has more information).

3. You can use an IOCDS that contains 254 (or 1024) devices.

If not all necessary information can be sensed, you will be asked to define these devices when you complete the initial installation ( Chapter 8, "Installation Part 3 - Native and VM," on page 95).

If a device is needed for the minimum configuration and it cannot be sensed, you are asked to enter command IPL ADD for that device.

#### Perform an IPL from the address of DOSRES.

Enter in CP mode:

```
IPL cuu                (cuu - address of DOSRES)
```

After having performed an IPL, the system waits for an interrupt from the console.

Press **ENTER** to continue.

```
BG 0000 0I04I IPLDEV=X'cuu',VOLSER=DOSRES,CPUID=xxxxxxxxxxxx
BG 0000 0J01I IPL=$IPLExx ,JCL=$JCL7xx
BG 0000 $$A$SUPX,VSIZE=nnM,VPOOL=nnnK,VIO=nnnK
BG 0000 0I30I DATE=xx/xx/xxxx,CLOCK=yy/yy/yy,ZONE=nnnn/00/00
BG 0000      THE DATE VALUE FORMAT IS MM/DD/YYYY
BG 0000 0J47I CHANNEL SUBSYSTEM:  nnnn DEVICE(S) FOUND OPERATIONAL.
BG 0000      ...
BG 0000      ...
BG 0000 ADD FDF,FBAV
BG 0000 ADD FEC,3505
BG 0000 ADD FFC,3505 ICCF DUMMY DEVICE DON'T DELETE
BG 0000      ...
BG 0000      ... (additional devices added)
BG 0000      ...
BG 0000 ADD FFF,CONS      DUMMY CONSOLE DON'T DELETE
BG 0000 DEF SYSCAT=DOSRES,SYSREC=SYSWK1
```

### More I/O Devices than Supported

Should you receive the message:

```
BG 0000 0J74D SUPERVISOR GENERATED FOR 254 DEVICES - nnnn DEVICES PRESENT  
ENTER DEL COMMAND FOR UNNEEDED DEVICES
```

then you may have more than 254 I/O devices turned on. In this case you must delete the additional devices, since VSE/ESA only accepts up to 254 I/O devices during initial installation. Please identify devices which you do not need for your installation process, and use the DEL command to delete the devices. **Make sure that you do not delete essential hardware devices, such as the disk volume SYSWK1.**

```
0 DEL cuu1:cuu2
```

Refer to the IBM manual *VSE/ESA System Control Statements* for more information on the IPL DEL command.

Pages 66 through 68 show messages that appear on the system console. Information enclosed in boxes describes exceptions to the normal installation process.

The installation for VSE/ESA under VM continues in “Installation Part 2 – Detailed Description” on page 71.

## Performing an IPL from DOSRES (Manual/Under VM)

### Insufficient System Configuration

If you get the following messages, follow these instructions.

```
BG 0000 IESI0101I INSUFFICIENT SYSTEM CONFIGURATION FOR
          INITIAL INSTALLATION
BG 0000 IESI0102A SPECIFY IPL ADD COMMAND FOR xxxxxxxxxx
```

The system checks whether the minimum hardware configuration for initial installation is available. If some devices are not sensed, the system displays the above messages.

The second message (IESI0102A) is displayed for each required device that was not sensed. xxxxxxxxx is the specific device type. It can be:

```
TAPE DEVICE
CICS TERMINAL/LOCAL SNA CONTROL UNIT
01 DASD DEVICE - TYPE AS SYSRES
```

Remember that you only need two disk volumes (DOSRES and SYSWK1) for the minimum configuration. The disk type of the unidentified but required disk must be of the same type as DOSRES.

Enter one IPL ADD command for **each** required device type that was not sensed (tape, terminal/control unit, disk).

**0 ADD cuu,device-type** (cuu - device address)

As an example, suppose the system displays the following messages:

```
BG 0000 IESI0102A SPECIFY IPL ADD COMMAND FOR CICS
BG 0000          TERMINAL/LOCAL SNA CONTROL UNIT
```

You would add the address of at least one terminal/local SNA control unit. For instance, you might enter:

**0 ADD 380,3277**

```
BG 0000 0J10I IPL RESTART POINT BYPASSED
```

### Duplicate Volume Identifiers Found

If you get the following message, follow these instructions.

```
BG 0000 IESI0120I VOLID xxxxxx FOUND ON FOLLOWING ADDRESSES (CUU):
BG 0000          cuu1 cuu2 ...
```

The system checks the volume identifiers (VOLIDs) of all disks. This is to ensure that the VOLIDs for VSE/ESA (DOSRES, SYSWK1) are unique. If two disks have the same VOLID, the system displays the above message, where xxxxxx is the VOLID that is duplicated. Following the message is a list of the disk addresses with the same VOLID (cuu1, cuu2 ...).

For DOSRES, VSE/ESA automatically uses the address of the disk that was IPLed as DOSRES. The system displays the following message:

```
BG 0000 IESI0123I DASD WITH ADDRESS xxx WILL BE USED AS DOSRES
```

For VOLID SYSWK1, the system displays the following message:

```
BG 0000 IESI0121D ENTER ADDRESS OF DASD TO BE USED AS SYSWK1: CUU
```

Enter the address (cuu) of the disk device that you are using for VSE/ESA installation.

**0 cuu** (cuu - disk address of SYSWK1)

All other disk devices with the same VOLID are set in *device down* status. The system displays the following message:

```
BG 0000 IESI0124I FOLLOWING DEVICE(S) WILL BE SET IN DEVICE DOWN STATUS:
BG 0000          cuu1 cuu2...
```

The message is followed by a list of the disk addresses that are set in *device down* status (cuu1, cuu2...).

```
BG 0000 SYS JA=YES
BG 0000 DLA VOLID=DOSRES,YYY=xxx,NYYY=x,DSF=N,NAME=AREA1
BG 00000I52I LABEL AREA ON  cuu:      LOW      HIGH
                .....   xxx x    xxx  xx

BG 0000 SVA PSIZE=nnnK,SDL=nnn,GETVIS=nnK
BG 0000 0J24I DASD SHARING SUPPORT RESET
BG 0000 0J62I ACTUAL CHANQ IS nnn
BG 0000 0J69I ACTUAL SIZE OF PRIVATE AREA IS xxxxxx
BG 0000 0I20I IPL COMPLETE FOR system identification
BG 0000      SUPVR USERID IS: ...

BG 0000 VMCF10I VM/VSE INTERFACE INITIALIZED
BG 0000 0J39I ACTUAL BUFSIZE IS nnnn
BG 0000 0J76I software/hardware COMPRESSION INITIALIZED
BG 0000 PRTY BG,FA,F9,F8,F6,F5,F4,F2,F7,F3,FB,F1
BG 0000 // JOB BGINIT
        DATE xx/xx/xxxx,CLOCK yy/yy/yy
BG 0000 1I93I RECORDER FILE IS  n% FULL
```

## Performing an IPL from DOSRES (Manual/Under VM)

### Additional Messages

Some systems also may display the following messages:

```
BG 0000 4301I NO FORMAT 1 LABEL FOUND IJSYSCN SYSREC=xxx SYSWK1
BG 0000 1194I HARD COPY OPEN FAILED, HC=CREATE FORCED
```

```
BG 0000 ALLOC BG=xxxxK
      SIZE BG=xxxxK
      :
      :
      (additional ALLOC and SIZE statements)
      :
      :
```

Because the VSE.CONTROL.FILE does not exist yet, you will get the following message:

```
FB 0011 // JOB SECSERV
      DATE xx/xx/xxxx, CLOCK yy/yy/yy
FB 0058 4228I FILE IJSYSCT OPEN ERROR X'B4'(180) CAT=..N/A..
      (OPNCT-20) VOLUME 'DOSRES' NOT OWNED BY VSAM
FB 0058 4228I FILE IESCNL OPEN ERROR X'B4'(180) CAT=VSESPUC ( 4,AD, 2)
      (OPNHC-10) RC X'00000004' FROM CATLG
FB 0058 BST300E THE II CONTROL FILE COULD NOT BE OPENED.
```

This error message is only informational and processing continues.

```
BG 0000 STOP
F1 0001 // JOB POWSTART
```

### If Second or Additional IPL from Disk

If you restart this step, you may get messages concerning the VSE/POWER QUEUE.FILE, DATA.FILE, or ACCOUNT.FILE, such as:

```
F1 0001 4733D EQUAL FILE ID IN VTOC .....
```

Enter

**1 DELETE**

```
      :
      :
      :
DATE xx/xx/xxxx,CLOCK yy/yy/yy
F1 0001 1Q20I AUTOSTART IN PROGRESS
F1 0001 1R75I BG AUTOSTARTED
F1 0001 1R75I F2 AUTOSTARTED
F1 0001 1R75I F3 AUTOSTARTED
F1 0001 1R75I F4 AUTOSTARTED
F1 0001 1R75I F5 AUTOSTARTED
F1 0001 1R88I OK
F1 0001 1Q12I VSE/POWER 6.7.0 INITIATION COMPLETED
F1 0001 1Q34I F3 WAITING FOR WORK
F1 0001 1Q34I F2 WAITING FOR WORK
F1 0001 1Q34I F4 WAITING FOR WORK
F1 0001 1Q34I F5 WAITING FOR WORK
BG 0000 * *****
BG 0000 *
BG 0000 *          INSTALLATION OF
BG 0000 * *****
BG 0000 *          *
```

## Performing an IPL from DOSRES (Manual/Under VM)

```
BG 0000 * VSE/ESA 2.7.0          xx/xx/xxxx *
BG 0000 *
BG 0000 * *****
BG 0000 * LICENSED MATERIALS - PROPERTY OF IBM *
BG 0000 * 5686-066 AND OTHER MATERIALS (C) COPYRIGHT*
BG 0000 * IBM CORP. 2002 AND OTHER DATES *
BG 0000 * ALL RIGHTS RESERVED. *
BG 0000 * US GOVERNMENT USERS RESTRICTED RIGHTS - *
BG 0000 * USE, DUPLICATION OR DISCLOSURE *
BG 0000 * RESTRICTED BY *
BG 0000 * GSA ADP SCHEDULE CONTRACT WITH IBM CORP. *
BG 0000 * *****
BG 0000 *
BG 0000 * *****
F3 0003 // JOB STARTF3
        DATE xx/xx/xxxx, CLOCK yy/yy/yy
F2 0002 // JOB STARTF2
        DATE xx/xx/xxxx, CLOCK yy/yy/yy
F4 0004 // JOB STARTF4
        DATE xx/xx/xxxx, CLOCK yy/yy/yy
F5 0005 // JOB STARTF5
        DATE xx/xx/xxxx, CLOCK yy/yy/yy
F3 0003 1N90I EOP WAS FORCED BY EOJ
F3 0003 EOJ STARTF3
        DATE xx/xx/xxxx, CLOCK yy/yy/yy, DURATION zz/zz/zz
F3 0001 1Q34I F3 WAITING FOR WORK
F2 0002 1N90I EOP WAS FORCED BY EOJ
F2 0002 EOJ STARTF2
        DATE xx/xx/xxxx, CLOCK yy/yy/yy, DURATION zz/zz/zz
F2 0001 1Q34I F2 WAITING FOR WORK
F4 0004 1N90I EOP WAS FORCED BY EOJ
F4 0004 EOJ STARTF4
        DATE xx/xx/xxxx, CLOCK yy/yy/yy, DURATION zz/zz/zz
F4 0001 1Q34I F4 WAITING FOR WORK
F5 0005 1N90I EOP WAS FORCED BY EOJ
F5 0005 EOJ STARTF5
        DATE xx/xx/xxxx, CLOCK yy/yy/yy, DURATION zz/zz/zz
F5 0001 1Q34I F5 WAITING FOR WORK
BG 0000 1S47I PRELEASE RDR INSTALL
BG 0000 1N90I EOP WAS FORCED BY EOJ
BG 0000 EOJ BGINIT MAX.RETURN CODE=xxxx
        DATE xx/xx/xxxx,CLOCK yy/yy/yy,DURATION zz/zz/zz
```

### Continuing Installation

To continue installation of VSE/ESA, refer to "Installation Part 2 – Detailed Description" on page 71. Part 2 of initial installation is the same for all users.

## Performing an IPL from DOSRES (Manual/Under VM)



---

## Installation Part 2 – Detailed Description

Installation part 2 consists of a number of steps that require your interaction. These are marked with an asterisk (\*). All the other steps run automatically. You do not have to enter any responses.

Here are the main steps of installation part 2:

- Deciding on migration (\*)
- Selecting a system environment (\*)
- Selecting security (\*)
- Choosing a telecommunication access method (\*)
- Creating print buffer (\*)
- Starting up a printer (\*)
- Restoring the system history file
- Defining VSE/VSAM catalogs, space, and clusters
- Defining VSE/VSAM libraries and sublibraries
- Restoring the VSE/ICCF DTSFILE
- Installing VSE/ESA base programs
- Starting VTAM and CICS

If you are an experienced VSE/ESA user, you may turn to “Installation Part 2” on page 22 and install VSE/ESA as described there.



---

## Chapter 7. Installation Part 2 - Native and VM

Installation part 2 describes how to continue with the VSE/ESA initial installation. It is the same for users installing VSE/ESA native or under VM.

---

### Job Stream Processing

One of the first installation jobs gathers information about your hardware and software configuration. You are asked to enter information about your system.

Periodically, you are asked if you want to continue. Enter YES to continue. If you enter NO, you will return to the point where you last answered YES. If you enter NO the first time the question is asked, you will return to the beginning of the installation job stream.

The installation job stream initializes the Job Manager and starts the controlled Job Manager sequence. If you have problems when the Job Manager has control, refer to Appendix A, "Overview of the Job Manager," on page 129.

If the installation job stream (INSTALL) itself cancels, you can run it again. Enter the following:

```
R RDR,INSTALL
```

You may want to refer to the IBM manual *VSE/ESA Messages and Codes, Volume 1* for an explanation of the messages that are displayed when the jobs run.

---

### Running the Install Program for VSE/ESA

```
BG 0001 1Q47I  BG INSTALL xxxxx FROM (SYSA), TIME=yy:yy:yy
BG 0000      // JOB INSTALL VSE/ESA INSTALL PROGRAM
              DATE xx/xx/xxxx,CLOCK yy/yy/yy

BG-0000 IESI0077D DO YOU WANT TO MIGRATE YOUR CONFIGURATION DATA FROM
BG=0000      A PREVIOUS VSE VERSION (VTAM ONLY)? YES/NO

0 xxx  (xxx - yes or no)
```

Please be aware that the MIGRAT job supports migration of up to **199 VSE/ICCF users or 199 VSE/ICCF libraries**. If you want to migrate **more** VSE/ICCF users or more VSE/ICCF libraries, refer to page 133.

For migrating your system, ensure that the hardware table configuration contains the complete and correct hardware specifications.

Answer **YES** if you want to migrate during installation. The migration job will run later in the installation process and ask you to mount the backup tapes. Make sure that the necessary information is stored on tapes that are of the same type as the VSE/ESA tape volumes.

If you do not want to migrate during installation, enter **NO**.

You are now asked if you want to install DB2. If you answer **YES** to this prompt, job DB2REST will run later in the installation process and ask you to mount the

## Installation Part 2 – Native and VM

extended base tape. If you do not want to install DB2 at this stage, you may do so later on. In this case, answer **NO** to the following prompt.

```
BG 0000 IESI0063D DB2 IS REQUIRED FOR THE DB2-BASED CONNECTORS. DO YOU WANT TO
INSTALL DB2 NOW? YES/NO
BG-0000
```

**0 xxx** (xxx - yes or no)

You can now configure TCP/IP. Note that you must also define VTAM terminals for initial startup of CICS.

```
BG 0000 IESI0051D DO YOU WANT TO CONFIGURE TCP/IP FOR INITIAL STARTUP? YES/NO
```

**0 xxx**

You are now asked to select one of the predefined environments that are shipped with VSE/ESA (refer to “Predefined Environments Shipped with VSE/ESA” on page 11 for more information).

```
BG-0000 IESI0078D SELECT AN ENVIRONMENT OUT OF A OR B
```

**0 x** (x is A or B)

The following system prompt appears:

```
BG-0000 IESI0079D DO YOU WANT TO RUN YOUR SYSTEM WITH SECURITY ON? YES/NO
```

**0 xxx** (xxx - yes or no)

YES results in the IPL command `SYS SEC=(YES,NOTAPE)`. This allows to restrict security checking to DASD files and libraries. Security will be active with the IPL that you perform **after** you have completed initial installation. Refer to chapter “Protecting Resources” in the IBM manual *VSE/ESA Administration* for details on security.

You now have the opportunity to check your answers:

```
BG-0000 IESI0062D CHECK YOUR ANSWERS. DO YOU WANT TO CONTINUE? YES/NO
```

**0 xxx** (xxx - yes or no)

## Defining User Terminals

If you have a System Network Architecture (SNA) control unit installed, you should answer **YES** to the next message.

### Users Installing under VM

If you install VSE/ESA under VM and access the system via the CP DIAL command, you must answer **NO** to the next message, because a DIALED terminal appears to VSE as a local non-SNA device.

```
BG-0000 IESI0065D IS THE LOCAL CONTROL UNIT AN SNA CU ? YES/NO
```

**0 xxx** (xxx - yes or no)

Table 7 gives you an overview of SNA and Non-SNA control units.

Table 7. List of Local SNA and Non-SNA Control Units

Local Non-SNA Control Units	Local SNA Control Units
Channel-attached non-SNA control unit (IBM 3174-S1L, 3174-T1L, 3174-01L )	Channel-attached SNA control unit (IBM 3174-S1L, 3174-T1L, 3174-01L)

Table 7. List of Local SNA and Non-SNA Control Units (continued)

Local Non-SNA Control Units	Local SNA Control Units
Channel-attached non-SNA control unit (IBM 3274-x1B, 3274-x1D)	Channel-attached SNA control unit (IBM 3274-x1A)

If you enter **YES**, continue with “Defining Local SNA VTAM Display Terminals.”

If you enter **NO**, continue with “Defining Local Non-SNA VTAM Display Terminals.”

### Defining Local Non-SNA VTAM Display Terminals

Local non-SNA VTAM users must define at least one, but not more than three, local VTAM display terminals.

You must specify the terminal addresses in **ascending** order. If you do not enter the terminal addresses in the correct order, the system will generate the startup books for VTAM incorrectly.

```
BG 0000 IESI0064I DEFINE UP TO 3 LOCAL VTAM TERMINALS
BG-0000 IESI0059D ENTER A 3270 ADDRESS (CUU) OR "END"
```

**0 cuu** (where cuu is a 3270 terminal address)

```
BG-0000 IESI0059D ENTER A 3270 ADDRESS (CUU) OR "END"
```

**0 cuu** (where cuu is a 3270 terminal address. If you want to define only one terminal, enter **0 END**.)

```
BG-0000 IESI0059D ENTER A 3270 ADDRESS (CUU) OR "END"
```

**0 cuu** (where cuu is a 3270 terminal address. If you want to define only two terminals, enter **0 END**.)

If you enter a third 3270 address, the terminal definition session ends.

```
BG-0000 IESI0062D CHECK YOUR ANSWERS. DO YOU WANT TO CONTINUE ? YES/NO
```

**0 xxx** (xxx - yes or no)

```
BG 0000 EOJ INSTALL MAX.RETURN CODE=xxxx
DATE xx/xx/xxxx,CLOCK yy/yy/yy,DURATION zz/zz/zz
```

Continue with “Cataloging Hardware Information” on page 76.

### Defining Local SNA VTAM Display Terminals

You have selected VTAM with a local SNA control unit. You will define your control unit and at least one, but not more than three, local 3270 display terminals.

```
BG-0000 IESI0071D ENTER ADDRESS OF 3270 CONTROL UNIT: CUU
```

**0 cuu** (where cuu is your control unit address)

```
BG 0000 IESI0066I DEFINE TERMINAL TYPE ATTACHED TO THIS CONTROL UNIT
BG 0000 IESI0067D ENTER 24x80, 32x80, 43x80
```

**0 nnnnn**

(where nnnnn is the size of your display terminal type, for example, 24x80)

For the following messages, you must specify the terminal addresses in **ascending order**. If you do not enter the terminal addresses in the correct order, you get the error message IESI0076A.

```
BG 0000 IESI0064I DEFINE UP TO 3 LOCAL VTAM TERMINALS
BG-0000 IESI0073D ENTER ADDRESS OF A 3270 TERMINAL
(2 TO 33) OR "END"
```

## Installation Part 2 – Native and VM

0 xx (where xx is an address 2 to 33 of a 3270 terminal)  
BG-0000 IESI0073D ENTER ADDRESS OF A 3270 TERMINAL  
(2 TO 33) OR "END"

0 xx (where xx is an address of 2 to 33 of a 3270 terminal) If you want to define only one terminal, enter 0 END  
BG-0000 IESI0073D ENTER address OF A 3270 TERMINAL  
(2 TO 33) OR "END"

0 xx (where xx is an address of 2 to 33 of a 3270 terminal. If you want to define only two terminals, enter 0 END

After the third address is entered, the terminal definition session ends.

BG-0000 IESI0062D CHECK YOUR ANSWERS. DO YOU WANT TO CONTINUE ? YES/NO

0 xxx (xxx - yes or no)  
BG 0000 EOJ INSTALL MAX.RETURN CODE=xxxx  
DATE xx/xx/xxxx,CLOCK yy/yy/yy,DURATION zz/zz/zz

## Cataloging Hardware Information

The job **DTRIHARD** catalogs hardware information from the IPL procedure.

BG 0001 1Q47I BG DTRIHARD nnnnn FROM LOCAL , TIME=yy:yy:yy  
BG 0000 // JOB DTRIHARD CATALOG HARDWARE RELATED INFORMATION  
DATE xx/xx/xxxx,CLOCK yy/yy/yy  
BG 0000 EOJ DTRIHARD MAX.RETURN CODE=xxxx  
DATE xx/xx/xxxx,CLOCK yy/yy/yy,DURATION zz/zz/zz

## Cataloging ASI IPL Procedure

The job **DTRIASI** catalogs the ASI IPL procedure.

BG 0001 1Q47I BG DTRIASI nnnnn FROM LOCAL , TIME=yy:yy:yy  
BG 0000 // JOB DTRIASI CATALOG ASI IPL PROCEDURE  
DATE xx/xx/xxxx,CLOCK yy/yy/yy  
BG 0000 EOJ DTRIASI MAX.RETURN CODE=xxxx  
DATE xx/xx/xxxx,CLOCK yy/yy/yy,DURATION zz/zz/zz

### If Second or Additional IPL from Disk

Please **ignore** the following messages if you get them:

```
F1 0001 1R72I PSTART VIRTUAL STORAGE FOR Fn SMALLER THAN 128K
:
F1 0001 1R65I PLOAD DYNAMIC PARTITION SCHEDULING NOT SUPPORTED
```

## Cataloging VTAM Startup Information

The job **DTRIVTAM** runs for **VTAM users** only. It catalogs VTAM startup information.

BG 0001 1Q47I BG DTRIVTAM nnnnn FROM LOCAL , TIME=yy:yy:yy  
BG 0000 // JOB DTRIVTAM CREATE VTAM STARTUP BOOK ...  
DATE xx/xx/xxxx,CLOCK yy/yy/yy  
BG 0000 EOJ DTRIVTAM MAX.RETURN CODE=xxxx  
DATE xx/xx/xxxx,CLOCK yy/yy/yy,DURATION zz/zz/zz

## Building the List of Jobs

The job **DTRIJB LD** builds the list of jobs that will run.

```

BG 0001 1Q47I  BG DTRIJB LD nnnnn FROM LOCAL , TIME=yy:yy:yy
BG 0000 // JOB DTRIJB LD BUILD ORDERED JOB LIST
          DATE xx/xx/xxxx,CLOCK yy/yy/yy
BG 0000 EOJ DTRIJB LD MAX.RETURN CODE=xxxx
          DATE xx/xx/xxxx,CLOCK yy/yy/yy,DURATION zz/zz/zz

```

## Running Job Manager Controlled Jobs

A number of jobs now run. The Job Manager automatically releases the jobs. Most jobs do not require any user responses.

Do **not** cancel any of the jobs that are running. If you do, Job Manager processing is interrupted. Refer to “Job Manager Commands” on page 129 for information about recovering.

## Creating Print Buffers for a System Printer

You should only read this section if you have a system printer controlled by VSE/POWER attached to your system.

The job **LFCBLINK** helps create a forms control buffer (FCB) and universal character set buffer (UCB) for your printer. An FCB controls the vertical format of the printed output page. This is important if you have to create special forms, for example.

A UCB controls the use of character sets. A variety of character arrays is offered. They contain, for example, language-dependent information.

You also have the option not to create an FCB or a UCB. In this case you enter:

**0**

when prompted for creating an FCB or a UCB. You then use the **default** settings.

### Users Installing under VM

If you have a dedicated real printer, you **must** create a UCB, except for IBM 4245, 4248, 1403 and 6262 printers.

If your physical print device is **not** dedicated, you can create an FCB, but you **cannot** create a UCB since the printer is not under the control of VSE/ESA. For more information, refer to the IBM manual *VSE/ESA System Control Statements* under “System Buffer Load (SYSBUFLD)”.

If you have one of the printer train/belt combinations shown in Table 8 on page 78, the default UCB supplied with VSE/ESA matches the train/belt.

## Installation Part 2 – Native and VM

Table 8. Default Printer Train/Belt Combinations

IBM Printer	Train/Belt
3211	A11 train
3203-5	AN or HN train
3262	64 character belt
3289-4	64 character belt
4245	Not applicable
1403U <sup>1</sup>	AN or HN train
4248	Not applicable
6262-014	Not applicable

The VSE/ESA standard FCB is generated with the following parameters:

- **6 lines per inch or 12 inch page.**

If you have different requirements, or if you do not have any of the defaults shown, refer to Table 9 or Table 10 on page 79.

```

BG 0001 1Q47I  BG LFCBLINK nnnnn FROM (SYSA) , TIME=yy:yy:yy
BG 0000 // JOB LFCBLINK
          DATE xx/xx/xxxx,CLOCK yy/yy/yy
BG 0000 * EXECUTE THE PROCEDURE FOR THE FORMS CONTROL BUFFER THAT YOU
BG 0000 * WANT LOADED INTO YOUR PRINTER OR IF NOT REQUIRED EXECUTE THE
BG 0000 * PROCEDURE FOR THE CHARACTER SET BUFFER YOU WANT LOADED INTO
BG 0000 * YOUR PRINTER. IF NEITHER IS REQUIRED REPLY "0 (END/ENTER)".
BG 0000 // PAUSE
BG 0000
  
```

If you accept the default FCB and UCB, reply

0

and proceed to “Starting a Printer Controlled by VSE/POWER” on page 81. The following two figures list the procedure names for the FCBs and UCBs.

Table 9. Procedure Names for FCBs

IBM Printer	6 LPI 11 inch page	6 LPI 12 inch page	8 LPI 8.5 inch page
3211	LFCB611A	LFCB612A	LFCB885A
3203-5	LFCB611C	LFCB612C	LFCB885C
3262	LFCB611E	LFCB612E	LFCB885E
3289-4	LFCB611F	LFCB612F	LFCB885F
4245	LFCB611G	LFCB612G	LFCB885G
4248	LFCB611H	LFCB612H	LFCB885H
6262-014	LFCB611H	LFCB612H	LFCB885H
1403U	Not Applicable	Not Applicable	Not Applicable

1. This printer requires a dual-feature so that the default UCB matches the HN train.



Table 10. Procedure Names for UCBs

IBM Printer	Train/Belt	UCB Procedure Name
3211	(P11 TRAIN)	LUCBP11A
3203-5	(PN TRAIN)	LUCBPNC
3262	(48 CHARACTER BELT)	LUCB48E
3262	(63 CHARACTER BELT)	LUCB63P
3262	(96 CHARACTER BELT)	LUCB96E
3289-4	(48 CHARACTER BELT)	LUCB48F
1403U	(PN Train)	LUCBPNG
4245	No Entry Required	No Entry Required
4248	No Entry Required	No Entry Required
6262-014	No Entry Required	No Entry Required

You can enter an FCB or UCB procedure name. The names are shown in Table 9 on page 78 and Table 10. You have two choices:

1. If you want to create an **FCB**, enter the FCB procedure name.
2. If you do not want an FCB, but you want to create a UCB, enter the UCB procedure name.

#### FCB Procedure

**0 EXEC PROC=LFCBxxxx** (xxxx - procedure name suffix)

Refer to Table 9 on page 78.

If you enter an FCB procedure name, the system displays:

```

BG 0000 * THIS PROC WILL CATALOG $$BFCBxx FCB PHASE FOR
BG 0000 * xx INCH LONG PAPER WITH A LINE DENSITY OF x LINES PER INCH
BG 0000 * FOR THE PRINTER TYPE : xxxx
BG 0000 *
BG 0000 * EXECUTE THE PROCEDURE FOR THE CHARACTER SET BUFFER YOU WANT
BG 0000 * LOADED INTO YOUR PRINTER OR REPLY
          "0 (END/ENTER)" IF NONE
BG 0000 * IS REQUIRED.
BG-0000 EOP LFCBxxxx
    
```

Enter the LFCB attention command for your printer type. Replace **cuu** with the address of your real printer.

**LFCB cuu,\$\$BFCBxx**

Now check the output of your printer. If the page format does not conform with the paper size, you probably have chosen a wrong FCB procedure. Select the correct FCB procedure and then repeat the steps described above.

If you **do not** want a UCB, enter:

**0**

**UCB Procedure**

0 exec proc=LUCBxxxx (xxxx - procedure name suffix)

Refer to Table 10 on page 79.

If you enter a UCB procedure name, the system displays:

```
BG 0000 * THIS PROC WILL LINK, AND CATALOG THE UCB PHASE: $$BUCBxx
BG 0000 * FOR A PRINTER TYPE : xxxx WITH A xx-YYYYYYY YYYYY
BG 0000 *
BG 0000 * ENTER THE LUCB ATTENTION COMMAND TO LOAD YOUR CHARACTER SET
BG 0000 * BUFFER INTO THE PRINTER. ONCE THAT IS COMPLETED REPLY
BG 0000 * "0 (END/ENTER)" TO CONTINUE.
BG-0000 EOP LUCBxxxx
```

Enter the LUCB attention command for your printer type. The commands are shown in Table 11. Replace **cuu** with the address of your real printer.

**LUCB cuu,\$\$BUCBxx,NOCHK[,FOLD]**

After entering the command, you may now check the output of your printer for readability. If you cannot read it, you probably have chosen a wrong UCB procedure. Select the correct UCB procedure and then repeat the steps described above.

```
AR 0015 1140I READY
BG-0000
```

Enter:

0

Table 11. LUCB Attention Commands

IBM Printer	LUCB Attention Command
3211	LUCB cuu,\$\$BUCB,NOCHK,FOLD
3203-5	LUCB cuu,\$\$BUCB00,NOCHK,FOLD
3262 (48 CHARACTER)	LUCB cuu,\$\$BUCB22,NOCHK,FOLD
3262 (63 CHARACTER)	LUCB cuu,\$\$BUCB22,NOCHK
3262 (96 CHARACTER)	LUCB cuu,\$\$BUCB22,NOCHK
3289-4	LUCB cuu,\$\$BUCB10,NOCHK,FOLD
1403U	LUCB cuu,\$\$BUCB4,NOCHK,FOLD
4245	Not Applicable
4248	Not Applicable
6262-014	Not Applicable

```
BG 0000 EOJ LFCBLINK MAX.RETURN CODE=xxxx
DATE xx/xx/xxxx,CLOCK yy/yy/yy,DURATION zz/zz/zz
```

## Starting a Printer Controlled by VSE/POWER

### Users Using Terminal Printers

If you have a terminal printer attached to your system instead of a printer controlled by VSE/POWER, you are **not** asked to start that printer at this time. Wait until CICS is started and then activate your terminal printer. “Telecommunications Access Method and CICS/ICCF Startup” on page 89 has more information available.

The address (cuu) you use to start a VSE/POWER printer must either be a real physical device address or, for VM users, a virtual device.

If there is no correct FCB and/or UCB for the printer (cuu) available, then you **should not** start the printer at this time.

Start your printer by entering:

```
S LST,cuu,class          (cuu - device address) (class - printer class)
F1 0001 1Q34I  LST WAITING FOR WORK ON cuu
```

### Users Installing Under VM

You can use the following command to start the printer:

```
S LST,cuu,class,D,VM      (cuu - device address)(class - printer class)
```

This starts a list-writer task to print spooled list output to the virtual printer with address cuu.

With the operand *D* you specify two input buffers and two output buffers, which will increase the performance. You can also enter 2 for two output buffers or two commas (,,) for one output buffer. The *VM* operand tells VSE/POWER that the device is a virtual device owned by VM. If you do not specify *VM*, output is not available to VM until the VSE operator issues a *CP CLOSE* for the device.

The operands in the *S LST* command are positional. You **must** insert the two commas (,,) between *class* and *VM* if you do not specify an operand for the input or output buffer.

The IBM manual *VSE/POWER Administration and Operation* describes the *PSTART* command in detail.

Review the following information about the printer:

1. If the printer has an FCB, the system displays the following message:  
F1 0016 1B19I X'cuu' LFCB WITH PHASE nnnnn EXECUTED
2. If you do not start the printer as a VM writer task, the system displays the following message when the first job with printer output ends:  
F1 0001 1Q40A ON cuu FORMS xxxx NEEDED FOR nnnnnnnn nnnnn

## Installation Part 2 – Native and VM

When this message is displayed, enter the PGO command:

**G cuu** (cuu - real VSE/POWER printer address)

3. If your real printer address is a different device type than PRT1, the system displays the following message whenever a print job is sent to the printer:  
1Q41I WRONG PRINTER/PUNCH FOR XXX YYY, cuu

You can avoid this message by ensuring that the dummy VSE/POWER printer device FEE has the same device type as your:

- Real printer. (You run without VM or dedicate a printer to the VSE/ESA guest system).
- VM virtual printer. (You run under VM without a printer dedicated to the VSE/ESA guest system).

### Restoring System History File

The job **HISTREST** restores the system history file.

```
BG 0001 1Q47I  BG HISTREST nnnnn FROM (SYSA) , TIME=yy:yy:yy
BG 0000 // JOB HISTREST RESTORE SYSTEM HISTORY FILE
          DATE xx/xx/xxxx,CLOCK yy/yy/yy
BG 0000 EOJ HISTREST  MAX.RETURN CODE=xxxx
          DATE xx/xx/xxxx,CLOCK yy/yy/yy,DURATION zz/zz/zz
```

### Defining VSAM Catalogs, Space, and Clusters

The job **VSAMDEFS** defines the VSAM master catalog, a VSAM user catalog, VSAM space, and clusters. The error message 4228I is expected and can be ignored.

```
BG 0001 1Q47I  BG VSAMDEFS nnnnn FROM (SYSA) , TIME=yy:yy:yy
BG 0000 // JOB VSAMDEFS - DEFINE VSAM MCAT, UCAT SPACE AND CLUSTERS
          DATE xx/xx/xxxx,CLOCK yy/yy/yy
BG 0000 * THIS JOB WILL DEFINE THE VSAM MASTER CATALOG, A USER CATALOG,
BG 0000 * VSAM DATA SPACE, AND VSAM CLUSTERS. FIRST TIME EXECUTION
BG 0000 * WILL RESULT IN A VSAM OPEN ERROR X'B4' (180) ON FILE IJSYSCT.
BG 0000 4228I FILE IJSYSCT  OPEN  ERROR X'B4'(180) CAT=..N/A..
          (IKQOPNCT) VOLUME 'DOSRES' NOT OWNED BY VSAM
BG 0000 EOJ VSAMDEFS  MAX.RETURN CODE=0000
          DATE xx/xx/xxxx,CLOCK yy/yy/yy,DURATION zz/zz/zz
```

**Note:** This job will define the control file. However, it is not yet initialized. In case you encounter problems later on, and you have a need to re-IPL the system, subsequent job **VSAMINIT** may fail unless you manually close the control file issuing the command **MSG FB,DATA='CLOSECNTL'**.

### Defining Libraries and Sublibraries

The job **LIBRDEFS** defines the necessary libraries and sublibraries for VSE/ESA.

```
BG 0001 1Q47I  BG LIBRDEFS nnnnn FROM (SYSA) , TIME=yy:yy:yy
BG 0000 // JOB LIBRDEFS DEFINE LIBRARIES AND SUBLIBRARIES
          DATE xx/xx/xxxx,CLOCK yy/yy/yy
BG 0000 EOJ LIBRDEFS  MAX.RETURN CODE=0000
          DATE xx/xx/xxxx,CLOCK yy/yy/yy,DURATION zz/zz/zz
```

## Restoring VSE/ICCF DTSFILE

The job **ICCFREST** restores the VSE/ESA-supplied VSE/ICCF DTSFILE.

```
BG 0001 1Q47I BG ICCFREST nnnnn FROM (SYSA) , TIME=yy:yy:yy
BG 0000 // JOB ICCFREST RESTORE THE VSE/ESA ICCF DTSFILE
        DATE xx/xx/xxxx,CLOCK yy/yy/yy
BG 000 K237I LIBRARY REALLOCATION FROM nnnn TO nnnn
BG 000 K236I USER REALLOCATION FROM nnnn TO nnnn
BG 000 EOJ ICCFREST MAX.RETURN CODE=xxxx
        DATE xx/xx/xxxx,CLOCK yy/yy/yy,DURATION zz/zz/zz
```

## Punching Install Information to VSE/ICCF DTSFILE

The job **ICCFLOAD** adds required system information to the VSE/ESA supplied VSE/ICCF DTSFILE.

```
BG 0001 1Q47I BG ICCFLOAD nnnnn FROM (SYSA) , TIME=yy:yy:yy
BG 0000 // JOB ICCFLOAD PUNCH INSTALL INFO TO ICCF LIBRARY
        DATE xx/xx/xxxx,CLOCK yy/yy/yy
BG 0000 K246I AT LEAST ONE DTSUTIL COMMAND FAILED
BG 0000 EOJ ICCFLOAD MAX.RETURN CODE=xxxx
        DATE xx/xx/xxxx,CLOCK yy/yy/yy,DURATION zz/zz/zz
```

## Installing VSE/ESA Base Macros

The job **MACREST** installs separate macros into PRD1.MACLIB.

```
BG 0001 1Q47I BG MACREST nnnnn FROM (SYSA) , time=yy:yy:yy
BG 0000 // JOB MACREST - RESTORE SUB-LIBRARY PRD1.MACLIB
        DATE xx/xx/xxxx,CLOCK yy/yy/yy
BG 0000 EOJ MACREST MAX.RETURN CODE=0000
        DATE xx/xx/xxxx,CLOCK yy/yy/yy,DURATION zz/zz/zz
```

## Installing LE/VSE

The job **LEREST** installs LE/VSE into the sublibrary PRD2.SCEEBASE.

```
BG 0001 1Q47I BG LEREST nnnnn FROM (SYSA) , TIME=yy:yy:yy
BG 0000 // JOB LEREST - RESTORE LE/VSE LIBRARY PRD2.SCEEBASE
        :
BG 0000 EOJ LEREST MAX.RETURN CODE=xxxx
```

## Restoring Language-Dependent Members

The job **NLLIBRES** restores national language-dependent members from tape into IJSYSRS.SYSLIB.

```
BG 0001 1Q47I BG NLLIBRES nnnnn FROM (SYSA) , TIME=yy:yy:yy
BG 0000 // JOB NLLIBRES - RESTORE LANGUAGE DEPENDENT MEMBERS INTO SYSLIB
        DATE xx/xx/xxxx,CLOCK yy/yy/yy
BG 0000 EOJ NLLIBRES MAX.RETURN CODE=xxxx
        DATE xx/xx/xxxx,CLOCK yy/yy/yy,DURATION zz/zz/zz
```

## Restoring Language-Dependent VSE/ICCF Members

The job **NLICFRES** restores national language-dependent VSE/ICCF members from tape into the VSE/ICCF DTSFILE.

```
BG 0001 1Q47I BG NLICFRES nnnnn FROM (SYSA) , TIME=yy:yy:yy
BG 0000 // JOB NLICFRES - RESTORE LANGUAGE DEPENDENT MEMBERS INTO DTSFILE
        DATE xx/xx/xxxx,CLOCK yy/yy/yy
BG 0000 EOJ NLICFRES MAX.RETURN CODE=xxxx
        DATE xx/xx/xxxx,CLOCK yy/yy/yy,DURATION zz/zz/zz
```

### Installing VSE/ESA Base Programs

The job **BASEREST** installs the VSE/ESA sublibrary PRD1.BASE.

**Note:** This job takes several minutes. Do not cancel this job.

```
BG 0001 1Q47I  BG BASEREST nnnnn FROM (SYSA) , TIME=yy:yy:yy
BG 0000 // JOB BASEREST - RESTORE SUB-LIBRARY PRD1.BASE
          DATE xx/xx/xxxx,CLOCK yy/yy/yy
BG 0000 * -----
BG 0000 *                RESTORING PRD1 - THIS STEP WILL TAKE SEVERAL MINUTES
BG 0000 * -----
BG 0000 EOJ BASEREST  MAX.RETURN CODE=xxxx
          DATE xx/xx/xxxx,CLOCK yy/yy/yy,DURATION zz/zz/zz
```

### Initializing and Loading VSE/VSAM Files

The job **VSAMINIT** initializes and loads VSAM files needed by VSE/ESA.

**Notes:**

1. This job takes several minutes. Do not cancel this job.
2. During this job, the control file is opened which activates full security support of the Basic Security Manager.

```
BG 0001 1Q47I  BG VSAMINIT nnnnn FROM (SYSA) , TIME=yy:yy:yy
BG 0000 // JOB VSAMINIT - INITIALIZE AND LOAD VSAM FILES
          DATE xx/xx/xxxx,CLOCK yy/yy/yy
BG 0000 EOJ VSAMINIT  MAX.RETURN CODE=xxxx
          DATE xx/xx/xxxx,CLOCK yy/yy/yy,DURATION zz/zz/zz
```

### Initializing Work Files for Info/Analysis

The job **DUMPINIT** initializes the Info/Analysis work files.

```
BG 0001 1Q47I  BG DUMPINIT nnnnn FROM (SYSA) , TIME=yy:yy:yy
BG 0000 // JOB DUMPINIT - INITIALIZE INFO/ ANALYSIS WORK FILES
          DATE xx/xx/xxxx,CLOCK yy/yy/yy
BG 0000 EOJ DUMPINIT  MAX.RETURN CODE=xxxx
          DATE xx/xx/xxxx,CLOCK yy/yy/yy,DURATION zz/zz/zz
```

### Performing Migration (optional)

The next step is only performed if you earlier answered **YES** to the question whether you want to migrate your previous VSE system to VSE/ESA 2.7. If you answered **NO**, continue at “Cataloging Members into VSE System Libraries” on page 86.

The migration step consists of the two jobs **MIGRAT** and **DTRMIGR**, which catalog configuration-related tables and user IDs from your previous VSE system into the new system.

#### More than 199 VSE/ICCF Users or More than 199 VSE/ICCF Libraries

If you want to migrate more than 199 VSE/ICCF users or more than 199 VSE/ICCF libraries, you must **first complete initial installation**. This means that you run the **MIGRAT** job as described on the next page and **complete installation part 2 and installation part 3**. Only at the end of installation part 3 you have to perform additional steps. This is described in Appendix B, “Migrating More than 199 VSE/ICCF Users or More than 199 VSE/ICCF Libraries,” on page 133.

**Wrong Tape Labels**

As stated, the system expects the label 'ICCF01' on the backup tape containing the VSE/ICCF DTSTFILE. If you used another tape label, the system issues message:

```
BG 0000 4112D VOL SERIAL NO. ERROR TLBL=XXXX01 YYYYYY SYS004=CUU ZZZZZZ
```

Reply **0 IGNORE**

to process the tape. Should the message (4112D) appear again, repeat this reply (0 ignore).

The system expects the label 'CF0001' on the backup tape containing the control file. If you used another tape label the system issues message:

```
BG 0000 4111D NO VOL1 LABEL FOUND CFCOPY SYS004=CUU
```

Reply **0 IGNORE**

```
BG 0000 4130D EOF OR EOV INQUIRY CFCOPY SYS004=CUU
```

Reply **0 EOF**

```
BG 0000 // JOB MIGRAT  MIGRATE VSE USER IDS AND HARDWARE TABLES
          DATE xx/xx/xxxx,CLOCK yy/yy/yy
BG 0000 * PLEASE MOUNT YOUR BACKUP TAPE CONTAINING THE DTSTFILE
BG 0000 *   ON TAPE DRIVE cuu
BG 0000 *
BG 0000 * IF YOU HAVE MORE THAN ONE BACKUP TAPE FOR THE DTSTFILE:
BG 0000 * -----
BG 0000 * THE DTSTUTIL RESTORE STEP WILL PROMPT YOU TO MOUNT THE SECOND BACKUP
BG 0000 * TAPE (MESSAGE 4140A NO ALTERNATE DRIVE ASSIGNED).
BG 0000 * AFTER MOUNTING THE SECOND DTSTUTIL BACKUP TAPE REPLY "NEWTAP" TO
BG 0000 * ABOVE MESSAGE.
BG 0000 * WHILE THE RESTORE CONTINUES PLEASE ENTER
BG 0000 * "PAUSE BG" (AR COMMAND).
BG 0000 * THIS WILL STOP PROCESSING AFTER THE
BG 0000 * RESTORE STEP. THE NEXT STEP WHICH IS IESBLDUP NEEDS THE FIRST
BG 0000 * DTSTUTIL BACKUP TAPE AGAIN. THAT MEANS WHEN THE PAUSE IS
BG 0000 * ACTIVE, MOUNT THE FIRST DTSTFILE BACKUP TAPE TO CONTINUE.
BG 0000 * CONTINUE ONLY IF THE CONTROL FILE IS CLOSED, SEE ABOVE MESSAGES.
BG 0000 // PAUSE PLEASE READ ABOVE TEXT, WHEN TAPE READY, REPLY "0 (END/ENTER)"
```

The job will close the Control File and reopen it after successful completion.

Mount the tape containing the backup of the VSE/ICCF DTSTFILE (of your previous VSE system) on the specified tape drive. After you have mounted the tape, enter:

**0**

```
BG 0000 1T20I SYSxxx HAS BEEN ASSIGNED TO cuu (TEMP)
BG 0000 IESU0020A DTSTFILE BACKUP PROCESSING COMPLETE,
BG 0000 MOUNT CONTROL FILE TAPE ON 'cuu', PRESS ENTER WHEN READY
BG 0000 OR ENTER 'CANCEL' TO CANCEL JOB
```

On the specified tape drive, mount the tape containing the VSE/VSAM copy of the control file from your previous VSE system. After you have mounted the tape, enter:

**0**

## Installation Part 2 – Native and VM

```
BG 0000 EOJ MIGRAT MAX.RETURN CODE=xxxx
        DATE xx/xx/xxxx,CLOCK yy/yy/yy,DURATION zz/zz/zz
BG 0001 1Q47I  BG DTRMIGR nnnnn FROM LOCAL, TIME=yy:yy:yy
BG 0000 // JOB DTRMIGR UPDATE ICCF DTSFILE
        DATE xx/xx/xxxx,CLOCK yy/yy/yy
BG 0000 EOJ DTRMIGR MAX.RETURN CODE=xxxx
        DATE xx/xx/xxxx,CLOCK yy/yy/yy,DURATION zz/zz/zz
```

### Installing DB2

The job **DB2REST** runs if you answered **YES** when asked if you want to install DB2.

```
BG 0001 1Q47I  BG DB2REST 00017 FROM (SYSA) , TIME=yy:yy:yy
BG 0000 // JOB DB2REST - INSTALL DB2/VSE
        DATE xx/xx/xxxx, CLOCK yy/yy/yy
BG 0000 * *****
BG 0000 * *
BG 0000 * *   THIS JOB INSTALLS DB2/VSE....7.x.0 FROM THE EXTENDED BASE
BG 0000 * *   TAPE.
BG 0000 * *   PLEASE MOUNT THE TAPE LABELED VSE/ESA2.X.X-BASE
BG 0000 * *   ON TAPE DRIVE cuu
BG 0000 * *   AND REPLY "(END/ENTER)" TO CONTINUE
BG 0000 * *   (ENTER '// GOTO NEXT' IN CASE YOU DO NOT WANT TO RUN THE JOB)
BG 0000 * *
BG 0000 * *****
BG-0000 // PAUSE
```

#### Dismount/Mount the VSE/ESA Cartridge/Tape

1. Dismount the VSE/ESA cartridge/tape labeled *VSE/ESA2.7.X-YY*.
2. Mount the VSE/ESA cartridge/tape labeled *VSE/ESA2.7.X-XBASE*. Reply END/ENTER to continue.

After you have mounted the tape, enter:

```
0
BG 0000 EOJ DB2REST  MAX.RETURN CODE=0000
        DATE xx/xx/xxxx, CLOCK yy/yy/yy, DURATION  zz/zz/zz
```

### Cataloging Members into VSE System Libraries

The job **SAVEMEMB** catalogs members into PRD2.CONFIG and PRD2.SAVE. It also renames certain VSE/Advanced Functions library members.

Under some circumstances, the job may complete with a return code of 4. This is **not** an error.

```
BG 0001 1Q47I  BG SAVEMEMB nnnnn FROM (SYSA) , TIME=yy:yy:yy
BG 0000 // JOB SAVEMEMB CATALOG MEMBERS INTO PRD2.CONFIG AND PRD2.SAVE
        DATE xx/xx/xxxx,CLOCK yy/yy/yy
BG 0000 EOJ SAVEMEMB  MAX.RETURN CODE=xxxx
        DATE xx/xx/xxxx,CLOCK yy/yy/yy,DURATION zz/zz/zz
```

### Configuring TCP/IP (Optional)

```
BG 0001 1Q47I  BG TCPIPCFG 00019 FROM (SYSA) , TIME=hh:mm:ss
BG 0000 // JOB TCPIPCFG - CONFIGURE TCP/IP
        DATE dd/mm/yyyy, CLOCK hh/mm/ss
BG 0000 * *****
BG 0000 * *
BG 0000 * *   THIS JOB WILL START A CONFIGURATION DIALOG TO SETUP AN
```



```

BG 0000 * *      INITIAL STARTUP FOR TCP/IP.
BG 0000 * *
BG 0000 * *****
BG 0000 TCPCONF: ***** SET IPADDR *****
BG-0000 TCPCONF: Enter your IP address in dotted decimal notation (as four
integers seperated by periods - such as 1.2.3.4)
0 10.0.20.58
BG 0000 TCPCONF: ***** SET MASK *****
BG 0000 TCPCONF:      identifies what portion of the host number in a
BG 0000 TCPCONF:      network address is used to identify a sub-network
BG 0000 TCPCONF:      Sample: SET MASK = 255.255.224.000
BG-0000 TCPCONF: Enter your IP mask in dotted decimal notation ( "n.n.n.n",
where n is the decimal representation of one byte)
0 255.255.224.000
BG 0000 TCPCONF: ***** DEFINE_LINK *****
BG 0000 TCPCONF: Syntax of DEFINE_LINK is:
BG 0000 TCPCONF: DEF LINK ID=name TY={CLAW|ETHER|TOKEN|3172|OSA|CTC|IPNET} D
BG 0000 EV=hexaddr ...
BG-0000 TCPCONF: Please enter your DEFINE LINK command.
0 DEFINE LINK,ID=VM_TCPIP,TYPE=CTCA,DEV=E58
BG-0000 TCPCONF: Do you want to add another LINK definition? Yes/No
0 no
BG 0000 TCPCONF: ***** DEFINE_ROUTE *****
BG 0000 TCPCONF: Syntax of DEFINE_ROUTE is:
BG 0000 TCPCONF: DEF ROUT ID=name LINK=name1 IP=ipaddr [GAT=ipaddr1] ...
BG-0000 TCPCONF: Please enter your DEFINE ROUTE command.
0 DEF ROUT ID=ALL LINK=VM_TCPIP IP=0.0.0.0 GATEWAY=9.164.188.224
BG-0000 TCPCONF: Do you want to add another ROUTE definition? Yes/No
0 no
BG 0000 TCPCONF: ***** DEFINE_TELNETD *****
BG 0000 TCPCONF: the following TELNETD definition:
BG 0000 TCPCONF: DEFINE TELNETD ID=TELNET TARGET=DBDCCICS TERMNAME=T1000 COU
BG 0000 NT=20 -
BG 0000 TCPCONF: LOGMODE=SP3272QN LOGMODE3=SP3272QN LOGMODE4=SP3272QN LOGMOD
BG 0000 E5=SP3272QN
BG 0000 TCPCONF: could be added
BG 0000 TCPCONF: together with a corresponding VTAM definition in PRD2.CONFI
BG 0000 G.TCPAPP00.B .
BG-0000 TCPCONF: Do you want to add these definitions for your TELNET terminal
sessions? Yes/No
0
BG-0000 TCPCONF: Do you want to add these definitions for your TELNET terminal
sessions? Yes/No
0 yes
BG 0000 TCPCONF: VTAM configuration member PRD2.CONFIG.TCPAPP00.B is created
BG 0000 ]
BG-0000 TCPCONF: Do you want to add another TELNETD definition? Yes/No
0 yes
BG 0000 TCPCONF: Syntax of DEFINE TELNETD is:
BG 0000 TCPCONF: DEF TEL ID=name TAR=name1 TERM=termlu CO=num [LOGM=name2].
BG-0000 TCPCONF: Please enter your DEFINE TELNETD command.
0 DEF TEL ID=TEL1 TAR=DBDCCICS TERM=TELT1 CO=5 LOGMODE=SP3272QN LOGMODE3=SP3272
QN LOGMODE5=SP3272QN
BG 0000 TCPCONF: the TELNETD definition:
BG 0000 TCPCONF: DEF TEL ID=TEL1 TAR=DBDCCICS TERM=TELT1 CO=5 LOGMODE=SP3272
BG 0000 QN LOGMODE3=SP3272QN LOGMODE5=SP3272QN
BG 0000 TCPCONF: could get a corresponding VTAM definition in member PRD2.CO
BG 0000 NFIG.TCPAPP00.B .
BG-0000 TCPCONF: Do you want to enhance VTAM configuration member PRD2.CONFIG.
TCPAPP00.B ? Yes/No
0 yes
BG 0000 TCPCONF: Old version of PRD2.CONFIG.TCPAPP00.B has been saved in PR
BG 0000 D2.CONFIG.TCPAPP00.BOLD1
BG 0000 TCPCONF: VTAM configuration member VTAM_BOOK is updated
BG-0000 TCPCONF: Do you want to add another TELNETD definition? Yes/No
0 yes
BG 0000 TCPCONF: Syntax of DEFINE TELNETD is:

```

## Installation Part 2 – Native and VM

```
BG 0000 TCPCONF: DEF TEL ID=name TAR=name1 TERM=term1u CO=num [LOGM=name2].
BG-0000 TCPCONF: Please enter your DEFINE TELNETD command.
0 DEF TEL ID=TEL2 TAR=DBDCCICS TERM=TELT2 CO=2 LOGMODE=SP3272QN LOGMODE3=SP3272
QN LOGMODE5=SP3272QN
BG 0000 TCPCONF: the TELNETD definition:
BG 0000 TCPCONF: DEF TEL ID=TEL2 TAR=DBDCCICS TERM=TELT2 CO=2 LOGMODE=SP3272
BG 0000 QN LOGMODE3=SP3272QN LOGMODE5=SP3272QN
BG 0000 TCPCONF: could get a corresponding VTAM definition in member PRD2.CO
BG 0000 NFIG.TCPAPP00.B .
BG-0000 TCPCONF: Do you want to enhance VTAM configuration member PRD2.CONFIG.
TCPAPP00.B ? Yes/No
0 yes
BG 0000 TCPCONF: Old version of PRD2.CONFIG.TCPAPP00.B has been saved in PR
BG 0000 D2.CONFIG.TCPAPP00.BOLD2
BG 0000 TCPCONF: VTAM configuration member VTAM_BOOK is updated]
BG-0000 TCPCONF: Do you want to add another TELNETD definition? Yes/No
0 no
BG 0000 TCPCONF: These are now the actual definitions
BG 0000 TCPCONF: that are relevant for TELNET sessions:
BG 0000 TCPCONF: *****
BG 0000 TCPCONF: SET IPADDR=10.0.20.58
BG 0000 TCPCONF: SET MASK=255.255.224.000
BG 0000 TCPCONF: DEFINE LINK ID=VM_TCPIP TYPE=CTCA DEV=E58
BG 0000 TCPCONF: DEFINE ROUTE ID=ALL LINK=VM_TCPIP IP=0.0.0.0 GATEWAY=9.164.
BG 0000 188.224
BG 0000 TCPCONF: DEFINE TELNETD ID=TELNET TARGET=DBDCCICS TERMNAME=T1000 COU
BG 0000 NT=20 LOGMODE=SP3272QN LOGMODE3=SP3272QN LOGMODE4=SP3272QN LOGMODE5=
BG 0000 SP3272QN
BG 0000 TCPCONF: DEFINE TELNETD ID=TEL1 TAR=DBDCCICS TERM=TELT1 CO=5 LOGMODE
BG 0000 =SP3272QN LOGMODE3=SP3272QN LOGMODE5=SP3272QN
BG 0000 TCPCONF: DEFINE TELNETD ID=TEL2 TAR=DBDCCICS TERM=TELT2 CO=2 LOGMODE
BG 0000 =SP3272QN LOGMODE3=SP3272QN LOGMODE5=SP3272QN
BG 0000 TCPCONF: *****
BG-0000 TCPCONF: Do you want to save them in PRD2.CONFIG.IPINIT00.L ? Yes/No
0 yes
BG 0000 TCPCONF: TCP/IP configuration changes saved in PRD2.CONFIG.IPINIT00.
BG 0000 L
BG 0000 TCPCONF: TCP/IP for VSE/ESA is licensed and enabled by a key.
BG-0000 TCPCONF: Do you want to install TCP/IP product keys now? Yes/No
0 yes
BG 0000 TCPCONF: ***** PRODKEY DEFINE *****
BG-0000 TCPCONF: Enter product key of Application Pak in format
XXXX-XXXX-XXXX-XXXX-XXXX
0 1234-5678-9012-3456-7890
BG-0000 TCPCONF: Enter product key of NFS in format XXXX-XXXX-XXXX-XXXX-XXXX
if you plan to use NFS - ENTER otherwise
0
BG-0000 TCPCONF: Enter product key of GPS in format XXXX-XXXX-XXXX-XXXX-XXXX
if you plan to use GPS - ENTER otherwise
0
BG 0000 TCPCONF: TCP/IP for VSE/ESA requires a customer definition.
BG-0000 TCPCONF: Do you want to update TCP/IP customer information? Yes/No
0 y
BG 0000 TCPCONF: ***** CUSTDEF DEFINE *****
BG-0000 TCPCONF: Enter name of Customer Information
0 CUSTOMERNAME
BG-0000 TCPCONF: Enter number of Customer Information
0 C111-111-1111
BG 0000 EOJ TCPCONF MAX.RETURN CODE=0000
```

## Telecommunications Access Method and CICS/ICCF Startup

Several things occur at the same time during this task. Messages from different partitions are displayed on the system console. Review them carefully.

The job **TPSTART** runs. It has several steps. For VTAM users, it releases the job **VTAMSTRT** which starts VTAM in partition F3. The partition controls the VTAM terminals defined earlier in the installation.

TPSTART also releases the job **CICSICCF**. It starts CICS and VSE/ICCF in partition F2. The job **CLEANUP** runs at the same time and completes initial installation processing.

**Note:** The messages for this task may appear on your screen in a different order than shown here.

```
BG 0001 1Q47I  BG TPSTART nnnnn FROM (SYSA), TIME=yy:yy:yy
BG 0000 // JOB TPSTART START ICCF, CICS AND VTAM (IF APPLICABLE)
DATE xx/xx/xxxx,CLOCK yy/yy/yy
```

The system displays the following messages:

```
BG 0000 1S47I  PRELEASE RDR,VTAMSTRT
:
:
BG 0001 1Q47I  F3 VTAMSTRT nnnnn FROM (SYSA), TIME=yy:yy:yy
F3 0003 // JOB VTAMSTRT START UP VTAM
:
:
BG 0000 1S47I  PRELEASE RDR,CICSICCF
BG 0001 1Q47I  F2 CICSICCF nnnnn FROM (SYSA), TIME=yy:yy:yy
F2 0002 // JOB CICSICCF CICS/ICCF STARTUP
DATE xx/xx/xxxx,CLOCK yy/yy/yy
BG 0000 EOJ TPSTART  MAX.RETURN CODE=xxxx
DATE xx/xx/xxxx,CLOCK yy/yy/yy,DURATION zz/zz/zz
```

The system displays the following messages:

```
:
F3 0024 IST093I VTMAPPL ACTIVE
F3 0024 IST093I VTMSNA ACTIVE
F3 0024 IST093I VTMSNA ACTIVE
:
:
F3 0024 IST093I VTMA1 ACTIVE
F3 0024 IST093I VTMA2 ACTIVE
:
:
F3 0024 IST093I VTMSW1 ACTIVE
:
F3 0024 IST020I VTAM INITIALIZATION COMPLETE FOR V4R2
:
:
:
(additional SESSION SETUP messages may be displayed)
:
```

## Completion of Initial Installation Processing

The job **CLEANUP** completes initial installation processing. Messages from job **CLEANUP** may be displayed, together with messages from the **CICS/ICCF** startup job.

```

:
F2 0002 // JOB CICSICCF          CICS/ICCF STARTUP
        DATE xx/xx/xxxx, CLOCK yy/yy/yy
F2 0002 1T20I  SYS009 HAS BEEN ASSIGNED TO X'01F' (TEMP)
F2 0002 LOG
F2 0002 ID (PARAMETERS SUPPRESSED)
F2 0002 NOLOG
F2 0002 *   WAITING FOR VTAM TO COME UP
F2 0002 1T20I  SYS020 HAS BEEN ASSIGNED TO X'FEE' (TEMP)
F2 0002 DFHPA1101 DBDCCICS DFHSITSP IS BEING LOADED.
F2 0002 DFHPA1108 DBDCCICS DFHSITSP HAS BEEN LOADED. (GENERATED AT: MM/DD=
        xx/xx HH:MM= yy:yy).
F2 0002 DFHPA1100 DBDCCICS OVERRIDE PARAMETERS FROM JCL EXEC STATEMENT:

F2 0002 DFHPA1927 DBDCCICS APPLID=DBDCCICS,START=COLD,EDSALIM=14M,SI

F2 0002 DFHPA1102 DBDCCICS OVERRIDE PARAMETERS FROM SYSIPT:
F2 0002 DFHPA1927 DBDCCICS SIT=SP,STATRCD=OFF,MXT=20,NEWSIT=YES

F2 0002 DFHPA1103 DBDCCICS END OF FILE ON SYSIPT.
F2 0002 DFHTR0103 TRACE TABLE SIZE IS 256K
F2 0002 DFHSM0122I DBDCCICS Limit of DSA storage below 16MB is n,nnnK.
F2 0002 DFHSM0123I DBDCCICS Limit of DSA storage above 16MB is nnM.
F2 0002 DFHSM0113I DBDCCICS Storage protection is not active.
F2 0082 DFHDM0101I DBDCCICS CICS is initializing.
F2 0083 DFHXS1100I DBDCCICS Security initialization has started.
F2 0083 DFHXB0109I DBDCCICS Web domain initialization has started.
F2 0083 DFHS00100I DBDCCICS Sockets domain initialization has started.
F2 0083 DFHDH0100I DBDCCICS Document domain initialization has started.
F2 0083 DFHSI1500 DBDCCICS CICS startup is in progress for CICS Transaction
        Server Version 1.1.1
F2 0083 DFHXS1105 DBDCCICS Resource profiles for class TCICSTRN have been
        built.
F2 0083 DFHXS1103I DBDCCICS Default security for userid CICSUSER has been
        established.
F2 0083 DFHSI1501I DBDCCICS Loading CICS nucleus.
F2 0083 DFHXS1101I DBDCCICS Security initialization has ended.
F2 0083 DFHXB0110I DBDCCICS Web domain initialization has ended.
F2 0083 DFHS00101I DBDCCICS Sockets domain initialization has ended.
F2 0083 DFHMN0105I DBDCCICS Using default Monitoring Control Table.
F2 0083 DFHMN0110I DBDCCICS CICS Monitoring is inactive.
F2 0083 DFHDH0101I DBDCCICS Document domain initialization has ended.
F2 0083 DFHSI1502I DBDCCICS CICS startup is Cold.
F2 0083 DFHSI1503I DBDCCICS Terminal data sets are being opened.
F2 0083 DFHDX0304I DBDCCICS Transaction Dump Data set DFHDMPA  opened.
F2 0083 DFHCP0101I DBDCCICS CPI initialization has started.
F2 0083 DFHPR0104I DBDCCICS Partner resource manager initialization has
        started.
F2 0083 DFHFC0100I DBDCCICS File Control initialization has started.
F2 0083 DFHFC0101I DBDCCICS File Control initialization has ended.
F2 0083 DFHTD0100I DBDCCICS Transient Data initialization has started.
F2 0083 DFHAI0101I DBDCCICS AITM initialization has started.
F2 0083 DFHTD0101I DBDCCICS Transient Data initialization has ended.
F2 0083 DFHTS0100I DBDCCICS Temporary Storage initialization has started.
F2 0083 DFHTS0102I DBDCCICS About to format the temporary storage data set
        (104 control intervals).
F2 0083 DFHTS0101I DBDCCICS Temporary Storage initialization has ended.
F2 0083 DFHCP0102I DBDCCICS CPI initialization has ended.
F2 0083 DFHPR0105I DBDCCICS Partner resource manager initialization has ended.

```

```

F2 0083 DFHAI0102I DBDCCICS AITM initialization has ended.
F2 0083 DFHSI1511I DBDCCICS Installing group list VSELIST .
F2 0083 DFHST0103 DBDCCICS A DMF error has occurred with return code X'10'.
BG 0000 EOJ TPSTART MAX.RETURN CODE=0000
        DATE xx/xx/xxxx, CLOCK yy/yy/yy, DURATION zz/zz/zz
BG 0001 1Q47I BG CLEANUP 00022 FROM (SYSA) , TIME=yy:yy:yy
F2 0083 DFHAP1203I DBDCCICS Language Environment for VSE/ESA is being
        initialized.
BG 0000 // JOB CLEANUP
        DATE xx/xx/xxxx, CLOCK yy/yy/yy
F2 0083 CEE3550I LE/VSE C/VSE Run-Time initialized
F2 0083 CEE3551I LE/VSE COBOL Run-Time initialized
F2 0083 CEE3552I LE/VSE PL/I Run-Time initialized
F2 0083 DFHWP1007 DBDCCICS Initializing CICS Web environment.
F2 0083 DFHWP1008 DBDCCICS CICS Web environment initialization is complete.
F2 0083 DFHSI8430I DBDCCICS About to link to PLT programs during the third
        stage of initialization.
F2 0085 K002I BEGIN ICCF INITIALIZATION
F2 0085 K042I VSE ACCESS CONTROL NOT ACTIVE, VSE/ICCF ACCESS CONTROL ACTIVE
F2 0085 K481I DYNAMIC FILE SPACE INITIALIZATION BYPASSED
F2 0085 K001I DEVICE TYPE IS nnnn
F2 0085 K088I HI FILE RECORDS= nnn,nnn (nn%)
F2 0083 K029I ICCF INITIALIZATION COMPLETED
F2 0083 DFHSI8434I DBDCCICS Control returned from PLT programs during the
        third stage of initialization.
F3 0003 IST899I RETRY OF AUTOLOGON(S) TO VTAM1.DBDCCICS IN PROGRESS
F2 0083 DFHSI1517 DBDCCICS Control is being given to CICS.

```

**Once message DFHSI1517 appears, the system is available for use. Turn to Installation Part 3 – Description for All Users to continue.**

```

:
BG 0000 * BASE INSTALL PROCESSING IS NOW FINISHED. COMPLETION OF THE
BG 0000 *
BG 0000 * INSTALL PROCESS MUST BE PERFORMED USING THE VSE/ESA DIALOGS
BG 0000 *
BG 0000 EOJ CLEANUP MAX.RETURN CODE=0000
        DATE xx/xx/xxxx, CLOCK yy/yy/yy, DURATION zz/zz/zz

```



---

## Installation Part 3 – Description for All Users

Installation Part 3 consists of a number of steps. All of them require decisions or answers from your part. Interactive Interface dialogs help you complete installation part 3.

The steps that you need to complete are:

- Signing on to VSE/ESA user ID: POST
  - Entering naming convention
  - Entering personalized data
- Signing on to VSE/ESA user ID: SYSA
  - Completing hardware tables
- Changing passwords
- Performing system shutdown
- Performing IPL of your VSE/ESA system.





## Chapter 8. Installation Part 3 - Native and VM

Installation part 3 describes how to complete the VSE/ESA initial installation. Part 3 **must be done before** you do any optional installation tasks or use the VSE/ESA system. If you do not complete this task, your system may not operate properly.

For this task, you use the Interactive Interface. VSE/ESA has a special user ID and password that is used **only** for this task.

The one, two, or three terminals which you specified during initial installation will display the VSE/ESA sign-on panel (*VSE/ESA Online* panel) if they were powered on during system startup. Figure 4 shows the *VSE/ESA Online* panel.

If the sign-on panel does not show up, try to log on with **APPLID(DBDCCICS)**. This will result in the sign-on panel.

**Note:** When you start up the system after initial installation, all terminals which are powered on display the sign-on panel.

```
IESADMS01                VSE/ESA ONLINE
5690-VSE and Other Materials (C) Copyright IBM Corp. 2002 and other dates

VV  VV  SSSSS  EEEEEEE  ++
VV  VV  SSSSSS  EEEEEEE  ++
VV  VV  SS      EE        ++  EEEEEEE  SSSSS  AA
VV  VV  SSSSSS  EEEEEEE  ++  EEEEEEE  SSSSSS  AAAA
VV  VV  SSSSSS  EEEEEEE  ++  EE        SS      AA  AA
VV  VV      SS  EE        ++  EEEEEEE  SSSSSS  AA  AA
VVVV  SSSSSS  EEEEEEE  ++  EEEEEEE  SSSSSS  AAAAAAA
VV    SSSSS  EEEEEEE  ++  EE        SS      AAAAAAA
      ++
      ++  EEEEEEE  SSSSSS  AA  AA
      ++  EEEEEEE  SSSSS  AA  AA

Your terminal is xxxx and its name in the network is xxxxxxxx
Today is xx/xx/xxxx To sign on to DBDCCICS -- enter your:

USER-ID..... _____ The name by which the system knows you
PASSWORD..... Your personal access code.

PF1=HELP      2=TUTORIAL      4=REMOTE APPLICATIONS
                          10=NEW PASSWORD
```

Figure 4. Panel - VSE/ESA Online

Users who access VSE/ICCF can have user IDs of up to four characters. All other users can have user IDs consisting of up to **eight** characters. User IDs are not case sensitive. Note that, compared to previous releases of VSE/ESA, the password can also have eight characters.

### Users Installing Under VM

You cannot return to your VM system during initial installation. **After** completing initial installation, that means, after having completed the **next** IPL, the PF3 key is available, and you may return to your VM system using PF3.

## Installation Part 3 - Native and VM

To complete initial installation, sign on to the system from the *VSE/ESA Online* panel using the predefined user ID **POST** and the password **BASE**.

```
USER-ID.....  POST
PASSWORD..... BASE
```

**Note:** The user ID **POST** is reserved. It only is used to complete initial installation and to do special processing. Once the system signs you off from the session, the user ID **POST** **cannot** be used again. All attempts to enter **POST/BASE** are rejected.

After sign on with the user ID *POST*, the system displays the following message:

```
INPUT ACCEPTED, PLEASE WAIT
```

The system now completes the online installation task of the initial installation.

**This processing takes several minutes. Do not interrupt it.**

Depending on whether you installed a completely new VSE/ESA 2.7 system or whether you migrated from a previous VSE system to VSE/ESA 2.7, you follow “Completing Initial Installation (Non-Migration)” or “Completing Initial Installation (Migration)” on page 97.

Starting with page 98, the tasks are the same for all users.

---

## Completing Initial Installation (Non-Migration)

You still are logged on to the user ID **POST**.

The following panel asks you to specify the naming convention you want to use for VTAM resource names. These names are generated in the hardware configuration dialogs.

```
ADM$CNV1      VSE/ESA NAMING CONVENTION FOR VTAM RESOURCES
Enter the required data and press ENTER.

CONVENTION..... 2          1 = naming convention to support
                             two byte subarea addressing
                             2 = naming convention to support
                             extended subarea addressing

PF1=HELP      2=REDISPLAY  3=END
```

Figure 5. VSE Naming Convention for VTAM Resources

Choose **convention 2** (4-digit subarea naming convention) if you plan to support more than 255 subareas.

Choose **convention 1** (2-digit subarea naming convention) only if you want to use VTAM resource names generated for a VSE/SP Version 4 or an earlier VSE/SP system. Also choose convention 1 if you are a new VSE/ESA user and do not want to support more than 255 subareas.

**Users Installing a Native VSE/ESA**

If you are installing a native VSE/ESA, the *Unidentified Device List* panel similar to the one shown in Figure 7 on page 100 may be displayed.

This happens when the system knows the address (cuu), but neither the device nor the device type code. To keep or delete a device, proceed as described on page 100.

## Completing Initial Installation (Migration)

If you are migrating your system from a previous VSE system, processing of the online installation task may take more than 30 minutes. You do **not** have to enter any information. **Do not interrupt the process.**

You will get the naming convention you used with your previous VSE system. Please remember that you cannot migrate from the 2-digit subarea naming convention to the 4-digit subarea naming convention. See “Restrictions for Migration During Initial Installation” on page 17 for more information.

Starting with VSE/ESA, the hardware dialog creates entries for the CICS System Definition file (CSD) instead of Terminal Control Tables (TCTs), as was the case with previous VSE/SP releases. Please note that CICS TS has no TCTs.

If you changed the IBM-supplied CICS parameter tables or defined your own CICS parameter tables, these newly defined tables are transferred to *group VSETYPE1* in the CSD. This is done via the job CSDMIGR, which is created and stored in library 10. This job is automatically submitted, and you get the following message:

```
JOB HAS BEEN SUBMITTED AND FILED AS CSDMIGR
```

For each changed or newly defined CICS parameter table, *typeterm names* are created, as follows:

**VSEDIxxx** (DI = display)

**VSEPRxxx** (PR = printer)

with xxx ascending from 001 to 999.

Detailed information about the relationship between the former CICS parameter table names and the new typeterm names is in table ADM\$CICF in library 50. This includes the following:

Column name in ADM\$CICF	Typeterms
FTNAME	Former CICS parameter table name
TYPETN	Non-SNA typeterms
TYPETSL	SNA-LU2/-LU3 typeterms

## Installation Part 3 - Native and VM

Column name in ADM\$CICF	Typeterms
TYPETSS	SNA-SCS typeterms

For previously defined devices which are no longer supported by the Interactive Interface of VSE/ESA, you get an *Unidentified Device List* panel similar to the one shown in Figure 7 on page 100. You have to delete these unsupported devices.

### Users Installing Under VM

You also should remove your **VM/CMS-related** disk devices, for example, 190 or 191.

Refer to the IBM manual *VSE/ESA Planning* for a list of supported devices for VSE/ESA under "Hardware Supported".

---

## Personalizing the History File

The dialog now asks you to enter data unique to your installation in the panel shown in Figure 6.

Type in your name, address and telephone number in the required fields. In the last field, type in the name of the person who is responsible for maintaining the system. This is usually the system administrator. After entering all required information, press **ENTER**.

```
ADM$FST5                COMPLETE INITIAL INSTALLATION

Enter the required data and press ENTER.

This panel accepts information for your system history file.
This information uniquely identifies your installation and is
placed in the general header record of the history file.

CUSTOMER NAME..... _____
ADDRESS..... _____
PHONE NUMBER..... _____
PROGRAMMER NAME... _____

PF1=HELP      2=REDISPLAY  3=END
```

Figure 6. Panel - Complete Initial Installation

**Note:** Please make sure that you enter at least your name and address.

The Interactive Interface uses the *Personalize History File* dialog to update system history data. If you need to change any system history information of that type after this task, use the dialog. "Updating Hardware Tables After Initial Installation" on page 103 has more information.

The dialog creates a job with the name FIRSTUSE. The job is automatically submitted to the VSE system. The system displays the following message:  
 JOB HAS BEEN SUBMITTED AND FILED AS FIRSTUSE

The job FIRSTUSE contains the control job PERSONAL. PERSONAL creates an MSHP job stream and updates the system history file with your personal data.

The hardware configuration table also is validated.

On the panel that appears, you are informed about these steps and also that initial installation is complete and final housekeeping is finished. Press **ENTER**. This automatically signs you off and displays the *VSE/ESA Online* panel.

Your *first* action after the POST session should be to use the *Hardware Configuration* dialog to create and activate VTAM and CICS definitions for your system.

## Completing the Hardware Tables

Sign on to the Interactive Interface with the SYSA user ID. On the *VSE/ESA Online* panel, enter:

```

  USER-ID.....  SYSA
  PASSWORD..... SYSA
  
```

You are now requested to change the password. The password can be 3 - 8 alphanumeric characters long, including the special characters @, #, \$. For security reasons, it is not displayed on the screen.

During the initial installation process, the IPL program sensed and defined the devices in your system. These definitions were used to create hardware configuration tables. The hardware configuration tables contain information about your devices and are used by other Interactive Interface dialogs.

If information is missing for one or more devices, the system asks you to define these devices. If the system has found all necessary information for all sensed devices, this step is **not required**. If you are migrating from an earlier release of VSE/ESA (or from VSE/SP), it may happen that devices known to one of these earlier systems will not be identified by this release of VSE/ESA. Define them using the *Configure Hardware* dialog as described below.

To add missing information, start with the *Function Selection* panel and select:

- 2 (Resource Definition)
- 4 (Hardware Configuration and IPL)
- 1 (Configure Hardware)

Administrator Fast Path: 241	Synonym Default:     ___   Yours:
---------------------------------	--------------------------------------

Figure 7 on page 100 shows an example of the Unidentified Device List. This panel lists all devices for which the system knows the address (cuu), but nothing else.

## Installation Part 3 - Native and VM

```
ADM$HDWF          HARDWARE CONFIGURATION: UNIDENTIFIED DEVICE LIST

OPTIONS: 1=DEFINE A DEVICE      5=DELETE A DEVICE
        '=' = REPEAT LAST DEFINED DEVICE

      OPT   ADDR   DEVICE   DEVICE TYPE   DEVICE SPECIFICATION
                        CODE   (MODE)
      -     009   ?         3277
      -     280   ?         3480
      -     380   ?         3277
      -     381   ?         3277
      -     382   ?         3277
      -     383   ?         3277
      -     384   ?         3277
      -     385   ?         3277
      -     386   ?         3277
      -     387   ?         3277

PF1=HELP      2=REDISPLAY  3=END      5=PROCESS
              8=FORWARD
```

Figure 7. Panel - Unidentified Device List

If you want to delete a device from the list of unidentified devices, enter **5** in the option column next to that device.

If devices are listed which are attached through a link that occupies more than **one** address (cuu), you cannot define these devices in this panel. Examples are links from:

- An integrated communication adapter into an X.25 network.
- A Token-Ring adapter into an IBM Token-Ring.

Delete these devices in this panel. To add and configure links/devices, use the *Configure Hardware* dialog **after** completing initial installation.

If you want to keep a device, you must define it by entering **1** in the option column next to the device you want to keep.

You can directly enter the device name on this panel. It may happen that the device name you entered is invalid or that you forgot to replace a question mark "?". In this case, the system displays some selection menus from which you may select the device name.

You must go through the complete list of devices and define or delete each of the given addresses before you can press **PF5** to process your input. The system displays the panel shown in Figure 8. This panel contains the information you added.

```

ADM$HDWB          HARDWARE CONFIGURATION: UNIT ADDRESS LIST

OPTIONS: 2 = ALTER DEVICE TYPE CODE/MODE      3 = SELECT FOR FURTHER PROCESSING
         4 = LIST SIMILAR DEVICES              5 = DELETE A DEVICE

   OPT   ADDR  DEVICE  DEVICE-TYPE  DEVICE SPECIFICATION  DEVICE DEF
         009  CONSOLE  3277          MODE                DOWN INCOMPL
   -     280  3480    3480
   -     380  24X80Q   3277
   -     381  24X80Q   3277
   -     382  24X80Q   3277
   -     383  24X80Q   3277
   -     384  24X80Q   3277
   -     385  24X80Q   3277
   -     490  3380-E   3380
   -     491  3380-E   3380          EML                X

POSITION NEAR ADDR == > _____
PF1=HELP      2=REDISPLAY  3=END          5=PROCESS      6=ADD ADDR
PF7=BACKWARD  8=FORWARD    9=PRINT
    
```

Figure 8. Hardware Configuration: Unit Address List (Information Added)

**Note:** The DEVICE DOWN option in the *Hardware Configuration* dialog only is supported for tape and disk devices. For more information on the *Hardware Configuration* dialog, refer to the IBM manual *VSE/ESA Administration* under “Selecting the Configure Hardware Dialog”.

Check carefully if your hardware configuration is complete or if there is a need to add or delete a device.

You can change but not delete the following VSE/POWER and VSE/ICCF dummy devices: FED, FEE, FEF, FFD, FFE.

You cannot change or delete the following VSE/POWER and VSE/ICCF dummy devices: FEC, FFA, FFC.

You cannot change or delete the dummy device FFF which is a place holder for a dedicated system console.

Do not delete the device FDF. It is the virtual disk for label area.

Press **PF5** again to process your input and display the following panel:

## Installation Part 3 - Native and VM

```
ADM$CRE1          HARDWARE CONFIGURATION: CATALOG STARTUP MEMBERS

Press ENTER to catalog the objects marked by an X. You may add or delete
an X as needed.

      X      IPL Procedures
      -      VTAM Book with Startup Options
      X      VTAM Books for Model Terminal Support
      -      VTAM Book for Local Non-SNA Terminals
      X      VTAM Book Local SNA Terminals
      -      VTAM Books for ICA attached Terminals
      -      VTAM Books for OSA or 3172 attached Terminals
      X      CICS CSD Group for terminals - VSETERM1
      -      CICS CSD Group for terminals - VSETERM2
      -      CICS CSD Group for terminals - VSETERM3

PF1=HELP      2=REDISPLAY  3=END

IPLPROC      VTAM      SOURCE CREATED.
```

Figure 9. Hardware Configuration : Catalog Startup Members

**Note:** The panel shown above is just an example for VTAM users. If you have a different hardware configuration, other objects may be marked by an x.

Press **ENTER** to build a job which makes the added information known to the system. When the *Job Disposition Panel* is displayed, **submit that job**.

If you need to change your hardware configuration at a later time, refer to the IBM manual *VSE/ESA Networking Support*. It has information on how to add or delete a device or change the characteristics of a device.

---

## Activating the VTAM Password

With VSE/ESA 2.7, you receive VTAM Version 4 Release 2. VTAM consists of three different levels. When you have ordered VTAM, you had to specify one of these levels. With the VSE/ESA distribution cartridge(s) or tapes, you also receive a unique VTAM password customized for your site.

For initial installation VSE/ESA uses a predefined password and no action on your side is necessary. However, when initial installation is complete and you tailor your system, you must activate your own VTAM password, by modifying skeleton SKVTAM. This skeleton is stored in VSE/ICCF library 59.

- Copy the skeleton into your primary VSE/ICCF library.
- Use the copy of the skeleton to modify the VTAM password.
- Submit the skeleton for processing.

For overview information and technical details, refer to the IBM manuals *VTAM Overview*, GC31-8114, and *VTAM Network Implementation Guide*, SC31-6494.

---

## Users Who Want to Use a System with Security Active

At the beginning of the installation process you are prompted with the message:  
BG 0000 IESI0079D DO YOU WANT TO RUN YOUR SYSTEM WITH SECURITY ON? YES/NO



By answering YES, the predefined table DTSECTAB will be generated, that defines access control for batch resources. This table becomes active at the first IPL after initial installation.

Security-related user profile information is stored in the VSE.CONTROL.FILE.

To modify DTSECTAB, use the source DTSECTRC in VSE/ICCF library 59 and catalog it into PRD2.SAVE. A detailed description of adding entries to DTSECTAB is in the manual *VSE/ESA Administration*, under “Defining Resource Entries in DTSECTAB”.

---

## Additional Considerations

The following are additional points which you may want to consider.

### Updating Hardware Tables After Initial Installation

If you need to update the hardware table or personalized data of the system history file **after** initial installation is completed, you can use two dialogs:

1. *Configure Hardware*
2. *Personalize History File*

The *Configure Hardware* dialog has several HELP panels for information about device type codes. If you are not sure of the type for the device you are using, press **PF1** for more information.

### Migrating Old TCTs into the CICS Transaction Server CSD File

If you did not migrate during initial installation, you can use the CICS MIGRATE command for migrating your self-defined and modified CICS parameter tables, or redefine your terminals via the *Hardware Configuration* dialog.

The CICS DFHCSDUP utility supports this command.

If you use the MIGRATE command be aware that:

- Many changes have to be made manually.
- There is no special VSE/ESA support for this type of migration.

For more information on the DFHCSDUP utility, refer to the IBM manual *CICS TS Resource Definition Guide*, SC33-1653.

**You should now perform a system shutdown.**

The following is an example of how to perform a system shutdown. For detailed information on a system shutdown, refer to the IBM manual *VSE/ESA Operation*.

- Shut down CICS as follows:  
**MSG F2,DATA='CEMT P SHUT I'**
- Shut down VTAM as follows:  
**Z NET,QUICK**
- Shut down VSE/POWER as follows:  
**PEND**

## Installation Part 3 - Native and VM

Be aware that if you have selected environment B (or if you have tailored the IPL procedures to your own needs), the changed disk layout will be active after the next IPL. Ensure that the enlarged page data set (250 MB) for predefined environment B is not occupied otherwise.

**You must now perform an IPL from DOSRES** to activate the new system setup before continuing with any further optional installation tasks.

**After you have performed the IPL, initial installation is complete.**

You can turn now to the optional installation tasks and:

1. Delete VSE/ESA component programs you do not need.
2. Install the VSE/ESA Generation Feature.
3. Install VSE/ESA optional programs.

To do this, please continue with Chapter 9, "Doing Optional Installation Tasks - Native and VM," on page 109.

If you install VSE/ESA under VM, you may also refer to Chapter 10, "Installing VM/VSE Interface Routines – VM Only," on page 125. It describes how to install the VM/VSE Interface.

Users who have to migrate **more** than 199 VSE/ICCF users or **more** than 199 VSE/ICCF libraries, refer to page 133.

---

## Changing Passwords for VSE/ESA User IDs

As the passwords for the predefined VSE/ESA user IDs are defined with an expiration date, you must change them during the first logon. Doing this helps ensure that unauthorized users do not have access to your system.

The predefined security support includes a user ID and password (**FORSEC**). User FORSEC is defined in the VSE.CONTROL.FILE and in DTSECTAB and provides appropriate access rights during **system startup**.

For more information about security functions, refer to the IBM manual *VSE/ESA Administration* under "Protecting Resources".

The following table shows the user IDs and passwords that VSE/ESA ships besides *POST/BASE* (which **only** is used to complete initial installation):

*Table 12. VSE/ESA Predefined User Profiles*

PROFILE	USER ID	PASSWORD
System administrator	SYSA	SYSA
Programmer	PROG	PROG
System console operator	OPER	OPER
Remote problem determination	\$SRV	\$SRV
System administrator	FORSEC	FORSEC
CICS default user	CICSUSER	CICSUS
CICS partition user	DBDCCICS	DBDCCI
CICS partition user	PRODCICS	PRODCI
Default user for CICS/TS default consoles	CNSL	CNSL

Table 12. VSE/ESA Predefined User Profiles (continued)

PROFILE	USER ID	PASSWORD
Connector Server partition user	VCSRVA	VCSRVA

For remote problem determination, VSE/ESA provides a special user ID \$SRV. With this user ID, an IBM Support Center, for example, can log on to your site and perform online system diagnosis if a data link exists. \$SRV can access and use VSE/ICCF, but has no administrative authority. The user ID \$SRV can perform the following tasks:

- Inspect the system console (without command authority).
- Look at VSE/POWER queues and inspect listings assigned to that user ID.
- Exchange messages with other users.
- Use the *Problem Handling* dialogs of VSE/ESA.

See the IBM manual *VSE/ESA Guide for Solving Problems* for further information about \$SRV.

Change the passwords from the *VSE/ESA Online* panel shown in Figure 4 on page 95. On the panel, type in the following. After pressing enter you get the *Change Password* panel.

```

USER-ID.....  PROG
PASSWORD..... PROG
    
```

Note that for security reasons the password is not displayed on the screen. At the *Change Password* panel, enter a new password in both NEW PASSSSWORD fields and the current password for verification. The passwords are not shown. The system checks that the two entries of the new password match. The password can be 3 - 8 alphanumeric characters long including the special characters @, #, \$.

After you entered the new password, you are signed on to the Interactive Interface. Press PF3 to sign off and redisplay the *VSE/ESA Online* panel. Follow the above instructions again to change the passwords of the following user IDs:

- OPER
- \$SRV
- CICSUSER

You can also change the password for FORSEC, but you will not be prompted by the system to do so.

In case of CICSUSER, a message is issued that selection panel DFLESEL is not defined. This user is not designed to sign-on to the system. Ignore this message, the password is changed by the system.

For the user IDs:

- DBDCCICS
- PRODCICS
- VCSRVA

change the passwords later via the *Maintain User Profiles* dialog, as explained in the manual *VSE/ESA Administration*.

If you want to specify an expiration date, you can use the *Maintain User Profiles* dialog. The dialog is described in the IBM manual *VSE/ESA Administration* under "Maintaining User Profiles".

## Installation Overview and Preparation

---

## Optional Installation Tasks

### Overview of Optional Installation Tasks

This section lists optional installation tasks. You may perform all, none, or some of them. All of the tasks run independently from each other.

#### Optional Installation Tasks for VSE/ESA Native or under VM

Delete programs that you do not need

You run DELETE jobs to delete those programs that you do not need

Install the VSE/ESA Generation Feature

You use Interactive Interface dialogs to install the VSE/ESA Generation Feature

Install VSE optional programs

You use Interactive Interface dialogs to install VSE optional programs

#### Optional Installation Tasks for VSE/ESA under VM

Install the VM/VSE Interface routines

You use a skeleton to install the VM/VSE Interface routines

#### Optional Installation Tasks for CICS Coexistence

Install CICS/VSE

Refer to the IBM manual: VSE/ESA Administration



---

## Chapter 9. Doing Optional Installation Tasks - Native and VM

This chapter describes optional installation tasks that you may perform when you install a native VSE/ESA or when you install VSE/ESA under VM.

---

### Deleting VSE/ESA Programs You Do Not Need

As soon as you have finished the initial installation of your VSE/ESA system, you may decide to delete certain VSE/ESA base programs that you do not need. You only can delete those programs which are **not** part of VSE Central Functions. (Refer to the IBM manual *VSE/ESA Planning* for more information on the component VSE Central Functions under “VSE/ESA Base Programs”.) Also, you must delete those programs for which you do not have a license. VSE/ESA provides *delete jobs* for this purpose in VSE/ICCF library 59.

The names of the delete jobs always start with *DEL*, followed by an identifier for the program (for example, *CICS* for the base program CICS Transaction Server). To use a delete job, switch to VSE/ICCF library 59 and copy it to your primary library. Then submit the delete job(s).

Delete jobs update the system history file. If a delete job completes with return code 4, this is **not** an error.

Before you submit a delete job, please consider the consequences of the loss of the program’s functions. **You may loose important system functions.** More information is in the “VSE/ESA Partial Functions Delete Instructions”, which are part of the *VSE/ESA Memo to User* shipped with the system.

Below is a list of the available delete jobs, together with the corresponding VSE/ESA base program.

*Table 13. Delete Jobs for VSE/ESA Programs*

Delete Job	VSE/ESA Program
DELCICS	CICS Transaction Server 1.1.1 including Report Control Feature, REXX, CICS and CWS
DELDB2	DB2 Server 7.1.0 and DataPropagator 7.1.0
DELDB273	DB2 Server 7.3.0
DELDIT	DITTO/ESA 1.3.0
DELHLASM	High Level Assembler/VSE 1.4.0
DELLECOB	COBOL/VSE 1.4.3
DELLEPLI	PL/I VSE 1.4.3
DELREXX	REXX/VSE 6.7.0
DELTCPIP	TCP/IP for VSE/ESA 1.5.0
DELVTM	VTAM 4.2.0
DELCOBII	COBOL II

## Deleting VSE/ESA Programs

### Please be aware that deleted programs:

- May not be reinstalled easily. Also, you may run into problems with your system if you delete VSE/ESA base programs.
- Must be deleted again, after having run a Fast Service Upgrade (FSU).

### Notes:

1. If you have run the delete job for DITTO/ESA and later recreate a stand-alone tape, DITTO/ESA will not be stored on the stand-alone tape.
2. Do **not** delete the VSE C Language Run-Time Support since it is required for CICS Transaction Server start-up.

---

## Overview of the Generation Feature

The VSE/ESA base tape/cartridge contains **source code** that provides generation capability for the supervisor. *Installation of this code (called the Generation Feature) is optional.* You only need it if the options of the pre-generated system are not adequate for your needs.

The approximate space allocations required for the PRD2.GEN1 sublibrary are shown in Table 14. The disk devices listed are those that can be used for initial installation of VSE/ESA.

Table 14. Space Requirements for PRD2.GEN1

IBM Disk Device	Required Space for PRD2.GEN1	Library Blocks
3380	453 tracks (30 cylinders, 3 tracks)	14048
3390	425 tracks (29 cylinders, 10 tracks)	14048
9345	503 tracks (33 cylinders, 8 tracks)	14048
FBA	28096 blocks	14048

**Note:** These values specify the minimum library blocks required for PRD2.GEN1.

## When to Install the Generation Feature

If you decide to install the Generation Feature, *it is recommended that you do so immediately after initial installation.*

The Generation Feature is part of the first distribution cartridge. Mount the device labeled **VSE/ESA2.7.X-YY** to install the Generation Feature.

To install the Generation Feature, use the *Install Generation Feature* dialog. The following pages describe this dialog and the VSE/ESA Generation Feature installation process in more detail.

**Note:** If you have ordered VSE/ESA on CD-ROM or downloaded it from the internet, the Generation Feature is installed either during FSU or, in case you copied the base tape to a real tape, you should install it from this real tape. Installing the Generation Feature from virtual tape is not supported.



## Installing VSE/ESA Generation Feature

The *Install Generation Feature* dialog creates a job which installs the Generation Feature in library PRD2.GEN1. It also updates the system history file for the installation. This ensures that the Generation Feature is available when you perform other tasks that require it (for example, if you install service that affects the Generation Feature). To access the dialog, start with the *VSE/ESA Function Selection* panel and select:

- 1 (Installation)
- 3 (Install Generation Feature)

Administrator Fast Path: 13	Synonym Default: _____ Yours:
--------------------------------	----------------------------------

You are asked only for the tape address, **cuu**. The dialog creates a job with the default name INSGEN. On the *Job Disposition* panel, you can submit the job to batch, file it in your default VSE/ICCF primary library, or both.

If you filed the job as a VSE/ICCF library member and you are now ready to install, you must submit the job to the VSE system by doing the following:

1. On the *VSE/ESA Function Selection* panel, select
  - 5 (Program Development)
2. On the *Program Development* panel, select
  - 1 (Program Development Library)

Administrator Fast Path: 51	Synonym Default: iccfs Yours:
--------------------------------	----------------------------------

3. On the *Program Development Library* panel, press **ENTER**.
4. On the *Primary Library* panel, type in
  - 7 (Submit)

in the option (OPT) column next to the library member INSGEN.

5. Press **ENTER** to submit the job.

The job asks you to mount the cartridge labeled VSE/ESA2.7.X-YY, which contains the VSE/ESA Generation Feature. Use the **same** tape unit you specified in the dialog.

The job INSGEN restores the supervisor generation macros into the sublibrary PRD2.GEN1. To actually regenerate the supervisor, you must execute an assembly job and catalog the phase into the system sublibrary IJSYSRS.SYSLIB. Refer to skeleton SKSUPASM in VSE/ICCF library 59.

## Installing the Generation Feature after Service Has Been Installed

In general, service to supervisor generation macros consists of two PTFs. If you have the Generation Feature installed, both PTFs for the pre-generated system and the Generation Feature are applied automatically.

- PTF1 applies service to the pre-generated system.
- PTF2 applies service to the Generation Feature.

## Installing the VSE/ESA Generation Feature

If you installed the Generation Feature but you keep it offline, you must restore it before you apply service which affects the supervisor generation macros. Doing this ensures that all required service is applied to your system.

If you **do not** have the Generation Feature installed, only service for the pre-generated system is installed.

**Please note that your pre-generated system and the Generation Feature must be at the same service level.** Thus, if you install the Generation Feature after having applied service to either supervisor generation macros, you must ensure that the pre-generated part and the Generation Feature are on the same service level.

This means that you have to do one of the following:

1. **If a service refresh of VSE/ESA is available that is at a service level higher than your present system:**
  - a. Order the refresh. The Generation Feature is automatically included.
  - b. Use the *Fast Service Upgrade (FSU)* dialogs to install the refresh.
  - c. Use the *Install Generation Feature* dialog to install the Generation Feature from the refresh tapes.
2. **If you want to install the originally received Generation Feature:**
  - a. Use the *Install Generation Feature* dialog to install the Generation Feature delivered with your system.
  - b. Reinstall the service for supervisor generation macros that you previously applied to the system. By specifying the reapplication of these PTFs, you force MSHP also to apply the related Generation Feature PTFs. To get a list of the service applied, you may use stage 0 (down-level check) of Fast Service Upgrade.

For a detailed description of the Fast Service Upgrade, refer to the IBM manual *VSE/ESA System Upgrade and Service*.

You must follow one of these two procedures to ensure that your system operates correctly. If you do not, you may mix service levels that affect the operation of the system.

### Further Considerations

The Generation Feature does not have to be resident on disk at all times. You can back up sublibrary PRD2.GEN1 and keep the feature on tape when it is not in use. However, the Generation Feature **must** be online whenever you do generation or service tasks that require it.

See the IBM manual *VSE/ESA System Upgrade and Service* for more information on applying service affecting the Generation Feature.

---

## Overview of Installing Additional Programs

### Installing a Program from the VSE/ESA Extended Base Tape

In case of IBM 3480 or IBM 3590 tapes, the VSE/ESA Extended Base Tape is the second tape of the two VSE/ESA base tapes. If you ordered VSE/ESA on CD-ROM, the file name of the tape image is VSEBAE27.AWS. If you downloaded VSE/ESA from the internet, the file name of the tape image is VSE27xXB.AWS. The VSE/ESA Extended Base Tape for VSE/ESA 2.7 includes the following base programs:

- DB2 Server for VSE

- DataPropagator Relational Capture
- CICS/VSE 2.3
- LE/VSE DBCS Locales
- OS/390 APIs

Although these programs are part of the base you must treat them as optional programs and use the Interactive Interface to install them. For details about the corresponding dialog, refer to “Using Installation Dialogs for Additional VSE Programs” on page 114.

### Installing Additional VSE Programs

VSE/ESA supports the installation of additional VSE programs. A subset of additional VSE programs is designated as VSE/ESA *optional programs*. These optional programs are tested together with VSE/ESA and supported for simplified installation via a dialog.

A list of VSE/ESA optional programs is shown in the IBM manual *VSE/ESA Planning*. For the most current information, refer to the *Program Directory* provided with the VSE/ESA distribution tapes, or CDs.

The VSE/ESA optional programs are shipped in Librarian Version 2 (V2) stacked format. Some additional VSE programs may be shipped in Librarian Version 1 (V1) stacked or non-stacked format.

- **Version 2 (V2) format**
  - The tape is in Librarian format of VSE/Advanced Functions Version 2.
  - One or more programs can be on the tape.
  - The tape can be scanned to determine the space needed by each additional VSE program on the tape.
  - Dialogs can be used to scan the tape(s).
- **Version 1 (V1) format**
  - The tape is in Librarian format (V1) of **pre-Version 2** VSE/Advanced Functions.
  - One or more programs can be on the tape.

### Installing Non-IBM Programs under VSE/ESA

You may want to install *vendor* programs or other programs from a non-IBM supplier. For those programs, you can use the VSE/ESA dialogs, assuming that the tape or cartridge you use is built in a specific format.

The following figure shows the layout of a distribution tape, (or file, in case of CD-ROM or internet delivery), built in such a format. Program 022A10 is simply an example. In case a vendor product is also provided on CD, this can only be installed if it was built by using the VSE/ESA virtual tape support.

Table 15. Layout of a Distribution Tape

File Number	Content	Sample
1	header file	HD022A10
2	product history file	history file for program 022A10
3	product libraries	DW202DA.PR\$A10
4	null file (tapemark)	null file
5	EOB (end of BACKUP information)	EOB

## Overview of Installing Additional Programs

Table 15. Layout of a Distribution Tape (continued)

File Number	Content	Sample
6	null file (tapemark)	null file

How to build a tape or cartridge correctly so that it can be installed through VSE/ESA dialogs, is described in detail in the IBM manual *Preparing a Product for VSE*, SC33-6331.

If the tape is built in the correct format, you install the additional programs using the dialog *Install Additional Programs – Version 2 Format*.

## Using Installation Dialogs for Additional VSE Programs

To install additional VSE/ESA programs, you can use the following dialogs via the *Install Programs - V2 Format* dialog:

1. *Prepare for Installation* dialog to print a tape scan report. The report provides information about the programs on the tape(s) and the amount of library space that is needed. In addition, the dialog creates internal tables for the installation. The information from the scan report is useful in planning for your library structure before installing the programs.
2. *Install Program(s) from Tape* dialog to install one or more programs.

**Note:** It is possible to install VSE optional programs without using the Interactive Interface dialogs. But if you later use the dialogs to apply maintenance to these programs, you must perform special steps. This is described under “Applying Service to VSE Programs that Were Installed Without Using Dialogs” in the IBM manual *VSE/ESA System Upgrade and Service*.

## Additional Considerations

1. Before you install an additional VSE program, you should ensure there is sufficient space in the library/sublibrary. Review the scan report for space requirements.
2. *Prepare for Installation* replaces any list that was saved previously.
3. Only the system administrator can access the *Install Programs - V2 Format* dialog. This user ID is authorized to ALTER any library (which is relevant for a VSE/ESA system with security active).
4. Note that some components also include VSE/ICCF type members, so called I-Books. These are automatically loaded by the dialog into the corresponding VSE/ICCF library.
5. If you have problems installing a feature for an additional VSE program, you may need a COMPATIBLE WITH statement for MSHP. This statement is used to indicate to MSHP at installation those programs which are compatible with the shipped program(s).

Refer to the IBM manual *VSE/ESA System Control Statements* for information about this MSHP statement.

## Having Multiple Program Versions on Your System

If you want to install a new **version** of an already installed program and if you want to:

- Keep the old version

You **must not** install the new version into the **same** sublibrary with the old version, even if the dialog offers this sublibrary as the default.

**Note that the MSHP support for a multiple version environment is restricted to the APPLY PTF function.** This means the APAR/Local Fix function is not supported in such an environment.

- Replace the old version

You must remove the old program information from the system history file using the MSHP REMOVE statement. This command does not, however, delete the corresponding members from the library. The subsequent installation replaces them.

For details, see the IBM manual *VSE/ESA System Control Statements*.

**Note:** A new program version does **not** mean a new release or modification level.

For COBOL for VSE/ESA 1.1.0, for example:

1 is the version indicator

1 is the release indicator

0 is the modification level indicator.

---

## Installing Additional VSE Programs

You can use the *Install Programs - V2 Format* dialog to install VSE/ESA optional programs or additional VSE programs distributed in the Librarian format of VSE/Advanced Functions Version 2.

This Librarian format enables distribution of more than one program on a single distribution tape. With this format, a facility of the Librarian scans the tape and gathers information about it. It provides information such as the library space required to install each program. You can install one, several, or all programs on the tape at one time.

The dialog creates job streams which use the Job Manager to manage the installation. "Additional Considerations" on page 114 describes Job Manager processing for the dialog. The dialog consists of two separate tasks:

1. *Prepare for Installation*

This dialog scans the distribution tape(s) and builds a list of up to 200 additional VSE programs, which can be located on one or several tapes. Using KEEP PRODUCT LIST, you can save this list. It prints a report on SYSLST.

If your optional product tapes contain more than 200 products, you need to split up this installation task. You can do the *Prepare for Installation* and *Install Program(s) from Tape* tasks that total up to 200 programs and then repeat the two steps for the tape(s) with the remaining programs.

2. *Install Program(s) from Tape*

The dialog shows a list of programs with their default libraries. You can select one or more programs for installation (into the appropriate library).

If you use the dialog for the first time or if you use a new tape, you should do both tasks 1 and 2.

If you have used the dialog before (with the same tape), you may have a program list saved and not need to perform *Prepare for Installation*.

The following sections describe the dialog process in more detail.

To access the dialog, start with the *VSE/ESA Function Selection* panel and select:

## Installing Additional VSE Programs

- 1 (Installation)
  - 1 (Install Programs - V2 Format)
  - 1 (Prepare for Installation)
- or
- 2 (Install Program(s) from Tape)

Administrator Fast Path: 111	Synonym Default: _____ Yours:
---------------------------------	----------------------------------

or

Administrator Fast Path: 112	Synonym Default: _____ Yours:
---------------------------------	----------------------------------

Select each of the two tasks in order (1, 2).

## Prepare for Installation Dialog

*Prepare for Installation* creates a job which:

- Scans one or more distribution tapes.
- Gathers program statistics.

The job prints a *scan report* on the system printer. It also creates an internal list of all additional VSE programs on a tape. The list is displayed when you use the dialog *Install Program(s) from Tape*.

**Note:** The dialog *Prepare for Installation* also can be used if the programs you want to install are not stacked on tape.

A program list saved from a previous installation is replaced whenever you perform *Prepare for Installation*.

```
INS$PRI2                PREPARE FOR INSTALLATION
Enter the required data and press ENTER.

TAPE ADDRESS..... ____ Address of input tape unit (cuu). For
                          valid addresses enter a "?".

VIRTUAL TAPE..... 2     Is it a virtual tape? Enter 1 if
                          it is a virtual tape, enter 2 if
                          not.

PF2=REDISPLAY 3=END
```

Figure 10. Prepare for Installation Dialog

Enter the tape address for creating the scan job, and if you are installing the product from a virtual tape. The *Job Disposition* panel is displayed, and you can submit the scan job to batch, file it in your VSE/ICCF primary library, or both.

If you ordered VSE/ESA on CD-ROM or downloaded it from the internet, enter 1 for using a virtual tape.

When you submit the job, you are asked to mount the first tape. Use the **same** tape drive that you specified in the dialog. You are prompted to mount any additional tapes sequentially.

When the job completes, review the scan report that it printed. **Before** you install any additional VSE programs decide if you want to do any of the following:

- Change the library or sublibrary defaults for the installation.
- Increase library space.

If you want to extend the space where a library/sublibrary resides, you can use the:

1. "File and Catalog Management" dialog and extend the VSE/VSAM master catalog space.

The IBM manual *VSE/ESA Planning* has a list of the default libraries used. Refer to the topic "VSE Libraries".

2. Skeleton SKLIBEXT in VSE/ICCF library 59 is for libraries which do not reside in VSE/VSAM-managed space. Use this skeleton only if you have specified explicitly that you want your additional VSE programs to be installed in a particular library not managed by VSE/VSAM.

The manual *VSE/ESA Administration* describes the dialog and the skeleton.

If an additional VSE program contains a generation sublibrary, the scan report shows two entries for the program:

1. The first entry is for the production sublibrary.
2. The second entry is for the generation sublibrary.

When you install an additional VSE program, both sublibraries are installed.

### Installing from Virtual Tape

If you entered 1 for installing from a virtual tape, the following panel is displayed, where you can enter the VSAM file name or the IP address of the location of the tape image file.

If you are installing the product from VSAM, the tape image file must have been first uploaded into a VSAM data set by using TCP/IP for VSE/ESA. For details refer to "Uploading the Base Tape to VSAM for FSU via Virtual Tape" on page 151.

In case you are running VSE/ESA on an IBM S/390 Multiprise 3000, the virtual tape format can be used directly. In this case, you can specify the emulated tape drive as a real tape.

## Installing Additional VSE Programs

```
UTL$VTAP          VIRTUAL TAPE: SPECIFY THE DATA SET

Enter the required data and press ENTER.

If the file resides on the VSE system specify the following:

VSAM FILE NAME .....      VTAPE1   Unique name of the VSAM file
                               containing the tape image.

If the file resides on a remote system specify the following:

IPADDR.....      ___ ___ ___ ___   IP address of the remote system
PORT.....        _____        TCP/IP port number

DATA SET NAME : _____
...              _____
...              _____
...              _____
...              _____

PF1=HELP      2=REDISPLAY  3=END
```

Figure 11. Panel - Virtual Tape: Specify the Data Set (VSAM)

If you are installing the product from a remote system, specify the IP address and the location of the file. Specifying the TCP/IP port number is optional.

As the files that are located on the workstation or on the CD are in virtual tape format, you can use them directly.

```
UTL$VTAP          VIRTUAL TAPE: SPECIFY THE DATA SET

Enter the required data and press ENTER.

If the file resides on the VSE system specify the following:

VSAM FILE NAME .....      _____   Unique name of the VSAM file
                               containing the tape image.

If the file resides on a remote system specify the following:

IPADDR.....      10 2 3 45           IP address of the remote system
PORT.....        _____        TCP/IP port number

DATA SET NAME :  __F:\DRIVER\VSEBAE27.AWS_____
...              _____
...              _____
...              _____
...              _____

PF1=HELP      2=REDISPLAY  3=END
```

Figure 12. Panel - Virtual Tape: Specify the Data Set (Remote System)

When you are ready to install, continue with “Install Program(s) from Tape Dialog.”

### Install Program(s) from Tape Dialog

*Install Program(s) from Tape* installs some or all additional VSE programs on the distribution tape.



A FULIST displays the programs on the tape. The list was created during the *Prepare for Installation* task.

```

INS$OP11          INSTALL ADDITIONAL PROGRAM(S) FROM TAPE

LIST OF PROGRAMS TO BE INSTALLED

OPTIONS:  1 = INSTALL   2 = SKIP INSTALLATION

      OPT      IDENTIFIER      LIBRARY  SUBLIBR.  SEQ.NO.  TAPE NO.
      OPT      IDENTIFIER      NAME     NAME      SEQ.NO.  TAPE NO.
      1      CICS.PRD...2.3.0 PRD2     CICSOLDP  1         1
      1      CICS.RC...2.3.0 PRD2     CICSOLDP  2         1
      1      CICS.GEN...2.3.0 PRD2     CICSOLDG  3         1
      1      CF.OS390...6.4.0 PRD2     OS390     4         1
      1      LEVSE.DBCS.1.4.3 PRD2     SCEEBASE  5         1
      1      DB2/VSE...7.3.0 PRD2     DB2730    6         1
      1      ASN/VSE...7.3.0 PRD2     ASN730    7         1
      -
      -
      -----
      -----

PF1=HELP      2=REDISPLAY  3=END          5=PROCESS

ALL SCANNED PRODUCTS NEED A MINIMUM OF 82427 LIBRARY-BLOCKS.
  
```

Figure 13. Panel - Install Additional Programs from Tape

**Note:** If you **did not** use *Prepare for Installation* and you **do not** have a list saved from a previous installation from the tape, refer to “Additional Considerations” on page 122 for more information about the dialog and the values you can specify.

The dialog creates a job stream which runs under the control of the Job Manager. You should **not** cancel any of the jobs in the sequence. This interrupts Job Manager processing. Appendix A, “Overview of the Job Manager,” on page 129 describes the Job Manager and what you should do if problems occur.

The following are the steps that you have to perform to install additional VSE programs from tape, using VSE/ESA dialogs.

### Step 1 – Install Additional Program(s) from Tape (Panel INS\$OP11)

On the FULIST, indicate which program you want to install. In the OPT column, enter:

- 1 - Install
- 2 - Skip Installation

The FULIST displays the following information:

#### IDENTIFIER

This identifies the program on the tape.

#### LIBRARY and SUBLIBRARY NAME

This is the default library/sublibrary where an additional program will be installed. You can change the library or sublibrary name.

If a program has a production and generation part, both will be installed in the same library. The sublibrary, shown in the dialog, will be used only for the production part.

## Installing Additional VSE Programs

For the generation part, the program provides a default sublibrary name for the installation. This default sublibrary **cannot** be changed using the dialog.

### SEQUENCE NUMBER

This shows the sequence of the programs on the tape. This is helpful if you want to check your entries with the program documentation.

You **cannot** change this value.

### TAPE NUMBER

This shows the tape number where a program resides. The information may be helpful if you want to check your entries with the additional VSE program documentation.

You **cannot** change this value.

Select the additional VSE programs you want to install. Press **PF5** to process the information. Another panel appears on your screen as described in the following section.

### Step 2 – Install Additional Program(s) from Tape (Panel INNS\$OPI2)

On this panel, enter whether you want to save or erase the list of additional VSE programs.

#### KEEP LIST OF PROGRAMS

Specify whether you want to save or erase the list of programs.

- 1 - Save the list
- 2 - Erase the list

If you save the list, it is displayed the next time you access the dialog. If you decide to install some programs now and others later (from the same tape(s)), the list is available. You do not have to perform *Prepare for Installation* again.

If you erase the list, you can create a new one by using the dialog *Prepare for Installation*. When you press ENTER, the panel described in the next section appears.

### Step 3 – Install Additional Program(s) from Tape (Panel INNS\$ODI2)

On this panel, you have to specify the tape address for the installation.

**TAPE ADDRESS** Specify the tape address (cuu) for the installation.

A job sequence is created. When you press ENTER, the *Job Disposition* panel appears.

### Step 4 – Job Disposition

From the *Job Disposition* panel, you can submit the job to batch, file it in your VSE/ICCF primary library, or both.

When you submit the job, mount the first tape. Use the **same** tape drive that you specified in the dialog. Do **not** reposition or dismount the tape until you are told to do so. The Job Manager manages the jobs which complete the installation. Refer to “Additional Considerations” on page 122 for more information. If you have more than one tape, you are asked to mount the next tape.

**Note:** You receive the following information message, where xxxxxxxx stands for V2-STACKED or NOT V2-STACKED.

```
IESI0083I  TAPE FORMAT IS xxxxxxxx
```

This message is for information only and can be ignored. The Librarian RESTORE job may end with a return code of 4, if the message was NOT V2-STACKED. This is not an error. Installation was successful.

If you install an additional VSE program which contains a generation sublibrary, the system displays the messages:

- M235I INSTALLATION WILL BE DONE AS FOLLOWS:

This message informs you which sublibraries will be restored into which target sublibraries.

- M089D ENTER "GO" TO CONTINUE, OR "CANCEL" TO TERMINATE

Enter **GO** to continue with the installation.

### Installing Programs without a Program List (Panel INS\$OPI3)

You would not have a program list if you did not:

1. Use the dialog *Prepare for Installation* or
2. Save a list from a previous installation.

However, you also can use the dialog *Install Program(s) from Tape* without having a program list. In this case, you do not have the information about the tape contents that is provided by the scan report. Therefore, there are special considerations for the entries you specify in *Install Program(s) from Tape*. These are described below.

The FULIST displays an additional option (5=DELETE). If you enter information on a particular line and make an error, you can enter 5 in the OPT column to delete the entry.

#### IDENTIFIER

You must enter the name that identifies the program. This is identical to the *backup ID*. The identifier must be unique.

Check the program documentation for the correct value. If you specify an incorrect identifier, the additional VSE program cannot be located on the tape.

#### LIBRARY and SUBLIBRARY NAME

If an additional VSE program has a production and generation part, you must specify **two** entries with the **same** identifier. For the generation part, enter **\*GEN** for the library name. The sublibrary, shown in the dialog, only is used for the production part. For the generation part, the program provides a default sublibrary name for the installation.

#### SEQUENCE NUMBER

You can ignore the sequence number.

#### TAPE NUMBER

This shows the tape number where the program resides. The numbers you specify must be in ascending order.

## Installing Additional VSE Programs

### Reinstalling Programs

You can use the *Install Programs - V2 Format* dialog to reinstall a program. If you specify a sublibrary other than the one where the program originally was installed, the dialog displays an additional panel. The panel shows the:

- Backup ID of the program.
- Sublibrary where it presently resides.
- New sublibrary where you want to reinstall it.

You can only install an additional program in one sublibrary. Therefore, you must specify the sublibrary you want to use:

- 1 - Install in new sublibrary
- 2 - Install in original sublibrary

If you install in a new sublibrary, the dialog updates the system history file. However, the program is **still** in the original sublibrary. You must **delete** it from the original sublibrary. Review the documentation for the individual program to determine the names of the library members you must delete from the particular sublibrary.

---

### Installing Programs in Version 1 Format

You **must** use the *Install Programs - V1 Format* dialog when you install additional VSE programs that are shipped in the Librarian Version 1 format (Librarian format of pre-Version 2 VSE/Advanced Functions). You can also use this dialog when you install additional VSE programs that are shipped in the Librarian Version 2 format, but are not stacked on tape.

Additional VSE programs distributed in Version 1 format differ from stacked Version 2 format in two ways:

1. Only one additional VSE program resides on a single tape.
2. The tape cannot be scanned to gather program statistics.

**Note:** Programs in Version 1 format are not distributed on CD or via the internet.VSE/ESA.

The dialog creates a job stream which installs the additional VSE programs under MSHP control, based on the sequence you specify in the dialog. Each program is installed from a single tape. The job stream requests that the next tape in the sequence be mounted.

The job stream installs a program into the appropriate library. Furthermore, it updates system information that is needed by the Interactive Interface.

The job stream runs under the control of the Job Manager. "Additional Considerations" has information about Job Manager processing for the dialog.

### Additional Considerations

1. Before you install an additional VSE program, you should ensure there is sufficient free space in the library/sublibrary.

Review the appropriate documentation that is shipped with the distribution tape. It has the latest available information about the space requirements for the program.

2. The job stream installs each program in the sequence used in the dialog. No checking can be done to make sure that the tape you have mounted contains the correct program. You should physically sort the tapes in the correct sequence. This can help ensure that the right tape is available when a mount is requested.
3. If you have problems installing a feature for an additional VSE program, you may need a COMPATIBLE statement for MSHP. Refer to *VSE/ESA System Control Statements* for information about this MSHP statement.

### Install Programs - V1 Format Dialog

To access the dialog, start with the *VSE/ESA Function Selection* panel and select:

- 1 (Installation)
- 2 (Install Programs - V1 Format)

Administrator Fast Path: 12	Synonym Default: _____ Yours:
--------------------------------	----------------------------------

#### Step 1 – Install Additional Program(s) from Tape (Panel INNSODI1)

This panel shows the list of program tapes to be installed. You need the following information:

##### TAPE NUMBER

This shows the sequence in which the program tapes must be mounted. You **cannot** change this value.

Physically sort the tapes in the order that they are to be used. This helps to ensure that the correct tape in the sequence is available when the job stream requests the tape mount. The dialog or job stream **cannot** check that the correct tape is mounted. Therefore, it is important that you have the tapes sorted to match the sequence used in the dialog.

##### TAPE LABEL

Enter a tape label for each program you want to install. This is an external label to help you identify the tape. The label is displayed in the mount request when the job stream runs.

You can enter up to sixteen characters. For each program installation, the label name must be unique.

##### LIBRARY and SUBLIBRARY NAME

Enter the library/sublibrary where you want the additional VSE program installed. The dialog displays a default library of PRD2 and sublibrary PROD.

Review the documentation that was shipped with the distribution tape. Determine the space that is required for the additional VSE program. Decide which library/sublibrary you want to use. This is important because you do not have a scan report to provide library space information. You must make sure that the library you use has adequate space available.

If an additional VSE program has a production and generation part, both are installed in the **same** sublibrary.

## Installing Programs in Version 1 Format

### TAPE ADDRESS

Enter the address of the tape unit to be used for the installation.

Enter information for **each** program you want to install.

### Step 2 – Job Disposition

From the *Job Disposition* panel, you can submit the job to batch, file it in your VSE/ICCF primary library, or both.

When you submit the job, you are asked to mount the first tape in the sequence. Use the **same** tape drive that you specified in the dialog. Do **not** reposition or dismount the tape until you are told to do so.

The job stream prompts the operator to mount each tape using the sequence specified in the dialog.

---

## Chapter 10. Installing VM/VSE Interface Routines – VM Only

This chapter describes how to **install** the VM/VSE Interface routines and gives an overview to their main functions. It only is for users who install VSE/ESA under VM.

The IBM manual *VSE/ESA Operation* explains how to **use** the VM/VSE Interface. It also describes how terminal users can access a VSE/ESA guest system. This includes the CP DIAL command, VTAM cross domain, and the VM/Pass-Through Facility.

---

### What Are the VM/VSE Interface Routines?

The VM/VSE Interface is a set of VSE phases and CMS modules supplied by VSE/ESA. These phases and modules provide functions for interfacing to one or more VSE/ESA guest systems from CMS. The VM/VSE Interface routines are distributed in IJSYSRS.SYSLIB. You must obtain the routines from the library and install them on a CMS minidisk.

The functions described in “Functions Supported by the VM/VSE Interface” can be used for communication with a VSE/ESA guest system using any of the delivered supervisors.

---

### Functions Supported by the VM/VSE Interface

Using the VM/VSE Interface, you can:

1. Have none, some, or all messages from a job or from the system echoed to a specified owner (CMS user ID).
2. Reply to messages resulting from the execution of a job. The job must have a unique job owner ID (CMS user ID).
3. Submit jobs from a CMS terminal to a VSE/ESA guest system.
4. Issue VSE commands (including REDISPLAY commands) to a VSE/ESA guest system and have the resulting messages echoed to the CMS user.
5. Issue CP commands for execution in the virtual machine and have the resulting CP messages routed to the CMS job owner.

The VM/VSE Interface takes advantage of the improved VSE/ESA console functions. Refer to the IBM manual *VSE/ESA Operation* for more information under “The VSE/ESA Console”.

### Overview to VM/VSE Interface Routines

Table 16. Modules and Phases of the VM/VSE Interface

CMS File Name (fn)	CMS File Type (ft)	VSE Library (Book) Name	Function
		\$IJBVMCF.PHASE	VM/VSE Interface processing routines.
SUBVSE	EXEC	SUBVSE.Z	Submit a job for execution on a virtual VSE system.
VSECMD	MODULE	VSECMD.Z	<ul style="list-style-type: none"><li>Execute VSE and CP commands on VSE/ESA system.</li><li>Retrieve messages from VSE/ESA system.</li></ul>
VSECMD	EXPLAIN	EXPCMD.Z	Help panel for VSECMD commands

Since VSE/ESA 2.1, the former files VSECP, VSEMSG, VSEREP, and their EXPLAIN files have been dropped. Their contents and functionality have been integrated in VSECMD.

### How to Install the VM/VSE Interface

Before you can use the VM/VSE Interface, you must distribute the CMS modules to all CMS users who are authorized to use the appropriate function.

The use of VSECMD should be carefully controlled. VSECMD is mainly intended for the system administrator.

VSE/ESA provides skeleton SKVMVSE in VSE/ICCF library 59 (shown in Figure 14 on page 127). You use this skeleton to punch the MODULES, EXPLAINS, and EXECs from the VSE/ESA guest system to the VM machine MAINT. (The VM ID MAINT is commonly used for this machine). To ensure that the punch job works correctly, the VSE/POWER punch writer must be started with the VM parameter and must be enabled to process class A jobs.

### List of Installation Tasks

1. You should first copy the skeleton SKVMVSE from VSE/ICCF library 59 to your primary library. You can use the *Program Development Library* dialog to copy VSE/ICCF library members.
2. You should then edit the copy of the skeleton. Replace the **-V001-** variable with the VSE/POWER destination parameter for punch output. This is the same name as the VM user ID where you want the VM/VSE Interface installed. **When completing the copy of the skeleton, do not overwrite the comma which is included in parenthesis. It is not part of the variable -V001-.**  
When the job is executed, the members are placed in the reader queue of the destination ID specified in the variable.



## Overview of Installing the VM/VSE Interface Routines

3. You should not use the same user IDs in VSE/ESA and VM. If identical user IDs exist, you must make sure that they identify the same person. Identical user IDs **cannot** be used **concurrently** to access VSE/ESA console functions both from CMS and a native VSE/ESA.
4. You should access the CMS minidisk where the routines will be loaded. (The default is the first accessed R/W minidisk). The minidisk can be:
  - MAINT 319 for general access.
  - A specific minidisk (for example, 301).
5. The VM/VSE Interface is activated during IPL (SYS command VMCF=YES).

```

* $$ JOB JNM=PUNVMVSE,CLASS=0,DISP=D
* $$ PUN CLASS=A,DISP=D,DEST=(,-V001-),JSEP=(0,N)
// JOB PUNVMVSE PUNCH VM/VSE MODULES FOR INSTALLATION
* *****
* *
* * - - - - - INSTALL VM/VSE FEATURE - - - - - *
* *
* * THIS JOB PUNCHES DIFFERENT CMS MODULES *
* * OF THE VM/VSE FEATURE TO A DEFINED VM USERID. *
* * AT THIS USER-ID, THE MODULES ARE INSTALLED VIA THE CMS *
* * 'DISK LOAD' COMMAND (NO OTHER ACTION REQUIRED). *
* *
* * THE FOLLOWING VARIABLE IS USED AND HAS TO BE CHANGED: *
* *
* * -V001- VSE/POWER DESTINATION PARAMETER FOR PUNCH OUTPUT. *
* * IDENTICAL TO THE NAME OF THE VM USERID AT WHICH *
* * THE VM/VSE FEATURE WILL BE INSTALLED, E.G. 'MAINT' *
* *
* *****
* AFTER YOU HAVE MODIFIED THE SKELETON ENTER '@DTRSEXIT' *
* FROM THE EDITOR'S COMMAND LINE. *
* THIS MACRO WILL DELETE ALL DESCRIPTIVE TEXT FROM THIS FILE, *
* BY DELETING ALL LINES WHICH ARE MARKED WITH THE CHARACTER C *
* IN COLUMN 71.
// LIBDEF *,SEARCH=(IJSYSRS.SYSLIB)
// UPSI 1
// EXEC DITTO
$$DITTO SET EOD=))))))
$$DITTO CC
* $$ SLI MEM=VSECMD.Z
* $$ SLI MEM=EXPCMD.Z
* $$ SLI MEM=SUBVSE.Z
))))))
$$DITTO EOJ
/*
/*
/&
* $$ EOJ

```

Figure 14. VSE/ESA Skeleton SKVMVSE

## Installation Overview and Preparation

---

## Appendix A. Overview of the Job Manager

The Job Manager is a VSE/ESA program that manages the run sequence of certain job streams. It helps you submit a job sequence without your intervention. You do not have to release individual jobs.

Beginning with “Installation Part 2 – Detailed Description” on page 71, the Job Manager controls processing and releases jobs for the remaining steps. This is called *installation job stream processing*. Job Manager processing is used by the following installation tasks, where apart from initial installation, all jobs are generated by the Interactive Interface.

- Initial installation of VSE/ESA
- Install Programs - V2 Format
- Install Programs - V1 Format
- Application of PTFs
- Installation of Fast Service Upgrade

At the beginning of the job stream, the Job Manager builds an ordered list of the jobs that should run. The Job Manager uses the list to selectively release the jobs from the VSE/POWER reader queue. The list is stored on disk for restart/recovery purposes.

---

### Special Considerations for Installation Dialogs

For installing VSE/ESA, four dialogs create job streams known as *Job Manager-managed sequences*. When submitted, they run under the control of the Job Manager.

The four dialogs are described in:

1. “Installing Additional VSE Programs” on page 115.
2. “Installing Programs in Version 1 Format” on page 122.
3. Chapters “Handling PTFs” and “Performing a Fast Service Upgrade” in the IBM manual *VSE/ESA System Upgrade and Service*.

Note that only one job-managed sequence can be started **per partition** at one time. In addition, only one job stream from any of the four dialogs can run at one time in one partition. The section Tips and Hints for Error Handling shows which options you have to handle error situations.

---

### Job Manager Commands

If problems occur when the Job Manager is activated, a predefined abend job gets control. You then receive instructions as to how to proceed.

**Be careful when canceling any jobs that the Job Manager manages.** You should only do that when the Job Manager is waiting for a response or when a job is waiting for the availability of a resource (such as, a tape to be mounted).

When the abend job gets control, you have three options:

**RESUME**      The job that was running at the time of abnormal termination is

## Job Manager Commands

restarted. If no job was running, the next job in the sequence runs. This is the recommended way to restart a job.

### RESET

It is recommended that you only use the RESET command in case of severe problems. Please make sure that you do not miss a job when using RESET.

If you choose RESET, another message asks you for the name of the job that should run next. This can be any job in the list. All jobs which follow the job that has been reset will also run.

Job streams may be very complex. Whenever you change the Job Manager sequence, you may run into problems. A job may have dependencies, for example, on a job that previously ran. Also, some jobs have to pass information or action along to a job that must follow in the Job Manager sequence.

### EXIT

Job Manager processing is stopped. The job that abended is flagged as incomplete. This gives you the possibility to analyze and fix the problem.

At any later time, you can restart the Job Manager to finish the task by doing the following:

1. Release the appropriate abend job. To do so, enter the following command

```
r rdr,xxxxxxx
```

where xxxxxx is the abend job name. The abend jobs for each particular task are shown in Table 17.

2. Later, you will be asked to select one of the three options described above.
  - RESUME
  - RESET
  - EXIT

Table 17. Abend Job Names for Job Manager Processing

TASK NAME	ABEND JOB NAME
VSE/ESA Initial Installation	INSABEND
Apply PTF dialog	DTRPTFAB
Install Fast Service Upgrade dialog	DTRFSUAB
Install Programs - V1 Format dialog	DTRABxx <sup>1</sup>
Install Programs - V2 Format dialog	DTRABxx <sup>1</sup>

<sup>1</sup> In the job names DTRABxx, the system generates xx internally. The job stream for the particular dialog will tell you the name of the DTRABxx abend job.

## Tips and Hints for Error Handling

If in a partition there is an unfinished job sequence not running currently and another sequence is submitted for the same partition, VSE/ESA issues a message.

If a problem occurs, proceed as follows:

1. Cancel the second job sequence. You can submit it when the current one has completed successfully.

or

2. Continue the second job sequence by canceling the currently running job sequence.

If one of the jobs managed by the Job Manager fails, a message will ask whether you want to resume, reset, or exit. To overcome a suspected software problem, perform the following steps:

- Enter **0 EXIT**. Job Manager processing stops. The abended job is flagged as incomplete. Analyze and fix the problem.
- Restart the Job Manager by entering **R RDR,xxxxxxx**. (xxxxxxx is the abend job name.)
- Enter **0 RESUME**. This starts the abended job. If no job was running, the next job in the sequence runs.

If these steps do not help you solve your problem, proceed as follows:

- Enter **0 RESET**. The system now asks you for the name of the job that should run next. This could be, for example, the job that ran before the failed job ran.
- Enter **0 xxxxxx**, where xxxxxx is the name of the job you want to run next. Note that you can specify any job in the list. All jobs which follow the job in the list will run, even if they already ran.

## Tips and Hints for Error Handling

---

## Appendix B. Migrating More than 199 VSE/ICCF Users or More than 199 VSE/ICCF Libraries

This section only applies to users who want to migrate more than 199 VSE/ICCF users or more than 199 VSE/ICCF libraries.

You must have completed initial installation of VSE/ESA before you can migrate more than 199 VSE/ICCF users or VSE/ICCF libraries. Perform the following steps:

1. Reformat the DTSFILE with the desired library and user entries
  - a. Back up the DTSFILE of the new VSE/ESA system on tape.
  - b. FORMAT the new DTSFILE with the desired number of users and libraries.
  - c. Restore the new DTSFILE with the new value used in the FORMAT command for libraries and users.
  - d. Add the libraries that exceed the number of 199.
2. MIGRATE the user profiles of your previous VSE system using the migration utility IESBLDUP.
3. Restore your private VSE/ICCF libraries of your previous VSE system.

### More Information

You will find more information about the commands you use to format the DTSFILE in:

- Topic “Reformatting VSE/ICCF DTSFILE” in the IBM manual *VSE/ESA Administration*.
- VSE/ESA Migration Utility IESBLDUP in Appendix C, “Migrating to a New Release,” on page 135.

## Migrating More than 199 VSE/ICCF Users or Libraries



---

## Appendix C. Migrating to a New Release

---

### VSE/ESA Migration Utility IESBLDUP

This chapter describes the VSE/ESA migration utility IESBLDUP. IESBLDUP is called during **initial installation** when you request migration. However, you can use IESBLDUP also at a later time, for example if you have installed a test system and want to migrate your user profiles and other control data after you have tested your new system.

#### Introducing the IESBLDUP Utility

IESBLDUP migrates DOS/VSE, VSE/SP, or previous VSE/ESA **user profiles** as well as user-tailored **selection panels** and **application profiles** to VSE/ESA 2.7. IESBLDUP updates and adds user profile or other data to the **current** VSE Control File (IESCNTL) and the **current** VSE/ICCF DTSTFILE.

During migration, the sources of input are processed in the following sequence:

1. Current VSE/ICCF DTSTFILE.
2. Copy of old VSE Control File and/or old VSE/ICCF DTSTFILE.
3. CICS/VSE sign-on table DFHSNT (from CICS/VSE 2.3 or a previous CICS system).

If duplicate user IDs are found, only the first occurrence of a user ID will be added. The user IDs defined for VSE/ICCF and CICS/VSE provide, together with a model VSE/ESA user profile, the data to define new users to VSE/ESA.

You can also use IESBLDUP to create a **status report** of your system's users. A status report lists all user IDs and related data defined in the VSE Control File, the VSE/ICCF DTSTFILE, and the CICS sign-on table (DFHSNT). Such a status report provides valuable information for maintaining user profiles and data.

#### Note on DFHSNT

CICS/VSE 2.3 was the last CICS system that had a DFHSNT (Sign-On Table). Its successor system, the CICS Transaction Server for VSE/ESA, does not support a DFHSNT.

If you want to migrate a DFHSNT, the easiest way is to migrate it first to your old VSE Control File. Run IESBLDUP to achieve this, and then create a backup copy of your old VSE Control File for the actual migration run. You can apply this method for CICS/DOS/VS 1.7 up to CICS/VSE 2.3. In case you want to migrate an even older CICS version, you must create a CICS coexistence environment under VSE/ESA 2.7 by installing CICS/VSE 2.3 in addition to the CICS Transaction Server. You must then recompile your old DFHSNT under CICS/VSE 2.3 and migrate.

#### The IESBLDUP Control Statement

You control the processing of IESBLDUP through options defined in the IESBLDUP control statement. If no control statement is used, the default options are in effect. The statement and its options are described under "The Control Statement" on page 145.

## Planning and Concept Information

### Migrating VSE/ICCF DTSFILE and VSE Control File to VSE/ESA 2.7

If you migrate from a VSE/SP or previous VSE/ESA system to VSE/ESA 2.7, the old VSE Control File and old DTSFILE are processed together when CF=YES is specified in the control statement.

The user profiles are copied from the old files. The records from the old VSE Control File are reformatted and merged into the current VSE Control File. No model profile and DFHSNT values are used as input. The old VSE Control File is also scanned for user selection panels which reference VSE/ESA reserved names (beginning with IES). If your panels contain names of VSE/ESA panels or applications which have been deleted, the names are changed to the corresponding VSE/ESA 2.7 functions and listed in the status report.

### Copying DOS/VSE User Definitions of VSE/ICCF DTSFILE Only

The old DTSFILE is read from SYS004. SYS005 must be assigned with IGN (//ASSGN SYS005,IGN) to ensure that the VSE Control File is not read even if CF=YES is specified. The user profiles from the old DTSFILE are copied directly into the current DTSFILE without change. You can add the VSE/ESA user profiles directly from the DTSFILE to the current VSE Control File (DTSFILE=YES). *This statement may be used to copy user definitions of the old DTSFILE to the current DTSFILE without using model profiles.*

### Migrating VSE/ICCF DTSFILE Only (DOS/VSE)

If migrating from DOS/VSE, the only input is a copy of your old DTSFILE. If a user ID is found that does not exist on the current VSE Control File, several actions take place:

- The user ID is added to the current VSE Control File.
- A user profile is created and added to the current VSE Control File.  
The user's ID, password, and VSE/ICCF library number are taken from the old DTSFILE records. The VSE/ESA options and VSE/ICCF specifications are taken from the model user profile specified by the ADMN or PROG keyword in the control statement.
- A DTSUTIL ADD statement is created to add the user to the DTSFILE.
- If you do not want to use the new model profiles (SYSA and PROG, for example) you must copy the users of the old DTSFILE, as described in "Copying DOS/VSE User Definitions of VSE/ICCF DTSFILE Only."

### VSE/ICCF DTSFILE

If DTSFILE=YES is specified in the control statement, users are added from the current DTSFILE. The user records (B\$ and E\$ records) are read from the current DTSFILE. For each unique ID found, a user profile is created and added to the current VSE Control File. The user's ID, password, VSE/ICCF library number, and VSE/ICCF specifications are taken from the current DTSFILE records. VSE/ESA options are taken from the model user profile.

### VSE/ESA Required VSE/ICCF Options

The VSE/ESA Interactive Interface requires user profiles to be defined with certain VSE/ICCF options in order to operate correctly. For example, if a type 1 user profile was specified as a model for a type 2 user, the VSE/ICCF option byte settings would be incorrect. If a new user profile is added to the current VSE Control File, incompatible VSE/ICCF options are listed in the status report.

If **ALT=YES** is specified in the control statement and a new user is found to be ADDED, it will be added with the VSE/ESA default values. The values for an existing user in the current DTSFILE will be ALTERed to the default values.

The VSE/ESA default values are as follows:

- OPTA, OPTB, and OPTC bytes.

User type 1 (Administrator):

```
OPTA - 011*00*1
OPTB - **111010
OPTC - **000*0*
```

User type 2 (Programmer):

```
OPTA - 000*01*0
OPTB - **000000
OPTC - **000*0*
```

\* bits not checked or changed

```
TIMEOUT - 600
LOGONRTN - @L$LOGON
DEL, TAB, BS, ESC, END, and HEX - Set to OFF
```

For more information on the VSE/ICCF options refer to “Maintaining User Profiles” in the IBM manual *VSE/ESA Administration*.

### Reserved VSE/ICCF Libraries

When adding VSE/ICCF users, the user’s library number is checked to determine if one of the VSE/ESA reserved libraries (50 - 68) has been specified. If so, the library is listed on the status report as being incompatible.

If **ALT=YES** has been specified in the control statement, the library number is altered to 10 for administrators and to 9 for programmers. If an alternate library has been specified as one of the VSE/ESA reserved libraries, it is not changed but indicated in the status report.

### CICS Sign-On Table (DFHSNT)

If **SNT=YES** is specified in the control statement, DFHSNT is scanned for entries. If there is no matching user ID defined in the current VSE Control File, the DFHSNT user ID is added as a type 3 user (non-VSE/ICCF user).

Refer also to “Note on DFHSNT” under “Introducing the IESBLDUP Utility” on page 135.

## Using the IESBLDUP Utility

IESBLDUP performs the following steps:

- It updates the VSE Control File with user profile and control data information.
- It creates job DTRMIGR and places it into the VSE/POWER reader queue.

DTRMIGR invokes the VSE/ICCF utility DTSUTIL to perform the following functions:

- Add new user profiles to the current VSE/ICCF DTSFILE.
- Alter VSE/ICCF DTSFILE options which are incompatible with VSE/ESA 2.7.
- Catalog a dummy table ADM\$USRT into VSE/ICCF library 50 for performance reasons. Table ADM\$USRT will be deleted after the *Maintain User Profiles* dialog is used for the first time.

To ensure that DTRMIGR is processed immediately after IESBLDUP has finished, run IESBLDUP as a CLASS=A job (DTRMIGR is created as CLASS=A, DISP=K).

### Assignments

For the IESBLDUP job stream, the following assignments are used:

- **SYS004**  
Defines the tape drive where the copy of the old VSE/ICCF DTSTFILE (DTSRSTR) is mounted.
- **SYS005**  
Defines the tape drive where the copy of the old VSE Control File is mounted. If only one physical tape drive is available and CF=YES is specified in the control statement, SYS005 must be unassigned (// ASSGN SYS005,UA). The operator will then be instructed to mount the old VSE Control File copy on SYS004 after processing of the DTSTFILE copy has been completed.  
In case of DOS/VSE, which uses as input the DTSTFILE only, SYS005 must be defined with // ASSGN SYS005,IGN to avoid reading of the old VSE Control File (even if CF=YES).
- **SYS010**  
Defines the disk device on which the current VSE/ICCF DTSTFILE resides. As shipped, the DTSTFILE resides on the SYSWK1 system disk. The assignment is done by procedure DTRICCF.

### Running IESBLDUP

When running IESBLDUP, you must observe the following:

- IESBLDUP must run in a batch partition controlled by VSE/POWER. VSE/POWER must be generated with the SPOOL=YES option, as delivered with VSE/ESA 2.7.
- If UPDATE=YES is specified and the Interactive Interface is active, enter the following CEMT command to close the VSE Control File (IESCNTL):

```
CEMT SET FILE(IESCNTL) CLOSE
```

Enter the following command to close the Security Server partition:

```
MSG FB,DATA=CLOSECNTL
```

To re-open the VSE Control File (IESCNTL), enter:

```
CEMT SET FILE(IESCNTL) OPEN
```

To re-open the Security Server partition, enter:

```
MSG FB,DATA=OPENCNTL
```

As long as IESCNTL is closed, you cannot sign on to the Interactive Interface.

You also are requested to disconnect the DTSTFILE before DTRMIGR runs. Enter the following command:

```
/DISC DTSTFILE
```

When DTRMIGR has finished, you should reconnect the DTSTFILE using the command:

```
/CON DTSTFILE
```

- If UPDATE=NO is specified in the control statement, both the current VSE Control File and DTSTFILE are used in read only mode and need not be closed or disconnected.
- The VSE/ICCF modules DTSFILRT and DTSUTIL must be in a VSE/ESA library accessible to IESBLDUP. The same is true for the CICS sign-on table (DFHSNT), if you have set SNT=YES (see Figure 17 on page 142).

## The Status Report

A status report, which shows the results of the migration process, is printed on SYSLST. The following items are listed:

- The existing user IDs defined in the VSE Control File, VSE/ICCF DTSTFILE, and the CICS sign-on table DFHSNT (if DFHSNT was migrated).
- Each user ID processed together with the VSE/ICCF library assigned, the model profile used, and an indication whether a matching DFHSNT entry was found in case SNT was specified.

If the VSE/ICCF options found are incompatible with VSE/ESA 2.7, the old values are shown on the status report.

## Model User Profiles

For each user profile added to the current VSE Control File (except for users from the old VSE Control File), an existing VSE/ESA user profile is used as a model for the new user. The model profile provides default values when creating a new user profile.

VSE/ESA provided user profiles (for example SYSA, PROG, and OPER) may be used as model profiles. You may also define your own model profile with the *Maintain User Profiles* dialog.

For users added to the current VSE Control File from the current or old DTSTFILE, the model selected is based on the user class defined in the VSE/ICCF DTSTFILE user record. The profile specified in the control statement for ADMN will be used as the model for the administrator (bit 2 of OPTB=1), and the name specified for PROG will be used for all other users. The defaults, which may be changed, are ADMN=SYSA and PROG=PROG. If you use different model users, the related users must be defined in the **new** (VSE/ESA 2.7) VSE Control File.

If users are to be added from the CICS sign-on table (DFHSNT) as type 3 users, a profile should be defined with the GENL parameter in the control statement. If no name is specified, the default is GENL=PROG with the user type changed from type 2 to type 3. When PROG is used as a default profile, the initial selection panel will offer selections that require access to VSE/ICCF. Type 3 users, however, do not have access to VSE/ICCF functions. It is therefore recommended that you create your own default profile for type 3 users.

## Adding New Users

If you want to add new user IDs to VSE/ESA, you can also use the batch program IESUPDCF, as described in the *System Utilities* manual. It is recommended to add new users **after** you have migrated your system.

## Migrating to VSE/ESA 2.7

### Backups Required from Your Old System

To perform migration you need a copy on tape of your old DTSFILE and your old VSE Control File.

If you want to migrate users defined in DFHSNT (the latest is the CICS/VSE 2.3 DFHSNT), you must ensure that the DFHSNT is in a library accessible to IESBLDUP.

1. If migrating from **VSE/SP** or an earlier version of **VSE/ESA**, create a copy of the old DTSFILE by using the *Backup/Restore Library Objects* dialog.

If you are a **DOS/VSE** user, use the VSE/ICCF utility DTSUTIL to create a copy of the DTSFILE. Note that step 2 does **not** apply to **DOS/VSE**, since in this case the VSE Control File is not used as input.

2. If migrating from **VSE/SP** or an earlier version of **VSE/ESA**, create a copy of the old VSE Control File (IESCNTL).

You can create a backup copy either by:

#### a. Using the Interactive Interface

Select the *Resource Definition* dialog from the *VSE Selection Panel*. In the *File and Catalog Management* dialog select the *Display or Process a File* panel for the VSE/VSAM user catalog VSESPUC. On the next panel, select the COPY function to copy the VSE Control File (IESCNTL). The COPY function uses the VSE/VSAM REPRO command. When requested, the following should be specified:

- Volume serial number (CF0001)
- RECORD FORMAT=3 (variable-length blocked records)
- BLOCK SIZE=4000

**Note:** Do *not* use VSE/VSAM Backup/Restore to create the VSE Control File copy. The VSE/VSAM REPRO command must be used.

#### b. Creating a jobstream for batch processing

```
* $$ JOB JNM=BACKNTR,CLASS=A,DISP=D,NTFY=YES
// JOB COPY FILE
// DLBL COPYIN,'VSE.CONTROL.FILE',,VSAM,                X
//          CAT=VSESPUC
// TLBL COPYOUT,'CONTROL.FILE',,CF0001
// ASSGN SYS005,181
// EXEC IDCAMS,SIZE=AUTO
// REPRO INFILE (COPYIN) -
//          OUTFILE (COPYOUT) -
//          ENVIRONMENT (BLOCKSIZE (4000) -
//          RECORDFORMAT (VARBLK) -
//          STDLABEL -
//          PRIMEDATADEVICE (2400 REW)) -
//          NOREUSE
/*
/&
* $$ E0J
```

Figure 15. Example Job for Backing Up the VSE Control File

## Precautionary Measures

The following measures help you recover in case migration failed during initial installation or later. Even if migration failed during initial installation, you can take a backup copy of the VSE Control File which is not damaged since no update takes place in case of a failure. The best point for creating a backup copy is after initial installation post-base processing.

1. A **backup** the DTSFILE of your new VSE/ESA 2.7 system using the *Backup/Restore Library Objects* dialog. Perform this step to ensure that you still have a correct version of the DTSFILE available in case of migration errors. If you encounter migration errors, see page 148. However, before backing up the DTSFILE a reformat run will be necessary if you want to migrate more libraries or users than the current DTSFILE allocation allows. The VSE/ESA-supplied DTSFILE contains an allocation for 199 libraries and 199 users.
2. A **backup** of the VSE Control File (IESCNTL) of your new VSE/ESA 2.7 system. For details on how to do this, see step 2 on page 140 under “Backups Required from Your Old System” on page 140.

Refer also to “Recovering from Migration Errors” on page 148.

## Migration Steps

The following summary of migration steps applies if you did **not** migrate during initial installation.

1. Create backup tapes of the old DTSFILE and the old VSE Control File.  
If you migrate a DFHSNT, ensure that it is in a library accessible to IESBLDUP.
2. Prepare the job stream to run IESBLDUP.  
The control statement must be placed immediately after the // EXEC statement. Refer to “The Control Statement” on page 145 for the default values active.
3. Run IESBLDUP first with UPDATE=NO in the control statement to get a status report.
4. Review the status report and correct any errors.
5. Change the control statement to UPDATE=YES and resubmit the job. If UPDATE=YES, close the VSE Control File if the corresponding message is issued.
6. Job DTRMIGR will be submitted as soon as IESBLDUP has finished processing. Disconnect the DTSFILE when instructed to do so.
7. Review the status report.

### Example 1: Migrating to VSE/ESA 2.7 from a VSE/SP or Previous VSE/ESA

**System:** The following example shows migration to VSE/ESA 2.7 from a VSE/SP or VSE/ESA system. The user profiles SYSA and PROG are implicitly used as user models for administrators and programmers.

This sample job stream is provided as skeleton IESBLDUP in VSE/ICCF library 59.

## Migration Utility IESBLDUP

```
* $$ JOB JNM=IESBLDUP,CLASS=A,DISP=D
// JOB IESBLDUP  MIGRATION FROM VSE/SP or VSE/ESA
// EXEC PROC=DTRICCF
// TLBL DTSRSTR,,ICCF01      **DTSFILE BACKUP**
// ASSGN SYS004,300
// TLBL CFCOPY,,CF0001      **CONTROL FILE COPY**
// ASSGN SYS005,301
// PAUSE  IESCNTRL MUST BE CLOSED IF UPDATE=YES IS SPECIFIED
// EXEC IESBLDUP,SIZE=64K
* CONTROL STATEMENT FOR MIGRATION FROM A VSE/SP OR VSE/ESA SYSTEM
CF=YES,DTSRSTR=YES,UPDATE=YES
/*
/&
* $$ E0J
```

Figure 16. Job Stream Example for Migrating from VSE/SP or Previous VSE/ESA System

**Example 2: Migrating to VSE/ESA 2.7 from a DOS/VSE System:** The following example shows migration to VSE/ESA 2.7 from a DOS/VSE system. User profiles are created from the IDs defined in the old DTSFILE and the CICS sign-on table DFHSNT (if a DFHSNT exists). USRA, USRB, and USRC are used as model user profiles. You must define them in the current VSE Control File before submitting the job stream.

Note that the DFHSNT must be CICS/DOS/VS version 1.7 or later. If you migrate from an earlier version, you must first create a job stream to process your old DFHSNT with macro DFHSNT of CICS/VSE 2.3 in the VSE/ESA 2.7 coexistence environment. Refer also to "Note on DFHSNT" under "Introducing the IESBLDUP Utility" on page 135.

```
* $$ JOB JNM=IESBLDUP,CLASS=A,DISP=D
// JOB IESBLDUP  MIGRATION FROM DOS/VSE
// EXEC PROC=DTRICCF
// TLBL DTSRSTR,,ICCF01      **DTSFILE BACKUP**
// ASSGN SYS004,300
// PAUSE  UPDATE=YES IS SPECIFIED, CLOSE IESCNTRL
        BEFORE PROCEEDING
// EXEC IESBLDUP,SIZE=64K
CF=NO,DTSRSTR=YES,SNT=YES,ALT=YES,UPDATE=YES
ADMN=USRA,PROG=USRB,GENL=USRC
/*
/&
* $$ E0J
```

Figure 17. Job Stream Example for Migrating from DOS/VSE

**Example 3: Creating a Status Report of Existing User IDs:** The following example produces a status report which lists the user IDs defined in the VSE Control File, VSE/ICCF DTSFILE, and the CICS sign-on table DFHSNT (if a DFHSNT exists).



```
* $$ JOB JNM=IESBLDUP,CLASS=A,DISP=D
// JOB IESBLDUP STATUS REPORT OF USER IDS
// EXEC PROC=DTRICCF
// EXEC IESBLDUP,SIZE=64K
CF=NO,DTSRSTR=NO,UPDATE=NO
/*
/&
* $$ E0J
```

Figure 18. Job Stream Example for Status Report

**Example 4: Status Report Example:** Figure 19 shows an example of a status report.

```
// JOB MIGRAT
// EXEC PROC=DTRICCF
// ASSGN SYS010,DISK,VOL=SYSWK1,SHR      DTSFILE EXTENT
1T20I  SYS010 HAS BEEN ASSIGNED TO X'141' (TEMP)
EOP DTRICCF
// EXEC IESBLDUP,SIZE=64K

10/13/98 VSE/ESA MIGRATION UTILITY
CF=NO,DTSRSTR=NO,UPDATE=NO,DTSFILE=YES
IESU0002I VSE CONTROL FILE 'IESCNTL' OPENED FOR INPUT
IESU0004I ICCF DTSFILE OPENED
10/13/98 VSE/ESA MIGRATION UTILITY
CONTROL
USER ID  DTSFILE  FILE
$SRV    N        2
AAAA    A
AAA2    A
AAA3    A
ABCDE   A        1
ADAM    A
ADMN    A
AMAD    A        1
?AMPR   A        2      WARNING, TYPE 1 OR 2 USER WITH NO ICCF USER PROFILE
ARMI    A
ASEC    A        2
AZZZ    A
A102    A
A103    A
A104    A
:
:
A138    A
A139    A
A140    A
10/13/98 VSE/ESA MIGRATION UTILITY
CONTROL
USER ID  DTSFILE  FILE
A141    A
A170    A
A171    A
```

DATE 10/13/98,CLOCK 07/39/48

-INITIALIZATION- PAGE 1

-STATUS OF EXISTING VSE USER IDS- PAGE 2

-STATUS OF EXISTING VSE USER IDS- PAGE 3

Figure 19. Example for a Status Report Output (Part 1 of 3)

# Migration Utility IESBLDUP

A172	A		
BGIG	A		
CALL	A		
CHIN		3	
DAVE	A		
DAVI	A	1	
DAV8	A		
DAV9	A		
DISP	A	1	
DUVE	N		
D112	A		
ENGL		3	
?FAC1		2	WARNING, TYPE 1 OR 2 USER WITH NO ICCF USER PROFILE
?FAC2		2	WARNING, TYPE 1 OR 2 USER WITH NO ICCF USER PROFILE
?FAC3		2	WARNING, TYPE 1 OR 2 USER WITH NO ICCF USER PROFILE
?FAC4		2	WARNING, TYPE 1 OR 2 USER WITH NO ICCF USER PROFILE
FORSEC		1	
GLAE	A GOEB		A
HAL0	A		
HANS	A		
HART	A		
HEIN	A		
HELD	A		
HSCZ	A	1	
IBMS	A	1	
JAPA		3	
JIM2	N		
JOER	A		
JORG	A	1	
JSCH	A	1	
?JSC1		1	WARNING, TYPE 1 OR 2 USER WITH NO ICCF USER PROFILE
JUST	A		
MOST	N		
NETT	A		
NLST	A	1	
NOICCF		1	
OPER	A	2	
POST	A	1	
PROG	N	2	
SCHA	A		
SPAN		3	
SYSA	A	1	
TES2	A		
USCH	A	1	
VOGL	A		

10/13/98 VSE/ESA MIGRATION UTILITY CONTROL -STATUS OF EXISTING VSE USER IDS- PAGE 4

USER ID	DTSFILE	FILE	
VOLK	A	1	
VOL0	A		
VOL1	A		
VOL2	A		
V111	A		
V222	A		
?WACK		1	WARNING, TYPE 1 OR 2 USER WITH NO ICCF USER PROFILE
WURS	A		
ZELL	A	1	
ZEL1	A		
1234	A		
2222	A		
9999	A		

Figure 19. Example for a Status Report Output (Part 2 of 3)

```

TOTAL          74      32
ALLOC          199
DTSFILE USER TYPE:
  A = ADMINISTRATOR
  N = NORMAL
CONTROL FILE USER TYPE:
  1 = ADMINISTRATOR
  2 = PROGRAMMER
  3 = GENERAL
10/13/98 VSE/ESA MIGRATION UTILITY                -CREATE USER PROFILES-                PAGE 5
          CONTROL  DEFAULT  ICCF  -----ICCF OPTIONS INCOMPATIBLE WITH VSE/ESA-----
          FILE      PROFILE  LIBR  LIBR ALT  OPTA  OPTB  OPTC  LOGON  TIMEO  DEL  TAB  BS  ESC  END  HEX
USERS ADDED FROM DTSFILE:
*$SRV          PROG      11  IGNORED, DUPLICATE ID ON CONTROL FILE
* = INDICATES THAT USER ID WAS NOT ADDED
IESU0150I      0 RECORDS WERE ADDED TO VSE CONTROL FILE
IESU0010I  IESBLDUP EXECUTION COMPLETED, END OF JOB
1S55I  LAST RETURN CODE WAS 0000
EOJ MIGRAT    MAX.RETURN CODE=0000                DATE 10/13/98,CLOCK 07/40/05,DURATION 00/00/17
    
```

Figure 19. Example for a Status Report Output (Part 3 of 3)

### The Control Statement

The control statement must follow directly the // EXEC IESBLDUP statement. Processing options are selected by keywords and may be specified on multiple statements.

### Control Statement Format

The control statement format is shown below.

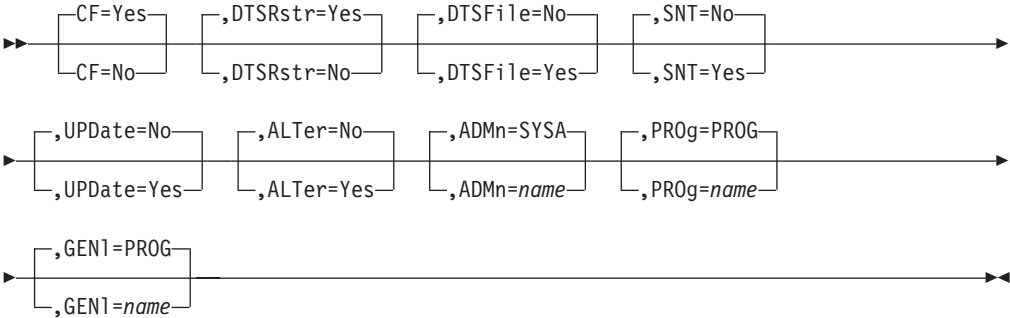

### Keyword Description

Default values are underlined.

- CF=Yes | No** Specifies whether a copy of an old VSE Control File is to be processed.
  - Yes** A copy of an old VSE Control File will be read from the tape drive assigned to SYS005. If only one tape drive is available SYS005 must be unassigned. After reading the DTSFILE copy, the VSE Control File copy is mounted on the drive assigned to SYS004. The records of the old VSE Control File are added to the current VSE Control File. Records with duplicate keys and reserved VSE/ESA record

types (IES records) are ignored. If this option is specified, DTSRSTR=YES must also be specified.

**No** No copy of an old VSE Control File is to be processed.

### DTSRstr=Yes | No

Specifies whether a copy of an old VSE/ICCF DTSTFILE is to be processed.

**Yes** If CF=YES is specified:

A copy of an old VSE/ICCF DTSTFILE will be read from the tape unit assigned to SYS004. The VSE/ICCF user profiles are copied to the current DTSTFILE. If there is a user ID on the old DTSTFILE which does not exist on the current DTSTFILE, it is copied to the current DTSTFILE from the old DTSTFILE.

If CF=NO is specified:

A copy of an old VSE/ICCF DTSTFILE will be read from the tape unit assigned to SYS004. For each ID found in the file, a user profile is created and added to the current VSE Control File and current DTSTFILE. If the ID is already in the current VSE Control File, the ID of the old DTSTFILE is ignored.

**No** No copy of an old DTSTFILE is to be read.

### DTSFile=Yes | No

Specifies whether VSE/ESA user profiles are to be created for user IDs defined on the current VSE/ICCF DTSTFILE.

**Yes** The current DTSTFILE will be read and for each ID found, a user profile will be created and added to the current VSE Control File. If the ID is already on the VSE Control File, it is ignored.

**No** No user profiles are to be created from the current DTSTFILE.

### SNT=Yes | No

Specifies whether the CICS sign-on table (DFHSNT) is to be processed. Refer also to "Note on DFHSNT" under "Introducing the IESBLDUP Utility" on page 135.

**Yes** Table DFHSNT is searched for a matching user ID when creating and adding user profiles to the current VSE Control File. The ID is compared to the USERID field in DFHSNT. If the IDs and passwords match, the DFHSNT entry is used to provide the CICS data for the new user ID (like CICS TIMEOUT and security keys). DFHSNT is not scanned for users being added from the old VSE Control File. The CICS data for them is taken from the old user profile.

If a DFHSNT entry contains a 4-8 character user ID and a three to six character password, and if there is no matching user ID defined on the current VSE Control File, the ID is added as a type 3 user.

**No** Table DFHSNT is not be processed. Default values are used for the CICS data in the current VSE Control File. No users are added from the DFHSNT.

**UPDate=Yes | No**

Specifies whether the current VSE Control File and VSE/ICCF DTSFILE are to be updated.

- Yes** New users are added to the current VSE Control File and the current DTSFILE is updated with new and changed VSE/ICCF users.
- No** The current VSE Control File is not updated and the job DTRMIGR is not submitted to update the current DTSFILE. The job is executed in edit mode only.

**ALTer=Yes | No**

Specifies whether VSE/ICCF options that are incompatible with VSE/ESA are to be altered.

- Yes** When adding VSE/ICCF users (type 1 and 2), the user's VSE/ICCF options are checked for VSE/ESA incompatible options. If the user being added has incompatible options specified, they will be altered to be VSE/ESA compatible. Refer to "Maintaining User Profiles" in *VSE/ESA Administration* for a description of the VSE/ICCF options.
- No** Incompatible VSE/ICCF options are not to be altered.

**ADMn=SYSA | name**

Specifies the user profile to be used as a "model" for administrators (bit 2 of OPTB=1) if the input is from the current DTSFILE or an old DTSFILE. This profile will supply the default data for the new user. The model user profile specified must be defined in the current VSE Control File before IESBLDUP is run.

**PROg=PROG | name**

Specifies the user profile to be used as a "model" users of type programmer (bit 2 of OPTB=0) if the input is from the current DTSFILE or old DTSFILE. This model user profile will supply the default data for the new user. The user profile specified must be defined in the current VSE Control File before IESBLDUP is run.

**GENI=PROG | name**

Specifies the user profile to be used as a "model" when adding users to VSE/ESA from the CICS sign-on table (DFHSNT) as type 3 users. The user profile specified must be defined in the current VSE Control File before IESBLDUP is run. If the profile specified is not of type 3, the VSE/ICCF options are ignored and the user is added as a type 3 user.

## Recovering from Migration Errors

If you encounter an error while migrating the (old) VSE Control File, you may have to perform the following steps to **restore** the previously saved (new) VSE Control File. Refer also to "Precautionary Measures" on page 141.

1. On the VSE/ESA Selection Panel, select the dialog *Resource Definition*.
2. Select the COPY function from the *Display or Process a File* dialog.
3. At the *Copy Files* panel specify the file as an output file and the second (input) file as tape.
4. Enter the file ID and name.
5. The following *must* be specified at the *Copy Files - Tape Specification* panel:
  - RECORD FORMAT=3 (variable-length blocked records)
  - BLOCK SIZE=4000

**Note:** Do **not** submit the job for immediate execution because you must edit it before submission.

6. Edit the job and insert the REPLACE option as shown in Figure 20.
7. Submit the job.

### Additional VSE Control File Information:

If migration fails during initial installation, the VSE Control File is not damaged. The status of the new control file is: hardware configuration information has been migrated but not user profiles and related data. User profiles may be migrated later in a separate job step using skeleton IESBLDUP. Refer also to Figure 16 on page 142.

### Example Job for Restoring the VSE Control File:

```
* $$ JOB JNM=RETCNTR,CLASS=A,DISP=D,NTFY=YES
// JOB AMAD COPY FILE
// DLBL COPYOUT,'VSE.CONTROL.FILE',,VSAM, X
      CAT=VSESPUC
// TLBL COPYIN,'CONTROL.FILE',,CF0001
// ASSGN SYS004,181
// EXEC IDCAMS,SIZE=AUTO
  REPRO INFILE (COPYIN -
    ENVIRONMENT (BLOCKSIZE (4000 ) -
      RECORDFORMAT (VARBLK) -
      STDLABEL -
      PRIMEDATADEVICE (2400) REW)) -
    OUTFILE (COPYOUT) -
    NOREUSE REPLACE
/*
/&
* $$ E0J
```

Figure 20. Restoring the VSE Control File

---

## Appendix D. Preparing for Initial Installation or FSU from Virtual Tape

Starting with VSE/ESA 2.7.2 there are two new distribution media, CD-ROM and electronic delivery (that is, you can download VSE/ESA from the internet). Both methods are based on virtual tape format (AWSTape format). The installation is similar for both methods. With electronic delivery, you must first download the files from the IBM Web site to your workstation and unzip the files. If VSE/ESA is distributed on CD-ROM, the data can be used directly on your workstation.

The following file names are used for the VSE/ESA tape images:

*Table 18. File Names of Tape Images*

Tape Image	CD-ROM	Electronic Delivery (downloaded from internet and unzipped)
Base Tape	VSEBAS27.aws	VSE27xYY.aws
Extended Base Tape	VSEBAE27.aws	VSE27xB.aws
DB2 Help Tape	DB2VSEHE.aws	DB2HELP.aws
Optional Products Tape	VSEOPT27.aws	VSEOPT27.aws

The first CD contains the files for the VSE/ESA Base, Extended Base, and DB2 Help tape images. The optional products are on the second CD. For electronic delivery, the Download Director creates a directory called DownloadDirector and downloads the zipped virtual tape image files (AWSTape image files) to this directory (for example, C:\DownloadDirector).

---

### Preparing the Installation

Before you can start to install VSE/ESA 2.7.x, you have to perform the following steps:

1. Prepare the virtual tape file for the base tape.
2. Depending on whether you want to perform an initial installation or an FSU,
  - copy the file containing the base tape to a real tape (see “Preparing the Virtual Tape Files on the Workstation”), or
  - transfer the file to VSAM for an FSU via virtual tape.
3. Install the extended base products and the optional products to complete the installation.

### Preparing the Virtual Tape Files on the Workstation

Unzip the downloaded files by using a compression utility (for example, PKUNZIP). The zipped files contain one virtual tape image file each. If you received VSE/ESA on CD, the virtual tape files are already in virtual tape format (aws) and ready to use.

The following sections describe the steps that are required to install or upgrade VSE/ESA from CD.

### Preparing for Initial Installation or FSU

If you are already running VSE/ESA 2.7, you can start the FSU from the virtual tape. In case you have VSE/ESA 2.6 installed, or in case you want to perform an initial installation, you should copy the base tape, which is in AWSTape format, to a real tape. If you plan to install VSE/ESA 2.7.x on a system that is capable to read tape images in virtual tape format (for example, an IBM S/390 Multiprise 3000), you do not need to copy the image to a real tape or VSAM, you can directly continue with the initial installation or FSU, by using the distribution file on an emulated tape device.

In order to copy the files to a real tape, the cartridge must be capable to hold at least 250 MB. If you use a 3480 cartridge, IDRC compression is required for the data to fit on a regular cartridge.

To be able to use the virtual tape function with VSE/ESA 2.6 and VSE/ESA 2.7, certain APARs must be installed. Refer to the Program Directory, or to the installation instructions available on the VSE/ESA Web site

<http://www.ibm.com/servers/eserver/zseries/os/vse/>

for the latest information about the required APARs.

To copy the virtual tape to a real tape, use the VSE Virtual Tape Support. This can be done either from the remote site (workstation) or via VSAM and FTP and subsequent DITTO tape-to-tape copy.

A document with operation considerations of the VSE Virtual Tape Support is available on the following VSE Web site:

[http://www.ibm.com/servers/eserver/zseries/os/vse/support/vtape/virtual\\_tape2.htm](http://www.ibm.com/servers/eserver/zseries/os/vse/support/vtape/virtual_tape2.htm)

### Using a Remote Tape Image on a Workstation to Copy the Base Tape to Real Tape

Perform the following steps to copy the tape image. Run the VSE job, as shown below, to copy the base tape image in virtual tape format residing on a workstation to a real tape (at least 3480 IDRC - only one cartridge). The job uses a virtual tape at address cuu1 and performs a DITTO tape-to-tape copy to a real tape at cuu2. See the example below for the parameters you must specify. Make sure that the VSE Virtual Tape Server is started on your workstation.

```
* $$ JOB JNM=COPYTAPE,CLASS=0,DISP=D
// JOB COPYTAPE
// PAUSE PLEASE MOUNT A TAPE ON <cuu2>
// UPSI 1
DVCDN <cuu1>
// PAUSE - DEVICE DOWN OK
// VTAPE START,UNIT=<cuu1>,LOC=<ip-address>,FILE='<tape image file>',READ
DVCUP <cuu1>
// ASSGN SYS010,<cuu2>,08 * OUTPUT MEDIA, 3480 COMPRESSED
// ASSGN SYS011,<cuu1> * INPUT MEDIA
// EXEC DITTO
$$DITTO REW OUTPUT=SYS010
$$DITTO REW OUTPUT=SYS011
$$DITTO TT INPUT=SYS011,OUTPUT=SYS010,NFILES=<36>
/*
DVCDN <cuu1>
// VTAPE STOP,UNIT=<cuu1>
DVCUP <cuu1>
/&
* $$ E0J
```



Before submitting the job, you must enter the following parameters:

<cuu1>

Device address of the input tape (virtual)

<cuu2>

Device address of the output tape (real)

<ip-address>

IP address of the workstation where the VSE Virtual Tape Server is running (in the format 10.3.4.56).

<tape image file>

File name and path of the remote virtual tape image containing the VSE/ESA base tape. (For example, C:\DownloadDirector\VSE272EN.AWS)

### Notes:

1. NFILES=<36> is only valid for the base tape. In case of the extended base tape, the value is 46.
2. FSU can also be done by using a real tape.

After you copied the tape image to a real tape, continue with the installation or FSU of the VSE/ESA 2.7 base tape.

## Using a VSAM Tape Image on a VSE/ESA System

Perform the following steps to use the VSAM tape image on your VSE/ESA system:

- Define a virtual tape file in VSAM using skeleton SKVTAPE (ICCF library 59). You need about 250 MB of VSAM space to copy the base tape.
- Transfer the base tape in virtual tape format (type aws) to VSAM using FTP. For more details, see "Uploading the Base Tape to VSAM for FSU via Virtual Tape."
- Copy the VSAM base virtual tape to a real tape with a DITTO job as described in "Using a Remote Tape Image on a Workstation to Copy the Base Tape to Real Tape" on page 150 with the following VTAPE command:

```
// VTAPE START,UNIT=<cuu1>,LOC=VSAM,FILE='<tape image file>',READ
```

<tape image file> is the label name of the VSAM file containing the tape image (for example, VTAPE1).

After copying the tape image to a real tape, continue with the installation or FSU of the VSE/ESA 2.7 base tape.

## Uploading the Base Tape to VSAM for FSU via Virtual Tape

In case you are installing a service refresh on VSE/ESA 2.7, use the skeleton SKVTAPE, provided in ICCF library 59, to define a VSAM ESDS cluster. The catalog should have about 250 MB free space.

Upload the tape image into a VSAM data set. The base tape is loaded into the VSAM data set using TCP/IP FTP. To do this you need to have an FTP daemon defined in the TCP/IP for VSE/ESA partition. Use the following commands for the upload:

```
C:\DownloadDirector>ftp 10.2.3.45          <-- IP address or hostname of VSE system
Connected to 10.2.3.45.
220-TCP/IP for VSE -- Version 01.05.00 -- FTP Daemon
Copyright (c) 1995,2001 Connectivity Systems Incorporated
220 Service ready for new user.
User (10.2.3.45:(none)): sysa             <-- enter your user id here
```

## Installing from Virtual Tape

```
331 User name okay, need password.
Password:                               <-- enter your password here
230 User logged in, proceed.
ftp> bin                                 <-- switch to binary mode
200 Command okay.
ftp> quote site lrecl 32758             <-- record size of your file
200 Command okay.
ftp> quote site recfm v                 <-- set record format to variable
200 Command okay.
ftp> put VSE272EN.AWS VSE.VTAPE.FILE    <-- enter your filenames
```

After loading the base tape you can start the FSU from virtual tape.

---

## Installing Additional Products

Products from the extended base tape as well as optional products can be installed from the remote server (workstation) using the Interactive Interface dialog. The related virtual tape files can also be transferred to VSAM by using FTP. Installation from a VSAM virtual tape is also done using the Interactive Interface dialog. If required, the virtual tape can also be copied to a real tape, the number of files to be copied depends on the amount of products on the tape. The DITTO tape-to-tape copy job can specify 999 files, but this will generate an error message on the virtual input tape.

To install the DB2 Help feature, either specify a virtual tape address referring to the remote virtual tape file during the DB2 installation, or copy the virtual DB2 Help tape to a real tape.

---

## Additional Information for Receiving VSE/ESA from the Internet

Depending on your order, it can contain items that are packaged in zipped format. In this case, perform the following:

1. Download the xxxxxxx.zip file to your workstation.
2. Extract the files using an unzip function.
3. Browse the extracted material for files like readme.txt, index.htm, or index.html to get started.

Most of the extracted files can be used directly. In some cases your order may contain ADDITIONAL MATERIAL or ADDITIONAL PUBLICATIONS that were originally packaged on CDs. These may be provided as ISO 9660 images with a file extension of .iso. An ISO 9660 CD-ROM image is a single large file that is an exact representation of the data and programs as they appear on a CD, reflecting both the content and logical format.

To use .iso files, you have two options:

1. Create a physical CD. This requires that your workstation has a CD-write capability and software that supports ISO 9660 format. When you create the physical CD, this is an exact copy of the original CD and has all of the characteristics of the original image (for example, special file names, and - if applicable - it is a bootable CD).
2. Use virtual CD software. Virtual CD software emulates your computer's CD-ROM drive, enabling you to execute programs, view and use data provided in the CD image directories and files. This is an alternative to creating a physical CD. This software must support .iso files.

## Installing from Virtual Tape

Read the license agreements and follow the procedures that are specific to any software that you use to process these packages.

## Installation Overview and Preparation

---

## Glossary

If you do not find the term you are looking for, refer to the index of this book or to the *IBM*

*Glossary of Computing Terms* at:

<http://www.ibm.com/ibm/terminology>

The glossary includes definitions with:

- Symbol \* where there is a one-to-one copy from the IBM Dictionary of Computing.
- Symbol (A) from the *American National Dictionary for Information Processing Systems*, copyright 1982 by the Computer and Business Equipment Manufacturers Association (CBEMA). Copies may be purchased from the American National Standards Institute, 1430 Broadway, New York, New York 10018. Definitions are identified by the symbol (A) after the definition.
- Symbols (I) or (T) from the *ISO Vocabulary - Information Processing* and the *ISO Vocabulary - Office Machines*, developed by the International Organization for Standardization, Technical Committee 97, Subcommittee 1. Definitions of published segments of the vocabularies are identified by the symbol (I) after the definition; definitions from draft international standards, draft proposals, and working papers in development by the ISO/TC97/SC1 vocabulary subcommittee are identified by the symbol (T) after the definition, indicating final agreement has not yet been reached among participating members.

**access control.** A function of VSE that ensures that the system and the data and programs stored in it can be accessed only by authorized users in authorized ways.

**access control table (DTSECTAB).** A table used by the system to verify a user's right to access a certain resource.

**access method.** A program, that is, a set of commands (macros), to define files or addresses and to move data to and from them; for example VSE/VSAM or VSE/VTAM.

\* **account file.** A direct access file maintained by VSE/POWER to hold the accounting information it generates and the programs that it controls.

**address space.** A range of up to two gigabytes of contiguous virtual storage addresses that the system creates for a user. Unlike a data space, an address space contains user data **and** programs, as well as system

data and programs, some of which are common to all address spaces. Instructions execute in an address space (not a data space). Contrast with *data space*.

**ASI (automated system initialization) procedure.** A set of control statements which specifies values for an automatic system initialization.

\* **assemble.** To translate an assembly language program into an object program. (T)

**attention routine (AR).** A routine of the system that receives control when the operator presses the Attention key. The routine sets up the console for the input of a command, reads the command, and initiates the system service requested by the command.

\* **autostart.** A facility that starts up VSE/POWER with little or no operator involvement.

**backup copy.** A copy, usually of a file or a library member, that is kept in case the original file or library member is unintentionally changed or destroyed.

**batch program.** A program that is processed in series with other programs and therefore normally processes data without user interaction.

**block.** Usually, a block consists of several records of a file that are transmitted as a unit. But if records are very large, a block can also be part of a record only. On an FBA disk, a block is a string of 512 bytes of data. See also *control block*.

\* **BTAM-ES (Basic Telecommunication Access Method Extended Storage).** An IBM supplied telecommunication access method that permits read and write communication with remote devices.

\* **catalog.** 1. A directory of files and libraries, with reference to their locations. A catalog may contain other information such as the types of devices in which the files are stored, passwords, blocking factors. (I) (A) 2. To store a library member such as a phase, module, or book in a sublibrary.

See also *VSAM master catalog*, *VSAM user catalog*.

\* **cataloged procedure.** A set of control statements placed in a library and retrievable by name.

\* **channel-attached.** Pertaining to attachment of devices directly by data channels (I/O channels) to a computer. Contrast with *link-attached*. Synonymous with *locally attached*.

**CICS Transaction Server for VSE/ESA.** This is the successor system to CICS/VSE.

\* **CICS/VSE.** Customer Information Control System/VSE.

**CKD device.** Count-key-data device.

\* **cluster controller.** A device that can control the input/output operations of more than one device connected to it. A cluster controller may be run by a program stored and executed in the unit; for example, the IBM 3601 Finance Communication Controller. Or it may be entirely controlled by hardware; for example, the IBM 3272 Control Unit.

\* **communication adapter.** A circuit card with associated software that enables a processor, controller, or other device to be connected to a network.

\* **communication controller.** 1. A device that directs the transmission of data over the data links of a network; its operation may be controlled by a program executed in a processor to which the controller is connected or it may be controlled by a program executed within the device. (T) 2. A type of communication control unit whose operations are controlled by one or more programs stored and executed in the unit. It manages the details of line control and the routing of data through a network.

**component.** 1. Hardware or software that is part of a computer system. 2. A functional part of a product, identified by a component identifier. 3. In VSE/VSAM, a named, cataloged group of stored records, such as the data component or index component of a key-sequenced file or alternate index.

\* **configuration.** The devices and programs that make up a system, subsystem, or network.

**control block.** An area within a program or a routine defined for the purpose of storing and maintaining control information.

**control unit.** See *communication controller* and *cluster controller*. Synonymous with *controller*.

\* **cross-domain.** In SNA, pertaining to control or resources involving more than one domain.

**Customer Information Control System/VSE (CICS/VSE).** A VSE/ESA base program that controls online communication between terminal users and a database. Transactions entered at remote terminals are processed concurrently by user-written application programs. The product includes facilities for building, using, and servicing databases.

Its successor system is called CICS Transaction Server for VSE/ESA.

**DASD sharing.** An option that lets independent computer systems use common data on shared disk devices.

**database.** A set of data available online that is organized by a common system and used for a common purpose.

**data file.** See *file*.

**data link.** In SNA, the combination of the link connection and the link stations joining network nodes, for example, a System/370 channel and its associated protocols. A link is both logical and physical.

In SNA, synonym for *link*.

**data set.** See *file*.

**data space.** A range of up to two gigabytes of contiguous virtual storage addresses that a program can directly manipulate through ESA/370 instructions. Unlike an address space, a data space can hold only user data; it does not contain shared areas, system data or programs. Instructions do not execute in a data space, although a program can reside in a data space as non-executable code. Contrast with address space.

\* **device address.** 1. The identification of an input/output device by its channel and unit number. 2. In data communication, the identification of any device to which data can be sent or from which data can be received.

\* **Device Support Facilities (DSF).** An IBM supplied system control program for performing operations on disk volumes so that they can be accessed by IBM and user programs. Examples of these operations are initializing a disk volume and assigning an alternate track.

\* **device type code.** The four- or five-digit code to be used for defining an I/O device to a computer system.

\* **dialog.** 1. In an interactive system, a series of related inquiries and responses similar to a conversation between two people. 2. For VSE/ESA, a set of panels that can be used to complete a specific task; for example, defining a file.

**direct access.** Accessing data on a storage device using their address and not their sequence. This is the typical access on disk devices as opposed to magnetic tapes. Contrast with *sequential access*.

**directory.** 1. A table of identifiers and references to the corresponding items of data. (I) (A) 2. In VSE, specifically, the index for the program libraries. See also *library directory* and *sublibrary directory*.

**disk operating system residence volume (DOSRES).** The disk volume on which the system sublibrary IJSYRS.SYSLIB is located including the programs and procedures required for system startup.

**disposition.** A means of indicating to VSE/POWER how job input and output is to be handled. A job may, for example, be deleted or kept after processing.

\* **distribution tape.** A magnetic tape that contains, for example, a preconfigured operating system like VSE/ESA. This tape is shipped to the customer for program installation.

**DITTO/ESA for VSE.** Data Interfile Transfer, Testing and Operations/ESA for VSE.

**domain.** The network resources under the control of a particular SSCP.

**DOSRES.** Disk operating system residence volume.

**dummy device.** A device address with no real I/O device behind it. Input and output for that device address are spooled on disk.

**dynamic partition.** A partition created and activated on an 'as needed' basis that does not use fixed static allocations. After processing, the occupied space is released. Contrast with *static partition*.

**ECKD device.** Extended count-key-data device.

**emulation.** The use of programming techniques and special machine features that permit a computer system to execute programs written for another system or for the use of I/O devices different from those that are available.

**Enterprise Systems Architecture (ESA).** See *ESA/390*.

**ESA/390.** IBM Enterprise Systems Architecture/390. The latest extension to the IBM System/370 architecture which includes the advanced addressability feature and advanced channel architecture.

**extent.** Continuous space on a disk or diskette occupied by or reserved for a particular file or VSAM data space.

**fast service upgrade (FSU).** A service function of VSE/ESA for the installation of a refresh release without regenerating control information such as library control tables.

\* **file.** A named set of records stored or processed as a unit. (T) Synonymous with *data set*.

\* **forms control buffer (FCB).** In the 3800 Printing Subsystem, a buffer for controlling the vertical format of printed output.

\* **fragmentation (of storage).** In virtual system, inability to assign real storage locations to virtual storage addresses because the available spaces are smaller than the page size.

**FULIST (FUNCTION LIST).** A type of selection panel that displays a set of files and/or functions for the choice of the user.

\* **generate.** To produce a computer program by selecting subsets of skeletal code under the control of parameters. (A)

**generation.** See *macro generation*.

**guest system.** A data processing system that runs under control of another (host) system.

**hardcopy file.** A system file on disk, used to log all lines of communication between the system and the operator at the system console, to be printed on request.

**hard wait.** The condition of a processor when all operations are suspended. System recovery from a hard wait is impossible without performing a new system startup.

\* **hardware.** All or part of the physical components of an information processing system, such as computers or peripheral devices. (T) (A) Contrast with *software*.

\* **help panel.** A display of information provided by the system in response to a user's help request.

\* **host system.** The controlling or highest level system in a data communication configuration.

\* **initial program load (IPL).** The process of loading system programs and preparing the system to run jobs.

**integrated communication adapter (ICA).** The part of a processor where multiple lines can be connected.

**Integrated console.** In VSE/ESA, the service processor console available on an IBM S/390 or zSeries processor that operates as the VSE/ESA system console. The integrated console is typically used during IPL and for recovery purposes when no other console is available.

**interface.** A shared boundary between two hardware or software units, defined by common functional or physical characteristics. It might be a hardware component or a portion of storage or registers accessed by several computer programs.

**job step.** One of a group of related programs complete with the JCL statements necessary for a particular run. Every job step is identified in the job stream by an EXEC statement under one JOB statement for the whole job.

**job stream.** The sequence of jobs as submitted to an operating system.

\* **librarian.** The set of programs that maintains, services, and organizes the system and private libraries.

**library.** See *VSE library* and *VSE/ICCF library*.

\* **library directory.** The index that enables the system to locate a certain sublibrary of the accessed library.

\* **library member.** The smallest unit of data that can be stored in and retrieved from a sublibrary.

\* **licensed program.** A separately priced program and its associated materials that bear an IBM copyright and are offered to customers under the terms and conditions of the IBM Customer Agreement (ICA).

**link.** 1. To connect items of data or portions of programs; for example, linking of object programs by the linkage editor or linking of data items by pointers. 2. In SNA, the combination of the link connection and the link stations joining network nodes, for example, a System/370 channel and its associated protocols. A link is both logical and physical. Synonymous with *data link*.

\* **link-attached.** Pertaining to devices connected to a control unit by a data link. Synonymous with *remote*. Contrast with *channel-attached*.

**logical partition.** In LPAR mode, a subset of the processor unit hardware that is defined to support the operation of an SCP.

**logical record.** A user record, normally pertaining to a single subject and processed by data management as a unit. Contrast with *physical record* which may be larger or smaller.

**LPAR mode.** Logically partitioned mode. The CP mode that is available on the Configuration (CONFIG) frame when the PR/SM feature is installed. LPAR mode allows the operator to allocate the hardware resources of the processor unit among several logical partitions.

\* **megabyte (MB).** 1 024 KB or 1 048 576 bytes.

\* **member.** The smallest unit of data that can be stored in and retrieved from a sublibrary. See also *library member*.

**message.** 1. In VSE, a communication sent from a program to the operator or user. It can appear on a console, a display terminal or on a printout. 2. In telecommunication, a logical set of data being transmitted from one node to another.

\* **migrate.** To move to a changed operating environment, usually to a new release or version of a system.

\* **module.** A program unit that is discrete and identifiable with respect to compiling, combining with other units, and loading; for example, the input to, or output from an assembler, compiler, linkage editor, or executive routine. (A)

**network.** 1. An arrangement of nodes (data stations) and connecting branches. 2. The assembly of equipment through which connections are made between data stations.

**object module (program).** A program unit that is the output of an assembler or compiler and is input to a linkage editor.

\* **operating system.** Software that controls the execution of programs and that may provide services such as resource allocation, scheduling, input/output control, and data management. Although operating systems are predominantly software, partial hardware implementations are possible. (T)

**page data set (PDS).** One or more extents of disk storage in which pages are stored when they are not needed in processor storage.

**page fault.** A program interruption that occurs when a program page marked "not in processor storage" is referred to by an active page.

**partition.** A division of the virtual address area available for running programs. See also *dynamic partition*, *static partition*.

**personal computer (PC).** A microcomputer for individuals or small businesses.

\* **physical record.** The amount of data transferred to or from auxiliary storage. Synonymous with *block*.

\* **preventive service.** The installation of one or more PTFs on a VSE system to avoid the occurrence of anticipated problems.

\* **primary library.** A VSE library owned and directly accessible by a certain terminal user.

**private area.** The part of an address space that is available for the allocation of private partitions. Its maximum size can be defined during IPL. Contrast with *shared area*.

**procedure.** See *cataloged procedure*.

\* **processing.** The performance of logical operations and calculations on data, including the temporary retention of data in processor storage while this data is being operated upon.

\* **processor.** In a computer, a functional unit that interprets and executes instructions. A processor consists of at least an instruction control unit and an arithmetic and logic unit. (T)

**processor storage.** The storage contained in one or more processors and available for running machine instructions. Synonymous with *real storage*.

**profile.** A description of the characteristics of a user or a computer resource.

\* **programmable workstation.** A workstation that has some degree of processing capability and that allows the user to change its functions.



**prompt.** To issue messages to a terminal or console user, requesting information necessary to continue processing.

\* **queue file.** A direct access file maintained by VSE/POWER that holds control information for the spooling of job input and job output.

**real storage.** See *processor storage*.

**record.** A set of related data or words, treated as a unit. See *logical record*, *physical record*.

\* **restore.** To write back onto disk data that was previously written from disk onto an intermediate storage medium such as tape.

\* **routine.** A program, or part of a program, that may have some general or frequent use. (T)

\* **routing.** The assignment of the path by which a message will reach its destination.

**schedule.** To select a program or task for getting control over the processor.

**security.** See *access control*.

\* **selection panel.** A displayed list of items from which a user can make a selection. Synonymous with *menu*.

**sequential access.** The serial retrieval of records in their entry sequence or serial storage of records with or without a premeditated order. Contrast with *direct access*.

\* **service program.** A computer program that performs functions in support of the system. Synonymous with *utility program*.

**shared area.** An area of storage that is common to all address spaces in the system. VSE/ESA has two shared areas:

1. The shared area (24 bit) is allocated at the start of the address space and contains the supervisor, the SVA (for system programs and the system GETVIS area), and the shared partitions.
2. The shared area (31 bit) is allocated at the end of the address space and contains the SVA (31 bit) for system programs and the system GETVIS area.

\* **skeleton.** A set of control statements, instructions, or both, that requires user-specific information to be inserted before it can be submitted for processing.

\* **software.** All or part of the programs, procedures, rules, and associated documentation of a data processing system. Software is an intellectual creation that is independent of the medium on which it is recorded. (T)

\* **stacked tape.** An IBM supplied product-shipment tape containing the code of several licensed programs.

**startup.** The process of performing IPL of the operating system and of getting all subsystems and application programs ready for operation.

**static partition.** A partition, defined at IPL time and occupying a defined amount of virtual storage that remains constant. Contrast with *dynamic partition*.

**station.** 1. One of the input or output points of a network that uses communication facilities; for example, the telephone set in the telephone system or the point where the business machine interfaces with the channel on a leased private line. 2. One or more computers, terminals, or devices at a particular location.

\* **subarea.** A portion of the SNA network consisting of a subarea node, attached peripheral nodes, and associated resources. Within a subarea node, all NAUs, links, and adjacent link stations in attached peripheral or subarea nodes that are addressable within the subarea share a common subarea address and have distinct element addresses.

**sublibrary.** A subdivision of a library. Members can only be accessed in a sublibrary.

**sublibrary directory.** An index for the system to locate a member in the accessed sublibrary.

**submit.** A VSE/POWER function that passes a job to the system for processing.

\* **subsystem.** A secondary or subordinate system, usually capable of operating independently of, or asynchronously with, a controlling system. (T)

\* **supervisor.** The part of a control program that coordinates the use of resources and maintains the flow of processor operations.

**supervisor mode.** See *ESA mode*.

**SYSRES.** System residence file.

\* **system console.** A console, usually equipped with a keyboard and display screen for control and communication with the system.

**system residence file (SYSRES).** The system sublibrary IJSYSRS.SYSLIB that contains the operating system. It is stored on the system residence volume DOSRES.

**system sublibrary.** The sublibrary that contains the operating system. It is stored on the system residence volume (DOSRES).

\* **tailor.** A process that defines or modifies the characteristics of the system.

\* **telecommunication.** Transmission of data between computer systems over telecommunication lines and between a computer system and remote devices.

\* **terminal.** A point in a system or network at which data can either enter or leave. (A) Usually a display screen with a keyboard.

**terminal control table (TCT).** A control block in which the system stores information about the characteristics and modes of operation of the terminals defined to the system.

**token ring.** A network configuration where series of attaching devices are connected by unidirectional transmission links to form a closed path. Tokens are passed from adapter to adapter.

\* **universal character set (UCS).** A printer feature that permits the use of a variety of character arrays.

**universal character set buffer (UCB).** A buffer to hold UCS information.

\* **utility program.** 1. A computer program in general support of computer processes; for example, a diagnostic program, a trace program, or a sort program. (T) Synonymous with *service program*. 2. A program designed to perform an everyday task such as copying data from one storage device to another. (A)

**virtual address.** An address that refers to a location in virtual storage. It is translated by the system to a processor storage address when the information stored at the virtual address is to be used.

\* **virtual address space.** A subdivision of the virtual address area available to the user for the allocation of private, nonshared partitions.

\* **virtual machine (VM).** A functional simulation of a computer system and its associated devices.

**Virtual Machine/Enterprise Systems Architecture (VM/ESA).** An IBM program providing operating system support. Among other services, it manages the resources of a single computer so that multiple computing systems seem to exist. Each of those virtual machines is the functional equivalent of an IBM computer system.

**virtual storage.** Addressable space image for the user from which instructions and data are mapped into processor (real) storage locations.

**VM/ESA.** Virtual Machine/Enterprise Systems Architecture.

**volume.** A data carrier that is mounted and demounted as a unit, for example, a reel of tape or a disk pack. (I) Some disk units have no demountable packs. In that case, a volume is the portion available to one read/write mechanism.

**volume ID.** The volume serial number, which is a number in a volume label assigned when a volume is prepared for use by the system.

**volume table of contents (VTOC).** A table on a disk volume that describes every file on it.

**VSE (Virtual Storage Extended).** A system that consists of a basic operating system (VSE/Advanced Functions) and any IBM supplied and user-written programs required to meet the data processing needs of a user. VSE and the hardware it controls form a complete computing system. Its current version is called VSE/ESA.

**VSE/Advanced Functions.** A program that provides basic system control and includes the supervisor and system programs such as the Librarian and the Linkage Editor. It is part of VSE Central Functions, a base program of VSE/ESA.

**VSE Central Functions.** A VSE/ESA base program.

**VSE/ESA (Virtual Storage Extended/Enterprise Systems Architecture).** The most advanced VSE system currently available.

\* **VSE/Fast Copy (VSE/Fast Copy Data Set program)..** A program for fast copy data operations from disk to disk and dump/restore operations via an intermediate dump file on magnetic tape or disk. It is part of VSE Central Functions, a base program of VSE/ESA.

**VSE/ICCF (VSE/Interactive Computing and Control Facility).** A program that serves as interface, on a time-slice basis, to authorized users of terminals linked to the system's processor. It is part of VSE Central Functions, a base program of VSE/ESA

**VSE/ICCF library.** A file composed of smaller files (libraries) including system and user data which can be accessed under the control of VSE/ICCF.

**VSE library.** A collection of programs in various forms and storage dumps stored on disk. The form of a program is indicated by its member type such as source code, object module, phase, or procedure. A VSE library consists of at least one sublibrary which can contain any type of member.

\* **VSE/POWER.** Part of the VSE/ESA base program VSE Central Functions. Primarily used to spool input and output. VSE/POWER's networking functions enable a VSE system to exchange files with or run jobs on another remote processor.

**VSE/VSAM (VSE/Virtual Storage Access Method).** Part of the VSE/ESA base program VSE Central Functions. An IBM access method for direct or sequential processing of fixed and variable length records on disk devices.

**VTAM (Virtual Telecommunications Access Method).** A VSE/ESA base program that controls communication and the flow of data in an SNA network. It provides single-domain, multiple-domain, and interconnected

network capability; it supports application programs and subsystems (VSE/POWER, for example).

**wait state.** The condition of a processor when all operations are suspended. System recovery from a hard wait is impossible without performing a new system startup. Synonym for *hard wait*.

**workstation.** See *programmable workstation*.

**31-bit addressing.** Provides addressability for address spaces of up to 2 gigabytes. (The maximum amount of addressable storage in previous systems was 16 megabytes.)



# Index

## Special characters

@server zSeries 900 processor 33

## Numerics

2-digit subarea naming convention 96  
254 devices 35, 41, 56  
3370 disk (Model 2) 45, 61  
3375 disk 45, 61  
3380 Model A disk 44, 45  
3380 track compatibility mode 15  
3390 disk device 15  
3480 tapes (cartridges) 7  
4-digit subarea naming convention 17, 96

## A

abend job names for Job Manager  
  CUSABEND 130  
  DTRABxx 130  
  DTRFSUAB 130  
  DTRPTFAB 130  
  INSABEND 130  
access control  
  access control table (DTSECTAB) 114  
  changing passwords 104  
accessing  
  dialogs xiv  
  integrated console 18  
  job CATSECT 99  
  table DTSECTAB 99  
activating VTAM password 102  
adapters 100  
adding new users 139  
adding VSE/ESA information to  
  VSE/ICCF DTSFILE 83  
additional VSE licensed programs  
  format of additional VSE/ESA  
  programs 113  
  types of additional VSE/ESA  
  programs 113  
  Version 1 and 2 formats of additional  
  VSE/ESA programs 113  
  Version 2 format 113  
ALTER authorization 114  
ASI IPL procedure 76  
automatic initial installation  
  default values 9  
  if problems occur 9  
  installation part 1 33  
  installation part 1 (quick) 21  
  installation part 2 73  
  installation part 2 (quick) 22  
  performing IPL from tape 34  
  short description 21  
  when to use 3

## B

backup  
  Backup/Restore Library Objects  
  dialog 16  
  DTSUTIL program 16  
  of VSE/ICCF DTSFILE 16  
Backup/Restore Library Objects 16  
BASE password 96  
base program deletion 109  
base tape or files of VSE/ESA,  
  overview 7  
BASEREST 84  
basic installation steps 5  
building list of jobs during initial  
  installation 76

## C

cartridge 7  
cataloging  
  ASI IPL procedure 76  
  hardware information 76  
  members into VSE/ESA libraries 86  
  VTAM startup information 76  
CD-ROM distribution 149  
CD-ROM shipment 7  
changing  
  passwords for VSE/ESA user  
  IDs 104  
CICS  
  CSD file 97  
CICS/ICCF startup  
  *See* telecommunications access method  
CICSUSER user ID 105  
CKD disk initialization  
  type 3380 43, 44, 58, 60  
  type 3390 43, 44, 58, 60  
  type 9345 43, 58  
CLEANUP 90  
CMS modules  
  SUBVSE 126  
  VSECMD 126  
commands  
  CP DISC 18  
  DEF STOR 35, 56  
  LUCB attention commands 80  
  PGO 82  
  SET DATE 41, 49  
  start printer 81  
COMPATIBLE statement for MSHP 114  
completing  
  hardware tables 99  
  initial installation 95  
  initial installation (migration) 97  
  initial installation (non-migration) 96  
  Job Manager 90  
  personalized data for initial  
  installation 98  
Completion of Initial Installation  
  Processing 90

configuration list for initial  
  installation 13  
configuring TCP/IP 74  
considerations for installation  
  dialogs 129  
console  
  CP DISC command 18  
  IPL ADD command 18  
  OPERATE command 18  
  type of console 17  
console mode definition 55  
contents of VSE/ESA base tape or  
  files 7  
continuing installation (native and  
  VM) 73  
control statement 145  
CP commands  
  CP DIAL 125  
  CP DISC command 18  
creating print buffers 77  
CSD (CICS System Definition) 97, 103  
CSDMIGR 97

## D

data  
  DASD 45, 61  
  protection 104  
DB2 Server for VSE 7  
DB2 Server for VSE Help 7  
DB2REST 27, 86  
DBDCCICS user ID 105  
dedicated disk 58  
DEF GRAF 35  
DEF STOR 35  
DEF STOR command 35, 56  
default values (automatic installation) 9  
defining  
  console mode 55  
  console mode (VM) 35  
  devices 13  
  hardware 13  
  libraries and sublibraries 82  
  local VTAM terminals  
  (NON-SNA) 75  
  local VTAM terminals (SNA) 75  
  storage (VM) 35  
  terminals (VM) 35  
  VSAM catalogs, space and  
  clusters 82  
  VTAM user terminals 74  
deleting unneeded VSE/ESA  
  programs 109  
DELxxx jobs (delete) 109  
descriptive overview of installation 5  
device down status 51, 67  
device sensing  
  at initial installation 13  
  automatic definition of devices 48, 64  
  devices which cannot be sensed 48

- device sensing (*continued*)
  - devices with more than one address 100
- device type code 7, 13
- DFHCSDUP 103
- DFHSNT 137
- dialogs
  - Apply PTF 129
  - Backup/Restore Library Objects 16
  - File and Catalog Management 117
  - Install Fast Service Upgrade 129
  - Install Generation Feature 111
  - Install Program(s) from Tape 115, 118
  - Install Programs - V1 Format 122, 129
  - Install Programs - V2 Format 115, 129
  - Install Programs - V2 Format for reinstallation 122
  - Prepare for Installation 115, 116
  - special considerations 129
- disconnecting system console 18
- disk
  - initialization 43
- documentation
  - VSE/ESA library xiv
- DOSRES 14, 42, 51, 57, 67
- download VSE/ESA from internet 7
- DTRABxx 130
- DTRFSUAB 130
- DTRIASI 76
- DTRIHARD 76
- DTRIJB LD 76
- DTRIVTAM 76
- DTRPTFAB 130
- DTSECTAB 103, 114
- DTSECTRC 103
- DTSFILE
  - restoring 83
- DTSUTIL utility program 16
- dummy devices 101
- DUMPINIT 84
- duplicate volume identifiers 51, 67

## E

- ECKD device 43, 58
- electronic delivery 149
- enable TOD switch 49
- entering
  - personalized history file information 98
- Enterprise Storage Server 12
- environments
  - selection 73
  - tailoring IPL and JCL procedures 73
- equal file ID in VTOC 52, 68
- EXIT option for Job Manager 130
- extended base tape 112
- extended subarea addressing 97

## F

- fast path xiv

- Fast Service Upgrade
  - synchronizing service of initial system and generation part 111
- FBA disk initialization
  - type 9336 60
- file ID
  - equal 52, 68
- filling in an installation worksheet 6
- FIRSTUSE (job) 99
- flow of installation xiii
- format of screen 12
- forms control buffer (FCB)
  - creating 77
  - procedure names 78
- FORSEC user ID 105
- four-digit subarea naming
  - convention 17, 96

## G

- generating own supervisor 13
- Generation Feature
  - installing 110, 111
  - installing after service installation 111
  - job INSGEN 111
- graphical overview of installation 4
- guest system, VSE under VM
  - access methods 125
  - installing the VM/VSE Interface 126
  - installing VSE/ESA 55
  - performing IPL from tape 55

## H

- hard copy file 18
- hardware
  - configuration 13
  - integrated console 17
  - processors supported 12
  - requirements 12
  - uniprocessors/multiprocessors 12
- hardware configuration tables
  - completing 99
  - unidentified device list 97, 99
  - updating 103
- having multiple program versions 114
- HISTREST 82

## I

- IBM @server zSeries 900 34, 39, 40
- IBM Service
  - Generation Feature 111
  - service levels 111
- IBM supplied supervisor 11
- ICCFLOAD 83
- ICCFREST 83
- identifying
  - of I/O devices 41, 49, 56, 65
- IESBLDUP 135, 137
- IESBLDUP utility 133
- IJSYSRS (restoring) 46
- IJSYSRS.SYSLIB (restoring) 62
- increasing library space 114, 117

- initial installation
  - building list of jobs 76
  - catalog ASI IPL procedure 76
  - catalog hardware information 76
  - catalog VTAM startup
    - information 76
    - completed 104
  - completing 95
  - completing Job Manager 90
  - configuration list 13
  - descriptive overview 5
  - graphical overview 4
  - installing Generation Feature 111
  - IPL VSE 48, 64
  - job BASEREST 84
  - job CATSECT 99
  - job CLEANUP 90
  - job CSDMIGR 97
  - job DB2REST 86
  - job DTRMIGR 84
  - job DUMPINIT 84
  - job FIRSTUSE 99
  - job HISTREST 82
  - job ICCFLOAD 83
  - job ICCFREST 83
  - job INSGEN 111
  - job LIBRDEFS 82
  - Job Manager processing 77
  - job MIGRAT 84
  - job NLICFRES 83
  - job NLLIBRES 83
  - job PERSONAL 99
  - job SAVEMEMB 86
  - job stream overview 71
  - job UPDSECT 99
  - job VSAMDEFS 82
  - job VSAMINIT 84
  - migration 84
  - restore system library 46, 62
  - sequence of steps 5
- Initial Program Load
  - See IPL
- initializing
  - and loading VSE/VSAM files 84
  - disks and placing the VTOC 42, 57
  - work files for info/analysis 84
- initializing disks
  - 3370 data DASD 45, 61
  - 3375 data DASD 45, 61
  - 3380, 3390 44, 60
  - 9345 44, 60
  - CKD 44, 60
  - CKD (type 3380) 43, 58
  - CKD (type 3390) 43, 58
  - CKD (type 9345) 43, 58
  - dedicated disks 59
  - disks 58
  - FBA 43, 44, 60
  - FBA device 58
- Input/Output Configuration Data Set 33
- Input/Output Configuration
  - Program 33, 39
  - downloading an IOCDS 33, 39
  - Input/Output configuration data set 33, 39
  - installing 33, 39
  - skeleton SKIOPCN 33, 39

INSABEND 130  
 INSGEN (job) 111  
 INSTALL program 73  
 Install Programs - V1 Format dialog 123  
 installation  
   automatic 33  
   basic installation steps 5  
   dialogs (special considerations) 129  
   job stream overview 71  
   of a native VSE/ESA system 39  
   of Generation Feature 110  
   of VM/VSE Interface 126  
   of VSE/ESA base programs 84  
   of VSE/ESA under VM 55  
   of VSE/ESA with security active 74  
   planning 11  
   short description 21  
   tailoring 11  
   tasks 129  
   worksheet 6  
 installing  
   a native VSE/ESA 39  
   from an integrated console 17  
   from virtual tape 150  
   Generation Feature 110  
   non IBM programs 113  
   on an IBM @server zSeries 900 34, 40  
   optional programs 113, 114  
   programs in version 1 format 122  
   programs in version 2 format 115  
   programs without a program list 121  
   starting manual installation (under VM) 56  
   the Input/Output Configuration Program 33, 39  
   VM/VSE Interface 126  
   VSE/ESA under VM 55  
 installing DB2 73, 86  
 insufficient system configuration 50, 66  
 integrated console 17  
 Interactive Interface (see also dialogs) xiv  
 introduction to  
   installing a native VSE/ESA 33  
   installing VSE/ESA 1  
   installing VSE/ESA under VM 55  
 IOCDs (data set) 33, 39  
 IOCP 33, 39  
 IOCP User's Guide 39  
 IPL  
   ADD command 18  
   ASI procedure 76  
   minimum configuration for 50, 66  
   second or additional IPL from disk 52, 68  
   tailoring IPL procedures 73  
   VSE from DOSRES 48, 64

## J

Job Manager  
   abend job names 130  
   commands 129  
   completing 90  
   EXIT option 130  
   Install Programs - V1 Format 119, 122

Job Manager (*continued*)  
   installing additional VSE programs (V2 format) 115  
   job BASEREST 84  
   job CLEANUP 90  
   job CSDMIGR 97  
   job DB2REST 86  
   job DTRMIGR 84  
   job DUMPINIT 84  
   job HISTREST 82  
   job ICCFLOAD 83  
   job ICCFREST 83  
   job INSABEND 130  
   job LFCBLINK 77  
   job LIBRDEFS 82  
   job MIGRAT 84  
   job NLICFRES 83  
   job NLLIBRES 83  
   job SAVEMEMB 86  
   job VSAMDEFS 82  
   job VSAMINIT 84  
   options 129  
   overview 129  
   problem handling 129  
   processing 77, 119  
   RESET option 130  
   restarting 129  
   RESUME option 129  
 job stream processing 73

## L

label information  
   about migration backup tapes 16  
   overview of base tape or files 7  
   VSE/ESA cartridge(s) 7  
   VSE/ESA CDs 7  
   VSE/ESA tape reels 7  
 language-dependent members 83  
 layout of a distribution tape 113  
 LEREST 83  
 LFCBLINK 77  
 Librarian format 115, 122  
 library space increase 114, 117  
 LIBRDEFS 82  
 loading VSE/VSAM files 84  
 local  
   SNA and non-SNA control units 74, 75  
   SNA and non-SNA VTAM users 75  
 logically partitioned (LPAR) mode 33, 39  
 LUCB attention commands 80

## M

MACREST 83  
 Maintain System History Program  
   COMPATIBLE statement 123  
   job PERSONAL 99  
 manual installation (native)  
   downloading IOCDs 39  
   initializing disks and placing VTOC 42  
   performing IPL from DOSRES 48  
   performing IPL from tape 40

manual installation (native) (*continued*)  
   preparatory tasks 39  
   restoring system library 46  
   starting installation 41  
 manual installation (under VM)  
   initializing disks and placing VTOC 57  
   performing IPL from DOSRES 64  
   performing IPL from tape 55  
   preparatory tasks (under VM) 55  
   restoring system library 62  
   starting installation 56  
 migrating from DOS/VSE 136  
 migrating to VSE/ESA 2.7 140  
 migration  
   during initial installation 15, 73, 84  
   IESBLDUP utility 133  
   naming conventions for VTAM resources 96  
   of more than 199 VSE/ICCF libraries 133  
   of more than 199 VSE/ICCF users 133  
   of TCTs into CSDs 97, 103  
   of unidentified devices 99  
   restrictions for 17  
   volume serial numbers required 16  
 migration errors 148  
 Migration Utility 135  
 minimum  
   configuration for IPL 50, 66  
   hardware requirement 12  
   mode specification for devices 13  
 modes  
   disk native mode 43, 58  
   emulation mode 43, 58  
 MSHP  
   *See* Maintain System History Program  
 multiple program versions 114  
 multiprocessors 12

## N

naming convention  
   for VTAM resources 96  
   four-digit subarea 17  
   two-digit subarea 17  
 National Language Support (NLS) 7  
 native VSE/ESA  
   automatic installation 33  
   manual installation 39  
 NLICFRES 83  
 NLLIBRES 83  
 non  
   SNA control units 74, 75  
   version 1 format 122  
 number of devices supported 13

## O

online panel 95  
 OPER user ID 105  
 OPERATE command 18  
 optional programs  
   *See* VSE/ESA optional programs

- overview of
  - base tape or files 7
  - descriptive overview 5
  - Generation Feature 110
  - graphical overview 4
  - installing additional programs 112
  - Job Manager 129
  - VM/VSE Interface routines 126
  - VSE/ESA installation 3

**P**

- password
  - BASE 101
  - changing 104
  - FORSEC 104
  - POST 104
  - PROG 105
  - SYSA 99
  - VTAM password 102
- performance
  - tuning the system 14
- performing
  - automatic initial installation 34
  - IPL (from SYSRES on DOSRES) 64
  - manual/native installation 39
  - manual/under VM installation 55
  - migration 84
- PERSONAL (job) 99
- personalized history file information 98
- planning initial installation 11
- POST user ID 96
- PRD2.CONFIG 86
- PRD2.SAVE 86
- predefined environments 11
- preparatory tasks (installation)
  - basic information 11
  - native (automatic) 33
  - native (manual) 39
  - under VM (automatic) 35
  - under VM (manual) 55
- preparing
  - an installation worksheet 6
  - hardware configuration list 13
  - installation of additional programs 116
- Preparing for Initial Installation or FSU from Virtual Tape 149
- printers
  - controlled by VSE/POWER 81
  - creating print buffers 77
  - print buffers 77
  - printer train/belt combinations 77
  - startup (for VM users) 81
- problem handling, Job Manager 129
- Processor Resource/Systems Manager
  - VSE/ESA running in LPAR mode 33, 39
- processors supported 12
- PRODCICS user ID 105
- PROG user ID 105
- program
  - list 114, 116
- punch install information to VSE/ICCF DTSFILE 83

**R**

- RAMAC Array Family 12
- recovering from migration errors 148
- reinstalling an additional VSE program 122
- remote
  - problem determination 105
- removing
  - VM-related disk devices 98
- requirements
  - for minimum hardware 12
- RESET option for Job Manager 130
- restoring
  - IJSYSRS from tape 46
  - language-dependent members 83
  - system history file 82
  - system library 46, 62
  - VSE/ICCF DTSFILE 83
- restrictions
  - for migration 17
- RESUME option for Job Manager 129
- running
  - Job Manager controlled jobs 77
  - the INSTALL program 73

**S**

- SAVEMEMB 86
- scan report 116
- screen format 12
- security 74, 104, 105
- short description (installation) 21
- sign-on panel 95
- Sign-On Table (DFHSNT) 137
- skeleton
  - SKLIBEXT 117
  - SKVMVSE 126
- SNA
  - control unit 74
  - non-SNA typeterms 97
  - typeterms 97
- space requirements 114
- starting
  - a printer controlled by VSE/POWER 81
  - Job Manager sequence 73
  - the system 11
- startup, system
  - See system startup
- summary of changes xv
- supervisor
  - generation (own) 13
  - generation parameters 110
  - IBM supplied 11
- supported
  - devices (number of) 13
  - processors 12
- SYSA user ID and password 99
- system
  - performance 14
  - printer 48
- system console
  - See also console
  - disconnecting 18

- system history file
  - personalized data for initial installation 98
  - update personalized data 99
- system library 46, 62
- restoring 46, 62
  - restoring IJSYSRS from tape 62
- system startup
  - CICS startup 71
- SYSWK1 14, 42, 51, 57, 67

**T**

- tailoring IPL and JCL procedures 73
- tapes (base) 7
- TCP/IP, configure 74
- TCT (Terminal Control Table) 97, 103
- telecommunication access method 89
- telecommunications access method
  - and CICS/ICCF startup 89
  - job CICSICCF 89
  - job TPSTART 89
  - job VTAMSTRT 89
- TERM CON 3270 35
- terminal printers
  - at initial installation 48
  - starting 81
- time-of-day clock (TOD) 41, 49
- TOD switch (enabling) 49
- Token-Ring (adapter) 100
- trademarks xii
- two-digit subarea naming convention 96
- typeterm names 97

**U**

- unidentified
  - device list panel 97, 99
  - devices (migrating from VSE/SP Version 2) 99
- uniprocessors 12
- universal character set buffer (UCB)
  - creating 77
  - LUCB attention commands 80
  - procedure names 79
- updating
  - hardware tables 103
- UPDSECT (JOB) 99
- user ID
  - \$SRV 105
  - CICSUSER 105
  - DBDCCICS 105
  - FORSEC 105
  - OPER 105
  - POST 96, 105
  - PRODCICS 105
  - PROG 105
  - SYSA 99
- user terminals
  - VTAM terminals 74
- users
  - installing on an IBM @server zSeries 900 34, 40
  - installing on an IBM @server zSeries processor 18



using  
  installation dialogs (for additional  
    VSE programs) 114  
  integrated console xiii  
  system console xiii  
  VM/VSE Interface routines 125  
utility IESBLDUP 133  
utility program DTSUTIL 16

## V

VCSRVR user ID 105  
Virtual Machine/System Product  
  *See* VM (VSE under VM)  
Virtual Storage Extended/System  
  Package  
  *See* VSE/ESA  
VM (VSE under VM)  
  DEF GRAF command 56  
  DEF STOR command 35, 56  
  installing VSE/ESA 55  
  IPL cuu 56  
  MAINT (user ID) 126  
  performing an IPL 56  
  preparatory tasks 35, 55  
  removing VM-related disk  
    devices 98  
  starting manual installation 56  
  support for VSE/ESA guest  
    systems 55  
  TERM CON 3270 command 56  
  VM/Pass-Through Facility 125  
  VM/Pass-Through Facility  
    program 55  
VM/Pass-Through Facility program 55  
VM/VSE Interface 55  
  CP DIAL 125  
  description of 125  
  functions supported 125  
  list of installation tasks 126  
  MAINT (VM user ID) 126  
  overview of 126  
  skeleton SKVMVSE 126  
  SUBVSE 126  
  VSECMD 126  
volume serial number  
  for VSE control file (tape) 16  
  for VSE/ICCF DTSFILE (tape) 16  
Volume Table of Contents  
  *See* VTOC  
VSAMDEFS 82  
VSAMINIT 84  
VSE Control File 136  
VSE Input/Output Configuration  
  Program 33, 39  
VSE/ESA  
  automatic installation 33  
  base tape or files, overview 7  
  continuing installation 73  
  disconnecting system console 18  
  install program 73  
  installation under VM 55  
  IOCP batch program 33, 39  
  IPL from DOSRES 48, 64  
  native installation 39  
  online panel 95  
  pre-generated system 1

VSE/ESA (*continued*)  
  program deletion 109  
  sign-on panel 95  
  under VM 55  
  VM/VSE Interface 55, 125  
VSE/ESA optional programs  
  installation (using dialogs) 113  
VSE/ICCF  
  DTSUTIL program 16  
  library 59 33, 39, 117, 126  
VSE/ICCF DTSFILE 136  
VSE/ICCF Libraries 137  
VSE/ICCF Options 136  
VSE/POWER  
  account file 52, 68  
  data file 52, 68  
  initiation completed 53, 68  
  printer start 81  
  queue file 52, 68  
VSE/VSAM  
  initializing files 84  
  loading files 84  
VTAM  
  activating password 102  
  cross domain 125  
  resource names 96  
  user terminals 74  
VTAM password 102  
VTOC 14  
  equal file ID 52, 68

## W

when to install the Generation  
  Feature 110  
work files (initializing) 84  
worksheet 6

## Z

z/VM 55  
zSeries 900 12



---

## Readers' Comments — We'd Like to Hear from You

IBM VSE/Enterprise Systems Architecture  
Installation  
Version 2 Release 7 Modification Level 2

Publication No. SC33-6704-06

Overall, how satisfied are you with the information in this book?

	Very Satisfied	Satisfied	Neutral	Dissatisfied	Very Dissatisfied
Overall satisfaction	<input type="checkbox"/>	<input type="checkbox"/>	<input type="checkbox"/>	<input type="checkbox"/>	<input type="checkbox"/>

How satisfied are you that the information in this book is:

	Very Satisfied	Satisfied	Neutral	Dissatisfied	Very Dissatisfied
Accurate	<input type="checkbox"/>	<input type="checkbox"/>	<input type="checkbox"/>	<input type="checkbox"/>	<input type="checkbox"/>
Complete	<input type="checkbox"/>	<input type="checkbox"/>	<input type="checkbox"/>	<input type="checkbox"/>	<input type="checkbox"/>
Easy to find	<input type="checkbox"/>	<input type="checkbox"/>	<input type="checkbox"/>	<input type="checkbox"/>	<input type="checkbox"/>
Easy to understand	<input type="checkbox"/>	<input type="checkbox"/>	<input type="checkbox"/>	<input type="checkbox"/>	<input type="checkbox"/>
Well organized	<input type="checkbox"/>	<input type="checkbox"/>	<input type="checkbox"/>	<input type="checkbox"/>	<input type="checkbox"/>
Applicable to your tasks	<input type="checkbox"/>	<input type="checkbox"/>	<input type="checkbox"/>	<input type="checkbox"/>	<input type="checkbox"/>

Please tell us how we can improve this book:

Thank you for your responses. May we contact you?  Yes  No

When you send comments to IBM, you grant IBM a nonexclusive right to use or distribute your comments in any way it believes appropriate without incurring any obligation to you.

---

Name

---

Address

---

Company or Organization

---

Phone No.



Fold and Tape

Please do not staple

Fold and Tape



NO POSTAGE  
NECESSARY  
IF MAILED IN THE  
UNITED STATES

# BUSINESS REPLY MAIL

FIRST-CLASS MAIL PERMIT NO. 40 ARMONK, NEW YORK

POSTAGE WILL BE PAID BY ADDRESSEE

IBM Deutschland Entwicklung GmbH  
Department 3248  
Schoenaicher Strasse 220  
D-71032 Boeblingen  
Federal Republic of Germany

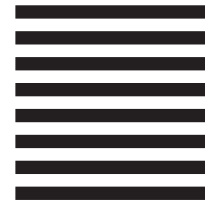

Fold and Tape

Please do not staple

Fold and Tape





File Number: S370/S390-34  
Program Number: 5690-VSE

Printed in USA

SC33-6704-06



Spine information:



IBM VSE/Enterprise Systems  
Architecture

**VSE/ESA Installation**

Version 2 Release 7  
Modification Level 2 SC33-6704-06