



Hints and Tips for VSE/ESA





Hints and Tips for VSE/ESA

Note !

The information contained in this document has not been submitted to any formal IBM test and is distributed AS IS. The use of this information or the implementation of any of these techniques is a customer responsibility and depends on the customer's ability to evaluate and integrate them into the customer's operational environment. While each item may have been reviewed by IBM for accuracy in a specific situation, there is no guarantee that the same or similar results will be obtained elsewhere. Customers attempting to adapt these techniques to their own environment do so at their own risk.

Sixth Edition (July 2002)

This book applies to Version 2 Release 6 of IBM Virtual Storage Extended/Enterprise Systems Architecture (VSE/ESA) and earlier releases.

A form for readers' comments is provided at the back of this publication. If the form has been removed, address your comments to:

IBM Deutschland Entwicklung GmbH
Department 3252
Schoenaicher Strasse 220
D-71032 Boeblingen
Federal Republic of Germany

When you send information to IBM, you grant IBM a non-exclusive right to use or distribute the information in any way it believes appropriate without incurring any obligation to you.

© **Copyright International Business Machines Corporation 1995, 2002. All rights reserved.**
US Government Users Restricted Rights – Use, duplication or disclosure restricted by GSA ADP Schedule Contract with IBM Corp.

Contents

About This Book	xv
Summary of Changes	xv
Chapter 1. System Control Program	1
Supervisor or Hardware Malfunctions	1
Determine Hard or Soft Wait	2
Processor Loops	3
Attention Not Responding	4
System Status	4
Soft Wait States	5
Hard Wait States	6
Diagnostic Messages	8
Problem Management Programs and Tools	13
ABEND Dump	13
DUMP Command	13
Stand-alone Dump Program	14
Interactive Trace Program	18
SDAID	19
Important VM/CP Functions	29
Lock Manager Service Enhancements	30
Error on Lock File	30
Display Facility	32
Trace Facility	33
System Date and Time	35
Chapter 2. Internal Attention Routine Commands	37
DEBUG	37
DEBUG STOP	38
DEBUG [{P N}]SHOW[,ALL]	39
GETVIS	39
SIR	43
SIR HELP	43
SIR (without any operand)	44
SIR SYS	52
SIR RESET	52
SIR SMF	52
SIR MON	56
SIR MIH	58
SIR CHPID	59
SIR CRWMSG	60
STACK	61
STATUS	71
TAPE	74
TIME	75
Effect of Day-Light Saving Time Changes	75
Adjusting Local Time Backwards	76
VOLUME TAPE	77
Chapter 3. VSE/ESA Turbo Dispatcher and Its Exploitation	79
VSE/ESA Version 2 - Turbo Dispatcher	79

Turbo Dispatcher Design	79
Advantages on Uni-Processors	81
Partition Balancing Enhancements	81
VSE/ESA 2.3 - Quiesce CPUs	82
Turbo Dispatcher Considerations	82
More Information	86
Chapter 4. Console	87
Console Types	87
VSE System Console	87
Interactive Interface Console	87
VMCF Console	88
Integrated Console	88
Console Diagnostics	88
Using the Trace Feature	88
Dump Console Router Trace Area	89
CORCMD	89
Dump and Trace Related Commands	89
Status Information	90
Operational Commands	95
Special Commands	96
Hints and Tips	96
What Does the Blinking 'MESSAGE' Indicator Mean ?	97
What Does Console SUSPENDED Mean ?	98
What Does 'WAITING FOR ROUTER BUFFER SPACE' Mean ?	98
What is to be Done If a Console Hangs ?	99
What Does the Reply-Id Mean ?	99
Chapter 5. Job Control	101
Storage Layout and Interaction of Job Control Phases	101
Job Control Dumps: Where to Look First?	105
How Job Control Handles Program Return Codes, ABEND and CANCEL Conditions	107
Job Control Error Handling	111
Job Control Statement Logging	114
Job Control Statement Logging on SYSLST	114
Job Control Statement Logging on SYSLOG	114
Job Control Comment Statements	115
VSE Label Area – Layout and Capacity Considerations	115
Label Information Record (LIR)	116
Label Area Segment (LAS)	119
Label Group (LG)	120
Frequently Asked Questions	121
Chapter 6. VSE/POWER	129
Overview	129
New SET Statements for VSE/POWER Startup	129
SET: Setting VSE/POWER Startup Control Values	130
New CUIF Operand for Queue Manipulation and Enhanced Feedback in Message 1R88I	134
Schedule VSE/POWER-Job More Than Once Per Day	134
Command Driven Job Output Segmentation	138
Internal Queue Entry Number Used in Displays and Commands	142
Showing Partition in Which Active Job Runs	143

Transmission Queue Disposition	144
Drop 'Last-One' and Print Shorter Separator Page	145
PSTART Command for Local Writer Task	146
RJE,SNA RUSIZE Increased from 256 Bytes to 4096 Bytes	146
New PICKUP Operand for VSE/POWER POFFLOAD	147
VSE/POWER Tape Processing	149
Queue Entries on Tape and Release Migration	149
Full Upward Migration of Tapes to Current Release	150
Limited Downward Migration of Tapes from Current Release	150
FORMAT 4: Backup or Saving to a Previous Release of VSE/POWER	151
When Print Output is Misaligned	152
VSE/POWER Spooling Considerations	154
Important VSE/POWER Specifications for Output Spooling	154
TCP/IP Connection to RSCS	156
Chapter 7. Librarian	159
Librarian Return Code Conventions	159
How to Analyze What Went Wrong	160
Important Messages	160
Recreation of Libraries	160
BACKUP Abends or Loops	161
RESTORE of Libraries Not Uniquely Assigned or Shared by Processors	162
RESTORE OLDLIB	163
What To Do In Error Cases?	164
Test of Libraries	164
What Can Damage a Library?	164
Other Problems	165
Member Not Found	165
Influences on Number of SIOs	165
Space Reclamation Attributes AUTOMATIC versus IMMEDIATE	167
Shared Libraries	169
Is There a Performance Impact if Libraries Are Shared by Processors?	170
Library Full	172
Scattered Library	173
Influences of BACKUP/RESTORE on Used Space	175
Cancel of Librarian Actions	175
TRACE	176
TEST TRACE=LEVEL2 SIO ALL	176
Important Librarian Level 2 Functions	176
Chapter 8. VSE/VSAM	177
Introduction	177
Capabilities and Limitations	177
VSAM File Size Limitations	177
Setup	178
Reorganize a File	178
Catalog Maintenance	178
Reorganize a Catalog	178
Re-Build a Catalog	180
Dataset Name Sharing	181
Open Errors	183
Return Code 168 x'A8'	183
Return Code 254 x'FE'	187
File Not Found	188

Migration	188
Migrating Master Catalog	188
IMPORT/EXPORT Problems from MVS	190
Backup / Restore	190
General Notes	190
Restore MSG IDC31340 (Backup File in Error)	191
Backup File Integrity (Return Code 41 x'29')	191
CMS/VSAM	191
Duplicate VOLIDs	191
I/O Tracing under CMS/VSAM	192
Initial Verification Procedure (IVP) for CMS/VSAM	192
Catalogs	194
Potential Corruption Causes	194
Catalog Precautions	196
Miscellaneous Problems	199
Read Integrity Problems	199
Catalog / File Prematurely Full	200
MSG 4226I / 4227I ("Automatic Close")	201
Default Models	201
Recovering From a Physical Medium Failure	203
CA Splits	204
Missing or Unreadable Print Information	205
Recent VSE/VSAM Enhancements (VSE/ESA Version 2).	207
Chapter 9. VSE/ICCF	213
Submit to Batch	213
ICCF Library	213
Increase Number of Users and Libraries	213
Increase Maximum Number of Members per Library	214
DTSFILE Extension	214
UPIP Flag	214
Compressed Members	214
Chapter 10. REXX/VSE	217
Setup	217
Initialization	217
ARXLINK RC=21	217
GETVIS Size	217
Setup for Using the REXX/VSE SOCKET Function	217
General REXX Tips	218
REXX Samples	218
REXX Functions	218
POWER Command Environment	219
Error Handling	219
CLASS Operand for GETQE	219
POWER Authorization	219
JCL Command Environment	220
DLBL Statements	220
SETPARM Statements	220
LINK Command Environment	222
Table of Authorized Programs ARXEOJTB	222
Console Command Environment	222
Return Codes From Macros MCSOPER, MCSOPMSG, MGCRE	222
Suspended Console	222

Retrieval of CICS Messages	223
Tracking of Operator Communication	223
Function SENDCMD	224
REXX SOCKET Function	224
Determine SOCKET Implementation	224
Debugging SOCKET Problems	224
REXX and Other VSE components	225
REXX and ICCF	225
REXX and VSAM	226
Chapter 11. 3494 Tape Library Support	227
Reason Codes From VGS	227
Reason Codes From LBSERV	229
MAPXPCCB Return Codes	231
MAPXPCCB Reason Codes	233
Reason Codes From LCDD	233
Reason Codes From DFSMS/RMS	235
Chapter 12. Language Environment for VSE/ESA (LE/VSE)	237
LE/VSE Big Picture	237
LE/VSE 1.4.2 in VSE/ESA 2.6	237
Mixed Language Applications under LE/VSE (involving Assembler)	238
Summary of LE/VSE Customization and Verification Jobs	238
Modifying Behavior of COBOL Reusable Environment	240
Languages and CICS Transaction Server	241
Generating Applications Capable of Running Under LE/VSE	241
Overriding Run-Time Options with an EXEC card (Batch)	242
AMODE 24 Applications in a LE/VSE-CICS Environment	242
Run-Time Options to Use with Caution	243
LE/CICS-wide Run-Time Options to VSE Console	243
CICS Table Parameter Settings	244
CICS Translator Options Required for COBOL Applications	244
Common Abend Conditions With LE/VSE	245
LE/VSE Related Service via Ordering PSP Bucket	247
LE/VSE Documentation Links	248
Chapter 13. VSE/ESA Security and CICS-Coexistence Beginning with VSE/ESA 2.4	249
Migrating from CICS/VSE 2.3 to the Basic Security Manager (BSM)	249
Migrate USER Definitions Stored in IESCNL	249
Migrate USER Definitions Stored in DFHSNT	249
Migrate Transaction Definitions Active in a CICS/VSE 2.3 System	249
Migrate Transaction Definitions Stored in DFHPCT.A (Macro)	253
Miscellaneous Problems	253
B-Transient Considerations	253
Array Overflow When Assembling DTSECTXN or DTSECTAB	254
CICS-Coexistence Beginning with VSE/ESA 2.4	254
Common User List for CICS TS and CICS/VSE	254
Debugging in a CICS Coexistence Environment	257
Storage Dump Management Dialog	257
Problem in Abend Processing	257
Skeletons for CICS Dumps	257
Jobs for CICS Dumps	257
Transaction Security	258

Where Can I Get More Information about Security	258
Chapter 14. Hints and Tips for "CICS TS for VSE/ESA 1.1.1"	261
Hints for Implementating CICS TS 1.1.1	261
CEMT I TASK - New States and Important New Information	261
CEMT SET PROGRAM(progrname) PHASEIN	262
CEDF Usability Enhanced	263
CEDX Transaction Allows Debugging of Non-Terminal Tasks	263
Priority Aging Set by PRTYAGE	263
Loading of Resident Programs	263
Autoinstall-Exit for Programs: DFHPGADX	264
Enhancements for TS Queues	264
CSD-File LSR Buffer Usage	264
VSAM LSR Buffer Hashing - Much Improved Data In Memory	264
Automated Operation with CICS TS from Batch via CLISTs or REXX	265
Error Messages DFHEV1020S and DFHST0103 During CICS TS Start Up	265
GETVIS 24 Usage	266
Behavior of CICS TS in Case of an SOS Condition	271
Automated Start of DB2	272
Translating and Compiling EXCI-programs	273
Translating Programs Containing System Programming Commands	273
Sample Application Programs	273
Hints about Statistics	273
Some Hints about Tracing	275
New Dump Tables and Dump Hints	275
CICS catalogs DFHGCD and DFHLCD	278
SVA Usage - Be Very Careful in a Coexistence Environment	278
Console Security and II-Console Full Function Usage	279
Assembly of CICS/VSE 2.3 Programs Beginning with VSE/ESA 2.5	279
Information about LE/VSE 1.4.1	279
CICS Applications Using TCP/IP Connections	280
Hints about CICS Web Support (CWS)	281
Hints for CICS Transaction Gateway with TCP/IP Connection	282
Where to Find Corrective Service for CICS TS	283
Chapter 15. IWS File Transfer	285
Basic Problem Solving Questions	285
Documentation Needed to Pursue Failures	286
Usage or Configuration Errors, Emulator Problems	287
Return Codes of VSE FILE TRANSFER IWS Messages	290
Chapter 16. Interactive Interface, System Files and Configuration	293
Display VSE/ESA Level	293
Problems Displaying Messages	293
History File Damaged	294
Mismatch History File - Dialogs	295
Restore of the Online Messages Explanation (OME) File	295
Message: User ID Already in Use	295
Deactivate the VSE/ESA Interactive Interface	296
Problems Using the Dialog "Storage Dump Management"	296
Abend DM02	297
Old CSD File	298
IPF Error	299
How to Find System Member DTR\$DTBL in ICCF Library	300

Hints and Tips for Fast Service Upgrade (FSU)	301
General Information for a Version Upgrade	301
Sizes Required	301
What To Do if Errors Occur	302
Replace Bootstrap Record (IJBREPB)	303
Sample Job for IJBREPB	303
Sharing the VSE Control File Between VSE/ESA Systems	304
Move the VSE/POWER Data File	304
Extend the VSE Dump Library	305
REXX program DMPMGR to Manage the Dump Library	306
Chapter 17. VSE/ESA e-business Connectors	309
Overview	309
Known Problems	309
Installation of the VSE/ESA Connector Client	309
IESC1017E SYNTAX ERROR IN CONFIG FILE	310
Codepage Problems with VSE/ESA Connectors and Navigator	310
Problems with Logon to the VSE/ESA Connector Server	310
Problems with CA TopSecret	310
Problems Accessing VSAM Catalogs	311
Error Message IESC1005E CANNOT SET UP TCP/IP LISTENER	311
Tracing the VSE/ESA Connector Server	312
VSE/ESA Connector Books	312
More Information and FAQs	312
Chapter 18. Debug Tool for VSE/ESA	313
Debug Tool for VSE/ESA 1.1.0 Documentation Reference	313
Debug Tool Run-Time Environment	313
VTAM Considerations	313
CICS Considerations	313
VSE Partition Requirements	314
General Remarks for Activating Debug Tool for VSE/ESA	315
Debug Tool Customization and Verification Jobs	315
Limitations of Debug Tool for VSE/ESA	316
Internet Link to Debug Tool for VSE/ESA 1.1.0	317
Debug Tool Related Service	317
Debug Tool Related Usage Problems	317
Chapter 19. Miscellaneous Hints and Tips	319
How to get Control in BG during System Startup	319
How to Re-Format the Recorder or Hardcopy File	319
SDAID GETVIS/FREEVIS TRACE	320
ICKDSF Changes with VSE/ESA 2.x	320
The BSD-C Trace Capability of TCP/IP for VSE/ESA	321
Overview	321
Installation	321
Output of the Trace	321
Special Considerations for Some Function Calls	322
Recommendation	322
Documentation	322
Index	323
Communicating Your Comments to IBM	325

Readers' Comments Form 327

Figures

1.	Important PSW bits	2
2.	LVTOC sample job	9
3.	Search a library sample job	10
4.	Test a library sample job	10
5.	Attention DUMP command to Printer or Tape	14
6.	Content of SADUMP tape after taking dump.	15
7.	Create a stand-alone dump program on a work disk	16
8.	Interactive Trace commands	19
9.	SDAID initialization via ATTENTION command	20
10.	SDAID initialization via SYSIN statements	20
11.	SDAID initialization via JCL procedure	21
12.	TRACE command examples	22
13.	SDAID OUTPut parameter	25
14.	SDAID JCL Procedures	28
15.	VM/CP monitoring facilities	29
16.	Sample of inconsistency between lock table and lock file	31
17.	LOCK SHOW command sample	33
18.	LOCK TRACE command sample 1	34
19.	LOCK TRACE command sample 2	34
20.	DEBUG activation and modification commands	38
21.	DEBUG STOP commands	38
22.	DEBUG SHOW commands	39
23.	GETVIS SVA,ALL command sample	41
24.	GETVIS SVA,DETAIL command sample	42
25.	SIR ? command sample	43
26.	SIR (without any operand) command sample	44
27.	SIR SMF command sample	53
28.	SIR MON command sample	58
29.	SIR MIH command sample	59
30.	SIR CHPID command sample	60
31.	SIR CRWMSG=ON command sample	61
32.	STACK command syntax	62
33.	STACK command sample 1	64
34.	STACK command sample 2	64
35.	STACK command sample 3-1	65
36.	STACK command sample 3-2	66
37.	STACK command sample 3-3	67
38.	STACK SET program	71
39.	STATUS command sample	72
40.	TIME command sample	75
41.	VOLUME TAPE command sample	77
42.	Processing Steps for Jobs A, B and C	80
43.	Migration Steps that will Impact CPU Time	84
44.	QUERY TD Output Example	85
45.	Relationship of Non-Parallel Workload and Exploitable CPUs	85
46.	Examples of our Measurement Results	86
47.	Job Control Storage Layout	101
48.	Command-to-subphase Cross-Reference	102
49.	Sample Job to Demonstrate Subphase Loading	105
50.	Partition Save Area Layout	105

51.	Eyecatcher of Job Control Root Phase	106
52.	Eyecatcher of Job Control Subphase	106
53.	Job Control Command Input Buffer	107
54.	Normal Termination of an Application Program	108
55.	Logging of Comment Statements	115
56.	Different Lengths of Label Information Records	117
57.	REXX Procedure for Inspecting LSERV Utility Output	117
58.	VSE/POWER SET Command	130
59.	Influencing Separator Pages and Layout	132
60.	SET Statements for VSE/POWER	133
61.	New Function for VSE/POWER	134
62.	New Function for VSE/POWER	134
63.	* \$\$ JOB statement - syntax updates including the operand DUEFRQ	136
64.	New Function for VSE/POWER	139
65.	New Function for VSE/POWER	142
66.	New Function for VSE/POWER	144
67.	New Function for VSE/POWER	144
68.	VSE/POWER PSTART Command	146
69.	New Function for VSE/POWER	146
70.	Characteristics of BACKUP, SAVE, and PICKUP Functions of the VSE/POWER POFFLOAD Command	148
71.	Format of POFFLOAD PICKUP Syntax	149
72.	VSE/POWER POFFLOAD Command	151
73.	Recreate library in BAM space	161
74.	Recreate library in VSAM space	161
75.	BACKUP library with defective member	162
76.	Copy Catalog Records to Tape Sample Job	179
77.	Restore User Catalog from Tape Sample Job	179
78.	Delete VSAM Space With IKQVDU Sample Job	180
79.	VSAM File Name Format	180
80.	Delete VSAM Data Spaces Sample Job	181
81.	Example Where Message 4228I Is Issued	185
82.	Example Where Message 4228I Is Not Issued	186
83.	Re-Build VSAM Master Catalog Console Log	189
84.	Verification if CMSVSAM or CMSAMS is Installed	192
85.	Definition of a CMS VSAM Master Catalog	193
86.	Messages Received for Missing DEFAULT.MODEL	202
87.	Define a DEFAULT.MODEL (SAM ESDS) Sample Job	202
88.	ICCF procedure PUNC to uncompress a member	215
89.	ICCF macro MUNC for multiple uncompress members	215
90.	Syntax of a Function Call in REXX - Expression	218
91.	Syntax of a Function Call in REXX - Call	218
92.	TO-user setting with REXX	219
93.	Sample 1: Symbolic parameters	220
94.	Sample 2: Symbolic parameters	221
95.	Sample 3: Symbolic parameters	221
96.	Sample: Reactivating a suspended console	223
97.	Sample: SENDCMD with retry-loop	224
98.	Sample: Read an ICCF member via SLI	225
99.	Sample: REXX in an interactive partition - REXX procedure	225
100.	Sample: REXX in an interactive partition - ICCF macro	226
101.	Sample: DITTO-REXX interface for VSAM	226
102.	Reason Codes Generated by VGS	227
103.	Reason Codes Generated by VSE	229

104. MAPXPCCB Macro Return Codes (IJBXRETC)	231
105. MAPXPCCB Reason Codes (IJBXREAS)	233
106. Reason Codes Generated by DFSMS	235
107. LE/VSE 1.4 Jobs in ICCF Library 62	238
108. CICS/VSE Security Migration Aid Screen (XSM01)	252
109. CICS/VSE Security Migration Aid Screen (XSM02)	252
110. CICS/VSE Sign-on Screen (CESN)	256
111. Security Documentation	258
112. Current VSE/ESA Releases	285
113. Send/Receive Examples	285
114. VTAM Commands to Get VTAM Buffer Trace	286
115. Get an SDAID Trace Job Sample	287
116. File transfer messages	290
117. DDM Error Codes	291
118. Display VSE/ESA Level	293
119. How to Get IESTRFL on a VSE System	293
120. Where to Find IESTRFL	294
121. Restore of IESTRFL	294
122. Restore History file	294
123. Update DTRIHIST.Z	295
124. Info/Analysis Dump Sample Job	296
125. Dump Management File	297
126. Define VSAM Space During FSU	302
127. Remove a Product from MSHP History File Sample Job	303
128. Replace IPL Bootstrap Record Sample Job	303
129. Sharing the Control File	304
130. Periodic Dump Library Management Job Example	307
131. Debug Tool Customization and Verification Jobs	316

About This Book

Judging by the feedback we received from our customers so far, the previous editions of *Hints and Tips for VSE/ESA* were a great success. In our continued effort to serve our customers as best as we can, we publish the sixth edition of this book. The VSE/ESA Development Team has updated existing information where needed and has added new information to reflect the latest VSE/ESA enhancements. If this book helps VSE/ESA customers to better understand new and existing functions and makes it easier for them to analyze and solve problems, it serves its purpose well.

Summary of Changes

This edition of the manual includes minor updates, corrections, and new information as listed below.

- In **Chapter 1, “System Control Program” on page 1** , the following section has been improved:
 - “Stand-alone Dump Program” on page 14.
- In **Chapter 2, “Internal Attention Routine Commands” on page 37** the following sections have been improved:
 - “GETVIS” on page 39
 - “TAPE” on page 74
- In **Chapter 5, “Job Control” on page 101** , the following sections are new:
 - “Job Control Statement Logging” on page 114.
 - “Job Control Statement Logging on SYSLST” on page 114.
 - “Job Control Statement Logging on SYSLOG” on page 114.
 - “Job Control Comment Statements” on page 115.
- In **Chapter 8, “VSE/VSAM” on page 177** , the following improvements have been made:
 - The section “Using Lock Trace to identify owner of VSE/VSAM lock” on page 184 has been added with examples
 - The section “Catalog Backups” on page 197 has been improved
 - The section “Missing or Unreadable Print Information” on page 205 has been added
 - The section “Recent VSE/VSAM Enhancements (VSE/ESA Version 2).” on page 207 has been added, including:
 - “Extending KSDS Files Above 4 GB” on page 207
 - “Multiple Catalog Backup” on page 208
 - “Compression Prediction Tool (IKQCPRED)” on page 208
 - “DB2 VSAM Transparency for VSE/ESA” on page 208
 - “IXFP/SnapShot and Fastcopy Support for VSAM Datasets” on page 209
 - “VSE/VSAM Buffer Hashing” on page 209
 - “VSE/ESA e-business Connectors” on page 209
 - “VSE/VSAM Record data mapping” on page 210
 - “Librarian Support of up to 32 VSE/VSAM Extents” on page 210
 - “Virtual tape” on page 210
 - “VSE/VSAM Redirector Connector” on page 210

Summary of Changes

- “VSE/VSAM Support of Large DASD” on page 211
- “Imbedded Index dropped” on page 211
- “VSAMIO” on page 211
- In **Chapter 10, “REXX/VSE” on page 217** samples have been added.
- **Chapter 12, “Language Environment for VSE/ESA (LE/VSE)” on page 237** has several changed sections including:
 - “LE/VSE Big Picture” on page 237.
 - “LE/VSE 1.4.2 in VSE/ESA 2.6” on page 237.
 - “Mixed Language Applications under LE/VSE (involving Assembler)” on page 238.
 - “Summary of LE/VSE Customization and Verification Jobs” on page 238.
 - “Modifying Behavior of COBOL Reusable Environment” on page 240.
 - “Languages and CICS Transaction Server” on page 241.
 - “Generating Applications Capable of Running Under LE/VSE” on page 241.
 - “Run-Time Options to Use with Caution” on page 243.
 - “LE/CICS-wide Run-Time Options to VSE Console” on page 243.
 - “CICS Table Parameter Settings” on page 244.
 - “Common Abend Conditions With LE/VSE” on page 245.
 - “LE/VSE Related Service via Ordering PSP Bucket” on page 247.
 - “LE/VSE Documentation Links” on page 248.
- In **Chapter 13, “VSE/ESA Security and CICS-Coexistence Beginning with VSE/ESA 2.4” on page 249** the following sections have been improved:
 - “Migrate Transaction Definitions Active in a CICS/VSE 2.3 System” on page 249
 - “Migrate Transaction Definitions Stored in DFHPCT.A (Macro)” on page 253
- In **Chapter 14, “Hints and Tips for “CICS TS for VSE/ESA 1.1.1”” on page 261** the following sections have been improved:
 - “Hints for Implementating CICS TS 1.1.1” on page 261
 - “CSD-File LSR Buffer Usage” on page 264
 - “Automated Operation with CICS TS from Batch via CLISTs or REXX” on page 265
 - “GETVIS 24 Usage” on page 266
 - “Behavior of CICS TS in Case of an SOS Condition” on page 271
 - “Automated Start of DB2” on page 272
 - “Hints about Statistics” on page 273
 - “CICS catalogs DFHGCD and DFHLCD” on page 278
 - “Console Security and II-Console Full Function Usage” on page 279
 - “Information about LE/VSE 1.4.1” on page 279
 - “CICS Applications Using TCP/IP Connections” on page 280 (new)
 - “Hints about CICS Web Support (CWS)” on page 281 (new)
 - “Hints for CICS Transaction Gateway with TCP/IP Connection” on page 282 (new)
 - “Where to Find Corrective Service for CICS TS” on page 283 (new)
- In **Chapter 15, “IWS File Transfer” on page 285** the following section has been improved:
 - “Basic Problem Solving Questions” on page 285
- In **Chapter 16, “Interactive Interface, System Files and Configuration” on page 293** the following sections have been improved:

- “History File Damaged” on page 294
- “Hints and Tips for Fast Service Upgrade (FSU)” on page 301
- “REXX program DMPMGR to Manage the Dump Library” on page 306
- **Chapter 17, “VSE/ESA e-business Connectors” on page 309** is new. It includes the following sections:
 - “Overview” on page 309
 - “Known Problems” on page 309
 - “Tracing the VSE/ESA Connector Server” on page 312
 - “VSE/ESA Connector Books” on page 312
 - “More Information and FAQs” on page 312
- In **Chapter 19, “Miscellaneous Hints and Tips” on page 319** the following section has been improved:
 - “SDAID GETVIS/FREEVIS TRACE” on page 320

Summary of Changes

Chapter 1. System Control Program

The different components of the VSE/ESA system carefully check any submitted job to see whether the prerequisites for the execution of the job are fulfilled. The user gets an information message if the Job Control statements are incorrect or incomplete. The Job Control statements assign and allocate system resources to the application program. A message may occur if these resources are not available in the system or if they are assigned to another user.

If an error occurs during the execution of the job, the VSE terminator routines provide error messages and cancel the failing program. If the proper dump options are active, the termination routines create a storage dump of the failing partition. This storage dump shows the PSW and the registers at the time of the failure, and it provides a snapshot of the storage contents of the failing partition. In most cases the diagnostic messages, the message explanation and the storage dump are sufficient to find the cause of the malfunction.

Besides the dumps which are automatically invoked by the VSE termination routines, there are the attention routine dumps. Via the DUMP command you may request a dump of parts of virtual storage.

If a dump does not give enough information to solve the problem, you may use the interactive trace program to follow selected instructions or all instructions of the program step by step. The interactive trace program may also be used if an application program contains logical errors and you do not understand why the program does not produce the wanted results.

Supervisor or Hardware Malfunctions

If a program malfunction occurs in the VSE supervisor itself, then we may or may not get a reasonable error message. Whether the system is able to communicate the problem to the console operator depends on the degree of the malfunction. Whenever the VSE system operator is suspecting a system failure, which could be a loop or a system hang condition, then it is his responsibility to intervene and determine the degree of the malfunction. He does so by first trying to issue some useful commands.

- DEBUG ON
- STATUS command, or
- CANCEL AR command
- REPLID

First try to issue the DEBUG ON command to make sure that the VSE system will start its internal monitoring capabilities. If that command is not being accepted or responded to, then the attention task is in some abnormal state and you should try the **CANCEL AR** or the **RC** command to get it freed again. In case that doesn't work either, then try the **REPLID** command to check if the console facility is responding. If the REPLID command is being responded to, then proceed as described under "Attention Not Responding" on page 4. If the REPLID command is not being responded to, then

System Control Program

The processor may be in

- a continuous disabled loop, or
- a disabled wait state.

Now it's time to intervene via the processor's monitoring facilities. The procedures to invoke and execute the monitoring facilities are different for different types of processors. Therefore they are not described in this report. For detailed information you may consult the Operations Guide of your Central Processing Complex. In a VSE system running under control of VM/ESA, the VM/Control Program provides the monitoring facilities. See "Important VM/CP Functions" on page 29 which describes the CP commands which monitor the system status of a virtual machine. The first thing you need to do is:

Stop the processor and display the PSW

Determine Hard or Soft Wait

The processor's monitoring facilities offer a function to display the Program Status Word (PSW). In a disastrous error state, the most important bit in the PSW is bit 14 the **Wait** bit. (This is the bit X'02' in the second byte of the PSW). If the **wait bit is zero** then the processor is active and you should conclude that the system is in a disabled loop.

The second full word in the PSW (the PSW address field) shows the instruction address where the processor has stopped. If you start and stop the processor repeatedly, you may be able to determine the scope of the loop. You could also try to activate the processors instruction trace facility to examine some loop details (see also Processor Loop).

If the **wait bit is one**, then the processor is in the wait state. That is, the processor does not execute any instructions. In this wait state the second full word of the PSW does not contain an instruction address but may contain useful information identifying the reason of why that wait state had been entered. Before you can draw such a conclusion, you need to examine bit 6 and 7 of the first byte of the PSW. If either of these two bits X'02' (I/O mask bit) or X'01' (external mask bit) is ON, then the processor is in a **SOFT WAIT** (see Soft Wait States). The processor is in a **HARD WAIT** if both these bits are OFF (see also Hard Wait States)

Figure 1 shows the bit positions of the above mentioned PSW bits:

02xxxx00 xxxxxxxx	I/O mask bit: If this bit is one, then the processor is enabled for I/O interruptions
01xxxx00 xxxxxxxx	External mask bit: If this bit is one, then the processor is enabled for external interruptions
xxx2xx00 xxxxxxxx	Wait bit: If the wait bit is one, then the processor is in the wait state

Figure 1. Important PSW bits

Processor Loops

Processor loops can have many causes. See some examples below and what you should do in case you are experiencing such a processor loop.

The Processor Runs in a Continuous Loop

Symptoms: The processor executes instructions but the VSE system seems to be idle. It does not respond to attention commands. When you stop and start the processor several times, the PSW is always active (the wait bit in the PSW is zero) and the PSW address field shows different addresses at any stop. The processor does not perform useful work; it is in a continuous loop.

What To Do: Collect information about the loop, and take a stand-alone dump

This is probably a situation where a stand-alone dump followed by a new IPL is the only measure to recover the VSE system. But before you take the stand-alone dump, retrieve some data about the processor loop and do a STORE STATUS afterwards. It is useful to find out whether the loop is short or long. Stop the processor, enter the single instruction mode, and press the start key several times. The processor executes single instructions and displays the address of any executed instruction. If the loop is short, then note the instruction addresses within the loop. If the loop is long, then note selected addresses within the loop. For that, you reset the processor status to normal instruction processing and stop and start the processor several times. Probably you will find that the processor loops between two or three blocks of processor storage. Any addresses occurring within the loop will later be useful to interpret the stand-alone dump data.

Processor Interrupt Loop

Symptoms: The processor loops on the same instruction.

What To Do: Take a stand-alone dump.

The worst case of a processor loop is a one-instruction interrupt loop. Such a loop may occur if a program with PSW key zero overwrites the low storage area. For example, a program that writes location X'68' with binary zeros. That will inevitably lead to a disaster error. On the next programming interruption (e.g. on a page fault), the processor stores the actual PSW into location x'28' and fetches a new PSW from location X'68'. Since location X'68' does not contain a valid PSW, the processor recognizes another programming interruption. The processor enters a loop, continuously fetching the same incorrect PSW from location X'68'. If the VSE system runs under control of VM/ESA, then the Control Program VM/CP interrupts the virtual machine and displays the message "CP ENTERED; PROGRAM INTERRUPT LOOP". The only possible operator action for a processor interrupt loop is a stand-alone dump followed by a new IPL of the VSE system.

Device Check Loop '07E6'

Symptoms: Check storage location 0. If you see X'07E6cuu' then you have detected a device check loop as explained here.

What To Do: Remove one ADD statement and re-IPL.

A disabled instruction loop may occur during IPL, if an added device does not respond to SSCH requests. The IPL program issues a SENSE command to any device for which an ADD statement exists. The IPL program moves the value

System Control Program

X'07E60cuu' to low storage location zero and checks the device status via a STSCH and a TSCH command. If the device does not answer, then the processor may run into an endless loop. These events show you that the IPL program is in a 'device check loop':

- the IPL program showed message 0J10I RESTART POINT BYPASSED as last message on the screen.
- the low storage location zero shows the value X'07E60cuu'
- the value 0cuu in byte 2 and 3 does not change (IPL always waits for the same device).

There is no way out of the disabled loop. The only way to bring up the system is to repeat the IPL procedure without the critical ADD statement.

SDAID Monopolizes the VSE System and Cannot Be Stopped

Symptoms: You started SDAID and can't do anything while SDAID is running.

What To Do: Reset control register 9 to zero.

This SDAID problem looks like a processor loop, but the system is not in a loop. You specified a comprehensive instruction or branch trace, e.g. an instruction trace with AREA=ALL and ADDRESS=0:*. The VSE system is 100 % busy; it executes instructions and processes programming interruptions all the time. The VSE system will not even accept a STOPSD or ENDSD command. In this situation use the processor's monitoring facilities to reset the tracing conditions in the first byte of control register 9. (The bits X'80', X'40', and X'20' control the branch trace, the instruction trace, and the storage alteration trace, respectively). If you have reset the relevant bits to zero, the VSE system will return to reasonable work and accept a STOPSD or an ENDSD command.

Attention Not Responding

You have issued the REPLID command and it did provide you the appropriate response, but the VSE system did NOT RESPOND to, or even accept VSE AR-commands (0D14I COMMAND IGNORED) and the **CANCEL AR** or the **RC** command did not free the Attention task either and you have made sure that Attention is not waiting on an I/O request which may require operator intervention, or the CANCEL cuu(,FORCE) command, then its about time to take a stand-alone (SA) dump followed by a new IPL to recover your VSE system. Please make sure that you have done a STORE STATUS prior to taking the SA Dump.

System Status

You have entered the DEBUG ON command and the Attention routine has replied with 1140I READY. Now do the following.

First check the status of the system via the Attention command STATUS. A STATUS command (without any operand) shows which tasks are ready to run and which tasks are in a bound state. Examine the waiting tasks and check the events they are waiting for. You may find out that a set of tasks (or even all tasks) are bound in a deadlock. You break the deadlock situation by canceling the partition which holds the critical resources.

In case the STATUS command doesn't indicate any failure symptoms, you should issue the DEBUG SHOW(,ALL) command (see DEBUG) and examine its output to eventually find a failure.

Soft Wait States

Soft Wait State (Waiting for I/O Completion)

Symptoms: If the processor is in the wait state (PSW bit 14 is one) and the processor is enabled for I/O interruptions (PSW bit 6 is one), then the system is in a soft wait state.

What To Do: Check system status carefully before taking a stand-alone dump.

The processor is waiting for an I/O interruption. In this situation check the activity of the system carefully before you start any recovery actions. The fact that you see the same soft wait PSW on any processor stop does not necessarily mean that the VSE system is idle. The VSE system may do reasonable work, e.g. copy some hundred cylinders from one disk to another disk. If you stop the processor during such an action several times, you may always see the same soft wait PSW. Only when you are sure that the soft wait is solid should you start recovery actions.

You can activate the processor by pressing the reset key (to remove pending device conditions) and entering an attention command, e.g. a STATUS command. The processor will process the interruption. If the processor falls back into the soft wait state and you don't see any actions after a while, then you should take the same actions which are proposed for a disastrous hard wait situation. Take a stand-alone dump and re-IPL the system. In case of an I/O wait, the low core locations 0 to 7 do not contain values important for problem determination. An exception from that general rule may occur during IPL.

Soft Wait '08C1' During IPL

Symptoms: Check storage location 0. If you see X'08C10cuu' then you have detected the softwait as explained here.

What To Do: Ready the referenced device.

If an 'INTERVENTION REQUIRED' condition occurs during IPL and the I/O message writer is not yet available, then the IPL routine enters the value X'08C10cuu' into low core location zero and enters a soft wait state. The only action required at that time is to make the referenced device ready. The IPL routine will continue processing. These events show you that the IPL program is in an 'intervention required' wait:

- the IPL program showed message 0J10I RESTART POINT BYPASSED as last message on the screen.
- the low storage location zero shows the value X'08C10cuu'
- the value 0cuu in byte 2 and 3 does not change (IPL always waits for the same device).

Soft Wait (Waiting for an External Interruption)

Symptoms: If the processor is in the wait state (PSW bit 14 is one) and the processor is enabled for external interruptions (PSW bit 7 is one), then the system is in this soft wait state.

What To Do: Check the PSW and perform the action the system is waiting for.

The processor is waiting for an external interruption. In this situation the contents of the PSW and the storage locations 0 to 4 define the required action. Soft waits

System Control Program

with a PSW enabled for external interruptions are often programmed waits. The system expects an action from the operator, followed by an external interruption. On some processors you generate an external interruption via the IRPT key; on other processors you enter the monitoring facilities and select the option INTERRUPTION. On a VM controlled system you issue the CP command EXTERNAL.

- **PSW = 010E0000 0000EEEE**

The SDAID program has created this soft wait PSW. A TRACE statement has been specified with the HALT option. The specified event has occurred and SDAID has entered a soft wait state. The operator may display some storage locations using the processor's monitoring facilities. The operator has two choices to resume normal operation

- generate a processor interruption. SDAID continues tracing and stops on the next traced event (again with a soft wait PSW of 010E0000 0000EEEE)
- set the value x'FF' into low core location 0 and generate a processor interruption.
SDAID will reset the HALT option and continue tracing.

- **PSW = 010E0000 00EEEEEE**

The SDAID program has created this soft wait PSW. The SDAID output device (OUTDEV) needs attention. The low core bytes 2 to 3 contain the device address (cuu) of the SDAID output device. The low core locations 0 to 1 display one of three information codes:

- 62C1** End of tape reel
- 62C5** Intervention required. Printer or tape is not ready
- 62E2** Intervention required. Byte 4 contains an error recovery action code

The operator should handle the device problem (mount new tape, feed paper to printer, etc.) and then generate a processor interruption.

If it is not possible to lift the 'intervention required condition', then generate a processor interruption, too. If you generate an external interruption and the SDAID output device is still unready, SDAID switches tracing off and the VSE/ESA system resumes operation without tracing. Then stop SDAID explicitly via a STOPSD command. SDAID will display the message 4C01A SDAID ALREADY STOPPED. This message describes the I/O problem and gives you the possibility to dump the SDAID area. Then issue the ENDS command to terminate SDAID finally.

Hard Wait States

Symptoms: If the PSW has one of the states as shown below, then the system has entered a hard wait condition.

What To Do: Check the PSW and re-IPL the system with or without a stand-alone dump.

If the PSW wait bit (bit 14) is one and the mask bits (bits 6 and 7) in the PSW are zero, then the processor is in a hard wait state. A hard wait state is not necessarily caused by a software or hardware malfunction. Often the hard wait state signals the normal completion of a stand-alone process. If the stand-alone dump program or the stand-alone restore program terminate processing, they enter a hard wait

state. This is a normal end of processing, and you should not think of taking a stand-alone dump. The proposed action is to IPL the VSE system. The following lines show the different hard wait codes and the proposed operator actions.

- **PSW = 000A0000 00001000, or PSW = 000A0000 00EEEEEE**

These hard wait PSWs show that a disaster error has occurred in the VSE/AF supervisor. The error may have occurred during IPL or during normal operation. If the address part of the hard wait PSW contains 00EEEEEE then the RAS routines have generated the hard wait state.

In any case it is important to check the low core locations 0 to 7. These bytes give information about the cause of the error. The chapter 'VSE/Advanced Functions Wait Codes' of the VSE message manual describes the meaning of the error codes found at low core locations 0 to 7. In a hard wait state with one of the above shown PSWs, the system is dead and there is no hope for recovery. The only proper action is to display the PSW, display low storage locations 0 to 7, take a stand-alone dump, and IPL the VSE system.

- **PSW = 000A0000 00CExxxx**

The stand-alone dump program has created this hard wait PSW. When the stand-alone dump program completes processing, it enters a hard wait state with the above PSW. The value xxxx in the address portion of the PSW shows the result of stand-alone dump processing. An address value of 00CE0000 signals successful completion. Other address values, like 00CE0100 (I/O error during tape IPL) or 00CE0080 (end of extent on stand-alone dump disk file), signal that the stand-alone dump program terminated abnormally.

These error codes from the rightmost two bytes of the hard wait PSW are explained in the chapter 'VSE/Advanced Functions Wait Codes' of the message manual. The recommended action after any stand-alone dump hard wait is to re-IPL the VSE system.

- **PSW = 000A0000 0000EEEE**

The DEBUG program has created this hard wait PSW. The Address Compare Stop event of the DEBUG feature has generated the above hard wait code. The operator has defined a DEBUG address compare stop, and the contents of the specified field matches the user specified pattern. **This is not an error Situation.** The operator established an address stop and the requested address stop came along.

You may analyze the system status and then restart the VSE system using the RESTART feature provided by the processor's monitoring facilities. The DEBUG feature has prepared a restart PSW in low core location 0. If the VSE system runs under control of VM/ESA, then use the CP command 'SYSTEM RESTART'. The DEBUG feature resets the address stop. The VSE system resumes operation as if no stop were encountered.

- **PSW = 040E0000 00002000**

The stand-alone supervisor has created this hard wait PSW. When a program running in the stand-alone environment completes and the operator decides to terminate the stand-alone environment, then the VSE system enters the above hard wait PSW. **This is not an error situation.** The stand-alone environment came to its normal end. There is no reason to take a stand-alone dump. The recommended action at this time is to re-IPL the VSE system.

- **Other hard wait codes**

The VSE system does not produce hard wait codes other than those mentioned above. If a VSE system enters a hard wait state and the address portion of the PSW contains another value, then the hard wait state was probably caused by a vendor product. In this case you should check the product documentation of the vendor products installed in your VSE system. In order to document the hard wait problem, note the PSW, take a stand-alone dump and re-IPL the VSE system.

Diagnostic Messages

The VSE system detects a problem and issued an error message

- read message explanation, and
- perform the recommended actions

The previous section discussed severe system errors, characterized by the fact that the processor looped or entered a wait state. This section discusses error situations where the VSE system keeps running and displays documented error messages.

The VSE/ESA message manual "Messages and Codes", SC33-6607 interprets the messages issued by the VSE/ESA package and its component licensed programs. The manual explains the reason for the message, it describes the action the system has taken, and it gives a recommendation for the proper programmer and operator response. The description of any message may be retrieved on-line via the On-line Message Explanation function (OME). In a VSE/ESA 2.1 system you move the cursor to the message number and press function key 9. In previous VSE system the OME function is available via the Interactive User Interface.

The VSE error messages contain a message number and the message text. Often the message text contains variables, like a return or reason code, an SVC number, a phase name, or a function code. These enclosed variables provide important diagnostic data. If you bring a VSE problem to the attention of your IBM service location, always report the message number **and** the complete message text.

If a VSE job fails, then all Job Control statements and all system responses may be important for the analysis of the problem. You get all JCL messages logged on the console if you include a // LOG statement immediately after the // JOB statement. This // LOG statement directs all JCL messages to the console and into the hard copy file. All logged messages are accessible via the REDISPLAY command, and they can be printed at a later time via the PRINTLOG utility program. If you pass an error report to an IBM service location, always submit the complete console log with all Job Control statements and all system messages to the service location.

Message 0P31A DEVICE NOT OPERATIONAL

What To Do: Try to wake up device via 'ONLINE cuu(,FORCE)'.

The above message occurs if an I/O unit is broken, power is switched off, or a device with the referenced address does not exist. You may get message 0P31A if you attach a device to your processor after IPL has completed. The IPL routines issue I/O commands to all possible unit addresses. If a device does not respond to the I/O command, then the IPL program may flag it internally as 'not operational'. Such late attachments often occur if a VSE system runs under control of VM/ESA

or in an LPAR environment, or if I/O devices are shared between systems via control unit or channel path switching.

If you attach an I/O device after IPL has completed, VSE will automatically recognize that the device(s) became operational and will thus initiate its ONLINE processing. You may want to issue the 'ONLINE cuu(,NOASN)' to tell the VSE system explicitly that the device is present and ready to execute I/O operations. NOASN is an option that will prevent devices (tapes) to be assigned to a particular system (LPAR).

Error When Opening a File

What To Do: Ensure that the file descriptions match.

When the VSE I/O routines open a file, they take file descriptions from three different sources. An error occurs if these different descriptions do not match.

1. The first source of information is the file description (called the 'DTF') in the application program. The DTF describes the file name, the file type and it provides some file characteristics. You can check the DTF only if you have a source listing of the failing application program.
2. The second source of information is the system's label area. This label area contains the DLBL statement and the EXTENT statement(s). You include label statements into your job stream or use label statements which have been put permanently into the system's label area in a previous job. The label statements describe the file name, the expiration date, and the track allocations. If the label statements are not contained in the failing job stream, use the LSERV utility program to retrieve the contents of the system's label area.
3. The third source of information is the VTOC, the Volume Table of Contents. The VTOC entry contains the file name, and it shows the tracks which are occupied by the file. The VTOC entry depends on the DLBL and EXTENT statements which were active when the file was created. You use the LVTOC program to list the contents of a disk pack. The LVTOC program needs assignments for SYS004 and SYS005.

You compare the output of the LSERV program with the output of the LVTOC program (and eventually with the DTF found in the application program). If you detect a mismatch in the different descriptions of the file, then correct the labels and rerun the job.

```
// JOB LVTOC
// ASSGN SYS004,cuu          address of disk unit
// ASSGN SYS005,cuu          address of printer unit
// EXEC LVTOC                list Volume Table of Contents
/&
```

Figure 2. LVTOC sample job

Phase Not Found

What To Do: Search the active libraries.

You specified a program name on an EXEC, an LFCB or an LUCB statement, or issued a LOAD macro within an application program. An information message or a return code informs you that the referenced phase name is not contained in the allocated program libraries. Use the Job Control LIBLIST statement to retrieve the actual library chain, and then use the Librarian program to inspect the contents of the assigned libraries. The SEARCH function checks whether a single phase is contained in a library, and the LISTDIR function prints the names of all library members.

```
// JOB  LIBRSRCH
// EXEC LIBR
SEARCH IJBSDUMP.PHASE L=IJSYSRS      search a phase in a library
LISTDIR L=IJSYSRS                    list all member names
/&
```

Figure 3. Search a library sample job

Corrupted Library

What To Do: TEST the library and repair or restore it (if necessary).

The structure of a system library or a private library may get damaged, if a disaster error occurs in the librarian program LIBR or in an implicitly called librarian routine. The librarian program LIBR provides a TEST feature to check the status of a library.

If the TEST function shows errors, then rerun the TEST function with the REPAIR option. If another TEST run still shows errors, then back up the library (if you do not already have a backup tape), and restore the library. If a following TEST run still shows errors, then contact the IBM support center and have the results of the TEST run available.

See also “Test of Libraries” on page 164 for more information.

```
// JOB  LIBRTEST
// EXEC LIBR
TEST L=IJSYSRS [REPAIR=YES]          test library integrity
/&
```

Figure 4. Test a library sample job

Message 4936I NO MORE AVAIL/MATCH XTNT

What To Do: Check if one of the following applies

- History File is too small, or
- History File is corrupted

The MSHP program issues the message 4936I. Any RETRACE listing shows a percentage of how much assigned space is used. If the percentage is higher than 80% then the history file is probably too small. It is recommended that you extend the history file. CREATE a larger history file and copy the old file into the new one.

If you get the message 4936I and the percentage is lower than 80 %, then the history file is probably corrupted. You have to take actions to recreate a correct history file.

- Use a backup of the history file if available. Re-application service or re-installation of a product may be necessary to reflect the latest changes to the system.
- If no backup of the history file is available, perform a MERGE of the system history file into a newly created history file. All history file information is transferred from the old history file to the new one, and the chain of free records is re-built. In many cases, this solves the problem.
- If no backup is available, and the MERGE could not solve the problem then the history file needs to be repaired. The history file analysis can be done by Level 2 support. Using an output of the "DUMP HISTORY SYSTEM" function and the 'MSHP Diagnosis Reference Manual (LY33-9153)', the record chains must be followed, until the invalid pointer is found. Once found, the DITTO program can be used to repair the record chain.

Message 0S06I A DUMP MACRO WAS ISSUED (Info/Analysis)

What To Do: Do the following

- increase partition size to at least 2 megabytes

Most problems occurring in Info/Analysis are caused by a shortage of GETVIS storage. If the partition is too small, you may get the above mentioned error message 0S06I or another BLN message explaining that an internal or external function is failing.

The GETVIS requirement of Info/Analysis depends on the size of the processed dump, on the size of the files BLNDMF and BLNXRTN, and on the storage requirements of the invoked exit routines, like DFHDAP. It is recommended that you run Info/Analysis in a partition with at least two megabytes of storage. It does, however, not help if you increase the SIZE parameter on the EXEC statement from SIZE=300k to a higher value. A SIZE=400k, for example, does just the opposite. SIZE=400k leaves 100k of bytes of the partition storage unused and decreases the available GETVIS storage by 100k.

- decrease size of Info/Analysis files BLNDMF and BLNXRTN

In the standard VSE systems, the dump management file BLNDMF and the external routines file BLNXRTN are defined with rich contingency. Even very big VSE installations do not require such big files. It seems that three tracks of a 3380 disk are sufficient for the dump management file BLNDMF, and that one track of a 3380 disk is sufficient for the external routines file BLNXRTN. Sometimes Info/Analysis reads these files - in total - into the partition GETVIS storage. You improve the space performance and the time performance of Info/Analysis if you decrease the size of BLNDMF and of BLNXRTN.

- check names of loaded dumps

Ensure that the dump names you define for loaded dumps do not conflict with system generated dump names. Problems may occur from the following two sources:

- You loaded two dumps whose name differ only in the first character or you loaded a stand-alone dump into a sub library and named it, let's say, JACK0001. When Info/Analysis processes this dump, it generates a mapping member and calls it MACK0001. (That's the way Info/Analysis builds the names of auxiliary library members. Info/Analysis generates a mapping member and an extension member and generates names for them by replacing just the first character). If you on-load another dump and name it PACK0001 then you will no longer have unique library member names. Info/Analysis searches the dump library for a mapping member named MACK0001 which may have been created in a previous Info/Analysis session. Info/Analysis will erroneously use the same mapping member MACK0001 for all dumps with names like BACK0001, JACK0001, PACK0001, and so on. This will lead to severe errors with different misleading error messages.
- You loaded a dump whose name is similar to a system generated dump name or you loaded a stand-alone dump and named it PE300007. Names of this form may conflict with dump names generated by the VSE termination routines. VSE creates dump names of the form DBG00001, DX700023, SF300004, SE300007, where the bytes 2 and 3 denote the partition-id and bytes 4 to 8 are a decimal number between zero and 99999. If you generate a dump with a name like PE300007, then Info/Analysis will create a mapping member for this dump which may conflict with mapping members created for ABEND dumps.

Solution: You avoid all naming problems if you introduce the following naming convention:

- do not use D, H, L, M, N, S, X as the first character of a dump name. Instead use **one** heading letter, for example the letter 'A' as first letter for all dump names within a dump sub library.
- place at least one alphabetic character in positions 4 to 8 of the dump name.

Message BLN2013I DUMP MANAGEMENT FILE IN ERROR

What To Do: Scratch the file, and run Info/Analysis UTILITY function.

The Info/Analysis Dump Management File BLNDMF is in error or it has been overwritten erroneously by another program. Before you build a new dump management file, you have to purge the defective file. Use the DITTO function PVT to scratch the VTOC entry of the file BLNDMF. (The DITTO function PVT runs in interactive mode only.)

If the DITTO program is not available in your installation, use another method to get rid of the old BLNDMF (e.g. overwrite the file with a file of a different name and answer 'DELETE' on the overlap file message).

Then specify labels for the dump management file, and call the Info/Analysis function UTILITY to create and format a new dump management file. On the next invocation of the dump management function, Info/Analysis scans the directory of the dump library SYSDUMP and builds entries for all available dumps.

Problem Management Programs and Tools

This chapter deals with the programs and functions available for error detection and error recording. It describes the following dump and trace features:

- the ABEND dump
- the DUMP command
- the Stand-Alone Dump program
- the Interactive Trace program
- the SDAID program
- the DEBUG feature
- the VM/CP TRACE function

ABEND Dump

If an application program terminates abnormally, then the VSE termination routines write an error message on the console and pass control to the dump routines. The VSE dump routines check the Job Control options to decide whether a dump is to be generated and to which output medium the dump should be directed. The operator or the programmer define JCL options which control the amount of dump data and the dump destination.

The JCL options DUMP, PARTDUMP, and NODUMP control the amount of dump data.

- option DUMP dumps the supervisor, important parts of the shared space, and the user partition.
- option PARTDUMP generates a dump of the user partition.
- option NODUMP suppresses the dump generation.
- options SYSDUMP and NOSYSDUMP control the dump destination.
- option SYSDUMP directs the dump to the dump library.
- option NOSYSDUMP directs the dump to SYSLST.

The dump output is also printed on SYSLST, if SYSDUMP is specified but the dump library is not defined (LIBDEF statement missing), or the dump library is full. If the dump is written into a dump library it can be processed via Info/Analysis.

DUMP Command

The operator uses the DUMP command to dump selected parts of the VSE system to a printer device or to a tape device. It is not possible to enter the dump output into the POWER list queue or to enter the dump directly into a dump library. If the dump is written on a tape device, then the dump tape may be loaded into the dump library.

If an SDAID session is active, you may dump the current contents of the trace buffer to a tape unit. It is recommended that you freeze the SDAID buffer via a STOPSD command, before you dump the buffer to tape. But you should not issue the ENSD command before you have dumped the buffer contents. The ENSD command returns all used resources to the VSE system and clears the SDAID buffer. The program DOSVSDMP formats the trace entries and prints them on SYSLST. Figure 5 on page 14 shows the usage of the DUMP command.

dump x7,5a7000-5a7fff,00e	dump an address range in the partition X7
dump b000-cfff,00e	dump an address range in the shared space
dump sva,280	dump selected parts of the Shared Virtual Area
dump sup,280	dump the VSE supervisor
dump dspace,myspace,bg,0-f00,00e	dump X'F00' bytes of the data space "MYSPACE" allocated to BG
dump buffer,480	dump SDAID buffer to tape

Figure 5. Attention DUMP command to Printer or Tape

Stand-alone Dump Program

If your VSE system enters a disastrous hard wait state or runs into a continuous processor loop, then no normal system action is possible. In order to collect information about the cause of the error you invoke the stand-alone dump program to save the status of the failing VSE system. However, **you can only invoke the stand-alone dump program if you have created it previously**. If you run into a disastrous error state, then it is too late for a program creation.

Important Hint: Always have a few stand-alone dump tapes ready, just in case you need it.

Stand-alone Dump Program Creation

The utility program DOSVSDMP creates the stand-alone dump program. You invoke DOSVSDMP with an EXEC statement without parameters. The program prompts you for the device type and the device address of the dump device.

The preferred storage medium for the stand-alone dump program is a tape device. You create the dump program at installation time and put the tape (cartridge or reel) aside for a possible error situation. DOSVSDMP creates the stand-alone dump program as the first file on an unlabeled tape. If you use the dump tape for taking a stand-alone dump, the dump program adds the dump data adjacent to the program on the same tape.

After taking the stand-alone dump, you will find 5 or more files on the tape as described in Figure 6 on page 15. The first 5 files are always in the same order, quantity and order of the next files depend on the SADUMP options you have set in your system.

File 1	Stand-Alone Dump program
File 2	Work Area used by SADUMP program
File 3	Supervisor and Shared Virtual Area (SVA-24 and SVA-31)
File 4	Page Manager Real Address Space
File 5	Page Manager Address Space 00
File 6	The first partition or data space to be dumped according their SADUMP options (or another Page Manager Address Space).
File 7-nnn	The next partitions and/or data spaces in order of their SADUMP options.

Figure 6. Content of SADUMP tape after taking dump.

The job control command `STDOPT SADUMP=n|,([n],m)` specifies the priority in which the partitions and data spaces should be included in a stand-alone dump. This priority applies to **all** partitions and data spaces in the system and may be overridden for a partition by a `// OPTION` statement, which defines the priority for the partition (and its owned data spaces). `SADUMP=n` indicates the priority of all partitions; `SADUMP=n|,([n],m)` indicates the priority (n) of all partitions, if specified and the priority of all data spaces (m).

- 0** Indicates that all/this partition or data space should not be dumped when a stand-alone dump is taken. This is the default.
- 1 - 9** Indicates the priority of the partition or data space for inclusion in a stand-alone dump.

When a stand-alone dump is taken, the partition or data space with the highest priority (starting with '9') is dumped first, then the one with the next lower priority, until all partitions or data spaces for which `SADUMP=0` has not been specified have been dumped (provided enough space is available on the dump device). Since APAR DY45896 progress of the stand-alone dump is indicated for each dumped partition by message

```
4G45I  START DUMPING OF PARTITION partition-id
```

VSE/ESA is delivered with `STDOPT` specified without `SADUMP`, so no partition or data space will be included in a stand-alone dump except the 3 static partitions F1, F2, F3, for which the corresponding `$xJCL.PROC` include `// OPTION SADUMP=5` as override.

When preparing a stand-alone dump tape, you should keep in mind the amount of data to be dumped, which will always be less than the `VSIZE` specified in the `IPL` statement. But if you plan to dump all partitions and all data spaces it may reach nearly `VSIZE`. If the complete dump does not fit on a single tape, the stand-alone dump program erases the last incomplete file and requests a new tape by message

```
4G36I  END OF VOLUME ON DUMP TAPE cuu MOUNT NEW TAPE
      OR RE-IPL VSE
```

Then the operator should mount a normal scratch tape and stand-alone dump continues dumping with the partition or data space which did not fit on the previous tape. If a partition does not even fit on a single tape, the stand-alone dump program will split the dump into several files. The symptom record at the end of the tape shows 'DUMP_CONTINUED_ON_NEXT_TAPE' in its section 5.

Note: In large VSE/ESA systems the VSIZE and sometimes even the size of large CICS partitions may exceed the capacity of a normal 3480 cartridge (200MB). So you should consider to use 3490E or 3590 cartridges as stand-alone dump tapes, because they supply a capacity of 800MB respectively 10GB.

If you run a tape-less VSE system or run the VSE system on an unattended node (without operator involvement) you may create a disk resident stand-alone dump program. The disk resident stand-alone dump program requires a program file IJSYSDI and a data file IJSYSDU on the same disk device. If more than one disk drive is available, you should create the dump program on a work disk.

It is possible to create the stand-alone dump program on the SYSRES disk. If SYSRES is selected as program residence then the dump program and the normal IPL program share the first tracks on SYSRES. Any IPL request first calls the stand-alone dump program and then the normal IPL function. If a dump is not needed, you avoid the time consuming dump processing by specifying option CLEAR on the IPL panel. The option CLEAR defines a fast path through the dump program, transferring control immediately to the normal IPL function.

If you create the stand-alone dump program on SYSRES, then DOSVSDMP needs a DLBL statement and an EXTENT statement for IJSYSDU. If you create the stand-alone dump program on a work disk, then DOSVSDMP needs labels for IJSYSDI and IJSYSDU. If you create the stand-alone dump program on a tape reel, then DOSVSDMP does not need any label statements. Below are the label statements for the files IJSYSDI and IJSYSDU. The labels for IJSYSDI must be coded exactly as described below. The file IJSYSDU may be allocated to any free cylinders.

```
// JOB ABCD
// DLBL IJSYSDI,'VSE.DUMP.PROGRAM'
// EXTENT ,,,1,7
// DLBL IJSYSDU,'VSE.DUMP.FILE'
// EXTENT ,,,10245,450
// EXEC DOSVSDMP
/ &
```

Figure 7. Create a stand-alone dump program on a work disk

Taking a Stand-Alone Dump

You use the processor's monitoring facilities to take a stand-alone dump.

1. stop the processor
2. display the low core locations 0 to x'17' and document it for the problem analysis
3. do a STORE STATUS
4. mount the dump tape
5. IPL the processor with the option LOAD NORMAL (LOAD CLEAR would wipe out all information you want to dump)

The stand-alone dump program dumps the shared areas and the selected user partitions without further operator actions. If processing completes successfully, the stand alone dump program enters a hard wait state with

PSW = 000A0000 00CE0000.

The recommended action after stand-alone dump completion is to re-IPL the VSE system.

Errors Occurring during Stand-alone Dump Processing

If an unrecoverable I/O error occurs on the tape device, the stand-alone dump program issues the message 4G37I ERROR ON DUNP TAPE cuu. MOUNT NEW TAPE OR RE-IPL VSE and enters an enabled processor loop. As soon as you mount a new tape reel and ready the tape unit, the dump program continues dumping on the next tape reel.

If a disaster error occurs during stand-alone dump processing, the dump program enters a hard wait state with a hard wait PSW of the form

PSW = 000A0000 00CExxxx

The value xxxx in the address portion of the PSW shows the cause of the error.

The error codes xxxx from the rightmost two bytes of the hard wait PSW are explained in the chapter 'VSE/Advanced Functions Wait Codes' of the VSE message manual. The recommended action after any stand-alone dump hard wait is to re-IPL the VSE system.

Capacity Problems

The stand-alone dump program always dumps the shared space i.e. the supervisor and the Shared Virtual Area. In addition it dumps those partitions which are explicitly elected for the stand-alone dump program via the JCL option SADUMP=n. The dump program puts the shared space and all partitions in separate dump files. If you select several partitions for being dumped, then the stand-alone dump tape or the dump data file on disk may be too small to hold all selected partitions.

The disk resident stand-alone dump program dumps all selected partitions until the capacity of the data file IJSYSDU is exhausted. All dump items which do not fit into IJSYSDU are dropped. The tape resident stand-alone dump is not limited to the capacity of one tape reel. If the dump tape is full then you may continue dumping on one or more other tapes. When a dump tape becomes full, the stand alone dump program issues message 4G36I and enters an enabled processor loop. As soon as you mount a new tape reel and ready the tape unit, the dump program continues dumping on the next tape reel. If the stand-alone dump program writes its output on more than one tape reel, then use the SCAN option of DOSVSDMP to find out which files are contained on the different tape reels. The dump program ensures that all tapes contain complete dump files. The dump files do not span tape reels.

Load the Stand-Alone Dump into a Dump Library

After you have taken a stand-alone dump, use the ONLOAD function of Info/Analysis to load the contents of the dump file in a dump library. If you load a disk dump file, specify labels for the file IJSYSDU in the ONLOAD job. Labels for IJSYSDI are not required. After you have loaded the dump tape or the disk file IJSYSDU in a dump library you may reuse the dump program for taking another stand-alone dump. Any other dump invocation preserves the program file and overwrites the previous dump file with a new dump file.

Real Dump

The stand-alone dump program normally takes a 'virtual' dump. It uses the page and segment tables to dump the different address spaces with ascending virtual addresses. In addition it uses the page data set on disk to retrieve the pages which are presently not in processor storage. The stand-alone dump program can only provide a virtual dump if a minimum of prerequisites is fulfilled. If the System Communications Region, the page and segment tables or the DPD table are destroyed, then the stand-alone dump program can only dump the real pages. That is, it dumps the pages which are presently in storage without address translation. Such a real dump may be helpful to analyze supervisor problems (since the supervisor is not pageable and its virtual addresses do not differ from the real addresses), but it is nearly useless to analyze problems in the private spaces.

If a Stand-Alone Dump Does Not Help

The stand-alone dump gives a snapshot of the VSE system at the time when the system or the operator detects the malfunction. The stand-alone dump shows the corrupted system, but it sometimes does not show how the error came about. If the information contained in the stand-alone dump is not sufficient to solve the problem and if the problem occurs again, activate a trace program to monitor important system data before the system runs into the disastrous situation. You have a choice between the SDAID program and the DEBUG feature. If the error is 'solid' (you know a way to reproduce the problem whenever you execute a specific program or a series of programs), then use the SDAID trace program. If the error occurs intermittent once a day or even once a week, then it is not feasible to run a time-consuming SDAID trace. In this case it is preferable to activate the internal DEBUG trace feature.

Interactive Trace Program

The interactive trace program traces the execution of application programs running in static or dynamic user partitions. It operates at the level of machine instructions and virtual storage addresses, similar to the CP debugging facilities in VM/ESA. The VSE users may activate the trace program independently in different partitions. The invoked tracing function is active for the duration of one job step.

You activate the interactive trace program via the EXEC statement. The TRACE parameter on the EXEC statement defines - as default - an instruction trace for all partition storage.

```
// EXEC ABCD,TRACE
```

You control tracing via the interactive trace commands. Figure 8 on page 19 shows the interactive trace commands. The lower case letters show the possible abbreviation. The TRace command defines or deletes traces. The Query command displays the active traces. The Display and Alter command display and alter storage and registers. The GO command resumes the stopped user program. A reply-id without any parameters is interpreted as a GO command.

TRace Inst ADDRess=41a3f0:42cfff	define instruction trace
TRace BRanch ADDRess=41a3f0.40	define branch trace for an interval of 64 bytes
TRace STor ADDRess=41a3f0	define storage alter trace for a one-byte field
TRace ABend	define abnormal-end trace
TRace END ALL	end all traces
TRace END 3	end the trace with number 3
Query	display all active traces
Display 4035a2	display one 16-byte line of storage data
Display 4035a2.50	display X'50' bytes of storage data
Display 4035a0:4035ff	display a storage interval
Display Gr	display all general purpose registers
Display G12	display general purpose register 12
Display Psw	display the program status word
Alter 4035a2 DATA=fefefe	alter three bytes in storage
Alter g7 DATA=12b	store the value 0000012b into general register 7
go	execute next program instruction(s)
GO OUTPut=SYSLST	switch to batch tracing
GO OPTION=PARTDUMP	modify the dump option

Figure 8. Interactive Trace commands

SDAID

SDAID (System Debugging Aid) is the trace program for VSE system routines. It offers a variety of trace types and output options. SDAID collects trace data and writes it on a printer device or on a tape device. The IBM manual VSE/ESA Diagnosis Tools (SC33-6614) describes the SDAID program in detail.

Trace Initialization and Execution

An SDAID session consists of two steps: the initialization step (the trace set-up), and the execution step (the tracing). You enter the trace initialization commands via attention routine commands or as SYSIN statements in any free batch partition.

In the attention routine you start the initialization process with the command SDAID. The SDAID command is followed by one OUTDEV command and up to ten TRACE commands. The OUTDEV command defines the SDAID output device. The TRACE command defines the trace type and the tracing conditions. The READY command ends the initialization process.

If you initialize the SDAID session via SYSIN, then you use the statement // EXEC SDAID. This statement is followed by one OUTDEV statement and up to ten TRACE statements. The OUTDEV and TRACE statements entered via SYSIN have the same format as the OUTDEV and TRACE commands. A /* statement completes the initialization process via SYSIN. When the initialization step is complete, the partition is free for the execution of any traced or not-traced program. The trace initialization is easier if you use the SDAID JCL procedures. See some

System Control Program

examples of a trace initialization via attention commands, via direct SYSIN statements, and via a JCL procedure below. Note that the three methods in this example initialize exactly the same SDAID session.

The trace execution is controlled via attention commands. The STARTSD (or STRTSD) command starts tracing. The STOPSD command stops the trace data collection temporarily. The ENDS command terminates the SDAID session finally. It returns all GETVIS space and frees all resources held by the SDAID program.

```
sdaid  
BG 0000 4C05I PROCESSING OF SDAID COMMAND SUCCESSFUL  
outdev printer=00e  
BG 0000 4C05I PROCESSING OF OUTDEV COMMAND SUCCESSFUL  
trace inst=* area=f3 address=41207a:4123b3  
BG 0000 4C05I PROCESSING OF TRACE COMMAND SUCCESSFUL  
ready  
BG 0000 4C05I PROCESSING OF READY COMMAND SUCCESSFUL
```

Figure 9. SDAID initialization via ATTENTION command

```
0 // exec sdaid  
BG 0000 4C40I SDAID  
BG 0000 4C05I PROCESSING OF SDAID COMMAND SUCCESSFUL  
BG-0000 4C41I ENTER YOUR SDAID COMMAND  
0 outdev printer=00e  
BG 0000 4C40I OUTDEV PRINTER=00E  
BG 0000 4C05I PROCESSING OF OUTDEV COMMAND SUCCESSFUL  
BG-0000 4C41I ENTER YOUR SDAID COMMAND  
0 trace inst=* area=f3 address=41207a:4123b3  
BG 0000 4C40I TRACE INST=* AREA=F3 ADDRESS=41207a:4123b3  
BG 0000 4C05I PROCESSING OF TRACE COMMAND SUCCESSFUL  
BG 0000 4C41I ENTER YOUR SDAID COMMAND  
0 /*  
BG 0000 4C40I READY  
BG 0000 4C05I PROCESSING OF READY COMMAND SUCCESSFUL  
BG 0000 4C44I ENTER 'STARTSD' ATTENTION COMMAND TO ACTIVATE SDAID  
BG 0000 1I00D READY FOR COMMUNICATIONS.
```

Figure 10. SDAID initialization via SYSIN statements

```

0 // exec proc=sdinst,area=f3,address='41207a:4123b3',printer=00e

***** SDAID Execution (always via attention commands) *****
startsd
...
now execute the program you want to trace
...
stopsd
...
startsd
execute another program step
endsd

```

Figure 11. SDAID initialization via JCL procedure

OUTDEV Command

OUTDEV {Printer=cuu|Tape=cuu}

The OUTDEV command defines a printer device or a tape device as SDAID output device. SDAID does not accept a spooled printer device. If the SDAID output is directed to a tape device, then you use the utility program DOSVSDMP to print the contents of the SDAID tape on SYSLST.

OUTDEV Command with Wrap-Around Buffer

OUTDEV [Buffer=nn] [{Printer=cuu|Tape=cuu}]

You use the parameter BUffer only to define a buffer which is filled in wrap-around mode. The value nn specifies the buffer size in units of 1024 bytes. If tape=cuu is specified, the buffer size is restricted to a value between 3 and 32. If the TAPE parameter is not specified, you may specify a value from 3 to 99. SDAID collects trace data in this wrap buffer, but it does not print the data if the buffer becomes full. It requires explicit actions to print such a wrap-around buffer. Figure 14 on page 28 (example 2-3) shows a method to print the buffer data within an SDAID session. SDAID traces selected instructions in a user partition and moves the trace data into a wrap-around buffer. It prints the buffer contents whenever a program check occurs in this partition.

TRACE Command

The TRACE command defines the trace type, the traced partition or program, the tracing range, the tracing output, and the tracing options. Figure 12 on page 22 shows several trace statement examples. The numbers in the following description refers to the numbers in the figure.

trace branch area=f3 output=(greg dump reg=7:100) option=nojcl	(1-1)
trace branch area=all address=ba398:ba398 output=greg option=(occ=1:5)	(1-2)
trace branch area=bg phase=abcd offset=200:*	(1-3)
trace cancel area=bg output=(greg dump partition)	(2)
trace EXT=0040 output=(greg creg lowcore lta pta)	(3)
trace inst=(d207 92) area=f3 address=41207a:4123b3	(4-1)
trace inst=* area=f3 address=7312:7bff output=greg option=sup	(4-2)
trace inst=branch jobname=abcd jobnum=134 output=greg	(4-3)
trace inst=44 area=x9 address=0:*	(4-4)
trace io area=bg unit=(360 361) output=(ccwd=500)	(5-1)
trace io area=all unit=01f output=ccw option=(occurrence=1:200)	(5-2)
trace pgmc=* area=f3 output=(greg ptab ttab dump partition)	(6-1)
trace pgmc=(1 5) jobname=test address=0:*	(6-2)
trace pgml phase=abcd output=(greg dump add=400000:420000)	(7)
trace ssch unit=280 output=tod	(8-1)
trace ssch area=f3 output=ccb option=(occ=1:500)	(8-2)
trace stor pattern=fefe address=3aa8:3aa9 output=greg	(9-1)
trace stor area=all starea=f3 address=4d13bc:4d13bc output=greg	(9-2)
trace stor jobname=abcd [stjnam=abcd] address=400abc:400abd output=greg option=sup	(9-3)
trace stor area=f3 stdspn=space1 address=4a123:4afff	(9-4)
trace svc=* area=f3 address=0:*	(10-1)
trace svc=(11 1b) area=f7 output=(greg dump reg=a:100)	(10-2)

Figure 12. TRACE command examples

1. Branch trace

The branch trace monitors successful branch instructions. SDAID displays all branch instructions which transfer control to an address which is contained in the tracing range. 'Successful' branch instruction means that the branching conditions are fulfilled and the processor branches to the specified address. Conditional branch instructions where the branching condition is not met are not traced.

- 1-1 this command traces instructions with a branch target address in the F3 partition. Since the parameter ADDRESS is omitted, SDAID traces only the area from partition start address to partition end address (default: offset=0:*). The JCL routines are not traced (OPTION=NOJCL). SDAID displays the general registers ("GREG"), and dumps an area of 256 bytes pointed to by register 7.
- 1-2 this command traces instructions branching to the address BA398. Only the first five occurrences of the specified event are traced (option=(occ=1:5)).
- 1-3 this command traces the BG branch instructions with a branch target address within the phase ABCD. Trace area is an address range starting from phase address + x'200' up to the end of the phase.

2. Cancel trace

The cancel trace provides an event record and output data whenever the main task in a partition terminates normally or abnormally.

3. External interrupt trace

This command collects trace data on the occurrence of an external interrupt. The parameter EXT=(...) defines one or more external interruption codes. The parameter EXT=0040 specifies that key interruptions are to be traced. The AREA or ADDRESS parameter are not applicable for the external interrupt trace.

4. Instruction trace

The instruction trace traces all or selected instructions in a specified area. The specification TRACE INST=BRanch traces all branch type instructions, not regarding the branching conditions. Note the difference from the branch trace which only monitors the branches actually taken.

- 4-1 this command traces instructions with selected operation codes.
- 4-2 this command traces supervisor routines working for the F3 partition : The specified address range is not part of the user partition. The parameter option=sup is required for an instruction trace monitoring supervisor routines
- 4-3 this command traces branch-type instructions. The specification TRACE INST=BRanch traces all branch type instructions, not regarding the branching conditions. Note the difference from the branch trace which only monitors the branches actually taken. The tracing range is the partition selected for the execution of the specified POWER job.
- 4-4 this command traces all EXECUTE instructions in the dynamic space X9.

5. I/O interruption trace

The IO trace monitors the I/O interruptions for selected or all I/O devices. The IO trace traces virtual devices, too. The parameter OUTPUT=GREG is not applicable for the IO trace.

- 5-1 this command traces I/O interruptions for the I/O devices 360 and 361. The parameter OUTPUT=(CCWD=500) monitors the TOD clock, the CCB, the CCWs, the input or output data up to a size of (hexadecimal) 500 bytes and the IRB.
- 5-2 this command traces I/O interruptions for the device 01f. The parameter OUTPUT=CCW shows the TOD clock, the CCB, the CCWs, and the IRB. Occurrence=1:200 means that only the first 200 occurrences of the traced event are recorded.

6. Program check trace

- 6-1 this command monitors all program checks except page faults occurring in the F3 partition. SDAID displays the general registers, the partition and task related control blocks and dumps the partition.
- 6-2 this command traces selected program checks (operation and addressing exception) occurring in the partition where the job TEST is executing. The specification AREA=0:* ensures that program checks in the SVA or in the supervisor are traced, too.

7. Program load trace

System Control Program

The program load trace monitors phase load instructions. The example traces just the load requests for the phase abcd. If you omit the PHase parameter, all load events are traced. SDAID dumps the general registers and the specified address range.

8. Start 0ubchannel trace

The SSCH trace monitors SSCH instructions for selected or all I/O devices. The SSCH trace traces virtual devices, too.

- 8-1 this command displays the SSCH instructions for the device 280. The parameter OUTPUT=TOD displays the time-of-day clock.
- 8-2 this command displays the first 500 SSCH instructions issued in the F3 partition. SDAID displays the time-of-day clock and the CCB

9. Storage alteration trace

The storage alteration trace writes an event record whenever an instruction alters the contents of a specified storage location.

The parameters AREA, JOBNAME, and JOBNUM describe the program which alters a storage location ('the source area'). The parameters STAREA, STJNAM, STJNUM describe the program area where the alteration takes place ('the target space'). The parameter STDSPN defines the name of a data space as target space. The parameters ADDRESS, OFFSET, PHASE and LTA define an address range in the target space. If the target space is a data space, then the sub parameters OFFSET, PHASE and LTA are not valid. You may define a storage alteration pattern. SDAID monitors a storage alteration event only if the specified storage area is set to the specified pattern. The length of the pattern must be equal to the length of the interval specified via the ADDRESS parameter.

- 9-1 this command traces all instructions (AREA=ALL by default) which alter the specified 2-byte field into the pattern X'FEFE'
- 9-2 this command traces all tasks (AREA=ALL) which alter the byte at location 4d13bc in the F3 partition
- 9-3 this command traces storage alterations in the partition where the job ABCD executes. SDAID displays the instructions which alter the half word at location 400abc. SDAID traces the program abcd and the supervisor routines invoked by the program abcd (option=sup). The target partition need not be specified. If JOBNAME=abcd is specified, SDAID takes STJNAM=ABCD per default.
- 9-4 this command traces all instructions in F3 which alter data at locations 4a123:4aff in the data space SPACE1. The supervisor routines working for F3 are not traced (option=sup is not specified).

10. SVC trace

The SVC trace monitors all or selected supervisor calls in a specified area.

- 10-1 this command traces all SVCs in F3. Routines in shared areas are traced, too (ADDRESS=0:*).
- 10-2 this command traces SVCs X'11' and X'1B' in the F7 partition. SVCs outside the partition space are not traced (OFFSET=0:* by default). SDAID dumps the general registers and an address range of (hexadecimal) 100 bytes pointed to by general register 10.

OUTPUT Parameter

The OUTPUT parameter is used to **include additional dump data into the trace record**. Several VSE control blocks may be specified directly by their names. Other storage areas may be specified via the operand DUMP. Figure 13 lists the control blocks which can be specified by name.

Control Block Name	Dumped Area
BUffer	Contents of actual SDAID buffer
CCB, CCW, CCWD=nn	I/O command blocks
COMReg	Partition Communications region
CReg	Control Registers
DUMP	see separate description below
FReg	Floating Point Registers
GReg	General Purpose Registers
IOTab	PUBTAB, LUB, ERBLOC, CHANQ
LTA	Logical Transient Area
LOWcore	Processor Storage from 0 to X'300'
PTA	Physical Transient Area
PTAB	Partition related Control Blocks
SUPvr	Supervisor, CREG, and GREG
SYSCom	System Communications Region
TOD	Time-of-Day Clock
TTAB	Task related Control Blocks

Figure 13. SDAID OUTPUT parameter

The parameter OUTPUT=(DUMP ...) may be used with the following sub parameters:

- DUMP PARTition [OFFset=off1:off2]
- DUMP PHase [OFFset=off1:off2]
- DUMP ADDRess=add1:add2
- DUMP REGister=reg:length
- DUMP PTR=reg:offset DMP=offset:length

OPTION Parameter

- **OPTION = NOJCL**
The option NOJCL is recommended if you want to trace only the application program and drop any events occurring while the job control statements are processed
- **OPTION = SUP**
The option SUP is applicable only for the branch trace, the instruction trace, and the storage alteration trace (the so-called PER traces). The option SUP sets the PER bit into the PSW of the application program **and** into the PSW of supervisor routines if they are active for the specified partition. Option=SUP is not applicable if you specify AREA=ALL or AREA=SUP.
- **OPTION = (OCCurrence= mm:nn)**
The option OCC=100:500 means that the first 99 events are dropped. If more than 500 events occur, then the surplus is dropped, too.
- **OPTION = Halt**
The option Halt stops the processor after the specified event has occurred. SDAID enters a soft wait state with a PSW of 010E0000 0000EEEE
- **OPTION = Terminate**
The option Terminate stops trace data collection. It monitors the specified event on printer or tape and then terminates trace data collection temporarily. The operator should issue the STOPSD or ENDSD command to terminate SDAID finally.

JCL Procedures for Frequently Used SDAID Functions

A trace initialization is easier if you use the available JCL procedures. The VSE/ESA system provides JCL procedures with reasonable default values for the most often used tracing functions. Each procedure generates a complete SDAID initialization step with an SDAID statement, an OUTDEV statement, one or two TRACE statements and a READY statement. The generated SDAID initialization statements with the chosen default values are displayed on the screen.

If you use the JCL procedures, observe the following restrictions:

- **enclose parameters in quotes**
Any parameter which contains a blank, an asterisk, an equal sign, a comma, a colon, or any other special character must be enclosed in quotes.
- **no parameter abbreviations**
The JCL procedures do not accept abbreviated parameters, like ADDR or PH. Exceptions are P for printer, T for tape, and BU for buffer.
- **command continuation**
If you enter the procedure statement via SYSIN, enter any non-blank character as continuation character in position 72 and start the continuation line in column 16. If you enter the procedure statement via SYSLOG, break the statement anywhere after a comma. Enter a minus sign as continuation character after a comma, and start the continuation line in column 1.

Procedure Examples

Figure 14 on page 28 gives examples of using the JCL procedures.

1. branch trace procedure SDBRANCH

The POWER job with the name TEST is traced as soon as it executes in a static or dynamic user partition. If the partition has a begin address of 400000, then SDAID traces all branch instructions with a target address between 40051a and 4006ff. Default value: OPTION=NOJCL. SDAID writes the trace records to the tape 280.

2. instruction trace procedure SDINST

The procedure SDINST has the following default values: INST=*, OUTPUT=GREG, OPTION=NOJCL

- 2-1 This procedure traces all instructions in the range 41207a:4123B3 in the F3 partition. The trace output is written to the printer 00E.
- 2-2 This procedure traces instructions with an operation code of d7 or d2 in the F3 partition. The parameter ADDRESS=0:* makes that instructions inside and outside the F3 partition are traced. Supervisor routines invoked by F3 are traced, too (OPTION=SUP).
- 2-3 This example shows the usage of a wrap-around buffer. The parameter buffer=10 defines a wrap-around buffer. SDAID traces F3 instructions and moves them into the wrap buffer. When a program check occurs in the F3 partition, SDAID writes the buffer contents to the tape device.

The procedure generates the following OUTDEV and TRACE statements:

```
outdev buffer=10 tape=281
```

```
trace inst=* area=f3 address=0:* option=sup
```

```
trace pgmc=* area=f3 address=0:* output=buffer
```

3. I/O trace procedure SDIO

The procedure SDIO generates an SSCH trace **and** an I/O interrupt trace. The default output parameter for the SSCH trace is OUTPUT=TOD, the default value for the IO trace is OUTPUT=(CCWD=256). The sample procedure monitors the I/O activity of the unit 431. Trace output device is tape unit 281.

4. Program load trace procedure SDLOAD

This procedure traces all load requests for the phase ABCD occurring in any partition.

5. Program check trace procedure SDPGMC

The sample procedure traces all program checks occurring in the attention routine or in a system task (AREA=SUP). It does not trace application programs or supervisor routines active for a user partition. The procedure provides the default value PGMC=*.

6. Storage alteration trace procedure SDSTOR

- 6-1 This procedure monitors all instructions (AREA=ALL) which alter data in the BG partition at address 41a234 and 41a235.
- 6-2 This procedure monitors all instructions which alter the contents of the full word at address 41b234 to the value x'12FE34ab'.

7. SVC trace

This procedure traces all GETVIS and FREEVIS SVCs in the F3 partition. The parameter ADDRESS='0:*' ensures that SVA and LTA routines are traced, too.

```
// exec proc=sdbranch,jobname=test,offset='51a:6ff',tape=280 (1)
// exec proc=sdinst,area=f3,address='41207a:4123b3',printer=00e (2-1)
// exec proc=sdinst,inst='d2 d7',area=f3,address='0:*',- (2-2)
tape=281,option='sup nojcl'
// exec proc=sdinst,area=f3,address='0:*',option=sup,- (2-3)
tape=281,buffer=10,bufferout=pgmc
// exec proc=sdio,unit=431,tape=281 (3)
// exec proc=sdload,phase=abcd,tape=281 (4)
// exec proc=sdpgmc,area=sup,printer=00e (5)
// exec proc=sdstor,area=all,starea=bg,address='41a234:41a235',- (6-1)
printer=00e
// exec proc=sdstor,pattern=12fe34ab,- (6-2)
address='41b234:41b237',printer=00e
// exec proc=sdsvc,svc='3d 3e',area=f3,address='0:*',tape=281 (7)
```

Figure 14. SDAID JCL Procedures

If SDAID Does Not Produce Output

Sometimes you trace a program in a static or dynamic partition and do not get any trace output. Often the problem is caused by one of the following reasons:

- Address parameter missing
You specified a partition trace (e.g. AREA=F7 or JOBNAME=ABCD) and did not specify an address parameter. If the address parameter is missing, only the area between partition start address and partition end address is traced. The default address specification for a partition trace is OFFSET=0:*. Specify AREA=F7 ADDRESS=0:* to trace all storage inside and outside the F7 partition.
- OPTION=SUP is missing.
You specified a branch trace, an instruction trace, or a storage alteration trace for an application program (e.g. AREA=BG or JOBNAME=ABCD). You also specified ADDRESS=0:* (all storage) or an address range in the supervisor area. For the mentioned trace types (BR, INST, STOR) you need to specify OPTION=SUP to set the PER bit into the PSW of the supervisor routines when they are active for the specified partition. The examples (4-2) and (9-3) in Figure 12 on page 22 show the usage of the SUP option.
- Incorrect use of a wrap-around buffer
You specified an instruction trace or an SVC trace and specified a wrap buffer via the command **OUTDEV BUFFER=nn PRINTER=uu**. SDAID fills the wrap buffer with trace data but it does not print the trace data on the specified printer or tape. You should specify another TRACE statement (e.g. a program check trace or an instruction trace for a single instruction) with the parameter **OUTPUT=BUFFER**. SDAID will print the buffer contents on the occurrence of this event.

Important VM/CP Functions

The Virtual Machine/Control Program VM/CP supplies monitoring functions which are similar to the monitoring functions on a native processor. It also supplies a TRACE command which allows to specify a variety of trace types.

VSE users can use the TRACE command only if the VSE/ESA system runs under control of VM/ESA. The TRACE function traces the actions of the virtual machine in interactive mode. The IBM manual 'VM/ESA CP Command and Utility Reference (SC24-5519)' describes the CP monitoring and tracing functions in detail.

Figure 15 shows some important monitoring functions. The left column shows the CP commands. The right column shows the corresponding monitoring function on a native processor. The figure shows also some TRACE examples. Lowercase letters on CP commands show the possible abbreviation.

***** VM CP Monitoring Commands *****	
lpl cuu	LOAD
lpl cuu CLEAR	LOAD CLEAR
Display 7a25c-7a3ff	display range of virtual storage
Display b51c.80	display an interval of (hex) 80 bytes
Display Psw	display PSW
EXTERNAL	INTERRUPT function or IRPT Key
STORE STATUS	Store status
SYSTEM RESTART	System restart
***** VM CP TRACE Command *****	
TRace BRANch INTO 6D2A-6D3B	trace branch instructions into specified target interval
TRace Instruction Range 374C2-374CF	trace instructions within specified interval
TRace I/O 180-182	trace I/O devices 180, 181, 182
TRace STore into 412.2	trace storage alterations at addresses 412 and 413
TRace SVC 3D	trace SVCs with code 3D
TRace END ALL	reset all specified traces

Figure 15. VM/CP monitoring facilities

Lock Manager Service Enhancements

The following lock manager enhancements should ease problem determination and minimize effort on questions around error situations in terms of resources or lock file.

Error on Lock File

Message **0T01E ERROR ON LOCK FILE** indicates one of these situations:

1. DLF statement incorrect
2. an unrecoverable I/O error
3. lock file format error
4. lock file logical error

The investigation of type 1, 2 and 3 errors does not necessarily require a standalone dump. Type 4, which is the most frequent one, however needs analysis of the current lock manager data at the point of failure. The system does not stop processing after issuing the message and therefore a dump at a later point might not show the reason of the problem. In order to speed up the error analysis of such situations a method to circumvent the standard procedure

1. take standalone dump
2. mail to IBM
3. analyze a dump

has to be established.

The lock manager writes together with the message **0T01E ERROR ON LOCK FILE** additional data that describes the error situation. This information can be sent in for analysis via FAX. The following output will be provided for VSE/ESA 1.3 APAR DY43438 and VSE/ESA 2.1 APAR DY43684. The contents is internal data and can be changed at any time by IBM if necessary and cannot be considered as an interface.

The example below shows an inconsistency between lock table and lock file when an UNLOCK function was performed.

```

F4 0025 0T01E ERROR ON LOCK FILE
F4 0025 LOCK MANAGER EMERGENCY DATA
V00051138 000C0025 0101000F 80000000 0025D9C5 *      Ø      RE*  R00051138
V00051148 E2D6E4D9 C3C560C5 F1F01110 00051148 *SOURCE-E10  ç*  R00051148
F4 0025 LOCKTAB ENTRY
V0004FE70 00000000 00000000 00000000 00000000 *      *  R0004FE70
V0004FE80 00000000 00000000 0004FE90 00000000 *      Ú°  *  R0004FE80
F4 0025 LOCK FILE DISK BLOCK
V00086198 D3C60000 D9C5E2D6 E4D9C3C5 60C5F1F0 *LF  RESOURCE-E10*  R00086198
V000861A8 11000000 00000000 00000000 00000000 *      *  R000861A8
V000861B8 00000000 00000000 00000000 00000000 *      *  R000861B8
V000861C8 00000000 00000000 00000000 00000000 *      *  R000861C8
. . . . .
F4 0025
V00086358 00000000 00000000 00000000 00000000 *      *  R00086358
V00086368 00000000 00000000 00000000 00000000 *      *  R00086368
V00086378 00000000 00000000 00000000 00000000 *      *  R00086378
V00086388 00000000 00000000 00000000 00000000 *      *  R00086388
F4 0025 LOCK MANAGER TRACE AREA
V0004FF78 D3C3D2E3 0004FF88 00050987 00050788 *LCKT  h  g  h*  R0004FF78
F4 0025 LOCK MANAGER TRACE AREA
V0004FF88 3F3F0B00 00902D80 01080000 01000000 *      ° Ø      *  R0004FF88
V0004FF98 E5C3E3E2 F2F2F0E4 D7D30000 0033B160 *VCTS220UPL  £-*  R0004FF98
V0004FFA8 0033B140 00000000 E5C3E3E2 F2F2F0E4 *  £      VCTS220U*  R0004FFA8
V0004FFB8 D7D30000 01800000 0033B180 0033B120 *PL  Ø      £Ø £ *  R0004FFB8
. . . . .
F4 0025
V00050748 25250B00 00600B90 01100000 01000000 *      - °      *  R00050748
V00050758 D9C5E2D6 E4D9C3C5 60C5F1F7 0033B520 *RESOURCE-E17 § *  R00050758
V00050768 0033B510 00000000 D9C5E2D6 E4D9C3C5 *  §      RESOURCE*  R00050768
V00050778 60C5F1F7 01900000 00000000 0033B4E0 *-E17 °      fl\*  R00050778
. . . . .
F4 0025
V00050948 3F3F0104 00902D80 11000000 01000000 *      ° Ø      *  R00050948
V00050958 E5F24000 9042CCC3 C1E70000 00000000 *V2  °äöCAX  *  R00050958
V00050968 000A0000 00000000 00000000 00000000 *      *  R00050968
V00050978 00007480 00003F00 070C0000 8007146A *  ÈØ      Ø ]*  R00050978

```

Figure 16. Sample of inconsistency between lock table and lock file

Display Facility

To allow faster diagnosis in case of resources being in use or deadlock situations it is now possible to display the actual locking status of

- the entire lock table
- all locks held by a specified partition (PIK)
- a given resource name
- a set of resource names, specified with name*
- a set of resource names held by a given partition

This feature is available via a new Attention Routine command **LOCK SHOW**. Examples for the usage of the command are

LOCK SHOW	shows all currently held locks (resources) of this VSE system .
LOCK SHOW=F4	shows all currently held locks (resources) of partition F4 .
LOCK SHOW,RESOURCE-E10	shows who is currently holding resource RESOURCE-E10 (if held at all).
LOCK SHOW,VSYSOPEN'00000001	shows who is currently holding resource VSYSOPEN00000001 (if held at all), where VSYSOPEN is interpreted as characters and 00000001 as hex value.
LOCK SHOW,RESOURC*	shows who is currently holding resources, starting with the character string RESOURC .
LOCK SHOW=F6,RES*	shows, if partition F6 is currently holding resources, starting with the character string RES .

This function is available with VSE/ESA 2.1 APAR DY43697. The output shows unformatted internal data and can be changed at any time by IBM if necessary and cannot be considered as an interface.

```

lock show
AR 0025 LOCKTAB ENTRY
V0004F344 003245A0 00000000 D9C5E2D6 E4D9C3C5 * äff RESOURCE* R0004F344
V0004F354 60C5F1F0 11900001 0004F364 00000000 *-E10 ° 3Ã * R0004F354
AR 0025 OWNER ELEMENT
V003245A0 00000000 002C0000 00011000 00000000 * * R0087F5A0
AR 0025 LOCKTAB ENTRY
V0004F364 0004F3E4 00000000 C4E3E2E5 C5C3E3C2 * 3U DTSVECTB* R0004F364
V0004F374 40404040 11800001 0004F384 0004F344 * Ø 3d 3ã* R0004F374
AR 0025 OWNER ELEMENT
V0004F3E4 00000000 00400000 00011000 00000000 * * R0004F3E4
AR 0025 LOCKTAB ENTRY
V0004F384 0004F3F4 00000000 E5C3E3E2 F2F2F000 * 34 VCTS220 * R0004F384
V0004F394 00000000 04C00000 0004F3A4 0004F364 * { 3u 3ã* R0004F394
AR 0025 OWNER ELEMENT
V0004F3F4 00000000 00230001 00000000 00000000 * * R0004F3F4
AR 0025 LOCKTAB ENTRY
V0004F3A4 0004F414 00000000 E5C3E3E2 F2F2F000 * 4 VCTS220 * R0004F3A4
V0004F3B4 00000001 04C00000 00324020 0004F384 * { 3d* R0004F3B4
AR 0025 OWNER ELEMENT
V0004F414 00000000 00230001 00000000 00000000 * * R0004F414
. . . . .
AR 0025 LOCKTAB ENTRY
V00324440 003245E0 00000000 D9C5E2D6 E4D9C3C5 * ä\ RESOURCE* R0087F440
V00324450 60C5F1F7 01900000 00000000 00324420 *-E17 ° ä * R0087F450
AR 0025 OWNER ELEMENT
V003245E0 00000000 002C0001 00000000 00000000 * * R0087F5E0
AR 0015 1I40I READY

```

Figure 17. LOCK SHOW command sample

Trace Facility

For the same reason a new trace facility for unsuccessful locks (RC<>0) and unlocks is provided. Trace contents can be specified according to the display facility from above. Besides that a command for trace deactivation is available. Traces can be done for

- all tasks and resources
- all resources belonging to a specified partition (PIK)
- a set of resource names, starting with name* for all tasks
- a set of resource names and a specified partition

The new Attention Routine command **LOCK TRACE** controls the various trace options. Examples for the usage of the command are

LOCK TRACE traces **all** unsuccessful locks and unlocks of **all partitions**.

LOCK TRACE=OFF sets the trace facility **off**.

LOCK TRACE=F4 traces **all** unsuccessful locks and unlocks of **partition F4**.

LOCK TRACE,RESOURCE-E10 traces **all** unsuccessful locks and unlocks of **RESOURCE-E10** of **all partitions**.

LOCK TRACE,VSYSOPEN'00000001 traces **all** unsuccessful locks and unlocks of **VSYSOPEN00000001**, where VSYSOPEN is

interpreted as characters and 00000001 as hex value, of **all partitions**.

- LOCK TRACE,RESOURC*** traces **all** unsuccessful locks and unlocks of resources, starting with the character string **RESOURC** of **all partitions**.
- LOCK TRACE=F6,RES*** traces **all** unsuccessful locks and unlocks of resources, starting with the character string **RES** of **partition F4**.

This function is available with VSE/ESA 2.1 APAR DY43697. The output shows unformatted internal data and can be changed at any time by IBM if necessary and cannot be considered as an interface.

```

lock trace=f4
AR 0015 1I40I  READY
F4 0025 LOCKTAB ENTRY
V0004F344 00324440 00000000 D9C5E2D6 E4D9C3C5 * à RESOURCE* R0004F344
V0004F354 60C5F1F0 11900001 0004F364 00000000 *-E10 ° 3Ã * R0004F354
F4 0025 OWNER ELEMENT
V00324440 00000000 002C0000 00011000 00000000 * * R0087F440
F4 0025 LOCKTAB ENTRY
V00324160 00324490 00000000 D9C5E2D6 E4D9C3C5 * à° RESOURCE* R0087F160
V00324170 60C5F1F1 11900001 00324420 00324400 *-E11 ° à à * R0087F170
F4 0025 OWNER ELEMENT
V00324490 00000000 002C0000 00011000 00000000 * * R0087F490
F4 0025 LOCKTAB ENTRY
V00324450 00324480 00324440 D9C5E2D6 E4D9C3C5 * à0 à RESOURCE* R0087F450
V00324460 60C5F1F3 01900000 003244A0 00324420 *-E13 ° äff à * R0087F460
F4 0025 OWNER ELEMENT
V00324480 00000000 002C0001 00000000 00000000 * * R0087F480
F4 0025 REQUEST ELEMENT
V00324440 00000000 00250000 00000000 00600B18 * - * R0087F440
AR 0015 1I40I  READY
lock trace=off
AR 0015 1I40I  READY
    
```

Figure 18. LOCK TRACE command sample 1

```

lock trace=f4,resource-e10
AR 0015 1I40I  READY
F4 0025 LOCKTAB ENTRY
V0004F344 003245C0 00000000 D9C5E2D6 E4D9C3C5 * á{ RESOURCE* R0004F344
V0004F354 60C5F1F0 11900001 0004F364 00000000 *-E10 ° 3Ã * R0004F354
F4 0025 OWNER ELEMENT
V003245C0 00000000 002C0000 00011000 00000000 * * R0087F5C0
F4 0025 LOCKTAB ENTRY
V0004F344 0004F404 003245E0 D9C5E2D6 E4D9C3C5 * 4 á\RESOURCE* R0004F344
V0004F354 60C5F1F0 11900001 0004F364 00000000 *-E10 ° 3Ã * R0004F354
F4 0025 OWNER ELEMENT
V0004F404 00000000 002C0000 00011000 00000000 * * R0004F404
F4 0025 REQUEST ELEMENT
V003245E0 00000000 00250000 00000000 00600ABE * - ** R0087F5E0
AR 0015 1I40I  READY
lock trace=off
AR 0015 1I40I  READY
    
```

Figure 19. LOCK TRACE command sample 2

System Date and Time

VM users may skip this chapter, because the date, clock and time zone values of the installation are extracted from VM, if VSE is running as a **guest under VM**. It is not necessary to have any of the SET commands discussed below included in the IPL procedure, unless the VSE guest machine is supposed to have a different time than the VM host. On a **native VSE system**, however, these values have to be initially provided to the system.

The system date and time of an installation and the TOD clock of the machine can be initialized by the following IPL command:

```
SET DATE= ,CLOCK= ,ZONE=
```

The operand CLOCK specifies the **local** time of the installation. The operand ZONE specifies the time difference between the local time and Greenwich mean time. The TOD clock is then calculated and set to Greenwich mean time, which for historical reasons is the geographical reference for all time zones. The time zone is kept separately. Once the TOD clock has been set, it will continue to run, even if the system is reIPLed. The time zone information, however, is lost.

```
SET DATE=10/31/1997,CLOCK=09/00/00,ZONE=WEST/04/00
```

The command above sets the TOD clock to October 31st, 1997, 1 o'clock p.m. GMT (9 o'clock local time + 4 hours difference to GMT). The system time zone is 4 hours west of Greenwich.

The time zone of the installation has to be specified at each IPL. So a SET ZONE= command is required during IPL, unless your installation is supposed to have Greenwich mean time.

```
SET ZONE=WEST/04/00
```

The command above sets the system time zone of the installation which is located 4 hours west of Greenwich. This would be eastern daylight saving time. The TOD clock is expected to be running, and to have the correct GMT standard time value.

If your machine was powered off, and the TOD clock has to be initially set, IPL will prompt the operator to enter a SET command. In this case please enter a SET command in the format SET DATE= ,CLOCK= ,ZONE= , so that the TOD clock can be calculated and set in relation to the local time of the installation. If the IPL procedure contains a SET ZONE= command, and this is processed **after** the operator was prompted for the SET command, it does not affect the TOD clock any more. The local time, however, would be affected, if the ZONE value differs from the one specified on the previously entered SET command.

The switch from standard time to daylight saving time and vice versa requires a change of the IPL procedure twice a year to adapt the SET ZONE value accordingly.

In VSE release 2.3 the **daylight saving function** makes the regular modification of the IPL procedure unnecessary. You may replace the SET ZONE command by a set of new commands, and the system will automatically determine the correct local time when IPL'ed. The new IPL commands allow

System Control Program

1. the definition of time zones,

```
SET ZONEDEF,ZONE=WEST/04/00,EDT
```

2. the begin specification of standard time and daylight saving time for a couple of years in advance

```
SET ZONEBDY,DATE=04/06/1997,CLOCK=02/00/00,EDT.
```

The first command tells the system, that the time zone with the zone id EDT (eastern daylight time) is located 4 hours west of Greenwich, and the second, that eastern daylight time starts at 2 o'clock on April 6, 1997.

Only an IPL is required to switch to the new time provided the IPL procedure has been updated with a set of the new commands as shown in the example below. It is recommended to place the commands behind the last ADD command.

```
SET ZONEDEF,ZONE=WEST/04/00,EDT
SET ZONEDEF,ZONE=WEST/05/00,EST
```

```
SET ZONEBDY,DATE=04/06/1997,CLOCK=02/00/00,EDT
SET ZONEBDY,DATE=10/26/1997,CLOCK=02/00/00,EST
```

```
SET ZONEBDY,DATE=04/05/1998,CLOCK=02/00/00,EDT
SET ZONEBDY,DATE=10/25/1998,CLOCK=02/00/00,EST
```

```
SET ZONEBDY,...
```

If you reIPLed your system, for example, at 3 o'clock eastern daylight time on October 26, 1997, then IPL would assume now, that the local time is eastern standard time.

You may add up to twenty SET ZONEBDY statements, that means for up to ten years in advance.

Note, that an explicit SET DATE= or SET ZONE= command given during the same IPL will overrule any SET ZONEDEF and SET ZONEBDY statements.

You might want to switch the time on a running system. This can be done, however, it is not officially supported for system integrity reasons. Refer to "TIME" on page 75. See also "Effect of Day-Light Saving Time Changes" on page 75 for some more information on daylight saving time setting.

Chapter 2. Internal Attention Routine Commands

There are quite a few internal commands that were mainly developed for IBM's internal use only, but also have been found to be very useful by system operators. The commands will be described in more detail on the following pages. Any concerns, recommendations and comments and/or complaints should be forwarded via Internet to:

PIEPER@DE.IBM.COM

However, the intend of these commands is NOT to be construed as an interface of any kind and it is subject to change without notice. Therefore any differences which you may encounter or experience on your system, compared to the description given herein can be the result of such changes.

DEBUG

The DEBUG facility consists of a set of tracing hooks placed at various points within the VSE/ESA system (mainly supervisor) which need to be activated via a VSE operator command. The DEBUG facility, once it has been activated, will create trace entries and save them into 31-bit fixed SVA storage in a wrap around mode fashion. This trace buffer is extremely useful and sometimes even required for problem determination. It will definitely help to decrease the problem solution turn-around-time and should therefor by activated whenever you suspect a system failure. The DEBUG facility, if active, could however impact your VSE system performance.

The command DEBUG ON activates a standard set of traces. The trace types defined by default, monitor the dispatcher program, the first level interrupts, and the I/O activity. If the size of the buffer is not explicitly specified, the system allocates three buffers with a size of 16k each. The command DEBUG TRACE allows to modify the set of tracing functions. Figure 20 on page 38 shows how you activate and modify the DEBUG function.

In recent VSE releases, some new functions have been added to the VSE DEBUGing facility. This report describes the functions available in VSE/ESA 2.4 and up. If you run an older VSE system some of the described functions may be missing and the appropriate command considered invalid. For details consult the appropriate version of the IBM manual "Diagnosis Reference Supervisor".

DEBUG ON[,nnnk]	activate tracing
DEBUG id	activate tracing for the specified partition where id is the partition SYSLOG-id (BG, F1,F2...,Zn)
DEBUG OFF	stop DEBUG temporarily
DEBUG END	stop tracing and free all allocated buffers
DEBUG	query tracing status. It will display the currently ACTIVE trace points. Any trace point can be selectively enabled or disabled as the following sample will show.
DEBUG TRACE=REGS,TASK	activate REGiSter and TASK-entry trace
DEBUG TRACE=NOINT,NOSIO	deactivate INTerrupt and Start-IO trace
DEBUG TRACE=ALL,NOSVC	activate all traces, except SVC trace
DEBUG TRACE=NONE,DISP	deactivate all traces, then activate DISpatching trace

Figure 20. DEBUG activation and modification commands

DEBUG STOP

The DEBUG address STOP command compares the contents of a specified storage location with a specified pattern. The VSE system performs the compare operation whenever one of the DEBUG event occurs, regardless of whether that entry is active or not. It is possible to compare for equal (EQ), not equal (NE), low (LO), or high (HI). When VSE detects a match, it enters a hard wait state with PSW = 000A0000 0000EEEE. You use the RESTART feature of the processor's monitoring facilities or the SYSTEM RESTART command when running under VM, to recover from this hard wait state. Figure 21 shows how you set a DEBUG address STOP.

DEBUG STOP,4B504.4,EQ,FE12ABCD	stop if the full word at 4B504 equals the pattern FE12ABCD.
DEBUG STOP,F4,5AC00C.1,NE,00,OR,180.4,HI,0004ABC0	STOP if the byte at 5AC00C within the F4 addressing scope differs from zero, OR STOP if the four bytes at address 180 are greater than 0004ABC0. You can also establish an AND condition if that should be required. The above sample would then read:
DEBUG STOP,F4,5AC00C.1,NE,00,AND,180.4,HI,0004ABC0	the system would now STOP only if both of the previously given conditions are true.

Figure 21. DEBUG STOP commands

DEBUG [{P|N}]SHOW[,ALL]

The DEBUG facility eventually fills three trace buffers in wrap-around mode. Whenever an application program terminates abnormally, the DEBUG facility freezes the current buffer and switches to the next buffer (unless switching has been suppressed (TRACE=NOSWCH). The buffer switching ensures that important trace data is not overlaid by entries generated by the dump routines.

The DEBUG SHOW command provides some options to show ALL or part of any of the three DEBUG-areas. The DEBUG SHOW command cause the traced entries to be formatted and displayed. It is possible to display the buffer contents on the screen or on a printer device. The SHOW command displays the most recent entries in the current buffer. The PSHOW command displays the most recent entries from the previous trace buffer and the DEBUG NSHOW command displays the most recent entries from the trace buffer which is going to be used next. This next buffer, if it contains trace data at all, contains the oldest trace entries which are available in the system.

You can also restrict the DEBUG SHOW output to certain event types only. In this case you would specify the event option e.g. **DEBUG SHOW=SIO,INT** to get only the SIO entries PLUS the INT entries to be displayed/printed.

It is recommended that you issue the command DEBUG OFF before you use the DEBUG SHOW command. Not required for PSHOW or NSHOW. Instead of the DEBUG SHOW command you can also use the command 'DUMP DEBUG,cuu' to print the current DEBUG buffer.

DEBUG SHOW[,CUU=cuu]	display the current DEBUG buffer
DEBUG PSHOW[,CUU=cuu]	display the previous DEBUG buffer
DEBUG NSHOW[,CUU=cuu]	display the next DEBUG buffer

Figure 22. DEBUG SHOW commands

GETVIS

The GETVIS command has been extended by some options which allow the retrieval of information about the occupancy of either system, or partition GETVIS storage.

Syntax: **GETVIS [{SVA|id},{ALL|DETAIL}] |id,RESET]**

This command is especially useful in case you are running short of GETVIS storage and suspect a program error.

SVA will provide information about the SYSTEM GETVIS areas.

id is the partition SYSLOG-id of the partition for which you want GETVIS storage allocation/usage information to be returned and optionally have the "MAX. EVER USED:" value be RESET and re-evaluated subsequently according to the current usage.

ALL indicates that you want a summary report about how many total storage has been consumed for the different sub-pools in the appropriate area.

DETAIL indicates that you want a detailed report with all the addresses of the pages that have been reserved for the different sub-pools in the appropriate area.

RESET indicates that you want the OLD values for the specified partition to be reset and that the current usage values are to be returned. This is specially useful for the CICS partition which consumes all available GETVIS storage during CICS bringup and thus causes the "MAX. EVER USED" value to reflect a much too high value which CICS is NOT going to consume while running production. The newly calculated "MAX. EVER USED" value should be used for CICS partition tuning purposes.

Explanation

Besides the information that is documented in the System Control Statements manual, some new fields have been added which have the following meaning:

SUBPOOL

contains the name of the subpool that has either explicitly been specified or which has been assumed by the system (Default). Appended to the 6-byte-subpool name, you may eventually find additional information to fully qualify the sub-pool-name within the system.

REQUEST

contains information about the type of GETVIS request that had been requested.

SPACE indicates that this was initially a DYNAMIC SPACE GETVIS request that had been routed into the SVA, because the program was not running in a dynamic partition.

<--SVA-24-AREA-->

contains the information about the areas that have been reserved in the 24-bit storage area. Since the 24-bit area is normally the most critical area, all the entries have been ordered according to their consumption within this area.

--SVA-ANY-AREA-->

contains the information about the areas that have been reserved in the 31-bit storage area.

An SVA sample will be shown below, but a partition-sample would be similar, except that the sub-pool names might be different.

```

getvis sva,all.
GETVIS USAGE   SVA-24   SVA-ANY           SVA-24   SVA-ANY
AREA SIZE:    1,404K   4,880K
USED AREA:    280K    624K MAX. EVER USED:  428K   1,320K
FREE AREA:    1,124K   4,256K LARGEST FREE:  1,008K   2,584K
SUMMARY REPORT
SUBPOOL      REQUEST  <--SVA-24-AREA-->  --SVA-ANY-AREA-->
Default                                128K                4K
IPWPWR                                32K                 0K
IJBFCB                                16K                 0K
INLSLD                                12K                 0K
IJBPRC0020  SPACE                8K                 0K
IJBPRC0090  SPACE                8K                 0K
IJBPRC00B0  SPACE                8K                 0K
IJBPRC00A0  SPACE                8K                 0K
IPTIB                                             8K                 8K
IJBFF100C0  SPACE                8K                 0K
IJBPRC00C0  SPACE                8K                 0K
IJBPRC0010  SPACE                8K                 0K
ISTMAQ                                             4K                 0K
IJBSSP                                             4K                 0K
IPSAV                                             4K                 0K
ISXECB                                             4K                 0K
INLC002200C0 SPACE                4K                 0K
$ARSMF                                             4K                 32K
IINIT                                             4K                 8K
$ARVIS                                             0K                 16K
$ARVIS                                             0K                 16K
$ARGFT                                             0K                 64K
IJBSCS                                             0K                 4K
VMCFSP                                             0K                 4K
IJBSCM                                             0K                 136K
ILSTCK                                             0K                 4K
SUBPOOL TOTALS                                280K                296K

```

Figure 23. GETVIS SVA,ALL command sample

Internal Attention Routine

```

getvis sva,detail
GETVIS USAGE   SVA-24   SVA-ANY           SVA-24   SVA-ANY
AREA SIZE:    1,404K   4,880K
USED AREA:    280K    624K MAX. EVER USED:  428K    1,320K
FREE AREA:    1,124K  4,256K LARGEST FREE:  1,008K   2,584K
SUMMARY REPORT
SUBPOOL      REQUEST  <--SVA-24-AREA---  --SVA-ANY-AREA-->
Default
                128K                                     4K
                00236000-00236FFF   02DC0000-02DC0FFF
                00238000-0023BFFF
                0023D000-0023DFFF
                0023F000-00240FFF
                00242000-00243FFF
                00245000-00257FFF
                00260000-00262FFF

IPWPWR                32K                                     0K
                00266000-0026DFFF

IJBFCB                16K                                     0K
                0023C000-0023CFFF
                0023E000-0023EFFF
                00241000-00241FFF
                00244000-00244FFF

INLSLD                12K                                     0K
                00258000-00258FFF
                00264000-00265FFF

IJBPRC0020   SPACE           8K                                     0K
                00277000-00278FFF

IJBPRC0090   SPACE           8K                                     0K
                0027D000-0027EFFF

IJBPRC00B0   SPACE           8K                                     0K
                00275000-00276FFF

IJBPRC00A0   SPACE           8K                                     0K
                00273000-00274FFF

IPTIB                8K                                     8K
                00271000-00271FFF   02DBE000-02DBEFFF
                00298000-00298FFF   02D31000-02D31FFF
                00298000-00298FFF   02D31000-02D31FFF

IJBFF100C0   SPACE           8K                                     0K
                00263000-00263FFF
                0026E000-0026EFFF

IJBPRC00C0   SPACE           8K                                     0K
                0025B000-0025BFFF
                0025D000-0025DFFF

IJBPRC0010   SPACE           8K                                     0K
                0025A000-0025AFFF
                0025C000-0025CFFF

ISTMAQ                4K                                     0K
                0027B000-0027BFFF

IJBSSP                4K                                     0K
                00272000-00272FFF

IPSAV                4K                                     0K
                00270000-00270FFF

ISXECB                4K                                     0K
                0026F000-0026FFFF

INLC002200C0 SPACE           4K                                     0K
                0025E000-0025EFFF

```

Figure 24 (Part 1 of 2). GETVIS SVA,DETAIL command sample

\$ARSMF	4K	32K
	00259000-00259FFF	02DD1000-02DD8FFF
IINIT	4K	8K
	00237000-00237FFF	02DD9000-02DDAFFF
ILCKSP	0K	4K
		02D35000-02D35FFF
IJBDSF	0K	4K
		02D73000-02D73FFF
IXXPDC	0K	4K
		02DBD000-02DBDFFF
IJBALE	0K	4K
		02DBF000-02DBFFFF
\$ARVIS	0K	16K
		02DB9000-02DBCFFF
\$ARGFT	0K	64K
		02DB9000-02DBCFFF
IJBCSC	0K	4K
		02DDB000-02DDBFFF
VMCFSP	0K	4K
		02DDC000-02DDCFFF
IJBSCM	0K	136K
		02DDD000-02DFEFFF
ILSTCK	0K	4K
		02DFF000-02DFFFFF
SUBPOOL TOTALS	280K	296K
1I40I READY		

Figure 24 (Part 2 of 2). GETVIS SVA,DETAIL command sample

SIR

This is the abbreviation for System Information Report and is a VSE/ESA Attention command that the operator should use to retrieve useful system information. It provides a variety of functions.

SIR HELP

Syntax: **SIR HELP** or **SIR ?**

This command provides HELP information about all the SIR sub-commands, which are currently available on your system.

The command will produce the following similar output.

```

sir ?
AR 0015      SIR COMMAND HELP
AR 0015 SIR   (<RESET|SYS>)          RESET/DISPLAY SYSTEM INFO
AR 0015 SIR   SMF(,<VSE>=<ON|OFF|cuu>) SUBSYSTEM MEASUREMENT DATA
AR 0015 SIR   MON(=<<id|ON(<NOSYM>|OFF>(option)) MONITORING DATA
AR 0015 SIR   MIH(=<nnnnnn|ON|OFF>)  DISPLAY/CHANGE MIH SETTING
AR 0015 SIR   CHPID(=chpid)          DISPLAY CHPID INFORMATION
AR 0015 SIR   VENDOR                  DISPLAY VENDOR PRODUCT INF
AR 0015 SIR   CRWMSG(=<ON|OFF>)       DSPLY/CHANGE CRW MSG-REPORTING
AR 0015 1I40I  READY

```

Figure 25. SIR ? command sample

Explanation

This command provides information about the various SIR sub-commands which are currently available on your system. The command has been provided for user information and convenience. It gives you the keywords and options of any sub-command in a condensed form. For a more detailed description of the sub-commands, you would have to refer to the appropriate description within this booklet.

SIR (without any operand)

This command provides general system information that might be interesting for System-Administrators and -Operators as well. All the timing information (if any) within the different output lines adhere to the following format.

hhh:mm:ss.nnn
 (hhh=hours,mm=minutes,ss=seconds and nnn=milliseconds).

The command will produce a report, similar to the following:

```

sir
(1.0) CPUID VM = 1806451096720000      VSE = FFFF100096720000
(2.0) VM-SYSTEM = VM/ESA (LPAR) 2.2.0 9702
(3.0) PROCESSOR = 9672-18 USERID = VSEESA
(4.0) PROC-MODE = ESA IPL(120) 09:45:57 CET 01/27/2000
(5.0) SYSTEM = VSE/ESA 2.4.1 10/21/1999
(5.5) VSE/AF 6.4.0 DY45290 12/28/1999
(5.55) VSE/POWER 6.4.0 DY-BASE
(6.0) IPL-PROC = $IPLESA JCL-PROC = $$JCLESA
(7.0) SUPVR = $$A$$SUPX TURBO-DISPATCHER (32) ACTIVE
(7.5) HARDWARE COMPRESSION ENABLED
(7.55) SEC. MGR. = BASIC SECURITY = ONLINE
(8.0) VIRTCPU = 0000:08:31.142 CP = 0000:04:05.431
(9.0) CPU-ADDR. = 0000(IPL) ACTIVE
(10.0) ACTIVE = 0000:00:13.602 WAIT = 0000:03:04.103
(11.0) PARALLEL= 0000:00:03.128 SPIN = 0000:00:00.002
(9.0) CPU-ADDR. = 0001 ACTIVE
(10.0) ACTIVE = 0000:00:12.514 WAIT = 0000:03:05.645
(11.0) PARALLEL= 0000:00:04.039 SPIN = 0000:00:00.003
(9.0) CPU-ADDR. = 0002 ACTIVE
(10.0) ACTIVE = 0000:00:02.783 WAIT = 0000:03:21.542
(11.0) PARALLEL= 0000:00:00.347 SPIN = 0000:00:00.000
(12.0) CPU timings MEASUREMENT INTERVAL 0000:03:28.494
(13.0) TASKS ATT.= 00000 HIGH-MARK = 00000 MAX = 00194
(14.0) DYN.PARTS = 00000 HIGH-MARK = 00000 MAX = 00018
(15.0)
(16.0) COPY-BLKS = 00258 HIGH-MARK = 00381 MAX = 01500
(17.0) CHANQ USED= 00004 HIGH-MARK = 00011 MAX = 00062
(17.5) LBL.-SEGM.= 00006 HIGH-MARK = 00032 MAX = 00717
(18.0) PGIN TOT.= 0000013796 EXP.AVRGE.= 0000000044/SEC
(19.0) PGOUT TOT.= 0000000337
(20.0) UNC.= 0000000225 EXP.AVRGE.= 0000000018/SEC
(21.0) PRE.= 0000000112 EXP.AVRGE.= 0000000002/SEC
(22.0) LOCKS EXT.= 0000000450 LOCKS INT.= 0000003636
(23.0) FAIL = 0000000006 FAIL = 0000000185
(24.0) LOCK I/O = 0000000000 LOCK WRITE= 0000000000
AR 0015 1I40I READY
    
```

Figure 26. SIR (without any operand) command sample

Explanation**(1.0) CPUID VM = 1806451096720000 VSE = FFFF100096720000**

This line contains the CPUID composed of the CPU Identification Number along with the Version Code followed by the Model Number your native system is running on. If you are running under VM, it also gives you the VIRTUAL CPUID (field VSE) that has been defined via the SET CPUID command under VM (appended with the real model number). In the above example the native processor has a serial number of '064510' and is a 9672 processor with version code '18'. The VM command to set the CPUID was: SET CPUID FF1000.

(2.0) VM-SYSTEM = VM/ESA (LPAR) 2.2.0 9702

This line is OPTIONAL and is only present if you are running under VM. It gives information regarding the version of VM you are running and in addition will indicate if your VM system is running in an LPAR (as is the case in this sample). In our sample we run on a VM/ESA Version 2, Release 2.0 system with a service level of 9702.

(3.0) PROCESSOR = 9672-18 USERID = VSEESA

PROCESSOR specifies the Processor-Model-Number and the Version-Code of the processor that you are running on.

USERID is OPTIONAL and is only present under VM. The VM-userid is the VSE guest system-id that you are running beneath VM.

(4.0) PROC-MODE = ESA IPL(120) 09:45:57 CET 01/27/2000

PROC-MODE specifies the processors mode of operation. ESA is the only choice for VSE/ESA 2.1.x and higher.

IPL specifies the cuu (e.g 120) that has been used to get your VSE/ESA system started. Appended is the time and date and OPTIONALLY the time zone of when the VSE/ESA system was IPL'ed, assuming the time zone is known to the system (defined via the ZONEBDY command). In this sample VSE/ESA was IPL'ed on the 27th of January 2000 at about 14 minutes before 10 am.

(5.0) SYSTEM = VSE/ESA 2.4.1 10/21/1999

This line gives you detailed information about the System refresh level that you are currently running. This sample indicates that it was the VSE/ESA 2.4.1 level from 10/21/1999.

(5.5) VSE/AF 6.4.0 DY45290 12/28/1999

This line gives you detailed information about the service level of a base component of your VSE/ESA system. It contains information about the last APAR which was applied to the given component together with the information of when the fix for that APAR had been certified. That date, as such, is an indication of how current your service level for that component is.

This information is extremely useful when you have to place a service problem call (PMR), which, if it is to happen, will enable 1st- and 2nd-Level service support groups to search IBM's data base for possible known problems.

This sample line indicates that the last APAR fix that had been applied to the AF (Advanced Function) component was DY45290 which had been certified on the 28th of December 1999. This was probably the most recent service level at the time the sample was extracted. (Just for those that want to argue: Since a PTF-number is automatically assigned AFTER an APAR has been CLOSED, there is no way to provide the PTF-number instead of the APAR number).

(5.55) VSE/POWER 6.4.0 DY45251 10/30/1999

This is another sample (see the description 5.5 above) which contains information about the last APAR fix which had been applied to the VSE/POWER component.

(6.0) IPL-PROC = \$IPLESA JCL-PROC = \$\$JCLESA

IPL-PROC specifies the IPL-procedure was chosen by either the system (based on specifications in the \$ASIPROC or based on defaults) or by the operator. The named procedure was executed to get your system started.

JCL-PROC specifies the JCL-procedure that had been chosen by either the system (based on specifications in the \$ASIPROC or based on defaults) or by the operator. The named procedure was executed to get your partitions started.

(7.0) SUPVR = \$\$SUPX TURBO-DISPATCHER (32) ACTIVE

SUPVR names the supervisor that had been loaded to control your VSE/ESA system. Appended to the supervisor name you may find information about the dispatcher that had been loaded. In this sample the TURBO DISPATCHER (only available with VSE/ESA 2.1.x and up), had been loaded as opposed to the STANDARD DISPATCHER which would have been loaded otherwise. The number enclosed in parenthesis (e.g. (20) in our sample) is a hexadecimal number which identifies the Turbo-Dispatcher level. This number will be incremented whenever need arises (which could be due to errors, or due to special services that had eventually been requested by vendors or other sources).

(7.5) HARDWARE COMPRESSION ENABLED

This line is OPTIONAL and gives information on whether the processor does provide the compression facilities (as is the case in our example), or if the software is providing this compression facility.

(7.55) SEC. MGR. = BASIC SECURITY = ONLINE

This line contains information about the Security-Manager program that had been chosen (SYS command EMS=name) or invoked by default (BASIC) and its current state.

SEC. MGR Names the security manager that had been requested or selected. When a failure has been recognized during security manager bringup, the name will be set to RECOVER indicating that the system is running WITHOUT a security manager.

BASIC is the synonym for the IBM supplied security manager which will always be loaded when no ESM had been specified.

SECURITY Informs you about the current state of the security manager. The different states are:

INIT FAILED indicates that the initialization of the security manager failed.

INITIALIZING indicates that the initialization of the security manager is ongoing and has not yet been completed.

(IN)ACTIVE indicates that the process of activating the security manager has either not yet been started (INACTIVE) or completed (ACTIVE).

ONLINE and BATCH indicate that the BSM transaction security together with the sign-on security are active. The optional parameter

"and BATCH" will only be appended if batch security has been specified in the SYS command (SEC=YES).

(8.0) VIRTCPU = 0000:08:31.142 CP = 0000:04:05.431

This line is OPTIONAL and only present when running under VM. It gives you information about the real processor time that your virtual system has consumed until now.

VIRTCPU is the total virtual time consumed by the virtual guest system and CP is that portion of the total virtual time (VIRTCPU) that CP had spent specifically on behalf of the virtual CPU. In our sample the total time consumed was 8 minutes, 31 seconds and 142 milliseconds whereof 4 minutes and 5.431 seconds were consumed by CP itself.

(9.0) CPU-ADDR. = 0000(IPL) ACTIVE

This line is OPTIONAL and only present if you are running the TURBO DISPATCHER and shows the different CPU addresses and their state of operation. This and the following lines (ref:10.0 and 11.0) will be repeated for each processor that exists in your system. The information subsequent to these line(s) (ref: 10.0 and 11.0) always applies to the CPU address (CPU-ADDR) named last.

CPU-ADDR is the CPU address that the subsequent information (ref 10.0 and ref 11.0) is associated to. Appended to the CPU address you find information about the current state of this processor. In this example the processor is ACTIVE. Other states could be INACTIVE, STOPPED, IN ERROR etc.. The information (IPL) is appended to one and only one processor out of a range of processors that constitute an MP system and it indicates that processor, that had been IPL'ed and it also indicates that this is the processor that can't be STOPPED by the operator.

(10.0) ACTIVE = 0000:00:13.602 WAIT = 0000:03:04.103

This line is OPTIONAL and only present if you are running the TURBO DISPATCHER and it is related to the processor address immediately preceding this line and it gives you information about the processors CPU time consumption. In our sample it indicates that the processor with the CPU address 0000 has ACTIVELY consumed 13 seconds and 602 milli-seconds and it had been in a WAITing state for 3 minutes 4 seconds and 103 milli-seconds. The active time does INCLUDE the SPIN time (ref:11.0).

(11.0) PARALLEL= 0000:00:03.128 SPIN = 0000:00:00.002

This line is OPTIONAL and only present if you are running the TURBO DISPATCHER and it is related to the last preceding processor address and gives information about the work-mix that this processor was executing.

PARALLEL is the time that this processor executed work where other processors could work concurrently. The higher this value, the better the utilization of Multiple Processors (MP). In our sample it indicates that the work-mix on this processor was such that about 23% (3.128 seconds out of 13.602 seconds ACTIVE time (ref 10.0) could be executed in parallel.

SPIN is the time that this processor spent in a very tight loop waiting for system resources occupied by other processors within the MP-system to be freed. In our sample processor 0000 spent 2 milliseconds in this tight loop.

(12.0) CPU timings MEASUREMENT INTERVAL 0000:03:28.494

This line is OPTIONAL and only present if you are running the TURBO DISPATCHER and it defines the time that has elapsed since the system was either IPLed, or since the measurement values have been reset (SYSDEF TD,.....). All the values from the preceding lines (ref:10.0 and 11.0) are related to this measuring interval. In our sample the processor activity (for all the processors mentioned before) was measured for 3 minutes and 28.494 seconds.

(13.0) TASKS ATT.= 00003 HIGH-MARK = 00008 MAX = 00194

This line informs you about the number of tasks that are, have maximal been, and could ever be ATTACHED concurrently.

TASK ATT. is the number of tasks currently ATTACHED.

HIGH-MARK is the maximum number of task that had ever been attached concurrently since IPL.

MAX is the maximum number of task that can ever be attached concurrently. It is the smaller value of: 256-32-NPARTS and 208 In the above example we have currently 3 tasks ATTACHED; we had, at a certain point in time, a maximum of 8 task(s) ATTACHED and we could attach a maximum of up to 194 tasks.

(14.0) DYN.PARTS = 00000 HIGH-MARK = 00000 MAX = 00018

This line informs you about the number of DYNAMIC PARTITIONS that are, have maximal been, or could ever be ALLOCATED concurrently.

DYN.PARTS is the number of DYNAMIC PARTITIONS currently active.

HIGH-MARK is the maximum number of DYNAMIC PARTITIONS that had been allocated concurrently since IPL.

MAX is the maximum number of DYNAMIC PARTITIONS that can be allocated concurrently.

(15.0)

This line is left blank intentionally

(16.0) COPY-BLKS = 00258 HIGH-MARK = 00381 MAX = 01500

COPY-BLKS is the number of COPY-BLOCKS (required to properly perform CCW-Translation) that currently are, have ever been (since last IPL), or can maximal ever be used concurrently by the currently running system.

In our sample we have currently 258 copy-blocks in use and this value includes the number of copy-blocks that are being held in use for FAST-CCW Translation.

HIGH-MARK gives the maximum number of copy-blocks that had ever been used concurrently (since the last IPL) and it includes the number of copy-blocks that had been held in use for FAST- CCW Translation.

In our sample the maximum number of copy-block that had been concurrently in use at a certain point in time (since last IPL) was 381.

MAX specifies the number of copy-blocks that the currently running system has allocated. This value can never be exceeded without IPL'ing the system.

Note: If HIGH-MARK ever gets close to the MAX-value, you should consider adding more BUFSIZE entries to prevent running out of them in the future, which could lead to performance degradation. For that purpose, if HIGH-MARK ever reaches the MAX-value, then you should first try to run with FASTTR=NO (Standard JCL Option) next time you IPL your system. If HIGH-MARK then still

reaches the MAX-value (although FASTR=NO was specified), then you should increase your BUFSIZE value to prevent performance degradation. If the HIGH-MARK never gets even close to the MAX-value, then it would be an indication to run with a smaller number of BUFSIZE entries (to save 72-bytes per entry) when you perform a new IPL.

(17.0) CHANQ USED= 00004 HIGH-MARK = 00011 MAX = 00062

CHANQ USED is the number of CHANnel Queue entries (one entry is required per I/O operation) that currently are, have ever been (since last IPL), or can maximal ever be used concurrently by the currently running system. In our sample we have currently 4 channel-queue entries in use. Having a channel queue entry in use does not necessarily indicate that an I/O operation is currently ongoing.

HIGH-MARK gives the maximum number of channel queue entries that had ever been used concurrently (since the last IPL). In our sample the maximum number of copy-block that had been concurrently in use at a certain point in time (since last IPL) was 11.

MAX specifies the number of channel queue entries that the currently running system has allocated. This value can never be exceeded without IPL'ing the system.

Note: If HIGH-MARK ever gets close to the MAX value, you should consider adding more CHANQ entries to prevent running out of them in the future, which could lead to performance degradation. If it never gets even close to the MAX value, then it would be an indication to try to run with a smaller number of CHANQ entries (to save 32-bytes per entry) when you perform a new IPL. A user specified number may, however, be overruled by IPL depending on the number and type of I/O devices ADDED.

(17.5) LBL.-SEGM.= 00006 HIGH-MARK = 00032 MAX = 00717

this line is optional and only present if the label area is on a virtual FBA disk (VDISK) and it contains the number of label segments (2K each) that are currently being used, that have ever been used (since last IPL) or which can maximal be used by the currently running system. In our sample we have currently 6 Label-segments in use. The number of label-segments is not telling anything about the number of labels being used, simply because part of that area is being used internally and because the labels are variable in length.

HIGH-MARK gives the maximum number of label-segments that had ever been used concurrently (since the last IPL). In our sample the maximum number of label-segments that had been concurrently in use at a certain point in time (since last IPL) was 32.

MAX specifies the number of label-segments that the currently running system has allocated. This value can never be exceeded without IPL'ing the system.

Note: If HIGH-MARK ever gets close to the MAX value, you should consider increasing your label area to prevent running out of label-segments which could result in problems during Job execution. If it never gets even close to the MAX value, then it would be an indication to try to run with a smaller label-area when you perform a new IPL.

The next lines (ref: 18.0 through 21.0) are OPTIONAL and only present if you are running a system with a PDS (Page Data Set) having been allocated during IPL.

(18.0) PGIN TOT.= 0000013796 EXP.AVRGE.= 0000000044/SEC

This line informs you about the PAGE-IN activity since you have IPL'ed the system. It is an indication of the total PAGE I/O activity that was (PGIN TOT) or is (EXP.AVRGE.) ongoing.

PGIN TOT. is the total number of PAGE-IN requests that have been performed since the last IPL.

EXP.AVRGE is the EXPOnential AVerAGE PAGE-IN rate measured in requests per second. Exponential Average means that the LATEST PAGE-IN activity, measured during the latest measuring interval (which is the time consumption between a predefined number of PAGE-IN requests, which is processor dependant) is taken into account with an equal weight, compared to the OLD exponential average, in calculating the NEW exponential average.

The formula is: $((LATEST-PAGE-IN/second)+(OLD-EXP.AVRGE))/2$ to illustrate this, assume an: EXP.AVRGE.= 000000038/SEC and assume a time difference from 200 milli-seconds between a 1st and the 10th PAGE-IN request (assuming a processor constant of 10), then the NEW EXP.AVRGE would calculate to:

LATEST PAGE-IN 200ms/10pgin = 50pgin/second
NEW EXP.AVRGE (50pgin/sec + 38pgin/sec) / 2 = 44
and thus our line would say: EXP.AVRGE.= 44

(19.0) PGOUT TOT.= 0000000337

This line informs you about the PAGE-OUT activity since you have IPL'ed the system.

PGOUT TOT. is the total number of PAGE-OUT requests that have been performed since the last IPL. This line is the accumulated value of the next two lines (ref:20.0 and 21.0).

(20.0) UNC.= 0000000225 EXP.AVRGE.= 0000000018/SEC

UNC. gives the number of UNCONDITIONAL PAGE-OUT requests which have either been explicitly requested, or which have been initiated by the PAGE MANAGER to free one or more PAGE FRAMEs.

EXP.AVRGE is the EXPOnential AVerAGE UNC.PGOUT rate measured in requests per second. Exponential Average means that the LATEST UNC.PGOUT activity, measured during the latest measuring interval (which is the time consumption between a predefined number of PAGE-IN requests, which is processor dependant) is taken into account with an equal weight, compared to the OLD exponential average, in calculating the NEW exponential average.

The formula is: $(LATEST-UNC.PGOUT/second)+(OLD-EXP.AVRGE)/2$ A detailed sample that you may want to refer to is given above (ref:18.0).

(21.0) PRE = 0000000112 EXP.AVRGE.= 0000000002/SEC

PRE gives the number of PRE PAGE-OUT requests which have been initiated by the PAGE MANAGER to ensure PAGE FRAME availability when a PAGE-IN request should be received. These values might serve as an indication of how often pages are being referenced by the system. Pages not being referenced any more, will be subject to destaging (PRE-PAGE-OUT) if need arises.

EXP.AVRGE is the EXPOnential AVeRaGE PRE.PGOUT rate measured in requests per second. Exponential Average means that the LATEST PRE.PGOUT activity, measured during the latest measuring interval (which is the time consumption between a predefined number of PAGE-IN requests, which is processor dependant) is taken into account with an equal weight, compared to the OLD exponential average, in calculating the NEW exponential average.

The formula is: $(LATEST-PRE.PGOUT/second)+(OLD-EXP.AVRGE)/2$ A detailed sample that you may want to refer to is given above (ref:18.0).

The next lines (ref: 22.0 through 24.0) give you some information about the LOCKTAB and/or LOCKFILE (DLF) usage and it tells you about conflicts that have been encountered due to attempts to access certain resources concurrently.

(22.0) LOCKS EXT.= 0000000450 LOCKS INT.= 0000003636

This line contains the total number of LOCK (USE) requests that have been issued since the last IPL.

LOCKS EXT. is the total number of EXTERNAL locks that had been requested. EXTERNAL means that the requestor has requested a resource in a SHARED environment for controlled access. It DOES NOT indicate that you are RUNNING a shared environment (e.g. the user could have requested an EXTERNAL LOCK, but the system is running WITHOUT a DLF command (see ref:24.0)). In the above sample there has been a total of 450 LOCK request to guarantee controlled access by other processors that do have access to the specified resource.

LOCKS INT. is the total number of INTERNAL locks that had been requested. INTERNAL means that the requestor has requested a resource in his own system to be locked for controlled access. Internal LOCKS are those for which controlled access by other tasks within this system is granted. In our sample we had 3636 LOCK (USE) requests with the attribute INTERNAL (grant controlled access by other tasks).

(23.0) FAIL = 0000000006 FAIL = 0000000185

This line contains the total number of UNSUCCESSFUL LOCK attempts either EXTERNAL (left column) or INTERNAL (right column)

FAIL is the total number of LOCK requests that had been unsuccessful due to access constrains with other requestors. In the above example, 6 EXTERNAL LOCK requests (out of 450 (ref:22.0)) had been unsuccessful and as such had to be re-issued. Similar, 185 out of 3636 INTERNAL LOCK requests had been unsuccessful and would have had to be re-issued.

(24.0) LOCK I/O = 0000000000 LOCK WRITE= 0000000000

This last line gives information about the LOCKFILE I/O accesses.

LOCK I/O is the total number of I/O operations, whereby the LOCK request itself might have been success-or unsuccessful, that had been issued to the LOCKFILE.

LOCK WRITE is the total number of I/O operations where an external lock was either obtained, or freed. The greater the difference between these two values is, the more unbalanced is the workload among the different processors that constitute the SHARED environment. The fact that in our sample the LOCK I/O is 00000000, indicates that we were running a NON-SHARED system.

SIR SYS

Syntax: **SIR SYS**

This command allows to retrieve only part of the data that SIR would have provided. The output will be limited to the static information only (ref: 1.0 through ref: 7.55)

SIR RESET

Syntax: **SIR RESET**

This command allows to reset the dynamic counters which are subject to the SIR command output (ref: 8.0 through 24.0) back to zero and to start another counting cycle.

SIR SMF

Syntax: **SIR SMF[={ON|OFF}][,VSE][,cuu]**

This command allows to retrieve I/O data maintained by either the channel subsystem, when the channel subsystem measurement facility exists, or by the I/O supervisor itself. It is mainly intended to assist in finding I/O performance problems. Since the channel subsystem does maintain these counters without posting an overflow condition, it is recommended to not run this activity report unlimited in order to prevent confusing results.

SMF is the keyword indicating that Subsystem Measurement Facility data is requested and, if specified without any further options, will retrieve that data, assuming that SMF had been activated before.

- ON** indicates that you want to activate I/O performance measurements functions in VSE and to also activate the Channel Subsystem Measurement Facility (if available). This is a prerequisite to retrieve SMF data.
- OFF** indicates that you want to deactivate the I/O performance measurement functions in VSE as well as in the Channel Subsystem.
- VSE** indicates that you want the I/O counters as maintained by the VSE I/O supervisor to be displayed assuming that SMF is already active. Differences that you may encounter between the counters maintained by VSE and those figures as retrieved from the Channel Subsystem could eventually be caused by either VM or other programs which may have intercepted the appropriate VSE code. So the difference is most likely the time that had been spend in VM or vendor program products or even both.
- cuu** indicates that you want the data for just one single device which had been identified by its device-Id (cuu).

The following page is some extracts from a console log which should help the reader to get a better understanding of the function of the SIR SMF command.

```

sir smf
(1.0) SUBSYSTEM MEASUREMENT FACILITY IS INACTIVE
sir smf=on
(2.0) SUBSYSTEM MEASUREMENT FACILITY HAS BEEN ACTIVATED
(3.0) NO SUBSYSTEM MEASUREMENT DATA YET AVAILABLE
-----here some I/O activity was forced-----
AR 0015 2FE 90E5 FBAV          UNUSED          DOWN
AR 0015 2FF 90E5 FBAV          UNUSED          DOWN
AR 0015 330 6E 3390-06 BAM330 CMS-D          DOWN
AR 0015 480 5408 TAPE          UNUSED          NOT OPER.
AR 0015 481 5408 TAPE          UNUSED          NOT OPER.
AR 0015 490 52D3 TAPE          UNUSED          NOT OPER.
AR 0015 491 52D3 TAPE          UNUSED          NOT OPER.
AR 0015 1I40I  READY
sir smf
(4.0) DEVICE  I/O-CNT      QUEUED      CONNECT      DISCONN      TOTAL
(4.1)                msec/SSCH    msec/SSCH    msec/SSCH    msec/SSCH
(5.0)
(6.0) 100        5        0.537      3.507      3.993      8.038
(6.0) 101        5        0.204      10.214     1.459     11.878
(6.1) 190        5        0.153      2.585      0.000     2.739
(6.0) 191        5        0.230      9.088      3.763     13.081
(6.0) 19B        5        0.179      7.987      0.870     9.036
(6.1) 19D        5        0.153      2.611      0.000     2.764
(6.0) 19E        5        0.230      6.579      1.331     8.140
(6.2) 110       13       3.810      2.491     17.723    24.024
(6.0) 130        3        0.256      2.816      0.000     3.072
(6.0) 131        3        0.213      3.456      3.029     6.698
(6.0) 132        3        0.170      5.290      2.602     8.064
(6.0) 133        3        0.170      4.138      4.608     8.917
(6.0) 140        3        0.170      1.706      3.242     5.120
(6.0) 230        3        0.213      5.546      2.688     8.448
(6.0) 240        3        0.170      2.090      1.664     3.925
(6.0) 330        5        0.204      3.865      5.376     9.446
(6.0) 1I40I  READY
-----
sir smf=182
(10.0) TIMINGS for 182 based on      11 I/O INSTRUCTIONS
(11.0)
(12.0) QUEUED      PENDING      CONNECT      DISCONN      DEV.BUSY      TOTAL
(13.0) msec/SSCH  msec/SSCH  msec/SSCH  msec/SSCH  msec/SSCH  msec/SSCH
(14.0) 0.128      0.128      6.272      8.704      0.000      15.232
(15.0) 1I40I  READY
-----
sir smf,vse,150
(10.0) TIMINGS FOR 150 BASED ON      11 I/O INSTRUCTION
(11.0)
(12.0) QUEUED      PENDING      CONNECT      DISCONN      DEV.BUSY      TOTAL
(13.0) msec/SSCH  msec/SSCH  msec/SSCH  msec/SSCH  msec/SSCH  msec/SSCH
(14.0) 0.011      0.000      2.478      0.000      0.000      2.490
(15.0) 1I40I  READY
sir smf=off
AR 0015 1I40I  READY
sir smf
(1.0) SUBSYSTEM MEASUREMENT FACILITY IS INACTIVE

```

Figure 27. SIR SMF command sample

Explanation

(1.0) SUBSYSTEM MEASUREMENT FACILITY IS INACTIVE

This message is telling you that the Subsystem Measurement Facility (SMF) is inactive, or has been deactivated (SIR SMF=OFF).

The operator would have to issue the SIR SMF=ON command to get the facility initialized properly.

(2.0) SUBSYSTEM MEASUREMENT FACILITY HAS BEEN ACTIVATED

This is the acknowledgement message that the Measurement Facility has now been successfully initialized.

(3.0) NO SUBSYSTEM MEASUREMENT DATA YET AVAILABLE

This message indicates that the Subsystem Measurement Facility is active, but that NO measurement data is yet available. Either no I/O operation has been issued since the Measurement Facility has been activated, or the device is not being supported by the measurement facility or by the I/O supervisor.

(4.0) DEVICE I/O-CNT QUEUED CONNECT DISCONN TOTAL

(4.1) msec/SSCH msec/SSCH msec/SSCH msec/SSCH

This line is a heading line describing the contents of the vertical fields below the headings subject. The heading line as well as the subheading line will be repeated after 16 detail lines to make the console output easier to read. Timing values are given in milli-seconds per SSCH (START SUBCHANNEL).

DEVICE specifies the cuu address of the device that is being measured.

I/O-CNT specifies the number of I/O operations that had been used in calculating the measurement data in the appropriate line. Watch-out, the I/O-CNT could have wrapped at 65,536 back to zero while the timings will be accumulated for about 153 hours which could cause inconsistent data once the I/O-CNT wraps. To prevent such inconsistent data, it is recommended to run the Suchannel Monitoring Facility only for a certain time and then turn it off via the SIR SMF=OFF command. A subsequent re-activation (SET SMF=ON) will start with all fields reset to zero.

QUEUED this field contains the average time (based on the I/O-CNT) that an I/O request was queued in VSE (I/O supervisor). If the PENDING time is not given explicitly (ref: 12.0) then the QUEUED time does also INCLUDE the time the request was PENDING in the Channel Subsystem. An I/O request is queued in VSE from the time the I/O request is enqueued up to the point where the Start I/O operation (SSCH) has successfully been initiated. Starting with the successful initiation of the SSCH instruction, the time will be counted as PENDING in Channel Subsystem. A request would be held pending in the Channel Subsystem if e.g. a channel or a Control Unit (CU) is currently busy. The values in this column would thus indicate a device, a channel or a CU (Control Unit) contention.

CONNECT this field contains the average time (based on the I/O-CNT) that a device is logically connected to a channel for purposes of transferring information between it and the Channel Subsystem.

DISCONN this field contains the average time (based on the I/O-CNT) that a device is logically disconnected from the Channel Subsystem while the device is still busy and has not yet presented primary interrupt (Channel End) status. In case a DEV.BUSY time is not outlined explicitly (ref: 12.0), then the DISCONN time does also INCLUDE the DEV.BUSY time which is the time between the primary status (CE) and the secondary device-end status (DE).

TOTAL this field contains the average time (based on the I/O-CNT) of a complete I/O operation and is actually the sum of QUEUED (+PENDING), CONNECT and DISCONN (+DEV.BUSY). An excessive value in this field could be the indication of a device problem.

(6.0) 100 5 0.537 3.507 3.993 8.038

This is a sample line telling you that the average time, that had been measured based on 5 SSCH-instructions, issued to the device with the address 100, had been 8 milli-seconds and 38 micro-seconds in total. From this 8.038 milli-seconds, the request was QUEUED in the VSE I/O supervisor and was PENDING in the channel subsystem for about half a milli-second (0.537), was doing data transfer operations for 3.507 milli-seconds and was executing SEEK/SEARCH type operations (DISCONNected) for about 3.993 milli-seconds. We can neglect the DEV.BUSY time which is also included here, since the sample line was for a DASD device. This sample might be considered a typical one for DASD timings. The other lines (ref: 6.0) are similar.

(6.1) 190 5 0.153 2.585 0.000 2.739

This is a sample line telling us that the average time, that had been measured based on 5 SSCH-instructions, issued to the device with the cuu=190, had been 2 milli-seconds and 739 micro-seconds in total. From this 2.738 milli-seconds, the request was QUEUED in VSE and in the channel subsystem for about 153 micro-seconds, was doing data transfer operations for 2.585 milli-seconds and was NOT executing SEEK/SEARCH type operations (DISCONNected). This sample might be considered a typical sample for CACHED DASD I/O operations with CACHE HITS. The other lines (ref: 6.1) are similar.

(6.2) 110 13 3.810 2.491 17.723 24.024

This is a sample that should be examined more carefully. It is telling you, that, based on 13 I/O-instructions, the average execution time was about 24 milli-seconds (TOTAL). The time it took VSE's I/O supervisor plus the Channel Subsystem to actually get the device started was about 3.810 milli-seconds. This, compared to the figures before, is quite some time, that needs interpretation. In the given scenario, where the 110 was a MINI-DASD (under VM) it could mean that there was some device contention on the REAL device. The long disconnect (DISCONN) time could be an indication that there might have been RPS (Rotational Position Sensing) misses on this device, or, it could indicate that there is heavy SEEK activity ongoing. I would suggest that you watch such devices for more than just a few I/O instructions and then draw your final conclusion(s).

If the TOTAL time ever gets higher than about 30 milli-seconds (for DASD), then this should raise your alert flag.

EXPLANATION for a single device:

(10.0) TIMINGS for 182 based on 11 I/O INSTRUCTIONS

This line gives the device-Id (in our sample 182) plus the number of I/O instructions (in the sample it was only 11) that the subsequent measuring data is based on.

(11.0)

This line is left blank intentionally

(12.0) QUEUED PENDING CONNECT DISCONN DEV.BUSY TOTAL

This line is a heading line describing the contents of the vertical fields below the headings subject. The heading line as well as the subheading line will be

Internal Attention Routine

repeated after 16 detail lines to make the console output easier to read. Timing values are given in milli-seconds per SSCH (START SUBCHANNEL).

- QUEUED** this field contains the average time (based on the I/O-CNT) that an I/O request was queued in VSE (I/O supervisor). An I/O request is queued in VSE from the time the I/O request is enqueued up to the point where the Start I/O operation (SSCH) has successfully been initiated. High values in this field would indicate a device contention.
- PENDING** this field contains the average time (based on the I/O-CNT) that an I/O request was held PENDING in the channel subsystem after the SSCH instruction had been accepted. A request would be held pending in the Channel Subsystem if e.g. a channel or a Control Unit (CU) is currently busy. The values in this column would thus indicate a channel or a CU (Control Unit) contention.
- CONNECT** this field contains the average time (based on the I/O-CNT) that a device is logically connected to a channel for purposes of transferring information between it and the Channel Subsystem.
- DISCONN** this field contains the average time (based on the I/O-CNT) that a device is logically disconnected from the Channel Subsystem while the device is still busy and has not yet presented primary interrupt (Channel End) status. This value does NOT include the time between Channel End (CE) and Device End (DE).
- DEV.BUSY** this field contains the average time (based on the I/O-CNT) that a device is still busy, while the subchannel is idle. Thus, it is the time between Channel End (CE) and Device End (DE).
- TOTAL** this field contains the average time (based on the I/O-CNT) of a complete I/O operation and is actually the sum of QUEUED, PENDING, CONNECT, DISCONN and DEV.BUSY time. It should be used to quickly check if there are any I/O-device problems.

(14.0) 0.128 0.128 6.272 8.704 0.000 15.232

This line (based on 11 SSCH instruction to device X'182') is now stating that the I/O operation was queued in VSE for about 128 micro-seconds, that it took the channel subsystem about 128 micro-seconds to get it initiated successfully and that the data-transfer operation (CONNECT) did last 6,272 milli-seconds. The time the device was DISCONNECTed from the channel (for DASD typically the SEEK/SEARCH times) was measured with 8.704 milli-seconds and there was 0.000 milli-seconds that the device was busy with the subchannel being idle. This indicates that we did not have split channel- and device end (CE and DE) interrupts. This resulted in a TOTAL of 15.232 milli-seconds for the whole I/O operation, which should be considered an average DASD I/O time for non-cached operations.

The second sample is similar to the first one, except that this time the figures are based on the counters maintained by VSE itself.

SIR MON

Syntax: **SIR MON**=[{id|ON[,NOSYM]]OFF [, {FAST|COUNTER|BOUND}]

This command provides monitoring data and is available with the TURBO DISPATCHER only. The information will consist of a certain function and the number of times this function has been executed. The function is either a symbolic name/macro or a hexadecimal value, whereas the execution count is always a decimal value.

MON is the keyword required to retrieve monitoring data.

- id** is the partition SYSLOG-Id which is to be monitored exclusively (BG,F1,F2...,Zn). You can also pass a task id in the form Txx, where xx would be the HEX value of the task that you want to monitor. Please note that before switching to another id, you should issue the **SYSDEF TD,RESETCNT** command to get all counters reset to zero. If specified without any further operands, it will cause ALL monitoring services to be activated (SVC, FAST, COUNTER and BOUND).
- ON** indicates that monitoring is to be started. If specified without any further operands, it will cause ALL monitoring services to be activated (SVC, FAST, COUNTER and BOUND).
- NOSYM** indicates that the function code substitution into symbol names is to be suppressed and that the function code is to be supplied by its hexadecimal value instead.
- OFF** indicates that monitoring is to be stopped. If specified without any further operands, it will cause all monitoring to be stopped. If FAST or BOUND or COUNTER have been specified, monitoring will be deactivated for that special service only. Please note that this option does **NOT** reset the counters. You must use the **SYSDEF TD,RESETCNT** command instead.
- FAST** indicates, that, in addition to the supervisor calls (SVCs, also the FAST-SVC calls (SVC-6B) be explicitly monitored by their function code.
- COUNTER** indicates, that, in addition to the supervisor calls (SVCs), also the Turbo Dispatcher (TD) tuning counters be explicitly monitored. These counters are intended for internal use only to assist in performance problem analysis.
- BOUND** indicates, that, in addition to the supervisor calls (SVCs), also the WAIT conditions (Bound states) be explicitly monitored.

To retrieve the monitoring data, you just need to issue the **SIR MON** command (without any further operand). The command will produce similar output as shown in the sample below. In the **SAMPLE** below, please notice that the heading line of the **MONITORING REPORT (FAST SVC)** does say **INACTIVE** which means this service had been deactivated by the operator prior to the issuance of the **SIR MON** command and that, as a result, the counters are not maintained any more.

Note: Before you start (another) monitoring cycle, please make sure that you have issued the **SYSDEF TD,RESETCNT** command **while monitoring was active** (MON=ON). Only if monitoring is active it will be ensured that all the counters are reset to zero.

```

sir mon
AR 0015                MONITORING REPORT (SVC)
AR 0015                (based on a 0013:44:35.960 interval)
AR 0015 EXCP          = 3645 FCH-$$B = 178 SVC-03 = 9
AR 0015 LOAD          = 1389 FCH-$$A = 8 WAIT = 5843
AR 0015 SVC-08        = 4 LBRET = 4 SETIME = 1
AR 0015 SVC-0B        = 74 SVC-0C = 44 SVC-0D = 1079
AR 0015 EOJ           = 6 SYSIO = 2894 STXIT IT = 1
AR 0015 EXIT IT       = 1 STXIT OC = 1 SVC-16 = 218
AR 0015 SETIME        = 9878 SVC-1A = 27 WAITM = 19914
AR 0015 COMREG        = 2217 GETIME = 185 FREE = 9
AR 0015 STXIT AB     = 2 ATTACH = 2 DETACH = 2
AR 0015 POST          = 1 DYNCLASS = 15 SVC-2C = 1
AR 0015 HIPROG        = 4 TTIMER = 9 GETPRTY = 8
AR 0015 INVPART       = 12 GETVIS = 2390 FREEVIS = 2350
AR 0015 CDLOAD        = 122 RUNMODE = 3 PFIX = 11
AR 0015 PFREE         = 1 REALAD = 22 SETPFA = 1
AR 0015 SECTVAL       = 543 SVC-4C = 2 ALLOCATE = 12
AR 0015 SETLIMIT      = 44 SVC-5B = 4 XECBTAB = 11
AR 0015 EXTRACT       = 49 GETVCE = 738 MODVCE = 51
AR 0015 EXTENT        = 33 SUBSID = 11 FASTSVC = 34177
AR 0015 SECHECK       = 133 (UN)LOCK = 3205 MSAT = 267
AR 0015 XPCC          = 30 VIO = 15 NPGR = 2
AR 0015 PGSER         = 2 SYSDEF = 1 PRODIG = 199
AR 0015 SVC-83        = 129 SVC-85 = 4 VSIUCV = 9
AR 0015 INACTIVE      MONITORING REPORT (FAST-SVC)
AR 0015 FC-02         = 121 FC-06 = 49 FC-1B = 48
AR 0015 FC-1E         = 63 FC-31 = 1 FC-3F = 55
AR 0015 FC-40         = 41 FC-42 = 5 FC-44 = 9
AR 0015 FC-46         = 55 FC-47 = 56 FC-49 = 5
AR 0015 FC-4A         = 8 FC-4B = 8 FC-4E = 17
AR 0015 FC-4F         = 10 FC-51 = 35 FC-59 = 2
AR 0015 FC-5D         = 1 FC-5F = 1 FC-62 = 4
AR 0015 FC-67         = 8 FC-73 = 60 FC-74 = 6
AR 0015 FC-7D         = 2 FC-7E = 1 FC-85 = 12
AR 0015 FC-90         = 98 FC-96 = 1 FC-AA = 1
AR 0015 CPU 0000      PERFORMANCE COUNTERS
AR 0015 CNT-00        = 105746 CNT-01 = 110743 CNT-02 = 110743
AR 0015 CNT-03        = 84683 CNT-08 = 18544 CNT-09 = 4999
AR 0015 CNT-0B        = 26629 CNT-0D = 34851 CNT-0E = 112566
AR 0015                MONITORING REPORT (BOUND STATE)
AR 0015 BND-49        = 3 BND-50 = 12429 BND-80 = 220
AR 0015 BND-82        = 440 BND-85 = 179 BND-87 = 1
AR 0015 1I40I READY

```

Figure 28. SIR MON command sample

SIR MIH

Syntax: **SIR MIH** [{nnnnnn|ON|OFF}]

This command provides the capability to change the invocation of the MIH (Missing Interrupt Handler) process in VSE, or to show the current settings of the MIH cycle time. The MIH process in VM, if running under VM, remains UNAFFECTED by this command.

MIH is the keyword indicating that MIH constants are to be displayed or altered.

- nnnnn is the numeric value in seconds, after which the MIH process is to be (re-)initiated. This is called the MIH cycle time which is normally set to 180 seconds. Any value between 1 and 999999 will be accepted.
- ON indicates that the MIH process with the existing constants is to be re-activated.
- OFF indicates that the MIH process is to be totally bypassed, and as a result no more lost interrupts, if any, will be recognized.

The following sample should document the functional capabilities, but it does NOT mean that you have to follow the given sample in order to change the MIH setting. You can of course change the MIH setting regardless of whether MIH is OFF or ON, but the new setting will become active only if MIH is ON.

The command will produce similar output as shown in the sample below.

```

sir mih
AR 0015 MIH ON   INTERVAL=   5 SECONDS
sir mih=off
AR 0015 MIH PROCESSING NOW INACTIVE
sir mih
AR 0015 MIH OFF  INTERVAL=   5 SECONDS
sir mih=180
AR 0015 MIH TIME INTERVAL SET TO 180 SECONDS
sir mih
AR 0015 MIH OFF  INTERVAL=  180 SECONDS
sir mih,on
AR 0015 MIH PROCESSING NOW ACTIVE
sir mih
AR 0015 MIH ON   INTERVAL=  180 SECONDS

```

Figure 29. SIR MIH command sample

SIR CHPID

Syntax: **SIR CHPID**

This command provides information about the Channel Paths (CHPID) defined to your system. This command may cause the Attention Routine to be canceled in case your processor or even your VM Release does NOT SUPPORT that request, like the PC Server 500 System/390.

The command will produce similar output as shown in the sample below.

```

sir chpid
AR 0015 CHPID CHLA SWLA LSN      CHANNEL-PATH-DESCRIPTION
AR 0015 00                      PARALLEL BYTE-MULTIPLEXER
AR 0015 01                      PARALLEL BLOCK-MULTIPLEXER
AR 0015 02                      PARALLEL BLOCK-MULTIPLEXER
AR 0015 03                      PARALLEL BLOCK-MULTIPLEXER
AR 0015 04                      PARALLEL BLOCK-MULTIPLEXER
AR 0015 08                      PARALLEL BLOCK-MULTIPLEXER
AR 0015 18 01                   SERIAL POINT-TO-POINT
AR 0015 19                      FIBER EXTENDED CHANNEL
AR 0015 18 01                   SERIAL POINT-TO-POINT
AR 0015 19                      FIBER EXTENDED CHANNEL
AR 0015 1A                      01 FIBER EXTENDED CHANNEL
AR 0015 1B                      SERIAL CHANNEL PATH (INIT)
AR 0015 CHPID CHLA SWLA LSN      CHANNEL-PATH-DESCRIPTION
AR 0015 1C C4 FE 01             SERIAL SWITCHED POINT-TO-POINT
AR 0015 1D C5 FE 01             SERIAL SWITCHED POINT-TO-POINT
AR 0015 1E C6 FE 01             SERIAL SWITCHED POINT-TO-POINT
AR 0015 1F 01                   SERIAL POINT-TO-POINT
AR 0015 1I40I READY

```

Figure 30. SIR CHPID command sample

Explanation:

- CHPID** is the CHannel Path ID to which this information applies.
- CHLA** CHannel Link Address indicates the link address assigned to the channel-subsystem link-level facility of the specified channel path (CHPID). This is used by control units as the destination link address when attempting to communicate with the channel subsystem on the specified channel path.
- SWLA** SWitch Link Address contains the link address assigned to the control unit link-level facility of the dynamic-switch. This is used as the destination link address when attempting to communicate with the dynamic-switch control unit on the specified channel path (CHPID).
- LSN** Logical Switch Number gives the logical switch number of the switch, if any, that is attached through the corresponding Channel-Path Link Address (CHLA).

SIR CRWMSG

Syntax: **SIR CRWMSG={ON|OFF}**

This command activates CRW (Channel Report Word) information to be provided on the system operator console. A CRW will typically be presented in case devices are being ATTACHed or DETACHed. The processing of CRW's itself remains unaffected by this command.

- CRWMSG** is the keyword required to display Channel Report Word information.
- ON** activates the facility to get CRW Information displayed on the system operator console.
 - OFF** no further CRW information will be provided on the system operator console.

The command will produce similar output as shown in the sample below.

```

sir crwmsg=on
AR 0015 CHANNEL REPORT MESSAGES are ENABLED

#cp def 480 481
TAPE 0481 DEFINED

AR 0017 CRW  TYPE  REPS  ERCC  REPSID  DVNUM
AR 0017      00   03   84   0010   0481

sir crwmsg=off
AR 0015 CHANNEL REPORT MESSAGES are DISABLED

```

Figure 31. SIR CRWMSG=ON command sample

Explanation:

TYPE	Basically contains information about the nature of this CRW; if it is a solicited, an unsolicited or a chaining CRW and also identifies if an CRW overflow had occurred.
REPS	Is the REPorting-Source identification Code. This could have been the monitoring facility (02), the subchannel (03 as in our sample), the channel path (04), the configuration alert facility (09) or the subchannel itself (0B).
ERCC	Is the Error Recovery Code if, when zero, indicates that the channel subsystem has presented event information, otherwise this code identifies the recovery state of the reporting-source code (REPS). In our sample (84) it indicates that the installed parameters for the given subchannel (ref: REPSID) have been initialized.
REPSID	Is the REPorting-Source-ID which, together with the Reporting-Source-Code, either contains the affected subchannel number or it contains the Channel-Path-Id. In the sample,(0010) it is the subchannel that had been initialized.
DVNUM	Is the Device-Id of the device as seen by the VSE system (cuu address) that is affected by this CRW.

STACK

Syntax: **(P)STACK**

The STACK command is a command that can be used for different purposes.

- It is a command that enables the system operator to prepare a sequence of commands and/or replies, give it a name and have this sequence executed whenever that name is being entered or submitted as a command.
- It is a command that enables the system operator to suppress or change any VSE command.
- It is a command that enables the system operator to abbreviate long VSE commands to just a few characters.

The STACK command will cause the associated data to be saved temporarily (just in storage) and as a result the data is lost after the next subsequent IPL. If, however, the PSTACK command (Permanently STACK) had been used instead, any data that needs to be saved will be written onto the CKD device that had been chosen for the last IPL and as a result will be maintained across further IPL processes. The PSTACK will not work on FBA devices from which VSE may have been IPLed.

Internal Attention Routine

The initial idea was to provide a means to shut-down a VSE system by using a single command as for example:

STACK SHUT|MSG F2|23 CEMT P,SHUT|Z NET QUICK|PEND|1 ROD

SHUT would be the name of the command that the operator would have issued to close down CICS, VTAM and finally POWER.

I would suggest that you start your STACK exploration on a test system first, of course not before you have read the description given on the next few pages.

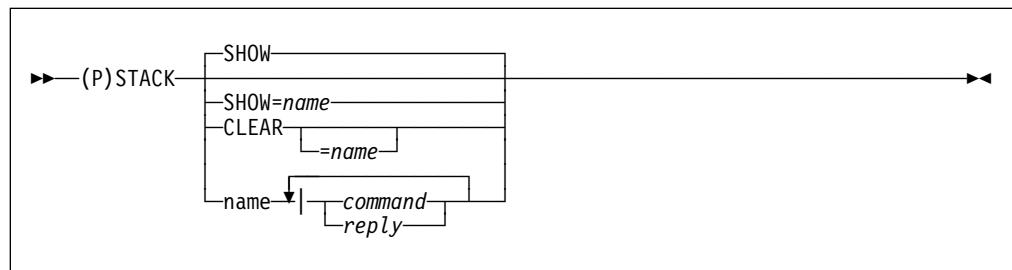

Figure 32. STACK command syntax

STACK identifies this command as a STACK command.

name This is a STACK-name that the user can freely choose and that he would have to specify to get the sequence of the specified commands and/or replies executed in the specified order. The whole entry is referred to as a STACK-entry and it will be saved in a special STACK-buffer for subsequent use and the whole STACK-buffer will be preserved throughout IPL. The preserved STACK-data can only be reset or purged via the STACK CLEAR command. It should be noted that a STACK-name does supersede a VSE command with the same name until this STACK command has been removed (see option CLEAR).

CLEAR This is a special keyword indicating that STACK entries currently defined in the STACK-buffer are to be cleared. If the user does not supply a STACK-name, then all STACK-entries (the whole STACK-buffer), will be purged, whereas, only the named STACK entry will be purged otherwise. The option CLEAR is required to enforce the system to also purge any eventually preserved STACK-data (a single STACK-entry versus the total STACK-buffer).

SHOW This is a special keyword indicating that STACK entries currently defined in the STACK-buffer are to be displayed on the operator console. If the user does not supply a STACK-name, then all STACK entries (the whole STACK-buffer), will be displayed, whereas, only the named STACK entry will be displayed otherwise. SHOW is the default option that will be executed in case the STACK command has been issued without any further operands.

Note: Caution when you use the STACK command without any further operands and you are not sure of whether you have applied the fix for APAR DY45629. It could cause your STACK-buffer to be purged unexpectedly.

- command** is a complete VSE-command which may have incorporated special variables (&0 through &9) which will be explained later. The command must be followed by a vertical bar (|) which serves as a separator.
- reply** is a complete VSE-reply which may contain incorporated special variables (&0 through &9) which will be explained later. The reply must be followed by a vertical bar (|) which serves as a separator. A system control statement is considered a reply in this sense.

You can concatenate as many commands or replies assuming the whole STACK command does not exceed 126 bytes, which is the max. VSE command buffer length. None of the operands in the STACK command will be validated at the time it is being entered, it will be saved unchanged into the STACK-buffer. An eventually existing STACK-entry with an identical STACK-name will be overwritten unconditionally. You may specify up to a max. of 32 STACK-entries. Any of the STACK-entries may contain variables, identified by &n where n is an integer ranging from 0 through 9. These variables will eventually be substituted by operands at execution time, which is when the STACK-name is being entered as a command. &0 will get the first positional parameter assigned, &1 the second positional parameter and so on. If a parameter is being omitted at execution time, then the appropriate variable will be omitted also.

To get a better understanding lets start with a simple command.

STACK VIS|GETVIS &0,ALL

This command will cause VSE to save a STACK-entry with the name **VIS** in the STACK-buffer and will subsequently cause VSE to execute a **GETVIS id,ALL** whenever **VIS id** is being entered on the operator console. The following samples will show how the &0 variable will be replaced by the parameter submitted in the **VIS** command.

Internal Attention Routine

```

stack vis|getvis &0,all
AR 0015 1I40I  READY

vis sva
AR 0015 1I40I  READY
AR 0015 GETVIS SVA,ALL
AR 0015 GETVIS USAGE   SVA-24   SVA-ANY           SVA-24   SVA-ANY
AR 0015 AREA SIZE:    1,404K    4,880K
AR 0015 USED AREA:    272K      608K MAX. EVER USED:    312K    648K
AR 0015 FREE AREA:    1,132K    4,272K LARGEST FREE:    1,112K  3,140K
AR 0015 SUMMARY REPORT
AR 0015 SUBPOOL      REQUEST <--SVA-24-AREA---  --SVA-ANY-AREA-->
AR 0015 Default          128K          4K
AR 0015 IPWPCR           32K           0K
AR 0015 IJBFCB           16K           0K
AR 0015 INLSLD           12K           0K
AR 0015 IJBPRC0020      SPACE          8K           0K
.
.
.
AR 0015 IJBCSC           0K           4K
AR 0015 VMCFSP           0K           4K
AR 0015 IJBSCM           0K          136K
AR 0015 ILSTCK           0K           4K
AR 0015 SUBPOOL TOTALS  272K          288K

vis f1
AR 0015 1I40I  READY
AR 0015 GETVIS F1,ALL
AR 0015 GETVIS USAGE   F1-24   F1-ANY           F1-24   F1-ANY
AR 0015 AREA SIZE:    832K    832K
AR 0015 USED AREA:    140K    140K MAX. EVER USED:    192K    192K
AR 0015 FREE AREA:    692K    692K LARGEST FREE:    684K    684K
AR 0015 SUMMARY REPORT
AR 0015 SUBPOOL      REQUEST <---F1-24-AREA---  ---F1-ANY-AREA-->
AR 0015 Default          120K          0K
AR 0015 IPWGEN            8K 0K
AR 0015 SUBPOOL TOTALS  128K          0K
AR 0015 1I40I  READY

```

Figure 33. STACK command sample 1

Now lets add another STACK-entry to prevent e.g. REIPL commands to be executed as valid VSE commands. We could do this by issuing a:

STACK REIPL]* REIPL command has been received.

Any REIPL command would thus be made a simple comment statement. The simple fact that we named the STACK-entry **REIPL** did it. As mentioned earlier, STACK-names supersede VSE command names and as a result the REIPL command will be transformed into a comment line as the following sample shows.

```

stack reipl]* reipl command has been received
AR 0015 1I40I  READY

reipl 120,noprompt
AR 0015 1I40I  READY
AR 0015 * REIPL COMMAND HAS BEEN RECEIVED

```

Figure 34. STACK command sample 2

As the above sample shows, the initial **REIPL 120,NOPROMPT** command has been transformed into the comment statement as we defined it in the STACK-command.

If we now issue the STACK SHOW command, we would get both the entries that we have issued so far.

```
stack show AR 0015 VIS|GETVIS &0,ALL
AR 0015 REIPL|* REIPL COMMAND HAS BEEN RECEIVED
AR 0015 1I40I  READY
```

If we just want to SHOW the STACK-entry with the name REIPL, we would have to submit the following command.

```
stack show=reipl
AR 0015 REIPL|* REIPL COMMAND HAS BEEN RECEIVED
AR 0015 1I40I  READY
```

Now lets add a third sample where we want to abbreviate a VSE command to just a few characters. As a sample I have used the POWER command to release a PAUSE Job. As you see the variable &0 has been appended to the PAUSE-Job, which means it will be substituted at execution time as the different samples will show.

```
STACK R|PRELEASE RDR,PAUSE&0
AR 0015 1I40I  READY

r bg
AR 0015 1I40I  READY
AR 0015 PRELEASE RDR,PAUSEBG
AR 0015 1C39I COMMAND PASSED TO VSE/POWER
F1 0001 1R88I  OK
BG 0001 1Q47I  BG PAUSEBG 00235 FROM (SYSA) , TIME=13:54:10
BG 0000 // JOB PAUSEBG
        DATE 10/20/1997, CLOCK 13/54/10
BG-0000 // PAUSE

r f2
AR 0015 1I40I  READY
AR 0015 PRELEASE RDR,PAUSEF2
AR 0015 1C39I COMMAND PASSED TO VSE/POWER
F1 0001 1R88I  OK
F2 0001 1Q47I  F2 PAUSEF2 00027 FROM (SYSA) , TIME=14:00:55
F2 0002 // JOB PAUSEF2
        DATE 10/20/1997, CLOCK 14/00/55
F2-0002 // PAUSE

r
AR 0015 1I40I  READY
AR 0015 PRELEASE RDR,PAUSE
AR 0015 1C39I COMMAND PASSED TO VSE/POWER
F1 0001 1R88I  NOTHING TO RELEASE

Note: No job was released because no such job-name (PAUSE) did
        exist.
```

Figure 35. STACK command sample 3-1

If we had used the following STACK-command, then this command would **NOT HAVE WORKED** and we would have received an error message because of the fact that **R** would have called **R** again and recursion is not allowed.

```
STACK R|R RDR,PAUSE&0
AR 0015 1I40I  READY

R BG
AR 0015 1I40I  READY
AR 0015 R RDR,PAUSEBG
AR 0015 1I40I  READY
AR 0015 R RDR,PAUSEBG
AR 0015 1P44I PREVIOUS 'STACK  '  COMMAND IGNORED
AR 0015 1I40I  READY
```

Figure 36. STACK command sample 3-2

To get this erroneous STACK-entry deleted, we issue the

```
stack clear=r
AR 0015 1I40I  READY
```

The last sample is a more complex one. It does use three STACK-entries, named LIBR, LI and LD and will cause a job to be executed automatically whenever LIBR with the appropriate parameter(s) is being entered as command. Just see the three samples below.

```

stack libr|r rdr,pausebg|0 exec libr|0 acc s=ijsysrs.syslib|&0
AR 0015 1I40I  READY
stack ld|0 ld &1.proc|0 end|0 /&|0
AR 0015 1I40I  READY
stack li|0 l &1.proc|0 end|0 /&|0
AR 0015 1I40I  READY
libr li,$asiproc
F1 0001 1R88I  OK
BG 0001 1Q47I  BG PAUSEBG 00236 FROM (SYSA) , TIME=16:09:08
BG 0000 // JOB PAUSEBG
        DATE 10/20/1997, CLOCK 16/09/08
BG-0000 // PAUSE
0 EXEC LIBR
BG 0000 L001A ENTER COMMAND OR END
BG-0000
0 ACC S=IJSYSRS.SYSLIB
BG 0000 L113I RETURN CODE OF ACCESS IS 0
BG 0000 L001A ENTER COMMAND OR END
BG-0000
0 L $ASIPROC.PROC
BG 0000
BG 0000 MEMBER=$ASIPROC.PROC      SUBLIBRARY=IJSYSRS.SYSLIB      DATE: 97-10
BG 0000                                                                    TIME: 16:09
BG 0000 -----
BG 0000 CPU=FF0880009672,IPL=$IPL088,JCL=$$JCL088 /* ESA
BG 0000 CPU=FF0890009672,IPL=$IPL089,JCL=$$JCL089 /* ESA
BG 0000 CPU=FF08A0009672,IPL=$IPL08A,JCL=$$JCL08A /* ESA
BG 0000 CPU=FF08B0009672,IPL=$IPL08B,JCL=$$JCL08B /* ESA
BG 0000 CPU=FF0010009672,IPL=$IPLESA,JCL=$$JCL001 /* ESA
BG 0000 CPU=FF08C0009672,IPL=$IPLESA,JCL=$$JCL08C /* ESA
BG 0000 CPU=FF18C0009672,IPL=$IPLESA,JCL=$$JCL18C /* ESA
BG 0000 CPU=FF18C0009672,IPL=$IPLESA,JCL=$$JCL18C /* ESA
BG 0000 L113I RETURN CODE OF LIST IS 0
BG 0000 L001A ENTER COMMAND OR END
0 END
BG-0000
BG 0000 1S55I  LAST RETURN CODE WAS 0000
BG-0000 1I00D  READY FOR COMMUNICATIONS.
0 /&
BG 0000 EOJ PAUSEBG  MAX.RETURN CODE=0000
        DATE 10/20/1997, CLOCK 16/32/36, DURATION 00/00/11
BG-0000
0
AR 0015 1I40I  READY
AR 0015 R RDR,PAUSEBG
AR 0015 1C39I  COMMAND PASSED TO VSE/POWER
AR 0015 LI
AR 0015 1I40I  READY
BG 0000 EOJ NO NAME
        DATE 10/20/1997, CLOCK 16/32/36
BG 0001 1Q34I  BG WAITING FOR WORK

```

Figure 37 (Part 1 of 3). STACK command sample 3-3

Internal Attention Routine

```
libr ld,$asiproc
F1 0001 1R88I OK
BG 0001 1Q47I BG PAUSEBG 00252 FROM (SYSA) , TIME=18:57:30
BG 0000 // JOB PAUSEBG
        DATE 10/20/1997, CLOCK 18/57/30
BG-0000 // PAUSE
0 EXEC LIBR
BG 0000 L001A ENTER COMMAND OR END
BG-0000
0 ACC S=IJSYSRS.SYSLIB
BG 0000 L113I RETURN CODE OF ACCESS IS 0
BG 0000 L001A ENTER COMMAND OR END
BG-0000
0 LD $ASIPROC.PROC
BG 0000
BG 0000 DIRECTORY DISPLAY          SUBLIBRARY=IJSYSRS.SYSLIB    DATE: 97-10
BG 0000                                     TIME: 18:57
BG 0000 -----
BG 0000 M E M B E R      CREATION   LAST      BYTES    LIBR CONT SVA  A-
BG 0000 NAME      TYPE      DATE      UPDATE   RECORDS  BLKS STOR ELIG MOD
BG 0000 -----
BG 0000 $ASIPROC PROC    97-05-28 97-05-28    19 R      2 YES  -  -
BG 0000 L113I RETURN CODE OF LISTDIR IS 0
BG 0000 L001A ENTER COMMAND OR END
BG-0000
0 END
BG 0000 1S55I LAST RETURN CODE WAS 0000
BG-0000 1I00D READY FOR COMMUNICATIONS.
0 /&
BG 0000 EOJ PAUSEBG MAX.RETURN CODE=0000
        DATE 10/20/1997, CLOCK 18/57/31, DURATION 00/00/00
0
AR 0015 1I40I READY
AR 0015 R RDR,PAUSEBG
AR 0015 1C39I COMMAND PASSED TO VSE/POWER
AR 0015 LD
AR 0015 1I40I READY
BG 0000 EOJ NO NAME
        DATE 10/20/1997, CLOCK 19/02/29
BG 0001 1Q34I BG WAITING FOR WORK
```

Figure 37 (Part 2 of 3). STACK command sample 3-3

```

libr ld,* F1 0001 1R88I OK
BG 0001 1Q47I  BG PAUSEBG 00254 FROM (SYSA) , TIME=19:06:25
BG 0000 // JOB PAUSEBG
          DATE 10/20/1997, CLOCK 19/06/25
BG-0000 // PAUSE
0 EXEC LIBR
BG 0000 L001A ENTER COMMAND OR END
BG-0000
0 ACC S=IJSYSRS.SYSLIB
BG 0000 L113I RETURN CODE OF ACCESS IS 0
BG 0000 L001A ENTER COMMAND OR END
BG-0000
0 LD *.PROC
BG 0000
BG 0000 DIRECTORY DISPLAY          SUBLIBRARY=IJSYSRS.SYSLIB    DATE: 97-10
BG 0000                                TIME: 19:06
BG 0000 -----
BG 0000  M E M B E R      CREATION   LAST      BYTES    LIBR CONT SVA  A-
BG 0000  NAME      TYPE      DATE      UPDATE   RECORDS  BLKS STOR ELIG MOD
BG 0000 $8JCL001 PROC    97-09-23 97-09-23   10 R      1 YES  -  -
BG 0000 $9JCLESA PROC    97-05-28 - -        10 R      1 YES  -  -
BG 0000 $9JCL001 PROC    97-09-23 97-09-23   10 R      1 YES  -  -
BG 0000 ALLOC      PROC    97-05-28 97-09-23   27 R      1 YES  -  -
BG 0000 ALLOCESA  PROC    97-05-28 97-09-23   14 R      1 YES  -  -
BG 0000 CPUVAR1   PROC    97-05-28 - -        62 R      2 YES  -  -
BG 0000 DL11A0    PROC    97-09-23 97-09-23   71 R      4 YES  -  -
BG 0000 DLZSAMJS  PROC    97-09-23 97-09-23    6 R      1 YES  -  -
.
.
.
BG 0000 STDLABEL  PROC    97-05-28 97-05-28   66 R      4 YES  -  -
BG 0000 STDLABUP  PROC    97-05-28 - -        124 R     6 YES  -  -
BG 0000 STDLABUS  PROC    97-05-28 - -        17 R      1 YES  -  -
BG 0000 STDLB001  PROC    97-09-23 97-09-23   71 R      4 NO   -  -
BG 0000 STDPROF   PROC    97-05-28 - -        11 R      1 YES  -  -
BG 0000 USERBG   PROC    97-05-28 - -        22 R      1 YES  -  -
BG 0000 L113I RETURN CODE OF LISTDIR IS 0
BG 0000 L001A ENTER COMMAND OR END
BG-0000
0 END
BG 0000 1S55I  LAST RETURN CODE WAS 0000
BG-0000 1I00D  READY FOR COMMUNICATIONS.
0 /&
BG 0000 EOJ NO NAME
          DATE 10/20/1997, CLOCK 19/06/32
BG-0000
0
AR 0015 1I40I  READY
AR 0015 R RDR,PAUSEBG
AR 0015 1C39I  COMMAND PASSED TO VSE/POWER
AR 0015 LD
AR 0015 1I40I  READY
BG 0000 EOJ NO NAME
          DATE 10/20/1997, CLOCK 19/06/32
BG 0001 1Q34I  BG WAITING FOR WORK

```

Figure 37 (Part 3 of 3). STACK command sample 3-3

Notes:

- If for some reason you should ever have problems with the STACK processing, then you just need to issue a **STACK CLEAR** command to get the STACK processing deactivated.
- While STACK processing is ongoing, you can not normally enter other VSE commands. To do so, you have to issue the **RC** command which will cause the currently ongoing STACK command processing to be suspended.
- If you are running a VSE-system with fix-level DY45926 or above, then the STACK-buffer will be preserved throughout subsequent IPL's.
- The whole STACK-buffer information will be lost in case you have NOT applied the fix for APAR DY45629 and your system has been newly IPLed. In this case, to ensure that you have always your STACK-entries set properly, you could run a simple job at start-up-time which could set up the STACK-entries by using the SVC-30 interface.

I have appended such a sample program on the next page. Once it has been assembled and catalogued, you can execute it during your system startup-procedure and it will load the STACK entries similar to what we discussed on the previous pages. The only purpose of this sample is to give you an idea of what can be done and how it should be done.

- You need of course to make modifications to this program (mainly the STACK1 and subsequent constants) to make it suit your installations needs. You can of course also use this skeleton program to submit any other VSE command during system-start-up time.

```

        TITLE 'VSE/ESA    STACK SET PROGRAM'
        PUNCH ' PHASE STACKSET,* '
        SPACE 1
        START X'78'
TESTBEG BALR RD,0
        USING TESTBEG+2,RD      BASE REGISTER
        B    TEST35A0          SKIP CONSTANTS
        DC   C'SAMPLE TO SET STACK ENTRIES (AXEL PIEPER 1997)'
        DC   CL8'STACKSET'
        DC   CL8'INITIAL '      CHANGE ACTIVITY
        SPACE 2
TEST35A0 SLR R0,R0              SET FUNCTION CODE
        LA  R1,SV30PARM        POINT TO PARAMETER LIST
        LA  RE,(STACK1-SV30PARM)/6 LOOP COUNT
TEST35B0 SVC 30                SUBMIT THE COMMAND
        CH  RF,H4              WAS TASK BUSY
        BE  TEST35B0           YES, TRY (UNLIMITED)
        LA  R1,6(,R1)          ADVANCE TO NEXT ENTRY
        BCT RE,TEST35B0
        EOJ                    END OF PROGRAM
H4      DC   H'4'              CONSTANT
SV30PARM DC AL2(STACK2-STACK1),AL4(STACK1)
        DC   AL2(STACK3-STACK2),AL4(STACK2)
        DC   AL2(STACK4-STACK3),AL4(STACK3)
        DC   AL2(STACK5-STACK4),AL4(STACK4)
        DC   AL2(STACK6-STACK5),AL4(STACK5)
        DC   AL2(STACKN-STACK6),AL4(STACK6)
* APPEND SIMILAR ENTRIES
* UP TO A MAXIMUM OF 32
        EJECT
STACK1  DC   C'STACK VIS|GETVIS &&,ALL'
STACK2  DC   C'STACK REIPL|* REIPL command has been received'
STACK3  DC   C'STACK R|PRELEASE RDR,PAUSE&&0'
STACK4  DC   C'STACK LIBR|R RDR,PAUSEBG|0 EXEC LIBR|'
        DC   C'0 ACC S=IJSYSRS.SYSLIB|&&0'
STACK5  DC   C'STACK LD|0 LD &&1.PROC|0 END|0 /&&|0'
STACK6  DC   C'STACK LI|0 L &&1.PROC|0 END|0 /&&|0'
* APPEND SIMILAR ENTRIES
* UP TO A MAXIMUM OF 32
STACKN  DS   0H'0'
        EJECT
R0      EQU  0
R1      EQU  1
R2      EQU  2
RC      EQU  12
RD      EQU  13
RE      EQU  14
RF      EQU  15
        END

```

Figure 38. STACK SET program

STATUS

Syntax: **STATUS cuu[,ALL]**

The STATUS cuu command allows retrieval of device status information and, if appended with the ALL option, will also provide addressing information about the related I/O control blocks. This command is especially useful in case of device hang conditions.

The command will produce similar output as shown in the sample below.

```

status 480,a11
(1.0) SCHIB DEV INT-PARM ISC FLG LP PNO LPU PI MBI PO PA CHPID0-3
(2.0) 0010 0480 00003710 3 83 80 00 80 80 0000 80 80 0AFFFFFF
(3.0) KEY SLCC FPIAUZEN FCTL ACTL SCTL CCW-ADDR DS CS CNT
(4.0) 0 0 00 40 0000 07 00027358 0C 00 000C
(5.0) REQUEST IS STARTED DEVICE IS BUSY
(6.0) PUB=00003710 PUBX=0007A228 PUB2=00072288 POWN=00003BBC
AR 0015 1I40I READY

```

Figure 39. STATUS command sample

Explanation

(1.0) this line is the heading line describing the information provided in the next line.

SCHIB this field contains the Subchannel Number of the device that has been inspected.

DEV this field contains the device number (cuu) which is being used within VSE to identify and address the device.

INT-PARM this field contains the INTerrupt-PARaMeter that had been passed in the ORB at SSCH time.

ISC this field contains the I/O Interruption Subclass Code that has been assigned to this subchannel. VSE normally only uses the subclass code three, except for SDAID, which has a different subclass code assigned.

FLG this field is the FLAg byte which identifies the status plus some features that have been enabled for this subchannel.

LP this field identifies the Logical-Path(es) that VSE did allow the channel subsystem to use in accessing the device.

PNO this field identifies the Path(es) that the channel subsystem found Not Operational when attempting to address the device via the identified path(es).

LPU this field identifies the Last-Path-Used by the channel subsystem to communicate with the device.

PI this field identifies the Path(es)-Installed for this device (as defined in the IOCDs).

MBI this field is the Measurement-Block-Index used by the channel subsystem to calculate the address of the measurement block for this subchannel, assuming that measuring is active (see SIR SMF).

PO this field identifies the Path(es) that where found Operational by the channel subsystem last time it did use that path.

PA this field identifies the Path(es) that where found Available but not necessarily operational by the channel subsystem.

CHPID0-3 and **CHPID4-7** these fields contains all the channel path Id's that have been defined (IOCDs) to access a certain device.

(2.0) this line is telling us that device X'480' with the subchannel number x'0010' and the interrupt parameter X'00003710' has been ENABLED (FLG=8x) for I/O interrupts for subclass 3 and can only be accessed via a single path (PI=X'80') with the CHannel-Path-ID X'0A'.

(3.0) this line is the heading line of dynamic subchannel information provided in the next subsequent line. This line as well as the next line will only be presented if an I/O interrupt is outstanding, or if they had explicitly been requested (option ALL or DEBUG active).

KEY	defines the storage protection KEY that had been used at SSCH time.
SLCC	this field contains information about the progress of the I/O operation. The important information is the cc-bits, which is the deferred condition code of the I/O operation in progress if it is unequal to zero.
FPIAUZEN	this field contains control bits which are of minor interest.
FCTL	this field contains Function ConTroL information which is: 40 start function 20 halt function 10 clear function
ACTL	this field contains Activity ConTroL information where the first byte contains PENDING I/O instruction information 04 start pending 02 halt pending 01 clear pending and the second byte contains the subchannel/device activity information 80 subchannel active 40 device active
SCTL	this field contains Status ConTroL information where the bits have the following meaning assigned. 10 ALERT status which normally indicates an error condition or the presentation of an unsolicited interrupt. 04 primary I/O interrupt status which normally indicates the completion of data transfer operations. 02 secondary I/O interrupt status which indicates the completion of an I/O operation at the device level. 01 status pending which indicates that I/O interrupt status as defined by the other SCTL bits is PENDING in the subchannel and waiting to be presented to the VSE system as soon as interrupts are enabled.
CCW-ADDR	this field contains the address+8 of the last CCW that had been executed.
DS	this field contains the device status information
CS	this field contains the channel status information
CNT	this field contains the residual count, that is the number of bytes that had not been transferred.

(4.0) this line is now telling us, that a SSCH operation (FCTL=40) has just completed its operation since primary plus secondary I/O interrupt status is pending (SCTL=07), which means it has not yet been presented to the system. The last executed CCW was at address X'27350 and has completed normally (CE+DE interrupt). 12 bytes of data (CNT=000C) had not been transferred.

(5.0) this line is simply repeating in plain text form the status of the device at the time it was interrogated. It should be self explanatory. REQUEST IS STARTED DEVICE IS BUSY; this is in sync with what we found out before

(ref:4.0), because the system has not yet received the I/O interrupt so from its point of view, the device is still busy.

- (6.0) this line contains the addresses of some I/O control blocks which might be interesting to know.

TAPE

Syntax: **TAPE [UNL={UNL|REW}][DSPLY={JNM|VOL}][WTM={SYNC|NOSYN}]**

The TAPE command allows you to activate special processing options for your tape devices. This command, if issued without any operands will display the options which are currently active.

- UNL** this option allows you to change the tape UNLoad processing which might be interesting if you are running a test-system.
- UNL** this parameter is the default and causes the VSE system to cause a tape to be unloaded if an UNLOAD command is being received.
- REW** this parameter should be specified if you want to PREVENT tape UNLOAD operations and have the system execute a REWIND command instead. This option might be of special interest in a test environment where the operator does not always want to re-mount the same tape just because the job has issued an UNLOAD request.
- DSPLY** this option allows you to have the system change the information that is normally displayed on the Load-Display LED. This option is applicable to 3480, 3490(E) and 3590 devices only.
- VOL** this is the standard setting and will cause the VOL1 label to be displayed on the drives Load-Display in the form that you already know and which remained unchanged.
- JNM** this option directs the AVR task (Automatic Volume Recognition) to also provide the Job-name of the partition that is currently the owner of the device. This option will cause the Load-Display to alternatively display either the VOL1 label or the Job-name. Following the VOL1 label (6-alphanumeric characters) you may find a "U" in case the volume is UNPROTECTED, or you will find a "P" if the cartridge is WRITE-PROTECTED. This VOL1 label flashes after about 2 seconds and the Job-Name of the owning partition will be displayed for another 2 seconds followed again by the VOL1 label and the sequence will be repeated.
- WTM** this option allows you to have the system Write Tape Marks, except those written during OPEN/CLOSE processing, in BUFFERED mode. It assumes that the tape controller (3590-A60) does accept the appropriate WRITE-MARK command and has been equipped with the appropriate micro-code level.
- SYNC** this is the standard setting and will cause the TAPE MARKs to be written after any cached data has been written onto the cartridge.
- NOSYN** this option will cause the Tape Marks (except those written at OPEN or CLOSE time) to be written in buffered mode, which means there will be no enforcement to synchronize the data in cache with the data on the cartridge.

TIME

Syntax: **TIME**

[DATE=mm/dd/yyyy,CLOCK=hh/mm/ss][ZONE={EAST|WEST|zid}/hh/mm]

The TIME command allows you to display or alter the current setting of the Time-Of-Day (TOD) clock and/or the time ZONE. It is a functional equivalent to the SET DATE.... command as described in the System Control Statements Manual.

However, special precautions must be adhered to, when using the TIME command in conjunction with other operand(s) because changes to the TOD or ZONE could impact subsystems or vendor programs products running under VSE and could also impact Job Accounting. For that purpose it is recommended to prevent TOD or ZONE updates **WHILE** such subsystems are up or while Jobs are running. Results could be unpredictable. See also "Effect of Day-Light Saving Time Changes."

Note: zid this operand does exist for VSE/ESA 2.3.x only.

The **TIME ZONE=VM** command has been added as a valid command and it will cause the currently active VM-ZONE settings to be immediately applied as the new VSE system zone. Eventually active partition ZONE settings will be adjusted according to the difference between the OLD VSE system zone setting and the NEW system zone setting (as retrieved from VM).

```

time
(1.0) TIME IS: 08:41:56 (GMT + 2 H) DATE 10/08/1997 WEDNESDAY
time date=10/26/97,clock=11/11/00
(2.0) TIME/ZONE HAS BEEN UPDATED
(3.0) TIME IS: 11:11:00 (GMT) DATE 10/26/1997 SUNDAY
time zone=CET
(2.0) TIME/ZONE HAS BEEN UPDATED
(4.0) TIME IS: 12:11:09 (CET) DATE 10/26/1997 SUNDAY

```

Figure 40. TIME command sample

Explanation:

- (1.0) this line displays the current LOCAL time as the result of the immediately preceding time command.
- (2.0) this line indicates that the time or zone has been updated.
- (3.0) this line displays the LOCAL time as the result of the immediately preceding time command. Note that the ZONE has been forced to GMT (Greenwich Mean Time) since no explicit ZONE operand was given.
- (4.0) this line displays the LOCAL time as the result of the immediately preceding time command. Note that the ZONE has been altered to CET (Central European Time) which must have been defined to the VSE system via the ZONEDEF operand during IPL.

Effect of Day-Light Saving Time Changes

Many countries operate a policy of adjusting clocks by one hour at the beginning and end of Summer to effect what is commonly referred to as 'day-light saving'. These time changes are also applied to the local times held in computers. Generally, all hardware clocks are set to Greenwich Mean Time (GMT). An offset value representing the local time-ZONE is maintained separately by the Operating Systems (VSE) and is required to properly calculate the LOCAL TIME. It is this

offset value that is adjusted when making day-light saving time changes, while the hardware clock remains unchanged.

Adjusting Local Time Forwards

A local time change forwards has normally no effect on subsystems operations, nor should it cause problems in IBM supplied, or user written accounting routines.

For example, moving the clock forward an hour has no effect on CICS partitions, or the way CICS reads back through the system log during an emergency restart.

Adjusting Local Time Backwards

A local time change backwards could affect subsystems or user written job accounting routines more severely.

CICS

A local time change backwards can affect the operation of a CICS emergency restart in the event of an abnormal termination that occurs after the time change. If the system log at the time of the CICS failure contains active units-of-work that span the point at which local time was changed, CICS emergency restart will fail to recover the relevant data for transaction backout owing to the discontinuity in time-stamps in the system log.

A local time change could also affect the operation of forward recovery utility programs on forward recovery logs since all CICS system log and journal records are time stamped in local time. For a CICS emergency restart to work correctly, the time stamps of the active records on the system log must not go backwards in time—that is, the records must be in chronological order. If you adjust local time backwards by an hour while CICS is running, the time stamps on system log and journal records become out of sequence. You can avoid problems with emergency restarts during a time change by adopting the following procedure:

- Shut down all CICS partitions, either normally or forced with the IMMEDIATE option, before changing local time.
- Adjust the local time backwards.
- Wait for the length of time by which the local time was adjusted.
- Restart the CICS regions.

VOLUME TAPE

Syntax: **VOLUME TAPE**

A new flavor of the already existing VOLUME command has been provided, which is the VOLUME TAPE commands. This command does provide information about the TAPE devices that had been ADDED (or sensed) during IPL processing. The information that the VOLUME TAPE command provides slightly differs from the normal VOLUME command output because it contains additional information that should be useful for system operators.

The command will produce similar output as shown in the sample below.

volume tape								
(1.0)	CUU	CODE	DEV.-TYP	VOLID	USAGE	SHARED	STATUS	CAPACITY
(2.0)	480	5400	3490-40	TAP634	BG		BUFD	22356
(2.5)							COMPR.-RATIO =	3.83
(3.0)	481	5400	3490-40	*NONE*	F4		SYNC	0
(4.0)	482	5408	3490-40	ISMINE	BG		2XF SYNC	1
(5.0)	483	5400	3490-40		UNUSED		NOT READY	
(6.0)	484	5400	3490-40		SHARED			

Figure 41. VOLUME TAPE command sample

Explanation:

- CUU specifies the device number under which the device is known to the VSE system.
- CODE contains the VSE device type code and the mode setting which is currently active for this tape device.
- DEVICE-ID is the device-type and model information of the tape device.
- VOLID is the VOL1 label (if any) of the media currently or last mounted on the tape drive. If no VOL1 label exists, *NONE* will be displayed.
- USE/STATUS in difference to the normal VOLUME command, this field contains information about the owner of the tape device if an owner exists. This is normally the partition Id (BG,FG1,F2...,xn).
UNUSED indicates that there is NO current user.
SHARED indicates that the device is currently being OWNED by another processor or LPAR.
- INFORMATION in difference to the normal VOLUME command, this field contains information about the media format mode 2XF versus XF and whether the media and the CU are currently operating in SYNC or in BUFD (synchronous versus buffered) mode. BUFD would indicate that record(s) are still in the CU buffer. This information is applicable to the 3480/3490(E) and 3590 only.
- CAPACITY in difference to the normal VOLUME command, this field contains information about the last block (record) which has been read from, or written to the storage media. This information is applicable to the 3480/3490(E) and 3590 only and could be used to examine the usage and progress of the tape operations. A value of zero would indicate that the media is positioned at Load-Point (LP).

(1.0) CUU CODE DEVICE-ID VOLID USE/STATUS-INFORMATION CAPACITY

This is the standard heading line for any VOLUME command.

(2.0) 480 5400 3490-40 TAP634 BG BUFD 22356

This line indicates that tape drive X'480', which is a 3490-40 type device with the VOL1 label of TAP634 is owned by partition BG and is running with mode X'00' (Data Compaction OFF). It has processed 22356 records and buffered data is available in the CU buffer.

(2.5) COMP.R-RATIO = 3.83

This line is optional and only present for 3480/3490 devices with IDRC. It indicates that the data that had been written to the cartridge has been compacted by the factor nn.nn (e.g. 3.83) whenever a value smaller than 1.00 is encountered, it would be an indication that the overhead, generated and appended to the user-data is greater as the savings due to compaction. This would typically be the case for small block (record) sizes. If the compaction is 1.00, that would be the indication that your records have been written uncompacted. Any value greater 1.00 would be real savings due to compaction. For 3590 type devices, there will be an additional field appended to the compaction ratio and this field will provide information on how much of the tape cartridge has already been occupied. Repeatedly issued VOLUME TAPE commands will get you more accurate data as your output file grows.

(3.0) 481 5400 3490-40 *NONE* F4 SYNC 0

This line indicates that tape drive X'481', which is a 3490-40 type device without a VOL1 label is owned by partition F4 and is running with mode X'00' (Data Compaction OFF). It has processed zero (0) records and is thus positioned at Load-Point.

(4.0) 482 5408 3490-40 ISMINE BG 2XF SYNC 1

This line indicates that tape drive X'482', which is a 3490-40 type device with the VOL1 label of ISMINE is owned by partition BG and is running with mode X'08' (Data Compaction). It has processed a single record (positioned behind the VOL1 label) and the CU does not have any buffered data (SYNC).

(5.0) 483 5400 3490-40 UNUSED NOT READY

This line indicates that tape drive X'483', which is a 3490-40 type device is currently UNUSED and that the device is NOT READY. The currently mode setting is Data-Compaction OFF.

(6.0) 484 5400 3490-40 SHARED

This line indicates that tape drive X'484', which is a 3490-40 type device is currently ASSIGNED ELSEWHERE and can thus not be accessed by this processor/LPAR.

Chapter 3. VSE/ESA Turbo Dispatcher and Its Exploitation

If you already know how the Turbo Dispatcher works, you may start reading with "Turbo Dispatcher Considerations" on page 82.

VSE/ESA Version 2 - Turbo Dispatcher

The Turbo Dispatcher was introduced with VSE/ESA 2.1.

Turbo Dispatcher Design

A VSE/ESA system with the Turbo Dispatcher (TD) active can run on any IBM ESA-capable uni- or multiprocessor (ESA/390 or ESA/370 architecture).

Note: VSE/ESA 2.4 and higher supports ESA/390 only.

The Turbo Dispatcher can utilize multiprocessors by distributing the workload across several processors (CPUs) of one Central Electronic Complex (CEC), enabling them to work in parallel and thus increase the overall throughput of a VSE/ESA system.

At Initial Program Load (IPL) the user of the VSE/ESA system has to decide, if he wants to run the 'standard' dispatcher, which is the default, or the new Turbo Dispatcher. The 'standard' dispatcher, known from VSE/ESA Version 1, supports the uni-processor environment only; it will no longer be enhanced.

Note: VSE/ESA 2.4 supports the Turbo Dispatcher only.

The VSE/ESA Turbo Dispatcher works on a partition (job) basis, that is, it dispatches an entire partition to a CPU waiting for work, instead of dispatching at a subtask level like OS/390 does. Subsequently "jobs" is used as a synonym for partitions. One job consists of many work units. A **work unit** is defined as a set of instructions that are executed from the selection by the VSE/ESA Turbo Dispatcher until the next interrupt. Only one work unit of a job can be processed at a time, that is, no other work unit of the same job can run on a different CPU. This means for jobs with multitasking applications (applications with attached VSE subtasks), that no other task of the same job can execute on a different CPU, when one task of that job is already active.

There are two different work unit types:

1. parallel work units (P)

Most customer applications in batch as well as the online (CICS/VSE) environment are processed as parallel work units. However, when an application calls a supervisor service, it has to process a non-parallel work unit in most cases.

2. non-parallel work units (N)

Most system services and key 0 applications (such as supervisor-, VSE/POWER and ACF/VTAM services) will be processed as non-parallel work units.

Only one CPU within the CEC may process a non-parallel work unit at a time, that is as long as this work unit type is active, no other CPU can execute a non-parallel work unit. Any other job, that wants to process a non-parallel work unit, has to wait until no other CPU processes a non-parallel work unit.

VSE/ESA Turbo Dispatcher

However, other CPUs may process parallel work units of other jobs.

Notes:

- a. With VSE/ESA 2.2 work units of the VSE/POWER maintask can be processed in parallel, if the VSE/POWER autostart statement
`SET WORKUNIT=PA`
 is specified in the VSE/POWER startup procedure.
- b. Some vendors adapted their applications to run parallel work units even if they are executing in key zero.

The following simplified example (no interrupts are considered, all work units have the same length) should give you an impression, how the VSE/ESA Turbo Dispatcher processes a given workload (see Figure 42). Job A, B and C are ready for selection, job A has highest, job C lowest priority. Each job consists of 3 work units, e.g. job A consists of work units A1, A2, and A3. Work unit A1 has to be processed before work unit A2 (of the same job) can be selected. Work units are either parallel (P) or non-parallel (N). On a uni-processor the three jobs would need 9 process steps (3 jobs times 3 work units), the VSE/ESA Turbo Dispatcher would need only 5 steps on a 2-way (dyadic) CEC as shown in the example (with CPU 0 and CPU 1):

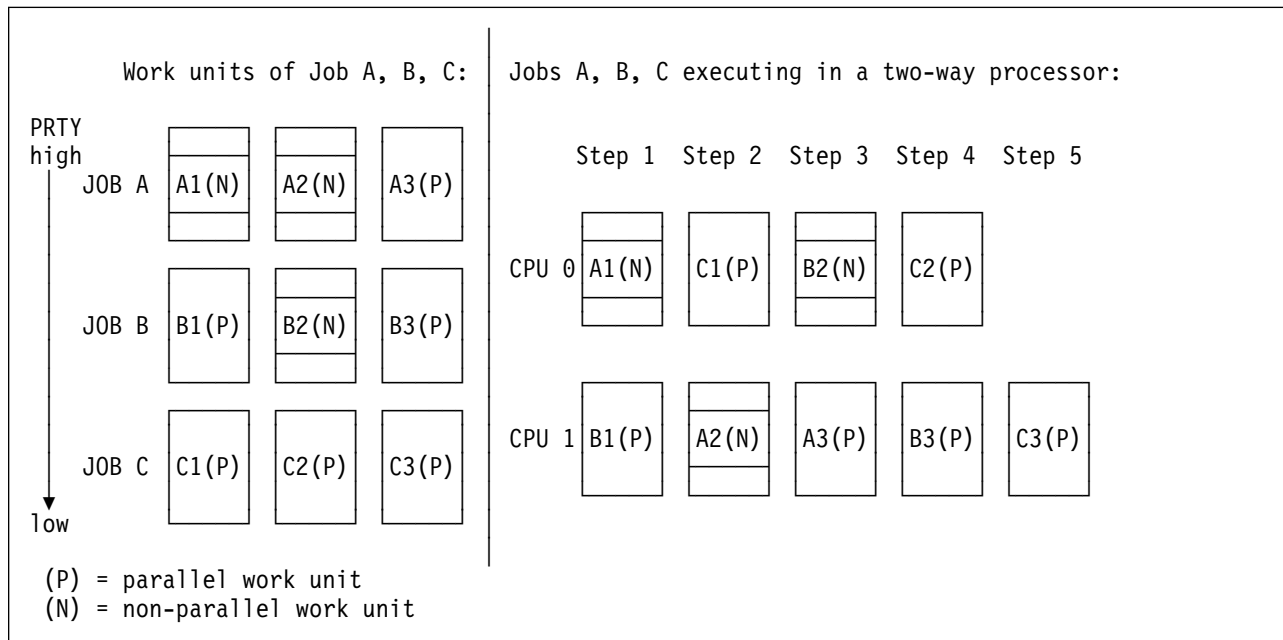

Figure 42. Processing Steps for Jobs A, B and C

- **Step 1:**
 CPU 0 selects non-parallel work unit A1, at the same time CPU 1 selects parallel work unit B1, because job A and B have a higher priority than job C.
- **Step 2:**
 The next two highest priority work units are A2 and B2. However, both work units are non-parallel and therefore cannot run at the same time. So the next lower priority parallel work unit C1 will be selected, that is this step is made of work unit A2 and C1. A2 may be selected by CPU 0 or CPU 1, in the example it executes on CPU 1.
- **Step 3:**

Now non-parallel work unit B2 and parallel work unit A3 will be processed, as given by their priority.

- *Step 4:*
Job A terminated. C2 and B3 are both parallel work units and will be processed by CPU 0 and CPU 1.
- *Step 5:*
Now also job B terminated. In our example CPU 1 processes the last available work unit C3 of job C.

Advantages on Uni-Processors

The Turbo Dispatcher provides advantages not only for multiprocessors but also for uni-processors in terms of

- multiprocessor exploitation prediction,
- measurement tools (SIR command),
- partition balancing enhancements,
- performance improvements for some environments (e.g. when VSE/ICCF is active) and
- preparation for future VSE/ESA releases, where the standard dispatcher is no longer available.

Partition Balancing Enhancements

The Turbo Dispatcher provides an improved partition balancing algorithm, which gives each partition, be it static or dynamic, equal weight within a balanced group. The PRTY command defines the balanced group, e.g.

```
PRTY F4,C=BG=F5,F3,F2,f1
```

In our example we have dynamic class C (which may hold up to 32 dynamic partitions), static partitions BG and F5 as **balanced group members**.

Balanced group members are time sliced. The calculation of a time slice size is based on the MSECs interval. The MSECs command may change this MSECs interval (default is about 1000 milliseconds).

With the standard dispatcher each balanced group member will receive a time slice. So dynamic partitions of dynamic class C would only get a fraction of the time slice (e.g. when C holds 3 dynamic partitions, only a third of the time slice). When the time slice expires, the corresponding balanced group member will receive a lower priority. That is, when the time slice of the dynamic class expires, the whole class (including all corresponding dynamic partitions) will receive a lower priority.

With the Turbo Dispatcher active all dynamic and static partitions of the balanced group will receive the same time slice. That is when a dynamic partition's time slice expires, only this partition will be moved to a lower priority, all other dynamic partitions of the same class will not change their priority.

VSE/ESA 2.2 - Relative CPU Shares

The PRTY SHARE command, introduced with VSE/ESA 2.2, allows to specify a **relative share** of CPU time for each static partition and dynamic class belonging to the balanced group. With this enhancement it is much easier, for example, to balance a CICS/VSE partition with batch partitions in a way that ensures acceptable throughput for the batch partitions and acceptable response times for the CICS/VSE transactions.

VSE/ESA 2.3 - Quiesce CPUs

This new support is especially implemented for VSE/ESA systems running as guests under VM/ESA. Before VSE/ESA 2.3 not active (stopped) CPUs excluded the VM/ESA guest from I/O assist, which may cause performance degradation. Now it is possible to quiesce a CPU, that is a CPU will be suspended from task selection, but the system continues to run with I/O assist active. A quiesced CPU which is not needed during a certain period of time (for example during off-shift) helps to minimize the overhead caused by idle additional CPUs.

Turbo Dispatcher Considerations

The Turbo Dispatcher support is transparent to most programs as well as IBM's subsystems such as CICS/VSE and ACF/VTAM. Apart from few exceptions, application programs can run functionally unchanged with the Turbo Dispatcher. However, there may be the need to adapt applications for better multiprocessor exploitation (e.g. by implementing larger I/O buffers or using data spaces).

A few system applications run in key zero, have interfaces with the dispatcher or supervisor areas or update the first 4 KB page. These applications may have the need for adaptations. Examples for such applications are performance monitors, accounting and scheduler routines.

Note: The traditional replacement of the **SVC new PSW** (Program-Status Word) e.g. by vendors cause performance degradations in the multiprocessor environment. VSE/ESA Version 2 provides vendor exits to get rid of that replacement.

Most vendor products adapted their applications to the Turbo Dispatcher environment and improved performance (compared to the standard dispatcher) by exploiting vendor exits.

Most user applications are written in high level languages (such as COBOL) and do not access internal system areas.

Before you migrate to VSE/ESA Version 2 you should consider your hardware and software requirements:

- Does my largest partition still fit into a single CPU of the target processor ?
- Is the processor capacity and speed still sufficient to run the workload ?
- Can the Turbo Dispatcher improve the overall throughput ?
- Does multiprocessing help to run the work load ?
- Is there a need to remove an I/O bottleneck or to add devices ?
- Do my vendor products run on VSE/ESA Version 2 ?

- Do my vendor products run on or exploit the Turbo Dispatcher ?
- Do I have system applications that interface with system routines or areas ?
- What is my expectation level ?

Note: Whenever possible you should not change hardware and software in one step.

A migration scenario could be

1. If you are a VSE/SP customer, move to VSE/ESA 1.4 or better to VSE/ESA Version 2 (using the standard dispatcher).
2. Change e.g. your processor and run your current VSE release on it. Remember, it has to be an ESA-capable processor.
3. Prepare for VSE/ESA Version 2, that is, migrate your workload to VSE/ESA Version 2 (standard dispatcher).
4. Run your workload on the VSE/ESA Version 2 standard dispatcher in production.
5. Switch to the Turbo Dispatcher in uni-processor mode and determine your non-parallel share (NPS) via the QUERY TD command.
6. Add additional CPUs as required to run your production workload.
7. Try to exploit the ESA functions like 31 bit addressing for larger I/O buffers or data spaces to **reduce the non-parallel share** via less I/Os, which will improve your multiprocessor exploitation.
8. Be aware that if you use VSE's job accounting information, you will have more overhead time (as provided by the job accounting table) in multiprocessor environments.

How to Calculate the Processor Size and the Number of CPUs

In general, workload migration from one release to the next release will increase the overall CPU time by a few percent, which is also dependent on the exploitation of new functions. In VSE/ESA Version 2 the Turbo Dispatcher on a uni-processor will have 5 to 12 percent overhead compared to the standard dispatcher running the same workload. The overhead is caused by the multiprocessing implementation and depends on the workload, e.g. an I/O intensive workload has more overhead as a CPU intensive workload. Our measurements showed a Turbo Dispatcher overhead of 12 % for a very I/O intensive batch work load and 5% for an online (CICS/VSE) workload. The Turbo Dispatcher with multiple CPUs active will increase the CPU time, part of that increase is caused by the spin time (SPIN_TIME, see Figure 44 on page 85). The spin time should be low compared to the overall CPU time.

The following figure shows migration steps into the n-way environment, that may impact CPU time:

Uni-processor:	
	CPU time increase on uni-processors caused by <ul style="list-style-type: none">- Release migration: VSE/ESA 1.3 to VSE/ESA Version 2- Turbo Dispatcher overhead on uni-processor
Multiprocessor:	
	CPU time increase, when moving from uni-processor and Turbo Dispatcher to multiprocessor <ul style="list-style-type: none">- Turbo Dispatcher overhead for multiprocessor exploitation (including n-way hardware overhead)- VM/ESA overhead for switch from uni- to multiprocessor

Figure 43. Migration Steps that will Impact CPU Time

Note: If you run your system with **DEBUG ON**, you may need 10 to 30 % more CPU time.

If your capacity planning shows that multiprocessing with the VSE/ESA Version 2 Turbo Dispatcher could be the right choice to run your workload, the following considerations can help in getting the right processor size:

- Determine the maximum requirements (e.g. response time, number of concurrent partitions/users, resource consumption of largest partition, etc.) for your current VSE system. Consider the additional overhead as described and the expected growth.
- Use your "largest" VSE partition (e.g. CICS/VSE) to determine the minimum size of one CPU, because one partition can only run on one CPU at a time. For that purpose you may get the required data out of performance monitors or (job) accounting information.
- Determine the maximum number of CPUs that can be exploited by your workload. On VSE/ESA Version 2 you may use the QUERY TD command to get the non-parallel share of your workload or any performance monitor. A VSE/ESA 2.3 QUERY TD output example for an I/O intensive workload is shown below:

CPU	STATUS	SPIN_TIME	NP_TIME	TOTAL_TIME	NP/TOT
00	ACTIVE	5137	1466775	3350836	0.437
01	ACTIVE	559	1443508	3648302	0.395
02	QUIESCED	0	0	0	*,***
03	INACTIVE				
TOTAL		5696	2910283	6999138	0.415
		NP/TOT: 0.415		SPIN/(SPIN+TOT): 0.000	
		OVERALL UTILIZATION: 154%		NP UTILIZATION: 63%	
		ELAPSED TIME SINCE LAST RESET: 4548364			

The CPU time values are shown in milli seconds for all partitions:

TOTAL_TIME - total CPU time
 NP_TIME - non-parallel CPU time, contained in TOTAL_TIME
 SPIN_TIME - spin CPU time waiting for a resource occupied by another CPU, not contained in TOTAL_TIME
 NP/TOT - non-parallel share = NP_TIME / TOTAL_TIME
 SPIN/(SPIN+TOT) = spin time ratio

Figure 44. QUERY TD Output Example

Note: Replacement of the **SVC new PSW** (Program-Status Word) will increase the SPIN_TIME.

The QUERY TD command is not available on VSE/ESA Version 1 systems. On these systems you should therefore use accounting information or performance monitors to estimate the non-parallel share of your workload. For example I/O intensive workloads have a higher non-parallel share as CPU intensive ones. The non-parallel share of a given workload is closely related to the amount of key 0 code to be processed and is an indicator for the number of CPUs that can be exploited at a maximum, if enough partitions are available:

Non-parallel Workload Share NP/TOT	0.30	0.35	0.40	0.50	0.55
Max. No. of Fully Exploitable CPUs	3.0	2.6	2.2	1.8	1.6

Figure 45. Relationship of Non-Parallel Workload and Exploitable CPUs

The actual number of CPUs exploited depends on the system resources needed by your workload and is usually less than the maximum values shown in table Figure 45.

Our experience of the past years showed that today's customer workloads can exploit up to 3 CPUs (dependent on NP/TOT).

The non-parallel share of an online (CICS/VSE) environment ranges from 0.20 to 0.45 and for a heavy I/O intensive batch workload from 0.45 to 0.55.

So a 2-way system will be a good choice for an I/O intensive environment, where Data-In-Memory (DIM) was not exploited.

- For multiprocessing exploitation there should be enough partitions available to get a high multiprocessor exploitation. So you may consider to add more batch workload (partitions) to your system or additional CICS/VSE partitions. If possible, you may also split large CICS/VSE partitions into smaller ones. These partitions may be independent or connected via MRO (Multi Region Option).

The following figure shows examples of our measurement results for batch and online workloads:

	Online Workload	Batch Workload
Workload type	3 CICS/VSE (2-way) 4 CICS/VSE (3-way) with 300 simulated terminals per CICS	8 static + 8 dyn. partitions with e.g. DL/I, SORT, COBOL applications 7 batch jobs/part. very I/O intensive
Non parallel share	0.29	0.45
TD overhead on uni-processor	about 4.5 %	about 12 %
2-way versus uni- processor throughput (CPU utilization)	1.75 (92 %)	1.5
3-way versus uni- processor throughput (CPU utilization)	2.3 (82 %)	---

Figure 46. Examples of our Measurement Results

Note: All performance data contained in this publication were obtained in a specific environment and are presented as an illustration. The results obtained in other operating environments may vary.

More Information

You will find further details about the Turbo Dispatcher in the following publications:

- *VSE/ESA Turbo Dispatcher Guide and Reference, SC33-6797*
- *ITSO VSE/ESA 2.1 Turbo Dispatcher, SG24-4674*
- *Hints and Tips for VSE/ESA* (latest version), available on the Internet at: <http://www.ibm.com/s390/vse/>
- *VSE/ESA Turbo Dispatcher Performance* document available on the Internet at: <http://www.ibm.com/s390/vse/>

Chapter 4. Console

This section deals with the new console support as shipped with VSE/ESA Version 2 and does not apply to the pre-Version 2 console.

Console Types

When talking about the VSE console then normally one thinks about the VSE system console. However, there are more consoles than just the system console where you IPLed from. This is particular important to remember when your system console hung up for whatever reason. Then you still have your other consoles from where you can operate your VSE system and eventually make your system console work again.

These are the consoles you usually have:

1. VSE system console. This is the console where you IPLed from.
2. IUI console. There can be many IUI consoles, however, this requires VTAM and CICS to be up and operational.
3. VMCF console. This console is only available when running under VM.
4. Integrated console. An integrated console must be supported by the hardware. This is the case with all ES/9000 and newer systems. The integrated console function is available also under VM.
5. Workstation Console If you are using the VSE/ESA workstation feature, you can also have a workstation console. This console requires CICS/APPC for communication.

VSE System Console

The VSE system console is the console where you IPLed from. On VM the VSE console screen layout is depending on the terminal definition and can be a line mode or a fullscreen console. A fullscreen console requires *'TERM CON 3270'*. With *'TERM CON 3215'* VSE will IPL in console line mode.

If you run natively, the console will be the terminal where you created the first interrupt (by pressing the enter key) after IPLing from the service processor. The native console must be a local non-SNA terminal. A local non-SNA terminal is not absolutely required to IPL VSE. If there is none, then the integrated console can be used instead (even under VM).

The console name is SYS and is displayed in the upper right hand corner of the fullscreen console.

Interactive Interface Console

You can have many Interactive Interface (IUI) consoles. Depending on the authority you defined in the user profile such an IUI console can have master or user authority. Master authority is the highest authority and the same as for the VSE system console.

User authority is more restrictive and should be given to all normal users that need to have access to the VSE console to monitor jobs, for example.

Console

The console name is the user ID of the IUI user.

VMCF Console

When running under VM, you also can have a VMCF console. In order to work with the VMCF console you must have installed the VM-VSE support on the VM userID from where to use the VMCF console function. Use member SKVMVSE in ICCF library 59 to install this support. After doing this you can use 'VSECMD' to send any VSE command to the VSE console. The command responses are routed back to the userID from where the command was issued.

The console name is VMC.

Integrated Console

On most systems (ES/9000 or newer) you will have an integrated console available. During normal operation this console is dormant. As soon as all consoles are inoperational, the integrated console wakes up automatically.

However, the integrated console can also be used while dormant. This is true no matter whether your VSE system runs natively or under VM.

When running natively, the integrated console function is a screen or window on your service processor. Depending on the hardware you are using it might show up differently. You can enter any VSE command from the integrated console. The command responses will be routed back to the integrated console, but might show up in a different message window.

VM also emulates the integrated console. To use the integrated console via VM, you must enter

VI VMSG vse-command

in CP mode under the userID where your VSE is running. This works with line mode and fullscreen consoles.

The console name is IC.

Console Diagnostics

There are two ways to get information about the condition of the console router.

1. Use the CORCMD to get information about the status of console queues and consoles.
2. If a problem is suspected in the console router then a console trace can be turned on. To further analyze the trace a dump must be taken.

Using the Trace Feature

The trace is normally turned off. In case of a problem the trace can be turned on by issuing the **DEBUG** or **CORCMD** command.

The easiest method to turn on and off the console trace is to enter **DEBUG ON** and **DEBUG OFF**.

Only if a console trace is needed before the attention routine command handler is available, the CORCMD must be used to turn on the trace.

If no trace area was allocated before, then the default size (currently 8 kB) of the trace area is allocated with this command. This size is normally sufficient. When a different size is needed enter, e.g., `CORCMD TRACE=16` which allocates a trace area of 16 kB.

Note: Do not use a trace area size larger than 31K because the current trace analyzer tool has a limitation of a maximum trace area of 32k. A trace area larger than 32K is rarely needed.

Dump Console Router Trace Area

As soon as the event to be traced has occurred, dump the trace area or better the whole console router storage area. The dump can then be analyzed by a trace utility (IBM internally only). To get the dump do one of the following:

1. Take a standalone dump
2. Take a SVA dump (24 and 31 bit)
3. If under VM, this method can be used as well, which produces the smallest amount of dump. Enter **CORCMD ADDR=DUMP**. Use the address returned by this command as start address of the dump command. Dump up to the end of storage. It is important to dump with translation, e.g.

```
d vt1800000-end
```

since the trace analyzer needs the translated part of the dump.

All console router related storage is in the SVA. Normally the 31-bit SVA is sufficient. In some cases also 24-bit SVA space is used by the console router.

Important Note: Since the trace area is used in wrap-around mode, every activity of the console router after the event occurred must be prevented. Keep in mind that every traffic to and from a console or application program causes console router trace entries to be written. In particular do not perform any redisplay or other commands after the event happened and before the dump was taken. All these activities can cause the trace area to wrap and then important trace information might be lost. Normally, it is OK to issue the `CORCMD ADDR=DUMP` after the event happened. This command does not cause a lot of traffic. Also just turning off the trace and then do some redisplay before dumping the storage might destroy important information since console router queue items might be reused by this activity.

CORCMD

You can use the **CORCMD** to retrieve console router internal information. No blanks are allowed in the expression following the command name `CORCMD`. For example, `CORCMD ADDR= WA` is invalid because of the blank before `WA`.

Dump and Trace Related Commands

These command options help to manage the console router trace facility and are useful when debugging.

CORCMD ADDR=COR

returns the address where the console router phase \$IJBCSIO is loaded.

CORCMD ADDR=TA

returns the address of the console router trace area.

CORCMD ADDR=WA

returns the address of the console router work area.

CORCMD ADDR=DUMP

returns an address from where to dump in case of problem. Dump the storage from this address up to the end of storage. It is important to dump with translation, since the trace analyzer needs the translated part of the dump. E.g. (VM), *dump vt15DD800-end*.

This address is not needed if the entire SVA is dumped or a standalone dump is to be taken. See “Dump Console Router Trace Area” on page 89 for details.

TRACE

returns the current trace setting (ON or OFF)

CORCMD TRACE=ON

sets the console router trace to on. If no trace area exists, then a trace area with the default size is allocated (8 kB).

CORCMD TRACE=OFF

sets the console router trace to off.

CORCMD TRACE=END

returns the storage used by the trace area to the system.

CORCMD TRACE=n

changes the size of the trace area. *n* is the value in Kbyte.

Status Information

The following commands are useful to check the status of the console router queues and consoles. In the following explanations the terms RI and ML are used.

RI stands for *Routing Item*. A routing item is a console router queue item to be routed to a destination which can be a console, if it is a message, or a command processor, if it is a command, or an application if it is a reply. A routing item contains one line of message if it is a message routing item.

ML stands for *Message Line*. Message lines are optionally appended to a routing item and contain one line of message. Up to 10 message lines can be appended to a routing item.

CORCMD STATUS=QUEUE

returns status info about the console router queues

```
corcmd status=queue
GETVIS for RI: Lim=0020 Cur=0000 ML: Lim=0028 Cur=0000
Non-returnable: RI=0000007F ML=000001F3 QMGEmpty: TIK=0021 Code=0001
Returnable RI: Lim=0064 Hi=0000 Cur=0000
Returnable ML: Lim=0064 Hi=0000 Cur=0000
Alert : Pct=0032 RI-Base=00000071 RI-Pct=00000038
CRQ: Cur=001B Hi=001B MRQ: Cur=0001 Hi=0001 DYQ: Cur=0000 Hi=0000
LRQ: Cur=0019 Hi=0019 DHQ: Cur=0000 Hi=0000
ARQ: Cur=0000 Hi=0001 HCQ: Cur=0000 Hi=0000
FRQ: Cur=0037 Hi=0044 YRQ: Cur=000A Hi=000A XRQ: Cur=0022 Hi=0031
DOQ: Cur=0002 Hi=0002 XTQ: Cur=0000 Hi=0000 MOQ: Cur=000B Hi=0000
MLQ: Cur=000E Hi=0048 YMQ: Cur=000A Hi=000A XMQ: Cur=0168 Hi=01A1
End of STATUS=QUEUE
```

Explanation:

```

Lim      max number (e.g. GETVIS)
Cur     current number
Hi      highest number ever (can exceed LIM for returnable RI and ML)
ALERT:  Pct      alert percentage (hex)
        RI-Base  number of RIs to calculate percentage
        RI-Pct   number of RIs used to signal alert
QMGEmpy: TIK      task ID of last unsuccessful request
        Code     QMGempty code of last unsuccessful request:
        00      no free RI or ML found
        01      RI requ for APNormal: too many undeliver. msgs for task (RI
        02      QMEXMLSP: no GETVIS in IPL stage 2
        03      QMEXMLSP: GETVIS failed
        04      QMEXRISP: no GETVIS in IPL stage 2
        05      QMEXRISP: max number of expansions reached
        06      QMEXRISP: GETVIS failed
        07      QMFREE1: CRQ is empty
        08      QMFREE1: cannot be reused since not logged yet
        09      QMFREE1: cannot be reused, blocked by a console
        0A      QMFREE1: no more RIs in CRQ
        0B      QMGETSRI: GETVIS for single RI failed
        0C      QMGETSML: GETVIS for single ML failed
        0D      PROCRIML: Did not get a ML
        0E      PROCRIML: Did not get a ML
        0F      PROCRIML: invalid condition
        10      RI requ for APNormal: too many undeliver. msgs for task (ML
        11      QMFREE1: cannot be reused, blocked by console, RCSUSPND

```

What does it tell:

1. Check this line

```
GETVIS for RI: Lim=0020 Cur=0000 ML: Lim=0028 Cur=0000
```

This line tells you whether the console router queues were possibly short on console buffer space. If *Cur=0000* is displayed, then this means that the console router was never short on storage. The first thing the console router does if there is heavy console traffic, is to get more system getvis to expand its buffer storage. Such storage will never be returned to the system. That's why it is limited to the limit shown in *Lim=0020*.

If *Cur* has reached the value of *Lim* then this tells that the console router buffer were extended to its maximum size. It does not necessarily mean that the console router is currently short on storage, it only tells that it happened at least once since last IPL.

2. Check this line

```
Returnable RI: Lim=0064 Hi=0000 Cur=0000
```

When the console router buffer space has extended to its maximum (via GETVIS requests) as shown above, the console router is very restrictive when it needs more queue items but cannot create it from the current buffer space. In this situation only privileged programs like POWER, CICS, and VTAM will get a queue item to write messages. Also, if a reply is entered at a console the console router will provide a queue item that the reply can be processed.

Such queue items might then be obtained from system getvis one by one as needed. As soon as they are no longer needed they will be returned to the system.

The numbers of *Hi* and *Cur* tell how often the console router needed to create such privileged queue items. If the numbers are 0, then

the console router probably was never really in a critical short on storage situation.

The numbers of *Hi* and *Cur* might even exceed the number of *Lim* if required. However, if *Lim* is reached the console router becomes even more restrictive.

3. Check this line

```
CRQ: Cur=001B Hi=001B   MRQ: Cur=0001 Hi=0001   DYQ: Cur=0000 Hi=0000
```

The numbers displayed in *CRQ* show the number of routing items currently in the console router main queue. If this number becomes very low, e.g. less than 10, then there might be a problem.

MRQ shows the number of outstanding replies plus some other special messages (e.g. action messages).

DYQ is the so called delayed message queue. In this queue all routing items are collected that must be kept for a longer period of time. Typically this is the last message of a task, or still outstanding replies, and other special messages like action messages. If this number is very high then this might indicate a potential problem.

4. Check this line

```
FRQ: Cur=0037 Hi=0044   YRQ: Cur=000A Hi=000A   XRQ: Cur=0022 Hi=0031
```

FRQ and *XRQ* show the number of available empty routing items. Any request is first honored from these queues. It is quite normal that these queues are empty after a while. When these queues are empty, the console router tries to reuse the oldest routing item of the queue.

YRQ contains empty routing items for emergency cases. If this queue is empty, then this might indicate a console buffer short on storage problem together with POWER, VTAM or CICS.

5. Check this line

```
Non-returnable: RI=0000007F ML=000001F3 QMGEmpty: TIK=0021 Code=0001
```

The *Non-returnable* numbers show the numbers of queue items in non returnable system getvis space.

Check the *QMGEmpty: TIK=0021 Code=0001* values. TIK indicates the task ID of the last requestor for a queue item that was not honored. The reason why it was not honored is shown in *Code=*.

It is quite normal that requests are not honored. In particular *Code=0001* happens frequently. This means that a task tries to write many messages to a console but the console does not retrieve such messages fast enough. In this case the requesting task is set into a wait condition until the console has retrieved these messages.

Other *Code* values might indicate a problem but don't have to.

It is important to understand that the information shown is the condition of the last unsuccessful request. There is no information available to tell how long ago this happened.

CORCMD STATUS=CONS

returns status info about the consoles known to the console router.

```
corcmd status=cons
Number of consoles: Act=00000003 Sus=00000000 Ud=00000001 A1=00000001
SYS      001BD3A4 A---   VMC      015DB891 A---   IC      015DB122 A--U
End of STATUS=CONS
```

Explanation:

Numer of consoles: ACTive, SUSPended, accepts UD msgs, accepts Alerts
Status: Active, Suspended, Netview(automa.), Undel. msgs

What does it tell:

This command shows all consoles currently registered to the console router. Typically you will see these consoles.

ConsName	Description
SYS	system console
VMC	VMCF console, only when running under VM
IC	integrated console, only when supported by hardware. All ES/9000 and newer /390 systems support the integrated console.
ConsName	typically the userID of a user, using the console function, or any other name as used by any console application (e.g. vendor products)

CORCMD STATUS=AR

returns status info about the interface between the console router and the AR cmd processor.

```
corcmd status=ar
Stat=Idle Flag=-- Cons=SYS      -00000001 PIK=0000
ARNxt=N ARDisp=D RIPtr=00000000
End of STATUS=AR
```

Explanation:

Stat Idle, Exec, Done, Erro
Flag X: explanation request; C: cancel request
Cons console (name & ID) where last cmd was entered
PIK PIK of console
ARNxt N: get next from Q; F: get first from Q
ARDisp Disposition: Keep, Delete, Passed
RIPtr ptr to last cmd routing item

What does it tell: Gives information whether an AR command is currently being executed and how the AR command handler requested the last AR command routing item.

CORCMD STATUS=HCF

returns status info about the interface between the console router and the HCF cmd processor.

```
corcmd status=hcf
Stat= Idle Stat2: R---1 StatH: H0
PRsn:-L-- CRq:-- CRC:04 HRq:LB HRC&colon00
End of STATUS=HCF
```

Explanation:

```

Stat      Idle, Exec, Done
Stat2    X---- HCREDCMD (last redisplay cmd)
          R: RED cmd
          E: RED cmd with implicit END
          C: Cancel
          N: Cancel/End
          O: cancel by deactivating console
Stat2    -X--- HCCURREQ (last request from HCF)
          H: get next HCF cmd
          L: read log RI
          I: read redisplay RI
          E: get empty RI
          A: add a RI
          U: return a RI
          R: read reply-message
          N: no operation
          C: cleanup - redisplay
          G: cleanup - logging
Stat2    --X-- HCWAIT
          W: HCF set into wait
Stat2    ---X- HCREPLY
          Y: HCF sends reply
Stat2    ----X HC1STLOG
          1: first RI was logged
StatH    H: HCF operational - redisplay possible
          L: logging possible, HC file not open yet
          O: logging possible, HC file open
PRsn     reason why HCF was posted
          A: alert; L: log; C: command; E: empty RI
CRq      last request from console router
          C: cancel; Y: reply to be sent by HCF
CRc      last return code of console router
HRq      last request from HCF cmd processor
          X-: like Stat2 -X---
          -X: last read sub request
              1: read first record for a console
              B: read next record backward
              F: read next record forward
              L: read last (not logged) for a console
              T: validate this record
HRC      last return code of HCF cmd processor
    
```

What does it tell: Gives information whether a HCF command is currently being executed and how the HCF command handler requested the last HCF command routing item.

CORCMD CONS=name

returns status info about a specific console.

```

corcmd cons=sys
Name=SYS      ID=001BD3A4  Date=1995072  Time=09:14:24.63  Stat=Nrm
RtCd=FFFFFFFFFFFFFFFFFFFFFFFFFFFFFFFF MLv1=FE00 Ud=N Al=Y Aut=N DOM=Def
EC=0000 RCS=08000000 CmdPnd=----- MsgDlv=SrcH CSAF1=---
QFrst=00000000 QSrcH=00000000 QDOM=00000000
MsgCt=00000000 DOMCt=00000000 SusCt=00000000
End of STATUS=CONS
    
```

Explanation:

```

Date & Time of last activate, suspend or resume
Stat      ACTive, SUSPended, RESumed, INItializing, NoRMal
RtCd      enabled routing codes
MLv1      enabled message level
Ud        undeliverable messages accepted: Y or N
Al        alert ECB specified: Y or N
Aut       automatable messages accepted: Y or N
DOM       DOM option: ALL, DEFault, NONE
EC        unique error code for specific return codes
    
```

RCS	last return and reason code
CmdPnd	command pending: A: AR cmd, H: HCF cmd, C: Console router cmd M: HCF cancel/end msg, X: explanation request
MsgDlv	message delivery option: SeARCh, FIFO, NONe
CSAF1	Console Status Area flags A: alerted, U: suspended, X: explain response
QFrst	next message to be delivered
QSrch	search (work) pointer
QDOM	next DOM to be delivered
MsgCt	number of undelivered messages
DOMCt	number of undelivered DOMs
SusCt	number of suspends since last activate

What does it tell: Besides the information what options a console application used to register to the console router some information can be useful if the status of a console is not clear.

CmdPnd=---- shows whether there is any command pending from this console. If a console does not accept any commands then this might be due to the fact that there is still a previous command pending. A console does only accept a new command if the previous command was entirely processed. The command pending status exists from the time were the command was entered until all of the command response was retrieved by the console.

MsgCt= shows the number of messages that were routed to this console but have not been retrieved yet. The console router expects this console to issue the `get_message` request to retrieve the outstanding messages

SusCt= shows how often this console was suspended since the last activation of this console. Console suspensions are not unusual. However, if it happens very often, then this indicates that this console does not retrieve messages fast enough. Not retrieving messages can be caused when a console enters the redisplay, help, or explanation mode. If the console is a program (e.g. vendor product) then the `get_message` request is possibly not issued often enough.

Operational Commands

CORCMD FORCE

CORCMD FORCE checks whether the oldest routing item of the console router main queue (CRQ) is blocked by a console and because of this the reusage of such a routing item is prevented. When this is the case, then such a console is suspended, no matter what console it is. The system responds with:

```
Number of consoles suspended due to CORCMD FORCE : 01
```

CORCMD FORCE=consname

With this command any console can be suspended. This might be useful if a console hung up for any reason. Normally forcing this console resolves this situation. The forced console can be reactivated by hitting the enter key.

The console name is either the userID of a CICS user or any of the predefined console names (SYS, VMC, IC).

When the system console hung up enter CORCMD FORCE=SYS from any other console.

Special Commands

Be extremely careful with these special commands. Use these commands only if you are exactly knowing what you do or if told so by IBM service personnel.

CORCMD TDALERT=nnnn, CORCMD TDSUSPEND=nnnn

Every console is monitored whether it still receives messages after it was posted that a new message is available. In case a console does not retrieve messages any more the console will be suspended. Before the suspend takes place, the console alert is set. The default time when a console is suspended is about 15 seconds.

Sometimes it can be bothering if console suspension takes place after such a short time, for example while debugging with VM PER. This CORCMD allows to change the time values of the timer driven suspend for alert and suspension.

CORCMD TDALERT=nnnn specifies the time after the console will be alerted.

CORCMD TDSUSPEND=nnnn specifies the time after the console will be suspended.

'nnnn' can be in the range of 5 to 9999. Values below 5 are set to 5. The unit of 'nnnn' is the high order fullword of the clock value which is approx. 1 second.

CORCMD GVLIMRI=nnnn, CORCMD GVLIMML=nnnn

The console router buffer storage management issues system getvis requests if it runs out of buffers. Since the retrieved system getvis will never be returned to the system, the number of getvis requests has been limited. The current limit for routing items is 32 (x'20) getvis requests. Every request is about 4 kB.

With CORCMD GVLIMRI=nnnn the maximum number of getvis request for routing items can be set to a new value.

With CORCMD GVLIMML=nnnn the maximum number of getvis request for message lines can be set to a new value.

'nnnn' can be set to any number between 0 and 9999. Use this command carefully, because the system getvis, once retrieved, will not be returned any more.

Hints and Tips

To better understand some situations you might experience, here is some information about the console support. Most of them have to do with the queueing concept used by the console router. All console traffic among the application programs and consoles goes through the console router queue. When a message enters the console router queue, the target console(s) are posted to retrieve this message. Only after such a message was retrieved by all target consoles, the queue item occupied by this message is eligible to be reused for a new message.

In general, the oldest queue item is reused for a new message, reply, or command. Therefore, not delivered message queue items are a potential bottleneck in the entire space management of the console router queue. All the following situations have to do with this. To prevent the console router queue from being flooded with

messages that cannot be delivered, because a console does not retrieve messages for any reason, two methods are used:

- slow down message writing application programs by setting such a program in a temporary wait condition
- suspend a console that does not retrieve messages

What Does the Blinking 'MESSAGE' Indicator Mean ?

The 'MESSAGE' indicator shows that there is at least one message available in the console router queue which has not been displayed (retrieved) by this console yet. A reason for not displaying a message can be the console state of redisplay, explanation or help mode a console can enter, or because the user stopped further displaying of messages by setting a console into a HOLD mode.

As the not retrieved message gets older, because new messages are being written, it moves through the queue to finally get reused to build a queue item for another new message. When such an undelivered message passes a certain limit in the queue, the console expected to retrieve this message is alerted. This alert state is indicated by the blinking 'MESSAGE' indicator. Please note that due to the presentation characteristics of some terminals, the blinking state might also be presented by a change in color.

Another reason why the blinking 'MESSAGE' indicator might show up is caused by the response to an AR command. While a master console is in redisplay mode, the user can enter an AR command. Depending on the amount of AR command response messages, the AR command processor might be set into a wait condition because the AR command response messages are not retrieved by the issuing console. Remember that the console where this command was entered, was, and probably still is, in redisplay (or help or explanation) mode and does not retrieve new messages. Since the AR command processor is a valuable resource and no other console can execute a new AR command, this console is alerted as a notification that it might be impacting the whole system.

As a general rule, a console will be alerted after a certain time has elapsed after a message was made available for this console and the console did not retrieve it. The time delay is about 10 seconds. After about 5 more seconds the console will be suspended.

What to do ? If you entered an AR command while not in normal console mode (master console only), be aware that nobody else can execute any AR command as long as you have not retrieved the entire command response of your AR command by going back into the normal console mode.

The blinking 'MESSAGE' indicator signifies that your console does not retrieve messages available for it because you are not in the normal console mode or your console entered a hold state. The console router might decide to suspend your console soon if necessary. When suspension takes place is not predictable and depends mainly on the amount of messages being written in the system.

What Does Console SUSPENDED Mean ?

Under certain circumstances, the console router can decide to suspend a console if such a console is preventing the reusage of queue items for new messages or input entered at a console. Once it is suspended, such a console is removed from the list of active consoles and all messages destined to this console are considered as delivered.

See also “What Does the Blinking 'MESSAGE' Indicator Mean ?” on page 97 for reasons why a console can be suspended since typically a console will be alerted before it is suspended.

What to do ? A suspended console can resume. If you are using a 3270 console just hit enter. With a CICS console just enter the console dialog again. In any case you have missed those messages that were in the console router queue for this console when suspension took place. This can be any number of messages.

Such messages are not really lost if they were subject to logging. In this case you can use the redisplay function to display the messages you missed.

What Does 'WAITING FOR ROUTER BUFFER SPACE' Mean ?

The console router returns control to an application program after the message was added to the console router queue. This means that a message has not necessarily been displayed at a console screen when the issuing program gets control back. Since consoles can enter a mode where they temporarily do not retrieve messages, for example redisplay mode, programs can continue to write messages to such a console. After a certain number of messages have been queued because they were not retrieved by all target consoles, the issuing program is set into a temporary wait condition. This state is called 'console buffer bound' and you see 'WAITING FOR ROUTER BUFFER SPACE' when entering the STATUS command.

Another situation where you might observe this status is when the reusage of the oldest queue item is prevented by a console that does not retrieve messages and would be a candidate for suspension but cannot be suspended. Such a console can be the system console or any other master console.

What to do ? This state is temporary and disappears as soon as the console(s) that does not retrieve messages resumes retrieval of messages. Master consoles are powerful and are allowed to slow down jobs or the entire system if they do not retrieve messages fast enough.

Therefore, be careful when using multiple master consoles. All master consoles have equal rights, and every user of a master console has the responsibility to let the console work in normal console mode to retrieve all messages.

Do not give master consoles to everybody. Use user consoles instead. A user console has enough authority for most general users.

What is to be Done If a Console Hangs ?

Sometimes a user claims that a console hangs. In this situation, first check whether possibly the whole system is affected (hardwait, loop) or just the console.

If the system is still working, then try to get up a second console. The easiest way normally is to logon to the IUI and use the console function.

Use the **CORCMD FORCE=consname** with the name of the affected console. If the console is the system console the console name is *SYS*. Entering this command normally frees the affected console immediately. Hitting the enter key at the console should reactivate it.

If an IUI console is not available, any other console (See "Console Types" on page 87) can be used. For example you could use one of these consoles:

1. under VM, use the VSECMD to issue the CORCMD.
2. the integrated console, if the hardware supports it. ES/9000 and later systems have an integrated console.
3. VM also emulates the integrated console. Enter *VI VMSG CORCMD ...*
4. Possibly a vendor console product is available.

What Does the Reply-Id Mean ?

Every message that is issued by the system or an application program gets a message prefix assigned in the front of its first line. This message prefix is built in the form

partition_id (+|-) reply_id

where

partition_id takes one of the values AR, BG, Fn, cn (c = dynamic class), and identifies the service owner partition. When the message is issued by a system task or by VSE/POWER, this is the partition that is being serviced (when applicable). In all other cases, it is the partition of the task that issued the message.

+ indicates a messages that needs an immediate reply because a system resource (e.g. the LTA) is being held

- indicates any other message needing a reply

reply_id takes the form **rnnn**, where **nnn** is a 3-digit numerical value derived from the task ID of the task that issued the message (algorithm see below), and **r** is a digit in the range 0 to 9 used to distinguish multiple outstanding replies for the same task. This digit is needed for tasks that are allowed to have more than 1 outstanding reply. Primarily these are subsystems, like CICS or POWER, that use internal tasking.

"nnn"	Related TaskID
000 to 011	x'21' (BG Main Task) to x'2C' (FB Main Task)
013	x'01' (Sense Task)
014	x'0B' (ERP Task)

Console

015	x'20' (Attention Routine Task)
016 to 024	x'02' to x'0A' (system tasks)
025 to 044	x'0C' to x'1F' (system tasks)
045 to 255	x'2D' to x'FF' (dynamic partitions main tasks or any subtask) You may note that with this group of reply_ids the reply_id value is decimal presentation of the hex task id.

Chapter 5. Job Control

Storage Layout and Interaction of Job Control Phases

During end-of-task (SVC14) processing, the terminator routine \$JOBSEOT will load the *job control root phase* \$JOBCTLA into the partition. The entry point is label JOBCTL. In VSE/ESA Version 2 this entry point is located at X'9000' relative to the partition start address. This code initializes job control and is only executed, when a new copy of \$JOBCTLA is loaded into the partition.

When initialization has completed and job control commands are being executed then this initialization code is overlaid by different job control phases \$JOBCTLx. Since these other job control phases \$JOBCTLx highly depend on the root phase \$JOBCTLA, these \$JOBCTLx phases are called *job control subphases*.

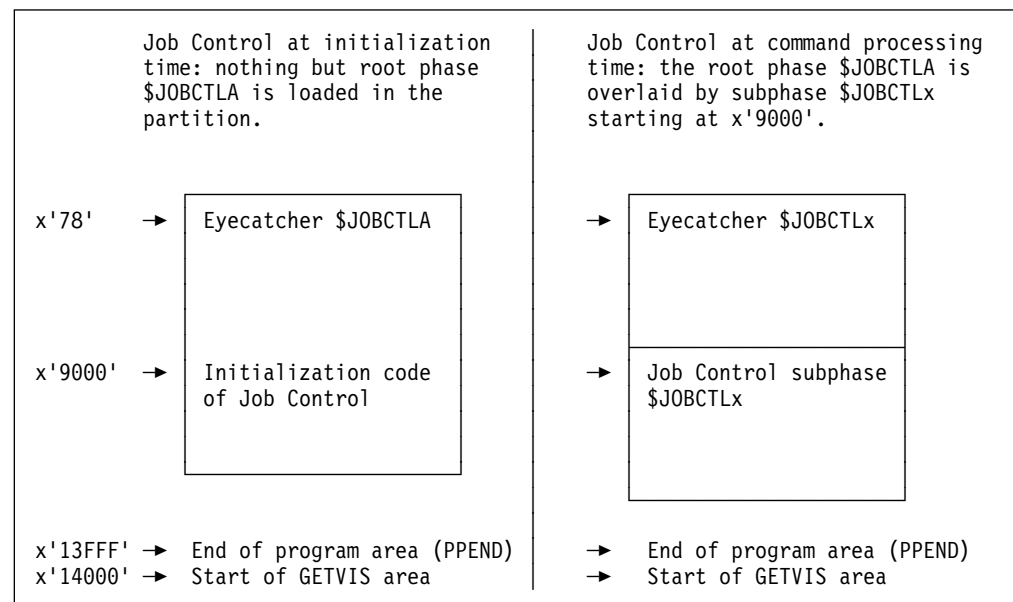

Figure 47. Job Control Storage Layout

Job Control command processing is controlled by \$JOBCTLA (subroutine CONTROL). This CONTROL routine

- Reads the next job control command into the command input buffer. This buffer is located at X'1BC' relative to the partition start address.
- Scans the command input buffer for the first operand (i.e. the command name).
- Loops through the command table for a match. This command table contains a 14-byte entry for each available job control command. Each entry contains the letter x identifying the proper job control subphase \$JOBCTLx, which will process the command.
- Passes the command to one or more job control user exit routine(s).
- Invokes subroutine EXIT, which will load the command processing subphase at X'9000' relative to the partition start address (provided it is not already in storage) and pass control to the subphase. The subphase will continue to process the command. It will use services provided by the root phase, such as

Job Control

operand scanning, substitution of symbolic parameters, concatenation of continuation lines, writing of messages to SYSLOG/SYSLST etc. When command processing has completed, the subphase will return to CONTROL.

So each job control command is processed by a subphase.

Figure 48 (Page 1 of 2). Command-to-subphase Cross-Reference

Command/Statement	Corresponding Subphase
ALLOC	\$JOBCTLJ
ASSGN	\$JOBCTLD
CANCEL	\$JOBCTLG
CLOSE	\$JOBCTLD
DATE	\$JOBCTLJ
DLBL	\$JOBCTLK
DVCDN	\$JOBCTLF
DVCUP	\$JOBCTLF
EXEC	\$JOBCTLE
EXTENT	\$JOBCTLK
GOTO	\$JOBCTLI
HOLD	\$JOBCTLJ
ID	\$JOBCTLG
IF	\$JOBCTLI
IGNORE	\$JOBCTLA
JCLEXIT	\$JOBCTLO
JOB	\$JOBCTLG
LIBDEF	\$JOBCTLH
LIBDROP	\$JOBCTLH
LIBLIST	\$JOBCTLH
LIBSERV	\$JOBCTLO \$IJBSLIB
LISTIO	\$JOBCTLF
LOG	\$JOBCTLJ
MAP	\$JOBCTLO \$JBMAP
MSECS	\$JOBCTLE
MTC	\$JOBCTLJ
NOLOG	\$JOBCTLJ
NPGR	\$JOBCTLJ
ON	\$JOBCTLI
OPTION	\$JOBCTLG
PAUSE	\$JOBCTLA
PROC	\$JOBCTLE
PRTY	\$JOBCTLO \$JBPRTY
PWR	\$JOBCTLE
QUERY	\$JOBCTLO \$JBSDSP
RESET	\$JOBCTLF
ROD	\$JOBCTLM
RSTRT	\$JOBCTLK
SET	\$JOBCTLJ

Figure 48 (Page 2 of 2). Command-to-subphase Cross-Reference

Command/Statement	Corresponding Subphase
SETPARM	\$JOBCTLE
SETPFIX	\$JOBCTLO
SETPRT	\$JOBCTLK
SIZE	\$JOBCTLJ
START	\$JOBCTLG
STDOPT	\$JOBCTLJ
STOP	\$JOBCTLJ
SYSDEF	\$JOBCTLO \$IJBSDSP
TLBL	\$JOBCTLK
UCS	\$JOBCTLJ
UNBATCH	\$JOBCTLF
UPSI	\$JOBCTLJ
VDISK	\$JOBCTLO \$IJBVDII
VTAPE	\$JOBCTLO \$IJBVTAP
ZONE	\$JOBCTLJ
*	\$JOBCTLA
./	\$JOBCTLA
/+	\$JOBCTLG
/&	\$JOBCTLG
/*	\$JOBCTLA

Notes:

1. The linkage editor commands ACTION, ENTRY, PHASE, MODE, INCLUDE are processed by subphase \$JOBCTLJ, that is they are written to SYSLNK.
2. Most Attention Routine commands are allowed if specified in \$0JCL.PROC. They are processed by subphase \$JOBCTLO, that is they are passed to the attention routine by means of an SVC 30 interface. Symbolic parameters are resolved.
3. 'Modern' job control commands (such as VTAPE, LIBSERV, MAP, PRTY, QUERY, SYSDEF, VDISK) are handled by SVA-resident command-processors (such as \$IJBVTAP, \$IJBSLIB, \$IJBMAP, \$IJBPRTY, \$IJBSDSP, \$IJBVDII). The interface between the SVA phase and root phase \$JOBCTLA is provided by subphase \$JOBCTLO.
4. Besides the above 6 SVA-resident command-processors there are 6 other SVA-resident service routines related to job control.

\$IJBASGN This phase is called in the expansion of the ASSIGN macro. Refer to the *System Macros Reference* manual for a description of the ASSIGN macro.

\$IJBCJC This phase is called in the expansion of the CONDJC macro. Refer to the *IPL and Job Control Diagnosis Reference* manual for a description of the CONDJC macro. \$IJBCJC stores and retrieves conditional job control information (such as ON conditions, last and maximal return code of a job step).

\$IJBCCN This phase is executed during EXEC PGM processing, after \$JOBCTLE has completed and before control is being passed to the user program. \$IJBCCN invalidates the partition, loads the user program into the partition (SVC 4) and passes control to the user program (SVC 133). When the user program returns (with BR R14 or EOJ macro), \$IJBCCN is invoked again to handle the return code passed by the user program (via R15 or via the RC operand of the EOJ macro).

\$IJBPROC This phase is called in the expansion of the GETSYMB, PARMMAC and PROCMAC macro. Refer to the *System Macros Reference* manual for a description of the GETSYMB macro. Refer to the *IPL and Job Control Diagnosis Reference* manual for a description of the PARMMAC macro. GETSYMB and PARMMAC provide services to store or retrieve symbolic parameters and their values (for example during SETPARM, PROC, EXEC PROC or EXEC REXX processing). PROCMAC invokes LIBR services to retrieve records from a cataloged procedure (for example during EXEC PROC or EXEC REXX processing).

\$IJBSLA This phase is called in the expansion of the LABEL macro. Refer to the *IPL and Job Control Diagnosis Reference* manual for a description of the LABEL macro. \$IJBSLA stores and retrieves label information records. It writes to or reads from the system's label information area.

\$IJBSLA consists of two modules:

IJBSLA	provides the label functions for a label information area on disk (CKD or FBA).
IJBSLAD	provides exactly the same label functions but with a label information area that resides in data space (created by the command VDISK.....USAGE=DLA)

\$IJBSTRT This phase is called in the expansion of the STARTP macro. Refer to the *Supervisor Diagnosis Reference* manual for a description of the STARTP macro.

For these SVA-resident service routines the entry point is identical to the load point, which can be retrieved by means of the LIBR LISTDIR SDL command. Control is passed via BALR/BASSM 14,15. Upon entry, Reg1 points to a parameter list, R14 points back to the caller and Reg0 may contain a function code.

Example: When entering \$IJBSLA, Reg1 contains the address of the LPL (label parameter list generated by the LPL macro). Reg0 contains the function code, such as 1 for GETLBL, 4 for ADDLBL or 6 for CLRGRPL etc.

Finally Figure 49 on page 105 illustrates, which subphases are loaded during execution of a simple job.

```
// JOB EXAMPLE          (load $JOBCTLG)1, pass control to $JOBCTLG
// OPTION PARSTD=ADD    pass control to $JOBCTLG
// DLBL EXAMPLE, 'EXAMPLE.FILE' load $JOBCTLK, pass control to $JOBCTLK
// EXTENT ,VSE200,,,1500,30 pass control to $JOBCTLK
// OPTION USRLABEL     load $JOBCTLG, pass control to $JOBCTLG
// ASSGN SYSLST,00E    load $JOBCTLD, pass control to $JOBCTLD
// EXEC LSERV,PARM='PARSTD=BG' load $JOBCTLE, pass control to $JOBCTLE
/ &                    load $JOBCTLG, pass control to $JOBCTLG
```

Figure 49. Sample Job to Demonstrate Subphase Loading

Job Control Dumps: Where to Look First?

The term “job control dump” denotes a partition dump taken at a time, when job control (and not a user program) was active in the partition. The most important storage area to look at is the save area located at the very start of the partition.

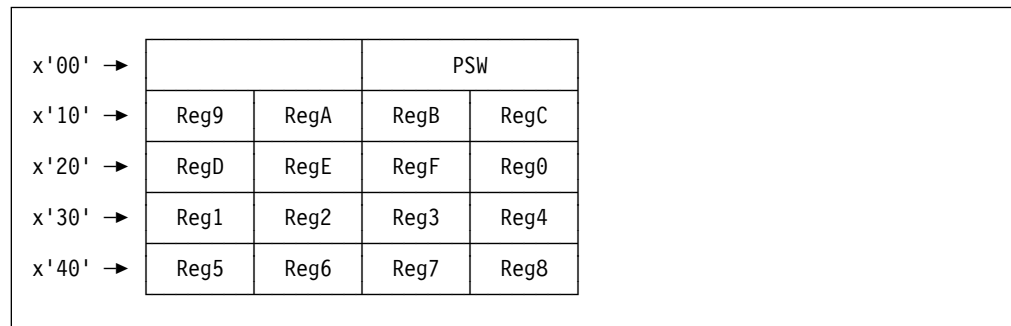

Figure 50. Partition Save Area Layout

For the examples discussed below we assume that the partition starts at X'600000'. When the root phase or one of the subphases is executing, the PSW contains instruction addresses in the range from X'600000' to X'613FFF'. In this case, the following register conventions are in effect:

RegA

Points to the partition's COMREG.

Reg7

Points to a branch vector table located at X'6000E0' in \$JOBCTLA. This branch vector table allows the job control subphases to exploit common service routines provided by \$JOBCTLA, such as operand scanners, message writers etc. Reg7 is also the first base register of root phase \$JOBCTLA.

Reg8

Start of the overlay area (X'609000'), where subphases are loaded. Reg8 is also the first base register of each subphase \$JOBCTLx.

Reg7, Reg6, Reg9, RegB

Base registers of root phase \$JOBCTLA.

Reg8, Reg9 (, Reg6 (, RegC))

Base registers of subphase \$JOBCTLx. It depends on the subphase, if 2, 3 or 4 base registers are needed.

¹ At this point a load of subphase \$JOBCTLG is not required, if the preceding command (that is the last command in the preceding job) was a /& and hence \$JOBCTLG is still in storage.

If however one of the SVA-resident command-processors or service routines is executing, the PSW contains instruction addresses from the SVA-24 or SVA-31 area. In this case there are no general register conventions: it is up to the (PLS or PLX) compiler to choose registers.

The next storage area to look at is the eyecatcher at X'78' relative to the partition start address.

V00600070	40404040	40404040	5BD1D6C2	C3E3D3C1	*	\$JOBCTLA*
V00600080	5CF6F5C3	5CC4E8F4	F4F7F1F8	5CF0F161	**65C*DY44718*01/*	
V00600090	F2F461F0	F15CF5F6	F8F660F0	F6F6404D	*24/01*5686-066 (*	
V006000A0	C35D40C3	D6D7E8D9	C9C7C8E3	40C9C2D4	*C) COPYRIGHT IBM*	
V006000B0	40C3D6D9	D74B40F1	F9F7F76B	40F1F9F9	* CORP. 1977, 199*	

Figure 51. Eyecatcher of Job Control Root Phase

This eyecatcher contains useful information. Separated by an asterisk we find:

\$JOBCTLA In this case this is (per chance) the name of the root phase itself. If a subphase (for example \$JOBCTLE) is loaded, the corresponding suffix (in this example E) will overlay the A, thus resulting in \$JOBCTLE and reflecting, which subphase is currently active (see Figure 47 on page 101). However the rest of the eyecatcher remains unchanged, that is it applies to \$JOBCTLA.

65C This is the release code of VSE/ESA Version 2, Release 6.
 The release code of VSE/ESA Version 2, Release 5, is 55C.
 The release code of VSE/ESA Version 2, Release 4, is 45C.
 The release code of VSE/ESA Version 2, Release 3, is 35C.
 The release code of VSE/ESA Version 2, Release 1 or 2, is 15C.

DY44718 This is the service level of the root phase \$JOBCTLA and therefore of particular interest for VSE Level 2.

01/24/01 This is the date of the last development activity for \$JOBCTLA.

If job control is in command processing mode (not in initialization mode) the next storage area to look at is the eyecatcher near X'9000' relative to the partition start address. This eyecatcher is preceded by a branch table. Each branch table entry relates to a job control command or to an internal function provided by the subphase. Figure 52 shows 6 branch table entries, the first 5 of which are corresponding to the RSTRT, DLBL, EXTNT, TLBL, and SETPRT commands.

V00609000	47F090C0	47F087D0	47F089B2	47F08116	*.0...0g..0i..0a.*
V00609010	47F097A8	47F08F66	5BD1D6C2	C3E3D3D2	*.0py.0..\$JOBCTLK*
V00609020	5CF5F5C3	5CC4E8F4	F5F6F5F5	5CF0F561	**55C*DY45655*05/*
V00609030	F1F761F0	F05CF5F6	F8F660F0	F6F6404D	*17/00*5686-066 (*
V00609040	C35D40C3	D6D7E8D9	C9C7C8E3	40C9C2D4	*C) COPYRIGHT IBM*
V00609050	40C3D6D9	D74B40F1	F9F7F76B	40F1F9F9	* CORP. 1977, 199*

Figure 52. Eyecatcher of Job Control Subphase

This eyecatcher contains useful information. Separated by an asterisk we find:

\$JOBCTLK
 This is the name of the subphase currently active (same as on location X'600078').

- 55C** This is the release code of VSE/ESA Version 2, Release 5.
- DY45655** This is the service level of the subphase \$JOBCTLK and therefore of particular interest for VSE Level 2.
- 05/17/00** This is the date of the last development activity for \$JOBCTLK.

Another storage location to look at is X'1BC' relative to the partition start address. There we find the command input buffer, showing, which command is currently being executed.

```
V006001B0 006051E4 40404040 40404040 616140C4 16 *.-.U // D*
V006001C0 D3C2D340 C1C2C36B 7DC1C2C3 4BE3C5E2 *LBL ABC,'ABC.TES*
V006001D0 E34BC6C9 D3C57D6B F2F0F0F3 61F3F6F5 *T.FILE',2003/365*
V006001E0 40404040 40404040 40404040 40404040 * *
```

Figure 53. Job Control Command Input Buffer

How Job Control Handles Program Return Codes, ABEND and CANCEL Conditions

This chapter discusses the different ways an application program can return to the operating system. Job control can react on these different ways by conditions specified in ON statements (such as \$CANCEL, \$ABEND, and \$RC).

Job control maintains private variables for \$RC (the return code of the last job step) and \$MRC (the maximal return code of all job steps executed so far). These variables are implemented as 4-byte fields containing either X'40404040' (initial value) or a number (the return code) in character representation. The following job control statements or commands cause an update of these variables:

1. Both JOB and /& statement initialize both variables (\$RC and \$MRC) to X'40404040'.
2. The SET RCZERO command re-initializes \$RC to X'40404040'.
3. The SET MRCZERO command re-initializes \$MRC to X'40404040'.
4. The EXEC PGM=pgmname statement re-initializes \$RC to X'40404040'. Then it is *up to the application program* to cause an update of \$RC and \$MRC or not. The return code variables are updated if the application program
 - a. returns control to the system by an explicit branch to the return address initially provided in register 14. Then the contents of register 15 is considered as a return code (see *Guide to System Functions*, chapter *Using Conditional Job Control*).
 - b. specifies an explicit return code in the RC operand of an EOJ or DUMP macro.

This behavior is illustrated by the control flow in Figure 54 on page 108.

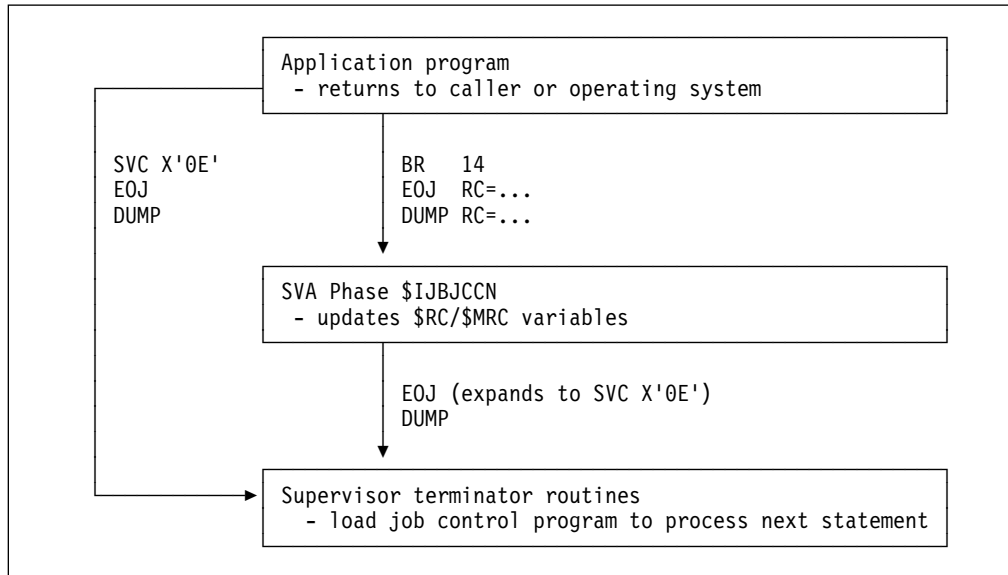

Figure 54. Normal Termination of an Application Program

If the RC operand is omitted in the EOJ or DUMP macro, or if the program returns via SVC X'0E', then there is *no* return code passed to job control, that is \$RC retains its initial value X'40404040' and \$MRC is not updated at all. For example system utility programs (such as LSERV or LVTOC) return via SVC X'0E' (that is the expansion of the EOJ macro without RC operand) and hence do *not* pass a return code.

At the end of each *job step*, job control checks whether the \$RC variable is different from its initial value. If so, the following message is written to SYSLST (unless OPTION NOLOG is in effect):

```
1S55I LAST RETURN CODE WAS nnnn
```

and nnnn is the contents of the \$RC variable.

At the end of each *job*, job control checks whether the \$MRC variable is different from its initial value. If so, the following information is part of the end-of-job message:

```
MAX.RETURN CODE=nnnn
```

and nnnn is the contents of the \$MRC variable.

Note: Only application programs can cause an update of the \$RC/\$MRC variable with a *return code*, that is with a value different from the initial value X'40404040'. The job control program itself only initializes the \$RC/\$MRC variables, any value different from the initial value is stored exclusively on request of an application program.

If \$RC and \$MRC have their initial values, then the comparisons in

```
IF $RC=0 THEN
IF $MRC=0 THEN
```

are evaluated as true. Also the symbolic parameters RC1 and MRC1 defined by

```
SETPARM RC1=$RC,MRC1=$MRC
```

are assigned the value 0000.

Only programs which terminate normally can cause an update of the \$RC/\$MRC variables (see Figure 54). Abending programs cannot pass a return code: there is no update of the \$RC/\$MRC variables and there is no message 1S55I. An application program raises a \$ABEND condition, that is terminates *abnormally* for various reasons, the most popular of which are listed below:

1. It produces a program check.
2. It issues a LOAD macro for a phase that could not be found in the LIBDEF phase search chain.
3. It executes an invalid SVC.
4. It executes an SVC 6 (expansion of a CANCEL macro).
5. It produces a LIOCS error (for example EXEC LVTOC, when SYS004 or SYS005 are unassigned or assigned incorrectly).

If a job contains one single job step and this job step terminates abnormally, then the \$RC/\$MRC variables still have their initial values. Hence there is no message 1S55I on SYSLST and the EOJ message does not contain the MAX. RETURN CODE=nnnn information.

A little confusion is sometimes caused by the following scenario: A job contains two (or more) job steps, the first of which terminates with return code 0 (for example via EOJ RC=0), whereas the second job step terminates abnormally. For the sake of clearness let's consider the following three simple assembler programs:

```
PUNCH ' PHASE SETRC0,S'
SR 15,15      SET RETURN CODE 0
BR 14         BACK TO CALLING PROGRAM $IJBCCN
END
```

```
PUNCH ' PHASE PGMCHECK,S'
DC XL2'0000'  CAUSE PROGRAM CHECK
END
```

```
PUNCH ' PHASE SETRC333,S'
LA 15,333    SET RETURN CODE 333
BR 14         BACK TO CALLING PROGRAM $IJBCCN
END
```

The sample job

```
// JOB SAMPLE1
// EXEC SETRC0    CAUSE UPDATE $RC=0000 and $MRC=0000
// EXEC PGMCHECK CAUSE PROGRAM CHECK
/&
```

will display the following, at first glance contradictory messages:

```
1S78I JOB TERMINATED DUE TO PROGRAM ABEND
EOJ SAMPLE1 MAX.RETURN CODE=0000
```

Program PGMCHECK did not terminate normally, and hence did not cause an update of \$RC/\$MRC. At end-of-job time \$RC contains its initial value (from EXEC processing) and \$MRC contains 0000 (from EXEC SETRC0), which is displayed in the end-of-job message. If you want your end-of-job message to reflect program abends by a special return code (for example 0333), you can modify job SAMPLE1 as follows.

```
// JOB SAMPLE2
```

```
// ON $ABEND GOTO ABNORMAL
// ON $RC=333 CONTINUE
// EXEC SETRC0 CAUSE UPDATE $RC=0000 and $MRC=0000
// EXEC PGMCHECK CAUSE PROGRAM CHECK
// GOTO ENDJOB
/. ABNORMAL
SET MRCZERO RE-INITIALIZE $MRC
// EXEC SETRC333 CAUSE UPDATE $RC=0333 and $MRC=0333
/. ENDJOB
/&
```

In case of erroneous job control, but also in case of program malfunction (for example a loop) the operator may want to cancel a job. This can be achieved by the following commands:

1. Job control CANCEL command: only applicable if the partition is waiting for an operator response.
2. Attention routine CANCEL partition command.
3. POWER PFLUSH partition command for POWER-controlled partitions.

If a job step is canceled via AR CANCEL or POWER PFLUSH, the job step is not able to cause an update of the \$RC/\$MRC variables. The maximum return code eventually displayed as part of the end-of-job message applies to the return codes set by preceding job steps (if any), not to the job step being canceled. So the messages

```
1S78I JOB TERMINATED DUE TO CANCEL COMMAND
EOJ LOOP MAX.RETURN CODE=0000
```

indicate, that before the CANCEL or PFLUSH command was executed there was at least one job step which completed successfully and had \$RC/\$MRC set to 0000.

Similar to job SAMPLE2 you can specify an ON \$CANCEL GOTO label to handle an operator's CANCEL or PFLUSH.

Notes:

1. No matter, whether a job step terminated normally or abnormally or whether it was canceled by the operator: the job accounting routine \$JOBACCT (see *Guide to System Functions* manual) is executed in any case. The cancel code (part of the job accounting table) indicates, whether the job step terminated normally or not. For cancel codes see chapter *VSE/Advanced Functions Cancel Codes* in the *Messages and Codes* manual.
2. Conditions which cause (normal or abnormal) termination of an application program can be handled by exit routines established by STXIT macros (see *System Macros Reference* manual for details). For example, program PGMCHECK from above can be modified to simply ignore the program check (operation exception):

```

                                PUNCH ' PHASE PGMCHECK,S'
                                BASR 4,0                                ESTABLISH ADDRESSABILITY
                                USING *,4
                                STXIT PC,PCRTN,PCSAV                    SET UP PROGRAM CHECK LINK
                                DC XL2'0000'                            CAUSE PROGRAM CHECK
                                EOJ                                       NORMAL TERMINATION
PCRTN BASR 4,0                                ESTABLISH ADDRESSABILITY
      USING *,4
      WTO '*** PC EXIT: PROGRAM CHECK IS IGNORED.'
```

```

PCSAV      EXIT  PC                RETURN FROM EXIT ROUTINE
           DS    (SVULNGTH)X'00'  SAVE AREA
           MAPSAVAR                MAP SAVE AREA
           END

```

In this case, the jobs SAMPLE1 or SAMPLE2 terminate normally and the action specified in an ON \$ABEND statement is not carried out.

Many IBM and vendor programs use STXIT to establish AB or PC exits. For example the Language Environment (LE/VSE) handles conditions raised by program interrupts or abends, provided the runtime option TRAP(ON) is in effect. If a program causes a program check in the LE runtime-environment, message CEE3321C is displayed rather than message 0S03I. For details see chapter *Understanding Abend Codes and VSE Cancel Codes* in the *LE/VSE Debugging Guide and Run-Time Messages* manual.

Job Control Error Handling

This chapter discusses job control errors and related messages, how they are affected by certain options (such as ACANCEL, JCANCEL, and SCANCEL) and how they can be trapped with ON \$CANCEL.

Job control error messages have prefix 1 followed by a letter other than H, I, P, Q, R, and V. They may have different action indicators, such as I (Information), D (Decision) or A (Action). One and the same message can appear with different action indicators. The action indicator depends on

1. the way the message is internally defined.
2. certain options (such as ACANCEL, JCANCEL, and SCANCEL). Unless otherwise stated we assume that the default options (NOACANCEL, NOJCANCEL and NOSCANCEL) are in effect.
3. whether the erroneous statement was read from SYSRDR or from SYSLOG.

There is a minority of job control messages that appear as I-type only: for example message 1S55I on SYSLST (provided OPTION LOG is in effect) and on SYSLOG, if the corresponding EXEC statement was issued from SYSLOG. Another example is message 1U76I in the output of the JCLEXIT command, which is written to SYSLOG, not to SYSLST. These pure I-type messages appear as responses to *valid* commands (such as EXEC or JCLEXIT in the examples above). If OPTION NOLOG is in effect, neither the valid command nor the subsequent I-type message is written to SYSLST.

There is another minority of job control messages that appear as D-type only, for example message 1I00D (READY FOR COMMUNICATIONS).

The majority of job control messages appear as both I-type and D-type (or A-type) message. These kind of messages appear as responses to *invalid* commands, therefore they are *error messages*. Both the invalid command and the subsequent error message are written to SYSLOG and SYSLST, regardless whether LOG and OPTION LOG are in effect or not. If an error message appears as I-type message, the job is cancelled, if it appears as D-type (or A-type) message, the system waits for an operator response. Let's consider two examples:

```

// JOB EXAMPLE1                                // JOB EXAMPLE2
// EXEC LSERV,SIZE=64K,PARM='PARSTD=BG',GRACE  // EXEC NOTTHERE
/;&                                           /;&

```

Job EXAMPLE1 will issue a D-type message

```
1S08D  INVALID STATEMENT.
```

and the fourth digit in the message identifier is pointing to the operand in error. In this case it is the 8th operand, that is the GRACE operand which should have been spelled as TRACE. When using this field count, you must start counting with 1 (for the // at the very left side of the statement) and move to the right by incrementing 1 when one of the following field separators (so-called scan stop characters) appears: blank, comma or equal sign. Items enclosed within apostrophes (for example 'PARSTD=BG') are counted as *one* field, even if they contain field separators, such as the equal sign in 'PARSTD=BG'. For more details see the beginning of chapter *1-Prefix VSE/ESA Messages* in the *Messages and Codes* manual.

1S0nt is one of the messages which are internally defined as D-type messages. This is because they relate to errors which are supposed to be corrected by the operator easily and immediately.

We assume that phase NOTTHERE is not in the LIBDEF phase search chain. Then job EXAMPLE2 will issue an I-type message

```
1U53I  PROGRAM NOT FOUND.
```

and job EXAMPLE2 is cancelled, that is the rest of the job's statements are flushed.

1U5nt is one of the messages which are internally defined as I-type messages and raise an internal cancel condition. This is because they relate to severe errors which are not only caused by the one preceding statement. In job EXAMPLE2 message 1U5nt can be caused by a typo, by a missing LIBDEF statement or by a programmer who forgot to catalog NOTTHERE. It is unlikely that an operator can determine the reason of the error message and correct the problem.

In case of multiple job steps, message 1U5nt and the subsequent messages can cause some confusion. If the first job steps completed successfully and passed return codes of 0 (see "How Job Control Handles Program Return Codes, ABEND and CANCEL Conditions" on page 107), then the failing EXEC NOTTHERE job step will produce the following output in job EXAMPLE3 (for program SETRC0 see page 109):

```
// JOB EXAMPLE3
// EXEC SETRC0    CAUSE UPDATE $RC=0000 and $MRC=0000
// EXEC NOTTHERE
/&
```

```
1U53I  PROGRAM NOT FOUND.
1I70I  JOB EXAMPLE3 CANCELLED DUE TO CONTROL STATEMENT ERROR
1S78I  JOB TERMINATED DUE TO PROGRAM ABEND
EOJ EXAMPLE3  MAX.RETURN CODE=0000
```

The second job step in EXAMPLE3 caused an I-type job control error message. Program NOTTHERE could not be executed, and hence could not cause an update of \$RC/\$MRC. At end-of-job time \$RC contains its initial value (from EXEC processing) and \$MRC contains 0000 (from EXEC SETRC0), which is displayed in the end-of-job message. If you want your end-of-job message to reflect job control problems by a special return code (for example 0333, compare page 109) you can modify job SAMPLE3 as follows. Note that you need to specify the SCANCEL option to have the internal cancel condition trapped by ON \$CANCEL.

```
// JOB EXAMPLE3
// ON $CANCEL GOTO JCLERROR
```

```
// ON $RC=333 CONTINUE
// OPTION SCANCEL TRAP JCL INTERNAL CANCEL CONDITIONS
// EXEC SETRC0 CAUSE UPDATE $RC=0000 and $MRC=0000
// EXEC NOTTHERE
// GOTO ENDOFJOB
/. JCLERROR
SET MRCZERO RE-INITIALIZE $MRC
// EXEC SETRC333 CAUSE UPDATE $RC=0333 and $MRC=0333
/. ENDOFJOB
/ &
```

```
1U53I PROGRAM NOT FOUND.
1I70I JOB EXAMPLE3 CANCELLED DUE TO CONTROL STATEMENT ERROR
EOJ EXAMPLE3 MAX.RETURN CODE=0333
```

So job control error messages may appear as I-type messages (serious error causing an internal cancel condition) or as D-type messages (easy to correct error waiting for operator response).

If you run in an unattended environment, you may want all job control error messages to appear as I-type messages. This can be achieved by specifying the JCANCEL option. If option JCANCEL were in effect for job EXAMPLE1, then message 1S0nt would appear as I-type and the job would be cancelled. If both JCANCEL and SCANCEL are in effect, then you can trap any job control error with an ON \$CANCEL condition. While option JCANCEL converts *all* D-type error messages into I-type, option ACANCEL converts only those D-type messages, that are caused by incorrect ASSGN or LIBDEF statements.

On the other hand, you may want all job control error messages to appear as D-type (or A-type) messages, thus waiting for operator response. To achieve this, OPTION NOJCANCEL (the default) is a necessary condition, but not sufficient. You need to specify both NOJCANCEL and the LOG command. If you want to determine the origin of a JCL error message, which would have been displayed as I-type and would have caused an internal cancel condition, the preceding statement is not enough: you need all the job's statements to find out what went wrong or what is missing. That's why the LOG command is a reasonable prerequisite to convert I-type messages to D-type (or A-type). Let's consider the following console output:

```
// JOB EXAMPLE4
DATE 03/10/2000, CLOCK 09/08/26
// EXTENT SYS005,VOL123,4,0,150,15
1L05I INVALID LABEL SYNTAX.
1I70I JOB EXAMPLE4 CANCELLED DUE TO CONTROL STATEMENT ERROR
1S78I JOB TERMINATED DUE TO PROGRAM ABEND
EOJ EXAMPLE4
```

The EXTENT statement is syntactically correct, but nevertheless it complains about the 5th field (extent type 4). The origin of the problem (and the error message) is that the DLBL and the EXTENT statement do not match: DLBL omitted the label type, so the default SD was assumed. EXTENT however tried to specify information for an ISC or ISE label type. This example shows that you may need more than the last statement to find out the source of the problem. So option NOJCANCEL together with the LOG command allows to debug job control statements by displaying the whole sequence of statements on SYSLOG:

```
// JOB EXAMPLE4
DATE 03/10/2000, CLOCK 09/49/11
```

```
LOG
// DLBL SAMPLE, 'SAMPLE.FILE'
// EXTENT SYS005, VOL123, 4, 0, 150, 15
1L05D  INVALID LABEL SYNTAX.
```

Job Control Statement Logging

This chapter describes job control statement logging on a plain-vanilla VSE system. OEM software may enable JCL exit routines as well as vendor exit routines which change the default way of logging statements on SYSLST or SYSLOG.

In the text which follows it is assumed that SYSLST is assigned.

Job Control Statement Logging on SYSLST

Statement logging on SYSLST is controlled by the following job control statements:

- // STDOPT LOG=YES|NO for the overall system - permanent option
- // OPTION LOG|NOLOG for each individual job - temporary option
- // LOG or // NOLOG for each individual job, which is equivalent to // OPTION LOG or // OPTION NOLOG respectively.

Per default the permanent LOG option is set to YES, that is *all* job control statements are logged on SYSLST. If the permanent LOG option is set to NO, only *invalid* job control statements are logged on SYSLST.

The LOG option provided in an OPTION statement overrides the permanent STDOPT value temporarily. It is reset to the permanent STDOPT value during EOJ processing.

Note: The LOG option only controls, whether job control statements are written to SYSLST. It does not affect program output to SYSLST. For example, if your job stream contains // EXEC LSERV, then the LSERV utility output is *always* written to SYSLST, whether the LOG option is in effect or not. The LOG option however controls whether the // EXEC LSERV statement itself is written to SYSLST or not.

Job Control Statement Logging on SYSLOG

Statement logging on SYSLOG is controlled by the job control or attention routine LOG command.

Note: Do not mistake the LOG command for the // LOG statement. The LOG command controls logging on SYSLOG while the // LOG statement controls logging on SYSLST.

After the LOG command has been specified, *all* job control statements are written to SYSLOG. The LOG command remains in effect, until a subsequent NOLOG command is given. The NOLOG command does not prevent *all* job control statements from being written to SYSLOG. Some statements, which are considered to be important for the operator, are logged unconditionally on the console, such as

- // JOB statement or EOJ message caused by /&-processing.
- The * (comment) statement.
- Commands affecting the partition layout such as ALLOC or SIZE.

- Commands affecting the I/O system such as DVCUP.
- Invalid commands.

Note: There are several job control commands displaying various system information, such as MAP, QUERY, LISTIO, JCLEXIT, or DVCDN. The output of these commands (not necessarily the command itself) is always displayed on SYSLOG, even if the NOLOG command is in effect.

Job Control Comment Statements

The job control comment statement begins with the symbol '*'.

* This comment is always displayed on SYSLOG.

It is *always* written to SYSLOG, whether LOG was specified or not. The comment statement is appropriate to inform the operator about a job's purpose. If followed by a PAUSE statement, the * statement can be used to request operator action.

Programmers who write job control may want to document their JCL by comments. Such internal comments should never be displayed on SYSLOG or SYSLST, so the comment statement is not suitable. The /* statement (end-of-data indicator for programs reading from SYSRDR or SYSIPT) however can be used to insert internal comments into jobs.

/* This comment is never displayed, neither on SYSLOG nor on SYSLST.

Such kind of comments must not be inserted into input data read by programs.

If you want comments to be displayed dependent on the LOG command (SYSLOG) or the LOG option (SYSLST), then the /. label statement can be a good choice. Provided that CMT is a label never referenced by any GOTO, then you can insert comments as follows:

/. CMT This comment is displayed dependent on LOG command/option.

Figure 55 summarizes the different comments and shows whether they are displayed on SYSLOG or SYSLST.

<i>Figure 55. Logging of Comment Statements</i>		
	Logged on SYSLOG?	Logged on SYSLST?
* Comment	always	dendedent on LOG option
/* Comment	never	never
/. CMT Comment	dependent on LOG command	dendedent on LOG option

Note: If job control is in skip mode, that is a GOTO statement is being executed, then all of the above mentioned comments are skipped.

VSE Label Area – Layout and Capacity Considerations

This section presents answers to frequently asked questions, such as:

- How many labels will fit in my label area?
- How can I tell how much space is left in my label area?

Throughout the entire chapter, I assume that *your label area resides in native data space*. This is highly recommended for the sake of performance and is the default since VSE/ESA 2.4.

Before providing answers to the questions listed above, I need to explain some basic design concepts and introduce three important terms:

1. Label Information Record (abbreviated as LIR),
2. Label Area Segment (abbreviated as LAS),
3. Label Group (abbreviated as LG), which is sometimes called label subarea.

If you are not interested in technical background information, the following three sections on LIRs, LASs and LGs may be boring rather than fun. You can skip them and go to “Frequently Asked Questions” on page 121 right away. If, however, you'd like to get an idea on what's inside label processing, I encourage you to continue reading.

Label Information Record (LIR)

An LIR is the smallest unit of information contained in the label area. Its length varies from a minimum of 32 bytes to a maximum of 5204 bytes.

While a TLBL statement *always* produces one single 80-byte LIR, things are more complicated with the DLBL statement. A DLBL-EXTENT statement sequence can produce one or more LIR(s) with different lengths, depending on the:

- File type code (SD, DA, DU, ISC, ISE, VSAM) in the DLBL and
- Number of EXTENT statements following the DLBL statement.

Consider the following sample DLBL-EXTENT statement sequences:

```
* SAMPLE1                                * SAMPLE2
// DLBL FILNAME, 'FILE ID', 2002/365, SD // DLBL IJDFILE, 'POWER.DATA.FILE', 99/365, DA
// EXTENT SYS005, 000020, 1, 0, 10, 2010 // EXTENT SYS002, , 1, 0, 15, 90
// EXTENT SYS005, 000020, 1, 1, 4000, 1510 // EXTENT SYS002, , 1, 1, 105, 60
// EXTENT SYS006, 000100, 1, 2, 64, 1300 // EXTENT SYS003, , 1, 2, 165, 90
* No more EXTENT statements follow      * No more EXTENT statements follow
```

SAMPLE1 produces 3 LIRs, each 104 bytes long; while SAMPLE2 produces 1 LIR, 144 bytes long. Why?

Basically it takes 84 bytes to store the information contained in one DLBL card and 20 bytes to store the information in one EXTENT card. How these 84-byte and 20-byte chunks are composed to make up an LIR depends on the file type code (and its access method). For non-sequential files (file type codes other than SD or DU), a DLBL-EXTENT statement sequence produces one single LIR with a length of $84+(n*20)$ bytes, where n denotes the number of EXTENT statements.

For sequential files (file type code SD or DU), a DLBL-EXTENT statement sequence produces n LIRs with a length of $84+20=104$ bytes each, where again n denotes the number of EXTENT statements.

Figure 56 shows the different kinds of LIR-producing job control statements and the number and length of LIRs being produced.

Figure 56. Different Lengths of Label Information Records

TLBL/DLBL-EXTENT Statement	Corresponding LIR(s)
TLBL	80-byte LIR
DLBL...SD DU – no EXTENT statement following	84-byte LIR
DLBL...DA ISC ISE – no EXTENT statement following	invalid
DLBL...VSAM – no EXTENT statement following	84-byte LIR plus one additional 32-byte LIR ²
DLBL...SD DU – n EXTENT statements following	n LIRs, 104-byte each
DLBL...DA ISC ISE – n EXTENT statements following	1 LIR, 84+n*20 bytes long
DLBL...VSAM – n EXTENT statements following	(84+n*20)-byte LIR plus one additional 32-byte LIR ²

If you want to know how many LIRs are currently stored in your label area, you can write a program invoking appropriate LABEL macro requests. Or you simply have a REXX procedure inspect the output of the LSERV utility:

```

/* REXX
i=0
i=I+1; cd.i = '* $$ JOB JNM=LSERV,CLASS=C,LOG=NO' /* Provide job input stem */
i=I+1; cd.i = '// JOB LSERV'
i=I+1; cd.i = '// EXEC LSERV'
i=I+1; cd.i = '/&'
i=I+1; cd.i = '* $$ EOJ'
cd.0 = i
ADDRESS POWER /* Have POWER execute job stem */
"PUTQE RDR JOBNAME LSERV JOBNUM JOBNR WAIT 500 STEM cd."
"GETQE LST JOBNAME LSERV JOBNUM" JOBNR "STEM lserv."

```

Figure 57 (Part 1 of 2). REXX Procedure for Inspecting LSERV Utility Output

² only if VSAM-specific operands such as DISP, RECORDS, RECSIZE, BUFND, or BUFNI are specified

```

tlblind = 'GENERATION NUMBER'          /* TLBL card identifier      */
dlblind = 'FILE TYPE'                  /* DLBL card identifier      */
extntind = 'EXTENT SEQUENCE NUMBER'    /* EXTENT card identifier    */
extnthdr = 'EXTENT INFORMATION          OMITTED'
vsamind = 'ADDITIONAL INFORMATION'     /* 2nd LIR for type code VSAM */
sequind = 'SEQUENTIAL'                 /* file type code SD or DU   */
bytes = 0; lirs = 0; dlbls = 0; tlbls = 0 /* initialize counts        */
do i=1 to lserv.0                       /* examine LSERV output lines */
  select                                 /*                            */
    when pos(tlblind,lserv.i) = 11 then do /* TLBL identifier in column 11 */
      bytes = bytes+80+2                /* TLBL LIR is 80 + length info */
      tlbls = tlbls+1; lirs = lirs+1; end /* Increment TLBL and LIR count */
    when pos(dlblind,lserv.i) = 11 then do /* DLBL identifier in column 11 */
      dlbls = dlbls+1                  /* Increment DLBL count       */
      if pos(sequind,lserv.i) = 56 then /* file type code SD or DU   */
        flag = 0                       /* set switch for EXTENT info */
      else do                            /*                            */
        flag = 1                        /* set switch for EXTENT info */
        bytes=bytes+84+2; lirs = lirs+1; end /* DLBL card info is 84...   */
      end                               /* ...plus 2 byte length info */
    when (pos(extnthdr,lserv.i) = 6),    /* EXTENT information omitted... */
      & (flag = 0) then do              /* ...for SD or DU file      */
      bytes = bytes+84+2; lirs = lirs+1; end /* SD|DU file without EXTENTS */
    when pos(vsamind,lserv.i) = 6 then do /* 2nd LIR for file type code... */
      bytes = bytes+32+2; lirs = lirs+1; end /* ...VSAM is 32 bytes long  */
    when pos(extntind,lserv.i) = 11 then do /* EXTENT identifier column 11 */
      if flag = 1 then                  /* EXTENT info for non-sequentl */
        bytes = bytes + 20              /* add 20 bytes for each EXTENT */
      else do                            /*                            */
        bytes=bytes+104+2; lirs = lirs+1; end /* SD/DU duplicates DLBL info */
      end                               /*                            */
    otherwise nop                       /*                            */
  end
end
say 'Number of LIRs currently stored in label area:' lirs
say 'Bytes needed to store all LIRs :' bytes
say 'DLBL statements currently active:' dlbls
say 'TLBL statements currently active:' tlbls
say 'Average number of DLBL/TLBLs accommodated in one LAS:' ,
2048 % ((bytes % (dlbls+tlbls))+1)

```

Figure 57 (Part 2 of 2). REXX Procedure for Inspecting LSERV Utility Output

Notes:

1. The number of labels displayed in the DITTO DLA (Display Label Area) function is *not* the number of LIRs. DITTO DLA does not consider multiple LIRs produced by one single DLBL-EXTENT statement sequence. For example, DITTO counts both the label information for FILNAME and IJDFILE as 1. See SAMPLE1 and SAMPLE2 on page 116.

Also, the label number displayed by DITTO DLA is not necessarily the number of DLBL and TLBL statements submitted. If the filenames used in your DLBL/TLBL statements are unique per label group, then both numbers match. If, however, you submit duplicate label information for one and the same filename, such as:

```
// TLBL TAPEFIL,'TAPE.OUTPUT.FILE'      (might be hidden in a PROC)
// TLBL TAPEFIL,'TAPE.OUTPUT.FILE',30
```

then DITTO will count them as one. Note that OPEN processing would pick up the first LIR for TAPEFIL, resulting in a 0-day retention period.

2. Neither LSERV output nor DITTO DLA output contain information on free-usage labels. If you have vendor software installed which exploits free-usage labels, the total amount of LIRs in your label area may be higher than the number displayed by the REXX procedure.
3. When an LIR is stored in an LAS, then it is always preceded by an additional two-byte length field. That's why we need to add 2 when incrementing the bytes count in the REXX procedure.

Label Area Segment (LAS)

I assume you use the default VDISK command to define the label area in native data space:

```
VDISK UNIT=FDL, BLKS=2880, VOLID=VDIDLA, USAGE=DLA
```

In this case, the volume layout of VDIDLA is as follows:

```
Blocks 0000 through 0001: VOL1 label
Blocks 0002 through 2871: File DOS.LABEL.FILE.ON.VIRTUAL.DISK
Blocks 2872 through 2879: VTOC
```

Only 2870 512-byte blocks are available to store LIRs, because 10 blocks are needed to store VOL1 label and VTOC. These 2870 blocks build a contiguous piece of virtual storage. You can think of it byte-wise, block-wise, or *LAS-wise*.

An LAS is a 2KB chunk of virtual storage starting on a block boundary. It is the physical allocation unit to store LIRs. LAS 0 comprises blocks 2 through 5; LAS 1 comprises blocks 6 to 9; and so forth. The last LAS available is LAS 716, comprising blocks 2866 through 2869. Two blocks – 2870 and 2871 – remain unused. Phase \$IJBSLA “reads” and “writes” label data LAS-wise³.

In VSE/ESA 2.5, SIR command output contains an additional line on LAS consumption. It looks like:

```
LBL.-SEGM.= 00009          HIGH-MARK = 00026      MAX = 00717
```

The first number (9) is the number of LASs currently in use. Note that LAS 0 is always in use by the system. Thus the number of LASs currently in use is always greater than or equal to 1. The second number (26) is the maximum number of LASs used since the last IPL. The third number (717) is the number of LASs you made available with the VDISK command discussed above.

From a program, you can retrieve these three values by means of the new CPCTYLBL function of the LABEL macro. For details, see *IPL and Job Control DRM* on the VSE Collection, Disc 1 (September 2000 or later).

If the second value (HIGH-MARK) is much smaller than the third value (MAX), then you should decrease the BLKS value in the VDISK command instead of wasting virtual storage. If, for example, you find HIGH-MARK to be always less than 400, then a BLKS value of 1920 (corresponding to MAX = 00477) will be sufficient.

On the other hand, if you find HIGH-MARK coming very close to MAX, then you risk that some batch job(s) hang or cancel with message 1L1nD (LABEL AREA

³ Actually it uses the MVCL instruction to move 2KB-pieces of data from or to the data space.

EXHAUSTED). It is not possible to increase the size of the label area. The default size (BLKS=2880) is already the maximum size. If you chose a higher BLKS value (for example, BLKS=3840), then the volume layout is as follows:

Blocks 0000 through 0001: VOL1 label
Blocks 0002 through 2880: File DOS.LABEL.FILE.ON.VIRTUAL.DISK
Blocks 2881 through 3831: Free
Blocks 3832 through 3839: VTOC

This is because label processing is currently restricted to deal with a maximum of 720 LASs (corresponding to a bitmap with $720/8 = 90$ bytes). This is a compromise between the label area capacity on the one hand and system GETVIS consumption on the other. The more LASs, the longer the bitmaps.

These bitmaps map the physical organization of the label area (LASs) to its logical organization (label groups). Each non-empty label group has a bitmap of its own, reflecting which LASs belong to it.

Label Group (LG)

Most label area display utilities (such as LSERV or DITTO DLA) list labels ordered by LG, such as *class C labels* or *F2 temporary partition labels* or *system labels*. The OPTION statement and its operands (STDLABEL, CLASSTD, PARSTD, USRLABEL) determine into which LG the LIRs created by subsequent DLBL/TLBL statements go.

Think of LGs as a set of empty buckets. There are quite many of them:

- 1 bucket for internal usage (for OPTION...=DELETE processing)
- 1 bucket for system LG
- 23 buckets for class LGs
- Up to 636 buckets for partition LGs. This is because each partition may require 3 LGs (free-usage, temporary, and permanent partition LG), and you can have up to 212 partitions concurrently active, depending on the NPARTS operand of the SYS command in your IPL procedure.

As long as these buckets are empty, they will not use any system resources. When LIRs are to be put into an empty bucket, then

1. One or more LASs are allocated to store the LIRs, and
2. A 97-byte chunk of storage is required to store the bitmap and other control information.

Label processing reserves this storage for the system bucket, the 23 class buckets and the 36 static partitions buckets. It also provides a pool of 27 chunks for dynamic partition buckets.

When more than 27 dynamic partition buckets are active, then the storage requests are satisfied by system GETVIS (112 bytes, LOC=ANY).

Now we have all pieces together. DLBL/TLBL statements create LIRs. LIRs are stored in LASs, which make up the physical label area. LASs are allocated to the LG determined by the OPTION statement (STDLABEL, CLASSTD, PARSTD, or USRLABEL) preceding the DLBL/TLBL. To illustrate, let's examine the very first statements in the BG startup procedure.

When the `VDISK UNIT=PDF,BLKS=2880,VOLID=VDIDLA,USAGE=DLA` command is executed during BG startup, all buckets are empty. LAS 0 is reserved for system use, and LAS 1 through 716 are available to store LIRs.

The `EXEC PROC=STDLABEL` statement is processed next, with `// OPTION STDLABEL` at the very top of `STDLABEL.PROC`. At this point, all following label information will be directed into the system LG, which is still empty. That is, it has no LASs allocated to it.

As soon as the first `DLBL-EXTENT` statement sequences and `TLBL` statements are processed, LAS 1 is allocated to store the corresponding LIRs. When LAS 1 is full, LAS 2 is allocated, and so on.

`EXEC PROC=STDLABUP` is executed next. Since `OPTION STDLABEL` is still in effect, all LIRs are stored in LASs allocated to the system LG.

On the VSE 2.5 system as shipped by IBM, it takes 5 LASs to store all system standard labels. Procedure `STDLABUS` is executed next, which only contains `OPTION` statements (no `DLBL` or `TLBL` follows). Thus the corresponding LG buckets remain empty and have no LASs allocated to them. Finally, the last statement in `STDLABEL.PROC` is executed, which is a `// OPTION USRLABEL` to have any subsequent LIRs stored in BG's temporary partition LG instead of in the system LG.

When foreground or dynamic partitions get active and they submit `DLBL` or `TLBL` statements, then a free LAS will be allocated to the individual partition's LG (temporary or permanent) to store the corresponding LIRs.

Frequently Asked Questions

How many labels will fit into my label area?

It depends on:

- Label area size (BLKS operand in `VDISK...USAGE=DLA` command).

The default is 717 LASs or 1434K.

- The kind of labels you deal with – tape labels (`TLBL`) or disk labels (`DLBL`).

For disk labels, the number and length of the LIR(s) depend on the file type code (SD, DA, DU, ISC, ISE, VSAM) and the number of EXTENTS. If multi-extent files are the exception (and not the rule), then assume an average of 128 bytes per `DLBL-EXTENT` statement sequence or `TLBL` as a rule of thumb.

With this assumption, an LAS can hold the LIRs corresponding to 16 `DLBL-EXTENT` statement sequences or `TLBL`s. If you had only the system LG and all 717 LASs allocated to it, then the default label area would hold all LIRs corresponding to $717 * 16 = 11472$ `DLBL-EXTENT` statement sequences or `TLBL` statements.

Our assumption that an LAS contains the LIRs corresponding to 16 `DLBL-EXTENT` statement sequences or `TLBL` statements must not be true for your site. A more reliable estimate is the number **k**, which is displayed by the

the last “say” instruction in the REXX procedure⁴. On the VSE 2.5 system as shipped by IBM, this number is 19 rather than 16.

- The number of non-empty LGs, especially those belonging to dynamic partitions.

Suppose you have class P enabled with maximal 32 dynamic partitions. Further suppose all 32 class P partitions are active and submit one single DLBL/EXTENT sequence for a sequential file. This will allocate 32 LASs (one for each temporary partition LG), each one containing one single LIR.

If you submitted the 32 DLBL/EXTENT sequences to the class P LG, then 2 LASs would be enough to store 32 LIRs. In both cases, the label area contains the same 32 LIRs. In the first case, they occupy 32 LASs; in the second case, only two!

The situation can be even worse if you have multiple VSE jobs in one VSE/POWER job, with the need for permanent dynamic partition labels or a vendor product active with the need of free-usage labels. As a rule of thumb, your label area should accommodate at least the LIRs created by:

$$(717 - i * \text{NPARTS} - 25) * k$$

DLBL-EXTENT statement sequences or TLBL statements.

k denotes the average number of DLBL/TLBL statements covered by one LAS, as displayed by the REXX procedure⁴.

i is the average number of non-empty LGs associated with each partition. Set **i** to 0, when you deal exclusively with system and class labels (no partition labels). Set **i** to 1 if each partition will submit label information in only 1 LG (either free-usage, temporary, or permanent partition LG) and to 2 or 3 respectively. Your LSERV output can give you a rough guess which value for **i** is adequate for your site.

In the VSE 2.5 system as shipped by IBM, **k** is 19, **i** is 1 (because I only deal with temporary partition labels), and NPARTS is 12 (the default). Thus you can accommodate label information created by approximately 12900 DLBL-EXTENT statement sequences or TLBL statements.

How can I tell how much space is left in my label area?

With the additional line in the SIR command's output⁵, the answer to this question is trivial. So let's discuss the question *What can I do when there is almost no space left in my label area?* An answer to this can be found by inspecting the LSERV output at peak times.

There are basically two approaches in order to free LASs.

1. If you find not so many labels (well below 10000) contained in many (more than 100) LGs, then the bottleneck might be caused by many (dynamic) partitions submitting label information into probably different partition LGs.

Try to re-arrange LGs. That is, try to exploit the class LG instead of using permanent and temporary partition LG for each single dynamic partition belonging to this class. Re-arranging LGs is always recommended when you

⁴ See “Label Information Record (LIR)” on page 116.

⁵ See “Label Area Segment (LAS)” on page 119 for details.

have many non-empty dynamic partition LGs containing only few (5 or less) labels.

A general recommendation – especially when enabling all 23 classes available in VSE/ESA 2.5 – is to store label information in the class LG, rather than in each individual partition's permanent or temporary LG.

2. If you find many labels (10000 or more) contained in few (less than 50) LGs, then re-arranging the LGs won't help much. You should inspect label-submitting jobs or PROCs and check whether all this label information – especially for multi-extent sequential files – is required all the time or only for one particular job step.

In terms of LAS consumption, it is always better to provide temporary label information for each job step, rather than for the whole job. This may reduce the number of LIRs and free LASs, unless you really need to process thousands of files at a time.

To illustrate, consider a job with 20 job steps, each step dealing with five step-specific disk files, and thus requiring five DLBLs. If your job first submits 100 DLBL statements, followed by 20 EXEC statements, then the temporary partition LG may need seven LASs. If, however, five step-specific DLBL statements precede each EXEC statement, then one single LAS is enough.

The same is true if you consider a VSE/POWER job containing multiple VSE jobs. In terms of LAS consumption, it is always better to put VSE job-specific label information in each individual job, rather than putting all label information in the first VSE job (via OPTION PARSTD).

Again, consider a VSE/POWER job containing 20 VSE jobs, each dealing with five job-specific disk files and thus requiring five DLBLs. If the first VSE job contained in the VSE/POWER job submits 100 DLBL statements to the partition's permanent LG, this may require seven LASs, whereas you need only one LAS to store each job's DLBLs in the partition's temporary LG.

Bottom line: If you have very specific label information required by only one or few jobs (or job steps) in a single partition, then submit it just in time to the partition's temporary LG. If you have label information common to many jobs in several partitions, submit it to the system or class LG rather than duplicating label information in the individual partition LGs.

What are free-usage labels for?

Each partition has a free-usage LG of its own, which will *never* be touched by job control processing. That is, there are no job control statements to manipulate it.

It is up to third-party products to make use of it by means of the LABEL macro. The free-usage LG is important in terms of the label information search order, because it is ahead of the LGs administered by job control. As a matter of fact, the *VSE/ESA Guide to System Functions* manual conceals the existence of free-usage LGs in order to avoid confusion.

The true and complete label search sequence for GETLBL requests (as invoked by OPEN processing) is as follows:

- For static partitions and dynamic partitions with non-empty permanent partition LG:
 1. Free-usage partition LG

2. Temporary partition LG
 3. Permanent partition LG
 4. System LG
- For dynamic partitions with empty permanent LG:
 1. Free-usage partition LG
 2. Temporary partition LG
 3. Class LG
 4. System LG

Is there a correlation between DLBL/TLBL statements and GETVIS consumption?

In case of dynamic partitions, there is a common misunderstanding about an apparent correlation between *dynamic space* GETVIS consumption on the one hand and TLBL/DLBL statements submitted on the other.

As we know by now, TLBL/DLBL statements produce LIRs, which are stored in LASs (2KB pieces of the data space). LASs are allocated to the respective LG. This allocation is reflected by a bitmap, which is either stored in a reserved pool of slots or in a 112-byte chunk of system GETVIS (LOC=ANY).

Thus there obviously is a correlation between the number of non-empty LGs and the consumption of system GETVIS (LOC=ANY). In the worst case, when 212 partitions are active using *all* three partition-related LGs (free-usage, temporary, and permanent), a little less than 63KB of system GETVIS (LOC=ANY) is required to store the bitmaps.

Are there any other storage requirements related to label processing?

1. In SVA 24, there is one 12KB chunk reserved for label processing. Furthermore, for each static partition, there is one 8KB chunk required by both job control and label processing. Together, these are $12 + 12 \cdot 8 = 108$ KB of SVA-24 storage.
2. For each dynamic partition, this above-mentioned 8KB chunk is allocated in dynamic space GETVIS. It is always there, whether the dynamic partition submits DLBL/TLBL statements or not.
3. For each partition, label processing tracks GETLBL/GETNXL requests in the so-called history table. Place for 39 history table entries is provided in the 8KB chunk mentioned above.

If a program needs to open more than 39 files, then the history table needs to be extended. Each 1104-byte extension is located in a GETVIS (SPACE=YES) subpool, the identifier of which starts with character string *IJBS*. It can be easily found in the output of GETVIS SVA,DETAIL.

Is the DLA statement still required when using virtual label area?

You may have wondered why the EXEC PROC=STDLABEL appears twice in your BG startup procedure. As a matter of fact, the standard \$0JCL.PROC starts as follows:

```
⋮  
// EXEC PROC=STDLABEL  
// VDISK UNIT=FDF, BLKS=2880, VOLID=VDIDLA, USAGE=DLA  
// EXEC PROC=STDLABEL
```

The first EXEC PROC will submit label information to the label area on a physical disk, as defined by the IPL DLA command. The VDISK...USAGE=DLA command defines a data space, in which all subsequently submitted label information is to be stored. At this point, all label information residing on physical disk will be ignored. All LABEL macro requests access label information residing in data space and disregard label information on physical disk.

So is the first EXEC PROC redundant? The answer is no. It is absolutely mandatory, especially if you run your system with SEC=YES. We need to provide system label information on the non-volatile physical disk, because it will be needed during *the next IPL* at a time when the VDISK is not yet available.

The Librarian security interface module (INLPLSIM, also IJBLBIPL) issues GETLBL requests for system libraries such as IJSYSRS. If no label information is found, this module will notify a security violation. This is why we need to duplicate system label information, one copy on physical disk needed during the next IPL and another copy on data space for the current system startup.

The default size of the label area on physical disk is three cylinders if located on a CKD device and 200 blocks (that is 50 LASs) if located on an FBA device. On CKD, a LAS (the allocation unit) is one track providing space for 54 LIRs (each 104 byte long). Thus the default size is abundant, since you only need to store system label information on physical disk.

How does /&-processing or program termination affect the lifetime of the different LGs?

There is a set of rules which needs to be considered when answering this question.

1. The OPTION statement with operands STDLABEL, CLASSTD, PARSTD or USRLABEL determines to which LG (think of it as a bucket) the subsequently submitted label information goes. Each OPTION (STDLABEL, CLASSTD, PARSTD or USRLABEL) immediately overwrites the preceding one. Program termination⁶, /&- or JOB-processing will reset the OPTION to its default, which is USRLABEL.

There are two differences between OPTION xxx on the one hand and OPTION xxx=ADD on the other:

- a. OPTION xxx=ADD only points to the bucket, where subsequent label information is to be stored. If the selected bucket is non-empty, all subsequent label information will be added to the existing one. Existing label information is preserved.

OPTION xxx will first empty the corresponding bucket and then point to it. Existing label information is destroyed.

- b. OPTION xxx does not check whether subsequent DLBLs or TLBLs specify identical filenames.

OPTION xxx=ADD checks for identical filenames and complains with message 1L30D (LABEL WITH SAME FILENAME IN SUBAREA) if necessary.

⁶ The term "program termination" (or "end of job step") denotes the program swap, which takes place when an application program gives control back to the VSE operating system and a new copy of the job control program is loaded into the partition.

2. The buckets for free-usage labels remain empty, unless a third-party program decides to write label information into the partition's free usage LG. It is up to the third-party program to delete this label information or to empty the bucket.
Job control statements will never touch free-usage labels. Therefore, they survive both program termination and /&-processing.
3. The buckets for partition permanent, class, and system labels survive both program termination and /&-processing. Dynamic partition permanent buckets will be emptied, however, during the processing of * \$\$ EOJ.
4. Partition temporary labels are cleared during /&- or JOB-processing. They are affected by program termination in the following way – when a new copy of the job control program is loaded into the partition, then diverse switches have their proper initial value. One of these switches controls what has to be done when a DLBL-EXTENT statement sequence or TLBL statement is to be processed.

Initially this switch is off, saying “Clear the partition's temporary LG before processing the DLBL-EXTENT statement sequence or TLBL statement.” After processing the DLBL-EXTENT statement sequence or TLBL statement, the switch is turned on, saying “Don't clear the partition's temporary LG.”

To illustrate, let's examine the following sample job

```
// JOB SAMPLE           1
// DLBL TEMP1          2
// OPTION PARSTD=ADD   3
// DLBL PERM           4
// EXEC LSERV JOBSTEP 1 5
// EXEC LSERV JOBSTEP 2 6
// DLBL TEMP2          7
// EXEC LSERV JOBSTEP 3 8
/&                       9
```

Statement **1** clears the partition's temporary LG. There was no OPTION statement so far. The default option (USRLABEL) is in effect, therefore; and statement **2** submits label information for filename TEMP1 into the partition's temporary LG.

Statement **3** overwrites the default (USRLABEL) in effect so far, and statement **4** submits label information for filename PERM into the partition's permanent LG.

Statement **5** gives control to program LSERV. When the job control program is back in the partition, the above-mentioned switch is off; and any following DLBL or TLBL would cause the partition's temporary LG to be cleared. However, there is no DLBL/TLBL statement between the first job step and the second. Therefore, both LSERV outputs (statements **5** and **6**) contain label information for filename TEMP1.

Since the preceding job steps caused the default option (USRLABEL) to be put in effect again and the switch is off, statement **7** first clears the partition's temporary LG (so TEMP1 is gone) and then submits label information for filename TEMP2 into the partition's temporary LG.

The third job step (statement **8**) displays label information for TEMP2 (not for TEMP1), and the /&-statement finally clears the partition's temporary LG (statement **9**). Then TEMP2 is gone as well.

Notes:

- a. If you submit job SAMPLE into the same partition for a second time, then the system issues message 1L30D when processing statement **4**.
- b. If you execute a REXX procedure instead of a program (that is, you replace EXEC LSERV by EXEC REXX=WHATEVER), then you find the same behavior in terms of partition labels as before. This is because an EOJ macro is issued at the end of EXEC REXX processing, which causes a new copy of the job control program to be loaded into the partition.

Chapter 6. VSE/POWER

Overview

In the past VSE/POWER has improved its reliability, availability and ease of use by introducing new functions either by new VSE/POWER releases or by APARs. Due the fact that information about service APARs is not so well known by customers, information about especially useful APARs is summarized here in the first part of this chapter.

- “New SET Statements for VSE/POWER Startup”
- “New CUIF Operand for Queue Manipulation and Enhanced Feedback in Message 1R88I” on page 134
- “Schedule VSE/POWER-Job More Than Once Per Day” on page 134
- “Command Driven Job Output Segmentation” on page 138
- “Internal Queue Entry Number Used in Displays and Commands” on page 142
- “Showing Partition in Which Active Job Runs” on page 143
- “Transmission Queue Disposition” on page 144
- “Drop 'Last-One' and Print Shorter Separator Page” on page 145
- “RJE,SNA RUSIZE Increased from 256 Bytes to 4096 Bytes” on page 146
- “New PICKUP Operand for VSE/POWER POFFLOAD” on page 147

The second part of this chapter deals with special hints on tape handling, output spooling and PNET via TCP/IP.

- “VSE/POWER Tape Processing” on page 149
- “When Print Output is Misaligned” on page 152
- “VSE/POWER Spooling Considerations” on page 154
- “TCP/IP Connection to RSCS” on page 156

New SET Statements for VSE/POWER Startup

To solve customer requirements, VSE/POWER has introduced new SET statements. This allows system administrators to customize VSE/POWER startup options without re-assembling the POWER macro. For availability of these new SET statements see table of applicable APARs at the bottom of this section.

- SET AUTONAME=FLUSH|HOLD
- SET CONFIRM=power-cmd
- SET DLSEP=YES|FORCE
- SET DYNOUTCL=DYNCL
- SET GETVQFL=ANY
- SET INTFLUSH=OPER
- SET LONGCMD=power-cmd
- SET OUTEXIT=SAS
- SET 1R33D=FLUSH|IGNORE

SET: Setting VSE/POWER Startup Control Values

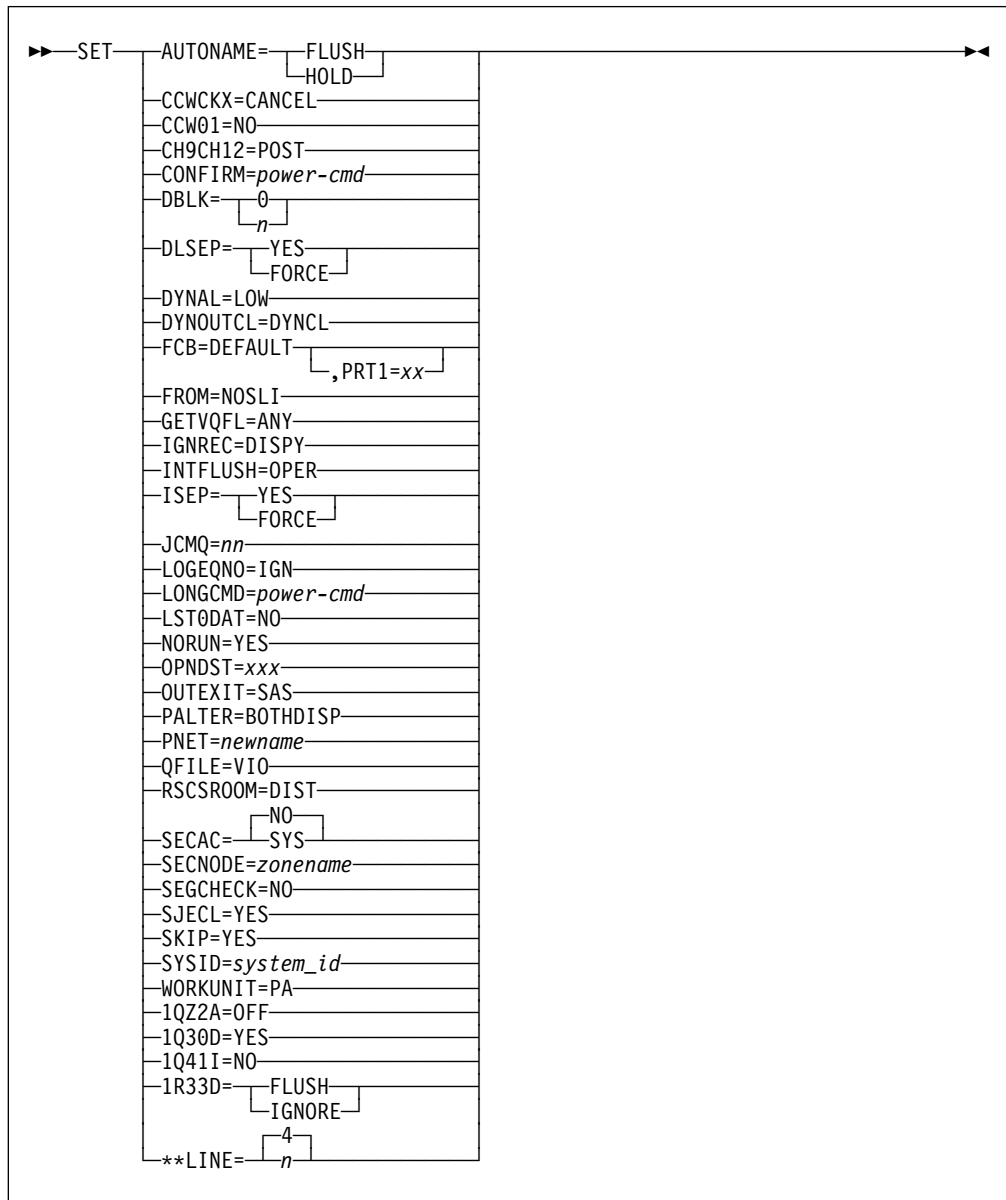

Figure 58. VSE/POWER SET Command

The operand descriptions not provided here can be found in VSE/POWER Administration & Operation 6.4, SC33-6733-00, and in VSE/POWER Administration & Operation 6.5, SC33-6733-01.

AUTONAME=FLUSH|HOLD

This operand applies to reading of job input through local or remote readers or submission from other partitions. When read-in data does not start with a valid * \$\$ JOB or // JOB statement, VSE/POWER adds it as an AUTONAME entry to the reader queue with DISP=D and CLASS=A. For details, see "Job Streams without JECL Delimiters" and "Job Streams with JECL Delimiters" in *VSE/POWER Administration & Operation*. With the following options, you can request VSE/POWER to prevent or delay processing of such AUTONAME jobs with questionable content:

FLUSH

will delete AUTONAME jobs immediately

HOLD

will add AUTONAME jobs to the reader queue with disposition HOLD.

In both cases, the local or remote operator, or the submitting program, is informed by message 1Q3HI.

Note: Whenever you use SET AUTONAME=, you should not specify AUTONAME as the intended jobname or submit * \$\$ JOB statements without the JNM= operand. Otherwise, the FLUSH|HOLD option will also apply to these jobs.

CONFIRM=power-cmd{,qualifier}

Use this operand to request confirmation of the specified VSE/POWER command (long form), provided the command is issued by the central (local) operator. Confirmation is requested by prompting message 1QZ3D CONFIRM COMMAND 'power-command' BY 'YES', ELSE 'NO'. For example SET CONFIRM=PEND will then prompt operator with

```
1QZ3D CONFIRM PROCESSING OF 'PEND' BY 'YES', ELSE 'NO'
```

If a qualifier is specified together with the VSE/POWER command then this specific command format will request confirmation. Currently only the following power-command,qualifier combinations are accepted by VSE/POWER:

```
PSTOP, PART
```

Note: As soon as you specify for example CONFIRM=PSTOP and CONFIRM=PSTOP,PART confirmation message 1QZ3D will be issued twice for a 'PSTOP partition' command.

DLSEP=YES|FORCE

Use DLSEP if you want to drop the 'Last-One' separator page for every list output. Via autostart statement SET **LINE you can define the size of the separator page by specifying how many perforation lines (normally, when DLSEP is not specified, 8 identical lines, starting with '*****') are printed. If 'SET **LINE=n' is not specified, a default of 4 perforation lines is printed. VSE/POWER takes the number of separator pages from the JSEP operand of the POWER generation macro.

If JSEP=0 was specified in the POWER generation macro, VSE/POWER will print no separator page for DLSEP=YES. Use DLSEP=FORCE to enforce one separator page.

DLSEP is useful when output is printed on a single sheet laser printer emulating an IBM endless forms printer. A single sheet has no perforation to be printed over, so the separator page should be shorter and the 'Last-One' separator page should be dropped.

Figure 59. Influencing Separator Pages and Layout

Invoke and influence printing function by	Number of separator pages/cards determined from	'Last-one' identical to all previous separator pages
PSTART LST/PUN	JSEP=n value of POWER macro, optional overwrite by <ul style="list-style-type: none"> JSEP value of * \$\$ LST SPLONSEP value of PUT-OPEN 	NO
SET DLSEP=YES and PSTART LST	same as above	not applicable
Set ISEP=YES and PSTART LST	same as above	YES
PSTART LST,....,ISEPJ	same as above	YES
PSTART LST/PUN,....,SEP	JSEP=n value of POWER macro, (without overwrite facility) if n=0, force n=1	NO
Set DLSEP=FORCE and PSTART LST	same as above	not applicable
Set ISEP=YES and PSTART LST	same as above	YES
PSTART LST,....,ISEP	same as above	YES
PSTART LST,....,DLSEP	same as above, no 'last-1'	not applicable
PSTART LST/PUN,....,NOSEP	0	not applicable

INTFLUSH=OPER

This operand applies to job execution: When a job is flushed by the operator, VSE/POWER passes the rest of the job stream to Job Control, when Job Control is in GOTO mode ("ON \$CANCEL GOTO label"). To cause VSE/POWER to act equally in case of internal flushing, use "SET INTFLUSH=OPER". Then VSE/POWER will pass the rest of the job stream to Job Control, if JOB CONTROL is in GOTO mode. For "internal flushing" refer to "Interaction with VSE/ESA Conditional Job Control Language" in *VSE/POWER Administration and Operation* .

LONGCMD=power-cmd

Use this operand to restrict the usage of the selected VSE/POWER command to its longform only.

For example SET LONGCMD=PDELETE in the autostart will reject the short command 'L queue,...' with message 1R9AI.

Note: To restrict multiple VSE/POWER commands to their longforms, repeat the SET statement for each command.

OUTEXIT=SAS

This operand enables Spool-Access GET service requests for the local LST|PUN output queue to pass control to an enabled user-written OUTEXIT routine.

1Q41I=NO

The operand applies to printing/punching output of locally executed jobs. When at real printing or punching time (PSTART LST|PUN,uu) the assigned printer or punch device is different from the printer or punch spooling device used at execution time (also called output spooling time), VSE/POWER warns you by

message 1Q41I. This happens for every output entry being addressed. Use the SET 1Q41I=NO statement to suppress message 1Q41I, if intentionally the device type at spooling time differs from the device type used for real print/punch time.

For further background on message 1Q41I see 'Showing Ignored Output Records'.

1R33D=FLUSH|IGNORE

This operand applies to job execution:

When a job is executed, VSE/POWER may detect an error in a VSE/POWER JECL statement supplied either directly in the job or by a SEGMENT macro call, and prompt the operator by message 1R33D to correct the flagged statement on the console or take other action. To avoid that the unanswered message 1R33D locks further VSE/POWER message processing, the SET statement offers two ways for an automated response and suppression of message 1R33D:

FLUSH

will show new message 1R33A and flush the job internally. The job will be retained in the RDR queue. For tracking of internally flushed jobs by Conditional Job Control refer to the SET INTFLUSH statement.

IGNORE

will show new message 1R33A and ignore the incorrect JECL statement. The job continues to run.

**LINE=n

With this operand you may influence the length of a separator page. n must be specified in the range from 1 to 8 and defines how many perforation lines (starting with '****') are printed if the LST task has been started with operand 'DLSEP'. Refer to "Drop 'Last-One' and print shorter Separator Page".

<i>Figure 60. SET Statements for VSE/POWER</i>			
SET	6.3	6.4	6.5
AUTONAME=FLUSH HOLD	DY44825	DY44844	included
CONFIRM=power-cmd	DY45597	DY45542	DY45543
DLSEP ISEP=YES FORCE	DY45592	DY45595	DY45701
DLSEP=YES	DY45597	DY45542	DY45543
DYNOUTCL=DYNCL	DY45069	DY44863	included
GETVQFL=ANY	DY44846	default	default
LONGCMD=power-cmd	DY45236	DY45251	included
INTFLUSH=OPER	DY45091	DY45095	included
OUTEXIT=SAS	DY44825	DY44844	included
1R33D=FLUSH IGNORE	DY45236	DY45251	included

New CUIF Operand for Queue Manipulation and Enhanced Feedback in Message 1R88I

The user information of jobs and outputs is often used to carry processing information and since VSE/ESA 2.3 it can be altered by PALTER queue,jobname,...,UINF=new_user_info. Now it is also possible to manipulate or display queue entries by searching for a specific user information using the new operand CUIF.

For example, PALTER LST,*OUT,CUIF=124.14.5.6,CLASS=Z,UINF=166.12.189.4 will change all LST queue entries with a jobname starting with 'OUT' and a current user information of '124.14.5.6' to class Z and new user information '166.12.189.4'.

The operand can be specified for PALTER, PDELETE, PDISPLAY, PHOLD, and PRELEASE queue commands in the same manner as in the UINF operand for the PALTER command, meaning the user information must be enclosed in quotes if it contains a blank. The operand may be specified as selection criteria for POFFLOAD SELECT.

To give the operator better information about the scope of the queue manipulation commands PALTER, PDELETE, PHOLD, and PRELEASE, the message '1R88I OK' has been extended to

```
1R88I OK : nnnnn ENTRY|ENTRIES PROCESSED BY command
```

Figure 61. New Function for VSE/POWER

Function Description	6.3	6.4	6.5
New CUIF Operand and 1R88I	DY45592	DY45595	DY45701

Schedule VSE/POWER-Job More Than Once Per Day

Summary: VSE/POWER supports a new function concerning Time Event Scheduling. Usually, dispatchable jobs run just once. Using time event scheduling parameters, a job may run more than once; for example, every first day of a month, every Monday, or even daily. Currently, a job can run only once on a specific scheduled day.

Using the new operand DUEFRQ (Due Time Frequency) in the VSE/POWER * \$\$ JOB statement, a job can be scheduled to run more than once on a specific day.

The support of DUEFRQ has been introduced by the APARs listed below:

Figure 62. New Function for VSE/POWER

SET	6.3	6.4	6.5
* \$\$ JOB ...,DUEFRQ	DY45257	DY45193	included

Detailed Description:

DUEFRQ Operand In * \$\$ JOB Statement The VSE/POWER * \$\$ JOB statement may now contain an operand which specifies a time after which a job is to be rescheduled and an ending time after which no more scheduling should occur.

DUEFRQ=(imm,11nn)

The Due Time Frequency operand specifies an interval using ii for hours and mm for minutes (from 0001 through 2359) after which the job has to be rescheduled and specifies a last time using ll for the hour and nn for the minute (from 0000 through 2400) after which the job is no longer to be scheduled for processing. Leading zeros must be specified.

This operand requires a DUETIME to be specified which defines the time when scheduling has to occur for the first time.

This operand is accepted only if DAILY or a Weekday-List has been specified for the operand DUEDAY. DUEFRQ is rejected, if a day-list has been specified for DUEDAY.

RERUN=YES must not be used for jobs with a DUEFRQ specification. Instead RERUN=NO becomes the default. Hence, if a job with a DUEFRQ specification misses a scheduling event due to system down time, the job gets scheduled at the next scheduling event.

Following samples describe the usage of the operands:

DUETIME=0000,DUEDAY=DAILY,DUEFRQ=(0030,2400)

A job with the above operands is scheduled every 30 minutes every day. If the job is read in at 3:01 p.m., the job is scheduled for the first run at 3:30 p.m.

DUETIME=0700,DUEDAY=(MON-FRI),DUEFRQ=(0100,1700)

A job with the above operands is scheduled every hour between 7 a.m. and 5 p.m. on every day from Monday through Friday (including any holidays). The first time the job is scheduled is at 7 a.m. and the last time is at 5 p.m.

If a job with the above operands is scheduled e.g. for the next run at 9 a.m. and its processing is finished after 10 a.m., the job gets rescheduled for 11 a.m. The scheduling at 10 am is missed. This behavior can not be changed by the RERUN operand.

Note: A job is scheduled every n minutes regardless how long the job needs for processing. If for example a job is scheduled every 5 minutes and is scheduled for 7:00 for the next run and finishes its processing at 7:04, the job is rescheduled for 7:05 and not for 7:09. If however the job finishes its processing at 7:06, the job is rescheduled for 7:10. As no seconds are considered when calculating the scheduling time, it even may occur that a job finishes its processing at 7:04:59 and gets rescheduled for 7:05:00.

The syntax diagram for the * \$\$ JOB statement is updated (see Figure 63 on page 136) with the following part including the operand DUEFRQ.

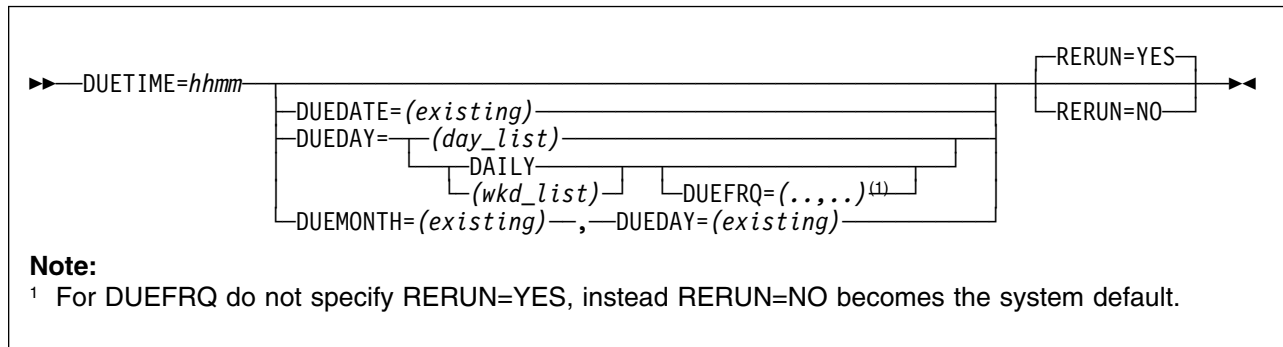

Figure 63. * \$\$ JOB statement - syntax updates including the operand DUEFRQ

Displaying The Information Of The DUEFRQ Operand: Once a job has been read in by VSE/POWER, the specified values for the DUEFRQ operand can be displayed by using the VSE/POWER PDISPLAY command together with the FULL=YES operand. The next scheduling time and date is displayed in the first line after the constant RUN=. The time in the second line after the constant DUETIME= is the time specified for DUETIME and identifies the time when the job has to be scheduled the first time for a selected day.

To demonstrate the displayed scheduling information assume the following sample jobs:

- * \$\$ JOB JNM=HUFQ001,DUETIME=0000,DUEDAY=DAILY,DUEFRQ=(0030,2400)
- * \$\$ JOB JNM=HUFQ002,DUETIME=0700,DUEDAY=(MON-FRI),DUEFRQ=(0100,1700)
- * \$\$ JOB JNM=HUFQ003,DUETIME=0600,DUEDAY=FRI,DUEFRQ=(0105,1300)

And assume they were read in on Tuesday, August 10th, 1999, at 9:15 a.m. and the subsequent display been requested immediately:

```

PDISPLAY RDR,HU*,FULL=YES

1R46I  READER QUEUE  P D C S  CARDS
1R46I  HUFQ001  01092 3 K A      3 RUN=09:30,08/10
      D=08/10/1999 DBGP=000001
      DUETIME=00:00 DUEDAY=DAILY DUEFRQ=(00:30,24:00) RERUN=NO
      QNUM=00469
1R46I  HUFQ002  01093 3 K A      3 RUN=10:00,08/10
      D=08/10/1999 DBGP=000001
      DUETIME=07:00 DUEDAY=(MON,TUE,WED,THU,FRI) DUEFRQ=(01:00,
      17:00) RERUN=NO
      QNUM=00490
1R46I  HUFQ003  01094 3 K A      3 RUN=06:00,08/13
      D=08/10/1999 DBGP=000001
      DUETIME=06:00 DUEDAY=(FRI) DUEFRQ=(01:05,13:00) RERUN=NO
      QNUM=00491

PDISPLAY WRUN

1R46I  READER QUEUE  P D C S  CARDS (WAIT FOR RUN SUBQUEUE)
1R46I  HUFQ001  01092 3 K A      3 RUN=09:30,08/10
1R46I  HUFQ002  01093 3 K A      3 RUN=10:00,08/10
1R46I  HUFQ003  01094 3 K A      3 RUN=06:00,08/13
    
```

Altering The Information Of The DUEFRQ Operand: Once a job has been read in by VSE/POWER, the specified values for the DUEFRQ operand can be nullified by using the VSE/POWER PALTER command together with the DUETIME=NULL operand. As till now, all specifications of time event scheduling time are ignored and lost.

Transferring Jobs With DUEFRQ Information To Other Systems: If a job gets read in by VSE/POWER, the DUEFRQ operand is processed and the specified values are saved for this job. If the job gets transferred to any other VSE/POWER system, this information never gets lost. The transfer may for example happen via PNET or by offloading the job to a tape and reloading it somewhere else. Whenever the job enters the reader queue the next scheduling date is calculated anew. Whenever the job is passed from one transmission queue to another transmission queue (at a store and forward node), no next scheduling date is calculated.

DUEFRQ Information On Backlevel Systems Without DUEFRQ Support: Once a job has been read in by a VSE/POWER system, the job may get transferred to another VSE/POWER system, which might be at a different level. If a job with DUEFRQ information is sent to a system without DUEFRQ support, the following is true:

1. No information about DUEFRQ is displayed when using the FULL=YES operand.
2. The next scheduling time is the value been determined as the next processing time at the originating system. The next scheduling day is calculated according to the usual rules when entering a system. (Note, the next scheduling time is the time displayed after the constant RUN= when using the PDISPLAY command.)
3. The time displayed for DUETIME is the time for the next scheduling event. This time might now differ on the receiving system from that time which was originally specified for the DUETIME operand on the transmitting system.
4. If at the sending system a job enters the transmit queue through the read-in process and is transmitted, then at the receiving system the next scheduling time is the time specified for the DUETIME operand.
5. If a job gets transferred from a system with DUEFRQ support to a system without DUEFRQ support and gets transferred back to the originating or another system with DUEFRQ support, all information of the DUEFRQ operand is available to the receiving system with DUEFRQ support.

Information Of The DUEFRQ Operand On Shared Systems: It is recommended to have all systems of a shared environment at the same service level. If however one system has included the DUEFRQ support, but the other has not, the following happens. If a job with DUEFRQ information gets processed by the system without the DUEFRQ support, the job does not get rescheduled once more for the same day. But the next scheduling date is calculated according to the next scheduling time for another day. If, next time, the job gets processed by the system with DUEFRQ support, the job may get rescheduled again for another run on the same day, as the DUEFRQ information is still available.

Interface To Application Programs: There exists also a fixed format display for programs using the spool-access support. This format is not changed or extended in order to display the information about the DUEFRQ operand. One reason for this is, that already today no day-list nor a month-list are contained within this format.

New/Changed Messages

If incorrect values have been specified for DUEFRQ, the already existing message 1Q37I is issued.

If inconsistent values have been specified for time event scheduling operands, the message 1R36I is issued. Due to the operand DUEFRQ following return codes may be issued and the explanation paragraph is updated.

1R36I *jobname jobnumber* WITH INCOMPLETE OR CONFLICTING TIME EVENT SCHEDULING PARAMETERS, RC=*nnnn*

Explanation: VSE/POWER has received an * \$\$ JOB statement with conflicting due date operands. The reason is implied by the return code (RC), which can be one of the following:

0001:

-changed- DUETIME is missing, but one of the following operands has been specified: DUEDAY, DUEMONTH, DUEDATE, DUEFRQ or RERUN.

0002-0006:

-unchanged-

0007:

-new- DUEFRQ and DUEMONTH or DUEFRQ and a day-list for DUEDAY have been specified, but are mutually exclusive.

0008:

-new- DUEFRQ has been specified and DUEDAY is missing (specify either DAILY or a weekday-list for DUEDAY).

0009:

-new- DUEFRQ and RERUN=YES have been specified, but are mutually exclusive.

0010:

-new:- DUEFRQ contains a value for the last scheduling time which is smaller than or equal to the first scheduling time as specified for the DUETIME operand.

System Action: *-unchanged-*

Programmer Response: *-unchanged-*

Operator Response: *-unchanged-*

Command Driven Job Output Segmentation

Summary: When the datafile is full and jobs continue to spool output, these jobs stall, until DBLK groups are made available, for example by deleting VSE/POWER queue entries. If the job must not be flushed, there is no way to segment the output by **command dynamically**, to process the created segment, delete it afterwards and free disk space for further processing and allow the job to continue. Even when the job is flushed by 'PFLUSH partition' command, it still stalls until at least one DBLK group becomes available, before flushing is processed (prematurely end the output with message 1Q39I, add output entry to e.g. LST queue).

With integrated APAR DY45291 both problems have been solved:

- The new PALTER operand SEGMENT=PAGE|CARD|IMM is introduced, which allows the operator to segment the output of a job by command at any time. The command can be used if already collected output of long running jobs, like CICS, should be made available at once, even when the Data File is full.

- The 'PFLUSH partition' command enables the flushed execution writer tasks to use the DBLK group cushion, which is a small share of DBLK groups kept to support critical functions. The DBLK group cushion is used only, if no other free DBLK groups are available and it is refilled as soon as DBLK groups are freed, for example when the flushed output is deleted.

The new 'PALTER...SEGMENT' command extends the three current types of job output segmentation by a new fourth type.

1. Count-Driven Output Segmentation by RBS= in * \$\$ LST|PUN statement.
2. Data-Driven Output Segmentation by multiple * \$\$ LST|PUN statements for the same spooled device.
3. Program-Driven Output Segmentation by IPWSEGM|SEGMENT macro calls in spooling program.
4. Command-Driven Output Segmentation by 'PALTER...SEGMENT' command. Although the command can be issued against any output in creation, it is **valid** only for output created by execution writer tasks.

The new 4th type of output segmentation produces output with the same attributes as the 1st type (Count-Driven Output Segmentation):

- same jobname, jobnumber, class, disposition,...
- incremented suffix number

Note: The new 'PALTER...SEGMENT=IMM' command produces output with a record count of zero, if it is used again but the execution writer task did not spool any record in between.

<i>Figure 64. New Function for VSE/POWER</i>			
Function Description	6.3	6.4	6.5
SEGMENT Job Output	DY45292	DY45291	included

With VSE/POWER 6.5, the rather long PALTER...,SEGMENT=PAGE|CARD command is still supported but the following new command is easier to use: PSEGMENT partition,cuu{,IMM}

Detailed Description

For the 'PFLUSH partition' command, the internal enabling to use the DBLK group cushion is transparent.

The PALTER command is extended by the new keyword operand **SEGMENT**, to trigger segmentation of the specified output. For example

```
PALTER LST,CICSICCF,1855,CQNUM=519,SEGMENT=PAGE
```

initiates segmentation for LST output CICSICCF,1855 which is currently created with queue entry number 519. Segmentation will be executed, when the top of the next page is reached, by spooling a Skip to Channel 1 .

Only output created by **execution writer tasks** with DISP=D|H|K|L can be segmented. For these tasks the 'PDISPLAY A,PART' has been extended to show the queue entry number (QNUM=), which must be specified in the 'PALTER...SEGMENT' command, for example

```

d a,part
- - -
F1 0001 1R48I  BG,FEC,A0I, PAUSEBG,02311,0
F1 0001 1R48I  F2,FEC,L2,  CICSICCF,01855,2
F1 0001 1R48I  F3,FEC,K3,  VTAMSTRT,01704,3
F1 0001 1R48I  F4,FEC,J4,      INACTIVE,
- - -
F1 0001 1R48I  F3,FEE,,  VTAMSTRT,01704,A      19 LINES SPOOLED,QNUM=00513
F1 0001 1R48I  F2,FEE,,  CICSICCF,01855,A      1436 LINES SPOOLED,QNUM=00519
F1 0001 1R48I  BG,FEE,,  PAUSEBG ,02311,A      7 LINES SPOOLED,QNUM=00704
F1 0001 1R48I  BG,FED,,  PAUSEBG ,02311,A      43 CARDS SPOOLED,QNUM=00699
- - -
PALTER LST,CICSICCF,1855,CQNUM=519,SEGMENT=PAGE

```

Note: To determine whether LST or PUN output is created, use the LINES or CARDS information of message 1R48I.

LINES SPOOLED

is shown for LST output.

CARDS SPOOLED

is shown for PUN output.

The command may be issued by a local operator or by a SAS program and initiates segmentation, which is then processed by the execution writer task.

Note: If the SAS program issues a **direct** CTL request, the direct option is ignored.

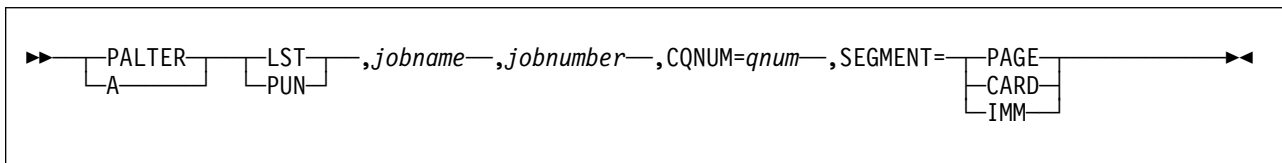

LST

Specify this queue, if 'PDISPLAY A' presents 'LINES SPOOLED' for the named queue entry or if 'PDISPLAY CRE' presents 'L' in the type indicator column (I)

PUN

Specify this queue, if 'PDISPLAY A' presents 'CARDS SPOOLED' for the named queue entry if 'PDISPLAY CRE' presents 'P' in the type indicator column (I)

CQNUM=

Specify the current queue entry number as presented by 'QNUM=' in 'PDISPLAY A' or by the QNUM column in 'PDISPLAY CRE' for the named queue entry

SEGMENT=PAGE|CARD|IMM

Specify the desired segmentation boundary
 PAGE - for LST output, to segment on the next page boundary
 CARD - for PUN output, to segment at the next data record
 IMM - for LST|PUN output, to segment immediately

Note, that 'PAGE' and 'CARD' are used synonymous.

Returned messages and codes:

- When the command is executed successfully, message 1R88I OK is returned to the local operator respectively RC/FDBK 00/01 to the SAS program.

- When the SEGMENT request has been finally processed (e.g. page boundary reached and segment created) by the execution writer task, the task issues message 1Q53I, which has been extended by the suffix number.

```
1Q53I OUTPUT SEGMENTED FOR jobname jobnumber [suffix]
partition-id , cuu
```

- When the specified queue entry can not be found due to incorrect specification or because the queue entry has been completed in between, message

```
1R88I NOTHING TO ALTER
```

is returned to the local operator and to the SAS program.

- A 'PALTER...SEGMENT' command specifying a queue entry created not by an execution writer task will also return message

```
1R88I NOTHING TO ALTER
```

- When the queue entry is spooled with DISP=I, the command is rejected with new message

```
1R9BI commandcode SEGMENT REQUEST IGNORED FOR DISP=I
```

- When the queue entry is spooled with DISP=T, the command is rejected with existing message

```
1R52I PALTER INVALID SPECIFICATION FOR KEYWORD CQNUM
```

because the queue entry number for DISP=T is 0000 and specification of CQNUM=0 is rejected.

- When no DBLK group is available at all, meaning that the DBLK group cushion is used up, the command is rejected with new message

```
1R9BI commandcode SEGMENT REQUEST IGNORED DUE TO EMPTY DBLKGP CUSHION
```

Restrictions: The command is rejected for output created with DISP=I or DISP=T and for all output created not by execution writer tasks.

Note: Because the DBLK group cushion has been increased from 10 DBLK groups to 20 DBLK groups, the minimum VSE/POWER data file size has also been increased from 16 to 32 DBLK groups.

Interaction With RBS Segmentation: If RBS segmentation is requested already by the '* \$\$ LST|PUN RBS=nnnn' statement for the output addressed by the 'PALTER...SEGMENT' command, the specified output entry will be segmented not on the desired RBS boundary, but on the next page or card or even immediately. This depends on the option of the PALTER command. Therefore the created segment will not show the RBS number of pages or cards. The next segment will be created using the original RBS value again.

New/Changed Messages

1Q53I **OUTPUT SEGMENTED FOR jobname jobnumber suffix partition-id , cuu**

Explanation: Output segmentation occurs because either:

- The number of records specified in the RBS operand of the * \$\$ LST statement or the * \$\$ PUN statement is exceeded, or
- Command-Driven segmentation has been requested by

```
PALTER LST|PUN,jobname,jobnumber,CQNUM=qnum,SEGMENT=CARD|IMM|PAGE
```

or

- EOVS is reached if output is spooled to tape.

System Action: Processing of this job continues. For tape spooling, message 1Q58A is issued.

Programmer Response: None.

Operator Response: Start a writer task. If tape spooling, mount another tape and activate the task again.

1R9BI commandcode SEGMENT REQUEST IGNORED {FOR DISP=I|DUE TO EMPTY DBLKGP CUSHION}

Explanation: The command PALTER LST|PUN,jobname,jobnumber,CQNUM=qnum,SEGMENT=CARD|IMM|PAGE has been issued, but either the selected output is spooled with disposition 'I' (must be PUN output) or the DBLK group cushion is empty.

System Action: The system continues to run

Programmer Response: None.

Operator Response: Check whether at least one free DBLK group is still available using PDISPLAY STATUS command. If all DBLK groups are occupied including the 20 DBLK groups for cushion, delete one or more queue entries or move them to tape using POFFLOAD BACKUP|PICKUP|SAVE command and delete them on the POWER queue(s) afterwards. Retry the command, when free DBLK groups are available again.

Internal Queue Entry Number Used in Displays and Commands

Summary: The internal queue entry number, which is for example needed for SAS Direct GET, was not supplied by VSE/POWER in queue displays on the console, but since the APARs listed below, it is shown in all queue displays issued with option 'FULL=YES'.

This queue entry number can now be used as an additional search argument in all queue manipulation commands (PALTER, PDELETE, PHOLD, PRELEASE), to select a specific queue entry out of a set of queue entries with same attributes.

If a job with disposition 'L' is for example not released, but altered to disposition 'K' multiple times, it will create output with the same jobnumber, each time it is started. The result is a set of identical queue entries, which can only be distinguished by their internal queue entry number as now shown in a queue display with 'FULL=YES'. To select such a specific queue entry, the new search operand 'CQNUM=qnum' had been introduced by the APARs listed below.

<i>Figure 65. New Function for VSE/POWER</i>			
Function Description	6.3	6.4	6.5
QNUM display	DY45072	DY45073	included
CQNUM as keyword search operand	DY45091	DY45095	included

Detailed Description

VSE/POWER shows now the internal queue entry number in the return of a 'PDISPLAY queue,FULL=YES'.

Example:

```
d rdr,WST*,full=yes
1R46I READER QUEUE P D C S CARDS
1R46I WST07 00027 5 D A 10 FROM=(WALB)
D=12/09/1996 DBGP=000001
SECN=ZONE04 QNUM=01234
```

QNUM

shows the internal queue entry number in decimal format.

The new operand 'CQNUM=nnnnn' is added to the list of **keyword search operands** for PALTER, PDELETE, PHOLD and PRELEASE commands and specifies the Current Queue entry NUMBER as presented by 'PDISPLAY queue,...,FULL=YES'

CQNUM=nnnnn

specifies the unique queue entry number assigned to the job by VSE/POWER. 1 to 5 digits may be specified. You can use the PDISPLAY command with option 'FULL=YES' to obtain this number.

Note: When this operand is specified, only 1 job can match the search criteria.

How to use CQNUM: Assuming, that 'PDISPLAY queue,FULL=YES' shows identical entries as in the following example.

```
d lst,pausebg
AR 0015 1C39I COMMAND PASSED TO VSE/POWER
1R46I LIST QUEUE P D C S PAGES CC FORM
1R46I PAUSEBG 00027 3 D A 10 1 TO=(SYSA) FROM=(SYSA)
D=12/01/2000 DBGP=000002 L=00000426
QNUM=01234
1R46I PAUSEBG 00027 3 D A 8 1 TO=(SYSA) FROM=(SYSA)
D=11/01/2000 DBGP=000001 L=00000379
QNUM=05517
1R46I PAUSEBG 00027 3 D A 49 1 TO=(SYSA) FROM=(SYSA)
D=11/01/2000 DBGP=000007 L=00002168
QNUM=03490
```

Then a queue manipulation command would normally address either the first queue entry or all queue entries.

Use the new operand 'CQNUM', to select only a single queue entry:

```
PALTER LST,PAUSEBG,...,CQNUM=5517,USER=MARTIN
```

Now only the queue entry with the unique queue entry number '5517' will be altered, if all other specified search operands match also.

Showing Partition in Which Active Job Runs

Summary: For active jobs, VSE/POWER did not indicate, in which partition the job is currently running. The operator could only identify the partition by using either the 'PDISPLAY A' command or by scrolling backward on the console and analyzing the console messages. Now with APARs listed below, VSE/POWER will identify the executing partition for active jobs.

<i>Figure 66. New Function for VSE/POWER</i>			
Function Description	6.3	6.4	6.5
Show active partition	DY45072	DY45073	included

Detailed Description

VSE/POWER will now show the partition where the job is executed, if the RDR queue entry is active (column D='*' in display of RDR queue) on the same system, where the PDISPLAY command is issued. That means column S shows the same System-ID as the output of 'PDISPLAY T' command. Output of a 'PDISPLAY queue' will be extended by 'PART=partition-id', which follows directly the fixed columns as first part of the variable output.

Example:

```
F1 001 1R46I  READER QUEUE  P D C S CARDS
F1 001 1R46I  PAUSEBG  01234 3 * 0 1      4 PART=BG FROM=SYSA
```

Transmission Queue Disposition

Summary: When jobs or output enter the transmit queue their default disposition is 'D'. After transmission the job/output becomes deleted. For multiple transmissions the disposition must be 'K' or 'L' which is difficult or even impossible to achieve. Now with APARs listed below, VSE/POWER has introduced a separate disposition used for transmitting jobs and output residing in the XMT queue.

<i>Figure 67. New Function for VSE/POWER</i>			
Function Description	6.3	6.4	6.5
New TDISP operand	DY44877	DY44880	included

Detailed Description

By default, jobs and output entries have obtained transmission disposition D, when they entered the XMT queue. Now the transmission disposition D|H|K|L can be specified by the new TDISP=D[disposition operand for jobs in the * \$\$ JOB statement and for output entries in the * \$\$ LST/PUN statement.

```
* $$ JOB JNM=MYJOB,CLASS=Q,PRI=9,DISP=D,XDEST=OTHERVSE,TDISP=K
```

This disposition becomes effective and visible, as soon as a job or output entry is added to the transmit queue.

For Spool-Access PUT-OPEN-OUTPUT requests, the transmission disposition D|H|K|L may be provided in PWRSP field SPLOTDP at offset X'CE'. This disposition takes effect, when the output entry is added to the XMT queue. The default transmission disposition is D. Any invalid specification is rejected by the existing PXPRETCD/FBKCD=08/0B.

Remember the following main disposition rules:

1. Disposition in a queue display of a local queue means local disposition, namely 'execution' disposition for jobs in the RDR queue or 'processing' disposition for output entries in the LST/PUN queue. The transmission disposition is invisible and cannot be altered on a local queue.

2. Disposition in a queue display of the XMT queue means transmission disposition. The local disposition is invisible and cannot be altered on the transmit queue.
3. All queue entries enter the transmit queue with their intended TDISP|SPLOTDP transmission disposition, unless overwritten by the PALTER command.
4. When jobs are read in, or output is created for the XMT queue by a specified target node name, they will enter this queue with transmission disposition H (see message 1RA1I), as soon as the node name is unknown to the originating system.
5. When queue entries are moved between transmit and local queues, the disposition of the queue just 'left' is preserved.
6. Whenever received entries enter the local queues of the final target node, the preserved local disposition becomes valid.

Drop 'Last-One' and Print Shorter Separator Page

Separator Pages are intended to be printed on continuous forms across the perforation to show the printer operator where an output ends and a new output starts. The number of separator pages is specified in the POWER macro (JSEP=*n*) and may be influenced by the *\$LST statement and by operands of the 'PSTART LST,...' command. All '*n*' separator pages contain the same information and are identical. The last lines of the '*n*'th separator page are printed on the next page which is then filled with an additional separator page, called 'Last-One'. This 'Last-One' separator page is different and does not print across the perforation, because it contains less lines than the preceding separator pages. All separator pages can be forced to be equal by the ISEP SET statement of the VSE/POWER autostart or by the ISEP|ISEPJ operand of the 'PSTART LST,...' command. Then the last lines of the 'Last-One' separator page are printed on page '*n*+2'.

For LASER printers, like the 3800, which can not print on the perforation or for OEM page printers, which emulate IBM impact printers but use single sheets, where no perforation exists, this VSE/POWER function is useless. The lines, which should cross the perforation, are printed at the top of the next page or sheet.

To avoid this, the operator has now the choice to start the local list task with the new operand DLSEP, which drops the 'Last-One' separator page and decreases the size of the preceding separator pages to let them fit on one page or one sheet. The size of the separator page is defined by the new VSE/POWER autostart statement 'SET **LINE=*n*', which is explained in 'New SET statements for VSE/POWER startup'. For a layout of a separator page refer to VSE/POWER Administration & Operation 6.1, SC33-6633-01, heading 'Separator Pages - Layout and Control'.

You may set DLSEP as default for each LST task using the SET statement 'SET DLSEP=YES|FORCE'.

PSTART Command for Local Writer Task

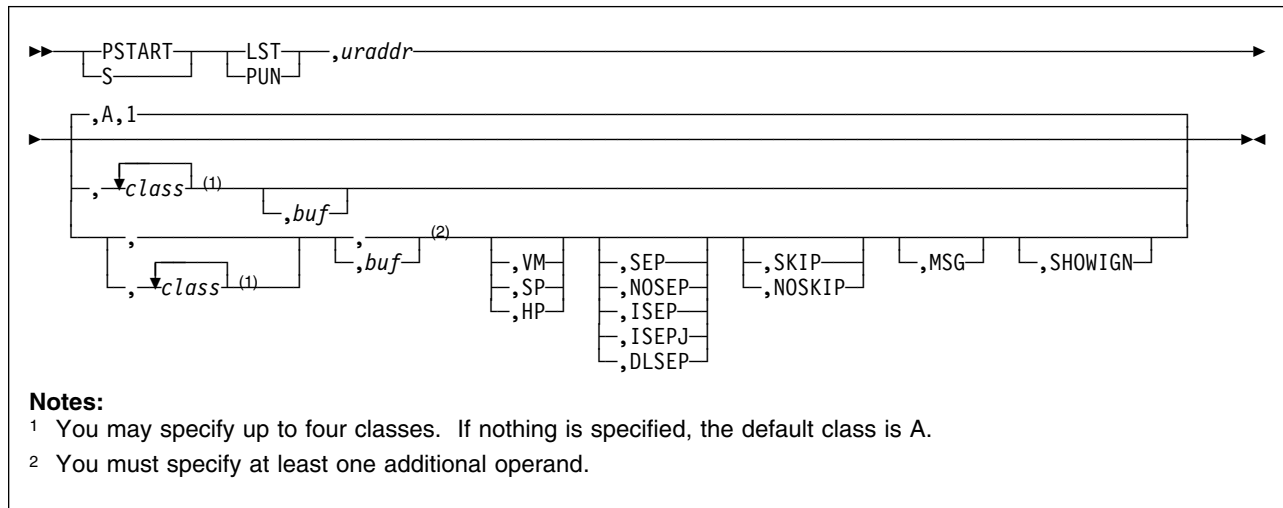

Notes:

- 1 You may specify up to four classes. If nothing is specified, the default class is A.
- 2 You must specify at least one additional operand.

Figure 68. VSE/POWER PSTART Command

DLSEP

Code this operand if you want to drop the 'Last-One' separator page for list output. Via autostart statement SET **LINE you can define the size of the separator page by specifying how many perforation lines (normally, when DLSEP is not specified, 8 identical lines, starting with '****') are printed. If 'SET **LINE=n' is not specified, a default of 4 perforation lines is printed. VSE/POWER takes the number of separator pages from the JSEP operand of the POWER generation macro. However, if JSEP=0 was specified in the POWER generation macro, VSE/POWER assumes one separator page.

RJE,SNA RUSIZE Increased from 256 Bytes to 4096 Bytes

Summary: The RJE,SNA function was limited to a request unit size (RU size) of 256 bytes. To exploit the facilities of modern RJE,SNA emulations capable of RU size of 4096 bytes or more and to reduce the non-parallel load caused by the countless VTAM calls for SEND and RECEIVE, the RU size may now be selected as 256, 512, 1024, 2048 or 4096 bytes.

Figure 69. New Function for VSE/POWER			
Function Description	6.3	6.4	6.5
RJE,SNA RUSIZE up to 4096 bytes	- n/a -	DY45454	DY45464

Detailed Description

The new parameter RUSIZE= 256|512|1024|2048|4096 is added to the PRMT Macro. This operand applies only to an SNA terminal and should only be specified if the terminal supports a SNA buffer size greater than 256 bytes. It specifies an upper limit for negotiation of the actual INBOUND and OUTBOUND Request Unit (RU) sizes. The following rules apply:

- 1. The RU size for INBOUND (BINSRUSZ) and OUTBOUND (BINPRUSZ), which are determined by the selected LOGMODE table entry, must be in the range of x'85' - x'89'. That means, only RU sizes of 256, 512, 1024, 2048 or 4096 bytes

- are supported. An unspecified value will be defaulted to x'85' = 256 bytes. Any other value will be rejected with BIND error.
2. The RUSIZE=(256|512|1024|2048|4096) sets an upper limit for the negotiation of the RU size. Default RUSIZE is 256 bytes.
 3. INBOUND and OUTBOUND RU size are negotiated separately, they may be different now: INBOUND RU size = minimum of BINSRUSZ and RUSIZE
OUTBOUND RU size = minimum of BINPRUSZ and RUSIZE
 4. If work storage can not be obtained during LOGON, LOGON is now rejected with new VTAM sense code 08120011.

LOGON message 1V09I does now show the INBOUND/OUTBOUND RU size:

```
1V09I REMOTE xxx LOGGED ON TO iiiiii ON luname,
      TIME=hh:mm:ss date, mmmm/nnnn=IN/OUT RUSIZE
```

New PICKUP Operand for VSE/POWER POFFLOAD

Summary: The POFFLOAD command is currently used as follows:

- To archive VSE/POWER spooling entries (BACKUP,SAVE) to tape.
- To retrieve the entries from tape (LOAD,SELECT).

With VSE/POWER 6.3, the POFFLOAD command will be enhanced to support the new **PICKUP** operand. The PICKUP function is similar to the BACKUP function.

Detailed Description

POFFLOAD Enhancements: The PICKUP operand indicates to save all entries of a queue, including those which are processing (DISP=*), by creating an offload tape. However, the disposition of an entry on the queue will not be altered (as in case of the POFFLOAD SAVE command).

In contrast to the BACKUP function, the POFFLOAD PICKUP command has the following characteristics:

1. It generally allows queue entries to be saved to tape **without locking the entire queue file** for exclusive use. The exception occurs when a processing entry (DISP=*) is being saved to tape - only then are the entire queues held against access by other tasks.
2. If a spool entry is not being processed at the time of saving to tape, then only that entry is locked and other spool entries are available as before.
3. All VSE/POWER commands that manipulate queue entries (PALTER, PDELETE, for example) are permitted during PICKUP processing.

Therefore, the new PICKUP function combines the advantages of both the BACKUP and SAVE commands, but avoids their inherent operational drawbacks. Figure 70 on page 148 provides further details.

Figure 70. Characteristics of BACKUP, SAVE, and PICKUP Functions of the VSE/POWER POFFLOAD Command

Description	BACKUP	SAVE	PICKUP
Scope of Locking:	Locks entire system while running.	Locks individual spool entry only.	Same as SAVE function.
Type of offload:	"Snapshot" of spool queue(s).	No "snapshot"; unlocked system permits spool queue changes.	Same as SAVE function.
Selection of Spool Entries:	Saves all entries regardless of disposition.	Saves dispatchables only: <ul style="list-style-type: none"> • no active entries (DISP=*) • no non-dispatchables • no time-event scheduling jobs. 	Same as BACKUP function.
Disposition Handling:	No change of entry.	Removes entries with DISP=D. Changes DISP=K to DISP=L.	Same as BACKUP function.
Parallelism:	<ul style="list-style-type: none"> • Only one BACKUP allowed, including shared systems. • BACKUP and PICKUP are mutually exclusive. 	Multiple SAVE tasks can run.	Same as BACKUP function.

When talking of a "snapshot" copy in Figure 70, a true point-in-time copy of the spool queue is meant.

Description of the POFFLOAD PICKUP Command: When the POFFLOAD PICKUP command is issued, only those queue entries that can be displayed at that time by the operator (PDISPLAY) are eligible for saving to tape. As with the BACKUP function, spool entries "in creation" will not be saved (e.g. print output being produced by a running job that has not segmented), even if checkpointed.

The user should also note that possibly not all spool entries displayable at the time the PICKUP command is issued and specified to be selected (by queue and class specification) will end up saved on tape - since generally only individual queue entries are locked during saving to tape, other eligible entries can experience normal spool processing and thereby may disappear from the spool file (DISP=D processing), or the operator may have changed the spool entry status with a VSE/POWER command (PDELETE, PALTER, for example).

If the output tape becomes full while processing the command, the operator will be prompted to mount another tape until all entries indicated have been processed. Similar to the BACKUP function, if during the pause between unmounting the full tape and mounting an empty tape, a processing queue entry (DISP=*) is being saved and continued to the next tape, then ALL queues will be locked during this period.

Processing: The PICKUP function will begin by flagging all eligible spool entries it finds as "scheduled" for offloading, and notifies the operator of the number of entries found by:

```
1Q6NI POFFLOAD PICKUP HAS SCHEDULED nnnnn SPOOL ENTRIES FOR OFFLOADING
ON cuu AT mm/dd/yyyy
```

It then begins saving those spool entries to tape. During processing the operator will be notified of the function progress every three minutes:

```
1Q6PI POFFLOAD PICKUP PROCEEDING WITH bbbbbb OUT OF cccccc SPOOL
ENTRIES STORED TO TAPE ON cuu
```

Invocation

```
POFFLOAD PICKUP,queue,cuu ... (same format as for BACKUP|SAVE)
or
POFFLOAD PICKUPxx,queue,cuu ... (same format as for BACKUPxx|SAVExx)
```

Figure 71. Format of POFFLOAD PICKUP Syntax

where 'xx' is '41' or '51' or '52' or '61' or '63'

Interactions: Only one POFFLOAD PICKUP command is permitted by VSE/POWER at a time, and the POFFLOAD PICKUP and POFFLOAD BACKUP are mutually exclusive at any one time. This is also the case across shared spooling systems.

VSE/POWER Tape Processing

Certain user or vendor programs want to process VSE/POWER OFFLOAD or Tape Spooling Tapes by own access. The following description presents the layout of these tapes in detail. Because the layout may differ from release to release, VSE/POWER has never supported the backward migration of such tapes to a lower level VSE/POWER release. With APAR DY43884, this limitation has been removed for VSE/POWER 6.1.0..

Queue Entries on Tape and Release Migration

VSE/POWER allows to spool queue entries to tape by the

- POFFLOAD BACKUP/SAVE function for RDR/LST/PUN/XMT entries
- Tape Spooling (* \$\$ LST/PUN DISP=T) function for LST/PUN entries

VSE/POWER produces unlabeled tapes of the following format:

```
T|HEAD| |DATA| |DATA| TRAIL|T|HEAD| |DATA| |DATA| TRAIL|TT
M|Q-REC|DBLK|...|DBLK|Q-REC|M|Q-REC|DBLK|.....|DBLK|Q-REC|MM
-----
```

The Queue Records (Q-REC) contain all attributes of the corresponding queue entry, the Data Blocks (DATA DBLK) contain POWER control records and user data records in VSE/POWER logical record format. Queue entries are preceded and separated by a single Tape Mark (TM), the logical end-of-tape is indicated by a double Tape Mark.

The Queue Record length depends on the release level of VSE/POWER:

VSE/POWER Release	Number of Bytes
4.1	240
5.1	240
5.2 and 5.2.1	256
6.1 and 6.1.1 and 6.1.2	256
6.3	256
6.4	368
6.5	368

The data block length is defined by the DBLK operand of the POWER generation macro. This length may vary between

- 1,000 - 12,288 bytes for releases up to VSE/POWER 5.2
- 1,000 - 65,024 bytes for releases VSE/POWER 6.1 and following.

The Data Block Group (DBLKGP) size is transparent on tape; this means DBLKs are not headed by SEH/SER control records. Due to the standard format, these tapes can be read in again and can be processed by the

- POFFLOAD LOAD/SELECT function for RDR/LST/PUN/XMT entries
- Tape Printing/Punching function for LST/PUN-queue entries, started by PSTART LST/PUN,cuu,X'tapeaddr' (Tape Writer Task)

The size of DBLKs on tape can be different from the DBLK size of the reading system, because VSE/POWER processes the DBLKs according to logical records contained therein.

Full Upward Migration of Tapes to Current Release

Although Offload or DISP=T tapes produced under an older release may contain **shorter** queue records than used by the current release, reloading of these tapes is always possible. Both the POFFLOAD LOAD/SELECT and the Tape Writer function can interpret and extend shorter queue records.

Limited Downward Migration of Tapes from Current Release

During the installation of a new current release there may be the need for passing queue entries on tape to a lower level VSE/POWER system. This works fine, as long as the tape queue record happens to have the same length as the queue record in use by the reading low level system. If however queue record lengths are different, the down level release rejects a tape with queue records longer than expected by message **1Q5AI INVALID TAPE MOUNTED ON cuu FOR R-OFF,cuu**

With Apar **DY43884** you may overcome this limitation as follows. Request your current higher level VSE/POWER to produce an Offload tape suitable for a low level system, by specifying the target level in the **POFFLOAD BACKUPxx/SAVExx** command. The subsequent command description applies to 'Administration and Operation' manual (SC33-6633) of VSE/POWER 6.1.0 and introduces a new 'Format 4' for the POFFLOAD command. Only levels below the current VSE/POWER level can be specified, that means you can not specify 'POFFLOAD BACKUP64...' on VSEPOWER 6.3 and below.

FORMAT 4: Backup or Saving to a Previous Release of VSE/POWER

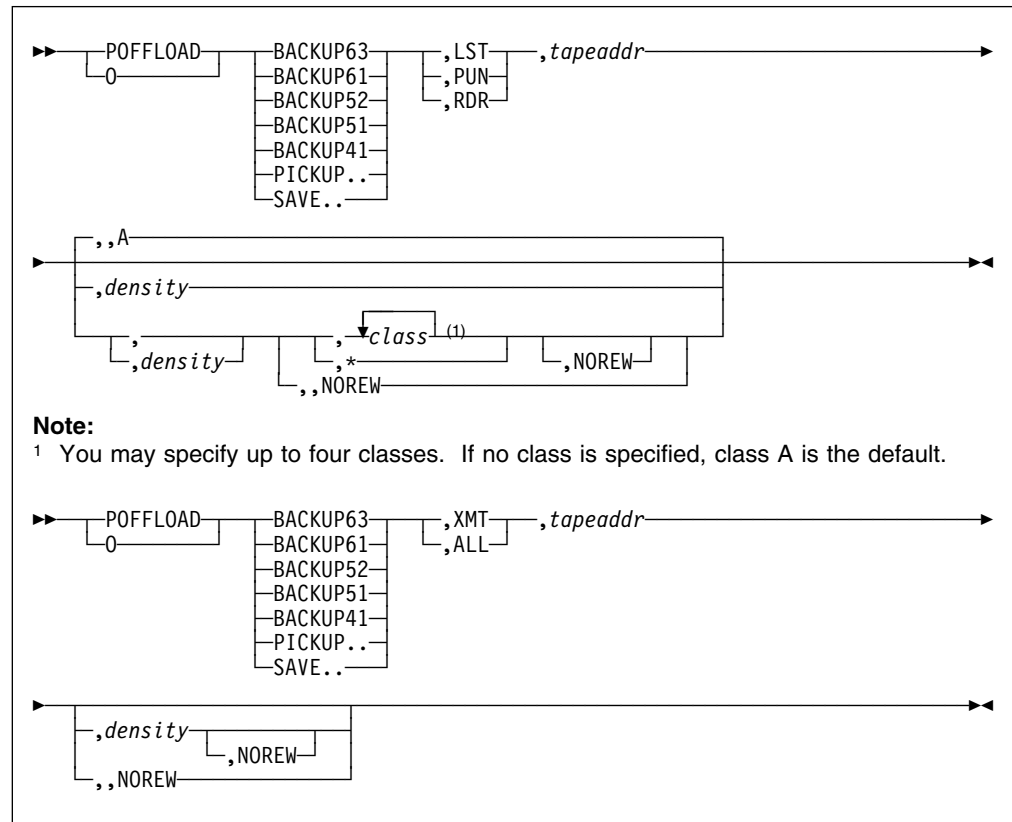

Figure 72. VSE/POWER POFFLOAD Command

BACKUP41/51/52/61/63 or PICKUP41/51/52/61/63 or SAVE41/51/52/61/63: The general description of the BACKUP or SAVE operand of Format 1 and 2 applies also to BACKUPxx and SAVExx. In addition, the suffix of the BACKUPxx or SAVExx operand specifies a previous VSE/POWER release contained in:

- 41 - POWER 4.1 - VSE/SP 4
- 51 - POWER 5.1 - VSE/ESA 1.1 and VSE/ESA 1.2
- 52 - POWER 5.2 - VSE/ESA 1.3
- 61 - POWER 6.1 - VSE/ESA 2.1 and VSE/ESA 2.2
- 63 - POWER 6.3 - VSE/ESA 2.3

According to the specified suffix, a POFFLOAD Tape with a queue record length of the target release is created. This tape can be used for the POFFLOAD LOAD/SELECT function on the previous release.

The DBLK size on the current system should not exceed 12288 bytes to allow the POFFLOAD migration to a previous release. If the DBLK size is bigger, the command is rejected with the new message **1RF0I**.

Note: Using the BACKUPxx or SAVExx operand limits the functionality and capability of queue entry attributes to that of the target VSE/POWER release.

New/Changed messages

1RF0I *commandcode* **OPERAND** *nn* **CURRENT DBLK SIZE** *nnnnn* **TOO BIG, MAXIMUM ALLOWED DBLK SIZE FOR PREVIOUS RELEASE IS** *mmmmm*

Explanation: A POFFLOAD BACKUPxx/SAVExx command has been issued whereby xx names a VSE/POWER release. *nnnnn* is the DBLK size defined on the current system and *mmmmm* is the maximum allowed DBLK size for the specified previous VSE/POWER release.

System Action: The command is rejected.

System Programmer Response: Generate your current VSE/POWER with the maximum DBLK size *mmmmm* allowed for the previous release. Backup your queues using the POFFLOAD function, re-format your queues and reload the queues. Then retry the POFFLOAD BACKUPxx/SAVExx command.

Operator Response: Notify your System Programmer.

When Print Output is Misaligned

Overview: The correct alignment of printed output can be achieved by specifying a Forms Control Buffer (FCB). The FCB describes the layout of the form on which the produced output will be printed by VSE/POWER later on. The minimum information contained in an FCB is 'number of lines per page', 'position of channel 1' and for PRT1 printers also whether 6 or 8 lines per inch should be printed. The specified FCB is used during spooling time by VSE/POWER to emulate a printer with such an FCB to the output producing application. When VSE/POWER prints the output, it loads the specified FCB into the printer for correct alignment. If no FCB is specified at spooling time, the LTAB (see "Detailed description") is used instead of an FCB and the printer's default FCB is used at print time. This may cause problems, if LTAB and FCB differ.

For jobs with no FCB specified in the * \$\$ LST statement, correct print page layout can now be achieved by

- Including the new SET FCB=DEFAULT statement into the VSE/POWER startup procedure. This triggers usage of the spooled devices' default FCB at output spooling time and generates a match to the default FCB loaded into the real printer at output printing time.

Please keep in mind that the IBM supplied standard FCBs \$\$BFCB.. are designed for 12 inch forms and a line density of 6 lines per inch (lpi). If you use different forms and/or a different line density, you should regenerate the FCB. For generating an FCB refer to VSE/ESA System Control Statements or VSE/ESA Installation.

This improvement has been made available for VSE/POWER 6.1.0 by APAR DY43586.

Detailed Description: VSE/POWER can serve modern FCB controlled printers as well as carriage control tape printers, whose print page layout is described by the LTAB specification of the POWER generation macro or of the * \$\$ LST statement.

An FCB (or LTAB) is used by VSE/POWER at two different times:

1. At **spool-time** a job is running in a partition and produces output using a printer device which is a 'spooled device' (a device controlled by VSE/POWER, defined as such when the partition is started). Then VSE/POWER intercepts

the I/O started to the printer device and writes the output data to the VSE/POWER spool file. At this time the FCB is loaded and used to control the number of lines written to a page and to determine the size of a separator page.

2. At **print-time** the print output (created 'long ago') is read from the spool file and passed to a real printer started with the PSTART LST,uu command. At this time the FCB is loaded into the printer buffer using the VSE/ESA LFCB macro.

Usually, the FCB used at spool time is the same one used at print time. If they are not the same, the layout of a page may not be as expected, for example, the number of lines per page will cause a splitting of pages at an unexpected position. Therefore, you should trigger the usage of the same FCB at spool and print time by explicitly specifying an FCB in a * \$\$ LST statement.

If you do **not** specify an FCB (nor LTAB) in a * \$\$ LST statement, VSE/POWER uses an LTAB at spool-time, namely the LTAB specified in the POWER macro or its VSE/POWER default. At print-time (for FCB type printers) VSE/POWER uses the system default FCB which is printer-type dependant. If the LTAB does not reflect the default FCB's specifications, it may lead to an incorrect layout of the printed pages.

To avoid incorrect layout, tell VSE/POWER not to refer to the LTAB but to use the printer's system default FCB already at spool time by placing the

```
SET FCB=DEFAULT
```

statement into the startup procedure. For the format of the SET statement see "New SET Statements for VSE/POWER Startup" on page 129.

FCB=DEFAULT

The operand causes VSE/POWER to use a default FCB when controlling the spooling of list output instead of the LTAB specified in the POWER macro.

This affects only list output spooled by a job running in a partition if neither the FCB nor the LTAB operand has been specified in a * \$\$ LST statement.

This operand does not apply to list output spooled via the Spool-Access support. This output is written to the VSE/POWER spool file by **not** using any FCB. If an FCB has been specified within the SPL, this FCB is used only at print-time.

The default FCB is selected as described in chapter "System Buffer Load" in "VSE/ESA System Control Statements".

Printer Type	FCB Name
1403	n.a.
3211 (PRT1)	\$\$BFCB
3203-5 (PRT1)	\$\$BFCB00
3289-4 (PRT1)	\$\$BFCB10
3262 (PRT1)	\$\$BFCB22
4245 (PRT1)	\$\$BFCB23
4248 (PRT1)	\$\$BFCB
4248 (Native) and 6262	\$\$BFCBWM

For example, the default FCB for a 6262 printer or a native 4248 printer is `$$BFCBWM`. As printers of different type (for example 3211, 4245, 3203, 3289, 3262) are added during IPL time with the same device type `PRT1`, the operand `PTR1=xx` may be specified to define the device specific default FCB. The `xx` are the two last characters of the device specific default FCB, for example the default FCB for a 4245 printer is `$$BFCB23` and therefore `PRT1=23` has to be specified.

Notes:

1. Only one default FCB for `PRT1` printers may be specified. If printers of two different device types have been added as `PRT1`, the same default FCB is used no matter which printer is currently used for the list output.
2. If the `PTR1=xx` operand is omitted, `$$BFCB` is used for printers added as `PRT1`.
3. The `PTR1=xx` operand does not influence the default FCB for printers added with a different device type code than `PRT1`.
4. If the default FCB is loaded, but `VSE/POWER` detects some error with this FCB, the message 1Q54I is issued and the `LTAB` is used as specified in the `POWER` macro.

VSE/POWER Spooling Considerations**Important VSE/POWER Specifications for Output Spooling**

In the following, the relationship between certain specifications for `VSE/POWER` Output Spooling are explained. For simplicity reasons, this is done only for `LIST` output; but the same rules, considerations and specifications are also valid for `PUNCH` output.

A) Specifications to be done for OUTPUT Spooling

During execution of a job in a '`VSE/POWER` controlled partition', output is produced using the following rules:

1. In your program you specify the logical unit to which the output will be written. For example, by:

```
DTFPR DEVADDR=SYSLST
```

2. With the `// ASSGN` statement of your job, you direct the output from the logical unit to a physical unit of your choice. For example:

```
// ASSGN SYSLST,F9E
```

3. If the output should be spooled by `VSE/POWER`, this physical unit must be specified in the `PRINTERS=cuu,cuu....` autostart statement for the corresponding partition. For example:

```
PSTART BG,...
READER=...
PRINTERS=...,,,F9E,...
PUNCHES=...
```

4. With the `* $$ LST` statement, you can specify several output attributes for your output entry (like `JNM`, `DISP`, `PRI`, etc.). With the `LST=cuu` operand of the `* $$ LST` statement, you tell `VSE/POWER` that this `* $$ LST` statement should be

taken for the output spooled to the cuu you specified in the LST=cuu operand.
For example:

* \$\$ LST JNM=...,...,LST=F9E,...

a) * \$\$ LST statement without LST=cuu operand

If the **LST=cuu operand is omitted** in the * \$\$ LST statement, the attributes specified in this statement are taken for the output spooled to that printer device which is specified **first** in the sequence of PRINTERS=cuu,cuu,... .

b) no * \$\$ LST statement at all

if you are spooling output to a printer device, for which no * \$\$ LST statement is provided, then this output entry gets default output attributes (like CLASS=A,DISP=D,PRI=3,etc).

Note: You may request VSE/POWER to warn you by console message

1Q8CI DEFAULT OUTPUT VALUES USED FOR *jobname jobnumber*, SPOOLED DEVICE *cuu*

whenever default output attributes are assigned to output being spooled - just place the NTFY=(*,R000) operand into the * \$\$ JOB statement of the questionable job to request notification of the central operator!

B) How to Link the OUTPUT Specifications

Respect the following rule:

Your output obtains only the desired * \$\$ LST attributes, if the spooled printer device ...

- selected by the ASSGN statement and
- addressed by your * \$\$ LST statement

... is the same!

In the following there are three cases explained:

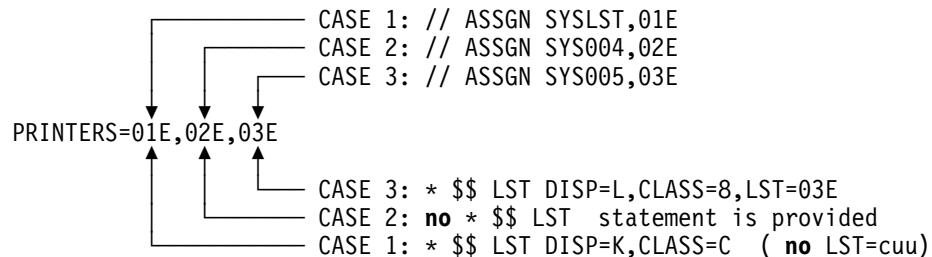

Case 1 :

- Your program writes output to SYSLST
- SYSLST is assigned to 01E
- 01E is specified as **first** printer in PRINTERS=01E,02E,03E chain.
- The LST=cuu operand is omitted in the * \$\$ LST statement, therefore this statement applies to the **first** of PRINTERS=01E,02E,03E , namely to 01E.
- **Result:** The output entry spooled to 01E gets the specified output attributes DISP=K,CLASS=C.

Case 2 :

- Your program writes output to SYS004
- SYS004 is assigned to 02E
- 02E is specified in PRINTERS=01E,02E,03E
- **no** * \$\$ LST statement is provided at all
- **Result:** The output entry spooled to 02E gets the default output attributes DISP=D,PRI=3,CLASS=A,etc.

Case 3 :

- Your program writes output to SYS005
- SYS005 is assigned to 03E
- 03E is specified in the PRINTERS=01E,02E,03E .
- By the LST=03E operand, the * \$\$ LST statement applies to the output entry spooled to printer 03E.
- **Result:** The output entry spooled to 03E gets the specified output attributes DISP=L,CLASS=8.

C) Specification Errors that Lead to the 'Ignored * \$\$ LST Statement' Sympton

For the following cases we assume that your program produces output for SYS004:

1. **Case 1:** The LST=cuu operand is omitted on the * \$\$ LST statement.

Specifications:

- PRINTERS=FEE,F9E,F8E
- * \$\$ LST JNM=... ,DISP=K,PRI=1
- // ASSGN SYS004,F9E

Result: The output entry spooled to F9E obtains the default output attributes. The provided * \$\$ LST statement is valid for device FEE because of the missing LST=F9E specification.

2. **Case 2:**The output is directed to another print device than specified in the LST=cuu operand.

Specifications:

- PRINTERS=FEE,F9E,F8E
- * \$\$ LST JNM=... ,DISP=K,CLASS=X,LST=F8E
- // ASSGN SYS004,F9E

Result: The output entry spooled to SYS004 obtains the default output attributes because the * \$\$ LST statement is valid for F8E (LST=F8E), but output is spooled to F9E.

TCP/IP Connection to RSCS

RSCS Specifications for NJE Communication to VSE/POWER via TCP/IP:
VSE/POWER 6.5 (running on VSE/ESA 2.5) exchanges data with remote systems via the NJE (Network Job Entry) TCP/IP protocol in addition to the BSC, SNA or virtual CTC protocol. The remote host can even be a VM/ESA system running RSCS V3.2 or a later release.

Once the TCP/IP connection to an RSCS node has been successfully established, the connection may stop every two hours, and restarts thereafter automatically. This happens because VM/ESA sends some keep-alive packets, which can not be

understood by all hosts, as it is described in *VM/ESA TCP/IP Function Level 320 Planning and Customization*, SC24-5847, (see paragraph *Usage Notes* of the KEEPALIVEOPTIONS statement). These keep-alive packets are sent every nn minutes, where nn is the value specified for the INTERVAL parameter of the KEEPALIVEOPTIONS statement. If no value is specified, the connection stops every 2 hours (default is 120 minutes).

In order to avoid that the TCP/IP connection to an RSCS node stops, the sending of the non-understandable keep-alive packets must be suppressed. This can be achieved in one of the following ways:

1. Specify "SENDGARBAGE TRUE" in the KEEPALIVEOPTIONS statement used by VM/ESA TCP/IP (see KEEPALIVEOPTIONS statement in *VM/ESA TCP/IP Function Level 320 Planning and Customization*, SC24-5847).
2. Specify "KEEPALIVE=NO" in the PARM statement used by RSCS to define a TCPNJE-type link (see PARM statement in *VM/RSCS Networking Planning and Installation*, SH24-5219).

Chapter 7. Librarian

You can use the VSE Librarian via these interfaces:

- Command Interface (EXEC LIBR). This is the interface used by most users.
- Macro Interface (LIBRM, LIBRDCB). Used by programs to access libraries.
- Internal Macros (used by Linkage Editor, IUI, DUMP, INFOANA and all LIBR functions). Used mostly by IBM programs.

Librarian Return Code Conventions

- Commands
 - Return code 0 : function completed
 - Return code 2 : indicates result (COMPARE: notequal; TEST: library damaged).
 - Return code 4 : function = noop (e.g. delete non-existent member)
 - Return code 8 : function (partially) failed
 - Return code 16: function abended

With every return code > 4 there is an additional message which says what exactly has failed. These messages are normally on SYSLST.

- Macros (LIBRM)
 - R15 = 0 : function completed
 - R15 = 4-12 : depends on function (see System Macro Reference)
 - R15 = 16 : external error; Feedback code is in R0.
 - R15 = 20 : internal error; Feedback code is in R0.
 - R15 = 32 : security violation.

With every r15 > 12 there is an additional message which says what exactly has failed. IALCMMSG points to this message.

- internal Macros
 - R15 = 0 : function completed
 - R15 = 4-12 : depends on function
 - R15 = 16 : external error; Feedback code in INLCLRPL or LBRACCD5.
 - R15 = 20 : internal error; Feedback code in INLCLRPL or LBRACCD5.
 - R15 = 32 : security violation.

With every R15 > 12 there is an additional message which says what exactly has failed. This message is returned in areas provided by the user in the INLCLAMB.

IUI suppresses Librarian messages.

Librarian commands normally ABEND after return code 16 or 20 with a DUMP (DUMP is always provided after Message L151/L152).

How to Analyze What Went Wrong

- Check which interface is used:
 - EXEC LIBR
 - Linkage Editor
 - IUI
 - MSHP
 - Info/Analysis
 - JOB CONTROL (e.g. LIBDEF/LIBDROP)
 - vendor programs
 - own applications which use LIBRM.
- Carefully check return codes and messages (normally on SYSLST).
- If a feedback code was given check the Librarian Diagnose Reference Manual (DRM).

Important Messages

- L151I UNEXPECTED RETURN CODE FROM MACRO/MODULE nnn IN MODULE mmm PHASE xxx - RC = nn

Check if MACRO/MODULE mentioned is a supervisor service (e.g. System Macro Reference). Often this message is caused by damaged libraries or overwritten control blocks. This message causes a dump.
- L152I ENTRY CONDITION FOR MODULE nnn IN PHASE xxx FAILED - FEEDBACK CODE = nn

The Feedback code specifies the reason of the error is described in the Librarian DRM or (partially) in SYSTEM MACRO REFERENCE. Often this message is caused by damaged libraries or overwritten control blocks. This message causes a dump.

Normal action is to run a TEST L=lib on the accessed library. If the library is damaged, the dump will not provide any additional information. Repair or recreate the library as soon as possible.

Recreation of Libraries

If one of the following conditions occurs, you may suspect that a library is damaged or in an inconsistent state:

- Messages L157 or L158 are displayed.
- FETCHing/LOADing a phase fails either with an error message or return code indicating retrieval error.
- Messages L150, L151, L152 are displayed. Although these messages are not directly triggered by library damages, you should verify that the libraries involved are in a consistent state.
- You get a 'library full' message even if the command LISTDIR LIB displays FREE SPACE.
- The number of sublibraries displayed with LISTDIR LIB does not match the number of sublibrary names listed.

- The number of members displayed with LISTDIR SUBLIB is not identical to the number of member names listed.

You may use the TEST command to verify the correctness of a library, sublibrary, or of an individual member.

What has to be done to repair a library ? If a part of a library is damaged always recreate the whole library, especially if any library block chains are damaged.

A library can be recreated as follows:

Library in BAM Space

```
BACKUP L=lib
DEFINE L=lib REPLACE=YES
RESTORE L=lib
```

Figure 73. Recreate library in BAM space

Note: BACKUP tries to back up all valid members. If it fails, an previously created backup-tape must be used for RESTORE.

Library in VSAM Space

```
BACKUP L=lib
DELETE L=lib
DELETE CLUSTER
DEFINE CLUSTER
DEFINE L=lib REPLACE=YES
RESTORE L=lib
```

Figure 74. Recreate library in VSAM space

Note: The step DELETE/DEFINE CLUSTER is recommended but not required.

DEFINE L=lib REPLACE=YES: Creates a new library without checking the old contents.

Problems might occur with VSAM managed space, if DELETE CLUSTER has been done before DELETE LIBRARY. After DEFINE CLUSTER the DEFINE LIBRARY might bring unpredictable results.

If a problem occurs with this sequence the library descriptor must be destroyed by DITTO. The library descriptor is located at the beginning of the first extent of the library and can be identified by the keyword 'LIBRARY' followed by the library name. Its length is 1024 bytes.

BACKUP Abends or Loops

In general BACKUP tries to back up all valid members. BACKUP might abend if the source library is damaged. The cause is normally a damaged library block chain in member data.

Example: Damaged member A.PROC is in OLDLIB.S1. As DELETE might not work, RENAME the defective member e.g. into ZZZ.ZZZ, so it will be the last member in the alphabetical order. Then copy all other members step by step into a

new (temporary) library.sublibrary and copy all other sublibraries contained in the damaged library into the temporary library. Afterwards recreate the damaged library and copy all sublibraries back.

```
ACCESS S=OLDLIB.S1
RENAME A.PROC ZZZ.ZZZ          /* rename defective member */
CONNECT S=OLDLIB.S1 : NEWLIB.HELP /* NEWLIB.HELP must exist */
COPY A*.*,B*.* ...           /* copy all members except ZZZ.ZZZ */
                             /* COPY or RESTORE other sublibs of OLDLIB to NEWLIB */
DEFINE L=OLDLIB REPLACE=YES   /* RESTORE/COPY sublibraries back */
```

Figure 75. BACKUP library with defective member

BACKUP LIB/SUBLIB tries to skip members or sublibraries in error. It informs you through the messages L080 and L081 which sublibraries or members are skipped due to retrieval failures.

Limitation: BACKUP is able to skip defective members consisting of up to 64 library blocks.

Defective members larger than 64 library blocks cannot be skipped by BACKUP, even if the partition size is increased. In this case you have to delete the member in error before restarting the BACKUP run. This restriction does not apply if the error is detected within the first 14 library blocks. In this case, BACKUP has not written any member data onto tape when it detects the error and, therefore, is able to skip the defective member.

RESTORE of Libraries Not Uniquely Assigned or Shared by Processors

You cannot restore libraries for which LIBDEF statements or Librarian commands (e.g. ACCESS) are active or are in use by two or more processors.

You have to deactivate the libraries by issuing LIBDROP statements and by terminating Librarian commands in all processors accessing these libraries. Failing to do so causes abnormal termination of all tasks retrieving members from these libraries after RESTORE since the in-storage information is kept for the LIBDEF statements or Librarian commands is not updated automatically in the other processors. The RELEASE SPACE command does not help in this situation since it does not update all in-storage information which might have been updated by RESTORE LIB.

You can, however, restore sublibraries which are attached to the system either through LIBDEF statements or Librarian commands. (Of course, you have to specify REPLACE=YES on the RESTORE command.)

The REUSE value of the sublibrary on disk will be maintained, that is, it will not be overridden by the REUSE value of the sublibrary on tape.

Replacing an existing sublibrary is done in the following system-internal steps:

1. All members in the existing sublibrary are deleted. The library blocks of the index are put unchanged into the space reclamation chain.

For sublibraries with attribute REUSE=IMMEDIATE, the member space is freed immediately and available for the sublibrary to be restored.

For sublibraries with attribute REUSE=AUTOMATIC which are shared by partitions or processors, the member space is put into the space reclamation chain of the sublibrary and therefore not available for the sublibrary to be restored. In this case, the free space of the library must be large enough to receive the contents of the new sublibrary.

For sublibraries with attribute REUSE=AUTOMATIC which are not shared by partitions or processors, the member space is freed immediately and available for the sublibrary to be restored.

2. The date in the sublibrary directory entry is updated. (The entry in the sublibrary directory is not removed.)
3. The new members are cataloged into the sublibrary and a new member index is built.
4. A fresh second-level directory (SLD) is built in the processor performing the RESTORE action if the sublibrary shows up on LIBDEF PHASE statements. The library control statements in the SVA are updated (specifically, the pointer in the sublibrary definition table entry pointing to the library block of the highest level of the member index).

As you see, there is a time slice when neither the old nor the new members may be found. Therefore, you have to ensure (by administrative actions) that programs relying on the availability of either the old or the new version of the members do not run concurrently to the RESTORE SUBLIB command.

For sublibraries with attribute REUSE=IMMEDIATE, you have to make sure that no local directory lists point to phases in the sublibrary being restored.

For sublibraries with attribute REUSE=AUTOMATIC, local directory lists continue to point to the old versions of the phases.

For sublibraries showing up on LIBDEF PHASE statements, SLDs are maintained in-storage. SLDs are updated automatically in the processor restoring the sublibrary.

Shared libraries: If a sublibrary restored in one processor is shared by other processors, you must perform, for libraries showing up on LIBDEF statements, the RELEASE SPACE command in all processors accessing the sublibrary.

RESTORE OLDLIB

Attention: Old tapes are often damaged and no longer readable.

Libraries in old format (pre VSE/SP V2) may contain members starting with /. Today's Librarian cannot process these members.

What To Do In Error Cases?

Unexplainable behavior, hardwait, program check or loop: apply TEST command to accessed/updated library after the system has been recreated. If a library is damaged (as indicated by the result of the TEST command) a BACKUP should be tried. If unsuccessful an older backup version has to be used for RESTORE.

Test of Libraries

To test the condition of a library issue this librarian command:

```
TEST L=lib
```

A test may run up to two hours for a large library.

Error conditions:

- Error Codes (described in DRM)
 - 402** uncritical, can be repaired by TEST L=xxx REPAIR=YES
 - 401** critical, BACKUP still possible, if this is the only fault.
 - 056** logical consequence of 402 or 401.
 - other** restore library from available backup.
- Test command loops: library block chains are damaged, restore library from an available backup
- Test command abends or program checks: restore library from an available backup

A test on a sublibrary (TEST S=lib.sublib) does only a subset of the tests that a test on a library does, so do not use it for problem determination.

If the TEST run produces the error '056' or '402', you may rerun the TEST LIB command with REPAIR=YES to resolve these error situations. Note that REPAIR=YES requires that

- the library is not used by any other task,
- the library is not specified on LIBDEF statements,
- the library does not reside on a DASD volume which is shared by processors (defined by the SHR parameter on the IPL ADD command).

What Can Damage a Library?

A library can be damaged by any forced interruption of the Librarian during write access (CANCEL with FORCE, hard wait, program check), or by any simultaneous update in a shared environment.

Error 402 might occur after an ABEND of any function writing or updating a member. Normally the Librarian (Commands and LIBRM) cleans up the library before abnormal termination - DUMP/INFOANA cleans up since VSE/ESA 1.2/1.3.

Other Problems

Member Not Found

You might detect one of these symptoms:

- LD *.* shows a member but LD membername.membertype not.
- A FETCH doesn't find an existing phase.

Reason: Two or more VSE's share a disk (shared library). The library was updated on System A. System B had some information about this library in storage (LIBDEFs, SDL entries etc.). These are not updated yet.

If a sublibrary is shared by processors and members of it cannot be found by one processor (or the old versions are still found). It is likely that the in-storage information of this processor is obsolete due to member index modification in other processors.

Solution: Run RELEASE SPACE for the updated library on every machine. Attention: during RELEASE SPACE no task should access this library, it might run into unpredictable results

The command RELEASE SPACE updates the system in-storage information (but not local directory lists).

Influences on Number of SIOs

A sublibrary is considered as large if it contains a large number of members, the member index of a large sublibrary consists of more index levels, each one causing a SIO when locating a member name in the sublibrary.

Note: Due to the member index structure (B-tree), all members in a specific sublibrary are located with the same number of SIOs or with a number which differs by one.

Using small sublibraries reduces the number of SIOs for locating a member in a sublibrary. However, you may have to increase the LIBDEF SEARCH chain, thus increasing the number of SIOs for going through the SEARCH chain.

Since the sublibraries of the LIBDEF PHASE SEARCH chain get in-storage second-level directories (SLDs), the size of a sublibrary generally does not impact the performance of the supervisor FETCH/LOAD-phase function or the overall system performance. However, you may notice a performance improvement when working with small sublibraries for all Librarian actions which modify the member index, for example COPY, RESTORE, RENAME or CATALOG.

With these contradictory aspects in mind, it is generally advisable to group members into sublibraries by application, product versions, vendors, etc. without caring much about sizes. An exception is if the above-mentioned Librarian commands are considered performance critical. Then you should choose small sublibraries.

The following figures give an idea of what is considered a small and large sublibrary in this discussion:

- small: up to about 300-420 members

- large: more than about 9000-125000 members

Sublibraries between the above ranges are considered medium-sized and will require 2-3 SIOs to locate a member name. Only rough figures can be provided here since the member index size depends on the filling up of the index library blocks, the number of different member types in a sublibrary, or the percentage of phases in the sublibrary (phases have larger entries in the member directory than other member types). The lower values apply to sublibraries containing only phases, the upper values to sublibraries containing non-PHASE member of predominantly the same type.

How to Find Out the Number of Member Index Levels of a Sublibrary

Use the Librarian command `TEST SUBLIB=lib.sublib`. A line near the end of the display output tells you the NUMBER OF INDEX LEVELS.

The number of member index levels reflects the number of SIOs needed to locate a member in a sublibrary. The number of SIOs is either identical to the number of index levels or one higher. However, the number of index levels does not affect the performance of the supervisor FETCH/LOAD-phase function since in-storage second-level directories (SLDs) which allow locating a phase in a sublibrary with just one SIO are provided.

This value is not displayed on the LISTDIR output since it is not considered important for most installations and might cause confusion for programmers unfamiliar with Librarian internals.

One Large Extent versus Several Smaller Extents

The Librarian allows you to define a private library with up to 16 extents in BAM controlled space and up to 32 extents in VSAM managed space.

For BAM controlled space, you have to specify the individual extents directly in the DLBL/EXTENT statements. For VSAM managed space, you have influence on the extent sizes through the primary and secondary allocation values when defining the VSAM cluster. The following evaluation should shed some light on the factors affected by the number of library extents:

- Opening a library: Each library extent is opened individually, that means, for each extent there is an invocation on the OPEN routines (this applies to libraries in BAM controlled space as well as in VSAM managed space). The effect is that the elapsed time for opening a library increases with the number of its extents. However, libraries which are already known to the system will not be re-opened again, for example, a library specified on a LIBDEF statement will not be re-opened in a processor as long as this LIBDEF statement is active (not LIBDROP'ed). Thus, the time for opening a library is not considered performance-critical for most installations. The picture changes for libraries which do not show up on a LIBDEF statement and are frequently accessed online through LIBR commands. In this case, the overhead for opening additional library extents may be noticed when, for example, a Librarian ACCESS command is entered.
- Start I/O's (SIOs): Once a library is open, the number of SIOs to the data (index as well as member data) is independent of the number of library extents. Spreading library extents on different volumes may give you the opportunity to help balance the channel/device activities. Whether you gain a noticeable

performance increase by doing so depends on how often the library data on these extents is accessed and on the other data traffic on the channel and device. Having only one large library extent on a volume instead of several smaller ones may or may not decrease the average SEEK time for data on this volume depending on the pattern of accesses to the library data and the other data on this volume. The Librarian does not offer a direct way to put selected sublibraries or members into a specific library extent. Usually, it will not be worth the effort of trying to balance the channel/device workload based on the accesses to library data. The accesses to non-library data sets probably have a greater influence.

- Path length: The only time the Librarian routines (and supervisor FETCH/LOAD) are confronted with multiple extents is when building the CCW chain for accessing library data. The path length needed by the Librarian routines (and supervisor FETCH/LOAD) to translate a logical address into its physical DASD address increases only slightly with the number of library extents. You will hardly notice the difference.

So the conclusion of the above discussion is: A higher number of library extents causes a noticeable performance decrease only in rare situations.

Space Reclamation Attributes **AUTOMATIC** versus **IMMEDIATE**

With the parameter REUSE= in the DEFINE SUBLIB command you select one of the two space reclamation algorithms provided by the Librarian. The algorithms are bound to individual sublibraries, not to entire libraries.

With attribute **AUTOMATIC** (default) local directory lists remain valid even if the corresponding phases are deleted/replaced. Also, long-running procedures will come to a normal end even if they are deleted/replaced concurrently to their execution. This system behavior is achieved by postponing the reuse of deleted/replaced member space of the sublibrary is not in unique use by one task/partition/processor when members are deleted/replaced.

Attribute **IMMEDIATE** makes the space of deleted/replaced members available for immediate reuse, even if the sublibrary is shared by several tasks or partitions or processors. Thus, programs with local directory lists or long-running procedures may terminate abnormally if the corresponding phases or the procedures in execution are deleted/replaced concurrently to their execution. However, integrity is not exposed since the system is able to detect library blocks which are reused for another member.

AUTOMATIC and **IMMEDIATE** are entirely identical in their effects:

- if the sublibrary is by only one partition/task at the time members are deleted/updated/replaced
- and**
- if the library (containing the sublibrary) does not reside on a volume which is shared by two or more processors.

If you want to change the attribute for an existing sublibrary, you may do so anytime by using the CHANGE SUBLIB command. When changing from **AUTOMATIC** to **IMMEDIATE**, data library blocks in the space reclamation chain are freed.

Based on the above discussion, you may prefer the attribute

- AUTOMATIC for sublibraries used for production runs,
- IMMEDIATE for sublibraries used for program development.

What Does the **RELEASE SPACE** Command Do ?

The **RELEASE SPACE** command performs the following actions for individual sublibraries (specification **SUBLIB=lib.sublib**) or for each sublibrary of a library (specification **LIB=lib**) in the following order:

1. It invalidates the phases in the space reclamation chain, thus preventing supervisor **FETCH/LOAD** from loading them into partitions. That means, in-storage directory entries can no longer be used to retrieve such phases.
2. It adds the library blocks of the space reclamation chain to the free space inventory, thus making these library blocks available for immediate reuse (the **DELAYED SPACE/DELAYED LB'S** values displayed by the **LISTDIR** command will be set to zero increasing the **FREE SPACE** values). The contents of the released library blocks remain unchanged except for phases (phases are invalidated).
3. It updates the second-level directory (**SLD**). (**SLDs** are built only for sublibraries showing up on **LIBDEF PHASE** or **LIBDEF *** statements.)
4. It updates the in-storage pointer (saved in the sublibrary definition table in the **SVA**) to the library block containing the highest level of the member index (this pointer is used to locate members in the sublibrary for retrieval).

If a sublibrary is shared by two or more processors, it is strongly recommended that you execute the **RELEASE** command in all processors accessing the sublibrary and not just in one. You are asked to do so by the messages **L047/L048** which are displayed on **SYSLOG**. The reason for this is that the above actions have to be performed in all processors, even if the space reclamation chain is empty after execution of the first **RELEASE** command.

For sublibraries showing up on **LIBDEF PHASE** statements you must refresh in-storage information in other processors:

1. Terminate programs with local directory lists pointing to replaced phases.
Execute the Job Control command **SET SDL** if phases in the **SVA** have to be replaced or if **SDL** pointers point to replaced phases in the system sublibrary **IJSYSRS.SYSLIB**.
Ensure that this action is performed in all processors accessing replaced phases before continuing.
2. Run the Librarian command **RELEASE SPACE** in all processors accessing the sublibrary to update in-storage information (**SLD**, pointer to highest member index library block).
3. Execute the Job Control command **SET SDL** if phases in the **SVA** have to be replaced or if **SDL** pointers point to replaced phases in the system sublibrary **IJSYSRS.SYSLIB**.
4. Restart programs with local directory lists.

If you fail to adhere to the above sequence of steps, you risk that tasks may terminate abnormally due to 'member not found' or 'member space reused'

conditions. Executing the RELEASE command (even in an incorrect step sequence) cannot destroy a library/sublibrary or cause integrity exposures.

Shared Libraries

Update of In-Storage Information for Shared Libraries

The following information about sublibraries is kept in virtual storage and subject to sublibrary changes:

- | | |
|---|------------------|
| - SLD (second-level directory) | owned by system |
| - Pointer to the highest level of member index | owned by system |
| - System Directory List (SDL) pointing to phases
in the system sublibrary IJSYSRS.SYSLIB | owned by system |
| - Local Directory Lists | owned by program |

SLDs are built only for sublibraries which show up on LIBDEF PHASE statements (which include LIBDEF * statements). They are used only by supervisor FETCH/LOAD to retrieve phases.

The pointer to the highest level of the member index is used to locate e.g. object modules for link-editing, source books for compilations, and procedures for EXEC PROC= execution. The Librarian uses this pointer for retrieval of members of any type (e.g. LIST, LISTDIR, PUNCH, BACKUP, COMPARE, COPY).

Updating local directories is always the user's responsibility (e.g. CICS-PPT via NEWCOPY). The SLD, the pointer to the highest member index level, and the SDL pointer are updated automatically by the system in the processor performing the sublibrary change.

If a sublibrary is shared by processors and its contents are changed, its in-storage information might have an old status in all processors except the one performing the change. The system-owned information is updated by the following actions in the processor performing the action:

- The SLD is updated automatically whenever supervisor FETCH/LOAD uses more than one SIO to locate a phase in a sublibrary of a permanent LIBDEF PHASE chain.
- The Librarian command RELEASE SPACE updates the SLD and the pointer to the highest member index level.
- If you detach the sublibrary from all partitions (LIBDROP) and attach it again (LIBDEF), a new SLD is built and the pointer to the highest member index level is refreshed.
- If you catalog, delete, rename members (of any type), the SLD and the pointer to the highest member index level are updated.
- The Job Control statement SET SDL updates the SDL pointers and phases in the SVA (using the LOAD macro).

Is There a Performance Impact if Libraries Are Shared by Processors?

For retrieval of members there is no performance impact if libraries are shared by two or more processors. The actions performed by Librarian routines and supervisor FETCH/LOAD are exactly the same as for non-processor-shared libraries (member retrieval does not require locking).

For library functions which store members in processor-shared libraries you may notice a performance decrease compared to storing in non-processor-shared libraries.

The reasons are two-fold:

- Locking of resources (for example, the free space inventory) has to be done across processors using the lock file. This increases the path length for the locking service and causes read/write SIOs to the lock file.
- When storing members in libraries which are neither shared by processors nor by other tasks/partitions, the Librarian keeps the free space inventory in partition storage, thus saving the read/write SIOs for updating it. This optimization cannot be done for processor-shared libraries.

Specifically the following Librarian functions may run faster for libraries which are neither shared by processors nor by other tasks/partitions:

```
RESTORE LIB/SUBLIB  
COPY LIB  
MOVE LIB
```

Since member-retrieval actions usually far outweigh member-cataloging actions, the overall system performance is unlikely to be affected by processor-shared libraries.

Note: Libraries are considered to be shared by processors when the first (or only) extent of a library resides on a volume which is shared (defined by the SHR parameter on the IPL ADD command). The Librarian treats such libraries as processor-shared regardless of whether they are used by other processors or not. Therefore, you may put the first extent of a multi-extent library on a non-shared volume to get better performance for the above Librarian actions in case a library is not actually shared by processors, but for DASD space reasons has to reside on a processor-shared volume.

Can I Share Libraries Without Having a Lock File?

If you share libraries between real processors or VSE guest machines running under VM, it is highly recommended that you

- specify the SHR parameter on the VSE IPL ADD command when defining the DASDs with the shared libraries,
- define or reference the lock file via the VSE IPL DLF command,
- attach the DASDs with the shared libraries for VSE guest machine running under VM in read/write access mode.

Without a lock file, the write SIOs to shared libraries from the sharing processors or VSE guest machines will not be serialized, thus destroying your libraries.

Thus layout is recommended even in situations when a real processor or a VSE guest machine accesses such libraries exclusively for member retrieval and never

runs library update jobs. The technical reasons for this recommendation are the following:

- Automatic space reclamation: Even if no library update jobs are submitted in one of the sharing processors or VSE guest machines, this processor or VSE guest machine may perform automatic space reclamation for a shared library causing write SIOs to this library. Without a lock file, you risk destroying these libraries. When the shared DASD is in 'read-only' status under VM, the write SIOs for space reclamation will be rejected causing abnormal termination of the VSE task triggering space reclamation. This can happen also at IPL time when LIBDEF statements are processed.
- Abnormal task termination: When a library is shared but its DASD is not added with parameter SHR, member retrieval tasks as well as library update tasks may be terminated abnormally with 'defect in library detected' or 'member not found' messages although the library is in good shape. A possible cause for these messages is dynamic extension of a library in VSAM managed space performed by another processor or VSE guest machine. For non-shared libraries, the system assumes that such a library is defective rather than verifying if the library was extended by another processor or VSE guest machine. The task is terminated abnormally when attempting to access the extended part of the library.
- No warning messages: You will not see any warning messages before a library or sublibrary is deleted if the system is not aware of the shared status.

In brief: You avoid a lot of potential problems by defining libraries as shared when they are actually shared.

Are Libraries Extended Automatically if They Are Shared?

Libraries in VSAM managed space are extended automatically even if they are shared and concurrently accessed by several processors. Libraries in BAM controlled space are never extended automatically.

Any of the shared processors can trigger the extension of a shared library and work immediately with the additional extents obtained. The other processors are not informed about the extension directly. They continue to work with the original library extents saved in their SVA until one of the following happens:

1. A Librarian service finds a disk address in the extended library which points outside the library extents known to the processor. This triggers an update of the library extent information in the SVA of the respective processor. This update may be initiated by a read-from-library or a write-into-library request. Thus, the added extents are automatically known to the other processors.
2. Supervisor FETCH/LOAD detects a disk address which points outside the range of library extents known to the processor. It will either cancel the task with message 0P92I or return to the invoking routine with return code 12 depending on the value of the RET parameter on the FETCH/LOAD macro. To recover from this situation, the operator should run the Librarian command TEST LIB=lib AREA=SPACE for the library indicated by message 0P92I or displayed by the failing routine. The TEST command will update the library extent information in the SVA when getting a disk address outside the known range of library extents.

This last described situation can happen only when libraries of LIBDEF PHASE chains have been extended in other processors and the added extents have not yet been accessed by Librarian services in the other processors.

To prevent such a situation from happening, the system displays the message L274 on the operator console whenever a shared library is extended automatically. This message informs the operator about the library extension and asks him to run the Librarian command TEST LIB=lib AREA=SPACE in all other processors which share the extended library (the TEST command with AREA=SPACE is recommended because it takes only a short period of time to execute it).

The library extent information in the SVA is refreshed automatically only for libraries which reside on DASD volumes added with parameter SHR at IPL time. For other libraries, it is assumed that a library is defective when disk addresses are pointing out of the range of the library extents recorded in the SVA. In this case the task will be terminated abnormally with a Librarian message.

Library Full

Check via

```
LD L=lib OUTPUT=STATUS      or
TEST L=lib AREA=SPACE
```

if there is any delayed space in the library. If so run RELEASE SPACE to free this.

Run TEST L=lib to check for 402 errors. Run

```
TEST L=lib REPAIR=YES
```

to remove errors 402. The library must be uniquely assigned.

What To Do if Library Space Is Exhausted ?

When you get one of the messages L201, L268, or L278, you should check the library status before taking steps to expand the library space:

1. Execute the Librarian command LISTDIR LIB=lib OUTPUT=STATUS and check the number of free library blocks in the list output line 'FREE SPACE'. This value must be large enough to take in the new member including a couple of library blocks possible needed for index update (when replacing a member, the Librarian first catalogues the new version before freeing the space of the old version).

When replacing members, you may decide to delete the existing members before cataloging the new ones.

2. If you can reasonably assume that the new member should fit into the available free space based on the LISTDIR output values, then the library may be in an inconsistent state. Execute the librarian command TEST LIB=lib REPAIR=YES to check the consistency of the library and to free library blocks marked as occupied in the free space map in spite of not belonging to a cataloged member or to an index. This situation may show up as the result of a prior system break-down or CANCEL FORCE command.

Be aware that the REPAIR function of the TEST command can only be executed if the library is not specified on LIBDEF statements and is not shared by processors. The TEST command with REPAIR=NO can be executed any time, but should not be executed concurrently to a library update. Otherwise,

TEST may display error messages based on temporary inconsistencies due to the update process.

3. Check the output line DELAYED SPACE of the LISTDIR command. If the DELAYED SPACE value is not zero, execute the Librarian command RELEASE SPACE to free this space and to make it available for reuse.

Be aware the the RELEASE command has to be executed in all processors accessing the library and that local directory lists should be refreshed if still pointing to deleted phases.

4. Check to see if there are members in the library which you do not need any longer. Delete these members with the Librarian command ACCESS SUBLIB=lib.sublib / DELETE mn.mt . For sublibraries with space reusage attribute AUTOMATIC, the space of the deleted members may show up under DELAYED SPACE/DELAYED LB's. Free it as described above.

If the above actions fail to provide enough free space, then you have to enlarge library space.

Perform the following steps dependent on the Librarian message:

L278 - VSAM data space exhausted when attempting to extend library
 IDCAMS: DEFINE SPACE increase VSAM data space
 ALTER-ADDVOLUMES add other volumes to VSAM data space

L268 - Maximum number of extents (16) allocated - no further extension possible

L201 - Library is full:
 Libraries in VSAM managed space: DEFINE CLUSTER with larger primary/secondary allocation values
 Libraries in BAM controlled space: Submit new DLBL/EXTENT statements

The execution of the LIBR step 'DELETE library' is strongly recommended. It performs the following actions:

- It verifies that the library is not in use.
- It destroys the library descriptor, thus making the extent inaccessible to Librarian services.

Scattered Library

Member data may get scattered under the following conditions:

1. All library space is used once. The Librarian does not start reusing library space until all space of all existing extents is used once. You can find out if a library is in space reusage mode by running the Librarian command TEST LIB=lib AREA=SPACE and checking the output line HIGH END REACHED under FREE SPACE DESCRIPTOR (YES means space is being reused).

So if the free library space is already scattered member data may be scattered after catalog.

2. Two (or more) members are cataloged in parallel into a library and the number of output buffers is too small to hold the entire member. This will trigger several library space requests to catalog a member and the library space

requests for one member may be intermixed with the library space requests for other members, thus causing fragmentation.

The number of output buffers allocated by the Librarian is dependent on the partition size.

The free space inventory contains a pointer to free library blocks to be used to fulfill the next library space request. When a library is in space reusage mode, this pointer is set to the beginning of the member deleted last.

To get an overview of the free and used library blocks, execute the Librarian command `TEST LIB=lib AREA=SPACE`. This command displays (among others) the free space inventory of a library on the format of a bit map: a '1' indicates that the library block is used, a '0' that it is free. By looking at the output line 'HIGH WATER MARK: POSITION' you can find out at which position the next member will be stored. Thus, by looking at the sequences of contiguous '0' and by knowing the sizes of the members to be cataloged next, you can roughly predict whether these members will be scattered heavily, slightly or not at all. On a pure command basis you cannot store a member in a specific piece of free space.

`COPY` or `BACKUP/RESTORE` of a whole library does a re-organization. But be aware that a copied library may be bigger than the original one, because for a new index there will be always done a space reservation.

Does Member Scattering Impact Performance?

Generally, you can expect that scattering member data will not impact performance noticeably. To substantiate this answer, we have to look at specifics of the library structure and discuss the effect of scattering on different activities.

With respect to performance, retrieval of members is considered more critical than cataloging members. Therefore the library structure is designed to allow minimization of read-SIOs via contiguity counts:

- The number of contiguous library blocks starting from the beginning of the member is stored in the member directory entry.
- The control field of each library block contains the number of library blocks contiguously following this library block.

Members stored scattered in a library require more SIOs for retrieval. However, the above described contiguity counts allow building CCW-chains to read all contiguous blocks of a scattered member with a single SIO.

With this in mind, we may have a look at the overall system performance and system throughput. From a library point of view, the overall system performance is influenced mainly by the time it takes to fetch programs, that is, to load phases into partitions. Thus, the number of read-SIOs is the predominant factor. To notice the impact of scattering on the system performance, that is, the increase of read-SIOs, lots of heavily scattered phases must be fetched constantly which is not likely to happen.

Looking at Librarian functions, scattering is expected to cause a noticeable performance decrease only when masses of scattered members are processed.

Influences of BACKUP/RESTORE on Used Space

When a new sublibrary is filled with members (e.g. through RESTORE), the library blocks of the member index are filled only to about 50%. When members are added later on, the index library blocks may be completely filled without the need to split library blocks.

If you backup a sublibrary whose index library blocks are filled above 50% and restore this sublibrary, the LISTDIR command will show a higher number of USED SPACE/USED LB'S after RESTORE than it showed before RESTORE due to the new 50% utilization of the index library blocks. Since RESTORE LIB is the sum of restoring its sublibraries, these explanations apply also to RESTORE LIB.

When a library or sublibrary is backed up, its current number of used library blocks is recorded on the backup tape. To compensate for the 50% utilization of the index library blocks after RESTORE, the command RESTORE LIB SCAN as well as RESTORE SUBLIB SCAN displays size values which are increased by 10 library blocks. Thus, RESTORE SCAN will display library or sublibrary sizes which are slightly different from the actual ones.

Before the Librarian starts to restore a library into BAM controlled space, it checks to see if the library on the backup tape will fit into the disk extents. Again, the library size value recorded on the backup tape is increased by 10 library blocks before the check is made. No size check is made when a library is to be restored into VSAM managed space.

Restoring a sublibrary (RESTORE SUBLIB) starts without checking if the sublibrary on the backup tape will fit into the free space of the library (either in BAM controlled space or in VSAM managed space).

Cancel of Librarian Actions

Entering the commands

```
CANCEL xx      (VSE/ESA)
/CANCEL        (VSE/ICCF)
PCANCEL, PFLUSH (VSE/POWER)
```

does not bring the Librarian to an immediate stop. Instead, the program continues to run until either the library is in a consistent state (when updating) or the next part of listing is completed (when displaying library contents).

If you cancel when working with the Librarian in prompting mode either from SYSLOG or from a VSE/ICCF terminal, only the Librarian command in process is terminated, not the entire Librarian session. The Librarian terminates the command in process (with proper cleanup of the library) and prompts for the next command to be entered. Cancelling when the Librarian is waiting for the next command to be entered terminates the entire Librarian session.

Cancelling the Librarian running in batch mode terminates the job step, not just the command in process.

Entering the VSE/ESA command CANCEL xx, FORCE stops the partition immediately without giving the Librarian a chance to do cleanup. Therefore, when cancelled with FORCE during update, the library in process may be in an inconsistent state afterwards, e.g.:

- Library blocks may erroneously be flagged as taken, thus not available for further usage.
- The number of members displayed with LISTDIR SUBLIB may not be identical to the actual number of members in the sublibrary.
- The member index may not be updated properly, causing additional SIOs to locate a member.

To find out if a library is in an inconsistent state, use the Librarian command TEST. Even if a library is in an inconsistent state, you are often able to read the members in that library and, thus, recover through BACKUP/RESTORE commands.

If the system breaks down during update of a library, the potential effects are the same as with CANCEL xx,FORCE.

TRACE

TEST TRACE=LEVEL2|SIO|ALL

TEST TRACE=LEVEL2|SIO|ALL causes a message for every executed module in the specified function range. This may be used to determine accessed libraries/members (in this case TEST TRACE=LEVEL2 is sufficient).

Important Librarian Level 2 Functions

LBACCESS	handles LIBDEFS/ACCESS/CONNECT <ul style="list-style-type: none">• MF=GET, gets sublibrary from chain• MF=ADD, puts sublibrary into chain• MF=REMOVE, removes sublibrary from chain
INLMLCON/INLMSCON	connects to a library/sublibrary
INLMMCON	connects to a member
INLMFIND	searches and connects to a member
INLMBLDL	searches a list of members/sublibraries
INLMGETR	reads a member record
INLMPUTR	writes a member record
INLMDIS	disconnects from a member
INLMSTOW	handles directory entries <ul style="list-style-type: none">• MF=ADD, writes directory entries• MF=DEL, removes directory entries• MF=REN, replaces directory entries• MF=PURGE, purges member data

Chapter 8. VSE/VSAM

Introduction

VSAM is the file management system for VSE/ESA. It is used to process files that are stored on DASD devices. VSAM is designed to meet the processing needs of demanding processing environments with high performance, ease-of-use, device independence, reliability, and recoverability. VSAM has been in use by numerous customers over many years and is the cornerstone to providing the 24-hour operation that VSE customers require. In the effort to meet all the requirements placed on it, VSAM can sometimes appear to behave in an unexpected manner. The following sections are the results of several years of experience with VSAM service and are intended to provide some insight into some potential VSAM problems. The capabilities and limitations of VSAM are discussed as well as suggestions for VSAM setup. Typical causes and solutions of VSAM open errors are described and migration pitfalls are also identified.

Capabilities and Limitations

VSAM File Size Limitations

There are several limiting factors in VSAM (number of tracks per extent, number of total extents). As quickly as we announce hardware that exceeds these limits, we release new VSAM code which supports the hardware, and extends the same limits.

There are really only six limiters on VSAM file size.

- You are allowed a maximum of 123 volumes for your file. However, with today's large volumes, you can very quickly get some very large files. For implicitly defined files, VSE/VSAM will extract up to 16 volumes from the default model
- Another limiter is the 4 byte RBA (Relative Byte Address). Every record in a VSAM file is ultimately accessed using its relative byte position from the beginning of the file. This means that you can only have 4.3 billion (4,294,967,295) bytes of data in a single VSAM file. This amounts to about 2 1/2 3380 model Ks dedicated to a single VSAM file. Since VSAM file compression occurs prior to the insertion of records into the control interval, usage of compressed files (introduced in VSE/ESA 2.1), substantially increases the amount of user data that can be "packed" into 4GB. The actual limit is 1 control area less than 4GB.

With VSE/ESA 2.3, a cluster can be defined as 'ExtraLargeDataset' or 'XXL', which allows up to 493GB for an extended KSDS or ESDS dataset.

- VSAM files are limited to 123 extents. This is normally only a problem if you specify a very small secondary extent relative to the primary extent. Remember, VSAM will sub-allocate an extent up to 5 times. So if you ask for 500 cylinders as a primary extent, and VSAM cannot find that much contiguous space, it will attempt to give the file up to 5 extents of 100 cylinders each (or

some combination thereof). This may quickly exceed the extent limit for the file. Unique files and reusable files are limited to 16 extents.

- The lock used by Shareoption(4) processing has a two byte field for the control area id (or index control interval id for KSDS files). Thus, a Shareoption(4) file may not have more than 64511 (64K-1024) control areas, and the maximum file size would be 64511 times your control area size.

If you use the maximum control area size for your file of one cylinder, define the file as XXL, and reside on 3380, with a CISIZE of 4K, this would set a maximum file size of 36.9GB.

- In addition, any single allocation (primary or secondary) cannot contain more than 16Meg records, if the user intends on using Backup/Restore. See APARs DY36234 and DY40943.
- When defining files using RECORDS(..), you can only specify up to 16 million records per extent. You can request more data by specifying a larger maximum recordsize for the file. Remember, if the file is compressed, VSAM uses the un-compressed maximum record length to calculate how much space to reserve for the file. This may give you more space than you actually need.

Actually, customers will start running into severe performance degradation before they reach the outer limit of VSAM file size (merely from the number of index levels you have to run through to find a single record).

Setup

Reorganize a File

Since IDCAMS BACKUP/RESTORE processes files at the control interval level, it cannot be used to reorganize a file. You must use REPRO, or some utility that processes the file at the record level. It is important that the file be deleted and re-defined. Some utilities do this automatically.

Catalog Maintenance

Check a LISTCAT to see where the catalog growth is occurring. If it is mostly in the high-key range, you can re-build the catalog by simply REPRO'ing it out and back in (do not delete or re-define the catalog). Otherwise, if the catalog is corrupted, the catalog must be rebuilt by backing up all files, deleting and re-defining the catalog, spaces and files. The catalog cannot extend onto a second volume, so if the primary catalog volume fills up, you must also rebuild the catalog.

Reorganize a Catalog

It is possible to enlarge a catalog using REPRO without backing up all files and deleting/redefining the catalog. These steps can also be used if a catalog is suffering from "wasteland" (see topic later in this chapter.) This can be a major time saver when a catalog owns a large number of files on many volumes. The indicated job streams are found in *VSE/VSAM Commands (SC33-6631)*.

1. Use the following jobstream to copy catalog records to tape.

```

// JOB      EXAMPL16
// ASSGN   SYS005,cuu      <===== Empty tape for backup
// MTC     REW,SYS005
// DLBL    IJSYSUC,'catalog filename',,VSAM
// TLBL    CATOUT,'PORTABLE.TAPE1',,TAPE01,1
// EXEC    IDCAMS,SIZE=AUTO
           REPRO INFILE(IJSYSUC/UCATMRPW)           -
           OUTFILE (CATOUT                          -
           ENVIRONMENT (PDEV(2400) RECFM(VARBLK) REW  -
           BLKSZ(5164) RECSZ(516)))
/*
/ &

```

Figure 76. Copy Catalog Records to Tape Sample Job

Follow steps 2 - 4 only if you are enlarging the catalog. Otherwise, if you are simply reorganizing the catalog in its previous extents, go to step 5.

2. Remove all files with allocations on the catalog volume. This can be done by backing them up, or moving them to another volume. This is important. When we define the catalog in a larger extent, we must, of necessity delete all files from the catalog volume. This is detected during restore by REPRO, who then marks all files residing on the catalog volume as "NOTUSEABLE". If you are simply reorganizing the catalog in its previous extents, this step is not required.
3. Scratch the VSAM spaces belonging to the user catalog from the catalog volume. If all space was owned by the user catalog, it is easier to scratch the entire catalog pack. Use a tool such as IKQVDU. Do not modify any of the other volumes belonging to this catalog.
4. Define a new, larger, user catalog on the original volume. Remember to define the CYL(.) parameter at the data and index level of the DEFINE UCAT. Space definitions at the cluster level only allocates general-use VSAM space, and the catalog is defined using a default of less than 10 tracks.
5. Restore the old user catalog from tape using the following:

```

// JOB      EXAMPL17
// ASSGN   SYS004,cuu      <=== Tape containing previous backup
// MTC     REW,SYS004
// DLBL    IJSYSUC,'D27UCAT2',,VSAM
// TLBL    CATIN,'PORTABLE.TAPE1',,TAPE01,1
// EXEC    IDCAMS,SIZE=AUTO
           REPRO INFILE (CATIN                       -
           ENVIRONMENT (PDEV(2400) RECFM(VARBLK) -
           BLKSZ(5164) RECSZ(516))) -
           OUTFILE(IJSYSUC/UCATMRPW)
/*
/ &

```

Figure 77. Restore User Catalog from Tape Sample Job

Re-Build a Catalog

If the catalog is corrupted, usage of the previous steps to re-organize the catalog will only copy the bad records into the new catalog. In order to correct the situation, all files in the catalog must be backed-up, the catalog and all controlled space deleted, re-defined, and all files restored. This re-builds all catalog information, including the corrupted pointers.

Please follow these steps:

1. Backup all files belonging to this catalog.

We recommend using BACKUP (*) IDCAMS command, but you can use REPRO, EXPORT, or several generally available OEM packages. Remember, VSAM Backup/Restore does not backup VSE libraries (use LIBR for that), nor does it backup empty files (including default models). Since some types of DL/I files consist of multiple inter-related VSAM files, the applicable DL/I utilities should be used to backup DL/I files.

2. Identify all volumes which contain space from this catalog.

This may be done with a LISTCAT SPACE IDCAMS job. It is important that no other VSAM catalog owns space on any of the affected volumes. If you have volumes on which multiple VSAM catalogs own space, you will have to identify which extents on the volume belong to this catalog by comparing the extent information. Otherwise, you can delete all VSAM spaces on the volume (see step 4).

3. If the catalog to be re-built is a user catalog, you will have to remove the pointer to the user catalog from the master catalog using an EXPORT DISCONNECT IDCAMS job. If you are re-building the master catalog, skip this step. However, you will have to re-IPL VSE in basic mode, since the PRD1 and PRD2 libraries (CICS, optional products, etc) are under VSAM control in the master catalog.

4. Delete all VSAM spaces on the affected volumes.

If the volumes only contain VSAM spaces, you may use the following job.

```
// ASSGN SYS000,X'cuu'
// UPSI 11
// EXEC IKQVDU,SIZE=AUTO
```

Figure 78. Delete VSAM Space With IKQVDU Sample Job

If the volume to be scratched also contains non-VSAM files, you must identify the VSAM file names from a VTOC listing. VSAM file names have the following format.

```
Z999999x.VSAMDSPC.Tnnnnnnn.Tnnnnnnn
```

```
where x = '2' for a normal data space
         '4' for a space containing a user catalog
         '6' for a space containing the master catalog
nnnnnnn = Time-of-day stamp when dataspace created.
```

Figure 79. VSAM File Name Format

Use the following job to delete data spaces.

```

// ASSGN SYS000,X'cuu'
// EXEC IKQVDU,SIZE=AUTO
  --- Enter following in response to operator prompt
RESET OWNERSHIP ==> Remove VSAM ownership flag
RESET CRA       ==> Only required if recoverable catalog
SCRATCH        ==> Remove a label from VTOC
<data set name> ==> Name of file to be deleted (when prompted)
END            ==> When all files deleted on this volume

```

Figure 80. Delete VSAM Data Spaces Sample Job

See “Maintaining VTOC and VOL1 Labels on DASD (IKQVDU)” in *VSE/VSAM User's Guide and Application Programming (SC33-6632)*.

5. After completely deleting all VSAM space and the affected catalog, if the catalog is a user catalog the catalog must be deleted from the master catalog. You do this using the IDCAMS command EXPORT DISCONNECT.
6. Now the user catalog must be redefined along with all data spaces.
Redefine all VSE libraries if you backed any up using LIBR. Also redefine any required empty files (including default models).
7. Restore all files from the backup tapes created in step 1.
8. If you are re-building the master catalog, you must reconnect all user catalogs in the system now. Use IDCAMS IMPORT CONNECT for this.

Note: If you are re-building a master catalog (or planning a migration of DOSRES or SYSWK1 between un-like devices), it is simpler to re-install VSE/ESA. The main problem is that you cannot enter IDCAMS commands (delete / re-define catalogs, spaces, clusters, backup / restore) from the console. So, in order to re-define the master catalog you have to be either running under VM, or have the jobs already prepared in the POWER reader. Remember, without the VSAM master catalog, you cannot bring up CICS and the interactive interface.

Hint: An interactive tool named 'IDCONS.PHASE' is distributed in the VSE/ESA system library. IDCONS can be invoked from a 'PAUSE' job and used to perform VSE/VSAM commands, e.g. DEFINE MASTERCATALOG, RESTORE, etc.

Dataset Name Sharing

Dataset Name Sharing allows multiple opens of the same file to use the same in-core VSAM control block structure (including buffers). It is not required that the ACBs all have the same ddname. VSAM automatically detects that the ACBs refer to the same VSAM cluster, and adds the new ACB to the existing cluster, if requested. DSN is requested by coding ACB MACRF=(DSN,...) on the first, and all subsequent ACBs to be shared. Under CICS, DSNshr=(ALL | UPDATE), BASE=<NAME> can be coded as an option to DFHFCT TYPE=FILE, or DSNSHARING under RDO (Resource Definition On-line) using CEDA.

Usage of dataset name sharing not only saves storage, but also prevents many variations of read integrity problems (see “Read Integrity Problems” on page 199) and allows read/write sharing of SHR(2) files (e.g. through alternate indexes). However, there are some pitfalls of which you should be aware. Programs accessing VM/VSAM using the MVS versions of COBOL and PL/1 automatically turn on dataset name sharing, with several undesirable results.

1. Return Code x'A2' (Opposite Input or Output mode)

The first open of a shared ACB determines the type of structure to be built (read/only or read/write). If the first ACB to be opened requests only read/only access, a read/only structure is built and all further ACBs to share this structure must be also for read/only. The same applies for read/write. If the first ACB requests read/write access, an attempt to open a read/only ACB against this structure will result in OPEN return code x'A2'.

Note: CICS automatically adjusts the SERVREQ definitions for all files defined in the FCT as "Data-set Name Sharing".

2. Return Code x'A3' (Insufficient strings BSTRNO)

The total number of strings (simultaneous accesses) for a shared structure must be specified in the initial open. A new ACB operand (BSTRNO) was added to allow specification of additional strings which would be available for sharing ACBs. This applies to alternate indexes as well, so opening a base cluster with five alternate indexes requires 6 strings. CICS will automatically calculate the number of strings using the name in the "BASE" operand. However, there is no way to specify additional strings in a COBOL or PL/1 program. In order to address this, VSAM automatically doubles the number of strings specified in the ACB, but ensures that it adds at least 5 additional. Thus, since there is no provision for specification of the number of strings in a PL/1 or COBOL file structure definition, you are limited to 6 ACBs which share the same structure.

Open Errors

Return Code 168 x'A8'

Example message.

```
F4 004 4228I FILE KSDS      OPEN  ERROR X'A8' (168) CAT=UCAT
(OCSHR--5) FILE ALREADY OPEN IN ANOTHER PARTITION
```

Following errors will result in return code x'A8' during OPEN.

1. Attempt to OPEN a non-SHR(4) file while the same file is opened in another partition or same partition. Extended message will tell customer is file is open in this partition or another partition. Remember that OPENS over a path (aix or base) count, unless the customer is using DataSet Namesharing.
2. KSDS files can be opened in one of three modes: Keyed, Addressed, or CI-mode. Once a SHR(4) file is opened in one of these modes, all other OPENS must be in the same mode. (OCSHR--2). This often happens sharing files between CICS partitions, particularly with the IESCNL file. IESCNL must be specified as SHR(4) if it is to be shared between CICS partitions.
3. If the file is shared between multiple systems, ensure that the CPUID has not changed. The external locks include the CPUID in the key, and if the CPUID is changed, old locks under the old CPUID are not cleared. If VSE systems are run second level under VM, changing the CPUID is often done using the CP SET CPUID command, which will drive a different ASI proc. This may result in ghost lock entries being left in the file, which are not freed. Use the AR UNLOCK command to release lock entries for the bogus CPUIDs.
4. If file is shared between multiple releases of VSE, check to ensure that DOSRES or SYSWK1 are not marked as ,SHR on either system. Even though each system has their own version of DOSRES or SYSWK1, or only link to the appropriate volume, all locks are done using only the volume of the catalog and the CI number within the catalog. Thus, if two catalogs are defined on DASD with a duplicate VOLID, it is easy to pick up a lock from one release / catalog, and find that it matches the CI from the other release / catalog, and reject the OPEN.
5. When a file is being initially loaded (prior to first CLOSE), the SHAREOPTIONS for the file are temporarily reset to '1'. This means, even if the SHAREOPTIONS are '2' or '4', another partition will get RC x'A8' attempting to open the file, even for input.
6. Close of a file under CICS may not always be successful. This is the case whether the close is issued via CEMT command, or from one of a number of available vendor products which issue a request from batch to CICS to close an on-line file so it can be opened for output in batch. CICS will not close the file if there is an outstanding request against the file. This includes an update request that has not been either returned or released to File Control.
7. When multiple files are defined to CICS FCT as "Dataset Name Sharing", CICS automatically adjusts the SERVREQ of all files to output. Thus, even if you close the FCT entry which has the file opened for output, other FCT entries defined only for input may be sharing the same structure and may have been opened for output.

As of VSE/ESA 1.3, a new lock trace option has been added to VSE. This will display, on the console, the VSE supervisor lock control blocks, and can be used to identify the partition owning a lock. Lockname may be generic, that is, "V*" will trace all VSAM locks.

See a detailed description of this command earlier in this document under *Lock Manager Service Enhancements*.

Using Lock Trace to identify owner of VSE/VSAM lock

```
LOCK TRACE=<partition>,V*
  -then-
LOCK TRACE=OFF
```

1. If the failing job is being run in a dynamic partition, remember that the partition control blocks do not exist until the job is actually run. Put a // PAUSE in the failing job and enter the "LOCK TRACE=<partition>" command at that point.
2. Locktab entries and Owner elements are matched pairs.
3. If the error produces Message 4228I rcx'A8', then it is easy. The Locktab and Owner entry are immediately prior to the Message in the console log.

Otherwise ...

4. Scan the trace entries ignoring all locktab entries which do not contain "V" plus the volume name of the user catalog where the file in question resides.
5. Ignore all locktab entries in the following format: "V"<volser>nnnnmmmm, where nnnn or mmmm = '0000' or '0001'
6. We are looking for a locktab entry in the following format: "V"<volser>iiiiii0000. iiii will be the control interval number of the file in question within the user catalog. In the example, x'E5C3E3E2 F2F2F000 005A0000' ('VCTS220..|.'). The user catalog resides on volume CTS220, and the file in question is ci# x'00005A'.
7. In some cases, there will be two locktab entries following each other, that match this format. This would be for a KSDS file, and the first one describes the data component, and the second, the index.
8. Having located the failing locktab entry, move to the Owner element immediately following. +5 (counting from zero) contains the task id of the owner of the file in question. x'21' = BG, x'22' = F1, x'23' = F2 ... x'2B' = FA, x'2C' = FB, x'30' - x'99' refer to either a VSE sub-task or dynamic partition. Use the AR "STATUS" command to identify the partition / sub-task.

In the following example, the file in question is owned by BG (task id = x'21').

```

F4 0004 // JOB LOADKSDS
      DATE 02/08/1999, CLOCK 21/41/38
F4 0004 READY TO OPEN KSDS FILE

F4 0025 LOCKTAB ENTRY
V0004EA18 02CD2EA0 00000000 E5E2E8E2 D4C3D600 * 0 ff VSYSMCO * R0004EA18
V0004EA28 00000000 11800001 0004EA38 00000000 * 0 5/8 * R0004EA28
F4 0025 OWNER ELEMENT
V02CD2EA0 00000000 00250000 00011000 00000000 * * R00975EA0
F4 0025 LOCKTAB ENTRY
V0004EA78 02CD2BB0 00000000 E5C3E3E2 F2F2F000 * 0 ~ VCTS220 * R0004EA78
V0004EA88 00000001 04C00000 02CD2FE0 0004EA58 * ä 0 0 5/8 i * R0004EA88
F4 0025 OWNER ELEMENT
V02CD2BB0 00000000 00210001 00000000 00000000 * * R00975BB0
F4 0025 LOCKTAB ENTRY
V0004EA18 02CD2EA0 00000000 E5E2E8E2 D4C3D600 * 0 ff VSYSMCO * R0004EA18
V0004EA28 00000000 11800001 0004EA38 00000000 * 0 5/8 * R0004EA28
F4 0025 OWNER ELEMENT
V02CD2EA0 00000000 00250000 00011000 00000000 * * R00975EA0
F4 0025 LOCKTAB ENTRY
V0004EA18 02CD2EA0 00000000 E5E2E8E2 D4C3D600 * 0 ff VSYSMCO * R0004EA18
V0004EA28 00000000 11800001 0004EA38 00000000 * 0 5/8 * R0004EA28
F4 0025 OWNER ELEMENT
V02CD2EA0 00000000 00250000 00011000 00000000 * * R00975EA0
F4 0025 LOCKTAB ENTRY
V02CD2FC0 02CD2BC0 00000000 E5C3E3E2 F2F2F000 * 0 ä VCTS220 * R00975FC0
V02CD2FD0 00010001 04C00000 02CD2FA0 02CD2FE0 * ä 0 ff 0 0 * R00975FD0
F4 0025 OWNER ELEMENT
V02CD2BC0 00000000 00210001 00000000 00000000 * * R00975BC0
F4 0025 LOCKTAB ENTRY
V0004EA18 02CD2EA0 00000000 E5E2E8E2 D4C3D600 * 0 ff VSYSMCO * R0004EA18
V0004EA28 00000000 11800001 0004EA38 00000000 * 0 5/8 * R0004EA28
F4 0025 OWNER ELEMENT
V02CD2EA0 00000000 00250000 00011000 00000000 * * R00975EA0

F4 0025 LOCKTAB ENTRY
V02CD2AE0 02CD2B10 00000000 E5C3E3E2 F2F2F000 * 0 V CTS220 * R00975AE0
V02CD2AF0 005A 0001 04C00000 02CD2AC0 02CD2B20 * | ä 0 ä 0 * R00975AF0
F4 0025 OWNER ELEMENT
V02CD2B10 00000000 0021 0001 00000000 00000000 * * R00975B10
F4 0025 LOCKTAB ENTRY
V02CD2AE0 02CD2B10 00000000 E5C3E3E2 F2F2F000 * 0 VCTS220 * R00975AE0
V02CD2AF0 005B0001 04C00000 02CD2AC0 02CD2B20 * | ä 0 ä 0 * R00975AF0
F4 0025 OWNER ELEMENT
V02CD2B10 00000000 00210001 00000000 00000000 * * R00975B10

F4 0004 4228I FILE KSDS OPEN ERROR X'A8'(168) CAT=IJSYSCT
      (OPNAB-15) DATASET ALREADY BEING LOADED BY ANOTHER ACB

F4 0004 RETURN CODE 008 (X"A8") FROM OPEN DISPLACEMENT: 0000CE

F4 0025 LOCKTAB ENTRY
V0004EA78 02CD2BB0 00000000 E5C3E3E2 F2F2F000 * 0 ~ VCTS220 * R0004EA78
V0004EA88 00000001 04C00000 02CD2FE0 0004EA58 * ä 0 0 5/8 i * R0004EA88
F4 0025 OWNER ELEMENT
V02CD2BB0 00000000 00210001 00000000 00000000 * * R00975BB0

```

Figure 81 (Part 1 of 2). Example Where Message 4228I Is Issued

```

F4 0025 LOCKTAB ENTRY
V02CD2FC0 02CD2BC0 00000000 E5C3E3E2 F2F2F000 * 0 ä VCTS220 * R00975FC0
V02CD2FD0 00010001 04C00000 02CD2FA0 02CD2FE0 * ä 0 ff 0 Ö* R00975FD0
F4 0025 OWNER ELEMENT
V02CD2BC0 00000000 00210001 00000000 00000000 * * R00975BC0
F4 0004 1S781 JOB TERMINATED DUE TO PROGRAM ABEND
F4 0004 EOJ LOADKSDS
DATE 02/08/1999, CLOCK 21/41/42, DURATION 00/00/03
    
```

Figure 81 (Part 2 of 2). Example Where Message 4228I Is Issued

Where:

- **CTS220** indicates the Catalog volume
- **005A** indicates the Cluster CI#
- **0021** indicates that partition (BG) has this cluster open

```

DELETE (TEST.KSDS.CLUSTER) CLUSTER PURGE -
CATALOG(VSAM.TEST.CATALOG)
IDC3028I DATA SET IN USE
IDC3009I ** VSAM CATALOG RETURN CODE IS 184 - REASON CODE IS IGG0CLCX-4
IDC0551I **ENTRY TEST.KSDS.CLUSTER NOT DELETED
IDC0001I FUNCTION COMPLETED, HIGHEST CONDITION CODE WAS 8

F4 0004 // JOB DELETE CLUSTER
DATE 02/08/1999, CLOCK 20/49/05
F4 0025 LOCKTAB ENTRY
V0004EA18 0004EAC8 00000000 E5E2E8E2 D4C3D600 * ½H VSYSMCO * R0004EA18
V0004EA28 00000000 11800001 0004EA38 00000000 * 0 ½ * R0004EA28
F4 0025 OWNER ELEMENT
V0004EAC8 00000000 00250000 00011000 00000000 * * R0004EAC8
F4 0025 LOCKTAB ENTRY
V0004EA78 02CD2BB0 00000000 E5C3E3E2 F2F2F000 * 0 - VCTS220 * R0004EA78
V0004EA88 00000001 04C00000 02CD2FE0 0004EA58 * ä 0 Ö ½i* R0004EA88
F4 0025 OWNER ELEMENT
V02CD2BB0 00000000 00210001 00000000 00000000 * * R00975BB0
F4 0025 LOCKTAB ENTRY
V0004EA18 0004EAC8 00000000 E5E2E8E2 D4C3D600 * ½H VSYSMCO * R0004EA18
V0004EA28 00000000 11800001 0004EA38 00000000 * 0 ½ * R0004EA28
F4 0025 OWNER ELEMENT
V0004EAC8 00000000 00250000 00011000 00000000 * * R0004EAC8
F4 0025 LOCKTAB ENTRY
V0004EA18 0004EAC8 00000000 E5E2E8E2 D4C3D600 * ½H VSYSMCO * R0004EA18
V0004EA28 00000000 11800001 0004EA38 00000000 * 0 ½ * R0004EA28
F4 0025 OWNER ELEMENT
V0004EAC8 00000000 00250000 00011000 00000000 * * R0004EAC8
F4 0025 LOCKTAB ENTRY
V02CD2FC0 02CD2BC0 00000000 E5C3E3E2 F2F2F000 * 0 ä VCTS220 * R00975FC0
V02CD2FD0 00010001 04C00000 02CD2FA0 02CD2FE0 * ä 0 ff 0 Ö* R00975FD0
F4 0025 OWNER ELEMENT
V02CD2BC0 00000000 00210001 00000000 00000000 * * R00975BC0
F4 0025 LOCKTAB ENTRY
V0004EA18 0004EAC8 00000000 E5E2E8E2 D4C3D600 * ½H VSYSMCO * R0004EA18
V0004EA28 00000000 11800001 0004EA38 00000000 * 0 ½ * R0004EA28
    
```

Figure 82 (Part 1 of 2). Example Where Message 4228I Is Not Issued

```

F4 0025 OWNER ELEMENT
V0004EAC8 00000000 00250000 00011000 00000000 * * R0004EAC8

F4 0025 LOCKTAB ENTRY
V02CD2B80 02CD2B60 00000000 E5C3E3E2 F2F2F000 * ö - V CTS220 * R00975B80
V02CD2B90 005A 0000 14C00001 02CD2B40 02CD2BE0 * | ä ö ö Ö* R00975B90
F4 0025 OWNER ELEMENT
V02CD2B60 00000000 0021 0000 00011000 00000000 * * R00975B60
F4 0025 LOCKTAB ENTRY
V02CD2AC0 02CD2AA0 00000000 E5C3E3E2 F2F2F000 * ö ff VCTS220 * R00975AC0
V02CD2AD0 005B0000 14C00001 02CD2A80 02CD2AE0 * $ ä ö ø ö Ö* R00975AD0
F4 0025 OWNER ELEMENT
V02CD2AA0 00000000 00210000 00011000 00000000 * * R00975AA0

F4 0025 LOCKTAB ENTRY
V0004EA78 02CD2BB0 00000000 E5C3E3E2 F2F2F000 * ö ~ VCTS220 * R0004EA78
V0004EA88 00000001 04C00000 02CD2FE0 0004EA58 * ä ö Ö ½i* R0004EA88
F4 0025 OWNER ELEMENT
V02CD2BB0 00000000 00210001 00000000 00000000 * * R00975BB0
F4 0025 LOCKTAB ENTRY
V02CD2FC0 02CD2BC0 00000000 E5C3E3E2 F2F2F000 * ö ä VCTS220 * R00975FC0
V02CD2FD0 00010001 04C00000 02CD2FA0 02CD2FE0 * ä ö ff ö Ö* R00975FD0
F4 0025 OWNER ELEMENT
V02CD2BC0 00000000 00210001 00000000 00000000 * * R00975BC0
F4 0004 EOJ DELETE MAX.RETURN CODE=0008
DATE 02/08/1999, CLOCK 20/49/10, DURATION 00/00/05

```

Figure 82 (Part 2 of 2). Example Where Message 4228I Is Not Issued

Where:

- **CTS220** indicates the Catalog volume
- **005A** indicates the Cluster Cl#
- **0021** indicates that partition (BG) has this cluster open

Return Code 254 x'FE'

IDCAMS RC254 documents a condition where the VSE/VSAM space map in the catalog does not match the VTOC (physical device characteristics). It is usually caused by a customer restoring (using Fast Copy, DDR, or a similar full-pack copy utility), a small disk (which is "owned" by a VSAM catalog) onto a larger drive. The problem is that VSAM catalogs maintain a "bit map" describing each volume owned by the catalog. The catalog also contains physical information relating to the DASD hardware characteristics (that is, type of DASD, number of tracks, cylinders, etc). Copying the volume using a full-pack copy utility does not change the internal description of the volume in the catalog, with results that can be predicted.

If the copy is between volumes with differing device characteristics, the results are usually immediate and disastrous. However, if the copy was between volumes with the same device characteristics, just a different number of cylinders, the problems don't normally show up until the customer attempts to define space in an area of the volume not covered by the catalog bitmap. Previously, this led directly to catalog corruption, where sometimes even the files could not be retrieved. To prevent this condition, APAR DY37188 added rc254 as a new return code to IDCAMS DEFINE SPACE.

OPEN Error X'FE' indicates a non-zero return code from the AF lock manager. The second line (extended message line) will list the AF lock manager return code. These are documented in the *VSE/ESA System Macros Reference (SC33-6516)*.

AF Lock Manager Return codes:

```
00 Successful
04 Resource Not Available (Lock queued if LOCK WAITECB)
08 Lock Table Full
12 Inconsistent Request
16 A Deadlock Would Occur
20 DTL Format Error
24 Already Owned
28 Lock File Full
32 Volume Not On-line
36 I/O Error On Lock File
```

File Not Found

```
return code x'80': DLBL not found
return code x'B4': Cannot open catalog
return code x'94': Cannot find file in catalog
```

When you receive one of the above messages, it is important to consider the source of the message before spending a lot of time and resource in problem correction.

Migration

Migrating Master Catalog

Please follow these steps to re-build your master catalog after migrating between un-like devices (that is, 3380D to 3380K).

1. All packs containing non-VSAM files (e.g. DOSRES) should be copied using Fast Copy or some other full-pack copy tool.
2. Re-build all user catalogs using instructions in "Re-Build a Catalog" on page 180. Remember, before you EXPORT DISCONNECT any catalog (particularly the one on SYSWK1 = VSESPUC), check to ensure it does not contain any libraries needed by any running programs.
3. Don't forget to catalog any default models which belong in the catalogs you have re-built (especially DEFAULT.MODEL.ESDS.SAM).
4. Now you can proceed to re-build the master catalog. In order to do this, you have take down any programs which may need files / libraries resident in the master catalog (ICCF, CICS, VTAM, etc). The easiest way (if you are running VSE as a guest under VM), is to re-ipl, and terminate the IPL procedure as soon as BG comes up, then run as a single partition. (See attached console log Figure 83 on page 189).
5. If you are running VSE as a guest under VM, you may punch the jobs from your CMS userid to the VSE machine using the following commands.

```
CP SP D <vsemachine> CL A NOHO NOCONT
PUNCH <job> (NOH
```

Otherwise, you will have to prepare the required jobs ahead of time, and leave them in a power reader, then bring-up VSE with only POWER ("MINI" configuration). To do this, enter MSG BG instead of CANCEL BG,NODUMP, then enter MINI when prompted.

6. Perform the following steps.
 - a. Delete VTOC entries for Master catalog using IKQVDU (Check ahead of time which extents are actually owned by the master catalog, because VSESPUC user catalog may also own extents on DOSRES).
 - b. IDCAMS job to define a new master catalog.
 - c. IDCAMS job to restore VSAM files back into master catalog.
 - d. LIBR job to restore libraries back into master catalog.
 - e. IDCAMS job to catalog new DEFAULT.MODEL.ESDS.SAM into mcat.
 - f. IDCAMS job to IMPORT CONNECT the user catalogs into mcat.
7. You should now be ready to re-ipl the system.

```

BG 000 // JOB BGINIT

DATE 07/11/94,CLOCK 14/49/39
BG 000 1I93I RECORDER FILE IS 1% FULL
BG 000 IESI0221I PARTITIONS F3 F2 F1 WILL BE INITIALIZED IN RECOV START MODE.
BG 000 IESI0222I REMAINING PARTITIONS WILL BE INITIALIZED IN WARM START MODE.
      IF YOU WANT TO INTERRUPT THEN ENTER " MSG BG ".
cancel bg,nodump
CANCEL BG,NODUMP
AR 015 1I40I READY
BG 000 0S01I THE OPERATOR CANCELED THE JOB
BG 000 0S00I JOB BGINIT CANCELED.
BG 000 1N90I EOP WAS FORCED BY EOJ
BG 000 1S78I JOB TERMINATED DUE TO CANCEL COMMAND
BG 000 EOJ BGINIT

DATE 07/11/94,CLOCK 14/49/43,DURATION 00/00/04
BG 000 1C10D PLEASE ASSIGN SYSRDR.
BG-000
0 assgn sysin,00c
0 ASSGN SYSIN,00C
BG-000
0 assgn sypch,00d
0 ASSGN SYSPCH,00D
BG-000
0 assgn syslst,00e
0 ASSGN SYSLST,00E
BG-000
#cp sp c cont noho cl a
#cp sp d <userid> nocont cl d
#cp sp e <userid> nocont cl e
RDR FILE 0025 SENT FROM <userid> PUN WAS 0496 RECS 0003 CPY 001 A NOHOLD NOKEE
0
0
BG 000 // JOB DEFINE MASTER CATALOG

DATE 07/11/94,CLOCK 14/52/11

BG 000 EOJ DEFINE

DATE 07/11/94,CLOCK 14/52/13,DURATION 00/00/02
BG 000 1C00A ATTN. 00C
BG-000

```

Figure 83. Re-Build VSAM Master Catalog Console Log

IMPORT/EXPORT Problems from MVS

Error Description: Customer migrated from DFP 3.2 (HDP3320) to DFSMS 1.1 (JDZ1110). Now VSAM KSDS exported on the DFSMS 1.1 System are no longer importable on VSE systems.

In JDZ1110, MVS has changed catalog information, which means the default size of the control record of the portable data set was increased. Trying to IMPORT these data sets to a VSE system will result in the following error messages.

```
MSGIDC3302I action error on <fileid>
MSGIDC3317I ** permanent i/o error
MSGIDC3606I portable dataset in error
MSGIDC3003I function terminated
```

See also MVS APAR OY62247.

Solution: VSE/VSAM does not provide a solution for this problem due to the following reason.

DFSMS/MVS has increased the default block size of the control record for portable data sets. This makes files, exported on DFSMS 1.1 no longer importable to VSE systems. MVS/DFP has built toleration PTFs for this problem (see OY62247). For VSE however, this is not possible, since a change of the default block size would make VSE files no longer importable, which were exported prior to the change.

In order to become compatible again, the user should specify the BLOCKSIZE (BLKSZ) parameter in both the EXPORT and the IMPORT job. This prevents both systems from using the (now different) default values. In case you want to IMPORT an already EXPORTed data set with the larger block size to a VSE system, you can specify BLKSZ(32760) in the VSE IMPORT job (32760 is the new MVS default block size).

Backup / Restore

General Notes

1. IDCAMS BACKUP is always done only at the physical record (Control Interval) level.
2. If the restore is being performed to exactly the same environment as the file had prior to backup (that is, device type, allocation, CISIZE then the restore will be performed in the "old" path (that is, without remap). In this format, only CAs will be restored (CA splits will be moved so that CAs are contiguous).
3. If anything changes, then the remap function will be invoked, and the restore will take place at the Control Interval level. This means that CIs will be moved to be contiguous. However, in no case does Backup or Restore actually manipulate individual records. Therefore, Backup/Restore cannot be used to reorganize a file at the record level.

Restore MSG IDC31340 (Backup File in Error)

If you experience msgIDC31340 “Backup File in Error”, consider the following.

1. Have you specified the STDLABEL parameter correctly in the IDCAMS RESTORE job?
2. Under some cases, DYNAM/T will cause this error. Please disconnect DYNAM/T and try the job again.
3. Did you attempt to stack multiple BACKUP passes on a single tape. This is not supported.

Backup File Integrity (Return Code 41 x'29')

After repeated complaints of corrupted backup files, VSAM implemented a locking mechanism to avoid updates to files while they are being backed up. Code was added in APAR DY41255 (February, 1992) to IDCAMS to detect that a file to be backed up is open for output in another partition. In this case, it issues Message 4228I OPEN return code x'29', which is a warning message; the backup writes a message to SYSLST with the 44-character name of the file which is suspect, then continues with return code x'04'.

Every attempt should be made to only backup files after they have been closed in all other partitions. Backup has been modified to lock the file during backup, as far as possible. If the file is not currently open for write access, Backup locks the file to prevent an application from opening it for output until backup for this file is complete. If the file is already opened for output, backup will proceed, but a warning message will be written to the console with additional information written to the backup log on SYSLST.

SYSLST file:

```
MSGIDC11310I <filename> MIGHT BE INCONSISTENT IN BACKUP
```

The following message is written to the system console:

```
4228I FILE VDWACB OPEN ERROR X'29' (041) CAT=<catname>
      (IKQOPNHC) WARNING : SHRx FILE ALREADY OPEN FOR OUTPUT DURING BACKUP!
```

CMS/VSAM

Duplicate VOLIDs

Some background to DLBL, ASSGN, and “VOLIDs” under CMS. In order to access a file under CMS, you have two possibilities. One is to run in native (MVS) mode, using MVS ACBs and RPLs, in which case you run under SET DOS OFF. If you are running DOS applications.

1. SET DOS ON (VSAM)
2. DLBL <fileid> <mode> DSN <dataset name> (VSAM)
3. ASSGN SYSxxx <mode>

VSAM uses the <mode> to find the SYSxxx from the DOSCB table. However, some VSAM accesses also use the virtual (minidisk) VOLID. Particularly, when a file is being extended, this extension is done using the VOLUMES parameter from the catalog definition. The VOLID is also used when the GETVCE macro is called

to get device information. It is also used in other places. Therefore, it is not allowed to have duplicate DASD VOLIDs accessible to VSAM at one time.

I/O Tracing under CMS/VSAM

Some have wondered why the CP TRACE I/O doesn't show VSAM I/O activity. VSAM (or, in this case, CMSBAM for tape) issues its I/Os via SVC0. DMSXCP then executes a Diagnose x'A8'. So a real I/O is never executed within the virtual machine. To setup an I/O trace within a virtual machine, you should issue:

```
TRACE DIAG A8 PSWA xxxx.yyy CMD D G
```

where the PSWA range covers the CMSDOS (or CMSVSAM) segment.

Also, see II05609 for TRSOURCE / TRSAVE instructions to trace VM/ESA CP I/O commands.

Initial Verification Procedure (IVP) for CMS/VSAM

To determine if CMSVSAM or CMSAMS is installed:

CP IPL CMS	Clears all DLBLs defined with "PERM"
QUERY SYSNAMES	CMSVSAM & CMSAMS
SEGMENT RESERVE CMSAMS	rc=0
SET DOS ON (VSAM	rc=0
AMSERV <fname>	May issue DMSAMS136S (Unable to load CMSAMS)
SEGMENT LOAD CMSAMS	May say "Already loaded"
Q SEGMENT *	CMSAMS loaded at xxxxxx
#CP D Txxxxxx.200	Should show segment directory: <name> <address> If it is all zeros, the segment is not loaded Pointer to next segment block is +x'10' after last entry (x'FFFFFFFF')
Repeat above with CMSVSAM	

Figure 84. Verification if CMSVSAM or CMSAMS is Installed

To define a master catalog:

```

CP DEF T3380 099 CYL 10
ICKDSF
  - Press enter twice (CONSOLE for both input and output)
  - INIT UNIT(099) NVFY VOLID(TST099) DEVTYP(3380)
  - U      To update volume contents
  - END    To end ICKDSF

ACC 099 F
LISTDS F (EXTENT      Should show VTOC extent
Create a file: DEFMCAT AMSERV:

                DEFINE MASTERCATALOG      -
                (DEDICATE NAME(...) -
                VOLUME(TST099))

SET DOS ON (VSAM      100K partition defined at 20000
DLBL * CLEAR          rc=0
                    Note: This will not clear DLBLs defined with "PERM".
                    To clear these, enter: "DLBL IJSYSCT CLEAR"

ASSGN SYSCAT F        rc=0
ASSGN SYSLST A        Not mandatory
ASSGN SYSIN A        Not mandatory
DLBL IJSYSCT F (SYSCAT VSAM rc=0

AMSERV DEFMCAT        rc=0
                    Output will be in DEFMCAT LISTING A

```

Figure 85. Definition of a CMS VSAM Master Catalog

Catalogs

Potential Corruption Causes

Although the probability of losing an entire catalog is very low, just as in all areas involving I/O in a computer system, the possibility of damage exists. As stated above, a VSE/VSAM catalog is itself a “file”. This means that anything that could cause a file corruption could theoretically cause a catalog corruption. This of course includes peremptory halting of some I/O process. This can include such things as a canceled task, a partition hang or a system outage due to electrical failure. The probability that such an event will cause a problem is primarily dependant on system configuration as discussed in “Large Number/Complexity of Files Defined in a Catalog” on page 195

The most common causes for catalog corruption are improper migration from one device type to another and improper data sharing configuration. VSAM migration will not be discussed here (it would require a chapter by itself) and proper data sharing configuration will only be briefly discussed. Other potential sources of VSAM catalog corruption are discussed, however, it is usually very difficult to identify the particular cause of a catalog corruption.

Unfortunately, catalog corruption is not necessarily immediately obvious. The catalog is in most cases still usable except for a few particular files. However, catalog corruption is self-propagating. Once a catalog is corrupted it only gets worse. Once a catalog corruption is detected, the catalog should be rebuilt as early as possible to prevent the damage from spreading to unaffected areas of the catalog. In any case all precautions that are discussed in this article should be considered for implementation.

Cross-Systems Sharing

VSE/VSAM allows for the sharing of catalogs and files across VSE/ESA systems. For sharing among systems, you must establish the DASD sharing environment through the correct system generation and IPL commands. The catalogs and files must reside on SHARED DEVICES.

You do not specifically invoke cross-system sharing when opening catalogs and files, because.

- Catalogs are automatically shared if they reside on shared devices.
- Files are automatically shared if they are owned by a shared catalog.

Basically to ensure correct sharing of VSAM catalogs.

- All VSE systems must share the same lock file
- All shared DASDs must be ADDED with the SHR option on all systems having access to the volume
- Under VM.
 - all shared MDISKs must be defined with MWV on the MDISK statement
 - all VSE systems must LINK..MW to that MDISK
- There can be NO DUPLICATE VOLIDS on the system because VSAM generates lock resource names using the catalog's VOLID.

- In a DASD sharing complex all VSE systems must be properly shut down to release all locks (End-of-task in all partitions). Otherwise the UNLOCK AR command may be used to free outstanding locks, or all systems must be shut down, and the first system to re-IPL should have a DLF...TYPE=F statement.

Data Sharing with CMS or GCS

When running several VSE/ESA systems, VSE/VSAM can normally guarantee the integrity of shared data through external locking by using the VSE/ESA LOCK facility. However, CMS and GCS, do not provide the facility of a lock file. Hence, data integrity across systems cannot be maintained if one of the participating systems is a CMS or GCS virtual machine that has a multiple-write link to a VSE/VSAM disk. A limited way to share data between a VSE/ESA guest machine and a CMS or GCS guest machine running under the same CP complex is to use read-only catalogs. This is discussed in “Using Read-Only Catalogs in a VSE/ESA Environment” on page 196.

Large Number/Complexity of Files Defined in a Catalog

A large number of files defined in a catalog is not directly a cause for catalog corruption, but can make recovery from a corrupted catalog more difficult and can possibly increase the probability of a catalog corruption. The number of files defined in a catalog have a direct impact on the performance of VSE/VSAM activities.

A large number of files in a single catalog (for example, a thousand files) can significantly increase the run time for most IDCAMS functions. This includes DEFINE, DELETE and LISTCAT functions. It also impacts open and close performance. The longer the run time the greater the window of opportunity for an I/O error.

The exact number of files at which the impact on performance becomes noticeable depends on several factors (for example, DASD access speed and file name pattern). As the number of files in a single catalog increases, you should carefully monitor the performance of the indicated IDCAMS functions. The main factor, however, is the complexity of the files in the catalog. What is meant here is the length of the associations for the file in the catalog. Satisfactory performance may be experienced with 500 or more files in a catalog when they all only have space on a single volume. On the other hand fewer files that have space on multiple volumes (even as CANDIDATE volumes, possibly as a result of a DEFAULT MODEL) could result in terrible performance. Multiple extents for each file make the situation even worse.

Each operation on one of these “complex” files requires significantly more operations and much more time. This provides an even larger window of opportunity in which an operation can fail.

Rogue Programs

There is also the possibility that a user application can cause catalog corruption. One possibility is when an application generates its own channel programs to write to DASD. This could result in the application inadvertently writing directly over catalog information on the DASD itself. It is also possible that an application can mistakenly access memory that does not belong to it. In this case, it would be conceivable that VSAM control blocks could be overwritten, and catalog information could be subsequently updated with incorrect values.

Catalog Precautions

Catalog Definitions

It is recommended that catalogs no longer be defined as RECOVERABLE or with IMBED.

When a catalog is defined as RECOVERABLE it specifies that a "Catalog Recovery Area" (CRA) be created on every volume on which the catalog owns space. A problem with this is that if any of the volumes become unavailable, you can no longer access any files through this catalog until recovery has been performed. This applies even to files that do not reside on the affected volume. Because it is much more likely that a single volume becomes damaged than that a catalog becomes corrupted, it is recommended to define catalogs as NOTRECOVERABLE.

IMBED was originally intended to improve DASD access performance by placing multiple copies of the lowest level of index in every Control Area (CA). This concept is rather counterproductive with today's caching techniques, possibly filling the cache with multiple copies of the same data. Therefore, it is recommended to define catalogs as NOIMBED. Because this is not the default, this must be explicitly coded in a catalog definition.

IMBED and REPLICATE are no longer supported beginning with VSE/ESA 2.6.

Using Read-Only Catalogs in a VSE/ESA Environment

A minidisk under VM can be linked in read-only mode, that is, the virtual machine is not allowed to write to this minidisk. VSE/VSAM support of catalogs that reside on read-only disks provide a limited way to share data between a VSE/ESA guest machine and a CMS or GCS guest machine running under the same CP complex. With this support.

- Only one virtual machine has write access to the catalog disk, and any other virtual machine has read-only access.
- If the data set is cataloged in a read-only catalog, only OPEN for input (MACRF=IN the ACB) is permitted.
- Statistic ("REC-RETRIEVED") will not show how many records are retrieved, because catalog information cannot be updated in a read-only catalog.

Normally, VSE/ESA determines whether a minidisk is linked in read-only mode during IPL and DVCUP processing. To change the access of a VSE/ESA system to a catalog volume from read/write to read-only mode proceed as follows.

1. From the VSE/ESA system, issue the DVCDN job control command against the device, followed by the OFFLINE attention routine command, for example.

```
DVCDN 400
OFFLINE 400
```

2. From the virtual machine console of the VSE/ESA guest machine, link the minidisk with the correct mode (usually RR for read-only and MR for write access), for example.

```
#CP LINK VSESYST 400 400 RR
```

3. From the VSE/ESA system, issue the ONLINE attention routine command, followed by the DVCUP job control command against the device., for example.

ONLINE 400
DVCUP 400

To check which volumes are currently treated as read-only devices, the VSE/ESA operator can issue the VOLUME attention routine command.

Notes:

1. Once VSE/VSAM has opened a catalog, it remains open until end of job step. Consequently, a volume on which a catalog resides may not be changed to a read-only status while the catalog is opened from any partition. If a catalog volume is changed from read-only to read/write mode while the catalog is opened from a partition, no output OPENS are permitted from this partition until the job step ends and the catalog is re-opened.
2. Only the IDCAMS functions LISTCAT, PRINT, REPRO and EXPORT TEMPORARY can be used with R/O catalogs.
3. If a cluster is exported through EXPORT TEMPORARY from a R/O catalog, then the cluster entry in the catalog cannot be marked as being temporary exported. The cluster must be deleted before the copy can be imported again.

Catalog Organization

Generally, it is recommended that all the VSAM space on a particular volume belong to one catalog. If practical, it is also recommended that every volume have its own catalog (as described in “VSE/Fast Copy” on page 198). This negates VSAM's ability to manage multiple volumes through a single catalog, however, it simplifies recovery drastically.

If a system contains only one (master) catalog and that catalog is destroyed, the resources of the whole system are lost and must be restored by the use of backup copies. When several user catalogs are used, only the resources controlled by the destroyed catalog are affected, and it can be rebuilt while processing on other data continues.

The DEFINE USERCATALOG command can be used to create many user catalogs (as many as one per volume) and reduce the number of files per catalog. If a catalog becomes unusable and has, for example, only ten files *cataloged in it, access to only those ten files has to be recovered.

If the master catalog is destroyed, you need only rebuild the master catalog and the resources directly connected to it because user catalogs (like the master catalog) are self-describing. You only need to rebuild the master catalog and re-establish access to the user catalogs through IMPORT CONNECT.

A bottom line recommendation, considering the aspects mentioned in “Large Number/Complexity of Files Defined in a Catalog” on page 195, is 300-400 files per catalog. This should provide acceptable performance in most cases.

Catalog Backups

Because VSE/VSAM catalogs are so important, you should consider them carefully in your backup strategy. If all of the files owned by a catalog are backed up individually, it is possible to recover from a destroyed catalog by restoring all files to a new catalog. The probability of losing an entire catalog is very low. However, to speed recovery or minimize exposure in the case of catalog damage or destruction, several backup methods are available.

VSE/Fast Copy: You can use VSE/Fast Copy to create a backup copy of an entire volume and restore that copy back to a volume. However, all volumes controlled by a VSE/VSAM catalog must be backed up and restored together. Otherwise, inconsistencies between the catalog and the physical data volumes may result in data corruption.

IDCAMS Backup / Restore: This is the preferred method to back up VSE/VSAM clusters. Individual clusters can be restored from a back-up tape, as required. Starting with VSE/ESA 2.4, multiple catalogs may be backed up onto a single tape. This does, however, require special handling to recover files (see separate section).

REPRO: can be used to reorganize individual files. The advantage over IDCAMS Backup / Restore is that the unload and load is performed at the record level, which reorganizes the file (serializes records and places them in contiguous extents). The disadvantage is that it is substantially slower, and requires that the file definition be performed separate from the load process.

REPRO the catalog itself does not backup all the files in a catalog; only catalog data is backed up (cluster definitions), not the data. However, under certain situations (see Section *Catalog / File Prematurely Full*), REPRO can be used to reorganize a catalog. The following restrictions apply:

- The catalog should be unloaded (REPRO'd) to a sequential file (such as tape), then immediately re-loaded. No files in the catalog should be updated between the unload and reload steps.
- Do not delete the catalog between the unload and reload step. Simply reload the catalog right over top of the previous copy. There is special code in IDCAMS REPRO which detects this condition, and performs a reorganization of the catalog.
- The catalog may be loaded over a newly-defined catalog of a larger extent. This is a quick way of enlarging a catalog, but all clusters defined in the previous catalog on the catalog volume will be flagged as “not useable” and must be restored.

Catalog Check

The CATALOG CHECK SERVICE AID (IKQVCHK) helps you to determine whether a catalog has been damaged and, if damaged, the type and extent of the damage. You should always run IKQVCHK to assess catalog integrity in the following circumstances.

- After a system failure.
- When a file or catalog does not behave as expected.
- As part of regular system maintenance.

It has also been recommended to incorporate IKQVCHK into normal operating procedures in some manner. This could take the form of running IKQVCHK once every morning and once every evening to validate the catalogs integrity prior to daily interactive processing and nightly batch processing.

IKQVCHK can not, however, detect space allocation mismatches in a catalog. If this is believed to be the case, there are diagnostic programs available from VSE Level 2 support that can perform detailed analysis of LISTCAT output. This is only recommended in cases where the cause of repeated catalog corruption can not be satisfactorily identified.

DASD File Protection

The DASDFP operand of the IPL SYS command can be used to specify whether disk file protection should be active. If you omit the operand, the system does not activate file protection. Using DASD file protection may only be beneficial for applications that generate their own channel programs as discussed above in “Rogue Programs” on page 195.

The DASD File Protection facility prevents programs from writing data outside the limits of their disk files. This might happen if, for example, a randomizing algorithm produces an unexpected disk address which is outside the file limits. Other files on a disk volume are thus protected against unintended destruction. However, if two disk files have been opened in the same partition and use the same programmer logical unit, these two files are not protected against destroying each other's data.

Miscellaneous Problems

Read Integrity Problems

Basically, read integrity problems arise whenever you have one program updating a file, while simultaneously, another program is reading the same area of the file. It doesn't make any difference whether these are two programs (transactions) in the same CICS partition, two programs in different partitions on the same VSE machine, two different VSE systems under VM, or two different physical CPUs. The problem is that a read task cannot see the updated control interval, until it is physically written to disk. Unfortunately, with SHR(2), various file components (data, index, alternate index) as they are updated, are only written to disk when VSAM needs the buffers for another I/O, so are not necessarily always “in synch”. This can cause a number of problems to a read task, including missing records, I/O errors, loops, or return code x'90' (indicating an alternative index pointer without a corresponding base record). There are several conditions which impact the frequency of read integrity problems.

1. Using SHR(4) results in records being written to disk much more frequently than SHR(2), whose updates may not be written to disk until close time. Normally, converting a file to SHR(4) will resolve most read integrity problems. However, this is done at the cost of much more I/O, since most record reads and updates are now read/written directly to/from disk, ignoring the content of the current buffer.
2. VSAM only guarantees read integrity if the user performs a “Get for Update”. This will ensure that the record is read from disk, not from a buffer already in the user storage. The only other condition where read integrity is guaranteed, is if the file is defined as SHR(1). This means if someone has the file open for output, no one else can open the file, even for input.
3. Records written to a file during initial file load (until first OPEN), are not available until the file is closed for the first time. Regardless of the defined file shareoption, VSAM opens an empty file for output as SHR(1). This prevents all other OPENs until at least one record has been written to the file, and it is closed.
4. Records updated using “Sequential Get for Update” may not be written out immediately upon being changed, even with Shareoption(4) files.

5. If a file frequently suffers read integrity problems, all update tasks should issue periodic ENDREQ commands. This “flushes” the buffers, and ensures a consistent file condition. It is used by an update transaction to complete processing on a string, and ensure that all changed buffers are written to disk. You do not have to close the file. Under CICS, see the UNLOCK command. See also *CICS/VSE Problem Determination Guide (SC33-0716)* Chapter 26.
6. If the read and write task are both within the same partition, some alleviation of the problem is possible without using “Get-for-Update”. Opening the file as “Dataset Name Sharing” shares the buffers between all ACBs, thus giving the read task direct access to the CI in the write task's buffer chain, before it is written to the disk. (This is particularly helpful for files which are accessed / updated over both the base and an alternate index). Defining the file as LSR, has much the same effect. This is not a complete fix, however, it only shortens the window.
7. Defining MACRF=(...DFR...) (Deferred Write) will result in records not being written out until a WRTBFR command is issued.

In addition, the problem is complicated by the rules for “look-aside”. “Look-aside” is a VSAM function, where, before reading a record in from disk, VSAM buffer management first checks to see if that record is already in storage. The following rules apply for “look-aside”.

1. VSAM can only do “look-aside” in the buffers attached to this ACB. Thus, when you use LSR, this increases the pool of buffers available to VSAM to search. Remember, LSR is only shared within a partition, not within a machine, or between machines. However, retrieval of a control interval from an LSR pool (even in read mode), will lock all other CICS transactions from retrieving this same control interval. This is not true of private buffers.
2. With Shareoption(1), since no one else can have the file open for write, while I have it open for either read or write, VSAM always does “look-aside” (with the restrictions indicated in point 1).
3. When records are read in sequential mode, VSAM maintains its positioning in the current control interval, and always checks there for the next record, before initiating a new I/O to disk.
4. With direct retrievals in a Shareoption(2) file, VSAM only does “look-aside” if I am the one with the file open for output. Otherwise, doing “look-aside” if I only have the file open for read means that I might miss an update submitted by another program with the file open for write.
5. With direct retrievals in Shareoption(3) or (4) files, VSAM does not do any “look-aside”, since the record may have already been updated by another program in a set of buffers to which I do not have access.

The emphasis in VSAM is on file integrity, not necessarily access speed.

Catalog / File Prematurely Full

Any KSDS file (including a VSAM catalog) can become prematurely full due to “wasteland” in the index. This is particularly true if the file has experienced a large number of adds and deletes, where whole ranges of records (or files, in the case of a catalog) have been deleted. Once VSAM fills up a control area and extends the file into a new control area, if all records in the previous control area are deleted, VSAM will not reclaim that space. If a new record (or file, in the case of a catalog)

is added, containing a key in the range previously serviced by that control area, VSAM will place the new record / file in the other-wise empty control area. Otherwise, it remains forever “wasteland”. The impact on performance comes when we do sequential retrievals or searches. Since there is no indication in the index that the control area is empty, VSAM must read each data control interval and check it, only to discover that there are no data records there matching the criteria. This can lead to excessive I/O and performance degradation.

To alleviate this situation, the file or catalog must be unloaded and reloaded using IDCAMS REPRO. See previous section under “Catalog Backups” on page 197.

Previous fears of catalog performance degradation do to overly large catalogs appear to have been unfounded. A customer reports about 60,000 files defined to a single VSE/VSAM catalog with no discernible difference in OPEN/CLOSE processing. However, disaster recovery considerations may still dictate small user catalogs.

MSG 4226I / 4227I (“Automatic Close”)

Normal Automatic Close messages are:

```
msg4A87I   Automatic Close has been started
msg4A88I   Automatic Close for nn files completed
```

These are warning messages that a file (ACB) was not closed prior to the program going to end-of-job. This is normally not a problem, unless msg4A87I is followed by one of the following:

```
Msg 4226I   Automatic Close could not be started. File = <.> R=<rc>
Msg 4227I   Automatic Close was not successful. File = <.> Close err code =
```

These last two messages should always be taken seriously, as they normally indicate overlay of VSAM control blocks. The file remains in an uncertain condition, with the statistics not having been updated, and, potentially, file updates missing. To debug this condition, however, an AR DUMP of the partition is require PRIOR to the program going to end-of-job. A dump after the message will only show Job Control in the partition.

If you are experiencing these errors, a patch is available from VSE/VSAM support to assist you in identifying which files are not being closed.

Default Models

Default Models can be used to catalogue a pattern which can be mapped to future cluster definitions. The most common application is for implicitly defining SAM ESDS files:

```
// DLBL IJSYS01, 'DOS.WORKFILE.SYS001', ,VSAM,RECORD=(1000,500),RECSIZE=(512)
```

The size of the file to be defined is calculated by multiplying the recordsize by the number of records, but VSAM needs to know where the space should be allocated. This is passed to VSAM via the default model:

```
DEFAULT.MODEL.ESDS.SAM.
```

Missing Default Model

The following series of messages appears rather intimidating, but in actuality only mean that you tried to open a SAM ESDS file (new file for output) without a DEFAULT.MODEL defined in the catalog (or perhaps included a VOLID on the // EXTENT card which did not match the candidate volumes in the default model.

```

4A37I FILE SAMFILE CATALOG ERROR DURING IMPLICIT DEFINE - 248 , BX ,000
4228I FILE SAMFILE OPEN ERROR X'4F' (079) CAT=UCAT ( 8 , CG , 6 )
(IKQOPN-3) RC X'0000004F' ON CALL TO IKQOPNHC
0V15I REQUEST FROM SYSTEM SERVICE ROUTINE
0S08I LOG. TRANS. AREA CANCELED, PHASE = $$BOSMXT
0S00I JOB RUN CANCELED.
1I51I DUMP COMPLETE
1S78I JOB TERMINATED DUE TO PROGRAM ABEND
EOJ RUN

```

Figure 86. Messages Received for Missing DEFAULT.MODEL

Where:

- **248** indicates "Volume Record not found"
- **BX** is IGG0CLBX, the VSAM Catalog Mgmt routine that caught the error
- **X'4F'** indicates an error during implicit define
- **8** and **6** indicates a no-record-found condition, in this case, the search for the default model
- **CG** is, of course, IGG0CLCG
- **\$\$BOSMXT** is the SAM interface to VSAM, so it is the one that catches any errors

Using a Reserved Name

The following message indicates that you attempted to define a cluster using IDCAMS with a reserved (default model) name. Default models must be defined as NOALLOC, REUSE files.

```

IDC3299I INVALID PARAMETER COMBINATION: RESERVED NAME/SUBALLOC/UNIQUE
IDC3003I FUNCTION TERMINATED. CONDITION CODE IS 12

```

Attempting to backup a default model using IDCAMS BACKUP/RESTORE:

(DY43005 suppresses msgIDC11345I during BACKUP for default models)

Defining a Default Model

The following should be used to define a default model for SAM ESDS:

```

// EXEC IDCAMS,SIZE=AUTO
  DEFINE CLUSTER
    (NAME(DEFAULT.MODEL.ESDS.SAM)
    NOALLOCATION NONINDEXED REUSE
    SHAREOPTIONS(1,3)
    VOLUMES(SYSWK1,DOSRES)
    TRK (1 1) RECORDFORMAT(U) UNORDERED
    RECSZ(2000 2000))
  CATALOG(...)
  LISTCAT ENTRIES (DEFAULT.MODEL.ESDS.SAM) ALL CATALOG(...)
/*

```

Figure 87. Define a DEFAULT.MODEL (SAM ESDS) Sample Job

Recovering From a Physical Medium Failure

1. Recoverable catalogs.

Recoverable catalogs are only useful for cases where the user catalog is ok, but one volume must be replaced. Using the catalog recovery areas, it is possible to reconnect other volumes to the user catalog. Since the catalog recovery area contains exactly the same information as in the user catalog, it is not possible to recover from a corrupted catalog using an IDCAMS RESETCAT.

2. Keep your user catalogs small.

One user catalog per volume, if possible. Use Fast Copy (or a similar full pack backup utility) to copy the entire catalog volume (including catalog and all files) to tape.

Recovery: Requires a simple copy of the entire volume back to the replaced drive. The target volume must exactly match the characteristics of the original drive. See "Return Code 254 x'FE'" on page 187.

3. If all files in the catalog are critical and require daily backup:

- Define the catalog as NOTRECOVERABLE
- Use IDCAMS BACKUP (or a similar utility) to individually backup all files in the catalog.

Recovery:

- Perform an IDCAMS EXPORT <user catalog> DISCONNECT, to remove the user catalog pointer from the master catalog.
- Initialize all volumes belonging to the user catalog by deleting all VSAM files on those volumes and resetting the "volume ownership" flag. This may be done by re-initializing the pack or using a utility such as DITTO or IKQVDU.
- Define a new user catalog and associated space.
- Restore all files from backup tapes.

4. If only a small number of the files in the catalog require daily backup, and the catalog controls a large number of volumes:

- Define the user catalog as RECOVERABLE.
- Keep full-pack backups of all volumes of the catalog
- Use IDCAMS BACKUP (or a similar file backup utility) to backup critical files daily.

Recovery:

- Restore the full pack copy of the volume which was replaced.
- Use IDCAMS RESETCAT. If the user catalog volume was replaced, this will synchronize the previous copy of the user catalog with the actual data residing on the other volumes. If another volume owned by the user catalog was replaced, this will synchronize the current user catalog with the new (replaced) volume.
- Restore all critical files with at least one extent on the volume which was replaced.

5. If you must replace a volume other than the one containing the user catalog, and do not wish to re-build the entire catalog: This requires removal of the old

volume entry from the user catalog, and definition of a new one. The problem is that IDCAMS will not allow a DELETE SPACE unless the volume, containing the VSAM extents, is physically on-line. We therefore have to trick IDCAMS into thinking the old volume is still accessible.

Note: For this condition, do not attempt DELETE SPACE FORCE or DELETE CLUSTER IGNOREERROR as this will only dig you deeper into the hole.

- Define a new user catalog on a different volume, which does not already contain a user catalog. Call the previous user catalog UCAT1. Call the new (temporary) user catalog UCAT2.
- Using IDCAMS SPACE, define a space in UCAT2 on the replaced volume, which matches, exactly, the original space still defined in UCAT1.
- From UCAT1, delete all clusters on the replaced volume, and the space. If UCAT2 is corrupted, and you are unable to delete the space, you have no choice at this point but to re-build the entire user catalog. For this reason, we recommend that you run IKQVCHK at least monthly against all VSE/VSAM catalogs.
- Remove the pointer to UCAT2 from the master catalog using EXPORT <ucatt2> DISCONNECT
- Physically remove the VTOC extent for UCAT2 using DITTO or IKQVDU.
- Re-define the space on the replaced volume in UCAT1, and restore the affected files.

CA Splits

Insertion of a record into a file may result in a Control Interval (CI) or Control Area (CA) split. During a CA split, CIs found after the insertion point in the original CA are moved to a new CA physically located at the end of the last extent of the file. There is a window of time where the same CI actually exists in two CAs at the same time. To keep track of this condition, VSAM first marks all CIs in the old CA to indicate they are being moved. This is done via a "CA-split-in-progress" bit located in the CIDF (last 4 bytes in the CI). If, prior to completing the move, the CA split is interrupted for any reason (program check, operator-initiated cancellation, I/O error, etc), the file is left in an incomplete condition. A cancellation during this window may cause duplicate record conditions, VSAM-reported I/O errors, or loops during sequential access. Many backup/restore products (e.g. FAVOR BACKUP) check for the CA-split-in-progress bit and log an error during backup.

Problems caused by operator-induced cancellations are much more common under VSE/ESA (CICS/VSE 2.1 and later) than under VSE/SP. Since under previous releases, CICS did not allow a transaction to be canceled if VSAM I/O was active. Because of the many cases where a VSAM error was causing the entire CICS partition to hang, this restriction was removed under CICS/VSE 2.1. CICS now passes an ENDREQ to VSAM after a cancel condition to allow VSAM to clean up its control blocks and buffers. However, this will not clean-up a CA split in progress.

The problem may be corrected as follows:

1. CA-splits may be minimized by defining FREESPACE during CLUSTER definition.

Note: Free Space is only used during initial load mode, or new extent allocation.

2. If the error is being detected by a backup utility (that is, FAVOR), ensure the file being backed-up is closed in all other partitions. Otherwise, the possibility exists that you have detected a CA-split in progress. You can also test this by re-running the backup job after waiting a suitable interval for the split to finish.
3. VSAM has automatic recovery code built in to correct this condition under certain conditions. Basically, the file must be open for output, and VSAM must perform a get-for-update in sequential mode of one of the CIs with the CA-split-in-progress bit turned on. When VSAM detects a data control interval with the “ci-split-in-progress” bit on, it calls IKQDDR, under the covers, which reads the previous CA and new CA, and attempts to complete the move. It is often possible to trigger this correction by writing a simple utility program which reads the entire file in sequential mode for update. After running this utility, re-run REPRO to verify that the condition has been corrected.
4. Failing the above, the file must be re-built. Many customers have had success by accessing the data component of the file (as an ESDS file) instead of the cluster. The data component is copied to a sequential dataset (using REPRO), sorted according to the primary key, duplicate records eliminated, then re-loaded at the cluster level.
5. Or you can always go back to the last valid backup.

If additional PD/PSI is desired, use DITTO DD, to print off the record with the CA-split-in-progress bit. The last 7 bytes of the CI should contain a valid RDF and CIDF. See “VSE/VSAM Logic” (LY33-9130), page 5-2). X”80” in the next-to last byte of the control interval indicates “CI-split-in-progress”.

Missing or Unreadable Print Information

Since VSE/VSAM printing of files is done in upper case characters without respect to, for example, lower case or foreign language special characters, some information may not be readable. This problem may be solved by a user-provided translate table for IDCAMS PRINT. The IDCAMS PRINT command is a basic method of listing records from a VSAM file. Through the use of the **PARM** parameter processing options for printed output can be specified.

The **GRAPHICS TABLE(mname)** parameter of the **PARM** command specifies the name of a module (accessible through VSE/VSAM CDLOAD) in the sublibrary that contains a 256-byte user-provided translate table. This table defines the graphic characters for each of the possible 256 bit patterns. Any character to be printed is translated to the bit pattern found in such a table at the position corresponding to its numeric value (0-255).

Restriction: If you specify the TABLE parameter, issue the PARM command early in the IDCAMS command stream to avoid having CDLOAD fail.

VSE/VSAM

An example of such a module that allows printing in upper and lower case is as follows:

```
* $$ JOB JNM=VSAMTRT,DISP=D,CLASS=0
// JOB VSAMTRT
// OPTION CATAL
// LIBDEF PHASE,CATALOG=IJSYSRS.SYSLIB
   PHASE VSAMTRT,*
// EXEC ASSEMBLY
VSAMTRT CSECT
        DC CL16'          '    hex 0X
        DC CL16'          '    hex 1X
        DC CL16'          '    hex 2X
        DC CL16'          '    hex 3X
        DC CL16'          .<(+|' hex 4X
        DC CL16'&&        $*); ' hex 5X
        DC CL16' -/      ,%>?' hex 6X
        DC CL16'         :#@'=" ' hex 7X
        DC CL16' abcdefghi '    hex 8X
        DC CL16' jklmnopqr '    hex 9X
        DC CL16' stuvwxyz  '    hex AX
        DC CL16'          '    hex BX
        DC CL16' ABCDEFGHI '    hex CX
        DC CL16' JKLMNOPQR '    hex DX
        DC CL16' STUVWXYZ  '    hex EX
        DC CL16'0123456789 '    hex FX
        END
/*
// EXEC LNKEDT
/&
* $$ E0J
```

An example of such a module that allows printing in upper and lower case with German characters enabled is as follows:

```

* $$ JOB JNM=VSAMTRT,DISP=D,CLASS=0
// JOB VSAMTRT
// OPTION CATAL
// LIBDEF PHASE,CATALOG=IJSYSRS.SYSLIB
   PHASE VSAMTRT,*
// EXEC ASSEMBLY
VSAMTRT CSECT
      DC CL16'                ' hex 0X
      DC CL16'                ' hex 1X
      DC CL16'                ' hex 2X
      DC CL16'                ' hex 3X
      DC CL16'                ¢.<(+' hex 4X
      DC CL16'&&                !$*); ' hex 5X
      DC CL16' -/                ],%>?' hex 6X
      DC CL16'                :#@'=''' hex 7X
      DC CL16' abcdefghi        ' hex 8X
      DC CL16' jklmnopqr        ' hex 9X
      DC CL16' stuvwxyz         ' hex AX
      DC CL16'                  ' hex BX
      DC CL16' {ABCDEFGHI        ' hex CX
      DC CL16' }JKLMNOPQR        ' hex DX
      DC CL16' \ STUVWXYZ        ' hex EX
      DC CL16' 0123456789        ' hex FX
      END
/*
// EXEC LNKEDT
/&
* $$ EOJ

```

The following JCL demonstrates how to use the **PRINT** command with this **PARM** parameter:

```

* $$ JOB JNM=FILEPRT,DISP=D,CLASS=0
// JOB FILEPRT
// DLBL UCAT,'EXAMPLE.USER.CATALOG',,VSAM
// DLBL KSDS,'SAMPLE.FILE',,VSAM,CAT=UCAT
// EXEC IDCAMS,SIZE=AUTO,PARM='GRAPHICS(TABLE(VSAMTRT))'
   PRINT INFILE (KSDS) DUMP
/*
/&
* $$ EOJ

```

Recent VSE/VSAM Enhancements (VSE/ESA Version 2).

The following section describes recent enhancements to the VSE/VSAM component, along with documentation references where a more detailed explanation is available.

Extending KSDS Files Above 4 GB

See also *VSE/VSAM Commands (SC33-6731)* under sections Define Cluster and Extralargedataset.

With VSE/ESA 2.3 it is possible to extend a VSE/VSAM KSDS file above 4 GB. Such an Extended Addressed KSDS can have a maximum size of 492 GB. The maximum number of extents supported is 123.

The new parameters for defining an Extended Addressed KSDS are EXTRALARGEDATASET or XXL. VSE/VSAM supports Keyed Access only to such a data set. This means that such a KSDS cannot be of type Imbed, Keyranged, reusable or unique.

Multiple Catalog Backup

See also *VSE/VSAM Commands (SC33-6731)* under sections Backup or Restore or Norewind.

In earlier releases of VSE/ESA, VSE/VSAM Backup/Restore allowed a backup of all objects of a single catalog to one or more tapes. This had the disadvantage that only a short portion of a large tape or cartridge would be used in case of, for example, small catalogs or data sets. To avoid this, the support for multiple catalog backup has been introduced with VSE/ESA 2.3. This support is of special advantage for IBM 3590 cartridges.

The Backup/Restore function has been enhanced for multiple catalog backup by introducing the NOREWIND parameter for the BACKUP and RESTORE command. The NOREWIND parameter is valid for standard labeled tapes (STDLABEL) only. When the NOREWIND parameter is specified, the tape is left at current positioning after the IDCAMS jobstep.

Note: No cross-reference of backup files is maintained either internally within VSE/VSAM or on the backup tape. Therefore, restoring from a multiple catalog backup tape requires user-initiated positioning.

Compression Prediction Tool (IKQCPRED)

See also *VSE/VSAM User's Guide and Application Programming (SC33-6732)*, Chapter 5: Working With Compressed Files.

Beginning with VSE/ESA Version 2, VSE/VSAM supports data compression. Before you compress data, you may want to know which of your VSE/VSAM data sets are suitable candidates for compression. IKQCPRED is a program that examines VSE/VSAM data and calculates how well it would compress.

A measure for compressibility is the compression ratio, which is the ratio of the length of the data in uncompressed format to the length in compressed format. IKQCPRED can compute the anticipated compression ratio for one or more data sets residing in the same VSE/VSAM catalog on a VSE/ESA Version 2 system.

```
// EXEC IKQCPRED,SIZE=IKQCPRED,PARM='catalog_id/cluster_specification/LIMIT=mm'
```

DB2 VSAM Transparency for VSE/ESA

See also *DB2 for VSE System Administration (GC09-2406)*, and *DB2 for VSE Database Administration (GC09-2398)*.

DB2 VSAM Transparency for VSE/ESA, available in VSE/ESA 2.3, gives you the benefits of a relational database manager without the need to immediately rewrite your VSE/VSAM applications. With DB2 VSAM Transparency for VSE/ESA, migration to a relational database no longer means you have to convert all your VSE/VSAM applications and replace VSE/VSAM calls with SQL/DS at once. DB2 VSAM Transparency for VSE/ESA lets you move some or all of your data to DB2 Server for VSE and allows you to continue using your existing applications without change.

IXFP/SnapShot and Fastcopy Support for VSAM Datasets

See *VSE/ESA Release Guide (SC33-6718)*

Starting with VSE/ESA 2.5, the IXFP/SnapShot support for the IBM RAMAC Virtual Array (RVA) and FlashCopy for IBM Enterprise Storage Server (ESS) is available for VSE/VSAM datasets. This allows a backup of a volume containing a VSE/VSAM master or user catalog in seconds or minutes, instead of hours. If a removable media backup (e.g. to tape) is required, this may be performed from the “snapped” copy of the catalog, significantly reducing the time when datasets may not be available to on-line processing. It also ensures a completely synchronized backup, since none of the files in the catalog will be changed during the backup process.

In order to accommodate the VSE/ESA restrictions on duplicate volids, VSE/ESA supports a new IDCAMS SNAP command, which you must use together with IDCAMS BACKUP and a new synonym list

VSE/VSAM Buffer Hashing

See *VSE/ESA Release Guide (SC33-6718)*

Large VSAM LSR (Local Shared Resources) buffer pools can significantly improve response time and reduce I/O operations. However, prior to VSE/ESA 2.5, sequentially searching a large buffer pool to find the requested buffer took increased CPU time, often reducing the performance benefits. To overcome this, VSAM Buffer Hashing has been implemented in which a VSAM hashing algorithm allows direct access to the required buffer.

VSAM buffer hashing replaces the current buffer management for applications that use the option. This new buffer management technique uses a hashing algorithm, to allow direct access to a requested buffer, thus significantly shortening the path length of the search. The path length does not depend upon the number of buffers (therefore the search time is independent of the buffer pool size).

VSE/ESA e-business Connectors

See *VSE/ESA Planning (SC33-6703)*, Chapter 3: VSE/ESA e-business Connectors, and *VSE/ESA e-business Connectors User's Guide (SC33-6719)*

The VSE/ESA e-business Connectors support allows a client user to access VSE/ESA host data (including VSE/VSAM clusters) from a Web-based environment. The support is based mainly on a 3-tier environment with a host, a middle tier, and clients connected to the middle tier over the Web. The support includes the following connectors:

1. Java-based connector
Provides access to the VSE/ESA resources VSE/VSAM, VSE/POWER, VSE/ICCF, Librarian, and Console and the data they maintain. This support is based on the functions provided by the VSE Connector Server and the VSE Connector Client.
2. DB2-based connector Provides access in a DB2 relational database environment to VSE/VSAM and DL/I data stored on the VSE/ESA host. This support requires the installation of the DB2 Server for VSE.

VSE/VSAM Record data mapping

See *VSE/ESA Planning (SC33-6703)*, Chapter 3: VSE/ESA e-business Connectors, and *VSE/ESA e-business Connectors User's Guide (SC33-6719)*

In order to access VSE/VSAM data via DRDA (Distributed Relational Database Architecture) using TCP/IP (or APPC), the VSE/VSAM data must first be mapped into a relational structure. Mapping means splitting a VSE/VSAM record into columns (data fields) that have name, length, and other attributes. Optionally, a data view can be created which contains a subset of the fields contained within a map. All this information is stored in the KSDS file

VSE.VSAM.RECORD.MAPPING.DEFS located in the user catalog (VSESP.USER.CATALOG). VSE/VSAM data can be mapped using the IDCAMS command RECMAP or by using the Java program provided.

Librarian Support of up to 32 VSE/VSAM Extents

See *VSE/ESA System Control Statements (SC33-6713)*, Chapter 5 Librarian, section Define Library or Sublibrary.

Beginning with VSE/ESA 2.5, the Librarian has been enhanced to support more than 16 VSE/VSAM extents. The Librarian DEFINE command has a new parameter: EXTENTS (MAX16, MAX32). This enhancement also affects the Librarian LD (List Directory) and TEST command. The OLDLIB parameter of the Librarian RESTORE command has been removed.

Virtual tape

See *VSE/ESA 2.6 Release Guide (SC33-6718-02)*, Chapter 7: Virtual Tape Support, and *VSE/ESA 2.6 System Control Statements (SC33-6713)*, statement VTAPE, sections Define Virtual Tape and Release Virtual Tape.

With VSE/ESA 2.6, applications which write to “real” tapes can have their output redirected to either a VSAM ESDS file, or a remote file (on remote host). The target change is transparent, and no changes are required for application.

The change involves a “Virtual Tape Simulation” hook in the VSE/ESA I/O Supervisor, and a “Virtual Tape Handler Client” running in a separate VSE/ESA partition. The target of the tape I/O is specified using a new JCL command: VTAPE.

VSE/VSAM Redirector Connector

See *VSE/ESA 2.6 e-business Connectors User's Guide (SC33-6719)*

Available in VSE/ESA 2.6, the VSE/VSAM Redirector processes requests to VSE/VSAM datasets and redirects them, for example, over TCP/IP to Linux. Using the Redirector, existing programs on the VSE/ESA host can also access data stored, for example, in a remote Linux file system. Such a VSE/ESA host program can be written in any programming language, can run in batch or as CICS transaction and requires no recompilation.

The “Redirector Connector” is called via an existing VSE/VSAM generic record management exit (IKQVEX01), and evaluates each VSE/VSAM request according to the values specified in a unique “Properties” or “Configuration” file. Requests for a remote destination are passed to a “Handler Routine”, running in a remote “Redirector Server”, which will perform data translation, field mapping, and writing to remote file. Two samples, written in Java (DB2 and HTML), are distributed with VSE/ESA 2.6.

VSE/VSAM Support of Large DASD

See *VSE/ESA 2.6 Release Guide (SC33-6718)*

Starting with VSE/ESA 2.6, VSE/VSAM supports disk devices with a large capacity of up to 65535 cylinders (64K-1) instead of 65535 tracks. This support applies to disk devices (here referred to as “large DASD”) such as the IBM 3390 Model 9 which has a capacity of 10,017 cylinders.

If a logical disk uses 15 tracks per cylinder, such as 3380 and 3390 DASD devices, these disks could have up to 65535 cylinders * 15 tracks = 983025 tracks. The maximum capacity of a “large DASD” device (with 64K-1 cylinders, 15 tracks per cylinder and 64K-1 bytes per track) could be up to 64 gigabytes, supported by VSE/VSAM. If the future DASD device architecture may change and one disk would support 64K-1 cylinders with 64K-1 tracks per cylinder and 64K-1 bytes per track, VSE/VSAM would support a maximum capacity of 281.462.092.005.375 bytes, about 280 terabytes per each single DASD device.

Implementation is transparent to existing applications and JCL. During Define Space, VSE/VSAM automatically detects a “large DASD”, and implements the required catalog changes. In most cases, clusters defined on “large DASD” will have their allocations converted from TRACKS or RECORDS to multiples of CYLINDERS. Catalogs defined on “large DASD” also have their default allocations modified.

Imbedded Index dropped

The definition of imbedded indices for catalogs, alternate indices and clusters will no longer be explicitly supported. To provide downward compatibility, if the keywords IMBED or REPLICATE are included in existing IDCAMS DEFINE jobs, they will simply be ignored. Existing files already defined with either of these two options will also be supported.

The support of the CRA (Catalog Recovery Area), keyword RECOVERABLE, will be dropped for SPACE defined on “large DASD”. Existing recoverable catalogs and CRAs on “small DASD” will be accepted and supported, new CRAs on “small DASD” could be defined, but no CRA may be defined on a “large DASD”. That means, recoverable catalogs cannot reside on “large DASD” and cannot own space on “large DASD”.

FBA disks are not supported as “large DASD”.

VSAMIO

See *REXX/VSE 2.6 Reference (SC33-6642)*

The new REXX command, VSAMIO, allows access of VSE/VSAM data from REXX/VSE. VSAMIO belongs to the host command environment ADDRESS VSE and supports KSDS, ESDS, and RRDS data sets. Supported operations are READ, WRITE, DELETE, and UPDATE. VSAMIO can read or write data from/to REXX stem variables.

Chapter 9. VSE/ICCF

Submit to Batch

To transfer VSE job streams from the ICCF library (DTSFILE) to VSE/POWER, ICCF provides SUBMIT procedure and program DTSSUBMT. This program is invoked by entering 'SUBMIT member' on the ICCF command line.

If you submit to batch from IUI panel IESLIBP, IUI's submit program (DTSIESSS) is used. There are substantial differences between the two submit programs. ICCF performs an extensive validation of POWER JECL operands depending on the user's authorization. (OPT A Bit 7 in the user's profile). The ICCF SUBMIT procedure can be modified to direct the job's to certain classes, assign specific dispositions or generally control any POWER JECL operand. DTSIESSS leaves the validation more or less to POWER.

If bit 7 of the OPTA option byte = on, user's POWER JECL specifications are not overwritten by the SUBMIT procedure values. OPTA bit 7 can be specified via DTSUTIL ALTER USER command.

If bit 7 of the OPTA byte = off, user's POWER JECL specifications will be overwritten by the SUBMIT procedure values. This is true even for a specified jobname which will be replaced by the ICCF member name. To allow the specification of certain operands by a 'OPTA_bit_7_off' user, this operand's value in the SUBMIT's procedure's model statement must be specified in parentheses.

```
Model:      * $$ PUN DISP=(D),CLASS=(A)
User:       * $$ PUN DISP=H
To Power:   * $$ PUN DISP=H,CLASS=A
```

To see the statements which are really transferred to POWER use the PRINT option of the SUBMIT procedure:

```
SUBMIT member PRINT
```

ICCF Library

Increase Number of Users and Libraries

The easiest way to increase maximum number of users and libraries is during DTSUTIL RESTORE. FORMAT is not necessary if only the numbers should be increased and the extent location and size remain the same.

```
RESTORE Libraries(200) Users(200)
```

Each new library requires a library header record to be established

```
ADD Library Maxdir(n) Freespace(percent) Date
```

Since VSE/ESA 2.x there is a DTSUTIL command available which returns maximum number of users and libraries specified.

DISPLAY Format

Increase Maximum Number of Members per Library

```
DTSUTIL ALTER LIB(nn) MAXDIR(mm)
```

This command can be issued while the DTSSFILE is connected.

DTSSFILE Extension

Indications for a necessary DTSSFILE extension are messages

- K088I HI FILE RECORDS = (0) or close to 0 especially after restoring the DTSSFILE
- Message * LIBRARY FILE IS FULL

Follow carefully the instructions given in the "VSE/ESA Administration" manual when extending the DTSSFILE.

UPIP Flag

The Update_in_progress flag is set for the member being edited. If another user tries to edit the same member message '*UPDATE IN PROGRESS-TRY LATER' is displayed. There are cases where this flag isn't reset like system crash or after a PEND IMM. The administrator has several ways of clearing this flag.

```
/PROTECT member UPIP  
DTSANALS RESET UPD
```

If the DTSSFILE has not been closed correctly, normally during the next startup of CICSICCF 'DTSANALS RECOVER OPT' will cause the recovery job to run and reset all UPIP flags. There are some cases where RECOVER OPT finds the DTSSFILE doesn't need recovery, but there are still members with UPIP on. If you are facing such events you could use 'DTSANALS RECOVER OPX'. This causes DTSANALS to scan all member directory records for UPIP flags, regardless if the file is intact. The flags are reset and a message for which member the flag has been cleared is written. Otherwise OPX is exactly the same as OPT. This function has been introduced with APAR PN80038 for VSE/ESA 2.1/2.2.

Compressed Members

Library members which have been compressed via the /SQUEEZE command can be converted back by entering input mode and using the /INSERT command. Here is a procedure for single members and a macro to uncompress multiple members of a library.

Syntax: PUNC membername passwrd

```
* *****
* PROCEDURE TO UNCOMPRESS
* *****
&&OPTIONS 0010011
/INPUT
/INSERT &&PARAM1 &&PARAM2
/END
/REPLACE &&PARAM1 &&PARAM2
&&IF &&RETCOD NE *REPLACE &&GOTO FAIL
&&TYPE MEMBER &&PARAM1 IS NOW UNCOMPRESSED
&&EXIT
&&LABEL FAIL
&&TYPE ERROR OCCURRED ... MAYBE MEMBER &&PARAM1 NOT FOUND
/PEND
/RUN
```

Figure 88. ICCF procedure PUNC to uncompress a member

```
@MACRO
@NOPRINT
PUNC CMEMB1
PUNC CMEMB2
PUNC CMEMB3
```

Figure 89. ICCF macro MUNC for multiple uncompress members

To get all compressed members of a library into macro MUNC you could:

1. Run ICCF procedure SDSERV. This will create member \$\$PRINT (ICCF's print area)
2. Enter ED and GET \$\$PRINT
3. Delete messages
4. FILE membername
5. Run 'SORT membername SEQ D3703 PUNCH membername2' if 2 digit year
6. Run 'SORT membername SEQ D3903 PUNCH membername2' if 4 digit year. Will sort for attribute CPR.
7. Edit member2 for macro MUNC
8. Run MUNC

Chapter 10. REXX/VSE

Setup

Initialization

Most of the REXX/VSE programs run only successfully, if the REXX/VSE initialization step has been executed in advance. The REXX/VSE initialization step is invoked via "// EXEC ARXLINK" and is usually contained in system startup procedure USERBG.PROC .

If problems occur with REXX commands or functions requiring one of the external or replaceable REXX routines, run the REXX/VSE initialization step first and try to rerun the REXX program.

ARXLINK RC=21

If the REXX initialization step ARXLINK returns with a RC=21, this means that a problem has occurred when trying to do a CDLOAD for one of the phases loaded during REXX initialization.

A CDLOAD may fail, if

- there is not sufficient GETVIS storage in the partition,
- but also if the phase to be loaded is not found within the active phase chain.

Phases to be loaded are for instance: ARXIOLAR, ARXPARDS, ARXANCHR, ARXOUT, the host command environment phases mentioned in ARXPARDS, and the function package phases mentioned in ARXPARDS.

GETVIS Size

You cannot run your REXX/VSE programs in partitions offering only a GETVIS size of 256K. In this case processing stops immediately with the following messages:

```
ARX0565I LIBRM ERROR OPEN RC=(0020,0100) ARXIOLAR
ARX0110I The REXX exec cannot be interpreted.
ARX0112I The REXX exec cannot be loaded.
R003I REXX/VSE EXEC PROCESSING FAILED, RETURN CODE 20
```

If you use a partition with a higher GETVIS size, the REXX interpreter starts at least processing. The finally required GETVIS size depends on your REXX program (for instance on the space required for stack contents and REXX variables).

Setup for Using the REXX/VSE SOCKET Function

There exist 2 implementations of the REXX SOCKET function with different functionality: One is from IBM and provides the standard low-level Socket interface available on many platforms, the other is from CSI with a CSI-specific interface on a higher level with more functionality.

The CSI SOCKET function is implemented within SOCKET.PHASE and can be used without additional configuration steps. The IBM SOCKET function is

implemented within function package ARXEFSO, which needs to be separately configured using REXX/VSE customization job ARXPARMS.Z (see SOCKET-specific comments). The single steps are described in detail at the end of Chapter 15 "REXX Sockets Application Program Interface" in the REXX/VSE Reference Manual.

To allow coexistence of both SOCKET functions, it is possible to rename the IBM SOCKET function to "SOCKEN" and activate function package ARXEFSN instead of ARXEFSO.

To use the IBM SOCKET function, you have to invoke subfunction 'INITIALIZE' first. If this invocation returns only an empty string, the setup for the IBM SOCKET function is not correct, because the CSI-delivered SOCKET.PHASE is used for processing, and not function package ARXEFSO.

General REXX Tips

REXX Samples

If you are interested in REXX/VSE samples, see the REXX/VSE homepage on <http://www.ibm.com/servers/eserver/zseries/os/vse/support/rexx/rexxhome.html>

REXX Functions

In the VSE/REXX Reference Manual the correct syntax to invoke a REXX function is not specified with every function described. Nevertheless the syntax rules for REXX function apply, thus it is not possible to invoke a REXX function like a REXX command, for instance

```
ASSGN(STDOUT,SYSLOG)
```

Such a command is usually unknown to REXX, and the following error message is given:

```
ARX0565I LIBRM ERROR STATE RC=(0008,0000) ARXR24 NO MATCH FOUND ASSGN
```

REXX function calls are treated as expressions within a REXX statement. They are coded as

```

      .---<-----,----->
>>--function_name('---,-----,---')--><
      '-expression-'
    
```

Figure 90. Syntax of a Function Call in REXX - Expression

Sample: `oldout = ASSGN('STDOUT','SYSLOG')`

Another valid syntax for function calls and subroutine calls is

```

      .---<-----,----->
>>--CALL---name---'---,-----,---'---><
      '-expression-'
    
```

Figure 91. Syntax of a Function Call in REXX - Call

Sample: `CALL ASSGN 'STDOUT','SYSLOG'`

For further information see the REXX/VSE Reference manual, Chapter 3 "Keyword Instructions", "CALL".

POWER Command Environment

Error Handling

Always check the contents of the OUTTRAP variable after issuing a POWER command from REXX.

This is even necessary if the return code from the POWER command is zero !

A return code of zero just means that the POWER command has been successfully transferred to POWER. POWER error information is written to the stem variable specified on the OUTTRAP function.

CLASS Operand for GETQE

POWER queue entries can only be retrieved using GETQE, if the correct class value is specified, otherwise error message "ARX0950E RC=0004,FDBK=0001 received from VSE/POWER command" is returned. If you use the GETQE command without specifying operand CLASS, the default class A is used.

POWER Authorization

Accessing existing queue entries requires to specify a user ID and/or password. Accessing means either a GETQE or a POWER command like PALTER. Use the SETUID command to set the corresponding user ID (and password, if necessary). You can specify the FROM or TO user ID. Entries without a defined FROM/TO user ID can only be accessed, if an installation specific POWER master password has been defined in the system (see MPWD operand within skeleton SKPWGEN in ICCF library 59, phase IPWPOWER). It provides access to all queue entries even if the user ID does not match.

Using the CONSOLE command environment, a TO-user may be set for an existing queue entry, like in the following sample:

```
fc = SENDCMD('PALTER LST,ENTRYX,USER=XXXX')
                                     /* set TO-user   */
'ADDRESS POWER'                       /* switch command environment */
'SETUID XXXX'                           /* set POWER user */
'GETQE LST JOBNAME ENTRYX ...'         /* read entry     */
```

Figure 92. TO-user setting with REXX

Some of the POWER commands are only accepted for authorized user via the spool-access interface used by REXX/VSE: PFLUSH, PGO, PLOAD, PRESTART, PSETUP, PSTART, PSTOP, PVAR, PXMIT (see list of commands for PWRSP Macro in the VSE/POWER Application Programming manual). If REXX/VSE users want to include those commands into their REXX procedure, the POWER master password should be defined during startup of POWER.

The REXX/VSE users specify this POWER master password in a SETUID statement, before issuing the POWER command. Code

```
"SETUID blabla mpwd"
```

in this case, where "blabla" is some non-blank string and "mpwd" is the defined POWER master password.

JCL Command Environment

DLBL Statements

REXX/VSE offers the ADDRESS JCL environment to imbed JCL commands. One JCL statement is processed after the other. This may cause a problem for DLBL statements, because JCL looks for further EXTENT statements before it updates the label area. If a REXX procedure issues a DLBL statement without any other JCL statement following, this DLBL is not activated!

If there is no further JCL statement following the DLBL statement within a REXX procedure, insert a dummy "/" statement after the DLBL statement as shown in the manual REXX/VSE REFERENCE in chapter JCL Command Environment. JCL recognizes this as end condition for the DLBL statement and updates the label area also for the last DLBL statement.

SETPARM Statements

It is possible to set a symbolic parameter within a REXX procedure. If its value should be active for the higher Job Control Level on return, the same methods of addressing symbolic parameters apply as for JCL procedures (see EXEC statement in the manual "System Control Statements").

Here are samples to demonstrate the usage of symbolic parameters:

```
// JOB TSTSETP1
ACC S=DEVLIB.USCH
CAT TSTSETP1.PROC R=Y
/* rexx procedure */
ARG TESTVAR
ADDRESS JCL "// SETPARM XXXX=" || TESTVAR
EXIT rc
/+
/*
// LIBDEF *,SEARCH=(DEVLIB.USCH,PRD1.BASE)
// SETPARM XXXX=' '
*                               look here: XXXX is mentioned!
// EXEC REXX=TSTSETP1,PARM='UP',XXXX
/*
// IF XXXX = 'UP' THEN
// GOTO PARMUP
// IF XXXX = 'DOWN' THEN
// GOTO PARMDOWN
/. PARMUP
* PARM IS UP
// GOTO $EOJ
/. PARMDOWN
* PARM IS DOWN
/*
/&
```

Figure 93. Sample 1: Symbolic parameters

```

// JOB TSTSETP2
ACC S=DEVLIB.USCH
CAT TSTSETP2.PROC R=Y
/* rexx procedure */
old = OUTTRAP(map.,'NOCONCAT')
ADDRESS JCL "MAP &PARTIT"
do i=1 to map.0
  say map.i
end
EXIT rc
/+
/*
// LIBDEF *,SEARCH=(DEVLIB.USCH,PRD1.BASE)
// EXEC REXX=TSTSETP2,PARTIT=BG
/*
/&

```

Figure 94. Sample 2: Symbolic parameters

```

// JOB TSTSETP3
ACC S=DEVLIB.USCH
CAT TSTSETP3.PROC R=Y
/* rexx procedure */
old = OUTTRAP(map.,'NOCONCAT')
ADDRESS JCL "MAP &REXXVAR"
do i=1 to map.0
  say map.i
end
ADDRESS JCL "// SETPARAM YYYY='NOT_SEEN'"
EXIT rc
/+
/*
// LIBDEF *,SEARCH=(DEVLIB.USCH,PRD1.BASE)
// SETPARAM YYYY=F1
// EXEC REXX=TESTSETP,REXXVAR=&YYYY
/*
// IF YYYY = 'F1' THEN
// GOTO PARMF1
// IF YYYY = 'NOT_SEEN'
// GOTO PARMNS
// GOTO $EOJ
/. PARMF1
* PARM IS F1, WHICH IS AS EXPECTED
// GOTO $EOJ
/. PARMNS
* ??? PARM IS NOT_SEEN, WHICH IS NOT EXPECTED ???
/*
/&

```

Figure 95. Sample 3: Symbolic parameters

LINK Command Environment

Table of Authorized Programs ARXEOJTB

Programs called from REXX via ADDRESS LINK can be added to the Table of Authorized Programs ARXEOJTB as described in the REXX/VSE Reference Manual in Chapter 13. This is especially necessary,

- if the called program uses the EOJ macro,
- if the called program is to be loaded into the program area via LOAD (instead of GETVIS storage via CDLOAD),
- if the REXX program containing ADDRESS LINK invocations does not terminate successfully.

Console Command Environment

Return Codes From Macros MCSOPER, MCSOPMSG, MGCRE

The implementation of REXX console commands and functions is based on a privileged macro interface consisting of macros called MCSOPER, MCSOPMSG, and MGCRE. If problems occur, return and reason codes of these macros are displayed in message ARX0565I. A REXX program can also access and check return and reason code by using function SYSVAR together with parameter 'SYSERRCODES'.

Return and Reason Codes are returned in decimal format within message ARX0565I as well as with function SYSVAR.

They are explained in the manual 'REXX/VSE Reference SC33-6642' or in the older manual 'REXX/VSE Console Automation SC33-6598'.

Suspended Console

When using function GETMSG, execution may fail with function code 8 and the message

```
ARX0565I MCSOPMSG FAILED RC=(0012,0000)
```

meaning that the console is suspended. This happens if at least one message is queued for this console, but it is not retrieved within the next 15 seconds after its arrival in the message queue for this console.

Another reason could be that the REXX console program creates many messages while its REXX console is active. If more messages are generated than the VSE Console Router can handle, the console is suspended. Or to be more specific, if more than 12 unretrieved console messages are queued for a console, this console is suspended.

Whenever possible, this situation should be avoided by following the hints and tips given in the manual REXX/VSE Reference in chapter REXX/VSE Console Automation.

Check the priority of the partition running the REXX Console program !

If a console is suspended, messages arriving during the suspended time are lost for this console. They are put on the hardcopy file, which may also be processed by a REXX console program invoking the REDISPLAY command.

A REXX program can react on a suspended console by deactivating this console and activating it again.

Here is a code sample:

```
fc = GETMSG(msg.,'MSG',,,15)
If fc > 7 Then
Do
  Call SYSVAR 'syserrcodes'
  If syserrcodes = '0012 0000' Then
  Do
    'DEACTIVATE MYCONS'
    'ACTIVATE NAME MYCONS PROFILE REXALLRC'
  End
End
End
```

Figure 96. Sample: Reactivating a suspended console

When using REXX/VSE function FINDMSG and console is suspended, messages

```
ARX0565I MCSOPMSG FAILED RC(0012,0000)
ARX0960E ERROR RUNNING FUNCTION FINDMSG, RC=8
ARX0040I ERROR RUNNING <name>, line <n> : Incorrect call to routine.
```

occur. Then the REXX procedure abends. Using the following hint the REXX procedure may continue, thus allowing to deactivate and activate the suspended console. Specify

SIGNAL ON SYNTAX NAME <label>

before invocation of FINDMSG. This definition can be deleted after invocation of FINDMSG with

SIGNAL OFF SYNTAX

At label <label> the DEACTIVATE and ACTIVATE can be placed followed by a branch back to FINDMSG. Thus, message ARX0040I does not show up anymore and the REXX interpreter continues to execute the REXX procedure.

Retrieval of CICS Messages

If a REXX console is activated and a CICS console command is issued, there is no response when invoking function GETMSG with type 'RESP'. The only way to receive CICS answers on a REXX console is via function GETMSG with type 'MSG'.

Tracking of Operator Communication

Responses to operator-given commands are only routed to the console the operator is using for his communication, not to other defined master consoles. Thus it is not possible to track ongoing operator communications via a REXX console program. Since operator dialogs are logged on the hardcopy file, they can be scanned using the REDISPLAY command.

Function SENDCMD

Invocation of function SENDCMD in REXX/VSE may return message
ARX0565I MGCRC FAILED, RC=(0008,0018).

Implementation of function SENDCMD uses a dummy console. If another program running in the system uses this dummy console too, macro MGCRC returns with return code 8 and reason code 18 (X'12'). You can either handle this situation by some kind of retry-loop or avoid this situation by using a dedicated REXX console. Such a console needs to be activated first. Afterwards you can issue the command via 'ADDRESS CONSOLE' as is without using function SENDCMD.

Here is a code sample that invokes SENDCMD in a subroutine with automatic retry-loop:

```

Send_Console_Command: Procedure
  Arg command
  fc = 0
  oldmsg = REXXMSG('OFF')
  Do Until fc = 0
    fc = SENDCMD(command)          /* issue console cmd */
    If fc /= 0
      Then Do
        Call SYSVAR 'syserrcodes' /* determine error code */
        If syserrcodes = '0008 0018' /* expected error */
          Then Call Sleep 1 /* wait 1 second */
        Else Return -1 /* unexpected error */
      End
    End
  msg = REXXMSG(oldmsg)
  Return 0

```

Figure 97. Sample: SENDCMD with retry-loop

REXX SOCKET Function

Determine SOCKET Implementation

Since there exist two implementations of the REXX/VSE SOCKET function, the implementation active at your installation must be determined first in case of a problem. The different setups are described in "Setup for Using the REXX/VSE SOCKET Function" on page 217. Error message ARX0960E is caused by the IBM-provided SOCKET implementation, error messages SOC... indicate that the CSI-provided SOCKET implementation is used.

Debugging SOCKET Problems

The REXX/VSE Socket function is implemented using the socket calls offered by LE/C, which are again based on the BSD/C Sockets of TCP/IP. Complex problems of Socket programs require debugging on the lowest socket level: Rename member *XSOCKDBG.PHASE* in PRD1.BASE to *\$SOCKDBG.PHASE* and check the console output.

REXX and Other VSE components

REXX and ICCF

Even though there exists no special ICCF-support in REXX, you can do the following:

1. Invoke DTSUTIL via ADDRESS LINK (include DTSUTIL into ARXEOJTB first!).
2. Read an ICCF member, by including it into SYSIPT via * \$\$ SLI and using either command EXECIO * DISKR SYSIPT or command PULL to store the member into a REXX stem variable.

```
// JOB TESTSLI
// EXEC LIBR
ACC S=PRIMARY.USCH
CAT TESTSLI.PROC R=Y
/* rexx procedure */
'EXECIO * DISKR SYSIPT ( STEM ipt.'
... /* further processing of ICCF-member within stem ipt. */
EXIT 0
/+
/*
// LIBDEF *,SEARCH=(PRIMARY.USCH,PRD1.BASE)
// EXEC REXX=TESTSLI
* $$ SLI ICCF=(OVERLAY2),LIB=(45)
/&
```

Figure 98. Sample: Read an ICCF member via SLI

3. At least some of the REXX procedures run in an ICCF interactive partition. Here is a small REXX procedure:

```
// JOB REXXICCF
// EXEC LIBR
ACC S=PRD1.BASE
CAT REXXICCF.PROC R=Y
/* rexx procedure */
/* to be invoked from ICCF */
old = ASSGN(STDOUT,SYSLOG)
say 'hello world'
exit 0
/+
/*
/&
* $$ EOJ
```

Figure 99. Sample: REXX in an interactive partition - REXX procedure

And here is the corresponding ICCF Macro that can be invoked from an ICCF interactive partition:

```

* $$ JOB JNM=DTSUTIL ,DISP=D,CLASS=0,LDEST=(,SRVPRM5)
// JOB DTSUTIL
// ASSGN SYS010,DISK,VOL=CTS220,SHR
* DISCONNECT DTSFILE
// PAUSE
// EXEC DTSUTIL
PURGE LIB(45) MEMBER(REXXICCF)
ADD MEMBER(45,REXXICCF,USCH)
@MACRO
/SET CLASS I NOWAIT
/SET DELAY BYPASS
/INPUT
/LOAD ARXJCL PARM='REXXICCF'
/OPTION GETVIS=900
/END
/RUN
END OF MEMBER
/*
/&
* $$ EOJ

```

Figure 100. Sample: REXX in an interactive partition - ICCF macro

REXX and VSAM

With VSE/ESA 2.6 a new REXX/VSE command VSAMIO is offered to provide access to VSAM data. If you are still running on an VSE/ESA release prior to 2.6, you can do the following:

1. Invoke IDCAMS via ADDRESS LINK. This allows for instance to read a VSAM file using IDCAMS PRINT. The IDCAMS output is stored into the stem defined with the OUTTRAP function.
2. Make use of the DITTO-REXX-Interface to write and read a VSAM file. DITTO offers extra commands to copy data from tape, library member or VSAM file to a REXX stem variable and vice versa. DITTO command \$VX allows to read a VSAM file into a stem and DITTO command \$XV allows to write a VSAM file from a given stem.

```

call 'DITSETUP' /* establish DITTO command environment */
ADDRESS DITTO /* switch to the DITTO command environment */
/* read file into stem vsam. */
'DITTO $VX DSNIN=VSE.MESSAGE.ROUTING.FILE UCAT=VSAM.MASTER.CATALOG' ,
'VARNAME=vsam.'

```

Figure 101. Sample: DITTO-REXX interface for VSAM

Chapter 11. 3494 Tape Library Support

Reason Codes From VGS

Figure 102 (Page 1 of 3). Reason Codes Generated by VGS

Reason	Meaning	Explanation/Action
5000	Request not authorized	The authorization user exit has determined that the request is not authorized.
5003	Insufficient data length	The length of the request data was smaller than the minimum required number of bytes. This is an internal program error; contact IBM service.
5008	Invalid request type	An unrecognized request type was specified. This is an internal program error; contact IBM service.
5011	Request to be cancelled not found	A request to cancel a mount request cannot be completed successfully, because the request is not longer in-process on the VGS machine. Issue rewind/unload to queue a dismount operation in the library.
5017	Request cancelled by a cancel-mount request	This request is the target request for a cancel-mount operation. The reason code in the response message for the original mount request. The mount operation was not completed.
5020	Request cancelled by an immediate machine shutdown	This request is purged from the VGS in-process files during immediate shutdown processing of the VGS machine. The mount operation may have completed successfully, but the status is not known to VGS at the time of shutdown.
5023	Device not found	The device specified for release is not found in the VGS device-use file. No action is taken.
5026	Library not known	The library name specified in a request is not found in the VGS library configuration file LIBCONFIG LIST A. Update or correct this file and retry the request.
5028	Device information not obtained	VGS is not able to get information about real tape drives currently attached to the requesting VSE guest. The request cannot be processed. Ensure that the VGS is machine has privilege-class B authorization in its directory record.
5029	Problem with CP ATTACH or DETACH operation	VGS is not able DETACH a device from the requesting guest or to re-ATTACH a guest device to itself for performing the requested function. Ensure that the VGS is machine has privilege-class B authorization in its directory record.
5030	Virtual cuu not provided	A mount, release, cancel, or query device operation has not specified the required virtual cuu field.
5031	Virtual cuu contains invalid characters	A mount, release, cancel, or query device operation does not use valid numeric or hex-digit characters.
5032	Volume label not provided when required	A mount, query volume, cancel,eject, or set volume category operation has not specified a volume serial number.
5033	Source category not provided when required	A mount from category operation has not specified a source category name.
5034	Target category not provided when required	A set volume category or manage inventory operation has not specified a target category name.

Figure 102 (Page 2 of 3). Reason Codes Generated by VGS

Reason	Meaning	Explanation/Action
5035	Member name not provided when required	A manage inventory operation has not specified a member name for the source file containing volume category assignments.
5040	Error reading result of Query or Manage Inventory request	The VGLIBSRV machine was not able to read the request final status information from the secondary inventory support machine's 191 disk. The result of the inventory operation is unknown.
5041	Timeout occurred during Query or Manage Inventory request	The VGLIBSRV machine did not receive final status on the request within the time limit specified by the INV_MAX_TIME customization variable. The request may still complete successfully, or the secondary machine may have encountered an error. Check the status of the secondary inventory support machine.
5042	Secondary inventory server is not logged on	The VGS machine has determined there the secondary inventory support server is not logged on, or its logon status is cannot be obtained. The inventory request cannot be processed.
5043	Secondary inventory server's 191 is not linked by VGLIBSRV	Inventory requests cannot be processed by VGS unless the secondary support server is defined, logged on, and it's 191 disk is linked by VGLIBSRV.
5044	Secondary inventory server is not identified to VGLIBSRV	The customization variable HELPER_ID in the customization exec does not specify a valid server name. Inventory requests cannot be processed.
5080	Locked failed, Librarian member already locked	The Librarian member specified in a Manage Inventory request or implied by category-inventory naming conventions for a Query Inventory request cannot be already locked. Member is locked by another user, wait and resubmit the request.
5081	Lock failed, fully-qualified Librarian member is not valid	The Librarian member specified in a Manage Inventory request could not be locked and most likely does not exist. Ensure that the Library and Sublibrary names specified in the customization exec are valid and that the specified member already exists in the sublibrary.
5082	Unspecified lock failure for Librarian member	The Librarian member specified in an Inventory request could not be locked for some unknown reason. This is most likely an internal error.
5083	Librarian write failure	The Librarian member specified in an Inventory request could not be successfully written in the Librarian file in the VSE guest machine.
5084	RMS error on Query Library Inventory command	An unspecified error occurred requesting the inventory report from the RMS machine. Retry the request. If the problem persists, logon to the secondary inventory support machine and check the console during request submission, and/or the RMS Master console.
5085	Invalid source category specified for Query Inventory	The source category requested for inventory is not supported or is not a valid category name.
5086	LIBRCMS server name not found for the requesting VSE guest	When multiple VSE guests are supported by VGS, a LIBRCMS server cross-reference file on the secondary inventory support machine 191 disk must provide the name of the LIBRCMS server for each VSE guest. This no server was found for the requesting VSE guest.
5090	Secondary inventory support internal error - Erase	The CMS ERASE command failed for a file in the inventory support server's 191 disk.

Figure 102 (Page 3 of 3). Reason Codes Generated by VGS

Reason	Meaning	Explanation/Action
5091	Secondary inventory support internal error - Disk I/O	The EXECIO command failed for a file in the inventory support server's 191 disk. Check for disk-full condition.
5092	Secondary inventory support internal error - Copyfile	The CMS COPYFILE command failed for a file in the inventory support server's 191 disk. Check for disk-full condition.
5093	Secondary inventory support internal error - Query Reader	The Query Reader command failed checking the reader for returned inventory report.
5094	Secondary inventory support internal error - Receive	The Receive command failed reading the report file from the reader to the 191 disk. Check for disk-full condition.
5095	Secondary inventory support internal error - Unexpected disk files	At least one previous inventory report was detected on the secondary inventory server's 191 disk. The integrity of inventory data cannot be guaranteed. Report is not updated in the VSE Librarian file.
5096	Secondary inventory support internal error - Mismatch	The name of the category inventoried on the RMS inventory report does not match the source category name in this request. The report is not updated in the VSE Librarian file.

Reason Codes From LBSERV

Figure 103 (Page 1 of 2). Reason Codes Generated by VSE

Reason	Meaning	Explanation/Action
61xx	XPCC internal error	<p>An XPCC internal error occurred, please check the return code and reason code coming from XPCC, where xx in reason code 61xx is the reason code from XPCC. A reason code of 6100 and following return code may caused by :</p> <p>0038 Reason 1: The maximum of possible XPCC connections may have been reached or the APPC connection is not available. Please try later.</p> <p>Reason 2: Check the SYS command in your IPL procedure. SYS=VM must specified if VGS is used, SYS=VSE must be specified if LCDD is used.</p> <p>0039 Please verify that you have specified enough PFIIX e.g // SETPFIIX LIMIT=(,100K),PERM for above the 16MB line</p> <p>If the error persists, please contact IBM service.</p>
62xx	APPC internal error	An APPC internal error occurred, maybe the XPCC/APPC connection went down. Please check the return code and reason code coming from APPC, where xx in reason code 62xx is the reason code coming from APPC. If the error persists, please contact IBM service.

<i>Figure 103 (Page 2 of 2). Reason Codes Generated by VSE</i>		
Reason	Meaning	Explanation/Action
63xx	LBSERV failure	<p>An error in LBSERV code occurred. Please check the reason code xx where xx means:</p> <ul style="list-style-type: none"> 01 The version of the service list mapping is incorrect or the service list specified by SERVL is less than the minimum requirement. If the version is less than 2, please recompile. 02 In a current RECEIVE request, the previous request was not one of the following: AQUERY, CMOUNT, CQUERY, DQUERY, EJECT, IQUERY, LQUERY, MINVENT, MOUNT, RELEASE (VGS only), SETVCAT, SQUERY; or the previous return code was not zero. 03 Phase IJJTLIB is not loaded in the SVA. 04 Either the previous request was LBSERV CANCEL and there is no more information available to receive or the previous function has already completed . 05 User submitted a RECEIVE request but the main ECB has not been posted. Issue a WAIT macro on the main ECB before submitting the RECEIVE request. 06 A MOUNT request is already pending for this CUU; try later. 07 There is no more to RELEASE for this CUU. 08 An invalid (out-of-partition) address has been specified for the ECB. 09 An invalid (out-of-partition) address has been specified for LIBNAME. 10 An invalid (out-of-partition) address has been specified for VOLSER. 11 An invalid (out-of-partition) address has been specified for SRCCAT. 12 A RELEASE request was given for a device not being ready , perhaps a rewind unload was already performed. Please continue anyway with a RECEIVE request. for SRCCAT. 13 An invalid CUU was specified for a MOUNT request. 14 The specified CUU in a MOUNT request is in use, CUU is ready state.
6400	GETVIS failed	<p>There is no more storage available in the GETVIS area. Please check the return code (which is the return code coming from the GETVIS macro).</p> <ul style="list-style-type: none"> 04 the size of the (real) partition GETVIS area is OK. 08 the specified length is negative or exceeds the GETVIS area. 12 no more virtual storage is available in the GETVIS area, or a GETVIS request with length zero has been specified for a non-existing subpool 16 the maximum number of subpools is exhausted. 20 invalid GETVIS option. 24 invalid subpool ID. 32 PFI for an SVA subpool request failed. 36 invalid subpool index was specified ... 40 no access to the specified subpool is allowed as long as a PFI request is pending.
6500	MODFLD failed	<p>An error in the MODFLD macro occurred. Please check the return code (which is the return code coming from the MODFLD macro).</p> <ul style="list-style-type: none"> 04 NEWVAL not zero and TLMECBSV already set. There is already a MOUNT pending for this cuu. 08 NEWVAL zero and TLMECBSV not set. There is nothing more to RELEASE for this cuu. 12 device not owned by issuing partition. 16 an invalid input CUU = parameter. 20 device specified by CUU = parameter is no tape or lib.

MAPXPCCB Return Codes

Reg. 15	IJBXRETC (Symbolic Name)	Reason
X'00'	X'00' (IJBXREOK)	Request completed successfully.
X'04'	X'01' (IJBXDAPP)	Identification with the same application was requested previously in different partition. The connection is granted.
	X'02' (IJBXAPSP)	Identification with the same application was requested previously in same partition. The connection is granted.
	X'03' (IJBXFCRQ)	More than one CONNECT request is pending for this application.
	X'04' (IJBXNIDN)	Other side did no IDENT until now.
	X'05' (IJBXNCNN)	Other side did no CONNECT for this application until now.
	X'1B' (IJBXOICL)	Request already cleared.
	X'20' (IJBXSSWI)	SENDI protocol switched to SEND protocol because RECEIVE area is too small.
	X'21' (IJBXWECB)	Invalid main ECB address (address ignored).
	X'22' (IJBXBUFS)	CLEAR request accepted, wait on IJBXSECB for completion.
X'08'	X'06' (IJBXWCBK)	XPCCB control block format error.
	X'07' (IJBXWIDK)	Wrong identify token. (Token is invalid, or application issued TERMQSCE already, or CONNECT from pseudo partition without an IDENTify.)
	X'08' (IJBXWPID)	Wrong path ID.
	X'09' (IJBXWOWN)	Request was done under a task that has an incorrect task ID.
	X'0A' (IJBXWIND)	Buffer list was specified for a function that does not support it.
	X'0B' (IJBXWLST)	Too many buffers, or buffer length exceeds 16M bytes, or length is smaller than 2 in a CMS connection
	X'0C' (IJBXWRAR)	Receiving buffer is too small.
	X'0D'	Reserved.
	X'0E' (IJBXNSTO)	Try later, not sufficient storage to allocate system control blocks.
	X'0F'	Reserved.
	X'10' (IJBXNREQ)	No request pending. (Line not busy, or SEND was from other side, or data already cleared).
	X'11' (IJBXCCLR)	Request was already cleared.

Figure 104 (Part 1 of 2). MAPXPCCB Macro Return Codes (IJBXRETC)

Reg. 15	IJBXRETC (Symbolic Name)	Reason
X'08'	X'12' (IJBXCBSY)	Communication link already busy (FUNC=SEND/R).
	X'13' (IJBXWSEQ)	REPLY was issued before data was received.
	X'14' (IJBXNTRM)	At least one connection is still busy for the application.
	X'15' (IJBXNDC1)	Busy from own SEND (FUNC=DISCONN).
	X'16' (IJBXNDC2)	SEND from other side pending (FUNC=DISCONN).
	X'17' (IJBXQSCE)	Other side issued TERMQSCE.
	X'18' (IJBXNOC1)	A connection was never existing.
	X'19' (IJBXNOC2)	The other side terminated normally
	X'1A' (IJBXNOC3)	The other side terminated abnormally.
	X'1C' (IJBXWCBA)	XPCCB address of this request differs from the one given with CONNECT.
	X'1D' (IJBXER25)	Input contains invalid address.
	X'1E' (IJBXWSIS)	Wrong sequence in SENDI protocol.
	X'1F' (IJBXWTSK)	Task requested communication with itself.
	X'23' (IJBXDUP)	Application name was specified twice, at least once with UNIQUE.
	X'24'	Reserved.
	X'26'	APPC/VM error occurred
	X'27'	not enough real storage available to fix the buffers (PFIX)
	to	
	X'29'	reserved
	X'2A' (IJBXINAM)	Invalid application name (application name contains a blank or all binary zeros).
	X'2B' (IJBXTIMO)	A connection never existed because TIMEOUT occurred, or TIMEOUT=0 was specified with CONNECT, but the target application has not yet issued CONNECT.

Figure 104 (Part 2 of 2). MAPXPCCB Macro Return Codes (IJBXRETC)

MAPXPCCB Reason Codes

Symbolic Name	Hex Value	Posted ECB	Description
One of the following reason codes will be set up in IJBXREAS:			
IJBXCPRG	X'01'	IJBXSECB	After SEND/SENDP the receiver issued PURGE.
IJBXCLEA	X'02'	IJBXRECB	Sender issued CLEAR before receiver was able to receive/reply.
IJBXRECX	X'03'	IJBXCECB	After SENDP command, RECEIVE is being executed by partner.
	X'04'		Reserved.
	X'05'		Reserved.
IJBXMQSD	X'06'	IJBXSECB IJBXRECB IJBXCECB	Maintask issued TERMQSCE and subtask has CONNECT requests open.
IJBXSWSR	X'07'	IJBXRECB	A SENDI was changed to SEND because RECEIVE area was too small.
	X'08'		Reserved.
	to X'0B'		
IJBXTOUT	X'0C'	IJBXCECB	The specified time interval elapsed and the requested application has not issued CONNECT (DISCONNECT is required for acknowledgement).
The next two reason codes are OR'ed to the reason code field.			
IJBXDISC	X'40'	IJBXSECB IJBXRECB IJBXCECB	Other side issued DISCONNECT.
IJBXABDC	X'80'	IJBXSECB IJBXRECB IJBXCECB	Other side was disconnected due to abnormal termination.

Figure 105. MAPXPCCB Reason Codes (IJBXREAS)

Reason Codes From LCDD

Code Explanation

- 0001 An internal error in LCDD processing, or LCDD cannot process the request due to an offline condition in the Library Manager. An error or information message on the console provides additional details.
- 0020 An invalid request type was sent to LCDD.
- 0024 A request was sent but LCDD is either completing its initialization processing or is quiescing.
- 3000 There is a library and device mismatch. A specified device is not found in the specified library.
- 3004 A source category unknown to LCDD was specified in a request.
- 3005 An invalid source category name was specified for this type of request.
- 3008 A specified CUU is not available in the active library device configuration.
- 3020 A library name unknown to LCDD was specified in a request.
- 3024 A category name unknown to LCDD was specified in a request.
- 3025 An invalid target category name was specified for this type of request.

3494 Tape Library

- 3030 An inventory file created by a Query Inventory request or referenced by a Manage Inventory request is currently in use by another inventory task. Reissue the request later.
- 3032 A Query Inventory or Manage Inventory request cannot be processed because control information for library location of inventory lists has not been specified.
- 3034 A Query Inventory or Manage Inventory request cannot be processed because an error occurred during execution of a LIBRM function.
- 3116 The request is rejected by the preprocessing user exit.
- 3136 No devices are available to service this request.
- 3140 The 3494 has determined that the specified device is not available for use.
- 3150 LCDD has found the specified device to be in use and is not issuing the request to the 3494.
- 3152 Unable to acquire I/O resource. An internal error prevents the request from being processed.
- 3156 Unable to send request to library. Communication with the library was not executed successfully.
- 3220 The volume category was not changed during request processing.
- 3300 The completion status for the request is not known.
- 3304 Volser involved in this request has an unreadable external label.
- 3308 The operation was cancelled by request.
- 3312 The request was cancelled due to an order-sequence condition.
- 3316 The request cannot be executed because the library is in manual mode.
- 3320 The failure is due to hardware malfunction.
- 3324 The volume is not accessible to the library.
- 3328 No volumes are currently assigned to the requested category.
- 3336 The volume is already in use.
- 3340 The volume was not found in the library.
- 3344 The category is empty.
- 3348 The library volume is misplaced.
- 3352 The volume is not accessible to the gripper.
- 3356 The volume was manually ejected.
- 3360 The category is in use.
- 3364 A mount is already in progress on the requested device.
- 3368 A mount is already pending on the requested device.
- 3372 A demount is already pending on the requested device.
- 3376 No volume is mounted on the device to which the demount is issued.
- 3500 The library failed the attachment check.
- 3504 The library manager is offline.
- 3508 There is a control unit and library manager error.
- 3512 The library has a vision system failure.
- 3516 The library is not capable of performing request.
- 3624 There is an unrecognized I/O error.
- 3692 There was an unload failure.
- 3740 Unsolicited sense information was received.
- 3800 A command reject was received from the 3494, possibly due to invalid information in a request. For example, a set volume-category request may have specified a source category to which the subject volume is not currently assigned.
- 3804 The function is incompatible. Media and drive types are incompatible.
- 3808 The library volume is reserved.
- 3816 All categories are reserved.

Reason Codes From DFSMS/RMS

This is only a subset of possible return/reason codes which may come from DFSMS/RMS. For a reason code not listed here in , please check the VM/ESA DFSMS/RMS User's Guide and Reference SC35-0141-00.

Figure 106 (Page 1 of 2). Reason Codes Generated by DFSMS

Return code	Reason code	Explanation/Action
12	3932	Communication error
8	3940	RMS master unavailable - RMS is not up and running
8	3952	Invalid Target category name
8	3962	Invalid Source category name
8	3964	Invalid real device number
8	3968	Invalid virtual device number
8	0024	Master not accepting commands
4	0036	Request not found for MOUNT CANcel
8	0064	Invalid request for MOUNT CANcel
8	2040	Request was already cancelled
8	3000	Library /Device mismatch - the specified device does not reside in the specified library
8	3012	Invalid manual request a request other than mount or demount request is received and the specified library is a manual library
8	3020	Invalid library name
8	3024	Target category not defined for input library, or for library in which specified device resides in
8	3028	Target or source category defined for mount issued to manual library
8	3032	Specified category not assigned to specified device
8	3034	Volume not currently assigned to the source category
8	3136	No device available
8	3140	Specified device not available
8	3208	Attach or Detach error after completion
8	3220	Category not changed
8	3324	The requested volume is in a position that is inaccessible to the library
8	3328	Source category empty
8	3332	Volume not in inventory
8	3336	Volume in use - the requested volume is already mounted or mount pending
8	3340	Volume not in library
8	3348	Library volume misplaced
8	3352	Volume inaccessible - the requested volume is in a position in which it is inaccessible to the robotic gripper
8	3356	Volume manually ejected
8	3364	Mount in progress - a mount is already in progress on the requested device
8	3368	Demount already pending
8	3376	No volume mounted - no volume is mounted on the device for which this demount is requested
4	3384	Request completed during restart

Figure 106 (Page 2 of 2). Reason Codes Generated by DFSMS

Return code	Reason code	Explanation/Action
4	3388	Request cannot be completed during restart
4	3504	Library manager off-line
8	3804	The function is incompatible. For a MOUNT request media and drive types are incompatible.

Chapter 12. Language Environment for VSE/ESA (LE/VSE)

LE/VSE Big Picture

While LE/VSE 1.4.0 introduced many changes and enhancements in different product areas its follow-on LE/VSE 1.4.1 (in VSE/ESA 2.5) focused on structural improvements. The current modification level, LE/VSE 1.4.2 (in VSE/ESA 2.6) for example, concentrates on dump facilities and optimization of storage tasks.

Further details on release/mod/level specific contents are available on LE/VSE Home Page (history section) via:

<http://www.ibm.com/servers/eserver/zseries/os/vse/1e/history.htm>

The following sections are intended to ease product usage, customization and problem follow-up.

LE/VSE 1.4.2 in VSE/ESA 2.6

The following table lists the component identifiers (COMP IDs) and component level codes (CLCs) relevant for LE/VSE 1.4.2.

Component-ID	CLC	Description
5686-066-32	65K	LE Common base, containing information written in: - Uppercase and mixed-case US English - Japanese NLF
5686-066-33	65L	LE C-specific base, containing information written in: - Uppercase and mixed-case US English - Japanese NLF
5686-066-34	65M	Optional LE DBCS Locale Component (see note below)
5686-094-03	6EW	LE COBOL-specific base and CICS, containing information written in: - Uppercase and mixed-case US English - Japanese NLF
5686-094-06	6EX	LE PL/I-specific base, containing information written in: - Uppercase and mixed-case US English - Japanese NLF

Notes:

1. The LE Base (\$SVACEE) and C Runtime (\$SVAEDCM) are pre loaded in the SVA. Please also see the *VSE/ESA Planning Guide*, SC33-6703.

Please notice that option modules (for example) CEECOPT.PHASE and CEEDOPT.PHASE are included in SVA loadlist \$SVACEE. Changing run-time options for batch and CICS environment therefore requires a SVA re-load via SET SDL command from BG partition. Supplied skeletons CEEWCOPT and CEEWDOPT in ICCF library 62 will take this into consideration.

2. The optional LE/VSE 1.4.2 DBCS locale component is shipped on the VSE/ESA 2.6 Extended Base tape.

For more information, please see the *VSE/ESA Release Guide* SC33-6718 which is also available on the *VSE/ESA Softcopy Collection Kit* SK2T-0060.

See *IBM LE/VSE Customization Guide*, SC33-6682, for related information.

Mixed Language Applications under LE/VSE (involving Assembler)

When creating or maintaining mixed language applications in an LE/VSE environment various supported techniques are available. In general the following macros and services can assist to ensure operating LE/VSE-conform.

- LE/VSE assembler macros (CEEENTRY/CEETERM)
- LE/VSE preinitialization service (CEEPIPI)
- LE/VSE C-specific macros (EDCPRLG/EDCEPIL)

Examples and further details not covered here are available on LE/VSE Home Page via

<http://www.ibm.com/servers/eserver/zseries/os/vse/1e/samples.htm>

Summary of LE/VSE Customization and Verification Jobs

Following is a list of LE/VSE related jobs, pre-installed in ICCF library 62. These members can assist you in various verification and customization tasks.

Figure 107 (Page 1 of 2). LE/VSE 1.4 Jobs in ICCF Library 62

ICCF Member	Purpose and Function
CEECCSD	LE/VSE base program definitions (CICS)
CEEWCCSD	Skeleton for enabling LE/VSE program definitions (CICS)
CEEWCEXT	Identify abnormal termination exit to LE/VSE (CICS)
CEEWCOPT	Installation-wide default LE/CICS run-time options
CEEWCXIT	Installation-wide assembler user exit
CEEWDCD0	Card-device run-time LIOCS phase
CEEWDDU0	Diskette-device run-time LIOCS phase
CEEWDEXT	Identify abnormal termination exit to LE/VSE (Batch)
CEEWDOPT	Installation-wide default LE/batch run-time options
CEEWDP0	Printer device run-time LIOCS phase
CEEWDXIT	Installation-wide assembler user exit (Batch)
CEEWHLLX	High level language user exit
CEEWINFG	Collect system status information related to LE/VSE
CEEWINFR	Summarize/condense information generated via CEEWINFG
CEEWIVP1	Verification of Assembler program interface
CEEWIVP2	Verification of LE/VSE COBOL Component

Figure 107 (Page 2 of 2). LE/VSE 1.4 Jobs in ICCF Library 62

ICCF Member	Purpose and Function
CEEWIVP3	Verification of LE/VSE PL/I Component
CEEWIVP4	Verification of LE/VSE C Component
CEEWIVP5	Verify the LE/VSE C Prelink Utility
CEEWMSVA	LE/VSE base routines eligible for putting into the SVA
CEEWUOPT	Application specific run-time options
CEEWUXIT	Application specific assembler user exit
EDCCCS	LE/VSE C-specific program definitions (CICS)
EDCLLOCL	Changing the C locale time information
EDCUCSD	Optional codeset converters (CICS)
EDCWMSV1	LE/VSE C-specific routines eligible for SVA
IBMCCSD	LE/VSE PL/I-specific program definitions (CICS)
IBMSVA1	LE/VSE PL/I-specific routines eligible for SVA
IGZCCSD	LE/VSE COBOL-specific program definitions (CICS)
IGZWARRE	Customize behavior of COBOL reusable environment
IGZWEPC	COBOL COBPACK tailoring
IGZWEPC	COBOL COBPACK tailoring
IGZWEPCO	COBOL COBPACK tailoring
IGZWESV1	LE/VSE COBOL-specific routines eligible for SVA
SKLE370	LE/VSE CICS CSD entries in GROUP(CEE)
CEETSCSD (*)	Sample code for USESVACOPY(YES) alteration, LE Base under CICS TS (pre-customized for VSE/ESA 2.6)
EDCTSCSD (*)	Sample code for USESVACOPY(YES) alteration, LE C under CICS TS (pre-customized for VSE/ESA 2.6)
IGZTSCSD (*)	Sample code for USESVACOPY(YES) alteration, LE COBOL under CICS TS (optional !)
IBMTSCSD (*)	Sample code for USESVACOPY(YES) alteration, LE PL/I under CICS TS (optional !)
EDCXDLY (#)	Sample C/VSE code exploiting new LE/VSE Callable Service CEE5DLY (introduced with LE 1.4.2)
IGZTDLY (#)	Sample COBOL/VSE code exploiting new LE/VSE Callable Service CEE5DLY (introduced with LE 1.4.2)

Notes:

- Members marked (#) provide sample code for new LE/VSE Callable Service CEE5DLY. Please refer to the LE/VSE 1.4.2 overview section in the *VSE/ESA Release Guide* for further details.
- Skeleton SKLE370 is located in ICCF Library 59. It reflects a pre-customized status of the shipped CICS region (for VSE/ESA 2.4 (and later) this is a CICS

TS based DBDCCICS). Hence there is no need to run SKLE370 unless LE/VSE definitions are modified or reestablished. For example this may apply when a second CICS region is built. CICS coexistence environments running CICS/VSE with a non-shared CICS System Definition (CSD) file should take care about a related DLBL statement and LIBDEF reference to sublibrary PRD2.CICSOLDP. Also be aware that you need LE/VSE C-specific support in order to start CICS TS, respectively make use of Debug Tool for VSE/ESA (orderable feature of LE/VSE enabled compilers).

3. All members marked (*) are sample code containing LE/VSE 1.4.2 component specific DFHCSDUP ALTER commands for USESVACOPY(YES) enablement under CICS Transaction Server. Please be aware that this change has to go along with a CICS SIT parameter setting of SIT SVA=YES as well as load of corresponding \$SVAxxxx loadlists. For details and possible impacts in a CICS coexistence environment please refer to CICS TS documentation and VSE/ESA Planning Guide.

For VSE/ESA 2.6 the delivered system is pre-customized with SIT SVA=YES:

- a. Making use of SVA loadlists \$SVACEE (LE/VSE 1.4.2 Base) and \$SVAEDCM (LE/VSE 1.4.2 C Language Support).
- b. Shipping USESVACOPY(YES) enabled CICS CSD definitions - via GROUP(CEE) - for LE/VSE 1.4.2 modules contained in these loadlists. Therefore do NOT run CEETSCSD and EDCTSCSD on this level. Everything is included.

Additional information:

- a. A set of new Z-books (allowing direct DFHCSDUP input) was provided to support the preload issue. Actually members CEETICSD.Z and EDCTICSD.Z which are integrated in common base install and service upgrade procedures. The LE COBOL and LE PL/I specific Z-books (IGZTICSD and IBMTICSD) complement this set (but aren't preloaded).
- b. All Z-books under a.) correspond to *TSCSD members outlined in Figure 51.

Modifying Behavior of COBOL Reusable Environment

This task is optional.

The COBOL reusable environment behavior can be modified to control how program checks are handled that occur in a non-Language Environment conforming driver. The COBOL reusable environment is established with the RTEREUS run-time option or a call to IGZERRE INIT.

Use the IGZWARRE sample job to change the behavior of COBOL's reusable environment. You must modify the IGZRREOP macro invocation, depending on the function that you want.

To run with VS COBOL II and DOS/VS COBOL run-time compatibility mode (i.e., the user has control of program checks that occur when the COBOL reusable environment is dormant, resulting in an additional performance cost), use:

- IGZRREOP REUSENV=COMPAT

To run with optimum performance (i.e., Language Environment intercepts all program checks that occur when the COBOL reusable environment is dormant and converts them to CEE3321C/CEE3320C, resulting in improved performance), use:

- IGZRREOP REUSENV=OPT

Languages and CICS Transaction Server

CICS Transaction Server for VSE/ESA supports:

- All LE/VSE conforming compilers (C/VSE, COBOL/VSE, PLI/VSE)
- High Level Assembler with LE/VSE
- DOS/VS COBOL and VS COBOL-II (if relinked / using LE run-time)

CICS Transaction Server will not support:

- DOS PL/1 and C/370 applications (recompilation with LE-conforming compiler is required)
- RPG-II (not supported by LE, either)

Note: Be aware that every CICS TS related transaction needs to be "security-enabled" prior to its first execution. The Interactive Interface provides associated support via dialog TAS\$SECF, accessible via main selection path "Resource Definition" --> "Define Transaction Security".

Generating Applications Capable of Running Under LE/VSE

Remember Interactive Interface capabilities when building your own applications (see Primary Library, OPTION 8, translate and compile)

Not only does it provides applicable JCL-coding, but it also ensures involving language independent stubs as well as useful compile options.

However there are further issues such as the common question of how to implement "application-specific" option overrides in a program. This is easy to realize based on JCL skeletons provided. Here is a short example:

```
// JOB COMPILE
// etc
// OPTION CATAL
  PHASE name,*
  INCLUDE DFHELII (language independent stub, only if CICS)
  INCLUDE CEEUOPT (the common way to include application specific overrides)
  INCLUDE MYOPTS,(CEEUOPT) (alternate way with user name + CSECT reference!)
// EXEC IGYCRCTL (compiler invocation)
  (source code goes here) etc...
```

Note: *LE/VSE Customization Guide*, SC33-6682, Chapter 2 shows an example on how to build a CEEUOPT.OBJ (application specific option module). Please also notice that the catalogued object name used is open, however never change the CSECT name used for option module generation. Finally, in case product related run-time options may change there might be a need to update old or obsolete application specific settings.

Overriding Run-Time Options with an EXEC card (Batch)

There may arise the need to override installation-wide run-time options (temporarily) while running a single application. For example if a dump needs to be taken. For batch you may wish to pass the desired run-time options via PARM-string definition in the EXEC statement. Then the following should be considered:

- The "/" character is used as a separator between program-arguments and run-time options.
- The position of the slash is related to the setting of run-time option CBLOPTS.
- Presuming a default setting of CBLOPTS(ON) there is a language dependent approach as follows.

- C or PL/I:

A trailing slash after the run-time options is required.
 // EXEC PGM,SIZE=PGM,PARM='RPTSTG(ON)/program arguments if any'
 This example overrides the default run-time option RPTSTG(OFF) producing a storage report to the current job output.

- COBOL:

Program arguments are expected before run-time options. Therefore the slash should be specified in a way like
 // EXEC PGM,SIZE=PGM,PARM='program arguments if any/RPTOPTS(ON)'
 This example overrides the default run-time option RPTOPTS(OFF) producing a run-time option report to the current job output.

- This difference mainly exists to support the way programmers are accustomed to interact with programs written in a specific language. A setting of CBLOPTS(OFF) would suit to support overrides in a common way (all languages).

Note: There are many related references in the LE/VSE Bookshelf, mainly in *LE/VSE Customization Guide*, SC33-6682, Appendix A + section "COBOL Compatibility", *LE/VSE Programming Guide* SC33-6684, Chapter 4,5 and *LE/VSE Programming Reference* SC33-6685 Chapter 2. Non-LE conforming assembler programs that act as drivers for LE-conforming applications cannot, by default, pass any runtime option overrides supplied on the JCL PARM card.

AMODE 24 Applications in a LE/VSE-CICS Environment

Under CICS, the supplied default LE/VSE run-time options ALL31(ON) and STACK(4K,4080,ANYWHERE,KEEP) are present.

These settings improve performance and storage utilization for a CICS region running AMODE31/ANY programs or applications that use CICS services to invoke AMODE24 programs from AMODE31/ANY applications. This is applicable unless AMODE31/ANY programs dynamically call AMODE24 programs (which are not automatically enabled for AMODE switching). In such cases a setting off ALL31(OFF) and STACK(4K,4080,BELOW,KEEP) is required. You may wish to implement it by use of an appropriate CEEUOPT.OBJ linked with the application.

Detailed information about run-time option changes are available in *LE/VSE Customization Guide*, SC33-6682.

Run-Time Options to Use with Caution

You may find these tips valuable in your environment:

- Use LE/VSE run-time option **TERMTHDACT(UADUMP)** for diagnosis in a batch environment. It generates a VSE partition dump and a corresponding LE/VSE dump. For problem determination under both CICS/VSE and CICS TS it is recommended to specify TERMTHDACT(DUMP).

Please also be aware that use of TERMTHDACT (UADUMP) with database managers will bypass backout processing that may be required after application failure. Any files still open at point of failure will not be closed. Additional reference will be available via Info APAR II11817.

- The default run-time option **HEAP(...,ANYWHERE,...)** is important because of the correlation to COBOL compile options DATA(24/31), RMODE and RENT. Be aware that there is a 64k limit for CICS/VSE 2.3 GETMAIN storage requests below the 16MB line.

Note: Avoid HEAP(BELOW), it ignores the COBOL DATA(xx) compile setting for location of dynamic data areas (such as working storage).

- Run-time option TRAP has changed. Setting **TRAP(ON,MAX)** ensures LE/VSE's integrity when handling abnormal conditions. TRAP(OFF) should only be activated on request of IBM service personal. TRAP(ON,MIN) is the recommended setting in place of TRAP(OFF).
- The **3rd parameter** of the **STORAGE** run-time option can be of importance in PL/I migration environments. It deals with PL/I automatic variable storage and provides an initialization service in case the programming style did not consider start values for variables. However the associated performance impact can be significant (dependent on how the application is coded). Since it deals with the LE/VSE stack it can degrade overall run-time performance for all languages ! Therefore a setting of STORAGE(00,NONE,00,xk) should be used very carefully, with respect to application specific, (for example, via tailored CEEUOPT.OBJ or JCL PARM override) settings.
- In general **PL/I users** should also take care about their run-time option settings for: DEPTHCONDLMT, ERRCOUNT, USRHDLR and XUFLOW.

LE/CICS-wide Run-Time Options to VSE Console

You may wish to display active LE/CICS-wide run-time option defaults immediately (without the need on global report option setting via run-time option RPTOPTS(ON)). This is supported via transaction "ROPC" (security enabled for CICS Transaction server) and shipped in CICS GROUP (CEE). Running this transaction will show LE/CICS-wide default options on VSE console. Also available is transaction "NEWC" which allows for the LE CICS-wide runtime options to be "newcopied" while CICS is still running. This is useful if the CEECOPT.PHASE options module has been changed and the new settings are required to be activated without a restart of the CICS system.

CICS Table Parameter Settings

Please ensure that you update the following CICS table(s) if you intend to run COBOL/VSE, VS COBOL II, DOS/COBOL or PLI/VSE programs under control of LE/VSE:

CICS System Definition Table (SIT):

- **COBOL2=NO**

LE/VSE will automatically provide you with the necessary run-time support for VS COBOL II.

- **PL1=NO**

This is the recommended setting in order to indicate to CICS/VSE that LE/VSE is going to provide PL/1 run-time support. In case of LE/VSE this must be a PLI/VSE compiled programs. On the contrary, PL1=YES should be used, if the obsolete DOS PL/I 1.6.0 run-time library which went out-of-service 06/30/1997, is also required. PL1=YES allows both the DOS PL/1 runtime and LE/VSE PL/1 runtime environments to be available to application programs. See the PL/1 for VSE/ESA Migration Guide (SC26-8056-01) for more information on DOS PL/1 and PL1/VSE application support with LE/VSE.

CICS Processing Program Table (PPT): (VS COBOL II only)

If there are VS COBOL II run-time PPT entries

- Do **not** include copy-book **IGZ9PPT.A** in your PPT
- Recompile your CICS PPT in order to update control information
- Recycle CICS via **cold-start**. This should be done once in conjunction with topic "Member SKLE370 provides LE/VSE support for CICS/VSE".
- If there are CICS CSD entries for VS COBOL II modules IGZCPAC & IGZCPCC (instead of macro definitions) - ensure they are removed

If you plan to use VS COBOL II with the LE/VSE run-time under CICS/VSE, you should observe the following when modifying your CICS/VSE PPT:

- Do **not** include the VS COBOL II copy-book, **IGZ9PPT.A** in your PPT. Instead include the copy-book, **IGZCPPT.A**, supplied in PRD2.SCEECICS.
- Recompile your CICS PPT
- Recycle CICS via **cold-start**

CICS Translator Options Required for COBOL Applications

For COBOL/VSE or VS COBOL II online programs (VS COBOL II must at least be relinked to involve LE/VSE run-time) one of the following CICS/VSE or CICS TS translator options must be used. This will apply to mainline programs as well as to COPY-books that may be translated separately.

- XOPTS(**COBOL2**) was a minimum setting for VS COBOL II type programs, preferable matching the ANSI74 standard. It may also be used in a COBOL/VSE context.
- XOPTS(**ANSI85**) implies COBOL2 and can also be applicable for COBOL/VSE or VS COBOL II compiled program units. However these settings are

appropriate in case the application exploits ANSI85 functionality such as nested programs.

- XOPTS(**COBOL3**) is a CICS TS only translator option which you may wish to use as an indicator for a COBOL/VSE or SAA AD/Cycle COBOL/370 cross compile program unit. It implies ANSI85 and COBOL2. By the way, CICS TS doesn't support the SIT COBOL2 parameter since the run-time must be LE/VSE. Please refer to CICS Transaction Server documentation for more details.

Note: Sometimes VS COBOL II programs, translated without either of these CICS translator options, executed without error with the former VS COBOL II run-time. However such programs will not execute successfully under LE/VSE and are likely to use the old and obsolete COBOL specific CICS stub DFHECI.

Common Abend Conditions With LE/VSE

LE/VSE Specific Abend Codes and Their Possible Causes

The following abend codes occur typically in the LE/VSE environment, and can be found in either LE error messages (beginning either with 'CEEnnnnn', 'EDCnnnnn', 'IBMnnnnn' or 'EGZnnnnn'), or in CICS error messages (beginning with 'DFHnnnnn'). The error codes can be found either in *IBM LE/VSE Debugging Guide and Run-Time Messages*, SC33-6681, or at the operator console by entering the string CEEABENDC in the command line and pushing PF9.

- | | |
|-------------|---|
| 4038 | For calls to AMODE 24 programs, LE/VSE run-time options for CICS should be ALL31(OFF) and STACK(4K,4K,BELOW,KEEP). This is also important if calling such programs from AMODE 31 applications dynamically. |
| 4083 | Back chain (user or system save areas) in error. Probably a storage overlay has occurred or an abend was experienced due to involving non-LE/VSE conforming subroutine(s). Please refer to the first paragraph of this document for possible causes and assistance. Most likely no LE/VSE dump can be provided in this situation. A setting of TERMTHDACT(UADUMP) or TRAP(ON,MIN) is therefore recommended for batch diagnostics. |
| 4086 | Library routine(s) could not be loaded, not enough storage available or phase not found. |
| 4087 | A recursive error occurred exceeding the number of nested conditions (maximized via the DEPTHCONDLMT run-time option). Also check on required application compile options (especially RENT for COBOL CICS). |
| 4088 | A storage condition has occurred. Most likely no LE/VSE dump can be provided in this situation. A setting of TERMTHDACT(UADUMP) or TRAP(ON,MIN) is recommended in batch for diagnostic purposes. |

If an application fails with a CEE3322C error message and this type of abend, it is possible that there is not enough below-the-line partition GETVIS storage. It can help to run the job in a bigger partition or customize ALLOC/SIZE partition values in order to fulfill this requirement.

Another source of trouble may be applications coded with the GETVIS macro (in order to set up application specific storage areas). Generally speaking, LE callable services should be used instead, as this is much less likely to cause problems.

Furthermore please make sure your application is written LE/VSE-conforming for example, using LE/VSE provided macros such as CEEENTRY and CEETERM if involving assembler routines.

4093 Shortage of GETVIS storage below 16MB. In general this code indicates a problem during LE/VSE initialization. Consider moving LE/VSE to the SVA.

If you experience:

```
DFH1562 LE FOR VSE/ESA IS BEING INITIALIZED CEE1000S LE/ESA INTERNAL
ABEND ABCODE=FFD REASON 28 DFH0401 Abend 4093 BY III TASK
```

... it is likely that you have not specified the correct LE/VSE program definitions in the CICS CSD file. Please run/rerun skeleton **SKLE370**, including the necessary LE/VSE module support. Since VSE/ESA 2.3.0 this is a precustomized task on shipped systems.

4094 Termination error.

4095 Fatal error in LE/VSE conforming language.

CICS Specific Abend Codes Related to LE/VSE and Their Possible Causes

The following abend codes occur typically in the LE/VSE environment, and can be found in CICS error messages beginning either with 'DTHnnnnn'. The error codes can be found in *IBM LE/VSE Messages and Codes*.

APCH This CICS abend may occur if COBOL2=YES has been specified in the CICS/VSE SIT. For COBOL/VSE and VS COBOL II running with LE/VSE under CICS/VSE, COBOL2=NO must be specified.

APCO Can indicate a lack of storage within the partition while LE/VSE is trying to establish its run-time environment (in particular when involving C support, for example during the CICS start-up phase). In such cases increasing the partition ALLOC value can help (due to more GETVIS 31 storage) in MODE=ESA environments. Nevertheless be aware that the partition SIZE value must leave enough partition GETVIS 24 storage. For CICS/VSE partitions a SIZE value around 5MB is a practical value (assuming the shipped SVA-24 area size and partition start addresses haven't changed). Similar applies to CICS TS however the DSA allocation mechanism is different here. Shipped ALLOC and SIZE settings are visible via SKALLOCx members in ICCF Library 59 (preferable SKALLOCB). Furthermore related CICS TS startup and SIT table settings such as DSALIM, EDSALIM can be cross-checked via members DFHSITxx and SKCICS.

The problem may also arise in conjunction with establishing the C Language Run-Time Support on MODE=370 systems (VSE/ESA 1.4.x). Then the C main event handler phase **CEEEV003** should be moved to the SVA.

It is also possible that there has been a request to load a program larger than 512k (in 370 mode/or AMODE 24). This is a restriction

in CICS/VSE. For details, refer to *IBM CICS/VSE Application Programming Reference Guide*, SC33-0713. One solution may be to put the offending phase(s) into the SVA. For more information refer to *IBM LE/VSE Installation and Customization Guide*, SC33-6682.

- APCS** CICS is unable to make a successful connection to LE/VSE in order to determine run-time characteristics of the application.
- APCW** The required level of support for the LE/VSE-enabled COBOL/VSE compiler is not present in the system (it may be that the corresponding LE/VSE run-time library is not connected or installed). Check that the CICS subsystem has an active LIBDEF chain containing LE/VSE ship library PRD2.SCEEBASE.
- APC2** This may be caused by incorrect specification of CICS translator options. For COBOL/VSE or VS COBOL II, check that XOPTS(COBOL2) or XOPTS(ANSI85) has been specified.
- APDB** An LE/VSE enabled AMODE 24 application is using LE/VSE run-time options STACK or HEAP requesting more than 65504 bytes of storage below the 16MB line. This is a restriction under CICS/VSE.

To avoid the problem, rewrite the application to be 31-bit enabled, or reduce working storage requirements < 64k.

This type of problem may occur if LE/VSE on-line applications are linked with user specific run-time options via macro CEEUOPT. This object will then be part of the link step while building the program phase. This macro is then used to override installation-wide LE/VSE run-time options in CICS. Incorrect LIBDEF settings may include a copy of CEEUOPT that is not intended. If in doubt, check for multiple CEEUOPT.OBJ members via the LIBRARIAN SEARCH command.

Note: More detailed references are available in *IBM LE/VSE Debugging Guide and Run-Time Messages*, SC33-6681.

LE/VSE Related Service via Ordering PSP Bucket

Please use VSE/ESA specific PSP buckets for upgrading LE/VSE. These packages are named "VSEESA2xy" (where x is the release and y the modification level). Appropriate versions can be ordered via IBM service teams. Current subsets for LE/VSE are named "IBMLANG/55K" (LE/VSE 1.4.1) and "IBMLANG/65K" (LE/VSE 1.4.2). Of further interest can be CICS subsets ensuring synchronization with LE/VSE.

Further general service assist will be available via the Service Update Facility (SUF):

<http://www.ibm.com/servers/eserver/zseries/zos/suf/>

or:

<http://techsupport.services.ibm.com>.

LE/VSE Documentation Links

- The following link provides further information:
<http://www.ibm.com/servers/eserver/zseries/os/vse/1e/books.htm>
The link also provides a 'doc sorted by LE/VSE release' view.
- The latest change is with *LE/VSE Programming Reference* which has been updated for the March 2002 *Softcopy Collection Kit SK2T-0060*, and placed into the VSE/ESA 2.6 bookshelf.

Chapter 13. VSE/ESA Security and CICS-Coexistence Beginning with VSE/ESA 2.4

Migrating from CICS/VSE 2.3 to the Basic Security Manager (BSM)

The BSM in VSE/ESA 2.4 and follow-on releases supports sign-on and transaction security functions. To migrate the related information of a current CICS/VSE 2.3 to CICS TS and the BSM, five scenarios are possible:

1. Migrate **user** definitions stored in IESCNTL using IESBLDUP.
2. Migrate **user** definitions stored in DFHSNT using IESBLDUP.
3. Migrate **transaction** definitions active in a CICS/VSE 2.3 system using CICS/VSE Security Migration Aid (stage 1) and skeleton SKSECTX2 from ICCF library 59 (stage 2).
4. Migrate **transaction** definitions stored in DFHPCT.A (Macro) using skeleton SKSECTXS from ICCF library 59.
5. Migrate **transaction** definitions stored in a library member containing CICS/VSE DFHCSDUP definitions of format

```
DEFINE TRANSACTION(xxxx) ... TRANSEC(yy) ...
```

 using skeleton SKSECTX3 from ICCF library 59.

Migrate USER Definitions Stored in IESCNTL

Information about this migration can be found in *VSE/ESA 2.4 System Utilities*, SC33-6717, Chapter 5, under "Migration Steps": *Example 1: Migrating to VSE/ESA 2.4/2.5/2.6 from a VSE/SP or Previous VSE/ESA System.*

The utility IESBLDUP is used for this migration. Ensure that the control options are set correctly:

```
* CONTROL STATEMENT FOR MIGRATION FROM A VSE/SP OR VSE/ESA SYSTEM
CF=YES,DTSRSTR=YES,UPDATE=YES
```

Migrate USER Definitions Stored in DFHSNT

Information about this migration can be found in *VSE/ESA 2.4 System Utilities*, SC33-6717, Chapter 5, under "Migration Steps": *Example 2: Migrating to VSE/ESA 2.4/2.5/2.6 from a DOS/VSE System*

The utility IESBLDUP is used for this migration. Ensure that the control options are set correctly:

```
CF=NO,DTSRSTR=YES,SNT=YES,ALT=YES,UPDATE=YES
ADMN=USRA,PROG=USRB,GENL=USRC
```

Migrate Transaction Definitions Active in a CICS/VSE 2.3 System

Stage 1: CICS Security Migration Aid with CICS/VSE 2.3

It is described in CICS/VSE Security Migration Guide - SC33-1406.

Note: Please refer also to APAR PQ50857, without this APAR being installed on CICS/VSE, there might be transactions missing in the security definition.

Note: When migrating to VSE/ESA 2.6, APAR PQ61103 will insure that the migration utility generates a compatible IPF table.

1. Run DFHCSDUP (LIBDEF PRD2.CICSOLDP and corresponding CSD-File) with UPGRADE USING(DFHCU22X) to create RDO-group DFHXSM:

```
* $$ JOB JNM=DFHCSDSM,CLASS=0,DISP=D
// JOB DFHCSDSM UPGRADE DFHCU22X
// LIBDEF *,SEARCH=(PRD2.CONFIG,PRD2.CICSOLDP,PRD2.SCEEBASE,PRD1.BASE)
// DLBL DFHCSD,'CICSO.CSD',0,VSAM, X
//          CAT=VSESPUC
// EXEC DFHCSDUP,SIZE=600K      INIT AND LOAD CICS CSD VSAM FILE
//          UPGRADE USING(DFHCU22X)
/*
/&
* $$ E0J
```

2. Use CEDA INSTALL group or CEDA ADD group to add group DFHXSM to your GRPLIST of CICS/VSE 2.3.
3. Add the DFHFCT entry to your FCT, recompile the FCT, and COLD-Start your CICS/VSE after defining the DFHX SMA dataset:

```
DFHX SMA DFHFCT TYPE=DATASET,DATASET=DFHX SMA,ACCMETH=VSAM, X
          SERVREQ=(UPDATE,ADD,BROWSE,DELETE),LOG=YES,
          RECFORM=(VARIABLE,BLOCKED),STRNO=2
```

Define dataset DFHX SMA as output file for security migration:

```

* $$ JOB JNM=DEFXSMA,CLASS=0,DISP=D,NTFY=YES
// JOB EBER DEFINE FILE
// EXEC IDCAMS,SIZE=AUTO
DEFINE CLUSTER ( -
    NAME (VSE15.DFHXSMA                               ) -
    CYLINDERS(2      2                               ) -
    SHAREOPTIONS (2) -
    RECORDSIZE (19   80   ) -
    VOLUMES (ESA010 ) -
    NOREUSE -
    INDEXED -
    FREESPACE (15 7) -
    KEYS (18 0   ) -
    NOCOMPRESSED -
    TO (99366   ) -
    DATA (NAME (VSE15.DFHXSMA.§D§                      ) -
    CONTROLINTERVALSIZE (4096   )) -
    INDEX (NAME (VSE15.DFHXSMA.§I§                      )) -
    CATALOG (ESCAT10.USER.CATALOG                       )
IF LASTCC NE 0 THEN CANCEL JOB
/*
// OPTION STDLABEL=ADD
// DLBL DFHXSMA,'VSE15.DFHXSMA',,VSAM,                X
    CAT=ESCAT10
/*
// EXEC IESVCLUP,SIZE=AUTO
A VSE15.DFHXSMA                                     DFHXSMA ESCAT10
/*
/&
* $$ E0J

```

4. COLD-start your CICS/VSE 2.3 system after adding a DLBL statement to the CICS-startup job. For example:

```
// DLBL DFHXSMA,'VSE15.DFHXSMA',,VSAM,CAT=ESCAT10
```

5. Use the CESH transaction to migrate all wanted resources. Note that CESH has defined RSCL=YES. If you do not want to define all applicable resources with RSL key values, do the following:

- a. CEDA COPY transaction CESH to a private group
- b. CEDA ALTER transaction CESH in this new group to RSLC=NO
- c. CEDA ADD this new group to GRPLIST
- d. CEDA INSTALL this new group

After entering CESH the following screen comes up:

```

XSM01          CICS/VSE Version 2.3 Security Migration Aid   Applid: A0006CI3

  _ Perform selective Update/Replace for this CICS system
  _ Replace all data for this CICS system
  _ Update all data for this CICS system

  _ Selectively display the contents of DFHX SMA

PF1=Help PF12=Quit ENTER=Continue
    
```

Figure 108. CICS/VSE Security Migration Aid Screen (XSM01)

6. Place an X to 'Perform selective'. The following screen is being displayed:

```

XSM02          CICS/VSE Version 2.3 Security Migration Aid   Applid: A0006CI3

  _ Transient Data      (DCT)      _ Replace
  _ Files               (FCT)      _ Update
  _ Journals            (JCT)
  _ Transactions        (PCT)
  _ Programs            (PPT)
  _ USER Profiles      (IUI/SNT/TCT)
  _ RCF authorized printers (TCT)
  _ Temporary Storage  (TST)

PF1=Help PF4=Main Menu PF12=Quit ENTER=Continue
    
```

Figure 109. CICS/VSE Security Migration Aid Screen (XSM02)

Placing an X in front of Transactions and in front of REPLACE will collect all of the transaction related security information of the running CICS/VSE 2.3 system and store it in DFHX SMA.

Stage 2: Relates to CICS TS 1.1.0/1.1.1 and VSE/ESA Beginning with VSE/ESA 2.4

A REXX procedure is provided in ICCF library 59 that allows to generate DTSECTXN definitions collected during stage 1.

SKSECTX2 uses the output of the CICS Migration Utility (Stage 1) as input.

Copy SKSECTX2 from ICCF library 59 to your own library and modify the following lines at the end of the skeleton according to your installation:

```

// LIBDEF *,SEARCH=(PRD2.CONFIG,PRD1.BASE)
// EXEC REXX=DTSECTX2,PARM='INFILE=VSE15.DFHXSMA           x
                        OUTFILE=PRD2.ANW.DTSECTX2.A'

REGION=
FORMAT=MACRO
CATALOG=ESCAT10
    
```

A description of the parameters required can be found within this REXX procedure.

Two different output formats are possible:

- IPF** is the format usable by the Interactive Interface dialog "Define Transaction Security". The generated member should be specified in the MERGE function of the dialog.
- MACRO** is the format consisting of DTSECTXN-macro definitions. This output must be assembled to create a DTSECTXN.PHASE and activated via "CEMT PERF SECURITY REBUILD".

Be sure that you have closed the DFHXSMA file in the CICS/VSE 2.3 partition before running this REXX procedure.

Migrate Transaction Definitions Stored in DFHPCT.A (Macro)

Copy skeleton SKSECTXS from ICCF library 59 to your own library and modify the following lines at the end of the skeleton according to your installation. An A-book of your current DFHPCT needs to be placed into the named INFILE library (in this sample PRD2.CONFIG).

```
/ LIBDEF *,SEARCH=(PRD2.CONFIG,PRD1.BASE)
// EXEC REXX=DTSECTXS,PARM='INFILE=PRD2.CONFIG.DFHPCTnn.A          x
                        OUTFILE=PRD2.ANW.DTSECTXS.A'

REGION=
FORMAT=MACRO
```

The description of the required parameters can be found within this REXX procedure.

Two different output formats are possible:

- IPF** is the format usable by the Interactive Interface dialog "Define Transaction Security". The output member is to be used with the MERGE function of the dialog.
- MACRO** is the format consisting of DTSECTXN-macro definitions. This output must be assembled to create a DTSECTXN.PHASE and activated via "CEMT PERF SECURITY REBUILD".

Miscellaneous Problems

B-Transient Considerations

B-Transients are a special kind of system phases.

In a system with batch security active (**SEC=YES**), B-transients can be:

- **loaded from protected libraries only**
- **cataloged into protected libraries only**

Libraries that contain B-transients of the VSE/ESA base programs are automatically protected by appropriate entries in the pregenerated access control table DTSECTAB.

For any other B-transients, the user has to define the LIBRARY containing the B-transients as PROTECTED.

In general, resources without an entry in DTSECTAB are NOT protected.

If an access violation occurs and the library was defined as protected, please check whether:

1. The library is in VSAM space or is a BAM library (this is shown by the output of the EXEC LIBR command LD L=libname O=ST).
 - For library in VSAM space an '*' has to be specified as VOLID
DTSECTAB TYPE=LIB,NAME=*.VSE.REP1.LIBRARY.REP1,UACC=CON
 - For libraries managed by BAM, the required 1 to 6 character volume identifier on which the library resides has to be coded in DTSECTAB:
DTSECTAB TYPE=LIB,NAME=888888.P.C.TEST.LIB1,UACC=CON
2. The B-transient phase exists more than once in the system. If that is the case, check if the LIBDEF chain points to a library which is NOT protected.

Array Overflow When Assembling DTSECTXN or DTSECTAB

If the number of entries in DTSECTXN or DTSECTAB is higher than the maximum defined in the macro source, two assembler messages (**ASMA254I**) like this will be shown:

```
4,ARRAY OVERFLOW, MAXIMUM TABLE SOURCE STATEMENTS ALLOWED IS 1001
4,CONTACT SYSTEM ADMINISTRATOR TO UPDATE DTSECTXN MAC SOURCE
```

The sample shows a limit of 1001 entries in the table DTSECTXN. This limit is specified in the macro source of DTSECTXN. At the beginning of the DTSECTXN and DTSECTAB macro sources there is a description of how to change this value.

1. Change all assignments of 1001 to your higher value (**maximum is 32767**).
For example:

```
          GBLC  &C(1001)          **TYPE= TRANSLATED CODE(B,C,..)
          GBLC  &I(1001)          **SUBTYPE=
          GBLC  &L(1001)          **LOGGING OPTIONS
          GBLC  &N(1001)          **NAME=
          GBLC  &S(1001)          **ACCESS CLASSES
          GBLC  &T(1001)          **TYPE=
          ...
&MAX    SETA   1001              **NUMBER OF ARRAY ENTRIES**
```

2. When the following message appears, the ACTR values have to be increased as well.

```
** ASMA013S ACTR counter exceeded - DTSEC
```

Note: There might be more than one ACTR statement to be changed.

CICS-Coexistence Beginning with VSE/ESA 2.4

VSE/ESA beginning with 2.4, allows to run the CICS Transaction Server (CICS TS) together with CICS/VSE 2.3.

Common User List for CICS TS and CICS/VSE

The standard setup of CICS/VSE 2.3 with VSE/ESA beginning with version 2.4 requires a DFHSNT table to let CICS/VSE check the user authority during sign-on (CESN transaction). The administrator has to create an SNT-entry for each user (does not apply for customers using an External Security Manager with CICS/VSE 2.3). The disadvantage with this approach is that users defined in SNT cannot change their password during sign-on. This may lead to the situation that passwords differ between CICS TS and CICS/VSE.

However, there is an acceptable solution for that problem as outlined in the following paragraphs. The CICS/VSE setup can be changed so that the sign-on check is delegated to the "Security Manager" (either BSM or ESM). The Security Manager checks the user's authorization against the security data stored; allows password changes, and even apply "user revoking" to users signing-on to CICS/VSE. The CICS user characteristics, like "transaction security keys" or "timeout" need to be specified in a default SNT-entry which applies for all users not explicitly listed in the SNT table. (The security exit programs support sign-on authorization checking but not resource checking).

Technical Details

Installation: The following steps are required:

1. The programs DFHXSE and DFHXSSCO implement the interface (from CICS/VSE 2.3) to the security manager. These programs are distributed in the CICS TS product library (Default: PRD1.BASE).
 - a. Rename the original CICS/VSE DFHXSE phase and A-book in library PRD2.CICSOLDP.
 - b. Both programs are stored as A-Books (Macro-level only) and have to be assembled with EXEC ASSEMBLY and specific LIBDEF definitions like LIBDEF
*,SEARCH=(PRD2.CICSOLDP,PRD2.GEN1,PRD1.BASE,PRD1.MACLIB...),
TEMP
LIBDEF PHASE,CATALOG=PRD2.CICSOLDP (when using EXEC ASMA90, be sure to use the default order E/A for the E-deck library exit program)
2. Define DFHXSSCO to CICS/VSE via the command:

Shared CSD file

When the CSD file is shared between CICS TS and CICS/VSE, you must issue the CEDA command from the CICS Transaction Server.

"CEDA DEF PROG(DFHXSSCO) GROUP(VSESPO) LANG(ASS) RES(YES) RSL(PUBLIC)"

3. Define a default SNT entry as shown below. The default entry must follow all other entries. Use skeleton DFHSNTCO in ICCF library 59 for defining the entry.

```
* DEFAULT ENTRY FOR ESM CONTROLLED USERS (LAST ENTRY IN SNT)
      DFHSNT TYPE=(ENTRY,DEFAULT),
      OPIDENT=OPR,
      OPPRTY=4,
      SCTYKEY=(4,5,10,24,37,60,61,62,63,64)
```
4. Activate the External Security Manager for CICS/VSE via entry EXTSEC=YES in DFHSIT.

Use skeleton DFHSITCO in ICCF library 59 for defining the entry.
5. Restart CICS/VSE

When the initialization of the CICS/ESM interface during CICS/VSE startup is complete the following message is issued:

```
DFH3532I EXTERNAL SECURITY INTERFACE ACTIVE
```

Interaction: Sign-on to CICS/VSE is performed with the CICS supplied transaction CESN.

```
CICS Signon

DFH3560I TYPE IN YOUR USERID AND OPTIONALLY PASSWORD

      Userid  ==>
      Password ==>
      Language ==>
      New Password ==>
```

Figure 110. CICS/VSE Sign-on Screen (CESN)

Note: The "New Password" line shows up only when the entry EXTSEC=YES is included in DFHSIT. For users who have an explicit SNT entry, input in the "New Password" line has no effect (sign-on is performed without further notice).

Problem Determination

Problems at CICS/VSE startup:

ESM not active (DFHXSE_RC = X'18')

DFH3531I SECURITY INTERFACE ERROR RC=18-REASON CODE

For "REASON CODE" see ESM failure description below.

Problems At User Sign-on:

Invalid Sign-on Attempt (DFHXSE_RC = X'10')

DFH3500I time INVALID SIGNON ATTEMPT

Multiple reasons can cause above message (Message DFH3608I in CICS/VSE listing, all with RETURN CODE X'10'):

- User profile not defined (DFH3608 with REASON CODE X'04')
- Password not authorized (DFH3608 with REASON CODE X'08')
- New password invalid (DFH3608 with REASON CODE X'10')
- User was revoked (DFH3608 with REASON CODE X'1C')

ESM Failure (DFHXSE_RC = X'18')

DFH3522I time SECURITY INTERFACE ERROR (rc). SIGNON IS TERMINATED

An error has been detected in the Security Manager. rc is the return code from the Security Manager. The DFHXSE/DFHXSSCO programs generate rc with the following meaning (notation in hexadecimal):

- 02** DFHXSSCO load failure (check install steps 1,2).
- 0C** DFHXSE request code out of range.
- 10** Working storage GETMAIN failure.
- 20** Security manager not active.

Other Errors (DFHXSE_RC > X'00'): Message on user screen should point to the failure.

Debugging in a CICS Coexistence Environment

In VSE/ESA beginning with version 2.4 , the CICS Transaction Server for VSE/ESA (CICS TS) runs in partition F2 and replaces CICS/VSE of former VSE/ESA releases.

VSE/ESA provides predefined support for the additional installation of CICS/VSE, the VSE/ESA system is then called Coexistence Environment.

For debugging in a CICS Coexistence Environment, you have to distinguish, if the problem comes from CICS TS or from CICS/VSE, then different procedures must be followed.

Storage Dump Management Dialog

In VSE/ESA beginning with version 2.4 the storage dump management dialog processes CICS TS as well as CICS/VSE dumps.

Starting with VSE/ESA 2.5, if the function analyze CICS dump is selected in a coexistence environment, the dialog automatically asks for the CICS version the dump was created with. Then the print job is created accordingly.

Problem in Abend Processing

In case the CICS/VSE is defined with IESCICIN in the startup PLT (default is DFHPLTPO), CICS/VSE will abend when the first abend occurs.

In this case the user should remove IESCICIN from the PCT table (IESCICIN works with CICS TS only).

Skeletons for CICS Dumps

In ICCF library 59 the following skeletons are available.

Task	CICS TS	CICS/VSE
Print auxtrace file	DFHAUXPR	DFHAUXOL
Print transaction ABEND information on dataset A	SKDFHDUP	-
Info Ana print format dump	storage dump management dialog	SKCIDUMP
Info Ana print trace out of dump	SKCIDTRA	-

Jobs for CICS Dumps

The following jobs to handle CICS dumps are available in the POWER reader queue.

Task	CICS TS	CICS/VSE
Print dump dataset A of DBDCCICS	PRTDUMPA	PRTDUCOA
Print dump dataset B of DBDCCICS	PRTDUMPB	PRTDUCOB
Print dump dataset A of CICS2	PRTDUC2A	-
Print dump dataset B of CICS2	PRTDUC2B	-

Transaction Security

If you see the following message, the transaction may not be defined to the basic security manager.

Use the dialog *Define Transaction Security* to add the definition.

```
DFHAC2033 09:41:23 DBDCCICS
    You are not authorized to use transaction XXXX.
    Check that the transaction name is correct.
```

Where Can I Get More Information about Security

The following table provides an overview of the available security documentation.

Figure 111 (Page 1 of 2). Security Documentation

Document	Description
VSE/ESA Planning (SC33-6703) ⁷	It describes VSE/ESA and provides information which helps you plan and setup VSE/ESA. Chapter: VSE/ESA Security Support Provides an overview of the VSE/ESA security support. Chapter: System Authorization Facility (SAF) and its External Security Interface (RACROUTE) This is additional information to write your own security routines.
VSE/ESA Administration (SC33-6705) ⁷	Chapter: Protecting Resources This is the main part of the security documentation. It contains a comprehensive description of the VSE/ESA security support.
VSE/ESA Software Newsletter 3/4Q,1998 (G225-4508-17)	Chapters: VSE/ESA 2.4 Security - Overview / Implementation Details Provides background information and additional technical details.
VSE/ESA Software Newsletter 1/2Q,1999 (G225-4508-18)	Chapter: VSE/ESA 2.4 Security - Miscellaneous Topics Provides background information and additional technical details.

⁷ This book is also available on CD (see VSE Collection SK2T-0060-15)

Figure 111 (Page 2 of 2). Security Documentation

Document	Description
Presentations from the 1999 VM and VSE Technical Conferences	Topic: VSE/ESA 2.4 Security It is a summary of the VSE/ESA 2.4 security changes.
OS/390 Security Server External Security Interface (RACROUTE) Macro Reference (GC28-1922) ⁷	Contains a description of the RACROUTE macro parameters which are required to code a security or a resource manager which issues security checks.
OS/390 Security Server (RACF) Data Areas (SY27-2640) ⁷	This book contains the description of data areas used by the RACROUTE macro. They are required to code a security or a resource manager which issues security checks.
CA-Top Secret for VSE/ESA Documentation ⁷	Starting with VSE/ESA 2.4, IBM distributes the External Security Manager (ESM) ' CA-Top Secret for VSE/ESA, Version 1 Release 3 '. The ESM books are available on the VSE Collection CDs.

Chapter 14. Hints and Tips for "CICS TS for VSE/ESA 1.1.1"

These hints and tips should help you better understanding some new functions in CICS TS for VSE/ESA.

"CICS TS for VSE/ESA 1.1.1" is shipped with VSE/ESA 2.5 and above.

Hints for Implementating CICS TS 1.1.1

As with CICS/VSE 2.3, **all remaining CICS TS tables have to be reassembled** after installation or refreshes. It is strongly recommended to use the tables, provided in ICCF Lib 59 as skeletons for own customization. Never use old tables from a previous CICS TS or CICS/VSE.

New parameters with VSE/ESA 2.5 (e.g. LE/VSE - specifying whether LE/VSE should be initialized or not) and VSE/ESA 2.6 (e.g. ENCRYPTION for SSL support) caused changes in DFHSIT macro.

DFHPPT and DFHPCT can no longer be used, DFHTCT for non-VTAM-Terminals only (e.g. sequential terminals).

Another example is **MXT=999** often used in CICS/VSE systems. If you do not change this value to about 50 (as shipped with VSE/ESA 2.4 and later), CICS TS will preallocate about 2.5 MB 24-bit-storage and 13 MB storage above the line in expectation of so many tasks.

It is also recommended to use the VSELIST as base for GRPLIST and to hold all user GROUPs in a separate LIST. It is now possible to specify up to four LISTS in GRPLIST. VSELIST and up to three user LISTS can be specified in GRPLIST:

```
GRPLIST=(VSELIST,user1st1,user1st2,user1st3),          C
```

That means mixing of system and user definitions in only one list is no longer required.

And do not forget: use EXEC DFHSIP,SIZE=DFHSIP,.....,OS390. ICCF member SKCICS in Lib 59 is a good starter.

ICCF/VSE in VSE/ESA 2.4 and later runs with CICS TS only. This is true for the Interactive Interface too.

CEMT I TASK - New States and Important New Information

Up to CICS/VSE 2.3 there were three states for a task, displayed with CEMT:

- ACT for tasks on active chain
- SUS for tasks on suspended task
- HEL for tasks held by CMXT reached (Class MaX Task)

Now with CICS TS there are the following three states:

- RUN for the task currently running - it's the CEMT task
- DIS for tasks which are dispatchable - ready to run
- SUS for tasks which are in any kind of a wait state

When you type a question mark in front of a listed task you get more information about the reason why e.g. that task is hold in a wait state. This extended display by typing a question mark is available for all CEMT INQUIRE commands. The following displays show an example:

Normal display

```
Tas(0000215) Tra(VSAM) Fac(A001) Sus Ter Pri( 001 )  
Sta(T0) Use(EBER ) Rec(X'B54D3A486B4E3800') Hty(FCIOWAIT)
```

Extended display

```
Task(0000215)  
Tranid(VSAM)  
Facility(A001)  
Runstatus(Suspended)  
Ftype(Term)  
Priority( 001 )  
Purgetype( )  
Startcode(T0)  
Userid(EBER)  
Recunitid(X'E77DC2F5F4C4F3C1')  
Htype(FCIOWAIT)  
Hvalue(FILEA)  
Htime(000000)  
Bridge()  
Identifier()
```

where e.g. Htype is Hold Type.

In the previous example VSAM is waiting for completion of a VSAM I/O for FILEA. Hold time is below 1 second.

There are 155 Hold Types, all described in the 'Problem Determination Guide'. With this information it is now possible to determine the wait reason, wait type and wait time for a task without having a CICS monitor.

CEMT SET PROGRAM(program) PHASEIN

In CICS/VSE 2.3 production systems it was not easy to NEWCOPY an application program, because NEWCOPY could only be done with RESCOUNT zero of this program.

With CICS TS there is a new newcopy command by saying:

```
CEMT SET PROGRAM(program) PHASEIN
```

This program will be fetched into storage independent of its RESCOUNT. All tasks currently using this program will run with the old copy, all new attached task will use the new copy of that program. The old copy will be invalidated after the last task using this copy has been finished.

CEDF Usability Enhanced

With CICS TS the CICS supplied transactions CECI and CEBR can now be invoked from a CEDF session. That's new.

This is done by going from a normal CEDF screen to WORKING STORAGE (PF5) and then pressing PF2 BROWSE TEMP STORAGE or PF5 INVOKE CECI.

CEDX Transaction Allows Debugging of Non-Terminal Tasks

Prior to CICS TS 1.1.1, non-terminal tasks couldn't be debugged with CEDF.

With CICS TS 1.1.1 debugging of such tasks is available with the new CICS supplied transaction CEDX. This is initiated by typing:

```
    CEDX xxxx - xxxx stands for TRANID
```

This includes debugging of tasks started by CICS Web Support (CWS).

Priority Aging Set by PRTYAGE

Beside the possibility of specifying terminal, transaction and operator priority for a task there is a new way of task prioritization: priority aging. If a task is ready to run (seen as DISpatchable) the priority of this task is raised by 1 each time PRTYAGE elapsed.

This new way of changing the priority automatically is useful especially in production systems with transactions consuming a high amount of CPU resources. The initial value of PRTYAGE, delivered with DFHSITSP, is 5000 milliseconds. This value can be changed via CEMT INQ SYSTEM. Just overwrite the value shown right of 'AGING'. There is no general recommendation for this setting, but a value of 500 to 1000 seems to be more appropriate. It has to be tried out in each individual installation.

Loading of Resident Programs

In CICS/VSE it was possible, to load a program during CICS/VSE start up just by specifying system related parameters, e. g. via DFHALT entries for RMODE(24) programs or RES=YES for RMODE(ANY) programs.

This has been changed in CICS TS. Programs are loaded on demand only. To load such programs during CICS TS startup it is recommended to start a PLTPI program which does a

```
    EXEC CICS LOAD PROGRAM(progname) HOLD
```

This could be useful in case of huge programs by avoiding long fetch time on first reference.

Autoinstall-Exit for Programs: DFHPGADX

With CICS TS the exit-program DFHPGADX allows you to customize the definition of program entries to your needs. Candidates for changes of parameters in this exit are e.g. EXECKEY and DATALOCATION, but **never** set the LANGUAGE. CICS will do it for you according to information provided in the command level stub of a program.

Enhancements for TS Queues

There are three new functions in CICS TS 1.1.1:

- Up to now the name of a TS queue specified in QUEUE was restricted to a length of 8 bytes.

Now in addition an up to 16 bytes long name can be specified along with the parameter QNAME.

- CEMT INQ TSQUEUE now shows much more information than before. It is like this:

```
Tsq(APPLNAME          ) Num(00036) Fle(00002304) Aux
    Max(00064) Min(00064) Xts(C1D7D7D3D5C1D4C5)
Tsq(IEOPADDQ         ) Num(00001) Fle(00000064) Mai
    Max(00064) Min(00064) Xts(C9C5D6D7C1C4C4D8)
```

Please note the field 'Tsq' is shown 16 bytes long for QNAME content.

- If a 'b' is entered in column 1 in front of an entry, CEBR is called and shows the content of all records belonging to that queue.

CSD-File LSR Buffer Usage

During initial installation of VSE/ESA 2.5 / 2.6 a CSD-File will be created automatically with a data and index CI size of 4K.

For CEDA functions at least 4 buffers of this size have to be available. If there are less than 4 buffers available some functions like

```
CEDA EXPAND GROUP(*)
```

will fail with CICS abend code 'AFCY'.

VSAM LSR Buffer Hashing - Much Improved Data In Memory

Starting with VSE/ESA 2.5 the new function of 'VSAM LSR Buffer Hashing' is available. This hashing for finding valid VSAM RBAs within an LSR subpool is a big performance enhancement. The CPU consumption for the search is independent of the number of LSR buffers in a subpool. So defining 1.000 or 10.000 (up to 32.768) buffers will introduce Data In Memory to a much higher degree.

This LSR Buffer Hashing does not depend on the CICS version but on VSAM only. Therefore CICS TS will have benefits as well as CICS/VSE 2.3, running in a coexistence environment.

Automated Operation with CICS TS from Batch via CLISTS or REXX

The REPLID for an MSG xx is not fixed but varying based on internal CICS TS structure. This is independent of running in a static or dynamic partition. Therefore automated operation for performing CICS TS commands cannot rely on a fixed REPLID.

The following example shows how to send a command to a CICS TS using the partition Id:

```
msg x1,data='cemt perf shut'
```

The following example shows how to send a command to a CICS TS using the job name of a CICS TS:

```
msg DBDCCICS,data='cemt perf shut'
```

CICS/VSE 2.3 is not prepared to accept such data.

Of course it is possible to use a REXX procedure for getting the correct REPLID.

The following example shows a CEMT I TASK:

```
ADDRESS CONSOLE
'ACTIVATE NAME CONSI PROFILE REXNORC'
'MSG C1'
FC = GETMSG(MSG.,'MSG',,,5)
GETREPLYID(MSG.1) 'CEMT INQ TASK'
'DEACTIVATE CONSI'
EXIT
GETREPLYID:
ARG MESSAGE
POSITION = POS('-',WORD(MESSAGE,1))
IF POSITION > 0
THEN
REPLYID = SUBSTR(WORD(MESSAGE,1),POSITION+1)
ELSE
REPLYID=WORD(MESSAGE,2)
RETURN REPLYID
END
/+
```

This works for CICS/VSE and for CICS TS running in any partition. For details about GetReplyId please refer to the 'VSE/REXX Reference' under 'Routing Messages From and Replies To a Specific Partition'.

Error Messages DFHEV1020S and DFHST0103 During CICS TS Start Up

If XRF is not active for CICS TS the following error message may be displayed at CICS TS startup:

```
DFHEV1020S DFHCXRF Logical Unit SYS020 is either invalid for this
partition or is set to UA or IGN.
```

To avoid this error message just define

```
// ASSGN SYS020,SYSLST
```

If the DMF partition is not active the following error messages will be displayed:

```
DFHST0103 A0006CI1 A DMF error has occurred with return code X'10'
```

Either start up DMF partition or ignore this error message. Ignoring means not to have consistent statistics information for being processed by DFHSTUP for statistics and DFH\$MOLS for monitoring.

GETVIS 24 Usage

Issuing the VSE AR command GETVIS 'xx' shows values for GETVIS 24 and ANY:

GETVIS USAGE	F2-24	F2-ANY		F2-24	F2-ANY
AREA SIZE:	11,260K	51,196K			
USED AREA:	8,696K	37,152K	MAX. EVER USED:	11,260K	39,828K
FREE AREA:	2,564K	14,044K	LARGEST FREE:	2,528K	13,976K

As in the example shown, F2-24 AREA SIZE and F2-24 MAX. EVER USED have the same size. This is due to a test made by CICS TS during startup to check for the size of GETVIS 24 available to it. With this test the high water mark is set to its maximum value.

Therefore MAX. EVER USED is misleading in CICS TS systems. USED AREA is correct, it's the currently used size of GETVIS 24.

With APAR DY45817 (available for VSE/ESA 2.5 and 2.6) there is a circumvention available, the new VSE console command:

```
GETVIS xx,RESET
```

(see "GETVIS" on page 39). This command resets the high water mark to the current allocated (USED) value. If issued directly after CICS TS startup, MAX EVER USED shows the correct value of the running system.

The above GETVIS command can also be issued by a program (e.g. in the PLTPI phase of CICS TS startup).

A sample of such a program is shown below:

```

*****
*      Program to send an AR Command to the VSE console.      *
*      It can be started during PLTPI-phase, with EXEC CICS START or*
*      from a 3270-screen                                     *
*      A. ZAMPINO VERSION 1.0      10.06.2002                ZAM00020
***** ZAM00030
*                                                                 ZAM00040
***** ZAM00050
* * * *      D U M M Y   S E C T I O N S      * * * * ZAM00060
***** ZAM00070
          DFHREGS ,          EQUATE REGISTERS          ZAM00080
***** ZAM00090
DFHEISTG DSECT ,          ZAM00100
TERFCI  DS  X          ZAM00110
          SPACE 3          ZAM00120
SAVEAREA DS  18F          ZAM00130
SAVER13  DS  F          ZAM00140
SAVER1   DS  F          ZAM00150
SAVEREG  DS  F          ZAM00160
CICSTAT  DS  F          ZAM00170
COMRGAD  DS  F          ZAM00180
PARMADR  DS  F          ZAM00190
PARMLNG  DS  H          ZAM00200
LOG      DS  H          ZAM00210
GETLNG   DS  F          ZAM00220
LNG      DS  H          ZAM00230
INAREA   DS  CL72       ZAM00240
OUT      DS  CL72       ZAM00250
INBUF    DS  CL72       ZAM00260
*                                                                 ZAM00270
ARCCICS  RMODE ANY          ZAM00280
ARCCICS  AMODE 31          ZAM00290
          DFHEJECT          ZAM00300
ARCCICS  DFHEIENT CODEREG=(R4),          INITIALISATION XZAM00310
          DATAREG=(R6),          XZAM00320
          EIBREG=(R11)          ZAM00330
          B      START          ZAM00340
*                                                                 ZAM00350
START    EQU  *          ZAM00360
***** ZAM00370
          SPACE 2          ZAM00380
***** ZAM00390
* *      THIS PROGRAM ALLOWS TO ISSUE AR COMMANDS FROM A CICS * * ZAM00400
* *      TERMINAL. FOR SECURITY REASONS, ONLY COMMANDS STARTING * * ZAM00410
* *      WITH 'D' 'Q' OR 'G' ARE ALLOWED * * ZAM00420
* *                                                                 * * ZAM00430
* *      DEFINING THIS PROGRAM IN PLTPI: * * ZAM00440
* *      COMMAND "GETVIS XX,RESET" WILL BE ISSUED >correction< * * ZAM00450
* *                                     (XX = CICS-PARTITION) * * ZAM00460
* *      WITH RESET EFFECTIVE USED HIGH WATER MARK >correction< * * ZAM00470
* *      SET INSTEAD OF MAX PARTITION 24-BIT AREA * * ZAM00480
* *                                                                 * * ZAM00490
* *      DEFINING THIS PROGRAM IN PLTSD: * * ZAM00500
* *      COMMAND "GETVIS XX"          WILL BE ISSUED * * ZAM00510
* *                                                                 * * ZAM00520
* *      REQUIRED DEFINITIONS: * * ZAM00530

```

```

* * * * * ZAM00540
* * TRANSID : 'ARCM' * * ZAM00550
* * PROGRAM : 'ARCCICS' DATALOCATION 'ANY' * * ZAM00560
* * DON'T FORGET TO ADD ARCM IN SEC-TABLE OF CICS (SECMAC) * * ZAM00570
* * * * * ZAM00580
***** ZAM00590
***** ZAM00600
* * * * * ZAM00610
***** ZAM00620
* EXEC CICS HANDLE CONDITION ERROR (ERROR) ZAM00630
* * * * * ZAM00640
* IN CASE OF ANY ERROR LEAVE PROGRAM QUICKLY ZAM00650
* * * * * ZAM00660
* USING COMREG,R1 MAKE ADDRESSABILITY FOR COMREG ZAM00680
COMRG REG=(R1) GET COMREG ADDR FOR PID ZAM00690
ST R1,COMRGAD ZAM00700
* * * * * ZAM00710
* L R1,COMRGAD ZAM00720
* * * * * ZAM00730
* GETFLD FIELD=LOGID,PART=PID GET LOGID FOR CICS PARTITION ZAM00740
* * * * * ZAM00750
* LTR R15,R15 GETFLD ERROR ZAM00760
BNZ RET1 YES, RETURN ZAM00770
* * * * * ZAM00780
* STCM R1,B'0011',LOG SAVE LOGID OF CICS PARTITION ZAM00790
* * * * * ZAM00800
* MVI INBUF,C' ' BLANC OUT INBUF ZAM00810
MVC INBUF+1(L'INBUF-1),INBUF ZAM00820
* * * * * ZAM00830
* EXEC CICS INQUIRE SYSTEM, *ZAM00840
CICSSTATUS(CICSTAT) ZAM00850
* * * * * ZAM00860
* CHECK CURRENT CICS STATUTS ZAM00870
* * * * * ZAM00880
* CLC CICSTAT,DFHVALUE(ACTIVE) IS CICS ACTIVE RUNNING ? ZAM00890
* * * * * ZAM00900
* BE CHKTRNID YES, CHECK TRAN ID ZAM00910
* * * * * ZAM00920
* CLC CICSTAT,DFHVALUE(STARTUP) IS CICS IN PLTPI PHASE ? ZAM00930
* * * * * ZAM00940
* BE PLTPI YES, .. ZAM00950
* * * * * ZAM00960
* CLC CICSTAT,DFHVALUE(FIRSTQUIESCE) IS CICS IN PLTSD STAT 1 ? ZAM00970
* * * * * ZAM00980
* BE PLTSD YES, .. ZAM00990
* * * * * ZAM01000
* CLC CICSTAT,DFHVALUE(FINALQUIESCE) IS CICS IN PLTSD STAT 2 ? ZAM01010
* BE PLTSD YES, .. ZAM01020
* * * * * ZAM01030
* B RET1 SHOULD NOT OCCUR ZAM01040
* * * * * ZAM01050
* PLTPI DS 0H ZAM01060
MVC INBUF(L'INBUFPI),INBUFPI MOVE GETV CMND>correction< ZAM01070
LA R5,L'INBUFPI LOAD LENGTH OF CONSTANT ZAM01080
STH R5,PARMLNG SAVE LENGTH ZAM01090

```

	MVC	INBUF+7(2),LOG	MOVE PARTID OF CICS	ZAM01100
	B	EXECUTE	BRANCH	ZAM01110
*				ZAM01120
PLTSD	DS	0H		ZAM01130
	MVC	INBUF(L'INBUFSD),INBUFSD	MOVE 'GETVIS LL'	ZAM01140
	LA	R5,L'INBUFSD	LOAD LENGTH OF CONSTANT	ZAM01150
	STH	R5,PARMLNG	SAVE LENGTH	ZAM01160
	MVC	INBUF+7(2),LOG	MOVE PARTID OF CICS	ZAM01170
	B	EXECUTE	BRANCH	ZAM01180
*				ZAM01190
CHKTRNID	DS	0H		ZAM01200
*				ZAM01210
	EXEC	CICS ASSIGN	FCI (TERFCI)	ZAM01220
*				ZAM01230
	CLI	TERFCI,X'01'	IS TRANSACTION FROM A TERMINAL INIT	ZAM01240
	BNE	RET1	NO, RETURN	ZAM01250
*				ZAM01260
	CLC	EIBTRNID,=CL4'ARCM'	TEST IF TRANSACTION CODE ARCM	ZAM01270
	BNE	RETURN	NO, RETURN	ZAM01280
*				ZAM01290
	LA	R5,72	LOAD 72 BYTES MAX INPUT LENGTH	ZAM01300
	STH	R5,LNG	SAVE IT	ZAM01310
*				ZAM01320
	EXEC	CICS RECEIVE INTO(INAREA)	LENGTH(LNG)	ZAM01330
*				ZAM01340
*	LH	R5,LNG	LOAD CURRENT INPUT LENGTH	ZAM01350
*				ZAM01360
	LH	R5,EIBCPOSN	LOAD CURRENT CURSOR POSITION	ZAM01370
	CH	R5,=H'72'	TO AVOID A TOO LONG CURS POSIT	ZAM01380
	BH	ERROR1	INPUT AREA IS MAX 72 BYTES LONG	ZAM01390
	SH	R5,=H'4'	SUBSTR TRANID FROM INPUT	ZAM01400
	LTR	R5,R5	NO INPUT GIVEN	ZAM01410
	BZ	ERROR1	INPUT ERROR	ZAM01420
	BCTR	R5,0	SUBSTR 1 FOR EXECUTE	ZAM01430
	EX	R5,MVC1	MOVE INPUT TO INBUF	ZAM01440
	LA	R5,1(,R5)	RECALCULATE COMMAND LENGTH	ZAM01450
	STH	R5,PARMLNG	SAVE IT	ZAM01460
	CLI	INBUF,C'D'	TEST IF COMMAND STARTS WITH 'D	ZAM01470
	BE	EXECUTE	YES, ..	ZAM01480
	CLI	INBUF,C'M'	TEST IF COMMAND STARTS WITH 'M	ZAM01490
	BE	EXECUTE	YES, ..	ZAM01500
	CLI	INBUF,C'G'	TEST IF COMMAND STARTS WITH 'G	ZAM01510
	BE	EXECUTE	YES, ..	ZAM01520
	CLI	INBUF,C' '	TEST IF BLANC AFTRER TRANS ID	ZAM01530
	BE	ERROR1	YES, .. INPUT ERROR	ZAM01540
	B	ERROR2	ANY OTHER INPUT IS NOT ALLOWED	ZAM01550
*				ZAM01560
EXECUTE	DS	0H		ZAM01570
*				ZAM01580
	LA	R2,L'PARMLIST+L'PARMAD+2	GET PARM LENGTH FOR SVC 30	ZAM01590
	ST	R2,GETLNG	SAVE IT	ZAM01600
*				ZAM01610
	EXEC	CICS GETMAIN SET(R5)	FLENGTH(GETLNG)	ZAM01620
*				ZAM01630
	ST	R5,PARMADR	SAVE ADDR OF GETMAIN	ZAM01640
	ST	R13,SAVER13	SAVE REG 13	ZAM01650

```

          STM  R14,R12,SAVEAREA  SAVE ALL OTHER REGS          ZAM01660
*
          L    R5,PARMADR        RELOAD PARM ADDR          ZAM01670
          LH   R1,PARMLNG        LOAD LENGTH OF PARM        ZAM01680
          STH  R1,2(R5)          STORE LENGTH AT OFFSET 2    ZAM01690
          LA   R1,INBUF          LOAD ADDR OF COMMAND        ZAM01700
          ST   R1,4(R5)          STORE AT OFFSET 4           ZAM01710
          LA   R2,2              LOAD 2 FOR BCT LOOP         ZAM01720
REPEAT   DS   0H                ZAM01730
          L    R1,PARMADR        RELOAD PARM ADDR OF COMMAND ZAM01740
          LA   R1,2(,R1)        POINT TO LENGTH FIELD        ZAM01750
          XR   R0,R0            CLEAR R0                     ZAM01760
*
*                                     FFLAAAAA             ZAM01770
*                                     ZAM01780
*                                     ZAM01790
*      FF :  FILLER (FOR ALIGNMENT OF COMMAND ADDRESS)    ZAM01800
*      LL :  LENGTH OF AR COMMAND                          ZAM01810
*      AAAA : ADDRESS OF COMMAND                           ZAM01820
*
*      SVC  30              ISSUE AR COMMAND                ZAM01830
*
*      CH   R15,=H'4'       TEST AR RETURN CODE            ZAM01840
*      BL   OKAY            LOWER 4                         ZAM01850
*
*      EXEC CICS DELAY INTERVAL (000001)                   ZAM01860
*
*      BCT  R2,REPEAT       LOOP TWICE                      ZAM01870
*
*      LM   R14,R12,SAVEAREA RELOAD SAVED REGISTERS        ZAM01880
*      LA   R13,SAVER13    RELOAD REG 13                   ZAM01890
*
*      EXEC CICS ASSIGN FCI (TERFCI)                       ZAM01900
*
*      CLI  TERFCI,X'01'   IS TRANSACTION FROM A TERMINAL INIT ZAM01910
*      BNE  RET1           NO, BYPASS COMMAND                ZAM01920
*
*      MVI  OUT,C' '      BLANC OUT OUTPUT AREA             ZAM01930
*      MVC  OUT+1(L'OUT-1),OUT ZAM01940
*      MVC  OUT,MSG2      MOVE MESSAGE                      ZAM01950
*      B    SENDMSG       BRANCH SEND MESSAGE               ZAM01960
*
*      ERROR1 DS  0H      ZAM01970
*      MVI  OUT,C' '      BLANC OUT OUTPUT AREA             ZAM01980
*      MVC  OUT+1(L'OUT-1),OUT ZAM01990
*      MVC  OUT,MSG3      MOVE MESSAGE                      ZAM02000
*      B    SENDMSG       BRANCH SEND MESSAGE               ZAM02010
*
*      ERROR2 DS  0H      ZAM02020
*      MVI  OUT,C' '      BLANC OUT OUTPUT AREA             ZAM02030
*      MVC  OUT+1(L'OUT-1),OUT ZAM02040
*      MVC  OUT,MSG4      MOVE MESSAGE                      ZAM02050
*      B    SENDMSG       BRANCH SEND MESSAGE               ZAM02060
*
*      ERROR DS  0H      ZAM02070
*      B    RET1          ZAM02080
*
*      ZAM02090
*      ZAM02100
*      ZAM02110
*      ZAM02120
*      ZAM02130
*      ZAM02140
*      ZAM02150
*      ZAM02160
*      ZAM02170
*      ZAM02180
*      ZAM02190
*      ZAM02200

```

```

OKAY   DS    0H                      SVC 30 OK                      ZAM02210
        LM   R14,R12,SAVEAREA        RELOAD SAVED REGISTERS      ZAM02220
        LA   R13,SAVER13             RELOAD REG 13                ZAM02230
*
        EXEC CICS ASSIGN FCI (TERFCI)                      ZAM02240
*
        CLI  TERFCI,X'01'            IS TRANSACTION FROM A TERMINAL INIT ZAM02270
        BNE  RET1                    NO, BYPASS COMMAND      ZAM02280
*
        MVI  OUT,C' '                BLANC OUT OUTPUT AREA      ZAM02300
        MVC  OUT+1(L'OUT-1),OUT      ZAM02310
        MVC  OUT,MSG1                MOVE MESSAGE            ZAM02320
        B    SENDMSG                 BRANCH SEND MESSAGE     ZAM02330
*
SENDMSG DS    0H                      ZAM02340
*
        EXEC CICS SEND FROM (OUT) LENGTH(72) ERASE CTLCHAR('C') ZAM02350
*
        B    RETURN                  ZAM02360
*
        B    RETURN                  ZAM02370
*
        B    RETURN                  ZAM02380
*
        B    RETURN                  ZAM02390
*
        B    RETURN                  ZAM02400
*****
* * *                               H E A D E R S           * * *
*****
RETURN  DS    0H                      ZAM02410
*
        EXEC CICS SEND CONTROL FREEKB                      ZAM02420
*
        EXEC CICS SEND CONTROL FREEKB                      ZAM02430
*
RET1    DS    0H                      ZAM02440
*
        EXEC CICS SEND CONTROL FREEKB                      ZAM02450
*
        EXEC CICS SEND CONTROL FREEKB                      ZAM02460
*
        EXEC CICS SEND CONTROL FREEKB                      ZAM02470
*
RET1    DS    0H                      ZAM02480
*
        EXEC CICS RETURN ,                      ZAM02490
*
        EXEC CICS RETURN ,                      ZAM02500
*
MVC1    MVC   INBUF(0),INAREA+4          ZAM02510
*
        MVC   INBUF(0),INAREA+4          ZAM02520
*
        DS    0F                          ZAM02530
*
        DS    0F                          ZAM02540
PARMLIST DS   H                          ZAM02550
PARMAD   DS   AL4                        ZAM02560
INBUFPI  DC   CL19'GETVIS LL,RESET      ' >correction< ZAM02570
INBUFS   DC   CL9'GETVIS LL'           ZAM02580
MSG1     DC   CL72'CONSOLE COMMAND SUCCESSFULLY COMPLETED' ZAM02590
MSG2     DC   CL72'CONSOLE COMMAND COULD NOT BE EXECUTED' ZAM02600
MSG3     DC   CL72'INPUT INVALID TRY AGAIN' ZAM02610
MSG4     DC   CL72'COMMAND NOT ALLOWED' ZAM02620
TRANID   DC   CL4'ARCM'                 ZAM02630
COMREG   MAPCOMR                       ZAM02640
        END  ARCCICS                          ZAM02650

```

Behavior of CICS TS in Case of an SOS Condition

There are new mechanisms to prevent CICS TS from going Short On Storage.

In case of SOS, CICS TS reduces the priority of newly attached tasks, to allow running tasks to finish faster. Beside of that, CICS TS will try to compress storage when reaching internally defined high water marks.

If a real stall condition occurs, the purging mechanism has changed compared to CICS/VSE:

There are two transaction parameters which control the possibility to purge tasks:

SPURGE(YES) now means SystemPURGEable - allow any kind of PURGE

DTIMOUT(mmss) defines the elapsed time after which PURGE can happen

In case of SOS only tasks defined with **both** transaction parameters are eligible for being purged.

The former DFHSIT parameter ICVS has disappeared.

Automated Start of DB2

It's an often used procedure to start up DB2 automatically during CICS start up by inserting the CIRB command into SYSIPT and by defining a sequential terminal in the DFHTCT:

```

DC    CL32'INPUT AND OUTPUT DTFS'
DFHTCT TYPE=SDSCI,
      DEVADDR=SYSRDR,
      DEVICE=2540,
      DSCNAME=READER
DFHTCT TYPE=SDSCI,
      DEVADDR=SYSLST,
      DEVICE=1403,
      DSCNAME=PRINTER
DC    CL32'S A M A  LINE AND TERMINAL ENTRY'
DFHTCT TYPE=LINE,
      ACCMETH=SEQUENTIAL,
      TRMTYPE=CRLP,
      ISADSCN=READER,
      OSADSCN=PRINTER,
      INAREAL=88
DFHTCT TYPE=TERMINAL,
      TRMIDNT=SAMA,
      TRMPRTY=32,
      TRMSTAT=(TRANSCIVE)

```

Up to CICS /VSE 2.3 the sequence was:

```

// EXEC DFHSIP,SIZE=10744K,PARM='SIT=03,MSGLVL=1,MCT=03,LESTG=1000,
      START=AUTO',DSPACE=2M
CIRB PASSWORD,8,XXX03,1,GER,PRODDBI
/*

```

With CICS TS this has been changed. An additional /*-line has to be inserted prior to user specified transactions, e.g. CIRB:

```

// EXEC DFHSIP,SIZE=DFHSIP,PARM='SIT=C3,START=COLD,SEC=NO,STATRCD=OFF,S*
      VA=NO,NEWSIT=YES,DSALIM=8M,EDSALIM=30M,SI ',DSPACE=2M,OS3*
      90
/*      <----- this line has to be inserted
CIRB PASSWORD,8,XXX03,1,GER,PRODDBI
/*

```

If this /* is not inserted, no error message will be sent to the console. The SYSIPT data for CIRB or other user transactions will be ignored completely.

Translating and Compiling EXCI-programs

A CICS TS controlled batch to CICS TS communication was introduced via the EXCI function. For translating and compiling such batch programs containing EXEC CICS commands, the normal translator/compile jobs for CICS programs available in ICCF library 2 can be used with minor changes. These changes are:

- Change translator option CICS to EXCI.
- Delete the INCLUDE DFHEAI or DFHELII statement after PHASE-card for Assembler, PL/I and C.
Change INCLUDE DFHELII to INCLUDE DFHXCSTB for COBOL.
- Insert an INCLUDE DFHXCSTB before EXEC LNKEDT-card for Assembler, PL/I and C.
Insert an ENTRY 'entryname of program' for COBOL before the EXEC LNKEDT-card.

Translating Programs Containing System Programming Commands

The new translator option 'SP' must be specified for application programs that contain special (System Programming) CICS commands or they will be rejected at translate time. These commands are ACQUIRE, COLLECT, DISABLE, DISCARD, ENABLE, EXTRACT, INQUIRE, PERFORM, RESYNC and SET.

Sample Application Programs

Information about CICS supplied sample application programs is now collected in the new manual 'Sample Application Guide', SC33-1713.

In short, sample program names start with

```
DFH$A for Assembler,
DFH0C for COBOL,
DFH$D for C,
DFH$P for PL/I.
```

These programs are available as source in library PRD1.BASE.

Hints about Statistics

DFH0STAT - Statistics Program for Test Purposes

DFH0STAT.C and the related map DFH0STM.A can be found in PRD1.BASE. First process DFH0STM as map and after that DFH0STAT as COBOL program. Prerequisite for compiling DFH0STAT is the COBOL FOR VSE/ESA compiler. To have DFH0STAT available to customers not having this compiler, there are two PTFs supplying skeleton DFH0STAT in library 59 as link job:

```
PQ57472 for VSE/ESA 2.5
PQ55920 for VSE/ESA 2.6
```

This program collects all statistics information with EXEC CICS commands:

```
EXEC CICS COLLECT STATISTICS
```

and writes it via EXEC CICS SPOOLWRITE to VSE/POWER List Queue (name is that of the CICS-Startup-Job).

If DFH0STAT should run in PLTSD phase the definition of the two LINKed programs DFH\$STAS and DFH\$STCN has to be changed from EXECCKEY(USER) to EXECCKEY(CICS). This is normal procedure for LINKed programs in PLTSD and PLTPI phase.

DFH0STAT can stay with EXECCKEY(USER). For consistency reasons it is recommended to change it also to EXECCKEY(CICS).

Its usage is best for test purposes.

It should not be used for a production CICS because, for example:

- there are no statistics information available for previously closed datasets, for autoinstall terminals, which made a logoff etc.
- all statistics counters are reset at statistics interval occurrence and at midnight or with a CEMT PERFORM STATISTICS ALL RESETNOW . It is possible to change the statistics interval with CEMT SET STATISTICS INTERVAL(230000) to avoid the reset of counters during the day. This can also be accomplished by a program with EXEC CICS SET STAT....

DFHSTUP - Statistics Program for Production Purposes

Statistics data collected with DMF are correct in any case. Therefore production statistics should be printed with DFHSTUP only. To limit the statistics output, use parameter SUMMARY in normal cases. A skeleton for such a print job (SKDMFPR) is in ICCF Library 59. To start DMF in a VSE partition use skeleton SKDMFST in Lib 59.

Statistics Information Taken from a System Dump

You can select some statistics information from a CICS driven system dump. This is accomplished by the INFOANA program.

The following example can be used as a skeleton for own customization. It was generated with Interactive Interface 'STORAGE DUMP MANAGEMENT' (option 4.3) and 'ANALYZE CICS DUMP' (option 9).

Please refer to 'CICS TS Problem Determination Guide' for a detailed description of the level (0,1,2 or 3), that can be specified for each Domain.

To get SUMMARY information, use dump level 1, but not all Domains allow this summary level. To suppress information use dump level 0. Dump level 2 means detailed information, dump level 3 means SUMMARY and DETAIL.

E.g. PG=1 will produce statistical information collected by the Program Domain.

```
// EXEC INFOANA,SIZE=INFOANA,OS390
SELECT DUMP MANAGEMENT
  DUMP NAME SYSDUMP.F5.DF500006
  RETURN
SELECT DUMP VIEWING
  CALL DFHPD410 DATA KE=0,DS=0,TR=0,LD=0, -
  DATA AI=0,CC=0,CP=0,CSA=0,DD=0,DM=0, -
  DATA DU=0,FCP=0,ICP=0,IND=0,JCP=0, -
  DATA LM=0,ME=0,MN=0,MRO=0,PA=0, -
  DATA PCT=0,PG=1,PR=0,RM=0,SM=1,SSA=0, -
  DATA ST=0,SZ=0,TCP=0,TDP=0,TI=0,TMP=0, -
  DATA TSP=1,UEH=0,US=0,XM=0, -
  DATA XRF=0,XS=0
  RETURN
  DUMP NAME SYSDUMP.F5.DF500006
SELECT DUMP VIEWING
  PRINT FORMAT
  RETURN
SELECT END
/*
```

Some Hints about Tracing

The Trace Domain in CICS TS is completely new. From a debugging point of view the new auxiliary trace is much better than the old one. Some examples for this:

- Exception conditions (abends etc.) are marked with an '*EXC*'. So it is a good practice to search for '*EXC*'.
- If a program is translated with the translator option DEBUG, the EI trace level 2 trace shows the line number of the source program. Of course this DEBUG option should be used during test state only - due to DEBUG the program becomes larger in size and needs more CPU power. EI trace level 2 can be set via CETR and PF4 - 'components'.
- Normal trace level 1 does not show the resource name for an EXEC CICS command. To see the resource name, use EI trace level 2. Now the resource name and even some data are shown. Example:

```
ENTRY READ          'FILEA ' .....
ENTRY READ_INT0    02122120 , .....
EXIT READ_INT0/OK  50,50,00000000,,LENGTH_OK
EXIT READ          'FILEA ' AT X'0063B1C8',' 000100W. DAVIS'
```

FILEA is the file name and '000100W. DAVIS' is the record content.

- The VSE shipped size of the Trace Table is 80K. For production systems a size of **768K** may be more appropriate. Even for test systems the default value may be insufficient.

New Dump Tables and Dump Hints

These new tables control whether a dump has to be taken, if a CICS shutdown is necessary and how many dumps for a specific dump code should be written.

You should consider some points:

- In case of an ASRA or ASRB a transaction **and** a system dump is taken by default.
To disable the system dump for ASRA and ASRB, the following two entries have to be applied to the system dump table, either via CEMT or EXEC CICS. Best way is to start a PLTPI program with these two commands:

```
CEMT SET SYDumpcode(AP0001) ADD NOSYSDUMP
CEMT SET SYDumpcode(SR0001) ADD NOSYSDUMP
or
EXEC CICS SET SYSDUMPCODE(AP0001) ADD NOSYSDUMP
EXEC CICS SET SYSDUMPCODE(SR0001) ADD NOSYSDUMP
```

- In case of a storage violation CICS will not shutdown by default. If STGRVCY(NO) is in effect, CICS abends the transaction but does not release the violated storage. If STGRVCY(YES) is set, CICS tries to recover the violated 'check zone' and continues to run the task.

If a shutdown of CICS TS is needed in these cases, the following entries have to be put to the system dump table:

```
CEMT SET SYDumpcode(SM0102) ADD SHUTDOWN
CEMT SET SYDumpcode(SM0103) ADD SHUTDOWN
or
EXEC CICS SET SYSDUMPCODE(SM0102) ADD SHUTDOWN
EXEC CICS SET SYSDUMPCODE(SM0103) ADD SHUTDOWN
```

After a cold start these entries have to be established again.

The small program looks as follows:

```

*ASM XOPTS(CICS SP)
*****
* Program for suppressing SDUMP in case of ASRA and ASRB *
* Optionally you can SHUTDOWN CICS TS in case of Storage Violation *
*****
        PRINT NOGEN
*****
DFHEISTG DSECT
STRTCODE DC      CL2
*****
*          Program start *
*****
SUPPDUMP CSECT
        EXEC CICS HANDLE CONDITION ERROR(ERROR)
        EXEC CICS SET SYSDUMPCODE('AP0001') ADD NOSYSDUMP
        EXEC CICS SET SYSDUMPCODE('SR0001') ADD NOSYSDUMP
*****
*          REMOVE * IN NEXT TWO LINES IF YOU WANT TO SHUTDOWN CICS TS *
*          IN CASE OF STORAGE VIOLATION *
*****
*          EXEC CICS SET SYSDUMPCODE('SM0102') ADD SHUTDOWN
*          EXEC CICS SET SYSDUMPCODE('SM0103') ADD SHUTDOWN
*****
        B          ASSIGN
ERROR    MVC      OUTMSG,ERRMSG
ASSIGN   EXEC CICS ASSIGN STARTCODE(STRTCODE)
        CLC      STRTCODE,TERMSTRT
        BNE     RETURN
        EXEC CICS SEND FROM(OUTMSG) WAIT LENGTH(LEN) CTLCHAR(CTLCHAR) *
        ERASE
RETURN   EXEC CICS RETURN
*****
OUTMSG   DC      CL80'SDUMP suppression activated'
ERRMSG   DC      CL80'SDUMP suppression could not be activated'
LEN      DC      H'80'
CTLCHAR  DC      C'3'
TERMSTRT DC      CL2'TD'
        SPACE 2
        END     SUPPDUMP
/*

```

- By specifying the SIT parameters SYDUMAX=1 and TRDUMAX=1 the limit of number of dumps per system and transaction dump code is set to one. Especially system dumps should be limited in this way. Default is 999.
- Program checks are shown as '0Cx' - CICS TS for VSE/ESA not only behaves like an OS/390 program, it is it.

Does a program check occur in a CICS TS Domain other than the Application Domain, the CICS TS abend code is AKEA: The Kernel Domain is setting the abend exits and returns control to the Domain with the failing instruction. AKEA is set, preceded by 0Cx.

If the program check occurs in the Application Domain that Domain gets control from Kernel Domain and calls DFHSRP which sets the ASRA abend code.

CICS catalogs DFHGCD and DFHLCD

There are two new datasets used by CICS TS for its own purposes:

- DFHGCD is the Global CICS Dataset. It contains information about installed definitions and warm/emergency start information. It is shared with any XRF tracking partition, but CANNOT be shared between normal CICS partitions.

The DFHRSD is only used for backout information during emergency restart.

- DFHLCD is the so called Local CICS Dataset and contains records that describe the status of the Domains and dump options. Each CICS TS partition (normal or XRF) has to have an own DFHLCD.

The Global and Local catalogs should always be defined and initialized together to avoid CICS startup errors.

Defining and initializing the Global and Local catalogs will force a COLD start also, if START=AUTO is used. This cold start is also known as 'ice cold start'.

SVA Usage - Be Very Careful in a Coexistence Environment

There are three types of SVA eligible phases:

- Mandatory CICS TS phases

DFHCSCV Always required - CICS TS SVC
 DFHDSPEX Always required - Dispatcher POST exit
 DFHCSEOT Always required - EOJ cleanup

DFHCDDAN Required for XRF

DFHIRP Required for MRO (IRC program)
 DFHIRW10 Required for MRO (work exit)
 DFHSCTE Required for MRO (SCTE control block)

DFHDT SVC Required for Data Tables (SVC)
 DFHDT SAN Required for Data Tables (Anchor control block)

A failure to load these phases into the SVA by SET SDL will cause CICS TS initialization failures.

- LIST=\$SVACICS from PRD1.BASE must be used.
- LIST=\$SVACICS from PRD2.CICSOLDO must NOT be used, CICS TS startup will fail.

- Non-Mandatory CICS TS phases

Loading of these phases is done by SET SDL also.

Usage of SVA resident phases is controlled by SIT-parameter SVA. Since VSE/ESA 2.6 the DFHSITSP in lib 59 specifies SVA=YES and contains in the CICS-startup skeleton SKCICS the PRVMOD member

```
$$$$ SLI MEM=DFH$SVEX.J,S=PRD1.BASE
```

as overwrite statement. This overwrite prevents CICS TS from using SVA phases in case of a coexistence environment.

If SVA=YES is specified but a requested SVA-phase is not loaded into SVA, it will be loaded into CICS TS (E)DSAs and message DFHLDDL1 or DFHLDDMI

is issued. Specify SVA=YES and startup CICS. The DFH-messages tell you which phases should be really loaded into the SVA.

- Non-Mandatory Non-CICS TS phases (e.g. LE-phases)

To use such SVA resident phases specify SIT parameter SVA=YES plus USESVACOPY(YES) in each RDO program entry.

Be aware of the following: program products may supply RDO definitions with USESVACOPY(NO) as default.

CICS will load a private copy of the phase even if it exists in the SVA. Update the eligible RDO program definitions.

Starting with VSE/ESA 2.6 some LE/VSE phases will be loaded into SVA as default. If not needed, please adapt the SVA load list.

In case of running CICS/VSE 2.3 on the same VSE/ESA stay with SVA=NO.

Console Security and II-Console Full Function Usage

- Default security of CNSL is CICSUSER. To have special security for CNSL, it is recommended to define a special user (e.g. named CNSL) to BSM or ESM with its own security settings and to alter CNSL terminal definition to USERID=CNSL. With this CNSL gets the security settings of user CNSL.
- If Interactive Interface users need to have full console support (e.g. use of CEMT-Commands for CICS TS partitions) they have to have a dedicated console definition. Actions needed:

Copy CNSL Terminal definition in RDO-Group VSESPG to an own group with COPY TO(IIKONS) AS(user). 'user' is the II userid.

This new TERMINAL(user) needs to be modified with:

```
NETNAME(user),CONSNAME(user).
```

After installing this new definition all console functions are available to this user.

There is a skeleton (SKCONSII) in Library 59 to define these RDO resources with DFHCSDUP.

Assembly of CICS/VSE 2.3 Programs Beginning with VSE/ESA 2.5

Some CICS provided macros are E-books with CICS/VSE 2.3 but A-books with CICS TS, e.g. DFHC SAD. To avoid assembly errors for CICS/VSE 2.3 programs, use the following ASMA90 statement with ORDER=EA:

```
// EXEC ASMA90,PARM='EXIT(LIBEXIT(EDECKXIT(ORDER=EA)))',SIZE=.....
```

Information about LE/VSE 1.4.1

There are very useful information in the Release Guide of LE/ESA 1.4.1, SC33-6779, covering CICS TS related items.

- Recommended CICS-Wide Run-Time Options

A setting of value n x 4096 minus 16 bytes instead of n times 4096 bytes for the second LE Run-Time Options such as ANYHEAP, HEAP and STACK, addressing can provide the following benefit:

Size n times 4096 minus 16 bytes gives additional space required by the CICS/VSE storage accounting areas (SAAs) to fit into one page frame of 4K. The same applies for CICS TS (where the corresponding areas to SAA are termed "crumbled zones"). The SAAs and crumbled zones are used to detect storage violations.

This minimizes the storage fragmentation. The general rule is 4k or a multiple of 4K minus 16 bytes.

- Activating Changed CICS-Wide Run-Time Options

By executing the new transid **NEWC** you can update new cataloged LE/VSE runtime options for CICS. This is done while the CICS system is still processing online transactions.

This transaction is available with CICS TS and CICS/VSE 2.3.

- Printing CICS-Wide Run-Time Options to Console

This function allows you to print LE/VSE CICS-wide run-time options to your VSE/ESA console.

Since VSE/ESA 2.5 and LE/VSE 1.4.1 the LE/VSE program EDCYCROP with the CICS transid already set to **ROPC** is shipped.

This transaction is available with CICS TS and CICS/VSE 2.3.

- Ensuring CICS Coexistence is Set Up Correctly

If you are running CICS/VSE and upgrade your system to VSE/ESA 2.5, you should adjust and execute skeleton SKLE370 (ICCF lib 59).

If you do not do so, you will receive LE/VSE initialization errors under CICS/VSE (such as the abend 4093 RC 36).

CICS Applications Using TCP/IP Connections

If a CICS application uses any TCP/IP connection you must add the statement:

```
// OPTION SYSPARM='nn'
```

to the JCL for these jobs. The value 'nn' (the system ID) is contained in the:

```
// EXEC IPNET,SIZE=IPNET,PARM='ID=nn,INIT=... '
```

statement of your TCP/IP startup job.

Note: The value of '00' is the default for the system ID. If you accept this default, you are not required to add the statement

```
// OPTION SYSPARM='00'.
```

Examples for such applications are:

- CICS Web Support
- CICS Transaction Gateway over TCP/IP
- MQSeries for VSE/ESA over TCP/IP
- CICS programs using socket interface

Hints about CICS Web Support (CWS)

A redbook available about this new function: *CICS Transaction Server for VSE/ESA - CICS Web Support*, SG24-5997. It contains information about implementation guidance for CWS, including 3270 Bridge functions and CWS examples.

As many experiences have shown, it's a good practice to use this redbook for first implementation and to follow step by step through that manual.

The following hints refer to the chapter numbers of the redbook and supplement or correct information found there.

- Chap.1.3.3 - Limitations of CICS Web Support SSL is now available for CWS.

Starting with VSE/ESA 2.6, Secure Socket Layer Support (SSL) was introduced in TCP/IP for VSE/ESA 1.4. This support is used, among other TCP/IP-applications, by CWS also. Up to VSE/ESA 2.6, CWS was recommended for Intranet mainly. For Internet an external SSL support was needed. Starting with VSE/ESA 2.6 SSL is an integral part of CWS. Introduction to and implementation of SSL can be found in *CICS TS for VSE/ESA 1.1.1 Enhancements Guide*, GC34-5763-02.

- Chap.2.3 - 3270 bridge solution

To generate the HTML-TEMPLATE (TYPE=TEMPLATE) you can use the skeleton for map generation, supplied in ICCF library 02 as C\$\$xxMAP. Answer '1' for 'TEMPLATE' and HTML code will be generated. This function is available with VSE/ESA 2.6.

- Chap.2.4 - CICS Web Support transactions The transaction CWBM and their associated program has been removed from CSD file, because these definitions are not needed for CWS.

Beside of the internal transaction CSOL there is a new internal transaction CSOX for SSL support.

- Chap.3.1.2 - CICS Transaction Server

RDO definitions

It is important to choose the correct port number for communication between the browser and CWS. The reserved ports for IP can be found under the URL <http://www.iana.org/assignments/port-numbers>

Do not use any port, that is mentioned in this document.

All samples in this redbook refer to port 1080. Please change this because it could be used by a sock application. Use port 1081, 1082 or 1085 to 1154 or any other unreserved port.

This port number should not be the same as for the HTTP daemon.

DFHCNV table

It is very important to have a correctly defined and assembled / cataloged DFHCNV - against the most current version of CICS TS.

Not having this done may cause unpredictable results like hieroglyphic characters shown on the browser or malfunctions of CWS 3270 bridge.

Defining all TRANSIDs to BSM or ESM

In addition to CWXN, CWBA and CSOL the new transid CSOX has to be defined. This should be done automatically by FSU to VSE/ESA 2.6, but please check it.

Virtual storage

A lot of measurements has shown the following values for storage usage by CICS Web Support:

- Initial storage below the 16 MB line: nearly nothing (less than 50 KB).
 - Initial storage above the 16 MB line: about 150 KB.
 - Storage per running CWS transactions:
 - Storage below the 16 MB line: between 8 and 60 KB.
 - Storage above the 16 MB line: between 150 and 250 KB.
 - These values are much lower than the values published in the redbook and are good news.
- Chap.3.1.3 - TCP/IP

Specifying a HTTPD daemon

It is strongly recommended to define at least one HTTPD daemon. Such a daemon is needed e. g. for loading of graphics etc.

If there are several graphics imbedded in the HTML data stream, more HTTPD definitions are recommended for performance reasons.

- Chap.5 - Accessing existing 3270 transactions

There are at least two restrictions of CWS to port existing applications:

- Applications which make use of 3270 controller function to submit cursor position from non-input-fields. This is not available on a browser.
 - Non-BMS-applications with Extended Data Stream. A PTF could be available within 2002.
- Chap.5.3.1 - Creating HTML templates from BMS definitions
- If the source for BMS maps is not available it can be recreated with utility DFHBMSUP. Its use is described in *CICS TS External interfaces Guide*, SC33-1669.
- Chap.5.3.2.1 - DFHMSX and DFHMDX
- In most cases it is advisable to customize DFHMDX with PROPFONT=NO. Default is =YES, what means, that consecutive blanks are compressed to one blank. With =NO this compression will not occur.

Hints for CICS Transaction Gateway with TCP/IP Connection

In addition to LU 6.2 connection, with VSE/ESA 2.6 connection via TCP/IP is available. Please notice, that there is a new transaction CIEP needed for this support. So this transaction has to be known to the External Security Manager (BSM or others).

Where to Find Corrective Service for CICS TS

An often raised question is: where can I find preventive and corrective service for CICS TS in the Internet ? The answer is to go to the URL shown below:

<http://techsupport.services.ibm.com/server/390.CAPARdb>

and type in an error message or indication or the product number of CICS TS to get all related APARs (and PTFs of course): 564805400

Chapter 15. IWS File Transfer

Basic Problem Solving Questions

1. Is the PC configured as CUT (Control Unit Terminal) or DFT (Distributed Function Terminal) ? Transaction INWQ may help to determine if the terminal is CUT or DFT.
2. How is the PC attached to the host (ICA, DPA, 3174, 3274-31A, Telnet-TCP/IP, HTERM)?

If the PC is attached by a DPA only CUT mode is supported.

3. For Telnet, the default terminal logmodes are without extended data stream, thus DFT is not possible. It is recommended to define the Telnet daemon with query-able terminals:

```
LOGMODE3=SP3272QN,LOGMODE4=SP3272QN,LOGMODE5=SP3272QN
```

Or with explicitly defined logmodes with extended data stream set on:

```
DEFINE TEL, ID=MYTEL, TAR=DBDCCICS, TERM=T1000, CO=20, LOGMODE=SP3272EN, -  
LOGMODE3=SP3273EN, LOGMODE4=NSX32704, LOGMODE5=NSX32705
```

Note: For Telnet, each terminal model needs to be defined, for a model 3 type, LOGMODE3 should be specified.

4. What is the model of the PC?
5. What 3270 emulation program is running on the PC ?
6. What release of VSE is running ? LIBRARIAN may be used to list SPLEVEL.PROC in IJSYSRS.SYSLIB.

```
568606601 45C VSE/SP Unique VSE ESA 2.4.X  
568606601 55C VSE/SP Unique VSE ESA 2.5.X  
568606601 65C VSE/SP Unique VSE ESA 2.6.X
```

Figure 112. Current VSE/ESA Releases

VSE file transfer is not called IND\$FILE however it does contain a transaction called IND\$, or in case of DBCS APVU. The VSE file transfer phase is called INWPCCOM. Some user refer to the VSE file transfer function as IWS (Intelligent Workstation Support), or IUI file transfer or CICS file transfer.

7. What messages are received on the PC ?
8. What messages are received upon toggling back to the HOST session ? There may also be messages in the INSPECT MESSAGE LOG dialog.
9. Do both the SEND and RECEIVE fail ?
10. What is the exact SEND or RECEIVE command that was entered including any options ?

```
SEND PC.FIL FILENAME (FILE=HTF ASCII CRLF REPLACE  
RECEIVE PC.FIL (FILE=LST KEEP
```

Figure 113. Send/Receive Examples

An easy way to find out is the so called IWS trace, see below.

11. Where is the send or receive directed to or from ?

File transfer can be performed to or from:

- VSE Host Transfer File (HTF)

This file is a large VSAM file that contains separate entries for each file that a user sends to it. The entries are connected to a directory within the HTF for that user. VSE provides dialogs to move the files from this large HTF to other VSAM files or ICCF members.

- CICS Temporary Storage

A CICS application can then manipulate the TS queue.

- VSE/POWER queues

- A file can be sent or received from the POWER LIST queue (output from HOST jobs).
- A file containing a VSE job can be sent to the POWER RDR queue.
- A file can be received from the POWER PUNCH queue.

- VSE library

- For CICS TS on VSE/ESA 2.4.0 and later, file transfer is possible only on CICS TS, not on coexisting CICS/VSE.

Documentation Needed to Pursue Failures

One of the following traces will be required to determine if the error is being caused by the VSE software or the 3270 emulator software. For abends in VSE code a CICS AUX trace may also be required.

1. IWS TRACE:

This is available as an option on the SEND/RECEIVE command. It is documented in the VSE Guide For Solving Problems.

2. VTAM BUFFER TRACE:

The VTAM buffer trace can be started and stopped by entering the following commands at the VSE system console:

```
F NET,TRACE,TYPE=BUF,ID=TERMID  
F NET,NOTRACE,TYPE=BUF,ID=TERMID
```

Figure 114. VTAM Commands to Get VTAM Buffer Trace

For TERMID use the entire VTAM NETNAME. Use TPRINT to print the trace. The following messages will be issued:

- IST907A - SNAPSHOT MODE TPRINT ENTER Y OR N
Reply 'NO' to this message.
- IST905A - ENTER TRACE PRINT OPTIONS OR 'CANCEL'
Reply 'PRINT BUF=ALL'

3. SDAIDS SIO/IO TRACE WITH CCWD:

This job will set up the SDAIDS trace:

```

// JOB SDAID
// EXEC SDAID
OUTDEV T=tcuu
TRACE SIO AR=Fn UN=cuu OUTP=(TOD CCWD=2000)
TRACE IO AR=Fn UN=cuu OUTP=(TOD CCWD=2000)
/*
/&

```

Figure 115. Get an SDAID Trace Job Sample

Fn is the CICS/ICCF partition. *tcuu=tape* device for trace output. *UN=cuu* is the line, terminal, or controller being traced. If controller is being traced be sure to reduce the traffic.

- a. Submit the above job.
- b. Enter STRTSD.
- c. Recreate the error.
- d. Enter STOPSD then ENDS.
- e. Use DOSVSDMP to print the trace.

4. TCP/IP File Transfer Program

For more information on how to trace TCP/IP FTP see the manual "TCP/IP for VSE/ESA - IBM Program Setup and Supplementary Information (SC33-6601)" and refer to the topics TRACES, DEFINE TRACE command, and for output DEFINE LINK.

Usage or Configuration Errors, Emulator Problems

1. MSGINW0002I from a module name ending with '0' and the PC is connected in DFT Mode.

This is a generation and tailoring error, the module names ending in '0' are used in CUT (Control Unit Terminal) Mode. The user has to make sure that the PC, controller, VTAM tables, and the CICS terminal entries are configured for EXTENDED DATA STREAMING when using the PC as a DFT (Distributed Function Terminal).

2. MSGINW0002I with RC=0001 and the error description for the affected module is 'INVALID REPLY (NO AID ENTER)'.

This means the response buffer did not begin with X'7D' (7D is the 3270 AID byte for an Enter Key). This message will also be issued if the user tries to toggle back to the host or if he uses Ctrl-Break to break a hang before file transfer is complete. The Ctrl-Break will send in data that will not begin with x'7D'. The reason for the hang should be investigated.

3. File transfer AID BIT problems: MSGINW0002I TRANS10 HANGS

MSGINW0002I TRANS10 hangs can occur if the 3174 Control Unit Hardware configuration Question #125 bit 6, 'FILE TRANSFER AID', is not set on. Without this bit turned on a RECEIVE will work but SEND will fail. A VTAM Buffer Trace will show empty data buffers.

Hardware configuration Question #125 also applies to D/T9221. See 'Planning For Your Workstation Subsystem.'

4. 3274 Control Unit, 9370 workstation adaptor

9370 Work Station Adaptors can have the same problem if all defaults are taken.

The FILE TRANSFER AID BIT needs to be set in the Work Station Adaptor. See *Planning For Your Workstation Subsystem GA24-4223 p.2-9*. This customer's CE also found that the WORKSTATION CONTROLLER FEATURE 6120 card in the 9370 expansion cage in the 9221 system was not properly configured to operate with 3270 emulation. It must be set to communicate with a 3174 not a 3274.

5. File transfer hang

Customer was experiencing a file transfer hang at the same exact byte count every time. The problem was intermittent and occurred mostly with larger files. SOLUTION: Hardware Configuration Question #164 PS TERMINAL BIT must be turned off to work correctly.

6. HUNG condition on PC. HANG WAIT or HUNG condition on PC using 4300 ICA and the 3270 Emulation Version 3 Control Program caused by not having EXTDS, Extended Data Streaming in the TCT and VTAM was not configured for DFT Mode.

7. FTTERM configuration problems

MSGTRANS10 TIMEOUT on PC running FTTERM with a D/T3174 AEA. If the 3174 AEA ports are configured as either FC (FTTERM COLOR) or FM (FTTERM MONO) then answer '1' to 'USE SPECIFIC KEYBOARD MAP (1=YES 0=NO) prompt on the FTTERM configuration. Problems uploading (SEND) files with PC3270 V3.0 attached through a 3708 which uses FTTERM are solved specifying IWS=Y in the setup file xxxxxx.ws under .AEA. See the 3174 Terminal User's Reference. There was no IND\$FILE coming in from the emulator on the PC.

8. When RECEIVE is used from PC TRANS10 TIMEOUT 0 BYTES RECEIVED and when you Hotkey back to the host and hit Enter Key, MSGINW0002I INWPRCVC RC1 is issued.

The TRANS10 was due to not having EXTDS coded. The INW0002I INWPRCVC RC1 was due to Hotkeying back to the and hitting the Enter Key. The problem is resolved by coding EXTDS in the TCT.

9. HANG OR MSGINW0002I INWPGET1 RC=0002 when using PERCOM Personal Communications 3270 V2 under Windows.

The customer signed on to the IUI and used PF6 to get into native CICS. He opened a window and sent a file to the host. He received MSGINW0001I File Transfer Complete at the PC but it did not show up on the host screen as it does in DOS Mode. He hit enter or PF3 on the host session and INW0002I INWPGET1 RC=0002 was issued. The RC2 means that no acknowledgement was received from the PC. The trace showed normal DFT protocol flow up until the host sent out the Insert Request + Data (msg) and then the PC never responded with an Insert Data acknowledgement positive. The user found that by increasing the TIMEOUT option from 30 to 60 on the windows panel the INW0001I would appear at the host.

10. Timeout on a SNA connected PC. Sending a file to HTF ended in message PCSxfer041 HOST HAS NOT RESPONDED WITHIN TIME-OUT PERIOD. The problem occurred mainly with large files. Increasing the second field of IOAREALENGTH from 4096 to 32K solved the problem. The size specified in the IOAREALENGTH is related to the transfer buffer size in the emulator.

11. Transferring to or from a VSE sublibrary, job PWSLTS is released executing program LIBRLTS to process librarian requests. This job will stay active in case of a connection error covered by the node error program. The job has to be cancelled in such an error situation, otherwise further file transfers to VSE sublibraries will not work.
12. Transferring to or from a VSE sublibrary, job PWSLTS is released executing program LIBRLTS to process librarian requests. This job will stay active in case of a connection error covered by the node error program. The job has to be cancelled in such an error situation, otherwise further file transfers to VSE sublibraries will not work.

Return Codes of VSE FILE TRANSFER IWS Messages

Message	Module	RC	Message Explanation
INW0001I	INWPROOT	----	FILE TRANSFER COMPLETE (NORMAL)
INW0002I	INWPCLS0	0001	INVALID REPLY (NO AID ENTER)
	INWPCLS1	0001	NO REPLY RECEIVED
	"	DDM	ERROR REPLY
	INWPGET	0002	LINK TO INWFMGR (RDFILE) FAILED
	INWPGET0	0001	INVALID REPLY (NO AID ENTER)
	INWPGET1	DDM	ERROR REPLY
	"	0001	NO POSITIVE REPLY X'63'
	"	0200	ARRIVAL SEQUENCE INVALID
	"	0001	ISSID NOT EQUAL TO X'63'
	"	0002	NO ACKNOWLEDGEMENT FROM PC
	INWPMSG	????	ERROR OCCURRED BUT MESSAGE COULD NOT BE DISPLAYED BECAUSE:
	"		1) MESSAGE FILE DISABLED OR NOT OPEN
	"		2) THE MESSAGE WAS NOT FOUND IN FILE INWPMSG. ???? IS THE HEX NUMBER OF THE MESSAGE.
	INWPOPNO	0001	INVALID REPLY (NO AID ENTER)
		00FF	DATA SET FULL OR PC ERROR PC USER RECEIVES MSGTRANS11
	INWPOPNI	FFFF	NO REPLY RECEIVED FROM OPEN
	"	EEEE	INVALID REPLY FROM OPEN
	"	DDM	ERROR REPLY
	INWPPUT	0001	ERROR DURING DELETEQ TS
	"	0002	LINK TO INWFMGR (STATE) FAILED
	"	0003	LINK TO INWFMGR (WRREP) FAILED
	"	0004	LINK TO INWFMGR (WREND) FAILED
	"	0005	LINK TO INWFMGR (GIVEF) FAILED
	INWPPUT0	0001	INVALID REPLY (NO AID ENTER)
	"	0002	INVALID SEQUENCE NUMBER
	"	0003	INVALID DATA LENGTH RECEIVED
	"	0004	CHECK SUMS DO NOT MATCH
	INWPPUT1	DDM	ERROR REPLY
	"	0001	REPLY NOT 'ACKNOWLEDGE DATA'
	"	5D00	UNSUPPORTED TYPE
	"	0200	ARRIVAL SEQUENCE INVALID
	"	4A00	RECORD LENGTH INVALID After APAR PL79999 ABENDAEIV may occur see II06689.

Figure 116 (Part 1 of 2). File transfer messages

Message	Module	RC	Message Explanation
	INWPQUER	0001	NON ZERO RETURN CODE ON EXEC
	"		CICS ASSIGN TO DETERMINE IF CU
	"		SUPPORTS EXTENDED DATA STREAM
	"	0002	NO REPLY FROM 'QUERY REPLY'
	"	0003	BAD LENGTH FROM 'QUERY REPLY'
	"	0004	BAD RESPONSE FROM 'QUERY REPLY'
	"	0005	EXEC CICS SEND FAILED
	INWPRCVE	0001	RECEIVE FROM PC FAILED
	INWPREAD	0001	ERROR DURING READQ TS
	"	0002	LINK TO INWFMGR (RDDAT) FAILED
	INWPROOT	0001	CICS HANDLE ABEND ROUTINE CALLED
	"	0002	ERROR RECEIVING INPUT COMMAND
	"	0003	ERROR FROM INWTUID CHECKING UID
	INWPSEND	0001	SEND TO PC FAILED
	INWPWTRE	0001	ERROR DURING READQ TS
	"	0002	ERROR DURING DELETEQ TS
	"	0003	LINK TO INWFMGR (WRDAT) FAILED
	"	0005	ERROR DURING WRITEQ TS
INW0003I	INWPGET	----	GETMAIN REQUEST FAILED
	INWPNIB0		"
	INWPPUT		"
	INWPROOT		"
INW0004I	INWPROOT	----	NO GET OR PUT REQUEST FROM PC
INW0005I	INWPROOT	----	INVALID FILENAME
INW0006I	INWPROOT	----	INVALID OR CONFLICTING OPTION
INW0007I	INWPPUT	----	CANNOT ACCESS HOST TRANSFER FILE
	INWPGET		"
INW0008I	INWPMMSG	----	RECORDS SEGMENTED
INW0009I	INWPROOT	----	INVALID USER ID
INW0010I	INWPPUT	----	FILE EXIST, REPLACE NOT ENTERED
INW0011I	INWPPUT	----	NO MORE VSAM SPACE IN XFER
	INWPWRTE		"
INW0012I	INWPGET	----	FILE NOT FOUND
INW0013I	INWPGET	----	FILE NOT SHARED OR PUBLIC
INW0014I	INWPGET	????	UNEXPECTED RETURN CODE ????
	INWPPUT		FROM INWFMGR
	INWPREAD		"
	INWPWRTE		"
INW0015I	INWPPUT	----	DEDICATE NOT SUCCESSFUL
INW0016I	INWPGET	----	ERASE NOT SUCCESSFUL

Figure 116 (Part 2 of 2). File transfer messages

DDM in the return code column indicates a DDM error code listed below:

0100 OPEN FAILED	5800 UNABLE TO FIND FILE
0200 ARRIVAL SEQUENCE INVALID	5D00 UNSUPPORTED TYPE
0300 CLOSE OF UNOPENED FILE	6000 COMMAND SYNTAX ERROR
1A00 FILE NAME INVALID	6200 PARAMETER MISSING
1B00 FILE NOT FOUND	6300 PARAMETER NOT SUPPORTED
1C00 FILE SIZE INVALID	6500 PARAMETER VALUE NOT SUPPORTED
2000 FUNCTION OPEN ERROR	6E00 DATA ELEMENT MISSING
3E00 OPERATION NOT AUTHORIZED	7100 RECORD LENGTH EQUALS ZERO
4700 RECORD NOT ADDED TO FILE	7100 INVALID FLAG VALUE

Figure 117. DDM Error Codes

Chapter 16. Interactive Interface, System Files and Configuration

Display VSE/ESA Level

The procedure SPLEVEL displays the VSE/ESA level, the installation date and the Copyright statement.

```
// EXEC PROC=SPLEVEL
```

Figure 118. Display VSE/ESA Level

The SIR command also provides general system information.

Problems Displaying Messages

If a user of the Interactive Interface gets any indication that messages can not be displayed, that file IESTRFL is destroyed or that in error cases there is no message at all, this might be due to the fact that the IESTRFL file got damaged or that it was deleted or that it is not accessible. The text repository file IESTRFL holds dialog messages, explanatory text provided through the Help function and also the text shown in selection panels.

In order to restore and repair the file, skeleton SKRSTRFL in ICCF library 59 can be used (VSE/ESA 2.3.0 and later)

On older systems, an easy way to repair the file would be to install a PTF which services member IESTRFL.V, the IBM support group can certainly help you identifying such a PTF fitting to your system. A second possibility is to restore member IESTRFL.V from the installation tape and run following job:

```
* $$ JOB JNM=TRFL,CLASS=0,DISP=D
// JOB TRFL CATALOG TO TEXT REPOSITORY FILE
* CEMT SET DA(IESTRFL) CLO
// PAUSE CLOSE IESTRFL (CEMT SET DA(IESTRFL) CLO
// UPSI 0
// DLBL IESTRFL,'VSE.TEXT.REPSTORY.FILE',,VSAM,CAT=VSESPUC
// EXEC IESTRFUT
* $$ SLI MEM=IESTRFL.V
/*
// PAUSE OPEN IESTRFL (CEMT SET DA(IESTRFL) OPE
/&
* $$ EOJ
```

Figure 119. How to Get IESTRFL on a VSE System

The IESTRFL.V member is on the NLS library on the tape or cartridge. Tape positioning for releases earlier than 2.3.0 is as follows:

```
// MTC FSF, cuu, 21      for tapes and cartridge VSE/ESA 2.1.x
// MTC FSF, cuu, 17      for cartridge VSE/ESA 1.x.y
// MTC FSF, cuu, 3       for tape number three of VSE/ESA 1.x.y
```

Figure 120. Where to Find IESTRFL

The IESTRFL.V member can be restored using the LIBR program as follows:

```
// EXEC LIBR
RESTORE WDSKNLS. ENGLISH. IESTRFL.V:..SYSLIB T=cuu REP=YES
/*
```

Figure 121. Restore of IESTRFL

For other system languages, 'ENGLISH' has to be replaced with 'GERMAN', 'SPANISH' or 'KANJI'.

History File Damaged

It is not quite easy to find out if the history file is damaged. An indication would be, for example, if service is shown as not installed but definitely was installed. There are also other possible hints for a defective history file like message M4321, in any case IBM should be contacted for a detailed analysis. Some OEM products establishing workfiles do generate message M4321, It is recommended to run MSHP, especially the repair job below, with this products disabled for that partition. Following is a sample job which repairs the internal structure of the history file by means of the merge function. This job may be used with a corrupted history file as well as a good one, it will be reorganized and compressed, so that it might also improve performance.

The job does first copy the history file to an auxiliary history file and afterwards merges the auxiliary back to the system history file. It is recommended to backup the history file before you run this job using the MSHP BACKUP HISTORY function.

```
// JOB RESTORE
// DLBL IJSYS02, 'WORK.HIST.FILE'
// EXTENT SYS018, SYSWK1, 1, 0, 960, 75
// ASSGN SYS018, DISK, VOL=SYSWK1, SHR
* CHECK THE ABOVE DLBL IF IT REFLECTS THE WORK HISTORY FILE ON
* YOUR SYSTEM, IT IS SET UP FOR 3380'S.
* WE SUGGEST TO BACKUP THE HISTORY FILE BEFORE YOU RUN THIS JOB.
// PAUSE
// EXEC MSHP
CREATE HIST AUX
COPY HIST SYS AUX
CREATE HIST SYS
MERGE HIST AUX SYS
/*
/&
```

Figure 122. Restore History file

Mismatch History File - Dialogs

The System History File holds information about the parts contained in your system and the service applied to them.

Some dialogs, especially the IBM Service Dialogs, do not work on the system history file directly, but on the table DTRIHIST.Z in IJSYSRS.SYSLIB. Each time a job created by a dialog changes the history file, the table DTRIHIST.Z is updated automatically by program DTRIPST.

In case, the history file was changed MSHP commands directly, the updates to the table DTRIHIST.Z are missing. Then the two sources of information reflect different states.

In that case, run DTRIPST to update DTRIHIST.Z out of the system history file.

```
// JOB UPDATE
* THIS JOB REFRESHES THE CONTENTS OF DTRIHIST.Z
* USING DATA COMING FROM THE SYSTEM HISTORY FILE
// EXEC DTRIPST,SIZE=250K
/*
/&
```

Figure 123. Update DTRIHIST.Z

Restore of the Online Messages Explanation (OME) File

In case the online messages explanation file IESMSG5 is damaged, it can be restored from the installation tape using skeleton SKOMERST in ICCF library 59 (for VSE/ESA 2.3.0 or later). On systems earlier than 2.3.0 please contact IBM for further assistance.

Message: User ID Already in Use

If this message occurs, in many cases it is caused by the fact that the related terminal used by this user got a connection error or was switched off without performing sign-off. It is also issued in case the user is still logged on at another terminal. In order to sign-off automatically from VSE/ICCF and also from the VSE/ESA Interactive Interface in case of an error, the system supplied node error program IESZNEP should be activated. IESZNEP is activated by default for VSE/ESA 2.4.0 or later. There is more information provided about this program in the VSE/ESA Administration manual.

With VSE/ESA 2.4.0 and later, you may use PF12 after you get message "User ID Already in Use" for the LOGON HERE function. You will not get PF12 in case you have set security off in the SIT.

Deactivate the VSE/ESA Interactive Interface

The interactive interface is started by program IESCICIN which is activated at PLT startup time through the DFHPLTPI phase. In order to deactivate the interactive interface, the related entry for IESCICIN should be deleted in the IESZPLTI copy book which is used in DFHPLTI. If VSE/ICCF should also be deactivated, entry DTSPSTI should also be deleted. During shutdown, the interactive interface is terminated through entry IESCICSD in copy book IESZPLTS. This copy book is used in the DFHPLTSD shutdown program. Again, if VSE/ICCF is also not used, entries DTSICCF and DTSSHUT should also be eliminated. The default DCT needs also to be changed - the indirect destinations IESN and IESM should not be used; that is, do not use the copy book IESZDCT, and also do not trigger transaction IEWR for destination IEP1.

Note: Deactivating the interactive interface implies that not only the dialogs will not work but also functions like the file transfer to and from workstations or the online problem determination program. How to use the file transfer without the interactive interface is described in the *Programming and Workstation Guide*.

Note: IESCICIN should not be activated in a coexisting CICS/VSE, OLPD will not work with CICS/VSE and will get an abend ASRA terminating CICS/VSE. Also do not activate DTSPSTI in a CICS/VSE.

Problems Using the Dialog "Storage Dump Management"

With the storage dump management dialog, Info/Analysis is run in the VSE/ICCF interactive partition to retrieve dump information from the dump management file. To improve performance, it is recommended to delete obsolete dumps from the library.

If the dialog does not work, following steps may help finding the reason for the problem. If messages indicate that there is not enough GETVIS available, or in any other problem case, check the following:

1. Does following job run in batch:

```
* $$ JOB JNM=DUMPLIST,DISP=D,CLASS=A,PRI=3
// JOB DUMPLIST PRINT COMPLETE FORMATTED DUMP
// EXEC PROC=DTRINFOA
// EXEC INFOANA,SIZE=300K
  SELECT DUMP MANAGEMENT
    PRINT DATA
    RETURN
  SELECT END
/*
/&
* $$ E0J
```

Figure 124. Info/Analysis Dump Sample Job

2. If the job runs in batch, it will show you the dumps stored in the dump library, you could also use the batch interface as a circumvention to print off a certain dump or to delete dumps.
3. If the job does not run in batch, check the messages you get from Info/Analysis in the *Messages and Codes* manual. The problem might be due to

Info/Analysis dump file being corrupted. In order to repair the dump management file, you should reformat it and initialize it. Before formatting, it can be scratched using DITTO - this will ensure the file is in fact cleared. To redefine the dump files, use skeleton SKDMPINI in library 59.

Note that in case you use the CICS coexistence environment, you should also activate the CICS/VSE dump analysis program. Please refer to skeleton SKPREPSO respectively SKPREPCO for initializing the external routine file.

Note that problems might occur if dumps of former releases are still in the dump library.

If problems persist: contact Info/Ana-Level2.

If the batch job worked but the dialog did not:

4. Did the dialog abend ? Which messages were issued ?
5. Check library member PRB\$TEM2 and/or PRB\$TEM3 in your primary ICCF library. If members PRB\$TEM2 and/or PRB\$TEM3 are present,
6. Check size and GETVIS of interactive partition (/MAP on console); It should be at least 768K (or 1024K).
7. Check size and GETVIS of CICSICCF-partition (default is F2; MAP F2 or GETVIS F2). Free GETVIS should be at least 150K. Free GETVIS must be below 16 MB.
8. Was the size of the Info/Analysis file increased ? E.g. BLN2013I Dump management file error. Reason=2008. The file is shipped on 3380 disks with 3 tracks on 2.3.0 or higher.

```
// DLBL BLNDMF, 'INFO.ANALYSIS.DUMP.MGNT.FILE',0
// EXTENT SYS016,SYSWK1,1,0,9030,3
// DLBL BLNXTRN, 'INFO.ANALYSIS.EXT.RTNS.FILE',1999/365,SD
// EXTENT SYS017,SYSWK1,1,0,9045,1
```

Figure 125. Dump Management File

9. If message PRB\$TEM1 not found occurs, you should update the system definitions for Selection Panels and Application Profiles. You can do this by logging on with users SYSA and pressing PF6 on fastpath 212 and fastpath 213.

Abend DM02

The dialog manager frequently abends with an abend DM02. In most cases, the reason for DM02 is that the primary library has reached the maximum number of members allowed. If the abend happens, a panel as following is displayed:

```
...+....1....+....2....+....3....+....4....+....5....+....6. <==MORE==> .+..RD
INTERACTIVE INTERFACE ABEND CODE: DM02
0S19I OPERATOR/ICCF SYSTEM REQUEST
0S00I SUB DTRDDMGR CANCELED
0S07I PROBLEM PROGRAM PSW = 07DD2000 00754022
*VSE ICCF PARTITION DUMP PROGRAM
K402I CSECT ENTERED = DTRDDMGR
K403I ICCF RETURN CODE = 07
K401I LOAD HI-PTN HI-PHS ORIGIN SCAN* ***STATUS***
ACTUAL: 7523C0 851FFF 78032F 7523C0 7523C0
RELATIV: 000000 0FFC3F 02DF6F 000000 000000
K442I PSW=07DD200000754022
K441I ACTUAL=754020 REL=001C60
K443I INSTR=0A0441E10008
.
GP 0-F 00000000 00754028 0079D0D8 00000000 0079D0A6 0079B09A 0079B09A 80753EC8
00000000 007A0A64 0079D000 007A0B0C 60753BC2 0079D058 B0754014 BF0003E7
K404D ENTER DUMP COMMAND
*ENTER DATA?
```

The Interactive Interface abend codes are described in the message manual section IICO.

As a quick solution for the problem you may delete some members in your primary library, or you may extend the maximum number of entries in your primary library. To do so, run \$DTSUTIL in ICCF command mode (fastpath 6) and perform command ALTER LIB(nn) MAXDIR(300) this would extend to a maximum of 300 entries.

Old CSD File

Some users restored the CICS CSD file from an old system after installing a new release. This leads to messages PROGRAM NOT DEFINED TO CICS. For VSE/ESA 2.3.0 and higher skeleton SKCSDFIL in ICCF library 59 can be used to upgrade the IBM provided CSD settings like for CICS, Interactive Interface and ICCF.

In case of VSE/ESA 2.4.0 and later, it is not possible to copy an old level CSD file, the CSD file needs to be migrated from CICS/VSE to CICS TS. It is recommended to use the newly created CSD file and add definitions to it with the help of DFHCSDUP or the migration of PPTs and PCTs. In case a secondary CICS TS is defined, related definitions must also be established. Refer to SKPREPC2 for more information. In a CICS/VSE coexistence environment, you also have to consider the CSD file setup for CICS/VSE. Refer to SKPREPCO and SKPREPSO.

If a Fast Service Upgrade (FSU) is performed (including a version upgrade), the CSD file for parts related to DBDCCICS is upgraded through the FSU process in FSU step 4C. For the production CICS PRODCICS, the VSELST2 needs also to be updated in case of an FSU from 2.4.x to 2.5.x, from 2.4.x to to 2.6.x, or from 2.5.x to 2.6.x. Skeleton SKCSDFC2 in ICCF library 59 can be used.

IPF Error

When the II dialog manager returns to the Service Manager, the Service Manager checks for an error return code. If there is an error, you may receive the following message on your terminal:

```
THE PROGRAM YOU WERE USING ENDED ABNORMALLY.
PRESS PF1 FOR MORE INFORMATION
```

The corresponding help gives the following information:

```
Up to 20 lines of information about the error were placed
in the online system's error log.
```

```
There may be more than 20 lines of information available.
If you want more information about the error, library member
DTRLxxxx (xxxx = your User ID) should have been created in
the ICCF library which was the primary library at the time
the program was called. This may be the library assigned as
your primary library or one you had previously switched to.
```

```
Edit (or list) member DTRLxxxx to get more information.
```

```
PF3=END
```

Please check the member DTRLxxx in your primary ICCF library. This member looks like the following example.

```
-----
DISPLAY COM$ICL 0146 DTRSDSP DP02                                COM$ICL1
-----
```

```
DP02 - PANEL FILE NOT FOUND OR A VALID HEADER RECORD COULD NOT
      BE FOUND. THE NAME OF THE PANEL FILE IN ERROR IS IN
      UCAERFN.
```

```
MEMBER DTRMSG OF LIBRARY 2 SHOWS THE FORMAT OF THE ABOVE RECORD.
```

The format of the error record is as follows:

```
*****
*                               FORMAT OF ERROR LOG ENTRY                               *
*****
```

FIELD DESCRIPTION	OFFSET	FIELD NAME
NAME OF CURRENT SERVICE	1-8	UCASERV
NAME OF INVOKING FUNCTION	10-17	UCAFUNCT
LINE NUMBER OF INVOKING FUNCTION	18-21	UCAERLNO
NAME OF ROUTINE DETECTING ERROR	23-30	UCAERRTN
ERROR CODE UNIQUE TO DIALOGUE MANAGER	32-35	UCAERCD
CURRENT LINE NUMBER OF DISPLAY PANEL	37-38	UCAERCL
OR HEXADECIMAL OFFSET WITHIN MODULE	37-39	
CURRENT COLUMN NUMBER OF DISPLAY PANEL	40-41	UCAERCC
INFORMATION ASSOCIATED WITH A MESSAGE: VARIABLE VALUE, VARIABLE NAME, MESSAGE IDENTIFICATION ETC.	43-50	UCAERVV
CURRENT RECORD NUMBER OF FILE IN ERROR	51-54	UCAERCR
ERROR CODE OF INTERACTIVE SUBSYSTEM	56-59	UCAERSYS
FILE NAME OF FILE IN ERROR	61-68	UCAERFN
FILE TYPE OF FILE IN ERROR	70-77	UCAERFT
FILE MODE IF CMS IMPLEMENTATION	79-80	UCAERFM

```
*****
```

How to Find System Member DTR\$DTBL in ICCF Library

Member DTR\$DTBL in ICCF library 58 is a central IPF control member. Here you can find synonym tables and PF-key tables.

The member tells in which ICCF library panels or tables with a specific prefix can be found. Also the ICCF library number for a specific system member can be found here.

Hints and Tips for Fast Service Upgrade (FSU)

General Information for a Version Upgrade

The following version upgrades are possible:

Older Versions:

```

From VSE/ESA 1.3.x --> VSE/ESA 2.1.x
                   --> VSE/ESA 2.2.x
                   --> VSE/ESA 2.3.x
From VSE/ESA 1.4.x --> VSE/ESA 2.1.x
                   --> VSE/ESA 2.2.x
                   --> VSE/ESA 2.3.x
From VSE/ESA 2.1.x --> VSE/ESA 2.3.x
From VSE/ESA 2.2.x --> VSE/ESA 2.3.x

```

Current Versions:

```

From VSE/ESA 2.4.x --> VSE/ESA 2.5.x
From VSE/ESA 2.4.x --> VSE/ESA 2.6.x
From VSE/ESA 2.5.x --> VSE/ESA 2.6.x

```

Note: VSE/ESA 2.4, VSE/ESA 2.5 and VSE/ESA 2.6 cannot be installed via FSU (version upgrade) from a system prior to 2.4.0; an initial installation is required to upgrade from such a system. For an FSU from 2.4.0 to 2.4.1 or 2.4.2, please note that the tape layout has changed and that the downlevel check should be performed after the preparation step. For an FSU from 2.4.x to 2.5.x, from 2.4 to 2.6 and from 2.5 to 2.6, the down level check should not be used.

Sizes Required

Performing an FSU is an easy way to upgrade the system. Basically there are two types of FSU, a normal refresh installation for example like an FSU from 2.6.0 to 2.6.1 and a so called release upgrade from, for example, 2.4.2 to 2.6.0. A release upgrade needs detailed planning for several reasons like system layout changes and similar topics. A service refresh normally does not change any storage sizes or layout specific things. For more details on what type of FSU you are performing refer to the Planning Guide and also to the System Upgrade and Service manual. Here just some remarks regarding version and release upgrades:

- Upgrading from 2.4.x to 2.6.x needs more space for the user catalog VSESPUC. Space for the master catalog needed for system libraries is nearly the same as on the old system. With 2.6.0 the VSAM space was enlarged by a second extent on SYSWK1 for the 3380 DASD, but this change will not get active by the FSU. Therefore for initial installation, 3380 model A is not supported. When performing an FSU on 3380's, make sure you have sufficient space available for the master catalog. It is recommended to define at least the amount of space shown in the disk layout on SYSWK1. To be on the safe side, you may define more space, the best is if you define in multiples of the above extent.
- The required SVA size changed, the FSU will show the correct values. Changes should be made before stage 1 of the FSU is started.

What To Do if Errors Occur

The System Upgrade and Service manual shows a couple of things that can help to solve problems during FSU. Since the FSU process changed with the new tape layout introduced with 2.5.0, not all steps perform the same function as in previous releases, so for example step 23 is now installing the LE code, in former releases it installed PRD1. Here are some other tips or more general nature:

- Invalid allocation message. Probably PASIZE is not correct. This should occur only for release or version upgrades.
- Wrong disk IPLed during Stage 2. In most cases the FSU will fail during step DTRFSU4C with message MEMBER IESTRFL.V not found. It may also fail earlier with message PROCEDURE \$0JCLFSU not found. If it does not fail in DTRFSU4C it will fail in step DTRFSU26, you will get a message that library IJSYSRS is in use. You should IPL from SYSWK1 and rerun the whole stage 2 or reset to the appropriate job.
- POWER does not come up during Stage 2. You should check for old level POWER phases in sublibrary PRD2.SAVE. Such a phase would be copied into IJSYSR1.SYSLIB and get activated.
- IPL does not work during Stage 2. This may be due to similar reason as last point, old level system phases should not be stored in PRD2.SAVE.
- VSAM space exhausted during Stage 2. Program IDCONS may be used to define space from the console directly releasing the PAUSEFSU job. IDCONS prompts for IDCAMS commands, the command to define space is as follows:

```
DEFINE SPACE ( TRACKS (150) ORIGIN (12000) VOLUME(SYSWK1)) -  
  CATALOG(VSAM.MASTER.CATALOG)
```

Figure 126. Define VSAM Space During FSU

After space has been defined you may resume the FSU by releasing job DTRFSUAB.

- VTAM does not come up after Stage 2 has finished. This is in most cases due to the fact that not enough DSPACE was defined. You may define more space using SYSDEF AR command SYSDEF DSPACE,DSIZE=20M. The problem might also be caused by an SVA not large enough.
- IPL from DOSRES does not work after FSU. This is probably due to the fact that the system was configured while IPLed from SYSWK1. All configuration dialogs will write changed procedures to IJSYSR1.SYSLIB on SYSWK1 in this case. The system library however already was copied back to DOSRES before the configuration was made. IPL from SYSWK1 (not with JCL=\$\$JCLFSU) and copy the changed parts back to IJSYSR2.SYSLIB on DOSRES.
- System tries to install PRD1.BASE in step DTRFSU23 into PRD2.PROD. There is one of the base products installed into PRD2.PROD, for example the high level assembler. Product should be removed first as described in the Planning guide. At this point, you should cancel DTRFSU23, release job PAUSEFSU, run MSHP from the console to remove the product (use the work history file). MSHP will prompt you. For example for 3380 this would be for the HLASM:

```
// DLBL IJSYSHF,'WORK.HIST.FILE'
// EXTENT SYS018,SYSWK1,1,0,900,75
// ASSGN SYS018,DISK,VOL=SYSWK1,SHR
// EXEC MSHP
REMOVE 234389
REMOVE 5696-234-00-389
/*
```

Figure 127. Remove a Product from MSHP History File Sample Job

After removing DTRFSU23 may be resumed.

Replace Bootstrap Record (IJBREPB)

When using program IJBREPB to update/rebuild the bootstrap record, special care should be taken with the required LIBDEF statement. In addition, IJBREPB is restricted to run in a static partition, the current version does not run in a dynamic partition.

Update of the bootstrap record is required when certain changes in the IPL routines are made. The IPL phases for VSE/ESA are stored in the SVA and addressed via the SDL.

If updates are done which require to rebuild the bootstrap record, the execution of program IJBREPB is required. For the execution of this program, the SDL is searched after the libraries containing the updated IPL phase. With standard LIBDEF processing, the SDL is always searched first. To change this, a LIBDEF PHASE,SEARCH=(lib.sublib,SDL),TEMP is required. As stated in the VSE/ESA System Control Statements manual, lib.sublib can not refer to IJSYSRS.SYSLIB or IJSYSR1-9.SYSLIB. It is therefore required to have the modified IPL phase in any other VSE/ESA library (not IJSYSR_x) when running IJBREPB, otherwise the original (old) IPL phase will be loaded.

Sample Job for IJBREPB

The following sample job is part of the II service dialogs and copies the IPL phases from IJSYSRS.SYSLIB into a new sublib of library PRD1 before invoking IJBREPB:

```
// ASSGN SYS005,DISK,VOL=SYSWK1,SHR
// EXEC LIBR,PARM='MSHP'
DEFINE SUBLIB=PRD1.$MSHP
CONNECT S=IJSYSR1.SYSLIB:PRD1.$MSHP
COPY $$A$IPL1.PHASE
COPY $$A$IPL0.PHASE
COPY $$A$PLBF.PHASE
COPY $$A$PLBK.PHASE
/*
// LIBDEF PHASE,SEARCH=(PRD1.$MSHP,SDL)
// UPSI 10
// EXEC IJBREPB
/*
```

Figure 128. Replace IPL Bootstrap Record Sample Job

Above job takes the new (upgraded) IPL phases from IJSYSR1.SYSLIB. Use skeleton SKBOOTST in ICCF library 59.

Sharing the VSE Control File Between VSE/ESA Systems

The VSE control file can be shared between VSE/ESA systems. Only systems with either CICS TS or CICS/VSE can share the control file. It is not possible to share the IESCNTRL between VSE/ESA 2.3.x or earlier systems and VSE/ESA 2.4 or later systems.

For sharing, the following steps must be performed:

1. In case of VSE/ESA 2.4 or higher, use *MSG FB,DATA=CLOSECNTL* to close the file in the basic security manager.
2. Close the VSE control file for all CICS TS systems.
 - In case of a pre-VSE/ESA 2.4 system, you only have to close the file in all CICS systems using *CEMT SET FILE(IESCNTRL) CLO*
3. Alter the shareoption to (4 4) using IDCAMS
4. In case of VSE/ESA 2.4 or higher, open the VSE control file from the basic security manager using *MSG FB,DATA=OPENCNTL*
5. Open the VSE control file.
 - In case of a pre-VSE/ESA 2.4 system, use *CEMT SET FILE(IESCNTRL) OPEN* for all CICS systems.

```
// JOB SHARE CHANGE SHAREOPTION
* MAKE SURE THAT THE CONTROL FILE IS CLOSED
// EXEC DTRIATTN,PARM='MSG FB,DATA=CLOSECNTL'
// EXEC DTRIATTN,PARM='MSG F2,DATA=CEMT SET FILE(IESCNTRL) CLO'
/*
// EXEC IDCAMS
  ALTER VSE.CONTROL.FILE.@D@ -
  SHAREOPTIONS(4 4)          -
  CATALOG(VSESP.USER.CATALOG)
  /**/
  ALTER VSE.CONTROL.FILE.@I@ -
  SHAREOPTIONS(4 4)          -
  CATALOG(VSESP.USER.CATALOG)
  /**/
/*
* MAKE SURE THAT THE CONTROL FILE IS OPENED
// EXEC DTRIATTN,PARM='MSG FB,DATA=OPENCNTL'
// EXEC DTRIATTN,PARM='MSG F2,DATA=CEMT SET FILE(IESCNTRL) OPE'
/*
/&
```

Figure 129. Sharing the Control File

Move the VSE/POWER Data File

The VSE/POWER data file is located on SYSWK1.

You may want to move the Power Data File to an other volume for performance reasons.

To do so, the following steps must be performed.

1. Change the label procedure `STDLABEL` in `IJSYSRS.SYSLIB`
2. Copy the changed procedure to `PRD2.SAVE` (needed for FSU).
3. Change the assignment procedure `DTRPOWR` in `IJSYSRS.SYSLIB`
4. Copy the changed procedure to `PRD2.SAVE` (needed for FSU).
5. Request a VSE/POWER cold start using `DTRSETP`
6. Shut down the system except VSE/POWER
7. Backup the VSE/POWER queues.
8. IPL the system, VSE/POWER cold start is performed
9. Restore the VSE/POWER queues

In case of VSE/ESA 2.4 or higher, the skeleton `SKPWREXT` in ICCF library 59 describes the steps in detail.

Note: Refer also to the Data File extension at warm start function in *VSE/POWER Administration and Operation*, SC33-6733.

Extend the VSE Dump Library

The VSE Dump Library holds dumps from all static and dynamic partitions. If the dump library is full, dumps are written directly to `SYSLST`.

If you need to enlarge the VSE dump library the following steps must be performed:

1. Delete the dumps, which are not needed.
2. Save the dumps, which are still needed (offload to tape).
3. Change the label procedure `STDLABEL` in `IJSYSRS.SYSLIB`
4. Copy the changed procedure to `PRD2.SAVE` (needed for FSU).
5. Since the dump sublibraries are assigned to the corresponding partitions via `LIBDEF DUMP` they can not be deleted directly, but only in a system without assignments to the dump sublibraries.
6. Shut down your system
7. IPL with a *mini start*. Note that the mini start does not have assignments to the dump sublibraries.
8. Define the `SYSDUMP` library and the sublibraries. The member `LIBRDEFS.Z` in `IJSYSRS.SYSLIB` may serve as example how to do this.
9. IPL your normal system.
10. Run the `DUMPINIT` job to initialize the dump library. You may use `SKDMPINI` in ICCF library 59 to do it.
11. You may onload necessary dumps from tape.

REXX program DMPMGR to Manage the Dump Library

With VSE/ESA 2.6 a new REXX procedure is provided that takes precautions against a full dump library. This program determines the current size of the dump library. If a certain limit is exceeded, certain actions are taken:

- a console message is written
- dumps of certain partitions are deleted
- dumps of certain partitions are printed
- dumps of certain partitions are offloaded

Deletion, printing, and offloading of dumps are done by INFOANA invocations in separate POWER jobs.

The parameters of REXX program DMPMGR are:

LIMIT=nn percentage of used library space that must be exceeded to trigger actions. Default is 90%.

MSG issue the highlighted console message "!!! Dump Library is almost full !!!", if dump library runs full. This parameter is optional.

DELETE=(p1,...,pn) or DELETE=p1
list of partitions whose dumps are to be deleted if dump library runs full. This parameter is optional.

PRINT=(p1,...,pn) or PRINT=p1
list of partitions whose dumps are to be printed if dump library runs full. This parameter is optional.

OFFLOAD=(p1,...,pn) or OFFLOAD=p1
list of partitions whose dumps are to be saved on tape. This parameter is optional.

TAPE_UNIT = ttt
tape unit to be used for offloading dumps

Here are 2 invocation samples: (see also SKDMPMGR in ICCF-lib 59)

```
// EXEC REXX=DMPMGR,PARM='LIMIT=85 DELETE=BG MSG PRINT=F2'
```

when using the PARM-operand to specify parameters.

```
// EXEC REXX=DMPMGR
MSG
DELETE=(F5,F6,F7)
OFFLOAD=(F2,F8)
LIMIT=89
TAPE_UNIT=181
```

when using SYSIPT to specify parameters.

DMPMGR ends with one of these Return Codes:

- | | |
|-----------|---|
| 0 | successful, limit not exceeded |
| 1 | successful, limit exceeded |
| 4 | syntax error |
| 8 | invocation of LIBR LD L=SYSDUMP failed |
| 12 | submission of INFOANA - PRINT DATA job failed |

- 14 retrieval of INFOANA - PRINT DATA job output failed
- 16 submission of INFOANA - PRINT job failed
- 18 submission of INFOANA - OFFLOAD job failed
- 20 submission of INFOANA - DELETE job failed

The following skeleton SKDMPMGR in ICCF library 59 demonstrates how to schedule such a job to handle the dump file repetitively. The job below with the given operands is scheduled every 30 minutes every day.

```

* $$ JOB JNM=DMPMGR,CLASS=Y,DISP=K,
* $$ DUETIME=0000,DUEDAY=DAILY,DUEFRQ=(0030,2400)
// JOB DMPMGR - REXX DUMP MANAGER
* *****
*
* ----- INVOKE REXX DUMP MANAGEMENT PROCEDURE -----
*
* THIS SKELETON MAY BE USED TO CHECK CURRENT USAGE OF DUMP SPACE.
* IF FILLED TO A CERTAIN DEGREE, CERTAIN ACTIONS ARE INITIATED.
*
* *****
// EXEC REXX=DMPMGR,PARM='LIMIT=85 TAPE_UNIT=181 MSG'
OFFLOAD=(F7 F8)
PRINT=(BG,DYN)
DELETE=F2
/*
/&
* $$ EOJ

```

Figure 130. Periodic Dump Library Management Job Example

Chapter 17. VSE/ESA e-business Connectors

Overview

The VSE/ESA e-business Connectors consist of several components:

- The Java-based Connector, which consists of the VSE/ESA Connector Server (part of VSE/ESA 2.5 and higher) and the VSE/ESA Connector Client (W-book IESINCON.W in PRD1.BASE, also downloadable from the VSE/ESA Connectors and Utilities Internet page (see “More Information and FAQs” on page 312) The VSE/ESA Connector Client consists of a Java class library, providing access to VSE/ESA resources from any kind of Java program (applets, servlets, EJBs, etc.), and extensive online documentation and coding samples.
- The DB2-based Connector, which provides support for DB2 Stored Procedures. Online documentation and coding samples are contained in the VSE/ESA Connector Client.
- The VSE/VSAM Redirector Connector, which allows to redirect access to a particular VSAM file to any remote platform, for example into a DB2 database on a Linux on zSeries. For download and online information refer to the web page “More Information and FAQs” on page 312.

The following sections are all related to the Java-based Connector.

Note: the VSE/ESA Navigator Function is not part of the VSE/ESA Connector component. It is a sample that shows the functionality of the Java-based Connector. The VSE/ESA Navigator is not shipped as part of VSE, but it can be downloaded freely from the VSE/ESA Connectors and Utilities web page (see “More Information and FAQs” on page 312)

If you have problems with the VSE/ESA Navigator, send an e-mail to

- vseesa@de.ibm.com

Known Problems

The following details information to aid the user in problem solving.

Installation of the VSE/ESA Connector Client

For a detailed description of how to install the VSE/ESA Connector Client on your workstation, please refer to the VSE/ESA Connectors and Utilities web page, see below.

There you will find also information about downloading Java Development Kits (JDKs) and Java Runtime Environments (JREs), which are prerequisite for working with the Java-based Connector.

IESC1017E SYNTAX ERROR IN CONFIG FILE

The messages

```
IESC1017E SYNTAX ERROR IN CONFIG FILE: member-name
```

(and also)

```
IESC1016E SYNTAX ERROR IN PLUGIN CONFIG FILE: member-name
```

normally occur when the VSE/ESA Connector Server detected a syntax error when reading a CONFIG file.

In case the vendor Computer Associates product FLEE is active, a bug in FLEE can cause this error (they mix up the contents of the member).

To solve this, FLEE must be started after the VSE/ESA Connector Server Partition. Deactivating FLEE in the Server Partition does not help.

Codepage Problems with VSE/ESA Connectors and Navigator

For a correct display of special characters, like ä, ö, ü etc., the client codepage must match the codepage used by the VSE/ESA Connector Server.

For example, a client codepage of Cp1252 corresponds to the server ASCII codepage IBM-1252. The server side codepages are defined in the VSE/ESA Connector Server main CONFIG member like:

```
ASCII_CP      = IBM-850  
EBCDIC_CP    = IBM-1047
```

The VSE/ESA Navigator shows the currently used client codepage when clicking on **Help->Show Codepage**. The client codepage is dependent on your country and keyboard settings of your workstation.

Problems with Logon to the VSE/ESA Connector Server

The VSE/ESA Connector Server does a RACROUT VERIFY call to check the user ID and password and to get the user's ACEE.

This implies that either the Basic Security Manager (BSM) or an External Security manager (ESM) like TopSecret must be active. The logon only works with VSE/ESA user IDs that are known to the Security Manager, i.e. users that are defined in the VSE/ESA control file.

There is a configuration member IESUSERS.Z (skeleton SKVCSUSR in ICCF Lib 59) which allows to restrict the access to the VSE/ESA Connector Server by IP address and/or user ID.

Problems with CA TopSecret

To be able to logon to the VSE/ESA Connector Server when the vendor Computer Associates product TopSecret is used, the VSE/ESA user IDs must be defined in TopSecret as shown in the output below of the TopSecret TSS transaction:

```

TSS LIST(SIE1) DATA(ALL)

ACCESSORID = SIE1      NAME      = JOHN DOE
TYPE       = CENTRAL  SIZE      =      512  BYTES
FACILITY   = *ALL*
CREATED    = 07/25/01  LAST MOD  = 10/04/01  09:29
PROFILES   = PROFGEN  PRFIRMSY
LAST USED  = 10/05/01 11:23 CPU(VSEA) FAC(BATCH  ) COUNT(00991)
----- SEGMENT CICS
OPCLASS    = 01
OPIDENT    = SYA
----- SEGMENT IESIS
IESFL1     = BAT,COD,VSAM
IESFL2     = BQA,ESC,COU,CMD,OLPD,XRM
IESINIT    = IESEADM
IESTYPE    = USERTYPE1,NEW,SELECT
----- ADMINISTRATION AUTHORITIES
RESOURCE   = *ALL*
ACCESS     = ALL
ACID       = *ALL*
FACILITIES = *ALL*
LIST DATA = *ALL*,PROFILES,PASSWORD,PWVIEW
MISC1      = *ALL*
MISC2      = *ALL*
MISC3      = SDT
MISC8      = LISTSTC,LISTRDT,REMASUSP,MCS,LISTSDT
MISC9      = *ALL*

TSS0300I LIST      FUNCTION SUCCESSFUL

```

Here is a sample command to add the necessary attributes to a user:

```

TSS ADD(user-acid) IESINIT(IESEADM) IESTYPE(USERTYPE1,NEW,SELECT)
IESFL1(BAT,PSL,COD,VSAM) IESFL2(BQA,ESC,COU,CMD,OLPD,XRM)

```

Problems Accessing VSAM Catalogs

There can be two error situations when accessing VSAM catalogs from the VSE/ESA Navigator or other VSE/ESA Connector clients:

- There are no catalogs shown at all.

This means that the VSAM.MASTER.CATALOG (IJSYSCT) can not be opened. This may be caused by a invalid label information for IJSYSCT. If the customer has a IJSYSUC in the standard labels which is not pointing to the master catalog, the customer should apply PTF UQ54777 which fixes this problem, or add the following DLBL to the startup job:

```
// DLBL IJSYSCT,'VSAM.MASTER.CATALOG',,VSAM,CAT=IJSYSCT
```

- All catalogs are shown, but accessing a specific user catalog fails.

This may be caused by a invalid label information for this catalog.

In both cases running an LSERV is helpful.

Error Message IESC1005E CANNOT SET UP TCP/IP LISTENER

The error message can have several causes:

- TCP/IP for VSE/ESA has not been started.
- TCP/UP for VSE/ESA has been started with a system ID, where the system ID is specified like:

```
// EXEC IPNET,SIZE=IPNET,PARM='ID=nn,INIT=.....
```

The default is 00.

To use the TCP/IP services from within another partition this partition has to 'know' the system ID. This is specified as follows:

```
// OPTION SYSPARM='nn'
```

where nn is the system ID.

Customers may use the skeleton SKVCSSTJ in ICCF lib 59 to add this statement.

- The \$EDCTCPV phase is missing or the wrong phase gets accessed.

The \$EDCTCPV phase is part of TCP/IP for VSE/ESA and implements the C-socket interface, which is used by the VSE/ESA Connector Server. This phase is also part of the LE-runtime library as a dummy phase. So check your LIBDEFs and make sure the right phase (the bigger one) gets accessed. The LE-runtime library is normally in PRD2.SCEEBASE, TCP/IP is normally in PRD1.BASE.

Tracing the VSE/ESA Connector Server

To get a full trace of the VSE/ESA Connector Server, issue the following command at the console:

```
MSG nn,DATA=SETTRACE DD:SYSLST 0xFFFFFFFF
```

In this case the trace goes to SYSLST. You may also specify SYSLOG to have the trace messages on the console.

VSE/ESA Connector Books

The following book is available and can be downloaded from the VSE/ESA e-business Connectors and Utilities Internet page in PDF format:

VSE/ESA e-business Connectors User's Guide, SC33-6719

More Information and FAQs

For more information, FAQs, and downloading latest code see our VSE/ESA e-business Connectors and Utilities home page at

<http://www.ibm.com/servers/eserver/zseries/os/vse/support/vseconn/conmain.htm>

Chapter 18. Debug Tool for VSE/ESA

This chapter gives some hints on how to use Debug Tool for VSE/ESA. It does NOT contain detailed information. For further questions about installation and usage, please refer to the documentation listed below.

Debug Tool for VSE/ESA 1.1.0 Documentation Reference

Following documentation is available for IBM Debug Tool for VSE/ESA :

SC26-8798-00 Debug Tool Installation and Customization Guide

An accumulation of all changes to the book until the next edition is released is kept in RETAIN InfoAPAR II10023.

SC26-8797-00 Debug Tool User's Guide and Reference

An accumulation of all changes to the book until the next edition is released is kept in RETAIN InfoAPAR II10286.

Debug Tool Run-Time Environment

Debug Tool requires the LE/VSE 1.4.0 run-time library (or later), and in particular the LE/VSE C-specific run-time library. This is achieved installing the VSE C Language Run-time Support feature of VSE/ESA Version 2 Release 2.

If you want to write and debug application programs in COBOL/VSE or PL/I VSE, the LE/VSE run-time library components matching the language used must be installed, too.

VTAM Considerations

Planning to use the tool to debug your applications interactively, you must add the Debug Tool VTAM definitions to your system by following the instructions on Page 18 of 'Debug Tool for VSE/ESA Installation and Customization Guide'.

IBM supplied job EQAWAPPL holding the predefined VTAM application names, should be used for enabling an interactive debug session. Otherwise the MFI-suboption of LE/VSE run time option TEST cannot be activated.

This member is available in ICCF library 62 after installation of Debug Tool for VSE/ESA.

CICS Considerations

If you plan to use Debug Tool with CICS applications, you must update your CICS system following the instructions on Page 19 of 'Debug Tool for VSE/ESA Installation and Customization Guide'.

You need to establish Debug Tool related program definitions within CICS CSD file. For this task assistance is available by using the IBM provided job skeletons and Z-Books.

The CSD file must hold the information about :

- the programs comprising the Debug Tool
EQACCSD.Z should be used to do the update
- the C Run Time Library
Job skeleton SKLE370 (in ICCF library 59) referring to EDCCCSD.Z (in PRD2.SCEEBASE) should be used to do the update
- the LE/VSE Common Run Time Library
SKLE370 referring to CEECCSD.Z should be used to do the update
- the Language Specific Run Time Library for COBOL and/or PL/I, in case your applications are coded in those programming languages.
SKLE370 referring to IGZCCSD.Z (for COBOL) and IBMCCSD.Z (for PL/I) should be used to do the update.

For details about the Run Time Libraries see LE/VSE Installation and Customization Guide SC33-6682-00.

Member EQACCSD also provides the necessary support to run Debug Tool transaction DTCN . This member can be either found in ICCF library 62 or in 'Debug Tool for VSE/ESA' installation sublibrary PRD2.PROD.

In general there are three mechanisms available to invoke Debug Tool under CICS :

- Debug Tool CICS Interactive Utility via transaction DTCN. This transactions allows you to specify all debugging related requirements. You can specify terminal-ids for the debug session, supply the transaction-id of the application you wish to debug, and you can specify run-time options (e.g. TEST option) to override the active LE/VSE CICS run time options dynamically.

On the application side an INCLUDE EQADCCXT statement is required for inclusion during the link step of building an executable phase. Adding this user exit will be sufficient to invoke DTCN.

This is the recommended way to activate Debug Tool under CICS. For details see Debug Tool User's Guide and Reference page 107 ff.

- Linking a CEEUOPT module into the application, containing the appropriate TEST option. This tells LE/VSE to invoke Debug Tool for VSE/ESA every time the application is run.
- Run-time directive #pragma runopts(test) for C, or the PLIXOPT string for PL/I or CALL CEETEST within the application.

VSE Partition Requirements

The minimum recommended partition size for batch programs running with Debug Tool is 6 MB. Batch programs can run with Debug Tool in either a static or dynamic partition. The partition in which an interactive Debug Tool session starts is unavailable to other users for the duration of the Debug Tool session.

General Remarks for Activating Debug Tool for VSE/ESA

This is the general principle to invoke Debug Tool for VSE/ESA.

1. Either - compile the LE/VSE Conforming Application with compile option TEST, or - code library services like CEETEST, PLITEST or ctest() function within your application program to generate calls to the Debug Tool.
2. Run the LE/VSE Conforming Application with TEST run-time option to start a debugging session.

Here are some general attributes of Debug Tool for VSE/ESA you should be aware of.

- The VTAMLU (running in batch mode), or the terminal-id (running under CICS), where the debugger window is supposed to show up, must not be in session with another application when the debug session is started.
- Debug Tool for VSE/ESA is operating on compiler listings and must have access to them. Exception: using C for VSE/ESA, Debug Tool needs access to the program source.

Therefore those files must be stored and available when activating the Debug Tool.

- Debug Tool will check on compile units via accessing SAM files or AF-members in the Librarian 'library sublibrary' hierarchy.
- There is a predefined printer exits EQALIST which assists the user in storing compiler listings during compile time.
- SYSLST assignment to a SAM file prior to running the compile unit is an alternative, too. In this case the SAM file must be part of the JCL specified in the form USERID.CUNAME.LIST, where CUNAME is the name of the compile unit.

Debug Tool Customization and Verification Jobs

This is the list of members punched to ICCF library 62 during installation of the Debug Tool for VSE/ESA via the Interactive Interface. These jobs will assist you in various verification and customization steps.

EQACCS	Debug Tool - CICS CSD Definitions
EQACPCT	Debug Tool - CICS PCT Definitions
EQACPPT	Debug Tool - CICS PPT Definitions
EQAWAPPL	Debug Tool - Sample VTAM APPL Book
EQAWIVC1	Debug Tool Example - Verify COBOL/VSE batch program
EQAWIVC2	Debug Tool Example - Verify COBOL/VSE batch interface
EQAWIVC3	Debug Tool - Assemble runtime options for EQAWIVC4
EQAWIVC4	Debug Tool Example - Verify COBOL/VSE CICS interface
EQAWIVH1	Debug Tool Example - Verify C/VSE batch
EQAWIVH2	Debug Tool Example - Verify C/VSE batch interface
EQAWIVH3	Debug Tool Example - Verify C/VSE with CICS
EQAWIVP1	Debug Tool Example - PL/I VSE batch
EQAWIVP2	Debug Tool Example - PL/I VSE batch interactive
EQAWIVP3	Debug Tool Example - PL/I VSE CICS
EQAWUGC1	Debug Tool Example - COBOL Financial Sample Program
EQAWUGH1	Debug Tool Example - C/VSE Simple Calculator
EQAWUGP1	Debug Tool Example - PL/I VSE Simple Calculator

Figure 131. Debug Tool Customization and Verification Jobs

Limitations of Debug Tool for VSE/ESA

Debug Tool for VSE fully supports the process of debugging multi-language applications. There are no limitations when all the programs in the application were compiled with an LE-conforming compiler.

However, if the application contains programs compiled with non- LE-conforming compiler, Debug Tool will not support source-level debugging of those program units.

The application will execute unhindered while control is within a program written in an unsupported language. Debug Tool will regain control and allow debug commands to be issued once execution returns to a program unit written in a supported language, and compiled with TEST option.

Debug Tool for VSE does NOT support the cooperative mode of operation where the program being debugged is executing on a VSE/ESA host system and Debug Tool is executing on a programmable workstation (PWS).

Debug Tool for VSE cannot execute without an active LE/VSE environment, Release 1.4 or later.

Internet Link to Debug Tool for VSE/ESA 1.1.0

For a small introduction to the interactive debugger you might like to visit WEB-page

<http://software.ibm.com/ad/dtvse/>

Debug Tool Related Service

Before installing Debug Tool for VSE/ESA, it is recommended to check via IBM Level 1 Support for fixes contained in the VSE Service Buckets DTVSE110, VSELE140, and CVSE110.

This is a list of essential program fixes for Debug Tool know before July 1997.

- UQ02058 CICS ASRA at EXEC CICS LINK
- UQ01075 CICS ASRA, or screen lock during debug session
- UQ05134 Debug session terminal hang on VTAM Cross Domain session
- UQ04231 Addressing Exception with a COBOL figurative constant
- PQ05534 CICS ASRA or Abend U4083 RC3 when Debug Tool is concurrently active with other CICS GLUE (Global User Exit)
- PQ05878 Error in EQA50END at QUIT of debug session.

Debug Tool Related Usage Problems

This is an overview about most common usage problems with Debug Tool for VSE/ESA :

- Not having installed the LE/VSE specific C component 5686-094-08 (and optionally 5686-094-09 for Japanese support). This will lead to various problems as Debug Tool depends on this run-time support being considered a "C/VSE application".
- Even if having installed the C component the associated CICS CSD-file entries (or alternatively CICS PPT program definitions) must be in place. A CICS coldstart should always be done before relying on this support. Use skeleton "SKLE370" in ICCF lib 59 for such enablement.
- Debug Tool and Service. Usually PTFs for Debug Tool will replace OBJ-type members, and therefore require access to LE/VSE sublibrary PRD2.SCEEBASE when re-linking new control modules, i.e. phases.

Therefore please make sure sublibrary PRD2.SCEEBASE is included in the PERMANENT SEARCH LIBDEF chain running service upgrades. Otherwise the link output will show unresolved external references.

Actually sublibrary PRD2.SCEEBASE is not yet part of LIBDEF.PROC used by IUI building the PTF apply jobs. This restriction will be removed in the future.

Current program directories for VSE/ESA releases also point to this subject.

- "Batch Interactive" Debug Tool applications e.g. installation verification program EQAWIVC2 (ICCF lib 62) rely on having exclusive access to the terminal defined via the TEST runtime option (and MFI suboption for VTAM LU id). Therefore the terminal where you expect the Debug Tool window to pop up

Debug Tool

must NOT be busy with other applications. Dial to such terminals via explicitly specifying the "cuu" address and keep the following VTAM application screen you get directed to untouched - do NOT enter CICS!

Entering CICS on the terminal may show you the LU-id needed for the MFI suboption of TEST run-time option, PF4 will bring you back to the VTAM screen.

- "CICS Interactive" applications like EQAWIVC3 / 4 also rely on having exclusive terminal access. Nevertheless they require a ready CICS session e.g. a available via PF6 selection on the main entry panel of the "Interactive interface".

Note the difference to the batch interactive debug scenario, needing the VTAM screen.

- Never forget to catalog VTAM-book EQAWAPPL.B in PRD2.CONFIG sublibrary (which is already part of the VTAM startup LIBDEF chain). Otherwise Debug Tool interactive sessions can't be enabled via console command "V NET,ACT,ID=EQAWAPPL".

In case the current status is unsure use "D NET,APPLS" command in order to see whether Debug Tool definitions are part of the customers system.

- If the Debug session can't be established, e.g. the VTAM ACB could not be opened due to missing activation of EQAWAPPL, the input usually read by the Debug Tool remains on SYSIPT, and VSE Job Control will finally end up with message

```
1S01D INVALID STATEMENT
```

when trying to interpret it as JCL statements.

Chapter 19. Miscellaneous Hints and Tips

These are some hints and tips that did not fit into one of the previous sections.

How to get Control in BG during System Startup

Sometimes it is necessary to get control in BG before the very first job card is executed. Typically this is true if the hard copy or recorder file needs to be re-created. This can only be done before job control has opened such files. Opening of these files, however, happens with the first job card.

This describes a method to get control in BG before job control starts allowing to enter any create command for e.g. recorder or hard copy file. Follow these steps:

1. stop a normal IPL via IPLSTOP or external interrupt (depending on hardware)
2. enter your usual IPL procedure name, but for the JCL name enter a name of a procedure that does not exist
3. IPL will now start until message
BG-0000 1N20D PROCEDURE NOT FOUND
comes up.
4. now enter any command that needs to be entered before job control has started

How to Re-Format the Recorder or Hardcopy File

The recorder or hardcopy file can only be recreated (formatted) during IPL before the first job card was executed. After the first job card was executed these files are opened and cannot be formatted any more.

See "How to get Control in BG during System Startup" how to get control in BG during IPL before the first job card is executed. Then enter the following to recreate the recorder file:

1. enter '**0 set rf=create**'
2. system responds
BG-0000 0D16D READY FOR COMMUNICATIONS
3. enter '**0 // JOB XXXX**'
4. system responds
BG-0000 4433D EQUAL FILE ID IN VTOC IJSYSRC
SYSREC = 159 SYSWK1 VSE RECORDER FILE
5. enter '**0 delete**', now formatting begins and control is returned to user after file was formatted
6. now IPL normally

The same procedure can be used to recreate the hardcopy file. Use

'0 set hc=create'

instead.

Important: If the hardcopy or recorder file must be moved to another volume, be aware that both files must reside on the same volume. If you need to move one file then both files must be removed. The IPL DEF SYSREC=cuu must also be changed along with the STDLABEL info for both files.

SDAID GETVIS/FREEVIS TRACE

Is opposed to a simple SVC trace (3E,3D) which only records the execution of instructions, this new trace type offers now the capability to record the full results of all GETVIS/FREEVIS requests as provided by the VSE GETVIS/FREEVIS supervisor routines.

GETVIS TRACE command

TRACE GETVIS=target SUBPOOL=name LOCATION=region

target = PARTition

SPACE

SVA

name = SUBPOOL NAME. If omitted all subpools are traced. If the

subpool name contains characters which have to be treated

treated as hex-characters, enclose them in <..>.

E.G: SUBPOOL=MYPOOL

SUBP=INLC<0021>

region = BELow Trace only requests in 24 bit getvis area

ANY Trace requests in 24/31 bit getvis area

if omitted, ANY is assumed.

All other TRACE parameters like OUTPUT, LOCATION etc are still valid.

You may invoke SDAID in PROMPTING MODE to get a step by step guidance when entering "15 ?" to the systems response.

ICKDSF Changes with VSE/ESA 2.x

With ICKDSF 16.0 (VSE/ESA 2.x) at least 8 MB of storage are needed. Under VM, enter DEF STOR xxM (8M or more) before IPL cuu.

ICKDSF command

INIT UNIT(cuu) ... MIMIC(MINI(...)) ..

to define minidisks is no longer supported.

The BSD-C Trace Capability of TCP/IP for VSE/ESA

Overview

TCP/IP for VSE/ESA provides two C application programming interfaces - the BSD-C interface and the TCP/IP-C-LE interface. Both interfaces are related to each other because the TCP/IP-C-LE interface is built on the BSD-C interface.

If it is important or required, for example for problem determination, to get an understanding which underlying BSD-C function calls are used by an application which is exploiting the TCP/IP-C-LE interface, the BSD trace capability of TCP/IP for VSE/ESA can be used.

Installation

To get the BSD trace active the phase XSOCKDBG.PHASE which is contained in the TCP/IP installation library PRD1.BASE must be renamed or copied to the member \$SOCKDBG.PHASE. After this change, the TCP/IP partition and any application which needs to be debugged must be recycled. For tracing it is important that the application which should be traced has the \$SOCKDBG.PHASE in access. If multiple TCP/IP applications exist but only one should be traced, the \$SOCKDBG.PHASE can be copied to a private library which is only accessible to this specific application.

Output of the Trace

Immediately after the TCP/IP-C-LE application is started again, which means as soon as the first socket() call is issued by the program, the following message is issued

```
BSD001I $SOCKLST 01.04.00 05/30/00 14.16 ...addresses...
```

and additionally the following (or similar) information is issued:

```
BSD001I IPNRSOCK 01.04.00 06/07/00 11.42 ...addresses...
BSD002I IPNRSOCK R15=00000000 RETCD=GOOD ERRNO=NONE
```

In this example, the IPNRSOCK indicates that the BSD-C call socket() was issued at that point in time.

The BSD001I message indicates that the module was entered. Here the date and time when this module was compiled can also be found.

The BSD002I message indicates that the module was left. R15=0 indicates no error during the processing which is also shown through RETCD=GOOD and ERRNO=NONE.

The following module names represent the most important related BSD-C function calls:

Miscellaneous Hints/Tips

IPNRACCP - accept()
IPNRAIOR - aio_read()
IPNRAIOW - aio_write()
IPNRBIND - bind()
IPNRCLOS - close()
IPNRCONN - connect()
IPNRGETC - getclientid()
IPNRGETS - getsockopt()
IPNRGHBA - gethostbyaddr()
IPNRGIVE - givesocket()
IPNRLIST - listen()
IPNRRECV - receive()
IPNRSELE - select()
IPNRSEND - send()
IPNRSETS - setsockopt()
IPNRSOCK - socket()
IPNRTAKE - takesocket()

Special Considerations for Some Function Calls

The following has to be considered when using some of the function calls.

When an accept() or takesocket() is successful, the R15 does not contain an error indication but contains the returned socket number.

If a call is returning unsuccessful with R15=FFFFFFFF (representing -1) the ERRNO contains the TCP/IP internal error indication. This error indication is translated by the TCP/IP-C-LE interface to an LE compliant ERRNO value.

Recommendation

In case a problem situation requires a more insight view as to which TCP/IP function calls are issued by a TCP/IP-C-LE application, the BSD trace should be analyzed together with other important trace data. If an MQSeries for VSE/ESA V2.1 problem has to be investigated the BSD trace should be analyzed together with a CICS AUX trace and relevant MQSeries trace information.

Documentation

Further documentation of the BSD trace capability of TCP/IP for VSE/ESA can be found in Info APAR II11836. The BSD-C function calls are described in the manual *TCP/IP for VSE 1.4 Programmer's Reference*, and the TCP/IP-C-LE interface in the manual *TCP/IP for VSE/ESA - IBM Program Setup and Supplementary Information*, SC33-6601.

Index

Special Characters

\$DTSUTIL 298

Numerics

3270 emulation program 285
3274 control unit 287

A

abend DM02 297
ABEND dump 13
AMODE 24 applications 242
APVU 285
AR commands, see COMMANDS 37
ARX0110I 217
ARX0112I 217
ARX0565I 217, 222, 224
ARXEOJTB 222
ARXLINK 217

B

BLN2013I 297
BLNDMF 11
BLNXRTN 11
bootstrap record, build 303
BSD Trace of TCP/IP 321

C

CANCEL 1, 4
CICS (VSAM) 180, 183
CICS PLT shutdown 296
CICS PLT startup 296
CICS-Coexistence 249
COBOL Reusable Environment (optional) 240
codes in low core, see 'low core'
COMMAND IGNORED 4
COMMANDS Internal
 (P)STACK 61
 DEBUG 37
 SHOW 39
 STOP 38
 GETVIS 39
 SIR 43
 ? 43
 CHPID 59
 CRWMSG 60
 HELP 43
 MIH 58
 MON 56
 no operand 44

COMMANDS Internal (*continued*)

SIR (*continued*)

 RESET 52
 SMF 52
 SYS 52
 STATUS 71
 cuu 71
 TAPE 74
 TIME 75
 VOLUME 77
 TAPE 77
common abend conditions, LE/VSE 245
 Related Service 247
compression (VSAM) 177
Conditional job control 107
connection error, terminal 295
Connectors (VSE/ESA e-Business) 309
 CA Flee 310
 CA TopSecret 310
 codepages 310
 installation 309
 known problems 309
 logon 310
 tracing 312
 VSAM access 311

Console

 buffer space, waiting for 98
 console diagnostics 88
 console dump, how to get a 89
 CORCMD 89
 fullscreen mode 87
 hints 323 tips 96
 hungup 99
 integrated console 88
 IUI console 87
 line mode 87
 MESSAGE indicator blinking 97
 Message Prefix 99
 Reply-Id 99
 suspended console 98
 system console 87
 VMCF console 88
CORCMD 89
corrupted history file 10
corrupted library 10
CSD file upgrade 298
customization jobs 238
 COBOL Reusable Environment (optional) 240
CUT mode 285

Hints and Tips for VSE/ESA

D

- DASD file protection 199
- date 324 time 34
- daylight saving time 35, 75
- DDM error code 291
- deactivate Interactive Interface 296
- deadlock 4
- DEBUG 1, 7
- DEBUG command 37
- DEBUG SHOW command 39
- DEBUG STOP command 38
- debug tool 313
 - activating the debug tool 315
 - CEEUOPT 314
 - CICS considerations 313
 - customization 315
 - DTCN 314
 - EQADCCXT 314
 - limitations 316
 - partition requirements 314
 - problems using debug tool 317
 - runtime environment 313
 - SKLE370 314
 - verification jobs 315
 - VTAM considerations 313
- debugging in a CICS coexistence environment 257
- device check loop 4
- DEVICE NOT OPERATIONAL 8
- DFHDAP 11
- DFHPLTSD 296
- DFSMS/RMS reason codes 235
- DFT mode 285
- display VSE/ESA level 293
- DITTO
 - DLA 118
- DLA statement 124
- DLBL, REXX JCL environment 220
- DM02 abend 297
- Doc links 248
- DOSRES (VSAM) 183
- DOSVSDMP 13, 14
- DTF 9
- DTR\$DTBL 300
- DTRLxxx 299
- DTSICCF 296
- DTSPSTI 296
- DTSSHUT 296
- DUMP 13
- DUMP command 1, 13
- dump management file BLNDMF 12
- dump management file, initialization 297
- dump options 13
- dumps, names of loaded 12

E

- ENDSD 6
- error messages, in general 8
- Extend the VSE Dump Library 305
- extended data stream 287
- external interruption 6

F

- Fast Service Upgrade (FSU) 298
- FCOPY (VSAM) 188
- file transfer AID bit 288
- file transfer return codes 290
- file transfer, IWS 285
- FINDMSG 222
- FSU, Hints and Tips 301
- FTTERM 288
- FTTERM configuration problems 288

G

- generating applications 241
 - Overriding Run-Time Options 242
- GETMSG 222
- GETQE 219
- GETVIS command 39

H

- hard copy file 8
- hard wait 2
- hard wait PSW 7
- hard wait states 6
- hardcopy file, reformat 319
- hardware configuration 287, 288
- Hints and Tips about "CICS TS for VSE/ESA 1.1.1" 261
- history file backup/restore 294
- history file corrupted 10
- history file damaged 294
- history file recreation 11
- history file, merge 294
- history file problem 10
- Host Transfer File (HTF) 286

I

- ICCF library, find system member 300
- ICKDSF, changes with VSE/ESA V2 320
- IDCAMS 180, 189
- IESCICIN 296
- IESCICSD 296
- IESCNTL 183
- IESMSGs, online message explanation file 295
- IESTRFL file damaged 293

IESZNEP, node error program 295
 IESZPLTI 296
 IJBREPB 303
 IJSYSDI 16
 IJSYSDU 16
 IKQVDU 180, 189
 IND\$ 285
 IND\$FILE 285
 Info/Analysis 13
 Info/Analysis partition space 11
 initialize dump management file 297
 Interactive Interface, deactivate 296
 INTERVENTION REQUIRED 5
 INW0001I 288
 INW0002I 288
 INWPCCOM 285
 INWPGET1 288
 INWPRCVE 288
 IPF error 299
 IPL date 325 time 34
 IPL statements
 DLA 124
 IPL, get control during 319
 IWS file transfer 285
 IWS messages, return codes 290
 IWS Trace 286

J

Job Control
 \$ABEND 109
 \$CANCEL 110
 \$JOBACCT 110
 \$MRC 107
 \$RC 107
 ACANCEL option 111, 113
 cataloged procedures 104
 CLASSTD option 120, 125
 command input buffer 101
 command table 101
 comment statements 115
 conditional job control 103, 107, 111
 error handling 111
 error messages 111
 eyecatcher 106
 initialization 101
 JCANCEL option 111, 113
 JCL phases 101
 job accounting 110
 job control dump 105
 job control phases 101
 label information area 104, 115
 label information record 104, 116
 LOG option 114
 maximal return code 107
 PARSTD option 120, 125

Job Control (*continued*)
 partition save area 105
 register conventions 105
 return code of a job step 107
 root phase 101
 SCANCEL option 111, 112
 statement logging 114
 STDLABEL option 120, 125
 subphases 101
 SVA-resident command-processors 103
 SVA-resident service routines 103
 symbolic parameters 104
 user exit routine(s) 101
 USRLABEL option 120, 125

Job Control Commands

/* 115
 * 115
 DLBL 116
 EXEC PROC=STDLABEL 121, 124
 EXTENT 116
 LOG 113, 114
 ON \$ABEND 109
 ON \$CANCEL 110, 111, 112
 ON \$RC 109, 112
 OPTION ACANCEL 111
 OPTION CLASSTD 120, 125
 OPTION JCANCEL 111
 OPTION LOG 114
 OPTION PARSTD 120, 125
 OPTION SCANCEL 111, 112
 OPTION STDLABEL 120, 125
 OPTION USRLABEL 120, 125
 SET MRCZERO 107, 109, 112
 SET RCZERO 107
 STDOPT 114
 TLBL 116
 VDISK 119, 121, 124
 Jobs for CICS Dumps 257

L

label area 9, 115
 /&-processing 125
 capacity 115, 121, 122
 DLA statement 124
 free-usage labels 119, 123, 126
 GETVIS consumption 124
 history table 124
 label area segment 119
 label group 120
 label information record 116
 label information search order 123
 label subarea 116
 layout 115
 lifetime of label groups 125
 program termination 125

Hints and Tips for VSE/ESA

label area (*continued*)
 SIR command 119
 storage requirements 124
languages and CICS TS 241
LBSERV reason codes 229
LCDD reason codes 233
LE/VSE
 common abend conditions 245
 customization jobs 238
 generating applications 241
 languages and CICS TS 241
 LE/VSE Big Picture 237
 run time options 243
LE/VSE Big Picture 237
 The LE/VSE 1.4.2 View 237
LIBLIST 10
LIBR (VSAM) 180
Librarian 159
 assigned, not uniquely 162
 BACKUP abends 161
 BACKUP/RESTORE, space usage 175
 cancel librarian 175
 corrupted library 160
 define library 161
 delayed space, releasing 168
 extending shared libraries 171
 level 2 functions 176
 library full 160, 172
 library in VSAM 180
 member not found 165
 performance 165
 RELEASE SPACE 162, 165, 168
 RESTORE 162
 REUSE attribute 167
 scattered library 173
 shared libraries 169
 TEST command 164
 TRACE command 176
 VSAM 181
library corrupted 10
LIBRM 159
LISTDIR 10
lock (VSAM) 183
lock file
 error on lock file 30
 LOCK SHOW command 32
 LOCK TRACE command 33
lock manager return codes 187
lock trace 33
LOG job control statement 8
loop 2
loop, processor 3
low core locations 7
low core, codes in
 07E6 3
 08C1 5

low core, codes in (*continued*)
 62C1 6
 62C5 6
 62E2 6
LPAR 9
LSERV 9, 117
LVTOC 9

M

MAPXPCCB reason codes 233
MAPXPCCB return codes 231
MCSOPER 222
MCSOPMSG 222
MERGE 11
merge history file 294
Messages
 0P31A Device Not Operational 8
 0S06I A Dump Macro Was Issued 11
 0T01E Error on Lock File 30
 1RF0I cmdcode Operand nn Current DBLK Size
 nnnnn Too Big 152
 4226I / 4227I Automatic Close 201
 4228I File Open Error 183, 191, 202
 4936I No More AVAIL/MATCH XTNT 10
 4G37I Error on Dump Tape cuu 17
 ARX0565I MCSOPMSG Failed
 RC=(0012,0000) 222
 ARX0565I MGCRE Failed, RC=(0008,0018) 224
 ARX0950E RC=0004,FDBK=0001 received from
 VSE/POWER command 219
 BLN2013I Dump Management File Error 297
 BLN2013I Dump Management File in Error 12
 IDC31340 Backup File in Error 191
 IDC3299I Invalid Parameter Combination ... 202
 INW0001I 288
 INW0002I 287, 288
 K088I HI FILE RECORDS = 0 214
 L151I Unexpected Return Code From
 MACRO/MODULE nnn ... 160
 L152I Entry Condition For Module nnn In Phase
 ... 160
 Program Not Defined To CICS 298
 R003I REXX/VSE Exec Processing Failed, Return
 Code 20 217
 TRANS10 timeout 288
MGCRE 222
Mismatch History File - Dialogs 295
mixed language applications 238
Move VSE/POWER Data File 304
MVS VSAM, import/export 190

N

node error program IESZNEP 295

NODUMP 13

O

OFFLOAD tape 149
 OME 8
 ONLINE command 8
 ONLINE cuu 9
 Online Messages Explanation file, restore 295
 open file error 9
 operator communication, tracking 223
 OUTTRAP 219
 Overriding Run-Time Options 242
 AMODE 24 applications 242

P

PARTDUMP 13
 partition balancing 81
 phase not found 10
 POWER
 Command Driven Job Output Segmentation 138
 Internal queue entry number used in displays and
 commands 142
 New PICKUP Operand for VSE/POWER
 POFFLOAD 147
 POFFLOAD command 151
 print output misaligned 152
 PSTART command for local writer 146
 RJE,SNA RUSIZE Increased from 256 Bytes to 4096
 Bytes 146
 Showing Partition in Which Active Job Runs 143
 spooling considerations 154
 startup values 130
 Tape Processing 149
 TCP/IP Connection to RSCS 156
 Transmission Queue Disposition 144
 PRB\$TEM1 not found 297
 PRB\$TEM2 297
 PRB\$TEM3, what is contained in this member 297
 PRINTLOG 8
 Problem Analysis 1
 Problem in abend processing 257
 processor loop 3
 PROGRAM INTERRUPT LOOP 3
 PROGRAM NOT DEFINED TO CICS message 298
 PSW
 000A0000 00001000 7
 000A0000 0000EEEE 7
 000A0000 00CE0000 17
 000A0000 00CExxxx 7, 17
 000A0000 00EEEEEE 7
 010E0000 0000EEEE 6
 010E0000 00EEEEEE 6
 040E0000 00002000 7
 Important PSW Bits 2

Q

quiesce CPUs 82

R

RBA (VSAM) 177
 real dump 18
 recorder file, reformat 319
 Recreation of libraries 160
 REDISPLAY 8
 Related Service 247
 Doc links 248
 REPLID 1
 RESTART POINT BYPASSED 4
 restore OME file 295
 RETRACE 11
 return code, Job Control 107
 return codes of file transfer 290
 return codes of lock manager 187
 REUSE attribute, librarian 162, 167
 REXX functions 218
 REXX program DMPMGR 306
 REXX samples 218
 REXX/VSE 217
 Console Command Environment 222
 console suspended 222
 JCL Command Environment 220
 LINK Command Environment 222
 POWER Command Environment 219
 REXX and ICCF 225
 REXX and VSAM 226
 REXX SOCKET function 217, 224
 tracking operator communication 223
 run time options, LE/VSE 243

S

SDAID 6, 13, 19
 branch trace 22
 cancel trace 22
 ENDSD 20
 I/O interruption trace 23
 instruction trace 23
 OUTDEV 19, 21
 program load trace 23
 SDINST 27
 SDLOAD 27
 SDPGMC 27
 STARTSD 20
 STOPSD 20
 storage alteration trace 24
 SVC trace 24, 27
 TRACE 21
 SDAID monopolizes system 4

Hints and Tips for VSE/ESA

- SDAID problem 4
 - SDAID start I/O trace 286
 - SEARCH library member 10
 - Security 249
 - Array overflow 254
 - ASMA013S 254
 - ASMA254I 254
 - B-Transients 253
 - CA-Top Secret 258
 - CICS coexistence 254
 - DFH3500I 254
 - DFH3522I 254
 - DFH3531I 254
 - DFH3608I 254
 - DFHSITCO 254
 - DFHSNT 254
 - DFHSNTCO 254
 - DFHXSE 254
 - DFHXSSCO 254
 - Documentation 258
 - DTSECTAB 253, 254
 - DTSECTXN 254
 - Shared CSD file 254
 - SEND CMD 224
 - SENSE 8
 - SETUID 219
 - shared libraries 169
 - SHAREOPTIONS (VSAM) 183
 - Sharing the VSE Control File between VSE/ESA systems 304
 - SHR (VSAM) 183
 - SIR CHPID command 59
 - SIR command 43, 119
 - SIR CRWMSG command 60
 - SIR MIH command 58
 - SIR MON command 56
 - SIR RESET command 52
 - SIR SMF 52
 - SIR SYS command 52
 - Skeletons for CICS Dumps 257
 - SKRSTRFL 293
 - SOCKET debugging, REXX/VSE 224
 - SOCKET implementation, REXX/VSE 224
 - SOCKET setup, REXX/VSE 217
 - soft wait 2
 - soft wait states 5
 - Spooling 154
 - STACK command 61
 - stand-alone dump 3
 - capacity problems 17
 - dump into a library 17
 - errors occurring during processing a 17
 - real dump 18
 - taking a 16
 - virtual dump 18
 - stand-alone dump program 14
 - stand-alone supervisor 7
 - STATUS 1
 - STATUS command 71
 - STOPSD 6
 - storage dump 1
 - Storage Dump Management Dialog 257, 296
 - STORE STATUS 16
 - suspended console, REXX 222
 - switch off, terminal 295
 - system date 328 time 34
 - system startup, get control during 319
 - SYSWK1 (VSAM) 183
- ## T
- TAPE command 74
 - TCP/IP BSD Trace 321
 - TERM CON 3215 87
 - TERM CON 3270 87
 - terminal connection error 295
 - terminal switched off 295
 - TEST library 10
 - TEST, librarian command 164
 - text repository file 293
 - The LE/VSE 1.4.2 View 237
 - mixed language applications 238
 - TIME command 75
 - time, adjusting daylight saving 75
 - time, daylight saving 35
 - TIMEOUT 288
 - TOD clock 34
 - TRACE a program 18
 - trace capability of TCP/IP (BSD-C trace) 321
 - tracing under VM 29
 - TRANS10 hangs 287
 - TRANS10 timeout 288
 - Transaction Security 258
 - Turbo Dispatcher
 - design 79
 - Example 80
 - partition balancing 81
 - quiesce CPUs 82
- ## U
- update DTRIHIST.Z 295
 - userid already in use 295
- ## V
- VGS reason codes 227
 - virtual dump 18
 - VM trace 29
 - VOL1 Label (VSAM) 181

VOLUME TAPE command 77

VSAM

- allocation 178
- backup file integrity 191
- backup/restore 178, 180, 181, 190
- blocks 190
- CA splits 204
- catalog 188, 189, 194
- catalog backup 197
- catalog check 198
- catalog corruption 180
- catalog corruption causes 194
- catalog cross-system sharing 194
- catalog full 200
- catalog maintenance 178
- catalog organization 197
- catalog precautions 196
- catalog, enlarge a 178
- catalog, re-build a 180
- catalog, read-only 196
- catalog, reorganize a 178
- CMS/VSAM 191
- COBOL 182
- DASD file protection 199
- dataset name sharing 181
- default model 180, 181, 188, 201
- default model, missing 202
- delete space 180
- DOSRES 183, 188, 189
- EXPORT 180
- EXPORT DISCONNECT 180, 188
- extent 189
- FCOPY 188
- file full 200
- file not found 188
- IDCAMS 180, 189
- IKQVCHK 198, 204
- IKQVDU 180, 189
- IMPORT CONNECT 181, 189
- import/export MVS 190
- index levels 178
- integrity problems, read 199
- LIBR 180
- library 181, 188
- LISTCAT 180
- lock 183
- master catalog 181, 188, 189
- master catalog migration 188
- migration 188
- MVS import/export 190
- OPEN 183
- open error 183
- performance degradation 178
- physical medium failure 203
- PL/I 182
- portable datasets 190

VSAM (continued)

- rc 168 x'A8' 183
- rc 254 x'FE' 187
- reorganize a catalog 178
- reorganize a file 178
- REPRO 180
- SHAREOPTIONS 183
- SHR 183
- SYSWK1 183, 188
- user catalog 188, 189
- VOL1 label 181
- VTOC 180, 181
- VTOC, delete entry 189
- VSE job fails 8
- VSE label area 115
- VSE/ICCF 213
 - compressed members 214
 - DTSFILE extension 214
 - library 213
 - submit to batch 213
 - uncompress members 214
 - UPIP flag 214
- VTAM buffer trace 286
- VTOC 9
- VTOC (VSAM) 180, 181

Z

- ZONE option on IPL SET command 34

Communicating Your Comments to IBM

If you especially like or dislike anything about this book, please use one of the methods listed below to send your comments to IBM. Whichever method you choose, make sure you send your name, address, and telephone number if you would like a reply.

Feel free to comment on specific errors or omissions, accuracy, organization, subject matter, or completeness of the book. However, the comments you send should pertain to only the information in this manual and the way in which the information is presented. To request additional publications, or to ask questions or make comments about the functions of IBM products or systems, you should talk to your IBM representative or to your IBM authorized remarketer.

When you send comments to IBM, you grant IBM a nonexclusive right to use or distribute your comments in any way it believes appropriate without incurring any obligation to you.

- If you prefer to send comments by mail, use the RCF form and send it directly to:

IBM Deutschland Entwicklung GmbH
Department 3252
Schoenaicher Strasse 220
D-71032 Boeblingen
Federal Republic of Germany

- If you prefer to send comments by FAX, use this number:

(Germany): 07031+16-2636
(Other countries): (+49)+7031-16-2636

- If you prefer to send comments electronically, use this Internet address:

s390id@de.ibm.com

Make sure to include the following in your note:

- Title and edition of this book
- Page number or topic to which your comment applies.

Readers' Comments Form

Overall, how satisfied are you with the information in this book?

	Very Satisfied	Satisfied	Neutral	Dissat.	Very Dissat.
Overall Satisfaction					

How satisfied are you that the information in this book is:

	Very Satisfied	Satisfied	Neutral	Dissat.	Very Dissat.
Accurate					
Complete					
Easy to find					
Easy to understand					
Well organized					
Applicable to your tasks					

Please tell us how we can improve this book:

Thank you for your responses. May we contact you? Yes No

When you send comments to IBM, you grant IBM a nonexclusive right to use or distribute your comments in any way it believes appropriate without incurring any obligation to you.

Name

Address

Company or Organization

Phone No.

Hints and Tips for VSE/ESA

1 Fold along this line

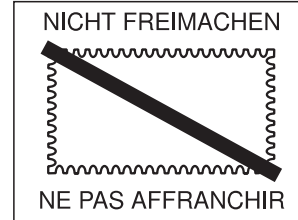

WERBEANTWORT / RÉPONSE PAYÉE
POSTAGE WILL BE PAID BY ADDRESSEE

RÉP. FÉD. D'ALLEMAGNE

IBM Entwicklung GmbH
Dept. 3252
Schönaicher Str. 220
D-71032 Böblingen

Federal Republic of Germany



2 Fold along this line

3 Fasten here with adhesive tape





Printed in Germany

